



MELSOFT

MR Configurator2 Version1

MODEL

SW1DNC-MRC2- _

INSTALLATION GUIDE

Thank you for choosing the MELSOFT MR Configurator2.
To optimize the use of the MR Configurator2, please read over this Installation Guide and the instruction manual of the servo amplifier unit and etc. to be used before using the software. After reading the Installation Guide, always place this Installation Guide in a safe place.

● Safety Instructions ●

(Always read these instructions before using the equipment.)

Do not attempt to install, operate, maintain or inspect the servo amplifier and servo motor until you have read through this Installation Guide, and appended documents carefully and can use the equipment correctly. Do not use the servo amplifier and servo motor until you have a full knowledge of the equipment, safety information and instructions.

In this Installation Guide, the safety instruction levels are classified into "WARNING" and "CAUTION".





Indicates that incorrect handling may cause hazardous conditions, resulting in death or severe injury.





Indicates that incorrect handling may cause hazardous conditions, resulting in medium or slight injury to personnel or may cause physical damage.

Note that the CAUTION level may lead to a serious consequence according to conditions. Please follow the instructions of both levels because they are important to personnel safety.

What must not be done and what must be done are indicated by the following diagrammatic symbols:

: Indicates what must not be done. For example, "No Fire" is indicated by .

: Indicates what must be done. For example, grounding is indicated by .

In this Installation Guide, instructions at a lower level than the above, instructions for other functions, and so on are classified into "POINT".

After reading this Installation Guide, always keep it accessible to the operator.

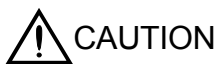

▪ Before executing the test mode, always read section 3.1 "Precautions for test mode".

CONTENTS

1. INTRODUCTION	1- 1 to 1-19
1.1 Specifications	1- 1
1.2 System configuration	1- 8
1.2.1 Components	1- 8
1.2.2 Configuration	1-10
1.3 Basic terms.....	1-13
1.4 Installation procedure.....	1-14
1.5 Automatic device driver software installation	1-18
2. HOW TO USE THE SOFTWARE	2- 1 to 2-10
2.1 Operation.....	2- 1
2.1.1 Start-up	2- 1
2.1.2 Project.....	2- 2
2.1.3 Servo parameters.....	2- 6
2.2 Commands and display windows	2- 8
3. PRECAUTIONS	3- 1 to 3- 2
3.1 Precautions for test mode.....	3- 1
3.2 Display language switching	3- 2
4. TROUBLESHOOTING	4- 1 to 4- 4

1. INTRODUCTION

1. INTRODUCTION

1.1 Specifications

Using the communication function of the servo amplifier, the MR Configurator2 allows functions, such as parameter setting change, graph, program operation mode and test mode, to be implemented from a personal computer.

When connecting to the servo amplifier (MR-J5 series/MR-JET series) *6

Servo amplifier		MR-J5-A (-RJ)	MR-J5-G (-RJ)*5	MR-J5-G -N1	MR-JET-G	MR-JET-G -N1
Communication Method	USB	○	○	○	○	○
	RS-422(RS-232C)	○	○	○	○	○
	Ethernet	○	○	○	○	○
Parameter	Parameter Setting	○	○	○	○	○
	Network Parameter	○	○	○	○	○
	Axis Name Setting	○	○	○	○	○
	Parameter Converter	○	○	○	○	○
Safety	Safety Parameter Setting	○	*7○	*7○	○	○
	Change Password	○	*7○	*7○	○	○
	Initialize Password	○	*7○	*7○	○	○
Positioning-data	Point Table	○	○	○	○	○
	Program	○	○	○	○	○
	Indirect Addressing	○	○	○	○	○
	Cam Data	○	○	○	○	○
Monitor	Display All	○	○	○	○	○
	I/O Monitor	○	○	○	○	○
	Graph	○	○	○	○	○
	ABS Data Display	○	○	○	○	○
	Object Monitor	○	○	○	○	○
Diagnosis	Alarm Display	○	○	○	○	○
	Alarm Onset Data	○	○	○	○	○
	Drive Recorder	○	○	○	○	○
	No Motor Rotation	○	○	○	○	○
	System Configuration	○	○	○	○	○
	Life Diagnosis	○	○	○	○	○
	Machine Diagnosis	○	○	○	○	○
	Gear Failure Diagnosis	○	○	○	○	○
	Encoder Communication Circuit Diagnosis	○	○	○	○	○
	Fully Closed Loop Diagnosis	*1○	*1○	*1○	○	○
Linear Diagnosis	*2○	*2○	*2○	*2○	*2○	
Test Mode	JOG Mode	*3○	*3○	*3○	*3○	*3○
	Positioning Mode	○	○	○	○	○
	Motor-less Operation	*4○	*4○	*4○	*4○	*4○
	DO Forced Output	○	○	○	○	○
	Program Operation	○	○	○	○	○
	Single-step Feed	○	○	○	○	○
	Test Mode Information	○	○	○	○	○
Adjustment	One-touch Tuning	○	○	○	○	○
	Tuning	○	○	○	○	○
	Multi-axis Tuning	○	○	○	○	○
	Machine Analyzer	○	○	○	○	○
	Advanced Gain Search	○	○	○	○	○
Tools	Update Parameter Setting Range	○	○	○	○	○
	Machine Unit Conversion Display Setting	○	○	○	○	○

*1 Only available when operation mode is Fully closed loop control mode.

*2 Only available when operation mode is Linear servo motor control mode.

*3 Not available when operation mode is Linear servo motor control mode.

*4 Only available when operation mode is Standard control mode.

*5 Switching to multi-axis project available.

*6 The software reset is supported.

*7 Only available when it is MR-J5-G-RJ, MR-J5W2-G or MR-J5W3-G.

1. INTRODUCTION

When connecting to the servo amplifier (MR-J4 series)

Servo amplifier		MR-J4-A (-RJ)	MR-J4-B (-RJ)*5 *6	MR-J4-B -LL	MR-J4-B -RJ010	MR-J4-TM	MR-J4-GF (-RJ)*13
Communication Method	USB	○	○	○	○	○	○
	RS-422(RS-232C)						
	Ethernet						○
Parameter	Parameter Setting	○	○	○	○	○	○
	Network Parameter						
	Axis Name Setting	○					
	Parameter Converter	*4○					*4○
Safety	Safety Parameter Setting	*7*8○	*8*9○			*8○	*8*12○
	Change Password	*7*8○	*8*9○			*8○	*8*12○
	Initialize Password	*7*8○	*8*9○			*8○	*8*12○
Positioning-data	Point Table	*7○					*11○
	Program	*7○					
	Indirect Addressing	*7○					
	Cam Data	*7○					*11○
Monitor	Display All	○	○	○	○	○	○
	I/O Monitor	○	○	○	○	○	○
	Graph	○	○	○	○	○	○
	ABS Data Display	○	○	○	○	○	○
	Object Monitor						
Diagnosis	Alarm Display	○	○	○	○	○	○
	Alarm Onset Data	○	○	○	○	○	○
	Drive Recorder	○	○	○	○	○	○
	No Motor Rotation	○	○	*10○	○	○	○
	System Configuration	○	○	○	○	○	○
	Life Diagnosis	○	○	○	○	○	○
	Machine Diagnosis	○	○	○	○	○	○
	Gear Failure Diagnosis						
	Encoder Communication Circuit Diagnosis						
	Fully Closed Loop Diagnosis	*1○	*1○			*1○	*1○
Linear Diagnosis	*2○	*2○			*2○	*2○	
Test Mode	JOG Mode	*3○	*3○	○	○	*3○	*3○
	Positioning Mode	○	○	○	○	○	○
	Motor-less Operation	*4○	*4○		○	*4○	*4○
	DO Forced Output	○	○		○	○	○
	Program Operation	○	○	○	○	○	○
	Single-step Feed	*7○					*11○
	Test Mode Information	○	○	○	○	○	○
Adjustment	One-touch Tuning	○	○	*10○	○	○	○
	Tuning	○	○	○	○	○	○
	Multi-axis Tuning						
	Machine Analyzer	○	○	○	○	○	○
	Advanced Gain Search						
Tools	Update Parameter Setting Range	○	○	○	○	○	○
	Machine Unit Conversion Display Setting		○	○	○		

*1 Only available when operation mode is Fully closed loop control mode.

*2 Only available when operation mode is Linear servo motor control mode.

*3 Not available when operation mode is Linear servo motor control mode.

*4 Only available when operation mode is Standard control mode.

*5 The same as MR-J3-B in MR-J3-B compatibility mode.

▪ Standard control mode: MR-J3-B

▪ Fully closed control mode: MR-J3-B-RJ006

▪ Linear servo motor control mode: MR-J3-B-RJ004

▪ DD Motor control mode: MR-J3-B-RJ080W

*6 The same as MR-J4-B (-RJ) in MR-J3-B extension function (Several restrictions).

Please select the "MR-J3-B extension function" when using as MR-J3-B extension function.

*7 Only available when it is MR-J4-A-RJ.

*8 Functional safety unit MR-D30 is necessary.

*9 Only available when it is MR-J4-B-RJ.

*10 Cannot be used in pressure control mode.

*11 Only available when station-specific mode is I/O mode.

*12 Only available when it is MR-J4-GF-RJ.

*13 Switching to multi-axis project available.

1. INTRODUCTION

When connecting to the servo amplifier (MR-JE series)

Servo amplifier		MR-JE-A	MR-JE-B(F)	MR-JE-C*1
Communication Method	USB	○	○	○
	RS-422(RS-232C)			
	Ethernet			○
Parameter	Parameter Setting	○	○	○
	Network Parameter			
	Axis Name Setting	○		
	Parameter Converter	○		
Safety	Safety Parameter Setting			
	Change Password			
	Initialize Password			
Positioning-data	Point Table	○		○
	Program	○		
	Indirect Addressing	○		
	Cam Data	○		
Monitor	Display All	○	○	○
	I/O Monitor	○	○	○
	Graph	○	○	○
	ABS Data Display		○	○
	Object Monitor			
Diagnosis	Alarm Display	○	○	○
	Alarm Onset Data	○	○	○
	Drive Recorder	○	○	○
	No Motor Rotation	○	○	○
	System Configuration	○	○	○
	Life Diagnosis	○	○	○
	Machine Diagnosis	○	○	○
	Gear Failure Diagnosis			
	Encoder Communication Circuit Diagnosis			
	Fully Closed Loop Diagnosis			
Linear Diagnosis				
Test Mode	JOG Mode	○	○	○
	Positioning Mode	○	○	○
	Motor-less Operation	○	○	○
	DO Forced Output	○	○	○
	Program Operation	○	○	○
	Single-step Feed	○		
	Test Mode Information	○	○	○
Adjustment	One-touch Tuning	○	○	○
	Tuning	○	○	○
	Multi-axis Tuning			
	Machine Analyzer	○	○	○
	Advanced Gain Search			
Tools	Update Parameter Setting Range	○	○	○
	Machine Unit Conversion Display Setting		○	

*1 Switching to multi-axis project available.

1. INTRODUCTION

When connecting to the servo amplifier (MR-J3 series/MR-JN-A)

Servo amplifier		MR-J3-A	MR-J3-B	MR-J3-B -RJ006	MR-J3-B -RJ004	MR-J3-B -RJ080W	MR-J3-T	MR-JN-A
Communication Method	USB	○	○	○	○	○	○	○
	RS-422(RS-232C)	○					○	
	Ethernet							
Parameter	Parameter Setting	○	○	○	○	○	○	○
	Network Parameter							
	Axis Name Setting	○					○	○
	Parameter Converter							
Safety	Safety Parameter Setting							
	Change Password							
	Initialize Password							
Positioning-data	Point Table						○	○
	Program							○
	Indirect Addressing							
	Cam Data							
Monitor	Display All	○	○	○	○	○	○	○
	I/O Monitor	○	○	○	○	○	○	○
	Graph	○	○	○	○	○	○	○
	ABS Data Display	○	○	○	○	○	○	
	Object Monitor							
Diagnosis	Alarm Display	○	○	○	○	○	○	○
	Alarm Onset Data	○	○	○	○	○	○	○
	Drive Recorder							○
	No Motor Rotation	○	○	○	○	○	○	○
	System Configuration	○	○	○	○	○	○	○
	Life Diagnosis	○	○	○	○	○	○	○
	Machine Diagnosis							
	Gear Failure Diagnosis							
	Encoder Communication Circuit Diagnosis							
	Fully Closed Loop Diagnosis			○				
Linear Diagnosis				○				
Test Mode	JOG Mode	○	○	○		○	○	○
	Positioning Mode	○	○	○	○	○	○	○
	Motor-less Operation	○	○	○			○	○
	DO Forced Output	○	○	○	○	○	○	○
	Program Operation	○	○	○	○	○	○	○
	Single-step Feed						○	○
	Test Mode Information	○	○	○	○	○	○	○
Adjustment	One-touch Tuning							
	Tuning	○	○	○	○	○	○	○
	Multi-axis Tuning							
	Machine Analyzer	○	○	○	○	○	○	
	Advanced Gain Search	○	○	○	○		○	
Tools	Update Parameter Setting Range	○	○	○	○	○	○	○
	Machine Unit Conversion Display Setting	○	○	○	○	○	○	○

1. INTRODUCTION

When via MT Developer2 *9

Item		Servo amplifier	MR-J4-B (-RJ)*6 *7	MR-J4-B -LL	MR-J3-B	MR-J3-B -RJ006	MR-J3-B -RJ004	MR-J3-B -RJ080W	MR- MT1200	MR-MT 2□□□ *12
Communication Method	SSCNET III				○	○	○	○	○	
	SSCNET III/H	○	○							○
Parameter	Parameter Setting	○	○	○	○	○	○	○	○	○
	Network Parameter									
	Axis Name Setting									
	Parameter Converter									
Safety	Safety Parameter Setting	*8*10○								
	Change Password	*8*10○								
	Initialize Password	*8*10○								
Positioning-data	Point Table									
	Program									
	Indirect Addressing									
	Cam Data									
Monitor	Display All	○	○	○	○	○	○	○		
	I/O Monitor	○	○	○	○	○	○	○		
	Graph	○	○	○	○	○	○	○		
	ABS Data Display	○	○	○	○	○	○	○		
	Object Monitor									
Diagnosis	Alarm Display	○	○	○	○	○	○	○	○	○
	Alarm Onset Data	○	○	○	○	○	○	○		
	Drive Recorder	○	○							
	No Motor Rotation	○	*11○	○	○	○	○	○		
	System Configuration	○	○	○	○	○	○	○	○	○
	Life Diagnosis	○	○	○	○	○	○	○		
	Machine Diagnosis	○	○							
	Gear Failure Diagnosis									
	Encoder Communication Circuit Diagnosis									
	Fully Closed Loop Diagnosis	*1○			○					
Linear Diagnosis	*2○					○				
Test Mode	JOG Mode	*3○	○	*5○	*5○			*5○		
	Positioning Mode	○	○	*5○	*5○	*5○	*5○			
	Motor-less Operation	*4○		○	○					
	DO Forced Output	○		○	○	○	○			
	Program Operation	○	○	*5○	*5○	*5○	*5○			
	Single-step Feed									
	Test Mode Information	○	○	*5○	*5○	*5○	*5○			
Adjustment	One-touch Tuning	○	*11○							
	Tuning	○	○	○	○	○	○			
	Multi-axis Tuning	○								
	Machine Analyzer	○	○	*5○	*5○	*5○	*5○			
	Advanced Gain Search			○	○	○				
Tools	Update Parameter Setting Range	○	○	○	○	○	○			
	Machine Unit Conversion Display Setting	○	○	○	○	○	○			

*1 Only available when operation mode is Fully closed loop control mode.

*2 Only available when operation mode is Linear servo motor control mode.

*3 Not available when operation mode is Linear servo motor control mode.

*4 Only available when operation mode is Standard control mode.

*5 Not available for Q17[]H.

*6 The same as MR-J3-B in MR-J3-B compatibility mode.

▪ Standard control mode: MR-J3-B

▪ Linear servo motor control mode: MR-J3-B-RJ004

▪ Fully closed control mode: MR-J3-B-RJ006

▪ DD Motor control mode: MR-J3-B-RJ080W

*7 Can not be used as MR-J3-B extension function.

Please select the "MR-J3-B" series from controller when connecting to MR-J3-B extension function.

*8 Functional safety unit MR-D30 is necessary.

*9 Each function of MR Configurator2 will be used as MT Developer2 function in MT Developer2 Version 1.100E or later.

*10 Only available when it is MR-J4-B-RJ.

*11 Cannot be used in pressure control mode.

*12 Available when it is MT Developer2 Version 1.128J or later.

1. INTRODUCTION

When via GX Works2/GX Works3 (Except MR-J5 series) *9 *13

Item		Servo amplifier	MR-J4 -B(-RJ) *6 *7	MR-J4 -B -RJ010	MR-J4 -GF(-RJ) *11	MR-JE -B(F)	MR-J3 -B	MR-J3 -B -RJ006	MR-J3 -B -RJ004	MR-J3 -B -RJ080W	MR- MT1200
Communication Method	SSCNET III						○	○	○	○	○
	SSCNET III/H	○									
	CC-Link IE Field		○	○							
	CC-Link IE TSN										
Parameter	Parameter Setting	○	○	○	○		*5○	*5○	*5○	*5○	*5○
	Network Parameter										
	Axis Name Setting										
	Parameter Converter										
Safety	Safety Parameter Setting	*8*10○			*8*14 *15○						
	Change Password	*8*10○			*8*14 *15○						
	Initialize Password	*8*10○			*8*14 *15○						
Positioning-data	Point Table				*12○						
	Program										
	Indirect Addressing										
	Cam Data				*12*15○						
Monitor	Display All	○	○	○	○	○	○	○	○	○	
	I/O Monitor	○	○	○	○	○	○	○	○	○	
	Graph	○	○	○	○	○	○	○	○	○	
	ABS Data Display	○	○	○	○	○	○	○	○	○	
	Object Monitor										
Diagnosis	Alarm Display	○	○	○	○	○	○	○	○	○	○
	Alarm Onset Data	○	○	○	○	○	○	○	○	○	
	Drive Recorder	○	○	○	○	○	○	○	○	○	
	No Motor Rotation	○	○	○	○	○	○	○	○	○	
	System Configuration	○	○	○	○	○	○	○	○	○	○
	Life Diagnosis	○	○	○	○	○	○	○	○	○	
	Machine Diagnosis	○	○	○	○	○	○	○	○	○	
	Gear Failure Diagnosis										
	Encoder Communication Circuit Diagnosis										
	Fully Closed Loop Diagnosis	*1○			*1○			○			
	Linear Diagnosis	*2○			*2○				○		
Test Mode	JOG Mode	*3○	○		*3○	○					
	Positioning Mode	○	○	○	○						
	Motor-less Operation	*4○	○		*4○	○					
	DO Forced Output	○	○	○	○	○	○	○	○	○	
	Program Operation	○	○	○	○	○	○	○	○	○	
	Single-step Feed				*12○						
	Test Mode Information	○	○	○	○	○	○	○	○	○	
Adjustment	One-touch Tuning	○	○	○	○	○	○	○	○	○	
	Tuning	○	○	○	○	○	○	○	○	○	
	Multi-axis Tuning	○	○	○	○	○	○	○	○	○	
	Machine Analyzer	○	○	○	○	○	○	○	○	○	
	Advanced Gain Search										
Tools	Update Parameter Setting Range	○	○	○	○	○	○	○	○	○	
	Machine Unit Conversion Display Setting	○	○		○	○	○	○	○	○	

*1 Only available when operation mode is Fully closed loop control mode.

*2 Only available when operation mode is Linear servo motor control mode.

*3 Not available when operation mode is Linear servo motor control mode.

*4 Only available when operation mode is Standard control mode.

*5 Not available for online setting in LD77MH[]. Please read/write parameters using GX Works2.

*6 The same as MR-J3-B in MR-J3-B compatibility mode.

▪ Standard control mode: MR-J3-B

▪ Fully closed control mode: MR-J3-B-RJ006

▪ Linear servo motor control mode: MR-J3-B-RJ004

▪ DD Motor control mode: MR-J3-B-RJ080W

*7 Can not be used as MR-J3-B extension function.

Please select the "MR-J3-B" series from controller when connecting to MR-J3-B extension function.

*8 Functional safety unit MR-D30 is necessary.

*9 Each function of MR Configurator2 will be used as GX Works2 function in GX Works2 Version 1.521T or later and GX Works3 function in GX Works3.

*10 Only available when it is MR-J4-B-RJ.

*11 Available when it is GX Works3 Version 1.022Y or later.

*12 Only available when station-specific mode is I/O mode.

*13 The setting/monitoring tool for C language controller and CW Configurator are also included.

*14 Only available when it is MR-J4-GF-RJ.

*15 Available when it is GX Works3 Version 1.030G or later.

1. INTRODUCTION

When via GX Works3 (MR-J5 series/MR-JET series) *2

Servo amplifier		MR-J5-G (-RJ)*1	MR-JET-G
Communication Method	SSCNET III		
	SSCNET III/H		
	CC-Link IE Field		
	CC-Link IE TSN	○	○
Parameter	Parameter Setting	○	○
	Network Parameter	○	○
	Axis Name Setting		
	Parameter Converter		
Safety	Safety Parameter Setting		
	Change Password		
	Initialize Password		
Positioning-data	Point Table		
	Program		
	Indirect Addressing		
	Cam Data		
Monitor	Display All		
	I/O Monitor		
	Graph		
	ABS Data Display		
	Object Monitor		
Diagnosis	Alarm Display		
	Alarm Onset Data		
	Drive Recorder		
	No Motor Rotation		
	System Configuration		
	Life Diagnosis		
	Machine Diagnosis		
	Gear Failure Diagnosis		
	Encoder Communication Circuit Diagnosis		
	Fully Closed Loop Diagnosis		
Linear Diagnosis			
Test Mode	JOG Mode		
	Positioning Mode		
	Motor-less Operation		
	DO Forced Output		
	Program Operation		
	Test Mode Information		
Adjustment	One-touch Tuning		
	Tuning		
	Multi-axis Tuning		
	Machine Analyzer		
Tools	Advanced Gain Search		
	Update Parameter Setting Range		
	Machine Unit Conversion Display Setting		

*1 Available when it is GX Works3 Version 1.055H or later.

*2 The software reset is supported.

1. INTRODUCTION

1.2 System configuration

1.2.1 Components

To use the MR Configurator2, the following components are required in addition to the servo amplifier and servo motor. Configure the system according to the Installation Guide of each equipment.

Equipment		Description
(Note 1, 2, 3, 4) Personal computer	OS	Microsoft® Windows® 10 Education Operating System
		Microsoft® Windows® 10 Enterprise Operating System
		Microsoft® Windows® 10 Pro Operating System
		Microsoft® Windows® 10 Home Operating System
		Microsoft® Windows® 10 IoT Enterprise 2016 LTSB Operating System *1
Microsoft® Windows® 8.1 Enterprise Operating System		
Microsoft® Windows® 8.1 Pro Operating System		
Microsoft® Windows® 8.1 Operating System		
Microsoft® Windows® 8 Enterprise Operating System		
Microsoft® Windows® 8 Pro Operating System		
Microsoft® Windows® 8 Operating System		
Microsoft® Windows® 7 Enterprise Operating System		
Microsoft® Windows® 7 Ultimate Operating System		
Microsoft® Windows® 7 Professional Operating System		
Microsoft® Windows® 7 Home Premium Operating System		
Microsoft® Windows® 7 Starter Operating System		
	CPU	Desktop PC: Intel® Celeron® Processor 2.8GHz or higher Laptop PC : Intel® Pentium® M Processor 1.7GHz or higher
	Memory	1GB or more recommended (For 32-bit edition) 2GB or more recommended (For 64-bit edition)
	Hard Disk	1.5GB or more of free space
Browser		Internet Explorer 4.0 or more
Display		One whose resolution is 1024 × 768 or more and that can provide a high color (16 bit) display. Connectable with the above personal computer.
Keyboard		Connectable with the above personal computer.
Mouse		Connectable with the above personal computer.
Printer		Connectable with the above personal computer.
USB cable		MR-J3USBCBL3M
Ethernet cable		Cable type: Category 5e or higher, (STP) straight cable Standard : IEEE802.3 1000BASE-T or ANSI/TIA/EIA-568-B (Higher than Category 5e) Connector: RJ-45 connector with shield

*1: Only the 64-bit edition is supported.

1. INTRODUCTION

Note 1. If .NET Framework 3.5 (including .NET 2.0 and 3.0) has been disabled, it is necessary to enable it.

2. If any of the following functions is used, this product may not operate normally.

- Start of application in Windows® compatible mode
- Fast user switching
- Remote desktop
- Windows XP Mode
- Windows Touch or Touch
- Modern UI
- Client Hyper-V
- Tablet Mode
- Virtual desktop
- High Contrast Mode
- Unified Write Filter

3. The screen of this product may not operate normally in the following occasions:

- The size of text and other items on the screen is other than 100% (96DPI, 9pt, etc.)
- Changed the resolution of the screen during operating
- Multi-display is set

4. Please use the product as "Standard User" or "Administrator".

1. INTRODUCTION

1.2.2 Configuration

(1) For use of USB

Run/operate the servo amplifier of axis 1. As the USB cable, use the optional MR-J3USBCBL3M.

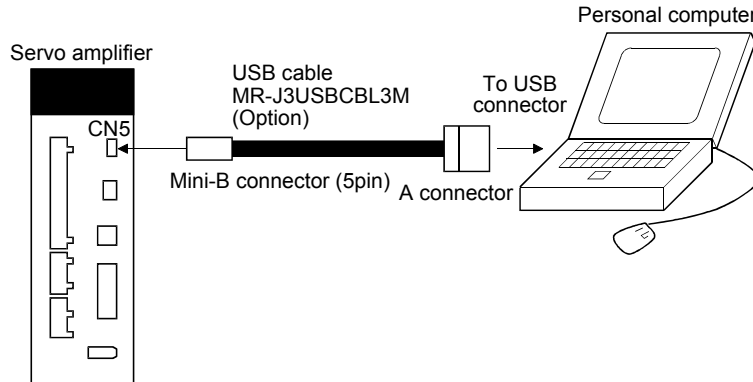

(2) For use of RS-422

Run/operate the servo amplifier of axis 1. It is recommended to use the following cable.

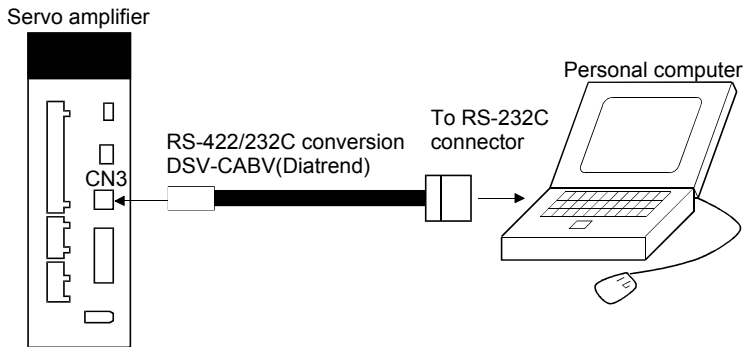

(3) For use of Ethernet

Run/operate the servo amplifiers of multiple axes.

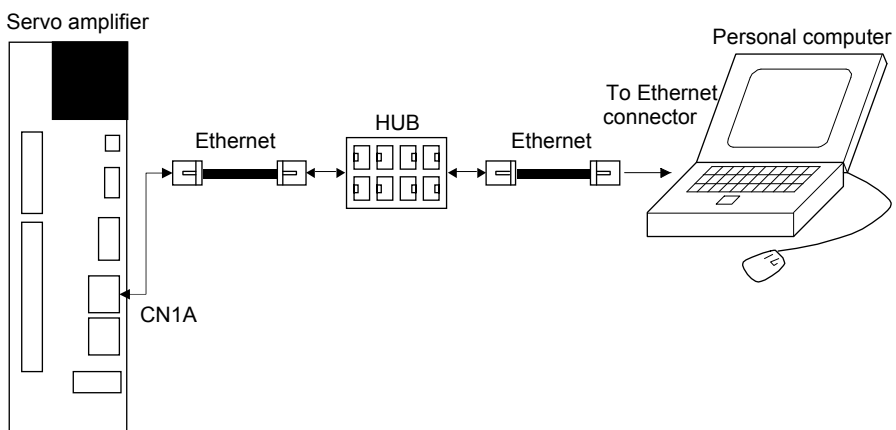

1. INTRODUCTION

(4) For setting up via MT Developer2

When controlling several servo amplifiers via a motion controller, start MR Configurator2 from MT Developer2 *1, and communicate through the following way.

*1 Each function of MR Configurator2 will be used as MT Developer2 function in MT Developer2 Version 1.100E or later.

MR Configurator2 cannot be started in the MT Developer2 before Version 1.100E.

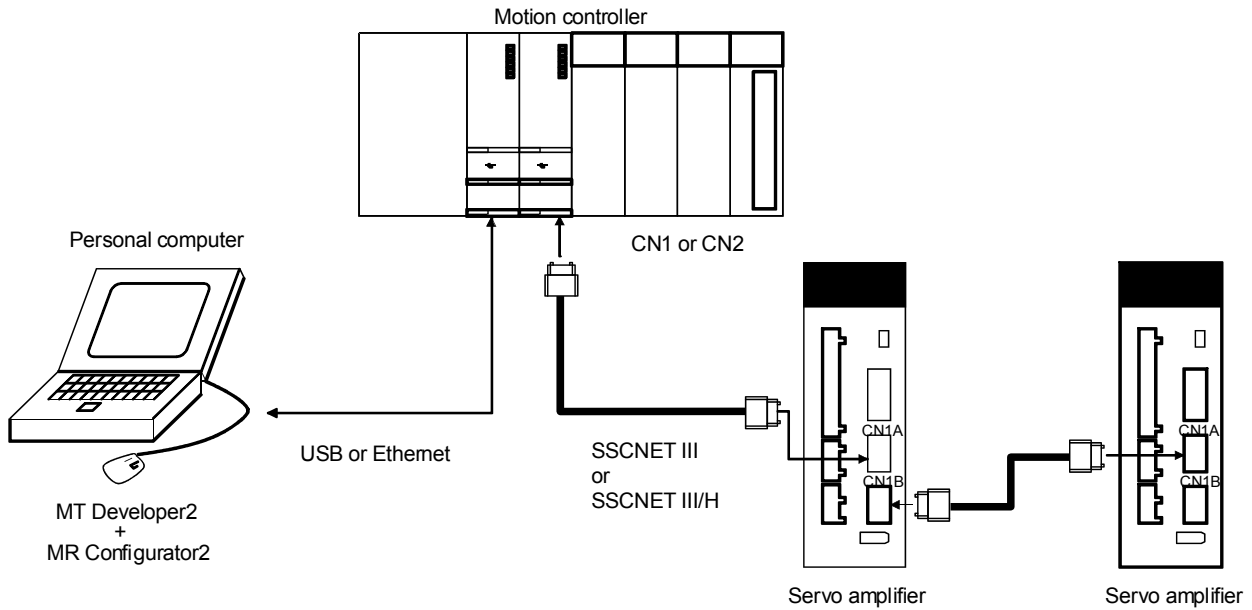

1. INTRODUCTION

(5) For setting up via GX Works2/GX Works3

When controlling several servo amplifiers via a simple motion module or a motion module, start MR Configurator2 from GX Works2/GX Works3 *2, and communicate through the following ways.

*2 Each function of MR Configurator2 will be used as GX Works2 and GX Works3 function in GX Works2 Version 1.521T or later and GX Works3.

MR Configurator2 cannot be started in the GX Works2 before Version 1.521T.

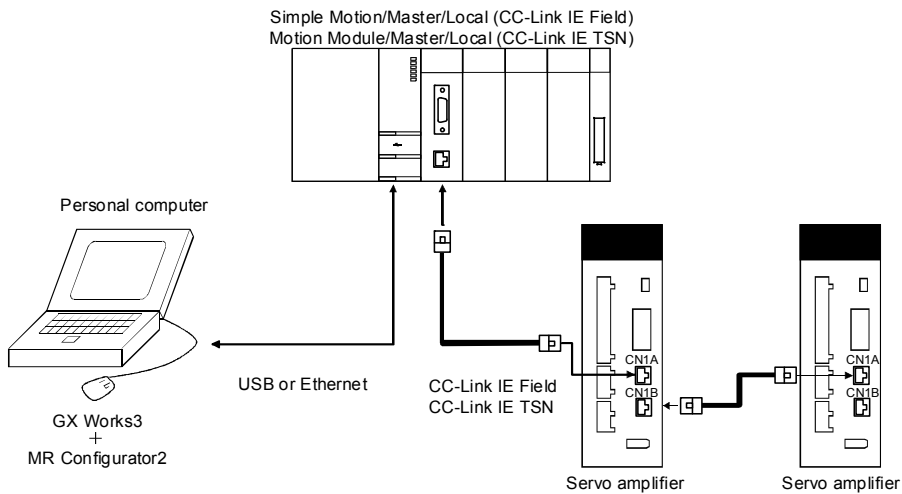
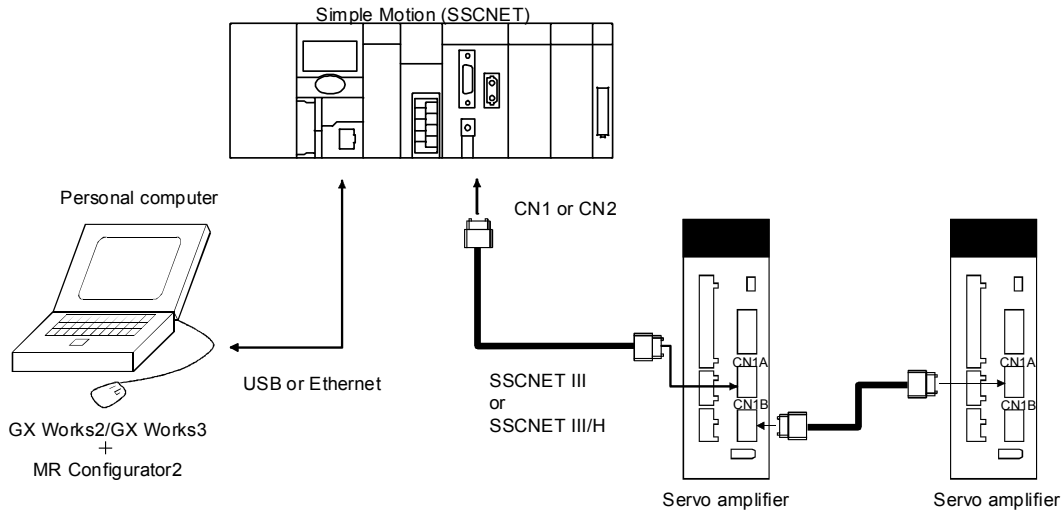

(When connecting with HUB)

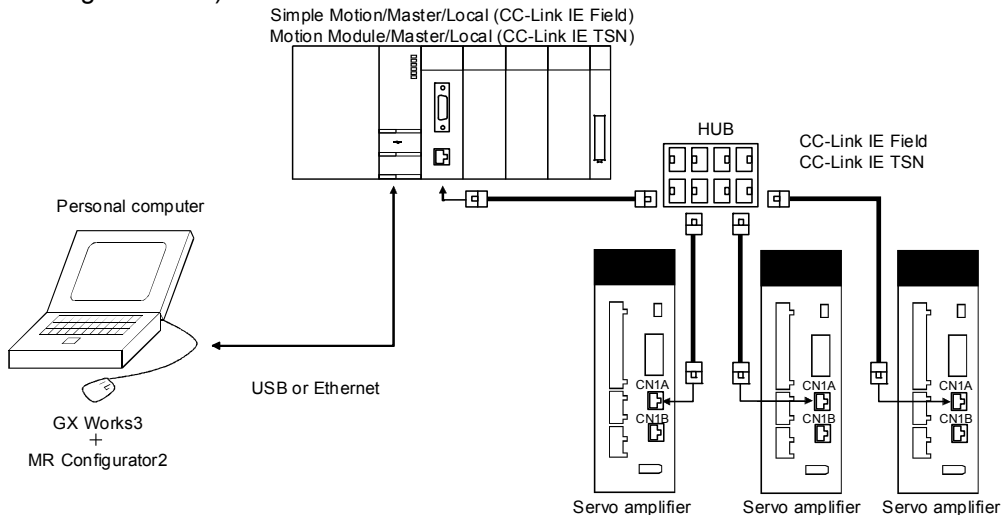

1. INTRODUCTION

1.3 Basic terms

1) Mouse pointer

An on-screen arrow which moves with movements of the mouse.

2) Point

To move the mouse pointer to a particular item or position on the screen.

3) Click

To press and release the left button of the mouse once.

4) Double-click

To press and release the left button of the mouse twice.

5) Drag

To hold down the left button of the mouse and move the mouse.

6) Focus

Highlights characters, button or the like when the menu or button is ready to accept an input from the keyboard.

7) Text box

Box used to enter characters.

8) List box

Box used to select one of several items.

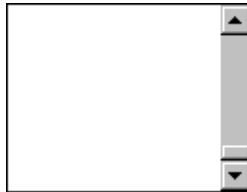

9) Combo box

Box used to select one of several items.



10) Check box

Box used to select one or more of several items. When a choice is made a mark appears in the box.

11) Option button

Button used to select only one of several items. When a choice is changed  moves to a new choice.

1. INTRODUCTION

1.4 Installation procedure

Perform installation with the administrator authority (computer administrator authority).

Here, the hard disk drive of the personal computer is explained as C and the CD drive as D.

Before executing this program, be sure to close all other Windows programs.

It is necessary to enable .NET Framework 3.5 (including .NET 2.0 and 3.0) on the personal computer when it is disabled.

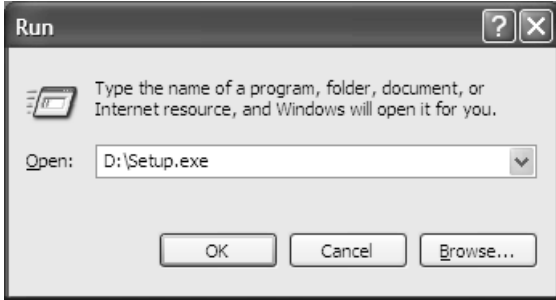

- 1) Insert the CD-ROM in Drive D (CD drive). Then, click the "Start" button on the task bar to open the menu, and click "RUN". When the left window as shown on the left appeared, enter "D:\Setup.exe" and click the "OK" button.

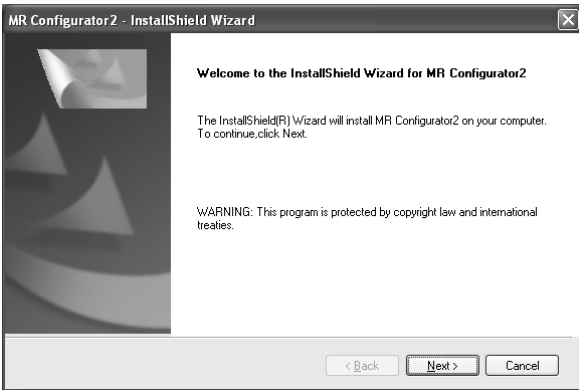

- 2) After the above window, the left window appears. Click the "Next" button.



- 3) After the Setup status screen, the User information screen appears. Enter the user name and company name. Also, enter the product ID on the license agreement which was provided with the product in single-byte alphanumeric characters, and click the "Next" button.

1. INTRODUCTION

- 4) The Select installation destination screen appears. Specify the installation destination, and click the "Next" button. This starts installation.

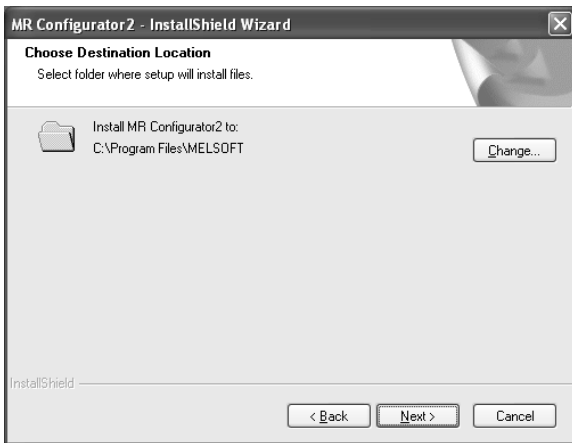

- 5) Information for starting the program file copy is displayed. Click the "Next" button to start the installation.



- 6) The Setup status screen appears.

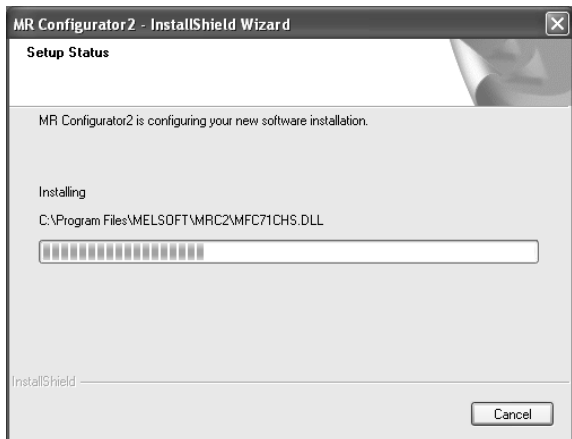

1. INTRODUCTION

7) The driver installation window appears.



POINT

- Either of the security warning screens shown below appears. Select "Install this driver software anyway" or click the "Install" button. (The screens do not appear after the USB driver is registered.)

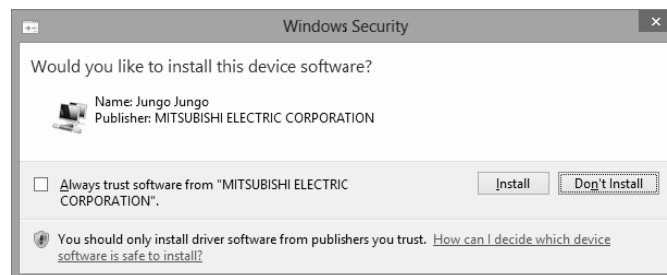
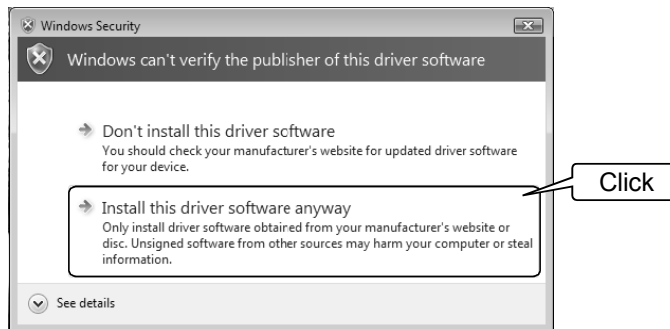

- If the driver is not installed, communication may be partly interrupted. In this case, reinstall MR Configurator2.

1. INTRODUCTION

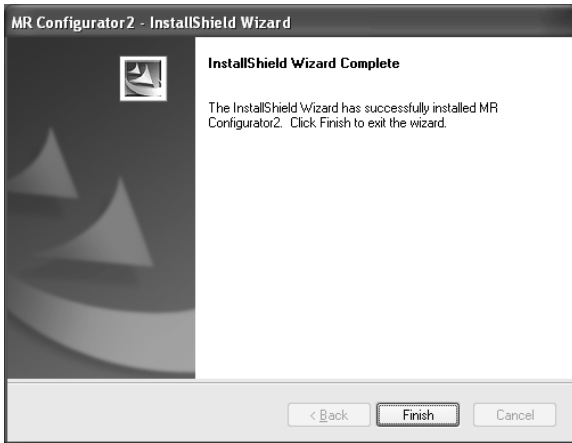

- 8) When installation is completed, the next screen appears. Click the "Finish" button to end the setup. When restart message appears, starting again to use MR Configurator2. The register of start menu changes from "MELSOFT Application" to "MELSOFT" in Ver. 1.45X.

POINT

- In the corresponding window, to stop installation, click the "Cancel" button.
- If an overwrite install has been done to upgrade the version of MR Configurator2, the following message may be displayed. In this case, select "This program installed correctly".

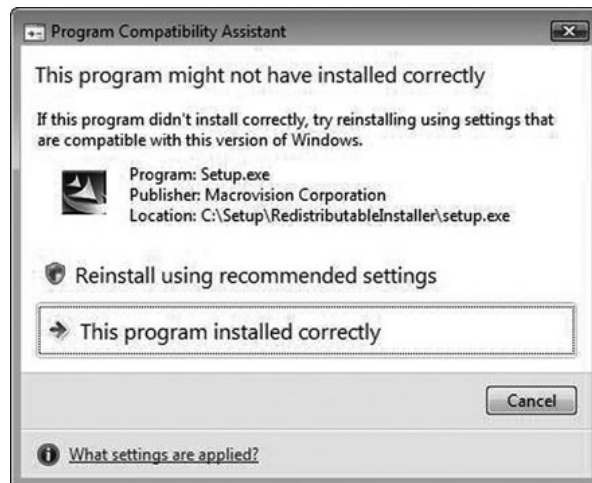

1. INTRODUCTION

1.5 Automatic device driver software installation

Device driver software is automatically installed when the servo amplifier powered on is connected with the personal computer via USB for the first time.

(1) When Windows® 7 is used

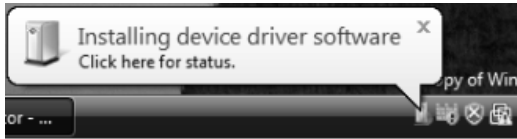

Indications on the left appear during automatic registration.
(Operation is not required.)

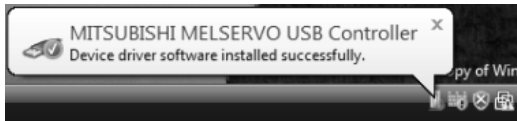

(2) When Windows® 8 or later is used

It will not be displayed.

2. HOW TO USE THE SOFTWARE

2. HOW TO USE THE SOFTWARE

2.1 Operation

The method of selecting the command is the operation procedures using the mouse.
Unavailable commands are grayed out.

2.1.1 Start-up

- (1) When connecting to the servo amplifier
Click "MR Configurator2" on the desktop.
- (2) When connecting to the servo amplifiers of multiple axes via Ethernet or Bus connection (via HUB)
Click "MR Configurator2" on the desktop.
- (3) When operating via motion controller (Before MT Developer2 Version 1.100E)
Double-click the "Servo Parameter" icon of the Motion controller programming software MT Developer2.
- (4) When operating via simple motion module (Before GX Works2 Version 1.521T)
Double-click the "Servo Parameter" icon of the simple motion module programming software tool, which is integrated in the PLC programming software GX Works2.
- (5) When operating via motion controller (MT Developer2 Version 1.100E or later)
Each function of MR Configurator2 will be used as MT Developer2 function. Refer to the "Operating Servo Amplifier" of MT Developer2 HELP when using each function of MR Configurator2.
- (6) When operating via SSCNET III/H compatible simple motion module (GX Works2 Version 1.521T or later and GX Works3)
Each function of MR Configurator2 will be used as GX Works2 and GX Works3 function. Refer to the "Servo Amplifier Operation" in Simple Motion Setting Tool HELP of GX Works2/GX Works3 when using each function of MR Configurator2.
- (7) When operating from the CC-Link IE Field Configuration screen of GX Works3 via CC-Link IE Field
From the [Navigation window] of GX Works3, select [Parameter] → [Module Information] → Target module → [Basic Settings] → [Network Configuration Settings] → <Detailed Setting> to open the CC-Link IE Field Configuration screen.
In the CC-Link IE Field Configuration screen, set up servo amplifier model manufactured by Mitsubishi Electric, and then double-click the "servo amplifier" icon.
- (8) When operating from the CC-Link IE TSN Configuration screen of GX Works3 via CC-Link IE TSN
From the [Navigation window] of GX Works3, select [Parameter] → [Module Information] → Target module → [Basic Settings] → [Network Configuration Settings] → <Detailed Setting> to open the CC-Link IE TSN Configuration screen.
In the CC-Link IE TSN Configuration screen, set up servo amplifier model manufactured by Mitsubishi Electric, and then double-click the "servo amplifier" icon.

2. HOW TO USE THE SOFTWARE

2.1.2 Project

(1) New

Clicking "Project" on the menu bar displays the following menu.

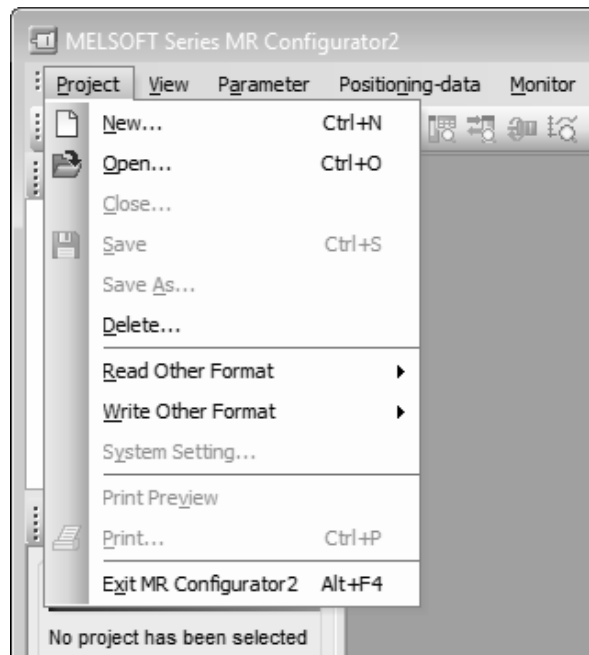

Clicking "New" in the sub menu displays the following window. To connect via network, please select "Switch to Multi-axis Project".

(When single axis project is used)



2. HOW TO USE THE SOFTWARE

(When multi-axis project is used)

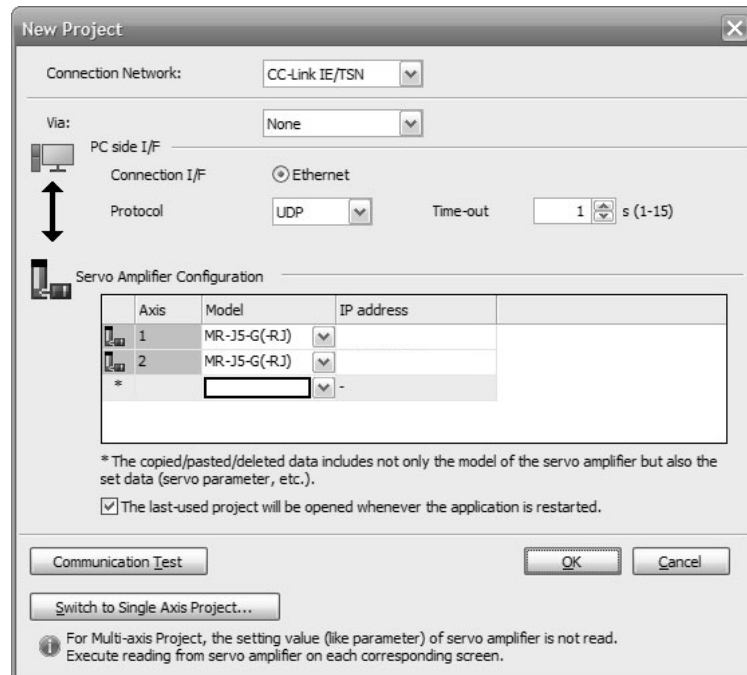

After the model selection and connection settings are done, clicking "OK" button displays the following window.

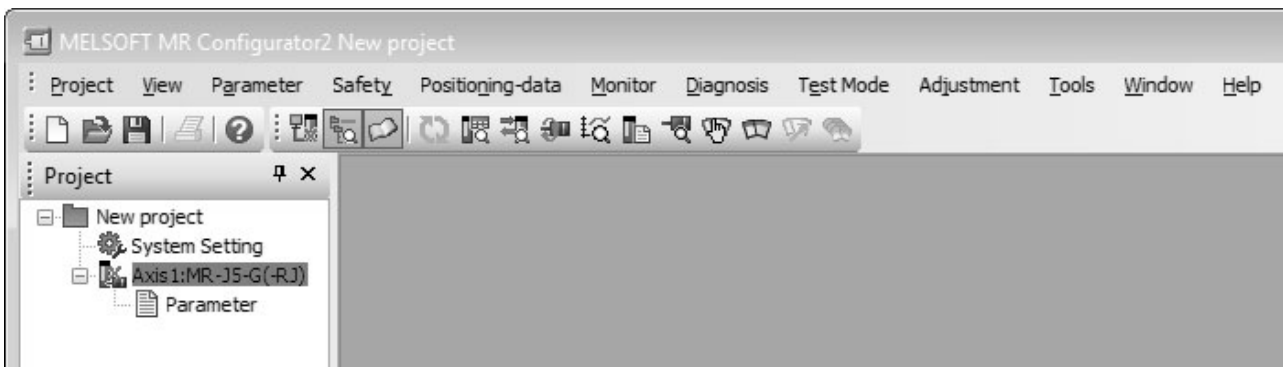

- (2) Open
Read the input information from the saved file.
Clicking "Open" in the sub menu opens a window, where you can specify the project.
- (3) Close
Close the currently open project.
Clicking "Close" in the sub menu closes the project.
- (4) Save
Modify and save the currently open project.
Clicking "Save as project" in the sub menu saves the project.

2. HOW TO USE THE SOFTWARE

(5) Save As

Save the current input information into a file. If the information to be repeatedly input is saved, that information can be read by clicking "Open".

Clicking "Save As" in the sub menu displays the following window.

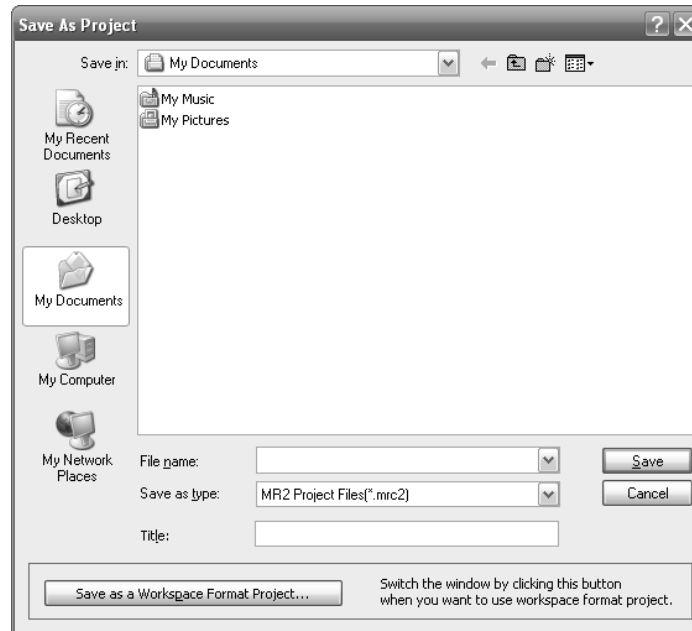

Note)

When you want to save the existing workspace format MR Configurator2 project, click the "Save as a Workspace Format Project" button.

(6) Delete

Delete the existing project for the workspace format MR Configurator2.

Clicking "Delete" in the sub menu displays the following window.

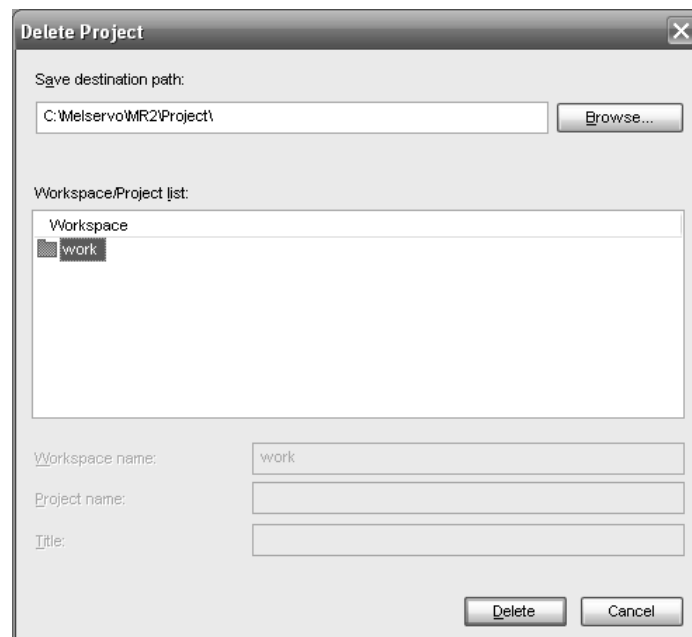

2. HOW TO USE THE SOFTWARE

(7) Open MR Configurator Project

Open an existing MR Configurator project.

Clicking "Read Other Format" - "Open MR Configurator Project" in the sub menu displays the following window.

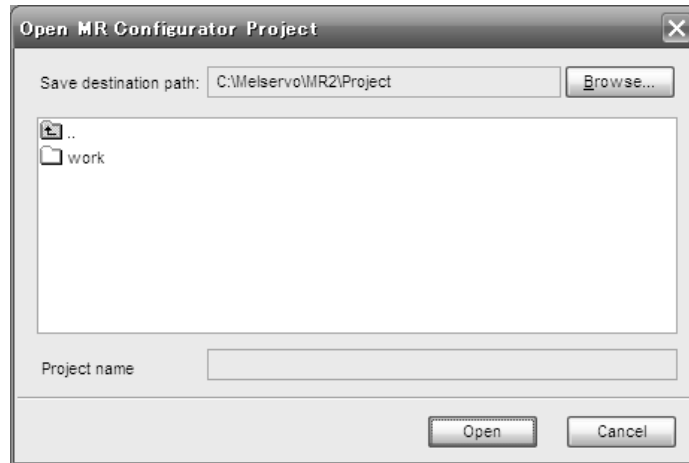

(8) Save MR Configurator Project

Save an existing MR Configurator project.

Clicking "Write Other Format" - "Save MR Configurator Project" in the sub menu displays the following window.

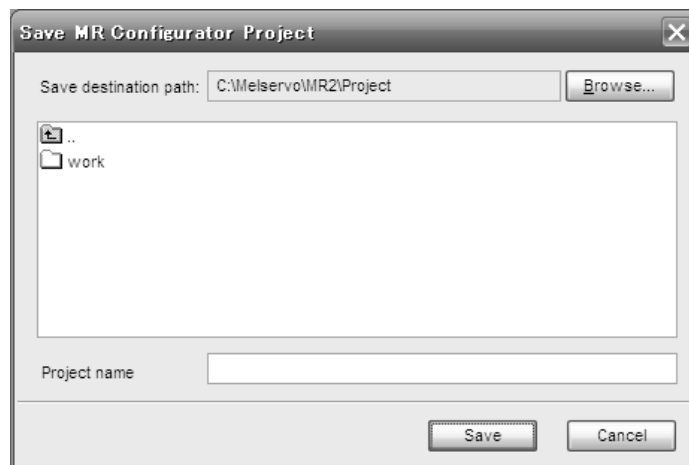

2. HOW TO USE THE SOFTWARE

2.1.3 Servo parameters

The following gives an overview about setting servo parameters.

(1) When connecting to the servo amplifier

After creating a new project, please open the Parameter Setting screen by selecting Parameter → Parameter Setting, to display or edit parameters, or write them to the servo amplifier.

For the details, please refer to the help.

(2) When connecting to the servo amplifiers of multiple axes via Ethernet or Bus connection (via HUB)

After creating a new project, please open the Parameter Setting screen by selecting Parameter → Parameter Setting, to display or edit parameters, or write them to the servo amplifiers.

For the details, please refer to the help.

(3) When operating via motion controller (MT Developer2 Version 1.100E or later)

After starting MT Developer2, please open the Servo Parameter screen by selecting Servo Parameter in the project tree, to display or edit parameters, or write them to the servo amplifier.

You can also write parameter values that you set offline to the controller, and they will be reflected when the servo amplifier and the controller are connected.

(4) When operating via SSCNET III/H compatible simple motion module (GX Works2 Version 1.521T or later and GX Works3)

After starting Simple Motion Module Setting Tool, please open the Servo Parameter screen by selecting Servo Parameter in the project tree, to display or edit parameters, or write them to the servo amplifier.

You can also write parameter values that you set offline to the controller, and they will be reflected when the servo amplifier and the controller are connected.

(5) When operating from the CC-Link IE Field Configuration screen of GX Works3 via CC-Link IE Field

After opening the CC-Link IE Field Configuration screen, set up servo amplifier model manufactured by Mitsubishi Electric, and then double-click the "servo amplifier" icon.

For the details, please refer to the help.

As parameter values that you set offline are not reflected to the servo amplifier, please write them to the servo amplifier online.

(6) When operating from the CC-Link IE TSN Configuration screen of GX Works3 via CC-Link IE TSN

After opening the CC-Link IE TSN Configuration screen, set up servo amplifier model manufactured by Mitsubishi Electric, and then double-click the "servo amplifier" icon.

Parameter values that you set in the CC-Link IE TSN Configuration screen are maintained as part of the module parameters of the master station.

If you write module parameters to the master station after enabling "Parameter Automatic Setting" in the CC-Link IE TSN Configuration screen, parameters maintained by the master station will be automatically set to servo parameters when the servo amplifier and the controller are connected. (*1, *2)

2. HOW TO USE THE SOFTWARE

(Example) CC-Link IE TSN Configuration screen

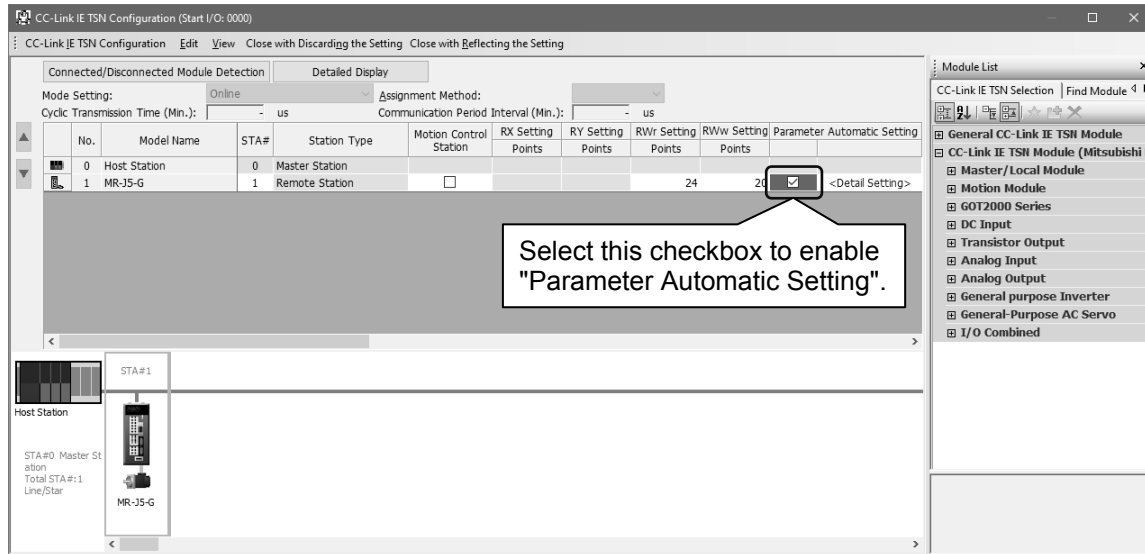

*1 If you want to use the parameter settings of the servo amplifier on startup, execute writing to the master station after disabling "Parameter Automatic Setting" in the configuration screen, and then connect the master station and the servo amplifier.

While the servo amplifier is connected, open the Parameter Setting screen from the CC-Link IE TSN Configuration screen and click the Read button to display or edit the parameter setting values of the servo amplifier.

(Example) Parameter Setting screen opened from the CC-Link IE TSN Configuration screen

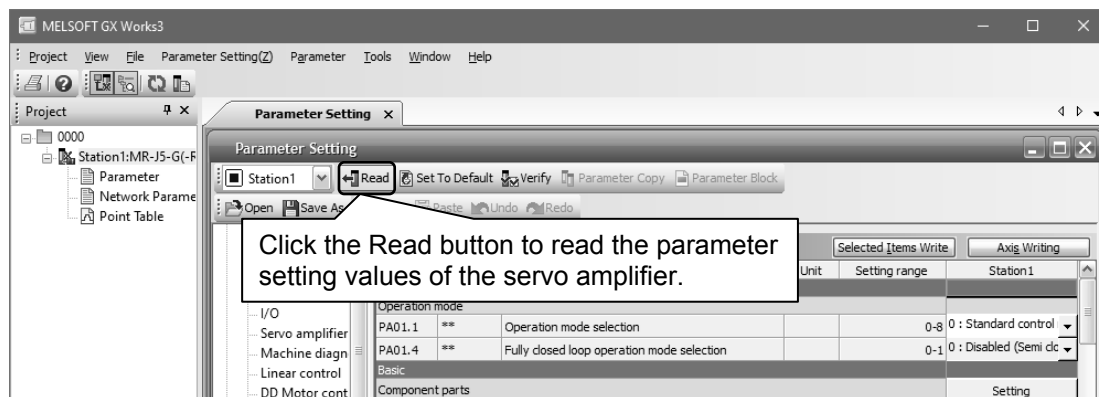

*2 For iQ-R series, if you enable "Parameter Automatic Setting" of the motion module, then parameters maintained by the master station will be automatically updated when any of the parameters of the servo amplifier is changed.

(For the details, please refer to "Parameter automatic setting" in the User's Manual (Communication Function) of the servo amplifier.)

To read automatically updated parameters, execute reading by selecting [Online] → [Read from PLC] → [Online Data Operation] in GX Works3, double-click the "servo amplifier" icon in the CC-Link IE TSN Configuration screen to open the Parameter Setting screen, and then you can display or edit the parameters.

To use the parameter settings of the servo amplifier instead of automatically updated parameters, please click the Read button on the Parameter Setting screen.

2. HOW TO USE THE SOFTWARE

2.2 Commands and display windows

This section provides commands and their main descriptions.

For the method of using each command, the detailed explanation is provided in the help function of the servo amplifier software.

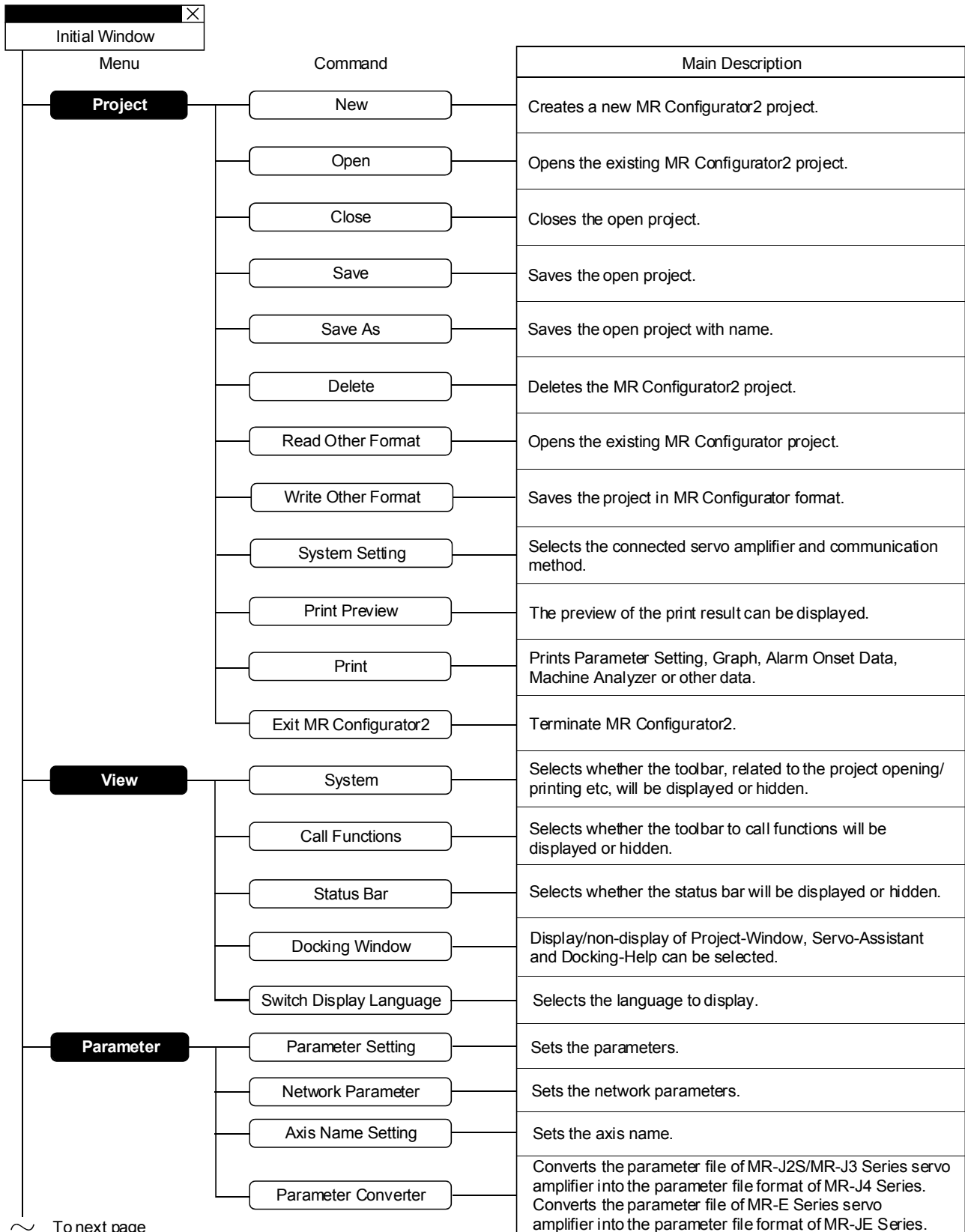

~ To next page

2. HOW TO USE THE SOFTWARE

Continued from previous page

Menu	Command	Main Description
Safety	Safety Parameter Setting	Sets the safety parameter setting.
	Change Password	Can change the password during writing safety parameter.
	Initialize Password	Can initialize the password during writing safety parameter.
Positioning-data	Point Table	Sets the point table.
	Program	Sets the program.
	Indirect Addressing	Can set the general register of servo amplifier.
	Cam Data	Can display/edit the cam data.
Monitor	Display All	Displays the servo status item-by-item numerically.
	I/O Monitor	Displays the I/O signal, analog monitor and other status.
	Graph	Displays the servo status in graphical form.
	ABS Data Display	Displays the ABS data.
	Object Monitor	Displays the object dictionary used for the servo amplifier.
Diagnosis	Alarm Display	Displays the detailed information if alarm or warning is currently occurring. List displays the history about the alarm or warning already occurred.
	Alarm Onset Data	Displays the monitored data at alarm occurrence if alarm or warning is currently occurring.
	Drive Recorder	Displays the drive recorder.
	No Motor Rotation	Displays the reason why the servo motor does not rotate.
	System Configuration	Displays the system configuration information.
	Life Diagnosis	Displays the life diagnosis information.
	Machine Diagnosis	Displays the machine diagnosis information.
	Gear Failure Diagnosis	Displays the gear failure diagnosis information.
	Encoder Communication Circuit Diagnosis	Displays the encoder communication circuit diagnosis information.
	Fully Closed Loop Diagnosis	Displays the monitor and parameters concerning the fully closed loop function.
	Linear Diagnosis	Displays the monitor and parameters concerning the linear function.

To next page

2. HOW TO USE THE SOFTWARE

Continued from previous page

Menu	Command	Main Description
Test Mode	JOG Mode	Executes JOG operation.
	Positioning Mode	Executes positioning operation.
	Motor-less Operation	Executes motor-less operation.
	DO Forced Output	Executes DO forced output.
	Program Operation	Executes programmed operation.
	Single-step Feed	Executes single-step feed operation.
	Test Mode Information	Displays the alarms and warnings which occurred at the start, end or during operation, in chronological order.
Adjustment	One-touch Tuning	Executes one-touch tuning.
	Tuning	Sets/adjusts the gain parameters.
	Multi-axis Tuning	Sets/adjusts the gain parameters among multiple axes.
	Machine Analyzer	Executes machine analyzer.
	Advanced Gain Search	Executes advanced gain search.
Tools	Update Parameter Setting Range	Acquires the parameter setting range from the connected amplifier and updates the data file of MR Configurator2.
	Machine Unit Conversion Display Setting	Sets the valid/invalid of machine unit conversion display and the unit/pulse/move distance for unit conversion.
	Options	Changes the option settings of MR Configurator2.
Window	Cascade	Displays superimposed screens.
	Tile Vertically	Tiles the screens vertically.
	Tile Horizontally	Tiles the screens horizontally.
	Arrange Icons	Arranges minimized screens.
	Close All Windows	Closes all windows which are displayed.
	Reset Window Layout	Resets all windows layout.
Help	MR Configurator2 Help	Displays Help of MR Configurator2.
	Connection to MITSUBISHI ELECTRIC FA Global Website	Displays the MITSUBISHI ELECTRIC FA Global Website.
	About MR Configurator2	Displays version information.

3. PRECAUTIONS

3. PRECAUTIONS

3.1 Precautions for test mode

 WARNING	<ul style="list-style-type: none"> ▪ Always touch the switches with dry hands. You may get an electric shock if you touch them with wet hands. ▪ Always operate the equipment with the front cover installed. Removing the front cover will expose the terminals and charged area having high voltages, which may lead to an electric shock. ▪ Keep the front cover closed while power is on the equipment is running. Otherwise, you may get an electric shock.
--	---

 CAUTION	<ul style="list-style-type: none"> ▪ Before starting operation, make sure that the parameters are set to correct values. Depending on machines, they may operate unpredictably. ▪ Take safety measures, e.g. provide covers, to prevent accidental contact of hands and parts (cables, etc.) with the servo amplifier heat sink, regenerative brake resistor, servo motor, etc. since they may be hot while power is on or for some time after power-off. Their temperatures may be high and you may get burnt or a parts may damaged.
--	--

(1) Servo on

In the JOG Mode, Positioning Mode, Program Operation, or Single-step Feed available in the Test, the servo amplifier's digital input signal Servo on (SON) is automatically switched on in the servo amplifier to start operation, independently of the ON/OFF status of Servo on (SON). Also, any external command pulse or input signal (except emergency stop) is not accepted until the test mode window is closed to terminate the command.

Servo on is automatically switched on by the following operation:

Test mode	Mouse
JOG Mode	Click the "Forward" or "Reverse" button.
Positioning Mode	
Program Operation	Click the "Operation Start" button.
Single-step Feed	

(2) Stop

POINT	<ul style="list-style-type: none"> ▪ To make an emergency stop, switch off the emergency stop signal of the servo amplifier or shut off the input power.
--------------	---

1) Perform the following operation to stop the test mode:

Test mode	Mouse
JOG Mode	When the check box for "Rotation only while the CCW or CW button is being pushed" on the JOG Mode window is not checked, click the "Stop" button. When the check box is checked, release the "Forward CCW" and "Reverse CW" buttons.
Positioning Mode	Click the "Pause" button or the "Stop" button.
Program Operation	
Single-step Feed	

3. PRECAUTIONS

2) The servo motor will stop if either of the following situations occurs in the test mode:

- The communication cable is disconnected.
- If the window is dragged or the other menu is opened, communication between the personal computer and the servo amplifier may be suspended temporarily, stopping the servo motor temporarily.
- Forced software stop is made.

3.2 Display language switching

When switching the display language in Windows® 10, supplemental fonts of the target language are required. Supplemental fonts can be added according to the following procedure.

Click the "Start" button on the Windows® Taskbar → [Settings] → [System] → [Apps & features] → [Manage optional features] → [Add a feature]

4. TROUBLESHOOTING

4. TROUBLESHOOTING

(1) Communication error

If communication between the personal computer and the servo amplifier is suspended and the communication error as shown in the following window occurs, check the detail code on the error message and remove its cause.

<Possible cause> Poor connection of communication cable, system setting mistake, noise entry, hard disk fault, etc.



*****001	Communication error
*****002	Communication time-out error
80A00107	
*****009	Insufficient memory error
80010400	Station number specification error
80010200	Communication port specification error
80070100	Write-protected parameter
80080200	The RD signals cannot be turn on

(2) Time-out error occurs at return from standby mode

POINT
<ul style="list-style-type: none"> ▪ Some personal computers cannot return to normal from a system standby. In this case, make the system standby of the personal computer invalid.

When a system standby has been set in the power option or power saving mode of a notebook PC, a time-out error will occur at a return from a system standby.

4. TROUBLESHOOTING

(3) Communication can never be made if USB is connected

The driver may not be set correctly. Check whether the USB driver is set correctly on the Device Manager screen and whether "MITSUBISHI MELSERVO USB Controller" is displayed under the "Universal Serial Bus controllers" folder on the Device Manager screen with the servo amplifier powered on. If "? USB Device" is displayed, delete the driver once, then power the servo amplifier off and then on, and reinstall the driver.

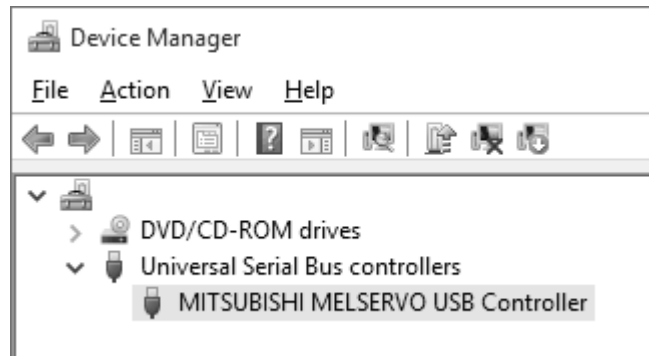

Set the Device Manager screen in any of the following methods.

(a) When Windows® 7 is used

Click the "Start" button on the task bar to open the menu. Right-click "Computer" and then click "Property". Open "System properties" and then click "Device Manager".

(b) When Windows® 8 or Windows® 8.1 is used

Press "Windows logo key + X" to open the menu on the bottom left, and then click "Device Manager".

(c) When Windows® 10 is used

Right-click the "Start" button on task bar to open the menu, and then click "Device Manager".

4. TROUBLESHOOTING

(4) The USB driver cannot be installed

It will show the manual installation instructions of USB driver.

1. Connect a personal computer and a servo amplifier with a USB cable, and then turn on the servo amplifier.
2. "Device driver software was not successfully installed" popup window is displayed. (It will not be displayed in Windows® 8 or later.) Select [Control Panel] – [System and Security] – [Administrative Tools] – [Computer Management], and select "Update Driver Software" of [Unknown device] in the Device Manager.
3. The [Update Driver Software - Unknown Device] dialog is displayed. Select "Don't search online". Check "Browse my computer for driver software (advanced)", and then set "EZsocket\EZSocketSv" of the folder where MR Configurator2 has been installed. If multiple MELSOFT products are installed previously, refer to their installed location. ("Program Files\MELSOFT\EZSocket\EZSocketSv" or "[Folder where this product is installed]\EZSocket\EZSocketSv")

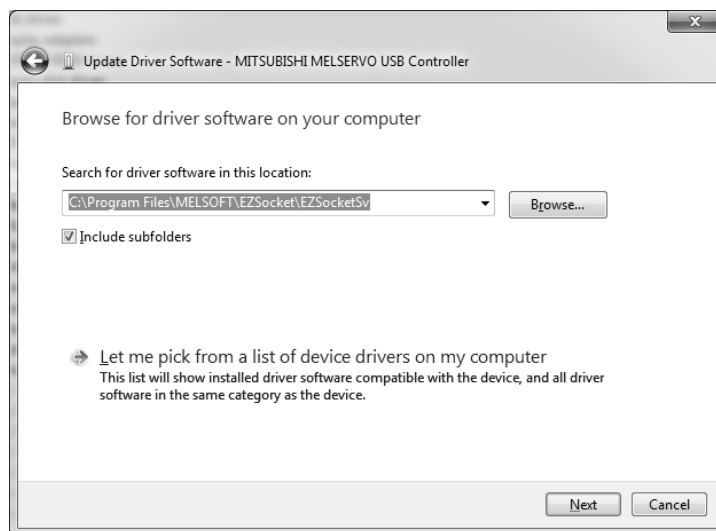

4. TROUBLESHOOTING

(5) Contents in the screen may not be displayed properly (for example, overlapping of icons, text overflowing from the frame of a button, etc.)

(a) Return the size of text and other items on the screen to 100% (96DPI, 9pt, etc.).

(b) When using Windows 10 (version 1703 or later) *1, the display of MR Configurator2 can be enlarged with high DPI scaling by using a Windows 10 function. *2

1) Select 'MR2.exe' *3, then select [Properties] on the right-click menu.

2) Select "Override high DPI scaling behavior. Scaling performed by:" in the [Compatibility] tab, then select "System" from the pull-down list.

3) Click the [OK] button.

*1 The Windows version can be checked by the following procedure.

1. Press [Windows] key and [R] key at the same time, or click the "Start" button on the Windows® Taskbar and select [Windows System] → [Run].
2. Enter 'winver' in the "Run" screen.
3. Check the version in the displayed screen.

*2 The display of MR Configurator2 will be blurred by enlarging.

The following lists the setting values for "Change the size of text, apps, and other items" and the recommended display resolution for each setting value in Windows 10.

Setting value: 100%, resolution of the display: 1024 x 768 dots or more

Setting value: 125%, resolution of the display: 1900 x 1200 dots or more

Setting value: 150%, resolution of the display: 1900 x 1200 dots or more

Setting value: 175%, resolution of the display: 2880 x 1620 dots or more

Setting value: 200%, resolution of the display: 2880 x 1620 dots or more

Setting value: 225%, resolution of the display: 3840 x 2160 dots or more

Setting value: 250%, resolution of the display: 3840 x 2160 dots or more

*3 'MR2.exe' is stored in the folder where MR Configurator2 has been installed.

The following is an example of a storage location.

64-bit version operating system: C:\Program Files (x86)\MELSOFT\MRC2\MR2.exe

32-bit version operating system: C:\Program Files\MELSOFT\MRC2\MR2.exe

REVISIONS

*The manual number is given on the bottom left of the back cover.

Print Date	*Manual Number	Revision
Sep., 2010	IB(NA)0300163-A	First edition
Mar., 2012	IB(NA)0300163-B	1-1 Add MR-J4-A, MR-J4-B, MR-J3-A, and MR-J3-T in the table 1-2 Add MR-J4-B in the table 1-3 Add MR-J4-B in the table 1-4 Add 64-bit OS 1-6 Add to SSCNETIII/H communication path in the figure 1-7 Add to SSCNETIII/H communication path in the figure 2-2 Changes to the MR-J4-B from MR-J3-B models in the figure 2-6 Add "Point table", "Drive Recorder" and "Machine Diagnosis" 2-7 Add "Single-step Feed", "One-touch Tuning" and "Reset Window Layout" 2-8 Add "Single-step Feed" 2-10 Delete the description of MR-J3-B 2-10 Add the description of MR-J4-A to column of SYNC command 2-11 Add SYNC command in the figure
Jun., 2012	IB(NA)0300163-C	1-1 Available "Update Parameter Setting Range" of MR-J4-A 1-1 Available "Fully Closed Loop Diagnosis" of MR-J4-B 1-2 Available "Fully Closed Loop Diagnosis" of MR-J4-B 1-3 Available "Fully Closed Loop Diagnosis" of MR-J4-B 1-1 Add "Parameter Converter" in the table 1-2 Add "Parameter Converter" in the table 1-3 Add "Parameter Converter" in the table 2-5 Add "Parameter Converter"
Feb., 2013	IB(NA)0300163-D	1-1 Add MR-J4-B-RJ010, MR-JN-A and MR-JE-A in the table 1-1 Add "Program" in the table 1-1 Available "Fully Closed Loop Diagnosis" of MR-J4-A 1-1 Available "Linear Diagnosis" of MR-J4-A 1-2 Add "Program" in the table 1-3 Add MR-J4-B-RJ010 in the table 1-3 Add "CC-Link IE Field" and "Program" in the table 1-7 Add "MR-J4-B-RJ010" to "(4) For setting up via a simple motion" 1-7 Describe the USB connection by SSCNET and CC-Link IE Field 1-7 Modify the description of GX Communication setting 2-3 Modify the description of "(5) Saving the project with name" 2-3 Modify the description of "(6) Deleting the project" 2-6 Add "Program" to "Positioning-data"

Print Date	*Manual Number	Revision
May, 2013	IB(NA)0300163-E	1-4 Modify the description of "Note 3, 4, 5" 1-4 Add the Windows® 8 to OS 1-6 Modify the description of "(3) For setting up via a motion controller" 1-7 Modify the description of "(4) For setting up via a simple motion" 1-9 Modify the description of "1.4 Installation procedure" 1-9 Add the description of Windows® 8 1-11 Modify the description of "POINT" 1-11 Add the description of Windows® 8 1-13 Modify the description of "1.5 New hardware detection wizard" 1-14 Add the description of Windows® 8 3-2 Add the description of Windows® 8
Mar., 2014	IB(NA)0300163-F	1-1 Add the J3 extension function 1-1 Add the safety menu, available "Positioning-data" of MR-J4-A 1-2 Add the J3 extension function and safety menu 1-3 Add the J3 extension function and safety menu 1-4 Add the Windows® 8.1/delete the Windows® 2000 to OS 1-9 Delete the description of Windows® 2000 1-11 Modify the security warning screen 1-13 Delete the description of Windows® 2000 1-14 Delete the description of Windows® 2000 2-1 Modify the start-up method 2-2 Change the image 2-6 Add the safety and indirect addressing menu 3-1 Delete the description of Windows® 2000 3-2 Delete the description of Windows® 2000
Jun., 2014	IB(NA)0300163-G	1-2 Add the description about MT Developer2 Version 1.100E or later 1-3 Add the description about GX Works3 1-6 Add the description about MT Developer2 Version 1.100E or later 1-7 Add the description about GX Works3 2-1 Add the description about MT Developer2 Version 1.100E or later/ GX Works3 2-5 Add "Switch Display Language" in View

Print Date	*Manual Number	Revision
Oct., 2014	IB(NA)0300163-H	A-2 Delete the memo page of "Safety Instructions" 2 Delete the memo page of "CONTENTS" 1-2 Modify the layout 1-3 Modify the layout 1-4 Modify the layout 1-7 Modify the layout 1-8 Modify the layout 2-6 Modify the description of "Alarm Display" 2-7 Add "Connection to MITSUBISHI ELECTRIC FA Global Website" in Help 2-7 Modify the description of "Update Parameter Setting Range" 2-12 Delete the memo page of "2. HOW TO USE THE SOFTWARE" 3-3 Delete the memo page of "3. TROUBLESHOOTING" Back cover Delete the three-diamond Mitsubishi mark before the company name
Nov., 2014	IB(NA)0300163-J	1-1 Available "Functional safety unit" of MR-J4-A/Add the description about MR-J4-B-RJ/Add MR-JE-B 1-2 Add the description about MR-J4-B-RJ 1-3 Add the description about MR-J4-B-RJ/Add MR-JE-B
Jan., 2015	IB(NA)0300163-K	1-1 Modify the description about MR-JE-A 1-1, 1-2 Divide the description about MR-J4 series and MR-J3 series/MR-JN-A to 1-1 and 1-2 pages 1-1, 1-2, 1-3, 1-4 Add "Cam data" to "Positioning-data" 1-1, 1-3 Add MR-J4-B-LL in the table 1-7 Modify the layout 1-8 Modify the layout 2-6 Add "Cam data" to "Positioning-data"
Apr., 2015	IB(NA)0300163-L	1-1 Change the model order in corresponding table 1-12 Add the description of "POINT" 1-13 Add the description of "POINT" 3-3, 3-4 Add the description of "TROUBLESHOOTING"
Jul., 2015	IB(NA)0300163-M	1-1, 1-3, 1-4 Modify the model name in corresponding table 1-5 Update the Windows® XP of the corresponding OS/Check the description of Note 3 1-7, 1-8 Modify the model name 1-13 Modify the contents 2-9 Modify the contents in Chapter 2
Sep., 2015	IB(NA)0300163-N	1-1 Add MR-J4-GF 1-6, 1-7, 1-8 Modify the contents 1-13 Modify the contents

Print Date	*Manual Number	Revision
Feb., 2016	IB(NA)0300163-P	1-1 Modify the model name in corresponding table to MR-J4-GF(-RJ) 1-1 Available "Point Table", "Fully Closed Loop Diagnosis", "Linear Diagnosis" and "Single-step Feed" of MR-J4-GF(-RJ) 1-3, 1-4 Modify the title 1-4 Add MR-J4-GF(-RJ) in corresponding table 1-5 Add Windows® 10 in corresponding OS 1-6 Modify the notes 1-8, 1-9 Modify the contents 3-2 Add the description of Windows® 10
Jun., 2016	IB(NA)0300163-Q	1-3 Add MR-MT2□□□ 1-5 Add Windows® 10 Education in corresponding OS 1-6 Modify the display of note 3 1-8, 1-9 Modify the passage 2-7 Add "Options" to "Tools" 3-1 Add the chapter of "PRECAUTIONS" 3-1, 3-2 Change the Precautions for test mode to chapter 3.1 3-2 Add the chapter of "Display language switching" 4-1, 4-2, 4-3, 4-4 Change the chapter of "TROUBLESHOOTING" to chapter 4
Oct., 2016	IB(NA)0300163-R	COVER FRONT Modify the passage A-1 Correct misentry 1-1, 1-4 Available "Safety Parameter Setting", "Change Password", "Initialize Password" and "Cam Data" of MR-J4-GF(-RJ) 1-3, 1-4, 1-6 Modify the notes
Dec., 2016	IB(NA)0300163-S	A-1 Modify the passage 1-1, 1-2 Divide the description about MR-JE series from MR-J4 series/MR-JE series and add MR-JE-C to JE series
Mar., 2017	IB(NA)0300163-T	1-2, 1-5 Change MR-JE-B to MR-JE-B(F)
May, 2017	IB(NA)0300163-U	1-5, 2-1 Add the version of GX Works2
Aug., 2017	IB(NA)0300163-V	1-1, 1-2, 1-3 Add "Ethernet" menu 1-1, 1-2, 1-3, 1-4, 1-5 Add "Multi-axis Tuning" menu 1-6 Add the item "Ethernet cable" 1-8 Add the description of Ethernet connection 2-7 Add "Multi-axis Tuning" to "Adjustment"
Mar., 2018	IB(NA)0300163-W	A-1 Move the description of trademarks to the behind of "REVISONS" 1-1 Available "Ethernet communication" of MR-J4-GF(-RJ) 1-7 Delete the description of trademarks 1-8, 1-9, 1-10 Delete the note of trademarks 2-1 Add the description of start-up via USB, etc. 4-5 Add the troubleshooting when contents in the screen are not displayed properly

Print Date	*Manual Number	Revision
Sep., 2018	IB(NA)0300163ENG-X	1-2 Available "Point Table" of MR-JE-C 1-6 Add Windows® 10 IoT Enterprise 2016 LTSB in corresponding OS
Apr., 2019	IB(NA)0300163ENG-Y	1-1 Add MR-J5 series 1-7 Add MR-J5 series to "When via GX Works3" 1-8 Modify the notes of components 1-12 Add the description of HUB connection to "(5) For setting up via GX Works2/GX Works3" 2-3 Add the new project screen of multi-axis project 2-6 Add "Network Parameter" to "Parameter" 2-7 Add "Gear Failure Diagnosis" and "Encoder Communication Circuit Diagnosis" to "Diagnosis"
Oct., 2019	IB(NA)0300163ENG-Z	1-1 Available "Network Parameter" and "Fully Closed Loop Diagnosis" of MR-J5-A 1-1 Available "Fully Closed Loop Diagnosis" of MR-J5-G, modify the notes 1-1 Add MR-J5-G-N1, MR-JET-G and MR-JET-G-N1 1-7 Available "Network Parameter" and "CC-Link IE TSN" of MR-J5-G when via GX Works3, modify the notes 1-7 Add MR-JET-G
Jul., 2020	IB(NA)0300163ENG-AA	1-1 Available "Safety Parameter", "Change Password" and "Initialize Password" of MR-J5-G and MR-J5-G-N1 1-1 Available "Linear Diagnosis" of MR-JET-G and MR-JET-G-N1 1-8 Delete Windows® XP/Windows Vista® from OS 1-9, 1-16, 1-18, 1-19, 4-1, 4-2, 4-3, 4-4 Delete the description of Windows® XP/Windows Vista®
Oct., 2020	IB(NA)0300163ENG-AB	1-1, 1-2, 1-3, 1-4, 1-5, 1-6, 1-7 Add "Object Monitor" menu 2-7 Add "Object Monitor" to "Monitor"
Jan., 2021	IB(NA)0300163ENG-AC	1-1 Available "Point Table" and "Single-step Feed" of MR-J5-G, MR-J5-G-N1, MR-JET-G and MR-JET-G-N1 1-2 Available "Parameter Converter" of MR-J4-GF 1-12 Add Motion Module (CC-Link IE TSN) to the explanation and figures of (5) 2-1, 2-2 Modify the contents 2-6, 2-7 Add chapter 2.1.3 Servo parameters

This manual confers no industrial property rights or any rights of any other kind, nor does it confer any patent licenses. Mitsubishi Electric Corporation cannot be held responsible for any problems involving industrial property rights which may occur as a result of using the contents noted in this manual.

The "Mitsubishi Electric General-purpose AC Servo MELSOFT MR Configurator2" is a production of Mitsubishi Electric Corporation.
Mitsubishi Electric Corporation reserves the copyright and all other rights of this software.
This Installation Guide may not be reproduced or copied, in whole or part, without written consent of Mitsubishi Electric Corporation.
Microsoft and Windows are registered trademarks or trademarks of Microsoft Corporation in the United States and other countries.
Intel, Pentium and Celeron are trademarks of Intel Corporation in the United States and other countries.
Ethernet is a registered trademark of Fuji Xerox Co., Ltd. in Japan.
Generally, the company names, system names and product names, etc. mentioned herein are registered trademarks or trademarks of their respective companies.
The trademark symbols (™, ®) mentioned herein may be unspecified.

MODEL	
MODEL CODE	

MITSUBISHI ELECTRIC CORPORATION

HEAD OFFICE : TOKYO BLDG MARUNOUCHI TOKYO 100-8310