



Logging Unit for Energy Measuring Unit (EcoMonitorLight, EcoMonitorPlus)

Model EMU4-LM
User's Manual (Digest)

- If you are considering using this unit for special purpose such as nuclear power plants, aerospace, medical care or passenger vehicles please refer to our sales representative.
- Before using this unit, please read both this manual and Details carefully with attention to safety to handle this unit correctly.
- Make sure that the end users read this manual and then keep the manual in a safe place for future reference.

ABOUT MANUALS
You can download User's manual (Details) of this unit from the following site.
http://www.mitsubishielectric.com/fa/worldwide/index.html

1. Features

- This unit can memorize the data of various quantities related to electricity such as voltage, current, power and energy (hereinafter referred to as measured data) measured by Energy Measuring Unit (EcoMonitorLight, EcoMonitorPlus) for a certain period.
- Memorized measured data can be output to an SD memory card in CSV format.
- You can check the data files output to the SD memory card by Microsoft Excel or GX LogViewer (Version 1.30G or after).

Microsoft Excel is the registered trademark of the U.S. Microsoft Corporation in the U.S. and other countries.
The SD and SDHC logos are either registered trademarks or trademarks of SD-3C, LLC.

2. Checking package contents

- The following items for this device are included in package. Check that no items are missing.
- Logging Unit x1
 - Battery (EMU4-BT) x1
 - User's Manual (Digest) x1

3. Safety Precautions

3.1 Precautions for Operating Environment and Conditions

This unit is premised on being used in pollution degree I environment. When used in higher pollution degree, protect this unit from pollution on another device side to be incorporated. (For the definition of the pollution degree and the over voltage category, refer to EN61010-1/2010.)
Do not use this product in the places listed below. Failure to follow the instruction may cause malfunctions and a life decrease of product.

- Places the operating humidity exceeds the range from 30 to 85%RH or places with dewfall
 - Places in strong electromagnetic field or places large amounts of external noise exist
 - Places the operating temperature exceeds the range from -5 to +55°C
 - Places exposed to direct sunlight
 - Operating altitude exceeds 2000m
 - Vibration and impact exceeds the specifications
 - Places the average daily temperature exceeds +35°C
 - Dust, corrosive gas, saline and oil smoke exist
 - Places exposed to rain or water drop
 - Places metal fragments or conductive substance are flying
- This unit is the open type device, which are designed to be housed within another device for prevention of electric shock. House this unit within the device such as the control panel before use.(indoor use)

3.2 Matters concerning the precaution before use

Use the unit in specified usage environment and conditions.

3.3 Installation and Wiring Precautions

- Do not touch the electrically charged portion. It may cause electric shock, electric burn injury or burnout of the device.
- Work under the electric outage condition when installing.
- Any person who is involved in installation and wiring of this unit should be fully competent to do this work.
- Work under electric outage condition when installing wiring. Failure to do so may cause electric shock, a failure of the unit, a fire etc.
- When tapping or wiring, take care not to enter any foreign objects such as chips and wire pieces into this unit.
- Check the connection way when connecting to the Energy Measuring Unit. Wrong wiring may cause failure of the unit, a fire or electric shock.

- Removed lithium batteries may have electric charge. Store them separately so as not to touch other metal, otherwise evolution of heat, burst or ignition may occur.

3.8 About packaging materials and this manual

For reduction of environment load, packaging materials are produced with cardboard.

4. Name and function of each part

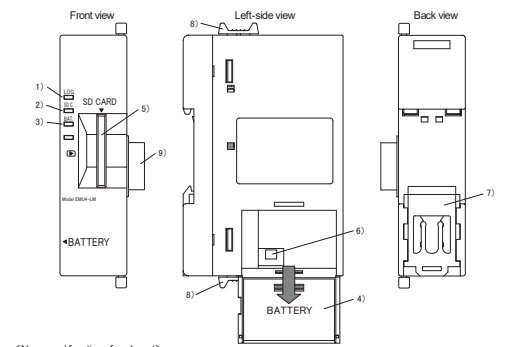

No.	Name	Function
1)	LOG LED	This indicates a state of logging operation. Turn on: Logging in running Turn off: Loggings stopped Blink slowly (Time: 1) (5 seconds): Change of logging condition settings finished Blink quickly (Time: 2) (20 seconds): Change of logging condition settings failed (Time: 3) Blink quickly (Time: 2): Error occurrence (Time: 3) Blink quickly (Time: 2): SD memory card error (Time: 3)
2)	SD C. LED	This indicates a state of communication with the SD memory card. Turn on: Communicating Turn off: Stop communicating
3)	BAT. LED	This indicates a state of battery voltage. Turn on: Low battery voltage (Time: 1) Turn off: Normal battery voltage (Time: 2)
4)	Battery box	This stores a battery to back up present time data, logging data and system log data.
5)	SD memory card slot	This is a slot to insert an SD memory card.
6)	Battery connector	This connects a battery.
7)	IEC rail stop	This is used to fix to an IEC rail.
8)	Connection stop	This is used to connect the Logging Unit to the Energy Measuring Unit.
9)	Connector	This is used to connect the Energy Measuring Unit.

- [Note 1] Blink slowly: Repetition of 0.5-second on and 0.5-second off
[Note 2] Blink quickly: Repetition of 0.25-second on and 0.25-second off
[Note 3] Refer to "Error display and measures" in this manual.
[Note 4] reset time data and logging data are erased by power-off with battery voltage low. ("Logging ID", "Logging mode", "Logging start time", "Detailed data logging cycle" and "Logging item" are not erased, which are memorized in the nonvolatile memory.) If BAT. LED turns on, change a battery.

- ### 3.4 Precautions for Use
- Before operating the product, check that active bare wire and so on does not exist around the product. If any exposed conductor is found, stop the operation immediately, and take an appropriate action such as isolation protection.
 - In the event of a power outage during the setting, the unit is not set correctly. Please set again after power recovery.
 - During communication with the SD memory card, the operations such as power-off, reset and ejection of the memory card may cause data corruption of the memory card or failure of this unit or the memory card. Power off or reset the unit, or eject the SD memory card after checking that SD C. LED turns off.
 - Make sure to use the SD memory card manufactured by Mitsubishi Electric Corporation (Model EMU4-SD2GB).
 - Using the other types of the SD memory card may cause the trouble such as data destruction of the memory card or system failure. For the SD memory card on the market, please refer to the Sales and Service No.YAMA192 from our site. However, at the time of use, please verify sufficient by the customer that there is no problem.
 - Format an SD memory card in the way specified in this manual. Format is done already as of the purchase, so a SD memory card made by Mitsubishi Electric Corporation (Model EMU4-SD2GB) has use just as it is, and is no problem.
 - Insert the SD memory card with the write protect switch "OFF". If the write protect switch is "ON", read/write to the SD memory card is stopped.
 - Present time data and logging data are erased by power-off with BAT. LED on. ("Logging ID", "Logging mode", "Logging start time", "Detailed data logging cycle" and "Logging item" are not erased, which are memorized in the nonvolatile memory.) If BAT. LED turns on, output logging data to the SD memory card and change a battery.
 - All logging data of the Logging Units erased when you change the setting of "Phase wire system", "Primary voltage (Use or non-use of VT, Direct Voltage, Primary voltage with VT, Special primary voltage)", "Primary current (Direct sensor, 5A sensor, Special primary current)" or "Sensor type" of the Energy Measuring Unit (EcoMonitorLight Model: EMU4-BD1-MB/EMU4-HD1-MB, EcoMonitorPlus Model: EMU4-BM1-MB/EMU4-HM1-MB/EMU4-VA2/EMU4-A2). All logging data of the Logging Units erased when you change the setting of "Phase wire system" and "Measurement mode" of the Energy Measuring Unit with Insulation Monitoring (EcoMonitorLight Model: EMU4-LG1-MB). Before changing the setting of the Energy Measuring Unit, output the logging data to the SD memory card and check the output data in the PC whether the logging data is memorized properly.
 - The Logging Unit should not be used for multiple Energy Measuring Units. Otherwise all logging data of the Logging Unit may be erased, or there may be some data for different Energy Measuring Units in the Logging Unit.

- Do not touch the electrically charged portion. It may cause electric shock, electric burn injury or burnout of the device.
- Work under the electric outage condition when installing.

- Do not disassemble or modify this unit. It may cause failure, malfunction, injury or fire.

3.5 Maintenance Precautions

- Use a soft dry cloth to clean off dirt of the unit surface. Do not let a chemical cloth remain on the surface for an extended period of time nor wipe the surface with thinner or benzene.
- Check for the following items to use this unit properly for long time.
 - Daily maintenance
 - No damage on this unit
 - No abnormally with LED indicators
 - No abnormal noise, smell or heat

3.6 Storage Precautions

- For long-time storage, avoid the following places. Failure to follow the instruction may cause a failure and reduced life of the unit.
 - Places the relative humidity exceeds the range from 30 to 85% or places with dewfall
 - Places the storage temperature exceeds the range from -10 to +60°C
 - Places the average daily temperature exceeds +35°C
 - Dust, corrosive gas, saline and oil smoke exist
 - Places exposed to rain, water drop or direct sunlight
 - Places metal fragments or conductive substance are flying

3.7 Disposal Precautions

- When disposing of this unit, treat it as industrial waste.
- Lithium batteries are disposed of according to local regulation.
- In EU member states, there is a separate collection system for waste batteries. Dispose of batteries' property at the local community waste collection/recycling center. The symbol shown upper right is printed on the packaging of the unit. [Note] This symbol mark is for EU countries only. This symbol mark is according to the directive 2012/19/EU Article 14 Information for users and Annex X, and to the directive 2006/66/EC Article 20 Information for end-users Annex II.
- This symbol means that electrical and electronic equipment, batteries and accumulators, at their end-of-life, should be disposed of separately from your household waste.

5. Procedure for operation

Procedure for operation of this unit is as follows: Please refer to User's Manual (Details).

No.	Procedure	Content
1)	Connect the battery to the Logging Unit	Refer to this manual 6.1 "How to connect the battery".
2)	Connect the Logging Unit to the Energy Measuring Unit	Refer to this manual 6.2 "How to connect the Logging Unit".
3)	Mount the Energy Measuring Unit and the Logging Unit to the panel	Refer to this manual 7 "Installation". * Refer to User's manual (Details) of Logging unit about "Panel mounting".
4)	Turn on the Energy Measuring Unit	
5)	Set the present time of the Logging Unit	EcoMonitorLight : Refer to User's manual (Details) "Set the present time of Energy Measuring Unit" EcoMonitorPlus : Refer to User's manual (Details) "Clock setup" for the settings for the clock of Small Type Display Unit for Energy Measuring Unit
6)	Set logging ID of the Logging Unit	EcoMonitorLight : Refer to User's manual (Details) "Setting menu 5. Logging setting" of Energy Measuring Unit. EcoMonitorPlus : Refer to User's manual (Details) "Logging setup" - the settings for the logging ID of "Small Type Display Unit for Energy Measuring Unit".
7)	Set logging condition in the Logging Unit	Refer to User's manual (Details) 7 "Directions "Set condition in the Logging Unit" of Logging Unit. * For setting, it is necessary to create a setting file using Logging unit utility or Microsoft Excel * Setting is necessary when connecting to Energy Measuring Unit with Insulation Monitoring. If not setting, an error occurs(system log codes:392)

6. How to connect

6.1 How to connect the battery

- Slide the battery box to open it.
- Connect the connector of the battery cable to the battery connector.

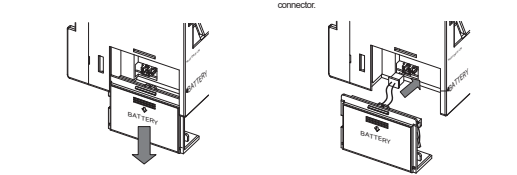

(3) Fix the battery box to the Logging Unit.

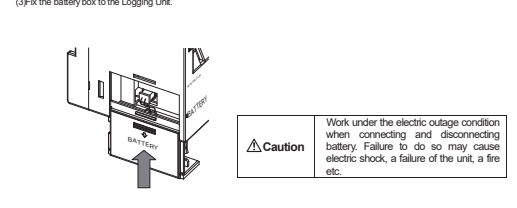

- Work under the electric outage condition when connecting and disconnecting battery. Failure to do so may cause electric shock, a failure of the unit, a fire etc.

- ### 6.2 How to connect the Logging Unit
- This unit can be attached to EcoMonitorLight in below. This unit can be attached to EcoMonitorPlus as well.
* In EcoMonitorPlus, connect to the base unit (model name: EMU4-BM1-MB/EMU4-HM1-MB/EMU4-LG1-MB/EMU4-CNT-MB).
- Remove the blank label stuck to the left side of the Energy (2) Insert the connector of the Logging Unit into that of the Energy Measuring Unit and contact the unit.
-
- (3) Slide the connection stops (green-colored) in upside and downside of the Logging Unit to lock it.

- Work under the electric outage condition when connecting and disconnecting battery. Failure to do so may cause electric shock, a failure of the unit, a fire etc.

6.3 How to insert the SD memory card

Slide the SD memory card straight into the slot until it clicks into place.



- Make sure to use the SD memory card manufactured by Mitsubishi Electric Corporation (Model EMU4-SD2GB). Using the other types of the SD memory card may cause the trouble such as data destruction of the memory card or system failure.
- Format an SD memory card in the way specified in this manual.
- Insert the SD memory card with the write protect switch "OFF". Otherwise read/write to the SD memory card is stopped.

6.4 How to eject the SD memory card

Push the SD memory card in unit it clicks into place. The SD memory card comes out by itself.

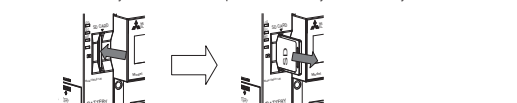

- During communication with the SD memory card, ejection of the memory card may cause data corruption of the memory card or failure of this unit or the memory card. Check that SD C. LED turns off to eject the SD memory card.

8. Dimensions

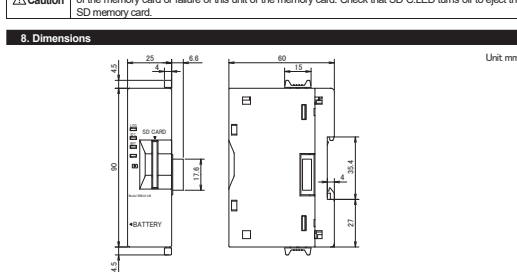

9. Specifications

<Basic specifications>

Item	Specifications
Model	EMU4-LM
Rating	6.4V DC (powered by the Energy Measuring Unit)
Compensation for power failure	Battery (EMU4-BT) Total time of compensation is 1 year (average daily temperature is not more than +35°C). It is recommended that the battery be changed every 3 years.
Setting values	Memorized in FRAM (non-volatile memory). The data is not erased during power failure.
Logging data	Memorized in SFRAM (volatile memory)
System log data	Data is entered if power failure occurs under low battery voltage condition (BAT. LED turns on).
Timing	Timing is stopped if power failure occurs under low battery voltage condition (BAT. LED turns on). After power recovery, timing is started from Jan. 1, 2013.00:00:00.
Clock accuracy	±1 minute per month
Memory media for data output (Time: 1)	SD memory card (SD, SDHC)
Accommodating model	Energy Measuring Unit EcoMonitorLight Model: EMU4-BD1-MB/EMU4-HD1-MB EcoMonitorPlus Model: EMU4-BM1-MB/EMU4-HM1-MB/EMU4-LG1-MB/EMU4-CNT-MB/EMU4-A2/EMU4-VA2/EMU4-PAK/EMU4-AK4
Standard	EMC: EN61326-1: 2013
Usage environment	-
Operating temperature	-5°C to +55°C (average daily temperature is not more than +35°C)
Operating humidity	30% to 85%RH (No condensation)
Storage temperature	-10°C to +60°C
Operating altitude	2000m or lower
Mass	0.1kg (Mass of the Logging Unit only)
Optional part	SD memory card (EMU4-SD2GB) (Time: 2)
Optional supplies	Battery (EMU4-BT) (Time: 2)

[Note 1] Make sure to use the SD memory card manufactured by Mitsubishi Electric Corporation (Model EMU4-SD2GB). Using the other types of the SD memory card may cause the trouble such as data destruction of the memory card or system failure. For the SD memory card on the market, please refer to the Sales and Service No.YAMA192 from our site.
[Note 2] For purchase of optional parts or supplies, contact the shop you bought this product.

- ### 7. Installation
- There are two installation methods, surface mounting and panel mounting. Refer to User's manual (Details) of Logging Unit about "Panel mounting".
- How to mount to an IEC rail
- This unit can be attached to EcoMonitorLight in below. This unit can be attached to EcoMonitorPlus as well.
- Applicable IEC rail
 - How to mount
 - Push the IEC rail stopdown
 - Hook on the rail
 - Push the unit
 - Push the IEC rail stop up
 - How to remove
 - Hold the unit and pull the IEC rail stop down
 - Push down the spring fitting
 - Push down the spring fitting in chassis at the lower part of the unit.
- (2) JIS agreement type attachment
- This unit can be attached to EcoMonitorLight in below. This unit can be attached to EcoMonitorPlus as well.
- Attachment plate
 - How to mount
 - Push the IEC rail stop above
 - Hook 3 chassis at upper part of the unit to the hook on the attachment plate
 - Push the unit down and fit in the spring fitting in chassis at the lower part of the unit.
 - How to remove
 - Push down the spring fitting
 - Lift the lower part of unit slowly and remove in reverse order of Attaching

<Logging specifications>

Item	Specifications
Logging mode	Auto start and stop by start time setting
Auto updating	Auto start and stop by start time setting
Type of logging data	Memorize measured data in the specified "Detailed data logging cycle" (1 second, 1 minute, 1 minute, 5 minutes, 10 minutes, 15 minutes or 30 minutes). Data is output as detailed data file.
One-hour data	Memorize measured data in one-hour cycle. Data is output as One-hour data file and One-day data file.
One-hour data	Up to 10 items If the detailed data logging cycle is not "1 second": Up to 4 items
Number of logging items	Up to 10 items
Internal memory logging period	Maximum logging period
One-hour data	Number of expansion (Time: 1)
One-hour data	Number of expansion (Time: 2)
One-hour data	Number of expansion (Time: 3)
One-hour data	Number of expansion (Time: 4)
One-hour data	Number of expansion (Time: 5)
One-hour data	Number of expansion (Time: 6)
One-hour data	Number of expansion (Time: 7)
One-hour data	Number of expansion (Time: 8)
One-hour data	Number of expansion (Time: 9)
One-hour data	Number of expansion (Time: 10)
One-hour data	Number of expansion (Time: 11)
One-hour data	Number of expansion (Time: 12)
One-hour data	Number of expansion (Time: 13)
One-hour data	Number of expansion (Time: 14)
One-hour data	Number of expansion (Time: 15)
One-hour data	Number of expansion (Time: 16)
One-hour data	Number of expansion (Time: 17)
One-hour data	Number of expansion (Time: 18)
One-hour data	Number of expansion (Time: 19)
One-hour data	Number of expansion (Time: 20)
One-hour data	Number of expansion (Time: 21)
One-hour data	Number of expansion (Time: 22)
One-hour data	Number of expansion (Time: 23)
One-hour data	Number of expansion (Time: 24)
One-hour data	Number of expansion (Time: 25)
One-hour data	Number of expansion (Time: 26)
One-hour data	Number of expansion (Time: 27)
One-hour data	Number of expansion (Time: 28)
One-hour data	Number of expansion (Time: 29)
One-hour data	Number of expansion (Time: 30)
One-hour data	Number of expansion (Time: 31)
One-hour data	Number of expansion (Time: 32)
One-hour data	Number of expansion (Time: 33)
One-hour data	Number of expansion (Time: 34)
One-hour data	Number of expansion (Time: 35)
One-hour data	Number of expansion (Time: 36)
One-hour data	Number of expansion (Time: 37)
One-hour data	Number of expansion (Time: 38)
One-hour data	Number of expansion (Time: 39)
One-hour data	Number of expansion (Time: 40)
One-hour data	Number of expansion (Time: 41)
One-hour data	Number of expansion (Time: 42)
One-hour data	Number of expansion (Time: 43)
One-hour data	Number of expansion (Time: 44)
One-hour data	Number of expansion (Time: 45)
One-hour data	Number of expansion (Time: 46)
One-hour data	Number of expansion (Time: 47)
One-hour data	Number of expansion (Time: 48)
One-hour data	Number of expansion (Time: 49)
One-hour data	Number of expansion (Time: 50)
One-hour data	Number of expansion (Time: 51)
One-hour data	Number of expansion (Time: 52)
One-hour data	Number of expansion (Time: 53)
One-hour data	Number of expansion (Time: 54)
One-hour data	Number of expansion (Time: 55)
One-hour data	Number of expansion (Time: 56)
One-hour data	Number of expansion (Time: 57)
One-hour data	Number of expansion (Time: 58)
One-hour data	Number of expansion (Time: 59)
One-hour data	Number of expansion (Time: 60)
One-hour data	Number of expansion (Time: 61)
One-hour data	Number of expansion (Time: 62)
One-hour data	Number of expansion (Time: 63)
One-hour data	Number of expansion (Time: 64)
One-hour data	Number of expansion (Time: 65)
One-hour data	Number of expansion (Time: 66)
One-hour data	Number of expansion (Time: 67)
One-hour data	Number of expansion (Time: 68)
One-hour data	Number of expansion (Time: 69)
One-hour data	Number of expansion (Time: 70)
One-hour data	Number of expansion (Time: 71)
One-hour data	Number of expansion (Time: 72)
One-hour data	Number of expansion (Time: 73)
One-hour data	Number of expansion (Time: 74)
One-hour data	Number of expansion (Time: 75)
One-hour data	Number of expansion (Time: 76)
One-hour data	Number of expansion (Time: 77)
One-hour data	Number of expansion (Time: 78)
One-hour data	Number of expansion (Time: 79)
One-hour data	Number of expansion (Time: 80)
One-hour data	Number of expansion (Time: 81)
One-hour data	Number of expansion (Time: 82)
One-hour data	Number of expansion (Time: 83)
One-hour data	Number of expansion (Time: 84)
One-hour data	Number of expansion (Time: 85)
One-hour data	Number of expansion (Time: 86)
One-hour data	Number of expansion (Time: 87)
One-hour data	Number of expansion (Time: 88)
One-hour data	Number of expansion (Time: 89)
One-hour data	Number of expansion (Time: 90)
One-hour data	Number of expansion (Time: 91)
One-hour data	Number of expansion (Time: 92)
One-hour data	Number of expansion (Time: 93)
One-hour data	Number of expansion (Time: 94)
One-hour data	Number of expansion (Time: 95)
One-hour data	Number of expansion (Time: 96)
One-hour data	Number of expansion (Time: 97)
One-hour data	Number of expansion (Time: 98)
One-hour data	Number of expansion (Time: 99)
One-hour data	Number of expansion (Time: 100)

System log data

Output format of logging data: CSV format (ASCII)

Log system log data

Number of measurement circuits varies depending on the connected unit. For details, please refer to the manual (detail).

[Note 4] It is the period until capacity of ZGB SD memory card is filled in always-on connection. Data amount depends on the number of characters. It is the logging period when data is output in maximum volume. When saving data from multiple Energy Measuring Units on a single SD memory card, make sure that the total period of the saved data does not exceed the maximum logging period.

10. Contained harmful substances

(1) 电器电子产品有害物质限制使用标识

根据《电器电子产品有害物质限制使用管理办法》，该标识适用于在中国销售的电器电子产品。其中的数字为产品的环保使用期限。只要遵守本产品安全和使用的注意事项，从生产之日起的环保使用期限内不会造成环境污染对人体，产生深刻的影响。
注) 产品正常使用废弃后，应按照国家和对地方的法律法规完成该电器电子产品的回收和再利用。此环保使用期限不涵盖产品附带的电池。产品所附带的电池，其环保使用期限为 3 年。

(2) 产品中有害物质名称及含量

本产品中所含有的 6 种有害物质的名称、含有信息及各部件如下所示。

产品中有害物质的名称及含量

部件名称	有害物质					
	铅 (Pb)	汞 (Hg)	镉 (Cd)	六价铬 (Cr(VI))	多溴联苯 (PBB)	多溴二苯醚 (PBDE)
基板	×	×	×	×	○	○
箱子	○	○	○	○	○	○
铭牌	○	○	○	○	○	○
电池	○	○	○	○	○	○
接线	○	○	○	○	○	○
接线板	○	○	○	○	○	○