

Energy Measuring Unit *Eco Monitor* **Plus**

Energy
Saving

+

Preventive
Maintenance



Energy measuring + α

Eco Monitor **Plus**

Energy Saving + Preventive Maintenance Providing energy visualization and More!

Introducing the EcoMonitorPlus, an energy measuring units that visualize "energy" to respond to a wide range of customer needs such as monitoring of power consumption, configuration of an energy-saving system, and stable operation of equipment.



The EcoMonitorPlus is suitable if you are thinking

Want to expand the energy-saving system in phases.

At first, use the EcoMonitorPlus to obtain measurements at locations you are concerned about. Then, when a need to increase the number of measuring points arises, add measuring, logging and communication units as needed.

Want to manage data measured at specific locations easily and use the data to check energy-saving effects.

The logging unit lets you collect measurement data via SD memory card. Using the documentation software, you can easily manage data and create graphs from data.

Eco Monitor **Plus**

about the following!

*Want to use the EcoMonitorPlus not only
for saving energy
but also for other purposes.*

By using the insulation monitor unit and measuring leakage current, you can ensure stable operation of equipment and utilize data for preventive maintenance.

C o n t e n t s

1. Product Lineup	P3
2. Features	P6
3. Specifications	P9
4. Names of Parts and External view	P15
5. External view	P17
6. Connection Configurations	P20
7. Simplified Comparison of EcoMonitor Prod	P22

1. Product Lineup

Energy Measuring Unit (Basic Unit)

* Photos are full-scale

Three types of basic measuring unit*¹ are available.
You can select the most suitable model according to the application.

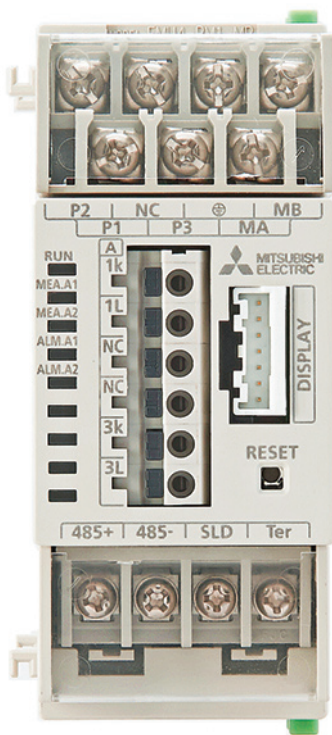

EMU4-BM1-MB

Energy Measuring Standard Model

EMU4-BM1-MB

Suitable for visualization of "energy" in a simple way!

- ① Equipped with basic functions for monitoring of voltage, current, power and electric energy.
- ② Standard-equipped with MODBUS® RTU communication.

Product name	Energy Measuring Unit [Energy Measuring Standard Model]
Model	EMU4-BM1-MB

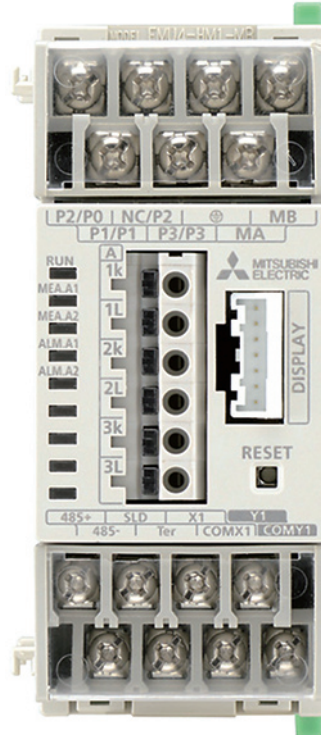

EMU4-HM1-MB

Energy Measuring High Performance Model

EMU4-HM1-MB

In addition to the functions of the Standard Model, this model comes with additional functions for the measurement of 3-phase 4-wire and pulse count.

- ① Same basic functions as the Standard Model.
- ② Standard-equipped with MODBUS® RTU communication.
- ③ Three-phase 3-wire, 440V direct voltage input is available.
- ④ Three-phase 4-wire, 270V/480V direct voltage input is available.
- ⑤ Capable of displaying harmonic current, voltage, apparent power, periodic electric energy and electric energy conversion value.

Product name	Energy Measuring Unit [Energy Measuring High Performance Model]
Model	EMU4-HM1-MB

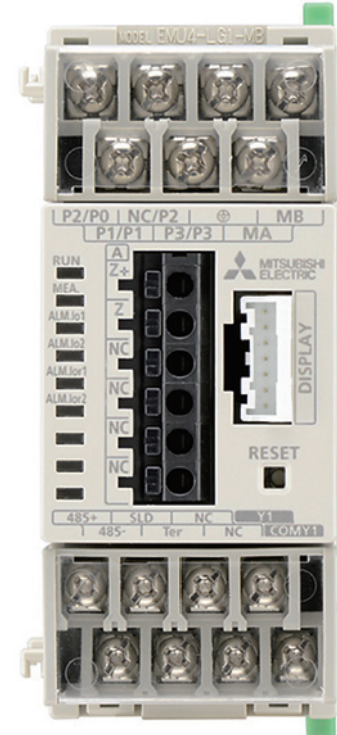

EMU4-LG1-MB

Insulation Monitor Model

EMU4-LG1-MB

Capable of Measuring Leakage Current.

- ① Measurement of leakage current.
- ② Equipped with a MODBUS® RTU communication function.
- ③ Capable of measuring Ior (resistive leakage current).
- ④ Equipped with alarm functions.

Product name	Energy Measuring Unit [Insulation Monitor Model]
Model	EMU4-LG1-MB

*¹ Basic unit cannot be used as an extension unit.

Energy Measuring Unit (Extension Unit^{*1*2})

Two types of extension energy measuring unit are available. You can select the most suitable model according to your need, such as measurement of same voltage or measurement of different voltages.

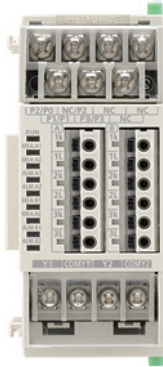

EMU4-VA2

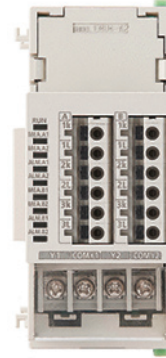

EMU4-A2

Energy Measuring Extension Unit for Different Voltage System

EMU4-VA2

For measurement of circuits of different voltages

- ① Measurement of two circuits (per unit).
- ② Capable of producing as many contact or pulse outputs as the number of circuits (selectable for each circuit).
- ③ Measurement of different transformer system by each unit (capable of measuring voltage different from that measured by the unit connected on the left side).

Product name	Energy Measuring Unit [Energy Measuring Extension Unit for Different Voltage System]
Model	EMU4-VA2

*1 Up to three extension units can be connected.

*2 Each extension unit can measure two circuits, but the circuits must be of the same voltage system. Different voltage system cannot be measured.

Energy Measuring Extension Unit for Same Voltage System

EMU4-A2

For measurement of circuits of same voltage

- ① Measurement of two circuits (per unit).
- ② Capable of producing as many contact or pulse outputs as the number of circuits (selectable for each circuit).
- ③ Connection wiring for voltage not necessary for measurement of same voltage (capable of measuring same voltage that measured by the unit connected on the left side).

Product name	Energy Measuring Unit [Energy Measuring Extension Unit for Same Voltage System]
Model	EMU4-A2

Optional Units^{*1}



EMU4-LM

For customers who want to easily manage data using SD memory cards!

Product name	Logging unit
Model	EMU4-LM

*1 One basic unit can be connected with one optional unit.



EMU4-CM-C



For CC-Link communication

Product name	CC-LINK communication unit
Model	EMU4-CM-C

1. Product Lineup

Option

► Split-type Current Sensor

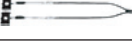
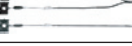
Product name	Model	External view	UL compatibility
Split-type current sensor	EMU-CT5-A		×
	EMU-CT50-A		×
	EMU-CT100-A		×
	EMU-CT250-A		×
	EMU-CT400-A		○
	EMU-CT600-A		○
	EMU-CT50		○
	EMU-CT100		○
	EMU-CT250		○
	EMU2-CT5		○
	EMU2-CT5-4W		○





*1 Use commercially available cables for the connection of current sensors.

Compatible cable: AWG22-14
(Single wire: $\phi 0.65$ to $\phi 1.62$ mm², Stranded wires: $\phi 0.33$ to $\phi 2.0$ mm²)

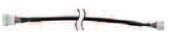

*2 Current sensor cable can be extended up to 50 m.
For the 5A current sensor (EMU2-CT5, EMU2-CT5-4W), cable can be extended to 10.5 m.

*3 In divided split-type Current Sensor (EMU2-CT5(4W) usa, EMU2-CB-Q5A(4W) is needed.



► Options for 5A Current Sensor (Current Sensor Cable)

Product name	Model	External view
5A Current sensor cable	EMU2-CB-Q5A (Single-phase 2-wire, single-phase 3-wire and three-phase 3-wire)	
	EMU2-CB-Q5A-4W (Three-phase 4-wire)	
Extension cable (Standard type)	EMU2-CB-T1M(1m)	
	EMU2-CB-T5M(5m)	
	EMU2-CB-T10M(10m)	
Extension cable (Separate type)	EMU2-CB-T1MS(1m)	
	EMU2-CB-T5MS(5m)	
	EMU2-CB-T10MS(10m)	

► Zero-phase Current converter

Product name	Model	External view
Split-type zero-phase current converter	CZ-22S	
	CZ-30S	
	CZ-55S	
	CZ-77S	
Through-type zero-phase current converter	ZT15B	
	ZT30B	
	ZT40B	
	ZT60B	
	ZT80B	
	ZT100B	
Zero-phase current transformer with primary conductor	ZTA600A	* See the external view.
	ZTA1200A	
	ZTA2000A	

► Compact Display Unit

Product name	Model	External view
Compact display unit	EMU4-D65	
Compact display unit connecting cable	EMU2-CB1-DP	
Compact display unit power cable	EMU4-CB-DPS	



*1 Commercially available DC power supply units are required for the connection of multiple EMU4-D65 units.

Compatible product: Cosel PBA15F-9-N1.

*2 Compact display unit connecting cables are required for the connection of multiple display units.

*3 Up to seven compact display units can be connected.

► Optional Parts for Logging Unit

Product name	Model	External view
SD memory card for logging unit	EMU4-SD2GB	
Lithium battery for logging unit	EMU4-BT	

*1 Each logging unit is supplied with one lithium battery (EMU4-BT).

Want to expand the energy-saving system in phases!

- You can start measurement at locations where you want to achieve energy saving.
- Expanding the system by adding more units as the number of measurement circuits increases.

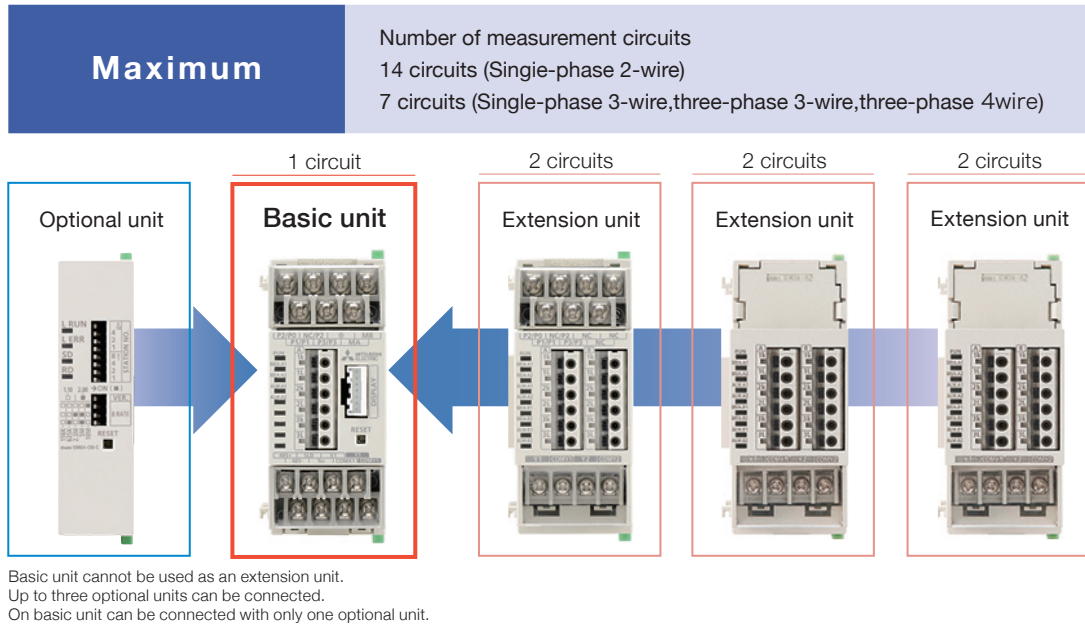

Want to use various functions!

440V direct measurement



VT not necessary

No VT necessary for voltage input
Space-saving installation to panel, reduced cost.
* Applicable to EMU4-HM1-MB, EMU4-LG1-MB and EMU4-VA2.

Conversion of electric energy to other units

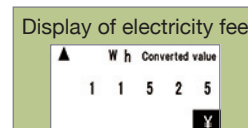

Measured electric energy can be converted and displayed in another unit of measurement.
* The unit of display value can be selected from none, Wh, kWh, MWh, J, m2, m3, L, kL, sec, min, hour, pieces, units, g, kg, t, ¥ and \$.

Test function for equipment communication and output check

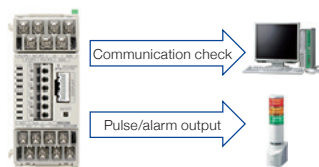

By supplying auxiliary power (voltage/current input not necessary), alarm/pulse test signal and communication test data for host system can be output for the confirmation of proper equipment operation.

Measurement of up to four different systems

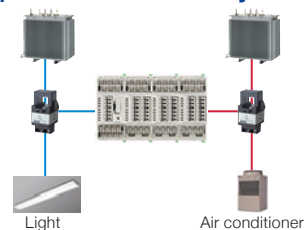

By adding Energy Measuring Extension Unit for Different Voltage System, a different transformer system can be measured by each unit.

2. Features

Want to create reports and graphs for simplified management of measurement data!

Easy collection of measurement data using SD memory card

- Using the logging unit, you can collect data without a host application program such as a PC-based application.
- Documentation software (Logging Unit Utility) enables easy creation of reports and graphs.

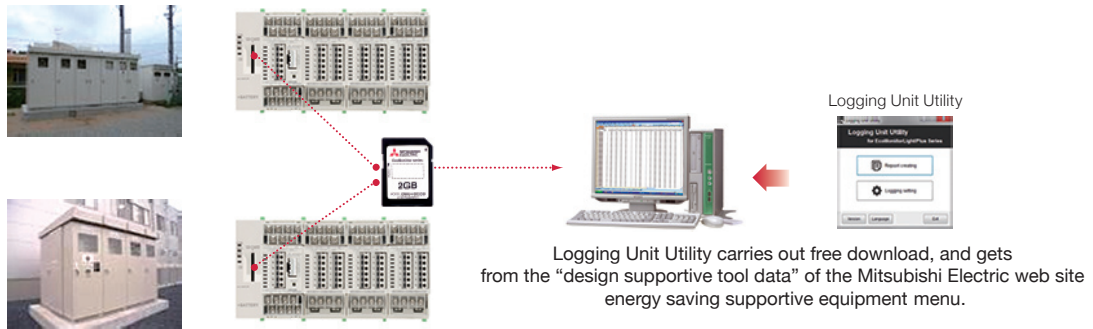

Logging Unit Utility carries out free download, and gets from the "design supportive tool data" of the Mitsubishi Electric web site energy saving supportive equipment menu.



Sample of report

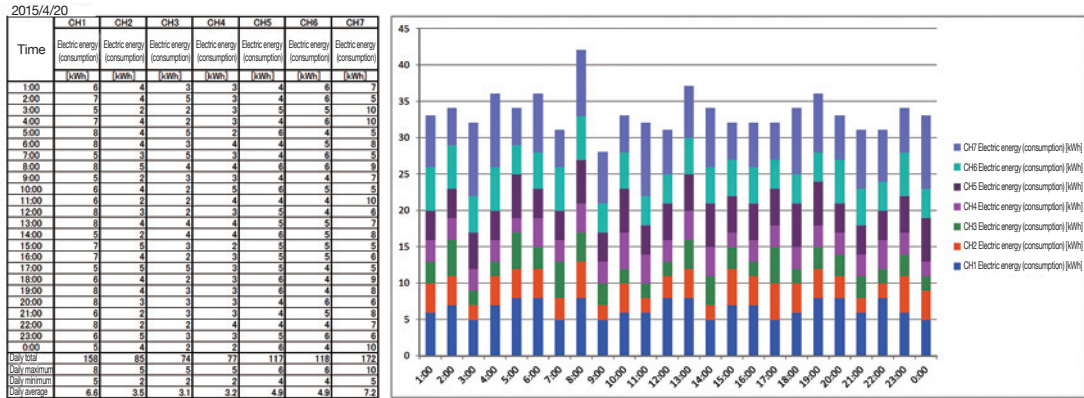

MODBUS® RTU (RS-485) communication function for maximum use of data acquisition software

- Providing MODBUS® RTU(RS-485) communication as standard equipment allows you data collection and report production by using software free(*1).



*1 Data acquisition software carries out free download, and gets from the "design supportive tool data" of the Mitsubishi Electric web site energy saving supportive equipment menu.
 *2 Used converter can be a LAN ⇔ RS-485 converter or USB ⇔ RS-485 converter.
 *3 Connectable devices: LINEEYE SI-65 (LAN ⇔ RS-485 converter) and LINEEYE SI-35USB (USB ⇔ RS-485 converter).

Want to use the EcoMonitorPlus for purposes other than energy saving!

Monitoring of leakage current and load current

< Measurement of leakage current >

① Capable of measuring even extremely low levels of leakage current.

Insulation monitor unit (EMU4-LG1-MB) Leakage current resolution: 0.01 mA
 ⇒ Capable of measuring leakage current in equipment groups, such as motors.

② Monitoring of equipment insulation degradation using Ior system

Since leakage current (Io) is affected by the Ioc of the whole equipment, the Ior measurement is effective for insulation deterioration diagnosis.

Method of leakage current measurement (Io and Ior measurements)

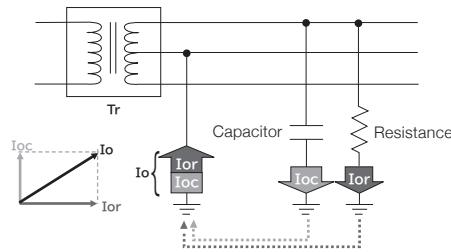

Ior : Leakage current (resistive leakage current) which flows due to degraded insulation
 Ioc : Leakage current (leakage current from electrostatic capacity) which flows even if the insulation condition is sound
 Io : Composite leakage current of Ior and Ioc (composition of vectors)

Ioc fluctuates on equipment with long wiring distance or inverter devices and filters.

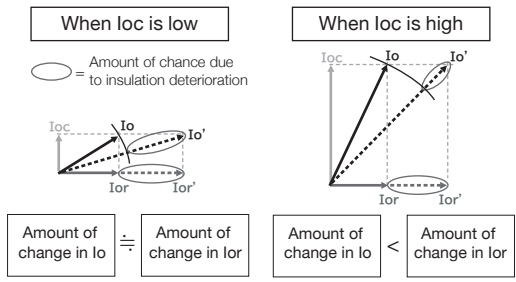

< Measurement of load current >

Alarm output + Current upper-/lower-limit monitoring

Using the contact output and current upper-/lower-limit monitoring function, the EcoMonitorPlus can detect abnormalities of production equipment before a problem actually occurs.

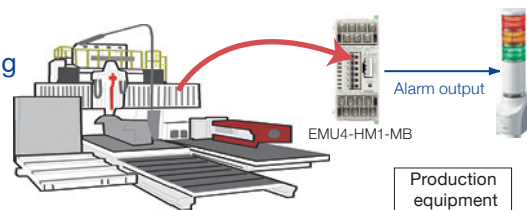

Application example

Monitoring of load/leakage current in emulsification/dispersion/dissolution equipment of beverage production line.

Problem



Heat seizure occurred in the motor for equipment due to electrical leakage. Line stopped operating, resulting in a decline of production efficiency. Repair of the motor costs several million yen!

Solution



Using the basic unit and extension unit to set the threshold values for electric leakage and load current, preventive maintenance/repair can be conducted before an equipment problem occurs so that unexpected equipment shutdown can be prevented.

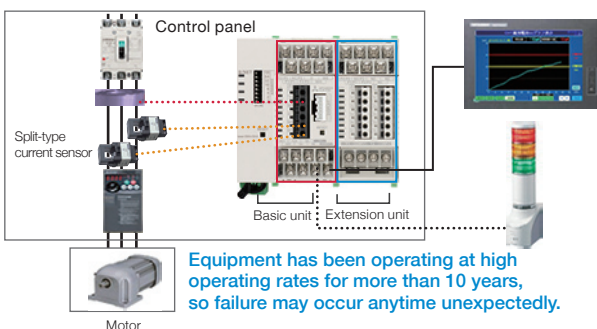

GOT for visualization of load/leakage current.

Output an alarm when the threshold is exceeded.

What EcoMonitorPlus can do

It measures leakage current and load current for predictive monitoring of problems due to insulation degradation or aged deterioration of motor, thus helping prevent unexpected equipment failure.

Reduction of equipment repair expenses and improvement of production efficiency.

3. Specifications

Energy Measuring Unit

Basic Unit

Item		Specification			
Model		Energy Measuring Standard Model EMU4-BM1-MB	Energy Measuring High Performance Model EMU4-HM1-MB	Insulation Monitor Model EMU4-LG1-MB	
Phase wire system		Single-phase 2-wire/single-phase 3-wire, 3-phase 3-wire common	Single-phase 2-wire/single-phase 3-wire, 3-phase 3-wire/ three-phase 4-wire common	Single-phase 2-wire/single-phase 3-wire, 3-phase 3-wire/ three-phase 4-wire common	
Instrument ratings	Voltage circuit	Single-phase 2-wire/ 3-phase 3-wire	110V, 220V AC common (*1)	110V, 220V, 440V AC common (*2)	
		Single-phase 3-wire	110V AC (between wires 1 and 2, and wires 2 and 3), 220V AC (between wires 1 and 3)	110V AC (between wires 1 and 2, and wires 2 and 3), 220V AC (between wires 1 and 3) 220V AC (between wires 1 and 2, and wires 2 and 3), 440V AC (between wires 1 and 3)	
	3-phase 4-wire	—	Minimum: 63.5V/110V AC, Maximum: 277V/480V AC (*3)	Minimum: 63.5V/110V AC, Maximum: 277V/480V AC (*12)	
Current circuit		50A, 100A, 250A, 400A, 600A (Dedicated split-type current sensor is used. All values indicate primary current values of current sensor.) 5A (Dedicated 5A current sensor is used. Current transformer (CT) is used in two-step configuration together with the 5A current sensor in order to allow a maximum primary current value setting of 30,000A) (*4)	—	1A (Mitsubishi ZCT is used. Primary current value of ZCT is indicated.)	
Frequency		50/60Hz (automatic frequency selection)			
Auxiliary power rating		100V – 240V AC (+10%, -15%) 50/60Hz			
No. of measurement circuits		1 circuit	1 circuit	1 circuit	
Consumption VA	Voltage circuit	For each phase: 0.1VA (110V AC), 0.2VA (220V AC)	For each phase: 0.1VA (110V AC), 0.2VA (220V AC), 0.4VA (440V AC)	For each phase: 0.1VA (110V AC), 0.2VA (220V AC), 0.4VA (440V AC)	
	Current circuit	For each phase: 0.1VA (current sensor primary side)			
	Auxiliary power circuit (*10)	110V AC:2.0VA AC220V:3.0VA			
Measurement items		Current, demanded current, voltage, power, demanded power, regenerative, consumption, reactive electric energy (*7), —	Apparent power, periodic electric energy, harmonic current, harmonic voltage, pulse count value, pulse conversion value, electric energy conversion value	Leakage current, demanded leakage current, resistance leakage current (*8), demanded resistance leakage current (*8), resistance leakage current difference conversion value (*9)	
Main unit tolerances (*5)		Current, voltage, power, reactive power, apparent power, frequency: ±1.0% (relative to rated input) Power factor: ±3.0% Electric energy: ±2.0% (in 5 to 100% range of rated values; power factor = 1) Reactive electric energy: ±2.5% (in 10 to 100% range of rated values; power factor = 0)	Current, voltage, power, reactive power, apparent power, frequency: ±1.0% (relative to rated input) Power factor: ±3.0% Electric energy: ±2.0% (in 5 to 100% range of rated values; power factor = 1) Reactive electric energy: ±2.5% (in 10 to 100% range of rated values; power factor = 0) Harmonic current, harmonic voltage: ±2.5%	Low sensitivity mode Leakage current lo, resistive leakage current lo: ±2.5% (relative to 10 to 100% of rating) Leakage current lo, resistive leakage current lo: ±2.5 mA (relative to 10% of rating or lower) High sensitivity mode Leakage current lo, resistive leakage current lo: ±2.5 mA	
Data update cycle		100msec			
External input specification	Input signal format	—	Non-voltage a contact, 1 input (Select function from below)	—	
	Function	—	Contact/pulse input	—	
		Contact input	—	Monitoring of contact and measurement of electric energy during operation (when contact is ON)	—
		Pulse input	—	Counting of input pulse (count: 0 to 999,999)	—
Rated input voltage/current	—	5V DC, 7 mA			
External output specification	Output signal format	—	Non-voltage a contact, 1 output (Select function from below)		
	Function	—	Alarm/pulse output	Alarm	
		Alarm output	—	Contact output of alarm generating status Select monitoring target from below. Monitoring of current demand upper limit, monitoring of current demand lower limit Monitoring of N-phase current demand upper limit Monitoring of line voltage upper limit Monitoring of line voltage lower limit Monitoring of phase voltage upper limit Monitoring of phase voltage lower limit Monitoring of power demand upper limit, monitoring of power demand lower limit Monitoring of power factor upper limit, monitoring of power factor lower limit Monitoring of pulse conversion value upper limit Monitoring of current imbalance rate upper limit Monitoring of voltage imbalance rate upper limit	Contact output of alarm generating status Select monitoring target from below Leakage current first stage alarm Leakage current second stage alarm Resistance leakage current first stage alarm Resistance leakage current second stage alarm Limit alarm of number of first stage alarm occurrences of leakage current Limit alarm of number of second stage alarm occurrences of leakage current Limit alarm of number of first stage alarm occurrences of resistance leakage current Limit alarm of number of second stage alarm occurrences of resistance leakage current
		Plus output	—	Pulse output of electric energy Select pulse unit from below. 0.001/0.01/0.1/1/10/100/1000/10000/100000(kWh/pulse)*6	—
Rated switching voltage/current	—	35V DC 75 mA, 24V AC 75 mA (Power factor = 1)			
Power interruption backup	Recorded item	Setting values, electric energy (consumption, regenerative), reactive electric energy, periodic electric energy, operating time, pulse count value, pulse conversion value, electric energy conversion value, maximum value, minimum value (Stored in the nonvolatile memory)		Setting values Number of alarm occurrences Maximum value (Stored in the nonvolatile memory)	
Compatible standard		EMC: EN-61326-1:2013, Safety: EN-61010-1:2010			
Operating environment	Operating temperature range	-5°C to +55°C (ave. daily temp. of 35°C or lower)			
	Operating humidity range	30% to 85%RH (no condensation)			
	Storage temperature range	-10°C to +60°C (ave. daily temp. of 35°C or lower)			
	Altitude	2,000 m or lower			
Commercial-frequency withstand voltage		Between all terminals (excluding communication circuit and frame GND terminal) and external casing: 2,000V AC for 1 min Between all current/voltage inputs and all auxiliary power terminals: 2,000V AC for 1 min Between all current/voltage inputs, auxiliary power terminals and all contact/pulse inputs, pulse/alarm outputs, communication terminals: 2,000V AC for 1 min			
Insulation resistance		At the same locations as above: 10 MΩ or more (500V DC)			
Compatible wire	Auxiliary power/voltage input terminal	A WG26-14 (single wire/stranded wires) (Single wire: φ0.41 to φ1.62 mm, Stranded wires: 0.13 to 2.0 mm ²)			
	Current input	Single wire: AWG24-17, Stranded wires: AWG20-26 (*9) (Single wire: φ0.5 to φ1.2 mm, Stranded wires: 0.5 to 1.3 mm ²)			
	Input/output terminal	—	AWG26-16 (single wire/stranded wires) (Single wire: φ0.41 to φ1.29 mm, Stranded wires: 0.13 to 1.3 mm ²)		
Weight		0.2 kg			
External dimensions (unit: mm)		37.5 (W) x 90 (H) x 94 (D) mm (excluding protruding parts)			

* 1 110V and 220V can be connected directly. Externally mounted voltage transformer (VT) for instrument is needed for voltages greater than those (primary voltage can be set to up to 11,000V, and secondary voltage can be set between 1 and 220V). For details, see the instruction manual.
* 2 110V, 220V and 440V can be connected directly. Externally mounted voltage transformer (VT) for instrument is needed for voltages greater than those (primary voltage can be set to up to 6,600V, and secondary voltage can be set between 1 and 220V). For details, see the instruction manual.
* 3 63.5V/110V – 277V/480V can be connected directly. An externally mounted voltage transformer (VT) for instrument is needed for voltages greater than those (primary voltage can be set to up to 6,600V, and secondary voltage can be set between 1 and 220V). For details, see the instruction manual.
* 4 The selectable primary current when using the 5A current sensor is as follows:
5A, 6A, 7.5A, 8A, 10A, 12A, 15A, 20A, 25A, 30A, 40A, 50A, 60A, 75A, 80A, 100A, 120A, 150A, 200A, 250A, 300A, 400A, 500A, 600A, 750A, 800A, 1000A, 1200A, 1500A, 1600A, 2000A, 2500A, 3000A, 4000A, 5000A, 6000A, 7500A, 8000A, 10000A, 12000A, 20000A, 25000A, 30000A (CT primary side can be set freely up to 30,000A. However, CT secondary side is fixed at 5A.)
* 5 Refer to the specifications of options (split-type current sensor, 5A current sensor) on page 13 for the current sensor error rates.
* 6 Refer to the instruction manual for the detail on the setting of pulse unit.
* 7 Measurements are conducted based on a setting other than 2-circuit measurement mode with single-phase 2-wire setting.
* 8 It measures only in the case of Single-phase 2-wire, Single-phase 3-wire, 3-phase 3-wire.
* 9 Recommended bar terminal: NichiHU TGV TC-1.25-1.1T.
* 10 Connected with optional units, it increases AC110V:4.5VA, AC220V:5.0VA.
* 11 110V, 220V and 440V can be connected directly. Externally mounted voltage transformer (VT) for instrument is needed for voltages greater than those (maximum:600V AC). For details, see the instruction manual.
* 12 63.5V/110V – 277V/480V can be connected directly. Externally mounted voltage transformer (VT) for instrument is needed for voltages greater than those (maximum:600V AC). For details, see the instruction manual.

Extension Unit

Item		Specification		
Model		Energy Measuring Extension Unit for Different voltage system EMU4-VA2	Energy Measuring Extension Unit for Same Voltage System EMU4-A2	
Phase wire system		Single-phase 2-wire/single-phase 3-wire, 3-phase 3-wire/3-phase 4-wire common		
Instrument ratings	Voltage circuit	Single-phase 2-wire/ 3-phase 3-wire	(Same as the unit connected on the left side)	
		Single-phase 3-wire		
	3-phase 4-wire			
Current circuit	Minimum: 63.5V/110V AC, Max.: 277V/480V AC (*3) 50A, 100A, 250A, 400A, 600A (Dedicated split-type current sensor is used. All values indicate primary current values of current sensor.)			
	(Dedicated 5A current sensor is used. Current transformer (CT) is used in two-step configuration together with the 5A current sensor in order to allow a maximum primary current value setting of 30,000A) (*4)			
Frequency		50/60Hz (automatic frequency selection)		
Auxiliary power rating		(Same as basic unit)		
No. of measurement circuits		2 circuits	2 circuits	
Consumption VA	Voltage circuit	For each phase: 0.1VA (110V AC), 0.2VA (220V AC), 0.4VA (440V AC)	—	
	Current circuit	For each phase: 0.1VA (current sensor primary side)		
	Auxiliary power circuit	AC110V:1.0VA AC220VA:1.5VA		
Measurement items		Current, demanded current, voltage, power, demanded power, reactive power, power factor, frequency, electric energy (regenerative, consumption), reactive electric energy(*7), current imbalance rate, voltage imbalance rate, operating time		
Main unit tolerances (*5)		Apparent power, harmonic current, harmonic voltage, electric energy conversion value Current, voltage, power, reactive power, apparent power, frequency: ±1.0% (relative to rated input) Power factor: ±3.0% Electric energy: ±2.0% (in 5 to 100% range of rated values; power factor = 1) Reactive electric energy: ±2.5% (in 10 to 100% range of rated values; power factor = 0) Harmonic current, harmonic voltage: ±2.5%		
Data update cycle		100msec		
External input specification	Input signal format	—	—	
	Function	—	—	
		Contact input	—	—
		Pulse input	—	—
Rated input voltage/current		—	—	
External output specification	Output signal format	Non-voltage a contact, 1 output (Select function from below)		
	Function	Alarm/pulse output		
		Contact output of alarm generating status Select monitoring target from below. Monitoring of current demand upper limit, monitoring of current demand lower limit Monitoring of N-phase current demand upper limit Monitoring of line voltage upper limit Monitoring of line voltage lower limit Monitoring of phase voltage upper limit Monitoring of phase voltage lower limit Monitoring of power demand upper limit, monitoring of power demand lower limit Monitoring of power factor upper limit, monitoring of power factor lower limit Monitoring of current imbalance rate upper limit Monitoring of voltage imbalance rate upper limit		
	Plus output	Pulse output of electric energy Select pulse unit from below. 0.001/0.01/0.1/1/10/100/1000/10000/100000(kWh/pulse)*6		
Rated switching voltage/current		35V DC 75 mA, 24V AC 75 mA (Power factor = 1)		
Power interruption backup	Recorded item	Setting values, electric energy (consumption, regenerative), reactive electric energy, periodic electric energy, operating time, pulse count value, pulse conversion value, electric energy conversion value, maximum value, minimum value (Stored in the nonvolatile memory)		
Compatible standard		EMC: EN-61326-1:2013, Safety: EN-61010-1:2010		
Operating environment	Operating temperature range	-5°C to +55°C (ave. daily temp. of 35°C or lower)		
	Operating humidity range	30% to 85%RH (no condensation)		
	Storage temperature range	-10°C to +60°C (ave. daily temp. of 35°C or lower)		
Altitude		2,000 m or lower		
Commercial-frequency withstand voltage		Between all terminals (excluding communication circuit and frame GND terminal) and external casing: 2,000V AC for 1 min Between all current/voltage inputs and all auxiliary power terminals: 2,000V AC for 1 min Between all current/voltage inputs, auxiliary power terminals and all contact/pulse inputs, pulse/alarm outputs, communication terminals: 2,000V AC for 1 min		
Insulation resistance		At the same locations as above: 10 MΩ or more (500V DC)		
Compatible wire	Voltage input terminal	A WG26-14 (single wire/stranded wires) (Single wire: φ0.41 to φ1.62 mm, Stranded wires: 0.13 to 2.0 mm ²)	—	
	Current input	Single wire: AWG24-17, Stranded wires: AWG20-26 (*9) (Single wire: φ0.5 to φ1.2 mm, Stranded wires: 0.5 to 1.3 mm ²)		
	Input/output terminal	AWG26-16 (single wire/stranded wires) (Single wire: φ0.41 to φ1.29 mm, Stranded wires: 0.13 to 1.3 mm ²)		
Weight		0.2kg		
External dimensions (unit: mm)		37.5 (W) x 90 (H) x 94 (D) mm (excluding protruding parts)		

* 1 110V and 220V can be connected directly. Externally mounted voltage transformer (VT) for instrument is needed for voltages greater than those (primary voltage can be set to up to 11,000V, and secondary voltage can be set between 1 and 220V). For details, see the instruction manual.
* 2 110V, 220V and 440V can be connected directly. Externally mounted voltage transformer (VT) for instrument is needed for voltages greater than those (primary voltage can be set to up to 6,600V, and secondary voltage can be set between 1 and 220V). For details, see the instruction manual.
* 3 63.5V/110V - 277V/480V can be connected directly. An externally mounted voltage transformer (VT) for instrument is needed for voltages greater than those (primary voltage can be set to up to 6,600V, and secondary voltage can be set between 1 and 220V). For details, see the instruction manual.
* 4 The settable primary current when using the 5A current sensor is as follows:
5A, 6A, 7.5A, 8A, 10A, 12A, 15A, 20A, 25A, 30A, 40A, 50A, 60A, 75A, 80A, 100A, 120A, 150A, 200A, 250A, 300A, 400A, 500A, 600A, 750A, 800A, 1000A, 1200A, 1500A, 1600A, 2000A, 2500A, 3000A, 4000A, 5000A, 6000A, 7500A, 8000A, 10000A, 12000A, 20000A, 25000A, 30000A (CT primary side can be set freely up to 30,000A. However, CT secondary side is fixed at 5A.)
* 5 Refer to the specifications of options (split-type current sensor, 5A current sensor) on page 13 for the current sensor error rates.
* 6 Refer to the instruction manual for the detail on the setting of pulse unit.
* 7 Measurements are conducted based on a setting other than 2-circuit measurement mode with single-phase 2-wire setting.
* 8 It measures only in the case of Single-phase 2-wire, Single-phase 3-wire, 3-phase 3-wire.
* 9 Recommended bar terminal: Nichifu TGV TC-1.25-11.

3. Specifications

► Specifications of MODBUS® RTU Communication

Item	Specification
Physical interface	RS-485 2wires half duplex
Communication protocol	MODBUS® RTU mode
Transmission method	Asynchronous
Transmission wiring type	Multi-drop bus (either directly on the trunk cable, forming a daisy-chain)
Baud rate	2400, 4800, 9600, 19200, 38400bps (default: 19,200 bps)
Data bit	8
Stop bit	1,2 (default: 1)
Parity bit	ODD, EVEN, NONE (default: EVEN)
Slave address	1~255 (FFh) (default: 1) 0: Broadcast
Response time	1s or shorter from completion of receiving query data to response transmission
Terminating resistor	120Ω 1/2W
Transmission distance	1,200m
Maximum connectable devices	31 devices
Recommended cable	SPEV(SB)-MPC-0.2x3P (Mitsubishi cable industries)

■ Compact display Unit

Item	Specification	
Model	EMU4-D65	
Supply power voltage	9V DC (Note 1)	
Auxiliary power	—	
Consumption VA	—	
Display device	LCD (with backlight)	
Display refresh interval	1000 ms	
Measurement value display	Wh+A+4 element Harmonic detail	Display of four elements: Electric energy, current and four other elements (selectable) Display of detailed harmonic order data of harmonic current and harmonic voltage (Note 2)
Alarm display	Alarm status display Alarm value display	Display of upper-/lower-limit alarm generating status and contact output status Display of upper-/lower-limit alarm values and generating time
Setting	EMU setting Clock setting Alarm setting Display setting	Setting of EcoMonitorPlus/EcoMonitorPro (phase wire, primary voltage, primary current, sensor type, demand time limit, pulse unit, measuring mode, etc.) Setting of internal clock of EMU4-LM Setting of upper-limit alarm value and lower-limit alarm value Setting of LCD (with backlight) contrast and backlight ON status
Data reset		Resetting of maximum value, minimum value, upper-/lower-limit alarm values, electric energy, reactive electric energy
Data preset		Presetting of electric energy (consumption), reactive electric energy, electric energy conversion value, operating time, electric energy (regenerative), pulse count value, pulse conversion value
Connection to energy measuring unit		Dedicated cable (supplied with product) used for connection. Cable extension: 10 m max. (Note 3)
Max. number of connectable units		7 units
Installation method		Installs to IEC rail or panel
Operating temperature range		-5°C to +55°C (ave. daily temp. of +35°C or lower)
Operating humidity range		30% to 80%RH (no condensation)
Storage temperature range		-10°C to +60°C (ave. daily temp. of +35°C or lower)
Weight		0.1 kg

*1 Supplied from energy measuring unit. However, when two or more units are connected, use commercial power supply units (compatible product: Cosel PBA15F-9-N1).

*2 Maximum value, minimal value and upper-/lower-limit alarm data are not displayed.

*3 When two or more units are connected, use the display unit connection cable (option). When extending the cable length, use the extension cable (option).

■ Logging Unit

► Basic Specification

Item	Specification	
Model	EMU4-LM	
Auxiliary power rating	6.4V DC (supplied from energy measuring unit)	
Power interruption backup	Total power interruption backup time of the battery (EMU4-BT) is one year (ave. daily temp. of 35°C or lower). It is recommended to replace the battery every three years.	
Set value	Saved in nonvolatile memory * Data will not be lost even if power outage occurs.	
	Logging data System log data	Saved in volatile memory * Data will be lost if power outage occurs when the battery voltage is low (BAT.LED is lit).
	Timer operation	Timer operation continues by using the battery in the event of power outage. * Timer operation stops if the battery voltage is low (BAT.LED is lit) when power outage occurs. After power is recovered, timer operation starts from 2013/01/01 00:00:00.
	Clock accuracy	1 min/month
Output data storage media*1	SD memory card (SD, SDHC)	
Compatible model	Energy measuring unit (EcoMonitorLight) Model: EMU4-BD1-MB, EMU4-HD1-MB Energy measuring unit (EcoMonitorPlus) Model: EMU4-BM1-MB, EMU4-HM1-MB, EMU4-LG1-MB, EMU4-VA2, EMU4-A2	
Compatible standard	EMC: EN-61326-1:2006	
Operating environment	Operating temperature range	-5°C to +55°C (ave. daily temp. of +35°C or lower)
	Operating humidity range	30% to 85%RH (no condensation)
	Storage temperature range	-10°C to +60°C (ave. daily temp. of +35°C or lower)
	Altitude	2,000m or lower
Weight	0.1 kg *Wight of logging unit only	
External dimensions (unit: mm)	25 (W) x 99 (H) x 60 (D) mm *Dimensions of logging unit only	
Parts sold separately	SD memory card (EMU4-SD2GB)*1*2	
Consumables sold separately	Battery (EMU4-BT)*2	

*1 Use Mitsubishi SD memory card (EMU4-SD2GB).

If an SD memory card other than above is used, data in the SD memory card may become damaged or problems such as a system shutdown may occur. Regarding the use of commercially available SD memory cards, access our FA website. Note that the customer is responsible for verifying safe use of those SD memory cards.

*2 To purchase parts and consumables that are sold separately, contact the dealer from which the product was purchased.

▶ Logging Specifications

Item	Specification					
Logging mode	Automatic update	Automatic overwrite/update				
	Date/time designation	Automatic start/stop according to start time setting				
Logging data type	Detailed data	Measurement data is saved according to set "Detailed Data Logging Cycle" (1 sec, 1 min, 5 min, 10 min, 15 min, 30 min). * Output as a detailed data file				
	1-Hour data	Measurement data is saved in 1-hour cycles. * Output as 1-hour and 1-day data files.				
Number of logging elements	Detailed data	Detailed data logging cycle of 1 sec → Maximum of 4 elements Detailed data logging cycle of other than 1 sec → Maximum of 10 elements				
	1-Hour data	Maximum of 10 elements				
Internal memory logging period	Detailed data	Number of connected extension units	None	1 unit	2 units	3 units
		Detailed data logging cycle: 1 sec	20 hours	6 hours	3 hours	2 hours
		Detailed data logging cycle: 1 min	20 days	6 days	3 days	2 days
		Detailed data logging cycle: 5 min	100 days	30 days	15 days	10 days
		Detailed data logging cycle: 10 min	200 days	60 days	30 days	20 days
		Detailed data logging cycle: 15 min	300 days	90 days	45 days	30 days
	Detailed data logging cycle: 30 min	600 days	180 days	90 days	60 days	
1-Hour data	Number of connected extension units	None	1unit	2unit	3unit	
		620 days (approx.20 months)	186 days (approx. 6 months)	93 days (approx. 3 months)	62 days (approx. 2 months)	
SD memory card (2GB) Logging period*1	Number of connected extension units	None	1unit	2unit	3unit	
	Detailed data logging cycle of 1sec	341 days (approx.11 months)	186 days (approx. 6 months)	93 days (approx. 3 months)	62 days (approx. 2 months)	
	Detailed data logging cycle of 1min	370 months	142 months	93 months	64 months	
	Detailed data logging cycle of 5min,10 min,15 min,30 min	→ 10 years or more				
System log data	3,600 records					
Logging data and system log data output format	CSV format (ASCII code)					

*1 The indicated period is the time period during which data can be saved in a 2GB SD memory card without exceeding its capacity. The amount of data varies depending on the number of characters. The logging period indicates output at maximum capacity.

■ CC-Link Communication Unit

▶ Basic Specifications

Item	Specification	
Model	EMU4-CM-C	
Rating	6.4V DC (supplied from energy measuring unit)	
Compatible model	Energy measuring unit (EcoMonitorLight) Model: EMU4-BD1-MB, EMU4-HD1-MB Energy measuring unit (EcoMonitorPlus) Model: EMU4-BM1-MB, EMU4-HM1-MB, EMU4-LG1-MB, EMU4-VA2, EMU4-A2	
Compatible standard	EMC: EN-61326-1:2006	
Operating environment	Operating temperature range	-5°C to +55°C (ave. daily temp. of +35°C or lower)
	Operating humidity range	30% to 85%RH (no condensation)
	Storage temperature range	-10°C to +60°C (ave. daily temp. of +35°C or lower)
	Altitude	2,000m or lower
Weight	0.1 kg *Wight of CC-Link communication unit only	
External dimensions (unit: mm)	25(W)×99(H)×60(D)	

▶ CC-Link Communication Specifications

Item	Specification
Number of Occupied Station	1 Station Remote device station (I/O) data and word data can be transmitted
CC-Link Ver.1.10 Ver.2.00 (Set by Version charge switch)	Ver.1.10, Ver 2.00 (Set by version charge switch)
Remote Station Number (Station Number)	1 to 64
Baud Rate	156k, 625k, 2.5M, and 10Mbps (changes according to setting) (The interstation cable length and maximum total extension distance vary according to the transmission speed.)
Max. connected device	A maximum of 42 units can be connected if configured using only this module.
Cable terminating resistance	Use a specified cable for CC-Link communication connection. Resistance values for terminating resistance are different according to the type of specialized cable used.

■ Optional Parts

▶ Split-type Current Sensor

Item	Specifications		
Model	EMU-CT50	EMU-CT100	EMU-CT250
Rated primary current	50A AC	100A AC	250A AC
Rated secondary current	16.66mA	33.33mA	66.66mA
Rated load	0.1VA		
Maximum use voltage	460V AC		
Ratio error	±1% (5 to 100% of rating, RL ≤ 10 Ω)		
Phase difference variation	±30 min. (5 to 100% of rating, RL ≤ 10 Ω)		
Measurement category	III		
Degree of contamination	2		
Operating temperature range	-5 °C to +55 °C (daily average temperature of 35°C or less)		
Operating humidity range	5% to 95% RH (no condensation)		
CE marking compatible standard	EN61010-2-32		
Maximum voltage compatible with CE marking	460V AC		
Weight (1 unit)	0.1kg	0.7kg	

▶ 5A Current Sensor

Item	Specifications
Model	EMU2-CT5, EMU2-CT5-4W
Rated primary current	5A AC
Rated secondary current	1.66mA
Rated load	0.1VA
Maximum use voltage	260V AC
Ratio error	±1% (5 to 100% of rating)
Phase difference variation	±30 min. (5 to 100% of rating, RL ≤ 10 Ω)
Measurement category	III
Degree of contamination	2
Operating temperature range	-5 °C ~ +55°C (daily average temperature of 35°C or less)
Operating humidity range	5% ~ 95% RH (no condensation)
CE marking compatible standard	EN61010-2-32
Maximum voltage compatible with CE marking	260V AC
Weight (1 unit)	0.1kg

3. Specifications

Optional Parts

Split-type Current Sensor

Item	Specification						
	Model	EMU-CT50-A	EMU-CT100-A	EMU-CT250-A	EMU-CT400-A	EMU-CT600-A	EMU-CT5-A
Rated primary current	50A AC	100A AC	250A AC	400A AC	600A AC	5A AC	
Rated secondary current	16.66mA	33.33mA	66.66mA	66.66mA	66.66mA	1.66mA	
Maximum operating voltage	460V AC(*1*2)						
Measurement category	—			III		—	
Degree of contamination	—			2		—	
Operating temperature range	-10~+55°C (ave. daily temp. of 35°C or lower)						—
Operating humidity range	25% to 95%RH (no condensation)						—
CE marking compatible standard				EN61010-2-32		—	
Maximum voltage compatible with CE marking				460V		—	
Weight (1 unit)	0.1kg	0.1kg	0.2kg	0.3kg	0.4kg	0.1kg	

*1 Current sensor does not support a non-insulation electric wire or a metal for a primary cable.
*2 Maximum operating voltage indicates voltage to ground.

SD Memory Card

Item	Specification
Model	EMU4-SD2GB
Memory capacity	2GB
Weight	2g

Lithium Battery for Logging Unit

Item	Specification
Model	EMU4-BT
Type	Manganese dioxide lithium battery
Nominal voltage	3V
Capacity	220mAh
Weight	3g

* One battery supplied with logging unit.

Split-type Zero-phase Current Transformer

Item	Specification				
	Model	CZ-22S	CZ-30S	CZ-55S	CZ-77S
Hole diameter (mm)	22	30	55	77	112
Allowable current (A)	50	100	300	600	1,000
Weight (kg)	0.5	0.6	1.8	2.8	2.8
Rated short-time current	50 kA (peak-to-peak value: 100 kA)				

Through-type Zero-phase Current Transformer

Item	Specification					
	Model	ZT15B	ZT30B	ZT40B	ZT60B	ZT80B
Hole diameter (mm)	15	30	40	60	80	100
Allowable current	Refer to the following table, *Zero-phase Current transformer (ZCT) inside Diameter, Maximum Through-wire Diameter and Allowable Current.*					
Weight (kg)	0.2	0.4	0.6	2.0	2.6	3.3
Rated short-time current	50 kA (peak-to-peak value: 100 kA)					

Zero-phase Current Transformer with Primary Conductor

Item	Specification		
	Model	ZTA600A	ZTA1200A
Allowable current (A)	600	1200	2000
Weight (kg)	6.5	11	27
Rated burden	3		
Number of polarities	AC600V		
Rated short-time current	100 kA (peak value)		

Zero-phase Current transformer (ZCT) inside Diameter, Maximum Through-wire Diameter and Allowable Current

Wiring			Maximum through-wire diameter (mm ²) (Allowable current (A) of wire)										
			Split type					Through type					
Phase wire	No. of wires	Wire type	CZ-22S	CZ-30S	CZ-55S	CZ-77S	CZ-112S	ZT15B	ZT30B	ZT40B	ZT60B	ZT80B	ZT100B
Single-phase 2-wire	2	600V polyvinyl-insulated wire (IV)	22 (115)	60 (217)	250 (556)	500 (842)	—	14 (88)	60 (217)	150 (395)	325 (650)	600 (992)	800 (1185)
		600V cross-linked polyethylene-insulated wire (Single-core wire (CV wire))	22 (130)	38 (190)	200 (545)	500 (920)	1000 (1465)	2 (33)	38 (190)	60 (260)	250 (655)	400 (870)	600 (1140)
Single-phase 3-wire 3-phase 3-wire	3	600V polyvinyl-insulated wire (IV)	22 (115)	38 (162)	200 (496)	500 (842)	—	8 (61)	38 (162)	100 (298)	250 (556)	500 (842)	725 (1095)
		600V cross-linked polyethylene-insulated wire (Single-core wire (CV wire))	14 (100)	22 (135)	150 (455)	325 (760)	800 (1285)	2 (33)	22 (135)	60 (260)	200 (560)	325 (760)	600 (1140)

*1 Note that the wire thickness may vary slightly depending on the manufacturer.

*2 The IV wire applies to cases where insulators are used.

*3 The IV wire applies to cases where insulation in a covered conduit in air.

(Cables of 600mm² or more have various structures. The values are shown for reference.)

■ Software

▶ Data Acquisition Software (EMU4-SW1)

Item		Specification
Recommended system environment	OS	<ul style="list-style-type: none"> •Microsoft Windows 8.1 Pro(32bit,64bit) •Microsoft Windows 7 Professional (32bit,64bit) SP1 •Microsoft Windows Vista Ultimate 32bit SP2
	Microsoft .NET Framework	<ul style="list-style-type: none"> •Microsoft .NET Framework 2.0 •Microsoft .NET Framework 3.5 •Microsoft .NET Framework 3.5.1
	Microsoft Excel	<ul style="list-style-type: none"> •Microsoft Excel 2003 SP3 •Microsoft Excel 2007 SP3 •Microsoft Excel 2010 SP1 •Microsoft Excel 2013 SP1
Basic specification	Max. number of connectable units	31 units
	Language	Japanese, English
Data collection function	Periodic collection	Data is collected in 1-min or 1-hr cycles. (Operated in background only when application is booting)
	Current value display	Constant communication is performed to display current values.
	Max. number of collection points	124 points
Setting function	Communication setting	MODBUS® RTU communication setting (baud rate, stop bit length, etc.)
	Terminal registration	Registration of terminals used for data collection
	Terminal setting	Function to write/read settings (such as phase wire, rated current and rated voltage) to/from terminals
	Measurement item registration	Registration of measurement items to be collected
	Export/import	Communication, terminal and measurement item settings can be saved to or read from file.
Report output	Output format	Pasting of aggregate data in master file (Excel file) (Master files can be added or changed freely.)
	Output type	Monthly report, daily report, details (1-min intervals)

* Data acquisition software carries out free download, and gets from the "design supportive tool data" of the Mitsubishi Electric web site energy saving supportive equipment menu.

▶ Logging Unit Utility

Item		Specification	
System requirements	OS	<ul style="list-style-type: none"> •Microsoft Windows 7 Professional SP1 (32bit/64bit) •Microsoft Windows 8.1 Pro Update(32bit/64bit) 	
	NET Framework	•Microsoft .NET Framework 4 Client Profile	
	Microsoft Excel	<ul style="list-style-type: none"> •Microsoft Excel 2010 SP2 (32bit) •Microsoft Excel 2013 SP1 (32bit) 	
	CPU	Conformity with OS system requirements	
	RAM	Conformity with OS system requirements	
	Hard disk	Software requires approximately 20 MB of free space to install (additional space is required for saving document files created by the software).	
	Display	XGA or higher resolution display monitor (65,536 colors, 1024 x 768 pixels or more)	
	Input device	Mouse and keyboard	
	External interface	SD memory card slot or SD memory card reader/writer	
Supported languages		Japanese, English	
Report creation	Output format	Logging data pasted to template Excel file (template Excel file is freely editable)	
	Max. number of sheets	Logging data can be pasted to maximum of 31 sheets (for data of 31 logging units)	
	Document type	Monthly report	Output of 1-day interval data of a period of 1 month
		Weekly report	Output of 1-hour interval data of a period of 7 days
		Daily report	Output of 1-hour interval data of a period of 1 day
		Details (min)	Output of 30-/15-/10-/5-/1-minute interval data of specified period (1 to 24 hours)
Details (sec)	Output of 1-sec interval data of a period of 1 hour		
Logging setting		Creation/editing of logging setting data file (set.csv)	

* Documentation software carries out free download, and gets from the "design supportive tool data" of the Mitsubishi Electric web site energy saving supportive equipment menu.

4. Names of Parts and External View

[Energy Measuring High Performance Model] EMU4-HM1-MB

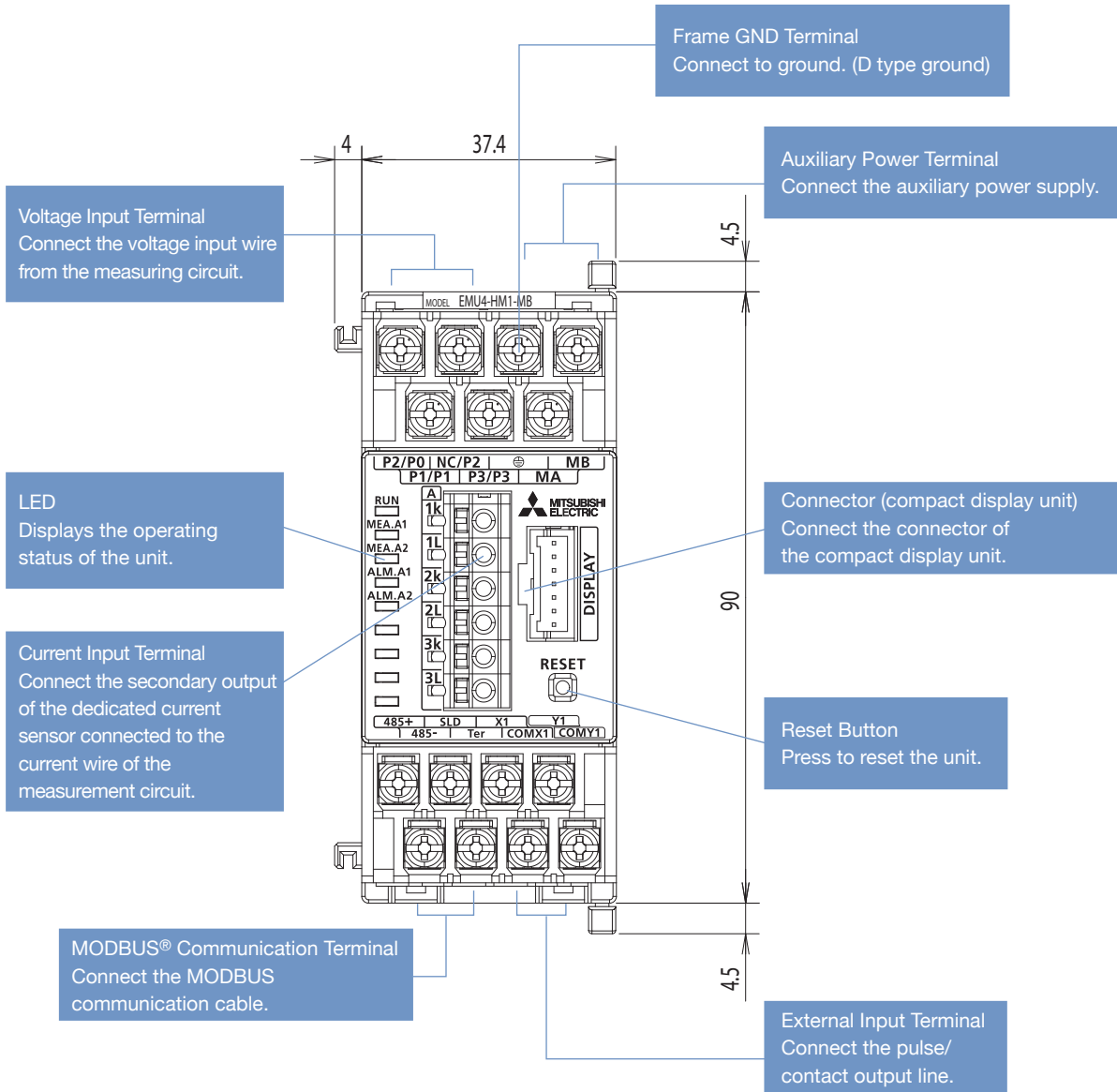

[Energy Measuring Standard Model] EMU4-HM1-MB

[Insulation Monitor Mode] EMU4-LG1-MB

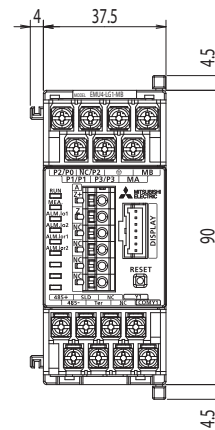
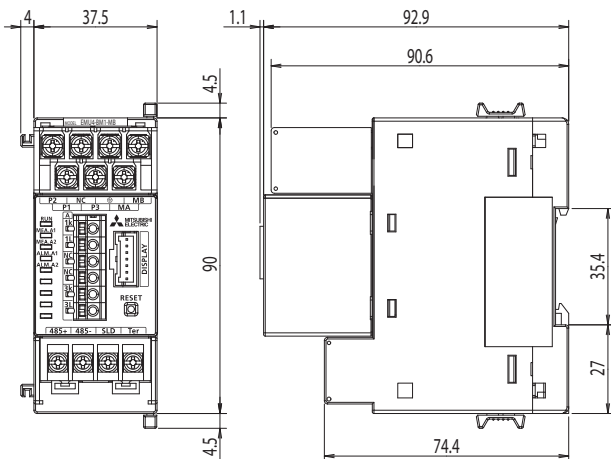

* This side view also applies to other basic unit models (EMU4-BM1-MB, EMU4-HM1-MB, EMU4-LG1-MB).

Product Lineup

Features

Specifications

Names of Parts and External view

External view

Connection Configurations

Simplified Comparison of EcoMonitor Prod

[Energy Measuring Extension Unit for Different Voltage System] EMU4-VA2

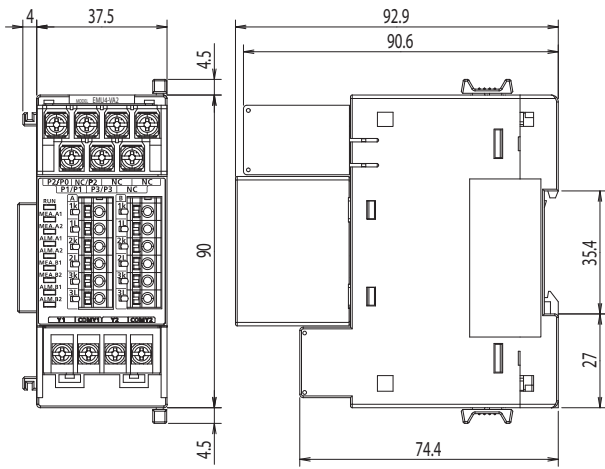

[Energy Measuring Extension Unit for Same Voltage System] EMU4-A2

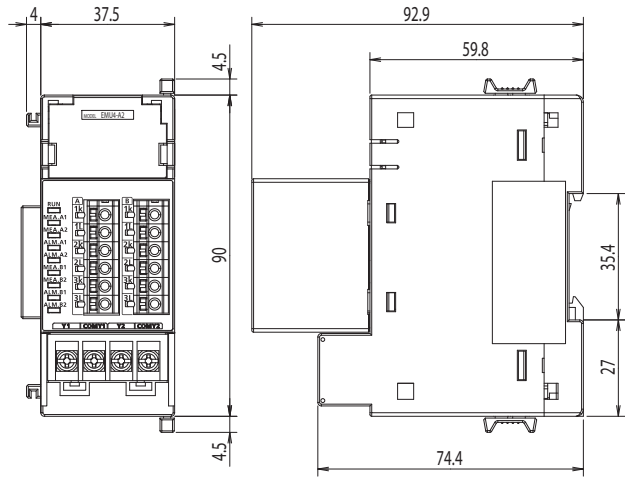

[Logging Unit] EMU4-LM

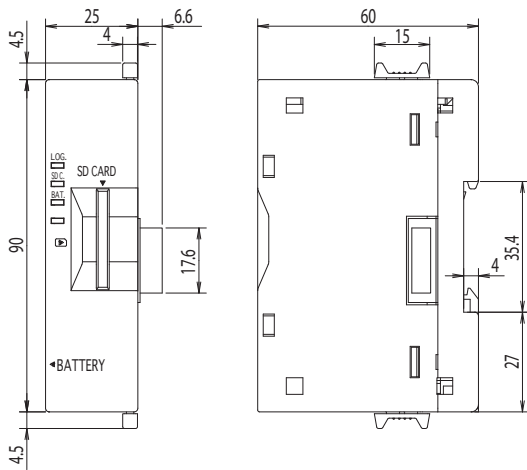

[CC-Link Communication Unit] EMU4-CM-C

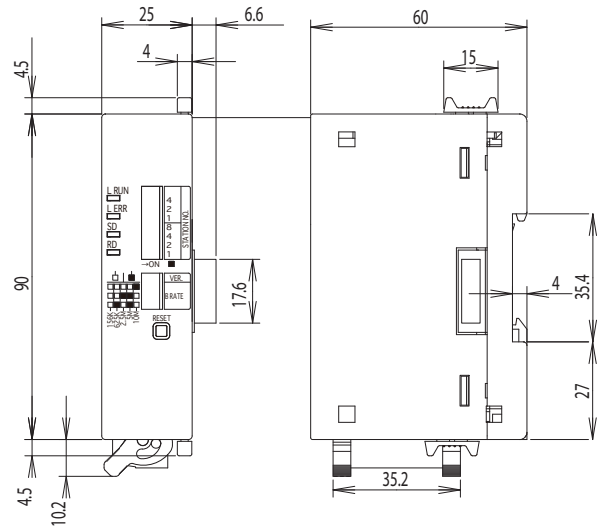

Product Lineup

Features

Specifications

Names of Parts and External view

External view

Connection Configurations

Simplified Comparison of EcoMonitor Pro

5. External View

[Compact Display Unit] EMU4-D65

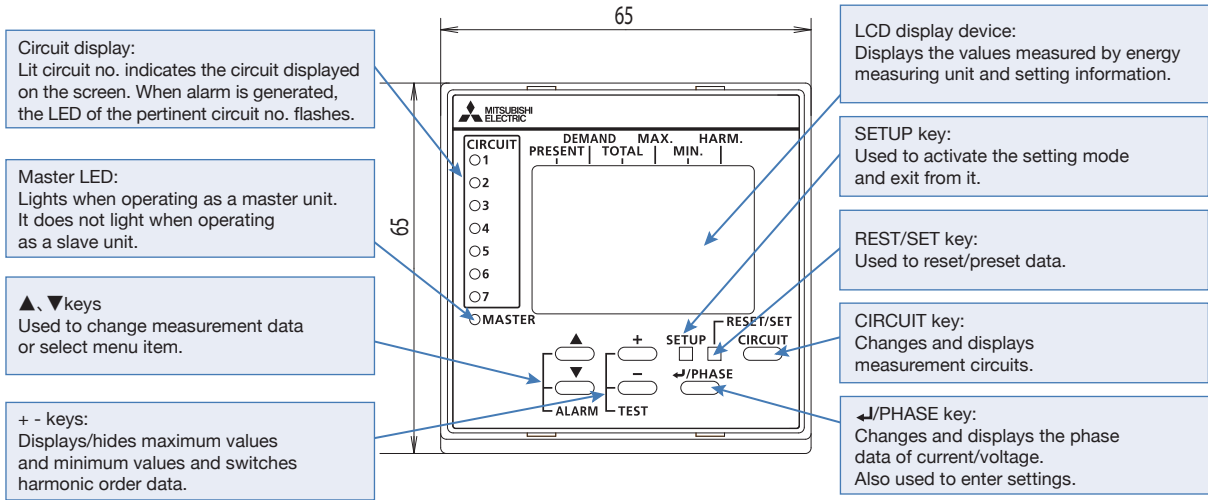

[Split-type Current Sensor] EMU-CT5-A, EMU-CT50-A

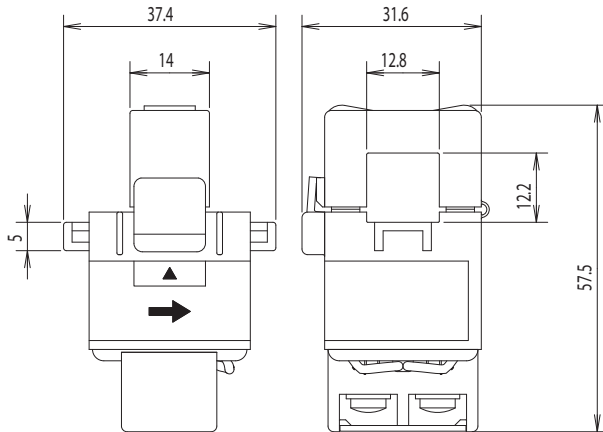

[Split-type Current Sensor] EMU-CT100-A

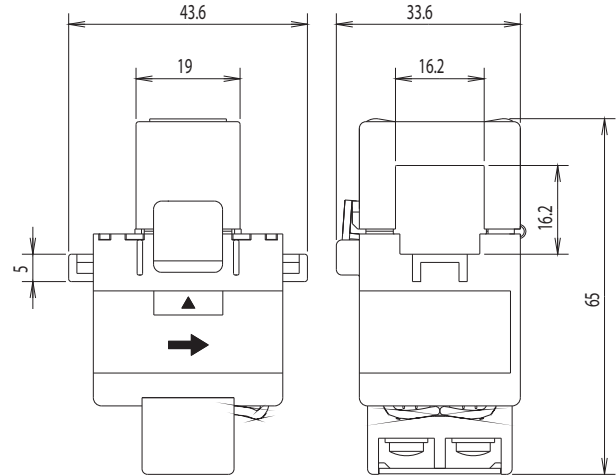

[Split-type Current Sensor] EMU-CT250-A

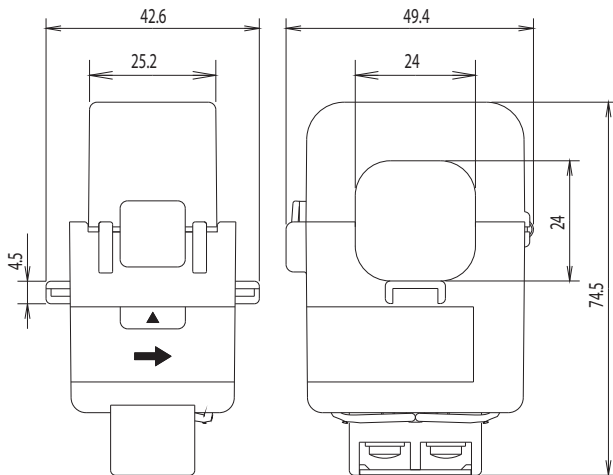

[Split-type Current Sensor] EMU-CT400-A, EMU-CT600-A

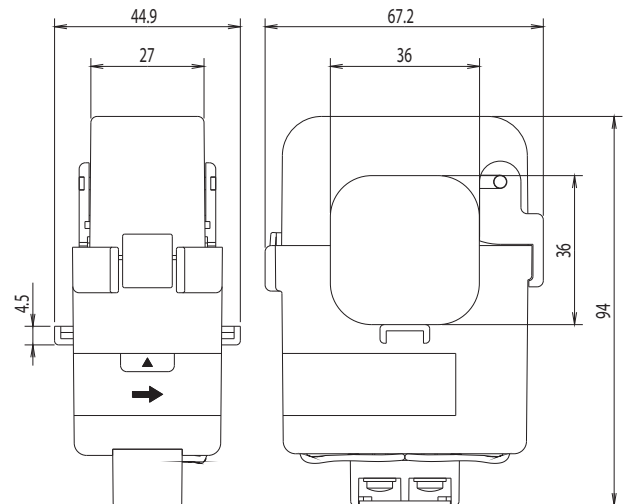

[Split-type Current Sensor]

Split-type Current Sensor EMU-CT50, EMU-CT100, EMU-CT250

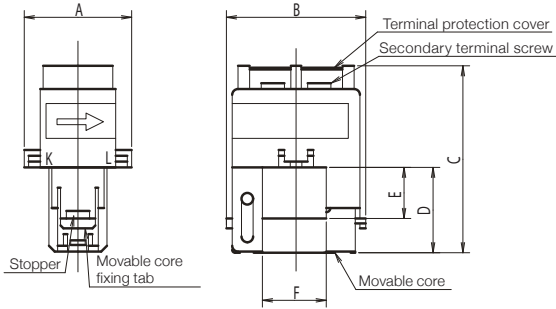

Model	A	B	C	D	E	F
EMU-CT50/CT100	31.5	39.6	55.2	25.7	15.2	18.8
EMU-CT250	36.5	44.8	66.0	32.5	22.0	24.0

5A Split-type Current Sensor

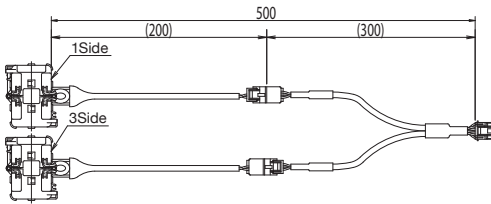

5A Split-type Current Sensor

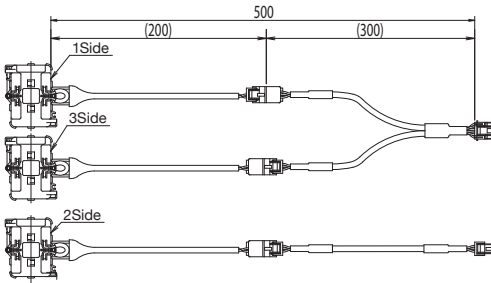

Detail of Sensor Part

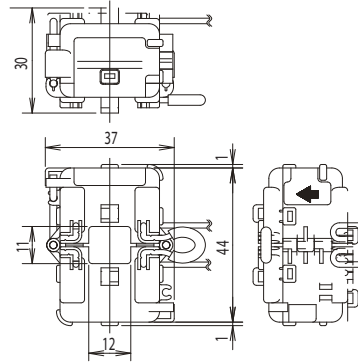

[Current Sensor Cable]

5A Split-type Current Sensor Cable EMU2-CB-Q5A

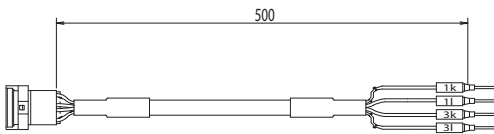

5A Split-type Current Sensor EMU2-CB-Q5A-4W

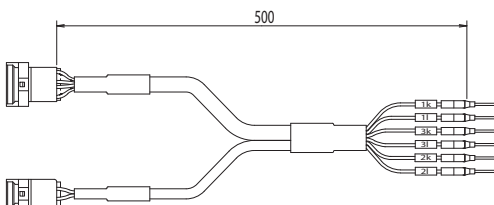

5A Split-type Current Sensor Extension Cable (Standard Type) EMU2-CB-T**M

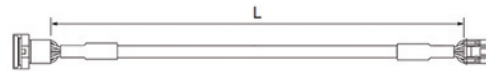

Model	EMU2-CB-T1M	EMU2-CB-T5M	EMU2-CB-T10M
L dimension	1m	5m	10m

5A Split-type Current Sensor Extension Cable (separate Type) EMU2-CB-T**MS

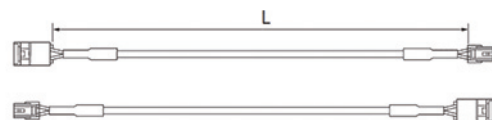

Model	EMU2-CB-T1MS	EMU2-CB-T5MS	EMU2-CB-T10MS
L dimension	1m	5m	10m

5. External View

[Zero-phase Current Transformer]

ZT15B·30B·40B

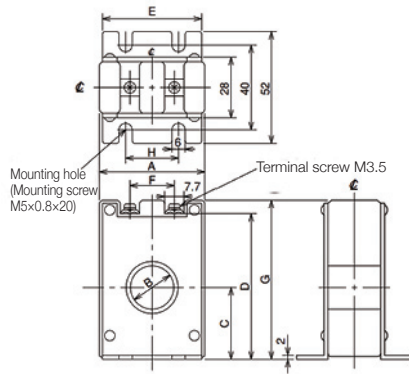

■ZT15B/30B/40B Dimensional variation table

	ZT15B	ZT30B	ZT40B
A	48	68	85
B	15	30	40
C	29	37	43
D	62	82	92
E	46	66	81
F	15	30	40
G	70	90	100
H	25	50	50

ZT60B·80B·100B

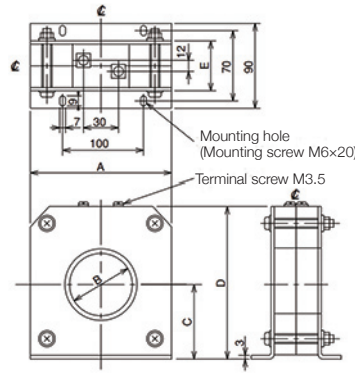

■ZT60B/80B/100B Dimensional variation table

	ZT60B	ZT80B	ZT100B
A	140	160	185
B	60	80	100
C	73	82	93
D	150	169	190
E	46	48	50

CZ-22S·30S·55S·77S·112S

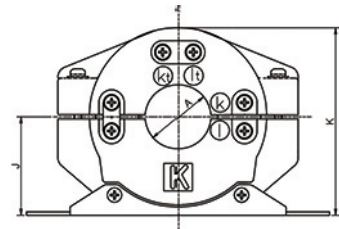

CZ-22S/30S/55S/77S

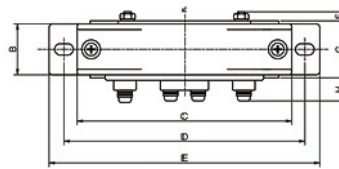

CZ-112S

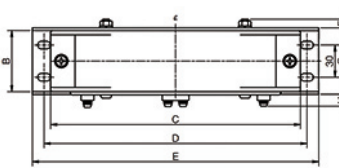

■ZT15B/30B/40B Dimensional variation table

	CZ-22S	CZ-30S	CZ-55S	CZ-77S	CZ-112S
A	22	30	55	77	112
B	27	27	32	41	57
C	100	114	148	198	234
D	112	130	160	210	246
E	128	144	177	232	268
F	5	5	8	10	8
G	30	30	36	45	62
H	12	12	12	12	12
J	41	47	66	90	109
K	77	89	124	171	207

ZTA600A (600A) · ZTA1200A (1200A) · ZTA2000A (2000A)

ZTA600A (600A)

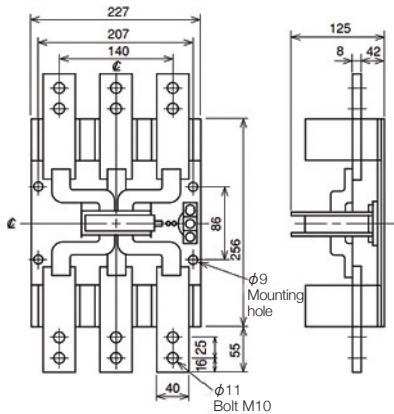

ZTA1200A (1200A)

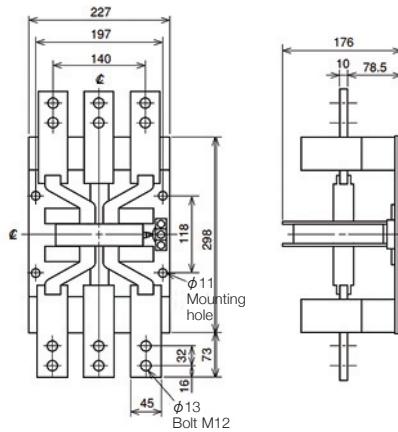

ZTA2000A (2000A)

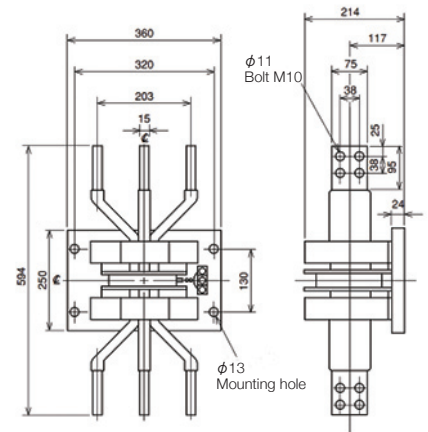

[Power Measurement]

Single-phase 2-wire (in the case of low-voltage circuit)

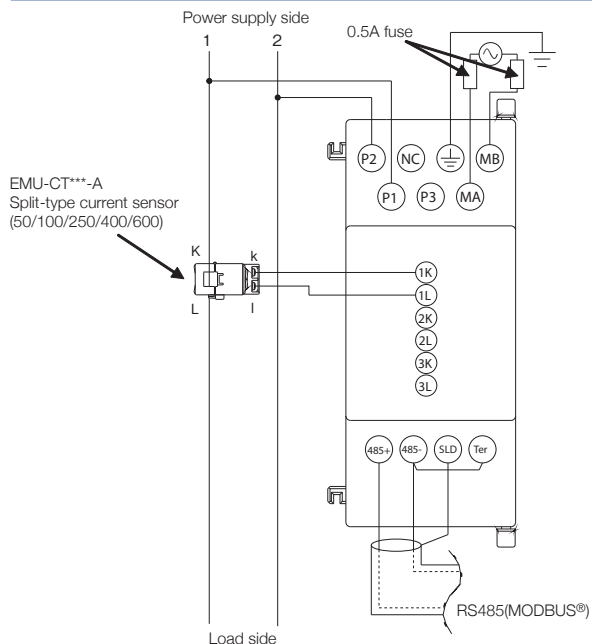

Name	Model	Quantity
EcoMonitorPlus (Standard Model)	EMU4-BM1-MB	1
Split-type current sensor	EMU-CT***-A (50/100/250/400/600)	1

Single-phase 3-wire/3-phase 3-wire (in the case of low-voltage circuit)

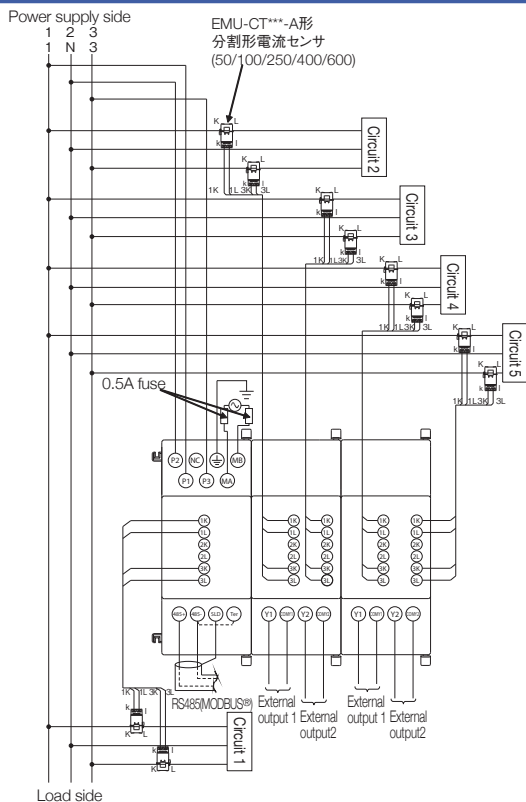

Name	Model	Quantity
EcoMonitorPlus (Standard Model)	EMU4-BM1-MB	1
EcoMonitorPlus (Extension Unit for Same Voltage System)	EMU4-A2	2
Split-type current sensor	EMU-CT***-A (50/100/250/400/600)	10

3-phase 4-wire (in the case of high-voltage circuit)

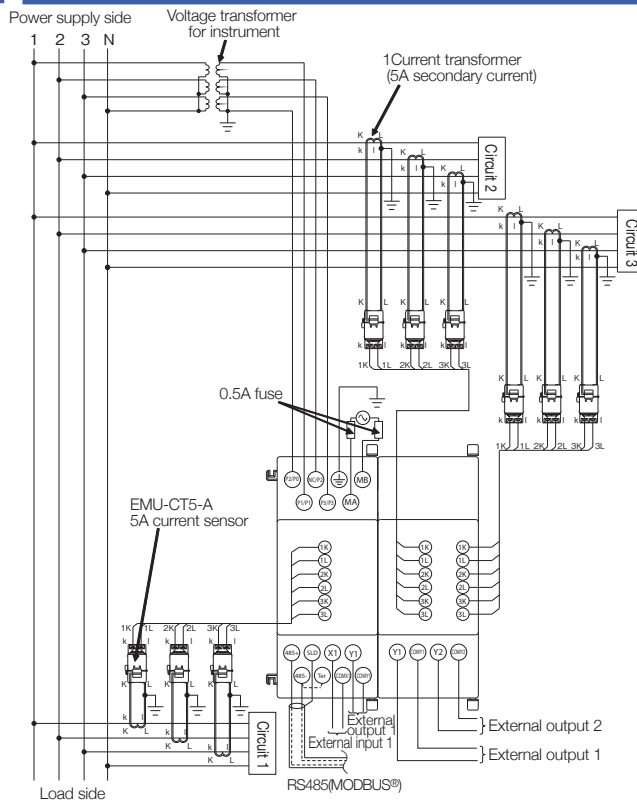

Name	Model	Quantity
EcoMonitorPlus (High Performance Model)	EMU4-HM1-MB	1
EcoMonitorPlus (Extension Unit for Same Voltage System)	EMU4-A2	1
5A current sensor	EMU-CT5-A	9

6. Connection Configuration

Single-phase 3-wire/3-phase 3-wire (in the case of high-voltage circuit)

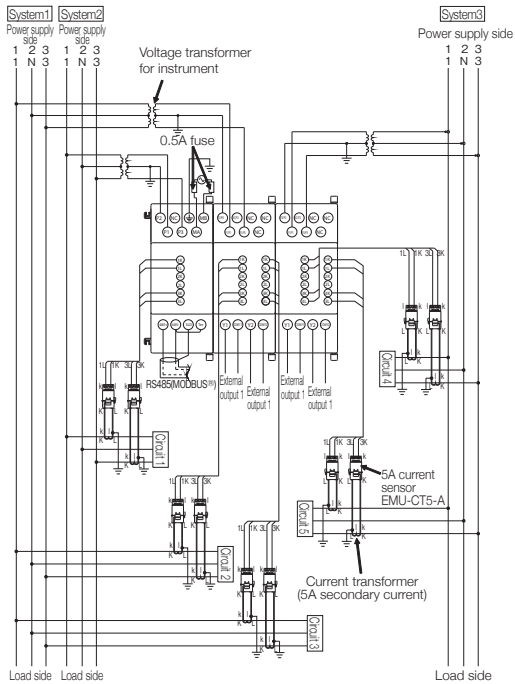

Name	Model	Quantity
EcoMonitorPlus (Standard Model)	EMU4-BM1-MB	1
EcoMonitorPlus (Extension Unit for Different Voltage System)	EMU4-VA2	2
5A current sensor	EMU-CT5-A	10

3-phase 4-wire (in the case of low-voltage circuit)

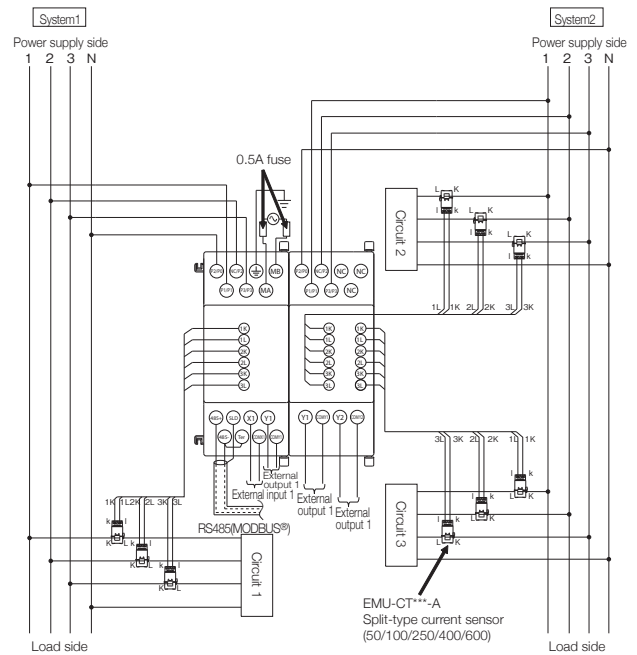

Name	Model	Quantity
EcoMonitorPlus (High Performance Model)	EMU4-HM1-MB	1
EcoMonitorPlus (Extension Unit for Different Voltage System)	EMU4-VA2	1
Split-type current sensor	EMU-CT***-A (50/100/250/400/600)	9

[Electric Leakage Measurement]

Single-phase/3-phase 3-wire

1P3W/3P3W

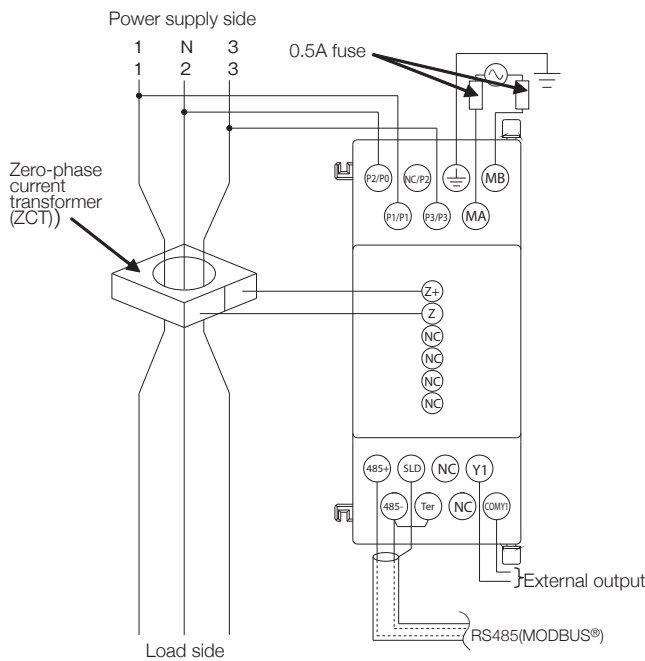

3-phase 3-wire(with the voltage transformer)

3P3W(with the voltage transformer) * Do not use high-voltage circuit.

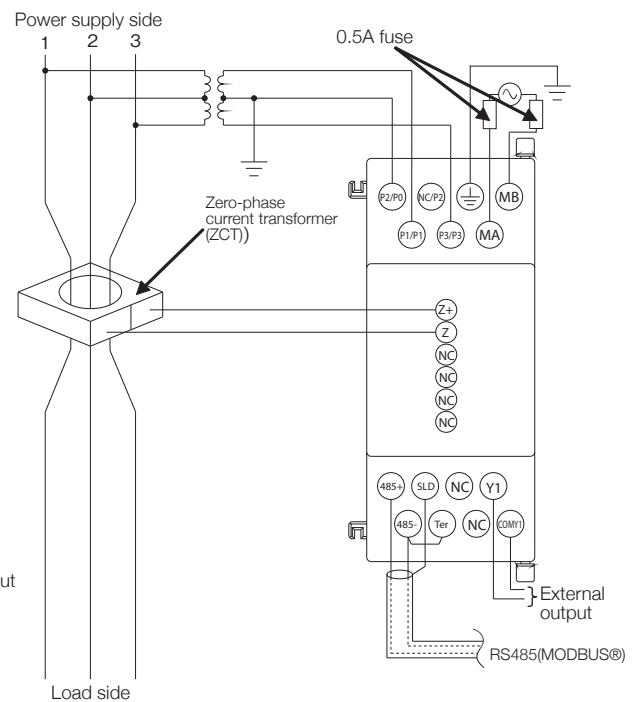

*Regarding the installation and connection of units, refer to the instruction manual.

Product Lineup
Features
Specifications
Names of Parts and External view
External view
Connection Configurations
Simplified Comparison of EcoMonitor Pro

EcoMonitorPlus

Obtain the most appropriate measurements according to applications!



[Features]

- Easy system expansion by adding units.
- Collection of data from multiple circuits (up to 14 circuits) and easy creation of reports.
- Monitoring of leakage currents and load currents for equipment maintenance and management.

Simple and easy measuring at low cost!



[Features]

- Reasonable price.
- Integrated setting display device.
- Easy installation and measuring operation.

EcoMonitorPro

Measure up to 7 circuits!



[Features]

- Capable of measuring a wide range of voltage from low to high.
- Single unit for measurement of different voltage/phase wires.
- A wide lineup of models with momentary voltage drop detection and pulse output functions.

Service Network

Country / Region	Company	Address	Telephone
Australia	Mitsubishi Electric Australia Pty. Ltd.	348 Victoria Road, Rydalmere, N.S.W. 2116, Australia	+61-2-9684-7777
USA	Mitsubishi Electric Automation Inc.	500 Corporate Woods Parkway Vernon Hills, IL 60061, USA	+1-847-478-2100
Brazil	MELCO-TEC Rep. Com. e Assessoria Tecnica Ltda.	Av. Paulista, 1439-Cj.72, Cerqueira Cesar CEP 01311-200, Sao Paulo, SP, CEP:01311-200, Brazil	+55-11-3146-2200
Chile	Rhona S.A.	Agua Santa 4211 P.O. Box 30-D Vina del Mar, Chile	+56-32-2-320-600
China	Mitsubishi Electric Automation (CHINA) Ltd.	No. 1386 Hongqiao Road, Mitsubishi Electric Automation Center Shanghai China, 200336	+86-21-2322-3030
China	Mitsubishi Electric Automation (HongKong) Ltd.	10/F., Manulife Tower, 169 Electric Road, North Point, Hong Kong	+852-2887-8810
Colombia	Proelectrico Representaciones S.A.	Carrera 53 No 29C-73 - Medellin, Colombia	+57-4-235-30-38
Egypt	Cairo Electrical Group	9, Rostoum St. Garden City P.O. Box 165-11516 Maglis El-Shaab, Cairo - Egypt	+20-2-27961337
Europe	Mitsubishi Electric Europe B.V.	Mitsubishi-Electric-Platz1,40882 Ratingen,Germany	+49-2102-486-0
India	Mitlite Electric Company Pvt Ltd	Plot No-32, Sector-6, IMT Maneser,	+91-124-4695300
Indonesia	P. T. Sahabat Indonesia	P.O.Box 5045 Kawasan Industri Pergudangan, Jakarta, Indonesia	+62-(0)21-6610651-9
Korea	Mitsubishi Electric Automation Korea Co., Ltd	1480-6, Gayang-Dong, Gangseo-Gu, Seoul, Korea	+82-2-3660-9572
Laos	Arounkit Corporation Import-Export Solt Co., Ltd.	Saphanmo Village. Sayaetha District,Vientiane Capital,Laos	+856-20-415899
Lebanon	Comptoir d'Electricite Generale-Liban	Cebaco Center - Block A Autostrade Dora, P.O. Box 11-2597 Beirut - Lebanon	+961-1-240445
Malaysia	Mitric Sdn Bhd	5 Jalan Pemberita U1/49, Temasya Industrial Park, Glenmarie 40150 Shah Alam, Selangor, Malaysia	+603-5569-3748
Myanmar	Peace Myanmar Electric Co.,Ltd.	NO137/139 Botataung Pagoda Road, Botataung Town Ship 11161, Yangon, Myanmar	+95-(0)1-202589
Nepal	Watt & Volt House	KHA 2-65, Volt House Dillibazar Post Box: 2108, Kathmandu, Nepal	+977-1-4411330
Middle East Arab Countries & Cyprus	Comptoir d'Electricite Generale-International-S.A.L.	Cebaco Center - Block A Autostrade Dora P.O. Box 11-1314 Beirut - Lebanon	+961-1-240430
Pakistan	Prince Electric Co.	1&16 Brandreth Road, Lahore-54000, Pakistan	+92-(0)42-7654342
Philippines	Edison Electric Integrated, Inc.	24th Fl. Galleria Corporate Center, Edsa Cr. Ortigas Ave., Quezon City Metro Manila, Philippines	+63-(0)2-634-8691
Saudi Arabia	Center of Electrical Goods	Al-Shuwayer St. Side way of Salahuddin Al-Ayoubi St. P.O. Box 15955 Riyadh 11454 - Saudi Arabia	+966-1-4770149
Singapore	Mitsubishi Electric Asia Pte. Ltd.	307, Alexandra Road, #05-01/02 Mitsubishi Electric Building, Singapore 159943	+65-6473-2308
South Africa	CBI-electric: low voltage	Private Bag 2016, Isando, 1600, South Africa	+27-(0)11-9282000
Taiwan	Setsuyo Enterprise Co., Ltd	6th Fl., No.105, Wu Kung 3rd, Wu-Ku Hsiang, Taipei, Taiwan, R.O.C.	+886-(0)2-2298-8889
Thailand	United Trading & Import Co., Ltd.	77/12 Bamrungmuang Road, Klong Mahanak, Pomprab Bangkok Thailand	+66-223-4220-3
Uruguay	Fierro Vignoli S.A.	Avda. Uruguay 1274, Montevideo, Uruguay	+598-2-902-0808
Venezuela	Adesco S.A.	Calle 7 La Urbina Edificio Los Robles Locales C y D Planta Baja, Caracas - Venezuela	+58-212-241-9952
Vietnam	Mitsubishi Electric Vietnam Co.,Ltd. Head Office	Unit01-04, 10th Floor, Vincom Center, 72 Le Thanh Ton Street, District 1, Ho Chi Minh City, Vietnam	+84-8-3910-5945
	Mitsubishi Electric Vietnam Co.,Ltd. Hanoi Branch	6th Floor, Detech Tower, 8 Ton That Thuyet Street, My Dinh 2 Ward, Nam Tu Liem District, Hanoi City, Vietnam	+84-4-3937-8075

For Safety : Please read the instruction manual carefully before using the products in this catalog. Wiring and connection must be done by the person who has specialized knowledge of electric construction and wirings.

●Trademarks

- Microsoft, Windows Vista, Windows XP, Windows7,Windows8, Excel are U.S. registered trademark in the U.S. of U.S. Microsoft Corporation,and other countries.
- MODBUS® is a registered trademark of Schneider Automation Inc.
- Other company names and product names in this document are trademarks or registered trademarks of their respective owners.



for a greener tomorrow

Eco Changes is the Mitsubishi Electric Group's environmental statement, and expresses the Group's stance on environmental management. Through a wide range of businesses, we are helping contribute to the realization of a sustainable society.



MITSUBISHI ELECTRIC CORPORATION

HEAD OFFICE: TOKYO BUILDING, 2-7-3, MARUNOUCHI, CHIYODA-KU, TOKYO 100-8310, JAPAN