

MDU BREAKER: BREAKER-MOUNTING



MODEL

NF400-SEW with MDU, NF400-HEW with MDU
NF800-SEW with MDU, NF800-HEW with MDU



INSTRUCTION MANUAL

- Read this Instruction Manual carefully prior to use, so that the product is used properly.
- After reading this manual, store it in a safe place so that it can be easily referenced when needed.
- Make sure that the end user receives this Instruction Manual.

Indications and what they mean are listed below.

 Danger	Wrong handling may cause dangerous situation in which possibility of fatal accidents or serious injuries assumed.
 Caution	Wrong handling may cause dangerous situation in which possibility of significant or minor injuries, or material damages assumed.

	Using this under certain conditions could cause electrical shock.
---	---

 Danger	
	● Do not touch the terminal area. Doing so may cause electrical shock.

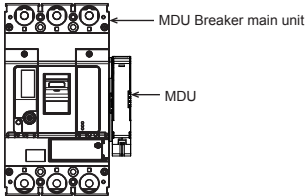
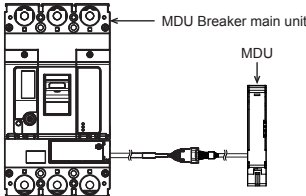
 Caution	
 <p>MDU Breaker (Breaker-mounting)</p>	 <p>MDU Breaker (Breaker-mounting unit separate installation)</p>
<p>Some items are not measured or displayed depending on models or specifications. These items and functions will be skipped.</p>	

For models with CC-Link communication, refer to the PLC User's Manual before reading this Instruction Manual.

• CC-Link System Master/Local Module User's Manual

* The CC-Link version is "CC-Link Ver. 1.10."

■ Table of Contents

1. Safety Precautions	3
2. Precautions for Use	3
2.1 Standard operating conditions	3
2.2 Withstand voltage test	4
2.3 Connection and installation	5
2.4 Preparation before use	6
2.5 Requests	6
2.6 Notes on usage	6
3. Cautionary Instructions for Handling MDU Breaker	7
3.1 Cautionary instructions for using MCCB	7
3.2 Periodic inspections	7
3.3 Setting method of overcurrent tripping characteristics	8
3.4 Testing method of overcurrent trip	9
4. Alarm Contact Output (Optional)	10
4.1 Contact capacity and combinations for alarm contact output	10
4.2 Precautions for alarm contact output usage	10
5. MDU Breaker Installation Procedure	11
5.1 Installing MDU Breaker main unit	11
5.2 Attaching connection cable to MDU Breaker (separate installation)	11
5.3 MDU installation (separate installation)	12
5.4 Wiring of MDU terminal block	13
6. MDU Features and Functions	15
6.1 Features of MDU	15
6.2 Functions of MDU	15
6.3 Measurement functions	16
6.3.1 Measurement function list	16
6.3.2 Measurement rated values/measurement range and accuracy	17
6.4 Monitoring functions	21
6.4.1 Monitoring function list	21
6.5 How to use monitoring functions	22
6.5.1 MDU Breaker alarms	22
6.5.2 MDU Breaker status	24
6.5.3 Fault causes	24
6.5.4 Electric current demand upper/lower limit alarms	24
6.5.5 Neutral line open phase alarm (NLA)	25
6.6 Electric energy pulse output/CC-Link communication section specifications	25
6.6.1 Electric energy pulse output	25
6.6.2 CC-Link communication	25

7. Names and Functions of MDU Parts	26
7.1 Display/operation panel	26
7.2 Terminal area	26
7.3 CC-Link setting area (with CC-Link communication option)	27
7.4 Number of CC-Link communication connectable units and precautions	28
7.5 Installation and wiring for products with CC-Link communication	29
7.5.1 Terminator installation	29
7.5.2 Shielded wire grounding	29
8. MDU Detailed Specifications	30
8.1 Precautions for measurement	30
9. MDU Operation Procedure	32
9.1 Operating method for main menu screen	32
9.2 Measurement value display and display contents	33
9.3 Display method for protection characteristic setting values	37
9.4 Fault/alarm display methods and display contents	39
9.5 Method for resetting fault cause/current, alarm, maximum value, electric energy, and reactive energy	39
9.6 Method for various settings	40
9.6.1 Setting method for measurement-related items	40
9.6.2 Setting method for alarms	42
9.6.3 Setting method for LCD	44
9.6.4 Setting method for date and time	46
9.6.5 Setting method for electric energy	46
9.7 Measurement display list	48
10. Appendix	50
10.1 Precautions for setting operation	50
10.2 Precautions when setting via CC-Link communication	50
10.3 Precautions for MDU with CC-Link communication	51
10.4 I/O signal list (with CC-Link communication)	51
10.5 Remote register allocation (with CC-Link communication)	52
10.6 Communication error codes and solutions	52
10.7 Troubleshooting	52

1. Safety Precautions

This Instruction Manual is meant mainly for those with specialized electrical knowledge who will use this product to manufacture assembled products, perform electrical work, or conduct maintenance and inspections. This also includes those who will operate this product (the end user).

Caution

- When installing or removing MDU Breaker main unit and a Measuring Display Unit (MDU), first turn the host circuit breaker OFF and confirm that no electricity is flowing.
- This product must be handled by someone with specialized knowledge.

2. Precautions for Use

Unless otherwise noted, the following terms in this Instruction Manual indicate the models shown below.

	400 A frame	800 A frame
Molded Case Circuit Breaker (MCCB)	NF400-SEW with MDU, NF400-HEW with MDU	NF800-SEW with MDU, NF800-HEW with MDU

2.1 Standard operating conditions

Caution

- The standard operating conditions are described below. Be sure to use MDU Breaker within these conditions.
 - [1] Operating ambient temperature: -10°C to +40°C (must not exceed an average of +35°C within a 24 hour period)
 - [2] Ambient storage temperature: -25°C to +55°C (no condensation/freezing)
 - [3] Relative operating/storage humidity: 85% RH or less (no condensation)
 - [4] Altitude: 2,000 m or lower
 - [5] Operating/storage atmosphere: Must contain hardly any dust, smoke, corrosive gas, combustible gas, moisture, salt, etc.
- If the ambient temperature of MDU Breaker exceeds +40°C, use with a decreasing continuous load current.
Ambient temperature of +50°C: 0.9 times, ambient temperature of +60°C: 0.7 times
- Do not install in abnormal environments subject to high temperature, high humidity, dust, corrosive gas, vibration, impact, etc. Doing so may cause electrical shock, fire, or may cause the product to stop working.
- Do not wipe the MDU Breaker main unit or MDU with thinner, detergent, or chemical cloth.
Doing so may fade printing, reduce insulation performance, or cause mold to form. Clean with air or by brushing.
- The case of the MDU may become discolored depending on the environment. However, this will not have any effect on performance.
- The LCD may have bright (always on) or dark (always off) pixels due to the characteristics of LCDs.
Because LCDs contain many display elements, there is no way to ensure that bright or dark pixels will never occur. Bright or dark pixels are not defects in the product itself.

2.2 Withstand voltage test



Caution

- When conducting a MDU terminal test, always connect the MDU Breaker main unit and MDU.
- A voltage measurement transformer is connected between poles on the load side of the MDU Breaker main unit.
In the table below, × indicates that, because it causes a failure, withstand voltage test between poles on the load side must not be performed.
In the table below, △ indicates that, although nothing broke during a 500 VDC insulation resistance test, there was a low insulation resistance value.
No problems found during withstand voltage test and insulation resistance test conducted on entire main circuit and between ground on MDU Breaker main unit.
- When checking DA, DB, DG, SLD, and FG terminal conductivity for models with CC-Link communication, do not allow the voltage between each terminal to reach 5 VDC or higher.
Doing so may cause failure.

Measurement point/test		Insulation resistance measurement		Withstand voltage test		Test conditions	
		ON	OFF	ON	OFF		
Status of handle		○	○	○	○		
Between live part and ground							
Between different poles	Line side	Between left and middle poles	△	○	×	○	2500 VAC 1 min.
		Between middle and right poles	△	○	×	○	
		Between left and right poles	△	○	×	○	
		Between left and neutral poles, Between middle and neutral poles, Between right and neutral poles (for a four-poles circuit breaker)	△	○	×	○	
	Load side	Between left and middle poles	△	△	×	×	
		Between middle and right poles	△	△	×	×	
		Between left and right poles	△	△	×	×	
		Between left and neutral poles, Between middle and neutral poles, Between right and neutral poles (for a four-poles circuit breaker)	△	△	×	×	
Between power supply and load terminal		-	○	-	○		
Between main circuit and MDU terminals (L1, L2, FG)		○	○	○	○		
Between main circuit and MDU terminals (114, 113, FG) (with electric energy pulse output)		○	○	○	○	2500 VAC 1 min. (*1)	
Between main circuit and MDU terminals (DA, DB, DG, SLD, FG) (with CC-Link communication) (*4)		○	○	○	○		
Between MDU terminals (L1, L2) and MDU terminal (FG)		○	○	○	○	1500 VAC 1 min. (*2)	
Between MDU terminals (L1, L2) and MDU terminals (114, 113, FG) (with electric energy pulse output)		○	○	○	○		
Between MDU terminals (L1, L2) and MDU terminals (DA, DB, DG, SLD, FG) (with CC-Link communication) (*3) (*4)		○	○	○	○		

*1. Test with MDU terminals (L1, L2, 114, 113, DA, DB, DG, SLD, FG) as ground side.

*2. Test with MDU terminals (114, 113, DA, DB, DG, SLD, FG) as ground side.

*3. Do not perform a withstand voltage test between MDU terminals (DA, DB, DG, SLD) and MDU terminal (FG).

*4. MDU terminals (DA, DB, DG, SLD, FG) must always be tested together.

2.3 Connection and installation

⚠ Caution

- MDU Breaker cannot be used with the power side and load side reversed.
- Do not forcefully pull the connection cable between the MDU and MDU Breaker main unit (15 N or less). Doing so may loosen or disconnect the cable.
- When installed to the MDU, if the MDU Breaker main unit cuts off a fault current and must be replaced with a new unit, also replace the MDU. It cannot be reused.
- The connection cable between the MDU and MDU Breaker main unit forms a small-signal circuit. Install it at least 10 cm away from strong circuits. Use with the area around the connector fixed in place, so that no external forces are applied to the connector connection area when opening/closing the front door. When bending the cable, maintain a radius of at least 20 mm.
- The connector area used to connect to the MDU is insulated from the inside of the MDU Breaker main unit. The product will operate normally and will not break even if the MDU Breaker main unit is powered with the connector area disconnected (open).
- If a MDU will be installed later, do so within 1.5 years from installing the MDU Breaker main unit.
- Do not insert and pull out cables from the connector area more than 20 times each on the MDU Breaker main unit and MDU.
- Pulling out the connection cable connector when MDU control power is applied may cause a MDU alarm or the like to be erroneously displayed. If this happens, reset the alarm and clear the memory when pulling out the connector and starting use.
- Control power is required for the MDU. Apply the control power supply voltage shown on the MDU between the L1 and L2 terminals. Measurement, display, electric energy pulse output, CG-Link communication, and MODBUS communication cannot be used without power. Install a short-circuit protector (using a circuit breaker or fuse) to the control circuit.
- If using MDU Breaker with a single-phase two-wire circuit, connect it as shown in Figure 1. The left pole (1-phase) load side is a live part, so be sure to insulate it.
Use the middle pole (2-phase) and the right pole (3-phase) current, and two voltage between the middle pole (2-phase) and the right pole (3-phase) as measurement data.
Ignore the left pole (1-phase) current, as well as the voltage between the left pole (1-phase) and the middle pole (2-phase) and between the right pole (3-phase) and the left pole (1-phase).
- If using MDU Breaker with a single-phase three-wire circuit, connect it as shown in Figure 2 below with the neutral line connected to the middle pole (2-phase).
If the neutral line is connected to either the left pole (1-phase) or the right pole (3-phase), it will be impossible to measure with MDU.

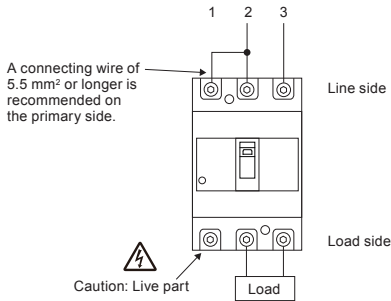

Figure 1. Connection method in a single-phase two-wire circuit

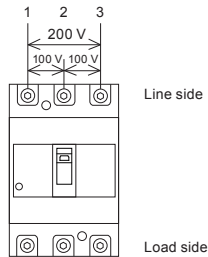

Figure 2. Connection method in a single-phase three-wire circuit

- Note that a three-pole MDU Breaker product cannot be used with a three-phase four-wire system.

The following table shows the items that can be measured when a three-pole product is used with a three-phase four-wire system.

Measurement item	Status	Reason
Load current	○ Voltage phase, × N phase	No CT on N phase, so measurement not possible
Line voltage	○ Between voltage phases, × Between voltage phase and N phase	No VT between N phases, so measurement not possible
Harmonic current	○ Voltage phase, × N phase	No CT on N phase, so measurement not possible
Electric power/ reactive power	×	No CT on N phase and no VT between N phases, so N phase not added
Electric energy/ reactive energy	×	No CT on N phase and no VT between N phases, so N phase not added
Power factor	×	No CT on N phase and no VT between N phases, so N phase not included

2.4 Preparation before use

The LCD display is covered with a scratch-proof protective sheet.

Remove it before operating.

When removing the sheet, the LCD display may light up due to static electricity, but this is not abnormal.

After natural electrostatic discharge, the illumination will turn off soon.

In addition, display may flicker due to the internal processing for the refresh of display.

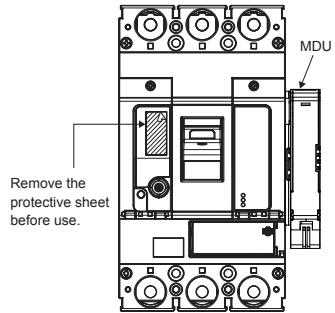

2.5 Requests

● The free warranty period and warranty scope for this product are as follows.

● Free warranty period

The free warranty period lasts for one year from the time of purchase.

● Warranty scope

(1) Any failures that occur during the warranty period will be repaired free of charge, assuming that the usage status, usage method, usage environment, etc. are as described in the product's catalog, User's Manual, warning labels, etc., and that the product was used under standard conditions as described in the precautions, etc.

However, the free warranty period shall last a maximum of 18 months after manufacture, with a maximum of six months for the distribution period after the product is shipped from Mitsubishi Electric.

(2) A fee will be charged for repairs under the following circumstances, even if the product is still within the free warranty period.

- Failures resulting from inappropriate storage/handling, carelessness, error, etc. on the customer's part.
- Failures resulting from installation mistakes.
- Failures resulting from misuse or unreasonable modification.
- Failures resulting from fires, abnormal voltage, or other external events beyond human control, or from earthquakes, wind disasters, or other natural disasters.
- Failures resulting from phenomena that could not be foreseen using the scientific technology standards at the time the product was shipped by Mitsubishi Electric.

The free warranty described here applies only to the delivered product, and does not apply to any damage or the like caused by failures in the delivered product.

● This free warranty does not apply to any damage or the like caused due to reprinting or reproducing the information included in this document in whole or in part in any form without the consent of Mitsubishi Electric.

● All efforts have been made to keep the information in this document current as software and hardware is revised. However, there may be cases where inconsistencies arise.

2.6 Notes on usage

- (1) The products described in this Instruction Manual were designed and manufactured as general-purpose items meant for general industrial use, etc. Please contact Mitsubishi Electric sales to discuss use for special purposes including atomic energy, electric power, aerospace, medical, or passenger transport devices or systems.
- (2) Mitsubishi Electric shall not be held responsible for damage caused for reasons not attributable to Mitsubishi Electric; opportunities or profit lost by customers caused by Mitsubishi Electric product failure; damage caused from extraordinary circumstances, secondary damage, accident compensation, damage to anything other than Mitsubishi Electric products, or compensation for any other work, whether foreseen or not by Mitsubishi Electric.

3. Cautionary Instructions for Handling MDU Breaker

3.1 Cautionary instructions for using MCCB

 Caution
<ul style="list-style-type: none"> ● Electrical work must be performed by a qualified person (electrical worker). ● Maintenance and inspections must be conducted by someone with specialized knowledge. Turn the host circuit breaker OFF and confirm that no electricity is flowing. Doing otherwise could cause electrical shock. ● Connect the line side and load side correctly. When connecting the power supply, make sure that the terminal screws are tightened at the torque listed on the included terminal screw case. Otherwise, a fire may be resulted. ● Install MDU Breaker so that no dirt or dust, concrete dust, iron dust, rainwater, or other foreign matter enters. Doing so may result in a fire or operation accident. ● Make sure protective grounding is performed for the load device. ● Be sure to connect the neutral line to the two-phase for a single-phase three-wire system, and connect the neutral line to the neutral-phase for a three-phase four-wire system. ● If the product automatically cuts off, resolve the issue before switching the handle to ON. Otherwise, an electric shock or a fire may be resulted. ● To configure, first set the MDU Breaker main unit to OFF or TRIP.

3.2 Periodic inspections

To prevent trouble and to maintain the performance of the breaker, inspect the breaker one month after starting use and periodically thereafter according to the operation environment.

 Caution
<ul style="list-style-type: none"> ● Make sure that the product is not energized prior to performing periodic inspections. Otherwise, an electrical shock, a device accident, or a fire may be resulted. ● Periodically tighten terminal screws. Otherwise, a fire may be resulted.

Yardstick for inspection periodicity

1	Clean and dry environment	Once every 2 to 3 years
2	Environment not exposed to severe dust, corrosive gas vapor, salt, etc.	Once a year
3	Other places than 1 and 2	Once every six months

Inspection item	Criterion
1. Is any conductor connection not loosened?	No loosening allowed. If loosened, the connection should be retightened with such appropriate torque as indicated in the Attached Table.
2. Are the cover and base not cracked or otherwise damaged? Is the handle not broken?	No crack nor damage on the cover and base. No broken handle.
3. Internal submersion by inundation or substantial mud or dust not adhered?	No internal submersion nor substantial mud and/or dust adhered to. In case of internal submersion, replace the circuit breaker with a new one, or have it overhauled at our service center.
4. Check whether the temperature has abnormally risen. Maximum allowable terminal temperature rise is 60K. (There is a slight temperature difference between the terminals on the line side and the load side, and between the middle pole and the left and right pole.)	By visual inspection, the rear studs of terminals, the tightening area of the main body, and the molded area must not discolor from burning. When the current of each phase is balanced, there is no terminal that shows an abnormally high temperature rise. When the load current is balanced, the temperature difference between the left and right of the base is small.
5. Is there ON/OFF operation by handle smooth?	Operation should be done smoothly.
6. Is there TRIP operation by trip button?	The circuit breaker should be able to reset after tripping.

3.3 Setting method of overcurrent tripping characteristics

(1) Open the transparent cover.

(2) Turn the dials to set the tripping characteristics. As shown in the figure below, use a screwdriver to turn the dials for setting tripping characteristics.

Turn the dial in the direction of the arrow to the desired setting.

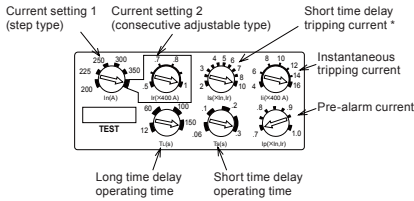
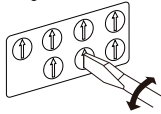

- Current setting 1 (In)
 - Long time delay operating time (TL)
 - Short time delay tripping current (Is)
 - Short time delay operating time (Ts)
 - Pre-alarm current (Ip)
- ... Step type
- Current setting 2 (Ir) (*1)
 - Instantaneous tripping current (Ii)
- ... Consecutive adjustable type
- * When setting Is, the value next to the value that was set may actually be set.

- A flathead screwdriver with a tip width of 4.5 mm and a thickness of 0.6 mm is ideal for changing settings.
- Do not use more force than necessary when changing settings. Doing so may cause accident. (The optimal operation torque is 0.05 N·m or less.)
- The arrows on all dials (except for adjustable current setting and instantaneous tripping current) must be set to setting values within the thick lines. Leaving the dial in an intermediate position may result in the next setting value being set.
- Setting values can be confirmed using the MDU or the separately sold "Y-351" breaker tester/setting device.
- To configure, first set the MDU Breaker main unit to OFF or TRIP.
- The dial for setting current setting 1 (In) provides a clicking sensation when turned.
- If the long time delay operating time is set to "12 s", long time delay operation may be performed prior to short time delay operation.

(3) Find the sticker for the set current setting from among the replacement stickers, and stick the current setting sticker to the rated value display location on the handle.

(4) Close the transparent cover. Affix a sealing sticker if required.

*1: The adjustable current setting dial functions when the current setting dial is set to maximum.

Setting example 1



Current setting 1 : Maximum
 Current setting 2 : 0.7
 Current setting : 280 A (= 400 A × 0.7)

Setting example 2



Current setting 1 : 250 A
 Current setting 2 : 0.7 (does not function)
 Current setting : 250 A

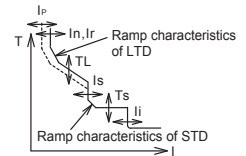

Ramp characteristics is fixed to ON.

Precautions when setting short time delay tripping current (Is) and instantaneous tripping current (Ii)

* Short time delay operation will not function if short time tripping current (Is) is set to the same value (or higher) as the value for instantaneous tripping current (Ii).

(1) Value of short time delay tripping current (Is) exceeds value of instantaneous tripping current (Ii)

Example: When NF400-SEW with MDU Ir = 200 A,

if "Is = 10 × Ir" and "Ii = 4 × rated current", Is = 2,000 A and Ii = 1,600 A, so instantaneous tripping operating functions prior to short time delay tripping operation.

The operating characteristic curve is shown in the figure below.

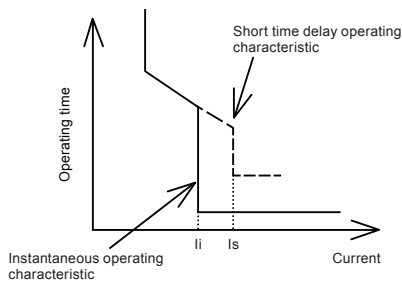

(2) Value of short time tripping current (Is) is the same as value of instantaneous tripping current (Ii)

Example: When NF400-SEW with MDU Ir = 200 A,

if "Is = 10 × Ir" and "Ii = 5 × rated current", Is = 2,000 A and Ii = 2,000 A, so instantaneous tripping operation is prioritized over short time delay tripping operation.

The operating characteristic curve is shown in the figure below.

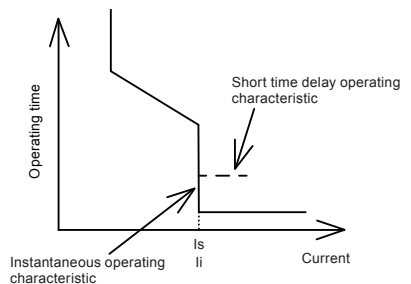

3.4 Testing method of overcurrent trip

Test by using the "Y-351" breaker tester (option) or by energizing the MDU Breaker main unit.
 If using the "Y-351" breaker tester, follow the instructions in that product's Instruction Manual.

⚠ Caution

- For the pre-alarm contact output for a MCCB (with alarm contact attached [optional]), the MDU is connected to the MDU Breaker main unit and will not operate unless control power is applied to the MDU and the alarm contact output.
- The MDU measurement function, alarm function, fault cause and current display, and communication function cannot be confirmed if the "Y-351" breaker tester is used.

This section describes how to test after energizing the MDU Breaker main unit.

- (1) Send AC power to the MDU Breaker main unit from a 3-phase power supply or 1-phase power supply.
 When using a 1-phase power supply, do so from two poles in series.

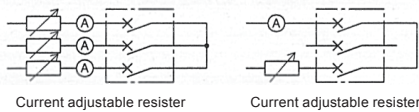

- (2) Each operating current can be confirmed by checking the LEDs on the front of the MDU Breaker main unit.

70% LED (green) : Acceptable when it begins to stay ON within 60% to 80% of current setting.

PAL LED (yellow) : With $I_p = 0.7 \times I_r$, acceptable when it starts to flash every 0.5 seconds within 60% to 80% of current setting.

OVER LED (red) : Acceptable when it begins to stay ON at 105% to 125% of current setting.

- (3) The long time delay and pre-alarm operating times can be confirmed by sending a current equivalent to 200% of current setting.

However, if a current exceeding current setting is sent prior to this test, the operating time will shorten and the first measurement will be invalid.

Tripping the MDU Breaker main unit will reset the trip circuit, allowing the following operating time to be measured correctly.

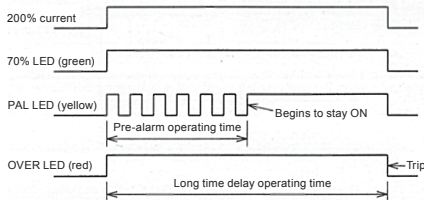

Acceptable if measured operating time is within range below.

Measurement item	TL = 12 s	TL = 60 s	TL = 100 s	TL = 150 s
Pre-alarm operating time	4.8 to 7.2 s	24 to 36 s	40 to 60 s	60 to 90 s
Long time delay operating time	9.6 to 14.4 s	48 to 72 s	80 to 120 s	120 to 180 s

4. Alarm Contact Output (Optional)

Caution

- Note that alarm contact output will not operate unless control power is applied to the MDU and the alarm contact output.
- Alarm contact output is a factory installed option. It cannot be installed after.
- The MDU is used as separate installation.

4.1 Contact capacity and combinations for alarm contact output

- Refer to the table below for alarm contact output contact capacity.

	$\text{COS}\phi = 1$	$\text{COS}\phi = 0.4,$ $\text{L/R} = 0.007$
125 VAC	3 A	2 A
250 VAC	3 A	2 A
30 VDC	2 A	2 A
100 VDC	0.4 A	0.3 A

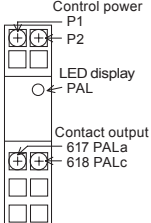
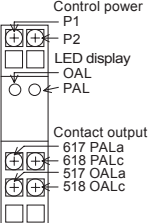
Accessory device name	PAL	TI
Alarm name	PAL OAL	
Part names	 <p>Control power P1 P2</p> <p>LED display PAL</p> <p>Contact output 617 PALa 618 PALc</p>	 <p>Control power P1 P2</p> <p>LED display OAL PAL</p> <p>Contact output 617 PALa 618 PALc 517 OALa 518 OALc</p>

4.2 Precautions for alarm contact output usage

Caution

- Control power is required for alarm contact output. Connect control power to terminals L1 and L2. (No polarity.)
Rated voltage: 100 to 240 VAC/DC common 50/60 Hz
VA consumption: 5 VA
Use a power supply to prevent power outages when the MDU Breaker is tripped.
- Note that alarm contact output will not operate unless control power is applied to the MDU. Confirm that the MDU Breaker and the MDU are securely connected with a connection cable.
- Make sure that terminal connections are tightened at the optimal tightening torque (0.9 to 1.2 N·m).
- Alarm contact output may generate a slight noise when control voltage is applied. This is due to the operation of the internal electronic circuit, and is not an abnormality.
- If alarm contact output is attached, internal accessory devices cannot be installed on the right pole side.

5. MDU Breaker Installation Procedure

5.1 Installing MDU Breaker main unit

Caution

- If installing with connection cables attached to the MDU Breaker main unit, make sure that connection cables and connectors are not caught and damaged.
- Connection cable connectors are precision parts. Be especially careful to protect them from damage during installation.
- This product uses dedicated connection cables. Using other cables or modifying them may prevent proper measurements from being made.
- Install with at least 40 mm of wiring space to the right and left sides of the MDU Breaker main unit, in order to wire connection cables and attach connection cable connectors.

- Use the included "circuit breaker fixing screws" to install the MDU Breaker. (Figures 1 and 2)

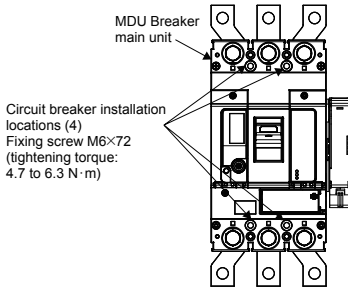

Figure 1. 400 A frame circuit breaker

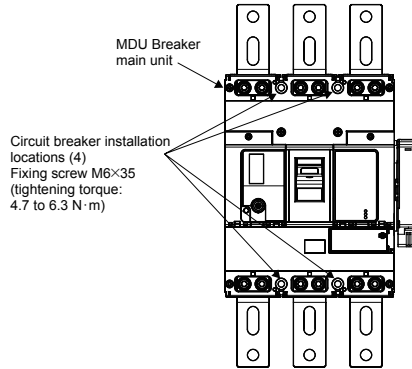
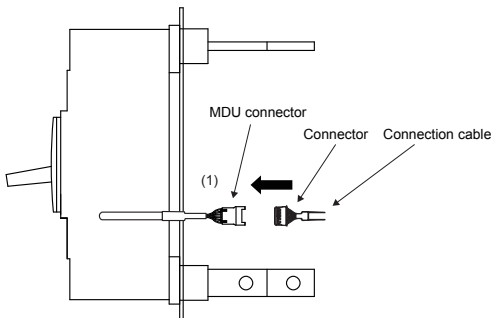

Figure 2. 800 A frame circuit breaker

5.2 Attaching connection cable to MDU Breaker (separate installation)

- (1) Connect the connector of the connection cable to the connector of the MDU Breaker main unit's right side.

- (2) Insert until you hear it click into place.



Caution

- Fasten the connection cable with clamps to avoid undue force.

5.3 MDU installation (separate installation)

Caution

- The MDU has the reset switch, address (station number) setting switch (when CC-Link communication functions are equipped) and communication speed setting switch (when CC-Link communication function is equipped).
Install the MDU onto a position where you can easily perform reset operation and change settings.

(1) Installation to the IEC rail (35 mm)

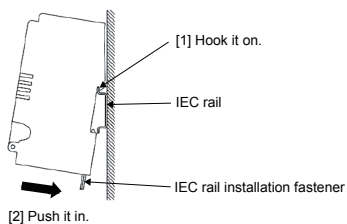

(2) Removal from the IEC rail (35 mm)

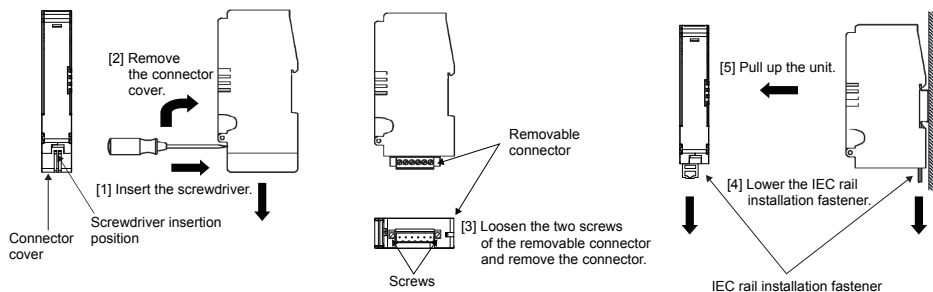

(3) Connection cable installation

Open the terminal cover of the MDU and connect the connection cable to the connector.

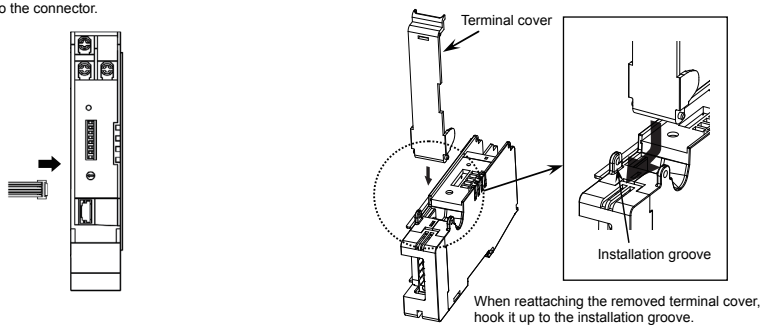

5.4 Wiring of MDU terminal block

[Breaker-mounting MDU]

Caution

- The power supply side terminals of the MDU are M3 screws.
For tightening, apply the suitable tightening torque (0.5 to 0.7 N·m).
- If two crimp terminals are used for transition wiring on the power supply side terminal of the MDU, it may be difficult to close the terminal cover depending on the wire and the crimp terminals.
In that case, close the terminal cover after taking measures such as bending the crimp terminals.
- From the load side terminal of the MDU, remove the connector cover and removable connector, and connect a wire. For the suitable size of terminal block wire, use those shown below. (In the case of no-transmission specification, the load side terminal is not provided.)

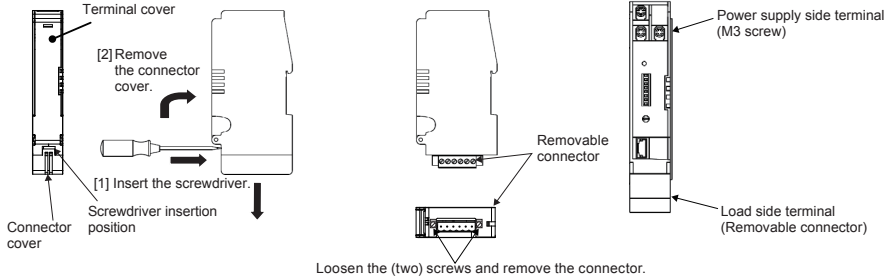

Suitable wire size	One connected	Two connected
Solid wire	0.2 to 2.5 mm ²	0.2 to 1.0 mm ² (*4)
Twisted wire	0.2 to 2.5 mm ²	0.2 to 1.5 mm ²
Twisted wire: Twisted wire with rod terminal (with no insulation sleeve)	0.25 to 2.5 mm ² (*1)	0.25 to 1.0 mm ² (*1)
Twisted wire: Twisted wire with rod terminal (with insulation sleeve)	0.25 to 2.5 mm ² (*2)	0.5 to 1.5 mm ² (*3)

*1. Pin terminals shown below: A series as applicable terminals

*2. Pin terminals shown below: AI series as applicable terminals

*3. Pin terminals shown below: AI-TWIN series as applicable terminals

*4. When polyethylene insulation vinyl sheath cables (equivalent to those with a CPEV shield) are used, the connection of two wires, up to 1.2 mm² as solid wires, is possible.

- After a wire is inserted into the terminal, tighten it with the adequate tightening torque.
In addition, when tightening a screw, start turning it slowly and straight.

Adequate tightening torque 0.5 to 0.6 N·m

Tool: Flathead screwdriver Blade edge thickness: 0.6 mm, full width: 3.5 mm

[Recommended screwdriver: PHOENIX CONTACT screwdriver model SZS 0.6 × 3.5]

Electric wire covering stripped length 7 mm

- Electric wire terminal treatment: For a solid wire, the electric wire can be connected with the covering stripped.
For a twisted wire, strip the covering, twist the core, and then insert it into the junction area.

Make sure that the core filler does not short neighboring electrodes. Do not solder plate the core.

The following pin terminals (crimp terminals) are also commercially available.

Rod terminal for one-wire connection

PHOENIX CONTACT

A series (with no insulation sleeve)

Wire cross-sectional area of 0.25 mm² : A 0.25 - 7 (product No.: 3202478) (*5)

Wire cross-sectional area of 0.5 mm² : A 0.5 - 8 (product No.: 3202481) (*5)

Wire cross-sectional area of 0.75 mm² : A 0.75 - 8 (product No.: 3202504) (*5)

Wire cross-sectional area of 1 mm² : A 1 - 8 (product No.: 3202517) (*5)

Wire cross-sectional area of 1.5 mm² : A 1.5 - 7 (product No.: 3200263)

Wire cross-sectional area of 2.5 mm² : A 2.5 - 7 (product No.: 3200289)

*5. With A 0.25 - 7 to A 1 - 8, two wires can be inserted to the connector.

AI series (with insulation sleeve)

Wire cross-sectional area of 0.25 mm² : AI 0.25 - 8 YE (product No.: 3200852)

Wire cross-sectional area of 0.5 mm² : AI 0.5 - 8 WH (product No.: 3200014)

Wire cross-sectional area of 0.75 mm² : AI 0.75 - 8 GY (product No.: 3200519)

Wire cross-sectional area of 1 mm² : AI 1 - 8 RD (product No.: 3200030)

Wire cross-sectional area of 1.5 mm² : AI 1.5 - 8 BK (product No.: 3200043)

Wire cross-sectional area of 2.5 mm² : AI 2.5 - 8 BU (product No.: 3200522)

Rod terminal for two-wire connection

PHOENIX CONTACT

AI - TWIN series (with insulation sleeve)

Wire cross-sectional area of 0.5 mm² × 2 : AI - TWIN 2 × 0.5 - 8 WH (product No.: 3200933)

Wire cross-sectional area of 0.75 mm² × 2 : AI - TWIN 2 × 0.75 - 8 GY (product No.: 3200807)

Wire cross-sectional area of 1 mm² × 2 : AI - TWIN 2 × 1 - 8 RD (product No.: 3200810)

Wire cross-sectional area of 1.5 mm² × 2 : AI - TWIN 2 × 1.5 - 8 BK (product No.: 3200823)

Caution

The products listed in page 13 may not be compatible with some electric wires. For details, contact the pin terminal (crimp terminal) manufacturer directly. However, if using a pin terminal (crimp terminal) with a metallic portion longer than 7 mm, cut the metallic portion to 7 mm as shown in the figure below.

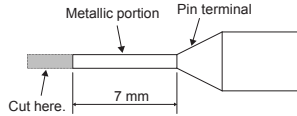

- After wire connection, attach the removable connector and tighten the screws. The adequate tightening torque is 0.2 to 0.3 N·m.

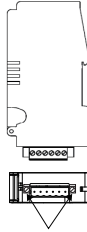

Tighten the (two) screws.
(Tightening torque: 0.2 to 0.3 N·m)

[Wiring for products with electric energy pulse output]

Caution

- The 114 and 113 terminals for pulse output use are available on the MDU that has the electric energy pulse output function.
- The pulse output line forms a small-signal circuit. Install it at least 10 cm away from strong circuits. The wiring length is determined by various conditions such as the anti-noise performance of the pulse receiver. However, the wiring should not exceed 100 m.
- If using A/C for the pulse output power supply, make sure that the pulse receiver does not erroneously operate due to leak current caused by conduit capacitance.

[Wiring for products with CC-Link communication]

Danger

- CC-Link communication terminals DA, DB, DG, and SLD are included with CC-Link communication MDUs. Connect these to the CC-Link transmission line. Never connect non-transmission line terminals (such as the L1 and L2 control power supply terminals). The CC-Link transmission line forms a small-signal circuit. Connecting it improperly is extremely dangerous.

Caution

- The CC-Link transmission line forms a small-signal circuit. Install it at least 10 cm away from strong circuits. Allocate a distance of 30 cm or more in the case of connection in parallel for a long distance.

6. MDU Features and Functions

6.1 Features of MDU

- The load current, line voltage, harmonic current (fundamental frequency; 3rd, 5th, 7th, 9th, 11th, 13th, 15th, 17th, and 19th order; and total), electric power, reactive power, electric energy, reactive energy, power factor, and frequency flowing to MDU Breaker can be measured and displayed.
- When MDU Breaker is tripped, the fault cause and fault current are stored in non-volatile memory. This information can be used to identify fault causes and recover.
- The maximum value of measurement items such as demand current and time electric energy is stored in non-volatile memory, along with when the maximum value occurred. This information can be used to identify peak energy usage times.
- The LCD backlight color changes from white to red when an alarm (such as PAL, OVER) or fault occurs, allowing users to notice abnormalities even from far away.
- Data such as measurement values, maximum values (and maximum value occurrence times), fault causes, fault current, and the alarm status can be sent over a field network (CC-Link).
- Some models do not measure or display (transmit) some items. These items and functions will be skipped.

6.2 Functions of MDU

Measurement functions (*1)	Load current I		○
	Line voltage V		○
	Harmonic current IH		○
	Electric Power P		○
	Reactive power Q		○
	Electric energy EP		○
	Reactive energy EQ		○
	Power factor PF		○
	Frequency Hz		○
	Fault cause, Fault current (*2)	Long time delay	
Short time delay			○
Instantaneous			○
Line system	3 ϕ 3W, 1 ϕ 3W (applied to three-pole products), 3 ϕ 4W (applied to four-pole products)		
Output specifications (*3)	No transmission (standard product)		○
	Electric energy pulse output (option)		○
	CC-Link communication (option) (*4)		○
MDU control power supply (permissible voltage range 85% to 110%)	100 to 240 VAC/DC common 12 VA (*5)		
Alarm contact (MDU Breaker main unit option) (Refer to "6.4 Monitoring functions") (*6)	PAL, TI		

Caution

- *1. Refer to "6.3 Measurement functions" for details of measurement functions.
- *2. Either the latest fault cause or the latest fault current is shown. They are not displayed simultaneously.
- *3. Electric energy pulse output and CC-Link communication cannot be installed at the same time.
- *4. The CC-Link version is "CC-Link Ver. 1.10."
During MDU panel installation, a CC-Link cable (part no. FANC-110SBH manufactured by Kuramo Electric Co., LTD.) is used from the front surface of the MDU to the terminal block on the rear surface.
- *5. When the MDU control power supply is turning on, a transitional inrush current will be generated. (Inrush current maximum value 2 A, energization time 1 ms [240 VAC].)
- *6. Refer to "4.1 Contact capacity and combinations for alarm contact output" in "MDU Breaker Instruction Manual for Main Unit" for alarm contact output combinations.

6.3 Measurement functions

6.3.1 Measurement function list

The following table lists measurement elements and elements that can be communicated/displayed.

Measurement elements that can be communicated and displayed

Measurement elements			Communication	Display	Display range*	
I Load current (± 1.0%)	Present value	Each-phase	●	●	0.0, 1.2 to 999.9, 1000 to 1600 A	
		Total harmonic (average value)	●	–	–	
		Maximum phase	●	–	–	
	Present demand value	Each-phase	●	●	0.0, 1.2 to 999.9, 1000 to 1600 A	
		Maximum value	●	●		
		All-phase demand maximum value	●	●		
V Line voltage (± 1.0%)	Present value	Between each line	●	●	0.0, 22.0 to 99.9, 100 to 759 V	
		Total harmonic (average value)	●	●		
	Maximum value between all wires	●	●			
	Maximum value occurrence time between all wires	●	●	00/01/01 00:00 to 99/12/31 23:59		
P Electric power (± 1.5%)	Present value		●	●	-2103 to -1000, -999.9 to 999.9, 1000 to 2013 kW	
	Demand value	Present value	●	●		
		Maximum value	●	●		
		Maximum value occurrence time	●	●		00/01/01 00:00 to 99/12/31 23:59
Q Reactive power (± 2.5%)	Present value		●	●	-2103 to -1000, -999.9 to 999.9, 1000 to 2013 kver	
	Demand value	Present value	●	●		
		Maximum value	●	●		
		Maximum value occurrence time	●	●		00/01/01 00:00 to 99/12/31 23:59
EP Electric energy (± 2.0%)	Integrated value		●	●	0.0 to 99999.9 kWh (250 A frame)	
	Latest one hour amount		●	●	0 to 999999 kWh (400/800 A frame)	
	One hour amount maximum value		●	●		
	Occurrence time of one hour amount maximum value		●	●	00/01/01 00:00 to 99/12/31 23:00	
EQ Reactive energy (± 3.0%)	Integrated value		●	●	0.0 to 99999.9 kverh (250 A frame)	
	Latest one hour amount		●	●	0 to 999999 kverh (400/800 A frame)	
	One hour amount maximum value		●	●		
	Occurrence time of one hour amount maximum value		●	●	00/01/01 00:00 to 99/12/31 23:00	
PF Power factor (± 5.0%)	Present value		●	●	LAG 50.0 to LAG 99.9, 100.0,	
	Maximum value		●	●	LEAD 99.9 to LEAD 50.0%	
	Maximum value occurrence time		–	●	00/01/01 00:00 to 99/12/31 23:59	
Hz Frequency (± 2.5%)	Present value		●	●	0.0, 45.0 to 65.0 Hz	
IH Harmonic current (± 2.5%)	Present value	Each-phase fundamental frequency	●	●	0.0, 2.5 to 99.9, 100 to 800 A	
		Each phase, each order (3rd, 5th, 7th, 9th, 11th, 13th, 15th, 17th, 19th order)	●	●		
		Total harmonic for each phase	●	●		
	Fundamental frequency maximum value for all phase		–	●	00/01/01 00:00 to 99/12/31 23:59	
	Each-order maximum value for all phase		●	●	0.0, 2.5 to 99.9, 100 to 800 A	
	Occurrence time of each-order maximum value for all phase		●	●	00/01/01 00:00 to 99/12/31 23:59	
	Demand value	Total harmonic for each phase		●	●	0.0, 2.5 to 99.9, 100 to 800 A
		Total harmonic maximum value for all phase		●	●	
		Occurrence time of total harmony maximum value for all phase		●	●	00/01/01 00:00 to 99/12/31 23:59
All-phase total distortion ratio		–	●	0.0 to 99.9, 100%		
All-phase each-order content ratio		–	●			
Fault current (± 15%)			●	●	0 to 12800 A	

* The minimum value and the maximum value of the display range differ depending on the rated current of the MDU breaker. For details, refer to "6.3.2 Measurement rated values/measurement range and accuracy".

6.3.2 Measurement rated values/measurement range and accuracy

(1) Electric current

[1] The present value is the effective value during a single cycle.

[2] "Each-phase" means the 1-, 2-, 3-, and N-phase.

[3] Totals (average value) are calculated as follows when setting the phase and wire (factory setting is three-phase three-wire for three-pole products, and three-phase four-wire for four-pole products).

The present value of the maximum phase electric current and present value of the maximum phase electric current demand indicate the maximum value of the following phases via setting the phase and wire.

Line system	Electric current total present value	Maximum phase applicable phase
Single-phase 2-wire	I3	I3
Single-phase 3-wire	$(I1 + I3) / 2$	I1, I3
Three-phase 3-wire	$(I1 + I2 + I3) / 3$	I1, I2, I3
Three-phase 4-wire		I1, I2, I3, IN

[4] The electric current demand time limit can be set as follows. The demand time limit is a bulk setting value that includes other measurement elements. (Factory setting is two min.)

Item	Setting value
Demand time limit	0 to 15 min. (per 1 min.)

[5] The all-phase demand maximum value indicates the maximum value of the demand value for all phases, from when usage began (after previous reset) to now.

[6] The electric current measurement rated value, measurement range, and measurement accuracy are shown below.

Rated current I_n (A)	400	630	800
Current setting I_r (A)	200-400 adjustable	300-630 adjustable	400-800 adjustable
Accuracy ($\pm 1.0\%$ of I_n) (*)	± 4.0 A	± 6.3 A	± 8.0 A
Measurement lower limit current (1% of I_n)	4.0 A	6.3 A	8.0 A
Measurement upper limit current ($I_n \times 2$)	800 A	1260 A	1600 A

* The measurement accuracy is the ratio versus I_n , regardless of the rated voltage.

[7] Display/communication values will be as follows in the following conditions.

	Display	Communication
Less than 1% of I_n	0 A	
Measurement upper limit current exceeded	Blinks at measurement upper limit current	Fixed at measurement upper limit current

(2) Voltage

[1] The present value is the effective value during a single cycle.

[2] "Between each line" means the between phases, such as between 1-phase and 2-phase, 2-phase and 3-phase, 3-phase and 1-phase, 1-phase and N-phase, 2-phase and N-phase, and 3-phase and N-phase.

[3] Totals (average value) are calculated as follows when setting the phase wire type. (Factory setting is three-phase three-wire for three-pole products, and three-phase four-wire for four-pole products.)

The maximum value between all wires indicates the maximum value of the following interphases via setting the phase and wire.

Line system	Voltage total present value	Maximum phase applicable phase
Single-phase 2-wire	V23	V23
Single-phase 3-wire	$(V12 + V23) / 2$	V12, V23
Three-phase 3-wire	$(V12 + V23 + V31) / 3$	V12, V23, V31
Three-phase 4-wire		

[4] The maximum value between all wires indicates the maximum value of all line voltages, from when usage began (after previous reset) to now.

[5] The voltage measurement rated value, measurement range, and measurement accuracy are shown below.

Measurement rated voltage	440 V
Accuracy	$\pm 4.4 \text{ V}$ ($\pm 1.0\%$ of measurement rated voltage)
Measurement lower limit voltage	80 V (displays up to 22 V, but anything less than 80 V is a reference value)
Measurement upper limit voltage	759 V

[6] Display/communication values will be as follows in the following conditions.

	Display	Communication
Less than 22 V	0 V	
Measurement upper limit voltage exceeded	Blinks at 759 V	Fixed at 759 V

(3) Electric power/Reactive power

[1] The present value is the effective value during a single cycle. (The electric power during reverse power flow is also measured.)

[2] The demand time limit is a bulk setting value that includes other measurement elements. (Factory setting is two min.)

Item	Setting value
Demand time limit	0 to 15 min. (per 1 min.)

[3] The measurement rated electric power/reactive power, measurement range, and measurement accuracy are shown below.

Measurement rated electric power	$\sqrt{3} \times I_n \times 440 \text{ V}$																				
Measurement rated reactive power																					
Electric power accuracy	Measurement rated electric power $\pm 1.5\%$																				
Reactive power accuracy	Measurement rated reactive power $\pm 2.5\%$																				
Measurement upper limit Measurement lower limit	<table border="1"> <thead> <tr> <th>Rated current I_n (A)</th> <th>400</th> <th>630</th> <th>800</th> </tr> </thead> <tbody> <tr> <td>Measurement upper limit electric power</td> <td>1,052 kW</td> <td>1,656 kW</td> <td>2,103 kW</td> </tr> <tr> <td>Measurement lower limit electric power</td> <td>-1,052 kW</td> <td>-1,656 kW</td> <td>-2,103 kW</td> </tr> <tr> <td>Measurement upper limit reactive power</td> <td>1,052 kvar</td> <td>1,656 kvar</td> <td>2,103 kvar</td> </tr> <tr> <td>Measurement lower limit reactive power</td> <td>-1,052 kvar</td> <td>-1,656 kvar</td> <td>-2,103 kvar</td> </tr> </tbody> </table>	Rated current I_n (A)	400	630	800	Measurement upper limit electric power	1,052 kW	1,656 kW	2,103 kW	Measurement lower limit electric power	-1,052 kW	-1,656 kW	-2,103 kW	Measurement upper limit reactive power	1,052 kvar	1,656 kvar	2,103 kvar	Measurement lower limit reactive power	-1,052 kvar	-1,656 kvar	-2,103 kvar
	Rated current I_n (A)	400	630	800																	
	Measurement upper limit electric power	1,052 kW	1,656 kW	2,103 kW																	
	Measurement lower limit electric power	-1,052 kW	-1,656 kW	-2,103 kW																	
	Measurement upper limit reactive power	1,052 kvar	1,656 kvar	2,103 kvar																	
Measurement lower limit reactive power	-1,052 kvar	-1,656 kvar	-2,103 kvar																		
<p>● If either the load current or line voltage exceeds the measurement upper limit, this will be the upper limit (lower limit) even if at or below the electric power/reactive power listed above.</p>																					

[4] Display/communication values will be as follows in the following conditions.

	Display	Communication
All I are less than 0.4% of I_n	0 kW / 0 kvar	
All V are 0 V (less than 22 V)		
Less than measurement lower limit electric power/reactive power	Blinks at measurement lower limit electric power/reactive power	Fixed at Measurement lower limit electric power/reactive power
Measurement upper limit electric power/reactive power exceeded	Blinks at measurement upper limit electric power/reactive power	Fixed at measurement upper limit electric power/reactive power

Note: The display value will also blink if either the load current or line voltage reaches the measurement upper limit value.

(4) Electric energy/Reactive energy

- [1] The integrated value is the cumulative total value, from when usage began (after previous reset) to now. (The electric energy during reverse power flow is not added.)
 [2] The electric energy and reactive energy can be set to any value.
 [3] The latest one hour amount is the one hour amount from one hour to the next hour as measured by the internal clock. (It is the latest one hour amount only.)
 [4] The one hour amount maximum value is the maximum value of the latest one hour amount, from when usage began (after previous reset) to now.
 [5] The measurement range and measurement accuracy for the electric energy and reactive energy are shown below.

Electric energy accuracy	± 2.0% of actual value for V (100 V to 440 V) × I (5 to 100% of In) (PF = 1) ± 2.5% of actual value for V (100 V to 440 V) × I (5 to 100% of In) (PF = 0.5)
Reactive energy accuracy	± 3.0% of actual value for V (100 V to 440 V) × I (10 to 100% of In) (PF = 0)
Range	0 to 99999.9 kWh/kvarh (250 A frame) 0 to 999999 kWh/kvarh (400/800 A frame)
<ul style="list-style-type: none"> ● The electric energy and reactive energy are measured if the electric current measurement value is around 0.4% or higher. ● If this exceeds 999999 kWh/kvarh addition will continue with the value reset to 0 kWh/kvarh. 	

(5) Power factor

- [1] The measurement accuracy and measurement range for the power factor are shown below.

Accuracy	± 5% for an electric angle of 90°	
Range	Display	Communication
	LEAD (forward) 50% to 100% to 50% LAG (delay) forward displays "LEAD" while delay displays "LAG"	LEAD (forward) 0% to 100% to 0% LAG (delay) forward is a negative value (values under 50% are reference values)
<ul style="list-style-type: none"> ● Power factor is measured for all phases combined. If 0 A is displayed because the electric current measurement value for a 1-phase was cut-off for the load current near cut-off, the measurement error could increase. 		

- [2] Display/communication values will be as follows in the following conditions.

	Display	Communication
I1, I2 and I3 are 0 A (less than 1.0% of In)	100%	
V12 and V32 are 0 V (less than 22 V)		
P is 0 kW		
PF exceeds measurement range	Blinks at 50%	–

- [3] Power factor sizes are shown below.

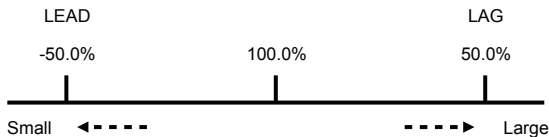

(6) Frequency

- [1] The measurement accuracy and measurement range for the frequency are shown below.

Accuracy	± 2.5% of actual value
Range	0.0, 45.0 to 65.0 Hz

- [2] Display/communication values will be as follows in the following conditions.

	Display	Communication
V12 and V32 are 0 V (less than 22 V)	0.0 Hz	
Less than 45 Hz	Blinks at 45.0 Hz	Fixed at 45.0 Hz
65 Hz exceeded	Blinks at 65.0 Hz	Fixed at 65.0 Hz

(7) Harmonic current

[1] The present value is the effective value during a single cycle.

[2] The present harmonic current value measures the fundamental frequency and order (3rd, 5th, 7th, 9th, 11th, 13th, 15th, 17th, 19th) of each phase (1-phase, 2-phase, 3-phase, N-phase).

[3] "Each-phase total present harmonic current value" is the total value of the harmonic components for the 3rd, 5th, 7th...17th, and 19th orders (excluding fundamental frequency components). The calculation formula is shown below.

$$I_{IH} = \sqrt{IH_3^2 + IH_5^2 + IH_7^2 + \dots + IH_{17}^2 + IH_{19}^2}$$

[4] The all-phase each-order maximum value indicates the maximum value of the present harmonic current values for all phases, from when usage began (after previous reset) to now.

[5] The demand time limit is a bulk setting value that includes other measurement elements. (Factory setting is 2 min.)

Item	Setting value
Demand time limit	0 to 15 min. (per 1 min.)

[6] Each-phase total distortion ratio and each-phase order (3rd, 5th, 7th, 9th, 11th, 13th, 15th, 17th, 19th) content ratio are values calculated as follows.

Each-phase total distortion ratio (%)	(Each-phase IH (ALL) / each-phase IH (1st)) × 100
Each-phase 3rd, 5th...19th order content ratio (%)	(Each-phase IH (3rd), IH (5th), ... IH (19th) / each-phase IH (1st)) × 100

[7] The harmonic current measurement rated value, measurement range, and measurement accuracy are shown below.

Rated current In (A)	400	630	800
Accuracy (± 2.5% of In) (")	± 10.0	± 15.8	± 20.0
Measurement lower limit current (2% of In) (A)	8.0	12.6	16.0
Measurement upper limit current (In × 1) (A)	400	630	800

* The measurement accuracy is the ratio versus In, regardless of the rated voltage.

[8] Display/communication values will be as follows in the following conditions.

	Display	Communication
Less than 2% of In	0 A	
Measurement upper limit current exceeded	Blinks at measurement upper limit electric current value	Measurement upper limit electric current value fixed

(8) Fault current

[1] The fault current measures the overload/short circuit current.

[2] The measurement accuracy and measurement range for the overload/short circuit current are shown below.

Rated current In (A)	400	630	800
Accuracy	± 15% of actual value		
Measurement upper limit fault current (A) (In × 16)	6400	10080	12800

[3] When a fault occurs, the measurement value blinks even if the fault current do not exceed the measurement upper limit value. (Fault cause/fault current display mode)

When the fault current exceeds the measurement upper limit value, the measurement value blinks even if the fault display mode is released.

6.4 Monitoring functions

6.4.1 Monitoring function list

- The following table shows monitoring elements, along with elements that can be displayed on the display or communicated.
 "Display" indicates that the item is displayed on the display. "Communication" indicates that the item can be communicated through CC-Link communication.

Monitoring element		Communication	Display
MDU Breaker alarm	Load current pre-alarm PAL	●	●
	Overcurrent alarm OVER	●	●
	Electric current demand alarm IDM_AL	●	●
	Electric current open phase alarm ILA_AL	●	●
	Electric current unbalance alarm IUB_AL	●	●
MDU Breaker status (*1)	Trip frequency	●	—
	Open/close frequency	●	—
Fault cause	Long time delay	●	●
	Short time delay	●	●
	Instantaneous	●	●
Electric current demand upper/lower limit alarm		●	—
Neutral line open phase alarm NLA (*2)		—	●

*1. Trip frequency and open/close frequency are enabled when "MDU transmission alarm switch (option)" and "MDU transmission auxiliary switch (option)" are installed, respectively.

*2. This function is turned ON when the line system is set to single-phase three-wire system. (The function is turned OFF when set to any other line system.)

6.5 How to use monitoring functions

6.5.1 MDU Breaker alarms

(1) PAL (load current pre-alarm)

Alarm details	The alarm is output to display/over communication when the load current \geq the pre-alarm current, and the duration \geq the pre-alarm operating time (1/2 the long time delay operating time (TL)).		
Setting method	No settings. (The pick up value set on the MDU Breaker main unit.)		
Reset method	Set to either self-hold or automatic reset via communication or on the display.		
	Reset method	Self-hold	Reset the alarm via communication or on the display.
	Automatic reset	Automatically resets when the cause of the alarm is removed.	

(2) OVER (overcurrent alarm)

Alarm details	The alarm is output to display/over communication when the load current exceeds 105 to 125% of the current setting of the circuit breaker.		
Setting method	No settings.		
Reset method	Automatic reset. (No settings.) Automatically resets when the cause of the alarm is removed.		

(3) IDM_AL (electric current demand alarm)

Alarm details	The alarm is output to display/over communication when the electric current demand value (*) exceeds the pick up current.		
Setting method	Set via communication or on the display Function: ON/OFF Pick up current: 50 to 100% (per 1%) Demand time limit: 1 to 10 min. (per 1 min), 15, 20, 25, 30 min. (*) (Factory setting is OFF.)		
Reset method	Set to either self-hold or automatic reset via communication or on the display.		
	Reset method	Self-hold	Reset the alarm via communication or on the display.
	Automatic reset	Automatically resets when the cause of the alarm is removed.	

* This differs from the demand time limit for each measurement value.

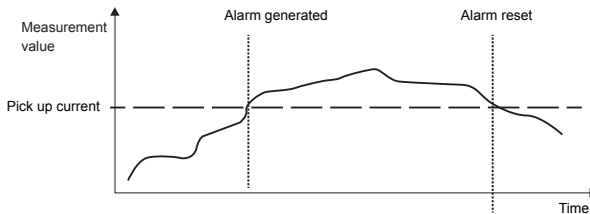

For automatic reset, the alarm will be reset if the value falls below the pick up current. For self-hold, the alarm will be maintained and will need to be reset manually.

(4) ILA_AL (electric current open phase alarm)

Alarm details	Monitoring starts when the load current for any phase reaches or exceeds 10% of the measurement rated current. The alarm is output to display/over communication when an energization phase equal to or less than the maximum phase current \times 10% is generated when monitoring starts and after 30 seconds have passed.				
Setting method	Set via communication or on the display Function: ON/OFF (Factory setting is OFF.) Pick up current: 10% fixed (no settings) Operating time: 30 s fixed (no settings)				
Reset method	Set to either self-hold or automatic reset via communication or on the display.				
	Reset method	<table border="1"> <tr> <td>Self-hold</td> <td>Reset the alarm via communication or on the display.</td> </tr> <tr> <td>Automatic reset</td> <td>Automatically resets when the cause of the alarm is removed.</td> </tr> </table>	Self-hold	Reset the alarm via communication or on the display.	Automatic reset
Self-hold	Reset the alarm via communication or on the display.				
Automatic reset	Automatically resets when the cause of the alarm is removed.				

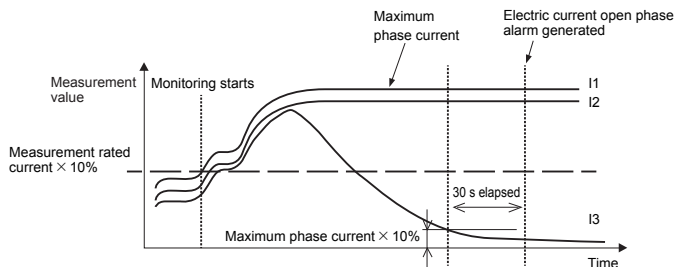

(5) IUB_AL (electric current unbalance alarm)

Alarm details	Monitoring starts when the load current for any phase reaches or exceeds 10% of the measurement rated current. The alarm is output to display/over communication when an energization phase equal to or less than the maximum phase current \times 30% is generated when monitoring starts and after 30 seconds have passed.				
Setting method	Set via communication or on the display Function: ON/OFF (Factory setting is OFF.) Pick up current: 30% fixed (no settings) Operating time: 30 s fixed (no settings)				
Reset method	Set to either self-hold or automatic reset via communication or on the display.				
	Reset method	<table border="1"> <tr> <td>Self-hold</td> <td>Reset the alarm via communication or on the display.</td> </tr> <tr> <td>Automatic reset</td> <td>Automatically resets when the cause of the alarm is removed.</td> </tr> </table>	Self-hold	Reset the alarm via communication or on the display.	Automatic reset
Self-hold	Reset the alarm via communication or on the display.				
Automatic reset	Automatically resets when the cause of the alarm is removed.				

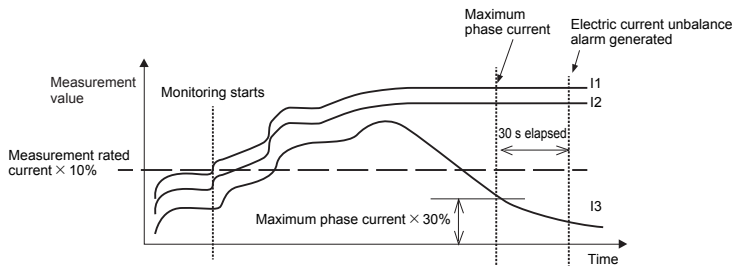

6.5.2 MDU Breaker status

MDU Breaker status details	Trip frequency	Communicates the total number of times the MDU Breaker has tripped from when usage began to now.
	Open/close frequency	Communicates the total number of times the MDU Breaker has opened/closed from when usage began to now.
Remarks	<ul style="list-style-type: none"> The following internal accessory devices are required to measure the trip frequency and open/close frequency. Measure trip frequency: "MDU transmission alarm switch" Measure open/close frequency: "MDU transmission auxiliary switch" Measure both trip frequency and open/close frequency: "MDU transmission alarm switch/auxiliary switch" 	

6.5.3 Fault causes

Fault cause details	Outputs to display/over communication the fault cause when MDU Breaker is tripped.
	Communicates/displays either long time delay (LTD), short time delay (STD), or instantaneous (INST).

6.5.4 Electric current demand upper/lower limit alarms

Upper/lower limit alarm	An alarm generation status is communicated if the electric current demand (current value of maximum phase electric current demand) exceeds the set upper limit value or falls below the set lower limit value. (It is not output to the display.)		
	Alarm generation status	Shows whether an alarm has been generated.	
Setting method	Sets the upper limit setting value and lower limit setting value via communication. (Cannot be set on display.)		
	Upper limit setting value	Sets the upper limit for the measurement value.	
	Lower limit setting value	Sets the lower limit for the measurement value.	
Alarm generation condition	Monitoring	Type	Alarm generation condition
	Upper limit monitoring	Generation	Measurement value > upper limit setting value
		Recovery	Measurement value ≤ upper limit setting value
	Lower limit monitoring	Generation	Measurement value < lower limit setting value
Recovery		Measurement value ≥ lower limit setting value	
Reset method	Automatic reset. (No settings.) Automatically resets when the cause of the alarm is removed.		

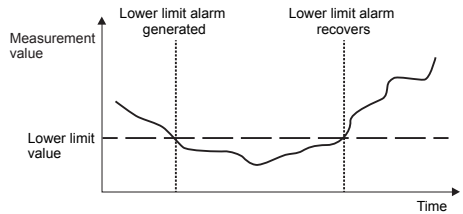
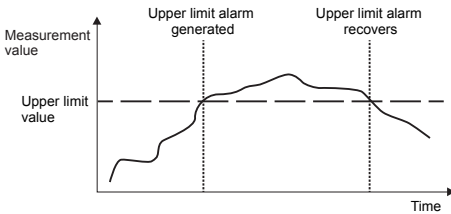

6.5.5 Neutral line open phase alarm (NLA)

Alarm details	The alarm generation status is displayed when the line voltage \geq rated operation overvoltage, and the duration \geq operating time. (It is not communicated.)		
Setting method	Set via communication or on the display This function is turned ON when the line system is set to single-phase three-wire system. (The function is turned OFF when set to any other line system.)		
	Rated operation overvoltage:	135 VAC fixed (no settings)	
	Operating time:	1 s fixed (no settings)	
	Rated inoperative overvoltage:	120 VAC	
	Overvoltage inertia inoperative time:	0.1 s or more	
Reset method	Set to either self-hold or automatic reset via communication or on the display.		
	Reset method	Self-hold	Reset the alarm via communication or on the display.
		Automatic reset	Automatically resets when the cause of the alarm is removed.

6.6 Electric energy pulse output/CC-Link communication section specifications

6.6.1 Electric energy pulse output

Item	Specification
Output elements	Solid state relay (SSR), No voltage a contact (113 and 114 terminals: no polarity)
Contact capacity	Compatible with 24 VDC and 100 to 200 VAC, 20 mA
Output pulse unit	1, 10, 100, 1000 and 10000 kWh/pulse (settable)
Output pulse width	0.35 to 0.45 s
Max. wiring length	100 m

6.6.2 CC-Link communication

Item	Specification
Communication method	Broadcast polling method
Communication speed	156 k/625 k/2.5 M/5 M/10 Mbps
Synchronization method	Frame synchronization method
Encoding method	NRZI
Transmission format	Conforming to HDLC
Number of occupied stations	Remote device occupying 1 station
CC-Link version	CC-Link Ver. 1.10
Max. total extension cable length	1200 m (156 kbps), 900 m (625 kbps), 400 m (2.5 Mbps), 160 m (5 Mbps), 100 m (10 Mbps)
Number of connected units	Max. 42
Connecting cable	Cables applicable to CC-Link Ver. 1.10 (shielded 3-core twisted pair cables)

Note: Refer to the CC-Link Partner Association website (<http://www.cc-link.org/>) for details.

7. Names and Functions of MDU Parts

Some items or functions are not measured or displayed (transmit) depending on models or specifications. These items and functions will be skipped.
 * Refer to "9. MDU Operation Procedure" for details.

7.1 Display/operation panel

Measurement values, alarms, setting values, etc. are displayed to allow you to make settings.

(1) Display

Measurement values, alarms, setting values, etc. are displayed.

In the display, the direction of display can be changed in accordance with the installation direction. Refer to "9.6.3 Setting method for LCD".

(2) Operation switch area

Use the switches to switch and set measurement values.

To switch screens and perform screen operations, use these upper (UP), lower (DOWN), left (RETURN), right (SELECT) and center (ENTER) switches.

The switches are in the four directions, and there is the center switch.

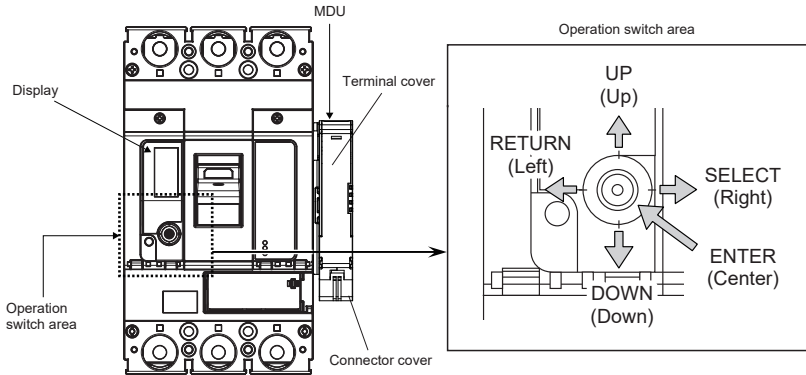

7.2 Terminal area

- (1) Control power supply terminals L1, L2
Connect to the MDU control power supply. They have no polarity.
- (2) Grounding terminal FG
Ground the FG terminal of the MDU as class D grounding.
- (3) Pulse output terminals 114, 113 (with power pulse output option)
These are power pulse output terminals. They have no polarity.
- (4) CC-Link communication terminals DA, DB, DG, SLD (with CC-Link communication option)
Connect to CC-Link communication signals DA, DB, DG, SLD.

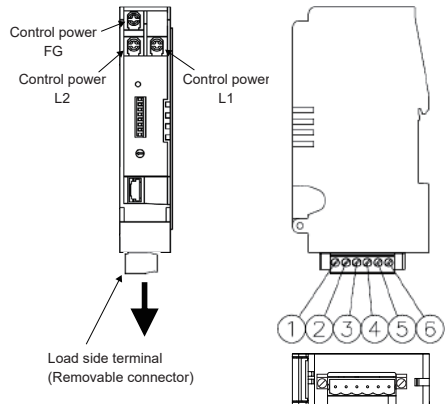

*In the figure, the terminal cover and the connector cover are removed.

*In the case of no-transmission specification, the load side terminal is not provided.

MDU	[1]	[2]	[3]	[4]	[5]	[6]
Pulse	-	-	-	-	113	114
CC-Link	-	SLD	-	DG	DB	DA

Terminal layout chart



Caution

- Do not connect anything to unused terminals.
Do not use such terminals for connecting.
The MDU may break down if unused terminals are connected for use.

7.3 CC-Link setting area (with CC-Link communication option)

The MDU is a remote station that occupies a single station.
MDU input data is retained if a sequencer CPU error or data ring error occurs.

(1) Station number (STATION No.) setting switches

Open the cover for the setting area on the front of the MDU, and use the station number setting switches to set the CC-Link communication station number via BCD code.

(Setting range: 1 to 64) (factory setting: 1)

Setting example: Value of switches when turned ON:

10s place..... $2 \times 10 = 20$,
1s place..... $8 \times 1 + 1 \times 1 = 9$,
 $20 + 9 = 29$, and then
station number is 29.

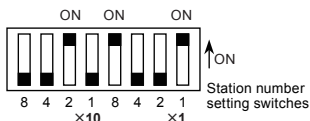

Configure so that there are no duplicate station numbers configured on the same transmission route.

Refer to "7.4 Number of CC-Link communication connectable units and precautions" for information on the number of connectable units and combinations with other devices.

(2) Communication speed (baud rate) setting switch

Use the communication speed setting switch to set the communication speed.

Switch setting	Communication speed
0	156 kbps (factory setting)
1	625 kbps
2	2.5 Mbps
3	5 Mbps
4	10 Mbps
5 to 9	Setting error (Turn ON L.ERR. LED when the error occurs)

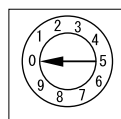

Communication speed setting switch

(3) Reset switch

The reset switch restarts the MDU status. If the station number (STATION No.) setting switches or communication speed (baud rate) setting switch are operated after the control power supply is turned on, be sure to press the reset switch.

(4) CC-Link communication LEDs

The CC-Link communication LEDs indicate the status of the transmission signal line and the error status of the MDU.

LED name	Details
L RUN LED	ON: Communication normal OFF: Communication stopped
L ERR. LED	ON: Communication data error Blinking: Communication data error OFF: Communication normal
SD LED	Turns ON when sending data
RD LED	Turns ON when receiving data

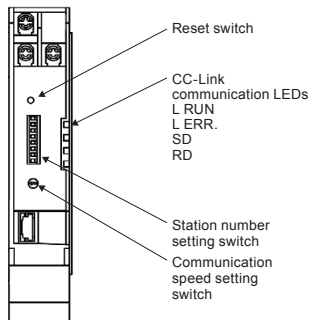

⚠ Caution

CC-Link operation precautions

- [1] Prior to powering the transmission line for CC-Link communication, set the station number for each device, while keeping the number of occupied stations in mind.
CC-Link devices use these station numbers to communicate, so configuring them is very important.
- [2] Use a thin stick to operate the station number setting switches, and make sure that they have been switched all the way to the number to set.
Operate the station number configuration switches at 10 N or less.
- [3] If the station number setting switches are operated after turning the control power supply on, the set station number will not be recognized unless the reset switch is pressed.
- [4] Use a thin stick to firmly press the reset switch.
- [5] Do not use a mechanical pencil to operate the switch. The lead could enter the gap in the switch, resulting in erroneous operation and even causing accident.

7.4 Number of CC-Link communication connectable units and precautions

The MDU is a remote device station that occupies a single station. The number of connectable units and combinations with other devices must satisfy both "number of connectable units in condition 1" and "number of connectable units in condition 2" below.

Number of connectable units in condition 1

$$\{(1 \times a) + (2 \times b) + (3 \times c) + (4 \times d)\} \leq 64$$

- a : Number of units occupying one station (this applies to the MDU)
- b : Number of units occupying two stations
- c : Number of units occupying three stations
- d : Number of units occupying four stations

Number of connectable units in condition 2

$$\{(16 \times A) + (54 \times B) + (88 \times C)\} \leq 2304$$

- A : Number of remote I/O single stations ≤ 64
- B : Number of remote device stations ≤ 42 (this applies to the MDU)
- C : Number of local stations ≤ 26

If only MDUs are connected, up to 42 devices can be connected.

$$\text{Number of connectable units in condition 1.....} \{(1 \times 42) + (2 \times 0) + (3 \times 0) + (4 \times 0)\} = 42 \leq 64$$

$$\text{Number of connectable units in condition 2.....} \{(16 \times 0) + (54 \times 42) + (88 \times 0)\} = 2268 \leq 2304$$

7.5 Installation and wiring for products with CC-Link communication

7.5.1 Terminator installation

Terminators (included with the master unit) must be installed on the units at both ends of the CC-Link transmission line.

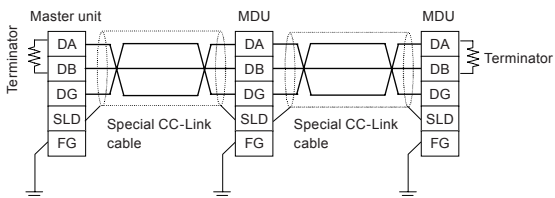

If the MDU is at the end of the CC-Link transmission line, connect a terminator between DA and DB in the MDU terminal block. Prepare the terminator included with the master unit as shown in the figure below.

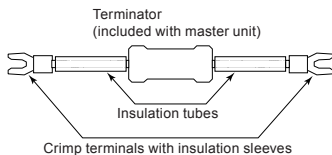

[Preparation method]

- (1) Cut the resistor legs on both sides of terminator (leave 15 mm on each side).

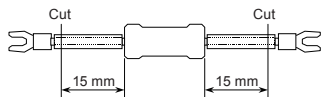

- (2) Cut the insulation tubes 5 mm from their ends.

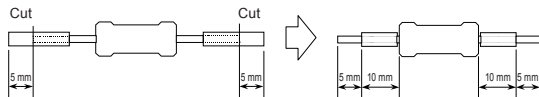

⚠ Caution

- Terminators are not included with this product. Use the terminator included with the master unit.
- Refer to the terminator manual included with the master unit for details on terminators.

7.5.2 Shielded wire grounding

Connect both ends of the shielded wires from the special CC-Link cable to "SLD" on each unit. Use "FG" on each unit as the dedicated ground.

Use class D grounding.

If a dedicated ground cannot be used, use a common ground as shown in the figure below.

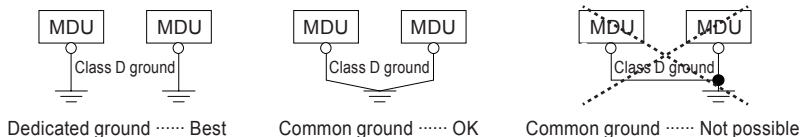

8. MDU Detailed Specifications

8.1 Precautions for measurement

(1) Electric current measurement accuracy

The MDU electric current measurement accuracy is $\pm 1.0\%$ of the maximum current setting (measurement rated current) of the circuit breaker. For example, the permissible difference of NF400-SEW with MDU is 4.0A ($400\text{ A} \times 1.0\%$), so the permissible difference from a current of 0 A to 400 A would be $\pm 4.0\text{ A}$.

If the measurement value is less than 1.0%, the display value is cut off to 0 A. However, if the current is 0.4% or more of the rated value, the electric power and electric energy are measured.

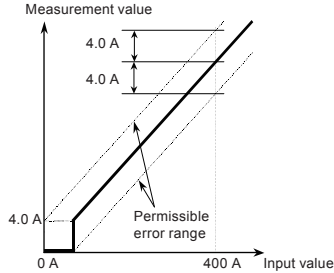

(2) Demand value

The demand value is generally the average value over the demand time limit.

The demand time limit (t_0) is the time until the measurement display value (I_0) when a fixed input (I) is continuously powered displays 95% of the input (I).

It will take an amount of time roughly equal to three times the time limit (t_0) to display 100% of the input (I).

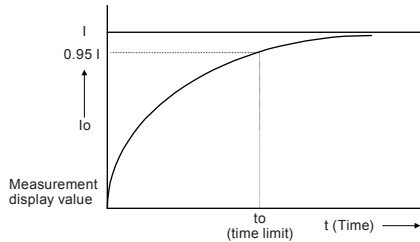

(3) Power factor measurement accuracy

The MDU power factor measurement accuracy is 5% for an electric angle 90° .

This is phase angle 4.5° . With regard to power factor this means that a display value up to around 0.3% (LEAD (forward) 99.7 to LAG (delay) 99.7) at 100% and around 6% (64.9 to 76.0) at 70.7% of LEAD or LAG will be allowed.

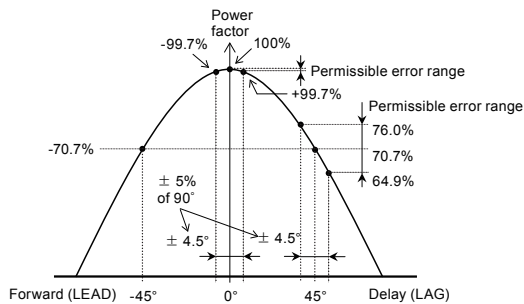

(4) Intermittent load (such as welder) measurement

Items such as current, voltage, and electric power are measured (sampled) once every 250 ms. Any values, such as current value, are calculated and the measurement value is updated at this timing.

However, the minimum update cycle for measurement results displayed on the display or output over communication data is 500 ms.

This will result in a larger errors if there is a continuous load (such as due to a resistance welder), and is therefore not suited for measurement in such cases.

If a subordinate circuit breaker operates during a short or earth leakage, the operating current might be measured at a low value.

Fault current is continuously monitored. However, the operating current of the MDU Breaker itself is measured, so the operating current of a subordinate circuit breaker cannot be measured.

(5) Operation during power outage/restoration

- The electric energy (integrated value) and reactive energy (integrated value) are stored in non-volatile memory when measurement values are updated or there is a power outage. When power is restored, it will continue measuring from the data that was stored prior to the power outage.
- Setting values are stored in non-volatile memory when set, so they do not need to be set again when power is restored.
- The device stores the last measurement display screen status prior to a power outage, and will return to this screen when the power is restored.
- The time setting might not be retained during a power outage. It should be reconfigured when power is restored. This setting is required to measure the "maximum value occurrence time" and "latest one hour amount" (the one hour amount from one hour to the next hour as measured by the internal clock).
- Maximum values and occurrence times are stored every 30 minutes. If there is a power outage, the data from 30 minutes prior to the power outage until the power outage may not be stored (in the worst case scenario).

9. MDU Operation Procedure

To set the display items and functions, use the operation switches as shown in the figure below.

Some models do not measure or display (transmit) some items or functions. These functions and items will be skipped.

9.1 Operating method for main menu screen

The main menu screen provides access to each display screen. Use the UP/DOWN switches to select a screen to display/set, and then press ENTER to switch to the selected screen.

* Text will be inverted (black background and white text) when selected.

[Main menu screen]



DOWN ↓ UP ↑

ENTER →
← RETURN

Select this item to display measurement values.
Refer to section 9.2.

[Measurement value display screen]
The screen displays the electric energy/compound (current), current, voltage, electric power, reactive power, power factor, frequency, present harmonic current, harmonic current content ratio, maximum harmonic current, harmonic current demand, and reactive energy.

* If having returned to the measurement value display screen after shifting from the measurement value display screen to the main menu screen, the screen will return to that shown before the shift to the main menu.

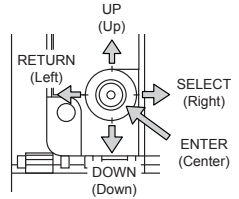

DOWN ↓ UP ↑

ENTER →
← RETURN

Select this item to display and set protection characteristics.
Refer to section 9.3.

[Protection characteristic display screen]
This is used to check overload, short-circuit protection characteristics, current setting, long time delay operating time, short time delay tripping current, short time delay operating time, and instantaneous tripping current.



DOWN ↓ UP ↑

ENTER →
← RETURN

Select this item to display the alarm status.
Refer to section 9.4.

[Fault/alarm display screen]
Fault cause/current
The screen displays the alarm status.



DOWN ↓ UP ↑

ENTER →
← RETURN

Select this item to make reset operations.
Refer to section 9.5.

[Reset screen]
This is used to delete fault causes/currents and to reset alarms, maximum values, electric energy and reactive energy.



ENTER →
← RETURN

Select this item to make settings.
Refer to section 9.6.

[Setting menu screen]
This is used to configure phase switching, demand limit time, line system setting, pulse unit setting, alarm setting, various LCD settings, clock setting, and electric energy/reactive energy setting.

9.2 Measurement value display and display contents

- Select METER in the main menu screen. The measurement display screen can be opened with ENTER.
- The options switch with UP/DOWN as follows: EP ⇔ I ⇔ V ⇔ P ⇔ Q ⇔ PF ⇔ Hz ⇔ HI (A) ⇔ HI (%) ⇔ HI (A) ⇔ HI (A) ⇔ EQ ⇔ Seq ⇔ EP...
- Press RETURN to return to the main menu screen from each screen.
- * When the screen has shifted to the main menu screen and then shifted to the measurement value display screen again, the screen selected before the shift will be displayed.

● EP	: Electric energy
● I	: Load current
● V	: Line voltage
● P	: Electric power
● Q	: Reactive power
● PF	: Power factor
● Hz	: Frequency
● HI (A)	: Harmonic current
● HI (%)	: Harmonic current content rate
● EQ	: Reactive energy
● Seq	: Phase sequence display

(1) Electric energy/Compound (current + electric energy)

- Measured electric energy values and compound values (current + electric energy) are displayed. Use SELECT to switch display screens.

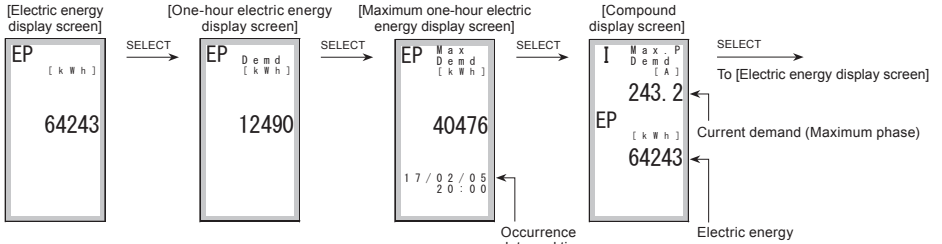

(2) Current of each phase

- The measured current values of the phases are displayed. Use SELECT to switch display screens.

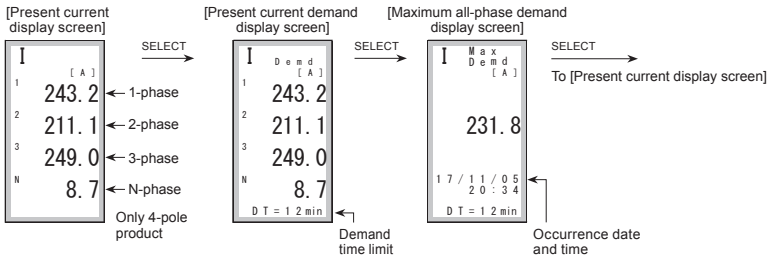

(3) Line voltage

- Measured line voltage values are displayed. Use SELECT to switch display screens.

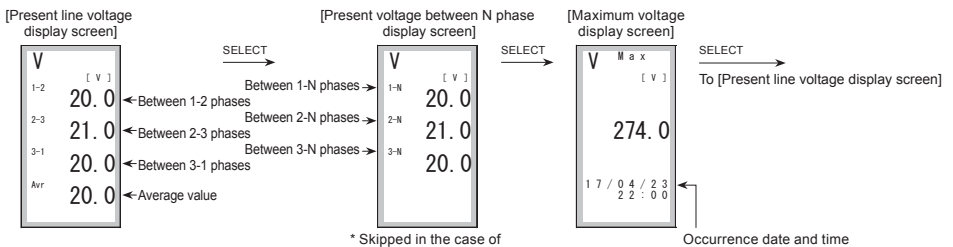

* Skipped in the case of a 3-pole product.

(4) Electric power

Measured electric power values are displayed. Use SELECT to switch display screens.

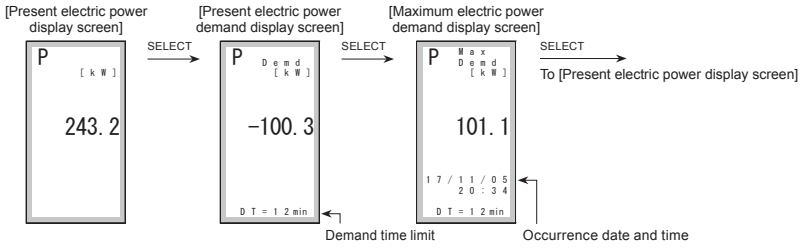

(5) Reactive power

Measured reactive power values are displayed. Use SELECT to switch display screens.

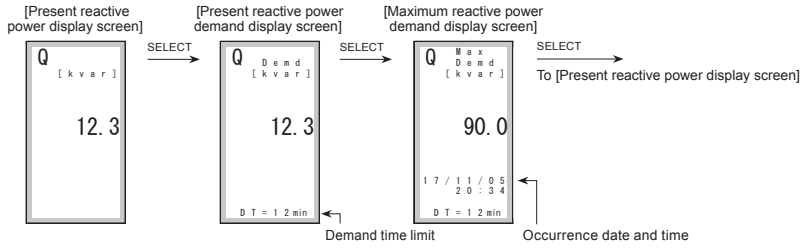

(6) Power factor

Measured power factor values are displayed. Use SELECT to switch display screens.

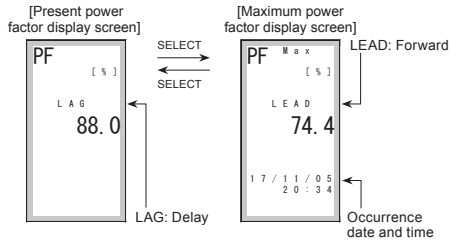

(7) Frequency

The present frequency is displayed.

[Present frequency display screen]

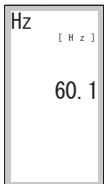

(8) Present harmonic current

The total value of present harmonic current value of each phase, and the measurement values of fundamental frequency and each harmonic order are displayed. Use SELECT to switch display screens.
 Display switches as follows: Total value → fundamental frequency (1st order) → 3rd order → ... 19th order → total value....

[Present harmonic current display screen]

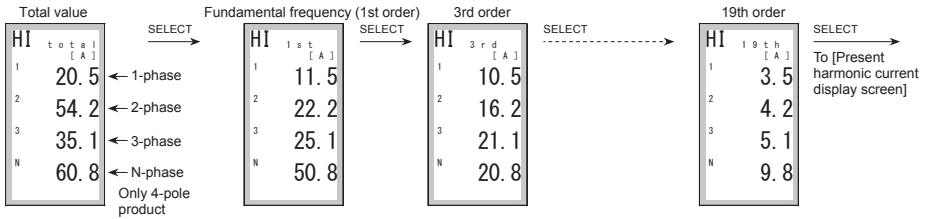

(9) Harmonic current content rate

The total value of harmonic current content rate of each phase, and the measurement value of each harmonic order are displayed. Use SELECT to switch display screens.
 Display switches as follows: Total value → 3rd order → ... 19th order → total value

[Harmonic current content rate display screen]

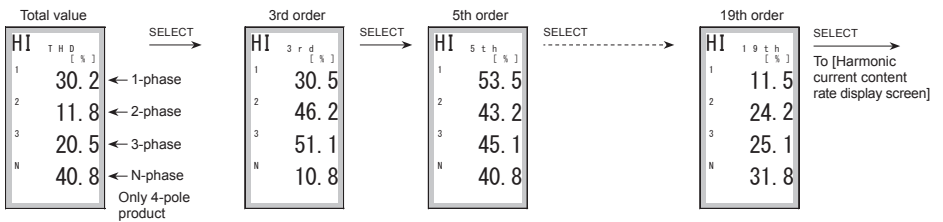

(10) Maximum harmonic current

The maximum harmonic current and maximum value occurrence time of each harmonic order are displayed. Use SELECT to switch display screens.
 Display switches as follows: Fundamental frequency (1st order) → 3rd order → ... 19th order → fundamental frequency (1st order)....

[Maximum harmonic current display screen]

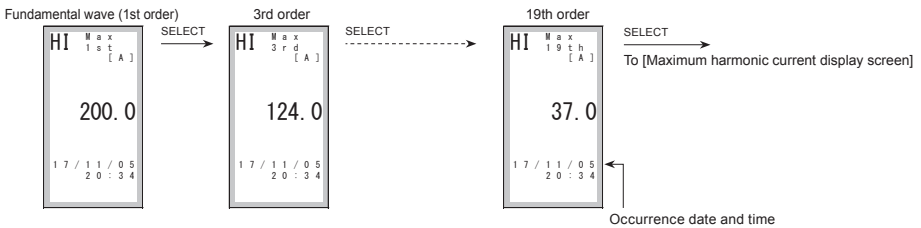

(11) Harmonic current demand value

The harmonic current demand, the maximum harmonic current demand value and the occurrence time are displayed. Use SELECT to switch display screens.

[Harmonic current demand display screen]

[Maximum harmonic current demand display screen]

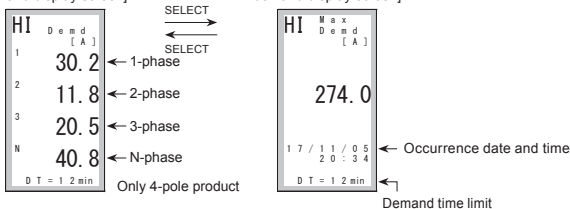

(12) Reactive energy

Measured reactive energy values are displayed. Use SELECT to switch display screens.

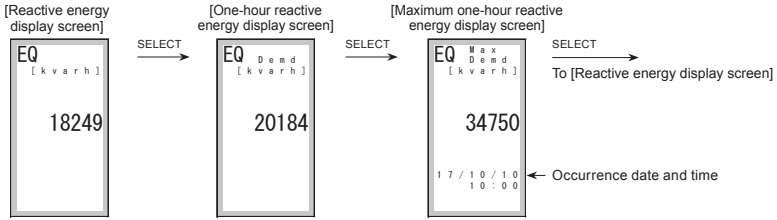

(13) Phase sequence

The phase sequence of the main circuit is displayed. (Enabled during three-phase, three-wire system. Displayed as "- -" when disabled.)

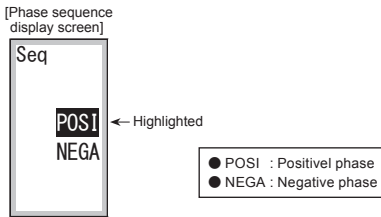

9.3 Display method for protection characteristic setting values

- Select PROTECT from the main menu screen and press ENTER to switch to the protection characteristics selection screen.
- The options switch as follows: LTD ⇄ STD/INST ⇄ ER ⇄ LTD
- * Protection characteristics cannot be set (changed). Use the setting dials on the MDU Breaker main unit to change them.

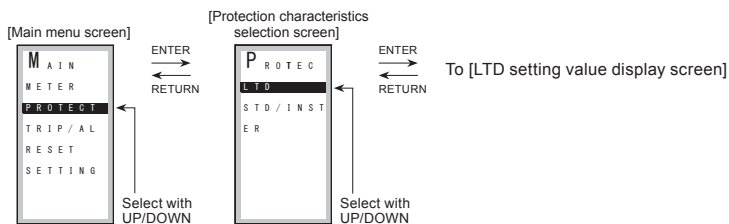

(1) Current setting check

- Select Ir in the LTD setting value display screen. The current setting of the MDU Breaker main unit can be checked.

[LTD setting value display screen]

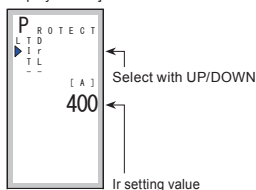

(2) Long limit operating time TL check

- Select TL in the LTD setting value display screen. The long limit operating time (TL) setting value of the MDU Breaker main unit can be checked.

[LTD setting value display screen]

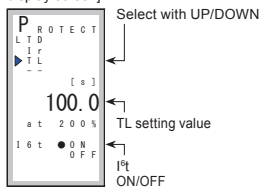

(3) Short time delay tripping current (Is)

- Select STD/INST in the protection characteristics selection screen. (Screen [1])
- The short time delay tripping current (Is) setting value can be checked in the STD/INST setting value display screen. (Screen [2])

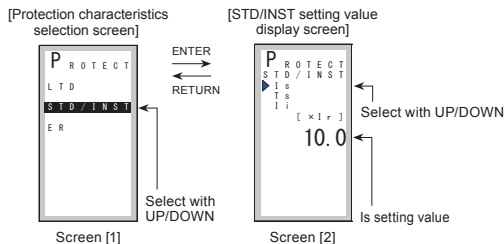

(4) Short time delay operating time (Ts) check

The short time delay operating time (Ts) setting value can be checked in the STD/INST setting value display screen.

[STD/INST setting value display screen]

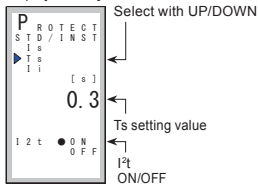

(5) Instantaneous tripping current (Ii) check

The instantaneous tripping current (Ii) setting value can be checked in the STD/INST setting value display screen.

[STD/INST setting value display screen]

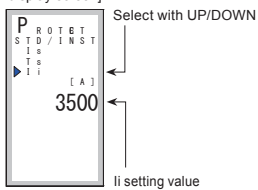

(6) Rated sensitivity current IΔn and maximum operating time (Te) display

Select ER in the protection characteristic selection screen. (Screen [1])
 * "-" displayed for MCCBs.

* ER: Electric leakage characteristic.

[Protection characteristics selection screen]

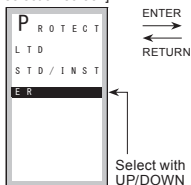

Screen [1]

[ER setting value display screen]

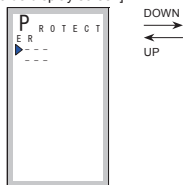

Screen [2]

[ER setting value display screen]



Screen [3]

- Ir : Current setting
- Ii : Instantaneous tripping current
- TL : Long time delay operating time (at 200%)
- Is : Short time delay tripping current
- Ts : Short time delay operating time (at Is × 1.5)
- I_{1t} : Long time delay lamp characteristics
- I_{2t} : Short time delay lamp characteristics
- IΔn : Rated sensitivity current
- Te : Maximum operating time

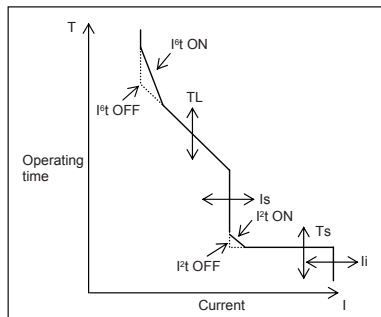

9.4 Fault/Alarm display methods and display contents

- Select TRIP/AL in the main menu screen and press ENTER to switch to the fault/alarm display screen.
- The screen switches between the fault cause/current display screen and the alarm display screen with UP/DOWN.

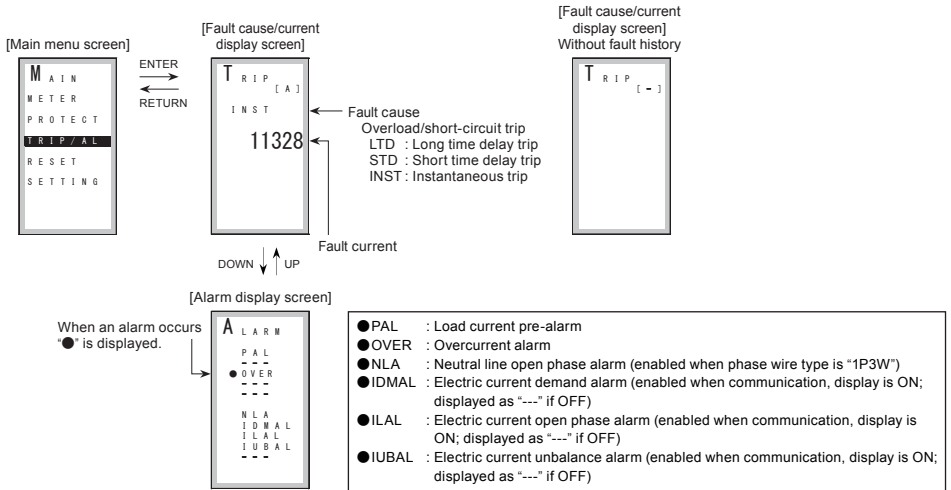

- The screen automatically switches and information is displayed in the fault cause/current display screen when a fault occurs, and in the alarm display screen when an alarm occurs. In addition, the backlight is lit in red.
- The illumination of the backlight goes back to white when any of the operation buttons is pressed, and the display screen also goes back to the previous screen that was being displayed before the alarm display screen was displayed. (An alarm that has been output keeps remaining in the alarm output status until it is reset.)
- The illumination of the backlight goes back to white if the cause of the alarm is removed when the alarm reset method is set to auto reset, and the display screen also goes back to the previous screen that was being displayed before the alarm display screen was displayed. (The output alarm is also reset.)

9.5 Method for resetting fault cause/current, alarm, maximum value, electric energy, and reactive energy

- Select RESET in the main menu screen and press ENTER to switch to the reset screen.
- The options switch as follows: TRIP ⇄ ALARM ⇄ ALL ⇄ EP (Wh) ⇄ EQ (varh) ⇄ TRIP...
- Select the item that you wish to reset, and apply the selection with ENTER.
- Select YES in the allow changes screen and execute the reset with ENTER.

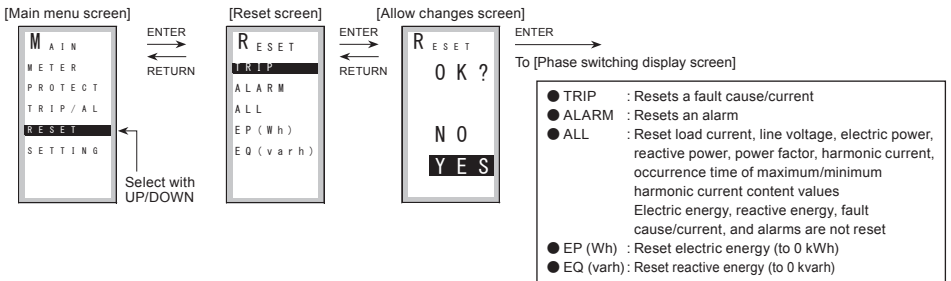

9.6 Method for various settings

- Select SETTING in the main menu screen and press ENTER to switch to the setting screen.
- The options switch as follows: Measure ⇄ Alarm ⇄ LCD ⇄ Date ⇄ EP/EQ ⇄ Measure....

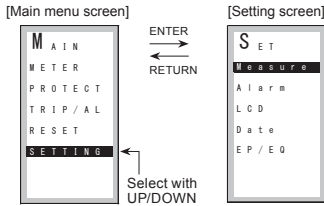

9.6.1 Setting method for measurement-related items

- Select Measure in the setting screen and press ENTER to switch to the measurement setting screen.
- The options switch as follows: Phase ⇄ Demand ⇄ LineSys ⇄ Pulse ⇄ Phase....

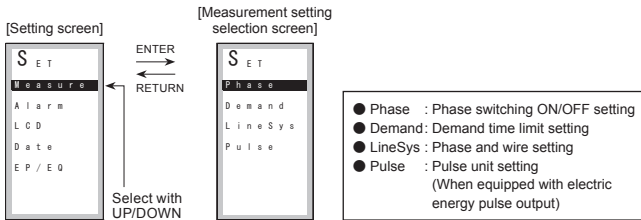

(1) Phase switching setting

[Default value: Normal (no phase switching)]

- Select Phase in the measurement setting selection screen. (Screen [1])
- Press ENTER to switch to the phase switching display screen. (Screen [2])
- Next, press ENTER to enable the change of the phase switching setting value. (Screen [3])
- Select Normal (with no phase switching) or Inverse (with phase switching) with UP/DOWN, and apply the setting with ENTER.
- Select YES on the allow changes screen and press ENTER to decide the setting. (Screen [4])



* When the setting of each item is changed, "NOW SETTING ..." is displayed until the setting is completed.

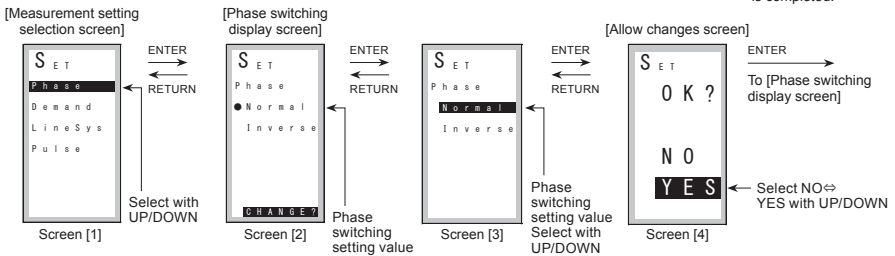

(2) Demand time limit setting

[Default value: 2 min]

- Select Demand on the measurement setting selection screen. (Screen [1])
- Press ENTER to switch to the demand time limit display screen. (Screen [2])
- Next, press ENTER to enable the change of the demand time limit display setting. (Screen [3]) 0 ⇔ 1 ⇔ 2 ⇔ ... ⇔ 14 ⇔ 15 ⇔ 0... (per 1 minute). Press ENTER to decide the setting.
- Select YES on the allow changes screen and press ENTER to decide the setting. (Screen [4])

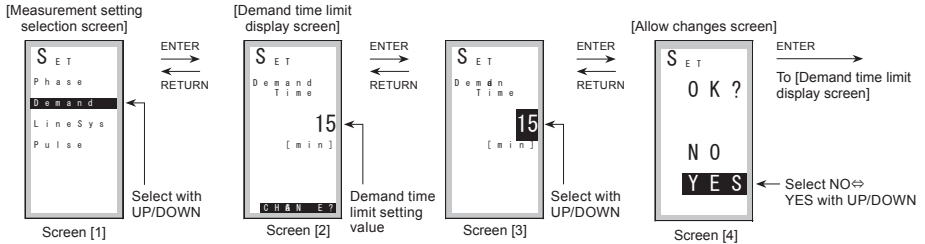

(3) Line system setting

[Default value: 3P3W] (3P4W for 4-pole products)

- Select LineSys on the measurement setting selection screen. (Screen [1])
- Press ENTER to switch to the line system display screen. (Screen [2])
- Next, press ENTER to enable changes in the line system display screen. (Screen [3])
- Select one of the following with UP/DOWN.
 - 1P2W (single-phase two-wire)
 - 1P3W (single-phase three-wire)
 - 3P3W (three-phase three-wire)
 - 3P4W (three-phase four-wire) *Only for 4-pole product
- Press ENTER to decide the setting.
- Select YES on the allow changes screen and press ENTER to decide the setting. (Screen [4])

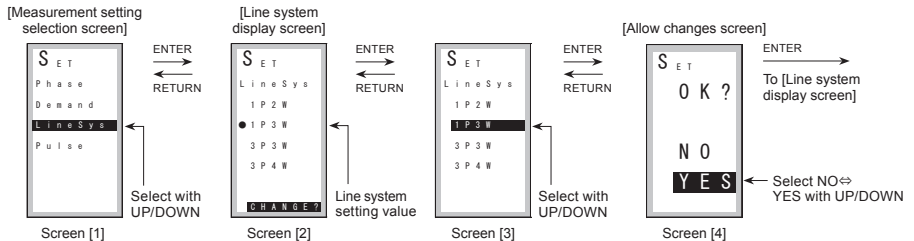

(4) Pulse unit setting

[Default value: 1 kWh]

- Select Pulse on the measurement setting selection screen. (Screen [1])
- Press ENTER to switch to the pulse unit display screen. (Screen [2])
- Next, press ENTER to change the pulse unit setting value. (Screen [3])
- The settings switch as follows: 1 ⇔ 10 ⇔ 100 ⇔ 1000 ⇔ 10000 ⇔ 1 ... (kWh/Pulse). Press ENTER to decide the setting.
- Select YES on the allow changes screen and press ENTER to change the setting. (Screen [4])

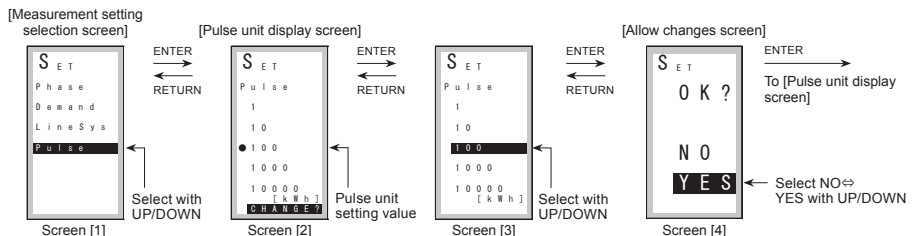

9.6.2 Setting method for alarms

- Select Alarm on the setting screen and press ENTER to switch to the alarm setting selection screen.
- The options switch as follows: PAL ⇄ IDM_AL ⇄ ILA_AL ⇄ IUB_AL ⇄ AL_Hold ⇄ PAL....

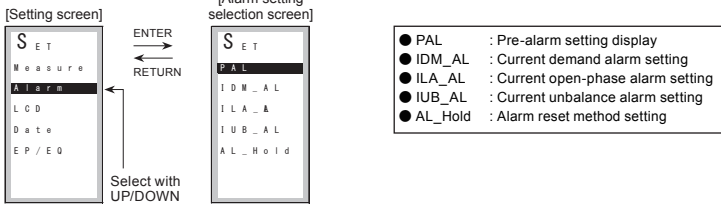

(1) Pre-alarm (PAL) setting check

- Select PAL on the alarm setting selection screen. (Screen [1])
- Press ENTER to open the PAL setting check screen that allows you to check the pre-alarm current (Ip) and pre-alarm operation time (Tp) setting values for the MDU Breaker main unit. (Screen [2])

*Characteristics cannot be set (changed). Use the setting dials on the MDU Breaker main unit to change them.
 *There is no setting dial for the pre-alarm operating time. The setting is 1/2 the long time delay operating time (TL).

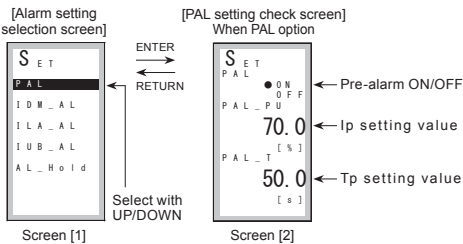

(2) Electric current demand alarm (IDM_AL) setting

[PU default value: 100%, TIME default value: 2 min.]

- Select IDM_AL on the alarm setting selection screen. (Screen [1])
- Press ENTER to switch to the electric current demand alarm setting display screen. (Screen [2])
- Press ENTER, select ON (function enabled) or OFF (function disabled), and press ENTER to decide the setting. (Screen [3])

[1] ON (function enabled) setting method

- The pickup current setting value can be changed between 50.0 and 100.0 (per 1.0%). (Screen [4])
- Press ENTER to switch to the demand time limit setting value.
- The demand time limit setting value can be changed between 1.0 and 10.0 (per 1.0 minute) ⇄ 15.0 ⇄ 20.0 ⇄ 25.0 ⇄ 30.0 (per 5.0 minutes). (Screen [5])
- Press ENTER to switch to the allow changes screen.
- Select YES on the allow changes screen and press ENTER to decide the setting. (Screen [6])

[2] OFF (function disabled) setting method

- After selecting OFF from the ON/OFF setting, press ENTER to switch to the allow changes screen. Select YES and press ENTER to decide the setting. (Screen [6])

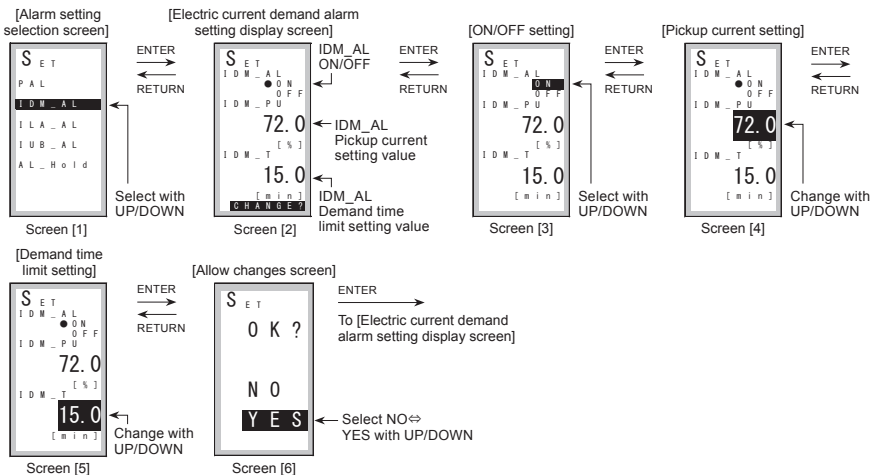

(3) Electric current open phase alarm (ILA_AL) setting

- Select ILA_AL on the alarm setting selection screen. (Screen [1])
- Press ENTER to switch to the electric current open phase alarm setting display screen. (Screen [2])
- Press ENTER again, select ON (function enabled) or OFF (function disabled), and press ENTER to decide the setting. (Screen [3])
- Select YES on the allow changes screen and press ENTER to decide the setting. (Screen [4])

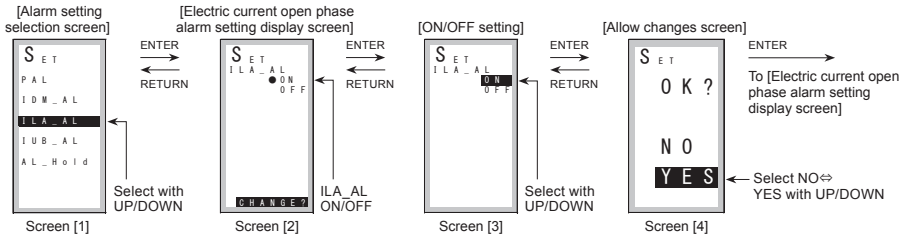

(4) Electric current unbalance alarm (IUB_AL) setting

- Select IUB_AL on the alarm setting selection screen. (Screen [1])
- Press ENTER to switch to the electric current unbalance alarm setting display screen. (Screen [2])
- Press ENTER again, select ON (function enabled) or OFF (function disabled), and press ENTER to decide the setting. (Screen [3])
- Select YES on the allow changes screen and press ENTER to decide the setting. (Screen [4])

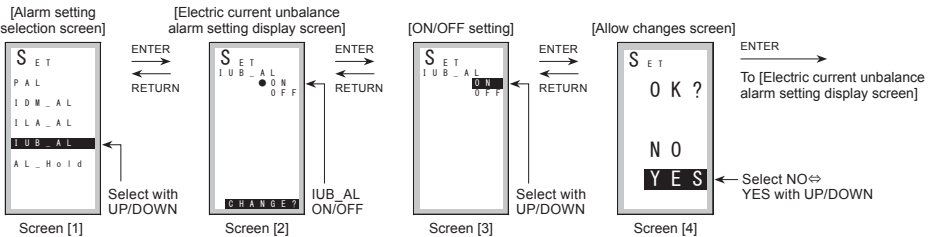

(5) Alarm reset method setting

[Default value: AutoRes (auto reset)]

- Select AL_HOLD on the alarm setting selection screen. (Screen [1])
- Press ENTER to switch to the alarm reset method setting display screen. (Screen [2])
- Press ENTER, select AutoRes (auto reset) or Holding (self holding), and press ENTER to decide the setting. (Screen [3])
- Select YES on the allow changes screen and press ENTER to decide the setting. (Screen [4])

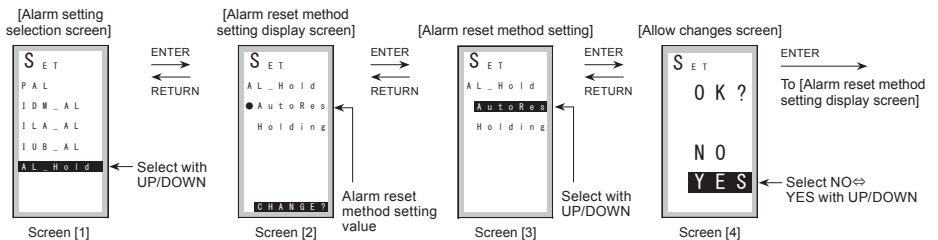

9.6.3 Setting method for LCD

- Select LCD on the setting screen and press ENTER to switch to the LCD setting selection screen.
- The options switch as follows: LCD-BL ⇄ Contrast ⇄ Direction ⇄ LCD-BL....

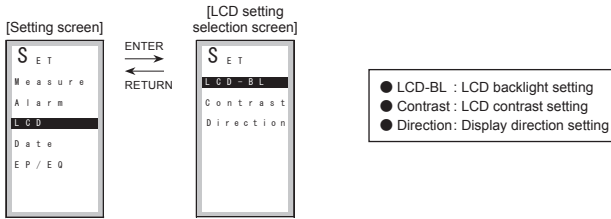

(1) LCD backlight setting

[Default value: AutoOFF (auto shutoff)]

- Select LCD-BL on the LCD setting selection screen and press ENTER to switch to the LCD backlight setting display screen. (Screens [1] [2])
- AutoOFF (Auto shutoff: The light automatically turns off when no operation is made for approximately 5 minutes. The light turns on again with switch operation.) Select ON (ON at all times) or OFF (OFF at all times) and press ENTER to decide the setting. (Screen [3])
- Select YES on the allow changes screen and press ENTER to decide the setting. (Screen [4])

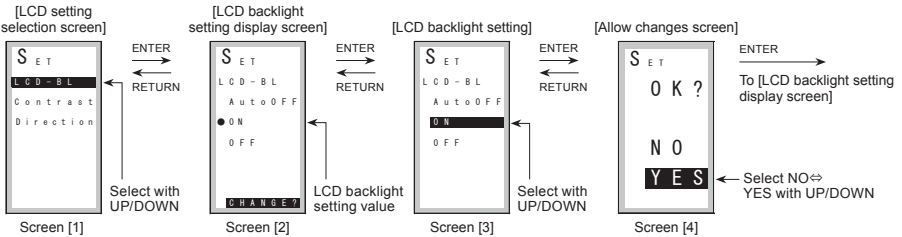

(2) LCD contrast setting

[Default value: 2 (middle value between 0 and 4)]

- Select Contrast on the LCD setting selection screen. (Screen [1])
- Press ENTER to switch to the LCD contrast setting display screen. (Screen [2])
- Use UP/DOWN to switch the contrast of the screen. Press ENTER to decide the setting.

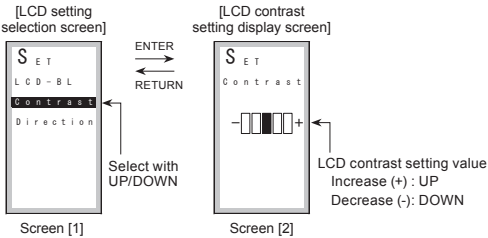

(3) Display method setting

[Default value: 1 2 (Vertical direction display)]

- Select Direction on the LCD setting selection screen. (Screen [1])
- Press ENTER to open the display direction setting display screen. (Screen [2])
- Press ENTER to open the display direction setting display screen. (Screen [2])
- Press ENTER and select one from the following options:

- 1 2 : Vertical direction display
- ↔ : Horizontal direction display - 1
- ↔ : Horizontal direction display - 2

- Apply the setting with ENTER. (Screen [3])
- Select YES on the allow changes screen and press ENTER to decide the setting. (Screen [4])
- * Returns to the screen in the display direction changed.
- * The direction of the operation switches is also changed to fit the installation direction of the MDU Breaker.

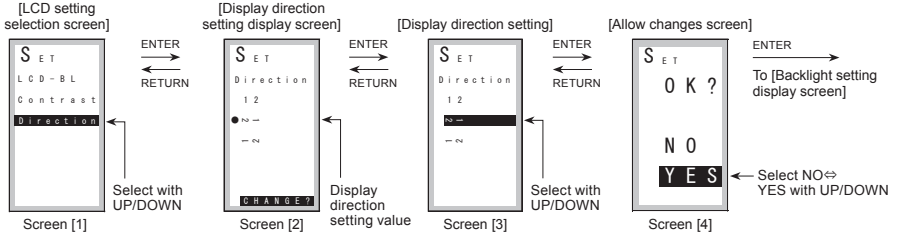

· Vertical direction display

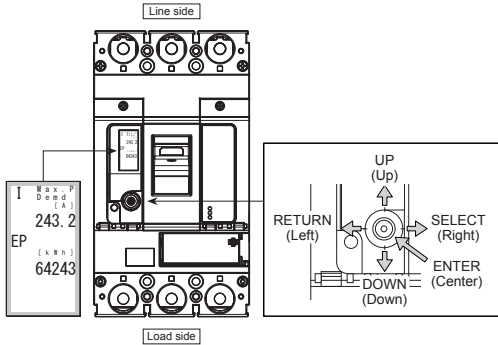

· Horizontal direction display - 1

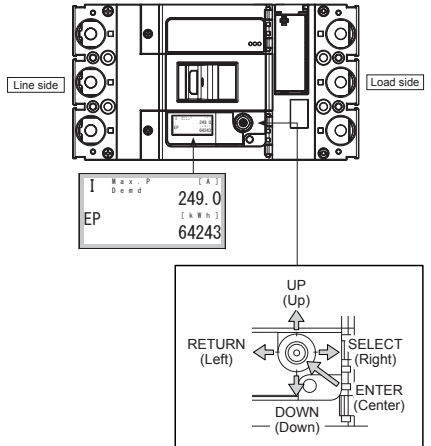

· Horizontal direction display - 2

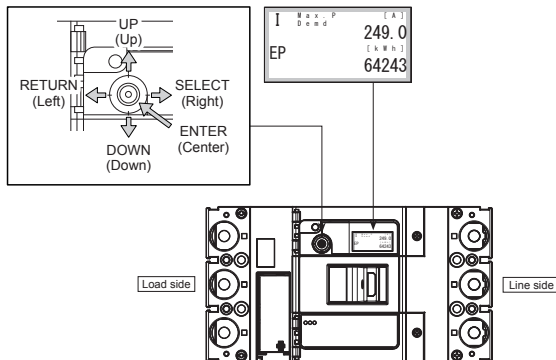

9.6.4 Setting method for date and time

[Default value: 10/01/01 00:00]

- Select Date on the setting screen. (Screen [1])
- Press ENTER to switch to the time setting display screen. (Screens [2] to [4])
- Press ENTER or SELECT to shift from Year → Month → Day → Hour → Minute. Press RETURN to return from Minute → Hour → Day → Month → Year.
- Select an item to change, and then change the value with UP/DOWN. (Screens [3] to [4])
- After setting the minute, press ENTER to switch to the allow changes screen. Select YES and press ENTER to decide the setting. (Screen [5])
- * The year setting takes a two digit number, where 00 to 99 corresponds to 2000 to 2099.

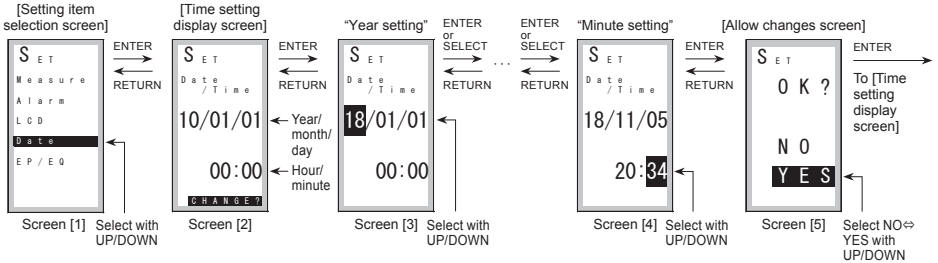

9.6.5 Setting method for electric energy

- Select EP/EQ from the setting item selection screen and press ENTER to switch to the electric energy setting selection screen.
- The options switch as follows: EP (Wh) ⇔ EQ (varh) ⇔ EP (Wh)....

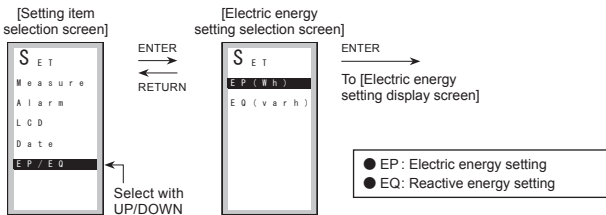

(1) Electric energy setting

- Select EP (Wh) in the electric energy setting selection screen and press ENTER to go to the electric energy setting display screen. (Screen [1])
- Press ENTER to enable the setting of electric energy. (Screen [2])
- Press ENTER or SELECT to toggle the options between Leftmost digit ... → ... Rightmost digit, or press RETURN to toggle in the reverse direction from Rightmost digit ... → Leftmost digit. (Screens [2] [3])
- Select a digit to change the value.
- After setting the rightmost digit, press ENTER to display the allow changes screen. Select YES and press ENTER to decide the setting. (Screen [4])

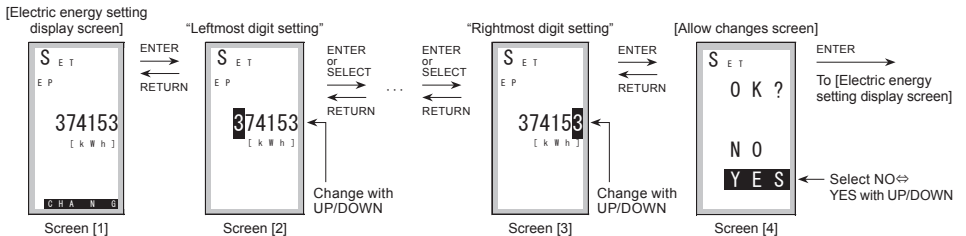

(2) Reactive energy setting

- Select EQ (varh) in the electric energy setting selection screen and press ENTER to go to the reactive energy setting display screen. (Screen [1])
- Press ENTER to enable the setting of reactive energy. (Screen [2])
- Press ENTER or SELECT to toggle the options between Leftmost digit ... → ... Rightmost digit, or press RETURN to toggle in the reverse direction from Rightmost digit ... → Leftmost digit. (Screens [2] [3])
- Select a digit to change the value.
- After setting the rightmost digit, press ENTER to display the allow changes screen. Select YES and press ENTER to decide the setting. (Screen [4])

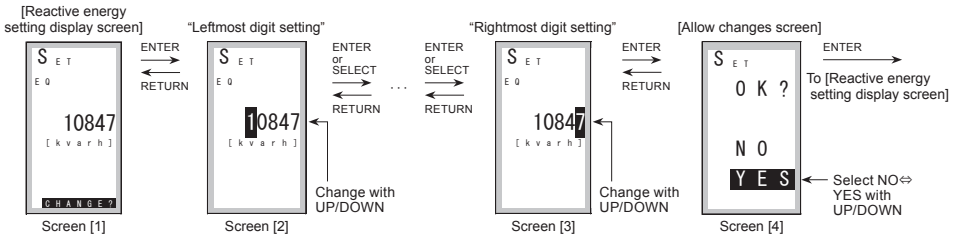

9.7 Measurement display list

(1) Vertical display

[1] Electric energy/Compound	<p>[Electric energy]</p> <p>EP [kWh]</p> <p>64243</p>	<p>[One-hour electric energy]</p> <p>EP Demand [kWh]</p> <p>12490</p>	<p>Maximum one-hour electric energy]</p> <p>EP Max Demand [kWh]</p> <p>40476</p> <p>17 / 11 / 05 20 : 34</p>	<p>[Compound]</p> <p>I Max Demand [A]</p> <p>243.2</p> <p>EP [kWh]</p> <p>64243</p>	<p>[Present harmonic current]</p> <table border="1"> <thead> <tr> <th>Total value</th> <th>Fundamental frequency</th> <th>3rd</th> <th>.....</th> <th>19th</th> </tr> </thead> <tbody> <tr> <td>HI total [A]</td> <td>HI 1st [A]</td> <td>HI 3rd [A]</td> <td></td> <td>HI 19th [A]</td> </tr> <tr> <td>1 20.5</td> <td>1 11.5</td> <td>1 10.5</td> <td></td> <td>1 3.5</td> </tr> <tr> <td>2 54.2</td> <td>2 22.2</td> <td>2 16.2</td> <td></td> <td>2 4.2</td> </tr> <tr> <td>3 35.1</td> <td>3 25.1</td> <td>3 21.1</td> <td></td> <td>3 5.1</td> </tr> <tr> <td>N 60.8</td> <td>N 50.8</td> <td>N 20.8</td> <td></td> <td>N 9.8</td> </tr> </tbody> </table>	Total value	Fundamental frequency	3rd	19th	HI total [A]	HI 1st [A]	HI 3rd [A]		HI 19th [A]	1 20.5	1 11.5	1 10.5		1 3.5	2 54.2	2 22.2	2 16.2		2 4.2	3 35.1	3 25.1	3 21.1		3 5.1	N 60.8	N 50.8	N 20.8		N 9.8
Total value	Fundamental frequency	3rd	19th																															
HI total [A]	HI 1st [A]	HI 3rd [A]		HI 19th [A]																															
1 20.5	1 11.5	1 10.5		1 3.5																															
2 54.2	2 22.2	2 16.2		2 4.2																															
3 35.1	3 25.1	3 21.1		3 5.1																															
N 60.8	N 50.8	N 20.8		N 9.8																															
[2] Current of each phase	<p>[Present current]</p> <p>I [A]</p> <p>1 243.2</p> <p>2 211.1</p> <p>3 249.0</p> <p>N 8.7</p>	<p>[Present current demand]</p> <p>I Demand [A]</p> <p>1 243.2</p> <p>2 211.1</p> <p>3 249.0</p> <p>N 8.7</p> <p>D T = 1.2 min</p>	<p>[Maximum all-phase demand]</p> <p>I Max Demand [A]</p> <p>231.8</p> <p>17 / 11 / 05 20 : 34</p>	<p>[Harmonic current content rate]</p> <table border="1"> <thead> <tr> <th>Total value</th> <th>3rd</th> <th>5th</th> <th>.....</th> <th>19th</th> </tr> </thead> <tbody> <tr> <td>HI THD [%]</td> <td>HI 3rd [%]</td> <td>HI 5th [%]</td> <td></td> <td>HI 19th [%]</td> </tr> <tr> <td>1 30.2</td> <td>1 30.5</td> <td>1 53.5</td> <td></td> <td>1 11.5</td> </tr> <tr> <td>2 11.8</td> <td>2 46.2</td> <td>2 43.2</td> <td></td> <td>2 24.2</td> </tr> <tr> <td>3 20.5</td> <td>3 51.1</td> <td>3 45.1</td> <td></td> <td>3 25.1</td> </tr> <tr> <td>N 40.8</td> <td>N 10.8</td> <td>N 40.8</td> <td></td> <td>N 31.8</td> </tr> </tbody> </table>	Total value	3rd	5th	19th	HI THD [%]	HI 3rd [%]	HI 5th [%]		HI 19th [%]	1 30.2	1 30.5	1 53.5		1 11.5	2 11.8	2 46.2	2 43.2		2 24.2	3 20.5	3 51.1	3 45.1		3 25.1	N 40.8	N 10.8	N 40.8		N 31.8	
Total value	3rd	5th	19th																															
HI THD [%]	HI 3rd [%]	HI 5th [%]		HI 19th [%]																															
1 30.2	1 30.5	1 53.5		1 11.5																															
2 11.8	2 46.2	2 43.2		2 24.2																															
3 20.5	3 51.1	3 45.1		3 25.1																															
N 40.8	N 10.8	N 40.8		N 31.8																															
[3] Line voltage	<p>[Present line voltage]</p> <p>V [V]</p> <p>1-2 20.0</p> <p>2-3 21.0</p> <p>3-1 20.0</p> <p>Arr 20.0</p>	<p>[Present voltage between N phases]</p> <p>V [V]</p> <p>1-N 20.0</p> <p>2-N 21.0</p> <p>3-N 20.0</p>	<p>[Maximum voltage]</p> <p>V Max [V]</p> <p>74.0</p> <p>17 / 04 / 23 22 : 00</p>	<p>[10] Maximum harmonic current</p> <table border="1"> <thead> <tr> <th>Total value</th> <th>3rd</th> <th>.....</th> <th>19th</th> </tr> </thead> <tbody> <tr> <td>HI Max 1st [A]</td> <td>HI Max 3rd [A]</td> <td></td> <td>HI Max 19th [A]</td> </tr> <tr> <td>200.0</td> <td>124.0</td> <td></td> <td>37.0</td> </tr> <tr> <td>17 / 11 / 05 20 : 34</td> <td>17 / 11 / 05 20 : 34</td> <td></td> <td>17 / 11 / 05 20 : 34</td> </tr> </tbody> </table>	Total value	3rd	19th	HI Max 1st [A]	HI Max 3rd [A]		HI Max 19th [A]	200.0	124.0		37.0	17 / 11 / 05 20 : 34	17 / 11 / 05 20 : 34		17 / 11 / 05 20 : 34															
Total value	3rd	19th																																
HI Max 1st [A]	HI Max 3rd [A]		HI Max 19th [A]																																
200.0	124.0		37.0																																
17 / 11 / 05 20 : 34	17 / 11 / 05 20 : 34		17 / 11 / 05 20 : 34																																
[4] Electric power	<p>[Present electric power]</p> <p>P [kW]</p> <p>243.2</p>	<p>[Present voltage demand]</p> <p>P Demand [kW]</p> <p>-100.3</p> <p>D T = 1.2 min</p>	<p>[Maximum electric power demand]</p> <p>P Max Demand [kW]</p> <p>101.1</p> <p>17 / 11 / 05 20 : 34</p>	<p>[11] Harmonic current demand</p> <table border="1"> <thead> <tr> <th>[Harmonic current demand]</th> <th>[Maximum harmonic current demand]</th> </tr> </thead> <tbody> <tr> <td>HI Demand [A]</td> <td>HI Max Demand [A]</td> </tr> <tr> <td>1 30.2</td> <td>74.0</td> </tr> <tr> <td>2 11.8</td> <td></td> </tr> <tr> <td>3 20.5</td> <td></td> </tr> <tr> <td>N 40.8</td> <td></td> </tr> <tr> <td>D T = 1.2 min</td> <td>D T = 1.2 min</td> </tr> <tr> <td>17 / 11 / 05 20 : 34</td> <td>17 / 11 / 05 20 : 34</td> </tr> </tbody> </table>	[Harmonic current demand]	[Maximum harmonic current demand]	HI Demand [A]	HI Max Demand [A]	1 30.2	74.0	2 11.8		3 20.5		N 40.8		D T = 1.2 min	D T = 1.2 min	17 / 11 / 05 20 : 34	17 / 11 / 05 20 : 34															
[Harmonic current demand]	[Maximum harmonic current demand]																																		
HI Demand [A]	HI Max Demand [A]																																		
1 30.2	74.0																																		
2 11.8																																			
3 20.5																																			
N 40.8																																			
D T = 1.2 min	D T = 1.2 min																																		
17 / 11 / 05 20 : 34	17 / 11 / 05 20 : 34																																		
[5] Reactive power	<p>[Present reactive power]</p> <p>Q [kvar]</p> <p>12.3</p>	<p>[Present reactive voltage demand]</p> <p>Q Demand [kvar]</p> <p>12.3</p> <p>D T = 1.2 min</p>	<p>[Maximum reactive power demand]</p> <p>Q Max Demand [kvar]</p> <p>90.0</p> <p>17 / 11 / 05 20 : 34</p>	<p>[12] Reactive energy</p> <table border="1"> <thead> <tr> <th>[Reactive energy]</th> <th>[One-hour reactive energy]</th> <th>[Maximum one-hour reactive energy]</th> </tr> </thead> <tbody> <tr> <td>EQ [kvarh]</td> <td>EQ Demand [kvarh]</td> <td>EQ Max Demand [kvarh]</td> </tr> <tr> <td>18249</td> <td>20184</td> <td>34750</td> </tr> <tr> <td></td> <td></td> <td>17 / 10 / 10 10 : 00</td> </tr> </tbody> </table>	[Reactive energy]	[One-hour reactive energy]	[Maximum one-hour reactive energy]	EQ [kvarh]	EQ Demand [kvarh]	EQ Max Demand [kvarh]	18249	20184	34750			17 / 10 / 10 10 : 00																			
[Reactive energy]	[One-hour reactive energy]	[Maximum one-hour reactive energy]																																	
EQ [kvarh]	EQ Demand [kvarh]	EQ Max Demand [kvarh]																																	
18249	20184	34750																																	
		17 / 10 / 10 10 : 00																																	
[6] Power factor	<p>[Present power factor]</p> <p>PF [%]</p> <p>LAG 88.0</p>	<p>[Maximum power factor]</p> <p>PF Max [%]</p> <p>LEAD 74.4</p> <p>17 / 11 / 05 20 : 34</p>	<p>[13] Phase sequence</p> <p>[Phase sequence]</p> <p>Seq</p> <p>POS</p> <p>NEGA</p>																																
[7] Frequency	<p>[Frequency]</p> <p>Hz [Hz]</p> <p>60.1</p>																																		

(2) Horizontal display

[1] Electric energy/Compound	[Electric energy] EP [kWh] 64243	[One-hour electric energy] EP Demand [kWh] 12490	[Maximum one-hour electric energy] EP Max Demand [kWh] 40476 17/11/05 20:00	[Compound] I Max P Demand [A] 249.0 EP [kWh] 64243
[2] Current of each phase	[Present current] I [A] 1 243.2 3 249.0 2 211.1 N 8.7	[Present current demand] I Demand DT=12min [A] 1 243.2 3 249.0 2 211.1 N 8.7	[Maximum all-phase demand] I Max Demand DT=12min [A] 243.2 17/11/05 20:34	
[3] Line voltage	[Present line voltage] V [V] 1-2 20.0 3-1 20.0 2-3 21.0 Avr 20.0	[Present voltage between N phases] V [V] 1-N 20.0 3-N 20.0 2-N 21.0	[Maximum voltage] V Max [V] 274.0 17/04/23 22:00	
[4] Electric power	[Present electric power] P [kW] 243.2	[Present voltage demand] P Demand DT=12min [kW] -100.3	[Maximum electric power demand] P Max Demand DT=12min [kW] 101.1 17/04/23 22:00	
[5] Reactive power	[Present reactive power] Q [kvar] 211.1	[Present reactive voltage demand] Q Demand DT=12min [kvar] 12.3	[Maximum reactive power demand] Q Max Demand DT=12min [kvar] 90.0 17/04/23 22:00	
[6] Power factor	[Present power factor] PF [%] LAG 88.0	[Maximum power factor] PF Max [%] LEAD 74.4 17/11/05 20:34	[7] Frequency [Frequency] Hz [Hz] 60.1	
[8] Present harmonic current	[Present harmonic current Total value] HI Total [A] 1 20.5 3 35.1 2 54.2 N 60.8	Fundamental frequency HI 1st [A] 1 11.5 3 25.1 2 22.2 N 50.8	3rd 19th HI 3rd [A] 1 10.5 3 21.1 2 16.2 N 20.8 HI 19th [A] 1 3.5 3 5.1 2 4.2 N 9.8	
[9] Harmonic current content rate	[Harmonic current content rate Total value] HI THD [%] 1 30.2 3 20.5 2 11.8 N 40.8	3rd 19th HI 3rd [%] 1 30.5 3 51.1 2 46.2 N 10.8	5th 19th HI 5th [%] 1 53.5 3 45.1 2 43.2 N 40.8 HI 19th [%] 1 11.5 3 25.1 2 24.2 N 31.8	
[10] Maximum harmonic current	[Maximum harmonic current Total value] HI Max Tot [A] 200.0 17/04/23 22:00	3rd 19th HI Max 3rd [A] 124.0 17/04/23 22:00	19th HI Max 19th [A] 37.0 17/04/23 22:00	
[11] Harmonic current demand	[Harmonic current demand] HI Demand DT=12min [A] 1 30.2 3 20.5 2 11.8 N 40.8	[Maximum harmonic current demand] HI Max Demand DT=12min [A] 274.0 17/04/23 22:00		
[12] Reactive energy	[Reactive energy] EQ [kvarh] 18249	[One-hour reactive energy] EQ Demand [kvarh] 20184	[Maximum one-hour reactive energy] EQ Max Demand [kvarh] 34750 17/10/10 10:00	
[13] Phase sequence	[Phase sequence] Seq POS NEGA			

10. Appendix

10.1 Precautions for setting operation

The display can be used to set and clear the items described in "9.5 Method for resetting fault cause/current, alarm, maximum value, electric energy, and reactive energy" and "9.6 Method for various settings."

When items are set or cleared, the non-volatile memory storage will be overwritten for all of these except for the items described in "9.6.4 Setting method for date and time."

It takes some time to overwrite the non-volatile memory storage, and items may not be properly overwritten in the non-volatile memory if they are set or cleared in quick succession. Therefore, as shown in the examples below, wait around three seconds after setting or clearing an item, before setting or clearing another item (regardless of whether the items are similar or different).

<Consecutive setting example 1> Consecutive setting of different settings (demand time limit, alarm reset method, storage clear)



<Consecutive setting example 2> Consecutive setting of different settings (demand time limit, storage clear)

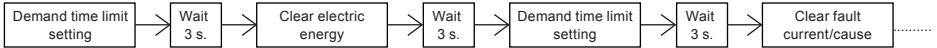

10.2 Precautions when setting via CC-Link communication

If using a product with CC-Link communication, CC-Link communication can also be used to send certain commands and setting values to a MDU, allowing items to be set and cleared just as when operating the display (as described above).

(Refer to "MDU Breaker Programming Manual" for details on what can be configured and cleared.)

The non-volatile memory storage is overwritten (depending on what is set or cleared) when setting and clearing over CC-Link communication, and items may not be properly overwritten in the non-volatile memory if set/clear commands are transmitted in quick succession. Therefore, as shown in the examples below, wait around three seconds after transmitting a set or clear command, before transmitting another command (regardless of whether the commands are similar or different).

<Consecutive transmission example 1> Consecutive transmission of different commands (demand time limit, alarm reset method, storage clear)

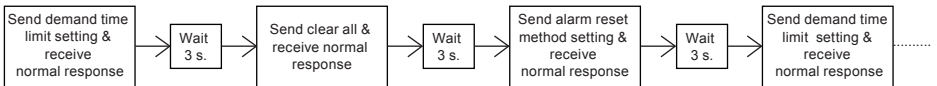

<Consecutive transmission example 2> Consecutive transmission of different commands (demand time limit, storage clear)

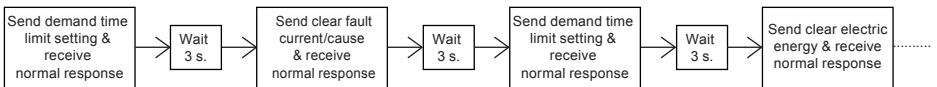

10.3 Precautions for MDU with CC-Link communication

- (1) Note that the special link registers of the master unit (SW0084 to SW0087) will not be set to "1" (ON), even if a watchdog timer error occurs in the MDU.
- (2) A power outage will occur in the CC-Link I/F section if the power turns OFF for at least 5 to 10 ms. When the power is restored, the initial data processing request flag (RX(n+1)8) will be set to "1" (ON), remote READY (RX(n+1)B) will be set to "0" (OFF), the bits that indicate the alarm and circuit breaker status (RXn0 to RXn7) and the upper/lower limit bits (RXn8 and RXn9) will be retained at their states prior to the power outage, and the remote registers (RWn to RWn+3) will be set to 00H.
- (3) Refer to "MDU Breaker Programming Manual" for details on PLC programs.

10.4 I/O signal list (with CC-Link communication)

The MDU uses 32 input contacts and 32 output contacts when sending and receiving data with the master unit.

The following table shows I/O signal assignment and signal names.

Device RX indicates an input signal from the MDU to the master unit, while device RY indicates an output signal from the master unit to the MDU.

Signal direction: MDU → Master unit		Signal direction: Master unit → MDU	
Device No.	Signal name	Device No.	Signal name
RXn0	ON/OFF (AX) status flag	RYn0 to RYnE	Unusable
RXn1	Trip (AL) status flag		
RXn2	Pre-alarm (PAL) status flag		
RXn3	Unusable		
RXn4	Unusable		
RXn5	Unusable		
RXn6	Overload cutoff (LTD) flag		
RXn7	Short cutoff (STD/INST) flag		
RXn8	Lower limit value UNDER		
RXn9	Upper limit value OVER		
RXnA RXnB	Unusable		
RXnC	Overcurrent alarm (OVER) status flag		
RXnD RXnE	Unusable		
RXnF	Command complete response flag		
RX(n+1)0 to RX(n+1)7	Unusable	RY(n+1)0 to RY(n+1)7	Unusable
RX(n+1)8	Initial data processing request flag	RY(n+1)8	Initial data processing complete flag
RX(n+1)9	Unusable	RY(n+1)9	Unusable
RX(n+1)A	Error status flag	RY(n+1)A	Error reset status flag
RX(n+1)B	Remote READY	RY(n+1)B to RY(n+1)F	Unusable
RX(n+1)C to RX(n+1)F	Unusable		

n: Address assigned by the station number setting

Note 1: If the alarm retention setting is set to "self-hold" and this is set once to "1" (ON), it will continue to be "1" (ON) until the alarm is reset on the MDU, even if the cause of the alarm is eliminated.

Note 2: When the error status flag (RX(n+1)A) is "1" (ON), the bit (RXn8, RXn9) status does not change.

If the error status flag is set to "1" (ON), we recommend eliminating the cause of the error immediately.

Note 3: If an unusable device is turned ON/OFF by a sequence program, MDU functionality is not guaranteed.

10.5 Remote register allocation (with CC-Link communication)

Remote register allocation is shown below.

Send/receive direction	Address	Details
Master ↓ Remote	RWwm	Command, channel, data, etc.
	RWwm+1	
	RWwm+2	
Remote ↓ Master	RWwm+3	Reply data from RWwm command
	RWwn	
	RWwn+1	
	RWwn+2	
	RWwn+3	

m, n: Address assigned by the station number setting

10.6 Communication error codes and solutions

(1) With CC-Link transmission option

Error code Note: The numbers in parentheses are in hexadecimal notation.		Error details	Solution
Standard command between devices	Digital command, analog command, or pulse command		
1 (01h)		Undefined command.	Set the correct command.
16 (10h)	192 (C0h)	Hardware error.	Turn the MDU control power supply OFF and then ON again, or press the reset switch.
65 (41h)	—	Group number out of range.	Set the group number to the correct value.
66 (42h)	193 (C1h)	Channel number out of range.	Set the channel number to the correct value.
81 (51h)	194 (C2h)	Setting value out of configuration range.	Set the setting value to the correct value.
83 (53h)	209 (D1h)	Upper limit value and lower limit value cross.	Set the upper limit value and lower limit value so that they do not cross.

Note: Errors other than those listed above are detected by the detector on the command transmission side. Refer to the Instruction Manual for that device for details.

Note: If the error status flag (RX(n+1)A) is set once to "1" (ON), the error status flag will not be set to "0" (OFF) even if the CPU of PLC is reset.

To set the error status flag to "0" (OFF), set the error reset status flag (RY(n+1)A) to "1" (ON).

However, even if the error status is released when the error reset status flag is set to "1" (ON), if there is an error in the retransmitted data, the error status flag will once again be set to "1" (ON). Therefore, refer to the error code and eliminate the cause of the error prior to retransmitting.

10.7 Troubleshooting

Check the following if your device appears to be failing.

- (1) Is the MDU applied control power?
- (2) Nothing is displayed on the display.
Is the connection cable connector fully plugged in? Is it disconnected?
- (3) The device is powered but the current is 0 A.
If the electric current measurement value is less than the measurement lower limit current (less than $\pm 1.0\%$ of the measurement rated current), it is cutoff so that the display value is 0 A.
- (4) Unable to monitor when transmitting/communicating even though a value is displayed on the display.
[1] With CC-Link communication
 - Confirm that there are no errors in the communication line connection, and that no wires are disconnected.
 - Are there any stations with the same station number on the same transmission route? If there are, configure the correct station number and then press the reset switch.
 - Is the communication speed set to the same value as the master device? If it is different, configure the correct communication speed and then press the reset switch.
- (5) The electric current value measured by the device differs from other measurement values. (Permissible error value or greater.)
 - Confirm that the measurement instrument used for comparison measures the effective value correctly. The device indicates the effective value.
 - If the measurement instrument used for comparison measures the average value instead of the effective value, distortion in the current flowing through the measurement circuit will create a significant difference.

Sales Network

Country / Region	Corporation Name	Address	Telephone
Australia	Mitsubishi Electric Australia Pty. Ltd.	348 Victoria Road, Rydalmere, N.S.W, 2116 Australia	+61-2-9684-7777
Bangladesh	PROGRESSIVE TRADING CORPORATION	Haque Tower, 2nd floor, 610/11, Jubilee Road, Chittagang, Bangladesh	+880-31-624-307
	ELECTRO MECH AUTOMATION & ENGINEERING LTD.	Purana Pallan Lane, (VIP Road), Rokaya Mansion(6th floor), Room702, Dhaka-1000, Bangladesh	+880-28-3211-791
Belarus	Tehnikon	Oktyabrskaya 19, Off. 705. BY-220030 Minsk, Belarus	+375(0)177210 46 26
Belgium	Koning & Hartman B.V.	Wolvleaan 31, BE-1800 Vilvoorde, Belgium	+32(0)27527040
Cambodia	DHIMNEX CO.,LTD	#245, St. Tpp Phan, Phnom Penh, Cambodia	+855-23-9971-725
China	Rhona S.A.	Via. Agua Santa 4211 Castilla 30-0 (P.O. Box) Vina del Mar, Chile	+56-32-3-320-600
	Mitsubishi Electric Automation (China) Ltd.	Mitsubishi Electric Automation Building, No.1368 Hongqiao Road, Shanghai, 200336	+86-21-3232-3030
	Mitsubishi Electric Automation (China) Ltd. Beijing Branch	5/F, ONE INDIGO, 20 Juxianqiao Road Chaoyang District, Beijing, China	+86-10-6518-8830
	Mitsubishi Electric Automation (China) Ltd. She-Zhen Branch	Room 2512-2516, Great China International Exchange Square, Jintian Rd., Futian District, Shenzhen, 518034	+86-755-2399-8272
	Mitsubishi Electric Automation (China) Ltd. GuangZhou Branch	Room 1609, North Tower, The Hub Center, No.1068, King Gang East Road, Haizhu District, Guang Zhou, China 519335	+86-20-8923-6730
	Mitsubishi Electric Automation (China) Ltd. ChengDu Branch	Block B, Room 407-408, Shangri-La Center Office Building, No.9 BinJiang East Road, Chengdu, China 61021	+86-28-8446-8030
	Mitsubishi Electric Automation (Hong Kong) Ltd.	20/F, Cityplaza One, 111 King's Road, Taikoo shing, Hong Kong	+852-2510-9555
Colombia	Productico Representaciones S.A	Camera 42 # 75-367 Box 109 Itagu Colombia	+57-44-441284
Czech Republic	AUTOCOINT CONTROL SYSTEMS S,R,O	Technologicka 374/6, CZ-708 00 Ostrava - Pustkovec	+420 595 691 150
Denmark	BEJER ELECTRONICS A/S	LYKKEGAARDSVEJ 17, DK-4000 ROSKILDE	+45(0)4675 76 66
Egypt	Cairo Electrical Group	9, Rostoum St, Garden City P.O, Box 165-11516 Maglis El-Shaab, Cairo - Egypt	+20-2-27961337
France	Mitsubishi Electric Europe B.V.	25, Boulevard des Bouvets, F-92741 Nanterre Cedex	+33(0)155 88 55 68
Germany	Mitsubishi Electric Europe B.V.	SAPHANIMO VILLAGE, SAYSETHA DISTRICT, VIENTIANE CAPITAL, LAOS	+49(0)2102 486-0
	KALAMARKIS - SAPHOUNAS S.A.	IONIAS & NEROMILIOU STR., CHAMOMILIOS ACHARNES, ATHENS, 13678 Greece	+30-210-6200000
Greece	UTECCO	5, MAVROGENOUS STR., 18542 PIRAEUS, Greece	+30 211-1206-900
Hungary	Meltrade Ltd.	Fertő utca 14, HU-1107 Budapest, Hungary	+36(0)1-4631-9726
India	Mitsubishi Electric India Private Limited	2nd Floor, Tower A&B, Cyber Greens, DLF Cyber City, DLF Phase-III, Gurgaon - 122 022 Haryana, India	+91-124-4303000
Indonesia	P. T. Sahabat Indonesia	P.O.Box 5045 Kawasan Industri Pergudangan, Jakarta, Indonesia	+62 (0)21-6610651-9
Indonesia	Mitsubishi Electric Europe B.V.	Westgate Business Park, Ballymore, Dublin 5, Ireland	+353(0)1-4198900
Israel	Gino Industries Ltd.	26, Ophir Street IL-32235 Haifa, Israel	+972(0)4-8674-6656
Italy	Mitsubishi Electric Europe B.V.	Viale Colleoni 7, I-20041 Agrate Brianza (MI), Italy	+39 039-60531
Kazakhstan	Kazpromavtomatika	Ula. Chymbaly 28, KAZ - 100017 Karaganda	+7-7212-501000
Korea	Mitsubishi Electric Automation Korea Co., Ltd	9F Gangseo Hangang x-tower, 401 Yangcheon-ro, Gangseo-gu, Seoul 07528 Korea	+82-2-3660-9572
Laos	AROUNNIT CORPORATION IMPORT-EXPORT SOLE CO., LTD	SAPHANIMO VILLAGE, SAYSETHA DISTRICT, VIENTIANE CAPITAL, LAOS	+855-20-415899
Lebanon	Comptoir d'Electricite Generale-Leban	Cebaco Center - Block A Autostrade Dora P.O. Box 11-2387 Beirut - Lebanon	+961-1-240445
Lithuania	Rifas UAB	Tirmu 29A, LT-5300 Panevezys, Lithuania	+370(0)45-582-728
Malaysia	Mittrich Sdn Bhd	No. 5, Jalan Pemberita U1/49, Temasy Industrial Park, Glenmarie 40150 Shah Alam, Selangor, Malaysia	+603-5569-3748
Malta	ALFATRADE LTD	99 PAOLA HILL, PAOLA PLA 1702, Malta	+356(0)21-697-816
Morocco	SCHIELE MAROC	KM 7,2 NOUVELLE ROUTE DE RABAT AIN SEBAA, 20600 Casablanca, Morocco	+212 661 45 15 86
Myanmar	Peace Myanmar Electric Co.,Ltd.	NO137/139 Botahtung Pagoda Road, Botahtung Town Ship 11161, Yangon, Myanmar	+95-(0)1-202589
Nepal	Watt&Voh House	KHA 2-65, Voh House Dillibazar Post Box: 2108, Kathmandu, Nepal	+977-1-4411330
Netherlands	Intech Marine & Offshore B.V.	Sluisjesdijk 155, NL-3087 AG Rotterdam, Netherlands	+31(0)10-487-1911
North America	Mitsubishi Electric Automation, Inc.	500 Corporate Woods Parkway, Vernon Hills, IL 60061 USA	+847-478-2100
Norway	Scanelec AS	Leirvikasen 43B, NO-5179 Godvik, Norway	+47(0)55-500600
Middle East Arab Countries & Cyprus	Comptoir d'Electricite Generale-International-S.A.,L.	Cebaco Center - Block A Autostrade Dora P.O. Box 11-1314 Beirut - Lebanon	+961-1-240430
Pakistan	Prince Electric Co.	2-P, GULBERG II, LAHORE - 54660 PAKISTAN	+92-4042-35752323
	AL-KAMAL GROUP	Office No. 7 & 8, 1st Floor, Barkat Ali Khan Center, 101 Circular Road, Lahore, Pakistan	+92-4042-3753373
Philippines	Edison Electric Integrated, Inc.	24th Fl. Galleria Corporate Center, Edsa Cr, Ortigas Ave., Quezon City Metro Manila, Philippines	+63-(0)2-634-8691
Poland	Mitsubishi Electric Europe B.V. Polish Branch	Krakowska 50, 32-083 Balice, Poland	+49(0)12 630 47 00
Republic of Moldova	Intishe SRL	161, Tron 231, MD-2000 Kishinev, Moldova	+373(0)23456-24242
Romania	Sirius Trading & Services SRL	RO-060841 Bucuresti, Sector 6 Aleea Lacul Morii Nr. 3	+40-(0)21-340-40-06
Russia	Mitsubishi Electric Europe B.V. Moscow Branch	52, bld. 3 Kosmodamianskaya Nab, 115054, Moscow, Russia	+7 495 121-72070
Saudi Arabia	Center of Electrical Goods	Al-Shuwayer St, Side way of Salahuddin Al-Ayubi St, P.O. Box 15955 Riyadh 11454 - Saudi Arabia	+966-1-4770149
Singapore	Mitsubishi Electric Asia Pte., Ltd.	3037 Alexandra Road, Mitsubishi Electric Building, Singapore 159943	+65-6473-2308
Slovakia	PROCOINT, Presov	Kupesna 17, SK-08031 Presov, Slovakia	+421(0)5-17560 611
	SIMPAP	Janka Derku 1671, SK - 91101 Trenčín, Slovakia	+42(0)32 743 04 72
Slovenia	Inea RBT d.o.o.	Stegne 11, SI-1000 Ljubljana, Slovenia	+386(0)1-513-8116
South Africa	CBI-electric: low voltage	Private Bag 2016, ZA-1600 Isando Gauteng, South Africa	+27(0)11-9282000
Spain	Mitsubishi Electric Europe B.V. Spanish Branch	Carretera de Rubi 76-80, E-08190 Sant Cugat del Valles (Barcelona), Spain	+34(0)93-565-3131
Sweden	Euro Energy Components AB	Järnvägsgatan 36, S-434 24 Kungälv, Sweden	+46(0)300-890040
Switzerland	TiElec AG	Munshentstrasse 136, CH-8201 Schaffhausen	+41(0)524528425
Taiwan	Setsuyo Enterprise Co., Ltd	5th Fl., No.105, Wu Kung 3rd, Wu-Ku Hsiang, Taipei, Taiwan, R.O.C.	+886-(0)2-2288-8889
Thailand	United Trading & Import Co., Ltd.	77/12 Bamrungmuang Road, Klomg Mahanak Pomprab Bangkok Thailand	+66-223-4220-3
Tunisia	MOTRA Electric	3, Residence Imen, Avenue des Martyrs Mourouj III, 2074 - El Mourouj III Ben Arous, Tunisia	+216-71 474 599
Turkey	GTS	Bayraktar Bulvarı Nutuk Sok. No:5, Posta Kutusu34384, TR-34775 Yukarı Dudulu-İcmranyay, Istanbul, Turkey	+90(0)216 526 3990
United Kingdom	Mitsubishi Electric Europe B.V.	Travellers Lane, Lich-Hatfield, Herts, AL10 8XS, United Kingdom	+44(0)1707-276100
Uruguay	Pierrro Vignoli S.A.	Avda. Uruguay 1274 Montevideo Uruguay	+598-2-902-0908
Venezuela	Adesco S.A.	Calle 7 La Urbina Edificio Los Robles Locales C y D Planta Baja, Caracas - Venezuela	+58-212-241-9945
Vietnam	Mitsubishi Electric Vietnam Co., Ltd, Head Office	Unit01-04, 10th Floor, Vincom Center, 72 Le Thanh Ton Street, District 1, Ho Chi Minh City, Vietnam	+84-28-3910-5945
	Mitsubishi Electric Vietnam Co., Ltd, Hanoi Branch	24th Floor, Hanoi Tower, Pham Hung Road khu 5 thoi Me Tri Ha, Nam Tu Liem District, Hanoi City, Vietnam	+84-24-3937-8075

For Safety : Wiring and connection must be done by the person who has specialized knowledge of electric construction and wirings.

● Trademarks

- Of this product, export (or service trade) permission under this law is required for exports that fall under the safety and trade control related cargo (or service) specified in the Foreign Exchange and Foreign Trade Control Law.

- MODBUS is registered trademark of Schneider USA Inc.

- About the QR code described in the product

The QR code described in this product is for use in manufacturing management and is not intended to be used by the customer.

We can not guarantee the operation when reading with a commercially available code reader.

(QR code is a registered trademark of DENSO WAVE INCORPORATED.)

- Other company names and product names in this document are trademarks or registered trademarks of their respective owners.



for a greener tomorrow

Eco Changes is the Mitsubishi Electric Group's environmental statement, and expresses the Group's stance on environmental management. Through a wide range of businesses, we are helping contribute to the realization of a sustainable society.



MITSUBISHI ELECTRIC CORPORATION

HEAD OFFICE: TOKYO BUILDING, 2-7-3, MARUNOUCHI, CHIYODA-KU, TOKYO 100-8310, JAPAN

