

mitsubishi







Mitsubishi Industrial Robot

RV-3SD/3SDJ/3SDB/3SDBJ Series

Standard Specifications Manual
(CR1DA/CR2DA-700 Controller)

Safety Precautions

Always read the following precautions and the separate "Safety Manual" before starting use of the robot to learn the required measures to be taken.

-  **CAUTION** All teaching work must be carried out by an operator who has received special training. (This also applies to maintenance work with the power source turned ON.)
Enforcement of safety training
-  **CAUTION** For teaching work, prepare a work plan related to the methods and procedures of operating the robot, and to the measures to be taken when an error occurs or when restarting. Carry out work following this plan. (This also applies to maintenance work with the power source turned ON.)
Preparation of work plan
-  **WARNING** Prepare a device that allows operation to be stopped immediately during teaching work. (This also applies to maintenance work with the power source turned ON.)
Setting of emergency stop switch
-  **CAUTION** During teaching work, place a sign indicating that teaching work is in progress on the start switch, etc. (This also applies to maintenance work with the power source turned ON.)
Indication of teaching work in progress
-  **WARNING** Provide a fence or enclosure during operation to prevent contact of the operator and robot.
Installation of safety fence
-  **CAUTION** Establish a set signaling method to the related operators for starting work, and follow this method.
Signaling of operation start
-  **CAUTION** As a principle turn the power OFF during maintenance work. Place a sign indicating that maintenance work is in progress on the start switch, etc.
Indication of maintenance work in progress
-  **CAUTION** Before starting work, inspect the robot, emergency stop switch and other related devices, etc., and confirm that there are no errors.
Inspection before starting work

The points of the precautions given in the separate "Safety Manual" are given below. Refer to the actual "Safety Manual" for details.

-  **CAUTION** Use the robot within the environment given in the specifications. Failure to do so could lead to a drop or reliability or faults. (Temperature, humidity, atmosphere, noise environment, etc.)
-  **CAUTION** Transport the robot with the designated transportation posture. Transporting the robot in a non-designated posture could lead to personal injuries or faults from dropping.
-  **CAUTION** Always use the robot installed on a secure table. Use in an instable posture could lead to positional deviation and vibration.
-  **CAUTION** Wire the cable as far away from noise sources as possible. If placed near a noise source, positional deviation or malfunction could occur.
-  **CAUTION** Do not apply excessive force on the connector or excessively bend the cable. Failure to observe this could lead to contact defects or wire breakage.
-  **CAUTION** Make sure that the workpiece weight, including the hand, does not exceed the rated load or tolerable torque. Exceeding these values could lead to alarms or faults.
-  **WARNING** Securely install the hand and tool, and securely grasp the workpiece. Failure to observe this could lead to personal injuries or damage if the object comes off or flies off during operation.
-  **WARNING** Securely ground the robot and controller. Failure to observe this could lead to malfunctioning by noise or to electric shock accidents.
-  **CAUTION** Indicate the operation state during robot operation. Failure to indicate the state could lead to operators approaching the robot or to incorrect operation.
-  **WARNING** When carrying out teaching work in the robot's movement range, always secure the priority right for the robot control. Failure to observe this could lead to personal injuries or damage if the robot is started with external commands.
-  **CAUTION** Keep the jog speed as low as possible, and always watch the robot. Failure to do so could lead to interference with the workpiece or peripheral devices.
-  **CAUTION** After editing the program, always confirm the operation with step operation before starting automatic operation. Failure to do so could lead to interference with peripheral devices because of programming mistakes, etc.
-  **CAUTION** Make sure that if the safety fence entrance door is opened during automatic operation, the door is locked or that the robot will automatically stop. Failure to do so could lead to personal injuries.
-  **CAUTION** Never carry out modifications based on personal judgments, or use non-designated maintenance parts.
Failure to observe this could lead to faults or failures.
-  **WARNING** When the robot arm has to be moved by hand from an external area, do not place hands or fingers in the openings. Failure to observe this could lead to hands or fingers catching depending on the posture.

⚠ CAUTION Do not stop the robot or apply emergency stop by turning the robot controller's main power OFF. If the robot controller main power is turned OFF during automatic operation, the robot accuracy could be adversely affected. Moreover, it may interfere with the peripheral device by drop or move by inertia of the arm.

⚠ CAUTION Do not turn off the main power to the robot controller while rewriting the internal information of the robot controller such as the program or parameters. If the main power to the robot controller is turned off while in automatic operation or rewriting the program or parameters, the internal information of the robot controller may be damaged.

⚠ CAUTION Use the network equipments (personal computer, USB hub, LAN hub, etc) confirmed by manufacturer. The thing unsuitable for the FA environment (related with conformity, temperature or noise) exists in the equipments connected to USB, RS-232 or LAN. When using network equipment, measures against the noise, such as measures against EMI and the addition of the ferrite core, may be necessary. Please fully confirm the operation by customer. Guarantee and maintenance of the equipment on the market (usual office automation equipment) cannot be performed.

C. Notes of the basic component are shown.

*SD series: CR1DA-700 series

⚠ CAUTION Please install the earth leakage breaker in the primary side supply power supply of the controller because of leakage protection.

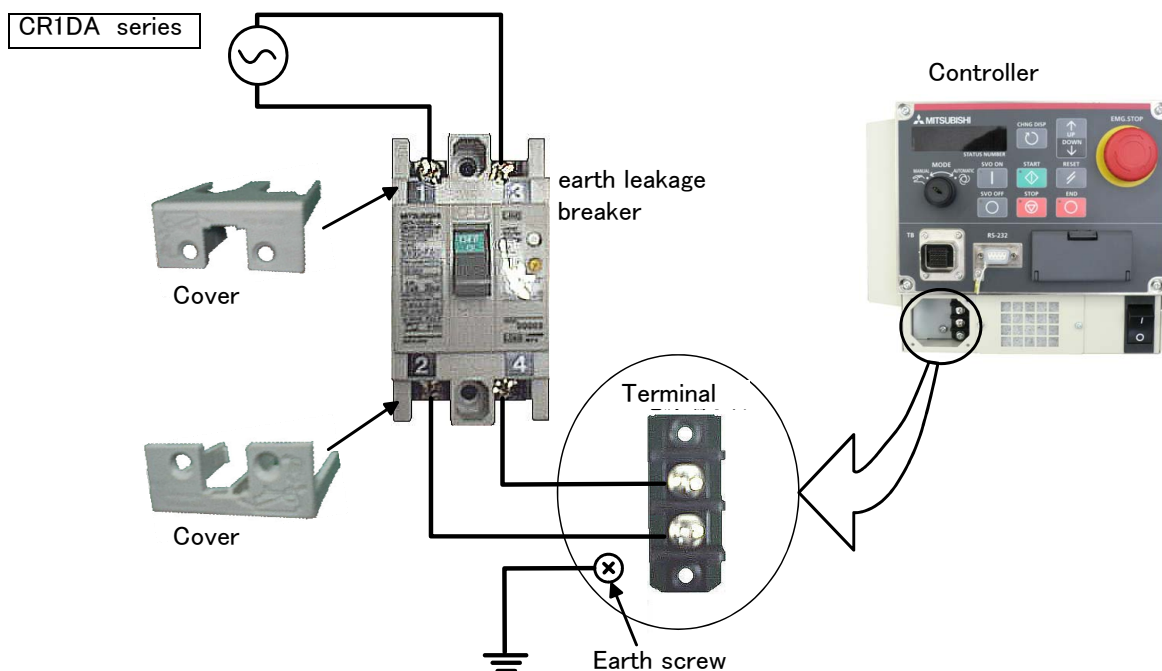

■ Revision history

Date of print	Specifications No.	Details of revisions
2008-07-26	BFP-A8652	First print.
2008-10-06	BFP-A8652-A	<ul style="list-style-type: none"> The example of filter installation to the servo amplifier for addition axes was added. MvTune, Fine J and Fine P commands were added. CE Marking specification was added.
2008-12-18	BFP-A8652-B	<ul style="list-style-type: none"> Difference of connector assignment of of sink and source type of parallel I/O interface/ unit were added.
2009-02-10	BFP-A8652-C	<ul style="list-style-type: none"> EC Declaration of Conformity were added.
2009-03-09	BFP-A8652-D	<ul style="list-style-type: none"> Notes of against wall specification were corrected. flange was changed into mechanical interface The description of the fretting was corrected. The example of emergency stop connection of the example of safety measures was improved. Functional description of the enabling device was improved. The screw depth of the mechanical interface was corrected.
2009-04-22	BFP-A8652-E	<p>The following expressions were corrected</p> <p>1.1.2 Special specifications, 1.1.3 Options, 1.1.4 Maintenance parts, 1.2 Model type name of robot, 1.5 Instruction manuals, 1.6.1 Robot arm, Extended machine cable(Table 1-3), Hand output cable(Table 1-3), Hand input cable(Table 1-3), CC-Link interface(Table 1-3), Controller specification with countermeasure against oil mist(Table 1-3), Recommendation article of the USB cable, 2.2.5 Protection specifications, (1)Machine cable(special specifications and option), Table 3-1 Standard specifications of controller, The operation lock of the power switch,</p> <p>The following errors in writing were corrected,</p> <p>Stopper for changing the operating range of the J1 axis(Table 1-3), Caster specifications controller(Table 1-3),</p> <p>The following was added</p> <p>Serial encoder interface(Table 3-1),</p>
2009-07-17	BFP-A8652-F	<p>Additional Axis Function and Tracking Function Manual were added to the product configuration of Instruction Manual.</p> <p>The English expression was corrected.</p> <p>Safety Precautions , 1.1.2 Special specifications , Table 1.3: The list of Option equipment and special specification , Caution of USB devices , 2.6.1 Shipping special specifications , 6.1.7 Examples of safety measures</p> <p>Parameter AREA*CS was added.</p>
2009-09-10	BFP-A8652-G	The examples of safety measures (Wiring example 3 ~ 5) were corrected.
2009-10-23	BFP-A8652-H	<ul style="list-style-type: none"> The figure of key switch in "3.6.3 Door switch function " was corrected. (Error in writing) The figure of example of safety measures in "6.1.7 Examples of safety measures " was corrected. (connects the enabling switch) The EC Declaration of Conformity was changed. (Correspond to the EMC directive; 2006/42/EC)
2009-12-04	BFP-A8652-J	<ul style="list-style-type: none"> Fuse rating of pneumatic hand interface (RZ365/375) was corrected. The text of "This interface is pre-installed on the controller" in pneumatic hand interface was deleted . The battery number by type of the robot arm was changed.
2009-12-11	BFP-A8652-K	<ul style="list-style-type: none"> The example of connection with the Mitsubishi sequencer of Parallel I/O unit was changed into Q series.
2010-05-26	BFP-A8652-L	<ul style="list-style-type: none"> CE specification of the CR1DA controller was added. Error in writing was corrected
2010-06-17	BFP-A8652-M	<ul style="list-style-type: none"> The type name of robot controller was changed with specification change. (CR1D to CR1DA, CR2D to CR2DA)
2010-07-27	BFP-A8652-N	<ul style="list-style-type: none"> Cover packing was added to the consumable part. The description of protection specification was changed. (The cutting oil which examined was updated, and replacement of the cover packing was added) EC Declaration of Conformity were added.
2010-08-25	BFP-A8652-P	<ul style="list-style-type: none"> The input voltage range of the CR2DA controller was corrected. ("3-phase, AC180 to 253" was the previous.)
2010-10-13	BFP-A8652-Q	<ul style="list-style-type: none"> The outside dimension of CR1DA controller (standard specification) was changed. The dimensions of the hole which draws the power cable were added (CR2DA controller). The EC Declaration of Conformity were added.
2010-11-30	BFP-A8652-R	<ul style="list-style-type: none"> The EC Declaration of Conformity were added.
2010-12-21	BFP-A8652-S	<ul style="list-style-type: none"> The sink / source expression of pin assignment of hand input cable was corrected. (Sink / Source are common)

Date of print	Specifications No.	Details of revisions
2011-02-02	BFP-A8652-T	<ul style="list-style-type: none"> • The outside dimension of CR1DA controller (CE marking specification) was changed. • The rear cover of the CR1DA controller was made unnecessary. • The note about temperature of the air to supply for hand was added. • Part code was added to the consumable part.
2011-05-09	BFP-A8652-U	<ul style="list-style-type: none"> • Table 1-4: Recommendation article of the USB cable was corrected. • The pressure of the dry air for pressurization was corrected (error in writing). • The depth in which the screw of the mechanical interface section is tightened was added.
2011-06-01	BFP-A8652-V	<ul style="list-style-type: none"> • The user's guide was added based on South Korean Radio Law. • Fuse rating of pneumatic hand interface (RZ365/375) was corrected. (error in writing). • The setting value range of parameter SFC*ME and AREA*ME were corrected. (error in writing).
2011-07-01	BFP-A8652-W	<ul style="list-style-type: none"> • The note about the connection of the emergency stop was added. • The signal assignment list of parallel I/O interface and parallel I/O unit were corrected. (Assignment of the dedicated signal was added)
2012-01-26	BFP-A8652-X	<ul style="list-style-type: none"> • EC Declaration of Conformity were changed.
2012-07-11	BFP-A8652-Y	<ul style="list-style-type: none"> • QJ61BT11N (Q series) was added to the master station of the CC-Link interface. • The "Emergency stop output" in the controller standard specification table was deleted. (Overlapped with "Robot error output".) • The "Table 3-3 : Emergency stop/Door switch input" in "3.4 External input/output" was deleted. (Overlapped with "Table 3-5 : Special input/output terminal".) • The EC Declaration of Conformity were changed. • The note about the connection of the emergency stop was added. • The notes about frequent installation and removal of TB and the dummy connector were added. • The explanation about the controller of KC mark specification was added to " ■ Introduction".

Contents

	Page
1 General configuration	1-1
1.1 Structural equipment	1-1
1.1.1 Standard structural equipment	1-1
1.1.2 Special specifications	1-1
1.1.3 Options	1-1
1.1.4 Maintenance parts	1-1
1.2 Model type name of robot	1-2
1.2.1 How to identify the robot model	1-2
1.2.2 Combination of the robot arm and the controller	1-2
1.3 CE marking specifications	1-2
1.4 Indirect export	1-2
1.5 Instruction manuals	1-2
1.6 Contents of the structural equipment	1-3
1.6.1 Robot arm	1-3
1.6.2 Controller	1-4
1.7 Contents of the Option equipment and special specification	1-5
2 Robot arm	2-7
2.1 Standard specifications	2-7
2.1.1 The counter-force applied to the installation surface	2-9
2.2 Definition of specifications	2-10
2.2.1 Pose repeatability	2-10
2.2.2 Rated load (mass capacity)	2-11
2.2.3 Relationships Among Mass Capacity, Speed, and Acceleration/Deceleration Speed	2-12
(1) Setting Load Capacity and Size (Hand Conditions)	2-12
2.2.4 Vibrations at the Tip of the Arm during Low-Speed Operation of the Robot	2-12
2.2.5 Protection specifications	2-13
(1) Types of protection specifications	2-13
(2) About the use with the bad environment	2-14
2.2.6 Clean specifications	2-15
(1) Types of clean specifications	2-15
2.3 Names of each part of the robot	2-16
2.4 Outside dimensions • Operating range diagram	2-17
(1) 6-axis type	2-17
(2) 5-axis type	2-19
2.5 Tooling	2-21
2.5.1 Wiring and piping for hand	2-21
2.5.2 Internal air piping	2-22
2.5.3 Internal wiring for the pneumatic hand output cable	2-22
2.5.4 Internal wiring for the hand check input cable (Standard type/Clean type)	2-22
2.5.5 Spare Wiring	2-22
(1) Standard type	2-22
2.5.6 Wiring and piping system diagram for hand	2-23
2.5.7 Electrical specifications of hand input/output	2-25
2.5.8 Air supply circuit example for the hand	2-26
2.6 Shipping special specifications, options, and maintenance parts	2-27
2.6.1 Shipping special specifications	2-27
(1) Machine cable	2-28
2.7 Options	2-29
(1) Machine cable extension	2-30
(2) Changing the operating range	2-32
(3) Solenoid valve set	2-33
(4) Hand input cable	2-35
(5) Hand output cable	2-36
(6) Hand curl tube	2-37
2.8 About Overhaul	2-38

Contents

	Page
2.9 Maintenance parts	2-38
3 Controller	3-40
3.1 Standard specifications	3-40
3.1.1 Standard specifications	3-40
3.1.2 Protection specifications and operating supply	3-42
3.2 Names of each part	3-43
(1) Padlock specification	3-45
3.3 Outside dimensions/Installation dimensions	3-50
3.3.1 Outside dimensions	3-50
3.3.2 Installation dimensions	3-53
3.3.3 Cable lead-in and dimension	3-55
3.4 External input/output	3-56
3.4.1 Types	3-56
3.5 Dedicated input/output	3-57
3.6 Emergency stop input and output etc.	3-59
3.6.1 Connection of the external emergency stop	3-59
3.6.2 Special stop input(SKIP)	3-63
3.6.3 Door switch function	3-65
3.6.4 Enabling device function	3-65
(1) When door is opening	3-65
(2) When door is closing	3-65
(3) Automatic Operation/Jog Operation/Brake Release and Necessary Switch Settings	3-66
3.7 Additional Axis Function	3-67
3.7.1 Wiring of the Additional Axis Interface	3-67
3.8 Magnet contactor control connector output (AXMC) for addition axes	3-72
3.9 Options	3-75
(1) Teaching pendant (T/B)	3-76
(2) Pneumatic hand interface	3-79
(3) Parallel I/O interface	3-82
(4) External I/O cable	3-88
(5) Parallel I/O unit	3-90
(6) External I/O cable	3-101
(7) Personal computer cable	3-103
(8) CC-Link interface	3-104
(9) Extension memory cassette	3-107
(10) RT ToolBox2/RT ToolBox2 mini	3-108
(11) Instruction Manual(bound edition)	3-110
3.10 Maintenance parts	3-111
4 Software	4-112
4.1 List of commands	4-112
4.2 List of parameters	4-115
5 Instruction Manual	5-117
5.1 The details of each instruction manuals	5-117
6 Safety	6-119
6.1 Safety	6-119
6.1.1 Self-diagnosis stop functions	6-119
6.1.2 External input/output signals that can be used for safety protection measures	6-120
6.1.3 Precautions for using robot	6-120
6.1.4 Safety measures for automatic operation	6-121
6.1.5 Safety measures for teaching	6-121
6.1.6 Safety measures for maintenance and inspections, etc.	6-121
6.1.7 Examples of safety measures	6-122

Contents

	Page
(1) External emergency stop connection [supplementary explanation]	6-126
6.2 Working environment	6-127
6.3 Precautions for handling	6-127
7Appendix	Appendix-129
Appendix 1 : Specifications discussion material	Appendix-129

■ Introduction

This series provides compact vertical multi-joint robots for use in machine processes and assemblies. This series is especially designed to answer the needs of users who want to create compact and highly flexible production facilities to cope with shortened product life cycles as well as the diffusion of small and high density product groups in recent years, such as personal computer related devices, information terminal devices and small car-mounted electronic devices. This series supports the oil mist environment as standard, offering variations of 5-axis type, 6-axis type and clean specification.

However, to comply with the target application, a work system having a well-balanced robot arm, peripheral devices or robot and hand section must be structured.

When creating these standard specifications, we have edited them so that the Mitsubishi robot's characteristics and specifications can be easily understood by users considering the implementation of robots. However, if there are any unclear points, please contact your nearest Mitsubishi branch or dealer.

Mitsubishi hopes that you will consider these standard specifications and use our robots.

The controller differ corresponding to the specification of robot. Please refer to [Page 2, "1.2 Model type name of robot"](#) or [Page 2, "1.3 CE marking specifications"](#).

Note that in this specification document the specifications related to the robot arm is described [Page 7, "2 Robot arm"](#), the specifications related to the controller [Page 40, "3 Controller"](#), and software functions and a command list [Page 112, "4 Software"](#) separately.

This document has indicated the specification of the following types robot.

- *RV-3SD, RV-3SDB
- *RV-3SDC, RV-3SDBC
- *RV-3SDJ, RV-3SDJB
- *RV-3SDJC, RV-3SDJBC
- *RV-3SDxBx-S12/-S312 (CE Marking specification)

About KC mark specifications

This robot acquires certification of KC mark by the special specification (S19).

Although about CR1DA controller the two kinds of controllers (standard specification / CE Marking specification) are described in this book and you can choose either one. The external form of controller which have KC mark specification is same as the controller which described as "CE Marking specification". Refer to the place described as "CE Marking specification" about the external form of KC mark specification's controller. (However, the parallel I/O interface (2D-TZ378) is not installed at shipping) Especially the places with no distinction are common specifications.

And, it is the same as that of the CE Marking specification in the same manner about CR2DA controller.

- No part of this manual may be reproduced by any means or in any form, without prior consent from Mitsubishi.
- The contents of this manual are subject to change without notice.
- The specifications values are based on Mitsubishi standard testing methods.
- The information contained in this document has been written to be accurate as much as possible. Please interpret that items not described in this document "cannot be performed." or "alarm may occur". Please contact your nearest dealer if you find any doubtful, wrong or skipped point.
- This specifications is original.
- Microsoft, Windows, Microsoft Windows NT are either registered trademarks or trademarks of Microsoft Corporation in the United States and/or other countries.

1 General configuration

1.1 Structural equipment

Structural equipment consists of the following types.

1.1.1 Standard structural equipment

The following items are enclosed as a standard.

- (1) Robot arm
- (2) Controller
- (3) Machine cable
- (4) Robot arm installation bolts
- (5) Earth leakage breaker (CR1DA-700 series only)
- (6) Safety manual, Instruction manual, CD-ROM (Instruction manual)
- (7) Guarantee card

1.1.2 Special specifications

For the special specifications, some standard configuration equipments and specifications have to be changed before factory shipping. Confirm the delivery date and specify the special specifications at the order.

1.1.3 Options

User can install options after their delivery.

1.1.4 Maintenance parts

Materials and parts for the maintenance use.

1.2 Model type name of robot

1.2.1 How to identify the robot model

RV-3SD J B C -Sxx
 (a) (b) (c) (d) (e)

- (a). RV-3SD Indicates the RV-3SD series.
- (b). J Indicates axis configuration.
 Examples)
 Blank: 6-axis type.
 J: 5-axis type.
- (c). B Indicates the existence of the brake.
 Examples)
 Blank: J4 and J6 axis has no brake.
 (The J4 axis exists only in 6 axis type.)
 B: All axes have the brake.(For CE Marking specifications)
- (d) C Indicates environment specification.
 Examples)
 Blank: Standard Specifications
 C: Clean Specifications
- (e) -SXX [1] Indicates a special model number. In order, limit special specification.
 [2] -SM** Indicates a specification with protection specification controller.

1.2.2 Combination of the robot arm and the controller

Table 1-1 : Combination of the robot arm and the controller

Protection specification	Robot arm	Axial constitution	Controller
Standard specification	RV-3SD	6-axis type	CR1DA-721
	RV-3SDJ	5-axis type	CR1DA-731
-SM ^{Note1)}	RV-3SD-SM	6-axis type	CR1DA-721 + CR1D-MB
	RV-3SDJ-SM	5-axis type	CR1DA-731 + CR1D-MB

Note1) The controller protection box is attached. (IP54) This box protects the controller.

1.3 CE marking specifications

The robot shown in the table is the CE Marking specification.

Table 1-2 : Robot models with CE marking specifications

Robot type	Controller	External signal logic	Language setting
RV-3SDB-S12/S15	CR1DA-721-S12/S15	Source type	English (ENG)
RV-3SDBJ-S12/S15	CR1DA-731-S12/S15		
RV-3SDB-S312	CR2DA-721-S312		
RV-3SDBJ-S312	CR2DA-731-S312		

1.4 Indirect export

The display in English is available by setting parameter LNG as "ENG."

1.5 Instruction manuals

The instruction manuals supplied in CD-ROM, except for the Safety Manual. This CD-ROM (electronic manual) includes instruction manuals in both Japanese and English versions.

1.6 Contents of the structural equipment

1.6.1 Robot arm

The list of structural equipment is shown in Fig. 1-1.

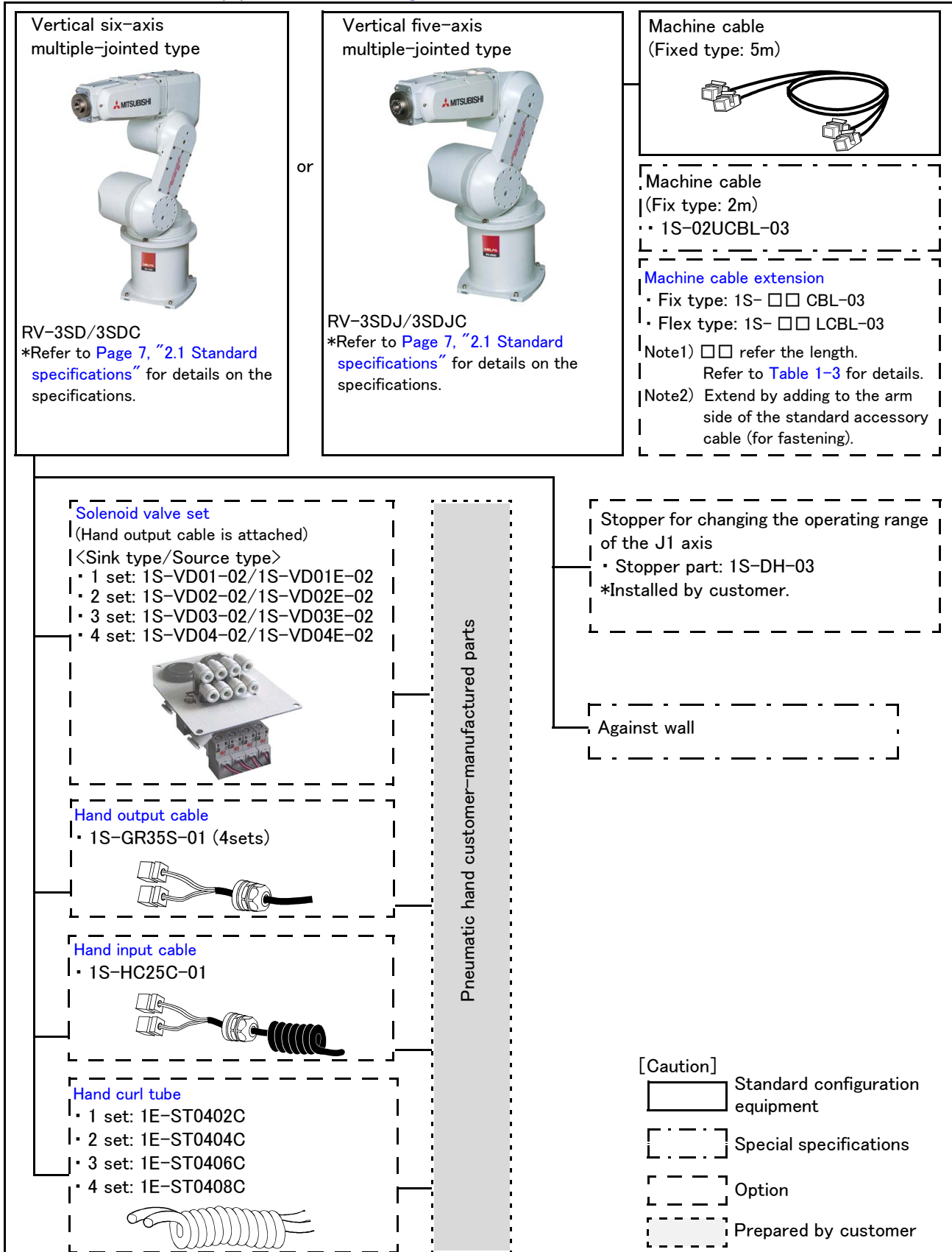

Fig.1-1 : Structural equipment (Robot arm)

1.6.2 Controller

The devices shown below can be installed on the controller.

The controllers that can be connected differ depending on the specification of the robot.

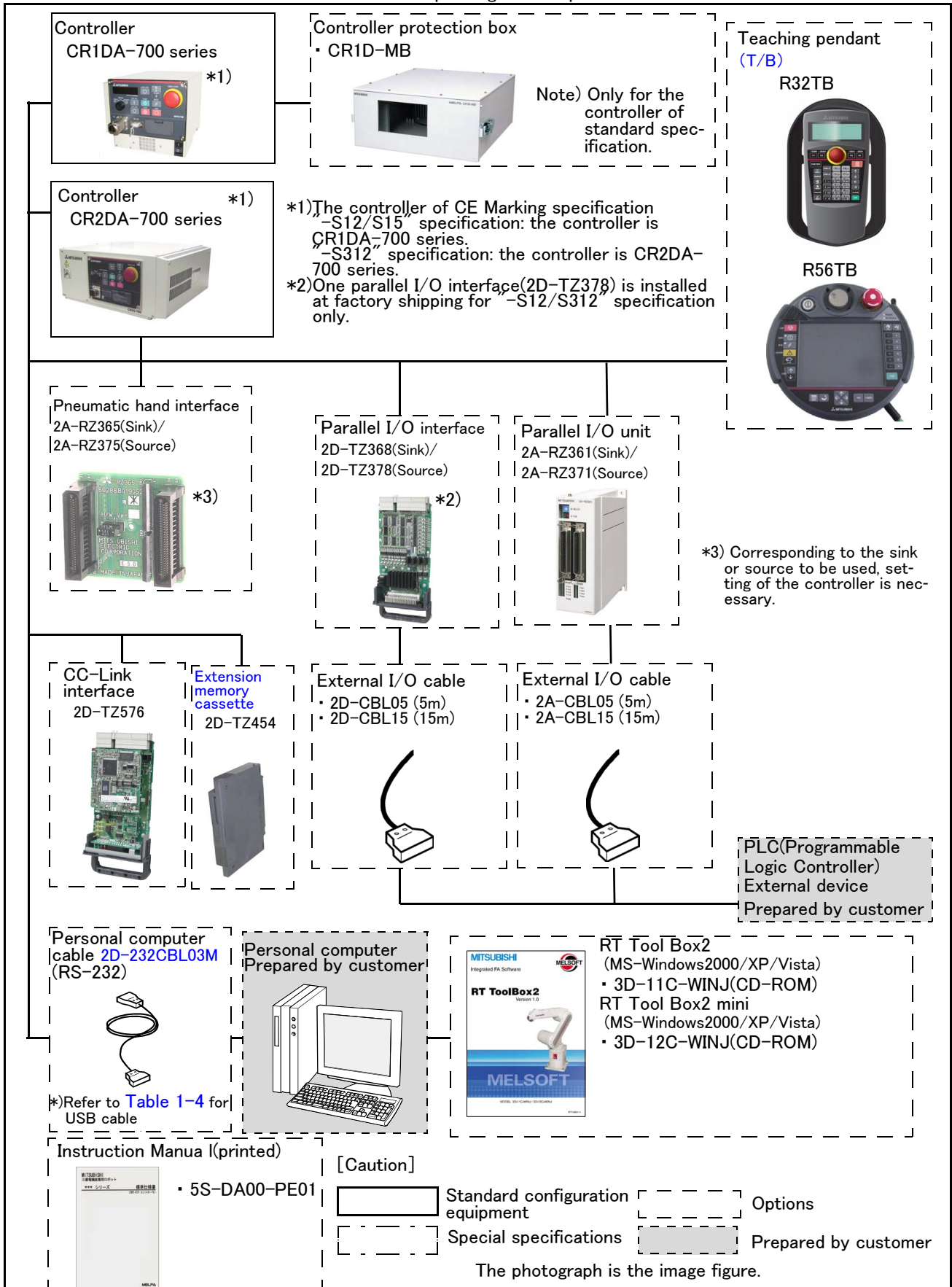

Fig.1-2 : Structural equipment

1.7 Contents of the Option equipment and special specification

A list of all Optional equipments and special specifications are shown below.

Table 1-3 : The list of Option equipment and special specification

Item	Type	Specifications	Classification Note1)	Description
Stopper for changing the operating range of the J1 axis	1S-DH-03	Stopper part One each of the following can be selected. + side: +120, +90, +60, or +30 deg. - side: -120, -90, -60, or -30 deg. ± 170 deg. are used for the standard specification.	○	This must be installed by the customer.
Machine cable(Replaced with shorter cable)	1S-02UCBL-03	For fixing (Set of power and signal)	○・□	2m(A 2 m cable is supplied instead of the 5 m cable that is supplied as standard)
Extended machine cable	1S-□□CBL-03	For fixing (Set of power and signal)	○	5, 10, 15m
	1S-□□LCBL-03	For bending (Set of power and signal)	○	5, 10, 15m
Solenoid valve set	1S-VD01-02/ 1S-VD01E-02	1 set (Sink type)/(Source type)	○	A solenoid valve set for the pneumatic hand
	1S-VD02-02/ 1S-VD02E-02	2 set (Sink type)/(Source type)	○	
	1S-VD03-02/ 1S-VD03E-02	3 set (Sink type)/(Source type)	○	
	1S-VD04-02/ 1S-VD04E-02	4 set (Sink type)/(Source type)	○	
Hand output cable	1S-GR35S-01	Robot side: connector. Hand side: wire.	○	The cable is connected to the hand output connector by the customer.
Hand input cable	1S-HC25C-01	Robot side: connector. Hand side: wire.	○	The cable is connected to the sensor by the customer.
Hand curl tube	1E-ST0402C	For solenoid valve 1set:Φ4x2	○	Curl type air tube
	1E-ST0404C	For solenoid valve 2set:Φ4x4	○	
	1E-ST0406C	For solenoid valve 3set:Φ4x6	○	
	1E-ST0408C	For solenoid valve 4set:Φ4x8	○	
Simple teaching pendant	R32TB	Cable length 7m	○	With 3-position deadman switch IP65
	R32TB-15	Cable length 15m	○	
Highly efficient teaching pendant	R56TB	Cable length 7m	○	
	R56TB-15	Cable length 15m	○	
Pneumatic hand interface	2A-RZ365	DO: 8 point(Sink type)	○	It is necessary when the hand output signal of the robot arm is used.
	2A-RZ375	DO: 8 point(Source type)	○	
Parallel I/O Interface	2D-TZ368	DO: 32 point (Sink type)/ DI: 32 point (Sink type) Insulated type output signal (100mA/ point)	○	The card type external input-and-output. Interface.Install to the slot of controller.
	2D-TZ378	DO: 32 point (Source type)/ DI: 32 point (Source type) Insulated type output signal (100mA/ point)	○Note2)	
External I/O cable (For Parallel I/O Interface)	2D-CBL05	5m	○	Use to connect the external peripheral device to the parallel input/output interface.
	2D-CBL15	15m	○	
Parallel I/O Unit	2A-RZ361	DO: 32 point (Sink type)/ DI: 32 point (Sink type)	○	The unit for expansion the external input/output. Electrical isolated Type (100mA/Point)
	2A-RZ371	DO: 32 point (Source type)/ DI: 32 point (Source type)	○	
External I/O cable (For Parallel I/O Unit)	2A-CBL05	5m	○	Use to connect the external peripheral device to the parallel input/output unit
	2A-CBL15	15m	○	
CC-Link interface	2D-TZ576	Local station	○	for MELSEC PLC with CC-Link connection.
Extended memory cassette	2D-TZ454	Teaching point number: 50,800 Steps number: 50,800 Program number: 512	○	The battery backup function is provided. The value combined with the standard
Controller protection box Note3)	CR1D-MB	IP54	□	The controller protection box is used to protect the controller from an oil mist or other operating environment
RT ToolBox2 (Personal computer Support software)	3D-11C-WINE	CD-ROM	○	MS-Windows2000/XP/Vista (With the simulation function)
RT ToolBox2 mini (Personal computer Support software mini)	3D-12C-WINE	CD-ROM	○	MS-Windows2000/XP/Vista
Personal computer cable Note4)	2D-232CBL03M	RS-232C cable 3m for PC-AT compatible model	○	
Instruction Manual	5S-DA00-PE01	RV-3SD/3SDJ series	○	A set of the instructions manual bookbinding editions

Note1) ○ : option, □ : special specifications.

Note2) One 2D-TZ378(Source type) is installed for CE Marking specification at shipping. (Only "-S312" or "-S12" specification)

Note3) This is provided as standard for the specification with the controller protection box. Use this option to protect the controller from the oil mist when the controller will be installed in the environment such as the oil mist.

Only for the CR1DA-700 series controller of standard specification.

Note4) The recommendation products of the USB cable are shown in [Table 1-4](#).

[Reference]:The recommendation products of the USB cable are shown below.

Table 1-4 : Recommendation article of the USB cable

Name	Type name	Supplier
USB cable (USB A type-USB mini B type)	KU-AMB530	SANWA SUPPLY INC.
	USB-M53	ELECOM CO., LTD.
	GT09-C30USB-5P	MITSUBISHI ELECTRIC SYSTEM & SERVICE CO., LTD.
	MR-J3USBCBL3M	MITSUBISHI ELECTRIC CO., LTD.
USB adapter (USB B type-USB mini B type)	AD-USBBFTM5M	ELECOM CO., LTD.



Caution

Be careful to the USB cable to apply neither the static electricity nor the noise. Otherwise, it becomes the cause of malfunction.



Caution

Use the network equipments (personal computer, USB hub, LAN hub, etc) confirmed by manufacturer. The thing unsuitable for the FA environment (related with conformity, temperature or noise) exists in the equipments connected to USB, RS-232 or LAN. When using network equipment, measures against the noise, such as measures against EMI and the addition of the ferrite core, may be necessary. Please fully confirm the operation by customer. Guarantee and maintenance of the equipment on the market (usual office automation equipment) cannot be performed.

2 Robot arm

2.1 Standard specifications

Table 2-1 : Standard specifications of robot

Item		Unit	Specifications					
Type			RV-3SD	RV-3SDC	RV-3D-SM	RV-3SDJ	RV-3SDJC	RV-3SDJ-SM
Type of robot			6-axis			5-axis		
	Environment		Standard (oil mist)	Clean	With the controller protection box	Standard (oil mist)	Clean	With the controller protection box
Degree of freedom			6			5		
Installation posture			On floor, hanging, (against wall ^{Note1)})					
Structure			Vertical, multiple-joint type					
Drive system			AC servo motor (J1 to J3:and J5: with brake)					
Position detection method			Absolute encoder					
Arm length	Upper arm	mm	245					
	Fore arm		270			300		
Operating range	Waist (J1) ^{Note1)}	Degree	340 (-170 to +170)					
	Shoulder (J2)		225 (-90 to +135)					
	Elbow (J3)		191 (-20 to +171)			237 (-100 to +137)		
	Wrist twist (J4)		320 (-160 to +160)			-		
	Wrist pitch (J5)		240 (-120 to +120)					
	Wrist roll (J6)		720 (-360 to +360)					
Speed of motion	Waist (J1)	Degree/s	250					
	Shoulder (J2)		187					
	Elbow (J3)		250					
	Wrist twist (J4)		412			-		
	Wrist pitch (J5)		412					
	Wrist roll (J6)		660					
Maximum resultant velocity ^{Note2)}		mm/sec	5,500			5,300		
Load	Maximum ^{Note3)}	kg	3.5 (34.3)					
	Rating	(N)	3 (29.4)					
Pose repeatability ^{Note4)}		mm	±0.02					
Ambient temperature		°C	0 to 40					
Mass		kg	37			33		
Allowable moment load	Wrist twist (J4)	N · m	5.83			-		
	Wrist pitch (J5)		5.83					
	Wrist roll (J6)		3.9					
Allowable inertia	Wrist twist (J4)	kg · m ²	0.137			-		
	Wrist pitch (J5)		0.137					
	Wrist roll (J6)		0.047 ^{Note5)}					
Arm reachable radius front p-axis center point		mm	642			641		
Tool wiring ^{Note6)}			Hand input 8 point, hand output 8 point, eight spare wires (AWG#24(0.2mm ²) with shielded)					
Tool pneumatic pipes			Primary side: Φ6 × 2 (Base to fore arm section) Secondary side: Φ4 × 8 (Optional)					
Supply pressure		MPa	0.5 ± 10%					
Protection specification ^{Note7)}			IP65 (all axes)	-	IP65 (all axes)	IP65 (all axes)	-	IP65 (all axes)
Degree of cleanliness ^{Note8)}			-	10(0.3 μm) Internal suction requirement	-	-	10(0.3 μm) Internal suction requirement	-
Painting color			Light gray (Equivalent to Munsell: 0.08GY7.64/0.81)					

Note1) When used by mounting on the wall, a special specification that limits the operating range of the J1 axis will be used. Please give an order separately.

Note2) This is the value on the mechanical interface surface when all axes are combined.

Note3) The maximum load capacity is the mass with the mechanical interface posture facing down word at the ±10° limit.

Note4) The pose repeatability details are given in [Page 10, "2.2.1 Pose repeatability"](#)

Note5) When the optimum acceleration/deceleration mode is in effect, up to twice the specification value indicated here can be set.

Note6) The pneumatic hand interface (option) is required when the tool (hand) output is used.

Note7) The protection specification details are given in [Page 13, "2.2.5 Protection specifications"](#).

Note8) The clean specification details are given in [Page 15, "2.2.6 Clean specifications"](#). A down flow(0.3m/s or more) in the clean room is the necessary conditions for the cleanliness.

Table 2-2 : Specifications of RV-3SDB/3SDJB series

Item		Unit	Specifications			
			RV-3SDB	RV-3SDBC	RV-3SDJB	RV-3SDJBC
Type			6-axis		5-axis	
Type of robot	Environment		Standard (oil mist)	Clean	Standard (oil mist)	Clean
Degree of freedom			6		5	
Installation posture			On floor, hanging, (against wall ^{Note1)})			
Structure			Vertical, multiple-joint type			
Drive system			AC servo motor (with brakes for all axes)			
Position detection method			Absolute encoder			
Arm length	Upper arm	mm	245			
	Fore arm		270		300	
Operating range	Waist (J1) ^{Note1)}	Degree	340 (-170 to +170)			
	Shoulder (J2)		225 (-90 to +135)			
	Elbow (J3)		191 (-20 to +171)		237 (-100 to +137)	
	Wrist twist (J4)		320 (-160 to +160)			
	Wrist pitch (J5)		240 (-120 to +120)			
	Wrist roll (J6)		720 (-360 to +360)			
Speed of motion	Waist (J1)	Degree/s	250			
	Shoulder (J2)		187			
	Elbow (J3)		250			
	Wrist twist (J4)		412		-	
	Wrist pitch (J5)		412			
	Wrist roll (J6)		660			
Maximum resultant velocity ^{Note2)}		mm/sec	5,500		5,300	
Load	Maximum ^{Note3)}	kg (N)	3.5 (34.3)			
	Rating		3 (29.4)			
Pose repeatability ^{Note4)}		mm	±0.02			
Ambient temperature		°C	0 to 40			
Mass		kg	37		33	
Allowable moment load	Wrist twist (J4)	N · m	5.83		-	
	Wrist pitch (J5)		5.83			
	Wrist roll (J6)		3.9			
Allowable inertia	Wrist twist (J4)	kg · m ²	0.137		-	
	Wrist pitch (J5)		0.137			
	Wrist roll (J6)		0.047 ^{Note5)}			
Arm reachable radius front p-axis center point		mm	642		641	
Tool wiring ^{Note6)}			Hand input 8 point, hand output 8 point, eight spare wires (AWG#24(0.2mm ²) with shielded)			
Tool pneumatic pipes			Primary side: Φ6 × 2 (Base to fore arm section) Secondary side: Φ4 × 8 (Optional)			
Supply pressure		MPa	0.5±10%			
Protection specification ^{Note7)}			IP65 (all axes)	-	IP65 (all axes)	-
Degree of cleanliness ^{Note8)}			-	10(0.3 μm) Internal suction requirement	-	10(0.3 μm) Internal suction requirement
Painting color			Light gray (Equivalent to Munsell: 0.08GY7.64/0.81)			

Note1) When used by mounting on the wall, a special specification that limits the operating range of the J1 axis will be used. Please give an order separately.

Note2) This is the value on the mechanical interface surface when all axes are combined.

Note3) The maximum load capacity is the mass with the mechanical interface posture facing down word at the ±10° limit.

Note4) The pose repeatability details are given in [Page 10, "2.2.1 Pose repeatability"](#)

Note5) When the optimum acceleration/deceleration mode is in effect, up to twice the specification value indicated here can be set.

Note6) The pneumatic hand interface (option) is required when the tool (hand) output is used.

Note7) The protection specification details are given in [Page 13, "2.2.5 Protection specifications"](#).

Note8) The clean specification details are given in [Page 15, "2.2.6 Clean specifications"](#). A down flow(0.3m/s or more) in the clean room is the necessary conditions for the cleanliness.

2.1.1 The counter-force applied to the installation surface

The counter-force applied to the installation surface for the strength design of the robot installation surface is shown.

Table 2-3 : Value of each counter-force

Item	Unit	Value
Falls moment: M_L	N•m	4 1 0
Torsion moment: M_T	N•m	4 0 0
Horizontal translation force: F_H	N	1, 0 0 0
Vertical translation force: F_V	N	1, 2 0 0

2.2 Definition of specifications

The accuracy of pose repeatability mentioned in catalogs and in the specification manual is defined as follows.

2.2.1 Pose repeatability

For this robot, the pose repeatability is given in accordance with JIS 8432 (Pose repeatability). Note that the value is based on 100 measurements (although 30 measurements are required according to JIS).

[Caution] The specified "pose repeatability" is not guaranteed to be satisfied under the following conditions.

- [1] Operation pattern factors
 - 1) When an operation that approaches from different directions and orientations are included in relation to the teaching position during repeated operations
 - 2) When the speed at teaching and the speed at execution are different
- [2] Load fluctuation factor
 - 1) When work is present/absent in repeated operations
- [3] Disturbance factor during operation
 - 1) Even if approaching from the same direction and orientation to the teaching position, when the power is turned OFF or a stop operation is performed halfway
- [4] Temperature factors
 - 1) When the operating environment temperature changes
 - 2) When accuracy is required before and after a warm-up operation
- [5] Factors due to differences in accuracy definition
 - 1) When accuracy is required between a position set by a numeric value in the robot's internal coordinate system and a position within the actual space
 - 2) When accuracy is required between a position generated by the pallet function *1) and a position within the actual space

*1)

The pallet function is a function that teaches only the position of the work used as reference (3 to 4 points) and obtains the remaining positions by calculations, for an operation that arranges works orderly or for an operation that unloads orderly arranged works. By using this function, for example, in the case of an operation that arranges works on grid points of 100 x 100, by teaching only three points of four corners, the remaining grid points are automatically generated; thus, it is not necessary to teach all 10,000 points. For more information about the pallet function, refer to the separate volume, "Instruction Manual/Detailed Explanation of Functions and Operations."

2.2.2 Rated load (mass capacity)

The robot's mass capacity is expressed solely in terms of mass, but even for tools and works of similar mass, eccentric loads will have some restrictions. When designing the tooling or when selecting a robot, consider the following issues.

- (1) The tooling should have the value less or equal than the smaller of the tolerable inertia and the tolerable moment found in Page 7, "Table 2-1 : Standard specifications of robot"
- (2) Fig. 2-1 shows the distribution dimensions for the center of gravity in the case where the volume of the load is relatively small. Use this figure as a reference when designing the tooling.
- (3) When the load is not mass, but force, you should design the tooling so that it does not exceed the value for allowable moment described in Page 7, "Table 2-1 : Standard specifications of robot"

[Caution] The mass capacity is greatly influenced by the operating speed of the robot and the motion posture. Even if you are within the allowable range mentioned previously, an overload or generate an overcurrnt alarm could occur. In such cases, it will be necessary to change the time setting for acceleration/deceleration, the operating speed, and the motion posture.

[Caution] The overhang amount of the load for the specified moment and inertia in this section is the dynamic limit value determined by the motor driving each axis and by the capacity of the reduction gears. Consequently, accuracy cannot be guaranteed for the entire tooling area. Since accuracy is based on the center point of the mechanical interface surface, position accuracy can diminish as you go away from the mechanical interface surface, or vibration can result, with tooling that is not rigid or that is long.

[Caution] Even within the allowable range previously mentioned, an overload alarm may be generated if an ascending operation continues at a micro-low speed. In such a case, it is necessary to increase the ascending speed.

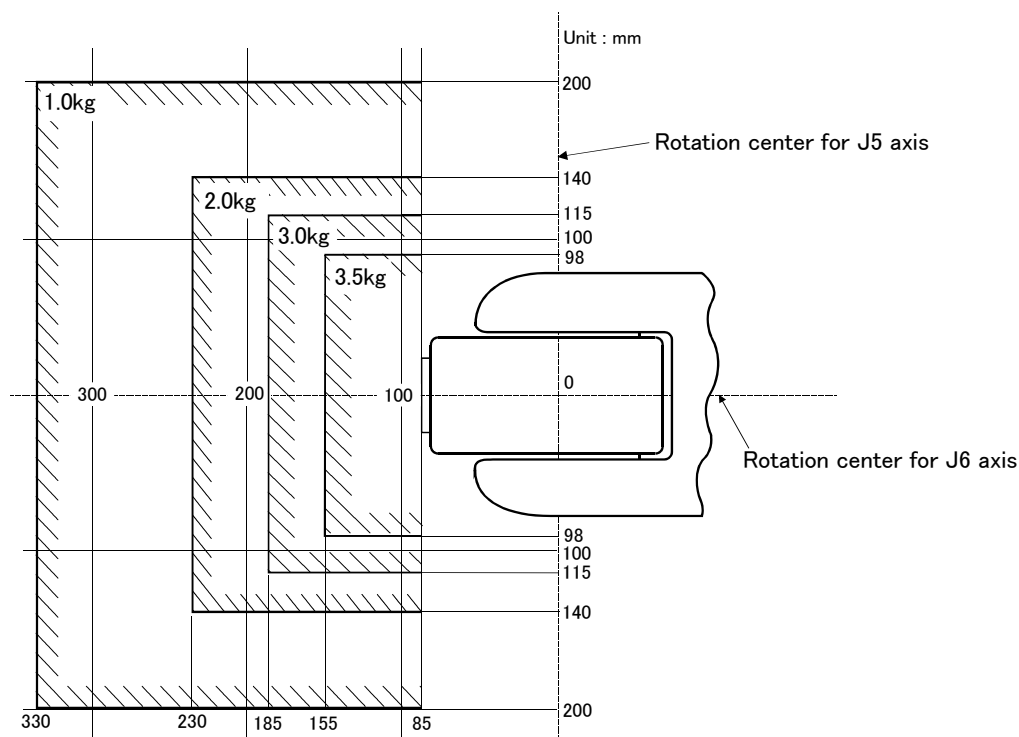

Fig.2-1 : Position of center of gravity for loads (for loads with comparatively small volume)

2.2.3 Relationships Among Mass Capacity, Speed, and Acceleration/Deceleration Speed

This robot automatically sets the optimum acceleration and deceleration speeds and maximum speed, according to the load capacity and size that have been set, and operates using these automatically set speeds.

To achieve that, it is necessary to correctly set the actual load data (mass and size of hand and work) to be used. However, vibration, overheating and errors such as excessive margin of error and overload may occur, depending on the robot operation pattern or ambient temperature. In such a case, change the setting value to the +20% range. If a setting is performed in such a way that it falls below the mounted load, the life span of the mechanism elements used in the robot may be shortened. In the case of a work requiring a high degree of accuracy, set up the load correctly and use the robot by lowering the ratios of the acceleration and deceleration speeds.

(1) Setting Load Capacity and Size (Hand Conditions)

Set up the capacity and size of the hand with the "HNDDAT*" parameter (optimum acceleration/deceleration setting parameter), and set up the capacity and size of the work with the "WRKDAT*" parameter. Numbers 0 to 8 can be used for the asterisk (*) part. Designate the "HNDDAT*" and "WRKDAT*" parameters to be used using the "LOADSET" command in a program.

For more details, refer to the separate "Instruction Manual/Detailed Explanation of Functions and Operations." It is the same meaning as "LOADSET 0.0" if not using the "LOADSET".

2.2.4 Vibrations at the Tip of the Arm during Low-Speed Operation of the Robot

Vibrations at the tip of the arm may increase substantially during the low-speed operation of the robot, depending on the combination of robot operation, hand mass and hand inertia. This problem occurs when the vibration count specific to the robot arm and the vibration count of the arm driving force are coming close to each other. These vibrations at the tip of the arm can be reduced by taking the following measures:

- 1) Lower the robot's operating speed by approximately 5% from high speed using the OvrD instruction.
- 2) Change and move the teaching points of the robot.
- 3) Change the hand mass and hand inertia.

2.2.5 Protection specifications

(1) Types of protection specifications

The robot arm has protection specifications that comply with the IEC Standards. The protection specifications and applicable fields are shown in [Table 2-4](#).

Even oil mist environment can be used in addition to the general environment.

Table 2-4 : Protection specifications and applicable fields

Type	Protection specifications (IEC Standards value)	Classification	Applicable field	Remarks
RV-3SD/3SDB RV-3SDJ/3SDJB	Robot arm:IP65(all axes)	General-purpose environment specifications and Oil mist specifications	General assembly Slightly dusty environment	
RV-3SD-SM ^{Note1)} RV-3SDJ-SM	Robot arm:IP65(all axes)		Machine tool (cutting) Machine shop with heavy oil mist Dusty work shop	Note that if the cutting machine contains abrasive materials, the robot machine line will be shortened.

Note1) The “-SM” specification (specification with the controller protection box) comes with the controller protection box (CR1D-MB) as standard.



CAUTION

Use the controller protection box (CR1D-MB) to protect the controller from the environment when the CR1DA-700 series controller will be used in the environment such as the oil mist shown in the [Table 2-4](#). A robot equipped with the controller protection box as standard is available. (Only for the controller of standard specification)

We are confirming examining with the cutting oil shown in [Table 2-5](#), and satisfying protection specification. Our warranty does not cover damages or failure resulting from the robot being operated in any environment where other cutting oils than those listed in the table are used (except cutting oils with respect to which the robot's compatibility with the protection specification is verified through our operability evaluation) or where the robot body may be directly splashed with water, oil or dust in quantities greater than stated in the protection specification.

Table 2-5 : Cutting oil which examined as oil mist environment

No.	Name	Maker	Property	Operating condition
1	CastrolHysol X	Castrol Co., Ltd	Water-soluble	Diluted by a factor of 20
2	CastrolSyntilo9954	Castrol Co., Ltd	Water-soluble	Diluted by a factor of 20
3	Yushiron Oil	YUSHIRO CHEMICAL INDUSTRY CO., LTD	Water-insoluble	-
4	YushirokenE10	YUSHIRO CHEMICAL INDUSTRY CO., LTD	Water-soluble	Diluted by a factor of 20
5	Yushiroken synthetic 770TG	YUSHIRO CHEMICAL INDUSTRY CO., LTD	Water-soluble	Diluted by a factor of 20
6	YushirokenFX90	YUSHIRO CHEMICAL INDUSTRY CO., LTD	Water-soluble	Diluted by a factor of 20
7	SUNCUT ES-50N	NIPPON GREASE CO., LTD	Water-insoluble	-
8	Searching cut SG555	KYOUWA OIL LUBRICANTS CO., LTD,	Water-insoluble	-
9	EMULCUT FA-800	KYODO YUSHI CO., LTD	Water-soluble	-

【Information】

• The IEC IP65

Protection against water infiltration as specified in IP65 indicates a protective structure that is not harmfully affected when $12.5 \pm 5\%$ liters of water is supplied from a test device at a position approx. 3m away in various directions and a water pressure of 30kPa at the nozzle section. The water is filled one minute per 1m^2 of test device surface area for a total of three minutes.

The IEC IP symbols define the degree of protection against solids and fluids, and do not indicate a protective structure against the entry of oil or water.

(2) About the use with the bad environment

This robot has protection methods that conform to IEC's IP65(all axis) standards (splashproof type). It has protection structure designed to prevent harmful effects caused by splashing water coming from various directions, as the robot is operating. Recommended usage conditions.

- 1) The robot is designed for use in combination with machining device.
- 2) We are confirming examining with the cutting oil shown in [Table 2-5](#), and satisfying protection specification. Our warranty does not cover damages or failure resulting from the robot being operated in any environment where other cutting oils than those listed in the table are used (except cutting oils with respect to which the robot's compatibility with the protection specification is verified through our operability evaluation) or where the robot body may be directly splashed with water, oil or dust in quantities larger than stated in the protection specification.
- 3) Take measures so that the robot will not be exposed to water, oil and/or chips for a long period of time.
- 4) Robot's protection performance can be improved by pressurizing its interior. If you use a robot in an environment where oil mist is present, it is recommended that the interior of the robot be pressurized to ensure its reliability over a long period of time. Please supply the dry air for pressurization from the phi-8 joint (AIR PURGE) of the robot-arm base rear.

Table 2-6 : Specification of the dry air for pressurization

Item	Dew point	Pressure
Specification	The atmospheric pressure dew point is -20 degree or less.	0 to 0.01MPa

The packing gets deteriorated with the passage of time and must be replaced as required. [Table 2-7](#) provides guidelines for replacing the packing.

Table 2-7 : Packing replacement guideline

Environment	Whether or not robot is pressurized	When packing must be replaced
General environment	Not pressurized ^{Note1)}	When signs of cracking or peeling are noted in the packing.
Clean room	Not pressurized ^{Note1)}	
Oil mist	Pressurized	
	Not pressurized	When removing and installing the cover.

Note1) The pressurization inside the robot arm is unnecessary in general environment and clean room environment.

Failure to replace deteriorated packing permits water or oil to enter the interior of the robot, possibly causing it to become inoperable.

[Table 2-28](#) lists packings requiring replacement and corresponding robot covers. Packing required and liquid gasket used therewith are available from dealer.

Also, entrained water droplets lead to the formation of rust on the robot, but would not usually affect the robot's ability to operate normally.

The warranty is invalid for any faults that occur when the robot is used under the following conditions.

Also, if the cover and/or other parts are damaged by interferences caused by the peripheral devices and the robot, the protection specification (seal performance, etc.) may be degraded. Therefore, please pay extra attention when handling the robot.

Refer to [Page 127, "6.2 Working environment"](#).

- 1) In surroundings that generate inflammable gases or corrosive gasses.
- 2) Atmosphere used excluding cutting oil shown in [Table 2-5](#).
- 3) Environment where the robot is exposed to water, oil and/or chips for a long period of time.
- 4) In surroundings where chips fall directly on the robot. In surroundings where the minimum diameter of chips is less than 0.5mm.
- 5) Mist atmosphere exceeding the specification.
- 6) Pressurization by the dry air exceeding the specification of [Table 2-6](#)

2.2.6 Clean specifications

(1) Types of clean specifications

The robot arm with clean specification is made by order. Please check the delivery schedule.

Table 2-8 : Clean specifications

Type	Degree of cleanliness	Internal suction	Remarks
RV-3SDC/ RV-3SDJC RV-3SDBC/ RV-3SDJBC	10(0.3 μm)	Concentrated suction with vacuum generating valve. Use it in the clean room with the down flow (flow velocity 0.3 m/s above).	The use of a vacuum generating valve is recommended.

■ Precautions for use

- 1) When using a device that moves or rotates the robot arm, the down flow may not be secured because of the air flow. In this case, the degree of cleanliness cannot be ensured.
- 2) A ϕ 8 coupling is provided in the base section of the robot arm for suction inside the robot arm. When using the robot, connect this coupling with the vacuum generating valve and vacuum pump (furnished by the customer).

[1]When the inside of the robot arm is sucked using the vacuum generator.

Table 2-9 : Specifications of vacuum generation valve (Confirmed in our company)

Type	Maker	Air pressure ^{Note1)}
MEDT 14	KONEGAI CORPORATION	<ul style="list-style-type: none"> • Vacuum rate (supply pressure is 0.5MPa): 96l. / min • Ultimate vacuum (supply pressure is 0.5MPa): -84KPa

Note1) Install the vacuum generating valve downstream of the downflow or install a filter in the exhaust air section so that the exhaust air from the vacuum generating valve does not affect cleanliness.
Recommended filter: Exhaust filter EF300-02, Koganei Corporation

[2]If any vacuum pump is prepared by the customer, assure on the vacuum side flow rate 30 liters/min.(ANR) or more.

- 3) When using the Mitsubishi standard option solenoid valve set, use the spare piping (Φ 6 pneumatic hose) of the primary piping to exhaust the air.
If the exhaust leaks into the robot arm, the degree of cleanliness could be affected.

2.3 Names of each part of the robot

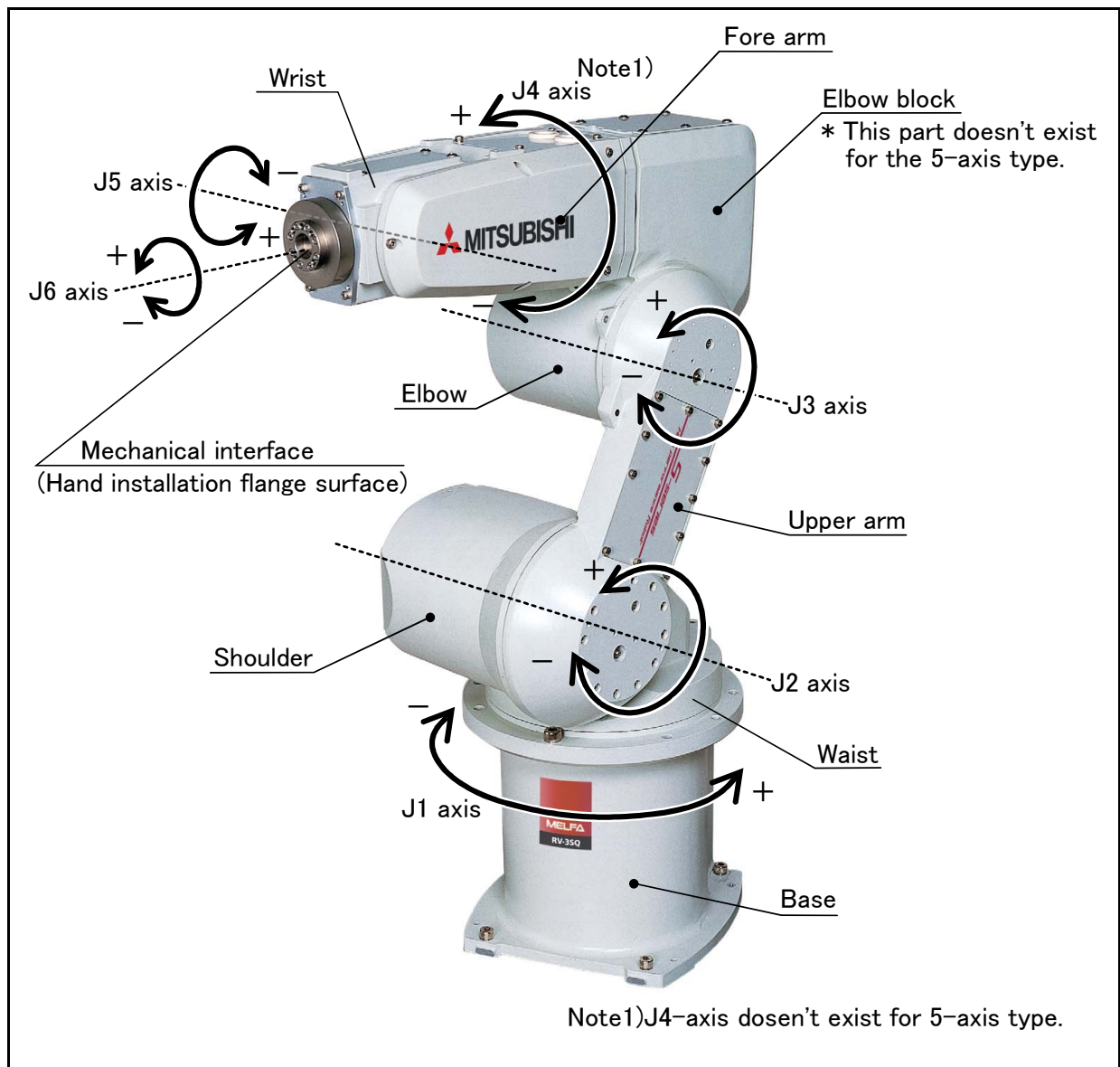

Fig.2-2 : Names of each part of the robot

2.4 Outside dimensions • Operating range diagram

(1) 6-axis type

The type in which all axes have the brake is also the same.

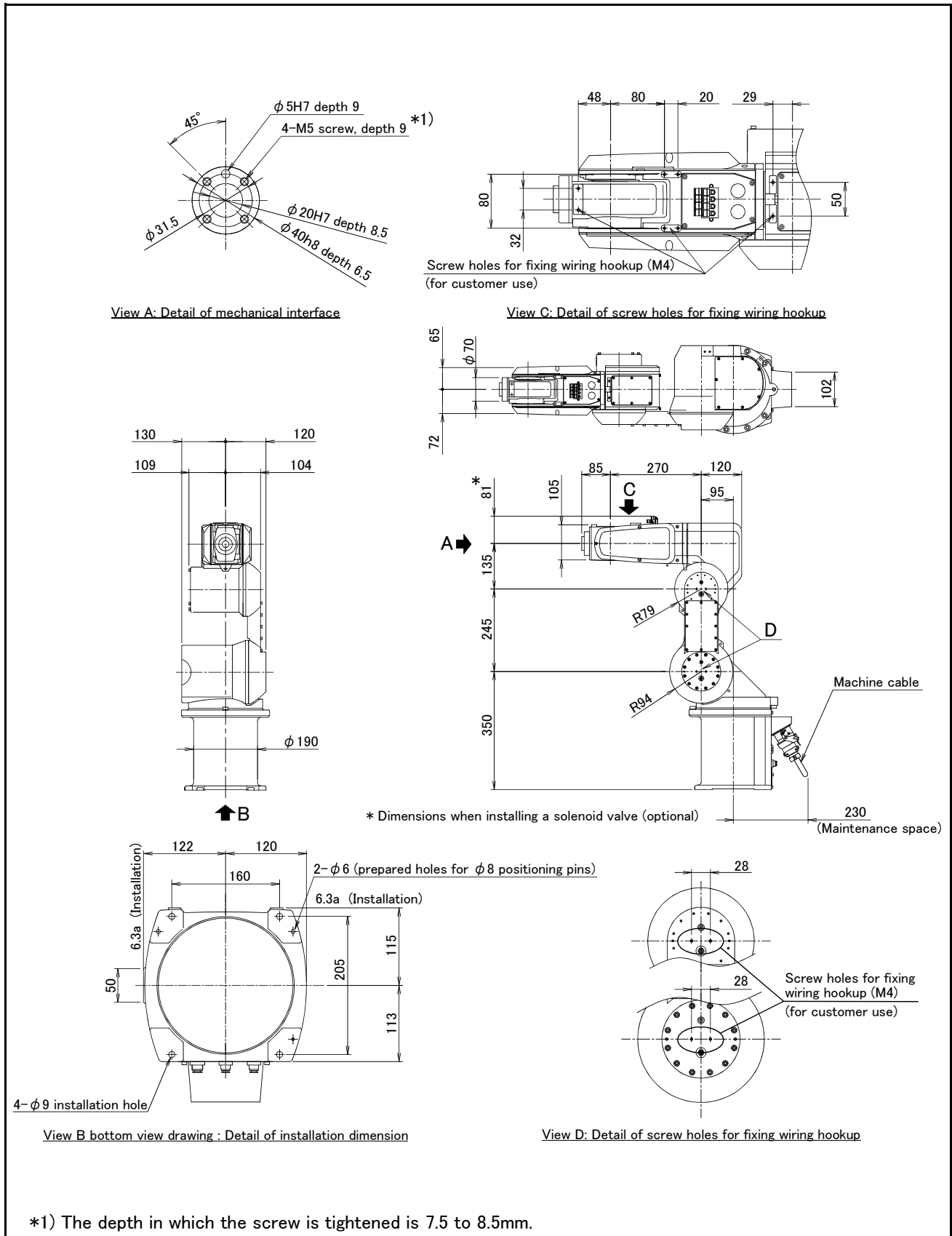

Fig.2-3 : Outside dimensions: (6-axis type)

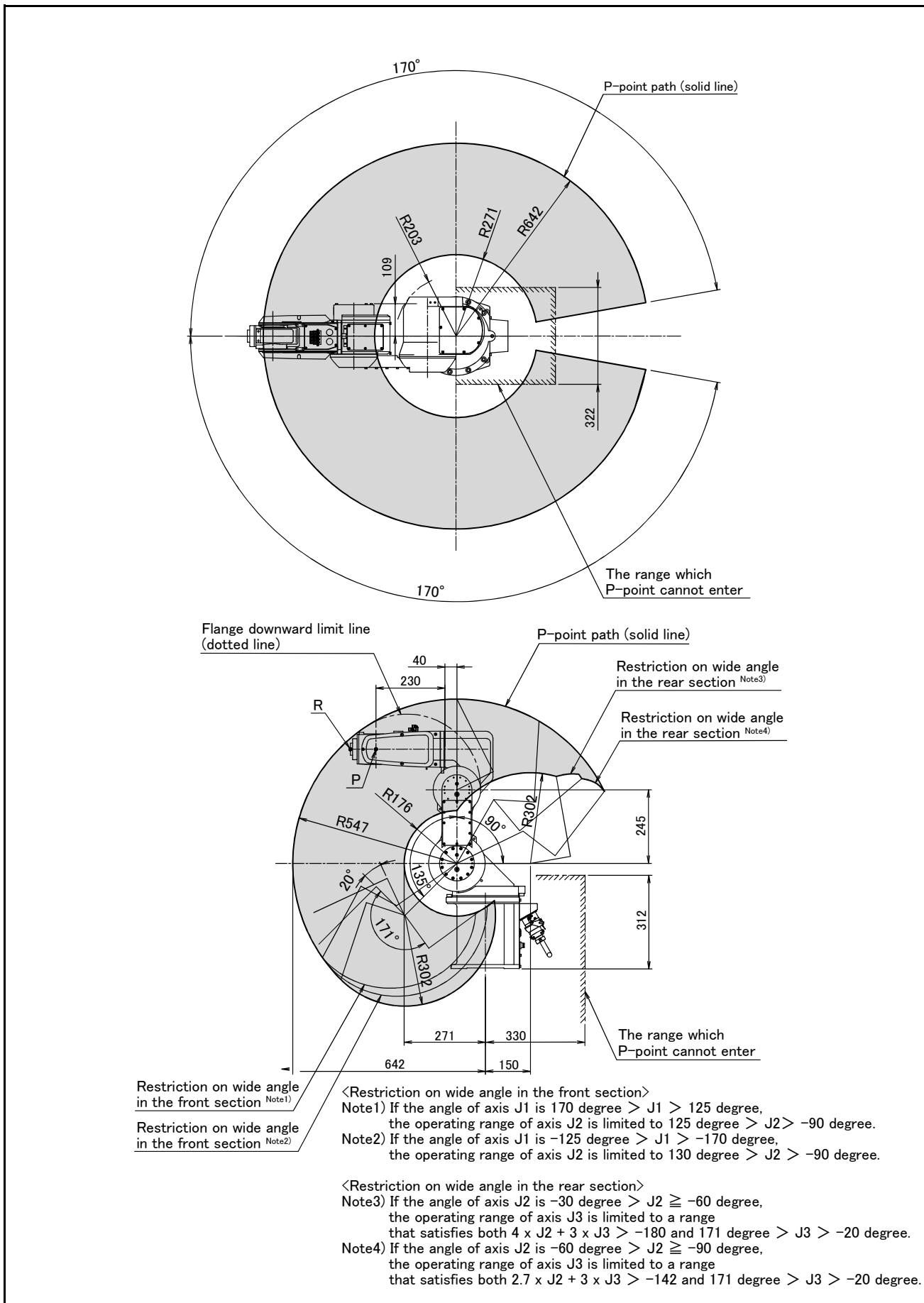

Fig.2-4 : Operating range diagram: (6-axis type)

(2) 5-axis type

The type in which all axes have the brake is also the same.

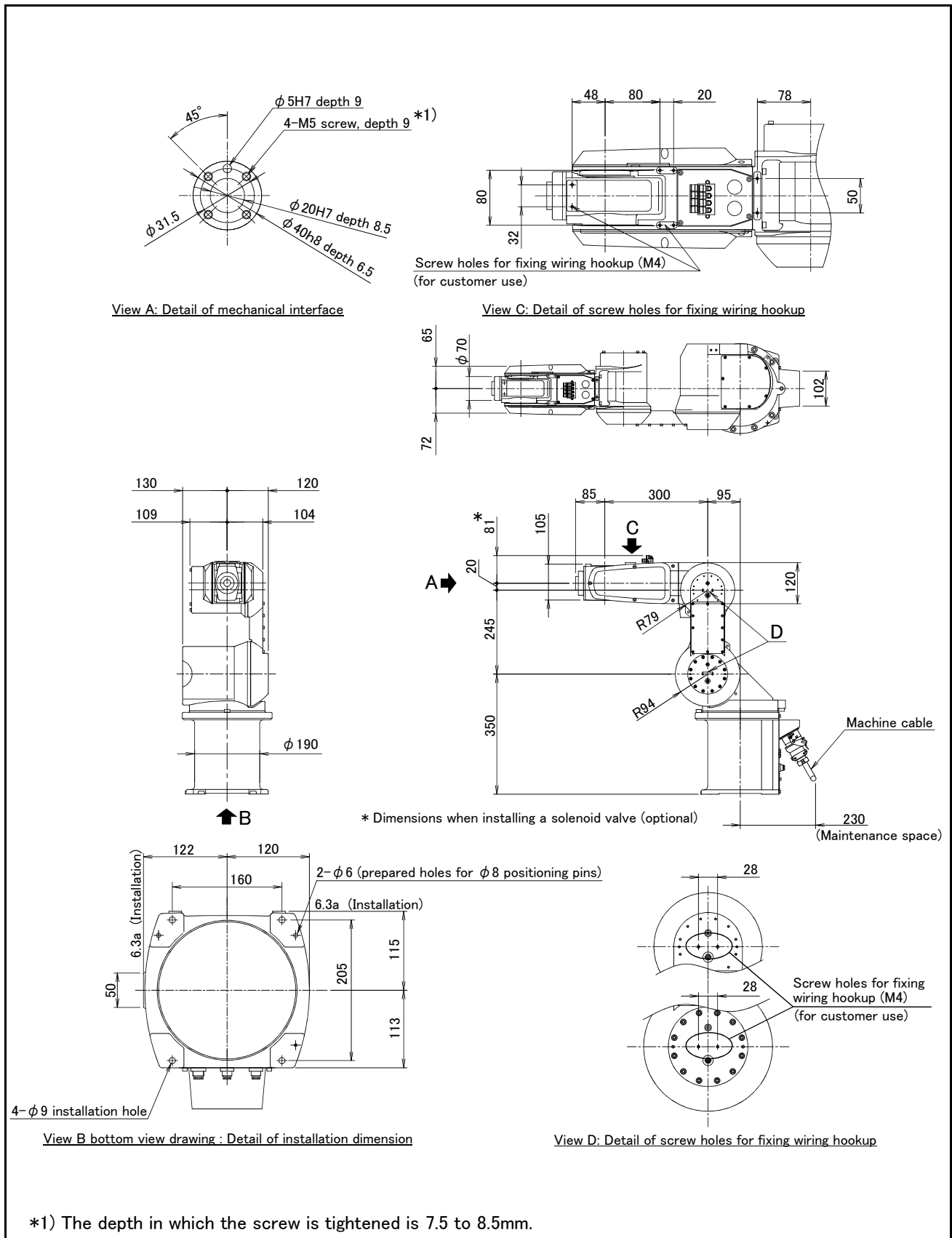

Fig.2-5 : Outside dimensions: (5-axis type)

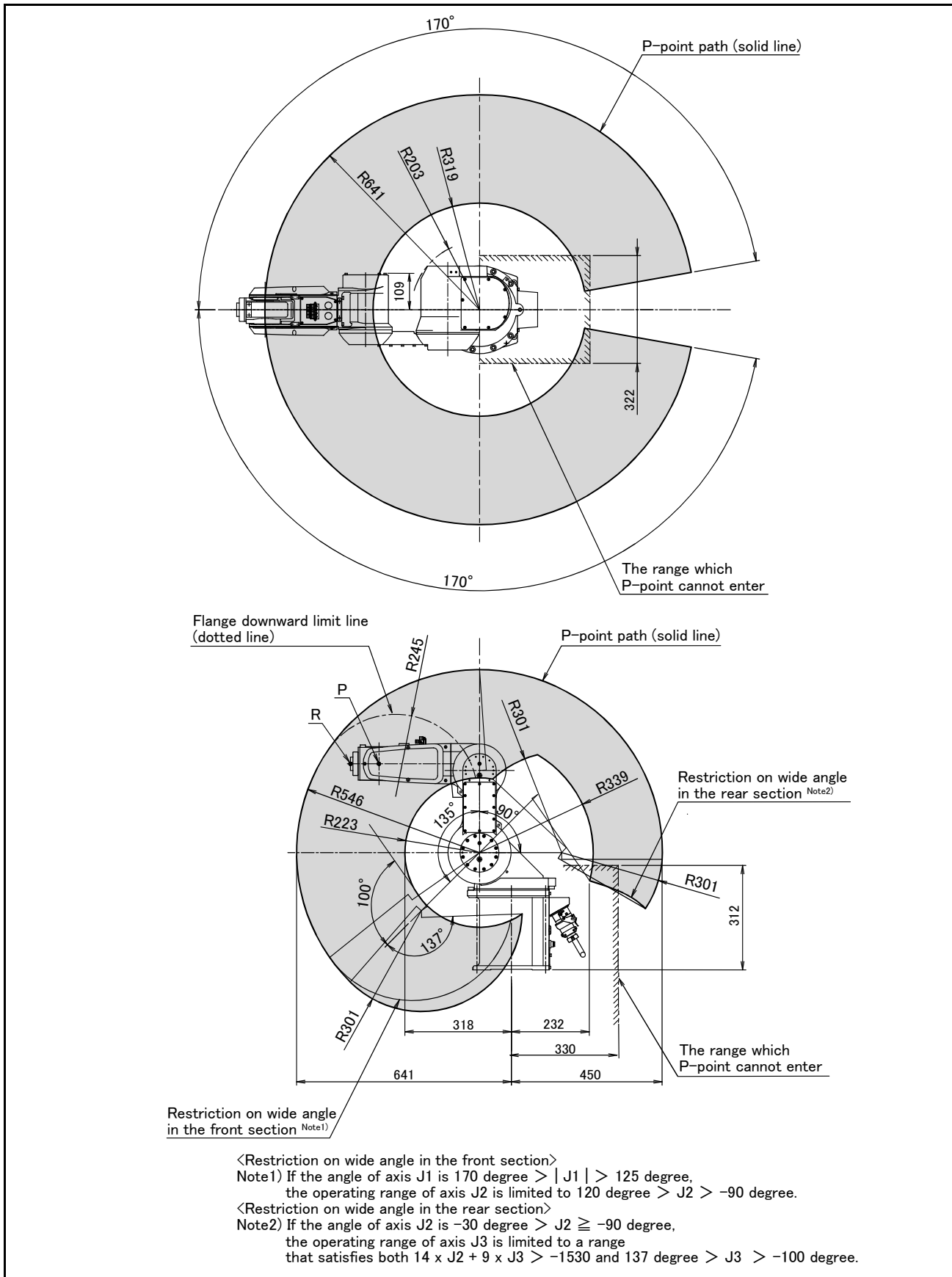

Fig.2-6 : Operating range diagram: (5-axis type)

2.5 Tooling

2.5.1 Wiring and piping for hand

Shows the wiring and piping configuration for a standard-equipped hand.

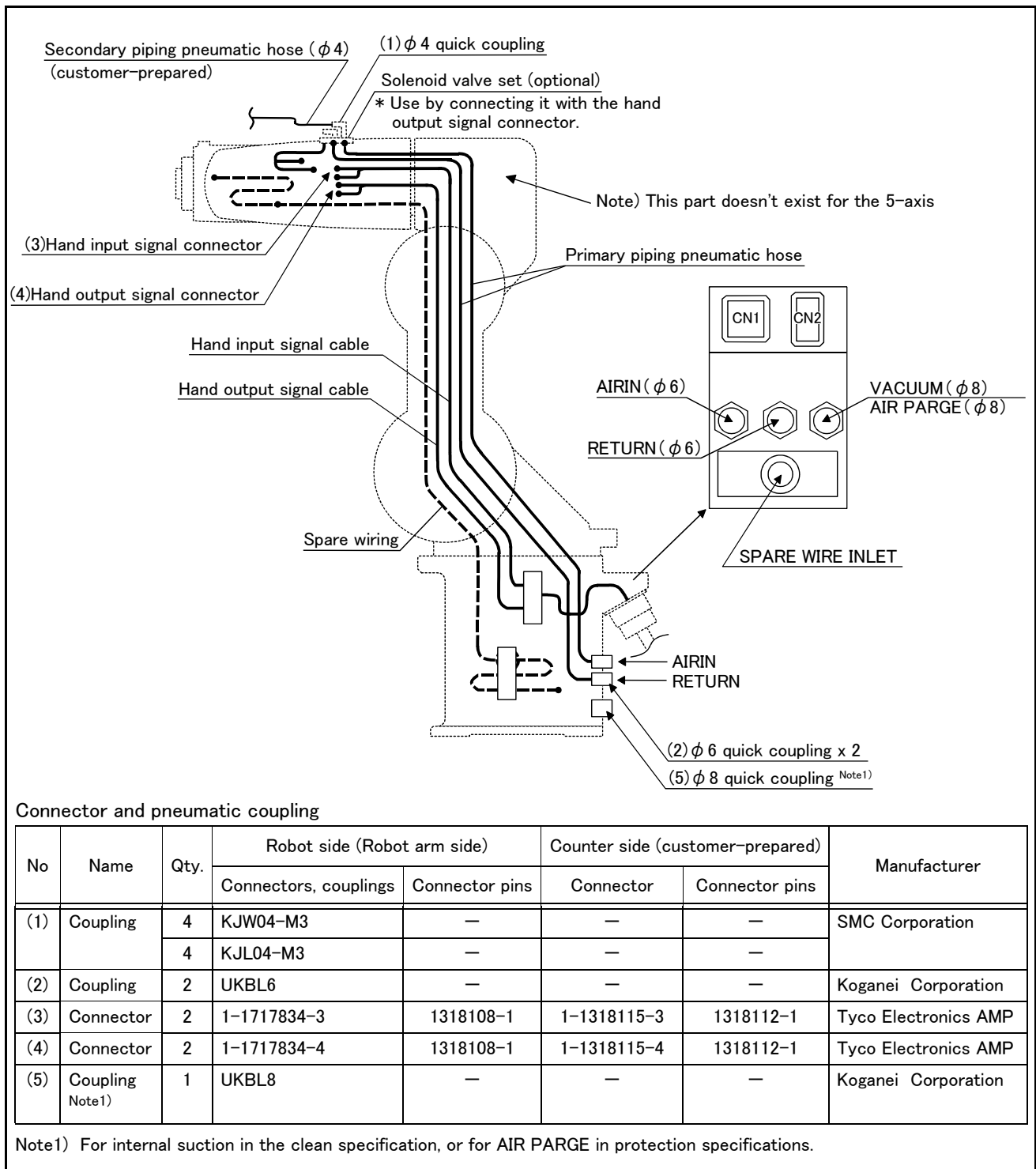

Fig.2-7 : Wiring and piping for hand

2.5.2 Internal air piping

1) General-purpose environment/Oil mist specifications

- The robot has two $\phi 6 \times 4$ urethane hoses from the pneumatic entrance on the base section to the shoulder cover.
- One hose is the primary piping for the pneumatic equipment. The remaining pipe is used for air exhaust.
- The optional solenoid is provided with a maximum of eight couplings for the $\phi 4$ air hose.
- The pneumatic inlet in the base section has a $\phi 6$ pneumatic coupling bridge.
- Refer to [Page 33, "\(3\) Solenoid valve set"](#) for details on the electronic valve set (optional).
- Protection performance can be improved by pressurizing the inside of the robot arm. Since the joint (AIR PURGE) of $\phi 8$ is prepared at the rear of the base section, please supply the dry air for pressurization from this joint. Refer to [Page 13, "2.2.5 Protection specifications"](#) for the details of dry air.

2) Clean specification

- The clean type basically includes the same piping as the standard type.
- With the clean specification, a $\phi 8$ coupling is provided in the base section for suction inside the machine. For use, connect it to the suction port of the vacuum pump or the coupling on the "VACUUM" side of the vacuum generating valve. Moreover, to clean the exhaust from the vacuum pump or vacuum generator, use the exhaust filter (prepared by the customer).
- Refer to [Page 15, "2.2.6 Clean specifications"](#) for details of the vacuum for suction.
- Use clean air as the air supplied to the vacuum generator.

2.5.3 Internal wiring for the pneumatic hand output cable

When the controller uses the optional pneumatic hand interface (2A-RZ365/2A-RZ375), the hand output signal works as the pneumatic hand cable.

- The hand output primary cable extends from the connector PCB of the base section to the inside of the forearm. (AWG#24(0.2mm²)x 2 : 8 cables) The cable terminals have connector bridges for eight hand outputs. The connector names are GR1 and GR2.

To extend the wiring to the outside of the arm, a separate cable (optional "hand output cable 1S-GR35S-01")

2.5.4 Internal wiring for the hand check input cable (Standard type/Clean type)

- The hand input cable extends from the connector PCB of the base section to the inside of the forearm. (AWG#24(0.2mm²)x 2 : 8 cables) The cable terminals have connector bridges for eight hand inputs. The connector names are HC1 and HC2.

- The hand check signal of the pneumatic hand is input by connecting this connector.

To extend the wiring to the outside of the arm, a separate cable (optional "hand input cable "1S-HC25C-01" IP65 is recommended) is required.

2.5.5 Spare Wiring

(1) Standard type

As spare wiring, four pairs of cable cables (AWG#24(0.2mm²) total is eight cores) are preinstalled between the base section and the forearm side section. Customer can utilize it. Refer to the separate "Instruction Manual/ROBOT ARM SETUP & MAINTENANCE" for details.

Both ends of the wire terminals are unprocessed. Use them under the following circumstances:

- For folding as the hand output cable when installing the solenoid valve in outside the robot.
- For when installing six or more hand I/O points for the sensor in the hand section (Connects to the parallel I/O general purpose input.)

Reference) Pin assignment of the connector, and the matching connector

Pin assignment

Pin	Color
A1	Red
A2	Brown
A3	Green
A4	Black
B1	Orange
B2	White
B3	Yellow
B4	Blue

Robot side connector

Connection place	Connector	Contact	Maker
Base portion	2-1318115-4	-	Tyco Electronics AMP K.K.
Fore arm portion	2-1717834-4	-	

Other party connector (recommendation)

Connection place	Connector	Contact	Maker
Base portion	2-1717834-4	1318108-1	Tyco Electronics AMP K.K.
Fore arm portion	2-1318115-4	1318112-1	

2.5.6 Wiring and piping system diagram for hand

Shows the wiring and piping configuration for a standard-equipped hand.

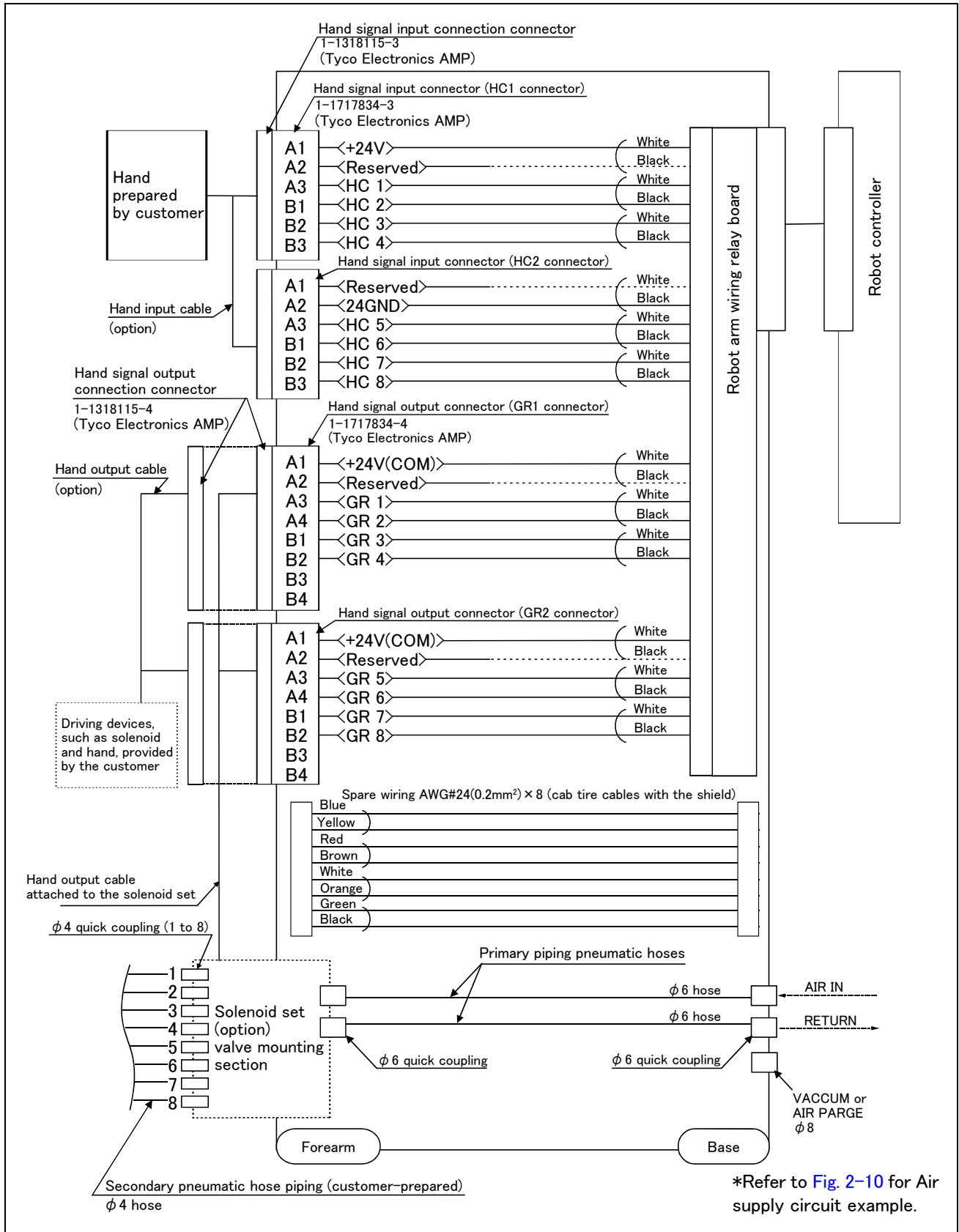

Fig.2-8 : Wiring and piping system diagram for hand and example the solenoid valve installation(Sink type)

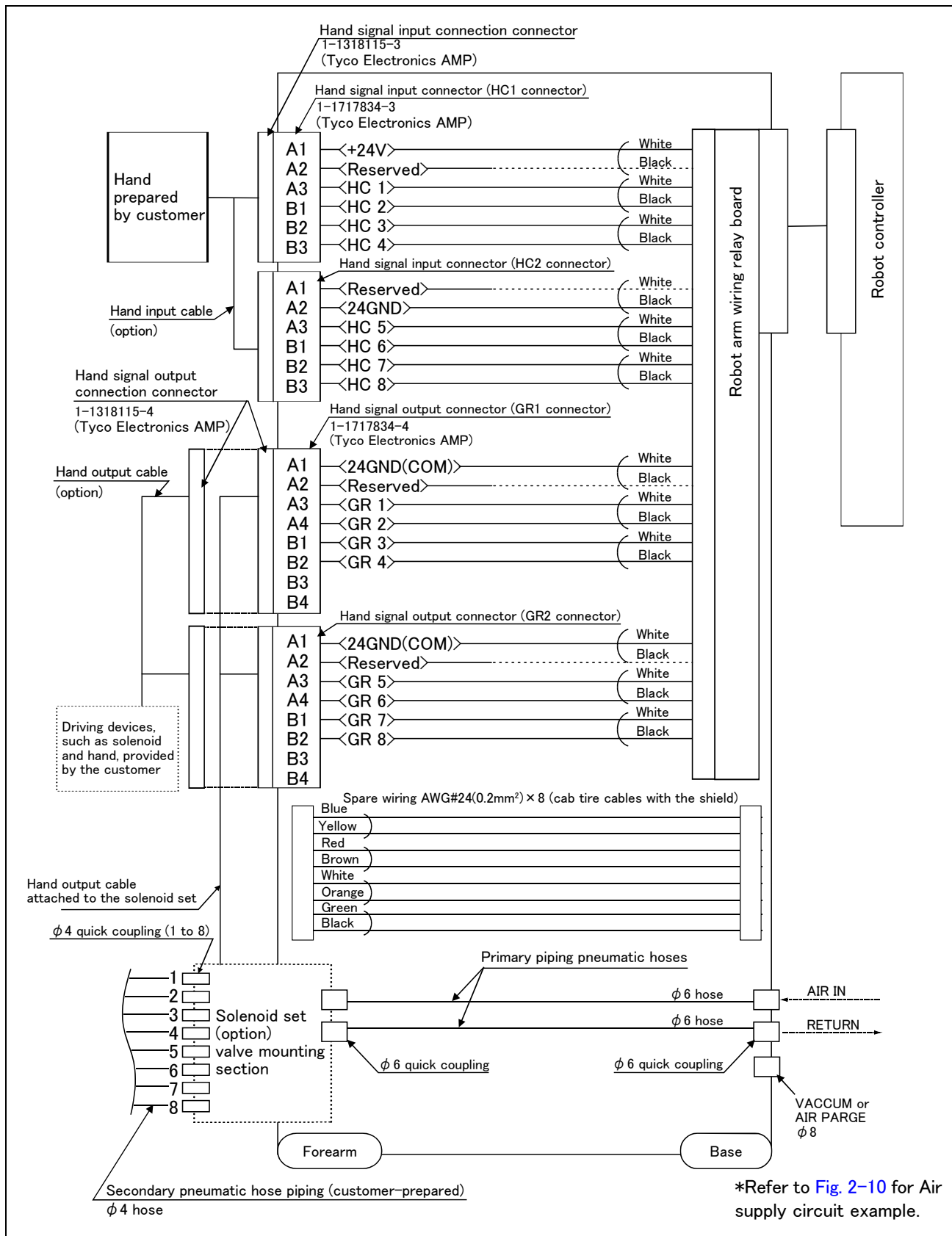

Fig.2-9 : Wiring and piping system diagram for hand and example the solenoid valve installation (Source type)

2.5.7 Electrical specifications of hand input/output

Table 2-10 : Electrical specifications of input circuit

Item		Specifications	Internal circuit
Type		DC input	<p><Sink type></p> <p><Source type></p> <p>* HCn = HC1 ~ HC8</p>
No. of input points		8	
Insulation method		Photo-coupler insulation	
Rated input voltage		12VDC/24VDC	
Rated input current		Approx. 3mA/approx. 7mA	
Working voltage range		DC10.2 to 26.4V(ripple rate within 5%)	
ON voltage/ON current		8VDC or more/2mA or more	
OFF voltage/OFF current		4VDC or less/1mA or less	
Input resistance		Approx. 3.3kΩ	
Response time	OFF-ON	10ms or less(DC24V)	
	ON-OFF	10ms or less(DC24V)	

Table 2-11 : Electrical specifications of output circuit

Item		Specification	Internal circuit
Type		Transistor output	<p><Sink type></p> <p><Source type></p> <p>* GRn = GR1 ~ GR8</p>
No. of output points		8	
Insulation method		Photo coupler insulation	
Rated load voltage		DC24V	
Rated load voltage range		DC21.6 to 26.4VDC	
Max. current load		0.1A/ 1 point (100%)	
Current leak with power OFF		0.1mA or less	
Maximum voltage drop with power ON		DC0.9V(TYP.)	
Response time	OFF-ON	2ms or less (hardware response time)	
	ON-OFF	2 ms or less (resistance load) (hardware response time)	
Fuse rating		1.0A (each one common) Cannot be exchanged	

Note) An optional pneumatic hand interface (2A-RZ365/2A-RZ375) is required to use hand output.

2.5.8 Air supply circuit example for the hand

Fig. 2-10 shows an example of pneumatic supply circuitry for the hand.

- (1) Place diodes parallel to the solenoid coil.
- (2) When the factory pneumatic pressure drops, as a result of the hand clamp strength weakening, there can be damage to the work. To prevent it, install a pressure switch to the source of the air as shown in Fig. 2-10 and use the circuit described so that the robot stops when pressure drops. Use a hand with a spring-pressure clamp, or a mechanical lock-type hand, that can be used in cases where the pressure switch becomes damaged.
- (3) The optional hand and solenoid valve are of an oilless type. If they are used, don't use any lubricator.
- (4) Supply clean air to the vacuum generation valve when you use clean type robot.
- (5) If the air supply temperature (primary piping) used for the tool etc. is lower than ambient air temperature, the dew condensation may occur on the coupling or the hose surface.

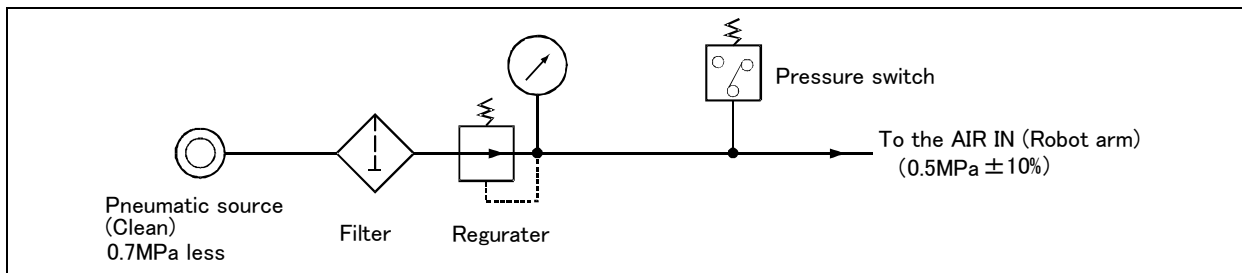

Fig.2-10 : Air supply circuit example for the hand

2.6 Shipping special specifications, options, and maintenance parts

2.6.1 Shipping special specifications

■ What are shipping special specifications?

Shipping special specifications are changed before shipping from the factory. Consequently, it is necessary to confirm the delivery date by the customer.

To make changes to the specifications after shipment, service work must be performed at the work site or the robot must be returned for service.

■ How to order

- (1) Confirm beforehand when the factory special specifications can be shipped, because they may not be immediately available.
- (2) Specified method ····· Specify the part name, model, and robot model type.

(1) Machine cable

■ Order type: ● Fixed type 1S-02UCBL-03 (2m)

■ Outline

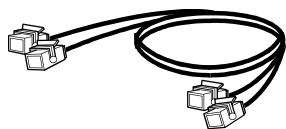

This cable is exchanged for the machine cable (5 m for fixed type) that was supplied as standard to shorten the distance between the controller and the robot arm.

■ Configuration

Table 2-12 : Configuration equipments and types

Part name		Type	Qty.	Mass(kg) ^{Note1)}	Remarks
Fixed	Set of signal and power cables	1S-02UCBL-03	1 set	2.6	2m
	Motor signal cable	BKO-FA0741H02	(1 cable)	-	
	Motor power cable	BKO-FA0768H02	(1 cable)	-	

Note1) Mass indicates one set.

Note) Standard 5 m (for fixed type) is not attached.

[Caution] Orders made after purchasing a robot are treated as purchases of optional equipment. In this case, the machine cable (5 m for fixed type) that was supplied as standard is not reclaimed.

2.7 Options

■ What are options?

There are a variety of options for the robot designed to make the setting up process easier for customer needs. customer installation is required for the options. Options come in two types: "set options" and "single options".

1. Set optionsA combination of single options and parts that together, from a set for serving some purpose.
2. Single optionsThat are configured from the fewest number of required units of a part. Please choose customer's purpose additionally.

(1) Machine cable extension

- Order type : ● Fixed type 1S- □□ CBL-03
 ● Flexed type 1S- □□ LCBL-03 Note) The numbers in the boxes □□ refer the length.

■ Outline

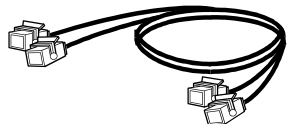

The distance between the robot controller and the robot arm is extensible by this option. This cable is extended to the machine cable attached as standard. (5m for fix type)

A fixed type and flexible type are available. The fix and flexible types are both configured of the motor signal cable and motor power cable.

■ Configuration

Table 2-13 : Configuration equipments and types

Part name	Type ^{Note1)}	Qty.		Mass(kg) Note2)	Remarks
		Fixed	Flexed		
Fixed Set of signal and power cables	1S- □□ CBL-03	1 set	-	4.3(5m)	5m, 10m, or 15m each
	Motor signal cable	(1 cable)	-	7.6(10m)	
	Motor power cable	(1 cable)	-	10.9(15m)	
Flexed Set of signal and power cables	1S- □□ LCBL-03	-	1 set	6.2.(5m)	5m, 10m, or 15m each
	Motor signal cable	-	(1 cable)	11.0(10m)	
	Motor power cable	-	(1 cable)	15.4(15m)	
Nylon clamp	NK-14N	-	2 pcs.	-	for motor signal cable
Nylon clamp	NK-18N	-	2 pcs.	-	for motor power cable
Silicon rubber		-	4 pcs.	-	

Note1) The numbers in the boxes □□ refer the length.

Note2) Mass indicates one set.

■ Specifications

The specifications for the fixed type cables are the same as those for standard cables.

Shows usage conditions for flexed type cables in [Table 2-14](#).

Table 2-14 : Conditions for the flexed type cables

Item	Specifications
Minimum flexed radius	100R or more
Cableveyor, etc., occupation rate	50% or less
Maximum movement speed	2000mm/s or less
Guidance of life count	7.5 million times
Environmental proof	Oil-proof specification sheath (for silicon grease, cable sliding lubricant type)
Cable configuration	Motor signal cable
	Motor power cable

[Caution] The guidance of life count may greatly differ according to the usage state (items related to [Table 2-14](#) and to the amount of silicon grease applied in the cable conduit.

[Caution] This option can be installed on clean-type, but its cleanliness is not under warranty.

■ Cable configuration

The configuration of the flexible cable is shown in Table 2-15. Refer to this table when selecting the cable bare.

Table 2-15 : Cable configuration

Item	Motor signal cable 1S- □□ LCBL(S)-01			Motor power cable 1D- □□ LCBL(P)-02
	AWG#24(0.2mm ²)-4P	AWG#24(0.2mm ²)-7P	AWG#18(0.75mm ²)	AWG#19(0.75mm ²) -3C
No. of cores	Approx. φ 6mm	Approx. φ 8.5mm	Approx. φ 1.7mm	Approx. φ 6mm
No. of cables used	5 cables	1 cable	1 cable	10 cables
No. in total	7 cables			10 cables

Note) The square in the cable name indicates the cable length.

■ Fixing the flexible cable

- (1) Connect the connector to the robot arm .
- (2) Wind the silicon rubber around the cable at a position 300 to 400 mm from the side of robot arm and extension section as shown in Fig. 2-11, and fix with the nylon clamp to protect the cable from external stress.

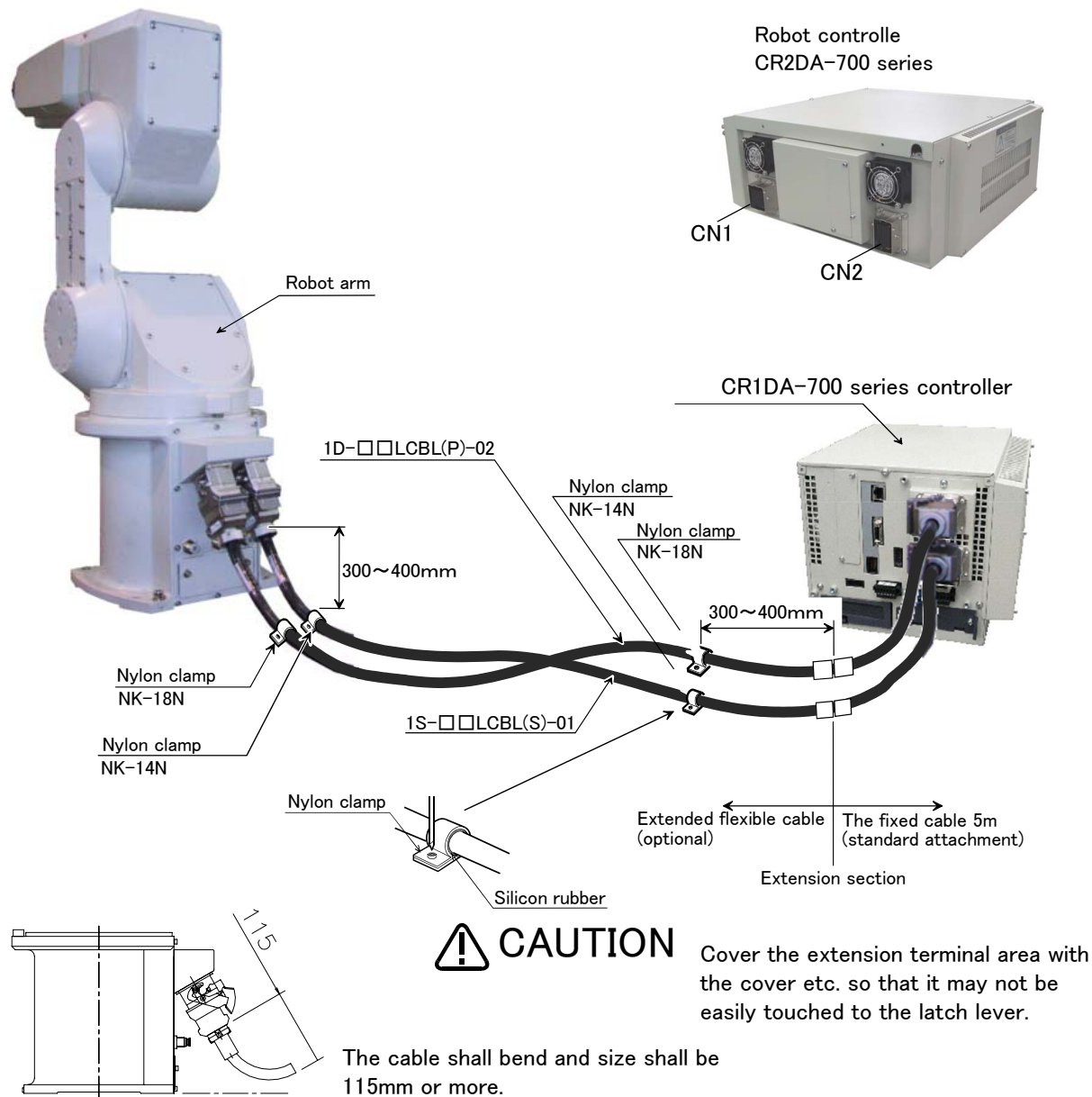

Fig.2-11 : Fixing the flexible cable

(2) Changing the operating range

■ Order type: J1 axis.....1S-DH-03

■ Outline



The operating range of J1 axis is limited by the robot arm's mechanical stopper and the controller parameters.

If the axis could interfere with the peripheral devices, etc., and the operating range need to be limited, use this.

■ Configuration

Table 2-16 : Configuration devices

Part name	Type	Qty.	Mass(kg)	Remarks
Stopper for changing the operating range of J1	1S-DH-03	2 pcs.	0.1	Hexagon socket bolt: M10 x 20 plating (strength classification 10.9)

■ Specifications

Table 2-17 : Specifications

Axis		Standard	Changeable angle
J1	+ side	+170°	One point from +120° , +90° , +60° , +30°
	- side	-170°	One point from -120° , -90° , -60° , -30°

- (1) The changeable angle shown in [Table 2-17](#) indicates the operation range by the software.
The limit by the mechanical stopper is positioned 2.5 degrees outward from that angle, so take care when designing the layout.
- (2) The changeable angle can be set independently on the + side and - side.
- (3) The operating range is changed with robot arm settings and parameter settings. Refer to the separate "Instruction Manual/ROBOT ARM SETUP & MAINTENANCE" or "Instruction Manual/Detailed Explanation of Functions and Operations" for details.

(3) Solenoid valve set

- Order type: One set: 1S-VD01-02(Sink type)/1S-VD01E-02(Source type)
Two sets: 1S-VD02-02(Sink type)/1S-VD02E-02(Source type)
Three sets: 1S-VD03-02(Sink type)/1S-VD03E-02(Source type)
Four sets: 1S-VD04-02(Sink type)/1S-VD04E-02(Source type)

■ Outline

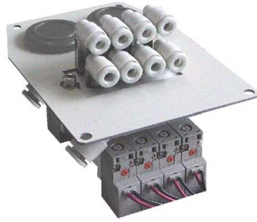

The solenoid valve set is an option that is used for controlling toolings when various toolings, such as the hand, are installed at the end of the arm. All have double solenoid specification, and either one or two or three sets can be selected. This solenoid valve set has a hand output cable attached to the solenoid valve. Also, for easy installation of this electromagnetic set onto the robot, it comes equipped with a manifold, couplings, silencers, among other things.

When using the robot arm's hand output signal, the pneumatic hand interface option*1) must be installed on the separate controller.

■ Configuration

Table 2-18 : Configuration equipment

Part name	Type	Q'ty				Mass(kg) Note1)	Remark
		One set	Two sets	Three sets	Four sets		
Solenoid valve set (1 set)	1S-VD01-02/ 1S-VD01E-02	1 pc.	—	—	—	0.3	M4x8 four screws (installation screws). 1S-VD01-02/VD02-02/VD03-02/ VD04-02 are the sink type. 1S-VD01E-02/VD02E-02/VD03E-02/ VD04E-02 are the source type.
Solenoid valve set (2 sets)	1S-VD02-02/ 1S-VD02E-02	—	1 pc.	—	—	0.4	
Solenoid valve set (3 sets)	1S-VD03-02/ 1S-VD03E-02	—	—	1 pc.	—	0.4	
Solenoid valve set (4 sets)	1S-VD04-02/ 1S-VD04E-02	—	—	—	1 pc.	0.5	

Note1) Mass indicates one set.

■ Specifications

Table 2-19 : Valve specifications

Item	Specifications
Number of positions	2
Port	5 Note1)
Valve function	Double solenoid
Operating fluid	Clean air Note2)
Operating method	Internal pilot method
Effective sectional area (CV value)	0.64mm
Oiling	Unnecessary
Operating pressure range	0.1 ~ 0.7MPa
Response time	22msec or less (at 0.5 MPa)
Max. operating frequency	5Hz
Ambient temperature	-10 to 50 °C (However, there must be no condensation.)

Note1) Couplings of unused solenoid valves must be blocked with plugs. If they are not blocked, supplied air will blow out from the couplings, lowering the air pressure of the solenoid valves being used and making them nonfunctional (recommended plugs: KQ2P-04 plugs made by SMC).

Note2)



CAUTION The air to be provided must be clean, i.e., filtered with a mist separator or air filter. Failing to do so may lead to malfunctions.

Table 2-20 : Solenoid specifications

Item	Specifications
Coil rated voltage	DC24V ±10%
Power consumption	0.55W
Voltage protection circuit with power surge protection	Diode

1) Use "2A-RZ365" for "1S-VD0-02 (sink type) " and use "2A-RZ375" for "1S-VD0*-02E (source type) "

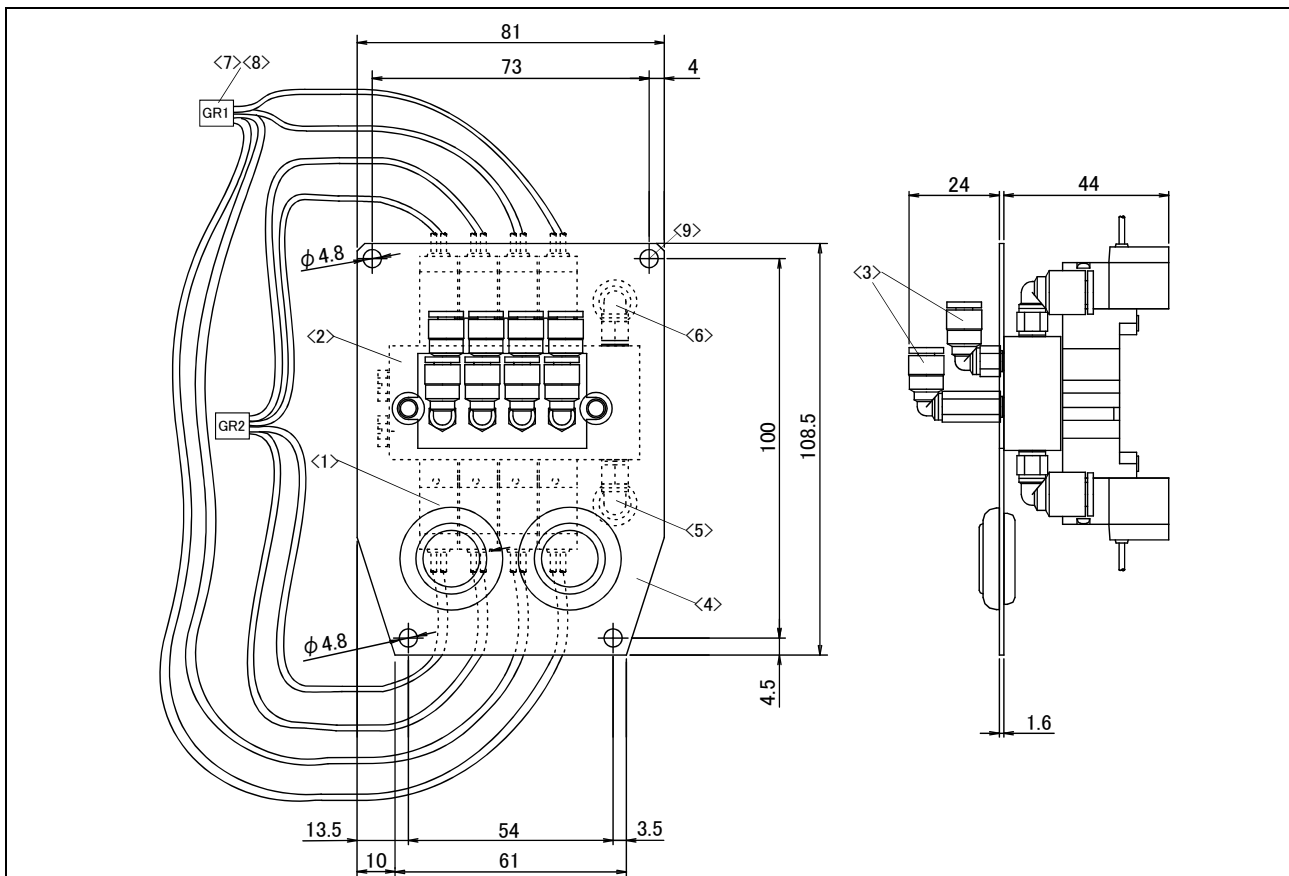

Part no.	Part name	1 sets	2 sets	3 sets	4 sets	Specifications
<1>	Solenoid valve	1	2	3	4	
<2>	Manifold block	1	1	1	1	
<3>	Quick coupling	2	4	6	8	$\phi 4$
<4>	Block plate	1	1	1	1	
<5>	Quick coupling	1	1	1	1	$\phi 6$
<6>	Quick coupling	1	1	1	1	$\phi 6$
<7>	Connector	1	1	2	2	1-1318115-4
<8>	Contact	6	6	12	12	1318112-1
<9>	Installation screw	4	4	4	4	M4 × 8

<Sink type>

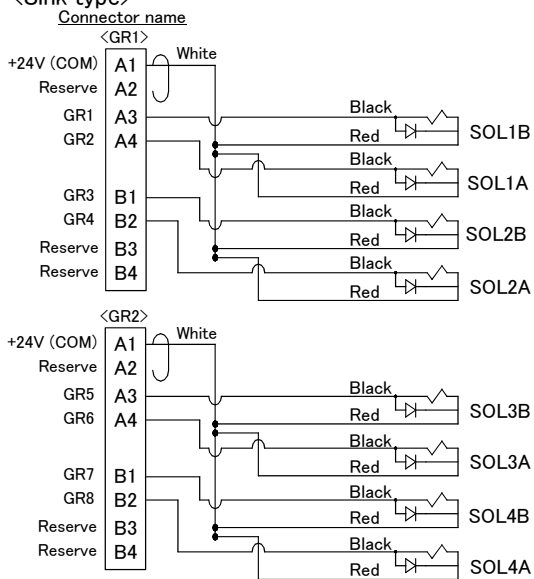

<Source type>

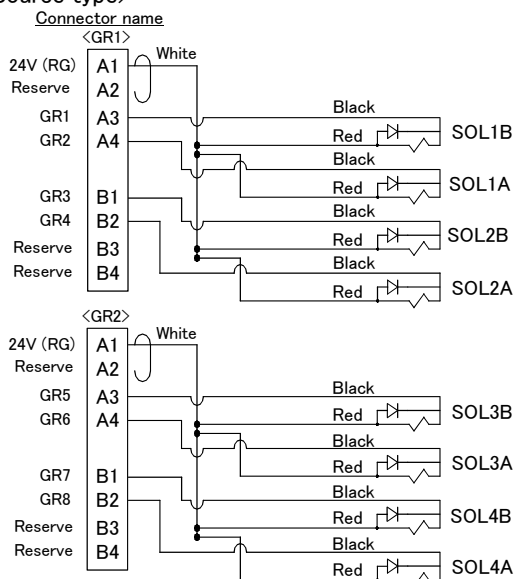
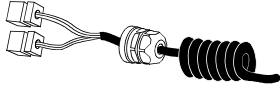

Fig.2-12 : Outline dimensional drawing

(4) Hand input cable

■ Order type: 1S-HC25C-01

■ Outline



The hand input cable is used for customer-designed pneumatic hands. It is necessary to use this to receive the hand's open/close confirmation signals and grasping confirmation signals, at the controller. One end of the cable connects to the connector for hand input signals, which is in the wrist section of the hand. The other end of the cable connects to the sensor inside the hand customer designed.

■ Configuration

Table 2-21 : Configuration equipment

Part name	Type	Qty.	Mass(kg) ^{Note1)}	Remarks
Hand input cable	1S-HC25C-01	1 cable	0.2	

Note1) Mass indicates one set.

■ Specifications

Table 2-22 : Specifications

Item	Specifications	Remarks
Size x cable core	AWG#24 (0.2mm ²) x 12	One-sided connector, one-sided cable bridging
Total length	800mm (Including the curl section, which is 300mm long)	

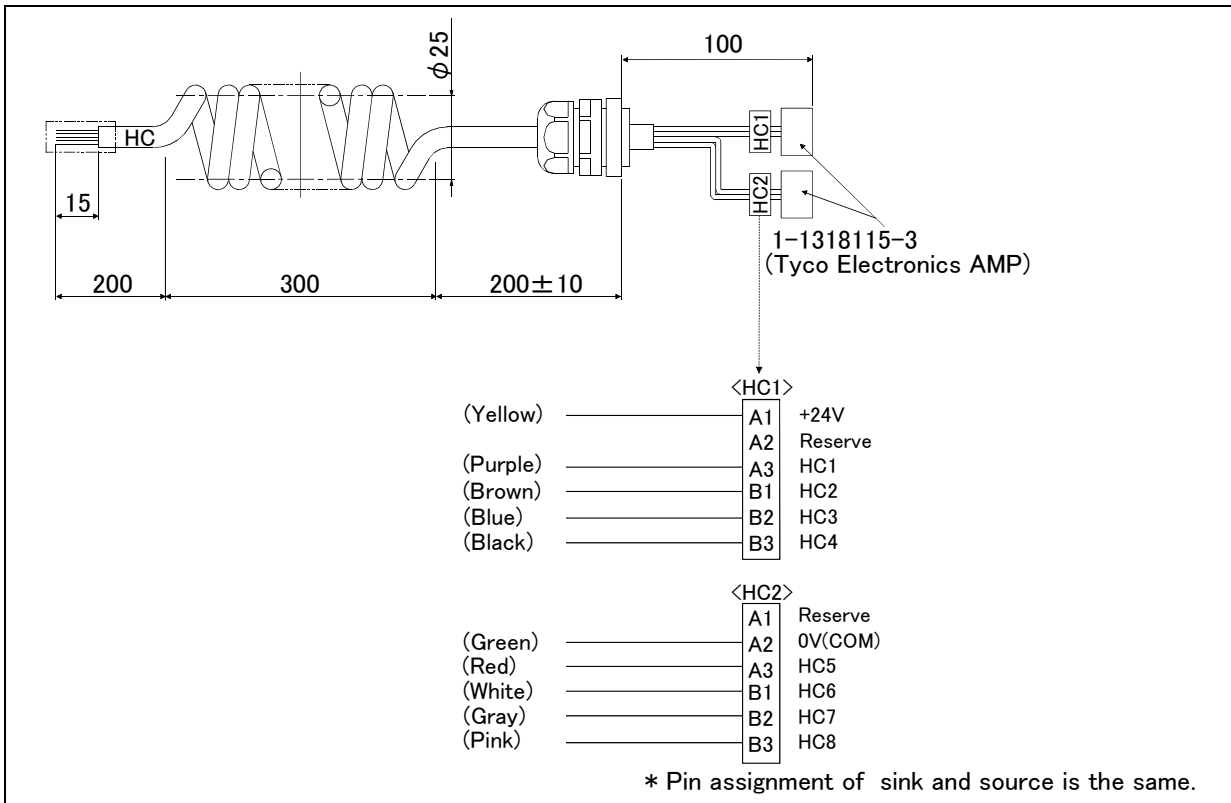

Fig.2-13 : Outside dimensional drawing and pin assignment

[Caution] This option can be installed on clean-type, but its cleanliness is not under warranty.

(5) Hand output cable

■ Order type: 1S-GR35S-01

■ Outline

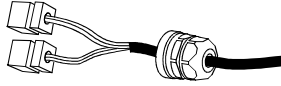

The hand output cable (solenoid valve connection cable) is an option that is used when a solenoid valve other than one of the solenoid valve set options, is used. One end of the cable has a connector that connects to the input terminal inside the robot. The other end of the cable is connected.

■ Configuration

Table 2-23 : Configuration equipment

Part name	Type	Qty.	Mass(kg) ^{Note1)}	Remarks
Hand output cable	1S-GR35S-01	1 cable	0.1	

Note1) Mass indicates one set.

■ Specifications

Table 2-24 : Specifications

Item	Specifications	Remarks
Size x Cable core	AWG#24(0.2mm ²) x 12 cores	One side connector and one side cable connection
Total length	400mm	

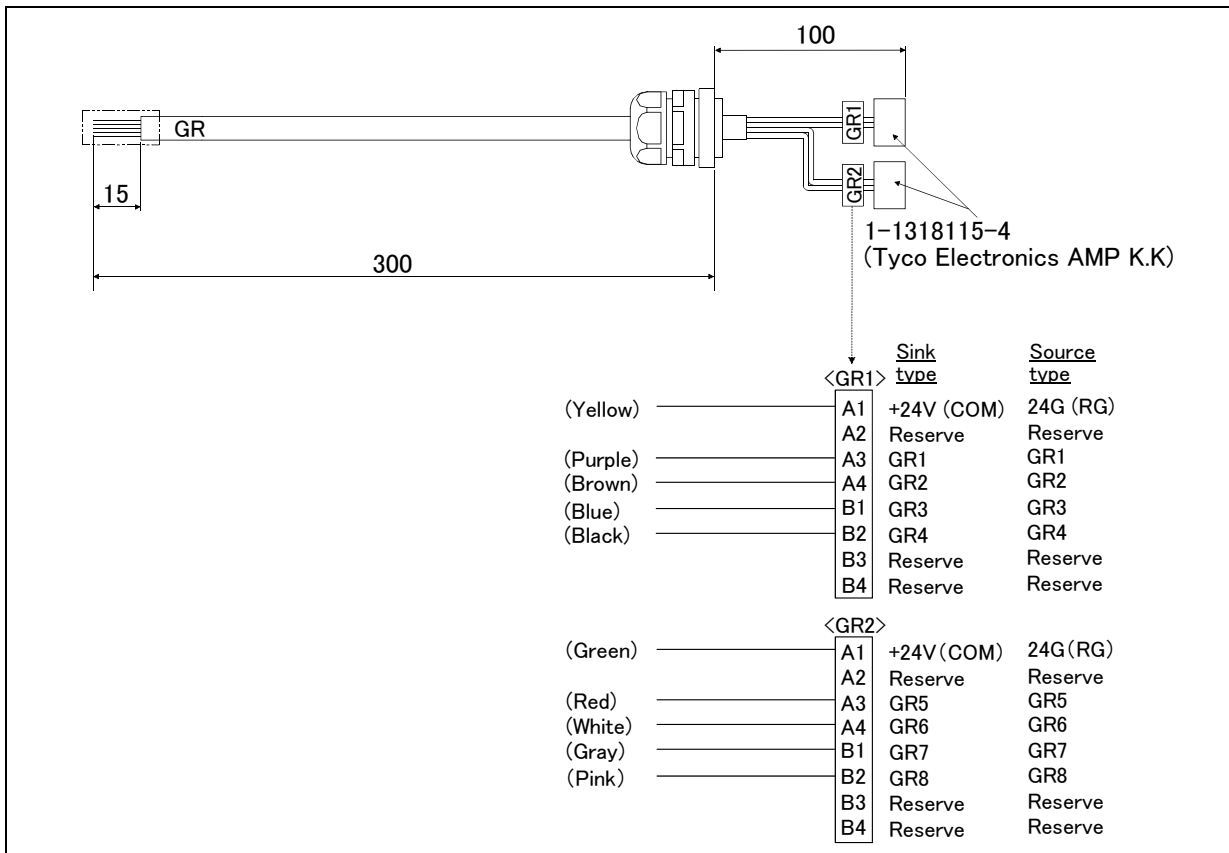

Fig.2-14 : Outline dimensional drawing and pin assignment

[Cautions] When you install this optional one in the protection specification type, please seal the fixing section of the robot with silicon rubber by the customer.

[Caution] This option can be installed on clean-type, but its cleanliness is not under warranty.

(6) Hand curl tube

- Order type: One set :1E-ST0402C
- Two sets :1E-ST0404C
- Three sets :1E-ST0406C
- Four sets :1E-ST0408C

■ Outline

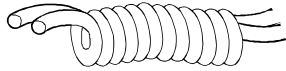

The hand curl tube is a curl tube for the pneumatic hand.

■ Configuration

Table 2-25 : Configuration equipment

Part name	Type	Qty.	Mass(kg) ^{Note1)}	Remarks
Hans curl tube (One set: 2 pcs.)	1E-ST0402C	1 pc.	0.1	Φ4 tube, 2pcs.
Hans curl tube (Two set: 4 pcs.)	1E-ST0404C	1 pc.	0.1	Φ4 tube, 4pcs.
Hans curl tube (Three set: 6 pcs.)	1E-ST0406C	1 pc.	0.1	Φ4 tube, 6pcs.
Hans curl tube (Four set: 8 pcs.)	1E-ST0408C	1 pc.	0.1	Φ4 tube, 8pcs.

Note1) Mass indicates one set.

■ Specifications

Table 2-26 : Specifications

Item	Specifications
Material	Urethane
Size	Outside diameter: ϕ x Inside diameter: ϕ

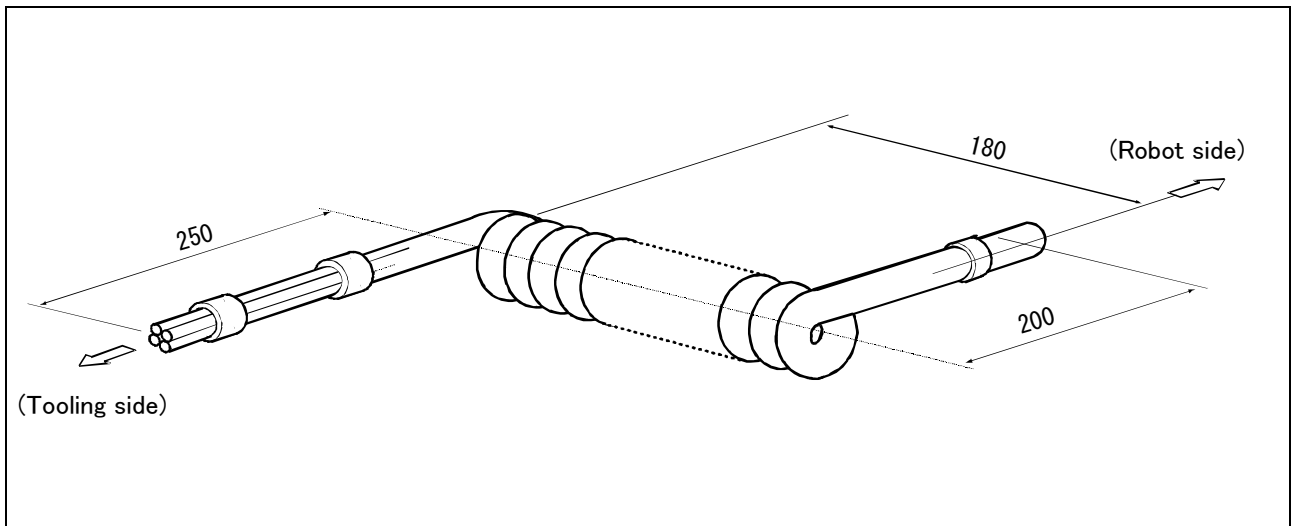

Fig.2-15 : Outline dimensional drawing

[Caution] This option can be installed on clean-type, but its cleanliness is not under warranty.

2.8 About Overhaul

Robots which have been in operation for an extended period of time can suffer from wear and other forms of deterioration. In regard to such robots, we define overhaul as an operation to replace parts running out of specified service life or other parts which have been damaged, so that the robots may be put back in shape for continued use. Overhaul interval for robots presumably varies with their operating conditions and thus with the degree of the equipment's wear and loss of performance. As a rule of thumb, however, it is recommended that overhaul be carried out before the total amount of servo-on time reaches the predetermined levels (24,000 hours for the robot body and 36,000 hours for the controller). (See Fig. 2-16.) For specific information about parts to be replaced and timing of overhaul, contact your local service representative.

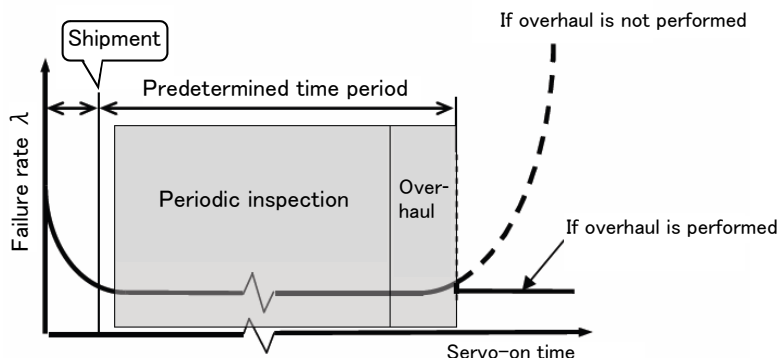

Fig.2-16 : Periodic inspection/overhaul periods

2.9 Maintenance parts

The consumable parts used in the robot arm are shown in Table 2-27. Purchase these parts from the designated maker or dealer when required. Some Mitsubishi-designated parts differ from the maker's standard parts. Thus, confirm the part name, robot arm and controller serial No. and purchase the parts from the dealer.

Table 2-27 : Consumable part list

No.	Part name	Type ^{Note1)}	Usage place	Qty.	Supplier
1	Grease	SK-1A	Reduction gears of each axis	As needed	Mitsubishi Electric
2	Lithium battery	A6BAT	In the shoulder cover A Type: All axis have brake	4	
3			In the shoulder cover A Type: J4 and J6 have no brake	5	

Note1) Confirm the robot arm serial No., and contact the dealer or service branch of Mitsubishi Electric Co., for the type.

Table 2-28 : Consumable part (packing) list

No.	part name	Details of configuration		Usage place		
		Packing name	Qty.	Cover name	Qty.	Sticking side
RV-3SD series						
1	Cover packing A set Part Code : K07S24021557	Conbox packing L	1	CONBOX cover	1	Cover side
		Conbox packing R	1		1	Cover side
		Shoulder A packing	1	Shoulder cover A	1	Cover side
		Shoulder B packing T	1	Shoulder cover B	1	Cover side
		Shoulder B packing B	1		1	Cover side
		Elbow B packing	1	Elbow cover B	1	Cover side
		ADD packing	1	ADD cover	1	Cover side
2	Cover packing B set Part Code : K07S24021558	Elbow A packing L	1	Elbow cover A	1	Cover side
		Elbow A packing R	1		1	Cover side
		Elbow C packing	1	Elbow cover C	1	Cover side
		Elbow D packing T	1	Elbow cover D	1	Cover side
		Elbow D packing B	1		1	Cover side
3	PackingA Part Code : K07S24409801	PackingA	1	No.1 arm cover	1	Robot arm side
				Bottom plate	2	Robot arm side
4	No.2 arm cover packing Part Code : K07S24342001	No.2 arm cover packing	1	No. 2 arm cover A	1	Cover side
5	No.2 arm cover C packing Part Code : K07S24401502	No.2 arm cover C packing	1	No. 2 arm cover C	1	Robot arm side
6	Wrist cover packing Part Code : K07S24401602	Wrist cover packing	1	Wrist cover	1	Robot arm side
RV-3SDJ/3SDJC						
7	Cover packing A set Part Code : K07S24021557	Conbox packing L	1	CONBOX cover	1	Cover side
		Conbox packing R	1		1	Cover side
		Shoulder A packing	1	Shoulder cover A	1	Cover side
		Shoulder B packing T	1	Shoulder cover B	1	Cover side
		Shoulder B packing B	1		1	Cover side
		Elbow B packing	1	Elbow cover B	1	Cover side
		ADD packing	1	ADD cover	1	Cover side
8	Elbow E packing Part Code : K07S24338651	Elbow E packing F	1	Elbow cover B	1	Cover side
		Elbow E packing B	1		1	Cover side
9	PackingA Part Code : K07S24409801	PackingA	1	No.1 arm cover	1	Robot arm side
				Bottom plate	2	Robot arm side
10	No.2 arm cover packing Part Code : K07S24342001	No.2 arm cover packing	1	No. 2 arm cover A	1	Cover side
11	No.2 arm cover C packing Part Code : K07S24401502	No.2 arm cover C packing	1	No. 2 arm cover C	1	Robot arm side
12	Wrist cover packing Part Code : K07S24401602	Wrist cover packing	1	Wrist cover	1	Robot arm side

3 Controller

3.1 Standard specifications

3.1.1 Standard specifications

Table 3-1 : Standard specifications of controller (CR1DA-700 series)

Item		Unit	Specification	Remarks
Type ^{Note1)}			CR1DA-700 series	RV-3SD(6-axis) : CR1DA-721 RV-3SDJ(5-axis) : CR1DA-731
Number of control axis			Simultaneously 6/5	
Memory capacity	Programmed positions and No. of steps	point step	13,000 26,000	
	Number of programs		256	
	Robot language			MELFA-BASIC V or MELFA-BASIC IV ^{Note2)}
Teaching method			Pose teaching method ,MDI method ^{Note3)}	
External input and output	input and output	point	0/0 ^{Note4)}	Max. 256/256 by option
	Dedicated input/output	point	Assigned with general-purpose input/output	
	Special stop input	point	1	
	Hand open/close input/output	point	Input 8 point/Output 0 point	Up to 8 output points can be added as an option ^{Note5)}
	Emergency stop input	point	1	Dual line, normal close
	Door switch input	point	1	Dual line, normal close
	Enabling device input	point	1	Dual line, normal close
	Mode output	point	1	Dual line
	Robot error output	point	1	Dual line
	Addition axis synchronization	point	1	Dual line
Interface	RS-232C	port	1	For expansion such as the personal computer, Vision sensor
	Ethernet	port	1: For T/B, 1: For customers	10BASE-T/100BASE-Tx
	USB		1	Ver. 2.0 Only device function
	Hand dedicated slot	slot	1	Dedicated for pneumatic hand interface
	Option slot	slot	1	
	Additional axis interface	Channel	1	SSCNET III
	Serial encoder interface	Channel	1	For encoder cable connection
Power source	Input voltage range	V	1-phase, AC180 to 253	^{Note6)}
	Power capacity	KVA	1.0	Does not include rush current ^{Note7)}
Outline dimensions ^{Note8)}		mm	CR1DA-700 (Standard specification) : 240(W)x290(D)x200(H) CR1DA-700 (CE marking specification) : 270(W)x290(D)x200(H)	Excluding protrusions
Mass		kg(lb)	Approx. 9(19.8)	
Construction			Self-contained floor type Opened type	IP20 ^{Note9)}
Operating temperature range		°C	0 to 40	
Ambient humidity		%RH	45 to 85	Without dew drops
Grounding		Ω	100 or less	D class grounding earth ^{Note10)}
Paint color			Light gray	Munsell 0.08GY7.64/0.81

Note1) The controller of CE marking specification

*"-S12" specification: the controller is CR1DA-700-S12 series.

*"-S312" specification: the controller is CR2DA-700-S312 series.

Note2) The program of MELFA-BASIC IV can be used by MELFA-BASIC V, if program is converted by RT ToolBox2 (option).

Note3) Pose teaching method: The method to register the current position of the robot arm.

MDI method: The method to register by inputting the numerical value Immediate.

Note4) The 32/32 points can be use for S12 specification only. (One parallel I/O interface(2D-TZ378) is installed at factory shipping)

Note5) It is when an pneumatic hand interface (2A-RZ365/2A-RZ375) is installed.

Note6) Please use the controller with an input power supply voltage fluctuation rate of 10% or less.

Note7) The power capacity is the rating value for normal operation. The power capacity does not include the rush current when the power is turned ON. The power capacity is a guideline and the actual operation is affected by the input power voltage. The short circuit breaker should use the following.

*Operate by the current leakage under the commercial frequency domain (50-60Hz). If sensitive to the high frequency ingredient, it will become the cause in which below the maximum leak current value carries out the trip.

Note8) Refer to Page 50, "3.3 Outside dimensions/Installation dimensions" for details.

Note9) This controller is a general environment specification. If the controller used in the clean environment, install to the place which does not have effect to cleanness.

Note10) The robot must be grounded by the customer.

Table 3-2 : CE Marking specifications of controller (CR2DA-700 series)

Item		Unit	Specification	Remarks
Type			CR2DA-721/731	RV-3SD(6-axis) : CR2DA-721 RV-3SDJ(5-axis) : CR2DA-731
Number of control axis			Simultaneously 6/5	
Memory capacity	Programmed positions and No. of steps	point step	13,000 26,000	
	Number of programs		256	
Robot language			MELFA-BASIC V or MELFA-BASIC IV ^{Note1)}	
Teaching method			Pose teaching method ,MDI method ^{Note2)}	
External input and output	input and output	point	0/0 ^{Note3)}	Max. 256/256 by option
	Dedicated input/output	point	Assigned with general-purpose input/output	
	Special stop input	point	1	
	Hand open/close input/output	point	Input 8 point/Output 0 point	Up to 8 output points can be added as an option ^{Note4)}
	Emergency stop input	point	1	Dual line, normal close
	Door switch input	point	1	Dual line, normal close
	Enabling device input	point	1	Dual line, normal close
	Mode output	point	1	Dual line
	Robot error output	point	1	Dual line
Addition axis synchronization	point	1	Dual line	
Interface	RS-232C	port	1	For expansion such as the personal computer, Vision sensor
	Ethernet	port	1: For T/B, 1: For customers	10BASE-T/100BASE-Tx
	USB		1	Ver. 2.0 Only device function
	Hand dedicated slot	slot	1	Dedicated for pneumatic hand interface
	Option slot	slot	3	
	Additional axis interface	Channel	1	SSCNET III
	Serial encoder interface	Channel	1	For encoder cable connection
Power source	Input voltage range	V	1-phase, AC180 to 253	^{Note5)}
	Power capacity	KVA	2.0	Does not include rush current ^{Note6)}
Outline dimensions ^{Note7)}		mm	467(W) x 400(D) x 200(H)	Excluding protrusions
Mass		kg(lb)	Approx. 21(46)	
Construction			Self-contained floor type, Opened type	IP20 ^{Note8)}
Operating temperature range		deg.	0 to 40	
Ambient humidity		%RH	45 to 85	Without dew drops
Grounding		Ω	100 or less	D class grounding earth ^{Note9)}
Paint color			Light gray	Munsell 0.08GY7.64/0.81

Note1) The program of MELFA-BASIC IV can be used by MELFA-BASIC V, if program is converted by RT ToolBox2 (option).

Note2) Pose teaching method: The method to register the current position of the robot arm.

MDI method: The method to register by inputting the numerical value Immediate.

Note3) The 32/32 points can be use for S312 specification only. (One parallel I/O interface(2D-TZ378) is installed at factory shipping)

Note4) It is when an pneumatic hand interface (2A-RZ365/2A-RZ375) is installed.

Note5) Please use the controller with an input power supply voltage fluctuation rate of 10% or less.

Note6) The power capacity is the rating value for normal operation. The power capacity does not include the rush current when the power is turned ON. The power capacity is a guideline and the actual operation is affected by the input power voltage. The power consumption in the specific operation pattern with the series is approx. .

Note7) Refer to Page 50, "3.3 Outside dimensions/Installation dimensions" for details.

Note8) This controller is a general environment specification.

Please contact to dealer, if you need the controller of protection specification of CE specification.

Note9) The robot must be grounded by the customer.

3.1.2 Protection specifications and operating supply

A protection method complying with the IEC Standard IP20(Opened type) is adopted for the controller.

The IEC IP symbols refer only to the degree of protection between the solid and the fluids, and don't indicated that any special protection has been constructed for the prevention against oil and water.

【Information】

- The IEC IP20

It indicates the protective structure that prevents an iron ball $12^{+0.05}_0$ mm diameter, which is being pressed with the power of $3.1 \text{ kg} \pm 10\%$, from going through the opening in the outer sheath of the supplied equipment.

- The IEC IP54

The IEC IP54 standard refers to protection structure designed to prevent any harmful effects by fresh water scattering vertically onto the testing equipment in a radius of 180 degrees from a distance of 300 to 500 mm, with 10 ± 0.5 liters of water every minute, at a water pressure of 80 to 100kPa , covering the entire area of the robot with the exception of the installation section at 1 m^2 per minute, for a total of 5 minutes or more.

Refer to the section [Page 127, "6.2 Working environment"](#) for details on the working environment.

CAUTION

If the robot is used in an oil mist environment, use the optional controller protection box (CR1D-MB) to protect the CR1DA-700 series controller from the oil mist environment. (Only for the controller of standard specification)

3.2 Names of each part

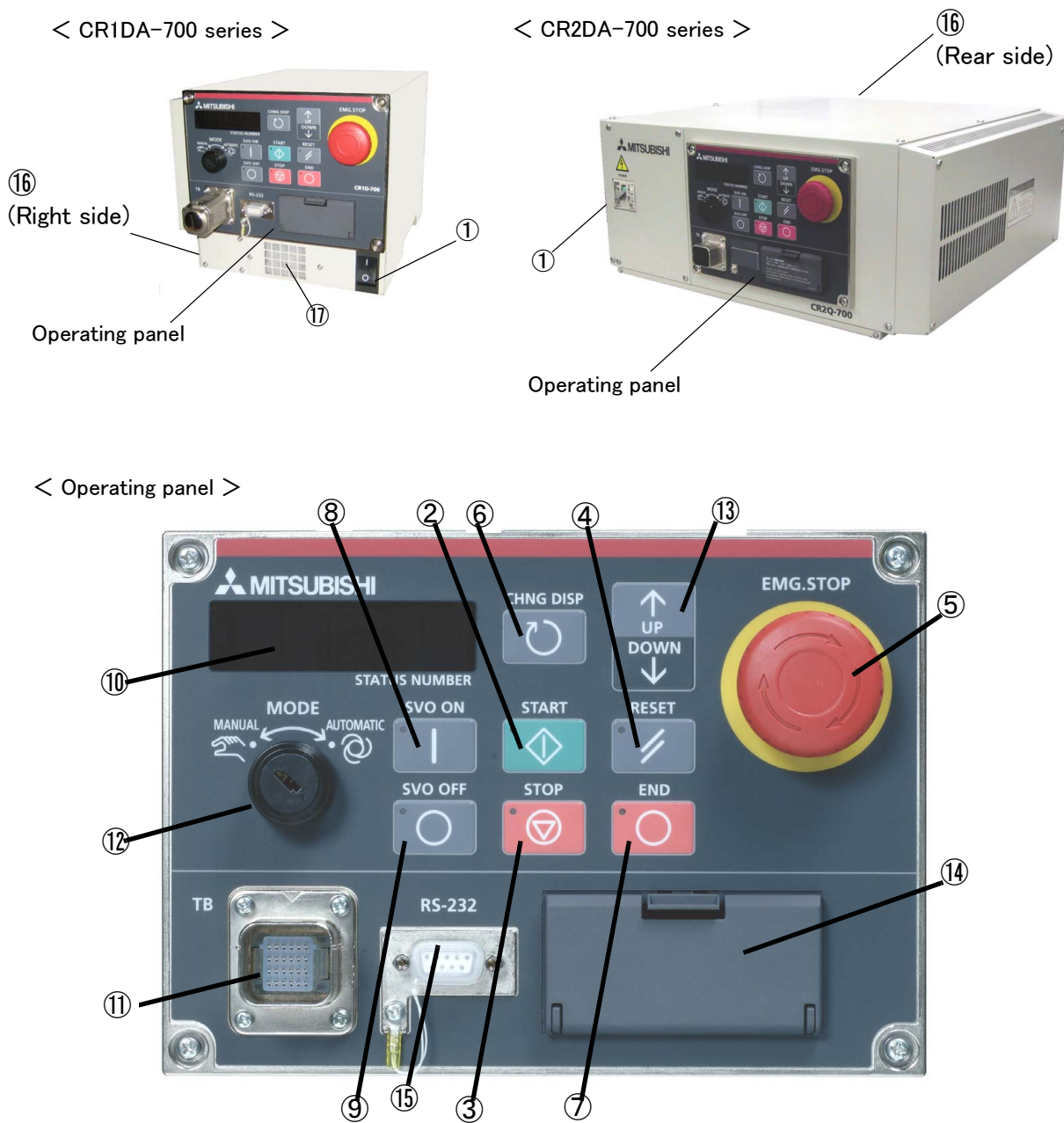

Fig.3-1 : Names of controller parts (CR1DA-700 series)

- ① POWER switch ^{Note 1)} This turns the control power ON/OFF. (With earth leakage breaker function)
- ② START button..... This executes the program and operates the robot. The program is run continuously.
- ③ STOP button..... This stops the robot immediately. The servo does not turn OFF.
- ④ RESET button..... This resets the error. This also resets the program's halted state and resets the program.
- ⑤ Emergency stop switch This stops the robot in an emergency state. The servo turns OFF.
- ⑥ CHNGDISP button..... This changes the details displayed on the display panel in the order of "Override" → "Program No." → "Line No.".
- ⑦ END button..... This stops the program being executed at the last line or END statement.
- ⑧ SVO.ON button..... This turns ON the servo power. (The servo turns ON.)
- ⑨ SVO.OFF button..... This turns OFF the servo power. (The servo turns OFF.)
- ⑩ STATUS NUMBER
(display panel)..... The alarm No., program No., override value (%), etc., are displayed.
- ⑪ T/B connection connector This is a dedicated connector for connecting the T/B. When not using T/B, connect the attached dummy connector.

- ⑫ MODE key switchThis changes the robot's operation mode.
 AUTOMATIC.....operations from the controller or external equipment are valid. Operations for which the operation mode must be at the external device or T/B are not possible. It is necessary to set the parameter for the rights of operation to connection between the operation panel and external equipment. For details, please refer to "INSTRUCTION MANUAL/Detailed explanations of functions and operations" of the separate volume.
 MANUAL.....When the T/B is valid, only operations from the T/B are valid. Operations for which the operation mode must be at the external device or controller are not possible.
- ⑬ UP/DOWN buttonThis scrolls up or down the details displayed on the "STATUS. NUMBER" display panel.
- ⑭ Interface coverUSB interface and battery are mounted.
- ⑮ RS-232 connector.....This is an RS-232C specification connector for connecting the personal computer.
- ⑯ Terminal cover (CR1DA-700 series)
The terminal which connects the primary power cable.
 Cable lead-in port(CR2DA-700 series)
Draw in the primary power cable.
- ⑰ Filter (intake vent).....The intake vent of the recirculating air for internal cooling.

Note 1) The operation lock of the power switch (CR1DA/CR2DA-700 series controller)

The power switch has the operation lock function. It is the mechanism in which the mistaken power supply ON is prevented with the padlock etc. at the time of the maintenance of the robot system etc. Prepare lock devices, such as the padlock, by the customer.

The usage of lock function is shown in the [Page 45, "\(1\) Padlock specification"](#).

Caution

Use the network equipments (personal computer, USB hub, LAN hub, etc) confirmed by manufacturer. The thing unsuitable for the FA environment (related with conformity, temperature or noise) exists in the equipments connected to USB, RS-232 or LAN. When using network equipment, measures against the noise, such as measures against EMI and the addition of the ferrite core, may be necessary. Please fully confirm the operation by customer. Guarantee and maintenance of the equipment on the market (usual office automation equipment) cannot be performed.

(1) Padlock specification

If the robot is not used, the power switch can be locked with the padlock so that power supply ON cannot be done easily. The specification is shown in the following.

< CR1DA-700 series >
CE marking specification

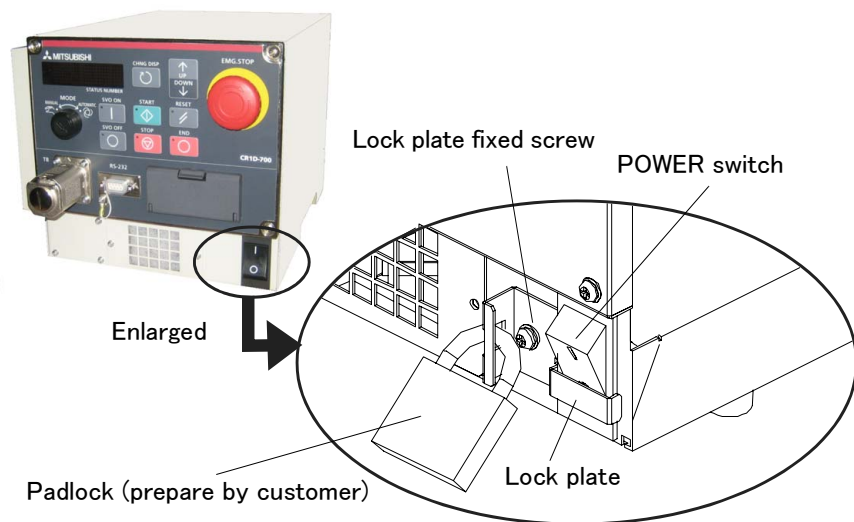

<The operation method>

(1) The lock method (power supply OFF)

- 1) Turn OFF the power switch.
 - 2) Loosen the lock plate fixing screw and make it slide upwards (cover the power switch). Tighten the fixing screw certainly in that position.
 - 3) Install the padlock (customer preparation) to the hole of the lock plate, and lock it.
- The lock is completion

(2) The release method (power supply ON)

- 1) Remove the padlock.
 - 2) Loosen the lock plate fixing screw and make it slide downward (position which does not cover the power switch). Tighten the fixing screw certainly in that position.
- Lock release is completion.

The lock device which can be used

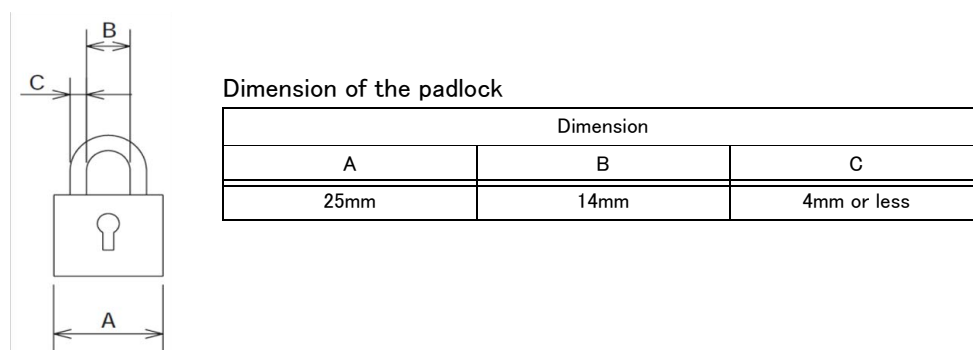
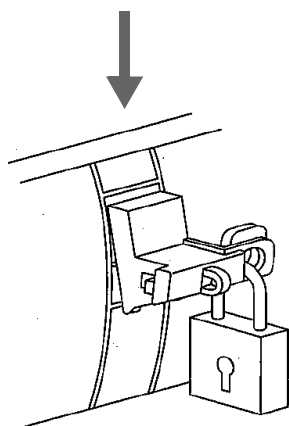
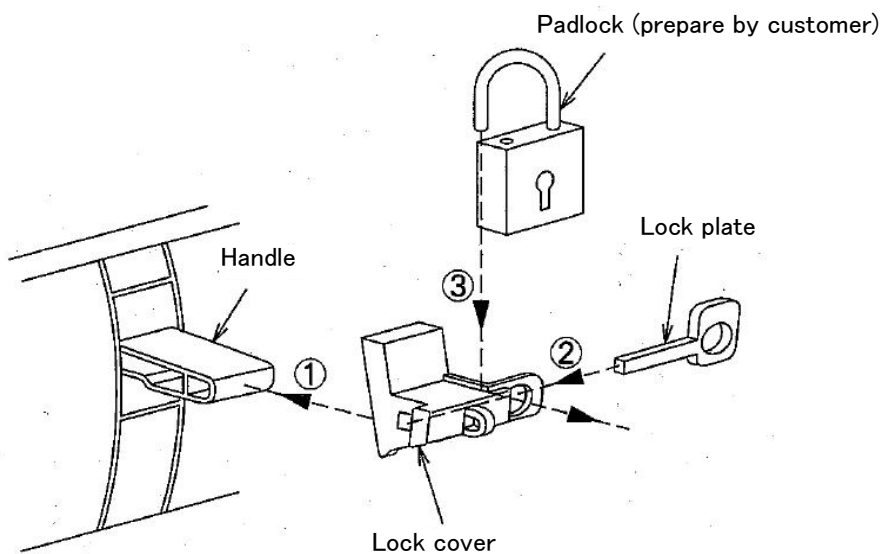

Fig.3-2 : Operation lock of the power switch (CR1DA-700 series)

< CR2DA-700 series >



⚠ CAUTION

Please use the robot in the condition that the key of the padlock is removed.

Do not operate the trip test by the trip button in the state of the power switch locked at OFF position.

The lock plate is installed strongly. Pull up strongly and remove.

The lock device which can be used

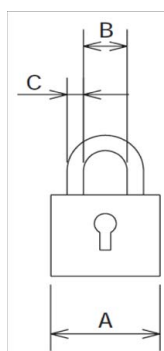

Dimension of the padlock

Dimension		
A	B	C
25mm	14mm	4mm or less

Fig.3-3 : Operation lock of the power switch(CR2DA-700 series)

⚠ CAUTION

The servo will turn OFF when the controller [MODE] switch is changed. Note that axes not provided with brakes could drop with their own weight.

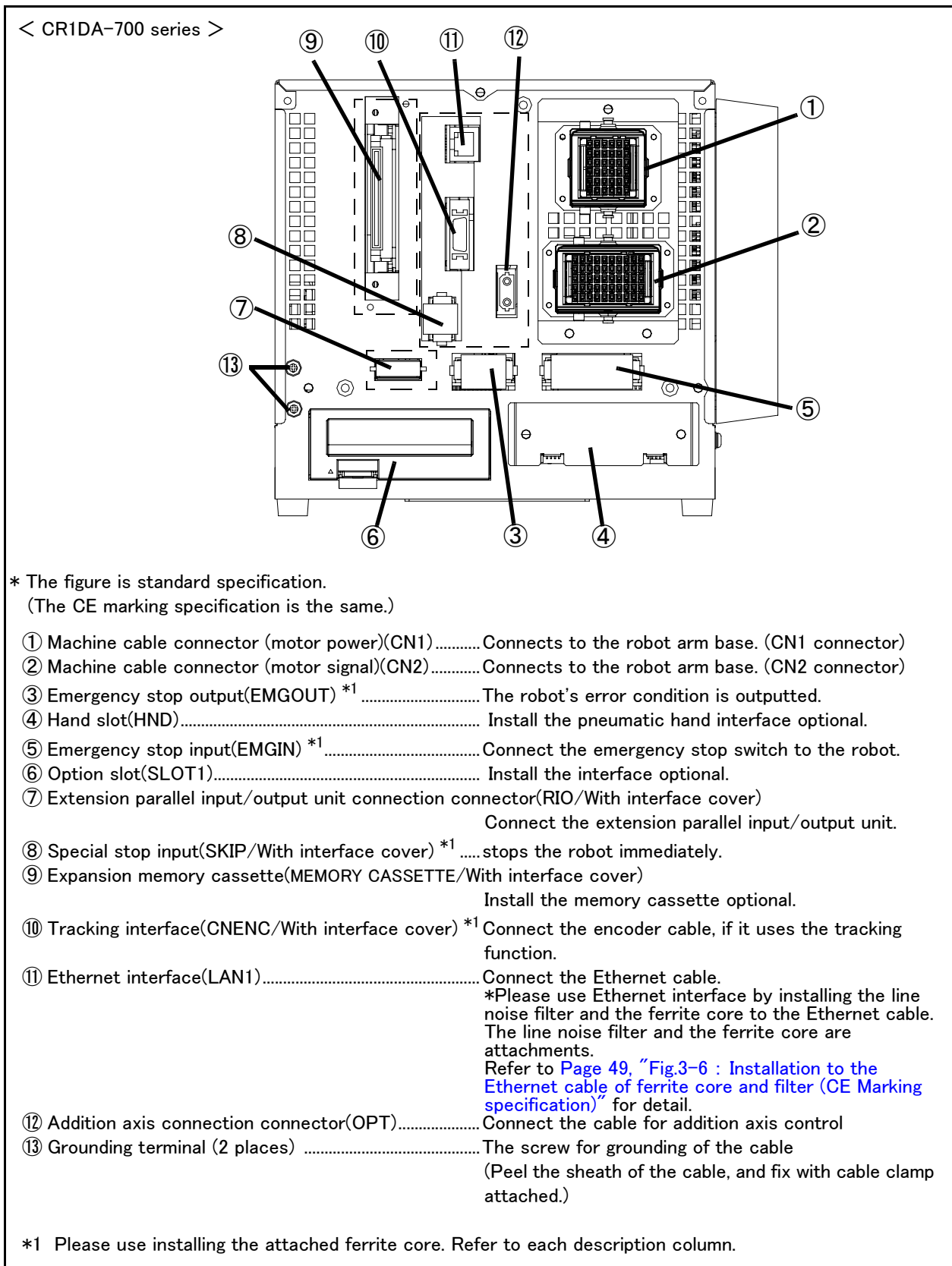

Fig.3-4 : Names of each part (Rear side CR1DA-700 series)

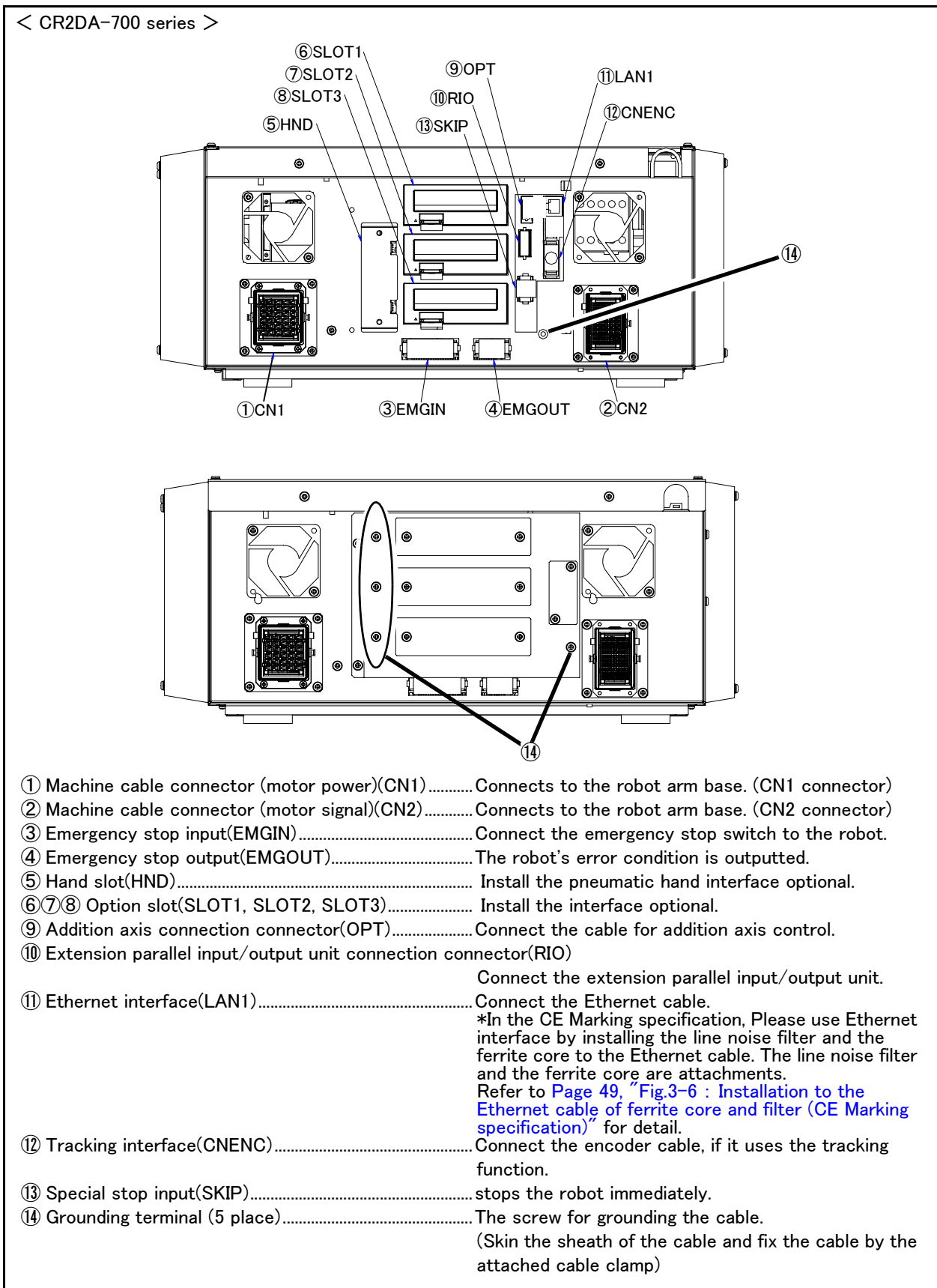
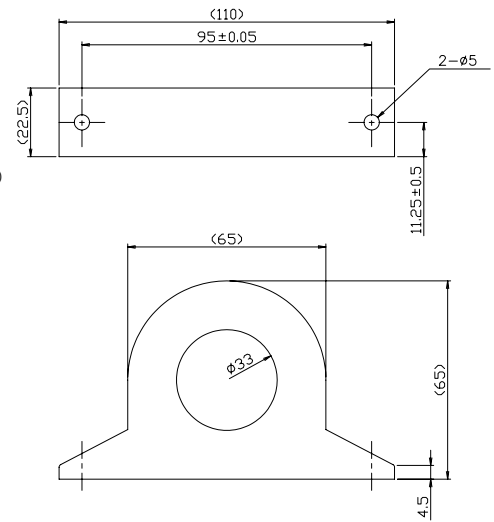
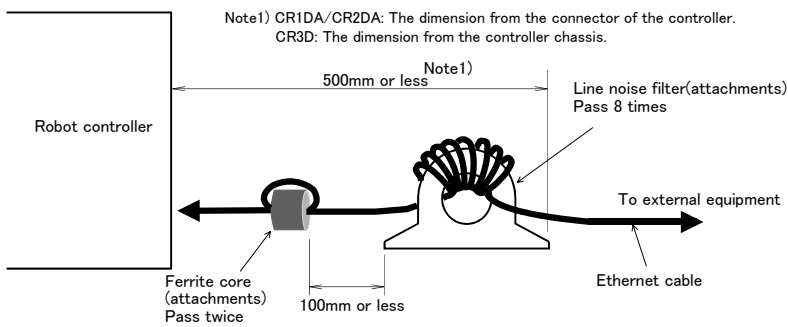

Fig.3-5 : Names of each part (Rear side CR2DA-700 series)

The installation conditions of the ferrite core and the line noise filter



Outside dimension of the line noise filter

Fig.3-6 : Installation to the Ethernet cable of ferrite core and filter (CE Marking specification)

3.3 Outside dimensions/Installation dimensions

3.3.1 Outside dimensions

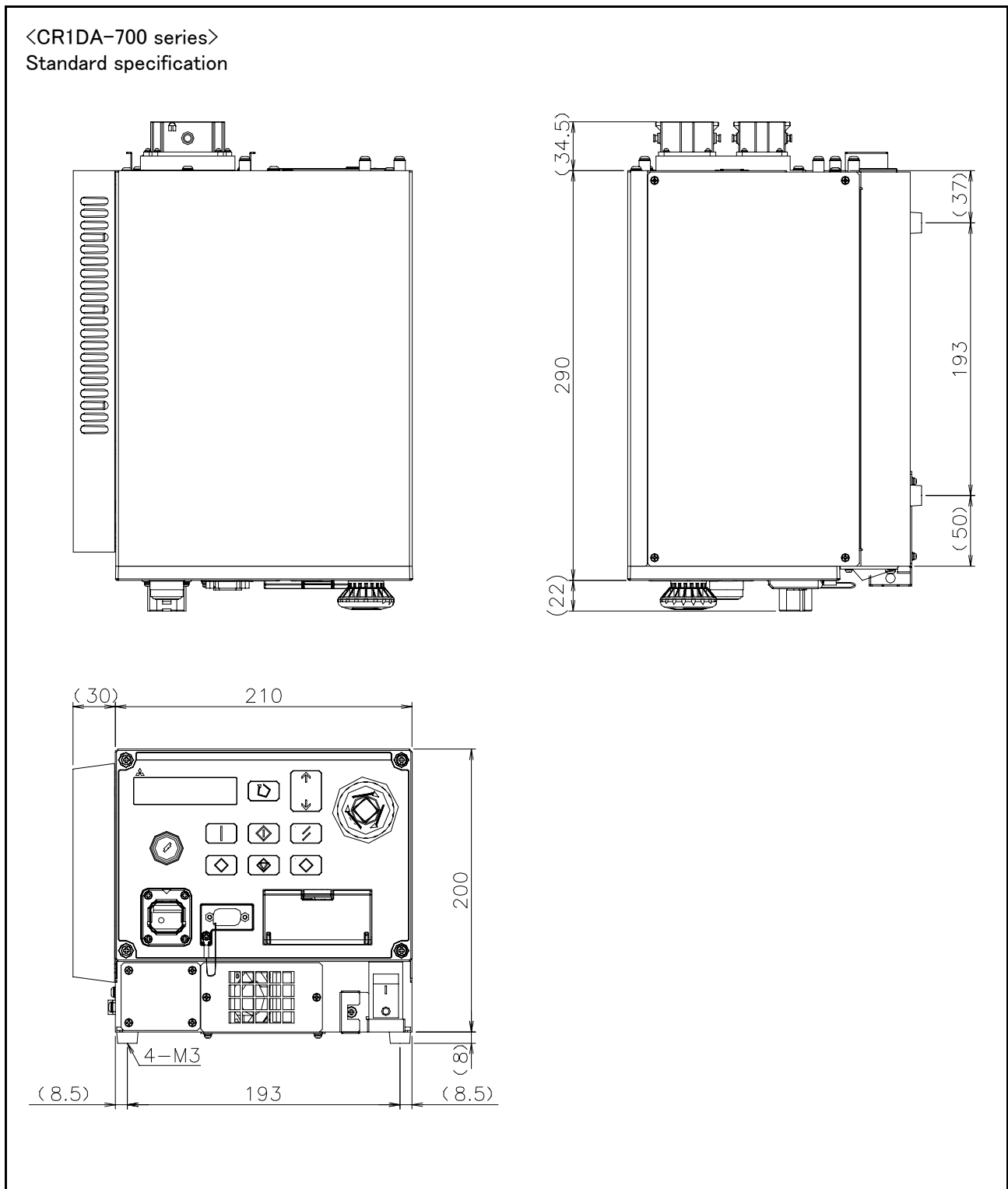

Fig.3-7 : Outside dimensions of controller (CR1DA-700)

<CR1DA-700-S12 series>
CE marking specification

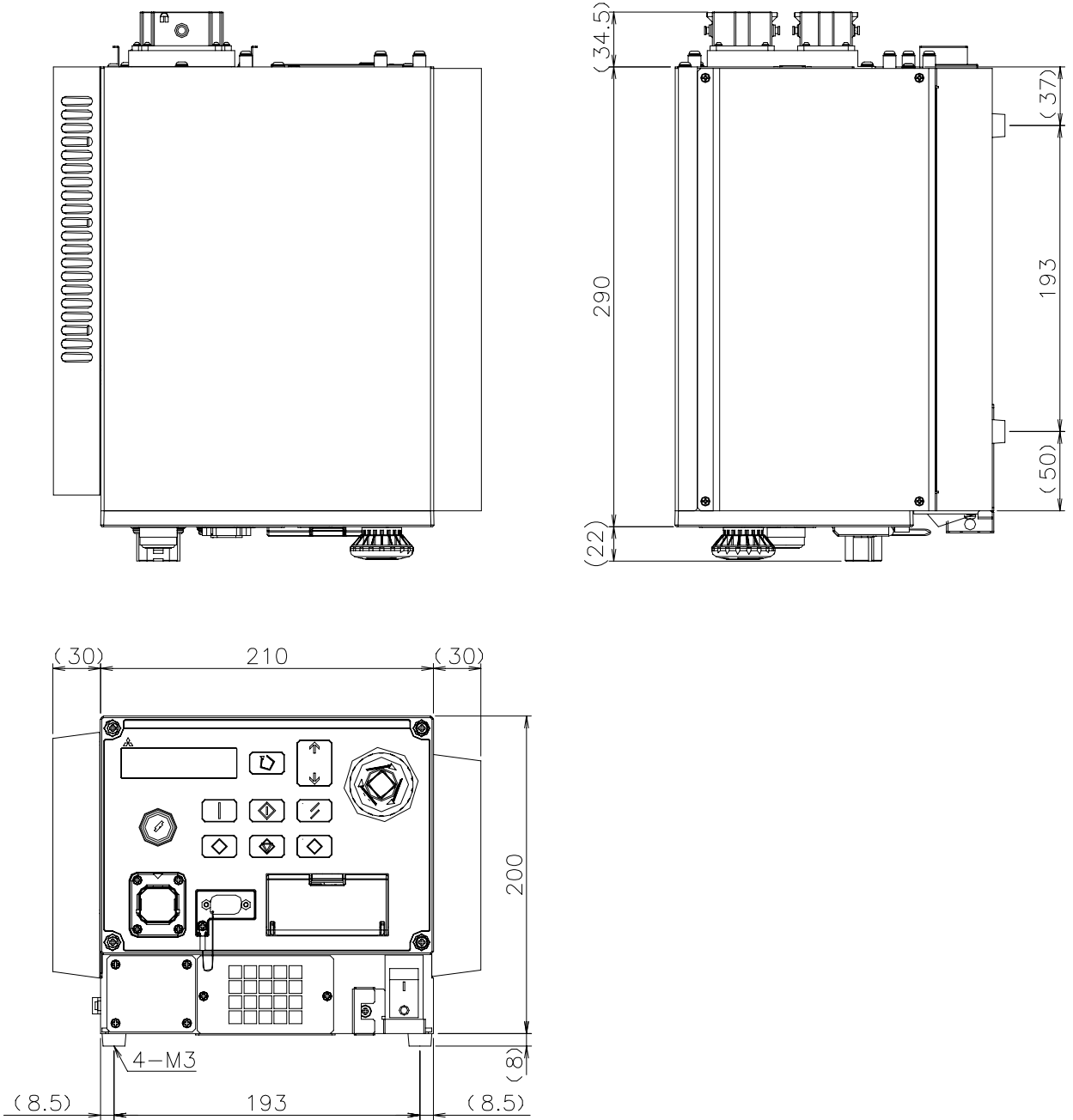

Fig.3-8 : Outside dimensions of controller (CR1DA-700-S12 series)

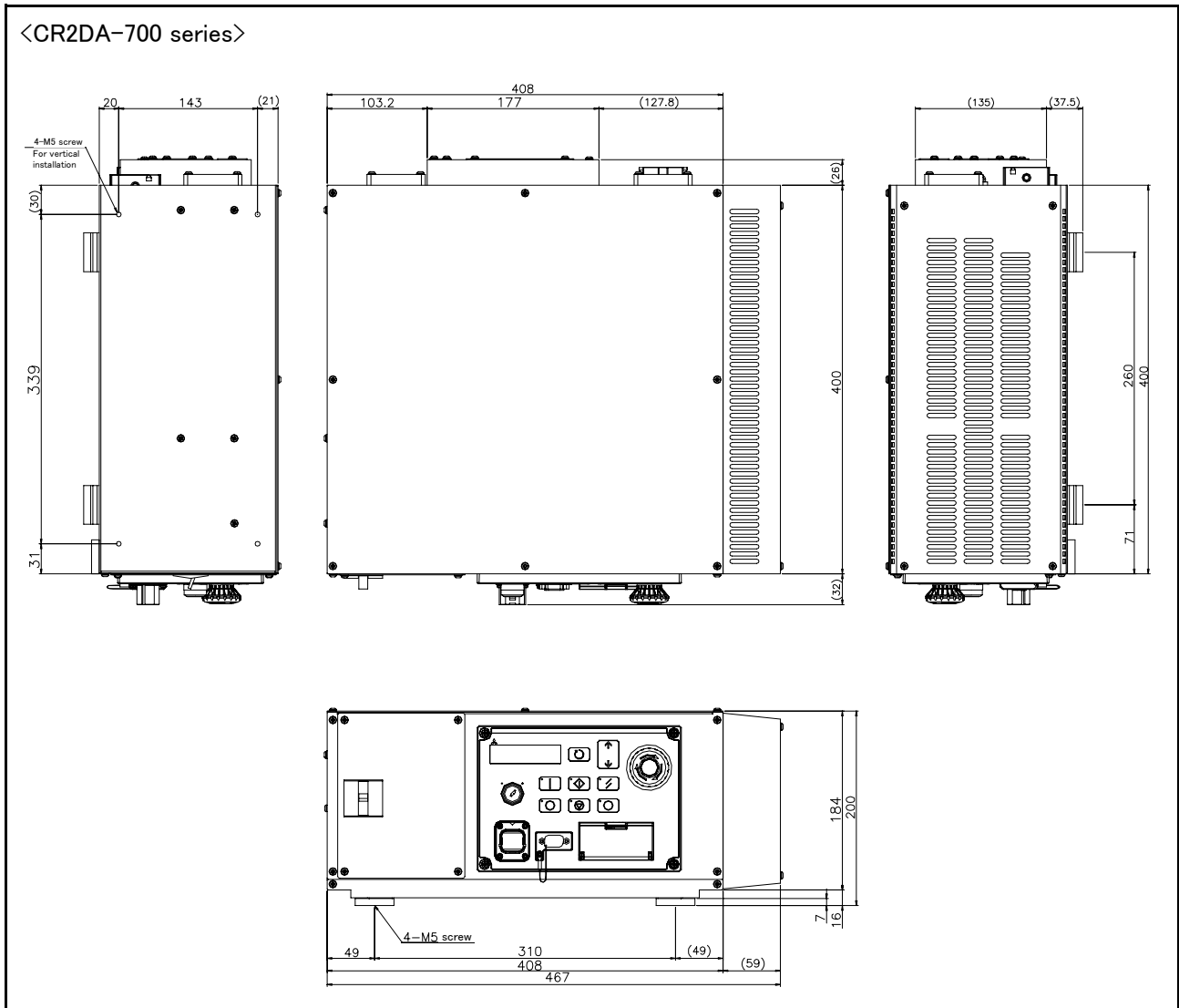

Fig.3-9 : Outside dimensions of controller(CR2DA-700)

3.3.2 Installation dimensions

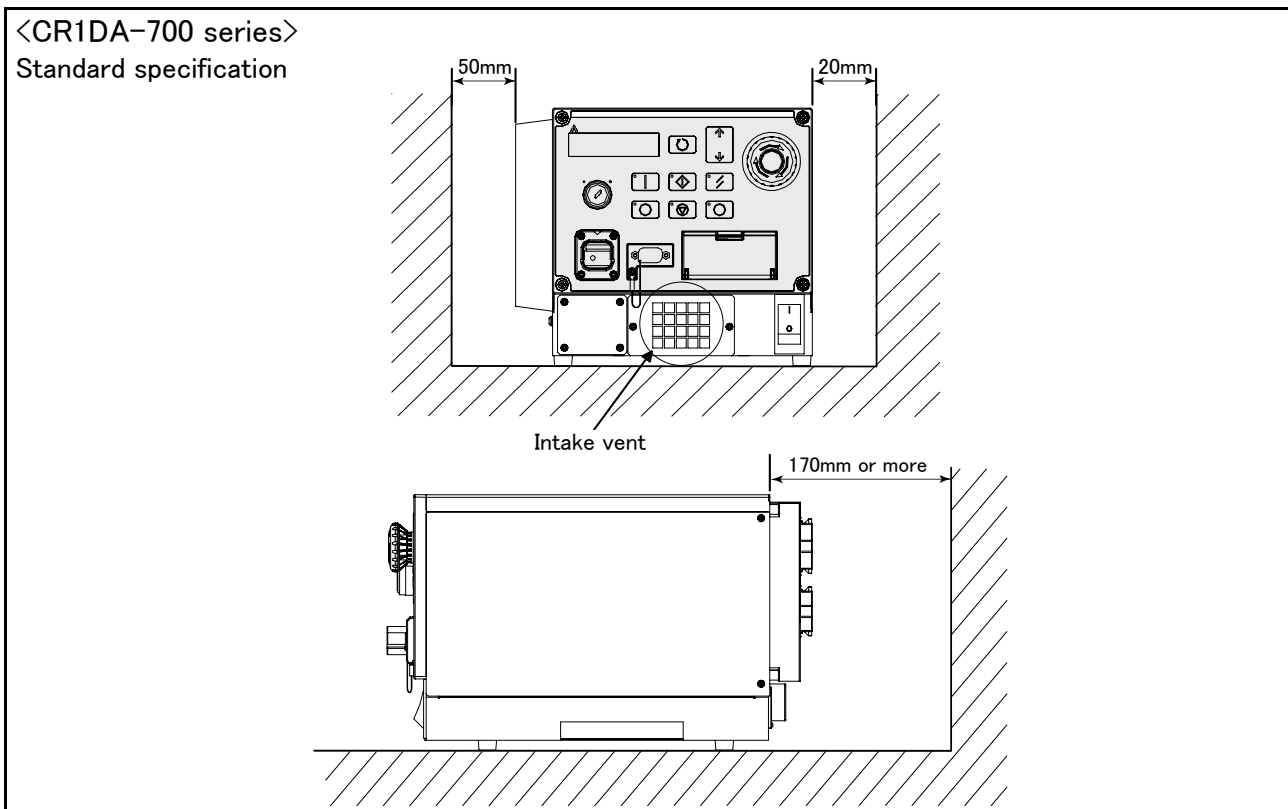

Fig.3-10 : Installation of controller (CR1DA-700 series)

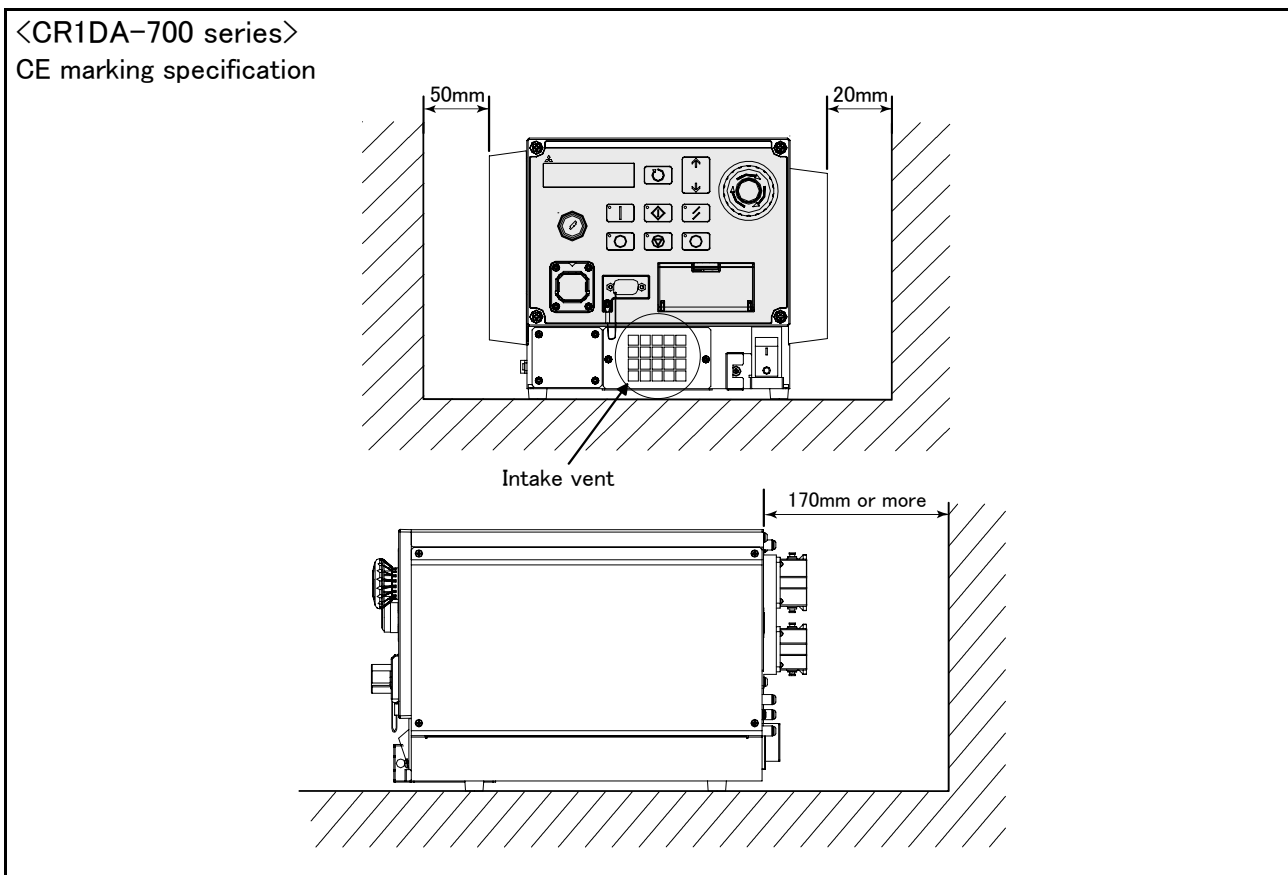
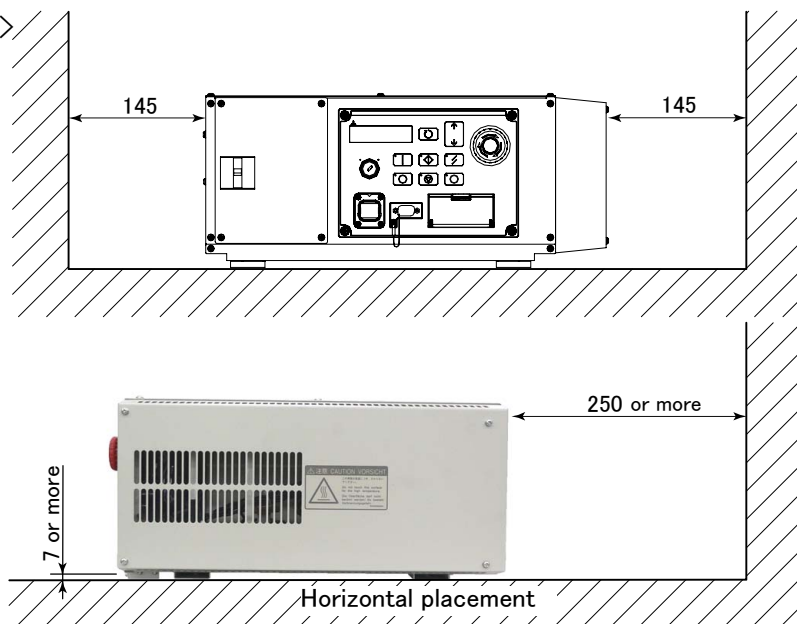
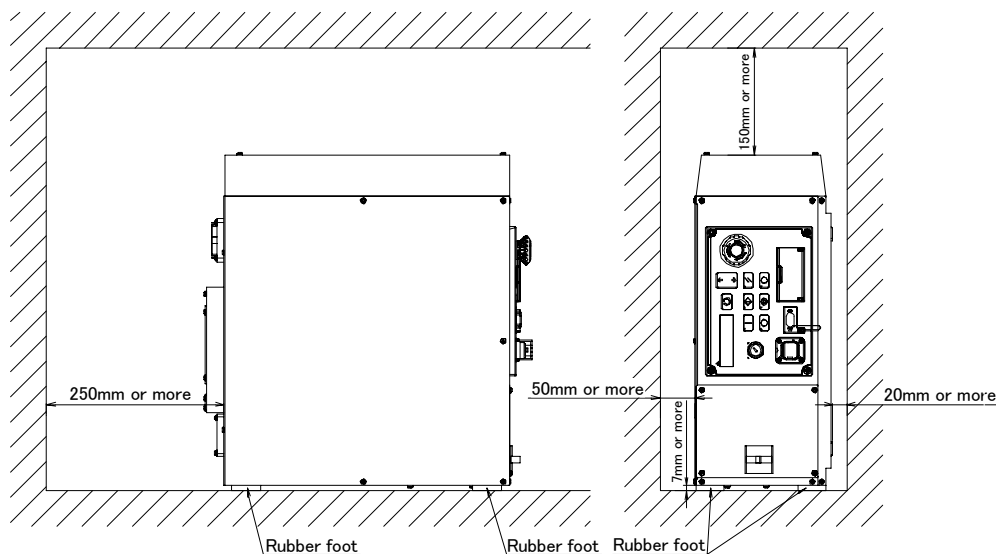

Fig.3-11 : Installation of controller (CR1DA-700 series)

<CR2DA-700 series>

**CAUTION**

Use the rubber foot (4 positions) at the bottom of the controller as it is, or put the spacer, and leave the space between the installation side and the controller installation side more than 7mm when you fix the controller with the installation screw. In smaller than 7mm case, the air intake hole at the bottom of the controller is occupied, and temperature rises in the board, and causes the trouble.

**CAUTION**

The installation section needs to be fixed so that the controller may not fall. When fixing the controller with the bolt, please use the bolt of the length which does not protrude 5mm or more into the controller case.

- (1) Remove the rubber foot at the bottom of the controller (four places, M5 x 10 screws).
- (2) Remove the controller side white round seal (four places).
- (3) Use the rubber foot and the 5xM10 screw which were removed by above-mentioned (1), and fix the rubber foot to the screw hole of the seal pasting place of (2).

Fig.3-12 : Installation of controller(CR2DA-700 series)

CAUTION

When storing the controller in a cabinet, etc., take special care to the heat radiating properties and ventilation properties so that the ambient temperature remains within the specification values.

3.3.3 Cable lead-in and dimension

The controller has the openings parts for pulling out the cable as shown in Fig. 3-13, Fig. 3-14 .

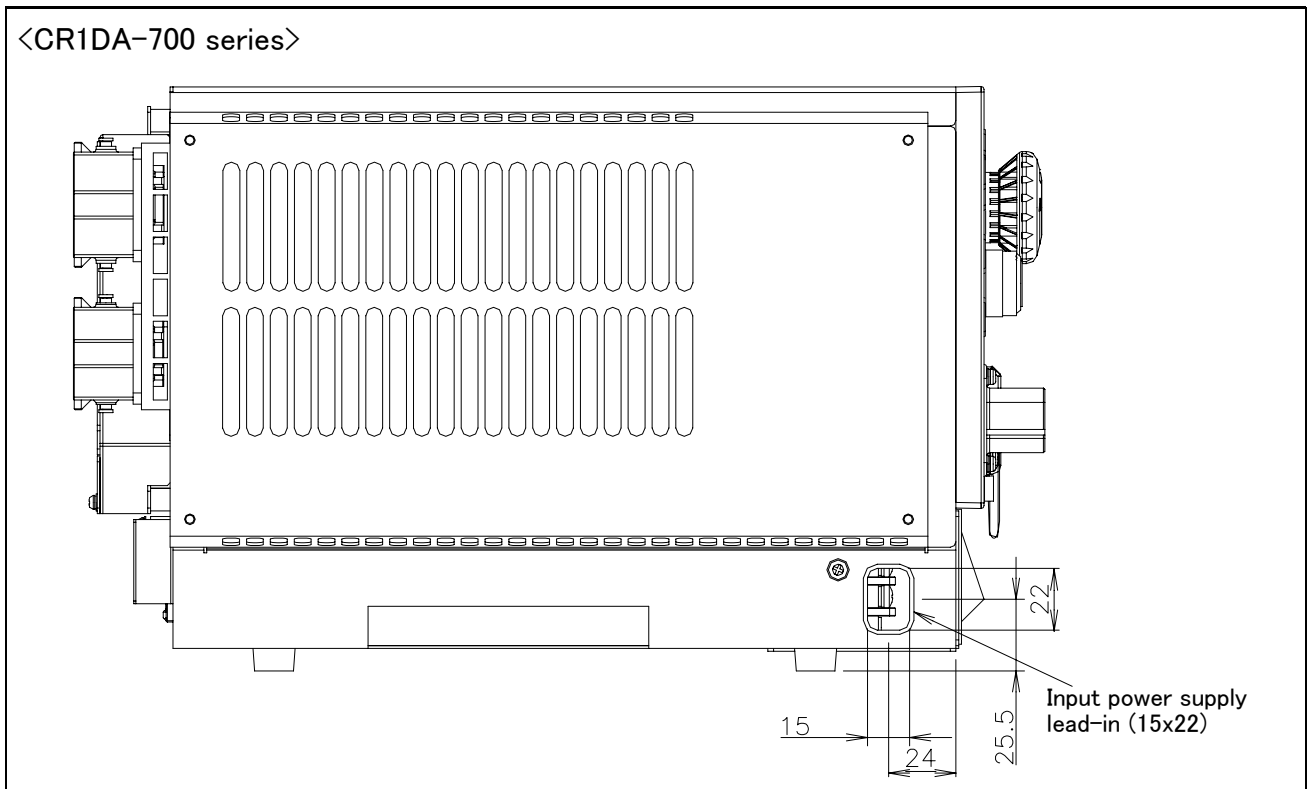

Fig.3-13 : Cable lead-in and dimension of the controller (CR1DA-700 series)

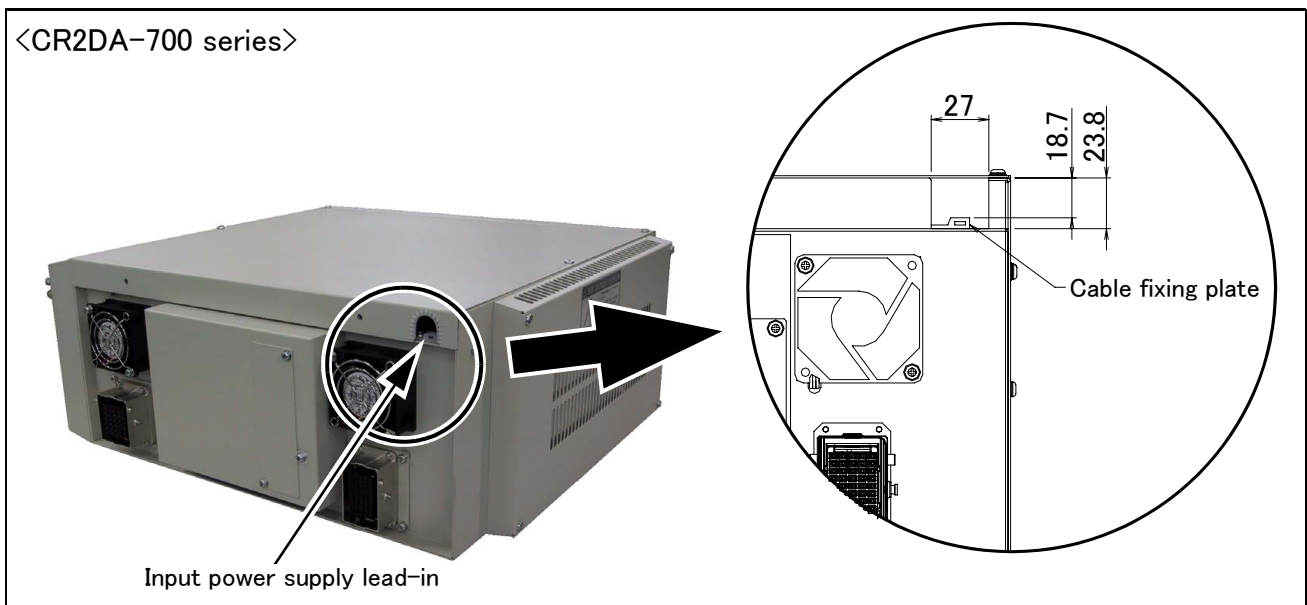

Fig.3-14 : Cable lead-in and dimension of the controller (CR2DA-700 series)

3.4 External input/output

3.4.1 Types

- (1) Dedicated input/output.....These inputs and outputs carry out the robot remote operation and status display.
- (2) General-purpose input/output.....These are inputs and outputs that the customer can program for peripheral device control.
- (3) Hand input/output.....These are inputs and outputs related to the hand that the customer can program. (The hand output is an option. The [Page 79, "\(2\) Pneumatic hand interface"](#) is required.)
- (4)Emergency stop/Door switch input.....The wiring for the safe security of the emergency stop etc. is shown in on [Page 59, "3.6 Emergency stop input and output etc."](#) and on [Page 122, "6.1.7 Examples of safety measures"](#).

<For Reference>

Linking our GOT1000 Series (GT15) display equipment to the robot controller over the Ethernet permits you to control robot controller's input/output from a GOT (graphic operation terminal). Refer to the examples of the use of GOT1000 Series display equipment given in a separate document titled "Detail Description of Functions and Operation."

3.5 Dedicated input/output

Show the main function of dedicated input/output in the [Table 3-3](#). Refer to attached instruction manual "Detailed explanations of functions and operations" in the product for the other functions. Each parameter indicated with the parameter name is used by designated the signal No., assigned in the order of input signal No. and output signal No.

Table 3-3 : Dedicated input/output list

Parameter name	Input <small>Note1)</small>			Output	
	Name	Function	Level	Name	Function
TEACHMD	None			Teaching mode output signal	Outputs that the teaching mode is entered.
ATTOPMD	None			Automatic mode output signal	Outputs that the automatic mode is entered.
ATEXTMD	None			Remote mode output signal	Outputs that the remote mode is entered.
RCREADY	None			Controller power ON complete signal	Outputs that external input signals can be received.
AUTOENA	Automatic operation enabled input signal	Allows automatic operation.	L	Automatic operation enabled output signal	Outputs the automatic operation enabled state.
START	Start input signal	Starts all slots.	E	Operating output signal	Outputs that the slot is operating.
STOP	Stop input signal	Stops all slots. The input signal No. is fixed to 0. Note) Use the emergency stop input for stop inputs related to safety.	L	Wait output signal	Outputs that the slot is temporarily stopped.
STOP2	Stop input signal	The program during operation is stopped. Unlike the STOP parameter, change of the signal number is possible. Notes) specification is the same as the STOP parameter.	L	Wait output signal	Outputs that the slot is temporarily stopped.
SLOTINIT	Program reset input signal	Resets the wait state.	E	Program selection enabled output signal	Outputs that the slot is in the program selection enabled state.
ERRRESET	Error reset input signal	Resets the error state.	E	Error occurring output signal	Outputs that an error has occurred.
CYCLE	Cycle stop input signal	Carries out cycle stop.	E	In cycle stop operation output signal	Outputs that the cycle stop is operating.
SRVOFF	Servo ON enabled input signal	Turns the servo OFF for all mechanisms.	L	Servo ON enabled output signal	Outputs servo-on disable status. (Echo back)
SRVON	Servo ON input signal	Turns the servo ON for all mechanisms.	E	In servo ON output signal	Outputs the servo ON state.
IOENA	Operation rights input signal	Requests the operation rights for the external signal control.	L	Operation rights output signal	Outputs the operation rights valid state for the external signal control.
MELOCK	Machine lock input signal	Sets/resets the machine lock state for all mechanisms.	E	In machine lock output signal	Outputs the machine lock state.
SAFEPOS	Evasion point return input signal	Requests the evasion point return operation.	E	In evasion point return output signal	Outputs that the evasion point return is taking place.
OUTRESET	General-purpose output signal reset	Resets the general-purpose output signal.	E	None	
EMGERR	None			Emergency stop output signal	Outputs that an emergency stop has occurred.
S1START : S32START	Start input	Starts each slot.	E	In operation output	Outputs the operating state for each slot.
S1STOP : S32STOP	Stop input	Stops each slot.	L	In wait output	Outputs that each slot is temporarily stopped.

Parameter name	Input Note 1)			Output	
	Name	Function	Level	Name	Function
PRGSEL	Program selection input signal	Designates the setting value for the program No. with numeric value input signals.	E	None	
OVRDSEL	Override selection input signal	Designates the setting value for the override with the numeric value input signals.	E	None	
IODATA Note2)	Numeric value input (start No., end No.)	Used to designate the program name, override value., mechanism value.	L	Numeric value output (start No., end No.)	Used to output the program name, override value., mechanism No.
PRGOUT	Program No. output request	Requests output of the program name.	E	Program No. output signal	Outputs that the program name is being output to the numeric value output signal.
LINEOUT	Line No. output request	Requests output of the line No.	E	Line No. output signal	Outputs that the line No. is being output to the numeric value output signal.
OVRDOUT	Override value output request	Requests the override output.	E	Override value output signal	Outputs that the override value is being output to the numeric value output signal.
ERROUT	Error No. output request	Requests the error No. output.	E	Error No. output signal	Outputs that the error No. is being output to the numeric value output signal.
JOGENA	Jog valid input signal	Validates jog operation with the external signals	E	Jog valid output signal	Outputs that the jog operation with external signals is valid.
JOGM	Jog mode input 2-bit	Designates the jog mode.	L	Jog mode output 2-bit	Outputs the current jog mode.
JOG+	Jog feed + side for 8-axes	Requests the + side jog operation.	L	None	
JOG-	Jog feed - side for 8-axes	Requests the - side jog operation.	L	None	
HNDCTRL1 : HNDCTRL3	None			Mechanism 1 hand output signal status : Mechanism 3 hand output signal status	Mechanism 1: Outputs the status of general-purpose outputs 900 to 907. Mechanism 2: Outputs the status of general-purpose outputs 910 to 917. Mechanism 3: Outputs the status of general-purpose outputs 920 to 927.
HNDSTS1 : HNDSTS3	None			Mechanism 1 hand input signal status : Mechanism 3 hand input signal status	Mechanism 1: Outputs the status of hand inputs 900 to 907. Mechanism 2: Outputs the status of hand inputs 910 to 917. Mechanism 3: Outputs the status of hand inputs 920 to 927.
HNDERR1 : HNDERR3	Mechanism 1 hand error input signal : Mechanism 3 hand error input signal	Requests the hand error occurrence.	L	Mechanism 1 hand error output signal : Mechanism 3 hand error output signal	Outputs that a hand error is occurring.
AIRERR1 : AIRERR3	Pneumatic pressure error 1 input signal : Pneumatic pressure error 3 input signal	Request the pneumatic pressure error occurrence.	L	Pneumatic pressure error 1 output signal. : Pneumatic pressure error 3 output signal.	Outputs that a pneumatic pressure error is occurring.
M1PTEXC : M3PTEXC	None		L	Maintenance parts replacement time warning signal	Outputs that the maintenance parts have reached the replacement time.
USERAREA Note3)	None			User-designated area 8-points	Outputs that the robot is in the user-designated area.

Note1) The level indicates the signal level.

L: Level signal → The designated function is validated when the signal is ON, and is invalidated when the signal is OFF.

E: Edge signal → The designated function is validated when the signal changes from the OFF to ON state, and the function maintains the original state even when the signal then turns OFF.

Note2) Four elements are set in the order of input signal start No., end No., output signal start No. and end No.

Note3) Up to eight points can be set successively in order of start output signal No. and end output signal No.

3.6 Emergency stop input and output etc.

Do wiring of the external emergency stop, the special stop input, the door switch, and the enabling device from the "special input/output" terminal connector.

Table 3-4 : Special input/output terminal

Item	Name	Function
Input	Emergency stop	Applies the emergency stop. Dual emergency line
Input	Special stop input	Applies the stop. (Refer to Page 63, "3.6.2 Special stop input(SKIP)")
Input	Door switch	Servo-off. Dual line, normal close (Page 65, "3.6.3 Door switch function")
Input	Enabling device	Servo-off. Dual line, normal close (Page 65, "3.6.4 Enabling device function")
Output	Robot error output	Contact is opening during error occurrence
Output	Mode output	MANUAL mode: contactor is opening, AUTO mode: contactor is closing.
Output	Magnet contactor control connector output for addition axes	When an additional axis is used, the servo ON/OFF status of the additional axis can be synchronized with the robot arm. (Page 72, "3.8 Magnet contactor control connector output (AXMC) for addition axes")

*At the time of the power supply OFF, the output point of contact is always open.

[Note] The contact capacity of each input/output terminal is DC24V/10mA – 500mA. Don't connect the equipment except for this range. The use exceeding contact capacity causes failure.

Pin number assignment of each terminal and the circuit diagram are shown in Fig. 3-17.

3.6.1 Connection of the external emergency stop

The external emergency stop input and door switch input and enabling device input are opened at shipment as shown in Fig. 3-17.

Connect the external emergency stop switch and door switch with the following procedure.

[Caution] Since the emergency stop, the enabling device, and the door switch circuits are made dual circuits inside the controller, all the emergency stop switches should use dual contact type. Remove the contact capacity sticker stuck on the connector (EMGIN, EMGOUT, SKIP) and connect the emergency switch.

- 1) Prepare the "emergency stop switch", "enabling device" and "door switch".
- 2) Securely connect the external emergency stop's contacts across 3A-4A, 3B-4B, and the door switch's contacts across 8A-9A, 8B-9B, and the enabling device switch's contacts across 10A-11A, 10B-11B, on the terminal block.

[Caution] When wiring the emergency stop switch (double emergency line type) and SKIP input signal, wire both contacts to the two terminal blocks on the controller. If both contacts are wired to only one of the terminal blocks, errors cannot be cancelled using the door switch. The cable uses the shielded cable and installs the ferrite core. Install the ferrite core in less than 30cm from the contact button.



CAUTION You should always connect doubly connection of the emergency stop, the door switch, and the enabling switch. (Connect with both of side-A and side-B of the controller rear connector) In connection of only one side, if the relay of customer use should break down, it may not function correctly.



CAUTION Please be sure to check that each function operates normally for the prevention of malfunction. Surely check that the operation of the emergency stop of the robot controller, the emergency stop of the teaching pendant, the customer's emergency stop, etc are normally.

CAUTION Be sufficiently careful and wiring so that two or more emergency stop switches work independently. Don't function only on AND conditions (Two or more emergency stop switch status are all ON).

<CR1DA-700 series>

* The figure is standard specification.
(The CE marking specification is the same.)

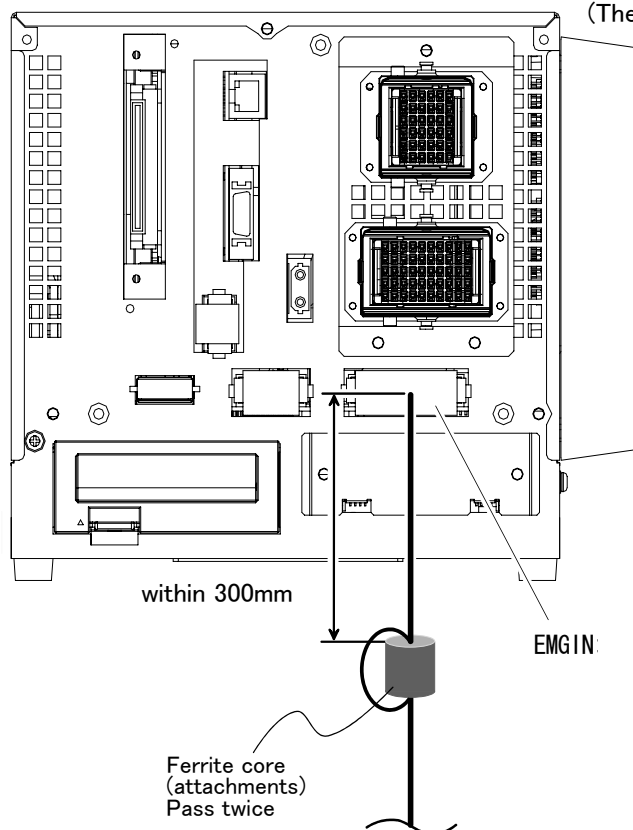

Pin allotment of EMGIN and the EMGOUT connector is shown in [Fig. 3-17](#).

Fig.3-15 : emergency stop cable connection (DR1DA-700)

<CR2DA-700>

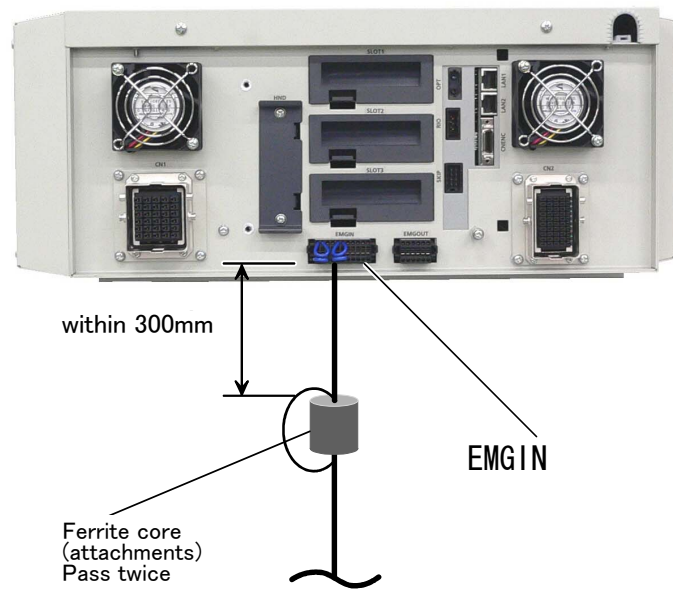

Pin allotment of EMGIN and the EMGOUT connector is shown in [Fig. 3-17](#).

Fig.3-16 : emergency stop cable connection(CR2DA-700)

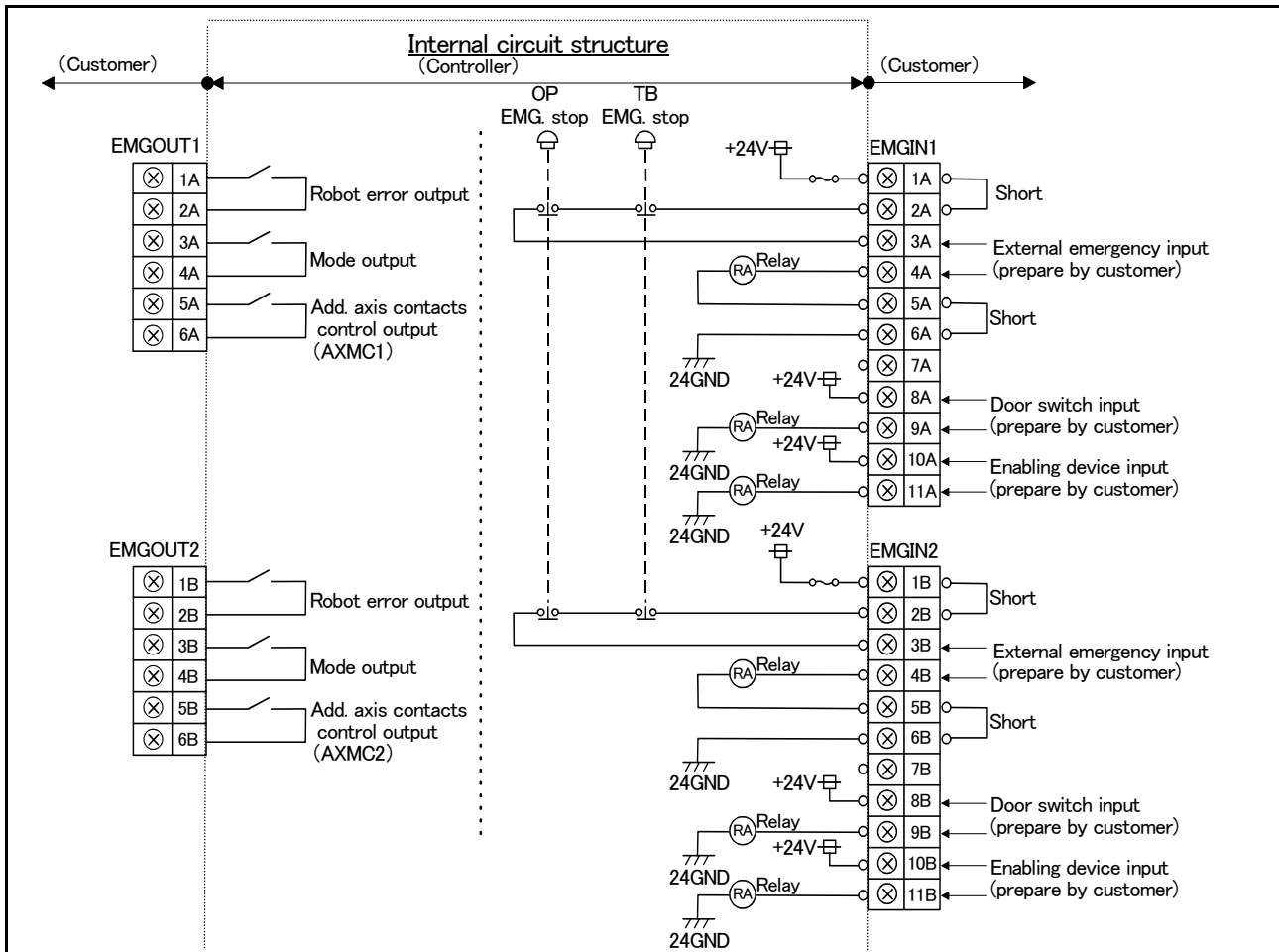

Warning Please do not do the withstand voltage examination. Moreover, it becomes the cause of failure if it connects incorrectly.

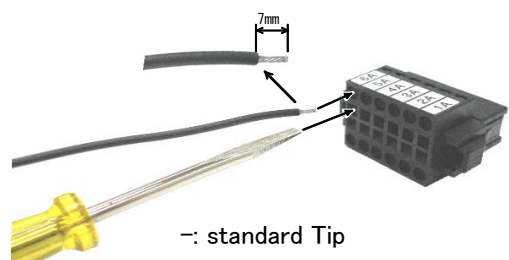
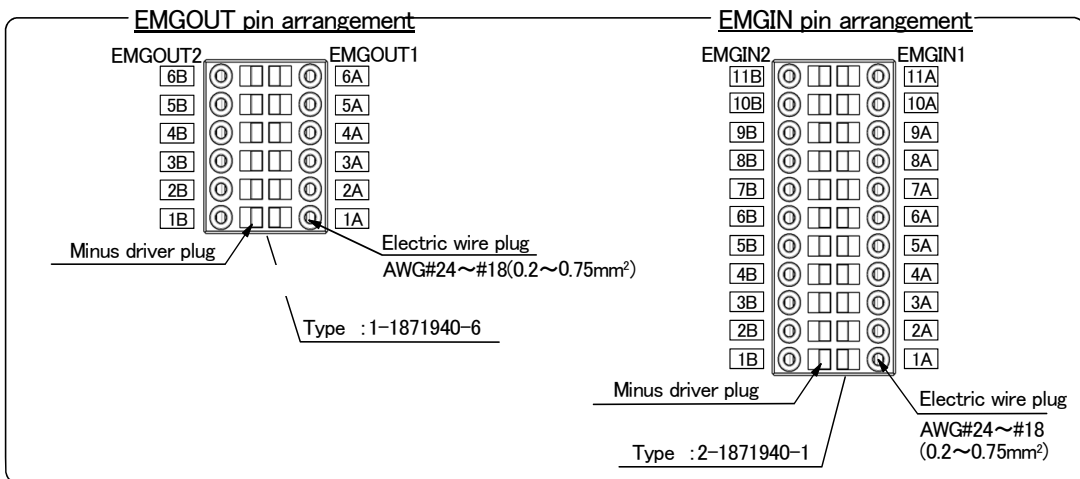

- <The connector connection>
- 1) Remove the Sticker on the connector.
 - 2) Remove the wire skin 7mm.
 - 3) Push the back spring with the small standard Tip.
 - 4) Insert the wire to the back.
 - 5) Remove the small standard Tip.
- *recommended Tip size is 1.4~2.4mm.
(The driver plug area of the connector is 2.5mm)

Fig.3-17 : External emergency stop connection

⚠ CAUTION Please be sure to install the emergency stop switch and its connection to the controller, to stop the robot immediately at emergency

⚠ CAUTION Be careful of the short circuit at cable connection. And, don't give plating solder to the electric wire. Loose connection may occur.

3.6.2 Special stop input(SKIP)

The skip is the input signal to stop the robot. Wire 1A-1B of the special stop connector (SKIP) shown in [Page 64, "Fig.3-18 : Connection of the special-stop-input"](#).

Table 3-5 : Special stop input electric specification

Item		Specifications	Internal circuit
Type		DC input	
No. of input point		1	
Insulation method		Photo-coupler insulation	
Rated input voltage		DC24V	
Rated input current		approx. 11mA	
Working voltage range		DC 21.6 ~ 26.4V (Ripple rate within 5%)	
ON voltage/ON current		DC 8V or more / 2mA or more	
OFF voltage/OFF current		DC 4V or less / 1mA or less	
Input resistance		approx. 2.2 k Ω	
Response time	OFF → ON	1ms or less	
	ON → OFF	1ms or less	
Common method		1 point per common	
External wire connection method		Connector	

<CR1DA-700 series>

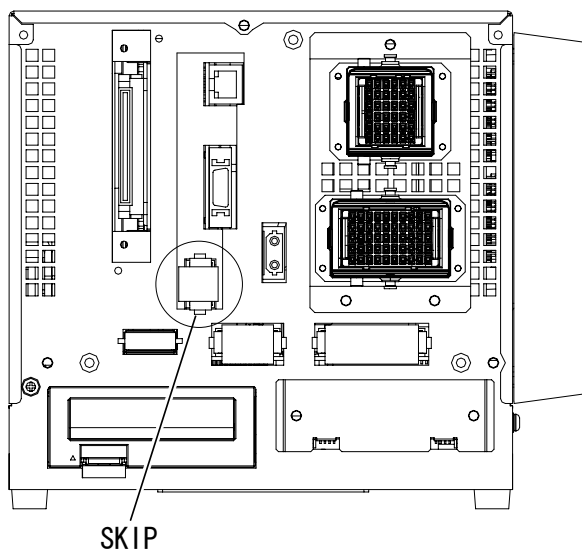

* The figure is standard specification.
(The CE marking specification is the same.)

<CR2DA-700 series>

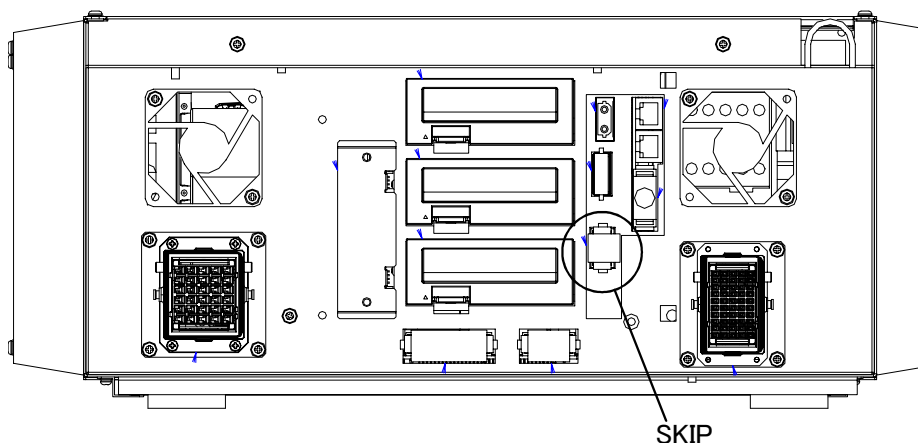

Special stop connector (SKIP)

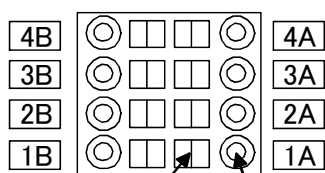

Minus driver plug area Electric wire plug area(AWG#24-18)

<The connector connection method>

The electric wire skins covering 7mm.

In the condition that the minus driver is inserted, insert the electric wire, and remove the minus driver.

The electric wire is locked by the connector.

Fig.3-18 : Connection of the special-stop-input

3.6.3 Door switch function

This function retrieves the status of the switch installed on the door of the safety fence, etc., and stops the robot when the door is opened. This differs from an emergency stop in that the servo turns OFF when the door is opened and an error does not occur. Follow the wiring example shown in Fig. 3-17, and wire so that the contact closes when the door is closed. Details of this function according to the robot status are shown below.

*During automatic operationWhen the door is opened, the servo turns OFF and the robot stops. An error occurs.

The process of the restoration : Close the door, reset the alarm, turn on the servo, and restart

*During teaching.....Even when the door is opened, the servo can be turned ON and the robot moved using the teaching pendant.

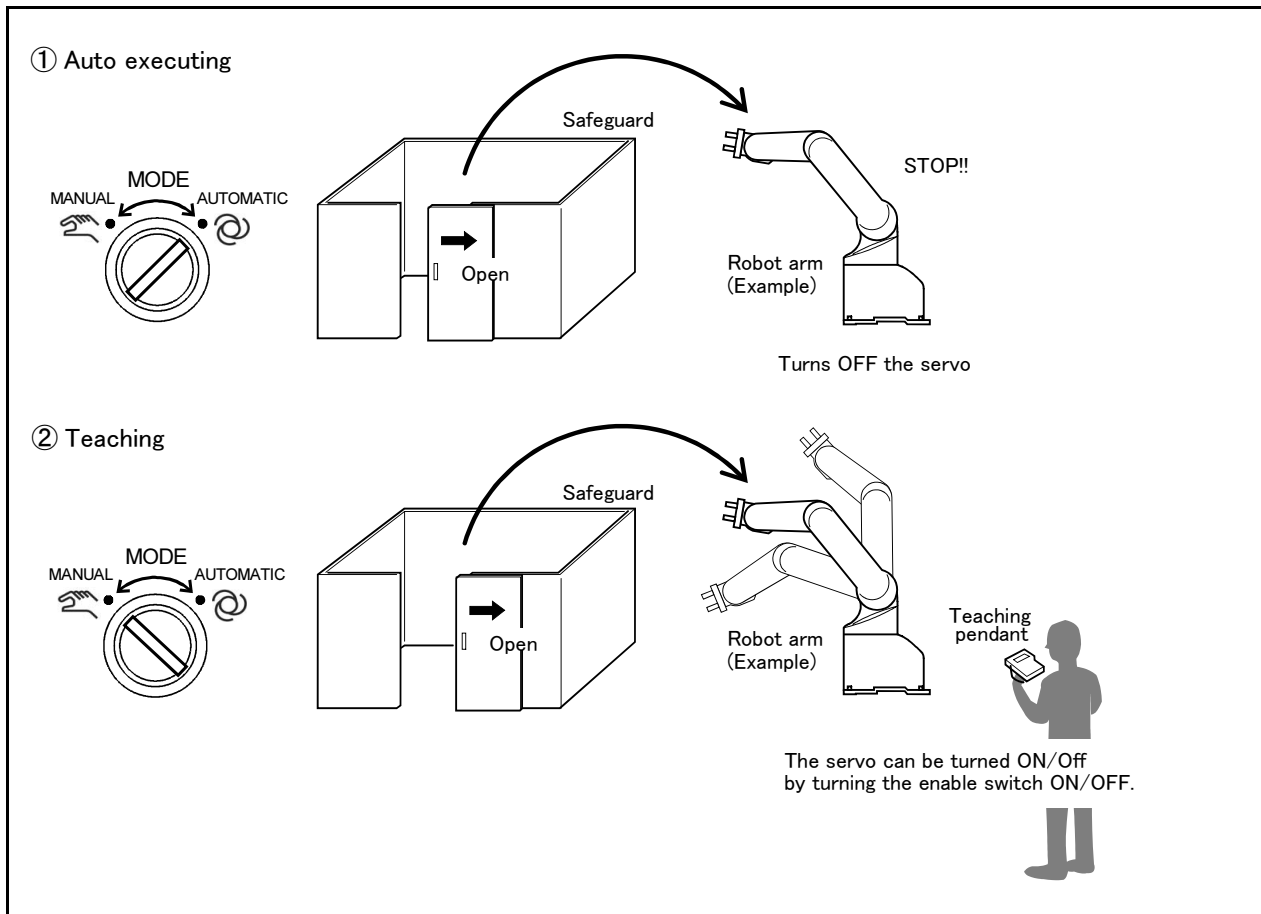

Fig.3-19 : Door switch function

3.6.4 Enabling device function

When the abnormalities occur in teaching operations etc., the robot's servo power can be immediately cut only by switch operation of the enabling device*1) (servo-off), and the safety increases. To use the robot safely, please be sure to connect the enabling device.

(1) When door is opening

Please do teaching by two-person operations. One person has T/B, the other has enabling device. Turn on the servo power, in the condition that both of switches are pushed. (Enable switch of T/B and enabling device) Then the jog operation will be available. You can off the servo power only by releasing the switch of the enabling device. And, care that the servo-on and releasing the brake cannot be done in the condition that the switch of the enabling device is released.

(2) When door is closing

You can turn on the servo power by operation of only T/B. In this case perform jog operation outside the safeguard sure.

*1) Recommendation products: HE1G-L20MB (IDEC)

(3) Automatic Operation/Jog Operation/Brake Release and Necessary Switch Settings

The following is a description of various operations performed on the robot and switch settings that are required.

Table 3-6 : Various operations and necessary switch settings

No	Operation	Related switch settings ^{Note1)}					Description
		Mode of controller	T/B enable/disable	T/B enable switch	Enabling device input terminal	Door switch input terminal	
1	Jog operation	Manual	Enable	ON	Close(ON)	—	If the enabling device input is set to Close (On), the state of door switch input does not matter.
2	Jog operation ^{Note2)}	Manual	Enable	ON	Open(OFF)	Close (Door Close)	If the enabling device input is set to Open (Off), door switch input must be in a state of Close
3	Brake release ^{Note3)}	Manual	Enable	ON	Close(ON)	—	Irrespective of the state of door switch input, enabling device input must be in a state of Close (On).
4	Automatic operation	Automatic	Disable	—	—	Close (Door Close)	Door switch input must always be in a state of Close (Door Close).

Note1) “—” in the table indicates that the state of switch concerned does not matter.

Note2) Jog operation, if door switch input is set for Close (Door Close), must be performed outside the safety barrier.

Note3) It is imperative that brake release operation be carried out by two persons. One person turns on the enabling device (“Close” on the enabling device input terminal) while the other manipulates the T/B. Brake release can be effected only when both of the enabling switch device and the T/B enable switch are placed in intermediate position (lightly gripped position). At this point, the state of door switch input does not matter.

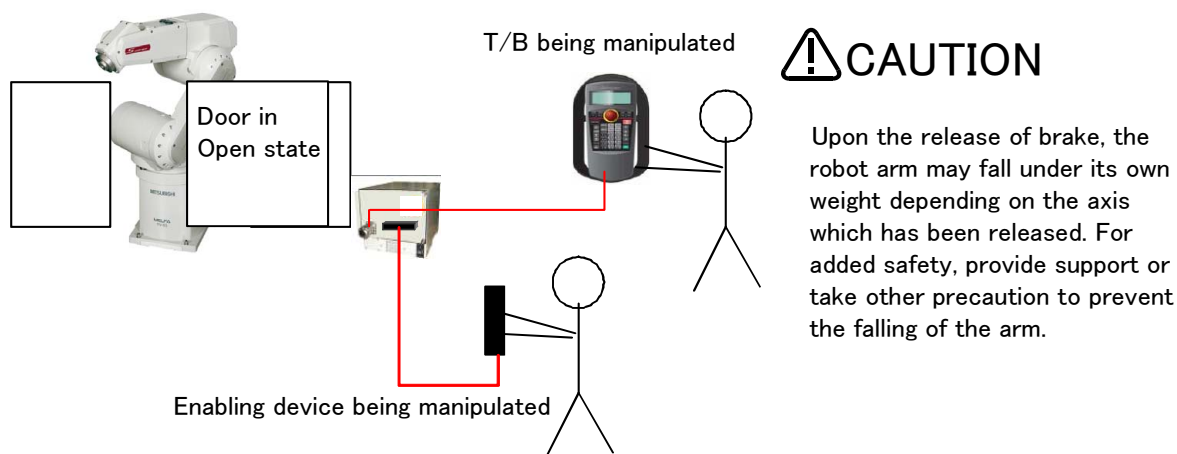

Fig.3-20 : Brake release operation

3.7 Additional Axis Function

This controller is equipped with an additional axis interface for controlling an additional axis when a traveling axis or rotary table is added to the robot. A maximum of eight axes of servo motors can be controlled at the same time by connecting a general-purpose servo amplifier (MR-J3-B series) that supports Mitsubishi's SSC Net III . Refer to the separate "Additional axis interface Instruction Manual" for details on the additional axis function.

3.7.1 Wiring of the Additional Axis Interface

Table 3-7 shows the connectors for additional axes inside the controller and Fig. 3-21 shows a connection example (configuration example). The magnet contactor control connector for additional axes, AXMC1, is designed to accommodate circuit connection with improved safety in Mitsubishi's industrial robot systems connecting additional axes.

Please be sure to install the noise filter in the power supply line of addition axis servo amplifier and to use the robot safely. The example of the installation of the noise filter is shown in Page 70, "(1) Example of the installation of the noise filter". Install by one of the methods.

Please implement the appropriate circuit connection by refer to Page 72, "3.8 Magnet contactor control connector output (AXMC) for addition axes".

Table 3-7 : Dedicated Connectors inside the Controller

Name	Connector name	Details
Connector for additional axes	CR1DA/CR2DA: OPT	The connector for connecting the general-purpose servo amplifier.
Magnet contactor control connector for additional axes	EMGOUT	This contact output is used to turn ON/OFF the motor power by connecting to general-purpose servo amplifiers.

<CR1DA-700>

* The figure is Standard specification.
 (The CE marking specification is the same.)

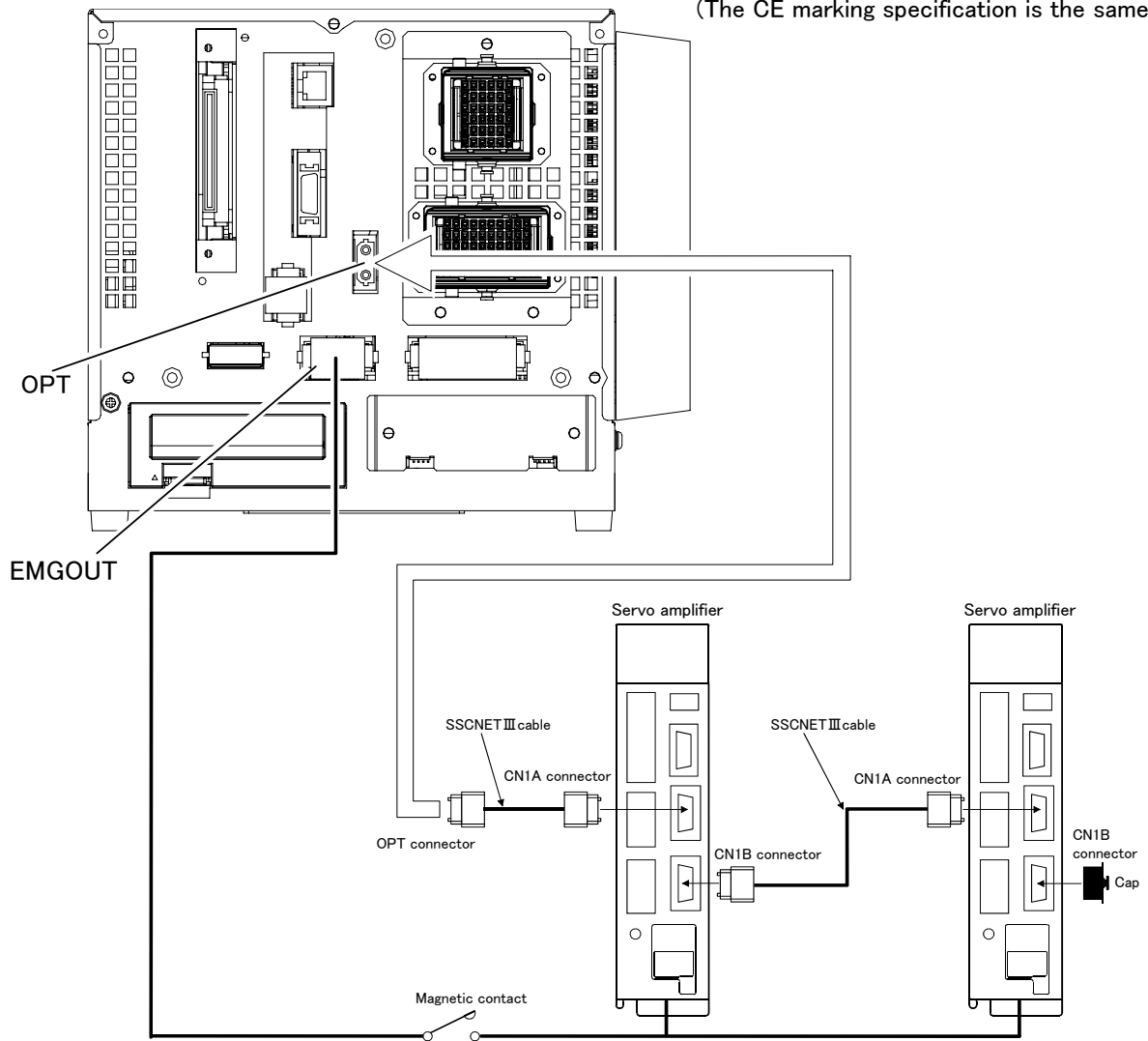

*It cannot communicate, if connection of CN1A and CN1B is mistaken.

Fig.3-21 : Example of addition axis connection (CR1DA-700)

<CR2DA-700>

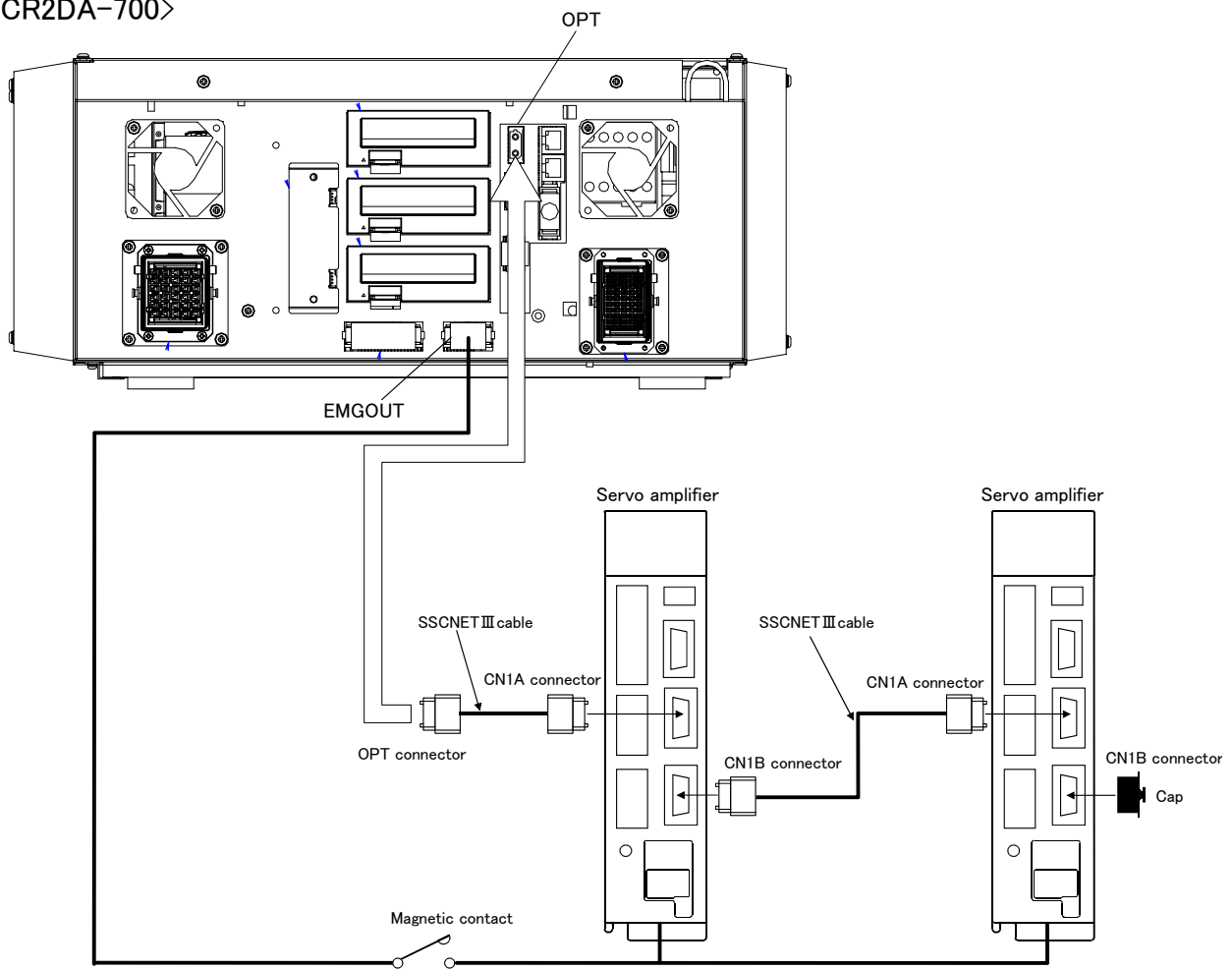

*It cannot communicate, if connection of CN1A and CN1B is mistaken.

Fig.3-22 : Example of addition axis connection (CR2AD-700)

(1) Example of the installation of the noise filter

1) EMC filter (recommended)

Please install the recommendation filter shown below according to the example of connection.

1) Combination with the servo amplifier

Servo amplifier	Recommended filter (Soshin Electric)		Mass [kg]([lb])
	Model	Leakage current [mA]	
MR-J3-10B to MR-J3-100B MR-J3-10B1 to MR-J3-40B1	(Note) HF3010A-UN	5	3 (6.61)
MR-J3-250B ▪ MR-J3-350B	(Note) HF3030A-UN		5.5 (12.13)
MR-J3-500B ▪ MR-J3-700B	(Note) HF3040A-UN	1.5	6.0 (13.23)
MR-J3-11KB to MR-J3-22KB	(Note) HF3100A-UN	6.5	15 (33.07)
MR-J3-60B4 ▪ MR-J3-100B4	TF3005C-TX	5.5	6(13.23)
MR-J3-200B4 to MR-J3-700B4	TF3020C-TX		7.5(16.54)
MR-J3-11KB4	TF3030C-TX		12.5(27.56)
MR-J3-15KB4	TF3040C-TX		
MR-J3-22KB4	TF3060C-TX		

Note. A surge protector is separately required to use any of these EMC filters.

2) Connection example

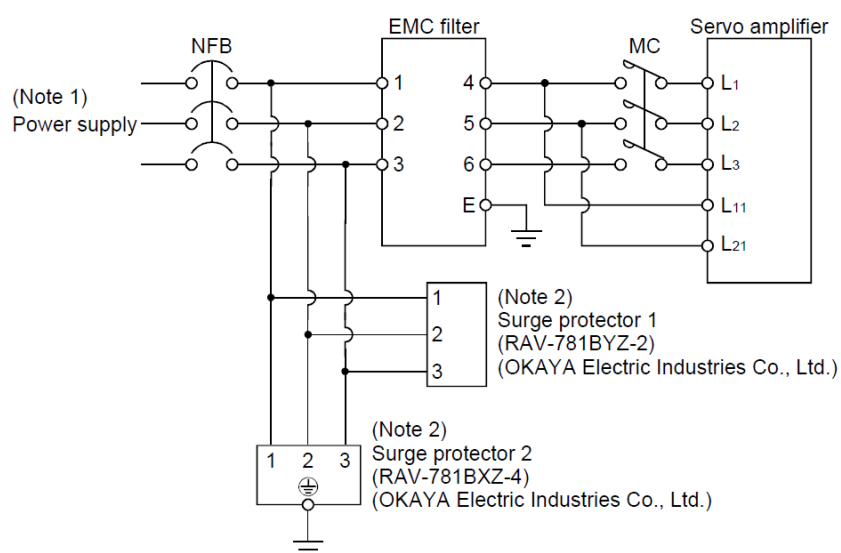

Note 1. For 1-phase 200V to 230VAC power supply, connect the power supply to L₁,L₂ and leave L₃ open.

There is no L₃ for 1-phase 100 to 120VAC power supply. Refer to section 1.3 for the power supply specification.

2. The example is when a surge protector is connected.

Fig.3-23 : Example of EMC noise filter installation

2) Line noise filter

This filter is effective in suppressing noises radiated from the power supply side and output side of the servo amplifier and also in suppressing high-frequency leakage current (zero-phase current) especially within 0.5MHz to 5MHz band.

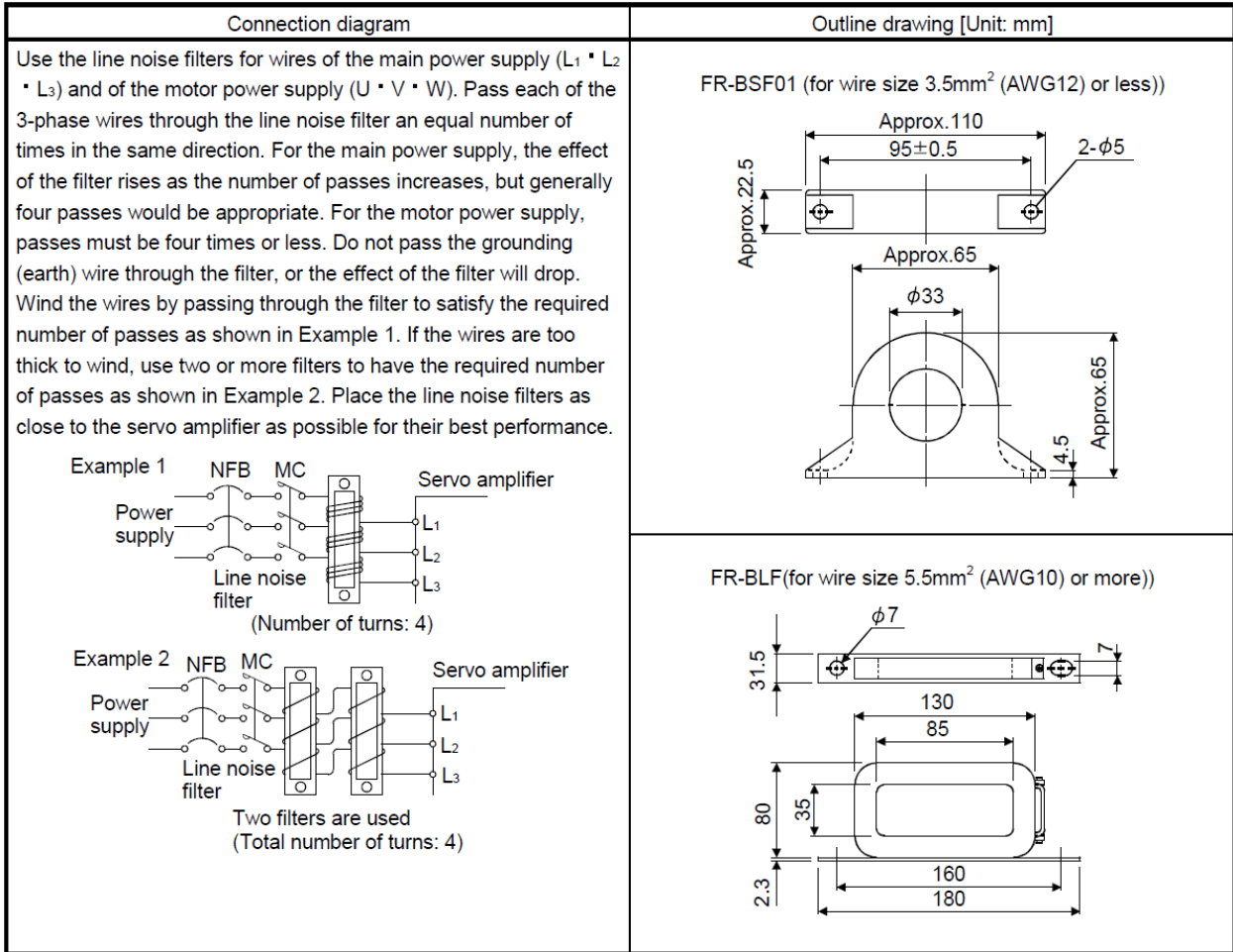

Fig.3-24 : Example of noise filter installation

3.8 Magnet contactor control connector output (AXMC) for addition axes

When an additional axis is used, the servo ON/OFF status of the additional axis can be synchronized with the servo ON/OFF status of the robot itself by using the output contact (AXMC) provided on the rear or inside of the controller and configuring a circuit so that the power to the servo amplifier for the additional axis can be turned off when this output is open.

Fig. 3-25 shows an example of its circuit, and Fig. 3-26 show the layout drawings of the output contact (EMGOUT). When you are using an additional axis, please perform appropriate circuit connections by referring to these drawings.

Refer to the separate "Additional axis interface Instruction Manual" for details on the additional axis function.

Note1) you use the addition axis function as a user mechanism who became independent of the robot arm, please do not connect this output signal. Servo-on of the user mechanism may be unable.

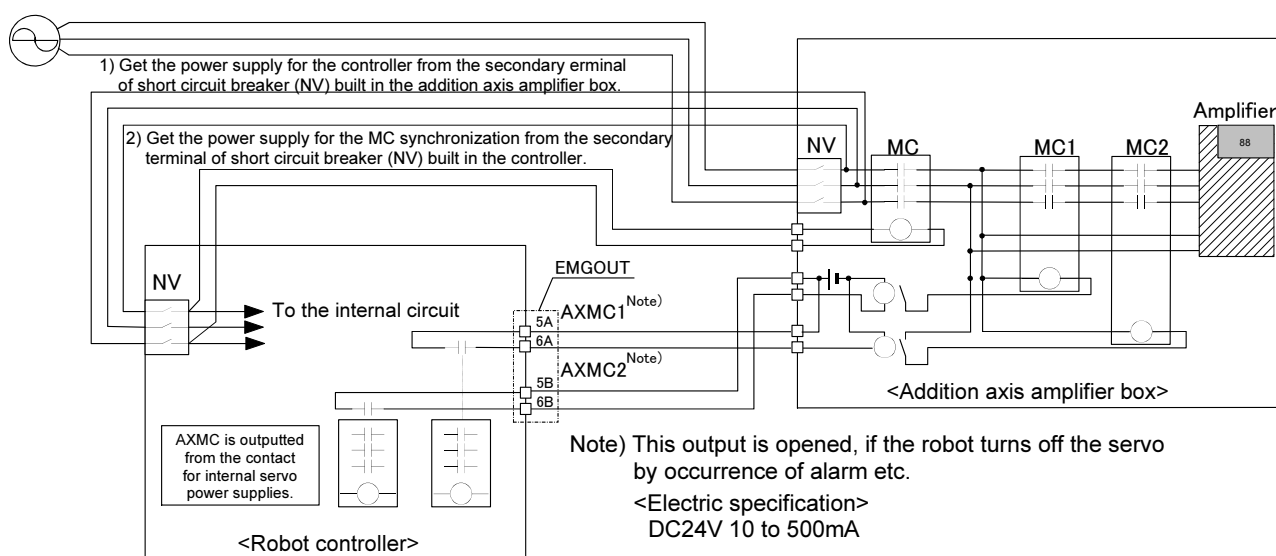
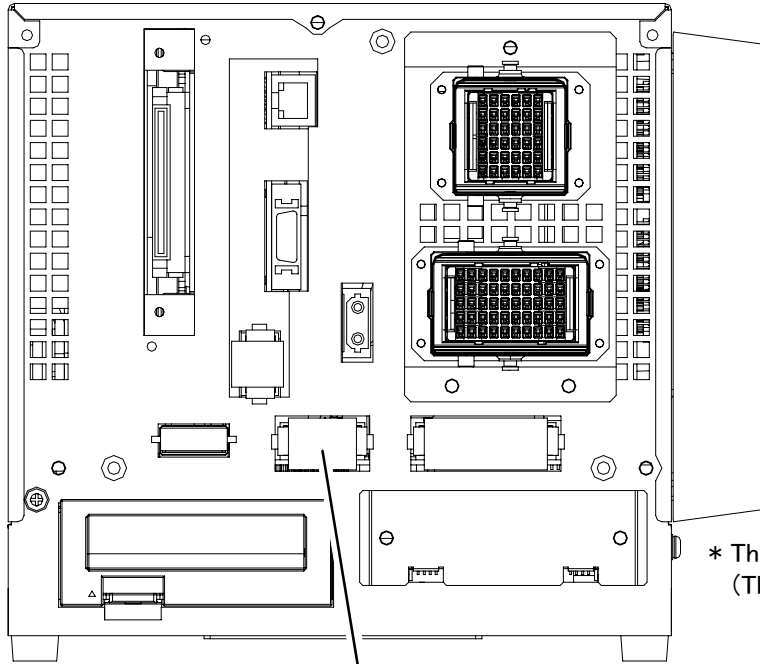

Fig.3-25 : Example of circuit for addition axes of Magnet contactor control output

<CR1DA-700>



* The figure is Standard specification.
(The CE marking specification is the same.)

EMGOUT

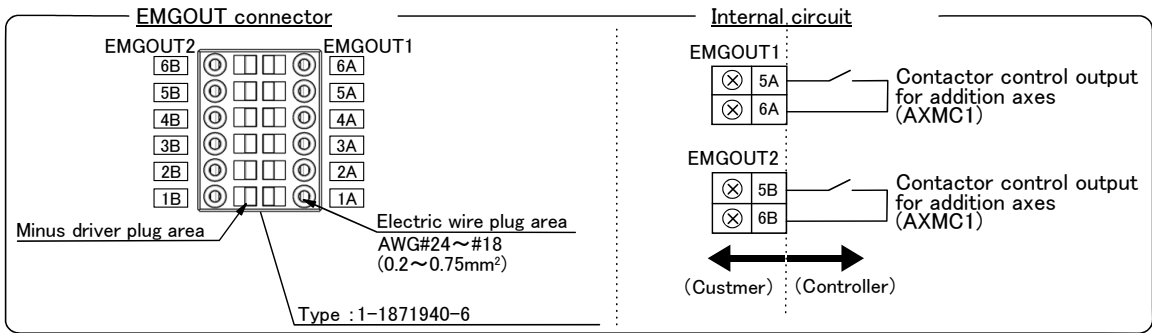

Fig.3-26 : EMGOUT connector (CR1DA-700)

<CR2DA-700>

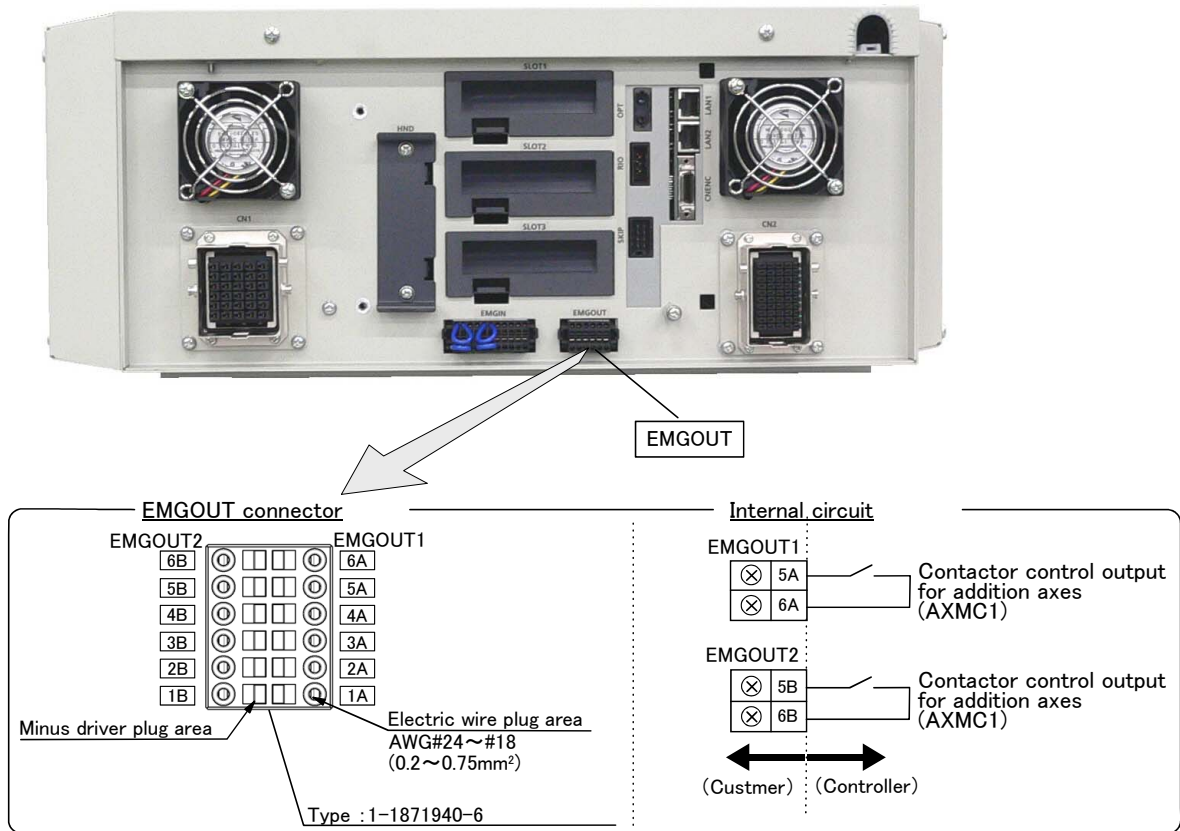

Fig.3-27 : EMGOUT connector (CR2DA-700)

3.9 Options

■ What are options?

There are a variety of options for the robot designed to make the setting up process easier for user needs.

User installation is required for the options.

Options come in two types: "set options" and "single options".

1. Set optionsA combination of single options and parts that together, form a set for serving some purpose.
2. Single optionsThat are configured from the fewest number of required units of a part. Please choose user's purpose additionally.

(1) Teaching pendant (T/B)

- Order type: R32TB :Cable length 7m
R32TB-15 :Cable length 15m

■ Outline



This is used to create, edit and control the program, teach the operation position and for jog feed, etc.

For safety proposes, a 3-position enable switch is mounted.*1)

■ Configuration

Table 3-8 : Configuration device

Part name	Type	Qty.	Mass(kg) ^{Note1)}	Remarks
Teaching pendant	R32TB	Either one pc.	1.7	Cable length is 7m. Hand strap is attached.
	R32TB-15		2.8	Cable length is 15m. Hand strap is attached.

Note1) Mass indicates one set.

■ Specifications

Table 3-9 : Specifications

Items	Specifications	Remarks
Outline dimensions	195(W) x 292(H) x 106(D) (refer to outline drawing)	
Body color	Dark gray	
Mass	Approx. 0.9kg (only arm, excluding cable)	
Connection method	Connection with controller and square connector (24-pin)	
Interface	RS-422	
Display method	LCD method: 24 characters x 8 lines, LCD illumination: with backlight	At 8x8 font
Operation section	36 keys	

*1) <3-position enable switch>

In ISO/10218 (1992) and JIS-B8433 (1993), this is defined as an "enable device". These standards specify that the robot operation using the teaching pendant is enabled only when the "enable device" is at a specified position. With the Mitsubishi Electric industrial robot, the above "enable device" is configured of an "Enable/Disable switch" and "Deadman switch".

The 3-position deadman switch has three statuses. The following modes are entered according to the switch state.

- a) "Not pressed"The robot does not operate. *)
- b) "Pressed lightly"The robot can be operated and teaching is possible.
- c) "Pressed with force"The robot does not operate. *)

*) Operations, such as program editing and status display, other than robot operation are possible.

Safety is secured as the servo power is turned OFF simultaneously with the input of the emergency stop.

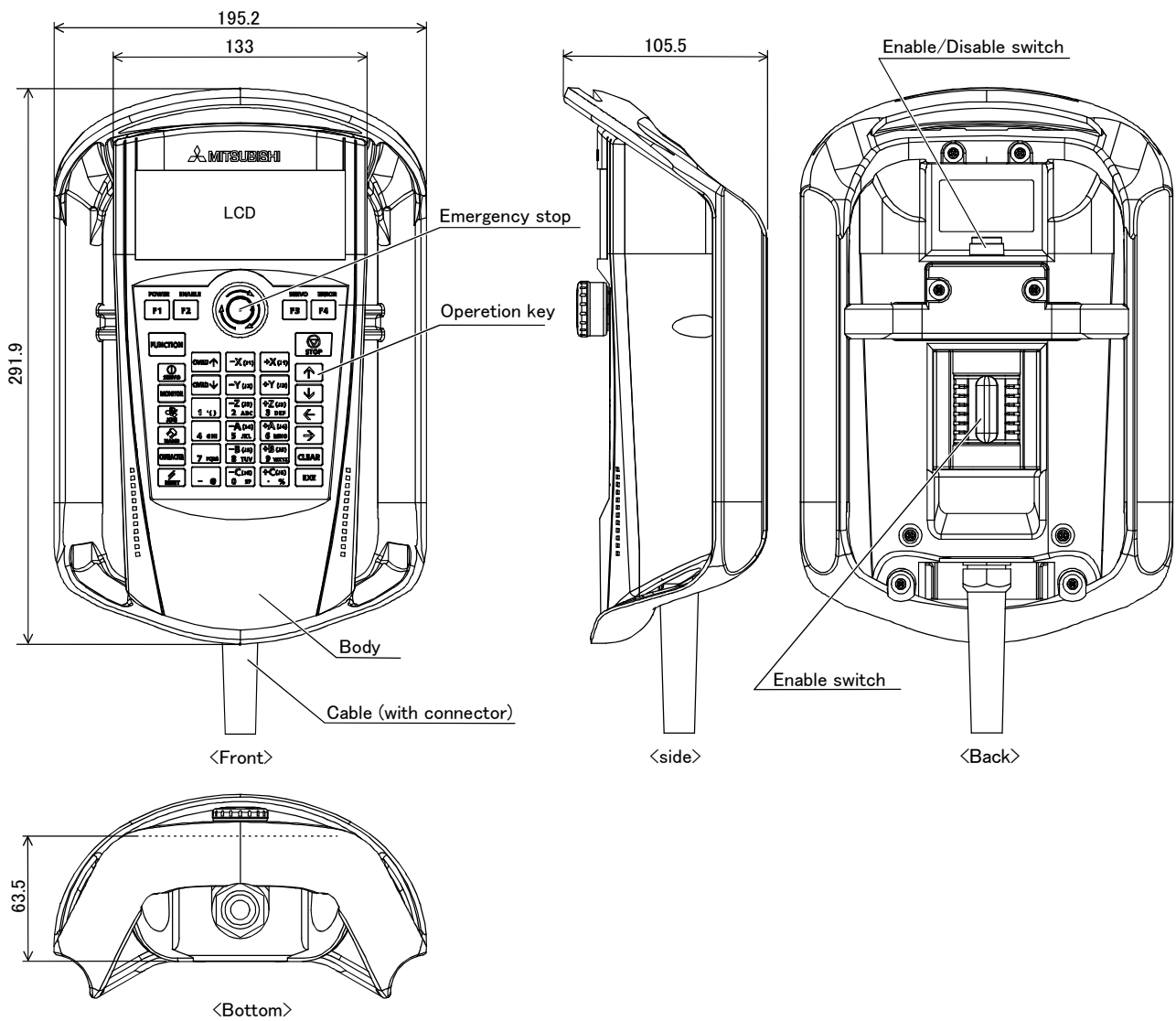

Fig.3-28 : Outside dimensions of teaching pendant

■ Installation method

The teaching pendant is connected to the T/B connector on the front of the controller.

Note) The connector may be felt hard if installation and removal of the teaching pendant or the dummy plug is repeated to the frequent.

■ Key layout and main functions



Fig.3-29 : Teaching pendant key layout and main functions

(2) Pneumatic hand interface

■ Order type: 2A-RZ365(Sink type)/2A-RZ375(Source type)

■ Outline



This interface is required to use the robot arm’s hand output signals.

- Up to eight hand output points can be used with this interface.
- The eight hand input points can be used without this interface.
- The previous pneumatic hand interface can be used.

■ Configuration

Table 3-10 : Configuration device

Part name	Type	Qty.	Mass(kg) ^{Note1)}	Remarks
Pneumatic hand interface	2A-RZ365(Sink type)	Either one pc.	0.1	Output 8 points expansion.
	2A-RZ375(Source type)		0.1	

Note1) Mass indicates one set.

■ Specifications

Table 3-11 : Specifications

Item	Specification	Internal circuit	
Type	Transistor output	<div style="display: flex; flex-direction: column; align-items: center;"> <div style="text-align: center;"> <p><Sink type></p> </div> <div style="text-align: center; margin-top: 20px;"> <p><Source type></p> </div> <p style="font-size: small;">* GRn = GR1 ~ GR8</p> </div>	
No. of output points	8		
Insulation method	Photo coupler insulation		
Rated load voltage	DC24V		
Rated load voltage range	DC21.6 to 26.4VDC		
Max. current load	0.1A/ 1 point (100%)		
Current leak with power OFF	0.1mA or less		
Maximum voltage drop with power ON	DC0.9V(TYP.) ^{Note1)}		
Response time	OFF-ON		2ms or less (hardware response time)
	ON-OFF		2 ms or less (resistance load) (hardware response time)
Fuse rating	Fuses 1.0A (each one common)		
Common method	8 points, 1 common		

Note1) The drop voltage maximum value at turning on the signal.
 The available solenoid valve is that the specification of rated voltage is DC24V ± 10%

■ Installation method

This is mounted in the controller.

Attach the pneumatic hand interface (2A-RZ365/2A-RZ375) to the CNHNDOUT/CNHND connector of the hand interface relay card (2D-TZ315) securely. Refer to separate "Instruction Manual/ Controller setup, basic operation, and maintenance" for details on the installing method.

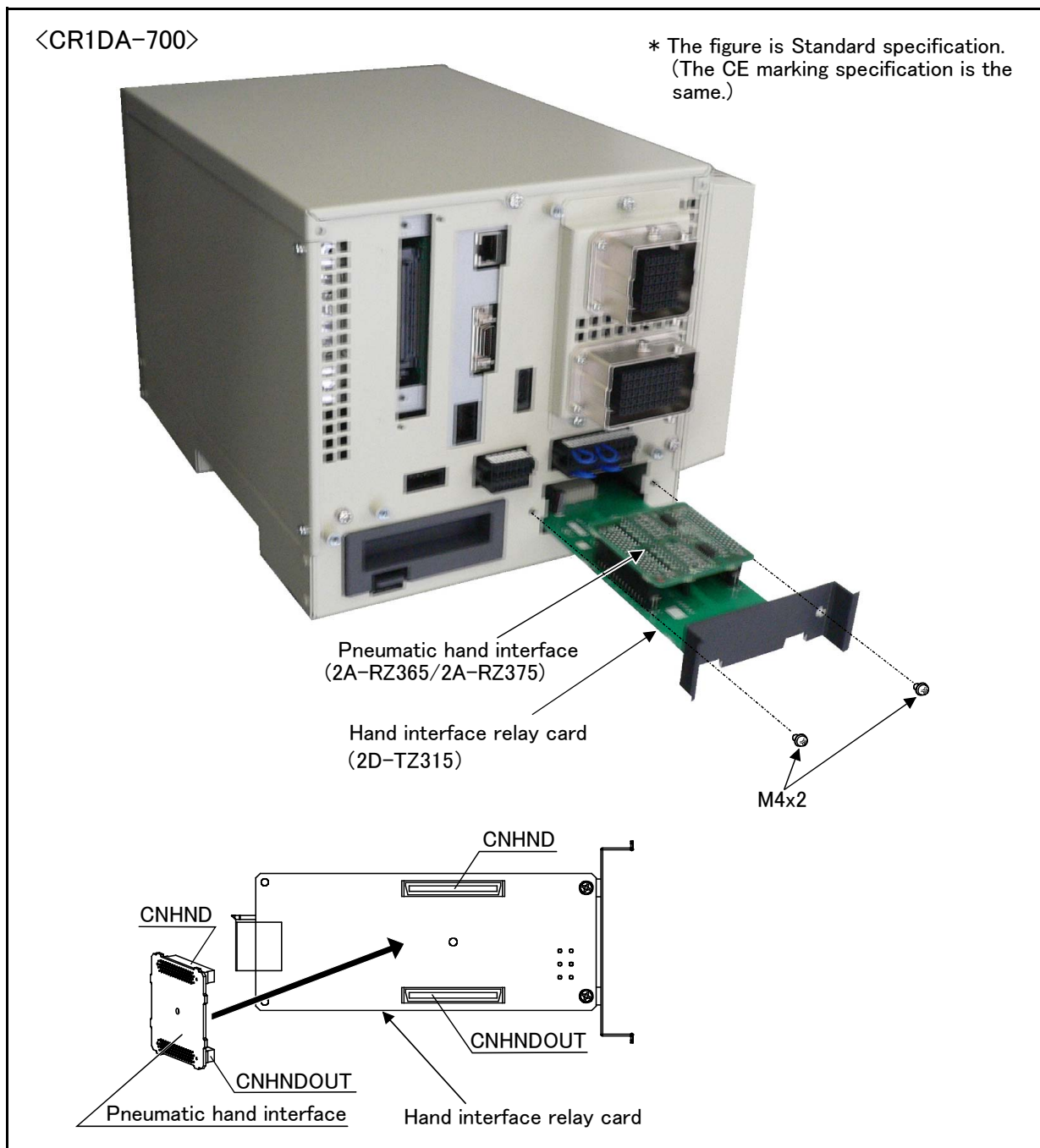

Fig.3-30 : Installation of the pneumatic hand interface (CR1DA-700)

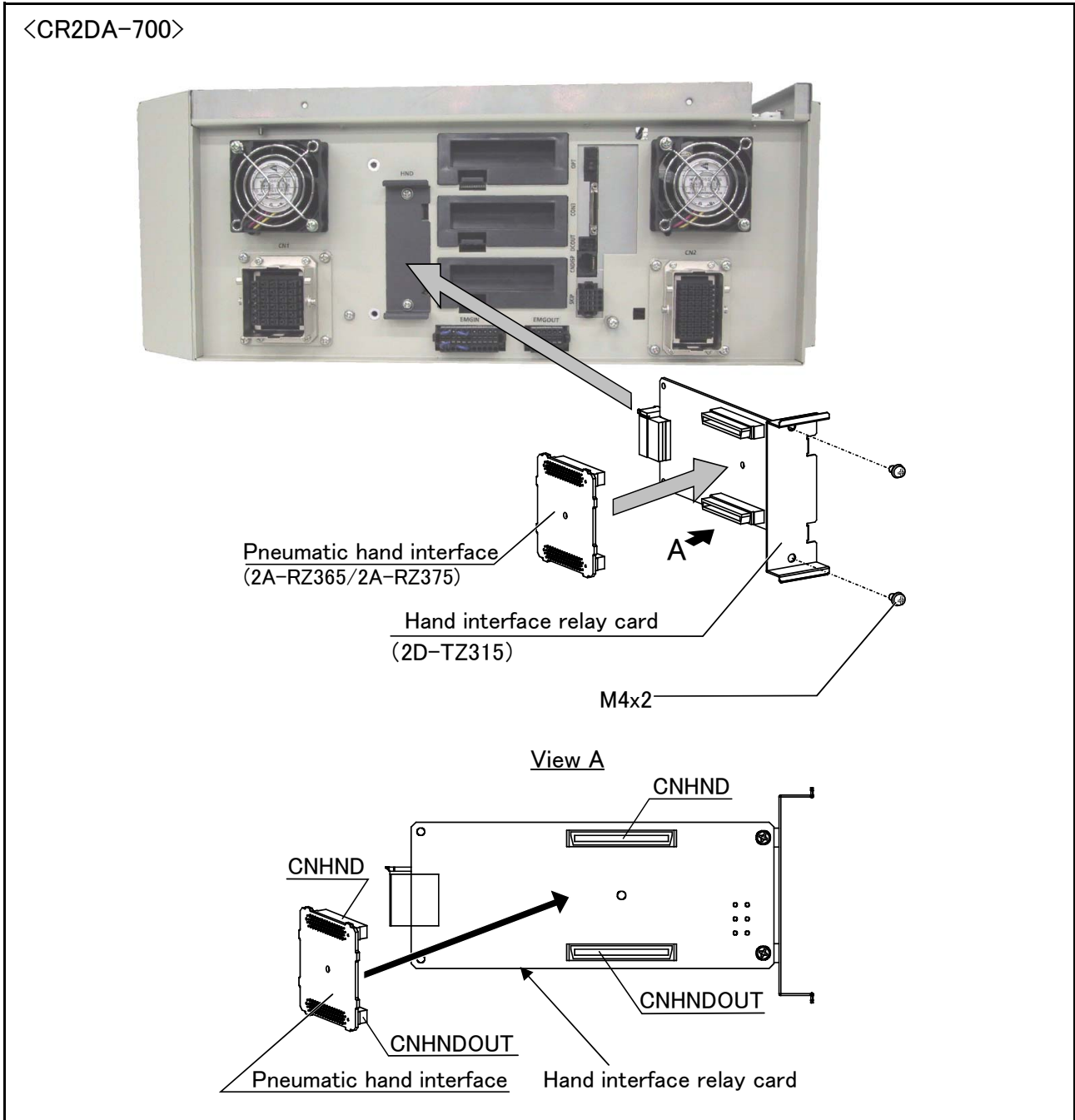

Fig.3-31 : Installation of the pneumatic hand interface (CR2DA-700)

(3) Parallel I/O interface

■ Order type : ● 2D-TZ368 (Sink type) /2D-TZ378 (Source type)

*One 2D-TZ378(Source type) is installed for CE Marking specification at shipping. (Only S312 and S12 specification)

■ Outline



This is used to expand the external inputs and outputs

• The connecting cable with external equipment is not attached. Since we are preparing the external input-and-output cable (2D-CBL05 or 2D-CBL15) as the option, please use.

Notes)Although the combined use with the parallel input-and-output unit (2A-RZ361/2A-RZ371) of another option is also possible, please use the setup of the station number by the different number separately. The station number is automatically determined by the position of the option slot which installed this interface. (station number 0 to 2)

■ Configuration

Table 3-12 : Configuration device

Part name	Type	Qty.	Mass(kg) Note1)	Remarks
Parallel I/O interface	2D-TZ368	Either one pc.	0.4	Input/output 32 points/32 points 2D-TZ368 is sink type. 2D-TZ378 is source type.
	2D-TZ378		0.4	

Note1) Mass indicates one set.

■ Specifications

- 1) The CR1DA-700 series controller can connect this one interface.
- 2) The CR2DA-700 and CR3D-700 series controller can connect this three interfaces.

Table 3-13 : Electrical specifications of input circuits

Item	Specification	Internal circuit	
Type	DC input	<p><Sink type></p> <p><Source type></p>	
Number of input points	32		
Insulation method	Photo coupler insulation		
Rated input voltage	DC12V/DC24V		
Rated input current	Approx. 3mA/7mA		
Working voltage range	DC10.2 ~ 26.4V (Ripple factor should be less than 5%)		
ON voltage/ON current	DC8V or more/2mA or more		
OFF voltage/ OFF current	DC4V or less/1mA or less		
Input resistance	Approx. 2.7k Ω		
Response time	OFF-ON		10ms or less(DC24V)
	ON-OFF		10ms or less(DC24V)
Common method	8points per common		
External cable connection method	Connector		

Table 3-14 : Electrical specifications for the output circuits

Item		Specification	Internal circuit
Type		Transistor output	<p><Sink type></p> <p><Source type></p>
No. of output points		32	
Insulation method		Photo-coupler insulation	
Rated load voltage		DC12V/DC24V	
Rated load voltage range		DC10.2 ~ 30V(peak voltage DC30V)	
Max. load current		0.1A/point (100%)	
Leakage current at OFF		0.1mA or less	
Max. voltage drop at ON		DC0.9V(TYP.) ^{Note1)}	
Response time	OFF-ON	10ms or less(Resistance load) (hardware response time)	
	ON-OFF	10ms or less(Resistance load) (hardware response time)	
Fuse rating		Fuse 1.6A(one per common) Replacement possible (max. 3)	
Common method		16 points per common (common terminal: 2points)	
External wire connection method		Connector	
External power supply	Voltage	DC12/24V(DC10.2 ~ 30V)	
	Current	60mA(TYP.DC24V per common)(base drive current)	

Note1) The maximum voltage drop value at signal ON Refer to it for the equipment connected to the output circuit.

Caution The protection fuse of the output circuit prevents the failure at the time of the load short circuit and incorrect connection. The load connected of the customer should be careful not to exceed maximum rating current. The internal transistor may be damaged if maximum rating current is exceeded.

■ Installation method

The expansion parallel input/output interface is installed in the controller. Refer to separate "Instruction Manual/ Controller setup, basic operation, and maintenance" for details on the installing method. If it installs in the option SLOT of the controller, the station number will be assigned automatically.

- SLOT1: station number 0(0 to 31)
- SLOT2: station number 1(32 to 63)
- SLOT3: station number 2(64 to 95)

Notes) The CR1DA-700 series controller can connect SLOT1 only.
All of SLOT1/SLOT2/SLOT3 can use CR2DA-700 and the CR3D-700 series controller.

Caution If it uses together with parallel input-and-output unit 2A-RZ361/2A-RZ371, please do not overlap with the station number of the parallel input-and-output interface.

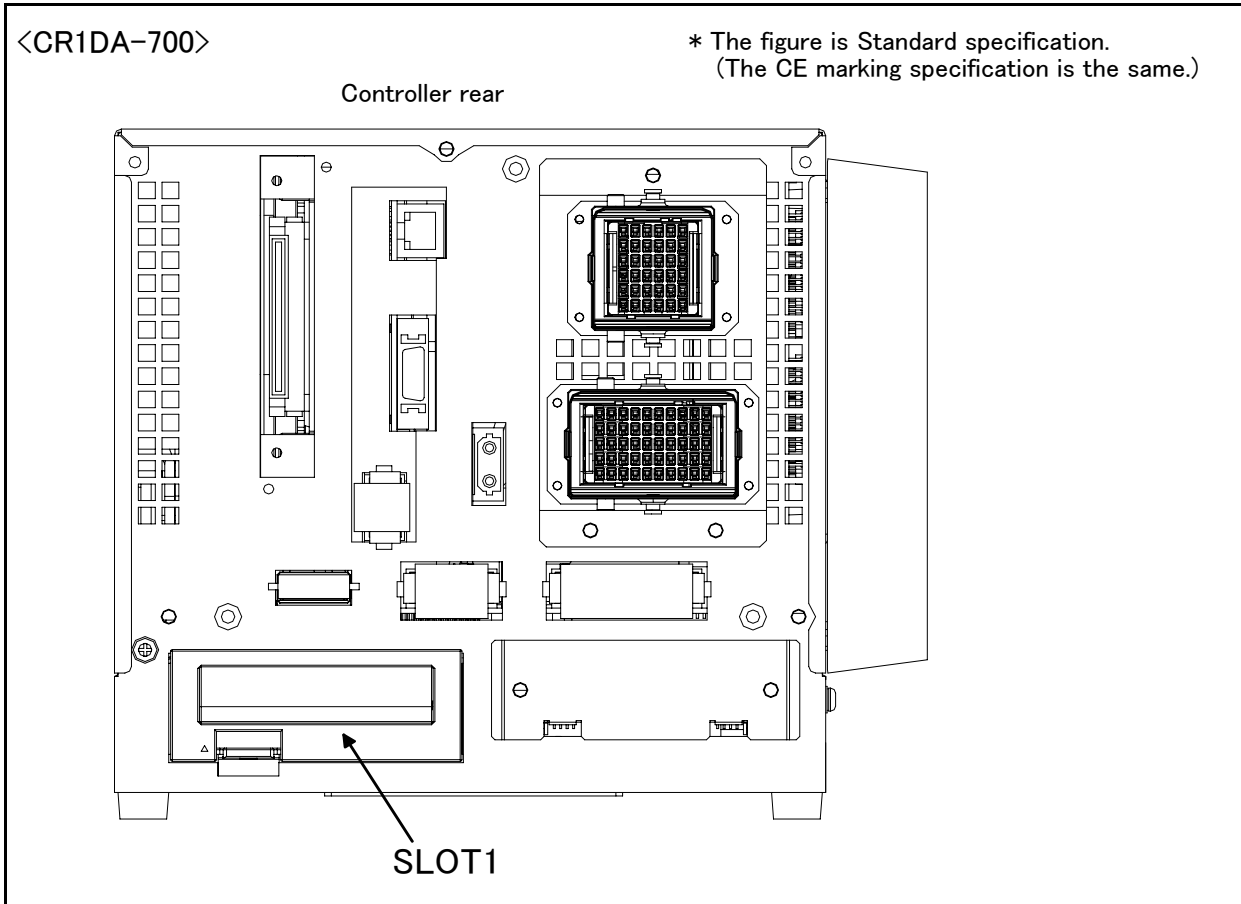

Fig.3-32 : Parallel I/O interface installation position (CR1DA-700)

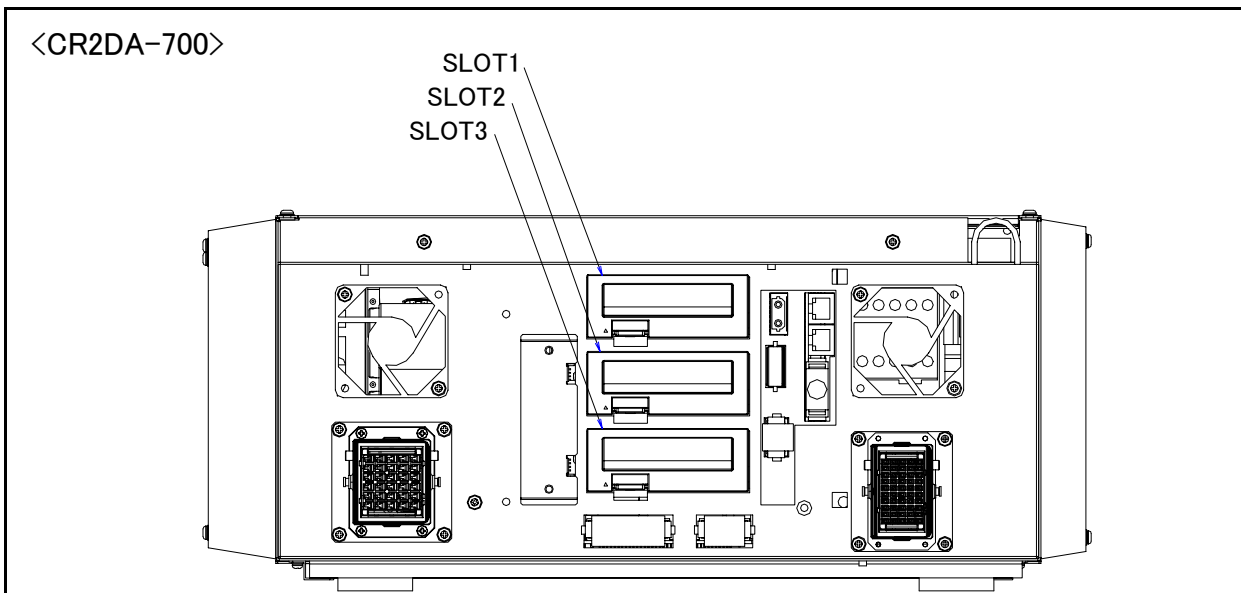

Fig.3-33 : Parallel I/O interface installation position (CR2DA-700)

■ Pin layout of connector

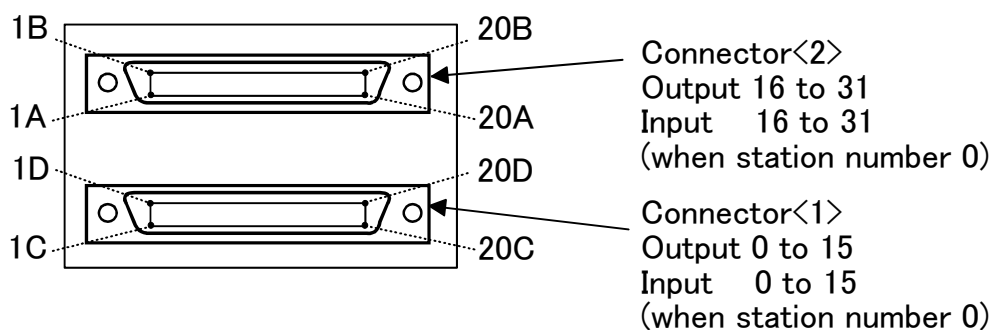

Fig.3-34 : Pin layout of connector

■ Connector pin No. and signal assignment

The station number is fixed by the slot to install and the allocation range of the general-purpose input-and-output signal is fixed.

Table 3-15 : The slot number and the station number

Slot number ^{Note1)}	Station number	Range of the general-purpose input-and-output signal	
		Connector <1>	Connector <2>
SLOT1	0	Input : 0 to 15 Output : 0 to 15	Input : 16 to 31 Output : 16 to 31
SLOT2	1	Input : 32 to 47 Output : 32 to 47	Input : 48 to 63 Output : 48 to 63
SLOT3	2	Input : 64 to 79 Output : 64 to 79	Input : 80 to 95 Output : 80 to 95

Note1) In case of the CR1DA controller, the available slot is only SLOT1.

The connector pin number of the parallel input-and-output interface installed in SLOT1 and signal number allocation are shown in [Table 3-16](#) and [Table 3-17](#).

Table 3-16 : Connector<1> pin assignment list and external I/O cable (2D-CBL**) color(SLOT1)

Pin No.	Line color	Function name		Pin No.	Line color	Function name	
		General-purpose	Dedicated/power supply, common			General-purpose	Dedicated/power supply, common
1C	Orange/Red a	General-purpose input 15	0V : For pins 5D-20D	1D	Orange/Black a	General-purpose output 15	12V/24V : For pins 5D-20D
2C	Gray/Red a		COM : For pins 5C-20C ^{Note1)}	2D	Gray/Black a		Reserved
3C	White/Red a		Reserved	3D	White/Black a		Reserved
4C	Yellow/Red a		Reserved	4D	Yellow/Black a		Reserved
5C	Pink/Red a			5D	Pink/Black a		
6C	Orange/Red b	General-purpose input 14		6D	Orange/Black b	General-purpose output 14	
7C	Gray/Red b	General-purpose input 13		7D	Gray/Black b	General-purpose output 13	
8C	White/Red b	General-purpose input 12		8D	White/Black b	General-purpose output 12	
9C	Yellow/Red b	General-purpose input 11		9D	Yellow/Black b	General-purpose output 11	
10C	Pink/Red b	General-purpose input 10		10D	Pink/Black b	General-purpose output 10	
11C	Orange/Red c	General-purpose input 9	Operation rights input signal ^{Note2)}	11D	Orange/Black c	General-purpose output 9	
12C	Gray/Red c	General-purpose input 8		12D	Gray/Black c	General-purpose output 8	
13C	White/Red c	General-purpose input 7		13D	White/Black c	General-purpose output 7	
14C	Yellow/Red c	General-purpose input 6		14D	Yellow/Black c	General-purpose output 6	
15C	Pink/Red c	General-purpose input 5		15D	Pink/Black c	General-purpose output 5	
16C	Orange/Red d	General-purpose input 4	Servo ON input signal ^{Note2)}	16D	Orange/Black d	General-purpose output 4	Operation rights output signal ^{Note2)}
17C	Gray/Red d	General-purpose input 3	Start input ^{Note2)}	17D	Gray/Black d	General-purpose output 3	
18C	White/Red d	General-purpose input 2	Error reset input signal ^{Note2)}	18D	White/Black d	General-purpose output 2	
19C	Yellow/Red d	General-purpose input 1	Servo OFF input signal ^{Note2)}	19D	Yellow/Black d	General-purpose output 1	
20C	Pink/Red d	General-purpose input 0	Stop input ^{Note3)}	20D	Pink/Black d	General-purpose output 0	

Note1) Sink type:12V/24V(COM),Source type:0V(COM)

Note2) The dedicated signal is assigned at shipping. It can change with the parameter.

Note3) The dedicated input signal (STOP) is assigned at shipping. The signal number is fixing.

Table 3-17 : Connector<2> pin assignment list and external I/O cable (2D-CBL**) color(SLOT1)

Pin No.	Line color	Function name		Pin No.	Line color	Function name	
		General-purpose	Dedicated/power supply, common			General-purpose	Dedicated/power supply, common
1A	Orange/Red a	General-purpose input 31	0V : For pins 5B-20B	1B	Orange/Black a	General-purpose output 31	12V/24V : For pins 5B-20B
2A	Gray/Red a		COM : For pins 5A-20A ^{Note1)}	2B	Gray/Black a		Reserved
3A	White/Red a		Reserved	3B	White/Black a		Reserved
4A	Yellow/Red a		Reserved	4B	Yellow/Black a		Reserved
5A	Pink/Red a			5B	Pink/Black a		
6A	Orange/Red b	General-purpose input 30		6B	Orange/Black b	General-purpose output 30	
7A	Gray/Red b	General-purpose input 29		7B	Gray/Black b	General-purpose output 29	
8A	White/Red b	General-purpose input 28		8B	White/Black b	General-purpose output 28	
9A	Yellow/Red b	General-purpose input 27		9B	Yellow/Black b	General-purpose output 27	
10A	Pink/Red b	General-purpose input 26		10B	Pink/Black b	General-purpose output 26	
11A	Orange/Red c	General-purpose input 25		11B	Orange/Black c	General-purpose output 25	
12A	Gray/Red c	General-purpose input 24		12B	Gray/Black c	General-purpose output 24	
13A	White/Red c	General-purpose input 23		13B	White/Black c	General-purpose output 23	
14A	Yellow/Red c	General-purpose input 22		14B	Yellow/Black c	General-purpose output 22	
15A	Pink/Red c	General-purpose input 21		15B	Pink/Black c	General-purpose output 21	
16A	Orange/Red d	General-purpose input 20		16B	Orange/Black d	General-purpose output 20	
17A	Gray/Red d	General-purpose input 19		17B	Gray/Black d	General-purpose output 19	
18A	White/Red d	General-purpose input 18		18B	White/Black d	General-purpose output 18	
19A	Yellow/Red d	General-purpose input 17		19B	Yellow/Black d	General-purpose output 17	
20A	Pink/Red d	General-purpose input 16		20B	Pink/Black d	General-purpose output 16	

Note1) Sink type:12V/24V(COM),Source type:0V(COM)

<Reference> The example of connection with our PLC

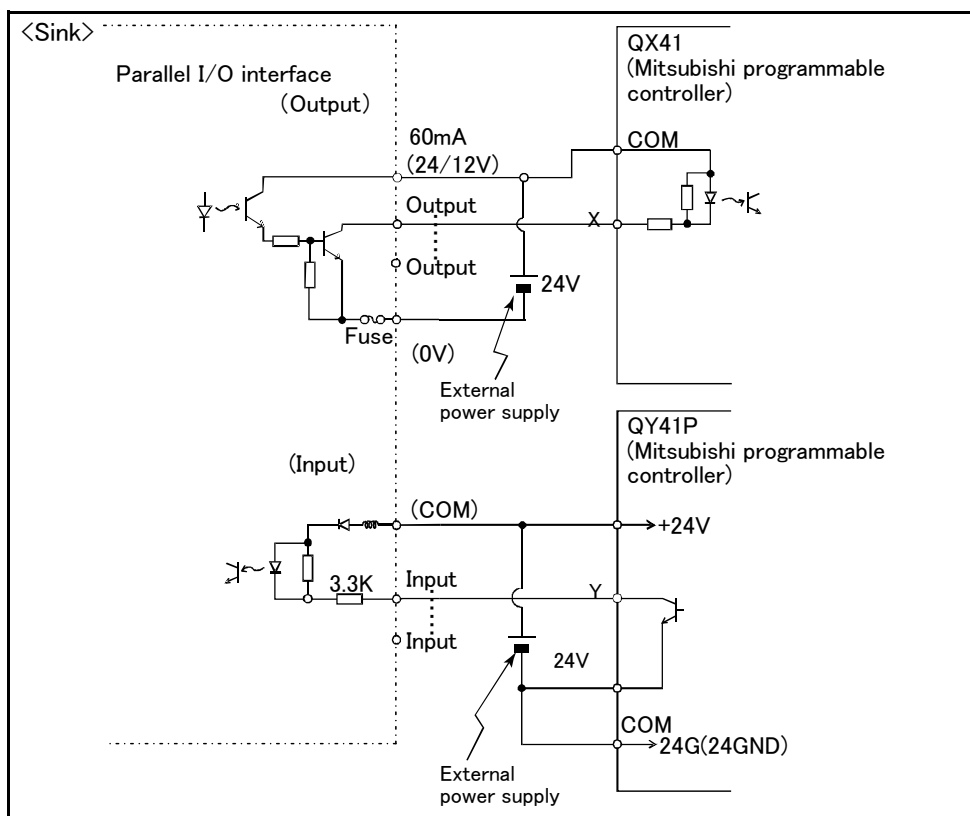

Table 3-18 : Connection with a Mitsubishi PLC (Example of sink type)

*The input/output circuit external power supply (24 VDC) must be prepared by the customer.

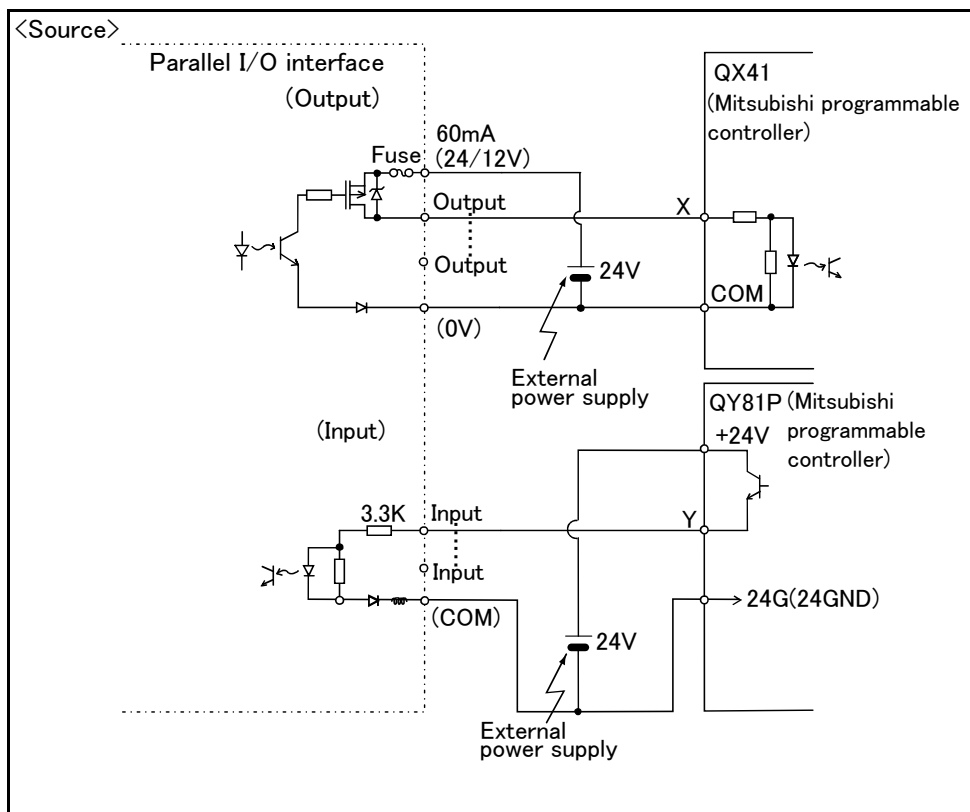

Table 3-19 : Connection with a Mitsubishi PLC (Example of source type)

*The input/output circuit external power supply (24 VDC) must be prepared by the customer.

(4) External I/O cable

■ Order type : ● 2D-CBL □□ (Note) The numbers in the boxes □□ refer to the length. (05: 5m, 15: 15m)

■ Outline



This is the dedicated cable used to connect an external peripheral device to the connector on the parallel I/O interface. For parallel I/O unit is another option 2A-CBL.**. One end matches the connector on the parallel input/output unit, and the other end is free. Connect the peripheral device's input/output signal using the free end. One cable correspond to the input 16 points and output 16 points. Two cables are needed to connection of (input 32 points and output 32 points) with built-in standard.

■ Configuration

Table 3-20 : Configuration device

Part name	Type	Qty.	Mass(kg) ^{Note1)}	Remarks
External I/O cable	2D-CBL □□	1 pc.	0.7(5m) 1.84(15m)	5m or 15m

Note1) Mass indicates one set.

■ Specifications

Table 3-21 : Specifications

Items	Specifications
Number of cables x cable size	AWG #28 x 20P (40 pairs)
Total length	5m, 15m

■ Connector pin numbers and cable colors

Table 3-22 : Connector pin numbers and cable colors

Pin no.	Cable colors	Pin no.	Cable colors	Pin no.	Cable colors	Pin no.	Cable colors
1A/C	Orange/Red a	11A/C	Orange/Red c	1B/D	Orange/Black a	11B/D	Orange/Black c
2A/C	Gray/Red a	12A/C	Gray/Red c	2B/D	Gray/Black a	12B/D	Gray/Black c
3A/C	White/Red a	13A/C	White/Red c	3B/D	White/Black a	13B/D	White/Black c
4A/C	Yellow/Red a	14A/C	Yellow/Red c	4B/D	Yellow/Black a	14B/D	Yellow/Black c
5A/C	Pink/Red a	15A/C	Pink/Red c	5B/D	Pink/Black a	15B/D	Pink/Black c
6A/C	Orange/Red b	16A/C	Orange/Red d	6B/D	Orange/Black b	16B/D	Orange/Black d
7A/C	Gray/Red b	17A/C	Gray/Red d	7B/D	Gray/Black b	17B/D	Gray/Black d
8A/C	White/Red b	18A/C	White/Red d	8B/D	White/Black b	18B/D	White/Black d
9A/C	Yellow/Red b	19A/C	Yellow/Red d	9B/D	Yellow/Black b	19B/D	Yellow/Black d
10A/C	Pink/Red b	20A/C	Pink/Red d	10B/D	Pink/Black b	20B/D	Pink/Black d

Notes) Pin number of connector<1> are 1C, 2C, ...,20C, 1D, 2D, ...,20D, connector<2> are 1A, 2A, ...,20A, 1B, 2B, ...,20B.

■ Connections and outside dimensions

The sheath of each signal cable (40 lines) is color indicated and marked with dots. Refer to the cable color specifications in "Table 3-33 Connector pin numbers and cable colors" when making the connections.

(Eg.) Pin number: color indication

1 : Orange / Red / A

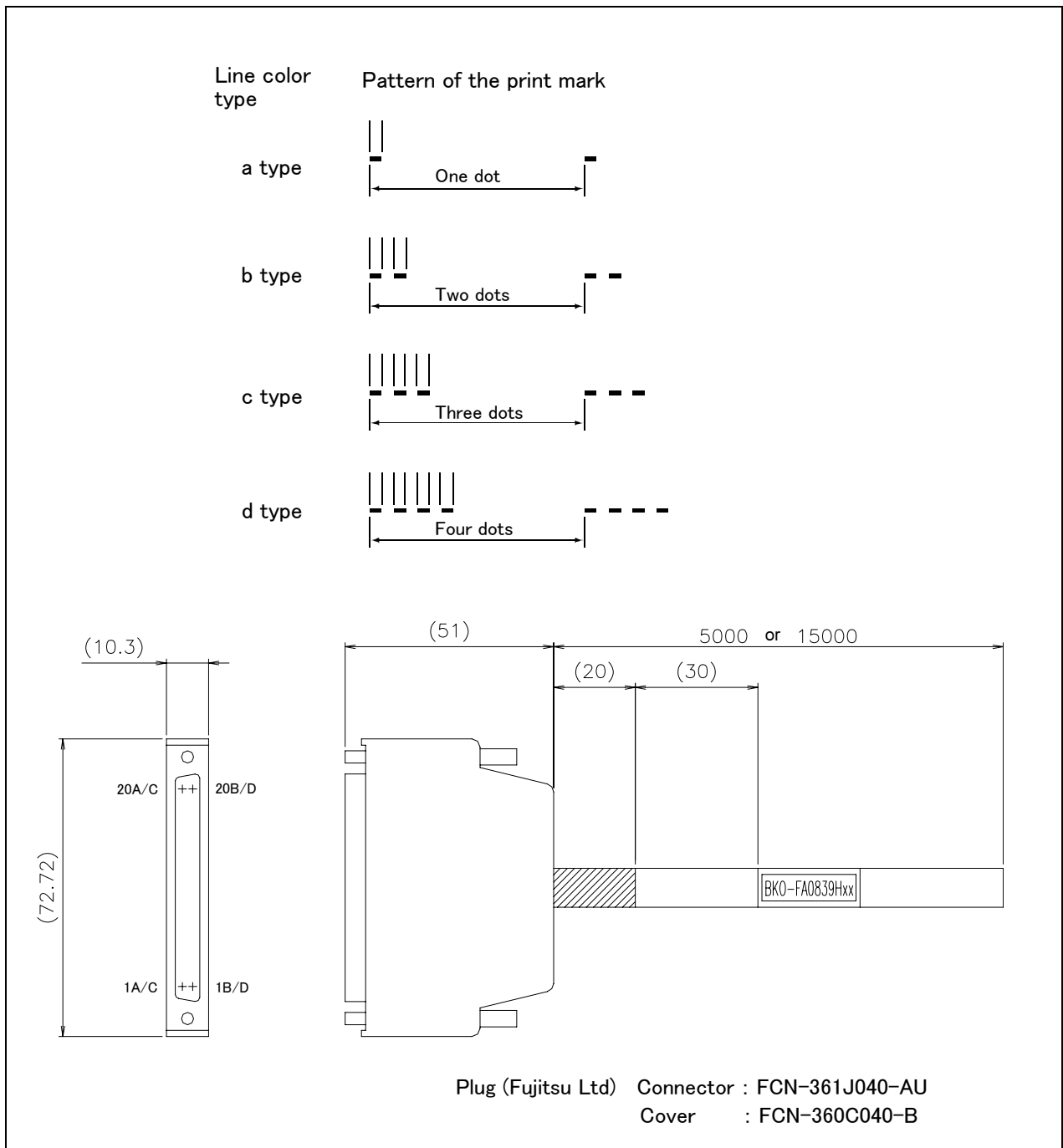
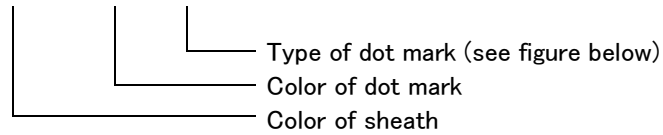

Fig.3-35 : Connections and outside dimensions

(5) Parallel I/O unit

- Order type: 2A-RZ361(Sink type)
2A-RZ371(Source type)

- Outline



This is used to expand the external inputs and outputs. One one equal with this unit is built into the control unit among controllers the standard.

- The connection cable is not included. Prepare the optional external input/output cable (2A-CBL05 or 2A-CBL15).
- Use 2A-RZ361 if the external input/output signal logic is of the sink type and 2A-RZ371 for source type signal logic.

Notes) Although the combined use with the parallel I/O interface (2D-TZ368) of another option is also possible, please use the setup of the station number by the different number separately. The station number is automatically fixed by the position of the option slot which installed the parallel I/O interface in 0-2.

- Configuration

Table 3-23 : Configuration device

Part name	Type	Qty.	Mass(kg) Note1)	Remarks
Parallel I/O unit	2A-RZ361	Either one pc.	0.7	Input/output 32 points/32 points 2A-RZ361 is the sink type. 2A-RZ371 is the source type.
	2A-RZ371		0.7	
Robot I/O link connection connector	NETcable-1	2 sets	-	Connector with pins. The cable must be prepared and wired by the customer.
Power connection connector	DCcable-2	1 set	-	Connector with pins. The cable must be prepared and wired by the customer.
Terminator	R-TM	1 pc.	-	100Ω (1/4W)

Note1) Mass indicates one set.

- Specifications

- The parallel I/O interface (2D-TZ368) of another option, and the a maximum of eight pieces in all. (One station occupies one unit.)
- The power supply (24V) must be prepared by the customer and connected with the power connection cable (DCcable-2)
A separate 24V power supply is required for the input/output circuit wiring.

Table 3-24 : Electrical specifications of input circuits

Item	Specification	Internal circuit
Type	DC input	<Sink type>
Number of input points	32	
Insulation method	Photo coupler insulation	
Rated input voltage	12VDC/24VDC	
Rated input current	Approx 3mA/7mA	
Working voltage range	10.2 to 26.4VDC(Ripple factor should be less than 5%)	
ON voltage/ON current	8VDC or more/ 2mA or more	
OFF voltage/ OFF current	4VDC or less/ 1mA or less	
Input resistance	Approx. 3.3kΩ	
Response time	OFF-ON 10ms or less (24VDC) ON-OFF 10ms or less (24VDC)	
Common method	8 points per common	
External cable connection method	Connector	

Table 3-25 : Electrical specifications for the output circuits

Item		Specification	Internal circuit
Type		Transistor output	<div style="display: flex; flex-direction: column; align-items: center;"> <div style="text-align: center; margin-bottom: 20px;"> <p><Sink type></p> </div> <div style="text-align: center;"> <p><Source type></p> </div> </div>
No. of output points		32	
Insulation method		Photo-coupler insulation	
Rated load voltage		12VDC/24VDC	
Rated load voltage range		10.2 to 30VDC(peak voltage 30VDC)	
Max. load current		0.1A/point (100%)	
Leakage current at OFF		0.1mA or less	
Max. voltage drop at ON		0.9VDC(TYP.) ^{Note1)}	
Response time	OFF-ON	2ms or less (hardware response time)	
	ON-OFF	2ms or less (Resistance load) (hardware response time)	
Fuse rating		Fuse 3.2A (one per common) Replacement not possible	
Common method		8 points per common (common terminal: 4 points)	
External wire connection method		Connector	
External power supply	Voltage	12VDC/24VDC(10.2 to 30VDC)	
	Current	60mA (TYP. 24VDC per common) (base drive current)	

Note1) The maximum voltage drop value at signal ON Refer to it for the equipment connected to the output circuit.

⚠ CAUTION

The output circuit protective fuses prevent failure in case of load short-circuit and improper connections. Please do not connect loads that cause the current to exceed the maximum rated current. If the maximum rated current is exceeded, the internal transistors may be damaged.

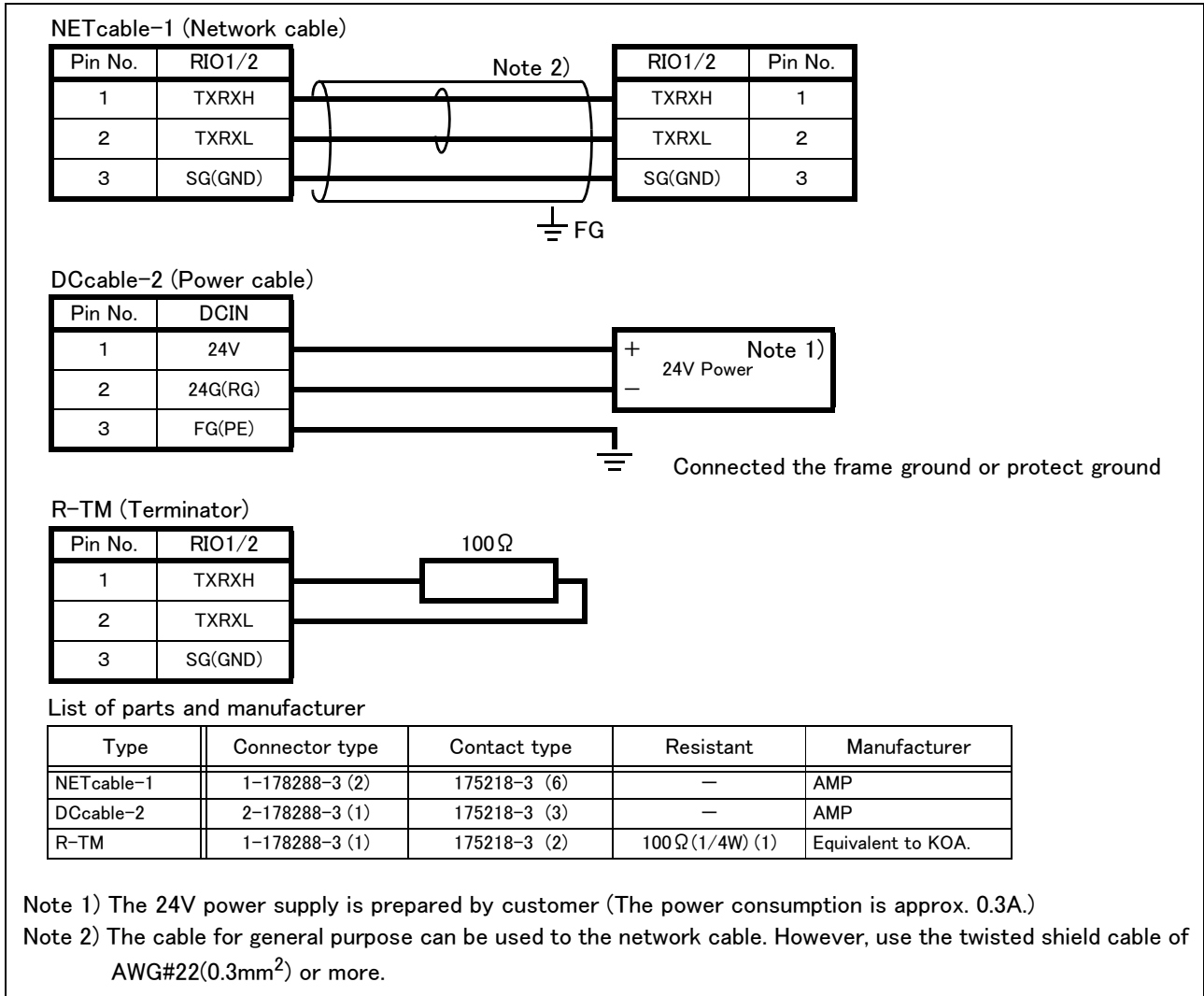

Fig.3-36 : Specifications for the connection cable

■ Installation method

The expansion parallel input/output unit is installed outside of the controller. Connect with the network connection cable (NETcable-1) from the RIO connector in the rear/into of the controller.(Terminator is connected at the time of shipment)

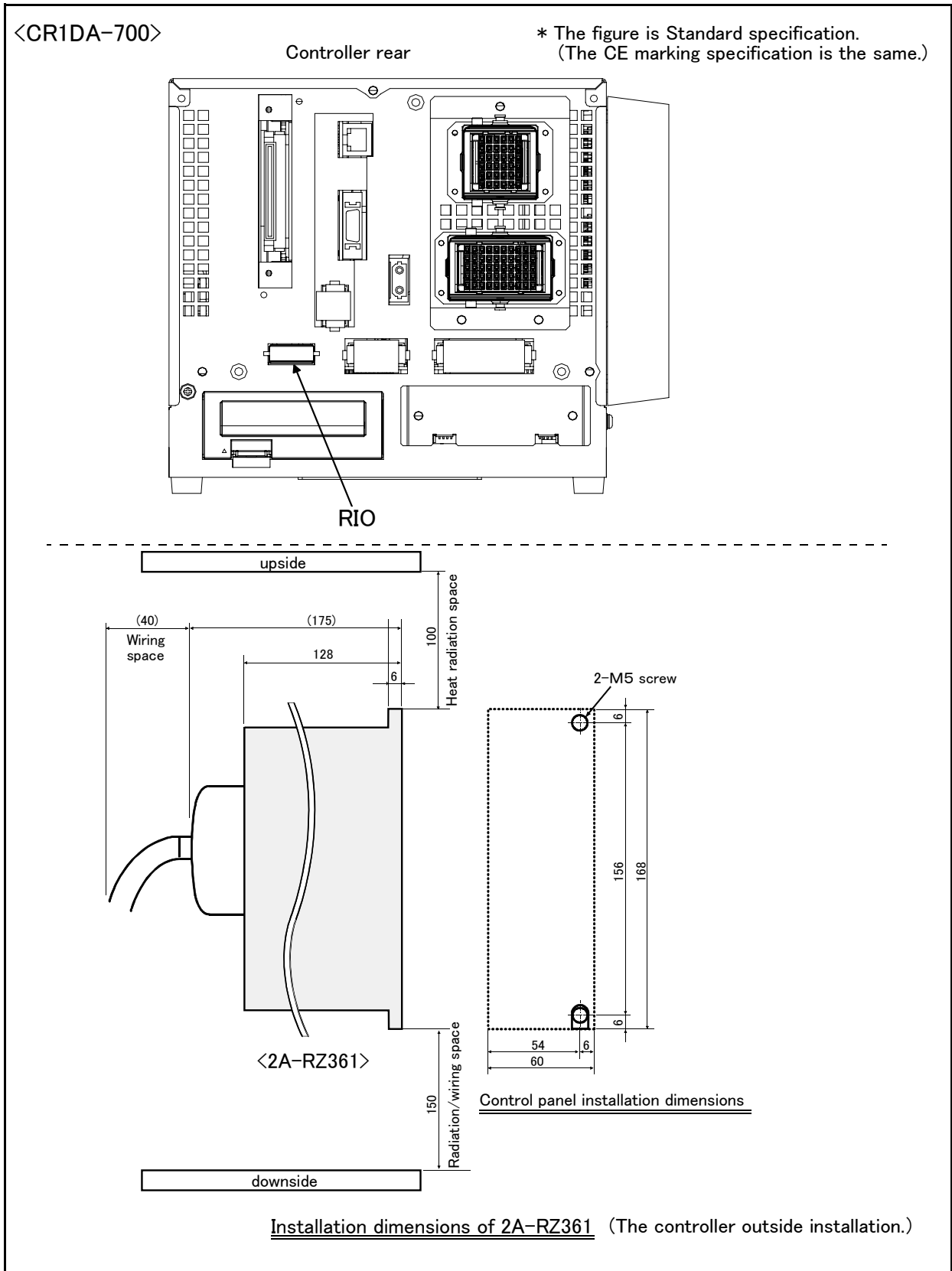

Fig.3-37 : Installing the parallel I/O unit (CR1DA-700)

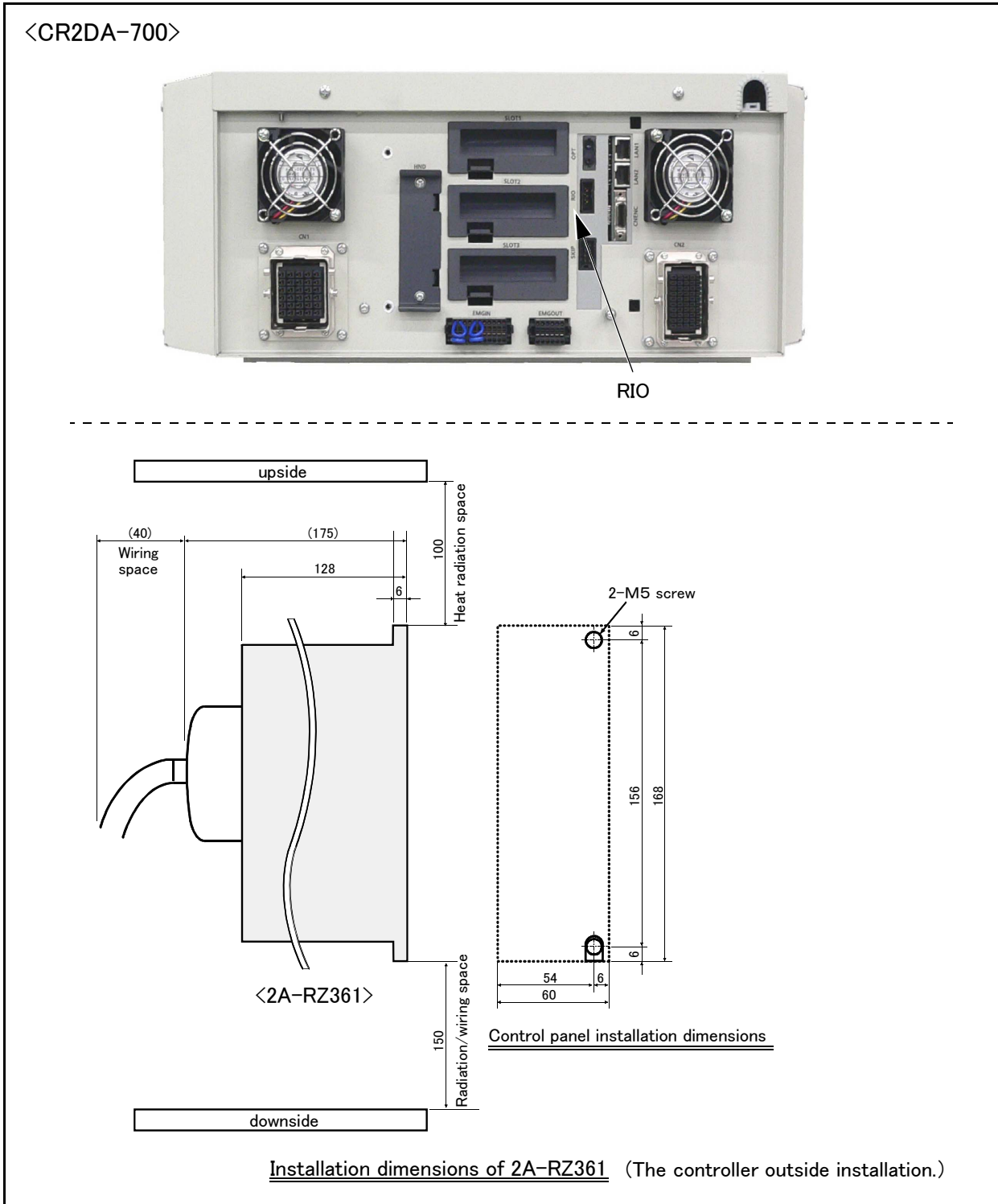

Fig.3-38 : Installing the parallel I/O unit (CR2DA-700)

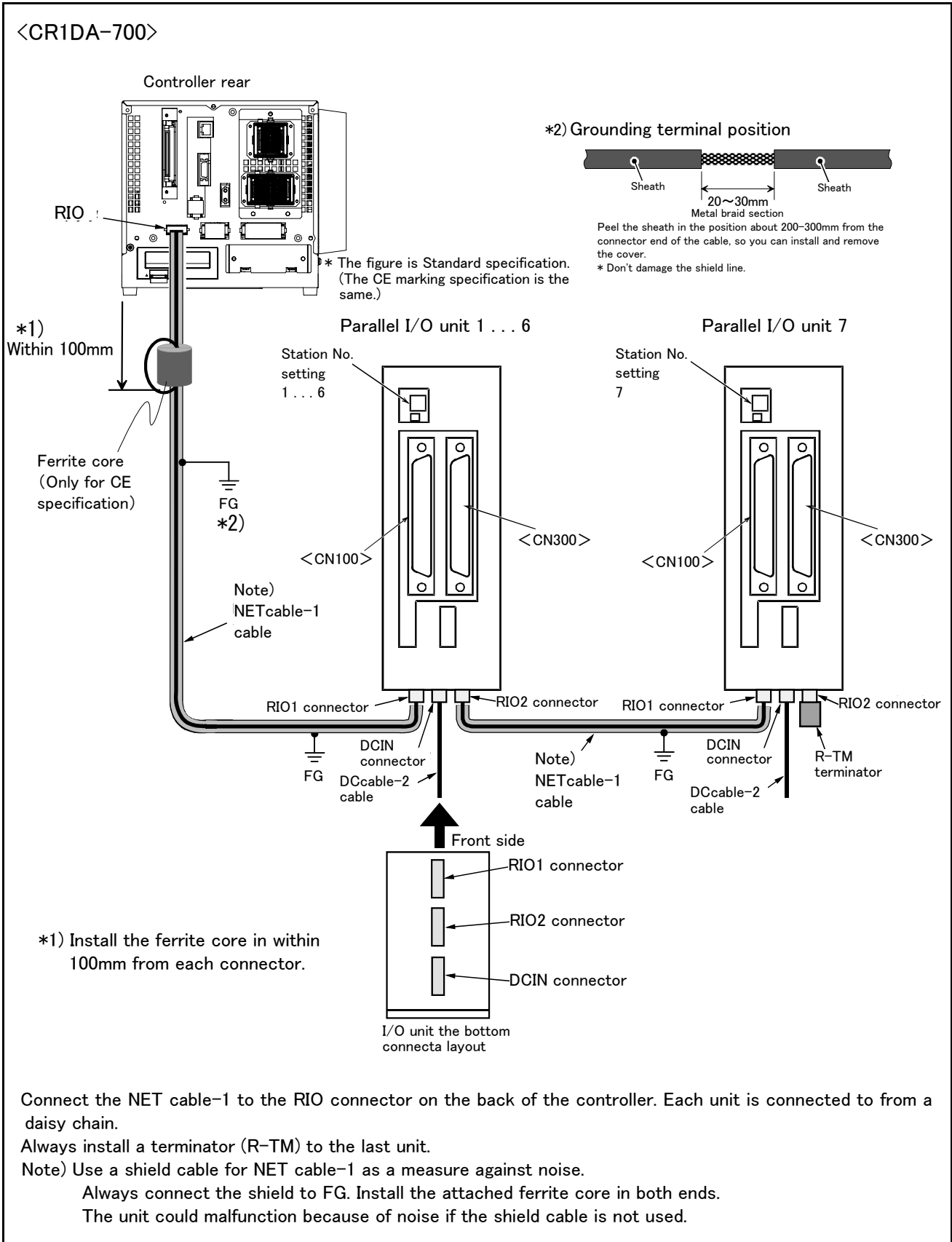

Fig.3-39 : Connection method of expansion parallel I/O unit (CR1DA-700)

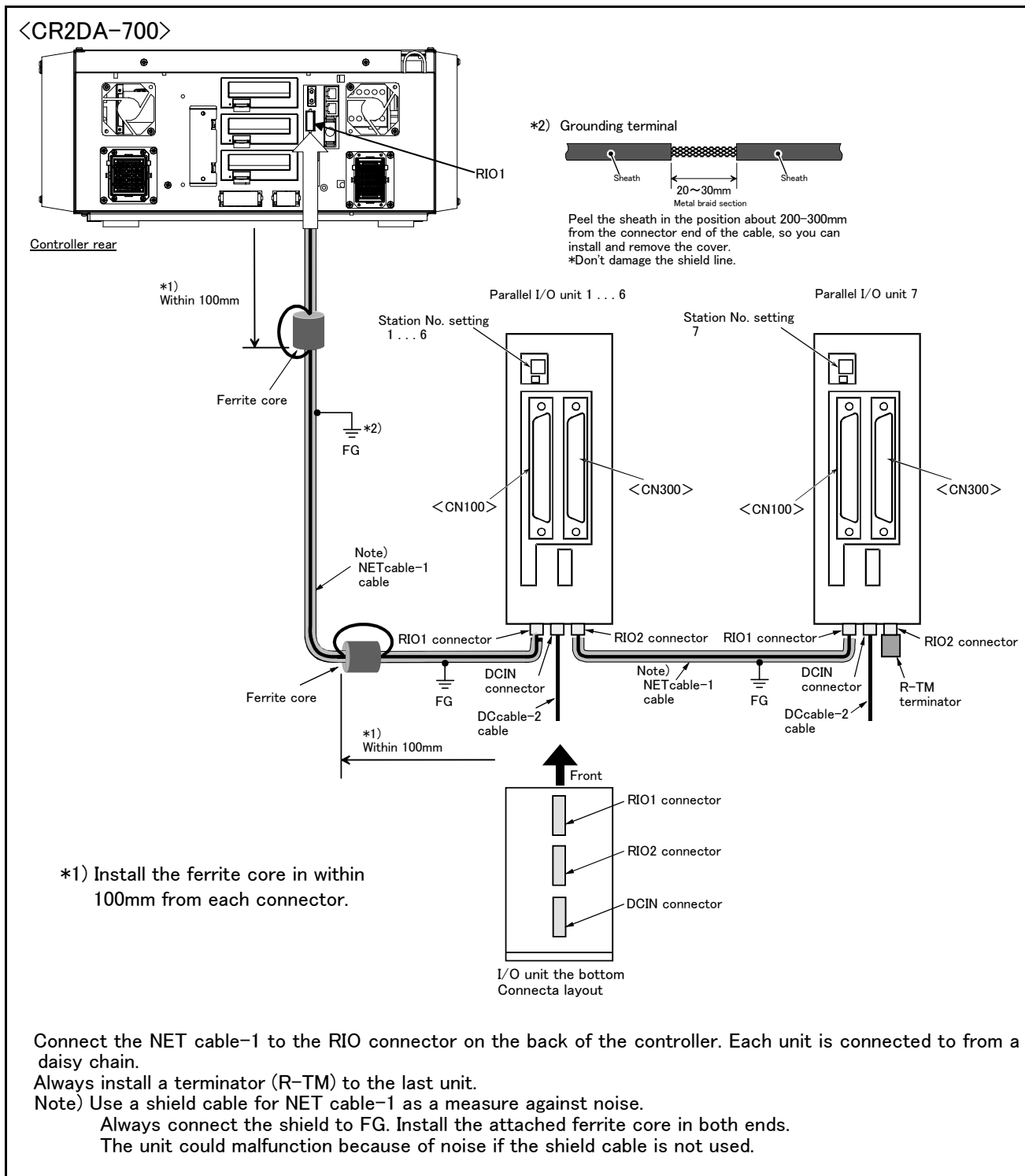
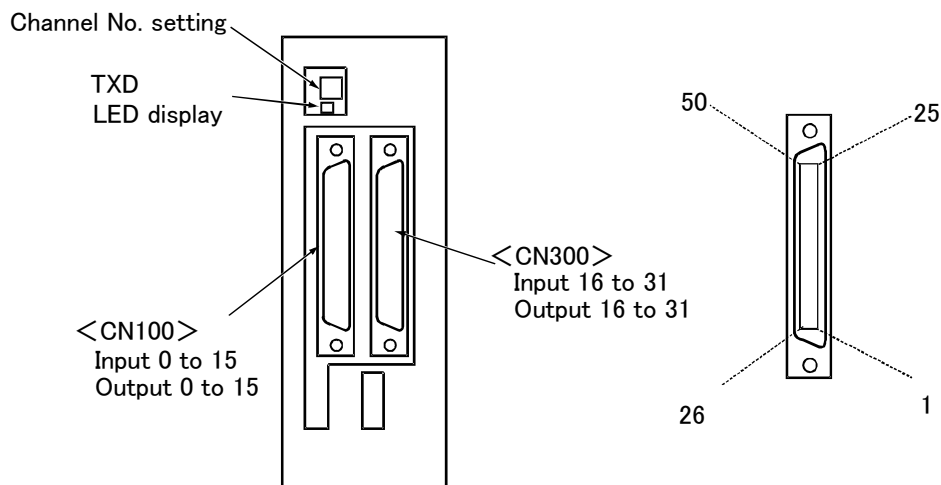

Fig.3-40 : Connection method of expansion parallel I/O unit (CR2DA-700)

■ Pin arrangement of the connector



*2A-RZ361/2 A-RZ371 are 32/32 input-and-output units. (One-station occupancy)

Fig.3-41 : Pin arrangement of the parallel I/O unit

■ Assignment of pin number and signal

The assignment range of the general-purpose input-and-output signal is fixed by the setup of the station number.

Table 3-26 : Assignment of pin number and signal

Unit Number	Station number	CN100	CN300
1st set	0	Input : 0 to 15 Output : 0 to 15	Input : 16 to 31 Output : 16 to 31
2nd set	1	Input : 32 to 47 Output : 32 to 47	Input : 48 to 63 Output : 48 to 63
3rd set	2	Input : 64 to 79 Output : 64 to 79	Input : 80 to 95 Output : 80 to 95
4th set	3	Input : 96 to 111 Output : 96 to 111	Input : 112 to 127 Output : 112 to 127
5th set	4	Input : 128 to 143 Output : 128 to 143	Input : 144 to 159 Output : 144 to 159
6th set	5	Input : 160 to 175 Output : 160 to 175	Input : 176 to 191 Output : 176 to 191
7th set	6	Input : 192 to 207 Output : 192 to 207	Input : 208 to 223 Output : 208 to 223
8th set	7	Input : 224 to 239 Output : 224 to 239	Input : 240 to 255 Output : 240 to 255

The connector pin number of the parallel I/O unit of the station number 0 and signal number assignment are shown in [Table 3-27](#) and [Table 3-28](#). If it is set as other station number, please interpret and utilize.

■ Parallel I/O interface (First expansion unit)

Table 3-27 : Connector CN100pin No. and signal assignment list (2A-CBL □□)

Pin No.	Line color	Function name		Pin No.	Line color	Function name	
		General-purpose	Dedicated/power supply, common			General-purpose	Dedicated/power supply, common
1	Orange/Red A		FG	26	Orange/Blue A		FG
2	Gray/Red A		0V:For pins 4-7, 10-13	27	Gray/Blue A		0V:For pins 29-32, 35-38
3	White/Red A		12V/24V:For pins 4-7	28	White/Blue A		12V/24V:For pins 29-32
4	Yellow/Red A	General-purpose output 0	Operating output ^{Note1)}	29	Yellow/Blue A	General-purpose output 4	
5	Pink/Red A	General-purpose output 1	In servo ON output signal ^{Note1)}	30	Pink/Blue A	General-purpose output 5	
6	Orange/Red B	General-purpose output 2	Error occurring output signal ^{Note1)}	31	Orange/Blue B	General-purpose output 6	
7	Gray/Red B	General-purpose output 3	Operation rights output signal ^{Note1)}	32	Gray/Blue B	General-purpose output 7	
8	White/Red B		0V:For pins 4-7, 10-13	33	White/Blue B		0V:For pins 29-32, 35-38
9	Yellow/Red B		12V/24V:For pins 10-13	34	Yellow/Blue B		12V/24V:For pins 35-38
10	Pink/Red B	General-purpose output 8		35	Pink/Blue B	General-purpose output 12	
11	Orange/Red C	General-purpose output 9		36	Orange/Blue C	General-purpose output 13	
12	Gray/Red C	General-purpose output 10		37	Gray/Blue C	General-purpose output 14	
13	White/Red C	General-purpose output 11		38	White/Blue C	General-purpose output 15	
14	Yellow/Red C		COM0:For pins 15-22 ^{Note2)}	39	Yellow/Blue C		COM1:For pins 40-47 ^{Note2)}
15	Pink/Red C	General-purpose input 0	Stop input ^{Note3)}	40	Pink/Blue C	General-purpose input 8	
16	Orange/Red D	General-purpose input 1	Servo OFF input signal ^{Note1)}	41	Orange/Blue D	General-purpose input 9	
17	Gray/Red D	General-purpose input 2	Error reset input signal ^{Note1)}	42	Gray/Blue D	General-purpose input 10	
18	White/Red D	General-purpose input 3	Start input ^{Note1)}	43	White/Blue D	General-purpose input 11	
19	Yellow/Red D	General-purpose input 4	Servo ON input signal ^{Note1)}	44	Yellow/Blue D	General-purpose input 12	
20	Pink/Red D	General-purpose input 5	Operation rights input signal ^{Note1)}	45	Pink/Blue D	General-purpose input 13	
21	Orange/Red E	General-purpose input 6		46	Orange/Blue E	General-purpose input 14	
22	Gray/Red E	General-purpose input 7		47	Gray/Blue E	General-purpose input 15	
23	White/Red E		Reserved	48	White/Blue E		Reserved
24	Yellow/Red E		Reserved	49	Yellow/Blue E		Reserved
25	Pink/Red E		Reserved	50	Pink/Blue E		Reserved

Note1) The dedicated signal is assigned at shipping. It can change with the parameter.

Note2) Sink type:12V/24V(COM),Source type:0V(COM)

Note3) The dedicated input signal (STOP) is assigned at shipping. The signal number is fixing.

Table 3-28 : Connector CN300pin No. and signal assignment list (2A-CBL □□)

Pin No.	Line color	Function name		Pin No.	Line color	Function name	
		General-purpose	Dedicated/power supply, common			General-purpose	Dedicated/power supply, common
1	Orange/Red A		FG	26	Orange/Blue A		FG
2	Gray/Red A		0V:For pins 4-7, 10-13	27	Gray/Blue A		0V:For pins 29-32, 35-38
3	White/Red A		12V/24V:For pins 4-7	28	White/Blue A		12V/24V:For pins 29-32
4	Yellow/Red A	General-purpose output 16		29	Yellow/Blue A	General-purpose output 20	
5	Pink/Red A	General-purpose output 17		30	Pink/Blue A	General-purpose output 21	
6	Orange/Red B	General-purpose output 18		31	Orange/Blue B	General-purpose output 22	
7	Gray/Red B	General-purpose output 19		32	Gray/Blue B	General-purpose output 23	
8	White/Red B		0V:For pins 4-7, 10-13	33	White/Blue B		0V:For pins 29-32, 35-38
9	Yellow/Red B		12V/24V:For pins 10-13	34	Yellow/Blue B		12V/24V:For pins 35-38
10	Pink/Red B	General-purpose output 24		35	Pink/Blue B	General-purpose output 28	
11	Orange/Red C	General-purpose output 25		36	Orange/Blue C	General-purpose output 29	
12	Gray/Red C	General-purpose output 26		37	Gray/Blue C	General-purpose output 30	
13	White/Red C	General-purpose output 27		38	White/Blue C	General-purpose output 31	
14	Yellow/Red C		COM0:For pins 15-22 ^{Note1)}	39	Yellow/Blue C		COM1:For pins 40-47 ^{Note1)}
15	Pink/Red C	General-purpose input 16		40	Pink/Blue C	General-purpose input 24	
16	Orange/Red D	General-purpose input 17		41	Orange/Blue D	General-purpose input 25	
17	Gray/Red D	General-purpose input 18		42	Gray/Blue D	General-purpose input 26	
18	White/Red D	General-purpose input 19		43	White/Blue D	General-purpose input 27	
19	Yellow/Red D	General-purpose input 20		44	Yellow/Blue D	General-purpose input 28	
20	Pink/Red D	General-purpose input 21		45	Pink/Blue D	General-purpose input 29	
21	Orange/Red E	General-purpose input 22		46	Orange/Blue E	General-purpose input 30	
22	Gray/Red E	General-purpose input 23		47	Gray/Blue E	General-purpose input 31	
23	White/Red E		Reserved	48	White/Blue E		Reserved
24	Yellow/Red E		Reserved	49	Yellow/Blue E		Reserved
25	Pink/Red E		Reserved	50	Pink/Blue E		Reserved

Note1) Sink type:12V/24V(COM),Source type:0V(COM)

<Reference> The example of connection with our PLC

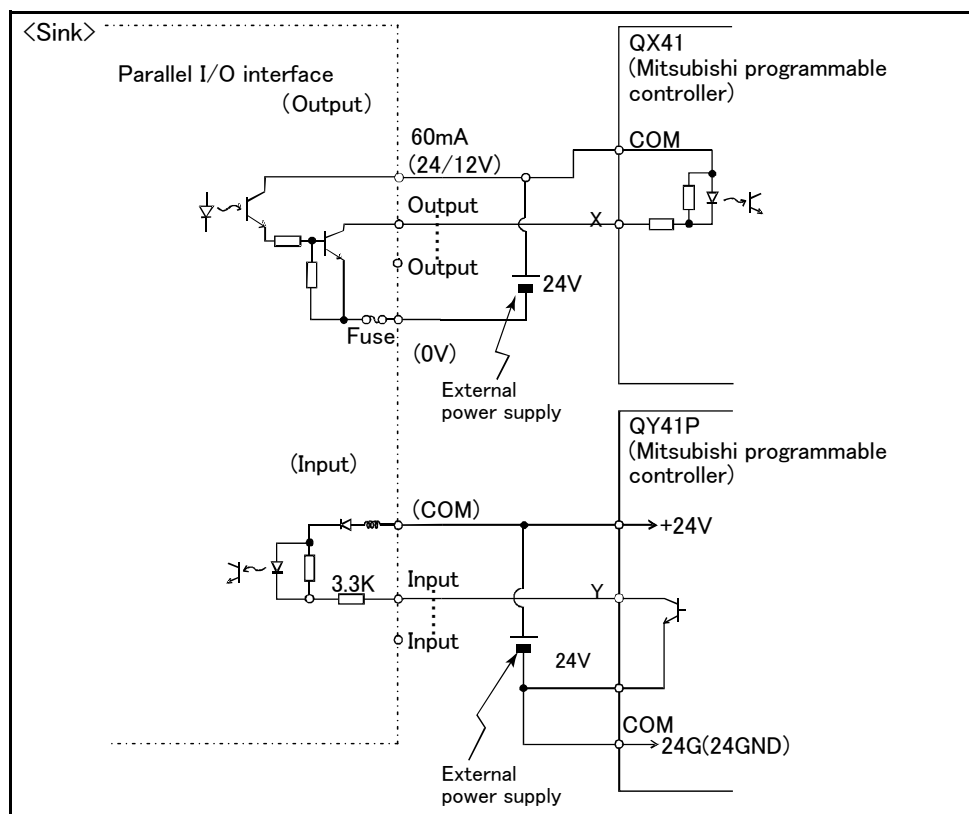

Table 3-29 : Connection with a Mitsubishi PLC (Example of sink type)

*The input/output circuit external power supply (24 VDC) must be prepared by the customer.

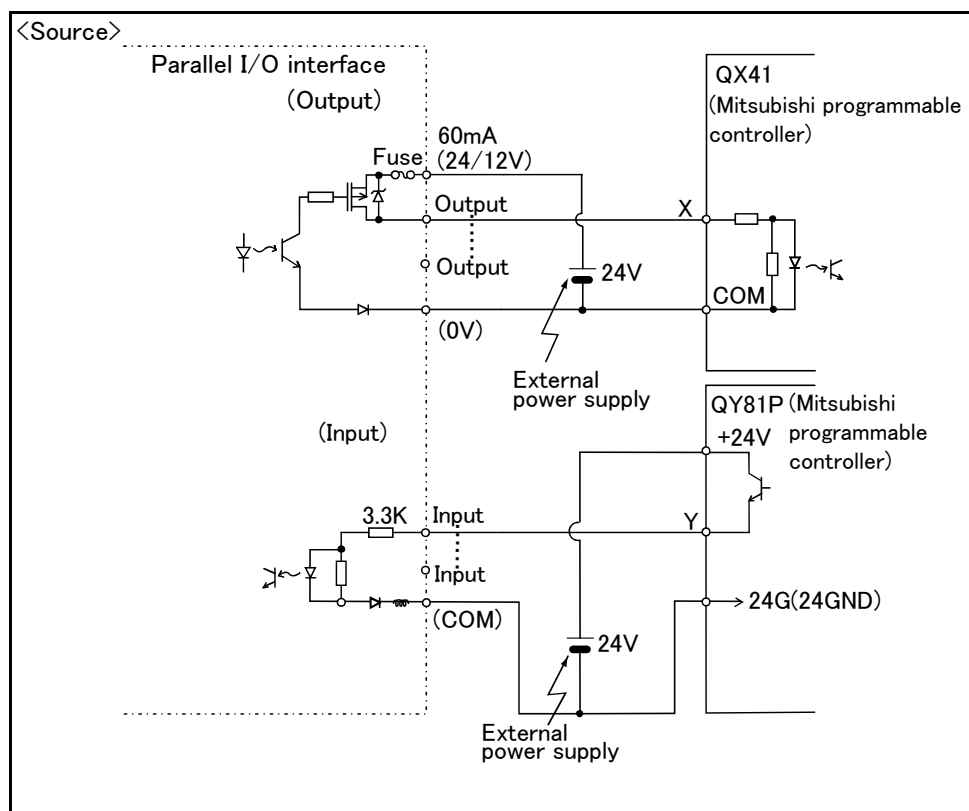

Table 3-30 : Connection with a Mitsubishi PLC (Example of source type)

*The input/output circuit external power supply (24 VDC) must be prepared by the customer.

(6) External I/O cable

■ Order type: 2A-CBL □□ Note) The numbers in the boxes □□ refer to the length. (05: 5m、15: 15m)

■ Outline



This is the dedicated cable used to connect an external peripheral device to the connector on the parallel input/output unit.
 One end matches the connector on the parallel input/output unit, and the other end is free. Connect the peripheral device's input/output signal using the free end.
 One cable correspond to the input 16 points and output 16 points.
 Two cables are needed to connection of (input 32 points and output 32 points) with built-in standard.

■ Configuration

Table 3-31 : Configuration device

Part name	Type	Qty.	Mass(kg) ^{Note1)}	Remarks
External I/O cable	2A-CBL □□	1pc.	0.7(5m) 1.84(15m)	5m or 15m

Note1) Mass indicates one set.

■ Specifications

Table 3-32 : Specifications

Items	Specifications
Number of cables x cable size	50 pairs x AWG #28
Total length	5m or 15m

■ Connector pin numbers and cable colors

Table 3-33 : Connector pin numbers and cable colors

Pin no.	Cable colors	Pin no.	Cable colors	Pin no.	Cable colors	Pin no.	Cable colors	Pin no.	Cable colors
1	Orange/Red A	11	Orange/Red C	21	Orange/Red E	31	Orange/Blue B	41	Orange/Blue D
2	Gray/Red A	12	Gray/Red C	22	Gray/Red E	32	Gray/Blue B	42	Gray/Blue D
3	White/Red A	13	White/Red C	23	White/Red E	33	White/Blue B	43	White/Blue D
4	Yellow/Red A	14	Yellow/Red C	24	Yellow/Red E	34	Yellow/Blue B	44	Yellow/Blue D
5	Pink/Red A	15	Pink/Red C	25	Pink/Red E	35	Pink/Blue B	45	Pink/Blue D
6	Orange/Red B	16	Orange/Red D	26	Orange/Blue A	36	Orange/Blue C	46	Orange/Blue E
7	Gray/Red B	17	Gray/Red D	27	Gray/Blue A	37	Gray/Blue C	47	Gray/Blue E
8	White/Red B	18	White/Red D	28	White/Blue A	38	White/Blue C	48	White/Blue E
9	Yellow/Red B	19	Yellow/Red D	29	Yellow/Blue A	39	Yellow/Blue C	49	Yellow/Blue E
10	Pink/Red B	20	Pink/Red D	30	Pink/Blue A	40	Pink/Blue C	50	Pink/Blue E

■ Connections and outside dimensions

The sheath of each signal cable (50 lines) is color indicated and marked with dots. Refer to the cable color specifications in "Table 3-33 Connector pin numbers and cable colors" when making the connections.

(Eg.) Pin number: color indication

1 : Orange / Red / A

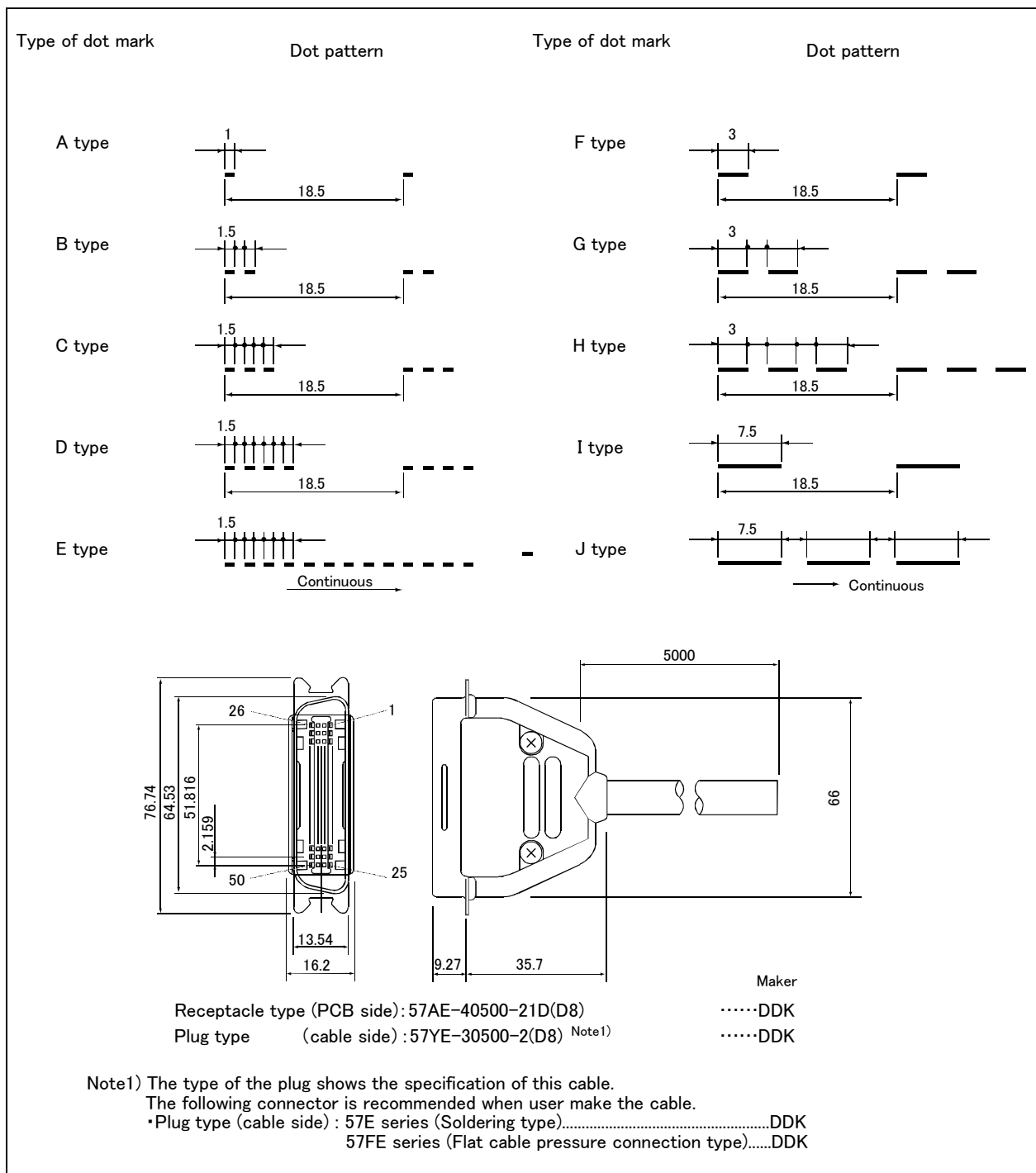
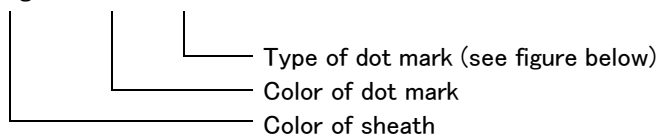

Fig.3-42 : Connections and outside dimensions

(7) Personal computer cable

■ Order type: ● For PC/AT : 2D-232CBL03M

■ Outline



This is the RS-232 interface cable used for connecting the controller with a personal computer. The personal computer on hand may be usable with the above interface cable. Confirm the connection specifications when placing an order.

Personal computer cables for the PC/AT compatible model is available.

■ Configuration

Table 3-34 : Configuration device

Part name	Type	Qty.	Mass(kg) ^{Note1)}	Remarks
Personal computer cable (for PC/AT)	2D-232CBL03M	1pc.	4	3m, D-SUB 9 pin

Note1) Mass indicates one set.

■ Specifications

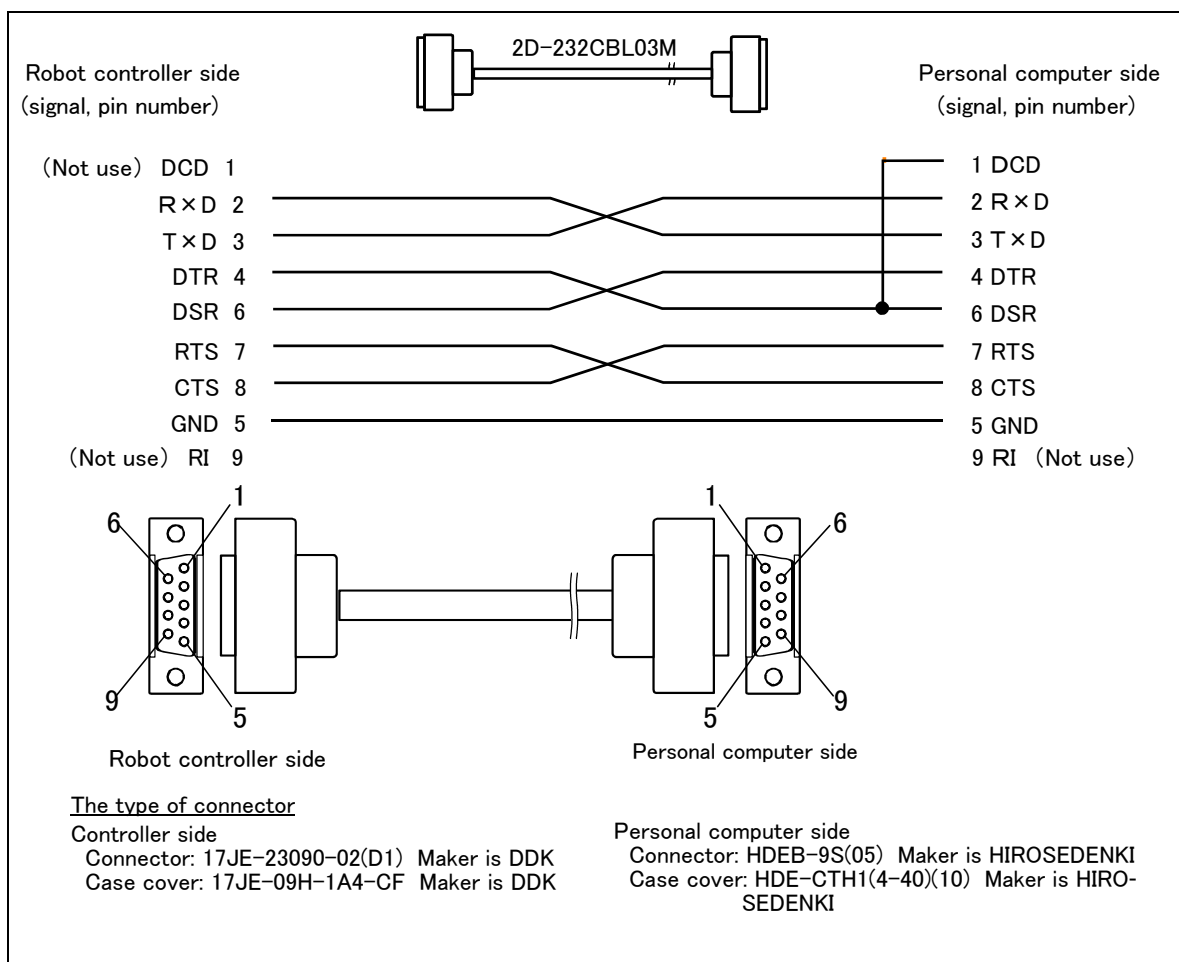

Fig.3-43 : Personal computer cable connection

(8) CC-Link interface

■ Order type: ● 2D-TZ576

■ Outline



The CC-Link interface is the option interface to not only add bit data to the robot controller, but also to add CC-Link field network function that allows cyclic transmission of word data.

■ Configuration

Table 3-35 : Configuration device

Part name	Type	Qty.	Mass(kg) ^{Note1)}	Remarks
CC-Link interface	2D-TZ576	1	0.4	
Manual	BFP-A8701	1	-	
Ferrite core	E04SR301334	2	-	Be sure to install this for noise countermeasure.
Cable clamp	AL4	2	-	
	AL5	2	-	

Note1) Mass indicates one set.

Table 3-36 : Procured by the customer

Part name	Type	Qty.	Remarks
Master station	QJ61BT11(Q series)	1	FX series products are not supported.
	QJ61BT11N(Q series)		
	AJ61QBT11(QnA series)		
	A1SJ61QBT11(QnAS series)		
	AJ61BT11(A series)		
	A1SJ61BT11(AnS series)		
	A80BD-J61BT11(personal computer board)		
Communication cable	-	1	Shielded 3-core twisted cable This cable may be manufactured by the customer.
Terminal resistor	-	1	110Ω or 130Ω is recommended.

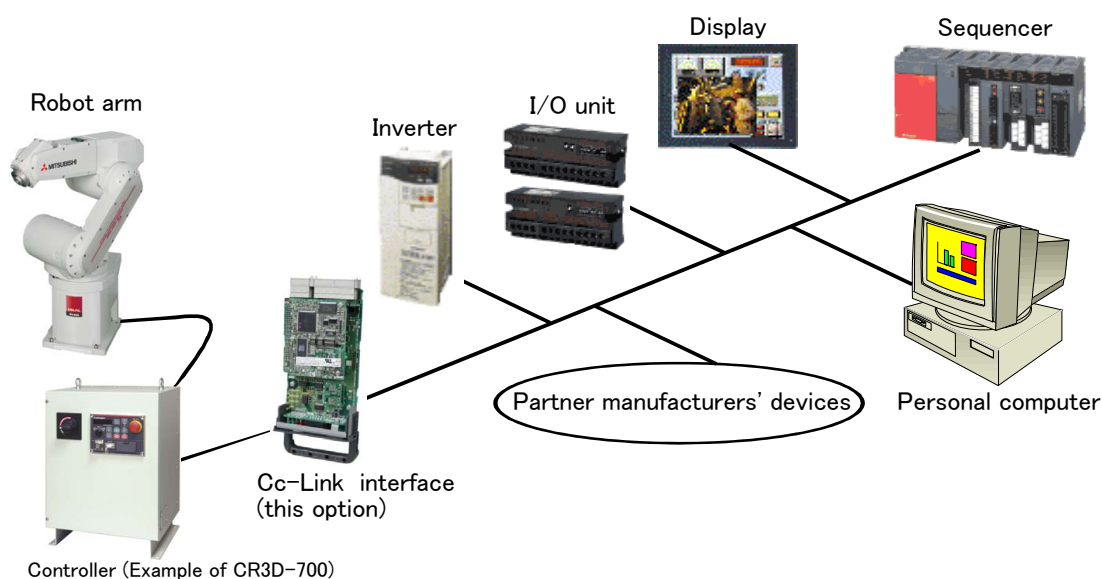

Fig.3-44 : Example of CC-Link Product Configuration

■ Specifications

Table 3-37 : Specifications

Item		Specifications				Remarks	
Communication function		Bit data and word data can be transmitted.				Word data are used by the registers.	
Station type		Intelligent device station ^{Note1)}					
Support station		Local station				No master station function	
The version corresponding to CC-Link		Ver.2				The extended cyclic setup is possible.	
Mountable option slot		Slot 1, 2, 3					
Number of mountable CC-Link interface cards		1				Multiple CC-Link interface cards cannot be inserted.	
Number of stations		1 to 64 stations				When four stations are occupied, continuous station numbers are used. The station numbers are set by a DIP switch.	
Transmission speed		10M/5M/2.5M/625K/156K bps				This is set by the rotary SW.	
Station number		1 to 64				When two or more stations are occupied, continuous station numbers are used.	
Number of occupied stations		1/2/3/4					
Extended cyclic setup		1/2/4/8					
Maximum link point		Remote I/O (RX, RY).	Each 896 points				The two last cannot be used.
		Remote register (RW _r , RW _w)	Each 128 register				16 bits/register
Extended cyclic setup		–	1 fold setup	2 fold setup	3 fold setup	4 fold setup	
Link point per set	When one station is occupied	Remote I/O (RX, RY).	32 point	32 point	64 point	128 point	
		Remote register (RW _w)	4 word	8 word	16 word	32 word	
		Remote register (RW _r)	4 word	8 word	16 word	32 word	
	When two stations is occupied	Remote I/O (RX, RY).	64 point	96 point	192 point	384 point	
		Remote register (RW _w)	8 word	16 word	32 word	64 word	
		Remote register (RW _r)	8 word	16 word	32 word	64 word	
	When three stations is occupied	Remote I/O (RX, RY).	96 point	160 point	320 point	640 point	
		Remote register (RW _w)	12 word	24 word	48 word	96 word	
		Remote register (RW _r)	12 word	24 word	48 word	96 word	
	When four stations is occupied	Remote I/O (RX, RY).	128 point	224 point	448 point	896 point	
		Remote register (RW _w)	16 word	32 word	64 word	128 word	
		Remote register (RW _r)	16 word	32 word	64 word	128 word	
Number of the maximum occupancy station		4 stations					
The I/O first number of the robot controller.		No. 6000 – The number corresponding to the station number by the setup of the parameter "CCFIX."					

Note1) The CC-Link interface supports neither the transient transmission function nor the FX series.

■ Functions**(1) Communication function**

- The number of usable points is 896 points maximum for bit control and 128 points maximum for word control.

(2) Easy setup

- The CC-Link interface card can be set by a rotary switch or DIP switch.
- No separate space is required to mount the CC-Link interface card as it is embedded in the robot controller (can only be mounted into slot 2).
- Easy wiring since only four terminals need to be connected.
- Dedicated commands have been added to MELFA-BASIC V (robot programming language); thus, no complex interface programming is required.

(3) High-speed response

- The link scan time when connecting 64 stations is approximately 7.2 ms, achieving superior high-speed response performance.
- A transmission speed can be selected from 10M, 5M, 2.5M, 625K and 156K bps according to the transmission distance.

(9) Extension memory cassette

■ Order type: ● 2D-TZ454

■ Outline



Used to increase the total number of teaching points in the robot program.

■ Configuration

Table 3-38 : Configuration device

Part name	Type	Qty.	Mass(kg) ^{Note1)}	Remarks
Extension memory cassette	2D-TZ454	1	0.1	

Note1) Mass indicates one set.

■ Specifications

Table 3-39 : Specifications

Items	Specifications	Remarks
External dimensions	Approx. 94(W)X65(D)X15(H) mm	Excluding the connection connector
Mass	Approx. 0.2 kg	
Connection method	Connection using a special connector	
Memory size ^{Note1)}	Teaching point number: 37,800 Steps number: 75,600 Program number: 256	The sum total value combined with the standard are Teaching point number: 50,800 Steps number: 101,600 Program number: 512
Backup	Backup using the controller's internal battery	

Note1) As for the standard points, after adding an expansion memory cassette, the information in all backup memory areas in the controller is copied into the expansion memory cassette. Therefore, please note that if the expansion memory cassette is removed after it has been added, there will be no program left in the controller.

[CAUTION]

· Inserting and removing the memory cassette

A memory cassette cannot be inserted or removed while the control power is on. Please turn off the control power before handling the memory cassette to avoid destroying the memory information in the cassette.

(10) RT ToolBox2/RT ToolBox2 mini

- Order type : ● RT ToolBox2
 *For windows CD-ROM : 3D-11C-WINE
 ● RT ToolBox2 mini
 *For windows CD-ROM : 3D-12C-WINE

■ Outline



This is handy software that fully uses the personal computer functions. It can be used in various stages from the robot specifications study (tact study, etc.) to the design support (creation and editing of programs), start up support (execution, control and debugging of program), and maintenance (remote maintenance.)

The "personal computer support software" which supports these function fully, and the "personal computer support software mini" which does not have the simulation function are available.

■ Configuration

Table 3-40 : Product configuration

Part name	Type	Medium	Mass(kg) ^{Note1)}	Remarks
RT ToolBox2	3D-11C-WINE	CD-ROM	0.2	
RT ToolBox2 mini	3D-12C-WINE	CD-ROM	0.2	

Note1) Mass indicates one set.

■ Features

- (1) Simple operation with guidance method and menu method
 The Windows standard is used for windows operation, so the controller initialization and startup operations can be carried out easily by following the instructions given on the screen. Even a beginner can easily carry out the series of operations from program creation to execution.
- (2) Increased work efficiency with ample support functions
 The work efficiency is greatly improved with the multi-window method that carries out multiple steps and displays in parallel. The renumbering function, and copy, search, syntax check and step execution are especially sufficient, and are extremely useful when editing or debugging the program.
 With the simulation function support, the program can be debugged and the tact checked before starting the machine at the site. This allows the on-site startup work efficiently to be greatly improved.
- (3) The maintenance forecast function increases the efficiency of maintenance work. Analyze the load condition while the robot is actually operating. Based on this analysis, calculate the time for maintenance, such as lubrication and belt replacement. By utilizing this information, the line stop time as well as the maintenance costs can be reduced.
- (4) The position recovery support function increases the recovery efficiency in the event of origin position displacement. This function compensates the origin settings and position data by just reproducing several previous teaching points when hand and/or arm displacement occurs, when replacing the motor and the belts, or when reloading the robot. This function can reduce the time required for recovery.

■ Functions

Table 3-41 : Functions

Function		Functional existence ^{Note1)}		Details
Compatible model		○	○	Personal computer running Microsoft Windows2000/XP/Vista.
Program editing functions	Editing functions	○	○	<ul style="list-style-type: none"> ▪ MELFA BASIC V language compatible ▪ Multiple editing screen simultaneously display ▪ Command input, comment writing ▪ Position data editing ▪ File operation (writing to controller, floppy disk, personal computer) ▪ Search and replace function (using characters, line Nos., labels) ▪ Copy, cut, paste, insert (per character, line), undo (per command statement, position conversion) ▪ Line No. automatic generation, renumbering ▪ Batch syntax check ▪ Command template ▪ Position conversion batch editing ▪ Position variable template ▪ Print, print preview
	Control functions	○	○	<ul style="list-style-type: none"> ▪ Program file control (list, copy, movement, delete, content comparison, name change, protect)
	Debugging functions	○	○	<ul style="list-style-type: none"> ▪ Direct editing of program in controller ▪ Confirmation of robot program operation (step execution, direct execution)
Simulation function		○	×	<ul style="list-style-type: none"> ▪ Off-line simulation of robot program operation using CG (computer graphics) ▪ Tact time calculation
Monitor functions		○	○	<ul style="list-style-type: none"> ▪ Robot operation monitor (robot operation state, stop signal, error monitor, program monitor (execution program, variables), general-purpose input/output signals (forced output possible), dedicated input/output signals, operation confirmation (operation range, current position, hand, etc.)) ▪ Operation monitor (working time statistics, production information, robot version) ▪ Servo monitor (load)
Maintenance function		○	○	<ul style="list-style-type: none"> ▪ Parameter setting ▪ Batch, divided backup

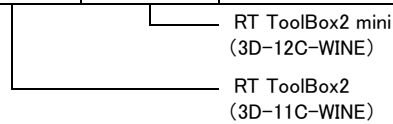

Note1) The functions included with the RT ToolBox2 and the RT ToolBox2 mini are shown below.

○ : Function provided × : Function not provided

(11) Instruction Manual(bound edition)

■ Order type : ● 5S-DA00-PE01 (RV-3SD/3SDJ series)

■ Outline



This is a printed version of the CD-ROM (instruction manual) supplied with this product.

■ Configuration

Table 3-42 : Product configuration(RV-3SD/3SDJ series)

Name	Type	Mass(kg) ^{Note1)}	Specifications
Instruction Manual	5S-DA00-PE01	2.6	
Safety Manual	BFP-A8006	-	Items relating to safety in handling the robot
Standard Specifications	BFP-A8652	-	Specification of the robot arm and controller
Robot Arm Setup & Maintenance	BFP-A8653	-	Installation method of the robot arm, jog operation, and maintenance and inspection procedures
Controller Setup, Basic Operation and Maintenance	BFP-A8660	-	Installation method of the controller, basic operation, and maintenance and inspection procedures
Detailed Explanation of Functions and Operations	BFP-A8586	-	Functions of the controller and T/B, operation method, and explanation of MELFA-BASIC V
Troubleshooting	BFP-A8588	-	Causes of errors occurred and their countermeasures
Additional axis function	BFP-A8663	-	Function of the additional axis, operation method.
Tracking Function Manual	BFP-A8664	-	Function of the Tracking, operation method.

Note1) Mass indicates one set.

3.10 Maintenance parts

The consumable parts used in the controller are shown in [Table 3-43](#). Purchase these parts from your dealer when required. Some Mitsubishi-designated parts differ from the maker's standard parts. Thus, confirm the part name, robot arm and controller serial No. and purchase the parts from your dealer.

Table 3-43 : Controller consumable parts list

No.	Name	Type ^{Note1)}	Qty.	Usage place	Supplier
CR1DA-700 series controller					
1	Lithium battery	Q6BAT	1	Front operation panel	Mitsubishi Electric System Service;Co.,Ltd
2	Filter		1	Front of the controller	
CR2DA-700 controller					
1	Lithium battery	Q6BAT	1	Front operation panel	Mitsubishi Electric System Service;Co.,Ltd
2	Filter		1	Front of the controller	

Note1) Confirm the robot arm serial No., and contact the dealer or service branch of Mitsubishi Electric Co., for the type.

4 Software

4.1 List of commands

The available new functions in MELFA-BASIC V are given in [Table 4-1](#).

Table 4-1 : List of MELFA-BASIC V commands

Type	Class	Function	Input format (example)
Position and operation control	Joint interpolation	Moves to the designated position with joint interpolation.	Mov P1
	Linear interpolation	Moves to the designated position with linear interpolation.	Mvs P1
	Circular interpolation	Moves along a designated arc (start point → passing point → start point (end point)) with 3-dimensional circular interpolation (360 degrees).	Mvc P1,P2,P1
		Moves along a designated arc (start point → passing point → end point) with 3-dimensional circular interpolation.	Mvr P1,P2,P3
		Moves along the arc on the opposite side of a designated arc (start point → reference point → end point) with 3-dimensional circular interpolation.	Mvr2 P1,P9,P3
		Moves along a set arc (start point → end point) with 3-dimensional circular interpolation.	Mvr3 P1,P9,P3
		Speed designation	Designates the speed for various interpolation operations with a percentage (0.1% unit).
	Designate the speed for joint interpolation operation with a percentage (0.1% unit).		JOvrd 100
	Designates the speed for linear and circular interpolation with a numerical value (mm/s unit).		Spd 123.5
	Designates the acceleration/deceleration time as a percentage in respect to the predetermined maximum acceleration/deceleration. (1% unit)		Accel 50,80
	Automatically adjusts the acceleration/deceleration according to the parameter setting value.		Oadl ON
	sets the hand and work conditions for automatic adjustment of the acceleration/deceleration.		LoadsetT 1,1
	Operation		Performance of movement is upgraded corresponding to the application.
		Adds a process unconditionally to the operation.	Wth
		Adds a process conditionally to the operation.	Wthif
		Designates smooth operation.	Cnt 1,100,200
		Designates the positioning completion conditions with a No. of pulses.	Fine 200
		Designates the positioning completion conditions with a joint interpolation.	Fine 0.5, J, 2
		Designates the positioning completion conditions with a distance in a straight line	Fine 1, P
		Turns the servo power ON/OFF for all axes.	Servo OFF
		Limits the operation of each axis so that the designated torque is not exceeded.	Torq 4,10
	Position control	Designates the base conversion data.	Base P1
		Designates the tool conversion data.	Tool P1
	Float control	The robot arm rigidity is lowered and softened. (XYZ coordinate system)	Cmp Pos ,&B00000011
		The robot arm rigidity is lowered and softened. (JOINT coordinate system)	Cmp Jnt ,&B00000011
		The robot arm rigidity is lowered and softened. (TOOL coordinate system)	Cmp Tool ,&B00000011
		The robot arm rigidity is returned to the normal state.	Cmp Off
		The robot arm rigidity is designated.	Cmpg 1.0,1.0,1.0,1.0,1.0,1.0,1.0,1.0
	Pallet	Defines the pallet.	Def Plt 1,P1,P2,P3,P4,5,3,1
		Operates the pallet grid point position.	Plt 1,M1
	Singular point passage	Move to a specified position using linear interpolation passing through a singular point.	Mvs P1 TYPE 0,2

Type	Class	Function	Input format (example)	
Program control	Branching	Branches unconditionally to the designated place.	GoTo 120	
		Branches according to the designated conditions.	If M1=1 Then GoTo *L100 Else GoTo 20 End If	
		Repeats until the designated end conditions are satisfied.	For M1=1 TO 10 Next M1	
		Repeats while the designated conditions are satisfied.	While M1<10 Wend	
		Branches corresponding to the designated expression value.	On M1 GoTo *La1, *Lb2, *Lc3	
		Executes program block corresponding to the designated expression value..	Select Case 1 Break Case 2 Break End Select	
		Moves the program process to the next line.	Skip	
	Impact detection	Set to enable/disable the impact detection.	CoLChk ON/OFF	
		Set the detection level of the impact detection.	CoLvl 100,80,.....	
	Subroutine	Executes the designated subroutine. (Within program)	GoSub *L200	
		Returns from the subroutine.	Return	
		Executes the designated program.	CallP "P10",M1,P1	
		Defines the program argument executed with the CALLP command.	FPrm M10,P10	
		Executes the subroutine corresponding to the designated expression value.	On M1 GoSub *La1, *Lb2, *Lc3	
	Interrupt	Defines the interrupt conditions and process.	Def Act 1, M1=1 GoTo *L100	
		Enables/disables the interrupt.	Act 1=1	
		Defines the start line of the program to be executed when an interrupt is generated from the communication line.	On Com(1) GoSub *L100	
		Enables the interrupt from the communication line.	Com(1) On	
		Disables the interrupt from the communication line.	Com(1) Off	
		Stops the interrupt from the communication line.	Com(1) Stop	
	Wait	Designates the wait time, and the output signal pulse output time. (0.01s unit)	Dly 0.5	
		Waits until the variable becomes the designated value.	Wait M_In(1)=1	
	Stop	Stops the program execution.	Hlt	
		Generates an error. During program execution, continue, stop or servo OFF can be designated.	Error 9000	
	End	Ends the program execution.	End	
	Hand	Hand open	Opens the designated hand.	HOpen 1
		Hand close	Closes the designated hand.	HClose 1
Input/output	Assignment	Defines the input/output variables.	Def IO PORT1=BIT,0	
	Input	Retrieves the general-purpose input signal.	M1=M_In(1)	
	Output	Calls out the general-purpose output signal.	M_Out(1)=0	
Parallel execution	Mechanism designation	Acquires the mechanism with the designated mechanism No.	GetM 1	
		Releases the mechanism with the designated mechanism No.	RelM 1	
	Selection	Selects the designated program for the designated slot.	XLoad 2,"P102"	
	Start/stop	Carries out parallel execution of the designated program.	XRun 3,"100",0	
		Stops parallel execution of the designated program.	XStp 3	
Returns the designated program's execution line to the head and enters the program selection enabled state.	XRst 3			

Type	Class	Function	Input format (example)
Others	Definition	Defines the integer type or real number type variable.	Def Inte KAISUU
		Defines the character string variable.	Def Char MESSAGE
		Defines the layout variable. (Up to 3-dimensional possible)	Dim PDATA(2,3)
		Defines the joint variable.	Def Jnt TAIHI
		Defines the position variable.	Def Pos TORU
		Defines the function.	Def FN TASU(A,B)=A+B
	Clear	Clears the general-purpose output signal, variables in program, variables between programs, etc.	Clr 1
	File	Opens a file.	Open "COM1:" AS #1
		Closes a file.	Close #1
		Inputs data from a file.	Input# 1,M1
		Outputs data to a file.	Print# 1,M1
	Comment	Describes a comment.	Rem "ABC"
	Label	Indicates the branching destination.	*SUB1

4.2 List of parameters

show the main parameter in the [Table 4-2](#).

Table 4-2 : List of parameters

Parameter		Details
Standard tool coordinates.	MEXTL	Set the default value for the tool data. Unit: mm or deg.
Standard base coordinates	MEXBS	Set the relation of the world coordinate system and robot coordinate system. Unit: mm or deg.
XYZ operation range	MEPAR	Designate the overrun limit value for the world coordinate system.
JOINT operation range	MEJAR	Set the overrun limit value for each joint axis.
Free plane limit		This is the overrun limit set with the free plane. Create a plane with the three coordinates x1, y1, z1 to x3, y3, z3, and set the outer side of the plane as the outside operation range (error). The following three types of parameters are used.
	SFC1P : SFC8P	Eight types of free plane limits can be set in SFC1P to SFC8P. There are nine elements, set in the order of x1, y1, z1, x2, y2, z2, x3, y3, z3.
	SFC1ME : SFC8ME	Designate which mechanism to use eight types of set free plane limits. The mechanism No. to use is set with 1 to 3.
	SFC1AT : SFC8AT	Set the validity of the eight types of set free plane limits. (Valid 1/Valid 2/invalid = 1/-1/0)
User-defined area		An area (cube) defined with two XYZ coordinate points can be designated and that area set as the outside operation range. Furthermore, a signal can be output when the axis enters that area. Up to 32 types of area can be designated.
	AREA1CS : AREA32CS	Specify the coordinate system of the user definition area *. 0: Base coordinate system (conventional compatibility) 1: Robot coordinate system
	AREA1P1 : AREA32P1	Designated the 1st point of the area. There are eight elements, set in the order of x, y, z, a, b, c, L1, L2. (L1 and L2 are the additional axes.)
	AREA1P2 : AREA32P2	Designated the 2nd point of the area. There are eight elements, set in the order of x, y, z, a, b, c, L1, L2. (L1 and L2 are the additional axes.)
	AREA1ME : AREA32ME	Designate which mechanism to use the 32 types of set area. The mechanism No. to use is set with 1 to 3.
	AREA1AT : AREA32AT	Designate the area check type. (Invalid/zone/interference = 0/1/2) Zone: The dedicated output signal USRAREA turns ON. Interference: An error occurs..
Automatic return setting	RETPATH	Set to restart the program after returning to the interrupt position when resuming operation after an interruption.
Buzzer ON/OFF	BZR	Designate whether to the turn buzzer ON or OFF.
Jog setting	JOGJSP	Designate the joint jog and step operation speed. (Set dimension H/L amount, max. override.)
	JOGPSP	Designate the linear jog and step operation speed. (Set dimension H/L amount, max. override.)
Jog speed limit value	JOGSPMX	Limit the operation speed during the teaching mode. Max. 250[mm/s]

Parameter		Details
Hand type	HANDTYPE	Set the hand type of the single/double solenoid, and the signal No. (Single/double = S/D) Set the signal No. after the hand type. Example) D900
Stop input B contact designation	INB	Change the dedicated input (stop) between the A contact and B contact.
User-designated origin	USERORG	Designate the user-designated origin position.
Program selection memory	SLOTON	Select the program selected previously when initializing the slot. The non-selected state will be entered when not set.
Communication setting	CBAU232	Set the baud rate.
	CLEN232	Set the character length.
	CPRTY232	Set the parity.
	CSTOP232	Set the stop bit.
	CTERM232	Set the end code.
Slot table	SLT1 : SLT32	Make settings (program name, operation type, order of priority, etc.) for each slot during slot initialization.
No. of multi-tasks	TASKMAX	Designate the No. of programs to be executed simultaneously. (Max. 32)
Select the function of singular point adjacent alarm	MESNGLSW	Designate the valid/invalid of the singular point adjacent alarm. (Invalid/Valid = 0/1) When this parameter is set up "VALID", this warning sound is buzzing even if parameter: BZR (buzzer ON/OFF) is set up "OFF".
Specification of singular point passage jog mode	FSPJOGMD	Specify an operation mode for singular point passage jog.
Display language.	LNG	Change the language to display on the LCD display of teaching pendant.

5 Instruction Manual

5.1 The details of each instruction manuals

The contents and purposes of the documents enclosed with this product are shown below. Use these documents according to the application.

Instruction manuals enclosed in dashed lines in the list below are for optional products.

For special specifications, a separate instruction manual describing the special section may be enclosed.

Safety Manual	Explains the common precautions and safety measures to be taken for robot handling, system design and manufacture to ensure safety of the operators involved with the robot.
Standard Specifications or special Specifications	Explains the product's standard specifications, factory-set special specifications, option configuration and maintenance parts, etc. Precautions for safety and technology, when incorporating the robot, are also explained.
Robot Arm Setup & Maintenance	Explains the procedures required to operate the robot arm (unpacking, transportation, installation, confirmation of operation), and the maintenance and inspection procedures.
Controller Setup, Basic Operation and Maintenance	Explains the procedures required to operate the controller (unpacking, transportation, installation, confirmation of operation), basic operation from creating the program to automatic operation, and the maintenance and inspection procedures.
Detailed Explanation of Functions and Operations	Explains details on the functions and operations such as each function and operation, commands used in the program, connection with the external input/output device, and parameters, etc.
Troubleshooting	Explains the causes and remedies to be taken when an error occurs. Explanations are given for each error No.
Additional axis function	Explains the specifications, functions and operations of the additional axis control.
Tracking Function Manual	Explains the control function and specifications of conveyor tracking

Extended Function Instruction Manual

Explains the detailed description of data configuration of shared memory, monitoring, and operating procedures, about the GOT (CRnD-700 series controller).

6 Safety

6.1 Safety

Measures to be taken regarding safety of the industrial robot are specified in the “Labor Safety and Sanitation Rules”. Always follow these rules when using the robot to ensure safety.

6.1.1 Self-diagnosis stop functions

This robot has the self-diagnosis stop functions shown in [Table 6-1](#) and the stop functions shown in [Table 6-2](#) for safe use.

Table 6-1 : Self-diagnosis stop functions

No.	Function		Details	Remarks
1	Overload protection function		Activates when the total servo current time exceeds the specified value.	The drive circuit is shut off. The robot stops, and an alarm displays.
2	Overcurrent diagnosis function		Activates when an overcurrent flows to the motor circuit.	The drive circuit is shut off. The robot stops, and an alarm displays.
3	Encoder disconnection diagnosis function		Activates when the encoder cable is disconnected.	The drive circuit is shut off. The robot stops, and an alarm displays.
4	Deflection over diagnosis function		Activates when an error occurs between the command value and actual position, and the error exceeds the specified amount.	The drive circuit is shut off. The robot stops, and an alarm displays.
5	AC power voltage drop diagnosis function		Activates when the AC power voltage drops below the specified value.	The drive circuit is shut off. The robot stops, and an alarm displays.
6	CPU error detection function		Activates when an error occurs in the CPU.	The drive circuit is shut off. The robot stops, and an alarm displays.
7	Overrun prevention function	Software limit detection	This is the limit provided by the software to enable operation only in the operation range.	The drive circuit is shut off. The robot stops, and an alarm displays.
		Mechanical stopper	This is the mechanical stopper provided outside the software.	The robot mechanically stops, and function 1 or 2 activates.

Table 6-2 : List of stop functions

Stop function	Operation panel	Teaching pendant	External input	Details
Emergency stop	○	○	○	This is the stop with the highest degree of emergency. The servo power is shut off, and the mechanical brakes (all axes) activate to stop the robot. To recover, reset the alarm, and turn the servo ON with the servo ON command.
Stop	○	○	○	This is a stop operation with a high degree of emergency. The robot immediately decelerates and stops. Note that the servo power is not shut off. Use this when using the collision evasion sensor, etc.

6.1.2 External input/output signals that can be used for safety protection measures

Table 6-3 : External input/output signals that can be used for safety protection measures

	Signal	Connection point	Parameter	Functions	Usage method	
Input	External emergency stop	Terminal (EMG IN)	-	This servo power is shut off, and the robot stops immediately.	Externally installed emergency stop switch. Door switch on safety protection fence. Stopping at high-level error occurrence.	
	Door switch		-			The door switch of the safe protection fence
	Enabling device input		-			Enabling device. The safety switch during teaching work
	Stop	Parallel I/O unit or interface	STOP	The program execution is stopped, and the robot stops. The servo power is not shut off.	The robot is stopped when a peripheral device fault occurs. The servo power is not shut off.	
	Servo OFF		SRVOFF	The servo power can be shut off.	The robot is stopped when a peripheral device fault occurs. The servo power is not shut off.	
	Automatic operation enable		AUTOENA	Disables automatic operation when inactive.	Door switch on safety protection fence	
Output	In servo ON	Parallel I/O unit or interface	SRVON	The servo power ON/OFF state is output.	The servo power ON/OFF state is shown and alerted with the display lamps.	
	Waiting		STOP	Outputs that the robot is temporarily stopped.	The temporary stop state is shown and alerted with the display lamps.	
	In alarm		ERRRESET	Outputs when an alarm occurs in the robot.	The alarm state is shown and alerted with the display lamps.	

[Caution] The external emergency stop input is prepared as a b contact for safety proposes. Thus, if the emergency stop input circuit is opened when the robot is started up, the robot will not operate. Refer to [Page 122, "6.1.7 Examples of safety measures"](#) for details.

6.1.3 Precautions for using robot

The safety measures for using the robot are specified in the "Labor Safety and Sanitation Rules". An outline of the rules is given below.

(1) Robot installation

- Secure sufficient work space required to safely perform work such as teaching and maintenance related to the robot.
- Install the controller outside the robot's motion space. (If a safety fence is provided, install outside the fence.)
- Install the controller where the entire robot operation can be viewed.
- Install display lamps, etc., to indicate the robot's operation state.
- Securely fix the robot arm onto the fixing table with the designated bolts.

(2) Prevention of contact with operator

- Install a safety fence or enclosure so that the operator cannot easily enter the robot's motion space.
- Install an interlock function that will stop the robot if the safety fence or enclosure door is opened.

(3) Work procedures

- Create and observe work procedures for the robot teaching, operation, inspection and emergencies.
- Create hand signals to be followed when several operators are working together.
- Create displays such as "Teaching in Progress" and "Inspection in Progress" to be put up when an operator is in the robot's motion space so that other operators will not operate the operation panel (controller, control panel).

(4) Training

- Train the operators about the operations, maintenance and safety required for the robot work.
- Only trained and registered operators must operate the robot.
Participation in the "Special training for industrial robots" sponsored by the Labor Safety and Sanitation Committee, etc., is recommended for safety training.

(5) Daily inspection and periodic inspection

- Always inspect the robot before starting daily operations and confirm that there are no abnormalities.
- Set the periodic inspection standards in view of the robot's ambient environment and operation frequency, and perform periodic inspections.
- Make records when periodic inspections and repairs have been done, and store the records for three or more years.

6.1.4 Safety measures for automatic operation

- (1) Install safety fences so that operators will not enter the operation area during operation and indicate that automatic operation is in progress with lamps, etc.
- (2) Create signals to be given when starting operation, assign a person to give the signal, and make sure that the operator follows the signals.

6.1.5 Safety measures for teaching

Observe the following measures when teaching, etc., in the robot's operation range.

- (1) Specify and follow items such as procedures related to teaching work, etc.
- (2) Take measures so that operation can be stopped immediately in case of trouble, and measures so that operation can be restarted.
- (3) Take measures with the robot start switch, etc., to indicate that teaching work is being done.
- (4) Always inspect that stop functions such as the emergency stop device before starting the work.
- (5) Immediately stop the work when trouble occurs, and correct the trouble.
- (6) Take measures so that the work supervisor can immediately stop the robot operation when trouble occurs.
- (7) The teaching operator must have completed special training regarding safety. (Training regarding industrial robots and work methods, etc.)
- (8) Create signals to be used when several operators are working together.

6.1.6 Safety measures for maintenance and inspections, etc.

Turn the power OFF and take measures to prevent operators other than the relevant operator from pressing the start switch when performing inspections, repairs, adjustments, cleaning or oiling.

If operation is required, take measures to prevent hazards caused by unintentional or mistaken operations.

- (1) Specify and follow items such as procedures related to maintenance work, etc.
- (2) Take measures so that operation can be stopped immediately in case of trouble, and measures so that operation can be restarted.
- (3) Take measures with the robot start switch, etc., to indicate that work is being done.
- (4) Take measures so that the work supervisor can immediately stop the robot operation when trouble occurs.
- (5) The operator must have completed special training regarding safety. (Training regarding industrial robots and work methods, etc.)
- (6) Create signals to be used when several operators are working together.

6.1.7 Examples of safety measures

Two emergency-stop input circuits are prepared on the user wiring terminal block of the controller. Create a circuit as shown below for safety measures. In addition, the figure shows the normal state which is not in the emergency stop state.

[Caution] Since we have omitted the information in part because of explanation, there is the section different from the product. Also refer to Page 126, "(1) External emergency stop connection [supplementary explanation]" and Page 59, "3.6.1 Connection of the external emergency stop".

[Note] In the emergency-stop related wiring by the customer, if the coil (is not the contact points) of the relay prepared by the customer is connected to the controller, please be sure to implement the measure against the noise by the customer in the coil section. And, please also take the lifetime of noise suppression parts into consideration.

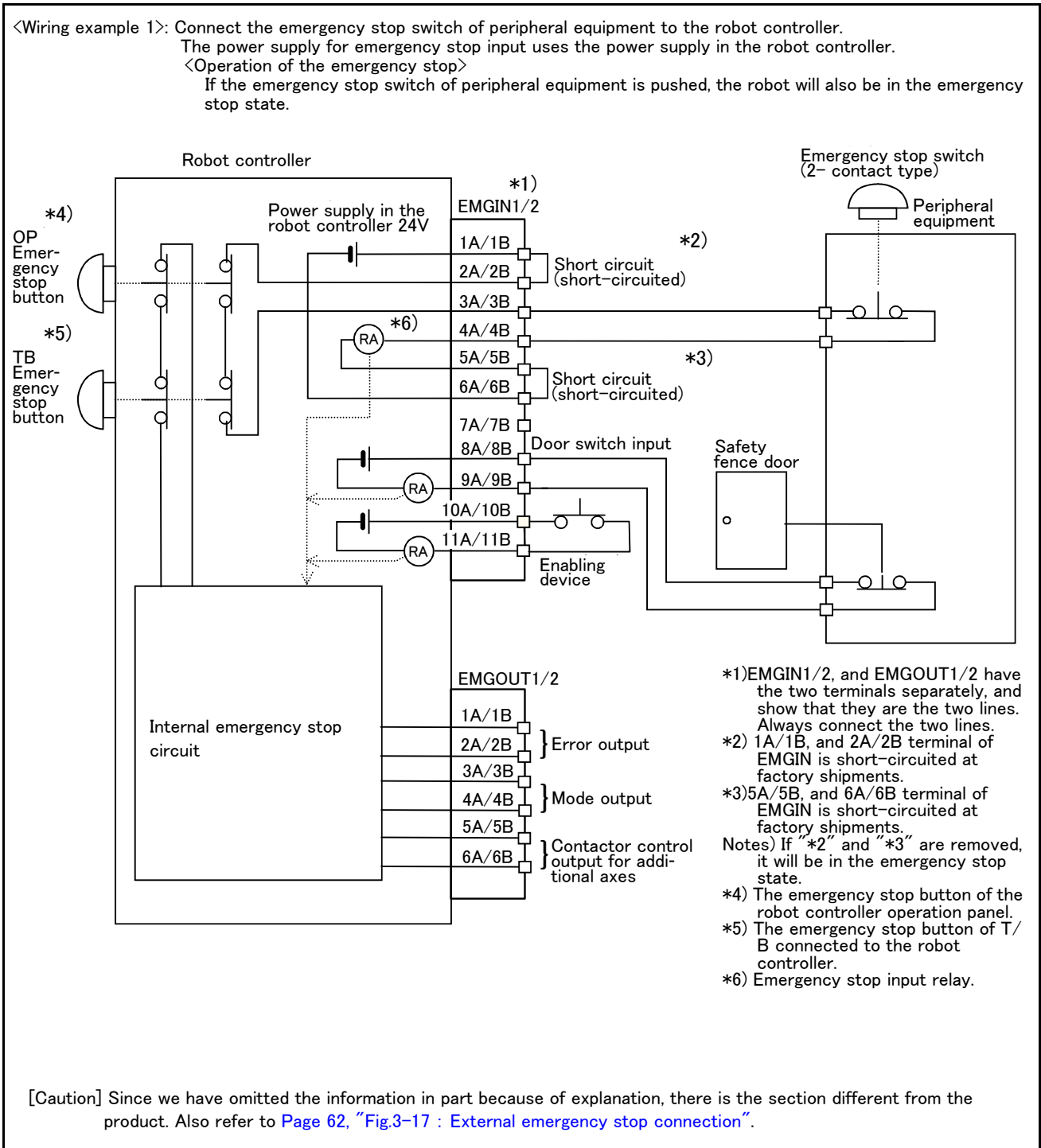
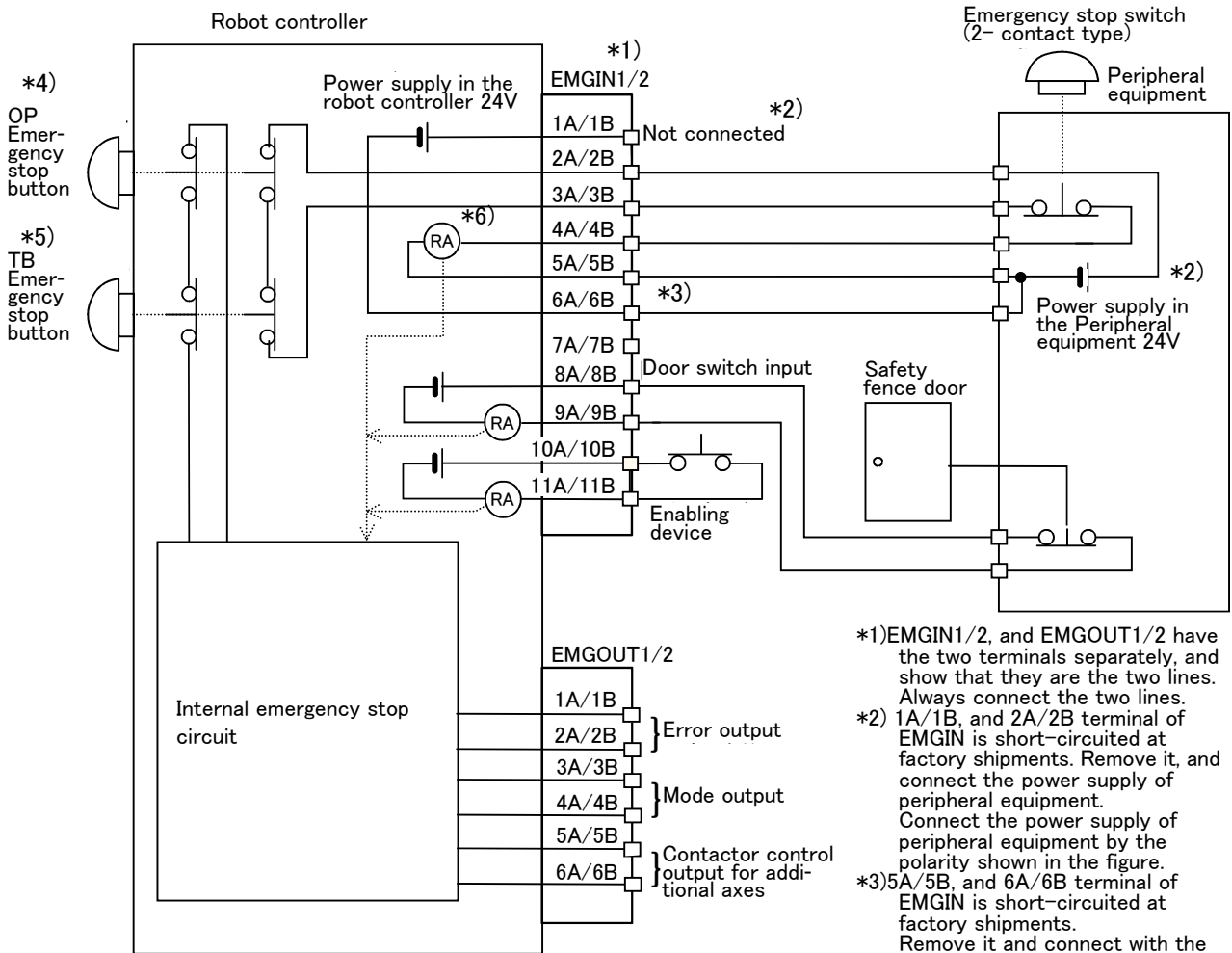

Fig.6-1 : Example of safety measures (Wiring example 1)

<Wiring example 2>: Connect the emergency stop switch of peripheral equipment to the robot controller.
 The power supply for emergency stop input uses the power supply of peripheral equipment.
 <Operation of the emergency stop>
 If the emergency stop switch of peripheral equipment is pushed, the robot will also be in the emergency stop state.



- *1)EMGIN1/2, and EMGO1/2 have the two terminals separately, and show that they are the two lines. Always connect the two lines.
- *2) 1A/1B, and 2A/2B terminal of EMGIN is short-circuited at factory shipments. Remove it, and connect the power supply of peripheral equipment by the polarity shown in the figure.
- *3)5A/5B, and 6A/6B terminal of EMGIN is short-circuited at factory shipments. Remove it and connect with the power supply ground of peripheral equipment.
- *4) The emergency stop button of the robot controller operation panel.
- *5) The emergency stop button of T/B connected to the robot controller.
- *6) Emergency stop input relay.

[Caution] Since we have omitted the information in part because of explanation, there is the section different from the product. Also refer to Page 62, "Fig.3-17 : External emergency stop connection".

Fig.6-2 : Example of safety measures (Wiring example 2)

<Wiring example 3>: Connect the emergency stop switch, door switch, and enabling device of peripheral equipment to the robot controller. The power supply for emergency stop input uses the power supply of peripheral equipment. Monitor the emergency stop state by the peripheral equipment side.

<Operation of the emergency stop>

If the emergency stop switch of peripheral equipment is pushed, the robot will also be in the emergency stop state. And, if the emergency stop switch of OP or T/B is pushed in the state of the power of robot controller OFF, peripheral equipment state can be the emergency stop also.

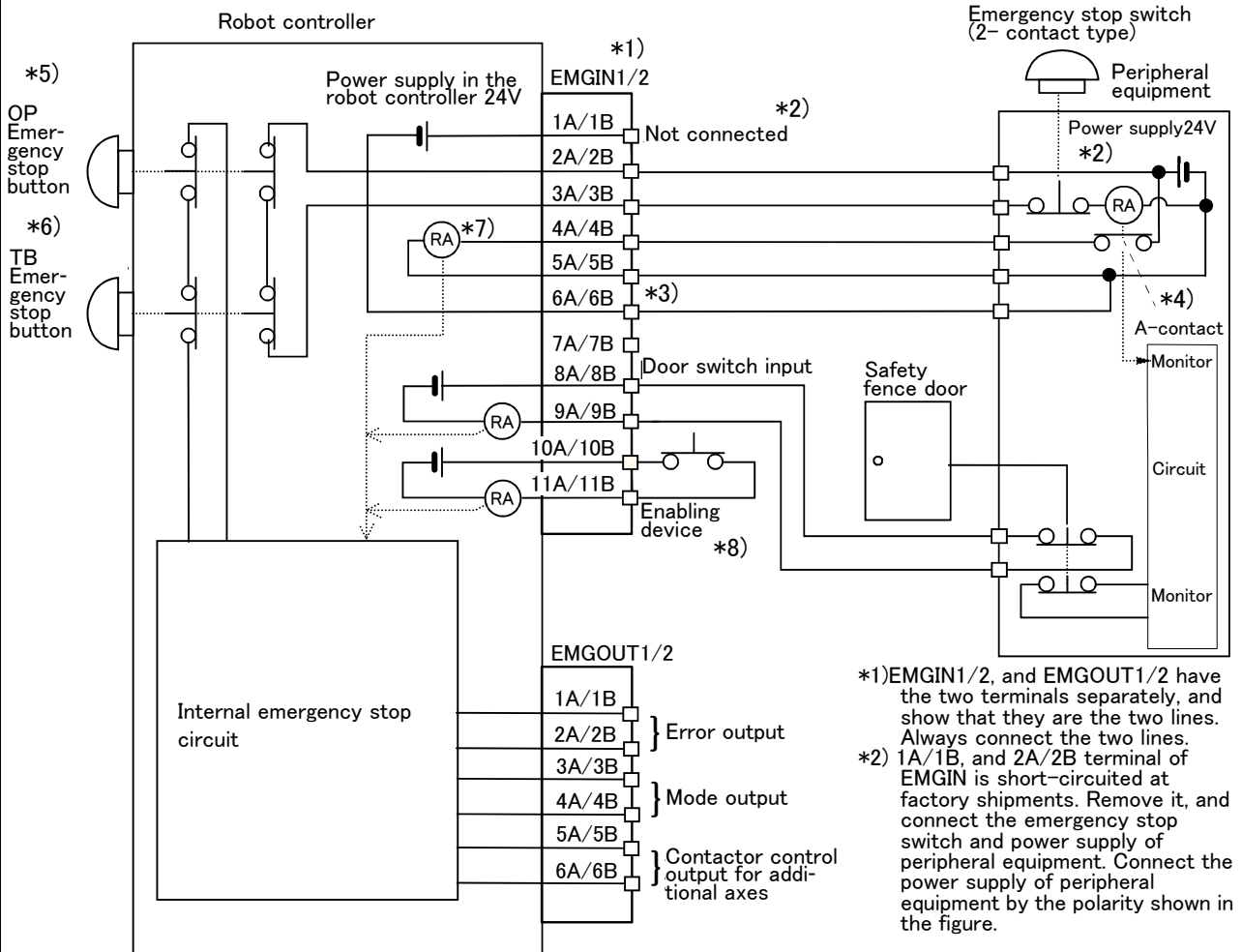

- *1) EMGIN1/2, and EMGOUT1/2 have the two terminals separately, and show that they are the two lines. Always connect the two lines.
- *2) 1A/1B, and 2A/2B terminal of EMGIN is short-circuited at factory shipments. Remove it, and connect the emergency stop switch and power supply of peripheral equipment. Connect the power supply of peripheral equipment by the polarity shown in the figure.

- *3) 5A/5B, and 6A/6B terminal of EMGIN is short-circuited at factory shipments. Remove it and connect with the power supply ground of peripheral equipment.
- *4) Please use a A contact type of the relay with the compulsive guide.
- *5) The emergency stop button of the robot controller operation panel.
- *6) The emergency stop button of T/B connected to the robot controller.
- *7) Emergency stop input relay.
- *8) Refer to Page 65, "3.6.4 Enabling device function" for the enabling device.

[Caution] Since we have omitted the information in part because of explanation, there is the section different from the product. Also refer to Page 62, "Fig.3-17 : External emergency stop connection".

Fig.6-3 : Example of safety measures (Wiring example 3)

<Wiring example 4>: Connect the emergency stop switch of peripheral equipment, and the door switch to two robot controllers, and it interlocks. Connect the enabling device to the robot controller. The power supply for emergency stop input uses the power supply of peripheral equipment. Monitor the emergency stop state by the peripheral equipment side.

<Operation of the emergency stop>

If the emergency stop switch of peripheral equipment is pushed, the robot will also be in the emergency stop state. And, if the emergency stop switch of OP or T/B is pushed in the state of the power of robot controller OFF, peripheral equipment state can be the emergency stop also.

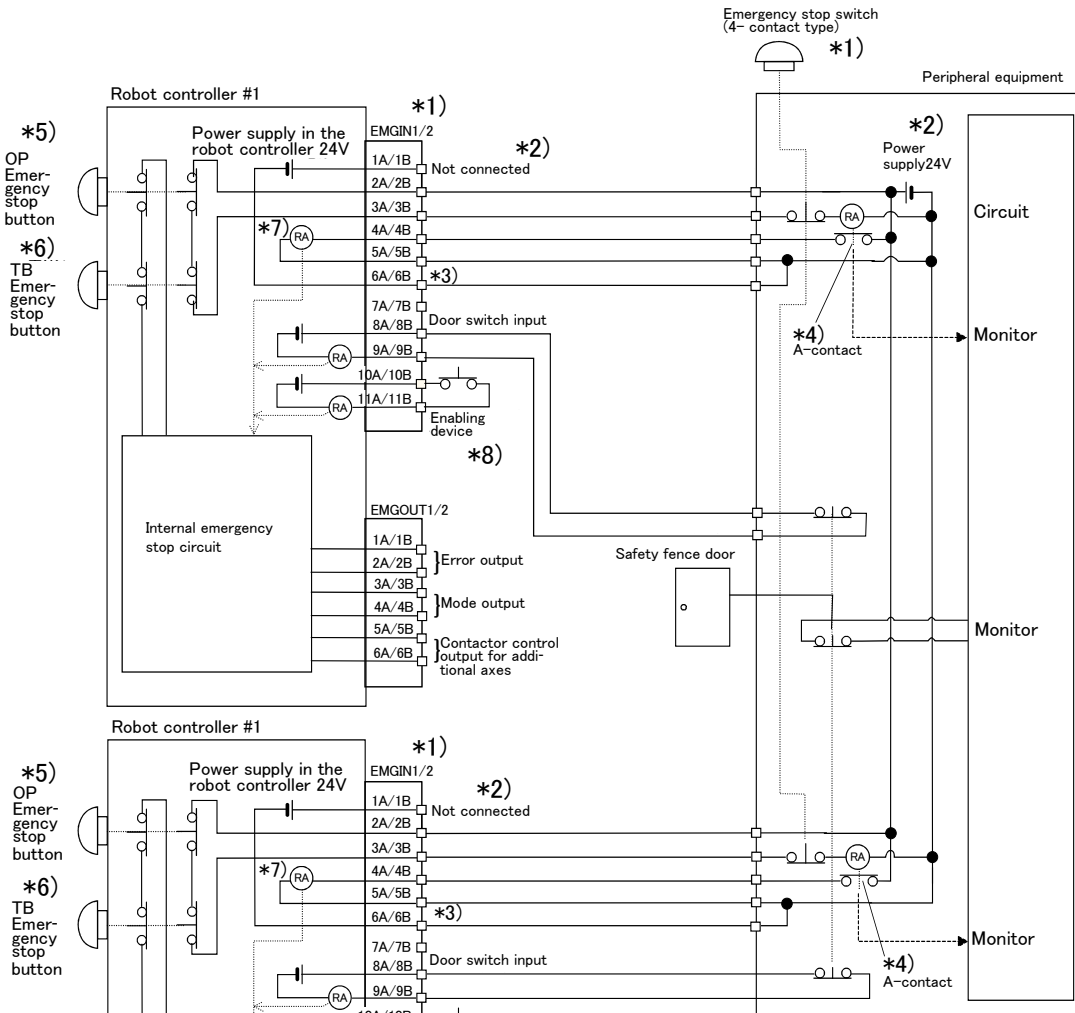

- *1) EMGIN1/2, and EMGOUT1/2 have the two terminals separately, and show that they are the two lines. Always connect the two lines.
If necessary to stop two robots simultaneously by one emergency stop switch please use the 4 contact type emergency stop switch.
- *2) 1A/1B, and 2A/2B terminal of EMGIN is short-circuited at factory shipments. Remove it, and connect the emergency stop switch and power supply of peripheral equipment. Connect the power supply of peripheral equipment by the polarity shown in the figure.
- *3) 5A/5B, and 6A/6B terminal of EMGIN is short-circuited at factory shipments. Remove it and connect with the power supply ground of peripheral equipment.
- Notes) Please use 5A/5B and 6A/6B terminal, connected.
- *4) Please use a A contact type of the relay with the compulsive guide.

- *5) The emergency stop button of the robot controller operation panel.
- *6) The emergency stop button of T/B connected to the robot controller.
- *7) Emergency stop input relay.
- *8) Refer to Page 65, "3.6.4 Enabling device function" for the enabling device.

[Caution] Since we have omitted the information in part because of explanation, there is the section different from the product. Also refer to Page 62, "Fig.3-17 : External emergency stop connection".

Fig.6-4 : Example of safety measures (Wiring example 4)

(1) External emergency stop connection [supplementary explanation]

- (1) Use a 2-contact type switch for all switches.
- (2) Install a limit switch on the safety fence's door. With a constantly open contact (a contact), wire to the door switch input terminal so that the switch turns ON (is conducted) when the door is closed, and turns OFF (is opened) when the door is open.
- (3) Use a manual-return type 2b-contact for the emergency stop button.
- (4) Classify the faults into minor faults (faults that are easily restored and that do not have a great effect) and major faults (faults that cause the entire system to stop immediately, and that require care in restoration), and wire accordingly.

[Caution] The emergency stop input (terminal block) on the user wiring in the controller can be used for safety measures as shown in Fig. 6-1 to Fig. 6-4. Note that there are limits to the No. of switch contacts, capacity and cable length, so refer to the following and install.

- Switch contact.....Prepare a 2-contact type.*1)
- Switch contact capacity.....Use a contact that operates with a switch contact capacity of approx. 1mA to 100mA/24V. *1)
If you connect the relay etc., rated current of the coil should use the relay which is 100mA/24V or less. (Refer to Fig. 6-5)
- Cable length.....The length of the wire between the switch and terminal block must be max. 15m or less. Please use the shield line, in case of the cable may receive the noise etc. by other equipment, such as servo amplifier. And, since the ferrite core is attached as noise measures parts, please utilize.

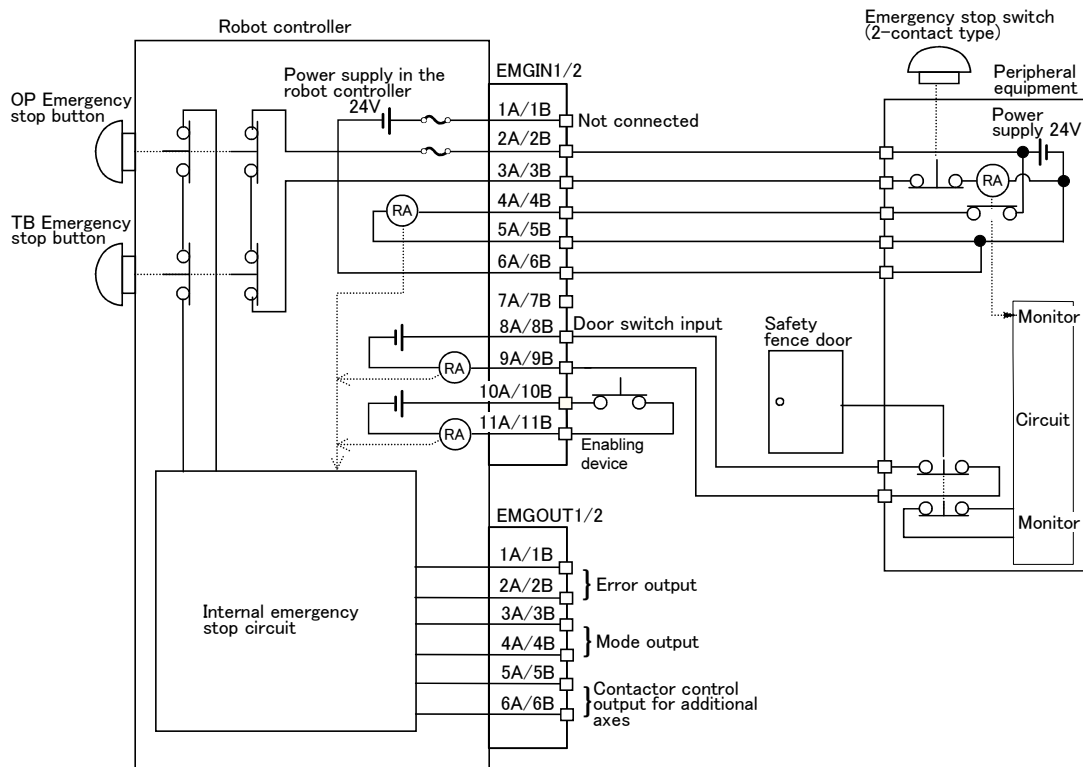

Fig.6-5 : Limitations when connecting the relay etc.



CAUTION You should always connect doubly connection of the emergency stop, the door switch, and the enabling switch. (Connect with both of side-A and side-B of the controller rear connector) In connection of only one side, if the relay of customer use should break down, it may not function correctly.



CAUTION Be sufficiently careful and wiring so that two or more emergency stop switches work independently. Don't function only on AND conditions (Two or more emergency stop switch status are all ON).

*1) The minimum load electric current of the switch is more than 5mA/24V.

6.2 Working environment

Avoid installation in the following places as the equipment's life and operation will be affected by the ambient environment conditions. When using in the following conditions, the customer must pay special attention to the preventive measures.

(1) Power supply

- Where the voltage fluctuation will exceed the input voltage range.
- Where a momentary power failure exceeding 20ms may occur.
- Where the power capacity cannot be sufficiently secured.

CAUTION

Please use the controller with an input power supply voltage fluctuation rate of 10% or less. In the case of 200 VAC input, for example, if the controller is used with 180 VAC during the day and 220 VAC during the night, turn the servo off once and then on again. If this is not performed, an excessive regeneration error may occur.

(2) Noise

- Where a surge voltage exceeding 1000V, 1 μ s may be applied on the primary voltage. Near large inverters, high output frequency oscillator, large contactors and welding machines. Static noise may enter the lines when this product is used near radios or televisions. Keep the robot away from these items.

(3) Temperature and humidity

- Where the atmospheric temperature exceeds 40 degree , lower than 0 degree.
- Where the relative humidity exceeds 85%, lower than 45%, and where dew may condense.
- Where the robot will be subject to direct sunlight or near heat generating sources such as heaters.

(4) Vibration

- Where excessive vibration or impact may be applied. (Use in an environment of 34m/s² or less during transportation and 5m/s² or less during operation.)

(5) Installation environment

- Where strong electric fields or magnetic fields are generated.
- Where the installation surface is rough. (Avoid installing the robot on a bumpy or inclined floor.)
- Where there is heavy powder dust and oil mist present.

6.3 Precautions for handling

- (1) The robot of RV-3SD/3SDJ series has brakes of J1 to J3 and J5 axes, and the robot of RV-3SDB/3SDJB series has brakes of all axes. The precision of the robot may drop, looseness may occur and the reduction gears may be damaged if the robot is moved with force with the brakes applied. Moreover, when the axis without the brake is servo-off, take care to falling by the self-weight.
- (2) Avoid moving the robot arm by hand. When unavoidable, gradually move the arm. If moved suddenly, the accuracy may drop due to an excessive backlash, or the backed up data may be destroyed.
- (3) Note that depending on the posture, even when within the movement range, the wrist section could interfere with the base section. Take care to prevent interference during jog. ^{*1)}
- (4) The robot arm is configured of precision parts such as bearings. Grease is used for lubricating these parts. When cold starting at low temperatures or starting operation after long-term stoppage, the position accuracy may drop or servo alarms may occur. If these problems occur, perform a 5 to 10 minute running-in operation at a low speed (about a half of normal operating speed).
- (5) The robot arm and controller must be grounded with Class D grounding to secure the noise resistance and to prevent electric shocks.
- (6) The items described in these specifications are conditions for carrying out the periodic maintenance and inspections described in the instruction manual.
- (7) When using the robot arm on a mobile axis or elevating table, the machine cables enclosed as standard configuration may break due to the fixed installation specifications. In this case, use the machine cable extension (for flexed)" factory shipment special specifications or options.

*1) Jog operation refers to operating the robot manually using the teaching pendant.

-
- (8) If this robot interferes with the workpiece or peripheral devices during operation, the position may deviate, etc.
Take care to prevent interference with the workpiece or peripheral devices during operation.
 - (9) The hanging installation jig can be borrowed from the maker. Order to dealer when need.
 - (10) Do not attach a tape or a label to the robot arm and the controller. If a tape or a label with strong adhesive power, such as a packaging tape, is attached to the coated surfaces of the robot arm and controller, the coated surface may be damaged when such tape or label is peeled off.
 - (11) If the robot is operated with a heavy load and at a high speed, the surface of the robot arm gets very hot. It would not result in burns, however, it may cause secondary accidents if touched carelessly.
 - (12) Do not shut down the input power supply to stop the robot. If the power supply is frequently shut down during a heavy load or high-speed operation, the speed reducer may be damaged, backlash may occur, and the program data may be destroyed.
 - (13) During the robot's automatic operation, a break is applied to the robot arm when the input power supply is shut down by a power failure, for instance. When a break is applied, the arm may deviate from the operation path predetermined by automatic operation and, as a result, it may interfere with the mechanical stopper depending on the operation at shutdown. In such a case, take an appropriate measure in advance to prevent any dangerous situation from occurring due to the interference between the arm and peripheral devices.
Example) Installing a UPS (uninterruptible power supply unit) to the primary power source in order to reduce interference.
 - (14) Do not conduct an insulated voltage test. If conducted by mistake, it may result in a breakdown.
 - (15) Fretting may occur on the axis which moving angle or moving distance move minutely, or not moves. Fretting is that the required oil film becomes hard to be formed if the moving angle is small, and wear occurs. The axis which not moved is moving slightly by vibration etc. To make no fretting recommends to move these axes about once every day the 30 degree or more, or the 30mm or more.
 - (16) The United Nations' Recommendations on the Transport of Dangerous Goods must be observed for trans-border transportation of lithium batteries by air, sea, and land. The lithium batteries (Q6BAT,A6BAT) used in Mitsubishi industrial robots contain less than 1 g of lithium and are not classified as dangerous goods. However, if the quantity of lithium batteries exceeds 24 batteries for storage, etc., they will be classified as Class 9: Miscellaneous dangerous substances and articles. Shipping less than 24 batteries is recommended to avoid having to carry out transport safety measures as the customer's consignor. Note that some transportation companies may request an indication that the batteries are not dangerous goods be included on the invoice. For shipping requirement details, please contact your transportation company.
 - (17) If the air supply temperature (primary piping) used for the tool etc. is lower than ambient air temperature, the dew condensation may occur on the coupling or the hose surface.

7 Appendix

Appendix 1 : Specifications discussion material

■ Customer information

Company name		Name	
Address		Telephone	

■ Purchased mode

Specification	Type ^{Note1)}			
Standard specification	<input type="checkbox"/> RV-3SD	<input type="checkbox"/> RV-3SDJ	<input type="checkbox"/> RV-3SDB	<input type="checkbox"/> RV-3SDJB
Clean specification	<input type="checkbox"/> RV-3SDC	<input type="checkbox"/> RV-3SDJC	<input type="checkbox"/> RV-3SDBC	<input type="checkbox"/> RV-3SDJBC
With the controller protection box ^{Note2)}	<input type="checkbox"/> RV-3SD-SM	<input type="checkbox"/> RV-3SDJ-SM		
CE Marking specification ^{Note3)}	<input type="checkbox"/> Not provided <input type="checkbox"/> "-S12" specification(CR1DA) <input type="checkbox"/> "-S15" specification(CR1DA) <input type="checkbox"/> "-S312" specification(CR2DA)			

Note1) Refer to the Page 2, "1.2 Model type name of robot" for the details of the robot arm type name.

Note2) Controller protection box(CR1D-MB) is attached.

Note3) The brake is attached to all axes for CE marking specification.

■ Shipping special specifications (Settings can be made only at time of shipment)

Item	Standard specifications	Special shipping specifications
Robot arm Machine cable	<input type="checkbox"/> 5m fixed type	<input type="checkbox"/> 2m fixed type : 1S-02UCBL-03

■ Options (Installable after shipment)

Item	Type	Provision, and specifications when provided.	
Robot arm	Operating range change	<input type="checkbox"/> Not provided <input type="checkbox"/> Provided	
	Machine cable extention	1S- <input type="checkbox"/> <input type="checkbox"/> CBL-03	<input type="checkbox"/> Not provided <input type="checkbox"/> 5m fixing <input type="checkbox"/> 10m fixing <input type="checkbox"/> 15m fixing
		1S- <input type="checkbox"/> <input type="checkbox"/> LOBL-03	<input type="checkbox"/> Not provided <input type="checkbox"/> 5m bending <input type="checkbox"/> 10m bending <input type="checkbox"/> 15m bending
	Solenoid valve set	1S-VD0 <input type="checkbox"/> -02	<input type="checkbox"/> Not provided Sink <input type="checkbox"/> 1 set <input type="checkbox"/> 2 sets <input type="checkbox"/> 3 sets <input type="checkbox"/> 4 sets
		1S-VD0 <input type="checkbox"/> E-02	Source <input type="checkbox"/> 1 set <input type="checkbox"/> 2 sets <input type="checkbox"/> 3 sets <input type="checkbox"/> 4 sets
	Hand input cable	1S-HC25C-01	<input type="checkbox"/> Not provided <input type="checkbox"/> Provided
Hand output cable	1S-GR35S-01	<input type="checkbox"/> Not provided <input type="checkbox"/> Provided	
Hand curl tube	1E-ST040 <input type="checkbox"/> C	<input type="checkbox"/> Not provided <input type="checkbox"/> 1 set <input type="checkbox"/> 2 sets <input type="checkbox"/> 3 sets <input type="checkbox"/> 4 sets	
Controller	Teaching pendant	R32TB- <input type="checkbox"/> <input type="checkbox"/>	<input type="checkbox"/> Not provided <input type="checkbox"/> 7m <input type="checkbox"/> 15m
		R56TB- <input type="checkbox"/> <input type="checkbox"/>	<input type="checkbox"/> Not provided <input type="checkbox"/> 7m <input type="checkbox"/> 15m
	Pneumatic hand interface	2A-RZ365/2A-RZ375	<input type="checkbox"/> Not provided <input type="checkbox"/> 2A-RZ365(Sink) <input type="checkbox"/> 2A-RZ375(Source)
	Parallel I/O interface ^{Note1)}	2D-TZ368/2D-TZ378	<input type="checkbox"/> Not provided 2D-TZ368(Sink) <input type="checkbox"/> -1pc. <input type="checkbox"/> -2pc. <input type="checkbox"/> -3pc. 2D-TZ378(Source) <input type="checkbox"/> -1pc. <input type="checkbox"/> -2pc. <input type="checkbox"/> -3pc.
	External I/O cable	2D-CBL <input type="checkbox"/> <input type="checkbox"/> (For 2D-TZ368/TZ378)	<input type="checkbox"/> Not provided <input type="checkbox"/> 5m-()pc. <input type="checkbox"/> 15m-1()pc.
	Parallel I/O unit	2A-RZ361/2A-RZ371	<input type="checkbox"/> Not provided Sink type: 2A-RZ361 ()unit Source type: 2A-RZ371 ()unit
	External I/O cable	2A-CBL <input type="checkbox"/> <input type="checkbox"/> (For 2A-RZ361/RZ371)	<input type="checkbox"/> Not provided <input type="checkbox"/> 5m-()pc. <input type="checkbox"/> 15m-1()pc.
	CC-Link interface	2D-TZ576	<input type="checkbox"/> Not provided <input type="checkbox"/> Provided
	Expansion memory	2D-TZ454	<input type="checkbox"/> Not provided <input type="checkbox"/> Provided
	Controller protection box	CR1D-MB	<input type="checkbox"/> Not provided <input type="checkbox"/> Provided
	RT ToolBox2	3D-11C-WINE	<input type="checkbox"/> Not provided <input type="checkbox"/> Windows2000/XP/Vista English CD-ROM
	RT ToolBox2 mini	3D-12C-WINE	<input type="checkbox"/> Not provided <input type="checkbox"/> Windows2000/XP/Vista English CD-ROM
Personal computer cable	2D-232CBL03M	<input type="checkbox"/> Not provided <input type="checkbox"/> Provided	
Instructions manual	5S-DA00-PE01	<input type="checkbox"/> Not provided <input type="checkbox"/> Provided () set	

Note1) One parallel I/O interface(2D-TZ378) is installed at factory shipping for "-S12" and "-S312" specification only.

■ Maintenance parts (Consumable parts)

Maintenance parts	<input type="checkbox"/> Backup batteries A6BAT () pcs. <input type="checkbox"/> Backup batteries Q6BAT () pcs. <input type="checkbox"/> Grease () cans
-------------------	--

■ Robot selection check list

Work description	<input type="checkbox"/> Material handling <input type="checkbox"/> Assembly <input type="checkbox"/> Machining L/UL <input type="checkbox"/> Sealing <input type="checkbox"/> Testing and inspection <input type="checkbox"/> Other ()			
Workpiece mass () g	Hand mass () g	Atmosphere	<input type="checkbox"/> General environment <input type="checkbox"/> Clean <input type="checkbox"/> Dust provided <input type="checkbox"/> Other()	
Remarks				

Copy this page and use the copy.



Product Service

EC-Statement of Compliance

No. E6 12 07 25554 044

Holder of Certificate: Mitsubishi Electric Corporation

Tokyo BILD., 2-7-3 Marunouchi,
Chiyoda-ku
Tokyo
100-8310 JAPAN

Name of Object: Industrial, Scientific and Medical
equipment
Industrial Robot

Model(s): SD series
(See Attachment for Nomenclature)

Description of Object:

Rated Voltage: 230 VAC(1 phase)/
230, 400 VAC(3 phase)
Rated Power: 0.6 kW (230 VAC)/
1.7 kW (230 VAC)/
3.4 kW (230, 400 VAC)
Protection Class: I

Tested according to: EN 61000-6-4:2007
EN 61000-6-2:2005

This EC-Statement of Compliance is issued according to the Directive 2004/108/EC relating to electromagnetic compatibility. It confirms that the listed apparatus complies with such aspects of the essential requirements of the EMC directive as specified by the manufacturer or his authorized representative in the European Community and applies only to the sample and its technical documentation submitted to TÜV SÜD Product Service GmbH for testing and certification. See also notes overleaf.

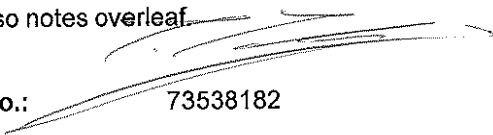
Technical report no.:  73538182



Date, 2012-07-18 (Johann Roidt)

TÜV SÜD Product Service GmbH is Notified Body to the Directive 2004/108/EC of the European Parliament and of the council with the identification number 0123.

Page 1 of 10

Attachment

Statement No.

E6 12 07 25554 044

Product Service

SD series Grouping Items

1. AC 400V /230V 3 phase 3.4kW

- | | |
|--------------------------|----------------------------|
| 1. RV-12SD(-S**) | 33. RH-12SDH7030M-SULM6** |
| 2. RV-12SDL(-S**) | 34. RH-12SDH5530M-SULM6** |
| 3. RV-12SDC(-S**) | 35. RH-12SDH8530M-SULM6** |
| 4. RV-12SDLC(-S**) | 36. RH-18SDH8530M-SULM6** |
| 5. RV-12SD-SUL** | 37. RH-6SDH4527M-SM6** |
| 6. RV-12SDL-SUL** | 38. RH-6SDH3527M-SM6** |
| 7. RV-12SDC-SUL** | 39. RH-6SDH5527M-SM6** |
| 8. RV-12SDLC-SUL** | 40. RH-6SDH4527M-SULM6** |
| 9. RV-18SD(-S**) | 41. RH-6SDH3527M-SULM6** |
| 10. RV-18SDC(-S**) | 42. RH-6SDH5527M-SULM6** |
| 11. RV-18SD-SUL** | 43. RH-12SDH7038M-SM6** |
| 12. RV-18SDC-SUL** | 44. RH-12SDH5538M-SM6** |
| 13. RV-6SD-SM6** | 45. RH-12SDH8538M-SM6** |
| 14. RV-6SDL-SM6** | 46. RH-12SDH7038M-SULM6** |
| 15. RV-6SD-SULM6** | 47. RH-12SDH5538M-SULM6** |
| 16. RV-6SDL-SULM6** | 48. RH-12SDH8538M-SULM6** |
| 17. RV-3SD-SM6** | 49. RH-20SDH8538M-SM6** |
| 18. RV-3SDB-SM6** | 50. RH-20SDH8530M-SM6** |
| 19. RV-3SDB-SULM6** | 51. RH-20SDH10038M-SM6** |
| 20. RV-3SDJ-SM6** | 52. RH-20SDH10030M-SM6** |
| 21. RV-3SDJB-SM6** | 53. RH-20SDH8538M-SULM6** |
| 22. RV-3SDJB-SULM6** | 54. RH-20SDH8530M-SULM6** |
| 23. RH-6SDH4517M-SM6** | 55. RH-20SDH10038M-SULM6** |
| 24. RH-6SDH3517M-SM6** | 56. RH-20SDH10030M-SULM6** |
| 25. RH-6SDH5517M-SM6** | 57. RH-3SDHR3512MW-SM6** |
| 26. RH-6SDH4517M-SULM6** | 58. RH-3SDHR5512MW-SM6** |
| 27. RH-6SDH3517M-SULM6** | 59. RH-3SDHR3512MW-SULM6** |
| 28. RH-6SDH5517M-SULM6** | 60. RH-3SDHR5512MW-SULM6** |
| 29. RH-12SDH7030M-SM6** | 61. RH-3SDHR3512M-SM6** |
| 30. RH-12SDH5530M-SM6** | 62. RH-3SDHR5512M-SM6** |
| 31. RH-12SDH8530M-SM6** | 63. RH-3SDHR3512M-SULM6** |
| 32. RH-18SDH8530M-SM6** | 64. RH-3SDHR5512M-SULM6** |

Attachment

Statement No.

E6 12 07 25554 044

Product Service

- 65. RH-3SDHR3512W-SM6**
- 66. RH-3SDHR5512W-SM6**
- 67. RH-3SDHR3512W-SULM6**
- 68. RH-3SDHR5512W-SULM6**

2. AC 230V 1 phase 1.7kW

- | | |
|------------------------|-------------------------|
| 1. RV-6SD(-S**) | 31. RH-6SDH3520-SUL3** |
| 2. RV-6SDL(-S**) | 32. RH-6SDH5520-SUL3** |
| 3. RV-6SDC(-S**) | 33. RH-6SDH4517M-SUL3** |
| 4. RV-6SDLC(-S**) | 34. RH-6SDH3517M-SUL3** |
| 5. RV-6SD-SUL** | 35. RH-6SDH5517M-SUL3** |
| 6. RV-6SDL-SUL** | 36. RH-6SDH4517C-SUL3** |
| 7. RV-6SDC-SUL** | 37. RH-6SDH3517C-SUL3** |
| 8. RV-6SDLC-SUL** | 38. RH-6SDH5517C-SUL3** |
| 9. RV-3SD-S3** | 39. RH-12SDH7035(-S**) |
| 10. RV-3SDC-S3** | 40. RH-12SDH5535(-S**) |
| 11. RV-3SDB-S3** | 41. RH-12SDH8535(-S**) |
| 12. RV-3SDBC-S3** | 42. RH-18SDH8535(-S**) |
| 13. RV-3SDB-SUL3** | 43. RH-12SDH7030M(-S**) |
| 14. RV-3SDBC-SUL3** | 44. RH-12SDH5530M(-S**) |
| 15. RV-3SDJ-S3** | 45. RH-12SDH8530M(-S**) |
| 16. RV-3SDJC-S3** | 46. RH-18SDH8530M(-S**) |
| 17. RV-3SDJB-S3** | 47. RH-12SDH7030C(-S**) |
| 18. RV-3SDJBC-S3** | 48. RH-12SDH5530C(-S**) |
| 19. RV-3SDJB-SUL3** | 49. RH-12SDH8530C(-S**) |
| 20. RV-3SDJBC-SUL3** | 50. RH-18SDH8530C(-S**) |
| 21. RH-6SDH4520-S3** | 51. RH-12SDH7035-SUL** |
| 22. RH-6SDH3520-S3** | 52. RH-12SDH5535-SUL** |
| 23. RH-6SDH5520-S3** | 53. RH-12SDH8535-SUL** |
| 24. RH-6SDH4517M-S3** | 54. RH-18SDH8535-SUL** |
| 25. RH-6SDH3517M-S3** | 55. RH-12SDH7030M-SUL** |
| 26. RH-6SDH5517M-S3** | 56. RH-12SDH5530M-SUL** |
| 27. RH-6SDH4517C-S3** | 57. RH-12SDH8530M-SUL** |
| 28. RH-6SDH3517C-S3** | 58. RH-18SDH8530M-SUL** |
| 29. RH-6SDH5517C-S3** | 59. RH-12SDH7030C-SUL** |
| 30. RH-6SDH4520-SUL3** | 60. RH-12SDH5530C-SUL** |

Attachment
Statement No.
E6 12 07 25554 044



Product Service

- 61. RH-12SDH8530C-SUL**
- 62. RH-18SDH8530C-SUL**
- 63. RV-12SD-S3**
- 64. RV-12SDL-S3**
- 65. RV-12SDC-S3**
- 66. RV-12SDLC-S3**
- 67. RV-12SD-SUL3**
- 68. RV-12SDL-SUL3**
- 69. RV-12SDC-SUL3**
- 70. RV-12SDLC-SUL3**
- 71. RH-20SDH8538M(-S**)
- 72. RH-20SDH8530M(-S**)
- 73. RH-20SDH10038M(-S**)
- 74. RH-20SDH10030M(-S**)
- 75. RH-20SDH8538C(-S**)
- 76. RH-20SDH8530C(-S**)
- 77. RH-20SDH10038C(-S**)
- 78. RH-20SDH10030C(-S**)
- 79. RH-20SDH8545 -SUL**
- 80. RH-20SDH8535-SUL**
- 81. RH-20SDH10045-SUL**
- 82. RH-20SDH10035-SUL**
- 83. RH-20SDH8538M-SUL**
- 84. RH-20SDH8530M-SUL**
- 85. RH-20SDH10038M-SUL**
- 86. RH-20SDH10030M-SUL**
- 87. RH-20SDH8538C-SUL**
- 88. RH-20SDH8530C-SUL**
- 89. RH-20SDH10038C-SUL**
- 90. RH-20SDH10030C-SUL**
- 91. RH-12SDH8538M-SUL**
- 92. RH-12SDH7038C-SUL**
- 93. RH-12SDH5538C-SUL**
- 94. RH-12SDH8538C-SUL**
- 95. RH-20SDH8545 (-S**)
- 96. RH-20SDH8535(-S**)
- 97. RH-20SDH10045(-S**)
- 98. RH-20SDH10035(-S**)
- 99. RH-6SDH4532-S3**
- 100. RH-6SDH3532-S3**
- 101. RH-6SDH5532-S3**
- 102. RH-6SDH4527M-S3**
- 103. RH-6SDH3527M-S3**
- 104. RH-6SDH5527M-S3**
- 105. RH-6SDH4527C-S3**
- 106. RH-6SDH3527C-S3**
- 107. RH-6SDH5527C-S3**
- 108. RH-6SDH4532-SUL3**
- 109. RH-6SDH3532-SUL3**
- 110. RH-6SDH5532-SUL3**
- 111. RH-6SDH4527M-SUL3**
- 112. RH-6SDH3527M-SUL3**
- 113. RH-6SDH5527M-SUL3**
- 114. RH-6SDH4527C-SUL3**
- 115. RH-6SDH3527C-SUL3**
- 116. RH-6SDH5527C-SUL3**
- 117. RH-12SDH7045(-S**)
- 118. RH-12SDH5545(-S**)
- 119. RH-12SDH8545(-S**)
- 120. RH-12SDH7038M(-S**)
- 121. RH-12SDH5538M(-S**)
- 122. RH-12SDH8538M(-S**)
- 123. RH-12SDH7038C(-S**)
- 124. RH-12SDH5538C(-S**)
- 125. RH-12SDH8538C(-S**)
- 126. RH-12SDH7045-SUL**
- 127. RH-12SDH5545-SUL**
- 128. RH-12SDH8545-SUL**
- 129. RH-12SDH7038M-SUL**
- 130. RH-12SDH5538M-SUL**
- 131. RH-3SDHR3515W(-S**)
- 132. RH-3SDHR5515W(-S**)

Attachment
Statement No.
E6 12 07 25554 044



Product Service

- | | |
|--------------------------|--------------------------|
| 133.RH-3SDHR3512MW(-S**) | 144.RH-3SDHR5515-SUL** |
| 134.RH-3SDHR5512MW(-S**) | 145.RH-3SDHR3512M-SUL** |
| 135.RH-3SDHR3515W-SUL** | 146.RH-3SDHR5512M-SUL** |
| 136.RH-3SDHR5515W-SUL** | 147.RH-3SDHR3512W (-S**) |
| 137.RH-3SDHR3512MW-SUL** | 148.RH-3SDHR5512W (-S**) |
| 138.RH-3SDHR5512MW-SUL** | 149.RH-3SDHR3512C (-S**) |
| 139.RH-3SDHR3515 (-S**) | 150.RH-3SDHR5512C(-S**) |
| 140.RH-3SDHR5515 (-S**) | 151.RH-3SDHR3512W-SUL** |
| 141.RH-3SDHR3512M (-S**) | 152.RH-3SDHR5512W-SUL** |
| 142.RH-3SDHR5512M(-S**) | 153.RH-3SDHR3512C-SUL** |
| 143.RH-3SDHR3515-SUL** | 154.RH-3SDHR5512C-SUL** |

3. AC 230V 1 phase 0.6kW

- | | |
|-----------------------|-------------------------|
| 1. RV-2SD(-S**) | 23. RH-6SDH3532(-S**) |
| 2. RV-2SDB(-S**) | 24. RH-6SDH5532(-S**) |
| 3. RV-2SD-S12 | 25. RH-6SDH4527M(-S**) |
| 4. RV-2SDB-S12 | 26. RH-6SDH3527M(-S**) |
| 5. RV-3SD-S** | 27. RH-6SDH5527M(-S**) |
| 6. RV-3SDC-S** | 28. RH-6SDH4527C(-S**) |
| 7. RV-3SDB-S** | 29. RH-6SDH3527C(-S**) |
| 8. RV-3SDBC-S** | 30. RH-6SDH5527C(-S**) |
| 9. RV-3SDJ-S** | 31. RH-3SDHR3515N(-S**) |
| 10. RV-3SDJC-S** | 32. RH-3SDHR5515N(-S**) |
| 11. RV-3SDJB-S** | 33. RP-1ADH (-S**) |
| 12. RV-3SDJBC-S** | 34. RP-3ADH (-S**) |
| 13. RH-6SDH4520-S** | 35. RP-5ADH (-S**) |
| 14. RH-6SDH3520-S** | 36. RP-1ADHC(-S**) |
| 15. RH-6SDH5520-S** | 37. RP-3ADHC (-S**) |
| 16. RH-6SDH4517M-S** | 38. RP-5ADHC (-S**) |
| 17. RH-6SDH3517M-S** | 39. RP-1ADHW (-S**) |
| 18. RH-6SDH5517M-S** | 40. RP-3ADHW (-S**) |
| 19. RH-6SDH4517C-S** | 41. RP-5ADHW (-S**) |
| 20. RH-6SDH3517C-S** | 42. RP-1ADHL (-S**) |
| 21. RH-6SDH5517C-S** | 43. RP-1ADHLC (-S**) |
| 22. RH-6SDH4532(-S**) | 44. RP-1ADHLW (-S**) |

Attachment
Statement No.
E6 12 07 25554 044



Product Service

Nomenclature

Group A, B Model name description is shown as follows.

R V - x SD x - x
(1) (2) (3) (4) (5)

(1) V: Vertical Robot

(2) Maximum Payload specification:

6 : 6kg

12 : 12kg

18 : 18kg

(3) **SD** : **SD** series robot

(4) **L** : Arm extension model

C : Clean room model

LC : Clean room arm

extension model

(5) Dimension and Ambient specification:

[none] : driven by R/C

CR3D-7*1M (for RV-12SD)

CR2D-7*1 / CR2DA-7*1 (for RV-6SD)

SM6xx: Oil mist model driven by R/C

CR3D-7*1M-SM6xx (only RV-6SD)

SULxx:UL specification/driven by R/C

CR3D-7*1M-SULxx (for RV-12SD)

CR2D-7*1-SULxx (for RV-6SD)

SULM6xx:UL specification/

Oil mist model driven by R/C

CR3D-7*1M-SULM6xx(only RV-6SD)

S3xx : driven by R/C CR2D-7*1-S3xx/ CR2DA-7*1-S3xx(only RV-12SD)

Group C Model name description is shown as follows.

RV-3 SD J B x - x
(1) (2) (3) (4) (5) (6) (7)

(1) V: Vertical Robot

(2) Rated Payload specification:

3 : 3kg

(3) **SD** : **SD** series robot

(4) **J** : 5 axes exist

[none] : 6 axes exist

(5) **B** : All axes are equipped with brake

[none] : Basic model

J4 axis and J6 axis are not equipped with brake.

Attachment
Statement No.
E6 12 07 25554 044



Product Service

- (6) **C** : Clean room model
[none] : Basic model
- (7) Special specification number
Pilot number and specification as follows
- Sxx** : driven by R/C CR1DA-7*1-Sxx
S3xx : driven by R/C CR2D-7*1-S3xx/ CR2DA-7*1-S3xx
SM6xx : R/C Oil mist model
driven by R/C CR3D-7*1M-SM6xx
SUL3xx: UL specification and R/C Oil mist model
driven by R/C CR2D-7*1-SUL3xx
SULM6xx: UL specification R/C Oil mist model
driven by R/C CR3D-7*1M-SULM6xx

Group D Model name description is shown as follows.

RH-x SDH xx xx x - xx

(1) (2) (3) (4) (5) (6) (7)

- (1)H: Horizontal Robot
(2) Maximum Payload specification:
- 6** : 6kg
12 : 12kg
18 : 18kg
20 : 20kg
- (3) **SD** : **SD** series robot
(4) Arm length(No1 and No2 arm) specification:
- 35** : 350 mm arm **70** : 700 mm arm
45 : 450 mm arm **85** : 850 mm arm
55 : 550 mm arm **100** : 1000 mm arm
- (5) Z axis working area specification:
- 17** : 170 mm arm **32** : 320 mm arm
20 : 200 mm arm **35** : 350 mm arm
27 : 270 mm arm **38** : 380 mm arm
30 : 300 mm arm **45** : 450 mm arm
- (6) Dimension and Ambient specification:
- M** : Oil mist model
C : Clean room model
[none] : Basic model

Attachment

Statement No.

E6 12 07 25554 044



Product Service

(7) Optional specification:

Sxx : RH-6SDH driven by R/C CR1DA-7*1-Sxx
RH-12/18/20SDH driven by R/C CR2D-7*1-Sxx/ R/C CR2DA-7*1-Sxx

S3xx: driven by R/C CR2D-7*1-S3xx/ CR2DA-7*1-S3xx
(only RH-6SDH)

SM6xx: Oil mist model driven by R/C
CR3D-7*1M-SM6xx

SULxx: UL specification driven by R/C
CR3D-7*1M-SULxx
(only RH-12 / 18SDH)

SUL3xx: UL specification driven by R/C
CR2D-7*1-SUL3xx (only RH-6SDH)

SULM6xx: UL specification /
Oil mist model driven by R/C
CR3D-7*1M-SULM6xx
(only RV-12 / 18SDH)

Group E Model name description is shown as follows.

RV-2 SD B - x
(1) (2) (3) (4) (5)

(1) V: Vertical Robot

(2) Rated Payload specification:

2 : 2kg

(3) **SD** : **SD** series robot

(4) **B** : All axes are equipped with brake

[none] : Basic model

J4 axis and J6 axis are not equipped with brake.

(5) Special specification number

Pilot number and specification as follows

Sxx : driven by R/C CR1DA-77*-Sxx

S12 : machine cable connectors (between Robot arm and Robot controller) are original square type.
driven by R/C CR1DA-77*-S12

Attachment

Statement No.

E6 12 07 25554 044



Product Service

Group F Model name description is shown as follows.

RH-3 SDHR xx xx x x - xx

(1) (2) (3) (4) (5) (6) (7) (8) (9)

(1)H: Horizontal Robot

(2) Maximum Payload specification:

3 : 3kg

(3) **SD** : **SD** series robot

(4) **R** : Reverse mount model

(5) Arm length(No1 and No2 arm) specification:

35 : 350 mm arm

55 : 550 mm arm

(6) Z axis working area specification:

12 : 120 mm arm

15 : 150 mm arm

(7) Dimension and Ambient specification:

[none] : Basic model

M : Oil mist model

W : Water proof model

C : Clean room model

(8) Special specification:

W : Basic model

N : the special machine cable model driven by CR1DA-781-Sxx

[none] : Basic model ,regular type (same with "**W**")

(9) Optional specification:

Sxx : RH-3SDHRxxxxN driven by R/C, CR1DA-781-Sxx

RH-3SDHRxxxxW

and RH-3SDHRxxxx driven by R/C, CR2DA-781-Sxx

SM6xx: Oil mist model driven by R/C, CR3D-781M-SM6xx

SULxx: UL specification driven by R/C, CR3D-781M-SULxx

SULM6xx:UL specification /Oil mist model driven by R/C, CR3D-781M-SULM6xx

Attachment

Statement No.

E6 12 07 25554 044



Product Service

Group G Model name description is shown as follows.

RP-x A DH xxx - xx

(1) (2) (3) (4) (5) (6)

(1)P: Parallel rink Robot

(2) Maximum Payload specification:

1 : 1kg

3 : 3kg

5 : 5kg

(3) **A** : **A** series robot

(4) **D** : stand alone type

(5) Dimension and Ambient specification

L : Arm extension model

C : Clean room model

W : Water proof model

LC : Clean room ,Long arm model

LW : Water proof, long arm model

[none] :standard model

(6) Optional specification:

[none] :standard model

Sxx : Shipping specification

EC Declaration of Conformity

We, the undersigned,

Manufacturer	MITSUBISHI ELECTRIC CORPORATION NAGOYA WORKS
Address, City	1-14,Yada-minami 5-chome, Higashi-ku, Nagoya 461-8670
Country	Japan
Phone number	+81 52 712 2354
Fax number/e-mail	+81 52 722 0384
Authorized representative in Europe	MITSUBISHI Electric Europe B.V
Address, City	40880 Ratingen
Country	Germany

Certify and declare under our sole responsibility that the following apparatus:

Type Name	Industrial Robot
Manufacturer	MITSUBISHI ELECTRIC CORPORATION NAGOYA WORKS
Brand	MELFA
Model No.	SD series
Restrictive use	For industrial environment only

Conforms with the essential requirements of the **EMC Directive 2004/108/EC** and the **Machinery Directive 2006/42/EC**, based on the following specifications applied:

EU Harmonized Standards		Non-harmonized Standard
EMC (2004/108/EC)	EN61000-6-4:2007 EN61000-6-2:2005	N/A
Machinery (2006/42/EC)	Type A: Fundamental safety standards EN ISO12100-1:2003 EN ISO12100-2:2003 EN 1050:1997 Type B: Group safety standards B1: Safety aspects EN60204-1:2006, EN294:1992, EN349:1993 ISO13849-1:2006 Type C: Machine Safety standard ISO10218-1:2011	N/A

and therefore complies with the essential requirements and provisions of the EMC Directive and the Machinery Directive.

The Technical documentation is kept at the following address:

Company	MITSUBISHI Electric Europe B.V
Address, City	Gothaer St. 8 40880 Ratingen
Country	Germany
Phone number	+49 2102 486 0
Fax number	+49 2102 486 1120

< Partly completed Machinery >

This product meets the specification and/or the performance by correct installing.

So it must not be used until being installed into the final machinery of the customer.

Date	June 14, 2012
Name and position of person binding the manufacturer	 <hr/> Tomoyuki Kobayashi Senior Manager Robot Manufacturing Department MITSUBISHI ELECTRIC CORPORATION NAGOYA WORKS

■ Declaration Type of models

Table 1 : The list of RV-12SD series for grouping certification. :A group

No.	Classification	Model name	Robot Controller
		12/18kg-Load	
1	Oil mist basic model	RV-12SD(-S**)	CR3D-701M(-S**)
2	Oil mist arm extension model	RV-12SDL(-S**)	
3	Oil mist /heavy load model	RV-18SD(-S**)	
4	Clean room basic model (Class 10)	RV-12SDC(-S**)	CR3D-701(-S**)
5	Clean room arm extension model (Class 10)	RV-12SDLC(-S**)	
6	Clean room /heavy load model (Class 10)	RV-18SDC(-S**)	
7	Oil mist basic model , 1Phase Power model Robot controller	RV-12SD-S3**	CR2D-701-S3**/ CR2DA-701-S3**
8	Oil mist arm extension model, with 1Phase Power model Robot controller	RV-12SDL-S3**	
9	Clean room basic model (Class 10) 1Phase Power model Robot controller	RV-12SDC-S3**	
10	Clean room arm extension model (Class 10) with 1Phase Power model Robot controller	RV-12SDLC-S3**	
11	UL specification oil mist basic model with 1Phase Power model Robot controller	RV-12SD-SUL3**	CR2D-701-SUL3**
12	UL specification oil mist arm extension model with 1Phase Power model Robot controller	RV-12SDL-SUL3**	
13	UL specification oil mist basic model with 1Phase Power model Robot controller	RV-12SDC-SUL3**	
14	UL specification oil mist arm extension model with 1Phase Power model Robot controller	RV-12SDCL-SUL3**	
15	UL specification oil mist basic model including oil mist model robot controller	RV-12SD-SUL**	CR3D-701M-SUL**
16	UL specification oil mist arm extension model including oil mist model robot controller	RV-12SDL-SUL**	
17	UL specification oil mist basic model including oil mist model robot controller	RV-12SDC-SUL**	CR3D-701-SUL**
18	UL specification oil mist arm extension model including oil mist model robot controller	RV-12SDCL-SUL**	
19	UL specification clean room /heavy load model	RV-18SD-SUL**	CR3D-709M-SUL**
20	UL specification clean room /heavy load model	RV-18SDC-SUL**	CR3D-709-SUL**

Table 2 : The list of RV-6SD series for grouping certification. B group

No.	Classification	Model name	Robot Controller
		6kg-Load	
1	Oil mist basic model	RV-6SD(-S**)	CR2D-711(-S**) / CR2DA-711(-S**)
2	Oil mist arm extension model	RV-6SDL(-S**)	
3	Clean room basic model (Class 10)	RV-6SDC(-S**)	
4	Clean room arm extension model (Class 10)	RV-6SDLC(-S**)	
5	Oil mist basic model including oil mist model robot controller	RV-6SD-SM6**	CR3D-711M(-S**)
6	Oil mist arm extension model including oil mist model robot controller	RV-6SDL-SM6**	
7	UL specification oil mist basic model	RV-6SD-SUL**	CR2D-711-SUL**
8	UL specification oil mist arm extension model	RV-6SDL-SUL**	
9	UL specification clean room basic model (Class 10)	RV-6SDC-SUL**	
10	UL specification clean room arm extension model (Class 10)	RV-6SDLC-SUL**	
11	UL specification oil mist basic model including oil mist model robot controller	RV-6SD-SULM6**	CR3D-711M-SULM6**
12	UL specification oil mist arm extension model including oil mist model robot controller	RV-6SDL-SULM6**	

Table 3 : The list of RV-3SD series robots for grouping certification; C group-1.

No.	Classification	Model name	Robot Controller
		6-axis	
1	Basic model (standard)	RV-3SD-S3**	CR2D-721-S3**/ CR2DA-721-S3**
2	Clean room basic model (standard)	RV-3SDC-S3**	
3	Basic model with brakes on all axis (standard)	RV-3SDB-S3**	
4	Clean room basic model with brakes on all axis (standard)	RV-3SDBC-S3**	
5	Oil mist basic model including robot controller *1	RV-3SD-SM6**	CR3D-721M-SM6**
6	Oil mist basic model with brakes on all axis including robot controller	RV-3SDB-SM6**	
7	UL specification and basic model with brakes on all axis (standard)	RV-3SDB-SUL3**	CR2D-721-SUL3**
8	UL specification clean room basic model with brakes on all axis (standard)	RV-3SDBC-SUL3**	
9	UL specification oil mist basic model with brakes on all axis including robot controller	RV-3SDB-SULM6**	CR3D-721M-SULM6**

Table 4 : The list of RV-3SD series robots for grouping certification; C group-2

No.	Classification	Model name	Robot Controller
		6-axis	
10	Basic model (standard) *1	RV-3SD(-S**)	CR1DA-721(-S**)
11	Clean room basic model (standard) *1	RV-3SDC(-S**)	
12	Basic model with brakes on all axis (standard)	RV-3SDB(-S**)	
13	Clean room basic model with brakes on all axis (standard)	RV-3SDBC(-S**)	

Table 5 : The list of RV-3SD series robots for grouping certification; C group -3.

No.	Classification	Model name	Robot Controller
		5-axis	
14	Basic model (standard)	RV-3SDJ-S3**	CR2D-731-S3**/ CR2DA-731-S3**
15	Clean room basic model (standard)	RV-3SDJC-S3**	
16	Basic model with brakes on all axis (standard)	RV-3SDJB-S3**	
17	Clean room basic model with brakes on all axis (standard)	RV-3SDJBC-S3**	
18	Oil mist basic model including robot controller *1	RV-3SDJ-SM6**	CR3D-731M-SM6**
19	Oil mist basic model with brakes on all axis including robot controller	RV-3SDJB-SM6**	
20	UL specification basic model with brakes on all axis (standard)	RV-3SDJB-SUL3**	CR2D-731-SUL3**
21	UL specification clean room basic model with brakes on all axis (standard)	RV-3SDJBC-SUL3**	
22	UL specification oil mist basic model with brakes on all axis including robot controller	RV-3SDJB-SULM6**	CR3D-731M-SULM6**

Table 6 : The list of RV-3SD series robots for grouping certification; C group -4.

No.	Classification	Model name	Robot Controller
		5-axis	
23	Basic model (standard) *1	RV-3SDJ(-S**)	CR1DA-731(-S**)
24	Clean room basic model (standard) *1	RV-3SDJC(-S**)	
25	Basic model with brakes on all axis (standard)	RV-3SDJB(-S**)	
26	Clean room basic model with brakes on all axis (standard)	RV-3SDJBC(-S**)	

Table 7 : The list of RH-xSDH robots for grouping certification; D group-1.

No.	Classification	Model name	Robot Controller
		6kg-Load	
1	Basic model	RH-6SDH4520-S3**	CR2D-761 -S3**/ CR2DA-761 -S3**
2	Short arm model	RH-6SDH3520-S3**	
3	Long arm model	RH-6SDH5520-S3**	
4	Oil mist model	RH-6SDH4517M-S3**	
5	Short arm/Oil mist model	RH-6SDH3517M-S3**	
6	Long arm/Oil mist model	RH-6SDH5517M-S3**	
7	Clean room model (Class 10)	RH-6SDH4517C-S3**	
8	Short arm/Clean room model	RH-6SDH3517C-S3**	
9	Long arm/Clean room model	RH-6SDH5517C-S3**	
10	Oil mist model including R/C	RH-6SDH4517M-SM6**	CR3D-761M -SM6**
11	Short arm/Oil mist model including R/C	RH-6SDH3517M-SM6**	
12	Long arm/Oil mist model including R/C	RH-6SDH5517M-SM6**	
13	UL specification basic model	RH-6SDH4520-SUL3**	CR2D-761 -SUL3**
14	UL specification short arm model	RH-6SDH3520-SUL3**	
15	UL specification long arm model	RH-6SDH5520-SUL3**	
16	UL specification oil mist model	RH-6SDH4517M-SUL3**	
17	UL specification short arm/Oil mist model	RH-6SDH3517M-SUL3**	
18	UL specification long arm/Oil mist model	RH-6SDH5517M-SUL3**	
19	UL specification clean room model (Class 10)	RH-6SDH4517C-SUL3**	
20	UL specification short arm/Clean room model	RH-6SDH3517C-SUL3**	
21	UL specification long arm/Clean room model	RH-6SDH5517C-SUL3**	
22	UL specification oil mist model including R/C	RH-6SDH4517M-SULM6**	CR3D-761M -SULM6**
23	UL specification short arm/Oil mist model including R/C	RH-6SDH3517M-SULM6**	
24	UL specification long arm/Oil mist model including R/C	RH-6SDH5517M-SULM6**	

Table 8 : The list of RH-xSDH robots for grouping certification; D group-2.

No.	Classification	Model name	Robot Controller
		6kg-Load	
25	Basic model	RH-6SDH4520-S**	CR1DA-761 -S**
26	Short arm model	RH-6SDH3520-S**	
27	Long arm model	RH-6SDH5520-S**	
28	Oil mist model	RH-6SDH4517M-S**	
29	Short arm/Oil mist model	RH-6SDH3517M-S**	
30	Long arm/Oil mist model	RH-6SDH5517M-S**	
31	Clean room model (Class 10)	RH-6SDH4517C-S**	
32	Short arm/Clean room model	RH-6SDH3517C-S**	
33	Long arm/Clean room model	RH-6SDH5517C-S**	

Table 9 : The list of RH-xSDH robots for grouping certification; D group -3.

No.	Classification	Model name	Robot Controller
		12/18kg-Load	
34	Basic model	RH-12SDH7035(-S**)	CR2D-741(-S**)/ CR2DA-741(-S**)
35	Short arm model	RH-12SDH5535(-S**)	
36	Long arm model	RH-12SDH8535(-S**)	
37	Long arm and heavy load model	RH-18SDH8535(-S**)	CR2D-751(-S**)/ CR2DA-751(-S**)
38	Oil mist model	RH-12SDH7030M(-S**)	CR2D-741(-S**)/ CR2DA-741(-S**)
39	Short arm/Oil mist model	RH-12SDH5530M(-S**)	
40	Long arm/Oil mist model	RH-12SDH8530M(-S**)	
41	Long arm and heavy load/Oil mist model	RH-18SDH8530M(-S**)	CR2D-751(-S**)/ CR2DA-751(-S**)
42	Clean room model (Class 10)	RH-12SDH7030C(-S**)	CR2D-741(-S**)/ CR2DA-741(-S**)
43	Short arm/Clean room model	RH-12SDH5530C(-S**)	
44	Long arm/Clean room model	RH-12SDH8530C(-S**)	
45	Long arm and heavy load/Clean room model (Class 10)	RH-18SDH8530C(-S**)	CR2D-751(-S**)/ CR2DA-751(-S**)
46	Oil mist model including R/C	RH-12SDH7030M-SM6**	CR3D-741M -SM6**
47	Short arm/Oil mist model including R/C	RH-12SDH5530M-SM6**	
48	Long arm/Oil mist model including R/C	RH-12SDH8530M-SM6**	
49	Long arm and heavy load/Oil mist model including R/C	RH-18SDH8530M-SM6**	CR3D-751M -SM6**
50	UL specification basic model	RH-12SDH7035-SUL**	CR2D-741-SUL**
51	UL specification short arm model	RH-12SDH5535-SUL**	
52	UL specification long arm model	RH-12SDH8535-SUL**	
53	UL specification long arm and heavy load model	RH-18SDH8535-SUL**	CR2D-751-SUL**
54	UL specification oil mist model	RH-12SDH7030M-SUL**	CR2D-741-SUL**
55	UL specification short arm/Oil mist model	RH-12SDH5530M-SUL**	
56	UL specification long arm/Oil mist model	RH-12SDH8530M-SUL**	
57	UL specification long arm and heavy load/Oil mist model	RH-18SDH8530M-SUL**	CR2D-751-SUL**
58	UL specification clean room model (Class 10)	RH-12SDH7030C-SUL**	CR2D-741-SUL**
59	UL specification short arm/Clean room model	RH-12SDH5530C-SUL**	
60	UL specification long arm/Clean room model	RH-12SDH8530C-SUL**	
61	UL specification long arm and heavy load/Clean room model (Class 10)	RH-18SDH8530C-SUL**	CR2D-751-SUL**
62	UL specification oil mist model including R/C	RH-12SDH7030M -SULM6**	CR3D-741M -SULM6**
63	UL specification short arm/Oil mist model including R/C	RH-12SDH5530M -SULM6**	
64	UL specification long arm/Oil mist model including R/C	RH-12SDH8530M -SULM6**	
65	UL specification long arm and heavy load/Oil mist model including R/C	RH-18SDH8530M -SULM6**	CR3D-751M -SULM6**

Table 10 : The list of robots for grouping certification; D group -4 .

No.	Classification	Model name	Robot Controller
		6kg-Load	
66	Z-Stroke variation , Basic model	RH-6SDH4532(-S**)	CR1DA-761 (-S**)
67	Z-Stroke variation , Short arm model	RH-6SDH3532(-S**)	
68	Z-Stroke variation , Long arm model	RH-6SDH5532(-S**)	
69	Z-Stroke variation , Oil mist model	RH-6SDH4527M(-S**)	
70	Z-Stroke variation , Short arm/Oil mist model	RH-6SDH3527M(-S**)	
71	Z-Stroke variation , Long arm/Oil mist model	RH-6SDH5527M(-S**)	
72	Z-Stroke variation , Clean room model (Class 10)	RH-6SDH4527C(-S**)	
73	Z-Stroke variation , Short arm/Clean room model	RH-6SDH3527C(-S**)	
74	Z-Stroke variation , Long arm/Clean room model	RH-6SDH5527C(-S**)	

RV-3SD is the test models.

Table 11 : The list of robots for grouping certification; D group-5.

No.	Classification	Model name	Robot Controller
		6kg-Load	
75	Z-Stroke variation ,Basic model	RH-6SDH4532-S3**	CR2DA-761 -S3**
76	Z-Stroke variation , Short arm model	RH-6SDH3532-S3**	
77	Z-Stroke variation , Long arm model	RH-6SDH5532-S3**	
78	Z-Stroke variation , Oil mist model	RH-6SDH4527M-S3**	
79	Z-Stroke variation , Short arm/Oil mist model	RH-6SDH3527M-S3**	
80	Z-Stroke variation , Long arm/Oil mist model	RH-6SDH5527M-S3**	
81	Z-Stroke variation , Clean room model (Class 10)	RH-6SDH4527C-S3**	
82	Z-Stroke variation , Short arm / Clean room model	RH-6SDH3527C-S3**	
83	Z-Stroke variation , Long arm / Clean room model	RH-6SDH5527C-S3**	
84	Z-Stroke variation , Oil mist model including R/C	RH-6SDH4527M-SM6**	CR3D-761M -SM6**
85	Z-Stroke variation , Short arm/Oil mist model including R/C	RH-6SDH3527M-SM6**	
86	Z-Stroke variation , Long arm/Oil mist model including R/C	RH-6SDH5527M-SM6**	
87	Z-Stroke variation , UL specification basic model	RH-6SDH4532-SUL3**	CR2D-761 -SUL3**
88	Z-Stroke variation , UL specification short arm model	RH-6SDH3532-SUL3**	
89	Z-Stroke variation , UL specification long arm model	RH-6SDH5532-SUL3**	
90	Z-Stroke variation , UL specification oil mist model	RH-6SDH4527M-SUL3**	
91	Z-Stroke variation , UL specification short arm /Oil mist model	RH-6SDH3527M-SUL3**	
92	Z-Stroke variation , UL specification long arm /Oil mist model	RH-6SDH5527M-SUL3**	
93	Z-Stroke variation , UL specification clean room model (Class 10)	RH-6SDH4527C-SUL3**	
94	Z-Stroke variation , UL specification short arm /Clean room model	RH-6SDH3527C-SUL3**	
95	Z-Stroke variation , UL specification long arm /Clean room model	RH-6SDH5527C-SUL3**	
96	Z-Stroke variation , UL specification oil mist model including R/C	RH-6SDH4527M-SULM6**	CR3D-761M -SULM6**
97	Z-Stroke variation , UL specification short arm /Oil mist model including R/C	RH-6SDH3527M-SULM6**	
98	Z-Stroke variation , UL specification long arm /Oil mist model including R/C	RH-6SDH5527M-SULM6**	

RV-12SDL-SUL** and **RV-6SDL-SUL**** are the tested models.

Table 12 : The list of RH-xSDH robots for grouping certification; D group -6.

No.	Classification	Model name	Robot Controller
		12/18kg-Load	
99	Z-Stroke variation , Basic model	RH-12SDH7045(-S**)	CR2DA-741(-S**)
100	Z-Stroke variation , Short arm model	RH-12SDH5545(-S**)	
101	Z-Stroke variation , Long arm model	RH-12SDH8545(-S**)	
102	Z-Stroke variation , Oil mist model	RH-12SDH7038M(-S**)	
103	Z-Stroke variation , Short arm/Oil mist model	RH-12SDH5538M(-S**)	
104	Z-Stroke variation , Long arm/Oil mist model	RH-12SDH8538M(-S**)	
105	Z-Stroke variation , Clean room model (Class 10)	RH-12SDH7038C(-S**)	
106	Z-Stroke variation , Short arm/Clean room model	RH-12SDH5538C(-S**)	
107	Z-Stroke variation , Long arm/Clean room model	RH-12SDH8538C(-S**)	
108	Z-Stroke variation , Oil mist model including R/C	RH-12SDH7038M-SM6**	CR3D-741M -SM6**
109	Z-Stroke variation , Short arm/Oil mist model including R/C	RH-12SDH5538M-SM6**	
110	Z-Stroke variation , Long arm/Oil mist model including R/C	RH-12SDH8538M-SM6**	
111	Z-Stroke variation , UL specification basic model	RH-12SDH7045-SUL**	CR2D-741-SUL**
112	Z-Stroke variation , UL specification short arm model	RH-12SDH5545-SUL**	
113	Z-Stroke variation , UL specification long arm model	RH-12SDH8545-SUL**	
114	Z-Stroke variation , UL specification oil mist model	RH-12SDH7038M-SUL**	
115	Z-Stroke variation , UL specification short arm /Oil mist model	RH-12SDH5538M-SUL**	
116	Z-Stroke variation , UL specification long arm/Oil mist model	RH-12SDH8538M-SUL**	
117	Z-Stroke variation , UL specification clean room model (Class 10)	RH-12SDH7038C-SUL**	
118	Z-Stroke variation , UL specification short arm /Clean room model	RH-12SDH5538C-SUL**	
119	Z-Stroke variation , UL specification long arm/Clean room model	RH-12SDH8538C-SUL**	
120	Z-Stroke variation , UL specification oil mist model including R/C	RH-12SDH7038M -SULM6**	CR3D-741M -SULM6**
121	Z-Stroke variation , UL specification short arm /Oil mist model including R/C	RH-12SDH5538M -SULM6**	
122	Z-Stroke variation , UL specification long arm/Oil mist model including R/C	RH-12SDH8538M -SULM6**	

Table 13 : The list of RH-xSDH robots for grouping certification; D group -7.

No.	Classification	Model name	Robot Controller
		20kg-Load	
123	Heavy load variation , Basic model	RH-20SDH8545 (-S**)	CR2DA-751(-S**)
124	Heavy load variation , Short Z-Stroke model	RH-20SDH8535(-S**)	
125	Heavy load variation , Long arm model	RH-20SDH10045(-S**)	
126	Heavy load variation , Long arm and Short Z-Stroke model	RH-20SDH10035(-S**)	
127	Heavy load variation / Oil mist model	RH-20SDH8538M(-S**)	
128	Heavy load variation , Short Z-Stroke /Oil mist model	RH-20SDH8530M(-S**)	
129	Heavy load variation , Long Arm /Oil mist model	RH-20SDH10038M(-S**)	
130	Heavy load variation , Long arm and Short Z-Stroke /Oil mist model	RH-20SDH10030M(-S**)	
131	Heavy load variation /Clean room model	RH-20SDH8538C(-S**)	
132	Heavy load variation , Short Z-Stroke /Clean room model	RH-20SDH8530C(-S**)	
133	Heavy load variation, Long arm /Clean room model	RH-20SDH10038C(-S**)	
134	Heavy load variation , Long arm and Short Z-Stroke /Clean room model	RH-20SDH10030C(-S**)	
135	Heavy load variation / Oil mist model including R/C	RH-20SDH8538M-SM6**	
136	Heavy load variation , Short Z-Stroke /Oil mist model including R/C	RH-20SDH8530M-SM6**	
137	Heavy load variation , Long Arm /Oil mist model including R/C	RH-20SDH10038M-SM6**	
138	Heavy load variation , Long arm and Short Z-Stroke /Oil mist model including R/C	RH-20SDH10030M-SM6**	
139	Heavy load variation , Basic model	RH-20SDH8545 -SUL**	CR2D-751 -SUL**
140	Heavy load variation , Short Z-Stroke model	RH-20SDH8535-SUL**	
141	Heavy load variation , Long arm model	RH-20SDH10045-SUL**	
142	Heavy load variation , Long arm and Short Z-Stroke model	RH-20SDH10035-SUL**	
143	Heavy load variation / Oil mist model	RH-20SDH8538M-SUL**	
144	Heavy load variation , Short Z-Stroke /Oil mist model	RH-20SDH8530M-SUL**	
145	Heavy load variation , Long Arm /Oil mist model	RH-20SDH10038M-SUL**	
146	Heavy load variation , Long arm and Short Z-Stroke /Oil mist model	RH-20SDH10030M-SUL**	
147	Heavy load variation /Clean room model	RH-20SDH8538C-SUL**	
148	Heavy load variation , Short Z-Stroke /Clean room model	RH-20SDH8530C-SUL**	
149	Heavy load variation, Long arm /Clean room model	RH-20SDH10038C-SUL**	
150	Heavy load variation , Long arm and Short Z-Stroke /Clean room model	RH-20SDH10030C-SUL**	
151	Heavy load variation / Oil mist model including R/C	RH-20SDH8538M-SULM6**	CR3D-751M -SULM6**
152	Heavy load variation , Short Z-Stroke /Oil mist model including R/C	RH-20SDH8530M-SULM6**	
153	Heavy load variation , Long Arm /Oil mist model including R/C	RH-20SDH10038M-SULM6**	
154	Heavy load variation , Long arm and Short Z-Stroke /Oil mist model including R/C	RH-20SDH10030M-SULM6**	

Table 14 : The list of RV-2SD robots for grouping certification; E group.

No.	Classification	Model name	Robot Controller
		6-axis	
1	Basic model (standard) ^{*1}	RV-2SD(-S**)	CR1DA-771(-S**) CR1DA-772(-S**)
2	Basic model with brakes on all axis	RV-2SDB(-S**)	
3	Special machine cable model ^{*1}	RV-2SD-S12	CR1DA-771-S12 CR1DA-772-S12
4	Special machine cable model with brakes on all axis	RV-2SDB-S12	

Table 15 : The list of RH-3SDHR series robots for grouping certification; F group -1.

No.	Classification	Model name	Robot Controller
		4-axis	
1	Basic model	RH-3SDHR3515W(-S**)	CR2DA-781(-S**)
2	Special machine cable model	RH-3SDHR3515N (-S**)	CR1DA-781(-S**)
3	Oil mist model	RH-3SDHR3512MW (-S**)	CR2DA-781(-S**)
4	Oil mist model including R/C	RH-3SDHR3512MW -SM6**	CR3D-781M-SM6**
5	Long arm model	RH-3SDHR5515W(-S**)	CR2DA-781(-S**)
6	Special machine cable model, Long arm type	RH-3SDHR5515N (-S**)	CR1DA-781(-S**)
7	Oil mist model , Long arm type	RH-3SDHR5512MW (-S**)	CR2DA-781(-S**)
8	Oil mist model including R/C, Long arm type	RH-3SDHR5512MW -SM6**	CR3D-781M-SM6**
9	UL specific type	RH-3SDHR3515W-SUL**	CR2DA-781-SUL**
10	Oil mist model, UL specific type	RH-3SDHR3512MW-SUL**	CR2DA-781(-S**)
11	Oil mist model including R/C, UL specific model	RH-3SDHR3512MW -SULM6**	CR3D-781M-SULM6**
12	Long arm model , UL specific type	RH-3SDHR5515W-SUL**	CR2DA-781-SUL**
13	Oil mist model , Long arm and UL specific type	RH-3SDHR5512MW -SUL**	CR2DA-781-SUL**
14	Oil mist model including R/C, Long arm and UL specific type	RH-3SDHR5512MW -SULM6**	CR3D-781M-SULM6**
15	Basic model, regular type	RH-3SDHR3515(-S**)	CR2DA-781(-S**)
16	Oil mist model , regular type	RH-3SDHR3512M (-S**)	CR2DA-781(-S**)
17	Oil mist model including R/C, regular type	RH-3SDHR3512M -SM6**	CR3D-781M-SM6**
18	Long arm model, regular type	RH-3SDHR5515(-S**)	CR2DA-781(-S**)
19	Oil mist model , Long arm type, regular type	RH-3SDHR5512M (-S**)	CR2DA-781(-S**)
20	Oil mist model including R/C, Long arm type regular type	RH-3SDHR5512M -SM6**	CR3D-781M-SM6**
21	UL specific type, regular type	RH-3SDHR3515-SUL**	CR2DA-781-SUL**
22	Oil mist model, UL specific type regular type	RH-3SDHR3512M-SUL**	CR2DA-781(-S**)
23	Oil mist model including R/C,UL specific model regular type	RH-3SDHR3512M-SULM6**	CR3D-781M-SULM6**
24	Long arm model ,UL specific type	RH-3SDHR5515-SUL**	CR2DA-781-SUL**
25	Oil mist model , Long arm and UL specific type regular type	RH-3SDHR5512M-SUL**	CR2DA-781-SUL**
26	Oil mist model including R/C, Long arm and UL specific type regular type	RH-3SDHR5512M-SULM6**	CR3D-781M-SULM6**
27	Water proof model , regular type	RH-3SDHR3512W (-S**)	CR2DA-781(-S**)
28	Clean room model (ISO Class 5), regular type	RH-3SDHR3512C (-S**)	CR2DA-781(-S**)
29	Water proof model including R/C, regular type	RH-3SDHR3512W -SM6**	CR3D-781M-SM6**

Table 16 : The list of RH-3SDHR series robots for grouping certification; F group -2.

No.	Classification	Model name	Robot Controller
		4-axis	
30	Water proof model, UL specific type regular type	RH-3SDHR3512W -SUL**	CR2DA-781-SUL**
31	Clean room model (ISO Class 5), UL specific type regular type	RH-3SDHR3512C-SUL**	CR2DA-781-SUL**
32	Water proof model including R/C,UL specific model regular type	RH-3SDHR3512W-SULM6**	CR3D-781M-SULM6**
33	Water proof model , Long arm type, regular type	RH-3SDHR5512W (-S**)	CR2DA-781(-S**)
34	Clean room model (ISO Class 5), Long arm type, regular type	RH-3SDHR5512C (-S**)	CR2DA-781(-S**)
35	Water proof model including R/C, Long arm type, regular type	RH-3SDHR5512W -SM6**	CR3D-781M-SM6**
36	Water proof model, Long arm and UL specific type regular type	RH-3SDHR5512W -SUL**	CR2DA-781-SUL**
37	Clean room model (ISO Class 5), Long arm and UL specific type regular type	RH-3SDHR5512C-SUL**	CR2DA-781-SUL**
38	Water proof model including R/C, Long arm and UL specific model regular type	RH-3SDHR5512W-SULM6**	CR3D-781M-SULM6**

Table 17 : The list of RP-1ADH series robots for grouping certification;G group.

No.	Classification	Model name	Robot Controller
		4-axis	
1	Basic model	RP-1ADH (-S**)	CR1DA-7A1(-S**)
2	Basic model,3kg load type	RP-3ADH (-S**)	CR1DA-7A1(-S**)
3	Basic model,5kg load type	RP-5ADH (-S**)	CR1DA-7A1(-S**)
4	Clean room model	RP-1ADHC(-S**)	CR1DA-7A1(-S**)
5	Clean room model,3kg load type	RP-3ADHC (-S**)	CR1DA-7A1(-S**)
6	Clean room model,5kg load type	RP-5ADHC (-S**)	CR1DA-7A1(-S**)
7	Water proof model	RP-1ADHW (-S**)	CR1DA-7A1(-S**)
8	Water proof model, 3kg load type	RP-3ADHW (-S**)	CR1DA-7A1(-S**)
9	Water proof model, 5kg load type	RP-5ADHW (-S**)	CR1DA-7A1(-S**)
10	Long arm model	RP-1ADHL (-S**)	CR1DA-7A1(-S**)
11	Long arm model / Clean room	RP-1ADHLC (-S**)	CR1DA-7A1(-S**)
12	Long arm model / Water proof	RP-1ADHLW (-S**)	CR1DA-7A1(-S**)

Revision history

Date	Specifications No.	Details of revisions	Rev.
September 22, 2008		First print	*
April 7,2009	P1 P3 Table.1	<Authorized representative in Europe> Change to "Mitsubishi Electric Europe B.V" <Machinery Directive> Added "EN954-1:1996" RV-18SD,RV-18SDC,RV-18SD-SUL,RV-18SDC-SUL added.	A
October 13,2009	P1	Standards update(2006/42/EC)	B
March 15,2010	P7	Added RV-2SDseries	C
May 11, 2010	P4,P5 P6	Added RV-3SD-Sxx series Added RH-6SDH-Sxx series	D
July 2, 2010	P3 Table 1 From P3 to P7	Added RV-12SD-S3xx series Added CR2DA-7xx controller	E
September 3,2010	From P8 to P11	Added RH-xSH series to arm length, Z-Stroke length, and heavy load models	F
October 1,2010	P12	Added RH-3SDHR series	G
November 9, 2010	P13	Added variation models("regular type") to RH-3SDHR series	H
January 26,2012	P1	Changed ISO10218-1 from 2006 version to 2011 version	J
February 20, 2012.	P13,14	Added variation models(No.27 to 38) to RH-3SDHR series	K
June 14, 2012	P14	Added RP-1ADH series	L

사용자안내문 User's Guide

기종별 Type of Equipment	사용자안내문 User's Guide
<p>A 급 기기 (업무용 방송통신기자재)</p> <p>Class A Equipment (Industrial Broadcasting & Communication Equipment)</p>	<p>이 기기는 업무용(A 급) 전자파적합기기로서 판매자 또는 사용자는 이 점을 주의하시기 바라며, 가정외의 지역에서 사용하는 것을 목적으로 합니다.</p> <p>This equipment is Industrial (Class A) electromagnetic wave suitability equipment and seller or user should take notice of it, and this equipment is to be used in the places except for home.</p>
<p>B 급 기기 (가정용 방송통신기자재)</p> <p>Class B Equipment (For Home Use Broadcasting & Communication Equipment)</p>	<p>이 기기는 가정용(B 급) 전자파적합기기로서 주로 가정에서 사용하는 것을 목적으로 하며, 모든 지역에서 사용할 수 있습니다.</p> <p>This equipment is home use (Class B) electromagnetic wave suitability equipment and to be used mainly at home and it can be used in all areas.</p>



Authorised representative:

MITSUBISHI ELECTRIC EUROPE B.V. GERMANY

Gothaer Str. 8, 40880 Ratingen / P.O. Box 1548, 40835 Ratingen, Germany