

**mitsubishi**  
**Mitsubishi Industrial Robot**

**RV-12S Series    INSTRUCTION MANUAL**  
**ROBOT ARM SETUP & MAINTENANCE**



# Supplemental Instruction

Thank you for purchasing the Mitsubishi Industrial Robot MELFA Series.

This document additionally explains about the service parts of Mitsubishi Industrial Robot "RV-6S/6SL, and RV-12S / 12SL series". Therefore, check the content, and use it together with your instruction manual.

## 1. Supplementary details

Resin stopper is installed in the J1 axis – the J3 axis. This is absorbing the energy when colliding with mechanical stopper by the incorrect setup of the origin etc. Please exchange, if the collision to mechanical stopper occurs and resin stopper is changed or damaged.

The resin stopper's shape, color, and fixing screw are change with the robot's manufacture periods. About resin stopper, either the cream-colored "resin stopper" or the gray "resin stopper A" is used. If you gets as service parts, please be sure to get the same thing as the resin stopper which is using it, and to use it.

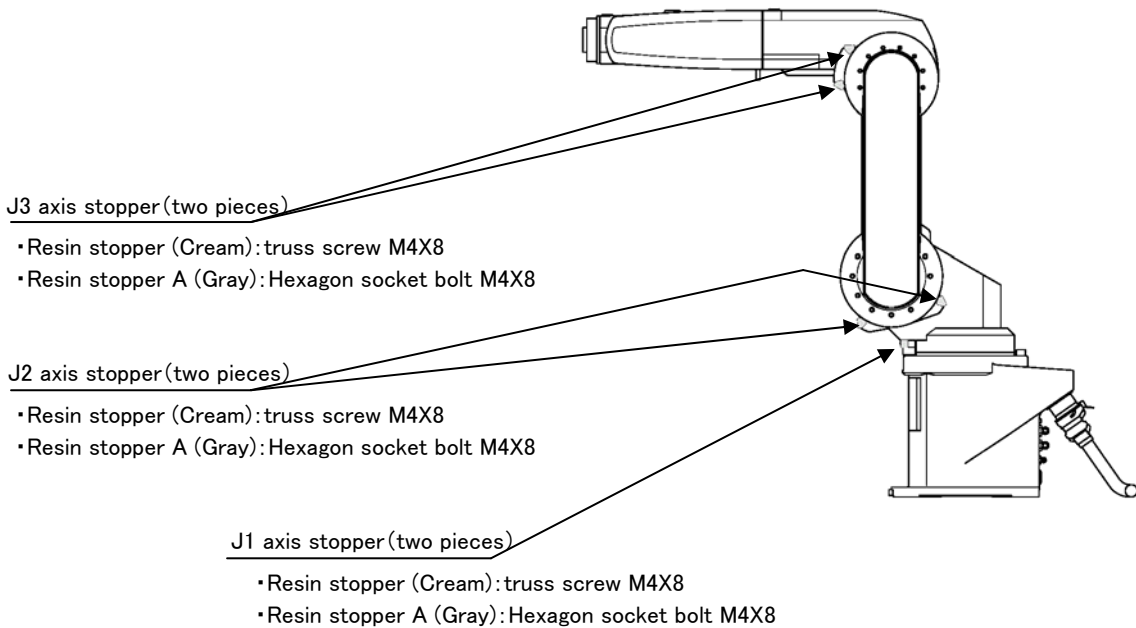

Table 1: Robot arm spare-parts list (A supplemented part)

No	Name	Type	Application part	Quantity	Purchase place
1	Resin stopper (Cream)	—	J1 to J3 axis	2 / axis	Dealer
2	Resin stopper A (Gray)	—	J1 to J3 axis	2/ axis	

Note) Please specify the color at order.

## Supplemental Instruction

Thank you for purchasing the Mitsubishi Industrial Robot MELFA Series.

This document additionally explains to the Mitsubishi Industrial Robot "RV-12S Series INSTRUVTION MANUAL (BFP-A8321)".

Therefore, check the content, and use it together with your instruction manual.

### 1. Outline

When lubricating, removal of the drain bolt or the cap is unnecessary.

The robot which is the target of these supplementary contents is shown below.

No.	Target products	The discrimination method
1	Produced in September, 2006 and afterwards.	The DATE columns of the rated plate of the robot arm are all the robots after '2006-09'.
2	Produced before August, 2006.	The robot by which the blue round sticker is stuck on the rated plate of the robot arm.

### 2. Correction of the lubrication port

#### Revision place

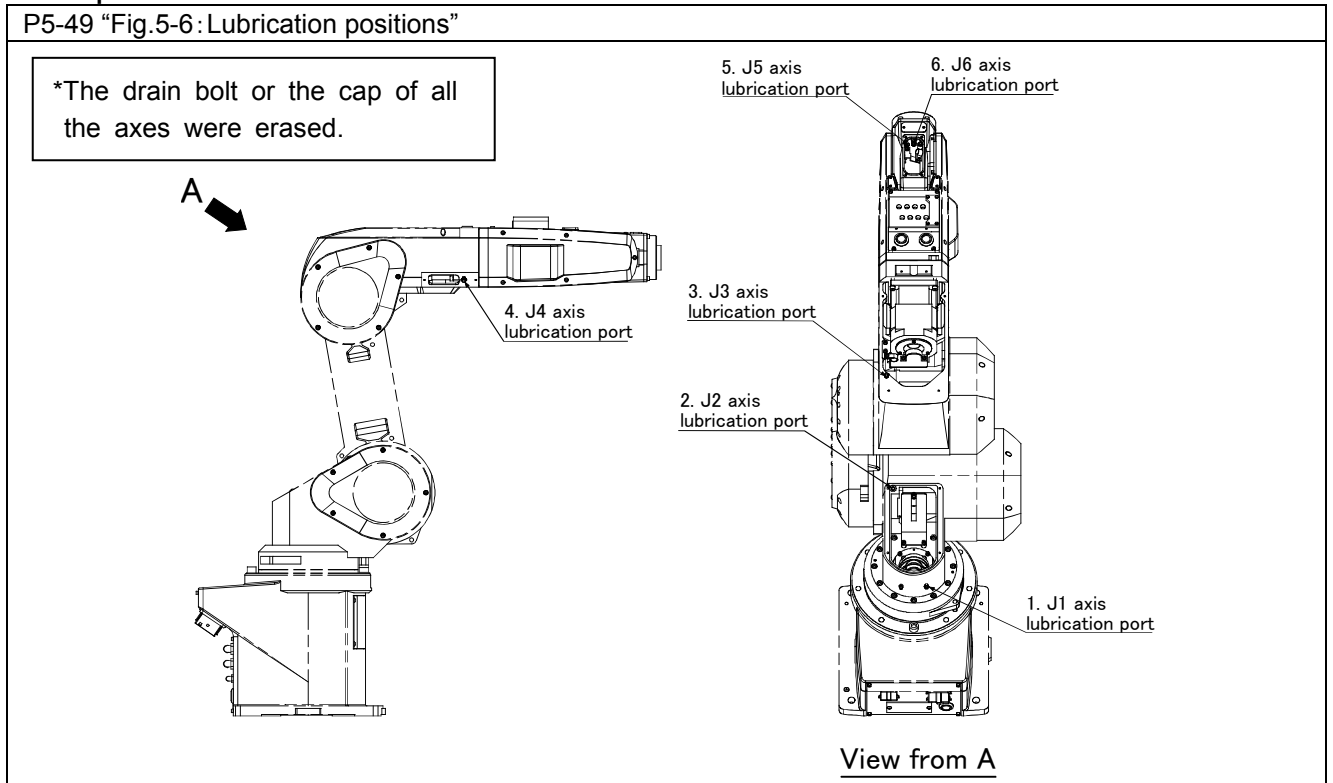

### 3. Change of the lubrication method and notes

#### Details of change and supplement

A procedure and precautions applicable to the products affected by the change were added to "(2) Lubrication method" on P5-50. The procedure applicable to the products affected by the change is described below. When lubricating all other products, follow the original procedure specified in the instruction manual.

#### (1) Lubrication method of products affected by the change

- 1) Set the robot to the posture shown in Fig. 5-6.
- 2) Refer to the "5.3.2 Installing/removing the cover" on page 44 and remove the covers.
- 3) Insert the grease shown in Table 5-5 using a grease gun of manual type from the lubrication grease nipple.
- 4) Replace the covers with the removal procedure in reverse.

#### (2) Precautions for lubrication

Take note of the following points when lubricating all products, regardless of whether or not they are affected by the change.



## CAUTION

Use manual grease gun, and inject grease with pressure 0.03Mpa or less.

Do not use the grease gun, which derived by the factory air presser to avoid injecting by too high pressure.

#### 4. Supplemental note for the installation surface receiving force

##### Supplemental details

Magnitude of each reaction force added to P2-8 “2.2.3 Installation procedures”.

Table 2-2 shows the maximum reaction force (design values) that may be applied to an installation stand. Please use these values as reference when designing the installation stand.

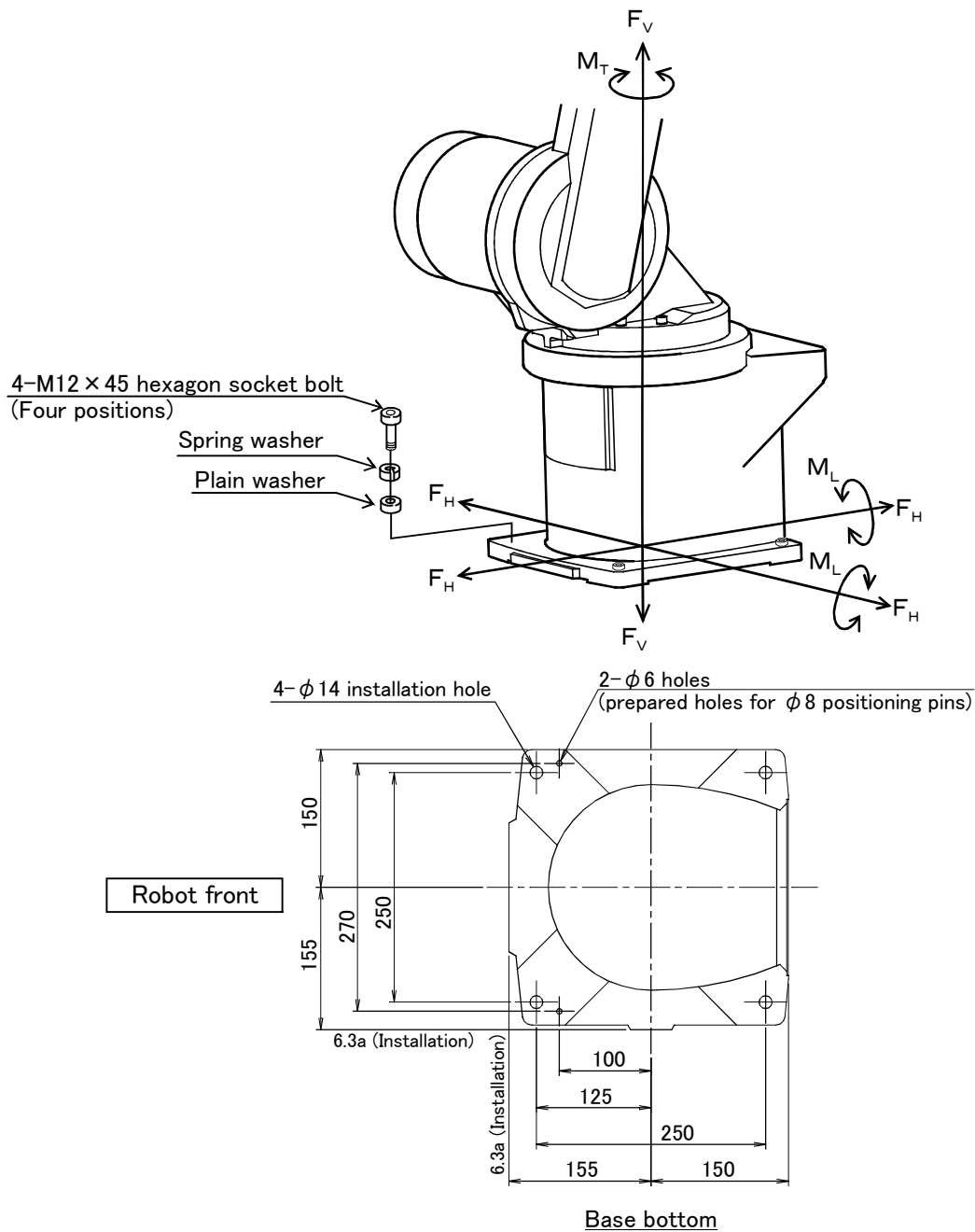

Fig.2-3 : Installation dimensions

Table 2-2: Magnitude of each reaction force

Item	Unit	Value
Tilt moment : $M_L$	N·m	1,530
Torsional moment : $M_T$	N·m	1,530
Horizontal direction translation force : $F_H$	N	1,300
Vertical direction translation force : $F_V$	N	2,300

## **To the User of the Machine Cable Extension Option**

Thank you for purchasing the Mitsubishi Industrial Robot MELFA Series.

This document additionally explains to the Mitsubishi Industrial Robot "RV-12S series INSTRUCTION MANUAL " (BFP-A8321-A).

Therefore, check the content, and use it together with your instruction manual.

### **Supplemental details**

This option, for each of fixed and flexed types, contains a ground cable in addition to a motor signal cable and a motor power cable. Please connect the ground cable when connecting the machine cable extension.

Be sure to securely fasten the connection terminal of the ground cable to the M5 screw underneath the controller panel and the M4 screw at the lower left of the rear surface of the robot arm's base section. If a flexed cable is used, fasten the ground cable together with the nylon clamp (NK-24N) that fastens the motor power cable.

BFP-A8321-A01

## Safety Precautions

Always read the following precautions and the separate "Safety Manual" before starting use of the robot to learn the required measures to be taken.

### CAUTION

All teaching work must be carried out by an operator who has received special training. (This also applies to maintenance work with the power source turned ON.)  
→ Enforcement of safety training

### CAUTION

For teaching work, prepare a work plan related to the methods and procedures of operating the robot, and to the measures to be taken when an error occurs or when restarting. Carry out work following this plan. (This also applies to maintenance work with the power source turned ON.)  
→ Preparation of work plan

### WARNING

Prepare a device that allows operation to be stopped immediately during teaching work. (This also applies to maintenance work with the power source turned ON.)  
→ Setting of emergency stop switch

### CAUTION

During teaching work, place a sign indicating that teaching work is in progress on the start switch, etc. (This also applies to maintenance work with the power source turned ON.)  
→ Indication of teaching work in progress

### WARNING

Provide a fence or enclosure during operation to prevent contact of the operator and robot.  
→ Installation of safety fence

### CAUTION

Establish a set signaling method to the related operators for starting work, and follow this method.  
→ Signaling of operation start

















### CAUTION

As a principle turn the power OFF during maintenance work. Place a sign indicating that maintenance work is in progress on the start switch, etc.  
→ Indication of maintenance work in progress

### CAUTION

Before starting work, inspect the robot, emergency stop switch and other related devices, etc., and confirm that there are no errors.  
→ Inspection before starting work

The points of the precautions given in the separate "Safety Manual" are given below. Refer to the actual "Safety Manual" for details.

-  **CAUTION** Use the robot within the environment given in the specifications. Failure to do so could lead to a drop or reliability or faults. (Temperature, humidity, atmosphere, noise environment, etc.)
-  **CAUTION** Transport the robot with the designated transportation posture. Transporting the robot in a non-designated posture could lead to personal injuries or faults from dropping.
-  **CAUTION** Always use the robot installed on a secure table. Use in an instable posture could lead to positional deviation and vibration.
-  **CAUTION** Wire the cable as far away from noise sources as possible. If placed near a noise source, positional deviation or malfunction could occur.
-  **CAUTION** Do not apply excessive force on the connector or excessively bend the cable. Failure to observe this could lead to contact defects or wire breakage.
-  **CAUTION** Make sure that the workpiece weight, including the hand, does not exceed the rated load or tolerable torque. Exceeding these values could lead to alarms or faults.
-  **WARNING** Securely install the hand and tool, and securely grasp the workpiece. Failure to observe this could lead to personal injuries or damage if the object comes off or flies off during operation.
-  **WARNING** Securely ground the robot and controller. Failure to observe this could lead to malfunctioning by noise or to electric shock accidents.
-  **CAUTION** Indicate the operation state during robot operation. Failure to indicate the state could lead to operators approaching the robot or to incorrect operation.
-  **WARNING** When carrying out teaching work in the robot's movement range, always secure the priority right for the robot control. Failure to observe this could lead to personal injuries or damage if the robot is started with external commands.
-  **CAUTION** Keep the jog speed as low as possible, and always watch the robot. Failure to do so could lead to interference with the workpiece or peripheral devices.
-  **CAUTION** After editing the program, always confirm the operation with step operation before starting automatic operation. Failure to do so could lead to interference with peripheral devices because of programming mistakes, etc.
-  **CAUTION** Make sure that if the safety fence entrance door is opened during automatic operation, the door is locked or that the robot will automatically stop. Failure to do so could lead to personal injuries.
-  **CAUTION** Never carry out modifications based on personal judgments, or use non-designated maintenance parts. Failure to observe this could lead to faults or failures.
-  **WARNING** When the robot arm has to be moved by hand from an external area, do not place hands or fingers in the openings. Failure to observe this could lead to hands or fingers catching depending on the posture.
-  **CAUTION** Do not stop the robot or apply emergency stop by turning the robot controller's main power OFF. If the robot controller main power is turned OFF during automatic operation, the robot accuracy could be adversely affected. Moreover, it may interfere with the peripheral device by drop or move by inertia of the arm.
-  **CAUTION** Do not turn off the main power to the robot controller while rewriting the internal information of the robot controller such as the program or parameters. If the main power to the robot controller is turned off while in automatic operation or rewriting the program or parameters, the internal information of the robot controller may be damaged.



### Revision history

Date of Point	Instruction Manual No.	Revision Details
2003-10-8	BFP-A8321	First print.
2004-05-20	BFP-A8321-A	Installing the hand input/output cable was added. Error in writing correction.
2008-09-01	BFP-A8321-B	Mechanical stopper of spare parts were added.
2009-09-30	BFP-A8321-C	The EC Declaration of Conformity was changed. (Correspond to the EMC directive; 2006/42/EC)

## ■ Introduction

Thank you for purchasing the Mitsubishi industrial robot.

This instruction manual explains procedures to be taken for unpacking, installing, servicing and inspecting the robot arm.

Always read through this manual before starting use to ensure correct usage of the robot.

- No part of this manual may be reproduced by any means or in any form, without prior consent from Mitsubishi.
- The details of this manual are subject to change without notice.
- An effort has been made to make full descriptions in this manual. However, if any discrepancies or unclear points are found, please contact your dealer.
- The information contained in this document has been written to be accurate as much as possible. Please interpret that items not described in this document "cannot be performed." or "alarm may occur".  
Please contact your nearest dealer if you find any doubtful, wrong or skipped point.
- This Instruction Manual is original.

Copyright(C) 2003-2009 MITSUBISHI ELECTRIC CORPORATION

# CONTENTS

Page

1 Before starting use .....	1-1
1.1 Using the instruction manuals .....	1-1
1.1.1 The details of each instruction manuals .....	1-1
1.1.2 Symbols used in instruction manual .....	1-2
1.2 Safety Precautions .....	1-3
1.2.1 Precautions given in the separate Safety Manual .....	1-4
2 Unpacking to Installation .....	2-5
2.1 Confirming the product .....	2-5
2.2 Installation .....	2-6
2.2.1 Unpacking .....	2-6
2.2.2 Transportation procedures (Transporting with a crane) .....	2-7
2.2.3 Installation procedures .....	2-8
2.2.4 Grounding procedures .....	2-9
(1) Grounding methods .....	2-9
(2) Grounding procedures .....	2-9
2.2.5 Connecting with the controller .....	2-10
2.3 Setting the origin .....	2-12
2.3.1 Installing the teaching pendant (T/B) .....	2-12
(1) Installing with the control power OFF .....	2-12
2.3.2 Setting the origin with the origin data input method .....	2-13
(1) Confirming the origin data .....	2-13
(2) Turning ON the control power .....	2-13
(3) Preparing the T/B .....	2-14
(4) Selecting the origin setting method .....	2-15
(5) Inputting the origin data .....	2-16
(6) Installing the shoulder coverB .....	2-17
2.4 Confirming the operation .....	2-18
(1) JOINT jog operation .....	2-21
(2) XYZ jog operation .....	2-23
(3) TOOL jog operation .....	2-25
(4) 3-axis XYZ jog operation .....	2-27
(5) CYLINDER jog operation .....	2-29
3 Installing the option devices .....	3-31
3.1 Installing the solenoid valve set (1S-VD01-01/VD02-01/VD03-01/VD04-01) .....	3-31
3.2 Installing the hand input cable .....	3-34
3.3 Installing the hand output cable .....	3-35
3.4 Changing the operating range .....	3-36
4 Basic operations .....	4-38
5 Maintenance and Inspection .....	5-39
5.1 Maintenance and inspection interval .....	5-39
5.2 Inspection items .....	5-40
5.2.1 Daily inspection items .....	5-40
5.2.2 Periodic inspection .....	5-41
5.3 Maintenance and inspection procedures .....	5-42
5.3.1 Robot arm structure .....	5-42
5.3.2 Installing/removing the cover .....	5-44
5.3.3 Inspection, maintenance and replacement of timing belt .....	5-46
(1) Timing belt replacement period .....	5-46
(2) Inspection, maintenance and replacement of J5-axis timing belt .....	5-47
(3) Timing belt tension .....	5-48
5.3.4 Lubrication .....	5-49
(1) Lubrication position and specifications .....	5-49

(2) Lubrication method .....	5-50
5.3.5 Replacing the backup battery .....	5-51
(1) Replacing the robot arm battery .....	5-51
5.4 Maintenance parts .....	5-52
5.5 Resetting the origin .....	5-53
5.5.1 Jig method .....	5-54
(1) J1 axis origin setting .....	5-55
(2) J2 axis origin setting .....	5-56
(3) J3 axis origin setting .....	5-57
(4) J4 axis origin setting .....	5-58
(5) J5 axis origin setting .....	5-59
(6) J6 axis origin setting .....	5-60
5.5.2 User origin method .....	5-61
5.5.3 ABS origin method .....	5-63
5.5.4 Recording the origin data .....	5-65
(1) Confirming the origin data label .....	5-65
(2) Confirming the origin data .....	5-65
(3) Recording the origin data .....	5-65
(4) Installing the cover .....	5-65
6Appendix .....	Appendix-66
Appendix 1 : Configuration flag .....	Appendix-66

## 1 Before starting use

This chapter explains the details and usage methods of the instruction manuals, the basic terminology and the safety precautions.

### 1.1 Using the instruction manuals

#### 1.1.1 The details of each instruction manuals

The contents and purposes of the documents enclosed with this product are shown below. Use these documents according to the application.



For special specifications, a separate instruction manual describing the special section may be enclosed.

Safety Manual	Explains the common precautions and safety measures to be taken for robot handling, system design and manufacture to ensure safety of the operators involved with the robot.
Standard Specifications	Explains the product's standard specifications, factory-set special specifications, option configuration and maintenance parts, etc. Precautions for safety and technology, when incorporating the robot, are also explained.
Robot Arm Setup & Maintenance	Explains the procedures required to operate the robot arm (unpacking, transportation, installation, confirmation of operation), and the maintenance and inspection procedures.
Controller Setup, Basic Operation and Maintenance	Explains the procedures required to operate the controller (unpacking, transportation, installation, confirmation of operation), basic operation from creating the program to automatic operation, and the maintenance and inspection procedures.
Detailed Explanation of Functions and Operations	Explains details on the functions and operations such as each function and operation, commands used in the program, connection with the external input/output device, and parameters, etc.
Troubleshooting	Explains the causes and remedies to be taken when an error occurs. Explanations are given for each error No.

1.1.2 Symbols used in instruction manual









The symbols and expressions shown in Table 1-1 are used throughout this instruction manual. Learn the meaning of these symbols before reading this instruction manual.

Table 1-1 : Symbols in instruction manual

Symbol	Meaning
 <b>DANGER</b>	Precaution indicating cases where there is a risk of operator fatality or serious injury if handling is mistaken. Always observe these precautions to safely use the robot.
 <b>WARNING</b>	Precaution indicating cases where the operator could be subject to fatalities or serious injuries if handling is mistaken. Always observe these precautions to safely use the robot.
 <b>CAUTION</b>	Precaution indicating cases where operator could be subject to injury or physical damage could occur if handling is mistaken. Always observe these precautions to safely use the robot.
[ JOINT ]	If a word is enclosed in brackets or a box in the text, this refers to a key on the teaching pendant.
[ + / FORWD ] + [ + X ] (A) (B)	This indicates to press the (B) key while holding down the (A) key. In this example, the [+ / Forward] key is pressed while holding down the [+X / +Y] key.
[ STEP / MOVE ] + ([ COND ] → [ RPL ↓ ] ) (A) (B) (C)	This indicates to hold down the (A) key, press and release the (B) key, and then press the (C) key. In this example, the [Step / Move] key is held down, the [Condition] key is pressed and released, and the [Replace ↓] key is pressed.
T / B	This indicates the teaching pendant.

















## 1.2 Safety Precautions

Always read the following precautions and the separate "Safety Manual" before starting use of the robot to learn the required measures to be taken.

-  **CAUTION** All teaching work must be carried out by an operator who has received special training. (This also applies to maintenance work with the power source turned ON.)  
→ Enforcement of safety training
-  **CAUTION** For teaching work, prepare a work plan related to the methods and procedures of operating the robot, and to the measures to be taken when an error occurs or when restarting. Carry out work following this plan. (This also applies to maintenance work with the power source turned ON.)  
→ Preparation of work plan
-  **WARNING** Prepare a device that allows operation to be stopped immediately during teaching work. (This also applies to maintenance work with the power source turned ON.)  
→ Setting of emergency stop switch
-  **CAUTION** During teaching work, place a sign indicating that teaching work is in progress on the start switch, etc. (This also applies to maintenance work with the power source turned ON.)  
→ Indication of teaching work in progress
-  **DANGER** Provide a fence or enclosure during operation to prevent contact of the operator and robot.  
→ Installation of safety fence
-  **CAUTION** Establish a set signaling method to the related operators for starting work, and follow this method.  
→ Signaling of operation start
-  **CAUTION** As a principle turn the power OFF during maintenance work. Place a sign indicating that maintenance work is in progress on the start switch, etc.  
→ Indication of maintenance work in progress
-  **CAUTION** Before starting work, inspect the robot, emergency stop switch and other related devices, etc., and confirm that there are no errors.  
→ Inspection before starting work

### 1.2.1 Precautions given in the separate Safety Manual

The points of the precautions given in the separate "Safety Manual" are given below.  
Refer to the actual "Safety Manual" for details.

-  **CAUTION** Use the robot within the environment given in the specifications. Failure to do so could lead to a drop or reliability or faults. (Temperature, humidity, atmosphere, noise environment, etc.)
-  **CAUTION** Transport the robot with the designated transportation posture. Transporting the robot in a non-designated posture could lead to personal injuries or faults from dropping.
-  **CAUTION** Always use the robot installed on a secure table. Use in an instable posture could lead to positional deviation and vibration.
-  **CAUTION** Wire the cable as far away from noise sources as possible. If placed near a noise source, positional deviation or malfunction could occur.
-  **CAUTION** Do not apply excessive force on the connector or excessively bend the cable. Failure to observe this could lead to contact defects or wire breakage.
-  **CAUTION** Make sure that the workpiece weight, including the hand, does not exceed the rated load or tolerable torque. Exceeding these values could lead to alarms or faults.
-  **WARNING** Securely install the hand and tool, and securely grasp the workpiece. Failure to observe this could lead to personal injuries or damage if the object comes off or flies off during operation.
-  **WARNING** Securely ground the robot and controller. Failure to observe this could lead to malfunctioning by noise or to electric shock accidents.
-  **CAUTION** Indicate the operation state during robot operation. Failure to indicate the state could lead to operators approaching the robot or to incorrect operation.
-  **WARNING** When carrying out teaching work in the robot's movement range, always secure the priority right for the robot control. Failure to observe this could lead to personal injuries or damage if the robot is started with external commands.
-  **CAUTION** Keep the jog speed as low as possible, and always watch the robot. Failure to do so could lead to interference with the workpiece or peripheral devices.
-  **CAUTION** After editing the program, always confirm the operation with step operation before starting automatic operation. Failure to do so could lead to interference with peripheral devices because of programming mistakes, etc.
-  **CAUTION** Make sure that if the safety fence entrance door is opened during automatic operation, the door is locked or that the robot will automatically stop. Failure to do so could lead to personal injuries.
-  **CAUTION** Never carry out modifications based on personal judgments, or use non-designated maintenance parts.  
Failure to observe this could lead to faults or failures.
-  **WARNING** When the robot arm has to be moved by hand from an external area, do not place hands or fingers in the openings. Failure to observe this could lead to hands or fingers catching depending on the posture.
-  **CAUTION** Do not stop the robot or apply emergency stop by turning the robot controller's main power OFF.  
If the robot controller main power is turned OFF during automatic operation, the robot accuracy could be adversely affected.
-  **CAUTION** Do not turn off the main power to the robot controller while rewriting the internal information of the robot controller such as the program or parameters.  
If the main power to the robot controller is turned off while in automatic operation or rewriting the program or parameters, the internal information of the robot controller may be damaged.



## 2 Unpacking to Installation

### 2.1 Confirming the product

The standard configuration of the robot arm, part of the purchased product, is shown in [Table 2-1](#).

Confirm the parts.

Users who have purchased optional products should refer to the separate "Standard Specifications".

Table 2-1 : Standard configuration

No.	Part name	Type	Qty.	Remarks
1	Robot arm	RV-12S series	1 unit	
2	Guarantee card		1 copy	
3	Installation bolts	M12x40	4 pcs.	
4	Spring washer for installation bolts	For M12	4 pcs.	
5	Plain washer for installation bolts	For M12	4 pcs.	
6	Suspension fitting		2 pcs.	
7	Suspension fitting installation bolt	M12x18	4 pcs.	
8	Eye bolt	M10	4 pcs.	

## 2.2 Installation

### 2.2.1 Unpacking

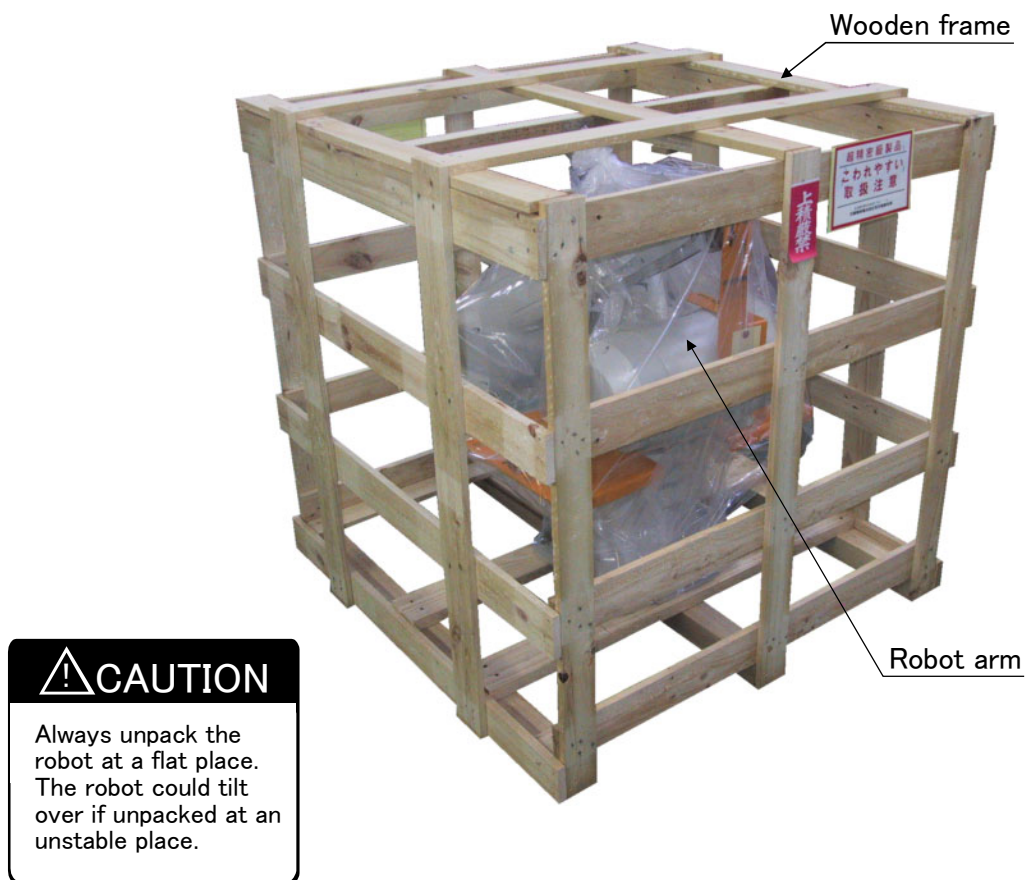

Fig.2-1 : Unpacking the robot arm

The robot is shipped from the factory in wooden frame packing. Handle the robot arm according to “[2.2.2 Transportation procedures \(Transporting with a crane\)](#)”.

The unpacking process is shown below.

- 1) Place the wooden frame on a level floor surface.
- 2) Remove the nails fastening the wooden frame.
- 3) Remove the wooden frame and cushioning material.
- 4) Remove the four bolts connecting the sleeper and the base unit.

## 2.2.2 Transportation procedures (Transporting with a crane)

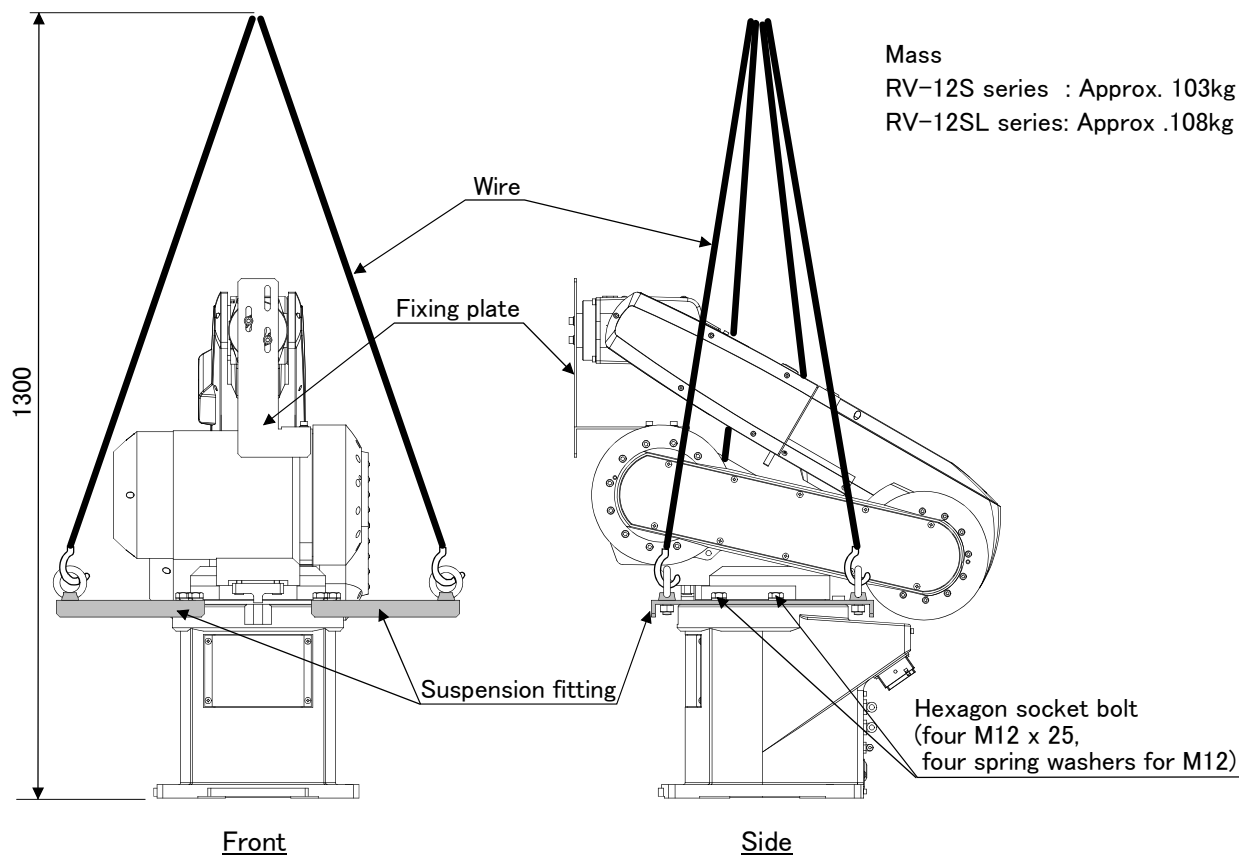
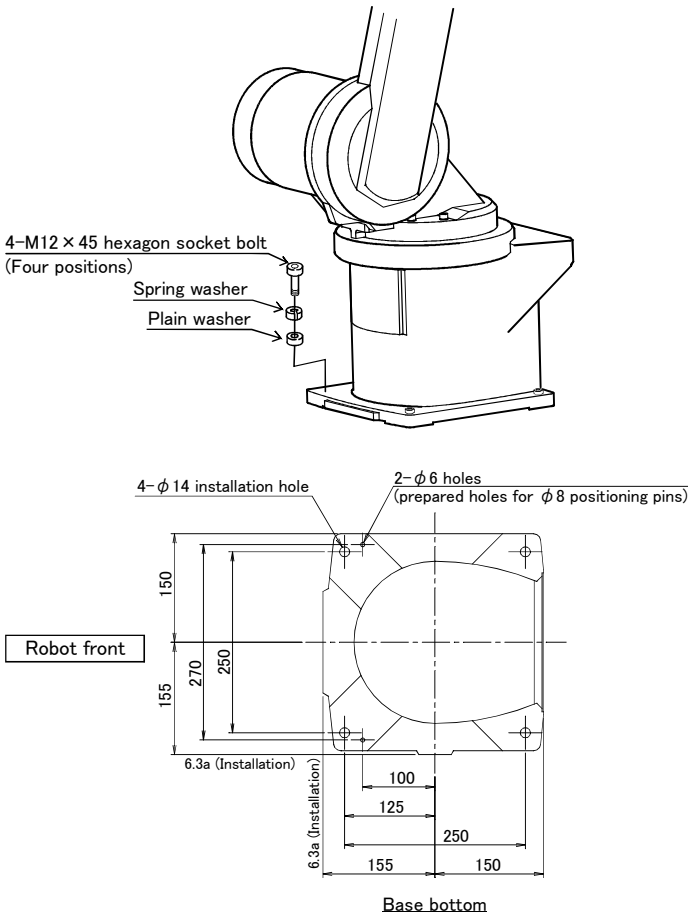

Fig.2-2 : Transportation procedures (transporting with a crane)

- 1) Attach the suspension fittings to the left and right sides of the shoulder section, and securely fix with bolts (four M12 x 25, four spring washers for M12). At this time, fix two of the suspension fitting's three holes at the side closest to the robot front.
- 2) Catch wires in the eye bolts installed on the suspension fittings, and quietly suspend the arm.
- 3) At this time, make sure that the wires, etc., do not interfere with the robot arm or covers. Always place cloth, etc., at interfering places.
- 4) When transferring to the installation place, take care not to apply vibration or impact.
- 5) After installing at the installation place, remove the above suspension fittings.
- 6) Always follow the above procedures and methods to transport the robot for secondary transportation, such as when changing the installation position.

If the arm is directly suspended without using the specified suspension fittings, or if it is suspended in the work posture, the configuration devices could be damaged, and the transportation workers will be subject to risk due to an inadequate center of gravity position.

2.2.3 Installation procedures



1) The robot installation surface has been machine finished. Use the installation holes (4-φ 14 holes) opened at the four corners of the base, and securely fix the robot with the enclosed installation bolts (M12x45 hexagon socket bolts).

Installation of the robot arm is a very important step for ensuring the optimum functions of the robot. Observe the following points when designing.

- 2) Install the robot on a level surface.
- 3) It is recommended that the surface roughness of the table onto which the robot is to be installed by 6.3a or more. If the installation surface is rough, the contact with the table will be poor, and positional deviation could occur when the robot moves.
- 4) When installing, use a common table to prevent the position of the devices and jigs subject to robot work from deviating.
- 5) The installation surface must have sufficient strength to withstand the arm reaction during operation, and resistance against deformation and vibration caused by the static (dynamic) load of the robot arm and peripheral devices, etc.
- 6) Remove the fixing plates after installing the robot.
- 7) When the robot is installed by hanging from the ceiling or on the wall, the MEGDIR parameter must be changed. For more information about parameters and how to change the parameters, refer to the separate "Instruction Manual/ Detailed Explanation of Functions and Operations".

Fig.2-3 : Installation dimensions

## 2.2.4 Grounding procedures

### (1) Grounding methods

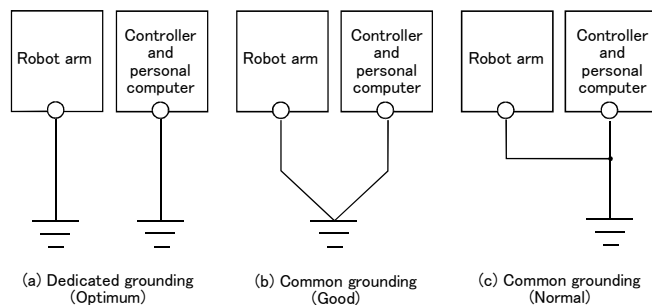

Fig.2-4 : Grounding methods

### (2) Grounding procedures

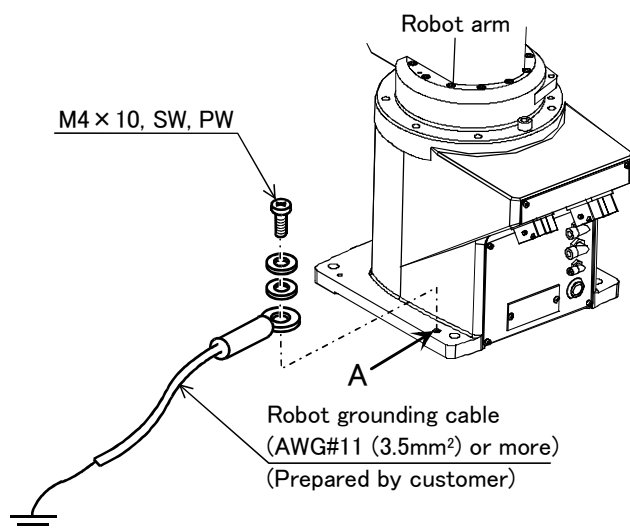

Fig.2-5 : Connecting the grounding cable

- 1) There are three grounding methods as shown in Fig. 2-4, but the dedicated grounding (Fig. 2-4 (a)) should be used for the robot arm and controller when possible. (Refer to the separate "Controller Setup, Basic Operation and Maintenance" for details on the controller grounding.)
- 2) Use Class D grounding (grounding resistance 100  $\Omega$  or less).  
Dedicated grounding separated from the other devices should be used.
- 3) Use a AWG#11(3.5mm<sup>2</sup>) or more stranded wire for the grounding wire. The grounding point should be as close to the robot arm and controller as possible, and the length of the grounding wire should be short.

- 1) Prepare the grounding cable (AWG#11(3.5mm<sup>2</sup>) or more) and robot side installation screw and washer.
- 2) If there is rust or paint on the grounding screw section (A), remove it with a file, etc.
- 3) Connect the grounding cable to the grounding screw section.

### 2.2.5 Connecting with the controller

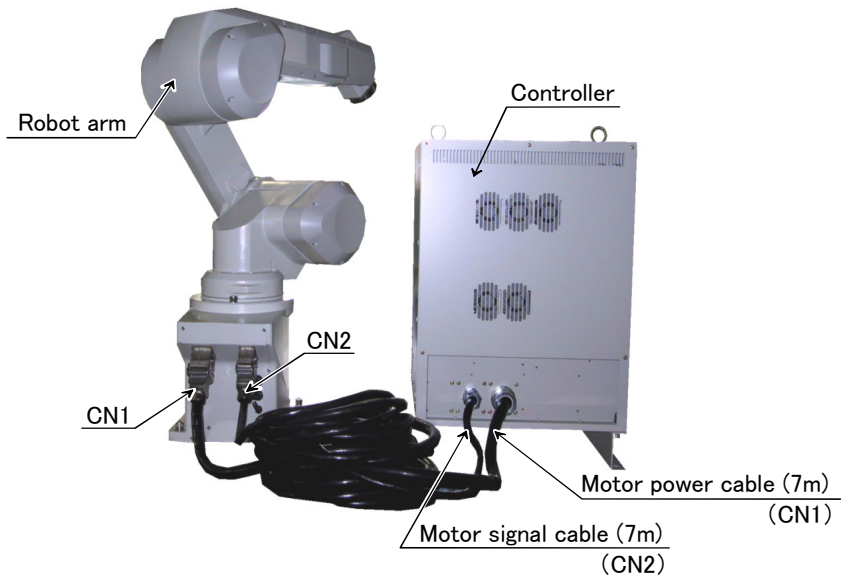
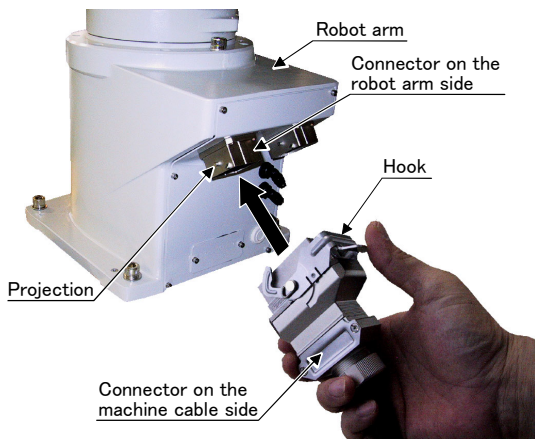

Fig.2-6 : Connecting the machine cables

Carry out the following procedure after installing the controller referring to the separate "Controller Setup, Basic Operation and Maintenance" manual.



1) Make sure that the power switch on the front of the controller is turned OFF.

2) Connect the machine cable to its corresponding connector on the robot arm side.

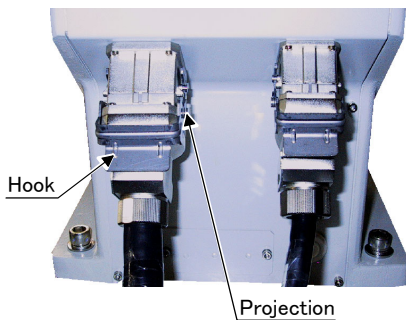

3) After connecting the connector, insert the hook attached to the connector on the machine cable side to the rear of the projection of the robot arm connector to fix securely in place.

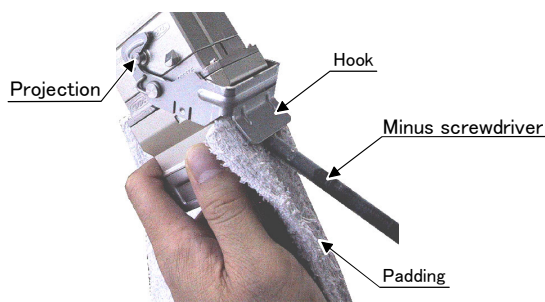

4) To remove the cable, insert a minus screwdriver into the hook while padding with a cloth, and remove the cable by lifting the hook.



## CAUTION

The machine cable connectors are dedicated for the controller side and robot arm side, so take special care when connecting.

If connected incorrectly, the connector pins could bend or break. Thus, even if connected correctly, the robot will not operate correctly, creating a dangerous situation.



## CAUTION

Take special care to the leading of the connection cable. If the cable is pulled with force or bent excessively, wires could break or the connector could be damaged.

### 2.3 Setting the origin

The origin is set so that the robot can be used with a high accuracy. After purchasing the robot, always carry out this step before starting work. This step must also be carried out if the combination of robot and controller being used is changed.

There are several methods for setting the origin, but the origin data input method will be explained here. Refer to "5.5 Resetting the origin" on page 53 for the other methods.

The teaching pendant is required for this operation.

[Caution] If the origin data at shipment is erased due to out of battery, it is necessary to set the origin again. Refer to "5.5 Resetting the origin" on page 53 and reset the origin using the jig method or ABS origin method.

#### 2.3.1 Installing the teaching pendant (T/B)

By using the "REMOVE T/B" switch, the T/B can be installed and removed while the controller's control power is ON. However, in this procedure, the teaching pendant will be installed with the control power OFF.

Refer to the separate "Controller setup, basic operation, and maintenance" for details on installing the teaching pendant with the control power ON.

##### (1) Installing with the control power OFF

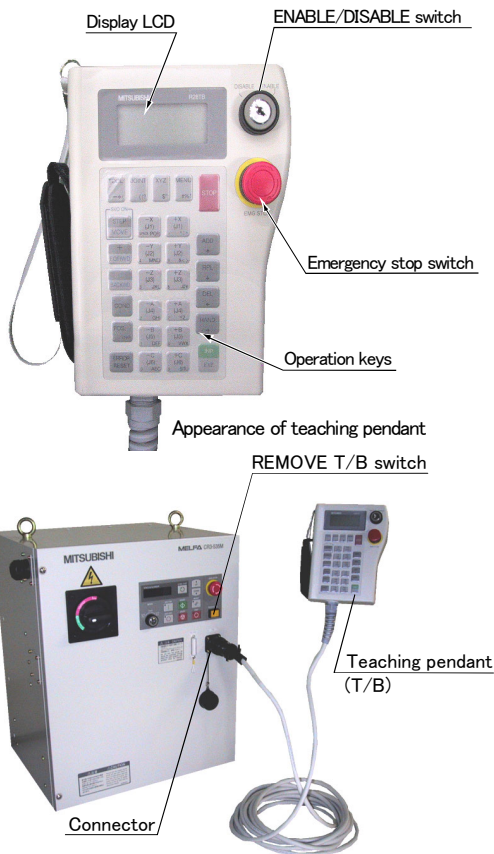

- 1) Confirm that the controller's power supply switch is OFF.
- 2) Connect the T/B connector to the RS-422 (T/B) connector on the controller.
- 3) Do not pull the cable with force or bend it excessively, as the cable could break or the connector could be damaged.
- 4) Confirm that the [REMOVE T/B] switch on the side of the controller is not depressed (is projected).
- 5) Set the T/B [ENABLE/DISABLE] switch to "DISABLE".

Fig.2-7 : Installing the T/B (control power OFF)

#### ◆◆◆ [REMOVE T/B] switch ◆◆◆

When using the robot with the T/B, this switch is used to invalidate the emergency stop from the T/B. This is also used to install the T/B with turning the controller's power supply ON.



## 2.3.2 Setting the origin with the origin data input method

### (1) Confirming the origin data

● Origin data history table (Origin Data History) Serial No.ES804008

Date	Default	. . .	. . .	. . .
D	V!#S29			
J 1	06DTYY			
J 2	2?HL9X			
J 3	1CP55V			
J 4	T6!M\$Y			
J 5	Z2!J%Z			
J 6	A12%Z0			
Method	E	E · N · S P	E · N · S P	E · N · S P

(O: AlphabetO, 0: Zero)

Note) Meanings of symbols in method column

E: Jig method

N: Not used

SP: Not used

The origin data to be input is noted in the origin data sheet enclosed with the arm, or on the origin data history table attached to the back side of the shoulder coverB. (Refer to Fig. 2-8).

Referring to “5.3.2 Installing/removing the cover” on page 44, remove the shoulder coverB, and confirm the value.

The value given in the default setting column is the origin settings set with the calibration jig before shipment.

Fig.2-8 : Origin data label (an example)



### WARNING

Always install/remove the cover with the controller control power turned OFF. Failure to do so could lead to physical damage or personal injury should the robot start moving due to incorrect operations.

### (2) Turning ON the control power



### CAUTION

Confirm that there are no operators near the robot before turning the power ON.

- 1) Turn the controller [POWER] switch ON.

The control power will be turned ON, and “ □ . 100 ” will appear on the STATUS NUMBER display on the front of the controller.

(3) Preparing the T/B

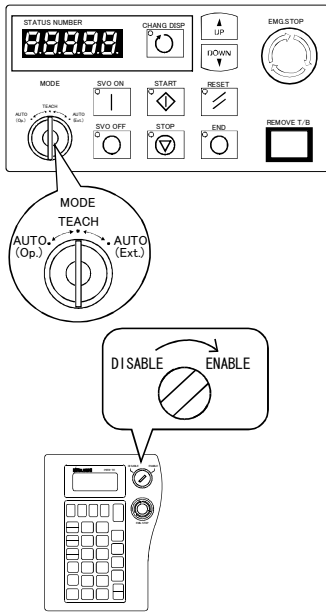

Next, prepare to use the T/B

1) Set the [MODE] switch on the front of the controller to "TEACH".

2) Set the T/B [ENABLE/DISABLE] switch to "ENABLE". The menu selection screen will appear.

The following operations are carried out with the T/B.

◆◆◆ Operating from the T/B ◆◆◆

Always set the [MODE] switch (mode selection key switch) on the front of the controller to "TEACH", and then set the T/B [ENABLE/DISABLE] switch to "ENABLE".

When the T/B is valid, only operations from the T/B are possible. Operations from the controller or external signals will not be accepted.

◆◆◆ When T/B operations are mistaken ◆◆◆

The displayed screen will return to the "menu selection screen" when the [MENU] key is pressed. Carry out the operations again from this screen. Operations can also be carried out again by setting the T/B [ENABLE/DISABLE] switch to "DISABLE" once and then setting to "ENABLE".

## (4) Selecting the origin setting method

&lt;T/B screen&gt; [Keys used]

```

<MENU>
1.TEACH 2.RUN
3.FILE  4.MONI
5.MAINT 6.SET

```

```

+ C
(J6)
5 STU

```

1) Press the [5] key on the menu screen, and display the maintenance screen.

```

<MAINT>
1.PARAM 2.INIT
3.BRAKE 4.ORIGIN
5.POWER

```

```

- Y
(J2)
4 MNO

```

2) Press the [4] key on the maintenance screen, and display the origin setting method selection screen.

```

<ORIGIN>
1.DATA 2.MECH
3.JIG  4.ABS
5.USER

```

```

- B
(J5)
1 DEF

```

```

INP
EXE

```

3) Press the [1] key on the origin setting method selection screen, and select the data input method.

The origin data input method will be selected, and the screen for turning OFF the servo power will appear.

```

<ORIGIN>
SERVO OFF
OK?( )
1:EXECUTE

```

```

- B
(J5)
1 DEF

```

```

INP
EXE

```

4) Press the [1] and [INP] keys to turn OFF the servo power. The screen for inputting the origin data will appear.

```

<DATA>D(000000)
1:000000 000000
3:000000 000000
5:000000 000000

```

## ◆◆◆ Selecting a menu ◆◆◆

The menu can be selected with one of the following methods.

A: Press the numeral key for the No. of the item to be selected.

B: Using the [ ↓ ] and [ ↑ ] keys, etc., move the cursor to the item to be selected, and then press the [INP] key.

(5) Inputting the origin data

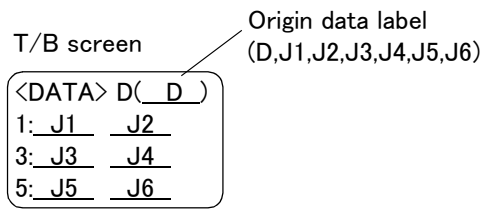

Input the value confirmed in section “(1) Confirming the origin data” on page 13.  
 The correspondence of the origin data label value and axis to be input is shown in Fig. 2-9.

Fig.2-9 : Correspondence of origin data label and axis

The method for inputting the origin data is explained below. The value shown in Fig. 2-8 will be input as an example.

<T/B screen>	[Keys used]	
<pre> &lt;DATA&gt;D(000000) 1:000000 000000 3:000000 000000 5:000000 000000                     </pre>		1) Confirm that the cursor is at the “D” position on the T/B display screen.
<pre> &lt;DATA&gt;D(V00000) 1:000000 000000 3:000000 000000 5:000000 000000                     </pre>	POS CHAR + +B (J5) 6 VWX	2) Input the D value V!%S29. <u>Inputting “V”</u> Press the [VWX] key once while holding down the [CHAR] key. “V” will appear, so release the [CHAR] key. “V” will be set.
<pre> &lt;DATA&gt;D(V!0000) 1:000000 000000 3:000000 000000 5:000000 000000                     </pre>	POS CHAR + SPD #%!	<u>Inputting “!”</u> Press the [#%!] key three times while holding down the [CHAR] key. “!” will appear, so release the [CHAR] key. “!” will be set.
<pre> &lt;DATA&gt;D(V!0000) 1:000000 000000 3:000000 000000 5:000000 000000                     </pre>	POS CHAR + SPD #%! POS CHAR + +C (J6) 5 STU -A (J4) 2 GHI    +Y (J2) 9 &<	In the same manner, while holding down the [CHAR] key, press the [“%”] key twice, and the [STU] key once (input “S”). Release the [CHAR] key, and press the [2] key (input “2”) and then the [9] key (input “9”). V!%S29 will appear at the “D” data on the teaching pendant screen.
<pre> &lt;DATA&gt;D(V!%S29) 1:000000 000000 3:000000 000000 5:000000 000000                     </pre>	RPL ↓	3) Press the [ ↓ ] key, and move the cursor to the J1 input position. 4) Input the J1 value in the same manner as above.
<pre> &lt;DATA&gt;D(V!%S29) 1:A@B&amp;8F G#\$Y5# 3:H+7%2H B=“!1L 5:59A37! K8#&amp;6P                     </pre>	INP EXE	5) Input the J2, J3, J4, J5 and J6 values in the same manner. 6) After inputting all of the values, press the [INP] key. The origin setting confirmation screen will appear.
<pre> &lt;DATA&gt;D(V!%S29) CHANGES TO ORIGIN OK? ( ) EXECUTE                     </pre>	-B (J5) 1 DEF    INP EXE	7) Press [1] (-B/-P) and [INP] key to end the origin setting

## ◆◆◆ Moving the cursor ◆◆◆

Press the [ ↑ ], [ ↓ ], [ ← ] and [ → ] keys.

## ◆◆◆ Inputting characters ◆◆◆

Hold down the [CHAR] key and press the key with the character to be input on the lower right. Three characters will scroll each time the character key is pressed.

## ◆◆◆ Correcting an input ◆◆◆

After returning one character by pressing the [DEL] key, input the character again.

## (6) Installing the shoulder coverB

Return the shoulder coverB, removed in section “(1) Confirming the origin data” on page 13 to its original position. This completes the setting of the origin with the origin data input method.

**WARNING**

Always remove and install the cover with the controller power turned OFF. Failure to do so could lead to the robot moving because of incorrect operations, or to physical damage or personal injury.

## ◆◆◆ If the origin input data is incorrect ◆◆◆

If the origin input data is incorrect, the alarm No. 1760 (origin setting data illegal) will occur when origin data input. In this case, reconfirm the value input for the origin data.

## 2.4 Confirming the operation

In this section, the robot will be moved manually using the T/B to confirm that the operation is correct. Moving the robot manually is called "jog operation". This operation includes the JOINT jog that moves each axis, the XYZ jog that moves along the base coordinate system, the TOOL jog that moves along the tool coordinate system, and the CYLINDER jog that moves along the circular arc.

This operation is carried out while pressing the deadman switch on the back of the T/B.

**CAUTION** The robot will move during this operation. Make sure that there are no operators near the robot, and that there are no obstacles, such as tools, in the robot operation range.

**CAUTION** To immediately stop the robot, release the deadman switch on the back of the T/B. The servo power will turn OFF, and the robot will stop. The robot will also stop if the [EMG.STOP] switch (emergency stop switch) on the front of the T/B or the [EMG.STOP] switch (emergency stop) on the front of the controller is pressed.

**WARNING** Confirm that the origin has been set. If the origin has not been set, "\*\*\*\*" will appear at the current position display on the teaching pendant, the JOINT jog operation will take place in any jog mode selected. Refer to "2.3 Setting the origin" on page 12 for details on setting the origin.

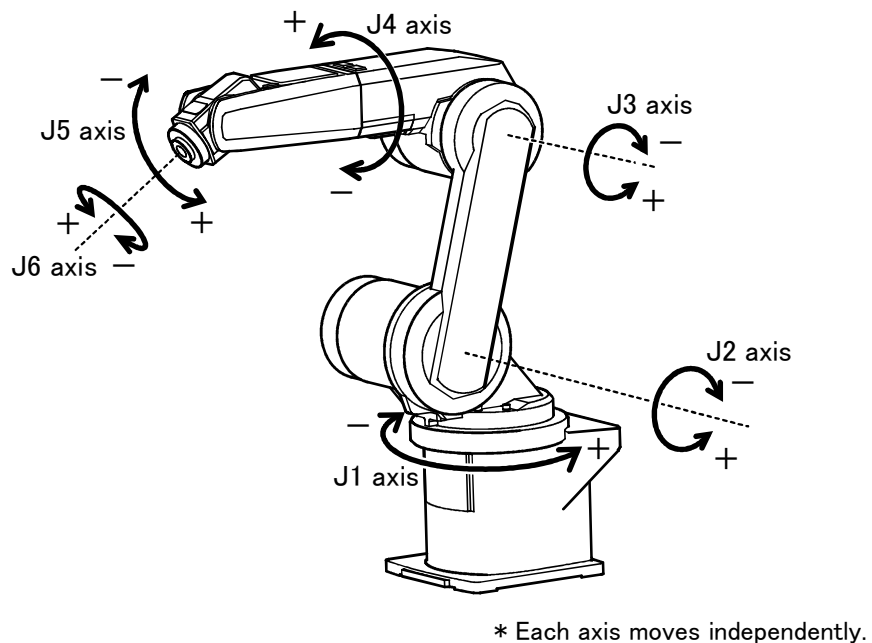
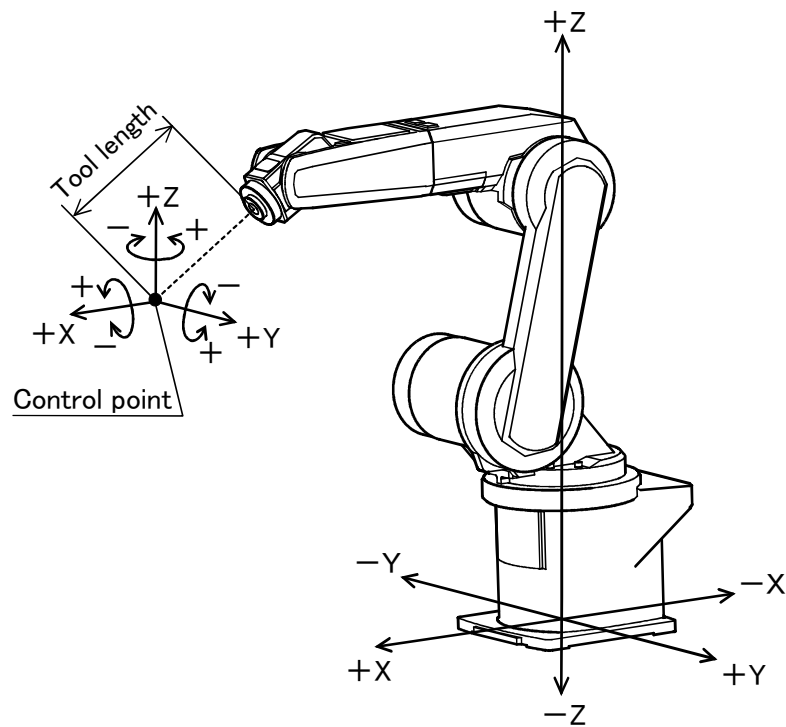
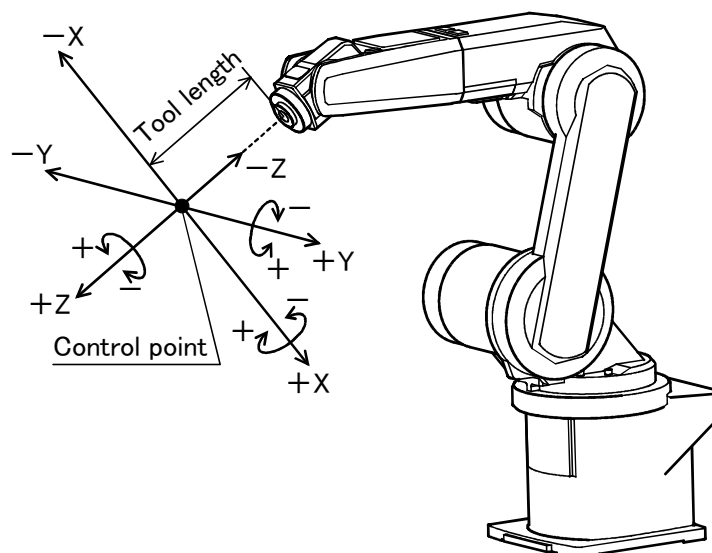

Fig.2-10 : JOINT jog operation



- \* While maintaining the flange surface posture, the axis moves straight along the base coordinate system.
- Also, while maintaining the flange surface position, the flange surface posture changes.

Fig.2-11 : XYZ jog operation



- \* While maintaining the flange surface posture, the axis moves straight along the tool coordinate system.
- Also, while maintaining the flange surface position, the flange surface posture changes.

Fig.2-12 : TOOL jog operation

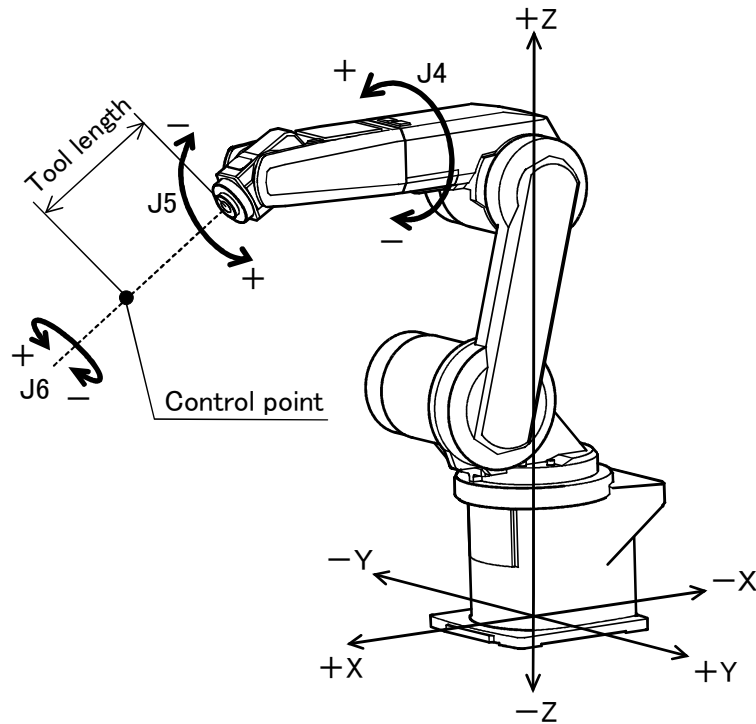

\* The axis moves straight along the base coordinate system. At this time, the flange surface posture is not maintained.  
 Also, the flange surface posture changes. The flange surface position changes at this time.

Fig.2-13 : 3-axis XYZ jog operation

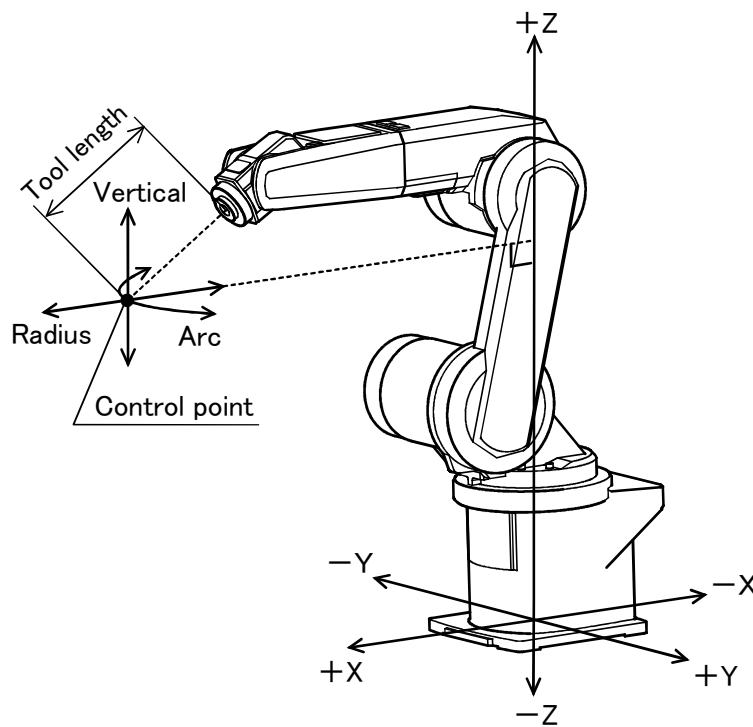

\* The current position is set as the arc centering on the Z axis, and the axis moves along that arc, expands and contracts in the radius direction, and moves vertically. At this time, the flange surface posture is maintained. Also, while maintaining the flange surface position, the flange surface posture changes.

Fig.2-14 : CYLINDER jog operation



(1) JOINT jog operation

Select the JOINT jog mode

JOINT	LOW
J1	+34.50
J2	+20.00
J3	+80.00

JOINT jog mode

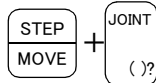

Press the [MOVE] + [JOINT] keys to select the JOINT jog mode. "JOINT" will appear at the upper left of the screen.

Set the jog speed

JOINT	LOW
J1	+34.50
J2	+20.00
J3	+80.00

Set the speed

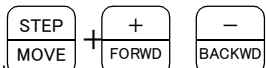

Each time the [MOVE] + [+] keys are pressed, the override will increase in the order of LOW → HIGH → 3 → 5 → 10 → 30 → 50 → 70 → 100%.

When the [MOVE] + [-] keys are pressed, the override will decrease in the reverse order.

The currently set speed will appear on the upper right of the screen.

Set the override to 10% here for confirmation work.

J1 axis jog operation

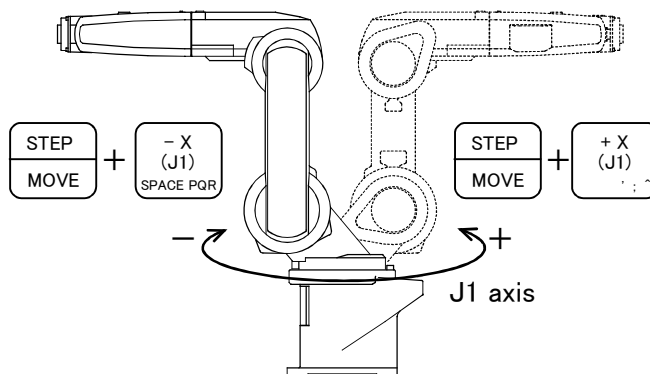

- When the [MOVE] + [+X (J1)] keys are pressed, the J1 axis will rotate in the plus direction.
- When the [MOVE] + [-X (J1)] keys are pressed, Rotate in the minus direction.

J2 axis jog operation

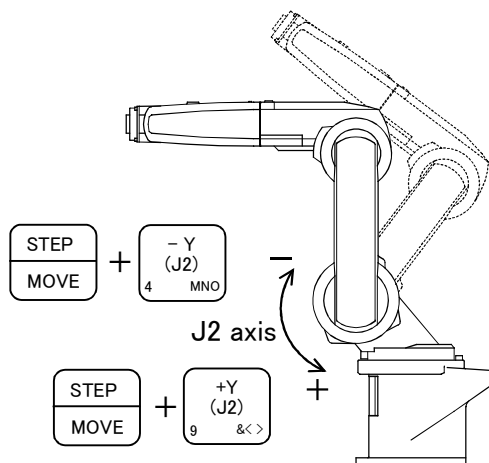

- When the [MOVE] + [+Y (J2)] keys are pressed, the J2 axis will rotate in the plus direction.
- When the [MOVE] + [-Y (J2)] keys are pressed, Rotate in the minus direction.

◆◆◆ When the robot is in the transportation posture ◆◆◆

The axes may be outside the movement area. Move these axes toward the inner side of the movement area. If moved outward, an **X** will appear on the T/B screen, and the robot will not move.

J3 axis jog operation

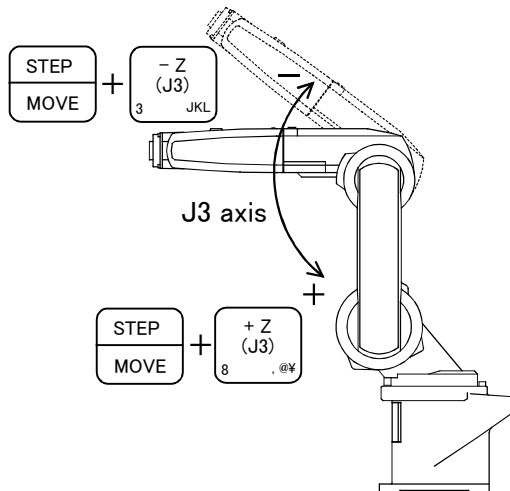

- When the [MOVE] + [+Z (J3)] keys are pressed, the J3 axis will rotate in the plus direction.  
When the [MOVE] + [-Z (J3)] keys are pressed, Rotate in the minus direction.

J4, J5 and J6 axis jog

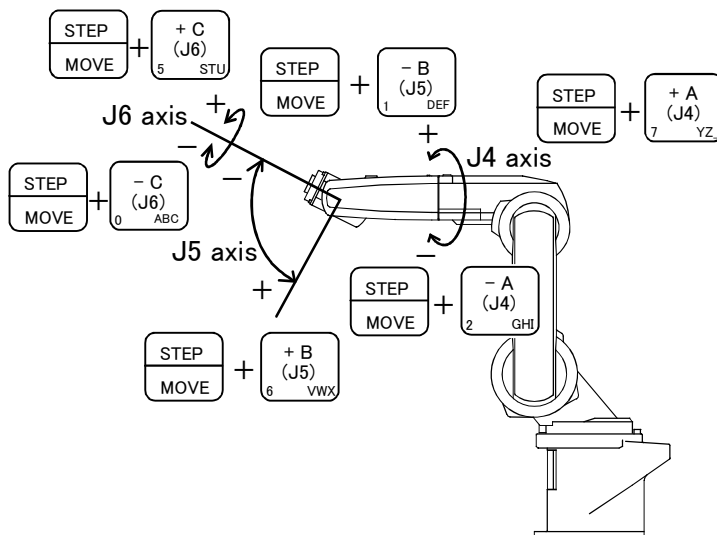

- When the [MOVE] + [+A (J4)] keys are pressed, the J4 axis will rotate in the plus direction.  
When the [MOVE] + [-A (J4)] keys are pressed, Rotate in the minus direction.
- When the [MOVE] + [+B (J5)] keys are pressed, the J5 axis will rotate in the plus direction  
When the [MOVE] + [-B (J5)] keys are pressed, Rotate in the minus direction.
- When the [MOVE] + [+C (J6)] keys are pressed, the J6 axis will rotate in the plus direction  
When the [MOVE] + [-C (J6)] keys are pressed, Rotate in the minus direction.

◆◆◆ When an  appears on the T/B screen display ◆◆◆

If the robot is moved outside the movement area, an  will appear. In this case, move the axis in the opposite direction.

JOINT	LOW
<input checked="" type="checkbox"/> J1	+160.00
J2	+20.00
J3	+80.00

In the example on the left, the J1 axis is at the limit of the plus side movement area.

(2) XYZ jog operation

Select the XYZ jog mode

XYZ	LOW
X	+134.50
Y	+220.00
Z	+280.00

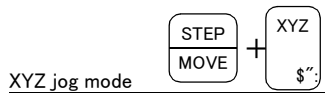

Press the [MOVE] + [XYZ] keys to select the XYZ jog mode. "XYZ" will appear at the upper left of the screen.

Set the jog speed

XYZ	LOW
X	+134.50
Y	+220.00
Z	+280.00

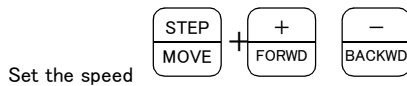

Each time the [MOVE] + [+] keys are pressed, the override will increase in the order of LOW → HIGH → 3 → 5 → 10 → 30 → 50 → 70 → 100%. When the [MOVE] + [-] keys are pressed, the override will decrease in the reverse order. The currently set speed will appear on the upper right of the screen. Set the override to 10% here for confirmation work.

Moving along the base coordinate system

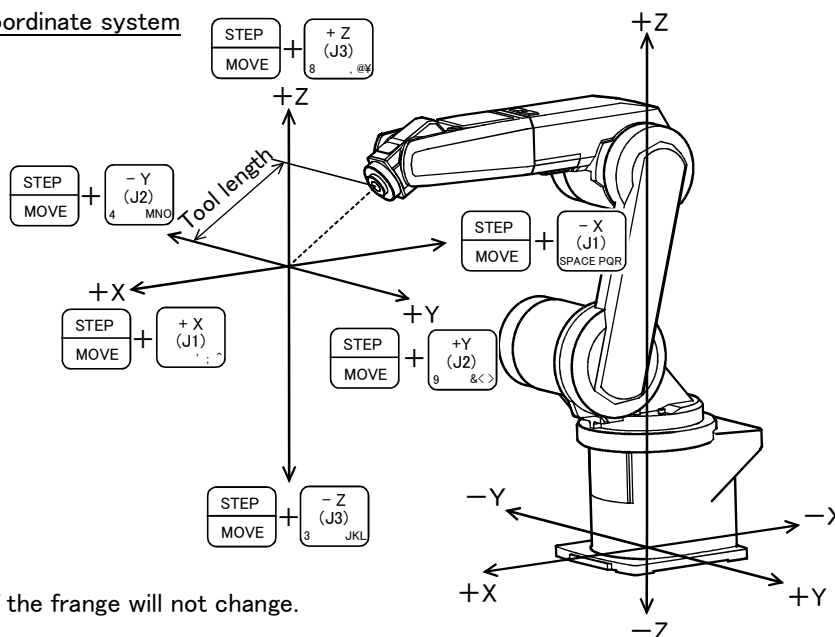

\* The direction of the frange will not change.

- When the [MOVE] + [+X (J1)] keys are pressed, the robot will move along the X axis plus direction. When the [MOVE] + [-X (J1)] keys are pressed, Move along the minus direction.
- When the [MOVE] + [+Y (J2)] keys are pressed, the robot will move along the Y axis plus direction. When the [MOVE] + [-Y (J2)] keys are pressed, Move along the minus direction.
- When the [MOVE] + [+Z (J3)] keys are pressed, the robot will move along the Z axis plus direction. When the [MOVE] + [-Z (J3)] keys are pressed, Move along the minus direction.

◆◆◆ When the robot is in the transportation posture ◆◆◆

There are directions from which linear movement is not possible from the transportation posture. In this case, an  will appear on the T/B screen, and the robot will not move. Refer to section "(1) JOINT jog operation" on page 21", and move the robot to a position where linear movement is possible, and then carry out XYZ jog.

◆◆◆ When an  appears on the T/B screen display ◆◆◆

If the robot is moved outside the movement area with any of the axes, an  will appear. In this case, move the axis in the opposite direction.

XYZ	LOW
<input checked="" type="checkbox"/> X	+360.00
<input checked="" type="checkbox"/> Y	+280.00
<input checked="" type="checkbox"/> Z	+170.00

In the example on the left, further linear movement in the same direction is not possible.

Changing the flange surface posture

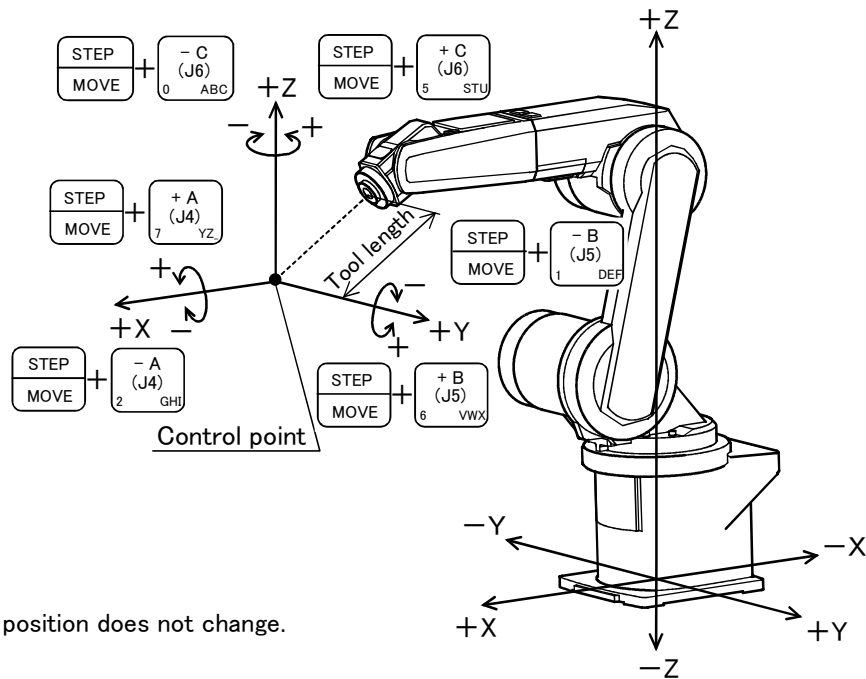

\* The flange position does not change.

- When the [MOVE] + [+A (J4)] keys are pressed, The X axis will rotate in the plus direction.  
When the [MOVE] + [-A (J4)] keys are pressed, Rotate in the minus direction.
- When the [MOVE] + [+B (J5)] keys are pressed, The Y axis will rotate in the plus direction.  
When the [MOVE] + [-B (J5)] keys are pressed, Rotate in the minus direction.
- When the [MOVE] + [+C (J6)] keys are pressed, The Z axis will rotate in the plus direction.  
When the [MOVE] + [-C (J6)] keys are pressed, Rotate in the minus direction.

◆◆◆ When alarm No. 5150 occurs ◆◆◆  
If alarm No. 5150 (ORIGIN NOT SET) occurs, the origin has not been set correctly. Reconfirm the value input for the origin data.

◆◆◆ Tool length ◆◆◆  
The default tool length is 0mm, and the control point is the center of the end axis.  
After installing the hand, set the correct tool length in the parameters. Refer to the separate manual "Detailed Explanation of Functions and Operations" for details.

(3) TOOL jog operation

Select the TOOL jog mode

TOOL	LOW
X	+134.50
Y	+220.00
Z	+280.00

TOOL jog mode

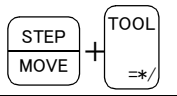

Press the [MOVE] + [TOOL] keys to select the TOOL jog mode. "TOOL" will appear at the upper left of the screen.

Set the jog speed

TOOL	LOW
X	+134.50
Y	+220.00
Z	+280.00

Set the speed

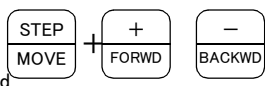

Each time the [MOVE] + [+] keys are pressed, the override will increase in the order of LOW → HIGH → 3 → 5 → 10 → 30 → 50 → 70 → 100%. When the [MOVE] + [-] keys are pressed, the override will decrease in the reverse order. The currently set speed will appear on the upper right of the screen. Set the override to 10% here for confirmation work.

Moving along the tool coordinate system

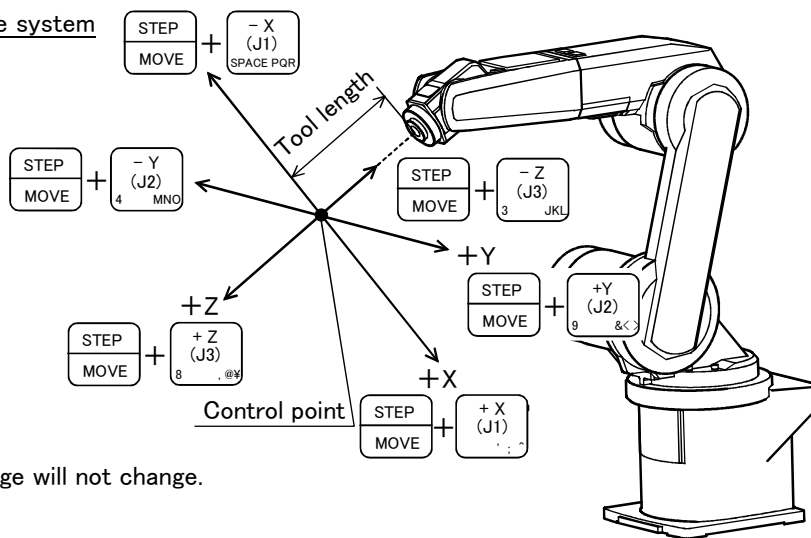

\* The direction of the frange will not change.

- When the [MOVE] + [+X (J1)] keys are pressed, the robot will move along the X axis plus direction of the tool coordinate system.  
When the [MOVE] + [-X (J1)] keys are pressed, Move along the minus direction.
- When the [MOVE] + [+Y (J2)] keys are pressed, the robot will move along the Y axis plus direction of the tool coordinate system.  
When the [MOVE] + [-Y (J2)] keys are pressed, Move along the minus direction.
- When the [MOVE] + [+Z (J3)] keys are pressed, the robot will move along the Z axis plus direction of the tool coordinate system.  
When the [MOVE] + [-Z (J3)] keys are pressed, Move along the minus direction.

◆◆◆ When the robot is in the transportation posture ◆◆◆

There are directions from which linear movement is not possible from the transportation posture. In this case, an  will appear on the T/B screen, and the robot will not move. Refer to section "(1) JOINT jog operation" on page 21, and move the robot to a position where linear movement is possible, and then carry out TOOL jog.

◆◆◆ When an  appears on the T/B screen display ◆◆◆

If the robot is moved outside the movement area with any of the axes, an  will appear. In this case, move the axis in the opposite direction.

TOOL	LOW
<input checked="" type="checkbox"/> X	+360.00
<input checked="" type="checkbox"/> Y	+280.00
<input checked="" type="checkbox"/> Z	+170.00

In the example on the left, further linear movement in the same direction is not possible.

Changing the flange surface posture

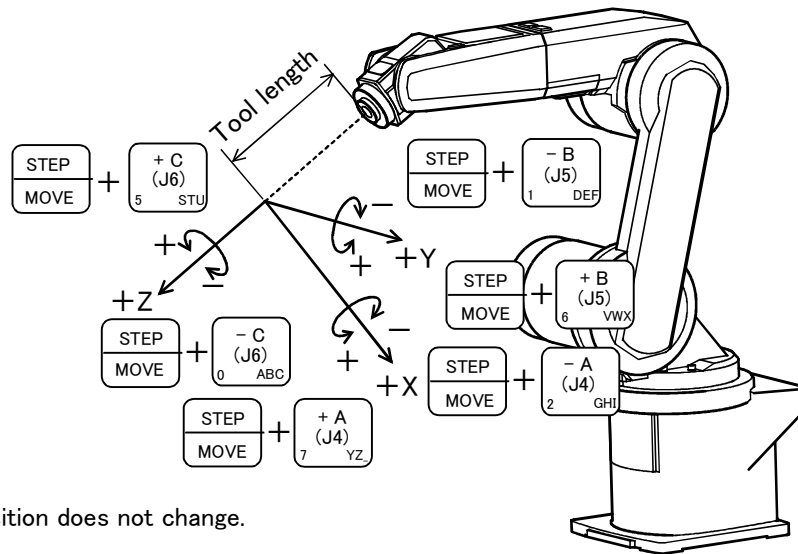

\* The flange position does not change.

- When the [MOVE] + [+A (J4)] keys are pressed, The X axis will rotate in the plus direction of the tool coordinate system.  
When the [MOVE] + [-A (J4)] keys are pressed, Rotate in the minus direction.
- When the [MOVE] + [+B (J5)] keys are pressed, The Y axis will rotate in the plus direction of the tool coordinate system.  
When the [MOVE] + [-B (J5)] keys are pressed, Rotate in the minus direction.
- When the [MOVE] + [+C (J6)] keys are pressed, The Z axis will rotate in the plus direction of the tool coordinate system.  
When the [MOVE] + [-C (J6)] keys are pressed, Rotate in the minus direction.

◆◆◆ When alarm No. 5150 occurs ◆◆◆

If alarm No. 5150 (ORIGIN NOT SET) occurs, the origin has not been set correctly. Reconfirm the value input for the origin data.

◆◆◆ Tool length ◆◆◆

The default tool length is 0mm, and the control point is the center of the end axis.  
After installing the hand, set the correct tool length in the parameters. Refer to the separate manual "Detailed Explanation of Functions and Operations" for details.

(4) 3-axis XYZ jog operation

Select the 3-axis XYZ jog mode

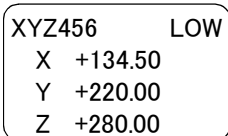

3-axis XYZ jog mode

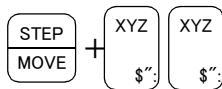

Press the [MOVE] + [XYZ] keys, and then press only the [XYZ] key. "XYZ456" will appear at the upper left of the screen.

Set the jog speed

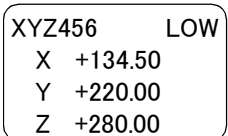

Set the speed

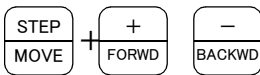

Each time the [MOVE] + [+] keys are pressed, the override will increase in the order of LOW → HIGH → 3 → 5 → 10 → 30 → 50 → 70 → 100%. When the [MOVE] + [-] keys are pressed, the override will decrease in the reverse order. The currently set speed will appear on the upper right of the screen. Set the override to 10% here for confirmation work.

Moving along the base coordinate system

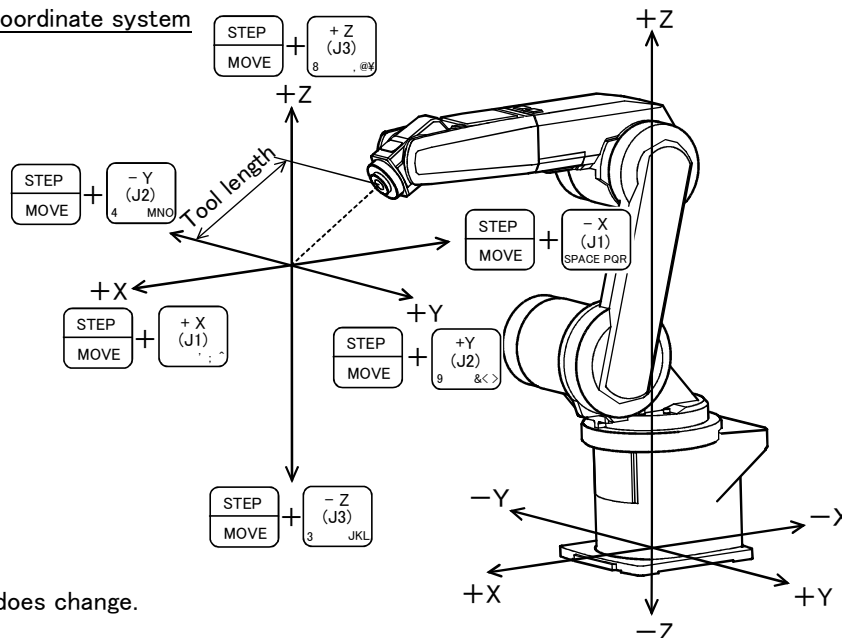

\* The flange position does change.

- When the [MOVE] + [+X (J1)] keys are pressed, the robot will move along the X axis plus direction. When the [MOVE] + [-X (J1)] keys are pressed, Move along the minus direction.
- When the [MOVE] + [+Y (J2)] keys are pressed, the robot will move along the Y axis plus direction. When the [MOVE] + [-Y (J2)] keys are pressed, Move along the minus direction.
- When the [MOVE] + [+Z (J3)] keys are pressed, the robot will move along the Z axis plus direction. When the [MOVE] + [-Z (J3)] keys are pressed, Move along the minus direction.

◆◆◆ Jog mode will change when only [XYZ] key is pressed again ◆◆◆  
 When the [MOVE] + [XYZ] keys are pressed and then only the [XYZ] key is pressed, the upper left display will change in the order of "XYZ" → "XYZ456" → "CYLINDER". Each jog mode can be selected.

◆◆◆ The flange surface end axis posture cannot be maintained with 3-axis XYZ jog. ◆◆◆  
 With 3-axis XYZ jog, the flange surface end axis posture (orientation) is not maintained when moving linearly in the X, Y or Z axis direction.  
 Use XYZ jog to maintain the posture.

Changing the flange surface posture

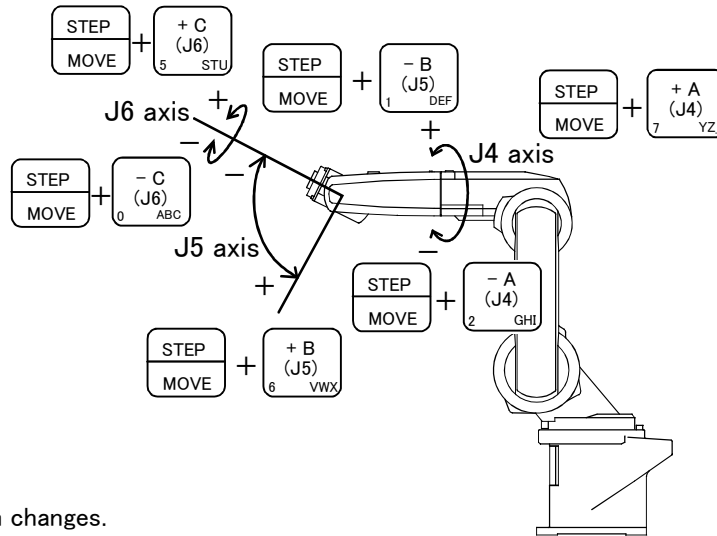

\* The flange position changes.

This is the same as the J4, J5 and J6 axis JOINT jog operation.

- When the [MOVE] + [+A (J4)] keys are pressed, the J4-axis will rotate in the plus direction.  
When the [MOVE] + [-A (J4)] keys are pressed, Rotate in the minus direction.
- When the [MOVE] + [+B (J5)] keys are pressed, the J5-axis will rotate in the plus direction.  
When the [MOVE] + [-B (J5)] keys are pressed, Rotate in the minus direction.
- When the [MOVE] + [+C (J6)] keys are pressed, the J6-axis will rotate in the plus direction.  
When the [MOVE] + [-C (J6)] keys are pressed, Rotate in the minus direction.



## (5) CYLINDER jog operation

Select the cylindrical jog mode

```

CYLINDER  LOW
R  +134.50
T  +220.00
Z  +280.00
  
```

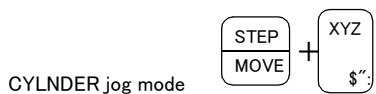

Press the [MOVE] + [XYZ] keys, and then press only the [XYZ] key. "CYLINDER" will appear at the upper left of the screen.

Set the jog speed

```

CYLINDER  LOW
R  +134.50
T  +220.00
Z  +280.00
  
```

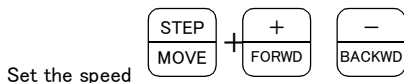

Each time the [MOVE] + [+] keys are pressed, the override will increase in the order of LOW → HIGH → 3 → 5 → 10 → 30 → 50 → 70 → 100%. When the [MOVE] + [-] keys are pressed, the override will decrease in the reverse order. The currently set speed will appear on the upper right of the screen. Set the override to 10% here for confirmation work.

Moving along an arc centering on the Z axis

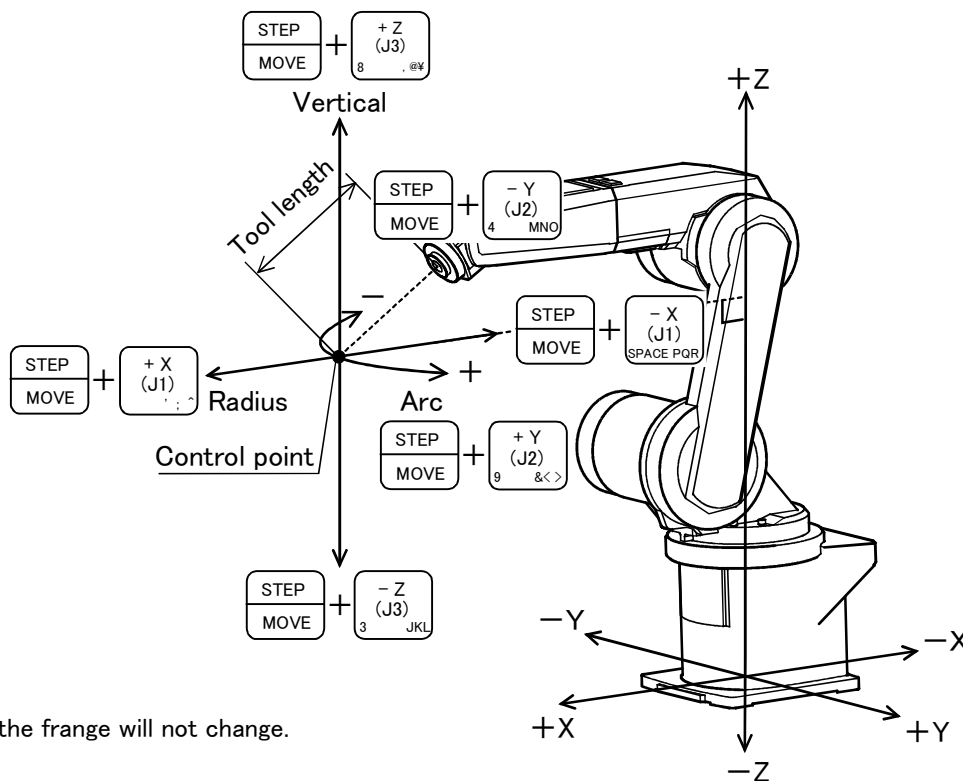

\* The direction of the frange will not change.

Assuming that the current position is on an arc centering on the Z axis, the robot moves along that arc.

- When the [MOVE] + [+Y (J2)] keys are pressed, the robot will move along the arc in the plus direction. When the [MOVE] + [-Y (J2)] keys are pressed, Move in the minus direction.
- When the [MOVE] + [+X (J1)] keys are pressed, the robot will expand in the radial direction. When the [MOVE] + [-X (J1)] keys are pressed, Contract in the radial direction.
- When the [MOVE] + [+Z (J3)] keys are pressed, the robot will move along the Z axis plus direction. When the [MOVE] + [-Z (J3)] keys are pressed, Move along the minus direction.

Changing the flange surface posture

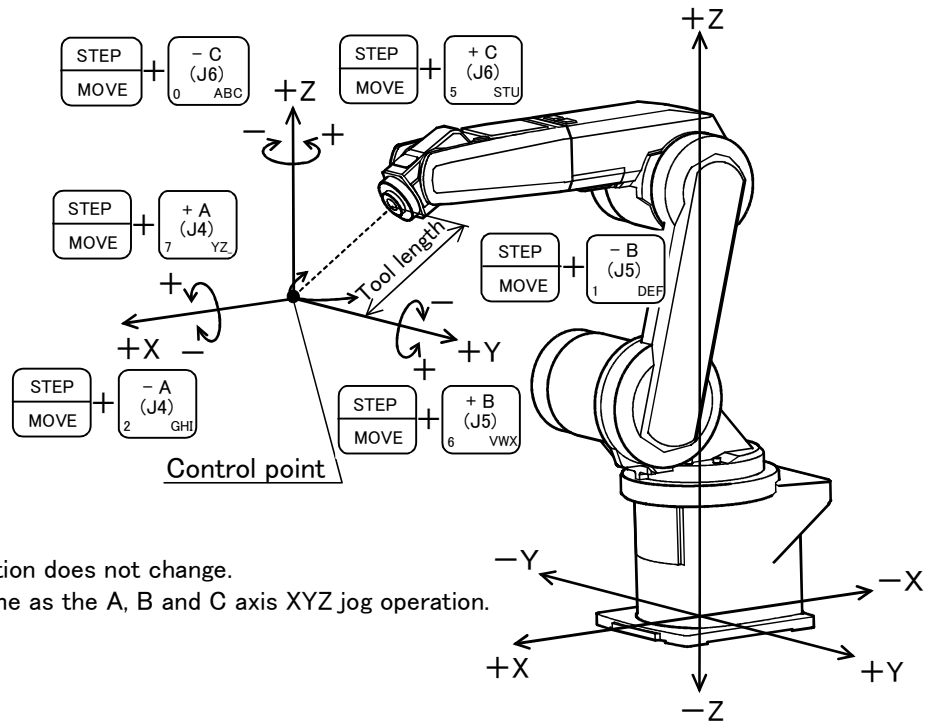

\* The flange position does not change.  
 This is the same as the A, B and C axis XYZ jog operation.

- When the [MOVE] + [+A (J4)] keys are pressed, The X axis will rotate in the plus direction.  
 When the [MOVE] + [-A (J4)] keys are pressed, Rotate in the minus direction.
  
- When the [MOVE] + [+B (J5)] keys are pressed, The Y axis will rotate in the plus direction.  
 When the [MOVE] + [-B (J5)] keys are pressed, Rotate in the minus direction.
  
- When the [MOVE] + [+C (J6)] keys are pressed, The Z axis will rotate in the plus direction.  
 When the [MOVE] + [-C (J6)] keys are pressed, Rotates in the minus direction.

### 3 Installing the option devices

#### 3.1 Installing the solenoid valve set (1S-VD01-01/VD02-01/VD03-01/VD04-01)

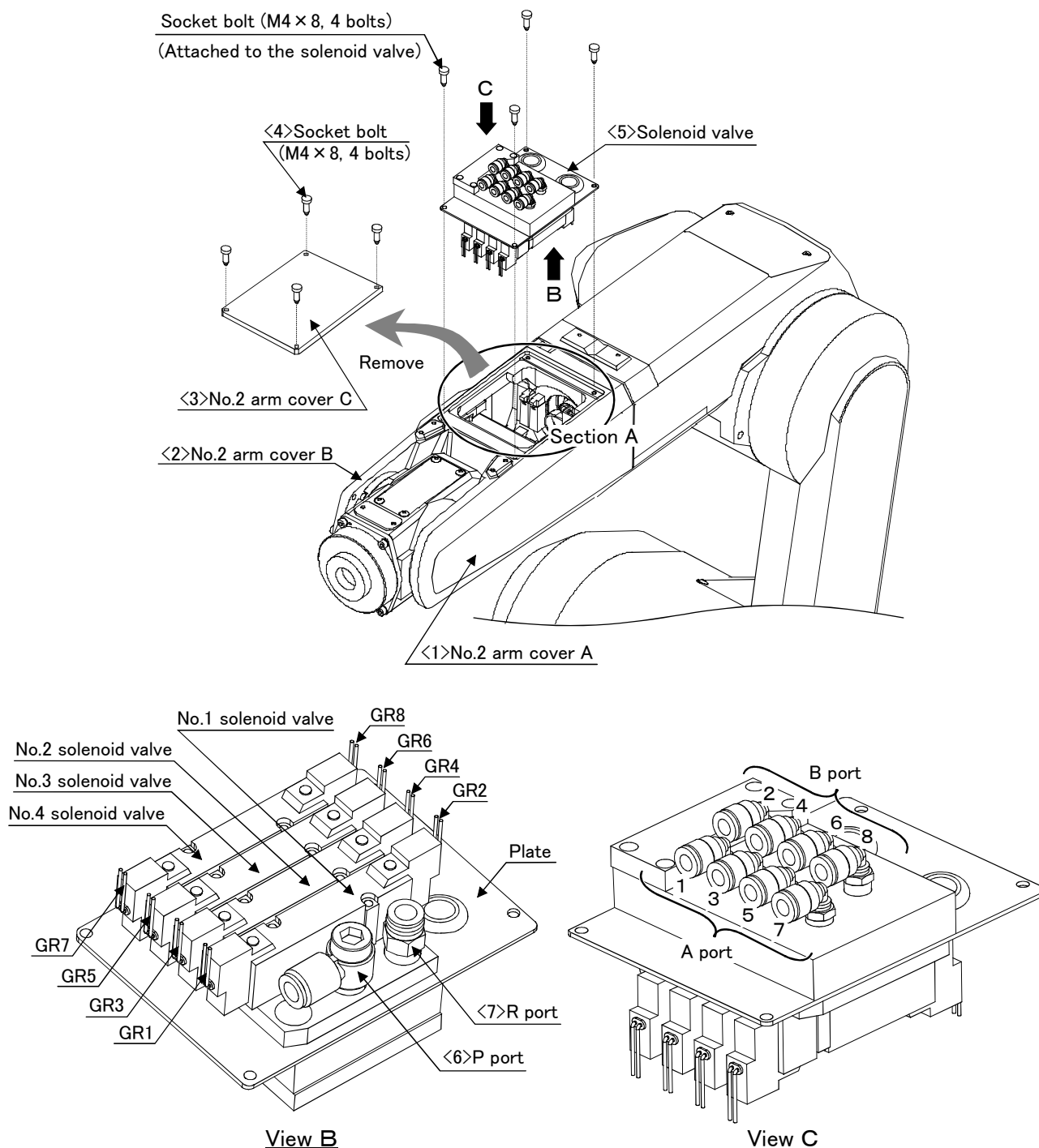

Fig.3-1 : Solenoid valve installation procedures

Fig. 3-1 and Fig. 3-2 shows the solenoid valve installation procedures and the solenoid valve connector connection procedures. The installation procedures are as follow. This work must be carried out with the controller power turned OFF.

- 1) Remove the hexagon socket bolts (five M4 x 10) and truss screw (three M3 x 8) that hold the No. 2 arm cover B <2>, and then remove both the No. 2 arm cover B <2>.
- 2) Remove the socket bolts <4> (four M4 x 8) that hold the No. 2 arm cover C <3>, and then remove both the No. 2 arm cover C <3>.
- 3) If you are not using the spare line (ADD: stored in a coil) in section A shown in Fig. 3-1, remove it. The spare line is connected to a connector inside section A.

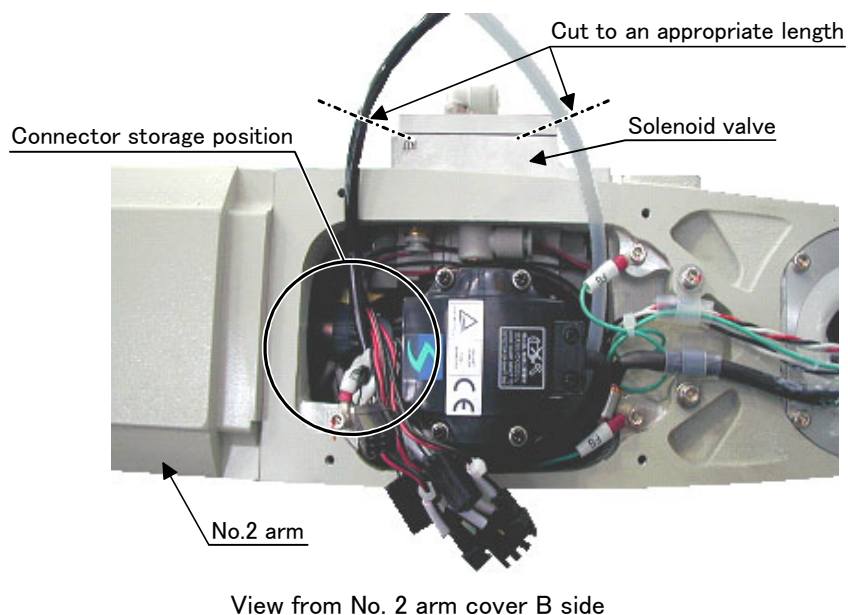

Fig.3-2 : Solenoid valve installation diagram details 1

- 4) The length of the two air hoses ( $\phi 6$ ) stored in section A is longer than necessary by assuming the use of a solenoid valve set not manufactured by Mitsubishi. Cut off the air hoses to an appropriate length, and connect them to the couplings.
- 5) Of the two air hoses ( $\phi 6$ ), the one marked with "AIR IN" is for connecting the quick coupling (P port) <6> of the solenoid valves, and the other marked with "RETURN" is for connecting the quick coupling (R port) <7> of the solenoid valves.
- 6) Using the screw holes of the No. 2 arm cover C <3>, mount the solenoid valves with the socket bolts (four M4 x 8) attached to the solenoid valves. When mounting the solenoid valves, be careful not to damage the sponge sealing material attached to the opening of section A. If the sealing material is damaged, it may degrade the protection specification.
- 7) Connect the connectors of GR1 to GR4 stored in section A to the plugs of GR1 to GR4 coming out of the solenoid valves. Store the connectors near the location marked with O shown in Fig. 3-2. Fig. 3-2 shows a view when stored.

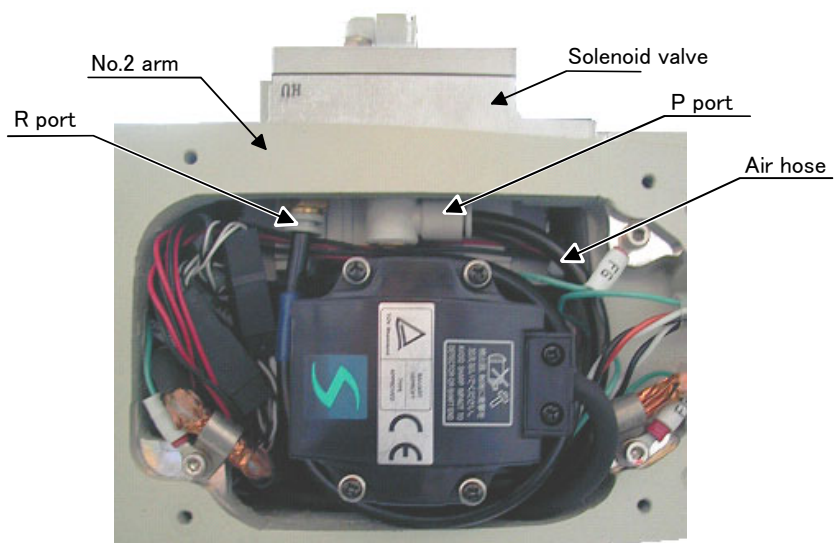

Fig.3-3 : Solenoid valve installation diagram details 2

- 8) When you have completed the installation, reinstall the No.2 arm cover B <2> to its original position, and be careful not to entangle the cables when you do so.

The connections after the installation appear as in [Table 3-1](#) for single type valves, hand 2 is not applicable.

Table 3-1 : Solenoid valve ports and hoses: Correspondence of couplings and hand ports

Hand	Hand port	Solenoid valve port	Solenoid valve used
Hand 1	OPEN	A	First set
	CLOSE	B	
Hand 2	OPEN	A	Second set
	CLOSE	B	
Hand 3	OPEN	A	Third set
	CLOSE	B	
Hand 4	OPEN	A	Fourth set
	CLOSE	B	

### 3.2 Installing the hand input cable

The procedure for installing the hand input cable is as follows. Conduct work by referring to “Fig. 3-1 Solenoid valve installation procedures” on page 31 and “Fig. 3-4Installing the hand input cable” on page 34 below. This work must be carried out with the controller power turned OFF.

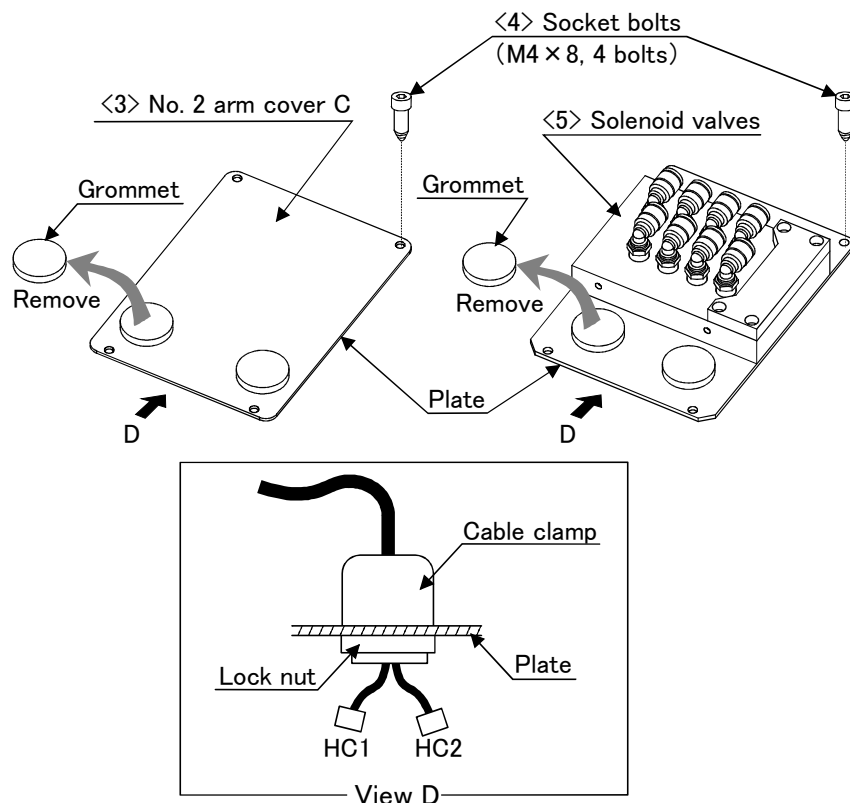

Fig.3-4 : Installing the hand input cable

- 1) Remove the hexagon socket bolts (five M4 x 10) and truss screw (three M3 x 8) that hold the No. 2 arm cover B <2>, and then remove both the No. 2 arm cover B <2>.
- 2) Remove the socket bolts <4> (four M4 x 8) that hold the No. 2 arm cover C <3> or the solenoid valves <5>, and then remove the No. 2 arm cover C <3> or the solenoid valves <5>.
- 3) If you are not using the spare line (ADD: stored in a coil) in section A shown in Fig. 3-1, remove it. The spare line is connected to a connector inside section A.
- 4) The hand input cable can be installed to both the No. 2 arm cover C <3> and the solenoid valves <5>.
- 5) Remove one of the two grommets on either the No. 2 arm cover C <3> or the solenoid valves <5>. After removing the grommet, peel off the sealing material left on the hole section of the plate.
- 6) After removing the lock nut attached to the hand input cable, feed the connector side of the hand input cable (with a cable clamp) through the hole on the plate. Replace the removed lock nut in position and fasten it securely.
- 7) Connect the connectors of “HC1” and “HC2” stored in section A shown in Fig. 3-1 to “HC1” and “HC2” of the hand input cable.
- 8) Mount the No. 2 arm cover C <3> or the solenoid valves <5> to section A shown in Fig. 3-1. When mounting, be careful not to damage the sponge sealing material attached to the opening of section A.
- 9) When you have completed the installation, reinstall the No.2 arm cover B <2> to its original position, and be careful not to entangle the cables when you do so.

### 3.3 Installing the hand output cable

The procedure for installing the hand output cable is as follows. Conduct work by referring to "Fig. 3-1 Solenoid valve installation procedures" on page 31 and "Fig. 3-5 Installing the hand output cable" on page 35 below.

This work must be carried out with the controller power turned OFF.

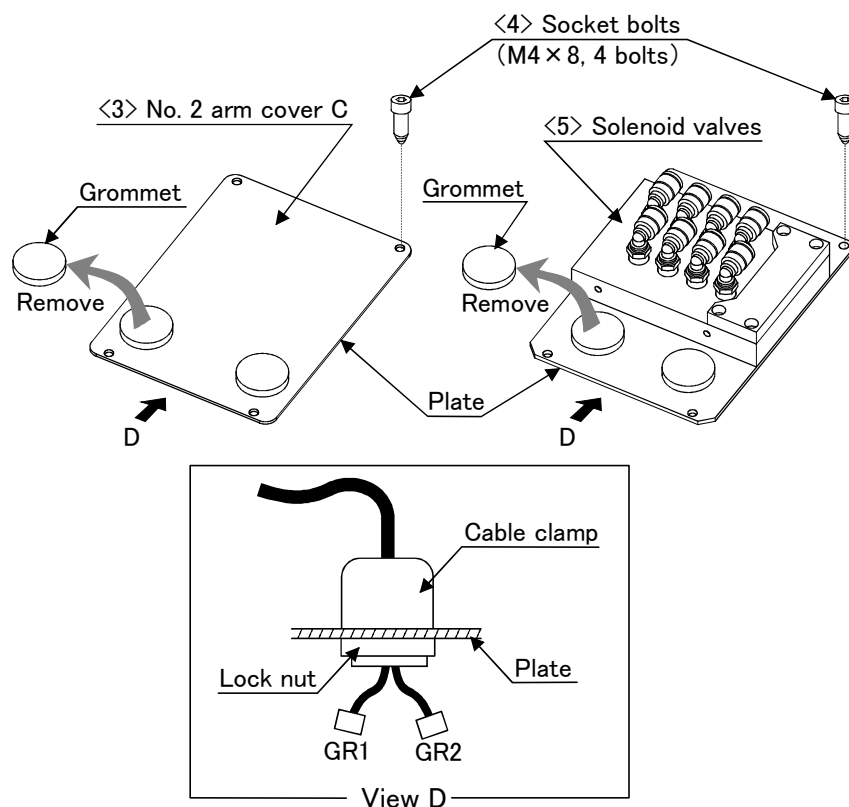

Fig.3-5 : Installing the hand output cable

- 1) Remove the hexagon socket bolts (five M4 x 10) and truss screw (three M3 x 8) that hold the No. 2 arm cover B <2>, and then remove both the No. 2 arm cover B <2>.
- 2) Remove the socket bolts <4> (four M4 x 8) that hold the No. 2 arm cover C <3> or the solenoid valves <5>, and then remove the No. 2 arm cover C <3> or the solenoid valves <5>.
- 3) If you are not using the spare line (ADD: stored in a coil) in section A shown in Fig. 3-1, remove it. The spare line is connected to a connector inside section A.
- 4) The hand output cable can be installed to both the No. 2 arm cover C <3> and the solenoid valves <5>. However, if solenoid valves of three rows or more are used, it is not possible to install a hand output cable separately because the hand output connectors (2 pcs.) in the forearm and the solenoid valves are already connected.
- 5) Remove one of the two grommets on either the No. 2 arm cover C <3> or the solenoid valves <5>. After removing the grommet, peel off the sealing material left on the hole section of the plate.
- 6) After removing the lock nut attached to the hand output cable, feed the connector side of the hand output cable (with a cable clamp) through the hole on the plate. Replace the removed lock nut in position and fasten it securely.
- 7) Connect the connectors of "GR1" and "GR2" stored in section A shown in Fig. 3-1 to "GR1" and "GR2" of the hand output cable.
- 8) Mount the No. 2 arm cover C <3> or the solenoid valves <5> to section A shown in Fig. 3-1. When mounting, be careful not to damage the sponge sealing material attached to the opening of section A.
- 9) When you have completed the installation, reinstall the No.2 arm cover B <2> to its original position, and be careful not to entangle the cables when you do so.

### 3.4 .Changing the operating range

The operating range of the J1 axis can be changed to the range shown in [Table 3-2](#). (Option)

Table 3-2 : Operating range alternative range

Axis		Standard	Alternative angle				One of the points shown on the left
J 1	+side	Angle	+170	+135	+90	+45	
		Insertion position	None	A	B	C	
	-side	Angle	-170	-135	-90	-45	
		Insertion position	None	a	b	c	

Note) The insertion position given in the table indicates the insertion position for the operating range change stopper. (Refer to [Fig. 3-6](#).)

The operating range is changed with robot arm settings and parameter settings.

(1) Setting the robot arm

- 1) Move the upper arm to the posture as shown in [Fig. 3-6](#) by jog operation.
- 2) Turn OFF the controller power.
- 3) By referring to [Table 3-2](#) and [Fig. 3-6](#), insert the two stoppers (M12 x 20) used to change the movement range of J1 axis at the angular position to be changed, and fix securely by applying a clamping torque of 120 N · m to 150 N · m.



**CAUTION** Do not remove the stopper for the standard specification of  $\pm 170$  degree shown in [Fig. 3-6](#).

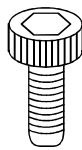

Type: 1S-DH-01  
 Specification:  
 Hexagon socket bolt (2 bolts)  
 M12 x 20 plating  
 Strength classification 10.9

Detail of the stopper used to change the operating range of the J1 axis

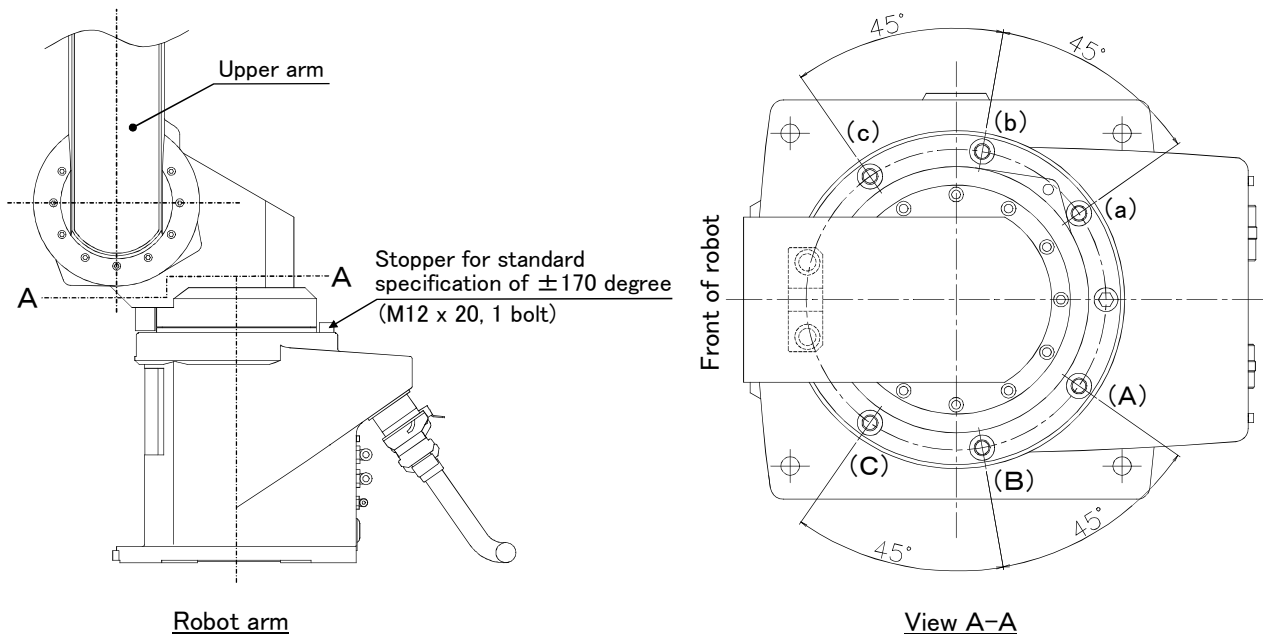

Fig.3-6 : Installation of operating range change option



(2) Setting the parameters

- 1) Change the values of the first element (J1 axis minus side) and second element (J1 axis plus side) of the joint operating range parameter MEJAR. Set the value to the angle corresponding to the position where the operating range change stopper was inserted in [“\(1\)Setting the robot arm”](#) above. Refer to the separate “Instruction Manual/Detailed Explanation of Functions and Operations” for details on changing the parameter.
- 2) When completed changing the parameters, turn the controller power OFF and ON. Move the waist axis to the operating range limit with JOINT jog operation, and confirm that the limit over occurs and the robot stops at the angle changed for both the +/- sides.

This completes setting the parameters and the changing of the operating range.

## 4 Basic operations

The basic operations from creating the program to automatic operation are explained in section "4. Basic operations" in the "From Controller Setup to Maintenance" manual. Refer that manual as necessary.

## 5 Maintenance and Inspection

The maintenance and inspection procedures to be carried out to use the robot for a long time without trouble are described in this chapter. The types and replacement methods of consumable parts are also explained.

### 5.1 Maintenance and inspection interval

Maintenance and inspection are divided into the inspections carried out daily, and the periodic inspections carry out at set intervals. Always carry these out to prevent unforeseen trouble, to maintain the product for a long time, and to secure safety.

#### (1) Inspection schedule

In addition to the monthly inspection, add the following inspection items every three months (estimated at 500 Hr operation hours).

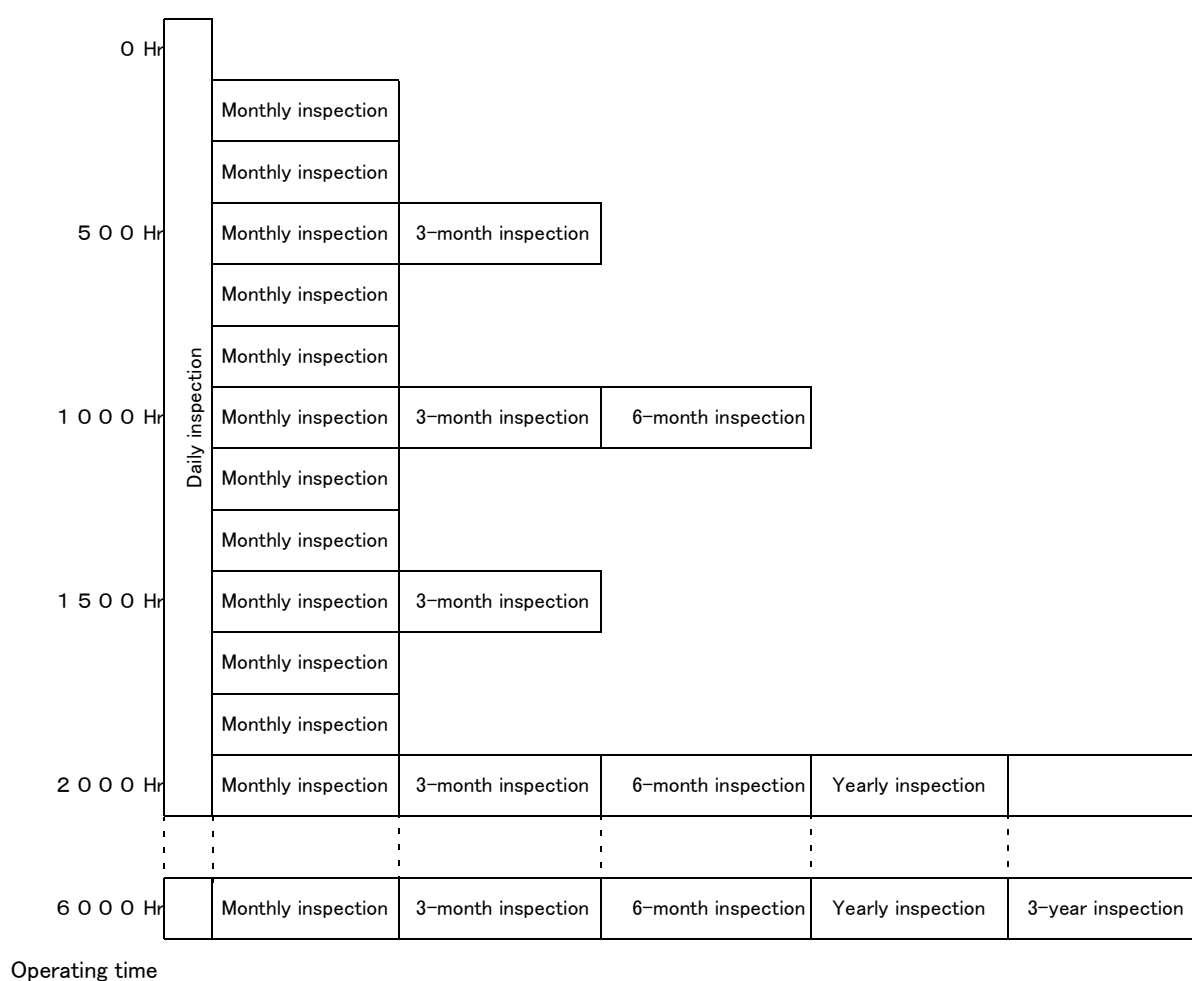

#### <Guideline for inspection period>

For one shift

$$8 \text{ Hr/day} \times 20 \text{ days/month} \times 3 \text{ months} = \text{approx. } 500 \text{ Hr}$$

$$10 \text{ Hr/day} \times 20 \text{ days/month} \times 3 \text{ months} = \text{approx. } 600 \text{ Hr}$$

For two shifts

$$15 \text{ Hr/day} \times 20 \text{ days/month} \times 3 \text{ months} = \text{approx. } 1000 \text{ Hr}$$

[Caution] When using two lines, the 3-month inspection, 6-month inspection and yearly inspection must be carried out when half the time has passed.

Fig.5-1 : Inspection schedule

## 5.2 Inspection items

The inspection items for the robot arm are shown below.

Also refer to section "5. Maintenance and inspection" in the "Controller setup, basic operation, and maintenance" manual, and inspect the controller.

### 5.2.1 Daily inspection items

Carry out the daily inspections with the procedures given in [Table 5-1](#).

Table 5-1 : Daily inspection items (details)

Procedure	Inspection item (details)	Remedies
Before turning power ON (Check the following items before turning the power ON.)		
1	Are any of the robot installation bolts loose? (Visual)	Securely tighten the bolts.
2	Are any of the cover tightening screws loose? (Visual)	Securely tighten the screws.
3	Are any of the hand installation bolts loose? (Visual)	Securely tighten the bolts
4	Is the power supply cable securely connected? (Visual)	Securely connect.
5	Is the machine cable between the robot and controller securely connected? (Visual)	Securely connect.
6	Are there any cracks, foreign contamination or obstacles on the robot and controller cover?	Replace with a new part, or take remedial measures.
7	Is any grease leaking from the robot arm? (Visual)	After cleaning, replenish the grease.
8	Is there any abnormality in the pneumatic system? Are there any air leaks, drain clogging or hose damage? Is the air source normal? (Visual)	Drain the drainage, and remedy the air leaks (replace the part).
After turning the power ON (Turn the power ON while monitoring the robot.)		
1	Is there any abnormal motion or abnormal noise when the power is turned ON?	Follow the troubleshooting section.
During operation (try running with an original program)		
1	Check whether the movement points are deviated? Check the following points if there is any deviation. 1. Are any installation bolts loose? 2. Are any hand installation section bolts loose? 3. Are the positions of the jigs other than the robot deviated? 4. If the positional deviation cannot be corrected, refer to "Troubleshooting", check and remedy.	Follow the troubleshooting section.
2	Is there any abnormal motion or abnormal noise? (Visual)	Follow the troubleshooting section.

## 5.2.2 Periodic inspection

Carry out periodic inspection with the procedures given in [Table 5-2](#).

Table 5-2 : Periodic inspection items (details)

Procedure	Inspection item (details)	Remedies
Monthly inspection items		
1	Are any of the bolts or screws on the robot arm loose?	Securely tighten the bolts.
2	Are any of the connector fixing screws or terminal block terminal screws loose?	Securely tighten the screws.
3	Remove the cover at each section, and check the cables for wear damage and adherence of foreign matter.	Check and eliminate the cause. If the cables are severely damaged, contact the Mitsubishi Service Department.
3-month inspection items		
1	Is the timing belt tension abnormal?	If the timing belt is loose or too tense, adjust it.
6-month inspection items		
1	Is the friction at the timing belt teeth severe?	If the teeth are missing or severe friction is found, replace the timing belt.
Yearly inspection items		
1	Replace the backup battery in the robot arm.	Exchange it referring to " <a href="#">5.3.5 Replacing the backup battery</a> " on page 51.
3-year inspection items		
1	Lubricate the grease at the harmonic reduction gears for each axis.	Lubricate it referring to " <a href="#">5.3.4 Lubrication</a> " on page 49.

### 5.3 Maintenance and inspection procedures

The procedures for carrying out the periodic maintenance and inspection are described in this section. Thoroughly read the contents, and follow the instructions. This work can be commissioned to the Mitsubishi Service Department for a fee. (Never disassemble, etc., the parts not described in this manual.)

The maintenance parts, etc., required for the customer to carry out maintenance and inspection are described in "5.4 Maintenance parts" on page 52 of this manual. Always contact your dealer when parts are needed.



#### CAUTION

The origin of the machine system could deviate when this work is carried out. "Review of the position data" and "re-teaching" will be required.

#### 5.3.1 Robot arm structure

An outline structure drawing is shown in . Each part is as shown below.

- 1) The J1 axis rotation is driven by the J1 axis motor <1> and reduction gears <2> arranged in the base.  
Non-excitation magnetic brakes are mounted in the J1 axis motor <1>.
- 2) The J2 axis rotation is driven by the J2 axis motor <3> and reduction gears <4> arranged in the shoulder.  
Non-excitation magnetic brakes are mounted in the J2 axis motor <3>.
- 3) The J3 axis rotation is driven by the J3 axis motor <5> and reduction gears <6> arranged in the shoulder.  
Non-excitation magnetic brakes are mounted in the J3 axis motor <5>.
- 4) The J4 axis rotation is driven by the J4 axis motor <7> and reduction gears <8> arranged in the elbow block.  
Non-excitation magnetic brakes are mounted in the J4 axis motor <7>.
- 5) The rotation of the J5 axis motor <9> arranged in the forearm is conveyed to the reduction gears <11> via the timing belt <10> to rotate the wrist housing and following parts.  
Non-excitation magnetic brakes are mounted in the J5 axis motor <9>.
- 6) The rotation of the J6 axis is driven by the J6 axis motor <12> arranged in the wrist housing and the reduction gears <13>.  
Non-excitation magnetic brakes are mounted in the J6 axis motor <12>.

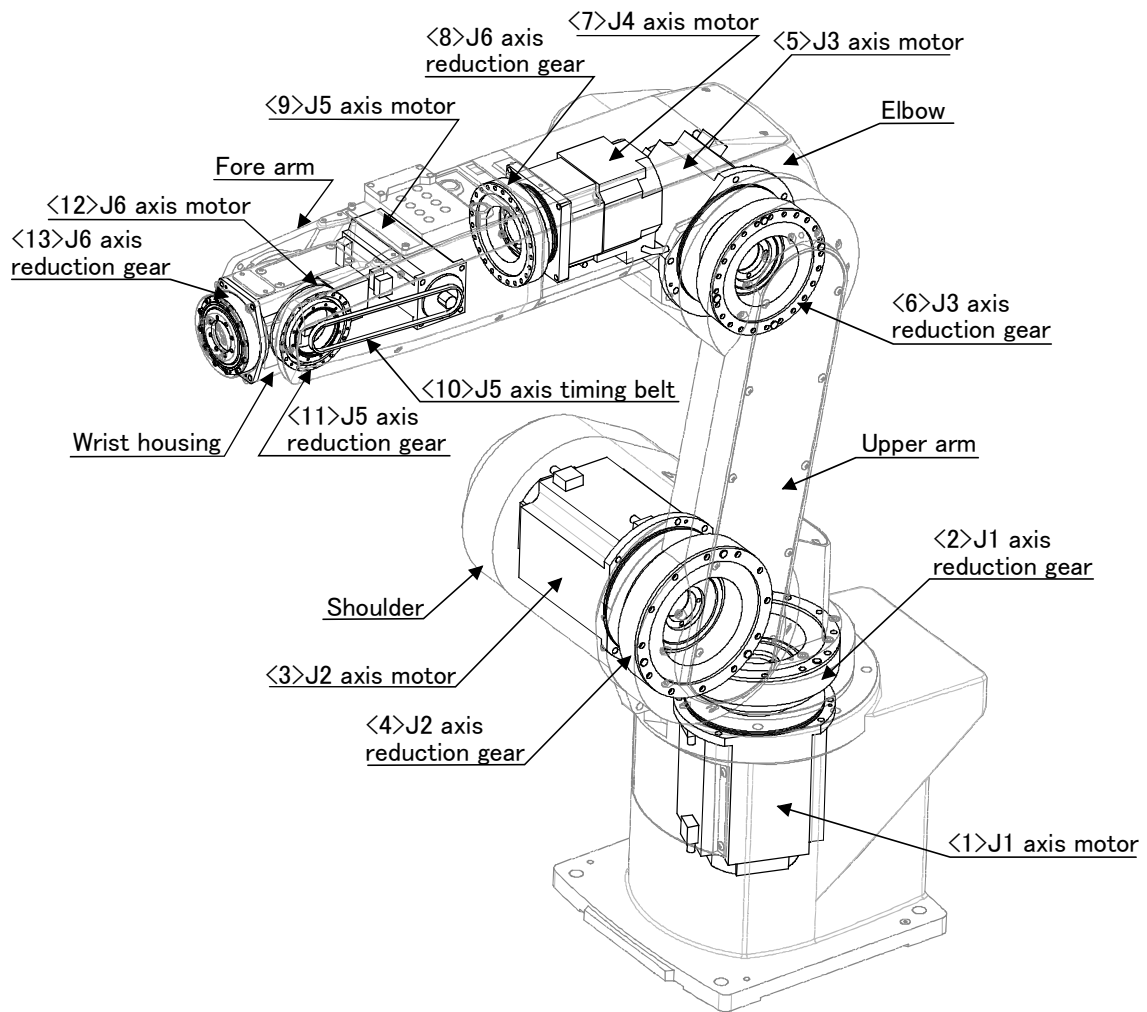

Fig 5-2 : Outline structure of robot arm

5.3.2 Installing/removing the cover

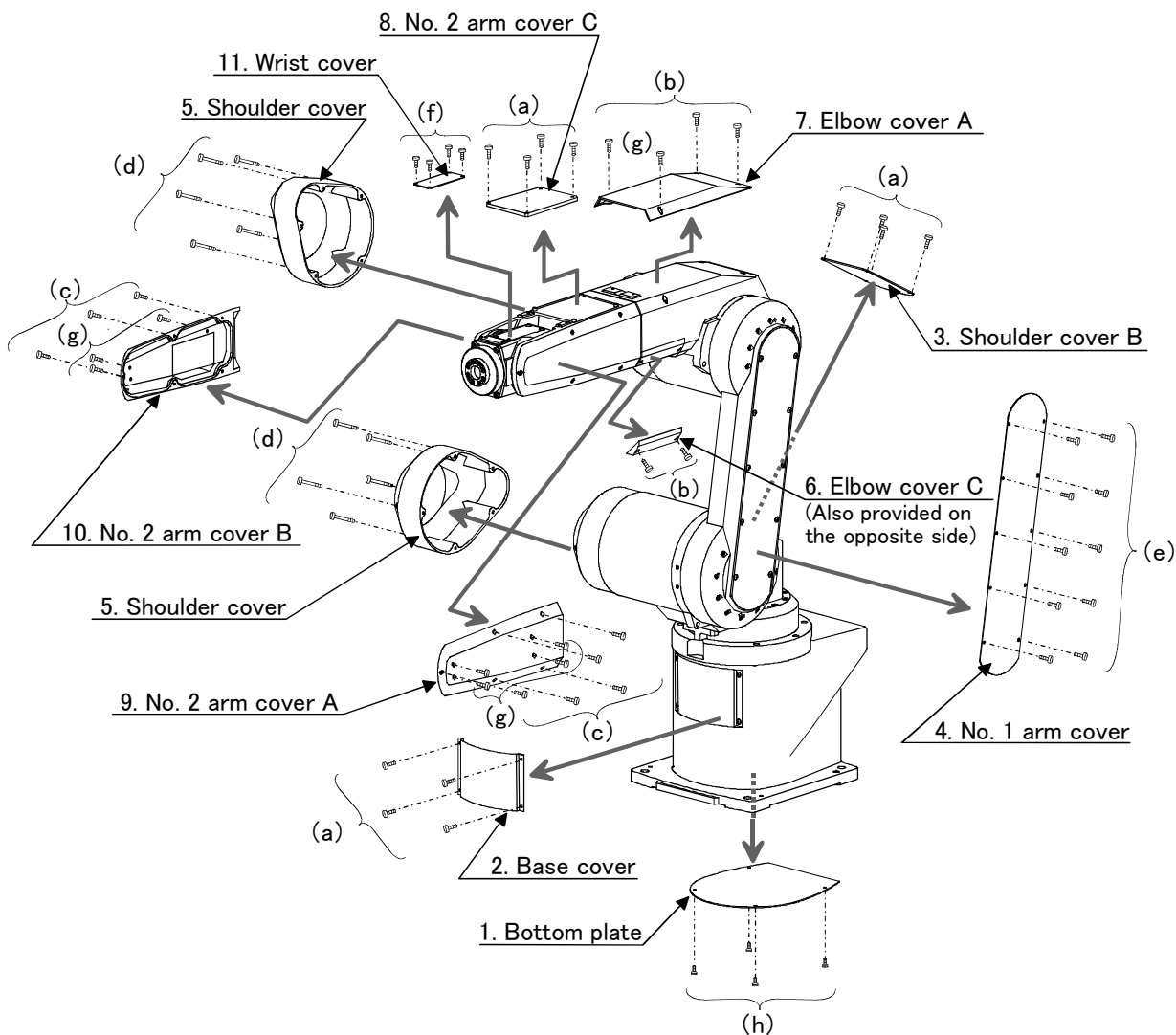

Fig.5-3 : Installing/removing the cover

**CAUTION**

Check to see that the packing has not been peeled off when the cover was mounted/removed. If it has been peeled off, report to dealer. If the cover is used with the packing peeled off, oil mist and others may enter inside the arm and cause a breakdown.



Table 5-3 : Cover names

No.	Cover names	Qty.	Remarks
1	Bottom plate	1	
2	Base cover	1	
3	Shoulder cover B	1	
4	No. 1 arm cover	1	
5	Shoulder cover	2	
6	Elbow cover C	2	
7	Elbow cover A	1	
8	No. 2 arm cover C	1	
9	No. 2 arm cover A	1	
10	No. 2 arm cover B	1	
11	Wrist cover	1	

Table 5-4 : Cover installation screw list

No.	Installation screw name	Q'ty	Remarks
a	Socket bolt M4 × 8	12	
b	Socket bolt M4 × 10	8	
c	Socket bolt M4 × 10	10	
d	Socket bolt M4 × 60	10	
e	Truss screw M4 × 8	10	for RV-12S
		14	for RV-12SL
f	Truss screw M4 × 8	4	
g	Truss screw M4 × 8	11	
h	Flat head screw M4 × 8	4	

- (1) Refer to [Fig. 5-3](#) and remove the cover.
- (2) The names of the covers are given in [Table 5-3](#), and a list of the cover installation screws is given in [Table 5-4](#).
- (3) There are some covers that may be difficult to remove due to the robot posture. In this case, change the robot posture with jog operation, and then remove the cover.
- (4) When attaching the cover after maintenance and inspection, use the detaching procedure in reverse.

The part Nos. and symbols in [Table 5-3](#) and [Table 5-4](#) correspond to [Fig. 5-3](#).

### 5.3.3 Inspection, maintenance and replacement of timing belt

This robot uses a timing belt for the drive conveyance system of the J5 axis. Compared to gears and chains, the timing belt does not require lubrication and has a low noise. However, if the belt usage method and tension adjustment are inadequate, the life could drop and noise could be generated. Sufficient aging to remove the initial elongation of the belt, and adjustment of the belt tension have been carried out before shipment from the factory. However, depending on the robot working conditions, elongation will occur gradually over a long time. The tension must be confirmed during the periodic inspection. The timing belt must be replaced in the following cases.

#### (1) Timing belt replacement period

The timing belt life is greatly affected by the robot working conditions, so a set time cannot be given. However, if the following symptoms occur, replace the belt.

- 1) When cracks form at the base or back of the belt teeth.
- 2) When the belt expands due to adherence of oil, etc.
- 3) When the belt teeth wear (to approx. half of the tooth width).
- 4) When the belt teeth jump due to belt teeth wear.
- 5) When the belt snaps.



#### CAUTION

Due to the manufacturing of the timing belt, initial wear will occur. Wear chips may accumulate in the cover after approx. 300 Hr of operating the robot, but this is not a fault. If the wear chips appear soon after wiping them off, replace the belt.



#### CAUTION

When the belt is replaced, the machine system origin may deviate. In this case, the position data must be reviewed.

## (2) Inspection, maintenance and replacement of J5-axis timing belt

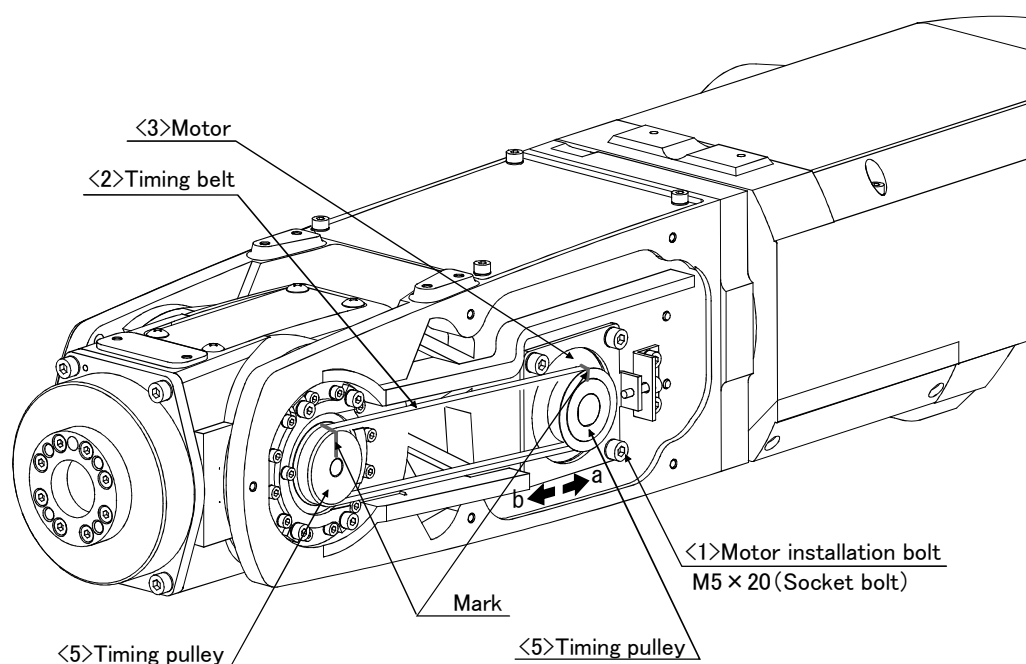

Fig.5-4 : Inspection, maintenance and replacement of J5-axis timing belt

#### ■ Inspecting the J5 axis timing belt

- 1) Confirm that the robot controller power is OFF.
- 2) Refer to "5.3.2 Installing/removing the cover" on page 44, and remove the No. 2 arm cover A, B.
- 3) Visually confirm that the symptoms indicated in "(1)Timing belt replacement period" have not occurred with the timing belt.
- 4) Confirm that the belt tension is adjusted to slacken approx. 2.5mm when the center of the belt is lightly pressed with a finger (approx. 2N) as shown in "Fig.5-5 : Belt tension".

#### ■ Adjusting the J5 axis timing belt

- 1) Carry out steps "1)" and "2)" indicated in "■ Inspecting the J5 axis timing belt" above.
- 2) Lightly loosen the three motor installation bolts <1>. (Do not loosen too much.)
- 3) Move the motor <3> in the directions of the arrows shown in Fig. 5-4, using the tension adjustment screw while checking the tension of the timing belt <2>. Lightly pushing the center of the belt with your finger (approximately 2 N), move the motor to the position where the belt flexes about 2.5 mm.
- 4) The belt tension will increase when moved in the direction of arrow "a", and will decrease when moved in the direction of arrow "b".
- 5) If the belt is loosened too much when adjusting the tension causing it to come off the timing pulleys <4> and <5>, or if the belt and pulley teeth engagement is deviated, the machine system's origin will deviate.
- 6) After adjusting, securely tighten the three motor installation bolts <1>. Improper tightening can cause the belt to loosen with vibration.

#### ■ Replacing the J5 axis timing belt

- 1) Fig. 5-4 shows the methods for inspecting, adjusting and replacing the timing belt.
- 2) Move the robot posture with the teaching pendant so that the J5 axis may be downward. (Turn it to the direction of gravity.)
- 3) Make sure that the pulleys do not move while replacing the belt.
- 4) If the pulley <4> and <5> position relation deviates, the position could deviate.
- 5) Make marks on the timing belt <2> and timing pulleys <4> and <5> with a felt-tip pen as shown in Fig. 5-4 so that the engagement of the timing belt <2> and timing pulleys <4> and <5> does not deviate.
- 6) Loosen the three motor installation screws <1>, and remove the belt.
- 7) Copy the marks onto the new timing belt. Make sure that both belts are tense when making the marks.
- 8) Align the new timing belt with the marks on the timing pulleys <4> and <5>, and install.
- 9) Refer to steps "3)" to "6)" in "■ Adjusting the J5 axis timing belt" and "(3)Timing belt tension" to adjust the tension.
- 10) The position could deviate after the belt is replaced. Confirm that the position has not deviated. If deviated, refer to "5.5 Resetting the origin" on page 53, and reset the origin position.

(3) Timing belt tension

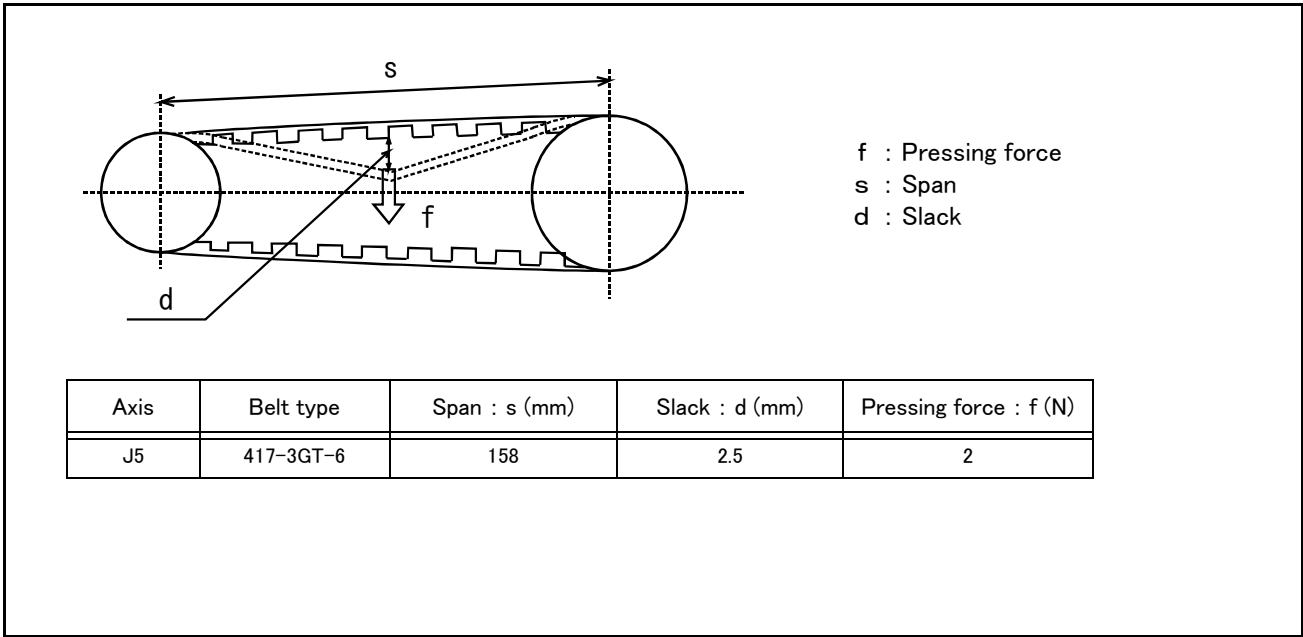

Fig.5-5 : Belt tension

The timing belt can satisfactorily convey the drive and keep a durable force only when it has an adequate tension. The belt tension should not be too tight or too loose. Instead, it should be adjusted to a degree that elasticity is felt when the belt is pressed with the thumb. If the belt tension is too weak, the belt loosening side will vibrate. On the other hand, if the belt tension is too strong, a sharp sound will be heard and the belt tension side will vibrate. The detailed adjustment (tension) is shown in Fig. 5-5.

Check and adjust with the belt pressing force f and the slack amount d between span s.

5.3.4 Lubrication

(1) Lubrication position and specifications

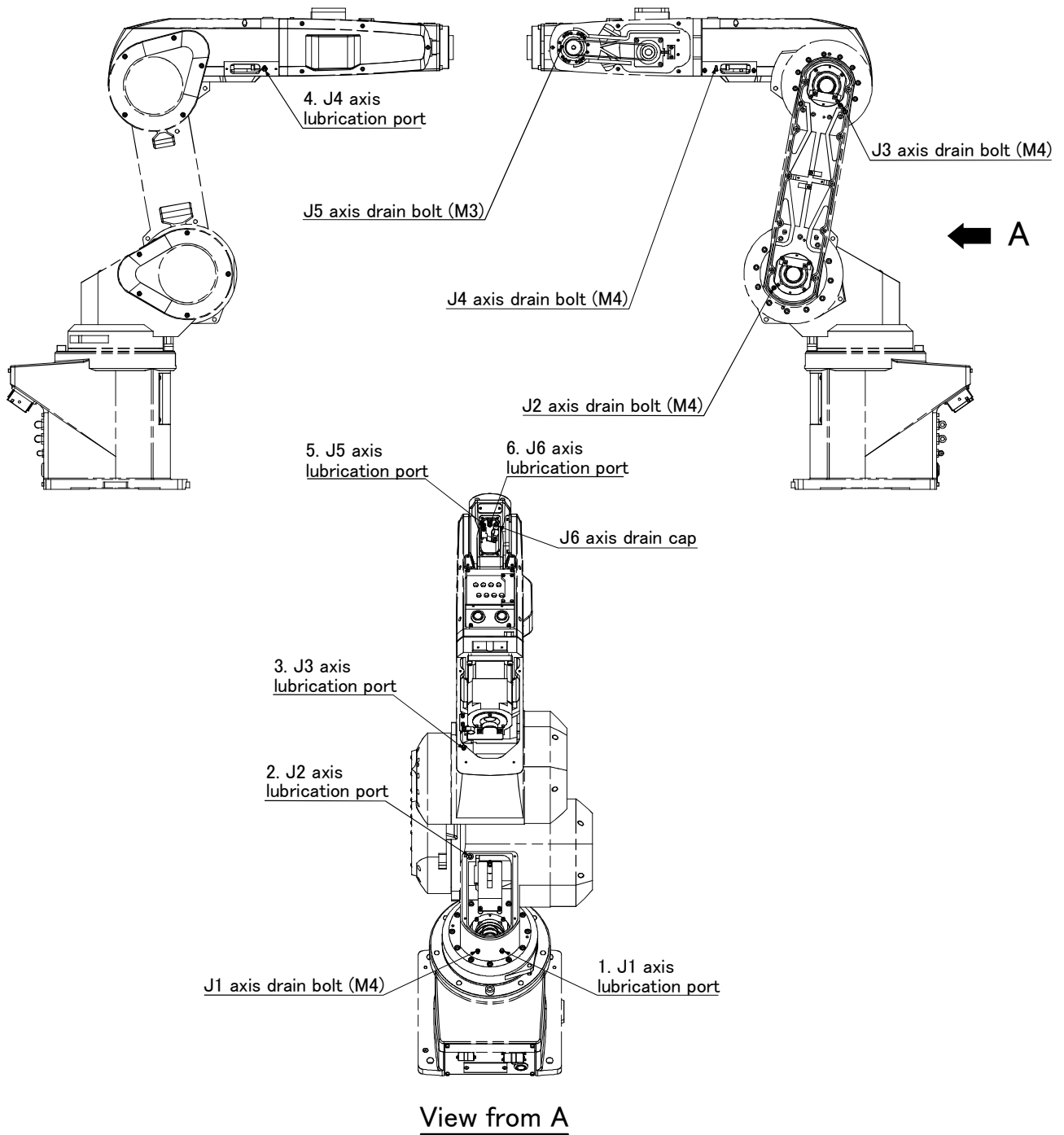

Fig.5-6 : Lubrication positions

Table 5-5 : Lubrication specifications

No.	Parts to be lubricated	Oiling method	Lubrication oil (maker)	Default charge amount	Lubrication interval	Lubrication amount	Cover to remove
1	J1 axis reduction gears	Grease nipple WA-610	Grease Harmonic grease SK-1A (Japan Harmonic Systems)	130g	6000Hr	30g	Shoulder cover B
2	J2 axis reduction gears			130g		20g	Shoulder cover B, No.1 arm cover
3	J3 axis reduction gears			60g		15g	Elbow cover A, No.1 arm cover
4	J4 axis reduction gears			30g		5g	Elbow cover C (Two places)
5	J5 axis reduction gears			16g		5g	No.2 arm cover (A) Wrist cover
6	J6 axis reduction gears			16g		2g	Wrist cover

The grease nipple position is shown in . The lubrication specifications for each place are shown in [Fig. 5-6](#)  
[Caution]

- The brands of grease given in [Table 5-5](#) are those filled when the robot is shipped.
- The lubrication time is a cumulative value of the operation at the maximum speed. If the operation has been suspended, or if the designated speed is slow, the lubrication time can be lengthened in proportion. (The "Lubrication interval" in [Table 5-5](#) is usually based on the three-year inspection. 8Hr x 20 days x 36 months = 6000Hr.)
- Depending on the robot operation state, the lubrication time will fluctuate, so determine the time according to the state so that the grease does not run out.
- With the maintenance forecast function of the personal computer support software (option), the guidance of lubrication time is calculated according to the operating environment of the customer.
- The numbers in the correspond to the supply positions in [Fig. 5-6](#).
- Avoid excessive lubrication since it may lead to grease leak. Also, the number of lubrications is limited to 3 times.

## (2) Lubrication method

- 1) Set the robot to the posture shown in [Fig. 5-6](#).
- 2) Refer to the "[5.3.2 Installing/removing the cover](#)" on page 44 and remove the covers.
- 3) Remove the drain bolt or cap.
- 4) Insert the grease shown in [Table 5-5](#) using a grease gun from the lubrication grease nipple.
- 5) Install the drain bolt or cap.
- 6) Replace the covers with the removal procedure in reverse.

### 5.3.5 Replacing the backup battery

An absolute encoder is used for the position detector, so the position must be saved with the backup battery when the power is turned OFF. The controller also uses a backup battery to save the program, etc. These batteries are installed when the robot is shipped from the factory, but as these are consumable parts, they must be replaced periodically by the customer.

The guideline for replacing the battery is one year, but this will differ according to the robot's usage state. When the battery life nears, the "Battery cumulative time over alarm (Alarm No. 7520)" will occur. Once the alarm occurs, replace all batteries in the robot arm and controller as soon as possible. Lithium batteries (type: A6BAT and ER6) are used in both the controller and robot arm.

#### (1) Replacing the robot arm battery



## CAUTION

Don't disconnect connector, etc. While replacing the battery, the encoder position data is saved by the power supplied from the controller. Thus, if the cable connection is incomplete, the encoder position data will be lost when the controller power is turned OFF. Several batteries are used in the robot arm, but replace all old batteries with new batteries at the same time.

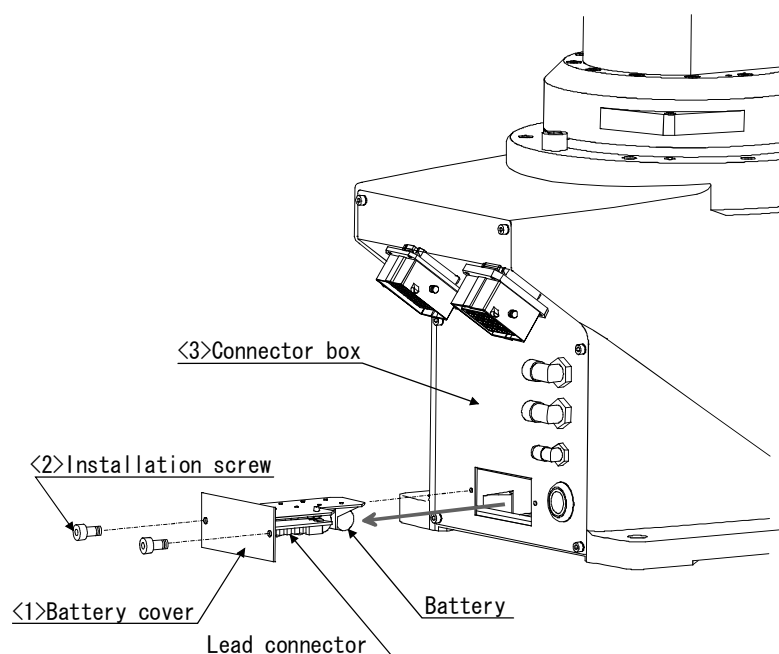

Fig.5-7 : Replacing the battery

- 1) Confirm that the robot arm and controller are connected with a cable.
- 2) Turn the controller control power ON.  
The position data is retained by the power supplied from the controller while replacing the battery. Thus, if the cable is not connected correctly, or if the controller power is OFF, the position data will be lost.
- 3) Press the emergency stop button to set the robot in the emergency stop state. This is a measure for safety, and must always be carried out.
- 4) Remove the two installation screws<2>, and remove the battery cover <1>.
- 5) The battery holder is located in the connector box <3>. Remove the old battery from the holder, and disconnect the lead connector.
- 6) Insert the new battery into the holder, and connect the lead connector. Replace all batteries with new ones at the same time.
- 7) Carry out steps 4) in reverse to install the parts.
- 8) Initialize the battery consumption time.

Always carry out this step after replacing the battery, and initialize the battery usage time. Refer to the separate "Instruction Manual/Detailed Explanation of Functions and Operations" for details on the operation methods.

[Caution] If the old battery is replaced because it has been used up, it is necessary to set the origin again. Refer to "5.5Resetting the origin" on page 53 and reset the origin using the jig method or ABS origin method.

## 5.4 Maintenance parts

The consumable parts that must be replaced periodically are shown in Table 5-6, and spare parts that may be required during repairs are shown in Table 5-7. Purchase these parts from the dealer when required. Some Mitsubishi-designated parts differ from the maker's standard parts. Thus, confirm the part name, robot arm and controller serial No. and purchase the parts from the dealer.

Table 5-6 : Consumable part list

No.	Part name	Type	Usage place	Q'ty	Supplier
1	Timing belt	417-3GT-6 M434N4	J5 axis	1	Mitsubishi Electric
2	Grease	SK-1A	Reduction gears of each axis	An needed	
3	Lithium battery	A6BAT	In battery cover	5	

Table 5-7 : Spare parts list

No.	Part name	Type	Usage place	Q'ty	Supplier
1	AC servo motor	BU240C011G51	J1 axis	1	Mitsubishi Electric
2		BU240C011G52	J2 axis	1	
3		BU240C011G53	J3 axis	1	
4		BU240C011G54	J4 axis	1	
5		BU240C010G51	J5 axis	1	
6		BU240C010G52	J6 axis	1	
7	Stopper	BU224D594H01	Mechanical stoppers of the J1 to J3 axes	2 per axis	
RV-12S/RV-12SC					
8	Reduction gears	P961K000P64	J1 axis	1	Mitsubishi Electric
9		P961K000P65	J2 axis	1	
10		P961K000P70	J3 axis	1	
11		P961K000P61	J4 axis	1	
12		P961K000P62	J5 axis	1	
13		P961K000P39	J6 axis	1	
RV-12SL/RV-12SLC					
14	Reduction gears	P961K000P66	J1 axis	1	Mitsubishi Electric
15		P961K000P67	J2 axis	1	
16		P961K000P71	J3 axis	1	
17		P961K000P61	J4 axis	1	
18		P961K000P62	J5 axis	1	
19		P961K000P39	J6 axis	1	

Note) Confirm the robot arm serial No., and contact the dealer for the type.



## 5.5 Resetting the origin

The origin is set so that the robot can be used with a high accuracy. After purchasing the robot, always carry out this step before starting work. The origin must be reset if the combination of robot and controller being used is changed or if the motor is changed causing an encoder area. The types of origin setting methods are shown in [Table 5-8](#).

[Caution] If the old battery is replaced because it has been used up, it is necessary to set the origin again. Reset the origin using the jig method or ABS origin method.

Table 5-8 : Origin setting method

No	Method	Explanation	Remarks
1	Origin data input method	The origin data set as the default is input from the T/B.	The setting method is explained in <a href="#">"2.3Setting the origin" on page 12</a> .
2	Jig method	The origin posture is set with the calibration jig installed.	The setting method is explained in <a href="#">"5.5.1Jig method" on page 54</a> .
3	User origin method	A randomly designated position is set as the origin posture.	Before using this method, the origin must be set with the other method. The setting method is explained in <a href="#">"5.5.2User origin method" on page 61</a> .
4	ABS origin method	This method is used when the encoder backup data lost in the cause such as battery cutting.	Before using this method, the origin must be set with the other method with same encoder. The setting method is explained in <a href="#">"5.5.3ABS origin method" on page 63</a> .

Note) Although "OP setting" by the mechanical stopper method can also be selected, it is not recommended for this robot. Please use one of the methods listed in [Table 5-8](#).

### 5.5.1 Jig method

The procedure of setting the origin with the calibration jig is shown below.

This operation is carried out with the teaching pendant. Set the [MODE] switch on the front of the controller to "TEACH", and set the [ENABLE/DISABLE] switch on the teaching pendant to "ENABLE" to enable the teaching pendant.

The following operation is carried out while lightly pressing the deadman switch on the teaching pendant.

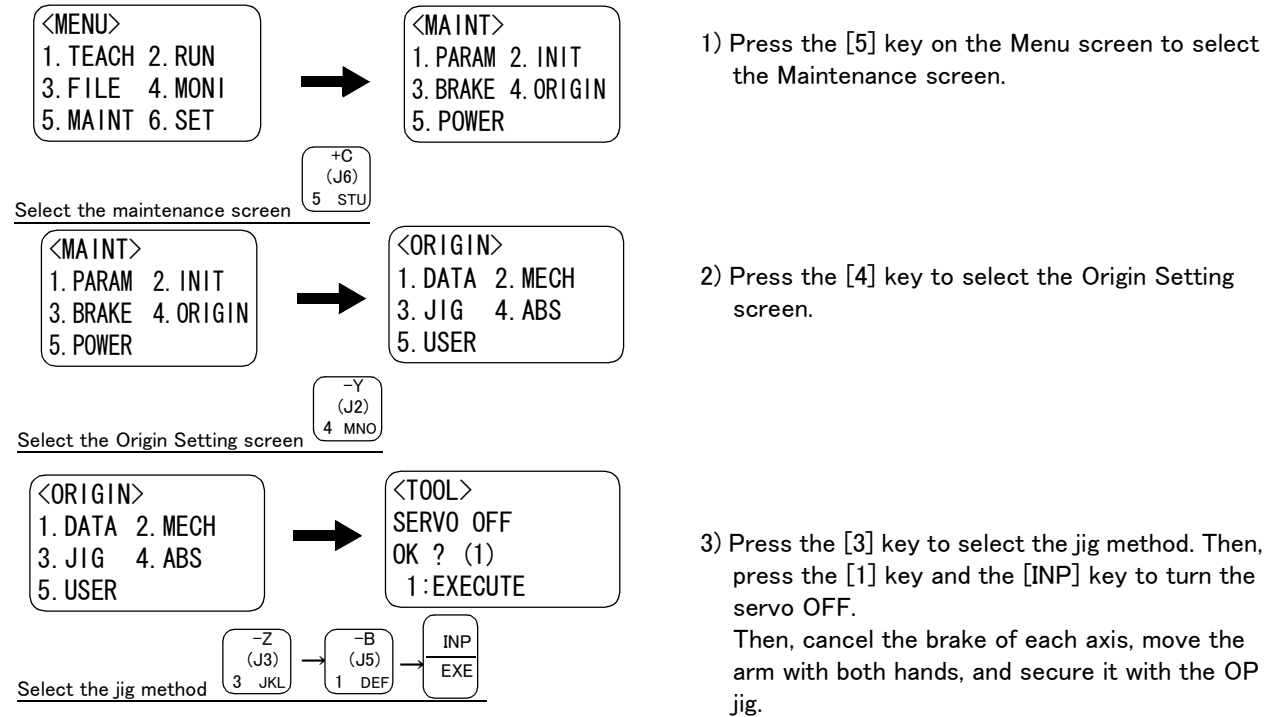

### CAUTION

At this point release the brakes and move the arm with both hands. To ensure safety, the brake-release procedure described below should always be done by two persons.

## (1) J1 axis origin setting

```

<TOOL> 12345678
BRAKE (00000000)
SET AXIS(11110000)
ORIGIN :NOT DEF

```

Designate the origin setting axis

```

-B
(J5)
1 DEF

```

- 1) Move the J1 axis slowly toward the front using both hands. Align the pinhole of the No.1 arm and the pinhole at the base section, feed through the origin jig ( $\phi 8$ ) into the pinholes and fasten.

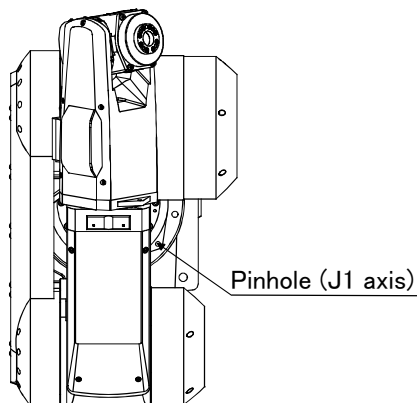

Diagram of the robot viewed from the top

Move the cursor

```

RPL
↓

```

```

<TOOL> 12345678
BRAKE (00000000)
SET AXIS(10000000)
ORIGIN :NOT DEF

```

Designate the origin setting axis

```

-B      -C      INP
(J5)    (J6)    EXE
1 DEF   0 ABC

```

- 2) Press the [ ↓ ] key. The cursor will move to "SET AXIS".

- 3) Designate the axis for which the origin is to be set.. Set "1" for the 1 axis, and set "0" for the other axes. Then, press [INP] key. Next, a confirmation screen will appear.

```

<TOOL>
SET ORIGIN
OK?(1)
1:EXECUTE

```

Set the origin

```

-B      INP
(J5)    EXE
1 DEF

```

- 4) Press the [1] and [INP] keys.  
The origin posture will be set.

- 5) Setting of the origin is completed.

```

<TOOL> 12345678
BRAKE (00000000)
SET AXIS (10000000)
ORIGIN :COMPLETED

```

- 6) Refer to "5.5.4 Recording the origin data" on page 65 in this manual, and record the origin data on the origin data seal.

## ◆◆◆ Origin setting axis designation ◆◆◆

Move the cursor to the "SET AXIS" axis No. in the origin setting with the [ ← ] or [ → ] key.

The origin is set only for the axis for which a "1" is displayed on the screen. If the origin is not to be set, press the [0] key and display a "0".

(2) J2 axis origin setting

```

<TOOL> 12345678
BRAKE (00000000)
SET AXIS(11110000)
ORIGIN :NOT DEF
    
```

Designate the origin setting axis

-B (J5)  
1 DEF

1) Slowly rotate the J2 axis in the direction of minus 90° with both hands. Align the pinholes of the No. 1 arm and shoulder, feed through the origin jig (φ8) into the pinholes and fasten.

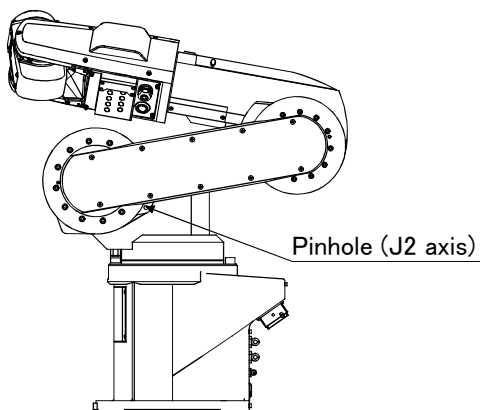

Move the cursor

RPL  
↓

```

<TOOL> 12345678
BRAKE (00000000)
SET AXIS(01000000)
ORIGIN :NOT DEF
    
```

Designate the origin setting axis

-B (J5) 1 DEF    -C (J6) 0 ABC    INP EXE

2) Press the [ ↓ ] key. The cursor will move to "SET AXIS".

3) Designate the axis for which the origin is to be set. Set "1" for the 2 axis, and set "0" for the other axes. Then, press [INP] key. Next, a confirmation screen will appear.

```

<TOOL>
SET ORIGIN
OK?(1)
1:EXECUTE
    
```

Set the origin

-B (J5) 1 DEF    INP EXE

4) Press the [1] and [INP] keys. The origin posture will be set.

```

<TOOL> 12345678
BRAKE (00000000)
SET AXIS (01000000)
ORIGIN :COMPLETED
    
```

5) Setting of the origin is completed.

6) Refer to "5.5.4 Recording the origin data" on page 65 in this manual, and record the origin data on the origin data seal.

◆◆◆ Origin setting axis designation ◆◆◆

Move the cursor to the "SET AXIS" axis No. in the origin setting with the [ ← ] or [ → ] key. The origin is set only for the axis for which a "1" is displayed on the screen. If the origin is not to be set, press the [0] key and display a "0".

## (3) J3 axis origin setting

```

<TOOL> 12345678
BRAKE (00000000)
SET AXIS(11110000)
ORIGIN :NOT DEF

```

Designate the origin setting axis

```

-B
(J5)
1 DEF

```

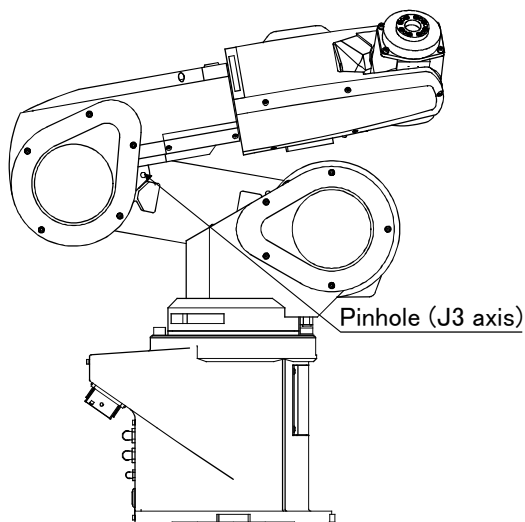

```

RPL
↓

```

Move the cursor

```

<TOOL> 12345678
BRAKE (00000000)
SET AXIS(00100000)
ORIGIN :NOT DEF

```

Designate the origin setting axis

```

-B      -C      INP
(J5)    (J6)    EXE
1 DEF   0 ABC

```

```

<TOOL>
SET ORIGIN
OK?(1)
1:EXECUTE

```

Set the origin

```

-B      INP
(J5)    EXE
1 DEF

```

```

<TOOL> 12345678
BRAKE (00000000)
SET AXIS (00100000)
ORIGIN :COMPLETED

```

- 1) Slowly rotate the J3 axis to the plus direction with both hands. Align the pinholes of the No. 1 and No. 2 arm, feed through the origin jig ( $\phi 8$ ) into the pinholes and fasten.

- 2) Press the [ ↓ ] key. The cursor will move to "SET AXIS".

- 3) Designate the axis for which the origin is to be set. Set "1" for the 3 axis, and set "0" for the other axes. Then, press [INP] key. Next, a confirmation screen will appear.

- 4) Press the [1] and [INP] keys. The origin posture will be set.

- 5) Setting of the origin is completed.

- 6) Refer to "5.5.4 Recording the origin data" on page 65 in this manual, and record the origin data on the origin data seal.

## ◆◆◆ Origin setting axis designation ◆◆◆

Move the cursor to the "SET AXIS" axis No. in the origin setting with the [ ← ] or [ → ] key.

The origin is set only for the axis for which a "1" is displayed on the screen. If the origin is not to be set, press the [0] key and display a "0".

(4) J4 axis origin setting

```
<TOOL> 12345678
BRAKE (00000000)
SET AXIS(11110000)
ORIGIN :NOT DEF
```

```
-B
(J5)
1 DEF
```

Designate the origin setting axis

- 1) Slowly rotate the J4 axis to the plus direction with both hands. Align the pinholes of the No. 2 arm and elbow, feed through the origin jig ( $\phi 6$ ) into the pinholes and fasten.

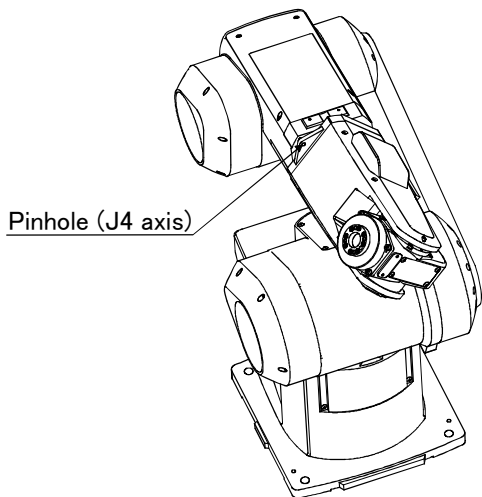

```
RPL
↓
```

Move the cursor

```
<TOOL> 12345678
BRAKE (00000000)
SET AXIS(00010000)
ORIGIN :NOT DEF
```

```
-B (J5)  -C (J6)  INP
1 DEF   0 ABC   EXE
```

Designate the origin setting axis

- 2) Press the [ ↓ ] key. The cursor will move to "SET AXIS".
- 3) Designate the axis for which the origin is to be set. Set "1" for the 4 axis, and set "0" for the other axes. Then, press [INP] key. Next, a confirmation screen will appear.

```
<TOOL>
SET ORIGIN
OK?(1)
1:EXECUTE
```

```
-B (J5)  INP
1 DEF   EXE
```

Set the origin

- 4) Press the [1] and [INP] keys. The origin posture will be set.

```
<TOOL> 12345678
BRAKE (00000000)
SET AXIS (00010000)
ORIGIN :COMPLETED
```

- 5) Setting of the origin is completed.
- 6) Refer to "5.5.4 Recording the origin data" on page 65 in this manual, and record the origin data on the origin data seal.

◆◆◆ Origin setting axis designation ◆◆◆

Move the cursor to the "SET AXIS" axis No. in the origin setting with the [ ← ] or [ → ] key. The origin is set only for the axis for which a "1" is displayed on the screen. If the origin is not to be set, press the [0] key and display a "0".

## (5) J5 axis origin setting

```

<TOOL> 12345678
BRAKE (00000000)
SET AXIS(11110000)
ORIGIN :NOT DEF

```

Designate the origin setting axis

```

-B
(J5)
1 DEF

```

- 1) Slowly rotate the J5 axis in the direction of plus 90° with both hands. Align the pinholes of the No. 2 arm and wrist housing, feed through the origin jig ( $\phi 6$ ) into the pinholes and fasten.

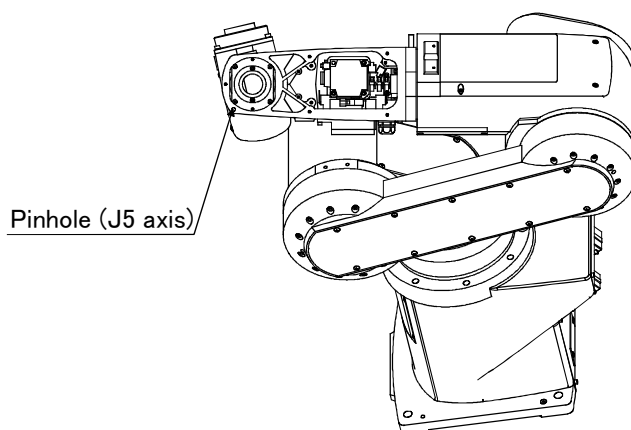

Move the cursor

```

RPL
↓

```

```

<TOOL> 12345678
BRAKE (00000000)
SET AXIS(00001000)
ORIGIN :NOT DEF

```

Designate the origin setting axis

```

-B      -C      INP
(J5)    (J6)    /
1 DEF   0 ABC   /

```

- 2) Press the [ ↓ ] key. The cursor will move to "SET AXIS".

- 3) Designate the axis for which the origin is to be set. Set "1" for the 5 axis, and set "0" for the other axes. Then, press [INP] key. Next, a confirmation screen will appear.

```

<TOOL>
SET ORIGIN
OK?(1)
1:EXECUTE

```

Set the origin

```

-B      INP
(J5)    /
1 DEF   /

```

- 4) Press the [1] and [INP] keys. The origin posture will be set.

```

<TOOL> 12345678
BRAKE (00000000)
SET AXIS (00001000)
ORIGIN :COMPLETED

```

- 5) Setting of the origin is completed.

- 6) Refer to "5.5.4 Recording the origin data" on page 65 in this manual, and record the origin data on the origin data seal.

## ◆◆◆ Origin setting axis designation ◆◆◆

Move the cursor to the "SET AXIS" axis No. in the origin setting with the [ ← ] or [ → ] key.

The origin is set only for the axis for which a "1" is displayed on the screen. If the origin is not to be set, press the [0] key and display a "0".

(6) J6 axis origin setting

```
<TOOL> 12345678
BRAKE (00000000)
SET AXIS(11110000)
ORIGIN :NOT DEF
```

Designate the origin setting axis

```
-B
(J5)
1 DEF
```

- 1) Slowly move the J6 axis with both hands, and align the ABS mark of the wrist housing with the ABS mark of the hand mounting flange.

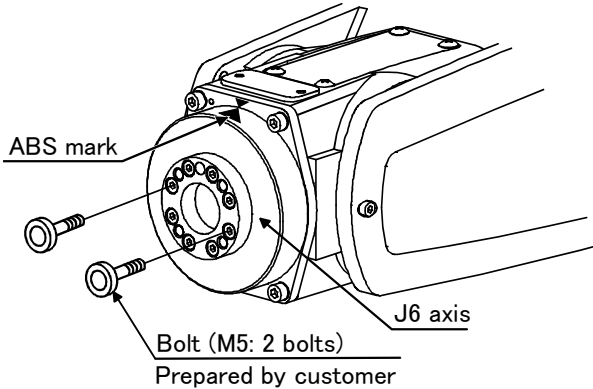

**CAUTION** The J6-axis dose not have a mechanical stopper. When setting the origin position , do not rotate the axis more than themotion range( ± 200 deg.).

Move the cursor

```
RPL
↓
```

- 2) Press the [ ↓ ] key. The cursor will move to "SET AXIS".

```
<TOOL> 12345678
BRAKE (00000000)
SET AXIS(0000100)
ORIGIN :NOT DEF
```

Designate the origin setting axis

```
-B (J5) 1 DEF
-C (J6) 0 ABC
[INP]
[EXE]
```

- 3) Designate the axis for which the origin is to be set. Set "1" for the 6 axis, and set "0" for the other axes. Then, press [INP] key. Next, a confirmation screen will appear.

```
<TOOL>
SET ORIGIN
OK?(1)
1:EXECUTE
```

Set the origin

```
-B (J5)
1 DEF → [INP]
[EXE]
```

- 4) Press the [1] and [INP] keys. The origin posture will be set.

```
<TOOL> 12345678
BRAKE (00000000)
SET AXIS (00000100)
ORIGIN :COMPLETED
```

- 5) Setting of the origin is completed.

- 6) Refer to "5.5.4Recording the origin data" on page 65 in this manual, and record the origin data on the origin data seal.

◆◆◆ Origin setting axis designation ◆◆◆

Move the cursor to the "SET AXIS" axis No. in the origin setting with the [ ← ] or [ → ] key. The origin is set only for the axis for which a "1" is displayed on the screen. If the origin is not to be set, press the [0] key and display a "0".

This completes the setting of the origin with the jig method.



## 5.5.2 User origin method

**CAUTION** Before using this method, the origin must be set with the other method. The setting method is explained in “5.5.2 User origin method” on page 61.

The procedure for setting the origin with the user origin method is explained below.

This operation is carried out with the teaching pendant. Set the [MODE] switch on the front of the controller to “TEACH”, and set the [ENABLE/DISABLE] switch on the teaching pendant to “ENABLE” to enable the teaching pendant.

The operation method is shown below.

When setting the origin for the first time using this method, carry out the operations in order from step 1). For the second and following time, move the robot arm to the user origin position with jog operation, and accurately position all axes. Then start the procedure from step 4).

## 1) Determine the user origin position

Move the robot to the position to be set as the origin with jog operation. Refer to “2.4 Confirming the operation” on page 18 for details on the jog operation.

**CAUTION** Choose the user origin position as the position where it doesn't move by the gravity. This position is left as a guideline to position all axes with jog operation when setting the origin again with this method.

2) Enter the JOINT jog mode, and display the joint coordinates on the teaching pendant screen. Record the value of the axis for which the origin is to be set.

3) Input the value recorded in the “user designated origin parameter (USRORG)”.

The parameter details and input methods are described in the separate “Instruction Manual/Detailed Explanation of Functions and Operations”. Refer to that manual and input the user designated origin position.

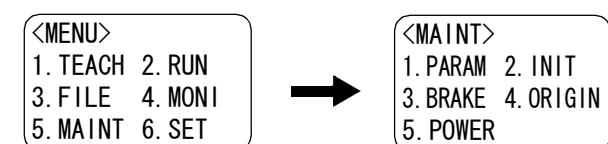

Display the maintenance screen

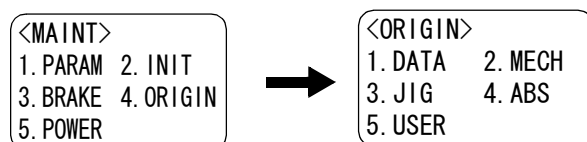

Display the origin setting method selection screen

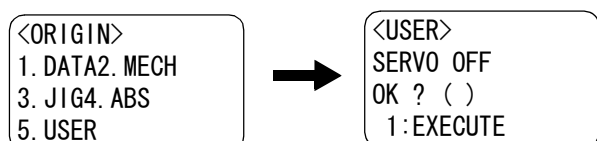

4) Next, set the origin.

Press the [MENU] key to display the Menu screen.

5) Press the [5] key to display the Maintenance screen.

6) Press the [4] key to select the Origin Setting screen.

7) Press the [5] key to select the user origin method.

Then, press [1] key and [INP] key to turn OFF the servo.

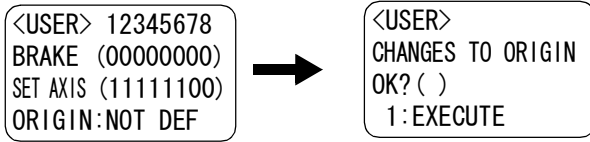

8) Press the [ ↓ ] key, and input “1” for the axis for which the origin is to be set. Press the [INP] key to display the Confirmation screen.

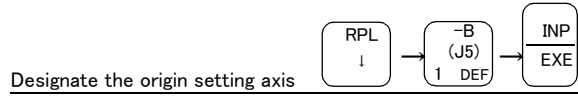

Designate the origin setting axis

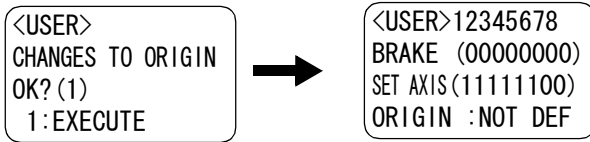

9) Press the [1] key and then the [INP] key. The origin will be set

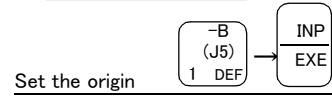

Set the origin

This completes the setting of the origin with the user origin method.

### 5.5.3 ABS origin method

When the origin setting of the robot is performed for the first time, this product records the angular position of the origin within one rotation of the encoder as the offset value. If the origin setting is performed according to the ABS origin method, this value is used to suppress variations in the origin setting operations and to reproduce the initial origin position accurately.

This operation is carried out with the teaching pendant. Set the [MODE] switch on the front of the controller to "TEACH", and set the [ENABLE/DISABLE] switch on the teaching pendant to "ENABLE" to enable the teaching pendant.

First, set to the ABS mark arrow of the axis for which the origin is to be set with jog operation. This can be set for all axes simultaneously or each axis independently.

When setting the ABS mark, always view the operations from the mark, and set at the end of the triangular mark. The positions where the ABS mark is attached are shown in Fig. 5-28. Refer to "(1)JOINT jog operation" on page 21" for details on the jog operation.

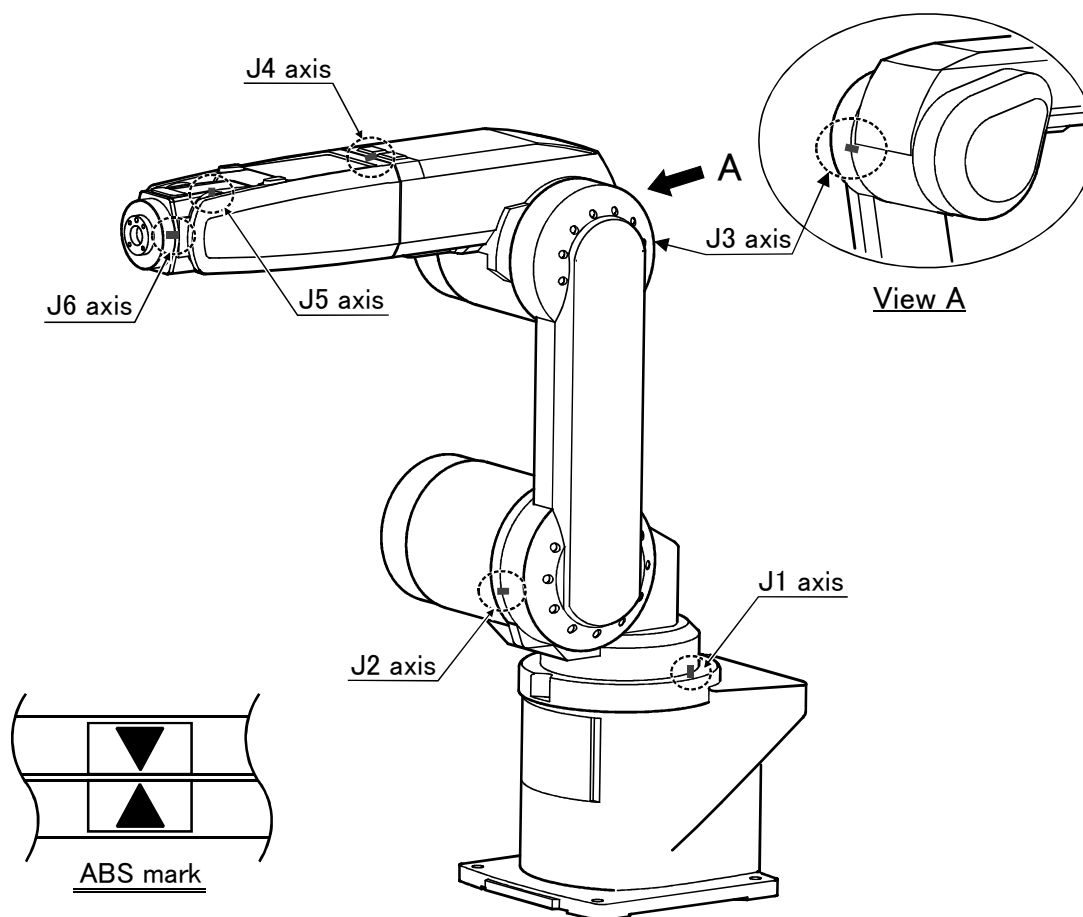

Fig.5-8 : ABS mark attachment positions

The procedures for setting the origin with the ABS method are explained below.

(1) Select the T/B

<MENU>  
1.TEACH 2.RUN  
3.FILE 4.MONI  
5.MAINT 6.SET



<MAINT>  
1.PARAM 2.INIT  
3.BRAKE 4.ORIGIN  
5.POWER

1) Press the [5] key on the Menu screen to select the Maintenance screen.

+C  
(J6)  
5 STU

Select the Maintenance screen

<MAINT>  
1.PARAM 2.INIT  
3.BRAKE 4.ORIGIN  
5.POWER



<ORIGIN>  
1.DATA 2.MECH  
3.JIG 4.ABS  
5.USER

2) Press the [4] key to select the Origin Setting screen.

-Y  
(J2)  
4 MNO

Select the Origin Setting screen

<ORIGIN>  
1.DATA 2.MECH  
3.JIG 4.ABS  
5.USER



<ABS>  
SERVO OFF  
OK ? (1)  
1:EXECUTE

3) Press the [4] key to select the ABS method. After that, press the [1] key and [INP] key to turn the servo OFF.

-Y  
(J2)  
4 MNO

-B  
(J5)  
1 DEF

INP  
EXE

Select the ABS method

<ABS> 12345678  
BRAKE(00000000)  
SET AXIS (11110000)  
ORIGIN :NOT DEF



<ABS>  
SERVO OFF  
OK ? (1)  
1:EXECUTE

4) Press the [ ↓ ] key, and input "1" for the axis to set the origin in "SET AXIS". Press the [INP] key to display the Confirmation screen.

RPL  
↓

-B  
(J5)  
1 DEF

INP  
EXE

Execute the origin setting (confirmation)

<ABS>  
SET ORIGIN  
OK?(1)  
1:EXECUTE



<ABS> 12345678  
BRAKE (00000000)  
SET JIG (11110000)  
ORIGIN :NOT DEF

5) Press the [1] key and then press the [INP] key. The origin will be set.

-B  
(J5)  
1 DEF

INP  
EXE

Execute the origin setting

This completes the setting of the origin with the ABS method.

### 5.5.4 Recording the origin data

When the origin has been set with the jig method, record that origin data on the origin data label. With this, the origin can be set with the origin data input method the next time.

Confirm the origin data on the teaching pendant screen (origin data input screen). The origin data label is enclosed with the arm or attached on the back of the shoulder coverB.

The teaching pendant operation method and shoulder coverB removal method for confirming the origin data is the same as the methods for setting the origin with the origin data input method. Refer to [“2.3.2 Setting the origin with the origin data input method” on page 13](#), and write the origin data displayed on the teaching pendant onto the origin label.

(1) Confirming the origin data label

Remove the shoulder coverB.

Refer to [“5.3.2 Installing/removing the cover” on page 44](#), and remove the shoulder coverB.

(2) Confirming the origin data

Confirm the value displayed on the teaching pendant's Origin Data Input screen.

Refer to [“2.3.2 Setting the origin with the origin data input method”](#) [“\(5\) Inputting the origin data”](#), and display the Origin Data Input screen on the teaching pendant display screen.

(3) Recording the origin data

Write the origin data displayed on the teaching pendant to the origin data label attached to the back of the shoulder coverB. Refer to [“Fig. 2-8 Origin data label \(an example\)” on page 13](#), and [“Fig. 2-9 Correspondence of origin data label and axis” on page 16](#) for details on the origin data label.

(4) Installing the cover

Install the shoulder coverB removed in step [“\(1\) Confirming the origin data label”](#) above.

Refer to [“5.3.2 Installing/removing the cover” on page 44](#), and replace the shoulder coverB.

This completes the recording of the origin data.

## 6 Appendix

### Appendix 1 : Configuration flag

The configuration flag indicates the robot posture.

For the 6-axis type robot, the robot hand end is saved with the position data configured of X, Y, Z, A, B and C. However, even with the same position data, there are several postures that the robot can change to. The posture is expressed by this configuration flag, and the posture is saved with FL1 in the position constant (X, Y, Z, A, B, C) (FL1, FL2).

The types of configuration flags are shown below.

#### (1) RIGHT/LEFT

Q is center of J5 axis rotation in comparison with the plane through the J2 axis vertical to the ground.

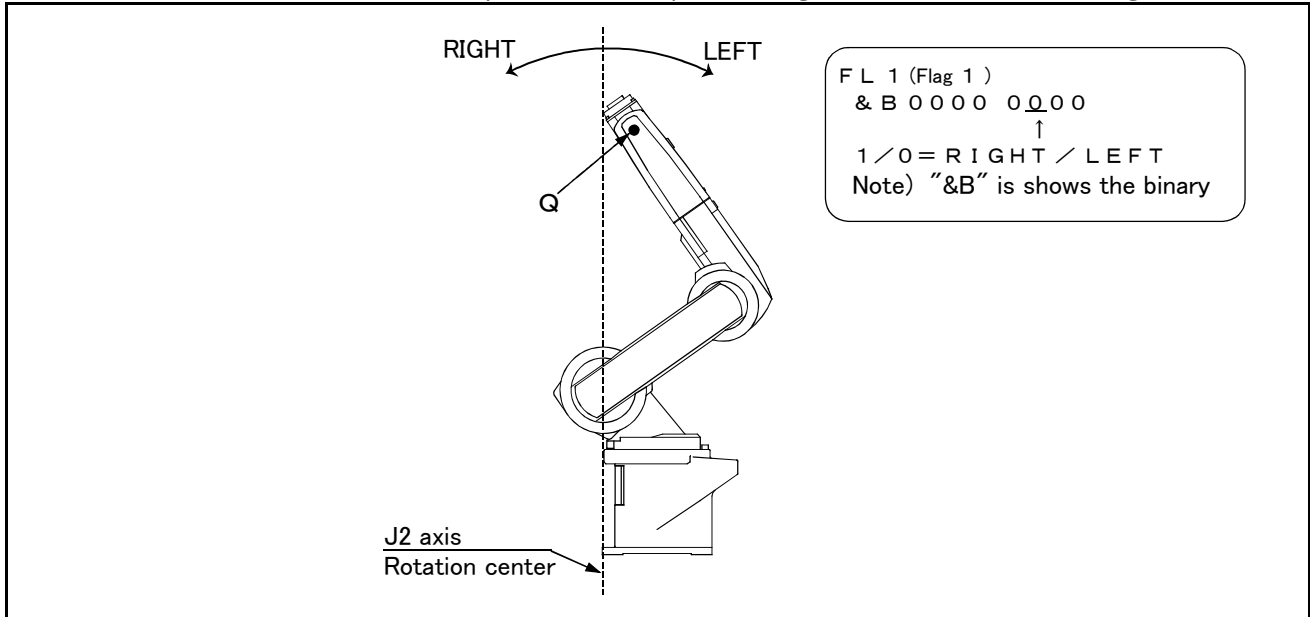

Fig.6-1 : Configuration flag (RIGHT/LEFT)

#### (2) ABOVE/BELOW

Q is center of J5 axis rotation in comparison with the plane through both the J3 and the J2 axis.

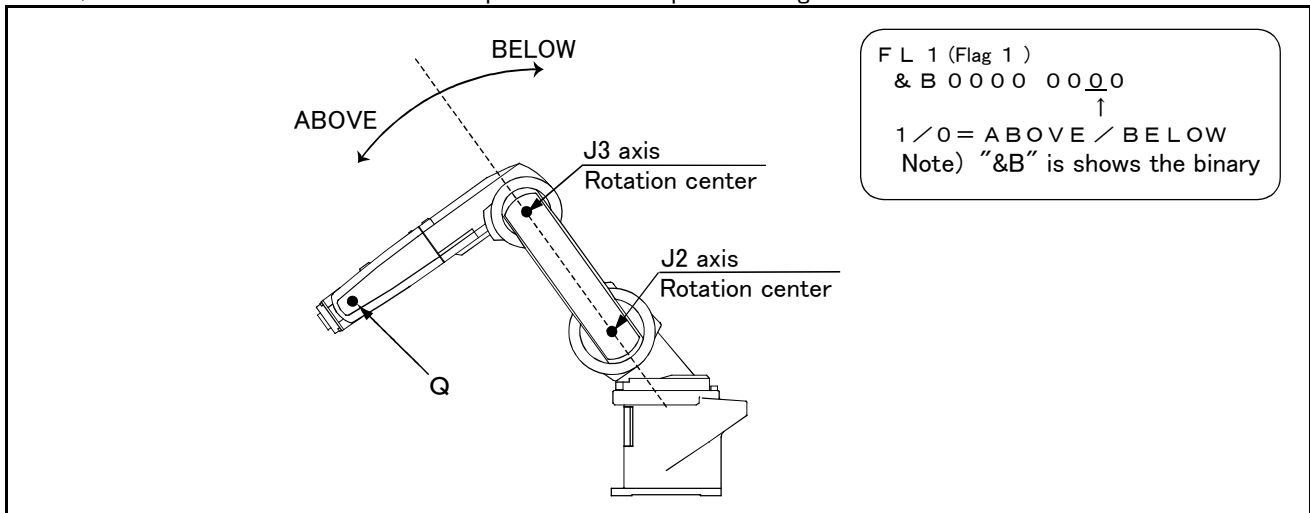

Fig.6-2 : Configuration flag (ABOVE/BELOW)

## (3) NONFLIP/FLIP (6-axis robot only.)

This means in which side the J6 axis is in comparison with the plane through both the J4 and the J5 axis..

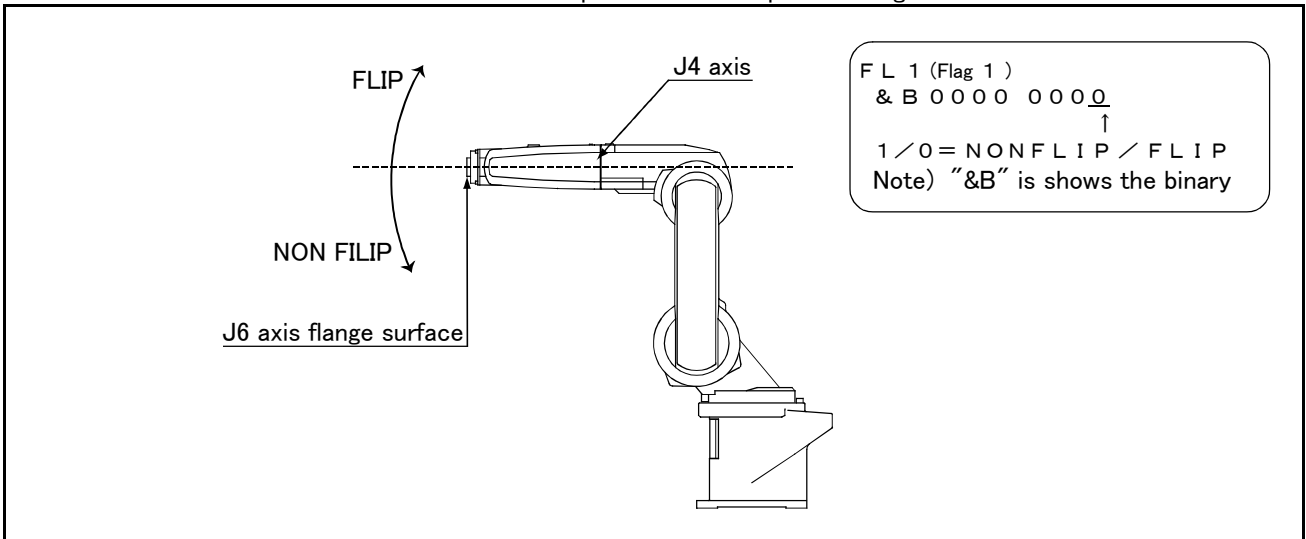

Fig.6-3 : Configuration flag (NONFLIP/FLIP)







HEAD OFFICE: TOKYO BUILDING, 2-7-3, MARUNOUCHI, CHIYODA-KU, TOKYO 100-8310, JAPAN  
NAGOYA WORKS: 5-1-14, YADA-MINAMI, HIGASHI-KU, NAGOYA 461-8670, JAPAN

Authorised representative:

MITSUBISHI ELECTRIC EUROPE B.V. GERMANY

Gothaer Str. 8, 40880 Ratingen / P.O. Box 1548, 40835 Ratingen, Germany