

mitsubishi
Mitsubishi Industrial Robot

RV-2A/RV-3AJ Series

Standard Specifications Manual
(CR1-571 Controller)

Safety Precautions

Always read the following precautions and the separate "Safety Manual" before starting use of the robot to learn the required measures to be taken.

CAUTION

All teaching work must be carried out by an operator who has received special training. (This also applies to maintenance work with the power source turned ON.)
→ Enforcement of safety training

CAUTION

For teaching work, prepare a work plan related to the methods and procedures of operating the robot, and to the measures to be taken when an error occurs or when restarting. Carry out work following this plan. (This also applies to maintenance work with the power source turned ON.)
→ Preparation of work plan

WARNING

Prepare a device that allows operation to be stopped immediately during teaching work. (This also applies to maintenance work with the power source turned ON.)
→ Setting of emergency stop switch

CAUTION

During teaching work, place a sign indicating that teaching work is in progress on the start switch, etc. (This also applies to maintenance work with the power source turned ON.)
→ Indication of teaching work in progress

WARNING

Provide a fence or enclosure during operation to prevent contact of the operator and robot.
→ Installation of safety fence

CAUTION

Establish a set signaling method to the related operators for starting work, and follow this method.
→ Signaling of operation start

















CAUTION

As a principle turn the power OFF during maintenance work. Place a sign indicating that maintenance work is in progress on the start switch, etc.
→ Indication of maintenance work in progress

CAUTION

Before starting work, inspect the robot, emergency stop switch and other related devices, etc., and confirm that there are no errors.
→ Inspection before starting work

The points of the precautions given in the separate "Safety Manual" are given below. Refer to the actual "Safety Manual" for details.

-  **CAUTION** Use the robot within the environment given in the specifications. Failure to do so could lead to a drop or reliability or faults. (Temperature, humidity, atmosphere, noise environment, etc.)
-  **CAUTION** Transport the robot with the designated transportation posture. Transporting the robot in a non-designated posture could lead to personal injuries or faults from dropping.
-  **CAUTION** Always use the robot installed on a secure table. Use in an instable posture could lead to positional deviation and vibration.
-  **CAUTION** Wire the cable as far away from noise sources as possible. If placed near a noise source, positional deviation or malfunction could occur.
-  **CAUTION** Do not apply excessive force on the connector or excessively bend the cable. Failure to observe this could lead to contact defects or wire breakage.
-  **CAUTION** Make sure that the workpiece weight, including the hand, does not exceed the rated load or tolerable torque. Exceeding these values could lead to alarms or faults.
-  **WARNING** Securely install the hand and tool, and securely grasp the workpiece. Failure to observe this could lead to personal injuries or damage if the object comes off or flies off during operation.
-  **WARNING** Securely ground the robot and controller. Failure to observe this could lead to malfunctioning by noise or to electric shock accidents.
-  **CAUTION** Indicate the operation state during robot operation. Failure to indicate the state could lead to operators approaching the robot or to incorrect operation.
-  **WARNING** When carrying out teaching work in the robot's movement range, always secure the priority right for the robot control. Failure to observe this could lead to personal injuries or damage if the robot is started with external commands.
-  **CAUTION** Keep the jog speed as low as possible, and always watch the robot. Failure to do so could lead to interference with the workpiece or peripheral devices.
-  **CAUTION** After editing the program, always confirm the operation with step operation before starting automatic operation. Failure to do so could lead to interference with peripheral devices because of programming mistakes, etc.
-  **CAUTION** Make sure that if the safety fence entrance door is opened during automatic operation, the door is locked or that the robot will automatically stop. Failure to do so could lead to personal injuries.
-  **CAUTION** Never carry out modifications based on personal judgments, or use non-designated maintenance parts.
Failure to observe this could lead to faults or failures.
-  **WARNING** When the robot arm has to be moved by hand from an external area, do not place hands or fingers in the openings. Failure to observe this could lead to hands or fingers catching depending on the posture.
-  **CAUTION** Do not stop the robot or apply emergency stop by turning the robot controller's main power OFF.
If the robot controller main power is turned OFF during automatic operation, the robot accuracy could be adversely affected.

C.Precautions for the basic configuration are shown below.(When CR1-571 is used for the controller.)

⚠ CAUTION

Provide an earth leakage breaker that packed together on the primary power supply of the controller as protection against electric leakage. Confirm the setting connector of the input power supply voltage of the controller, if the type which more than one power supply voltage can be used. Then connect the power supply.
Failure to do so could lead to electric shock accidents.

Power supply *RV-1A/2AJ series and RP-1AH/3AH/5AH series: Single phase 90-132VAC, 180-253VAC.
*Except the above: Single phase 180-253VAC.

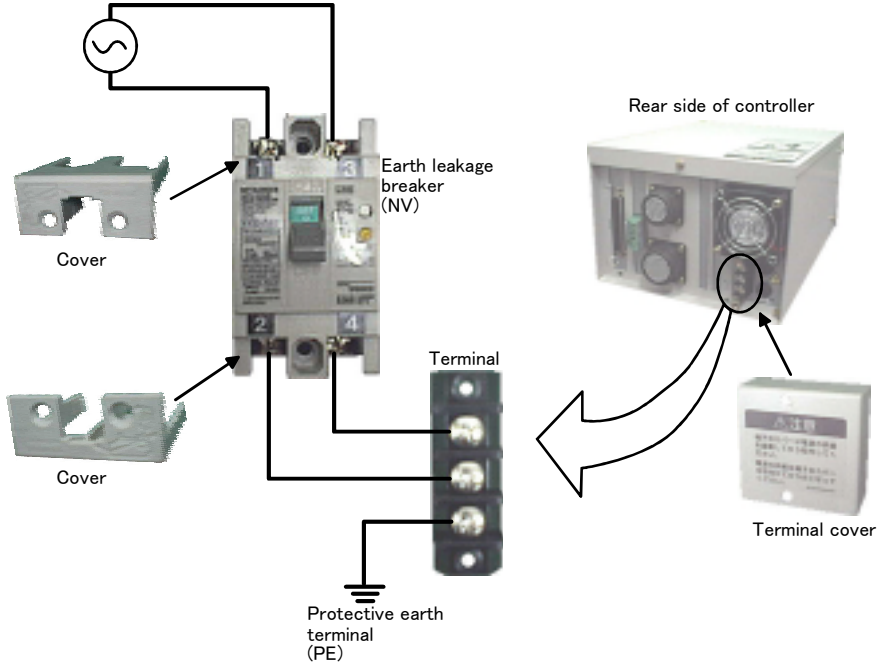

■ Revision history

Date of print	Specifications No.	Details of revisions
2001-09-12	BFP-A8182Z	First print
2001-09-25	BFP-A8182	Formal style
2002-01-23	BFP-A8182-A	MESNGLSW parameter was added. Error in writing correction.
2002-04-02	BFP-A8182-B	CR1-MB (controller protection box) was added. Error in writing correction.
2002-06-13	BFP-A8182-C	The description of input/output circuit terminal was corrected. Error in writing correction.

■ Introduction

The "RV-2A/3AJ Series" is a vertical articulated compact robot, based on the <E Series> that has been greatly upgraded. These robots respond to users needs for compact and flexible production facilities generated due to the recent diffusion of compact and highly accuracy products such as personal computer related devices, information terminal devices and compact electronic devices for mounting on vehicles, and due to shorter product life cycles. The protect and clean specifications are prepared for in addition to the general environment specification in the same way as the usual series.

However, to comply with the target application, a work system having a well-balanced robot arm, peripheral devices or robot and hand section must be structured.

When creating these standard specifications, we have edited them so that the Mitsubishi robot's characteristics and specifications can be easily understood by users considering the implementation of robots. However, if there are any unclear points, please contact your nearest Mitsubishi branch or dealer.

Mitsubishi hopes that you will consider these standard specifications and use our robots.

In this manual, the specifications regarding the robot arm are given in [Page 5, "2 Robot arm"](#) and following, and the specifications regarding the controller are given in [Page 41, "3 Controller"](#) and following. Refer to the corresponding sections for details on the specifications, options and maintenance parts, etc.

Note:

- No part of this manual may be reproduced by any means or in any form, without prior consent from Mitsubishi.
- The contents of this manual are subject to change without notice.
- The specifications values are based on Mitsubishi standard testing methods.
- The information contained in this document has been written to be accurate as much as possible. Please interpret that items not described in this document "cannot be performed".
Please contact your nearest dealer if you find any doubtful, wrong or skipped point.

Contents

	Page
1 General configuration	1-1
1.1 Structural equipment	1-1
1.1.1 Standard structural equipment	1-1
1.1.2 Shipping special specifications	1-1
1.1.3 Options	1-1
1.1.4 Maintenance parts	1-1
1.2 Contents of the structural equipment	1-2
1.2.1 Robot arm	1-2
1.3 Controller	1-3
1.4 Contents of the Option equipment and special specification	1-4
2 Robot arm	2-5
2.1 Standard specifications	2-5
2.2 Definition of specifications	2-6
2.2.1 Pose repeatability and distance accuracy	2-6
2.2.2 Rated load (mass capacity)	2-7
2.2.3 Protection specifications and working environment	2-9
(1) Types of protection specifications	2-9
(2) About the use with the bad environment	2-9
2.2.4 Clean specifications	2-10
(1) Types of clean specifications	2-10
(2) SA type suction fan wiring	2-11
2.3 Names of each part of the robot	2-12
2.4 Outside dimensions • Operating range diagram	2-13
(1) RV-2A/2AM/2AC-SB	2-13
(2) RV-2AC-SA	2-14
(3) RV-3AJ/3AJM/3AJC-SB	2-15
(4) RV-3AJC-SA	2-16
(5) Mechanical interface and Installation surface (RV-2A/2AM/2AC-SB, RV-3AJ/3AJM/3AJC-SB)	2-17
(6) Mechanical interface and Installation surface (RV-2AC-SA, RV-3AJC-SA)	2-18
2.5 Tooling	2-19
2.5.1 Wiring and piping for hand	2-19
(1) RV-2A/2AM, RV-3AJ/3AJM (General environment, Protection specifications)	2-19
(2) RV-2AC-SA/SB, RV-3AJC-SA/SB (Clean specifications)	2-20
2.5.2 Internal air piping	2-21
2.5.3 Internal wiring for the pneumatic/motorized hand output cable	2-21
2.5.4 Internal wiring for the hand check input cable	2-21
2.5.5 Source typeElectrical specifications of hand input/output	2-24
2.5.6 Air supply circuit example for the hand	2-25
2.6 Shipping special specifications, options, and maintenance parts	2-26
2.6.1 Shipping special specifications	2-26
(1) Machine cable extension	2-27
(2) Changing the operating range	2-29
2.7 Options	2-30
(1) Motorized hand set	2-31
(2) Pneumatic hand set	2-33
(3) Solenoid valve set	2-35
(4) Hand input cable	2-37
(5) Hand output cable	2-38
(6) Hand curl tube	2-39
2.8 Maintenance parts	2-40
3 Controller	3-41
3.1 Standard specifications	3-41
3.1.1 Standard specifications	3-41

3.1.2 Protection specifications and operating supply	3-42
3.2 Names of each part	3-43
3.3 Outside dimensions/Installation dimensions	3-45
3.3.1 Outside dimensions	3-45
3.3.2 Installation dimensions	3-46
3.4 External input/output	3-47
3.4.1 Types	3-47
3.4.2 Explanation	3-47
3.5 Dedicated input/output	3-48
3.6 Emergency stop input/output	3-50
3.6.1 Connection of the external emergency stop	3-50
3.6.2 Door switch function	3-51
3.7 Parallel input/output unit	3-52
3.8 Options	3-56
(1) Teaching pendant (T/B)	3-57
(2) Pneumatic hand interface	3-60
(3) Controller protection box	3-62
(4) Expansion option box	3-65
(5) Parallel I/O unit	3-67
(6) External I/O cable	3-75
(7) Personal computer cable	3-77
(8) Personal computer support software/Personal computer support software mini	3-79
3.9 Maintenance parts	3-81
4 Software	4-83
4.1 List of commands	4-83
(1) The procedure of robot language selection	4-83
(2) MELFA-BASIC IV commands	4-84
(3) MOVEMASTER commands	4-86
4.2 List of parameters	4-89
(1) List of parameters	4-89
(2) Change the display language / 表示言語の切り替え	4-91
5 Safety	5-93
5.1 Safety	5-93
5.1.1 Self-diagnosis stop functions	5-93
5.1.2 External input/output signals that can be used for safety protection measures	5-93
5.1.3 Precautions for using robot	5-94
5.1.4 Safety measures for automatic operation	5-94
5.1.5 Safety measures for teaching	5-94
5.1.6 Safety measures for maintenance and inspections, etc.	5-94
5.1.7 Examples of safety measures	5-95
5.2 Working environment	5-96
5.3 Precautions for handling	5-96
6 Appendix	Appendix-97
Appendix 1 : Specifications discussion material	Appendix-97

1 General configuration

1.1 Structural equipment

Structural equipment consists of the following types.

1.1.1 Standard structural equipment

The following items are enclosed as a standard.

- (1) Robot arm
- (2) Controller
- (3) Machine cable
- (4) Robot arm installation bolts
- (5) Instruction manual, Safety manual
- (6) Guarantee card

1.1.2 Shipping special specifications

Part of the standard structural equipment is changed at the time of factory shipment. Consequently, kindly confirm the delivery date.

To make changes to the specifications after shipment, service work must be performed at the work site or the robot must be returned for service.

1.1.3 Options

Installation is possible after shipment. Customer needs to perform the installation work.

1.1.4 Maintenance parts

Consumable parts and spare parts for maintenance use.

For items not listed, contact the dealer where you made your purchase.

1.2 Contents of the structural equipment

1.2.1 Robot arm

The list of structural equipment is shown in Fig. 1-1.

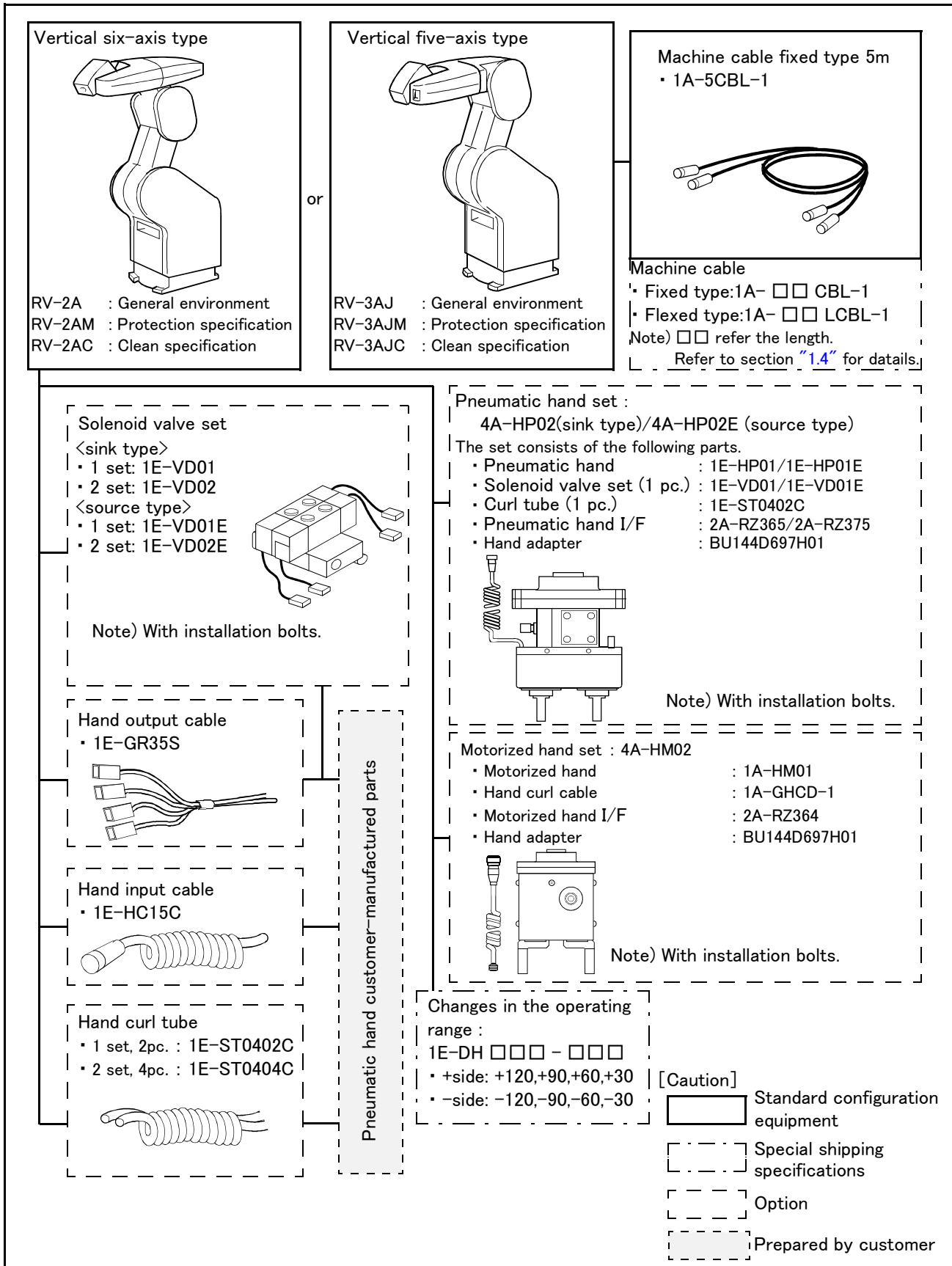

Fig.1-1 : Structural equipment (Robot arm)

1.3 Controller

The devices shown below can be installed on the controller.

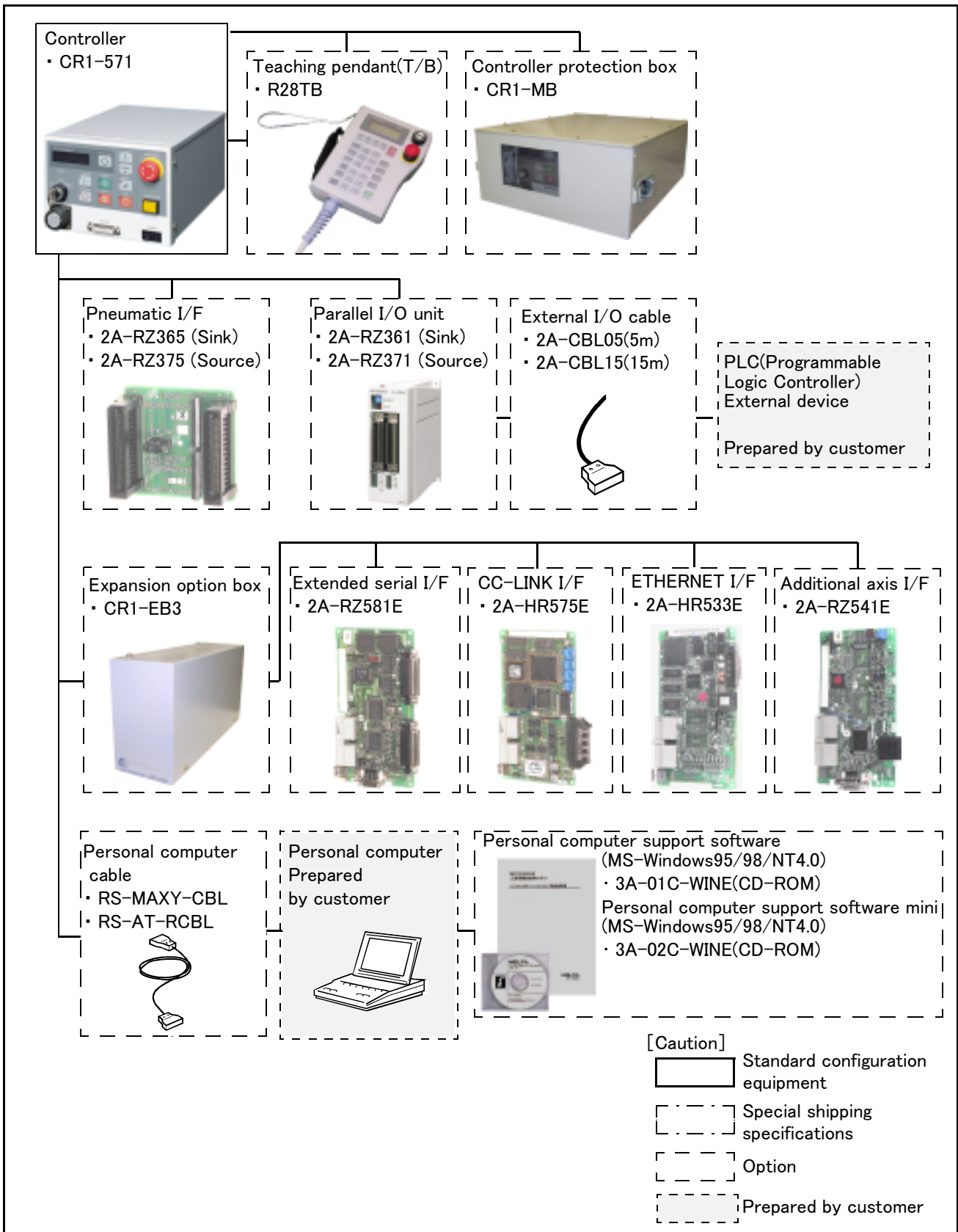

Fig.1-2 : Structural equipment(Controller)

1.4 Contents of the Option equipment and special specification

A list of all Optional equipments and special specifications are shown below.

Table 1-1 : The list of Option equipment and special specification

Item	Type	Specifications	Classification	Description
J1-axis operating range change	1E-DH**-**	+ side : +120, +90, +60, +30 ° one point out of the above. - side : -120, -90, -60, -30 ° one point out of the above.	<input type="checkbox"/>	The J1 axis operating range is changed. The angle is inserted in ** in the order of (+ side) (- side). The standard specification is 160 degrees.
Extended machine cables	1A-10CBL-1	For fixing (Two sets for power and signal)	<input type="checkbox"/>	10m
	1A-15CBL-1		<input type="checkbox"/>	15m
	1A-05LCBL-1	For flexed (Two sets for power and signal)	<input type="checkbox"/>	5m
	1A-10LCBL-1		<input type="checkbox"/>	10m
	1A-15LCBL-1		<input type="checkbox"/>	15m
Pneumatic hand set	4A-HP02	Pneumatic hand, Solenoid valve set (1 pc.), Curl tube(1 pc.), Pneumatic hand I/F, Hand adapter, Installation bolts	<input type="checkbox"/>	The pneumatic hand and required parts are prepared in a set.(sink type)
	4A-HP02E		<input type="checkbox"/>	The pneumatic hand and required parts are prepared in a set.(source type)
Motorized hand set	4A-HM02	Motorized hand, Hand curl cable, Motorized hand I/F, Hand adapter, Installation bolts	<input type="checkbox"/>	The motorized hand and required parts are prepared in a set.
Solenoid valve set	1E-VD01	1 set(Sink type)	<input type="checkbox"/>	A solenoid valve set for the pneumatic hand.
	1E-VD02	2 set(Sink type)	<input type="checkbox"/>	
	1E-VD01E	1 set(Source type)	<input type="checkbox"/>	
	1E-VD02E	2 set(Source type)	<input type="checkbox"/>	
Hand output cable	1E-GR35S	Length 350mm with robot side connector. One terminal is not treated.	<input type="checkbox"/>	The cable is connected to the hand output connector by the customer.
Hand input cable	1E-HC15C	Length 370mm with robot side connector. One terminal is not treated.	<input type="checkbox"/>	The cable is connected to the sensor by the customer.
Hand curl tube	1E-ST0402C	For solenoid valve 1set.:Φ4x2	<input type="checkbox"/>	Curl type air tube
	1E-ST0404C	For solenoid valve 2set.:Φ4x4	<input type="checkbox"/>	
Teaching pendant	R28TB	Cable length 7m	<input type="checkbox"/>	With 3-position deadman switch/ IP 65
	R28TB-15	Cable length 15m (special specification)	<input type="checkbox"/>	
Pneumatic hand interface	2A-RZ365	DO: 8 point (Sink type)	<input type="checkbox"/>	It is necessary when the hand output signal of the robot arm is used. (Integrated in the controller.)
	2A-RZ375	DO: 8 point (Source type)	<input type="checkbox"/>	
Parallel I/O interface	2A-RZ361	DO: 32 point (Sink type)/ DI: 32 point (Sink type)	<input type="checkbox"/>	The unit for expansion the external input/output. Electrical isolated Type (100mA/Point)
	2A-RZ371	DO: 32 point (Source type)/ DI: 32 point (Source type)	<input type="checkbox"/>	
External I/O cable	2A-CBL05	5m	<input type="checkbox"/>	Use to connect the external peripheral device to the parallel input/output unit
	2A-CBL15	15m	<input type="checkbox"/>	
Personal computer cable	RS-MAXY-CBL	RS-232C cable 3m for PC-AT compatible model	<input type="checkbox"/>	Use RS-AT-RCBL for the connection from the expansion option box.
	RS-AT-RCBL		<input type="checkbox"/>	
Personal computer Support software	3A-01C-WINE	CD-ROM	<input type="checkbox"/>	MS-Windows95/98/NT4.0 (With the simulation function)
Personal computer Support software mini	3A-02C-WINE	CD-ROM	<input type="checkbox"/>	MS-Windows95/98/NT4.0 (Without the simulation function)
Expansion option box	CR1-EB3	Up to three option cards can be mounted	<input type="checkbox"/>	Install on the side of the controller
Extended serial interface	2A-RZ581E	RS-232C x 1 RS-232C or RS-422 x 1	<input type="checkbox"/>	CR-EB3 is need.
CC-Link interface	2A-HR575E	Local station (The local station alone is supported.)	<input type="checkbox"/>	for MELSEC PLC with CC-Link connection. CR-EB3 is need.
ETHERNET interface	2A-HR533E	ETHERNET x 1	<input type="checkbox"/>	CR-EB3 is need.
Additional axis interface	2A-RZ541E	SSC x 1 Up to 8 axes can be added	<input type="checkbox"/>	MR-J2 servoAmplifier Unit connection. CR-EB3 is need.
Controller protection box	CR1-MB	IP54	<input type="checkbox"/>	The controller protection box is used to protect the controller from an oil mist or other operating environment. ^{Note2)}

Note1) In the classification column, refers to an option, and to a Shipping special specifications.

Note2) Use this option to protect the controller from the oil mist when the controller will be installed in the environment such as the oil mist.

2 Robot arm

2.1 Standard specifications

2.1.1 Standard specifications

Table 2-1 : Standard specifications of robot arm

Item		Unit	Specifications							
Type			RV-2A	RV-2AM	RV-2AC -SB	RV-2AC -SA	RV-3AJ	RV- 3AJM	RV-3AJC -SB	RV-3AJC -SA
Degree of freedom			6				5			
Installation posture			On floor							
Structure			Vertical, multiple-joint type							
Drive system			ACservo motor (J1 to J3 : 80W with brake, J4,J6 : 40W no brake, J5 : 40Wwith brake)							
Position detection method			Absolute encoder							
Arm length	Shoulder shift	mm	100							
	Upper arm		250							
	Fore arm		250				280			
	Elbow shift		130				20			
	Wrist length		85							
Operating range	J1	Degree	320(-160 to +160)							
	J2		180(-45 to +135)							
	J3		120(+50 to +170)				135(0 to +135)			
	J4		320(-160 to +160)				—			
	J5		240(-120 to +120)							
	J6		400(-200 to +200)							
Speed of motion	J1	Degree/s	150							
	J2		150							
	J3		180							
	J4		240				—			
	J5		180							
	J6		330							
Maximum resultant velocity		mm/s	Approx. 3500							
Load	Rating		2				3			
Pose repeatability ^{Note1)}		mm	± 0.04							
Ambient temperature		°C	0 to 40							
Mass ^{Note2)}		kg	Approx. 37	Approx. 38	Approx. 41	Approx. 33	Approx. 34	Approx. 37		
Allowable moment load	J4	N · m	3.6				—			
	J5		3.6				5.4			
	J6		2.6				3.9			
Allowable inertia	J4	kg · m ²	1.1x10 ⁻¹				—			
	J5		1.1x10 ⁻¹				—			
	J6		4.1x10 ⁻²							
Arm reachable radius (front J5 axis center point)		mm	621				630			
Tool wiring ^{Note3)}			Six cables for hand check (For four input signals contains the two power cable, Hand section), Four output signal for pneumatic hand(Shoulder section), One output signal for Motorized hand.(Hand section) Four spare wires (stored between the base to the tip of the fore arm : A.W.G#22(0.3mm ²))							
Tool pneumatic pipes			Primary side:Φ 6x2 Secondary side:Φ 4x4	Primary side:Φ 6x2 Secondary side:Φ 4x6	Primary side:Φ 6x2 Secondary side:Φ 4x5 Suction:Φ 4x1	Primary side:Φ 6x2 Secondary side:Φ 4x4	Primary side:Φ 6x2 Secondary side:Φ 4x6	Primary side:Φ 6x2 Secondary side:Φ 4x5 Suction:Φ 4x1		
Supply pressure		MPa	0.5 ± 10%							
Protection specification ^{Note4)}			IP30	IP54	—		IP30	IP54	—	
Cleanness ^{Note5)}	J1 to J3		—		1000(0.3 μ m)	10(0.3 μ m)	—		1000(0.3 μ m)	10(0.3 μ m)
	J4 to J6		—		100(0.3 μ m)	—		100(0.3 μ m)		
Paint color			Arm section: Light gray (Equivalent to Munsell: 7.65Y7.6/0.73) Base section: Dark gray (Equivalent to Munsell: 4.94GY13/0.39)							

Note1)The pose repeatability details are given in [Page 6, "2.2.1 Pose repeatability and distance accuracy"](#)

Note2)The mass of RV-2AC-SA and RV-3AJC-SA are include the blower base.

Note3)When using the 4-point hand output, the pneumatic hand interface (option) is required.

Note4)The protection specification details are given in [Page 9, "2.2.3 Protection specifications and working environment"](#)

Note5)The clean specification details are given in [Page 10, "2.2.4 Clean specifications"](#). Please confirm the delivery date, because both are special specifications. A down flow (0.3m/s or more) in the clean room is the necessary conditions for the cleanliness.

2.2 Definition of specifications

The accuracy of pose repeatability mentioned in catalogs and in the specification manual is defined as follows.

2.2.1 Pose repeatability and distance accuracy

This robot, the pose repeatability and distance accuracy are defined and calculated in [Table 2-2](#).

- (1) The pose accuracy in terms of coordinates (XYZ) for the standard point which is obtained repeatedly under the same conditions and motions when the robot is on an operating course.
- (2) The standard point is the intersection between the J6 axis and the flange surface for tooling installation.

Table 2-2 : Specified accuracy

Item	Specified conditions
Pose repeatability	The value equal to the average of the maximum value and the minimum value of the group of attained poses, with (+) or (-) added.
Distance accuracy	The distance from the teaching point to the point that is equal to the average of the maximum value and the minimum value of the group of attained poses.

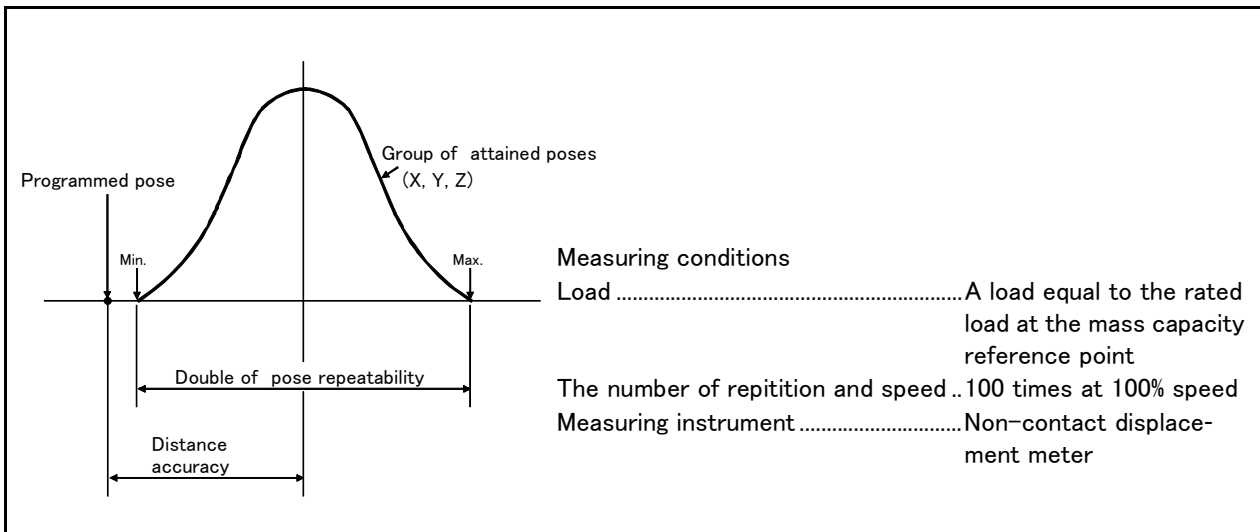

Fig.2-1 : Specified accuracy

[Caution] The pose accuracy given in the specifications is the accuracy measured under the same conditions. It does not include the effect of the robot working environment or conditions. Thus, even when used on the same path, the repeatability according to the presence of a workpiece, or the repeatability when the temperature changes will cause arm slack or expansion, so the accuracy will drop slightly. This also applies to when the teaching speed and actual speed are different or when the coordinates set with values.

2.2.2 Rated load (mass capacity)

The robot's mass capacity is expressed solely in terms of mass, but even for tools and works of similar mass, eccentric loads will have some restrictions. When designing the tooling or when selecting a robot, consider the following issues.

- (1) The tooling should have the value less or equal than the smaller of the tolerable inertia and the tolerable moment found in Page 5, "Table 2-1 : Standard specifications of robot arm".
- (2) Fig. 2-2 and Fig. 2-3 shows the distribution dimensions for the center of gravity in the case where the volume of the load is relatively small. Use this figure as a reference when designing the tooling.
- (3) When the load is not mass, but force, you should design the tooling so that it does not exceed the value for allowable moment described in Page 5, "Table 2-1 : Standard specifications of robot arm".

[Caution] The mass capacity is greatly influenced by the operating speed of the robot and the motion posture. Even if you are within the allowable range mentioned previously, an overload or generate an overcurrent alarm could occur. In such cases, it will be necessary to change the time setting for acceleration/deceleration, the operating speed, and the motion posture.

[Caution] The overhang amount of the load for the specified moment and inertia in this section is the dynamic limit value determined by the motor driving each axis and by the capacity of the reduction gears. Consequently, accuracy cannot be guaranteed for the entire tooling area. Since accuracy is based on the center point of the mechanical interface surface, position accuracy can diminish as you go away from the flange surface, or vibration can result, with tooling that is not rigid or that is long.

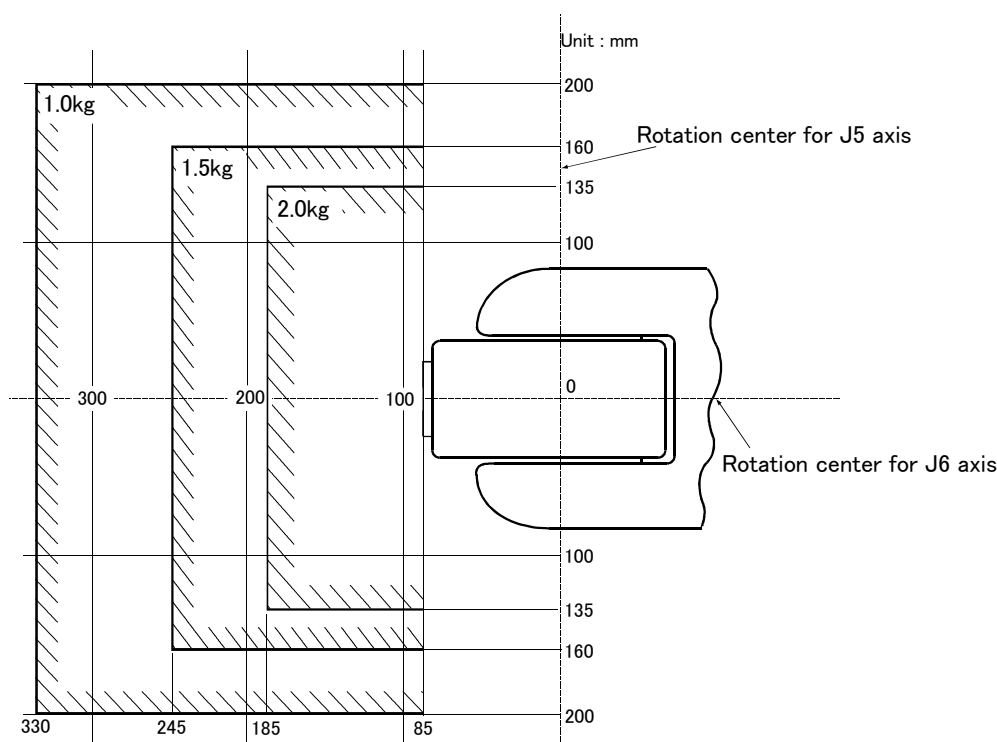

Fig.2-2 : Position of center of gravity for loads (for loads with comparatively small volume) : RV-2A/2AM/2AC-S*

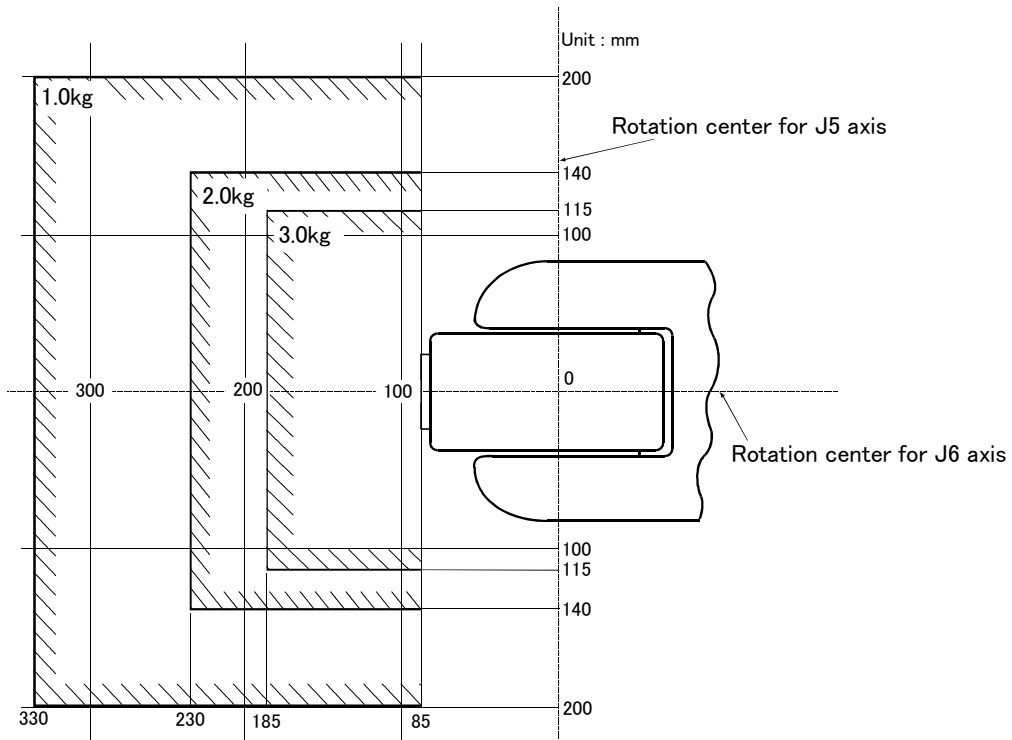

Fig.2-3 : Position of center of gravity for loads(for loads with comparatively small volume): RV-3AJ/3AJM/3AJC-S*

2.2.3 Protection specifications and working environment

(1) Types of protection specifications

The robot arm has protection specifications that comply with the IEC Standards. The protection specifications and applicable fields are shown in [Table 2-3](#).

Table 2-3 : Protection specifications and applicable fields

Type	Protection specifications (IEC Standards value)	Classification	Applicable field	Remarks
RV-2A RV-3AJ	IP30	General-purpose environment specifications	General assembly Slightly dusty environment	
RV-2AM RV-3AJM	IP54F(drip-proof type)	Oil mist specifications	Machine tool (cutting) Machine shop with heavy oil mist Dusty work shop	Note that if the cutting machine contains abrasive materials, the machine line will be shortened

Note) Both the fixed and flexible machine cables are compatible with IP54F (drip-proof type).



CAUTION

Use the controller protection box (CR1-MB) optional to protect the controller from the environment when the controller will be used in the environment such as the oil mist shown in the [Table 2-3](#). Refer to the section [Page 62, "\(3\) Controller protection box"](#) for details on the controller protection box.

The IEC IP symbols define the degree of protection against solids and fluids, and do not indicate a protective structure against the entry of oil or water.

The evaluation regarding oil mist specifications has been confirmed with Mitsubishi's standard testing methods using the cutting oils shown in [Table 2-4](#).

Table 2-4 : Tested cutting oil for oil mist specifications

Name	Maker	Relevant JIS	Main characteristics	Application
Emulcut FA-800	Kyodo Yushi Co., Ltd	Equivalent to Class W1 No. 1	Water soluble cutting oil <ul style="list-style-type: none"> • Base oil50-60% • Surfactant and rust inhibitor30-40% • Additives.....5% or less • WaterThe rest 	Water soluble cutting oil Emulcut

【Information】

• The IEC IP30

IP30 refers to a protective structure with which the tip of a solid object, such as a tool or wire, having a diameter or thickness exceeding 2.5mm cannot enter. No particular protection is provided against the entry of water.

• The IEC IP54

The IEC IP54 standard refers to protection structure designed to prevent any harmful effects by fresh water scattering vertically onto the testing equipment in a radius of 180 degrees from a distance of 300 to 500 mm, with 10 ± 0.5 liters of water every minute, at a water pressure of 80 to 100kPa, covering the entire area of the robot with the exception of the installation section at 1 m² per minute, for a total of 5 minutes or more.

(2) About the use with the bad environment

The protection specifications robot has protection methods that conform to IEC's IP54 standards (splashproof type).It has protection structure designed to prevent harmful effects caused by splashing water coming from various directions, as the robot is operating.

Recommended usage conditions

- 1) The robot is designed for use in combination with machining device.
- 2) Please examine cutting oil referring to [Table 2-4](#) used by a standard examination of our company.
- 3) Take measures so that water, oil, and chips do not directly fall on the robot.

The warranty is invalid for any faults that occur when the robot is used under the following conditions.

- 1) In surroundings that generate inflammable gases or corrosive gasses.
- 2) Robot is used for cutting.
- 3) Atmosphere used excluding cutting oil shown in [Table 2-4](#).
- 4) In surroundings where water, oil, and chips fall directly on the robot.
- 5) In surroundings where chips fall directly on the robot.In surroundings where the minimum diameter of chips is less than 0.5mm.
- 6) Mist atmosphere exceeding the specification.

2.2.4 Clean specifications

(1) Types of clean specifications

The robot arm clean specifications include the SA type and SB type shown in [Table 2-5](#).

Please confirm the delivery date, because both are special specifications.

Table 2-5 : Clean specifications

Clean specifications	Type	Degree of cleanliness	Internal suction	Remarks
Type SA	RV-2AC-SA RV-3AJC-SA	10(0.3 μ m)	Combination of internal suction with fan blower (installed in fan blower base), and concentrated suction with vacuum generating valve. (The concentrated suction is provided only for the 2nd arm section.)	A fan and vacuum generating valve (refer to Table 2-6) are enclosed.
Type SB	RV-2AC-SB RV-3AJC-SB	J1 to J3 1000(0.3 μ m) J4 to J6 100(0.3 μ m)	Concentrated suction with vacuum generating valve. (The concentrated suction is provided only for the 2nd arm section.)	A vacuum generating valve (refer to Table 2-6) is enclosed.

Table 2-6 : Specifications of vacuum generation valve

Type	Maker	Air pressure
MEDT 10	Koganei	0.2 to 0.6 MPa

■ Precautions for use

- 1) For the SA type, provide an exhaust hole on the robot installation surface.
The robot arm outline drawings are shown in [Fig. 2-7](#), and [Fig. 2-9](#) according to type for reference.
- 2) When using a device that moves or rotates the robot arm, the down flow may not be secured because of the air flow. In this case, the degree of cleanliness cannot be ensured.
- 3) For suction in the robot arm, one hose of $\Phi 4 \times 2.5$ is routed from the inside of the fore arm to the joint at the rear of the base section. Prepare the hose of $\Phi 4 \times 2.5$ and connect this joint to the appended vacuum generating valve or the vacuum pump prepared by the customer.
 - * If the appended vacuum generating valve is used, connect the rear joint of the robot to the joint on the "VACUUM" side of the vacuum generating valve. Moreover, in order to prevent the exhaust of the vacuum generating valve from impairing the cleanliness, install the vacuum generating valve on the downstream side of the down flow or attach the filter to the exhaust section as possible.
Recommended filter: Exhaust filter EF300-02, Koganei Corporation
 - * If any vacuum pump is prepared by the customer, assure on the vacuum side flow rate 50 liters/min.(ANR) or more .
- 4) When using the Mitsubishi standard option solenoid valve set, use the spare piping ($\Phi 6$ pneumatic hose) of the primary piping to exhaust the air.
If the exhaust leaks into the robot arm, the degree of cleanliness could be affected.

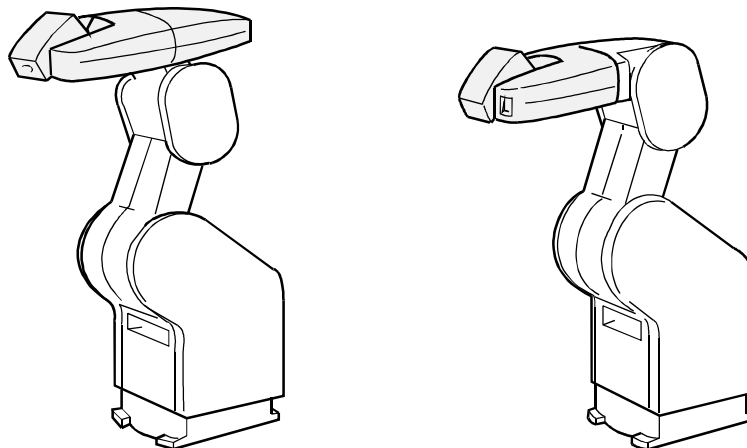

Fig.2-4 : Clean section of RV-2AC-SB, RV-3AJC-SB

(2) SA type suction fan wiring

The suction fan specifications are shown in Table 2-7, the suction fan signal wire specifications in Table 2-8, and the lock sensor output signal specifications in Fig. 2-5.

Table 2-7 : Suction fan specifications

Item	Specification	Remarks
Voltage used by fan (range)	24V (20.4 ~ 27.6V)	
Rated current for fans	0.14A x 2	
Fan attachment function	Motion detection	
Cable Finished outline	ϕ 4.6mm	Flexible specification

Table 2-8 : Signal cable specifications

Wire color	Signal name	Function	Remarks
Black	Lock sensor output (Fan no. 1)	Rotary state of fan No. 1 is checked.	The specifications are shown in Fig. 2-5.
White	Lock sensor output (Fan no. 2)	Rotary state of fan No. 2 is checked.	
Red	+24V	Power is supplied for operation.	
Blue	GND		

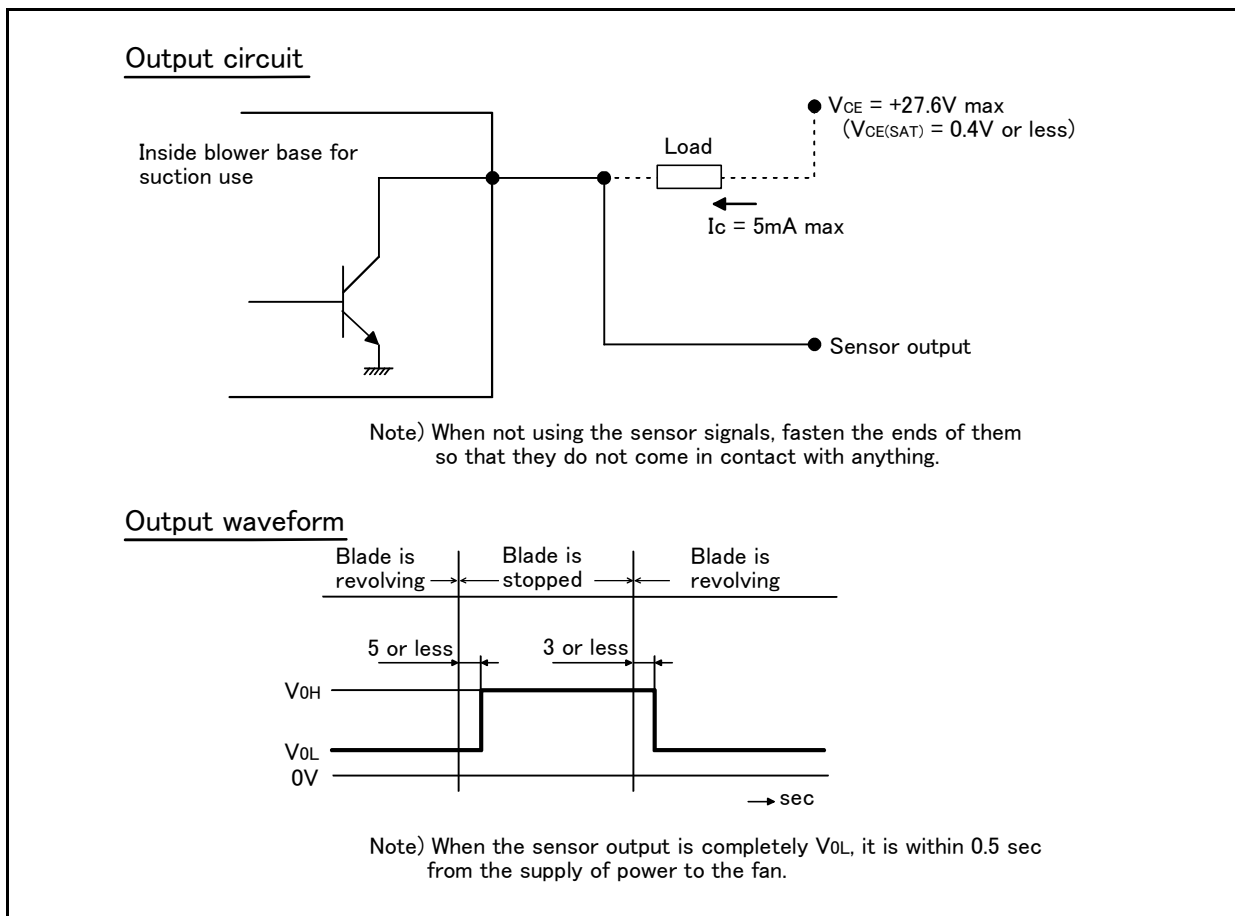

Fig.2-5 : Specifications for lock sensor signal

2.3 Names of each part of the robot

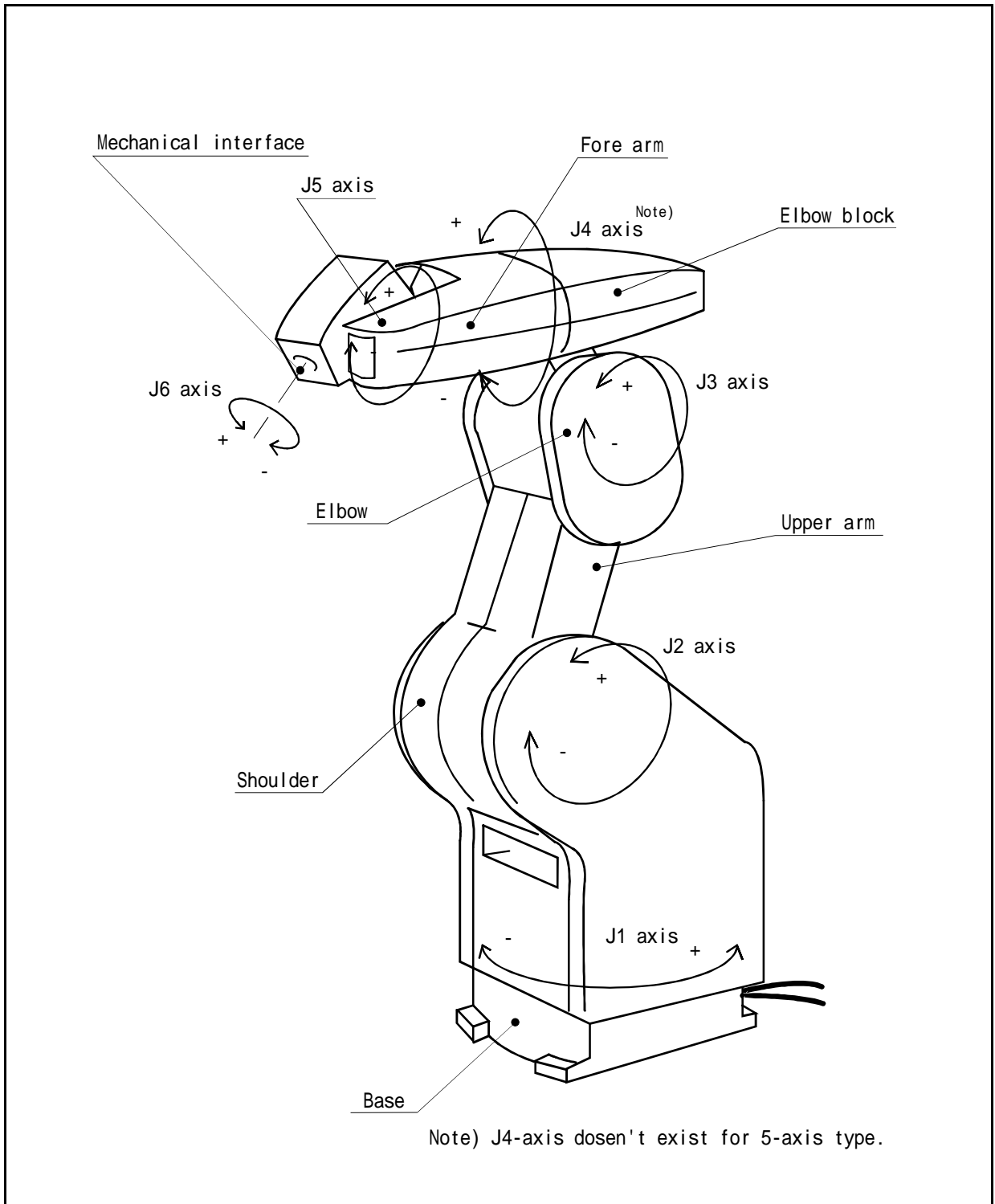

Fig.2-6 : Names of each part of the robot

2.4 Outside dimensions • Operating range diagram

(1) RV-2A/2AM/2AC-SB

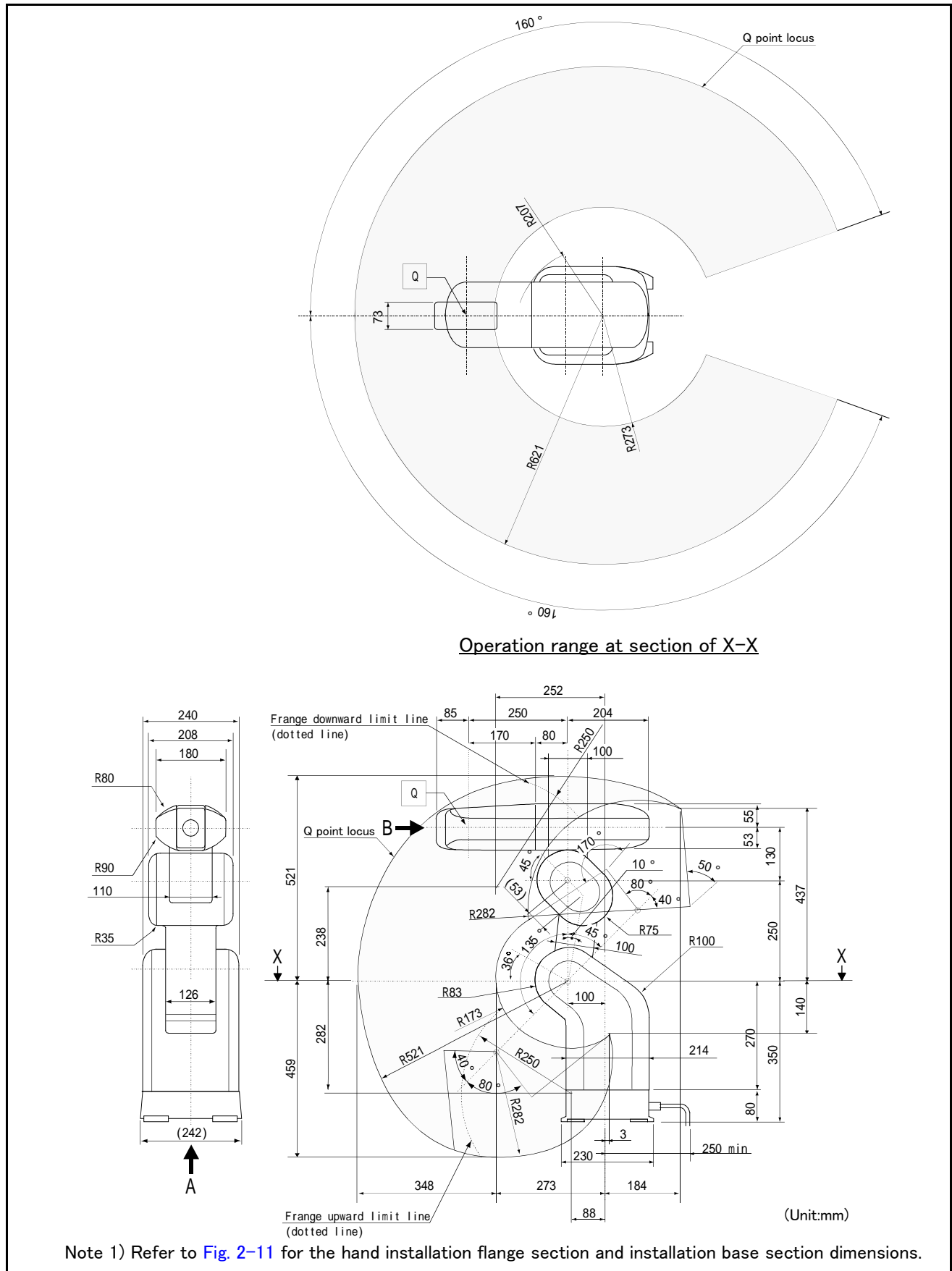

Fig.2-7 : Outside dimensions for RV-2A/2AM/2AC-SB

(2) RV-2AC-SA

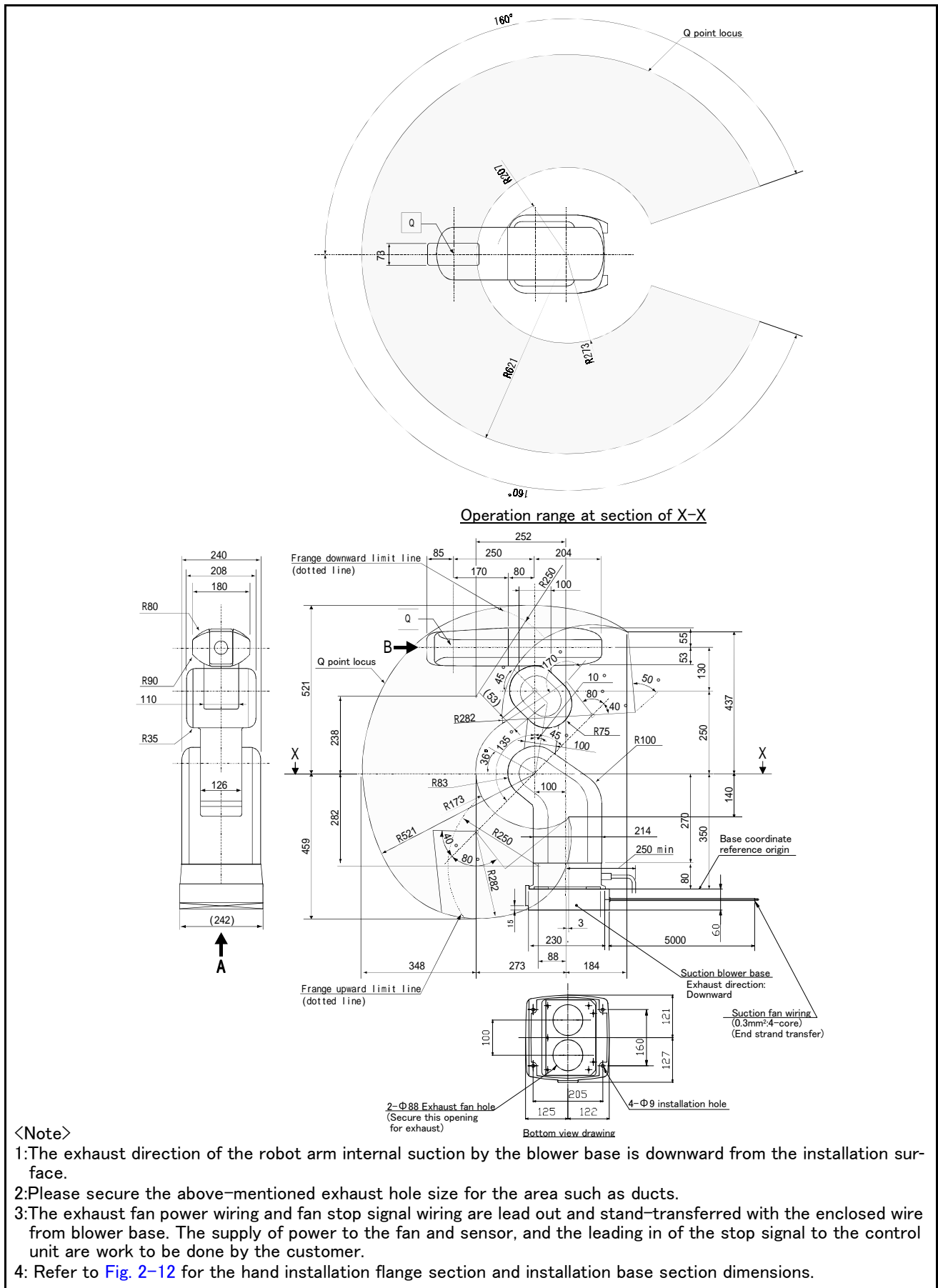

Fig.2-8 : Outside dimensions for RV-2AC-SA

(3) RV-3AJ/3AJM/3AJC-SB

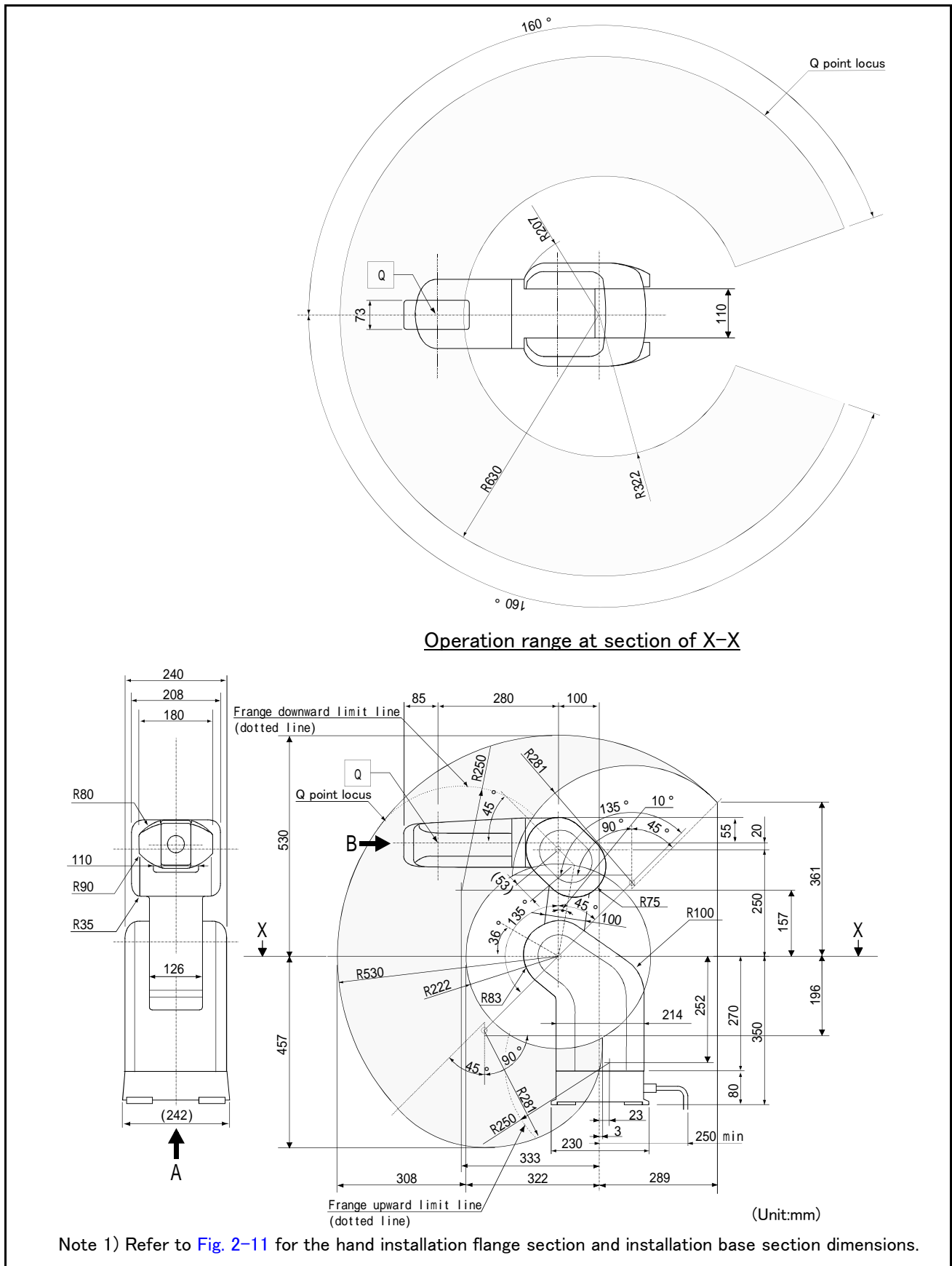

Fig.2-9 : Outside dimensions for RV-3AJ/3AJM/3AJC-SB

(4) RV-3AJC-SA

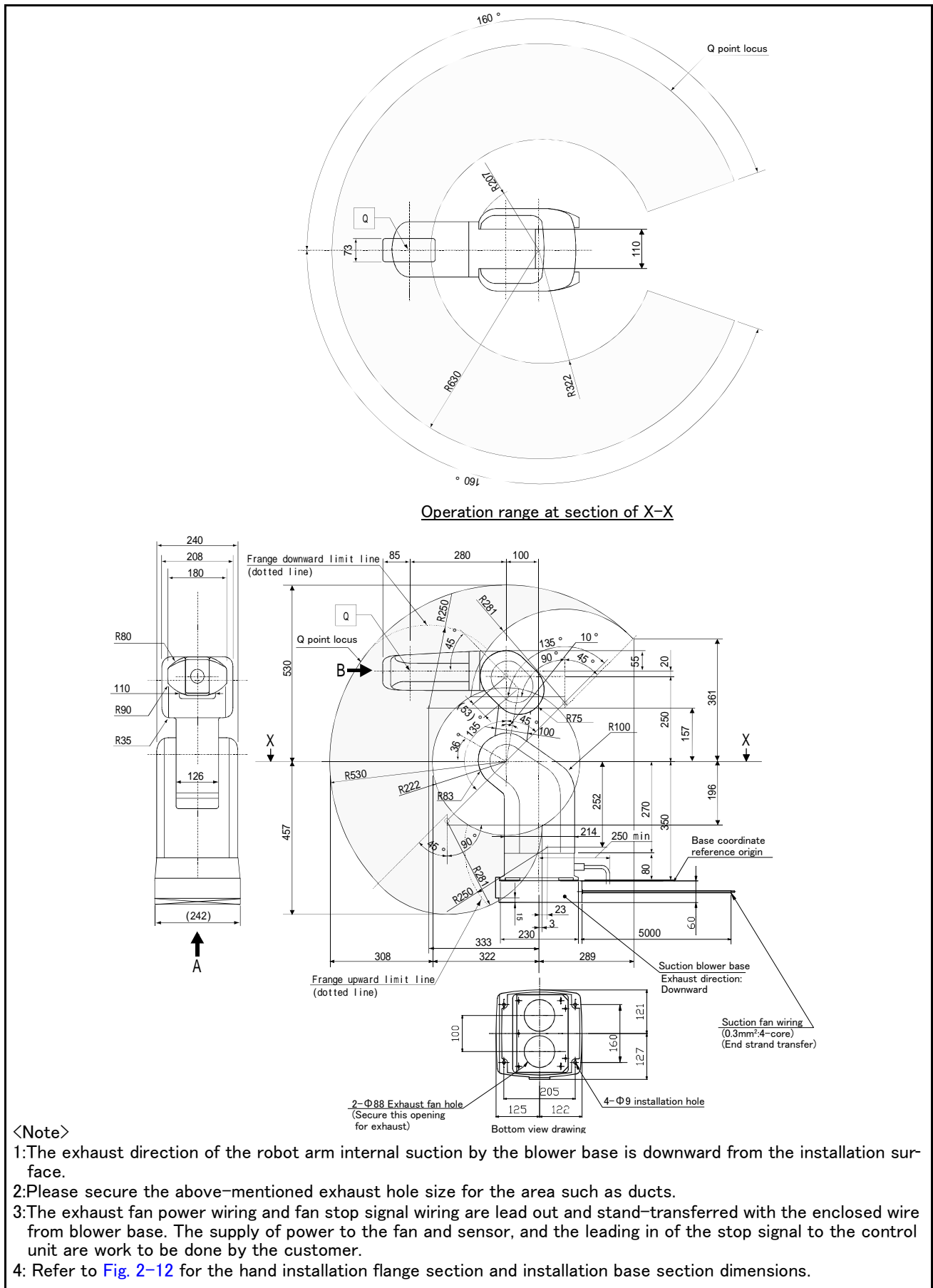

Fig.2-10 : Outside dimensions for RV-3AJC-SA

(5) Mechanical interface and Installation surface
 (RV-2A/2AM/2AC-SB, RV-3AJ/3AJM/3AJC-SB)

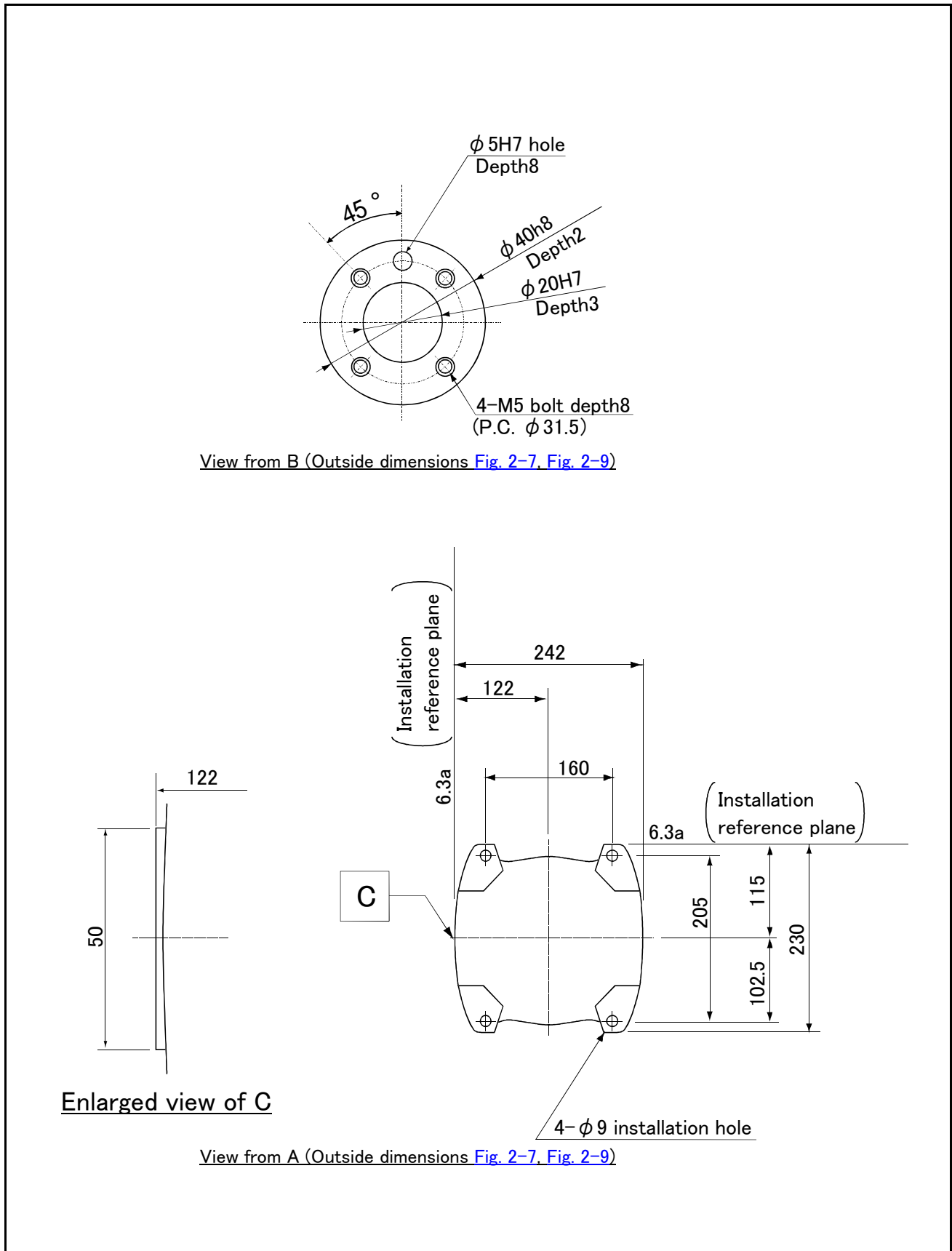

Fig.2-11 : Mechanical interface and Installation surface(RV-2A/2AM/2AC-SB, RV-3AJ/3AJM/3AJC-SB)

(6) Mechanical interface and Installation surface (RV-2AC-SA, RV-3AJC-SA)

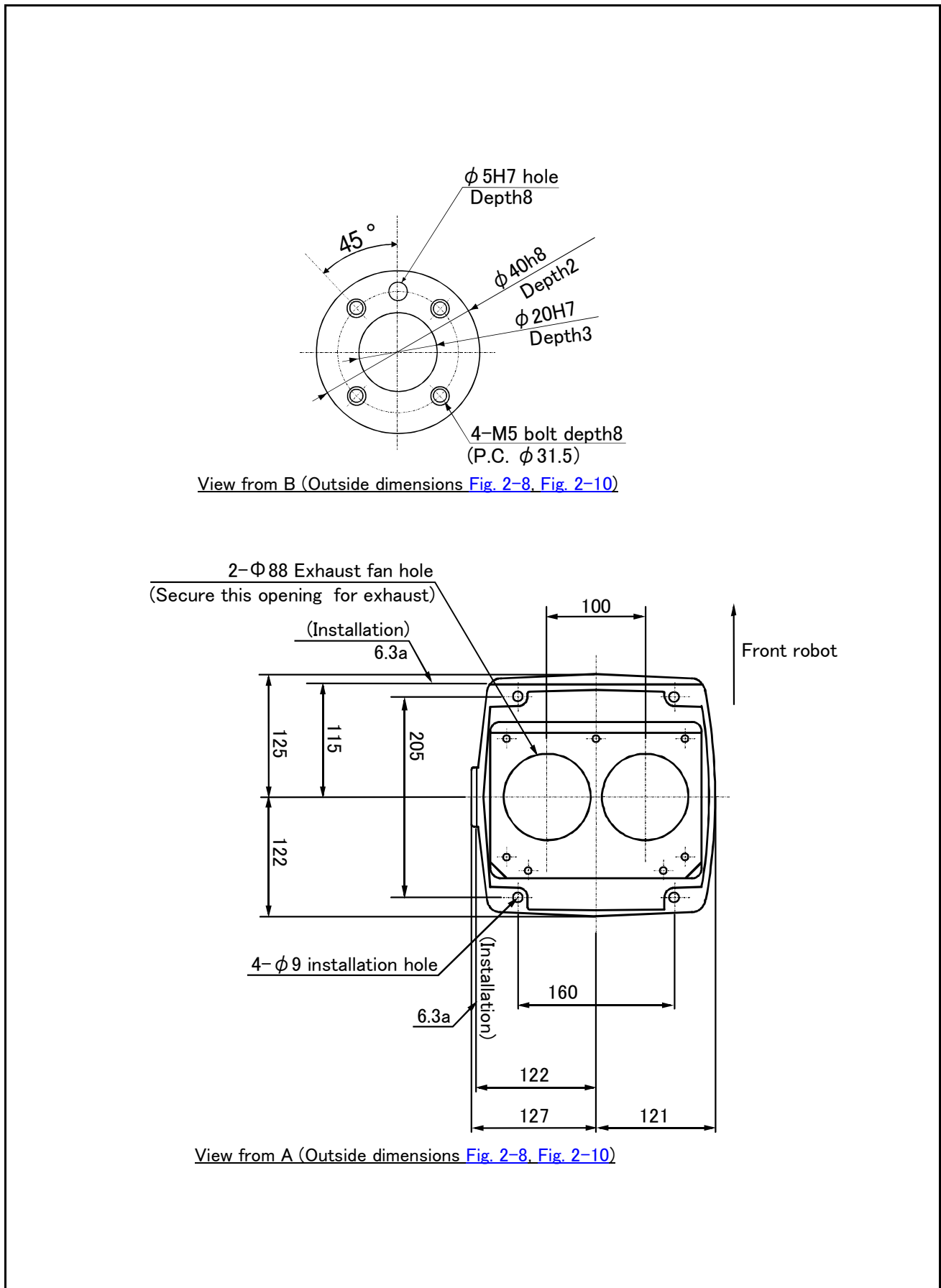

Fig.2-12 : Mechanical interface and Installation surface(RV-2AC-SA, RV-3AJC-SA)

2.5 Tooling

2.5.1 Wiring and piping for hand

Shows the wiring and piping configuration for a standard-equipped hand.

(1) RV-2A/2AM, RV-3AJ/3AJM (General environment, Protection specifications)

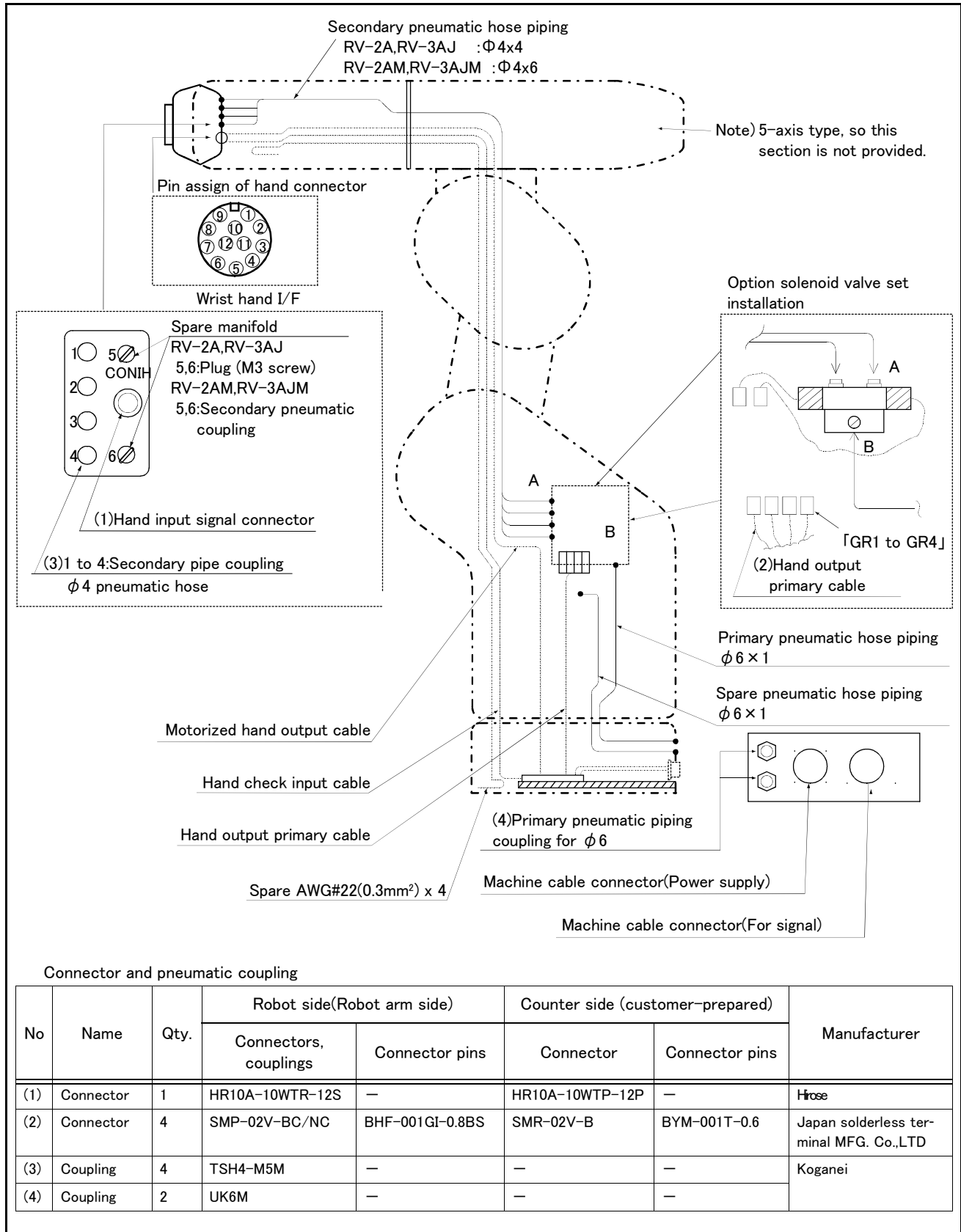

Fig.2-13 : Wiring and piping for hand (RV-2A/2AM, RV-3AJ/3AJM)

(2) RV-2AC-SA/SB, RV-3AJC-SA/SB (Clean specifications)

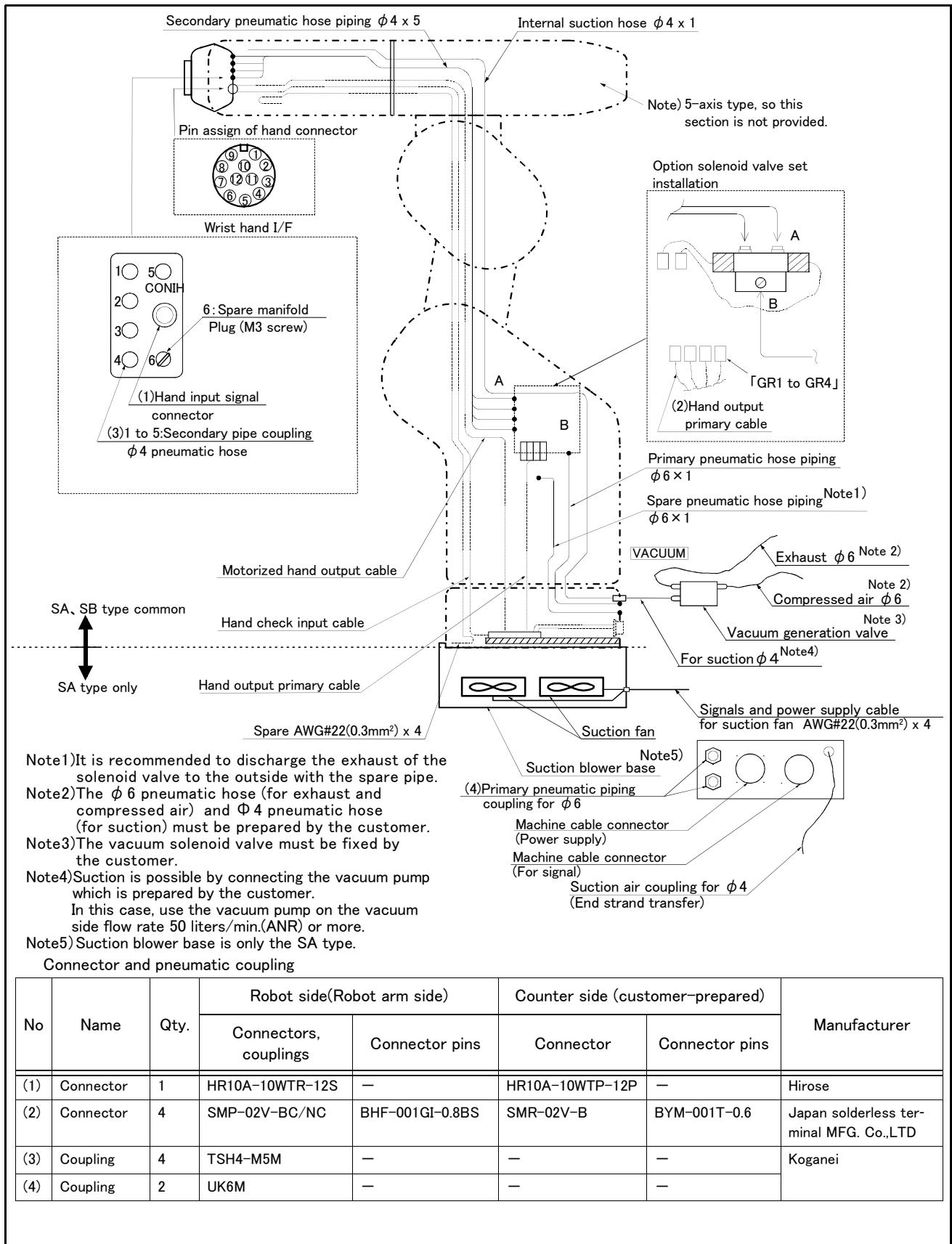

Fig.2-14 : Wiring and piping for hand (RV-2AC-SA/SB, RV-3AJC-SA/SB)

2.5.2 Internal air piping

- (1) Two $\phi 6 \times 4$ urethane hoses are provided from the pneumatic inlet on the base section to the shoulder cover for the primary piping. One hose is the primary piping for the pneumatic device. The other hose is spare piping for the air blowing, forced exhausting or the suction hand, etc.

The air inlet of the base section is pneumatic pipe coupling for $\Phi 6$.

- (2) A $\phi 4 \times 2.5$ urethane hose is provided from inside the shoulder cover to the forearm side for the secondary piping. The number of the hoses will differ according to the type as shown below.

- RV-2A/RV-3AJ (General purpose).....4 hoses
- RV-2AM/RV-3AJM (Protection specifications)6 hoses: Two are for the blower.
- RV-2AC-SA/SB, RV-3AJC-SA/SB (Clean specifications)5 hoses: One is for the spare.

All hose terminals have a hose bridge in the shoulder base. In the fore arm, there are pneumatic coupling bridges for $\Phi 4$ -hoses.

- (3) In the RV-2AC-SA/SB and RV-3AJC-SA/SB type, the one urethane hose of $\phi 6 \times 2.5$ is provided from the pneumatic inlet on the base section to the inside of fore arm for the suction.

The hose terminal have a hose bridge at the back of base. (hose head 300mm) For use, connect it to the suction port of the vacuum pump or the coupling on the "VACUUM" side of the vacuum generating valve.

Moreover, to clean the exhaust from the vacuum pump or vacuum generator, use the exhaust filter (prepared by the customer). Table 2-9 shows the specifications of the vacuum generating valve.

- (4) A maximum of two solenoid valve sets (option) can be installed in the shoulder base.

Refer to Page 35, "(3) Solenoid valve set" for details on the electronic valve set (optional).

Table 2-9 : Vacuum generating valve specifications

Type	Maker	Air pressure
MEDT 10	Koganei	0.2 to 0.6 MPa

2.5.3 Internal wiring for the pneumatic/motorized hand output cable

- (1) The pneumatic hand output cable (AWG#24(0.2mm²) x 2-core : 4 cables) are provided from the connector PCB in the base to the shoulder as the primary hand output cable. The terminals are connector bridged to correspond to the 4-point hand output. The connector names are "GR1" to "GR4".

- (2) The motorized hand output cable (AWG#24(0.2mm²) x 2-core : 1 cables) is wired from the shoulder to the forearm.

The terminals are connected to the No.7 and 8 pins of the connector.

2.5.4 Internal wiring for the hand check input cable

- (1) The hand check input cable is directly wired from the base. The terminals are connected to the No.1 to 6 pins of the connector at the forearm.

- (2) The pneumatic hand check signals are input to this connector.

- (3) AWG#22(0.3mm²) x 4 spare wires are mounted from the base to the side of the forearm. The terminals are not treated on either end.

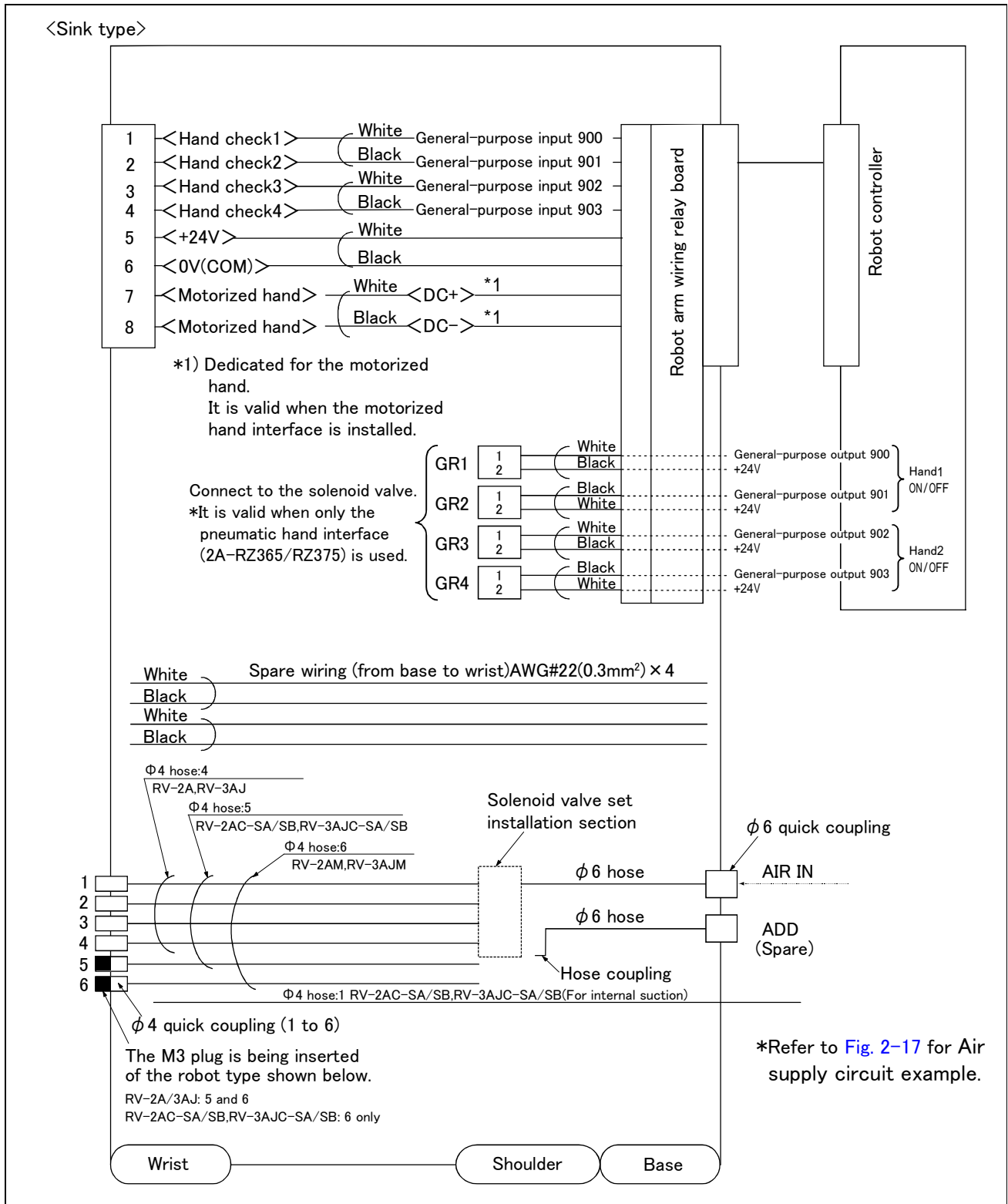

Fig.2-15 : Wiring and piping system diagram for hand and example the solenoid valve installation(Sink type)

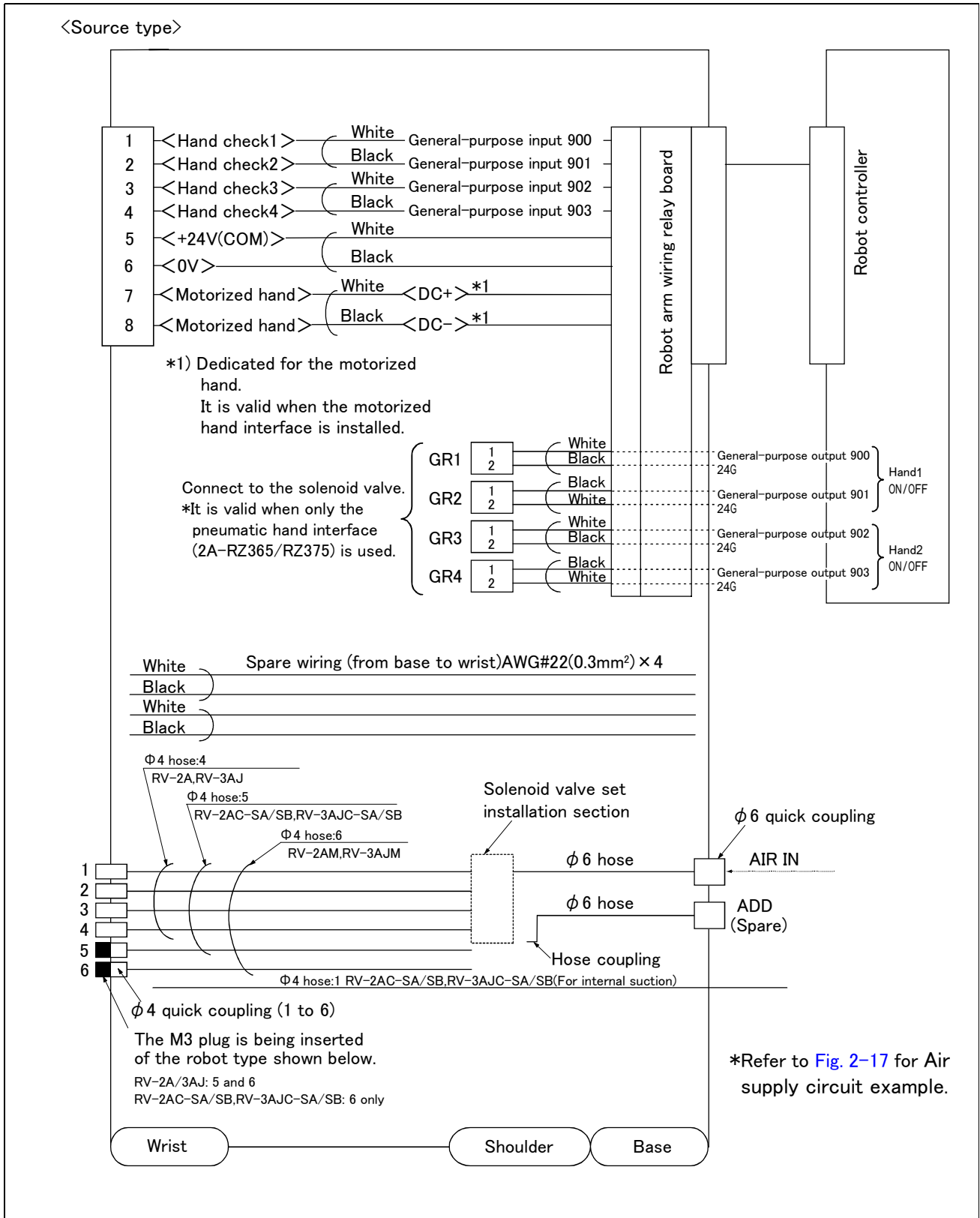

Fig.2-16 : Wiring and piping system diagram for hand and example the solenoid valve installation(Source type)

2.5.5 Source type Electrical specifications of hand input/output

Table 2-10 : Electrical specifications of input circuit

Item		Specifications	Internal circuit
Type		DC input	<p><Sink type></p>  <p><Source type></p>  <p>* HCn = HC1 ~ HC4</p>
No. of input points		4	
Insulation method		Photo-coupler insulation	
Rated input voltage		12VDC/24VDC	
Rated input current		Approx. 3mA/ approx. 7mA	
Working voltage range		DC10.2 to 26.4V(ripple rate within 5%)	
ON voltage/ON current		8VDC or more/2mA or more	
OFF voltage/OFF current		4VDC or less/1mA or less	
Input resistance		Approx. 3.3kΩ	
Response time	OFF-ON	10ms or less(DC24V)	
	ON-OFF	10ms or less(DC24V)	

Table 2-11 : Electrical specifications of output circuit

Item		Specification	Internal circuit
Type		Transistor output	<p><Sink type></p>  <p><Source type></p>  <p>* GRn = GR1 ~ GR4</p>
No. of output points		4	
Insulation method		Photo coupler insulation	
Rated load voltage		DC24V	
Rated load voltage range		DC21.6 to 26.4VDC	
Max. current load		0.1A/ 1 point (100%)	
Current leak with power OFF		0.1mA or less	
Maximum voltage drop with power ON		DC0.9V(TYP.)	
Response time	OFF-ON	2ms or less (hardware response time)	
	ON-OFF	2 ms or less (resistance load) (hardware response time)	
Fuse rating		1.6A (each one common) Cannot be exchanged	

Note) An optional air hand interface (2A-RZ365/RZ375) is required to use hand output.

2.5.6 Air supply circuit example for the hand

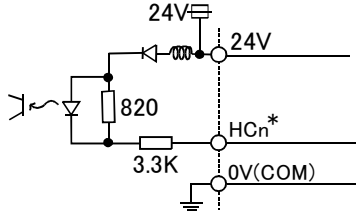
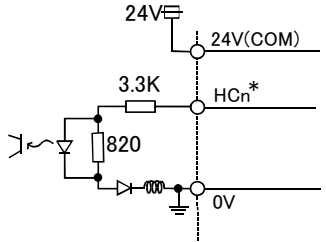
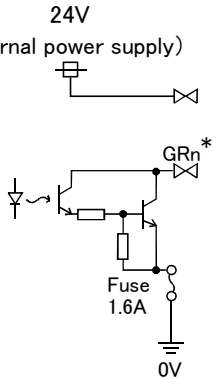
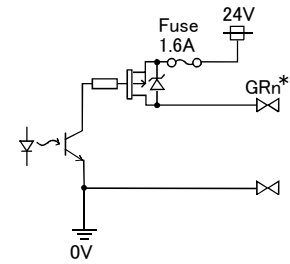
Fig. 2-17 shows an example of pneumatic supply circuitry for the hand.

- (1) Place diodes parallel to the solenoid coil.
- (2) When the factory pneumatic pressure drops, as a result of the hand clamp strength weakening, there can be damage to the work. To prevent it, install a pressure switch to the source of the air as shown in Fig. 2-17 and use the circuit described so that the robot stops when pressure drops. Use a hand with a spring-pressure clamp, or a mechanical lock-type hand, that can be used in cases where the pressure switch becomes damaged.
- (3) The optional hand and solenoid valve are of an oilless type. If they are used, don't use any lubricator.
- (4) Supply clean air to the vacuum generation valve when you use clean type robot.

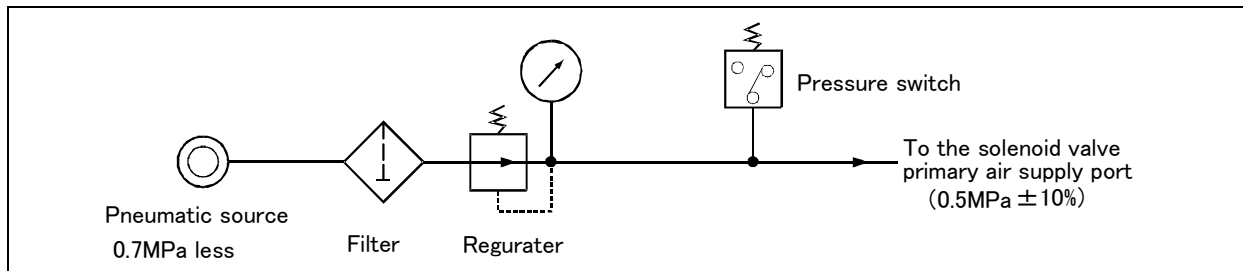

Fig.2-17 : Air supply circuit example for the hand

2.6 Shipping special specifications, options, and maintenance parts

2.6.1 Shipping special specifications

■ What are Shipping special specifications?

Shipping special specifications are changed at the time of shipment from the factory. Consequently, customer need to confirm the delivery date.

To make changes to the specifications after shipment, service work must be performed at the work site or the robot must be returned for service.

■ How to order

- (1) Confirm beforehand when the Factory special specifications can be shipped, because they may not be immediately available.
- (2) Order before the factory shipping date.
- (3) Specified method ····· Specify the part name, model, and robot model type.

(1) Machine cable extension

- Order type : ● Fixed type(10m) :1A-10CBL-1
- Fixed type(15m) :1A-15CBL-1
- Flexed type(5m) :1A-05LCBL-1
- Flexed type(10m) :1A-10LCBL-1
- Flexed type(15m) :1A-15LCBL-1

■ Outline



This cable is exchanged with the standard machine cable (5m) accessory to extend the distance between the controller and the robot arm.

A fixed type and flexible type are available.

Exchanges after shipment will be charged (for packaging, shipping costs).

The fixing and flexible types are both configured of the motor signal cable and motor power cable .

■ Configuration

Table 2-12 : Configuration equipments and types

Part name	Model	Qty.		Remarks
		Fixed	Flexed	
Motor signal cable (for fixed type)	1E- □□ CBL(S)-N	1 cable	—	10m, or 15m each
Motor power cable (for fixed type)	1A- □□ CBL(P)-1	1 cable	—	10m, or 15m each
Motor signal cable (for flexed type)	1E- □□ LCBL(S)-N	—	1 cable	5m, 10m, or 15m each
Motor power cable (for flexed type)	1A- □□ LCBL(P)-1	—	1 cable	5m, 10m, or 15m each
Nylon clamp	NK-14N	—	2 pcs.	
Nylon clamp	NK-28N	—	2 pcs.	
Silicon rubber		—	4 pcs.	

Note) The numbers in the boxes □□ refer the length.

■ Specifications

The specifications for the fixed type cables are the same as those for standard cables except the length.

Shows usage conditions for flexed type cables in [Table 2-13](#).

Table 2-13 : Conditions for the flexed type cables

Item	Specifications	
Minimum flexed radius	100R or more	
Cable bare, etc., occupation rate	50% or less	
Maximum movement speed	2000mm/s or less	
Warranty life (no.)	7.5 million times	
Environmental proof	Oil-proof specification sheath (for silicon grease, cable sliding lubricant type)	
Cable configuration	Motor power cable	Φ6.5x10
	Motor signal cable	Φ7x6 and Φ1.7x1

[Caution] The warranty life may greatly differ according to the usage state (items related to [Table 2-13](#) and to the amount of silicon grease applied in the cable conduit.

[Caution] This option can be installed on clean-type, but its cleanliness is not under warranty.

■ Cable configuration

The configuration of the flexible cable is shown in Table 2-14. Refer to this table when selecting the cable bare.

Table 2-14 : Cable configuration

Item	Motor signal cable 1E- □□ LCBL(S)-N		Motor power cable 1A- □□ LCBL(P)-1
	No. of cores	AWG#24(0.2mm ²) -4P	AWG#18(0.75mm ²)
Finish dimensions	Approx. φ 7mm	Approx. φ 1.7mm	Approx. φ 6.5mm
No. of cables used	6 cables	1 cable	10 cables
No. in total	7 cables		10 cables

Note. The square in the cable name indicates the cable length.

■ Fixing the flexible cable

- (1) Connect the connector to the robot arm and controller.
- (2) Wind the silicon rubber around the cable at a position 300 to 400 mm from the robot arm and controller as shown in Fig. 2-18, and fix with the nylon clamp to protect the cable from external stress.

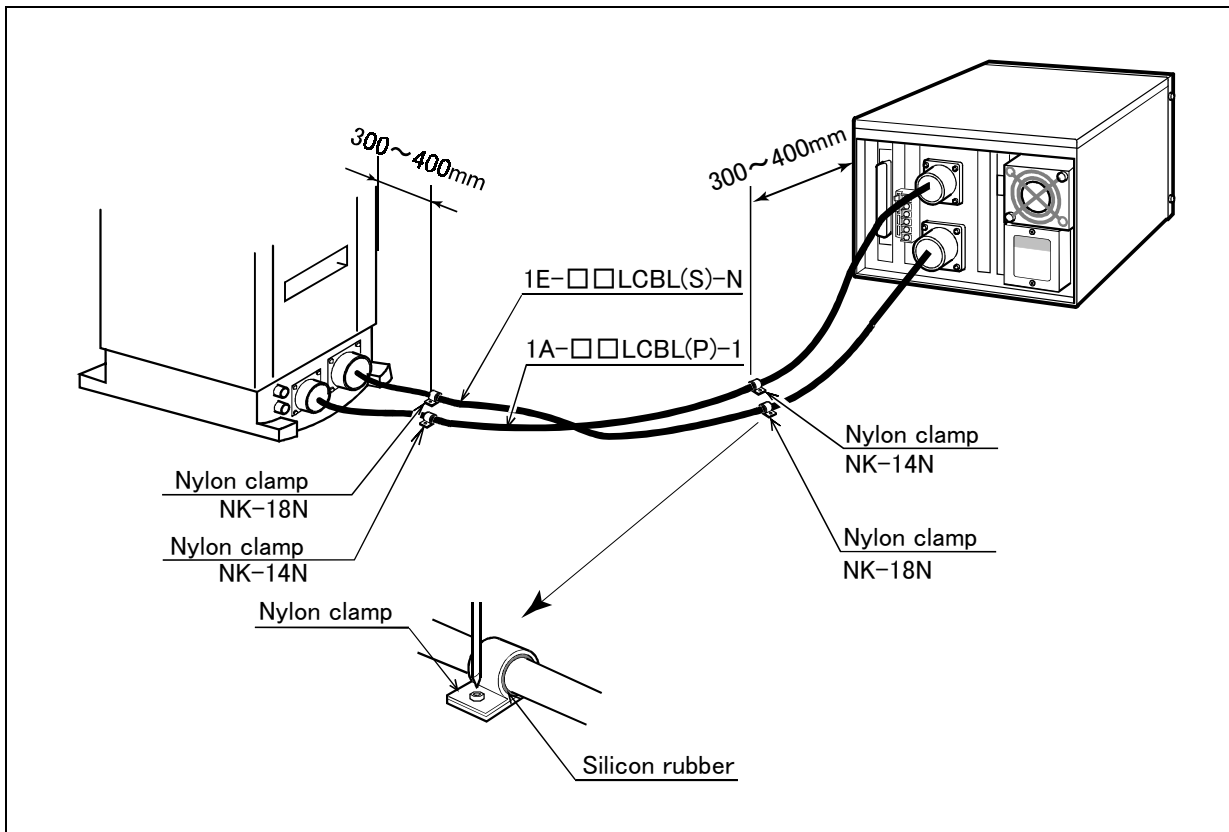

Fig.2-18 : Fixing the flexible cable

(2) Changing the operating range

■ Order type: 1E-DH □□□ - □□□

Note) □□□ indicates the [+ side angle]- [- side angle].

Example) 1E-DH120-90: + angle is +120 degrees, - side is -90 degrees.

■ Outline

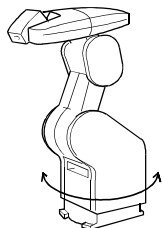

The J1 axis operating range is limited by the robot arm's mechanical stopper and the controller parameters.

If the axis could interfere with the peripheral devices, etc., and the operating range need to be limited, use this.

■ Configuration

Table 2-15 : Configuration devices

Part name	Type	Qty.	Remarks
Operating range change	1E-DH □□□ - □□□	1 pc.	The following work is done in our company. <ul style="list-style-type: none"> • The installation of the mecha stopper. • The change of the S/W parameter.

■ Specifications

Table 2-16 : Robot arm operating range changeable angle

Axis		Standard	Changeable angle
J1	+ side	+160°	One point from +120° , +90° , +60° , +30°
	- side	-160°	One point from -120° , -90° , -60° , -30°

(1) The changeable angle shown in [Table 2-16](#) indicates the operation range by the software.

The limit by the mechanical stopper is positioned five degrees outward from that angle, so take care when designing the layout.

(2) The changeable angle can be set independently on the + side and - side.

2.7 Options

■ What are options?

There are a variety of options for the robot designed to make the setting up process easier for customer needs. customer installation is required for the options. Options come in two types: "set options" and "single options".

1. Set optionsA combination of single options and parts that together, from a set for serving some purpose.
2. Single optionsThat are configured from the fewest number of required units of a part. Please choose customer's purpose additionally.

■ Precautions for optional of motorized hand, pneumatic hand and solenoid valve

(1) About clean specification robot

The motorized hand and pneumatic hand can be installed, but its cleanliness is not under warranty.

Though the solenoid valve set can be installed, the exhaust of solenoid valve must be discharged to outside of clean room by using spare hose etc.

(2) About protection specification robot

The motorized hand can be installed, but as these do not have oil mist specifications, the quality cannot be guaranteed.

(3) About customer manufactured hand

Though the motorized hand can't be manufactured by customer, the pneumatic hand can be manufactured.

Put the precaution together in the following.

Item	General environment specification RV-2A/3AJ	Protection specification RV-2AM/3AM	Clean specification RV-2AC/3AJC
Pneumatic hand set	Installation possible		Installation possible But the cleanliness cannot be guaranteed.
Motorized hand set	Installation possible	Installation possible But the quality cannot be guaranteed.	
Solenoid valve set	Installation possible		Since exhaust is required, it cannot be installed as is.
Pneumatic hand	This can be manufactured by customer		
Motorized hand	This cannot be manufactured by customer		

(1) Motorized hand set

■ Order type : 4A-HM02

■ Outline

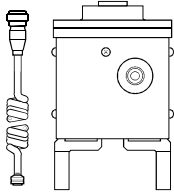

- Motorized hand and the required parts come in a set.
- As air is not required, the hand can be used in laboratories.
- The gripping force can be adjusted.
- The life is 10,000,000 times at a 50% load. The 50% load refers to when the max. load mass in Table 2-18 are all within 50%.
- Installation on the protection specification or clean specification is possible, but quality and cleanness cannot be guaranteed.

■ Configuration

Table 2-17 : Configuration equipment

Part name	Type	Qty.	Remarks
Motorized hand	1A-HM01	1 pc.	
Hand curl cable	1A-GHCD-1	1 pc.	
Motorized hand I/F	2A-RZ364	1 pc.	
Installation bolt (with hole)	M5 × 16	4 bolts	
	M3 × 12	2 bolts	
Hand adapter	BU144D697H01	1 pc.	The adapter for installing the motorized hand to the robot's mechanical interface.

■ Specifications

Table 2-18 : Motorized hand specifications

Item	Specifications	Remarks	
Drive method	DC servo motor		
Grip force	4.9 ~ 68.6N (Each side grip is 2.45 ~ 34.3N)		
Life	1,000,000 times cycle 100% load. 10,000,000 times cycle 50% load.		
Repetition accuracy	0.03mm		
Ambient temperature	0 to 40 °C		
Ambient humidity	45 to 85%		
Atomosphere	With no of oil mist, chip, powder dust.		
Operation confirmation sensors	None		
Mass	0.59kg	Including the adapter.	
Maximum load per finger	Radial	300N	When installing the finger attachment, avoid shock or excessive moment to the tips.
	Mpo moment	6.2N · m	
	Mro moment	10.8N · m	
	Myo moment	6.0N · m	
Others	The stroke cannot be adjusted. Prepare the finger procured by the customer.		

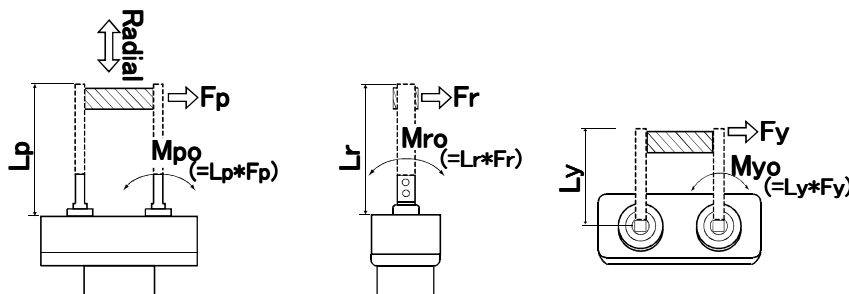

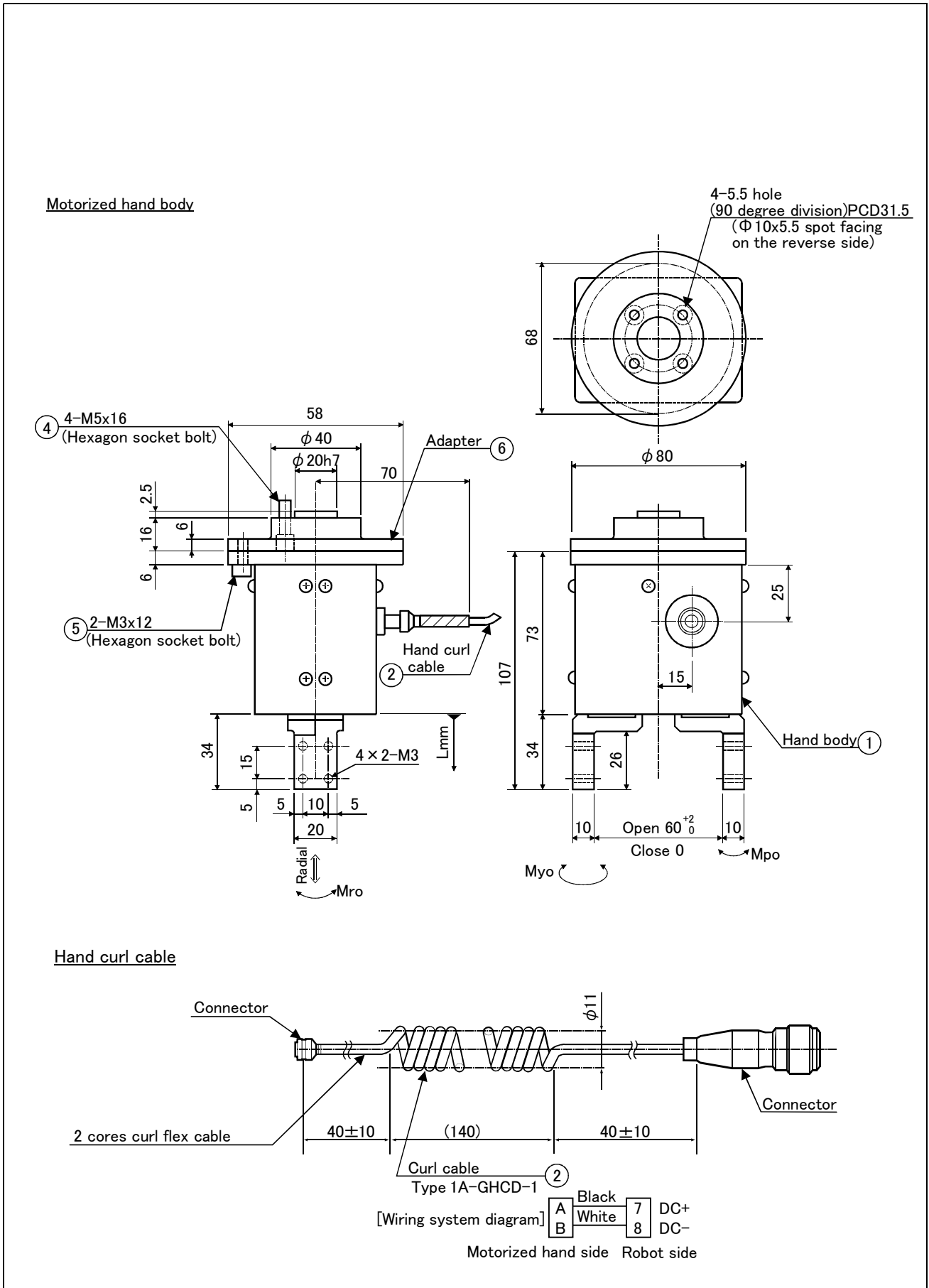
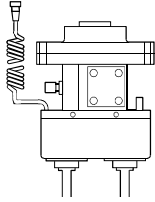

Fig.2-19 : Motorized hand outside dimensional drawing

(2) Pneumatic hand set

- Order type: 4A-HP02 (Sink type)
4A-HP02E (Source type)

■ Outline



- Pneumatic hand and the required parts come in a set.
- The hand has a life of 10 million cycles.
- There is a sensor at the open/close end.
- Installation on the clean specification is possible, but cleanness cannot be guaranteed.

■ Configuration

Table 2-19 : Configuration equipment

Part name	Type	Qty.		Remarks
		4A-HP02	4A-HP02E	
Pneumatic hand	1E-HP01	1 pc.	-	Pneumatic hand body.
	1E-HP01E	-	1 pc.	
Hand curl tube (1 set: 2pc.)	1E-ST0402C	1 pc.	1 pc.	Refer to the section on Page 39, "(6) Hand curl tube".
Pneumatic hand interface	2A-RZ365	1 pc.	-	Refer to the section on Page 60, "(2) Pneumatic hand interface".
	2A-RZ375	-	1 pc.	
Solenoid valve set (1 set)	1E-VD01	1 pc.	-	Refer to the section on Page 35, "(3) Solenoid valve set".
	1E-VD01E	-	1 pc.	
Installation bolt (with hole)	M5 x 16	4 bolts	4 bolts	
	M3 x 12	4 bolts	4 bolts	
Adapter	BU144D697H01	1 pc.	1 pc.	The adapter for installing the pneumatic hand to the robot's mechanical interface.

■ Specifications

Table 2-20 : Pneumatic hand specifications

Item	Specifications	Remarks	
Operating fluid	Clean air		
Operating pressure range	0.04 to 0.7MPa		
Operating temperature range	0 to 40 °C		
Open/close stroke	12_0^{+2} mm		
Life	10 million cycles or more		
Operating method	Double action		
Mass	0.45kg	Includes the adapter	
Open/close confirmation sensor	Open edge and close edge		
Pneumatic coupling size	Φ4 (quick coupling)	Connection hose diameter: Φ4	
Maximum load per finger	Radial	700N	When installing the finger attachment, avoid shock or excessive moment to the tips.
	Mpo moment	$6.2\text{N} \cdot \text{m}$	
	Mro moment	$10.8\text{N} \cdot \text{m}$	
	Myo moment	$6.0\text{N} \cdot \text{m}$	

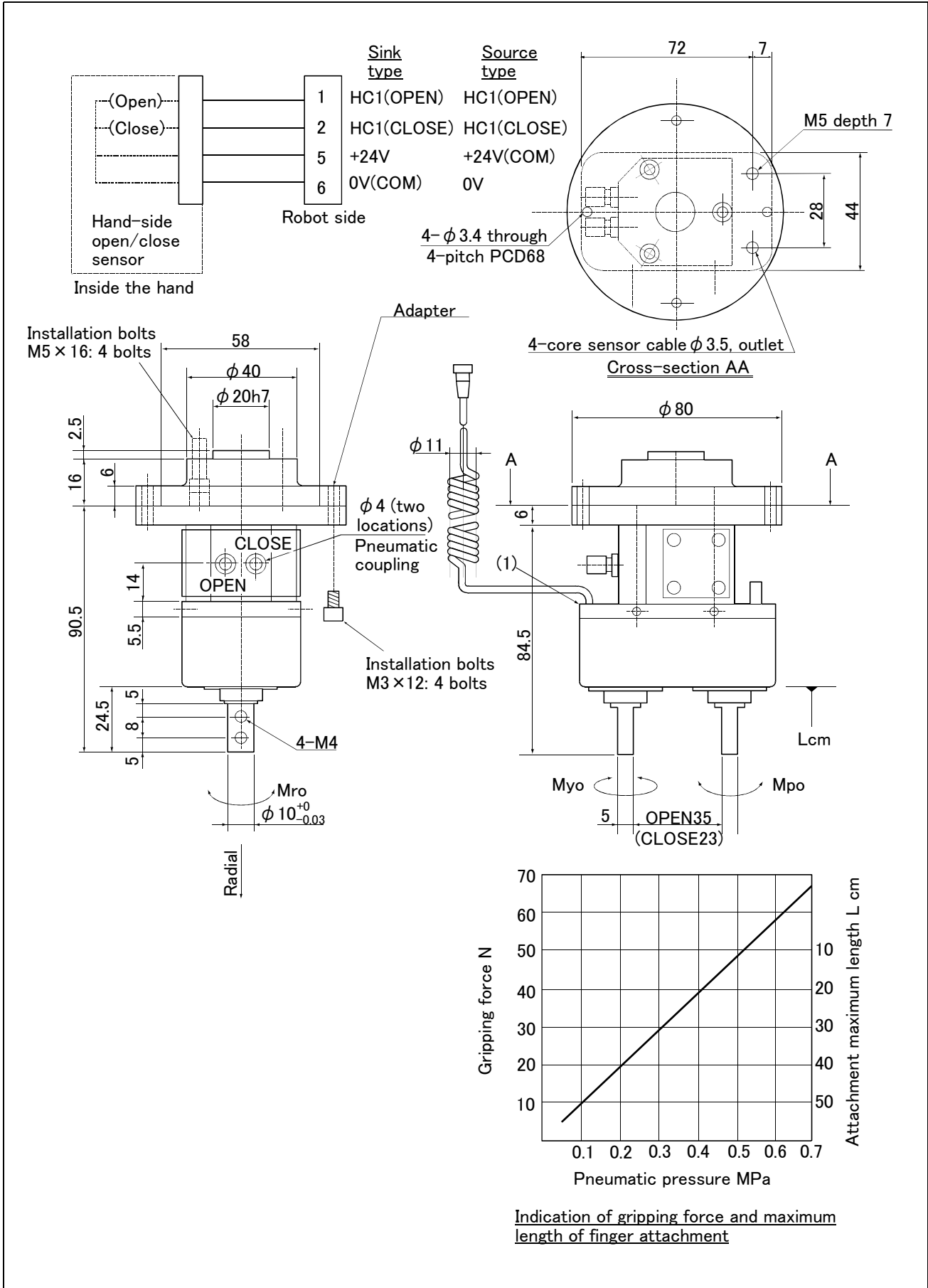
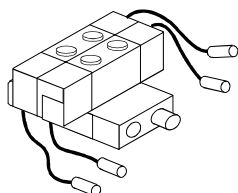

Fig.2-20 : Pneumatic hand outside dimensional drawing

(3) Solenoid valve set

- Order type: One set: 1E-VD01(Sink type)/1E-VD01E(Source type)
Two sets: 1E-VD02(Sink type)/1E-VD02E(Source type)

■ Outline



The solenoid valve set is an option that is used for controlling toolings when various toolings, such as the hand, are installed at the end of the arm. All have double solenoid specification, and either one or two or three sets can be selected. This solenoid valve set has a hand output cable attached to the solenoid valve. Also, for easy installation of this electromaagnetic set onto the robot, it comes equipped with a manifold, couplings, silencers, among other things.

When using the robot arm's hand output signal, the pneumatic hand interface option must be installed on the separate controller.

■ Configuration

Table 2-21 : Configuration equipment

Part name	Type	Qty.		Remark
		One set	Two sets	
Solenoid valve set (1 set)	1E-VD01/ 1E-VD01E	1 pc.	—	Connecting the Page 38, "(5) Hand output cable" . M3x25 Two screws (Installation screws)
Solenoid valve set (2 sets)	1E-VD02/ 1E-VD02E	—	1 pc.	1E-VD01/VD02 are the sink type. 1E-VD01E/VD02E are the source type.

■ Specifications

Table 2-22 : Valve specifications

Item	Specifications
Number of positions	2
Port	5
Valve function	Double solenoid
Operating fluid	Clean air
Operating method	Pilot type
Effective sectional area (CV value)	1.5mm(0.08)
Oiling	Unnecessary
Operating pressure range	0.2 to 0.7MPa
Guaranteed proof of pressure	1.0MPa or more
Response time	12msec or less
Max. operating frequency	5c/s
Ambient temperature	-5 to 50 °C

Table 2-23 : Solenoid specifications

Item	Specifications
Method	Built-in fly-wheel diodes with surge protection
Operation voltage	DC24V ± 10%
Current value	40mA
Insulation	B type
Insulation resistance	100MΩ or mor
Surge protection	Fly-wheel diode

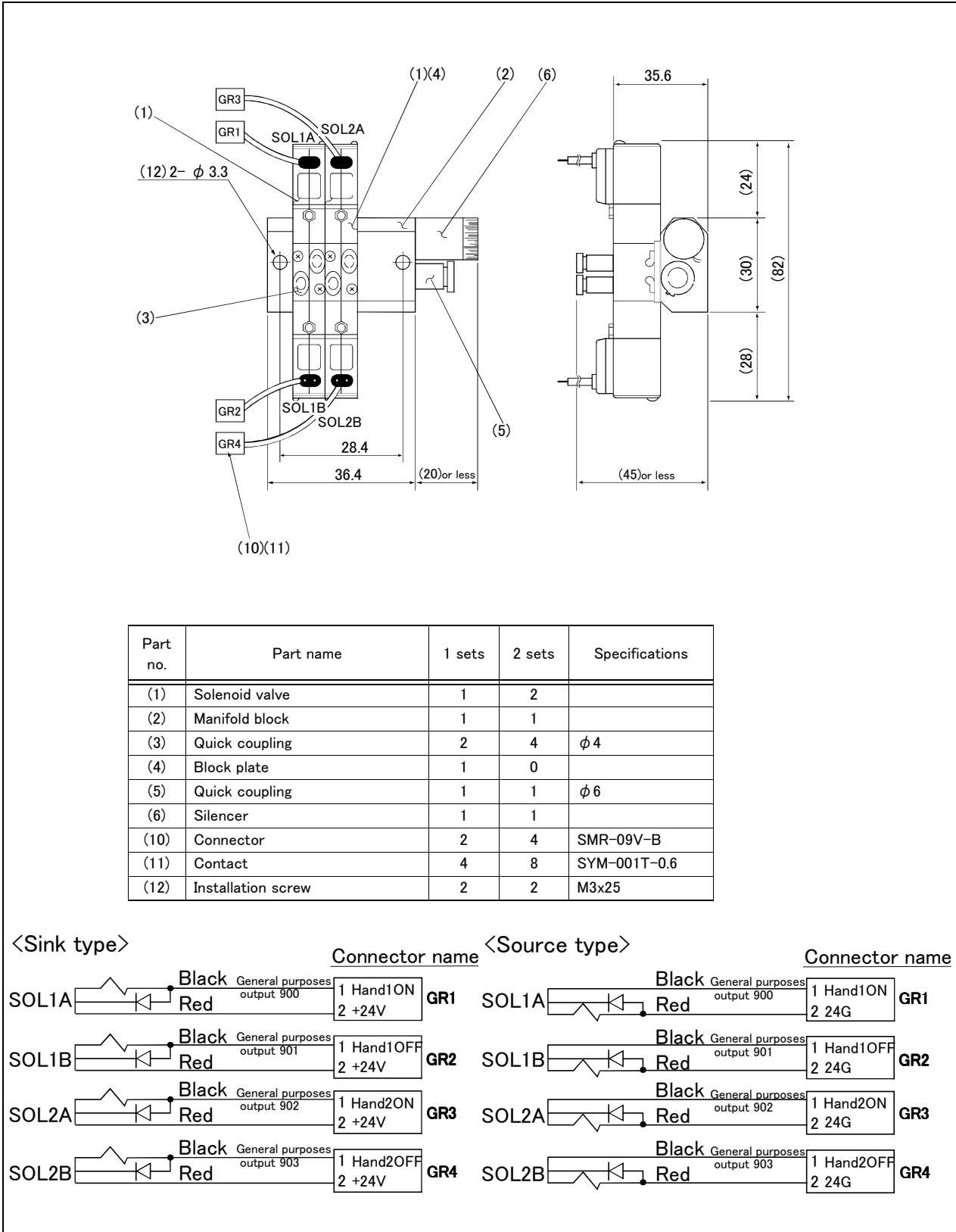

Fig.2-21 : Outline dimensional drawing

(4) Hand input cable

■ Order type: 1E-HC15C

■ Outline

The hand input cable is used for customer-designed pneumatic hands. It is necessary to use this to receive the hand's open/close confirmation signals and grasping confirmation signals, at the controller.

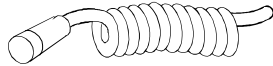

One end of the cable connects to the connector for hand input signals, which is in the wrist section of the hand. The other end of the cable connects to the sensor inside the hand customer designed.

■ Configuration

Table 2-24 : Configuration equipment

Part name	Type	Qty.	Remarks
Hand input cable	1E-HC15C	1 cable	

■ Specifications

Table 2-25 : Specifications

Item	Specifications	Remarks
Size x cable core	AWG#24(0.2mm ²) x 8 cores	
Total length	370mm (Including the curl section, which is 150mm long)	

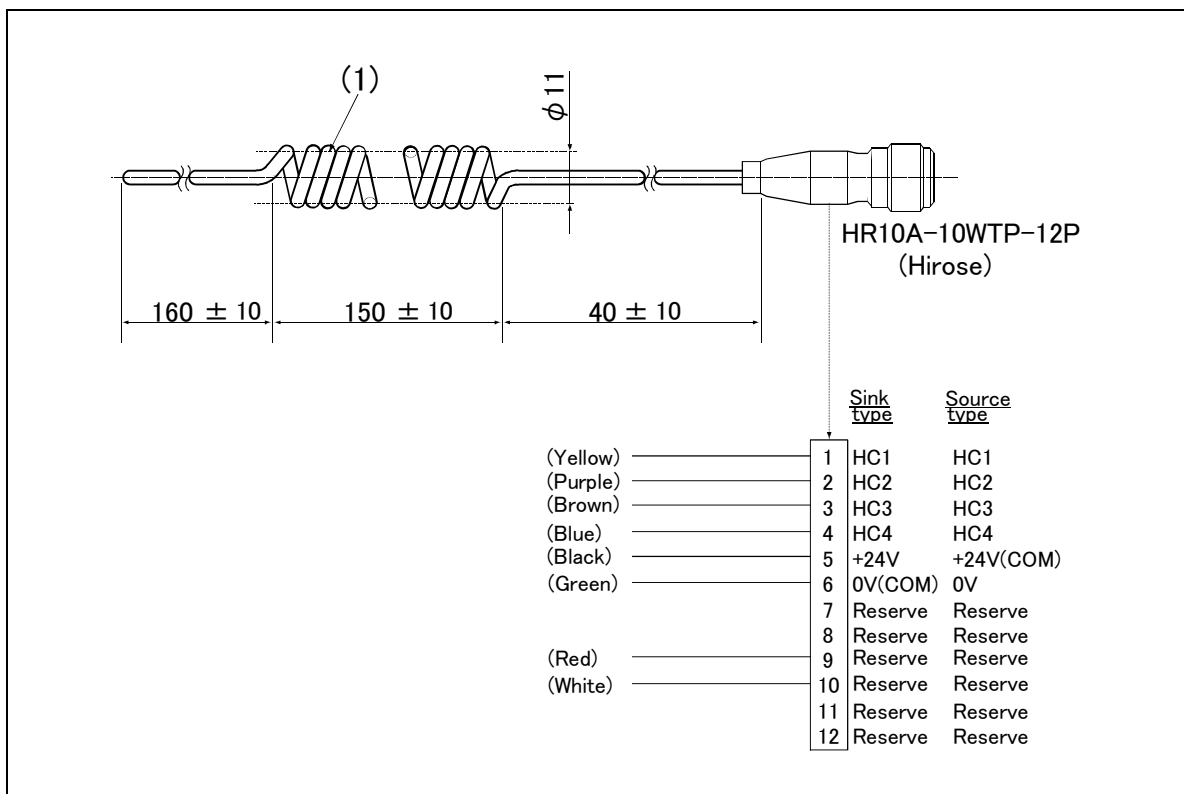

Fig.2-22 : Outside dimensional drawing and pin assignment

[Caution] This option can be installed on clean-type, but its cleanliness is not under warranty.

(5) Hand output cable

■ Order type: 1E-GR35S

■ Outline

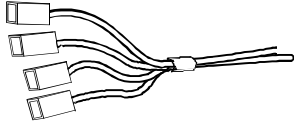

The hand output cable (solenoid valve connection cable) is an option that is used when a solenoid valve other than one of the solenoid valve set options is used. One end of the cable has a connector that connects to the input terminal inside the robot. The other end of the cable is connected.

■ Configuration

Table 2-26 : Configuration equipment

Part name	Type	Qty.	Remarks
Hand output cable	1E-GR35S	1 cable	

■ Specifications

Table 2-27 : Specifications

Item	Specifications	Remarks
Size x Cable core	AWG#22(0.3mm ²) x 2 cores x 4 sets (total 8 cores)	One side connector and one side cable connection
Total length	350mm	

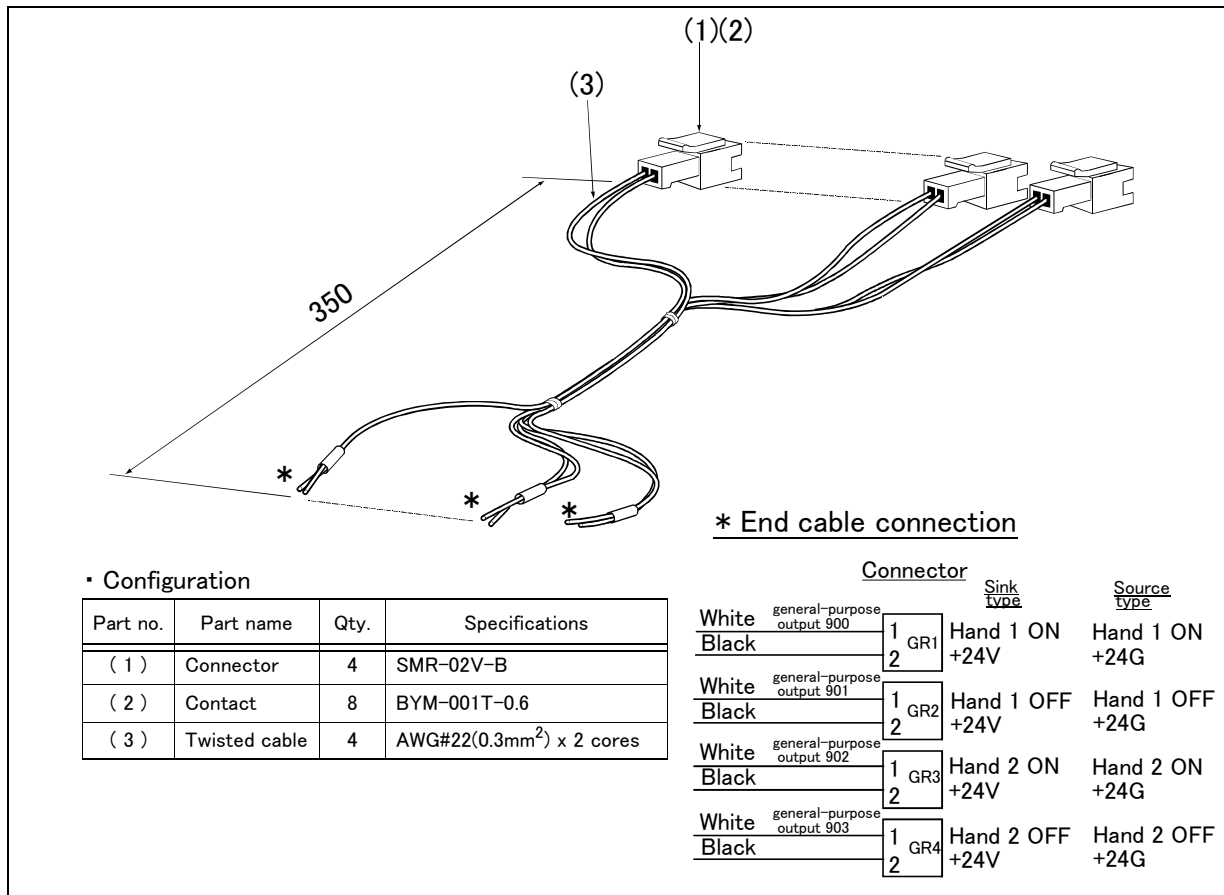

▪ Configuration

Part no.	Part name	Qty.	Specifications
(1)	Connector	4	SMR-02V-B
(2)	Contact	8	BYM-001T-0.6
(3)	Twisted cable	4	AWG#22(0.3mm ²) x 2 cores

(6) Hand curl tube

- Order type: One set (2 pcs.) : 1E-ST0402C
- Two sets (4 pcs.) : 1E-ST0404C

■ Outline

The hand curl tube is a curl tube for the pneumatic hand.

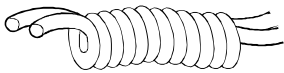

■ Configuration

Table 2-28 : Configuration equipment

Part name	Type	Qty.	Remarks
Hans curl tube (One set: 2 pcs.)	1E-ST0402C	1 pc.	For single-hand: $\Phi 4$ tube, 2pcs.
Hans curl tube (Two set: 4 pcs.)	1E-ST0404C	1 pc.	For double hand: $\Phi 4$ tube, 4pcs.

■ Specifications

This option can be installed on clean-type, but its cleanliness is not under warranty.

Table 2-29 : Specifications

Item	Specifications
Material	Urethane
Size	Outside diameter: $\Phi 4$ x Inside diameter: $\Phi 2.5$

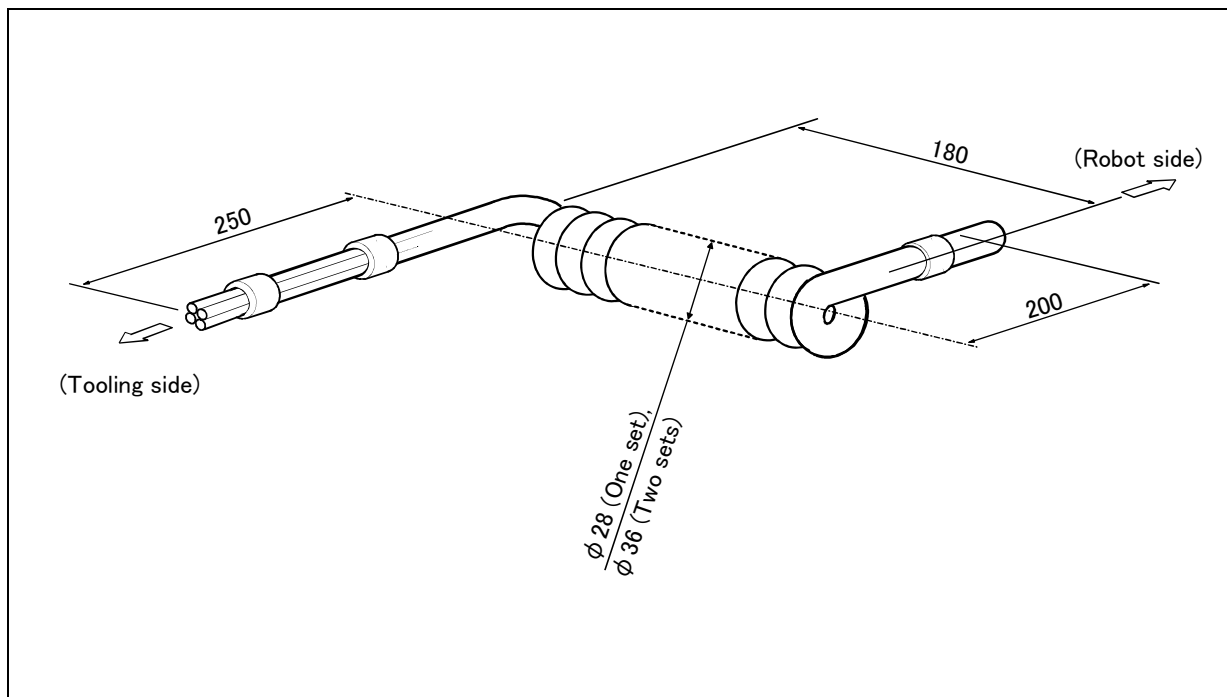

Fig.2-23 : Outline dimensional drawing

[Caution] This option can be installed on clean-type, but its cleanliness is not under warranty.

2.8 Maintenance parts

The consumable parts used in the robot arm are shown in [Table 2-30](#). Purchase these parts from the designated maker or dealer when required. Some Mitsubishi-designated parts differ from the maker's standard parts. Thus, confirm the part name, robot arm and controller serial No. and purchase the parts from the dealer.

Table 2-30 : Consumable part list

No.	Part name	Type	Qty.	Usage place	Supplier
1	Lithium battery	A6BAT	5	In the shoulder cover	Mitsubishi Electric
2	Grrase	SK-1A	As needed	Reduction gears of each axis	

3 Controller

3.1 Standard specifications

3.1.1 Standard specifications

Table 3-1 : Standard specifications of controller

Item		Unit	Specification	Remarks
Type			CR1-571	
Number of control axis			Simultaneously 6(Maximum)	
CPU			64 bit RISC, and DSP	
Memory capacity	Programmed positions and No. of steps	point step	2,500 5,000	
	Number of programs		88	
	Robot language			MELFA-BASIC IV or MOVEMASTER COMMAND
Teaching method			Pose teaching method ,MDI method	
External input and output	input and output	point	16/16	Max. 240/240 ^{Note1)}
	Dedicated input/output	point	Assigned with general-purpose input/output	"STOP" 1 point is fixed
	Hand open/close input/output	point	Input 4 point/Output 0 point	Up to output points can be added as an option ^{Note2)}
	Emergency stop input/output	point	1	Single emergency line
	Door switch input	point	1	Single door switch line
Interface	RS-232C	port	1	For expansion such as the personal computer, Vision sensor
	RS-422	port	1	Dedicated for T/B
	Hand dedicated slot	slot	1	Dedicated for pneumatic hand/motorized hand interface
	Expansion slot	slot	0	3 slot expansion is possible when using expansion option box.
	Robot input/output link	channel	1	Used for general-purpose input/output (Max. 240/240)
Power source	Input voltage range	V	1-phase, AC180 to 253	^{Note3)} ^{Note4)}
	Power capacity	KVA	0.7	Does not include rush current ^{Note5)}
Outline dimensions		mm	212(W)x290(D)x151(H)	Excluding protrusions
Mass		kg	Approx. 8	
Construction			Self-contained floor type, Opened type	IP20 ^{Note6)}
Operating temperature range		deg.	0 to 40	
Ambient humidity		%RH	45 to 85	Without dew drops
Grounding		Ω	100 or less	D class grounding earth ^{Note7)}
Paint color			Light gray	Munsell 7.65Y7.64/0.73

Note1) It is the value when seven maximums expand (224/224) the Parallel I/O unit.
(2A-RZ361 or 2A-RZ371:Input 32 points / Output 32 points.)

Note2) It is when an pneumatic hand interface (2A-RZ365 or 2A-RZ375) is installed. Note that the pneumatic hand interface has 8 output points, but the robot arm side has 4 points.

Note3) 1-phase, AC180 to 253. This specification is changed for CE-Marking model.

Note4) It can be used with single phase 95 VAC to 132 VAC. However, with 100 VAC power supply, an alarm may be generated due to the robot arm's lift operation, etc. even if the acceleration/deceleration time, the maximum speed and other items are set within the range of the robot's standard specification. As a result, the robot's maximum performance may not be achieved. Therefore, use the standard specification when a production line requires stringent conditions for the tact time, load, speed and duty.

Input voltage is restricted for the specification of an earth leakage breaker (NV30-**).

The voltage of the underline part is default.

· 95 to 132VAC, or 180 to 242VAC ("NV30-FA", Japan spec.).

· 230VAC ± 10 % ("NV30-FAU", CE spec.)

· 95 to 132VAC, or 180 to 253VAC ("NV30-FAU", except CE spec.).

Note5) The power capacity (0.7kVA) is the maximum rating value for normal operation. The power capacity does not include the rush current when the power is turned ON. The power capacity is a guideline and the actual operation is affected by the input power voltage. The power consumption in the specific operation pattern with the RV-2A/3AJ is approx. 0.6kw.

Note6) The controller (CR1-571) of this robot is a general environment specification. If the robot is used in an oil mist environment, use the optional controller protection box (CR1-MB) to protect the controller from the oil mist environment. (Refer to [Page 9, "2.2.3 Protection specifications and working environment"](#))
Install to the place not to influence the cleanliness when using in the clean environment. (Refer to [Page 10, "2.2.4 Clean specifications"](#))

Note7) The robot must be grounded by the customer.

3.1.2 Protection specifications and operating supply

A protection method complying with the IEC Standard IP20 (Opened type) is adopted for the controller.

IEC's IP symbols refer only to the degree of protection between the solid and the fluids, and don't indicated that any special protection has been constructed for the prevention against oil and water.

Refer to the section [Page 96, "5.2 Working environment"](#) for details on the working environment.

CAUTION

If the robot is used in an oil mist environment, use the optional controller protection box (CR1-MB) to protect the controller from the oil mist environment.

Refer to the section [Page 62, "\(3\) Controller protection box"](#) for details on the controller protection box.

3.2 Names of each part

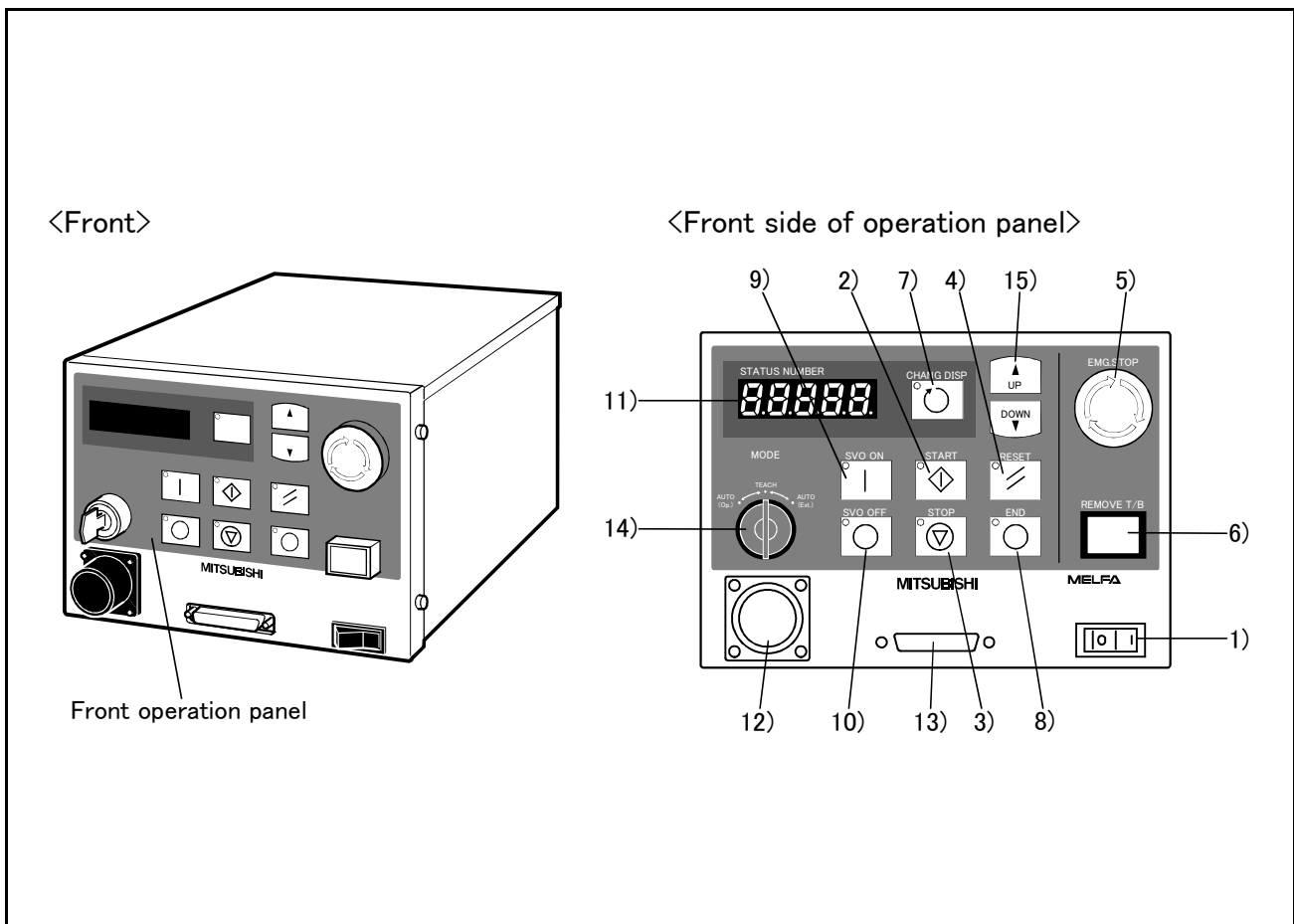

Fig.3-1 : Names of controller parts

- 1) POWER switch..... This turns the control power ON/OFF.
- 2) START button..... This executes the program and operates the robot. The program is run continuously.
- 3) STOP button..... This stops the robot immediately. The servo does not turn OFF.
- 4) RESET button..... This resets the error. This also resets the program's halted state and resets the program.
- 5) Emergency stop switch..... This stops the robot in an emergency state. The servo turns OFF.
- 6) T/B remove switch..... This is used to connect/disconnect the T/B without turning OFF the controller's control power.
- 7) CHNGDISP button..... This changes the details displayed on the display panel in the order of "Override" → "Program No." → "Line No.".
- 8) END button..... This stops the program being executed at the last line or END statement.
- 9) SVO.ON button..... This turns ON the servo power. (The servo turns ON.)
- 10) SVO.OFF button..... This turns OFF the servo power. (The servo turns OFF.)
- 11) STATUS NUMBER
(display panel)..... The alarm No., program No., override value (%), etc., are displayed.
- 12) T/B connection connector This is a dedicated connector for connecting the T/B.
- 13) Personal computer
connection connector..... This is an RS-232C specification connector for connecting the personal computer.
- 14) MODE key switch..... This changes the robot's operation mode. ^{Note)}
 - AUTO (Op.)..... Only operations from the controller are valid. Operations for which the operation mode must be at the external device or T/B are not possible.
 - TEACH..... When the T/B is valid, only operations from the T/B are valid. Operations for which the operation mode must be at the external device or controller are not possible.
 - AUTO (Ext.)..... Only operations from the external device are valid. Operations for which the operation mode must be at the T/B or controller are not possible.
- 15) UP/DOWN button..... This scrolls up or down the details displayed on the "STATUS. NUMBER" display panel.

CAUTION

Note) The servo will turn OFF when the controller's [MODE] switch is changed.
Note that axes not provided with brakes could drop with their own weight.

Carry out the following operations to prevent the servo from turning OFF when the [MODE] switch is changed.

The servo on status can be maintained by changing the mode with keeping pressing lightly the deadman switch of T/B. The operating method is shown below.

- (1) When the mode is changed from TEACH to AUTO.
 - 1) While holding down the deadman switch on the T/B, set the [ENABLE/DISABLE] switch to "DISABLE".
 - 2) While holding down the deadman switch on the T/B, set the controller [MODE] switch to "AUTO".
 - 3) Release the T/B deadman switch.
- (2) When the mode is changed from AUTO to TEACH.
 - 1) While the [ENABLE/DISABLE] switch on the T/B is "DISABLE", hold down the deadman switch.
 - 2) While holding down the deadman switch on the T/B, set the controller [MODE] switch to "TEACH".
 - 3) While holding down the deadman switch on the T/B, set the [ENABLE/DISABLE] switch to "ENABLE", then do the operation of T/B that you wish.

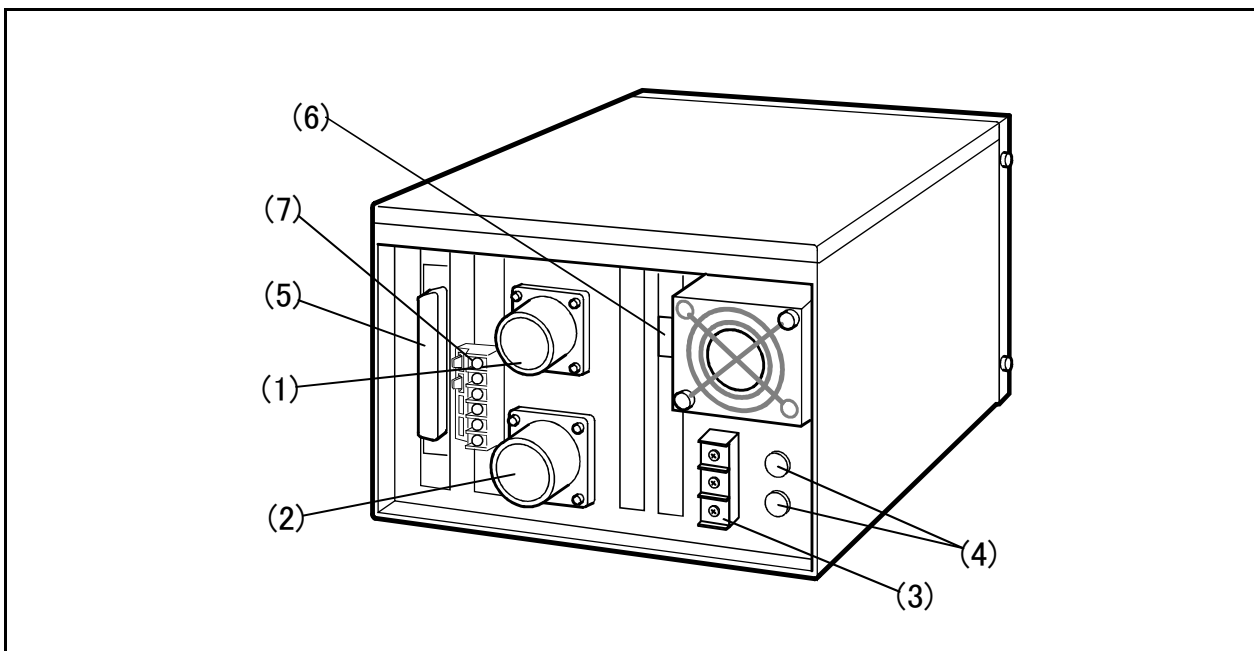

Fig.3-2 : Names of each controller part (Rear side)

- (1) Machine cable connector (for motor power) Connects to the robot arm base. (CN1 connector)
- (2) Machine cable connector (for motor signals)..... Connects to the robot arm base. (CN2 connector)
- (3) Power supply terminals.
- (4) Fuse box.
- (5) External input/output signal connector.
- (6) Network cable connector for parallel I/O unit expansion.
- (7) Emergency stop switch and door switch terminals.

3.3 Outside dimensions/Installation dimensions

3.3.1 Outside dimensions

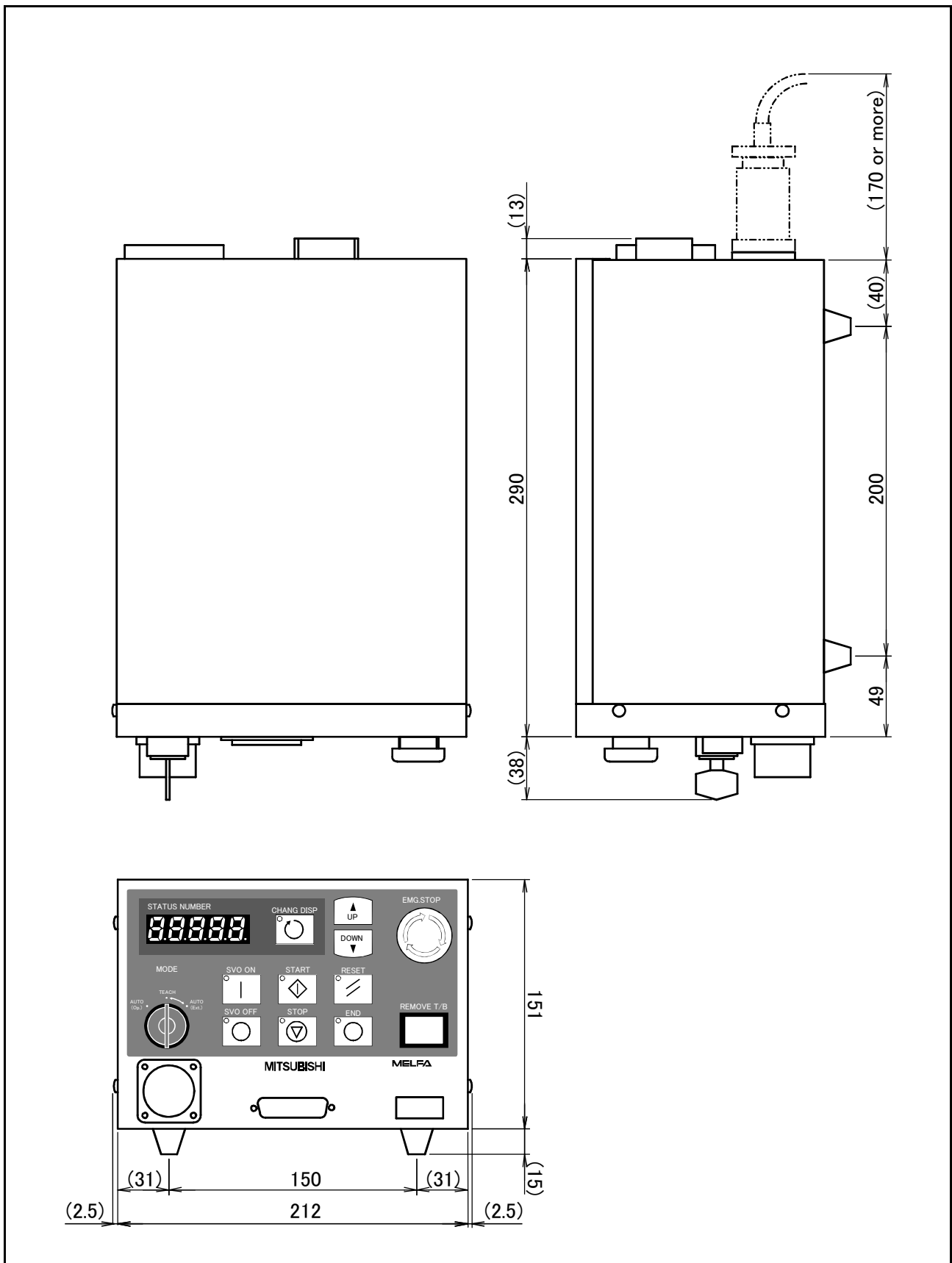

Fig.3-3 : Outside dimensions of controller

3.3.2 Installation dimensions

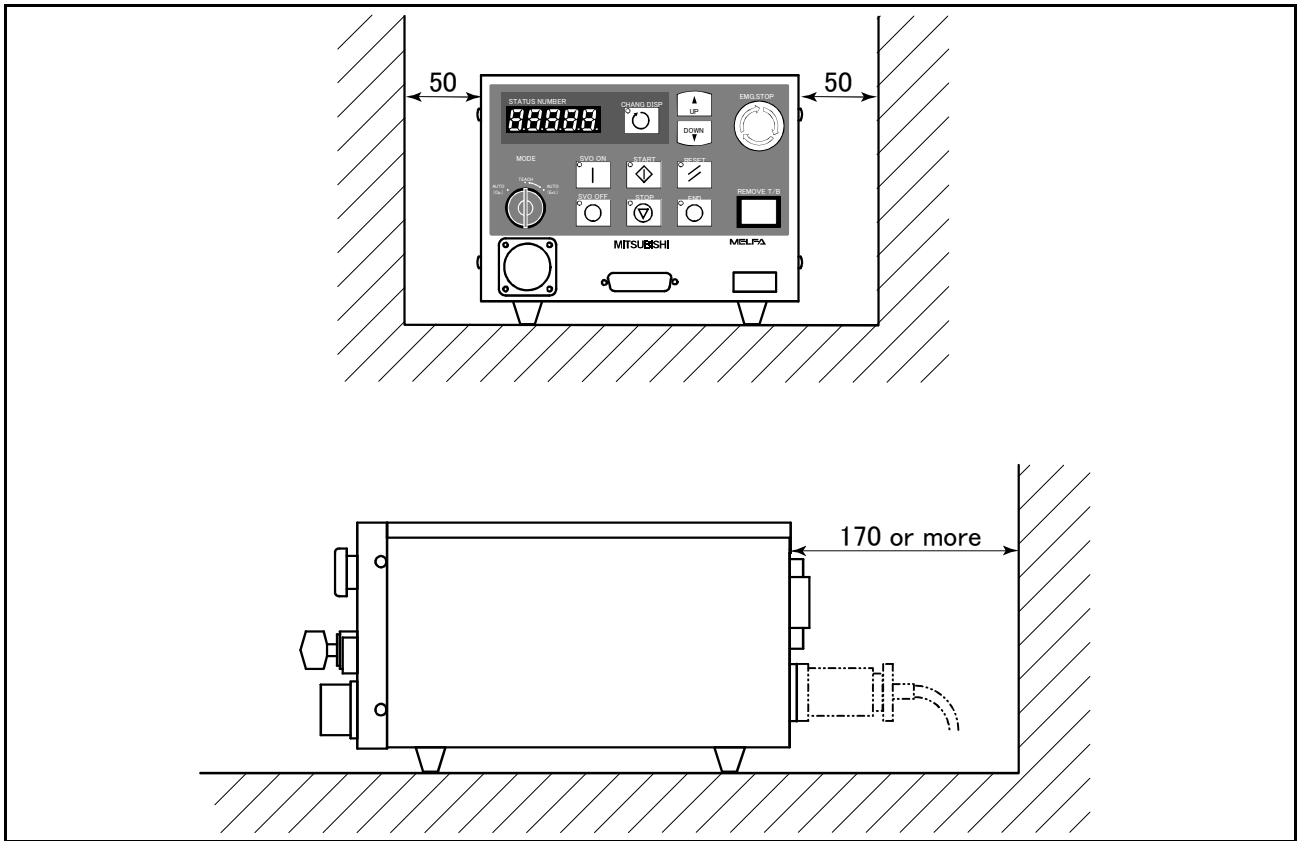

Fig.3-4 : Installation of controller

3.4 External input/output

3.4.1 Types

- (1) Dedicated input/output.....These inputs and outputs carry out the robot remote operation and status display.
- (2) General-purpose input/output.....These are inputs and outputs that the customer can program for peripheral device control.
- (3) Hand input/output.....These are inputs and outputs related to the hand that the customer can program. (The hand output is an option. The [Page 60, "\(2\) Pneumatic hand interface"](#) is required.)

Class	Name	No. of input/output points		Connection format
		Input	Output	
Standard	Emergency stop	1	1	Terminal block
Standard	Door switch	1		
Standard	Parallel input/output	Occupies 16 general-purpose points/(6) dedicated points in general-purpose	Occupies 16 general-purpose points/(4) dedicated points in general-purpose	Connector

3.4.2 Explanation

The parallel input/output unit uses connector bridging. Purchase the "External I/O cable" for connection with external devices.

The hand output is an option. Refer to [Page 60, "\(2\) Pneumatic hand interface"](#) for details

The parallel input/output unit can be expanded outside of the controller.

The expansion parallel input/output unit is connected with the control unit in the controller using a robot I/O link cable. Parallel input and output units can be expand as an option to seven maximums. With allows up to input 240 points and output 240 points of maximums can be used including 16 points input and 16 points output of standard.

Refer to [Page 67, "\(5\) Parallel I/O unit"](#) for details on the parallel input/output unit.

3.5 Dedicated input/output

Show the main function of dedicated input/output in the [Table 3-2](#). Refer to attached instruction manual “CR1/CR2/CR4/CR7/CR8 Controller Detailed explanations of functions and operations” in the product for the other functions. Each parameter indicated with the parameter name is used by designated the signal No., assigned in the order of input signal No. and output signal No. If the number of dedicated inputs and general-purpose input points used exceeds the standard No. of input/output points, install the parallel input/output unit (1st to 7th station: option).

Table 3-2 : Dedicated input/output list

Parameter name	Input <small>Note1)</small>			Output	
	Name	Function	Level	Name	Function
TEACHMD	None			Teaching mode output signal	Outputs that the teaching mode is entered.
ATTOPMD	None			Automatic mode output signal	Outputs that the automatic mode is entered.
ATEXTMD	None			Remote mode output signal	Outputs that the remote mode is entered.
AUTOENA	Automatic operation enabled input signal	Disables automatic operation when inactive, and enables automatic operation when active.	L	Automatic operation enabled output signal	Outputs the automatic operation enabled state.
START	Start input signal	Starts all slots.	E	Operating output signal	Outputs that the slot is operating.
STOP	Stop input signal	Stops all slots. The input signal No. is fixed to 0. Note) Use the emergency stop input for stop inputs related to safety.	L	Wait output signal	Outputs that the slot is temporarily stopped.
SLOTINIT	Slot initialization input signal	Resets the wait state, and initializes all slots.	E	Program selection enabled output signal	Outputs that the slot is in the program selection enabled state.
ERRRESET	Error reset input signal	Resets the error state.	E	Error occurring output signal	Outputs that an error has occurred.
CYCLE	Cycle stop input signal	Carries out cycle stop.	E	In cycle stop operation output signal	Outputs that the cycle stop is operating.
SRVOFF	Servo ON enabled input signal	Sets all mechanisms to servo ON enabled.	L	Servo ON enabled output signal	Outputs the servo ON enabled state. (Echo back)
SRVON	Servo ON input signal	Turns the servo ON for all mechanisms.	E	In servo ON output signal	Outputs the servo ON state.
IOENA	Operation rights input signal	Requests the operation rights for the external signal control.	E	Operation rights output signal	Outputs the operation rights valid state for the external signal control.
MELOCK	Machine lock input signal	Sets/resets the machine lock state for all mechanisms.	E	In machine lock output signal	Outputs the machine lock state.
SAFEPOS	Evasion point return input signal	Requests the evasion point return operation.	E	In evasion point return output signal	Outputs that the evasion point return is taking place.
OUTRESET	General-purpose output signal reset	Resets the general-purpose output signal.	E	None	
EMGERR	None			Emergency stop output signal	Outputs that an emergency stop has occurred.
S1START : S32START	Start input	Starts each slot.	E	In operation output	Outputs the operating state for each slot.
S1STOP : S32STOP	Stop input	Stops each slot.	L	In wait output	Outputs that each slot is temporarily stopped.
PRGSEL	Program selection input signal	esignates the setting value for the program No. with numeric value input signals.	E	None	
OVRDSEL	Override selection input signal	esignates the setting value for the override with the numeric value input signals.	E	None	

Parameter name	Input Note1)			Output	
	Name	Function	Level	Name	Function
IODATA Note2)	Numeric value input (start No., end No.)	Used to designate the program No., override value., mechanism value.	L	Numeric value output (start No., end No.)	Used to output the program No., override value., mechanism No.
PRGOUT	Program No. output request	Requests output of the program No.	E	Program No. output signal	Outputs that the program No. is being output to the numeric value output signal.
LINEOUT	Line No. output request	Requests output of the line No.	E	Line No. output signal	Outputs that the line No. is being output to the numeric value output signal.
OVRDOUT	Override value output request	Requests the override output.	E	Override value output signal	Outputs that the override value is being output to the numeric value output signal.
ERROUT	Error No. output request	Requests the error No. output.	E	Error No. output signal	Outputs that the error No. is being output to the numeric value output signal.
JOGENA	Jog valid input signal	Validates jog operation with the external signals	E	Jog valid output signal	Outputs that the jog operation with external signals is valid.
JOGM	Jog mode input 2-bit	Designates the jog mode.	L	Jog mode output 2-bit	Outputs the current jog mode.
JOG+	Jog feed + side for 8-axes	Requests the + side jog operation.	L	None	
JOG-	Jog feed - side for 8-axes	Requests the - side jog operation.	L	None	
HNDERR1 : HNDERR5	Mechanism 1 hand error input signal : Mechanism 5 hand error input signal	Requests the hand error occurrence.	L	Mechanism 1 hand error output signal : Mechanism 5 hand error output signal	Outputs that a hand error is occurring.
AIRERR1 : AIRERR5	Mechanism 1 pneumatic pressure error input signal : Mechanism 5 pneumatic pressure error input signal	Request the pneumatic pressure error occurrence.	L	Mechanism 1 pneumatic pressure error output signal. : Mechanism 5 pneumatic pressure error output signal.	Outputs that a pneumatic pressure error is occurring.
USER-AREA ^{Note3)}	None			User-designated area 8-points	Outputs that the robot is in the user-designated area.

Note1) The level indicates the signal level.

L: Level signal → The designated function is validated when the signal is ON, and is invalidated when the signal is OFF.

E: Edge signal → The designated function is validated when the signal changes from the OFF to ON state, and the function maintains the original state even when the signal then turns OFF.

Note2) Four elements are set in the order of input signal start No., end No., output signal start No. and end No.

Note3) Up to eight points can be set successively in order of start output signal No. and end output signal No.

3.6 Emergency stop input/output

This signal is input from the "emergency stop input" terminal in the controller.

Table 3-3 : Dedicated input terminals in controller

Class	Name	Details
Input	Emergency stop	Applies the emergency stop (Single emergency line.)
Input	Door switch	The servo turns OFF.
Output	Emergency stop	This output indicates that the emergency stop input or the door switch input is turned on.

3.6.1 Connection of the external emergency stop

The external emergency stop input and door switch input are short-circuited with a short cable at shipment as shown in Fig. 3-5.

Connect the external emergency stop switch and door switch with the following procedure.

- 1) Prepare the "emergency stop switch" and "door switch".
- 2) Remove the two short pieces 1 and 2.
- 3) Securely connect the external emergency stop's contacts across "1)-2)", and the door switch's contacts across 3)-4)" on the terminal block.

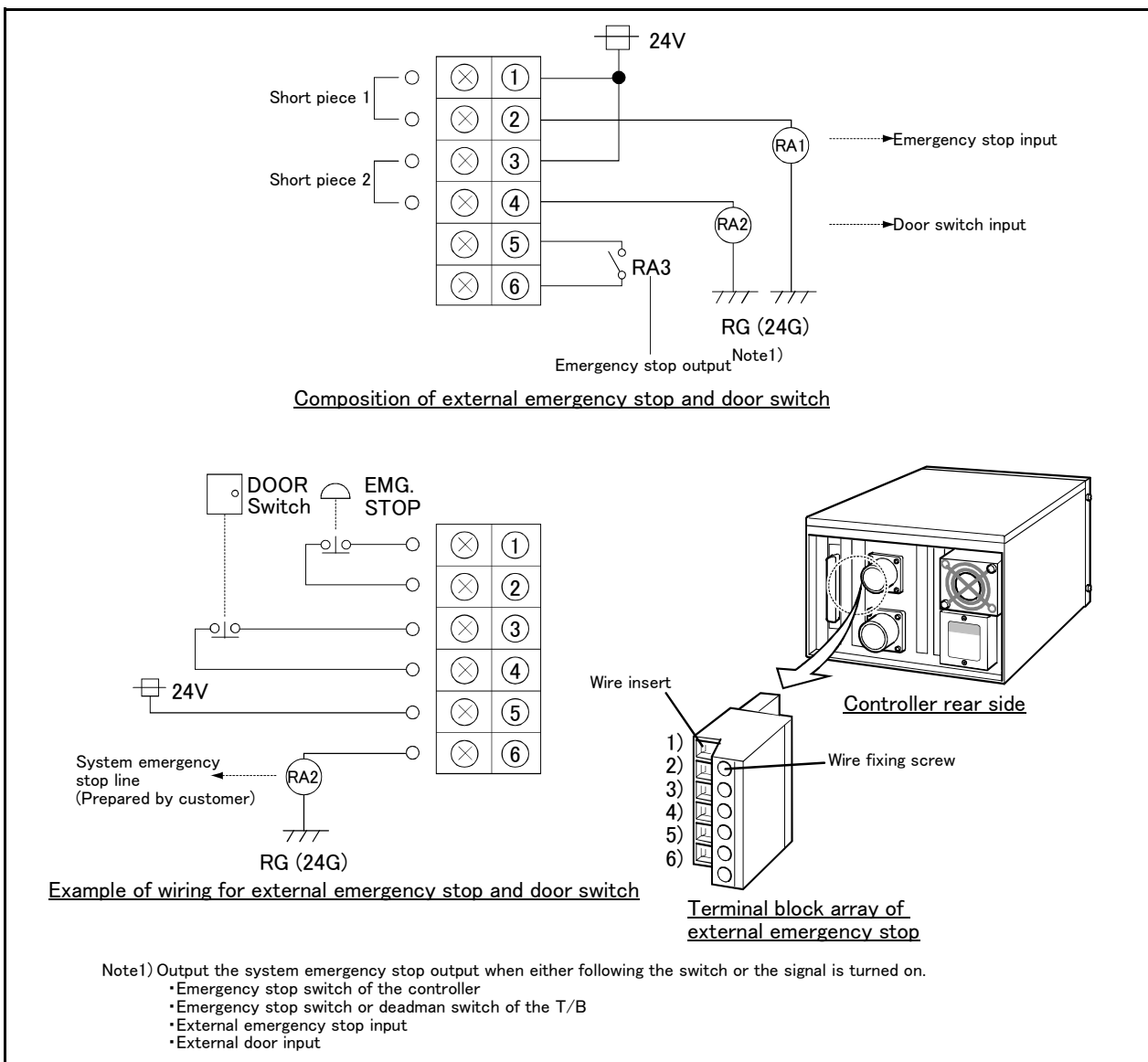

Fig.3-5 : Connection of the external emergency stop

[Note] Refer to Page 95, "5.1.7 Examples of safety measures" together, and carry out wiring to the emergency stop.

3.6.2 Door switch function

This function retrieves the status of the switch installed on the door of the safety fence, etc., and stops the robot when the door is opened. This differs from an emergency stop in that the servo turns OFF when the door is opened and an error does not occur. Follow the wiring example shown in Fig. 3-5, and wire so that the contact closes when the door is closed. Details of this function according to the robot status are shown below.

•During automatic operation When the door is opened, the servo turns OFF and the robot stops. An error occurs.

The process of the restoration : Close the door, reset the alarm, turn on the servo, and restart

•During teaching Even when the door is opened, the servo can be turned ON and the robot moved using the teaching pendant.

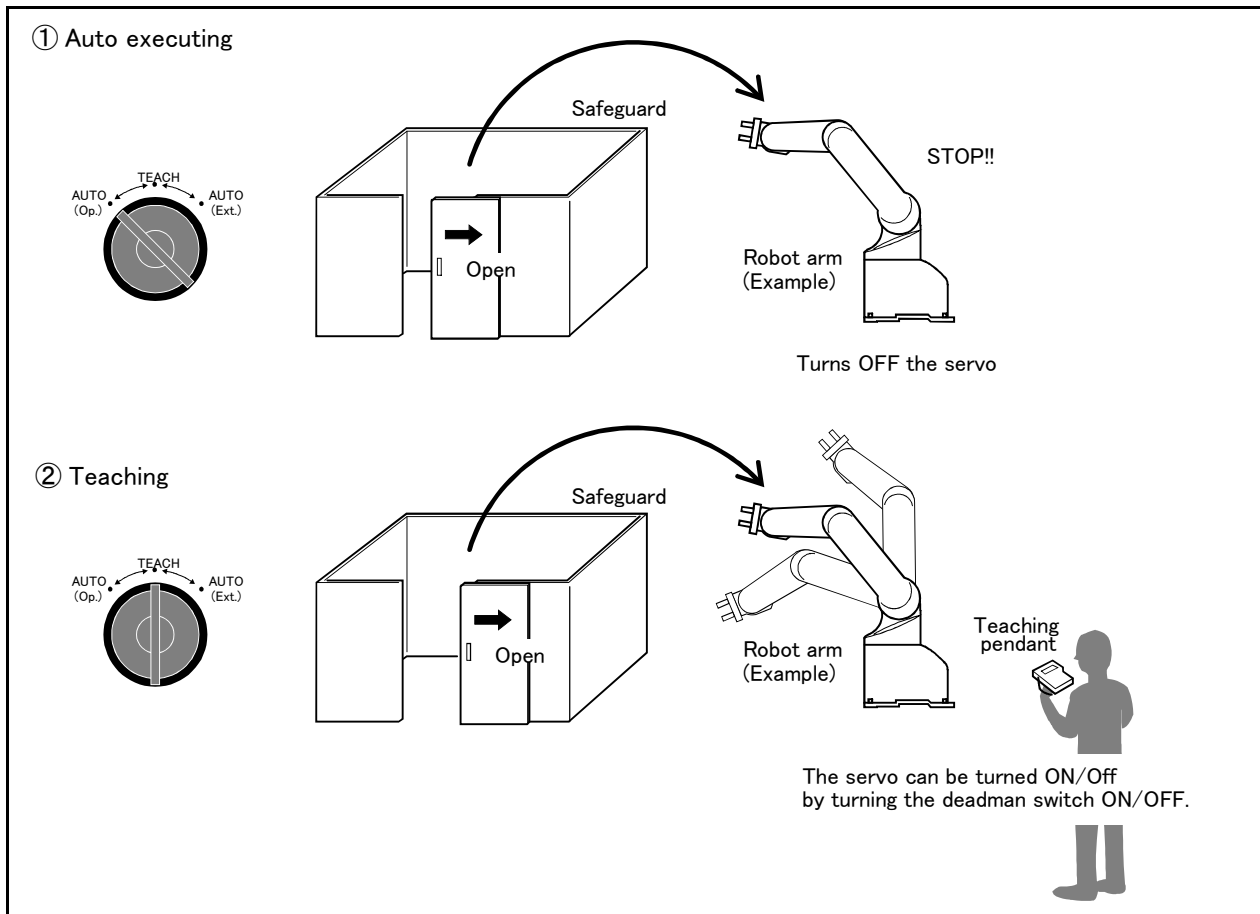

Fig.3-6 : Door switch function

3.7 Parallel input/output unit

- A parallel input/output card is mounted as a standard in the controller's control unit.
- The external input/output circuit specifications are shown in Table 3-4 and Table 3-5.
- The correspondence of the external input/output connector pin No. and the colors of the connected "external input/output cable" wires (separate option) is as shown in Page 54, "Table 3-6" and Table 3-7. Refer to Page 75, "(6) External I/O cable" for details of external I/O cable.
- Pin Nos. described as both general-purpose signal and dedicated signal can be shared.
- The other dedicated input/output signals that are not assigned can be assigned to required general-purpose input/output pins when creating the program.
- If the standard inputs and outputs are insufficient, install the parallel input/output unit connection option outside the controller.

Table 3-4 : Electrical specifications of input circuit

Item		Specifications	Internal circuit
Type		DC input	<div style="display: flex; flex-direction: column; align-items: center;"> <div style="margin-bottom: 20px;"> <p><Sink type></p> </div> <div> <p><Source type></p> </div> </div>
No. of input points		16	
Insulation method		Photo-coupler insulation	
Rated input voltage		12VDC/24VDC	
Rated input current		Approx. 3mA/approx. 7mA	
Working voltage range		10.2VDC to 26.4VDC(ripple rate within 5%)	
ON voltage/ON current		8VDC or more/2mA or more	
OFF voltage/OFF current		4VDC or less/1mA or less	
Input resistance		Approx. 3.3kΩ	
Response time	OFF-ON	10ms or less(DC24V)	
	ON-OFF	10ms or less(DC24V)	
Common method		8 points per common	
External wire connection method		Connector	

Table 3-5 : Electrical specifications of output circuit

Item		Specifications	Internal circuit
Type		Transistor output	<div style="display: flex; flex-direction: column; align-items: center;"> <div style="margin-bottom: 20px;"> <p><Sink type></p> </div> <div> <p><Source type></p> </div> </div>
No. of output points		16	
Insulation method		Photo-coupler insulation	
Rated load voltage		DC12V/DC24V	
Rated load voltage range		DC10.2 ~ 30V(peak voltage 30VDC)	
Max. load current		0.1A/point (100%)	
Leakage current at OFF		0.1mA or less	
Max. voltage drop at ON		DC0.9V(TYP.)	
Response time	OFF-ON	2ms or less (hardware response time)	
	ON-OFF	2ms or less (Resistance load) (hardware response time)	
Fuse rating		Fuse 3.2A (one per common) Replacement not possible	
Common method		4 points per common (common terminal: 4 points)	
External wire connection method		Connector	
External power supply	Voltage	DC12/24V(DC10.2 ~ 30V)	
	Current	60mA (TYP. 24VDC per common) (base drive current)	

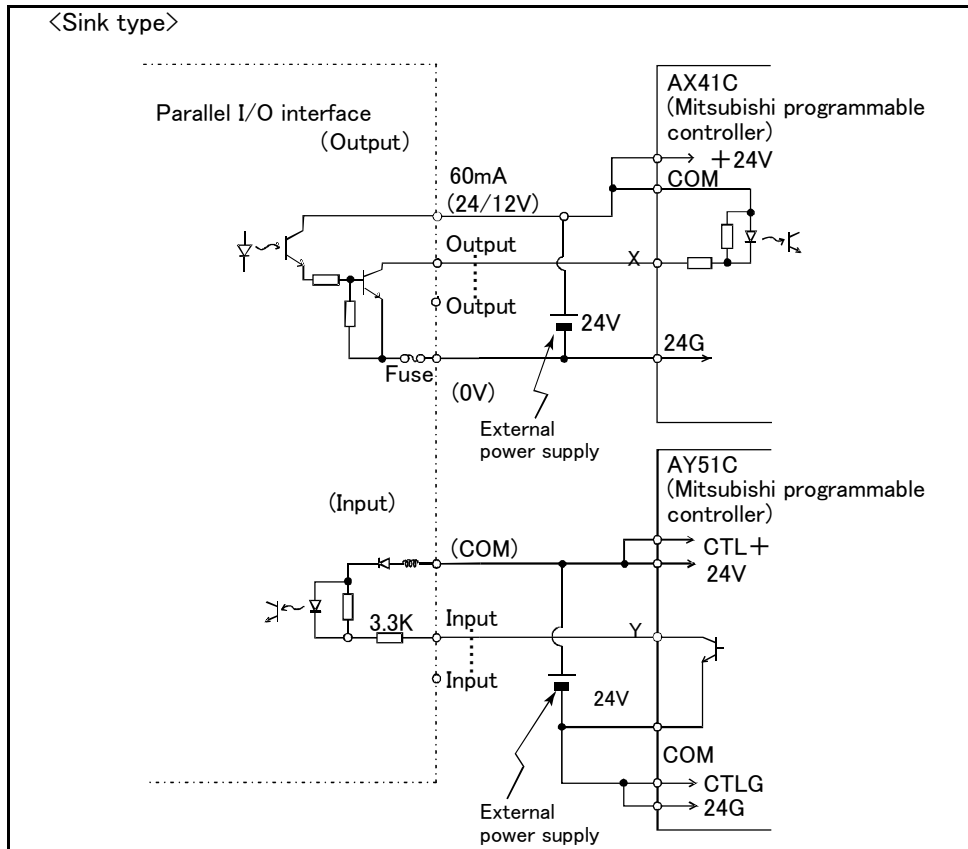

Fig.3-7 : Connection with a Mitsubishi PLC (Example of sink type)

*The input/output circuit external power supply (24 VDC) must be prepared by the customer.

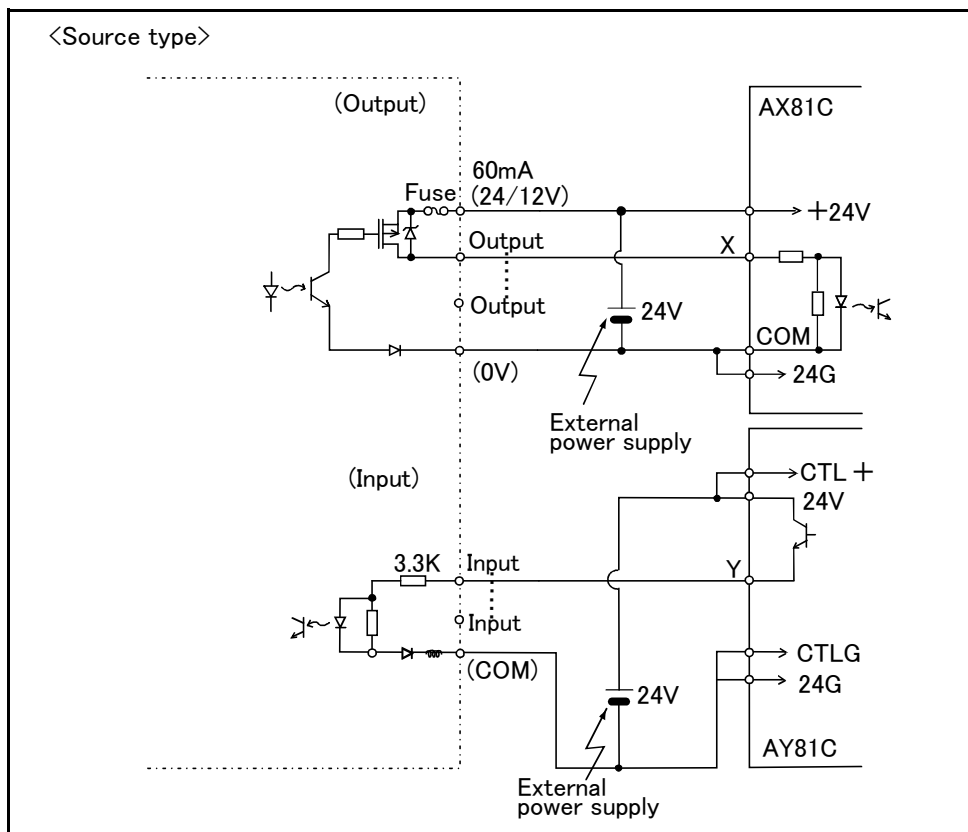

Fig.3-8 : Connection with a Mitsubishi PLC (Example of source type)

*The input/output circuit external power supply (24 VDC) must be prepared by the customer.

Table 3-6 : Standard parallel I/O interface CN100pin No. and signal assignment list <Sink type> (2A-CBL □□)

Pin No.	Line color	Function name		Pin No.	Line color	Function name	
		General-purpose	Dedicated/power supply, common			General-purpose	Dedicated/power supply, common
1	Orange/Red A		FG	26	Orange/Blue A		FG
2	Gray/Red A		0V:For pins 4-7	27	Gray/Blue A		0V:For pins 29-32
3	White/Red A		12V/24V:For pins 4-7	28	White/Blue A		12V/24V:For pins 29-32
4	Yellow/Red A	General-purpose output 0	Running	29	Yellow/Blue A	General-purpose output 4	
5	Pink/Red A	General-purpose output 1	Servo on	30	Pink/Blue A	General-purpose output 5	
6	Orange/Red B	General-purpose output 2	Error	31	Orange/Blue B	General-purpose output 6	
7	Gray/Red B	General-purpose output 3	Operation rights	32	Gray/Blue B	General-purpose output 7	
8	White/Red B		0V:For pins 10-13	33	White/Blue B		0V:For pins 35-38
9	Yellow/Red B		12V/24V:For pins 10-13	34	Yellow/Blue B		12V/24V:For pins 35-38
10	Pink/Red B	General-purpose output 8		35	Pink/Blue B	General-purpose output 12	
11	Orange/Red C	General-purpose output 9		36	Orange/Blue C	General-purpose output 13	
12	Gray/Red C	General-purpose output 10		37	Gray/Blue C	General-purpose output 14	
13	White/Red C	General-purpose output 11		38	White/Blue C	General-purpose output 15	
14	Yellow/Red C		COM0:For pins 15-22 ^{Note1)}	39	Yellow/Blue C		COM1:For pins 40-47 ^{Note1)}
15	Pink/Red C	General-purpose input 0	Stop(All slot) ^{Note2)}	40	Pink/Blue C	General-purpose input 8	
16	Orange/Red D	General-purpose input 1	Servo off	41	Orange/Blue D	General-purpose input 9	
17	Gray/Red D	General-purpose input 2	Error reset	42	Gray/Blue D	General-purpose input 10	
18	White/Red D	General-purpose input 3	Start	43	White/Blue D	General-purpose input 11	
19	Yellow/Red D	General-purpose input 4	Servo on	44	Yellow/Blue D	General-purpose input 12	
20	Pink/Red D	General-purpose input 5	Operation rights	45	Pink/Blue D	General-purpose input 13	
21	Orange/Red E	General-purpose input 6		46	Orange/Blue E	General-purpose input 14	
22	Gray/Red E	General-purpose input 7		47	Gray/Blue E	General-purpose input 15	
23	White/Red E		Reserved	48	White/Blue E		Reserved
24	Yellow/Red E		Reserved	49	Yellow/Blue E		Reserved
25	Pink/Red E		Reserved	50	Pink/Blue E		Reserved

Note1)Sink type:24V/12V(COM), Source type:0V(COM)

Note2)The assignment of the dedicated input signal "STOP" is fixed.

Table 3-7 : Standard parallel I/O interface CN100pin No. and signal assignment list <Source type> (2A-CBL □□)

Pin No.	Line color	Function name		Pin No.	Line color	Function name	
		General-purpose	Dedicated/power supply, common			General-purpose	Dedicated/power supply, common
1	Orange/Red A		FG	26	Orange/Blue A		FG
2	Gray/Red A		0V:For pins 4-7, 10-13	27	Gray/Blue A		0V:For pins 29-32, 35-38
3	White/Red A		12V/24V:For pins 4-7, 10-13	28	White/Blue A		12V/24V:For pins 29-32, 35-38
4	Yellow/Red A	General-purpose output 0	Running	29	Yellow/Blue A	General-purpose output 4	
5	Pink/Red A	General-purpose output 1	Servo on	30	Pink/Blue A	General-purpose output 5	
6	Orange/Red B	General-purpose output 2	Error	31	Orange/Blue B	General-purpose output 6	
7	Gray/Red B	General-purpose output 3	Operation rights	32	Gray/Blue B	General-purpose output 7	
8	White/Red B		Reserved	33	White/Blue B		Reserved
9	Yellow/Red B		Reserved	34	Yellow/Blue B		Reserved
10	Pink/Red B	General-purpose output 8		35	Pink/Blue B	General-purpose output 12	
11	Orange/Red C	General-purpose output 9		36	Orange/Blue C	General-purpose output 13	
12	Gray/Red C	General-purpose output 10		37	Gray/Blue C	General-purpose output 14	
13	White/Red C	General-purpose output 11		38	White/Blue C	General-purpose output 15	
14	Yellow/Red C		COM0:For pins 15-22 ^{Note1)}	39	Yellow/Blue C		COM1:For pins 40-47 ^{Note1)}
15	Pink/Red C	General-purpose input 0	Stop(All slot) ^{Note2)}	40	Pink/Blue C	General-purpose input 8	
16	Orange/Red D	General-purpose input 1	Servo off	41	Orange/Blue D	General-purpose input 9	
17	Gray/Red D	General-purpose input 2	Error reset	42	Gray/Blue D	General-purpose input 10	
18	White/Red D	General-purpose input 3	Start	43	White/Blue D	General-purpose input 11	
19	Yellow/Red D	General-purpose input 4	Servo on	44	Yellow/Blue D	General-purpose input 12	
20	Pink/Red D	General-purpose input 5	Operation rights	45	Pink/Blue D	General-purpose input 13	
21	Orange/Red E	General-purpose input 6		46	Orange/Blue E	General-purpose input 14	
22	Gray/Red E	General-purpose input 7		47	Gray/Blue E	General-purpose input 15	
23	White/Red E		Reserved	48	White/Blue E		Reserved
24	Yellow/Red E		Reserved	49	Yellow/Blue E		Reserved
25	Pink/Red E		Reserved	50	Pink/Blue E		Reserved

Note1)Sink type:24V/12V(COM), Source type:0V(COM)

Note2)The assignment of the dedicated input signal "STOP" is fixed.

- The signals assigned as dedicated inputs can be used as general-purpose inputs during program execution. Note that for safety proposes, these should not be shared with the general-purpose inputs other than for numeric value inputs. The signals assigned as dedicated outputs cannot be used in the program. An alarm will occur during operation if used.

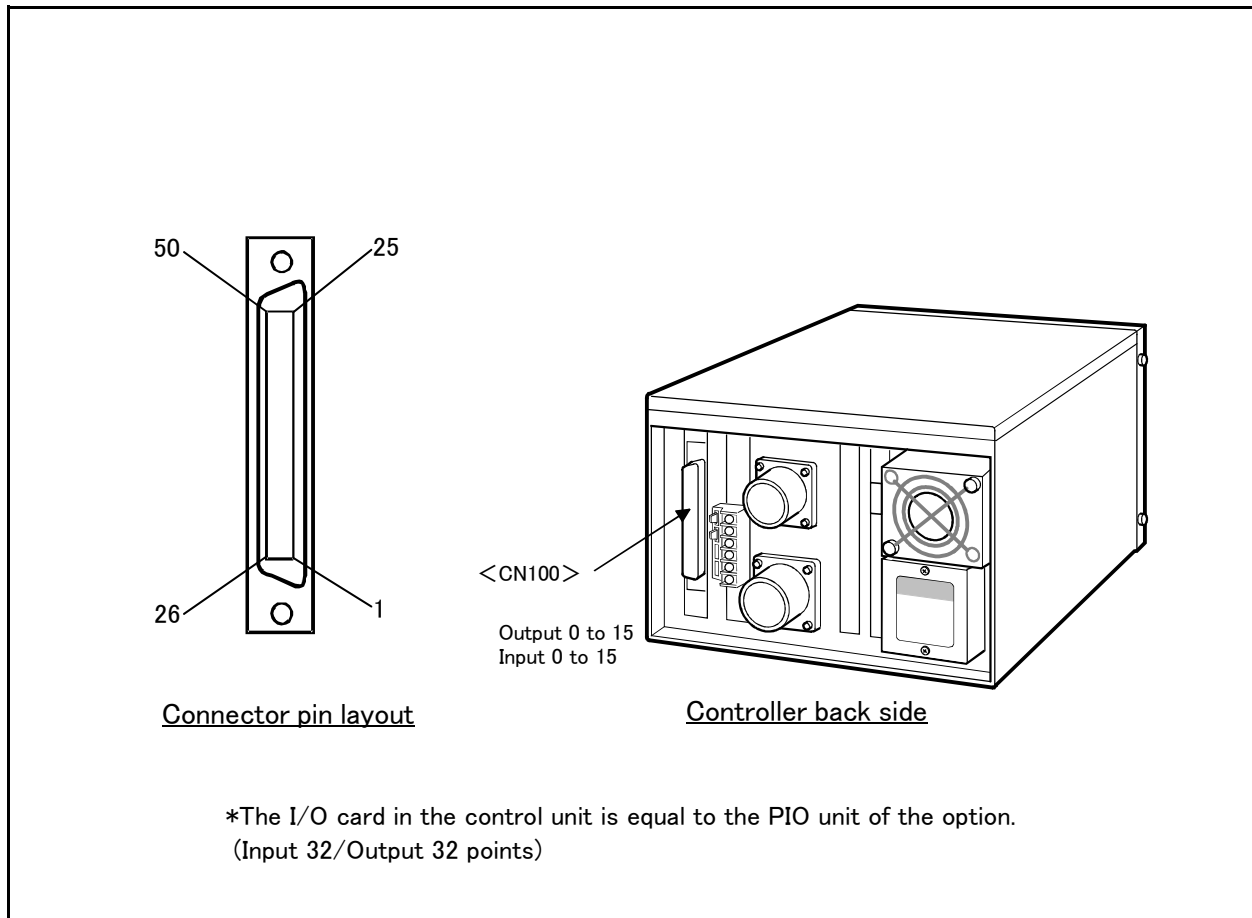

Fig.3-9 : Parallel input/output unit (in the control unit) connection and pin layout

3.8 Options

■ What are options?

There are a variety of options for the robot designed to make the setting up process easier for user needs.

User installation is required for the options.

Options come in two types: "set options" and "single options".

1. Set options.....A combination of single options and parts that together, form a set for serving some purpose.
2. Single options.....That are configured from the fewest number of required units of a part. Please choose user's purpose additionally.

(1) Teaching pendant (T/B)

- Order type: R28TB :Cable length 7m
R28TB-15 :Cable length 15m

Note) There is a cable length 15m as special specification. Confirm the delivery date.

■ Outline



This is used to create, edit and control the program, teach the operation position and for jog feed, etc.

For safety proposes, a 3-position deadman switch is mounted.^{Note1)}

If there are several robots, one teaching pendant can be used by connecting it to the respective robot.

■ Configuration

Table 3-8 : Configuration device

Part name	Type	Qty.	Remarks
Teaching pendant	R28TB	Either one pc.	Cable length is 7m. Hand strap is attached.
	R28TB-15		Cable length is 15m. Hand strap is attached.

■ Specifications

Table 3-9 : Specifications

Items	Specifications	Remarks
Outline dimensions	95(W) x 236(H) x 34(D) (refer to outline drawing)	
Body color	Light gray (reference Munsell color: 7.65Y7.64/0.73)	
Mass	Approx. 0.5kg (only arm, excluding cable)	
Connection method	Connection with controller and round connector (30-pin)	
Interface	RS-422	
Display method	LCD method: 16 characters x 4 lines, LCD illumination: with backlight	
Operation section	28 keys	
Protection specifications	IP65	Note2)

Note2) The manual operation section of the teaching pendant has a protection method that complies with the IEC Standards IP65 (protection type).

[Reference] The IEC Standards IP65 refers to installing the test device in the testing room, and suspending talc powder, which passes through a nominal dimension $75\mu\text{m}$ mesh sieve, as specified with JISZ8001 (standard sieve). This powder is continuously suspended around the device at a rate of 2kg per 1m^3 volume of the testing room. The air in the testing device is discharged at a discharge rate less than 60-times the volume per hour. When the air is discharged at 80-times the test device capacity, the talc powder does not accumulate inside the test device even after eight hours.

Note1) <3-position deadman switch>

In ISO/10218 (1992) and JIS-B8433 (1993), this is defined as an "enable device". These standards specify that the robot operation using the teaching pendant is enabled only when the "enable device" is at a specified position. With the Mitsubishi Electric industrial robot, the above "enable device" is configured of an "Enable/Disable switch" and "Deadman switch".

The 3-position deadman switch has three statuses. The following modes are entered according to the switch state.

"Not pressed"The robot does not operate. *)

"Pressed lightly"The robot can be operated and teaching is possible.

"Pressed with force"The robot does not operate. *)

*) Operations, such as program editing and status display, other than robot operation are possible.

Safety is secured as the servo power is turned OFF simultaneously with the input of the emergency stop.

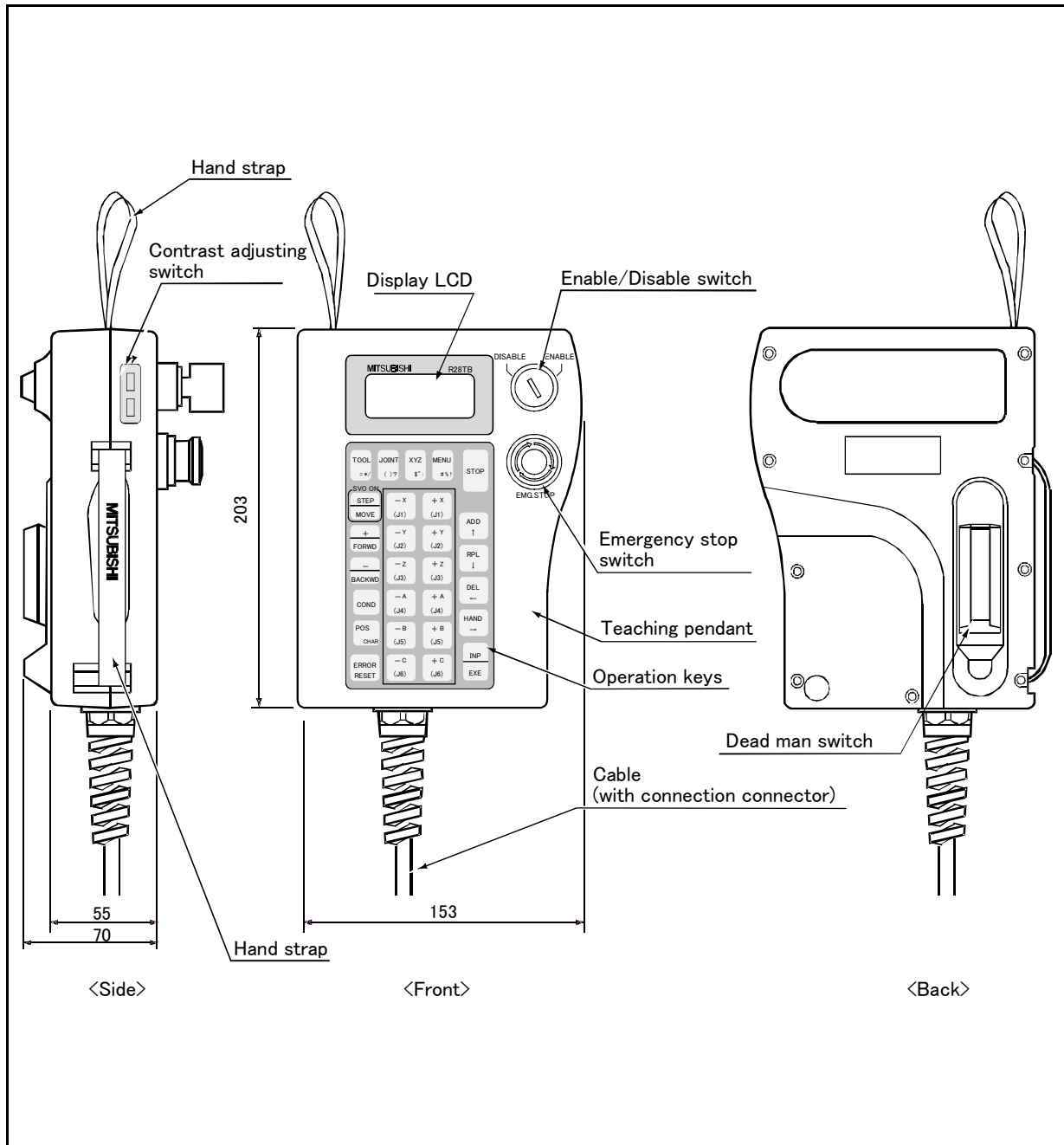

Fig.3-10 : Outside dimensions of teaching pendant

■ Installation method

The teaching pendant is connected to the T/B connector on the front of the controller.

■ Key layout and main functions

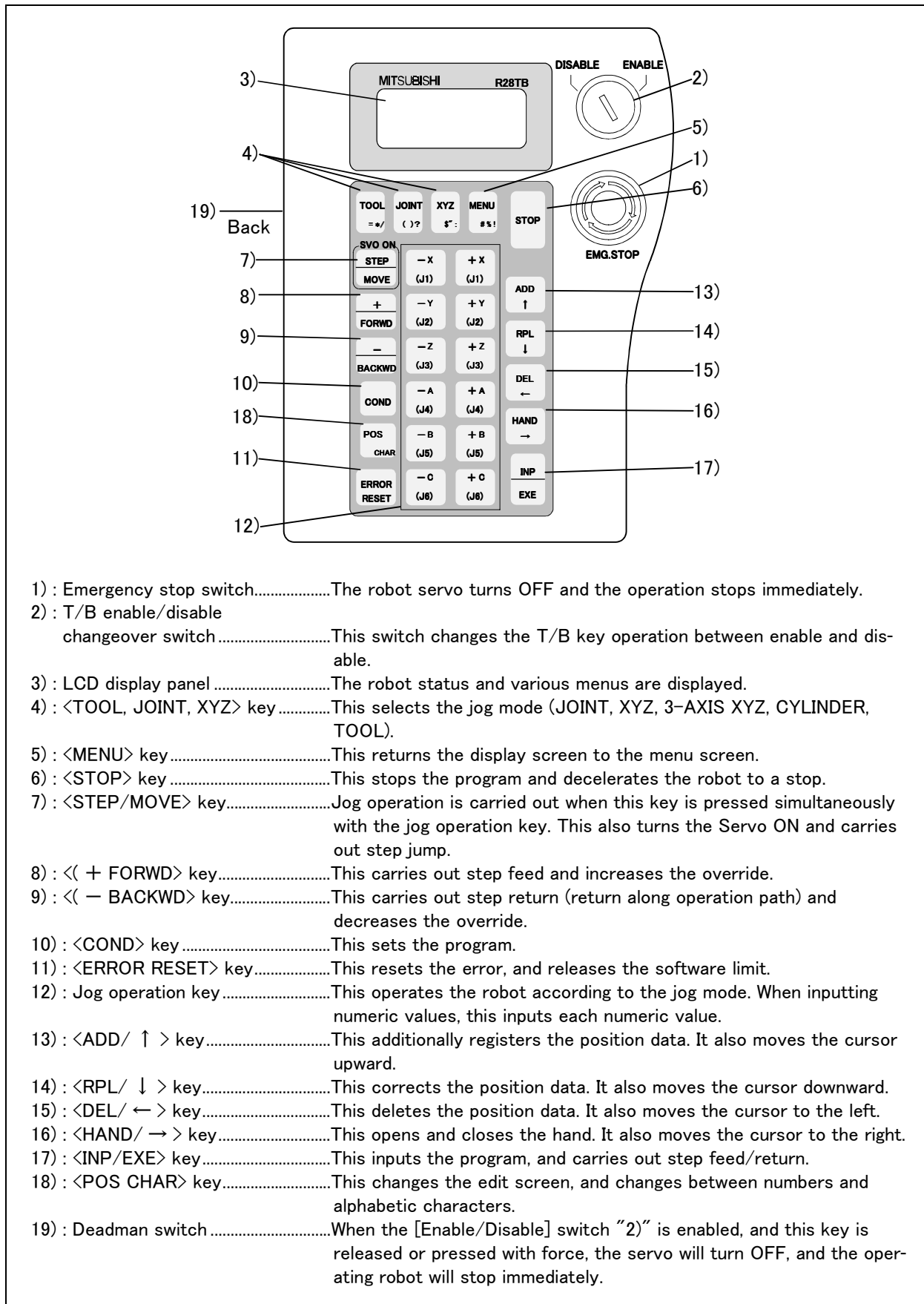

Fig.3-11 : Teaching pendant key layout and main functions

(2) Pneumatic hand interface

- Order type: 2A-RZ365(Sink type)
2A-RZ375(Source type)

Outline



This interface is required to use the robot arm's hand output signals.

- Up to eight hand output points can be used with this interface.
- The eight hand input points can be used without this interface.
- When using more than eight hand input/output points, install the "Parallel I/O unit". Refer to Page 67, "Parallel I/O unit" for detail.

Configuration

Table 3-10 : Configuration device

Part name	Type	Qty.	Remarks
Pneumatic hand interface	2A-RZ365/ 2A-RZ375	1pc.	Output 8 point expansion. 2A-RZ365 is the sink type. 2A-RZ375 is the source type.

Specifications

Table 3-11 : Specifications

Item	Specification	Internal circuit	
Type	Transistor output	<p><Sink type></p> <p><Source type></p> <p>* GRn = GR1 ~ GR8</p>	
No. of output points	8 ^{Note1)}		
Insulation method	Photo coupler insulation		
Rated load voltage	DC24V		
Rated load voltage range	DC21.6 to 26.4VDC		
Max. current load	0.1A/ 1 point (100%)		
Current leak with power OFF	0.1mA or less		
Maximum voltage drop with power ON	DC0.9V(TYP.)		
Response time	OFF-ON		2ms or less (hardware response time)
	ON-OFF		2 ms or less (resistance load) (hardware response time)
Fuse rating	Fuses 1.6A (each one common)		
Common method	8 points, 1 common		
External cable connection method	Connector (Connected from RZ386 or RZ387) ^{Note2)}		
Supply voltage	DC5V (Supplied from RZ386 or RZ387)		

Note1)Wiring to the robot side will differ according to the model. The No. of output points that can be used will differ according to the state of the wiring on the robot arm side. Example) RV-2A/3AJ has 4 points.

Note2)RZ386:The control card mounted on the controller of the sink type.

RZ387:The control card mounted on the controller of the source type.

■ Installation method

This is mounted on the control unit (RZ386 or RZ387 card) in the controller.

Securely insert the pneumatic hand interface (2A-RZ365/375) into the CNHNDOUT/CNHND connector on the control unit. Refer to separate "Instruction Manual/CR1 controller Controller setup, basic operation, and maintenance" for details on the installing method.

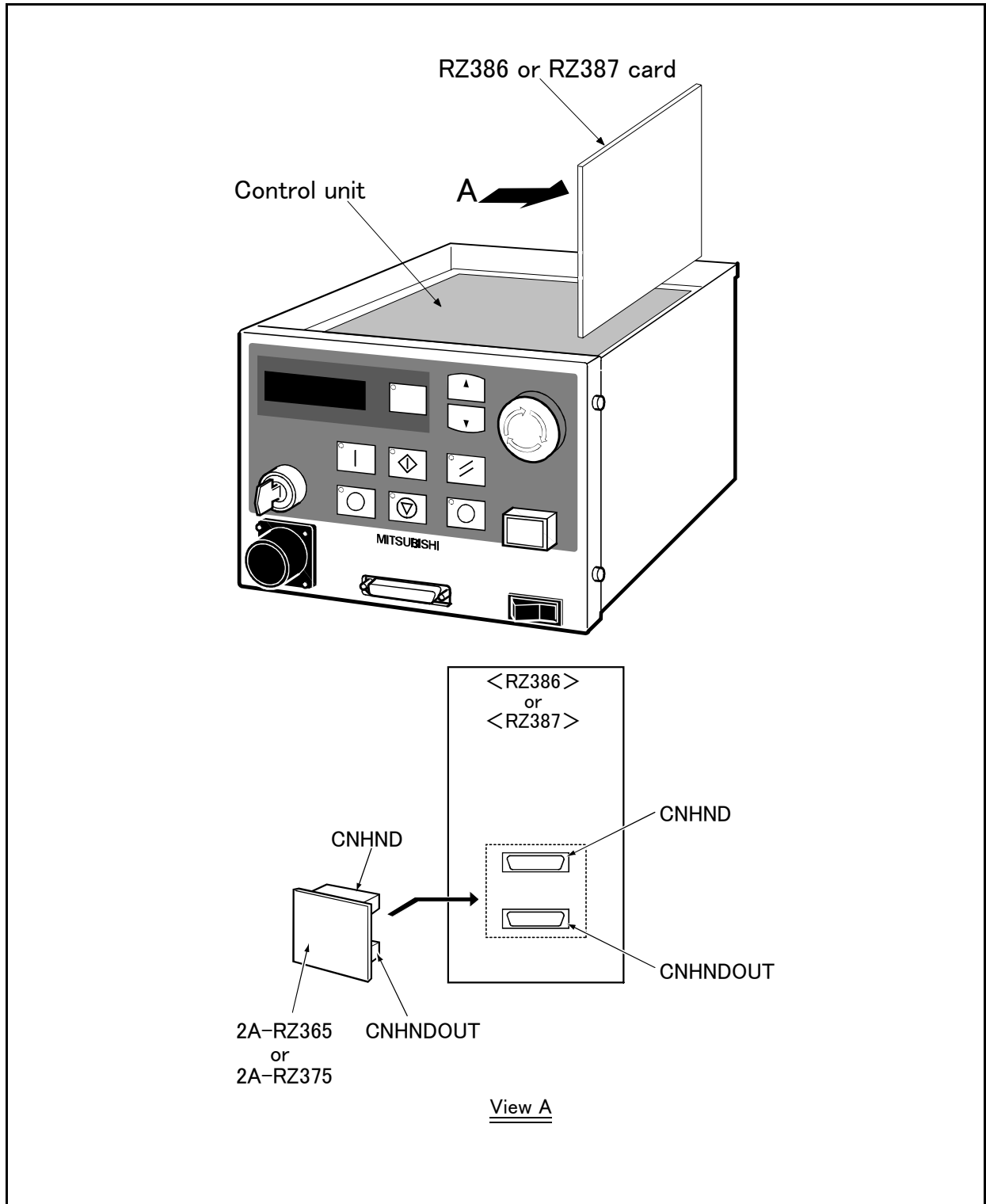

Fig.3-12 : Installation of pneumatic hand interface

Note)The hand output doesn't work correctly in the case of "RZ386" + "RZ365" or "RZ387" + "RZ375" combination.

Choose either of sink type/source type properly, and use it.

(3) Controller protection box

■ Order type : ● CR1-MB

■ Outline



The controller protection box is used to protect the CR1-571 controller from an oil mist or other operating environment. Put the controller and the earth leakage breaker, etc. in controller protection box, and use it. Since the front cover of the controller protection box can be removed, it is possible to operate the controller's front panel and to install and remove the T/B.

■ Configuration

Table 3-12 : Configuration device

Part name	Type	Qty.	Remarks
Controller protection box	CR1-MB	1 unit	
Serial number posting label		1	
Protection seal transparent		1	Protection for the serial number posting label.
Cable tie		2	
Power supply wiring cable		1	For connecting the power relay terminal and the controller inside the box.
Grounding cable		1	For connecting the FG terminal and the controller inside the box.
External emergency stop box (Controll box)	HW1X-BV401R	1 unit	Single emergency line. Install at a location outside the controller protection box where operation can be performed easily. The outside dimensions is shown in Fig. 3-15.

■ Specifications

Table 3-13 : Specifications

Item	Unit	Specifications	Remarks
Outside dimensions	mm	414(W) × 492(D) × 202(H)	Excluding protrusions
Mass	Kg	10	
Structure		Self-contained floor type	IP54
Grounding		D class grounding earth	
Coating color		Light gray	Munsell 7.65Y7.64/0.73

- (1) The installation of the controller, earth leakage breaker and wiring are constructed by customer.
 - (2) Prepare the 2 power cable and 1 grounding cable (both AWG#14(2mm²) or more).
 - (3) The emergency stop box does not come with a cable clamp (wiring connector). The cable clamp must be provided by the customer according to the size of the cable.
- The following table shows recommended cable clamps for your reference.

Table 3-14 : Cable clamp for external emergency stop box (recommendation)

Type	JIS wiring tube	Adaptation cable outside diameter	Manufacturer
OA-W1606	G1/2	4 ~ 6 φ	OHM electric Corp
OA-W1608		6 ~ 8 φ	
OA-W1609		7 ~ 9 φ	
OA-W1611		9 ~ 11 φ	
OA-W1613		11 ~ 13 φ	

■ Names of each part

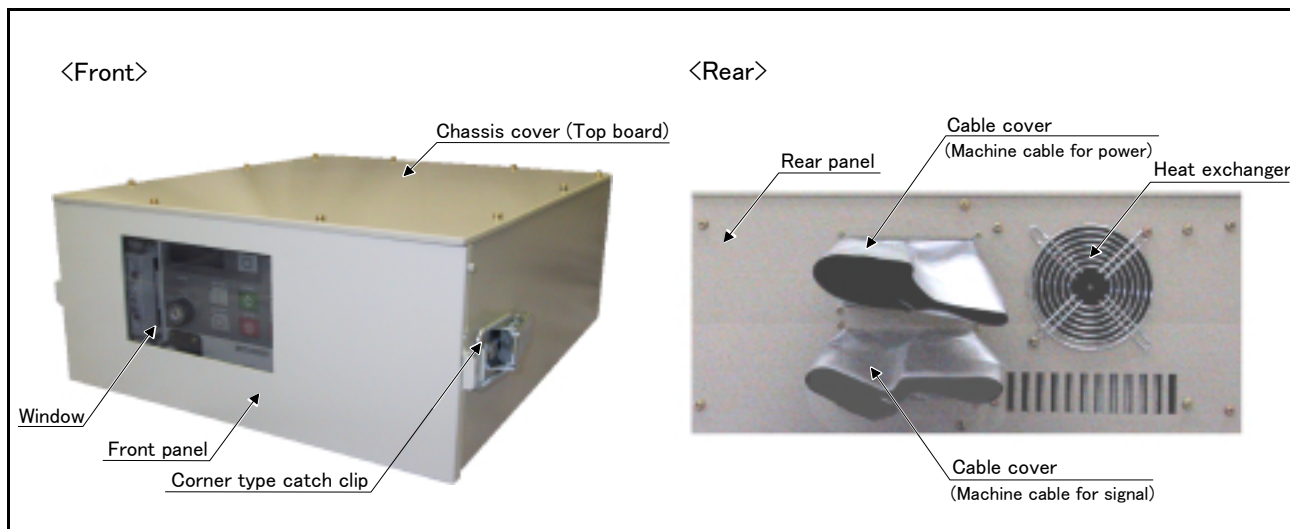

Fig.3-13 : Names of controller parts

■ The outside dimension and controller layout

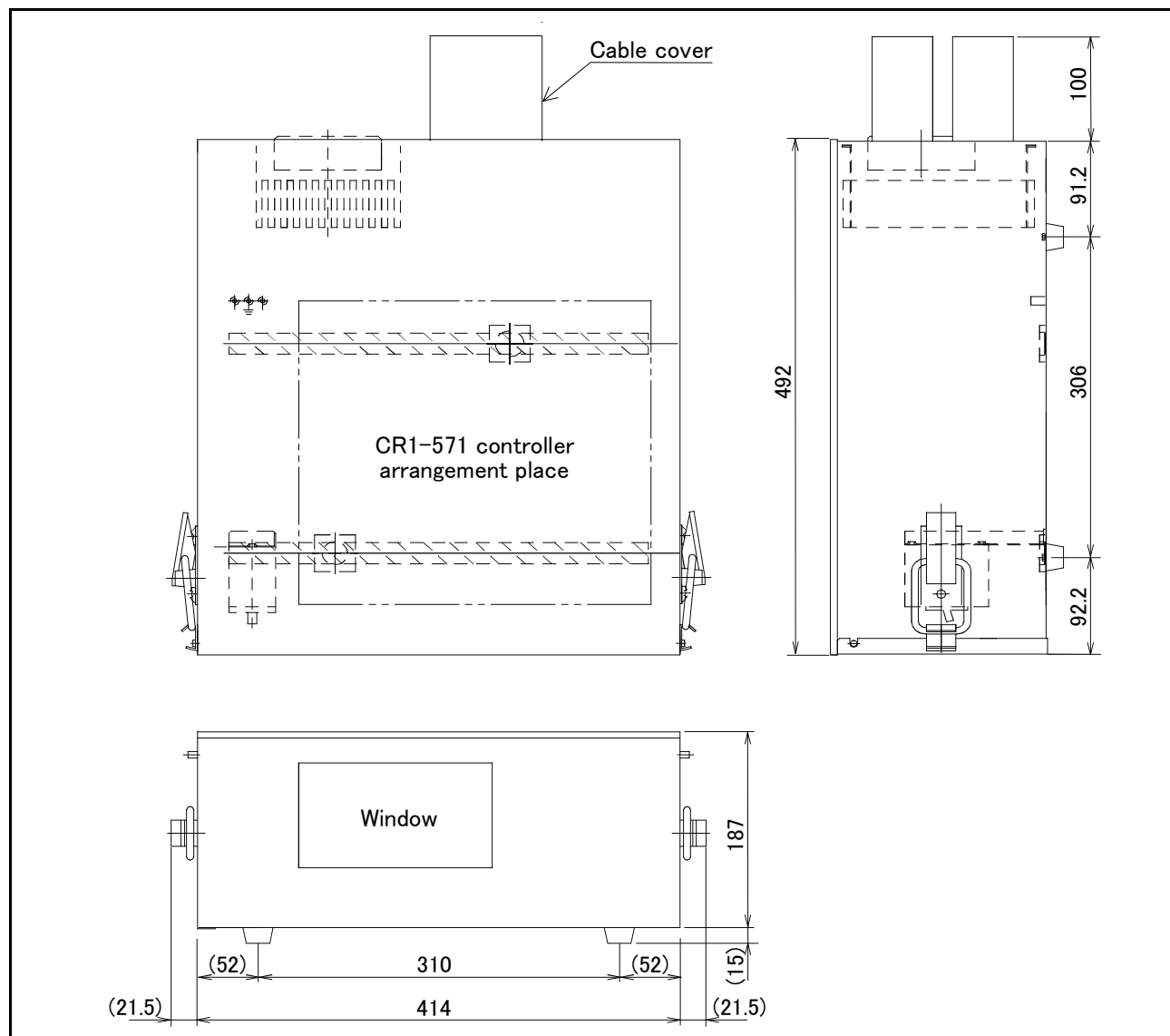

Fig.3-14 : The outside dimension and controller layout

■ The outside dimensions and installation dimensions of emergency stop box

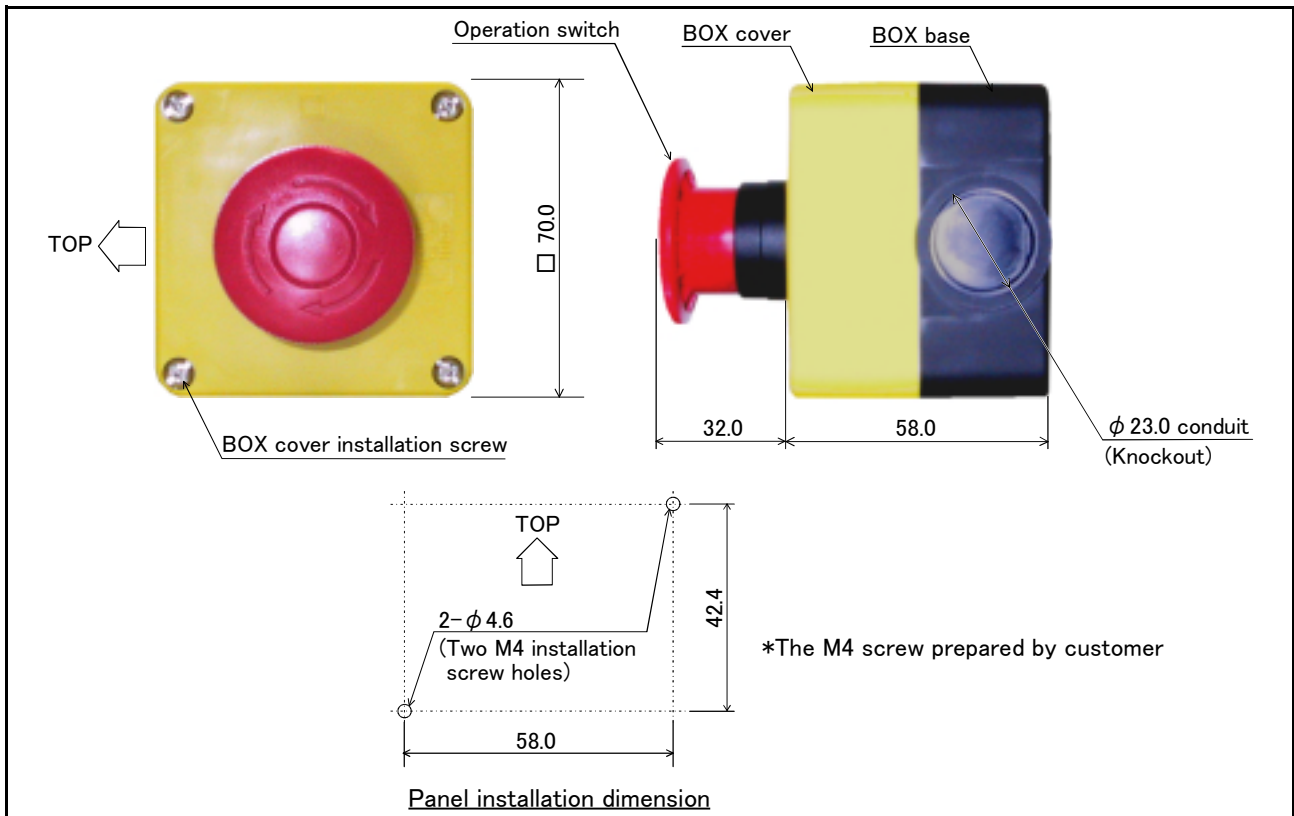

Fig.3-15 : The outside dimensions and installation dimensions of emergency stop box

■ Installation dimensions

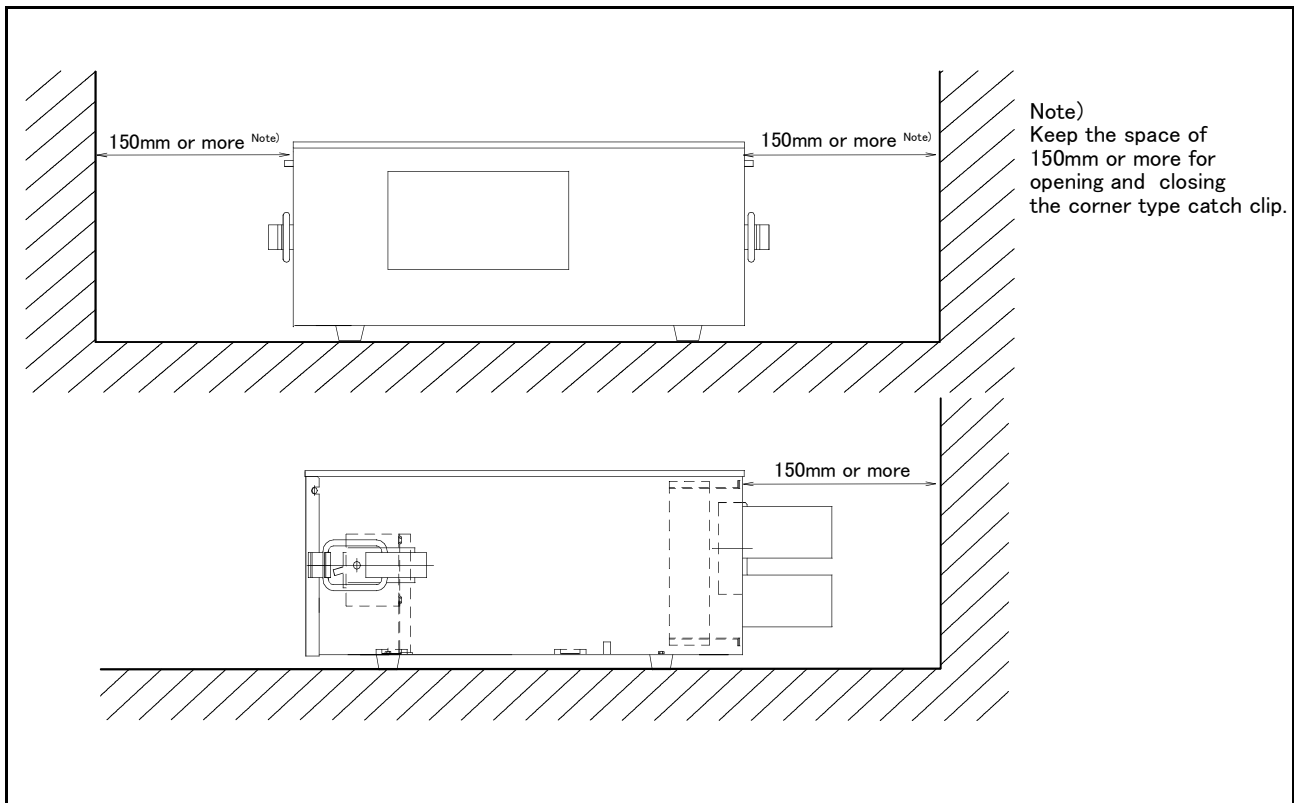

Fig.3-16 : Installation of controller

(4) Expansion option box

■ Order type : ● CR1-EB3

■ Outline



By installing this expansion option box to the side of the CR1-571 controller, the expansion serial interface, CC-Link interface and Ethernet interface can be used. Up to three option cards can be mounted.

■ Configuration

Table 3-15 : Configuration device

Part name	Type	Qty.	Remarks
Expansion option box	CR1-EB3	1	With rubber foot
Installation screw		4	

■ Specifications

Table 3-16 : Specifications

Item	Unit	Specifications	Remarks
Number of slot	slot	3	RT-Bus 1, 2, 3
Power supply method		Power supply is supplied from controller by the RT-Bus coupling(+5V/SG)	
Current value	A	Max. 3	Max. 1A/slot
Ambient temperature	deg.	0 to 40	
Ambient humidity	%RH	45 to 85	Without dew drops
Grounding		D class grounding earth	Grounding from external terminal
Structure		Self-contained floor type opened structure	Note1)
Outside dimensions	mm	85(W) x 290(D) x 165(H)	
Mass	kg	Approx. 3	

Note1) Self-contained floor type, under the condition combined with the body.

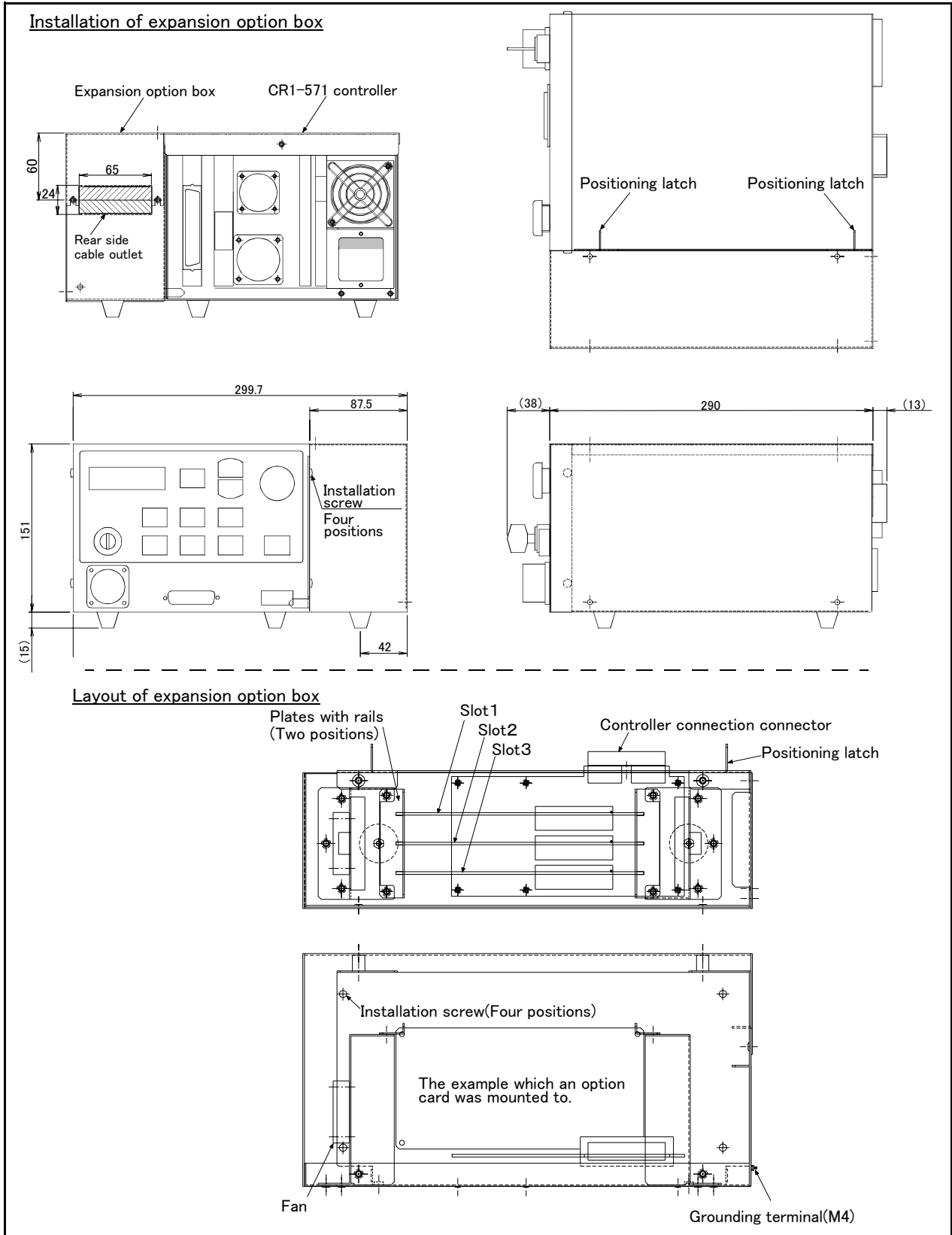

Fig.3-17 : Outside dimensions and layout

■ Installation method

Remove the side plate of the CR1-571 controller, connect the connectors, and fix to the controller with the four fixing screws in the expansion option box.

The option cards mounted in the slot are fixed with the plates with rails.

The cables required for the option card are lead out from the cable outlet on the rear side.

(5) Parallel I/O unit

- Order type: 2A-RZ361(Sink type)
2A-RZ371(Source type)

- Outline



This is used to expand the external inputs and outputs.

- The connection cable is not included. Prepare the optional external input/output cable (2A-CBL05 or 2A-CBL15).

- Configuration

Table 3-17 : Configuration device

Part name	Type	Qty.	Remarks
Parallel I/O unit	2A-RZ361/ 2A-RZ371	1	Input/output 32 points/32 points 2A-RZ361 is the sink type. 2A-RZ371 is the source type.
Robot I/O link connection connector	NETcable-1	2 sets	Connector with pins. The cable must be prepared and wired by the customer.
Power connection connector	DCcable-2	1 sets	Connector with pins. The cable must be prepared and wired by the customer.
Terminator	R-TM	1	150Ω (1/4W)

- Specifications

- Up to eight stations can be connected to this unit. (One station occupies one unit.)
One unit is built into the controller as a standard, so up to seven units can be installed as expansions.
- The power supply (24V) must be prepared by the customer and connected with the power connection cable (DCcable-2)
A separate 24V power supply is required for the input/output circuit wiring.

The detailed specifications of the input/output circuit are the same as the parallel input/output unit mounted as a standard. Refer to [Page 52, "3.7 Parallel input/output unit"](#) for details.

Table 3-18 : Electrical specifications of input circuits

Item	Specification	Internal circuit
Type	DC input	<div style="display: flex; flex-direction: column; align-items: center;"> <div style="text-align: center; margin-bottom: 20px;"> <p><Sink type></p> </div> <div style="text-align: center;"> <p><Source type></p> </div> </div>
Number of input points	32	
Insulation method	Photo coupler insulation	
Rated input voltage	DC12V/DC24V	
Rated input current	Approx 3mA/7mA	
Working voltage range	DC10.2 to 26.4V(Ripple factor should be less than 5%)	
ON voltage/ON current	8VDC or more/ 2mA or more	
OFF voltage/ OFF current	4VDC or less/ 1mA or less	
Input resistance	Approx. 3.3kΩ	
Response time	OFF-ON 10ms or less (24VDC) ON-OFF 10ms or less (24VDC)	
Common method	8 point 1 common	
External cable connection method	Connector	

Table 3-19 : Electrical specifications for the output circuits

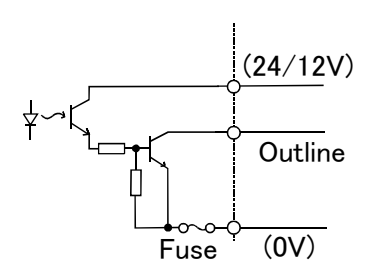
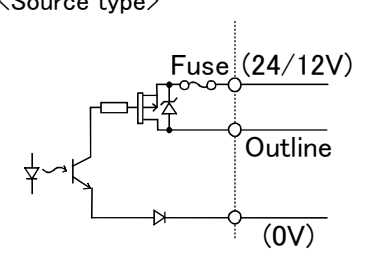
Item		Specification	Internal circuit
Type		Transistor output	<p><Sink type></p>  <p><Source type></p> 
No. of output points		32	
Insulation method		Photo-coupler insulation	
Rated load voltage		DC12V/DC24V	
Rated load voltage range		DC10.2 ~ 30V(peak voltage 30VDC)	
Max. load current		0.1A/point (100%)	
Leakage current at OFF		0.1mA or less	
Max. voltage drop at ON		DC0.9V(TYP.)	
Response time	OFF-ON	2ms or less (hardware response time)	
	ON-OFF	2ms or less (Resistance load) (hardware response time)	
Fuse rating		Fuse 3.2A (one per common) Replacement not possible	
Common method		4 points per common (common terminal: 4 points)	
External wire connection method		Connector	
External power supply	Voltage	DC12/24V(DC10.2 ~ 30V)	
	Current	60mA (TYP. 24VDC per common) (base drive current)	

NETcable-1 (Network cable)

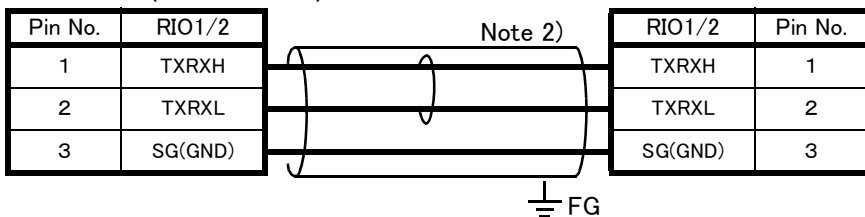

DCcable-2 (Power cable)

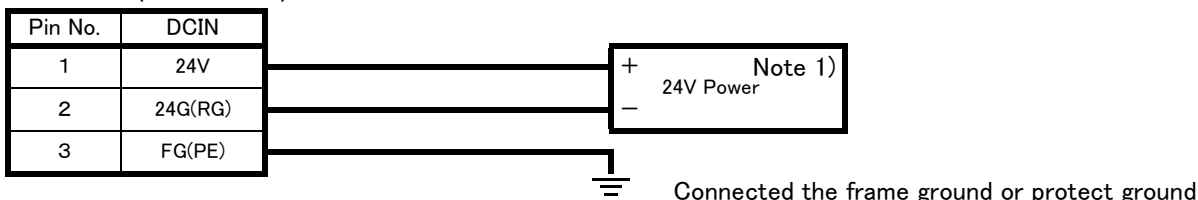

R-TM (Terminator)

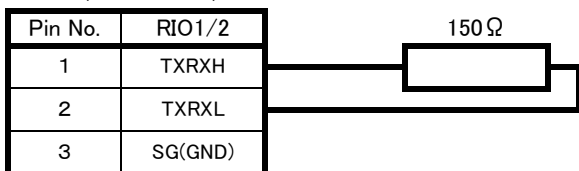

List of parts and manufacturer

Type	Connector type	Contact type	Resistant	Manufacturer
NETcable-1	1-178288-3 (2)	175218-3 (6)	—	AMP
DCcable-2	2-178288-3 (1)	175218-3 (3)	—	AMP
R-TM	1-178288-3 (1)	175218-3 (2)	150Ω (1/4W) (1)	Equivalent to KOA.

Note 1) The 24V power supply is prepared by customer (The power consumption is approx. 0.3A.)

Note 2) The cable for general purpose can be used to the network cable. However, use the twisted shield cable of AWG#22(0.3mm²) or more.

Fig.3-18 : Specifications for the connection cable

■ Installation method

The expansion parallel input/output unit is installed outside of the controller. Connect with the network connection cable (NETcable-1) from the RIO1 connector in the rear of the controller. (Terminator is connected at the time of shipment)

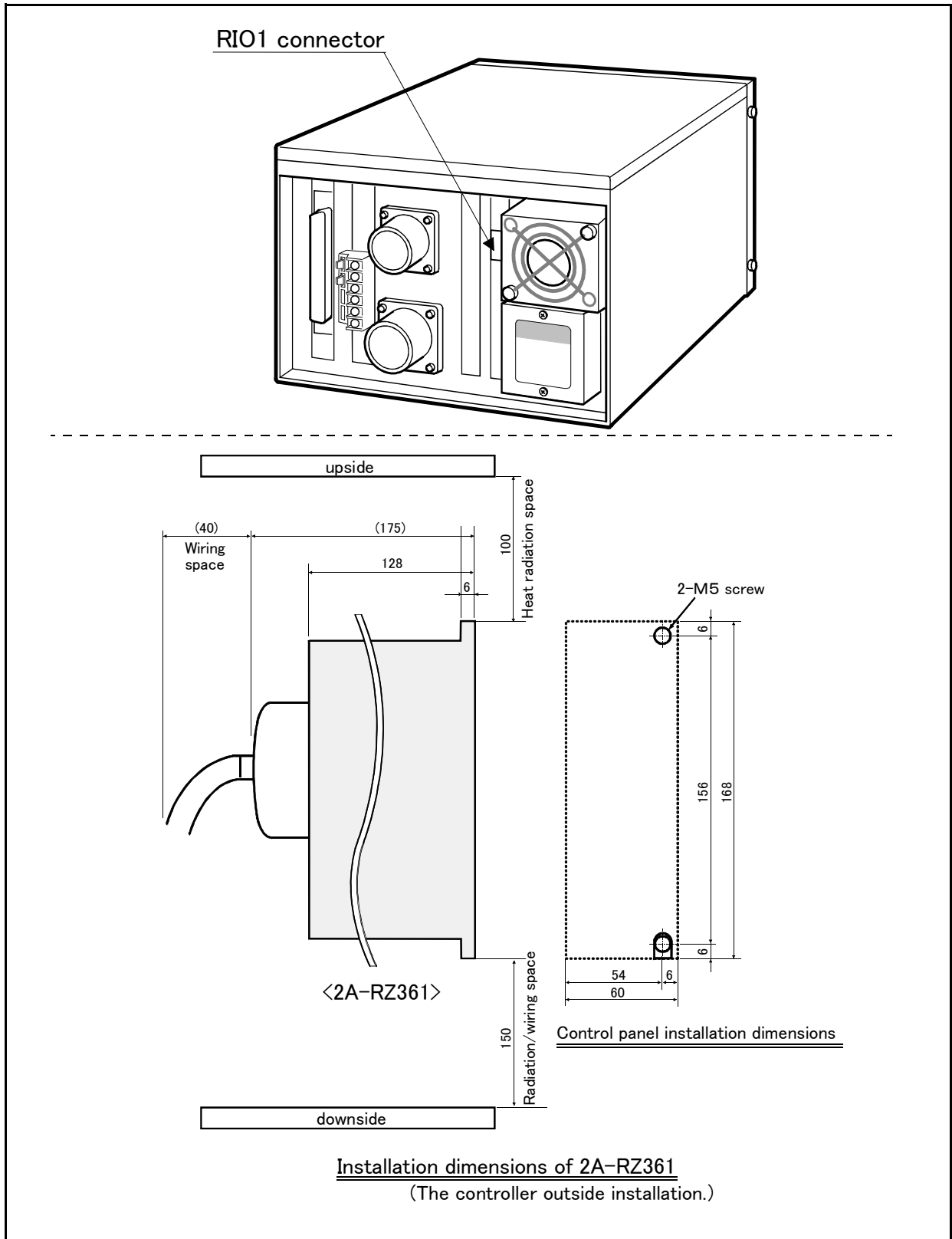

Fig.3-19 : Installing the parallel input/output unit

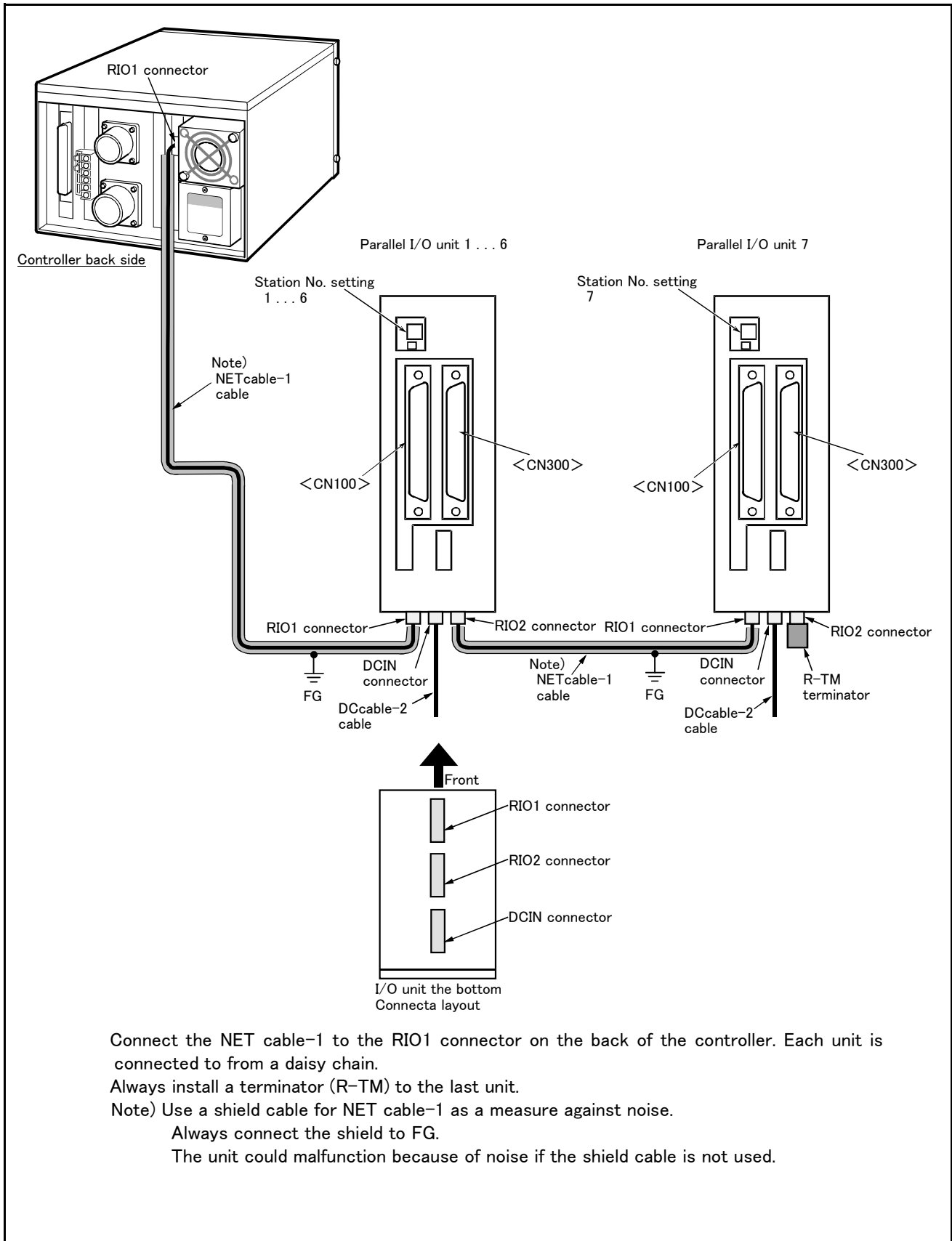

Fig.3-20 : Connection method of expansion parallel input/output unit

■ Parallel I/O interface (First expansion unit)

Table 3-20 : Connector CN100pin No. and signal assignment list (2A-CBL □□)

Pin No.	Line color	Function name		Pin No.	Line color	Function name	
		General-purpose	Dedicated/power supply, common			General-purpose	Dedicated/power supply, common
1	Orange/Red A		FG	26	Orange/Blue A		FG
2	Gray/Red A		0V:For pins 4-7	27	Gray/Blue A		0V:For pins 29-32
3	White/Red A		12V/24V:For pins 4-7	28	White/Blue A		12V/24V:For pins 29-32
4	Yellow/Red A	General-purpose output 32		29	Yellow/Blue A	General-purpose output 36	
5	Pink/Red A	General-purpose output 33		30	Pink/Blue A	General-purpose output 37	
6	Orange/Red B	General-purpose output 34		31	Orange/Blue B	General-purpose output 38	
7	Gray/Red B	General-purpose output 35		32	Gray/Blue B	General-purpose output 39	
8	White/Red B		0V:For pins 10-13	33	White/Blue B		0V:For pins 35-38
9	Yellow/Red B		12V/24V:For pins 10-13	34	Yellow/Blue B		12V/24V:For pins 35-38
10	Pink/Red B	General-purpose output 40		35	Pink/Blue B	General-purpose output 44	
11	Orange/Red C	General-purpose output 41		36	Orange/Blue C	General-purpose output 45	
12	Gray/Red C	General-purpose output 42		37	Gray/Blue C	General-purpose output 46	
13	White/Red C	General-purpose output 43		38	White/Blue C	General-purpose output 47	
14	Yellow/Red C		COM0:For pins 15-22 Note1)	39	Yellow/Blue C		COM1:For pins 40-47 Note1)
15	Pink/Red C	General-purpose input 32		40	Pink/Blue C	General-purpose input 40	
16	Orange/Red D	General-purpose input 33		41	Orange/Blue D	General-purpose input 41	
17	Gray/Red D	General-purpose input 34		42	Gray/Blue D	General-purpose input 42	
18	White/Red D	General-purpose input 35		43	White/Blue D	General-purpose input 43	
19	Yellow/Red D	General-purpose input 36		44	Yellow/Blue D	General-purpose input 44	
20	Pink/Red D	General-purpose input 37		45	Pink/Blue D	General-purpose input 45	
21	Orange/Red E	General-purpose input 38		46	Orange/Blue E	General-purpose input 46	
22	Gray/Red E	General-purpose input 39		47	Gray/Blue E	General-purpose input 47	
23	White/Red E		Reserved	48	White/Blue E		Reserved
24	Yellow/Red E		Reserved	49	Yellow/Blue E		Reserved
25	Pink/Red E		Reserved	50	Pink/Blue E		Reserved

Note1) Sink type:24V/12V(COM), Source type:0V(COM)

Table 3-21 : Connector CN300pin No. and signal assignment list (2A-CBL □□)

Pin No.	Line color	Function name		Pin No.	Line color	Function name	
		General-purpose	Dedicated/power supply, common			General-purpose	Dedicated/power supply, common
1	Orange/Red A		FG	26	Orange/Blue A		FG
2	Gray/Red A		0V:For pins 4-7	27	Gray/Blue A		0V:For pins 29-32
3	White/Red A		12V/24V:For pins 4-7	28	White/Blue A		12V/24V:For pins 29-32
4	Yellow/Red A	General-purpose output 48		29	Yellow/Blue A	General-purpose output 52	
5	Pink/Red A	General-purpose output 49		30	Pink/Blue A	General-purpose output 53	
6	Orange/Red B	General-purpose output 50		31	Orange/Blue B	General-purpose output 54	
7	Gray/Red B	General-purpose output 51		32	Gray/Blue B	General-purpose output 55	
8	White/Red B		0V:For pins 10-13	33	White/Blue B		0V:For pins 35-38
9	Yellow/Red B		12V/24V:For pins 10-13	34	Yellow/Blue B		12V/24V:For pins 35-38
10	Pink/Red B	General-purpose output 56		35	Pink/Blue B	General-purpose output 60	
11	Orange/Red C	General-purpose output 57		36	Orange/Blue C	General-purpose output 61	
12	Gray/Red C	General-purpose output 58		37	Gray/Blue C	General-purpose output 62	
13	White/Red C	General-purpose output 59		38	White/Blue C	General-purpose output 63	
14	Yellow/Red C		COM0:For pins 15-22 Note1)	39	Yellow/Blue C		COM1:For pins 40-47 Note1)
15	Pink/Red C	General-purpose input 48		40	Pink/Blue C	General-purpose input 56	
16	Orange/Red D	General-purpose input 49		41	Orange/Blue D	General-purpose input 57	
17	Gray/Red D	General-purpose input 50		42	Gray/Blue D	General-purpose input 58	
18	White/Red D	General-purpose input 51		43	White/Blue D	General-purpose input 59	
19	Yellow/Red D	General-purpose input 52		44	Yellow/Blue D	General-purpose input 60	
20	Pink/Red D	General-purpose input 53		45	Pink/Blue D	General-purpose input 61	
21	Orange/Red E	General-purpose input 54		46	Orange/Blue E	General-purpose input 62	
22	Gray/Red E	General-purpose input 55		47	Gray/Blue E	General-purpose input 63	
23	White/Red E		Reserved	48	White/Blue E		Reserved
24	Yellow/Red E		Reserved	49	Yellow/Blue E		Reserved
25	Pink/Red E		Reserved	50	Pink/Blue E		Reserved

Note1) Sink type:24V/12V(COM), Source type:0V(COM)

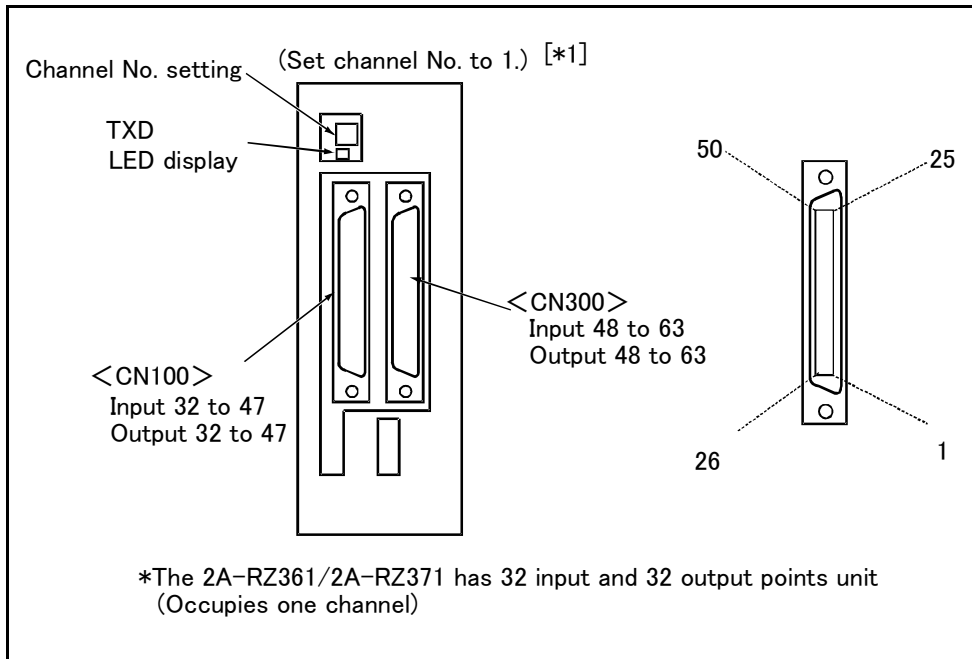

Fig.3-21 : Parallel input/output unit <2A-RZ361/2A-RZ371:First expansion> connection and pin layout

⚠ CAUTION

[*1] For the 1st expansion unit, set the channel No. to "1".
The channel No. of 8 to F is used for the maker test. If any value of 8 to F is set, it may be dangerous since the robot unexpectedly moves. Don't set any value of 8 to F.

■ Parallel I/O interface (Second expansion unit)

Table 3-22 : Connector CN100pin No. and signal assignment list (2A-CBL □□)

Pin No.	Line color	Function name		Pin No.	Line color	Function name	
		General-purpose	Dedicated/power supply, common			General-purpose	Dedicated/power supply, common
1	Orange/Red A		FG	26	Orange/Blue A		FG
2	Gray/Red A		0V:For pins 4-7	27	Gray/Blue A		0V:For pins 29-32
3	White/Red A		12V/24V:For pins 4-7	28	White/Blue A		12V/24V:For pins 29-32
4	Yellow/Red A	General-purpose output 64		29	Yellow/Blue A	General-purpose output 68	
5	Pink/Red A	General-purpose output 65		30	Pink/Blue A	General-purpose output 69	
6	Orange/Red B	General-purpose output 66		31	Orange/Blue B	General-purpose output 70	
7	Gray/Red B	General-purpose output 67		32	Gray/Blue B	General-purpose output 71	
8	White/Red B		0V:For pins 10-13	33	White/Blue B		0V:For pins 35-38
9	Yellow/Red B		12V/24V:For pins 10-13	34	Yellow/Blue B		12V/24V:For pins 35-38
10	Pink/Red B	General-purpose output 72		35	Pink/Blue B	General-purpose output 76	
11	Orange/Red C	General-purpose output 73		36	Orange/Blue C	General-purpose output 77	
12	Gray/Red C	General-purpose output 74		37	Gray/Blue C	General-purpose output 78	
13	White/Red C	General-purpose output 75		38	White/Blue C	General-purpose output 79	
14	Yellow/Red C		COM0:For pins 15-22 Note1)	39	Yellow/Blue C		COM1:For pins 40-47 Note1)
15	Pink/Red C	General-purpose input 64		40	Pink/Blue C	General-purpose input 72	
16	Orange/Red D	General-purpose input 65		41	Orange/Blue D	General-purpose input 73	
17	Gray/Red D	General-purpose input 66		42	Gray/Blue D	General-purpose input 74	
18	White/Red D	General-purpose input 67		43	White/Blue D	General-purpose input 75	
19	Yellow/Red D	General-purpose input 68		44	Yellow/Blue D	General-purpose input 76	
20	Pink/Red D	General-purpose input 69		45	Pink/Blue D	General-purpose input 77	
21	Orange/Red E	General-purpose input 70		46	Orange/Blue E	General-purpose input 78	
22	Gray/Red E	General-purpose input 71		47	Gray/Blue E	General-purpose input 79	
23	White/Red E		Reserved	48	White/Blue E		Reserved
24	Yellow/Red E		Reserved	49	Yellow/Blue E		Reserved
25	Pink/Red E		Reserved	50	Pink/Blue E		Reserved

Note1)Sink type:24V/12V(COM), Source type:0V(COM)

Table 3-23 : Connector CN300pin No. and signal assignment list (2A-CBL □□)

Pin No.	Line color	Function name		Pin No.	Line color	Function name	
		General-purpose	Dedicated/power supply, common			General-purpose	Dedicated/power supply, common
1	Orange/Red A		FG	26	Orange/Blue A		FG
2	Gray/Red A		0V:For pins 4-7	27	Gray/Blue A		0V:For pins 29-32
3	White/Red A		12V/24V:For pins 4-7	28	White/Blue A		12V/24V:For pins 29-32
4	Yellow/Red A	General-purpose output 80		29	Yellow/Blue A	General-purpose output 84	
5	Pink/Red A	General-purpose output 81		30	Pink/Blue A	General-purpose output 85	
6	Orange/Red B	General-purpose output 82		31	Orange/Blue B	General-purpose output 86	
7	Gray/Red B	General-purpose output 83		32	Gray/Blue B	General-purpose output 87	
8	White/Red B		0V:For pins 10-13	33	White/Blue B		0V:For pins 35-38
9	Yellow/Red B		12V/24V:For pins 10-13	34	Yellow/Blue B		12V/24V:For pins 35-38
10	Pink/Red B	General-purpose output 88		35	Pink/Blue B	General-purpose output 92	
11	Orange/Red C	General-purpose output 89		36	Orange/Blue C	General-purpose output 93	
12	Gray/Red C	General-purpose output 90		37	Gray/Blue C	General-purpose output 94	
13	White/Red C	General-purpose output 91		38	White/Blue C	General-purpose output 95	
14	Yellow/Red C		COM0:For pins 15-22 Note1)	39	Yellow/Blue C		COM1:For pins 40-47 Note1)
15	Pink/Red C	General-purpose input 80		40	Pink/Blue C	General-purpose input 88	
16	Orange/Red D	General-purpose input 81		41	Orange/Blue D	General-purpose input 89	
17	Gray/Red D	General-purpose input 82		42	Gray/Blue D	General-purpose input 90	
18	White/Red D	General-purpose input 83		43	White/Blue D	General-purpose input 91	
19	Yellow/Red D	General-purpose input 84		44	Yellow/Blue D	General-purpose input 92	
20	Pink/Red D	General-purpose input 85		45	Pink/Blue D	General-purpose input 93	
21	Orange/Red E	General-purpose input 86		46	Orange/Blue E	General-purpose input 94	
22	Gray/Red E	General-purpose input 87		47	Gray/Blue E	General-purpose input 95	
23	White/Red E		Reserved	48	White/Blue E		Reserved
24	Yellow/Red E		Reserved	49	Yellow/Blue E		Reserved
25	Pink/Red E		Reserved	50	Pink/Blue E		Reserved

Note1)Sink type:24V/12V(COM), Source type:0V(COM)

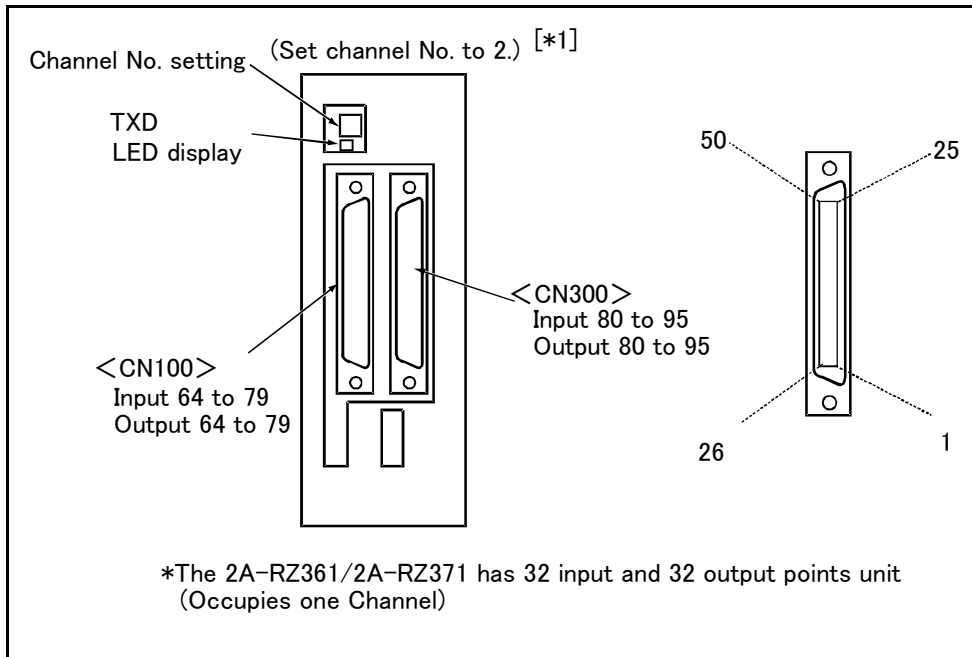

Fig.3-22 : Parallel input/output unit <2A-RZ361/2A-RZ371:Second expansion unit> connection and pin layout

⚠ CAUTION

[*1] For the 2nd expansion unit, set the channel No. to "2".
The channel No. of 8 to F is used for the maker test. If any value of 8 to F is set, it may be dangerous since the robot unexpectedly moves. Don't set any value of 8 to F.

(6) External I/O cable

■ Order type: 2A-CBL □□ Note) The numbers in the boxes □□ refer to the length. (05: 5m、15: 15m)

■ Outline



This is the dedicated cable used to connect an external peripheral device to the connector on the parallel input/output unit.

One end matches the connector on the parallel input/output unit, and the other end is free. Connect the peripheral device's input/output signal using the free end.

One cable correspond to the input 16 points and output 16 points.

Two cables are needed to connection of (input 32 points and output 32 points) with built-in standard.

■ Configuration

Table 3-24 : Configuration device

Part name	Type	Qty.	Remarks
External I/O cable	2A-CBL □□	1pc.	5m or 15m

■ Specifications

Table 3-25 : Specifications

Items	Specifications
Number of cables x cable size	50 pairs x AWG #28
Total length	5m or 15m

■ Connector pin numbers and cable colors

Table 3-26 : Connector pin numbers and cable colors

Pin no.	Cable colors	Pin no.	Cable colors	Pin no.	Cable colors	Pin no.	Cable colors	Pin no.	Cable colors
1	Orange/Red A	11	Orange/Red C	21	Orange/Red E	31	Orange/Blue B	41	Orange/Blue D
2	Gray/Red A	12	Gray/Red C	22	Gray/Red E	32	Gray/Blue B	42	Gray/Blue D
3	White/Red A	13	White/Red C	23	White/Red E	33	White/Blue B	43	White/Blue D
4	Yellow/Red A	14	Yellow/Red C	24	Yellow/Red E	34	Yellow/Blue B	44	Yellow/Blue D
5	Pink/Red A	15	Pink/Red C	25	Pink/Red E	35	Pink/Blue B	45	Pink/Blue D
6	Orange/Red B	16	Orange/Red D	26	Orange/Blue A	36	Orange/Blue C	46	Orange/Blue E
7	Gray/Red B	17	Gray/Red D	27	Gray/Blue A	37	Gray/Blue C	47	Gray/Blue E
8	White/Red B	18	White/Red D	28	White/Blue A	38	White/Blue C	48	White/Blue E
9	Yellow/Red B	19	Yellow/Red D	29	Yellow/Blue A	39	Yellow/Blue C	49	Yellow/Blue E
10	Pink/Red B	20	Pink/Red D	30	Pink/Blue A	40	Pink/Blue C	50	Pink/Blue E

■ Connections and outside dimensions

The sheath of each signal cable (50 lines) is color indicated and marked with dots. Refer to the cable color specifications in "Table 3-26 Connector pin numbers and cable colors" when making the connections.

(Eg.) Pin number: color indication

1 : Orange / Red / A

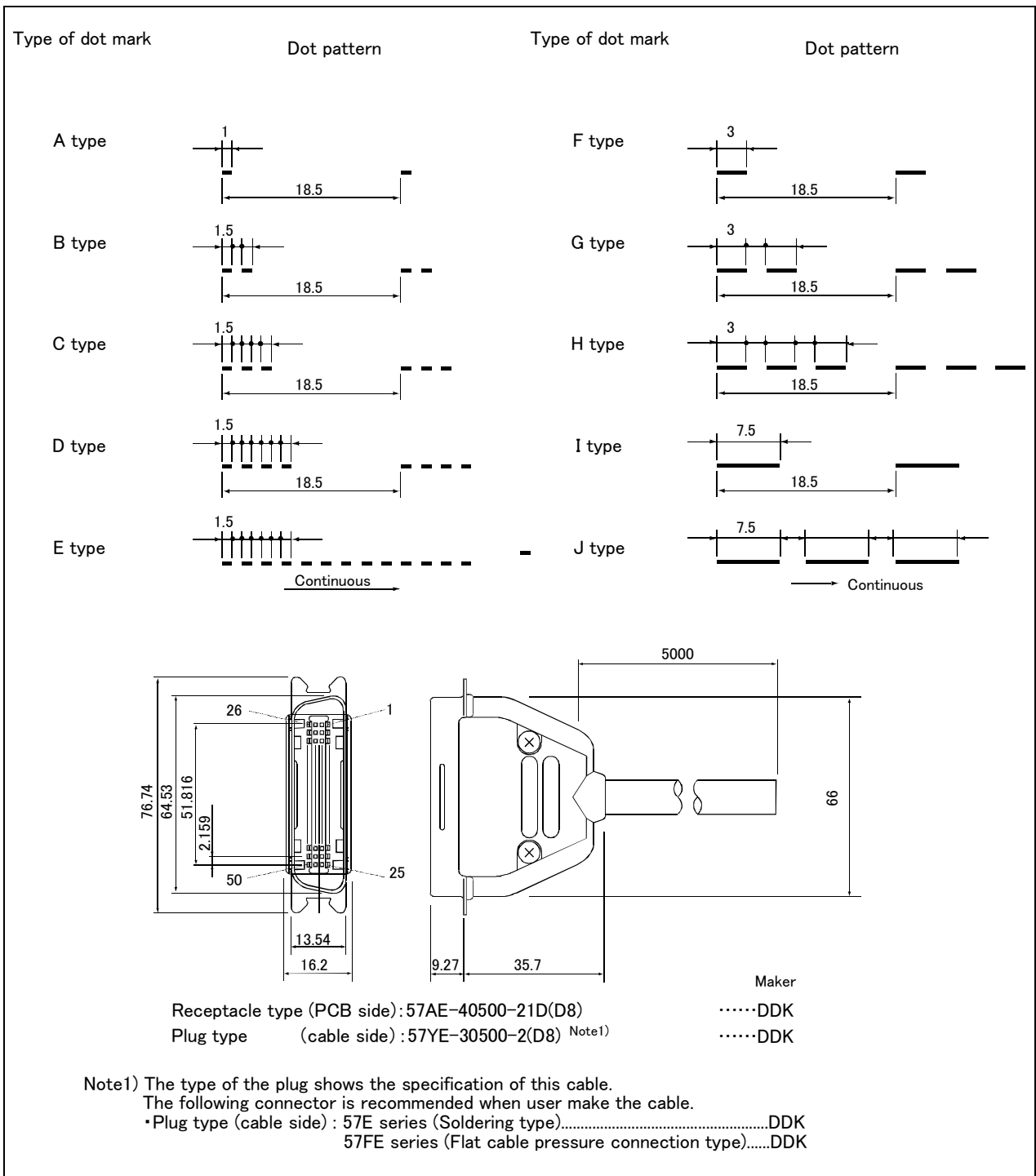
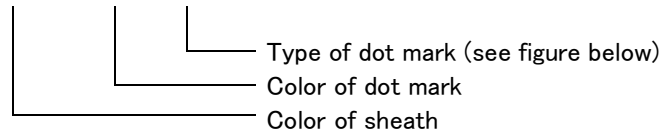

Fig.3-23 : Connections and outside dimensions

(7) Personal computer cable

- Order type: ● For PC/AT : RS-MAXY-CBL
RS-AT-RCBL (For expansion option box(CR1-EB3).)

Outline



This is the RS-232C interface cable used for connecting the controller with a personal computer. The personal computer on hand may be usable with the above interface cable. Confirm the connection specifications when placing an order. Personal computer cables for the PC/AT compatible model is available. The cable for the NEC PC9821 (half-pitch 14-pin) must be manufactured by the customer. Use "RS-AT-RCBL" when you use expansion serial I/F with the expansion option box.

Configuration

Table 3-27 : Configuration device

Part name	Type	Qty.	Remarks
Personal computer cable (for PC/AT)	RS-MAXY-CBL	1pc.	3m, D-SUB 9 pin ^{Note1)}
	RS-AT-RCBL	1pc.	3m, D-SUB 9 pin For expansion serial I/F at expansion option box(CR1-EB3).

Note1)The personal computer cable is the same as that for use with "Movemaster M1/M2/E/EN series".

Specifications

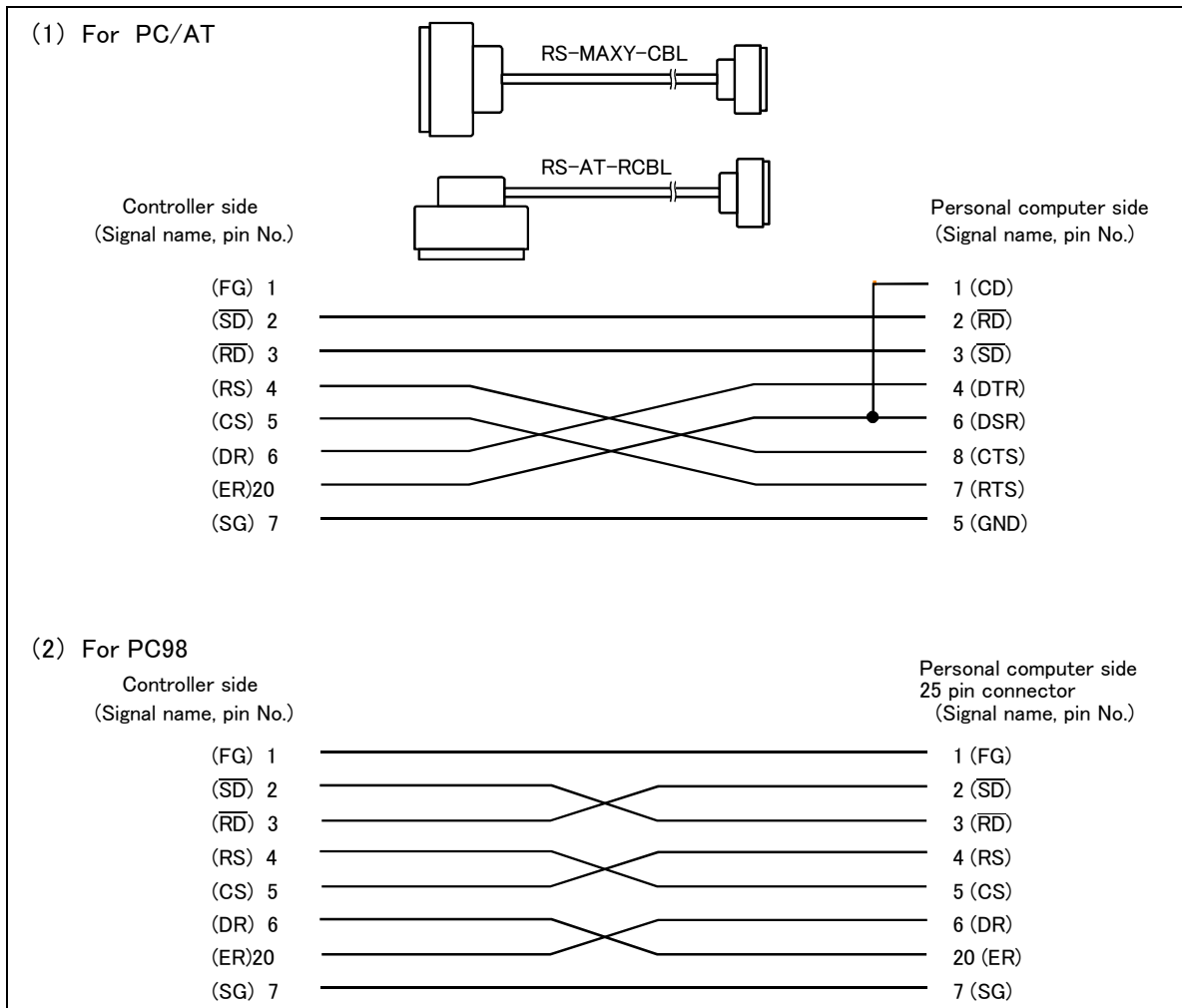

Fig.3-24 : Personal computer cable connection

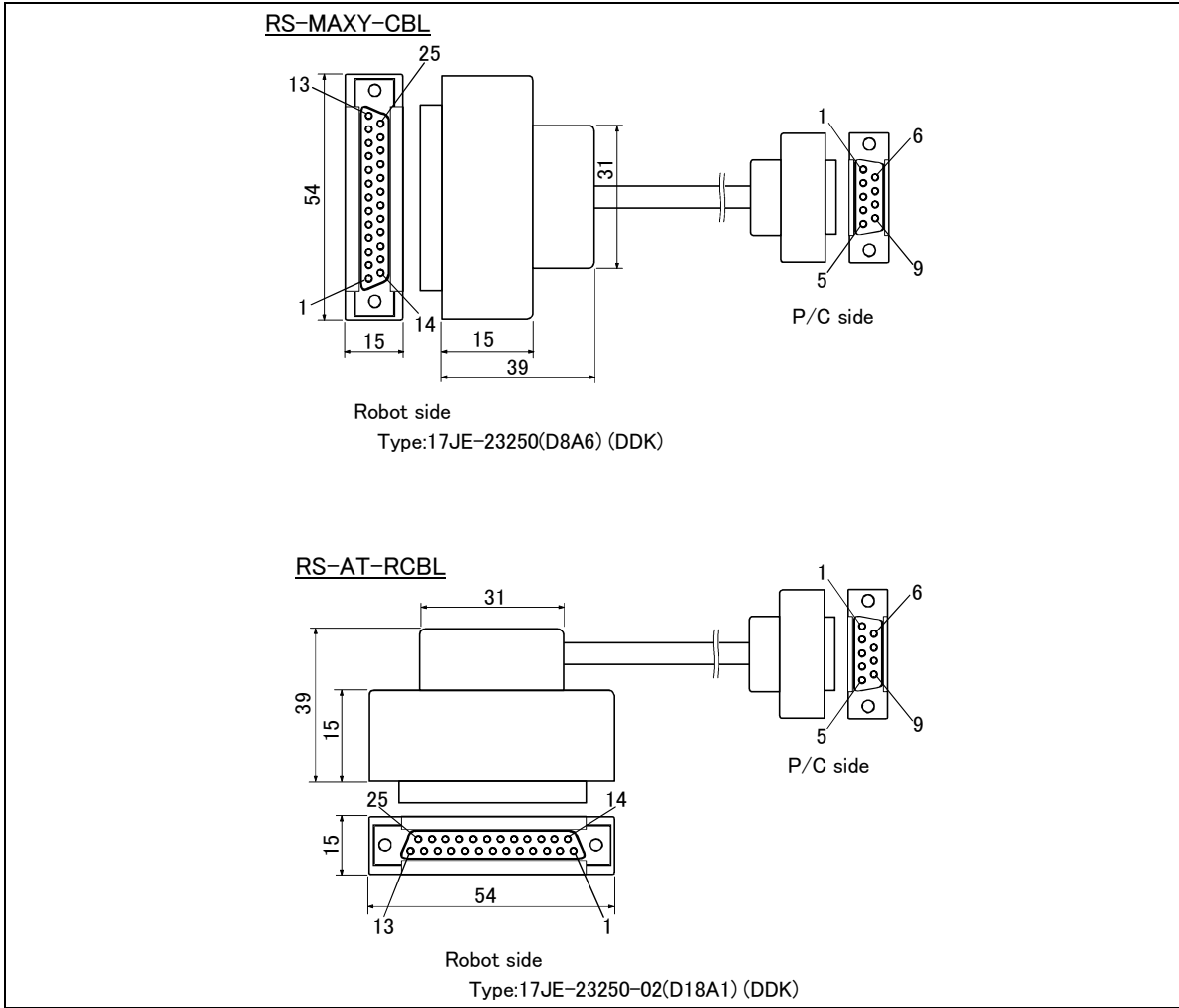

Fig.3-25 : Personal computer cable connector

(8) Personal computer support software/Personal computer support software mini

- Order type : ● Personal computer support software
 *For windows CD-ROM : 3A-01C-WINE
 ● Personal computer support software mini
 *For windows CD-ROM : 3A-02C-WINE

■ Outline



This is handy software that fully uses the personal computer functions. It can be used in various stages from the robot specifications study (tact study, etc.) to the design support (creation and editing of programs), start up support (execution, control and debugging of program), and maintenance (remote maintenance.)

The "personal computer support software" which supports these function fully, and the "personal computer support software mini" which does not have the simulation function are available. Select according to the required application.

■ Configuration

Table 3-28 : Product configuration

Part name	Type	Medium	Remarks
Personal computer support software	3A-01C-WINE	CD-ROM	One operation manual included
Personal computer support software mini	3A-02C-WINE	CD-ROM	One operation manual included

■ Features

(1) Simple operation with guidance method and menu method

The Windows standard is used for windows operation, so the controller initialization and startup operations can be carried out easily by following the instructions given on the screen. Even a beginner can easily carry out the series of operations from program creation to execution.

(2) Increased work efficiency with ample support functions

The work efficiency is greatly improved with the multi-window method that carries out multiple steps and displays in parallel. The renumbering function, and copy, search, syntax check and step execution are especially sufficient, and are extremely useful when editing or debugging the program.

With the simulation function support, the program can be debugged and the tact checked before starting the machine at the site. This allows the on-site startup work efficiently to be greatly improved.

(3) Increased maintenance efficiency with remote maintenance function

With remote operations over a telephone line, the robot's operation status can be monitored without going to the site. Losses incurred while moving to the site can be reduced, and the time required to investigate the trouble and determine measures to be taken can be shortened.

■ Functions

Table 3-29 : Functions

Function		Functional existence ^{Note1)}		Details
Compatible model		○	○	Personal computer running Microsoft Windows 95/98/NT 4.0
Program editing functions	Editing functions	○	○	<ul style="list-style-type: none"> ▪ MELFA BASIC IV language compatible ▪ Multiple editing screen simultaneously display ▪ Command input, comment writing ▪ Position data editing ▪ File operation (writing to controller, floppy disk, personal computer) ▪ Search and replace function (using characters, line Nos., labels) ▪ Copy, cut, paste, insert (per character, line), undo (per command statement, position conversion) ▪ Line No. automatic generation, renumbering ▪ Batch syntax check ▪ Command template ▪ Position conversion batch editing ▪ Position variable template ▪ Print, print preview
	Control functions	○	○	<ul style="list-style-type: none"> ▪ Program file control (list, copy, movement, delete, content comparison, name change, protect)
	Debugging functions	○	○	<ul style="list-style-type: none"> ▪ Direct editing of program in controller ▪ Confirmation of robot program operation (step execution, direct execution) ▪ Tact time measurement^{Note2)}
Simulation function ^{Note3)}		○	×	<ul style="list-style-type: none"> ▪ Off-line simulation of robot program operation using CG (computer graphics) ▪ Tact time calculation
Monitor functions		○	○	<ul style="list-style-type: none"> ▪ Robot operation monitor (robot operation state, stop signal, error monitor, program monitor (execution program, variables), general-purpose input/output signals (forced output possible), dedicated input/output signals, operation confirmation (operation range, current position, hand, etc.) ▪ Operation monitor (working time statistics, production information, robot version) ▪ Servo monitor (position, speed, current, load, power)
Maintenance function		○	○	<ul style="list-style-type: none"> ▪ Parameter setting ▪ Batch, divided backup
Remote maintenance function		○	○	<ul style="list-style-type: none"> ▪ Monitoring and maintenance of robot state at remote site using telephone line. (A separate modem is required for this function.)

○ Personal computer support software mini (3A-01C-WINE)
 ○ Personal computer support software (3A-02C-WINE)

Note1)The functions included with the personal computer support software and the personal computer support software mini are shown below. ○ : Function provided × : Function not provided

Note2)When using the "personal computer support software mini", connect with the controller and measure.

Note3)A simulation function is available only with "MELFA-BASIC IV".

3.9 Maintenance parts

The consumable parts used in the controller are shown in [Table 3-30](#). Purchase these parts from your dealer when required. Some Mitsubishi-designated parts differ from the maker's standard parts. Thus, confirm the part name, robot arm and controller serial No. and purchase the parts from your dealer.

Table 3-30 : Controller consumable parts list

No.	Part name	Type	Qty.	Usage place	Manufacturer
1	Lithium battery	ER6 BKO-NC2157H01	1	RZ182 card	Mitsubishi Electric

4 Software

4.1 List of commands

The robot language to use can choose "MELFA-BASIC IV" (default setting) or "MOVEMASTER language (MOVEMASTER commands)" by changing the parameter.

Use of "MELFA-BASIC IV" is recommended to effectively use this controller's functions.

The available new functions in MELFA-BASIC IV are given in [Table 4-1](#).

Table 4-1 : The available new functions in MELFA-BASIC IV

Class	Command example	Function
Robot Status Variable	P_TOOL	keep current tool length
	M_SPD	keep current speed (linear/circular interpolation)
Built-in functions	ABS	Produces the absolute value
	VAL	Converts a character string into a numeric value
	ATN	Calculates the arc tangent
	STR\$	Converts the numeric expression value into a decimal character string
	ZONE	Check current position area
Operation function	P1=P1*P2	Relative calculation of position data
	M1=M1*M2	Multiplication of numerical variable
	P1.X=10	Operation of the position element data
Conditional branching	SELECT CASE	More than one condition branch
	ON GOSUB	Condition branch by the value
	WHILE WEND	Repeat with condition
Optimum acceleration/ deceleration control	LOADSET	Load condition setting
	OADL	valid/invalid setting for the optimum acceleration/deceleration
Float control (compliance in the XYZ coordinate system)	CMP POS	Compliance control
	CMPG	Force control
Parallel execution (Multitask)	XRUN, XSTP, XRST, XLOAD	Parallel executions of another task, the stops, the resets, and, the loads
Conveyor trucking [Special specification]	TRKON, TRKOFF	Valid/invalid of the trucking
	TRBASE	Setting the base coordinate for the trucking

(1) The procedure of robot language selection

Table 4-2 : Robot language parameter

Parameter	Parameter name	No. of arrays No. of characters	Details explanation	Factory setting
Robot language	RLNG	Integer 1	Select the robot language to use 1 : MELFA-BASIC IV 0 : MOVEMASTER COMMAND	1

Note 1) "MELFA-BASIC IV" is default setting.

Note 2) Refer to the separate manual "Explanation of MOVEMASTER COMMANDS"(BFP-A8056) for details of "MOVEMASTER COMMAND".

(2) MELFA-BASIC IV commands

Table 4-3 : List of MELFA-BASIC IV commands

Type	Class	Function	Input format (example)
Position and operation control	Joint interpolation	Moves to the designated position with joint interpolation.	MOV P1
	Linear interpolation	Moves to the designated position with linear interpolation.	MVS P1
	Circular interpolation	Moves along a designated arc (start point → passing point → start point (end point)) with 3-dimensional circular interpolation (360 degrees).	MVC P1,P2,P1
		Moves along a designated arc (start point → passing point → end point) with 3-dimensional circular interpolation.	MVR P1,P2,P3
		Moves along the arc on the opposite side of a designated arc (start point → reference point → end point) with 3-dimensional circular interpolation.	MVR2 P1,P9,P3
		Moves along a set arc (start point → end point) with 3-dimensional circular interpolation.	MVR3 P1,P9,P3
		Speed designation	Designates the speed for various interpolation operations with a percentage (0.1% unit).
		Designate the speed for joint interpolation operation with a percentage (0.1% unit).	JOVRD 100
		Designates the speed for linear and circular interpolation with a numerical value (0.1mm/s unit).	SPD 123.5
		Designates the acceleration/deceleration time as a percentage in respect to the predetermined maximum acceleration/deceleration. (1% unit)	ACCEL 50,80
		Automatically adjusts the acceleration/deceleration according to the parameter setting value.	OADL 1,5,20
		sets the hand and work conditions for automatic adjustment of the acceleration/deceleration.	LOADSET 1,1
	Operation	Adds a process unconditionally to the operation.	WTH
		Adds a process conditionally to the operation.	WTHIF
		Designates smooth operation.	CNT 1,100,200
		Designates the positioning completion conditions with a No. of pulses.	FINE 200
		Turns the servo power ON/OFF for all axes.	SERVO OFF
		Limits the operation of each axis so that the designated torque is not exceeded.	TORQ 4,60
	Position control	Designates the base conversion data.	BASE P1
		Designates the tool conversion data.	TOOL P1
	Float control	The robot arm rigidity is lowered and softened. (XYZ coordinate system)	CMP POS ,00000011
		The robot arm rigidity is lowered and softened. (JOINT coordinate system)	CMP JNT ,00000011
		The robot arm rigidity is lowered and softened. (TOOL coordinate system)	CMP TOOL ,00000011
		The robot arm rigidity is returned to the normal state.	CMP OFF
		The robot arm rigidity is designated.	CMPG 1.0,1.0,1.0,1.0,1.0,1.0,1.0
	Pallet	Defines the pallet.	DEF PLT 1,P1,P2,P3,P4,5,3,1
		Operates the pallet grid point position.	PLT 1,M1
Program control	Branching	Branches unconditionally to the designated place.	GOTO 120
		Branches according to the designated conditions.	IF IN1=1 THEN GOTO 100 ELSE GOTO 20
	Repeats	Repeats until the designated end conditions are satisfied.	FOR M1=1 to 10 NEXT
		Repeats while the designated conditions are satisfied.	WHILE M1<10 WEND
		Branches corresponding to the designated expression value.	ON M1 GOTO 100,200,300

Type	Class	Function	Input format (example)
Program control	Branching	Executes program block corresponding to the designated expression value..	SELECT CASE 1 CASE 2 END SELECT
		Moves the program process to the next line.	SKIP
	Subroutine	Executes the designated subroutine. (Within program)	GOSUB 200
		Returns from the subroutine.	RETURN
		Executes the designated program.	CALLP "P10",M1,P1
		Defines the program argument executed with the CALLP command.	FPRM M10,P10
		Executes the subroutine corresponding to the designated expression value.	ON M1 GOSUB 100,200,300
	Interrupt	Defines the interrupt conditions and process.	DEF ACT 1 IN1=1 GOTO 100
		Enables/disables the interrupt.	ACT 1=1
		Defines the start line of the program to be executed when an interrupt is generated from the communication line.	ON COM(1) GOSUB 100
		Enables the interrupt from the communication line.	COM(1) ON
		Disables the interrupt from the communication line.	COM(1) OFF
		Stops the interrupt from the communication line.	COM(1) STOP
	Wait	Designates the wait time, and the output signal pulse output time. (0.01s unit)	DLY 0.5
		Waits until the variable becomes the designated value.	WAIT M_IN(1)=1
	Stop	Stops the program execution.	HLT
		Generates an error. During program execution, continue, stop or servo OFF can be designated.	ERROR 9000
End	Ends the program execution.	END	
Hand	Hand open	Opens the designated hand.	HOPEN
	Hand close	Closes the designated hand.	HCLOSE
Input/output	Assignment	Defines the input/output variables.	DEF IO PORT1=BIT,0
	Input	Retrieves the general-purpose input signal.	M1=IN 1
	Output	Calls out the general-purpose output signal.	OUT 1=0
Parallel execution	Mechanism designation	Acquires the mechanism with the designated mechanism No.	GETM 1
		Releases the mechanism with the designated mechanism No.	RELM 1
	Selection	Selects the designated program for the designated slot.	XLOAD 2,"P102"
	Start/stop	Carries out parallel execution of the designated program.	XRUN 3,"100",0
		Stops parallel execution of the designated program.	XSTOP 3
	Returns the designated program's execution line to the head and enters the program selection enabled state.	XRST 3	
Others	Definition	Defines the integer type or real number type variable.	DEF INT KAISUU
		Defines the character string variable.	DEF CHAR MESSAGE
		Defines the layout variable. (Up to 3-dimensional possible)	DIM PDATA(2,3)
		Defines the joint variable.	DEF JNT TAIHI
		Defines the position variable.	DEF POS TORU
		Defines the function.	DEF FNTASU(A,B)=A+B
	Clear	Clears the general-purpose output signal, variables in program, variables between programs, etc.	CLR 1
	File	Opens a file.	OPEN "COM1:" AS #1
		Closes a file.	CLOSE #1
		Inputs data from a file.	INPUT# 1,M1
		Outputs data to a file.	PRINT# 1,M1
	Comment	Describes a comment.	REM "ABC"
Label	Indicates the branching destination.	*SUB1	

(3) MOVEMASTER commands

Table 4-4 : List of MOVEMASTER command

Type	Class	Function	Input format (example)
Position and operation control	Joint interpolation	Moves to the designated position variable with joint interpolation.	MO 1
		Moves to the designated position with joint interpolation.	MP 100,200,125.3,0,90
		Moves to a position obtained by adding two position variables.	MA 1,2
		Turns the joint by the specified angle from the current position.	MJ 10,20,0,0,0,0
		Moves the axis by the designated amount from the current position.	DJ 1,15
		Moves by the specified distance from current position.	DW 100,80,0
		Moves to the next position in number from current position.	IP
		Moves to the previous position in number from current position.	DP
		Moves to a position separated by the designated distance (+/- direction) in the Z axis direction of the tool coordinates from the designated position variable's position.	MT 1,-50
		Moves to the origin in the axis order designated in the parameters.	NT
	Moves to the user specified origin position.	OG	
	Linear interpolation	Moves to the designated position variable with linear interpolation.	MS 1
		Moves by the specified distance from current position.	DS 10,20,0
		Continuously moves the position variable with linear interpolation between the two designated position variables.	MC 10,20
		Moves to a position separated by the designated distance (+/- direction) in the Z axis direction of the tool coordinates from the designated position variable position.	MTS 1,-50
	Circular interpolation	Moves along a designated arc (start point → transient point → end point) with three-dimensional circular interpolation.	MR 1,2,3
		Moves with circular interpolation with the position data of two MRA commands designated previously or subsequently.	MRA 4
	Speed designation	Establishes program over-ride. (0.1% unit)	OVR 100
		Designate the speed level and acceleration/deceleration rate for various interpolation operations.	SP 25,H
		Designate the speed, time constant, acceleration/deceleration rate and CNT setting validity for linear and circular interpolation.	SD 123.5,50,50,0
	Position control	It establishes die length to hand nose from hand installation.	TL 128
		Designates the tool matrix.	TLM 0,0,128,0,0,0
		Waits for in position till all axis ring inward pulse appointing.	PW 10
		Adds ± 360 degrees to current R axis joint position and rewrites current position.	JRC +1
		Memorizes current position as the position number.	HE 1
		Memorizes current position as the origin.	HO
		Sets the designated coordinate value (x, y, z, a, b, c) in the designated position variable.	PD 1,100,200,300,0,90,0
		Deletes the position variable between two designated position variables.	PC 1,20
	Pallet	Changes the pose of the robot at position.	CF 1,R,A,F
		Defines the pallet.	PA 1,5,3
		Operates the designated pallet No. grid point position, and substitutes into the corresponding position variable.	PT 1

Type	Class	Function	Input format (example)
Program control	Branching	Jump to line number.	GT 120
		Jump to line number if internal register value/strings equals specified value/strings.	EQ 20,120 EQ "OK",120
		Jump to line number if internal register value/strings does not equal specified value/strings.	NE 20,120 NE "NG",120
		Jump to line number if internal register value/strings is greater than specified value/strings.	LG 20,120 LG "NG",120
		Jump to line number if internal register value/strings is smaller than specified value/strings.	SM 20,120 SM "NG",120
		Jump to line number by internal register bit status.	TB +5,100
		Jump to line number by external input signal bit status.	TBD +5,100
		Repeats the loop specified by command NX.	RC 8
		Specifies the range of a loop in a program by command RC.	NX
	Subroutine	Executes the subroutine of the line designated in the designated program.	GS 3,10
Returns from the subroutine. (The return line No. can be designated.)		RT RT 200	
Program control	Interrupt	Validates the interrupt by the bit designated by the external input terminal, and designated the branching method and branching line at the interrupt.	EA +16,100,1
		Disables interrupt by the bit of external input signal.	DA 16
	Wait	Stops the operation for the designated time. (0.1 sec unit)	TI 50
	Select	Selects the program.	N 1
	Start	Executes the program between the designated line numbers.	RN 10,50
	Stop	Halts the program.	HLT
Hand	End	Ends the program.	ED
	Open	Opens the specified hand.	GO
		Closes the specified hand.	GC
	Setting	Sets the motorized hand's gripping force and open/close time.	GP 40,30,50
Sets the hand open/close state when the "PD" command is executed.		GF 1	
Input/output	Input	Gets signal from external input.	ID
	Output	Outputs data to external output signal.	OD 20
		Outputs the counter value to external output signal.	OC 1
Operation/Substitution	addition	Adds the designated value to the internal register value.	ADD 10
		Adds 1 to the designated number's counter.	IC 5
		Adds the coordinate values of the designated position variable to the coordinate values of the designated position variable.	SF 1,2
	Subtraction	Subtracts the designated value from the designated register value.	SUB 10
		Subtracts one from the designated number's counter.	DC 5
	Multiplication	Multiplies the designated value to the internal register value.	MUL 2
	Division	Divides the internal register value by the designated value.	DIV 10
	AND	Logical AND of the internal register value and specified value.	AN 7
	OR	Logical OR of the internal register value and specified value.	OR 3
	XOR	Logical exclusive OR of the internal register value and specified value.	XO 2
	Substitution	Substitutes the designated value (character string) in the designated counter.	SC 1,10 SC \$1,"OK"
		Substitutes the designated position variable coordinate value in the designated position variable.	PL 1,2
		Substitutes the internal register value (character string) in the designated number's counter.	CL 1
		Sets the designated number's counter value (character string) in the internal register.	CP 1
	Exchange	Exchanges the coordinate values of two designated position variables.	PX 1,2

Type	Class	Function	Input format (example)
Other	RS-232C read	Reads the selected program No. or designated program information.	QN 1
		Reads the program of specified line number.	LR 10
		Reads the program of specified step number.	STR 10
		Reads the coordinate value of specified position number.	PR 1
		Reads the value/strings of specified counter number.	CR 1
		Reads the hand input signal, internal register value and the 16-bit width data from the designated external output signal bit.	DR 16
		Reads the current error No. or error history.	ER 10
		Reads the coordinate value of current position.	WH
		Reads the value of current tool length.	WT
		Reads the current tool matrix.	WTM
		Reads the name of system software version.	VR
		Reads the value of specified parameter.	PMR "HANDINIT"
	Clear	Deletes the program between the designated line numbers.	DL 10,90
		Deletes the selected program and position variables.	NW
	File	Opens the file.	OPEN 1,1
		Reads the data from the file.	INP 1,2,0
		Sends the value to the file.	PRN 2
		Sets the contents of the designated parameter.	PMW 1,0,1,0,1,0,1,0
	Reset	Resets the error, or program line number.	RS
	Comment	Describes a comment.	'

4.2 List of parameters

(1) List of parameters

show the main parameter in the [Table 4-5](#).

Table 4-5 : List of parameters

Parameter		Details
Standard tool coordinates.	MEXTL	Set the default value for the tool data. Unit: mm or deg.
Standard base coordinates	MEXBS	Set the relation of the world coordinate system and robot coordinate system. Unit: mm or deg.
XYZ operation range	MEPAR	Designate the overrun limit value for the world coordinate system.
JOINT operation range	MEJAR	Set the overrun limit value for each joint axis.
Free plane limit		This is the overrun limit set with the free plane. Create a plane with the three coordinates x1, y1, z1 to x3, y3, z3, and set the outer side of the plane as the outside operation range (error). The following three types of parameters are used.
	SFC1P : SFC8P	Eight types of free plane limits can be set in SFC1P to SFC8P. There are nine elements, set in the order of x1, y1, z1, x2, y2, z2, x3, y3, z3.
	SFC1ME : SFC8ME	Designate which mechanism to use eight types of set free plane limits. The mechanism No. to use is set with 1 to 8.
	SFC1AT : SFC8AT	Set the validity of the eight types of set free plane limits. (Valid/invalid = 1/0)
User-defined area		An area (cube) defined with two XYZ coordinate points can be designated and that area set as the outside operation range. Furthermore, a signal can be output when the axis enters that area. Up to eight types of area can be designated.
	AREA1P1 : AREA8P1	Designated the 1st point of the area. There are eight elements, set in the order of x, y, z, a, b, c, L1, L2. (L1 and L2 are the additional axes.)
	AREA1P2 : AREA8P2	Designated the 2nd point of the area. There are eight elements, set in the order of x, y, z, a, b, c, L1, L2. (L1 and L2 are the additional axes.)
	AREA1ME : AREA8ME	Designate which mechanism to use the eight types of set area. The mechanism No. to use is set with 1 to 8
	AREA1AT : AREA8AT	Designate the area check type. (Invalid/zone/interference = 0/1/2) Zone: The dedicated output signal USRAREA turns ON. Interference: An error occurs..
Automatic return setting	RETPATH	Set to restart the program after returning to the interrupt position when resuming operation after an interruption.
Buzzer ON/OFF	BZR	Designate whether to the turn buzzer ON or OFF.
Automatic operation speed.	SPI	Designate the initial level for the automatic operation speed.
Automatic operation override	EOV	Designate the initial override for automatic operation. (External override, program override)
Jog setting	JOGJSP	Designate the joint jog and step operation speed. (Set dimension H/L amount, max. override.)
	JOGPSP	Designate the linear jog and step operation speed. (Set dimension H/L amount, max. override.)
Jog speed limit value	JOGSPMX	Limit the operation speed during the teaching mode. Max. 250[mm/s]
Hand type	HANDTYPE	Set the hand type of the single/double solenoid, and the signal No. (Single/double = S/D) Set the signal No. after the hand type. Example) D900

Parameter		Details
Stop input B contact designation	INB	Change the dedicated input (stop) between the A contact and B contact.
User-designated origin	USERORG	Designate the user-designated origin position.
Program selection memory	SLOTON	Select the program selected previously when initializing the slot. The non-selected state will be entered when not set.
Communication setting	CBAU232	Set the baud rate.
	CLEN232	Set the character length.
	CPRTY232	Set the parity.
	CSTOP232	Set the stop bit.
	CTERM232	Set the end code.
Slot table	SLT : SLT32	Make settings (program name, operation type, order of priority, etc.) for each slot during slot initialization.
No. of multi-tasks	TASKMAX	Designate the No. of programs to be executed simultaneously.
Robot language setting	RLNG	Select the robot language ("MELFA-BASIC IV"/"MOVEMASTER COMMAND")
Select the function of singular point adjacent alarm	MESNGLSW	Designate the valid/invalid of the singular point adjacent alarm. (Invalid/Valid = 0/1) When this parameter is set up "VALID", this warning sound is buzzing even if parameter: BZR (buzzer ON/OFF) is set up "OFF".
Display language. ^{Note1)} 表示言語 ^{Note1)}	LNG	Change the language to display on the LCD display of teaching pendant. ティーチングボックスの表示 LCD などに表示する言語を切り替えます。

Note1)The procedure of Language as shown in "(2) Change the display language / 表示言語の切り替え".

注 1) 表示言語切り替え方法の詳細を "(2) Change the display language / 表示言語の切り替え" に示します。

(2) Change the display language / 表示言語の切り替え

The language to display on the LCD display of teaching pendant can be changed by "the display language parameter". (Japanese or English)

Show the details of the parameter in the Table 4-5. Refer to the separate "Instruction Manual/Detailed Explanation of Functions and Operations" for details on changing the parameter.

The parameter is set up based on the order specifications before shipment. Order to dealer when the instruction manual of the other language is necessity.

More, the caution seals that stuck on the robot arm and the controller are made based on the language of the order specification. Use it carefully when selecting the other language.

表示言語設定パラメータによって、ティーチングボックスの表示 LCD などに表示する言語を切り替えることができます。(日本語、または英語) Table 4-5 にそのパラメータの詳細を示します。パラメータの変更方法は、別冊の「取扱説明書／機能と操作の詳細解説」を参照願います。

なお、出荷時はご注文仕様に基づき弊社で設定いたします。別の言語の取扱説明書をご希望の場合はご用命願います。

また、ロボット本体とコントローラに貼り付けてある注意シールは、ご注文仕様に基づいた言語で製作いたします。本パラメータを変更して言語を切り替えてご使用の場合はご注意願います。

Table 4-5 : Display language parameter / 表示言語設定パラメータ

Parameter パラメータ	Parameter name パラメータ名	No. of arrays No. of characters 配列数 文字数	Details explanation 内容説明	Default setting 出荷時 設定
Display lan- guage 表示言語設定	LNG	Character string 1 文字列 1	<p>Set up the display language. "JPN" : Japanese "ENG" : English</p> <p>The following language is changed. (1)The display LCD of teaching pendant. (2) Personal computer support software. *alarm message of the robot. *Parameter explanation list. (3)Alarm message that read from the robot with external communication. (Standard RS232C, Extended serial I/F, Ethernet I/F)</p> <p>表示言語を設定します。 "JPN" : 日本語表示 "ENG" : 英語表示</p> <p>以下に示す表示言語が変更されます。 (1) ティーチングボックスの表示 LCD (2) パソコンサポートソフトウェア ・ ロボットのアラームメッセージ ・ パラメータ説明リスト (3) 外部通信でロボットから読み出したアラームメッセージ (標準 RS232C、増設シリアルインタフェース、イーサネットインタフェース)</p>	1

5 Safety

5.1 Safety

Measures to be taken regarding safety of the industrial robot are specified in the "Labor Safety and Sanitation Rules". Always follow these rules when using the robot to ensure safety.

5.1.1 Self-diagnosis stop functions

This robot has the self-diagnosis stop functions shown in [Table 5-1](#) and the stop functions shown in [Table 5-2](#) for safe use.

Table 5-1 : Self-diagnosis stop functions

No.	Function	Details	Remarks
1	Overload protection function	Activates when the total servo current time exceeds the specified value.	The drive circuit is shut off. The robot stops, and an alarm displays.
2	Overcurrent diagnosis function	Activates when an overcurrent flows to the motor circuit.	The drive circuit is shut off. The robot stops, and an alarm displays.
3	Encoder disconnection diagnosis function	Activates when the encoder cable is disconnected.	The drive circuit is shut off. The robot stops, and an alarm displays.
4	Deflection over diagnosis function	Activates when an error occurs between the command value and actual position, and the error exceeds the specified amount.	The drive circuit is shut off. The robot stops, and an alarm displays.
5	AC power voltage drop diagnosis function	Activates when the AC power voltage drops below the specified value.	The drive circuit is shut off. The robot stops, and an alarm displays.
6	CPU error detection function	Activates when an error occurs in the CPU.	The drive circuit is shut off. The robot stops, and an alarm displays.
7	Overrun prevention function	Software limit detection	This is the limit provided by the software to enable operation only in the operation range.
		Mechanical stopper	This is the mechanical stopper provided outside the software.

Table 5-2 : List of stop functions

Stop function	Operation panel	Teaching pendant	External input	Details
Emergency stop	○	○	○	This is the stop with the highest degree of emergency. The servo power is shut off, and the mechanical brakes (all axes) activate to stop the robot. To recover, reset the alarm, and turn the servo ON with the servo ON command.
Stop	○	○	○	This is a stop operation with a high degree of emergency. The robot immediately decelerates and stops. Note that the servo power is not shut off. Use this when using the collision evasion sensor, etc.

5.1.2 External input/output signals that can be used for safety protection measures

Table 5-3 : External input/output signals that can be used for safety protection measures

	Signal	Command	Functions	Usage method
Input	External emergency stop	(Input signal)	This servo power is shut off, and the robot stops immediately.	Externally installed emergency stop switch. Door switch on safety protection fence. Stopping at high-level error occurrence.
	Stop	STOP	The program execution is stopped, and the robot stops. The servo power is not shut off.	The robot is stopped when a peripheral device fault occurs. The servo power is not shut off.
	Servo OFF	SRVOFF	The servo power can be shut off.	The robot is stopped when a peripheral device fault occurs. The servo power is not shut off.
	Automatic operation enable	AUTOENA	Disables automatic operation when inactive.	Door switch on safety protection fence
Output	In servo ON	SRVON	The servo power ON/OFF state is output.	The servo power ON/OFF state is shown and alerted with the display lamps.
	Waiting	STOP	Outputs that the robot is temporarily stopped.	The temporary stop state is shown and alerted with the display lamps.
	In alarm	ERRRESET	Outputs when an alarm occurs in the robot.	The alarm state is shown and alerted with the display lamps.

[Caution] The external emergency stop input is prepared as a b contact for safety proposes. Thus, if the emergency stop input circuit is opened when the robot is started up, the robot will not operate. Refer to "Fig. 5-1 Example of safety measures" for details.

5.1.3 Precautions for using robot

The safety measures for using the robot are specified in the "Labor Safety and Sanitation Rules". An outline of the rules is given below.

(1) Robot installation

- Secure sufficient work space required to safely perform work such as teaching and maintenance related to the robot.
- Install the controller outside the robot's motion space. (If a safety fence is provided, install outside the fence.)
- Install the controller where the entire robot operation can be viewed.
- Install display lamps, etc., to indicate the robot's operation state.
- Securely fix the robot arm onto the fixing table with the designated bolts.

(2) Prevention of contact with operator

- Install a safety fence or enclosure so that the operator cannot easily enter the robot's motion space.
- Install an interlock function that will stop the robot if the safety fence or enclosure door is opened.

(3) Work procedures

- Create and observe work procedures for the robot teaching, operation, inspection and emergencies.
- Create hand signals to be followed when several operators are working together.
- Create displays such as "Teaching in Progress" and "Inspection in Progress" to be put up when an operator is in the robot's motion space so that other operators will not operate the operation panel (controller, control panel).

(4) Training

- Train the operators about the operations, maintenance and safety required for the robot work.
- Only trained and registered operators must operate the robot.
Participation in the "Special training for industrial robots" sponsored by the Labor Safety and Sanitation Committee, etc., is recommended for safety training.

(5) Daily inspection and periodic inspection

- Always inspect the robot before starting daily operations and confirm that there are no abnormalities.
- Set the periodic inspection standards in view of the robot's ambient environment and operation frequency, and perform periodic inspections.
- Make records when periodic inspections and repairs have been done, and store the records for three or more years.

5.1.4 Safety measures for automatic operation

- (1) Install safety fences so that operators will not enter the operation area during operation and indicate that automatic operation is in progress with lamps, etc.
- (2) Create signals to be given when starting operation, assign a person to give the signal, and make sure that the operator follows the signals.

5.1.5 Safety measures for teaching

Observe the following measures when teaching, etc., in the robot's operation range.

- (1) Specify and follow items such as procedures related to teaching work, etc.
- (2) Take measures so that operation can be stopped immediately in case of trouble, and measures so that operation can be restarted.
- (3) Take measures with the robot start switch, etc., to indicate that teaching work is being done.
- (4) Always inspect that stop functions such as the emergency stop device before starting the work.
- (5) Immediately stop the work when trouble occurs, and correct the trouble.
- (6) Take measures so that the work supervisor can immediately stop the robot operation when trouble occurs.
- (7) The teaching operator must have completed special training regarding safety. (Training regarding industrial robots and work methods, etc.)
- (8) Create signals to be used when several operators are working together.

5.1.6 Safety measures for maintenance and inspections, etc.

Turn the power OFF and take measures to prevent operators other than the relevant operator from pressing the start switch when performing inspections, repairs, adjustments, cleaning or oiling.

If operation is required, take measures to prevent hazards caused by unintentional or mistaken operations.

- (1) Specify and follow items such as procedures related to maintenance work, etc.
- (2) Take measures so that operation can be stopped immediately in case of trouble, and measures so that operation can be restarted.
- (3) Take measures with the robot start switch, etc., to indicate that work is being done.
- (4) Take measures so that the work supervisor can immediately stop the robot operation when trouble occurs.
- (5) The operator must have completed special training regarding safety. (Training regarding industrial robots and work methods, etc.)
- (6) Create signals to be used when several operators are working together.

5.1.7 Examples of safety measures

Emergency stop input circuits are prepared on the user wiring terminal block of the controller. Create a circuit as shown below for safety measures

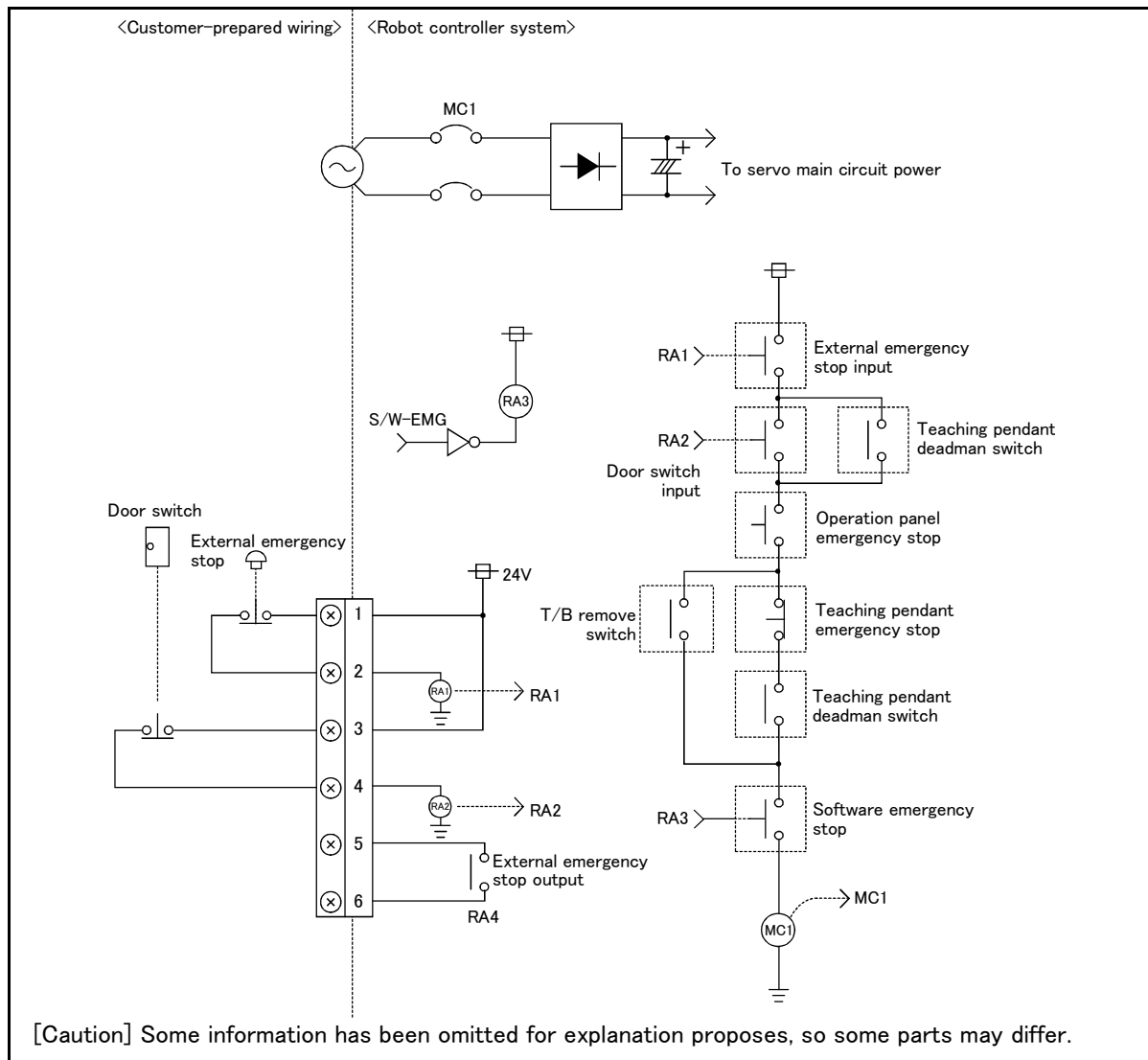

Fig.5-1 : Example of safety measures

- (1) Install a limit switch on the safety fence's door. With a constantly open contact (a contact), wire to the door switch input terminal so that the switch turns ON (is conducted) when the door is closed, and turns OFF (is opened) when the door is open.
- (2) Use a b contact manual-return type operator emergency stop switch.
- (3) Classify the faults into minor faults (faults that are easily restored and that do not have a great effect) and major faults (faults that cause the entire system to stop immediately, and that require care in restoration), and wire accordingly.

[Caution] The emergency stop input (terminal block) on the user wiring in the controller can be used for safety measures as shown in Fig. 5-1. Note that there are limits to the No. of switch contacts, capacity and cable length, so refer to the following and install.

- Switch contact capacity..... Use a contact that operates with a switch contact capacity of approx. 1mA to 100mA/24V.
- Cable length..... The length of the wire between the switch and terminal block must be max. 15m or less.

[Reference] The specifications of the RA1 and RA2 coil shown in Fig. 5-1 are as follow.

- Rated voltage..... DC24V \pm 10%
- Rated excitation current..... 12.5mA \pm 10% (at 25 deg.)

* Note that these specifications are subject to change without prior notice for modification purposes.

5.2 Working environment

Avoid installation in the following places as the equipment's life and operation will be affected by the ambient environment conditions. When using in the following conditions, the customer must pay special attention to the preventive measures.

(1) Power supply

- Where the voltage fluctuation will exceed the input voltage range.
- Where a momentary power failure exceeding 20ms may occur.
- Where the power capacity cannot be sufficiently secured.

(2) Noise

- Where a surge voltage exceeding 1000V, 1 μ s may be applied on the primary voltage. Near large inverters, high output frequency oscillator, large contactors and welding machines. Static noise may enter the lines when this product is used near radios or televisions. Keep the robot away from these items.

(3) Temperature and humidity

- Where the atmospheric temperature exceeds 40 degree , lower than 0 degree.
- Where the relative humidity exceeds 85%, lower than 45%, and where dew may condense.
- Where the robot will be subject to direct sunlight or near heat generating sources such as heaters.

(4) Vibration

- Where excessive vibration or impact may be applied. (Use in an environment of 34m/s² or less during transportation and 5m/s² or less during operation.)

(5) Installation environment

- Where strong electric fields or magnetic fields are generated.
- Where the installation surface is rough. (Avoid installing the robot on a bumpy or inclined floor.)

5.3 Precautions for handling

- (1) The robot arm has a molded cover. Parts cannot be installed and excessive force cannot be applied to the cover. A high grade of oil-proof resin is used for the molded cover.
- (2) This robot has brakes J1 to J3 and J5. The precision of the robot may drop, looseness may occur and the reduction gears may be damaged if the robot is moved with force with the brakes applied.
- (3) Avoid moving the robot arm by hand. When unavoidable, gradually move the arm. If moved suddenly, the accuracy may drop due to an excessive backlash, or the backed up data may be destroyed.
- (4) Note that depending on the posture, even when within the movement range, the wrist section could interfere with the base section. Take care to prevent interference during jog. ^{Note1)}
- (5) The robot arm is configured of precision parts such as bearings. Grease is used for lubricating these parts. When cold starting at low temperatures or starting operation after long-term stoppage, the position accuracy may drop or servo alarms may occur. If these types of phenomena occur, run the robot with low-speed operation for a short time.
- (6) The robot arm and controller must be grounded with Class D grounding to secure the noise resistance and to prevent electric shocks.
- (7) The items described in these specifications are conditions for carrying out the periodic maintenance and inspections described in the instruction manual.
- (8) When using the robot arm on a mobile axis or elevating table, the machine cables enclosed as standard configuration may break due to the fixed installation specifications. In this case, use the machine cable extension (for flexed)" factory shipment special specifications or options.
- (9) If this robot interferes with the workpiece or peripheral devices during operation, the position may deviate, etc. Take care to prevent interference with the workpiece or peripheral devices during operation.
- (10) Do not attach a tape or a label to the robot arm and the controller. If a tape or a label with strong adhesive power, such as a packaging tape, is attached to the coated surfaces of the robot arm and controller, the coated surface may be damaged when such tape or label is peeled off.

Note1) Jog operation refers to operating the robot manually using the teaching pendant.

6 Appendix

Appendix 1 : Specifications discussion material

■ Customer information

Company name		Name	
Address		Telephone	

■ Purchased mode

Specification	Type			
General environment	<input type="checkbox"/> RV-2A	<input type="checkbox"/> RV-3AJ		
Protection specification	<input type="checkbox"/> RV-2AM	<input type="checkbox"/> RV-3AJM		
Clean specification	<input type="checkbox"/> RV-2AC-SA	<input type="checkbox"/> RV-3AJC-SA	<input type="checkbox"/> RV-2AC-SB	<input type="checkbox"/> RV-3AJC-SB

■ Shipping special specifications (Settings can be made only at time of shipment)

Item		Standard specifications	Special shipping specifications
Robot arm	Operating range	J1 axis + side <input type="checkbox"/> +160°	<input type="checkbox"/> +120° <input type="checkbox"/> +90° <input type="checkbox"/> +60° <input type="checkbox"/> +30°
		J1 axis - side <input type="checkbox"/> -160°	<input type="checkbox"/> -120° <input type="checkbox"/> -90° <input type="checkbox"/> -60° <input type="checkbox"/> -30°
	Machine cable	<input type="checkbox"/> 5m fixed type	<input type="checkbox"/> 10m fixed type <input type="checkbox"/> 15m fixed type <input type="checkbox"/> 5m flexed type <input type="checkbox"/> 10m flexed type <input type="checkbox"/> 15m flexed type
Controller	Controller structure	<input type="checkbox"/> Floor type	

■ Options (Installable after shipment)

Item		Provision, and specifications when provided.
Robot arm	Pneumatic hand set	4A-HP02/4A-HP02E <input type="checkbox"/> Not provided <input type="checkbox"/> 4A-HP02 <input type="checkbox"/> 4A-HP02E
	Motorized hand set	4A-HM02 <input type="checkbox"/> Not provided <input type="checkbox"/> Provided
	Solenoid valve set	1E-VD0 <input type="checkbox"/> / 1E-VD0 <input type="checkbox"/> E <input type="checkbox"/> Not provided 1E-VD0 <input type="checkbox"/> : <input type="checkbox"/> 1 set <input type="checkbox"/> 2 sets 1E-VD0 <input type="checkbox"/> E: <input type="checkbox"/> 1 set <input type="checkbox"/> 2 sets
	Hand input cable	1E-HC15C <input type="checkbox"/> Not provided <input type="checkbox"/> Provided
	Hand output cable	1E-GR35S <input type="checkbox"/> Not provided <input type="checkbox"/> Provided
	Hand curl tube	1E-ST04 <input type="checkbox"/> C <input type="checkbox"/> Not provided <input type="checkbox"/> 1 pc. <input type="checkbox"/> 2 pc.
	Hand adapter	1A-HA01 <input type="checkbox"/> Not provided <input type="checkbox"/> Provided
Controller	Teaching pendant	R28TB- <input type="checkbox"/> <input type="checkbox"/> <input type="checkbox"/> Not provided <input type="checkbox"/> 7m <input type="checkbox"/> 15m
	Pneumatic hand interface	2A-RZ365/2A-RZ375 <input type="checkbox"/> Not provided <input type="checkbox"/> Provided
	Parallel I/O interface	2A-RZ361/2A-RZ371 <input type="checkbox"/> Not provided <input type="checkbox"/> 1pc. <input type="checkbox"/> 2pc. <input type="checkbox"/> 3pc. <input type="checkbox"/> 4pc. <input type="checkbox"/> 5pc. <input type="checkbox"/> 6pc. <input type="checkbox"/> 7pc.
	External I/O cable	2A-CBL <input type="checkbox"/> <input type="checkbox"/> <input type="checkbox"/> Not provided <input type="checkbox"/> 5m-1pc. <input type="checkbox"/> 5m-2pc. <input type="checkbox"/> 5m-3pc. <input type="checkbox"/> 15m-1pc. <input type="checkbox"/> 15m-2pc. <input type="checkbox"/> 15m-3pc.
	CC-LINK interface	2A-HR575E <input type="checkbox"/> Not provided <input type="checkbox"/> Provided
	ETHERNET interface	2A-HR533E <input type="checkbox"/> Not provided <input type="checkbox"/> Provided
	Extended serial interface	2A-RZ581E <input type="checkbox"/> Not provided <input type="checkbox"/> Provided
	Additional axis interface	2A-RZ541E <input type="checkbox"/> Not provided <input type="checkbox"/> Provided
	Personal computer cable	RS-MAXY-CBL/ RS-AT-RCBL <input type="checkbox"/> Not provided <input type="checkbox"/> RS-MAXY-CBL <input type="checkbox"/> RS-AT-RCBL
	Personal computer support software	3A-01C-WINE <input type="checkbox"/> Not provided <input type="checkbox"/> Windows95/98/NT4.0 CD-ROM
	Personal computer support software mini	3A-02C-WINE <input type="checkbox"/> Not provided <input type="checkbox"/> Windows95/98/NT4.0 CD-ROM
	Expansion option box	CR1-EB3 <input type="checkbox"/> Not provided <input type="checkbox"/> Provided
	Controller protection box	CR1-MB <input type="checkbox"/> Not provided <input type="checkbox"/> Provided

Note1) Up to eight units, including the one unit mounted as a standard.

■ Maintenance parts (consumable parts)

Maintenance parts	<input type="checkbox"/> Backup batteries A6BAT () pcs. <input type="checkbox"/> Backup batteries ER6 () pcs. <input type="checkbox"/> Grease () cans
-------------------	--

■ Robot selection check list

Work description	<input type="checkbox"/> Material handling <input type="checkbox"/> Assembly <input type="checkbox"/> Machining L/UL <input type="checkbox"/> Sealing <input type="checkbox"/> Testing and inspection <input type="checkbox"/> Other ()			
Workpiece mass ()g	Hand mass ()g	Atmosphere	<input type="checkbox"/> General environment <input type="checkbox"/> Clean <input type="checkbox"/> Dust provided <input type="checkbox"/> Other()	
Remarks				

Copy this page and use the copy.

DECLARATION OF CONFORMITY

We

(Company) : MITSUBISHI ELECTRIC CORPORATION
MITSUBISHI DENKI BLDG., Marunouchi, Tokyo 100-0081, Japan
(Factory) : NAGOYA WORKS
1-14, Yadaminami 5, Higashiku, Nagoya 461-8670, Japan

explain in own responsibility, that the products:

Kind of equipment :
INDUSTRIAL ROBOT
Type-designation :
RV-2A / 3AJ Series
(See attached sheet to identify the type of model.)

are in compliance with following norms or documents:

1. Machinery Directive(89/392/EEC),Amendment(91/368/EEC),(93/68/EEC)
 - (a) Type A : Fundamental safety standards
EN292-1/1991, EN292-2/1991, EN1050/1996
 - (b) Type B : Group safety standards
 - B1 : Safety aspects
EN60204-1/1997(partly unconformed), EN294/1992, EN349/1993,
EN457/1992, EN999/1993, prEN1005-2/1993
 - B2 : Safety related devices
EN418 : 1992
 - (c) Type C : Machine safety standards
EN775 : 1992

2. EMC Directive(89/336/EEC),Amendment(92/31/EEC)
 - (a) EN55011/May.1998, Group1, Class A
 - (b) EN61000-6-2/ 1999

Manager
Robot Systems Department in Nagoya Works

Nagoya, Japan / January 31, 2002

Norio Kodaira 

Manufacture/Authorized representative

Place and date of issue name and signature

■ Declaration Type of models

A.6-axis Robot Arm

Model Name	Language	Robot Arm	Controller	Software Version
RV-2A	Japanese	BU160C475G21	TU117C151G01	H3 and Later
	/English/German	BU160C475G22	TU117C154G01	
RV-2AM	Japanese	BU160C504G21	TU117C151G01	H3 and Later
	/English/German	BU160C504G22	TU117C154G01	
RV-2AC-SB	Japanese	BU160C567G21	TU117C151G01	H3 and Later
	/English/German	BU160C567G22	TU117C154G01	
RV-2AC-SA	Japanese	BU160C569G21	TU117C151G01	H3 and Later
	/English/German	BU160C569G22	TU117C154G01	

B.5-axis Robot Arm

Model Name	Language	Robot Arm	Controller	Software Version
RV-3AJ	Japanese	BU160C476G21	TU117C151G01	H3 and Later
	/English/German	BU160C476G22	TU117C154G01	
RV-3AJM	Japanese	BU160C505G21	TU117C151G01	H3 and Later
	/English/German	BU160C505G22	TU117C154G01	
RV-3AJC-SB	Japanese	BU160C568G21	TU117C151G01	H3 and Later
	/English/German	BU160C568G22	TU117C154G01	
RV-3AJC-SA	Japanese	BU160C570G21	TU117C151G01	H3 and Later
	/English/German	BU160C570G22	TU117C154G01	
RV-3AJR	Japanese	BU160C571G21	TU117C151G01	H3 and Later
	/English/German	BU160C571G22	TU117C154G01	
RV-3AJRM	Japanese	BU160C600G21	TU117C151G01	H3 and Later
	/English/German	BU160C600G22	TU117C154G01	



HEAD OFFICE : MITSUBISHI DENKI BLDG MARUNOUCHI TOKYO 100-8310 TELEX : J24532 CABLE MELCO TOKYO
NAGOYA WORKS : 1-14, YADA-MINAMI 5, HIGASHI-KU, NAGOYA, JAPAN