



Mitsubishi Industrial Robot



RH-1FHR-S60 Series

INSTRUCTION MANUAL

ROBOT ARM SETUP & MAINTENANCE

Safety Precautions

Always read the following precautions and the separate "Safety Manual" before starting use of the robot to learn the required measures to be taken.

-  **CAUTION** All teaching work must be carried out by an operator who has received special training. (This also applies to maintenance work with the power source turned ON.)
Enforcement of safety training
-  **CAUTION** For teaching work, prepare a work plan related to the methods and procedures of operating the robot, and to the measures to be taken when an error occurs or when restarting. Carry out work following this plan. (This also applies to maintenance work with the power source turned ON.)
Preparation of work plan
-  **WARNING** Prepare a device that allows operation to be stopped immediately during teaching work. (This also applies to maintenance work with the power source turned ON.)
Setting of emergency stop switch
-  **CAUTION** During teaching work, place a sign indicating that teaching work is in progress on the start switch, etc. (This also applies to maintenance work with the power source turned ON.)
Indication of teaching work in progress
-  **DANGER** Provide a fence or enclosure during operation to prevent contact of the operator and robot.
Installation of safety fence
-  **CAUTION** Establish a set signaling method to the related operators for starting work, and follow this method.
Signaling of operation start
-  **CAUTION** As a principle turn the power OFF during maintenance work. Place a sign indicating that maintenance work is in progress on the start switch, etc.
Indication of maintenance work in progress
-  **CAUTION** Before starting work, inspect the robot, emergency stop switch and other related devices, etc., and confirm that there are no errors.
Inspection before starting work

The points of the precautions given in the separate "Safety Manual" are given below. Refer to the actual "Safety Manual" for details.

- ⚠ DANGER** When automatic operation of the robot is performed using multiple control devices (GOT, programmable controller, push-button switch), the interlocking of operation rights of the devices, etc. must be designed by the customer.
- ⚠ CAUTION** Use the robot within the environment given in the specifications. Failure to do so could lead to a drop or reliability or faults. (Temperature, humidity, atmosphere, noise environment, etc.)
- ⚠ CAUTION** Transport the robot with the designated transportation posture. Transporting the robot in a non-designated posture could lead to personal injuries or faults from dropping.
- ⚠ CAUTION** Always use the robot installed on a secure table. Use in an instable posture could lead to positional deviation and vibration.
- ⚠ CAUTION** Wire the cable as far away from noise sources as possible. If placed near a noise source, positional deviation or malfunction could occur.
- ⚠ CAUTION** Do not apply excessive force on the connector or excessively bend the cable. Failure to observe this could lead to contact defects or wire breakage.
- ⚠ CAUTION** Make sure that the workpiece weight, including the hand, does not exceed the rated load or tolerable torque. Exceeding these values could lead to alarms or faults.
- ⚠ WARNING** Securely install the hand and tool, and securely grasp the workpiece. Failure to observe this could lead to personal injuries or damage if the object comes off or flies off during operation.
- ⚠ WARNING** Securely ground the robot and controller. Failure to observe this could lead to malfunctioning by noise or to electric shock accidents.
- ⚠ CAUTION** Indicate the operation state during robot operation. Failure to indicate the state could lead to operators approaching the robot or to incorrect operation.
- ⚠ WARNING** When carrying out teaching work in the robot's movement range, always secure the priority right for the robot control. Failure to observe this could lead to personal injuries or damage if the robot is started with external commands.
- ⚠ CAUTION** Keep the jog speed as low as possible, and always watch the robot. Failure to do so could lead to interference with the workpiece or peripheral devices.
- ⚠ CAUTION** After editing the program, always confirm the operation with step operation before starting automatic operation. Failure to do so could lead to interference with peripheral devices because of programming mistakes, etc.
- ⚠ CAUTION** Make sure that if the safety fence entrance door is opened during automatic operation, the door is locked or that the robot will automatically stop. Failure to do so could lead to personal injuries.
- ⚠ CAUTION** Never carry out modifications based on personal judgments, or use non-designated maintenance parts. Failure to observe this could lead to faults or failures.

 **WARNING**

When the robot arm has to be moved by hand from an external area, do not place hands or fingers in the openings. Failure to observe this could lead to hands or fingers catching depending on the posture.

 **CAUTION**

Do not stop the robot or apply emergency stop by turning the robot controller's main power OFF. If the robot controller main power is turned OFF during automatic operation, the robot accuracy could be adversely affected. Moreover, it may interfere with the peripheral device by drop or move by inertia of the arm.

 **CAUTION**

Do not turn off the main power to the robot controller while rewriting the internal information of the robot controller such as the program or parameters. If the main power to the robot controller is turned off while in automatic operation or rewriting the program or parameters, the internal information of the robot controller may be damaged.

 **DANGER**

Do not connect the Handy GOT when using the GOT direct connection function of this product. Failure to observe this may result in property damage or bodily injury because the Handy GOT can automatically operate the robot regardless of whether the operation rights are enabled or not.

 **DANGER**

Do not remove the SSCNET III cable while power is supplied to the controller. Do not look directly at light emitted from the tip of SSCNET III connectors or SSCNET III cables. Eye discomfort may be felt if exposed to the light. (Reference: SSCNET III employs a Class 1 or equivalent light source as specified in JIS C 6802 and IEC60825-1 (domestic standards in Japan).)

 **DANGER**

Attach the cap to the SSCNET III connector after disconnecting the SSCNET III cable. If the cap is not attached, dirt or dust may adhere to the connector pins, resulting in deterioration connector properties, and leading to malfunction.

 **CAUTION**

Make sure there are no mistakes in the wiring. Connecting differently to the way specified in the manual can result in errors, such as the emergency stop not being released. In order to prevent errors occurring, please be sure to check that all functions (such as the teaching box emergency stop, customer emergency stop, and door switch) are working properly after the wiring setup is completed.

 **CAUTION**

Use the network equipments (personal computer, USB hub, LAN hub, etc) confirmed by manufacturer. The thing unsuitable for the FA environment (related with conformity, temperature or noise) exists in the equipments connected to USB. When using network equipment, measures against the noise, such as measures against EMI and the addition of the ferrite core, may be necessary. Please fully confirm the operation by customer. Guarantee and maintenance of the equipment on the market (usual office automation equipment) cannot be performed.

*CR751-D or CR751-Q controller
Notes of the basic component are shown.

⚠ CAUTION Please install the earth leakage breaker in the primary side supply power supply of the controller of CR751-D or CR751-Q because of leakage protection.

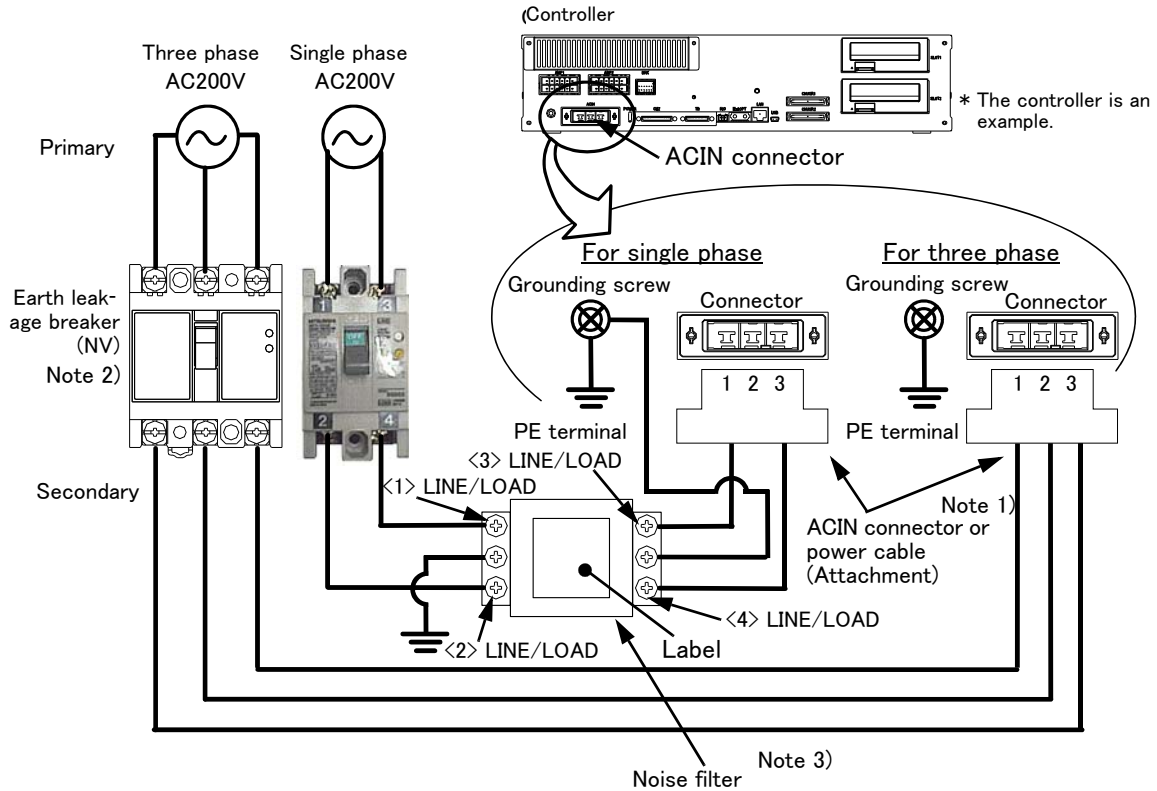

Note 1) Crimping swage is recommended for connecting the attachment ACIN connector (soldering is also possible)
Recommendation compression tools: 234171-1(Tyco Electronics)

Note 2) The earth leakage breaker is the customer preparation. Always use the cover below.
Recommendation:

For single primary power supply NV30FAU-2P-10A-AC100-240V-30mA, (Cover: TCS-05FA2)

For three primary power supply NV30FAU-3P-10A-AC100-240V-30mA, (Cover: TCS-05FA3)

Note 3) If necessary, as shown in the figure, connects the noise filter between ACIN terminal blocks and primary power supply.
(Recommended noise filter: SUP-EL20-ER6 *OKAYA ELECTRIC INDUSTRIES)

- 1) Please prepare the following: Leakage current breaker (with terminal cover), cable for connecting the primary power supply, cable for connecting the secondary power supply (both AWG #14 (2mm²)), cables to ground the primary power supply (AWG #12 (3.5mm² or above).
- 2) Confirm that the primary power matches the specifications.
- 3) Confirm that the primary power is OFF and that the earth leakage breaker power switch is OFF.
- 4) Connect the secondary power cable to secondary terminal (lower terminal) of earth leakage breaker. Connect the opposite side of this cable with following pin numbers of the ACIN connector attached.
For single phase: 1 and 3
For three phase: 1, 2, and 3
Recommends connection by the Solderless terminal.
Or, connect by the attachment power cable.
- 5) Connect this connector to the ACIN connector on the controller.
- 6) Connect the grounding cable to the PE terminal. (M4 screw)
- 7) Connect the primary power cable to the primary side terminal (upper terminal) of the earth leakage breaker.

⚠ CAUTION

Be careful of interference with peripheral equipment.

Especially don't give a shock to the shaft (J3 axis). When you install the hand, be careful not to knock at the shaft end by the hammer etc. The shaft may be damaged.

Take care also of the following items.

(1) The robot's locus of movement may change with specified speed.

Especially as for the corner section, short cut distance may change. Therefore, when beginning automatic operation, moves at low speed at first, and you should gather speed slowly with being careful of interference with peripheral equipment.

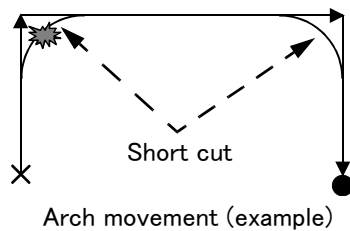

(2) It can be confirmed whether the specified position exist in the defined area by using the instruction command "Zone". It can utilize as one of the methods for collision evasion. Refer to the "detailed description of the instructions manual/function, and operation" of the separate volume for the details of the instruction command.

Revision history

Date of Point	Instruction Manual No.	Revision Details
2014-08-09	BFP-A3335	• First print

*Introduction

Thank you for purchasing the Mitsubishi industrial robot.

This instruction manual explains the method of unpacking, installation and maintenance and inspection of the robot arm.

Always read through this manual before starting use to ensure correct usage of the robot.

The information contained in this document has been written to be accurate as much as possible. Please interpret that items not described in this document "cannot be performed."

And, when maintenance and inspection of the robot, to access the arm and the base section is necessary. Please prepare the environment which can access the robot with the stepladder etc. in RH-3FHR.

This document explains for the following robot type.

Robot type · RH-1FHR series

- No part of this manual may be reproduced by any means or in any form, without prior consent from Mitsubishi.
- The details of this manual are subject to change without notice.
- The information contained in this document has been written to be accurate as much as possible. Please interpret that items not described in this document "cannot be performed." or "alarm may occur".
Please contact your nearest dealer if you find any doubtful, wrong or skipped point.
- This specifications is original.
- Company names and production names in this document are the trademarks or registered trademarks of their respective owners.

CONTENTS

	Page
1 Before starting use	1-1
1.1 Using the instruction manuals	1-1
1.1.1 The details of each instruction manuals	1-1
1.1.2 Symbols used in instruction manual	1-2
1.2 Safety Precautions	1-3
1.2.1 Precautions given in the separate Safety Manual	1-4
2 Unpacking to Installation	2-6
2.1 Confirming the product	2-6
2.2 Installation	2-7
2.2.1 Unpacking	2-7
2.2.2 Transportation procedures	2-8
(1) Transporting with a crane	2-8
(2) Transporting with a manual pallet jack	2-9
2.2.3 Installation procedures	2-10
2.2.4 Grounding procedures	2-12
(1) Grounding methods	2-12
(2) Grounding procedures	2-12
2.2.5 Connecting with the controller	2-13
(1) CR750 controller	2-13
(2) CR751 controller	2-15
2.2.6 Ethernet Cables	2-17
(1) No.2 arm	2-17
(2) Base area	2-18
2.2.7 Passing air hoses and cables through the shaft	2-20
(1) Specifications of internal air hoses and cables	2-20
(2) Customer prepared products	2-20
(3) Installation procedure	2-21
2.3 Setting the origin	2-23
2.3.1 Installing the teaching pendant (T/B)	2-23
(1) CR750 controller	2-23
(2) CR751 controller	2-24
2.3.2 Setting the origin with the origin data input method	2-25
(1) Confirming the origin data	2-25
(2) Turning ON the control power	2-25
(3) Preparing the T/B	2-26
(4) Selecting the origin setting method	2-27
(5) Inputting the origin data	2-28
(6) Installing the battery cover.	2-29
2.4 Confirming the operation	2-30
(1) JOINT jog operation	2-34
(2) XYZ jog operation	2-36
(3) TOOL jog operation	2-38
(4) 3-axis XYZ jog operation	2-40
(5) CYLINDER jog operation	2-42
(6) Work jog operation	2-44
3 Installing the option devices	3-51
3.1 Installing the solenoid valve set	3-51
(1) Hand number and solenoid valve ports (common to RH-FH series)	3-52
3.2 Installing the hand input cable	3-53
3.3 Installing the hand output cable	3-54
3.4 Hand internal wiring and piping set	3-55
(1) Installation procedure	3-55
3.5 External Wiring and Piping Box	3-58
3.6 Installing the vacuum valve set	3-61

CONTENTS

	Page
4 Basic operations	4-63
5 Maintenance and Inspection	5-64
5.1 Maintenance and inspection interval	5-64
5.2 Inspection items	5-65
5.2.1 Daily inspection items	5-65
5.2.2 Periodic inspection	5-66
5.3 Maintenance and inspection procedures	5-67
5.3.1 Robot arm structure	5-67
5.3.2 Installing/removing the cover	5-68
5.3.3 Packing Replacement Procedure	5-69
(1) Packing Replacement Instructions	5-69
5.3.4 Inspection, maintenance and replacement of timing belt	5-73
(1) Timing belt replacement period	5-73
(2) Inspecting/Adjusting the J3 axis timing belt	5-74
(3) Replacing the J3 axis timing belt	5-75
(4) Inspecting/Adjusting the J4 axis timing belt	5-78
(5) Timing belt tension	5-81
5.3.5 Replacing the bellows (Option)	5-82
5.3.6 Lubrication	5-83
(1) Lubrication position and specifications	5-83
(2) Lubrication method to the J1, J2 axis	5-84
(3) Lubrication method to the shaft	5-84
5.3.7 Replacing the backup battery	5-85
(1) Replacing the battery (robot arm)	5-86
5.4 About Overhaul	5-87
5.5 Maintenance parts	5-88
5.6 Resetting the origin	5-89
5.6.1 Mechanical stopper method	5-90
(1) J1 axis origin setting (mechanical stopper)	5-90
(2) J2 axis origin setting (mechanical stopper)	5-92
(3) J3 and J4 axis origin setting (mechanical stopper)	5-94
5.6.2 Jig method	5-97
(1) J1 axis origin setting	5-98
(2) J2 axis origin setting	5-100
(3) J3 and J4 axis origin setting	5-101
5.6.3 ABS origin method	5-102
(1) Select the T/B	5-103
5.6.4 User origin method	5-104
5.6.5 Recording the origin data	5-106
(1) Confirming the origin data label	5-106
(2) Confirming the origin data	5-106
(3) Recording the origin data	5-106
(4) Installing the battery cover	5-106
6 Appendix	Appendix-107
Appendix 1 : Configuration flag	Appendix-107

1 Before starting use

This chapter explains the details and usage methods of the instruction manuals, the basic terminology and the safety precautions. Moreover, handling and operation of a teaching pendant (T/B) are described based on R32TB (R33TB) in instruction manuals. If using other T/B, such as R56TB (R57TB), refer to a supplied instruction manual of the T/B.

1.1 Using the instruction manuals

1.1.1 The details of each instruction manuals

The contents and purposes of the documents enclosed with this product are shown below. Use these documents according to the application.



For special specifications, a separate instruction manual describing the special section may be enclosed.

Safety Manual	Explains the common precautions and safety measures to be taken for robot handling, system design and manufacture to ensure safety of the operators involved with the robot.
Special Specifications	Explains the product's standard specifications, factory-set special specifications, option configuration and maintenance parts, etc. Precautions for safety and technology, when incorporating the robot, are also explained.
Robot Arm Setup & Maintenance	Explains the procedures required to operate the robot arm (unpacking, transportation, installation, confirmation of operation), and the maintenance and inspection procedures.
Controller Setup, Basic Operation and Maintenance	Explains the procedures required to operate the controller (unpacking, transportation, installation, confirmation of operation), basic operation from creating the program to automatic operation, and the maintenance and inspection procedures.
Detailed Explanation of Functions and Operations	Explains details on the functions and operations such as each function and operation, commands used in the program, connection with the external input/output device, and parameters, etc.
Troubleshooting	Explains the causes and remedies to be taken when an error occurs. Explanations are given for each error No.
Additional axis function	Explains the specifications, functions and operations of the additional axis control.
Tracking Function Manual	Explains the control function and specifications of conveyor tracking
Extended Function Instruction Manual	Explains the detailed description of data configuration of shared memory, monitoring, and operating procedures, about the PLC(CR750-Q/CR751-Q controller) and the GOT(CR750-D/CR751-D controller).

1.1.2 Symbols used in instruction manual

The symbols and expressions shown in [Table 1-1](#) are used throughout this instruction manual. Learn the meaning of these symbols before reading this instruction manual.

Table 1-1: Symbols in instruction manual

Terminology	Item/Symbol	Meaning
Item	iQ Platform	
	Controller	Indicates the controller which controls the robot arm. It consists of the robot CPU system and the drive unit.
	The robot CPU unit or robot CPU	Indicates the CPU unit for the robots which installed to the sequencer base unit (Q3 □ DB) of MELSEC-Q series. It is connected with the drive unit by the dedicated cable.
	The robot CPU system	Multi-CPU system. It consists of MELSEC units, such as the sequencer base unit, the sequencer CPU unit, and the robot CPU unit, etc.
	Drive unit	Indicates the box which mounts the servo amplifier for robot, and the safety circuit, etc.
Item	Stand-alone type	
	Controller	Indicates the box which arranged control parts, such as robot CPU, servo amplifier, and the safety circuit.
Symbol	 DANGER	Precaution indicating cases where there is a risk of operator fatality or serious injury if handling is mistaken. Always observe these precautions to safely use the robot.
	 WARNING	Precaution indicating cases where the operator could be subject to fatalities or serious injuries if handling is mistaken. Always observe these precautions to safely use the robot.
	 CAUTION	Precaution indicating cases where operator could be subject to injury or physical damage could occur if handling is mistaken. Always observe these precautions to safely use the robot.
	[JOG]	If a word is enclosed in brackets or a box in the text, this refers to a key on the teaching pendant.
	[RESET] + [EXE] (A) (B)	This indicates to press the (B) key while holding down the (A) key. In this example, the [RESET] key is pressed while holding down the [EXE] key.
	T/B	This indicates the teaching pendant.
	O/P	Indicates the operating panel on the front of controller or drive unit for the controller which installed the operating panel
	CR751 (Thin type) CR751 (Heavy type)	There are two kinds of CR751 controller; one is "Thin type" (the height is 98mm) and the other is "Heavy type" (the height is 174mm), each of which are different in height. Thin type: CR751-03HD/Q, CR751-06HD/Q, CR751-12HD/Q, CR751-20HD/Q, CR751-03HRD/Q, CR751-02VD/Q, CR751-04VD/Q, CR751-04VJD/Q, CR751-07VD/Q. Heavy type: CR751-13VD/Q, CR751-20VD/Q, CR751-07VLD/Q. * Refer to separate Standard Specifications Manual for the outside dimension of CR751 controller.

1.2 Safety Precautions

Always read the following precautions and the separate "Safety Manual" before starting use of the robot to learn the required measures to be taken.

⚠ CAUTION All teaching work must be carried out by an operator who has received special training. (This also applies to maintenance work with the power source turned ON.)
Enforcement of safety training

⚠ CAUTION For teaching work, prepare a work plan related to the methods and procedures of operating the robot, and to the measures to be taken when an error occurs or when restarting. Carry out work following this plan. (This also applies to maintenance work with the power source turned ON.)
Preparation of work plan

⚠ WARNING Prepare a device that allows operation to be stopped immediately during teaching work. (This also applies to maintenance work with the power source turned ON.)
Setting of emergency stop switch

⚠ CAUTION During teaching work, place a sign indicating that teaching work is in progress on the start switch, etc. (This also applies to maintenance work with the power source turned ON.)
Indication of teaching work in progress

⚠ DANGER Provide a fence or enclosure during operation to prevent contact of the operator and robot.
Installation of safety fence

⚠ CAUTION Establish a set signaling method to the related operators for starting work, and follow this method.
Signaling of operation start

⚠ CAUTION As a principle turn the power OFF during maintenance work. Place a sign indicating that maintenance work is in progress on the start switch, etc.
Indication of maintenance work in progress

⚠ CAUTION Before starting work, inspect the robot, emergency stop switch and other related devices, etc., and confirm that there are no errors.
Inspection before starting work

1.2.1 Precautions given in the separate Safety Manual

The points of the precautions given in the separate "Safety Manual" are given below. Refer to the actual "Safety Manual" for details.

DANGER

When automatic operation of the robot is performed using multiple control devices (GOT, programmable controller, push-button switch), the interlocking of operation rights of the devices, etc. must be designed by the customer.

CAUTION

Use the robot within the environment given in the specifications. Failure to do so could lead to a drop or reliability or faults. (Temperature, humidity, atmosphere, noise environment, etc.)

CAUTION

Transport the robot with the designated transportation posture. Transporting the robot in a non-designated posture could lead to personal injuries or faults from dropping.

CAUTION

Always use the robot installed on a secure table. Use in an instable posture could lead to positional deviation and vibration.

CAUTION

Wire the cable as far away from noise sources as possible. If placed near a noise source, positional deviation or malfunction could occur.

CAUTION

Do not apply excessive force on the connector or excessively bend the cable. Failure to observe this could lead to contact defects or wire breakage.

CAUTION

Make sure that the workpiece weight, including the hand, does not exceed the rated load or tolerable torque. Exceeding these values could lead to alarms or faults.

WARNING

Securely install the hand and tool, and securely grasp the workpiece. Failure to observe this could lead to personal injuries or damage if the object comes off or flies off during operation.

WARNING

Securely ground the robot and controller. Failure to observe this could lead to malfunctioning by noise or to electric shock accidents.

CAUTION

Indicate the operation state during robot operation. Failure to indicate the state could lead to operators approaching the robot or to incorrect operation.

WARNING

When carrying out teaching work in the robot's movement range, always secure the priority right for the robot control. Failure to observe this could lead to personal injuries or damage if the robot is started with external commands.

CAUTION

Keep the jog speed as low as possible, and always watch the robot. Failure to do so could lead to interference with the workpiece or peripheral devices.

CAUTION

After editing the program, always confirm the operation with step operation before starting automatic operation. Failure to do so could lead to interference with peripheral devices because of programming mistakes, etc.

CAUTION

Make sure that if the safety fence entrance door is opened during automatic operation, the door is locked or that the robot will automatically stop. Failure to do so could lead to personal injuries.

CAUTION

Never carry out modifications based on personal judgments, or use non-designated maintenance parts. Failure to observe this could lead to faults or failures.

WARNING

When the robot arm has to be moved by hand from an external area, do not place hands or fingers in the openings. Failure to observe this could lead to hands or fingers catching depending on the posture.

⚠ CAUTION

Do not stop the robot or apply emergency stop by turning the robot controller's main power OFF.
If the robot controller main power is turned OFF during automatic operation, the robot accuracy could be adversely affected.

⚠ CAUTION

Do not turn off the main power to the robot controller while rewriting the internal information of the robot controller such as the program or parameters. If the main power to the robot controller is turned off while in automatic operation or rewriting the program or parameters, the internal information of the robot controller may be damaged.

⚠ CAUTION

Do not connect the Handy GOT when using the GOT direct connection function of this product. Failure to observe this may result in property damage or bodily injury because the Handy GOT can automatically operate the robot regardless of whether the operation rights are enabled or not.

⚠ DANGER

Do not connect the Handy GOT to a programmable controller when using an iQ Platform compatible product with the CR750-Q/CR751-Q controller. Failure to observe this may result in property damage or bodily injury because the Handy GOT can automatically operate the robot regardless of whether the operation rights are enabled or not.

⚠ DANGER

Do not remove the SSCNET III cable while power is supplied to the multiple CPU system or the servo amplifier. Do not look directly at light emitted from the tip of SSCNET III connectors or SSCNET III cables of the Motion CPU or the servo amplifier. Eye discomfort may be felt if exposed to the light. (Reference: SSCNET III employs a Class 1 or equivalent light source as specified in JIS C 6802 and IEC60825-1 (domestic standards in Japan).)

⚠ DANGER

Do not remove the SSCNET III cable while power is supplied to the controller. Do not look directly at light emitted from the tip of SSCNET III connectors or SSCNET III cables. Eye discomfort may be felt if exposed to the light. (Reference: SSCNET III employs a Class 1 or equivalent light source as specified in JIS C 6802 and IEC60825-1 (domestic standards in Japan).)

⚠ DANGER

Attach the cap to the SSCNET III connector after disconnecting the SSCNET III cable. If the cap is not attached, dirt or dust may adhere to the connector pins, resulting in deterioration connector properties, and leading to malfunction.

⚠ CAUTION

Make sure there are no mistakes in the wiring. Connecting differently to the way specified in the manual can result in failures, such as the emergency stop not being released. In order to prevent from occurring, please be sure to check that all functions (such as the teaching box emergency stop, customer emergency stop, and door switch) are working properly after the wiring setup is completed

⚠ CAUTION

Use the network equipments (personal computer, USB hub, LAN hub, etc) confirmed by manufacturer. The thing unsuitable for the FA environment (related with conformity, temperature or noise) exists in the equipments connected to USB. When using network equipment, measures against the noise, such as measures against EMI and the addition of the ferrite core, may be necessary. Please fully confirm the operation by customer. Guarantee and maintenance of the equipment on the market (usual office automation equipment) cannot be performed.

2 Unpacking to Installation

2.1 Confirming the product

The standard configuration of the robot arm, part of the purchased product, is shown in [Table 2-1](#).

Confirm the parts.

Users who have purchased optional products should refer to the separate "Special Specifications".

Table 2-1 : Standard configuration

No.	Part name	Type	Qty.	Remarks
1	Robot arm	RH-1FHR series	1 unit	
2	Guarantee card		1 copy	
3	Installation bolts	M12 x 45	4 pcs.	For robot arm installation
4	Spring washer for installation bolts	For M12	4 pcs.	
5	Plain washer for installation bolts	For M12	4 pcs.	
6	Fixing plate		1 set	For robot arm transportation
7	Fixing plate installation bolt		1 set	
8	Transportation tool		1 set	
9	Transportation tool installation bolt		1 set	

2.2 Installation

2.2.1 Unpacking

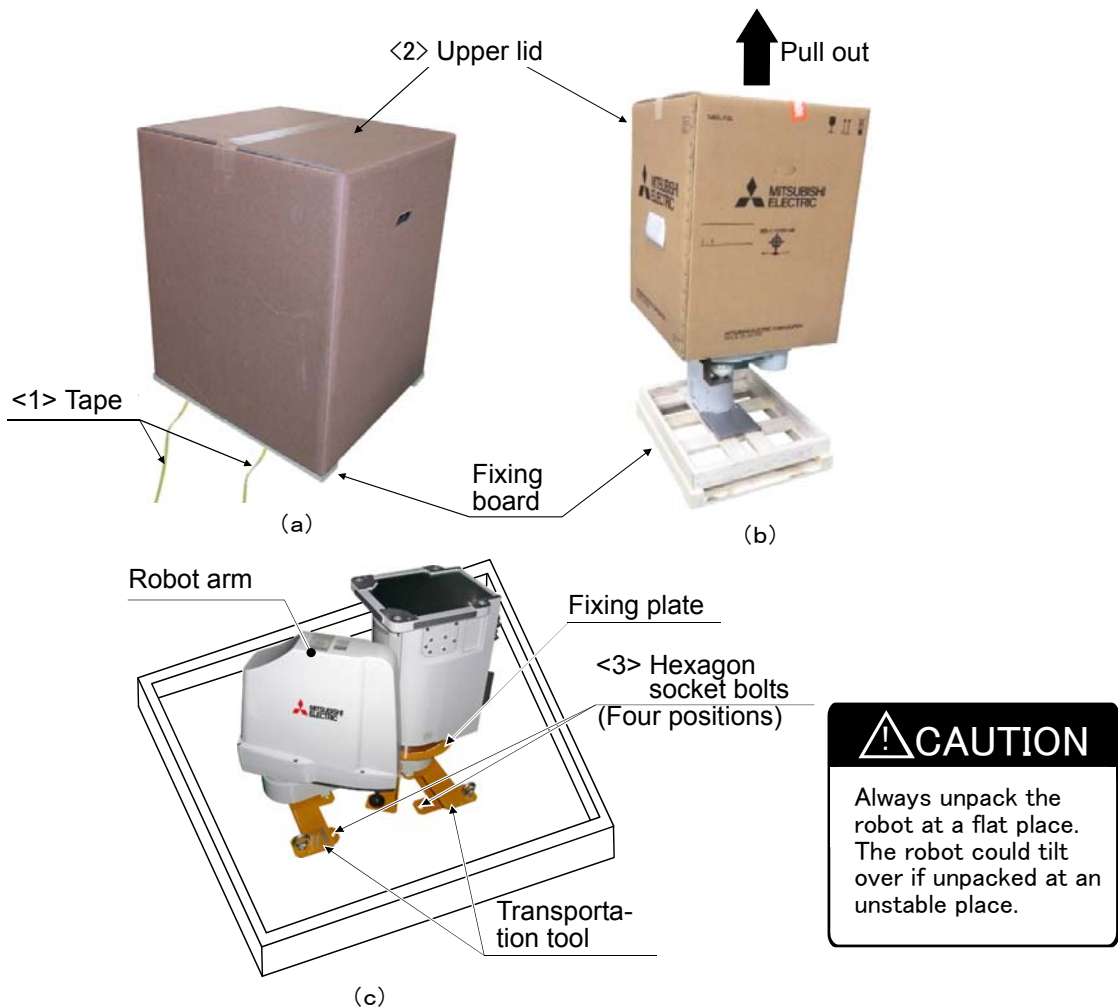

Fig.2-1 : Unpacking the robot arm

The robot is shipped from the factory in cardboard and plywood frame packing. Always refer to Fig. 2-1 and unpack the robot.

Handle the robot arm according to "2.2.2 Transportation procedures".

CAUTION Always unpack the robot at a flat place. The robot could tilt over if unpacked at an unstable place.

The unpacking process is shown below.

- 1) Using a knife, etc., slit the tape <1> fixing the upper lid <2> of the cardboard box. (Fig. 2-1 (a))
- 2) Pull the upper lid <2> of the cardboard box off with both hands. (Fig. 2-1 (b))
- 3) Remove the hexagon socket bolts <3> (four positions) which fix the robot. (Fig. 2-1 (c))

This completes the unpacking.

Note) The robot must be transported without removing the fixing plate. Remove after installing.

CAUTION When repackaging the robot in the wooden frame, always use the fixing plate.

2.2.2 Transportation procedures

(1) Transporting with a crane

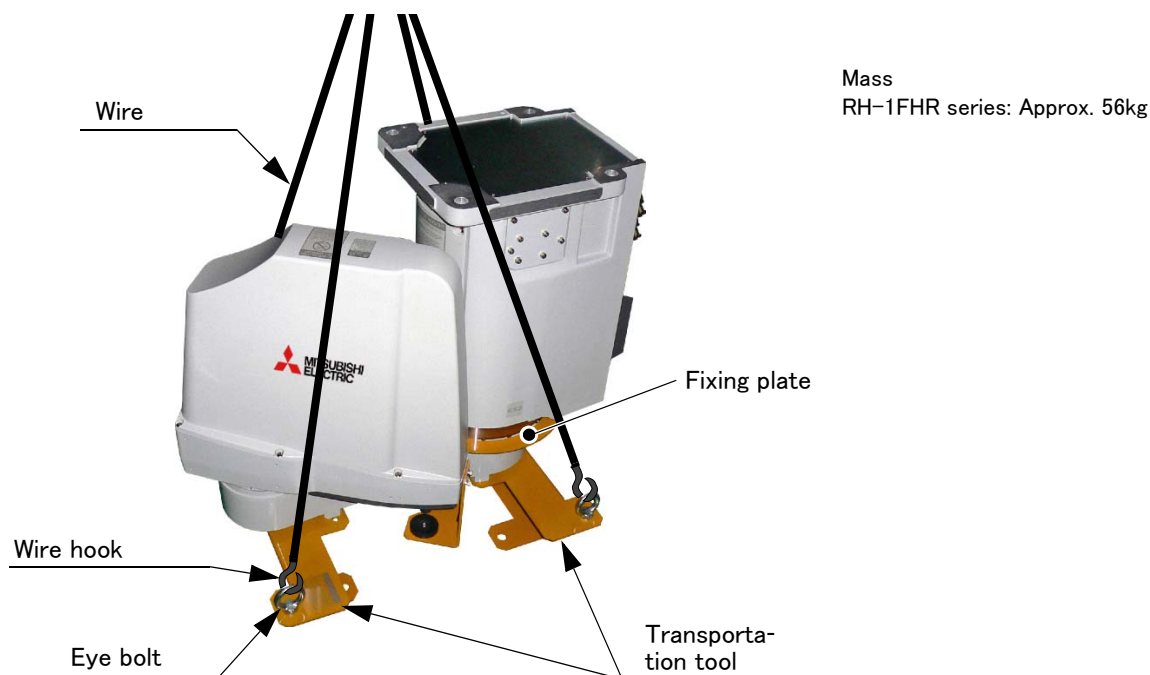

Fig.2-2 : Transportation of robot arm

- 1) Hook the wires to each of the four eyebolts attached to the transportation tool. (Make sure the bolts are securely hooked.)
- 2) Lift with a crane to transport the robot to the designated location.
- 3) At this time, make sure that the wires, etc., do not interfere with the robot arm or the covers. Always place the cloth, etc., at interfering places.
- 4) Be careful not to subject the robot to physical shock during transport.
- 5) After installing the robot (refer to [Page 10, "2.2.3 Installation procedures"](#)), remove the wires, the wire hooks, transportation tool and fixing plate.
- 6) Always follow the above procedures and methods to transport the robot for secondary transportation, such as when changing the installation position.

If the arm is directly suspended without using the specified transportation tool, or if it is suspended in the work posture, the configuration devices could be damaged, and the transportation workers will be subject to risk due to an inadequate center of gravity position.

CAUTION When transporting a robot, always attach four wires.

CAUTION To reattach the fixing plate again, set the axes of the robot to the positions according to [Table 2-2](#).

CAUTION The robot should keep vertical. (not be horizontal)
It becomes the cause of the grease leakage or the trouble.

(2) Transporting with a manual pallet jack



Fig.2-3 : Transportation of robot arm

- 1) Insert the forks of a manual pallet jack surely into the fork insertion segment of the transportation tool.
- 2) Lift up the robot with a manual pallet jack to transport it to the designated location.
- 3) Be careful not to subject the robot to physical shock during transport.
- 4) After installing the robot (refer to [Page 10, "2.2.3 Installation procedures"](#)), pull out the forks and remove the transportation tool and fixing plate.
- 5) Always follow the above procedures and methods to transport the robot for secondary transportation, such as when changing the installation position.

If the arm is directly lift up without using the specified transportation tool, or if it is lifted up in the work posture, the configuration devices could be damaged, and the transportation workers will be subject to risk due to an inadequate center of gravity position.

CAUTION

To reattach the fixing plate again, set the axes of the robot to the positions according to [Table 2-2](#).

CAUTION

The robot should keep vertical. (not be horizontal)
It becomes the cause of the grease leakage or the trouble.

Table 2-2 : Transportation posture

Axis	Posture
J1	0°
J2	145°
J3	-480mm
J4	Not fixed

2.2.3 Installation procedures

The installation procedure of the robot arm is shown below.

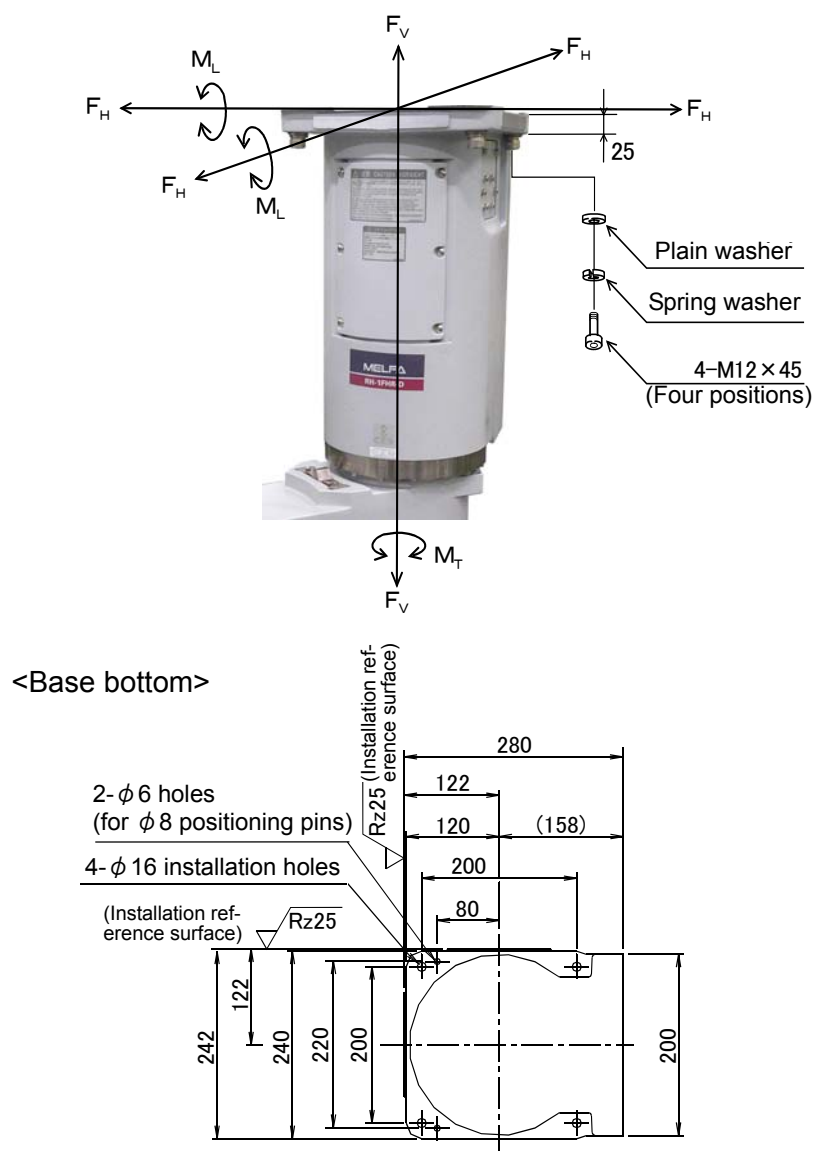

Fig.2-4 : Installation dimensions

- 1) The robot installation surface has been machine finished. Use the installation holes (4- ϕ 16 holes) opened at the four corners of the base, and securely fix the robot with the enclosed installation bolts (hexagon socket bolts).
- 2) Install the robot on a level surface.
- 3) It is recommended that the surface roughness of the table onto which the robot is to be installed by Rz25 or more. If the installation surface is rough, the contact with the table will be poor, and positional deviation could occur when the robot moves.
- 4) When installing, use a common table to prevent the position of the devices and jigs subject to robot work from deviating.
- 5) The installation surface must have sufficient strength to withstand the arm reaction during operation, and resistance against deformation and vibration caused by the static (dynamic) load of the robot arm and peripheral devices, etc.
- 6) After installing the robot, remove the fixing plate and transportation tool.
- 7) If you operate the robot at a high speed, reaction forces are applied to the installation stand by the robot's operation. Make sure that the installation stand on which the robot is placed has sufficient strength and rigidity. Table 2-3 shows the maximum reaction force (design values) that may be applied to an installation stand. Please use these values as reference when designing the installation stand.

Table 2-3 : Magnitude of each reaction force

	Unit	Value
Tilt moment : M_L	N · m	610
Torsional moment : M_T	N · m	807
Horizontal direction translation force : F_H	N	1,575
Vertical direction translation force : F_V	N	712

⚠ CAUTION

When installing the robot, secure following space.

- Connection space for connecting machine cables behind the robot.
- Maintenance space for replacing the batteries in front of the robot.
- Maintenance space for removing No.2 arm cover above the robot.

And don't install the robot arm in the position where direct rays or the heat of lighting hits. The skin temperature of the robot arm may rise, and the error may occur.

⚠ CAUTION

When leading machine cables, fix cables in the position near connectors as much as possible not to apply excessive force or the cable's weight on the connectors.

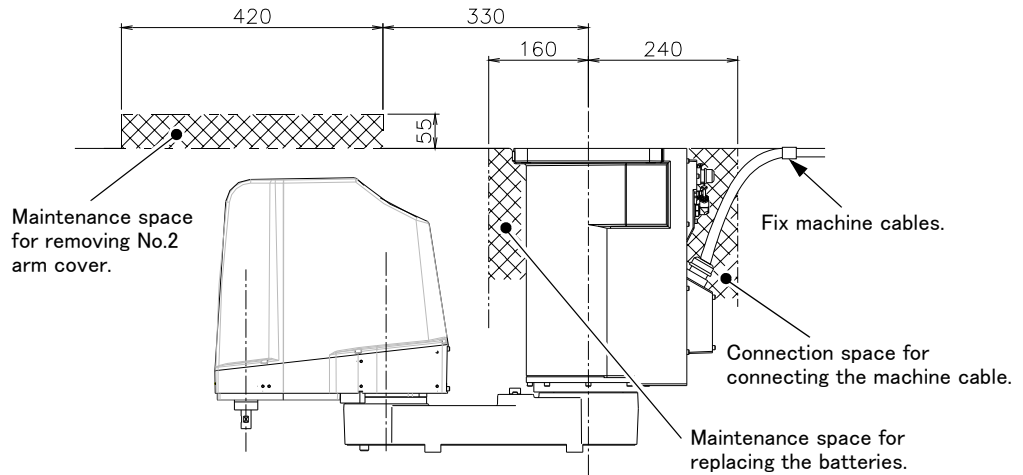

⚠ CAUTION

This robot is hanging installation type. Do not put the robot in an inverted position. It may cause oil leakage or faults.

2.2.4 Grounding procedures

(1) Grounding methods

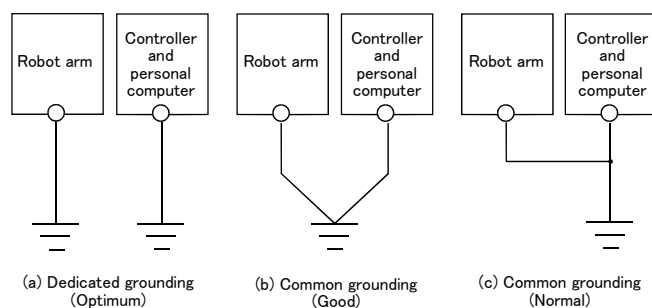

Fig.2-5 : Grounding methods

(2) Grounding procedures

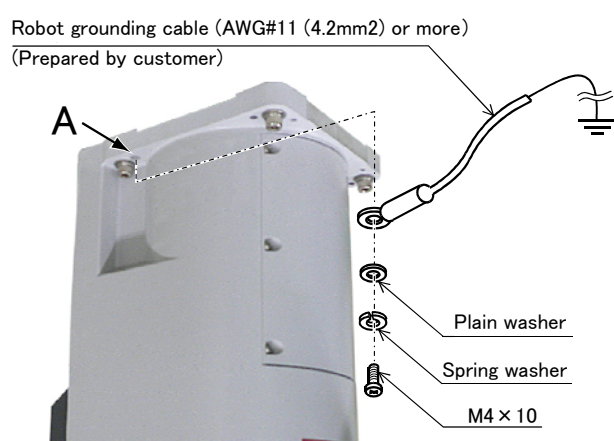
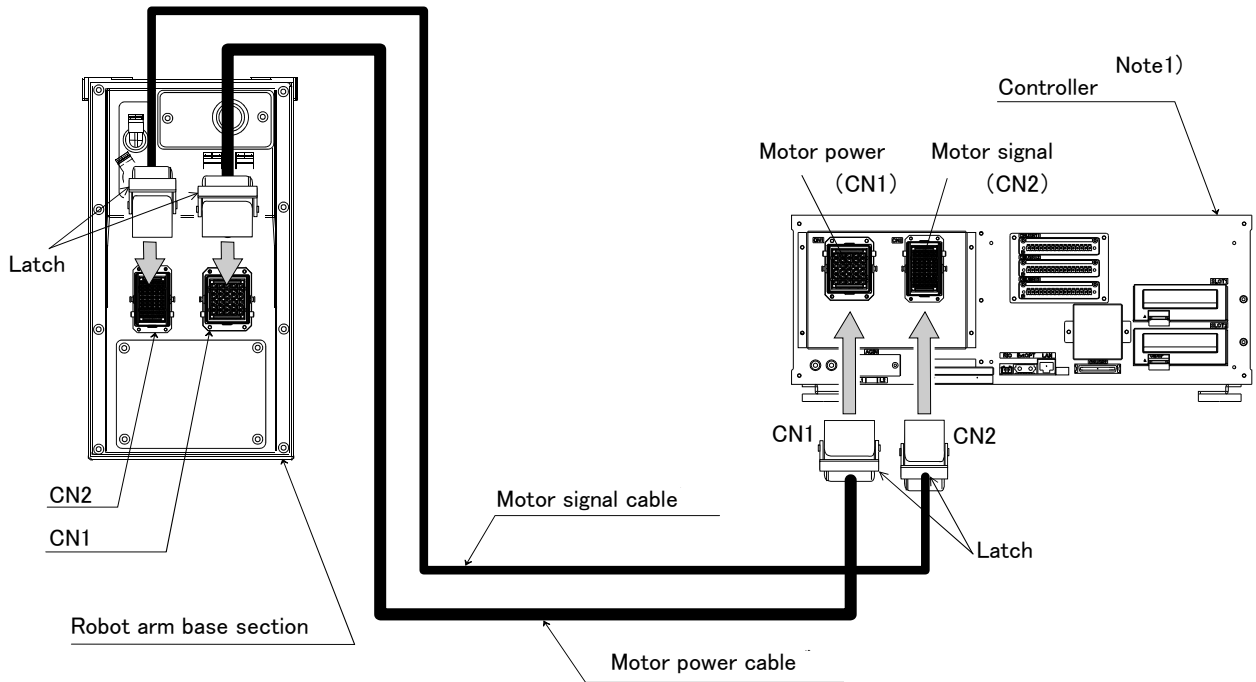

Fig.2-6 : Connecting the grounding cable

- 1) There are three grounding methods as shown in Fig. 2-5, but the dedicated grounding (Fig. 2-5 (a)) should be used for the robot arm and controller when possible. (Refer to the separate "Controller Setup, Basic Operation and Maintenance" for details on the controller grounding.)
- 2) Use Class D grounding (grounding resistance 100 Ω or less). Dedicated grounding separated from the other devices should be used.
- 3) Use a AWG#11(4.2mm²) or more stranded wire for the grounding wire. The grounding point should be as close to the robot arm and controller as possible, and the length of the grounding wire should be short.

- 1) Prepare the grounding cable (AWG#11(4.2mm²) or more) and robot side installation screw and washer.
- 2) If there is rust or paint on the grounding screw section (A), remove it with a file, etc.
- 3) Connect the grounding cable to the grounding screw section.

2.2.5 Connecting with the controller
 (1) CR750 controller



Note 1) Although the picture is the CR750-D controller, also the connection method is the same in the CR750-Q controller

Fig.2-7 : Connecting the machine cables

Carry out the following procedure after installing the controller referring to the separate "Controller Setup, Basic Operation and Maintenance" manual.

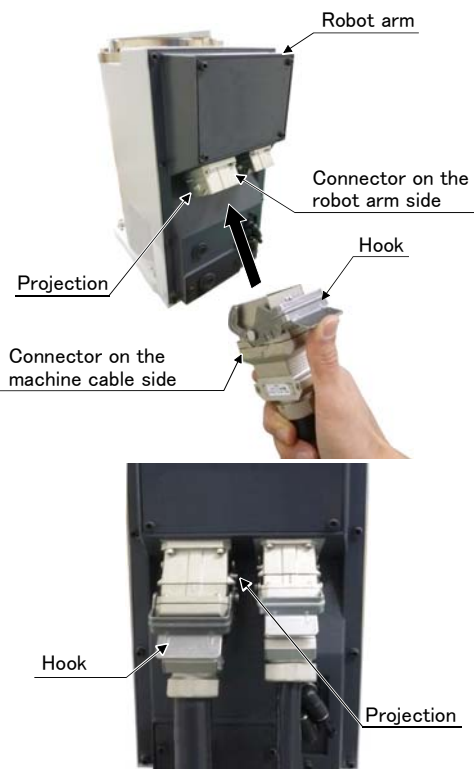

- 1) Make sure that the power switch on the front of the controller is turned OFF.
- 2) Connect the machine cable to its corresponding connector on the robot arm side.

- 3) After connecting the connector, insert the hook attached to the connector on the machine cable side to the rear of the projection of the robot arm connector to fix securely in place.

CAUTION Be careful not to get your hand pinched.

This complete the connection of machine cable.

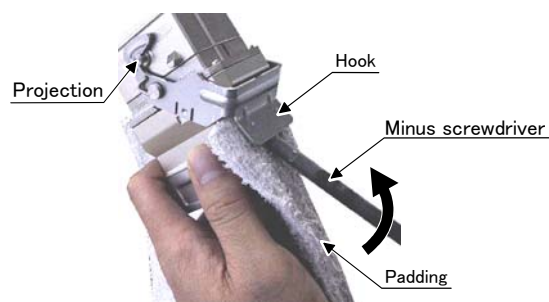

To remove the cable, insert a minus screwdriver into the hook while padding with a cloth, and remove the cable by lifting the hook.

CAUTION

When installing or removing the connector, to the connector of the other party in parallel, install or remove. If load strong against one side is applied, the connector pin may be damaged and it may not be connected securely.

CAUTION

The machine cable connectors are dedicated for the controller side and robot arm side, so take special care when connecting.

If connected incorrectly, the connector pins could bend or break. Thus, even if connected correctly, the robot will not operate correctly, creating a dangerous situation.

CAUTION

Take special care to the leading of the connection cable. If the cable is pulled with force or bent excessively, wires could break or the connector could be damaged.

CAUTION

Connect the machine cable at the place without the effect of the dust or oil mist. Please keep the dust and oil mist from being applied to of the robot-arm connector section, in the condition that the machine cable is removed. Since it becomes the cause of failure.

CAUTION

Please be careful not to catch the hand at installation and removal.

(2) CR751 controller

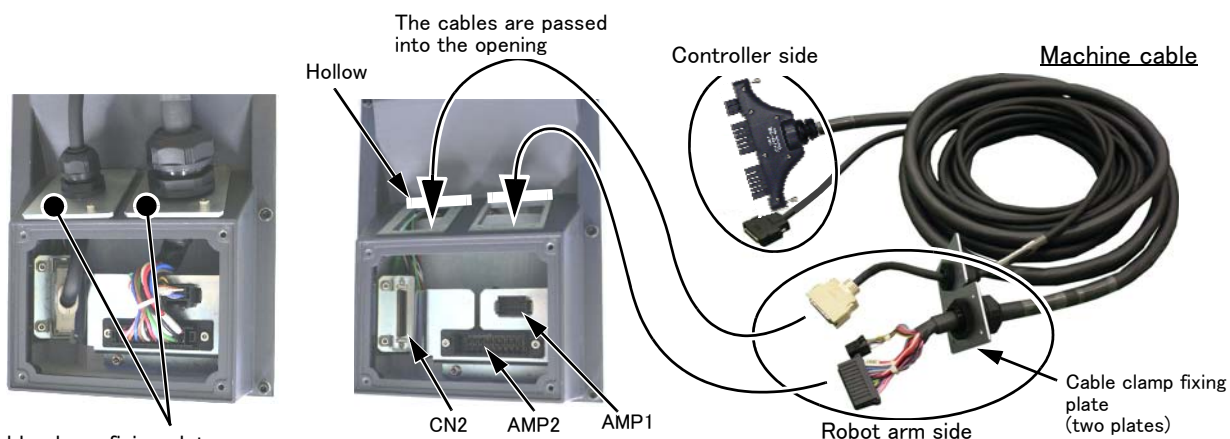
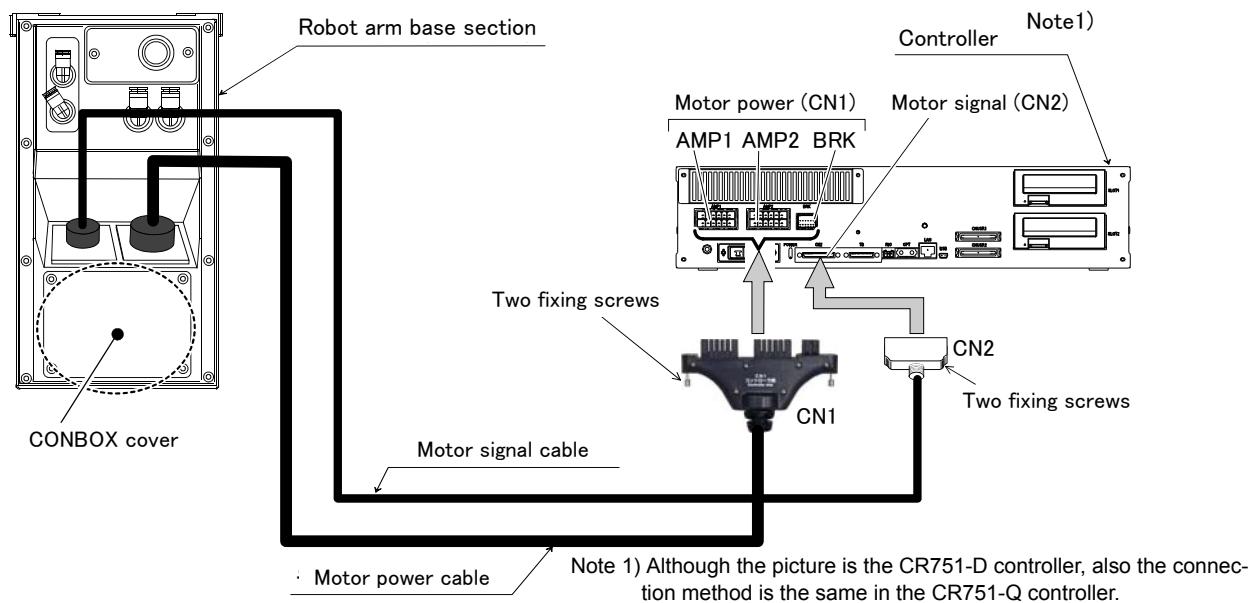

Cable clamp fixing plate

The each boards are fixed in the condition of having been inserted in the hollow.

Fig.2-8 : Connecting the machine cables

Install a controller while referring to "Installation procedures" in the separate "Controller setup, basic operation, and maintenance" manual and attach a cable fixation plate referring to "Attachments installation procedures". Then connect a robot arm and controller with machine cables. The procedure of connecting the machine cable is shown below.

- 1) Make sure that the power switch of the controller is turned OFF.
- 2) Connect the machine cable to its corresponding connector on the robot arm side.
 - a) Refer to [Page 68](#), "5.3.2 Installing/removing the cover", and remove the CONBOX cover.
 - b) Feed the connector of robot side to the opening on the back of the robot base.
 - c) Insert the cable clamp fixing plate attached to the machine cable into the hollow just under the opening. Fixing the plate by two screws securely under the condition that the plates inserted into the hollow.
 - d) Connect the machine cable to its corresponding connector on the robot arm side. Connect the connector (AMP1, AMP2, CN2) securely.
 - e) Install the CONBOX cover securely as before.
- 3) Connects the machine cable to the corresponding connector of the controller. Connects the connector CN1 (AMP1, AMP2, BRK) and CN2 surely. Fix CN2 connector by tightening two screws. Tighten the fixing screw of CN2 by 0.06-0.07 Nm.

This completes connecting the machine cables.



CAUTION

The machine cable connectors are dedicated for the controller side and robot arm side, so take special care when connecting. If connected incorrectly, the connector pins could bend or break. Thus, even if connected correctly, the robot will not operate correctly, creating a dangerous situation.



CAUTION

Take special care to the leading of the connection cable. If the cable is pulled with force or bent excessively, wires could break or the connector could be damaged. In order to prevent a breaking of cables and a damage of connectors, always use the controller after installing the attachment cable fixation plate.



CAUTION

Connect the machine cable at the place without the effect of the dust or oil mist. Please keep the dust and oil mist from being applied to of the robot-arm connector section, in the condition that the machine cable is removed. Since it becomes the cause of failure.



CAUTION

Please be careful not to catch the hand at installation and removal.

2.2.6 Ethernet Cables

Ethernet cables (4 pairs, totaling 8 lines, of AWG#26 (0.13mm²) cabtyre cables) are installed within the robot arm from the base unit up to the No. 2 arm, and can be used.

LAN connectors are mounted to both ends of the cables, and can therefore be used to connect to LAN connection devices. Users may also remove the LAN connectors, replace them with their own connectors, and use them as spare wiring by connecting them to user supplied cables.

Further, when passing through the inside of the shaft and using, please use the optional hand internal wiring and piping set in order to prevent the cable disconnection. (Re-cover the connector of the hand input cable that is attached to this option before using)

(1) No.2 arm

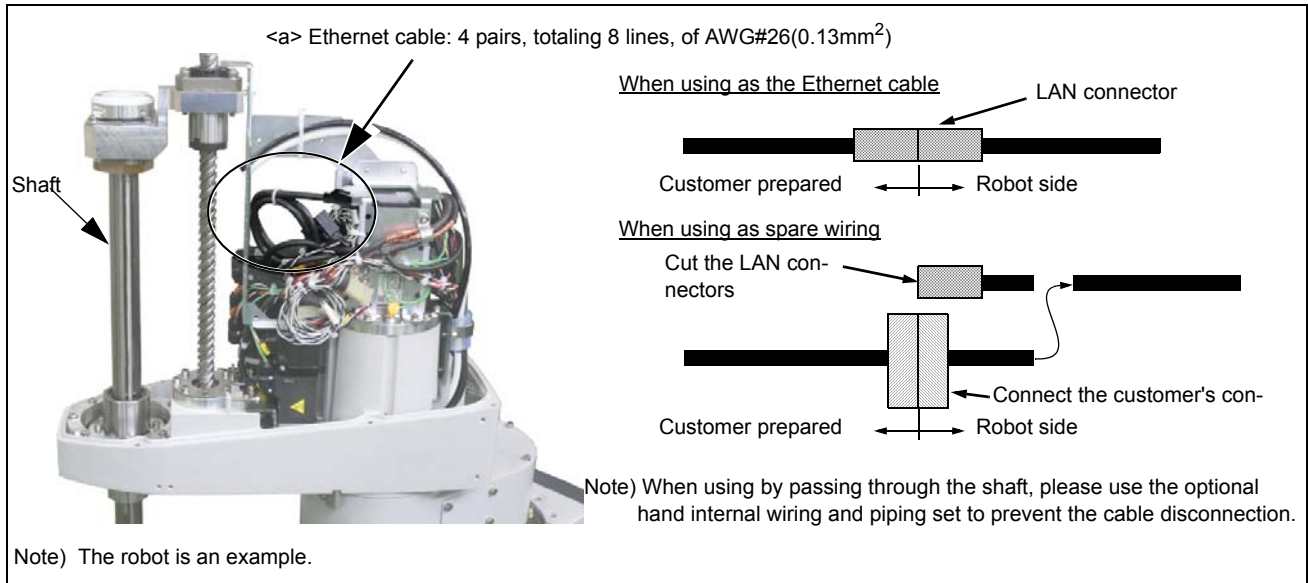

Fig.2-9 : Pulling out the Ethernet cable

How to connect the Ethernet cable is shown below.

- 1) Remove the screws used to fix the No. 2 arm cover U, and then remove the No. 2 arm cover U.
- 2) Ethernet cables are located in the positions shown in Fig. 2-9 <a> (coiled and stored).
- 3) Remove the tying band used to coil the Ethernet cable.
- 4) Connect the cable on the customer supplied tool.
(When using as spare wiring please remove the LAN connectors and replace with customer's connector)
- 5) It is possible to use the optional hand internal wiring and piping set to feed the tool cable through the inside of the shaft.
Replace the connector of the hand input cable that is attached to the hand wiring and piping set, and then connect. Please reference Page 55, "3.4 Hand internal wiring and piping set".
- 6) After the optional hand wiring and piping set has been installed, install the No. 2 arm cover U to its original position. When installing the cover please take care not to damage the spongy sealant material.

This completed connection of the Ethernet cables on the No. 2 arm.

⚠ CAUTION

When installing the No. 2 arm cover U to its original position please take care not to trap any cables or air hoses. If the cables/hoses are trapped when fixing the cover then cables may be disconnected or hoses punctured, leading to the robot and air driving devices to not operate properly. The sealing property of the packing may also

become seriously impaired and there is a risk that the specified level of product protection may not be achievable.

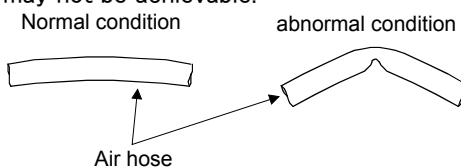

⚠ CAUTION

When fixing the cable, please keep too much load from being applied to the cables. If too much load is applied, they may break when the robot moves.

⚠ CAUTION

When operating the robot, friction may result in dust being generated from the tip of the shaft.

When an optional bellows set has been installed to the robot and then required cleanliness, be sure to seal the shaft tip with a gasket. If this is not done there is a risk that the level of cleanliness will be reduced.

(2) Base area

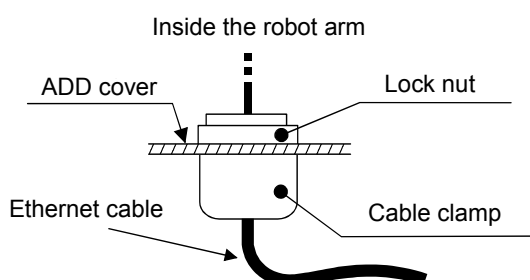
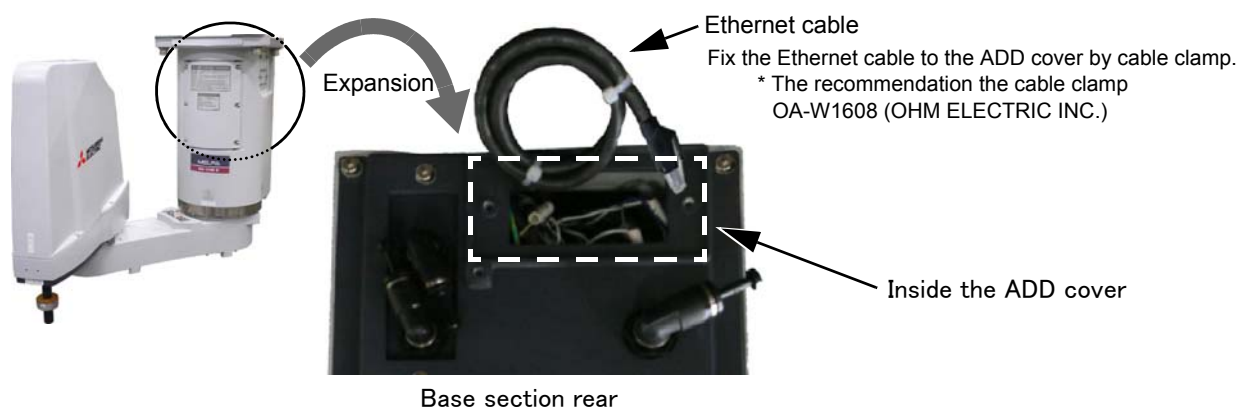

[Note]: Measures against the noise

If the communication error considered to originate by the noise occurs, specify and remove the noise source. And, implement the measures against the noise by grounding of the Ethernet cable, and the addition of the ferrite core if needed.

The recommendation the ferrite core

Type: E04SR301334 (SEIWA ELECTRIC MFG. CO., LTD.)

Fig.2-10 : Pull out the Ethernet cable (Base side)

- 1) Loosen the two screws and remove the ADD cover located at the back of the robot base.
- 2) Pull out the Ethernet cable that is stored inside the cover (coiled and stored).
- 3) Remove the cable tie of Ethernet cable.
- 4) Remove the lock nut attached to the cable clamp (customer prepared) and pass through the Ethernet cable
- 5) Remove the grommet of ADD cover. After removing the grommet please remove the sealant material that remains in the hole in the plate.
- 6) Feed the Ethernet cable through the hole that was created by removing the grommet.
- 7) Feed the end of the Ethernet cable through the cable clamp and securely fasten the ADD cover with the lock nut.
- 8) Install the ADD cover in its original position. When installing the cover please take care not to damage the spongy sealing material stuck to the hole.

This completed pull out the Ethernet cables of the base section.

 CAUTION

Take care against applying big force to the Ethernet cable, other cables, and the air hose.

 CAUTION

Please confirm not having broken or not having stripped the packing when installing or removing the cover. Contact to the dealer. Failure will be caused if the robot is used under the condition that the packing is broken or stripped, because oil mist etc. will invade in the arm.

 CAUTION

When ADD cover is installed, please keep too much load from being applied to the cables and the air hoses. If too much load is applied, the cable will be broken and the hose is bent, therefore robot and pneumatic drive equipment cannot operate normally.

 CAUTION

When ADD cover is installed, catch neither the cable nor the air hose. If the bolt is tightened while it had been caught, the cable will be broken and the hose is bent, and the robot and pneumatic drive equipment cannot operate normally. Moreover, packing does not stick securely and protection specification cannot be secured.

2.2.7 Passing air hoses and cables through the shaft

For this robot, customer prepared air hoses and cables can be pulled out from the No. 2 arm by passing through the shaft. For how to pass air hoses and cables through the shaft, refer to the following.

(1) Specifications of internal air hoses and cables

Use the air hoses and the cables, which have flexibility, capability of being repeatedly bent and twisted, and high wear resistance, for the internal use.

Select the air hose and the cable according to the specifications shown in [Table 2-4](#).

Table 2-4 : Specifications of internal air hoses and cables

Model	Shaft inside diameter	Space factor (recommended)	Highest speed of J3 axis	Minimum R of bending	Operating angle of J4 axis
RH-1FHR	φ 11mm	50% or less	1,100mm/sec	20mm	±360deg

(2) Customer prepared products

[Table 2-5](#) shows the necessary products for passing air hoses and cables through the shaft. The user needs to prepare the products.

Table 2-5 : Customer prepared products

Name	Qty.	Usage and recommended product
Expanding sleeve	Moderate quantity	Protecting the air hoses and cables, and improving the twisting rigidity Recommended expanding sleeve: EXP-13-PT (manufactured by Kitagawa Industries Co., Ltd.)
Cushion rubber	Moderate quantity	Protecting the bent portion and the fixed portion of the twisted end. Recommended cushion rubber: silicon rubber, thickness of 1mm, dimensions of 30mm × 80mm
Cable tie	Moderate quantity	Fixing the air hoses and the cables
Silicon grease	Moderate amount	Reducing friction and wear when the air hoses and the cables slide Recommended silicon grease: G-501 (manufactured by Shin-Etsu Chemical Co., Ltd.)
Liquid gasket	Moderate amount	Sealing the outlet at the tip of the shaft Recommended liquid gasket: 1212 (manufactured by Three Bond Co., Ltd.)

【Precautions for implementation of moving part】

- 1) The internal air hoses and cables are bent and twisted according to the operations of the J3 and J4 axes. Structurally, the twisting occurs inside the shaft, and the bending occurs inside the expanding sleeve. Without the expanding sleeve, the twisted air hoses and cables may run onto the guide portion of the fixing plate, and the air hoses may be bent or broken.
- 2) Do not place the connector connecting part and the air hose relay part in the binding or twisting range.

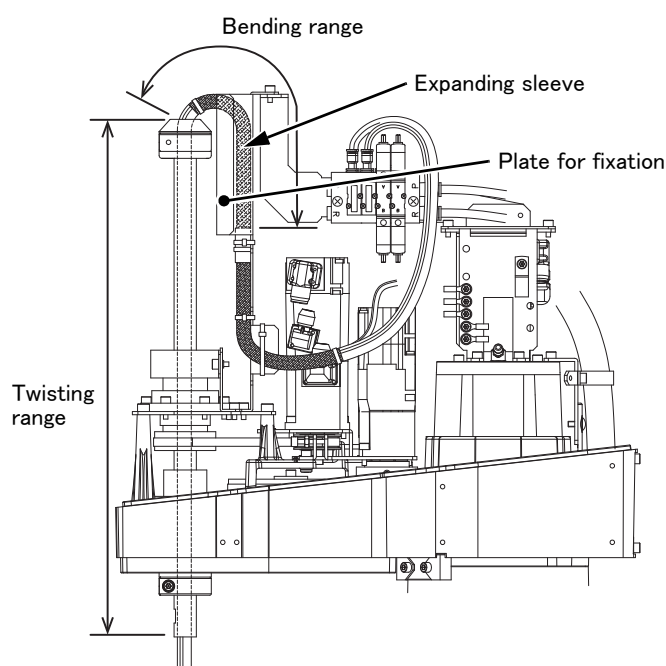

(3) Installation procedure

The installation procedure is shown below.

Refer to the installation diagram shown from the next section, and perform the installation correctly.

- 1) Move the J3 axis to the top end with a jog operation and shut off the controller's power supply. This is necessary for space standard settings when feeding the air hose and hand input cable through the inside of the shaft.
- 2) Remove the screws fixing the No. 2 arm cover U, and remove the No. 2 arm cover U.
- 3) Pass the tool (hand) side of the internal air hoses and cables through the shaft. Make sure that the air hoses and the cables are not twisted or crossed.
- 4) Fix the air hoses and the cables with a cable tie so as to position the end of the expanding sleeve 10mm away from the opening of the shaft.
- 5) The highest point of the curved section of the air hoses and cables should be matched up with the top of the fixing plate.

CAUTION

If the air hoses and the cables are not long enough or too long, when the robot operates, excessive bending and friction with the shaft upper end or the cover may result in a break or abnormal operations of the tool (hand).

- 6) In the state of the steps 4) and 5), fix the air hoses and the cables to the (a) and (b) portions of the plate with cable ties. For the (a) portion, wrap the air hoses and the cables with cushion rubber before fixing.
- 7) When using the hand input signal or the optional solenoid valve, refer to [Page 55, "3.4 Hand internal wiring and piping set"](#).
- 8) The connected connectors are stored to the (c) portion.

CAUTION

Do not remove the cable ties which fixing connectors.
Fix the plate on the No. 2 arm, other cables and air hoses with cable ties. In this way, the internal cables and connectors do not touch the plate edge and others, or break due to the vibration during the robot operation.

- 9) Carry out piping and wiring on the tool side.
Fix the air hoses and the cables, which are pulled out from the shaft lower end, to the hand side. Check again that the highest point of the curved section of the air hoses and the cables reaches the height of the fixing plate upper end, and then fix the air hoses and the cables at the outlet of the shaft.
When an optional bellows set has been installed to the robot and then required cleanliness, to ensure the cleanliness level, use liquid gasket and others to seal the outlet on the shaft tip where the air hoses and the cables are pulled out.
- 10) Apply silicon grease to the contact surface between the air hoses of the fixing plate and the cables, the cable sliding portion from the shaft upper end to the fixed portion, and the opening on the shaft upper end.
- 11) Power on the controller, perform the jog operation for the J3 and J4 axes, and check that the air hoses and the cables do not interfere with other components.

CAUTION

Do not power on the controller when the internal cables are connected to the connectors on the robot.
If the end of the cables on the tool side is not processed, troubles such as fuse blown by ground fault or short circuit may occur. Check that the end of the cables has been processed before powering on the controller.

- 12) Turn off the controller's power supply, then install the No.2 arm cover U securely as before with fixing screws (tightening torque: 1.39 to 1.89 Nm).
When installing the cover, check that no air hose or cable is pinched, and no air hose is bent.
Note) The installation surface of covers is using sealing material. In the event that the sealing material has been removed or has been bent or broken to the extent that it cannot be return to the original form, be sure to replace the sealing material. Please contact dealer when the sealing material needs to be replaced.

This completes installing cables and air hoses inside the robot's shaft.

Refer to Page 21, "(3) Installation procedure" and install cables and air hoses correctly. The numbers in Fig. 2-11 are correspond to the same numbers in "(3)Installation procedure".

Turn the controller's power OFF before this operation. Refer to Page 68, "5.3.2 Installing/removing the cover" for removing/ installing the cover.

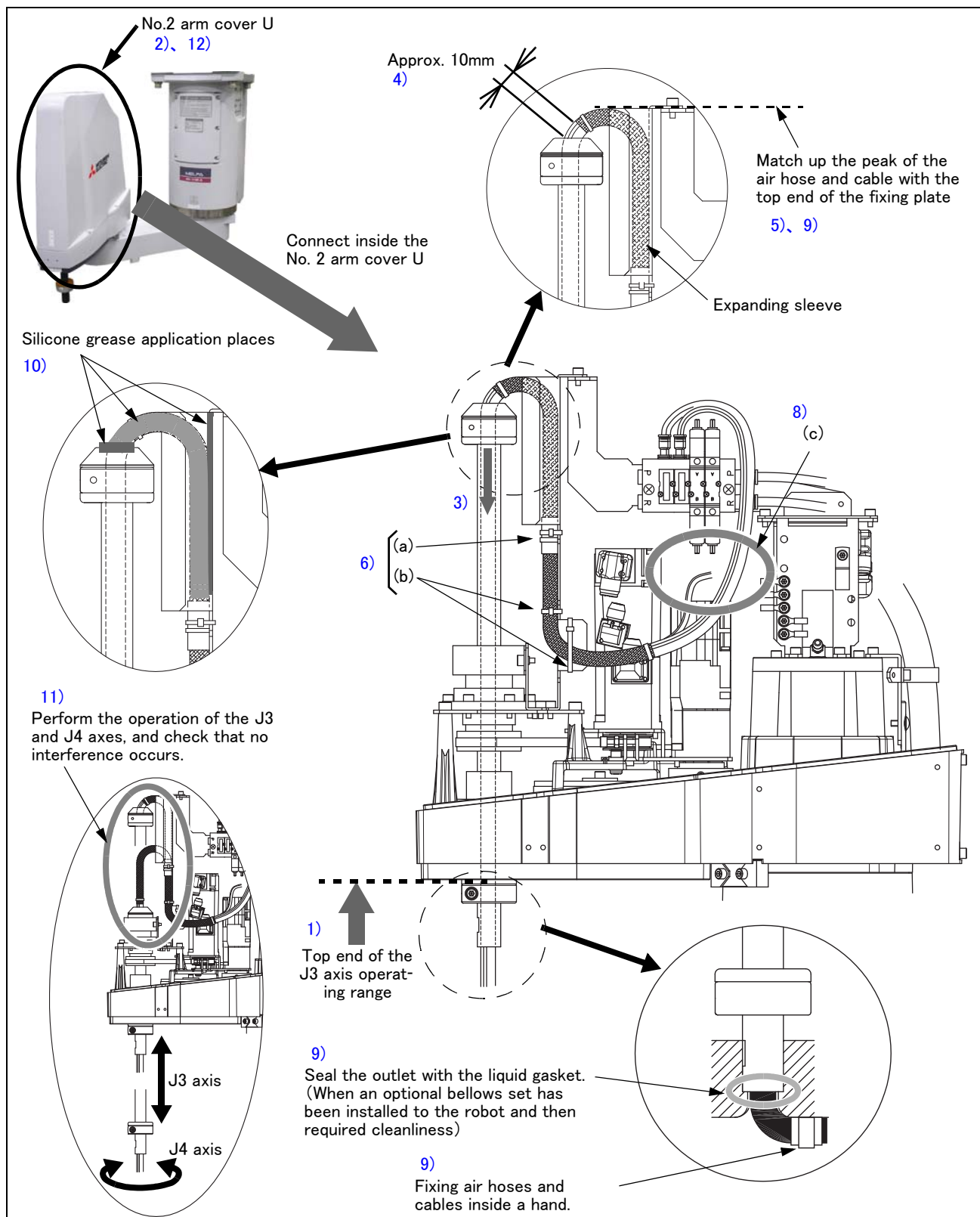

Fig.2-11 : Installation of air hoses and cables inside the robot's shaft

2.3 Setting the origin

The origin is set so that the robot can be used with a high accuracy. After purchasing the robot, always carry out this step before starting work. This step must also be carried out if the combination of robot and controller being used is changed.

There are several methods for setting the origin, but the origin data input method will be explained here. Refer to Page 89, "5.6 Resetting the origin" for the other methods.

The teaching pendant is required for this operation.

[Caution] If the origin data at shipment is erased due to out of battery, it is necessary to set the origin again. Refer to Page 89, "5.6 Resetting the origin" and reset the origin using the jig method, mechanical stopper method or ABS method.

2.3.1 Installing the teaching pendant (T/B)

When installing and removing the T/B, turn off the controller power supply. If T/B is installed or removed in the state of power supply ON, emergency stop alarm will occur.

If you use the robot wherein T/B is removed, please install the attached dummy connector. With the connector, put the dummy connector or draw it out.

CAUTION Please do not pull the cable of T/B strongly or do not bend it too much. It becomes the breaking of a wire of the cable and the cause of breakage of the connector. Please installing and removing so that stress does not start the cable with the connector itself.

(1) CR750 controller

Explain the installation method of T/B below.

- 1) Check that the POWER (power supply) switch of the robot controller is OFF.
- 2) Connects T/B connector to the robot controller. Use as the upper surface the lock lever shown in Fig. 2-12, and push in until there is sound.

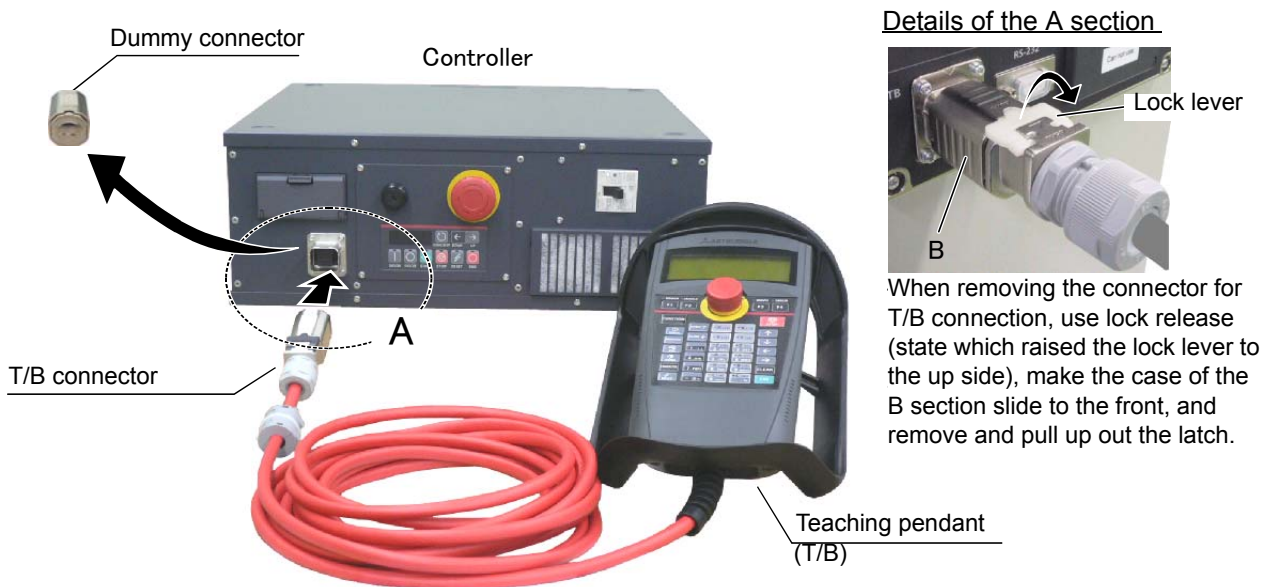

Fig.2-12 : Installing and removing the T/B (CR750 controller)

The installation of T/B is finished.

◆◆◆ If error C0150 occurs ◆◆◆

At the time of the first power supply injection, error:C0150 (the serial number of the robot arm has not been set up) occur the robot after purchase.

Parameter: Please input the serial number of the robot body into RB SERIAL. Refer to "instructions manual / controller setup, and basic operation & maintenance" for the operation method.

(2) CR751 controller

Explain the installation method of T/B below.

- 1) Check that the POWER (power supply) switch of the robot controller is OFF.
- 2) Connect the T/B connector to the controller's T/B connector. Make sure to fix it securely by fastening the hand locks (in 2 places), as shown in Fig. 2-13.

Controller

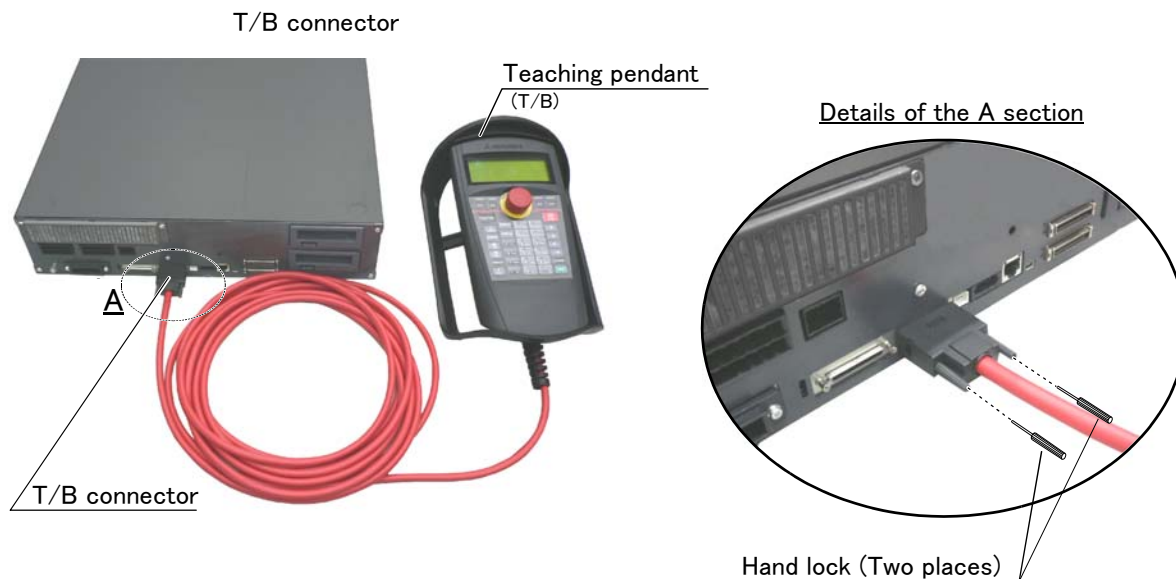

Fig. 2-13 : Installing and removing the T/B (CR751controller)

The installation of T/B is finished.

◆◆◆ If error C0150 occurs ◆◆◆

At the time of the first power supply injection, error:C0150 (the serial number of the robot arm has not been set up) occur the robot after purchase.

Parameter: Please input the serial number of the robot body into RB SERIAL. Refer to "instructions manual / controller setup, and basic operation & maintenance" for the operation method.

2.3.2 Setting the origin with the origin data input method

(1) Confirming the origin data

● Origin data history table (Origin Data History) Serial No.ES804008

Date	Default
D	V!#S29			
J 1	06DTYY			
J 2	2?HL9X			
J 3	1CP55V			
J 4	T6!M\$Y			
J 5				
J 6				
Method	E	E · N · S P	E · N · S P	E · N · S P

(O: O(Alphabet), 0: Zero)

Note) Meanings of symbols in method column

E: Jig method

N: Not used

SP: Not used

The origin data to be input is noted in the origin data sheet enclosed with the arm, or on the origin data history table attached to the back side of the battery cover. (Refer to Fig. 2-14).

Referring to Page 68, "5.3.2 Installing/removing the cover", remove the battery cover and confirm the value.

The value given in the default setting column is the origin settings set with the calibration jig before shipment.

Fig.2-14 : Origin data label (an example)



WARNING

Always install/remove the cover with the controller control power turned OFF. Failure to do so could lead to physical damage or personal injury should the robot start moving due to incorrect operations.

(2) Turning ON the control power



CAUTION

Confirm that there are no operators near the robot before turning the power ON.

1) Turn the controller [POWER] switch ON.

The CR750 controller turns ON the front power switch.

The CR751 controller turns ON the switch of the earth leakage breaker of installation outside.

(3) Preparing the T/B



Next, prepare to use the T/B

- 1) Set the mode of the controller to "MANUAL".
(The figure is example for CR750 controller)

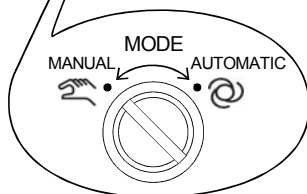

- 2) Set the T/B [ENABLE] switch to "ENABLE". The menu selection screen will appear.

The following operations are carried out with the T/B.

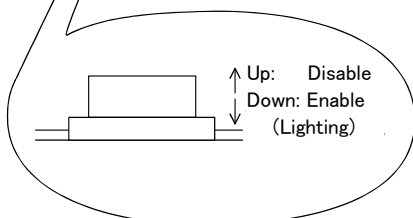

◆◆◆ Operating from the T/B ◆◆◆

Always set the mode of the controller to "MANUAL", and then set the T/B [ENABLE] switch to "ENABLE". When the T/B is valid, only operations from the T/B are possible. Operations from the controller or external signals will not be accepted.

(4) Selecting the origin setting method

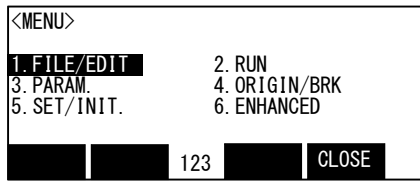

1) Press the [4] key on the menu screen, and display the ORIGIN/BRAKE screen.

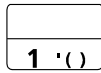
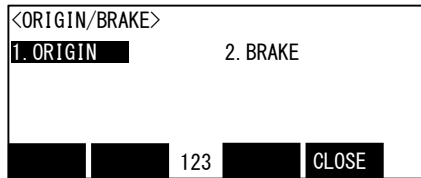

2) Press the [1] key on the ORIGIN/BRAKE screen, and display the origin setting method selection screen.

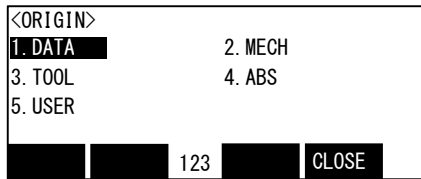

3) Press the [1] key on the origin setting method selection screen, and select the data input method.

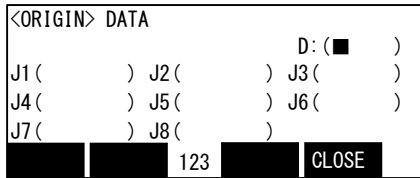

4) Display the origin data input screen

◆◆◆ Selecting a menu ◆◆◆

The menu can be selected with one of the following methods.

A: Press the numeral key for the No. of the item to be selected.

B: Using the [↓] and [↑] keys, etc., move the cursor to the item to be selected, and then press the [INP] key.

◆◆◆ The input method of numeral ◆◆◆

The number can be inputted if the key displayed on the lower left of each key is pressed. Press the

[CHARACTER] key, and in the condition that "123" is displayed on the screen lower side, press the number key.

(5) Inputting the origin data



Input the value confirmed in section [Page 25, "\(1\) Confirming the origin data"](#).

The correspondence of the origin data label value and axis to be input is shown in [Fig. 2-15](#).

Fig.2-15 : Correspondence of origin data label and axis

The method for inputting the origin data is explained below. The value shown in [Fig. 2-14](#) will be input as an example.

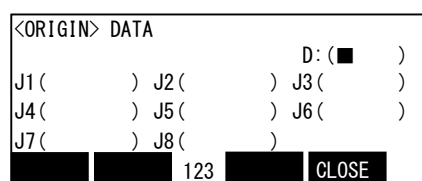

1) Confirm that the cursor is at the "D" position on the T/B display screen.

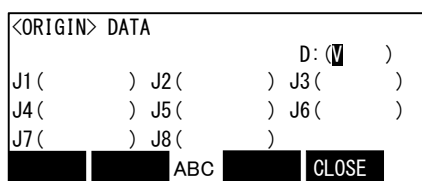

CHARACTER

-B (J5)
8 TUV

2) Input the D value "V!%S29".

Inputting "V"

Press the [CHARACTER] key and set to the character input mode. (Condition that "ABC" was displayed under the screen)

Press the [TUV] key three times. "V" will be set.

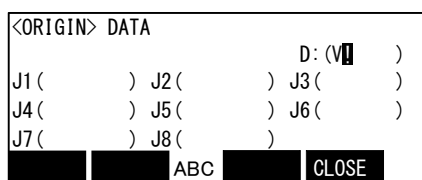

+C (J6)
· , %

→

+C (J6)
· , %

Inputting "!"

Press the [, %] key five times. "!" will be set.

Press the [→] key once and advance the cursor.

Press the [, %] key twice (input "%"), and press the [PQRS] key four times (input "S").

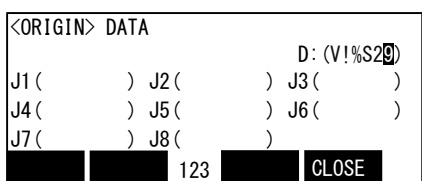

CHARACTER

-Z (J3)
2 ABC

+B (J5)
9 WXYZ

Press the [CHARACTER] key and set to the numeral input mode. (Condition that "123" was displayed under the screen)

Press the [2] key (input "2"), and press the [9] key (input "9").

"V!%S29" will appear at the "D" data on the teaching pendant screen.

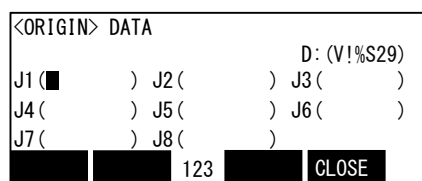

↓

⋮
⋮
⋮

3) Press the [↓] key, and move the cursor to the J1 input position.

4) Input the J1 value in the same manner as above.

5) Input the J2, J3 and J4 values in the same manner.

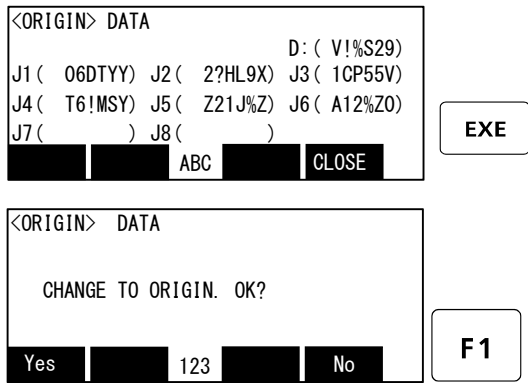

6) After inputting all of the values, press the [EXE] key. The origin setting confirmation screen will appear.

7) Press [F1] (Yes) to end the origin setting

◆◆◆ Moving the cursor ◆◆◆
Press the [↑], [↓], [←] and [→] keys.

◆◆◆ Inputting characters ◆◆◆
Press the [CHARACTER] key and set to the character input mode. (Condition that "ABC" was displayed under the screen). The displayed character is scrolled each time at pressing the key.

◆◆◆ How to input symbols ◆◆◆
The symbol is allocated to [()], [@=], and [,%] key. Please repress each key until the symbol to wish is displayed.
a) [()] key ' () " ^ ; ¥ ?
b) [@ =] key @ = + - * / < >
c) [, %] key , % # \$! & _ .

◆◆◆ Correcting an input ◆◆◆
After returning one character by pressing the [CLEAR] key, input the character again.

(6) Installing the battery cover.
Return the battery cover removed in section [Page 25, "\(1\) Confirming the origin data"](#) to its original position.
This completes the setting of the origin with the origin data input method.

⚠ WARNING Removing and installing the cover by always turning off the controller power. Failure to do so could lead to the robot moving because of incorrect operations, or to physical damage or personal injury.

◆◆◆ If the origin input data is incorrect ◆◆◆
If the origin input data is incorrect, the alarm No. 1760 (origin setting data illegal) will occur when origin data input. In this case, reconfirm the value input for the origin data.

2.4 Confirming the operation

In this section, the robot will be moved manually using the T/B to confirm that the operation is correct. Moving the robot manually is called "jog operation". This operation includes the JOINT jog that moves each axis, the XYZ jog that moves along the base coordinate system, the TOOL jog that moves along the tool coordinate system, and the CYLNDER jog that moves along the circular arc.

This operation is carried out while pressing the deadman switch on the back of the T/B.

Note) The figure of the robot which indicated to the explanation page in each jog mode is an example.

 **CAUTION** The robot will move during this operation. Make sure that there are no operators near the robot, and that there are no obstacles, such as tools, in the robot operation range.

 **CAUTION** To immediately stop the robot, release the deadman switch on the back of the T/B. The servo power will turn OFF, and the robot will stop. The robot will also stop if the [EMG.STOP] switch (emergency stop switch) on the front of the T/B or the [EMG.STOP] switch (emergency stop) on the front of the controller is pressed.

 **WARNING** Confirm that the origin has been set. If the origin has not been set, "****" will appear at the current position display on the teaching pendant, the JOINT jog operation will take place in any jog mode selected. Refer to [Page 23, "2.3 Setting the origin"](#) for details on setting the origin.

◆◆◆ How to choose the jog mode ◆◆◆

<CURRENT>	JOINT	100%	M1	TO	B1
J1: +0.00	J5: +0.00				
J2: +0.00	J6: +0.00				
J3: +90.00	:				
J4: +0.00	:				
XYZ TOOL JOG 3-XYZ CYLDR ⇒					

Choose the jog mode

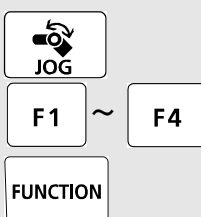

Press the [JOG] key, the jog screen will be displayed, and display the jog mode which can be chosen at the bottom of the screen. Because these correspond to the function key of [F1] – [F4], press the function key corresponding to the jog mode to wish. And, if the [FUNCTION] key is pressed, selection in jog modes other than the present display is possible. The override (100%), the mechanism number (M1), and the tool number (T1), and the base coordinate number (B1) are displayed on the upside of the screen following the present jog mode (JOINT).

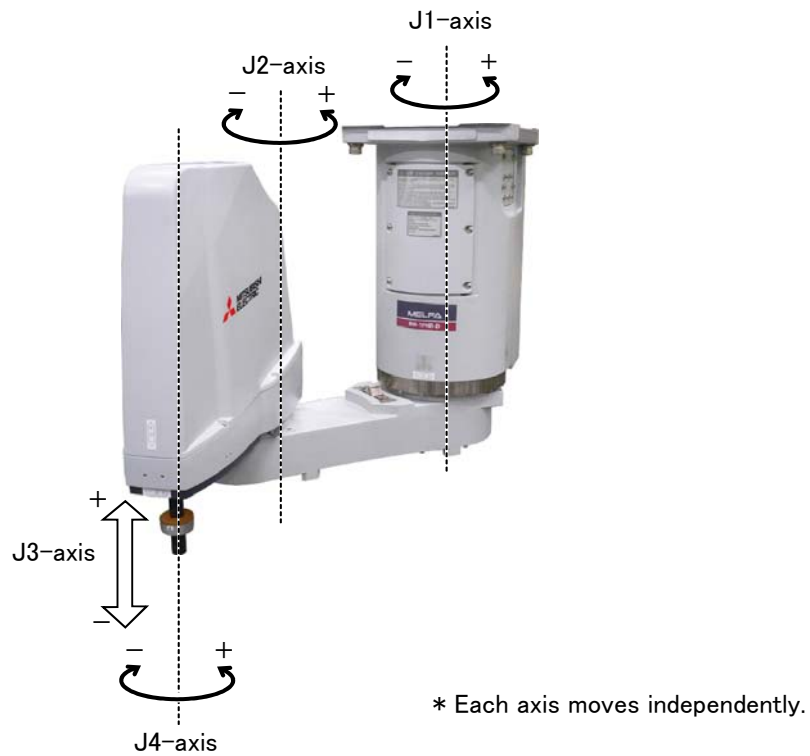

Fig.2-16 : JOINT jog operation

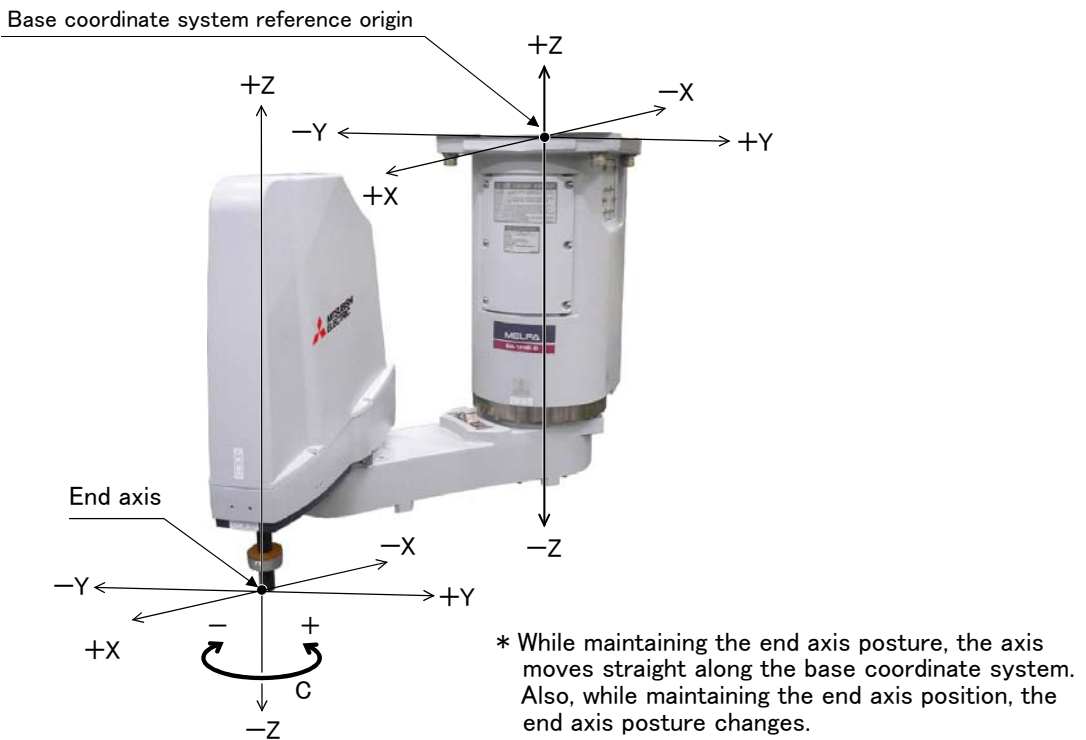

Fig.2-17 : XYZ jog operation

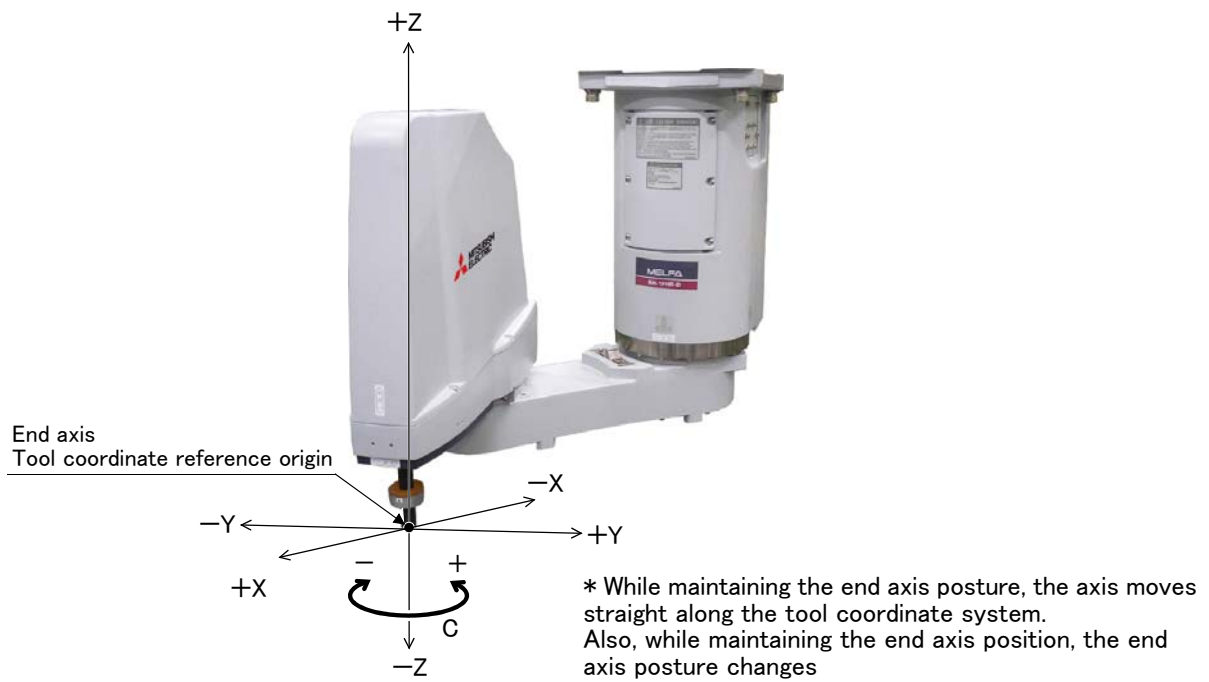

Fig.2-18 : TOOL jog operation

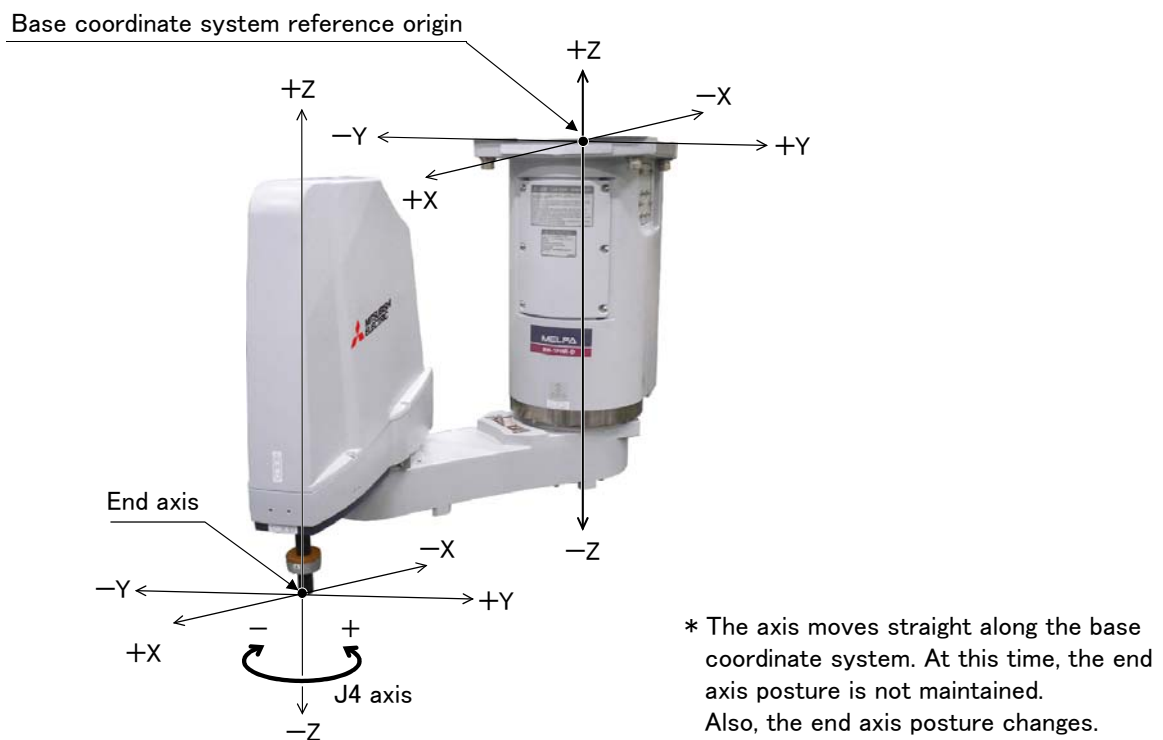
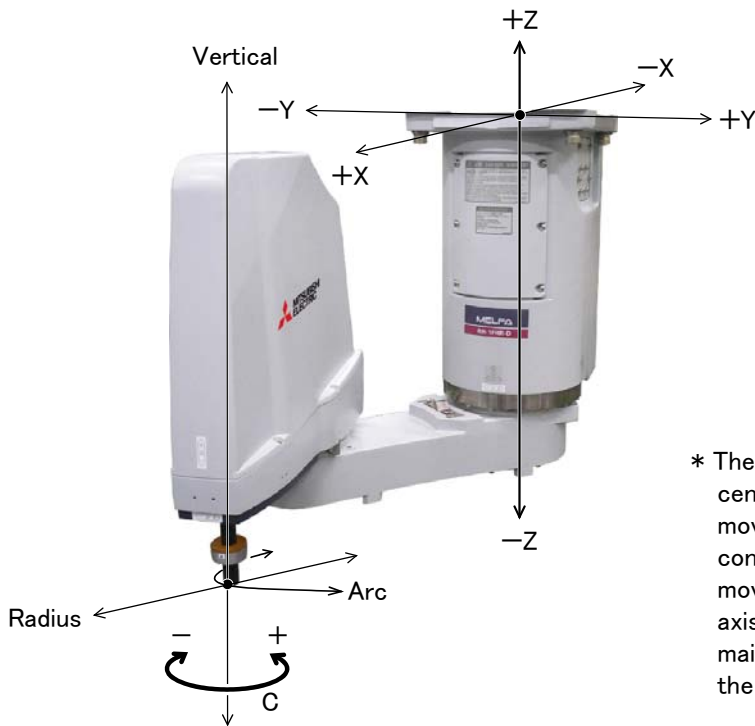
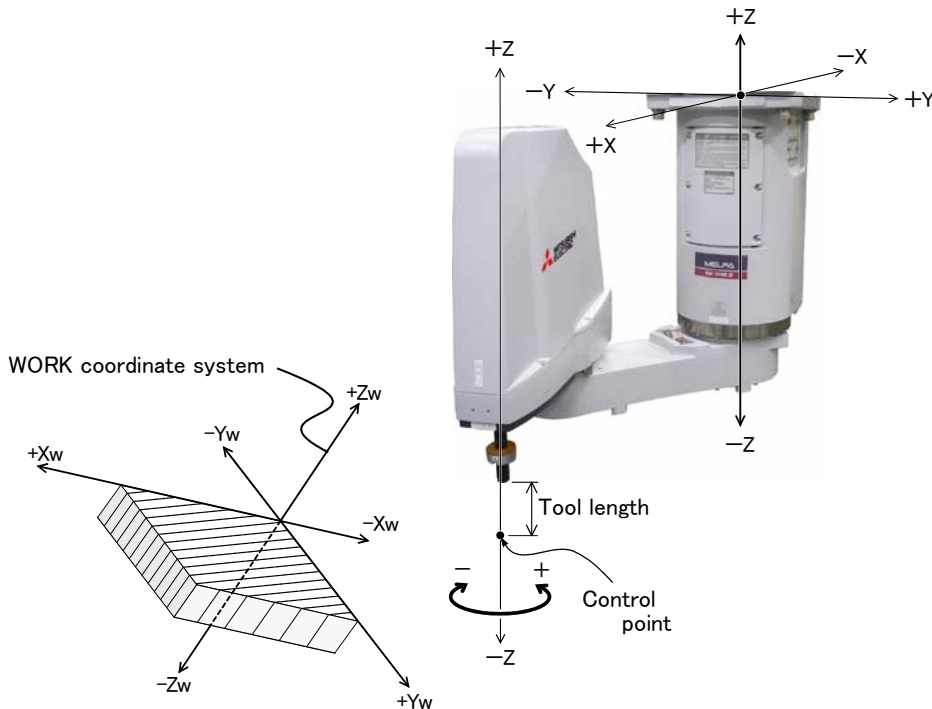

Fig.2-19 : 3-axis XYZ jog operation



* The current position is set as the arc centering on the Z axis, and the axis moves along that arc, expands and contracts in the radius direction, and moves vertically. At this time, the end axis posture is maintained. Also, while maintaining the axis posture position, the end axis posture changes.

Fig.2-20 : CYLINDER jog operation



- * While maintaining the end axis posture, the axis moves straight along the work coordinate system. Also, while maintaining the end axis position, the end axis posture changes.
- * When the controller software version is R5 (F-Q series)/S5 (F-D series) or later, jog operation around the work coordinates system is available (EX-T jog). In this jog operation, when the jog operation is performed for the posture elements, the posture rotates on the Xw axis, Yw axis, or Zw axis of the work coordinates system while the control point is changed.

Fig.2-21 : WORK jog operation

(1) JOINT jog operation

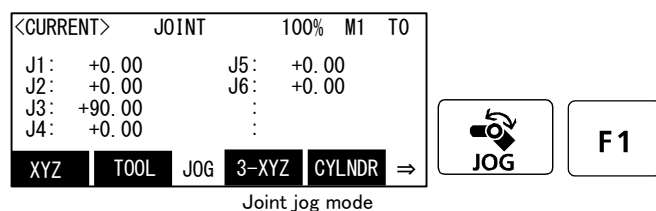
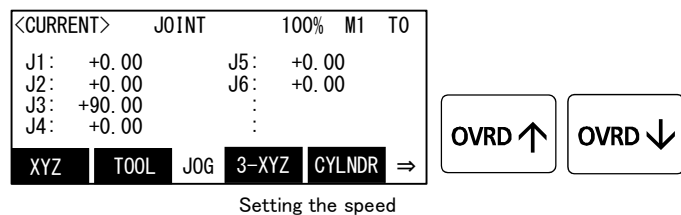
Select joint jog modeSet jog speed

[JOG] Press the key and display the jog screen. ("JOG" is displayed on the screen bottom)

Check that the "joint" in jog mode is displayed on the screen.

If other jog modes are displayed, please press the function key corresponding to the "joint." (If the jog mode which he wishes under the screen is not displayed, it is displayed that the [FUNCTION] key is pressed)

If it finishes jog operation, press the [JOG] key again, or function key which correspond to "close."

Whenever it presses the key of [OVRD ↑], the override goes up. Conversely, if the [OVRD ↓] key is pressed, it will go down.

The current setting speed is displayed on screen upper right, and "STATUS NUMBER" of the controller.

Set the override to 10% here for confirmation work.

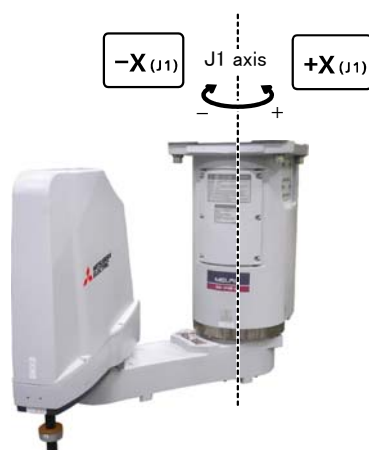
J1 axis jog operation

- When the [+X (J1)] keys are pressed, the J1 axis will rotate in the plus direction.
When the [-X (J1)] keys are pressed, rotate in the minus direction.

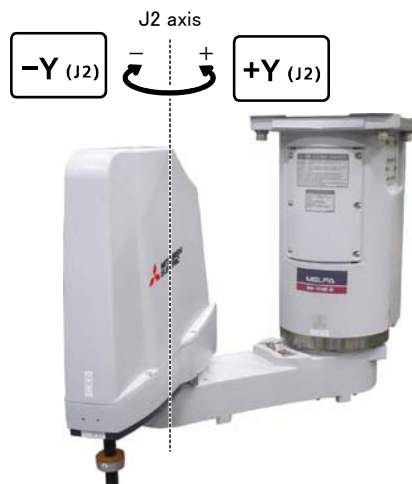
J2 axis jog operation

- When the [+Y (J2)] keys are pressed, the J2 axis will rotate in the plus direction.
When the [-Y (J2)] keys are pressed, rotate in the minus direction.

◆◆◆ When the robot is in the transportation posture ◆◆◆
The axes may be outside the movement area. Move these axes toward the inner side of the movement area.

J3 axis jog operation



- When the [+Z (J3)] keys are pressed, the J3 axis will rotate in the plus direction.
When the [-Z (J3)] keys are pressed, rotate in the minus direction.

J4 axis jog operation

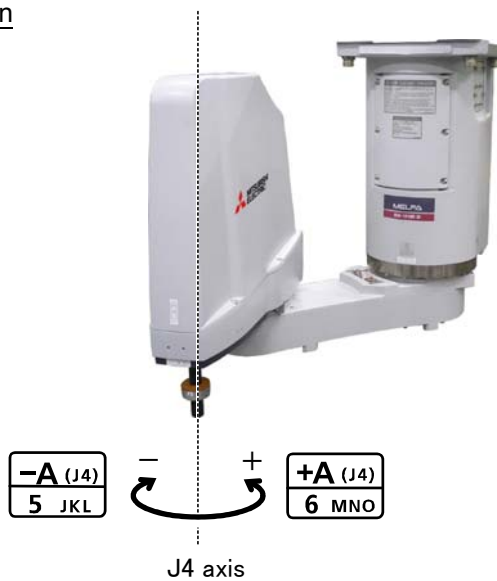

- When the [+A (J4)] keys are pressed, the J4 axis will rotate in the plus direction.
When the [-A (J4)] keys are pressed, rotate in the minus direction.

◆◆◆ If the buzzer of T/B sounds and the robot does not move ◆◆◆
If it is going to move the robot across the operation range, the buzzer of T/B sounds and the robot does not move. In this case, please move to the counter direction.

(2) XYZ jog operation

Select XYZ jog mode

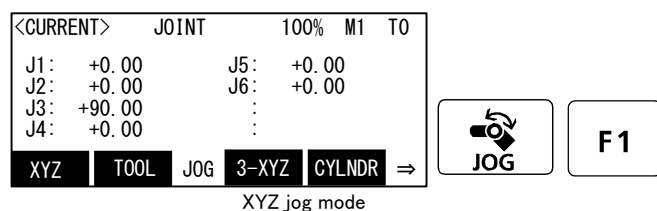

Set jog speed

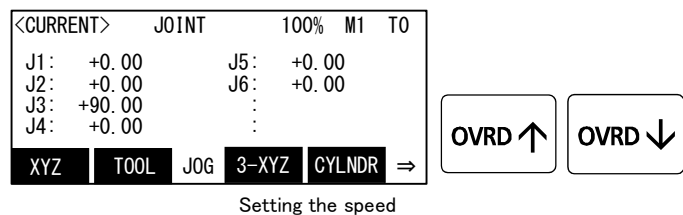

[JOG] Press the key and display the jog screen. ("JOG" is displayed on the screen bottom)

Check that the "XYZ" in jog mode is displayed on the screen.

If other jog modes are displayed, please press the function key corresponding to the "XYZ." (If the jog mode which he wishes under the screen is not displayed, it is displayed that the [FUNCTION] key is pressed)

If it finishes jog operation, press the [JOG] key again, or function key which correspond to "close."

Whenever it presses the key of [OVRD ↑], the override goes up. Conversely, if the [OVRD ↓] key is pressed, it will go down.

The current setting speed is displayed on screen upper right, and "STATUS NUMBER" of the controller.

Set the override to 10% here for confirmation work.

Moving along the base coordinate system

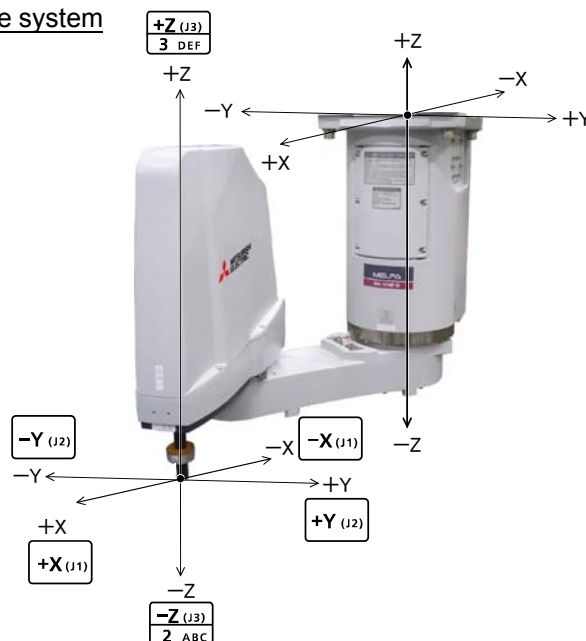

- When the [+X (J1)] keys are pressed, the robot will move along the X axis plus direction.
When the [-X (J1)] keys are pressed, move along the minus direction.
- When the [+Y (J2)] keys are pressed, the robot will move along the Y axis plus direction.
When the [-Y (J2)] keys are pressed, move along the minus direction.
- When the [+Z (J3)] keys are pressed, the robot will move along the Z axis plus direction.
When the [-Z (J3)] keys are pressed, move along the minus direction.

◆◆◆ When the robot is in the transportation posture ◆◆◆

There are directions from which linear movement is not possible from the transportation posture. In this case, the robot will not move. Refer to section [Page 34, "\(1\) JOINT jog operation"](#), and move the robot to a position where linear movement is possible, and then carry out XYZ jog.

◆◆◆ If the buzzer of T/B sounds and the robot does not move ◆◆◆
 If it is going to move the robot across the operation range, the buzzer of T/B sounds and the robot does not move. In this case, please move to the counter direction.

Changing the end axis posture



*The Position of the end axis will not change.

- When the [+C (J6)] keys are pressed, the Z axis will rotate in the plus direction.
 When the [-C (J6)] keys are pressed, rotate in the minus direction.

◆◆◆ When alarm No. 5150 occurs ◆◆◆
 If alarm No. 5150 (ORIGIN NOT SET) occurs, the origin has not been set correctly. Reconfirm the value input for the origin data.

◆◆◆ Tool length ◆◆◆
 The default tool length is 0mm, and the control point is the center of the end axis.
 After installing the hand, set the correct tool length in the parameters. Refer to the separate manual "Detailed Explanation of Functions and Operations" for details.

(3) TOOL jog operation

Select TOOL jog mode

<CURRENT>	JOINT	100%	M1	TO
J1: +0.00	J5: +0.00			
J2: +0.00	J6: +0.00			
J3: +90.00	:			
J4: +0.00	:			

XYZ TOOL JOG 3-XYZ CYLNR =>

TOOL jog mode

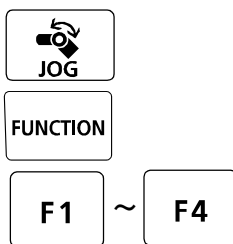

Set jog speed

<CURRENT>	JOINT	100%	M1	TO
J1: +0.00	J5: +0.00			
J2: +0.00	J6: +0.00			
J3: +90.00	:			
J4: +0.00	:			

XYZ TOOL JOG 3-XYZ CYLNR =>

Setting the speed



[JOG] Press the key and display the jog screen. ("JOG" is displayed on the screen bottom)

Check that the "TOOL" in jog mode is displayed on the screen.

If other jog modes are displayed, please press the function key corresponding to the "TOOL." (If the jog mode which he wishes under the screen is not displayed, it is displayed that the [FUNCTION] key is pressed)

If it finishes jog operation, press the [JOG] key again, or function key which correspond to "close."

Whenever it presses the key of [OVRD ↑], the override goes up. Conversely, if the [OVRD ↓] key is pressed, it will go down.

The current setting speed is displayed on screen upper right, and "STATUS NUMBER" of the controller.

Set the override to 10% here for confirmation work.

Moving along the tool coordinate system

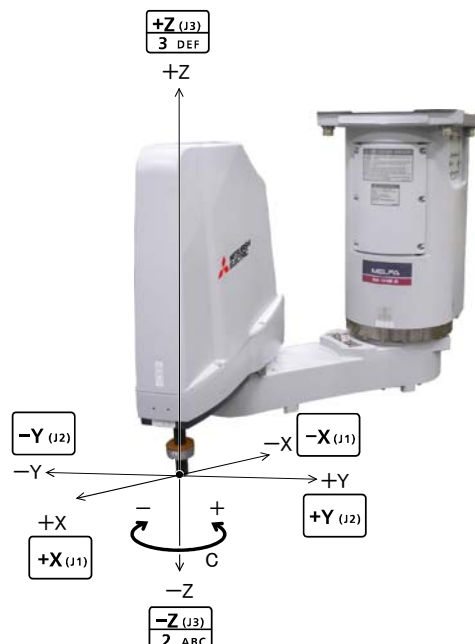

- When the [+X (J1)] keys are pressed, the robot will move along the X axis plus direction of the tool coordinate system.
- When the [-X (J1)] keys are pressed, move along the minus direction.
- When the [+Y (J2)] keys are pressed, the robot will move along the Y axis plus direction of the tool coordinate system.
- When the [-Y (J2)] keys are pressed, move along the minus direction.
- When the [+Z (J3)] keys are pressed, the robot will move along the Z axis plus direction of the tool coordinate system.
- When the [-Z (J3)] keys are pressed, move along the minus direction.

◆◆◆ When the robot is in the transportation posture ◆◆◆
 There are directions from which linear movement is not possible from the transportation posture. In this case, the robot will not move. Refer to section [Page 34, "\(1\) JOINT jog operation"](#), and move the robot to a position where linear movement is possible, and then carry out XYZ jog.

◆◆◆ If the buzzer of T/B sounds and the robot does not move ◆◆◆
 If it is going to move the robot across the operation range, the buzzer of T/B sounds and the robot does not move. In this case, please move to the counter direction.

Changing the end axis posture



*The Position of the end axis will not change.

- When the [+C (J6)] keys are pressed, the Z axis will rotate in the plus direction of the tool coordinate system. When the [-C (J6)] keys are pressed, rotate in the minus direction.

◆◆◆ When alarm No. 5150 occurs ◆◆◆
 If alarm No. 5150 (ORIGIN NOT SET) occurs, the origin has not been set correctly. Reconfirm the value input for the origin data.

◆◆◆ Tool length ◆◆◆
 The default tool length is 0mm, and the control point is the center of the end axis. After installing the hand, set the correct tool length in the parameters. Refer to the separate manual "Detailed Explanation of Functions and Operations" for details.

(4) 3-axis XYZ jog operation

Select XYZ456 jog mode

<CURRENT>	JOINT	100%	M1	T0
J1: +0.00	J5: +0.00			
J2: +0.00	J6: +0.00			
J3: +90.00	:			
J4: +0.00	:			

XYZ TOOL JOG **3-XYZ** CYLNR =>

XYZ456 jog mode

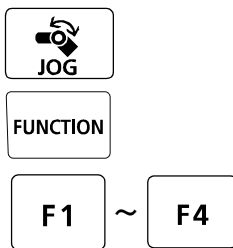

Set jog speed

<CURRENT>	JOINT	100%	M1	T0
J1: +0.00	J5: +0.00			
J2: +0.00	J6: +0.00			
J3: +90.00	:			
J4: +0.00	:			

XYZ TOOL JOG **3-XYZ** CYLNR =>

Setting the speed

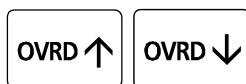

[JOG] Press the key and display the jog screen. ("JOG" is displayed on the screen bottom)

Check that the "XYZ456" in jog mode is displayed on the screen.

If other jog modes are displayed, please press the function key corresponding to the "XYZ456." (If the jog mode which he wishes under the screen is not displayed, it is displayed that the [FUNCTION] key is pressed)

If it finishes jog operation, press the [JOG] key again, or function key which correspond to "close."

Whenever it presses the key of [OVRD ↑], the override goes up. Conversely, if the [OVRD ↓] key is pressed, it will go down.

The current setting speed is displayed on screen upper right, and "STATUS NUMBER" of the controller.

Set the override to 10% here for confirmation work.

Moving along the base coordinate system

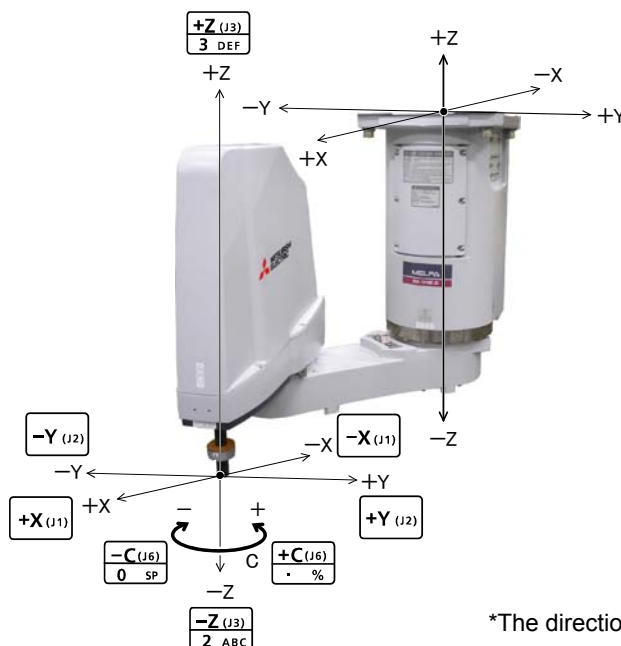

*The direction of the end axis will change.

- When the [+X (J1)] keys are pressed, the robot will move along the X axis plus direction.
When the [-X (J1)] keys are pressed, move along the minus direction.
- When the [+Y (J2)] keys are pressed, the robot will move along the Y axis plus direction.
When the [-Y (J2)] keys are pressed, move along the minus direction.
- When the [+Z (J3)] keys are pressed, the robot will move along the Z axis plus direction.
When the [-Z (J3)] keys are pressed, move along the minus direction.

◆◆◆ The flange surface end axis posture cannot be maintained with 3-axis XYZ jog. ◆◆◆

With 3-axis XYZ jog, the flange surface end axis posture (orientation) is not maintained when moving linearly in the X, Y or Z axis direction.

Use XYZ jog to maintain the posture.

Changing the end axis posture

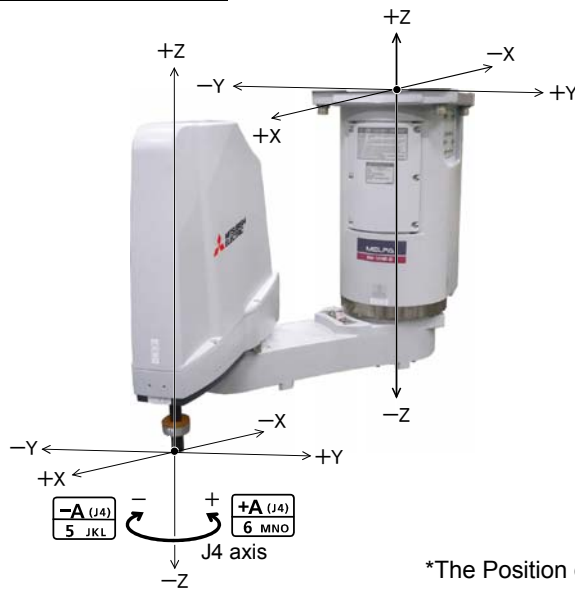

*The Position of the end axis will not change.

- When the [+C (J6)] keys are pressed, the J4-axis will rotate in the plus direction.
When the [-C (J6)] keys are pressed, rotate in the minus direction.

(5) CYLINDER jog operation

Select cylindrical jog mode

<CURRENT>	JOINT	100%	M1	TO
J1:	+0.00	J5:	+0.00	
J2:	+0.00	J6:	+0.00	
J3:	+90.00	:	:	
J4:	+0.00	:	:	

XYZ TOOL JOG 3-XYZ CYLNR =>

CYLINDER jog mode

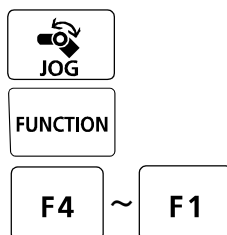

Set jog speed

<CURRENT>	JOINT	100%	M1	TO
J1:	+0.00	J5:	+0.00	
J2:	+0.00	J6:	+0.00	
J3:	+90.00	:	:	
J4:	+0.00	:	:	

XYZ TOOL JOG 3-XYZ CYLNR =>

Setting the speed

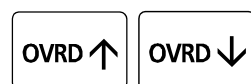

[JOG] Press the key and display the jog screen. ("JOG" is displayed on the screen bottom)

Check that the "CYLINDER" in jog mode is displayed on the screen.

If other jog modes are displayed, please press the function key corresponding to the "CYLINDER." (If the jog mode which he wishes under the screen is not displayed, it is displayed that the [FUNCTION] key is pressed)

If it finishes jog operation, press the [JOG] key again, or function key which correspond to "close."

Whenever it presses the key of [OVRD ↑], the override goes up. Conversely, if the [OVRD ↓] key is pressed, it will go down.

The current setting speed is displayed on screen upper right, and "STATUS NUMBER" of the controller.

Set the override to 10% here for confirmation work.

Moving along an arc centering on the Z axis

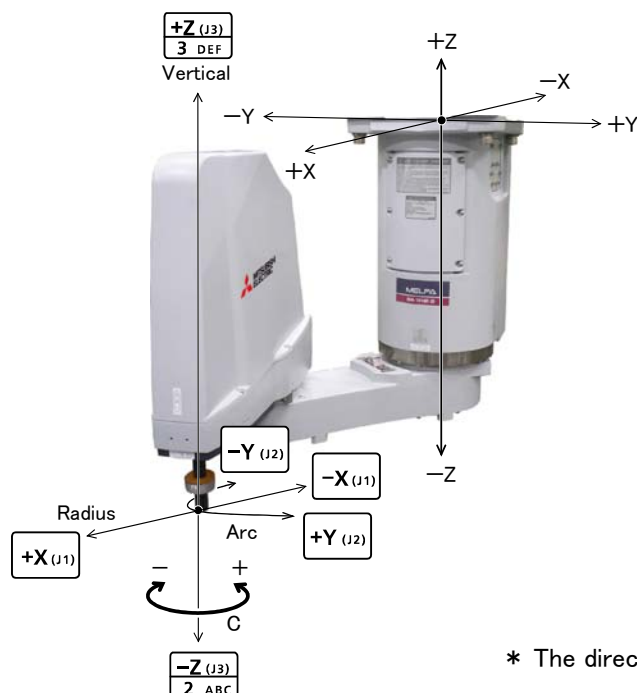

* The direction of the fringe will not change.

Assuming that the current position is on an arc centering on the Z axis, the robot moves along that arc.

- When the [+X (J1)] keys are pressed, the robot will expand in the radial direction.
When the [-X (J1)] keys are pressed, contract in the radial direction.
- When the [+Y (J2)] keys are pressed, the robot will move along the arc in the plus direction.
When the [-Y (J2)] keys are pressed, move in the minus direction.
- When the [+Z (J3)] keys are pressed, the robot will move along the Z axis plus direction.
When the [-Z (J3)] keys are pressed, move along the minus direction.

Changing the flange surface posture

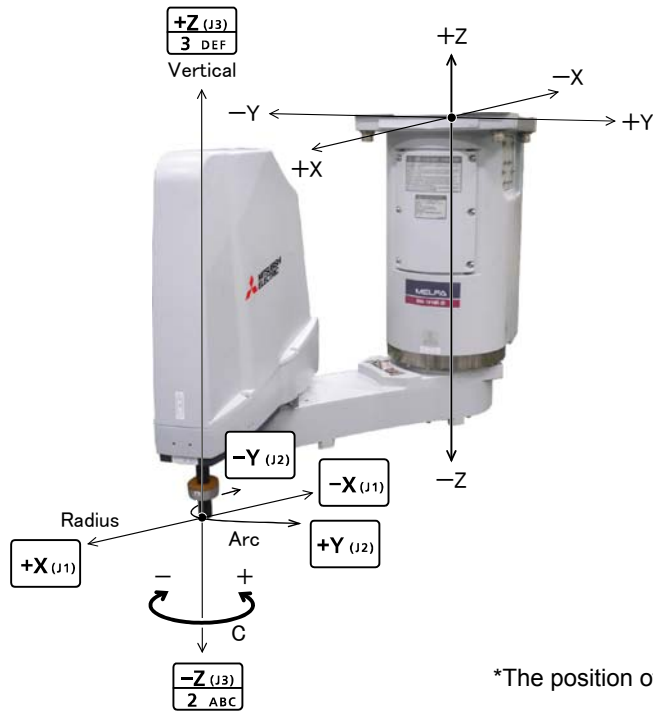

- When the [+C (J6)] keys are pressed, the Z axis will rotate in the plus direction.
When the [-C (J6)] keys are pressed, rotates in the minus direction.

(6) Work jog operation

Setting of the work coordinates system is necessary.

By this jog operation, robot can be move along with the direction of work (or working table etc.), so teaching operations get easier.

When jog operation, select by which work coordinates the robot moves

The setting method of the work coordinates system using T/B (R32TB) is shown in the following.

(Parameter: Setting the coordinate value to WK n CORD ("n" is meaning the number (1-8) of work coordinates) can also set up the work coordinates system. Refer to the separate manual "Detailed Explanation of Functions and Operations" for details of parameter.)

The work coordinates system teaches and sets up the three points (WO, WX, WY).

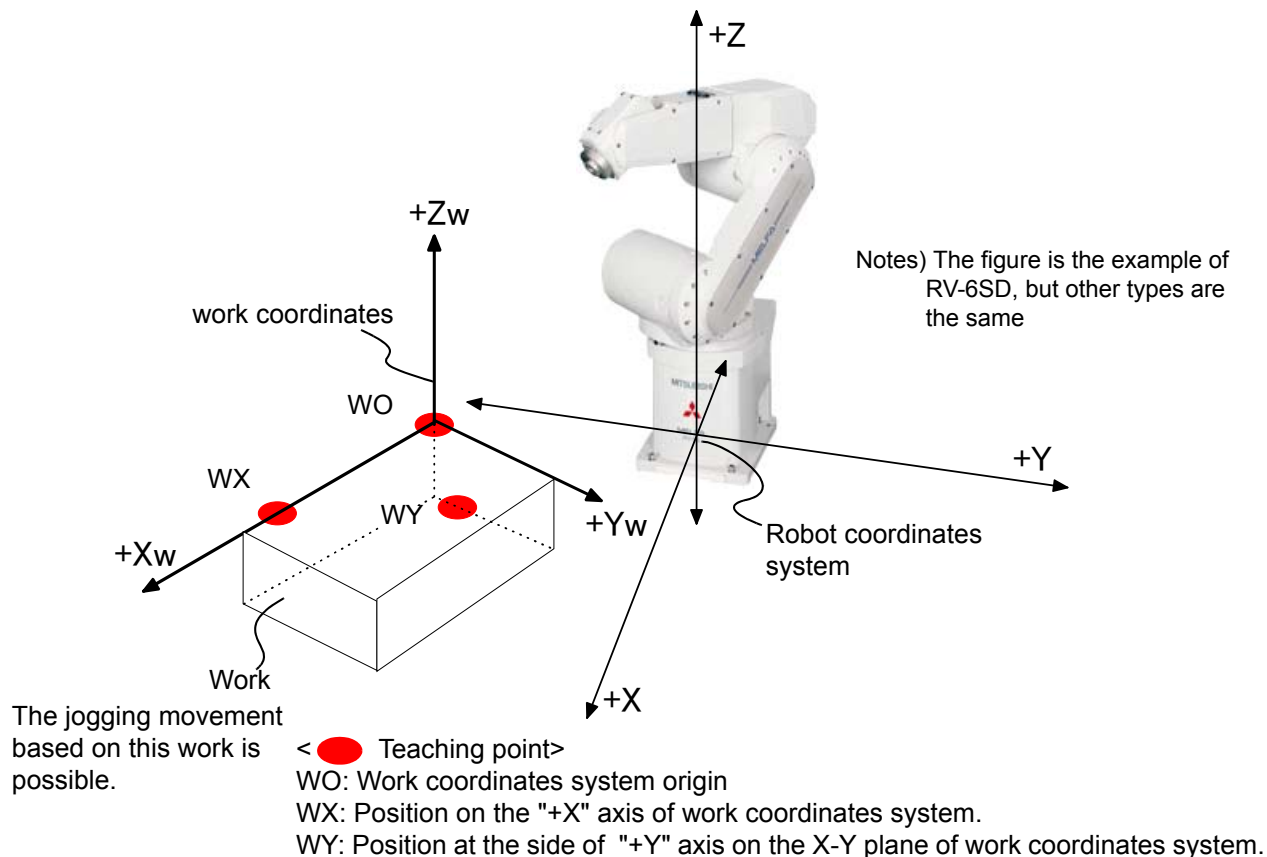

[Supplement] : The coordinate values which use all three teaching points for setting of the work coordinates system are each only X, Y, and the Z-axis. Although the coordinate value of A, B, and C axis is not used, positioning will get easy if the XYZ jog or TOOL jog movement is effected with the same value. (The direction of the hand is the same)

Fig.2-22 : Setting of the work coordinates system (teaching point)

The setting (definition) method of the work coordinates system is shown in the following.

1) Select "6.ENHANCED" screen on the <MENU> screen.

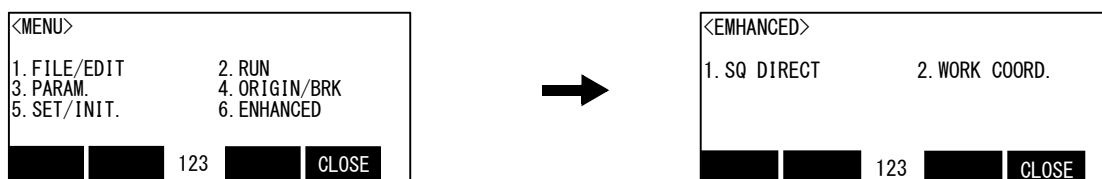

2) Press the [2] keys in the menu screen and select "2. WORK COORD."

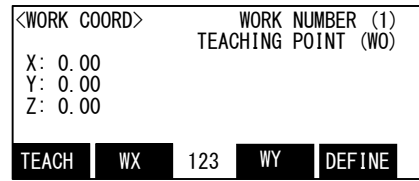
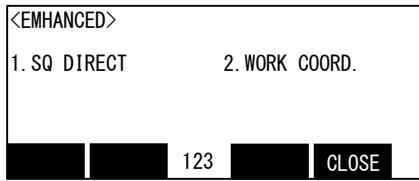

The screen shows the coordinate value of the origin (WO) of the work coordinates number 1.

3) Selection of the work coordinates number

Press the [FUNCTION] keys, and display "W: JUMP" function. Press the function key corresponding to "W: JUMP"

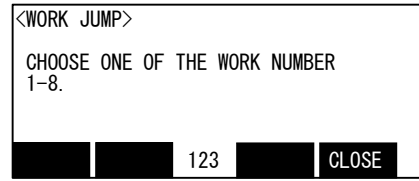
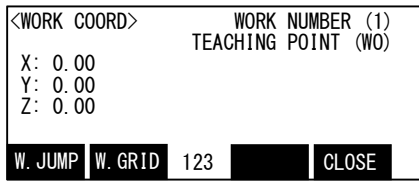

Press numeral key [1] - [8] and specify the work coordinates number. The coordinate value of the specified work coordinates system is displayed.

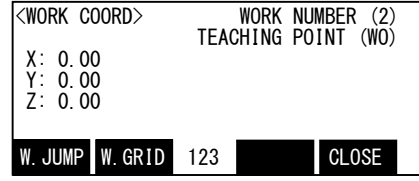
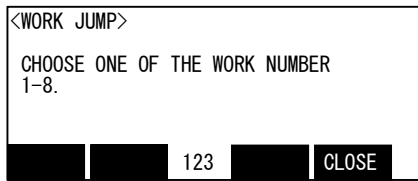

The screen is the example which specified the work coordinates number 2. ("2" at the upper right of the screen)

Operation will be canceled if the [CLOSE] key is pressed.

4) The teaching of the work coordinates system

Teach the three points shown in Fig. 2-22. Confirm the name currently displayed on the "TEACHING POINT" at the upper right of the screen. If it differs, press the function key corresponding to each point(WO, WX, WY) to teach. Move the robot's arm by jog operation (other jogging movement), and press the function key corresponding to "TEACH."([F1]) The confirmation screen is displayed.

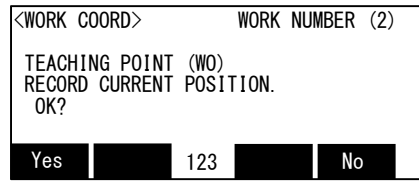
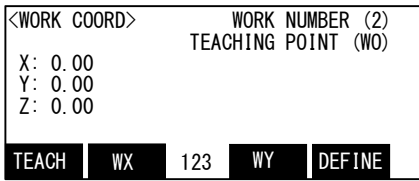

Specify the teaching point [WO],[WX],[WY] teaching the position [TEACH]

Presses the function key corresponding to "Yes", the robot's current position is registered, and the registered coordinates value is displayed. Operation will be canceled if the [CLOSE] key is pressed.

<WORK COORD>		WORK NUMBER (2)	
TEACHING POINT (WO) RECORD CURRENT POSITION. OK?			
Yes	123	No	

➔

<WORK COORD>		WORK NUMBER (2)	
TEACHING POINT (WO)			
X: 214.12 Y: -61.23 Z: 553.30			
W. JUMP	W. GRID	123	CLOSE

Teach the three points, WO, WX, and WY, by the same operation.

The position data taught here is each registered into the following parameters. ("n" means the work coordinates numbers 1-8)

WO= parameter: WKnWO

WX= parameter: WKnWX

WY= parameter: WKnWY

5) Setting of work coordinates (definition)

If the function key corresponding to "DEFINE" ([F1]) is pressed, the work coordinates system will be calculated using the three points, and the result will be displayed.

<WORK COORD>		WORK NUMBER (2)	
TEACHING POINT (WO)			
X: 214.12 Y: -61.23 Z: 553.30			
TEACH	WX	123	WY DEFINE

➔

<WORK COORD>		WORK NUMBER (2)	
WORK COORDINATES DATA			
(3.53, -220.00, 5.14, 0.00, 0.00, 0.00)			
		123	CLOSE

The alarm occurs if the work coordinates system is incalculable. (There are the three points on the straight line, or the two points have overlapped) In this case, reset alarm and re-teach the three points.

This work coordinate data is registered into parameter: WKnCORD. ("n" means the work coordinates numbers 1-8)

If the function key corresponding to "CLOSE" is pressed, it will return to the previous screen.

<WORK COORD>		WORK NUMBER (2)	
WORK COORDINATES DATA			
(3.53, -220.00, 5.14, 0.00, 0.00, 0.00)			
		123	CLOSE

➔

<WORK COORD>		WORK NUMBER (2)	
TEACHING POINT (WO)			
X: 214.12 Y: -61.23 Z: 553.30			
TEACH	WX	123	WY DEFINE

6) Finishing of setting the work coordinates

Press the [FUNCTION] keys, and display "CLOSE" function. Press the function key corresponding to "CLOSE". Returns to the <MENU> screen.

<WORK COORD>		WORK NUMBER (2)	
TEACHING POINT (WO)			
X: 214.12 Y: -61.23 Z: 553.30			
W. JUMP	W. GRID	123	CLOSE

➔

<EMHANCED>			
1. SQ DIRECT		2. WORK COORD.	
		123	CLOSE

Although setting of work coordinates is finishing above, confirmation of work coordinates can be done by pressing the function key corresponding to "W GRID."([F2])

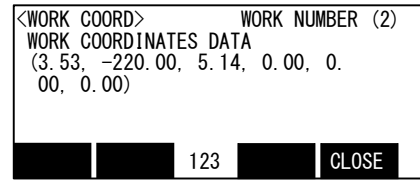
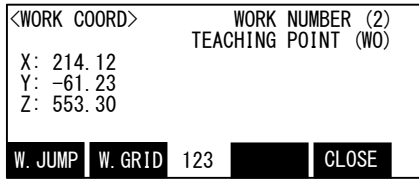

Return to the previous screen by pressing the [CLOSE] ([F4]) key.

Then, the operation method of the work jog is shown. Change to the work jog after nearing the work.

Select WORK jog mode

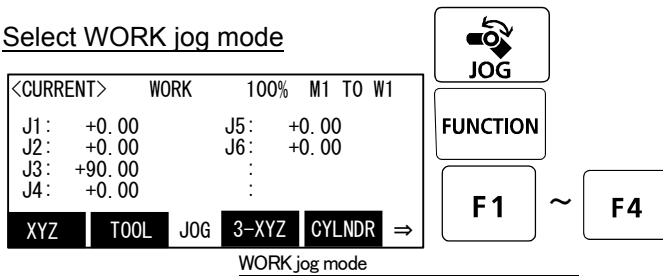

[JOG] Press the key and display the jog screen. ("JOG" is displayed on the screen bottom)

Check that the "WORK" in jog mode is displayed on the screen.

If other jog modes are displayed, please press the function key corresponding to the "WORK." (If the jog mode which he wishes under the screen is not displayed, it is displayed that the [FUNCTION] key is pressed)

If it finishes jog operation, press the [JOG] key again, or function key which correspond to "close."

Confirmation and selection of the work coordinates system

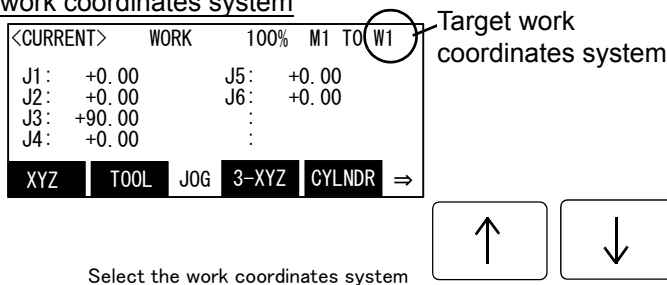

Confirm the target work coordinates system.

The current target number is displayed on the screen upper right. (W1 - W8)

The number of work coordinates can be changed by the arrow key [Upper arrow], [Lower arrow]

Push the key [Upper arrow], the number will increase. (W1, W2, W8) Conversely, push the key [Lower arrow], the number will decrease

CAUTION

Always confirm that the number of the target work coordinates system is displayed correctly (Display of W1-W8 at the upper right of the screen)

If mistaken, the robot will move in the direction which is not meant and will cause the damage and the personal injuries.

Set jog speed

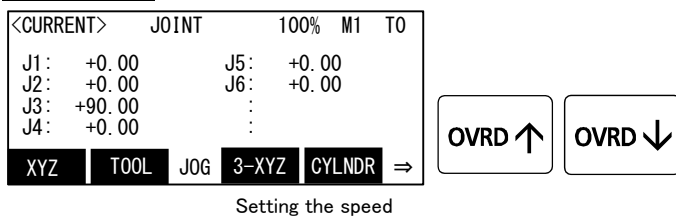

Whenever it presses the key of [OVRD(Upper arrow)], the override goes up. Conversely, if the [OVRD(Lower arrow)] key is pressed, it will go down.

The current setting speed is displayed on screen upper right, and "STATUS NUMBER" of the controller.

Set the override to 10% here for confirmation work

When the software version is R5 (F-Q series)/S5 (F-D series) or later, the additional WORK jog operation, Ex-T jog, is available. The conventional WORK jog operation and the Ex-T jog operation can be switched by setting the parameters WK1JOGMD to WK8JOGMD of each work coordinates system.

The respective operations are as follows.

WORK jog operation mode	Conventional WORK jog	Ex-T jog
Parameters WK n JOGMD (n is 1 to 8) setting	0 (initial value)	1
XYZ key operation	Moves along each axis of the work coordinates system	Same as the conventional WORK jog
C key operation	With the control point position maintained, the direction changes along the work coordinates system.	While the control point position is changed, the direction changes on the Z axis of the work coordinates system (Z w).
AB key operation	The robot does not move.	The robot does not move.

The jog movement based on work coordinates system

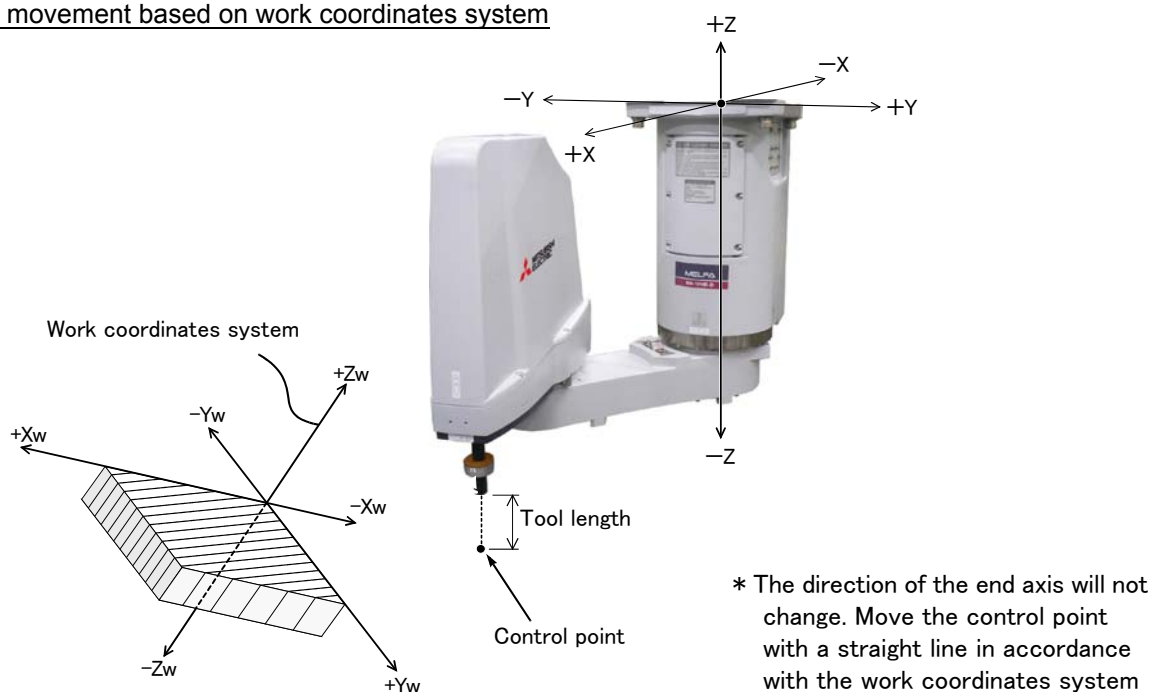

- When the [+X (J1)] keys are pressed, the robot will move along the X axis (X w) plus direction on the work coordinates system.
When the [-X (J1)] keys are pressed, Move along the minus direction.
- When the [+Y (J2)] keys are pressed, the robot will move along the Y axis (Y w) plus direction on the work coordinates system.
When the [-Y (J2)] keys are pressed, Move along the minus direction.
- When the [+Z (J3)] keys are pressed, the robot will move along the Z axis (Z w) plus direction on the work coordinates system.
When the [-Z (J3)] keys are pressed, Move along the minus direction.

When the X, Y, or Z keys are used, the operation is the same in the WORK jog and the Ex-T jog modes.

Changing the end axis posture
 <1> Work jog mode

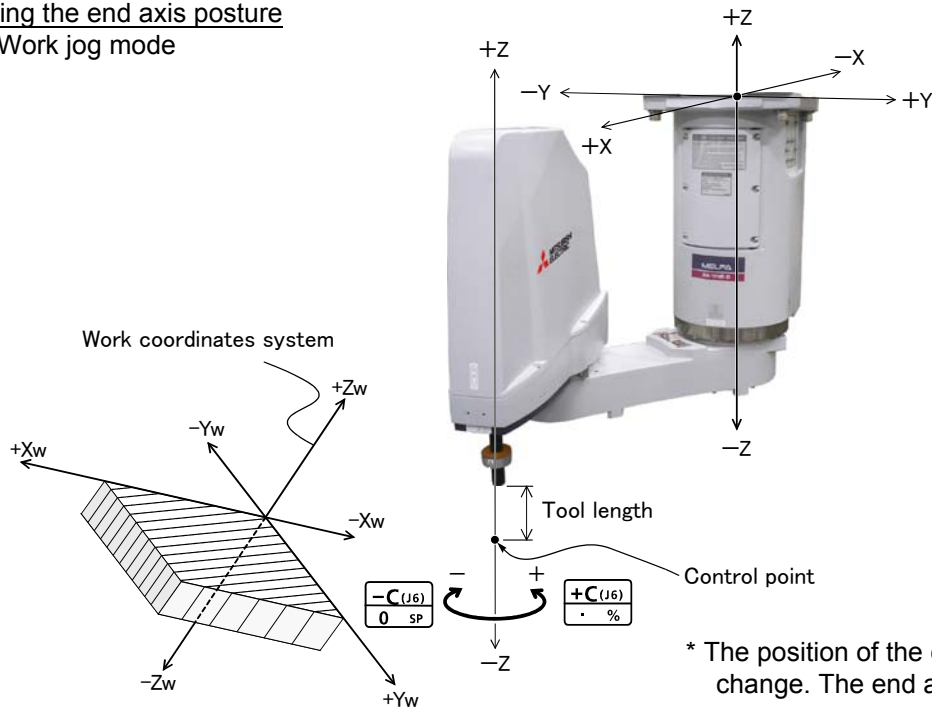

- When the $[+C (J6)]$ keys are pressed, the Z axis will rotate in the plus direction of the XYZ coordinate system. When the $[-C (J6)]$ keys are pressed, rotate in the minus direction.

<2> Ex-T jog mode

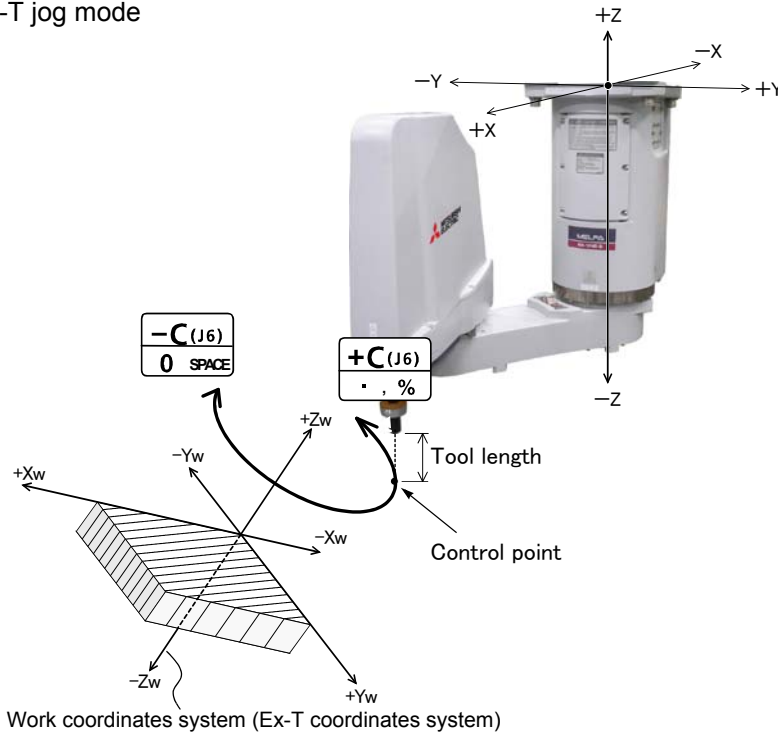

- When the $[+C (J6)]$ keys are pressed, the control point will rotate in the plus direction around the Z axis (Z_w) of work coordinates system (Ex-T coordinates system). When the $[-C (J6)]$ keys are pressed, the control point will rotate in the minus direction.

◆◆◆ When the robot is in the transportation posture ◆◆◆

There are directions from which linear movement is not possible from the transportation posture. In this case, the robot will not move. Refer to section [Page 34, "\(1\) JOINT jog operation"](#), and move the robot to a position where linear movement is possible, and then carry out XYZ jog.

◆◆◆ If the buzzer of T/B sounds and the robot does not move ◆◆◆

If it is going to move the robot across the operation range, the buzzer of T/B sounds and the robot does not move. In this case, please move to the counter direction.

◆◆◆ Tool length ◆◆◆

The default tool length is 0mm, and the control point is the center of the end axis.

After installing the hand, set the correct tool length in the parameters. Refer to the separate manual "Detailed Explanation of Functions and Operations" for details.

3 Installing the option devices

3.1 Installing the solenoid valve set

The installation summary of the solenoid valve is shown in Fig. 3-1. Remove the No.2 arm cover U, and install the solenoid valve on the No.2 arm. Turn the controller's power OFF before this installing operation. Refer to Page 68, "5.3.2 Installing/removing the cover" for removing/ installing the cover.

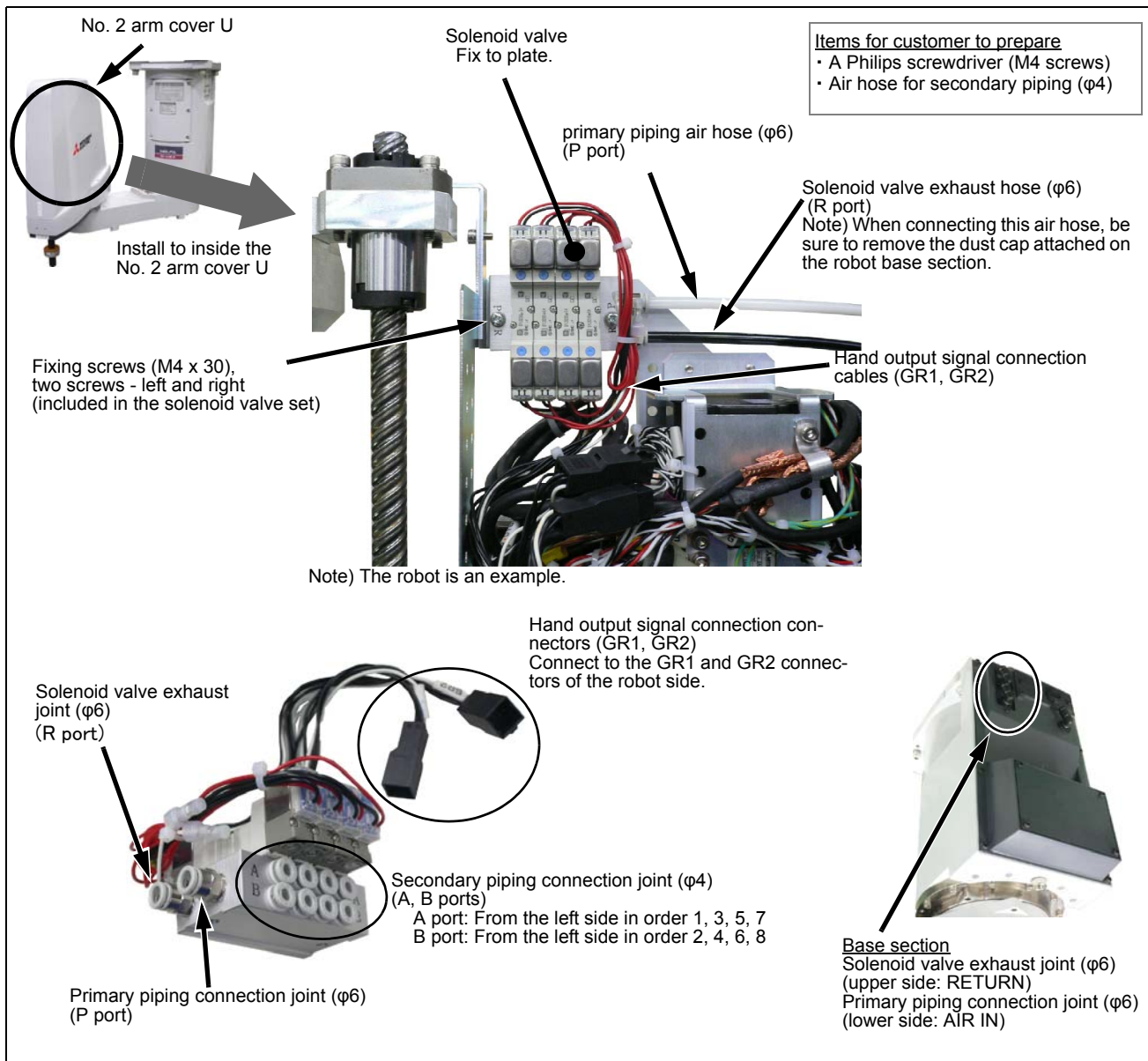

Fig.3-1 : Solenoid valve installation procedures

The installation procedure is detailed below.

- 1) Remove the screws fixing the No. 2 arm cover U, and remove the No. 2 arm cover U.
- 2) Fix the solenoid valve to the plate in the position indicated in Fig. 3-1. Place it so that the solenoid valve's primary piping connection joints (P, R ports) are located on the right hand side, and fix it securely using the M4 screws included (tightening torque: 1.39 to 1.89N · m).
- 3) Connect the connector (GR1, GR2) of solenoid valve with connector of robot arm side (GR1, GR2). Connect with the same names. The hand output signal cables of the robot arm side are located close to where the solenoid valve is installed and are tied up with cable tie. Pull out and connect them to the connectors.
- 4) Connect the primary piping air hose (φ6). The air hoses are located close to where the solenoid valve is installed and are tied up with cable tie. Cut the cable tie and connect them. Of the two air hoses, connect the one marked "AIR IN" to the solenoid valve's P port, and the one marked "RETURN" to the R port.

Note) When connecting the RETURN air hose, be sure to remove the dust cap attached at the RETURN joint on the robot base section. If the cap is not removed, exhaust air pressure will increase and the solenoid valve may not operate properly. By connecting the exhaust air hose ($\phi 6$: customer preparation) to this RETURN air joint, exhaust air from the solenoid valve is able to escape to the designated point.

5) Connect the secondary piping air hose ($\phi 4$).

The optional hand curl tube, the hand internal wiring and piping set, or the air hose prepared by customer can all be used, however when pulling the tip of the air hose out from the shaft please be sure to use the optional hand internal wiring and piping set.

Connect the air hoses to solenoid valve port A and port B. Please refer to [Table 3-1](#) and connect to the necessary ports. Covers the unused solenoid valve joints with the plugs included.

Note) When pulling the tip of the air hose out from the shaft, please be sure to use the optional hand internal wiring and piping set. Silicon grease to apply to friction points is included with the product (please refer to [Page 55, "3.4 Hand internal wiring and piping set"](#)). Further, when using the optional external wiring and piping box, the air hose can be pulled out from the rear of the No. 2 arm (please refer to [Page 58, "3.5 External Wiring and Piping Box"](#)).

6) If the hand output cable and the air hose have excess length, please tie the excess section by cable tie and fix it to the plate. The plate have some holes for fixing the cable/hose with a cable tie.

7) Install securely the No.2 arm cover U as before with fixing screws (tightening torque: 1.39 to 1.89 Nm).

Note) The installation surface of the covers is using sealing material. In the event that the sealing material has been removed or has been bent or broken to the extent that it cannot be return to the original form, be sure to replace the sealing material. Please inform the dealer, if exchange is necessary.

This completes installing the solenoid valve set.

(1) Hand number and solenoid valve ports (common to RH-FH series)

The connection correspondence after installation is as shown in [Table 3-1](#).

Table 3-1 : Solenoid valve ports and hoses: Correspondence of couplings and hand ports

Hand	Hand port	Solenoid valve port	Solenoid valve used
Hand 1	OPEN	1	1 st row
	CLOSE	2	
Hand 2	OPEN	3	2 nd row
	CLOSE	4	
Hand 3	OPEN	5	3 rd row
	CLOSE	6	
Hand 4	OPEN	7	4 th row
	CLOSE	8	

3.2 Installing the hand input cable

Fig. 3-2 shows the hand input cable's storage location on the robot.

Please use the optional external wiring and piping box to pull the hand input cable out externally. After connecting the hand input cable connector, reference Page 58, "3.5 External Wiring and Piping Box", and pull it out from the robot arm.

When passing through the inside of the shaft and using it, please use the optional hand internal wiring and piping set.

Remove the No. 2 arm cover U and connect the connector above the No. 2 arm. Turn the controller's power OFF before this operation. Refer to Page 68, "5.3.2 Installing/removing the cover" for removing/ installing the cover.

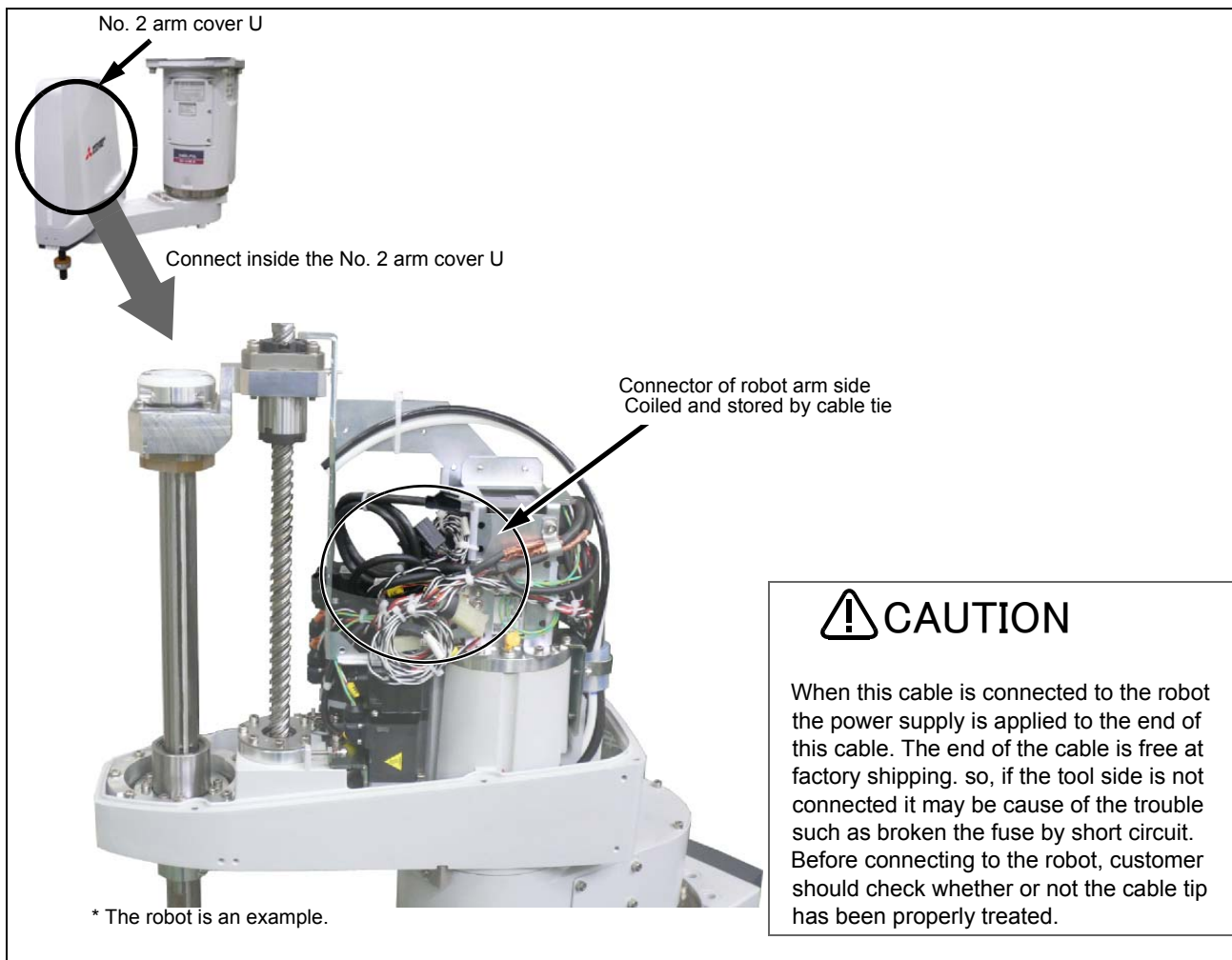

Fig.3-2 : Installing the hand input cable

The installation procedure for the hand input cable is shown below

- 1) Remove the screws fixing the No. 2 arm cover U, and remove the No. 2 arm cover U.
- 2) The hand input cable is stored in the location shown in Fig. 3-2. Pull out and check the connectors (HC1, HC2).
- 3) Connect the connector (HC1,HC2) of optional cable with connector of robot arm side (HC1, HC2). Connect with the same names.
- 4) Pull the hand input cables out of the robot arm. Referencing Page 58, "3.5 External Wiring and Piping Box", pull the cable out.

When installation of the optional external wiring and piping box finished, Installing the hand input cable is complete.

3.3 Installing the hand output cable

Fig. 3-3 shows the hand output cable's storage location on the robot.

Please use the optional external wiring and piping box to pull the hand output cable out externally. After connecting the hand output cable connector, reference Page 58, "3.5 External Wiring and Piping Box", and pull it out from the robot arm.

Remove the No. 2 arm cover U and connect the connector above the No. 2 arm. Turn the controller's power OFF before this operation. Refer to Page 68, "5.3.2 Installing/removing the cover" for removing/ installing the cover.

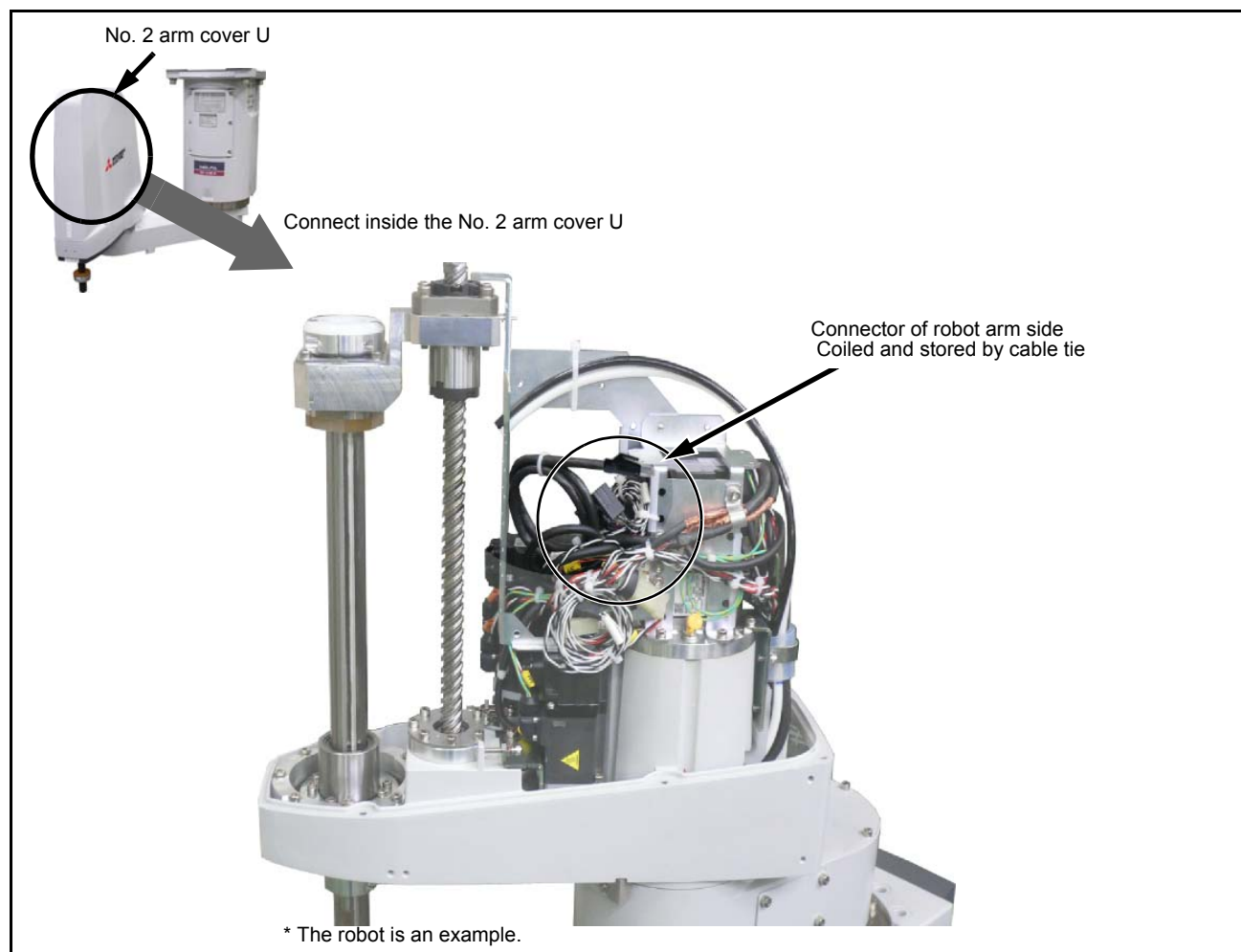

Fig.3-3 : Installing the hand output cable

The installation procedure for the hand output cable is shown below

- 1) Remove the screws fixing the No. 2 arm cover U, and remove the No. 2 arm cover U.
- 2) The hand output cable is stored in the location shown in Fig. 3-3. Pull out and check the connectors (GR1, GR2).
- 3) Connect the connector (GR1, GR2) of optional cable with connector of robot arm side (GR1, GR2). Connect with the same names.
- 4) Pull the hand output cables out of the robot arm. Referencing Page 58, "3.5 External Wiring and Piping Box", pull the cable out.

When installation of the optional external wiring and piping box finished, Installing the hand output cable is complete.

3.4 Hand internal wiring and piping set

Remove the No. 2 arm cover U and fix this option to the plate on the No. 2 arm.

Turn the controller's power OFF before this operation. Refer to [Page 68](#), "5.3.2 Installing/removing the cover" for removing/ installing the cover.

(1) Installation procedure

The installation procedure is shown below.

Refer to the installation diagram shown from the next section, and perform the installation correctly. Installation diagram is shown in [Fig. 3-4](#).

- 1) Move the J3 axis to the top end with a jog operation and shut off the controller's power supply. This is necessary for space standard settings when feeding the air hose and hand input cable through the inside of the shaft.
- 2) Remove the screws fixing the No. 2 arm cover U, and remove the No. 2 arm cover U.
- 3) Pass the tool (hand) side of the secondary piping air hoses and hand input cables through the shaft. Make sure that the air hoses and the cables are not twisted or crossed.
- 4) Fix the air hoses and the cables with a cable tie so as to position the end of the expanding sleeve 10mm away from the opening of the shaft.
- 5) The highest point of the curved section of the air hoses and cables should be matched up with the top of the fixing plate.

CAUTION

If the air hoses and the cables are not long enough or too long, when the robot operates, excessive bending and friction with the shaft upper end or the cover may result in a break or abnormal operations of the tool (hand).

- 6) In the state of the steps [4](#)) and [5](#)) , fix the air hoses and the cables to the (a) and (b) portions of the plate with cable ties. For the (a) portion, wrap the air hoses and the cables with cushion rubber before fixing.
- 7) Cut the secondary piping air hoses in appropriate length, and connect the air hoses to the solenoid valve. The diagram shows the connection to the optional solenoid valve as an example. The air hoses can also be pulled out from the rear of the No. 2 arm by using another option: an external wiring and piping box. For the details, refer to [Page 58](#), "3.5 External Wiring and Piping Box".
For the connection to the optional solenoid valve, connect the air hoses to the A and B ports of the solenoid valve.
- 8) When using the hand input cable connect the connectors (HC1, HC2) of optional hand input cable to connectors (HC1, HC2) of robot side. Connect with the same names. The connectors of robot side and cables are tied up by cable tie at (c) portion. Cut the cable tie and pull them out.
The connected connectors are stored to the (c) portion.
When the hand input cable is not used tie up the connector and fix to the plate by cable tie.

CAUTION

Do not remove the cable ties which fixing connectors.

Fix the plate on the No. 2 arm, other cables and air hoses with cable ties. In this way, the internal cables and connectors do not touch the plate edge and others, or break due to the vibration during the robot operation.

- 9) Carry out piping and wiring on the tool side.
Fix the air hoses and the cables, which are pulled out from the shaft lower end, to the hand side. Check again that the highest point of the curved section of the air hoses and the cables reaches the height of the fixing plate upper end, and then fix the air hoses and the cables at the outlet of the shaft. When an optional bellows set has been installed to the robot and then required cleanliness, to ensure the cleanliness level, use liquid gasket and others to seal the outlet on the shaft tip where the air hoses and the cables are pulled out.
- 10) Apply silicon grease to the contact surface between the air hoses of the fixing plate and the cables, the cable sliding portion from the shaft upper end to the fixed portion, and the opening on the shaft upper end.
- 11) Power on the controller, perform the jog operation for the J3 and J4 axes, and check that the air hoses and the cables do not interfere with other components.

CAUTION

Do not power on the controller when the internal cables are connected to the connectors on the robot.

If the end of the cables on the tool side is not processed, troubles such as fuse blown by ground fault or short circuit may occur. Check that the end of the cables has been processed before powering on the controller.

- 12) Turn off the controller's power supply, then install the No.2 arm cover U securely as before with fixing screws (tightening torque: 1.39 to 1.89 Nm).

When installing the cover, check that no air hose or cable is pinched, and no air hose is bent.

Note) The installation surface of a covers is using sealing material. In the event that the sealing material has been removed or has been bent or broken to the extent that it cannot be return to the original form, be sure to replace the sealing material. Please contact dealer when the sealing material needs to be replaced.

This completes installing the Hand internal wiring and piping set.

Refer to Page 55, "(1) Installation procedure" and install cables and air hoses correctly. The numbers in Fig. 3-4 are correspond to the same numbers in "(1)Installation procedure".

Turn the controller's power OFF before this operation. Refer to Page 68, "5.3.2 Installing/removing the cover" for removing/ installing the cover.

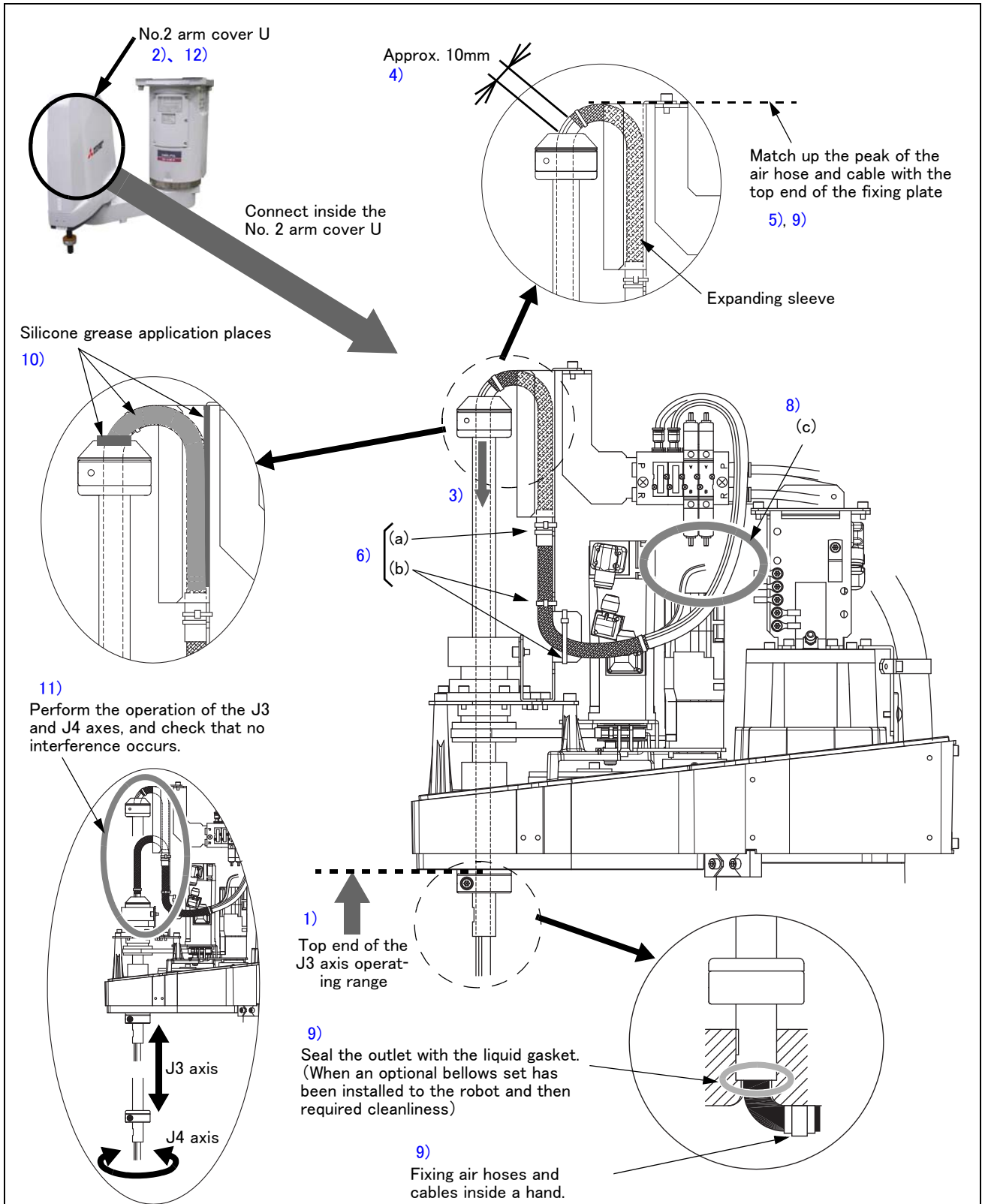

Fig.3-4 : Installing the hand internal wiring and piping set

3.5 External Wiring and Piping Box

The air hose that is connected inside the robot, the optional hand output cable, the hand input cable, etc., can all be pulled out from the rear of the No. 2 arm.

These can be used to connect a customer supplied solenoid valve to the hand output cable, etc.

When using this option, J1 axis operating range is limited ± 120 degree. And a stopper for changing the operating range option is required.

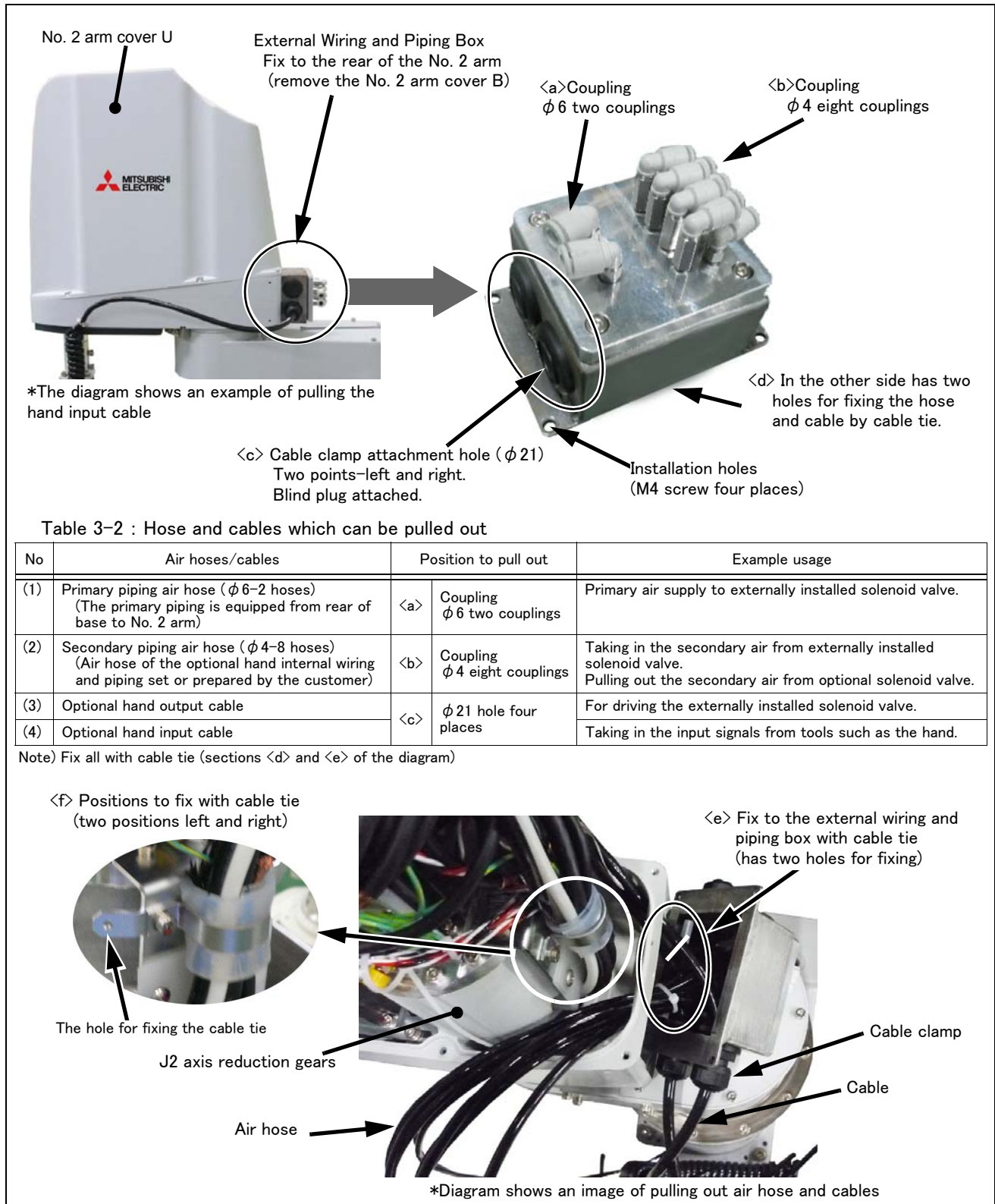

Fig.3-5 : External Wiring and Piping Box

Fig. 3-5 shows the installation procedure for the external wiring and piping box. Remove the No. 2 arm cover B and install this option using the same screw holes. The installation procedure is shown below.
 Turn the controller's power OFF before this operation. Refer to Page 68, "5.3.2 Installing/removing the cover" for removing/ installing the cover.

- 1) Remove the each fixing screws and remove the No. 2 arm cover U and the No. 2 arm cover B.
- 2) Pull out the air hoses or cables from the opening which removed the No. 2 arm cover B.
- 3) Fix (or connect) the air hoses and cables to this option box.
 Previously adjust the air hose and cables to an appropriate length. Make sure that the wiring and piping lines avoid the side of the J2 reducer (because gap is narrow, it interfere with the No. 2 arm cover U).
 Connect the air hoses with the joint inside this option box.
 Remove the blind plug attached to this option box and fix the cable with the cable clamp.

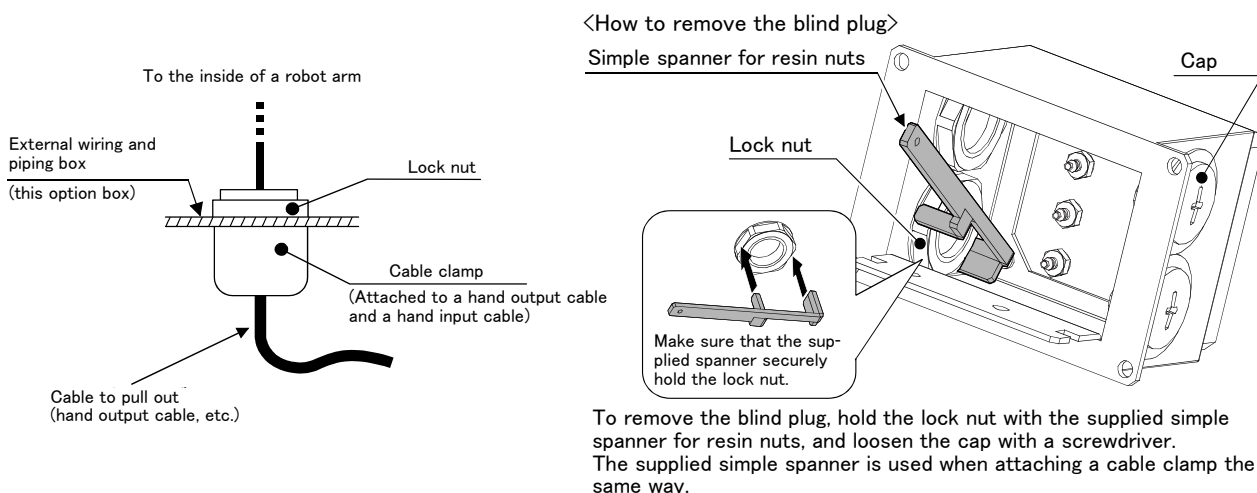

Fig.3-6 : Fixing the Cable

- 4) Fix the air hoses and cables to the hole inside of this box by using the attached cable tie. (section <e> of Fig. 3-5)
 Note) Be sure to fix the air hoses and cables to prevent the hoses falling out and breaking the cable. Also, fix carefully so that the air hose and cables may not be pulled too much.
- 5) Install securely the external wiring and piping box to the screw holes that previously installed the No. 2 arm cover B by attached screw. (tightening torque: 1.39 to 1.89Nm).
 When installing pull it little by little from the No. 2 arm side, making sure that the air hose and cables are not bent or trapped.
- 6) Make sure that the wiring and piping lines on the No.2 arm avoid the side of the J2 reducer (because gap is narrow, it interfere with the No. 2 arm cover U).
 Fix the hoses and cables to the hole shown in section <f> of Fig. 3-5 using cable tie. There are 2 holes, located left and right.
- 7) If the cables and the air hoses have excess length, please tie the excess section using cable tie.
- 8) Install securely the No.2 arm cover U as before with fixing screws (tightening torque: 1.39 to 1.89 Nm).
 Note) The installation surface of the covers is using sealing material. In the event that the sealing material has been removed or has been bent or broken to the extent that it cannot be return to the original form, be sure to replace the sealing material. Please contact dealer when the sealing material needs to be replaced.
 When an optional bellows set has been installed to the robot and then required cleanliness, to ensure the cleanliness level, use liquid gasket and others to seal the outlet on the shaft tip where the air hoses and the cables are pulled out.
- 9) Turn on the power supply, and set the parameter to change the operating range.

Parameter	Factory default setting	Contents of the change
MEJAR	-170, 170, □, □, □, □, □, □, ……	-120, 120 , □, □, □, □, □, …… (J1 axis operating range is limited ±120 degree)

Note) Refer to the separate "Instruction manual/Detailed Explanation of Functions and Operations" for the details of the setting method.

 **CAUTION**

The parameter must be changed to limit J1 axis operating range to ± 120 degree. If the parameter not be changed, this option and a robot could interfere and cause breakage.

- 10) After changing the parameter, turn off the controller power and turn on again. And, move the axis changed by joint jog operation to the limit of the operating range. Confirm that the robot stops by limit over at the changed angle.

This completes installing the External Wiring and Piping Box.

3.6 Installing the vacuum valve set

The installation summary of the vacuum valve is shown below. Remove the No.2 arm cover U, and install the vacuum valve on the No.2 arm. Turn the controller's power OFF before this installing operation. Refer to [Page 68](#), "5.3.2 Installing/removing the cover" for removing/ installing the cover.

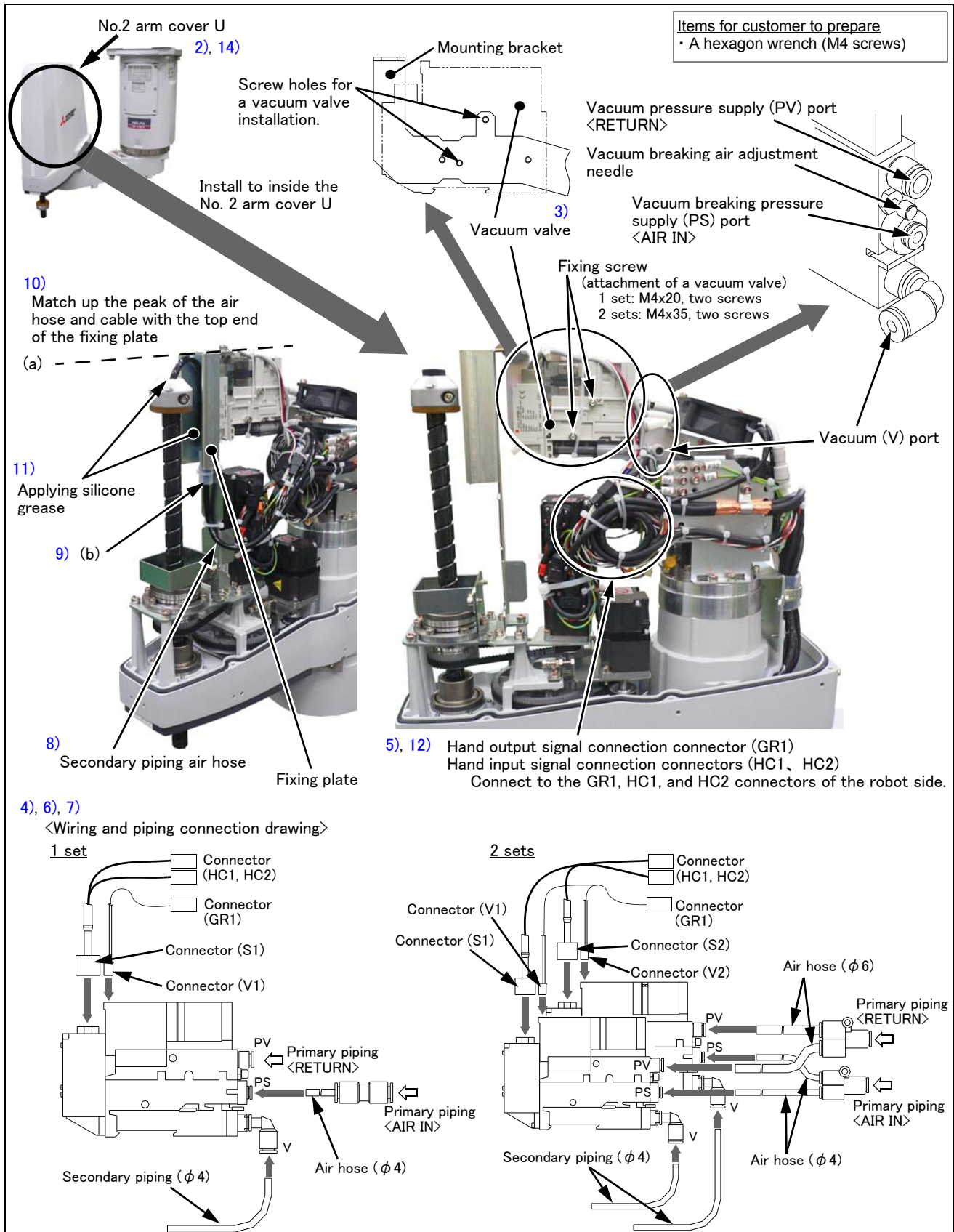

Fig.3-7 : Vacuum valve installation procedures

The installation procedure is detailed below.

- 1) Move the J3 axis to the top end with a jog operation and shut off the controller's power supply. This is necessary for space standard settings when feeding the air hose and hand input cable through the inside of the shaft.
- 2) Remove the screws fixing the No. 2 arm cover U, and remove the No. 2 arm cover U.
- 3) Fix the vacuum valve to the mounting bracket in the position indicated in Fig. 3-1. Place it so that the vacuum valve's primary piping connection joints (PV, PS, V ports) are located on the right hand side, and fix it securely using the attachment M4 screws (tightening torque: 1.39 to 1.89N · m).
When using a 2 sets vacuum valve, two vacuum valves are jointly fastened to the mounting bracket with screws.
- 4) Connect supplied cables and air hoses. The cables are connected to the vacuum valve by using the following connector.
 - 1 set: connector S1 and V1
 - 2 sets: connector of S1, S2, V1, and V2
- 5) Connect the hand input/output signal connection connectors (GR1, HC1, and HC2) of the vacuum valve with hand input/output signal connection connectors of robot arm side (GR1, HC1, and HC2). Connect with the same names.
The hand output signal cables of the robot arm side are located close to where the vacuum valve is installed and are tied up with cable tie. Pull out and connect them to the connectors.
- 6) Connect the primary piping air hose ($\phi 6$). The air hoses are located close to where the vacuum valve is installed and are tied up with cable tie. Cut the cable tie and connect them. Of the two air hoses, connect the one marked "AIR IN" to the vacuum valve's PS port, and the one marked "RETURN" to the PV port.
- 7) Connect the secondary piping air hose ($\phi 4$).
- 8) Pass the secondary piping air hose through the shaft.
- 9) The silicon rubber is supplied together with the vacuum valve to prevent bending the air hose. Wrap a secondary piping air hose in the silicon rubber and fix them with supplied cable tie at (b) portion shown in Fig. 3-1.
- 10) Carry out piping on the tool side.



CAUTION

Fix the air hose to the hand side. Check again that the highest point of the curved section of the air hose reaches the height of the fixing plate upper end, and then fix the air hose at the tool side. If the air hose is not long enough or too long, when the robot operates, excessive bending and friction with the shaft upper end or the cover may result in a break or abnormal operations of the tool (hand).

- 11) Apply silicon grease to the contact surface between the air hose of the fixing plate, the air hose sliding portion from the shaft upper end to the fixed portion, and the opening on the shaft upper end.
- 12) If the air hose have excess length, fix the excess section of the air hose at the plate with the cable tie.
- 13) Power on the controller, perform the jog operation for the J3 and J4 axes, and check that the air hose do not interfere with other components.
- 14) Turn off the controller's power supply, then install the No.2 arm cover U securely as before with fixing screws (tightening torque: 1.39 to 1.89 Nm).

Note) The installation surface of the cover is using sealing material. In the event that the sealing material has been removed or has been bent or broken to the extent that it cannot be return to the original form, be sure to replace the sealing material. Please contact dealer when the sealing material needs to be replaced.

This completes installing the solenoid valve set.

4 Basic operations

The basic operations from creating the program to automatic operation are explained in section "4. Basic operations" in the "From Controller Setup to Maintenance" manual. Refer that manual as necessary.

5 Maintenance and Inspection

The maintenance and inspection procedures to be carried out to use the robot for a long time without trouble are described in this chapter. The types and replacement methods of consumable parts are also explained.

5.1 Maintenance and inspection interval

Maintenance and inspection are divided into the inspections carried out daily, and the periodic inspections carry out at set intervals. Always carry these out to prevent unforeseen trouble, to maintain the product for a long time, and to secure safety.

(1) Inspection schedule

In addition to the monthly inspection, add the following inspection items every three months (estimated at 1,000 Hr operation hours).

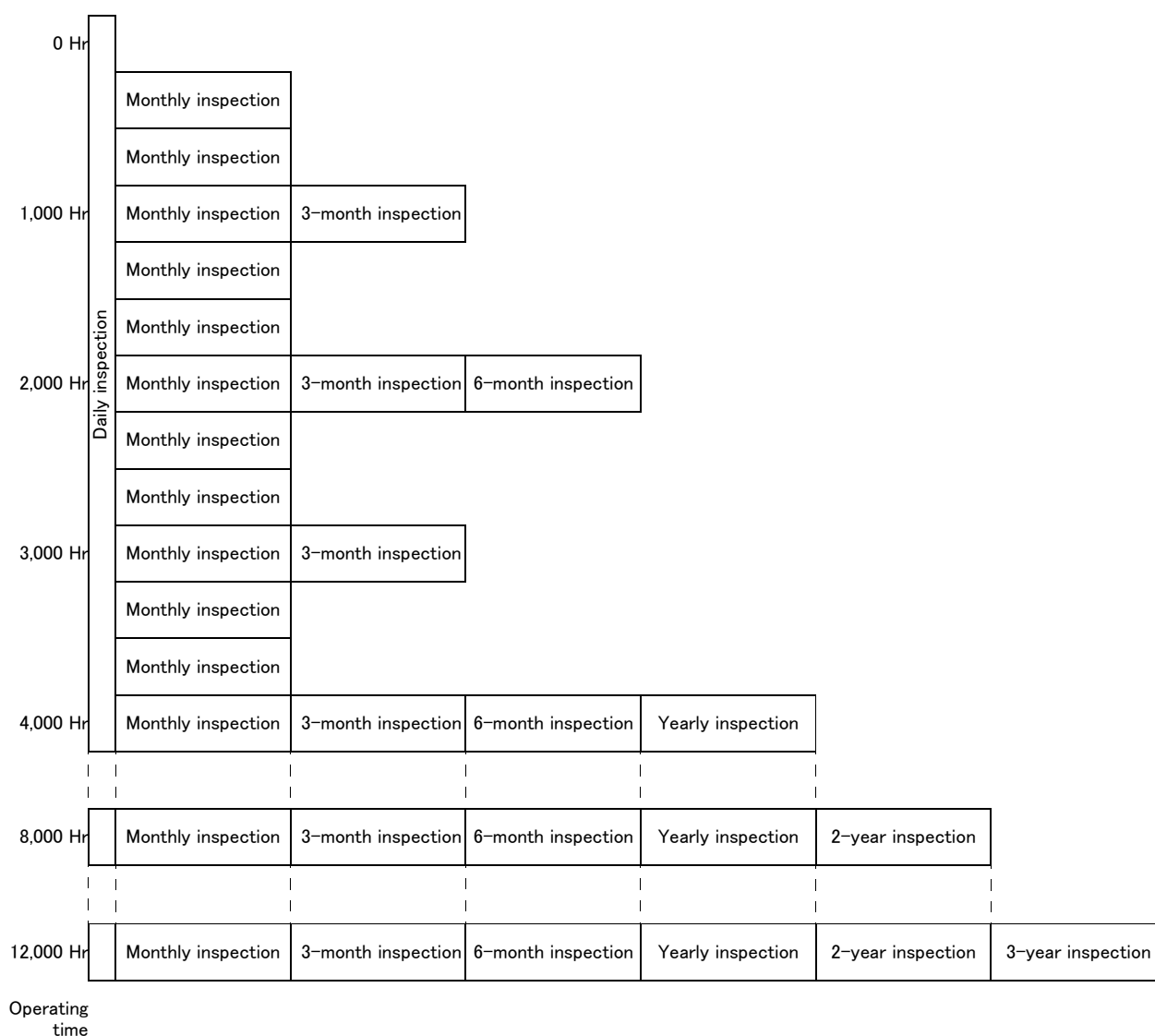

<Guideline for inspection period>

For one shift..... $10 \text{ Hr/day} \times 20 \text{ days/month} \times 3 \text{ months} = \text{approx. } 600 \text{ Hr}$

For two shifts..... $15 \text{ Hr/day} \times 20 \text{ days/month} \times 3 \text{ months} = \text{approx. } 1,000 \text{ Hr}$

[Caution] When using two lines, the 3-month inspection, 6-month inspection and yearly inspection must be carried out when half the time has passed.

Fig.5-1 : Inspection schedule

5.2 Inspection items

The inspection items for the robot arm are shown below.

Also refer to section “5. Maintenance and inspection” in the “Controller setup, basic operation, and maintenance” manual, and inspect the controller.

5.2.1 Daily inspection items

Carry out the daily inspections with the procedures given in [Table 5-1](#).

Table 5-1 : Daily inspection items (details)

Procedure	Inspection item (details)	Remedies
Before turning power ON (Check the following items before turning the power ON.)		
1	Are any of the robot installation bolts loose? (Visual)	Securely tighten the bolts.
2	Are any of the cover tightening screws loose? (Visual)	Securely tighten the screws.
3	Are any of the hand installation bolts loose? (Visual)	Securely tighten the bolts
4	Is the power supply cable securely connected? (Visual)	Securely connect.
5	Is the machine cable between the robot and controller securely connected? (Visual)	Securely connect.
6	Are there any cracks, foreign contamination or obstacles on the robot and controller cover?	Replace with a new part, or take remedial measures.
7	Is there any abnormality in the pneumatic system? Are there any air leaks, drain clogging or hose damage? Is the air source normal? (Visual)	Drain the drainage, and remedy the air leaks (replace the part).
8	Are there any cracks, foreign contamination or obstacles on the bellows? (For bellows-installed robot) (Visual)	Replace with a new bellows.
After turning the power ON (Turn the power ON while monitoring the robot.)		
1	Is there any abnormal motion or abnormal noise when the power is turned ON?	Follow the troubleshooting section.
During operation (try running with an original program)		
1	Check whether the movement points are deviated? Check the following points if there is any deviation. 1. Are any installation bolts loose? 2. Are any hand installation section bolts loose. 3. Are the positions of the jigs other than the robot deviated? 4. If the positional deviation cannot be corrected, refer to “Troubleshooting”, check and remedy.	Follow the troubleshooting section.
2	Is there any abnormal motion or abnormal noise? (Visual)	Follow the troubleshooting section.

5.2.2 Periodic inspection

Carry out periodic inspection with the procedures given in [Table 5-2](#).

Table 5-2 : Periodic inspection items (details)

Procedure	Inspection item (details)	Remedies
Monthly inspection items		
1	Are any of the bolts or screws on the robot arm loose?	Securely tighten the bolts.
2	Are any of the connector fixing screws or terminal block terminal screws loose?	Securely tighten the screws.
3-month inspection items		
1	Is there any grease of the shaft section still?	Wipe off the old grease and supply the new grease.
6-month inspection items		
1	Has the dust accumulated into bellows? (For bellows-installed robot. When environment with much dust)	Remove bellows and clean the inside. (Refer to Page 82 , "5.3.5 Replacing the bellows (Option)" for how to remove bellows)
Yearly inspection items		
1	Replace the backup battery in the robot arm.	Exchange it referring to Page 85 , "5.3.7 Replacing the backup battery".
2-year inspection items		
1	Is the friction at the timing belt teeth severe?	If the teeth are missing or severe friction is found, replace the timing belt.
2	Is the timing belt tension abnormal?	If the timing belt is loose or too tense, adjust it.
3-year inspection items		
1	Replace the bellows (J3 axis). (For bellows-installed robot)	Replace it referring to Page 82 , "5.3.5 Replacing the bellows (Option)"

Note) Supply the grease to each axis with referring to [Page 83](#), "5.3.6 Lubrication".

5.3 Maintenance and inspection procedures

The procedures for carrying out the periodic maintenance and inspection are described in this section. Thoroughly read the contents, and follow the instructions. This work can be commissioned to the Mitsubishi Service Department for a fee. (Never disassemble, etc., the parts not described in this manual.)

The maintenance parts, etc., required for the customer to carry out maintenance and inspection are described in Page 88, "5.5 Maintenance parts" of this manual. Always contact your dealer when parts are needed.

CAUTION The origin of the machine system could deviate when this work is carried out. "Review of the position data" and "re-teaching" will be required.

5.3.1 Robot arm structure

The outline drawing is shown in Fig. 5-2.

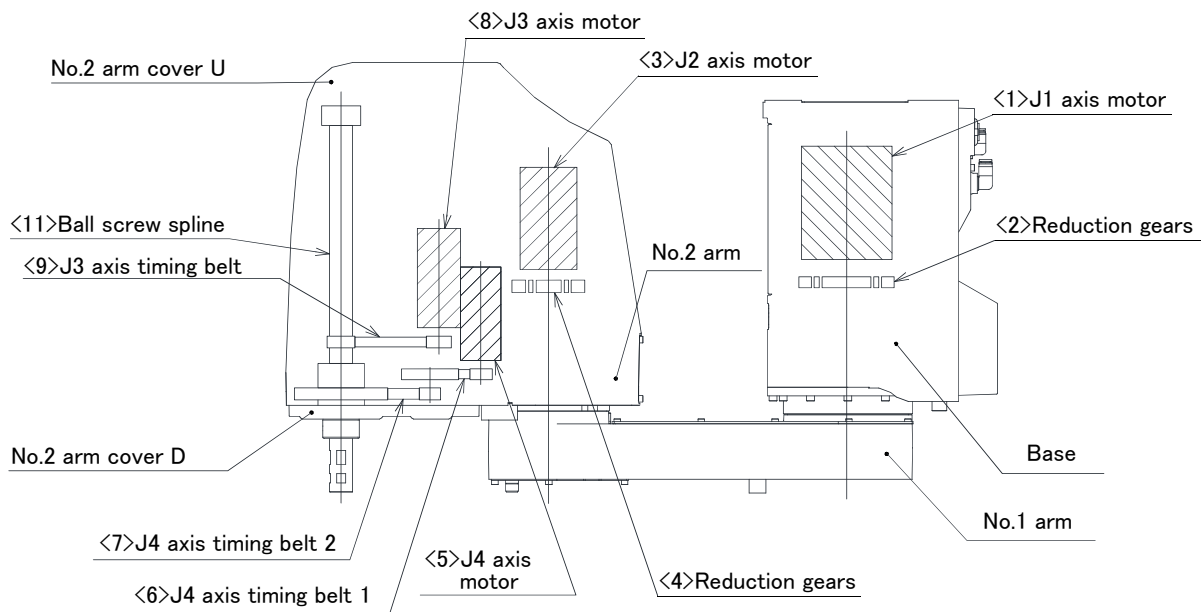

Fig.5-2 : Outline structure drawing of robot arm

5.3.2 Installing/removing the cover

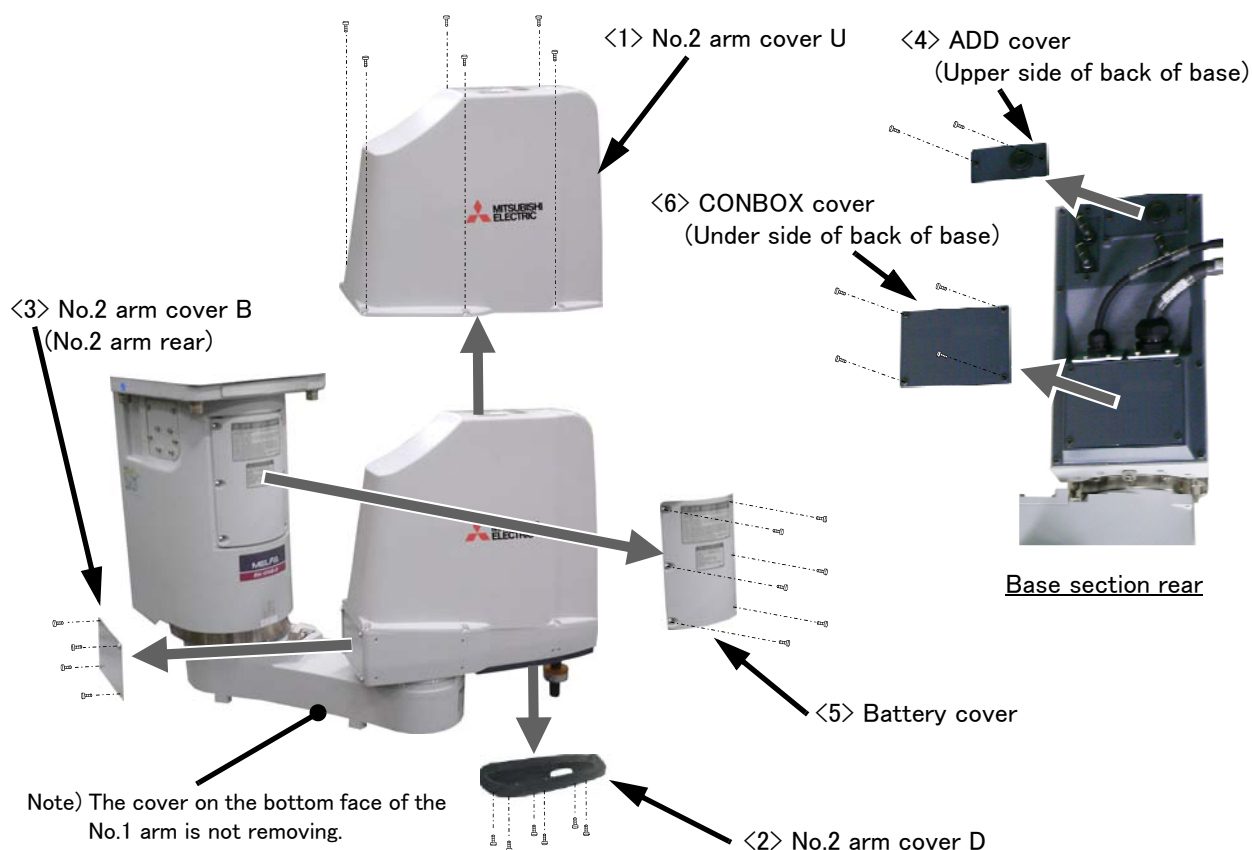

Fig.5-3 : Installing/removing the cover

**CAUTION**

Check to see that the packing has not been torn or peeled off when the cover was mounted/removed. If it has been torn or peeled off, please contact dealer. If the cover is used with the packing torn or peeled off, oil mist and other substances may enter inside the arm and cause a malfunction.

Table 5-3 : Cover fixing screw list

No.	Cover name	Installation screw name: Qty. ^{Note1)}	Remarks
<1>	No.2 arm cover U	Truss head screw, M4 x 10: 6	
<2>	No.2 arm cover D	Truss head screw, M4 x 10: 6	
<3>	No.2 arm cover B	Hexagon socket screw, M4 x 8: 4	
<4>	ADD cover	Hexagon socket screw, M4 x 8: 2	
<5>	Battery cover	Truss head screw, M4 x 10: 6	
<6>	CONBOX cover	Hexagon socket screw, M4 x 8: 4	

Note1) The fixing torque for each screw are 1.39–1.89Nm.

- (1) Referring to Fig. 5-3, remove the covers.
- (2) The names of the covers and installation screws are given in Table 5-3.
- (3) When reattaching the covers after a maintenance inspection, proceed in the reverse order of their removal. Tightening the screw with the torque shown in Table 5-3.

[Note] Sealant is applied to the installation surface of cover. Be sure to replace the sealant if it has been dislocated and bent or crushed and does not return to its original shape. Moreover, when replacing a sealant, it is necessary to remove the optional bellows. Refer to Page 82, "5.3.5 Replacing the bellows (Option)" for details on how to remove bellows.

5.3.3 Packing Replacement Procedure

When signs of cracking or peeling are noted in the packing, they must be replaced. Replace the packing in accordance with the instructions given below. If the packing is not replaced in a timely manner, water or oil will be allowed to intrude the robot, possibly making it inoperative.

(1) Packing Replacement Instructions

Stick again new packing as before.

- 1) Remove the old packing, and clean and degrease the surface on which it has been placed.
- 2) The sticking surface of packing is double-coated adhesive tape. Referring to "Fig.5-4 : Example of sticking packing (good example)" and "Fig.5-6 : Sticking the cord-like packing", and stick the packing in line with form . Be careful for the packing not to slide. The example of unsuitable packing slid is shown in "Fig.5-5 : Example of sticking packing (bad example)".
- 3) Although the No.2 arm cover (U) sticks two or more packings per place, it has length with which packing ends overlap. Stick packing in the following procedures. For more information, see "Fig.5-7 : Examples of packing overlaps". Examples of improperly treated cut edge are shown, as well.
 - a) Stick packing in line with form of the sticking surface. Finally, cut packing so that adjoining pieces have a 1mm overlap at the end.
 - b) Apply liquid gasket to the cut edges. (Designated liquid gasket: 1212 (Maker: Three Bond))
 - c) Stick so that the gap may not be made to each other's packing.

⚠ CAUTION Do not install the cover immediately after sticking packing. Install the cover, after the 6 hours pass after sticking packing for gasket hardening.

- 4) Confirm that packing is stuck correctly and install the cover. When tightening the bolts fixing the cover, avoid tightening them to a specified torque at a time. Tighten the bolt in the order shown as much as possible in the "Fig. 5-8 Example of order which tighten bolts" The torque which tightens the fixing bolt of each cover is shown in "Table 5-3 : Cover fixing screw list".

⚠ CAUTION Stick the packing securely, pressing down with the finger. If sticking is insufficient, when the cover is installed, packing slides by the pressure, and there is a possibility that it may become impossible to secure protection performance.

Completion of packing replacement



Fig.5-4 : Example of sticking packing (good example)

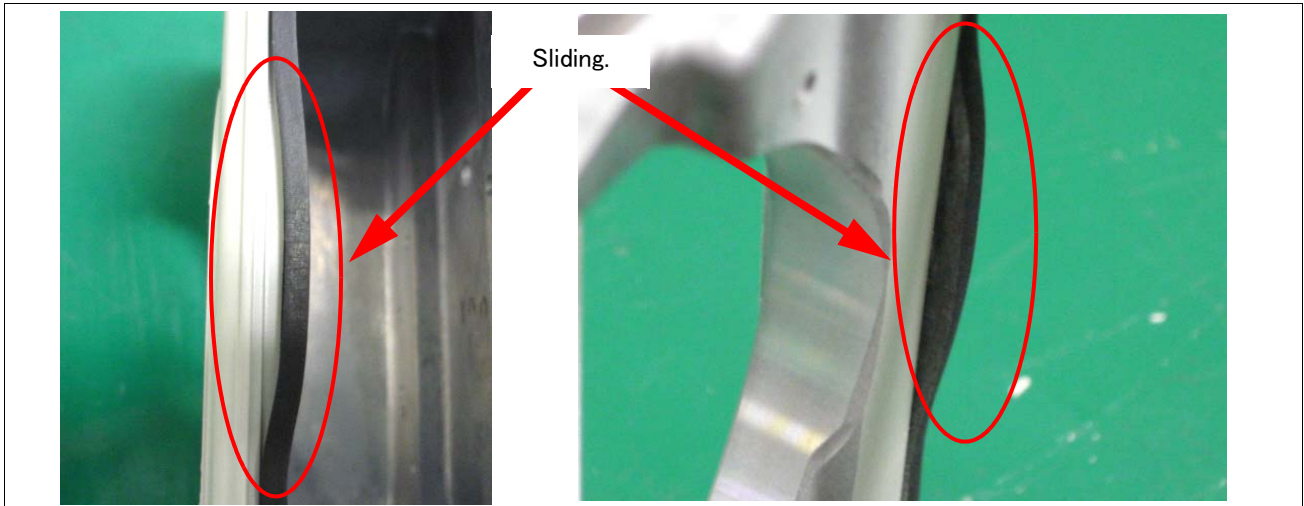

Fig.5-5 : Example of sticking packing (bad example)

Some of the packings to be used are cord-like.
Stick such packings by bending in line with the form.

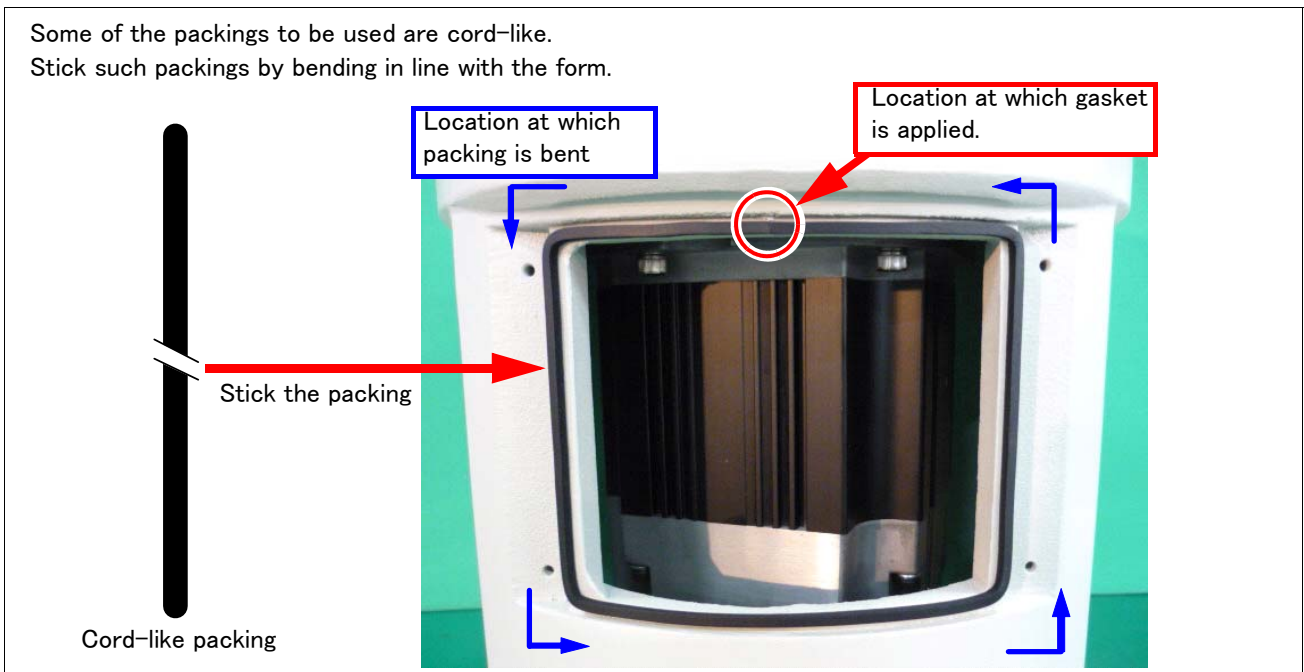
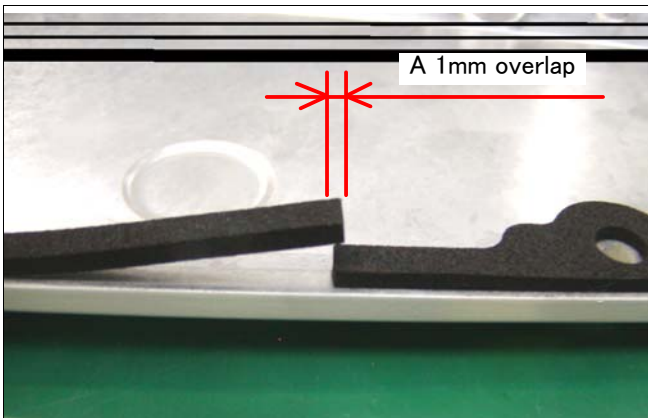
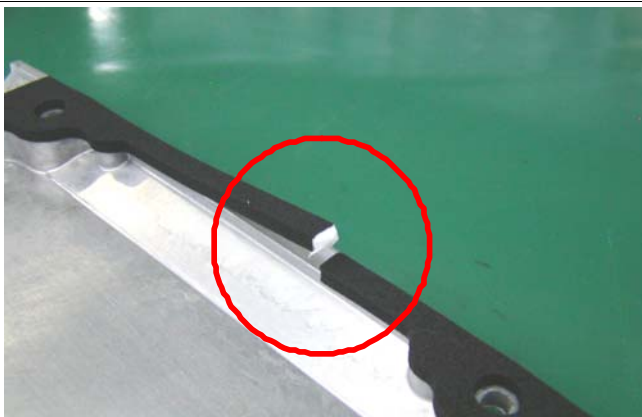

Fig.5-6 : Sticking the cord-like packing



A 1mm overlap



[1] Cut the packing so that there is a 1mm overlap at the end.

[2] Apply liquid gasket to the cut edges.

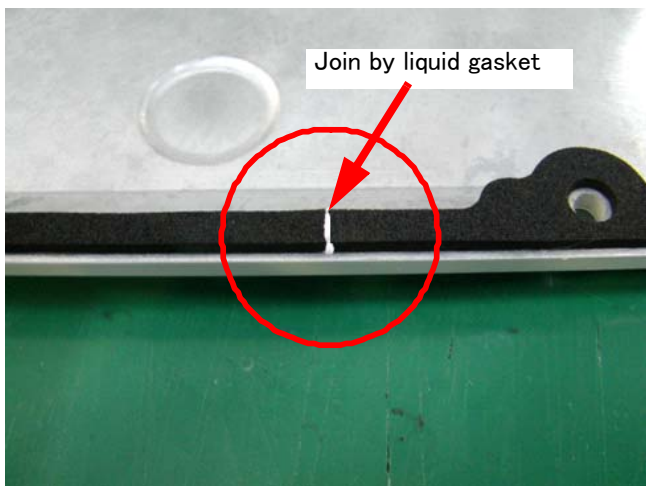

Join by liquid gasket

[3] Stick the packing so that there is no gap between the adjacent pieces.

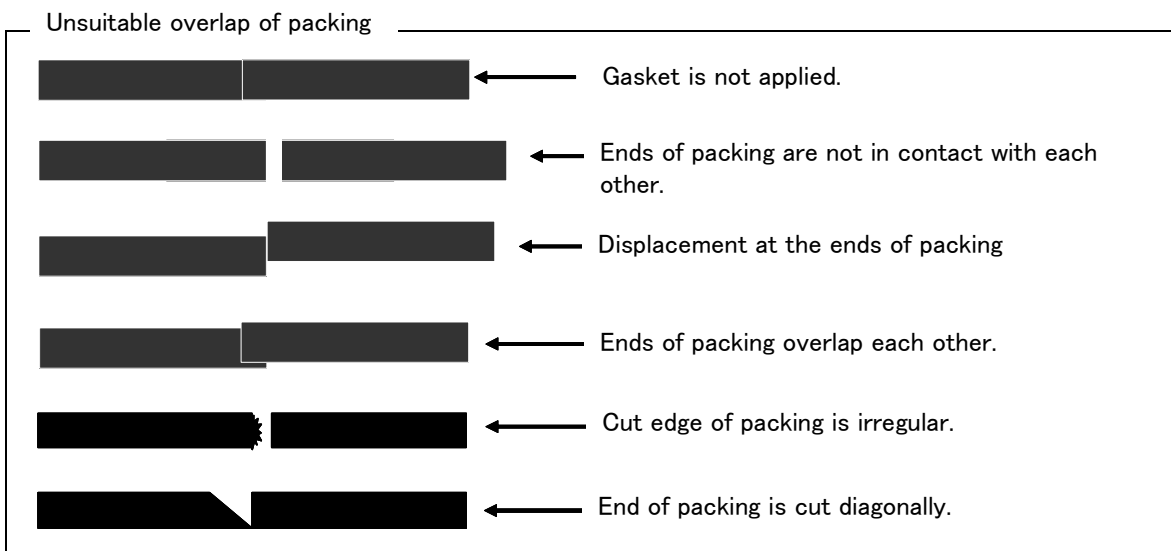

Fig.5-7 : Examples of packing overlaps

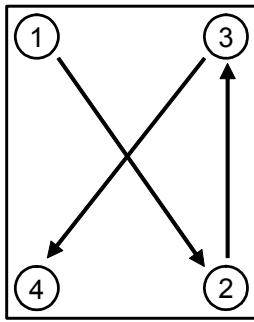

Fig.5-8 : Example of order which tighten bolts

5.3.4 Inspection, maintenance and replacement of timing belt

This robot uses a timing belt for the drive conveyance system of the J5 axis. Compared to gears and chains, the timing belt does not require lubrication and has a low noise. However, if the belt usage method and tension adjustment are inadequate, the life could drop and noise could be generated. Sufficient aging to remove the initial elongation of the belt, and adjustment of the belt tension have been carried out before shipment from the factory. However, depending on the robot working conditions, elongation will occur gradually over a long time. The tension must be confirmed during the periodic inspection.

The replacement is necessary if the timing belt is in the condition which showed in “(1)Timing belt replacement period”. The inspection and adjustment and replacement method of the timing belt of each axis is shown below. Please check, and adjust and replace if necessary.

In addition, it is serviceable if there is the sound wave type belt tension gauge in inspection and adjustment of the timing belt. The recommendation gauge is shown below. Please prepare by customer. Refer to the Page 81, “(5) Timing belt tension” for the tension adjustment value of the timing belt.

Maker:Gates Unitta Asia Company,
Type:U-505



Image of Measurement by the sound wave type belt tension gauge



Measurement by the push-pull gauge

Fig.5-9 : Tension adjustment method of timing belt

(1) Timing belt replacement period

The timing belt life is greatly affected by the robot working conditions, so a set time cannot be given. However, if the following symptoms occur, replace the belt.

- 1) When cracks form at the base or back of the belt teeth.
- 2) When the belt expands due to adherence of oil, etc.
- 3) When the belt teeth wear (to approx. half of the tooth width).
- 4) When the belt teeth jump due to belt teeth wear.
- 5) When the belt snaps.

CAUTION

Due to the manufacturing of the timing belt, initial wear will occur. Wear chips may accumulate in the cover after approx. 300 Hr of operating the robot, but this is not a fault. If the wear chips appear soon after wiping them off, replace the belt.

CAUTION

When the belt is replaced, the machine system origin may deviate. In this case, the position data must be reviewed.

(2) Inspecting/Adjusting the J3 axis timing belt

The section related to J3 axis timing belt and adjustment is shown in Fig. 5-10. The picture is the image which removed the No.2 arm cover.

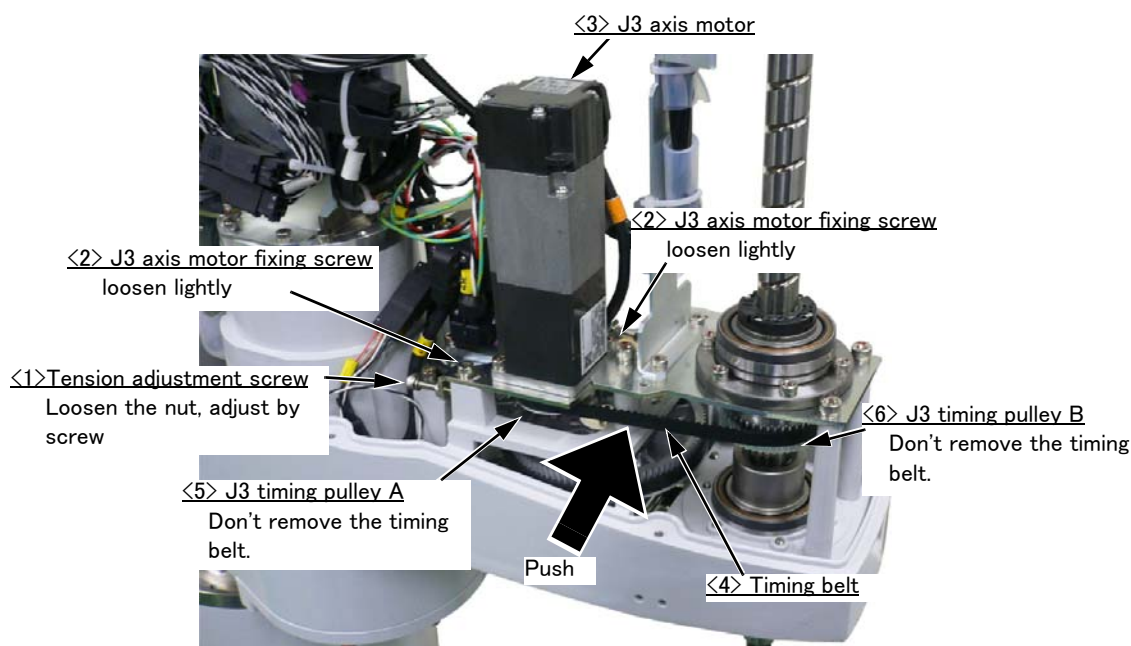

Fig.5-10 : Inspecting/Adjusting the J3 axis timing belt

Inspection and adjustment procedure of the timing belt of J3 axis are shown below.

- 1) Confirm that the power supply of the controller is OFF.
- 2) Refer to Page 68 "Fig. 5-3: Installing/removing the cover", and remove the No.2 arm cover U.
- 3) Visually confirm that the symptoms indicated in "(1)Timing belt replacement period" have not occurred with the <4> timing belt.
- 4) Lightly press the center of the belt, and confirm that the value of belt slack is in Page 81 "Fig. 5-12: Belt tension". Or measure the tension of the belt with tension meters, and confirm that the value is in the range of standard tension shown in Page 81 "Fig. 5-12: Belt tension".

When adjustment is necessary, continue to follow the procedure shown below.

When adjustment is not necessary, install the No.2 arm cover U as before and finish the inspection.

- 5) Lightly loosen J3 motor installation screws <2> (Be careful not to overly loosen the screws.).
- 6) The nut which is fixing tension adjustment screw <1> is loosened, turn tension adjustment screw <1>, and adjust the tension of timing belt <4>.

When the screw is turned to the right, the belt will be stretched, and when turned to the left, will loosen. Adjust tension to the above-mentioned value.

Note) Be careful, if the belt is removed from pulley <5> <6>, or the mesh of belt and pulley <5> <6> is shifted by loosening the screw too much, the origin will deviate. If the position deviated, reset the origin. (Refer to Page 89, "5.6 Resetting the origin")
- 7) After adjustment, fasten securely the two J3 axial motor fixing screws <2>, and the nut of tension adjustment screw <1>. Improper tightening may cause the belt to loosen with vibration.
- 8) Install No.2 arm cover U securely as before and finish adjustment.

This completes adjustment of the J3 axis timing belt.

(3) Replacing the J3 axis timing belt

The procedure for replacing the J3 axis timing belt is shown below. The diagram shows an image of the removed No. 2 arm cover U.

After replacing the J3 axis timing belt the resetting the origin of J3 and J4 axis is necessary.

1) Move the J3 axis to the position lowered about 30mm from the upper limit by jog operation. This position makes the space for removing the belt.

After moving the J3 axis turn the controller's power supply OFF.

2) Refer to Page 68 "Fig. 5-3: Installing/removing the cover", and remove the No.2 arm cover U.

3) Loosen the nut of tension adjustment screw <1>, and loosen the tension adjustment screw <1>.

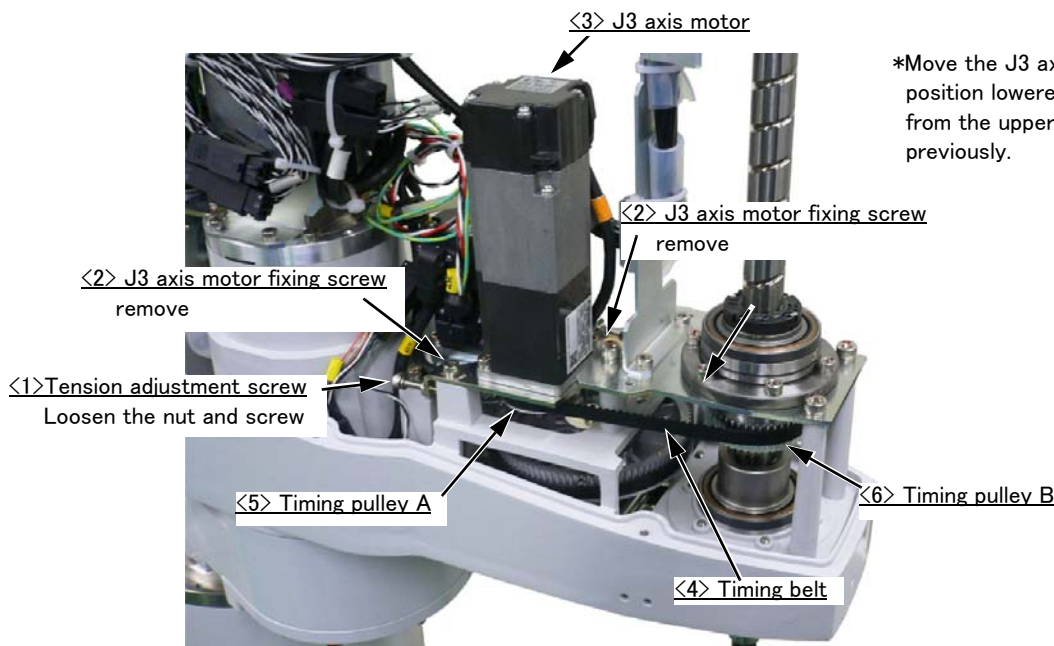

4) Remove two fixing screws <2>, remove the J3 axis motor <3>, remove the timing belt <4> from the timing pulley A <5>.

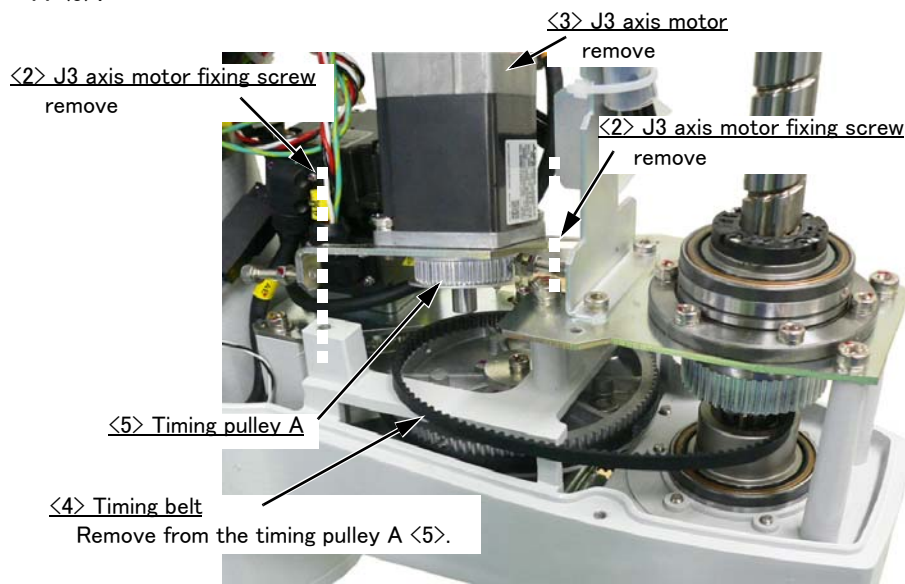

- 5) Remove the timing belt <4> from the shaft to upward.
 Remove the fixing screw <7> of shaft fixing plates and lift up the shaft fixing plate <8>.
 When using the optional hand internal wiring and piping set remove the fixing screws fixed to the top.
 Remove the timing belt <4> from the timing belt removal space <9> created under the shaft fixing plate <8> by lift up.

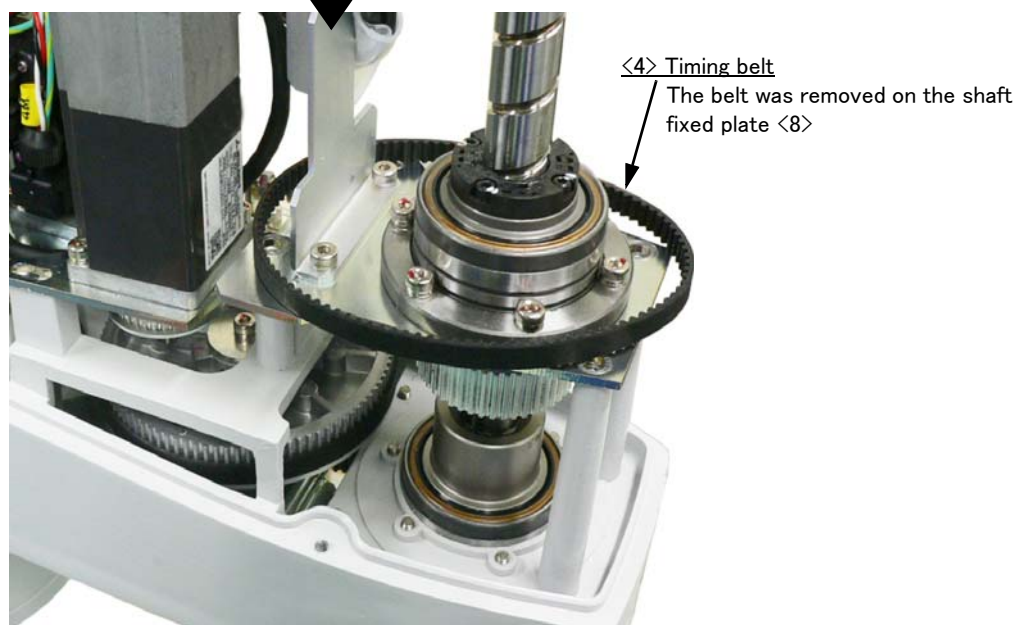
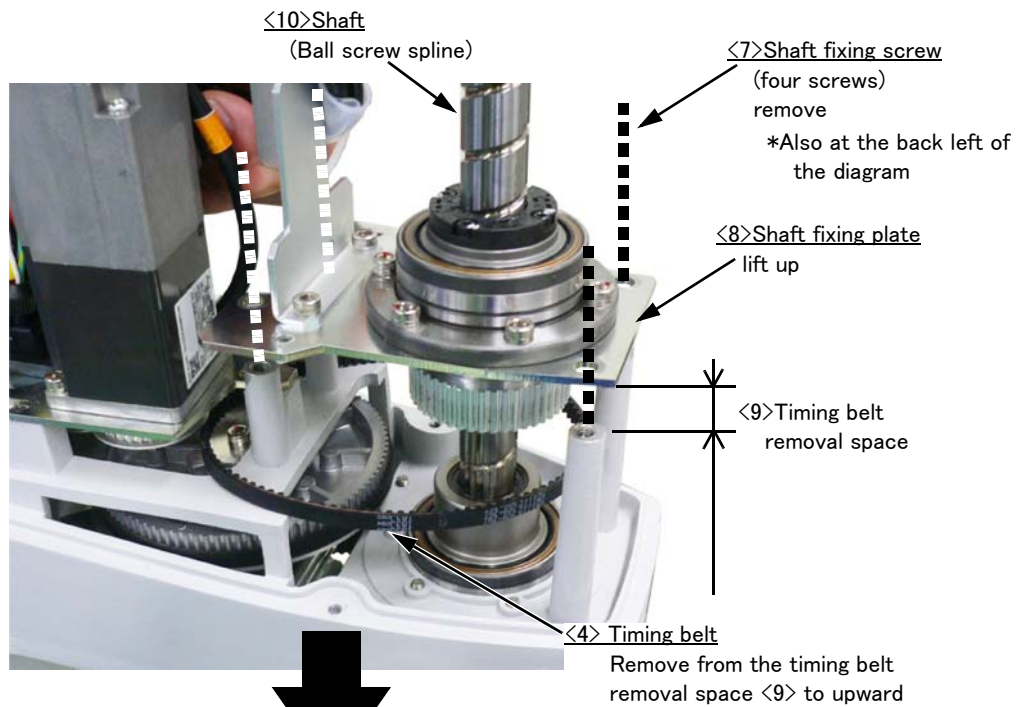

- 6) Remove the timing belt <4> from the top of the shaft
If using the optional hand internal wiring and piping set, temporarily remove the hand input cable connector <11> and air hoses <12> of solenoid valve side. And remove the timing belt to upward.

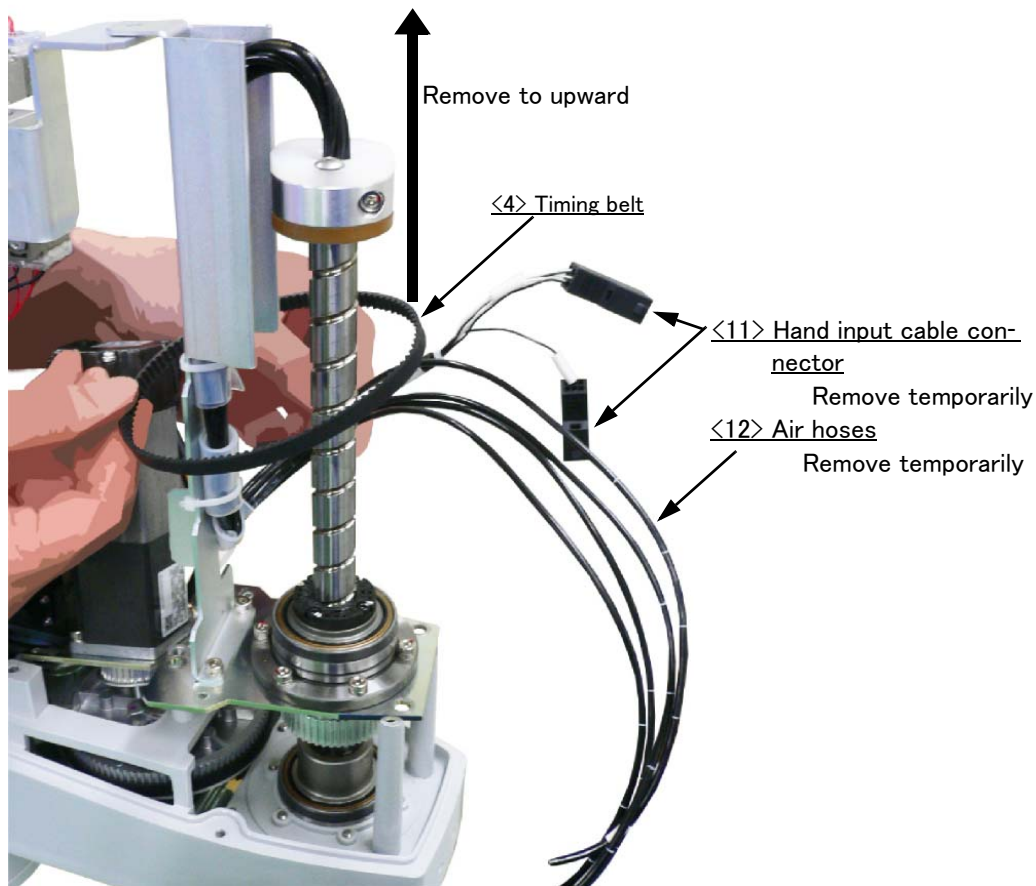

- 7) Install the new timing belt in reverse procedure of removal.
Install the new belt to the timing pulley (on the motor) <5> and timing pulley B <6> securely.
Fix the shaft fixing plate <8> by fastening the original fixing screws securely.
If using the hand input cables <11> and air hoses <12>, connect them as before.
- 8) Install the J3 axis motor <3> by tightening lightly the J3 axis motor fixing screw <2> (two screws)
- 9) Adjust the tension of J3 axis timing belt with referring to [Page 74, "\(2\) Inspecting/Adjusting the J3 axis timing belt"](#).
- 10) Install No.2 arm cover U securely as before.
- 11) Reset the origin of J3 and J4 axis with referring to the [Page 89, "5.6 Resetting the origin"](#)
- 12) When the maintenance forecast function is valid, reset the accumulation data about the belt. Reset by the dedicated screen or parameter MFBRST of RT ToolBox2. Refer to "Instruction Manual/RT ToolBox2 User's Manual" for operation of RT2 and refer to "Instruction Manual/Detailed Explanation of Functions and Operations" for the parameter.

This completes replacement of the J3 axis timing belt.

(4) Inspecting/Adjusting the J4 axis timing belt

As shown in Fig. 5-11, the J4 axis timing belt consists of two timing belts: timing belt A <1> and timing belt B <2>. When adjusting the timing belts, first adjust timing belt B <2> and then proceed to adjust timing belt A <1>.

<The No.2 arm bottom view (Inside of the No.2 arm cover D)>

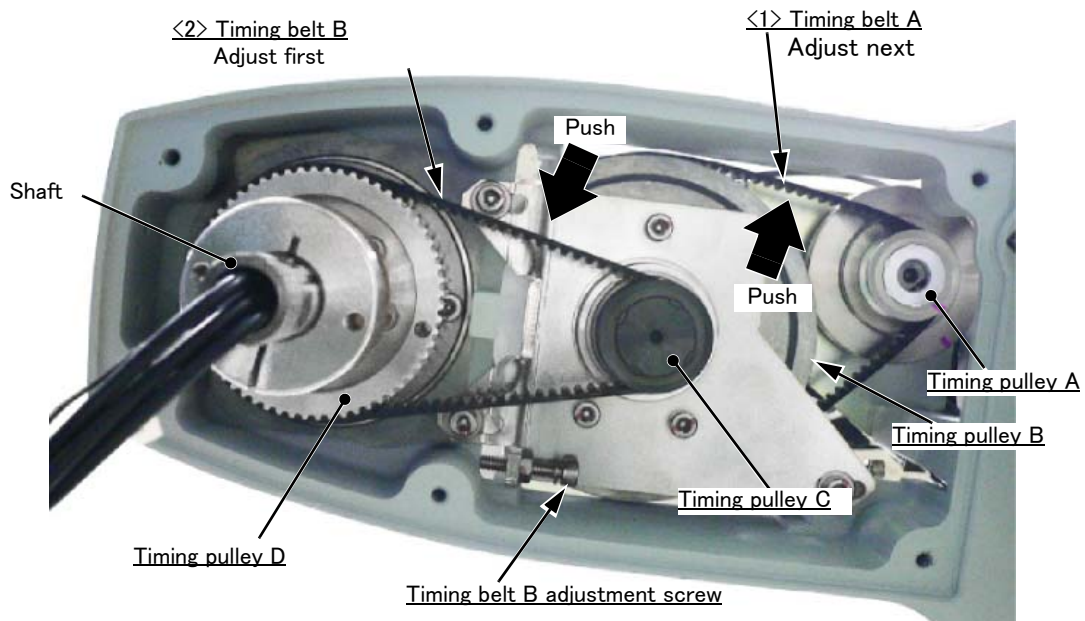

<The No.2 arm upper view (Inside of the No.2 arm cover U)>

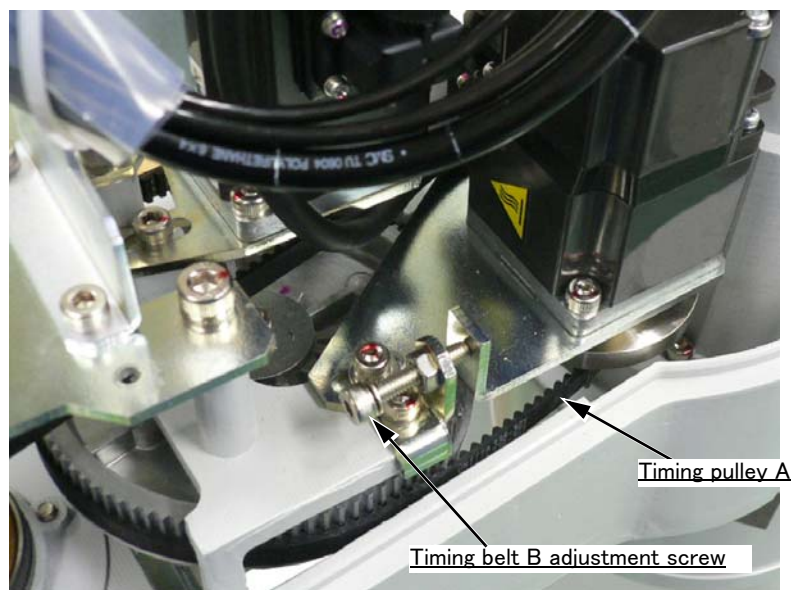

Fig.5-11 : Inspecting/Adjusting the J4 axis timing belt

Inspection and adjustment procedure of the timing belt of J4 axis are shown below.

- 1) Confirm that the power supply of the controller is OFF.
- 2) Refer to Page 68 "Fig. 5-3: Installing/removing the cover", and remove the No.2 arm cover U and No.2 cover D.
- 3) Visually confirm that the symptoms indicated in "(1)Timing belt replacement period" have not occurred with the timing belt.
- 4) Lightly press the center of the belt, and confirm that the value of belt slack is in Page 81 "Fig. 5-12: Belt tension".
Or measure the tension of the belt with tension meters, and confirm that the value is in standard tension shown in Page 81 "Fig. 5-12: Belt tension".

When adjustment is necessary, continue to follow the procedure shown below.

When adjustment is not necessary, install the No.2 arm cover U and No.2 arm cover D as before and finish the inspection.

- 5) Adjusts the tension of the timing belt B <2>.
Lightly loosen timing pulley <C> fixing screws <3> (Be careful not to overly loosen the screws.)
- 6) Loosen the nut of tension adjustment screw <4> for timing belt B. Adjusts by turning the tension adjustment screw <4> slowly and moving the timing pulley C <5> little by little.
When the screw is turned to the right, the belt will be stretched, and when turned to the left, will loosen. Adjust tension to the above-mentioned value.
Note) Be careful, if the belt is removed from pulley <5> <6>, or the mesh of belt and pulley <5> <6> is shifted by loosening the screw too much, the origin will deviate. If the position deviated, reset the origin. (Refer to Page 89, "5.6 Resetting the origin")

<The No.2 arm bottom view (Inside of the No.2 arm cover D)>

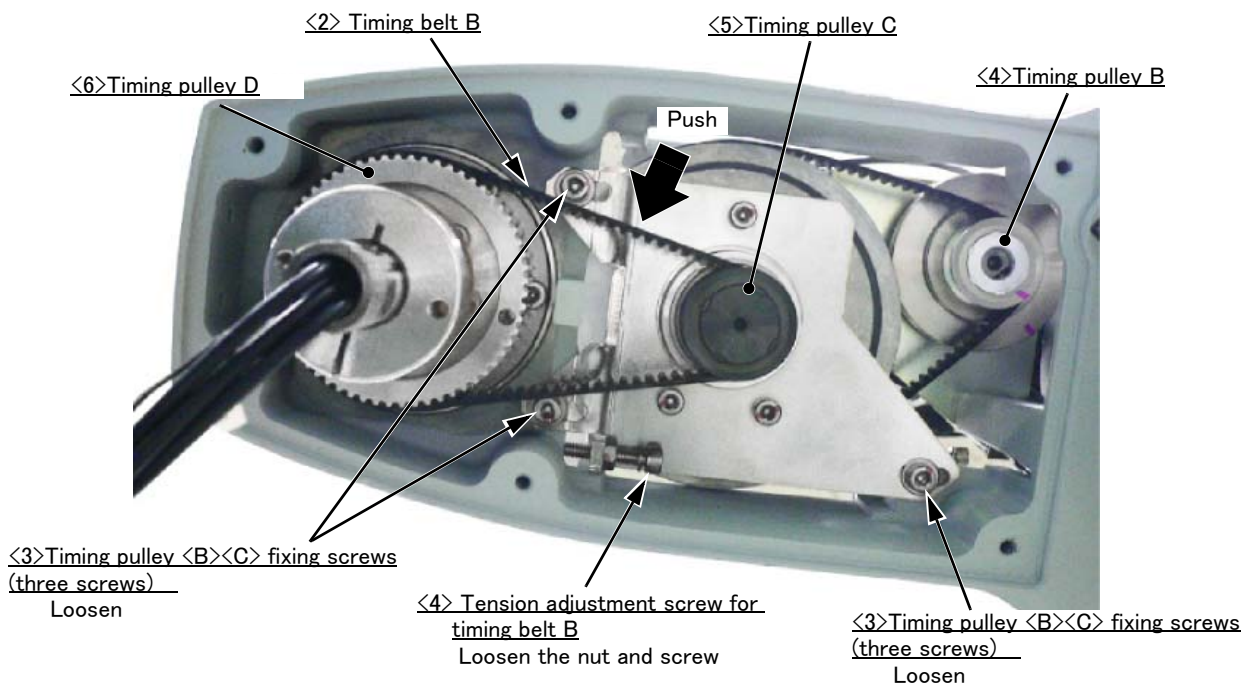

- 7) After adjustment, fasten certainly the three timing pulley <C> fixing screws <3>. And fasten certainly the nut of tension adjustment screw <4>. Improper tightening may cause the belt to loosen with vibration.

8) Next, adjust the tension of the timing belt A <1>.

Lightly loosen two J4 motor fixing screws <7> (Be careful not to overly loosen the screws.).

9) Loosen the nut of tension adjustment screw <8> for timing belt A. Adjust by turning the tension adjustment screw <8> slowly and moving the J4 axis motor <9> little by little.

When the screw is turned to the right, the belt will be stretched, and when turned to the left, will loosen. Adjust tension to the above-mentioned value.

Note) Be careful, if the belt is removed from pulley <10> <4>, or the mesh of belt and pulley <10> <4> is shifted by loosening the screw too much, the origin will deviate. If the position deviated, reset the origin. (Refer to [Page 89](#), "5.6 Resetting the origin")

<The No.2 arm upper view (Inside of the No.2 arm cover U)>

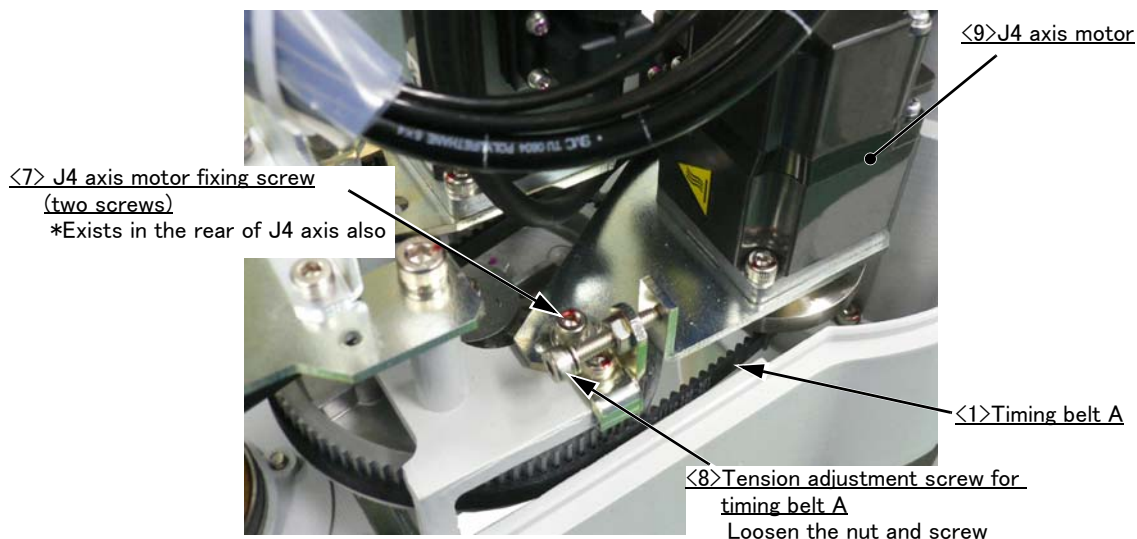

<The No.2 arm bottom view (Inside of the No.2 arm cover D)>

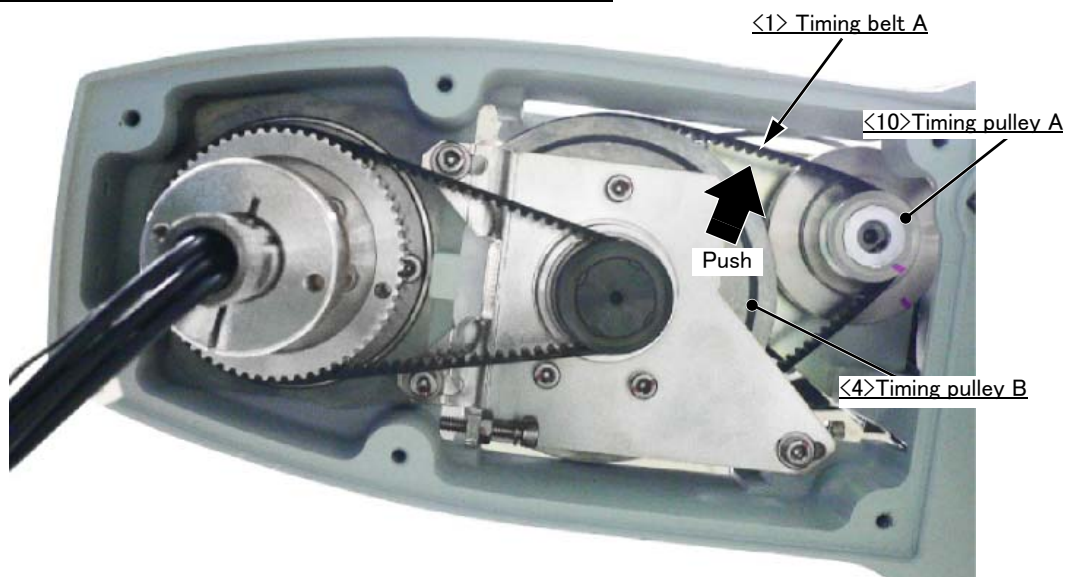

10) After adjustment, fasten certainly the two J4 motor fixing screws <7> And fasten certainly the nut of tension adjustment screw <8>. Improper tightening may cause the belt to loosen with vibration.

11) Install No.2 arm cover U and No.2 arm cover D securely as before and finish adjustment.

This completes adjustment of the J4 axis timing belt.

(5) Timing belt tension

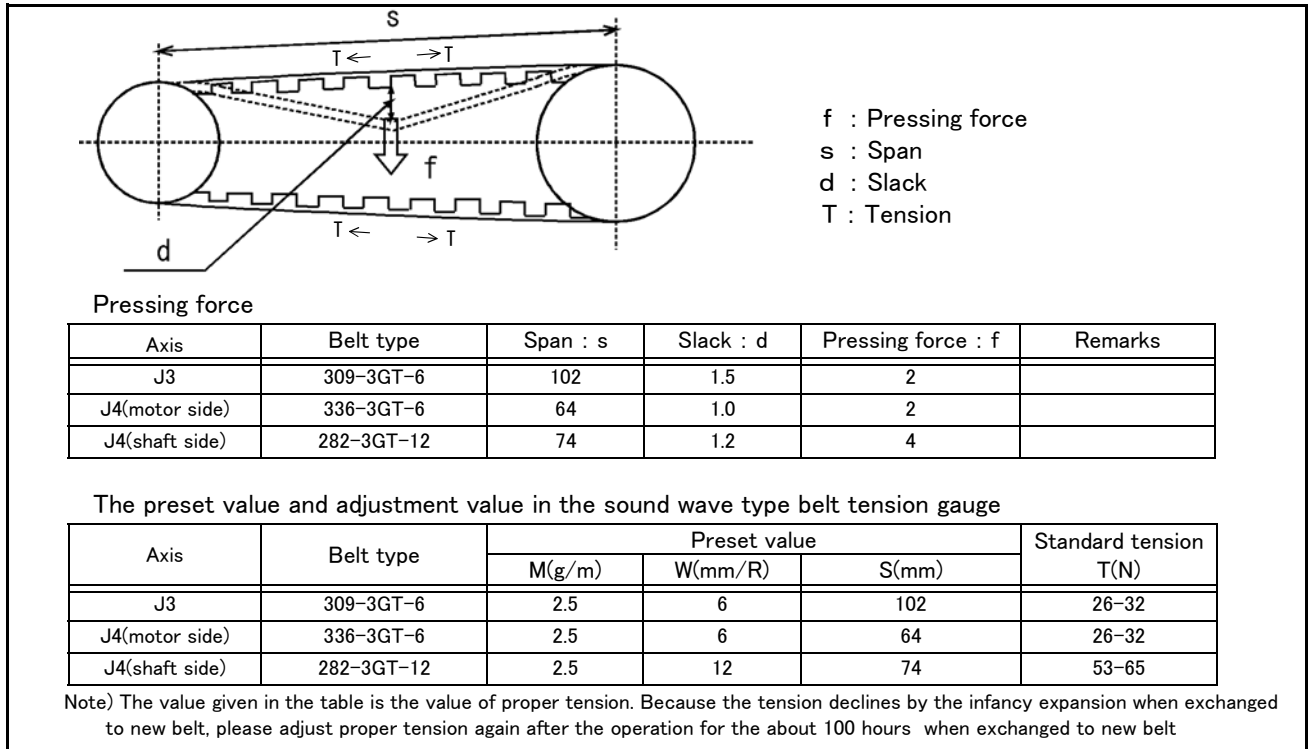

Fig.5-12 : Belt tension

The timing belt can satisfactorily convey the drive and keep a durable force only when it has an adequate tension. The belt tension should not be too tight or too loose. Instead, it should be adjusted to a degree that elasticity is felt when the belt is pressed with the thumb. If the belt tension is too weak, the belt loosening side will vibrate. On the other hand, if the belt tension is too strong, a sharp sound will be heard and the belt tension side will vibrate. The detailed adjustment (tension) is shown in Fig. 5-12.

Check and adjust with the belt pressing force f and the slack amount d between spans.

5.3.5 Replacing the bellows (Option)

With reference to Fig. 5-13, exchanges the bellows (option). Replacement method of bellows is shown below.

- 1) Loosen the two set screws (M4) and remove the shaft fixation part from the shaft. Then completely remove a liquid gasket filling the gap between the shaft fixation part and the shaft.
- 2) Refer to Page 68, "Fig.5-3 : Installing/removing the cover", and remove the No.2 arm cover D and the bellows together.
- 3) Fix the new bellows to the No.2 arm cover D with six truss screws (M4).
- 4) Fix the bellows to the shaft with adjusting the position of the bottom of the shaft fixation part to 30mm from end of shaft. Align two set screws (M4) to the D cut surface and fix them securely. (Tightening torque: 1.39 to 1.89 Nm)
- 5) Fill the gap between the shaft fixation part and the shaft with a liquid gasket to prevent dust emergence. Recommendation gasket: 1212 (Supplier: Three Bond Holdings Co., Ltd.)
- 6) Stick the attached ABS mark stickers on the bottom surface of the bellows fixation part and the side face of the shaft fixation part. Makes the J4 axis into the position of 0 degree by jog operation etc., and stick the ABS mark stickers.

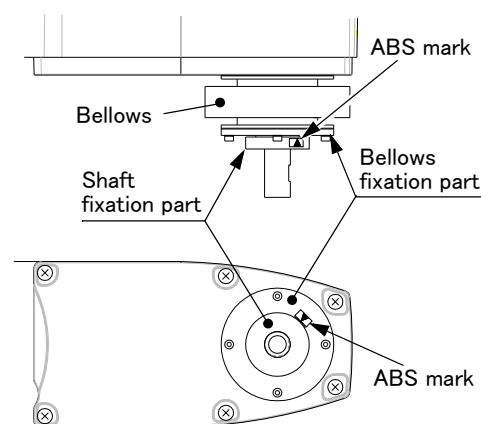
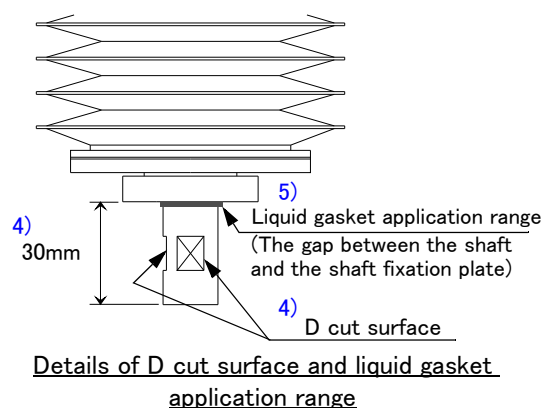
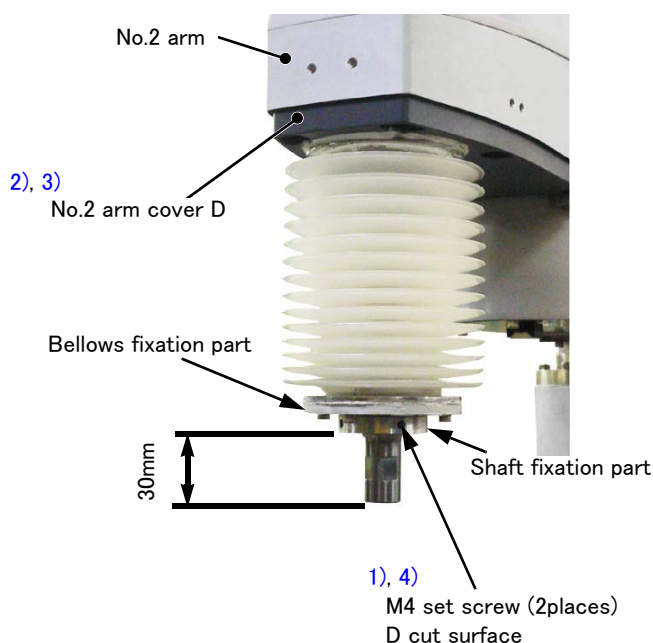

Fig.5-13 : Replace the bellows (option)

5.3.6 Lubrication

(1) Lubrication position and specifications

The grease nipple position is shown in Fig. 5-14. The lubrication specifications for each place are shown in Table 5-4. Refer to the Page 68, "5.3.2 Installing/removing the cover" for the method of removing and installing the cover.

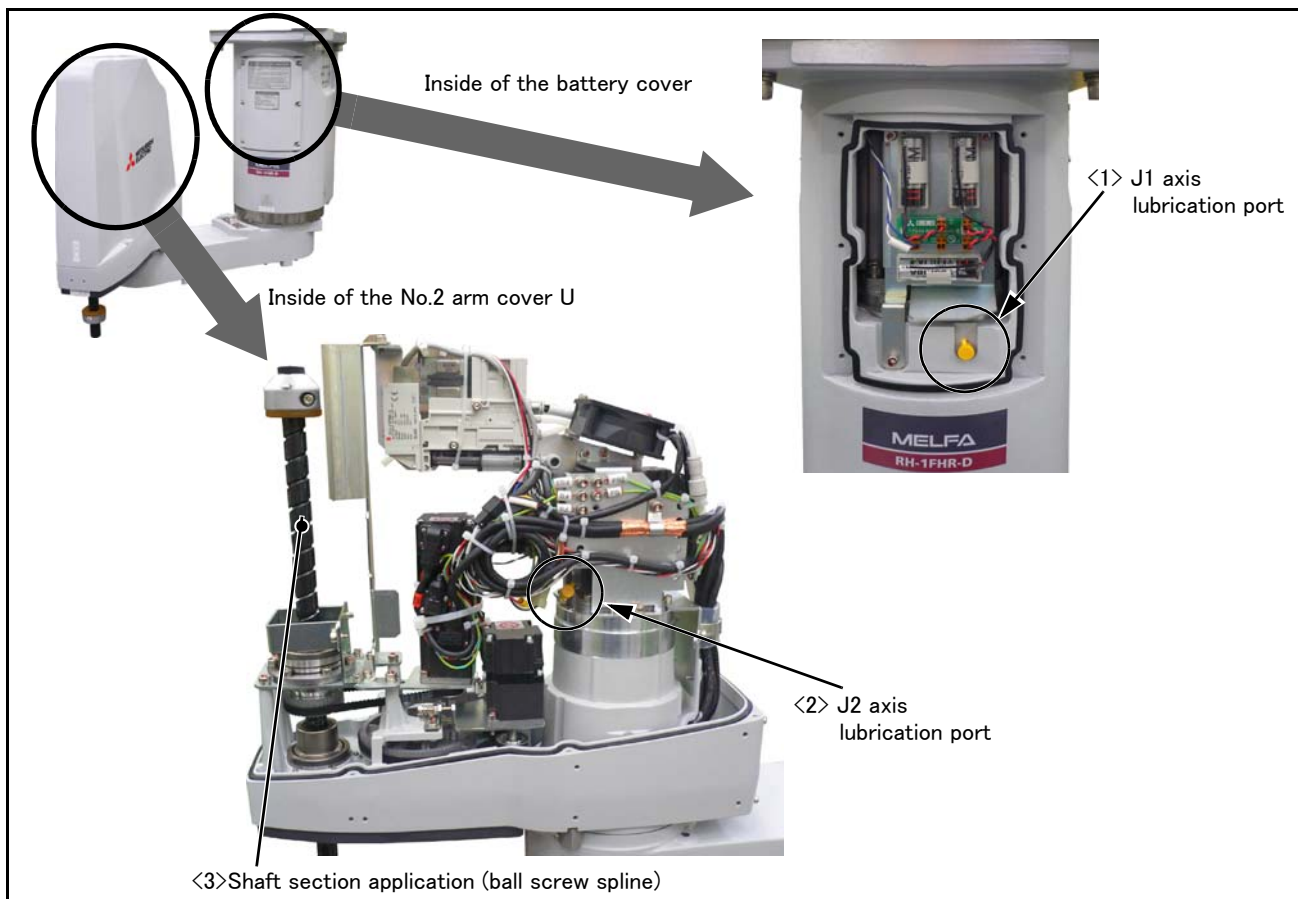

Fig.5-14 : Lubrication positions

Table 5-4 : Lubrication specifications

No.	Parts to be lubricated ^{Note1)}	Oiling method	Lubrication oil (maker)	Lubrication interval	Lubrication amount	Cover to remove
<1>	J1 axis reduction gears	Grease nipple WA-610 (Only addition)	4BNo2 (Harmonic Drive Systems Inc.)	21,000 Hr	12g	Battery cover
<2>	J2 axis reduction gears	Grease nipple WB-610 (Only addition)		21,000 Hr	8g	No.2 arm cover U
<3>	Shaft (ball screw spline)	Wipe the old grease, and applies	NOK Klubersynth UH1 14-222 (NOK CORPORATION)	Every 2,000km movement	1g	

Note1) When the screw is installed in the illustrated lubrication point, install the attached grease nipple and supply the grease.

[Caution]

- The brand name of the grease shown in the Table 5-4 is the grease put in at shipping.
- The lubrication time is a cumulative value of the operation at the maximum speed. If the operation has been suspended, or if the designated speed is slow, the lubrication time can be lengthened in proportion.
- Depending on the robot operation state, the lubrication time will fluctuate, so determine the time according to the state so that the grease does not run out.
- By the maintenance forecast function of RT ToolBox2 (option) computes the guide of the lubrication hours put together with the customer's operation status.

- The numbers in the [Table 5-4](#) correspond to the supply positions in [Fig. 5-14](#).
- Because excessive lubrication leads to the grease leak, avoid it. And, the number of times of lubrication limits to 3 times. The maintenance after it needs the overhaul work which replaces internal grease. Please ask dealer.

(2) Lubrication method to the J1, J2 axis

- 1) Turn off the controller's power supply.
- 2) Refer to the "[Fig.5-3 : Installing/removing the cover](#)" and remove the covers.
- 3) Insert the grease shown in [Table 5-4](#) using a grease gun from the lubrication grease nipple. Add only the specified amount of grease. Adding excess grease may cause grease to leak.



CAUTION

Use manual grease gun, and inject grease with pressure 0.03Mpa or less. Do not use the grease gun, which derived by the factory air presser to avoid injecting by too high pressure.

Recommendation grease gun: KH35 (Yamada Corporation Inc.,)

- 4) Install the removed cover as before.
 - Note) Sealant is applied to the installation surface of the cover. Be sure to replace the sealant if it has been dislocated and bent or crushed and does not return to its original shape.
- 5) If the maintenance forecast function is enable, please reset the accumulated data about grease. Carries out the resetting operation by RT ToolBox or parameter (MFGRST). Refer to separate "RT ToolBox2 / RT ToolBox2 mini User's Manual" for the operation method of RT ToolBox, and refer to separate "Instruction Manual/Detailed Explanation of Functions and Operations" for details of parameter (MFGRST).

This complete of lubricating to J1, J2 axis.

(3) Lubrication method to the shaft

- 1) Refer to [Page 68 "Fig. 5-3: Installing/removing the cover"](#), remove the No. 2 arm cover-U.
- 2) Wipe the old grease off the shaft. Wipe off the grease inside the No. 2 arm cover-U and the bracket attached vertically to the shaft fixing area.
- 3) Apply the specified amount of grease to the shaft. If too much grease is applied, grease can spread inside the No. 2 arm, and if it reaches to the timing belt, can cause the timing belt to deteriorate quicker than usual.
- 4) Install the No.2 arm cover U as before.

This completes of applying grease to shaft.

5.3.7 Replacing the backup battery

An absolute encoder is used for the position detector, so while power of controller is turned off the position must be saved by the backup battery. The controller also uses a backup battery to save the program, etc. The battery is the lithium battery. These batteries are installed when the robot is shipped from the factory, but as these are consumable parts, they must be replaced periodically by the customer.

The guideline for replacing the battery is one year, but this will differ according to the robot's usage state. There exists the kinds of the errors about the battery shown in [Table 5-5](#). If error 7500 occurs, please exchange the battery of the robot arm and the controller simultaneously.

Table 5-5 : The error about the battery

Item	Error number	Description	Measure
Controller	7520	The battery consumption time was exceeded	Replace the battery
	7510	Battery voltage low	
	7500	No battery voltage	The backup data cannot be guaranteed if this error occurs.
Robot arm	7520	The battery consumption time was exceeded	Replace the battery
	133n ^{Note1)}	Encoder battery voltage low.	
	112n	Encoder ABS position data lost	The backup data cannot be guaranteed if this error occurs.

Note1) "n" indicates the axis number

The method of replacing the battery of robot arm is shown below.

refer to the separate "Instruction manual/Controller setup, basic operation, and maintenance" about controller's battery.

About the purchase of the battery, refers to [Page 88](#), "5.5 Maintenance parts".



If error 7500 or 112n occurs, the program data and other data in the controller is lost and it becomes necessary to load the data such as program and origin data again.

(1) Replacing the battery (robot arm)

⚠ CAUTION

The power supply for the encoder is supplied by cable connected with battery board. The cable must be connected while replacing the battery or operating usually. Thus, if the cable connection is incomplete, the encoder position data will be lost, and resetting the origin is necessary.

⚠ CAUTION

Replace the battery one by one . If all batteries are removed the encoder data will be lost, and resetting the origin is necessary.

The battery installation position is shown in Fig. 5-15. Refers to the figure and replaces the batteries in the following procedures.

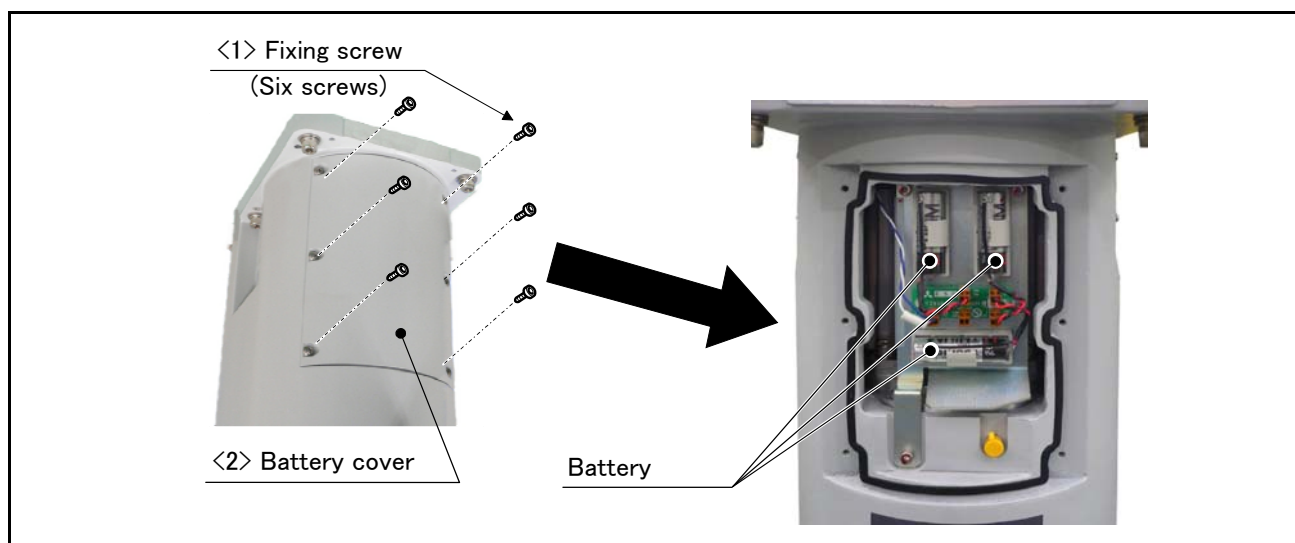

Fig.5-15 : Replacing the battery

- 1) Confirm that the robot arm and controller are connected with a cable.
- 2) Turn the controller control power ON.
The position data is retained by the power supplied from the controller while replacing the battery. Thus, if the cable is not connected correctly, or if the controller power is OFF, the position data will be lost.
- 3) Press the emergency stop button to set the robot in the emergency stop state. This is a measure for safety, and must always be carried out.
- 4) Remove the six fixing screws <1>, and remove the battery cover <2>.
- 5) Replaces the backup battery one by one. Remove the old battery from the holder, and disconnect the lead connector.
- 6) Insert the new battery into the holder, and connect the lead connector. Replace all batteries with new ones at the same time.
- 7) All the batteries should check that it has been exchanged newly. If the old battery is contained, generating heat and damaging may occur.
- 8) Install the battery cover <2> as before. Be careful so that the cable may not be inserted.
- 9) Initialize the battery consumption time.

Always carry out this step after replacing the battery, and initialize the battery usage time. Refer to the separate "Instruction Manual/Detailed Explanation of Functions and Operations" for details on the operation methods.

[Note] If the reason for replacement is power down of the battery, resetting the origin is necessary. (Page 89, "5.6 Resetting the origin")

5.4 About Overhaul

Robots which have been in operation for an extended period of time can suffer from wear and other forms of deterioration. In regard to such robots, we define overhaul as an operation to replace parts running out of specified service life or other parts which have been damaged, so that the robots may be put back in shape for continued use. Overhaul interval for robots presumably varies with their operating conditions and thus with the degree of the equipment's wear and loss of performance. As a rule of thumb, however, it is recommended that overhaul be carried out before the total amount of servo-on time reaches the predetermined levels (24,000 hours for the robot body and 36,000 hours for the controller). (See Fig. 5-16.) For specific information about parts to be replaced and timing of overhaul, contact your local service representative.

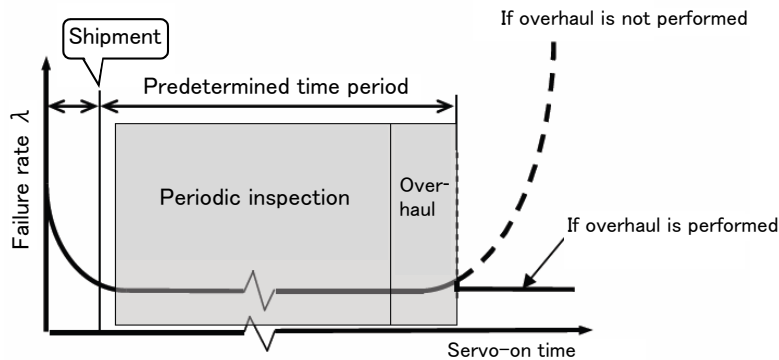

Fig.5-16 : Periodic inspection/overhaul periods

5.5 Maintenance parts

The consumable parts that must be replaced periodically are shown in [Table 5-6](#), and spare parts that may be required during repairs are shown in [Table 5-7](#). Purchase these parts from the dealer when required. Some Mitsubishi-designated parts differ from the maker's standard parts. Thus, confirm the part name, robot arm and controller serial No. and purchase the parts from the dealer.

Table 5-6 : Consumable part list

No.	Part name	Type	Usage place	Q'ty	Supplier
1	Grease		Reduction gears of each axis	An needed	Mitsubishi Electric
			Shaft	An needed	
2	Lithium battery	ER6	Inside the battery cover	3	
3	Liquefied gasket		Packing ^{Note1)}	An needed	
4	Timing belt		J3 axis	1	
5			J4 axis motor side	1	
6			J4 axis shaft side	1	
7	Bellows set (option)		J4 axis shaft	1	

Note1)The liquefied gasket is necessary for the place which uses two or more packings to connect.

Table 5-7 : Spare parts list

No.	Names	Usage place	Q'ty	Supplier
1	AC servo motor	J1 axis	1	Mitsubishi Electric
2		J2 axis	1	
3		J3 axis	1	
4		J4 axis	1	
5	Reduction gears	J1 axis	1	
6		J2 axis	1	
7	Ball screw spline	J3 axis	1	
8	Liquid gasket	Bellows	An needed	

5.6 Resetting the origin

The origin is set so that the robot can be used with a high accuracy. After purchasing the robot, always carry out this step before starting work. The origin must be reset if the combination of robot and controller being used is changed or if the motor is changed causing an encoder area. The types of origin setting methods are shown in [Table 5-8](#).

[Caution] If the old battery is replaced because it has been used up, it is necessary to set the origin again. Reset the origin using the jig method or mechanical stopper method or ABS origin method. How to reset the origin depends on the origin loss condition.

- 1) Origin data loss caused by replacement of the motor
 Reset the origin using the jig method or mechanical stopper method. Higher precision can be achieved by using the jig.
 Since the absolutely same condition as before the origin loss cannot be established, adjust positions for the robot operation (teaching positions) as required.
- 2) Origin data loss caused by flat battery
 Reset the origin using the ABS origin method. By using the present origin data, restore the condition before the origin loss. However, if correct origin data are not stored, the condition before the origin loss cannot be restored. Reset the origin according to "1)".
- 3) Position shift caused by a factor other than the origin data loss, such as a collision
 Reset the origin using the jig method or mechanical stopper method as "1)". Higher precision can be achieved by using the jig.
 Since the absolutely same condition as before the origin loss cannot be established, adjust positions for the robot operation (teaching positions) as required.

Table 5-8 : Origin setting method

No	Method	Explanation	Remarks
1	Origin data input method	The origin data set as the default is input from the T/B.	The setting method is explained in Page 23, "2.3 Setting the origin" .
2	Mechanical stopper method	This origin posture is set by contacting each axis against the mechanical stopper.	The setting method is explained in Page 90, "5.6.1 Mechanical stopper method" .
3	Jig method	The origin posture is set with the calibration jig installed.	The setting method is explained in Page 97, "5.6.2 Jig method" .
4	User origin method	A randomly designated position is set as the origin posture.	The setting method is explained in Page 104, "5.6.4 User origin method" .
5	ABS origin method	This method is used when the encoder backup data lost in the cause such as battery cutting.	Before using this method, the origin must be set with the other method with same encoder. The setting method is explained in Page 102, "5.6.3 ABS origin method" .

5.6.1 Mechanical stopper method

The method for setting the origin with the transportation jig is explained below.

This operation is carried out with the T/B. Set the mode of the controller to "MANUAL", and set the T/B [ENABLE] switch to "ENABLE" to validate the T/B.

CAUTION The brakes are released here, and the J3 axis (shaft) is moved with both hands. For safety purposes, the brakes must be released by two workers.

(1) J1 axis origin setting (mechanical stopper)

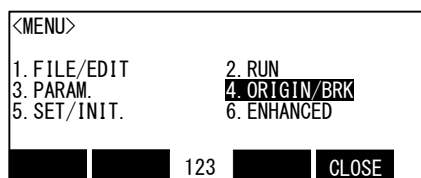

1) Press the [4] key on the menu screen, and display the Origin/Break selection screen.

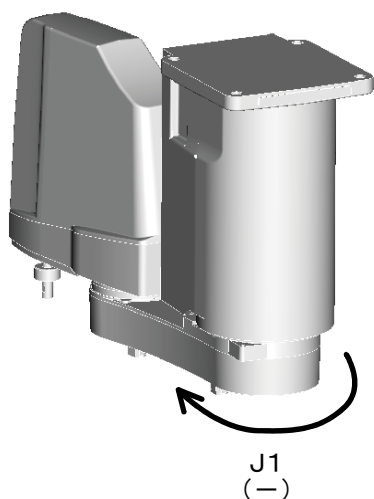

2) With both hands, slowly move the J1 axis in - (minus) direction, and contact the axis against the mechanical stopper.

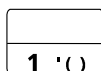
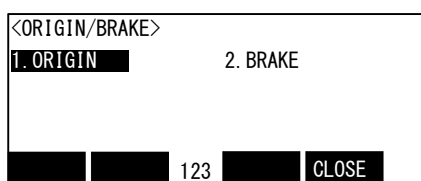

3) Press the [1] key, and display the Origin setting selection screen.

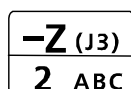
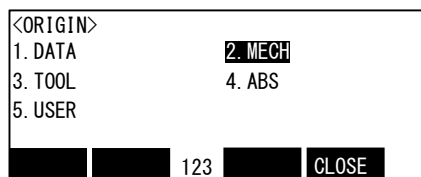

4) Press the [2] key, and display the Mechanical stopper selection screen.

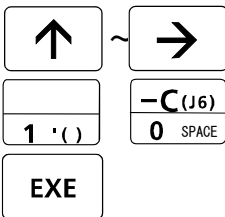
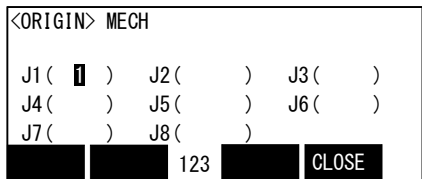

- 5) Input "1" into the J1 axis. Set "0" to other axes.
- 6) Press the [EXE] key, and display Confirmation screen.

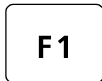
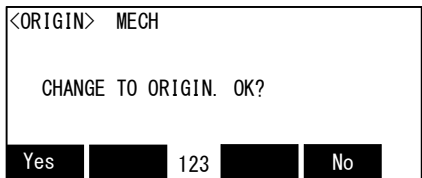

- 7) Press the [F1] key, and the origin position is set up.

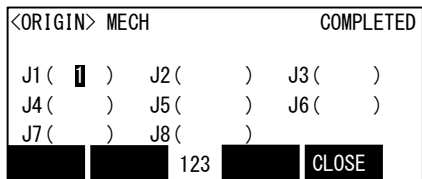

- 8) Setting of the origin is completed.
- 9) Refer to [Page 106, "5.6.5 Recording the origin data"](#) in this manual, and record the origin data on the origin data seal.

◆◆◆ Release the brake ◆◆◆

Do cursor movement into the parenthesis of each axis by the arrow key. The brakes can be released only for the axis for which a "1" is displayed on the screen. If the brakes are not to be released, press the [0] key and display a "0". If the [F1] key on the teaching pendant or the enabling switch is detached while the brakes are released, the brakes will be work immediately.

◆◆◆ Select the axis of origin setting ◆◆◆

Do cursor movement into the parenthesis of each axis by the arrow key. The origin is set only for the axis for which a "1" is displayed on the screen. If the origin is not to be set, press the [0] key and display a "0".

(2) J2 axis origin setting (mechanical stopper)

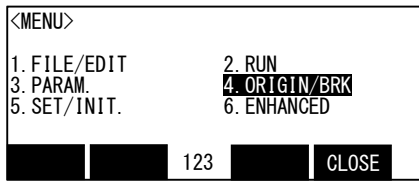

1) Press the [4] key on the menu screen, and display the Origin/Break selection screen.

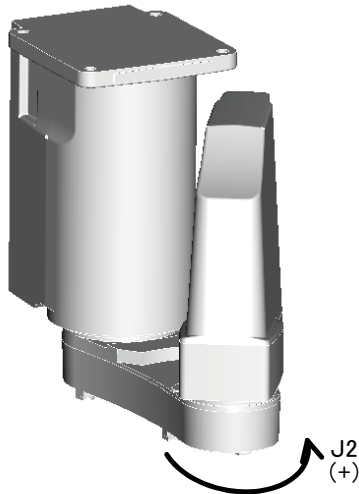

2) With both hands, slowly move the J2 axis in + (plus) direction, and contact the axis against the mechanical stopper.

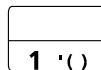
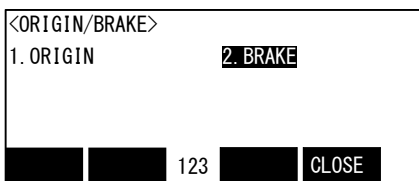

3) Press the [1] key, and display the Origin setting selection screen.

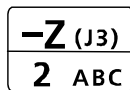
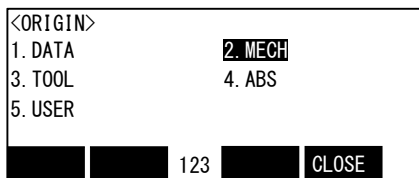

4) Press the [2] key, and display the Mechanical stopper selection screen.

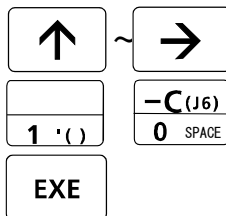
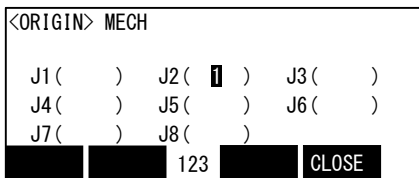

5) Input "1" into the J2 axis. Set "0" to other axes.

6) Press the [EXE] key, and display Confirmation screen.

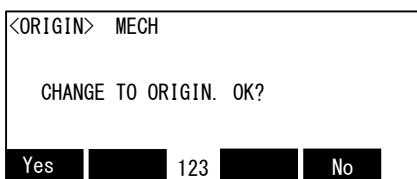

7) Press the [F1] key, and the origin position is set up.

<ORIGIN> MECH		COMPLETED
J1 ()	J2 (1)	J3 ()
J4 ()	J5 ()	J6 ()
J7 ()	J8 ()	
	123	CLOSE

8) Setting of the origin is completed.

9) Refer to [Page 106](#), "5.6.5 Recording the origin data" in this manual, and record the origin data on the origin data seal.

◆◆◆ Release the brake ◆◆◆

Do cursor movement into the parenthesis of each axis by the arrow key. The brakes can be released only for the axis for which a "1" is displayed on the screen. If the brakes are not to be released, press the [0] key and display a "0". If the [F1] key on the teaching pendant or the enabling switch is detached while the brakes are released, the brakes will be work immediately.

◆◆◆ Select the axis of origin setting ◆◆◆

Do cursor movement into the parenthesis of each axis by the arrow key. The origin is set only for the axis for which a "1" is displayed on the screen. If the origin is not to be set, press the [0] key and display a "0".

(3) J3 and J4 axis origin setting (mechanical stopper)

Always perform origin setting of the J3 axis and the J4 axis simultaneously. If the wiring and piping is passed in the shaft, remove the No.2 arm cover U and operate the origin setting.

Note) If origin setting is carried out with the No.2 arm cover U installed, the origin may not be set up correctly because the wiring and the piping interfere with the No.2 arm cover U.

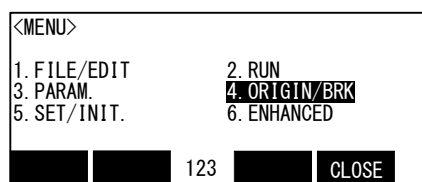

- 1) If the wiring and piping is passed in the shaft, removes the No.2 arm cover U referring the [Page 68, "5.3.2 Installing/removing the cover"](#). It is not necessary to remove the cover if wiring and piping is not passed.
- 2) Press the [4] key on the menu screen, and display the Origin/Break selection screen.

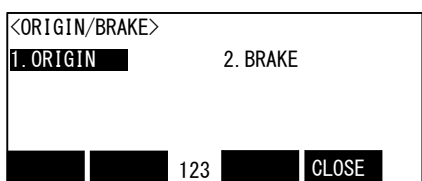

- 3) Press the [2] key, and display the Break release selection screen.

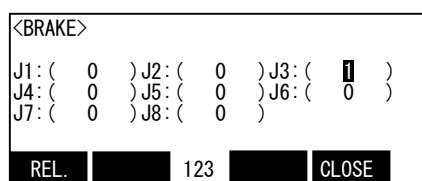

- 4) Release the brake of the J3 axis. Input "1" into the J3 axis. Set "0" to other axes.

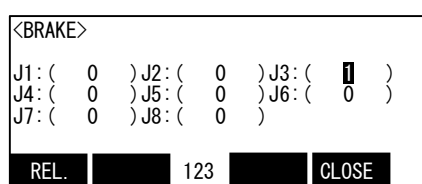

- 5) Confirm the axis for which the brakes are to be released.

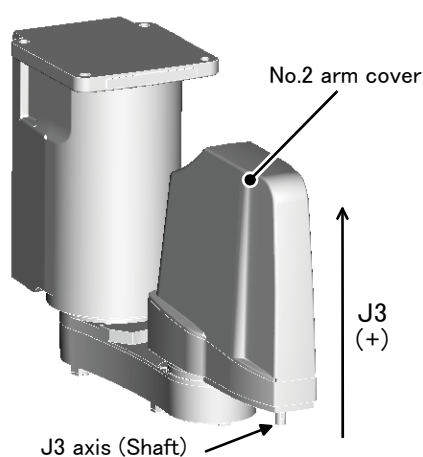

- 6) Pressing the [F1] key is kept with the enabling switch of T/B pressed down. The brake is released while pressing the key.

Note) The brake of the axis shown below repeats release/lock at the interval in each about 200ms for dropping the J3 axis slowly.

- 7) With both hands, slowly move the J3 axis in + (plus) direction, and contact the axis against the mechanical stopper.

CAUTION

For safety purposes, the step for releasing the brakes must be carried out by two workers. One worker must operate the T/B, and the other must support the J3 axis (shaft). When the brake is released, the J3 axis could drop with its own weight.

CAUTION If [F1] key or enable switch of T/B is released, the brakes will be work immediately.

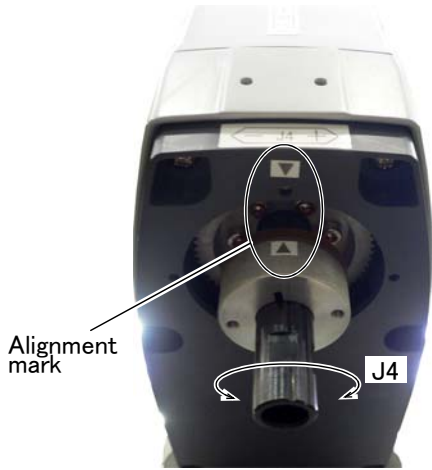

8) Hold the J4 axis with your hand and rotate it slowly to match the alignment marks.
 *Move the J4 axis with maintaining the condition that the releasing brake of the J3 axis and the J3 axis contact to the mechanical stopper.

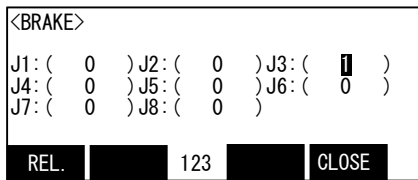

9) Detach the [F1] key and work the brake.
 Press the [F4] key and return to the origin / brake screen.

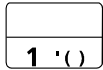
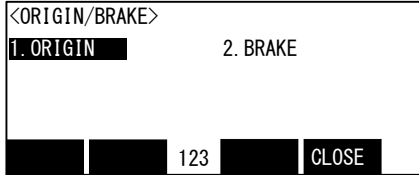

10) Press the [1] key, and display the Origin setting selection screen.

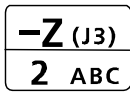
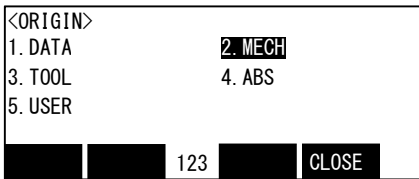

11) Press the [2] key, and display the Mechanical stopper selection screen.

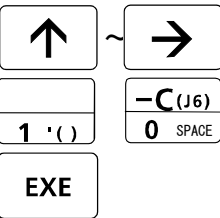
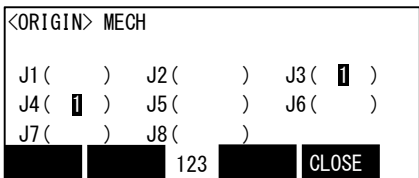

12) Input "1" into the J3 and J4 axis. Set "0" to other axes.

13) Press the [EXE] key, and display Confirmation screen.

<ORIGIN> MECH			
CHANGE TO ORIGIN. OK?			
Yes	123	No	

F1

<ORIGIN> MECH			COMPLETED
J1 ()	J2 ()	J3 (1)	
J4 (1)	J5 ()	J6 ()	
J7 ()	J8 ()		
	123	CLOSE	

14) Press the [F1] key, and the origin position is set up.

15) When No.2 arm cover U was removed, installs as before.

16) Setting of the origin is completed.

17) Refer to [Page 106](#), "5.6.5 Recording the origin data" in this manual, and record the origin data on the origin data seal.

◆◆◆ Release the brake ◆◆◆

Do cursor movement into the parenthesis of each axis by the arrow key. The brakes can be released only for the axis for which a "1" is displayed on the screen. If the brakes are not to be released, press the [0] key and display a "0". If the [F1] key on the teaching pendant or the enabling switch is detached while the brakes are released, the brakes will be work immediately.

◆◆◆ Select the axis of origin setting ◆◆◆

Do cursor movement into the parenthesis of each axis by the arrow key. The origin is set only for the axis for which a "1" is displayed on the screen. If the origin is not to be set, press the [0] key and display a "0".

5.6.2 Jig method

This method is using the origin setting tool. If the origin setting tool is required, please ask nearby dealer. The reference figure of the origin setting tool is shown in Fig. 5-17.

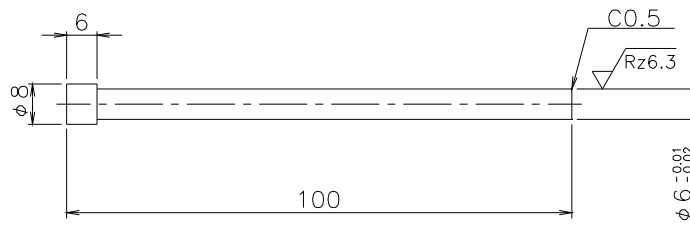

Fig.5-17 : Reference dimension of origin setting tool

The procedure of setting the origin with the origin setting tool is shown below.

Carry out this method for each axis.

First, set each axis by the origin position. There are the method of releasing the brake and adjusting with the origin position manually and the method of adjusting with the origin position by jog feed. Here, explains operation by brake release.

Then, do origin setting operation and set up the origin.



CAUTION

To ensure safety, the brake-release procedure described below should always be done by two persons.

This operation is carried out with the teaching pendant. Set the mode of the controller to "MANUAL", and set the [ENABLE] switch on the teaching pendant to "ENABLE" to enable the teaching pendant.

Do the following operations, pressing down the enabling switch of T/B lightly.

(1) J1 axis origin setting

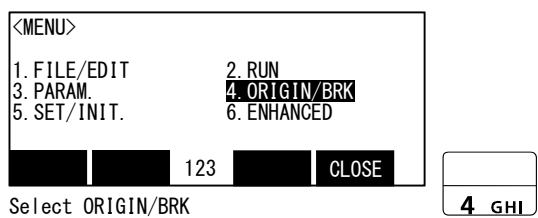

1) Press the [4] key on the menu screen, and display the Origin/Break selection screen.

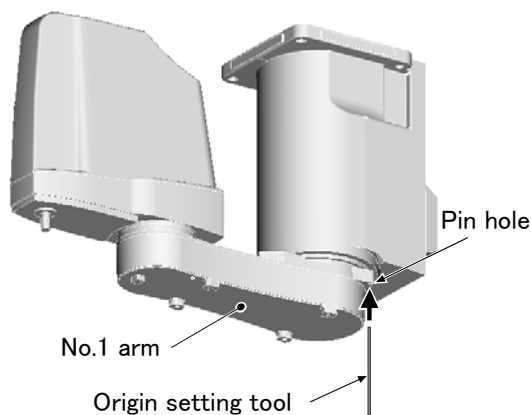

2) Move the J1 axis slowly toward the front using both hands. Align the pinhole of the No.1 arm and the pinhole at the base section, feed through the origin jig into the pinholes and fasten.

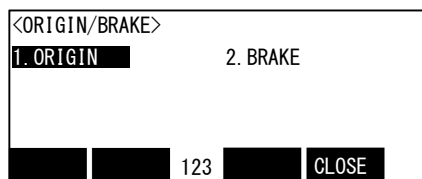

3) Press the [1] key, and display the Origin setting selection screen.

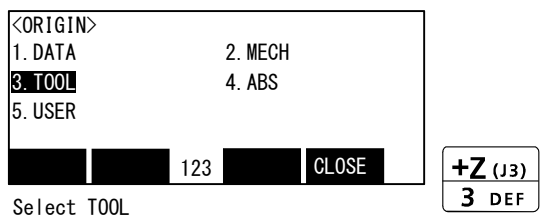

4) Press the [3] key, and display the Tool selection screen.

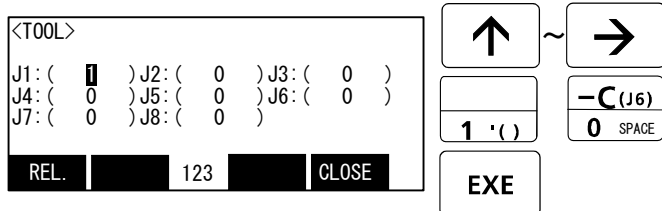

5) Input "1" into the J1 axis. Set "0" to other axes.

6) Press the [EXE] key, and display Confirmation screen.

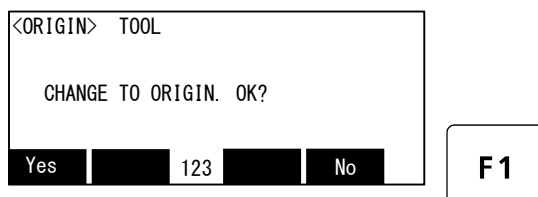

7) Press the [F1] key, and the origin position is set up.

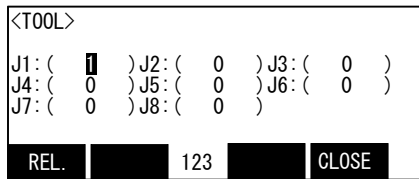

8) Setting of the origin is completed.

9) Refer to [Page 106](#), "5.6.5 Recording the origin data" in this manual, and record the origin data on the origin data seal.

◆◆◆ Release the brake ◆◆◆

Do cursor movement into the parenthesis of each axis by the arrow key. The brakes can be released only for the axis for which a "1" is displayed on the screen. If the brakes are not to be released, press the [0] key and display a "0". If the [F1] key on the teaching pendant or the enabling switch is detached while the brakes are released, the brakes will be work immediately.

◆◆◆ Select the axis of origin setting ◆◆◆

Do cursor movement into the parenthesis of each axis by the arrow key. The origin is set only for the axis for which a "1" is displayed on the screen. If the origin is not to be set, press the [0] key and display a "0".

(2) J2 axis origin setting

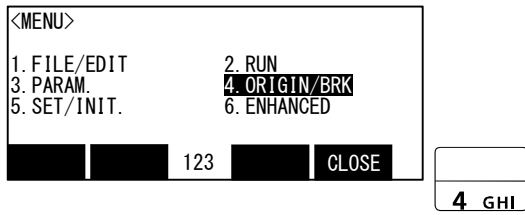

1) Press the [4] key on the menu screen, and display the Origin/Break selection screen.

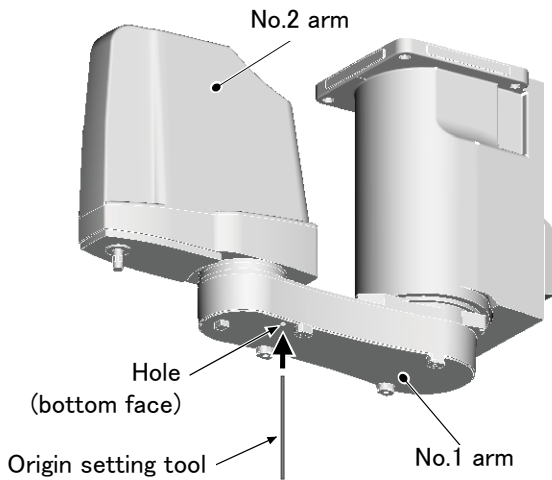

2) Slowly rotate the J2 axis 0 degree with both hands. And align the pinholes of the No. 1 and No. 2 arms, feed through the origin jig into the pinholes and fasten.

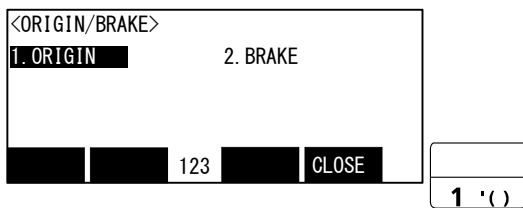

3) Press the [1] key, and display the Origin setting selection screen.

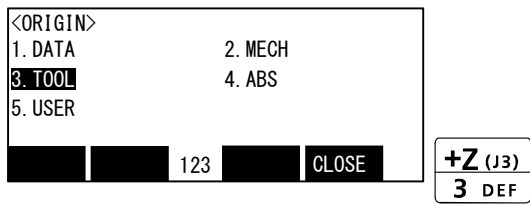

4) Press the [3] key, and display the Tool selection screen.

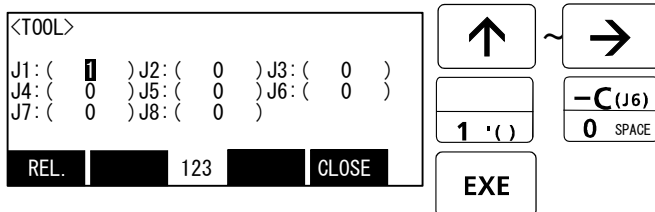

5) Input "1" into the J2 axis. Set "0" to other axes.

6) Press the [EXE] key, and display Confirmation screen.

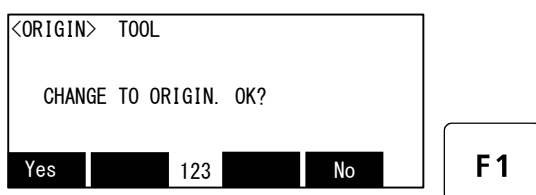

7) Press the [F1] key, and the origin position is set up.

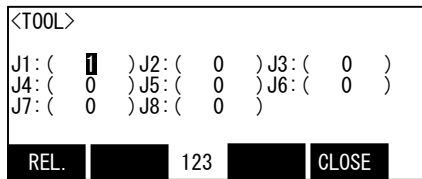

8) Setting of the origin is completed.

9) Refer to [Page 106](#), “5.6.5 Recording the origin data” in this manual, and record the origin data on the origin data seal.

◆◆◆ Release the brake ◆◆◆

Do cursor movement into the parenthesis of each axis by the arrow key. The brakes can be released only for the axis for which a “1” is displayed on the screen. If the brakes are not to be released, press the [0] key and display a “0”. If the [F1] key on the teaching pendant or the enabling switch is detached while the brakes are released, the brakes will be work immediately.

◆◆◆ Select the axis of origin setting ◆◆◆

Do cursor movement into the parenthesis of each axis by the arrow key. The origin is set only for the axis for which a “1” is displayed on the screen. If the origin is not to be set, press the [0] key and display a “0”.

(3) J3 and J4 axis origin setting

Origin settings for the J3 and J4 axes must be performed at the same time.

The method of origin setting is the same as the mechanical stopper method. Refer to [Page 94](#), “(3) J3 and J4 axis origin setting (mechanical stopper)”, perform the required origin setting operations.

This complete the Origin setting by the Jig method.

5.6.3 ABS origin method

When the origin setting of the robot is performed for the first time, this product records the angular position of the origin within one rotation of the encoder as the offset value. If the origin setting is performed according to the ABS origin method, this value is used to suppress variations in the origin setting operations and to reproduce the initial origin position accurately.

This operation is carried out with the teaching pendant. Set the mode of the controller to "MANUAL", and set the [ENABLE] switch on the teaching pendant to "ENABLE" to enable the teaching pendant.

First, set to the ABS mark arrow of the axis for which the origin is to be set with jog operation. This can be set for all axes simultaneously or each axis independently.

When setting the ABS mark, always view the operations from the mark, and set at the end of the triangular mark. The positions where the ABS mark is attached are shown in below. Refer to [Page 30, "2.4 Confirming the operation"](#) for details on the jog operation.

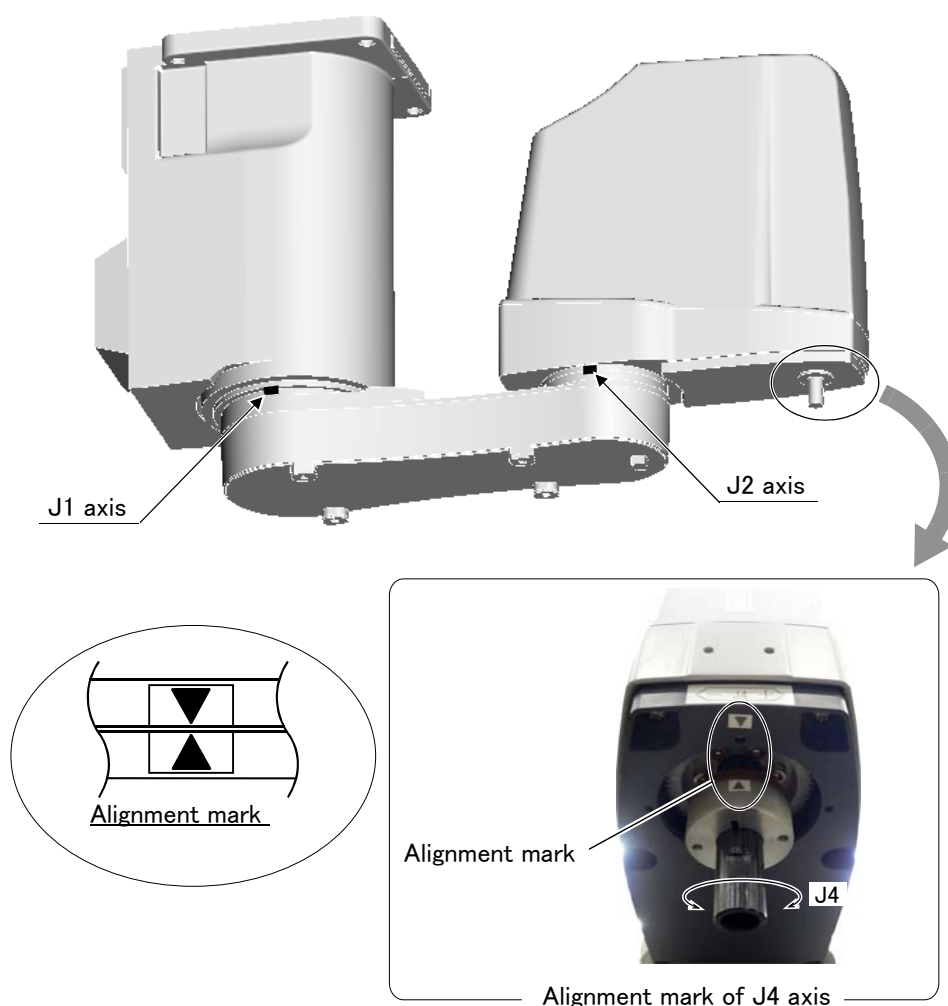

Note) There is no alignment mark of the J3 axis. Contact the J3 axis against mechanical stopper as the mechanism stopper method.

Fig.5-18 : ABS mark attachment positions

The procedures for setting the origin with the ABS method are explained below.

(1) Select the T/B

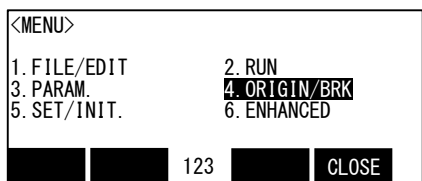

1) Press the [4] key on the menu screen, and display the Origin/Break selection screen.

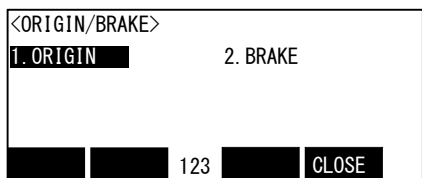

2) Press the [1] key, and display the Origin setting selection screen.

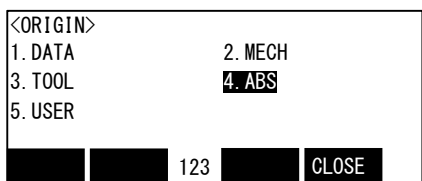

3) Press the [4] key, and display the ABS selection screen.

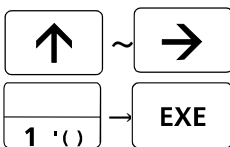
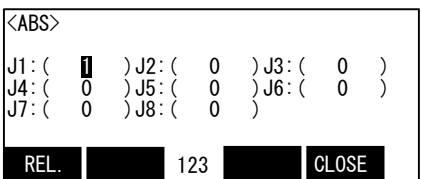

4) Input "1" into the axis to origin setting. Press the [EXE] key, and display Confirmation screen.

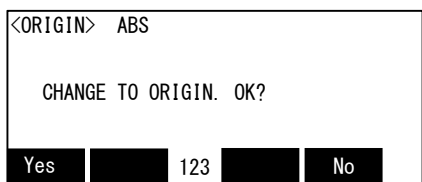

5) Press the [F1] key, and the origin position is set up.

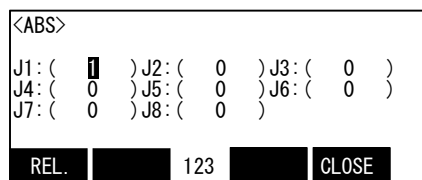

This complete the Origin setting by the ABS method.

5.6.4 User origin method

**CAUTION**

Before using this method, the origin must be set with the other method.

The setting method is explained in [Page 89, "Table 5-8 : Origin setting method"](#).

The procedure for setting the origin with the user origin method is explained below.

This operation is carried out with the teaching pendant. Set the mode of the controller to "MAMNUAL", and set the [ENABLE] switch on the teaching pendant to "ENABLE" to enable the teaching pendant.

The operation method is shown below.

When setting the origin for the first time using this method, carry out the operations in order from step 1). For the second and following time, move the robot arm to the user origin position with jog operation, and accurately position all axis. Then start the procedure from step 4).

1) Determine the user origin position

Move the robot to the position to be set as the origin with jog operation. Refer to [Page 30, "2.4 Confirming the operation"](#) for details on the jog operation.

**CAUTION**

Choose the user origin position as the position where it doesn't move by the gravity.

This position is left as a guideline to position all axes with jog operation when setting the origin again with this method.

2) Enter the JOINT jog mode, and display the joint coordinates on the teaching pendant screen. Record the value of the axis for which the origin is to be set.

3) Input the value recorded in the "user designated origin parameter (USERORG)".

The parameter details and input methods are described in the separate "Instruction Manual/Detailed Explanation of Functions and Operations". Refer to that manual and input the user designated origin position.

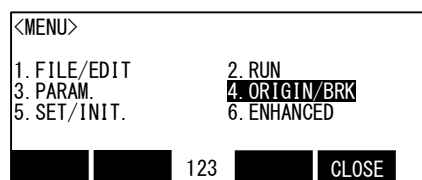

4) Next, set the origin.

Display the menu screen.

5) Press the [4] key on the menu screen, and display the Origin/Break selection screen.

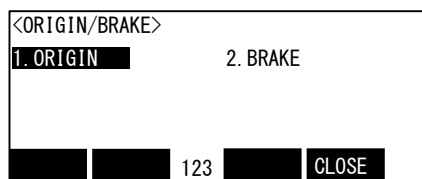

6) Press the [1] key, and display the Origin setting selection screen.

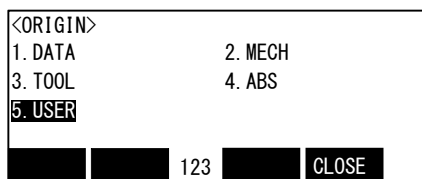

7) Press the [5] key, and display the User selection screen.

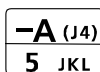
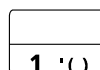
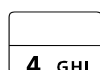

```
<USER>
J1: ( 1 ) J2: ( 0 ) J3: ( 0 )
J4: ( 0 ) J5: ( 0 ) J6: ( 0 )
J7: ( 0 ) J8: ( 0 )
REL. 123 CLOSE
```

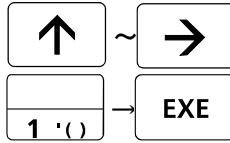

8) Input "1" into the axis to origin setting. Press the [EXE] key, and display Confirmation screen.

```
<ORIGIN> USER
CHANGE TO ORIGIN. OK?
Yes 123 No
```



9) Press the [F1] key, and the origin position is set up.

This complete the Origin setting by the User origin method.

5.6.5 Recording the origin data

When the origin has been set with the jig method, record that origin data on the origin data label. With this, the origin can be set with the origin data input method the next time.

Confirm the origin data on the teaching pendant screen (origin data input screen). The origin data label is enclosed with the arm or attached on the back of the battery cover.

The teaching pendant operation method and battery cover removal method for confirming the origin data is the same as the methods for setting the origin with the origin data input method. Refer to [Page 25, "2.3.2 Setting the origin with the origin data input method"](#), and write the origin data displayed on the teaching pendant onto the origin label.

(1) Confirming the origin data label

Remove the battery cover.

Refer to [Page 68, "5.3.2 Installing/removing the cover"](#), and remove the battery cover.

(2) Confirming the origin data

Confirm the value displayed on the teaching pendant's Origin Data Input screen.

Refer to [Page 25, "2.3.2 Setting the origin with the origin data input method"](#), ["\(5\)Inputting the origin data"](#) and display the Origin Data Input screen on the teaching pendant display screen.

(3) Recording the origin data

Write the origin data displayed on the teaching pendant to the origin data label attached to the back of the battery cover. Refer to [Page 25, "Fig.2-14 : Origin data label \(an example\)"](#), and [Page 28, "Fig.2-15 : Correspondence of origin data label and axis"](#) for details on the origin data label.

(4) Installing the battery cover

Install the battery cover removed in step ["\(1\)Confirming the origin data label"](#) above.

Refer to [Page 68, "5.3.2 Installing/removing the cover"](#), and replace the battery cover.

This completes the recording of the origin data.

6 Appendix

Appendix 1 : Configuration flag

The configuration flag indicates the robot posture.

For the 6-axis type robot, the robot hand end is saved with the position data configured of X, Y, Z, A, B and C. However, even with the same position data, there are several postures that the robot can change to. The posture is expressed by this configuration flag, and the posture is saved with FL1 in the position constant (X, Y, Z, A, B, C) (FL1, FL2).

The types of configuration flags are shown below.

(1) RIGHT/LEFT

Indicates the location of the end axis relative to the line that passes through both the rotational center of the J1 axis and the rotational center of the J2 axis.

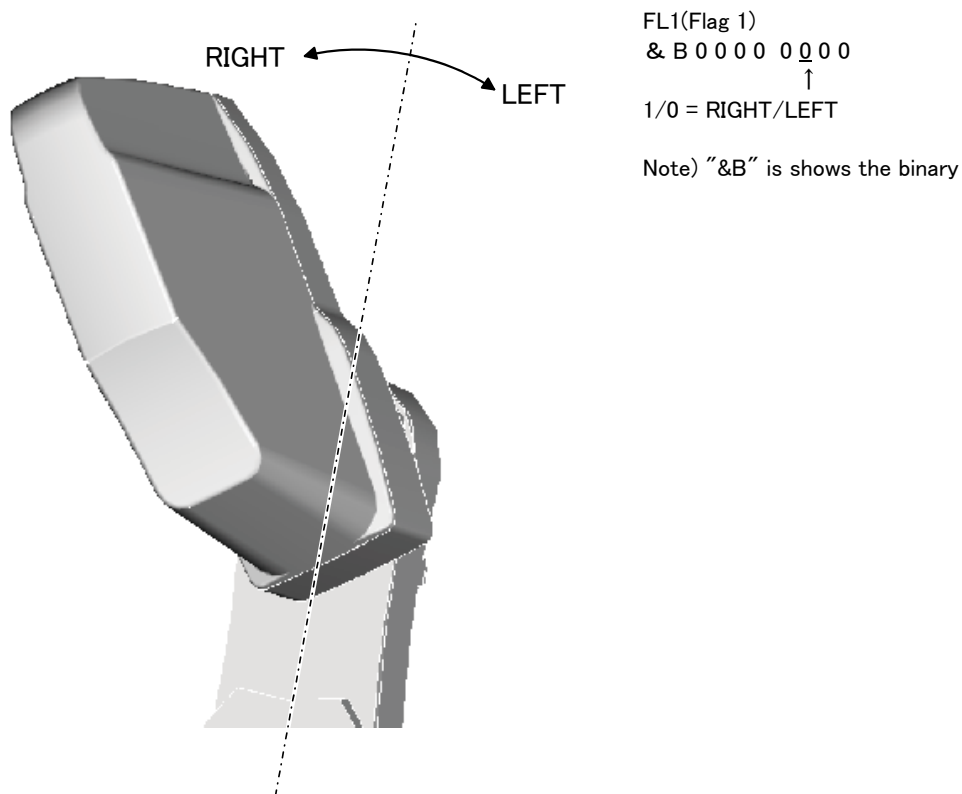

Fig.6-1 : Configuration flag (RIGHT/LEFT)

mitsubishi electric corporation

HEAD OFFICE: TOKYO BUILDING, 2-7-3, MARUNOUCHI, CHIYODA-KU, TOKYO 100-8310, JAPAN
NAGOYA WORKS: 5-1-14, YADA-MINAMI, HIGASHI-KU NAGOYA 461-8670, JAPAN

Authorised representative:

MITSUBISHI ELECTRIC EUROPE B.V. GERMANY
Gothaer Str. 8, 40880 Ratingen / P.O. Box 1548, 40835 Ratingen, Germany