

**mitsubishi**  
**Mitsubishi Industrial Robot**

**RH-5AH/10AH/15AH Series**

**Standard Specifications Manual**  
**(CR2A-572 Controller)**

## Safety Precautions

Always read the following precautions and the separate "Safety Manual" before starting use of the robot to learn the required measures to be taken.

### CAUTION

All teaching work must be carried out by an operator who has received special training. (This also applies to maintenance work with the power source turned ON.)  
→ Enforcement of safety training

### CAUTION

For teaching work, prepare a work plan related to the methods and procedures of operating the robot, and to the measures to be taken when an error occurs or when restarting. Carry out work following this plan. (This also applies to maintenance work with the power source turned ON.)  
→ Preparation of work plan

### WARNING

Prepare a device that allows operation to be stopped immediately during teaching work. (This also applies to maintenance work with the power source turned ON.)  
→ Setting of emergency stop switch

### CAUTION

During teaching work, place a sign indicating that teaching work is in progress on the start switch, etc. (This also applies to maintenance work with the power source turned ON.)  
→ Indication of teaching work in progress

### WARNING

Provide a fence or enclosure during operation to prevent contact of the operator and robot.  
→ Installation of safety fence

### CAUTION

Establish a set signaling method to the related operators for starting work, and follow this method.  
→ Signaling of operation start

















### CAUTION

As a principle turn the power OFF during maintenance work. Place a sign indicating that maintenance work is in progress on the start switch, etc.  
→ Indication of maintenance work in progress

### CAUTION

Before starting work, inspect the robot, emergency stop switch and other related devices, etc., and confirm that there are no errors.  
→ Inspection before starting work

The points of the precautions given in the separate "Safety Manual" are given below. Refer to the actual "Safety Manual" for details.

-  **CAUTION** Use the robot within the environment given in the specifications. Failure to do so could lead to a drop or reliability or faults. (Temperature, humidity, atmosphere, noise environment, etc.)
-  **CAUTION** Transport the robot with the designated transportation posture. Transporting the robot in a non-designated posture could lead to personal injuries or faults from dropping.
-  **CAUTION** Always use the robot installed on a secure table. Use in an instable posture could lead to positional deviation and vibration.
-  **CAUTION** Wire the cable as far away from noise sources as possible. If placed near a noise source, positional deviation or malfunction could occur.
-  **CAUTION** Do not apply excessive force on the connector or excessively bend the cable. Failure to observe this could lead to contact defects or wire breakage.
-  **CAUTION** Make sure that the workpiece weight, including the hand, does not exceed the rated load or tolerable torque. Exceeding these values could lead to alarms or faults.
-  **WARNING** Securely install the hand and tool, and securely grasp the workpiece. Failure to observe this could lead to personal injuries or damage if the object comes off or flies off during operation.
-  **WARNING** Securely ground the robot and controller. Failure to observe this could lead to malfunctioning by noise or to electric shock accidents.
-  **CAUTION** Indicate the operation state during robot operation. Failure to indicate the state could lead to operators approaching the robot or to incorrect operation.
-  **WARNING** When carrying out teaching work in the robot's movement range, always secure the priority right for the robot control. Failure to observe this could lead to personal injuries or damage if the robot is started with external commands.
-  **CAUTION** Keep the jog speed as low as possible, and always watch the robot. Failure to do so could lead to interference with the workpiece or peripheral devices.
-  **CAUTION** After editing the program, always confirm the operation with step operation before starting automatic operation. Failure to do so could lead to interference with peripheral devices because of programming mistakes, etc.
-  **CAUTION** Make sure that if the safety fence entrance door is opened during automatic operation, the door is locked or that the robot will automatically stop. Failure to do so could lead to personal injuries.
-  **CAUTION** Never carry out modifications based on personal judgments, or use non-designated maintenance parts.  
Failure to observe this could lead to faults or failures.
-  **WARNING** When the robot arm has to be moved by hand from an external area, do not place hands or fingers in the openings. Failure to observe this could lead to hands or fingers catching depending on the posture.
-  **CAUTION** Do not stop the robot or apply emergency stop by turning the robot controller's main power OFF.  
If the robot controller main power is turned OFF during automatic operation, the robot accuracy could be adversely affected.

 **WARNING**

For using RH-5AH/10AH/15AH.

While pressing the brake releasing switch on the robot arm, beware of the arm which may drop with its own weight.

Dropping of the hand could lead to a collision with the peripheral equipment or catch the hands or fingers.

■ Revision history

Date of print	Specifications No.	Details of revisions
2001-03-28	BFP-A8174Z	First print
2001-09-25	BFP-A8174	Formal style.
2001-10-30	BFP-A8174-A	The explanation of the RH-5AH series was added. Error in writing correction.
2001-12-17	BFP-A8174-B	The parameter "Select the function of singular point adjacent alarm (MESNGLSW)" was added. Error in construction equipment of hand output cable(1N-GR35S) was corrected. The parameter RLNG was removed.
2002-02-06	BFP-A8174-C	RLNG parameter was added. The installation method of memory cassette was modified. Error in writing correction.
2002-04-01	BFP-A8174-D	CR2A-MB (controller protection box) was added. Error in writing correction.
2002-06-27	BFP-A8174-E	The description of input/output circuit terminal was corrected. Error in writing correction.

## ■ Introduction

The RH-5AH/10AH/15AH Series offers small-size industrial robots developed using Mitsubishi's latest technology. They are especially designed to handle and assemble mechanical parts. They are Mitsubishi's answer to the customer's need to achieve a compact manufacturing facility capable of highly flexible production, as necessitated by the diffusion of high-density product groups and the shorter product life cycles that have become commonplace in recent years.

However, to comply with the target application, a work system having a well-balanced robot arm, peripheral devices or robot and hand section must be structured.

When creating these standard specifications, we have edited them so that the Mitsubishi robot's characteristics and specifications can be easily understood by users considering the implementation of robots. However, if there are any unclear points, please contact your nearest Mitsubishi branch or dealer.

Mitsubishi hopes that you will consider these standard specifications and use our robots.

In this manual, the specifications regarding the robot arm are given in [Page 7, "2 Robot arm"](#) and following, and the specifications regarding the controller are given in [Page 57, "3 Controller"](#) and following. Refer to the corresponding sections for details on the specifications, options and maintenance parts, etc.

### Note:

- No part of this manual may be reproduced by any means or in any form, without prior consent from Mitsubishi.
- The contents of this manual are subject to change without notice.
- The specifications values are based on Mitsubishi standard testing methods.
- The information contained in this document has been written to be accurate as much as possible. Please interpret that items not described in this document "cannot be performed." Though this specifications is produced with extreme care, please contact your nearest dealer if you find any doubtful, wrong or skipped point.

# Contents

	Page
1 General configuration .....	1-1
1.1 Structural equipment .....	1-1
1.1.1 Standard structural equipment .....	1-1
1.1.2 Shipping special specifications .....	1-1
1.1.3 Options .....	1-1
1.1.4 Maintenance parts .....	1-1
1.2 Contents of the structural equipment .....	1-2
1.2.1 Robot arm .....	1-2
1.3 Controller .....	1-3
1.4 Contents of the Option equipment and special specification .....	1-4
2 Robot arm .....	2-7
2.1 Standard specifications .....	2-7
2.2 Definition of specifications .....	2-9
2.2.1 Pose repeatability and distance accuracy .....	2-9
2.2.2 Mass capacity and the allowable moment .....	2-10
2.2.3 Relationships Among Mass Capacity, Speed, and Acceleration/Deceleration Speed .....	2-10
(1) Setting Load Capacity and Size (Hand Conditions) .....	2-10
(2) Relationship Between Mass Capacity and Speed .....	2-11
(3) Relationship Between Height of Shaft (J3 Axis) and Acceleration/Deceleration Speed .....	2-11
(4) Time to reach the position repeatability (only for RH-15AH85) .....	2-12
2.2.4 Protection specifications and working environment .....	2-13
(1) Types of protection specifications .....	2-13
(2) About the use with the bad environment .....	2-13
2.2.5 Clean specifications (RH-5AH series) .....	2-14
(1) Types of clean specifications .....	2-14
2.3 Names of each part of the robot .....	2-15
2.4 Outside dimensions • Operating range diagram .....	2-16
2.4.1 Outside dimensions • Operating range diagram of RH-5AH series .....	2-16
(1) RH-5AH35 .....	2-16
(2) RH-5AHM35 .....	2-17
(3) RH-5AHC35-SA .....	2-18
(4) RH-5AH45 .....	2-19
(5) RH-5AHM45 .....	2-20
(6) RH-5AHC45-SA .....	2-21
(7) RH-5AH55 .....	2-22
(8) RH-5AHM55 .....	2-23
(9) RH-5AHC55-SA .....	2-24
2.4.2 Outside dimensions, Operating range diagram of RH-10AH Series .....	2-25
(1) RH-10AH55 .....	2-25
(2) RH-10AHM55 .....	2-26
(3) RH-10AH70 .....	2-27
(4) RH-10AHM70 .....	2-28
(5) RH-10AH85/RH-15AH85 .....	2-29
(6) RH-10AHM85/RH-15AHM85 .....	2-30
2.4.3 Change the operating range .....	2-31
2.4.4 Mechanical interface and Installation surface .....	2-33
(1) Mechanical interface and Installation surface of RH-5AH series .....	2-33
(2) Mechanical interface and Installation surface of RH-10AH/15AH series .....	2-34
2.5 Tooling .....	2-35
2.5.1 Wiring and piping for hand .....	2-35
2.5.2 Internal air piping .....	2-36
2.5.3 Internal wiring for the pneumatic hand output cable .....	2-36
2.5.4 Internal wiring for the hand check input cable .....	2-36
2.5.5 Precautions for piping to the flexible cable .....	2-36
2.5.6 About the Installation of Tooling Wiring and Piping (Examples of Wiring and Piping) .....	2-37
2.5.7 Electrical specifications of hand input/output .....	2-42
2.5.8 Air supply circuit example for the hand .....	2-43
2.6 Shipping special specifications, options, and maintenance parts .....	2-44

	Page
2.6.1 Shipping special specifications .....	2-44
(1) Machine cable extension .....	2-45
2.7 Options .....	2-47
(1) Solenoid valve set .....	2-48
(2) Hand input cable (Hand chack cable) .....	2-52
(3) Hand output cable .....	2-53
(4) Hand curl tube .....	2-54
2.8 Maintenance parts .....	2-55
3 Controller .....	3-57
3.1 Standard specifications .....	3-57
3.1.1 Standard specifications .....	3-57
3.1.2 Protection specifications and operating supply .....	3-58
3.2 Names of each part .....	3-59
3.3 Outside dimensions/Installation dimensions .....	3-61
3.3.1 Outside dimensions .....	3-61
3.3.2 Installation dimensions .....	3-62
3.4 External input/output .....	3-63
3.4.1 Types .....	3-63
3.4.2 Explanation .....	3-63
3.5 Dedicated input/output .....	3-64
3.6 Emergency stop input/output .....	3-66
3.6.1 Connection of the external emergency stop .....	3-66
3.6.2 Door switch function .....	3-67
3.7 Parallel input/output unit .....	3-68
3.8 Options .....	3-72
(1) Teaching pendant (T/B) .....	3-73
(2) Pneumatic hand interface .....	3-76
(3) Controller protection box .....	3-78
(4) Parallel I/O unit .....	3-81
(5) External I/O cable .....	3-89
(6) Personal computer cable .....	3-91
(7) Extension memory cassette .....	3-92
(8) Personal computer support software/Personal computer support software mini .....	3-94
3.9 Maintenance parts .....	3-96
4 Software .....	4-97
4.1 List of commands .....	4-97
(1) The procedure of robot language selection .....	4-97
(2) MELFA-BASIC IV commands .....	4-98
(3) MOVEMASTER commands .....	4-100
4.2 List of parameters .....	4-103
(1) List of parameters .....	4-103
(2) Change the display language / 表示言語の切り替え .....	4-105
5 Safety .....	5-107
5.1 Safety .....	5-107
5.1.1 Self-diagnosis stop functions .....	5-107
5.1.2 External input/output signals that can be used for safety protection measures .....	5-107
5.1.3 Precautions for using robot .....	5-108
5.1.4 Safety measures for automatic operation .....	5-108
5.1.5 Safety measures for teaching .....	5-108
5.1.6 Safety measures for maintenance and inspections, etc. ....	5-108
5.1.7 Examples of safety measures .....	5-109
5.2 Working environment .....	5-110
5.3 Precautions for handling .....	5-110
6 Appendix .....	Appendix-111
Appendix 1 : Specifications discussion material .....	Appendix-111



## 1 General configuration

### 1.1 Structural equipment

Structural equipment consists of the following types.

#### 1.1.1 Standard structural equipment

The following items are enclosed as a standard.

- (1) Robot arm
- (2) Controller
- (3) Machine cable
- (4) Robot arm installation bolts
- (5) Instruction manual, Safety manual
- (6) Guarantee card

#### 1.1.2 Shipping special specifications

Part of the standard structural equipment is changed at the time of factory shipment. Consequently, kindly confirm the delivery date.

To make changes to the specifications after shipment, service work must be performed at the work site or the robot must be returned for service.

#### 1.1.3 Options

Installation is possible after shipment. Customer needs to perform the installation work.

#### 1.1.4 Maintenance parts

Consumable parts and spare parts for maintenance use.

For items not listed, contact the dealer where you made your purchase.

## 1.2 Contents of the structural equipment

### 1.2.1 Robot arm

The devices shown below can be installed on the robot arm.

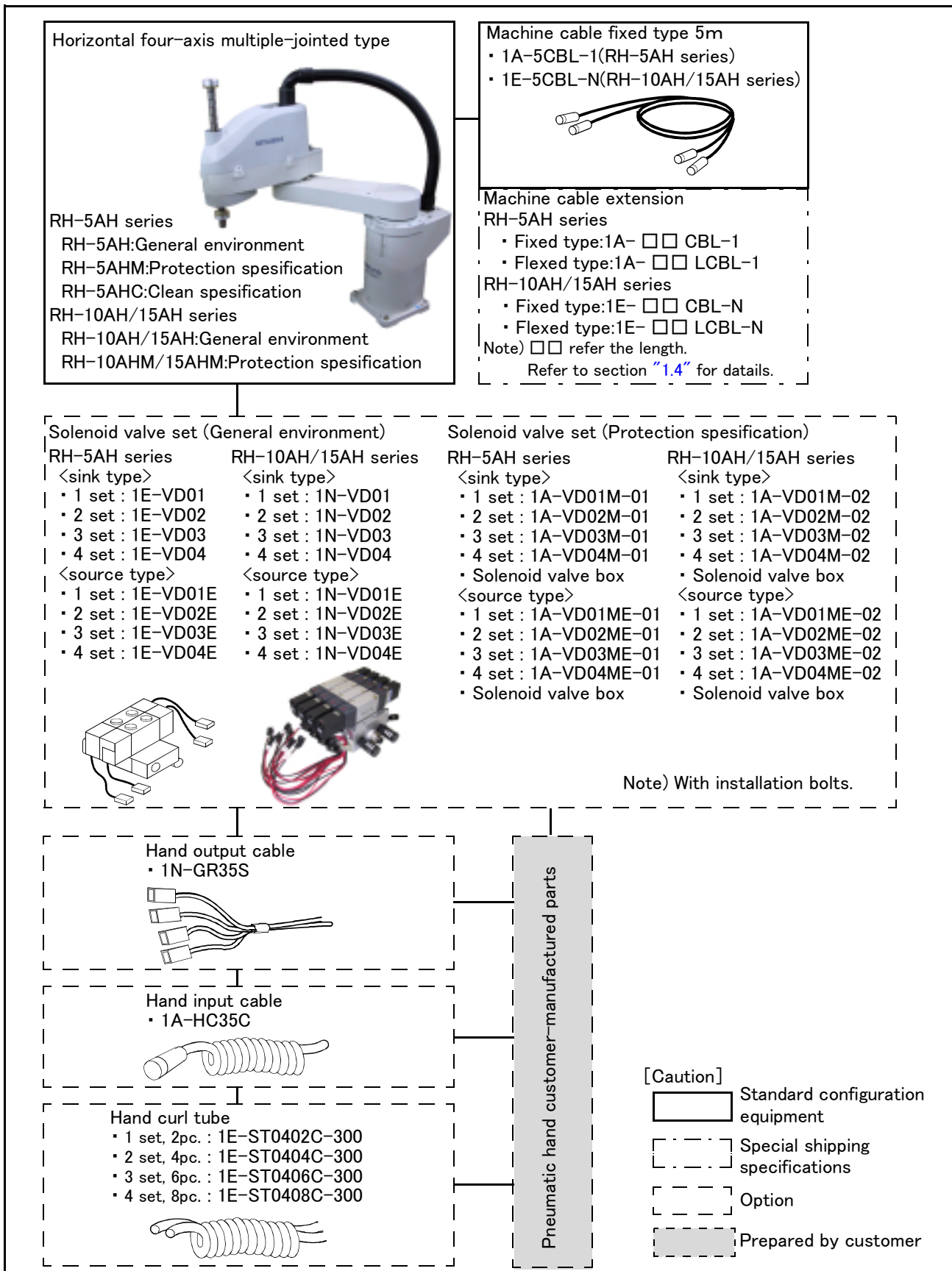

Fig.1-1 : Structural equipment (Robot arm)

### 1.3 Controller

The devices shown below can be installed on the controller.

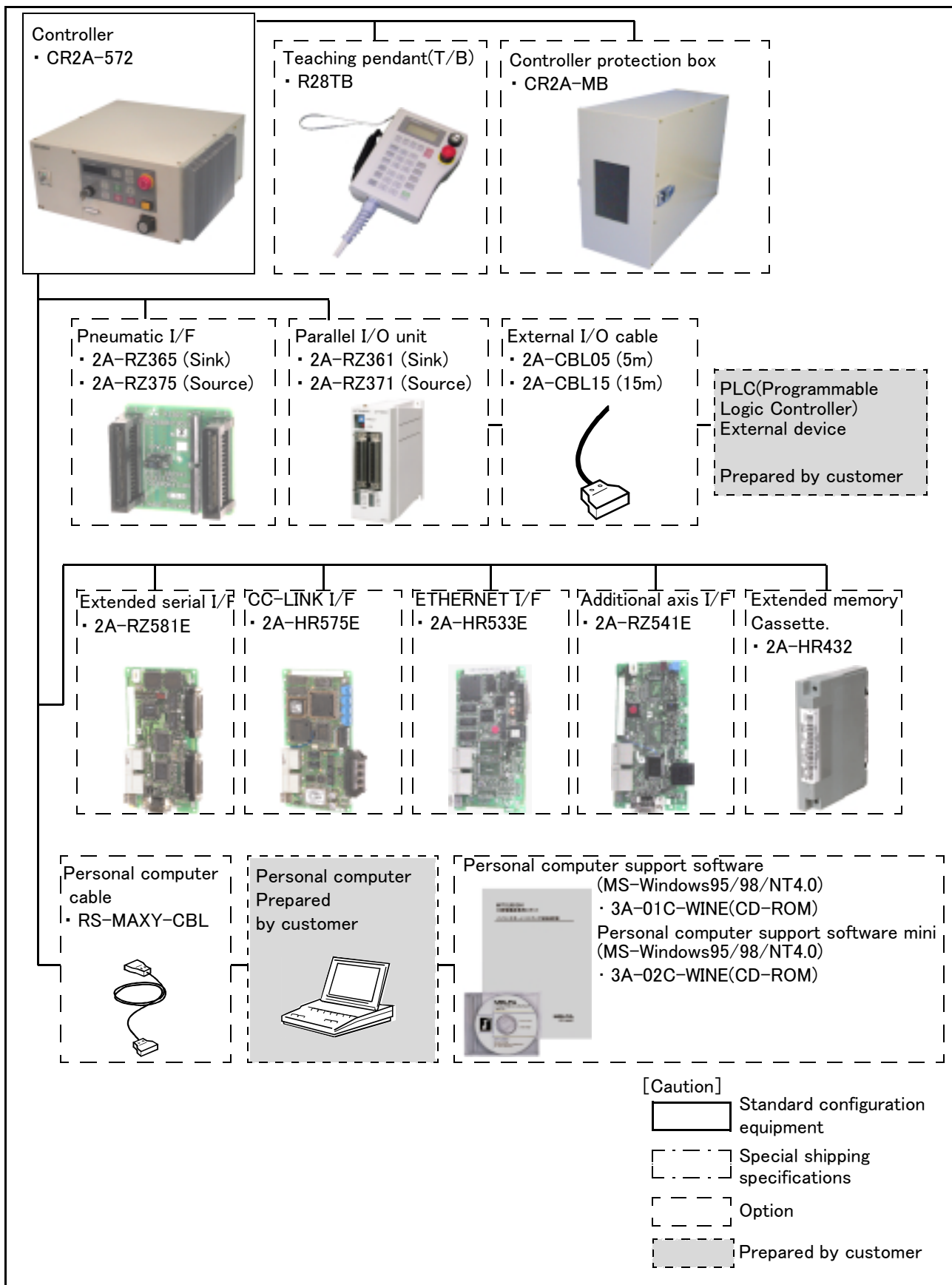

Fig.1-2 : Structural equipment(Controller)

## 1.4 Contents of the Option equipment and special specification

A list of all Optional equipments and special specifications are shown below.

Table 1-1 : The list of Option equipment and special specification (RH-5AH series)

Item	Type	Specifications	Classification Note1)	Description	
<b>Solenoid valve set</b>					
Standard specification	1E-VD01	1 set(Sink type)	○	The solenoid valve set is for the pneumatic hand prepared by customer.	
	1E-VD02	2 set(Sink type)	○		
	1E-VD03	3 set(Sink type)	○		
	1E-VD04	4 set(Sink type)	○		
	1E-VD01E	1 set(Source type)	○		
	1E-VD02E	2 set(Source type)	○		
	1E-VD03E	3 set(Source type)	○		
	1E-VD04E	4 set(Source type)	○		
	Protection specification <sup>Note2)</sup>	1A-VD01M-01	1 set(Sink type)		○
		1A-VD02M-01	2 set(Sink type)		○
		1A-VD03M-01	3 set(Sink type)		○
		1A-VD04M-01	4 set(Sink type)		○
		1A-VD01ME-01	1 set(Source type)		○
		1A-VD02ME-01	2 set(Source type)		○
1A-VD03ME-01		3 set(Source type)	○		
1A-VD04ME-01		4 set(Source type)	○		
Hand input cable <sup>Note3)</sup>	1A-HC35C	Length 1,150mm with robot side connector. One terminal is not treated.	○	The cable is to connect with the hand sensor, etc by customer.	
Hand output cable <sup>Note3)</sup>	1N-GR35S	Length 350mm with robot side connector. One terminal is not treated.	○	The cable is to connect with the solenoid valve prepared by customer and output connector	
Hand curl tube <sup>Note3)</sup>	1E-ST0402C-300	For solenoid valve 1set.:Φ4x2	○	Curl type air tube	
	1E-ST0404C-300	For solenoid valve 2set.:Φ4x4	○		
	1E-ST0406C-300	For solenoid valve 3set :Φ4x6	○		
	1E-ST0408C-300	For solenoid valve 4set :Φ4x8	○		
Extended machine cable	1A-10CBL-1	For fixing	□	10m	
	1A-15CBL-1	(Two sets for power and signal)	□	15m	
	1A-05LCBL-1		□	5m	
	1A-10LCBL-1	For flexing	□	10m	
	1A-15LCBL-1	(Two sets for power and signal)	□	15m	
Teaching pendant	R28TB	Cable length 7m	○	With 3-position deadman switch/ IP 65	
	R28TB-15	Cable length 15m (special specification)	○		
Pneumatic hand interface	2A-RZ365	DO: 8 point (Sink type)	○	It is necessary when the hand output signal of the robot arm is used. (Integrated in the controller.)	
	2A-RZ375	DO: 8 point (Source type)	○		
Parallel I/O interface	2A-RZ361	DO: 32 point (Sink type)/ DI : 32 point (Sink type)	○	The unit for expansion the external input/output. Electrical isolated Type (100mA/Point)	
	2A-RZ371	DO: 32 point (Source type)/ DI : 32 point (Source type)	○		
External I/O cable	2A-CBL05	5m	○	Use to connect the external peripheral device to the parallel input/output unit	
	2A-CBL15	15m	○		
Personal computer cable	RS-MAXY-CBL	RS-232C cable 3m for PC-AT compatible model	○		
Personal computer Support software	3A-01C-WINE	CD-ROM	○	MS-Windows95/98/NT4.0 (With the simulation function)	
Personal computer Support software mini	3A-02C-WINE	CD-ROM	○	MS-Windows95/98/NT4.0 (Without the simulation function)	
Extended serial interface	2A-RZ581E	RS-232C x 1 RS-232C or RS-422 x 1	○		
CC-Link interface	2A-HR575E	Local station (The local station alone is supported.)	○	for MELSEC PLC with CC-Link connection.	
ETHERNET interface	2A-HR533E	ETHERNET x 1	○		
Additional axis interface	2A-RZ541E	SSC x 1 Up to 8 axes can be added	○	MR-J2 servoAmplifier Unit connection. CR-EB3 is need.	
Extended memory cassette	2A-HR432	Teaching point is 25,400 points.	○	Expand the teaching point up to 27,900 points, including 2,500 points of standard	
Controller protection box	CR2A-MB	IP54	□	The controller protection box is used to protect the controller from an oil mist or other operating environment. <sup>Note4)</sup>	

Note1) In the classification column, ○ refers to an option, and □ to a Shipping special specifications.

Note2) Use this option for solenoid valve set when use with the bad environment such as oil mist. The solenoid valve box which protects the solenoid valve is attached to this option.

Note3) A procedure for securing protection and cleanliness is required for customers. For more details, refer to the Page 44, "2.6 Shipping special specifications, options, and maintenance parts".

Note4) Use this option to protect the controller from the oil mist when the controller will be installed in the environment such as the oil mist.

Table 1-2 : The list of Option equipment and special specification (RH-10AH/15AH series)

Item	Type	Specifications	Classification Note1)	Description	
Solenoid valve set					
Standard specification	1N-VD01	1 set(Sink type)	○	The solenoid valve set is for the pneumatic hand prepared by customer.	
	1N-VD02	2 set(Sink type)	○		
	1N-VD03	3 set(Sink type)	○		
	1N-VD04	4 set(Sink type)	○		
	1N-VD01E	1 set(Source type)	○		
	1N-VD02E	2 set(Source type)	○		
	1N-VD03E	3 set(Source type)	○		
	1N-VD04E	4 set(Source type)	○		
	Protection specification Note2)	1A-VD01M-02	1 set(Sink type)		○
		1A-VD02M-02	2 set(Sink type)		○
		1A-VD03M-02	3 set(Sink type)		○
		1A-VD04M-02	4 set(Sink type)		○
		1A-VD01ME-02	1 set(Source type)		○
		1A-VD02ME-02	2 set(Source type)		○
		1A-VD03ME-02	3 set(Source type)		○
		1A-VD04ME-02	4 set(Source type)		○
Hand input cable	1A-HC35C	Length 1,150mm with robot side connector. One terminal is not treated.	○	The cable is to connect with the hand sensor, etc by customer.	
Hand output cable Note3)	1N-GR35S	Length 350mm with robot side connector. One terminal is not treated.	○	The cable is to connect with the solenoid valve prepared by customer and output connector	
Hand curl tube	1E-ST0402C-300	For solenoid valve 1set.:Φ4x2	○	Curl type air tube	
	1E-ST0404C-300	For solenoid valve 2set.:Φ4x4	○		
	1E-ST0406C-300	For solenoid valve 3set :Φ4x6	○		
	1E-ST0408C-300	For solenoid valve 4set :Φ4x8	○		
Extended machine cable	1E-10CBL-N	For fixing	□	10m	
	1E-15CBL-N	(Two sets for power and signal)	□	15m	
	1E-05LCBL-N		□	5m	
	1E-10LCBL-N	For flexing	□	10m	
	1E-15LCBL-N	(Two sets for power and signal)	□	15m	
Teaching pendant	R28TB	Cable length 7m	○	With 3-position deadman switch/ IP 65	
	R28TB-15	Cable length 15m (special specification)	○		
Pneumatic hand interface	2A-RZ365	DO: 8 point (Sink type)	○	It is necessary when the hand output signal of the robot arm is used. (Integrated in the controller.)	
	2A-RZ375	DO: 8 point (Source type)	○		
Parallel I/O interface	2A-RZ361	DO: 32 point (Sink type)/ DI : 32 point (Sink type)	○	The unit for expansion the external input/output. Electrical isolated Type (100mA/Point)	
	2A-RZ371	DO: 32 point (Source type)/ DI : 32 point (Source type)	○		
External I/O cable	2A-CBL05	5m	○	Use to connect the external peripheral device to the parallel input/output unit	
	2A-CBL15	15m	○		
Personal computer cable	RS-MAXY-CBL	RS-232C cable 3m for PC-AT compatible model	○		
Personal computer Support software	3A-01C-WINE	CD-ROM	○	MS-Windows95/98/NT4.0 (With the simulation function)	
Personal computer Support software mini	3A-02C-WINE	CD-ROM	○	MS-Windows95/98/NT4.0 (Without the simulation function)	
Extended serial interface	2A-RZ581E	RS-232C x 1 RS-232C or RS-422 x 1	○		
CC-Link interface	2A-HR575E	Local station (The local station alone is supported.)	○	for MELSEC PLC with CC-Link connection.	
ETHERNET interface	2A-HR533E	ETHERNET x 1	○		
Additional axis interface	2A-RZ541E	SSC x 1 Up to 8 axes can be added	○	MR-J2 servoAmplifier Unit connection. CR-EB3 is need.	
Extended memory cassette	2A-HR432	Teaching point is 25,400 points.	○	Expand the teaching point up to 27,900 points, including 2,500 points of standard	
Controller protection box	CR2A-MB	IP54	□	The controller protection box is used to protect the controller from an oil mist or other operating environment. Note4)	

Note1) In the classification column, ○ refers to an option, and □ to a Shipping special specifications.

Note2) Use this option for solenoid valve set when use with the bad environment such as oil mist. The solenoid valve box which protects the solenoid valve is attached to this option.

Note3) A procedure for securing protection is required for customers. For more details, refer to the [Page 44, "2.6 Shipping special specifications, options, and maintenance parts"](#).

Note4) Use this option to protect the controller from the oil mist when the controller will be installed in the environment such as the oil mist.



## 2 Robot arm

### 2.1 Standard specifications

#### 2.1.1 Standard specifications

Table 2-1 : Tab Standard specifications of robot (RH-5AH series)

Item	Unit	Specifications									
		Arm length 350m			Arm length 450m			Arm length 550m			
Type		RH-5AH35	RH-5AHM35	RH-5AHC55-SA	RH-5AH45	RH-5AHM45	RH-5AHC45-SA	RH-5AH55	RH-5AHM55	RH-5AH55C-SA	
		General	Protection	Clean	General	Protection	Clean	General	Protection	Clean	
Installation posture		On floor									
Degree of freedom		4									
Structure		Horizontal, multiple-joint type									
Drive system		AC servo motor									
Position detection method		Absolute encoder									
Motor capacity	J1	W	200								
	J2	W	100								
	J3 (Z)	W	100								
	J4 ( $\theta$ axis)	W	100								
Brake		J1, J2, J4 : no brake J3 : with brake									
Arm length	No. 1 arm	mm	125			225			325		
	No. 2 arm	mm	225								
Max.reach radius( No. 1+ No. 2)		mm	350			450			550		
Operating range	J1	deg	$\pm 127$								
	J2	deg	$\pm 137$			$\pm 143$					
	J3 (Z) <sup>Note1)</sup>	mm	200								
	J4 ( $\theta$ axis)	deg	$\pm 360$								
Speed of motion	J1	deg/s	337.5								
	J2	deg/s	540								
	J3 (Z)	mm/s	1,000								
	J4 ( $\theta$ axis)	deg/s	1,870								
Maximum horizontal composite speed	mm/s	4,180			4,770			5,360			
Cycle time <sup>Note2)</sup>	sec	0.46			0.47			0.48			
Load (Including hand)	Rating	kg	2								
	Maximum	kg	5								
Allowable moment load	Rating	kg · m <sup>2</sup>	0.01								
	Maximum	kg · m <sup>2</sup>	0.04								
Pose repeatability <sup>Note3)</sup>	X-Y direction	mm	$\pm 0.02$								
	J3 (Z)	mm	$\pm 0.01$								
	J4 ( $\theta$ axis)	deg	$\pm 0.03$								
Ambient temperature	°C	0 to 40									
Mass	kg	Approx. 19									
Tool wiring <sup>Note4)</sup>		Input 8 points/Output 8 points									
Tool pneumatic pipes <sup>Note5)</sup>		$\Phi 6 \times 2$ 、 $\Phi 4 \times 1$									
Protection specification <sup>Note6)</sup>		IP30	IP54	-	IP30	IP54	-	IP30	IP54	-	
Cleanness <sup>Note7)</sup>		-	10 (0.3 $\mu$ m)	-	-	10 (0.3 $\mu$ m)	-	-	10 (0.3 $\mu$ m)	-	
Painting color		Light gray (Equivalent to Munsell : 7.65Y7.6/0.73)									

Note1) 200 mm (97 mm to 297 mm) for the general environment specifications, and 200 mm (67 mm to 267 mm) for both the oil mist resistant specifications and the clean specifications.

Note2)The value of the following operation for rated weight capacity.

- The cycle time may increase when the positioning accuracy or other criterion of a work is required, or depending on the position of operation.

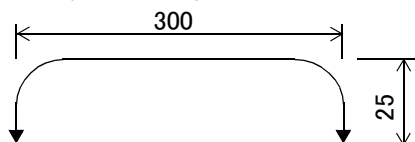

Note3)The pose repeatability details are given in Page 9, "2.2.1 Pose repeatability and distance accuracy".

Note4)An optional pneumatic hand interface (option) is required to use hand output.

Note5)For the clean specifications, one  $\phi 6$  is for supply and the other  $\phi 6$  is for exhaust of the solenoid valve, and one  $\phi 4$  is for tooling (it can also be used for suction).

Note6)The protection specification details are given in Page 13, "2.2.4 Protection specifications and working environment".

Note7)The details of the clean specifications are described in Page 14, "2.2.5 Clean specifications (RH-5AH series)". To secure cleanliness, a clean room down flow of 0.3 m/s or more and an internal robot suction of 60 NL/min are required. A coupling of  $\phi 8$  is provided in the rear of the base for suction.

Table 2-2 : Tab Standard specifications of robot (RH-10AH/15AH series)

Item		Unit	Specifications							
Type			Arm length 550m		Arm length 700m		Arm length 850m		Arm length 850m	
			RH-10AH55	RH-10AHM55	RH-10AH70	RH-10AHM70	RH-10AH85	RH-10AHM85	RH-15AH85	RH-15AHM85
			General	Protection	General	Protection	General	Protection	General	Protection
Installation posture			On floor							
Degree of freedom			4							
Structure			Horizontal, multiple-joint type							
Drive system			AC servo motor							
Position detection method			Absolute encoder							
Motor capacity	J1	W	400							
	J2	W	200							
	J3 (Z)	W	200							
	J4 (θ axis)	W	100							
Brake			J1, J2, J4 : no brake J3 : with brake (RH-10AH55/70/85) J1, J2 : no brake J3, J4 : with brake (RH-15AH85)							
Arm length	No. 1 arm	mm	225		375		525			
	No. 2 arm	mm	325							
Max.reach radius (No. 1+No. 2)		mm	550		700		850			
Operating range	J1	deg	± 140							
	J2	deg	± 145				± 153			
	J3 (Z) <sup>Note1)</sup>	mm	350	300	350	300	350	300	350	300
	J4 (θ axis)	deg	± 360							
Speed of motion	J1	deg/s	315				252			
	J2	deg/s	337.5							
	J3 (Z)	mm/s	1,125				1,000			
	J4 (θ axis)	deg/s	1,274							
Maximum horizontal composite speed		mm/s	4,930		5,760		5,650			
Cycle time <sup>Note2)</sup>		sec	0.49		0.5		0.52		0.57	
Load (Including hand)	Rating	kg	2							
	Maximum	kg	10							
Allowable moment load	Rating	kg · m <sup>2</sup>	0.02							
	Maximum	kg · m <sup>2</sup>	0.1				0.2			
Pose repeatability <sup>Note3)</sup>	X-Y composition	mm	± 0.02		± 0.025					
	J3 (Z)	mm	± 0.01							
	J4 (θ axis)	deg	± 0.03							
Mass		kg	38		39		40		42	
Ambient temperature		°C	0 to 40							
Tool wiring <sup>Note4)</sup>			Input 8 points/Output 8 points							
Tool pneumatic pipes			Φ 6x2, Φ 4x1							
Protection specifications <sup>Note5)</sup>			IP30	IP54	IP30	IP54	IP30	IP54	IP30	IP54
Painting color			Light gray (Equivalent to Munsell : 7.65Y7.6/0.73)							

Note1) 350 mm (-10 mm to 340 mm) for the general environment specifications, and 300 mm (-10 mm to 290 mm) for the oil mist resistant specifications.

Note2) These values are for the rated weight capacity. The cycle time may increase when a higher work positioning accuracy is required, or depending on the operating position.

Note3) The pose repeatability details are given in Page 9, "2.2.1 Pose repeatability and distance accuracy".

Note4) An optional pneumatic hand interface (option) is required to use hand output.

Note5) The protection specification details are given in Page 13, "2.2.4 Protection specifications and working environment".



## 2.2 Definition of specifications

The accuracy of pose repeatability mentioned in catalogs and in the specification manual is defined as follows.

### 2.2.1 Pose repeatability and distance accuracy

This robot, the pose repeatability and distance accuracy are defined and calculated in [Table 2-3](#).

- (1) The pose accuracy in terms of coordinates (XYZ) for the standard point which is obtained repeatedly under the same conditions and motions when the robot is on an operating course.
- (2) The standard point is the intersection between the J4 axis and the flange surface for tooling installation.

Table 2-3 : Specified accuracy

Item	Specified conditions
Pose repeatability	The value equal to the average of the maximum value and the minimum value of the group of attained poses, with (+) or (-) added.
Distance accuracy	The distance from the teaching point to the point that is equal to the average of the maximum value and the minimum value of the group of attained poses.

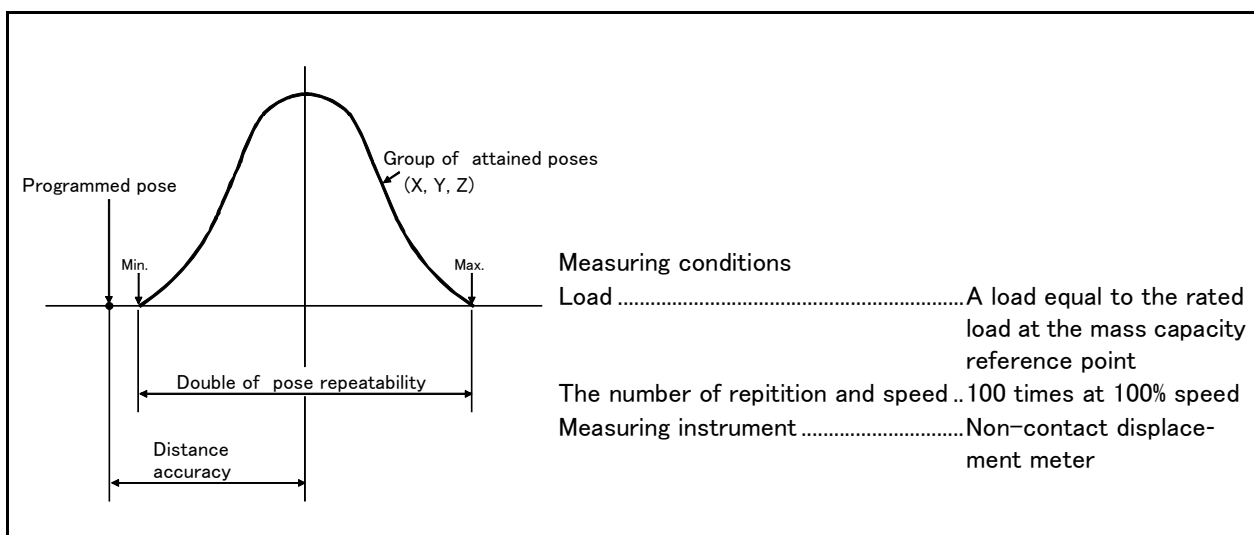

Fig.2-1 : Specified accuracy

[Caution] The pose accuracy given in the specifications is the accuracy measured under the same conditions. It does not include the effect of the robot working environment or conditions. Thus, even when used on the same path, the repeatability according to the presence of a workpiece, or the repeatability when the temperature changes will cause arm slack or expansion, so the accuracy will drop slightly. This also applies to when the teaching speed and actual speed are different or when the coordinates set with values.

### 2.2.2 Mass capacity and the allowable moment

The robot's mass capacity is expressed solely in terms of mass, but even for tools and works of similar mass, eccentric loads will have some restrictions. When designing the tooling or when selecting a robot, consider the following issues.

- (1) The tooling should have the value less or equal than the smaller of the allowable moment found in [Page 7, "Table 2-1 : Tab Standard specifications of robot \(RH-5AH series\)"](#) and [Page 8, "Table 2-2 : Tab Standard specifications of robot \(RH-10AH/15AH series\)"](#).

[CAUTION]The mass capacity and the allowable moment of inertia are significantly affected by the operating speed and operating posture of the robot. Even when these values are within the allowable range described above, an overload or overcurrent alarm may occur. In such cases, the acceleration/deceleration time settings, operating speed and/or operating posture must be adjusted.

[CAUTION]The overhang amount of the load, such as the mass capacity and the allowable moment of inertia defined in this section, are dynamic limit values determined by the capacity of the motor that drives axes or the capacity of the speed reducer. Therefore, it does not guarantee the accuracy on all areas of tooling. Guaranteed accuracy is measured from the center point of the mechanical interface surface. Please note that if the point of operation is kept away from the flange surface by long and low-rigid tooling, the positioning accuracy may deteriorate or may cause vibration.

### 2.2.3 Relationships Among Mass Capacity, Speed, and Acceleration/Deceleration Speed

This robot automatically sets the optimum acceleration and deceleration speeds and maximum speed, according to the load capacity and size that have been set, and operates using these automatically set speeds.

To achieve that, it is necessary to correctly set the actual load data (mass and size of hand and work) to be used. However, vibration and errors such as excessive margin of error and overload may occur, depending on the robot operation pattern or ambient temperature. In such a case, change the setting value to the +20% range. If a setting is performed in such a way that it falls below the mounted load, the life span of the mechanism elements used in the robot may be shortened. In the case of a work requiring a high degree of accuracy, set up the load correctly and use the robot by lowering the ratios of the acceleration and deceleration speeds.

#### (1) Setting Load Capacity and Size (Hand Conditions)

Set up the capacity and size of the hand with the "HNDDAT\*" parameter (optimum acceleration/deceleration setting parameter), and set up the capacity and size of the work with the "WRKDAT\*" parameter. Numbers 1 to 8 can be used for the asterisk (\*) part. Designate the "HNDDAT\*" and "WRKDAT\*" parameters to be used using the "LOADSET" command in a program.

For more details, refer to the CR1/CR2/CR4/CR7/CR8 INSTRUCTION MANUAL entitled "Detailed explanations of functions and operations."

<Factor default settings>

	Hand mass (kg)	size X (mm)	size Y (mm)	size Z (mm)	center-of-gravity position X (mm)	center-of-gravity position Y (mm)	center-of-gravity position Z (mm)
RH-5AH series							
HNDDAT*	5.0	219.0	219.0	60.0	0.0	0.0	-30.0
WRKDAT*	0.0	0.0	0.0	0.0	0.0	0.0	0.0
RH-10AH/15AH series							
HNDDAT*	10.0	100.0	100.0	60.0	0.0	0.0	-30.0
WRKDAT*	0.0	0.0	0.0	0.0	0.0	0.0	0.0

Note 1)The center-of-gravity position is located at the center of the lower edge surface of the shaft. X, Y and Z set the center-of-gravity position in the tool's coordinate direction.

(For the center-of-gravity position Z, the downward direction is the minus direction.)

(2) Relationship Between Mass Capacity and Speed

A function to optimize the maximum speed of each axis according to the setting value of the load capacity will be activated (Refer to Fig. 2-2).

However, this function does not work with the setting of 2kg (5kg in the case of RH-15AH85) or lighter load mass. When the setting of the load mass is changed to 2kg (5kg in the case of RH-15AH85) or heavier, the maximum speed is compensated according to the load mass.

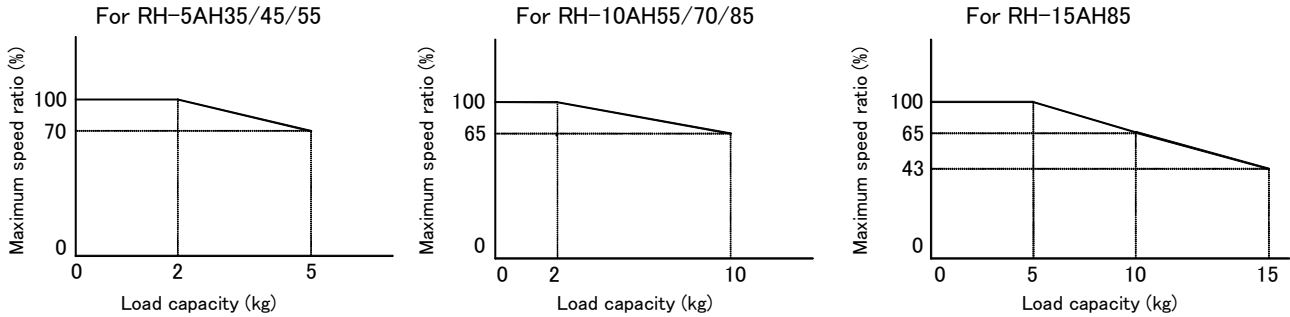

Fig.2-2 : Automatic compensation of speed

(3) Relationship Between Height of Shaft (J3 Axis) and Acceleration/Deceleration Speed

A function to optimize the acceleration/deceleration speed according to the height of the shaft (Refer to Fig. 2-4) will be activated. However, this function will not be activated if the shaft (J3 axis) operates at a position higher than the position indicated by Fig. 2-3.

If the center of gravity position of the load mass is at the tip of the shaft, the acceleration and deceleration speeds are compensated at the position 50 mm below the top edge of the stroke (200 mm), i.e., 150 mm, in the case of RH-5AH.

For more details, refer to the "Fig. 2-3Area in which acceleration/deceleration speed is compensated".

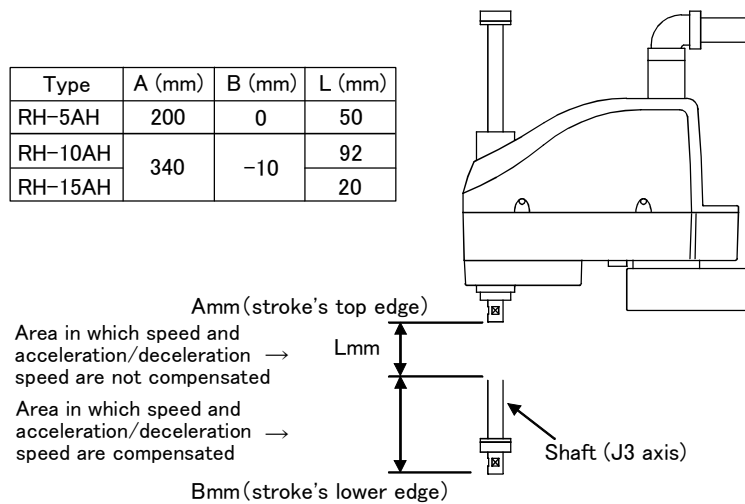

Fig.2-3 : Area in which acceleration/deceleration speed is compensated

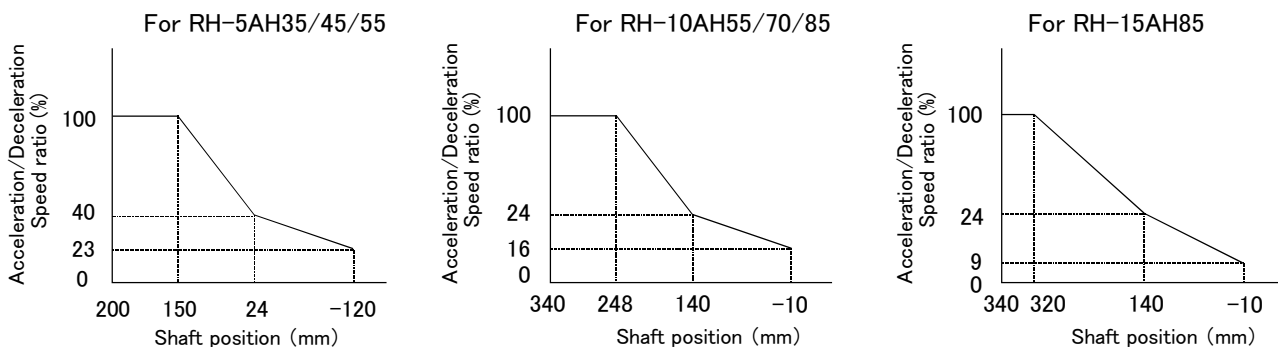

Fig.2-4 : Automatic compensation of acceleration/deceleration speed

(4) Time to reach the position repeatability (only for RH-15AH85)

When using this robot, the time to reach the position repeatability may be prolonged due to the effect of residual vibration at the time of stopping. If this happens, take the following measures:

- 1) Change the operation position of the Z axis to the location near the top as much as possible.
- 2) Increase the operation speed prior to stopping.
- 3) When positioning the work near the bottom edge of the Z axis, if no effectiveness is achieved in step <2> above, perform operation <1> (robot path: O → A → C). In the case of operation 2 (robot path: O → B → C), residual vibration may occur. (Refer to Fig. 2-5.)

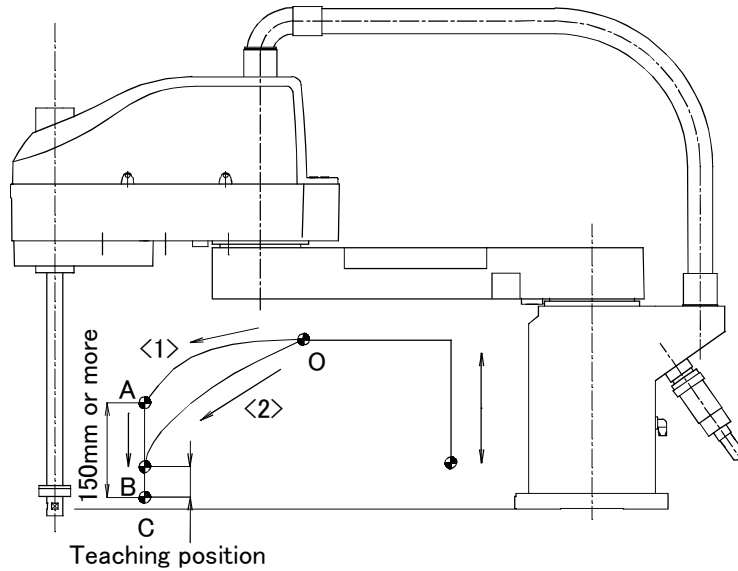

Fig.2-5 : Recommended path when positioning at the bottom edge of the Z axis

## 2.2.4 Protection specifications and working environment

### (1) Types of protection specifications

The robot arm has protection specifications that comply with the IEC Standards. The protection specifications and applicable fields are shown in [Table 2-4](#). Because the products with the protection specifications are produced upon receiving an order, please check the delivery schedule.

Table 2-4 : Protection specifications and applicable fields

Type	Protection specifications (IEC Standards value)	Classification	Applicable field	Remarks
RH-5AH35/45/55 RH-10AH55/70/85, RH-15AH85	IP30	General environment specifications	General assembly Slightly dusty environment	
RH-5AHM35/45/55 RH-10AHM55/70/85, RH-15AHM85	IP54 (drip-proof type)	Protection environment specifications	Machine tool (cutting) Machine shop with heavy oil mist Dusty work shop	Note that if the cutting machine contains abrasive materials, the machine line will be shortened

Note) Both the fixed and flexible machine cables are compatible with IP54 (drip-proof type).



### CAUTION

The controller (CR2A-572) of this robot is a general environment specification. Use the controller protection box (CR2A-MB) optional to protect the controller from the environment when the controller will be used in the environment such as the oil mist shown in the [Table 2-4](#). Refer to the section [Page 78, "\(3\) Controller protection box"](#) for details on the controller protection box.

The IEC IP symbols define the degree of protection against solids and fluids, and do not indicate a protective structure against the entry of oil or water.

The evaluation regarding oil mist specifications has been confirmed with Mitsubishi's standard testing methods using the cutting oils shown in [Table 2-5](#).

Table 2-5 : Tested cutting oil for oil mist specifications

Name	Maker	Relevant JIS	Main characteristics	Application
Emulcut FA-800	Kyodo Yushi Co., Ltd	Equivalent to Class W 1 No. 1	Water soluble cutting oil <ul style="list-style-type: none"> <li>• Base oil ..... 50-60 %</li> <li>• Surfactant and rust inhibitor ..... 30-40 %</li> <li>• Additives ..... 5 % or less</li> <li>• Water ..... The rest</li> </ul>	Water soluble cutting oil Emulcut

#### 【Information】

- The IEC IP30

IP30 refers to a protective structure with which the tip of a solid object, such as a tool or wire, having a diameter or thickness exceeding 2.5mm cannot enter. No particular protection is provided against the entry of water.

- The IEC IP54

The IEC IP54 standard refers to protection structure designed to prevent any harmful effects by fresh water scattering vertically onto the testing equipment in a radius of 180 degrees from a distance of 300 to 500 mm, with  $10 \pm 0.5$  liters of water every minute, at a water pressure of 80 to 100kPa, covering the entire area of the robot with the exception of the installation section at  $1 \text{ m}^2$  per minute, for a total of 5 minutes or more.

### (2) About the use with the bad environment

The protection specifications robot has protection methods that conform to IEC's IP54 standards (splashproof type). It has protection structure designed to prevent harmful effects caused by splashing water coming from various directions, as the robot is operating.

Recommended usage conditions

- 1) The robot is designed for use in combination with machining device.
- 2) Please examine cutting oil referring to [Table 2-5](#) used by a standard examination of our company.
- 3) Take measures so that water, oil, and chips do not directly fall on the robot.

The warranty is invalid for any faults that occur when the robot is used under the following conditions.

Refer to [Page 109, "5.1.7 Examples of safety measures"](#) together.

- 1) In surroundings that generate inflammable gases or corrosive gasses.
- 2) Robot is used for cutting.
- 3) Atmosphere used excluding cutting oil shown in [Table 2-5](#).
- 4) In surroundings where water, oil, and chips fall directly on the robot.
- 5) In surroundings where chips fall directly on the robot. In surroundings where the minimum diameter of chips is less than 0.5mm.
- 6) Mist atmosphere exceeding the specification.

## 2.2.5 Clean specifications (RH-5AH series)

## (1) Types of clean specifications

Because the products with the clean specifications are produced upon receiving an order, please check the delivery schedule.

Table 2-6 : Clean specifications

Clean specifications	Type	Degree of cleanliness	Internal suction	Remarks
Type SA	RH-5AHC35-SA RH-5AHC45-SA RH-5AHC55-SA	10(0.3 $\mu$ m)	Internal suction	Internal suction: 60 NL/min *Prepare the above suction by customer.

■ Precautions for use

- 1) When using a device that moves or rotates the robot arm, the down flow may not be secured because of the air flow. In this case, the degree of cleanliness cannot be ensured.
- 2) For suction inside the robot arm, couplings of  $\phi 8$  are provided in the base section of the robot arm. Connect these couplings with your vacuum generating valve or vacuum pump.
- 3) Moreover, in order to prevent the exhaust of the vacuum generating valve from impairing the cleanliness, install the vacuum generating valve on the downstream side of the down flow or attach the filter to the exhaust section as possible.

Table 2-7 : Specifications of vacuum generation valve

Type	Maker	Air pressure
MEDT 14	Koganei	0.2 to 0.6 MPa

Recommended filter: Exhaust filter EF300-02, Koganei Corporation

- \* If any vacuum pump is prepared by the customer, assure the flow rate of internal suction: 60 NL/min. or more.
- 4) When using the Mitsubishi standard option solenoid valve set, use the spare piping ( $\phi 6$  pneumatic hose) of the primary piping to exhaust the air.  
Be aware that exhausting near the solenoid valve set installation area may give adverse effects on cleanliness.

 CAUTION

Controllers with the RH-5AHC\*\*-SA clean specifications are of the general environment specifications. When installing these controllers, be sure to install them at locations where cleanliness is not affected.

## 2.3 Names of each part of the robot

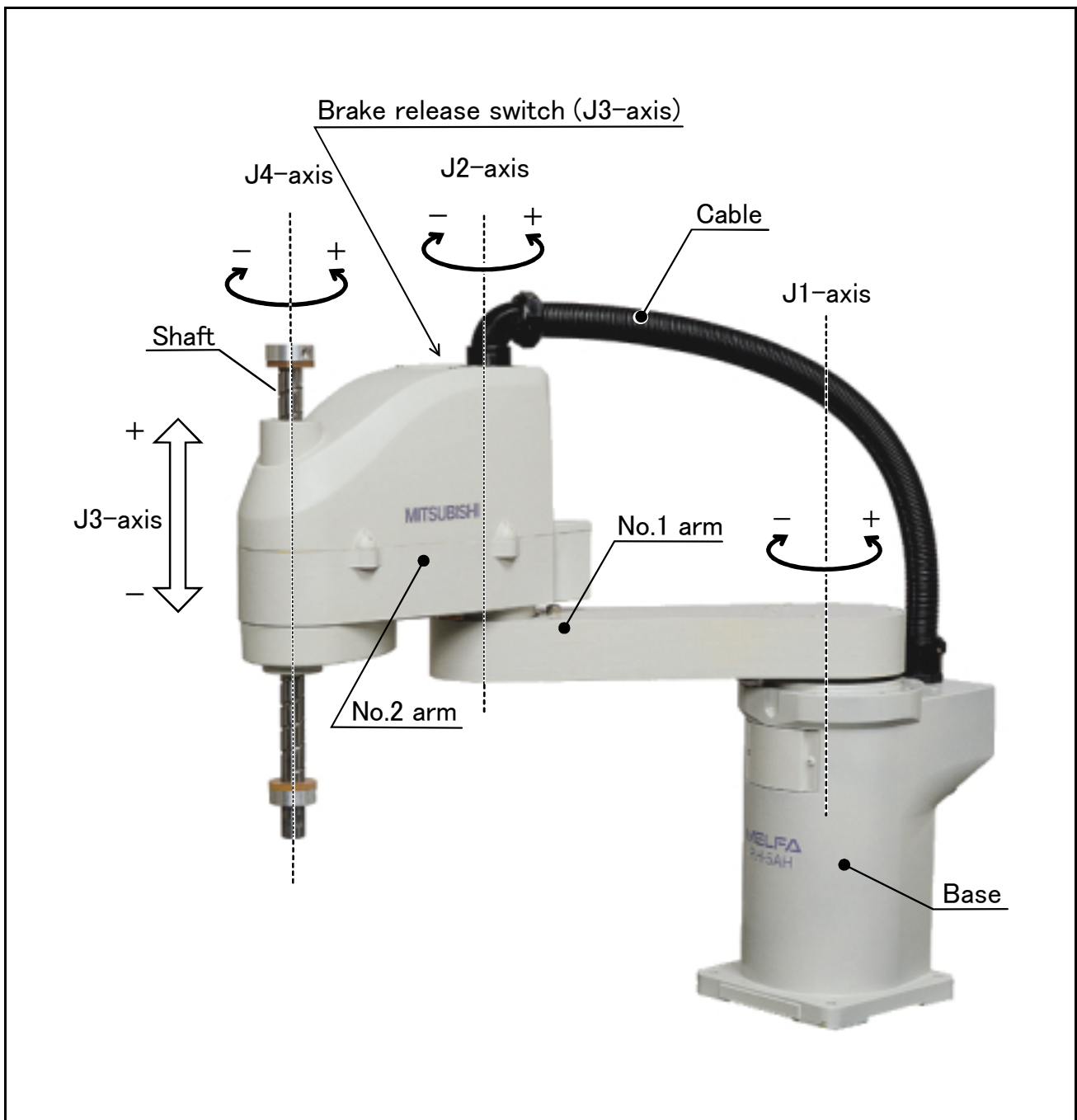

Fig.2-6 : Names of each part of the robot

2.4 Outside dimensions ▪ Operating range diagram

2.4.1 Outside dimensions ▪ Operating range diagram of RH-5AH series

(1) RH-5AH35

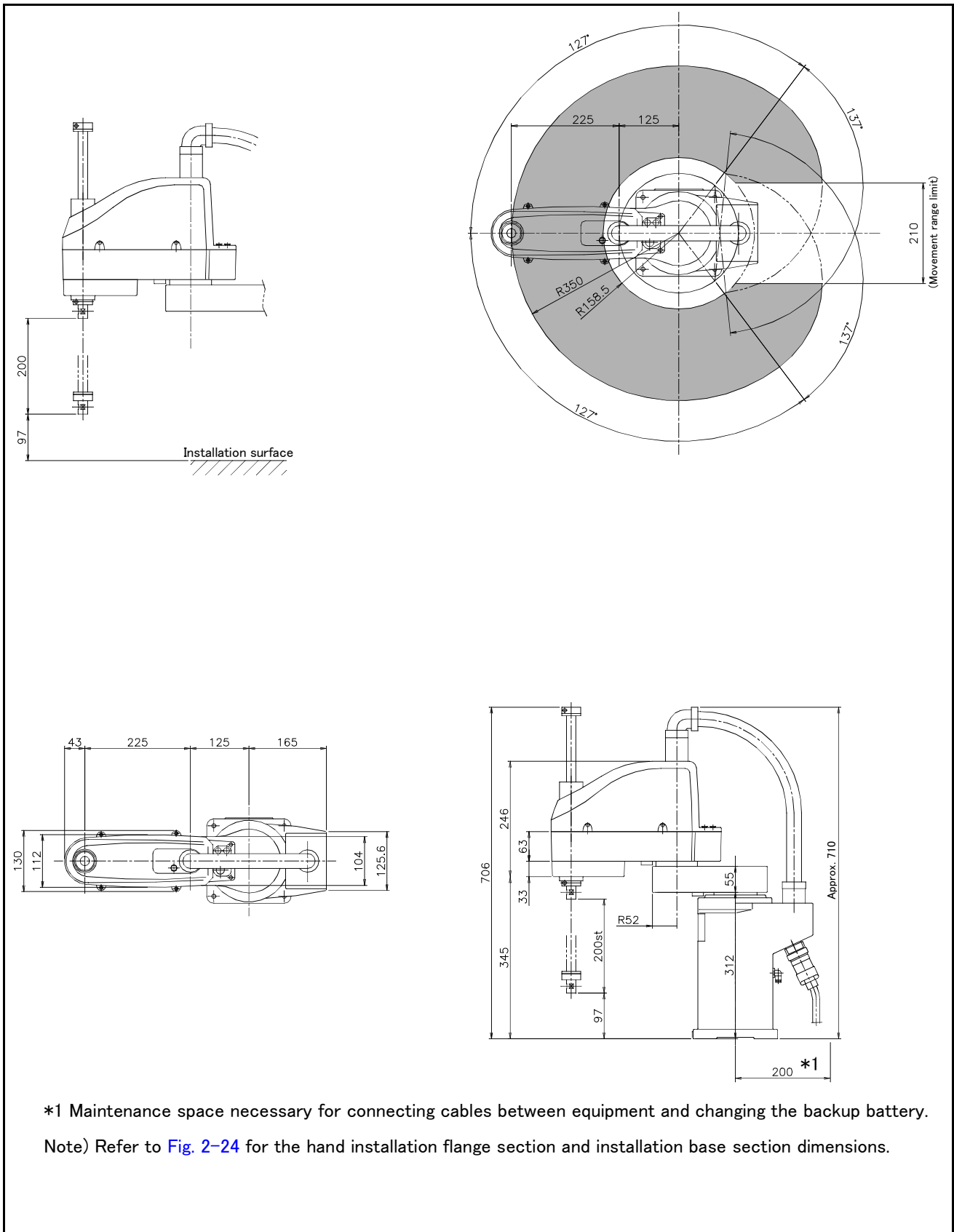

Fig.2-7 : Outside dimensions, Operating range diagram of RH-5AH35



(2) RH-5AHM35

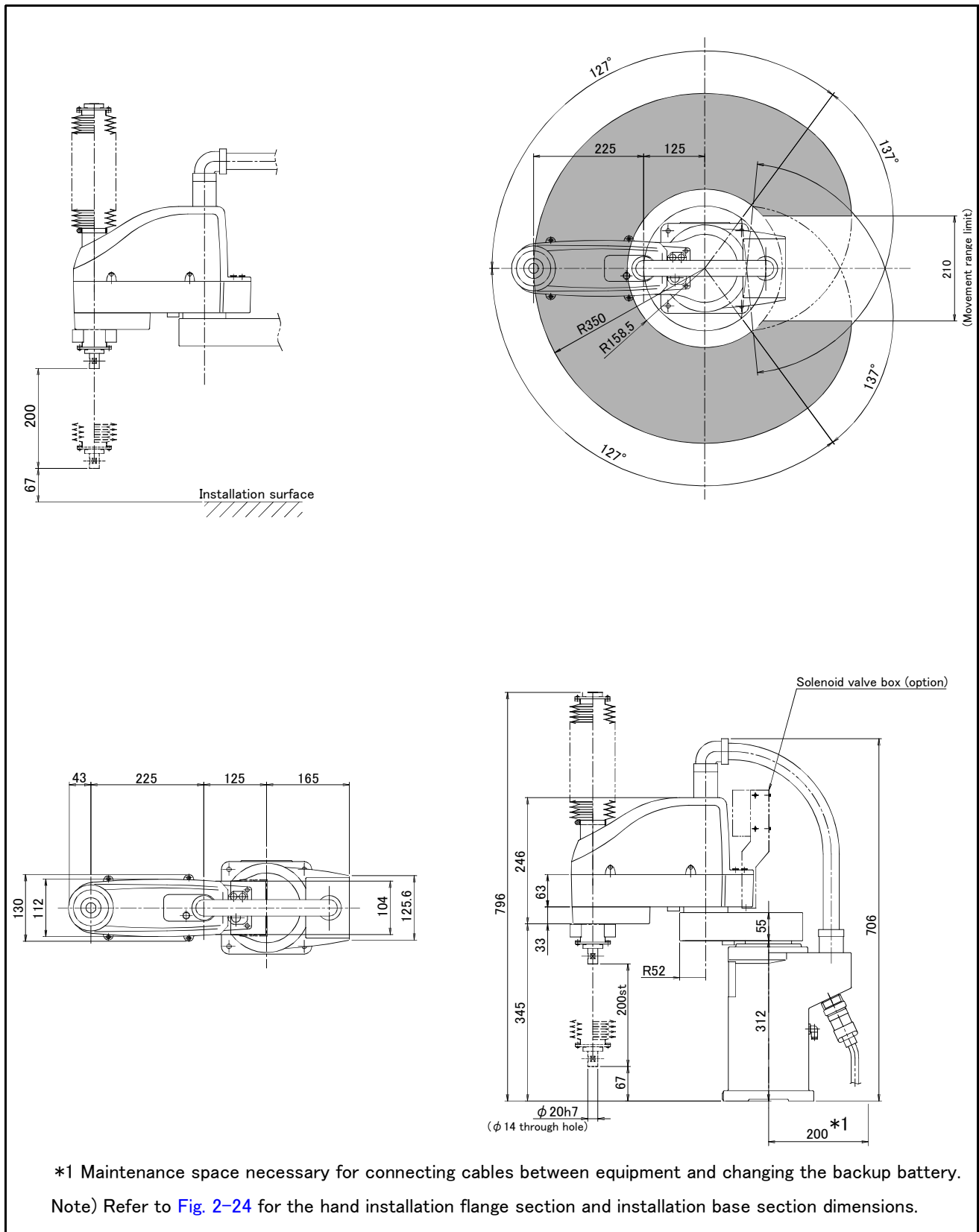

Fig.2-8 : Outside dimensions, Operating range diagram of RH-5AHM35

(3) RH-5AHC35-SA

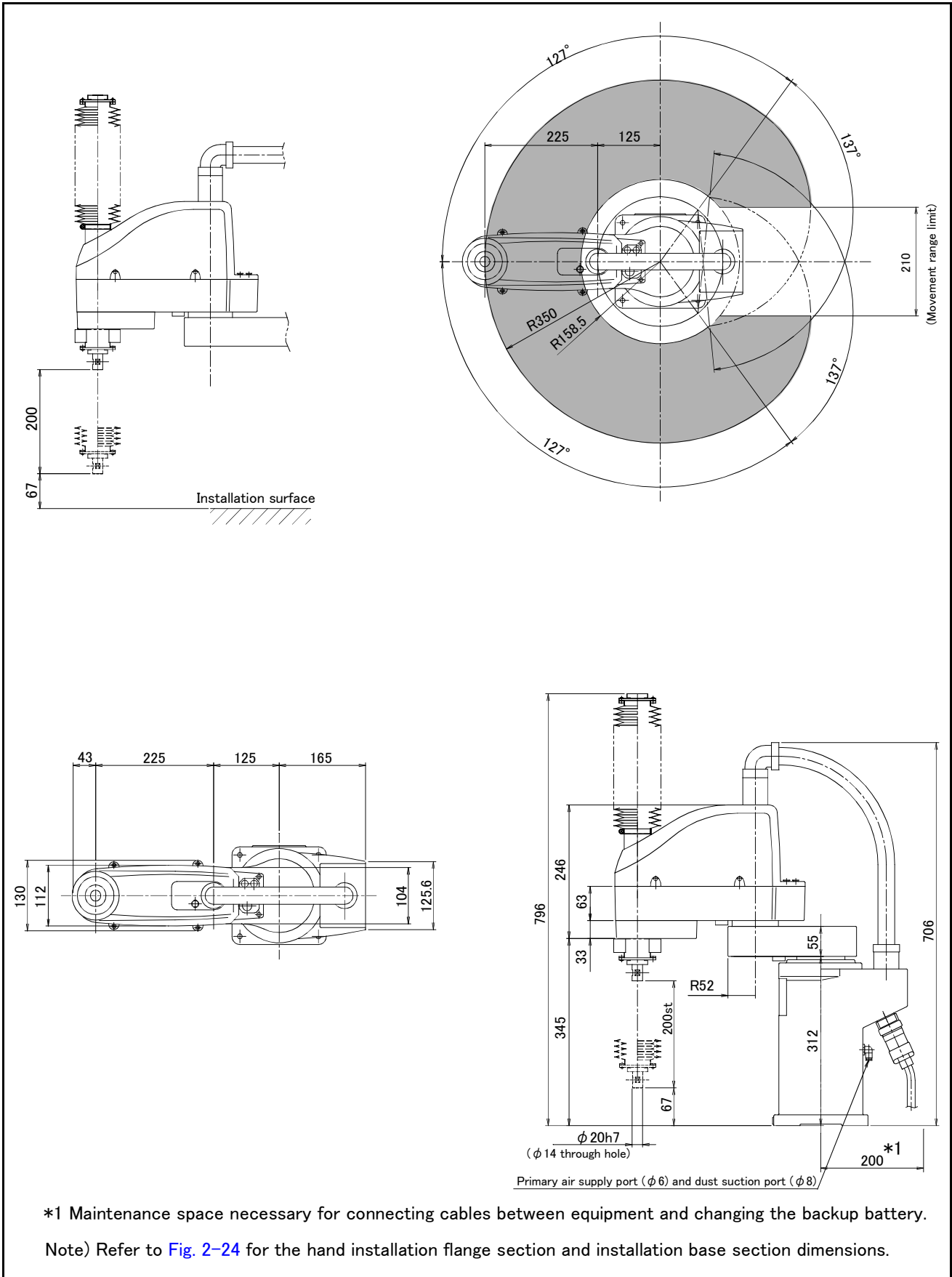

Fig.2-9 : Outside dimensions, Operating range diagram of RH-5AHC35-SA

(4) RH-5AH45

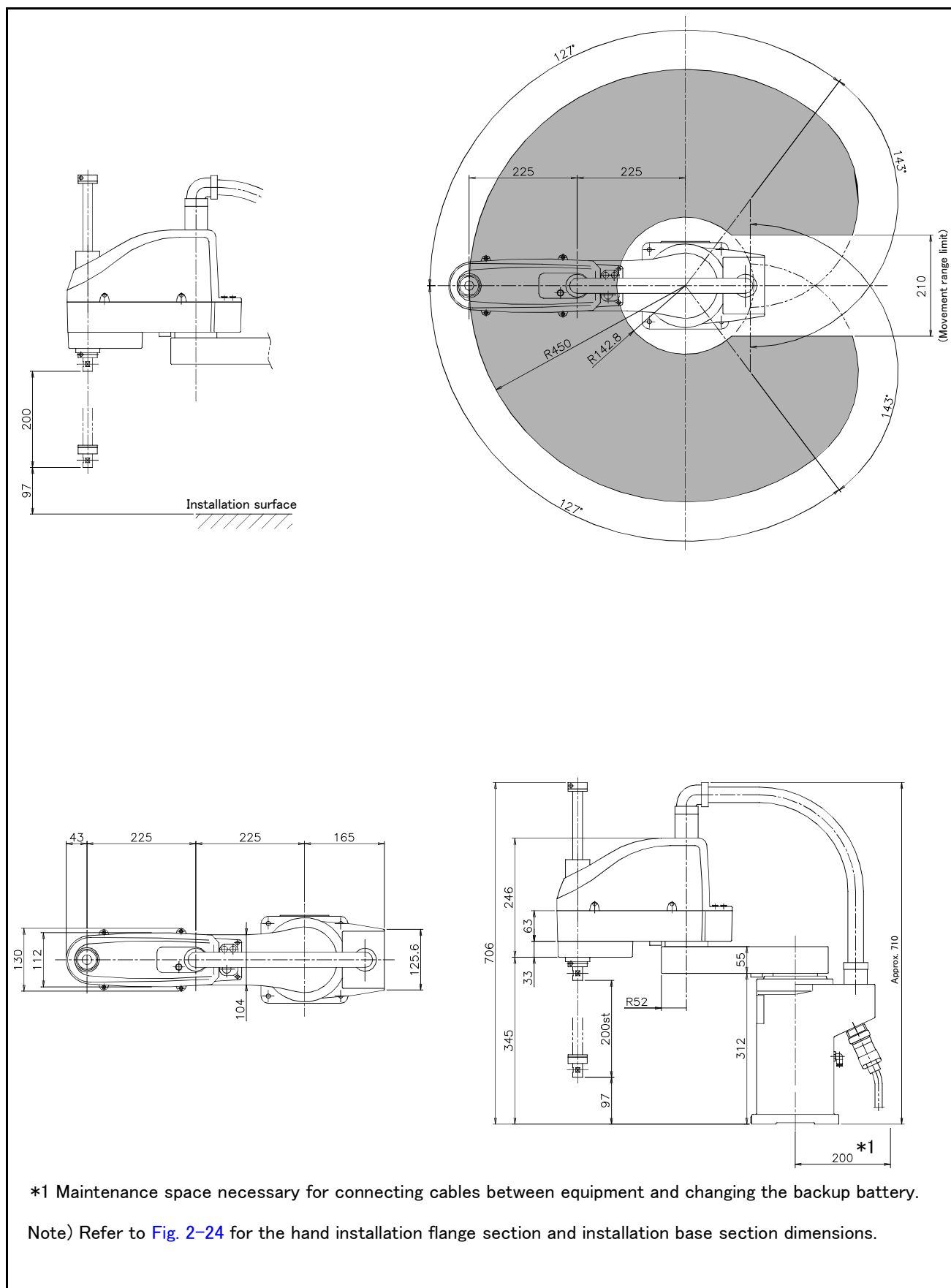

Fig.2-10 : Outside dimensions, Operating range diagram of RH-5AH45

(5) RH-5AHM45

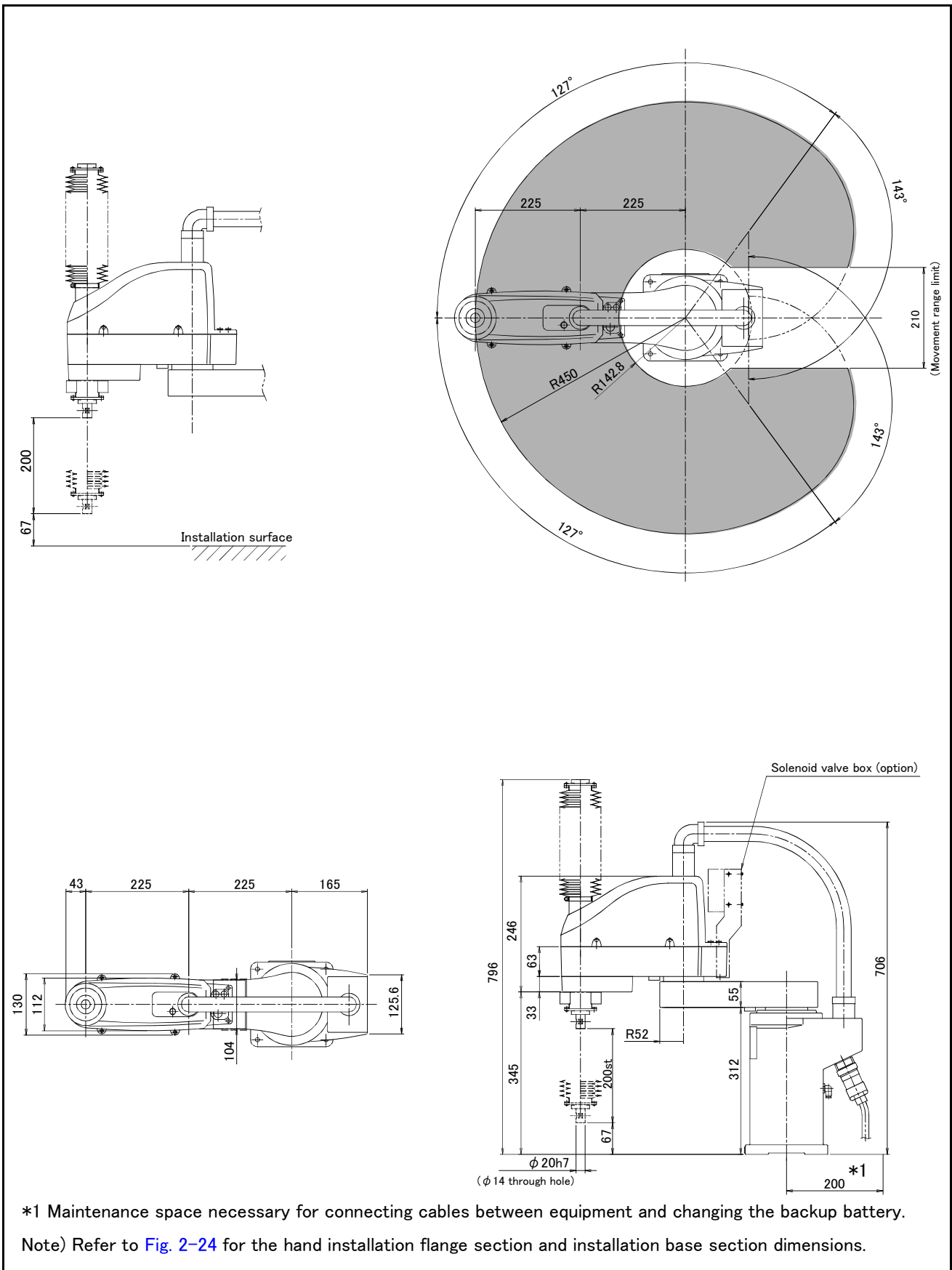

Fig.2-11 : Outside dimensions, Operating range diagram of RH-5AHM45

(6) RH-5AHC45-SA

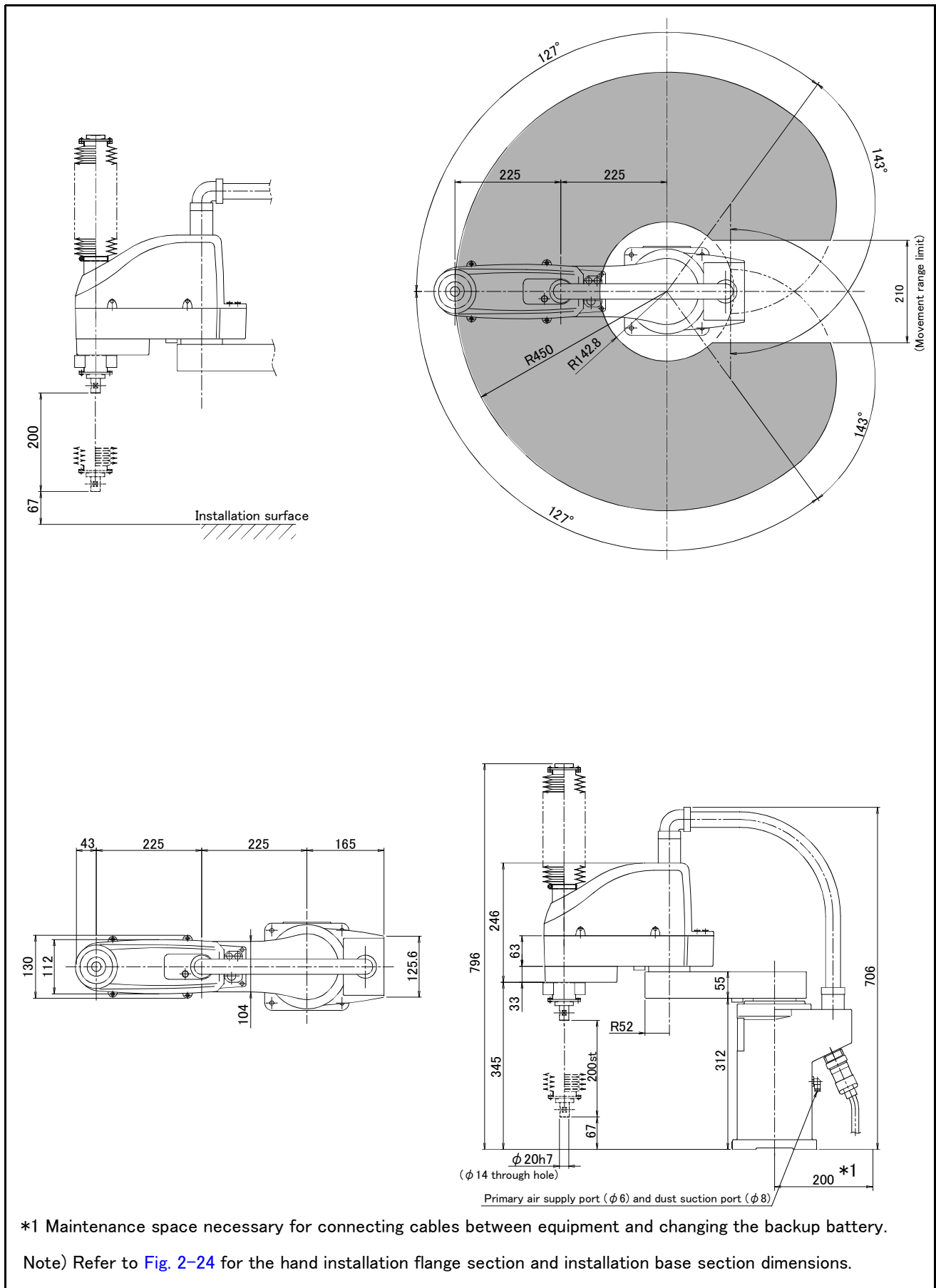

Fig.2-12 : Outside dimensions, Operating range diagram for RH-5AHC45-SA

(7) RH-5AH55

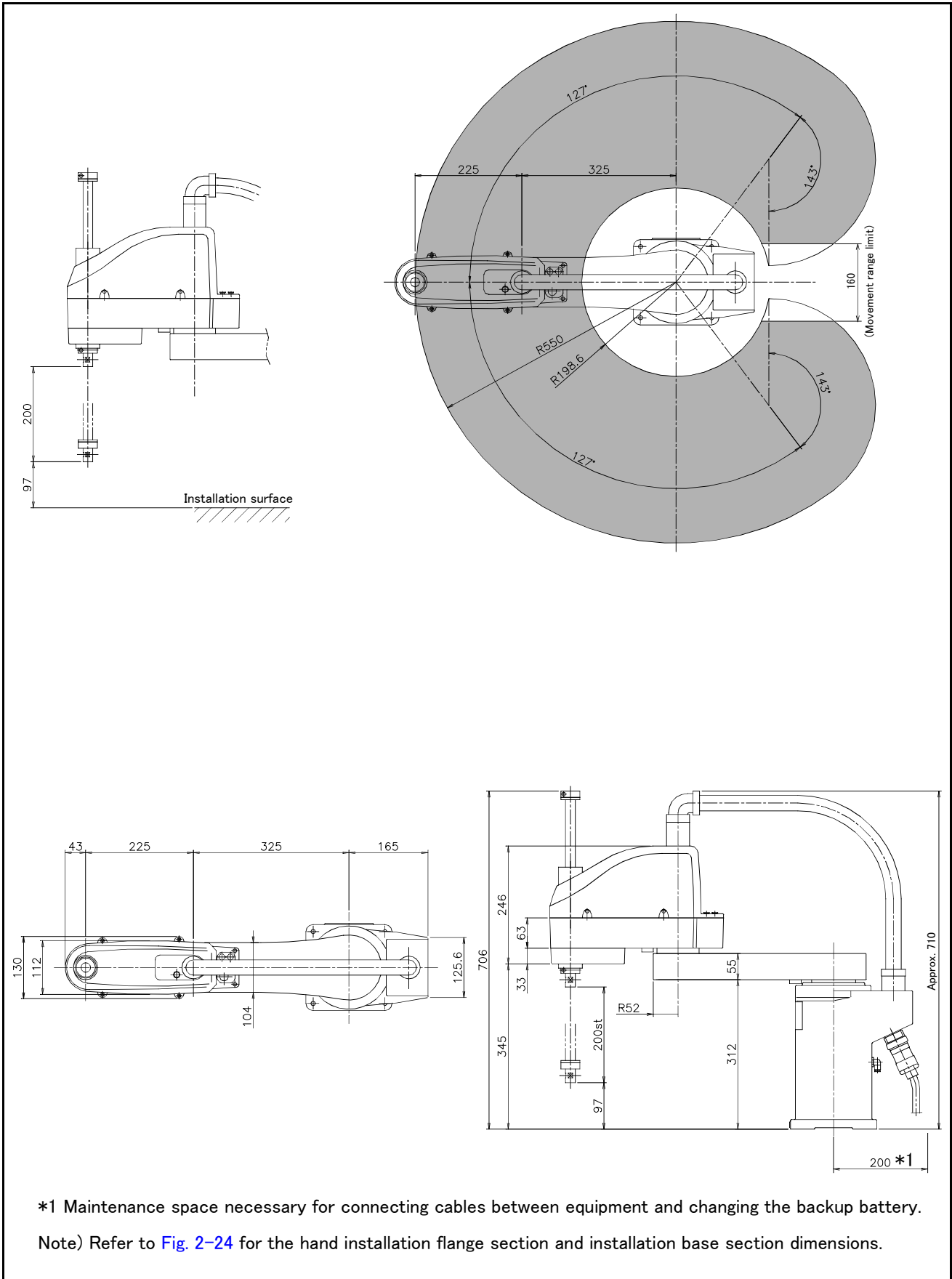

Fig.2-13 : Outside dimensions, Operating range diagram of RH-5AH55

(8) RH-5AHM55

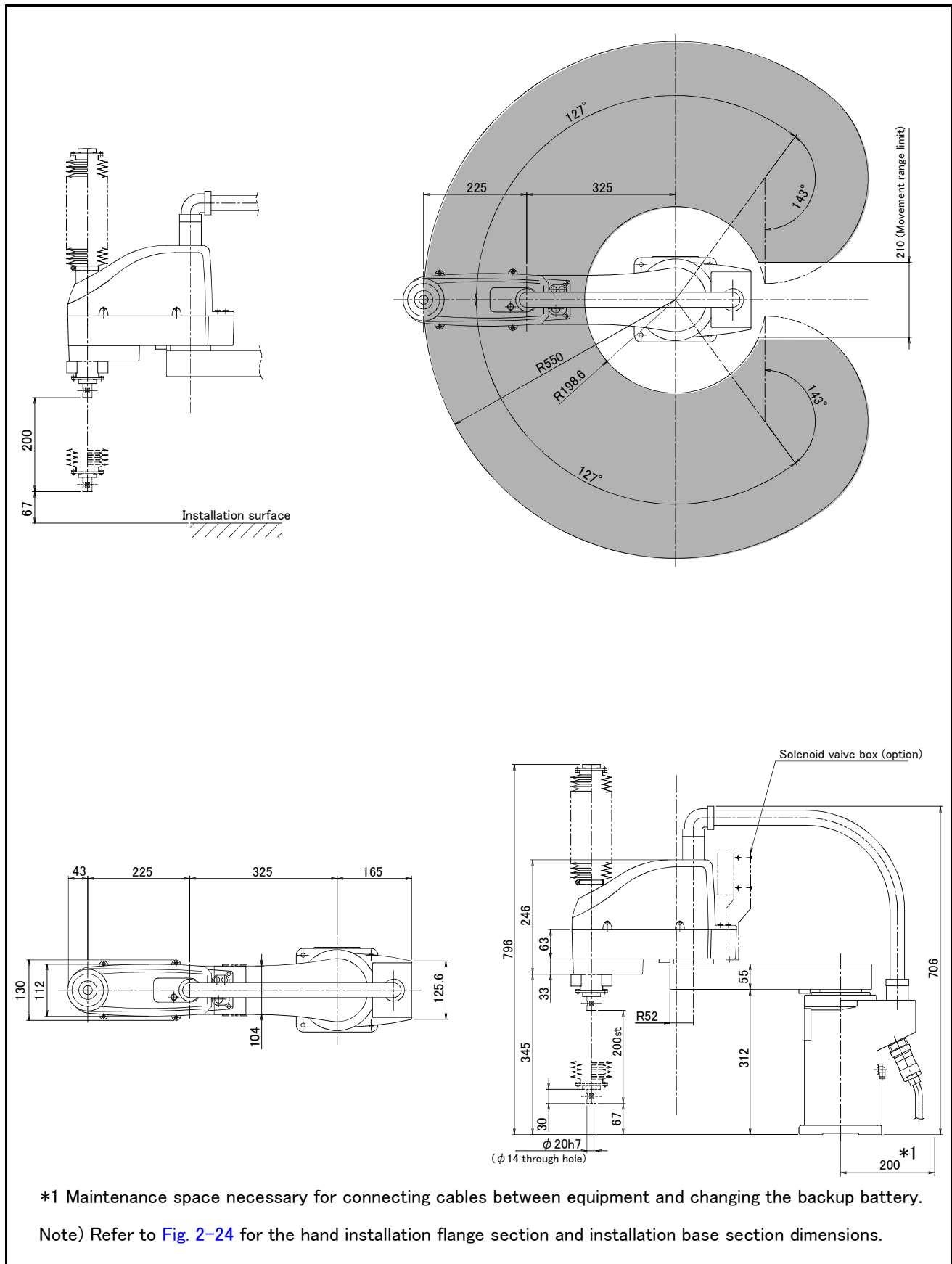

Fig.2-14 : Outside dimensions, Operating range diagram of RH-5AHM55

(9) RH-5AHC55-SA

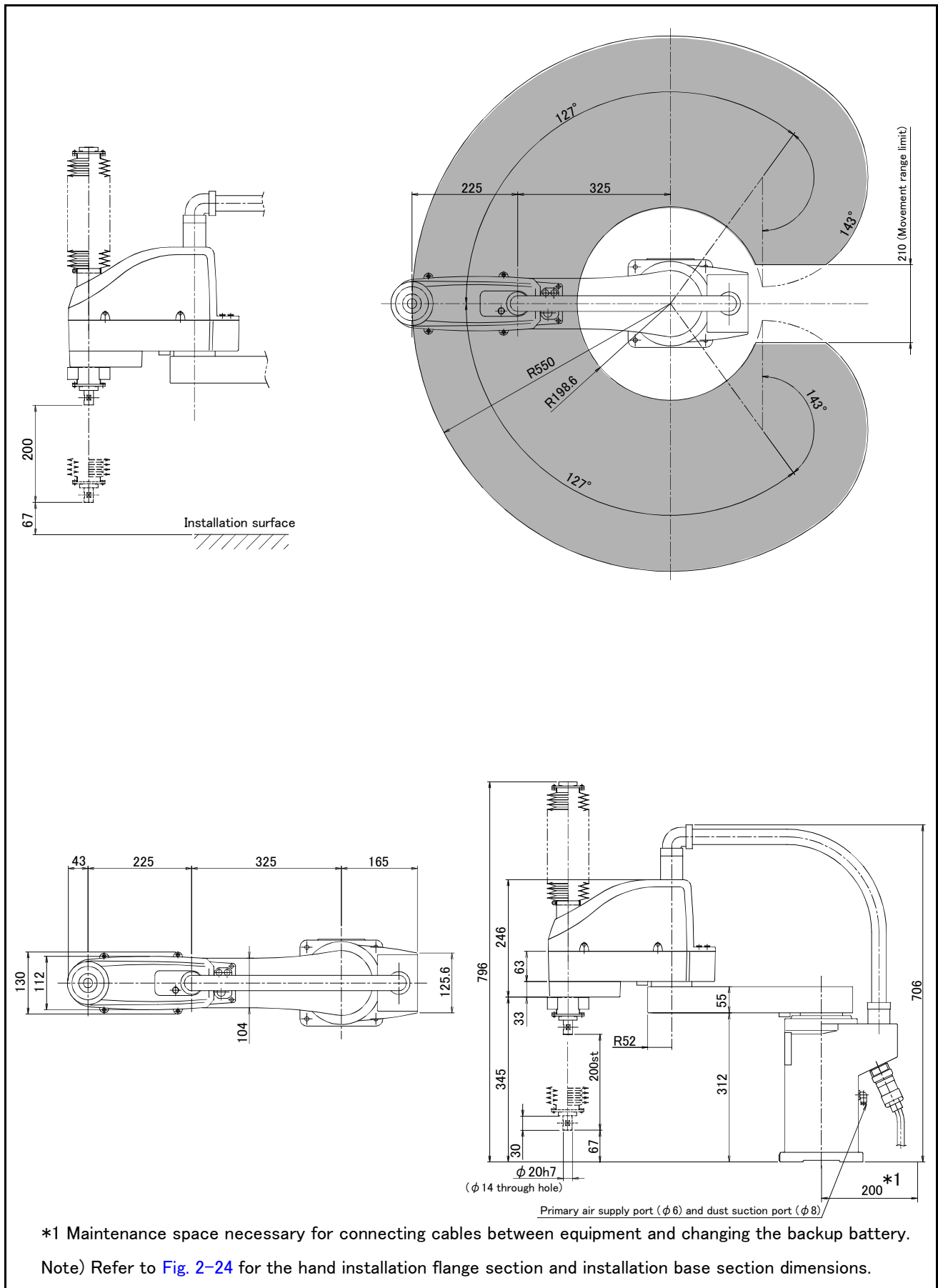

Fig.2-15 : Outside dimensions, Operating range diagram of RH-5AHC55-SA



2.4.2 Outside dimensions, Operating range diagram of RH-10AH Series

(1) RH-10AH55

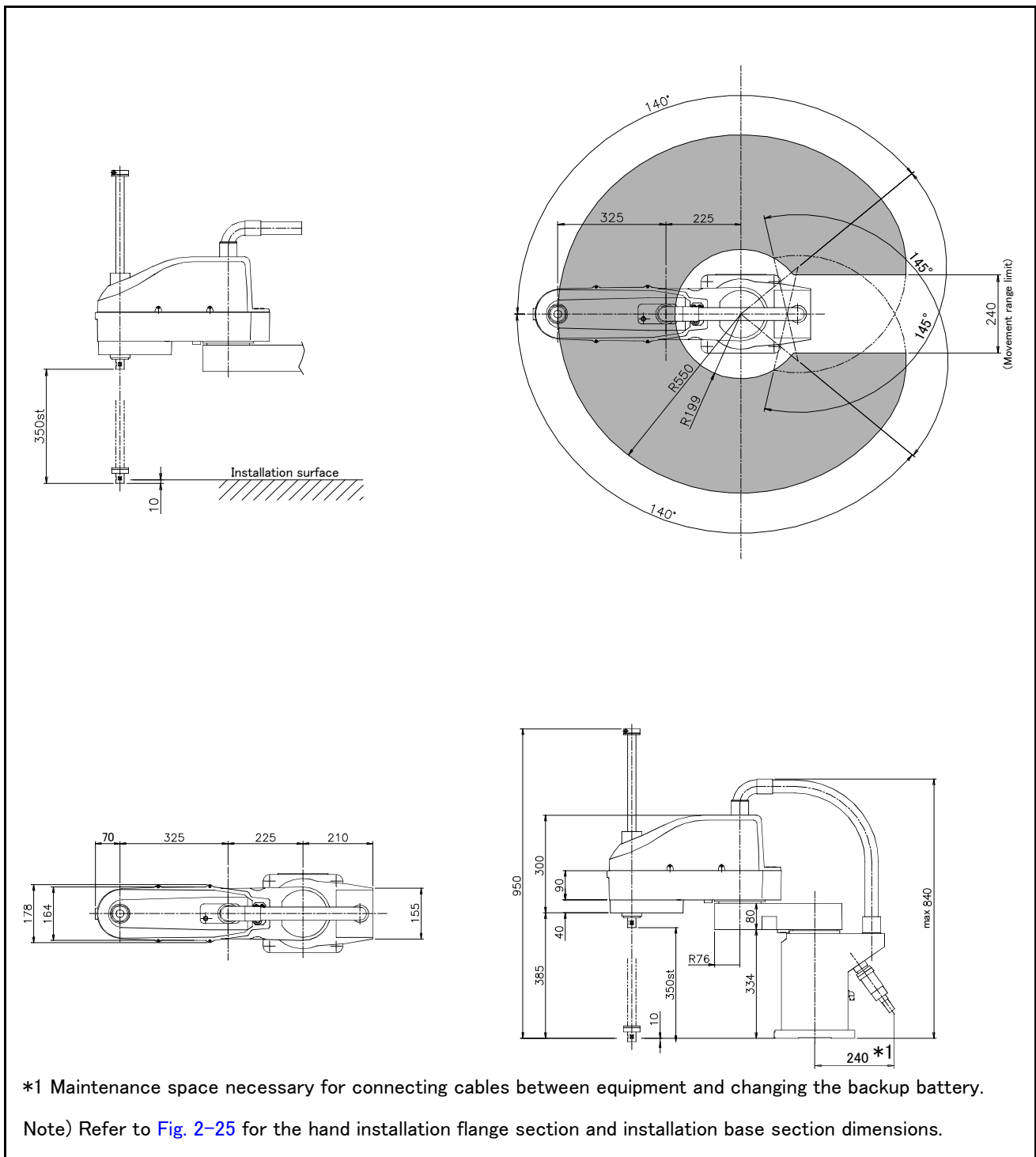

Fig.2-16 : Outside dimensions, Operating range diagram of RH-10AH55

(2) RH-10AHM55

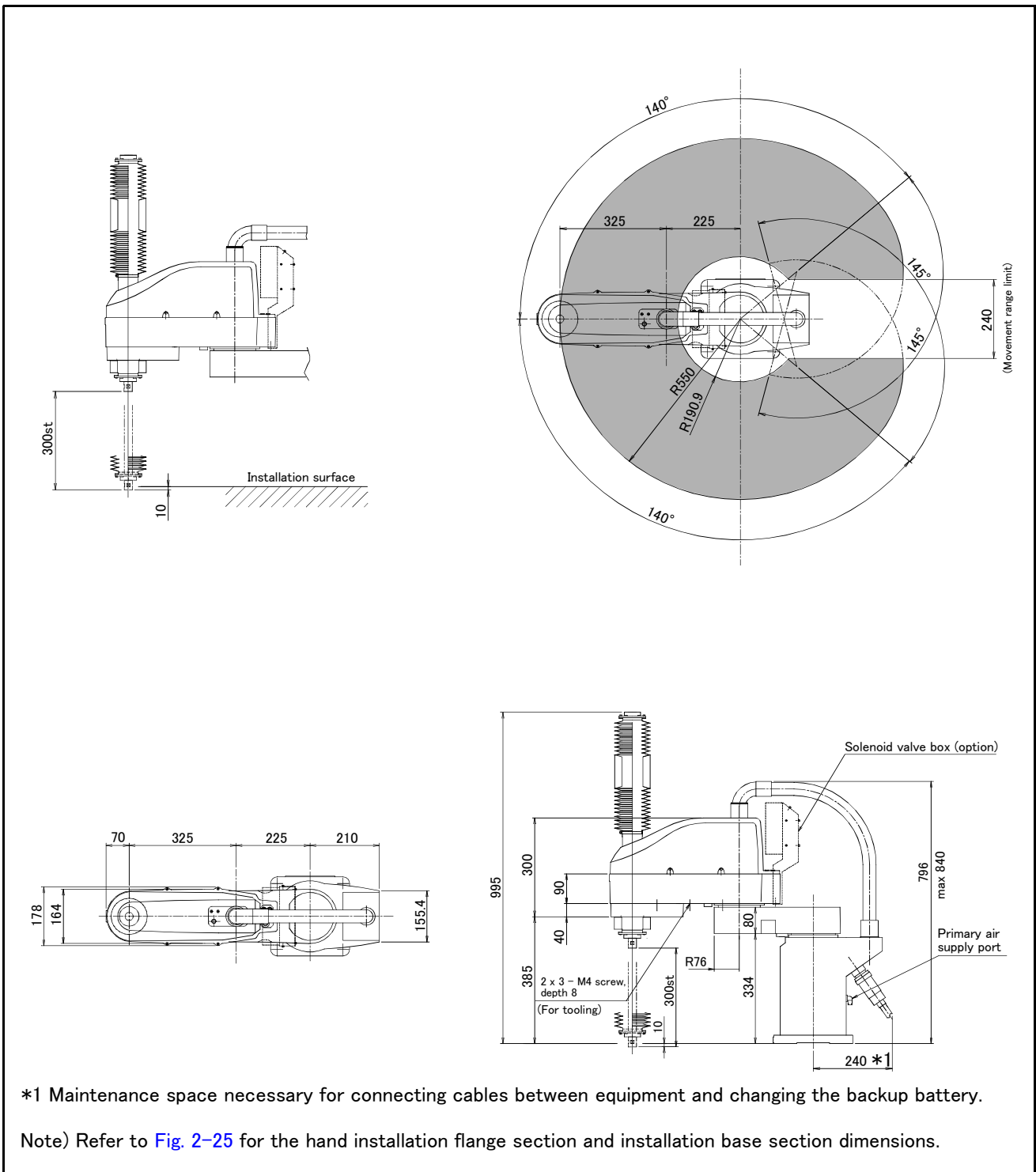

Fig.2-17 : Outside dimensions, Operating range diagram of RH-10AHM55

(3) RH-10AH70

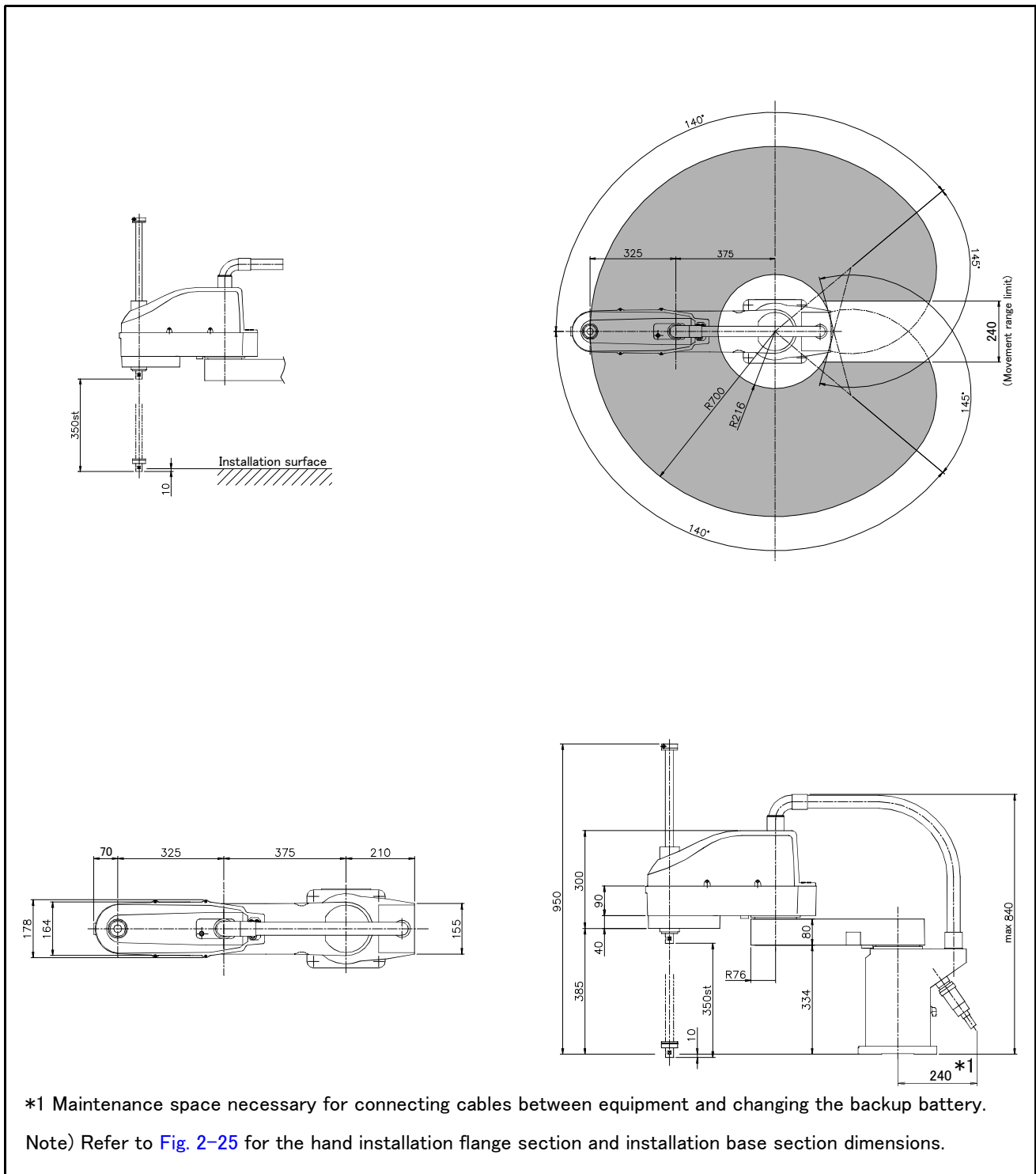

Fig.2-18 : Outside dimensions, Operating range diagram of RH-10AH70

(4) RH-10AHM70

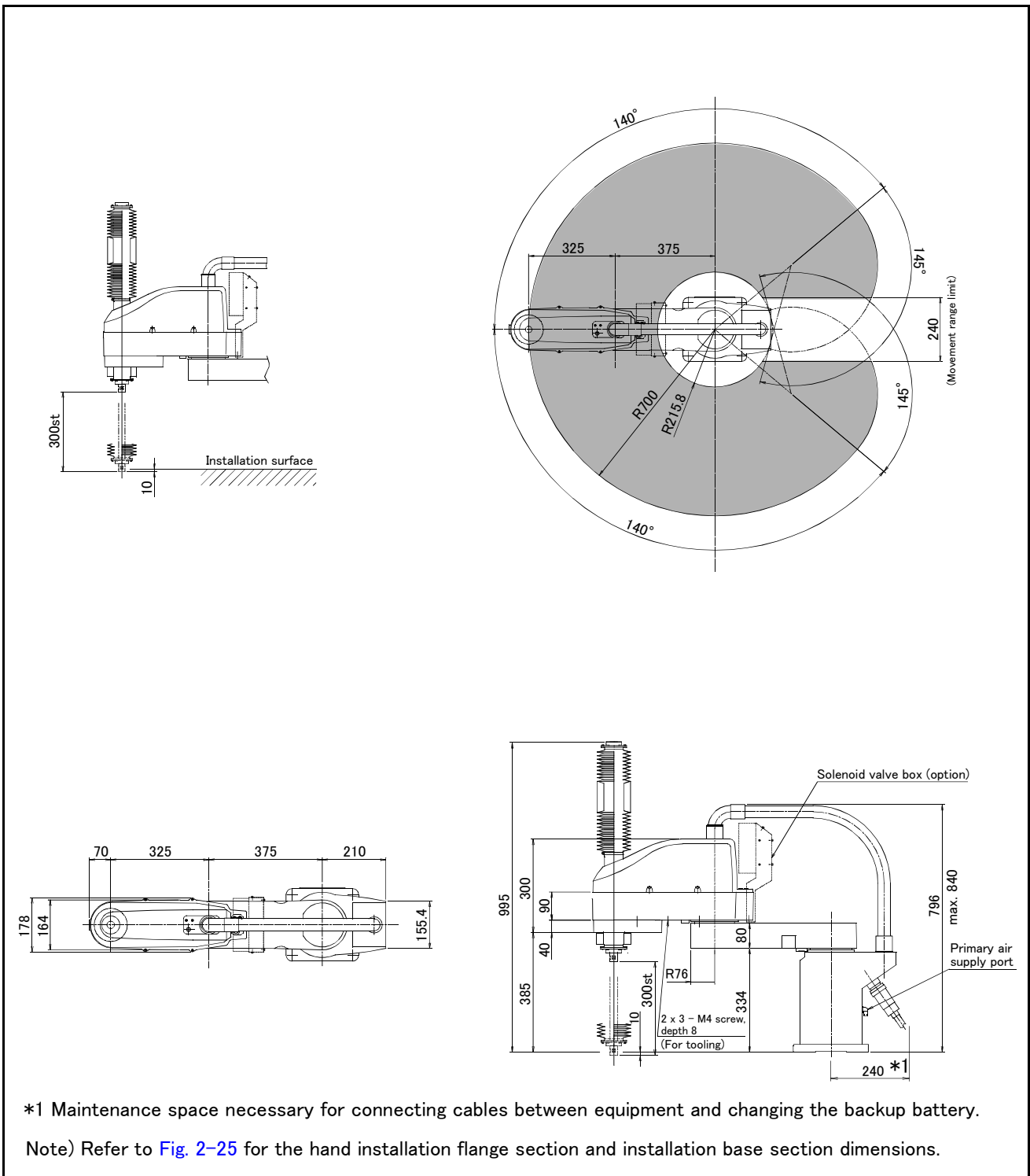

Fig.2-19 : Outside dimensions, Operating range diagram of RH-10AHM70

(5) RH-10AH85/RH-15AH85

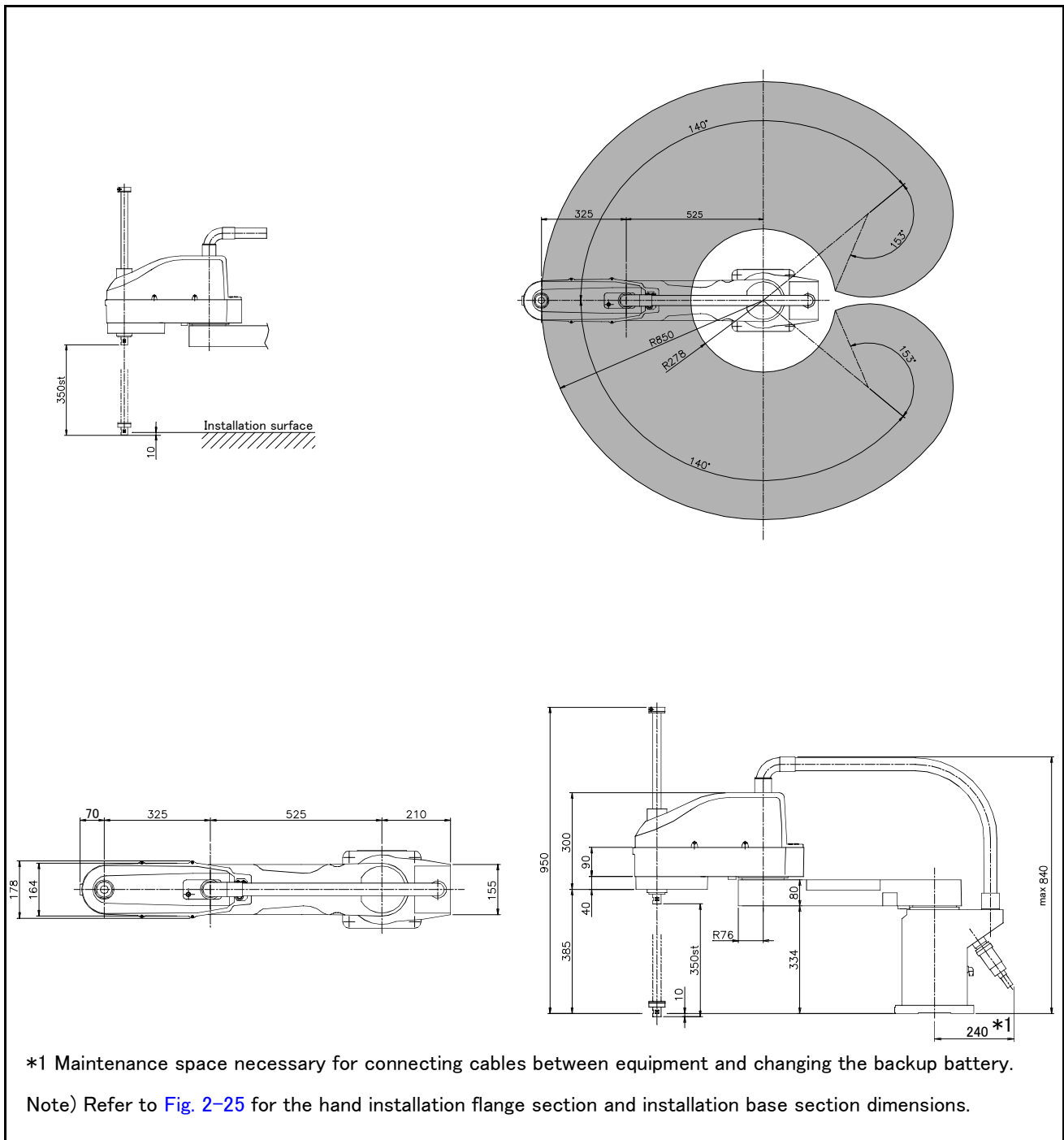

Fig.2-20 : Outside dimensions, Operating range diagram of RH-10AH85/15AH85

(6) RH-10AHM85/RH-15AHM85

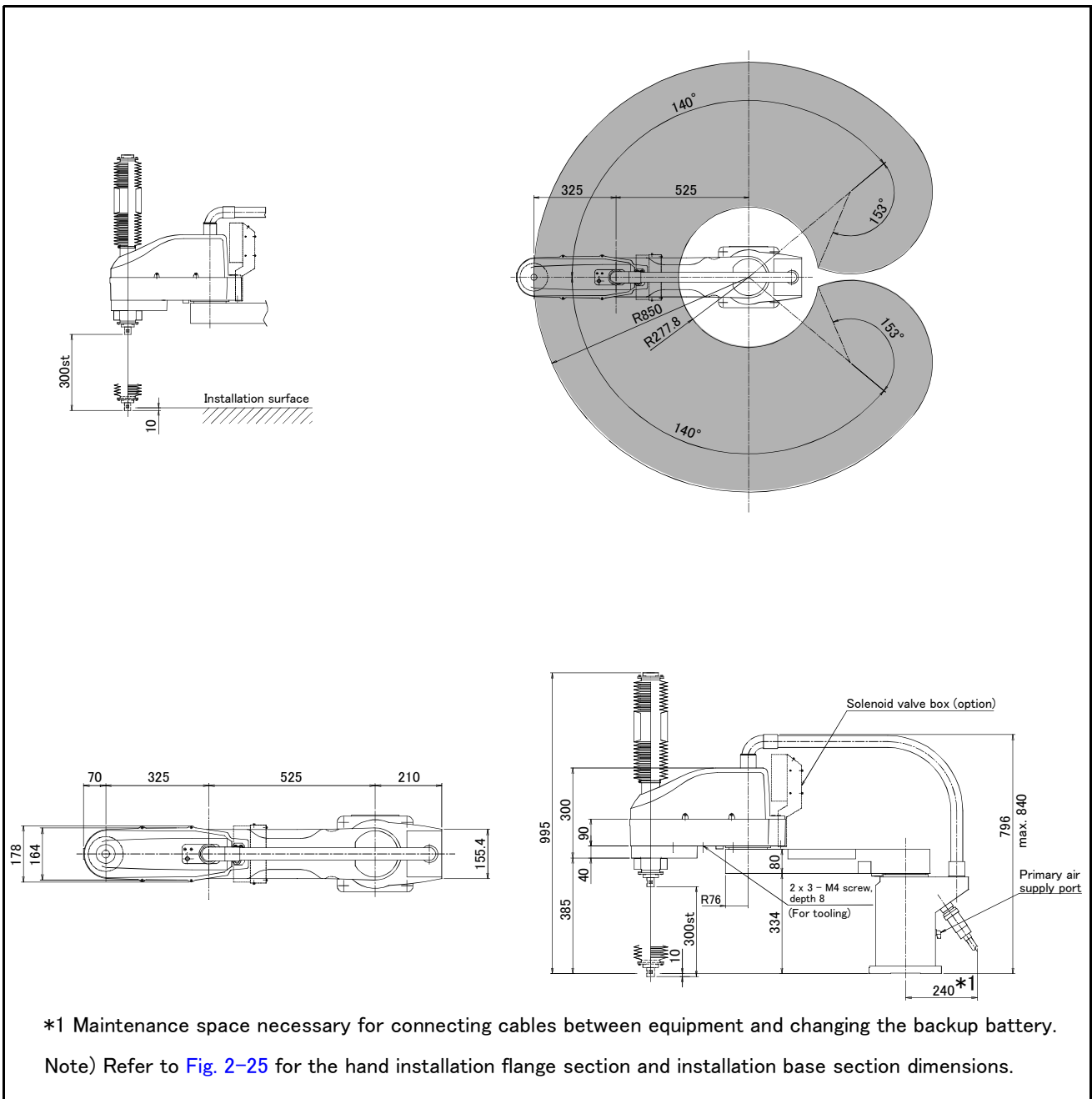

Fig.2-21 : Outside dimensions, Operating range diagram of RH-10AHM85/15AHM85

### 2.4.3 Change the operating range

The operating ranges of both the J1 and J2 axes can be limited. Change the mechanical stopper and the operating range to be set inside of that area.

If the operating range must be limited for example, to avoid interference with peripheral devices or to ensure safety—set up the operating range as shown below.

#### ■ Operating range changeable angle

The operating range must be set up at angles indicated by [Table 2-8](#).

Table 2-8 : Operating range changeable angle

Axis	Type	Direction	Standard	Changeable angle					
RH-5AH series									
J1	RH-5AH35/45/55	+ side	+127 deg.	+90 deg.	+60 deg.	+30 deg.	+0 deg.	Any one point shown at the left	
		Mechanical stopper angle	+130 deg.	+95 deg.	+65 deg.	+35 deg.	+5 deg.		
		Mechanical stopper position	P11	P12	P13	P14	P15		
		- side		-127 deg.	-90 deg.	-60 deg.	-30 deg.	-0 deg.	Any one point shown at the left
			Mechanical stopper angle	-130 deg.	-95 deg.	-65 deg.	-35 deg.	-5 deg.	
			Mechanical stopper position	N11	N12	N13	N14	N15	
J2	RH-5AH35	+ side	+137 deg.	+117 deg.	+97 deg.	-	-	Any one point shown at the left	
		Mechanical stopper angle	+140 deg.	+120 deg.	+100 deg.				
		Mechanical stopper position	P21	P22	P23				
		- side		-137 deg.	-117 deg.	-97 deg.	-	-	Any one point shown at the left
			Mechanical stopper angle	-140 deg.	-120 deg.	-100 deg.			
			Mechanical stopper position	N21	N22	N23			
	RH-5AH45/55	+ side	+143 deg.	+123 deg.	+103 deg.	-	-	Any one point shown at the left	
		Mechanical stopper angle	+146 deg.	+126 deg.	+106 deg.				
		Mechanical stopper position	P21	P22	P23				
		- side		-143 deg.	-123 deg.	-103 deg.	-	-	Any one point shown at the left
			Mechanical stopper angle	-146 deg.	-126 deg.	-106 deg.			
			Mechanical stopper position	N21	N22	N23			
RH-10AH/15AH series									
J1	RH-10AH55/70/85 RH-15AH85	+ side	+140 deg.	+105 deg.	+75 deg.	+45 deg.	+15 deg.	Any one point shown at the left	
		Mechanical stopper angle	+143 deg.	+110 deg.	+80 deg.	+50 deg.	+20 deg.		
		Mechanical stopper position	P11	P12	P13	P14	P15		
		- side		-140 deg.	-105 deg.	-75 deg.	-45 deg.	-15 deg.	Any one point shown at the left
			Mechanical stopper angle	-143 deg.	-110 deg.	-80 deg.	-50 deg.	-20 deg.	
			Mechanical stopper position	N11	N12	N13	N14	N15	
J2	RH-10AH55/70	+ side	+145 deg.	+125 deg.	-	-	-	Any one point shown at the left	
		Mechanical stopper angle	+150 deg.	+130 deg.					
		Mechanical stopper position	P21	P22					
		- side		-145 deg.	-125 deg.	-	-	-	Any one point shown at the left
			Mechanical stopper angle	-150 deg.	-130 deg.				
			Mechanical stopper position	N21	N22				
	RH-10AH85 RH-15AH85	+ side	+153 deg.	+125 deg.	-	-	-	Any one point shown at the left	
		Mechanical stopper angle	+155 deg.	+130 deg.					
		Mechanical stopper position	P21	P22					
		- side		-153 deg.	-125 deg.	-	-	-	Any one point shown at the left
			Mechanical stopper angle	-155 deg.	-130 deg.				
			Mechanical stopper position	N21	N22				

Note1) The changeable angle shown in [Table 2-8](#) indicates the operation range by the software.

The mechanical stopper angle in the table shows the limit angle by the mechanical stopper. Use caution when laying out the robot during the designing stage.

Note2) The changeable angle can be set independently on the + side and - side.

Note3) Refer to [Fig. 2-22](#) and [Fig. 2-23](#) for mechanical stopper position.

## ■ Changing the operating range

### (1) Installing the mechanical stopper

- 1) Turn the controller power OFF.
- 2) Refer to [Table 2-8](#) and [Fig. 2-22](#) and [Fig. 2-23](#), install the hexagonal socket head bolts in the screw holes corresponding to the angles to be set. [Fig. 2-22](#) shows the mechanical stopper position and bolt size of the J1 axis, and [Fig. 2-23](#) shows those of the J2 axis. If the screw holes are hidden behind the arms, slowly move the No. 1 and No. 2 arms.

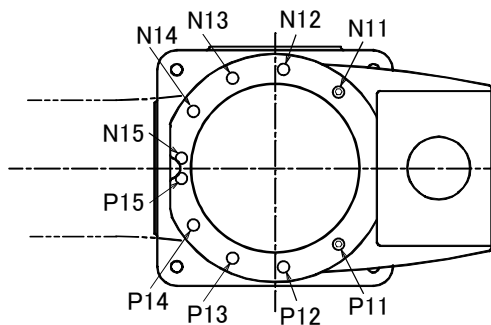

\*Hexagon socket bolt = M8 x 16

For RH-5H series

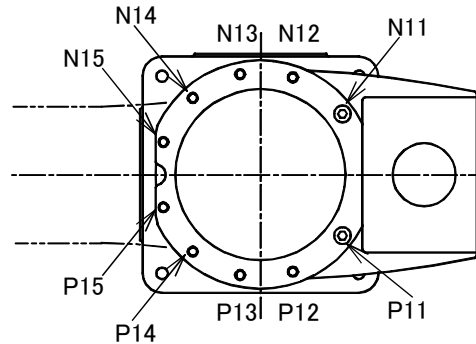

\*Hexagon socket bolt = M12 x 25

For RH-10AH/15AH series

Fig.2-22 : Mechanical stopper position (J1 axis)

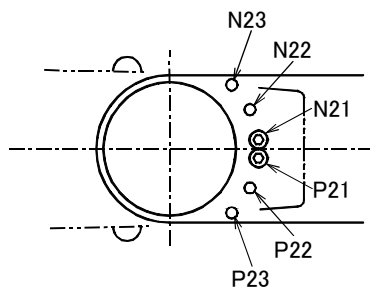

For RH-5AH35 series

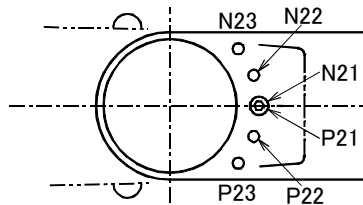

For RH-5AH45/55 series

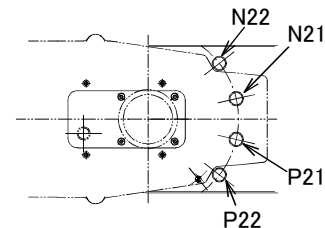

For RH-10AH/15AH series

\*Hexagon socket bolt = M8 x 16

Fig.2-23 : Mechanical stopper position (J2 axis)

### (2) Setting the operation range parameter

Set up the operation range (Changeable angle in [Table 2-8](#)) to the Joint movement range parameter MEJAR.

- 1) Turn the controller power ON.
- 2) Set up the changed operation range to the Joint movement range parameter.

MEJAR: (J1 plus side movement range, J1 minus side movement range, J2 plus side movement range, J2 minus side movement range, .....)

### (3) Setting the mechanical stopper origin parameter

If the movement range of either the minus (-) side of the J1 axis or the plus (+) side of the J2 axis has been changed, change the mechanical stopper origin parameter MORG.

- 1) Change the parameter MORG to the angle of the mechanical stopper position that has been set.
- MORG: (J1 minus side mechanical stopper position, J1 plus side mechanical stopper position, .....)

### (4) Confirming the operation range

When completed changing the parameters, turn the controller power OFF and ON. Move the changed axis to the operation range limit with joint jog operation, and confirm that the limit over occurs and the robot stops at the angle changed for both the +/- side.

This completes the changing the operating range.



## 2.4.4 Mechanical interface and Installation surface

## (1) Mechanical interface and Installation surface of RH-5AH series

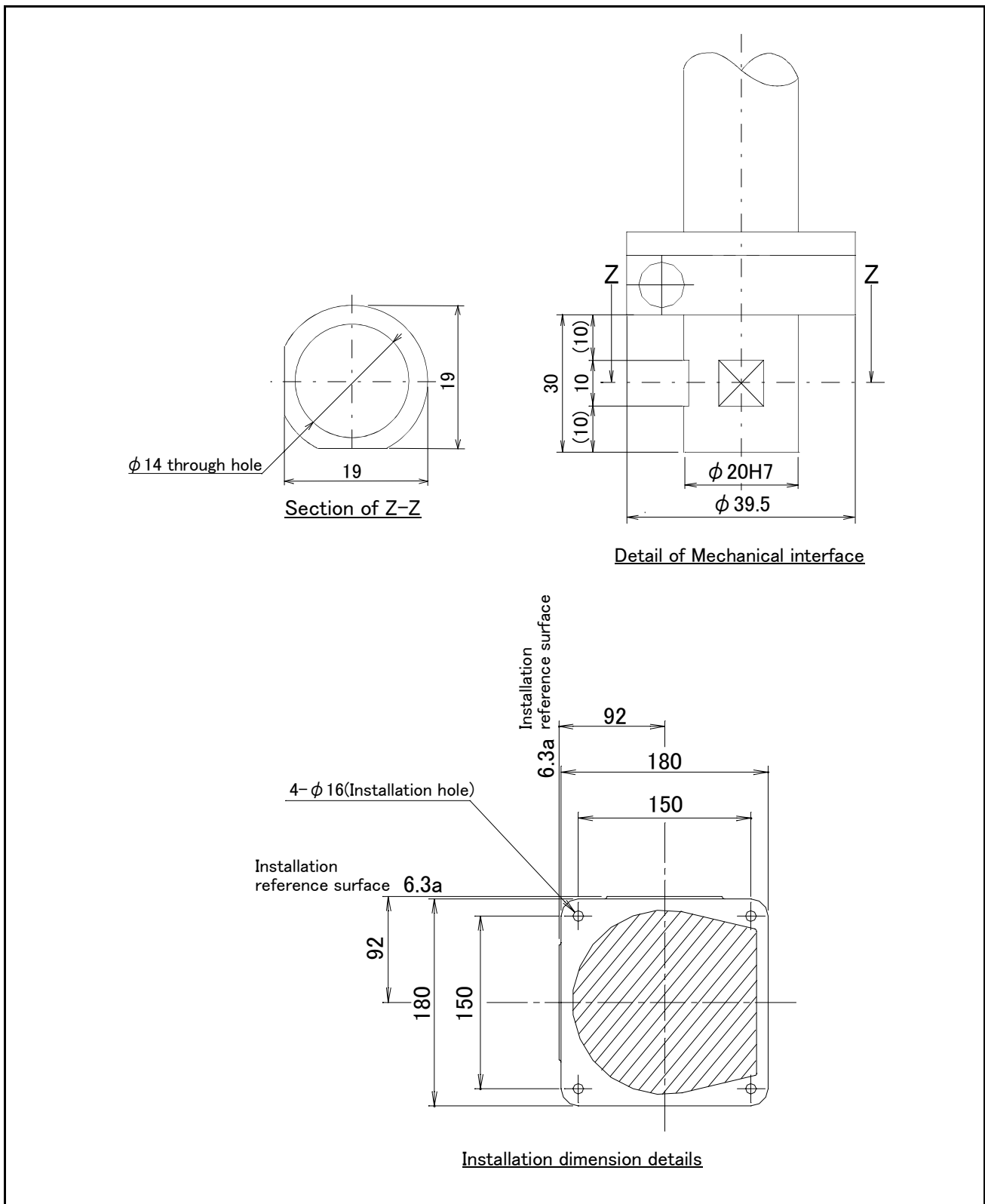

Fig.2-24 : Mechanical interface and Installation surface of RH-5AH series

(2) Mechanical interface and Installation surface of RH-10AH/15AH series

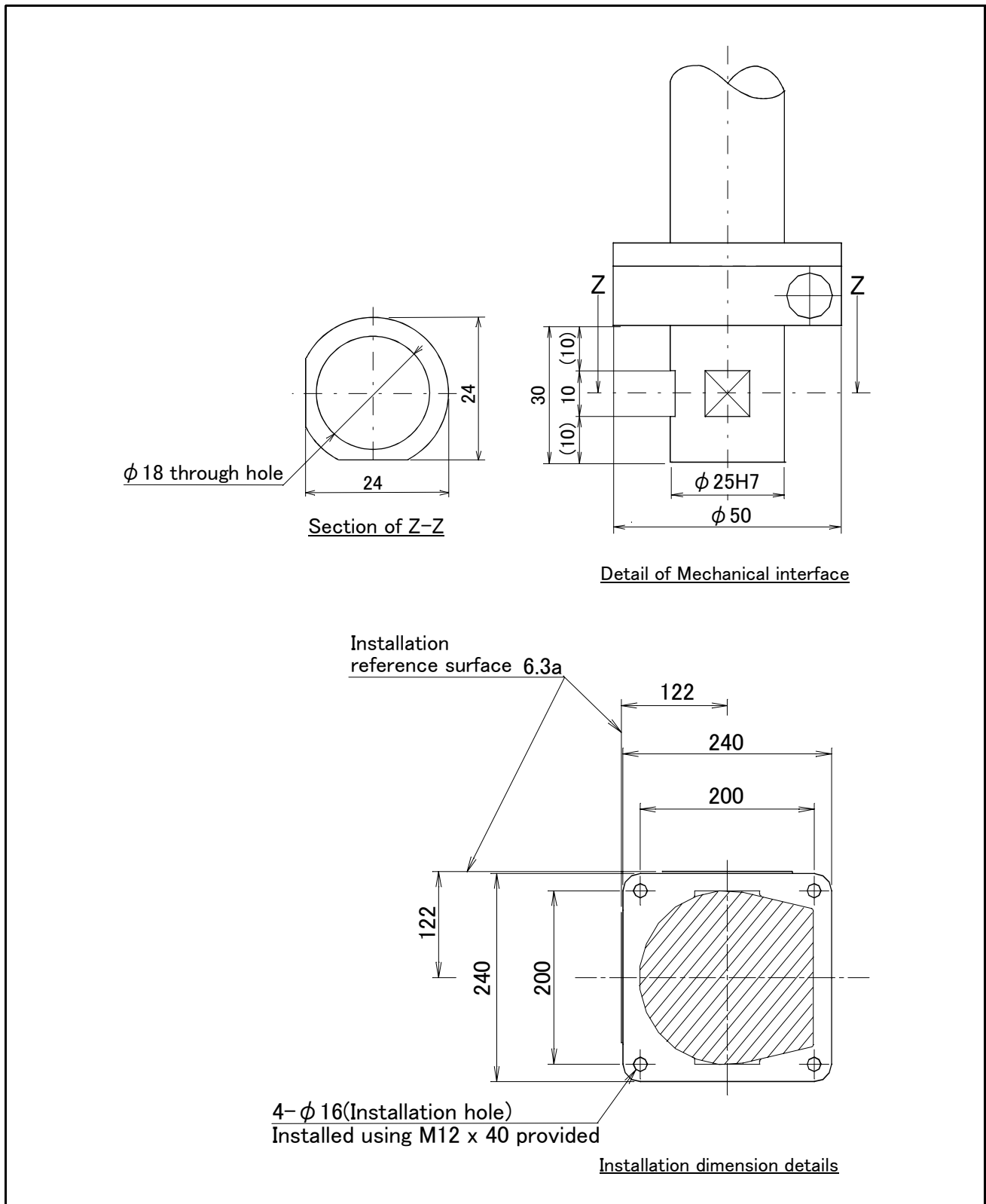
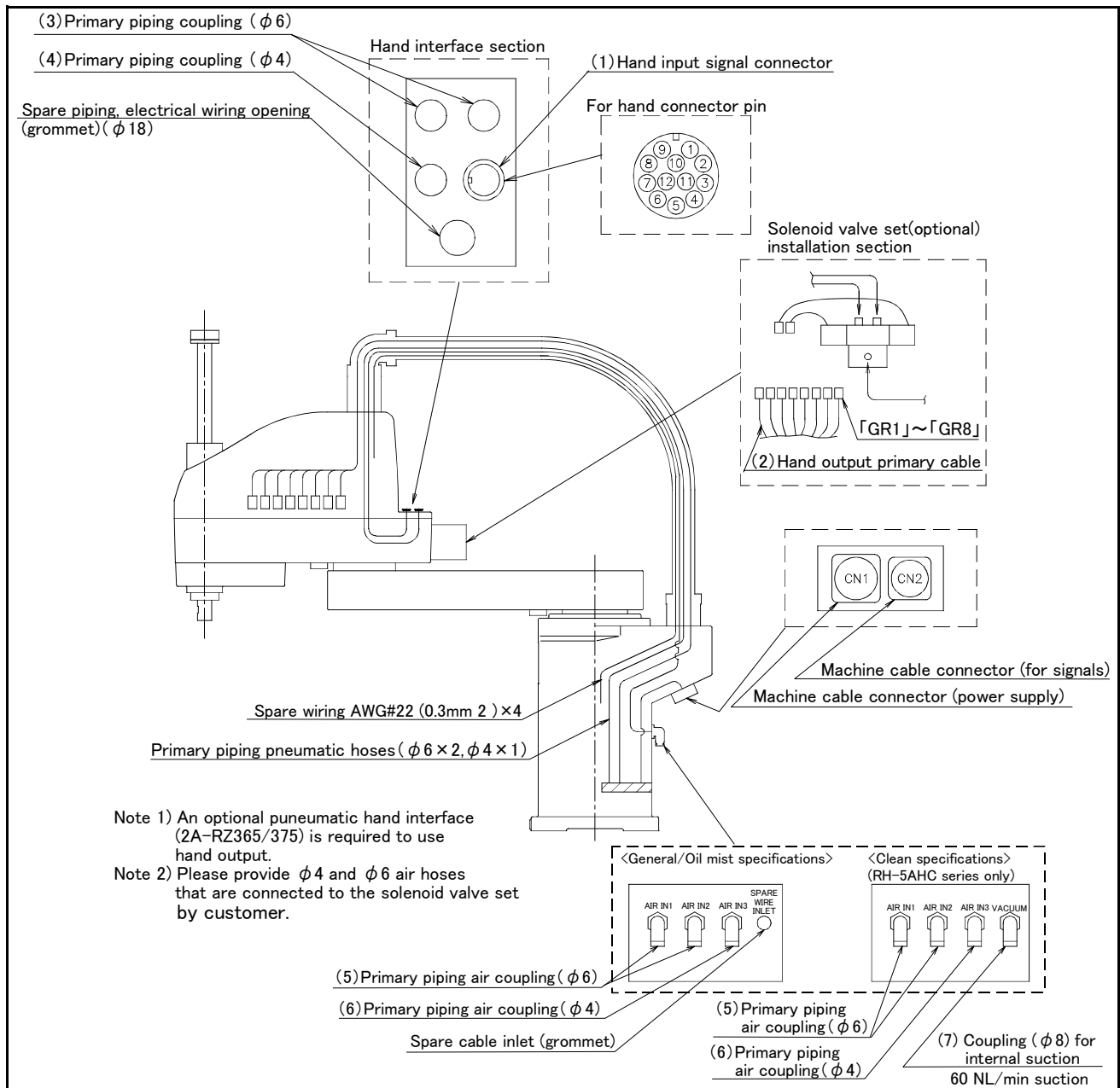

Fig.2-25 : Mechanical interface and Installation surface of RH-10AH/15AH series

## 2.5 Tooling

### 2.5.1 Wiring and piping for hand

Shows the wiring and piping configuration for a standard-equipped hand.



#### Connector and pneumatic coupling

No	Name	Qty.	Robot side (Robot arm side)		Counter side (customer-prepared)		Manufacturer
			Connectors, couplings	Connector pins	Connector	Connector pins	
(1)	Connector	1	HR10A-10WTR-12S		HR10A-10WTP-12P		Hirose
(2)	Connector	8	SMP-02V-BC	BHF-001Gi-0.8BS	SMR-02V-B	BYM-001T-0.6	Japan solderless terminal MFG. Co.,LTD
(3)	Coupling	2	UK6M	—	—	—	Koganei
(4)	Coupling	1	UK4M	—	—	—	Koganei
(5)	Coupling	2	UKBL6	—	—	—	Koganei
(6)	Coupling	1	UKBL4	—	—	—	Koganei
(7)	Coupling	1	UKBL8	—	—	—	Koganei

Fig.2-26 : Wiring and piping for hand

### 2.5.2 Internal air piping

- (1) For piping, two  $\phi 6 \times 4$  urethane hoses and one  $\phi 4 \times 2.5$  urethane hose are preinstalled from the air suction port of the base section to the No. 2 arm's rear section.
- (2) Two pneumatic couplings for the  $\phi 6$  hoses and one pneumatic coupling for the  $\phi 4$  hose are provided at the hose end section on both the base and No. 2 arm sides.
- (3) The  $\phi 8$  hose coupling (VACUUM) is used especially for centralized suction only in the case of the RH-5AHC\*\*.
- (4) A solenoid valve set (optional) with a maximum of four sets can be attached to the rear section of the No. 2 arm.
- (5) Refer to [Page 48, "Solenoid valve set"](#) for details on the electronic valve set (optional).

### 2.5.3 Internal wiring for the pneumatic hand output cable

- (1) The wiring of the hand output cable (eight wires of AWG#24(0.2 mm<sup>2</sup>) x 2 cores) extends into the No. 2 arm, ending in an 8-point connector. These eight points of connections are named "GR1" through "GR8." The hand output cable is located outside at the time of shipping. If this cable is not used, place the connectors for GR1 to GR8 inside, and install the attached grommet. For the protection specifications, fill the fringe of the grommet with silicon rubber.

### 2.5.4 Internal wiring for the hand check input cable

- (1) The wiring of the hand input cable extends from the base to the eight points in the hand input signal connector on the back of the No. 2 arm.

### 2.5.5 Precautions for piping to the flexible cable

If the piping of the hand is performed to the flexible cable of this robot, be sure to perform wiring and piping by following the precautions listed below so that they will not interfere with the functionality of the flexible cable.

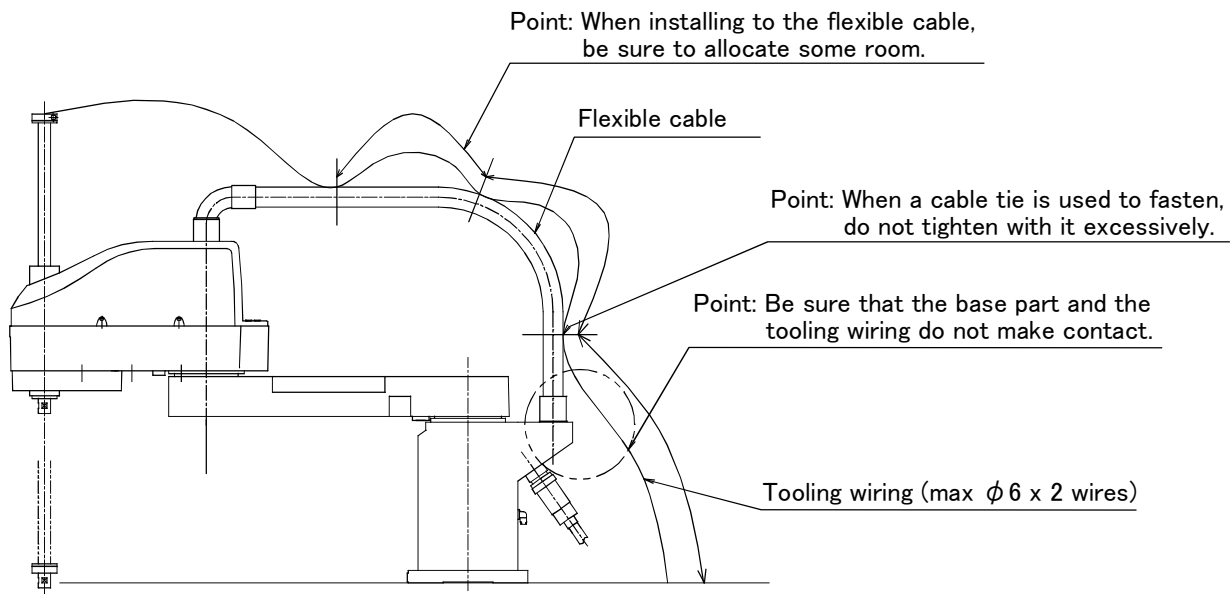

If many hand cables are installed to the flexible cable and depending on the manner of installation, excessive force may be applied to the flexible cable and the life span of the flexible cable may be shortened and also the mounting nuts of the flexible cable may come loose.

### 2.5.6 About the Installation of Tooling Wiring and Piping (Examples of Wiring and Piping)

The customer is required to provide tooling wiring, piping and metal fixtures.

Screw holes are provided on the robot arm for the installation of tooling wiring, piping and metal fixtures. (See the drawing below.)

The length of wiring and piping and the installation position on the robot must be adjusted according to the work to be done by the robot. Please use the following example as reference. Pay extra attention to the precautions and interfering points described in the example during the adjustment.

- A hand input cable and a hand curl cable are available as optional accessories for your convenience.
- After performing wiring and piping to the robot, operate the robot at low speed to make sure that each part does not interfere with the robot arm and the peripheral devices. (Interfering points and precautions are indicated in the example.)
- When used with the RH-5AHC\*\* clean specifications, be careful that dust may be generated if wiring or piping touches the robot arm.

RH-5AH series

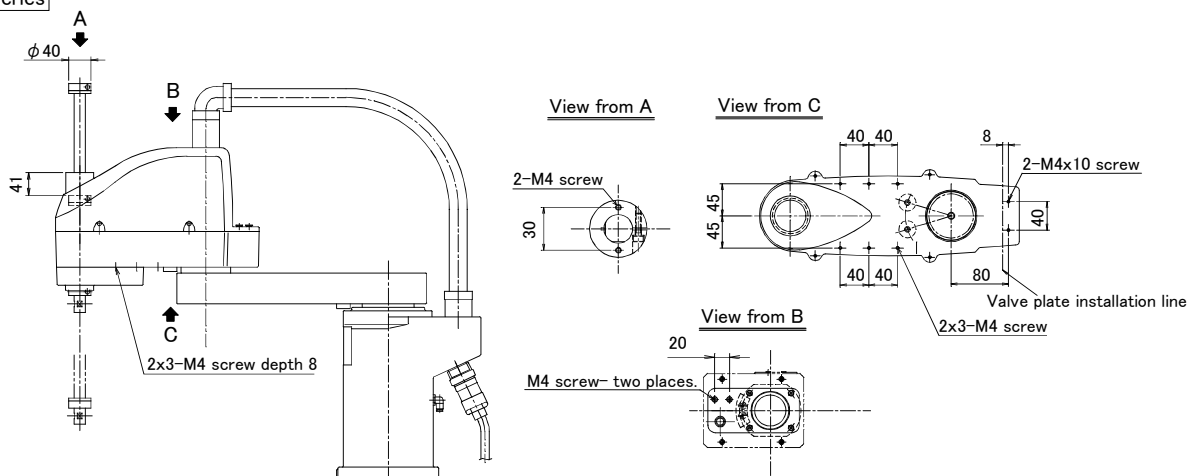

RH-10AH/15AH series

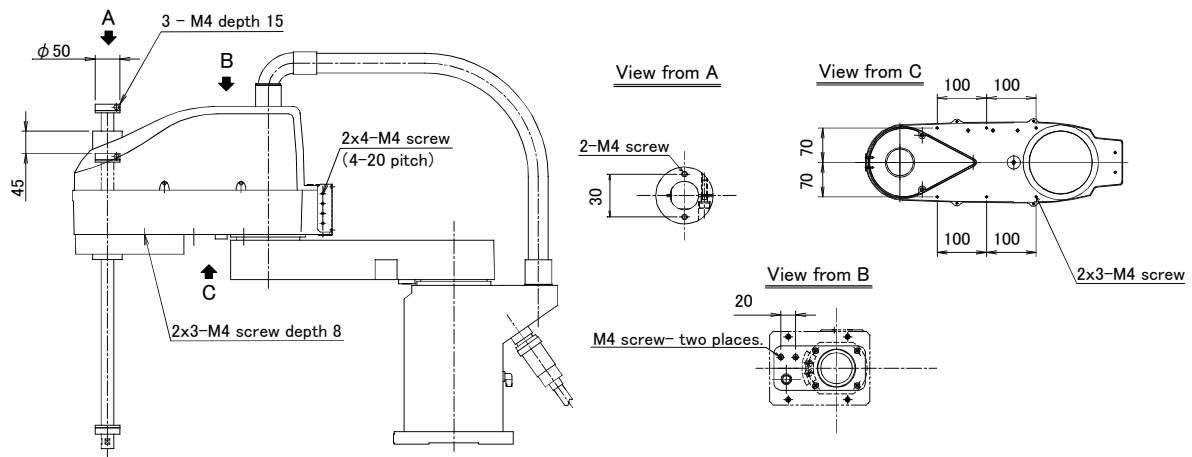

(1) Example of wiring and piping <1>

This method is effective when the rotation of the hand is small (within  $\pm 90$  deg.) and provides easy maintenance of the robot arm as well as during the replacement of wiring and piping.

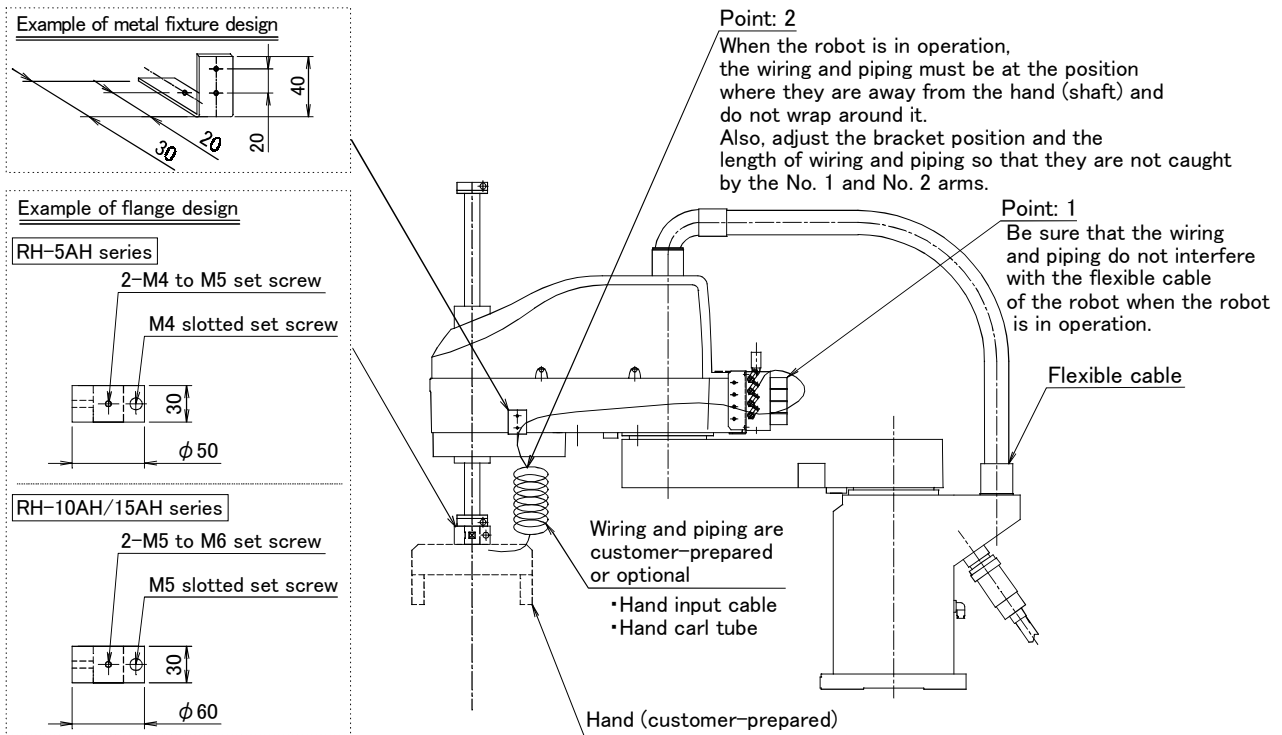

(2) Wiring and piping example <2>

If wiring and piping are fed through the hollow section of the shaft, the wiring and piping to the hand can be streamlined.

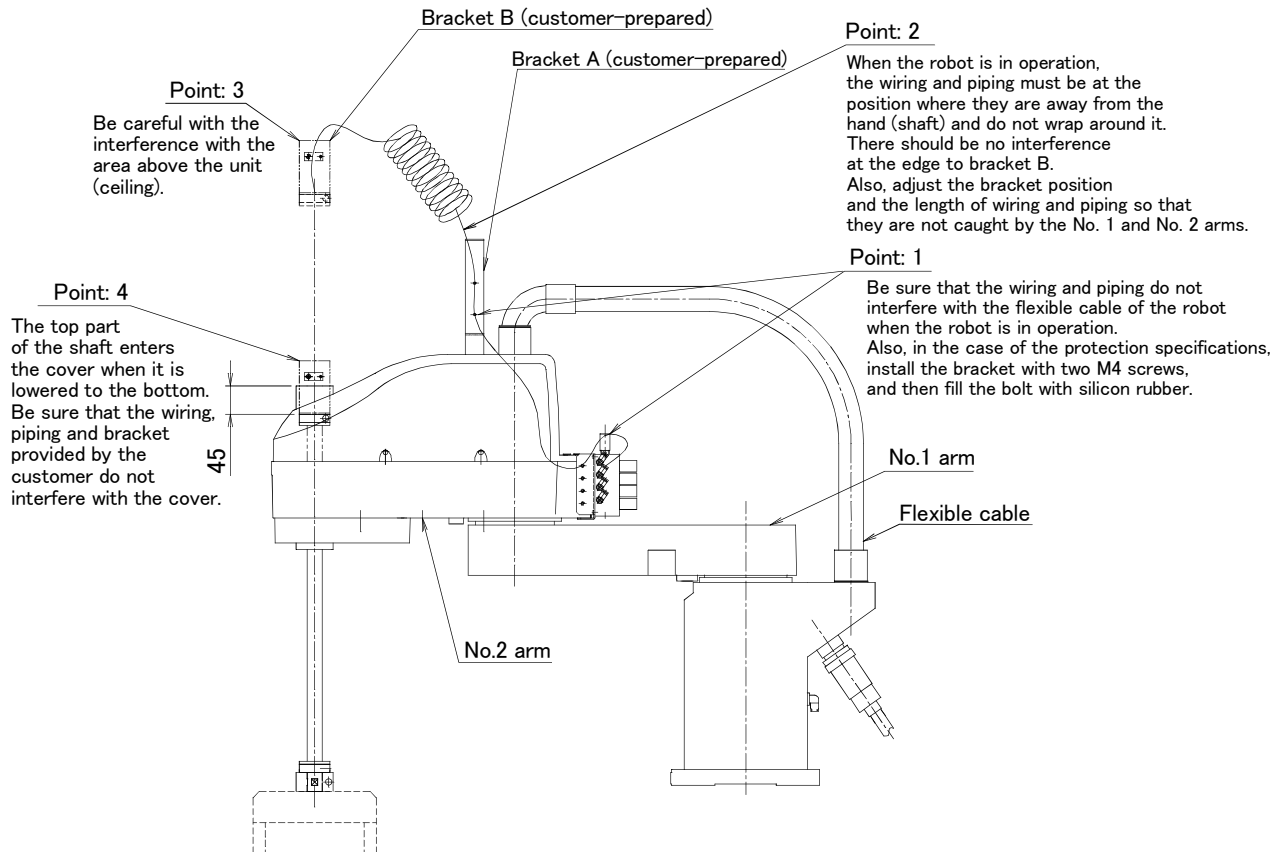

## [Precautions for the protection specification and clean specification]

- Bellows are attached to the tips so confirm not interfering in the tooling wiring, piping, and the flexible tube.
- Please use wiring materials that are sufficiently flexible. Furthermore, please perform the wiring in such a way that the bending radii of the selection tube and wires will not become less than the minimum values allowed while the robot is operating.

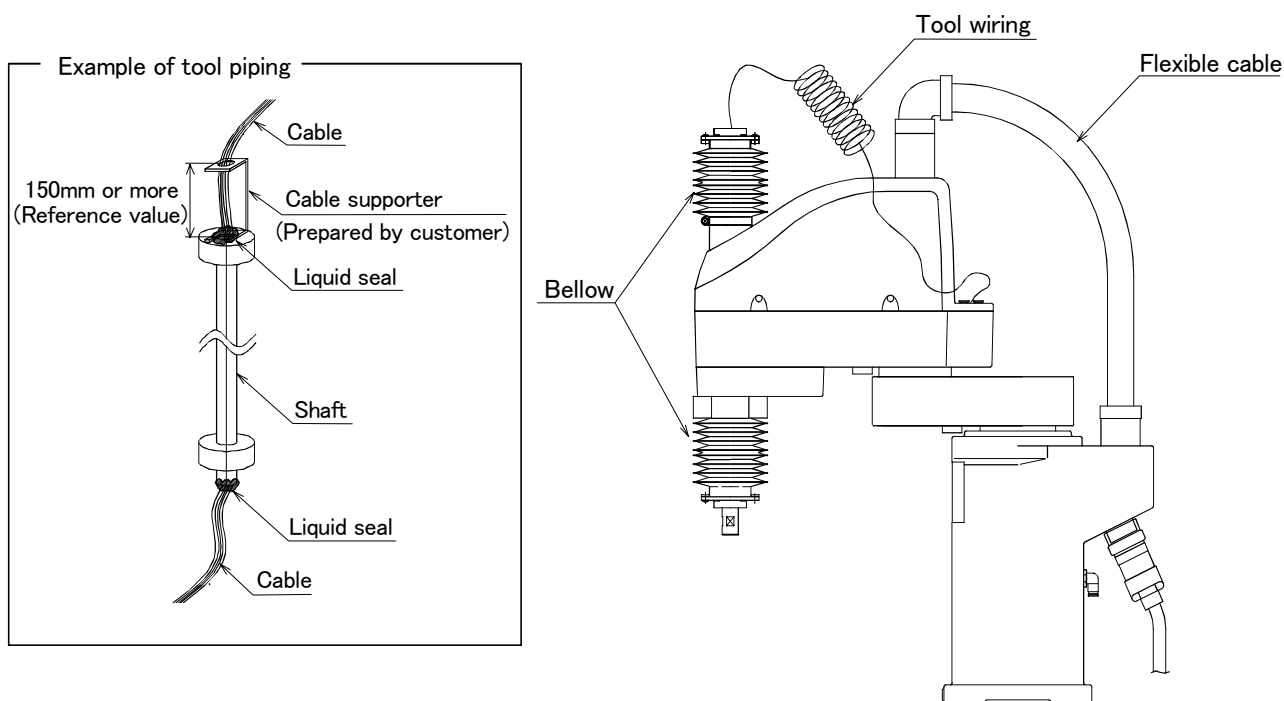

## [Precautions for the clean specification]

The top and bottom parts of the through hole of the tip shaft are taped at shipment.

Perform the following actions as necessary in order to ensure that the robot is sufficiently clean during the operation:

- 1) When the through hole of the shaft is not used
  - Keep the tip shaft taped while the robot is in use.
- 2) When the through hole of the shaft is used for wiring.
  - Peel the tape of the tip shaft off and perform the necessary wiring. Once the wiring is completed, seal the tip shaft using liquid seal in order to avoid accumulation of dust.
  - Perform the wiring in such a way that the wires around the area below the tip shaft will not get into contact with other parts while the robot is operating.

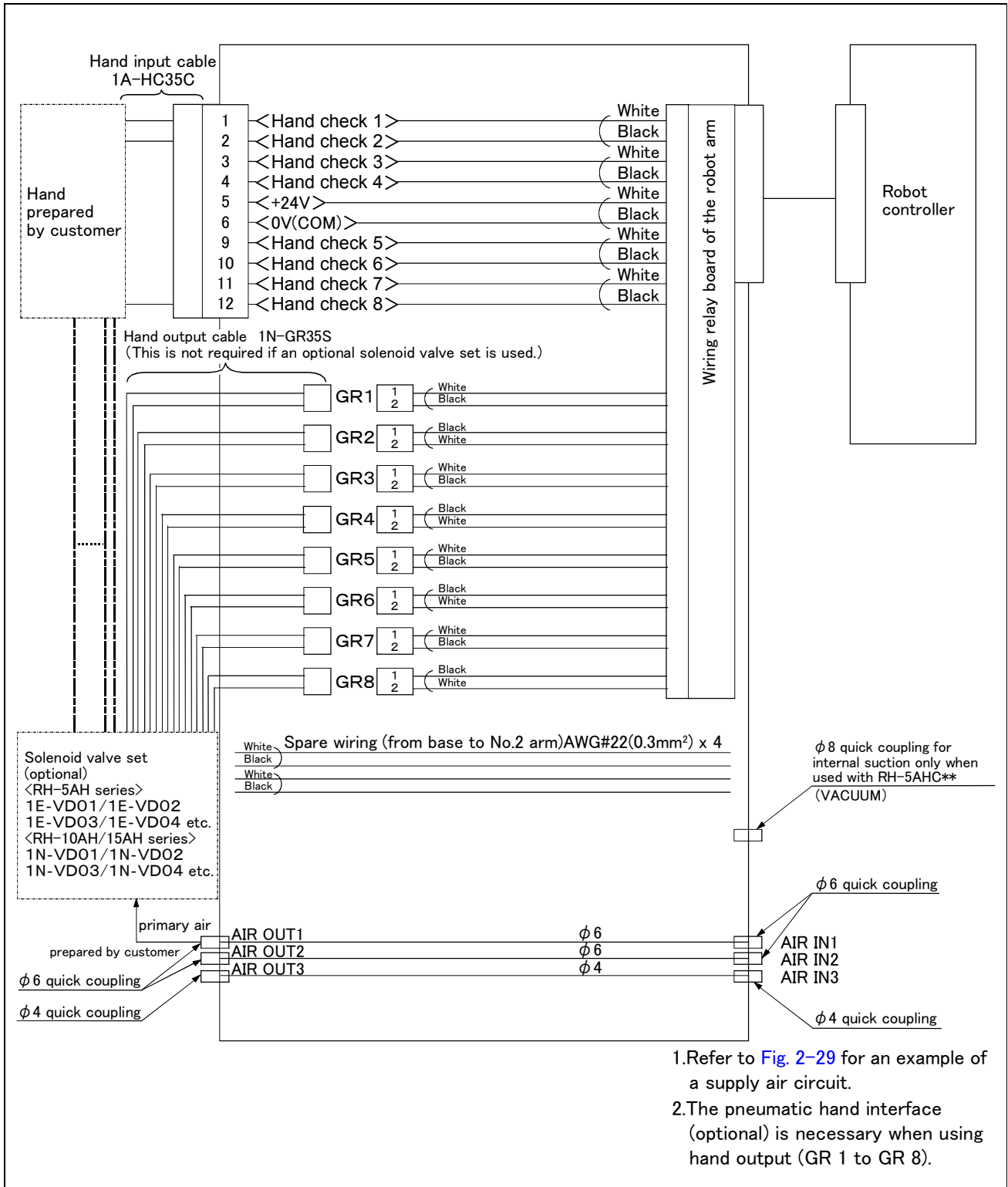

Fig.2-27 : Wiring and piping system diagram for hand and example the solenoid valve installation(Sink type)



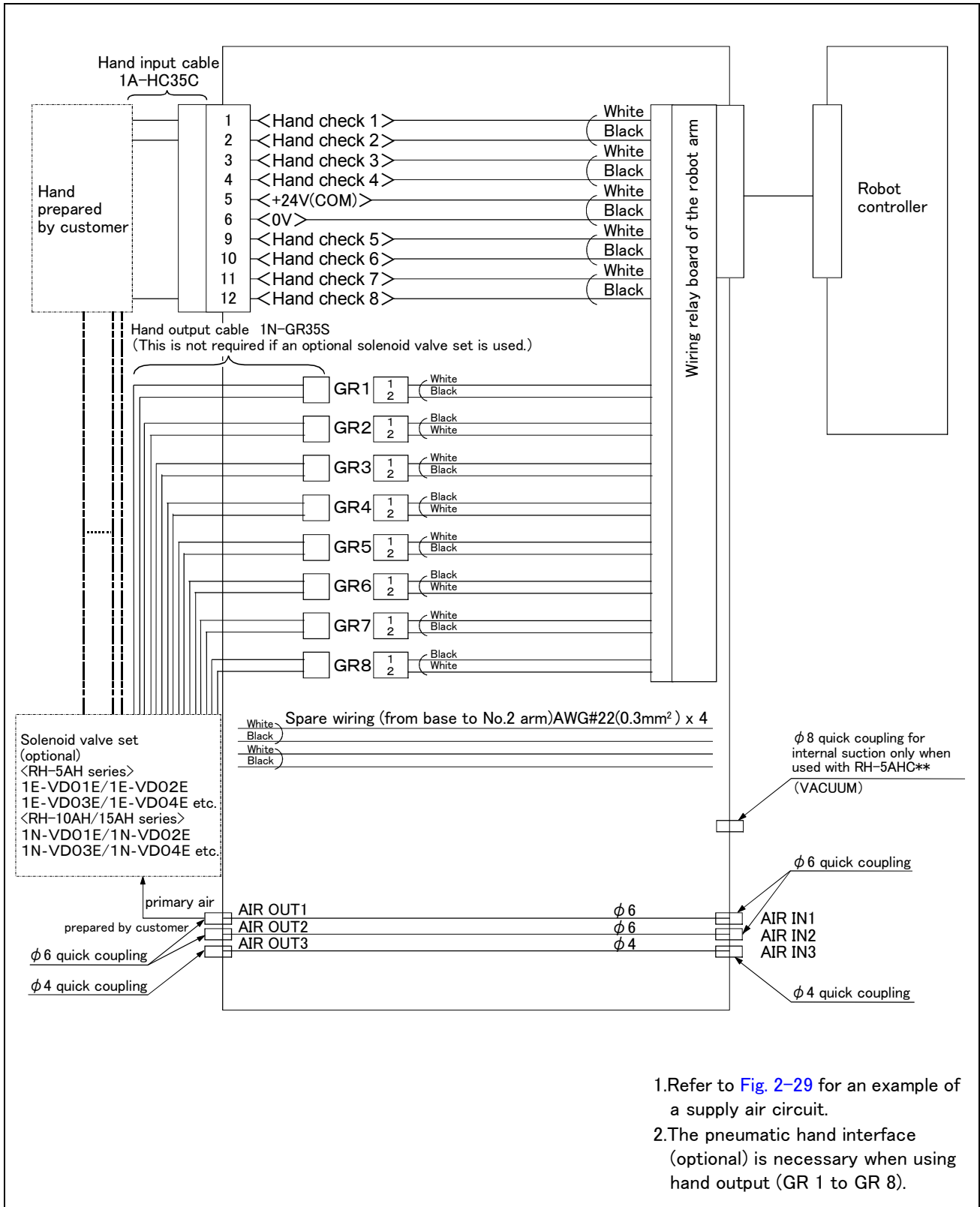

Fig.2-28 : Wiring and piping system diagram for hand and example the solenoid valve installation(Source type)

1. Refer to Fig. 2-29 for an example of a supply air circuit.
2. The pneumatic hand interface (optional) is necessary when using hand output (GR 1 to GR 8).

2.5.7 Electrical specifications of hand input/output

Table 2-9 : Electrical specifications of input circuit

Item		Specifications	Internal circuit
Type		DC input	<p>&lt;Sink type&gt;</p>  <p>&lt;Source type&gt;</p>  <p>* HCn = HC1 ~ 8</p>
No. of input points		8	
Insulation method		Photo-coupler insulation	
Rated input voltage		12VDC/24VDC	
Rated input current		Approx. 3mA/ approx. 7mA	
Working voltage range		DC10.2 to 26.4V(ripple rate within 5)	
ON voltage/ON current		8VDC or more/2mA or more	
OFF voltage/OFF current		4VDC or more/1mA or less	
Input resistance		Approx. 3.3kΩ	
Response time	OFF-ON	10ms or less(DC24V)	
	ON-OFF	10ms or less(DC24V)	

Table 2-10 : Electrical specifications of output circuit

Item		Specification	Internal circuit
Type		Transistor output	<p>&lt;Sink type&gt;</p> <p>24V (Internal power supply)</p>  <p>&lt;Source type&gt;</p>  <p>* GRn = GR1 ~ GR8</p>
No. of output points		8	
Insulation method		Photo coupler insulation	
Rated load voltage		DC24V	
Rated load voltage range		DC21.6 to 26.4VDC	
Max. current load		0.1A/ 1 point (100%)	
Current leak with power OFF		0.1mA or less	
Maximum voltage drop with power ON		DC0.9V(TYP.)	
Response time	OFF-ON	2ms or less (hardware response time)	
	ON-OFF	2 ms or less (resistance load) (hardware response time)	
Fuse rating		Fuses 1.6A (each one common) Cannot be exchanged	

Note) The pneumatic hand interface (2A-RZ365/RZ375) is necessary when using hand output.

## 2.5.8 Air supply circuit example for the hand

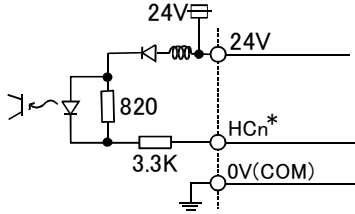
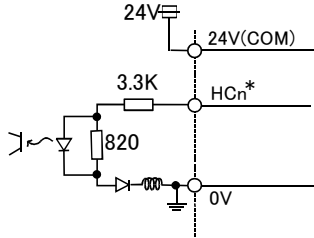
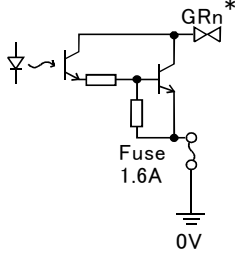
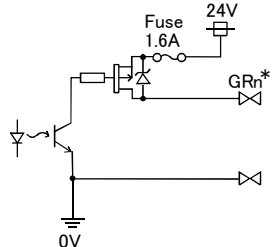
Fig. 2-29 shows an example of pneumatic supply circuitry for the hand.

- (1) Place diodes parallel to the solenoid coil.
- (2) When the factory pneumatic pressure drops, as a result of the hand clamp strength weakening, there can be damage to the work. To prevent it, install a pressure switch to the source of the air as shown in Fig. 2-29 and use the circuit described so that the robot stops when pressure drops. Use a hand with a spring-pressure clamp, or a mechanical lock-type hand, that can be used in cases where the pressure switch becomes damaged.
- (3) The optional hand and solenoid valve are of an oilless type. If they are used, don't use any lubricator.

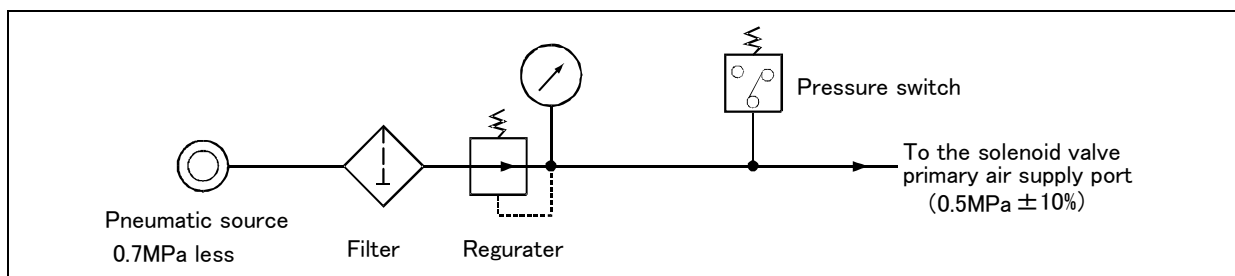

Fig.2-29 : Air supply circuit example for the hand

## 2.6 Shipping special specifications, options, and maintenance parts

### 2.6.1 Shipping special specifications

#### ■ What are Shipping special specifications?

Shipping special specifications are changed at the time of shipment from the factory. Consequently, customer need to confirm the delivery date.

To make changes to the specifications after shipment, service work must be performed at the work site or the robot must be returned for service.

#### ■ How to order

- (1) Confirm beforehand when the Factory special specifications can be shipped, because they may not be immediately available.
- (2) Order before the factory shipping date.
- (3) Specified method ····· Specify the part name, model, and robot model type.

## (1) Machine cable extension

- Order type : RH-5AH series.....● Fixed type(10m) 1A-10CBL-1  
 ● Fixed type(15m) 1A-15CBL-1  
 ● Flexed type(5m) 1A-05LCBL-1  
 ● Flexed type(10m) 1A-10LCBL-1  
 ● Flexed type(15m) 1A-15LCBL-1  
 RH-10AH/15AH series.....● Fixed type(10m) 1E-10CBL-N  
 ● Fixed type(15m) 1E-15CBL-N  
 ● Flexed type(5m) 1E-05LCBL-N  
 ● Flexed type(10m) 1E-10LCBL-N  
 ● Flexed type(15m) 1E-15LCBL-N

## ■ Outline



This cable is exchanged with the standard machine cable (5m) accessory to extend the distance between the controller and the robot arm.

A fixed type and flexible type are available.

Exchanges after shipment will be charged (for packaging, shipping costs).

The fixing and flexible types are both configured of the motor signal cable and motor power cable.

## ■ Configuration

Table 2-11 : Configuration equipments and types

Part name	Type	Qty.		Remarks
		Fixed	Flexed	
<b>RH-5AH series</b>				
Motor signal cable (for fixed type)	1E- □□ CBL(S)-N	1 cable	—	10m, or 15m each
Motor power cable (for fixed type)	1A- □□ CBL(P)-1	1 cable	—	10m, or 15m each
Motor signal cable (for flexed type)	1E- □□ LCBL(S)-N	—	1 cable	5m, 10m, or 15m each
Motor power cable (for flexed type)	1A- □□ LCBL(P)-1	—	1 cable	5m, 10m, or 15m each
Nylon clamp	NK-18N	—	2 pcs.	
Nylon clamp	NK-14N	—	2 pcs.	
Silicon rubber		—	4 pcs.	
<b>RH-10AH/15AH series</b>				
Motor signal cable (for fixed type)	1E- □□ CBL(S)-N	1 cable	—	10m, or 15m each
Motor power cable (for fixed type)	1E- □□ CBL(P)-N	1 cable	—	10m, or 15m each
Motor signal cable (for flexed type)	1E- □□ LCBL(S)-N	—	1 cable	5m, 10m, or 15m each
Motor power cable (for flexed type)	1E- □□ LCBL(P)-N	—	1 cable	5m, 10m, or 15m each
Nylon clamp	NK-24N	—	2 pcs.	
Nylon clamp	NK-16N	—	2 pcs.	
Silicon rubber		—	4 pcs.	

Note) The numbers in the boxes □□ refer the length.

## ■ Specifications

The specifications for the fixed type cables are the same as those for standard cables.

Shows usage conditions for flexed type cables in [Table 2-12](#).

Table 2-12 : Conditions for the flexed type cables

Item	Specifications	
Minimum flexed radius	100R or more	
Cable bare, etc., occupation rate	50% or less	
Maximum movement speed	2000mm/s or less	
Warranty life (no.)	7.5 million times	
Environmental proof	Oil-proof specification sheath (for silicon grease, cable sliding lubricant type)	
Cable configuration	Motor power cable	$\phi 6.5 \times 10$ (RH-5AH series) / $\phi 8.9 \times 3$ and $\phi 6.5 \times 6$ (RH-10AH/15AH series)
	Motor signal cable	$\phi 7 \times 6$ and $\phi 1.7 \times 1$

[Caution] The warranty life may greatly differ according to the usage state (items related to [Table 2-12](#) and to the amount of silicon grease applied in the cable conduit.

[Caution] This option can be installed on clean-type, but its cleanliness is not under warranty.

■ Cable configuration

The configuration of the flexible cable is shown in Table 2-13. Refer to this table when selecting the cable bare.

Table 2-13 : Cable configuration

Item	Motor signal cable		Motor power cable	
RH-5AH series				
Model	1E- □□ LCBL(S)-N		1A- □□ LCBL(P)-1	
No. of cores	AWG#24(0.2mm <sup>2</sup> )-4P	AWG#18(0.75mm <sup>2</sup> )	AWG#18(0.75mm <sup>2</sup> )	
Finish dimensions	Approx. φ 7mm	Approx. φ 1.7mm	Approx. φ 6.5mm	
No. of cables used	6 cables	1 cable	10 cables	
Total	7 cables		10 cables	
RH-10AH/15AH series				
Model	1E- □□ LCBL(S)-N		1E- □□ LCBL(P)-N	
No. of cores	AWG#24(0.2mm <sup>2</sup> )-4P	AWG#18(0.75mm <sup>2</sup> )	AWG#16(1.25mm <sup>2</sup> )-4C	AWG#18(0.75mm <sup>2</sup> )-4C
Finish dimensions	Approx. φ 7mm	Approx. φ 1.7mm	Approx. φ 8.9mm	Approx. φ 6.5mm
No. of cables used	6 cables	1 cable	3 cables	6 cables
Total	7 cables		9 cables	

Note) The square in the cable name indicates the cable length.

■ Fixing the flexible cable

- (1) Connect the connector to the robot arm and controller.
- (2) Wind the silicon rubber around the cable at a position 300mm to 400mm from the robot arm and controller as shown in Fig. 2-30, and fix with the nylon clamp to protect the cable from external stress.

RH-5AH series

RH-10AH/15AH series

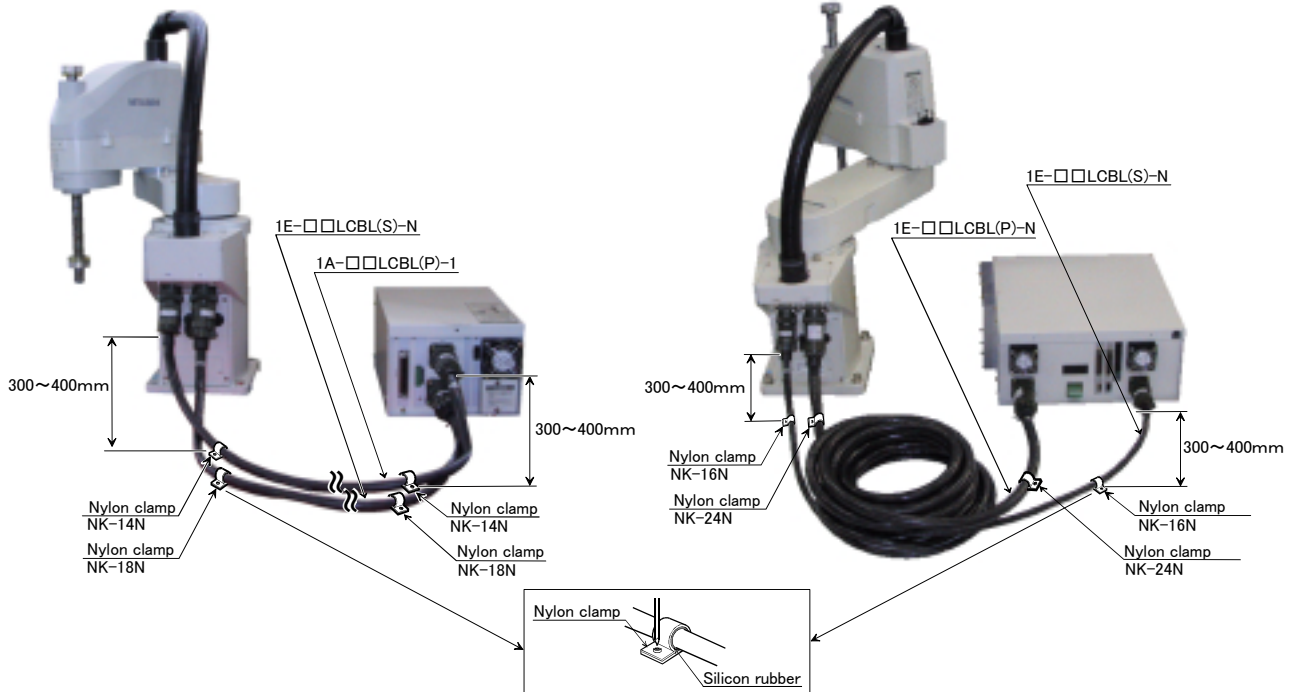

Fig.2-30 : Fixing the flexible cable

## 2.7 Options

### ■ What are options?

There are a variety of options for the robot designed to make the setting up process easier for customer needs. customer installation is required for the options. Options come in two types: "set options" and "single options".

1. Set options ..... A combination of single options and parts that together, from a set for serving some purpose.
2. Single options ..... That are configured from the fewest number of required units of a part.  
Please choose customer's purpose additionally.

(1) Solenoid valve set

- Order type: RH-5AH series.....General environment specifications
  - One set: 1E-VD01(Sink type)/1E-VD01E(Source type)
  - Two sets: 1E-VD02(Sink type)/1E-VD02E(Source type)
  - Three sets: 1E-VD03(Sink type)/1E-VD03E(Source type)
  - Four sets: 1E-VD04(Sink type)/1E-VD04E(Source type)
 Protection environment specifications (IP54)
  - One set: 1A-VD01M-01(Sink type)/1A-VD01ME-01(Source type)
  - Two sets: 1A-VD02M-01(Sink type)/1A-VD02ME-01(Source type)
  - Three sets: 1A-VD03M-01(Sink type)/1A-VD03ME-01(Source type)
  - Four sets: 1A-VD04M-01(Sink type)/1A-VD04ME-01(Source type)
- RH-10AH/15AH series....General environment specifications (RH-10AH/15AH)
  - One set: 1N-VD01(Sink type)/1N-VD01E(Source type)
  - Two sets: 1N-VD02(Sink type)/1N-VD02E(Source type)
  - Three sets: 1N-VD03(Sink type)/1N-VD03E(Source type)
  - Four sets: 1N-VD04(Sink type)/1N-VD04E(Source type)
 Protection environment specifications (IP54)
  - One set: 1A-VD01M-02(Sink type)/1A-VD01ME-02(Source type)
  - Two sets: 1A-VD02M-02(Sink type)/1A-VD02ME-02(Source type)
  - Three sets: 1A-VD03M-02(Sink type)/1A-VD03ME-02(Source type)
  - Four sets: 1A-VD04M-02(Sink type)/1A-VD04ME-02(Source type)

■ Outline



Example of "1N-VD04".

The solenoid valve set is an option that is used for controlling toolings when various toolings, such as the hand, are installed at the end of the arm. All have double solenoid specification, and either one, two, three, or four sets can be selected. This solenoid valve set has a hand output cable attached to the solenoid valve. Also, for easy installation of this electromaagnetic set onto the robot, it comes equipped with a manifold, couplings, silencers, among other things.

When using the robot arm's hand output signal, the pneumatic hand interface option must be installed on the separate controller.

This solenoid valve set is installed in robots with the clean specifications. However, it is necessary to discharge the solenoid valve exhaust to the outside of the machine (outside of the clean room) using a spare pipe, for example. In operating environments where substantial oil mist and dust are present, use the protection specifications that include the solenoid valve box.



## ■ Configuration

Table 2-14 : Configuration equipment

Part name	Type	Qty.				Remark	
	Sink type/Source type	1 set	2 sets	3 sets	4 sets		
RH-5AH series general environment specifications							
Solenoid valve set (1 set)	1E-VD01/1E-VD01E	1 pc.	—	—	—	Connecting the Page 53, "(3) Hand output cable". <RH-5AH series> M3x25 2 screws (Installation screws) <RH-10AH/15AH series> M4x45 4 screws (Installation screws)	
Solenoid valve set (2 sets)	1E-VD02/1E-VD02E	—	1 pc.	—	—		
Solenoid valve set (3 sets)	1E-VD03/1E-VD03E	—	—	1 pc.	—		
Solenoid valve set (4 sets)	1E-VD04/1E-VD04E	—	—	—	1 pc.		
RH-5AH series protection specifications							
Solenoid valve set (1 set)	1A-VD01M-01/1A-VD01ME-01	1 pc.	—	—	—		
Solenoid valve set (2 sets)	1A-VD02M-01/1A-VD02ME-01	—	1 pc.	—	—		
Solenoid valve set (3 sets)	1A-VD03M-01/1A-VD03ME-01	—	—	1 pc.	—		
Solenoid valve set (4 sets)	1A-VD04M-01/1A-VD04ME-01	—	—	—	1 pc.		
Solenoid valve box		1 pc.	1 pc.	1 pc.	1 pc.		
RH-10AH/15AH series general environment specifications							
Solenoid valve set (1 set)	1N-VD01/1N-VD01E	1 pc.	—	—	—		
Solenoid valve set (2 sets)	1N-VD02/1N-VD02E	—	1 pc.	—	—		
Solenoid valve set (3 sets)	1N-VD03/1N-VD03E	—	—	1 pc.	—		
Solenoid valve set (4 sets)	1N-VD04/1N-VD04E	—	—	—	1 pc.		
RH-10AH/15AH series protection specifications							
Solenoid valve set (1 set)	1A-VD01M-02/1A-VD01ME-02	1 pc.	—	—	—		
Solenoid valve set (2 sets)	1A-VD02M-02/1A-VD02ME-02	—	1 pc.	—	—		
Solenoid valve set (3 sets)	1A-VD03M-02/1A-VD03ME-02	—	—	1 pc.	—		
Solenoid valve set (4 sets)	1A-VD04M-02/1A-VD04ME-02	—	—	—	1 pc.		
Solenoid valve box		1 pc.	1 pc.	1 pc.	1 pc.		

## ■ Specifications

Table 2-15 : Valve specifications

Item	Specifications	
	RH-5AH series	RH-10AH/15AH series
Number of positions	2	
Port	5	
Valve function	Double solenoid	
Operating fluid	Clean air	
Operating method	Pilot type	
Effective sectional area (CV value)	1.5mm(0.08)	10.2mm(0.57)
Oiling	Unnecessary	
Operating pressure range	0.2 to 0.7MPa	0.15 to 0.7MPa
Guaranteed proof of pressure	1.0MPa or more	
Response time	12msec or less (DC24V)	25msec or less
Max. operating frequency	5c/s	
Ambient temperature	5 to 50 °C	

Table 2-16 : Solenoid specifications

Item	Specifications	
	RH-5AH series	RH-10AH/15AH series
Method	Built-in fly-wheel diodes with surge protection	
Operation voltage	DC24V ± 10%	
Current value	40mA	60mA
Insulation	B type	
Insulation resistance	100MΩ or more	
Surge protection	Fly-wheel diode	

**RH-5AH series**

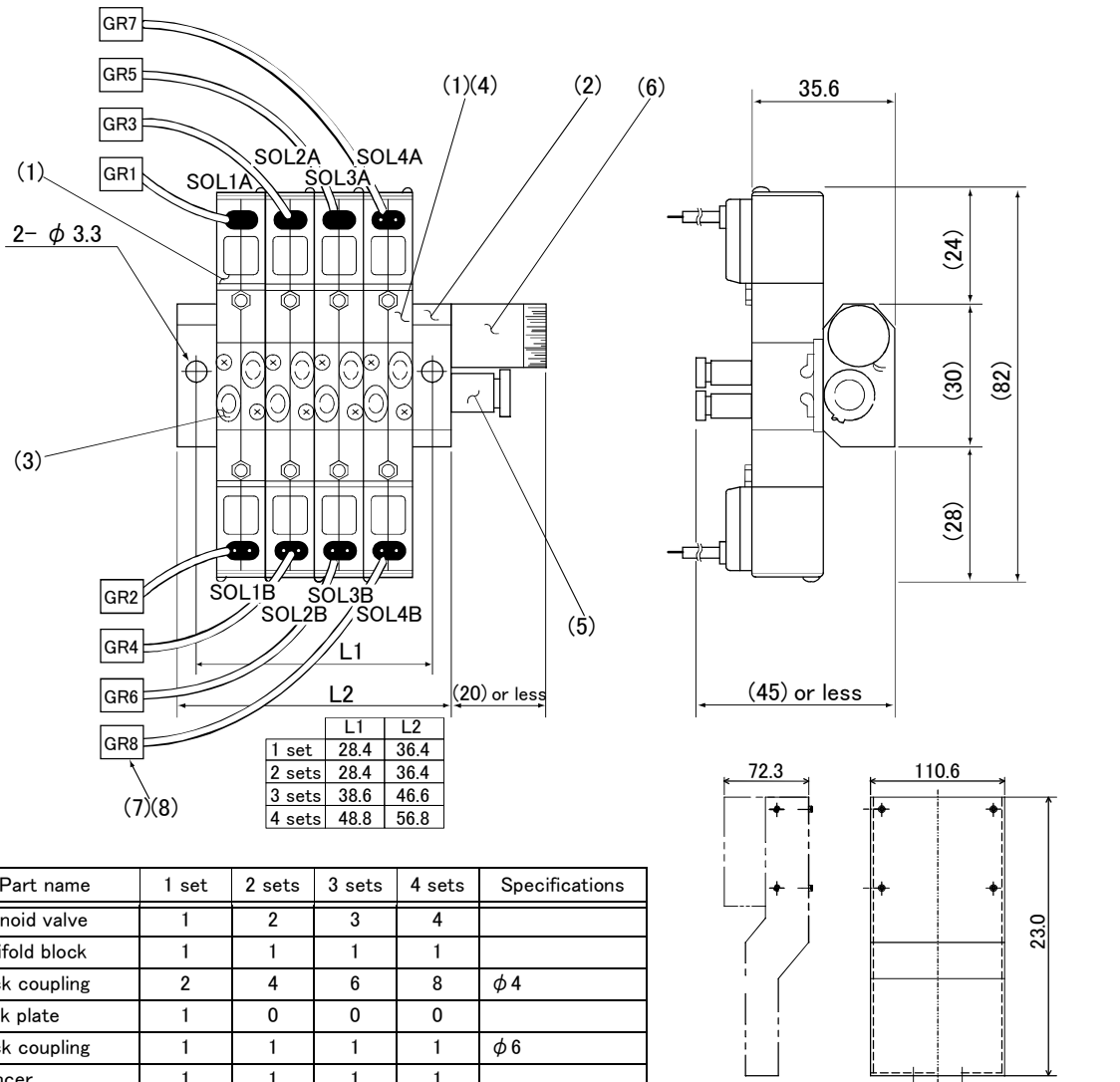

Partno.	Part name	1 set	2 sets	3 sets	4 sets	Specifications
(1)	Solenoid valve	1	2	3	4	
(2)	Manifold block	1	1	1	1	
(3)	Quick coupling	2	4	6	8	φ 4
(4)	Block plate	1	0	0	0	
(5)	Quick coupling	1	1	1	1	φ 6
(6)	Silencer	1	1	1	1	
(7)	Connector	2	4	6	8	SMR-02V-B
(8)	Contact	4	8	12	16	SYM-001T-0.6
—	Solenoid valve box	1	1	1	1	
—	Installation screw	2	2	2	2	M3 × 25

Outside dimensions of solenoid valve box<sup>Note)</sup>

Note)The solenoid valve box is provided only for the protection specifications.

<Sink type>

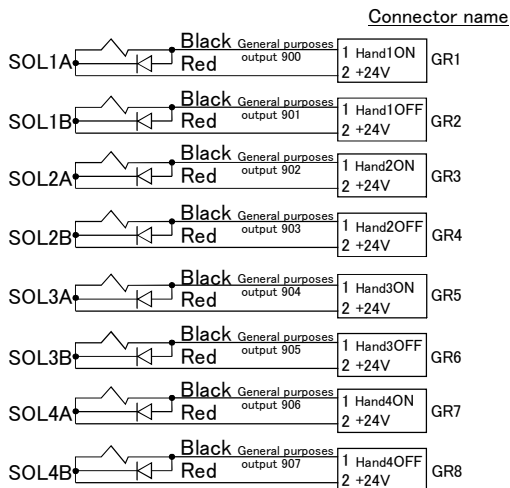

<Source type>

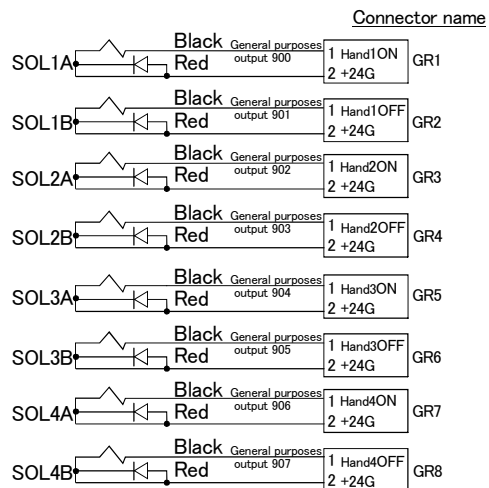
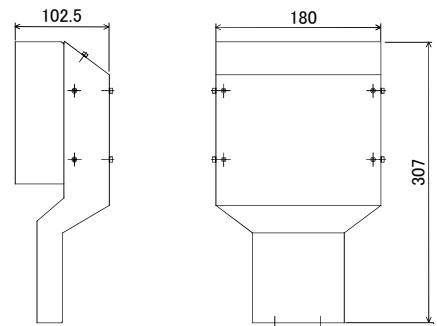
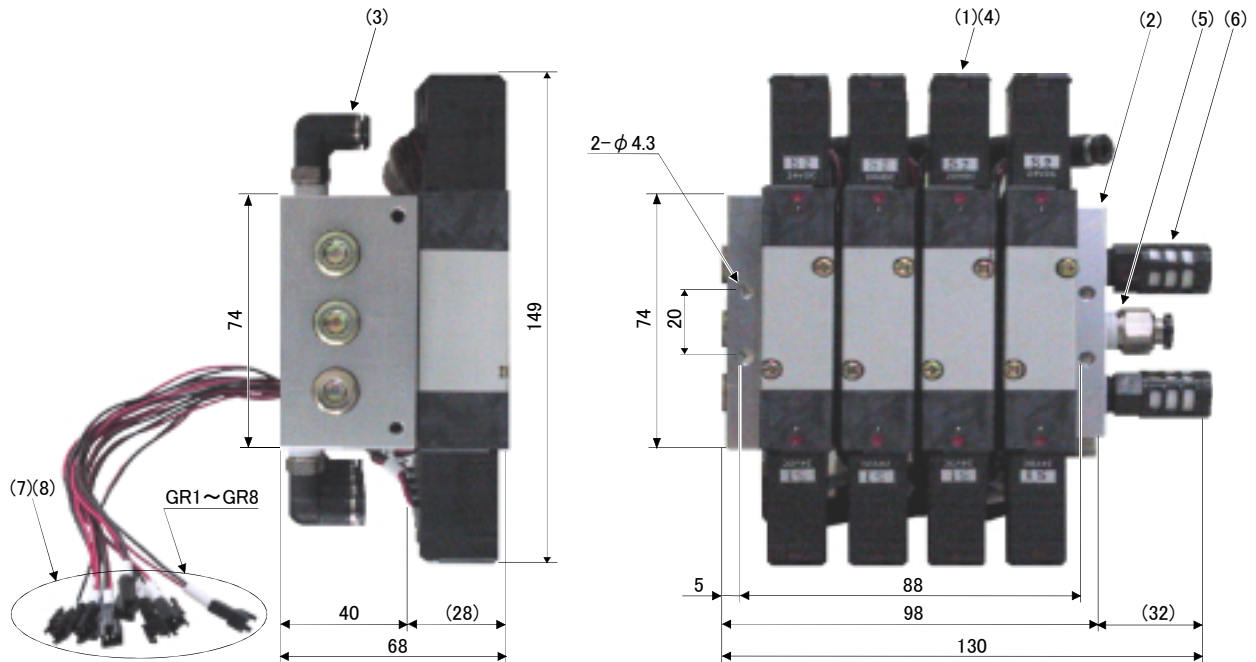

Fig.2-31 : Outside dimensional drawing of RH-5AH series

RH-10AH/15AH series



Outside dimensions of solenoid valve box<sup>Note)</sup>

Partno.	Part name	1 set	2 sets	3 sets	4 sets	Specifications
(1)	Solenoid valve	1	2	3	4	
(2)	Manifold block	1	1	1	1	
(3)	Quick coupling	2	4	6	8	φ 4
(4)	Block plate	3	2	1	0	
(5)	Quick coupling	1	1	1	1	φ 6
(6)	Silencer	2	2	2	2	
(7)	Connector	2	4	6	8	SMR-02V-B
(8)	Contact	4	8	12	16	SYM-001T-0.6
—	Solenoid valve box	1	1	1	1	
—	Installation screw	4	4	4	4	M4 × 45

Note)The solenoid valve box is provided only for the protection specifications.

<Sink type>

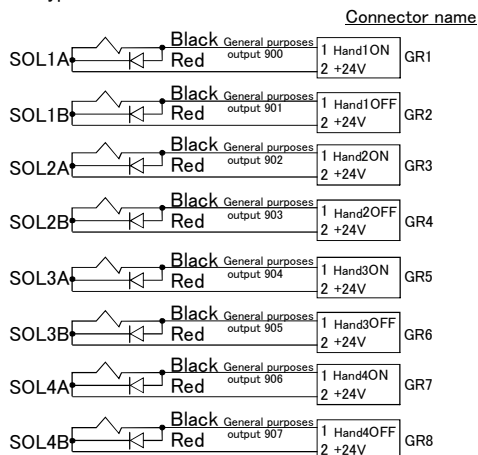

<Source type>

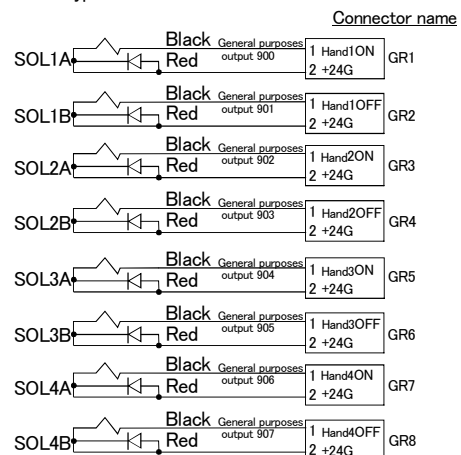

Fig.2-32 : Outside dimensional drawing of RH-10AH/15AH series

(2) Hand input cable (Hand check cable)

■ Order type: 1A-HC35C

■ Outline

The hand input cable is used for customer-designed pneumatic hands. It is necessary to use this to receive the hand's open/close confirmation signals and grasping confirmation signals, at the controller.

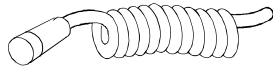

One end of the cable connects to the connector for hand input signals, which is in the No.2 arm back side. The other end of the cable connects to the sensor inside the hand customer designed.

■ Configuration

Table 2-17 : Configuration equipment

Part name	Type	Qty.	Remarks
Hand input cable	1A-HC35C	1 cable	

■ Specifications

Table 2-18 : Specifications

Item	Specifications	Remarks
Size x cable core	AWG#24(0.2mm <sup>2</sup> ) x 12 cores	
Total length	1,150mm (Including the curl section, which is 300mmlong)	

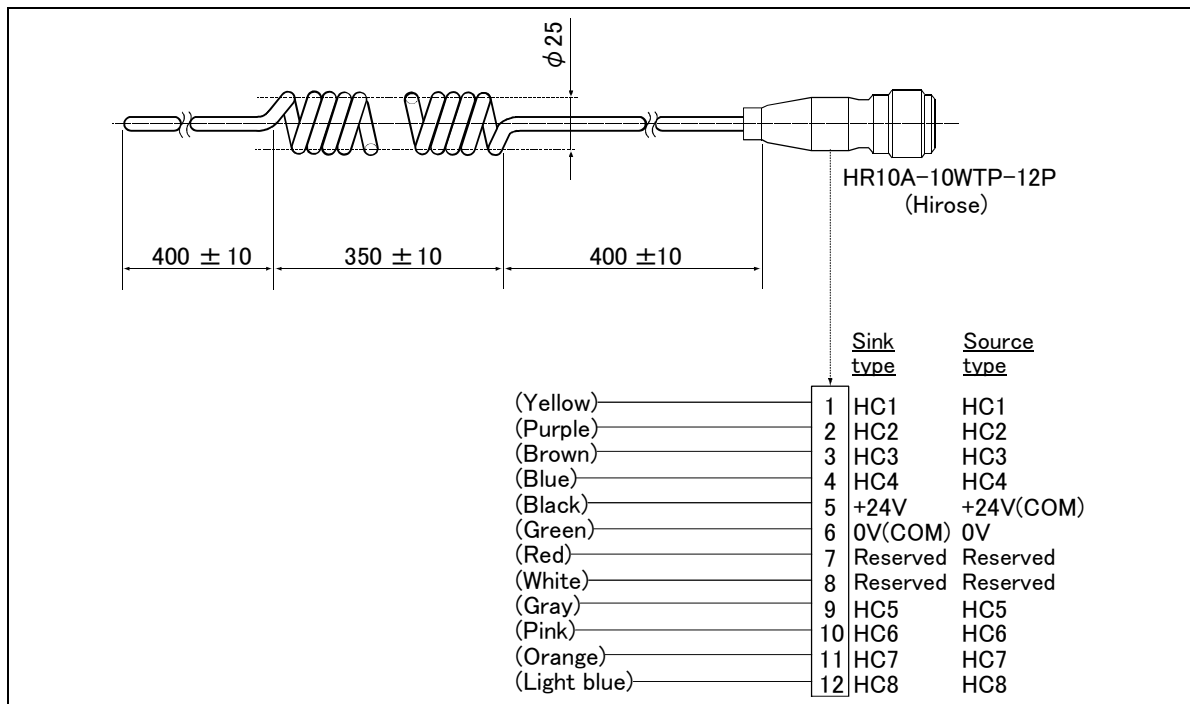

Fig.2-33 : Outside dimensional drawing and pin assignment

[Caution] This option can be installed on clean-type, but its cleanliness is not under warranty.

(3) Hand output cable

■ Order type: 1N-GR35S

■ Outline

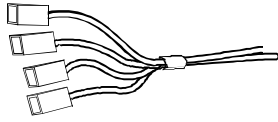

The hand output cable (solenoid valve connection cable) is an option that is used when an solenoid valve other than one of the solenoid valve set options, is used. One end of the cable has a connector that connects to the input terminal inside the robot. The other end of the cable is connected.

■ Configuration

Table 2-19 : Configuration equipment

Part name	Type	Qty.	Remarks
Hand output cable	1N-GR35S	1 cable	

■ Specifications

Table 2-20 : Specifications

Item	Specifications	Remarks
Size x Cable core	AWG#22(0.3mm <sup>2</sup> ) x 2 cores x 8 sets (total 16 cores)	One side connector and one side cable connection
Total length	350mm	

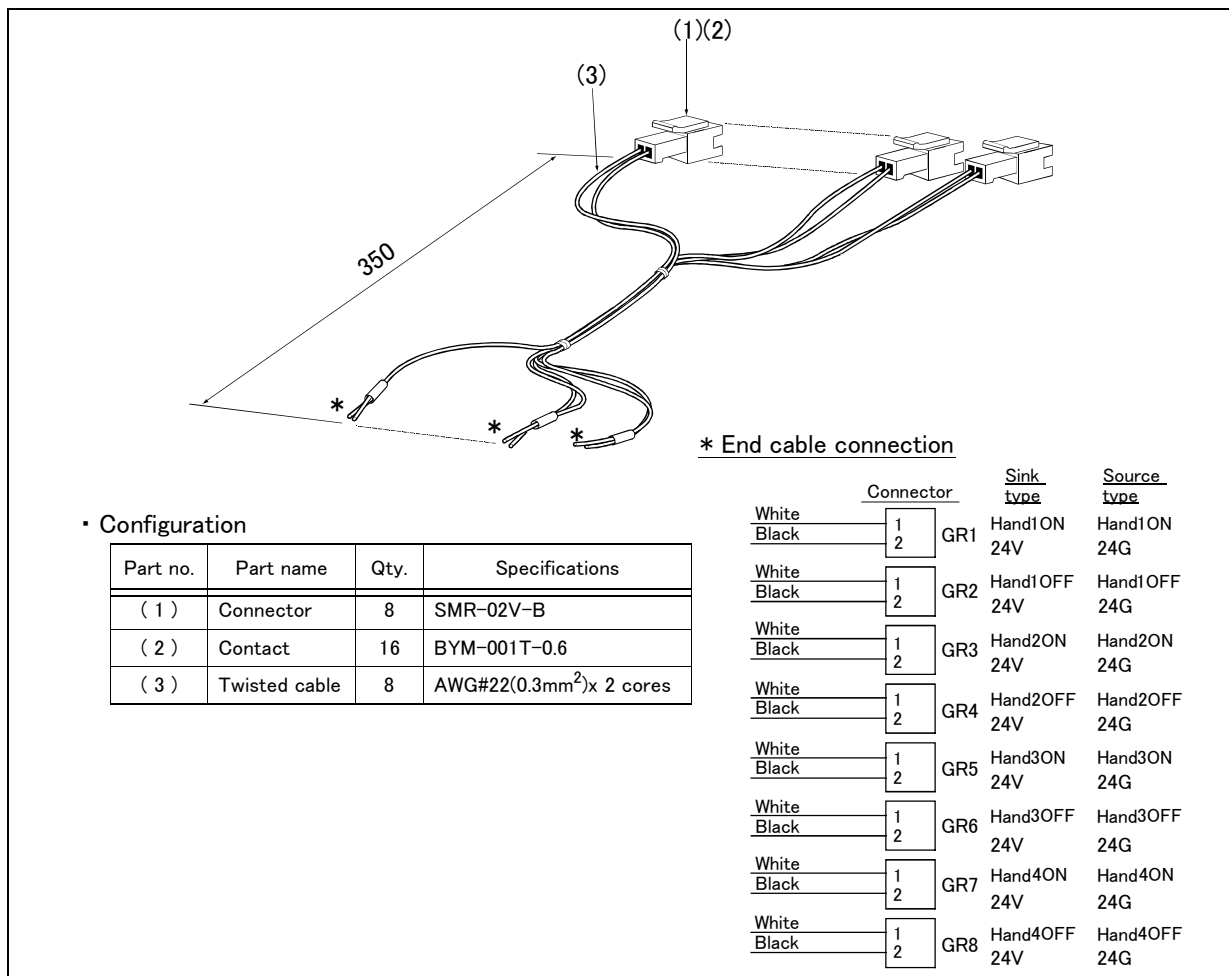

Fig.2-34 : Outline dimensional drawing and pin assignment

[Caution] To install this option to a machine with either the protection or clean specifications, the customer needs to seal the robot outlet by the silicon rubber.

[Caution] This option can be installed on clean-type, but its cleanliness is not under warranty.

(4) Hand curl tube

- Order type: One set (2 pcs.) : 1E-ST0402C-300
- Two sets (4 pcs.) : 1E-ST0404C-300
- Three sets (6 pcs.) : 1E-ST0406C-300
- Four sets (8 pcs.) : 1E-ST0408C-300

■ Outline

The hand curl tube is a curl tube for the pneumatic hand.

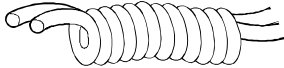

■ Configuration

Table 2-21 : Configuration equipment

Part name	Type	Qty.	Remarks
Hans curl tube (One set: 2 pcs.)	1E-ST0402C-300	1 pc.	Φ4 tube, 2pcs.
Hans curl tube (Two set: 4 pcs.)	1E-ST0404C-300	1 pc.	Φ4 tube, 4pcs.
Hans curl tube (Three set: 6 pcs.)	1E-ST0406C-300	1 pc	Φ4 tube, 6pcs.
Hand curl tube (Four set: 8 pcs.)	1E-ST0408C-300	1 pc.	Φ4 tube, 8pcs.

■ Specifications

This option can be installed on clean-type, but its cleanliness is not under warranty.

Table 2-22 : Specifications

Item	Specifications
Material	Urethane
Size	Outside diameter: Φ4 x Inside diameter Φ2.5

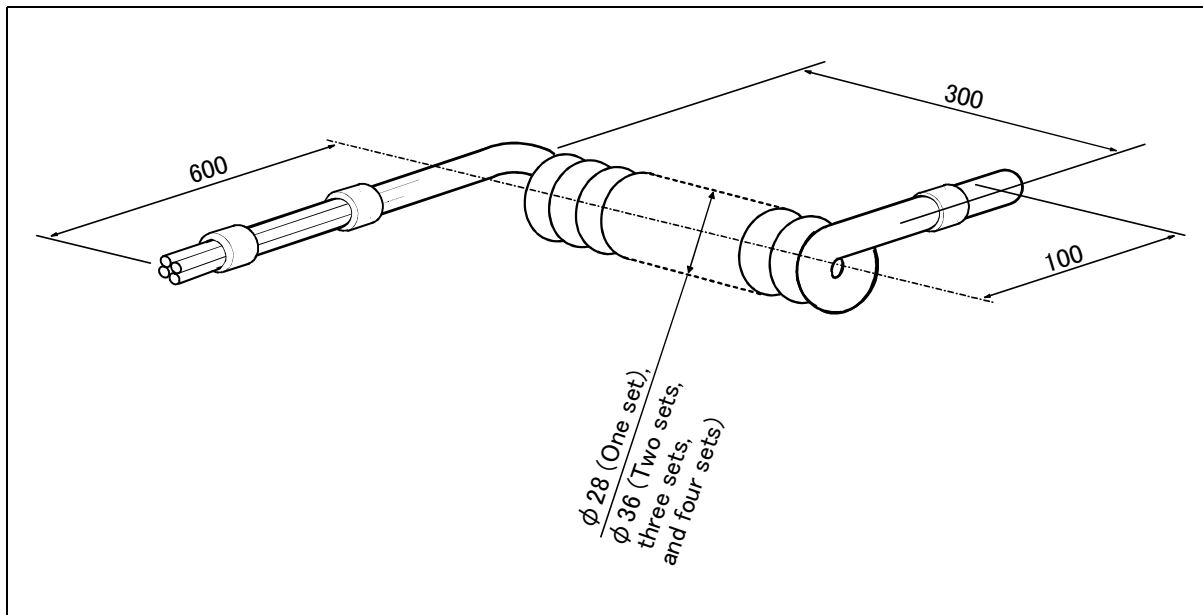

Fig.2-35 : Outline dimensional drawing

[Caution] This option can be installed on clean-type, but its cleanliness is not under warranty.

## 2.8 Maintenance parts

The consumable parts used in the robot arm are shown in [Table 2-23](#). Purchase these parts from the designated maker or dealer when required. Some Mitsubishi-designated parts differ from the maker's standard parts. Thus, confirm the part name, robot arm and controller serial No. and purchase the parts from the dealer.

Table 2-23 : Consumable part list

No.	Part name	Type	Usage place		Qty.	Supplier
			RH-5AH series	RH-10AH/15AH series		
1	Grease	SK-1A	J 1 , J2, J4 axis:Reduction gears	Reduction gears of each axis	As needed	Mitsubishi Electric
2		Marutenpu PS No.2	Ball screw, linear guide of J3 axis	Shaft	As needed	
3	Lithium battery	A6BAT	Inside the battery cover of base	Rear section of the base	4	





## 3 Controller

### 3.1 Standard specifications

#### 3.1.1 Standard specifications

Table 3-1 : Standard specifications of controller

Item		Unit	Specification	Remarks
Type			CR2A-572	
Number of control axis			Simultaneously 4	
CPU			64 bit RISC, and DSP	
Memory capacity	Programmed positions and No. of steps	point step	2,500 5,000	
	Number of programs		88	
	Robot language			MELFA-BASIC IV or MOVEMASTER COMMAND
Teaching method			Pose teaching method ,MDI method	
External input and output	input and output	point	32/32	Max. 256/256 <sup>Note1)</sup>
	Dedicated input/output	point	Assigned with general-purpose input/output	"STOP" 1 point is fixed
	Hand open/close input/output	point	Input 8 point/Output 0 point	Up to 8 output points can be added as an option <sup>Note2)</sup>
	Emergency stop input/output	point	1	Dual emergency line
	Door switch input	point	1	Dual door switch line
Interface	RS-232C	port	1	For expansion such as the personal computer, Vision sensor
	RS-422	port	1	Dedicated for T/B
	Hand dedicated slot	slot	1	Dedicated for pneumatic hand interface
	Expansion slot	slot	3	
	Robot input/output link	channel	1	Used for general-purpose input/output (Max. 256/256)
Power source	Input voltage range	V	1-phase, AC180 to 253	<sup>Note3)</sup>
	Power capacity	KVA	0.7 (RH-5AH series) 3.5 (RH-10AH/15AH series)	Does not include rush current <sup>Note4)</sup>
Outline dimensions		mm	400(W) x 400(D) x 200(H)	The height includes the length of the foot.
Mass		kg	Approx. 18	
Construction			Self-contained floor type, Opened type	<sup>Note5)</sup>
Operating temperature range		deg.	0 to 40	
Ambient humidity		%RH	45 to 85	Without dew drops
Grounding		Ω	100 or less	D class grounding earth <sup>Note6)</sup>
Paint color			Light gray	Munsell 7.65Y7.64/0.73

Note1) It is the value when seven maximums expand (224/224) the Parallel I/O unit.  
(2A-RZ361 or 2A-RZ371:Input 32 points / Output 32 points.)

Note2) It is when a pneumatic hand interface (2A-RZ365 or 2A-RZ375) is installed.

Note3) 1-phase, AC180 to 253. This specification is changed for CE-Marking model.

Note4) The power capacity (0.7 or 3.5 kVA) is the maximum rating value for normal operation. The power capacity does not include the rush current when the power is turned ON. The power capacity is a guideline and the actual operation is affected by the input power voltage.

Note5) The controller (CR2A-572) of this robot is a general environment specification. If the robot is used in an oil mist environment, use the optional controller protection box (CR2A-MB) to protect the controller from the oil mist environment. (Refer to [Page 8](#), "2.2.3 Protection specifications and working environment")

Install to the place not to influence the cleanliness when using in the clean environment. (Refer to [Page 14](#), "2.2.5 Clean specifications (RH-5AH series)")

Note6) The robot must be grounded by the customer.

### 3.1.2 Protection specifications and operating supply

A protection method complying with the IEC Standard IP20 (Opened type) is adopted for the controller.

IEC's IP symbols refer only to the degree of protection between the solid and the fluids, and don't indicated that any special protection has been constructed for the prevention against oil and water.

Refer to the section [Page 110, "5.2 Working environment"](#) for details on the working environment.

#### CAUTION

If the robot is used in an oil mist environment, use the optional controller protection box (CR2A-MB) to protect the controller from the oil mist environment.

Refer to the section [Page 78, "\(3\) Controller protection box"](#) for details on the controller protection box.

## 3.2 Names of each part

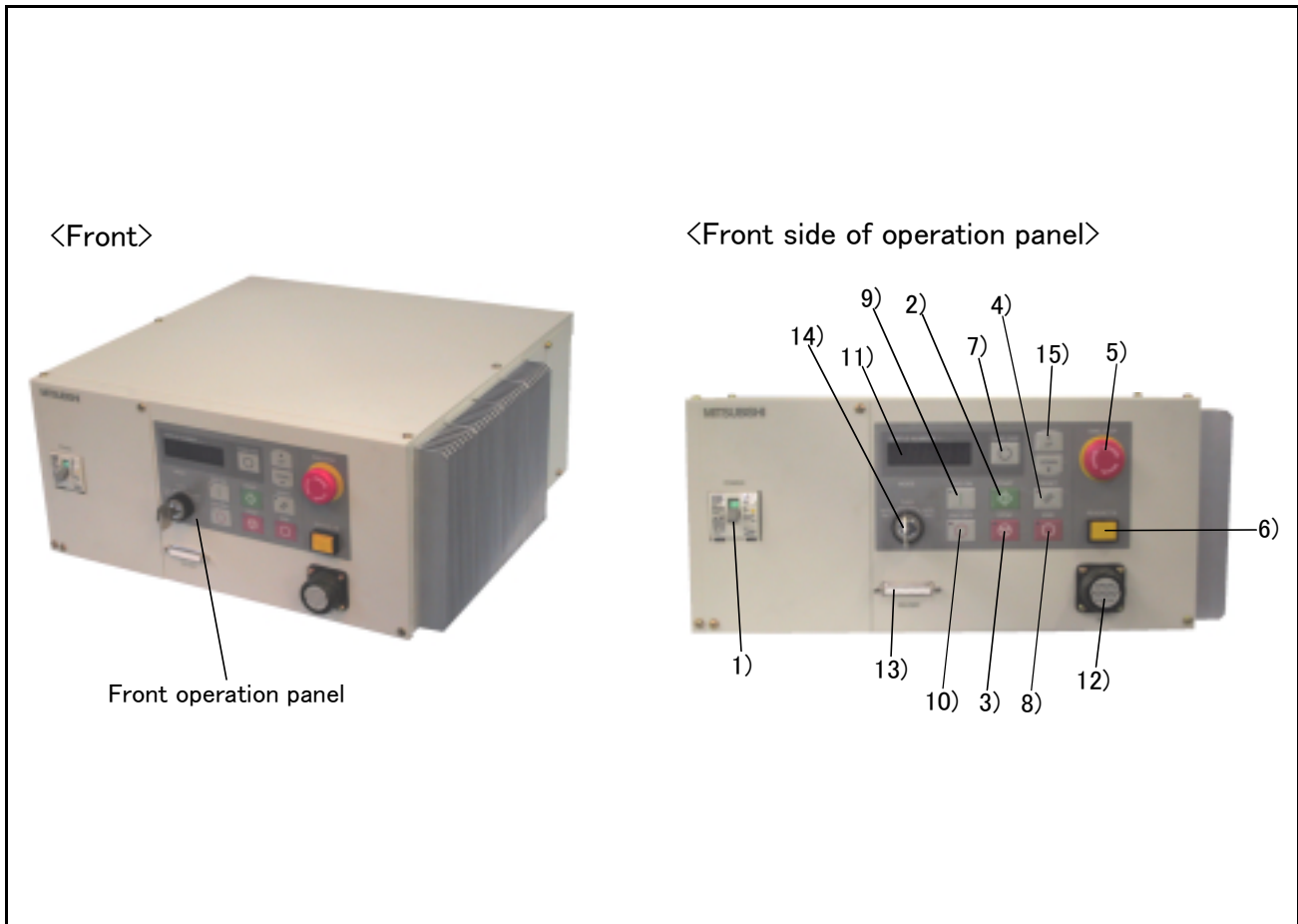

Fig.3-1 : Names of controller parts

- 1) POWER switch..... This turns the control power ON/OFF.
- 2) START button..... This executes the program and operates the robot. The program is run continuously.
- 3) STOP button..... This stops the robot immediately. The servo does not turn OFF.
- 4) RESET button..... This resets the error. This also resets the program's halted state and resets the program.
- 5) Emergency stop switch..... This stops the robot in an emergency state. The servo turns OFF.
- 6) T/B remove switch..... This is used to connect/disconnect the T/B without turning OFF the controller's control power.
- 7) CHNGDISP button..... This changes the details displayed on the display panel in the order of "Override" → "Program No." → "Line No.".
- 8) END button..... This stops the program being executed at the last line or END statement.
- 9) SVO.ON button..... This turns ON the servo power. (The servo turns ON.)
- 10) SVO.OFF button..... This turns OFF the servo power. (The servo turns OFF.)
- 11) STATUS NUMBER  
(display panel)..... The alarm No., program No., override value (%), etc., are displayed.
- 12) T/B connection connector ..... This is a dedicated connector for connecting the T/B.
- 13) Personal computer  
connection connector..... This is an RS-232C specification connector for connecting the personal computer.
- 14) MODE key switch..... This changes the robot's operation mode. <sup>Note)</sup>
- AUTO (Op.)..... Only operations from the controller are valid. Operations for which the operation mode must be at the external device or T/B are not possible.
- TEACH..... When the T/B is valid, only operations from the T/B are valid. Operations for which the operation mode must be at the external device or controller are not possible.
- AUTO (Ext.)..... Only operations from the external device are valid. Operations for which the operation mode must be at the T/B or controller are not possible.
- 15) UP/DOWN button..... This scrolls up or down the details displayed on the "STATUS. NUMBER" display panel.

**CAUTION**

Note) The servo will turn OFF when the controller's [MODE] switch is changed.  
Note that axes not provided with brakes could drop with their own weight.

Carry out the following operations to prevent the servo from turning OFF when the [MODE] switch is changed.(Only CR2A-572 controller)

The servo on status can be maintained by changing the mode with keeping pressing lightly the deadman switch of T/B. The operating method is shown below.

- (1) When the mode is changed from TEACH to AUTO.
  - 1) While holding down the deadman switch on the T/B, set the [ENABLE/DISABLE] switch to "DISABLE".
  - 2) While holding down the deadman switch on the T/B, set the controller [MODE] switch to "AUTO".
  - 3) Release the T/B deadman switch.
  
- (2) When the mode is changed from AUTO to TEACH.
  - 1) While the [ENABLE/DISABLE] switch on the T/B is "DISABLE", hold down the deadman switch.
  - 2) While holding down the deadman switch on the T/B, set the controller [MODE] switch to "TEACH".
  - 3) While holding down the deadman switch on the T/B, set the [ENABLE/DISABLE] switch to "ENABLE", then do the operation of T/B that you wish.

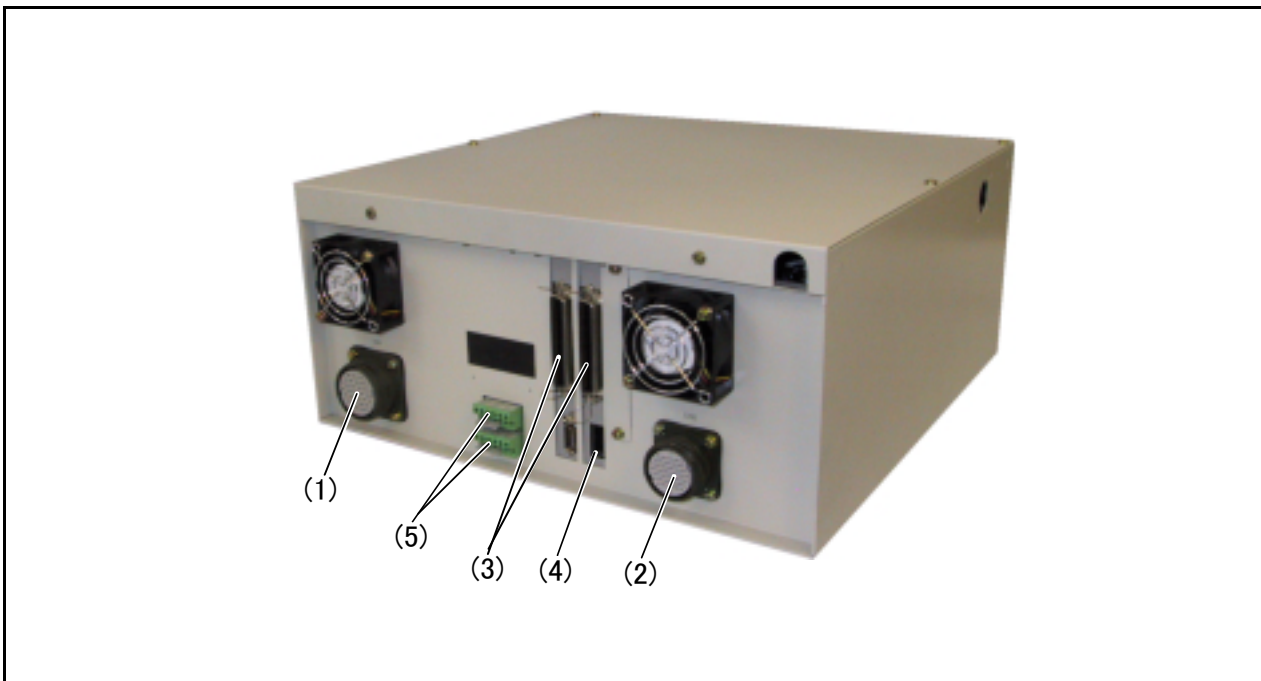

Fig.3-2 : Names of each controller part (Rear side)

- (1) Machine cable connector (for motor power )..... Connects to the robot arm base. (CN1 connector)
- (2) Machine cable connector (for motor signals)..... Connects to the robot arm base. (CN2 connector)
- (3) External input/output signal connector.
- (4) Network cable connector for parallel I/O unit expansion.
- (5) Emergency stop switch and door switch terminals.

## 3.3 Outside dimensions/Installation dimensions

## 3.3.1 Outside dimensions

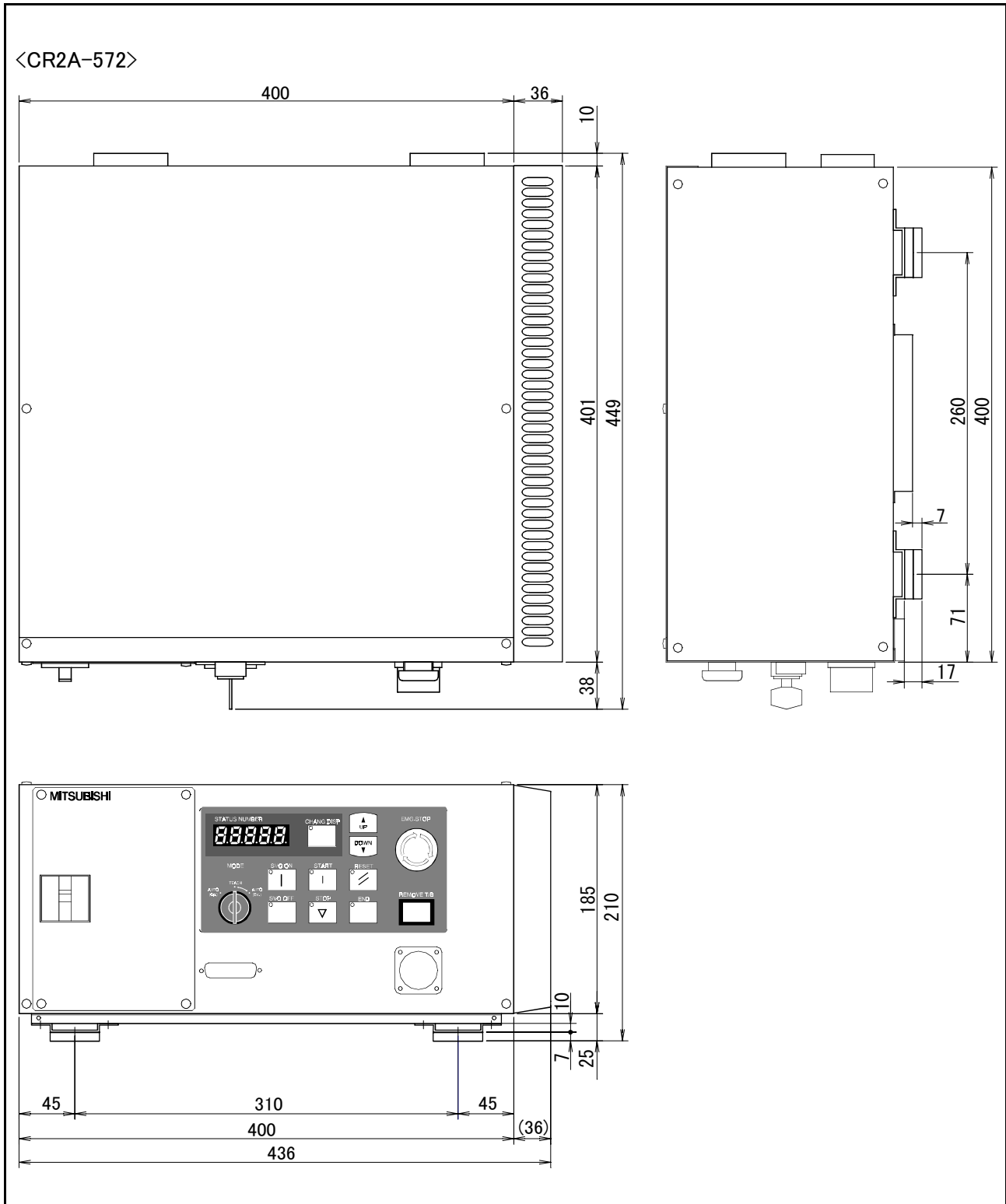

Fig.3-3 : Outside dimensions of controller

### 3.3.2 Installation dimensions

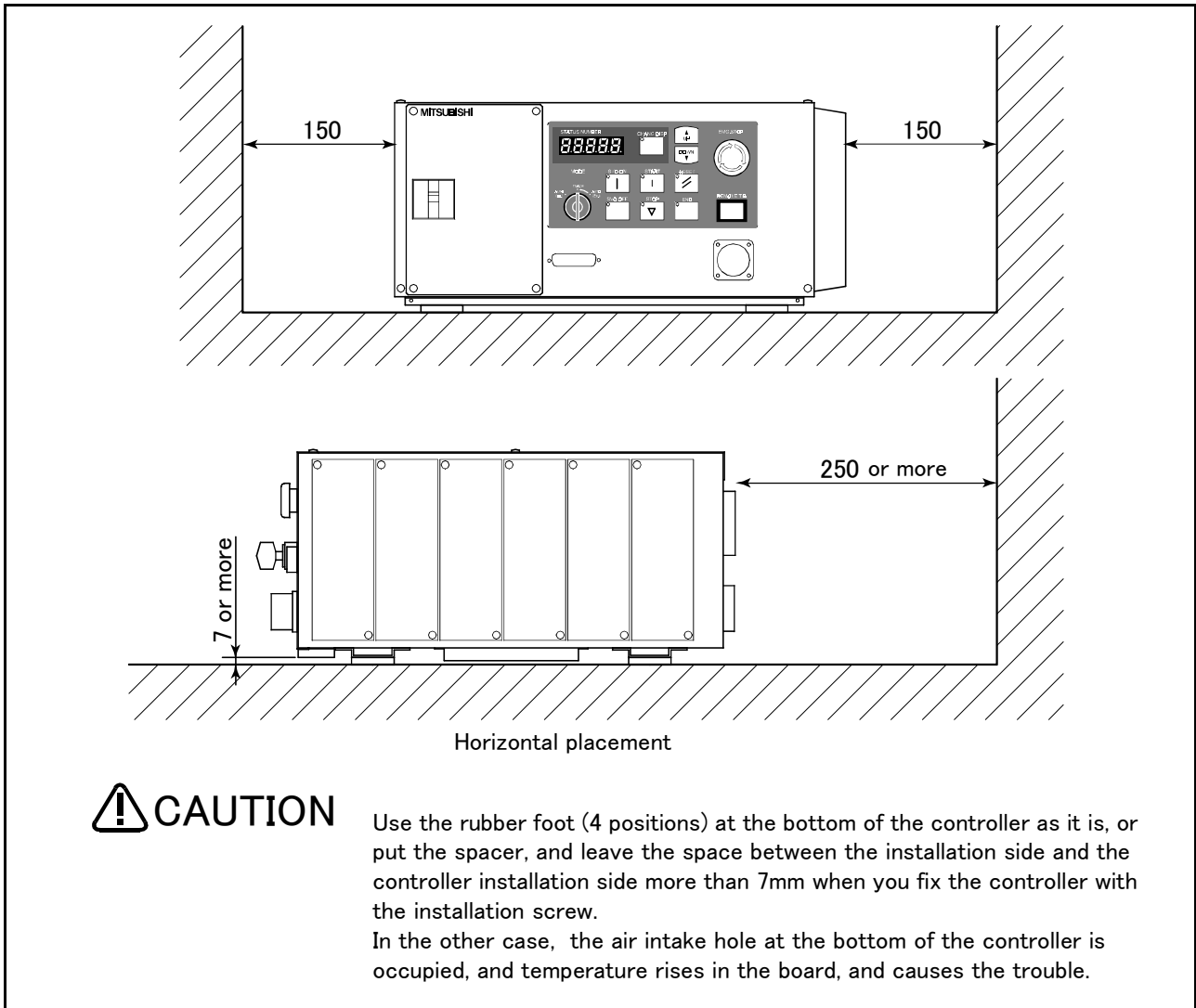

Fig.3-4 : Installation of controller

### 3.4 External input/output

#### 3.4.1 Types

- (1) Dedicated input/output.....These inputs and outputs carry out the robot remote operation and status display.
- (2) General-purpose input/output.....These are inputs and outputs that the customer can program for peripheral device control.
- (3) Hand input/output.....These are inputs and outputs related to the hand that the customer can program. (The hand output is an option. The [Page 76, "\(2\) Pneumatic hand interface"](#) is required.)

Class	Name	No. of input/output points		Connection format
		Input	Output	
Standard	Emergency stop	1	1	Terminal block
Standard	Door switch	1		
Standard	Parallel input/output	Occupies 32 general-purpose points/(6) dedicated points in general-purpose	Occupies 32 general-purpose points/(4) dedicated points in general-purpose	Connector

#### 3.4.2 Explanation

The parallel input/output unit uses connector bridging. Purchase the "External I/O cable" for connection with external devices.

The hand output is an option. Refer to [Page 76, "\(2\) Pneumatic hand interface"](#) for details

The parallel input/output unit can be expanded outside of the controller.

The expansion parallel input/output unit is connected with the control unit in the controller using a robot I/O link cable. Parallel input and output units can be expand as an option to seven maximums. With allows up to input 256 points and output 256 points of maximums can be used including 32 points input and 32 points output of standard.

Refer to [Page 81, "\(4\) Parallel I/O unit"](#) for details on the parallel input/output unit.

### 3.5 Dedicated input/output

Show the main function of dedicated input/output in the [Table 3-2](#). Refer to attached instruction manual “CR1/CR2/CR4/CR7/CR8 Controller Detailed explanations of functions and operations” in the product for the other functions. Each parameter indicated with the parameter name is used by designated the signal No., assigned in the order of input signal No. and output signal No. If the number of dedicated inputs and general-purpose input points used exceeds the standard No. of input/output points, install the parallel input/output unit (1st to 7th station: option).

Table 3-2 : Dedicated input/output list

Parameter name	Input <small>Note1)</small>			Output	
	Name	Function	Level	Name	Function
TEACHMD	None			Teaching mode output signal	Outputs that the teaching mode is entered.
ATTOPMD	None			Automatic mode output signal	Outputs that the automatic mode is entered.
ATEXTMD	None			Remote mode output signal	Outputs that the remote mode is entered.
AUTOENA	Automatic operation enabled input signal	Disables automatic operation when inactive, and enables automatic operation when active.	L	Automatic operation enabled output signal	Outputs the automatic operation enabled state.
START	Start input signal	Starts all slots.	E	Operating output signal	Outputs that the slot is operating.
STOP	Stop input signal	Stops all slots. The input signal No. is fixed to 0. Note) Use the emergency stop input for stop inputs related to safety.	L	Wait output signal	Outputs that the slot is temporarily stopped.
SLOTINIT	Slot initialization input signal	Resets the wait state, and initializes all slots.	E	Program selection enabled output signal	Outputs that the slot is in the program selection enabled state.
ERRRESET	Error reset input signal	Resets the error state.	E	Error occurring output signal	Outputs that an error has occurred.
CYCLE	Cycle stop input signal	Carries out cycle stop.	E	In cycle stop operation output signal	Outputs that the cycle stop is operating.
SRVOFF	Servo ON enabled input signal	Sets all mechanisms to servo ON enabled.	L	Servo ON enabled output signal	Outputs the servo ON enabled state. (Echo back)
SRVON	Servo ON input signal	Turns the servo ON for all mechanisms.	E	In servo ON output signal	Outputs the servo ON state.
IOENA	Operation rights input signal	Requests the operation rights for the external signal control.	E	Operation rights output signal	Outputs the operation rights valid state for the external signal control.
MELOCK	Machine lock input signal	Sets/resets the machine lock state for all mechanisms.	E	In machine lock output signal	Outputs the machine lock state.
SAFEPOS	Evasion point return input signal	Requests the evasion point return operation.	E	In evasion point return output signal	Outputs that the evasion point return is taking place.
OUTRESET	General-purpose output signal reset	Resets the general-purpose output signal.	E	None	
EMGERR	None			Emergency stop output signal	Outputs that an emergency stop has occurred.
S1START : S32START	Start input	Starts each slot.	E	In operation output	Outputs the operating state for each slot.
S1STOP : S32STOP	Stop input	Stops each slot.	L	In wait output	Outputs that each slot is temporarily stopped.
PRGSEL	Program selection input signal	esignates the setting value for the program No. with numeric value input signals.	E	None	
OVRDSEL	Override selection input signal	esignates the setting value for the override with the numeric value input signals.	E	None	



Parameter name	Input <span style="float: right;">Note1)</span>			Output	
	Name	Function	Level	Name	Function
IODATA Note2)	Numeric value input (start No., end No.)	Used to designate the program No., override value., mechanism value.	L	Numeric value output (start No., end No.)	Used to output the program No., override value., mechanism No.
PRGOUT	Program No. output request	Requests output of the program No.	E	Program No. output signal	Outputs that the program No. is being output to the numeric value output signal.
LINEOUT	Line No. output request	Requests output of the line No.	E	Line No. output signal	Outputs that the line No. is being output to the numeric value output signal.
OVRDOUT	Override value output request	Requests the override output.	E	Override value output signal	Outputs that the override value is being output to the numeric value output signal.
ERROUT	Error No. output request	Requests the error No. output.	E	Error No. output signal	Outputs that the error No. is being output to the numeric value output signal.
JOGENA	Jog valid input signal	Validates jog operation with the external signals	E	Jog valid output signal	Outputs that the jog operation with external signals is valid.
JOGM	Jog mode input 2-bit	Designates the jog mode.	L	Jog mode output 2-bit	Outputs the current jog mode.
JOG+	Jog feed + side for 8-axes	Requests the + side jog operation.	L	None	
JOG-	Jog feed - side for 8-axes	Requests the - side jog operation.	L	None	
HNDERR1 : HNDERR5	Mechanism 1 hand error input signal : Mechanism 5 hand error input signal	Requests the hand error occurrence.	L	Mechanism 1 hand error output signal : Mechanism 5 hand error output signal	Outputs that a hand error is occurring.
AIRERR1 : AIRERR5	Mechanism 1 pneumatic pressure error input signal : Mechanism 5 pneumatic pressure error input signal	Request the pneumatic pressure error occurrence.	L	Mechanism 1 pneumatic pressure error output signal. : Mechanism 5 pneumatic pressure error output signal.	Outputs that a pneumatic pressure error is occurring.
USER-AREA <sup>Note3)</sup>	None			User-designated area 8-points	Outputs that the robot is in the user-designated area.

Note1) The level indicates the signal level.

L: Level signal → The designated function is validated when the signal is ON, and is invalidated when the signal is OFF.

E: Edge signal → The designated function is validated when the signal changes from the OFF to ON state, and the function maintains the original state even when the signal then turns OFF.

Note2) Four elements are set in the order of input signal start No., end No., output signal start No. and end No.

Note3) Up to eight points can be set successively in order of start output signal No. and end output signal No.

### 3.6 Emergency stop input/output

This signal is input from the "emergency stop input" terminal in the controller.

Table 3-3 : Dedicated input terminals in controller

Class	Name	Details
Input	Emergency stop	Applies the emergency stop (Dual emergency line.)
Input	Door switch	The servo turns OFF.
Output	Emergency stop	This output indicates that the emergency stop input or the door switch input is turned on.

#### 3.6.1 Connection of the external emergency stop

The external emergency stop input and door switch input are short-circuited with a short cable at shipment as shown in Fig. 3-5.

Connect the external emergency stop switch and door switch with the following procedure.

- 1) Prepare the "emergency stop switch" and "door switch".
- 2) Remove the two short pieces 1 and 2.
- 3) Securely connect the external emergency stop's contacts across "1)-2)", and the door switch's contacts across 3)-4)" on the terminal block.

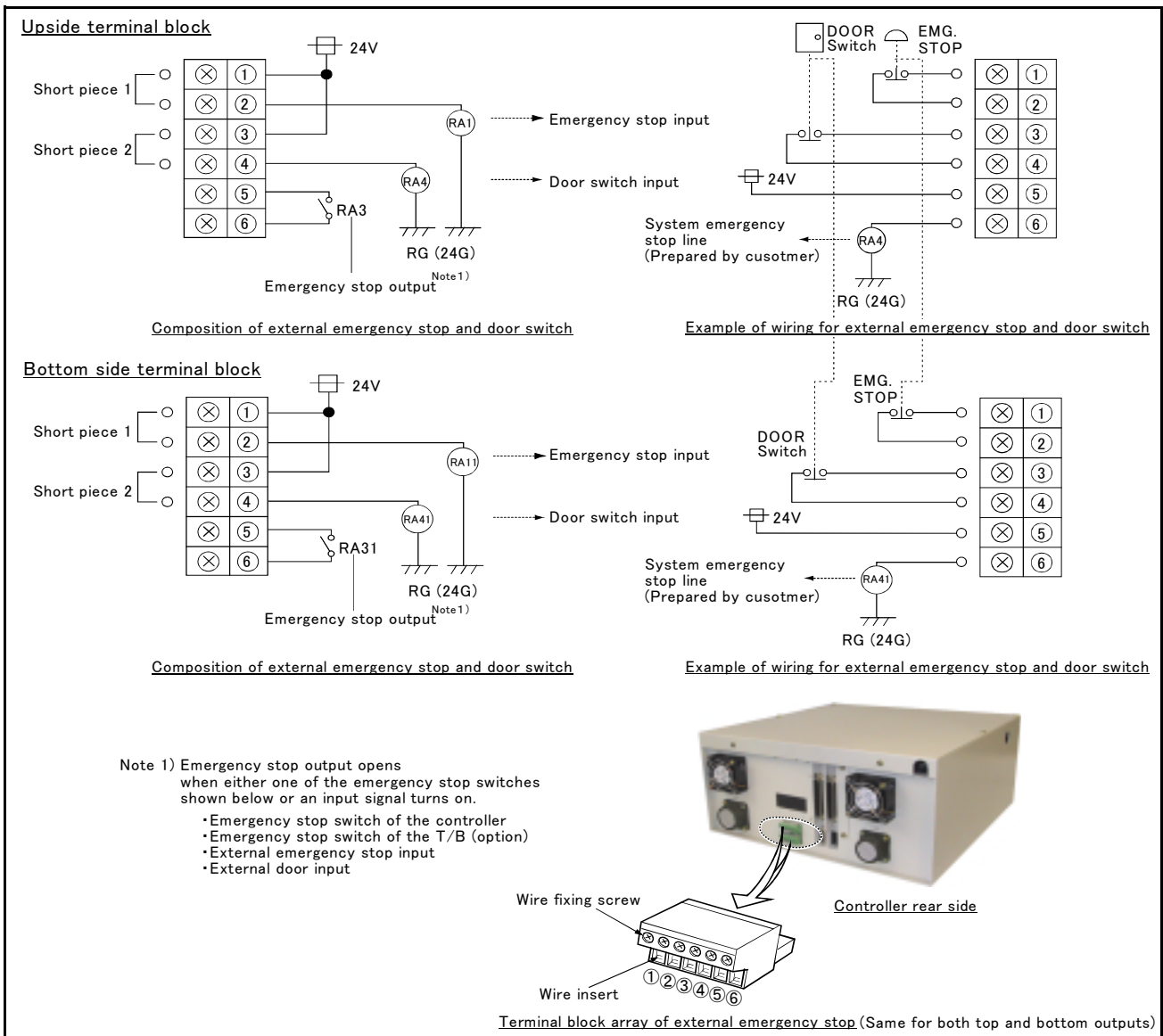

Fig.3-5 : Connection of the external emergency stop

[Note] Refer to Page 109, "5.1.7 Examples of safety measures" together, and carry out wiring to the emergency stop.

### 3.6.2 Door switch function

This function retrieves the status of the switch installed on the door of the safety fence, etc., and stops the robot when the door is opened. This differs from an emergency stop in that the servo turns OFF when the door is opened and an error does not occur. Follow the wiring example shown in Fig. 3-5, and wire so that the contact closes when the door is closed. Details of this function according to the robot status are shown below.

▪During automatic operation ..... When the door is opened, the servo turns OFF and the robot stops. An error occurs.

The process of the restoration : Close the door, reset the alarm, turn on the servo, and restart

▪During teaching ..... Even when the door is opened, the servo can be turned ON and the robot moved using the teaching pendant.

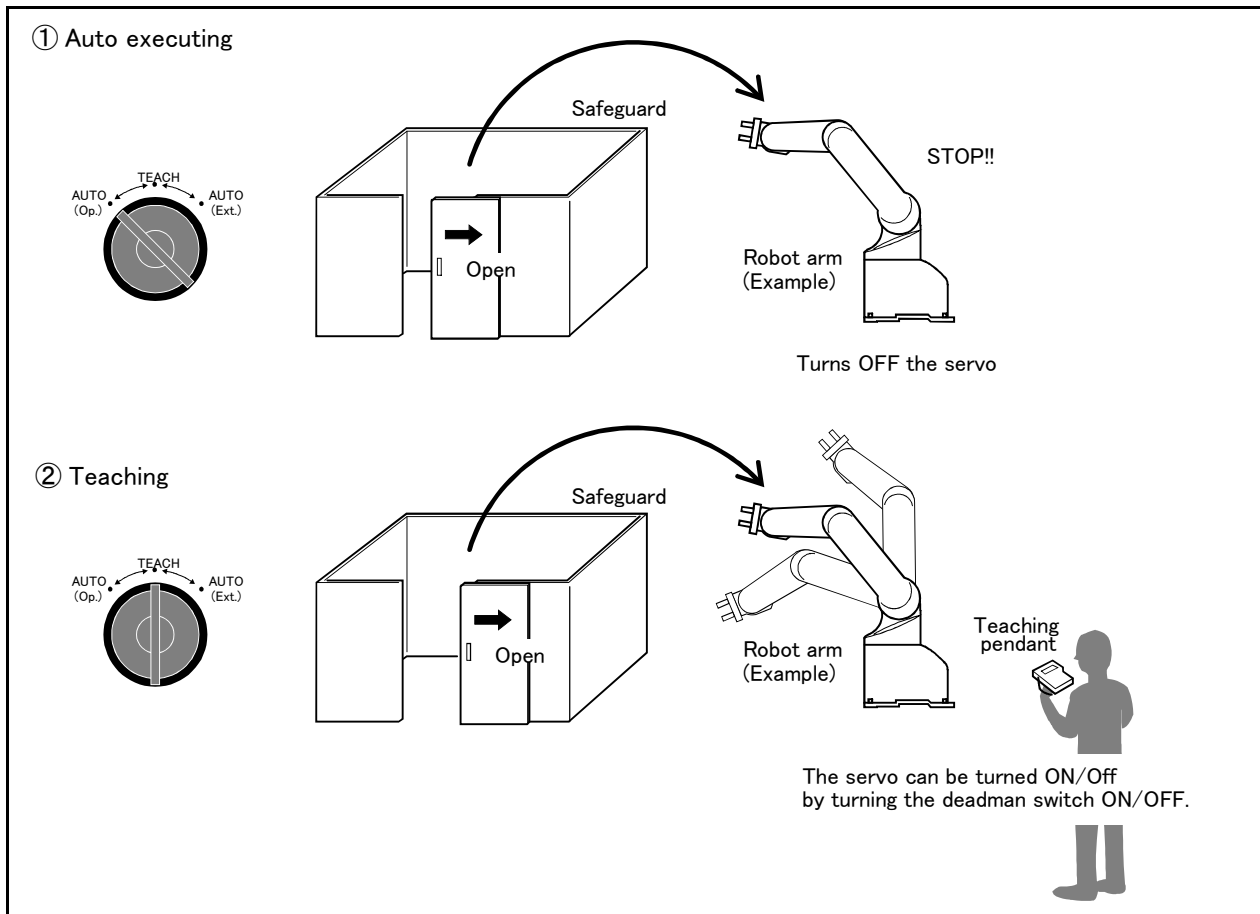

Fig.3-6 : Door switch function

### 3.7 Parallel input/output unit

- A parallel input/output card is mounted as a standard in the controller's control unit.
- The external input/output circuit specifications are shown in Table 3-4 and Table 3-5.
- The correspondence of the external input/output connector pin No. and the colors of the connected "external input/output cable" wires (separate option) is as shown in Page 70, "Table 3-6" and Table 3-7. Refer to Page 89, "(5) External I/O cable" for details of external I/O cable.
- Pin Nos. described as both general-purpose signal and dedicated signal can be shared.
- The other dedicated input/output signals that are not assigned can be assigned to required general-purpose input/output pins when creating the program.
- If the standard inputs and outputs are insufficient, install the parallel input/output unit connection option outside the controller.

Table 3-4 : Electrical specifications of input circuit

Item		Specifications	Internal circuit
Type		DC input	<p>&lt;Sink type&gt;</p> <p>&lt;Source type&gt;</p>
No. of input points		32	
Insulation method		Photo-coupler insulation	
Rated input voltage		12VDC/24VDC	
Rated input current		Approx. 3mA/approx. 7mA	
Working voltage range		10.2VDC to 26.4VDC(ripple rate within 5%)	
ON voltage/ON current		8VDC or more/2mA or more	
OFF voltage/OFF current		4VDC or less/1mA or less	
Input resistance		Approx. 3.3kΩ	
Response time	OFF-ON	10ms or less(DC24V)	
	ON-OFF	10ms or less(DC24V)	
Common method		8 points per common	
External wire connection method		Connector	

Table 3-5 : Electrical specifications of output circuit

Item		Specifications	Internal circuit
Type		Transistor output	<p>&lt;Sink type&gt;</p> <p>&lt;Source type&gt;</p>
No. of output points		32	
Insulation method		Photo-coupler insulation	
Rated load voltage		DC12V/DC24V	
Rated load voltage range		DC10.2 ~ 30V(peak voltage 30VDC)	
Max. load current		0.1A/point (100%)	
Leakage current at OFF		0.1mA or less	
Max. voltage drop at ON		DC0.9V(TYP.)	
Response time	OFF-ON	2ms or less (hardware response time)	
	ON-OFF	2ms or less (Resistance load) (hardware response time)	
Fuse rating		Fuse 3.2A (one per common) Replacement not possible	
Common method		4 points per common (common terminal: 4 points)	
External wire connection method		Connector	
External power supply	Voltage	DC12/24V(DC10.2 ~ 30V)	
	Current	60mA (TYP. 24VDC per common) (base drive current)	

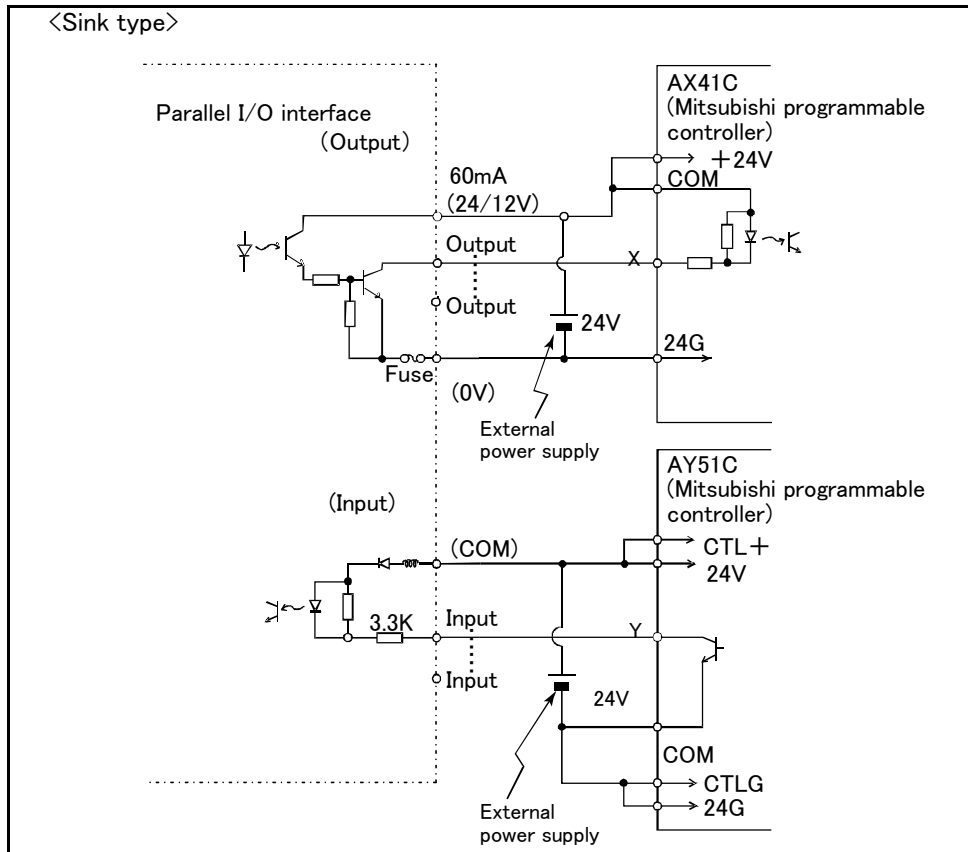

Fig.3-7 : Connection with a Mitsubishi PLC (Example of sink type)

\*The input/output circuit external power supply (24 VDC) must be prepared by the customer.

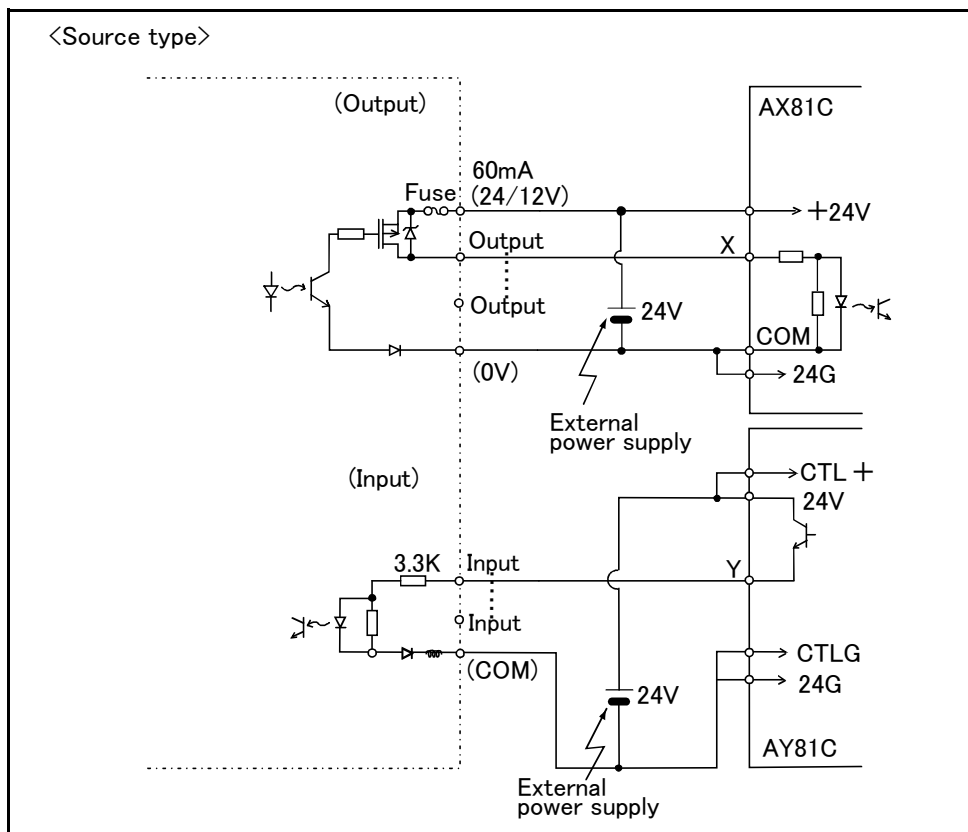

Fig.3-8 : Connection with a Mitsubishi PLC (Example of source type)

\*The input/output circuit external power supply (24 VDC) must be prepared by the customer.

Table 3-6 : Standard parallel I/O interface CN100pin No. and signal assignment list (2A-CBL □□ )

Pin No.	Line color	Function name		Pin No.	Line color	Function name	
		General-purpose	Dedicated/power supply, common			General-purpose	Dedicated/power supply, common
1	Orange/Red A		FG	26	Orange/Blue A		FG
2	Gray/Red A		0V:For pins 4-7	27	Gray/Blue A		0V:For pins 29-32
3	White/Red A		12V/24V:For pins 4-7	28	White/Blue A		12V/24V:For pins 29-32
4	Yellow/Red A	General-purpose output 0	Running	29	Yellow/Blue A	General-purpose output 4	
5	Pink/Red A	General-purpose output 1	Servo on	30	Pink/Blue A	General-purpose output 5	
6	Orange/Red B	General-purpose output 2	Error	31	Orange/Blue B	General-purpose output 6	
7	Gray/Red B	General-purpose output 3	Operation rights	32	Gray/Blue B	General-purpose output 7	
8	White/Red B		0V:For pins 10-13	33	White/Blue B		0V:For pins 35-38
9	Yellow/Red B		12V/24V:For pins 10-13	34	Yellow/Blue B		12V/24V:For pins 35-38
10	Pink/Red B	General-purpose output 8		35	Pink/Blue B	General-purpose output 12	
11	Orange/Red C	General-purpose output 9		36	Orange/Blue C	General-purpose output 13	
12	Gray/Red C	General-purpose output 10		37	Gray/Blue C	General-purpose output 14	
13	White/Red C	General-purpose output 11		38	White/Blue C	General-purpose output 15	
14	Yellow/Red C		COM0:For pins 15-22 <sup>Note1)</sup>	39	Yellow/Blue C		COM1:For pins 40-47 <sup>Note1)</sup>
15	Pink/Red C	General-purpose input 0	Stop(All slot) <sup>Note2)</sup>	40	Pink/Blue C	General-purpose input 8	
16	Orange/Red D	General-purpose input 1	Servo off	41	Orange/Blue D	General-purpose input 9	
17	Gray/Red D	General-purpose input 2	Error reset	42	Gray/Blue D	General-purpose input 10	
18	White/Red D	General-purpose input 3	Start	43	White/Blue D	General-purpose input 11	
19	Yellow/Red D	General-purpose input 4	Servo on	44	Yellow/Blue D	General-purpose input 12	
20	Pink/Red D	General-purpose input 5	Operation rights	45	Pink/Blue D	General-purpose input 13	
21	Orange/Red E	General-purpose input 6		46	Orange/Blue E	General-purpose input 14	
22	Gray/Red E	General-purpose input 7		47	Gray/Blue E	General-purpose input 15	
23	White/Red E		Reserved	48	White/Blue E		Reserved
24	Yellow/Red E		Reserved	49	Yellow/Blue E		Reserved
25	Pink/Red E		Reserved	50	Pink/Blue E		Reserved

Note1)Sink type:24V/12V(COM), Source type:0V(COM)

Note2)The assignment of the dedicated input signal "STOP" is fixed.

Table 3-7 : Standard parallel I/O interface CN300pin No. and signal assignment list (2A-CBL □□ )

Pin No.	Line color	Function name		Pin No.	Line color	Function name	
		General-purpose	Dedicated/power supply, common			General-purpose	Dedicated/power supply, common
1	Orange/Red A		FG	26	Orange/Blue A		FG
2	Gray/Red A		0V:For pins 4-7	27	Gray/Blue A		0V:For pins 29-32
3	White/Red A		12V/24V:For pins 4-7	28	White/Blue A		12V/24V:For pins 29-32
4	Yellow/Red A	General-purpose output 16		29	Yellow/Blue A	General-purpose output 20	
5	Pink/Red A	General-purpose output 17		30	Pink/Blue A	General-purpose output 21	
6	Orange/Red B	General-purpose output 18		31	Orange/Blue B	General-purpose output 22	
7	Gray/Red B	General-purpose output 19		32	Gray/Blue B	General-purpose output 23	
8	White/Red B		0V:For pins 10-13	33	White/Blue B		0V:For pins 35-38
9	Yellow/Red B		12V/24V:For pins 10-13	34	Yellow/Blue B		12V/24V:For pins 35-38
10	Pink/Red B	General-purpose output 24		35	Pink/Blue B	General-purpose output 28	
11	Orange/Red C	General-purpose output 25		36	Orange/Blue C	General-purpose output 29	
12	Gray/Red C	General-purpose output 26		37	Gray/Blue C	General-purpose output 30	
13	White/Red C	General-purpose output 27		38	White/Blue C	General-purpose output 31	
14	Yellow/Red C		COM0:For pins 15-22 <sup>Note1)</sup>	39	Yellow/Blue C		COM1:For pins 40-47 <sup>Note1)</sup>
15	Pink/Red C	General-purpose input 16		40	Pink/Blue C	General-purpose input 24	
16	Orange/Red D	General-purpose input 17		41	Orange/Blue D	General-purpose input 25	
17	Gray/Red D	General-purpose input 18		42	Gray/Blue D	General-purpose input 26	
18	White/Red D	General-purpose input 19		43	White/Blue D	General-purpose input 27	
19	Yellow/Red D	General-purpose input 20		44	Yellow/Blue D	General-purpose input 28	
20	Pink/Red D	General-purpose input 21		45	Pink/Blue D	General-purpose input 29	
21	Orange/Red E	General-purpose input 22		46	Orange/Blue E	General-purpose input 30	
22	Gray/Red E	General-purpose input 23		47	Gray/Blue E	General-purpose input 31	
23	White/Red E		Reserved	48	White/Blue E		Reserved
24	Yellow/Red E		Reserved	49	Yellow/Blue E		Reserved
25	Pink/Red E		Reserved	50	Pink/Blue E		Reserved

Note1)Sink type:24V/12V(COM), Source type:0V(COM)

- The signals assigned as dedicated inputs can be used as general-purpose inputs during program execution. Note that for safety proposes, these should not be shared with the general-purpose inputs other than for numeric value inputs. The signals assigned as dedicated outputs cannot be used in the program. An alarm will occur during operation if used.

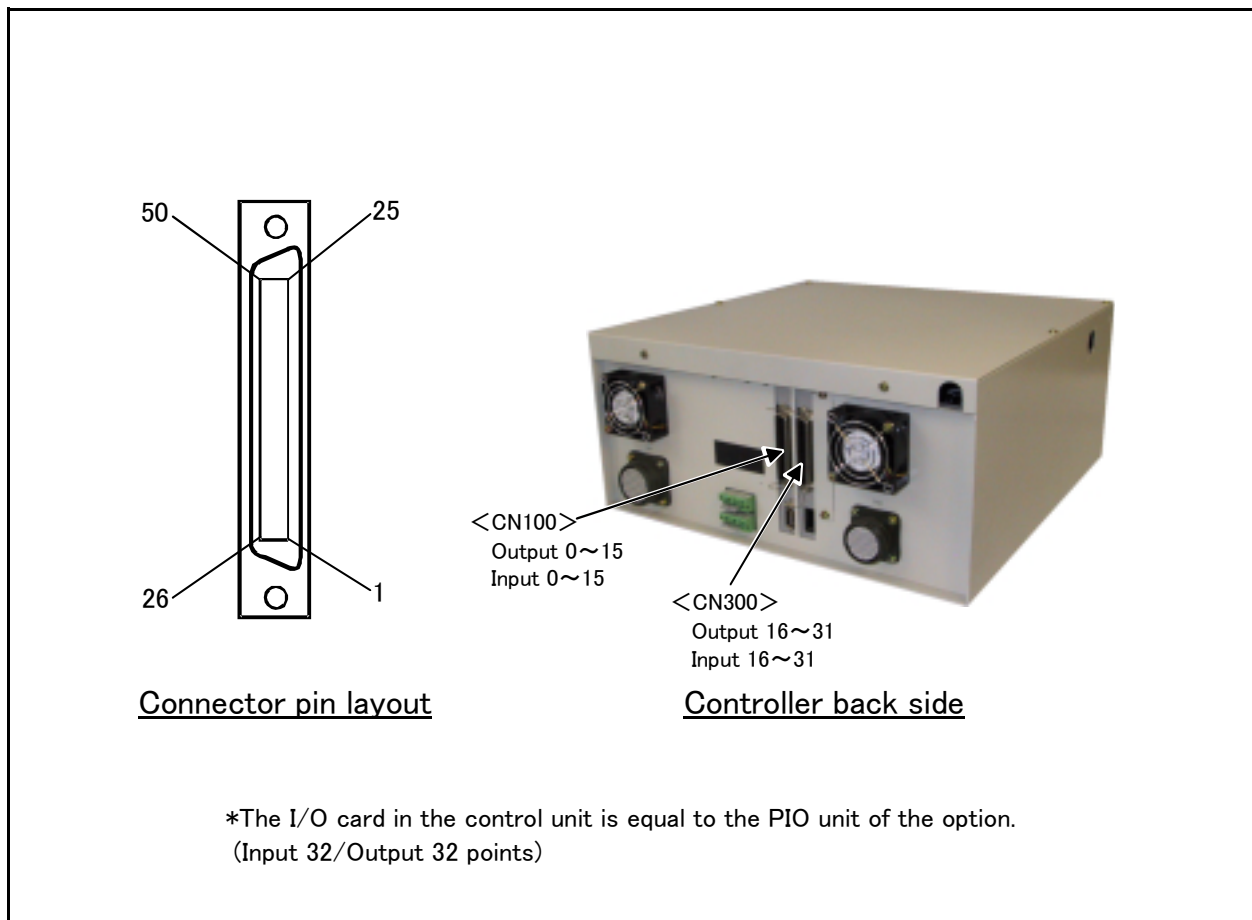

Fig.3-9 : Parallel input/output unit (in the control unit) connection and pin layout

### 3.8 Options

■ What are options?

There are a variety of options for the robot designed to make the setting up process easier for user needs.

User installation is required for the options.

Options come in two types: "set options" and "single options".

1. Set options.....A combination of single options and parts that together, form a set for serving some purpose.
2. Single options.....That are configured from the fewest number of required units of a part. Please choose user's purpose additionally.



## (1) Teaching pendant (T/B)

- Order type: R28TB :Cable length 7m
- R28TB-15 :Cable length 15m

Note) There is a cable length 15m as special specification. Confirm the delivery date.

## ■ Outline



This is used to create, edit and control the program, teach the operation position and for jog feed, etc.

For safety proposes, a 3-position deadman switch is mounted.<sup>Note1)</sup>

If there are several robots, one teaching pendant can be used by connecting it to the respective robot.

## ■ Configuration

Table 3-8 : Configuration device

Part name	Type	Qty.	Remarks
Teaching pendant	R28TB	Either one pc.	Cable length is 7m. Hand strap is attached.
	R28TB-15		Cable length is 15m. Hand strap is attached.

## ■ Specifications

Table 3-9 : Specifications

Items	Specifications	Remarks
Outline dimensions	95(W) x 236(H) x 34(D) (refer to outline drawing)	
Body color	Light gray (reference Munsell color: 7.65Y7.64/0.73)	
Mass	Approx. 0.5kg (only arm, excluding cable)	
Connection method	Connection with controller and round connector (30-pin)	
Interface	RS-422	
Display method	LCD method: 16 characters x 4 lines, LCD illumination: with backlight	
Operation section	28 keys	
Protection specifications	IP65	Note2)

Note2) The manual operation section of the teaching pendant has a protection method that complies with the IEC Standards IP65 (protection type).

[Reference] The IEC Standards IP65 refers to installing the test device in the testing room, and suspending talc powder, which passes through a nominal dimension  $75\mu\text{m}$  mesh sieve, as specified with JISZ8001 (standard sieve). This powder is continuously suspended around the device at a rate of 2kg per  $1\text{m}^3$  volume of the testing room. The air in the testing device is discharged at a discharge rate less than 60-times the volume per hour. When the air is discharged at 80-times the test device capacity, the talc powder does not accumulate inside the test device even after eight hours.

## Note1) &lt;3-position deadman switch&gt;

In ISO/10218 (1992) and JIS-B8433 (1993), this is defined as an "enable device". These standards specify that the robot operation using the teaching pendant is enabled only when the "enable device" is at a specified position. With the Mitsubishi Electric industrial robot, the above "enable device" is configured of an "Enable/Disable switch" and "Deadman switch".

The 3-position deadman switch has three statuses. The following modes are entered according to the switch state.

"Not pressed" .....The robot does not operate. \*)

"Pressed lightly" .....The robot can be operated and teaching is possible.

"Pressed with force" .....The robot does not operate. \*)

\*) Operations, such as program editing and status display, other than robot operation are possible.

Safety is secured as the servo power is turned OFF simultaneously with the input of the emergency stop.

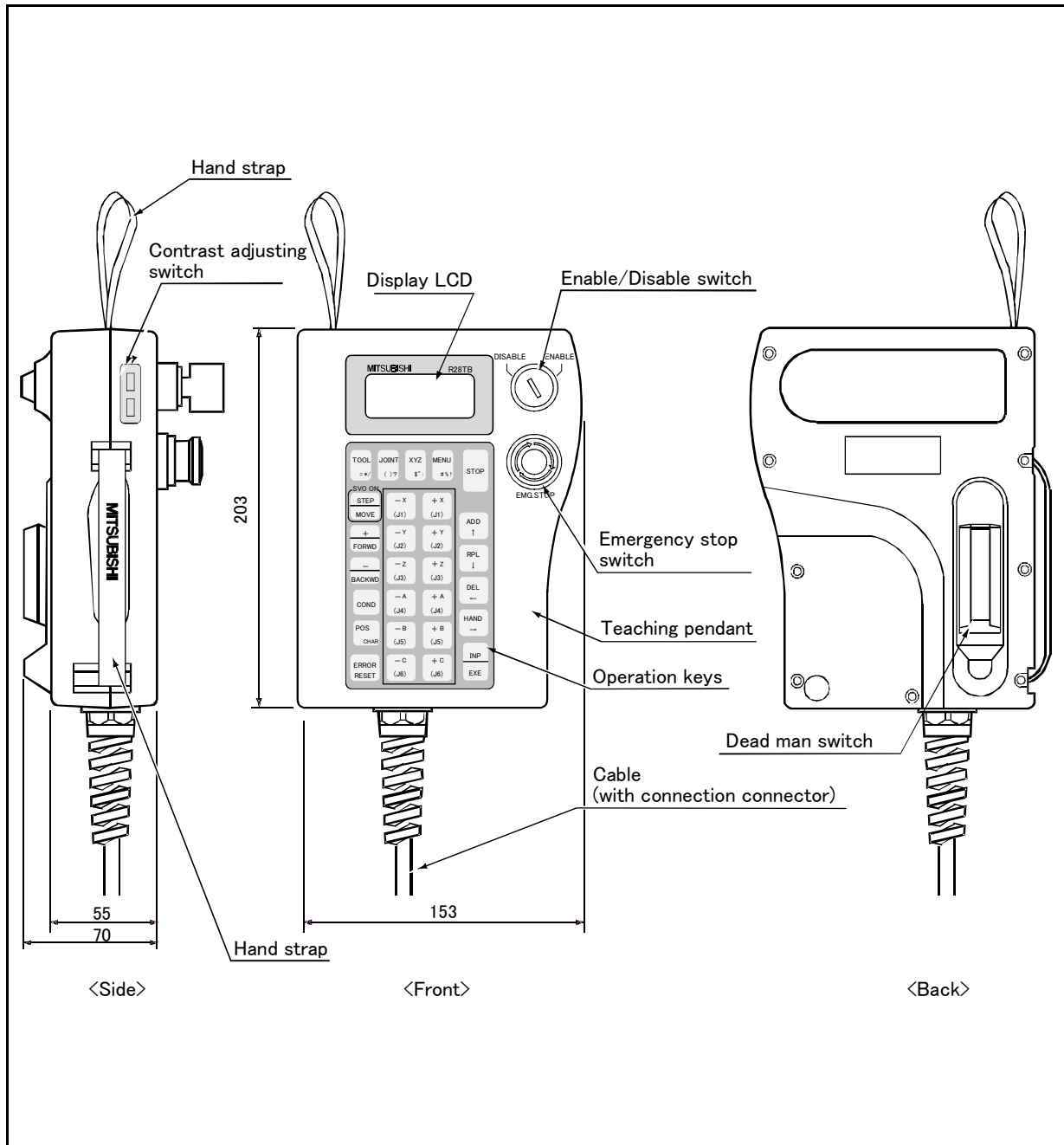

Fig.3-10 : Outside dimensions of teaching pendant

■ Installation method

The teaching pendant is connected to the T/B connector on the front of the controller.

## ■ Key layout and main functions

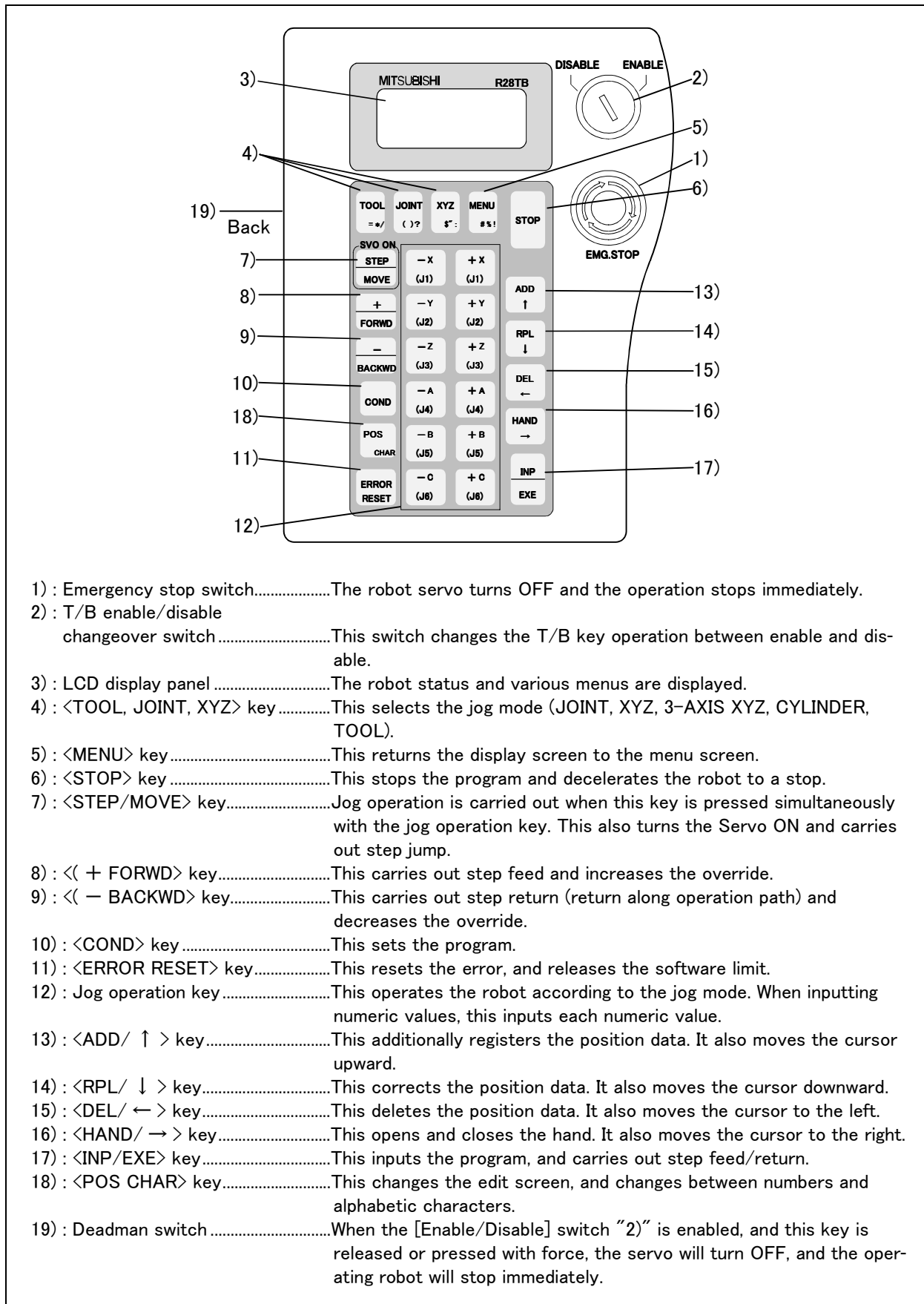

Fig.3-11 : Teaching pendant key layout and main functions

(2) Pneumatic hand interface

- Order type: 2A-RZ365(Sink type)  
2A-RZ375(Source type)

Outline



This interface is required to use the robot arm's hand output signals.

- Up to eight hand output points can be used with this interface.
- The eight hand input points can be used without this interface.
- When using more than eight hand input/output points, install the "Parallel I/O unit". Refer to Page 81, "Parallel I/O unit" for detail.

Configuration

Table 3-10 : Configuration device

Part name	Type	Qty.	Remarks
Pneumatic hand interface	2A-RZ365/ 2A-RZ375	1pc.	Output 8 point expansion. 2A-RZ365 is the sink type. 2A-RZ375 is the source type.

Specifications

Table 3-11 : Specifications

Item	Specification	Internal circuit	
Type	Transistor output	<p>&lt;Sink type&gt;</p> <p>&lt;Source type&gt;</p> <p>* GRn = GR1 ~ GR8</p>	
No. of output points	8		
Insulation method	Photo coupler insulation		
Rated load voltage	DC24V		
Rated load voltage range	DC21.6 to 26.4VDC		
Max. current load	0.1A/ 1 point (100%)		
Current leak with power OFF	0.1mA or less		
Maximum voltage drop with power ON	DC0.9V(TYP.)		
Response time	OFF-ON		2ms or less (hardware response time)
	ON-OFF		2 ms or less (resistance load) (hardware response time)
Fuse rating	Fuses 1.6A (each one common)		
Common method	8 points, 1 common		
External cable connection method	Connector (Connected from RZ326A/RZ327)		
Supply voltage	DC5V (Supplied from RZ326A/RZ327)		

### ■ Installation method

This is mounted on the control unit (RZ326A/RZ327 card) in the controller.

Securely insert the pneumatic hand interface (2A-RZ365/375) into the CNHNDOUT/CNHND connector on the control unit. Refer to separate "Instruction Manual/CR2/CR2A controller Controller setup, basic operation, and maintenance" for details on the installing method.

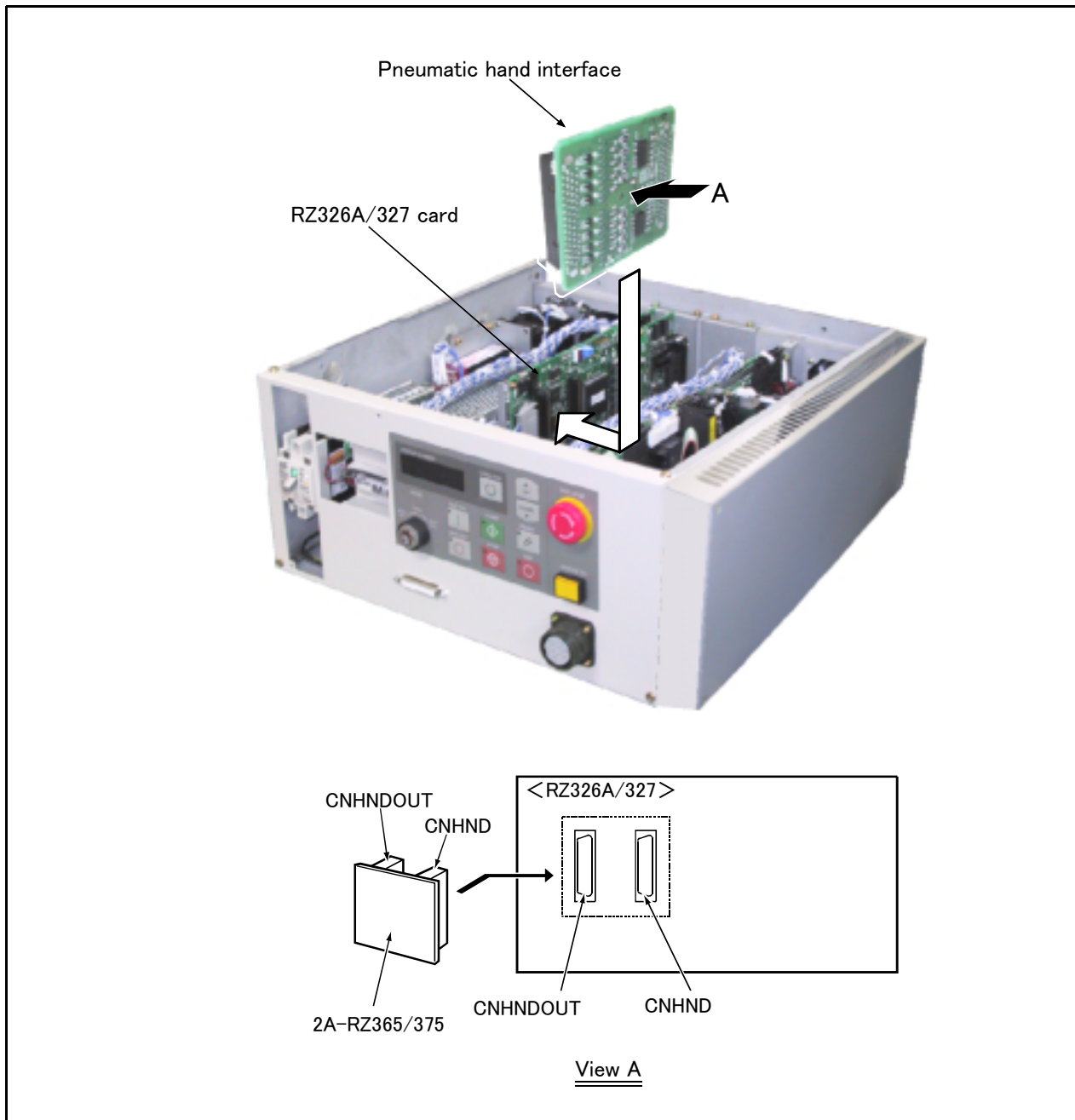

Fig.3-12 : Installation of pneumatic hand interface

Note)The hand output doesn't work correctly in the case of "RZ386" + "RZ365" or "RZ387" + "RZ375" combination.

Choose either of sink type/source type properly, and use it.

(3) Controller protection box

■ Order type : ● CR2A-MB

■ Outline

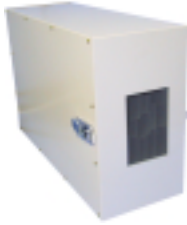

The controller protection box is used to protect the CR2A-572 controller from an oil mist or other operating environment. Put the controller in controller protection box, and use it. Since the front cover of the controller protection box can be removed, it is possible to operate the controller's front panel and to install and remove the T/B.

■ Configuration

Table 3-12 : Configuration device

Part name	Type	Qty.	Remarks
Controller protection box	CR2A-MB	1 unit	
Serial number posting label		1	
Protection seal transparent		1	Protection for the serial number posting label.
Cable tie		2	
Power supply wiring cable		1	For connecting the power relay terminal and the controller inside the box.
Grounding cable		1	For connecting the FG terminal and the controller inside the box.
Rubber foot installation screw	M4 × 10	4	For changing the rubber foot.
External emergency stop box (Controll box)	HW1X-BV402R	1 unit	Dual emergency line. Install at a location outside the controller protection box where operation can be performed easily. The outside dimensions is shown in Fig. 3-15.

■ Specifications

Table 3-13 : Specifications

Item	Unit	Specifications	Remarks
Outside dimensions	mm	276(W) × 646(D) × 500(H)	Excluding protrusions
Mass	Kg	16	
Structure		Self-contained floor type	IP54
Grounding		D class grounding earth	
Coating color		Light gray	Munsell 7.65Y7.64/0.73

- (1) The installation of the controller and wiring are constructed by customer.
- (2) Prepare the 2 power cable and 1 grounding cable (both AWG#14(2mm<sup>2</sup>) or more).

[Note] While the primary power supply is being supplied, the fan rotate through of ON/OFF of the controller power supply.

- (3) The emergency stop box does not come with a cable clamp (wiring connector). The cable clamp must be provided by the customer according to the size of the cable.

The following table shows recommended cable clamps for your reference.

Table 3-14 : Cable clamp for external emergency stop box (recommendation)

Type	JIS wiring tube	Adaptation cable outside diameter	Manufacturer
OA-W1606	G1/2	4 ~ 6 φ	OHM electric Corp
OA-W1608		6 ~ 8 φ	
OA-W1609		7 ~ 9 φ	
OA-W1611		9 ~ 11 φ	
OA-W1613		11 ~ 13 φ	

■ Names of each part

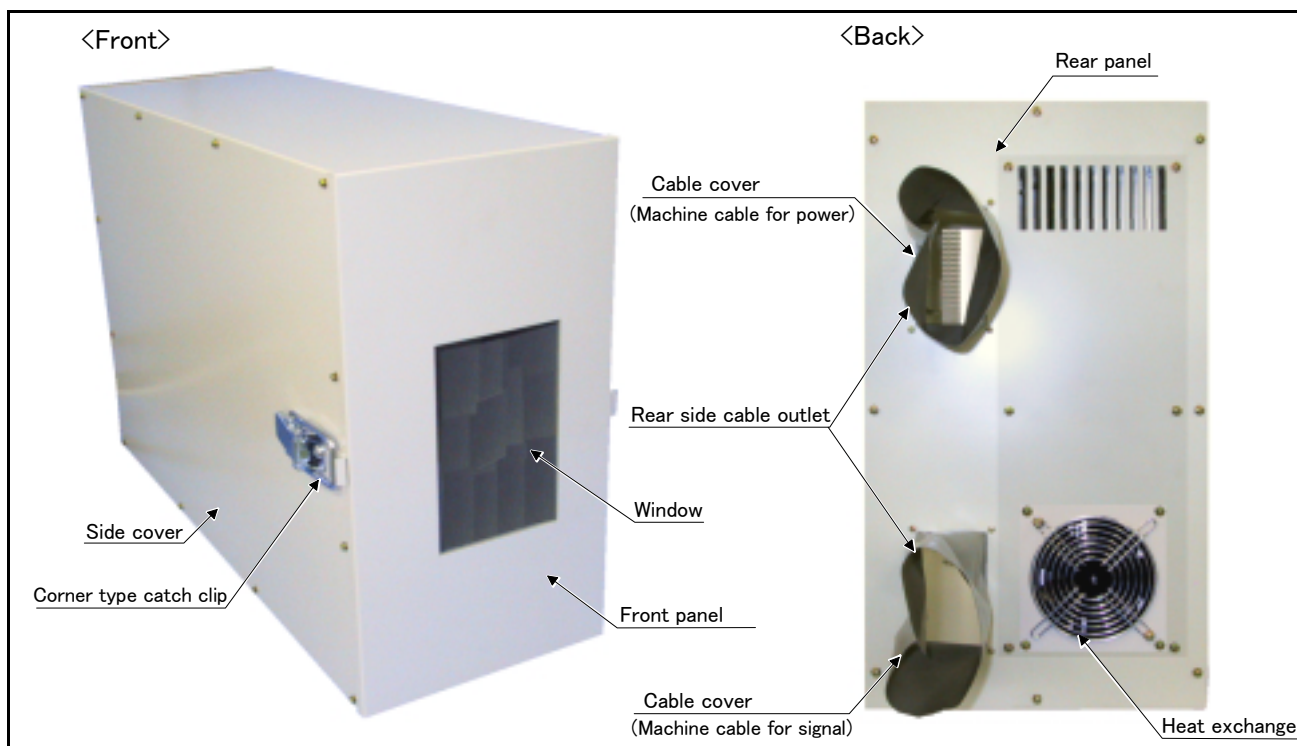

Fig.3-13 : Names of controller parts

■ The outside dimension and controller layout

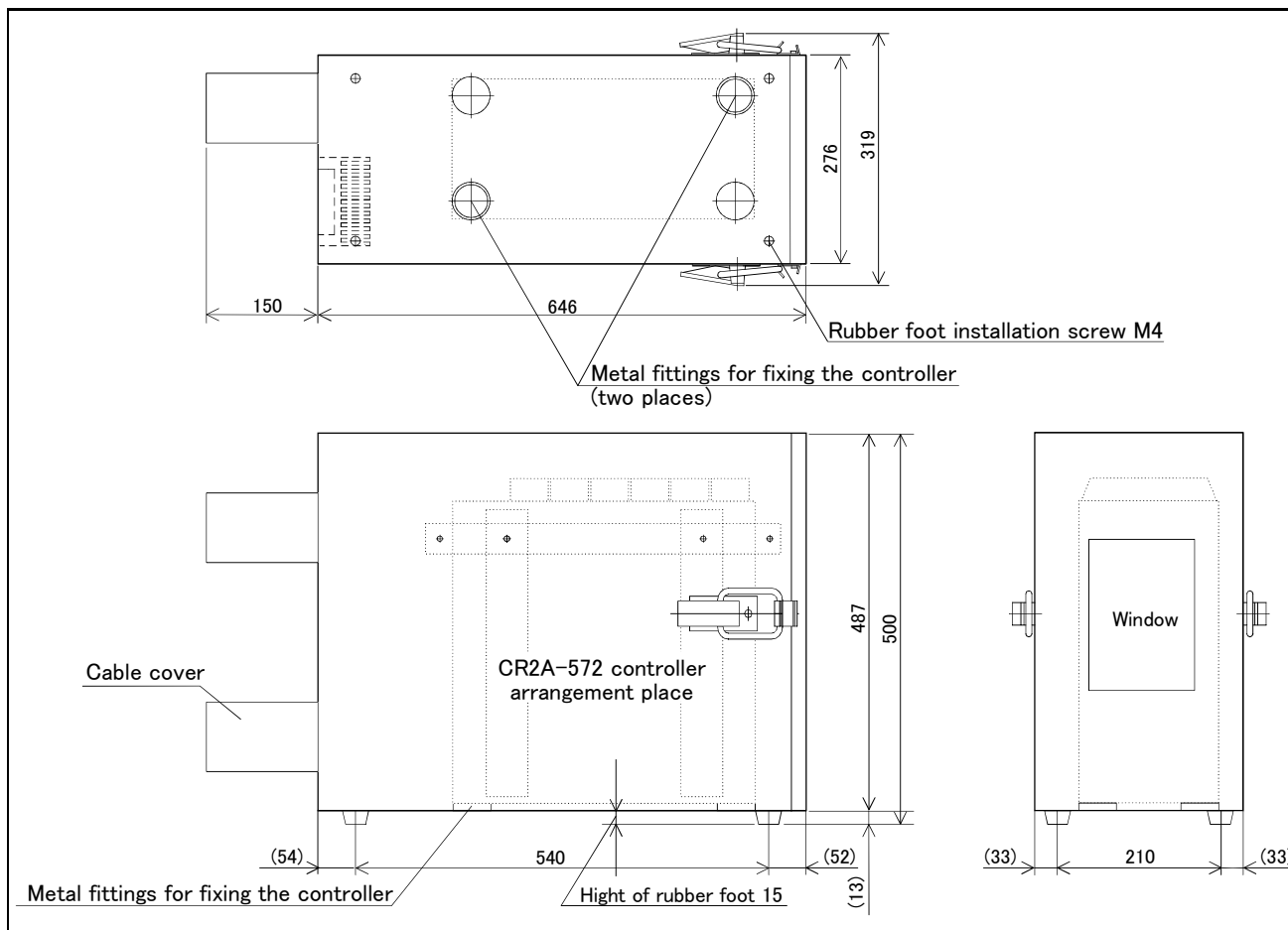

Fig.3-14 : The outside dimension and controller layout

■ The outside dimensions and installation dimensions of emergency stop box

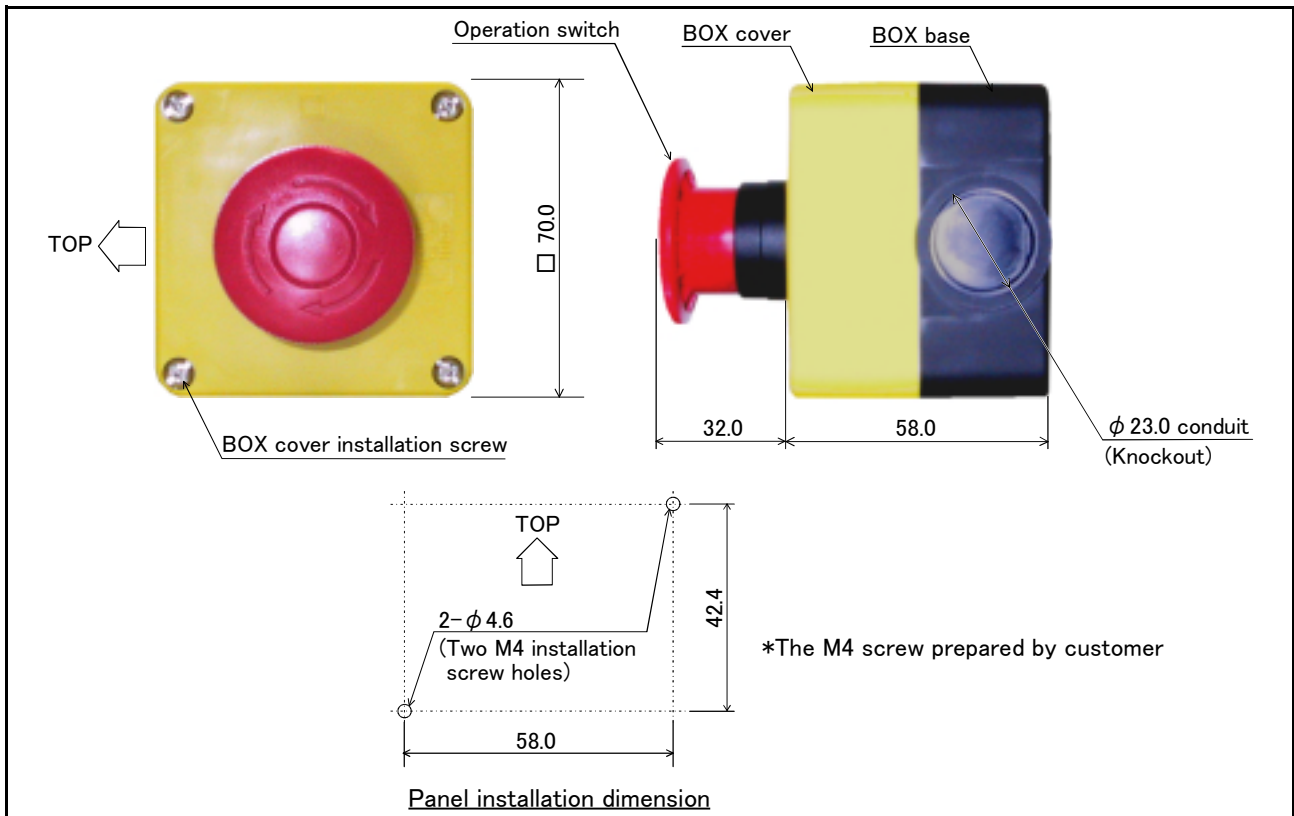

Fig.3-15 : The outside dimensions and installation dimensions of emergency stop box

■ Installation dimensions

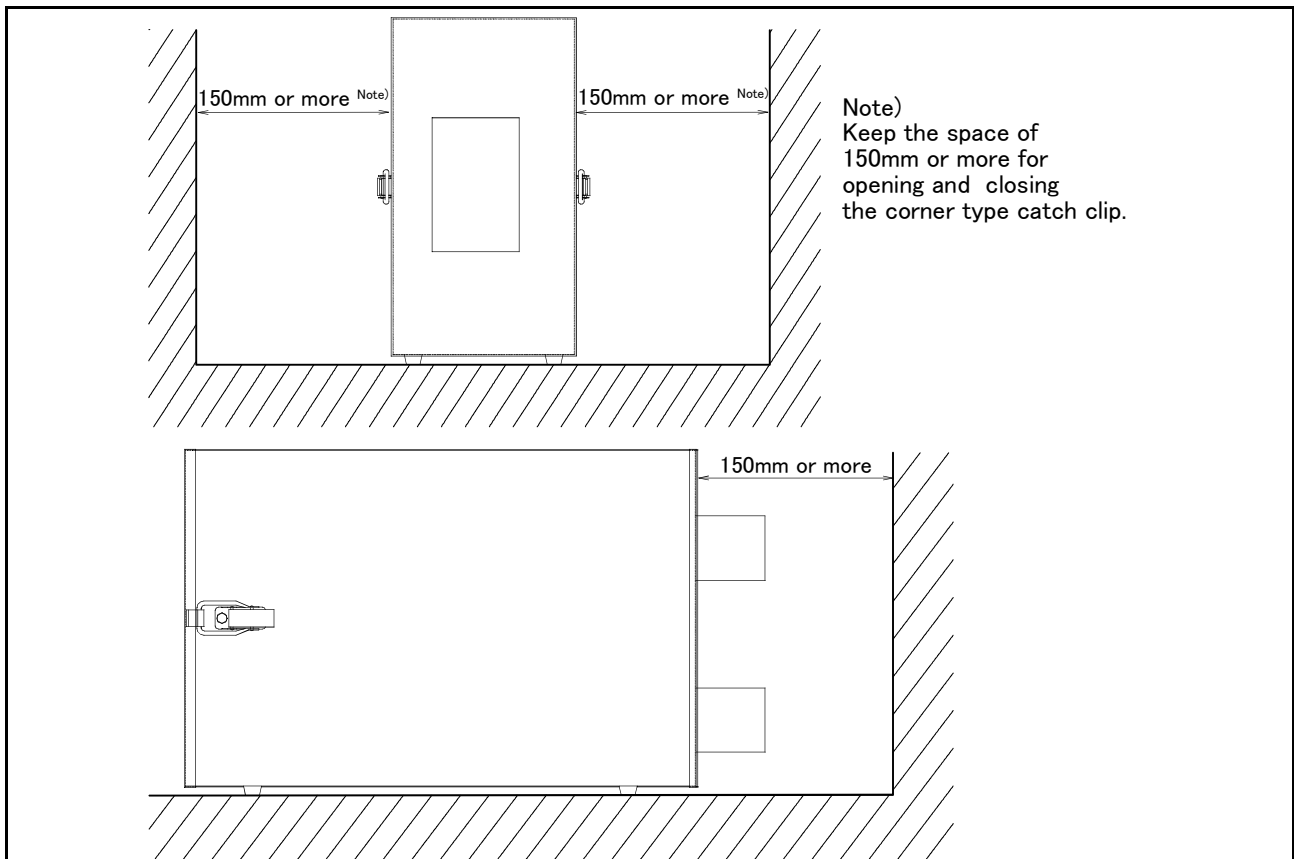

Fig.3-16 : Installation of controller



(4) Parallel I/O unit

- Order type: 2A-RZ361(Sink type)  
2A-RZ371(Source type)

Outline



This is used to expand the external inputs and outputs.

- The connection cable is not included. Prepare the optional external input/output cable (2A-CBL05 or 2A-CBL15).

Configuration

Table 3-15 : Configuration device

Part name	Type	Qty.	Remarks
Parallel I/O unit	2A-RZ361/ 2A-RZ371	1	Input/output 32 points/32 points 2A-RZ361 is the sink type. 2A-RZ371 is the source type.
Robot I/O link connection connector	NETcable-1	2 sets	Connector with pins. The cable must be prepared and wired by the customer.
Power connection connector	DCcable-2	1 sets	Connector with pins. The cable must be prepared and wired by the customer.
Terminator	R-TM	1	150Ω (1/4W)

Specifications

- Up to eight stations can be connected to this unit. (One station occupies one unit.)  
One unit is built into the controller as a standard, so up to seven units can be installed as expansions.
- The power supply (24V) must be prepared by the customer and connected with the power connection cable (DCcable-2)  
A separate 24V power supply is required for the input/output circuit wiring.

The detailed specifications of the input/output circuit are the same as the parallel input/output unit mounted as a standard. Refer to Page 68, "3.7 Parallel input/output unit" for details.

Table 3-16 : Electrical specifications of input circuits

Item	Specification	Internal circuit
Type	DC input	<div style="display: flex; flex-direction: column; align-items: center;"> <div style="text-align: center; margin-bottom: 20px;"> <p>&lt;Sink type&gt;</p> </div> <div style="text-align: center;"> <p>&lt;Source type&gt;</p> </div> </div>
Number of input points	32	
Insulation method	Photo coupler insulation	
Rated input voltage	DC12V/DC24V	
Rated input current	Approx 3mA/7mA	
Working voltage range	DC10.2 to 26.4V(Ripple factor should be less than 5%.)	
ON voltage/ON current	8VDC or more/ 2mA or more	
OFF voltage/ OFF current	4VDC or less/ 1mA or less	
Input resistance	Approx. 3.3kΩ	
Response time	OFF-ON 10ms or less (24VDC) ON-OFF 10ms or less (24VDC)	
Common method	8 point 1 common	
External cable connection method	Connector	

Table 3-17 : Electrical specifications for the output circuits

Item		Specification	Internal circuit
Type		Transistor output	<p>&lt;Sink type&gt;</p> <p>&lt;Source type&gt;</p>
No. of output points		32	
Insulation method		Photo-coupler insulation	
Rated load voltage		DC12V/DC24V	
Rated load voltage range		DC10.2 ~ 30V(peak voltage 30VDC)	
Max. load current		0.1A/point (100%)	
Leakage current at OFF		0.1mA or less	
Max. voltage drop at ON		DC0.9V(TYP.)	
Response time	OFF-ON	2ms or less (hardware response time)	
	ON-OFF	2ms or less (Resistance load) (hardware response time)	
Fuse rating		Fuse 3.2A (one per common) Replacement not possible	
Common method		4 points per common (common terminal: 4 points)	
External wire connection method		Connector	
External power supply	Voltage	DC12/24V(DC10.2 ~ 30V)	
	Current	60mA (TYP. 24VDC per common) (base drive current)	

NETcable-1 (Network cable)

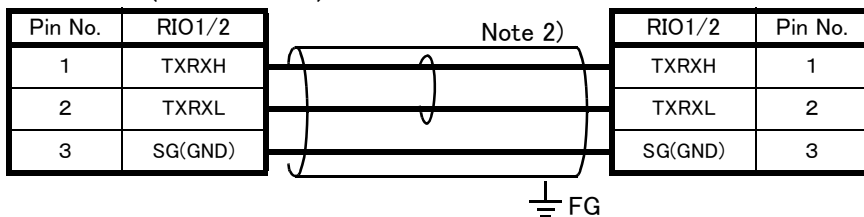

DCcable-2 (Power cable)

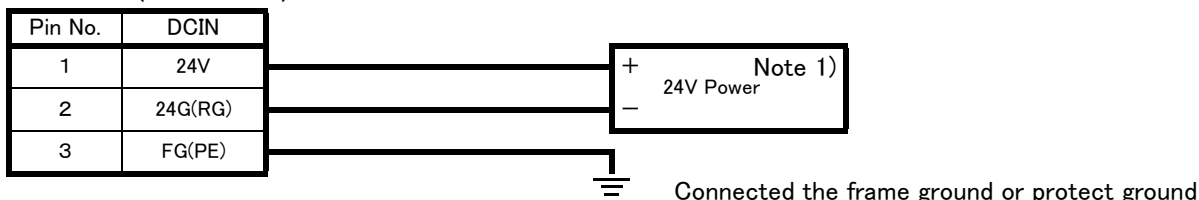

R-TM (Terminator)

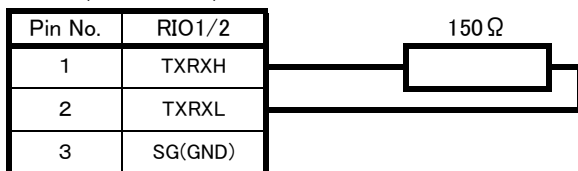

List of parts and manufacturer

Type	Connector type	Contact type	Resistant	Manufacturer
NETcable-1	1-178288-3 (2)	175218-3 (6)	—	AMP
DCcable-2	2-178288-3 (1)	175218-3 (3)	—	AMP
R-TM	1-178288-3 (1)	175218-3 (2)	150 Ω (1/4W) (1)	Equivalent to KOA.

Note 1) The 24V power supply is prepared by customer (The power consumption is approx. 0.3A.)

Note 2) The cable for general purpose can be used to the network cable. However, use the twisted shield cable of AWG#22(0.3mm<sup>2</sup>) or more.

Fig.3-17 : Specifications for the connection cable

### ■ Installation method

The expansion parallel input/output unit is installed outside of the controller. Connect with the network connection cable (NETcable-1) from the RIO1 connector in the rear of the controller. (Terminator is connected at the time of shipment)

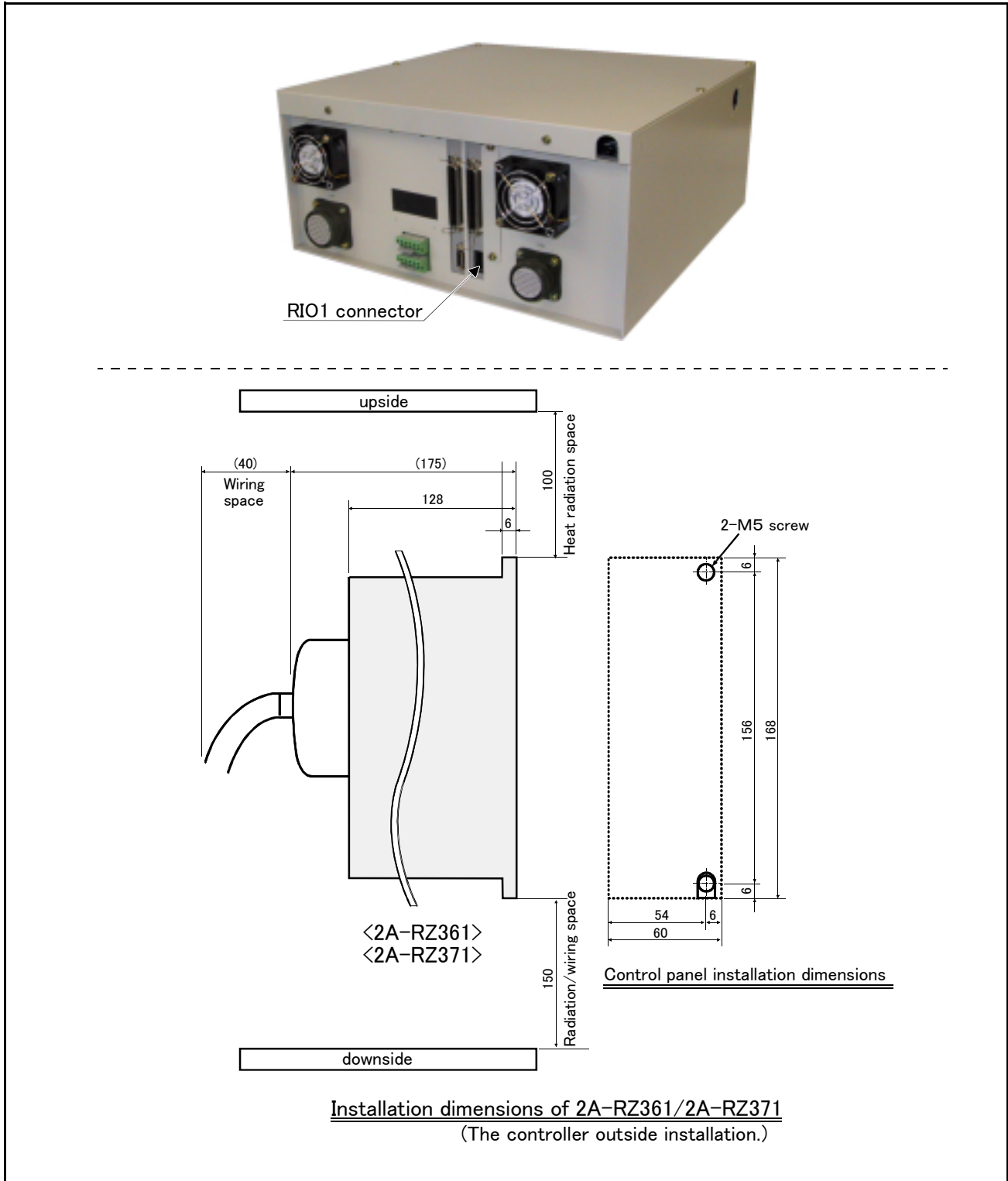

Fig.3-18 : Installing the parallel input/output unit

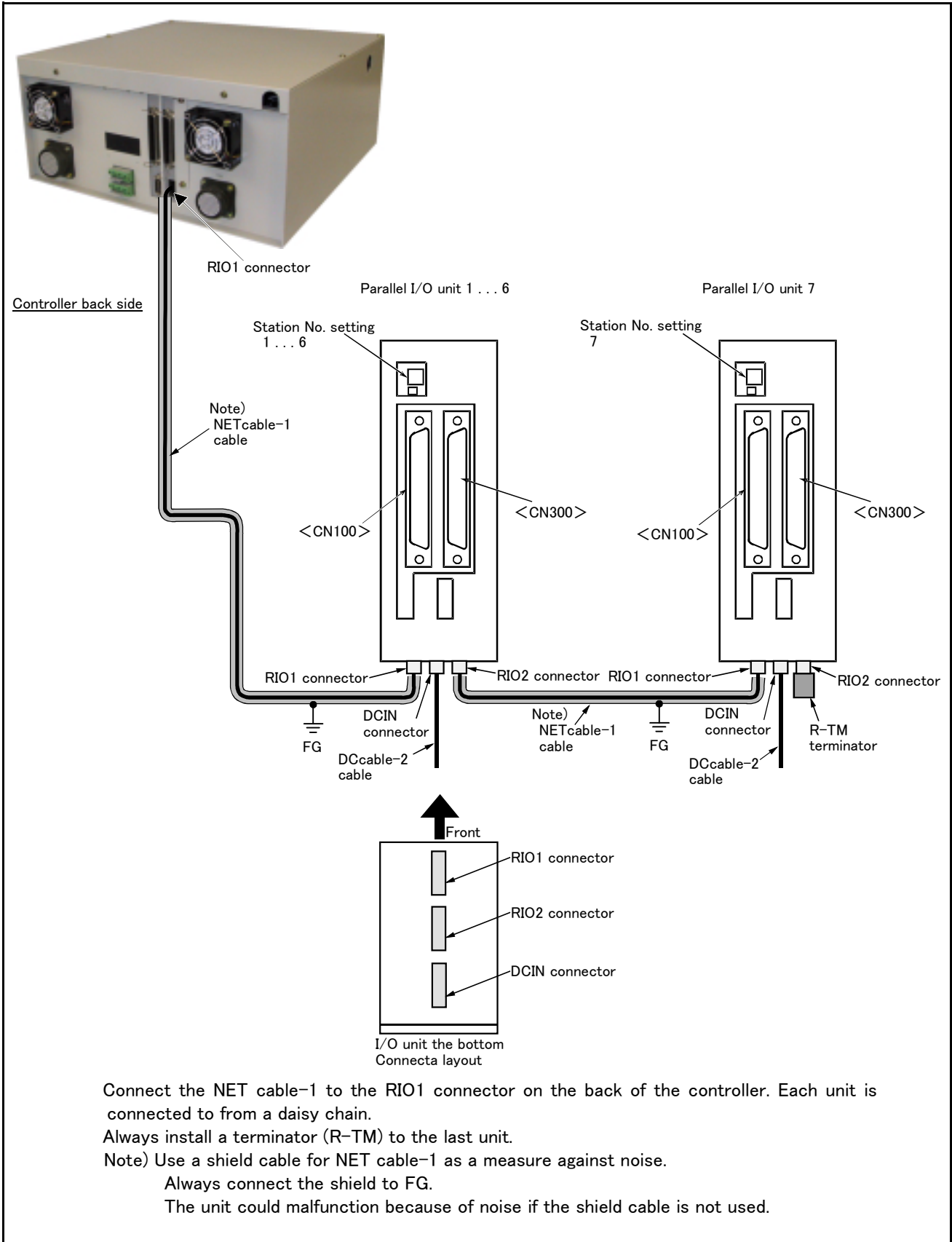

Fig.3-19 : Connection method of expansion parallel input/output unit

■ Parallel I/O interface (First expansion unit)

Table 3-18 : Connector CN100pin No. and signal assignment list (2A-CBL □□ )

Pin No.	Line color	Function name		Pin No.	Line color	Function name	
		General-purpose	Dedicated/power supply, common			General-purpose	Dedicated/power supply, common
1	Orange/Red A		FG	26	Orange/Blue A		FG
2	Gray/Red A		0V:For pins 4-7	27	Gray/Blue A		0V:For pins 29-32
3	White/Red A		12V/24V:For pins 4-7	28	White/Blue A		12V/24V:For pins 29-32
4	Yellow/Red A	General-purpose output 32		29	Yellow/Blue A	General-purpose output 36	
5	Pink/Red A	General-purpose output 33		30	Pink/Blue A	General-purpose output 37	
6	Orange/Red B	General-purpose output 34		31	Orange/Blue B	General-purpose output 38	
7	Gray/Red B	General-purpose output 35		32	Gray/Blue B	General-purpose output 39	
8	White/Red B		0V:For pins 10-13	33	White/Blue B		0V:For pins 35-38
9	Yellow/Red B		12V/24V:For pins 10-13	34	Yellow/Blue B		12V/24V:For pins 35-38
10	Pink/Red B	General-purpose output 40		35	Pink/Blue B	General-purpose output 44	
11	Orange/Red C	General-purpose output 41		36	Orange/Blue C	General-purpose output 45	
12	Gray/Red C	General-purpose output 42		37	Gray/Blue C	General-purpose output 46	
13	White/Red C	General-purpose output 43		38	White/Blue C	General-purpose output 47	
14	Yellow/Red C		COM0:For pins 15-22 Note1)	39	Yellow/Blue C		COM1:For pins 40-47 Note1)
15	Pink/Red C	General-purpose input 32		40	Pink/Blue C	General-purpose input 40	
16	Orange/Red D	General-purpose input 33		41	Orange/Blue D	General-purpose input 41	
17	Gray/Red D	General-purpose input 34		42	Gray/Blue D	General-purpose input 42	
18	White/Red D	General-purpose input 35		43	White/Blue D	General-purpose input 43	
19	Yellow/Red D	General-purpose input 36		44	Yellow/Blue D	General-purpose input 44	
20	Pink/Red D	General-purpose input 37		45	Pink/Blue D	General-purpose input 45	
21	Orange/Red E	General-purpose input 38		46	Orange/Blue E	General-purpose input 46	
22	Gray/Red E	General-purpose input 39		47	Gray/Blue E	General-purpose input 47	
23	White/Red E		Reserved	48	White/Blue E		Reserved
24	Yellow/Red E		Reserved	49	Yellow/Blue E		Reserved
25	Pink/Red E		Reserved	50	Pink/Blue E		Reserved

Note1)Sink type:24V/12V(COM), Source type:0V(COM)

Table 3-19 : Connector CN300pin No. and signal assignment list (2A-CBL □□ )

Pin No.	Line color	Function name		Pin No.	Line color	Function name	
		General-purpose	Dedicated/power supply, common			General-purpose	Dedicated/power supply, common
1	Orange/Red A		FG	26	Orange/Blue A		FG
2	Gray/Red A		0V:For pins 4-7	27	Gray/Blue A		0V:For pins 29-32
3	White/Red A		12V/24V:For pins 4-7	28	White/Blue A		12V/24V:For pins 29-32
4	Yellow/Red A	General-purpose output 48		29	Yellow/Blue A	General-purpose output 52	
5	Pink/Red A	General-purpose output 49		30	Pink/Blue A	General-purpose output 53	
6	Orange/Red B	General-purpose output 50		31	Orange/Blue B	General-purpose output 54	
7	Gray/Red B	General-purpose output 51		32	Gray/Blue B	General-purpose output 55	
8	White/Red B		0V:For pins 10-13	33	White/Blue B		0V:For pins 35-38
9	Yellow/Red B		12V/24V:For pins 10-13	34	Yellow/Blue B		12V/24V:For pins 35-38
10	Pink/Red B	General-purpose output 56		35	Pink/Blue B	General-purpose output 60	
11	Orange/Red C	General-purpose output 57		36	Orange/Blue C	General-purpose output 61	
12	Gray/Red C	General-purpose output 58		37	Gray/Blue C	General-purpose output 62	
13	White/Red C	General-purpose output 59		38	White/Blue C	General-purpose output 63	
14	Yellow/Red C		COM0:For pins 15-22 Note1)	39	Yellow/Blue C		COM1:For pins 40-47 Note1)
15	Pink/Red C	General-purpose input 48		40	Pink/Blue C	General-purpose input 56	
16	Orange/Red D	General-purpose input 49		41	Orange/Blue D	General-purpose input 57	
17	Gray/Red D	General-purpose input 50		42	Gray/Blue D	General-purpose input 58	
18	White/Red D	General-purpose input 51		43	White/Blue D	General-purpose input 59	
19	Yellow/Red D	General-purpose input 52		44	Yellow/Blue D	General-purpose input 60	
20	Pink/Red D	General-purpose input 53		45	Pink/Blue D	General-purpose input 61	
21	Orange/Red E	General-purpose input 54		46	Orange/Blue E	General-purpose input 62	
22	Gray/Red E	General-purpose input 55		47	Gray/Blue E	General-purpose input 63	
23	White/Red E		Reserved	48	White/Blue E		Reserved
24	Yellow/Red E		Reserved	49	Yellow/Blue E		Reserved
25	Pink/Red E		Reserved	50	Pink/Blue E		Reserved

Note1)Sink type:24V/12V(COM), Source type:0V(COM)

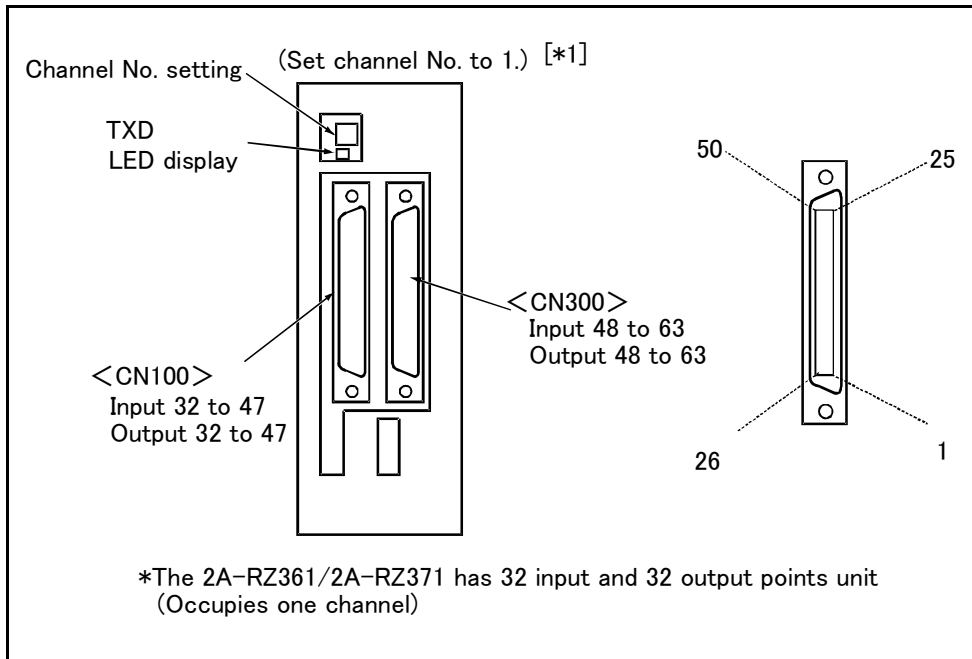

Fig.3-20 : Parallel input/output unit <2A-RZ361/2A-RZ371:First expansion> connection and pin layout

**⚠ CAUTION**

[\*1] For the 1st expansion unit, set the channel No. to "1".  
The channel No. of 8 to F is used for the maker test. If any value of 8 to F is set, it may be dangerous since the robot unexpectedly moves. Don't set any value of 8 to F.

■ Parallel I/O interface (Second expansion unit)

Table 3-20 : Connector CN100pin No. and signal assignment list (2A-CBL □□)

Pin No.	Line color	Function name		Pin No.	Line color	Function name	
		General-purpose	Dedicated/power supply, common			General-purpose	Dedicated/power supply, common
1	Orange/Red A		FG	26	Orange/Blue A		FG
2	Gray/Red A		0V:For pins 4-7	27	Gray/Blue A		0V:For pins 29-32
3	White/Red A		12V/24V:For pins 4-7	28	White/Blue A		12V/24V:For pins 29-32
4	Yellow/Red A	General-purpose output 64		29	Yellow/Blue A	General-purpose output 68	
5	Pink/Red A	General-purpose output 65		30	Pink/Blue A	General-purpose output 69	
6	Orange/Red B	General-purpose output 66		31	Orange/Blue B	General-purpose output 70	
7	Gray/Red B	General-purpose output 67		32	Gray/Blue B	General-purpose output 71	
8	White/Red B		0V:For pins 10-13	33	White/Blue B		0V:For pins 35-38
9	Yellow/Red B		12V/24V:For pins 10-13	34	Yellow/Blue B		12V/24V:For pins 35-38
10	Pink/Red B	General-purpose output 72		35	Pink/Blue B	General-purpose output 76	
11	Orange/Red C	General-purpose output 73		36	Orange/Blue C	General-purpose output 77	
12	Gray/Red C	General-purpose output 74		37	Gray/Blue C	General-purpose output 78	
13	White/Red C	General-purpose output 75		38	White/Blue C	General-purpose output 79	
14	Yellow/Red C		COM0:For pins 15-22 Note1)	39	Yellow/Blue C		COM1:For pins 40-47 Note1)
15	Pink/Red C	General-purpose input 64		40	Pink/Blue C	General-purpose input 72	
16	Orange/Red D	General-purpose input 65		41	Orange/Blue D	General-purpose input 73	
17	Gray/Red D	General-purpose input 66		42	Gray/Blue D	General-purpose input 74	
18	White/Red D	General-purpose input 67		43	White/Blue D	General-purpose input 75	
19	Yellow/Red D	General-purpose input 68		44	Yellow/Blue D	General-purpose input 76	
20	Pink/Red D	General-purpose input 69		45	Pink/Blue D	General-purpose input 77	
21	Orange/Red E	General-purpose input 70		46	Orange/Blue E	General-purpose input 78	
22	Gray/Red E	General-purpose input 71		47	Gray/Blue E	General-purpose input 79	
23	White/Red E		Reserved	48	White/Blue E		Reserved
24	Yellow/Red E		Reserved	49	Yellow/Blue E		Reserved
25	Pink/Red E		Reserved	50	Pink/Blue E		Reserved

Note1)Sink type:24V/12V(COM), Source type:0V(COM)

Table 3-21 : Connector CN300pin No. and signal assignment list (2A-CBL □□)

Pin No.	Line color	Function name		Pin No.	Line color	Function name	
		General-purpose	Dedicated/power supply, common			General-purpose	Dedicated/power supply, common
1	Orange/Red A		FG	26	Orange/Blue A		FG
2	Gray/Red A		0V:For pins 4-7	27	Gray/Blue A		0V:For pins 29-32
3	White/Red A		12V/24V:For pins 4-7	28	White/Blue A		12V/24V:For pins 29-32
4	Yellow/Red A	General-purpose output 80		29	Yellow/Blue A	General-purpose output 84	
5	Pink/Red A	General-purpose output 81		30	Pink/Blue A	General-purpose output 85	
6	Orange/Red B	General-purpose output 82		31	Orange/Blue B	General-purpose output 86	
7	Gray/Red B	General-purpose output 83		32	Gray/Blue B	General-purpose output 87	
8	White/Red B		0V:For pins 10-13	33	White/Blue B		0V:For pins 35-38
9	Yellow/Red B		12V/24V:For pins 10-13	34	Yellow/Blue B		12V/24V:For pins 35-38
10	Pink/Red B	General-purpose output 88		35	Pink/Blue B	General-purpose output 92	
11	Orange/Red C	General-purpose output 89		36	Orange/Blue C	General-purpose output 93	
12	Gray/Red C	General-purpose output 90		37	Gray/Blue C	General-purpose output 94	
13	White/Red C	General-purpose output 91		38	White/Blue C	General-purpose output 95	
14	Yellow/Red C		COM0:For pins 15-22 Note1)	39	Yellow/Blue C		COM1:For pins 40-47 Note1)
15	Pink/Red C	General-purpose input 80		40	Pink/Blue C	General-purpose input 88	
16	Orange/Red D	General-purpose input 81		41	Orange/Blue D	General-purpose input 89	
17	Gray/Red D	General-purpose input 82		42	Gray/Blue D	General-purpose input 90	
18	White/Red D	General-purpose input 83		43	White/Blue D	General-purpose input 91	
19	Yellow/Red D	General-purpose input 84		44	Yellow/Blue D	General-purpose input 92	
20	Pink/Red D	General-purpose input 85		45	Pink/Blue D	General-purpose input 93	
21	Orange/Red E	General-purpose input 86		46	Orange/Blue E	General-purpose input 94	
22	Gray/Red E	General-purpose input 87		47	Gray/Blue E	General-purpose input 95	
23	White/Red E		Reserved	48	White/Blue E		Reserved
24	Yellow/Red E		Reserved	49	Yellow/Blue E		Reserved
25	Pink/Red E		Reserved	50	Pink/Blue E		Reserved

Note1)Sink type:24V/12V(COM), Source type:0V(COM)

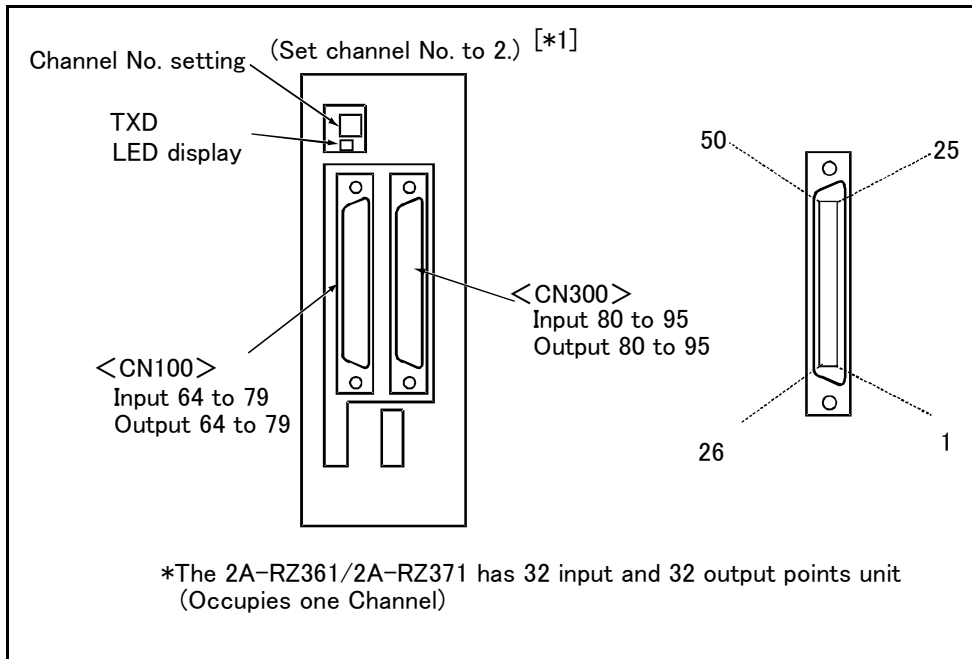

Fig.3-21 : Parallel input/output unit <2A-RZ361/2A-RZ371:Second expansion unit> connection and pin layout

**⚠ CAUTION**

[\*1] For the 2nd expansion unit, set the channel No. to "2".  
The channel No. of 8 to F is used for the maker test. If any value of 8 to F is set, it may be dangerous since the robot unexpectedly moves. Don't set any value of 8 to F.



## (5) External I/O cable

■ Order type: 2A-CBL □□ Note) The numbers in the boxes □□ refer to the length. (05: 5m、15: 15m)

## ■ Outline



This is the dedicated cable used to connect an external peripheral device to the connector on the parallel input/output unit.

One end matches the connector on the parallel input/output unit, and the other end is free. Connect the peripheral device's input/output signal using the free end.

One cable correspond to the input 16 points and output 16 points.

Two cables are needed to connection of (input 32 points and output 32 points) with built-in standard.

## ■ Configuration

Table 3-22 : Configuration device

Part name	Type	Qty.	Remarks
External I/O cable	2A-CBL □□	1pc.	5m or 15m

## ■ Specifications

Table 3-23 : Specifications

Items	Specifications
Number of cables x cable size	50 pairs x AWG #28
Total length	5m or 15m

## ■ Connector pin numbers and cable colors

Table 3-24 : Connector pin numbers and cable colors

Pin no.	Cable colors	Pin no.	Cable colors	Pin no.	Cable colors	Pin no.	Cable colors	Pin no.	Cable colors
1	Orange/Red A	11	Orange/Red C	21	Orange/Red E	31	Orange/Blue B	41	Orange/Blue D
2	Gray/Red A	12	Gray/Red C	22	Gray/Red E	32	Gray/Blue B	42	Gray/Blue D
3	White/Red A	13	White/Red C	23	White/Red E	33	White/Blue B	43	White/Blue D
4	Yellow/Red A	14	Yellow/Red C	24	Yellow/Red E	34	Yellow/Blue B	44	Yellow/Blue D
5	Pink/Red A	15	Pink/Red C	25	Pink/Red E	35	Pink/Blue B	45	Pink/Blue D
6	Orange/Red B	16	Orange/Red D	26	Orange/Blue A	36	Orange/Blue C	46	Orange/Blue E
7	Gray/Red B	17	Gray/Red D	27	Gray/Blue A	37	Gray/Blue C	47	Gray/Blue E
8	White/Red B	18	White/Red D	28	White/Blue A	38	White/Blue C	48	White/Blue E
9	Yellow/Red B	19	Yellow/Red D	29	Yellow/Blue A	39	Yellow/Blue C	49	Yellow/Blue E
10	Pink/Red B	20	Pink/Red D	30	Pink/Blue A	40	Pink/Blue C	50	Pink/Blue E

■ Connections and outside dimensions

The sheath of each signal cable (50 lines) is color indicated and marked with dots. Refer to the cable color specifications in "Table 3-24 Connector pin numbers and cable colors" when making the connections.

(Eg.) Pin number: color indication

1 : Orange / Red / A

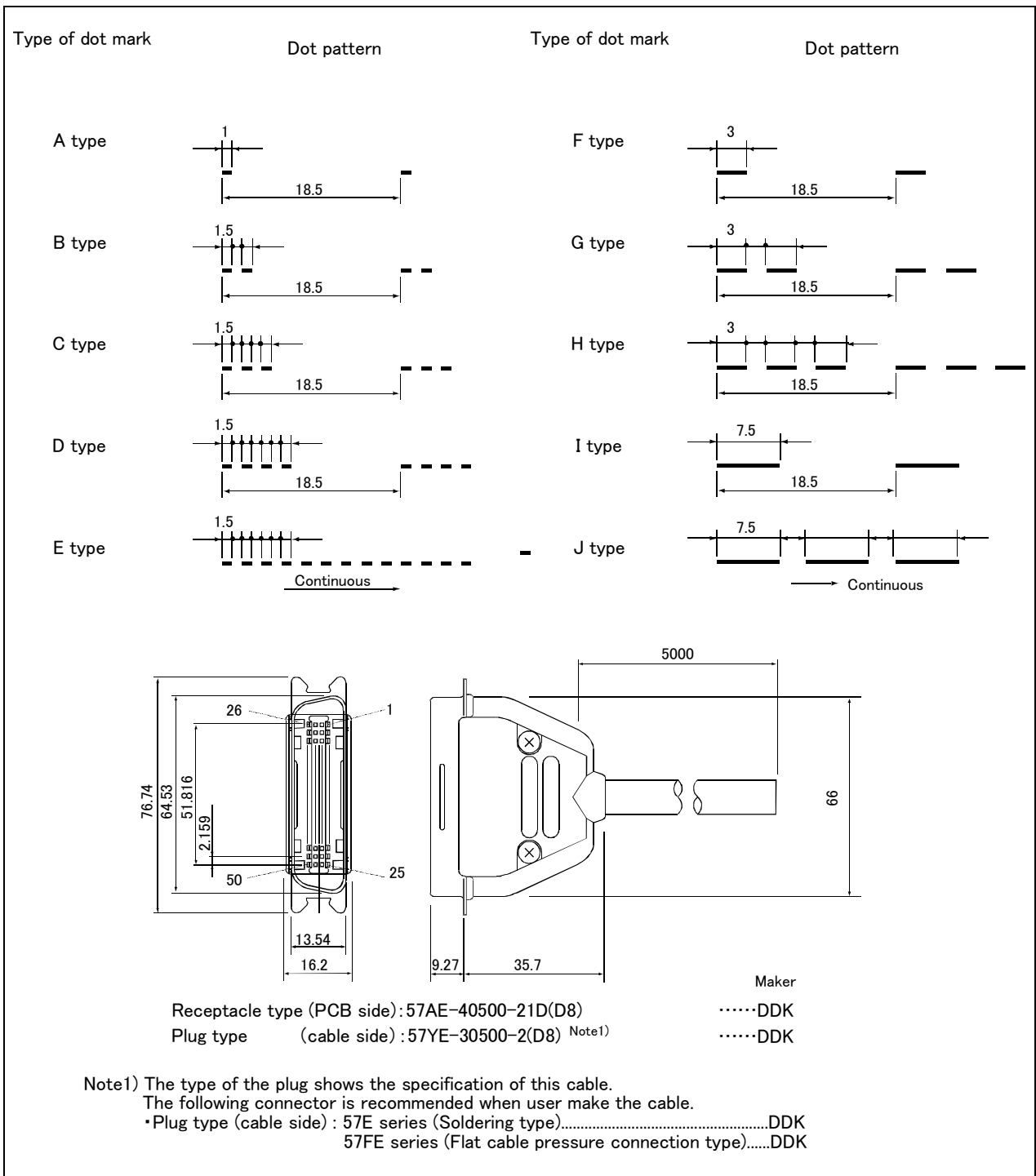
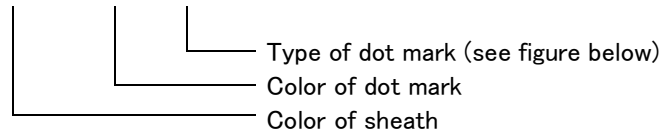

Fig.3-22 : Connections and outside dimensions

(6) Personal computer cable

■ Order type: ● For PC/AT : RS-MAXY-CBL

■ Outline



This is the RS-232C interface cable used for connecting the controller with a personal computer. The personal computer on hand may be usable with the above interface cable. Confirm the connection specifications when placing an order. Personal computer cables for the PC/AT compatible model is available. The cable for the NEC PC9821 (half-pitch 14-pin) must be manufactured by the customer.

■ Configuration

Table 3-25 : Configuration device

Part name	Type	Qty.	Remarks
Personal computer cable (for PC/AT)	RS-MAXY-CBL	1 pc.	3m, D-SUB 9 pin <sup>Note1)</sup>

Note1)The personal computer cable is the same as that for use with "Movemaster M1/M2/E/EN series".

■ Specifications

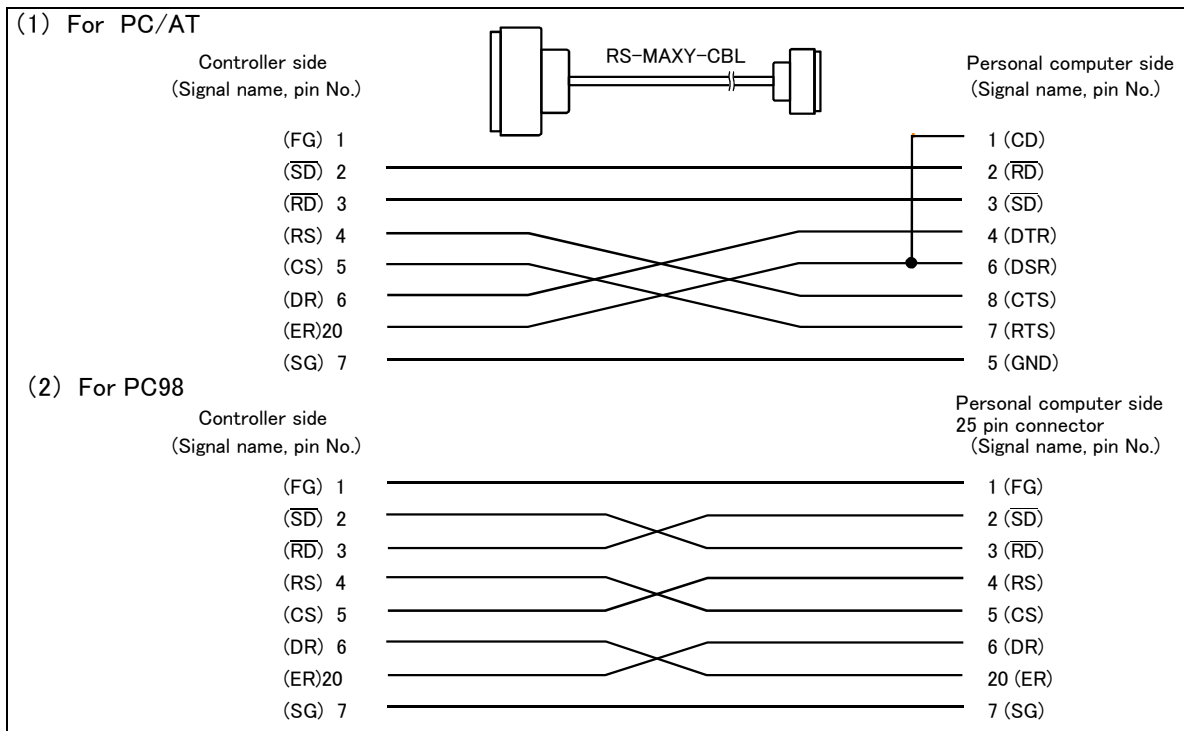

Fig.3-23 : Personal computer cable connection

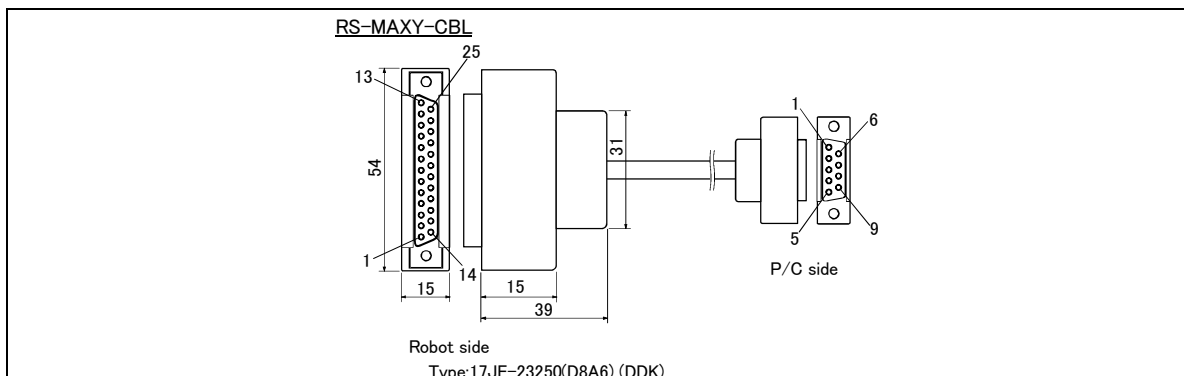

Fig.3-24 : Personal computer cable connector

(7) Extension memory cassette

■ Order type: ● 2A-HR432

■ Outline



Used to increase the total number of teaching points in the robot program.

■ Configuration

Table 3-26 : Configuration device

Part name	Type	Qty.	Remarks
Extension memory cassette	2A-HR432	1	27,900 total teaching points With a battery backup feature

■ Specifications

Table 3-27 : Specifications

Items	Specifications	Remarks
External dimensions	Approx. 95(W)X65(D)X15(H) mm	Excluding the connection connector
Mass	Approx. 0.2 kg	
Connection method	Connection using a special connector	
Memory size	25,400 teaching points	Can be increased up to 27,900 points together with the standard 2,500 points. <sup>Note1)</sup>
Backup	Backup using the controller's internal battery	

Note1) As for the standard 2,500 points, after adding an expansion memory cassette, the information in all backup memory areas in the controller is copied into the expansion memory cassette. Therefore, please note that if the expansion memory cassette is removed after it has been added, there will be no program left in the controller.

[CAUTION]

· Inserting and removing the memory cassette

A memory cassette cannot be inserted or removed while the control power is on. Please turn off the control power before handling the memory cassette to avoid destroying the memory information in the cassette.

· Memory backup

Retaining the contents of memory in a memory cassette is not covered by the warrantee when the memory cassette is removed from the control unit. Nonetheless, memory is retained under the following conditions.

(Conditions) If the power has been on for at least a half-hour before the power is turned off and the cassette is removed, the contents of memory can be retained for approximately one hour. (Not covered by the warrantee.)

## ■ Installation

The installation method to the CR2A-572 controller is shown below.

- 1) Completely back up the memory information in the robot controller using the personal computer support software. (This must be performed as a preventive measure in case the contents of the internal memory are destroyed while inserting a memory cassette.)
  - 2) Turn off the controller power.
  - 3) Remove the dust-proof cover installed in the rear of the controller.
  - 4) Install the attached fixing plate of memory cassette with the screw which fixed the dust-proof cover.
  - 5) Attach a memory cassette to the controller.
    - As shown in Fig. 3-25, insert the memory cassette all the way to the back with the "▲" facing up.
    - Securely tighten the fixing screws.
 Note) Be careful not to over-tighten the screws, as it may deform the memory cassette.
  - 6) Turn on the controller power.
- This should generate a "C.0011" error. Press the reset button to clear the error.

At this point, a new file system has been created in the memory cassette.

### [CAUTION]

The programs that are stored in the control unit will be copied into the memory cassette; they will be deleted from the memory in the control unit. Please be careful not to remove the memory cassette, since if you remove it, there will be no program information residing in the controller (the information is in the memory cassette). Although the program information (\*\*\*.MB4) is copied into the memory cassette, the parameter information (\*\*\*.PRM) is still stored in the control unit.

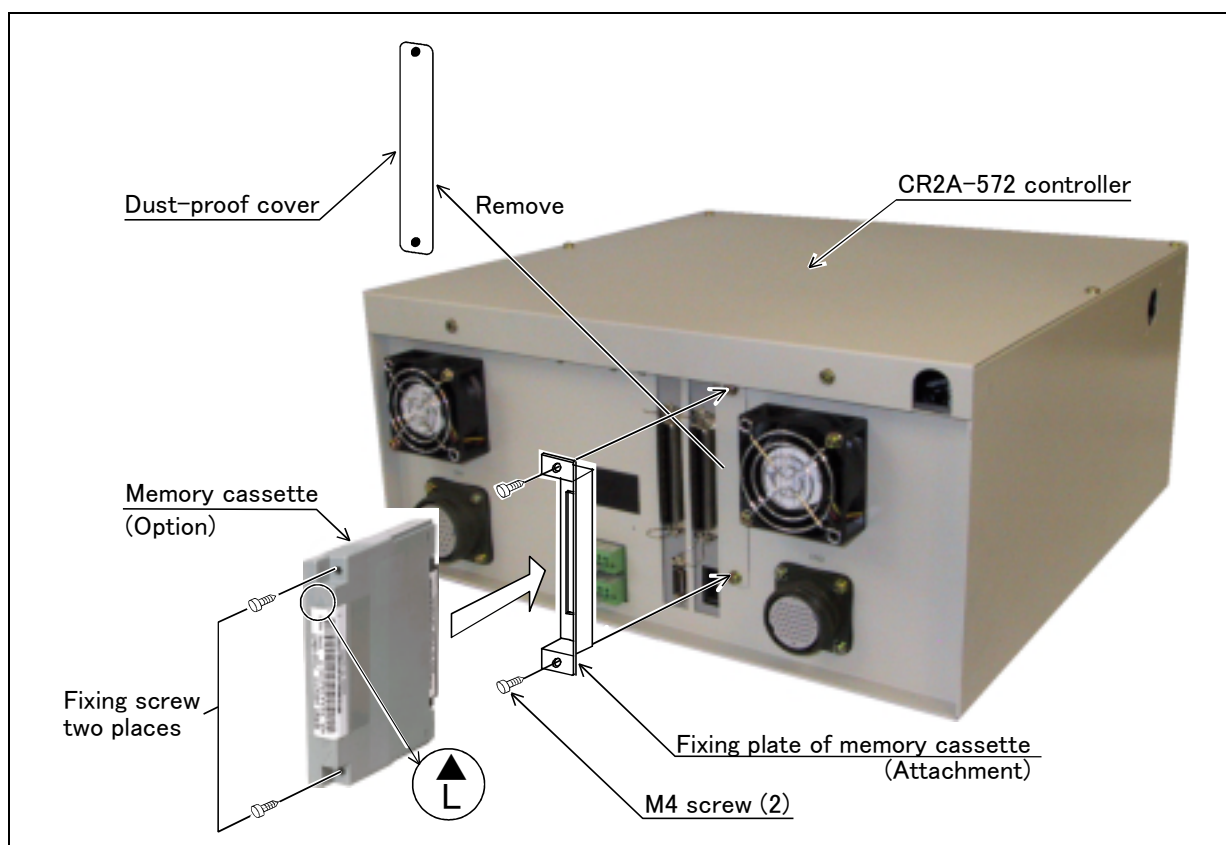

Fig.3-25 : Installation method of extension memory cassette

(8) Personal computer support software/Personal computer support software mini

- Order type : ● Personal computer support software  
                   \*For windows CD-ROM : 3A-01C-WINE
- Personal computer support software mini  
                   \*For windows CD-ROM : 3A-02C-WINE

■ Outline



This is handy software that fully uses the personal computer functions. It can be used in various stages from the robot specifications study (tact study, etc.) to the design support (creation and editing of programs), start up support (execution, control and debugging of program), and maintenance (remote maintenance.)

The "personal computer support software" which supports these function fully, and the "personal computer support software mini" which does not have the simulation function are available. Select according to the required application.

■ Configuration

Table 3-28 : Product configuration

Part name	Type	Medium	Remarks
Personal computer support software	3A-01C-WINE	CD-ROM	One operation manual included
Personal computer support software mini	3A-02C-WINE	CD-ROM	One operation manual included

■ Features

- (1) Simple operation with guidance method and menu method  
 The Windows standard is used for windows operation, so the controller initialization and startup operations can be carried out easily by following the instructions given on the screen. Even a beginner can easily carry out the series of operations from program creation to execution.
- (2) Increased work efficiency with ample support functions  
 The work efficiency is greatly improved with the multi-window method that carries out multiple steps and displays in parallel. The renumbering function, and copy, search, syntax check and step execution are especially sufficient, and are extremely useful when editing or debugging the program.  
 With the simulation function support, the program can be debugged and the tact checked before starting the machine at the site. This allows the on-site startup work efficiently to be greatly improved.
- (3) Increased maintenance efficiency with remote maintenance function  
 With remote operations over a telephone line, the robot's operation status can be monitored without going to the site. Losses incurred while moving to the site can be reduced, and the time required to investigate the trouble and determine measures to be taken can be shortened.

## ■ Functions

Table 3-29 : Functions

Function		Functional existence <sup>Note1)</sup>		Details
Compatible model		○	○	Personal computer running Microsoft Windows 95/98/NT 4.0
Program editing functions	Editing functions	○	○	<ul style="list-style-type: none"> <li>• MELFA BASIC IV language compatible</li> <li>• Multiple editing screen simultaneously display</li> <li>• Command input, comment writing</li> <li>• Position data editing</li> <li>• File operation (writing to controller, floppy disk, personal computer)</li> <li>• Search and replace function (using characters, line Nos., labels)</li> <li>• Copy, cut, paste, insert (per character, line), undo (per command statement, position conversion)</li> <li>• Line No. automatic generation, renumbering</li> <li>• Batch syntax check</li> <li>• Command template</li> <li>• Position conversion batch editing</li> <li>• Position variable template</li> <li>• Print, print preview</li> </ul>
	Control functions	○	○	<ul style="list-style-type: none"> <li>• Program file control (list, copy, movement, delete, content comparison, name change, protect)</li> </ul>
	Debugging functions	○	○	<ul style="list-style-type: none"> <li>• Direct editing of program in controller</li> <li>• Confirmation of robot program operation (step execution, direct execution)</li> <li>• Tact time measurement<sup>Note2)</sup></li> </ul>
Simulation function <sup>Note3)</sup>		○	×	<ul style="list-style-type: none"> <li>• Off-line simulation of robot program operation using CG (computer graphics)</li> <li>• Tact time calculation</li> </ul>
Monitor functions		○	○	<ul style="list-style-type: none"> <li>• Robot operation monitor (robot operation state, stop signal, error monitor, program monitor (execution program, variables), general-purpose input/output signals (forced output possible), dedicated input/output signals, operation confirmation (operation range, current position, hand, etc.))</li> <li>• Operation monitor (working time statistics, production information, robot version)</li> <li>• Servo monitor (position, speed, current, load, power)</li> </ul>
Maintenance function		○	○	<ul style="list-style-type: none"> <li>• Parameter setting</li> <li>• Batch, divided backup</li> </ul>
Remote maintenance function		○	○	<ul style="list-style-type: none"> <li>• Monitoring and maintenance of robot state at remote site using telephone line. (A separate modem is required for this function.)</li> </ul>

Personal computer support software mini  
(3A-01C-WINE)

Personal computer support software  
(3A-02C-WINE)

Note1) The functions included with the personal computer support software and the personal computer support software mini are shown below. ○ : Function provided × : Function not provided

Note2) When using the "personal computer support software mini", connect with the controller and measure.

Note3) A simulation function is available only with "MELFA-BASIC IV".

### 3.9 Maintenance parts

The consumable parts used in the controller are shown in [Table 3-30](#). Purchase these parts from your dealer when required. Some Mitsubishi-designated parts differ from the maker's standard parts. Thus, confirm the part name, robot arm and controller serial No. and purchase the parts from your dealer.

Table 3-30 : Controller consumable parts list

No.	Part name	Type	Qty.	Usage place	Manufacturer
1	Lithium battery	ER6 BKO-NC2157H01	1	Control unit	Mitsubishi Electric
2	Filter mat	BKO-FA0688H01	1	Control unit	



## 4 Software

### 4.1 List of commands

The robot language to use can choose "MELFA-BASIC IV" (default setting) or "MOVEMASTER language (MOVEMASTER commands)" by changing the parameter.

Use of "MELFA-BASIC IV" is recommended to effectively use this controller's functions.

The available new functions in MELFA-BASIC IV are given in [Table 4-1](#).

Table 4-1 : The available new functions in MELFA-BASIC IV

Class	Command example	Function
Robot Status Variable	P_TOOL	keep current tool length
	M_SPD	keep current speed (linear/circular interpolation)
Built-in functions	ABS	Produces the absolute value
	VAL	Converts a character string into a numeric value
	ATN	Calculates the arc tangent
	STR\$	Converts the numeric expression value into a decimal character string
	ZONE	Check current position area
Operation function	P1=P1*P2	Relative calculation of position data
	M1=M1*M2	Multiplication of numerical variable
	P1.X=10	Operation of the position element data
Conditional branching	SELECT CASE	More than one condition branch
	ON GOSUB	Condition branch by the value
	WHILE WEND	Repeat with condition
Optimum acceleration/ deceleration control	LOADSET	Load condition setting
	OADL	valid/invalid setting for the optimum acceleration/deceleration
Float control (compliance in the XYZ coordinate system)	CMP POS	Compliance control
	CMPG	Force control
Parallel execution (Multitask)	XRUN, XSTP, XRST, XLOAD	Parallel executions of another task, the stops, the resets, and, the loads
Conveyor trucking [Special specification]	TRKON, TRKOFF	Valid/invalid of the trucking
	TRBASE	Setting the base coordinate for the trucking

#### (1) The procedure of robot language selection

Table 4-2 : Robot language parameter

Parameter	Parameter name	No. of arrays No. of characters	Details explanation	Factory setting
Robot language	RLNG	Integer 1	Select the robot language to use 1 : MELFA-BASIC IV 0 : MOVEMASTER COMMAND	1

Note 1) "MELFA-BASIC IV" is default setting.

Note 2) Refer to the separate manual "Explanation of MOVEMASTER COMMANDS"(BFP-A8056) for details of "MOVEMASTER COMMAND". Order to dealer when using the "MOVEMASTER COMMAND".

## (2) MELFA-BASIC IV commands

Table 4-3 : List of MELFA-BASIC IV commands

Type	Class	Function	Input format (example)
Position and operation control	Joint interpolation	Moves to the designated position with joint interpolation.	MOV P1
	Linear interpolation	Moves to the designated position with linear interpolation.	MVS P1
	Circular interpolation	Moves along a designated arc (start point → passing point → start point (end point)) with 3-dimensional circular interpolation (360 degrees).	MVC P1,P2,P1
		Moves along a designated arc (start point → passing point → end point) with 3-dimensional circular interpolation.	MVR P1,P2,P3
		Moves along the arc on the opposite side of a designated arc (start point → reference point → end point) with 3-dimensional circular interpolation.	MVR2 P1,P9,P3
		Moves along a set arc (start point → end point) with 3-dimensional circular interpolation.	MVR3 P1,P9,P3
		Speed designation	Designates the speed for various interpolation operations with a percentage (0.1% unit).
		Designate the speed for joint interpolation operation with a percentage (0.1% unit).	JOVRD 100
		Designates the speed for linear and circular interpolation with a numerical value (0.1mm/s unit).	SPD 123.5
		Designates the acceleration/deceleration time as a percentage in respect to the predetermined maximum acceleration/deceleration. (1% unit)	ACCEL 50,80
		Automatically adjusts the acceleration/deceleration according to the parameter setting value.	OADL 1,5,20
		sets the hand and work conditions for automatic adjustment of the acceleration/deceleration.	LOADSET 1,1
	Operation	Adds a process unconditionally to the operation.	WTH
		Adds a process conditionally to the operation.	WTHIF
		Designates smooth operation.	CNT 1,100,200
		Designates the positioning completion conditions with a No. of pulses.	FINE 200
		Turns the servo power ON/OFF for all axes.	SERVO OFF
		Limits the operation of each axis so that the designated torque is not exceeded.	TORQ 4,60
	Position control	Designates the base conversion data.	BASE P1
		Designates the tool conversion data.	TOOL P1
	Float control	The robot arm rigidity is lowered and softened. (XYZ coordinate system)	CMP POS ,00000011
		The robot arm rigidity is lowered and softened. (JOINT coordinate system)	CMP JNT ,00000011
		The robot arm rigidity is lowered and softened. (TOOL coordinate system)	CMP TOOL ,00000011
		The robot arm rigidity is returned to the normal state.	CMP OFF
		The robot arm rigidity is designated.	CMPG 1,0,1,0,1,0,1,0,1,0,1,0
	Pallet	Defines the pallet.	DEF PLT 1,P1,P2,P3,P4,5,3,1
		Operates the pallet grid point position.	PLT 1,M1
	Program control	Branching	Branches unconditionally to the designated place.
Branches according to the designated conditions.			IF IN1=1 THEN GOTO 100 ELSE GOTO 20
Repeats		Repeats until the designated end conditions are satisfied.	FOR M1=1 to 10  NEXT
		Repeats while the designated conditions are satisfied.	WHILE M1<10  WEND
		Branches corresponding to the designated expression value.	ON M1 GOTO 100,200,300

Type	Class	Function	Input format (example)
Program control	Branching	Executes program block corresponding to the designated expression value..	SELECT CASE 1  CASE 2  END SELECT
		Moves the program process to the next line.	SKIP
	Subroutine	Executes the designated subroutine. (Within program)	GOSUB 200
		Returns from the subroutine.	RETURN
		Executes the designated program.	CALLP "P10",M1,P1
		Defines the program argument executed with the CALLP command.	FPRM M10,P10
		Executes the subroutine corresponding to the designated expression value.	ON M1 GOSUB 100,200,300
	Interrupt	Defines the interrupt conditions and process.	DEF ACT 1 IN1=1 GOTO 100
		Enables/disables the interrupt.	ACT 1=1
		Defines the start line of the program to be executed when an interrupt is generated from the communication line.	ON COM(1) GOSUB 100
		Enables the interrupt from the communication line.	COM(1) ON
		Disables the interrupt from the communication line.	COM(1) OFF
		Stops the interrupt from the communication line.	COM(1) STOP
	Wait	Designates the wait time, and the output signal pulse output time. (0.01s unit)	DLY 0.5
		Waits until the variable becomes the designated value.	WAIT M_IN(1)=1
	Stop	Stops the program execution.	HLT
Generates an error. During program execution, continue, stop or servo OFF can be designated.		ERROR 9000	
End	Ends the program execution.	END	
Hand	Hand open	Opens the designated hand.	HOPEN
	Hand close	Closes the designated hand.	HCLOSE
Input/output	Assignment	Defines the input/output variables.	DEF IO PORT1=BIT,0
	Input	Retrieves the general-purpose input signal.	M1=IN 1
	Output	Calls out the general-purpose output signal.	OUT 1=0
Parallel execution	Mechanism designation	Acquires the mechanism with the designated mechanism No.	GETM 1
		Releases the mechanism with the designated mechanism No.	RELM 1
	Selection	Selects the designated program for the designated slot.	XLOAD 2,"P102"
	Start/stop	Carries out parallel execution of the designated program.	XRUN 3,"100",0
		Stops parallel execution of the designated program.	XSTOP 3
	Returns the designated program's execution line to the head and enters the program selection enabled state.	XRST 3	
Others	Definition	Defines the integer type or real number type variable.	DEF INT KAISUU
		Defines the character string variable.	DEF CHAR MESSAGE
		Defines the layout variable. (Up to 3-dimensional possible)	DIM PDATA(2,3)
		Defines the joint variable.	DEF JNT TAIHI
		Defines the position variable.	DEF POS TORU
		Defines the function.	DEF FNTASU(A,B)=A+B
	Clear	Clears the general-purpose output signal, variables in program, variables between programs, etc.	CLR 1
	File	Opens a file.	OPEN "COM1:" AS #1
		Closes a file.	CLOSE #1
		Inputs data from a file.	INPUT# 1,M1
		Outputs data to a file.	PRINT# 1,M1
	Comment	Describes a comment.	REM "ABC"
Label	Indicates the branching destination.	*SUB1	

## (3) MOVEMASTER commands

Table 4-4 : List of MOVEMASTER command

Type	Class	Function	Input format (example)
Position and operation control	Joint interpolation	Moves to the designated position variable with joint interpolation.	MO 1
		Moves to the designated position with joint interpolation.	MP 100,200,125.3,0,90
		Moves to a position obtained by adding two position variables.	MA 1,2
		Turns the joint by the specified angle from the current position.	MJ 10,20,0,0,0,0
		Moves the axis by the designated amount from the current position.	DJ 1,15
		Moves by the specified distance from current position.	DW 100,80,0
		Moves to the next position in number from current position.	IP
		Moves to the previous position in number from current position.	DP
		Moves to a position separated by the designated distance (+/- direction) in the Z axis direction of the tool coordinates from the designated position variable's position.	MT 1,-50
		Moves to the origin in the axis order designated in the parameters.	NT
		Moves to the user specified origin position.	OG
	Linear interpolation	Moves to the designated position variable with linear interpolation.	MS 1
		Moves by the specified distance from current position.	DS 10,20,0
		Continuously moves the position variable with linear interpolation between the two designated position variables.	MC 10,20
		Moves to a position separated by the designated distance (+/- direction) in the Z axis direction of the tool coordinates from the designated position variable position.	MTS 1,-50
	Circular interpolation	Moves along a designated arc (start point → transient point → end point) with three-dimensional circular interpolation.	MR 1,2,3
		Moves with circular interpolation with the position data of two MRA commands designated previously or subsequently.	MRA 4
	Speed designation	Establishes program over-ride. (0.1% unit)	OVR 100
		Designate the speed level and acceleration/deceleration rate for various interpolation operations.	SP 25,H
		Designate the speed, time constant, acceleration/deceleration rate and CNT setting validity for linear and circular interpolation.	SD 123.5,50,50,0
	Position control	It establishes die length to hand nose from hand installation.	TL 128
		Designates the tool matrix.	TLM 0,0,128,0,0,0
		Waits for in position till all axis ring inward pulse appointing.	PW 10
		Adds ± 360 degrees to current R axis joint position and rewrites current position.	JRC +1
		Memorizes current position as the position number.	HE 1
		Memorizes current position as the origin.	HO
		Sets the designated coordinate value (x, y, z, a, b, c) in the designated position variable.	PD 1,100,200,300,0,90,0
		Deletes the position variable between two designated position variables.	PC 1,20
		Changes the pose of the robot at position.	CF 1,R,A,F
	Pallet	Defines the pallet.	PA 1,5,3
		Operates the designated pallet No. grid point position, and substitutes into the corresponding position variable.	PT 1

Type	Class	Function	Input format (example)
Program control	Branching	Jump to line number.	GT 120
		Jump to line number if internal register value/strings equals specified value/strings.	EQ 20,120 EQ "OK",120
		Jump to line number if internal register value/strings does not equal specified value/strings.	NE 20,120 NE "NG",120
		Jump to line number if internal register value/strings is greater than specified value/strings.	LG 20,120 LG "NG",120
		Jump to line number if internal register value/strings is smaller than specified value/strings.	SM 20,120 SM "NG",120
		Jump to line number by internal register bit status.	TB +5,100
		Jump to line number by external input signal bit status.	TBD +5,100
		Repeats the loop specified by command NX.	RC 8
		Specifies the range of a loop in a program by command RC.	NX
	Subroutine	Executes the subroutine of the line designated in the designated program.	GS 3,10
Returns from the subroutine. (The return line No. can be designated.)		RT RT 200	
Program control	Interrupt	Validates the interrupt by the bit designated by the external input terminal, and designated the branching method and branching line at the interrupt.	EA +16,100,1
		Disables interrupt by the bit of external input signal.	DA 16
	Wait	Stops the operation for the designated time. (0.1 sec unit)	TI 50
	Select	Selects the program.	N 1
	Start	Executes the program between the designated line numbers.	RN 10,50
	Stop	Halts the program.	HLT
Hand	End	Ends the program.	ED
	Open	Opens the specified hand.	GO
		Closes the specified hand.	GC
	Setting	Sets the motorized hand's gripping force and open/close time.	GP 40,30,50
Sets the hand open/close state when the "PD" command is executed.		GF 1	
Input/output	Input	Gets signal from external input.	ID
	Output	Outputs data to external output signal.	OD 20
		Outputs the counter value to external output signal.	OC 1
		Sets the output signal bit status.	OB +16
Operation/Substitution	addition	Adds the designated value to the internal register value.	ADD 10
		Adds 1 to the designated number's counter.	IC 5
		Adds the coordinate values of the designated position variable to the coordinate values of the designated position variable.	SF 1,2
	Subtraction	Subtracts the designated value from the designated register value.	SUB 10
		Subtracts one from the designated number's counter.	DC 5
	Multiplication	Multiplies the designated value to the internal register value.	MUL 2
	Division	Divides the internal register value by the designated value.	DIV 10
	AND	Logical AND of the internal register value and specified value.	AN 7
	OR	Logical OR of the internal register value and specified value.	OR 3
	XOR	Logical exclusive OR of the internal register value and specified value.	XO 2
	Substitution	Substitutes the designated value (character string) in the designated counter.	SC 1,10 SC \$1,"OK"
		Substitutes the designated position variable coordinate value in the designated position variable.	PL 1,2
		Substitutes the internal register value (character string) in the designated number's counter.	CL 1
		Sets the designated number's counter value (character string) in the internal register.	CP 1
Exchange	Exchanges the coordinate values of two designated position variables.	PX 1,2	

Type	Class	Function	Input format (example)
Other	RS-232C read	Reads the selected program No. or designated program information.	QN 1
		Reads the program of specified line number.	LR 10
		Reads the program of specified step number.	STR 10
		Reads the coordinate value of specified position number.	PR 1
		Reads the value/strings of specified counter number.	CR 1
		Reads the hand input signal, internal register value and the 16-bit width data from the designated external output signal bit.	DR 16
		Reads the current error No. or error history.	ER 10
		Reads the coordinate value of current position.	WH
		Reads the value of current tool length.	WT
		Reads the current tool matrix.	WTM
		Reads the name of system software version.	VR
		Reads the value of specified parameter.	PMR "HANDINIT"
	Clear	Deletes the program between the designated line numbers.	DL 10,90
		Deletes the selected program and position variables.	NW
	File	Opens the file.	OPEN 1,1
		Reads the data from the file.	INP 1,2,0
		Sends the value to the file.	PRN 2
		Sets the contents of the designated parameter.	PMW 1,0,1,0,1,0,1,0
	Reset	Resets the error, or program line number.	RS
	Comment	Describes a comment.	'

## 4.2 List of parameters

### (1) List of parameters

show the main parameter in the [Table 4-5](#).

Table 4-5 : List of parameters

Parameter		Details
Standard tool coordinates.	MEXTL	Set the default value for the tool data. Unit: mm or deg.
Standard base coordinates	MEXBS	Set the relation of the world coordinate system and robot coordinate system. Unit: mm or deg.
XYZ operation range	MEPAR	Designate the overrun limit value for the world coordinate system.
JOINT operation range	MEJAR	Set the overrun limit value for each joint axis.
Free plane limit		This is the overrun limit set with the free plane. Create a plane with the three coordinates x1, y1, z1 to x3, y3, z3, and set the outer side of the plane as the outside operation range (error). The following three types of parameters are used.
	SFC1P : SFC8P	Eight types of free plane limits can be set in SFC1P to SFC8P. There are nine elements, set in the order of x1, y1, z1, x2, y2, z2, x3, y3, z3.
	SFC1ME : SFC8ME	Designate which mechanism to use eight types of set free plane limits. The mechanism No. to use is set with 1 to 8.
	SFC1AT : SFC8AT	Set the validity of the eight types of set free plane limits. (Valid/invalid = 1/0)
User-defined area		An area (cube) defined with two XYZ coordinate points can be designated and that area set as the outside operation range. Furthermore, a signal can be output when the axis enters that area. Up to eight types of area can be designated.
	AREA1P1 : AREA8P1	Designated the 1st point of the area. There are eight elements, set in the order of x, y, z, a, b, c, L1, L2. (L1 and L2 are the additional axes.)
	AREA1P2 : AREA8P2	Designated the 2nd point of the area. There are eight elements, set in the order of x, y, z, a, b, c, L1, L2. (L1 and L2 are the additional axes.)
	AREA1ME : AREA8ME	Designate which mechanism to use the eight types of set area. The mechanism No. to use is set with 1 to 8
	AREA1AT : AREA8AT	Designate the area check type. (Invalid/zone/interference = 0/1/2) Zone: The dedicated output signal USRAREA turns ON. Interference: An error occurs..
Automatic return setting	RETPATH	Set to restart the program after returning to the interrupt position when resuming operation after an interruption.
Buzzer ON/OFF	BZR	Designate whether to the turn buzzer ON or OFF.
Automatic operation speed.	SPI	Designate the initial level for the automatic operation speed.
Automatic operation override	EOV	Designate the initial override for automatic operation. (External override, program override)
Jog setting	JOGJSP	Designate the joint jog and step operation speed. (Set dimension H/L amount, max. override.)
	JOGPSP	Designate the linear jog and step operation speed. (Set dimension H/L amount, max. override.)
Jog speed limit value	JOGSPMX	Limit the operation speed during the teaching mode. Max. 250[mm/s]
Hand type	HANDTYPE	Set the hand type of the single/double solenoid, and the signal No. (Single/double = S/D) Set the signal No. after the hand type. Example) D900

Parameter		Details
Stop input B contact designation	INB	Change the dedicated input (stop) between the A contact and B contact.
User-designated origin	USERORG	Designate the user-designated origin position.
Program selection memory	SLOTON	Select the program selected previously when initializing the slot. The non-selected state will be entered when not set.
Communication setting	CBAU232	Set the baud rate.
	CLEN232	Set the character length.
	CPRTY232	Set the parity.
	CSTOP232	Set the stop bit.
	CTERM232	Set the end code.
Slot table	SLT : SLT32	Make settings (program name, operation type, order of priority, etc.) for each slot during slot initialization.
No. of multi-tasks	TASKMAX	Designate the No. of programs to be executed simultaneously.
Robot language setting	RLNG	Select the robot language ("MELFA-BASIC IV"/"MOVEMASTER COMMAND")
Select the function of singular point adjacent alarm	MESNGLSW	Designate the valid/invalid of the singular point adjacent alarm. (Invalid/Valid = 0/1) When this parameter is set up "VALID", this warning sound is buzzing even if parameter: BZR (buzzer ON/OFF) is set up "OFF".
Display language. <sup>Note1)</sup> 表示言語 <sup>Note1)</sup>	LNG	Change the language to display on the LCD display of teaching pendant. ティーチングボックスの表示 LCD などに表示する言語を切り替えます。

Note1)The procedure of Language as shown in "(2) Change the display language / 表示言語の切り替え".

注 1) 表示言語切り替え方法の詳細を "(2) Change the display language / 表示言語の切り替え" に示します。



## (2) Change the display language / 表示言語の切り替え

The language to display on the LCD display of teaching pendant can be changed by "the display language parameter". (Japanese or English)

Show the details of the parameter in the Table 4-5. Refer to the separate "Instruction Manual/Detailed Explanation of Functions and Operations" for details on changing the parameter.

The parameter is set up based on the order specifications before shipment. Order to dealer when the instruction manual of the other language is necessity.

More, the caution seals that stuck on the robot arm and the controller are made based on the language of the order specification. Use it carefully when selecting the other language.

表示言語設定パラメータによって、ティーチングボックスの表示 LCD などに表示する言語を切り替えることができます。(日本語、または英語) Table 4-5 にそのパラメータの詳細を示します。パラメータの変更方法は、別冊の「取扱説明書／機能と操作の詳細解説」を参照願います。

なお、出荷時はご注文仕様に基づき弊社で設定いたします。別の言語の取扱説明書をご希望の場合はご用命願います。

また、ロボット本体とコントローラに貼り付けてある注意シールは、ご注文仕様に基づいた言語で製作いたします。本パラメータを変更して言語を切り替えてご使用の場合はご注意願います。

Table 4-5 : Display language parameter / 表示言語設定パラメータ

Parameter パラメータ	Parameter name パラメータ名	No. of arrays No. of characters 配列数 文字数	Details explanation 内容説明	Default setting 出荷時 設定
Display lan- guage 表示言語設定	LNG	Character string 1 文字列 1	<p>Set up the display language. "JPN" : Japanese "ENG" : English</p> <p>The following language is changed. (1)The display LCD of teaching pendant. (2) Personal computer support software. *alarm message of the robot. *Parameter explanation list. (3)Alarm message that read from the robot with external communication. (Standard RS232C, Extended serial I/F, Ethernet I/F)</p> <p>表示言語を設定します。 "JPN" : 日本語表示 "ENG" : 英語表示</p> <p>以下に示す表示言語が変更されます。 (1) ティーチングボックスの表示 LCD (2) パソコンサポートソフトウェア ・ ロボットのアラームメッセージ ・ パラメータ説明リスト (3) 外部通信でロボットから読み出したアラームメッセージ (標準 RS232C、増設シリアルインタフェース、イーサネットインタフェース)</p>	1



## 5 Safety

### 5.1 Safety

Measures to be taken regarding safety of the industrial robot are specified in the "Labor Safety and Sanitation Rules". Always follow these rules when using the robot to ensure safety.

#### 5.1.1 Self-diagnosis stop functions

This robot has the self-diagnosis stop functions shown in [Table 5-1](#) and the stop functions shown in [Table 5-2](#) for safe use.

Table 5-1 : Self-diagnosis stop functions

No.	Function	Details	Remarks
1	Overload protection function	Activates when the total servo current time exceeds the specified value.	The drive circuit is shut off. The robot stops, and an alarm displays.
2	Overcurrent diagnosis function	Activates when an overcurrent flows to the motor circuit.	The drive circuit is shut off. The robot stops, and an alarm displays.
3	Encoder disconnection diagnosis function	Activates when the encoder cable is disconnected.	The drive circuit is shut off. The robot stops, and an alarm displays.
4	Deflection over diagnosis function	Activates when an error occurs between the command value and actual position, and the error exceeds the specified amount.	The drive circuit is shut off. The robot stops, and an alarm displays.
5	AC power voltage drop diagnosis function	Activates when the AC power voltage drops below the specified value.	The drive circuit is shut off. The robot stops, and an alarm displays.
6	CPU error detection function	Activates when an error occurs in the CPU.	The drive circuit is shut off. The robot stops, and an alarm displays.
7	Overrun prevention function	Software limit detection	This is the limit provided by the software to enable operation only in the operation range.
		Mechanical stopper	This is the mechanical stopper provided outside the software.

Table 5-2 : List of stop functions

Stop function	Operation panel	Teaching pendant	External input	Details
Emergency stop	○	○	○	This is the stop with the highest degree of emergency. The servo power is shut off, and the mechanical brakes (all axes) activate to stop the robot. To recover, reset the alarm, and turn the servo ON with the servo ON command.
Stop	○	○	○	This is a stop operation with a high degree of emergency. The robot immediately decelerates and stops. Note that the servo power is not shut off. Use this when using the collision evasion sensor, etc.

#### 5.1.2 External input/output signals that can be used for safety protection measures

Table 5-3 : External input/output signals that can be used for safety protection measures

	Signal	Command	Functions	Usage method
Input	External emergency stop	(Input signal)	This servo power is shut off, and the robot stops immediately.	Externally installed emergency stop switch. Door switch on safety protection fence. Stopping at high-level error occurrence.
	Stop	STOP	The program execution is stopped, and the robot stops. The servo power is not shut off.	The robot is stopped when a peripheral device fault occurs. The servo power is not shut off.
	Servo OFF	SRVOFF	The servo power can be shut off.	The robot is stopped when a peripheral device fault occurs. The servo power is not shut off.
	Automatic operation enable	AUTOENA	Disables automatic operation when inactive.	Door switch on safety protection fence
Output	In servo ON	SRVON	The servo power ON/OFF state is output.	The servo power ON/OFF state is shown and alerted with the display lamps.
	Waiting	STOP	Outputs that the robot is temporarily stopped.	The temporary stop state is shown and alerted with the display lamps.
	In alarm	ERRRESET	Outputs when an alarm occurs in the robot.	The alarm state is shown and alerted with the display lamps.

[Caution] The external emergency stop input is prepared as a b contact for safety proposes. Thus, if the emergency stop input circuit is opened when the robot is started up, the robot will not operate. Refer to "Fig. 5-1 Example of safety measures" for details.

### 5.1.3 Precautions for using robot

The safety measures for using the robot are specified in the "Labor Safety and Sanitation Rules". An outline of the rules is given below.

#### (1) Robot installation

- Secure sufficient work space required to safely perform work such as teaching and maintenance related to the robot.
- Install the controller outside the robot's motion space. (If a safety fence is provided, install outside the fence.)
- Install the controller where the entire robot operation can be viewed.
- Install display lamps, etc., to indicate the robot's operation state.
- Securely fix the robot arm onto the fixing table with the designated bolts.

#### (2) Prevention of contact with operator

- Install a safety fence or enclosure so that the operator cannot easily enter the robot's motion space.
- Install an interlock function that will stop the robot if the safety fence or enclosure door is opened.

#### (3) Work procedures

- Create and observe work procedures for the robot teaching, operation, inspection and emergencies.
- Create hand signals to be followed when several operators are working together.
- Create displays such as "Teaching in Progress" and "Inspection in Progress" to be put up when an operator is in the robot's motion space so that other operators will not operate the operation panel (controller, control panel).

#### (4) Training

- Train the operators about the operations, maintenance and safety required for the robot work.
- Only trained and registered operators must operate the robot.  
Participation in the "Special training for industrial robots" sponsored by the Labor Safety and Sanitation Committee, etc., is recommended for safety training.

#### (5) Daily inspection and periodic inspection

- Always inspect the robot before starting daily operations and confirm that there are no abnormalities.
- Set the periodic inspection standards in view of the robot's ambient environment and operation frequency, and perform periodic inspections.
- Make records when periodic inspections and repairs have been done, and store the records for three or more years.

### 5.1.4 Safety measures for automatic operation

- (1) Install safety fences so that operators will not enter the operation area during operation and indicate that automatic operation is in progress with lamps, etc.
- (2) Create signals to be given when starting operation, assign a person to give the signal, and make sure that the operator follows the signals.

### 5.1.5 Safety measures for teaching

Observe the following measures when teaching, etc., in the robot's operation range.

- (1) Specify and follow items such as procedures related to teaching work, etc.
- (2) Take measures so that operation can be stopped immediately in case of trouble, and measures so that operation can be restarted.
- (3) Take measures with the robot start switch, etc., to indicate that teaching work is being done.
- (4) Always inspect that stop functions such as the emergency stop device before starting the work.
- (5) Immediately stop the work when trouble occurs, and correct the trouble.
- (6) Take measures so that the work supervisor can immediately stop the robot operation when trouble occurs.
- (7) The teaching operator must have completed special training regarding safety. (Training regarding industrial robots and work methods, etc.)
- (8) Create signals to be used when several operators are working together.

### 5.1.6 Safety measures for maintenance and inspections, etc.

Turn the power OFF and take measures to prevent operators other than the relevant operator from pressing the start switch when performing inspections, repairs, adjustments, cleaning or oiling.

If operation is required, take measures to prevent hazards caused by unintentional or mistaken operations.

- (1) Specify and follow items such as procedures related to maintenance work, etc.
- (2) Take measures so that operation can be stopped immediately in case of trouble, and measures so that operation can be restarted.
- (3) Take measures with the robot start switch, etc., to indicate that work is being done.
- (4) Take measures so that the work supervisor can immediately stop the robot operation when trouble occurs.
- (5) The operator must have completed special training regarding safety. (Training regarding industrial robots and work methods, etc.)
- (6) Create signals to be used when several operators are working together.

### 5.1.7 Examples of safety measures

Emergency stop input circuits are prepared on the user wiring terminal block of the controller. Create a circuit as shown below for safety measures

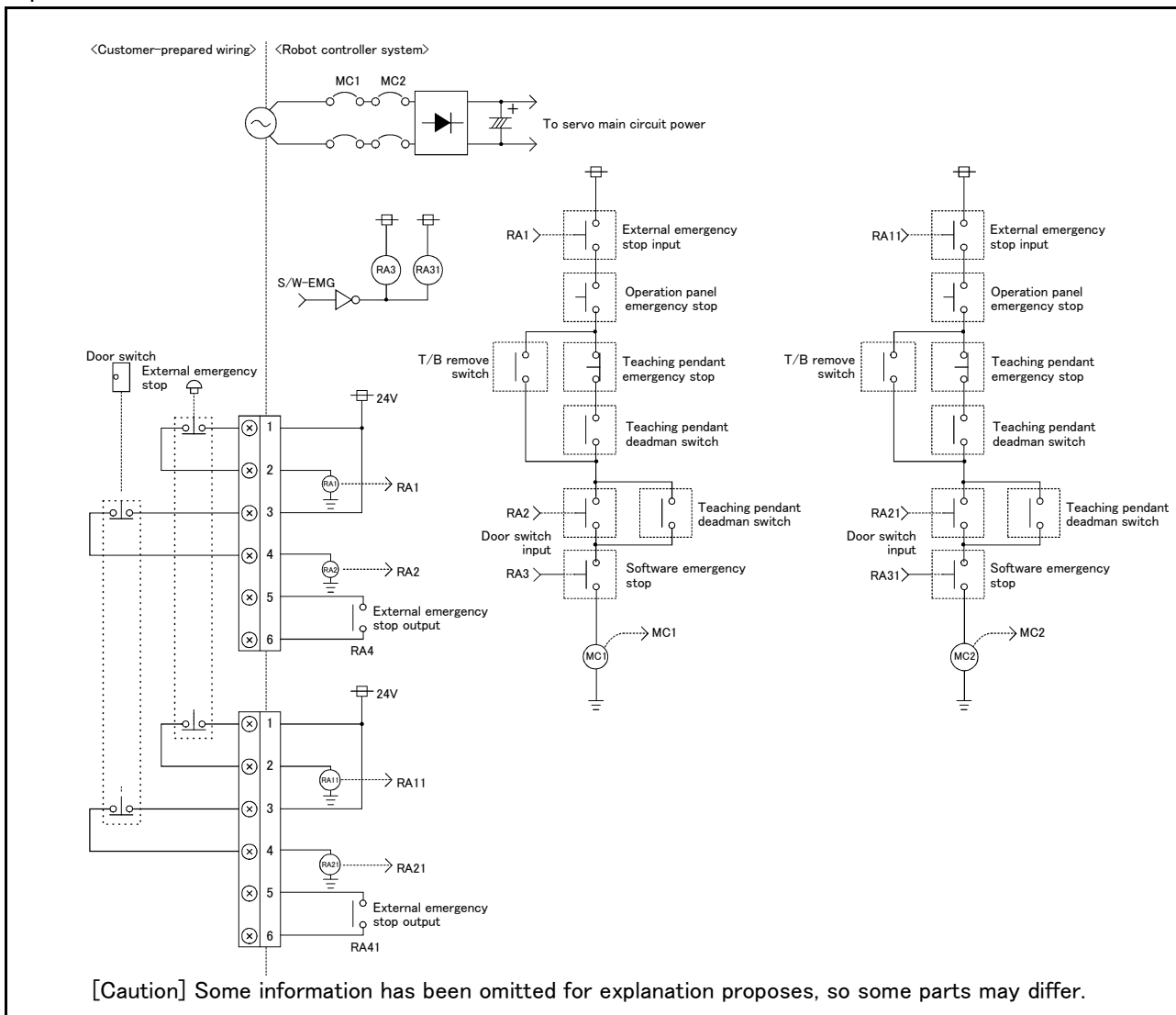

Fig.5-1 : Example of safety measures

- (1) Use a 2-contact type switch for all switches.
- (2) Install a limit switch on the safety fence's door. With a constantly open contact (a contact), wire to the door switch input terminal so that the switch turns ON (is conducted) when the door is closed, and turns OFF (is opened) when the door is open.
- (3) Use a 2b contact manual-return type operator emergency stop switch.
- (4) Classify the faults into minor faults (faults that are easily restored and that do not have a great effect) and major faults (faults that cause the entire system to stop immediately, and that require care in restoration), and wire accordingly.

[Caution] The emergency stop input (terminal block) on the user wiring in the controller can be used for safety measures as shown in Fig. 5-1. Note that there are limits to the No. of switch contacts, capacity and cable length, so refer to the following and install.

- Switch contact ..... Prepare a 2-contact type.
- Switch contact capacity ..... Use a contact that operates with a switch contact capacity of approx. 1mA to 100mA/24V.
- Cable length ..... The length of the wire between the switch and terminal block must be max. 15m or less.

[Reference] The specifications of the RA1 and RA2 coil shown in Fig. 5-1 are as follow.

- Rated voltage ..... DC24V  $\pm$  10%
- Rated excitation current ..... 12.5mA  $\pm$  10% (at 25 deg.)

\* Note that these specifications are subject to change without prior notice for modification purposes.

## 5.2 Working environment

Avoid installation in the following places as the equipment's life and operation will be affected by the ambient environment conditions. When using in the following conditions, the customer must pay special attention to the preventive measures.

(1) Power supply

- Where the voltage fluctuation will exceed the input voltage range.
- Where a momentary power failure exceeding 20ms may occur.
- Where the power capacity cannot be sufficiently secured.

(2) Noise

- Where a surge voltage exceeding 1000V, 1  $\mu$  s may be applied on the primary voltage. Near large inverters, high output frequency oscillator, large contactors and welding machines. Static noise may enter the lines when this product is used near radios or televisions. Keep the robot away from these items.

(3) Temperature and humidity

- Where the atmospheric temperature exceeds 40 degree , lower than 0 degree.
- Where the relative humidity exceeds 85%, lower than 45%, and where dew may condense.
- Where the robot will be subject to direct sunlight or near heat generating sources such as heaters.

(4) Vibration

- Where excessive vibration or impact may be applied. (Use in an environment of 34m/s<sup>2</sup> or less during transportation and 5m/s<sup>2</sup> or less during operation.)

(5) Installation environment

- Where strong electric fields or magnetic fields are generated.
- Where the installation surface is rough. (Avoid installing the robot on a bumpy or inclined floor.)

## 5.3 Precautions for handling

- (1) This robot has brakes on J3 axis. The RH-15AH85 has brakes on J3 and J4 axes. The precision of the robot may drop, looseness may occur and the reduction gears may be damaged if the robot is moved with force with the brakes applied.
- (2) Avoid moving the robot arm by hand. When unavoidable, gradually move the arm. If moved suddenly, the accuracy may drop due to an excessive backlash, or the backed up data may be destroyed.
- (3) Note that depending on the posture, even when within the movement range, the shaft section could interfere with the base section. Take care to prevent interference during jog. <sup>Note1)</sup>
- (4) The robot arm is configured of precision parts such as bearings. Grease is used for lubricating these parts. When cold starting at low temperatures or starting operation after long-term stoppage, the position accuracy may drop or servo alarms may occur. If these types of phenomena occur, run the robot with low-speed operation for a short time.
- (5) The robot arm and controller must be grounded with Class D grounding to secure the noise resistance and to prevent electric shocks.
- (6) The items described in these specifications are conditions for carrying out the periodic maintenance and inspections described in the instruction manual.
- (7) When using the robot arm on a mobile axis or elevating table, the machine cables enclosed as standard configuration may break due to the fixed installation specifications. In this case, use the machine cable extension (for flexed)" factory shipment special specifications or options.
- (8) If this robot interferes with the workpiece or peripheral devices during operation, the position may deviate, etc. Take care to prevent interference with the workpiece or peripheral devices during operation.
- (9) Do not attach a tape or a label to the robot arm and the controller. If a tape or a label with strong adhesive power, such as a packaging tape, is attached to the coated surfaces of the robot arm and controller, the coated surface may be damaged when such tape or label is peeled off.

---

Note1)Jog operation refers to operating the robot manually using the teaching pendant.

## 6 Appendix

## Appendix 1 : Specifications discussion material

## ■ Customer information

Company name		Name	
Address		Telephone	

## ■ Purchased mode

Specification	Type			
Standard specification	<input type="checkbox"/> RH-5AH35	<input type="checkbox"/> RH-5AH45	<input type="checkbox"/> RH-5AH55	
	<input type="checkbox"/> RH-10AH55	<input type="checkbox"/> RH-10AH70	<input type="checkbox"/> RH-10AH85	<input type="checkbox"/> RH-15AH85
Protection specifications	<input type="checkbox"/> RH-5AHM35	<input type="checkbox"/> RH-5AHM45	<input type="checkbox"/> RH-5AHM55	
	<input type="checkbox"/> RH-10AHM55	<input type="checkbox"/> RH-10AHM70	<input type="checkbox"/> RH-10AHM85	<input type="checkbox"/> RH-15AHM85
Clean specifications	<input type="checkbox"/> RH-5AHC35-SA	<input type="checkbox"/> RH-5AHC45-SA	<input type="checkbox"/> RH-5AHC55-SA	

## ■ Shipping special specifications (Settings can be made only at time of shipment)

Item		Standard specifications	Special shipping specifications
Robot arm	Machine cable	<input type="checkbox"/> 5m type	<input type="checkbox"/> 10m fixed type <input type="checkbox"/> 15m fixed type <input type="checkbox"/> 5m flexed type <input type="checkbox"/> 10m flexed type <input type="checkbox"/> 15m flexed type
Controller	Controller structure	<input type="checkbox"/> Floor type	

## ■ Options (Installable after shipment)

Item		Provision, and specifications when provided.
Robot arm	Solenoid valve set (Standard specification:RH-5AH)	1E-VD0 <input type="checkbox"/> /VD0 <input type="checkbox"/> E <input type="checkbox"/> Not provided 1E-VD0 <input type="checkbox"/> : <input type="checkbox"/> 1 set <input type="checkbox"/> 2 sets <input type="checkbox"/> 3 sets <input type="checkbox"/> 4 sets 1E-VD0 <input type="checkbox"/> E: <input type="checkbox"/> 1 set <input type="checkbox"/> 2 sets <input type="checkbox"/> 3 sets <input type="checkbox"/> 4 sets
	Solenoid valve set (Protection specifications:RH-5AH)	1A-VD0 <input type="checkbox"/> M-01/ 1A-VD0 <input type="checkbox"/> ME-01 <input type="checkbox"/> Not provided 1A-VD0 <input type="checkbox"/> M-01 : <input type="checkbox"/> 1 set <input type="checkbox"/> 2 sets <input type="checkbox"/> 3 sets <input type="checkbox"/> 4 sets 1A-VD0 <input type="checkbox"/> ME-01: <input type="checkbox"/> 1 set <input type="checkbox"/> 2 sets <input type="checkbox"/> 3 sets <input type="checkbox"/> 4 sets
	Solenoid valve set (Standard specification:RH-10AH/15AH)	1N-VD0 <input type="checkbox"/> /VD0 <input type="checkbox"/> E <input type="checkbox"/> Not provided 1N-VD0 <input type="checkbox"/> : <input type="checkbox"/> 1 set <input type="checkbox"/> 2 sets <input type="checkbox"/> 3 sets <input type="checkbox"/> 4 sets 1N-VD0 <input type="checkbox"/> E: <input type="checkbox"/> 1 set <input type="checkbox"/> 2 sets <input type="checkbox"/> 3 sets <input type="checkbox"/> 4 sets
	Solenoid valve set (Protection specifications:RH-10AH/15AH)	1A-VD0 <input type="checkbox"/> M-02/ 1A-VD0 <input type="checkbox"/> ME-02 <input type="checkbox"/> Not provided 1A-VD0 <input type="checkbox"/> M-02 : <input type="checkbox"/> 1 set <input type="checkbox"/> 2 sets <input type="checkbox"/> 3 sets <input type="checkbox"/> 4 sets 1A-VD0 <input type="checkbox"/> ME-02: <input type="checkbox"/> 1 set <input type="checkbox"/> 2 sets <input type="checkbox"/> 3 sets <input type="checkbox"/> 4 sets
	Hand input cable	1A-HC35C <input type="checkbox"/> Not provided <input type="checkbox"/> Provided
	Hand output cable	1N-GR35S <input type="checkbox"/> Not provided <input type="checkbox"/> Provided
	Hand curl tube	1E-ST040 <input type="checkbox"/> C-300 <input type="checkbox"/> Not provided <input type="checkbox"/> 1 pc. <input type="checkbox"/> 2 pc. <input type="checkbox"/> 3 pc. <input type="checkbox"/> 4 pc.
Controller	Teaching pendant	R28TB- <input type="checkbox"/> <input type="checkbox"/> <input type="checkbox"/> Not provided <input type="checkbox"/> 7m <input type="checkbox"/> 15m
	Pneumatic hand interface	2A-RZ365/2A-RZ375 <input type="checkbox"/> Not provided <input type="checkbox"/> Provided
	Parallel I/O interface	2A-RZ361/2A-RZ371 <input type="checkbox"/> Not provided <input type="checkbox"/> 1pc. <input type="checkbox"/> 2pc. <input type="checkbox"/> 3pc. <input type="checkbox"/> 4pc. <input type="checkbox"/> 5pc. <input type="checkbox"/> 6pc. <input type="checkbox"/> 7pc.
	External I/O cable	2A-CBL <input type="checkbox"/> <input type="checkbox"/> <input type="checkbox"/> Not provided <input type="checkbox"/> 5m-1pc. <input type="checkbox"/> 5m-2pc. <input type="checkbox"/> 5m-3pc. <input type="checkbox"/> 15m-1pc. <input type="checkbox"/> 15m-2pc. <input type="checkbox"/> 15m-3pc.
	CC-LINK interface	2A-HR575E <input type="checkbox"/> Not provided <input type="checkbox"/> Provided
	ETHERNET interface	2A-HR533E <input type="checkbox"/> Not provided <input type="checkbox"/> Provided
	Extended serial interface	2A-RZ581E <input type="checkbox"/> Not provided <input type="checkbox"/> Provided
	Additional axis interface	2A-RZ541E <input type="checkbox"/> Not provided <input type="checkbox"/> Provided
	Extended memory cassette	2A-HR432 <input type="checkbox"/> Not provided <input type="checkbox"/> Provided
	Personal computer cable	RS-MAXY-CBL <input type="checkbox"/> Not provided <input type="checkbox"/> Provided
	Personal computer support software	3A-01C-WINE <input type="checkbox"/> Not provided <input type="checkbox"/> Windows95/98/NT4.0 CD-ROM
	Personal computer support software mini	3A-02C-WINE <input type="checkbox"/> Not provided <input type="checkbox"/> Windows95/98/NT4.0 CD-ROM
	Controller protection box	CR2A-MB <input type="checkbox"/> Not provided <input type="checkbox"/> Provided

Note1) Up to eight units, including the one unit mounted as a standard.

## ■ Maintenance parts (Consumable parts)

Maintenance parts	<input type="checkbox"/> Backup batteries A6BAT ( ) pcs. <input type="checkbox"/> Backup batteries ER6 ( ) pcs. <input type="checkbox"/> Grease SK-1 ( ) cans. <input type="checkbox"/> Grease Marutenpu PS2 ( ) cans.
-------------------	---

## ■ Robot selection check list

Work description	<input type="checkbox"/> Material handling <input type="checkbox"/> Assembly <input type="checkbox"/> Machining L/UL <input type="checkbox"/> Sealing <input type="checkbox"/> Testing and inspection <input type="checkbox"/> Other ( )			
Workpiece mass ( )g	Hand mass ( )g	Atmosphere	<input type="checkbox"/> General environment <input type="checkbox"/> Clean <input type="checkbox"/> Dust provided <input type="checkbox"/> Other( )	
Remarks				

Copy this page and use the copy.





ZERTIFIKAT ◆ CERTIFICATE ◆ 認証証書 ◆ CERTIFICADO ◆ CERTIFICAT

# EC Certificate of Conformity



**No.: E9 02 04 25554 005**

concerning the EMC protection requirements in accordance with Article 10 of the Council Directive 89/336/EEC on electromagnetic compatibility for

**Mitsubishi Electric Corporation  
Mitsubishi Denki Bldg.  
Marunouchi, Tokyo 100-8310  
Japan**

**Item Identification: Industrial Scientific and Medical Equipment  
RH-5AHxx, RH-10AHxx, RH-15AHxx series  
(see Attachment 1 for Grouping)**

**Item Description: Industrial Robot  
230VAC, 3.5kVA  
Protection class I**

**Project-/TCF No.: TYOEMC13143A**

This Certificate of Conformity was issued in accordance with Article 10.2 of the Council Directive 89/336 EEC on the harmonization of the laws of the Member States relating to electromagnetic compatibility. It was transposed into the "Gesetz über die elektromagnetische Verträglichkeit von Geräten vom 9. November 1992 (EMVG, § 5.2)" in Germany. This certificate does not contain any statements pertaining to the EMC protection requirements governed by other laws which serve to implement EC Directives other than the aforementioned Council Directive 89/336 EEC. This certificate or the technical report refers only to the tested sample or product family listed in the above mentioned Project-/TCF documentation.

This certificate does not permit the use of a TÜV PRODUCT SERVICE certification mark on the tested product.

Released with the above mentioned certificate number by the certification body of TÜV PRODUCT SERVICE.

  
**Robert Binder**  
Stv. des Leiters  
der zuständigen Stelle



**Department: TYOEMC/Robert Binder  
Date: 22.04.2002**

TÜV Product Service GmbH is Competent Body in accordance with EMC Directive 89/336/EEC (BMPT VFG. 91/1992).

Anlage 1 zum Zertifikat  
Certificate Attachment 1

Seite 1 von 1  
Page 1 of 1

Zertifikat Nr./  
Certificate No. **E9 02 04 25554 005**

Grouping:

RH-5AH35  
RH-5AH45  
RH-5AH55  
RH-5AHM35  
RH-5AHM45  
RH-5AHM55  
RH-5AHC35-SA  
RH-5AHC45-SA  
RH-5AGC55-SA  
RH-10AH55  
RH-10AH70  
RH-10AH85  
RH-15AH85  
RH-10AHM55  
RH-10AHM70  
RH-10AHM85  
RH-15AHM85

Total: 17

Organisationseinheit / Organization unit: / Robert Binder / SS  
Datum / Date: 4/22/02

TÜV PRODUCT SERVICE GMBH, Ridlerstrasse 65, D-80339 Munich, Germany

  
\_\_\_\_\_

## DECLARATION OF CONFORMITY

We

(Company) : MITSUBISHI ELECTRIC CORPORATION  
MITSUBISHI DENKI BLDG., Marunouchi, Tokyo 100-0081, Japan  
(Factory) : NAGOYA WORKS  
1-14, Yadaminami 5, Higashiku, Nagoya 461-8670, Japan

explain in own responsibility, that the products:

Kind of equipment :  
**INDUSTRIAL ROBOT**  
Type-designation :  
**RH-5AHxx Series**  
(See attached sheet to identify the type of model.)

are in compliance with following norms or documents:

1. Machinery Directive(89/392/EEC),Amendment(91/368/EEC),(93/68/EEC)  
(a) Type A : Fundamental safety standards  
EN292-1/1991, EN292-2/1991, EN1050/1996  
(b) Type B : Group safety standards  
B1 : Safety aspects  
EN60204-1/1997(partly unconformed), EN294/1992, EN349/1993,  
EN457/1992, EN999/1993, prEN1005-2/1993  
B2 : Safety related devices  
EN418 : 1992  
(c) Type C : Machine safety standards  
EN775 : 1992

2. EMC Directive(89/336/EEC),Amendment(92/31/EEC)  
(a) EN55011/May.1998, Group1, Class A  
(b) EN61000-6-2/ 1999

Manager  
Robot Systems Department in Nagoya Works

Nagoya, Japan / October 15, 2001

\_\_\_\_\_  
Manufacture/Authorized representative

Takeshi Yatomi *Takeshi Yatomi*  
Place and date of issue name and signature

■ Declaration Type of models

A.4-axis Robot Arm (RH-5AHxx Series)

Model Name	Language	Robot Arm	Controller	Software Version
<b>RH-5AH35</b>	Japanese	BU160C364G51	—	G9 or Later
	English	BU160C364G54	TU117C233G01	
	German	BU160C364G57	TU117C234G01	
<b>RH-5AH45</b>	Japanese	BU160C364G52	—	G9 or Later
	English	BU160C364G55	TU117C233G01	
	German	BU160C364G58	TU117C234G01	
<b>RH-5AH55</b>	Japanese	BU160C364G53	—	G9 or Later
	English	BU160C364G56	TU117C233G01	
	German	BU160C364G59	TU117C234G01	
<b>RH-5AHM35</b>	Japanese	BU160C364G61	—	G9 or Later
	English	BU160C364G64	TU117C233G01	
	German	BU160C364G67	TU117C234G01	
<b>RH-5AHM45</b>	Japanese	BU160C364G62	—	G9 or Later
	English	BU160C364G65	TU117C233G01	
	German	BU160C364G68	TU117C234G01	
<b>RH-5AHM55</b>	Japanese	BU160C364G63	—	G9 or Later
	English	BU160C364G66	TU117C233G01	
	German	BU160C364G69	TU117C234G01	
<b>RH-5AHC35-SA</b>	Japanese	BU160C364G71	—	G9 or Later
	English	BU160C364G74	TU117C233G01	
	German	BU160C364G77	TU117C234G01	
<b>RH-5AHC45-SA</b>	Japanese	BU160C364G72	—	G9 or Later
	English	BU160C364G75	TU117C233G01	
	German	BU160C364G78	TU117C234G01	
<b>RH-5AHC55-SA</b>	Japanese	BU160C364G73	—	G9 or Later
	English	BU160C364G76	TU117C233G01	
	German	BU160C364G79	TU117C234G01	

## DECLARATION OF CONFORMITY

We

(Company) : MITSUBISHI ELECTRIC CORPORATION  
MITSUBISHI DENKI BLDG., Marunouchi, Tokyo 100-0081, Japan  
(Factory) : NAGOYA WORKS  
1-14, Yadaminami 5, Higashiku, Nagoya 461-8670, Japan

explain in own responsibility, that the products:

Kind of equipment :  
**INDUSTRIAL ROBOT**  
Type-designation :  
**RH-10AHxx, RH-15AHxx Series**  
(See attached sheet to identify the type of model.)

are in compliance with following norms or documents:

1. Machinery Directive(89/392/EEC),Amendment(91/368/EEC),(93/68/EEC)
  - (a) Type A : Fundamental safety standards  
EN292-1/1991, EN292-2/1991, EN1050/1996
  - (b) Type B : Group safety standards
    - B1 : Safety aspects  
EN60204-1/1997(partly unconformed), EN294/1992, EN349/1993,  
EN457/1992, EN999/1993, prEN1005-2/1993
    - B2 : Safety related devices  
EN418 : 1992
  - (c) Type C : Machine safety standards  
EN775 : 1992

2. EMC Directive(89/336/EEC),Amendment(92/31/EEC)
  - (a) EN55011/May.1998, Group1, Class A
  - (b) EN61000-6-2/ 1999

Manager  
Robot Systems Department in Nagoya Works

Nagoya, Japan / December 25, 2001

\_\_\_\_\_  
Manufacture/Authorized representative

Takeshi Yatomi *Takeshi Yatomi*  
Place and date of issue name and signature

■ Declaration Type of models

A.4-axis Robot Arm (RH-10/15AH)

Model Name	Language	Robot Arm	Controller	Software Version
<b>RH-10AH55</b>	Japanese	BU160C381G51	TU117C221G01	G9 or Later
	English	BU160C381G55		
	German	BU160C381G59		
<b>RH-10AH70</b>	Japanese	BU160C381G52	TU117C221G01	G9 or Later
	English	BU160C381G56		
	German	BU160C381G60		
<b>RH-10AH85</b>	Japanese	BU160C381G53	TU117C221G01	G9 or Later
	English	BU160C381G57		
	German	BU160C381G61		
<b>RH-15AH85</b>	Japanese	BU160C381G54	TU117C221G01	G9 or Later
	English	BU160C381G58		
	German	BU160C381G62		
<b>RH-10AHM55</b>	Japanese	BU160C381G63	TU117C221G01	G9 or Later
	English	BU160C381G67		
	German	BU160C381G71		
<b>RH-10AHM70</b>	Japanese	BU160C381G64	TU117C221G01	G9 or Later
	English	BU160C381G68		
	German	BU160C381G72		
<b>RH-10AHM85</b>	Japanese	BU160C381G65	TU117C221G01	G9 or Later
	English	BU160C381G69		
	German	BU160C381G73		
<b>RH-15AHM85</b>	Japanese	BU160C381G66	TU117C221G01	G9 or Later
	English	BU160C381G70		
	German	BU160C381G74		



HEAD OFFICE : MITSUBISHI DENKI BLDG MARUNOUCHI TOKYO 100-8310 TELEX : J24532 CABLE MELCO TOKYO  
NAGOYA WORKS : 1-14, YADA-MINAMI 5, HIGASHI-KU, NAGOYA, JAPAN