



TRANSISTORIZED INVERTER
INSTRUCTION MANUAL

HIGH-DUTY BRAKE RESISTOR

FR-ABR-(H)0.4K to 22K

Thank you for choosing the Mitsubishi Electric transistorized inverter option unit.

This Instruction Manual provides handling information and precautions for use of this product.

Incorrect handling might cause an unexpected fault. Before using this product, read all relevant Instruction Manuals carefully to ensure proper use.

Please forward this Instruction Manual to the end user.

Safety Instructions

Do not attempt to install, operate, maintain or inspect this product until you have read this Instruction Manual and supplementary documents carefully.

Do not use this product until you have a full knowledge of this product, safety information and instructions.

In this manual, the safety instruction levels are classified into "WARNING" and "CAUTION".



Denotes that incorrect handling may cause hazardous conditions, resulting in death or severe injury.



Denotes that incorrect handling may cause hazardous conditions, resulting in medium or slight injury, or may cause physical damage only.

Note that even the  CAUTION level may lead to a serious consequence under some circumstances. Please follow the instructions of both levels as they are important to personnel safety.

SAFETY INSTRUCTIONS

1. Electric Shock Prevention



WARNING

- Before wiring or inspection, check that the display of the inverter operation panel is OFF. Any person who is involved in wiring or inspection shall wait for 10 minutes or longer after power OFF and check that there are no residual voltage using a tester or the like. The capacitor is charged with high voltage for some time after power OFF, and it is dangerous.
- Any person who is involved in wiring or inspection of this product shall be fully competent to do the work.

2. Fire Prevention

CAUTION

- Mount the brake resistor on a nonflammable surface. Installing it directly on or near a flammable surface could cause a fire.
- Use the alarm signal to switch power OFF. A failure to do so can overheat the brake resistor due to a brake transistor failure etc., causing a fire.

3. Injury Prevention

CAUTION

- Ensure that the cables are connected to the correct terminals. Otherwise, damage, etc. may occur.
- While power is ON or for some time after power-OFF, do not touch the brake resistor as it is hot. Touching it can cause burns.

4. Additional Instructions

Also note the following points to prevent an accidental failure, injury, electric shock, etc.:

(1) Transportation and installation

CAUTION

- Transport products in a correct manner according to their weights. Not doing so can cause injury.
- Install the product in a place secure enough to withstand its weight according to the Instruction Manual.

(2) Usage

WARNING

- Do not modify this product.
- Do not perform parts removal which is not instructed in this manual. Doing so may lead to fault or damage of the inverter.

(3) Disposal

CAUTION

- Dispose of this product as general industrial waste.

(4) General instructions

Many of the diagrams and drawings in this Instruction Manual show the inverter without a cover, or partially open. Never run the inverter like this. Always replace the cover and follow the Instruction Manual when operating the inverter.

Instructions for compliance with the EU Directives

The EU Directives are issued to standardize different national regulations of the EU Member States and to facilitate free movement of the equipment, whose safety is ensured, in the EU territory.

Since 1996, compliance with the EMC Directive that is one of the EU Directives has been legally required. Since 1997, compliance with the Low Voltage Directive, another EU Directive, has been also legally required. When a manufacturer confirms its equipment to be compliant with the EMC Directive and the Low Voltage Directive, the manufacturer must declare the conformity and affix the CE marking.

- The authorized representative in the EU
The authorized representative in the EU is shown below.
Name: Mitsubishi Electric Europe B.V.
Address: Mitsubishi-Electric-Platz 1, 40882 Ratingen, Germany

- **Low Voltage Directive**

We declare that the FR-ABR (high-duty brake resistor as an inverter option) is compliant with the Low Voltage Directive (Conforming standard EN 61800-5-1) and affix the CE marking on the resistor.

- Use the brake resistor with the inverters compliant with the EU Directive. Refer to the table on page 1 for the applicable inverters.
- **Installation precautions**
 - The brake resistor may be mounted horizontally or vertically, depending on a suitable location.
 - When the brake resistor is mounted externally to the enclosure housing the inverter, install a solid enclosure at least 8 times the volume size of the brake resistor that incorporates mesh or perforated steel type ventilation openings at each end of the resistor. Note, the vent openings shall not be greater than 10 mm diameter.
 - The brake resistor has been approved as the open type products (IP00).
To use the brake resistor under the conditions of pollution degree 2, install it in the enclosure of IP2X or higher.
To use the brake resistor under the conditions of pollution degree 3, install it in the enclosure of IP54 or higher.
 - Install the brake resistor on nonflammable material.
 - When installing the brake resistor inside of the enclosure that contains the inverter, the mesh or slit of the enclosure surface is not necessarily required. Keep the temperature inside the enclosure lower than 50°C.
 - A burn may be caused by a high temperature surface of the brake resistor enclosure. Place an IEC 60417-5041 warning symbol and the following notice (font at least 3.2 mm high) on the front panel of the enclosure in a place that is easily visible.

CAUTION: HOT SURFACE. TO REDUCE RISK OF BURN - DO NOT TOUCH.

- **Wiring precautions**

When using the brake resistor with a lead wire extended, use wires of the type and size set forth in EN 60204-1, and the wiring length should be five meters or less. Perform wiring in accordance with any applicable local codes.

- **Installation environment**

The brake resistor must be used under the following environment. When using the brake resistor with the inverter, use it under the environment for the inverter.

	During operation	In storage	During transportation
Surrounding air temperature	-10°C to +50°C	-20°C to +65°C	-20°C to +65°C
Ambient humidity	95% RH or less	95% RH or less	95% RH or less
Maximum altitude	3000m	3000m	10000m

INSTALLATION INSTRUCTIONS FOR COMPLIANCE WITH UL

Install the high-duty brake resistor FR-ABR as follows:

- The brake resistor may be mounted horizontally or vertically, depending on a suitable surface location.
- When the brake resistor is mounted externally to the enclosure housing the inverter, install a solid Type 1 enclosure at least 8 times the volume size of the brake resistor that incorporates mesh or perforated steel type ventilation openings at each end of the resistor.

Note, the vent openings shall not be greater than 10 mm diameter.

- Secure the enclosure to a nonflammable surface only, such as metal or concrete.
- Mount the brake resistor inside the Type 1 enclosure and wire it in accordance with the NEC for North America installations or any other local codes.

Note, when the brake resistor and inverter are mounted together within a suitable enclosure, the mesh covering is not required. Take care that the temperature inside the enclosure does not exceed 50°C.

Since the enclosure surface becomes a high temperature, its presents a possible burn hazard. After installation, the following marking in minimum 3.2 mm (1/8 in.) sized lettering shall be provided on the enclosure where visible:

CAUTION: HOT SURFACE. TO REDUCE RISK OF BURN - DO NOT TOUCH.

- The brake resistor is a UL listed accessory that can be used with the UL listed inverters listed in the table on page 1.

Instructions for EAC



The product certified in compliance with the Eurasian Conformity has the EAC marking.

Note: EAC marking

In 2010, three countries (Russia, Belarus, and Kazakhstan) established a Customs Union for the purposes of revitalizing the economy by forming a large economic bloc by abolishing or reducing tariffs and unifying regulatory procedures for the handling of articles.

Products to be distributed over these three countries of the Customs Union must comply with the Customs Union Technical Regulations (CU-TR), and the EAC marking must be affixed to the products.

1. UNPACKING AND CHECKING THE MODEL AND APPLICABLE INVERTERS

Take the brake resistor out of the package and confirm that the product is as you ordered and intact.

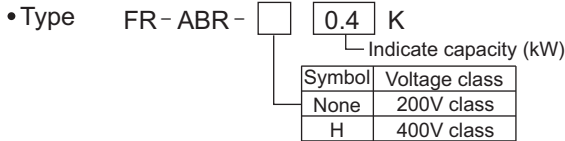

(For the FR-ABR-H15K, a terminal block for connecting resistors is enclosed as two resistors need to be connected in series.) FR-ABR-15K is indicated on the resistor. (A type name indicated on the package is different.)

To use the FR-ABR Series brake resistor as a UL listed or EU Directive compliant accessory, use it with the following UL listed or EU Directive compliant inverters.

High-Duty Brake Resistor Model		Applicable Inverter Models
200V Class	FR-ABR-0.4K	FR-A720-0.4K(-**), FR-E720(EX)-0.4K(-**), FR-E720S-0.4K(-**), FR-E710W-0.4K(-**), FR-D720-0.4K(-**), FR-D720S-0.4K(-**), FR-D710W-0.4K(-**), FR-F720PJ-0.4K(-**), FR-A820-00046(0.4K)(-**)
	FR-ABR-0.75K	FR-A720-0.75K(-**), FR-E720(EX)-0.75K(-**), FR-E720S-0.75K(-**), FR-E710W-0.75K(-**), FR-D720-0.75K(-**), FR-D720S-0.75K(-**), FR-D710W-0.75K(-**), FR-F720PJ-0.75K(-**), FR-A820-00077(0.75K)(-**)
	FR-ABR-2.2K	FR-A720-1.5K(-**), FR-A720-2.2K(-**), FR-E720(EX)-1.5K(-**), FR-E720(EX)-2.2K(-**), FR-E720S-1.5K(-**), FR-E720S-2.2K(-**), FR-D720-1.5K(-**), FR-D720-2.2K(-**), FR-D720S-1.5K(-**), FR-D720S-2.2K(-**), FR-F720PJ-1.5K(-**), FR-F720PJ-2.2K(-**), FR-A820-00105(1.5K)(-**), FR-A820-00167(2.2K)(-**)
	FR-ABR-3.7K	FR-A720-3.7K(-**), FR-E720(EX)-3.7K(-**), FR-D720-3.7K(-**), FR-F720PJ-3.7K(-**), FR-A820-00250(3.7K)(-**)
	FR-ABR-5.5K	FR-A720-5.5K(-**), FR-E720-5.5K(-**), FR-D720-5.5K(-**), FR-F720PJ-5.5K(-**), FR-A820-00340(5.5K)(-**)
	FR-ABR-7.5K	FR-A720-7.5K(-**), FR-E720-7.5K(-**), FR-D720-7.5K(-**), FR-F720PJ-7.5K(-**), FR-A820-00490(7.5K)(-**)
	FR-ABR-11K	FR-A720-11K(-**), FR-E720-11K(-**), FR-D720-11K(-**), FR-F720PJ-11K(-**), FR-A820-00630(11K)(-**)
	FR-ABR-15K	FR-A720-15K(-**), FR-E720-15K(-**), FR-D720-15K(-**), FR-F720PJ-15K(-**), FR-A820-00770(15K)(-**)
	FR-ABR-22K	FR-A720-18.5K(-**), FR-A720-22K(-**), FR-A820-00930(18.5K)(-**), FR-A820-01250(22K)(-**)

Note: ** indicates alpha numeric combination which means an inverter type such as A1 and A2.

High-Duty Brake Resistor Model		Applicable Inverter Models
400V Class	FR-ABR-H0.4K	FR-A740-0.4K(-**), FR-E740-0.4K(-**), FR-D740-0.4K(-**), FR-F740PJ-0.4K(-**), FR-A840-00023(0.4K)(-**)
	FR-ABR-H0.75K	FR-A740-0.75K(-**), FR-E740-0.75K(-**), FR-D740-0.75K(-**), FR-F740PJ-0.75K(-**), FR-A840-00038(0.75K)(-**)
	FR-ABR-H1.5K	FR-A740-1.5K(-**), FR-E740-1.5K(-**), FR-D740-1.5K(-**), FR-F740PJ-1.5K(-**), FR-A840-00052(1.5K)(-**)
	FR-ABR-H2.2K	FR-A740-2.2K(-**), FR-E740-2.2K(-**), FR-D740-2.2K(-**), FR-F740PJ-2.2K(-**), FR-A840-00083(2.2K)(-**)
	FR-ABR-H3.7K	FR-A740-3.7K(-**), FR-E740-3.7K(-**), FR-D740-3.7K(-**), FR-F740PJ-3.7K(-**), FR-A840-00126(3.7K)(-**)
	FR-ABR-H5.5K	FR-A740-5.5K(-**), FR-E740-5.5K(-**), FR-D740-5.5K(-**), FR-F740PJ-5.5K(-**), FR-A840-00170(5.5K)(-**)
	FR-ABR-H7.5K	FR-A740-7.5K(-**), FR-E740-7.5K(-**), FR-D740-7.5K(-**), FR-F740PJ-7.5K(-**), FR-A840-00250(7.5K)(-**)
	FR-ABR-H11K	FR-A740-11K(-**), FR-E740-11K(-**), FR-D740-11K(-**), FR-F740PJ-11K(-**), FR-A840-00310(11K)(-**)
	FR-ABR-H15K	FR-A740-15K(-**), FR-E740-15K(-**), FR-D740-15K(-**), FR-F740PJ-15K(-**), FR-A840-00380(15K)(-**)
	FR-ABR-H22K	FR-A740-18.5K(-**), FR-A740-22K(-**), FR-A840-00470(18.5K)(-**), FR-A840-00620(22K)(-**)

Note: ** indicates alpha numeric combination which means an inverter type such as A1 and A2.

The brake resistor can be used with the inverters listed in the following table. Note that the brake resistor is not used as a UL listed nor EU Directive-compliant accessory when used with the following inverters.

High-Duty Brake Resistor Model		Applicable Inverter Models
200V Class	FR-ABR-0.4K	FR-A520-0.4K(-**), FR-E520-0.4K(C)(-**), FR-E520S-0.4K(-**), FR-E510W-0.4K(-**), FR-A024-0.4K(-**), FR-S520E-0.4K(-**),
	FR-ABR-0.75K	FR-A520-0.75K(-**), FR-E520-0.75K(C)(-**), FR-E520S-0.75K(-**), FR-E510W-0.75K(-**), FR-A024-0.75K(-**), FR-S520E-0.75K(-**),
	FR-ABR-2.2K	FR-A520-1.5K(-**), FR-A520-2.2K(-**), FR-E520-1.5K(C)(-**), FR-E520-2.2K(C)(-**), FR-V520-1.5K(-**), FR-V520-2.2K(-**), FR-A024-1.5K(-**), FR-A024-2.2K(-**), FR-S520E-1.5K(-**), FR-S520E-2.2K(-**),
	FR-ABR-3.7K	FR-A520-3.7K(-**), FR-E520-3.7K(C)(-**), FR-V520-3.7K(-**), FR-A024-3.7K(-**), FR-S520E-3.7K(-**),
	FR-ABR-5.5K	FR-A520-5.5K(-**), FR-E520-5.5K(C)(-**), FR-V520-5.5K(-**),
	FR-ABR-7.5K	FR-A520-7.5K(-**), FR-E520-7.5K(C)(-**), FR-V520-7.5K(-**),
	FR-ABR-11K	FR-V520-11K(-**),
	FR-ABR-15K	FR-V520-15K(-**),
400V Class	FR-ABR-H0.4K	FR-A540-0.4K(-**), FR-E540-0.4K(C)(-**), FR-A044-0.4K(-**),
	FR-ABR-H0.75K	FR-A540-0.75K(-**), FR-E540-0.75K(C)(-**), FR-A044-0.75K(-**),
	FR-ABR-H1.5K	FR-A540-1.5K(-**), FR-E540-1.5K(C)(-**), FR-V540-1.5K(-**), FR-A044-1.5K(-**),
	FR-ABR-H2.2K	FR-A540-2.2K(-**), FR-E540-2.2K(C)(-**), FR-V540-2.2K(-**), FR-A044-2.2K(-**),
	FR-ABR-H3.7K	FR-A540-3.7K(-**), FR-E540-3.7K(C)(-**), FR-V540-3.7K(-**), FR-A044-3.7K(-**),
	FR-ABR-H5.5K	FR-A540-5.5K(-**), FR-E540-5.5K(C)(-**), FR-V540-5.5K(-**),
	FR-ABR-H7.5K	FR-A540-7.5K(-**), FR-E540-7.5K(C)(-**), FR-V540-7.5K(-**),
	FR-ABR-H11K	FR-V540-11K(-**),
FR-ABR-H15K	FR-V540-15K(-**),	

Note: ** indicates alpha numeric combination which means an inverter type such as A1 and A2.

2. GENERAL INSTRUCTIONS FOR INSTALLATION

**(For compliance with UL standard, refer to page A-4.
To meet the EU Directive, refer to page A-3.)**

- Never mount the resistor near wood, paper or any other flammable material. Doing so can cause a fire.
- To prevent burns, do not install the resistor in a place where it is readily accessible. If it is easily accessible, mount in a well-ventilated enclosure (e.g. punched metal), suitable for the environment.
- Mount the resistor carefully so that the leads do not come from the top of the resistor.
- Avoid contact with the resistor when running the leads of the resistor and any other wiring.

Install the resistor in a place with good heat dissipation. The reason for this is that the surface temperature of the resistor may exceed 360°C in an operation pattern where the resistor is used frequently.

To increase the heat dissipation effect, we recommend you to install the resistor on a metal surface outside the enclosure.

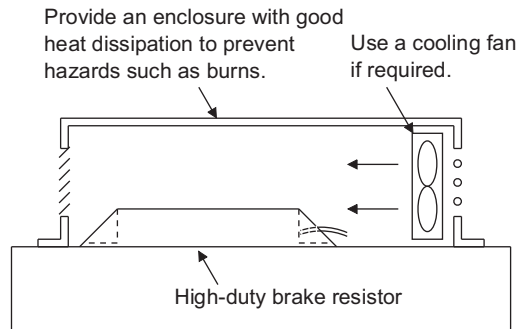

How to Install the Resistor

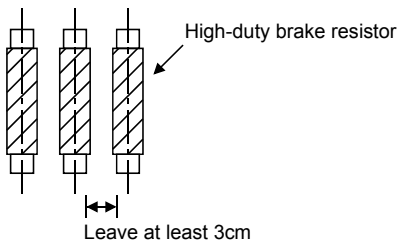

Interval between resistors Installed

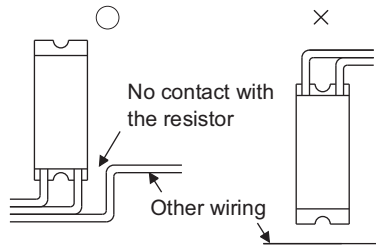

Orientation of installed resistor

3. INSTRUCTIONS FOR WIRING

When the regenerative brake transistor is damaged, the wiring sequence as shown in the following diagrams is recommended to prevent overheating and burnout of the brake resistor.

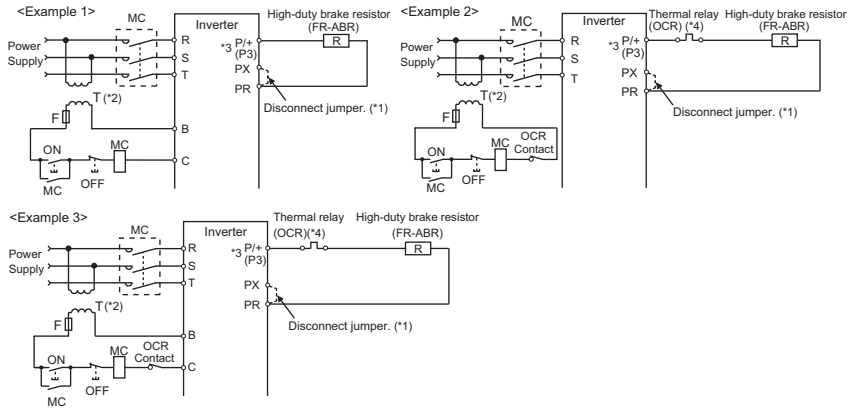

- Remove the jumper from across the PR and PX terminals of the inverter. (*1) This disables (switches OFF) the built-in brake resistor. (Refer to the Instruction Manual of the inverter for details.)

Note that the built-in brake resistor need not be removed. The leads of the built-in brake resistor need not be disconnected from the terminals.

- *1 Some inverters do not have the terminal PX. Some inverters do not have the terminal PX and in this case there is no jumper that needs to be removed. (For details, refer to Instruction Manual of the inverter.)
- *2 For the 400V class power supply, install a voltage-reducing transformer.
- *3 For the inverters equipped with terminal P3 (FR-A820-00770(15K) to 01250(22K) and FR-A840-00470(18.5K) to 01800(55K)), connect the FR-ABR between terminals P3 and PR.
- *4 Refer to the table below for the type number of each capacity of thermal relay and the diagram below for the connection. (Always install a thermal relay when using the 11K, 15K, 22K.)

Power Supply Voltage	High-duty Brake Resistor	Thermal Relay Type (Mitsubishi Electric product)	Rated operating current
200V	FR-ABR-0.4K	TH-T25-0.7A	120VAC: 2A(NO contact)/3A (NC contact), 240VAC: 1A(NO contact)/2A (NC contact)(AC15 class) 110VDC: 0.2A, 220VDC: 0.1A(DC13 class)
	FR-ABR-0.75K	TH-T25-1.3A	
	FR-ABR-2.2K	TH-T25-2.1A	
	FR-ABR-3.7K	TH-T25-3.6A	
	FR-ABR-5.5K	TH-T25-5A	
	FR-ABR-7.5K	TH-T25-6.6A	
	FR-ABR-11K	TH-T25-11A	
	FR-ABR-15K	TH-T25-11A	
FR-ABR-22K	TH-T65-22A		
400V	FR-ABR-H0.4K	TH-T25-0.24A	
	FR-ABR-H0.75K	TH-T25-0.35A	
	FR-ABR-H1.5K	TH-T25-0.9A	
	FR-ABR-H2.2K	TH-T25-1.3A	
	FR-ABR-H3.7K	TH-T25-2.1A	
	FR-ABR-H5.5K	TH-T25-2.5A	
	FR-ABR-H7.5K	TH-T25-3.6A	
	FR-ABR-H11K	TH-T25-6.6A	
	FR-ABR-H15K	TH-T25-6.6A	
	FR-ABR-H22K	TH-T25-9A	

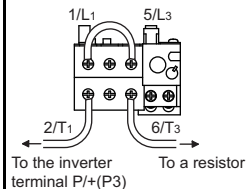

- Connect the leads of the high-duty brake resistor to the P/(P3) and PR terminals of the inverter. For the following high-duty brake resistors, connect them as specified in the table below.

High-duty brake resistor	Resistance(Ω)	Connection method
FR-ABR-15K	18	2 units in parallel
FR-ABR-22K	13	2 units in parallel
FR-ABR-H15K	18	2 units in series (as shown below)
FR-ABR-H22K	52	2 units in parallel

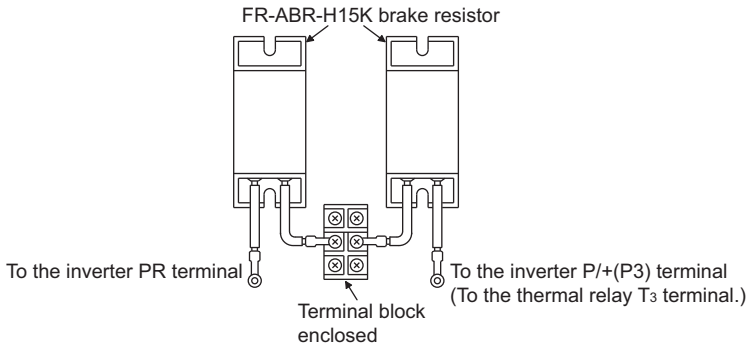

- If you extend the high-duty resistor lead wire to use, use the wire with a size as noted below and not exceeding 5 m in length.
- For the installation in the United States or Canada, perform wiring in accordance with the North American Electrical Code or the Canadian Electrical Code and any applicable local codes (in each provincial state).
- For the use as a product compliant with the Low Voltage Directive, perform wiring in accordance with any applicable local codes (in each country), using wires of the type and size set forth in EN 60204-1.

CAUTION

1. **The high-duty brake resistor cannot be used with a brake unit, high power factor converter, power return converter, built-in brake, etc.**
2. **Twist the leads of the high-duty brake resistor when increasing their length 2 m or more. (The wire size used should be minimum 14 AWG (2.1 mm²)).**
Note that even the twisted leads cannot be made longer than 5 m. Doing so can cause an inverter failure.
3. **The FR-ABR-(H)11K, 15K, 22K cannot be used with the FR-A500 series.**

4. INSTRUCTIONS FOR USE

- Setting of inverter parameters
 The parameter setting method varies with the inverter series. Refer to the Instruction Manual of the inverter.

5. SPECIFICATIONS

Permissible duty and torque

Item	FR-ABR-□ (200V Class)								FR-ABR-H□ (400V Class)									
	0.4K	0.75K	2.2K	3.7K	5.5K	7.5K	11K	15K	22K	0.4K	0.75K	1.5K	2.2K	3.7K	5.5K	7.5K	11K	15K
Braking torque	150% 5s		100% 5s								100% 5s							
Permissible duty*	10%ED				6%ED				10%ED				6%ED					

* The permissible duty represents the braking capability including the motor loss.
The actual duty of the resistor is slightly lower than that.

6. OUTLINE DIMENSIONS

- FR-ABR-0.4K to 7.5K, H0.4K to H7.5K

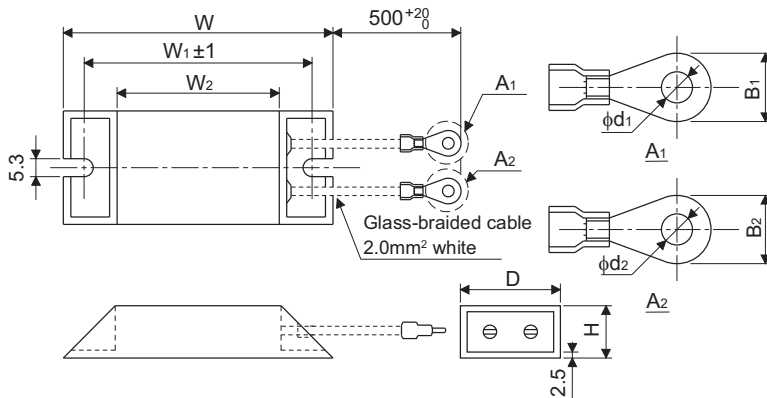

Brake Resistor Model		Dimensions (Unit: mm)					Resistance (Ω)	Crimping Terminal (Unit: mm)			
		W	W ₁	W ₂	D	H		A ₁		A ₂	
								B ₁	d ₁	B ₂	d ₂
200V Class	FR-ABR-0.4K	140	125	100	40	21	7.0	4.3	7.0	4.3	
	FR-ABR-0.75K	215	200	175	40	21					
	FR-ABR-2.2K*1	240	225	200	50	26					
	FR-ABR-3.7K	215	200	175	61	33	9.5	5.3	9.5	5.3	
	FR-ABR-5.5K	335	320	295	61	33					
	FR-ABR-7.5K	400	385	360	80	40					
400V Class	FR-ABR-H0.4K	115	100	75	40	21	7.0	4.3	7.0	4.3	
	FR-ABR-H0.75K	140	125	100	40	21					
	FR-ABR-H1.5K	215	200	175	40	21					
	FR-ABR-H2.2K	240	225	200	50	26	9.5	5.3	9.5	5.3	
	FR-ABR-H3.7K	215	200	175	61	33					
	FR-ABR-H5.5K	335	320	295	61	33					
FR-ABR-H7.5K	400	385	360	80	40	75					

*1 Used for 1.5K and 2.2K.

- FR-ABR-11K, 15K, 22K, H11K, H15K, H22K

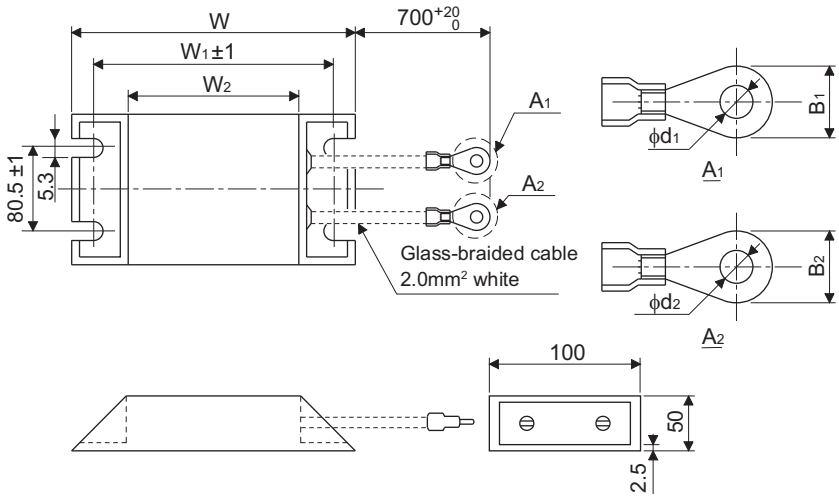

Brake Resistor Model		Dimensions (Unit: mm)			Resistance (Ω)	Crimping Terminal (Unit: mm)			
		W	W ₁	W ₂		A ₁		A ₂	
						B ₁	d ₁	B ₂	d ₂
200V Class	FR-ABR-11K	400	385	360	13	12	6.4	9.5	5.3
	FR-ABR-15K* ¹	300	285	260	18	12	8.4	12	8.4
	FR-ABR-22K* ³	400	385	360	13	12	8.4	12	8.4
400V Class	FR-ABR-H11K	400	385	360	52	12	6.4	9.5	5.3
	FR-ABR-H15K* ²	300	285	260	18	12	8.4	12	8.4
	FR-ABR-H22K* ⁴	450	435	410	52	9.0	6.4	9.0	6.4

*1 For the 15K, connect two resistors (18Ω) in parallel.

*2 For the H15K, connect two resistors (18Ω) in series. FR-ABR-15K is indicated on the resistor. (Same resistor as the 200V class 15K)

*3 For the 22K brake resistor, configure so that two 13Ω resistors are connected in parallel. FR-ABR-22K is indicated on the resistor.

*4 For the H22K brake resistor, configure so that two 52Ω resistors are connected in parallel. FR-ABR-H22K is indicated on the resistor.

7. BRAKING CAPABILITIES

7.1 Continuous Permissible Power

200V Class			400V Class		
Model	Resistance	Continuous Permissible Power	Model	Resistance	Continuous Permissible Power
FR-ABR-0.4K	200Ω	60W	FR-ABR-H0.4K	1200Ω	45W
FR-ABR-0.75K	100Ω	80W	FR-ABR-H0.75K	700Ω	75W
FR-ABR-2.2K	60Ω	120W	FR-ABR-H1.5K	350Ω	115W
FR-ABR-3.7K	40Ω	155W	FR-ABR-H2.2K	250Ω	120W
FR-ABR-5.5K	25Ω	185W	FR-ABR-H3.7K	150Ω	155W
FR-ABR-7.5K	20Ω	340W	FR-ABR-H5.5K	110Ω	185W
FR-ABR-11K	13Ω	560W	FR-ABR-H7.5K	75Ω	340W
FR-ABR-15K	9Ω* ¹	805W	FR-ABR-H11K	52Ω	530W
FR-ABR-22K	6.5Ω* ¹	1120W	FR-ABR-H15K	36Ω* ²	870W
			FR-ABR-H22K	26Ω* ³	1060W

*1 When two resistors are connected in parallel.

*2 When two resistors are connected in series.

*3 When two resistors are connected in parallel.

7.2 Short-Duration Permissible Power per Braking

• 200V Class

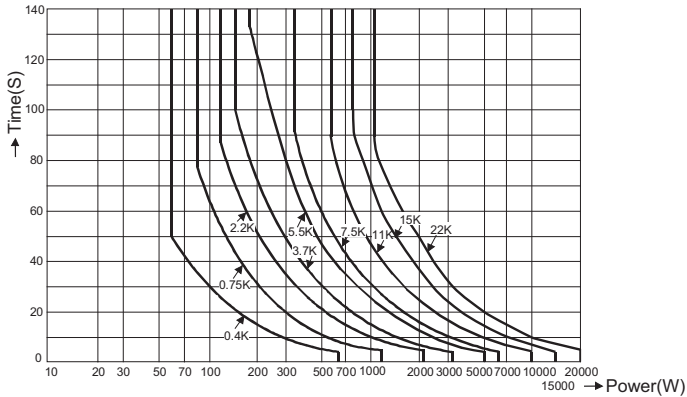

• 400V Class

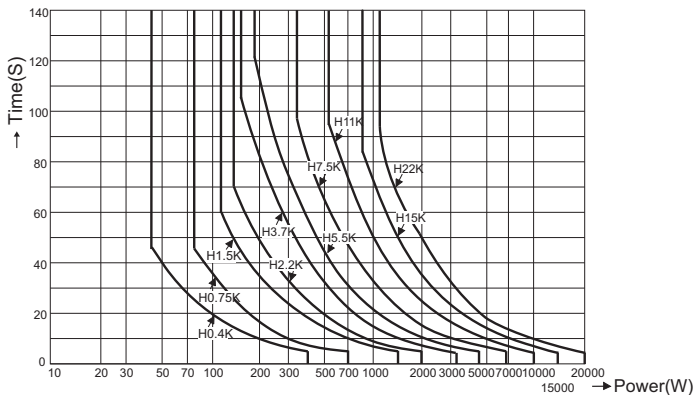

MEMO

MEMO

REVISIONS

*The manual number is given on the bottom left of the back cover.

Revision Date	*Manual Number	Revision
Nov. 1998	IB(NA)-66891-A	First edition
Mar. 2001	IB(NA)-66891-B	<div style="border: 1px solid black; padding: 2px;">Partial Addition</div> <ul style="list-style-type: none"> • Applicable inverters • Instructions for wiring
Apr. 2002	IB(NA)-66891-C	<div style="border: 1px solid black; padding: 2px;">Addition</div> FR-ABR-11K, FR-ABR-15K
Aug. 2002	IB(NA)-66891-D	<div style="border: 1px solid black; padding: 2px;">Addition</div> FR-ABR-H11K, FR-ABR-H15K <div style="border: 1px solid black; padding: 2px;">Partial Addition</div> Instructions for wiring
Oct. 2003	IB(NA)-66891-E	<div style="border: 1px solid black; padding: 2px;">Addition</div> UL compliance
Mar. 2004	IB(NA)-66891-F	<div style="border: 1px solid black; padding: 2px;">Modification</div> Outline dimensions, outline dimension drawings
Aug. 2005	IB(NA)-66891-G	<div style="border: 1px solid black; padding: 2px;">Addition</div> FR-ABR-22K
Nov. 2005	IB(NA)-66891-H	<div style="border: 1px solid black; padding: 2px;">Addition</div> <ul style="list-style-type: none"> • FR-ABR-H22K • FR-A740 specifications
Aug. 2008	IB(NA)-66891-J	<div style="border: 1px solid black; padding: 2px;">Partial Addition</div> Applicable inverters
Oct. 2012	IB(NA)-66891-K	<div style="border: 1px solid black; padding: 2px;">Modification</div> <ul style="list-style-type: none"> • 3. INSTRUCTIONS FOR WIRING
Dec. 2017	IB(NA)-66891-L	<div style="border: 1px solid black; padding: 2px;">Addition</div> <ul style="list-style-type: none"> • FR-D700, FR-F700PJ, FR-A800 specifications
Jan. 2019	IB(NA)-66891-M	<div style="border: 1px solid black; padding: 2px;">Addition</div> <ul style="list-style-type: none"> • Instructions for compliance with the EU Directives • Instructions for EAC <div style="border: 1px solid black; padding: 2px;">Modification</div> <ul style="list-style-type: none"> • Combinations with the inverters to meet to the UL standards and the EU Directives

mitsubishi electric corporation

HEAD OFFICE: TOKYO BUILDING 2-7-3, MARUNOUCHI, CHIYODA-KU, TOKYO 100-8310, JAPAN

