



# INVERTER

Plug-in option

# FR-A8NS INSTRUCTION MANUAL

---

*SSCNET III(/H)*  
*communication function*

---

PRE-OPERATION INSTRUCTIONS	1
INSTALLATION	2
WIRING	3
SSCNET III(/H) COMMUNICATION STATUS	4
INVERTER SETTING	5
RESTRICTIONS ON THE FUNCTIONS	6
Instructions for SSCNET III(/H) communication	7
PROTECTIVE FUNCTIONS	8
TROUBLESHOOTING	9

## Safety instructions

---

Thank you for choosing this Mitsubishi Electric inverter plug-in option.

This Instruction Manual provides handling information and precautions for use of this product. Incorrect handling might cause an unexpected fault. Before using this product, read all relevant instruction manuals carefully to ensure proper use.

Please forward this Instruction Manual to the end user.

Do not attempt to install, operate, maintain or inspect the product until you have read through this Instruction Manual and supplementary documents carefully and can use the equipment correctly. Do not use this product until you have a full knowledge of this product mechanism, safety information and instructions. In this Instruction Manual, the safety instruction levels are classified into "WARNING" and "CAUTION".

 **WARNING** Incorrect handling may cause hazardous conditions, resulting in death or severe injury.

 **CAUTION** Incorrect handling may cause hazardous conditions, resulting in medium or slight injury, or may cause only material damage.

The  **CAUTION** level may even lead to a serious consequence according to conditions. Both instruction levels must be followed because these are important to personal safety.

### ◆ Electric shock prevention

---

#### **WARNING**

- Do not remove the front cover or the wiring cover of the inverter while the inverter power is ON. Do not operate the inverter with any cover or wiring cover removed, as accidental contact with exposed high-voltage terminals and internal components may occur, resulting in an electrical shock.
  - Even if power is OFF, do not remove the front cover of the inverter except for wiring or periodic inspection as you may accidentally touch the charged circuits and get an electric shock.
  - Before wiring or inspection, check that the display of the inverter operation panel is OFF. Any person who is involved in wiring or inspection shall wait for 10 minutes or longer after power OFF and check that there are no residual voltage using a tester or the like. The capacitor is charged with high voltage for some time after power OFF, and it is dangerous.
  - Any person who is involved in wiring or inspection of this product shall be fully competent to do the work.
  - This product must be installed before wiring. Otherwise you may get an electric shock or be injured.
  - Do not subject the cables to scratches, excessive stress, heavy loads or pinching. Doing so may cause an electric shock.
  - Do not touch this product or handle the cables with wet hands. Doing so may cause an electric shock.
-

## ◆ Injury prevention

---

### CAUTION

- The voltage applied to each terminal must be as specified in the Instruction Manual. Otherwise an explosion or damage may occur.
- The cables must be connected to the correct terminals. Otherwise an explosion or damage may occur.
- The polarity (+ and -) must be correct. Otherwise an explosion or damage may occur.
- While power is ON or for some time after power OFF, do not touch the inverter as it will be extremely hot. Doing so may cause burns.

## ◆ Additional instructions

The following instructions must be also followed. If this product is handled incorrectly, it may cause unexpected fault, an injury, or an electric shock.

---

### CAUTION

#### Transportation and installation

- Do not stand or place heavy objects on this product.
- Ensure the mounting orientation of this product is correct.
- Do not install or operate this product if it is damaged or has parts missing.
- Foreign conductive objects must be prevented from entering the inverter. That includes screws and metal fragments or other flammable substance such as oil.
- If halogens (including fluorine, chlorine, bromine, and iodine) contained in fumigants for wood packages enter this product, the product may be damaged. Prevent the entry of fumigant residuals or use an alternative method such as heat disinfection. Note that sterilization or disinfection of wood packages should also be performed before packing the product.

#### Test operation

- Before starting operation, confirm or adjust the parameter settings. Failure to do so may cause some machines to make unexpected motions.
- 

### WARNING

#### Usage

- Do not modify this product.
  - Do not remove any part which is not instructed to be removed in the Instruction Manuals. Doing so may lead to a failure or damage of this product.
- 



---

## CAUTION

---

### Usage

- As all parameters return to their initial values after Parameter clear or All parameter clear is performed, the needed parameters for operation of the inverter and this product must be set again before the operation is started.
- To avoid damage to this product due to static electricity, static electricity in your body must be discharged before you touch this product.
- To maintain the security (confidentiality, integrity, and availability) of the inverter and the system against unauthorized access, DoS\*1 attacks, computer viruses, and other cyberattacks from external devices via network, take appropriate measures such as firewalls, virtual private networks (VPNs), and antivirus solutions. We shall have no responsibility or liability for any problems involving inverter trouble and system trouble by DoS attacks, unauthorized access, computer viruses, and other cyberattacks.
- Depending on the network environment, the inverter may not operate as intended due to delays or disconnection in communication. Carefully consider what type of environment the inverter will be used in and any safety issues related to its use.

### Maintenance, inspection and parts replacement

- Do not carry out a megger (insulation resistance) test.

### Disposal

- This product must be treated as industrial waste.

---

\*1 DoS: A denial-of-service (DoS) attack disrupts services by overloading systems or exploiting vulnerabilities, resulting in a denial-of-service (DoS) state.

---

## General instruction

---

- For clarity, illustrations in this Instruction Manual may be drawn with covers or safety guards removed. Ensure all covers and safety guards are properly installed prior to starting operation.
-

# — CONTENTS —

<b>Safety instructions</b>	<b>1</b>
<hr/>	
<b>1 PRE-OPERATION INSTRUCTIONS</b>	<b>7</b>
<hr/>	
1.1 <b>Unpacking and checking the product</b> .....	7
1.1.1 Product confirmation .....	7
1.1.2 SERIAL number check.....	8
1.2 <b>Component names</b> .....	13
1.3 <b>Related manuals</b> .....	15
1.4 <b>Operation overview</b> .....	16
1.5 <b>Communication specifications of SSCNET III and SSCNET III/H</b> .....	19
<b>2 INSTALLATION</b>	<b>20</b>
<hr/>	
2.1 <b>Pre-installation instructions</b> .....	20
2.2 <b>Installation procedure</b> .....	21
2.3 <b>Axis number setting</b> .....	28
<b>3 WIRING</b>	<b>29</b>
<hr/>	
3.1 <b>System configuration</b> .....	29
3.2 <b>Wiring example (when FR-A8AP is used)</b> .....	30
3.3 <b>SSCNET III cable</b> .....	33
3.3.1 Mitsubishi Electric SSCNET III cable .....	33
3.3.2 SSCNET III cables manufactured by Mitsubishi Electric System & Service Co., Ltd.....	36
3.3.3 Instructions for laying the SSCNET III cable.....	37
3.4 <b>Wiring</b> .....	39



<b>4</b>	<b>SSCNET III(/H) COMMUNICATION STATUS</b>	<b>40</b>
4.1	SSCNET III(/H) communication status monitor selection .....	40
4.2	State transition diagram of the inverter.....	41
4.3	List of SSCNET III(/H) communication status .....	43
<b>5</b>	<b>INVERTER SETTING</b>	<b>45</b>
5.1	Parameter list.....	45
5.2	Operation at communication error occurrence .....	47
5.2.1	Fault and measures .....	47
5.3	Inverter reset.....	48
5.4	Setting SSCNET III(/H) communication function .....	49
5.4.1	Pr.499 SSCNET III(/H) operation selection.....	49
5.4.2	SSCNET III(/H) communication disabled signal.....	54
5.4.3	Pr.379 SSCNET III(/H) rotation direction selection .....	55
5.4.4	Pr.449 SSCNET III(/H) input filter setting.....	56
5.4.5	Input terminal function selection .....	57
5.4.6	Control method selection .....	57
<b>6</b>	<b>RESTRICTIONS ON THE FUNCTIONS</b>	<b>61</b>
6.1	Function restriction list.....	61
6.2	Inverter parameter list.....	64
6.2.1	Invalid parameters when the FR-A8NS is used .....	64
6.2.2	Invalid parameters when the FR-A8NS is used and "0 or 1" is set in Pr.499.....	74

<b>7</b>	<b>Instructions for SSCNET III(/H) communication</b>	<b>78</b>
<b>8</b>	<b>PROTECTIVE FUNCTIONS</b>	<b>79</b>
<b>9</b>	<b>TROUBLESHOOTING</b>	<b>82</b>
	<b>APPENDIX</b>	<b>83</b>
Appendix 1	Instructions for compliance with the EU Directives .....	83
Appendix 2	Instructions for EAC .....	84
Appendix 3	Restricted Use of Hazardous Substances in Electronic and Electrical Products .....	85
Appendix 4	Referenced Standard (Requirement of Chinese standardized law) .....	86
Appendix 5	Compliance with the UK certification scheme .....	87
Appendix 6	List of error codes displayed on the Mitsubishi Electric motion controllers .....	88
	<b>REVISIONS</b>	<b>92</b>





# 1 PRE-OPERATION INSTRUCTIONS

## 1.1 Unpacking and checking the product

Take the plug-in option out of the package, check the product name, and confirm that the product is as you ordered and intact. This product is a plug-in option made for the FR-A800 series inverters.

### 1.1.1 Product confirmation

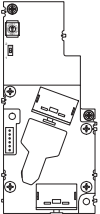
Check the enclosed items.

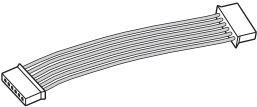
<p>Plug-in option 1</p> 	<p>Mounting screw (M3 × 8 mm) 2 (Refer to <a href="#">page 21.</a>)</p> 	<p>Encoder interface option connection cable (CON2 connector cable) 1 (Refer to <a href="#">page 24.</a>)<sup>*1</sup></p> 
---	---	---

\*1 Use this cable for connecting this product and the FR-A8AP or FR-A8AL.

#### NOTE

- In this Instruction Manual, Servo System Controller Network III(/H) is abbreviated to "SSCNET III(/H)".
- The encoder interface option connection cable is hereafter referred to as the CON2 connector cable.
- For information on applicable inverter models, contact your sales representative.



## 1.1.2 SERIAL number check

The FR-A8NS can be used with the models of inverters listed below which have the following SERIAL number. Check the SERIAL number indicated on the inverter rating plate or package.

Rating plate example

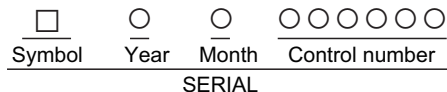
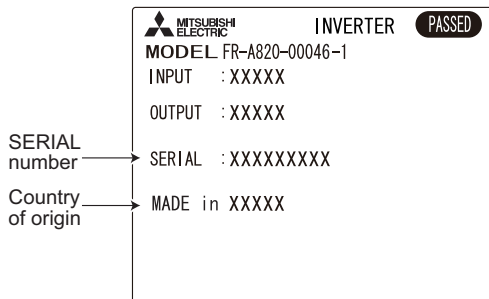

The SERIAL consists of one symbol, two characters indicating the production year and month, and six characters indicating the control number.

The last digit of the production year is indicated as the Year, and the Month is indicated by 1 to 9, X (October), Y (November), or Z (December).

- SSCNET III communication supported

Model	Country of origin indication	SERIAL number
FR-A820-00046(0.4K) to 04750(90K) FR-A840-00023(0.4K) to 06830(280K) FR-A842-07700(315K) to 12120(500K) FR-A846-00023(0.4K) to 03610(132K)	MADE in Japan	<input type="checkbox"/> 58 ○○○○○○ or later
	MADE in China	<input type="checkbox"/> 59 ○○○○○○ or later

- SSCNET III/H communication supported

Model	Country of origin indication	SERIAL number
FR-A820-00046(0.4K) to 04750(90K) FR-A840-00023(0.4K) to 06830(280K) FR-A842-07700(315K) to 12120(500K) FR-A846-00023(0.4K) to 03610(132K)	MADE in Japan	<input type="checkbox"/> 5Y○○○○○○ or later
	MADE in China	<input type="checkbox"/> 5Z○○○○○○ or later

- **Pr.290 Monitor negative output selection** and **Pr.1018 Monitor with sign selection** supported

Model	Country of origin indication	SERIAL number
FR-A820-00046(0.4K) to 04750(90K) FR-A840-00023(0.4K) to 06830(280K) FR-A842-07700(315K) to 12120(500K) FR-A846-00023(0.4K) to 03610(132K)	MADE in Japan	<input type="checkbox"/> 63○○○○○○ or later
	MADE in China	<input type="checkbox"/> 64○○○○○○ or later

- Settings "100" and "101" of **Pr.499 SSCNET III(/H) operation selection** supported (Speed control and torque control available)

Model	Country of origin indication	SERIAL number
FR-A820-00046(0.4K) to 04750(90K) FR-A840-00023(0.4K) to 06830(280K) FR-A842-07700(315K) to 12120(500K) FR-A846-00023(0.4K) to 03610(132K)	MADE in Japan	<input type="checkbox"/> 6Y○○○○○○ or later
	MADE in China	<input type="checkbox"/> 6Z○○○○○○ or later

- Settings "100" and "101" of **Pr.499 SSCNET III(/H) operation selection** supported (Speed control, torque control, and position control available)

Model	Country of origin indication	SERIAL number
FR-A820-00046(0.4K) to 04750(90K) FR-A840-00023(0.4K) to 06830(280K) FR-A842-07700(315K) to 12120(500K) FR-A846-00023(0.4K) to 03610(132K)	MADE in Japan	<input type="checkbox"/> 75○○○○○○ or later
	MADE in China	<input type="checkbox"/> 74○○○○○○ or later

## NOTE

- As shown in the following table, the availability of communication methods and function depends on a SERIAL number combination of the applied inverter and FR-A8NS. Check the circuit board of the FR-A8NS for its SERIAL number.
- Availability of communication methods

For the inverter manufactured in Japan

SERIAL number of the FR-A8NS	SERIAL number of the FR-A800 series inverter	
	<input type="checkbox"/> 58○○○○○○ or later	<input type="checkbox"/> 5Y○○○○○○ or later
A○○○○○	SSCNET III communication	SSCNET III communication
B○○○○○ or later	SSCNET III communication	SSCNET III(/H) communication

For the inverter manufactured in China

SERIAL number of the FR-A8NS	SERIAL number of the FR-A800 series inverter	
	<input type="checkbox"/> 59 ○○○○○○ or later	<input type="checkbox"/> 5Z○○○○○○ or later
A○○○○○	SSCNET III communication	SSCNET III communication
B○○○○○ or later	SSCNET III communication	SSCNET III(/H) communication

- Availability of the settings "100" and "101" of Pr.499

For the inverter manufactured in Japan

SERIAL number of the FR-A8NS	SERIAL number of the FR-A800 series inverter		
	□6Y□□□□□□ or earlier	□6Z□□□□□□ to □74□□□□□□	□75□□□□□□ or later
□6X□□□ or earlier	—	Invalid (E.OPT occurs.)	Invalid (E.OPT occurs.)
□6Y□□□□ to □74□□□□	Not available	Valid (speed control and torque control)	Valid (speed control and torque control)
□75□□□□ or later	Not available	Valid (speed control and torque control)	Valid (speed control, torque control, and position control)

For the inverter manufactured in China

SERIAL number of the FR-A8NS	SERIAL number of the FR-A800 series inverter		
	□6Y□□□□□□ or earlier	□6Z□□□□□□ to □73□□□□□□	□74□□□□□□ or later
□6X□□□ or earlier	—	Invalid (E.OPT occurs.)	Invalid (E.OPT occurs.)
□6Y□□□□ to □74□□□□	Not available	Valid (speed control and torque control)	Valid (speed control and torque control)
□75□□□□ or later	Not available	Valid (speed control and torque control)	Valid (speed control, torque control, and position control)

- SERIAL number example of the FR-A8NS

<u>B</u>	<u>5</u>	<u>X</u>	<u>000</u>
Symbol	Year	Month	Control number

The SERIAL consists of one symbol, two characters indicating the production year and month, and three characters indicating the control number.

The last digit of the production year is indicated as the Year, and the Month is indicated by 1 to 9, X (October), Y (November), or Z (December).

- For the differences in the specifications between the SSCNET III and SSCNET III/H communications, refer to [page 19](#).
-

## 1.2 Component names

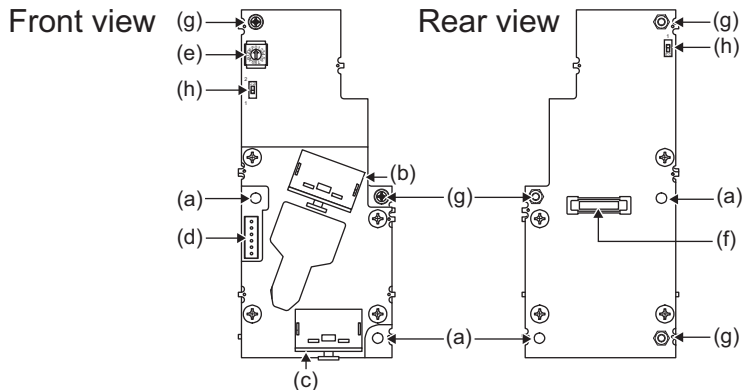

Symbol	Name	Description	Refer to page
a	Mounting hole	Used to fix this product to the inverter by inserting a mounting screw or a spacer.	21
b	SSCNET III cable connector (CN1A)	Used to connect the servo system controller, or the preceding axis inverter/servo amplifier.	39
c	SSCNET III cable connector (CN1B)	Used to connect the succeeding axis inverter/servo amplifier. For the final axis, do not remove the connector cap.	39
d	CON2 connector	Used to connect this connector and the CON2 connector on the FR-A8AP or FR-A8AL with the enclosed CON2 connector cable. Connecting to the FR-A8AP/FR-A8AL enables the inverter to receive encoder feedback data.	24
e	Axis number switch (SW1)	Set the axis number. (In the initial setting, "0" is set.)	28
f	Board mounted option connector	Used to connect this product to the option connector on the inverter.	21
g	Spacer	Used for a stable connection to the inverter.	—

<b>Symbol</b>	<b>Name</b>	<b>Description</b>	<b>Refer to page</b>
h	Switch for manufacturer setting (SW2, SW3)	Do not change the switch setting from the initial setting (1: OFF).	—

## 1.3 Related manuals

For the details of the servo system controller, refer to the manual or the software Help of each model.  
Refer to the following manuals for information on the MELSEC iQ-R series motion controller.

Manual name	Manual number
MELSEC iQ-R Motion Controller User's Manual	IB-0300235
MELSEC iQ-R Motion Controller Programming Manual (Common)	IB-0300237
MELSEC iQ-R Motion Controller Programming Manual (Program Design)	IB-0300239
MELSEC iQ-R Motion Controller Programming Manual (Positioning Control)	IB-0300241
MELSEC iQ-R Motion Controller Programming Manual (Advanced Synchronous Control)	IB-0300243



## 1.4 Operation overview

In communication with the Mitsubishi Electric servo system controller, the inverter operation or monitoring is enabled with a program in the servo system controller.

Application of optical communication method enabled high speed communication of SSCNET III(/H).

- Example of Vector control (When the FR-A8AP/FR-A8AL is installed and "0 or 1" is set in **Pr.499**)

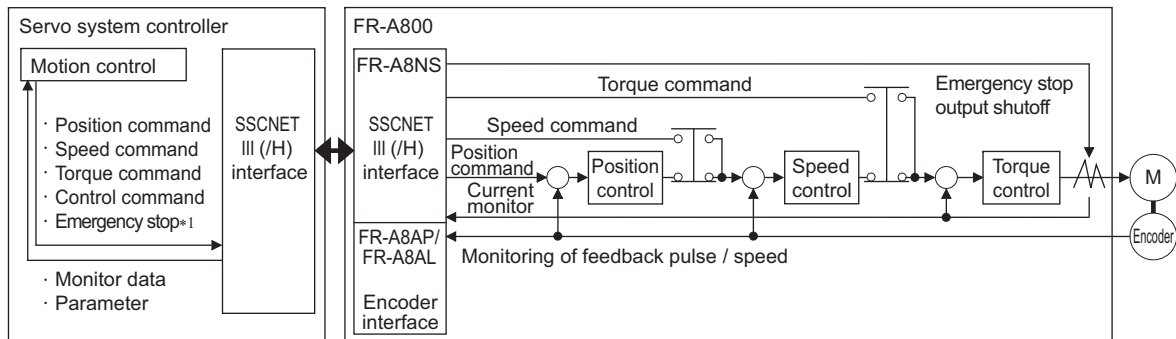

\*1 When the Emergency stop signal is input, the inverter shuts off the output and the motor coasts.

### NOTE

- To operate the inverter under Vector control when "0 or 1" is set in **Pr.499**, use the CON2 connector cable for connection between the FR-A8NS and the FR-A8AP/FR-A8AL (refer to [page 21](#)). An option fault (E.OPT) occurs when any cable other than the CON2 connector cable is used (refer to [page 80](#)). (If the CON2 connector cable is accidentally detached during inverter operation, the fault such as overcurrent trip (E.OC3) or excessive position fault (E.OD) may occur depending on the status of the motor current and droop pulses.)

- Example of Vector control (When a feedback device interface option is installed and "100 or 101" is set in **Pr.499**)

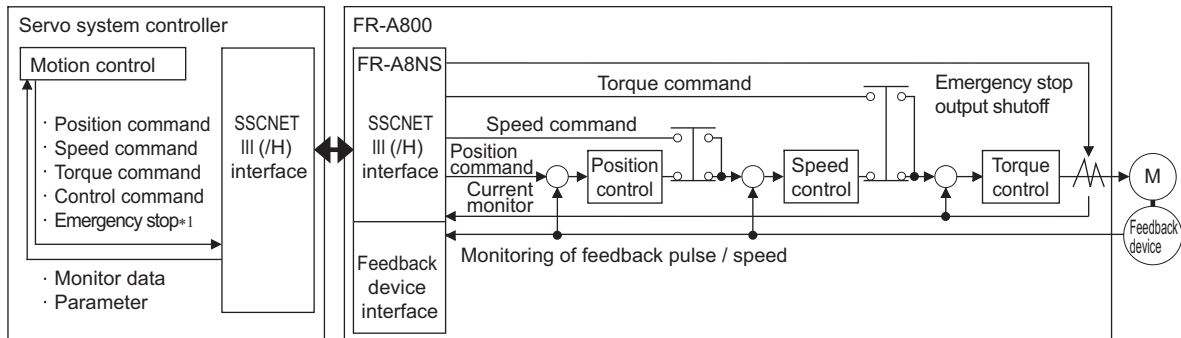

\*1 When the Emergency stop signal is input, the inverter shuts off the output and the motor coasts.

## NOTE

- For the inverter operation under Vector control while "100 or 101" is set in **Pr.499**, the CON2 connector cable is not required.

- Example of PM sensorless vector control (When the MM-CF motor is used, no feedback device interface option is installed, and "100 or 101" is set in **Pr.499**)

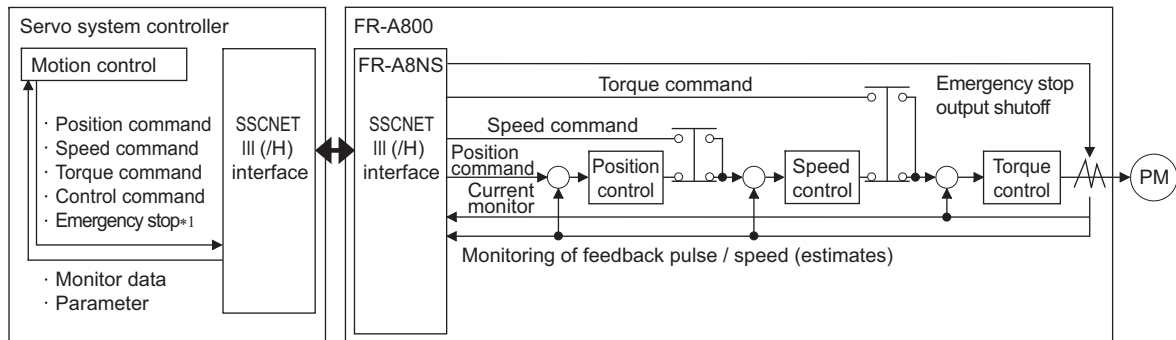

\*1 When the Emergency stop signal is input, the inverter shuts off the output and the motor coasts.

## NOTE

- For the inverter operation under PM sensorless vector control while "100 or 101" is set in **Pr.499**, the CON2 connector cable and any feedback device interface option are not required.

## 1.5 Communication specifications of SSCNET III and SSCNET III/H

- The following table shows the communication specifications of SSCNET III and SSCNET III/H.

Item	Communication specifications	
	SSCNET III	SSCNET III/H
Communication speed	50 Mbps for two-way	150 Mbps for two-way
Wiring distance between stations	Up to 50 m	Up to 100 m
Overall length	Up to 800 m	Up to 1600 m
Selectable calculation cycle	0.444 ms, 0.888 ms or more	0.222 ms, 0.444 ms, 0.888 ms or more

- There are some restrictions on the SSCNET III communication according to the setting of the calculation cycle.

Calculation cycle	Restrictions for SSCNET III communication
0.222 ms	Not available.
0.444 ms	Up to 8 axes controlled in a system. <sup>*1</sup> Set the axis number between 0 to 7 using the axis number switch on the FR-A8NS. An inverter set as the axis number between 8 to F cannot be recognized.
0.888 ms or more	No restriction.

\*1 If this calculation cycle is set for the system requiring 9 axes or more, the calculation cycle of 0.888 ms is applied.

## 2 INSTALLATION

---

### 2.1 Pre-installation instructions

---

Check that the inverter's input power and the control circuit power are both OFF.

---

#### CAUTION

---

- Do not install or remove this product while the inverter power is ON. Doing so may damage the inverter or this product.
  - To avoid damage due to static electricity, static electricity in your body must be discharged before you touch the product.
-

## 2.2 Installation procedure

### ◆ Installation of the FR-A8NS

1. Fit the board mounted option connector on this product to the guide of the option connector on the inverter, and insert the option as far as it goes. (Attach this product to option connector 1 on the inverter.)
  2. Fasten this product to the inverter using the two mounting screws through the holes on either side (tightening torque: 0.33 to 0.40 N·m). If the screw holes do not line up, the connector may not be inserted deep enough. Check the connector.
- Example of installation to connector 1

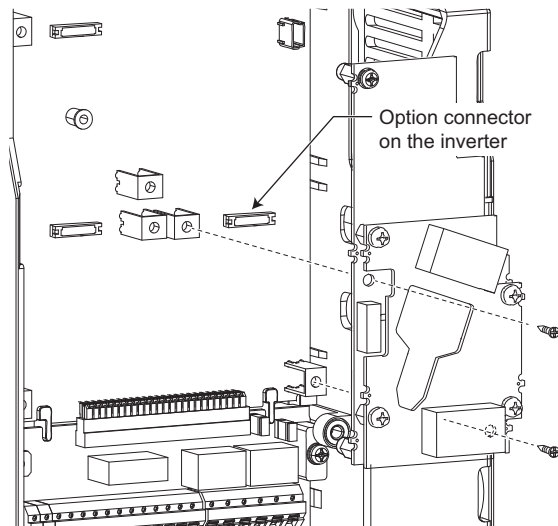

## ■ Insertion positions for screws

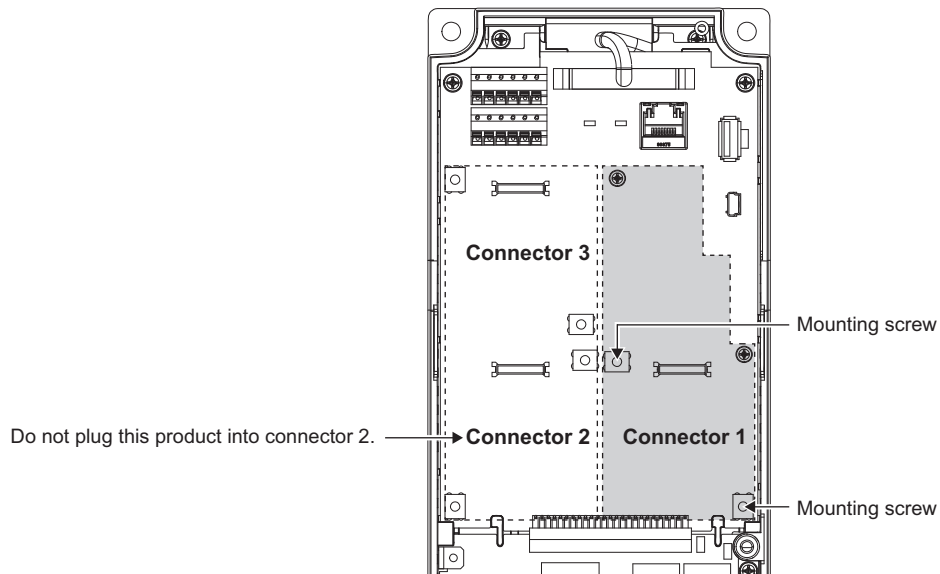

Install an appropriate feedback device interface option according to a desired control method and feedback device.

Control method	Feedback device	Option	FR-A800	FR-A800-E	Position control
Vector control	Encoder	FR-A8AL	Case 1	Case 1 <sup>*1</sup>	Available
		FR-A8AP	Case 1	Case 4	Available
		FR-A8TP	Case 2	Case 2	Available
	Resolver	FR-A8APR	Case 3	Case 3	Available
	Endat	FR-A8APS	Case 3	Case 3	Available
	SinCos	FR-A8APA	Case 3	Case 3	Available
PM sensorless vector control (MM-CF motor)	Not required	Not required	—	—	Available
V/F control / Advanced magnetic flux vector control / PMsensorless vector control	Not required	Not required	—	—	Not available

- \*1 To perform SSCNET III(H) communication using the FR-A800-E inverter with the FR-A8AL installed, remove the pre-installed Ethernet board from the inverter.  
For instructions for removing the Ethernet board, refer to the Instruction Manuals of the inverter.



◆ **Case 1: FR-A8AP installation (FR-A800) / FR-A8AL installation (FR-A800 and FR-A800-E)**

1. Attach the FR-A8AP/FR-A8AL to option connector 2 on the inverter.
2. Connect the enclosed CON2 connector cable (refer to [page 7](#)) between the CON2 connector on the FR-A8NS and the CON2 connector on the FR-A8AP/FR-A8AL. (For replacement from the former model FR-A7NS, do not use the FR-A7AP/FR-A7NS connection cable used for the FR-A7NS because it is not compatible.)

FR-A8AP installation

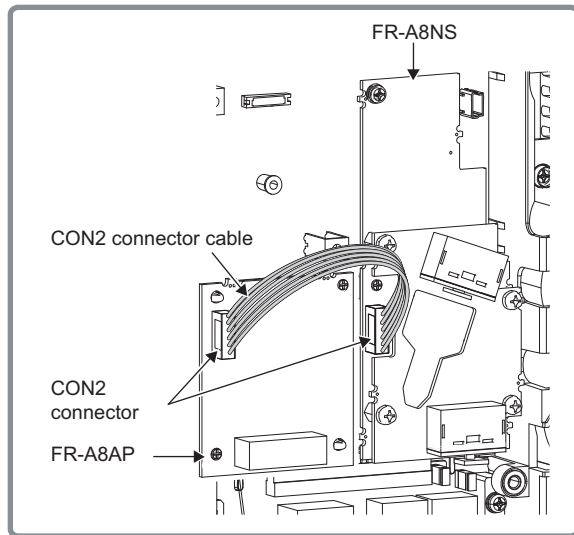

FR-A8AL installation

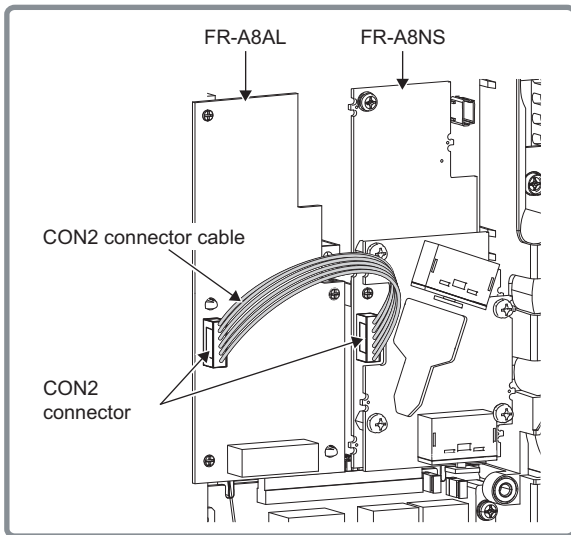

◆ **Case 2: FR-A8TP installation**

1. Follow the instructions for installation of the FR-A8TP in the Instruction Manual of the FR-A8TP.
2. The enclosed CON2 connector cable is not required.

◆ **Case 3: FR-A8APR/FR-A8APS/FR-A8APA installation**

1. Attach the FR-A8APR/FR-A8APS/FR-A8APA to option connector 2 or 3 on the inverter. For details of the installation, refer to the Instruction Manual of each plug-in option.
2. The enclosed CON2 connector cable is not required.

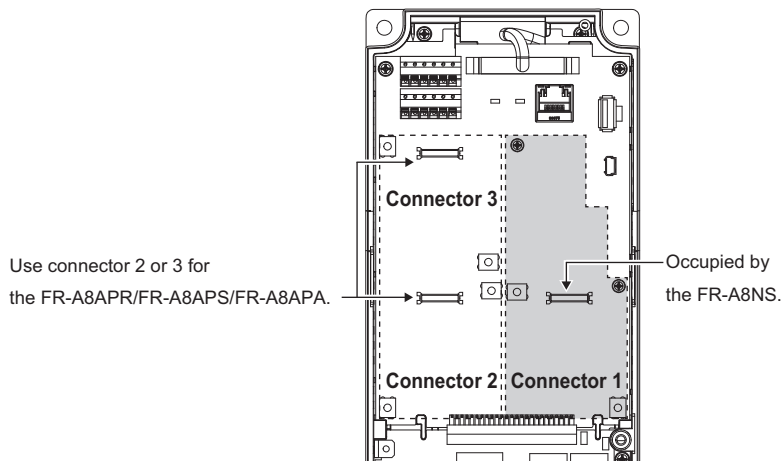

◆ **Case 4: FR-A8AP installation (FR-A800-E)**

1. Attach the FR-A8AP into option connector 3 on the inverter. For details of the installation, refer to the Instruction Manual of the FR-A8AP.
2. Set "100 or 101" in **Pr.499 SSCNET III/(H) operation selection**.
3. The enclosed CON2 connector cable is not required.

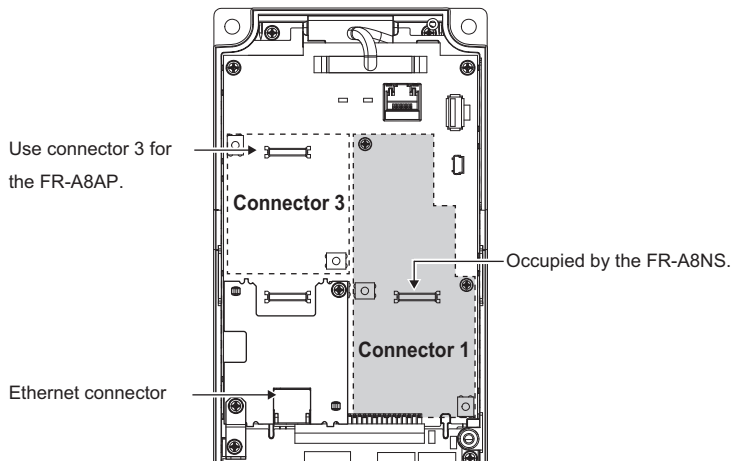

**NOTE**

- When installing/removing the plug-in option, hold the sides of the option. Do not press on the parts on the option circuit board. Stress applied to the parts by pressing, etc. may cause a failure.
- Be careful not to drop mounting screws during the installation or removal of the plug-in option.
- Attach this product to option connector 1 on the inverter. If it is attached to option connector 2 or 3, the protective function (E.2 or E.3) is activated and the inverter will not operate. Even if this product is attached to option connector 1, when the inverter cannot recognize that the option is mounted due to improper installation, etc., the protective function (E.1) is activated.

Mounted position	Fault indication
Option connector 1	E. 1
Option connector 2	E. 2
Option connector 3	E. 3

- When removing the FR-A8NS, remove the two screws on either side, then pull it straight out. Pressure applied to the connector and to the option board may break the option.
- To perform SSCNET III(/H) communication using the FR-A800-E inverter with the FR-A8AL installed, remove the pre-installed Ethernet board from the inverter. (For instructions for removing the Ethernet board, refer to the Instruction Manuals of the inverter.)

## 2.3 Axis number setting

Set the axis number between 0 to F using the axis number switch (refer to [page 13](#)) on the FR-A8NS. The setting is applied at the next power-on or inverter reset.

Set the switch marked with an arrow () to the axis number (0-9, A-F) corresponding to the desired axis.

Axis number	Definition	Axis number	Definition
0 (initial status)	1st axis	8	9th axis
1	2nd axis	9	10th axis
2	3rd axis	A	11th axis
3	4th axis	B	12th axis
4	5th axis	C	13th axis
5	6th axis	D	14th axis
6	7th axis	E	15th axis
7	8th axis	F	16th axis

### NOTE

- Do not change the axis number while the inverter power is ON. Otherwise you may get an electric shock.
- Set the axis number switch with precision so that the arrow on the switch points just a number or letter position. If the switch is set between numbers, normal data communication cannot be made.

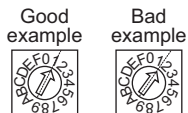

- You cannot set the same axis number to other devices on the network. (Doing so disables proper communication.)

# 3 WIRING

## 3.1 System configuration

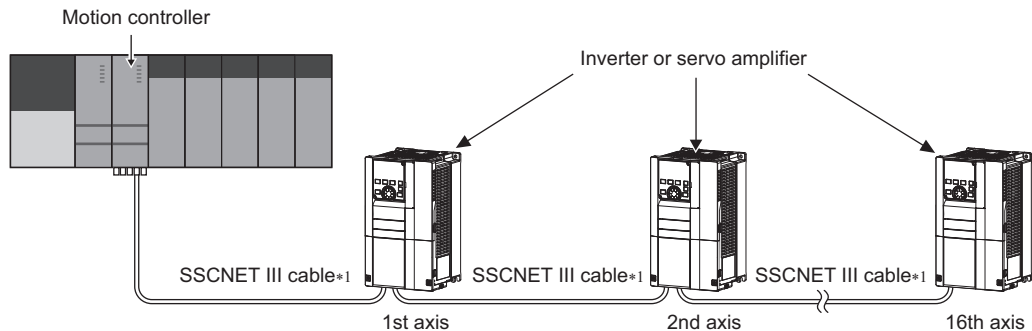

\*1 For selection of the SSCNET III cable, refer to [page 33](#).

### NOTE

- Up to 16 inverters (with the FR-A8NS each) can be used for axis number setting in a system.
- When using MT Developer2, refer to the following table to select the appropriate amplifier model according to your system setting on the amplifier setting screen.

Interface	FR-A800 inverter type	Amplifier model
SSCNETIII	FR-A800-1/-E1 (FM type)	FR-A700
	FR-A800-2/-E2 (CA type)	FR-A700
SSCNETIII/H	FR-A800-1/-E1 (FM type)	FR-A800-1
	FR-A800-2/-E2 (CA type)	FR-A800-2

## 3.2 Wiring example (when FR-A8AP is used)

### ◆ Vector control dedicated motor (SF-PR-SC, SF-V5RU, or SF-THY), 12 V complementary

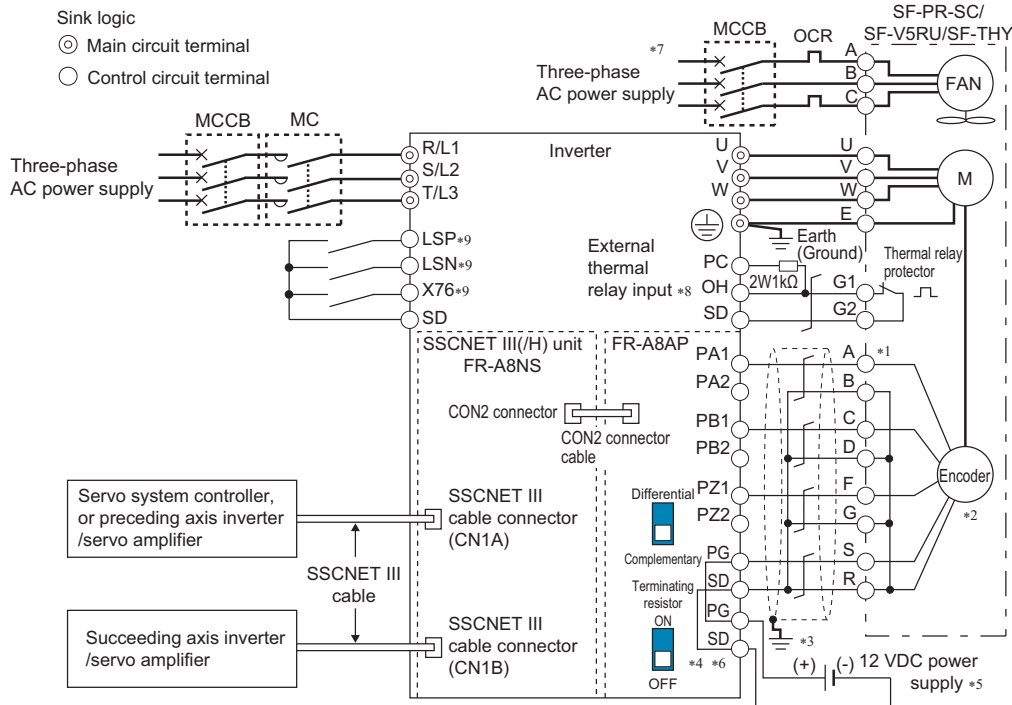

- \*1 The pin number differs according to the encoder used.  
Speed control and torque control are properly performed even without connecting Z phase.
- \*2 Connect the encoder to the motor shaft so that there is no looseness. Speed ratio should be 1:1.
- \*3 Earth (Ground) the shielded cable of the encoder cable to the enclosure with a P clip, etc.
- \*4 For the complementary, set the terminating resistor selection switch to off position.
- \*5 A separate power supply of 5 V/12 V/15 V/24 V is necessary according to the encoder power specification.  
Make the voltage of the external power supply the same as the encoder output voltage, and connect the external power supply across PG and SD.
- \*6 For terminal compatibility of the FR-JCBL, FR-V7CBL and FR-A8AP, refer to the Instruction Manual of the FR-A8AP.
- \*7 For the fan of the 7.5 kW or less dedicated motor, the power supply is single phase. (200 V/50 Hz, 200 to 230 V/60 Hz)
- \*8 Connect the recommended 2 W 1 k $\Omega$  resistor between terminals PC and OH. (Recommended product: MOS2C102J 2W1k $\Omega$  by KOA Corporation) Insert the input line and the resistor to a 2-wire blade terminal, and connect the blade terminal to terminal OH. (For the recommended 2-wire blade terminals, refer to the Instruction Manual of the FR-A8AP.)  
Insulate the lead wire of the resistor, for example by applying a contraction tube, and shape the wires so that the resistor and its lead wire will not touch other cables. Caulk the lead wire securely together with the thermal protector input line using a 2-wire blade terminal. (Do not subject the lead wire's bottom area to an excessive pressure.)  
To use an input terminal for the OH (External thermal O/L relay input) signal, assign the OH signal to the terminal. (Set "7" in any of **Pr.178 to Pr.189** (Input terminal function selection).)

When the OH signal is assigned to terminal RH (**Pr.182** = "7")

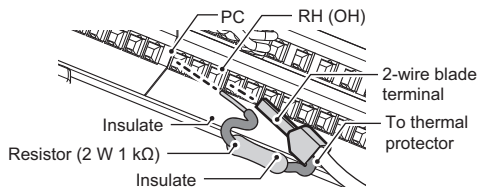

- \*9 Use any of **Pr.178 to Pr.189** (Input terminal function selection) to assign the function.



 **NOTE**

- For the details of the input terminals of the inverter, refer to the Instruction Manual (Detailed) of the FR-A800 inverter.
- For the details of the FR-A8AP, refer to the Instruction Manual of the FR-A8AP.
- On the FR-A8AL, connect encoder cables to terminals PA, PAR, PB, PBR, PZ, PZR, PG, and SD. For the details, refer to the Instruction Manual of the FR-A8AL.
- On the FR-A8TP, connect encoder cables to terminals PA3, PAR3, PB3, PBR3, PZ3, PZR3, PG, and SD. For the details, refer to the Instruction Manual of the FR-A8TP.
- On the FR-A8APR, connect encoder cables to terminals R1, R2, S1, S3, S2, S4, and CM. For the details, refer to the Instruction Manual of the FR-A8APR.
- On the FR-A8APS, connect encoder cables to terminals UP, UN, DT+, DT-, CK+, and CK-. For the details, refer to the Instruction Manual of the FR-A8APS.
- On the FR-A8APA, connect encoder cables to terminals EA+, EA-, EB+, EB-, ER+, ER-, EC+, EC-, ED+, ED-, UP, and UN. For the details, refer to the Instruction Manual of the FR-A8APA.

### 3.3 SSCNET III cable

It is recommended to use the following SSCNET III cables. Generally use the SSCNET III cables manufactured by Mitsubishi Electric System & Service Co., Ltd. for long distance cables of up to 100 m and ultra-long flex life cables. (Refer to [page 36.](#))

#### 3.3.1 Mitsubishi Electric SSCNET III cable

##### ◆ Cable model name

Model <sup>*1</sup>	Type	Cable length (m)	Distance between electrodes (m)	Flex life	Application
MR-J3BUS□M	POF	0.15, 0.3, 0.5, 1, 3	3	Standard	Standard cord inside panel
MR-J3BUS□M-A		5, 10, 20	20		Standard cable outside panel
MR-J3BUS□M-B <sup>*2</sup>	HPCF	30, 40, 50	50	Long flex	Long-distance cable

\*1 □ in the type represents the cable length. (Refer to the following.)

Symbol	015	03	05	1	3	5	10	20	30	40	50
Cable length (m)	0.15	0.3	0.5	1	3	5	10	20	30	40	50

\*2 For cable of 30 m or less, contact our company.

## ◆ Specifications

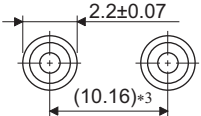
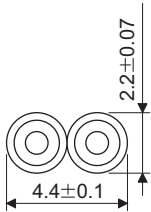
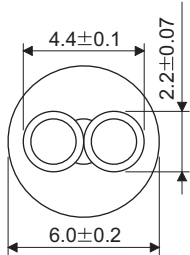
Item		MR-J3BUS□M		MR-J3BUS□M-A	MR-J3BUS□M-B
Cable length (m)		0.15	0.3 to 3	5 to 20	30 to 50
Optical cable (cord)	Minimum bend radius (mm) <sup>*1</sup>	25		Enforced covering cord: 50 Cord: 25	Enforced covering cord: 50 Cord: 30
	Tension strength	70 N	140 N	420 N (Enforced covering cord)	980 N (Enforced covering cord)
	Temperature range for use <sup>*2</sup>	-40 to 80°C			-20 to 70°C
	Ambient	Indoors (no direct sunlight), no solvent or oil			
	Cross-section dimensions (mm)				

\*1 Make sure to lay the cable with greater radius than the minimum bend radius. Do not press the cable to edges of equipment or others.

\*2 This temperature range for use is the value for optical cable (cord part) only. Temperature condition for the connector is the same as that for inverter.

\*3 Dimension of connector fiber insert location. The distance of two cords is changed by how to bend it.

## ◆ Outline drawings

- MR-J3BUS015M

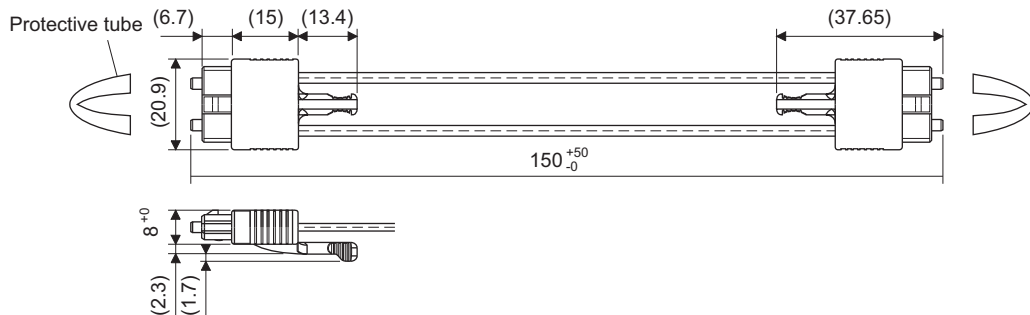

(Unit: mm)

- MR-J3BUS03M to MR-J3BUS3M

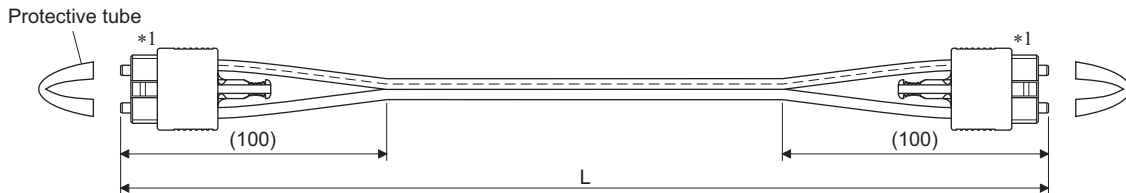

(Unit: mm)

Model	MR-J3BUS03M	MR-J3BUS05M	MR-J3BUS1M	MR-J3BUS3M
L (m)	0.3	0.5	1	3

\*1 Dimension of connector part is the same as that of MR-J3BUS015M.

- MR-J3BUS5M-A to MR-J3BUS20M-A, MR-J3BUS30M-B to MR-J3BUS50M-B

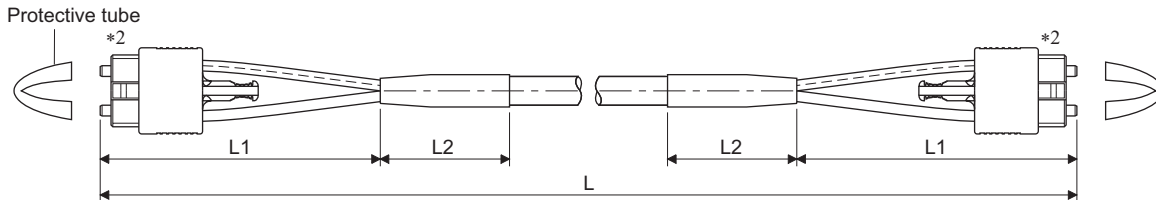

Model	MR-J3BUS5M-A	MR-J3BUS10M-A	MR-J3BUS20M-A	MR-J3BUS30M-B	MR-J3BUS40M-B	MR-J3BUS50M-B
L1 (mm)	100			150		
L2 (mm)	30			50		
L (m)	5	10	20	30	40	50

\*2 Dimension of connector part is the same as that of MR-J3BUS015M.

### 3.3.2 SSCNET III cables manufactured by Mitsubishi Electric System & Service Co., Ltd.

The cable is available per 1 [m] up to 100 [m].

Model <sup>*1</sup>	Length (m)	Bending life	Application
SC-J3BUS[]M-C	1 to 100	Ultra-long bending life	Long distance cable

\*1 Brackets [ ] in a model name indicate the cable length (1 to 100).

#### NOTE

- For the details of the SC-J3BUS[]M-C, contact Mitsubishi Electric System & Service Co., Ltd.

### 3.3.3 Instructions for laying the SSCNET III cable

SSCNET III cable is made of optical fiber. Application of a power such as a major shock, abrupt bending, haul, lateral pressure, or torsion to the fiber-optic cable will deform or break the inside, disabling optical transmission.

Read described item of this subsection carefully and handle it with caution.

In addition, the optical fiber of the MR-J3BUS[M] and the MR-J3BUS[M-A] may melt if they are exposed to fire or high temperature, as they are made of synthetic resin. Therefore, prevent the cable from contacting with the hot sections such as heat sinks of the inverter or regenerative options.

#### ◆ Minimum bend radius

Make sure to lay the cable with greater radius than the minimum bend radius. Do not press the cable to edges of equipment or others. For the SSCNET III cable, the appropriate length should be selected with due consideration for the dimensions and arrangement of the inverter. Ensure that the cable bend will not become smaller than the minimum bend radius if the SSCNET III cable is pressed down when the door of the enclosure is closed. For the minimum bend radius, refer to [page 34](#).

#### ◆ Bundle fixing

When fixing the SSCNET III cable using cable ties, keep a bend in the cord part of the fiber-optic cable slightly curved so that a radius of curvature of the cord stays larger than the minimum permissible radius, and keep the cord from being twisted.

In binding the cord with a cable tie, use a cushioning material such as plasticizer-free sponge or rubber, and fasten the cord tight.

Never use vinyl tape for the cord. Plasticizing material in vinyl tape may go into optical fiber and degrade the optical characteristic, which causes wire breakage. If using adhesive tape for binding cables, the flame-retardant acetate cloth adhesive tape 570F (Teraoka Seisakusho Co., Ltd.) is recommended.

If laying the cable together with other wires, keep the cable away from the wires or cables made from soft polyvinyl chloride (PVC), polyethylene resin (PE), fluorocarbon resin or nylon which contains plasticizing material.

#### ◆ Tension

Applied tension to fiber optics causes external force to concentrate in the section where fiber optics are fixed and an optical connector is connected, increasing transmission loss. If a larger pressure is further applied, this could cause disconnection of optical fibers and damage to the optical connector. For cable laying, handle without putting forced tension. For the tension strength, refer to [page 34](#).

### ◆ **Lateral pressure**

Applying a lateral pressure to the fiber cable deforms the cable itself and applies pressure to the internal fiber, resulting in increase in transmission loss. If a larger pressure is further applied, the cable may be disconnected. As the same condition also occurs at cable laying, do not tighten up optical cable with a thing such as nylon band (TY-RAP).

Do not trample it down or tuck it down with the door of enclosure or others.

### ◆ **Twisting**

If optical fiber is twisted, it will become the same stress added condition as when local lateral pressure or bend is added. This could increase a transmission loss. If a larger pressure is further applied, the cable may be disconnected.

Keep the SSCNET III cable from being twisted during laying operations.

### ◆ **Dust**

If the end face of cord tip for the SSCNET III cable is dirty, optical transmission is interrupted and it may cause malfunctions. If it becomes dirty, wipe with a bonded textile, etc. Do not use solvent such as alcohol.

### ◆ **Disposal**

When incinerating optical cable (cord) used for SSCNET III cable, hydrogen fluoride gas or hydrogen chloride gas which is corrosive and harmful may be generated. For disposal of SSCNET III cable, request for specialized industrial waste disposal services who has incineration facility for disposing hydrogen fluoride gas or hydrogen chloride gas.

---

#### **NOTE**

- Do not look directly into the light beam emitted from SSCNET III fiber-optic cable. Doing so may cause eye discomfort. (The light source of SSCNET III(/H) cable complies with class1 defined in JISC6802 or IEC60825-1.)
-

## 3.4 Wiring

Remove the inverter front cover and the connector cap of the SSCNET III cable connector (CN1A, CN1B) on the FR-A8NS to insert the SSCNET III cable to the connectors.

Refer to [page 33](#) for types of the SSCNET III cable.

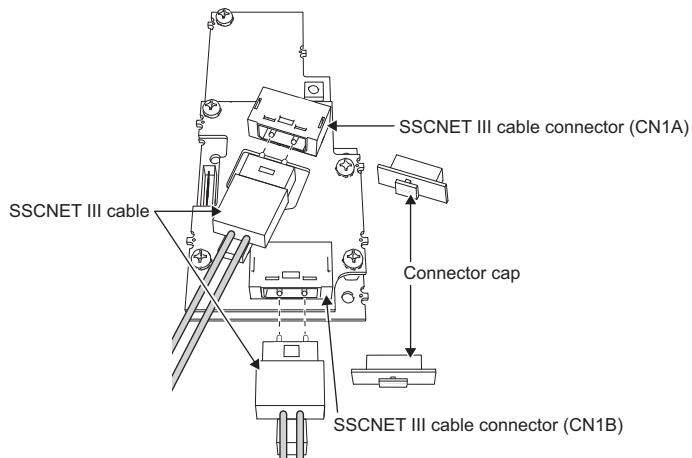

### NOTE

- For the final axis, do not remove the connector cap of the SSCNET III cable connector (CN1B).

### CAUTION

- After wiring, wire offcuts must not be left in the inverter. Wire offcuts can cause an alarm, failure, or malfunction.



## 4 SSCNET III(/H) COMMUNICATION STATUS

---

When the inverter is powered ON while **Pr.499 SSCNET III(/H) operation selection** is set to a value other than "9999" and the X85 signal is turned OFF, the inverter is ready to start the SSCNET III(/H) initial data communication (initialized communication). As the inverter is set in the SSCNET III(/H) operation mode as soon as it is in the state, the operation mode cannot be switched to the External operation mode or the PU operation mode. Also, the following settings are disabled: **Pr.79 Operation mode selection**, **Pr.338 Communication operation command source**, **Pr.339 Communication speed command source**, **Pr.340 Communication startup mode selection**, and **Pr.550 NET mode operation command source selection**.

The SSCNET III(/H) communication status with the servo system controller can be monitored. (Refer to [page 40](#).)

For the state transition of the inverter during the SSCNET III(/H) communication, refer to [page 41](#).

For the details of the SSCNET III(/H) communication status, refer to [page 43](#).

### 4.1 SSCNET III(/H) communication status monitor selection

---

The SSCNET III(/H) communication status can be monitored on the PU (operation panel or parameter unit) when "39" is set in the monitor selection parameters (**Pr.52**, **Pr.774 to Pr.776**, and **Pr.992**). (When "39" is set in **Pr.52**, the SSCNET III(/H) communication status is displayed in the third monitor screen.)

The SSCNET III(/H) communication status can be monitored using the graph function of FR Configurator2 when "39" is set in the analog source selection parameters (**Pr.1027 to Pr.1034**).

For how to check the SSCNET III(/H) communication status with the master, refer to [page 40](#).

#### NOTE

- If the warning "CF" is activated, the SSCNET III(/H) communication status and the warning indication "CF" is displayed alternately on the operation panel. On the LED operation panel or the parameter unit, both of them are displayed together. (For the details of warnings, refer to [page 79](#).)
  - For the details of any setting value other than "39" in the parameters above, refer to the Instruction Manual (Detailed) of the inverter.
-

## 4.2 State transition diagram of the inverter

The number in a box  in the diagram below is the indicated monitor data of the SSCNET III(/H) communication status. (Refer to [page 43](#).)

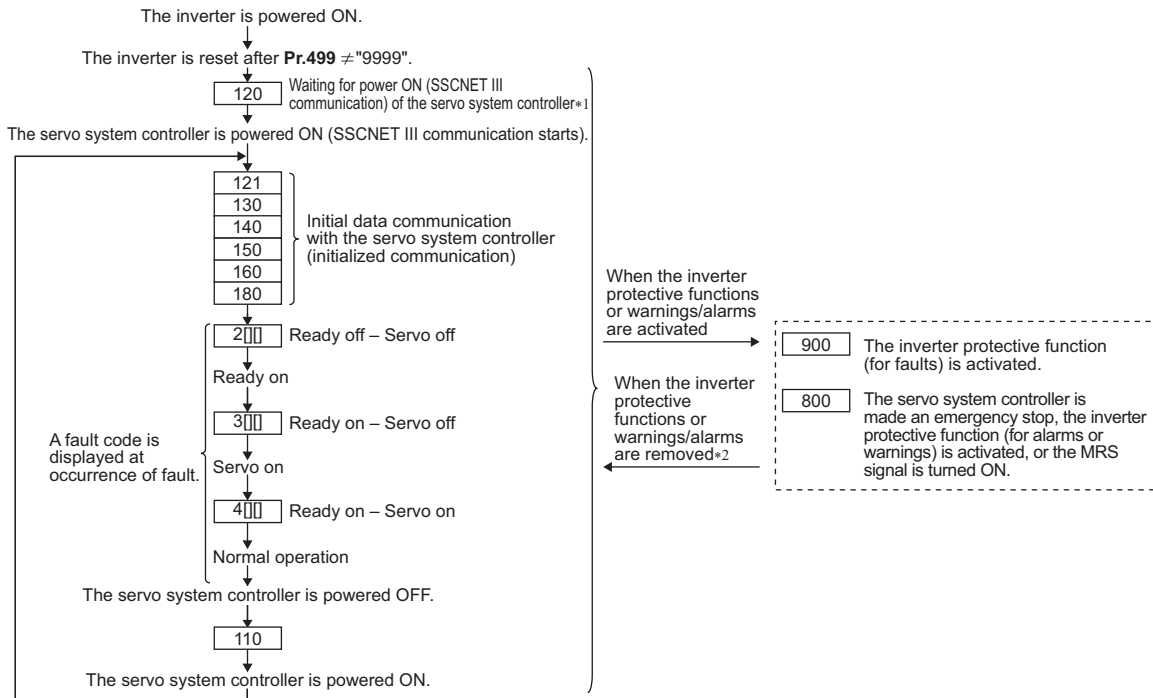

- \*1 The inverter is set in the SSCNET III(/H) operation mode and cannot be switched in the External operation or PU operation mode. In addition the operation mode setting in **Pr.79 Operation mode selection** is invalid.
- \*2 Refer to [page 53](#) for the reset method of the inverter protective function. If the inverter protective function is reset by the inverter power reset, the inverter recovers in the communication waiting status after powering on again.

## 4.3 List of SSCNET III(/H) communication status

SSCNET III(/H) communication status	Inverter operation	Description		
110	During initialization *1	<ul style="list-style-type: none"> <li>When the servo system controller power is OFF after SSCNET III(/H) communication is established</li> <li>When <b>Pr.499 SSCNET III(/H) operation selection</b> = "9999" or the X85 signal is turned ON (SSCNET III(/H) operation is disabled)</li> </ul>		
120		<ul style="list-style-type: none"> <li>When the inverter power is ON while the servo system controller power is OFF</li> <li>When the setting of the axis number switch in the servo system controller does not match the actual setting of the axis number on the FR-A8NS</li> <li>When an inverter failure or a communication error with the servo system controller occurs and the indication of the SSCNET III(/H) communication status is as follows: "120"→"130"→"140"→"120"</li> <li>When the servo system controller is in faulty</li> <li>When the first initialization has not completed after powering ON</li> </ul>		
121		<ul style="list-style-type: none"> <li>During initial setting of the communication specifications</li> <li>When the setting of the axis number switch in the servo system controller does not match the actual setting of the axis number on the FR-A8NS and the indication of the SSCNET III(/H) communication status is as follows: "120"↔"121"</li> </ul>		
130		When communication initialization setting has completed and the inverter is in synchronization with the servo system controller		
140		During preliminary communication with the servo system controller		
150		During motor and encoder data communication with the servo system controller		
160		During initial signal data communication with the servo system controller		
180		During completion operation of initial data communication with the servo system controller		
2□□		Ready off	Ready off-Servo off	□□ represents the axis number. For example, the first axis is represented as 201, 301, or 401.
3□□		Servo off	Ready on-Servo off	
4□□	Servo on	Ready on-Servo on		
800	Warning	<ul style="list-style-type: none"> <li>A warning (inverter protective function for alarms or warnings), an emergency stop of servo system controller, or the MRS signal ON</li> <li>At servo-on, the control mode set in the servo system controller is not supported by the inverter, or the control mode of the servo system controller and the control mode of the inverter do not match.*2</li> </ul>		

SSCNET III(/H) communication status	Inverter operation	Description
900	Fault	A fault (inverter protective function for faults)

- \*1 During initialization, the warning indication "CF" may be displayed on the PU. On the operation panel, the warning indication "CF" and the communication status is displayed alternately when the warning CF is activated. (For how to monitor the SSCNET III(/H) communication status, refer to [page 40](#).)
- \*2 Only the communication status monitor displays the inverter status and does not notify the servo system controller of the status.

# 5 INVERTER SETTING

## 5.1 Parameter list

The following parameters are used for the FR-A8NS.

Set the values according to need. For the parameter details, which depend on the applicable model of the inverter, refer to the Instruction Manual (Detailed) of the inverter.

Pr.	Pr. group	Name	Setting range	Minimum setting increments	Initial value	Refer to page
52	M100	Operation panel main monitor selection	39: SSCNET III(/H) communication status <sup>*5</sup>	1	0	40
81	C102	Number of motor poles	2, 4, 6, 8, 10, 12, 9999	1	9999	58
178	T700	STF terminal function selection	76: Proximity dog 85: SSCNET III(/H) communication disabled 88: Upper stroke limit 89: Lower stroke limit <sup>*5</sup>	1	60	54, 57
179	T701	STR terminal function selection		1	61	
180	T702	RL terminal function selection		1	0	
181	T703	RM terminal function selection		1	1	
182	T704	RH terminal function selection		1	2	
183	T705	RT terminal function selection		1	3	
184	T706	AU terminal function selection		1	4	
185	T707	JOG terminal function selection		1	5	
186	T708	CS terminal function selection		1	6	
187	T709	MRS terminal function selection		1	24 <sup>*6/</sup> 10 <sup>*7</sup>	
188	T710	STOP terminal function selection		1	25	
189	T711	RES terminal function selection	1	62		
379 <sup>*1*2</sup>	N300 <sup>*1*2</sup>	SSCNET III(/H) rotation direction selection	0, 1	1	0	55

Pr.	Pr. group	Name	Setting range	Minimum setting increments	Initial value	Refer to page
449 <sup>*1</sup>	N301 <sup>*1</sup>	SSCNET III(/H) input filter setting	0 to 4	1	4	56
499 <sup>*1*3</sup>	N302 <sup>*1*3</sup>	SSCNET III(/H) operation selection	0, 1, 100, 101, 9999	1	9999	49
774	M101	Operation panel monitor selection 1	39: SSCNET III(/H) communication status <sup>*5</sup>	1	9999	40
775	M102	Operation panel monitor selection 2		1	9999	
776	M103	Operation panel monitor selection 3		1	9999	
800 <sup>*4</sup>	G200 <sup>*4</sup>	Control method selection	0 to 6, 9 to 14, 20, 100 to 106, 109 to 114	1	20	57
992	M104	Operation panel setting dial push monitor selection	39: SSCNET III(/H) communication status <sup>*5</sup>	1	0	40
1027	A910	Analog source selection (1ch)	39: SSCNET III(/H) communication status <sup>*5</sup>	1	201	40
1028	A911	Analog source selection (2ch)		1	202	
1029	A912	Analog source selection (3ch)		1	203	
1030	A913	Analog source selection (4ch)		1	204	
1031	A914	Analog source selection (5ch)		1	205	
1032	A915	Analog source selection (6ch)		1	206	
1033	A916	Analog source selection (7ch)		1	207	
1034	A917	Analog source selection (8ch)		1	208	

\*1 Available when the FR-A8NS is installed.

\*2 The setting is applied after the CPU reset of the servo system controller or at the next inverter power-ON.

\*3 When the **Pr.499** setting is switched between "9999" and any of other than "9999", the setting is applied after an inverter reset or power-ON.

\*4 When the **Pr.800** setting is changed while "0 or 1" is set in **Pr.499**, the setting is applied after an inverter reset or next power-ON.

\*5 For other settings, refer to the Instruction Manual (Detailed) of the inverter.

\*6 For standard models and IP55 compatible models

\*7 For separated converter types

## 5.2 Operation at communication error occurrence

### 5.2.1 Fault and measures

#### ◆ Inverter operation in each operation mode at error occurrences

Location	Status	Operation mode			
		SSCNET III(/H) operation	External operation	PU operation	
Inverter	Inverter operation	Output shutoff	Output shutoff	Output shutoff	
	Data communication	Continued	Continued	Continued	
Communication line	Inverter operation	Output shutoff	Continued	Continued	
	Data communication	Stop	Stop	Stop	
Communication option	Communication option connection error	Inverter operation	Output shutoff	Output shutoff <sup>*1</sup>	Output shutoff <sup>*1</sup>
		Data communication	Continued	Continued	Continued
	Error of communication option itself	Inverter operation	Output shutoff	Continued	Continued
		Data communication	Stop	Stop	Stop

\*1 Depends on the Pr.502 setting.

#### ◆ Measures at error occurrences

Fault indication	Error definition	Measures
E.OP1	Communication line error	Inspect the master.
E.1, E.2, E.3	Option fault	<ul style="list-style-type: none"> <li>Install the communication option into the inverter option connector 1.</li> <li>Check connections between the inverter and option units for poor contact, etc. and remove the cause of the error.</li> </ul>

\*1 When faults other than the above are displayed, refer to the Instruction Manual (Detailed) of the inverter and remove the cause of the error.



## 5.3 Inverter reset

---

The following methods are available for the inverter reset during SSCNET III(/H) communication (SSCNET III(/H) operation mode).

- Servo system controller error reset at fault occurrence in the inverter (reset can be made only when the protective function of the inverter is activated.)
- CPU reset of the servo system controller
- Turning ON the RES signal
- Inverter power reset
- Reset command from the PU
- Reset command from the PU at fault occurrence in the inverter



### NOTE

- Refer to **Pr. 499 SSCNET III(/H) operation selection** for the inverter operation selection at the inverter reset by the servo system controller. (Refer to [page 49](#).)
  - When the inverter operation in the SSCNET III(/H) operation mode is reset, the inverter restarts the operation in the same operation mode.
  - The inverter cannot be controlled for about one second after release of a reset command.
  - The new setting of the axis number is applied after the inverter reset or power-ON. Therefore, be sure to perform the inverter reset again when the setting of the axis number has been changed after the inverter reset.
-

## 5.4 Setting SSCNET III(/H) communication function

### 5.4.1 Pr.499 SSCNET III(/H) operation selection

Use **Pr.499 SSCNET III(/H) operation selection** to set the SSCNET III(/H) communication availability or the inverter operation at communication disconnection. The **Pr.499** setting is applied after an inverter reset.

Pr.499 setting	SSCNET III(/H) communication	Inverter operation at SSCNET III(/H) communication disconnection	Inverter reset by CPU reset of the servo system controller	Description
0, 100 <sup>*1</sup>	Enabled <sup>*2</sup>	Output shutoff or deceleration stop	Available	The inverter output is shutoff at occurrence of communication disconnection. The inverter decelerates the motor to a stop when "100" is set in <b>Pr.499</b> in the speed control or torque control mode. (If a communication disconnection occurs after the inverter protective function is activated, the inverter is automatically reset and the fault indication on the inverter is also reset.)
1, 101 <sup>*1</sup>		Output shutoff, and then communication option fault (E.OP1)	Not available	The inverter output is shutoff at occurrence of communication disconnection, and the communication option fault "E.OP1" is displayed (refer to <a href="#">page 80</a> ). (Inverter reset is necessary to restart the inverter operation.)
9999 (initial value)	Disabled	—	—	SSCNET III(/H) communication is disabled, and the inverter does not communicate with the master or the preceding or succeeding axis unit. As the SSCNET III(/H) operation mode imposes limitations on the operation mode selection and parameter settings of the inverter, set "9999" in <b>Pr.499</b> to remove these limitations.

\*1 When "100 or 101" is set in **Pr.499**, the control method can be selected ([page 57](#)).

\*2 When the SSCNET III(/H) communication disabled (X85) signal is turned ON, SSCNET III(/H) communication is disabled. (For the setting of the X85 signal, refer to [page 54](#).)

**NOTE**

- If an error such as a CRC check error, etc. occurs in the communication data, the communication option fault E.OP1 occurs regardless of the **Pr.499** or X85 setting.
- Refer to [page 53](#) for the reset method of the inverter protective function.
- The E.OP1 occurs in the inverter and the servo system controller when "1" is set in **Pr.499** at occurrence of communication disconnection. If the E.OP1 in the servo system controller cannot be reset by the inverter reset, reset the CPU of the servo system controller.

**◆ Pr.499 setting**

When a value other than "9999" is set in Pr.499, SSCNET III(/H) communication is available and the SSCNET III(/H) communication disabled (X85) signal can be used. The setting becomes valid after inverter reset.



Pr.499	0 or 1	100 or 101	Refer to page
Vector control compatible option	FR-A8AP and FR-A8AL	All options supported by the FR-A800 standard model	21
CON2 connector cable	Required	Not required	21
Control method	Vector control of induction motor	Depends on the inverter setting.	58
Control mode	Same as that of the master.	Depends on the inverter setting.	57
Data transmission delay	Shorter	Longer	60

Pr.499	0 or 100	1 or 101	Refer to page
Inverter operation at SSCNET III(/H) communication disconnection	Output shutoff or deceleration stop	Output shutoff, and then communication option fault (E.OP1)	49
Fault reset by CPU reset of the servo system controller	Available	Not available	49
Reset method for the protective functions	Inverter reset only	Inverter reset, or error reset in the master	53

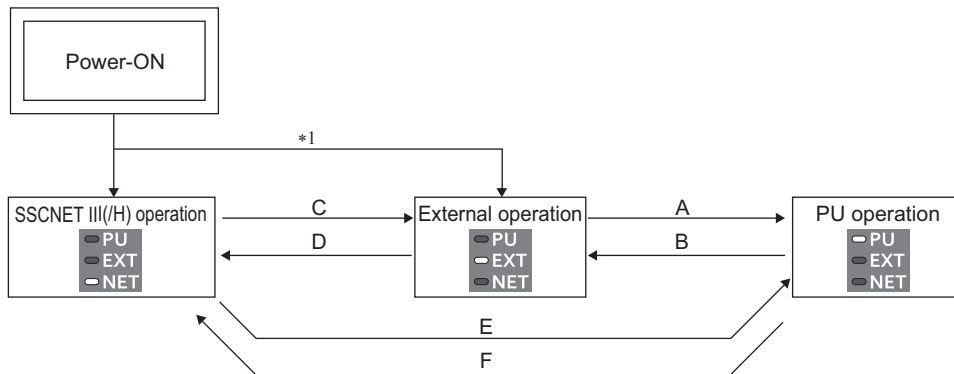
◆ **Operation mode switchover method when the SSCNET III(/H) communication is enabled (Pr.79 = "0")**



\*1 The inverter starts up in the External operation mode when the X85 signal is turned ON.

Symbol	Operation mode switching	Switchover method
A	External operation → PU operation	Press  on the PU.
B	PU operation → External operation	
C	SSCNET III(/H) operation → External operation	Turn ON the X85 signal.
D	External operation → SSCNET III(/H) operation	Turn OFF the X85 signal.
E	SSCNET III(/H) operation → PU operation	Turn ON the X85 signal, then press  on the PU.
F	PU operation → SSCNET III(/H) operation	Turn OFF the X85 signal.

## NOTE

- In the SSCNET III(/H) operation mode, the following settings are disabled: **Pr.79 Operation mode selection**, **Pr.338 Communication operation command source**, **Pr.339 Communication speed command source**, **Pr.340 Communication startup mode selection**, and **Pr.550 NET mode operation command source selection**.
- When **Pr.75 Reset selection/disconnected PU detection/PU stop selection** = "14 (initial value) to 17",  on the PU can be used to stop operation commands even during the SSCNET III(/H) operation. (PU stop) The deceleration time at this time is according to the setting of **Pr.8 Deceleration time**. For the details of **Pr.8** and **Pr.75**, refer to the Instruction Manual (Detailed) of the inverter. When stop is performed by the PU stop function, the warning indication "PS" is displayed on the PU.

## ◆ Reset method of the inverter faults

- When Pr.499 = "0 or 100"

In the SSCNET III(/H) operation mode, the following faults can be reset by the inverter reset only by power supply reset, turning

ON the RES signal, or pressing  on the PU.

They cannot be reset by the servo system controller error reset or CPU reset.

Indication	Name
E.BE	Brake transistor alarm detection
E.GF	Output side earth (ground) fault overcurrent
E.OPT	Option fault
E.OP2	Communication option fault
E.OP3	
E.PE	Parameter storage device fault
E.CPU	CPU fault
E.ILF	Input phase loss
E.ECT	Signal loss detection
E.ECA	Encoder signal loss for orientation
E.MB1 to 7	Brake sequence fault
E.P24	24 VDC power fault
E.CTE	Operation panel power supply short circuit

Indication	Name
E.LF	Output phase loss
E.PE2	Parameter storage device fault
E.IOH	Inrush current limit circuit fault
E.1	Option fault
E.2	
E.3	
E.5	CPU fault
E.6	
E.7	
E.11	Opposite rotation deceleration fault
E.EP	Encoder phase fault
E.16	User definition error by the PLC function
E.17	

Indication	Name
E.18	User definition error by the PLC function
E.19	
E.20	
E.AIE	Analog input fault
E.SAF	Safety circuit fault
E.PBT	Internal circuit fault
E.13	
E.IAH	Abnormal internal temperature
E.LCI	4 mA input fault
E.PCH	Pre-charge fault
E.PID	PID signal fault
E.LUP	Upper limit fault detection
E.LDN	Lower limit fault detection
E.PE6	Internal storage device fault

- When **Pr.499** = "1 or 101"

The inverter reset by the servo system controller error reset is also enabled to reset any inverter fault.  
(The fault cannot be reset by the servo system controller CPU reset.)

### 5.4.2 SSCNET III(/H) communication disabled signal

- Input of the SSCNET III(/H) communication disabled (X85) signal disables the SSCNET III(/H) communication operation.

Pr.499 setting	X85 signal	SSCNET III(/H) communication <sup>*1</sup>
Other than 9999	OFF	Valid
	ON	Invalid
9999 (initial value)	—	Invalid

\*1 When the status of SSCNET III(/H) communication is switched between enabled and disabled, the inverter is automatically reset and stops communication with the master (or the preceding axis unit) or the succeeding axis unit.

- To switch the status of SSCNET III(/H) communication between enabled and disabled with the inverter input signal, set "85" (for the X85 signal) in any of **Pr.178 to Pr.189 (Input terminal function selection)**.



### 5.4.3 Pr.379 SSCNET III(/H) rotation direction selection

The rotation direction of the motor can be changed using **Pr.379**. (Setting of **Pr.379** is required regardless of the control method.)

To operate the inverter under Vector control when "0 or 1" is set in **Pr.499 SSCNET III(/H) operation selection**, always match the setting of **Pr.359 Encoder rotation direction** (0, 100/1, 101) and rotation direction (CW/CCW) of the encoder as viewed from the load side of the motor before setting **Pr.379 SSCNET III(/H) rotation direction selection**.

Pr.359 setting	Pr.379 setting	Motor rotation direction (as viewed from the load side) <sup>*1</sup>	
		When positioning address becomes greater	When positioning address becomes smaller
0, 100	0 (initial value)	CW	CCW
	1	CCW	CW
1 (initial value), 101	0 (initial value)	CCW	CW
	1	CW	CCW

\*1 The motor direction (CW, CCW) is as follows:

Motor rotation direction	Description
CW	Set when using a motor for which forward rotation (encoder) is clockwise (CW) viewed from the shaft 
CCW	Set when using a motor for which forward rotation (encoder) is counterclockwise (CCW) viewed from the shaft 



## 5.4.4 Pr.449 SSCNET III(/H) input filter setting

Use **Pr.449 SSCNET III(/H) input filter setting** to select a filter setting for the following input signals.

Input signal	Parameter setting
LSP (Upper stroke limit) signal	<b>Pr.178 to Pr.189 (Input terminal function selection) = "88"</b>
STF (Upper stroke limit) signal	<b>Pr.178 STF terminal function selection = "60"</b>
LSN (Lower stroke limit) signal	<b>Pr.178 to Pr.189 (Input terminal function selection) = "89"</b>
STR (Lower stroke limit) signal	<b>Pr.179 STR terminal function selection = "61"</b>
X76 (Proximity dog) signal	<b>Pr.178 to Pr.189 (Input terminal function selection) = "76"</b>

Pr.449 setting <sup>*1</sup>	Input signal filter (maximum)
0	N/A (0.88 ms sampling)
1	0.88 ms
2	1.77 ms
3	2.66 ms
4 (initial value)	3.55 ms

\*1 Change in the **Pr.449** setting is immediately applied.

## 5.4.5 Input terminal function selection

- To use home position return with proximity dog (to input the DOG signal to the servo system controller via an inverter input terminal) in SSCNET III(/H) communication, set "76" (for the X76 signal and proximity dog) in any of **Pr.178 to Pr.189 (Input terminal function selection)**.
- To input the FLS or RLS signal to the servo system controller via an inverter input terminal, set "88" (for the LSP signal, upper stroke limit) or "89" (for the LSN signal, lower stroke limit) in any of **Pr.178 to Pr.189 (Input terminal function selection)**. (Though the FLS or RLS signal can be input to the servo system controller similarly with the STF signal (when "60" (initial value) is set in **Pr.178 STF terminal function selection**) or the STR signal (when "61" (initial value) is set in **Pr.179 STR terminal function selection**), the LSP or LSN signal has a higher priority than the STF or STR signal.)
- When "100 or 101" is set in **Pr.499 SSCNET III(/H) operation selection**, do not assign the LX (Pre-excitation/servo on) signal to an input terminal by setting "23" in **Pr.178 to Pr.189 (Input terminal function selection)**.

## 5.4.6 Control method selection

### ◆ Pr.800 Control method selection

Specifications of **Pr.800 Control method selection** when the FR-A8NS is installed are as follows depending on the setting of **Pr.499 SSCNET III(/H) operation selection**.

Pr.499 setting	Pr.800 setting <sup>*1</sup>	Control method	Control mode (speed, torque, position)	Operation without motor
0, 1	Other than 9 <sup>*4</sup>	Vector control	As commanded by the servo system controller	Invalid
	9	Vector control test operation <sup>*2*3</sup>		Valid
100,101	Control method depending on the parameter setting of the inverter <sup>*4*5*6</sup>			

\*1 Reset the inverter after the **Pr.800** setting is switched between "9" and any of other than "9". The setting is applied after an inverter reset.

\*2 When "9" is set in **Pr. 800**, test run is available without connecting a motor.

\*3 When "9" (vector control test operation) is set in **Pr. 800**, it is recommended to set "0" in **Pr. 880 Load inertia ratio**. For the details of **Pr.880**, refer to the Instruction Manual (Detailed) of the inverter.

\*4 Setting **Pr.800** = "100 or higher" does not select the fast-response operation. (Normal-response operation is applied during vector control.)

\*5 For the setting method of the control method and control mode, refer to the Instruction Manual (Detailed) of the inverter.

\*6 When the control mode can be switched (**Pr.800** = "2", etc.), the control mode depends on the command from the servo system controller.

## ◆ Availability of control mode when the FR-A8NS is used

Control method		Pr.499 = "0 or 1"			Pr.499 = "100 or 101"		
		Control mode					
		Speed control	Torque control	Position control	Speed control	Torque control	Position control
V/F control		×	—	—	○ <sup>*1</sup>	—	—
Advanced magnetic flux vector control		×	—	—	○	—	—
Real sensorless vector control		×	×	—	○	○	—
Vector control	Induction motor	○ <sup>*3</sup>	○ <sup>*3</sup>	○ <sup>*3</sup>	○ <sup>*2*4</sup>	○ <sup>*4</sup>	○ <sup>*4*5</sup>
	PM motor	×	—	×	○ <sup>*2*4</sup>	—	○ <sup>*4</sup>
PM sensorless vector control		×	—	×	○	—	○

○: Valid, ×: Invalid, —: Unsupported

- \*1 Set **Pr.81 Number of motor poles** even under V/F control. When "9999" is set in **Pr.81**, the setting of 4 poles is applied to the operation.
- \*2 When "6" (torque control by a variable-current limiter) is set in **Pr.800**, select the speed control for the command from the servo system controller.
- \*3 The plug-in option FR-A8AP/FR-A8AL is required. Use the CON2 connector cable for connection between the FR-A8AP/FR-A8AL and the FR-A8NS.
- \*4 A Vector control compatible option is required.
- \*5 When using the FR-A8AL, use the FR-A8AL manufactured in May 2017 or later.

## ◆ The number of pulses per motor rotation

The number of pulses output by a feedback device per motor rotation depends on the control method and the feedback control option as follows.

Control method	Feedback control option	Number of pulses	
Vector control	FR-A8AP/FR-A8AL/FR-A8APA	Pr.862 = "0"	Pr.369 setting
		Pr.862 = "1"	Pr.851 setting
	FR-A8APR	Pr.862 = "0"	Fixed to 1024
		Pr.862 = "1"	Pr.851 setting
	FR-A8APS	Pr.862 = "0"	Number of pulses actually sent from feedback device
		Pr.862 = "1"	Pr.851 setting
	FR-A8TP	Pr.862 = "0"	Pr.851 setting
		Pr.862 = "1"	
PM sensorless vector control (MM-CF motor)	None	1024 × number of motor poles / 2	
V/F control Advanced magnetic flux vector control Real sensorless vector control	None	Pr.369 setting	

### NOTE

- When the setting of the control method or the number of pulses per motor rotation is changed, the change is applied after the CPU of servo system controller is reset or at the next power-ON.
- Use MT Developer2 to check the number of pulses per motor rotation. Use the transient command (encoder resolution) of the optional data monitor setting function of MT Developer2.

## ◆ Data and device for position control

The following shows the availability and difference of data by the type of devices for position control.

Position information	Description of information	Data by device type				
		Encoder	Resolver	Endat	SinCos	IPM motor (MM-CF)
Position feedback	Accumulated value of feedback pulses sent from a feedback device since power-ON	Actual feedback from the device				Estimates by the motor speed
Absolute position	Once the home position is set at start-up, the current position information is retained even after power-OFF.	Not available	Not available	Not available <sup>*1</sup>	Not available	Not available

\*1 Even if an absolute multi-revolution encoder is used, only incremental positioning is available.

## ◆ Data transmission delay

Due to periodic data update in the inverter, data transmission is delayed by a period required for data update and communication cycle. The required time for data update varies depending on the setting of **Pr.499 SSCNET III(/H) operation selection**. The affected items and the required time are as follows.

Item	Pr.499 = "0 or 1"	Pr.499 = "100 or 101"
Motor load factor	10 ms	10 ms
Position feedback	222 μs	1.5 ms
Position of the encoder within one revolution	222 μs	1.5 ms
Multi-revolution encoder counter	222 μs	1.5 ms
Load inertia moment ratio	10 ms	10 ms
Position loop gain	10 ms	10 ms
Converter output voltage	5 ms	5 ms

# 6 RESTRICTIONS ON THE FUNCTIONS

## 6.1 Function restriction list

Invalid inverter functions during SSCNET III(/H) communication operation are as follows.

While the following functions are invalid, signal input/output and monitoring related to the functions are disabled. For the details of the related I/O signals and monitors, refer to the Instruction Manual (Detailed) of the inverter.

Item	Function
A: Application parameters	<ul style="list-style-type: none"><li>• Automatic restart after instantaneous power failure</li><li>• Electronic bypass function</li><li>• Brake sequence function</li><li>• Stop-on-contact control</li><li>• Load torque high-speed frequency control</li><li>• Traverse function</li><li>• Anti-sway control</li><li>• Orientation control</li><li>• PID control</li><li>• Power failure time deceleration-to-stop function</li><li>• Stop selection function</li><li>• Inverter operation lock mode setting (Pr.415)</li><li>• PLC function</li></ul>
B: Position control parameters	<ul style="list-style-type: none"><li>• Simple positioning function by parameters</li><li>• Position control by inverter pulse train input</li><li>• Position command source selection (Pr.419)</li><li>• Position command constant value during acceleration/deceleration (Pr.424)</li><li>• Clear signal selection (Pr.429)</li><li>• Model position control gain (Pr.446)<sup>*3</sup></li></ul>
C: Motor constant parameters	<ul style="list-style-type: none"><li>• Offline auto tuning</li><li>• Encoder position tuning</li><li>• Online auto tuning at startup (Pr.95 = "1")</li></ul>
D: Parameters for operation command and frequency command	<ul style="list-style-type: none"><li>• Operation mode selection</li><li>• Operation command source and speed command source during communication operation</li><li>• Multi-speed setting, JOG operation, remote setting, pulse train input</li></ul>

Item	Function
E: Environment setting parameters	<ul style="list-style-type: none"> <li>• IPM parameter initialization<sup>*3</sup></li> </ul>
F: Parameters for settings of acceleration/ deceleration time and acceleration/ deceleration pattern	<ul style="list-style-type: none"> <li>• Acceleration/deceleration time, acceleration/deceleration pattern selection<sup>*3</sup>Remote setting</li> <li>• Starting frequency<sup>*1</sup> during speed control or position control, and start-time hold function<sup>*3</sup></li> <li>• Automatic acceleration/deceleration</li> <li>• Emergency stop function (<b>Pr.1103</b>)</li> </ul>
G: Control Parameters	<ul style="list-style-type: none"> <li>• V/F control, adjustable 5 points V/F, Advanced magnetic flux vector control, Real sensorless vector control, PM sensorless vector control<sup>*3</sup></li> <li>• DC injection brake<sup>*3</sup></li> <li>• Brake operation selection<sup>*3</sup></li> <li>• Output stop function</li> <li>• Stop selection</li> <li>• Regeneration avoidance function<sup>*3</sup></li> <li>• Strengthened excitation deceleration<sup>*3</sup></li> <li>• Torque bias</li> </ul>
H: Protective function parameters	<ul style="list-style-type: none"> <li>• Speed limit selection, forward rotation speed limit, reverse rotation speed limit/reverse-side speed limit, speed limit method selection</li> <li>• Torque limit level during acceleration/deceleration</li> <li>• Fault definition<sup>*3</sup></li> <li>• Retry function</li> <li>• Ground fault detection enable/disable selection at start<sup>*3</sup></li> <li>• Minimum frequency<sup>*3</sup></li> <li>• Frequency jump<sup>*3</sup></li> <li>• Speed limit (<b>Pr.873</b>)<sup>*3</sup></li> <li>• Speed deviation excess (<b>Pr.285</b>)<sup>*3</sup></li> <li>• Deceleration check time</li> <li>• Emergency drive</li> </ul>
T: Multi-function input terminal parameters	<ul style="list-style-type: none"> <li>• Override function</li> <li>• Functions for terminals 1, 4, 6<sup>*2</sup></li> <li>• Second function selection signal (RT)</li> <li>• Third function selection signal (X9) (except second/third output frequency detection)</li> </ul>

Item	Function
N: Parameters for communication operation and its settings	<ul style="list-style-type: none"> <li>• Stop mode selection at communication error (<b>Pr.502</b>)</li> <li>• Operation frequency during communication error (<b>Pr.779</b>)</li> </ul>
Parameters for vector control	<ul style="list-style-type: none"> <li>• Magnetic flux command</li> <li>• Torque command reverse selection (<b>Pr.1114</b>)<sup>*3</sup></li> <li>• Fast-response operation under vector control (when <b>Pr.800</b> = "100 or higher")</li> </ul>
Plug-in options	<ul style="list-style-type: none"> <li>• FR-A8AX, FR-A8APR<sup>*3</sup>, FR-A8APS<sup>*3</sup></li> </ul>

\*1 Except starting frequency during torque control

\*2 Terminal 6 can be used only when the FR-A8AZ is installed.

\*3 The function is enabled when "100 or 101" is set in **Pr.499**.



## NOTE

- Do not execute Parameter clear or All parameter clear during the SSCNET III(/H) communication.



## 6.2 Inverter parameter list

The setting of the following parameters is invalid when the FR-A8NS is installed.

### 6.2.1 Invalid parameters when the FR-A8NS is used

Pr.	Name
4	Multi-speed setting (high speed)
5	Multi-speed setting (middle speed)
6	Multi-speed setting (low speed)
15	Jog frequency
16	Jog acceleration/deceleration time
24	Multi-speed setting (speed 4)
25	Multi-speed setting (speed 5)
26	Multi-speed setting (speed 6)
27	Multi-speed setting (speed 7)
28	Multi-speed input compensation selection
44	Second acceleration/deceleration time
45	Second deceleration time
46	Second torque boost
47	Second V/F (base frequency)
48	Second stall prevention operation level
49	Second stall prevention operation frequency
51	Second electronic thermal O/L relay
57	Restart coasting time
58	Restart cushion time
59	Remote function selection
61	Reference current

Pr.	Name
62	Reference value at acceleration
63	Reference value at deceleration
64	Starting frequency for elevator mode
65	Retry selection
67	Number of retries at fault occurrence
68	Retry waiting time
69	Retry count display erase
73	Analog input selection
74	Input filter time constant
79	Operation mode selection
96	Auto tuning setting/status
110	Third acceleration/deceleration time
111	Third deceleration time
112	Third torque boost
113	Third V/F (base frequency)
114	Third stall prevention operation level
115	Third stall prevention operation frequency
125	Terminal 2 frequency setting gain frequency
126	Terminal 4 frequency setting gain frequency
127	PID control automatic switchover frequency
128	PID action selection
129	PID proportional band
130	PID integral time
131	PID upper limit
132	PID lower limit
133	PID action set point
134	PID differential time
135	Electronic bypass sequence selection

Pr.	Name
136	MC switchover interlock time
137	Start waiting time
138	Bypass selection at a fault
139	Automatic switchover frequency from inverter to bypass operation
147	Acceleration/deceleration time switching frequency
148	Stall prevention level at 0 V input
149	Stall prevention level at 10 V input
155	RT signal function validity condition selection
159	Automatic switchover frequency range from bypass to inverter operation
162	Automatic restart after instantaneous power failure selection
163	First cushion time for restart
164	First cushion voltage for restart
165	Stall prevention operation level for restart
232	Multi-speed setting (speed 8)
233	Multi-speed setting (speed 9)
234	Multi-speed setting (speed 10)
235	Multi-speed setting (speed 11)
236	Multi-speed setting (speed 12)
237	Multi-speed setting (speed 13)
238	Multi-speed setting (speed 14)
239	Multi-speed setting (speed 15)
241	Analog input display unit switchover
242	Terminal 1 added compensation amount (terminal 2)
243	Terminal 1 added compensation amount (terminal 4)
248	Self power management selection
250	Stop selection

Pr.	Name
252	Override bias
253	Override gain
254	Main circuit power OFF waiting time
261	Power failure stop selection
262	Subtracted frequency at deceleration start
263	Subtraction starting frequency
264	Power-failure deceleration time 1
265	Power-failure deceleration time 2
266	Power failure deceleration time switchover frequency
267	Terminal 4 input selection
270	Stop-on contact/load torque high-speed frequency control selection
271	High-speed setting maximum current
272	Middle-speed setting minimum current
273	Current averaging range
274	Current averaging filter time constant
275	Stop-on contact excitation current low-speed multiplying factor
276	PWM carrier frequency at stop-on contact
278	Brake opening frequency
279	Brake opening current
280	Brake opening current detection time
281	Brake operation time at start
282	Brake operation frequency
283	Brake operation time at stop
284	Deceleration detection function selection
285	Overspeed detection frequency
291	Pulse train I/O selection

Pr.	Name
292	Automatic acceleration/deceleration
293	Acceleration/deceleration separate selection
294	UV avoidance voltage gain
298	Frequency search gain
299	Rotation direction detection selection at restarting
300	BCD input bias
301	BCD input gain
302	BIN input bias
303	BIN input gain
304	Digital input and analog input compensation enable/disable selection
305	Read timing operation selection
325	Terminal 40 input selection
329	Digital input unit selection
338	Communication operation command source
339	Communication speed command source
340	Communication startup mode selection
345	DeviceNet address
346	DeviceNet/ControlNet baud rate
347	CANopen address
348	CANopen baud rate
349	Communication reset selection
350	Stop position command selection
351	Orientation speed
352	Creep speed
353	Creep switchover position
354	Position loop switchover position
355	DC injection brake start position

Pr.	Name
356	Internal stop position command
357	Orientation in-position zone
358	Servo torque selection
360	16-bit data selection
361	Position shift
362	Orientation position loop gain
363	Completion signal output delay time
364	Encoder stop check time
365	Orientation limit
366	Recheck time
373	Encoder position tuning setting/status
384	Input pulse division scaling factor
385	Frequency for zero input pulse
386	Frequency for maximum input pulse
387	Initial communication delay time
388	Send time interval at heart beat
389	Minimum sending time at heart beat
390	% setting reference frequency
391	Receive time interval at heart beat
392	Event driven detection width
393	Orientation selection
394	Number of machine side gear teeth
395	Number of motor side gear teeth
396	Orientation speed gain (P term)
397	Orientation speed integral time
398	Orientation speed gain (D term)
399	Orientation deceleration ratio
406	High resolution analog input selection

Pr.	Name
415	Inverter operation lock mode setting
419	Position command source selection
420	Command pulse scaling factor numerator (electronic gear numerator)
421	Command pulse multiplication denominator (electronic gear denominator)
424	Position command acceleration/deceleration time constant
428	Command pulse selection
429	Clear signal selection
432	Pulse train torque command bias
433	Pulse train torque command gain
434	Network number (CC-Link IE)
435	Station number (CC-Link IE)
447	Digital torque command bias
448	Digital torque command gain
450	Second applied motor
451	Second motor control method selection
453	Second motor capacity
454	Number of second motor poles
455	Second motor excitation current
456	Rated second motor voltage
457	Rated second motor frequency
458	Second motor constant (R1)
459	Second motor constant (R2)
460	Second motor constant (L1) / d-axis inductance (Ld)
461	Second motor constant (L2) / q-axis inductance (Lq)
462	Second motor constant (X)
463	Second motor auto tuning setting/status

Pr.	Name
464	Digital position control sudden stop deceleration time
465	First target position lower 4 digits
466	First target position upper 4 digits
467	Second target position lower 4 digits
468	Second target position upper 4 digits
469	Third target position lower 4 digits
470	Third target position upper 4 digits
471	Fourth target position lower 4 digits
472	Fourth target position upper 4 digits
473	Fifth target position lower 4 digits
474	Fifth target position upper 4 digits
475	Sixth target position lower 4 digits
476	Sixth target position upper 4 digits
477	Seventh target position lower 4 digits
478	Seventh target position upper 4 digits
479	Eighth target position lower 4 digits
480	Eighth target position upper 4 digits
481	Ninth target position lower 4 digits
482	Ninth target position upper 4 digits
483	Tenth target position lower 4 digits
484	Tenth target position upper 4 digits
485	Eleventh target position lower 4 digits
486	Eleventh target position upper 4 digits
487	Twelfth target position lower 4 digits
488	Twelfth target position upper 4 digits
489	Thirteenth target position lower 4 digits
490	Thirteenth target position upper 4 digits
491	Fourteenth target position lower 4 digits

Pr.	Name
492	Fourteenth target position upper 4 digits
493	Fifteenth target position lower 4 digits
494	Fifteenth target position upper 4 digits
498	PLC function flash memory clear
500	Communication error execution waiting time
501	Communication error occurrence count display
502	Stop mode selection at communication error
514	Emergency drive dedicated retry waiting time
515	Emergency drive dedicated retry count
522	Output stop frequency
523	Emergency drive mode selection
524	Emergency drive running speed
541	Frequency command sign selection
542	Communication station number (CC-Link)
543	Baud rate selection (CC-Link)
544	CC-Link extended setting
550	NET mode operation command source selection
551	PU mode operation command source selection
553	PID deviation limit
554	PID signal operation selection
560	Second frequency search gain
562	ControlNet data
565	Second motor excitation current break point
566	Second motor excitation current low-speed scaling factor
569	Second motor speed control gain
573	4 mA input check selection
574	Second motor online auto tuning
575	Output interruption detection time

Pr.	Name
576	Output interruption detection level
577	Output interruption cancel level
592	Traverse function selection
593	Maximum amplitude amount
594	Amplitude compensation amount during deceleration
595	Amplitude compensation amount during acceleration
596	Amplitude acceleration time
597	Amplitude deceleration time
606	Power failure stop external signal input selection
608	Second motor permissible load level
609	PID set point/deviation input selection
610	PID measured value input selection
611	Acceleration time at a restart
635	Cumulative pulse clear signal selection
636	Cumulative pulse division scaling factor
637	Control terminal option-Cumulative pulse division scaling factor
638	Cumulative pulse storage
639	Brake opening current selection
640	Brake operation frequency selection
641	Second brake sequence operation selection
642	Second brake opening frequency
643	Second brake opening current
644	Second brake opening current detection time
645	Second brake operation time at start
646	Second brake operation frequency
647	Second brake operation time at stop
648	Second deceleration detection function selection

Pr.	Name
650	Second brake opening current selection
651	Second brake operation frequency selection
668	Power failure stop frequency gain
679	Second droop gain
680	Second droop filter time constant
681	Second droop function activation selection
682	Second droop break point gain
683	Second droop break point torque
690	Deceleration check time
692	Second free thermal reduction frequency 1
693	Second free thermal reduction ratio 1
694	Second free thermal reduction frequency 2
695	Second free thermal reduction ratio 2
696	Second free thermal reduction frequency 3
738	Second motor induced voltage constant ( $\phi f$ )
739	Second motor Ld decay ratio
740	Second motor Lq decay ratio
741	Second starting resistance tuning compensation
742	Second motor magnetic pole detection pulse width
743	Second motor maximum frequency
744	Second motor inertia (integer)
745	Second motor inertia (exponent)
746	Second motor protection current level
747	Second motor low-speed range torque characteristic selection
753	Second PID action selection
754	Second PID control automatic switchover frequency
755	Second PID action set point

Pr.	Name
756	Second PID proportional band
757	Second PID integral time
758	Second PID differential time
759	PID unit selection
760	Pre-charge fault selection
761	Pre-charge ending level
762	Pre-charge ending time
763	Pre-charge upper detection level
764	Pre-charge time limit
765	Second pre-charge fault selection
766	Second pre-charge ending level
767	Second pre-charge ending time
768	Second pre-charge upper detection level
769	Second pre-charge time limit
777	4 mA input check operation frequency
778	4 mA input check filter
779	Operation frequency during communication error
802	Pre-excitation selection
804	Torque command source selection
805	Torque command value (RAM)
806	Torque command value (RAM, EEPROM)
807	Speed limit selection
808	Forward rotation speed limit/speed limit
809	Reverse rotation speed limit/reverse-side speed limit
810	Torque limit input method selection
822	Speed setting filter 1
826	Torque setting filter 1
829	Number of machine end encoder pulses

Pr.	Name
832	Speed setting filter 2
833	Speed detection filter 2
836	Torque setting filter 2
837	Torque detection filter 2
840	Torque bias selection
841	Torque bias 1
842	Torque bias 2
843	Torque bias 3
844	Torque bias filter
845	Torque bias operation time
846	Torque bias balance compensation
847	Fall-time torque bias terminal 1 bias
848	Fall-time torque bias terminal 1 gain
849	Analog input offset adjustment
858	Terminal 4 function assignment
860	Second motor torque current/Rated PM motor current
863	Control terminal option-Encoder pulse division ratio
868	Terminal 1 function assignment
876	Thermal protector input
C2 (902)	Terminal 2 frequency setting bias frequency
C3 (902)	Terminal 2 frequency setting bias
125 (903)	Terminal 2 frequency setting gain frequency
C4 (903)	Terminal 2 frequency setting gain
C5 (904)	Terminal 4 frequency setting bias frequency

Pr.	Name
C6 (904)	Terminal 4 frequency setting bias
126 (905)	Terminal 4 frequency setting gain frequency
C7 (905)	Terminal 4 frequency setting gain
C12 (917)	Terminal 1 bias frequency (speed)
C13 (917)	Terminal 1 bias (speed)
C14 (918)	Terminal 1 gain frequency (speed)
C15 (918)	Terminal 1 gain (speed)
C16 (919)	Terminal 1 bias command (torque/magnetic flux)
C17 (919)	Terminal 1 bias (torque/magnetic flux)
C18 (920)	Terminal 1 gain command (torque/magnetic flux)
C19 (920)	Terminal 1 gain (torque/magnetic flux)
C30 (926)	Terminal 6 bias frequency (speed)
C31 (926)	Terminal 6 bias (speed)
C32 (927)	Terminal 6 gain frequency (speed)
C33 (927)	Terminal 6 gain (speed)
C34 (928)	Terminal 6 bias command (torque)

Pr.	Name
C35 (928)	Terminal 6 bias (torque)
C36 (929)	Terminal 6 gain command (torque)
C37 (929)	Terminal 6 gain (torque)
C8 (930)	Current output bias signal
C9 (930)	Current output bias current
C10 (931)	Current output gain signal
C11 (931)	Current output gain current
C38 (932)	Terminal 4 bias command (torque/magnetic flux)
C39 (932)	Terminal 4 bias (torque/magnetic flux)
C40 (933)	Terminal 4 gain command (torque/magnetic flux)
C41 (933)	Terminal 4 gain (torque/magnetic flux)
C42 (934)	PID display bias coefficient
C43 (934)	PID display bias analog value
C44 (935)	PID display gain coefficient
C45 (935)	PID display gain analog value
1013	Running speed after emergency drive retry reset

Pr.	Name
1015	Integral stop selection at limited frequency
1072	DC brake judgment time for anti-sway control operation
1073	Anti-sway control operation selection
1074	Anti-sway control frequency
1075	Anti-sway control depth
1076	Anti-sway control width
1077	Rope length
1078	Trolley weight
1079	Load weight
1105	Encoder magnetic pole position offset
1109	PROFIBUS communication command source selection
1110	PROFIBUS format selection
1113	Speed limit method selection
1114	Torque command reverse selection
1134	PID upper limit manipulated value
1135	PID lower limit manipulated value
1136	Second PID display bias coefficient
1137	Second PID display bias analog value
1138	Second PID display gain coefficient
1139	Second PID display gain analog value
1140	Second PID set point/deviation input selection
1141	Second PID measured value input selection
1142	Second PID unit selection
1143	Second PID upper limit
1144	Second PID lower limit
1145	Second PID deviation limit
1146	Second PID signal operation selection
1147	Second output interruption detection time



Pr.	Name
1148	Second output interruption detection level
1149	Second output interruption cancel level
1150 to 1199	User parameters 1 to 50
1220	Target position/speed selection
1221	Start command edge detection selection
1222	First positioning acceleration time
1223	First positioning deceleration time
1224	First positioning dwell time
1225	First positioning sub-function
1226	Second positioning acceleration time
1227	Second positioning deceleration time
1228	Second positioning dwell time
1229	Second positioning sub-function
1230	Third positioning acceleration time
1231	Third positioning deceleration time
1232	Third positioning dwell time
1233	Third positioning sub-function
1234	Fourth positioning acceleration time
1235	Fourth positioning deceleration time
1236	Fourth positioning dwell time
1237	Fourth positioning sub-function
1238	Fifth positioning acceleration time
1239	Fifth positioning deceleration time
1240	Fifth positioning dwell time
1241	Fifth positioning sub-function
1242	Sixth positioning acceleration time

Pr.	Name
1243	Sixth positioning deceleration time
1244	Sixth positioning dwell time
1245	Sixth positioning sub-function
1246	Seventh positioning acceleration time
1247	Seventh positioning deceleration time
1248	Seventh positioning dwell time
1249	Seventh positioning sub-function
1250	Eighth positioning acceleration time
1251	Eighth positioning deceleration time
1252	Eighth positioning dwell time
1253	Eighth positioning sub-function
1254	Ninth positioning acceleration time
1255	Ninth positioning deceleration time
1256	Ninth positioning dwell time
1257	Ninth positioning sub-function
1258	Tenth positioning acceleration time
1259	Tenth positioning deceleration time
1260	Tenth positioning dwell time
1261	Tenth positioning sub-function
1262	Eleventh positioning acceleration time
1263	Eleventh positioning deceleration time
1264	Eleventh positioning dwell time
1265	Eleventh positioning sub-function
1266	Twelfth positioning acceleration time
1267	Twelfth positioning deceleration time
1268	Twelfth positioning dwell time
1269	Twelfth positioning sub-function
1270	Thirteenth positioning acceleration time

Pr.	Name
1271	Thirteenth positioning deceleration time
1272	Thirteenth positioning dwell time
1273	Thirteenth positioning sub-function
1274	Fourteenth positioning acceleration time
1275	Fourteenth positioning deceleration time
1276	Fourteenth positioning dwell time
1277	Fourteenth positioning sub-function
1278	Fifteenth positioning acceleration time
1279	Fifteenth positioning deceleration time
1280	Fifteenth positioning dwell time
1281	Fifteenth positioning sub-function
1282	Home position return method selection
1283	Home position return speed
1284	Home position return creep speed
1285	Home position shift amount lower 4 digits
1286	Home position shift amount upper 4 digits
1287	Travel distance after proximity dog ON lower 4 digits
1288	Travel distance after proximity dog ON upper 4 digits
1289	Home position return stopper torque
1290	Home position return stopper waiting time
1292	Position control terminal input selection
1293	Roll feeding mode selection
1294	Position detection lower 4 digits
1295	Position detection upper 4 digits
1296	Position detection selection
1297	Position detection hysteresis width
1298	Second position control gain
1299	Second pre-excitation selection

Pr.	Name
1300 to 1343	Option parameter 1 to 44
1350 to 1359	Option information 1 to 10
1400 *1	Low-speed range speed control P gain 1
1401 *1	Low-speed range speed control P gain 2
1402 *1	Low-speed range gain corner frequency 1
1403 *1	Low-speed range gain corner frequency 2
1404 *1	Shortest-time torque startup selection
1405 *1	Overload detection time
1406 *1	Inching prevention time
1407 *1	Magnetic flux command during pre-excitation
1408 *1	Brake opening current for reverse rotation
1409 *1	Second brake opening current for reverse rotation
1412	Motor induced voltage constant (phi f) exponent
1413	Second motor induced voltage constant (phi f) exponent

Pr.	Name
1432 *2	Ethernet communication check time interval
1449 *2	Ethernet command source selection IP address 1
1450 *2	Ethernet command source selection IP address 2
1451 *2	Ethernet command source selection IP address 3
1452 *2	Ethernet command source selection IP address 4
1453 *2	Ethernet command source selection IP address 3 range specification
1454 *2	Ethernet command source selection IP address 4 range specification

\*1 This parameter is used for the FR-A800-CRN.

\*2 This parameter is used for the FR-A800-E.

## 6.2.2 Invalid parameters when the FR-A8NS is used and "0 or 1" is set in Pr.499

Pr.	Name
0	Torque boost
2	Minimum frequency
3	Base frequency
7	Acceleration time
8	Deceleration time
10	DC injection brake operation frequency
11	DC injection brake operation time
12	DC injection brake operation voltage

Pr.	Name
13	Starting frequency
14	Load pattern selection
19	Base frequency voltage
20	Acceleration/deceleration reference frequency
21	Acceleration/deceleration time increments
23	Stall prevention operation level compensation factor at double speed
29	Acceleration/deceleration pattern selection
31	Frequency jump 1A
32	Frequency jump 1B
33	Frequency jump 2A
34	Frequency jump 2B
35	Frequency jump 3A
36	Frequency jump 3B
41	Up-to-frequency sensitivity
60	Energy saving control selection
66	Stall prevention operation reduction starting frequency
85	Excitation current break point
86	Excitation current low-speed scaling factor
89	Speed control gain (Advanced magnetic flux vector)
100	V/F1 (first frequency)
101	V/F1 (first frequency voltage)
102	V/F2 (second frequency)
103	V/F2 (second frequency voltage)
104	V/F3 (third frequency)
105	V/F3 (third frequency voltage)
106	V/F4 (fourth frequency)
107	V/F4 (fourth frequency voltage)

Pr.	Name
108	V/F5 (fifth frequency)
109	V/F5 (fifth frequency voltage)
140	Backlash acceleration stopping frequency
141	Backlash acceleration stopping time
142	Backlash deceleration stopping frequency
143	Backlash deceleration stopping time
154	Voltage reduction selection during stall prevention operation
245	Rated slip
246	Slip compensation time constant
247	Constant-power range slip compensation selection
249	Earth (ground) fault detection at start
285	Speed deviation excess detection frequency
380	Acceleration S-pattern 1
381	Deceleration S-pattern 1
382	Acceleration S-pattern 2
383	Deceleration S-pattern 2
446	Model position control gain
516	S-pattern time at a start of acceleration
517	S-pattern time at a completion of acceleration
518	S-pattern time at a start of deceleration
519	S-pattern time at a completion of deceleration
552	Frequency jump range
555	Current average time
556	Data output mask time
557	Current average value monitor signal output reference current
571	Holding time at a start
617	Reverse rotation excitation current low-speed scaling factor

Pr.	Name
653	Speed smoothing control
654	Speed smoothing cutoff frequency
660	Increased magnetic excitation deceleration operation selection
661	Magnetic excitation increase rate
662	Increased magnetic excitation current level
665	Regeneration avoidance frequency gain
673	SF-PR slip amount adjustment operation selection
674	SF-PR slip amount adjustment gain
702	Maximum motor frequency
706	Induced voltage constant (phi f)
711	Motor Ld decay ratio
712	Motor Lq decay ratio
717	Starting resistance tuning compensation
721	Starting magnetic pole position detection pulse width
725	Motor protection current level
788	Low speed range torque characteristic selection
791	Acceleration time in low-speed range
792	Deceleration time in low-speed range
802	Pre-excitation selection
816	Torque limit level during acceleration
817	Torque limit level during deceleration
850	Brake operation selection
851	Control terminal option-Number of encoder pulses
852	Control terminal option-Encoder rotation direction
855	Control terminal option-Signal loss detection enable/disable selection
862	Encoder option selection

Pr.	Name
873	Speed limit
875	Fault definition
882	Regeneration avoidance operation selection
883	Regeneration avoidance operation level
884	Regeneration avoidance at deceleration detection sensitivity
885	Regeneration avoidance compensation frequency limit value
886	Regeneration avoidance voltage gain
998	PM parameter initialization
1002	Lq tuning target current adjustment coefficient
1424 *1	Ethernet communication network number
1425 *1	Ethernet communication station number
1426 *1	Link speed and duplex mode selection
1427 *1	Ethernet function selection 1
1428 *1	Ethernet function selection 2
1429 *1	Ethernet function selection 3
1431 *1	Ethernet signal loss detection function selection
1434 *1	Ethernet IP address 1
1435 *1	Ethernet IP address 2

Pr.	Name
1436 *1	Ethernet IP address 3
1437 *1	Ethernet IP address 4
1438 *1	Subnet mask 1
1439 *1	Subnet mask 2
1440 *1	Subnet mask 3
1441 *1	Subnet mask 4
1442 *1	Ethernet IP filter address 1
1443 *1	Ethernet IP filter address 2
1444 *1	Ethernet IP filter address 3
1445 *1	Ethernet IP filter address 4
1446 *1	Ethernet IP filter address 2 range specification
1447 *1	Ethernet IP filter address 3 range specification
1448 *1	Ethernet IP filter address 4 range specification
1455 *1	Keepalive time
1480	Load characteristics measurement mode

Pr.	Name
1481	Load characteristics load reference 1
1482	Load characteristics load reference 2
1483	Load characteristics load reference 3
1484	Load characteristics load reference 4
1485	Load characteristics load reference 5
1486	Load characteristics maximum frequency
1487	Load characteristics minimum frequency
1488	Upper limit warning detection width
1489	Lower limit warning detection width
1490	Upper limit fault detection width
1491	Lower limit fault detection width
1492	Load status detection signal delay time / load reference measurement waiting time

\*1 This parameter is used for the FR-A800-E.

# 7 Instructions for SSCNET III(/H) communication

---

- During SSCNET III(/H) communication, the inverter parameter cannot be changed with the servo system controller. When **Pr.77 Parameter write selection** = "2", the parameter settings can be changed on the PU even if the inverter is set in the SSCNET III(/H) operation mode.
- The valid command for an inverter start or stop is given via the SSCNET III(/H) communication. Though the STF and STR signals are invalid, the STF signal is used as the Upper stroke limit signal and the STR signal as the Lower stroke limit signal.
- Before starting operation, always give the servo-ON signal from the host controller to the motor in order to set the motor in the servo lock state.
- Running speed depends on the command from the servo system controller. (The rotation direction depends on the setting of **Pr.379 SSCNET III(/H) rotation direction selection**.)
- Droop control cannot be performed when "0 or 1" is set in **Pr.499 SSCNET III(/H) operation selection** and "0 or 10" (droop control is disabled during acceleration/deceleration) is set in **Pr.288 Droop function activation selection**. Set a value other than "0 or 10" in **Pr.288**. (For the details, refer to the Instruction Manual (Detailed) of the inverter.)
- The fault indication "E.OC3" or "E.OV3" is displayed when the inverter stops due to an overcurrent trip or overvoltage trip during SSCNET III(/H) operation. (For the details, refer to the Instruction Manual (Detailed) of the inverter.)
- Offline auto tuning and encoder position tuning cannot be performed with the servo system controller. Perform these tunings with the inverter before starting communication.
- Before shutting off the communication temporarily by resetting the inverter power, disconnecting the SSCNET III cable, or other methods, it is necessary to perform the disconnection/reconnection function for the servo system controller. Refer to the MELSEC iQ-R Motion Controller Programming Manual (Common) for details.
- When the MRS signal is ON, create the motion SFC program that turns ON the servo-OFF command of the target axis. To turn OFF the MRS signal or the servo-OFF command signal, the motor speed must be at 20 r/min or less.
- During the SSCNET III(/H) communication, **Pr.998 PM parameter initialization** must be set to "0" (initial value) when "0 or 1" is set in **Pr.499 SSCNET III(/H) operation selection**.

## 8 PROTECTIVE FUNCTIONS

The causes of faults and corrective actions to be taken are as follows.

### ◆ Warning

When the protective function is activated, the inverter does not shut off the output.

Operation panel indication	CF		FR-LU08	CF
Name	Initialize communication waiting status <sup>*1</sup>			
Description	The warning indication is displayed when the inverter is not in communication with the servo system controller after the inverter is powered ON in the SSCNET III(H) operation mode. The warning indication is also displayed when the communication is established and then shut off. The warning indication disappears when the communication is established with the servo system controller. Then the inverter becomes ready for operation. The CF warning indication is displayed during initialization (when the SSCNET III(H) communication status is "110" to "180"). (Refer to <a href="#">page 40</a> .)			
Check point	Check the communication cable for a fault. Check that the communication equipment (personal computer) and servo system controller have not been powered OFF.			
Corrective action	Change the communication cable. Power ON the communication equipment (personal computer) and servo system controller.			

\*1 Not displayed when the SSCNET III(H) operation is disabled (**Pr.499 SSCNET III(H) operation selection** = "9999" (initial value) or the X85 signal is turned ON).



## ◆ Fault

When a protective function is activated, the inverter output is shut off and a fault signal is output.

To resume the inverter operation after any protective function has been activated, refer to the Instruction Manual (Detailed) of the inverter to take an appropriate corrective action and reset the inverter.

Operation panel indication	E.OPT		FR-LU08	Option Fault
Name	Option fault			
Description	The warning indication is displayed when the FR-A8AP/FR-A8AL is not attached to option connector 2 on the inverter or the CON2 connector cable is not used correctly for connection between the FR-A8NS and the FR-A8AP/FR-A8AL to operate the inverter with "0 or 1" set in <b>Pr.499</b> .			
Check point	Check that the FR-A8AP/FR-A8AL is attached to option connector 2 on the inverter. Check that the CON2 connector cable is used for connection between the FR-A8NS and the FR-A8AP/FR-A8AL.			
Corrective action	Attach the FR-A8AP or FR-A8AL correctly to option connector 2 on the inverter. (Refer to <a href="#">page 24</a> .) Use the CON2 connector cable correctly for connection between the FR-A8NS and the FR-A8AP/FR-A8AL. (Refer to <a href="#">page 24</a> .) Alternatively, set "100 or 101" in <b>Pr.499</b> .			

Operation panel indication	E.OP1		FR-LU08	Option1 Fault
Name	Communication option fault			
Description	When the communication line error occurs between the inverter with FR-A8NS installed and the servo system controller, or when the command frequency from the servo system controller is too high, the output from the inverter is stopped. The output from the inverter is also stopped when the SSCNET III cable between the FR-A8NS and the servo system controller or the preceding axis inverter/servo amplifier is disconnected under the setting of <b>Pr. 499 SSCNET III/(H) operation selection = "1, 101"</b> .			
Check point	<p>Check that the SSCNET III cable is not disconnected.</p> <p>Check the end of the SSCNET III cable for contamination or dirt.</p> <p>Check that the SSCNET III cable is not damaged or broken.</p> <p>Check that electromagnetic noise has not come in the FR-A8NS or the servo system controller.</p> <p>Check for too high command frequency from the servo system controller.</p>			
Corrective action	<p>Connect the SSCNET III cable securely after turning OFF the inverter power.</p> <p>Remove the dirt from the end of the SSCNET III cable.</p> <p>Change the SSCNET III cable.</p> <p>Take measures against electromagnetic noise for the inverter or the servo system controller.</p> <p>Review the operation program of the servo system controller.</p>			

## 9 TROUBLESHOOTING

---

### ◆ Operation mode does not switch to the SSCNET III(/H) operation mode

Check the following points.

- Check that the plug-in option is correctly installed to the inverter. (Check for contact fault, cable disconnection, etc.) Check that the CON2 connector cable is used correctly for connection between the FR-A8NS and the FR-A8AP/FR-A8AL to operate the inverter with "0 or 1" set in **Pr.499**. (Refer to [page 24](#).)
- Check that the SSCNET III cable is connected correctly to the SSCNET III cable connectors (CN1A and CN1B) on the FR-A8NS. (Refer to [page 39](#).)
- Check if **Pr.499 SSCNET III(/H) operation selection** is set to "9999 (initial value)" or the X85 signal is turned ON. (Refer to [page 49](#).)

# APPENDIX

## Appendix 1 Instructions for compliance with the EU Directives

The EU Directives are issued to standardize different national regulations of the EU Member States and to facilitate free movement of the equipment, whose safety is ensured, in the EU territory.

Since 1996, compliance with the EMC Directive that is one of the EU Directives has been legally required. Since 1997, compliance with the Low Voltage Directive, another EU Directive, has been also legally required. When a manufacturer confirms its equipment to be compliant with the EMC Directive and the Low Voltage Directive, the manufacturer must declare the conformity and affix the CE marking.

- The authorized representative in the EU

The authorized representative in the EU is shown below.

Name: Mitsubishi Electric Europe B.V.

Address: Mitsubishi-Electric-Platz 1, 40882 Ratingen, Germany

### ◆ EMC Directive

We declare that this product conforms with the EMC Directive when installed in a compatible inverter, and affix the CE marking on the packaging plate.

- EMC Directive: 2014/30/EC
- Standard(s): EN 61800-3:2004+A1:2012 (Second environment / PDS Category "C3")

### ■ Note

- To install and wire the inverter, refer to the "Instructions for compliance with the EU Directives" in the Instruction Manual enclosed with the inverter.
- Confirm that the final integrated system with the inverter conforms with the EMC Directive.

### ◆ EU RoHS Directive

We declare that this product conforms with the EU RoHS Directive (2011/65/EU) when installed in a compatible inverter, and affix the CE marking on the packaging plate.



## Appendix 2 Instructions for EAC

The product certified in compliance with the Eurasian Conformity has the EAC marking on the packaging plate.

Note: EAC marking

In 2010, three countries (Russia, Belarus, and Kazakhstan) established a Customs Union for the purposes of revitalizing the economy by forming a large economic bloc by abolishing or reducing tariffs and unifying regulatory procedures for the handling of articles.

Products to be distributed over these three countries of the Customs Union must comply with the Customs Union Technical Regulations (CU-TR), and the EAC marking must be affixed to the products.

For information on the country of origin, manufacture year and month, and authorized sales representative (importer) in the CU area of this product, refer to the following:

- Country of origin indication

Check the package of this product.

Example: MADE IN JAPAN

- Manufactured year and month

Check the SERIAL number indicated on this product.

<u>□</u>	<u>○</u>	<u>○</u>	<u>○ ○ ○</u>
Symbol	Year	Month	Control number
SERIAL			

The SERIAL consists of one symbol, two characters indicating the production year and month, and three characters indicating the control number. The last digit of the production year is indicated as the Year, and the Month is indicated by 1 to 9, X (October), Y (November), or Z (December).

- Authorized sales representative (importer) in the CU area

The authorized sales representative (importer) in the CU area is shown below.

Name: Mitsubishi Electric (Russia) LLC

Address: 52, bld 1 Kosmodamianskaya Nab 115054, Moscow, Russia

Phone: +7 (495) 721-2070

Fax: +7 (495) 721-2071

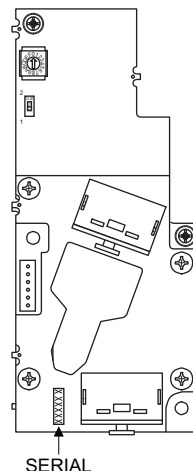

## Appendix 3 Restricted Use of Hazardous Substances in Electronic and Electrical Products

The mark of restricted use of hazardous substances in electronic and electrical products is applied to the product as follows based on the "Management Methods for the Restriction of the Use of Hazardous Substances in Electrical and Electronic Products" of the People's Republic of China.

电器电子产品有害物质限制使用标识要求



本产品中所含有的有害物质的名称、含量、含有部件如下表所示。

• 产品中所含有害物质的名称及含量

部件名称 *2	有害物质 *1					
	铅 (Pb)	汞 (Hg)	镉 (Cd)	六价铬 (Cr (VI))	多溴联苯 (PBB)	多溴二苯醚 (PBDE)
电路板组件 (包括印刷电路板及其构成的零部件, 如电阻、电容、集成电路、连接器等)、电子部件	×	○	×	○	○	○
金属壳体、金属部件	×	○	○	○	○	○
树脂壳体、树脂部件	○	○	○	○	○	○
螺丝、电线	○	○	○	○	○	○

上表依据 SJ/T11364 的规定编制。

○：表示该有害物质在该部件所有均质材料中的含量均在 GB/T26572 规定的限量要求以下。

×：表示该有害物质在该部件的至少一种均质材料中的含量超出 GB/T26572 规定的限量要求。

\*1 即使表中记载为 ×，根据产品型号，也可能会有有害物质的含量为限制值以下的情况。

\*2 根据产品型号，一部分部件可能不包含在产品中。

## **Appendix 4 Referenced Standard (Requirement of Chinese standardized law)**

---

This Product is designed and manufactured accordance with following Chinese standards.

EMC: GB/T 12668.3

## Appendix 5 Compliance with the UK certification scheme

---

We declare that this product conforms with the related technical requirements under UK legislation when installed in a compatible inverter, and affix the UKCA (UK Conformity Assessed) marking on the packaging plate.

Approval conditions are the same as those for the EU Directives. (Refer to [page 84.](#))



UKCA marking:

The UKCA marking is used for products sold in the markets of Great Britain (England, Wales, and Scotland) from January 1, 2021 after the departure of the UK from the EU on January 31, 2020.



## Appendix 6 List of error codes displayed on the Mitsubishi Electric motion controllers

The following shows the error codes displayed on the Mitsubishi Electric motion controllers.

Refer to the Instruction Manual of the inverter for more information of the fault indications.

If the displayed message does not correspond to any of the following or if you have any other problem, contact your sales representative.

### ◆ Warning

Error codes	Inverter's operation panel indication	Name
HB3	EHR	Ethernet communication fault
HD0	SA	Safety stop
HD1	FL	Low flow rate input warning
HD3	UF	USB host error
HD4	MT1	Maintenance signal output
HD5	MT2	
HD6	MT3	
HD7	HP3	Home position return parameter setting error
HD8	HP2	Home position return uncompleted
HD9	HP1	Home position return setting error

Error codes	Inverter's operation panel indication	Name
HF0	OL	Stall prevention (overcurrent)
HF1	oL	Stall prevention (overvoltage)
HF2	PS	PU stop
HF3	Rb	Regenerative brake pre-alarm
HF4	TH	Electronic thermal relay function pre-alarm
HF6	CP	Parameter copy
HF7	SL	Speed limit indication
HF9	—	Other warning

### ◆ Alarm

Error codes	Inverter's operation panel indication	Name
HD2	FN2	Internal fan alarm
HF8	FN	Fan alarm

### ◆ Fault

Error codes	Inverter's operation panel indication	Name
H10	E.OC1	Overcurrent trip during acceleration
H11	E.OC2	Overcurrent trip during constant speed

Error codes	Inverter's operation panel indication	Name
H12	E.OC3	Overcurrent trip during deceleration or stop
H13	E.OV1	Regenerative overvoltage trip during acceleration
H14	E.OV2	Regenerative overvoltage trip during constant speed
H15	E.OV3	Regenerative overvoltage trip during deceleration or stop
H16	E.THM	Motor overload trip (electronic thermal relay function)
H17	E.THT	Inverter overload trip (electronic thermal relay function)
H18	E.IPF	Instantaneous power failure
H19	E.UVT	Undervoltage
H20	E.BE	Brake transistor alarm detection
H21	E.GF	Output side earth (ground) fault overcurrent
H22	E.OHT	External thermal relay operation
H23	E.OLT	Stall prevention stop
H24	E.OPT	Option fault
H25	E.OP3	Communication option fault
H26	E.OP2	
H27	E.PE	Parameter storage device fault
H28	E.PUE	PU disconnection
H29	E.RET	Retry count excess
H30	E.CPU	CPU fault

Error codes	Inverter's operation panel indication	Name
H31	E.ILF	Input phase loss
H32	E.FIN	Heat sink overheat
H33	E.OS	Overspeed occurrence
H34	E.OSD	Speed deviation excess detection
H35	E.ECT	Signal loss detection
H36	E.OD	Excessive position fault
H37	E.ECA	Encoder signal loss for orientation
H38	E.MB1	Brake sequence fault
H39	E.MB2	
H40	E.MB3	
H41	E.MB4	
H42	E.MB5	
H43	E.MB6	
H44	E.MB7	
H45	E.P24	24 VDC power fault
H46	E.CTE	Operation panel power supply short circuit/ RS-485 terminals power supply short circuit
H47	E.LF	Output phase loss
H48	E.PTC	PTC thermistor operation
H49	E.PE2	Parameter storage device fault
H50	E.CDO	Abnormal output current detection
H51	E.IOH	Inrush current limit circuit fault

Error codes	Inverter's operation panel indication	Name
H52	E.SER	Communication fault (inverter)
H53	E.AIE	Analog input fault
H55	E.USB	USB communication fault
H56	E.1	Option fault
H57	E.2	
H58	E.3	
H60	E.5	CPU fault
H61	E.6	
H62	E.7	
H66	E.11	Opposite rotation deceleration fault
H68	E.13	Internal circuit fault
H70	E.EP	Encoder phase fault
H69	E.14	Other fault
H72	E.16	User definition error in the PLC function
H73	E.17	
H74	E.18	
H75	E.19	
H76	E.20	

Error codes	Inverter's operation panel indication	Name
H90	E.OP1	Communication option fault
H91		
H92		
H93		
HA0	E.SAF	Safety circuit fault
HA1	E.PBT	Internal circuit fault
HA2	E.MP	Magnetic pole position unknown
HA4	E.IAH	Abnormal internal temperature
HA7	E.LCI	4 mA input fault
HA8	E.PCH	Pre-charge fault
HA9	E.PID	PID signal fault
HB1	E.SOT	Loss of synchronism detection
HB2	E.EHR	Ethernet communication fault
HB7	E.EF	External fault during output operation

#### ◆ Others

Error codes	Inverter's operation panel indication	Name
HB4	RD	Backup in progress
HB5	WR	Restoration in progress
HE6	—	Output stop

Error codes	Inverter's operation panel indication	Name
HE7	—	Emergency stop

## REVISIONS

\*The manual number is given on the bottom left of the back cover.

Revision date	*Manual number	Revision
Aug. 2015	IB(NA)-0600599ENG-A	First edition
Nov. 2015	IB(NA)-0600599ENG-B	Added <ul style="list-style-type: none"> <li>• Compatibility with the SSCNET III/H communication</li> </ul>
May 2016	IB(NA)-0600599ENG-C	Edited <ul style="list-style-type: none"> <li>• <b>Pr.290 Monitor negative output selection</b> and <b>Pr.1018 Monitor with sign selection</b> settings are valid.</li> </ul> Added <ul style="list-style-type: none"> <li>• APPENDIX Restricted Use of Hazardous Substances in Electronic and Electrical Products</li> </ul>
Oct. 2016	IB(NA)-0600599ENG-D	Added <ul style="list-style-type: none"> <li>• Setting values "100" and "101" of <b>Pr.499 SSCNET III(/H) operation selection</b></li> </ul>
Apr. 2017	IB(NA)-0600599ENG-E	Added <ul style="list-style-type: none"> <li>• Availability of position control at setting "100 or 101" in <b>Pr.499 SSCNET III(/H) operation selection</b></li> </ul>
Feb. 2018	IB(NA)-0600599ENG-F	Added <ul style="list-style-type: none"> <li>• Compatibility with the FR-A8APA</li> </ul>
Oct. 2022	IB(NA)-0600599ENG-G	Added <ul style="list-style-type: none"> <li>• Instructions for compliance with the EU Directives</li> <li>• Instructions for EAC</li> <li>• Referenced Standard (Requirement of Chinese standardized law)</li> <li>• Compliance with the UK certification scheme</li> </ul>

INVERTER

**mitsubishi** **MITSUBISHI ELECTRIC CORPORATION**

HEAD OFFICE: TOKYO BUILDING 2-7-3, MARUNOUCHI, CHIYODA-KU, TOKYO 100-8310, JAPAN