



INVERTER

Plug-in option

FR-A8AZ

INSTRUCTION MANUAL

Bipolar analog output function

High resolution analog input function

Motor thermistor interface

PRE-OPERATION INSTRUCTIONS	1
INSTALLATION AND WIRING	2
PARAMETER LIST	3
BIPOLAR ANALOG OUTPUT	4
HIGH RESOLUTION ANALOG INPUT	5
MOTOR THERMISTOR INTERFACE	6

Thank you for choosing this Mitsubishi inverter plug-in option.

This Instruction Manual provides handling information and precautions for use of this product. Incorrect handling might cause an unexpected fault. Before using this product, always read this Instruction Manual carefully to use this product correctly.

Please forward this Instruction Manual to the end user.

Safety instructions

Do not attempt to install, operate, maintain or inspect the product until you have read through this Instruction Manual and appended documents carefully and can use the equipment correctly. Do not use this product until you have a full knowledge of the equipment, safety information and instructions. In this Instruction Manual, the safety instruction levels are classified into "Warning" and "Caution".



Warning

Incorrect handling may cause hazardous conditions, resulting in death or severe injury.



Caution

Incorrect handling may cause hazardous conditions, resulting in medium or slight injury, or may cause only material damage.

The  **Caution** level may even lead to a serious consequence according to conditions. Both instruction levels must be followed because these are important to personal safety.

◆ Electric Shock Prevention



Warning

- While the inverter power is ON, do not open the front cover or the wiring cover. Do not run the inverter with the front cover or the wiring cover removed. Otherwise you may access the exposed high voltage terminals or the charging part of the circuitry and get an electric shock.
- Do not remove the inverter front cover even if the power supply is disconnected. The only exception for this would be when performing wiring and periodic inspection. You may accidentally touch the charged inverter circuits and get an electric shock.
- Before wiring or inspection, LED indication of the inverter unit operation panel must be switched OFF. Any person who is involved in wiring or inspection shall wait for at least 10 minutes after the power supply has been switched OFF and check that there is no residual voltage using a tester or the like. For some time after the power-OFF, a high voltage remains in the smoothing capacitor, and it is dangerous.
- Any person who is involved in wiring or inspection of this equipment shall be fully competent to do the work.
- The plug-in option must be installed before wiring. Otherwise you may get an electric shock or be injured.
- Do not touch the plug-in option or handle the cables with wet hands. Otherwise you may get an electric shock.
- Do not subject the cables to scratches, excessive stress, heavy loads or pinching. Otherwise you may get an electric shock.

◆ Injury Prevention



Caution

- The voltage applied to each terminal must be the ones specified in the Instruction Manual. Otherwise a burst, damage, etc. may occur.
- The cables must be connected to the correct terminals. Otherwise a burst, damage, etc. may occur.
- The polarity (+ and -) must be correct. Otherwise a burst or damage may occur.
- While power is ON or for some time after power OFF, do not touch the inverter as it will be extremely hot. Touching these devices may cause a burn.

◆ Additional Instructions

The following instructions must be also followed. If the product is handled incorrectly, it may cause unexpected fault, an injury, or an electric shock.

Caution

Transportation and mounting

- Do not install or operate the plug-in option if it is damaged or has parts missing.
- Do not stand or rest heavy objects on the product.
- The mounting orientation must be correct.
- Foreign conductive objects must be prevented from entering the inverter. That includes screws and metal fragments or other flammable substance such as oil.
- If halogen-based materials (fluorine, chlorine, bromine, iodine, etc.) infiltrate into a Mitsubishi product, the product will be damaged. Halogen-based materials are often included in fumigant, which is used to sterilize or disinfest wooden packages. When packaging, prevent residual fumigant components from being infiltrated into Mitsubishi products, or use an alternative sterilization or disinfection method (heat disinfection, etc.) for packaging. Sterilization or disinfection of wooden package should also be performed before packaging the product.

Trial run

- Before starting operation, each parameter must be confirmed and adjusted. A failure to do so may cause some machines to make unexpected motions.

Warning

Usage

- Do not modify the equipment.
- Do not perform parts removal which is not instructed in this manual. Doing so may lead to fault or damage of the product.

Caution

Usage

- When parameter clear or all parameter clear is performed, the required parameters must be set again before starting operations. Because all parameters return to their initial values.
- Static electricity in your body must be discharged before you touch the product.

Maintenance, inspection and parts replacement

- Do not carry out a megger (insulation resistance) test.

Disposal

- The product must be treated as industrial waste.

General instruction

- Many of the diagrams and drawings in this Instruction Manual show the inverter without a cover or partially open for explanation. Never operate the inverter in this manner. The cover must be reinstalled and the instructions in the Instruction Manual must be followed when operating the inverter.

— CONTENTS —

1	PRE-OPERATION INSTRUCTIONS	6
1.1	Unpacking and product confirmation.....	6
1.1.1	Product confirmation.....	6
1.1.2	SERIAL number check.....	7
1.2	Component names.....	8
2	INSTALLATION AND WIRING	9
2.1	Pre-installation instructions.....	9
2.2	Installation procedure.....	9
2.3	Wiring.....	12
3	PARAMETER LIST	14
4	BIPOLAR ANALOG OUTPUT	16
4.1	Connection diagram.....	16
4.2	Terminals.....	17
4.3	Bipolar analog outputting parameter.....	17
4.3.1	Parameter list.....	17
4.3.2	Calibration of the indicator (Pr.838, Pr.857, C0).....	18
4.3.3	Monitor item list.....	19
4.3.4	Terminal DA1 response level adjustment (Pr.839).....	20
5	HIGH RESOLUTION ANALOG INPUT	21
5.1	Connection diagram.....	21
5.2	Terminals.....	22
5.3	High resolution analog input parameter.....	23

5.3.1	Parameter list	23
5.3.2	Selection of terminal 6 function (Pr.406)	24
5.3.3	Calibration of terminal 6 (Pr.148, Pr.149, Pr.846 to Pr.848, C30 to C37).....	26
5.4	Noise reduction techniques.....	29
5.5	Specifications	30
6	MOTOR THERMISTOR INTERFACE	31
<hr/>		
6.1	Connection diagram	31
6.2	Terminals.....	32
6.3	Motor thermistor parameter.....	33
6.3.1	Parameter list	33
6.3.2	Thermistor setting.....	33
6.3.3	Thermistor calibration (C29).....	34
6.3.4	Motor thermal	37
6.3.5	Motor temperature detection signal.....	38
6.3.6	Motor temperature monitor output.....	39
6.3.7	Slip compensation	41

<Notes on descriptions in this Instruction Manual>

Connection diagrams in this Instruction Manual appear with the control logic of the input terminals as sink logic, unless otherwise specified.



1 PRE-OPERATION INSTRUCTIONS

1.1 Unpacking and product confirmation

Take the plug-in option out of the package, check the product name, and confirm that the product is as you ordered and intact. This product is a plug-in option dedicated for the FR-A800 series.

1.1.1 Product confirmation

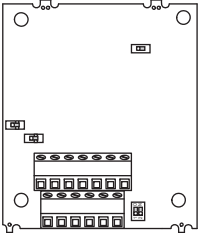
Check the enclosed items.

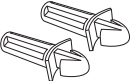
<p>Plug-in option 1</p> 	<p>Mounting screw (M3 × 8 mm) 2 (Refer to page 9.)</p> 	<p>Spacer 2 (Refer to page 9.)</p> 
---	--	--

1.1.2 SERIAL number check

The FR-A8AZ can be used with the inverter models listed below which have the following SERIAL number or later. Check the SERIAL number indicated on the inverter rating plate or package.

Rating plate example

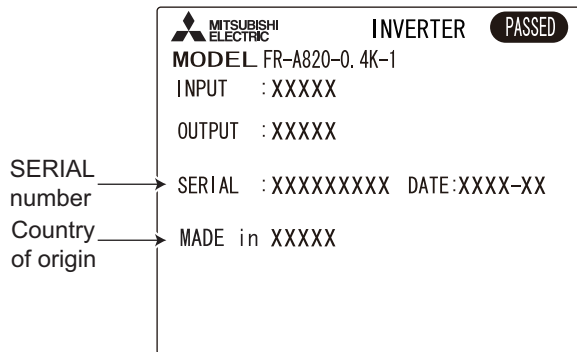

□	○	○	○○○○○○
Symbol	Year	Month	Control number
—————			
SERIAL			

The SERIAL consists of one symbol, two characters indicating the production year and month, and six characters indicating the control number.

The last digit of the production year is indicated as the Year, and the Month is indicated by 1 to 9, X (October), Y (November), or Z (December).

FR-A800 series

Model	Country of origin indication	SERIAL number
FR-A820-00046(0.4K) to 04750(90K) FR-A840-00023(0.4K) to 06830(280K) FR-A842-07700(315K) to 12120(500K) FR-A846-00023(0.4K) to 03610(132K)	MADE in Japan	□52○○○○○○ or later
	MADE in China	□53○○○○○○ or later

1.2 Component names

Terminal layout

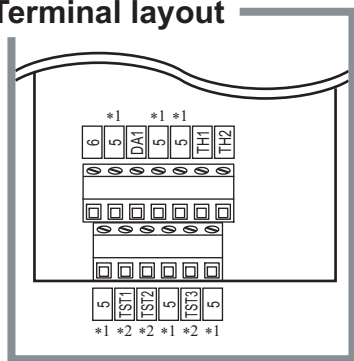

*1 All terminals 5 are connected internally.

*2 Terminals TST1 to TST3 are not used. Keep these open.
Accidental connection will damage the option.

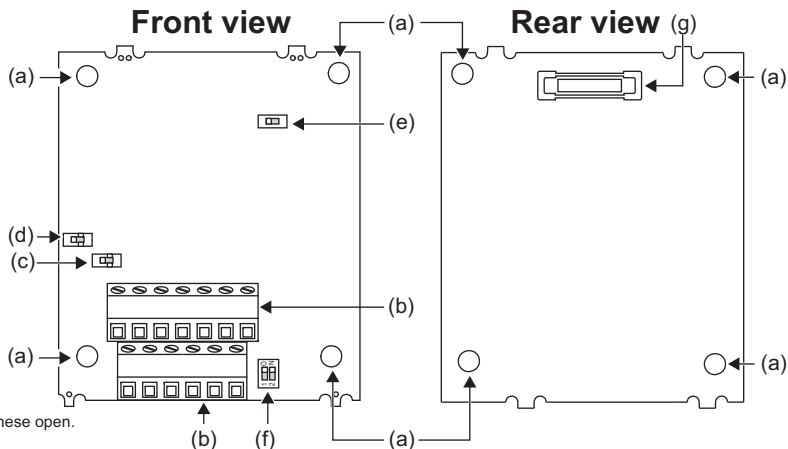

Symbol	Name	Description	Refer to page
a	Mounting hole	Fixes the option to the inverter with screws, or installs spacers.	9
b	Terminal block	Wire the input or output devices.	12
c	Switch for thermistor calibration (SW2)	Change the setting when calibrating the thermistor.	34
d	Switch for manufacturer setting (SW1)	Do not change the initially-set status. (OFF)	—
e	Switch for manufacturer setting (SW3)	Do not change the initially-set status. (OFF)	—
f	Switch for manufacturer setting (SW4)	Do not change the initially-set status. (Switches 1 and 2 are ON .)	—
g	Connector	Connects to the option connector of the inverter.	9

2 INSTALLATION AND WIRING

2.1 Pre-installation instructions

Check that the inverter's input power and the control circuit power are both OFF.

Caution

- With input power ON, do not install or remove the plug-in option. Otherwise, the inverter and plug-in option may be damaged.
- To avoid damage due to static electricity, static electricity in your body must be discharged before you touch the product.

2.2 Installation procedure

- (1) Remove the inverter front cover. (Refer to Chapter 2 of the Instruction Manual (Detailed) of the inverter for details on how to remove the front cover.)
- (2) For the two mounting holes (as shown in the next page) that will not be tightened with mounting screws, insert spacers.
- (3) Fit the connector of the plug-in option to the guide of the connector on the inverter unit side, and insert the plug-in option as far as it goes.
- (4) Fit the two locations, the left and right, of the plug-in option securely to the inverter unit by screwing in the supplied mounting screws. (tightening torque 0.33 N·m to 0.40 N·m) If the screw holes do not line up, the connector may not be inserted deep enough. Check the connector.

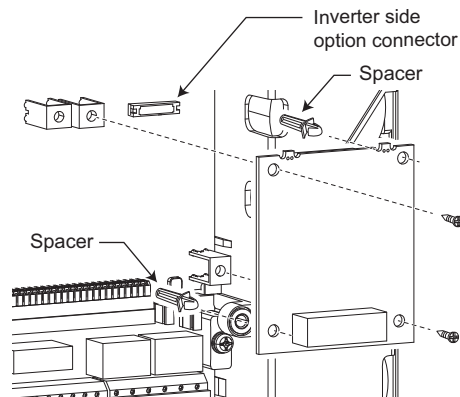

Example of installation to connector 1

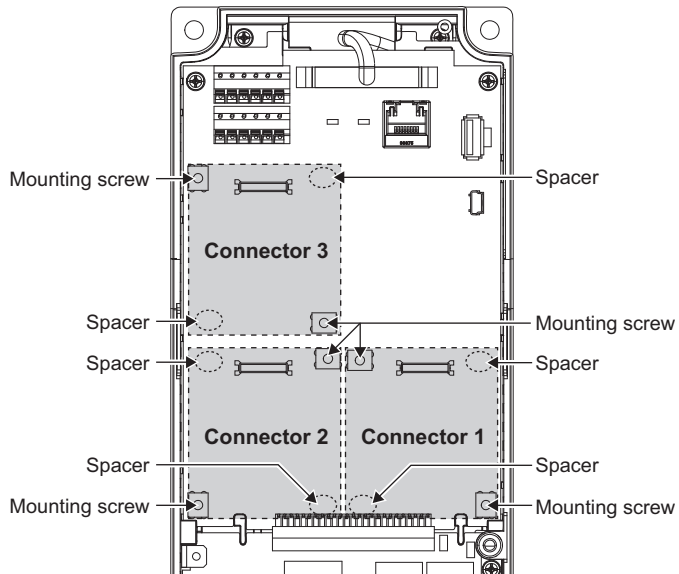

Insertion positions for screws and spacers

 **NOTE**

- When mounting/removing the plug-in option, hold the sides of the option. Do not press on the parts on the option circuit board. Stress applied to the parts by pressing, etc. may cause a failure.
- Caution must be applied to mounting screws falling off when removing and mounting the plug-in option.
- Only one option can be used. When multiple options are mounted, priority is given to option connectors 1, 2 and 3 on the inverter in this order, and options having a lower priority do not function.
- When the inverter cannot recognize that the option unit is mounted due to improper installation, etc., the protective function (E.1 to E.3) is activated. A different indication will appear according to the mounted position (option connector 1 to 3).

Mounted position	Fault indication
Option connector 1	E. 1
Option connector 2	E. 2
Option connector 3	E. 3

- When removing the plug-in option, remove the two screws on the left and right, then pull it straight out. Pressure applied to the connector and to the option board may break the option.

2.3 Wiring

(1) Wire the shielded twisted pair cable after stripping its sheath to make its cables loose. Also, protect the shielded cable of the shielded twisted pair cable to ensure that it will not make contact with the conductive area.

Strip off the sheath for the below length. If the length of the sheath peeled is too long, a short circuit may occur with neighboring wires. If the length is too short, wires might come off.

Wire the stripped cable after twisting it to prevent it from becoming loose. In addition, do not solder it.

Cable stripping length

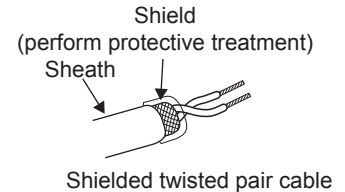
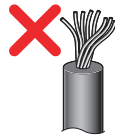
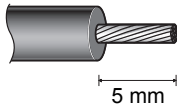

Use a blade terminal as necessary.

When using the blade terminal, use care so that the twisted wires do not come out.

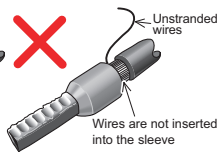
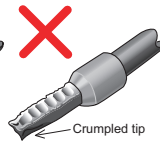
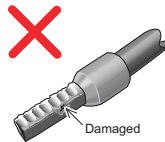
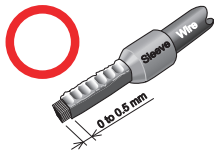

 **NOTE**

- Blade terminals commercially available (as of January 2015. The product may be changed without notice.)

Terminal screw size	Wire size (mm ²)	Ferrule terminal model		Manufacturer	Crimping tool name
		With insulation sleeve	Without insulation sleeve		
M2	0.3 to 0.5	AI 0,5-6WH	A 0,5-6	Phoenix Contact Co.,Ltd.	CRIMPFOX 6

(2) Loosen the terminal screw and insert the cable into the terminal.

Screw size	Tightening torque	Cable size	Screwdriver
M2	0.22 N·m to 0.25 N·m	0.3 mm ² to 0.75 mm ²	Small  flat-blade screwdriver (Tip thickness: 0.4 mm/tip width: 2.5 mm)

 **NOTE**

- The wiring length should be 30 m at the maximum.
- Undertightening can cause cable disconnection or malfunction. Overtightening can cause a short circuit or malfunction due to damage to the screw or unit.
- When wiring cables to the inverter's RS-485 terminals while a plug-in option is mounted, take caution not to let the cables touch the circuit board of the option or of the inverter. Otherwise, electromagnetic noises may cause malfunctions.

 **CAUTION**

- Do not use terminals TST1 to TST3 as junction terminals because they are used in the option unit. If they are used as the junction terminals, the option unit may be damaged.
- After wiring, wire offcuts must not be left in the inverter. They may cause a fault, failure or malfunction.

3 PARAMETER LIST

Use the following parameters with the FR-A8AZ.
Set these as required.

Pr.	Pr. group	Name	Setting range	Minimum setting increments	Initial value	Refer to page
326*1	G062	Motor temperature feedback reference	0 to 150°C, 9999	1°C	9999	41
406*1	T060	High resolution analog input selection	0, 2 to 6, 9999	1	9999	21
407*1	T620	Motor temperature detection filter	0 to 100 s, 9999	1 s	9999	31
408*1	H023	Motor thermistor selection	0, 1	1	0	31
750*1	M061	Motor temperature detection level	0 to 200°C	1°C	75°C	31
751*1	M046	Reference motor temperature	1 to 200°C	1°C	150°C	31
838*1	M304	DA1 terminal function selection	*3	1	2	16
839*1	M350	DA1 output filter	0 to 5 s	0.001 s	0.05 s	16
846	G236	Torque bias balance compensation	0 to 10 V, 9999	0.1 V	9999	21
847	G237	Fall-time torque bias terminal 1 bias	0 to 400%, 9999	1%	9999	21
848	G238	Fall-time torque bias terminal 1 gain	0 to 400%, 9999	1%	9999	21
857*1	M380	DA1-0V adjustment	900 to 1100%	1%	1000%	16
C0(900)*2	M310	FM/CA terminal calibration	—	—	—	16
C29(925)*1, *2	H041	Motor temperature detection calibration (analog input)	0 to 200%	0.1%	100%	31
C30(926)*2	T680	Terminal 6 bias frequency (speed)	0 to 590 Hz	0.01 Hz	0 Hz	21

Pr.	Pr. group	Name	Setting range	Minimum setting increments	Initial value	Refer to page
C31(926)*2	T681	Terminal 6 bias (speed)	0 to 300%	0.1%	0%	21
C32(927)*2	T682	Terminal 6 gain frequency (speed)	0 to 590 Hz	0.01 Hz	60 Hz/50 Hz*4	21
C33(927)*2	T683	Terminal 6 gain (speed)	0 to 300%	0.1%	100%	21
C34(928)*2	T684	Terminal 6 bias command (torque)	0 to 400%	0.1%	0%	21
C35(928)*2	T685	Terminal 6 bias (torque)	0 to 300%	0.1%	0%	21
C36(929)*2	T686	Terminal 6 gain command (torque)	0 to 400%	0.1%	150%	21
C37(929)*2	T687	Terminal 6 gain (torque)	0 to 300%	0.1%	100%	21

*1 Setting can be made only when the FR-A8AZ is mounted.

*2 The parameter number in parentheses is the one for use with the LCD operation panel and the parameter unit.

*3 Same as the setting range of **Pr.158 AM terminal function selection**. For the details, refer to the Instruction Manual (Detailed) of the inverter.

*4 Differs according to types. (FM type/CA type)

4 BIPOLAR ANALOG OUTPUT

Bipolar analog output is available with FR-A8AZ.

Outputting 0 to ± 10 VDC enables output frequency, output voltage, etc. to be monitored with a DC voltage meter.

4.1 Connection diagram

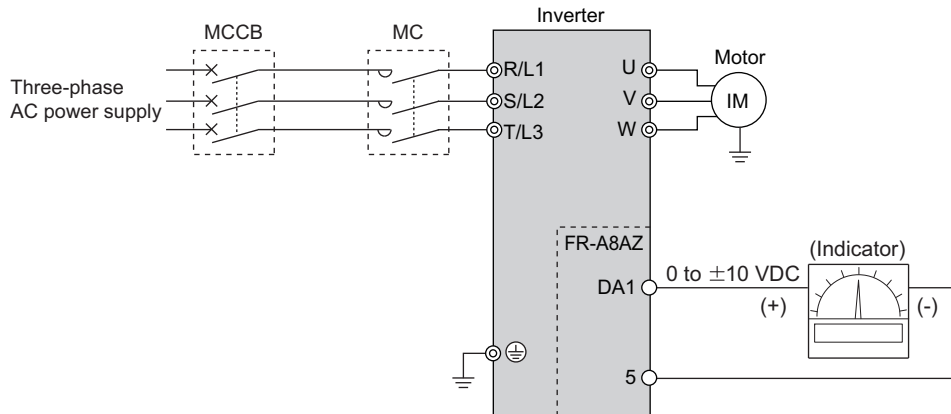

4.2 Terminals

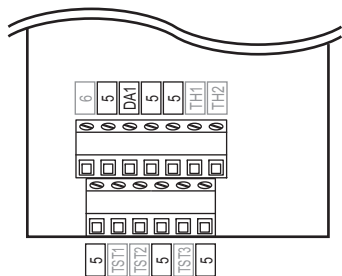

Terminal symbol	Terminal name	Description
DA1	Bipolar analog output terminal	Connect a DC indicator (± 10 VDC).
5	Common terminal	Common terminal of terminal DA1

4.3 Bipolar analog outputting parameter

4.3.1 Parameter list

The following parameters are used for outputting bipolar analog.

Pr.	Pr. group	Name	Setting range	Minimum setting increments	Initial value
838*1	M304	DA1 terminal function selection	*3	1	2
839*1	M350	DA1 output filter	0 to 5 s	0.001 s	0.05 s
857*1	M380	DA1-0V adjustment	900 to 1100%	1%	1000%
C0(900)*2	M310	FM/CA terminal calibration	—	—	—

*1 Setting can be made only when the FR-A8AZ is mounted.

*2 The parameter number in parentheses is the one for use with the LCD operation panel and the parameter unit.

*3 Same as the setting range of **Pr.158 AM terminal function selection**. For the details, refer to the Instruction Manual (Detailed) of the inverter.

4.3.2 Calibration of the indicator (Pr.838, Pr.857, C0)

Refer to the following flow chart to calibrate the indicator.

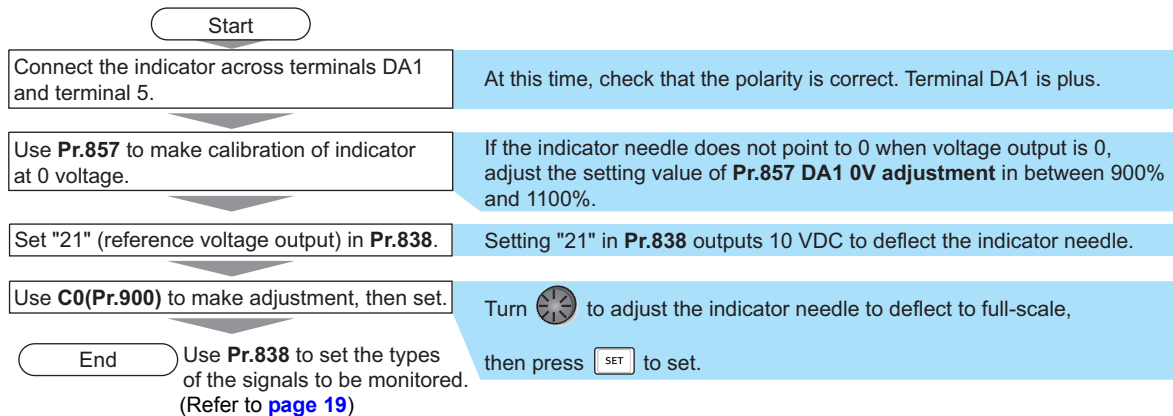

NOTE

- If calibration is performed without setting "21" (reference voltage output) in **Pr.838**, terminal FM of the inverter is calibrated.
- When FR-A8AZ is remounted on other inverter, use **Pr.857** and **C0(Pr.900)** of the inverter with the option to calibrate again.
- When FR-A8AZ and FR-A8AY are used together with "1 or 11" set in **Pr.309 Analog output signal voltage/current switchover** and "21" set in **Pr.310 Analog meter voltage output selection**, **C0(Pr.900)** calibrates terminal AM0 of the FR-A8AY. (**Pr.309** and **Pr.310** are parameters for FR-A8AY. Refer to the Instruction Manual of the FR-A8AY for details of **Pr.309** and **Pr.310**.)

4.3.3 Monitor item list

- Set the monitor to be output to the terminal DA1 (bipolar analog output (0 to ± 10 VDC voltage output)) in **Pr.838 DA1 terminal function selection**. The settings of **Pr.838** are the same as those of **Pr.158 AM terminal function selection**. For the details of **Pr.158**, refer to the Instruction Manual (Detailed) of the inverter.
- For the following monitor items, values with minus signs can be output from terminal DA1. Setting **Pr.290** and **Pr.1018** is not required.

Pr.838	Types of monitor	Full-scale value
1	Output frequency*1	Pr.55
6	Running speed*1	Value is Pr.55 converted by Pr.37 , Pr.144 .
7	Motor torque*2	Pr.866
17	Load meter*2	Pr.866
32	Torque command*2	Pr.866
33	Torque current command*2	Pr.866
34	Motor output*3	Rated motor capacity
36	Torque monitor (driving/regenerative polarity switching)*3	Pr.866
46	Motor temperature	Pr.751
54	PID deviation	100%

Pr.838	Types of monitor	Full-scale value
70	PLC function analog output (SD1301)	100%
87	Remote output value 1	1000%
88	Remote output value 2	1000%
89	Remote output value 3	1000%
90	Remote output value 4	1000%
91	PID manipulated variable	100%
94	Second PID deviation	100%
96	Second PID manipulated variable	100%
98	Control circuit temperature	100°C

*1 Positive (plus) output during forward rotation and negative (minus) output during reverse rotation.

*2 Positive voltage is output during forward driving/reverse regeneration and negative voltage is output during reverse driving/forward regeneration.

*3 Positive voltage is output during forward driving/reverse driving and negative voltage is output during forward regeneration/reverse regeneration.

4.3.4 Terminal DA1 response level adjustment (Pr.839)

- The response level of the output voltage of the terminal DA1 can be adjusted between 0 and 5 s with **Pr.839**.
- Increasing the setting stabilizes the terminal DA1 output more but reduces the response level.



- Response time of the terminal DA1 is a total of the set value in **Pr.839 DA1 output filter** and a variable (up to 5 ms).
- When **Pr.839="0"**, the instantaneous values are monitored for the following items.

Pr.838	Types of monitor
6	Running speed
7	Motor torque
17	Load meter
32	Torque command
33	Torque current command
36	Torque monitor (driving/regenerative polarity switching)

- **Pr.1106 Torque monitor filter** and **Pr.1107 Running speed monitor filter** are disabled to terminal DA1 output.

5 HIGH RESOLUTION ANALOG INPUT

High resolution analog input is available with FR-A8AZ.

Inputting 0 to ± 10 VDC voltage enables speed command, torque limit command, torque command, torque bias, and stall prevention operation level input.

5.1 Connection diagram

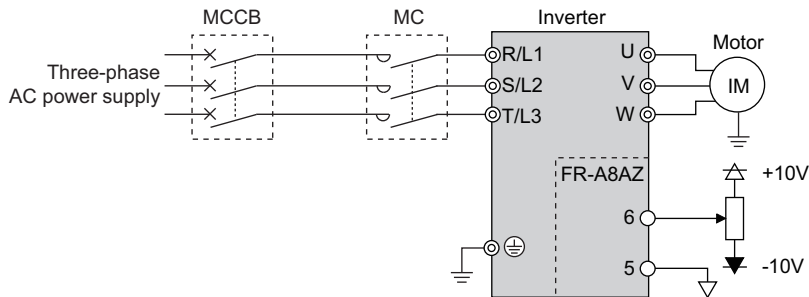

5.2 Terminals

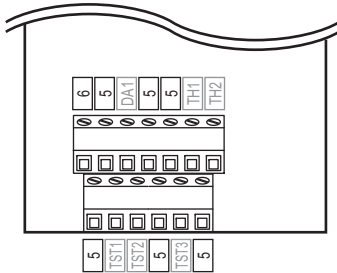

Terminal symbol	Terminal name	Description
6	High resolution input terminal	Terminal for 0 to ± 10 VDC high resolution (16 bits) analog voltage input. Use Pr.406 High resolution analog input selection to select terminal function. Maximum permissible voltage: ± 20 VDC
5	Common terminal	Common terminal of terminal 6

5.3 High resolution analog input parameter

5.3.1 Parameter list

Use the following parameters for high resolution analog input.

Pr.	Pr. group	Name	Setting range	Minimum setting increments	Initial value
406*1, *2	T060	High resolution analog input selection	0, 2 to 6, 9999	1	9999
846	G236	Torque bias balance compensation	0 to 10 V, 9999	0.1 V	9999
847	G237	Fall-time torque bias terminal 1 bias	0 to 400%, 9999	1%	9999
848	G238	Fall-time torque bias terminal 1 gain	0 to 400%, 9999	1%	9999
C30(926)*3	T680	Terminal 6 bias frequency (speed)	0 to 590 Hz	0.01 Hz	0 Hz
C31(926)*3	T681	Terminal 6 bias (speed)	0 to 300%	0.1%	0%
C32(927)*3	T682	Terminal 6 gain frequency (speed)	0 to 590 Hz	0.01 Hz	60 Hz/50 Hz*4
C33(927)*3	T683	Terminal 6 gain (speed)	0 to 300%	0.1%	100%
C34(928)*3	T684	Terminal 6 bias command (torque)	0 to 400%	0.1%	0%
C35(928)*3	T685	Terminal 6 bias (torque)	0 to 300%	0.1%	0%
C36(929)*3	T686	Terminal 6 gain command (torque)	0 to 400%	0.1%	150%
C37(929)*3	T687	Terminal 6 gain (torque)	0 to 300%	0.1%	100%

*1 Setting can be made only when the FR-A8AZ is mounted.

*2 For **Pr.406**, write is disabled during operation even when "2" is set in **Pr.77**. When changing the parameter setting, stop the operation.

*3 The parameter number in parentheses is the one for use with the LCD operation panel and the parameter unit.

*4 Differs according to types. (FM type/CA type)

5.3.2 Selection of terminal 6 function (Pr.406)

◆ Terminal 6 function list

Functions of terminal 6 change according to the **Pr.406** setting and control method.

When a function is assigned to the terminal 6 while the same function is assigned to the terminal 1, 2, or 4, the input to the terminal 1, 2 or 4 becomes invalid.

Pr.406 setting	V/F control/ Advanced magnetic flux vector control	Real sensorless vector control/ vector control/PM sensorless vector control			Remarks
		Speed control	Torque control	Position control	
0	Speed command	Speed command	Speed limit	—	Speed command and speed limit are not available with terminal 2.
2	—	Regenerative torque limit (Pr.810 = "1")	—	Regenerative torque limit (Pr.810 = "1")	Regenerative torque limit is not available with terminal 1.
3	—	—	Torque command (Pr.804 = "0")	—	Torque command is not available with terminal 1.
4	Stall prevention operation level input	Torque limit (Pr.810 = "1")	Torque command (Pr.804 = "0")	Torque limit (Pr.810 = "1")	Stall prevention operation level input and torque limit are not available with terminal 1 or 4. Torque command is not available with terminal 1.
5	—	—	Forward/reverse rotation speed limit (Pr.807 = "2")	—	Forward/reverse rotation speed limit is not available with terminal 1.
6	—	Torque bias (Pr.840 = "1, 2, 3")	—	—	Torque bias is not available with terminal 1.
9999 (initial value)	—	—	—	—	Terminal 6 is invalid.

◆ **Filter of terminal 6 input**

When giving the speed command or limiting the speed from terminal 6 input, settings of **Pr.822 Speed setting filter 1** and **Pr.832 Speed setting filter 2** are valid.

When giving the torque command or limiting the torque from terminal 6 input, settings of **Pr.826 Torque setting filter 1** and **Pr.836 Torque setting filter 2** are valid.

Refer to the Instruction Manual (Detailed) of the inverter for details of **Pr.822**, **Pr.832**, **Pr.826**, and **Pr.836**.

◆ **Calibration and adjustment of terminal 6**

When "0" is set in **Pr.406**, terminal 6 is used for speed command and speed limit inputs, and terminal 2 becomes invalid for those inputs.

Pr.242 Terminal 1 added compensation amount (terminal 2) becomes valid for terminal 6 and compensation of terminal 6 input is made by terminal 1 input.

Pr.849 Analog input offset adjustment becomes valid for terminal 6 and terminal 6 input is provided with offset.

Refer to the Instruction Manual (Detailed) of the inverter for details of **Pr.242** and **Pr.849**.

◆ **Torque bias of terminal 6**

When "6" is set in **Pr.406**, terminal 6 is used for torque bias input.

Pr.846 Torque bias balance compensation, **Pr.847 Fall-time torque bias terminal 1 bias**, **Pr.848 Fall-time torque bias terminal 1 gain** become valid for terminal 6.

5.3.3 Calibration of terminal 6 (Pr.148, Pr.149, Pr.846 to Pr.848, C30 to C37)

◆ Terminal 6 calibration parameter

Use the following parameters for calibration of terminal 6 according to the Pr.406 setting.

Pr.406 setting	Terminal 6 function	Calibration parameters		Related parameters
		Bias setting	Gain setting	
0	Speed command/ speed limit	C30(Pr.926) Terminal 6 bias frequency (speed) C31(Pr.926) Terminal 6 bias (speed)	C32(Pr.927) Terminal 6 gain frequency (speed) C33(Pr.927) Terminal 6 gain (speed)	Pr.822, Pr.832, Pr.242, Pr.849
2	Regenerative torque limit	C34(Pr.928) Terminal 6 bias command (torque) C35(Pr.928) Terminal 6 bias (torque)	C36(Pr.929) Terminal 6 gain command (torque) C37(Pr.929) Terminal 6 gain (torque)	Pr.826, Pr.836
3	Torque command	C34(Pr.928) Terminal 6 bias command (torque) C35(Pr.928) Terminal 6 bias (torque)	C36(Pr.929) Terminal 6 gain command (torque) C37(Pr.929) Terminal 6 gain (torque)	Pr.826, Pr.836
4	Torque limit/ torque command	C34(Pr.928) Terminal 6 bias command (torque) C35(Pr.928) Terminal 6 bias (torque)	C36(Pr.929) Terminal 6 gain command (torque) C37(Pr.929) Terminal 6 gain (torque)	Pr.826, Pr.836
	Stall prevention operation level	Pr.148 Stall prevention level at 0 V input	Pr.149 Stall prevention level at 10 V input	—
5	Forward rotation reverse rotation speed limit	C30(Pr.926) Terminal 6 bias frequency (speed) C31(Pr.926) Terminal 6 bias (speed)	C32(Pr.927) Terminal 6 gain frequency (speed) C33(Pr.927) Terminal 6 gain (speed)	Pr.822, Pr.832
6	Torque bias	C34(Pr.928) Terminal 6 bias command (torque) C35(Pr.928) Terminal 6 bias (torque) Pr.846 Torque bias balance compensation Pr.847 Fall-time torque bias terminal 1 bias	C36(Pr.929) Terminal 6 gain command (torque) C37(Pr.929) Terminal 6 gain (torque) Pr.846 Torque bias balance compensation Pr.848 Fall-time torque bias terminal 1 gain	Pr.826, Pr.836
9999 (initial value)	—	—	—	—

◆ **Calibration of speed command/speed limit (Pr.406 = "0, 5")**

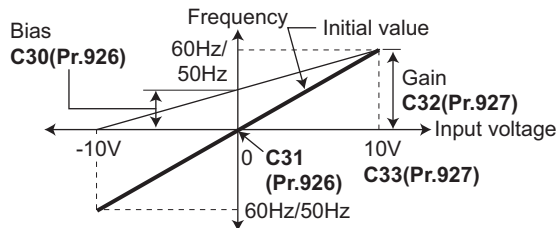

When **Pr.406** = "0, 5", terminal 6 acts as speed command or speed limit input and **C30 to C33** are used for calibration parameter.

◆ **Calibration of torque command/torque limit (Pr.406 = "2, 3, 4")**

When **Pr.406** = "2, 3, 4" under Real sensorless vector control, vector control, or PM sensorless vector control, terminal 6 acts as torque command or torque limit input and **C34 to C37** are used for calibration parameters.

<Torque limit, regenerative torque limit>

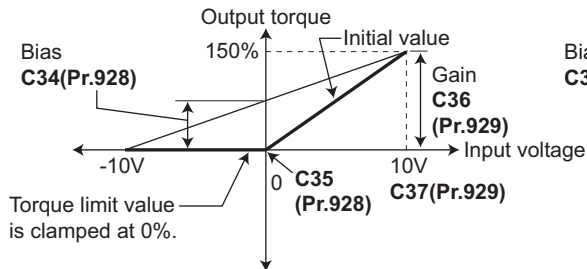

<Torque command>

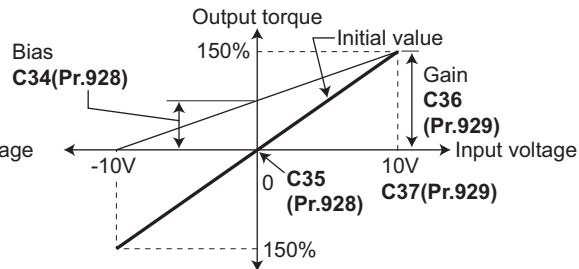

◆ **Calibration of stall prevention operation level (Pr.406 = "4")**

When Pr.406 = "4" under V/F control and Advanced magnetic flux vector control, terminal 6 acts as stall prevention operation level and Pr.148 and Pr.149 are used for calibration parameter.

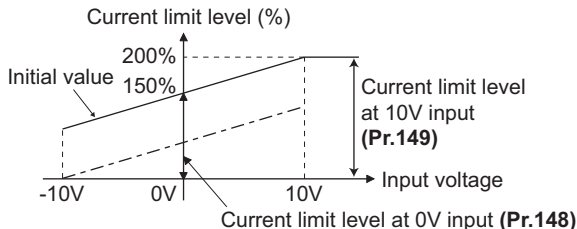

◆ **Calibration of torque bias input (Pr.406 = "6")**

When Pr.406 = "6", terminal 6 acts as torque bias input and Pr.846 to Pr.848, C34 to C37 are used for calibration parameter.

Pr.840 = "1" (at driving when the motor is in forward rotation)

<When the motor runs in forward rotation direction>

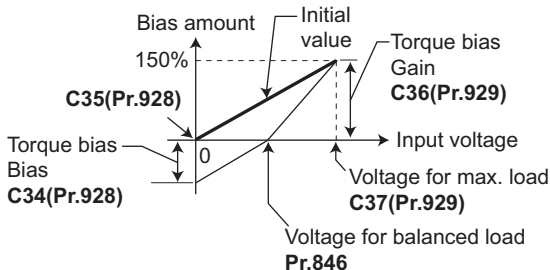

<When the motor runs in reverse rotation direction>

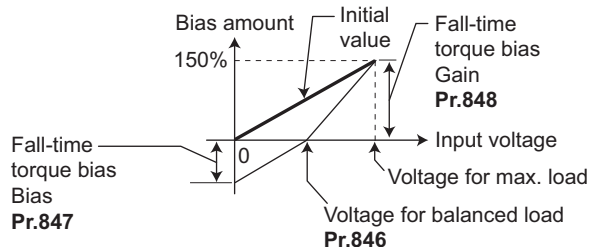

Pr.840 = "2" (at regeneration when the motor is in forward rotation)

<When the motor runs in forward rotation direction>

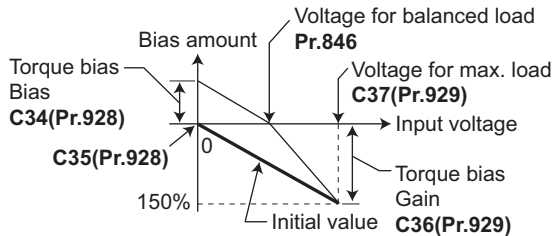

<When the motor runs in reverse rotation direction>

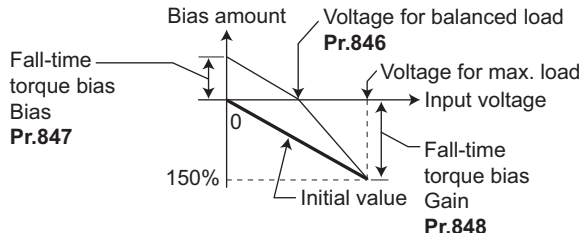

5.4 Noise reduction techniques

When operation is unstable due to Electro-Magnetic Interference (EMI), take measures referring to below.

(1) Measures at wiring

- Separate the power cable as far away as possible from the signal cable.
- Use a shielded twisted pair cable for a signal cable.
Take one of appropriate measures below for the shielded cable.

- Connect to terminal 5 of the FR-A8AZ.
- Connect to the common terminal of an analog command device.
- Connect to both terminal 5 of the FR-A8AZ and common terminal of the analog command device.
- Leave both terminal 5 of the FR-A8AZ and common terminal of the analog command device open. (Float the potential of the shield cable.)

(2) Measures of inverter

- If a large value is set in **Pr.72 PWM frequency selection**, decrease the **Pr.72** setting. (Noise from the motor increases.)
- Increase the setting of speed (torque) setting filter **Pr.822, Pr.832 (Pr.826, Pr.836)**.

 **NOTE**

- As changing the speed (torque) setting filter will affect the response level of the inverter to the command, adjust the setting by looking at the machine movement.

(3) Measures of option

- Install the line noise filter FR-BLF (FR-BSF01 for the 3.7K or lower).

 **NOTE**

- Refer to the Instruction Manual (Detailed) of the inverter for details of measures for EMI.

5.5 Specifications

Frequency setting resolution	0.01 Hz/0 to 60 Hz (-10 to +10 V)
	(0.015 Hz/0 to 60 Hz when option is not mounted)
Torque setting resolution	0.024%/0 to 100% (-10 to +10 V)
	(0.1%/0 to 100% when option is not mounted)
Input resistance	10 k Ω
Maximum input voltage.....	± 20 VDC

6 MOTOR THERMISTOR INTERFACE

A vector-controlled motor with thermistor (SF-V5RU□□□□□T/A) detects the motor temperature with the motor-side thermistor and sends the detected temperature to the inverter as a feedback. This operation reduces fluctuation of the generated torque due to temperature changes. The detected motor temperature can be output as an output signal (Y55 signal) or be displayed on the monitor.

Torque accuracy is $\pm 3\%$.

6.1 Connection diagram

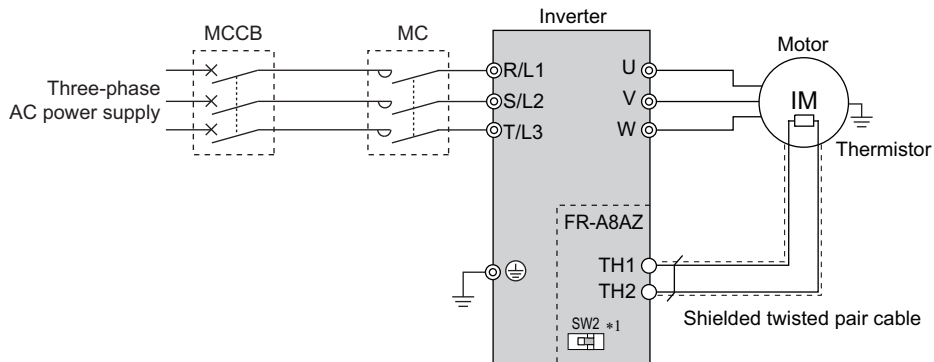

*1 When calibrating the thermistor, change the thermistor calibration status switch. (Refer to [page 34](#))

NOTE

- The motor temperature detection is valid for the first motor. When applying the second motor (RT signal is ON), temperature detection is not performed.
- To detect temperature with FR-A8AZ, be sure to use the SF-V5RU□□□□□T/A, a dedicated motor with thermistor.

6.2 Terminals

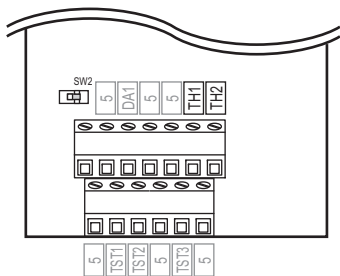

Terminal symbol	Terminal name	Description
TH1	Thermistor input 1	Input the motor side thermistor output signal.
TH2	Thermistor input 2	
SW2	Thermistor calibration status switch	When calibrating at installation, change the switch to place the inverter in calibration status.

6.3 Motor thermistor parameter

6.3.1 Parameter list

Parameters below are used for motor thermistor interface.

Following parameters are available only when used with FR-A8AZ.

Pr.	Pr. group	Name	Setting range	Minimum setting increments	Initial value
326*1	G062	Motor temperature feedback reference	0 to 150°C, 9999	1°C	9999
407*1	T620	Motor temperature detection filter	0 to 100 s, 9999	1 s	9999
408*1	H023	Motor thermistor selection	0, 1	1	0
750*1	M061	Motor temperature detection level	0 to 200°C	1°C	75°C
751*1	M046	Reference motor temperature	1 to 200°C	1°C	150°C
C29(925)*1, *2	H041	Motor temperature detection calibration (analog input)	0 to 200%	0.1%	100%

*1 Setting can be made only when the FR-A8AZ is mounted.

*2 The parameter number in parentheses is the one for use with the LCD operation panel and the parameter unit.

6.3.2 Thermistor setting

When using the thermistor interface, set **Pr.408 Motor thermistor selection** according to the motor type.

Its initial value is "0" (SF-V5RU□□□□□T). Set this parameter according to the motor.

Pr.	Pr. group	Name	Initial value	Minimum setting increments	Setting range	Description
408	H023	Motor thermistor selection	0	1	0	SF-V5RU□□□□□T
					1	SF-V5RU□□□□□A

6.3.3 Thermistor calibration (C29)

Perform calibration of the inverter and FR-A8AZ (thermistor interface) at installation, before starting the motor.



NOTE

- Calibration must be performed at installation.

◆ Calibration method

- (1) Set the thermistor calibration status switch (SW2) to the line to place the FR-A8AZ in the calibration status.

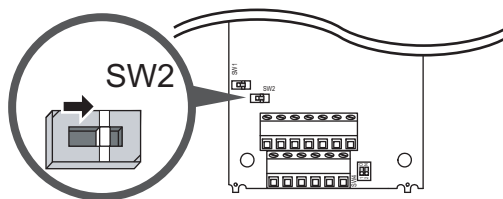

- (2) Read **C29(Pr.925)** and set the compensation value.
 - Compensation using the operation panel (FR-DU08) Refer to [page 35](#)
 - Compensation using the LCD operation panel (FR-LU08) Refer to [page 36](#)
- (3) After compensation, reset the thermistor calibration status switch (SW2) to the original position.

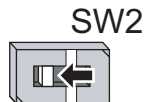

NOTE

- Always return the SW2 to the original position after calibration. If the motor is started in the calibration status, the inverter protective function (E.THM) is activated, shutting off the inverter output.

◆ Operation example of compensation value setting

- Calibration using the operation panel (FR-DU08)

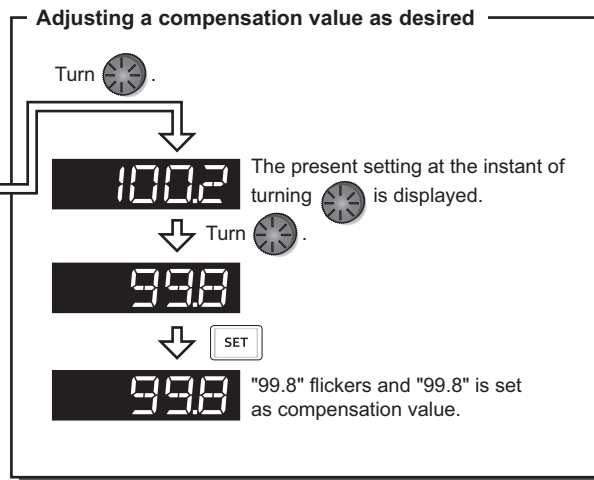
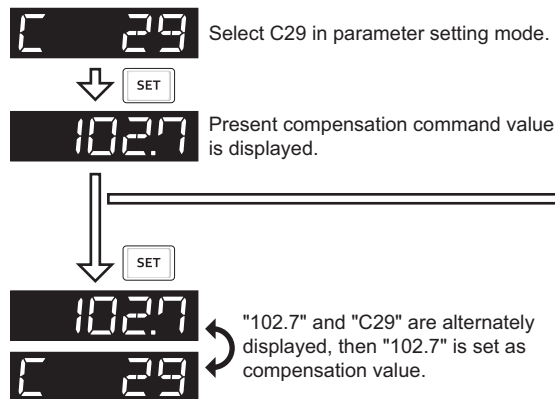

- Calibration using the LCD operation panel (FR-LU08)

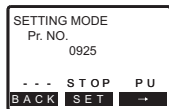

Select **Pr.925** in parameter setting mode.
(Also selectable from the functional list in the quick menu, the initial value list or the parameter change list in the function menu.)

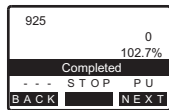
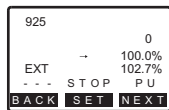
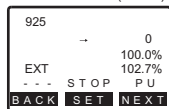

"102.7" is set as compensation value.

Adjusting a compensation value as desired

Turn until "99.2" appears.

"99.2" is set as compensation value.

The diagram shows a sequence of LCD screens. The first screen shows '925', '0', 'EXT → 100.0%', and '102.7%'. A down arrow and SET button lead to a second screen showing '925', '0', 'EXT → 99.2%', and '102.7%'. A second down arrow and SET button lead to a third screen showing '925', '0', 'Completed', and '99.2%'. A final down arrow and SET button lead to a fourth screen showing '925', '0', 'Completed', and '99.2%'.

6.3.4 Motor thermal

When **Pr.407**≠"9999", the thermal protective function with the motor thermistor is available.

When **Pr.407**="9999 (initial value)", the thermal protective function with the motor thermistor is not activated. (The electronic thermal O/L relay operation depends on the current set in **Pr.9 Electronic thermal O/L relay**.)

- Normally set about "30 s" in **Pr.407**.
- When the response is slow to the motor temperature, set a smaller value.
- When the motor temperature remains at 145°C or higher for 10 s, inverter protective function (E.THM) activates to shut off the inverter output.
- When the motor temperature goes to -30°C or lower during operation, inverter protective function (E.THM) activates to shut off the inverter output. Motor overload trip (E.THM) does not occur during a stop.



- When operation is performed with the thermal protection function valid without a thermistor or in the calibration status, protection function activates to shut off the inverter output.
- Since a dedicated motor with thermistor has no thermal protector, always set a value other than "9999" in **Pr.407 Motor temperature detection filter** to make the thermal protection function valid. When the setting remains "9999", motor protection is not activated.

6.3.5 Motor temperature detection signal

When motor temperature exceeds the detection level, motor temperature detection signal (Y55) is output. (Set **Pr.407 Motor temperature detection filter** ≠ "9999")

Set "55 (positive logic)" or "155 (negative logic)" in the following parameters to output the motor temperature detection signal (Y55) when motor temperature exceeds the detection level.

- **Pr.190 to Pr.196 Output terminal function selection** (Refer to the Instruction Manual (Detailed) of the inverter for details.)
- **Pr.313 to Pr.319 DO0 to DO6 output function selections** (Refer to the Instruction Manual of FR-A8AY for details.)
- **Pr.320 to Pr.322 RA1 to RA3 output function selections** (Refer to the Instruction Manual of FR-A8AR for details.)

Pr.	Pr. group	Name	Setting range	Minimum setting increments	Initial value
750 ^{*1}	M061	Motor temperature detection level	0 to 200°C	1°C	75°C

*1 Setting can be made only when the FR-A8AZ is mounted.

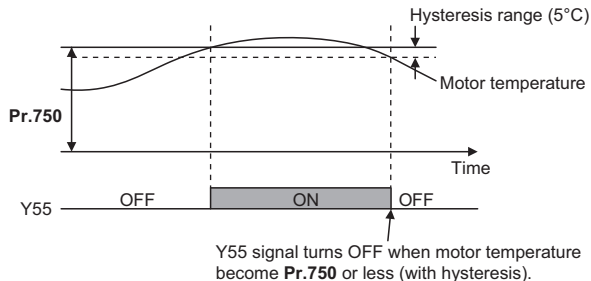

NOTE

- The motor temperature detection signal is not available when **Pr.407** = "9999".

6.3.6 Motor temperature monitor output

The motor temperature can be monitored using PU, DU, terminal AM, terminal FM/CA, RS-485 communication, or each output option. (Set **Pr.407 Motor temperature detection filter** ≠ "9999")

Set "46" in the following parameters.

- **Pr.52 Operation panel main monitor selection, Pr.54 FM/CA terminal function selection, Pr.158 AM terminal function selection** (Refer to the Instruction Manual (Detailed) of the inverter for details.)
- **Pr.306 Analog output signal selection, Pr.310 Analog meter voltage output selection** (Refer to the Instruction Manual of FR-A8AY for details.)
- **Pr.838 DA1 terminal function selection** (Refer to [page 17](#))

Set the following parameter to adjust the motor temperature on the full scale.

Pr.	Pr. group	Name	Setting range	Minimum setting increments	Initial value
751*1	M046	Reference motor temperature	1 to 200°C	1°C	150°C

*1 Setting can be made only when the FR-A8AZ is mounted.

Output from terminal FM (CA)

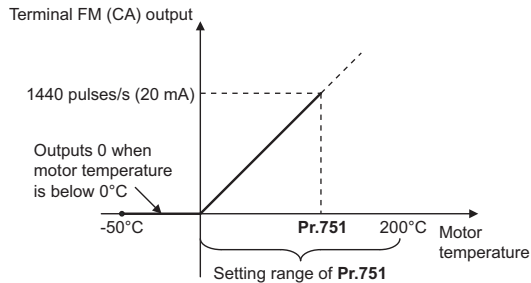

Output from terminal DA1 (AM *1)

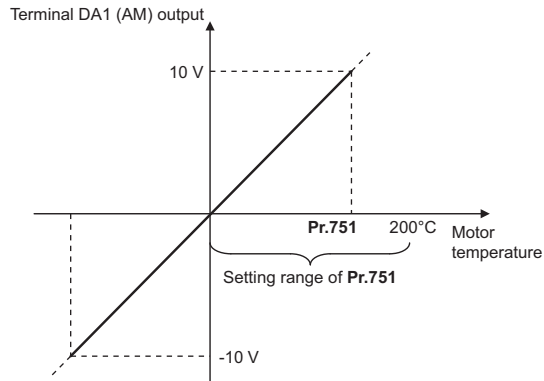

*1 When **Pr.290 Monitor negative output selection** = "1, 3, 5, or 7"

NOTE

- When **Pr.407** = "9999", motor temperature monitor is not activated.

6.3.7 Slip compensation

When **Pr.407 Motor temperature detection filter** ≠ "9999", slip compensation is enabled under vector control for the motor with an encoder. The slip frequency is compensated by **Pr.326 Motor temperature feedback reference** and the detected temperature.

When using the motor constant set by offline auto tuning or set directly, set in **Pr.326** the motor temperature for when the motor constant (R2) was determined.

Pr.	Pr. group	Name	Initial value	Minimum setting increments	Setting range	Description
326 ^{•1}	G062	Motor temperature feedback reference	9999	1°C	0 to 150°C	Set the motor temperature for when the motor constant (R2) was determined.
					9999	The slip frequency is compensated with a reference temperature of 75°C.

*1 Setting can be made only when the FR-A8AZ is mounted.



NOTE

- When **Pr.407** ≠ "9999", magnetic flux observer under vector control for the motor with an encoder (**Pr.95 Online auto tuning selection** = "2") is invalid.

MEMO



REVISIONS

*The manual number is given on the bottom left of the back cover.

Print Date	*Manual Number	Revision
Feb. 2015	IB(NA)-0600578ENG-A	First edition

INVERTER

mitsubishi **MITSUBISHI ELECTRIC CORPORATION**

HEAD OFFICE: TOKYO BUILDING 2-7-3, MARUNOUCHI, CHIYODA-KU, TOKYO 100-8310, JAPAN