



INVERTER

Plug-in option

FR-A8AR

INSTRUCTION MANUAL

Relay output function

PRE-OPERATION INSTRUCTIONS

1

INSTALLATION AND WIRING

2

RELAY OUTPUT

3

Thank you for choosing this Mitsubishi Electric inverter plug-in option.

This Instruction Manual provides handling information and precautions for use of this product. Incorrect handling might cause an unexpected fault. Before using this product, read all relevant instruction manuals carefully to ensure proper use.

Please forward this Instruction Manual to the end user.

Safety instructions

Do not attempt to install, operate, maintain or inspect this product until you have read this Instruction Manual and appended documents carefully. Do not use this product until you have a full knowledge of this product mechanism, safety information and instructions. In this Instruction Manual, the safety instruction levels are classified into "WARNING" and "CAUTION".



WARNING

Incorrect handling may cause hazardous conditions, resulting in death or severe injury.



CAUTION

Incorrect handling may cause hazardous conditions, resulting in medium or slight injury, or may cause only material damage.

Note that even the  **CAUTION** level may lead to a serious consequence depending on conditions. Be sure to follow the instructions of both levels as they are critical to personnel safety.

◆ Electric shock prevention



WARNING

- Do not remove the front cover or the wiring cover of the inverter while the inverter power is ON. Do not operate the inverter with any cover or wiring cover removed, as accidental contact with exposed high-voltage terminals and internal components may occur, resulting in an electrical shock.
- Even if power is OFF, do not remove the front cover of the inverter except for wiring or periodic inspection as you may accidentally touch the charged circuits and get an electric shock.
- Before wiring or inspection, check that the display of the inverter operation panel is OFF. Any person who is involved in wiring or inspection shall wait for 10 minutes or longer after power OFF and check that there are no residual voltage using a tester or the like. The capacitor is charged with high voltage for some time after power OFF, and it is dangerous.
- Any person who is involved in wiring or inspection of this product shall be fully competent to do the work.
- This product must be installed before wiring. Otherwise you may get an electric shock or be injured.
- Do not subject the cables to scratches, excessive stress, heavy loads or pinching. Doing so may cause an electric shock.
- Do not touch this product or handle the cables with wet hands. Doing so may cause an electric shock.

◆ Injury prevention



CAUTION

- The voltage applied to each terminal must be as specified in the Instruction Manual. Otherwise a burst, damage, etc. may occur.
- The cables must be connected to the correct terminals. Otherwise a burst, damage, etc. may occur.
- The polarity (+ and -) must be correct. Otherwise a burst, damage, etc. may occur.
- While power is ON or for some time after power OFF, do not touch the inverter as it will be extremely hot. Doing so may cause a burn.

◆ **Additional instructions**

The following instructions must be also followed. If this product is handled incorrectly, it may cause unexpected fault, an injury, or an electric shock.

 **CAUTION**

Transportation and installation

- Do not stand or place heavy objects on this product.
- The installing orientation of this product must be correct.
- Do not install or operate this product if it is damaged or has parts missing.
- Foreign conductive objects must be prevented from entering the inverter. That includes screws and metal fragments or other flammable substance such as oil.
- If halogen-based materials (fluorine, chlorine, bromine, iodine, etc.), included in fumigants to sterilize or disinfect wooden packages, infiltrate into this product, the product may be damaged. Prevent residual fumigant components from being infiltrated into the product when packaging, or use an alternative sterilization or disinfection method (heat disinfection, etc.). Note that sterilization or disinfection of wooden package should also be performed before packing the product.

Test operation

- Before starting operation, confirm or adjust the parameter settings. Failure to do so may cause some machines to make unexpected motions.

 **WARNING**

Usage

- Do not modify this product.
- Do not remove any part which is not instructed to be removed in the Instruction Manuals. Doing so may lead to a failure or damage of this product.

 **CAUTION**

Usage

- As all parameters return to their initial values after Parameter clear or All parameter clear is performed, the needed parameters for operation of the inverter and this product must be set again before the operation is started.
- To avoid damage to this product due to static electricity, static electricity in your body must be discharged before you touch this product.

Maintenance, inspection and parts replacement

- Do not carry out a megger (insulation resistance) test.

Disposal

- This product must be treated as industrial waste.

General instruction

- For clarity purpose, illustrations in this Instruction Manual may be drawn with covers or safety guards removed. Ensure all covers and safety guards are properly installed prior to starting operation.

— CONTENTS —

1	PRE-OPERATION INSTRUCTIONS	5
1.1	Unpacking and checking the product.....	5
1.1.1	Product confirmation.....	5
1.2	Component names	6
1.3	Specifications	7
2	INSTALLATION AND WIRING	8
2.1	Pre-installation instructions	8
2.2	Installation procedure	8
2.3	Wiring	11
3	RELAY OUTPUT	15
3.1	Internal block diagram	15
3.2	Terminals.....	16
3.3	Parameter list.....	16
3.4	Parameter setting	17
3.5	Connection diagram when using electronic bypass sequence function	18
APPENDIX		19
Appendix1	Instructions for compliance with the EU Directives	19
Appendix2	Instructions for EAC.....	20
Appendix3	Restricted Use of Hazardous Substances in Electronic and Electrical Products	21
Appendix4	Referenced Standard (Requirement of Chinese standardized law)	22





1 PRE-OPERATION INSTRUCTIONS

1.1 Unpacking and checking the product

Take the plug-in option out of the package, check the product name, and confirm that the product is as you ordered and intact. The product is a plug-in made option made for the FR-A800/F800 series.

1.1.1 Product confirmation

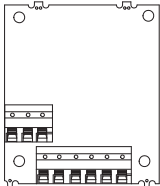
Check the enclosed items.

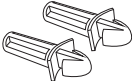
<p>Plug-in option1</p>  A technical drawing of a rectangular plug-in option. It features a top edge with two circular mounting holes. The bottom edge has a series of electrical contacts and a larger rectangular component with multiple pins.	<p>Mounting screw (M3 × 8 mm)2 (Refer to page 8.)</p>  Two screws with a cross-shaped head, representing M3 x 8 mm screws.	<p>Spacer2 (Refer to page 8.)</p>  Two cylindrical spacers with a flange on one end and a hole on the other.
---	---	--

1.2 Component names

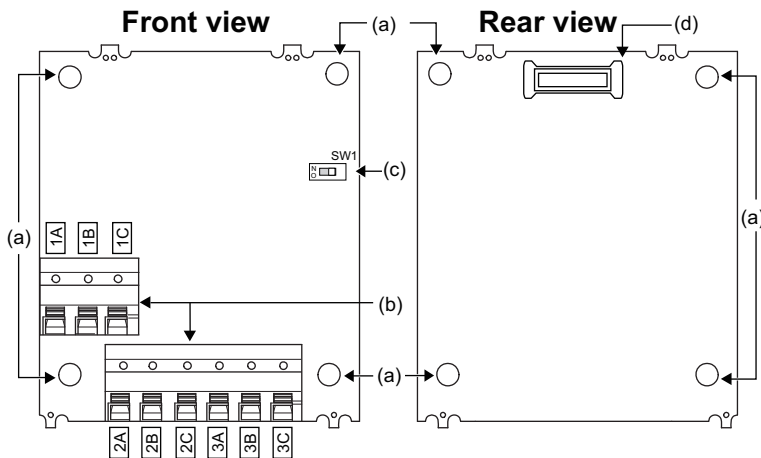

Symbol	Name	Description	Refer to page
a	Mounting hole	Fixes the option to the inverter with screws, or installs spacers.	8
b	Terminal block	Connects to devices that receive signals from the inverter.	11
c	Switch for manufacturer setting (SW1)	Switch for manufacturer setting. Do not change the initial setting. (OFF )	—
d	Connector	Connects to the option connector of the inverter.	8

1.3 Specifications

◆ **Type of output signal**

1 changeover contact output (three relays provided)

◆ **Contact capacity**

230 VAC...0.3 A

30 VDC...0.3 A



- Use contacts within the rated capacity. Failure to do so may cause contacts to wear out quickly or to be welded.

2 INSTALLATION AND WIRING

2.1 Pre-installation instructions

Check that the inverter's input power and the control circuit power are both OFF.

CAUTION

- Do not install or remove this product while the inverter power is ON. Doing so may damage the inverter or this product.
- To avoid damage due to static electricity, static electricity in your body must be discharged before you touch this product.

2.2 Installation procedure

- (1) Remove the inverter front cover. (Refer to Chapter 2 of the Instruction Manual (Detailed) of the inverter for instructions for removing the front cover.)
- (2) Insert two spacers into the mounting holes that will not be filled with mounting screws (see the diagrams on the next page to identify the holes).
- (3) Fit the board mounted option connector on this product to the guide of the option connector on the inverter and insert the plug-in option as far as it goes. (Select option connector 1 or 2 on the inverter.)
- (4) Fit the two locations, the left and right, of the plug-in option securely to the inverter unit by screwing in the supplied mounting screws (tightening torque 0.33 N·m to 0.40 N·m). If the screw holes do not line up, the connector may not be inserted deep enough. Check the connector.

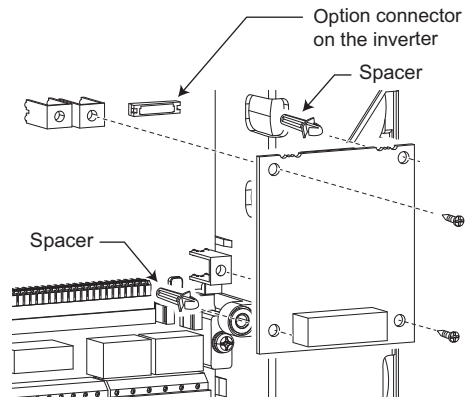

Example of installation to connector 1

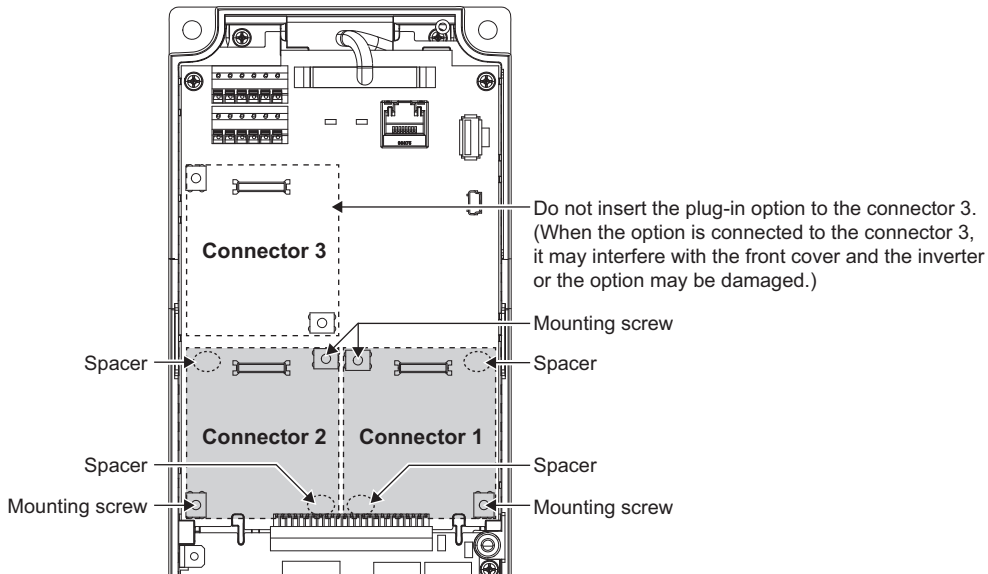

Insertion positions for screws and spacers

 **NOTE**

- When installing/removing the plug-in option, hold the sides of the option. Do not press on the parts on the option circuit board. Stress applied to the parts by pressing, etc. may cause a failure.
- Be careful not to drop mounting screws during the installation or removal of the plug-in option.
- Only one option can be used. When multiple options are mounted, priority is given to option connectors 1, 2 and 3 on the inverter in this order, and options having a lower priority do not function.
- When the inverter cannot recognize the option due to improper installation or any reason, the protective function (E.1 to E.3) is activated and the inverter cannot be operated. The indication shown (when a fault occurs) depends on the connector used (option connector 1 to 3).

Mounted position	Fault indication
Option connector 1	E. 1
Option connector 2	E. 2
Option connector 3	E. 3

- When removing the plug-in option, remove the two screws on either side, and then pull it straight out. Pressure applied to the option connector and to the option board may break the option.

2.3 Wiring

(1) For the wiring, strip off the sheath of a cable, and use it with a blade terminal. For single wire, the stripped wire can be used without crimp terminal. Connect the end of wires (crimp terminal or stranded wire) to the terminal block.

Strip the signal wires as shown below. If too much of the wire is stripped, a short circuit may occur with neighboring wires. If not enough of the wire is stripped, wires may become loose and fall out.

Twist the stripped end of wires to prevent them from fraying. Do not solder it.

Wire strip length



Crimp the terminals on the wire.

Insert wires to the crimp terminal, and check that the wires come out for about 0 to 0.5 mm from a sleeve.

Check the condition of the crimp terminals after crimping. Do not use the crimp terminals of which the crimping is inappropriate, or the face is damaged.

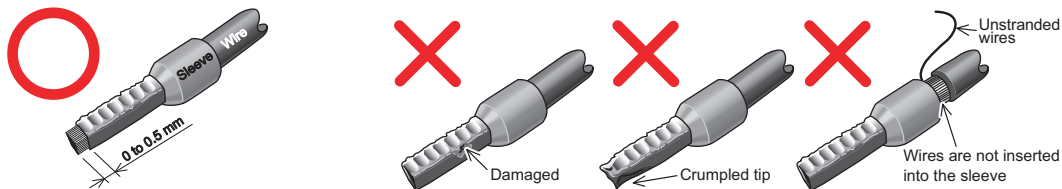

CAUTION

- After wiring, wire offcuts must not be left in the inverter. They may cause a fault, failure or malfunction.

Crimp terminals commercially available (as of January 2017. The product may be changed without notice.)

Wire gauge (mm ²)	Ferrule part No.			Manufacturer	Crimping tool model No.
	With insulation sleeve	Without insulation sleeve	For UL wire *1		
0.3	AI 0,34-10TQ	—	—	Phoenix Contact Co., Ltd.	CRIMPFOX 6
0.5	AI 0,5-10WH	—	AI 0,5-10WH-GB		
0.75	AI 0,75-10GY	A 0,75-10	AI 0,75-10GY-GB		
1	AI 1-10RD	A 1-10	AI 1-10RD/1000GB		
1.25, 1.5	AI 1,5-10BK	A 1,5-10	—		
0.75 (for two cables)	AI-TWIN 2 × 0,75-10GY	—	—		

*1 A ferrule terminal with an insulation sleeve compatible with the MTW wire which has a thick wire insulation.

Wire gauge (mm ²)	Blade terminal part No.	Insulation cap part No.	Manufacturer	Crimping tool model No.
0.3 to 0.75	BT 0.75-11	VC 0.75	NICHIFU Co.,Ltd.	NH 69

(2) Insert the wire into the terminal block.

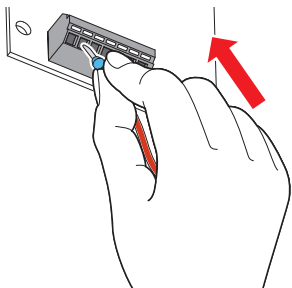

When using single wire or stranded wires without crimp terminal, push an open/close button all the way down with a flathead screwdriver, and insert the wire.

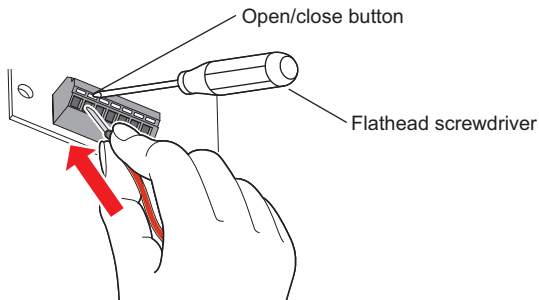

- Wire removal

Pull the wire while pushing the open/close button all the way down firmly with a flathead screwdriver.

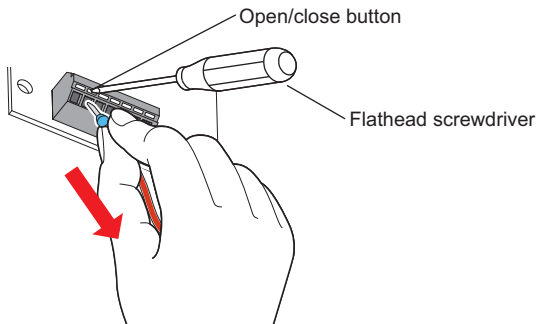

 **NOTE**

- When using stranded wires without crimp terminal, twist enough to avoid short circuit with a nearby terminals or wires.
- Pulling out the wire forcefully without pushing the open/close button all the way down may damage the terminal block.
- Use a small flathead screwdriver (tip thickness: 0.4 mm/tip width: 2.5 mm). If a flathead screwdriver with a narrow tip is used, terminal block may be damaged.

Commercially available products (as of February 2012. The product may be changed without notice.)

Product name	Model	Manufacturer
Screwdriver	SZF 0- 0,4 × 2,5	Phoenix Contact Co., Ltd.

- Place the flathead screwdriver vertical to the open/close button. In case the blade tip slips, it may cause an inverter damage or injury.
- When wiring cables to the inverter's RS-485 terminals while a plug-in option is mounted, take caution not to let the cables touch the circuit board of the option or of the inverter. Otherwise, electromagnetic noises may cause malfunctions.

3 RELAY OUTPUT

3.1 Internal block diagram

Three signals can be selected among inverter's standard signals (RUN, SU, FU, etc.) to be output as relay contact (1C) signals.

The following figure is the internal block diagram of the FR-A8AR.

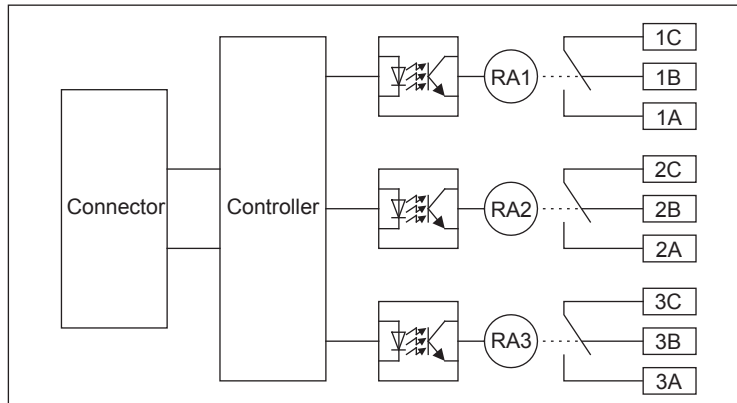

3.2 Terminals

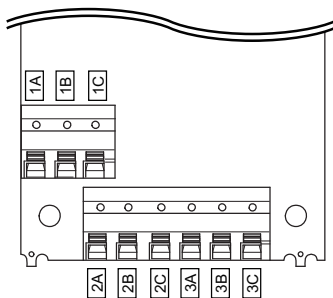

Terminal symbol	Description
1A	Normally open contact terminal of relay RA1
1B	Normally closed contact terminal of relay RA1
1C	Common contact terminal for relay RA1
2A	Normally open contact terminal of relay RA2
2B	Normally closed contact terminal of relay RA2
2C	Common contact terminal for relay RA2
3A	Normally open contact terminal of relay RA3
3B	Normally closed contact terminal of relay RA3
3C	Common contact terminal for relay RA3

*1 The operation of each relay depends on the output signal selected.

3.3 Parameter list

When the FR-A8AR is mounted on the inverter, the following parameters are extended. Perform the settings as required.

Pr.	Pr. Group	Name	Initial value	Setting range
320	M420	RA1 output selection	0	The setting range depends on the inverter. For details, refer to Pr.190 to Pr.196 (output terminal function selection) in the Instruction Manual (Detailed) of the inverter.
321	M421	RA2 output selection	1	
322	M422	RA3 output selection	2	
418	M432	Extension output terminal filter	9999	5 to 50 ms, 9999

3.4 Parameter setting

◆ Setting output signals

Use **Pr.320 to Pr.322** to assign signals to the terminals ABC (1 to 3). The settings of **Pr.320 to Pr.322** are the same as those of **Pr.190 to Pr.196 (output terminal function selection)**. For the details of **Pr.190 to Pr.196**, refer to the Instruction Manual (Detailed) of the inverter.

NOTE

- All the outputs are shut off when the protective functions (E.1 to E.3) are activated.
- Negative logic cannot be set.

◆ Adjusting the output terminal response level (Pr.418)

- The response level of the output terminals can be delayed in a range of 5 to 50 ms. (Operation example for the RUN signal.)

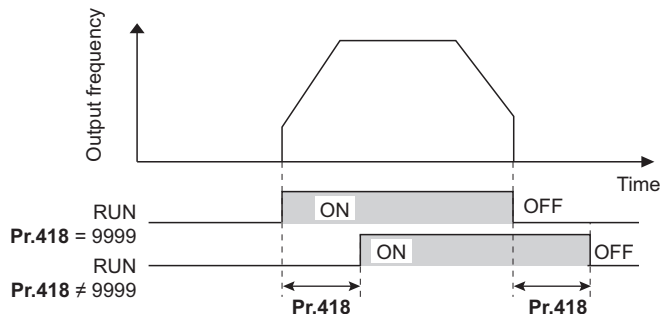

NOTE

- The response level is not adjusted while **Pr.418 = "9999"**.
- When **Pr.157 OL signal output timer** is set for the Overload warning (OL) signal output, the OL signal is output when the set time of **(Pr.157 + Pr.418)** elapses.

3.5 Connection diagram when using electronic bypass sequence function

When using the electronic bypass sequence function with the FR-A8AR mounted to the FR-A800/F800 series inverter, the following connections are recommended.

- Recommended connection diagram 1

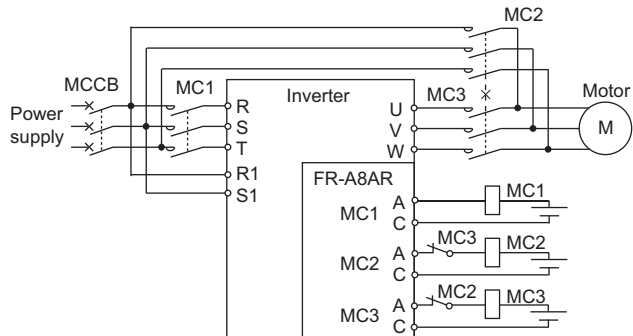

- Recommended connection diagram 2

When using the relay output of the FR-A8AR, instead of the MC1 signal, set the output signal to fault output signal (ALM) and output it from contacts B and C.

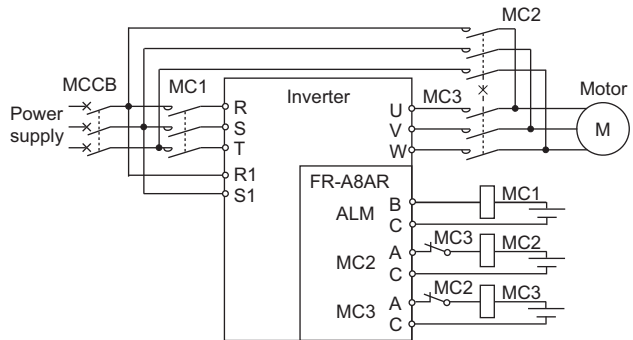

APPENDIX

Appendix1 Instructions for compliance with the EU Directives

The EU Directives are issued to standardize different national regulations of the EU Member States and to facilitate free movement of the equipment, whose safety is ensured, in the EU territory.

Since 1996, compliance with the EMC Directive that is one of the EU Directives has been legally required. Since 1997, compliance with the Low Voltage Directive, another EU Directive, has been also legally required. When a manufacturer confirms its equipment to be compliant with the EMC Directive and the Low Voltage Directive, the manufacturer must declare the conformity and affix the CE marking.



- The authorized representative in the EU

The authorized representative in the EU is shown below.

Name: Mitsubishi Electric Europe B.V.

Address: Mitsubishi-Electric-Platz 1, 40882 Ratingen, Germany

- ◆ **Note**

- To use this product in the EU, the operating capacity of the relay outputs should be 30 VDC, 0.3 A. (Relay output has basic isolation from the inverter internal circuit.)

- ◆ **EMC Directive**

We declare that this product conforms with the EMC Directive when installed in a compatible inverter, and affix the CE marking on the packaging plate.

- EMC Directive: 2014/30/EC
- Standard(s): EN 61800-3:2004+A1:2012 (Second environment / PDS Category "C3")

- ◆ **Note**

- To install and wire the inverter, refer to the "Instructions for compliance with the EU Directives" in the Instruction Manual enclosed with the inverter.
- Confirm that the final integrated system with the inverter conforms with the EMC Directive.

Appendix2 Instructions for EAC

The product certified in compliance with the Eurasian Conformity has the EAC marking on the packaging plate.

Note: EAC marking

In 2010, three countries (Russia, Belarus, and Kazakhstan) established a Customs Union for the purposes of revitalizing the economy by forming a large economic bloc by abolishing or reducing tariffs and unifying regulatory procedures for the handling of articles.

Products to be distributed over these three countries of the Customs Union must comply with the Customs Union Technical Regulations (CU-TR), and the EAC marking must be affixed to the products.

For information on the country of origin, manufacture year and month, and authorized sales representative (importer) in the CU area of this product, refer to the following:

- Country of origin indication

Check the package of this product.

Example: MADE IN JAPAN

- Manufactured year and month

Check the SERIAL number indicated on this product.

<u>□</u>	<u>○</u>	<u>○</u>	<u>○○○</u>
Symbol	Year	Month	Control number

SERIAL

The SERIAL consists of one symbol, two characters indicating the production year and month, and three characters indicating the control number. The last digit of the production year is indicated as the Year, and the Month is indicated by 1 to 9, X (October), Y (November), or Z (December).

- Authorized sales representative (importer) in the CU area

The authorized sales representative (importer) in the CU area is shown below.

Name: Mitsubishi Electric (Russia) LLC

Address: 52, bld 1 Kosmodamianskaya Nab 115054, Moscow, Russia

Phone: +7 (495) 721-2070

Fax: +7 (495) 721-2071

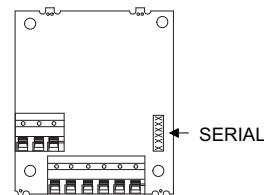

Appendix3 Restricted Use of Hazardous Substances in Electronic and Electrical Products

The mark of restricted use of hazardous substances in electronic and electrical products is applied to the product as follows based on the "Management Methods for the Restriction of the Use of Hazardous Substances in Electrical and Electronic Products" of the People's Republic of China.

电器电子产品有害物质限制使用标识要求



本产品中所含有的有害物质的名称、含量、含有部件如下表所示。

- 产品中所含有害物质的名称及含量

部件名称*2	有害物质*1					
	铅 (Pb)	汞 (Hg)	镉 (Cd)	六价铬 (Cr (VI))	多溴联苯 (PBB)	多溴二苯醚 (PBDE)
电路板组件 (包括印刷电路板及其构成的零部件, 如电阻、电容、集成电路、连接器等)、电子部件	×	○	×	○	○	○
金属壳体、金属部件	×	○	○	○	○	○
树脂壳体、树脂部件	○	○	○	○	○	○
螺丝、电线	○	○	○	○	○	○

上表依据 SJ/T11364 的规定编制。

○: 表示该有害物质在该部件所有均质材料中的含量均在 GB/T26572 规定的限量要求以下。

×: 表示该有害物质在该部件的至少一种均质材料中的含量超出 GB/T26572 规定的限量要求。

*1 即使表中记载为 ×, 根据产品型号, 也可能会有有害物质的含量为限制值以下的情况。

*2 根据产品型号, 一部分部件可能不包含在产品中。

Appendix4 Referenced Standard (Requirement of Chinese standardized law)

This Product is designed and manufactured accordance with following Chinese standards.

EMC: GB/T 12668.3

REVISIONS

*The manual number is given on the bottom left of the back cover.

Print Date	*Manual Number	Revision
Aug. 2013	IB(NA)-0600499ENG-A	First edition
Oct. 2014	IB(NA)-0600499ENG-B	Addition <ul style="list-style-type: none">• Compatibility with the FR-F800 series
Mar. 2019	IB(NA)-0600499ENG-C	Addition <ul style="list-style-type: none">• Instructions for compliance with the EU Directives• Instructions for EAC• Restricted Use of Hazardous Substances in Electronic and Electrical Products• Referenced Standard (Requirement of Chinese standardized law)

INVERTER

mitsubishi **MITSUBISHI ELECTRIC CORPORATION**

HEAD OFFICE: TOKYO BUILDING 2-7-3, MARUNOUCHI, CHIYODA-KU, TOKYO 100-8310, JAPAN

