

**MITSUBISHI
ELECTRIC**
INVERTER
FR-A800/F800



Safety Stop Function Instruction Manual

CONTENTS

1. GENERAL DESCRIPTION	2
2. INSTALLATION AND WIRING.....	3
3. EXAMPLE OF SAFETY SYSTEM CONFIGURATION	7
4. TEST AND CHECKING FAILURE	10
5. SAFETY PARAMETERS OF FR-A800/F800	11

Compliance with the EU Machinery Directive – Functional Safety

Warning

- Any misuse of safety function could lead to personal injury or death, property damage, or economic loss. To ensure that the system complies fully with requirement of safety, make a system-level risk assessment. Mitsubishi Electric Corporation. cannot assume responsibility for any system to comply with safety directive.

Caution

- The information of this manual is merely a guide for proper installation.
- Mitsubishi Electric Corporation. cannot assume responsibility for the compliance or the noncompliance to any code, national, local, or otherwise for the proper installation of this equipment.
- A hazard of personal injury and/or equipment damage exists if codes are ignored during installation.

Warning

- To avoid an electric shock hazard, verify that the voltage on the bus capacitors has discharged before performing any work on the inverter. Measure the DC bus voltage between the terminals P(+) and N(-) or at test points (refer to your inverter's [Instruction Manual](#) for locations and discharging time). The voltage must be zero.

Warning

- The safety stop function do not isolate electrically between the inverter and the motor. To avoid an electric shock hazard, disconnect/isolate power to the inverter and verify to ensure that the voltage is zero before performing any work on the motor (refer to your inverter's [Instruction Manual](#) for discharging time).

1 GENERAL DESCRIPTION

Features

The safety stop function of the Mitsubishi FR-A800/F800 inverter can be used to prevent the inverter from supplying rotational energy to motors. Dual input terminals S1 and S2 can be used to cut off the gate-drive power to the IGBT.

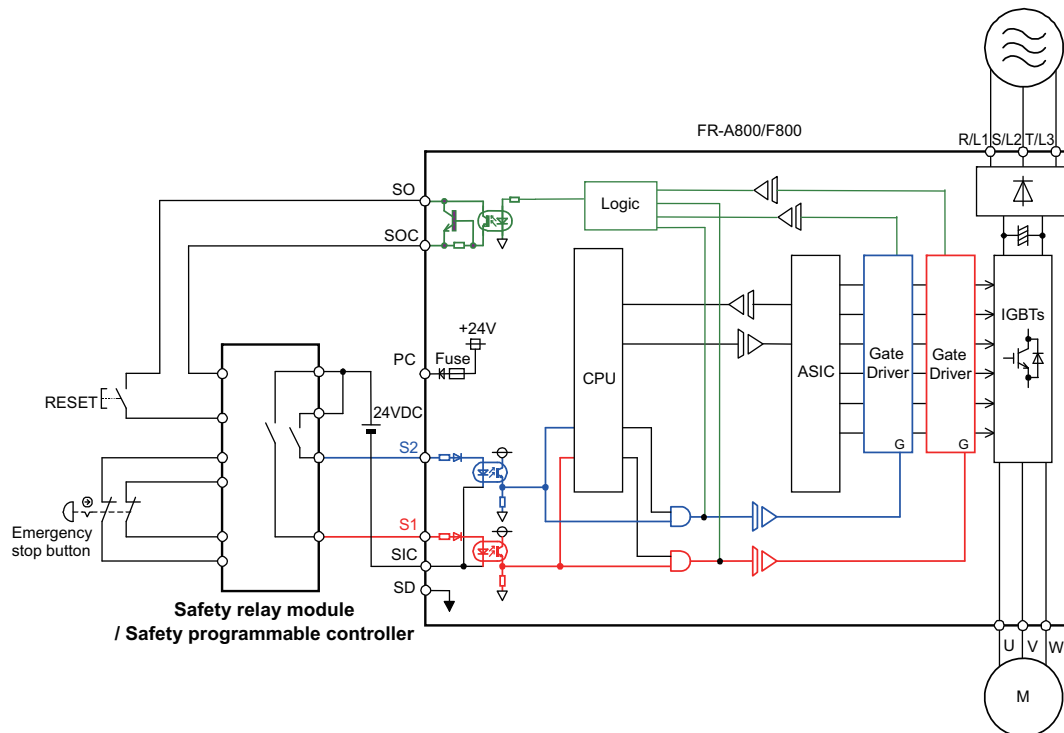

Figure 1 FR-A800/F800 safety stop function diagram

Warning

- Disconnecting the power to the gate driver by the safety stop function does not isolate electrically between the inverter and the motor. To avoid an electric shock hazard, disconnect power to the inverter and verify that the main circuit capacitor voltage is zero (across terminals P and N) before performing any work on the motor (refer to your inverter's [Instruction Manual](#) for discharging time).

Standards

The safety stop function of the Mitsubishi FR-A800/F800 inverter meets the following standards and categories.

ISO13849-1:2008 Category 3/PLd

IEC62061:2005 / IEC61800-5-2:2007 / IEC61508 SIL2

IEC60204-1:2010 / IEC61800-5-2:2007 Stop category 0

Warning

- The misuse of safety function leads to personal injury or death, property damage, or economic loss. To ensure that the system complies fully with requirement of safety, make a system-level risk assessment. Mitsubishi Electric Corporation. cannot assume responsibility for any system to comply with safety standards.

2 INSTALLATION AND WIRING

Caution

- The following information is merely a guide for proper installation.
- Mitsubishi Electric Corporation. cannot assume responsibility for the compliance or the noncompliance to any code, national, local, or otherwise for the proper installation of this equipment.
- A hazard of personal injury and/or equipment damage exists if codes are ignored during installation.

Caution

- Ensure the safety relay unit and the FR-A800/F800 inverter are mounted closely in an enclosure meeting IP54 and all interconnection wiring is short and protected against open and short circuit faults. Refer ISO/IEC13849-2.

Installation

The safety stop function of the Mitsubishi FR-A800/F800 inverter should be used under the following conditions and environment.

Table 1 Conditions and environment for using the safety stop function

Item		Condition
Surrounding air temperature	LD, ND, HD*1	-10°C to +50°C (non-freezing)
	SLD	-10°C to +40°C (non-freezing)
Storage temperature		-20°C to +65°C*2
Ambient humidity		With circuit board coating (conforming to IEC60721-3-3 3C2/3S2): 95% RH or less (non-condensing), Without circuit board coating: 90% RH or less (non-condensing)
Vibration		5.9 m/s ² or less at 10 to 55 Hz (directions of X, Y, Z axes)
Altitude		Maximum 2500 m above sea level*3
Atmosphere		Indoors (free from corrosive gas, flammable gas, oil mist, dust and dirt)
Overvoltage category		III or lower
Pollution degree		II or lower
Mounting		Wall mounting / vertical orientation

*1 The ND and HD ratings can be selected only for the FR-A800 inverter.

*2 Temperature applicable for a short time, e.g. in transit.

*3 For the installation at an altitude above 1,000 m up to 2,500 m, derate the rated current 3% per 500 m.

⚠ Caution

- In order to meet safety standards, a safety relay module compliant with ISO13849-1 safety category 3 or higher shall be used in conjunction with the FR-A800/F800 inverter as shown in example. In addition, all other components in the safety stop loop shall be 'safety approved' types.

⚠ Warning

- To avoid an electric shock hazard, insert the magnetic contactor (MC) between power source and inverter.
- Open the contact of MC and keep away from the inverter for discharging time (refer to your inverter's [Instruction Manual](#) for information) before performing any work on the inverter. And verify that the voltage on the bus capacitors has discharged before measuring the DC bus voltage between the terminals P(+) and N(-) or at test points (refer to your inverter's [Instruction Manual](#) for locations). The voltage must be zero.

⚠ Caution

- To avoid system faults, check the safety function at system installation, any software changes, parameter setting changes, and at least once per year. Refer to 4. TEST AND CHECKING FAILURE.

●Wiring

The safety related terminals are described in Table 2 and Table 3.

Table 2 Safety related terminals

Terminal symbol	Terminal name	Terminal function description*2	Rating*1
S1	Safety stop input (Channel 1)	For input of safety stop channel 1 Between S1 and SIC OFF: In safety stop mode ON: Other than the safety stop mode	Input resistance: 4.7 kΩ Input current : 4 to 6 mADC (In case of 24 VDC input)
S2	Safety stop input (Channel 2)	For input of safety stop channel 2 Between S2 and SIC OFF: In safety stop mode ON: Other than the safety stop mode	
SIC	Common terminal	Common terminal for terminal S1 and terminal S2	
SO	Open collector output common	For output for failure detection and alarm (Open collector output) Between SO and SOC OFF: Failure or alarm detected ON: No failure detected Note: Terminal SO cannot be used for safety signals in a safety system. Use terminal SO to output a fault and to prevent restarting of the inverter.	Load: 24 VDC/0.1 A max. Voltage drop: 3.4 V max. (In case of 'ON' state)
SOC	Safety monitor output terminal common	Common terminal for terminal SO	

*1 Specifications for conforming to safety standards.

*2 ON: The transistor is conducted. OFF: The transistor is not conducted.

Table 3 Truth table of safety related signals

Input power	Internal safety circuit status	Input terminal*1, *2		Output terminal	Output signal *8, *9	Inverter running status	Operation panel indication	
		S1	S2	SO	SAFE		E.SAF*6	SA*7
OFF	—	—	—	OFF	OFF	Output shutoff (Safe state)	Not displayed	Not displayed
ON	Normal	ON	ON	ON*3	OFF	Drive enabled	Not displayed	Not displayed
	Normal	ON	OFF	OFF*4	OFF*4	Output shutoff (Safe state)	Displayed	Displayed
	Normal	OFF	ON	OFF*4	OFF*4	Output shutoff (Safe state)	Displayed	Displayed
	Normal	OFF	OFF	ON*3	ON*3	Output shutoff (Safe state)	Not displayed	Displayed
	Fault	ON	ON	OFF	OFF	Output shutoff (Safe state)	Displayed	Not displayed*5
	Fault	ON	OFF	OFF	OFF	Output shutoff (Safe state)	Displayed	Displayed
	Fault	OFF	ON	OFF	OFF	Output shutoff (Safe state)	Displayed	Displayed
	Fault	OFF	OFF	OFF	OFF	Output shutoff (Safe state)	Displayed	Displayed

*1 ON: The transistor is conducted. OFF: The transistor is not conducted.

*2 When not using the safety stop function, short across terminals S1 and PC, S2 and PC, and SIC and SD to use the inverter. (In the initial status, terminals S1 and PC, S2 and PC, and SIC and SD are respectively shorted with shorting wires.)

*3 If any of the protective functions shown in the following table is activated, the terminal SO and the SAFE output signal turns OFF.

Error definition	Operation panel indication
Option fault.	E.OPT
Communication option fault	E.OP1 to E.OP3
Parameter storage device fault	E.PE
Retry count excess	E.RET
Parameter storage device fault	E.PE2
Operation panel power supply short circuit/ RS-485 terminals power supply short circuit	E.CTE
24 VDC power fault	E.P24
Safety circuit fault	E.SAF
Overspeed occurrence	E.OS

Error definition	Operation panel indication
Speed deviation excess detection	E.OSD
Signal loss detection	E.ECT
Excessive position fault	E.OD
Brake sequence fault	E.MB1 to E.MB7
Encoder phase fault	E.EP
Magnetic pole position unknown	E.MP
CPU fault	E.CPU
	E.5 to E.7
Internal circuit fault	E.13

*4 If the internal safety circuit is operated normally, the terminal SO and the SAFE output signal remain ON until E.SAF is displayed, and the terminal SO and the SAFE output signal turn OFF when E.SAF is displayed.

*5 SA is displayed when the terminals S1 and S2 are identified as OFF due to the internal safety circuit failure.

*6 If another fault occurs at the same time as E.SAF, the other fault can be displayed.

*7 If another warning occurs at the same time as SA, the other warning can be displayed.

*8 For the SAFE signal, refer to the following table and assign the function using **Pr.190 to Pr.196 (output terminal function selection)**. The ON/OFF state of the output signal is the one for the positive logic. The ON and OFF are reversed for the negative logic.

Output signal	Pr.190 to Pr.196 settings	
	Positive logic	Negative logic
SAFE	80	180

*9 The use of SAFE signal has not been certified for compliance with safety standards.

NOTE

- The response time from safety stop signal input to drive shutoff (safe state) is faster than 8ms.
- Hold the ON or OFF status for 2 ms or longer to input signal to terminal S1 or S2. Signal input shorter than 2 ms is not recognized.

●Wiring and ferrule terminal specifications

Table 4 Wiring and Ferrule terminal specifications

Cable gauge (mm ²)	Ferrule terminal model*1	Crimping tool name*1
0.3 / 0.5	AI 0,5-10WH	CRIMPFOX 6
0.75	AI 0,75-10GY	
1	AI 1-10RD	
1.25 / 1.5	AI1,5-10BK	
0.75 (for two wires)	AI TWIN 2 X 0,75-10GY	

*1 Ferrule terminals and the tool are distributed by Phoenix Contact Co., Ltd.

●Shorting wire

The shorting wire are installed between terminals S1/S2 and PC and between terminals SIC and SD in the initial status as shown in Figure 2.

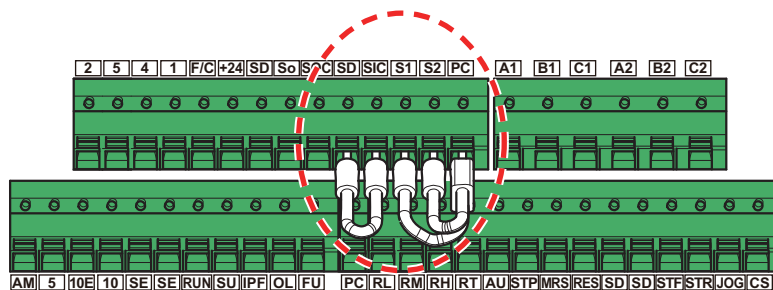
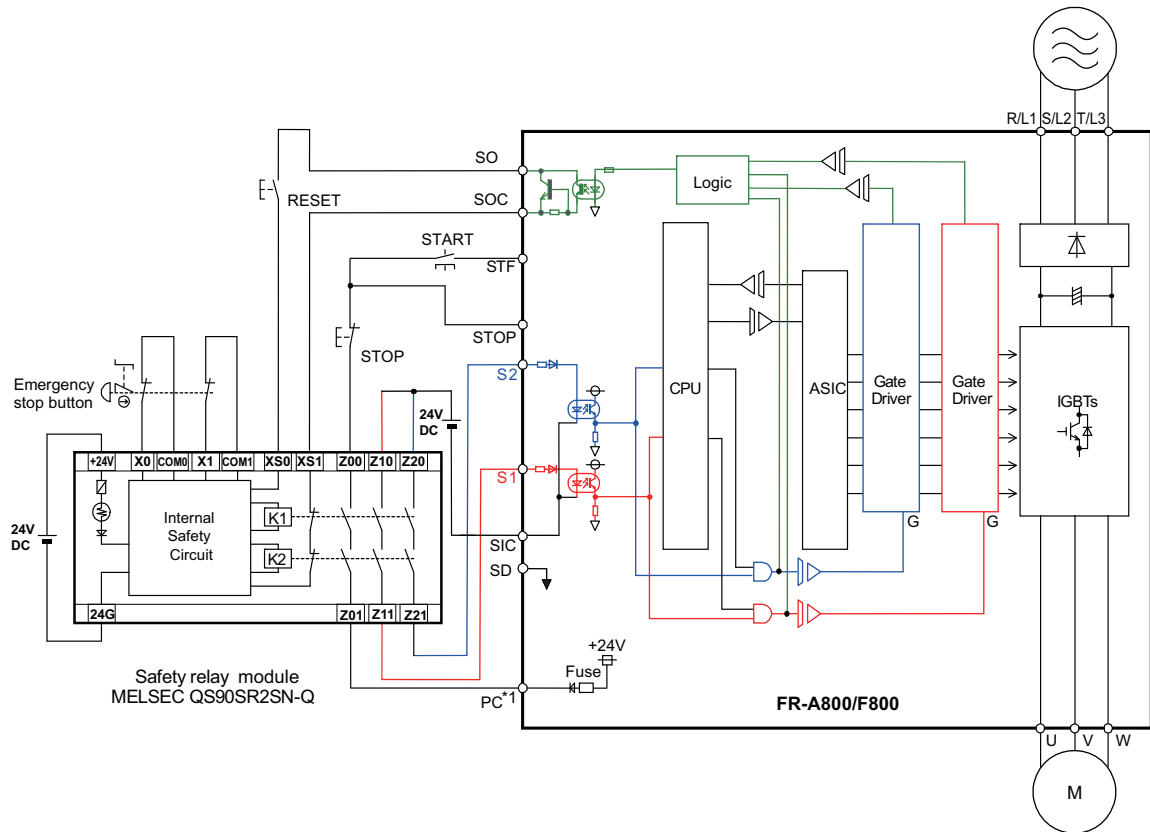

Figure2 Shorting wire

Before connecting the wires for the safety stop function to terminals S1, S2, and SIC, remove the shorting wires.

3 EXAMPLE OF SAFETY SYSTEM CONFIGURATION

•FR-A800/F800 configuration example



*1 If the control logic is the sink logic, the common terminal is terminal SD.

Figure 3 Safety system example of the FR-A800/F800 inverter

NOTE

- When starting up the system operation, press the RESET switch to reset the safety stop function first, then turn ON the START switch to run the motor.
- In the above configuration, after resetting the of emergency stop button, the inverter will be in the safe-state until the RESET switch is pressed.

Caution

- To prevent restart of the inverter when the power is restored after a power failure, 3-wire connection is recommended for the START/STOP control. In case of 2-wire connection and using latching type switch to short between STF and SD/PC for starting, ensure the compliance with safety standards for the restarting when the inverter power is restored after a power failure.

Multiple inverter configuration example

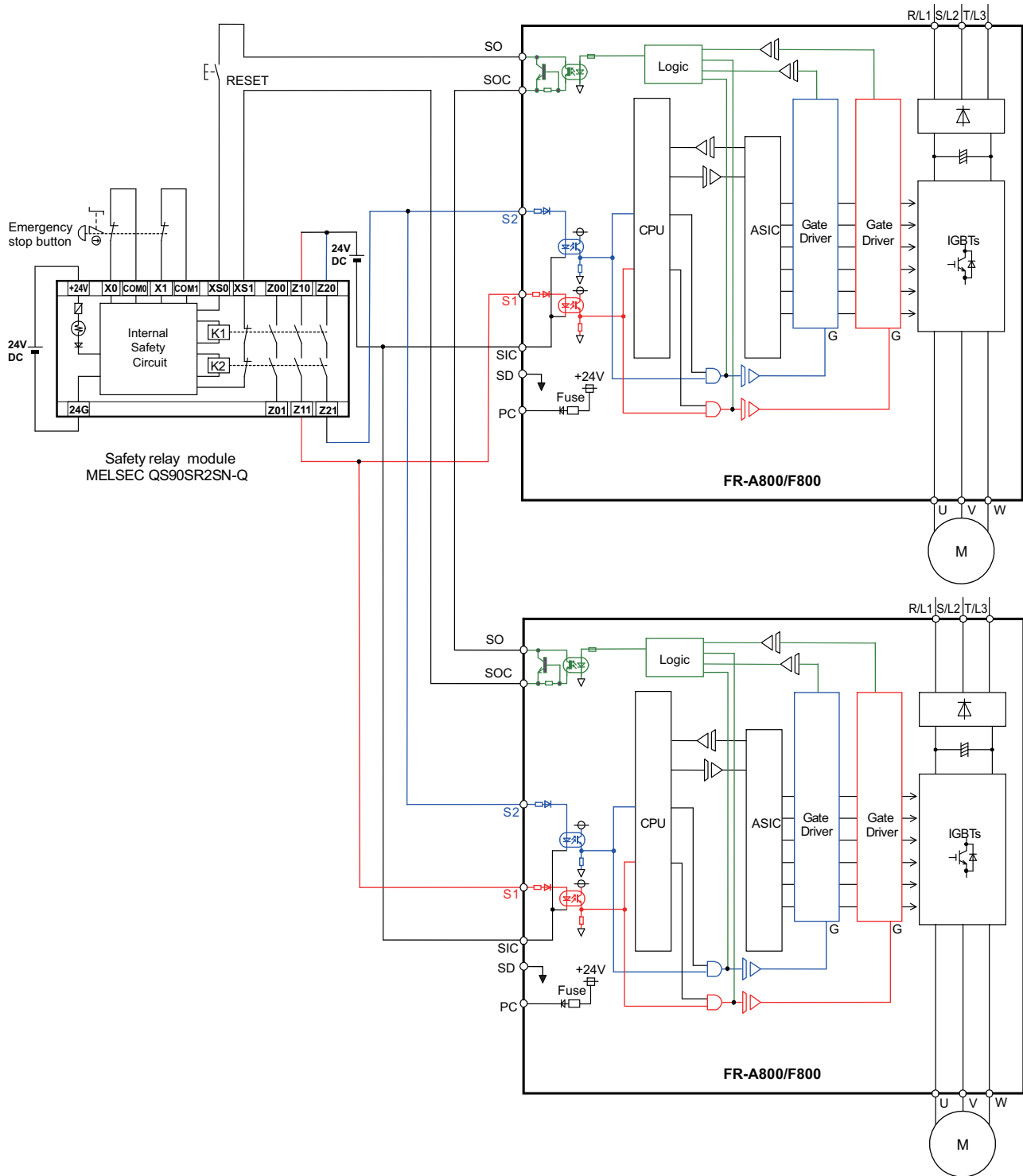

Figure 4 When using multiple safety stop function inverters (FR-A800/F800)

NOTE

- Some models cannot be used together because their control logics are different. Refer to the [Safety Stop Function Manual](#) of each model.

● Safety controller configuration example

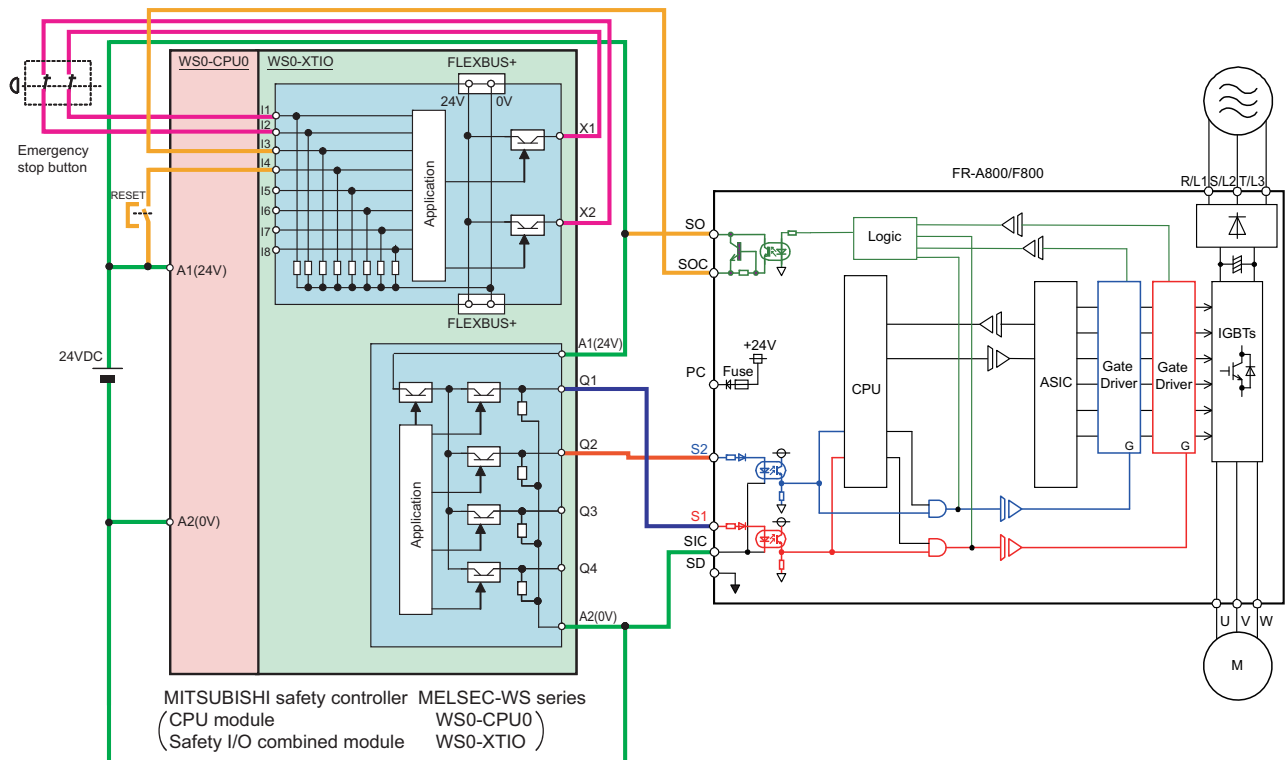

Figure 5 Safety system example of the FR-A800/F800 inverter

NOTE

- When starting up the system operation, press the RESET switch to reset the safety stop function first.
- In the above configuration, after resetting the emergency stop button, the inverter will be in the safe-state until the RESET switch is pressed.

4 TEST AND CHECKING FAILURE

⚠ Caution

- To avoid system faults, check the safety function at system installation, any software changes, parameter setting changes, and at least once per year.

I/O status and inverter operation

The FR-A800/F800 inverter's safety related I/O status obeys the following truth table.

Table 5 Truth table of safety related signals

Input power	Internal safety circuit status	Input terminal*1, *2		Output terminal	Output signal *8, *9	Inverter running status	Operation panel indication	
		S1	S2	SO	SAFE		E.SAF*6	SA*7
OFF	—	—	—	OFF	OFF	Output shutoff (Safe state)	Not displayed	Not displayed
ON	Normal	ON	ON	ON*3	OFF	Drive enabled	Not displayed	Not displayed
	Normal	ON	OFF	OFF*4	OFF*4	Output shutoff (Safe state)	Displayed	Displayed
	Normal	OFF	ON	OFF*4	OFF*4	Output shutoff (Safe state)	Displayed	Displayed
	Normal	OFF	OFF	ON*3	ON*3	Output shutoff (Safe state)	Not displayed	Displayed
	Fault	ON	ON	OFF	OFF	Output shutoff (Safe state)	Displayed	Not displayed*5
	Fault	ON	OFF	OFF	OFF	Output shutoff (Safe state)	Displayed	Displayed
	Fault	OFF	ON	OFF	OFF	Output shutoff (Safe state)	Displayed	Displayed
	Fault	OFF	OFF	OFF	OFF	Output shutoff (Safe state)	Displayed	Displayed

- *1 ON: The transistor is conducted. OFF: The transistor is not conducted.
- *2 When not using the safety stop function, short across terminals S1 and PC, S2 and PC, and SIC and SD to use the inverter. (In the initial status, terminals S1 and PC, S2 and PC, and SIC and SD are respectively shorted with shorting wires.)
- *3 If any of the protective functions shown in the following table is activated, the terminal SO and the SAFE output signal turns OFF.

Error definition	Operation panel indication
Option fault.	E.OPT
Communication option fault	E.OP1 to E.OP3
Parameter storage device fault	E.PE
Retry count excess	E.RET
Parameter storage device fault	E.PE2
Operation panel power supply short circuit/ RS-485 terminals power supply short circuit	E.CTE
24 VDC power fault	E.P24
Safety circuit fault	E.SAF
Overspeed occurrence	E.OS

Error definition	Operation panel indication
Speed deviation excess detection	E.OSD
Signal loss detection	E.ECT
Excessive position fault	E.OD
Brake sequence fault	E.MB1 to E.MB7
Encoder phase fault	E.EP
Magnetic pole position unknown	E.MP
CPU fault	E.CPU
	E.5 to E.7
Internal circuit fault	E.13

- *4 If the internal safety circuit is operated normally, the terminal SO and the SAFE output signal remain ON until E.SAF is displayed, and the terminal SO and the SAFE output signal turn OFF when E.SAF is displayed.
- *5 SA is displayed when the terminals S1 and S2 are identified as OFF due to the internal safety circuit failure.
- *6 If another fault occurs at the same time as E.SAF, the other fault can be displayed.
- *7 If another warning occurs at the same time as SA, the other warning can be displayed.
- *8 For the SAFE signal, refer to the following table and assign the function using **Pr.190 to Pr.196 (output terminal function selection)**. The ON/OFF state of the output signal is the one for the positive logic. The ON and OFF are reversed for the negative logic.

Output signal	Pr.190 to Pr.196 settings	
	Positive logic	Negative logic
SAFE	80	180

- *9 The use of SAFE signal has not been certified for compliance with safety standards.

NOTE

- The response time from safety stop signal input to drive shutoff (safe state) is faster than 8ms.
- Hold the ON or OFF status for 2 ms or longer to input signal to terminal S1 or S2.
Signal input shorter than 2 ms is not recognized.

Diagnostic

If a failure is detected, the FR-A800/F800 inverter outputs a fault signal and 'E.SAF' is indicated at the display. When the FR-A800/F800 inverter outputs a fault signal, take following actions.

- 1) Check that the input signal logic is the same between S1-SIC and S2-SIC. If these are different, correct the input signal and reset the FR-A800/F800 inverter.
- 2) Disconnect the wires from terminals S1, S2, and SIC, then reset or turn OFF and ON the power. If the 'SA' is indicated on the operation panel, there is a failure in the system except for the FR-A800/F800 inverter. When 'E.SAF' is indicated and a fault signal is output, a fault may be occurring in the FR-A800/F800 inverter.

Self diagnostic test

The FR-A800/F800 inverter has the self-diagnostic test function at power-ON.

If the FR-A800/F800 inverter outputs a fault signal (SA, E.SAF) at power-ON, take the action described above.

Operation check procedure

Check the operation of the safety stop function as follows.

- 1) Change and check the I/O state between S1-SIC and S2-SIC shown in Table 5.
- 2) If the inverter operation differs from the one shown in Table 5, the FR-A800/F800 may have a fault.
- 3) If the inverter operates as described in Table 5, check the system performance. Press the emergency switch, press the start/restart button while a failure is detected (SO-SOC opened), and so on.
- 4) Finally clear the faults history of the FR-A800/F800 inverter (see the Instruction Manual for how to clear the faults history).

5 SAFETY PARAMETERS OF FR-A800/F800

The safety parameters of the FR-A800/F800 inverter are depicted as follows.

Table 6 Safety parameters of FR-A800/F800

Parameter	Value
PFD _{AVG}	5.17×10^{-4}
PFH _D	5.90×10^{-9}
PL	d
MTTF _D	660 years
DC _{AVG}	60%

REVISIONS

Print Date	Manual Number	Revision
Apr. 2013	BCN-A23228-001(E)	First edition
Jun. 2013	BCN-A23228-001-A(E)	<p>Modification</p> <ul style="list-style-type: none"> • Multiple inverter configuration example
Jul. 2014	BCN-A23228-001-B(E)	Compatibility with the FR-F800 series
May 2016	BCN-A23228-001-C(E)	<p>Addition</p> <ul style="list-style-type: none"> • SAFE signal (2. INSTALLATION AND WIRING, 4. TEST AND CHECKING FAILURE) <p>Modification</p> <ul style="list-style-type: none"> • 5. SAFETY PARAMETERS OF FR-A800/F800

HEADQUARTERS

MITSUBISHI ELECTRIC EUROPE
EUROPE B.V.
German Branch
Mitsubishi-Electric-Platz 1,
40882 Ratingen, Germany
Phone: +49 (0) 21 02 / 486-0
Hotline: +49(0)2102 - 1037914
Fax: +49 (0) 21 02 / 4 86-1 12 0
e mail: info@mitsubishi-automation.com
(ENG) https://eu3a.mitsubishielectric.com
(GER) https://de3a.mitsubishielectric.com

MITSUBISHI ELECTRIC FRANCE
FRANCE
25, Boulevard des Bouverts
F-92741 Nanterre Cedex
Phone: +33 1 55 68 55 68
Fax: +33 1 49 01 07 25
e mail: factory.automation@fra.mee.com

MITSUBISHI ELECTRIC ITALY
EUROPE B.V.
Italian Branch
C.D. Colleoni-P. Perseo Ing. 2
Via Paracelso 12
I-20041 Agrate Brianza (MI)
Phone: +39 (0) 39 / 60 53 1
Fax: +39 (0) 39 / 60 53 312
e mail: factory.automation@it.mee.com

MITSUBISHI ELECTRIC SPAIN
EUROPE B.V.
Pol. Ind. Can Magi-C.
Calle Joan Buscallá, 2-4 AC 420
E-08190 Sant Cugat del Vallés
Phone: +34 (9) 3 / 565 31 31
Fax: +34 (9) 3 / 589 29 48

MITSUBISHI ELECTRIC UK
EUROPE B.V.
UK Branch
Travellers Lane
Hatfield, Hertfordshire, AL10 8 XB
Phone: +44 (0) 1707 / 27 61 00
Fax: +44 (0) 1707 / 27 86 95

MITSUBISHI ELECTRIC JAPAN
CORPORATION
Tokyo Bldg.
2-7-3 Marunouchi Chiyoda-Ku
Tokyo 100-8310
Phone: +81 (0) 3 / 32 18 31 76
Fax: +81 (0) 3 / 32 18 24 22

MITSUBISHI ELECTRIC USA
AUTOMATION
500 Corporate Woods Parkway
Vernon Hills, Illinois 60061
Phone: +1 (0) 847 / 478 21 00
Fax: +1 (0) 847 / 478 03 27

EUROPEAN REPRESENTATIVES

GEVA AUSTRIA
Wiener Straße 89
A-2500 Baden
Phone: +43 (0) 2252 / 85 55 20
Fax: +43 (0) 2252 / 488 60
e mail: office@geva.co.at

Getronics b.v. BELGIUM
Control Systems
Pontbeeklaan 43
B-1731 Asse-Zellik
Phone: +32 (0) 2 / 4 67 17 51
Fax: +32 (0) 2 / 4 67 17 45
e mail: infoautomation@getronics.com

TELECON CO. BULGARIA
4, A. Ljapchev Blvd.
BG-1756 Sofia
Phone: +359 92 / 97 44 05 8
Fax: +359 92 / 97 44 06 1
e mail: —

AutoCont CZECHIA
Control Systems s.r.o.
Nemocnicni 12
CZ-70200 Ostrava 2
Phone: +420 (0) 69 / 615 21 11
Fax: +420 (0) 69 / 615 21 12
e mail: —

louis poulsen DENMARK
industri & automation
Geminivej 32
DK-2670 Greve
Phone: +45 (0) 43 / 95 95 95
Fax: +45 (0) 43 / 95 95 91
e mail: lpia@lpmail.com

UTU Elektrotehnika AS ESTONIA
Pärnu mnt. 160i
EE-10621 Tallinn
Phone: +372 6 / 51 72 80
Fax: +372 6 / 51 72 88
e mail: utu@utu.ee

URHO TUOMINEN OY FINLAND
Hevoshaankatu 3
FIN-28600 Pori
Phone: +358 (0) 2 / 55 08 00
Fax: +358 (0) 2 / 55 088 41
e mail: —

UTEKO A.B.E.E. GREECE
5, Mavrogenous Str.
GR-18542 Piraeus
Phone: +30 (0) 1 / 42 10 050
Fax: +30 (0) 1 / 42 12 033
e mail: uteco@uteco.gr

EUROPEAN REPRESENTATIVES

MITSUBISHI ELECTRIC IRELAND
EUROPE B.V.-Irish Branch
Westgate Business Park
Ballymount
IRL-Dublin 24
Phone: +353 (0) 1 / 419 88 00
Fax: +353 (0) 1 / 419 88 90
e mail: sales.info@meuk.mee.com

ALFATRADE LTD. MALTA
99 Paola Hill
Paola PLA 08
Phone: +356 / 697816
Fax: +356 / 697817
e mail: paul.licari@alfatrx.com

Getronics bv NETHERLANDS
Control Systems
Donauweg 10
NL-1043 AJ-Amsterdam
Phone: +31 (0) 20 / 586 15 92
Fax: +31 (0) 20 / 586 19 27
e mail: infoautomation@getronics.com

Beijer Electronics AS NORWAY
Teglverksveien 1
N-3002 Drammen
Phone: +47 (0) 32 / 24 30 00
Fax: +47 (0) 32 / 84 85 77
e mail: —

MPL Technology SP.Z.o.o POLAND
ul.Wroclawska 53
PL-30-011 Kraków
Phone: +48 (0) 12 / 632 28 85
Fax: +48 (0) 12 / 632 47 82
e mail: krakow@mpl.com.pl

Sirius Trading&Services srl ROMANIA
Bd. Ghica nr. 112, Bl. 41
RO-72335 Bucuresti 2
Phone: +40 (0) 1 / 210 55 11
Fax: +40 (0) 1 / 210 55 11
e mail: sirius_t_s@fx.ro

ACP AUTOCOMP a.s. SLOVAKIA
Chalupkova 7
SK-81109 Bratislava
Phone: +421 (0) 7 592 22 54
Fax: +421 (0) 7 592 22 48
e mail: —

INEA d.o.o. SLOVENIA
Ljubljanska 80
SI-1230 Domžale
Phone: +386 (0) 17 21 80 00
Fax: +386 (0) 17 24 16 72
e mail: inea@inea.si

EUROPEAN REPRESENTATIVES

Beijer Electronics AB SWEDEN
Box 426
S-20123 Malmö
Phone: +46 (0) 40 / 35 86 00
Fax: +46 (0) 40 / 93 23 02
e mail: —

ECONOTEC AG SWITZERLAND
Postfach 282
CH-8309 Nürensdorf
Phone: +41 (0) 1 / 838 48 11
Fax: +41 (0) 1 / 838 48 12
e mail: —

GTS TURKEY
Darülaceze Cad. No. 43A KAT: 2
TR-80270 Okmeydani-Istanbul
Phone: +90 (0) 212 / 320 1640
Fax: +90 (0) 212 / 320 1649
e mail: —

EURASIAN REPRESENTATIVES

MITSUBISHI ELECTRIC RUSSIA
EUROPE B.V.
12/1 Goncharnaya St, suite 3C
RUS-109240 Moscow
Phone: +7 (0) 95 / 915-8624/02
Fax: +7 (0) 95 / 915-8603
e mail: —

STC Drive Technique RUSSIA
Poslannikov per., 9, str. 1
RUS-107005 Moscow
Phone: +7 (0) 95 / 786 21 00
Fax: +7 (0) 95 / 786 21 01
e mail: —

JV-CSC Automation UKRAINE
15, M. Raskovoyi St., Floor 10,
Office 1010
U-02002 Kiev
Phone: +380 (4) 4 / 238 83 16
Fax: +380 (4) 4 / 238 83 17
e-Mail: mkl@csc-a.kiev.ua

MIDDLE EAST REPRESENTATIVE

SHERF Motion Techn. LTD ISRAEL
Rehov Hamerkava 19
IL-58851 Holon
Phone: +972 (0) 3 / 559 54 62
Fax: +972 (0) 3 / 556 01 82
e mail: —

MITSUBISHI ELECTRIC CORPORATION

HEAD OFFICE: TOKYO BUILDING 2-7-3, MARUNOUCHI, CHIYODA-KU, TOKYO 100-8310, JAPAN