

# **INVERTER A800 Plus**

## **FR-A800-LC (LIQUID COOLED TYPE) Safety Stop Function Instruction Manual**

---

### **CONTENTS**

<b>1. GENERAL DESCRIPTION .....</b>	<b>2</b>
<b>2. INSTALLATION AND WIRING.....</b>	<b>4</b>
<b>3. EXAMPLE OF SAFETY SYSTEM CONFIGURATION ....</b>	<b>8</b>
<b>4. TEST AND CHECKING FAILURE .....</b>	<b>13</b>
<b>5. SAFETY PARAMETERS OF FR-A800-LC.....</b>	<b>14</b>

---

## **Compliance with the EU Machinery Directive – Functional Safety**

To achieve functional safety, any work on the product such as wiring and inspections must be performed according to the Instruction Manual by technicians who took a safety standard training.

### **Warning**

- Any misuse of safety function could lead to personal injury or death, property damage, or economic loss. To ensure that the system complies fully with requirement of safety, make a system-level risk assessment. Mitsubishi Electric Corporation. cannot assume responsibility for any system to comply with safety standards.
- To avoid an electric shock hazard, verify that the voltage on the bus capacitors has discharged before performing any work on the inverter. Measure the DC bus voltage between the terminals P(+) and N(-) or at test points (refer to your inverter's Instruction Manual for locations and discharging time). The voltage must be zero.
- The safety stop function do not isolate electrically between the inverter and the motor. To avoid an electric shock hazard, disconnect/isolate power to the inverter and verify to ensure that the voltage is zero before performing any work on the motor (refer to your inverter's Instruction Manual for discharging time).

### **Caution**

- The information of this manual is merely a guide for proper installation.
- Mitsubishi Electric Corporation. cannot assume responsibility for the compliance or the noncompliance to any code, national, local, or otherwise for the proper installation of this equipment.
- A hazard of personal injury and/or equipment damage exists if codes are ignored during installation.

# 1 GENERAL DESCRIPTION

## Features

The safety stop function of the Mitsubishi Electric FR-A800-LC inverter can be used to prevent the inverter from supplying rotational energy to motors. (In this Instruction Manual, the STO (safe torque off) function specified in IEC 61800-5-2 is referred to as the safety stop function.)

Dual input terminals S1 and S2 can be used to cut off the gate-drive power to the IGBT.

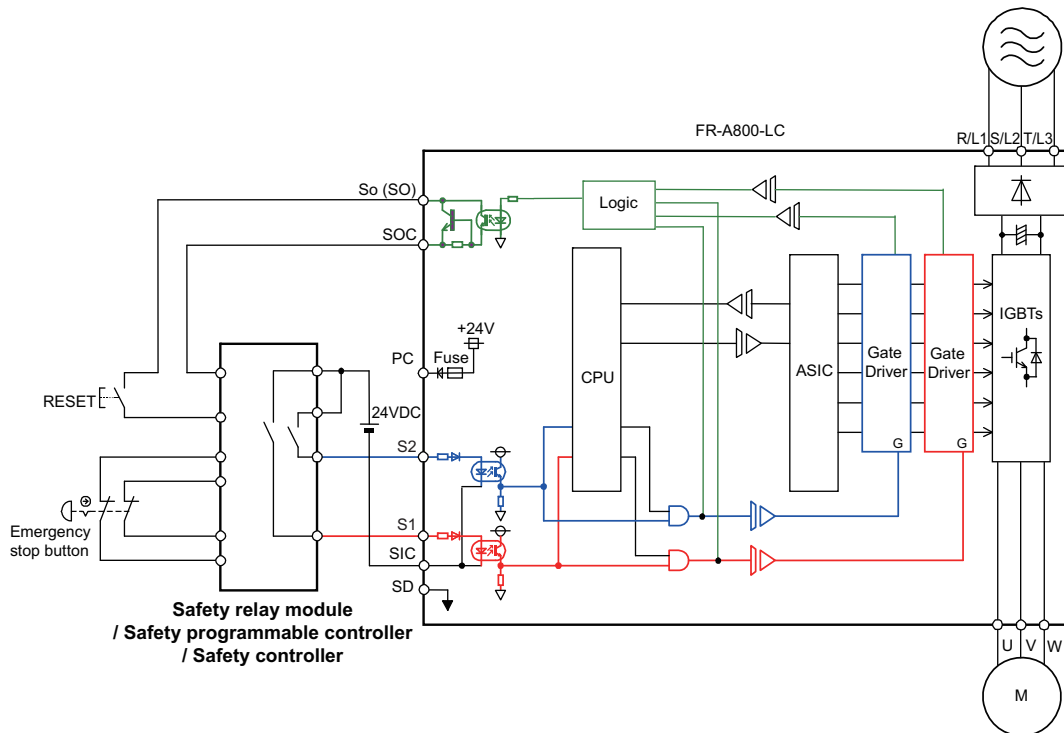

Figure 1 FR-A800-LC safety stop function diagram

## Warning

- **Disconnecting the power to the gate driver by the safety stop function does not isolate electrically between the inverter and the motor. To avoid an electric shock hazard, disconnect power to the inverter and verify that the main circuit capacitor voltage is zero (across terminals P and N) before performing any work on the motor (refer to your inverter's Instruction Manual for discharging time).**

## Standards

The safety stop function of the Mitsubishi FR-A800-LC inverter meets the following standards and categories.

- FR-A840-LC
  - Safety Integrity Level (SIL) 2
    - ISO13849-1:2015 Category 3/PLd
    - IEC62061:2021 / IEC61800-5-2:2016 / IEC61508:2010 SIL2
    - IEC61800-5-2:2016 Stop category 0
- FR-A870-LC
  - Safety Integrity Level (SIL) 2
    - ISO13849-1:2015 Category 3/PLd
    - IEC62061:2021 / IEC61800-5-2:2016 / IEC61508:2010 SIL2
    - IEC61800-5-2:2016 Stop category 0
  - Safety Integrity Level (SIL) 3
    - ISO13849-1:2015 Category 3/PLe
    - IEC62061:2021 / IEC61800-5-2:2016 / IEC61508:2010 SIL3
    - IEC61800-5-2:2016 Stop category 0

### ◆ Safety stop function with SIL 3 certification

The Mitsubishi Electric FR-A870-LC inverters now comply with safety integrity level 3 (SIL 3) of the IEC EC61508:2010 functional safety standard.

- Target models  
Mitsubishi Electric FR-A870-LC inverters

- Change of the compliance  
The Mitsubishi Electric FR-A870-LC inverters now comply with SIL 3.

**Table 1 Compliance with SIL 3**

	Before change	After change
Safety performance (Standards)	ISO13849-1:2008 Category 3/PLd IEC62061:2005 / IEC61800-5-2:2007 / IEC61508 SIL2 IEC61800-5-2:2007 Stop category 0	ISO13849-1:2015 Category 3/PLe IEC62061:2021 / IEC61800-5-2:2016 / IEC61508:2010 SIL3 IEC61800-5-2:2016 Stop category 0

- Schedule  
Check the SERIAL number indicated on the inverter rating plate or package.  
For the products, this change has been made sequentially from the June 2018 production.

### ◆ Safety stop function with SIL 2 certification

The Mitsubishi Electric FR-A840-LC inverters now comply with safety integrity level 2 (SIL 2) of the IEC EC61508:2010 functional safety standard.

- Target models  
Mitsubishi Electric FR-A840-LC inverters

- Change of the compliance  
The Mitsubishi Electric FR-A840-LC inverters now comply with SIL 3.

**Table 2 Compliance with SIL 2**

Safety performance (Standards)	Safety Integrity Level (SIL) 2 ISO13849-1:2015 Category 3/PLd IEC62061:2021 / IEC61800-5-2:2016 / IEC61508:2010 SIL2 IEC61800-5-2:2016 Stop category 0
--------------------------------	---

- Schedule  
Check the SERIAL number indicated on the inverter rating plate or package.  
For the products, this change has been made sequentially from the June 2018 production.

### ◆ Rating plate example

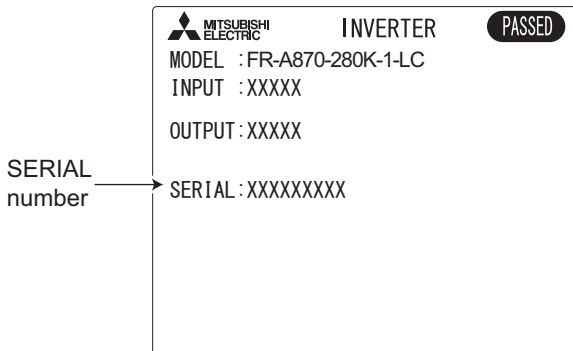

□
○
○
○○○○○○  
 Symbol    Year    Month    Control number  

---

 SERIAL

The SERIAL consists of one symbol, two characters indicating the production year and month, and six characters indicating the control number. The last digit of the production year is indicated as the Year, and the Month is indicated by 1 to 9, X (October), Y (November), or Z (December).

## ! Warning

- **The misuse of safety function leads to personal injury or death, property damage, or economic loss. To ensure that the system complies fully with requirement of safety, make a system-level risk assessment. Mitsubishi Electric Corporation. cannot assume responsibility for any system to comply with safety standards.**

# 2 INSTALLATION AND WIRING

## ⚠ Caution

- The following information is merely a guide for proper installation. Mitsubishi Electric Corporation. cannot assume responsibility for the compliance or the noncompliance to any code, national, local, or otherwise for the proper installation of this equipment. A hazard of personal injury and/or equipment damage exists if codes are ignored during installation.
- Ensure the safety relay unit/ Safety programmable controller/ Safety controller and the FR-A800-LC inverter are mounted closely in an enclosure meeting IP54 and all interconnection wiring is short and protected against open and short circuit faults. Refer ISO/IEC13849-2.

### Installation

The safety stop function of the Mitsubishi Electric FR-A800-LC inverter should be used under the following conditions and environment.

**Table 3 Conditions and environment for using the safety stop function**

Item		Condition	
Surrounding airtemperature	ND/ LD*1	-10°C to +50°C (non-freezing)*3	
	SLD*2	-10°C to +40°C (non-freezing)*3	
Storage temperature		-20°C to +65°C*4	
Ambient humidity		With circuit board coating (conforming to IEC60721-3-3:1994 3C2/3S2): 95% RH or less (non-condensing), Without circuit board coating: 90% RH or less (non-condensing)	
Coolant	Coolant temperature	1 to +40°C (non-freezing)	
	Coolant flow rate	FR-A840-03250(110K)-LC FR-A840-03610(132K)-LC	3.0 to 3.7 L/min*5
		FR-A840-04320(160K) to FR-A840-06830(280K)-LC FR-A870-03950(280K)-LC FR-A870-04560(355K)-LC	6.0 to 7.5 L/min*6
	Maximum permissible pressure		300 kPa
Vibration	FR-A840-03250(110K)-LC FR-A840-03610(132K)-LC	5.9 m/s <sup>2</sup> or less at 10 to 55 Hz (directions of X, Y, Z axes)	
	FR-A840-04320(160K) to FR-A840-06830(280K)-LC FR-A870-03950(280K)-LC FR-A870-04560(355K)-LC	2.9 m/s <sup>2</sup> or less at 10 to 55 Hz (directions of X, Y, Z axes)	
Altitude		Maximum 2000 m *7	
Atmosphere		Indoors (free from corrosive gas, flammable gas, oil mist, dust and dirt)	
Overvoltage category		III or lower	
Pollution degree		II or lower	
Mounting		Wall mounting / vertical orientation	

\*1 The LD ratings can be selected only for the FR-A840-LC inverter.

\*2 The SLD ratings can be selected only for the FR-A870-LC inverter.

\*3 Condensation may occur depending on the humidity and the coolant temperature. Adjust the humidity and the coolant temperature to prevent condensation.

\*4 Temperature applicable for a short time, e.g. in transit.

To store the inverter after the coolant has passed through the pipes, fill the pipes with coolant sufficiently enough, that it contains antifreezing agent to prevent corrosion. Or fill the pipes with nitrogen gas after the inside of the pipes is fully dried. If any moisture remains inside the pipes, it may react with oxygen in the air to form corrosion.

\*5 Under normal condition, keep the flow rate between 3.2 and 3.5 L/m.

\*6 Under normal condition, keep the flow rate between 6.5 and 7.0 L/m.

\*7 For the installation at an altitude above 1,000 m, derate the rated current 3% per 500 m.

## ⚠ Warning

- To avoid an electric shock hazard, insert the magnetic contactor (MC) between power source and inverter.
- Open the contact of MC and keep away from the inverter for discharging time (refer to your inverter's Instruction Manual for information) before performing any work on the inverter. And verify that the voltage on the bus capacitors has discharged before measuring the DC bus voltage between the terminals P(+) and N(-) or at test points (refer to your inverter's Instruction Manual for locations). The voltage must be zero.

## ⚠ Caution

- In order to meet safety standards, a safety relay module/ Safety programmable controller/ Safety controller compliant with ISO13849-1 safety category 3 or higher shall be used in conjunction with the FR-A800-LC inverter (refer to [page 12](#)). In addition, all other components in the safety stop loop shall be 'safety approved' types.
- To avoid system faults, check the safety stop function at least once per year. To comply with SIL 3, the safety stop function must be checked at least once in three months. Also, check the safety stop function at system installation, any software changes, and parameter setting changes. For details, refer to [Chapter 4 TEST AND CHECKING FAILURE](#).

### ●Wiring

The safety related terminals are described in Table 4 and Table 5.

Table 4 Safety related terminals

Terminal symbol	Terminal name	Terminal function description*2	Rating*1
S1	Safety stop input (Channel 1)	For input of safety stop channel 1 Between S1 and SIC OFF: In safety stop mode ON: Other than the safety stop mode	Input resistance: 4.7 kΩ Input current : 4 to 6 mADC (In case of 24 VDC input)
S2	Safety stop input (Channel 2)	For input of safety stop channel 2 Between S2 and SIC OFF: In safety stop mode ON: Other than the safety stop mode	
SIC	Common terminal	Common terminal for terminal S1 and terminal S2	
So (SO)	Open collector output common	For output for failure detection and alarm (Open collector output) Between So (SO) and SOC OFF: Failure or alarm detected ON: No failure detected  <b>Note:</b> Terminal So (SO) cannot be used for safety signals in a safety system. Use terminal So (SO) to output a fault and to prevent restarting of the inverter.	Load: 24 VDC / 0.1 A max. Voltage drop: 3.4 V max. (In case of 'ON' state)
SOC	Safety monitor output terminal common	Common terminal for terminal So (SO)	

\*1 Specifications for conforming to safety standards.

\*2 ON: The transistor is conducted. OFF: The transistor is not conducted.

**Table 5 Truth table of safety related signals**

Input power	Internal safety circuit status	Input terminal*1, *2		Output terminal	Output signal *8, *9, *10	Inverter running status	Operation panel indication	
		S1	S2	So (SO)	SAFE		E.SAF*6	SA*7
OFF	—	—	—	OFF	OFF	Output shutoff (Safe state)	Not displayed	Not displayed
ON	Normal	ON	ON	ON*3	OFF	Drive enabled	Not displayed	Not displayed
	Normal	ON	OFF	OFF*4	OFF*4	Output shutoff (Safe state)	Displayed	Displayed
	Normal	OFF	ON	OFF*4	OFF*4	Output shutoff (Safe state)	Displayed	Displayed
	Normal	OFF	OFF	ON*3	ON*3	Output shutoff (Safe state)	Not displayed	Displayed
	Fault	ON	ON	OFF	OFF	Output shutoff (Safe state)	Displayed	Not displayed*5
	Fault	ON	OFF	OFF	OFF	Output shutoff (Safe state)	Displayed	Displayed
	Fault	OFF	ON	OFF	OFF	Output shutoff (Safe state)	Displayed	Displayed
	Fault	OFF	OFF	OFF	OFF	Output shutoff (Safe state)	Displayed	Displayed

- \*1 ON: The transistor is conducted. OFF: The transistor is not conducted.
- \*2 When not using the safety stop function, short across terminals S1 and PC, S2 and PC, and SIC and SD to use the inverter. (In the initial status, terminals S1 and PC, S2 and PC, and SIC and SD are respectively shorted with shorting wires.)
- \*3 If any of the faults shown in the following table occurs, terminal So (SO) and the SAFE signal turn OFF.

Fault	Operation panel indication	Fault	Operation panel indication
Option fault	E.OPT	Overspeed occurrence	E.OS
Communication option fault	E.OP1 to E.OP3	Speed deviation excess detection	E.OSD
Internal storage device fault	E.PE6	Signal loss detection	E.ECT
Parameter storage device fault	E.PE	Excessive position fault	E.OD
Retry count excess	E.RET	Encoder signal loss for orientation	E.ECA
Parameter storage device fault	E.PE2	Brake sequence fault	E.MB1 to E.MB7
Operation panel power supply short circuit/ RS-485 terminals power supply short circuit	E.CTE	Encoder phase fault	E.EP
24 VDC power fault	E.P24	CPU fault	E.CPU
Safety circuit fault	E.SAF		E.5 to E.7
		Internal circuit fault	E.13

- \*4 When the internal safety circuit is operated normally, the terminal So (SO) and the SAFE signal remain ON until E.SAF is displayed, and the terminal So (SO) and the SAFE signal turn OFF when E.SAF is displayed.
- \*5 SA is displayed when the terminals S1 and S2 are identified as OFF due to the internal safety circuit failure.
- \*6 If another fault occurs at the same time as E.SAF, the other fault can be displayed.
- \*7 If another warning occurs at the same time as SA, the other warning can be displayed.
- \*8 The ON/OFF state of the output signal is the one for the positive logic. The ON and OFF are reversed for the negative logic.
- \*9 For the SAFE signal, refer to the following table and assign the function using **Pr.190 to Pr.196 (output terminal function selection)**.

Output signal	Pr.190 to Pr.196 settings	
	Positive logic	Negative logic
SAFE	80	180

- \*10 The use of SAFE signal has not been certified for compliance with safety standards.

**NOTE**

- The response time from safety stop signal input to drive shutoff (safe state) is faster than 8ms.
- Hold the ON or OFF status for 2 ms or longer to input signal to terminal S1 or S2. Signal input shorter than 2 ms is not recognized.

●Wiring and ferrule terminal specifications

Table 6 Wiring and Ferrule terminal specifications

Cable gauge (mm <sup>2</sup> )	Ferrule terminal model*1	Crimping tool name*1
0.3	AI 0,34-10TQ	CRIMPFOX 6
0.5	AI 0,5-10WH	
0.75	AI 0,75-10GY	
1	AI 1-10RD	
1.25 / 1.5	AI1,5-10BK	
0.75 (for two wires)	AI TWIN 2 X 0,75-10GY	

\*1 Ferrule terminals and the tool are distributed by Phoenix Contact Co., Ltd.

●Shorting wire

The shorting wire are installed between terminals S1/S2 and PC and between terminals SIC and SD in the initial status as shown in Figure 2.

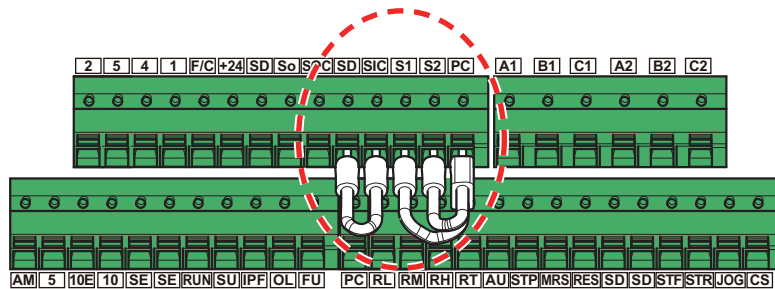

Figure 2 Shorting wire

Before connecting the wires for the safety stop function to terminals S1, S2, and SIC, remove the shorting wires.



# 3 EXAMPLE OF SAFETY SYSTEM CONFIGURATION

•FR-A800-LC configuration example(Using Safety relay module)

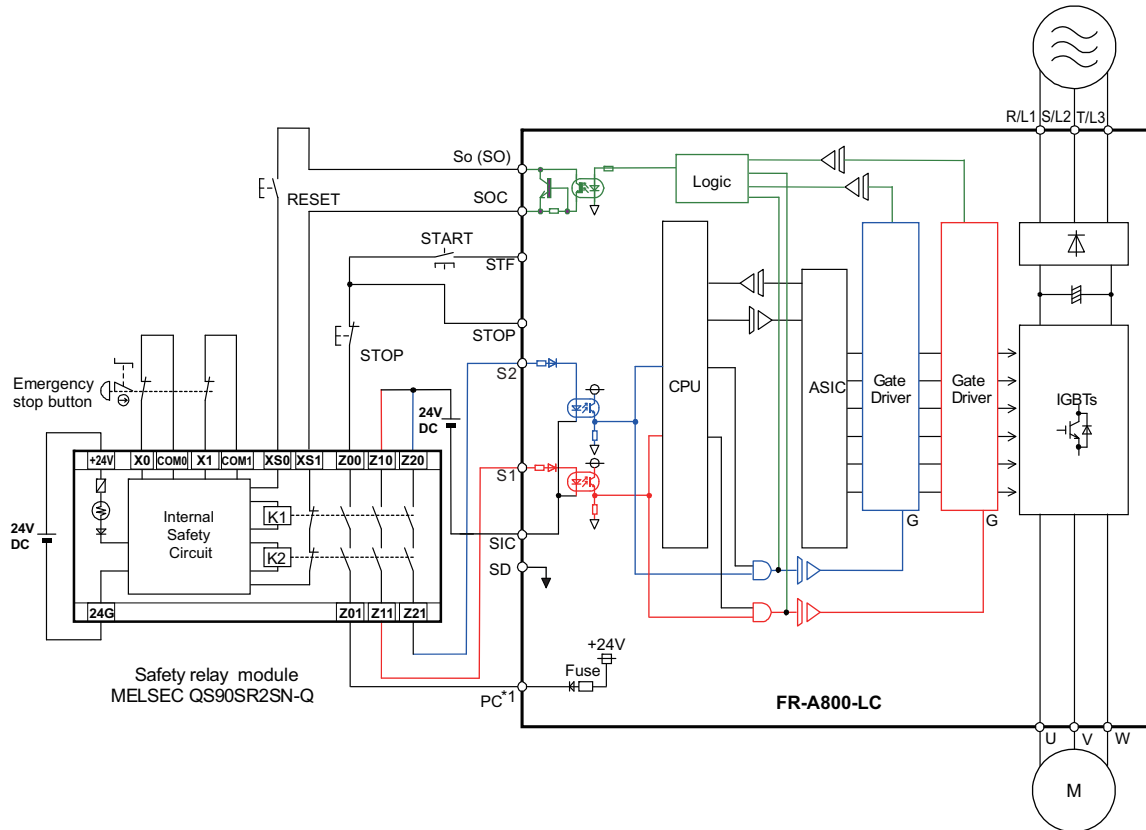

\*1 When the control logic is the sink logic, the common terminal is terminal SD.

**Figure 3 Safety system example of the FR-A800-LC inverter**

●FR-A800-LC configuration example(Using Programmable Controller Remote I/O Module)

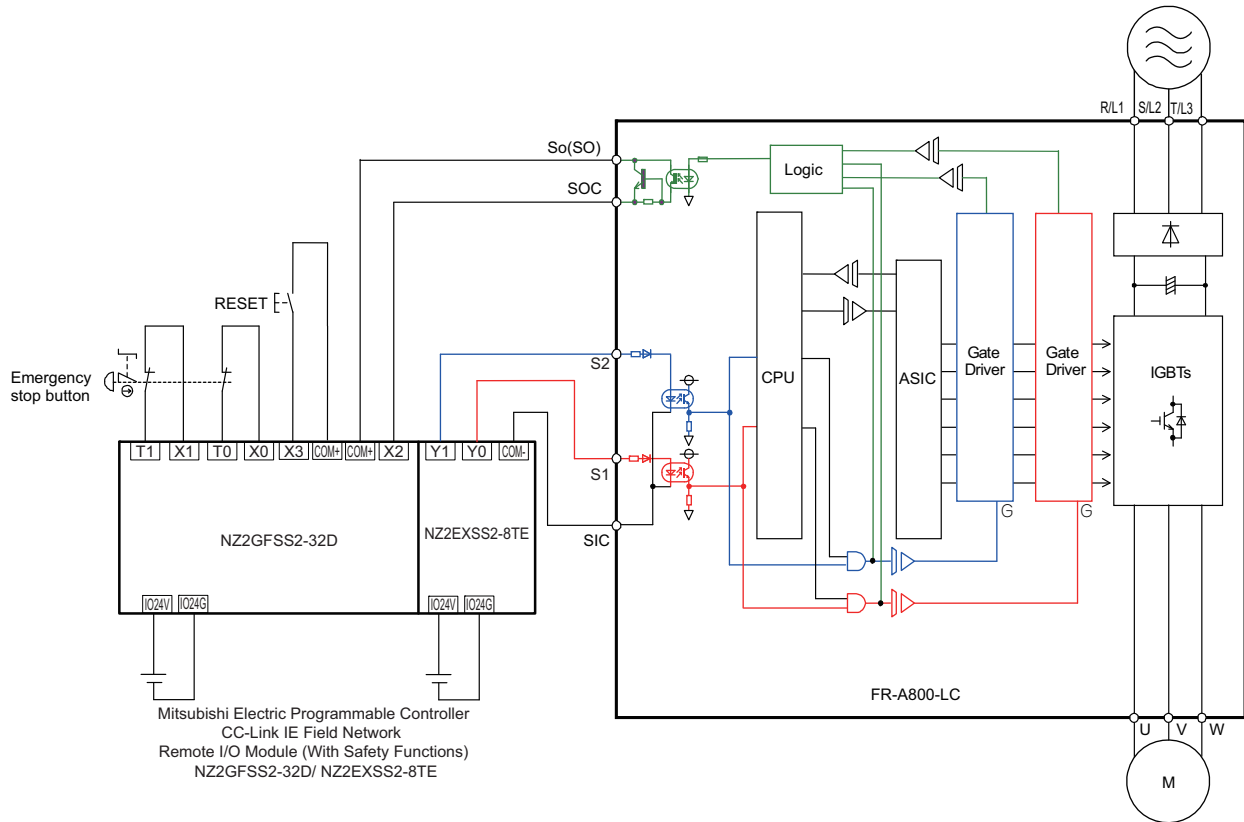

Figure 4 Safety system example of the FR-A800-LC inverter

**NOTE**

- When starting up the system operation, press the RESET switch to reset the safety stop function first, then turn ON the START switch to run the motor.
- In the above configuration, after resetting the of emergency stop button, the inverter will be in the safe-state until the RESET switch is pressed.

**Caution**

- To prevent restart of the inverter when the power is restored after a power failure, 3-wire connection is recommended for the START/STOP control. In case of 2-wire connection and using latching type switch to short between STF and SD/PC for starting, ensure the compliance with safety standards for the restarting when the inverter power is restored after a power failure.

● Multiple inverter configuration example(Using Safety relay module)

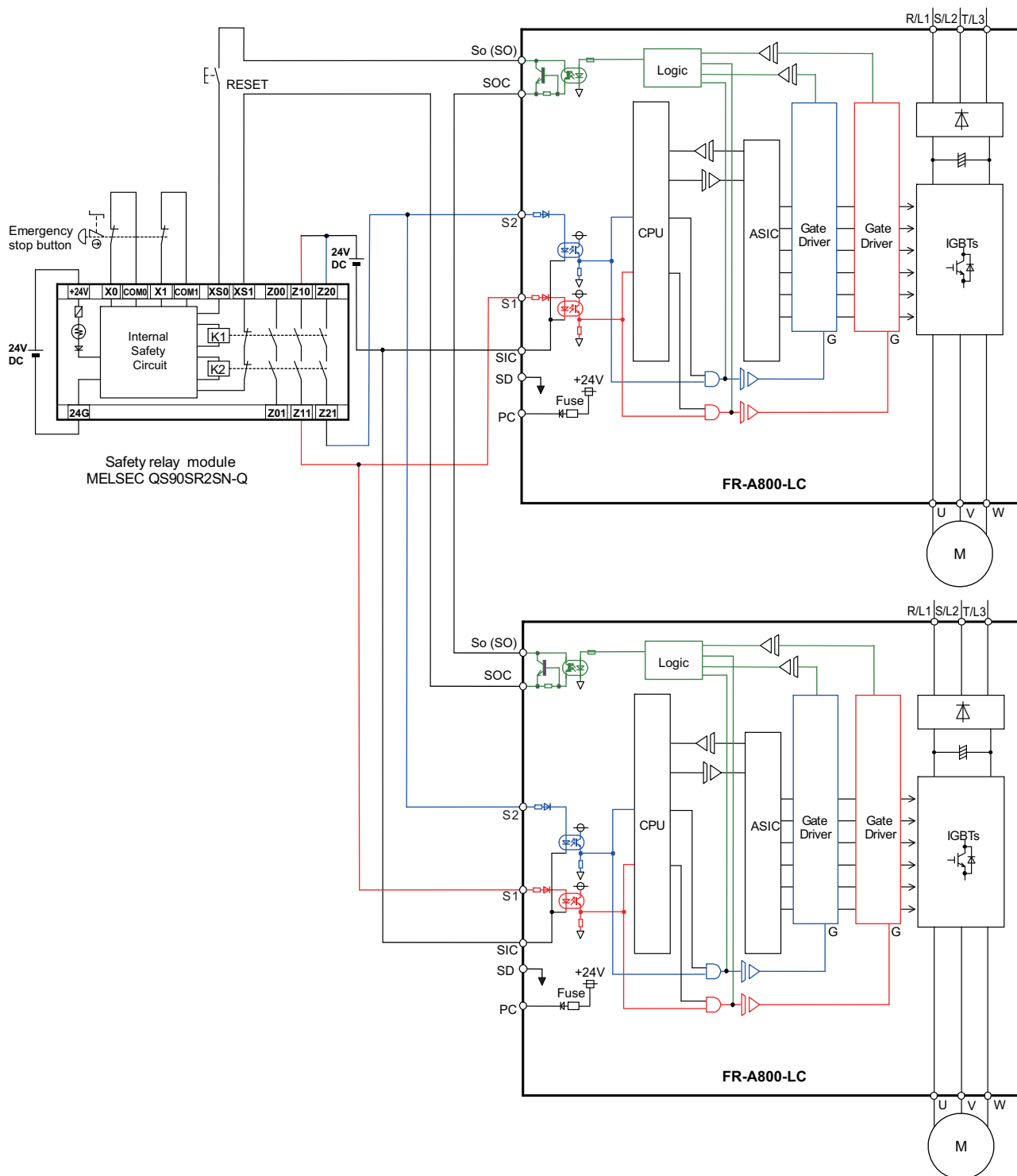

Figure 5 When using multiple safety stop function inverters (FR-A800-LC)

**NOTE**

- Some models cannot be used together because their control logics are different. Refer to the SAFETY STOP FUNCTION MANUAL of each model.

●Multiple inverter configuration example(Using Programmable Controller Remote I/O Module)

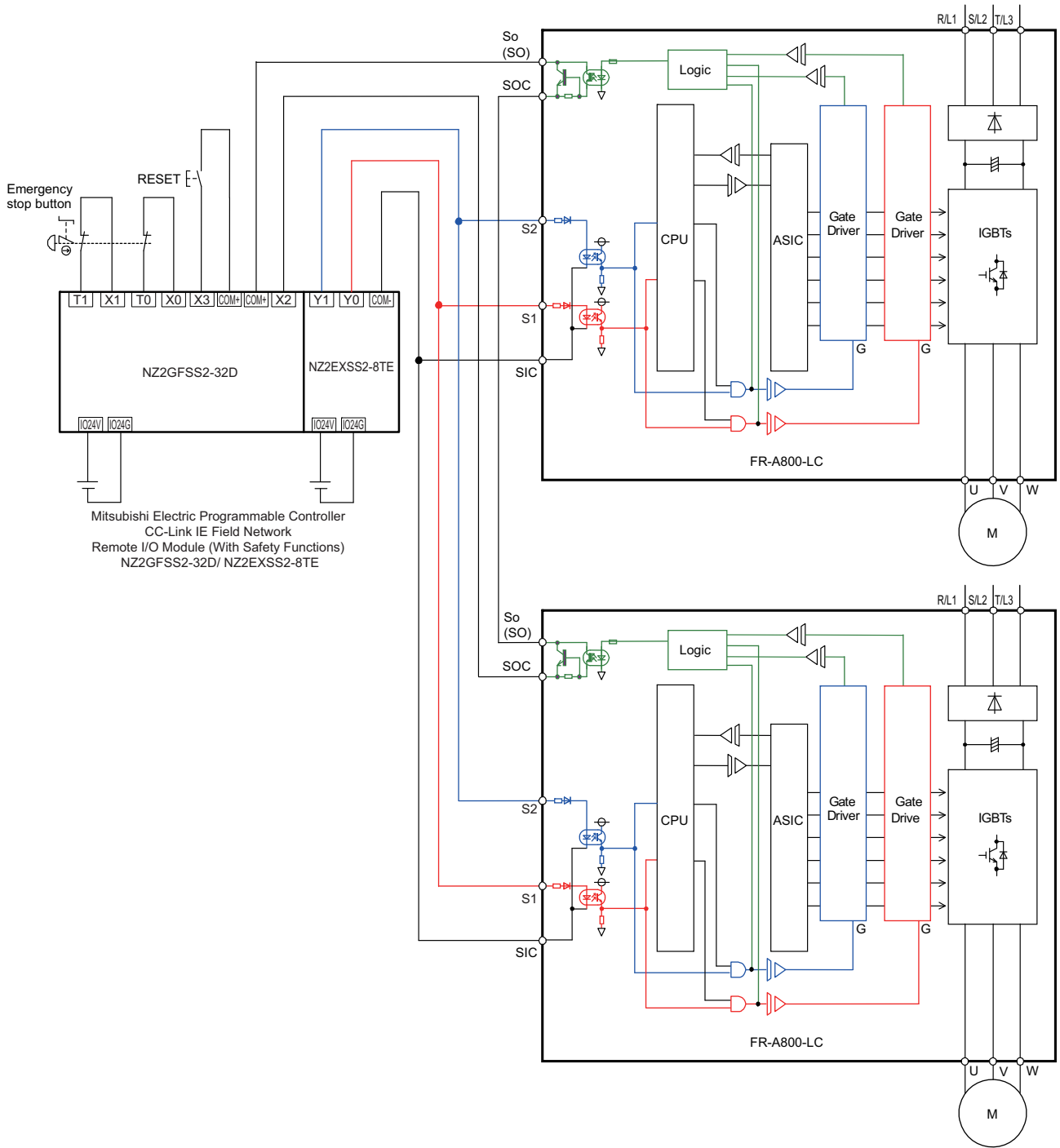

Figure 6 When using multiple safety stop function inverters (FR-A800-LC)

**NOTE**

- Some models cannot be used together because their control logics are different. Refer to the SAFETY STOP FUNCTION MANUAL of each model.

## • Safety controller configuration example

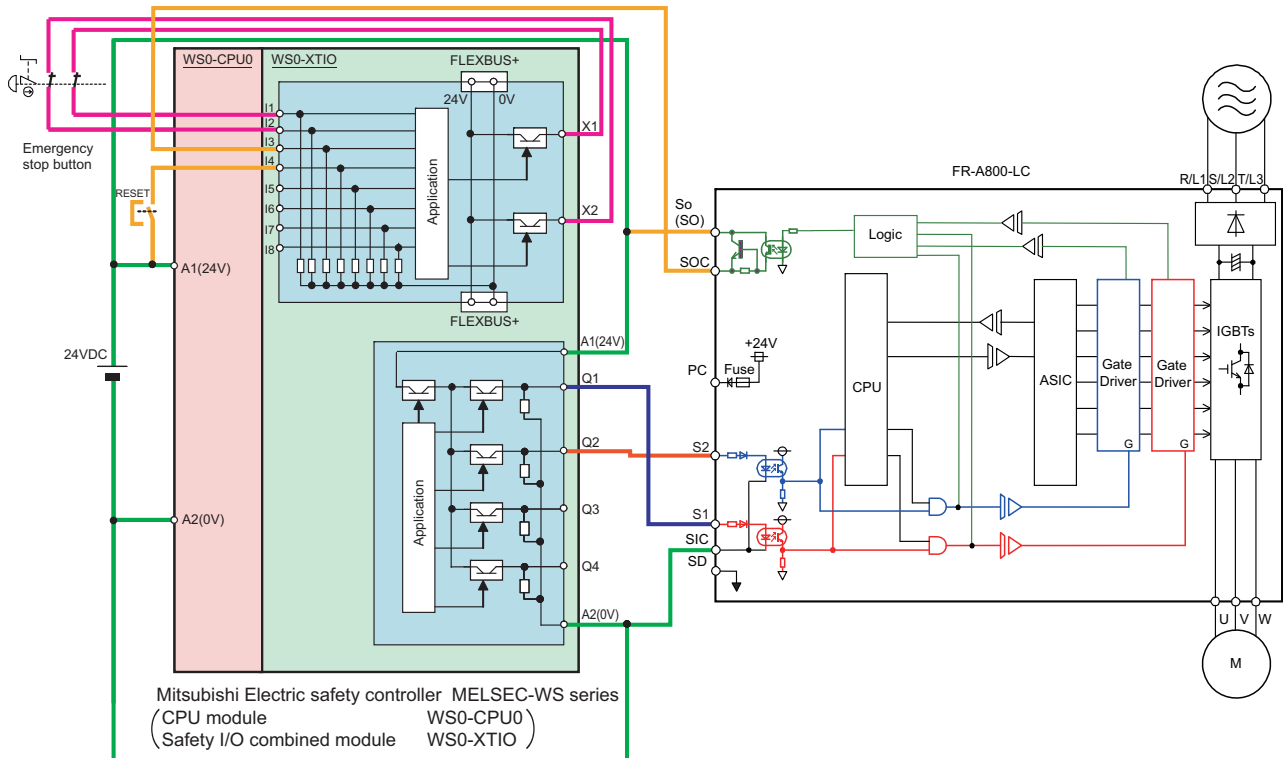

Figure 7 Safety system example of the FR-A800-LC inverter

### NOTE

- When starting up the system operation, press the RESET switch to reset the safety stop function first.
- In the above configuration, after resetting the emergency stop button, the inverter will be in the safe-state until the RESET switch is pressed.

# 4 TEST AND CHECKING FAILURE

## ⚠ Caution

- To avoid system faults, check the safety stop function at least once per year. To comply with SIL 3, the safety stop function must be checked at least once in three months. Also, check the safety stop function at system installation, any software changes, and parameter setting changes.

### I/O status and inverter operation

The FR-A800-LC inverter's safety related I/O status obeys the following truth table.

Table 7 Truth table of safety related signals

Input power	Internal safety circuit status	Input terminal*1, *2		Output terminal So (SO)	Output signal *8, *9, *10 SAFE	Inverter running status	Operation panel indication	
		S1	S2				E.SAF*6	SA*7
OFF	—	—	—	OFF	OFF	Output shutoff (Safe state)	Not displayed	Not displayed
ON	Normal	ON	ON	ON*3	OFF	Drive enabled	Not displayed	Not displayed
	Normal	ON	OFF	OFF*4	OFF*4	Output shutoff (Safe state)	Displayed	Displayed
	Normal	OFF	ON	OFF*4	OFF*4	Output shutoff (Safe state)	Displayed	Displayed
	Normal	OFF	OFF	ON*3	ON*3	Output shutoff (Safe state)	Not displayed	Displayed
	Fault	ON	ON	OFF	OFF	Output shutoff (Safe state)	Displayed	Not displayed*5
	Fault	ON	OFF	OFF	OFF	Output shutoff (Safe state)	Displayed	Displayed
	Fault	OFF	ON	OFF	OFF	Output shutoff (Safe state)	Displayed	Displayed
	Fault	OFF	OFF	OFF	OFF	Output shutoff (Safe state)	Displayed	Displayed

\*1 ON: The transistor is conducted. OFF: The transistor is not conducted.

\*2 When not using the safety stop function, short across terminals S1 and PC, S2 and PC, and SIC and SD to use the inverter. (In the initial status, terminals S1 and PC, S2 and PC, and SIC and SD are respectively shorted with shoring wires.)

\*3 If any of the faults shown in the following table occurs, terminal So (SO) and the SAFE signal turn OFF.

Fault	Operation panel indication	Fault	Operation panel indication
Option fault.	E.OPT	Overspeed occurrence	E.OS
Communication option fault	E.OP1 to E.OP3	Speed deviation excess detection	E.OSD
Internal storage device fault	E.PE6	Signal loss detection	E.ECT
Parameter storage device fault	E.PE	Excessive position fault	E.OD
Retry count excess	E.RET	Encoder signal loss for orientation	E.ECA
Parameter storage device fault	E.PE2	Brake sequence fault	E.MB1 to E.MB7
Operation panel power supply short circuit/ RS-485 terminals power supply short circuit	E.CTE	Encoder phase fault	E.EP
24 VDC power fault	E.P24	CPU fault	E.CPU
Safety circuit fault	E.SAF		E.5 to E.7
		Internal circuit fault	E.13

\*4 When the internal safety circuit is operated normally, the terminal So (SO) and the SAFE signal remain ON until E.SAF is displayed, and the terminal So (SO) and the SAFE signal turn OFF when E.SAF is displayed.

\*5 SA is displayed when the terminals S1 and S2 are identified as OFF due to the internal safety circuit failure.

\*6 If another fault occurs at the same time as E.SAF, the other fault can be displayed.

\*7 If another warning occurs at the same time as SA, the other warning can be displayed.

\*8 The ON/OFF state of the output signal is the one for the positive logic. The ON and OFF are reversed for the negative logic.

\*9 For the SAFE signal, refer to the following table and assign the function using Pr.190 to Pr.196 (output terminal function selection).

Output signal	Pr.190 to Pr.196 settings	
	Positive logic	Negative logic
SAFE	80	180

\*10 The use of SAFE signal has not been certified for compliance with safety standards.

**NOTE**

- The response time from safety stop signal input to drive shutoff (safe state) is faster than 8ms.
- Hold the ON or OFF status for 2 ms or longer to input signal to terminal S1 or S2.  
Signal input shorter than 2 ms is not recognized.

**Diagnostic**

If a failure is detected, the FR-A800-LC inverter outputs a fault signal and 'E.SAF' is indicated at the display. When the FR-A800-LC inverter outputs a fault signal, take following actions.

- 1) Check that the input signal logic is the same between S1-SIC and S2-SIC. If these are different, correct the input signal and reset the FR-A800-LC inverter.
- 2) Disconnect the wires from terminals S1, S2, and SIC, then reset or turn OFF and ON the power. If the 'SA' is indicated on the operation panel, there is a failure in the system except for the FR-A800-LC inverter. When 'E.SAF' is indicated and a fault signal is output, a fault may be occurring in the FR-A800-LC inverter.

**Self diagnostic test**

The FR-A800-LC inverter has the self-diagnostic test function at power-ON.

If the FR-A800-LC inverter outputs a fault signal (SA, E.SAF) at power-ON, take the action described above.

**Operation check procedure**

Check the operation of the safety stop function as follows.

- 1) Change and check the I/O state between S1-SIC and S2-SIC shown in Table 5.
- 2) If the inverter operation differs from the one shown in Table 5, the FR-A800-LC may have a fault.
- 3) If the inverter operates as described in Table 5, check the system performance. Press the emergency switch, press the start/restart button while a failure is detected (So (SO) -SOC opened), and so on.
- 4) Finally clear the fault history of the FR-A800-LC inverter (see the Instruction Manual for how to clear the fault history).

## 5 SAFETY PARAMETERS OF FR-A800-LC

The safety parameters of the FR-A800-LC inverter are depicted as follows.

**Table 8 Safety parameters of FR-A800-LC**

Parameter	Value	
	Safety Integrity Level (SIL) 2	Safety Integrity Level (SIL) 3
PFD <sub>AVG</sub>	6.10x10 <sup>-4</sup>	6.10x10 <sup>-4</sup>
PFH <sub>d</sub>	6.90x10 <sup>-9</sup>	6.90x10 <sup>-9</sup>
PL	d	e
MTTF <sub>d</sub>	639 years	100 years
DC <sub>AVG</sub>	60%	90%

# MEMO



---

## REVISIONS

Revision Date	Manual Number	Revision
Jun. 2016	BCN-A23228-015-A(E)	First edition
Jun. 2018	BCN-A23228-015-B(E)	<input type="checkbox"/> Added ● Safety Integrity Level (SIL) 3 ● FR-A840-LC
Oct. 2023	BCN-A23228-015-C(E)	<input type="checkbox"/> Edited ● Functional safety standards

**HEADQUARTERS**

Mitsubishi Electric Europe B.V. **EUROPE**  
 Mitsubishi-Electric-Platz 1  
**D-40882 Ratingen**  
 Phone: +49 (0)2102 / 486-0  
 Fax: +49 (0)2102 / 486-1120

Mitsubishi Electric Europe B.V. **CZECH REP.**  
 Pekařská 621/7  
**CZ-155 00 Praha 5**  
 Phone: +420 255 719 200  
 Fax: +420 251 551 471

Mitsubishi Electric Europe B.V. **FRANCE**  
 25, Boulevard des Bouvets  
**F-92741 Nanterre Cedex**  
 Phone: +33 (0)1 / 55 68 55 68  
 Fax: +33 (0)1 / 55 68 57 57

Mitsubishi Electric Europe B.V. **IRELAND**  
 Westgate Business Park, Ballymount  
**IRL-Dublin 24**  
 Phone: +353 (0)1 4198800  
 Fax: +353 (0)1 4198890

Mitsubishi Electric Europe B.V. **ITALY**  
 Viale Colleoni 7 Palazzo Sirio  
**I-20864 Agrate Brianza (MB)**  
 Phone: +39 039 / 60 53 1  
 Fax: +39 039 / 60 53 312

Mitsubishi Electric Europe B.V. **NETHERLANDS**  
 Nijverheidsweg 23C  
**NL-3641RP Mijdrecht**  
 Phone: +31 (0) 297 250 350

Mitsubishi Electric Europe B.V. **POLAND**  
 ul. Krakowska 50  
**PL-32-083 Balice**  
 Phone: +48 (0) 12 347 65 00  
 Fax: +48 (0) 12 630 47 01

Mitsubishi Electric (Russia) LLC **RUSSIA**  
 2 bld. 1, Letnikovskaya st.  
**RU-115114 Moscow**  
 Phone: +7 495 / 721 2070  
 Fax: +7 495 / 721 2071

Mitsubishi Electric Europe B.V. **SPAIN**  
 Carretera de Rubí 76-80 Apdo. 420  
**E-08190 Sant Cugat del Vallés (Barcelona)**  
 Phone: +34 (0) 93 / 5653131  
 Fax: +34 (0) 93 / 5891579

Mitsubishi Electric Europe B.V. (Scandinavia) **SWEDEN**  
 Hedvig Möllers gata 6,  
**SE- 223 55 Lund**  
 Phone: +46 (0) 8 625 10 00

Mitsubishi Electric Turkey Elektrik Ürünleri A.Ş. **TURKEY**  
 Fabrika Otomasyonu Merkezi  
 Şerifali Mahallesi Nutuk Sokak No.5  
**TR-34775 Ümraniye-İSTANBUL**  
 Phone: +90 (216) 969 25 00  
 Fax: +90 (216) / 526 39 95

Mitsubishi Electric Europe B.V. **UK**  
 Travellers Lane  
**UK-Hatfield, Herts. AL10 8XB**  
 Phone: +44 (0)1707 / 28 87 80  
 Fax: +44 (0)1707 / 27 86 95

Mitsubishi Electric Europe B.V. **UAE**  
 Dubai Silicon Oasis  
**United Arab Emirates - Dubai**  
 Phone: +971 4 3724716  
 Fax: +971 4 3724721

Mitsubishi Electric Corporation **JAPAN**  
 Tokyo Building 2-7-3  
 Marunouchi, Chiyoda-ku  
**Tokyo 100-8310**  
 Phone: +81 (3) 3218-2111  
 Fax: +81 (3) 3218-2185

Mitsubishi Electric Automation, Inc. **USA**  
 500 Corporate Woods Parkway  
**Vernon Hills, IL 60061**  
 Phone: +1 (847) 478-2100  
 Fax: +1 (847) 478-0328

**EUROPEAN REPRESENTATIVES**

GEVA **AUSTRIA**  
 Wiener Straße 89  
**A-2500 Baden**  
 Phone: +43 (0)2252 / 85 55 20  
 Fax: +43 (0)2252 / 488 60

OOO TECHNIKON **BELARUS**  
 Prospect Nezavisimosti 177-9  
**BY-220125 Minsk**  
 Phone: +375 (0)17 / 393 1177  
 Fax: +375 (0)17 / 393 0081

INEA RBT d.o.o. **BOSNIA AND HERZEGOVINA**  
 Stegne 11  
**SI-1000 Ljubljana**  
 Phone: +386 (0)1 / 513 8116  
 Fax: +386 (0)1 / 513 8170

AKHNATON **BULGARIA**  
 4, Andrei Ljapchev Blvd., PO Box 21  
**BG-1756 Sofia**  
 Phone: +359 (0)2 / 817 6000  
 Fax: +359 (0)2 / 97 44 06 1

INEA CR **CROATIA**  
 Losinjska 4 a  
**HR-10000 Zagreb**  
 Phone: +385 (0)1 / 36 940 - 01 / -02 / -03  
 Fax: +385 (0)1 / 36 940 - 03

AutoCont C. S. S.R.O. **CZECH REPUBLIC**  
 Kalkova 1853/3  
**CZ-702 00 Ostrava 2**  
 Phone: +420 595 691 150  
 Fax: +420 595 691 199

HANS FØLSGAARD A/S **DENMARK**  
 Theilgaardsgade 1  
**DK-4600 Køge**  
 Phone: +45 4320 8600  
 Fax: +45 4396 8855

Electrobit OÜ **ESTONIA**  
 Pärnu mnt. 160i  
**EST-11317, Tallinn**  
 Phone: +372 6518 140

UTU Automation Oy **FINLAND**  
 Peltotie 37i  
**FIN-28400 Uvivila**  
 Phone: +358 (0)207 / 463 500  
 Fax: +358 207 / 463 501

UTEKO A.B.E.E. **GREECE**  
 5, Mavrogenous Str.  
**GR-18542 Piraeus**  
 Phone: +30 (0)211 / 1206-900  
 Fax: +30 (0)211 / 1206-999

MELTRADE Kft. **HUNGARY**  
 Fertő utca 14.  
**HU-1107 Budapest**  
 Phone: +36 (0)1 / 431-9726  
 Fax: +36 (0)1 / 431-9727

OAK Integrator Products SIA **LATVIA**  
 Rītausmas iela 23  
**LV-1058 Rīga**  
 Phone: +371 67842280

Automatikos Centras, UAB **LITHUANIA**  
 Neries krantinė 14A-101  
**LT-48397 Kaunas**  
 Phone: +370 37 262707  
 Fax: +370 37 455605

ALFATRADE Ltd. **MALTA**  
 99, Paola Hill  
**Malta-Paola PLA 1702**  
 Phone: +356 (0)21 / 697 816  
 Fax: +356 (0)21 / 697 817

**EUROPEAN REPRESENTATIVES**

INTEHSIS SRL **MOLDOVA**  
 bld. Traian 23/1  
**MD-2060 Kishinev**  
 Phone: +373 (0)22 / 66 4242  
 Fax: +373 (0)22 / 66 4280

Fonseca S.A. **PORTUGAL**  
 R. João Francisco do Casal 87/89  
**PT-3801-997 Aveiro, Esgueira**  
 Phone: +351 (0)234 / 303 900  
 Fax: +351 (0)234 / 303 910

SIRIUS TRADING & SERVICES SRL **ROMANIA**  
 Aleea Lacul Morii Nr. 3  
**RO-060841 Bucuresti, Sector 6**  
 Phone: +40 (0)21 / 430 40 06  
 Fax: +40 (0)21 / 430 40 02

INEA SR d.o.o. **SERBIA**  
 Ul. Karadjordjeva 12/217  
**SER-11300 Smederevo**  
 Phone: +386 (026) 461 54 01

SIMAP SK (Západné Slovensko) **SLOVAKIA**  
 Dolné Pažite 603/97  
**SK-911 06 Trenčín**  
 Phone: +421 (0)32 743 04 72  
 Fax: +421 (0)32 743 75 20

INEA RBT d.o.o. **SLOVENIA**  
 Stegne 11  
**SI-1000 Ljubljana**  
 Phone: +386 (0)1 / 513 8116  
 Fax: +386 (0)1 / 513 8170

OMNI RAY AG **SWITZERLAND**  
 Im Schörl 5  
**CH-8600 Dübendorf**  
 Phone: +41 (0)44 / 802 28 80  
 Fax: +41 (0)44 / 802 28 28

CSC- AUTOMATION Ltd. **UKRAINE**  
 4 B, Yevhena Sverstyuka Str.  
**UA-02002 Kiev**  
 Phone: +380 (0)44 / 494 33 44  
 Fax: +380 (0)44 / 494-33-66

**EURASIAN REPRESENTATIVES**

TOO Kazpromavtomatika **KAZAKHSTAN**  
 UL. ZHAMBYLA 28,  
**KAZ-100017 Karaganda**  
 Phone: +7 7212 / 50 10 00  
 Fax: +7 7212 / 50 11 50

**MIDDLE EAST REPRESENTATIVE**

EIM Energy **EGYPT**  
 3 Roxy Square  
**ET-11341 Heliopolis, Cairo**  
 Phone: +202 24552559  
 Fax: +202 245266116

SHERF Motion Techn. Ltd. **ISRAEL**  
 Rehov Hamerkava 19  
**IL-58851 Holon**  
 Phone: +972 (0)3 / 559 54 62  
 Fax: +972 (0)3 / 556 01 82

CEG LIBAN **LEBANON**  
 Cebaco Center/Block A Autostrade DORA  
**Lebanon-Beirut**  
 Phone: +961 (0)1 / 240 445  
 Fax: +961 (0)1 / 240 193

**AFRICAN REPRESENTATIVE**

ADROIT TECHNOLOGIES **SOUTH AFRICA**  
 20 Waterford Office Park 189 Witkoppen Road  
**ZA-Fourways**  
 Phone: + 27 (0)11 / 658 8100  
 Fax: + 27 (0)11 / 658 8101

**MITSUBISHI ELECTRIC CORPORATION**

HEAD OFFICE: TOKYO BUILDING 2-7-3, MARUNOUCHI, CHIYODA-KU, TOKYO 100-8310, JAPAN