

INVERTER

A800-F/G

FR-A802-F/G (SEPARATED CONVERTER TYPE) INSTRUCTION MANUAL (HARDWARE)

High functionality and high performance

FR-A842-07700 to 12120-F/G

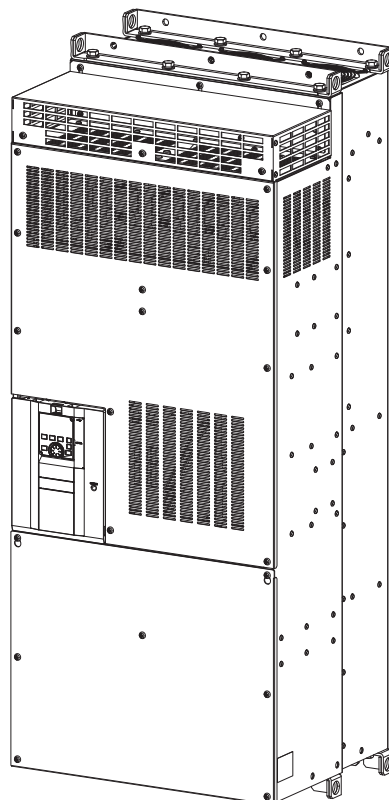

Safety instructions	5
-------------------------------	---

Chapter 1 INTRODUCTION 12

1.1 Product checking and accessories	13
1.2 Inverter component names	15
1.3 Compliance with the EU Machinery Directive—Safety sub-functions	17
1.3.1 Specifications	19
1.4 Related manuals	20

Chapter 2 INSTALLATION AND WIRING 22

2.1 Peripheral devices	22
2.1.1 Inverter and peripheral devices	22
2.1.2 Peripheral devices	24
2.2 Removal and reinstallation of the operation panel or the front covers	25
2.3 Installation of the inverter and enclosure design	27
2.3.1 Inverter installation environment	27
2.3.2 Amount of heat generated by the inverter	30
2.3.3 Cooling system types for inverter enclosure	31
2.3.4 Inverter installation	32
2.3.5 Protruding the heat sink through a panel	34
2.4 Terminal connection diagrams	36
2.5 Main circuit terminals	42
2.5.1 Details on the main circuit terminals of the inverter	42
2.5.2 Details on the main circuit terminals of the converter unit (FR-CC2)	42
2.5.3 Terminal layout of the main circuit terminals, wiring of power supply and the motor	43
2.5.4 Recommended cables and wiring length	44
2.5.5 Earthing (grounding) precautions	47
2.6 Control circuit	48
2.6.1 Details on the control circuit terminals of the inverter	48
2.6.2 Details on the control circuit terminals of the converter unit (FR-CC2)	52
2.6.3 Control logic (sink/source) change	54
2.6.4 Wiring of inverter control circuit	56
2.6.5 Wiring precautions	58
2.6.6 When using separate power supplies for the control circuit and the main circuit	59
2.6.7 When supplying 24 V external power to the control circuit	61
2.7 Communication connectors and terminals	63
2.7.1 PU connector	63
2.7.2 RS-485 terminal block (RS-485 model)	64
2.7.3 Ethernet connector (Ethernet model)	64
2.7.4 USB connector	65

2.8	Connection to a motor with encoder (Vector control)	67
2.9	Parameter settings for a motor with encoder	73
2.10	Connection of stand-alone option units	74
2.10.1	Connection of the brake unit (FR-BU2)	74
2.10.2	Connection of the high power factor converter (FR-HC2)	75
2.10.3	Connection of the power regeneration converter (MT-RC)	77
2.11	Connection of the earthing (grounding) cable (Ethernet model)	78

Chapter 3 PRECAUTIONS FOR USE OF THE INVERTER 80

3.1	Electro-magnetic interference (EMI) and leakage currents	80
3.1.1	Leakage currents and countermeasures	80
3.1.2	Techniques and measures for electromagnetic compatibility (EMC)	82
3.1.3	Converter unit (FR-CC2) built-in EMC filter	85
3.2	Power supply harmonics	86
3.2.1	Power supply harmonics	86
3.2.2	Harmonic suppression guidelines in Japan	86
3.3	Installation of a reactor	89
3.4	Power shutdown and magnetic contactor (MC)	90
3.5	Countermeasures against deterioration of the 400 V class motor insulation	92
3.6	Checklist before starting operation	93
3.7	Failsafe system which uses the inverter	96

Chapter 4 PROTECTIVE FUNCTIONS 100

4.1	Inverter fault and alarm indications	100
4.2	Reset method for the protective functions	101
4.3	Check and clear of the fault history	102
4.4	List of fault displays	104

Chapter 5 PRECAUTIONS FOR MAINTENANCE AND INSPECTION. 108

5.1	Inspection item.	108
5.1.1	Daily inspection.	108
5.1.2	Periodic inspection	108
5.1.3	Daily and periodic inspection	109
5.1.4	Checking the inverter and converter semiconductor devices	110
5.1.5	Cleaning	111
5.1.6	Replacement of parts	111
5.1.7	Removal and reinstallation of the control circuit terminal block	113
5.2	Measurement of main circuit voltages, currents, and powers	115
5.2.1	Measurement of powers	117
5.2.2	Measurement of voltages	118
5.2.3	Measurement of currents	118
5.2.4	Example of measuring converter unit (FR-CC2) input power factor	118
5.2.5	Measurement of converter output voltage (between terminals P and N)	118
5.2.6	Measurement of inverter output frequency	118
5.2.7	Insulation resistance test using megger	119
5.2.8	Withstand voltage test.	119

Chapter 6 SPECIFICATIONS 122

6.1	Inverter rating.	122
6.2	Common specifications	123
6.3	Outline dimension drawings.	125

Chapter 7 APPENDIX 128

7.1	Comparison with FR-A840.	128
7.2	Comparison with FR-A800.	129
7.3	Compatible plug-in option	130
7.4	Instructions for compliance with the EU Directives	131
7.5	Instructions for UL and cUL	134
7.6	Instructions for EAC.	136
7.7	Restricted Use of Hazardous Substances in Electronic and Electrical Products.	137
7.8	Referenced Standard (Requirement of Chinese standardized law)	137

7.9	Compliance with the UK certification scheme	138
7.10	EU Declaration of Conformity	138

Safety instructions

Thank you for choosing Mitsubishi Electric inverter.

This Instruction Manual describes handling and cautions about the hardware, such as installation and wiring, for the FR-A802 (separated converter type) inverter that are different from the FR-A800.

Information about the software, such as basic operations and parameters, is described in the FR-A800 Instruction Manual (Detailed) in the CD-ROM enclosed with the product. For details on Ethernet communication, refer to the FR-A800-E Ethernet Function Manual in the enclosed CD-ROM. In addition to this manual, read all the relevant instruction manuals on the enclosed CD-ROM carefully to ensure proper use. Do not use this product until you have full knowledge of this product's workings, safety information and instructions.

Please forward this Instruction Manual to the end user.

Do not attempt to install, operate, maintain or inspect this product until you have read the Instruction Manuals and supplementary documents carefully. Do not use this product until you have full knowledge of this product mechanism, safety information and instructions.

Installation, operation, maintenance and inspection must be performed by qualified personnel. Here, qualified personnel means a person who meets all the following conditions:

- A person who possesses a certification in regard with electric appliance handling, or person took a proper engineering training. Such training may be available at your local Mitsubishi Electric office. Contact your local sales office for schedules and locations.
- A person who can access operating manuals for the protective devices (for example, light curtain) connected to the safety control system, or a person who has read these manuals thoroughly and familiarized themselves with the protective devices.

In this Instruction Manual, the safety instruction levels are classified into "WARNING" and "CAUTION".



WARNING

Incorrect handling may cause hazardous conditions, resulting in death or severe injury.



CAUTION

Incorrect handling may cause hazardous conditions, resulting in medium or slight injury, or may cause only material damage.

Note that even the  **CAUTION** level may lead to a serious consequence depending on conditions. Be sure to follow the instructions of both levels as they are critical to personnel safety.

◆ Electric shock prevention

WARNING

- Do not remove the front cover or the wiring cover while the power of this product is ON, and do not run this product with the front cover or the wiring cover removed as the exposed high voltage terminals or the charging part of the circuitry can be touched. Otherwise you may get an electric shock.
- Even if power is OFF, do not remove the front cover except for wiring or periodic inspection as the inside of this product is charged. Otherwise you may get an electric shock.
- Before wiring or inspection, check that the LED display of the operation panel is OFF. Any person who is involved in wiring or inspection shall wait for 10 minutes or longer after the power supply has been cut off, and check that there are no residual voltage using a digital multimeter or the like. The capacitor is charged with high voltage for some time after power OFF, and it is dangerous.
- This product must be earthed (grounded). Earthing (grounding) must conform to the requirements of national and local safety regulations and electrical code (NEC section 250, IEC 61140 class 1 and other applicable standards). A neutral-point earthed (grounded) power supply must be used to be compliant with EN standard.
- Any person who is involved in wiring or inspection of this product shall be fully competent to do the work.
- This product body must be installed before wiring. Otherwise you may get an electric shock or be injured.
- Do not touch the setting dial or keys with wet hands. Doing so may cause an electric shock.
- Do not subject the cables to scratches, excessive stress, heavy loads or pinching. Doing so may cause an electric shock.
- Do not change the cooling fan while power is ON as it is dangerous.
- Do not touch the printed circuit board or handle the cables with wet hands. Doing so may cause an electric shock.
- A PM motor is a synchronous motor with high-performance magnets embedded inside. High-voltage is generated at the motor terminals while the motor is running even after the inverter power is turned OFF. Before wiring or inspection, the motor must be confirmed to be stopped. In an application, such as fan and blower, that the motor may be driven by the load, connect a low-voltage manual contactor at the output side of this product and keep it open during wiring and inspection of this product. Otherwise you may get an electric shock.

◆ Fire prevention

CAUTION

- This product must be installed on a nonflammable wall without holes in it so that its components cannot be touched from behind. Installing it on or near flammable material may cause a fire.
- If this product becomes faulty, the product power must be switched OFF. A continuous flow of large current may cause a fire.
- Be sure to perform daily and periodic inspections as specified in the Instruction Manual. There is a possibility of explosion, damage, or fire if this product is used without inspection.

◆ Injury prevention

CAUTION

- The voltage applied to each terminal must be as specified in the Instruction Manual. Otherwise an explosion or damage may occur.
- The cables must be connected to the correct terminals. Otherwise an explosion or damage may occur.
- The polarity (+ and -) must be correct. Otherwise an explosion or damage may occur.
- While power is ON or for some time after power-OFF, do not touch this product as it will be extremely hot. Doing so may cause burns.

◆ Additional instructions

The following instructions must be also followed. If this product is handled incorrectly, it may cause unexpected fault, an injury, or an electric shock.

CAUTION

Transportation and installation

- To prevent injury, wear cut-resistant gloves when opening packaging with sharp tools.
- Use proper lifting techniques or a trolley when carrying products. Failure to do so may lead to injuries.
- Do not stand or place any heavy object on this product.
- Do not stack the boxes containing this product higher than the number recommended.
- When carrying this product, do not hold it by the front cover. It may fall or break.
- During installation, caution must be taken not to drop this product as doing so may cause injuries.
- The product must be installed on a surface that withstands the weight of the product.
- Do not install this product on a hot surface.
- Ensure the mounting orientation of this product is correct.
- Ensure this product is mounted securely in its enclosure.
- Do not install or operate this product if it is damaged or has parts missing.
- Foreign conductive objects must be prevented from entering this product. That includes screws and metal fragments or other flammable substance such as oil.
- As this product is a precision instrument, do not drop or subject it to impact.
- The surrounding air temperature must be between -10°C and +50°C (non-freezing) for this product at HD (heavy duty), ND (normal duty) (initial setting), or LD (light duty) rating, and between -10°C and +40°C (non-freezing) for this product at SLD (super light duty) rating. Otherwise this product may be damaged.
- The ambient humidity must be 90% RH or less (non-condensing). Otherwise this product may be damaged. (Refer to [page 27](#) for details.)
- The temporary storage temperature (applicable to a short limited time such as a transportation time) must be between -20°C and +65°C. Otherwise this product may be damaged.
- This product must be used indoors (without corrosive gas, flammable gas, oil mist, dust and dirt). Otherwise this product may be damaged.
- Do not use this product at an altitude above 2500 m. Vibration should not exceed 2.9 m/s² at 10 to 55 Hz in X, Y, and Z directions. Otherwise this product may be damaged. (Refer to [page 27](#) for details.)
- If halogens (including fluorine, chlorine, bromine, and iodine) contained in fumigants for wood packages enter this product, the product may be damaged. Prevent the entry of fumigant residuals or use an alternative method such as heat disinfection. Note that sterilization or disinfection of wood packages should be performed before packing the product.

Wiring

- Do not install a power factor correction capacitor, surge absorber, or radio noise filter on the output side of this product. These devices may overheat or burn out.
- The output of this product (output terminals U, V, W) must be correctly connected to a motor. Otherwise the motor will rotate inversely.
- Even with the power OFF, high voltage is still applied to the terminals U, V, and W while the PM motor is running. Ensure the PM motor has stopped before carrying out any wiring. Otherwise you may get an electric shock.
- Never connect a PM motor to a commercial power supply. Connecting a commercial power supply to the input terminals (U, V, W) of a PM motor will burn it out. The PM motor must be applied a power from this product with the output terminals (U, V, W).

Test operation

- Before starting the test operation, confirm or adjust the parameter settings. Failure to do so may cause some machines to make unexpected motions.
-

 **WARNING**

Usage

- Stay away from the equipment after using the retry function in this product as the equipment will restart suddenly after the output shutoff of this product.
 - Depending on the function settings of this product, the product does not stop its output even when the STOP/RESET key on the operation panel is pressed. To prepare for it, provide a separate circuit and switch (to turn OFF the power of this product, or apply a mechanical brake, etc.) for an emergency stop.
 - Be sure to turn OFF the start (STF/STR) signal before clearing the fault as this product will restart the motor suddenly after a fault is cleared.
 - Do not use a PM motor for an application that the motor may be driven by the load and run at a speed higher than the maximum motor speed.
 - Use only a three-phase induction motor or PM motor as a load on this product. Connection of any other electrical equipment to the output of this product may damage the equipment.
 - Performing pre-excitation (by using the LX or X13 signal) during torque control (under Real sensorless vector control) may rotate a motor at a low speed even though a start command (STF or STR) is not given. This product with the start command ON may also rotate the motor at a low speed when the speed limit value is set to zero. Confirm that the motor running does not cause any safety problems before performing pre-excitation.
 - Do not modify this product.
 - Do not remove any part which is not instructed to be removed in the Instruction Manuals. Doing so may lead to a failure or damage of this product.
-

CAUTION

Usage

- The electronic thermal O/L relay function may not be enough for protection of a motor from overheating. It is recommended to install an external thermal relay or a PTC thermistor for overheat protection.
- Do not repeatedly start or stop this product with a magnetic contactor on its input side. Doing so may shorten the life of this product.
- Use a noise filter or other means to minimize electromagnetic interference with other electronic equipment used nearby this product.
- Appropriate precautions must be taken to suppress harmonics. Otherwise harmonics in power systems generated from this product may heat/damage a power factor correction capacitor or a generator.
- To drive a 400 V class motor with this product, use an insulation-enhanced motor, or take measures to suppress surge voltage. Otherwise surge voltage, which is attributed to the length and thickness of wire, may occur at the motor terminals, causing the motor insulation to deteriorate.
- As all parameters return to their initial values after the Parameter clear or All parameter clear is performed, the needed parameters for this product operation must be set again before the operation is started.
- This product can be easily set for high-speed operation. Therefore, consider all things related to the operation such as the performance of a motor and equipment in a system before the setting change.
- This product's brake function cannot be used as a mechanical brake. Use a separate device instead.
- Perform an inspection and test operation of this product if it has been stored for a long period of time.
- To avoid damage to this product due to static electricity, static electricity in your body must be discharged before you touch this product.
- Only one PM motor can be connected to one inverter.
- A PM motor must be used under PM sensorless vector control. Do not use a synchronous motor, induction motor, or synchronous induction motor.
- Do not connect a PM motor to this product with it set to the induction motor control setting (initial setting). Do not connect an induction motor to this product with it set to the PM sensorless vector control setting. Doing so will cause failure.
- As a process of starting a PM motor, turn ON the power of this product first, and then close the contactor on the output side of this product.
- To maintain the security (confidentiality, integrity, and availability) of the inverter and the system against unauthorized access, DoS^{*1} attacks, computer viruses, and other cyberattacks from external devices via network, take appropriate measures such as firewalls, virtual private networks (VPNs), and antivirus solutions. We shall have no responsibility or liability for any problems involving inverter trouble and system trouble by DoS attacks, unauthorized access, computer viruses, and other cyberattacks.
- Depending on the network environment, this product may not operate as intended due to delays or disconnection in communication. Carefully consider what type of environment this product will be used in and any safety issues related to its use.

Emergency stop

- A safety backup such as an emergency brake must be provided for devices or equipment in a system to prevent hazardous situations from occurring in case of failure of this product or an external device controlling this product.
- If the breaker installed on the input side of this product trips, check for wiring faults (such as short circuits) and damage to internal parts of this product, etc. Identify and remove the cause of the trip before resetting the tripped breaker (or before applying the power to this product again).
- When any protective function is activated, take an appropriate corrective action before resetting this product to resume the operation.

Maintenance, inspection and parts replacement

- Do not carry out a megger (insulation resistance) test on the control circuit of this product. Doing so will cause failure.

Disposal

- This product must be treated as industrial waste.

*1 DoS: A denial-of-service (DoS) attack disrupts services by overloading systems or exploiting vulnerabilities, resulting in a denial-of-service (DoS) state.

Application of caution labels

Caution labels are used to ensure safety during use of Mitsubishi Electric inverters.

Apply the following labels to the inverter if the "retry function" and/or "automatic restart after instantaneous power failure" have been enabled.

- For the retry function

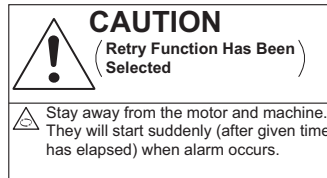

- For automatic restart after instantaneous power failure

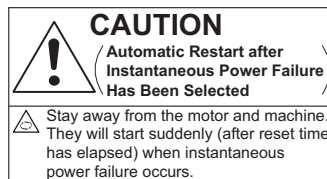

Application of motor control labels

Apply the following labels to the inverter to avoid connecting a motor different from those intended for the motor control setting.

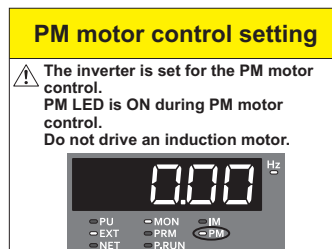
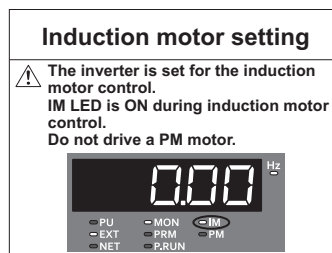

General instruction

- For clarity, illustrations in this Instruction Manual may be drawn with covers or safety guards removed. Ensure all covers and safety guards are properly installed prior to starting operation. For details on the PM motor, refer to the Instruction Manual of the PM motor.

This Instruction Manual is a translation of the Japanese version. (The Japanese version is the original version.)

CHAPTER 1 INTRODUCTION

1.1	Product checking and accessories	13
1.2	Inverter component names	15
1.3	Compliance with the EU Machinery Directive—Safety sub-functions.....	17
1.4	Related manuals.....	20

1 INTRODUCTION

The contents described in this chapter must be read before using this product.

Always read the instructions before use.

◆ Abbreviations

Item	Description
DU	Operation panel (FR-DU08)
Operation panel	Operation panel (FR-DU08) and LCD operation panel (FR-LU08)
Parameter unit	Parameter unit (FR-PU07)
PU	Operation panel and parameter unit
Inverter	Mitsubishi Electric FR-A800 series inverter (separated converter type)
Ethernet board	Ethernet communication board (FR-A8ETH)
Vector control compatible option	FR-A8AP/FR-A8AL/FR-A8APA/FR-A8APR/FR-A8APS (plug-in option), FR-A8TP (control terminal option)
Pr.	Parameter number (Number assigned to function)
PU operation	Operation using the PU (operation panel / parameter unit)
External operation	Operation using the control circuit signals
Combined operation	Combined operation using the PU (operation panel / parameter unit) and External operation

◆ Trademarks

- The company and product names herein are either trademarks or registered trademarks of their respective owners.

◆ Notes on descriptions in this Instruction Manual

- Connection diagrams in this Instruction Manual appear with the control logic of the input terminals as sink logic, unless otherwise specified. (For the control logic, refer to [page 54.](#))

◆ Harmonic Suppression Guidelines

All the models of the inverters used by specific consumers are covered by the Harmonic Suppression Guidelines for Consumers Who Receive High Voltage or Special High Voltage. (For details, refer to [page 86.](#))

1.1 Product checking and accessories

Unpack the product and check the rating plate and the capacity plate of the inverter to ensure that the model is as ordered and the product is intact.

◆ Inverter model

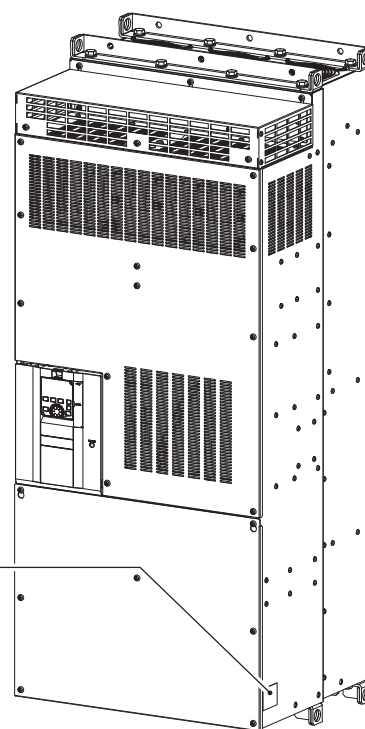
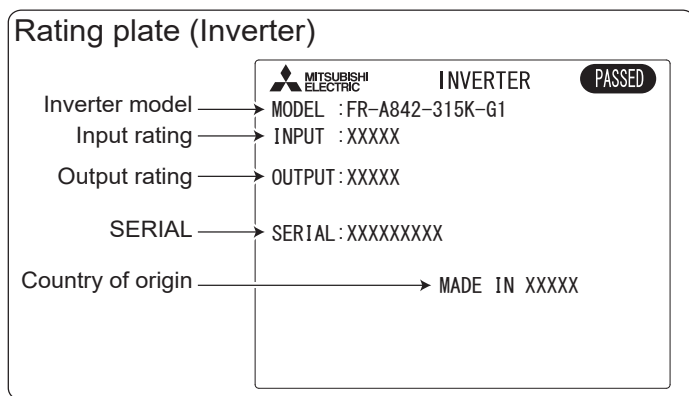
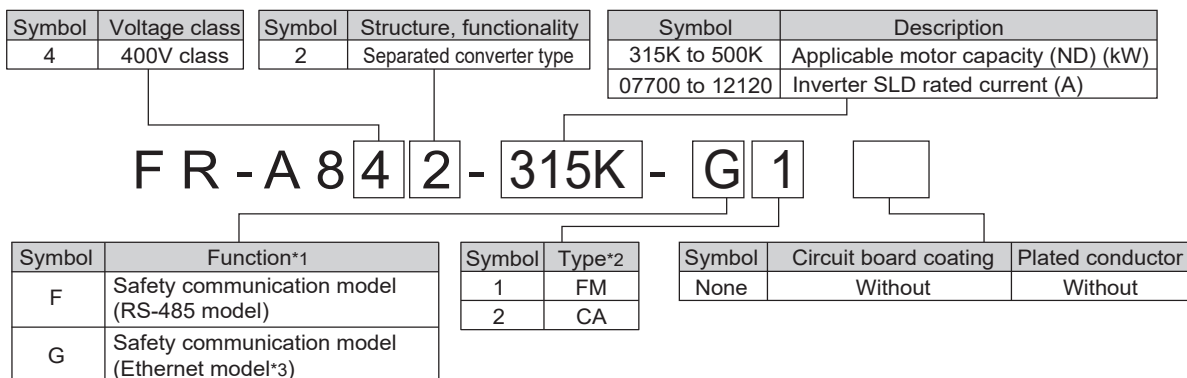

*1 Use the inverter with the FR-A8NCG-S or with the PROFIsafe communication option (A8SPRS) manufactured by HMS Industrial Networks AB. For any questions concerning the PROFIsafe communication option, contact your sales representative.

*2 Specification differs by the type as follows.

Type	Monitor output	Initial setting		
		Control logic	Rated frequency	Pr.19 Base frequency voltage
FM (terminal FM equipped model)	Terminal FM (pulse train output) Terminal AM (analog voltage output (0 to ±10 VDC))	Sink logic	60 Hz	9999 (same as the power supply voltage)
CA (terminal CA equipped model)	Terminal CA (analog current output (0 to 20 mADC)) Terminal AM (analog voltage output (0 to ±10 VDC))	Source logic	50 Hz	8888 (95% of the power supply voltage)

*3 Inverter equipped with a built-in Ethernet board (FR-A8ETH).

NOTE

- In this Instruction Manual, the inverter model name consists of the applicable motor capacity and the rated current.
(Example) FR-A842-07700(315K)

◆ How to read the SERIAL number

Rating plate example

□ ○ ○ ○○○○○○
Symbol Year Month Control number
SERIAL

The SERIAL consists of one symbol, two characters indicating the production year and month, and six characters indicating the control number.

The last digit of the production year is indicated as the Year, and the Month is indicated by 1 to 9, X (October), Y (November), or Z (December).

◆ Accessory

- Earthing (grounding) cable (1): For connection with a communication option (for an Ethernet model). (Refer to [page 78](#).)
- CD-ROM (1): Including the Instruction Manual (Detailed) and other documents.

1.2 Inverter component names

Component names are as follows.

◆ RS-485 model

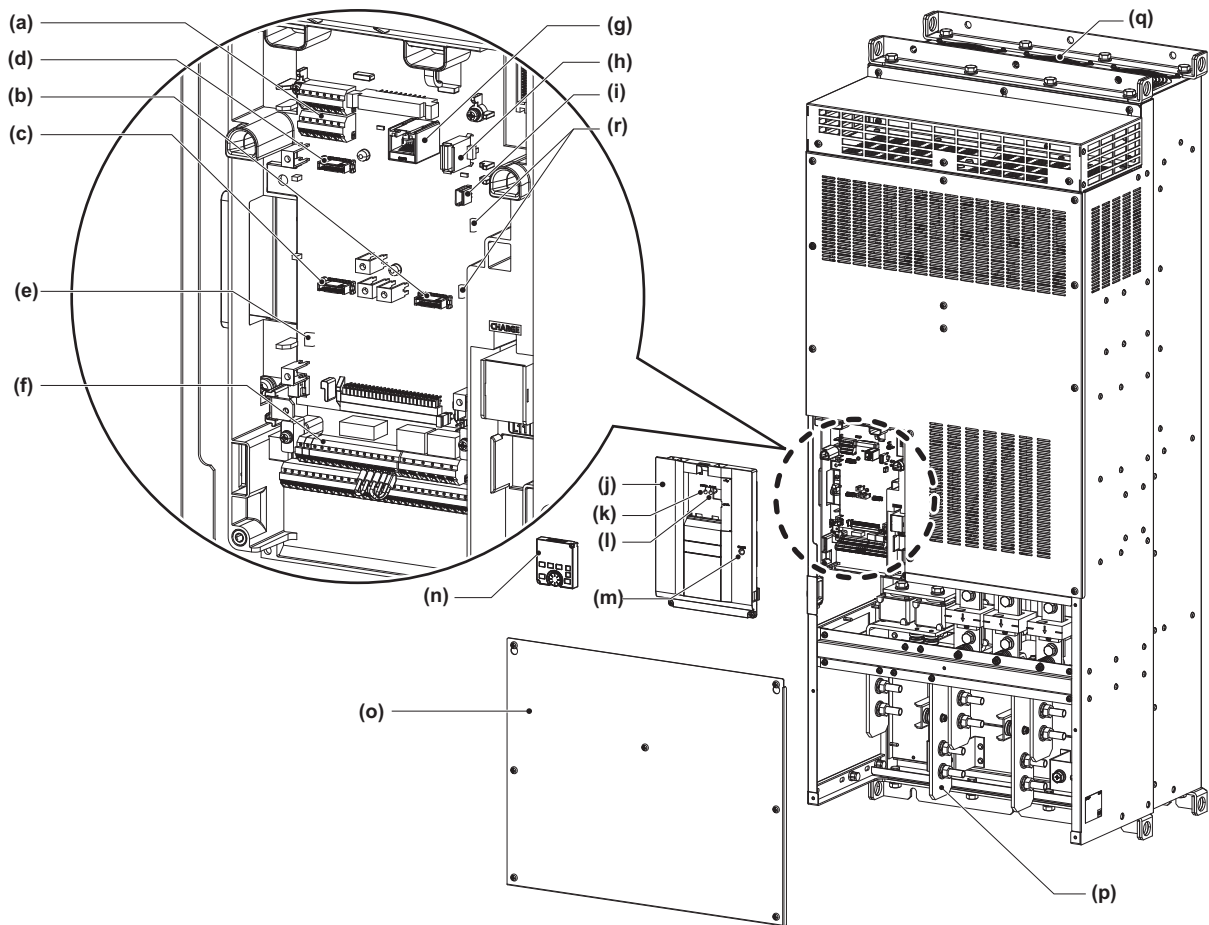

Symbol	Name	Description	Refer to page
(a)	RS-485 terminal	Enables RS-485 communication.	64
(b)	Plug-in option connector 1	Connects a plug-in option or a communication option.	Instruction Manual of the option
(c)	Plug-in option connector 2		
(d)	Plug-in option connector 3		
(e)	Voltage/current input switch	Select voltage or current for the input via terminals 2 and 4.	*1
(f)	Control circuit terminal block	Connects cables for the control circuit.	48
(g)	PU connector	Connects the operation panel (FR-DU08) or the parameter unit (FR-PU07). This connector also enables the RS-485 communication.	63
(h)	USB A connector	Connects a USB memory device.	65
(i)	USB mini B connector	Connector for a personal computer. Enables communication with FR Configurator2.	65
(j)	Upper front cover	Remove this cover for the installation of the product, installation of a plug-in (communication) option, RS-485 terminal wiring, switching of the voltage/current input switches, etc.	25
(k)	Power lamp	Stays ON while the power is supplied to the control circuit (R1/L11, S1/L21).	43
(l)	Alarm lamp	Turns ON when the protective function of the inverter is activated.	100
(m)	Charge lamp	Stays ON while the power is supplied to the main circuit.	43
(n)	Operation panel (FR-DU08)	Operates and monitors the inverter.	*1
(o)	Lower front cover	Remove this cover for wiring.	25
(p)	Main circuit terminal block	Connects cables for the main circuit.	42
(q)	Cooling fan	Cools the inverter.	111
(r)	Switches for safety sub-functions (SW3 and SW4)	Do not change the initial setting (ON  OFF).	—

*1 Refer to the Instruction Manual (Detailed).

◆ Ethernet model

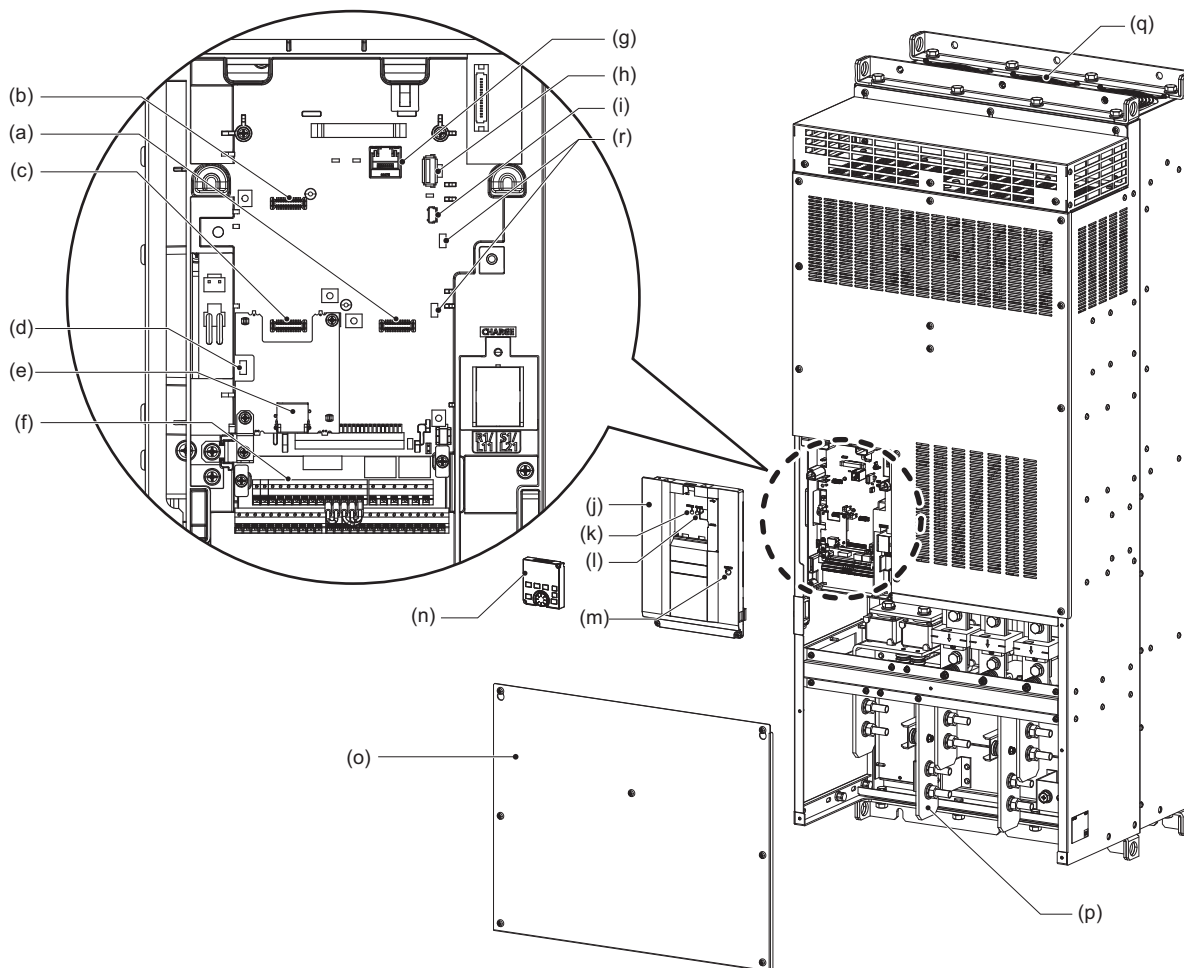

Symbol	Name	Description	Refer to page
(a)	Plug-in option connector 1	Connects a plug-in option or a communication option.	Instruction Manual of the option
(b)	Plug-in option connector 3		
(c)	Plug-in option connector 2	The connector 2 cannot be used because the Ethernet board is installed in the initial status. The Ethernet board must be removed to install a plug-in option to the connector 2. (However, Ethernet communication is disabled in that case.)	*1
(d)	Voltage/current input switch (SW2)	Select voltage or current for the input via terminals 2 and 4.	*2
(e)	Ethernet communication connector	Connect the Ethernet dedicated cable for connection to the network.	64
(f)	Control circuit terminal block	Connects cables for the control circuit.	48
(g)	PU connector	Connects the operation panel (FR-DU08) or the parameter unit (FR-PU07). This connector also enables the RS-485 communication.	63
(h)	USB A connector	Connects a USB memory device.	65
(i)	USB mini B connector	Connector for a personal computer. Enables communication with FR Configurator2.	65
(j)	Upper front cover	Remove this cover for the installation of the product, installation of a plug-in (communication) option, switching of the voltage/current input switches, etc.	25
(k)	Power lamp	Stays ON while the power is supplied to the control circuit (R1/L11, S1/L21).	43
(l)	Alarm lamp	Turns ON when the protective function of the inverter is activated.	100
(m)	Charge lamp	Stays ON while the power is supplied to the main circuit.	43
(n)	Operation panel (FR-DU08)	Operates and monitors the inverter.	*2
(o)	Lower front cover	Remove this cover for wiring.	25
(p)	Main circuit terminal block	Connects cables for the main circuit.	42
(q)	Cooling fan	Cools the inverter.	111
(r)	Switches for safety sub-functions (SW3 and SW4)	Do not change the initial setting (ON ).	—

*1 For details on how to remove the Ethernet board, refer to the Ethernet Function Manual.

*2 Refer to the Instruction Manual (Detailed).

1.3 Compliance with the EU Machinery Directive— Safety sub-functions

◆ FR-A800-F/G (with CC-Link IE TSN safety communication option (FR-A8NCG-S) installed)

This product with the CC-Link IE TSN safety communication option (FR-A8NCG-S) installed supports safety sub-functions (STO and SS1-t) specified in IEC 61800-5-2. By connecting the inverter with a safety programmable controller with an Ethernet cable, signal input via safety communication is enabled.

For compliance with the EU Machinery Directive, refer to the FR-A8NCG-S Instruction Manual.

The inverters manufactured in October 2023 (SERIAL: □3X○○○○○○) or later with the FR-A8NCG-S manufactured in October 2023 (SERIAL: □3X○○○) or later are compliant with the directive.

To use safety sub-functions, any work on the product such as wiring and inspections must be performed according to this Instruction Manual and the Instruction Manual of the CC-Link IE TSN safety communication option (FR-A8NCG-S) by technicians who took a safety standard training.

WARNING

- Any misuse of safety sub-functions may cause physical injury, damage to property, or economic loss. To confirm that the system is compliant with safety standards, a risk assessment must be conducted for the entire system. We shall not be liable for the compliance of the system with safety standards.
- To avoid an electric shock hazard, verify that the voltage on the bus capacitors has discharged before working on the inverter. Measure the DC bus voltage between terminals P/+ and N/- or other measurement points to verify zero voltage. (For the measurement points and the capacitor discharge time, refer to the Instruction Manual of the inverter.)
- When the power supply to the gate drive circuit is shut off by a safety sub-function, the inverter and the motor are not insulated each other. To avoid an electric shock hazard, verify that the voltage on the bus capacitors has discharged before wiring or inspection of the motor. Measure the DC bus voltage between terminals P/+ and N/- or other measurement points to verify zero voltage. (For the measurement points and the capacitor discharge time, refer to the Instruction Manual of the inverter.)

CAUTION

- Check safety sub-functions at least once per three months. Note that the CC-Link IE TSN safety communication option (FR-A8NCG-S) must be restarted before the operation check.
- The following information is merely a guide for proper installation.
We shall not be liable for the compliance or non-compliance with any local, national, or international codes or regulations for the installation of this product. Installation not compliant with applicable codes or directives may cause physical injury or damage to property.

◆ FR-A800-F/G (with PROFIsafe communication option (A8SPRS) installed)

This product with the PROFIsafe communication option (A8SPRS) installed supports safety sub-functions (STO, SS1, SS2, SOS, SLS, SDI, SLP, SSM, and SBC) specified in IEC 61800-5-2. By connecting the inverter with a safety programmable controller with an Ethernet cable, signal input via safety communication is enabled.

For compliance with the EU Machinery Directive, refer to the A8SPRS Instruction Manual.

To use safety sub-functions, any work on the product such as wiring and inspections must be performed according to this Instruction Manual and the Instruction Manual of the PROFIsafe communication option (A8SPRS) by technicians who took a safety standard training.

WARNING

- Any misuse of safety sub-functions may cause physical injury, damage to property, or economic loss. To confirm that the system is compliant with safety standards, a risk assessment must be conducted for the entire system. We shall not be liable for the compliance of the system with safety standards.
- To avoid an electric shock hazard, verify that the voltage on the bus capacitors has discharged before working on the inverter. Measure the DC bus voltage between terminals P/+ and N/- or other measurement points to verify zero voltage. (For the measurement points and the capacitor discharge time, refer to the Instruction Manual of the inverter.)
- When the power supply to the gate drive circuit is shut off by a safety sub-function, the inverter and the motor are not insulated each other. To avoid an electric shock hazard, verify that the voltage on the bus capacitors has discharged before wiring or inspection of the motor. Measure the DC bus voltage between terminals P/+ and N/- or other measurement points to verify zero voltage. (For the measurement points and the capacitor discharge time, refer to the Instruction Manual of the inverter.)

CAUTION

- Check safety sub-functions at least once per three months. Note that the PROFIsafe communication option (A8SPRS) must be restarted before the operation check. For details on the operation check, refer to the Instruction Manual of the PROFIsafe communication option (A8SPRS).
- The following information is merely a guide for proper installation.
We shall not be liable for the compliance or non-compliance with any local, national, or international codes or regulations for the installation of this product. Installation not compliant with applicable codes or directives may cause physical injury or damage to property.

1.3.1 Specifications

Function			Safety level	Description	Safety communication option	
					FR-A8NCG-S	A8SPRS
Safety sub-function (IEC 61800-5-2)	STO (Safe torque off)	Safe torque off	SIL3/Cat.3/PLe	Driving power to the motor is electronically shut off by responding to the input signal from the safety controller. This function is available even without a safety encoder installed.	○	○
	SS1-t (Safe stop 1 (time controlled))	Safe stop 1 (time controlled)		Deceleration starts by responding to the input signal from the safety controller. The STO function is activated after the specified time to confirm the stop state elapses. This function is available even without a safety encoder installed.	○	○
	SS1-r (Safe stop 1 (ramp monitored))	Safe stop 1 (ramp monitored)		Deceleration starts by responding to the input signal from the safety controller. Deceleration is monitored based on the motor deceleration rate. The STO function is activated after the specified time to confirm the stop state elapses.	—	○
	SS2-t (Safe stop 2 (time controlled))	Safe stop 2 (time controlled)		Deceleration starts by responding to the input signal from the safety controller. The SOS function is activated after the specified time to confirm the stop state elapses.	—	○
	SS2-r (Safe stop 2 (ramp monitored))	Safe stop 2 (ramp monitored)		Deceleration starts by responding to the input signal from the safety controller. Deceleration is monitored based on the motor deceleration rate. The SOS function is activated after the specified time to confirm the stop state elapses.	—	○
	SOS (Safe operating stop)	Safe operating stop		The motor position is monitored so that the motor stops within the specified range from the stop position. Power is still supplied to the motor during the SOS function.	—	○
	SLS (Safely-limited speed)	Safely-limited speed		The motor speed is monitored so that the predetermined speed limit is not exceeded. If the limit is exceeded, the STO function is activated.	—	○
	SDI (Safe direction)	Safe direction		The motor rotation direction is monitored. If the direction changes from the specified one, the STO function is activated.	—	○
	SLP (Safely-limited position)	Safely-limited position		The motor travel distance (position) is monitored. If the motor travels over the specified distance (position range), the STO function is activated.	—	○
	SSM (Safe speed monitor)	Safe speed monitor		A safety output signal is output when the motor speed is within the speed limit.	—	○
SBC (Safe brake control)	Safe brake control	When the STO or SS1 command is input, a safety output signal is output to control an external brake. When the STO command is input, this function is available even without a safety encoder installed.	—	○		
—	SMS (Safe maximum speed)	Safe maximum speed	The motor speed is monitored so that the maximum speed is not exceeded. If the maximum speed is exceeded, the STO function is activated.	—	○	

○: Supported, —: Not supported

1.4 Related manuals

Manuals related to the FR-A800 inverter are shown in the following table.

Name	Manual number
FR-A800 Instruction Manual (Detailed)	IB-0600503ENG
FR-A800-E Ethernet Function Manual	IB-0600628ENG
FR-CC2 Instruction Manual	IB-0600543ENG
FR-A8NCG-S Instruction Manual	IB-0600975ENG
FR Configurator2 Instruction Manual	IB-0600516ENG
PLC Function Programming Manual	IB-0600492ENG

CHAPTER 2 INSTALLATION AND WIRING

- 2.1 Peripheral devices22
- 2.2 Removal and reinstallation of the operation panel or the front covers.....25
- 2.3 Installation of the inverter and enclosure design27
- 2.4 Terminal connection diagrams.....36
- 2.5 Main circuit terminals42
- 2.6 Control circuit.....48
- 2.7 Communication connectors and terminals.....63
- 2.8 Connection to a motor with encoder (Vector control)67
- 2.9 Parameter settings for a motor with encoder73
- 2.10 Connection of stand-alone option units74
- 2.11 Connection of the earthing (grounding) cable (Ethernet model).....78

2 INSTALLATION AND WIRING

This chapter explains the installation and the wiring of this product.
Always read the instructions before use.

2.1 Peripheral devices

2.1.1 Inverter and peripheral devices

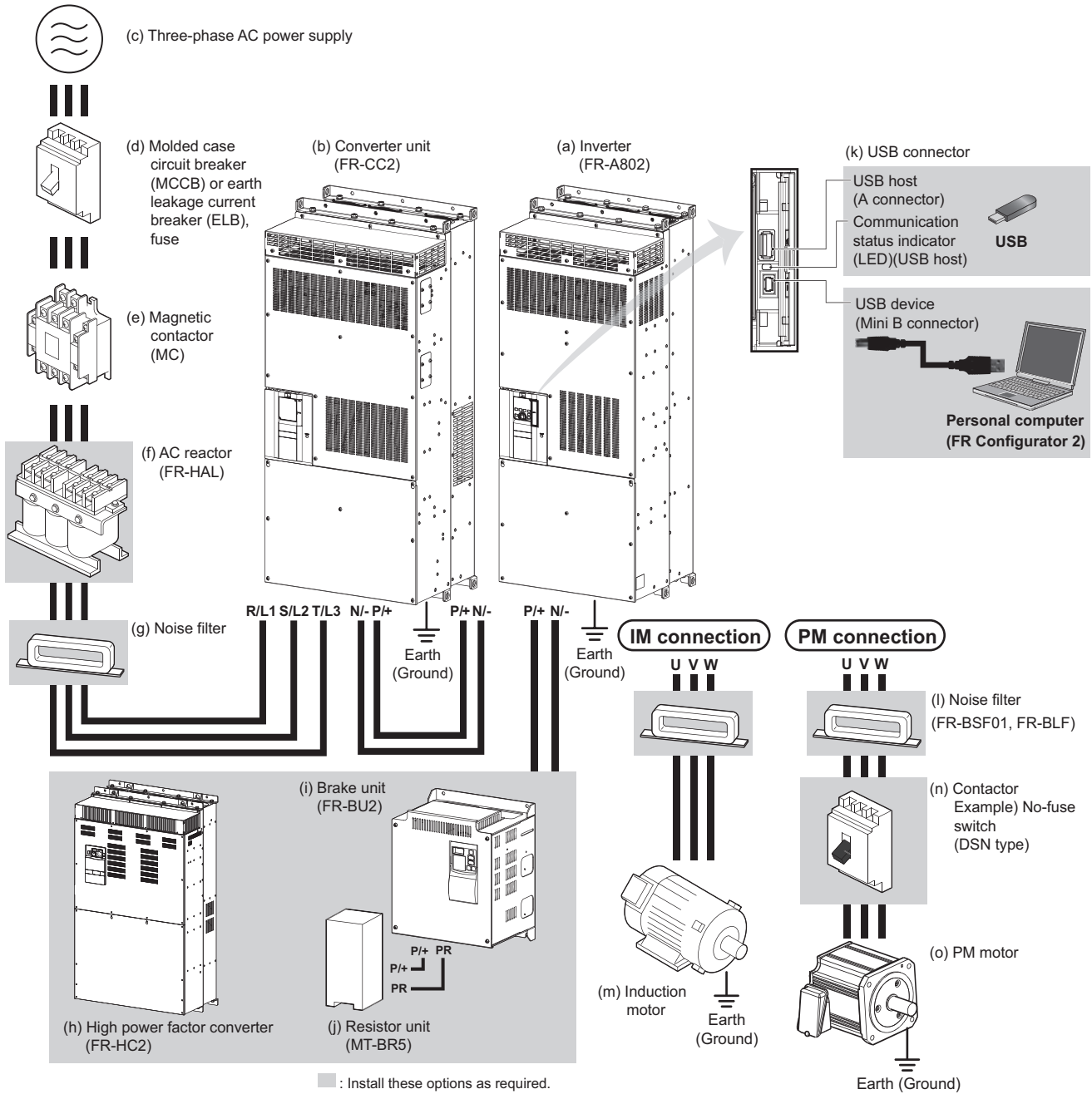

NOTE

- To prevent an electric shock, always earth (ground) the motor, the inverter, and the converter unit.
- Do not install a power factor correction capacitor, surge suppressor, or capacitor type filter on the inverter's output side. Doing so will cause the inverter shut off or damage the capacitor or surge suppressor. If any of the above devices is connected, immediately remove it. When installing a molded case circuit breaker on the output side of the inverter, contact the manufacturer of the molded case circuit breaker.
- Electromagnetic wave interference:
The input/output (main circuit) of the inverter or the converter unit includes high frequency components, which may interfere with the communication devices (such as AM radios) used near the inverter or the converter unit. In this case, activating the EMC filter of the converter unit may minimize interference. (Refer to [page 85](#).)
- For details on options and peripheral devices, refer to the respective Instruction Manual.
- A PM motor cannot be driven by the commercial power supply.
- A PM motor is a motor with permanent magnets embedded inside. High voltage is generated at the motor terminals while the motor is running. Before closing the contactor at the output side, make sure that the inverter power is ON and the motor is stopped.

Symbol	Name	Overview	Refer to page
(a)	Inverter (FR-A802)	The life of the inverter and the converter unit is influenced by the surrounding air temperature. The surrounding air temperature should be as low as possible within the permissible range. This must be noted especially when the inverter is installed in an enclosure. Incorrect wiring may lead to damage of the inverter and the converter unit. The control signal lines must be kept fully away from the main circuit lines to protect them from noise. The built-in EMC filter of the converter unit can reduce the noise.	27, 36, 85
(b)	Converter unit (FR-CC2)		
(c)	Three-phase AC power supply	Must be within the permissible power supply specifications of the converter unit.	122
(d)	Molded case circuit breaker (MCCB), earth leakage circuit breaker (ELB), or fuse	Must be selected carefully since an inrush current flows in the converter unit at power ON.	24
(e)	Magnetic contactor (MC)	Install this to ensure safety. Do not use this to start and stop the inverter. Doing so will shorten the life of the inverter and the converter unit.	90
(f)	AC reactor (FR-HAL)	Install this to suppress harmonics and to improve the power factor. An AC reactor (FR-HAL) (option) is required when installing the inverter near a large power supply system (1000 kVA or more). The inverter or the converter unit may be damaged if you do not use a reactor. Select a reactor according to the applied motor capacity.	89
(g)	Noise filter	Suppresses the noise radiated from the power supply side of the converter unit.	82
(h)	High power factor converter (FR-HC2)	Suppresses the power supply harmonics significantly. Install this as required. When FR-HC2 is used, FR-CC2 is not required.	75
(i)	Brake unit (FR-BU2)	Allows the inverter to provide the optimal regenerative braking capability. Install this as required.	74
(j)	Resistor unit (MT-BR5)		
(k)	USB connection	Connect between the inverter and a personal computer with a USB (ver. 1.1) cable. Use a USB memory device to copy parameter settings or use the trace function.	65
(l)	Noise filter	Install this to reduce the electromagnetic noise generated from the inverter and the converter unit. The noise filter is effective in the range from about 0.5 to 5 MHz.	82
(m)	Induction motor	Connect a squirrel-cage induction motor.	—
(n)	Contactor Example) No-fuse switch (DSN type)	Connect this for an application where a PM motor is driven by the load even while the inverter power is OFF. Do not open or close the contactor while the inverter is running (outputting).	—
(o)	PM motor	A PM motor can be used. A PM motor cannot be driven by the commercial power supply.	—

2.1.2 Peripheral devices

◆ Selecting the converter unit (FR-CC2)

Select the capacity of the FR-CC2 converter unit according to the connected motor capacity.

Motor capacity (kW) ^{*1}	Converter unit FR-CC2-[]	Inverter												
		SLD (superlight duty)			LD (light duty)			ND (normal duty, initial value)			HD (heavy duty)			
		Model FR-A842-[]	Rated current (A)		Model FR-A842-[]	Rated current (A)		Model FR-A842-[]	Rated current (A)		Model FR-A842-[]	Rated current (A)		
280	H315K	—	—	—	—	—	—	—	—	—	—	315K	07700	547
315	H315K	—	—	—	—	—	—	315K	07700	610	355K	08660	610	
355	H355K	—	—	—	315K	07700	683	355K	08660	683	400K	09620	683	
400	H400K	315K	07700	770	355K	08660	770	400K	09620	770	450K	10940	770	
450	H450K	355K	08660	866	400K	09620	866	450K	10940	866	500K	12120	866	
500	H500K	400K	09620	962	450K	10940	962	500K	12120	962	—	—	—	
560	H560K	450K	10940	1094	500K	12120	1094	—	—	—	—	—	—	
630	H630K	500K	12120	1212	—	—	—	—	—	—	—	—	—	

*1 The motor capacity indicated is the maximum capacity applicable for use of the Mitsubishi Electric standard 4-pole motor.

◆ Selecting the breaker / magnetic contactor

Check the model name of the inverter and the converter unit you purchased. Appropriate peripheral devices must be selected according to the capacity.

Refer to the following table to prepare appropriate peripheral devices.

- 400 V class

Motor output (kW)	Applicable converter model ^{*1}	Molded case circuit breaker (MCCB) ^{*1*2} or earth leakage circuit breaker (ELB) (NF or NV type)	Magnetic contactor (MC) ^{*1*3} on converter unit's input side
315	FR-CC2-H315K	700 A	S-N600
355	FR-CC2-H355K	800 A	S-N600
400	FR-CC2-H400K	900 A	S-N800
450	FR-CC2-H450K	1000 A	1000 A rated product
500	FR-CC2-H500K	1200 A	1000 A rated product
560	FR-CC2-H560K	1500 A	1200 A rated product
630	FR-CC2-H630K	2000 A	1400 A rated product

*1 Assumes the use of a Mitsubishi Electric standard 4-pole motor with the power supply voltage of 400 VAC 50 Hz.

*2 Select an MCCB according to the power supply capacity.

Install one MCCB per converter unit. For the use in the United States or Canada, refer to [page 134](#), and select the appropriate fuse.

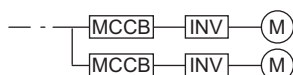

*3 The matrix shows the magnetic contactor selected according to the standards of Japan Electrical Manufacturers' Association (JEM standards) for AC-1 class. The electrical durability of magnetic contactor is 500,000 times. When the MC is used for emergency stops during motor driving, the electrical durability is 25 times.

Use the converter unit input current as a reference for selection of an MC to perform an emergency stop during motor operation, and select the MC conforming to JEM 1038-AC-3 class rated operational current. Use the rated motor current as a reference for selection of an MC on the inverter output side to switch to the commercial-power supply operation while running a general-purpose motor, and select the MC conforming to JEM 1038-AC-3 class rated operational current.

NOTE

- When the converter unit capacity is larger than the motor capacity, select an MCCB and a magnetic contactor according to the converter unit model, and select cables and reactors according to the motor output.
- When the breaker on the converter unit's input side trips, check for the wiring fault (short circuit), damage to internal parts of the inverter or the converter unit, etc. The cause of the output shutoff must be identified and removed before turning ON the power of the breaker.

2.2 Removal and reinstallation of the operation panel or the front covers

2

◆ Removal and reinstallation of the operation panel

- Loosen the two screws on the operation panel. (These screws cannot be removed.)
- Press the upper edge of the operation panel while pulling out the operation panel.

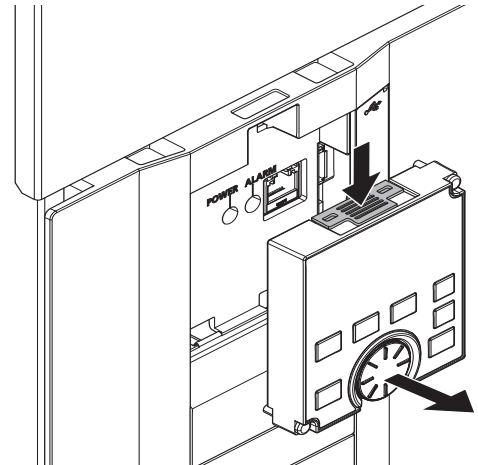
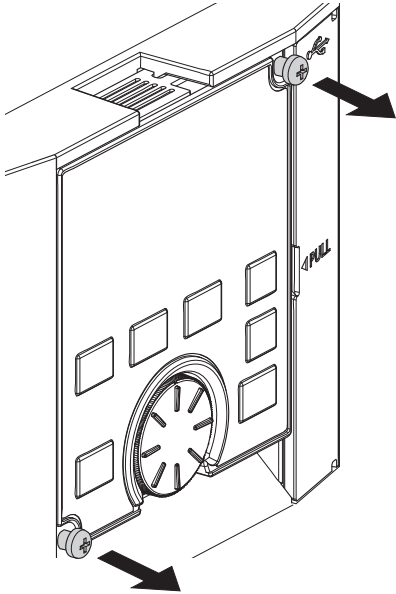

To reinstall the operation panel, align its connector on the back with the PU connector of the inverter, and insert the operation panel. After confirming that the operation panel is fit securely, tighten the screws. (Tightening torque: 0.40 to 0.45 N·m)

◆ Removal of the lower front cover

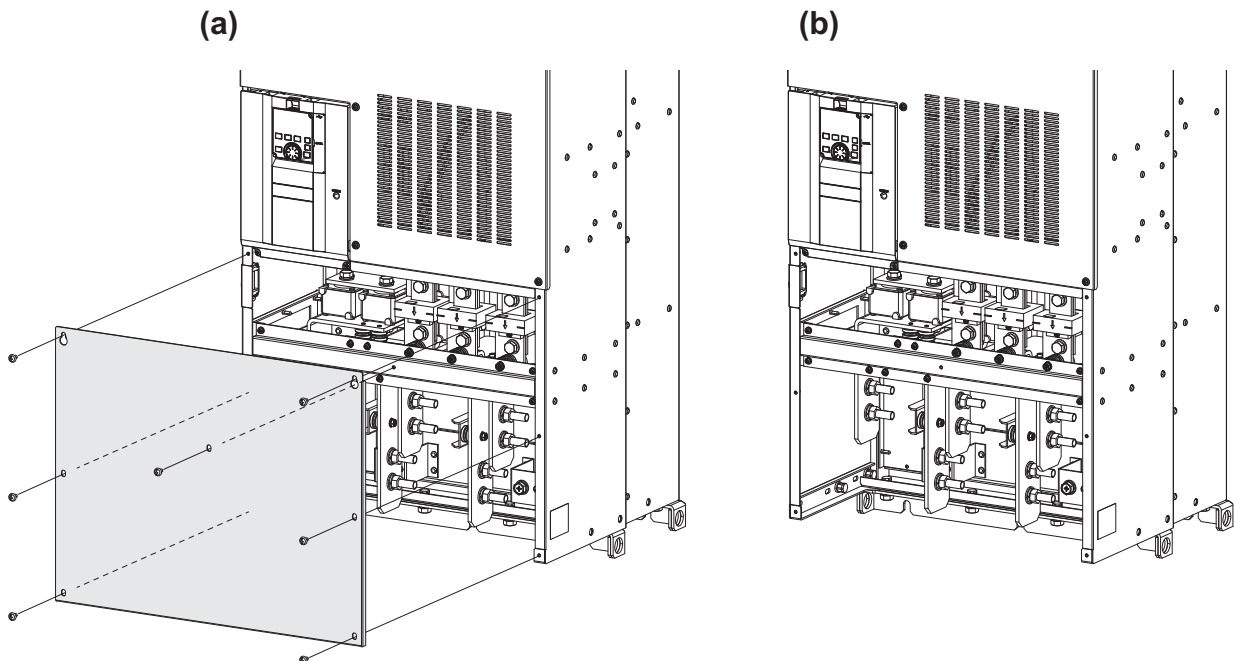

- (a) Remove the mounting screws to remove the lower front cover. (The number of screws differs depending on the capacity of the inverter.)
- (b) With the lower front cover removed, the main circuit can be wired.

◆ Removal of the upper front cover

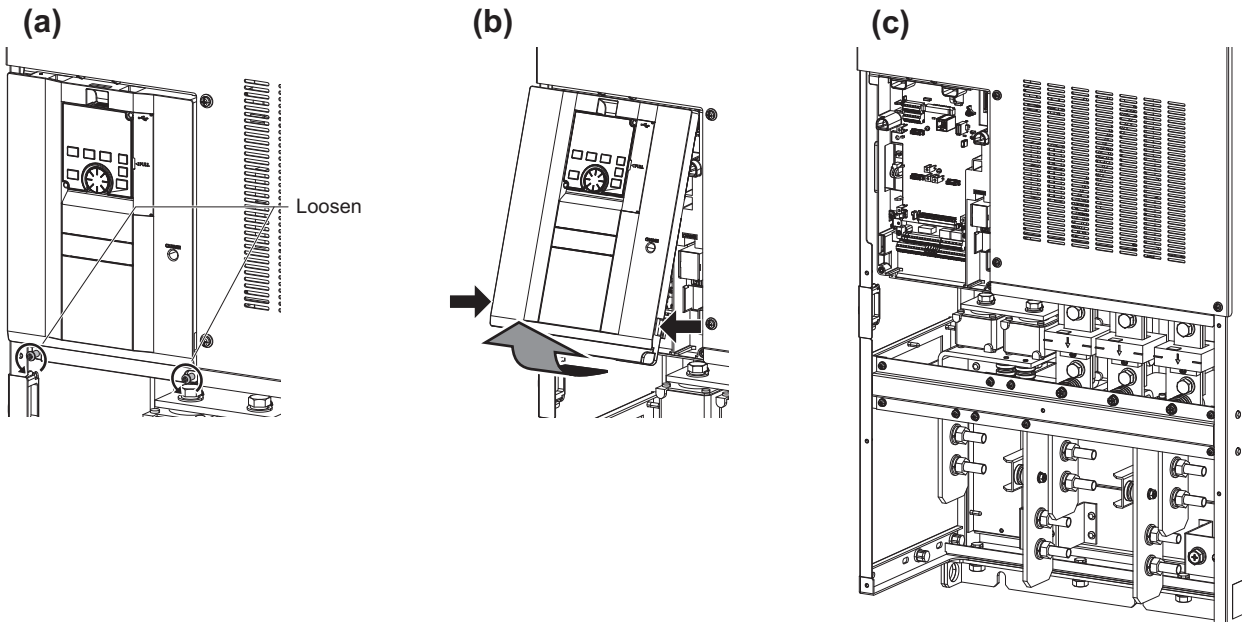

- (a) With the lower cover removed, loosen the mounting screws on the upper cover. (These screws cannot be removed.)
- (b) While holding the areas around the installation hooks on the sides of the upper front cover, pull out the cover using its upper side as a support.
- (c) With the upper cover removed, the control circuit can be wired and the plug-in option can be installed.

◆ Reinstallation of the front cover

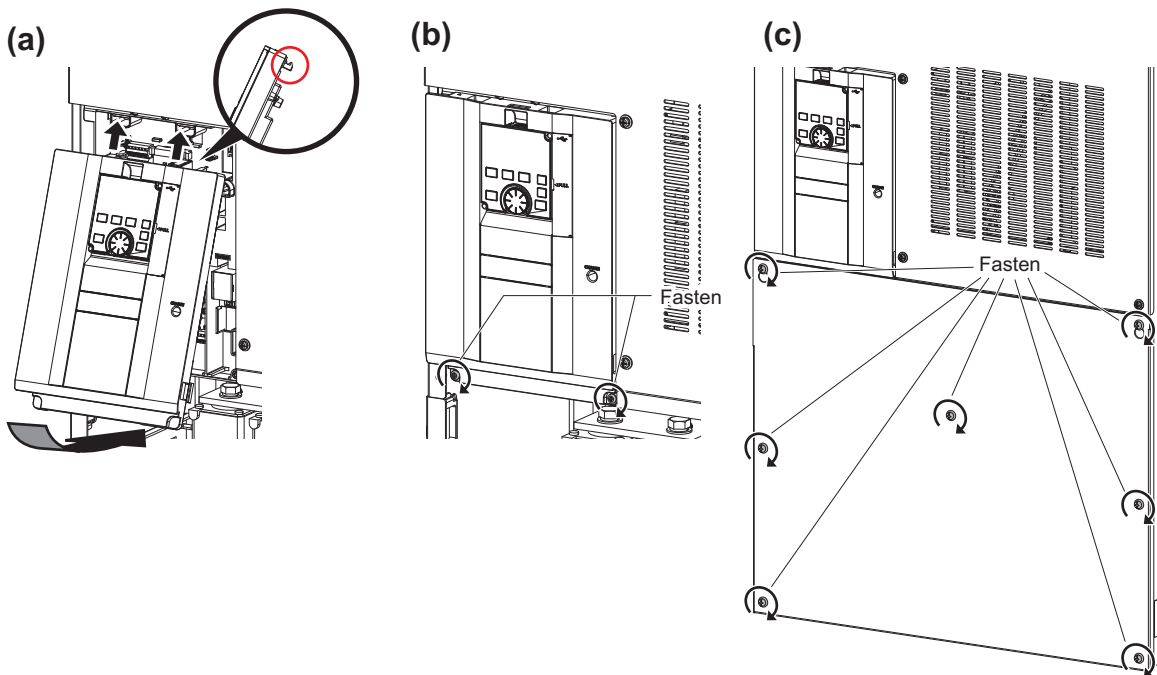

- (a) Insert the upper hooks of the upper front cover into the sockets of the inverter.
Securely install the cover to the inverter by fixing the hooks on the sides of the cover into place.
- (b) Tighten the screws on the lower part of the cover.
- (c) Attach the lower front cover using the screws. (The number of screws differs depending on the capacity of the inverter.)

NOTE

- When installing the upper front cover, fit the connector of the operation panel securely along the guides of the PU connector.
- Fully make sure that the front cover has been reinstalled securely. Always tighten the installation screws of the front cover.

2.3 Installation of the inverter and enclosure design

When designing or manufacturing an inverter enclosure, determine the structure, size, and device layout of the enclosure by fully considering the conditions such as heat generation of the contained devices and the operating environment. An inverter uses many semiconductor devices. To ensure higher reliability and long period of operation, operate the inverter in the ambient environment that completely satisfies the equipment specifications.

2.3.1 Inverter installation environment

The following table lists the standard specifications of the inverter installation environment. Using the inverter in an environment that does not satisfy the conditions deteriorates the performance, shortens the life, and causes a failure. Refer to the following points, and take adequate measures.

◆ Standard environmental specifications of the inverter

Item		Description	
Surrounding air temperature	LD, ND (initial setting), HD	-10°C to +50°C (non-freezing)	
	SLD	-10°C to +40°C (non-freezing)	
Ambient humidity		90% RH or less (non-condensing)	
Storage temperature		-20°C to +65°C ^{*1}	
Atmosphere		Indoors (free from corrosive gas, flammable gas, oil mist, dust and dirt)	
Altitude		Maximum 2500 m ^{*2}	
Vibration		2.9 m/s ² or less at 10 to 55 Hz (in either X, Y, or Z direction)	

*1 Temperature applicable for a short time, for example, in transit.

*2 For installation at an altitude above 1000 m, consider a 3% reduction in the rated current per 500 m increase in altitude.

◆ Temperature

The permissible surrounding air temperature of the inverter is between -10°C and +50°C (-10°C and +40°C at the SLD rating). Always operate the inverter within this temperature range. Operation outside this range will considerably shorten the service lives of the semiconductors, parts, capacitors and others. Take the following measures to keep the surrounding air temperature of the inverter within the specified range.

■ Measures against high temperature

- Use a forced ventilation system or similar cooling system. (Refer to [page 31](#).)
- Install the enclosure in an air-conditioned electric chamber.
- Block direct sunlight.
- Provide a shield or similar plate to avoid direct exposure to the radiated heat and wind of a heat source.
- Ventilate the area around the enclosure well.

■ Measures against low temperature

- Provide a space heater in the enclosure.
- Do not power OFF the inverter. (Keep the start signal of the inverter OFF.)

■ Sudden temperature changes

- Select an installation place where temperature does not change suddenly.
- Avoid installing the inverter near the air outlet of an air conditioner.
- If temperature changes are caused by opening/closing of a door, install the inverter away from the door.

NOTE

- For the amount of heat generated by the inverter unit, refer to [page 30](#).

◆ Humidity

Normally operate the inverter within the ambient air humidity of 45% to 90%. Too high humidity will pose problems of reduced insulation and metal corrosion. On the other hand, too low humidity may cause a spatial electrical breakdown. The humidity conditions for the insulation distance defined in JEM 1103 standard "Insulation Distance from Control Equipment" is 45% to 85%.

■ Measures against high humidity

- Make the enclosure enclosed, and provide it with a hygroscopic agent.
- Provide dry air into the enclosure from outside.
- Provide a space heater in the enclosure.

■ Measures against low humidity

Air with proper humidity can be blown into the enclosure from outside. Also, when installing or inspecting the unit, discharge your body (static electricity) beforehand, and keep your body away from the parts and patterns.

■ Measures against condensation

Condensation may occur if frequent operation stops change the in-enclosure temperature suddenly or if the outside air temperature changes suddenly.

Condensation causes such faults as reduced insulation and corrosion.

- Take the measures against high humidity.
- Do not power OFF the inverter. (Keep the start signal of the inverter OFF.)

◆ Dust, dirt, oil mist

Dust and dirt will cause such faults as poor contacts, reduced insulation and cooling effect due to the moisture-absorbed accumulated dust and dirt, and in-enclosure temperature rise due to a clogged filter. In an atmosphere where conductive powder floats, dust and dirt will cause such faults as malfunction, deteriorated insulation and short circuit in a short time.

Since oil mist will cause similar conditions, it is necessary to take adequate measures.

■ Countermeasure

- Place the inverter in a totally enclosed enclosure.
Take measures if the in-enclosure temperature rises. (Refer to [page 31](#).)
- Purge air.
Pump clean air from outside to make the in-enclosure air pressure higher than the outside air pressure.

◆ Corrosive gas, salt damage

If the inverter is exposed to corrosive gas or to salt near a beach, the printed board patterns and parts will corrode or the relays and switches will result in poor contact.

In such places, take the measures given in the previous paragraph.

◆ Explosive, flammable gases

As the inverter is non-explosion proof, it must be contained in an explosion-proof enclosure. In places where explosion may be caused by explosive gas, dust or dirt, an enclosure cannot be used unless it structurally complies with the guidelines and has passed the specified tests. This makes the enclosure itself expensive (including the test charges). The best way is to avoid installation in such places and install the inverter in a non-hazardous place.

◆ High altitude

Use the inverter at an altitude of within 2500 m. For use at an altitude above 1000 m, consider a 3% reduction in the rated current per 500 m increase in altitude.

If it is used at a higher place, it is likely that thin air will reduce the cooling effect and low air pressure will deteriorate dielectric strength.

◆ Vibration, impact

The vibration resistance of the inverter is up to 2.9 m/s^2 at 10 to 55 Hz frequency and 1 mm amplitude for the directions of X, Y, Z axes. Subjecting the product to vibration and impacts over a long period of time may loosen the structure and cause poor contacts of connectors, even if those vibration and impacts are within the specified values.

Especially when impacts are applied repeatedly, caution must be taken because such impacts may break the installation feet.

2

Countermeasure

- Provide the enclosure with rubber vibration isolators.
- Strengthen the structure to prevent the enclosure from resonance.
- Install the enclosure away from the sources of the vibration.

2.3.2 Amount of heat generated by the inverter

◆ Installing the heat sink inside the enclosure

When the heat sink is installed inside the enclosure, the amount of heat generated by the inverter unit and converter unit is shown in the following tables.

Converter FR-CC2-H□	Amount of heat generated (W)
315K	2350
355K	2600
400K	3050
450K	3400
500K	3800
560K	4400
630K	4920

Inverter FR-A842-□	Amount of heat generated (W)			
	SLD	LD	ND	HD
315K	5800	5050	4450	3900
355K	6690	5800	5100	4410
400K	7370	6480	5650	4930
450K	8600	7340	6500	5650
500K	9810	8630	7400	6490

NOTE

- The figures indicate the amount of heat generated when the output current is the rated current and the carrier frequency is 2 kHz.

◆ Installing the heat sink outside the enclosure

When the heat sink is installed outside the enclosure, the amount of heat generated by the inverter unit and the converter unit is shown in the following tables. (For the details on protruding the heat sink outside the enclosure, refer to [page 34](#).)

Converter FR-CC2-H□	Amount of heat generated (W)	
	Heat sink section (outside of enclosure)	Control section (inside of enclosure)
315K	1640	710
355K	1820	780
400K	2130	920
450K	2380	1020
500K	2660	1140
560K	3080	1320
630K	3440	1480

Inverter FR-A842-□	Amount of heat generated (W)							
	Heat sink section (outside of enclosure)				Control section (inside of enclosure)			
	SLD	LD	ND	HD	SLD	LD	ND	HD
315K	4060	3530	3110	2730	1740	1520	1340	1170
355K	4680	4060	3570	3080	2010	1740	1530	1330
400K	5160	4530	3950	3450	2210	1950	1700	1480
450K	6020	5140	4550	3950	2580	2200	1950	1700
500K	6860	6040	5180	4540	2950	2590	2220	1950

NOTE

- The figures indicate the amount of heat generated when the output current is the rated current and the carrier frequency is 2 kHz.

2.3.3 Cooling system types for inverter enclosure

From the enclosure that contains the inverter, the heat of the inverter and other equipment (transformers, lamps, resistors, etc.) and the incoming heat such as direct sunlight must be dissipated to keep the in-enclosure temperature lower than the permissible temperatures of the in-enclosure equipment including the inverter.

The cooling systems are classified as follows in terms of the cooling calculation method.

- Cooling by natural heat dissipation from the enclosure surface (totally enclosed type)
- Cooling by heat sink (aluminum fin, etc.)
- Cooling by ventilation (forced ventilation type, pipe ventilation type)
- Cooling by heat exchanger or cooler (heat pipe, cooler, etc.)

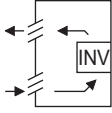
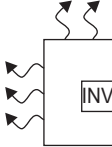
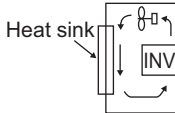
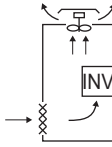
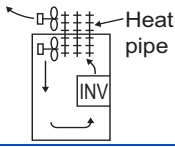
Cooling system		Enclosure structure	Comment
Natural	Natural ventilation (enclosed type / open type)		This system is low in cost and generally used, but the enclosure size increases as the inverter capacity increases. This system is for relatively small capacities.
	Natural ventilation (totally enclosed type)		Being a totally enclosed type, this system is the most appropriate for hostile environment having dust, dirt, oil mist, etc. The enclosure size increases depending on the inverter capacity.
Forced air	Heat sink cooling		This system has restrictions on the heat sink mounting position and area. This system is for relatively small capacities.
	Forced ventilation		This system is for general indoor installation. This is appropriate for enclosure downsizing and cost reduction, and often used.
	Heat pipe		This system is a totally enclosed type, and is appropriate for enclosure downsizing.

2.3.4 Inverter installation

◆ Inverter placement

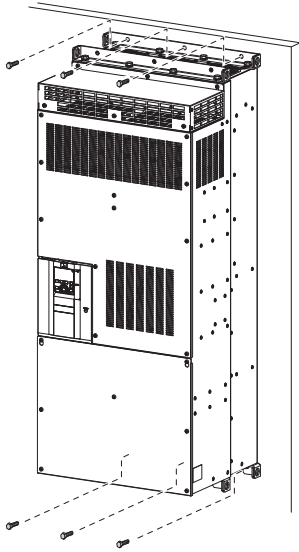

- Install the inverter on a strong surface securely with screws.
- Leave enough clearances and take cooling measures.
- Avoid places where the inverter is subjected to direct sunlight, high temperature and high humidity.
- Install the inverter on a nonflammable wall surface.
- When encasing multiple inverters in an enclosure, install them in parallel as a cooling measure.
- For heat dissipation and maintenance, keep clearance between the inverter and the other devices or enclosure surface. The space below the inverter is required for wiring, and the space above the inverter is required for heat dissipation.
- When designing or building an enclosure for the inverter, carefully consider influencing factors such as heat generation of the contained devices and the operating environment.

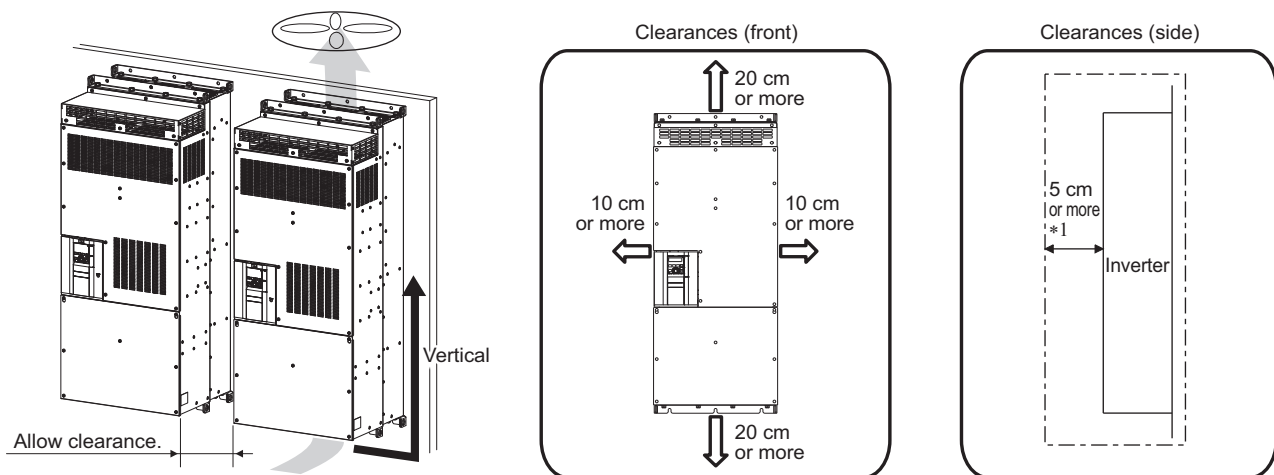

*1 There needs to be a space of at least 30 cm in front of the inverter to replace the cooling fan. Refer to [page 111](#) for fan replacement.

◆ Installation orientation of the inverter

Install the inverter on a wall as specified. Do not mount it horizontally or in any other way.

◆ Above the inverter

Heat is blown up from inside the inverter by the small fan built in the unit. Any equipment placed above the inverter should be heat resistant.

◆ Encasing multiple inverters and converter units

When multiple inverters and converter units are placed in the same enclosure, arrange them horizontally as shown in the figure below. Do not place multiple products vertically. The exhaust air temperature of the inverter and the converter unit may be increased.

When mounting multiple inverters and converter units, fully take caution not to make the surrounding air temperature of the inverter and the converter unit higher than the permissible value by providing ventilation and increasing the enclosure size.

2

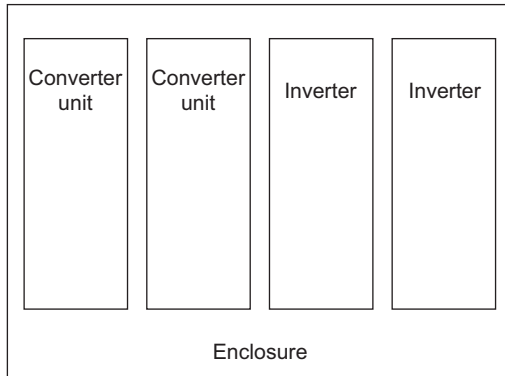

Arrangement of multiple inverters and converter units

◆ Arrangement of the ventilation fan and inverter

Heat generated in the inverter is blown up from the bottom of the unit as warm air by the cooling fan. When installing a ventilation fan for that heat, determine the place of ventilation fan installation after fully considering an air flow. (Air passes through areas of low resistance. Make an airway and airflow plates to expose the inverter to cool air.)

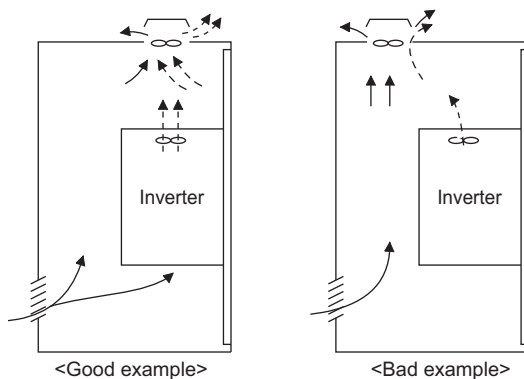

Arrangement of the ventilation fan and inverter

2.3.5 Protruding the heat sink through a panel

When encasing the inverter to an enclosure, the heat generated in the enclosure can be greatly reduced by protruding the heat sink of the inverter.

When installing the inverter in a compact enclosure, etc., this installation method is recommended.

■ Panel cutting

Cut the panel of the enclosure according to the inverter capacity.

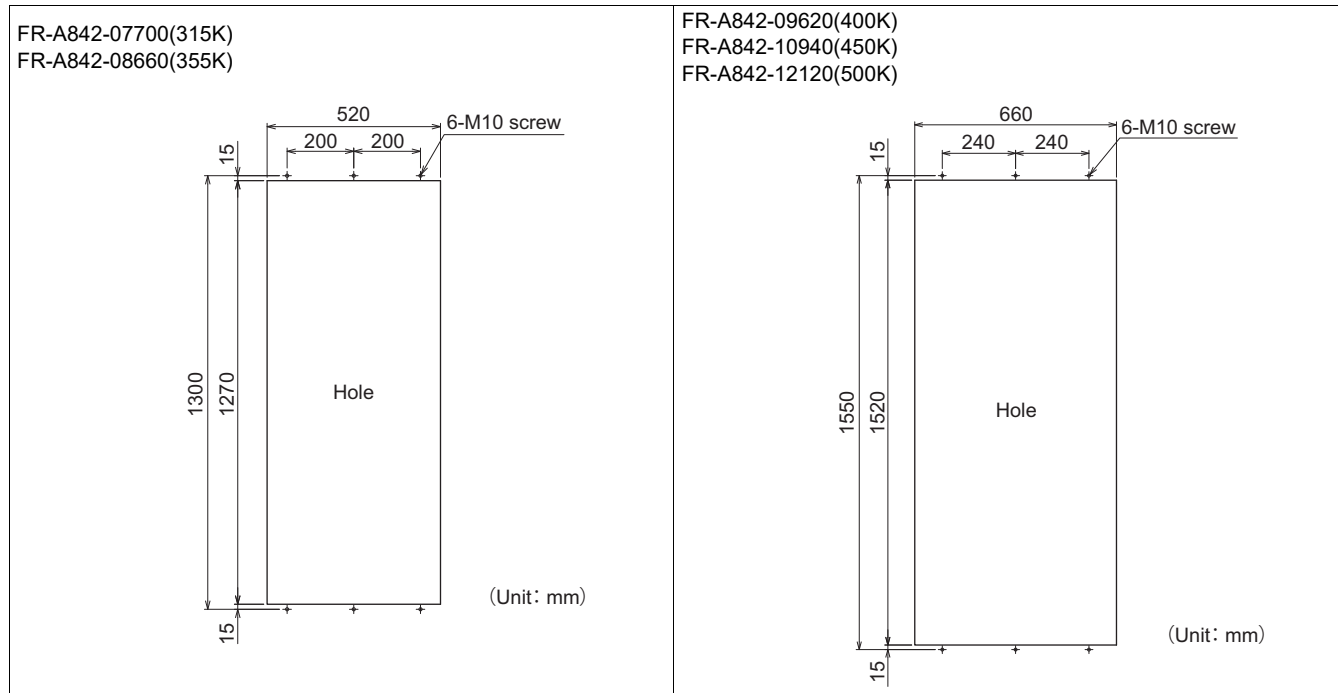

■ Removal of the rear installation frame

The upper and lower installation frames are attached on the inverter (two for each position).

Remove the rear installation frames on the top and bottom of the inverter as follows.

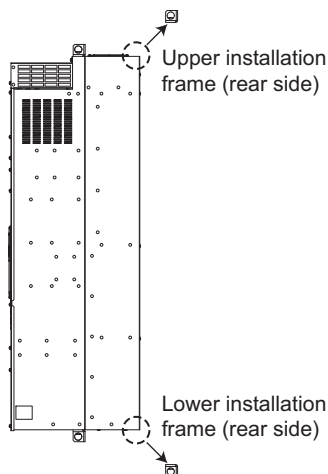

■ Installation of the inverter on the enclosure

Push the inverter heat sink part outside the enclosure, and fix the inverter to the panel with upper and lower installation frames.

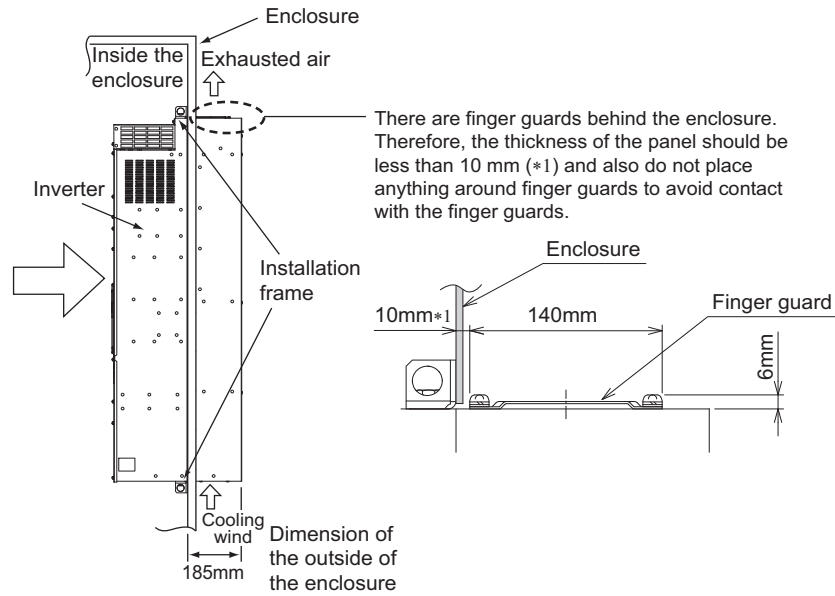

2

NOTE

- As the heat sink part protruded through the panel includes a cooling fan, this type of installation is not suitable for the environment of water drops, oil, mist, dust, etc.
- Be careful not to drop screws, dust etc. into the inverter and cooling fan section.

2.4 Terminal connection diagrams

◆ FM type (RS-485 model)

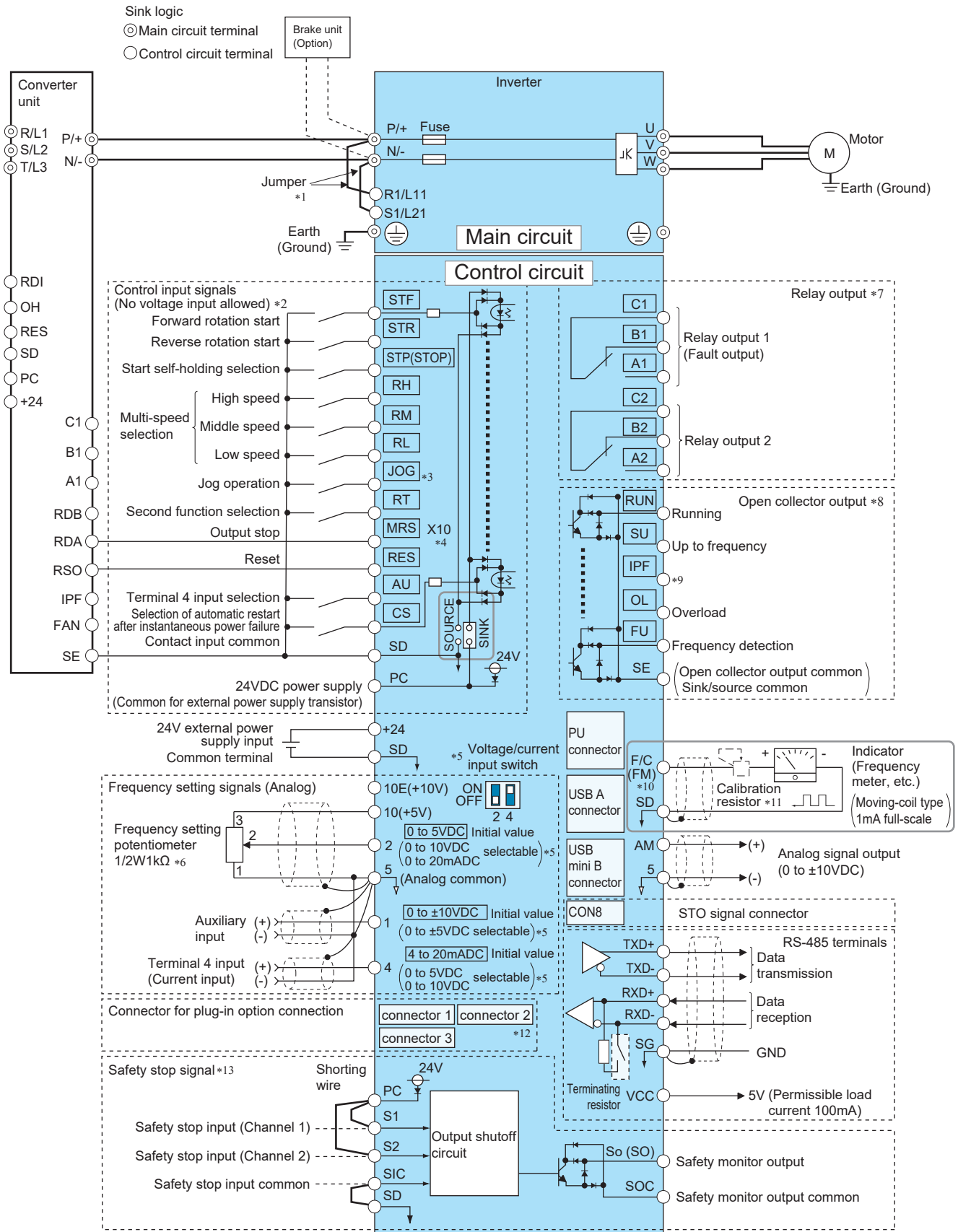

- *1 A jumper is installed across terminal R1/L11 and terminal P/+, and across terminal S1/L21 and terminal N/-. When using a separate power supply for the control circuit, remove the jumpers connected to terminals R1/L11 and S1/L21.
- *2 The function of these terminals can be changed using the Input terminal function selection (**Pr.178 to Pr.189**).
- *3 Terminal JOG is also used as a pulse train input terminal. Use **Pr.291** to choose JOG or pulse.
- *4 The X10 signal (NC contact input specification) is assigned to terminal MRS in the initial setting. Set **Pr.599** = "0" to change the input specification of the X10 signal to NO contact.
- *5 Terminal input specifications can be changed by analog input specification switchover (**Pr.73, Pr.267**). To input voltage (0 to 5 V/0 to 10 V), set the voltage/current input switch OFF. To input current (4 to 20 mA), set the voltage/current input switch ON. Terminals 10 and 2 are also used as a PTC input terminal. (**Pr.561**)
- *6 It is recommended to use 2 W 1 k Ω when the frequency setting signal is changed frequently.
- *7 The function of these terminals can be changed using the Output terminal function selection (**Pr.195 or Pr.196**).
- *8 The function of these terminals can be changed using the Output terminal function selection (**Pr.190 to Pr.194**).
- *9 No function is assigned in the initial setting. Use **Pr.192** for function assignment.
- *10 Terminal FM can be used to output pulse trains as open collector output by setting **Pr.291**.
- *11 Not required when calibrating the scale with the operation panel.
- *12 When the FR-A8NCG-S is installed, other options can be connected to the connectors 2 and 3. When the A8SPRS is installed, other options can be connected to the connector 3. For the options available when the safety communication option is installed, refer to [page 130](#).
- *13 Do not remove the jumpers from terminals S1, S2, and SIC. Do not use terminals S1, S2, SIC, and So (SO).

NOTE

- To prevent a malfunction due to noise, keep the signal cables 10 cm or more away from the power cables. Also, keep the cables of the main circuit for input and output separated.
- After wiring, wire offcuts must not be left in the inverter.
Wire offcuts can cause a fault, failure or malfunction. Always keep the inverter clean.
When drilling mounting holes in an enclosure etc., take caution not to allow chips and other foreign matter to enter the inverter.
- Set the switches of the voltage/current input selection switch assembly correctly. Incorrect setting may cause a fault, failure or malfunction.

◆ FM type (Ethernet model)

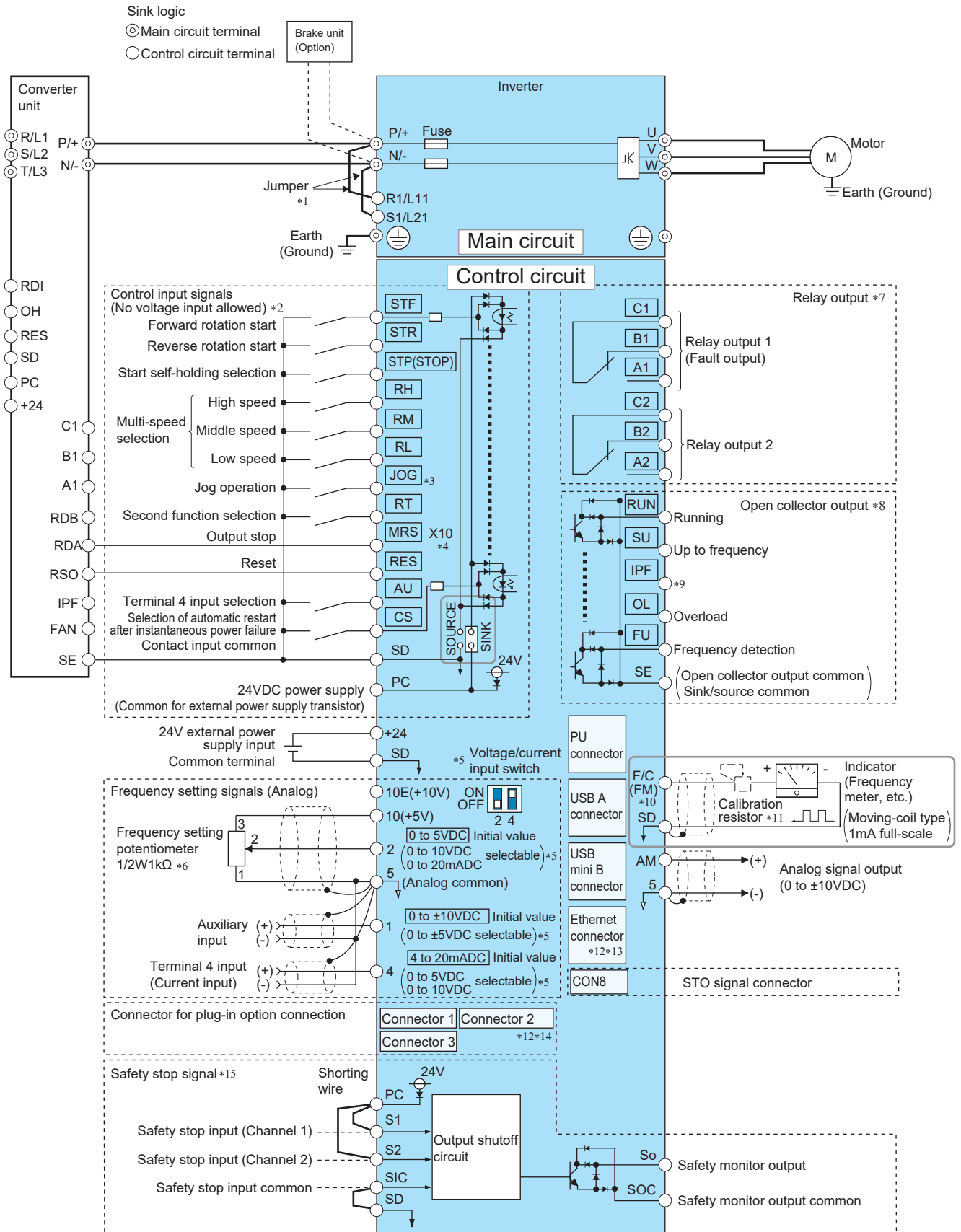

*1 A jumper is installed across terminal R1/L11 and terminal P/+, and across terminal S1/L21 and terminal N/-. When using a separate power supply for the control circuit, remove the jumpers connected to terminals R1/L11 and S1/L21.

*2 The function of these terminals can be changed using the Input terminal function selection (Pr.178 to Pr.189).

*3 Terminal JOG is also used as a pulse train input terminal. Use Pr.291 to choose JOG or pulse.

*4 The X10 signal (NC contact input specification) is assigned to terminal MRS in the initial setting. Set Pr.599 = "0" to change the input specification of the X10 signal to NO contact.

- *5 Terminal input specifications can be changed by analog input specification switchover (**Pr.73, Pr.267**). To input voltage (0 to 5 V/0 to 10 V), set the voltage/current input switch OFF. To input current (4 to 20 mA), set the voltage/current input switch ON. Terminals 10 and 2 are also used as a PTC input terminal. (**Pr.561**)
- *6 It is recommended to use 2 W 1 k Ω when the frequency setting signal is changed frequently.
- *7 The function of these terminals can be changed using the Output terminal function selection (**Pr.195 or Pr.196**).
- *8 The function of these terminals can be changed using the Output terminal function selection (**Pr.190 to Pr.194**).
- *9 No function is assigned in the initial setting. Use **Pr.192** for function assignment.
- *10 Terminal FM can be used to output pulse trains as open collector output by setting **Pr.291**.
- *11 Not required when calibrating the scale with the operation panel.
- *12 The option connector 2 cannot be used because the Ethernet board is installed in the initial status. The Ethernet board must be removed to install a plug-in option to the option connector 2. (However, Ethernet communication is disabled in that case.)
- *13 The Ethernet board must be removed to install the PROFI-safe communication option (A8SPRS).
- *14 When the FR-A8NCG-S is installed, other options can be connected to the connectors 2 and 3. When the A8SPRS is installed, other options can be connected to the connector 3. For the options available when the safety communication option is installed, refer to [page 130](#).
- *15 Do not remove the jumpers from terminals S1, S2, and SIC. Do not use terminals S1, S2, SIC, and So (SO).

NOTE

- To prevent a malfunction due to noise, keep the signal cables 10 cm or more away from the power cables. Also, keep the cables of the main circuit for input and output separated.
- After wiring, wire offcuts must not be left in the inverter.
Wire offcuts can cause a fault, failure or malfunction. Always keep the inverter clean.
When drilling mounting holes in an enclosure etc., take caution not to allow chips and other foreign matter to enter the inverter.
- Set the switches of the voltage/current input selection switch assembly correctly. Incorrect setting may cause a fault, failure or malfunction.

◆ CA type (Ethernet model)

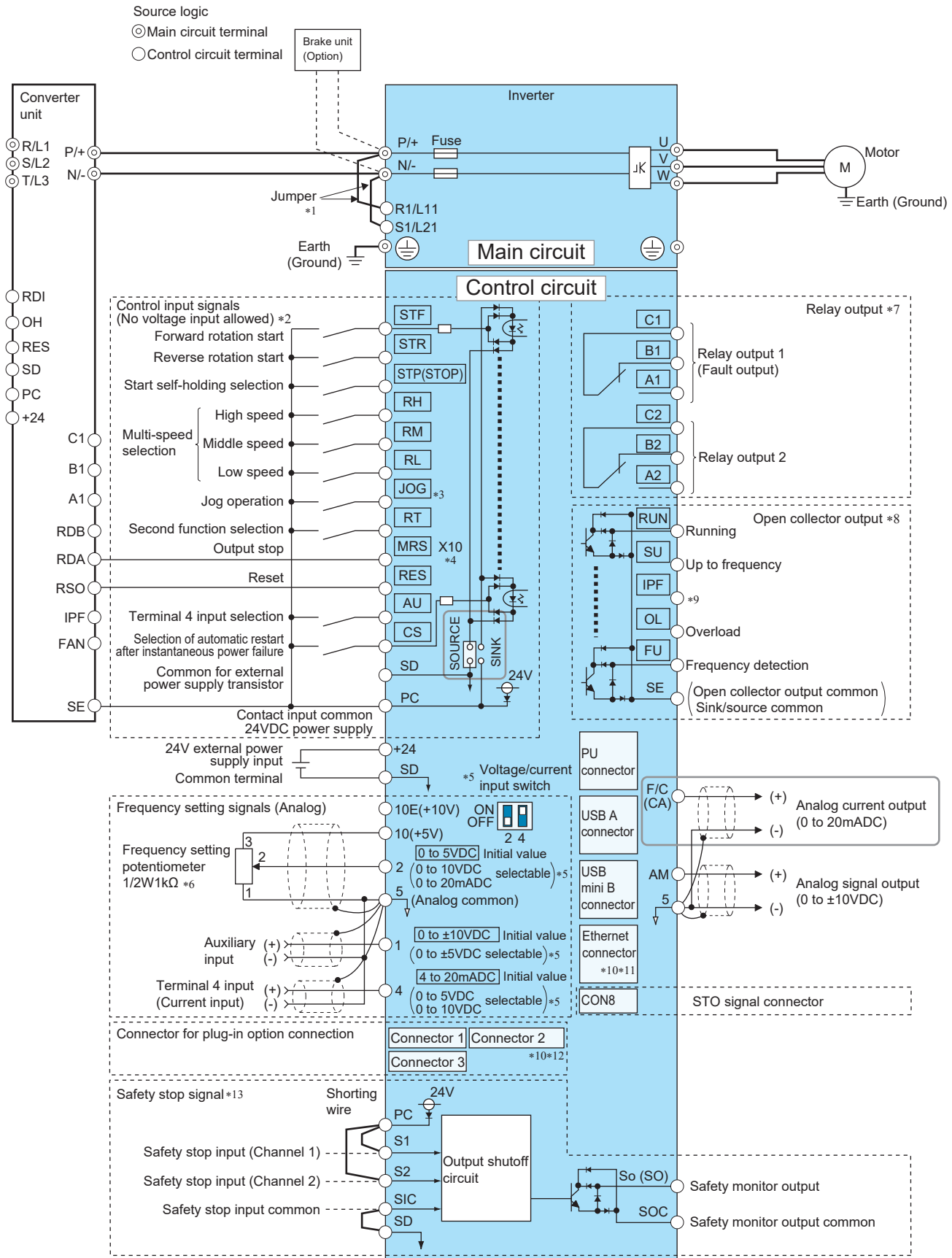

*1 A jumper is installed across terminal R1/L11 and terminal P/+, and across terminal S1/L21 and terminal N/-. When using a separate power supply for the control circuit, remove the jumpers connected to terminals R1/L11 and S1/L21.

*2 The function of these terminals can be changed using the Input terminal function selection (Pr.178 to Pr.189).

*3 Terminal JOG is also used as a pulse train input terminal. Use Pr.291 to choose JOG or pulse.

- *4 The X10 signal (NC contact input specification) is assigned to terminal MRS in the initial setting. Set **Pr.599** = "0" to change the input specification of the X10 signal to NO contact.
- *5 Terminal input specifications can be changed by analog input specification switchover (**Pr.73, Pr.267**). To input voltage (0 to 5 V/0 to 10 V), set the voltage/current input switch OFF. To input current (4 to 20 mA), set the voltage/current input switch ON. Terminals 10 and 2 are also used as a PTC input terminal. (**Pr.561**)
- *6 It is recommended to use 2 W 1 kΩ when the frequency setting signal is changed frequently.
- *7 The function of these terminals can be changed using the Output terminal function selection (**Pr.195 or Pr.196**).
- *8 The function of these terminals can be changed using the Output terminal function selection (**Pr.190 to Pr.194**).
- *9 No function is assigned in the initial setting. Use **Pr.192** to assign a function to the terminal.
- *10 The option connector 2 cannot be used because the Ethernet board is installed in the initial status. The Ethernet board must be removed to install a plug-in option to the option connector 2. (However, Ethernet communication is disabled in that case.)
- *11 The Ethernet board must be removed to install the PROFIsafe communication option (A8SPRS).
- *12 When the FR-A8NCG-S is installed, other options can be connected to the connectors 2 and 3. When the A8SPRS is installed, other options can be connected to the connector 3. For the options available when the safety communication option is installed, refer to [page 130](#).
- *13 Do not remove the jumpers from terminals S1, S2, and SIC. Do not use terminals S1, S2, SIC, and So (SO).

NOTE

- To prevent a malfunction due to noise, keep the signal cables 10 cm or more away from the power cables. Also, keep the cables of the main circuit for input and output separated.
- After wiring, wire offcuts must not be left in the inverter.
Wire offcuts can cause a fault, failure or malfunction. Always keep the inverter clean.
When drilling mounting holes in an enclosure etc., take caution not to allow chips and other foreign matter to enter the inverter.
- Set the switches of the voltage/current input selection switch assembly correctly. Incorrect setting may cause a fault, failure or malfunction.

◆ Connection between the converter unit and the inverter

Wire correctly to ensure the command transmission from the converter unit to the inverter. Otherwise, the converter unit and the inverter may be damaged.

For the wiring length, refer to the following tables.

Location	Total wiring length
Across terminals P and P and terminals N and N	50 m or shorter
Other control signal cables	30 m or shorter

For the wire gauge of the wire across the main circuit terminals P/+ and N/- (P and P, N and N), refer to [page 44](#).

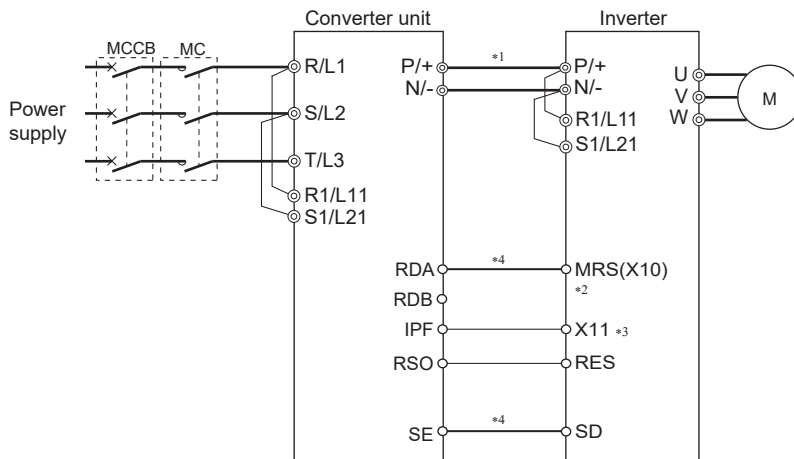

- *1 Do not install an MCCB across terminals P/+ and N/- (between terminals P and P/+ or between terminals N and N/-). Connecting the opposite polarity of terminals N/- and P/+ will damage the inverter.
- *2 For the X10 signal input, set "10" in any parameter from **Pr.178 to Pr.189 (Input terminal function selection)** to assign the function. (The X10 signal is assigned to terminal MRS in the initial setting.)
The state of contact at terminal MRS is initially set to normally closed (NC). To change the contact state to normally open (NO), set **Pr.599** = "0".
- *3 For the X11 signal input, set "11" in any parameter from **Pr.178 to Pr.189 (Input terminal function selection)** to assign the function.
For RS-485 or any other form of communication where the start command is only transmitted once, use the X11 signal to save the operation mode at the time of an instantaneous power failure.
- *4 Always connect terminal RDA of the converter unit and terminal MRS (X10) of the inverter, and terminal SE of the converter unit and terminal SD (sink logic) of the inverter. Otherwise, the converter unit may be damaged.

2.5 Main circuit terminals

2.5.1 Details on the main circuit terminals of the inverter

Terminal symbol	Terminal name	Terminal function description	Refer to page
U, V, W	Inverter output	Connect these terminals to a three-phase squirrel cage motor or a PM motor.	—
R1/L11, S1/L21	Power supply for the control circuit	Connected to terminals P/+ and N/-. To retain the fault display and fault output, or to use the converter unit (FR-CC2), remove the jumpers installed in terminals R1/L11 and S1/L21, and apply external power supply to these terminals. When using a separate power supply connected to terminals R1/L11 and S1/L21, the required power capacity is 80 VA.	59
P/+, N/-	Converter unit connection	Connect the converter unit (FR-CC2), brake unit (FR-BU2), or high power factor converter (FR-HC2).	36, 74
	Earth (ground)	For earthing (grounding) the inverter chassis. Be sure to earth (ground) the inverter.	47

2.5.2 Details on the main circuit terminals of the converter unit (FR-CC2)

Terminal symbol	Terminal name	Terminal function description	Refer to page
R/L1, S/L2, T/L3	AC power input	Connect these terminals to the commercial power supply. (When the converter unit is connected to the 12-phase rectifier power transformer, refer to the Instruction Manual of the FR-CC2.)	—
R1/L11, S1/L21	Power supply for the control circuit	Connected to the AC power supply terminals R/L1 and S/L2. To retain the fault display and fault output, remove the jumpers across terminals R/L1 and R1/L11 and across S/L2 and S1/L21, and apply external power to these terminals. When using a separate power supply connected to terminals R1/L11 and S1/L21, the required power capacity is 80 VA.	59
P/+, N/-	Inverter connection	Connected to the inverter terminals P/+ and N/-.	36
	Earth (ground)	For earthing (grounding) the converter unit chassis. This product must be earthed (grounded).	47

2.5.3 Terminal layout of the main circuit terminals, wiring of power supply and the motor

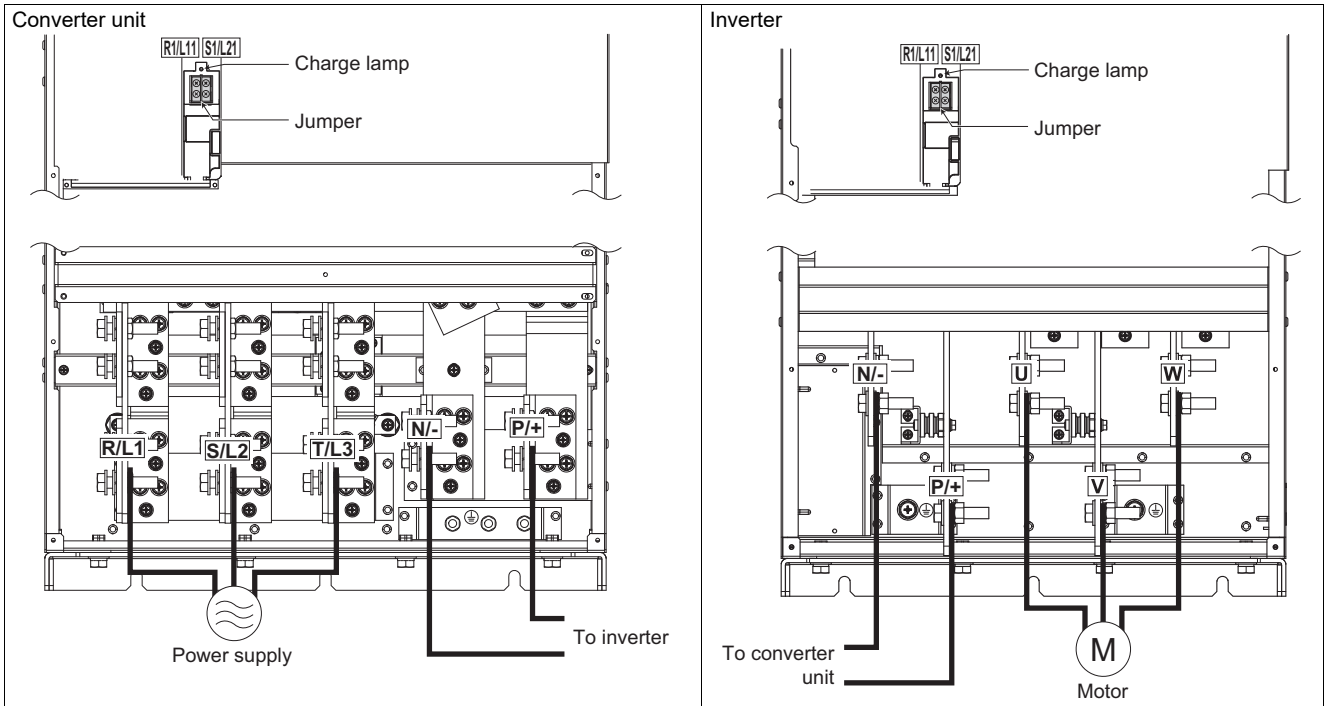

NOTE

- Make sure the power cables are connected to the R/L1, S/L2, and T/L3 of the converter unit. (Phase need not be matched.) Never connect the power cable to the U, V, and W of the inverter. Doing so will damage the inverter.
- Connect the motor to the U, V, and W of the inverter. (The phases must be matched.)
- When wiring cables to the main circuit conductor, tighten each nut from the right of the conductor as seen from the front of the unit.
When wiring two cables, place cables on both sides of the conductor. (Refer to the diagram below.)
For wiring, use bolts (nuts) provided with the inverter.

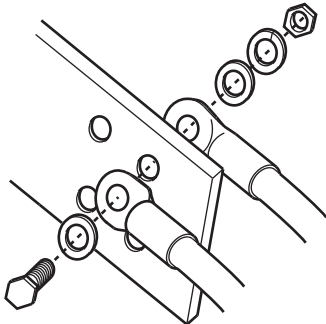

- When wiring cables to the main circuit conductor (R/L1, S/L2, T/L3) of the converter unit (FR-CC2), use the bolts (nuts) for main circuit wiring, which are provided on the front side of the conductor.

FR-CC2-H315K, H355K

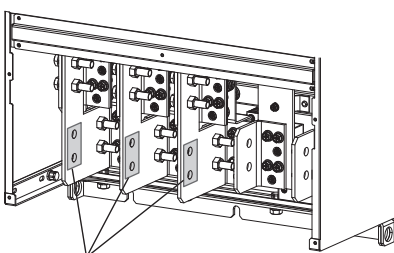

Connect the cables here.

FR-CC2-H400K to H500K

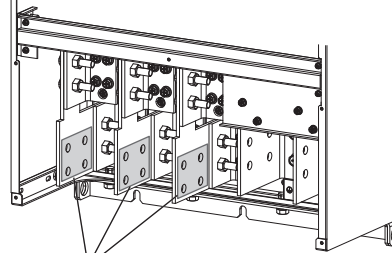

Connect the cables here.

2.5.4 Recommended cables and wiring length

Select a recommended size cable to ensure that the voltage drop ratio is within 2%.

If the wiring distance is long between the inverter and motor, the voltage drop in the main circuit will cause the motor torque to decrease especially at a low speed.

The following tables show converter/cable combinations for a wiring length of 20 m (at 440 V input power supply).

- Converter unit (FR-CC2)

Converter model FR-CC2-H□	Terminal screw size ^{*4}	Tightening torque (N·m)	Crimp terminal	Cable gauge					
				HIV cables, etc. (mm ²) ^{*1}			AWG/MCM ^{*2}	PVC cables, etc. (mm ²) ^{*3}	
				R/L1, S/L2, T/L3	R/L1, S/L2, T/L3	P/+, N/-	Earthing (grounding) cable	R/L1, S/L2, T/L3	R/L1, S/L2, T/L3
315K	M12 (M10)	46	150-12	2×150	2×150	100	2×300	2×150	150
355K	M12 (M10)	46	C2-200	2×200	2×200	100	2×350	2×185	2×95
400K	M12 (M10)	46	C2-200	2×200	2×200	100	2×400	2×185	2×95
450K	M12 (M10)	46	C2-250	2×250	2×250	100	2×500	2×240	2×120
500K	M12 (M10)	46	C2-200	3×200	3×200	2×100	2×500	2×240	2×120
560K	M12 (M10)	46	C2-200	3×200	3×200	2×100	3×350	3×185	2×150
630K	M12 (M10)	46	C2-200	3×200	3×200	2×100	3×400	3×185	2×150

- Inverter (ND rating)

Inverter model FR-A842-□	Terminal screw size ^{*4}	Tightening torque (N·m)	Crimp terminal	Cable gauge					
				HIV cables, etc. (mm ²) ^{*1}			AWG/MCM ^{*2}	PVC cables, etc. (mm ²) ^{*3}	
				U, V, W	U, V, W	P/+, N/-	Earthing (grounding) cable	U, V, W	U, V, W
07700(315K)	M12 (M10)	46	150-12	2×150	2×150	100	2×300	2×150	150
08660(355K)	M12 (M10)	46	C2-200	2×200	2×200	100	2×350	2×185	2×95
09620(400K)	M12 (M10)	46	C2-200	2×200	2×200	100	2×400	2×185	2×95
10940(450K)	M12 (M10)	46	C2-250	2×250	2×250	100	2×500	2×240	2×120
12120(500K)	M12 (M10)	46	C2-250	2×250	3×200	2×100	2×500	2×240	2×120

- Inverter (SLD rating)

Inverter model FR-A842-□	Terminal screw size ^{*4}	Tightening torque (N·m)	Crimp terminal	Cable gauge					
				HIV cables, etc. (mm ²) ^{*1}			AWG/MCM ^{*2}	PVC cables, etc. (mm ²) ^{*3}	
				U, V, W	U, V, W	P/+, N/-	Earthing (grounding) cable	U, V, W	U, V, W
07700(315K)	M12 (M10)	46	C2-200	2×200	2×200	100	2×400	2×185	2×95
08660(355K)	M12 (M10)	46	C2-250	2×250	2×250	100	2×500	2×240	2×120
09620(400K)	M12 (M10)	46	C2-250	2×250	3×200	2×100	2×500	2×240	2×120
10940(450K)	M12 (M10)	46	C2-200	3×200	3×200	2×100	3×350	3×185	2×150
12120(500K)	M12 (M10)	46	C2-200	3×200	3×200	2×100	3×400	3×185	2×150

- Inverter (LD rating)

Inverter model FR-A842-□	Terminal screw size ^{*4}	Tightening torque (N·m)	Crimp terminal	Cable gauge					
				HIV cables, etc. (mm ²) ^{*1}			AWG/MCM ^{*2}	PVC cables, etc. (mm ²) ^{*3}	
				U, V, W	U, V, W	P/+, N/-	Earthing (grounding) cable	U, V, W	U, V, W
07700(315K)	M12 (M10)	46	C2-200	2×200	2×200	100	2×350	2×185	2×95
08660(355K)	M12 (M10)	46	C2-200	2×200	2×200	100	2×400	2×185	2×95
09620(400K)	M12 (M10)	46	C2-250	2×250	2×250	100	2×500	2×240	2×120
10940(450K)	M12 (M10)	46	C2-250	2×250	3×200	2×100	2×500	2×240	2×120
12120(500K)	M12 (M10)	46	C2-200	3×200	3×200	2×100	3×350	3×185	2×150

- Inverter (HD rating)

Inverter model FR-A842-□	Terminal screw size ^{*4}	Tightening torque (N·m)	Crimp terminal	Cable gauge					
				HIV cables, etc. (mm ²) ^{*1}			AWG/MCM ^{*2}	PVC cables, etc. (mm ²) ^{*3}	
				U, V, W	U, V, W	P/+, N/-	Earthing (grounding) cable	U, V, W	U, V, W
07700(315K)	M12 (M10)	46	150-12	2×125	2×150	100	2×250	2×120	150
08660(355K)	M12 (M10)	46	150-12	2×150	2×150	100	2×300	2×150	150
09620(400K)	M12 (M10)	46	C2-200	2×200	2×200	100	2×350	2×185	2×95
10940(450K)	M12 (M10)	46	C2-200	2×200	2×200	100	2×400	2×185	2×95
12120(500K)	M12 (M10)	46	C2-250	2×250	2×250	100	2×500	2×240	2×120

*1 LMFC cable (heat resistant flexible cross-linked polyethylene insulated cable), etc. with a continuous maximum permissible temperature of 90°C or higher. It is assumed that the cables will be used in a surrounding air temperatures of 50°C or less and housed in an enclosure.

*2 THHN cable with a continuous maximum permissible temperature of 90°C. It is assumed that the cables will be used in a surrounding air temperatures of 40°C or less and housed in an enclosure.
(For the use in the United States or Canada, refer to [page 134](#).)

*3 XLPE cable with a continuous maximum permissible temperature of 90°C. It is assumed that the cables will be used in a surrounding air temperatures of 40°C or less and housed in an enclosure (mainly for use in Europe).

*4 The screw size for terminals R/L1, S/L2, T/L3, U, V, W, P/+, N/-, and the earthing (grounding) terminal are shown.
The size of the earthing (grounding) screw is indicated in parentheses.

The line voltage drop can be calculated by the following formula:

$$\text{Line voltage drop [V]} = \frac{\sqrt{3} \times \text{wire resistance [m}\Omega\text{/m]} \times \text{wiring distance [m]} \times \text{current [A]}}{1000}$$

Use a larger diameter cable when the wiring distance is long or when the voltage drop (torque reduction) in the low speed range needs to be reduced.

NOTE

- Tighten the terminal screw to the specified torque.
A screw that has been tightened too loosely can cause a short circuit or malfunction.
A screw that has been tightened too tightly can cause a short circuit or malfunction due to the unit breakage.
- Use crimp terminals with insulation sleeves to wire the power supply and motor.

◆ Total wiring length

■ With induction motor

Connect one or more general-purpose motors within the total wiring length 500 m. (The wiring length should be 100 m or shorter under Vector control.)

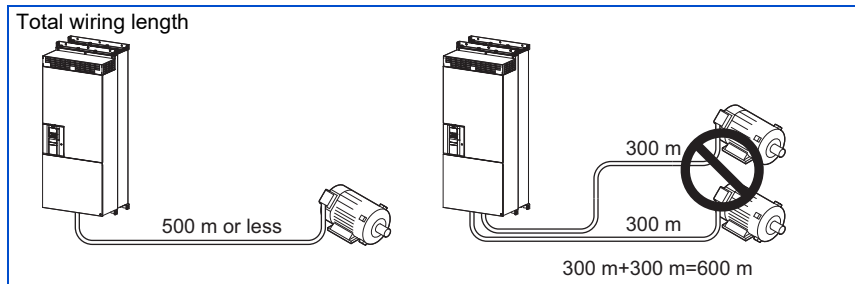

When driving a 400 V class motor by the inverter, surge voltages attributable to the wiring constants may occur at the motor terminals, deteriorating the insulation of the motor. In this case, take one of the following measure.

- Use a "400 V class inverter-driven insulation-enhanced motor" and set **Pr.72 PWM frequency selection** according to the wiring length.

Wiring length 100 m or shorter	Wiring length longer than 100 m
6 (6 kHz) or lower	4 (4 kHz) or lower

- If the motor capacity is 280 kW or lower, connect the sine wave filter (MT-BSL/BSC) to the output side.

■ With PM motor

Use the wiring length of 100 m or shorter when connecting a PM motor.

Use one PM motor for one inverter. Multiple PM motors cannot be connected to an inverter.

When the wiring length exceeds 50 m for a 400 V class motor driven by an inverter under PM sensorless vector control, set "9" (6 kHz) or less in **Pr.72 PWM frequency selection**.

NOTE

- Especially for long-distance wiring, the inverter may be affected by a charging current caused by stray capacitance of the wiring, leading to an activation of the overcurrent protection, malfunction of the fast-response current limit operation, or even to an inverter failure. It may also cause a malfunction or fault of the equipment connected on the inverter output side. If the fast-response current limit function malfunctions, disable the function. (For details on **Pr.156 Stall prevention operation selection**, refer to the Instruction Manual (Detailed).)
- A sine wave filter (MT-BSL/BSC) can be used under V/F control. Do not use the filters under different control methods.
- For details on **Pr.72 PWM frequency selection**, refer to the Instruction Manual (Detailed).
- Refer to [page 92](#) to drive a 400 V class motor by an inverter.
- The carrier frequency is limited during PM sensorless vector control. (Refer to the Instruction Manual (Detailed).)

2.5.5 Earthing (grounding) precautions

- Always earth (ground) the motor, the inverter, and the converter unit.

◆ Purpose of earthing (grounding)

Generally, an electrical apparatus has an earth (ground) terminal, which must be connected to the ground before use.

An electrical circuit is usually insulated by an insulating material and encased. However, it is impossible to manufacture an insulating material that can shut off a leakage current completely, and actually, a slight current flows into the case. The purpose of earthing (grounding) the case of an electrical apparatus is to prevent operators from getting an electric shock from this leakage current when touching it.

To avoid the influence of external noises, the earthing (grounding) is important to EMI-sensitive equipment that handle low-level signals or operate very fast such as audio equipment, sensors, computers.

◆ Earthing (grounding) system to be established

As described previously, the purpose of earthing (grounding) is roughly classified into the electrical shock prevention and the prevention of malfunction due to the influence of electromagnetic noise. These two purposes should be clearly distinguished, and the appropriate earth (ground) system must be established to prevent the leakage current having the inverter's high frequency components from reversing through another earth (ground) point for malfunction prevention by following these instructions:

- Make the separate earth (ground) connection (I) for high frequency products such as the inverter from any other devices (EMI-sensitive devices described above) wherever possible.

Establishing adequate common (single-point) earth (ground) system (II) shown in the following figure is allowed only in cases where the separate earth (ground) system (I) is not feasible. Do not make inadequate common (single-point) earth (ground) connection (III).

As leakage currents containing many high frequency components flows into the earthing (grounding) cables of the inverter and peripheral devices (including a motor), the inverter must also be earthed (grounded) separately from EMI-sensitive devices described above.

In a high building, it may be effective to use its iron structure frames as earthing (grounding) electrode for EMI prevention in order to separate from the earth (ground) system for electric shock prevention.

- Earthing (grounding) must conform to the requirements of national and local safety regulations and electrical codes (NEC section 250, IEC 61140 class 1 and other applicable standards).

A neutral-point earthed (grounded) power supply must be used to be compliant with EN standard.

- Use the thickest possible earthing (grounding) cable. The size of the earthing (grounding) cable should be the same or larger than the one indicated in the table on [page 44](#).
- The earthing (grounding) point should be as close as possible to the inverter, and the earth (ground) wire length should be as short as possible.
- Run the earthing (grounding) cable as far away as possible from the I/O wiring of the EMI-sensitive devices and run them in parallel in the minimum distance.

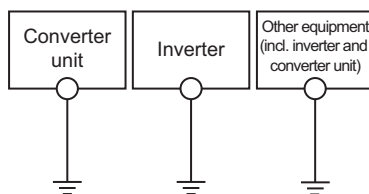

(I) Separate earthing (grounding).....Good

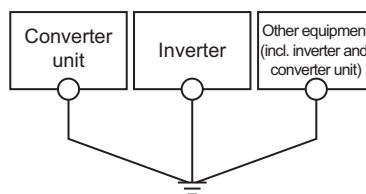

(II) Common (single-point) earthing (grounding).....OK

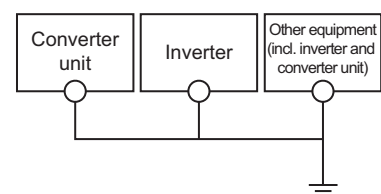

(III) Inadequate common (single-point) earthing (grounding).....Bad

NOTE

- To be compliant with the EU Directive (Low Voltage Directive), refer to [page 131](#).

2.6 Control circuit

2.6.1 Details on the control circuit terminals of the inverter

For the parameter details, refer to the Instruction Manual (Detailed).

◆ Input signal

Type	Terminal symbol	Common	Terminal name	Terminal function description		Rated specification
Contact input	STF ^{*1}	SD (sink (negative common)) PC (source (positive common))	Forward rotation start	Turn ON the STF signal to start forward rotation and turn it OFF to stop.	When the STF and STR signals are turned ON simultaneously, the stop command is given.	Input resistance: 4.7 kΩ, voltage when contacts are open: 21 to 27 VDC, current when contacts are short-circuited: 4 to 6 mADC
	STR ^{*1}		Reverse rotation start	Turn ON the STR signal to start reverse rotation and turn it OFF to stop.		
	STOP ^{*1}		Start self-holding selection	Turn ON the STOP signal to self-hold the start signal.		
	RH RM RL ^{*1}		Multi-speed selection	Multi-speed can be selected according to the combination of RH, RM and RL signals.		
	JOG ^{*1}		Jog mode selection	Turn ON the JOG signal to enable JOG operation (initial setting) and turn ON the start (STF or STR) signal to start JOG operation.	Terminal JOG is also used as a pulse train input terminal. To use as a pulse train input terminal, change the Pr.291 setting. (maximum input pulse: 100k pulses/s)	Input resistance: 2 kΩ, current when contacts are short-circuited: 8 to 13 mADC
			Pulse train input			
	RT ^{*1}		Second function selection	Turn ON the RT signal to enable the second function. When the second function such as "second torque boost" and "second V/F (base frequency)" is set, turning ON the RT signal enables the selected function.	Input resistance: 4.7 kΩ, voltage when contacts are open: 21 to 27 VDC, current when contacts are short-circuited: 4 to 6 mADC	
	MRS (X10) ^{*1}		Output stop (Inverter operation enable)	Connected to terminal RDA of the converter unit (FR-CC2). When the RDA signal is turned OFF, the inverter output is shut off. The X10 signal (NC contact) is assigned to terminal MRS in the initial setting. Use Pr.599 to change the specification to NO contact.		
	RES ^{*1}		Reset	Use this signal to reset a fault output provided when a protective function is activated. Turn ON the RES signal for 0.1 second or longer, then turn it OFF. In the initial setting, reset is always enabled. Setting Pr.75 makes reset possible only after the occurrence of a inverter fault. The inverter will restart about 1 second after reset.		
	AU ^{*1}		Terminal 4 input selection	The terminal 4 function is available only when the AU signal is ON. Turning the AU signal ON makes terminal 2 invalid.		
CS ^{*1}	Selection of automatic restart after instantaneous power failure	When the CS signal is left ON, the inverter restarts automatically at power restoration. Note that restart setting is necessary on both the inverter and the converter unit for this operation. In the initial setting, a restart is disabled.				

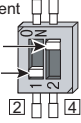
Type	Terminal symbol	Common	Terminal name	Terminal function description	Rated specification
Frequency setting	10E	5	Frequency setting power supply	When connecting the frequency setting potentiometer at an initial status, connect it to terminal 10. Change the input specifications of terminal 2 using Pr.73 when connecting it to terminal 10E.	10 ±0.4 VDC, permissible load current: 10 mA
	10	5			5 ±0.5 VDC, permissible load current: 10 mA
	2	5	Frequency setting (voltage)	Inputting 0 to 5 VDC (or 0 to 10 V, 0 to 20 mA) provides the maximum output frequency at 5 V (10 V, 20 mA) and makes input and output proportional. Use Pr.73 to switch among input 0 to 5 VDC (initial setting), 0 to 10 VDC, and 0 to 20 mA. Set the voltage/current input switch in the ON position to select current input (0 to 20 mA). ^{*2}	For voltage input, Input resistance: 10 to 11 kΩ, maximum permissible voltage: 20 VDC. For current input, Input resistance: 245 ±5 Ω, maximum permissible current: 30 mA.
	4	5	Frequency setting (current)	Inputting 4 to 20 mADC (or 0 to 5 V, 0 to 10 V) provides the maximum output frequency at 20 mA and makes input and output proportional. This input signal is valid only when the AU signal is ON (terminal 2 input is invalid). Use Pr.267 to switch among input 4 to 20 mA (initial setting), 0 to 5 VDC, and 0 to 10 VDC. Set the voltage/current input switch in the OFF position to select voltage input (0 to 5 V / 0 to 10 V). ^{*2} Use Pr.858 to switch terminal functions.	
	1	5	Frequency setting auxiliary	Input 0 to ±5 VDC or 0 to ±10 VDC to add this signal to the frequency setting signal input via terminal 2 or 4. Use Pr.73 to switch between input 0 to ±5 VDC and 0 to ±10 VDC (initial setting). Use Pr.868 to switch terminal functions.	Input resistance: 10 to 11 kΩ, maximum permissible voltage: ±20 VDC.
Thermistor	10 2	—	PTC thermistor input	For receiving PTC thermistor outputs. When PTC thermistor is valid (Pr.561 ≠ "9999"), terminal 2 is not available for frequency setting.	Applicable PTC thermistor specification, overheat detection resistance: 0.5 to 30 kΩ (set by Pr.561)
Power supply input	+24	SD	24 V external power supply input	For connecting a 24 V external power supply. If a 24 V external power supply is connected, power is supplied to the control circuit while the main power circuit is OFF.	Input voltage: 23 to 25.5 VDC, input current: 1.4 A or less

*1 Terminal functions can be selected using **Pr.178 to Pr.189 (Input terminal function selection)**.

*2 Set **Pr.73**, **Pr.267**, and the voltage/current input switch correctly, then input an analog signal in accordance with the setting.
Applying a voltage with the switch ON (current input is selected) or applying a current with the switch OFF (voltage input is selected) could cause component damage of the inverter or analog circuits of output devices. (Refer to the Instruction Manual (Detailed).)

◆ Output signal

Type	Terminal symbol	Common	Terminal name	Terminal function description	Rated specification
Relay	A1, B1, C1 ^{*1}	—	Relay output 1 (fault output)	1 changeover contact output that indicates that an inverter's protective function has been activated and the outputs are stopped. Fault: discontinuity across B and C (continuity across A and C), Normal: continuity across B and C (discontinuity across A and C)	Contact capacity: 230 VAC 0.3 A (power factor = 0.4), 30 VDC 0.3 A
	A2, B2, C2 ^{*1}	—	Relay output 2	1 changeover contact output	
Open collector	RUN ^{*1}	SE	Inverter running	The output is in LOW state when the inverter output frequency is equal to or higher than the starting frequency (initial value: 0.5 Hz). The output is in HIGH state during stop or DC injection brake operation.	Permissible load: 24 VDC (27 VDC at maximum) 0.1 A (The voltage drop is 2.8 V at maximum while the signal is ON.) The open collector transistor is ON (conductive) in LOW state. The transistor is OFF (not conductive) in HIGH state.
	SU ^{*1}	SE	Up to frequency	The output is in LOW state when the output frequency is within the set frequency range $\pm 10\%$ (initial value). The output is in HIGH state during acceleration/deceleration and at a stop.	
	OL ^{*1}	SE	Overload alarm	The output is in LOW state when stall prevention is activated by the stall prevention function. The output is in HIGH state when stall prevention is canceled.	
	IPF ^{*1}	SE	Open collector output	No function is assigned in the initial setting. Use Pr.192 to assign a function to the terminal.	
	FU ^{*1}	SE	Frequency detection	The output is in LOW state when the inverter output frequency is equal to or higher than the preset detection frequency, and is in HIGH state when it is less than the preset detection frequency.	
Pulse	FM ^{*2}	SD	For meter	Among several monitor items such as output frequency, select one to output it via these terminals. The signal is not output during an inverter reset. The size of output signal is proportional to the magnitude of the corresponding monitor item. Use Pr.55 , Pr.56 , and Pr.866 to set full scales for the monitored output frequency, output current, and torque.	Output item: Output frequency (initial setting)
			NPN open collector output		This terminal can be used for open collector outputs by setting Pr.291 .
Analog	AM	5	Analog voltage output	Output item: Output frequency (initial setting)	Output signal: 0 \pm 10 VDC, permissible load current: 1 mA (load impedance 10 k Ω or more), resolution: 13 bits
	CA ^{*3}	5	Analog current output		Load impedance: 200 to 450 Ω , output signal: 0 to 20 mADC

*1 Terminal functions can be selected using **Pr.190 to Pr.196 (Output terminal function selection)**.

*2 Terminal FM is provided in the FM-type inverter.

*3 Terminal CA is provided in the CA-type inverter.

◆ Safety stop signal

Terminal symbol	Common	Terminal name	Terminal function description
S1	SIC	Safety stop input (Channel 1)	Do not remove the jumpers from terminals S1, S2, and SIC. Do not use terminals S1, S2, and So (SO).
S2		Safety stop input (Channel 2)	
So (SO)	SOC	Safety monitor output (open collector output)	

2

◆ Common terminal

Terminal symbol	Common	Terminal name	Terminal function description	Rated specification
SD	—	Contact input common (sink) ^{*1}	Common terminal for the contact input terminal (sink logic) and terminal FM.	—
		External transistor common (source) ^{*2}	Connect this terminal to the power supply common terminal of a transistor output (open collector output) device, such as a programmable controller, in the source logic to avoid malfunction by undesirable current.	
		24 VDC power supply common	Common terminal for the 24 VDC power supply (terminal PC, terminal +24). Isolated from terminals 5 and SE.	
PC	—	External transistor common (sink) ^{*1}	Connect this terminal to the power supply common terminal of a transistor output (open collector output) device, such as a programmable controller, in the sink logic to avoid malfunction by undesirable current.	Power supply voltage range: 19.2 to 28.8 VDC, permissible load current: 100 mA
		Contact input common (source) ^{*2}	Common terminal for contact input terminal (source logic).	
	SD	24 VDC power supply	Can be used as a 24 VDC 0.1 A power supply.	
5	—	Frequency setting common	Common terminal for the frequency setting signal (via terminal 2, 1, or 4) and for the analog output terminals AM and CA. Do not earth (ground).	—
SE	—	Open collector output common	Common terminal for terminals RUN, SU, OL, IPF, FU	—

*1 Sink logic is initially set for the FM-type inverter.

*2 Source logic is initially set for the CA-type inverter.

◆ Communication

Type	Terminal symbol	Terminal name	Terminal function description	
Safety communication	CON8	STO signal connector	For connecting a safety communication option. For the connection method, refer to the Instruction Manual of the installed safety communication option.	
Ethernet	—	Ethernet connector	Communication can be made via Ethernet. Category: 100BASE-TX/10BASE-T Data transmission speed: 100 Mbps (100BASE-TX) / 10 Mbps (10BASE-T) Transmission method: Baseband Maximum segment length: 100 m between the hub and the inverter Number of cascade connection stages: Up to 2 (100BASE-TX) / up to 4 (10BASE-T) Interface: RJ-45 Number of interfaces available: 1 IP version: IPv4	
RS-485	—	PU connector	RS-485 communication can be made through the PU connector (For connection on a 1:1 basis only) Conforming standard: EIA-485 (RS-485) Transmission format: Multidrop link Communication speed: 4800 to 115200 bps Wiring length: 500 m	
USB	—	USB A connector	A connector (receptacle). Plug a USB memory device into this connector to copy parameter settings or use the trace function.	Interface: conforms to USB 1.1 (USB 2.0 full-speed compatible) Transmission speed: 12 Mbps
		USB B connector	Mini B connector (receptacle). By connecting the inverter to a personal computer via this connector, FR Configurator2 installed on the computer can be used for setting the inverter, or monitoring or testing the inverter operation.	

2.6.2 Details on the control circuit terminals of the converter unit (FR-CC2).

For the parameter details, refer to the FR-CC2 Instruction Manual.

◆ Input signal

Type	Terminal symbol	Common	Terminal name	Terminal function description	Rated specification
Contact input	RES ^{*1}	SD (sink (negative common))	Reset	Use this signal to reset a fault output provided when a protective function is activated. Turn ON the RES signal for 0.1 second or longer, then turn it OFF. In the initial setting, reset is always enabled. Setting Pr.75 makes reset possible only after the occurrence of a converter unit fault. The converter will restart about 1 second after reset.	Input resistance: 4.7 kΩ, voltage when contacts are open: 21 to 27 VDC, current when contacts are short-circuited: 4 to 6 mA
	OH ^{*1}	PC (source (positive common))	External thermal relay input	The External thermal relay input (OH) signal is used when using the external thermal relay or the thermal protector built into the motor to protect the motor from overheating. When the thermal relay is activated, the inverter output is shut off by the external thermal relay operation (E.OHT).	
	RDI ^{*1}		Contact input	Use Pr.178 to assign a function to the terminal.	
Power supply input	+24	SD	24 V external power supply input	For connecting a 24 V external power supply. If a 24 V external power supply is connected, power is supplied to the control circuit while the main power circuit is OFF.	Input voltage: 23 to 25.5 VDC, input current: 1.4 A or less

*1 Terminal functions can be selected using **Pr.178**, **Pr.187**, or **Pr.189** (Output terminal function selection).

◆ Output signal

Type	Terminal symbol	Common	Terminal name	Terminal function description	Rated specification
Relay	A1, B1, C1 ^{*1}	—	Relay output 1 (fault output)	1 changeover contact output that indicates that the protective function of the converter unit has been activated and the outputs are stopped. Fault: discontinuity across B and C (continuity across A and C), Normal: continuity across B and C (discontinuity across A and C)	Contact capacity: 230 VAC 0.3 A (power factor = 0.4), 30 VDC 0.3 A
	88R, 88S	—	For manufacturer setting. Do not use.		
Open collector	RDA ^{*1}	SE	Inverter operation enable (NO contact)	Switched to LOW when the converter unit operation is ready. Assign the signal to terminal MRS (X10) of the inverter. The inverter can be started when the RDA status is LOW.	Permissible load: 24 VDC (27 VDC at maximum) 0.1 A (The voltage drop is 2.8 V at maximum while the signal is ON.) The open collector transistor is ON (conductive) in LOW state. The transistor is OFF (not conductive) in HIGH state.
	RDB ^{*1}	SE	Inverter operation enable (NC contact)	Switched to LOW when a converter unit fault occurs or the converter is reset. The inverter can be started when the RDB status is HIGH.	
	RSO ^{*1}	SE	Inverter reset	Switched to LOW when the converter is reset (RES-ON). Assign the signal to terminal RES of the inverter. The inverter is reset when it is connected with the RSO status LOW.	
	IPF ^{*1}	SE	Instantaneous power failure	Switched to LOW when an instantaneous power failure is detected.	
	FAN ^{*1}	SE	Cooling fan fault	Switched to LOW when a cooling fan fault occurs.	

*1 Terminal functions can be selected using Pr.190 to Pr.195 (Output terminal function selection).

◆ Common terminal

Terminal symbol	Common	Terminal name	Terminal function description	Rated specification
SD	—	Contact input common (sink)	Common terminal for the contact input terminal (sink logic) and terminal FM.	—
	—	External transistor common (source)	Connect this terminal to the power supply common terminal of a transistor output (open collector output) device, such as a programmable controller, in the source logic to avoid malfunction by undesirable current.	
	—	24 VDC power supply common	Common terminal for the 24 VDC power supply (terminal PC, terminal +24). Isolated from terminals 5 and SE.	
PC	—	External transistor common (sink)	Connect this terminal to the power supply common terminal of a transistor output (open collector output) device, such as a programmable controller, in the sink logic to avoid malfunction by undesirable current.	Power supply voltage range: 19.2 to 28.8 VDC, permissible load current: 100 mA
	—	Contact input common (source)	Common terminal for contact input terminal (source logic).	
	SD	24 VDC power supply	Can be used as a 24 VDC 0.1 A power supply.	
SE	—	Open collector output common	Common terminal for terminals RDA, RDB, RSO, IPF, FAN Connect this terminal to terminal SD (sink logic) or PC (source logic) of the inverter.	—

⚠ CAUTION

- Do not use the empty terminals (NC) of the control circuit. Doing so may lead to damage of the converter unit and the inverter.
- Always connect terminal RDA of the converter unit and terminal MRS (X10) of the inverter, and terminal SE of the converter unit and terminal SD (terminal PC in the source logic) of the inverter. Not doing so may lead to damage of the converter unit.

2.6.3 Control logic (sink/source) change

Switch the control logic of input signals as necessary.

To change the control logic, change the jumper connector position on the control circuit board.

Connect the jumper connector to the connector pin of the desired control logic.

The control logic of input signals is initially set to the sink logic (SINK) for the type FM inverter.

The control logic of input signals is initially set to the source logic (SOURCE) for the type CA inverter.

(The output signals may be used in either the sink or source logic independently of the jumper connector position.)

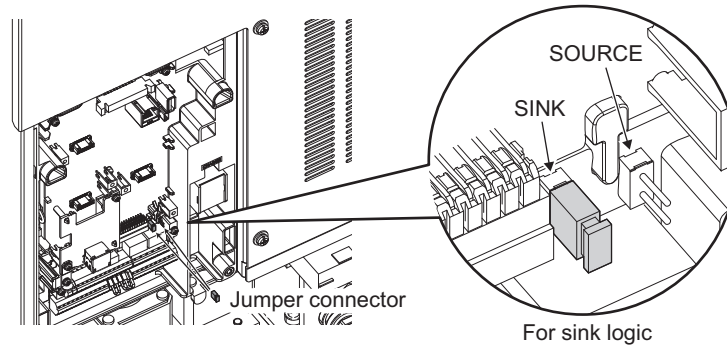

NOTE

- Make sure that the jumper connector is installed correctly.
- Never change the control logic while power is ON.

◆ Sink logic and source logic

- In the sink logic, a signal turns ON when a current exits from the corresponding signal input terminal. Terminal SD is common to the contact input signals. Terminal SE is common to the open collector output signals.
- In the source logic, a signal turns ON when a current enters into the corresponding signal input terminal. Terminal PC is common to the contact input signals. Terminal SE is common to the open collector output signals.

● Current flow concerning the input/output signal when sink logic is selected

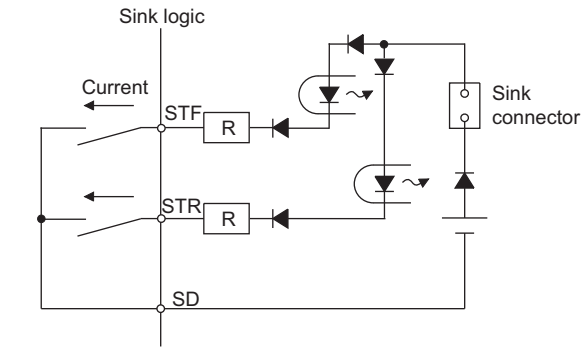

● Current flow concerning the input/output signal when source logic is selected

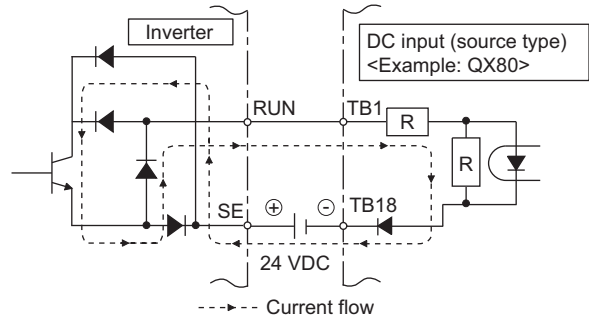
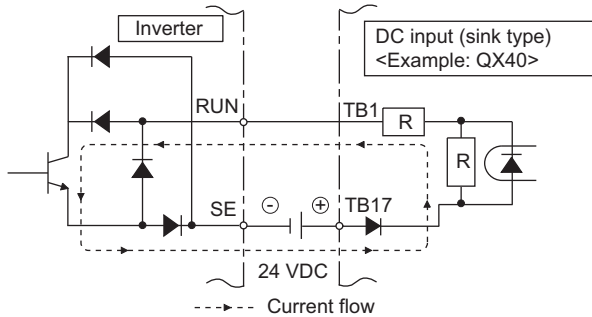
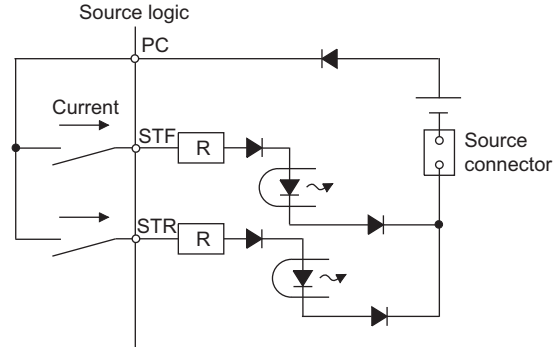

- When using an external power supply for transistor output

Sink logic

Use terminal PC as a common terminal, and perform wiring as follows. (Do not connect terminal SD on the inverter with the terminal of 0 V for the external power supply. When using terminals PC-SD as a 24 VDC power supply, do not install an external power supply in parallel with the inverter. Doing so may cause a malfunction in the inverter due to undesirable currents.)

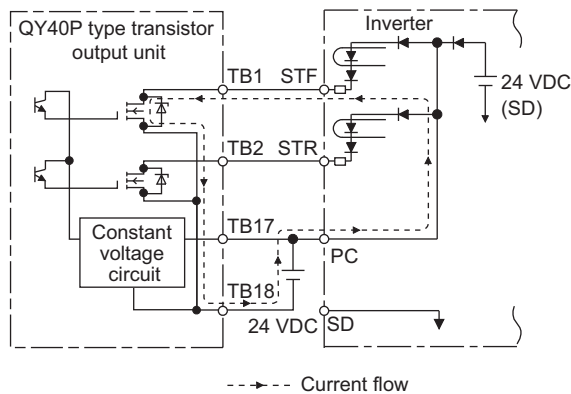

Source logic

Use terminal SD as a common terminal, and perform wiring as follows. (Do not connect terminal PC on the inverter with the terminal of +24 V for the external power supply. When using terminals PC-SD as a 24 VDC power supply, do not install an external power supply in parallel with the inverter. Doing so may cause a malfunction in the inverter due to undesirable currents.)

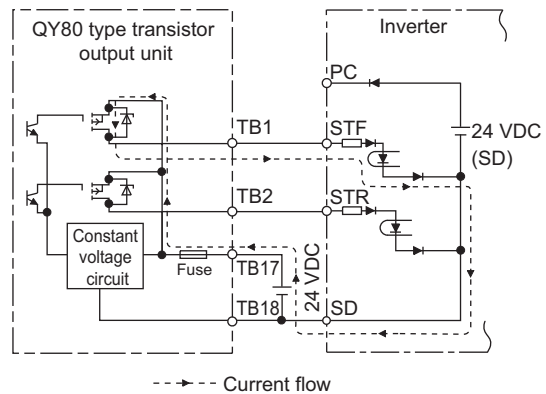

2.6.4 Wiring of inverter control circuit

◆ Control circuit terminal layout

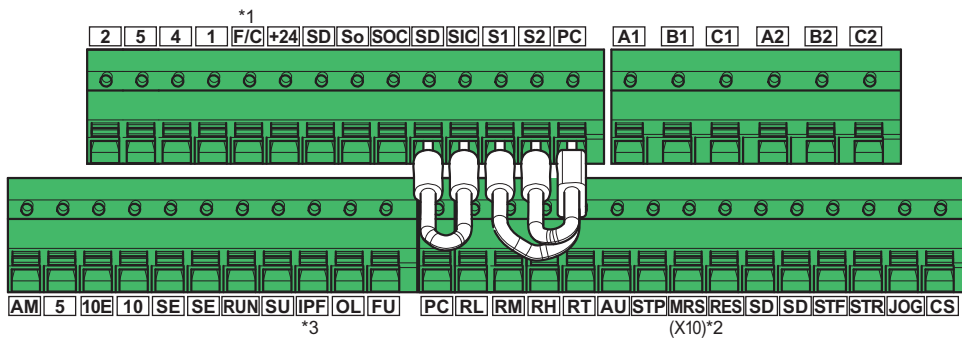

*1 This terminal operates as terminal FM for the type FM inverter. For the type CA inverter, the terminal operates as terminal CA.

*2 The X10 signal is assigned to terminal MRS in the initial setting.

*3 No function is assigned in the initial setting.

◆ Wiring method

■ Power supply connection

For the control circuit wiring, strip off the sheath of a cable, and use it with a blade terminal. For a single wire, strip off the sheath of the wire and apply directly.

Insert the blade terminal or the single wire into a socket of the terminal.

- Strip the signal wires as follows. If too much of the wire is stripped, a short circuit may occur with neighboring wires. If not enough of the wire is stripped, wires may become loose and fall out. Twist the stripped end of wires to prevent them from fraying. Do not solder them.

Cable sheath stripping length

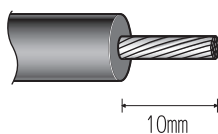

- Crimp the terminals on the wire. Insert the wire into a crimp terminal, making sure that 0 to 0.5 mm of the wire protrudes from the end of the sleeve. Check the condition of the crimp terminals after crimping. Do not use the crimp terminals of which the crimping is inappropriate, or the face is damaged.

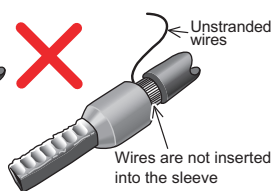
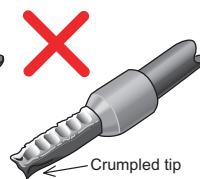
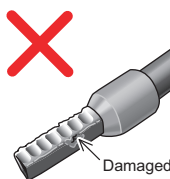
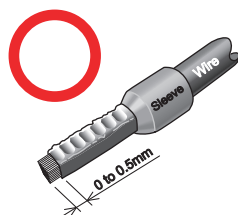

Crimp terminals commercially available (as of October 2020)

- Phoenix Contact Co., Ltd.

Wire gauge (mm ²)	Ferrule part No.			Crimping tool model No.
	With insulation sleeve	Without insulation sleeve	For UL wire ^{*1}	
0.3	AI 0,34-10TQ	—	—	CRIMPFOX 6
0.5	AI 0,5-10WH	—	AI 0,5-10WH-GB	
0.75	AI 0,75-10GY	A 0,75-10	AI 0,75-10GY-GB	
1	AI 1-10RD	A 1-10	AI 1-10RD/1000GB	
1.25, 1.5	AI 1,5-10BK	A 1,5-10	AI 1,5-10BK/1000GB ^{*2}	
0.75 (two-wire product)	AI-TWIN 2×0,75-10GY	—	—	

*1 A ferrule terminal with an insulation sleeve compatible with the MTW wire which has a thick wire insulation.

*2 Applicable for terminals A1, B1, C1, A2, B2, C2.

• NICHIFU Co., Ltd.

Wire gauge (mm ²)	Blade terminal part No.	Insulation cap part No.	Crimping tool product number
0.3 to 0.75	BT 0.75-11	VC 0.75	NH 69

3. Insert the wires into a socket.

When using single wire or stranded wire without crimp terminal, push an open/close button all the way down with a flathead screwdriver, and insert the wire.

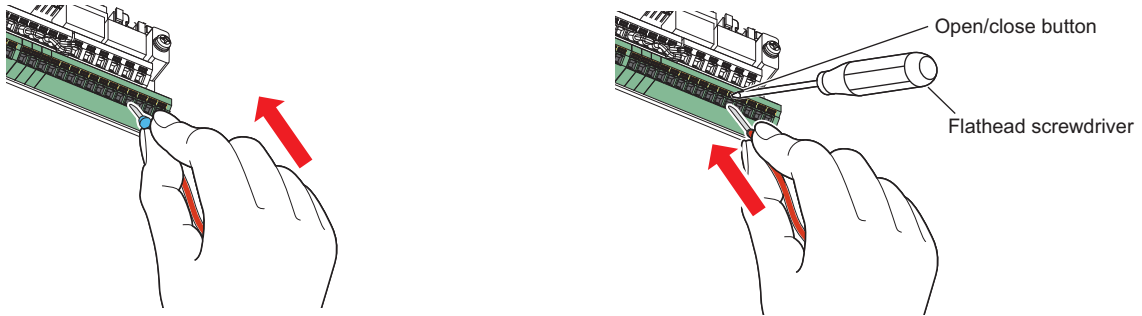

NOTE

- When using stranded wires without a blade terminal, twist enough to avoid short circuit with a nearby terminals or wires.
- Place the flathead screwdriver vertical to the open/close button. In case the blade tip slips, it may cause an inverter damage or injury.

■ Wire removal

Pull the wire while pushing the open/close button all the way down firmly with a flathead screwdriver.

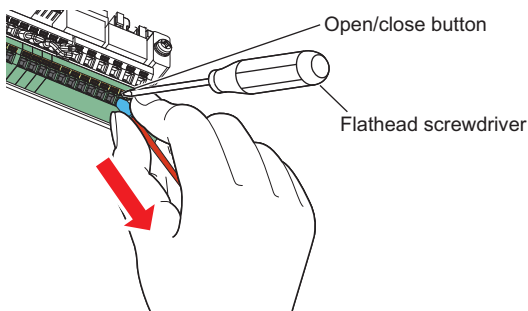

NOTE

- Pulling out the wire forcefully without pushing the open/close button all the way down may damage the terminal block.
- Use a small flathead screwdriver (tip thickness: 0.4 mm / tip width: 2.5 mm).
If a flathead screwdriver with a narrow tip is used, terminal block may be damaged.
Commercially available products (as of October 2020)

Product name	Model	Manufacturer
Screwdriver	SZF 0- 0,4 × 2,5	Phoenix Contact Co., Ltd.

- Place the flathead screwdriver vertical to the open/close button. In case the blade tip slips, it may cause an inverter damage or injury.

◆ Common terminals of the control circuit (SD, PC, 5, SE)

- Terminals SD (sink logic), PC (source logic), 5, and SE are common terminals (0 V) for I/O signals. (All common terminals are isolated from each other.) Do not earth (ground) these terminals. Avoid connecting terminal SD (sink logic) with terminal 5, terminal PC (source logic) with terminal 5, and terminal SE with terminal 5.

- In the sink logic, terminal SD is a common terminal for the contact input terminals (STF, STR, STP (STOP), RH, RM, RL, JOG, RT, MRS, RES, AU, and CS) and the pulse train output terminal (FM^{*1}). The open collector circuit is isolated from the internal control circuit by photocoupler.
- In the source logic, terminal PC is a common terminal for the contact input terminals (STF, STR, STP (STOP), RH, RM, RL, JOG, RT, MRS, RES, AU, CS). The open collector circuit is isolated from the internal control circuit by photocoupler.
- Terminal 5 is a common terminal for the frequency setting terminals (1, 2, and 4) and the analog output terminals (AM and CA^{*2}). It should be protected from external noise using a shielded or twisted cable.
- Terminal SE is a common terminal for the open collector output terminals (RUN, SU, OL, IPF, and FU). The contact input circuit is isolated from the internal control circuit by photocoupler.

*1 Terminal FM is provided in the FM-type inverter.

*2 Terminal CA is provided in the CA-type inverter.

◆ Signal inputs by contactless switches

The contact input terminals of the inverter (STF, STR, STP (STOP), RH, RM, RL, JOG, RT, MRS, RES, AU, and CS) can be controlled using a transistor instead of a contact switch as follows.

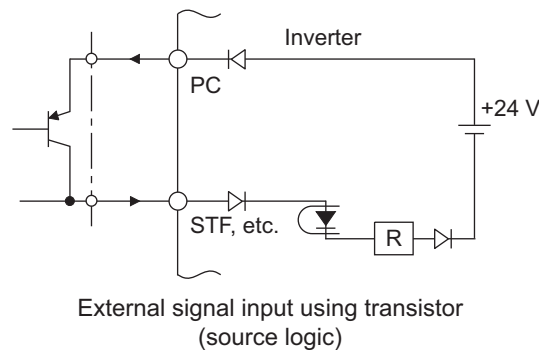
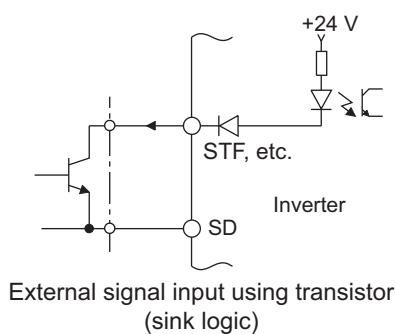

2.6.5 Wiring precautions

- It is recommended to use a cable of 0.3 to 0.75 mm² for the connection to the control circuit terminals.
- The wiring length should be 30 m (200 m for terminal FM) at the maximum.
- Use two or more parallel micro-signal contacts or twin contacts to prevent contact faults when using contact inputs since the control circuit input signals are micro-currents.

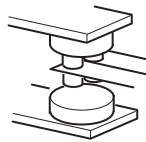
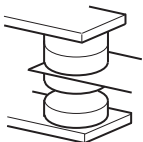

Micro signal contacts

Twin contacts

- To suppress EMI, use shielded or twisted cables for the control circuit terminals and run them away from the main and power circuits (including the 200 V relay sequence circuit). For the cables connected to the control circuit terminals, connect their shields to the common terminal of the connected control circuit terminal. When connecting an external power supply to terminal PC, however, connect the shield of the power supply cable to the negative side of the external power supply. Do not directly earth (ground) the shield to the enclosure, etc.
- Always apply a voltage to the fault output terminals (A1, B1, C1, A2, B2, C2) via a relay coil, lamp, etc.

- Separate the wiring of the control circuit away from the wiring of the main circuit.
Make cuts in rubber bush of the inverter side and lead the wires through.

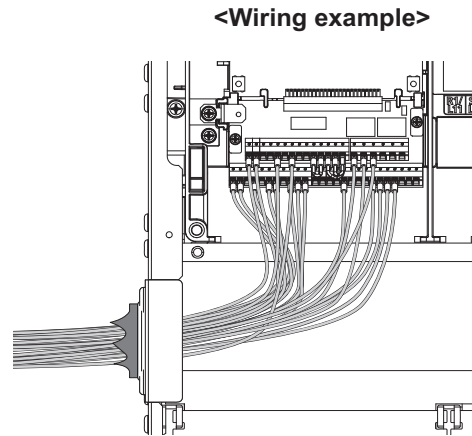
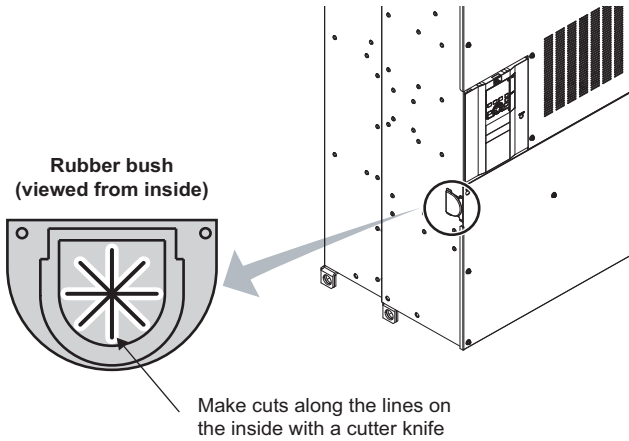

2.6.6 When using separate power supplies for the control circuit and the main circuit

◆ Cable size for the control circuit power supply (terminals R1/L11 and S1/L21)

- Terminal screw size: M4
- Cable gauge: 0.75 to 2 mm²
- Tightening torque: 1.5 N·m

◆ Connection method

If a fault occurs and the electromagnetic contactor (MC) installed at the inverter's input line is opened, power supply to the control circuit is also stopped and the fault signals cannot be output anymore. Terminals R1/L11 and S1/L21 of the control circuit are provided to keep outputting the fault signals in such a case. Follow the following steps to wire terminals R1/L11 and S1/L21 on the inverter to the power input lines of the MC.

A jumper is installed across terminal R1/L11 and terminal P/+, and across terminal S1/L21 and terminal N/-. Do not connect the power cable to incorrect terminals. Doing so may damage the inverter.

Connection diagram

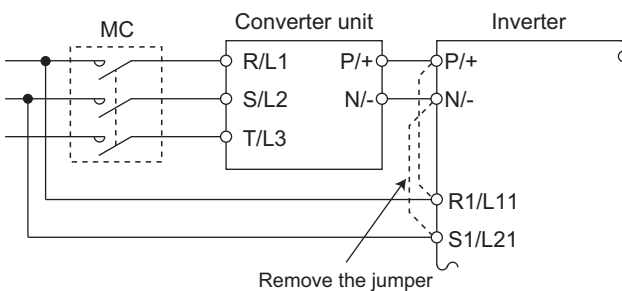

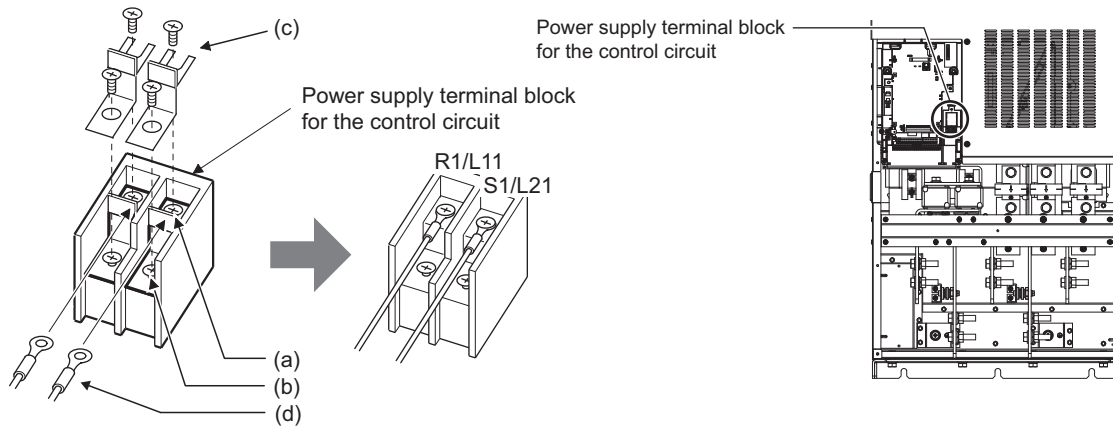

- (a) Remove the upper screws.
- (b) Remove the lower screws.
- (c) Pull the jumper toward you to remove.
- (d) Connect the separate power supply cable for the control circuit to the upper terminals (R1/L11, S1/L21).

NOTE

- When using separate power supplies, always remove the jumpers connected to terminals R1/L11 and S1/L21. The inverter may be damaged if the jumpers are not removed.
- When the control circuit power is supplied from other than the input line of the MC, the voltage of the separate power supply must be the same as that of the main control circuit.
- When using a separate power supply connected to terminals R1/L11 and S1/L21, the required power capacity is 80 VA.
- If the main circuit power is switched OFF (for 0.1 second or more) then ON again, the inverter is reset and a fault output will not be held.
- When a power supply is provided for the control circuit separately from the main circuit and a capacitive device (such as an EMC filter) is connected, refer to the following diagram. (For the wiring example to comply with ship classification standards, refer to the FR-A800 Instruction Manual (Detailed).)

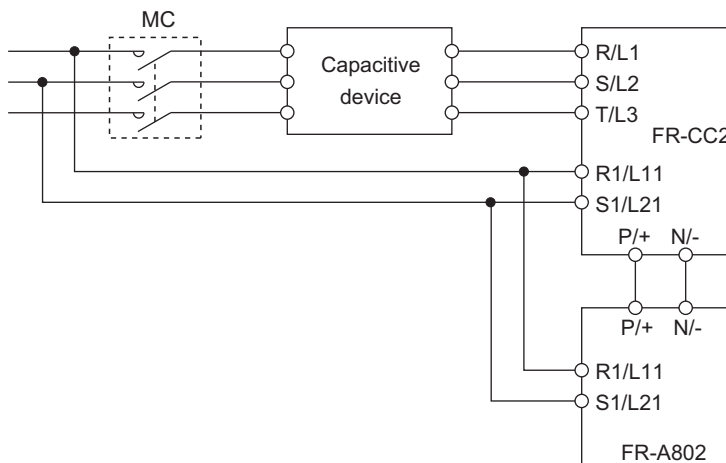

Connect two of the three phases.

2.6.7 When supplying 24 V external power to the control circuit

Connect the 24 V external power supply across terminals +24 and SD to turn ON/OFF the I/O terminal, keep the operation panel ON, and carry out communication with other devices even at power-OFF state of inverter's main circuit power supply. When the main circuit power supply is turned ON, the power supply is switched from the 24 V external power supply to the main circuit power supply.

◆ Specification of the applied 24 V external power supply

Item	Rated specification ^{*1}
Input voltage	23 to 25.5 VDC
Input current	1.4 A or less

*1 Prepare a 24 V external power supply according to the rated specification.

Commercially available products (as of October 2020)

Model	Product overview	Manufacturer
S8FS-G05024C ^{*1}	Specifications: Capacity 50 W, output voltage 24 VDC, output current 2.2 A Installation method: Direct installation, screw type terminal block with cover Input: Single-phase 100 to 240 VAC	OMRON Corporation
S8VK-S06024 ^{*1}	Specifications: Capacity 60 W, output voltage 24 VDC, output current 2.5 A Installation method: DIN rail, push-in (spring) type terminal block Input: Single-phase 100 to 240 VAC	
S8VK-WA24024 ^{*1}	Specifications: Capacity 240 W, output voltage 24 VDC, output current 10 A Installation method: DIN rail, push-in (spring) type terminal block Input: Three-phase 200 to 240 VAC	

*1 For the latest information about OMRON power supply, contact OMRON corporation.

◆ Starting and stopping the 24 V external power supply operation

- While the main circuit power is ON and 24 V external power is supplied across terminals +24 and SD, turning OFF the main circuit power starts the 24 V external power supply operation.
- Turning ON the main circuit power stops 24 V external power supply operation and enables the normal operation.

NOTE

- When the 24 V external power is supplied while the main circuit power supply is OFF, the inverter operation is disabled.
- In the initial setting, when the main power supply is turned ON during the 24 V external power supply operation, a reset is performed in the inverter, then the power supply changes to the main circuit power supply. (The reset can be disabled using **Pr.30**.)
- When 24 V external power is supplied across terminals +24 and SD while the main circuit power is OFF, a protective function (E.SAF) is activated by a safety sub-function. While both the main circuit power and the 24 V external power are OFF, E.SAF can be canceled by turning ON the main circuit power.

◆ Confirming the 24 V external power supply input

- During 24 V external power supply operation, "EV" blinks on the operation panel. The alarm LED also blinks. Thus, the 24 V external power supply operation can be confirmed even when the operation panel is removed.

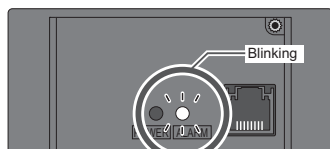

- During 24 V external power supply operation, the 24 V external power supply operation (EV) signal is output. To use the EV signal, set "68 (positive logic) or 168 (negative logic)" in one of **Pr.190 to Pr.196 (Output terminal function selection)** to assign function to an output terminal.

◆ Operation while the 24 V external power is supplied

- Fault records and parameters can be read and parameters can be written (when the parameter write from the operation panel is enabled) using the operation panel keys.
- During the 24 V external power supply operation, the monitor items related to inputs to main circuit power supply, such as the output current and converter output voltage, are invalid.
- The alarms, which have occurred when the main circuit power supply is ON, continue to be output after the power supply is changed to the 24 V external power supply. Perform the inverter reset or turn OFF then ON the power to reset the faults.
- The output data is retained when "1 or 11" is set in **Pr.495 Remote output selection**.

NOTE

- Inrush current equal to or higher than the 24 V external power supply specification may flow at power-ON. Confirm that the power supply and other devices are not affected by the inrush current and the voltage drop caused by it. Depending on the power supply, the overcurrent protection may be activated to disable the power supply. Select the power supply and capacity carefully.
- When the wiring length between the external power supply and the inverter is long, the voltage often drops. Select the appropriate wiring size and length to keep the voltage in the rated input voltage range.
- In a serial connection of several inverters, the current increases when it flows through the inverter wiring near the power supply. The increase of the current causes voltage to drop further. When connecting different inverters to different power supplies, use the inverters after confirming that the input voltage of each inverter is within the rated input voltage range. Depending on the power supply, the overcurrent protection may be activated to disable the power supply. Select the power supply and capacity carefully.
- When an external 24 V power supply is used, "E.SAF" or "E.P24" may appear if the power supply start-up time is too long (less than 1.5 V/s).
- "E.P24" may appear when the 24 V external power supply input voltage is low. Check the external power supply input.
- Do not touch the control circuit terminal block (circuit board) during the 24 V power supply operation (when conducted). Otherwise you may get an electric shock or burn.

2.7 Communication connectors and terminals

2.7.1 PU connector

◆ Mounting the operation panel or the parameter unit on the enclosure surface

- Having an operation panel or a parameter unit on the enclosure surface is convenient. With a connection cable, the operation panel or the parameter unit can be mounted to the enclosure surface and connected to the inverter.

Use the option FR-CB2[], or connectors and cables available on the market.

(To mount the operation panel, the optional connector (FR-ADP) is required.)

Securely insert one end of the cable into the PU connector and the other end into the connection connector on the parameter unit or the FR-ADP attached on the operation panel until the stoppers are fixed.

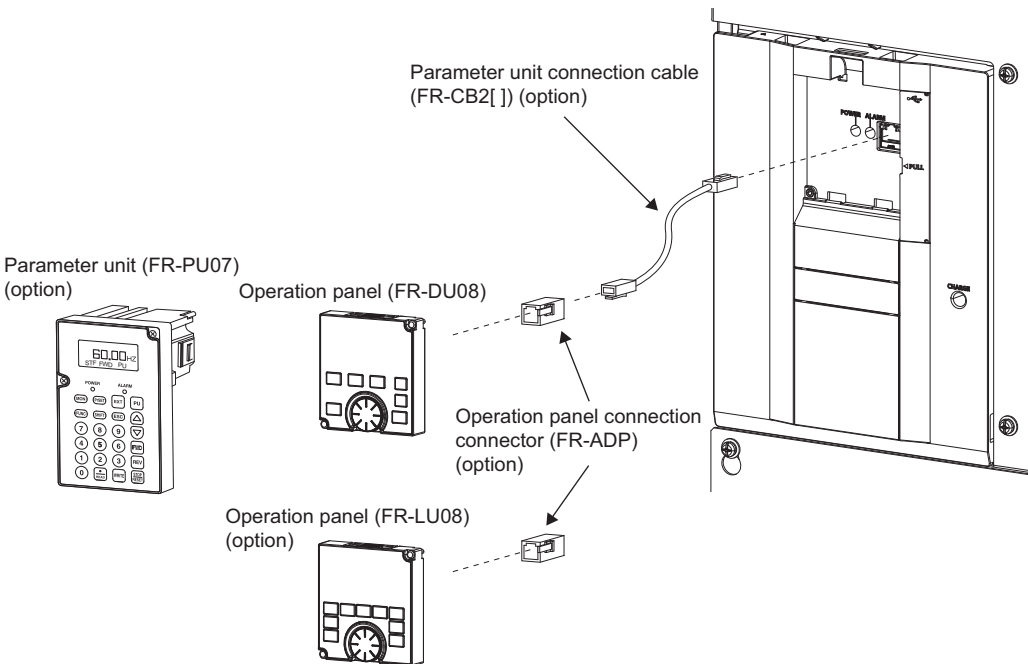

NOTE

- Refer to the following table when fabricating the cable on the user side. Keep the total cable length within 20 m.

Name	Remarks
Communication cable	Cable compliant with EIA-568 (such as 10BASE-T cable)

◆ Communication operation

- Using the PU connector as a computer network port enables communication operation from a personal computer, etc. When the PU connector is connected with a personal, FA or other computer by a communication cable, a user program can run to monitor the inverter or read and write parameters.

Communication can be performed with the Mitsubishi inverter protocol (computer link operation).

For details, refer to the Instruction Manual (Detailed).

2.7.2 RS-485 terminal block (RS-485 model)

◆ Communication operation

Conforming standard	EIA-485 (RS-485)
Transmission format	Multidrop link
Communication speed	Maximum 115200 bps
Overall length	500 m
Connection cable	Twisted pair cable (4 pairs)

The RS-485 terminals enable communication operation from a personal computer, etc. When the inverter is connected with a personal, FA or other computer by a communication cable, a user program can run to monitor the inverter or read and write parameters.

Communication can be performed with the Mitsubishi inverter protocol (computer link operation) and MODBUS RTU protocol. For details, refer to the Instruction Manual (Detailed).

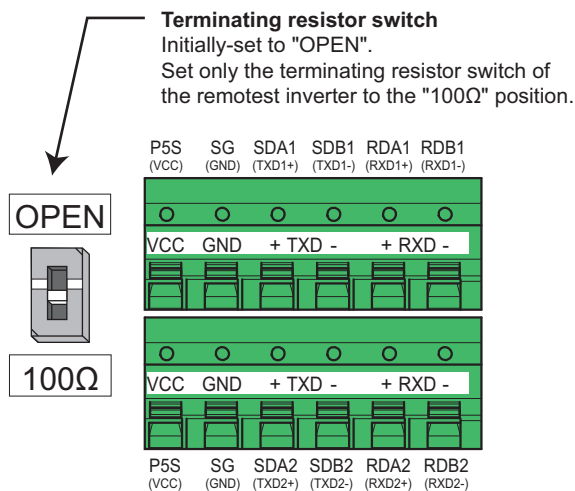

NOTE

- To avoid malfunction, keep the RS-485 terminal wires away from the control circuit board.
- For wiring of the RS-485 terminals used with a plug-in option, lead the wires on the left side of the plug-in option.

2.7.3 Ethernet connector (Ethernet model)

◆ Ethernet communication specifications

Item	Description
Category	100BASE-TX/10BASE-T
Data transmission speed	100 Mbps (100BASE-TX) / 10 Mbps (10BASE-T)
Transmission method	Baseband
Maximum segment length	100 m between the hub and the inverter
Number of cascade connection stages	Up to 2 (100BASE-TX) / up to 4 (10BASE-T)
Interface	RJ-45
Number of interfaces available	1
IP version	IPv4

◆ Connection cable

Use Ethernet cables compliant with the following standards.

Communication speed	Cable	Connector	Standard
100 Mbps	Category 5 or higher, (shielded / STP) straight cable	RJ-45 connector	100BASE-TX
10 Mbps	Category 3 or higher, (shielded / STP) straight cable		10BASE-T
	Category 3 or higher, (UTP) straight cable		

◆ Hubs

Use a hub that supports a desired transmission speed of the Ethernet.

2.7.4 USB connector

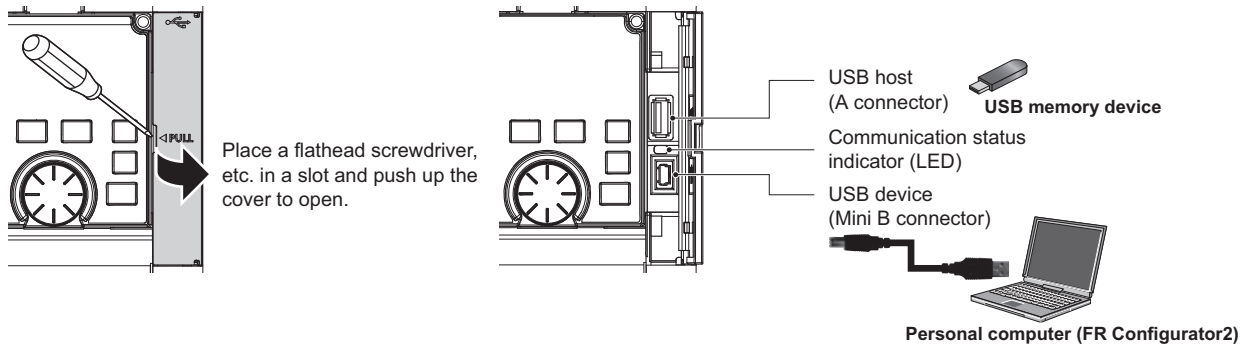

◆ USB host communication

Interface		Conforms to USB 1.1
Transmission speed		12 Mbps
Wiring length		Maximum 5 m
Connector		USB A connector (receptacle)
Compatible USB memory	Format	FAT32
	Capacity	1 GB or more (used in the recorder mode of the trace function)
	Encryption function	Not available

- Different inverter data can be saved in a USB memory device.
The USB host communication enables the following functions.

Function	Description
Parameter copy	<ul style="list-style-type: none"> • Copies the parameter settings from the inverter to the USB memory device. A maximum of 99 parameter setting files can be saved in a USB memory device. • The parameter setting data copied in the USB memory device can be copied to other inverters. This function is useful in backing up the parameter setting or for sharing the parameter setting among multiple inverters. • The parameter setting file can be copied onto a personal computer from the USB memory device and edited using FR Configurator2.
Trace	<ul style="list-style-type: none"> • The monitoring data and output status of the signals can be saved in a USB memory device. • The saved data can be imported to FR Configurator2 to diagnose the operating status of the inverter.
PLC function data copy	<ul style="list-style-type: none"> • This function copies the PLC function project data to a USB memory device when the PLC function is used. • The PLC function project data copied in the USB memory device can be copied to other inverters. • This function is useful in backing up the parameter setting and for allowing multiple inverters to operate by the same sequence programs.

- When the inverter recognizes the USB memory device without any problem, **USB-A** is briefly displayed on the operation panel.
- When the USB memory device is removed, **USB--** is briefly displayed on the operation panel.
- The operating status of the USB host can be checked on the LED display of the inverter.

LED display status	Operating status
OFF	No USB connection.
ON	The communication is established between the inverter and the USB device.
Fast blinking	The USB memory device is being accessed. (Do not remove the USB memory device.)
Slow blinking	Error in the USB connection.

- When a device such as a USB charger is connected to the USB connector and an excessive current (500 mA or higher) flows, USB host error "**UF**" (UF warning) is displayed on the operation panel.
- When the UF warning appears, the USB error can be canceled by removing the USB device and setting **Pr.1049 = "1"**. (The UF warning can also be canceled by resetting the inverter power or resetting with the RES signal.)

NOTE

- Do not connect devices other than a USB memory device to the inverter.
- If a USB device is connected to the inverter via a USB hub, the inverter cannot recognize the USB memory device properly.
- For details on usage, refer to the Instruction Manual (Detailed).

◆ USB device communication

The inverter can be connected to a personal computer with a USB (ver. 1.1) cable.

Parameter setting and monitoring can be performed by using FR Configurator2.

Interface	Conforms to USB 1.1
Transmission speed	12 Mbps
Wiring length	Maximum 5 m
Connector	USB mini B connector (receptacle)
Power supply	Self-powered

NOTE

- For details on FR Configurator2, refer to the Instruction Manual of FR Configurator2.

2.8 Connection to a motor with encoder (Vector control)

Using encoder-equipped motors together with a Vector control compatible option enables speed, torque, and positioning control operations under orientation control, encoder feedback control, and full-scale Vector control.

This section explains wiring for use of the FR-A8AP.

◆ Appearance and parts name of the FR-A8AP

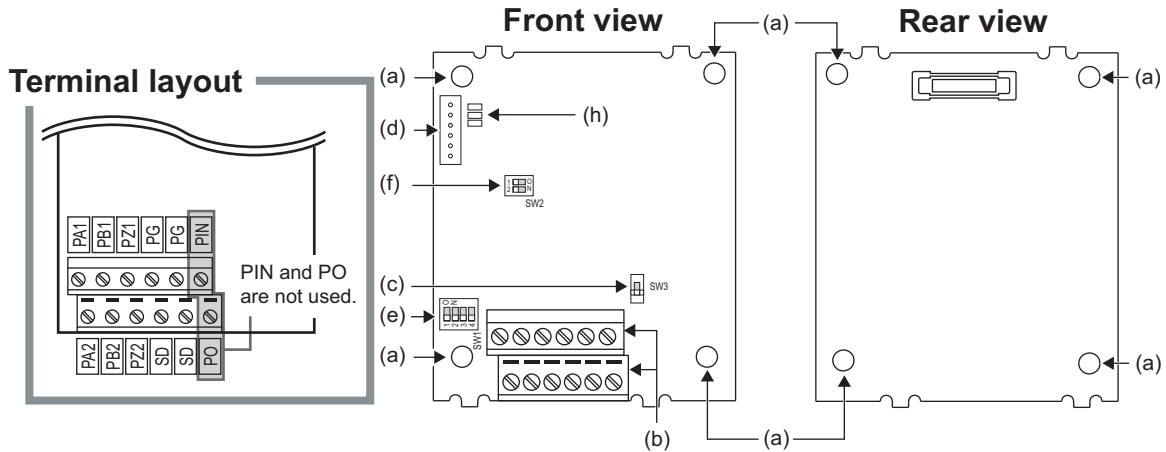

Symbol	Name	Description	Refer to page
(a)	Mounting hole	Used for installation to the inverter.	—
(b)	Terminal block	Connected with the encoder.	70
(c)	Encoder type selection switch (SW3)	Switches the encoder type (differential line driver/complementary).	68
(d)	CON2 connector	Used for extension.	—
(e)	Terminating resistor selection switches (SW1)	Switch ON or OFF the internal terminating resistor.	68
(f)	Switches (SW2) for manufacturer setting	Do not change the initial setting (both SW2-1 and SW2-2 switches: OFF setting).	—
(g)	Board mounted option connector	Used to connect this product to the option connector on the inverter.	15
(h)	LED for manufacturer check	Not used.	—

◆ Terminals of the FR-A8AP

Terminal symbol	Terminal name	Description
PA1	Encoder A-phase signal input terminal	A-, B- and Z-phase signals are input from the encoder.
PA2	Encoder A-phase inverse signal input terminal	
PB1	Encoder B-phase signal input terminal	
PB2	Encoder B-phase inverse signal input terminal	
PZ1	Encoder Z-phase signal input terminal	
PZ2	Encoder Z-phase inverse signal input terminal	
PG	Encoder power supply (positive) input terminal	Input terminal for the encoder power supply.
SD	Encoder power supply ground terminal	Connect the external power supply and the encoder power cable. When the encoder output is the differential line driver type, only 5 V can be input. Make the voltage of the external power supply same as the encoder output voltage. (Check the encoder specification.)
PIN	Not used.	
PO		

NOTE

- When the encoder's output voltage differs from its input power supply voltage, the signal loss detection (E.ECT) may occur.
- Incorrect wiring or faulty setting to the encoder will cause a fault such as an overcurrent (E.OCC) and an inverter overload (E.THT). Correctly perform the encoder wiring and setting.

◆ Switches on the FR-A8AP

- Encoder type selection switch (SW3)

Selects either the differential line driver or complementary setting.

It is initially set to the differential line driver. Switch its position according to the output circuit.

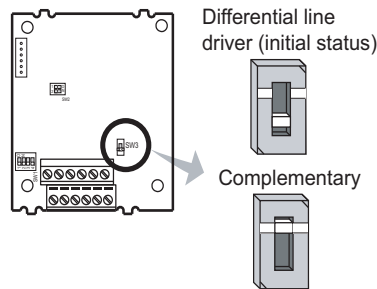

- Use the terminating resistor selection switches (SW1) to select ON/OFF of the internal terminating resistor. Set the switches ON (initial status) when an encoder output type is differential line driver, and set OFF when complementary.

ON: With internal terminating resistor (initial status)

OFF: Without internal terminating resistor

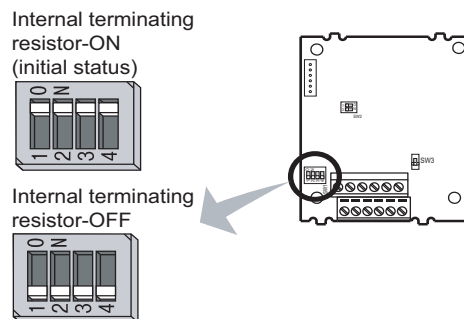

NOTE

- Set all switches to the same setting (ON/OFF).
- Set the switches OFF when sharing an encoder with another unit (NC (computerized numerical controller), etc.) having a terminating resistor under the differential line driver setting.
- Prepare the power supply (5 V/12 V/15 V/24 V) for the encoder according to the encoder's output voltage. When the control terminal option FR-A8TP is installed, 24 V power supply can be provided from the FR-A8TP. When the encoder output is the differential line driver type, only 5 V can be input.
- The SW2 switches are for manufacturer setting. Do not change the setting.
- When the power supply of the inverter is turned OFF, also turn off the power supply of the encoder. Otherwise, the plug-in option may be damaged.

- Encoder specification

Item	Specification
Resolution	0 to 4096 Pulse/Rev (setting by Pr.369)
Power supply voltage	5 V, 12 V, 15 V, or 24 V
Output signal form	A, B phases (90° phase shift), Z phase: 1 pulse/rev
Output circuit	Differential line driver or complementary

◆ Encoder cable

■ FR-JCBL

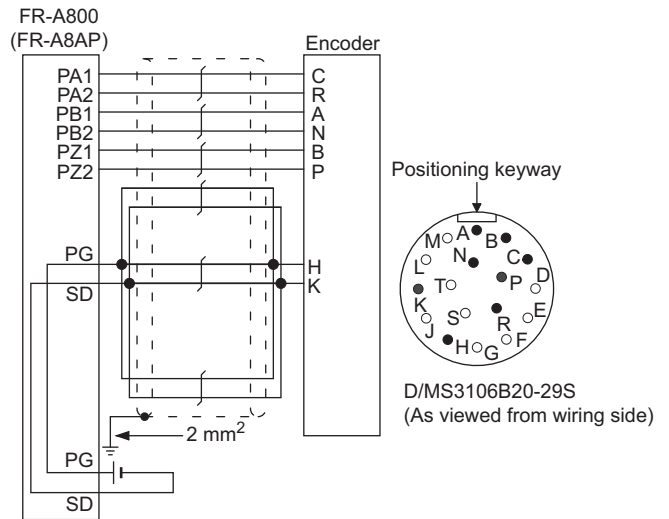
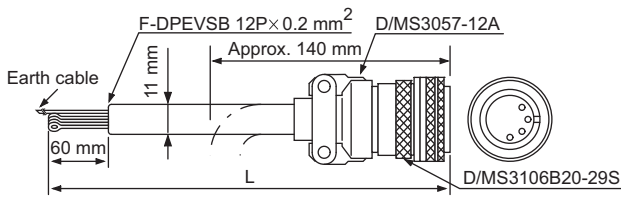

Model	Length L (m)
FR-JCBL5	5
FR-JCBL15	15
FR-JCBL30	30

■ FR-V7CBL

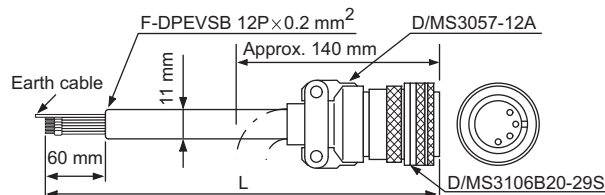

A P clip for earthing (grounding) a shielded cable is provided.

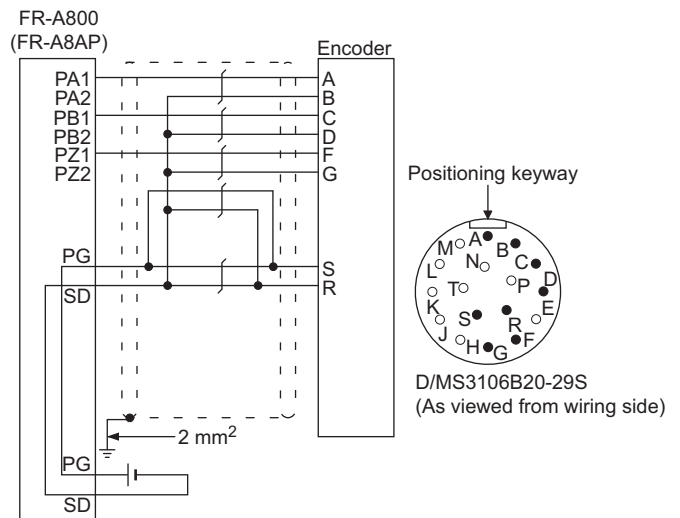

Model	Length L (m)
FR-V7CBL5	5
FR-V7CBL15	15
FR-V7CBL30	30

- As the terminal block of the FR-A8AP is an insertion type, cables need to be treated when the encoder cables of the inverter are crimping terminals. Cut the crimp terminal of the encoder cable and strip its sheath to make its cable wires loose. Also, treat the shielding wires of the shielded twisted pair cable to ensure that they do not contact conductive areas. Twist the stripped end of wires to prevent them from fraying. Do not solder them.

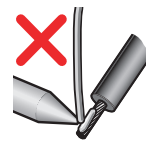
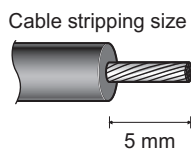

NOTE

- Information on crimp terminals
Commercially available products (as of October 2020)
Phoenix Contact Co., Ltd.

Terminal screw size	Wire gauge (mm ²)	Ferrule part No.		Crimping tool model No.
		With insulation sleeve	Without insulation sleeve	
M2	0.3	AI 0,34-6TQ	A 0,34-7	CRIMPFOX 6
	0.5	AI 0,5-6WH	A 0,5-6	

NICHIFU Co., Ltd.

Terminal screw size	Wire gauge (mm ²)	Blade terminal part No.	Insulation cap part No.	Crimping tool product number
M2	0.3 to 0.75	BT 0.75-7	VC 0.75	NH 69

- When using the crimp terminal without insulation sleeve, make sure that the twisted stripped end do not come out of the terminal.

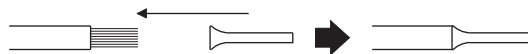

- Connection terminal compatibility table

Encoder cable	FR-V7CBL	FR-JCBL
FR-A8AP terminal	PA1	PA
	PA2	Do not connect anything to this.
	PB1	PB
	PB2	Do not connect anything to this.
	PZ1	PZ
	PZ2	Do not connect anything to this.
	PG	PG
	SD	SD
		AG2

◆ Wiring example

- Speed control

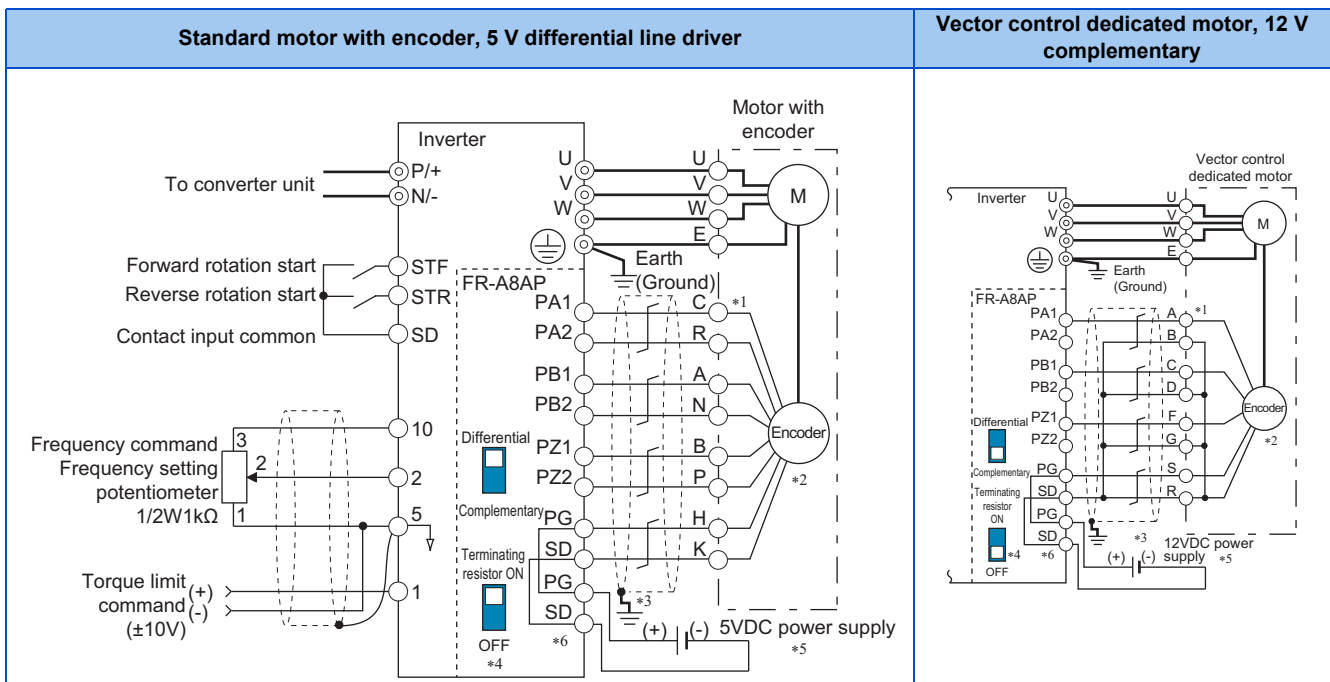

- Torque control

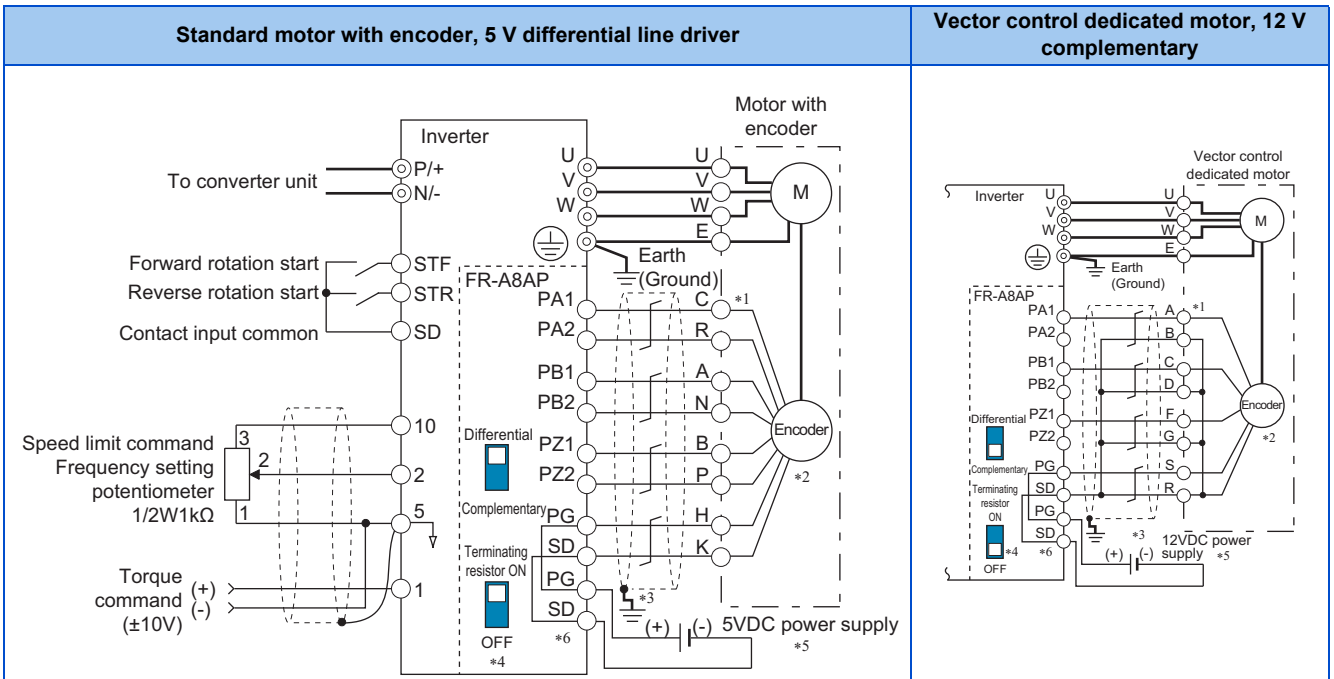

- Position control

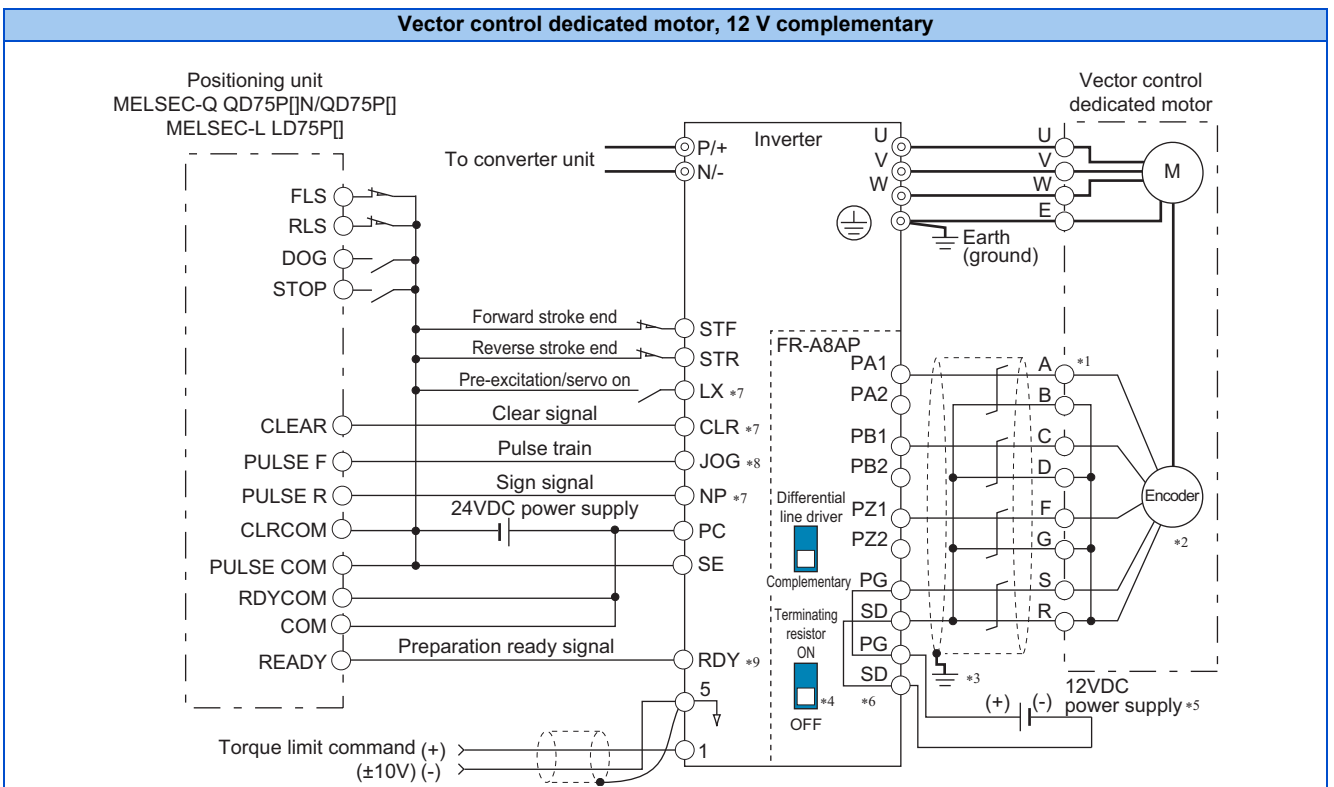

- *1 The pin number differs according to the encoder used.
- Speed, control, torque control, and position control by pulse train input are available with or without the Z-phase being connected.
- *2 Connect the encoder so that there is no looseness between the motor and motor shaft. Speed ratio must be 1:1.
- *3 Earth (ground) the shield of the encoder cable to the enclosure using a tool such as a P-clip. (Refer to page 72.)
- *4 For the complementary, set the terminating resistor selection switches in the OFF position. (Refer to page 68.)
- *5 A separate external power supply is necessary according to the encoder power specification.
- When the encoder output is the differential line driver type, only 5 V can be input.
- Make the voltage of the external power supply same as the encoder output voltage, and connect the external power supply between PG and SD.
- *6 For terminal compatibility of the FR-JCBL, FR-V7CBL, and FR-A8AP, refer to page 70.
- *7 Assign the function using Pr.178 to Pr.184, Pr.187 to Pr.189 (Input terminal function selection).
- *8 When position control is selected, terminal JOG function is invalid and simple position pulse train input terminal becomes valid.
- *9 Assign the function using Pr.190 to Pr.194 (Output terminal function selection).

◆ Instructions for encoder cable wiring

- Use shielded twisted pair cables (0.2 mm² or larger) to connect the FR-A8AP. For the wiring to terminals PG and SD, use several cables in parallel or use a thick cable, according to the wiring length.
- To protect the cables from noise, run them away from any source of noise (such as the main circuit and power supply voltage).

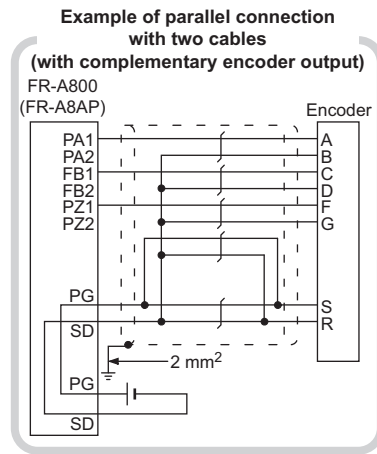

Wiring length	Parallel connection	Cable gauge	Larger-size cable
Within 10 m	At least two cables in parallel	0.2mm ²	0.4 mm ² or larger
Within 20 m	At least four cables in parallel		0.75 mm ² or larger
Within 100 m ^{*1}	At least six cables in parallel		1.25 mm ² or larger

*1 When differential line driver is set and a wiring length is 30 m or more.

The wiring length can be extended to 100 m by increasing the 5 V power supply (approximately to 5.5 V) while using six or more 0.2 mm² gauge cables in parallel or a 1.25 mm² or larger gauge cable. The voltage applied must be within power supply specifications of encoder.

- To reduce noise of the encoder cable, earth (ground) the encoder's shielded cable to the enclosure (as close as possible to the inverter) with a metal P-clip or U-clip.

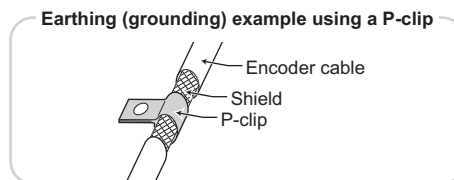

- When one encoder is shared between the FR-A8AP and CNC (computerized numerical controller), its output signal should be connected as follows. In this case, the wiring length between the FR-A8AP and CNC should be as short as possible, within 5 m.

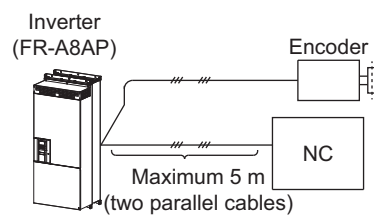



NOTE

- For details on the optional encoder dedicated cable (FR-JCBL/FR-V7CBL), refer to [page 69](#).
- The FR-V7CBL is provided with a P-clip for earthing (grounding) shielded cables.

2.9 Parameter settings for a motor with encoder

◆ Parameter for the encoder (Pr.359, Pr.369, Pr.851, Pr.852)

- Set the encoder specifications.

Pr.		Name	Initial value	Setting range	Description	
359 C141	852 C241*1	Encoder rotation direction	0 (in Pr.359) / 1 (in Pr.852)	0	Set when using a motor for which forward rotation (encoder) is clockwise (CW) viewed from the shaft	Set for the operation at 120 Hz or less.
				100		Set for the operation at a frequency higher than 120 Hz.
				1*1	Set when using a motor for which forward rotation (encoder) is counterclockwise (CCW) viewed from the shaft.	Set for the operation at 120 Hz or less.
				101*1		Set for the operation at a frequency higher than 120 Hz.
369 C140*1	851 C240*1	Number of encoder pulses	1024	0 to 4096	Set the number of encoder pulses. Set the number of pulses before it is multiplied by 4.	

*1 Setting is not available when the A8SPRS is installed.

The parameters above can be set when a Vector control compatible option is installed.

- The following table shows parameters to be set according to the Vector control compatible option to be used (when the FR-A8NCG-S is used).

Item	FR-A8AP/FR-A8AL/FR-A8APA parameter	FR-A8APR parameter	FR-A8APS parameter	FR-A8TP parameter
Encoder/Resolver rotation direction	Pr.359			Pr.852
Number of detector pulses	Pr.369	— (fixed pulses of 1024)	— (obtained via communication from the encoder)	Pr.851

◆ Parameter settings for the motor under Vector control

Motor model	Pr.9 Electronic thermal O/L relay	Pr.71 Applied motor	Pr.80 Motor capacity	Pr.81 Number of motor poles	Pr.359/Pr.852 Encoder rotation direction	Pr.369/Pr.851 Number of encoder pulses
Standard motor	Rated motor current	0 (3)*1	Motor capacity	Number of motor poles	*2	*2
Constant-torque motor	Rated motor current	1 (13)*1	Motor capacity	Number of motor poles	*2	*2

*1 Offline auto tuning is required. (Refer to the Instruction Manual (Detailed).)

*2 Set this parameter according to the motor.

2.10 Connection of stand-alone option units

The inverter accepts a variety of stand-alone option units as required.

Incorrect connection will cause inverter damage or accident. Connect and operate the option unit carefully in accordance with the Instruction Manual of the corresponding option unit.

2.10.1 Connection of the brake unit (FR-BU2)

Connect the brake unit (FR-BU2) as follows to improve the braking capability during deceleration.

After making sure that the wiring is correct and secure, set "11 or 111" in **Pr.30 Regenerative function selection**.

Set **Pr.0 Brake mode selection** = "2" in the brake unit FR-BU2.

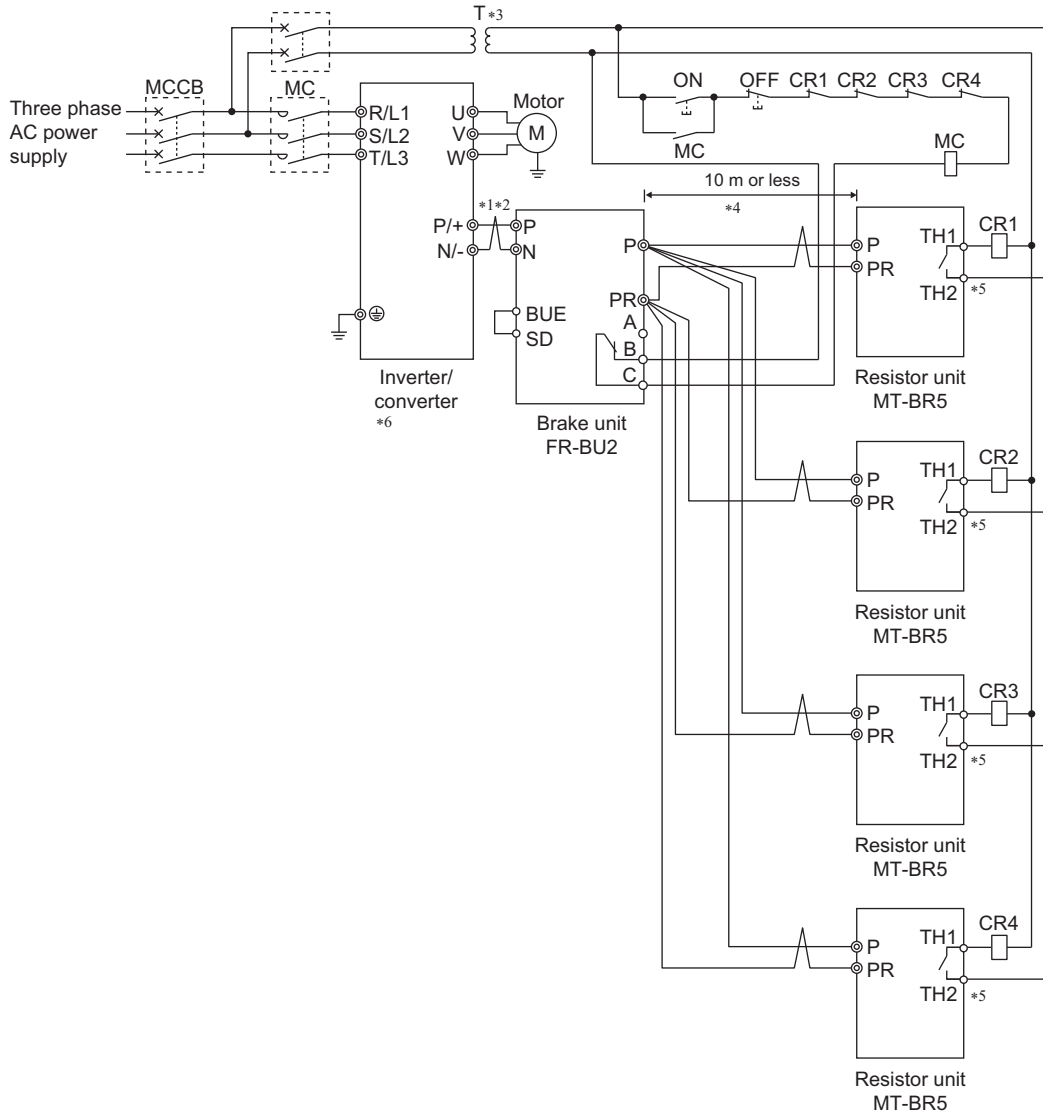

- *1 When wiring, make sure to match the terminal symbols (P/+, N/-) on the inverter and on the brake unit (FR-BU2). (Incorrect connection will damage the inverter and brake unit.)
- *2 For the FR-A842-08660(355K) or lower, up to two cables can be connected to terminals P/+ and N/-. For the FR-A842-09620(400K) or higher, up to four cables can be connected. To use more cables, use a bus bar.
- *3 When the power supply is 400 V class, install a stepdown transformer.
- *4 The wiring distance between the inverter, brake unit (FR-BU2) and resistor unit (MT-BR5) must be within 5 m. When using twisted pair cable, use the cable within 10 m.
- *5 The contact between TH1 and TH2 is open in the normal status and is closed at a fault.
- *6 The CN8 connector used with the MT-BU5 type brake unit is not used.

- The warning "oL" of the stall prevention (overvoltage) is disabled while **Pr.30 Regenerative function selection = "11 or 111"**.
- For the parameter details, refer to the Instruction Manual (Detailed).

2.10.2 Connection of the high power factor converter (FR-HC2)

When connecting the high power factor converter (FR-HC2) to suppress power harmonics, perform wiring securely as follows. Incorrect connection will damage the high power factor converter and the inverter.

After making sure that the wiring is correct and secure, set the rated motor voltage in **Pr.19 Base frequency voltage** (under V/F control) or **Pr.83 Rated motor voltage** (under other than V/F control) and "2 or 102" in **Pr.30 Regenerative function selection**.

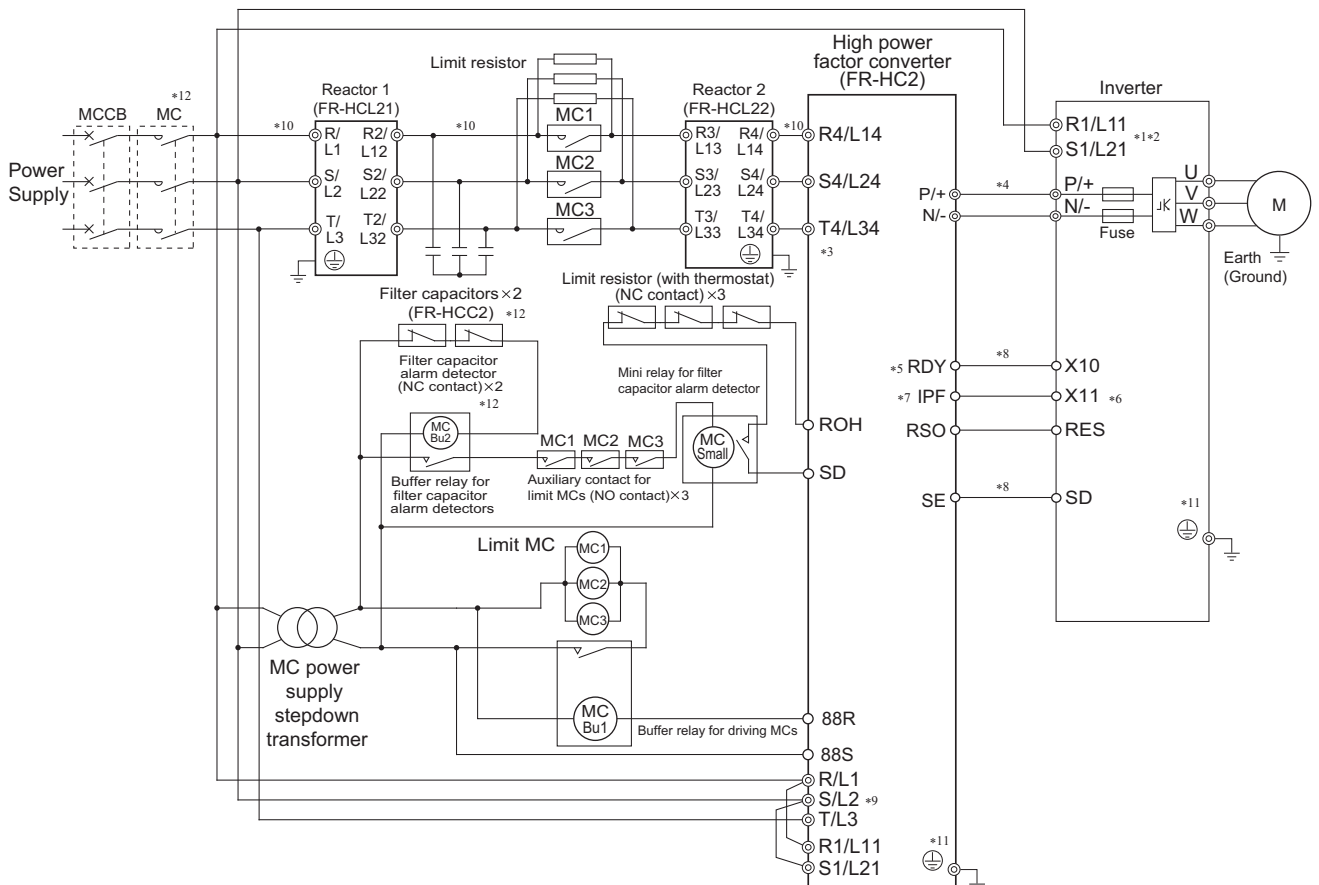

- *1 Remove jumpers installed between terminals R1/L11 and S1/L21 of the inverter, and connect the power supply for the control circuit to terminals R1/L11 and S1/L21.
- *2 When a separate power supply is not required for the control circuit of the inverter, terminals R1/L11 and S1/L21 need not be connected to the AC power supply. Use the inverter with jumpers installed across terminals R1/L11 and P/+ and across terminals S1/L21 and N/- (initial status). In this case, do not connect the terminals to the AC power supply. Incorrect connection will damage the inverter.
- *3 For wiring, the power phase must be consistent between terminals R4/L14, S4/L24, and T4/L34 and terminals R/L1, S/L2, and T/L3.
- *4 Do not install an MCCB across terminals P/+ and N/- (between terminals P and P/+ or between terminals N and N/-). Connecting the opposite polarity of terminals N/- and P/+ will damage the inverter.
When using the FR-HC2 with this product, installation of a fuse is not required.
- *5 Change the FR-HC2 parameter setting to **Pr.10 RDY signal logic selection = "0"** (positive logic).
- *6 Use **Pr.178 to Pr.189 (Input terminal function selection)** to assign the function to a terminal used for the X11 signal.
For RS-485 or any other form of communication where the start command is only transmitted once, use the X11 signal to save the operation mode at the time of an instantaneous power failure.
- *7 Assign the IPF signal to a terminal on the FR-HC2. (Refer to the FR-HC2 Instruction Manual.)
- *8 Always connect between the FR-HC2 terminal RDY and the inverter terminal MRS (X10), and between the FR-HC2 terminal SE and the inverter terminal SD. Not connecting these terminals may damage the FR-HC2.
- *9 Always connect terminals R/L1, S/L2, and T/L3 on the FR-HC2 to the power supply. Operating the inverter without connecting them will damage the FR-HC2.
- *10 Do not install an MCCB or MC (except for the inrush current limit MC) across terminals (R/L1, S/L2, T/L3) on the reactor 1 and terminals (R4/L14, S4/L24, T4/L34) on the FR-HC2. Doing so disrupts proper operation.
- *11 Securely perform grounding (earthing) by using the grounding (earthing) terminal.

*12 The number of connected peripheral devices differs according to the capacity. For details, refer to the FR-HC2 Instruction Manual.

 **NOTE**

- The voltage phases of terminals R/L1, S/L2, and T/L3 and the voltage phases of terminals R4/L14, S4/L24, and T4/L34 must be matched.
- The control logic (sink logic/source logic) of the high power factor converter and the inverter must be matched. (Refer to [page 54.](#))
- When using a sine wave filter and FR-HC2 together, use MT-BSL-HC for the sine wave filter.
- For the parameter details, refer to the Instruction Manual (Detailed).

2.10.3 Connection of the power regeneration converter (MT-RC)

When connecting the power regeneration converter (MT-RC), perform wiring securely as follows. Incorrect connection will damage the power regeneration converter and the inverter. After making sure that the wiring is correct and secure, set "10 or 110" in **Pr.30 Regenerative function selection**.

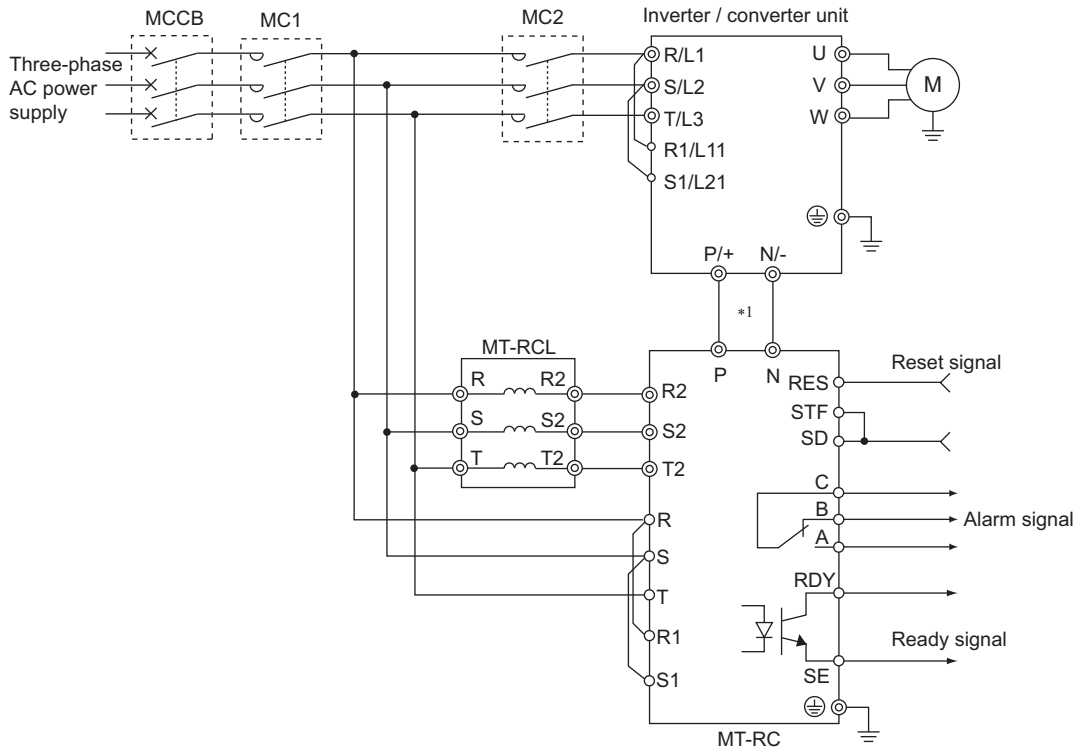

*1 For the FR-A842-08660(355K) or lower, up to two cables can be connected to terminals P/+ and N/-. For the FR-A842-09620(400K) or higher, up to four cables can be connected. To use more cables, use a bus bar.

NOTE

- When using the inverter with the MT-RC, install a magnetic contactor (MC) at the input side of the inverter so that power is supplied to the inverter after one second or more has elapsed after powering ON the MT-RC. When power is supplied to the inverter prior to the MT-RC, the inverter and the MT-RC may be damaged or the MCCB may trip or be damaged.

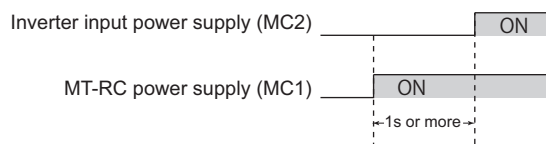

- When connecting the power coordination reactor and others, refer to Instruction Manual of the MT-RC for precautions.

2.11 Connection of the earthing (grounding) cable (Ethernet model)

To use a safety communication option, the enclosed earthing (grounding) cable needs to be installed. Install the cable according to the following procedure. (For how to install the safety communication option, refer to the Instruction Manual of the safety communication option.)

No.	Description
1	Insert spacers into the mounting holes that will not be tightened with the option mounting screws.
2	Fit the connector of the safety communication option to the guide of the connector of the inverter, and insert the option as far as it goes. (Insert it to the inverter option connector 1.)
3	Remove the mounting screw (lower) of the Ethernet board earth plate. Fit the one terminal of the earthing (grounding) cable on the Ethernet board earth plate and fix it securely to the inverter with the mounting screw (tightening torque 0.33 to 0.40 N·m).
4	Fix the left part of the safety communication option securely with the option mounting screw, and place another terminal of the earthing (grounding) cable on the right part of the option and fix the cable terminal and the option with the option mounting screw (tightening torque: 0.33 to 0.40 N·m). If the screw holes do not line up, the connector may not be inserted deep enough. Check the connector.

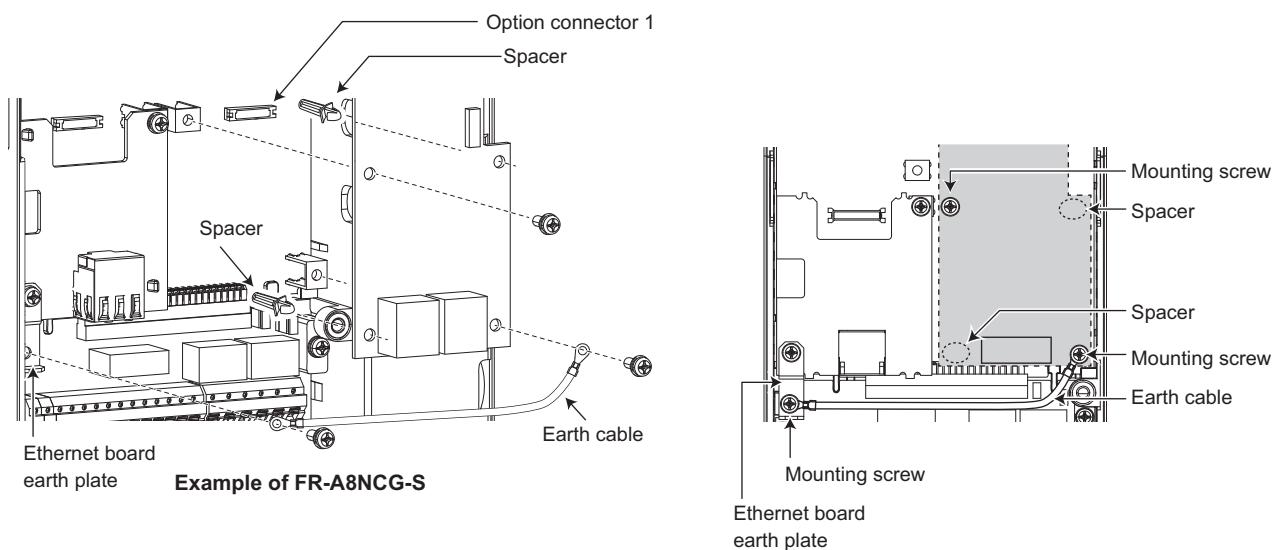

NOTE

- The number and shape of the spacers used differ depending on the communication option type. Refer to the Instruction Manual of each communication option for details.
- The earth plate enclosed with a safety communication option is not used.

CHAPTER 3 PRECAUTIONS FOR USE OF THE INVERTER

3.1	Electro-magnetic interference (EMI) and leakage currents	80
3.2	Power supply harmonics.....	86
3.3	Installation of a reactor	89
3.4	Power shutdown and magnetic contactor (MC).....	90
3.5	Countermeasures against deterioration of the 400 V class motor insulation.....	92
3.6	Checklist before starting operation	93
3.7	Failsafe system which uses the inverter	96

3 PRECAUTIONS FOR USE OF THE INVERTER

This chapter explains the precautions for use of this product.
Always read the instructions before use.

3.1 Electro-magnetic interference (EMI) and leakage currents

3.1.1 Leakage currents and countermeasures

Capacitance exists between the inverter I/O cables, other cables and earth and in the motor, through which a leakage current flows. The amount of current leakage depends on the factors such as the size of the capacitance and the carrier frequency. Low acoustic noise operation at an increased carrier frequency of the inverter will increase current leakage. Take the following precautions to prevent current leakage. Earth leakage circuit breakers should be selected based on their rated current sensitivity, independently of the carrier frequency setting.

◆ To-earth (ground) leakage currents

Leakage currents may flow not only into the power system of the inverter but also into the other power systems through the earthing (grounding) cable, etc. These leakage currents may operate earth leakage circuit breakers and earth leakage relays unnecessarily.

■ Precautions

- If the carrier frequency setting is high, decrease the **Pr.72 PWM frequency selection** setting.
Note that motor noise increases. Selecting **Pr.240 Soft-PWM operation selection** makes the sound inoffensive.
- By using earth leakage circuit breakers designed to suppress harmonics and surge voltage in the power system of the inverter and other devices, operation can be performed with the carrier frequency kept high (with low noise).

■ To-earth (ground) leakage currents

- Take caution as long wiring will increase the leakage current. Decreasing the carrier frequency of the inverter reduces the leakage current.
- High motor capacity will increase the leakage current.

◆ Line-to-line leakage currents

Harmonics of leakage currents flowing in static capacitance between the inverter output cables may operate the external thermal relay unnecessarily.

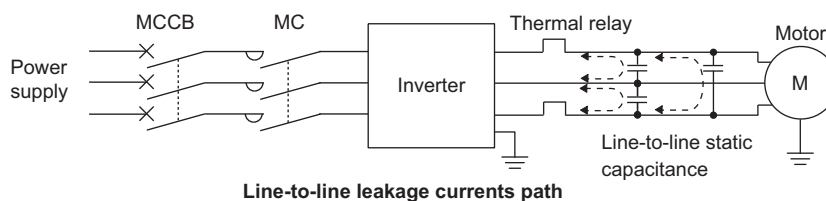

■ Precautions

- Use **Pr.9 Electronic thermal O/L relay**.
- If the carrier frequency setting is high, decrease the **Pr.72 PWM frequency selection** setting.
Note that motor noise increases. Selecting **Pr.240 Soft-PWM operation selection** makes the sound inoffensive.
To ensure that the motor is protected against line-to-line leakage currents, it is recommended to use a temperature sensor to directly detect motor temperature.

■ Installation and selection of the molded case circuit breaker

Install a molded case circuit breaker (MCCB) on the power receiving side to protect the wiring at the inverter input side. Select an MCCB according to the inverter input side power factor, which depends on the power supply voltage, output frequency and load. Especially for a completely electromagnetic MCCB, a slightly large capacity must be selected since its operation characteristic varies with harmonic currents. (Check it in the data of the corresponding breaker.) As an earth leakage current breaker, use the Mitsubishi earth leakage current breaker designed for harmonics and surge suppression.

◆ Selecting the rated sensitivity current for the earth leakage circuit breaker

To install the earth leakage circuit breaker on the inverter circuit, select its rated sensitivity current as follows, independently of the PWM carrier frequency.

- Breaker designed for harmonic and surge suppression
 Rated sensitivity current
 $I\Delta n \geq 10 \times (I_{g1} + I_{gn} + I_{gi} + I_{g2} + I_{gm})$
 - Standard breaker
 Rated sensitivity current
 $I\Delta n \geq 10 \times \{I_{g1} + I_{gn} + I_{gi} + 3 \times (I_{g2} + I_{gm})\}$
- I_{g1}, I_{g2} : Leakage currents in wire path during commercial power supply operation
 I_{gn} : Leakage current from noise filters on the input side of the inverter
 I_{gm} : Leakage current from the motor during commercial power supply operation
 I_{gi} : Leakage current of inverter unit

Example of leakage current of cable path per 1km during the commercial power supply operation when the CV cable is routed in metal conduit

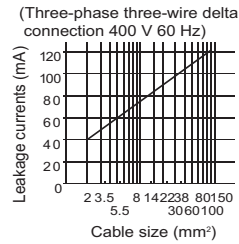

Leakage current example of three-phase induction motor during the commercial power supply operation

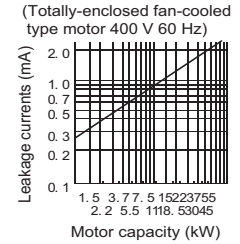

For "Δ" connection, the amount of leakage current is approx. 1/3 of the above value.

- Selection example for the Δ connection of the 400 V class

Example

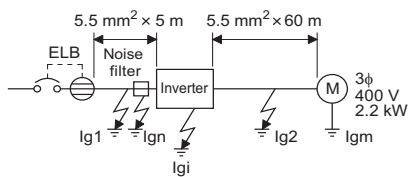

Item	Breaker designed for harmonic and surge suppression	Standard breaker
Leakage current I_{g1} (mA)	$\frac{1}{3} \times 66 \times \frac{5m}{1000m} = 0.11$	
Leakage current I_{gn} (mA)	0 (without noise filter)	
Leakage current I_{gi} (mA)	1 (without EMC filter). For the leakage current of the inverter, refer to the following table.	
Leakage current I_{g2} (mA)	$\frac{1}{3} \times 66 \times \frac{60m}{1000m} = 1.32$	
Motor leakage current I_{gm} (mA)	0.36	
Total leakage current (mA)	2.79	6.15
Rated sensitivity current (mA) ($\geq I_g \times 10$)	30	100

- Inverter/converter unit leakage current (mA)

Inverter / converter unit	FR-A800 (standard model)		FR-A802 (separated converter type)	Converter unit FR-CC2		Remarks
	EMC filter ON	EMC filter OFF		ON	OFF	
Phase earthing (grounding)	35	2	2	70	2	Input power conditions (440 V/60 Hz, power supply imbalance within 3%)
Earthed-neutral system	2	1	1	2	1	

NOTE

- Install the earth leakage circuit breaker (ELB) on the input side of the converter unit.
- In the Δ connection earthed-neutral system, the sensitivity current is blunt against a ground fault in the inverter output side. Earthing (Grounding) must conform to the requirements of national and local safety regulations and electrical codes. (NEC section 250, IEC 61140 class 1 and other applicable standards)
- When the breaker is installed on the output side of the inverter, it may be unnecessarily operated by harmonics even if the effective value is within the rating.
In this case, do not install the breaker since the eddy current and hysteresis loss will increase, leading to temperature rise.
- The following models and products are standard breakers: BV-C1, BC-V, NVB, NV-L, NV-G2N, NV-G3NA, NV-2F, earth leakage relay (except NV-ZHA), NV with AA neutral wire open-phase protection
The other models are designed for harmonic and surge suppression: NV-C/NV-S/MN series, NV30-FA, NV50-FA, BV-C2, earth leakage alarm breaker (NF-Z), NV-ZHA, and NV-H.
- For the leakage current of a 75 kW or higher motor, contact the motor manufacturer.

3.1.2 Techniques and measures for electromagnetic compatibility (EMC)

Some electromagnetic noises enter the inverter or the converter unit to cause its malfunction, and others are radiated by the inverter or the converter unit to cause the peripheral devices to malfunction. Though the inverter or the converter unit is designed to have high immunity performance, it handles low-level signals, so it requires the following basic techniques. Pay attention to the electromagnetic noises that could be generated by the inverter since the inverter chops outputs at high carrier frequency. If these electromagnetic noises cause peripheral devices to malfunction, EMI countermeasures should be taken to suppress noises. These techniques differ slightly depending on EMI paths.

◆ Basic measures

- Do not run the power cables (I/O cables) and signal cables of the inverter or the converter unit in parallel with each other and do not bundle them.
- Use shielded twisted pair cables for the detector connecting and control signal cables and connect the sheathes of the shielded cables to terminal SD.
- Ground (Earth) the inverter or the converter unit, motor, etc. at one point.

◆ Techniques to reduce electromagnetic noises that enter and cause a malfunction of the inverter or the converter unit (EMI countermeasures)

When devices that generate many electromagnetic noises (which use magnetic contactors, electromagnetic brakes, many relays, for example) are installed near the inverter or the converter unit and it may malfunction due to electromagnetic noises, the following countermeasures must be taken:

- Provide surge suppressors for devices that generate many electromagnetic noises to suppress electromagnetic noises.
- Install data line filters ([page 83](#)) to signal cables.
- Ground (Earth) the shields of the detector connection and control signal cables with cable clamp metal.

◆ Techniques to reduce electromagnetic noises that are radiated by the inverter or the converter unit to cause the peripheral devices to malfunction (EMI countermeasures)

Noises generated from the inverter or the converter unit are largely classified into those radiated by the cables connected to the inverter or the converter unit and its main circuits (I/O), those electromagnetically and electrostatically induced to the signal cables of the peripheral devices close to the main circuit power supply, and those transmitted through the power supply cables.

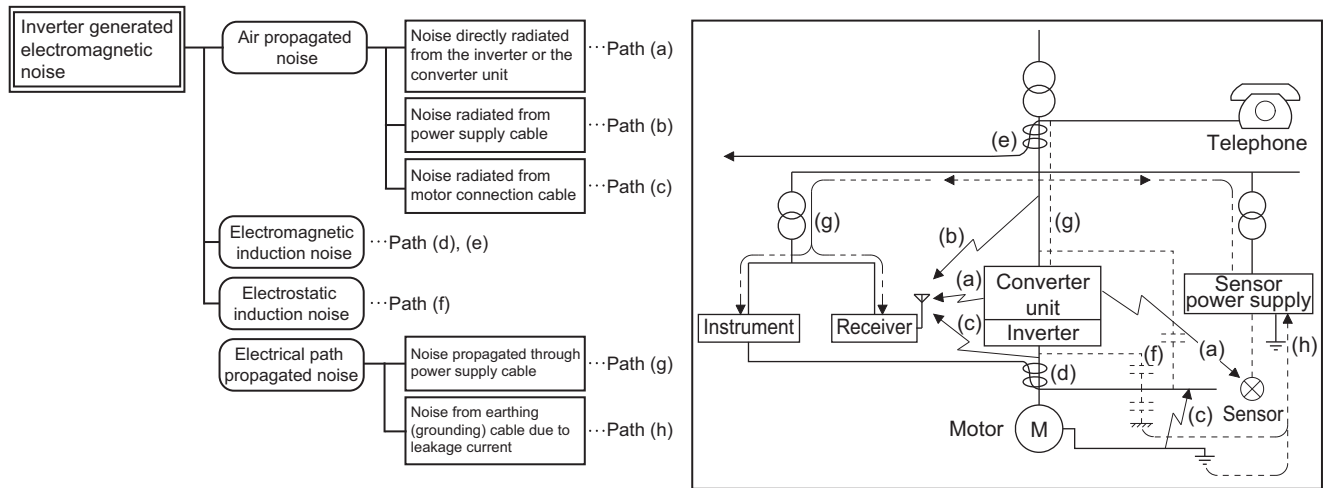

Noise propagation path	Precautions
(a), (b), (c)	<p>When devices that handle low-level signals and are liable to malfunction due to electromagnetic noises, e.g. instruments, receivers and sensors, are contained in the enclosure that contains the inverter or the converter unit, or when their signal cables are run near the inverter, the devices may malfunction due to by air-propagated electromagnetic noises. The following countermeasures must be taken:</p> <ul style="list-style-type: none"> • Install easily affected devices as far away as possible from the inverter or the converter unit. • Run easily affected signal cables as far away as possible from the inverter or the converter unit, and its I/O cables. • Do not run the signal cables and power cables (inverter or converter unit I/O cables) in parallel with each other, and do not bundle them. • Set the EMC filter ON/OFF connector of the converter unit to the ON position. (Refer to page 85.) • Inserting a line noise filter into the output suppresses the radiated noise from the cables. • Use shielded cables as signal cables and power cables and run them in individual metal conduits to produce further effects.
(d), (e), (f)	<p>When the signal cables are run in parallel with or bundled with the power cables, magnetic and static induction noises may be propagated to the signal cables to cause malfunction of the devices and the following countermeasures must be taken:</p> <ul style="list-style-type: none"> • Install easily affected devices as far away as possible from the inverter or the converter unit. • Run easily affected signal cables as far away as possible from the inverter or the converter unit, and its I/O cables. • Do not run the signal cables and power cables (inverter or converter unit I/O cables) in parallel with each other, and do not bundle them. • Use shielded cables as signal cables and power cables and run them in individual metal conduits to produce further effects.
(g)	<p>When the peripheral devices use the power system of the inverter or the converter unit, its generated noises may flow back through the power supply cables to cause malfunction of the devices and the following countermeasures must be taken:</p> <ul style="list-style-type: none"> • Set the EMC filter ON/OFF connector of the converter unit to the ON position. (Refer to page 85.) • Install the line noise filter to the power cables (output cables) of the inverter.
(h)	<p>When a closed loop circuit is formed by connecting the peripheral device wiring to the inverter or the converter unit, leakage currents may flow through the earthing (grounding) cable of the inverter or the converter unit to cause the device to malfunction. In that case, disconnecting the earthing (grounding) cable from the device may stop the malfunction of the device.</p>

■ Data line filter

Data line filter is effective as an EMI countermeasure. Provide a data line filter for the detector cable, etc.

- Commercially available data line filter: ZCAT3035-1330 (by TDK), ESD-SR-250 (by TOKIN)

- Specification example (ZCAT3035-1330 by TDK)

Item	Description	
Impedance (Ω)	10 to 100 MHz	80
	100 to 500 MHz	150
Outline dimension drawings (mm)		

The impedance values above are reference values, and not guaranteed values.

■ EMI measure example

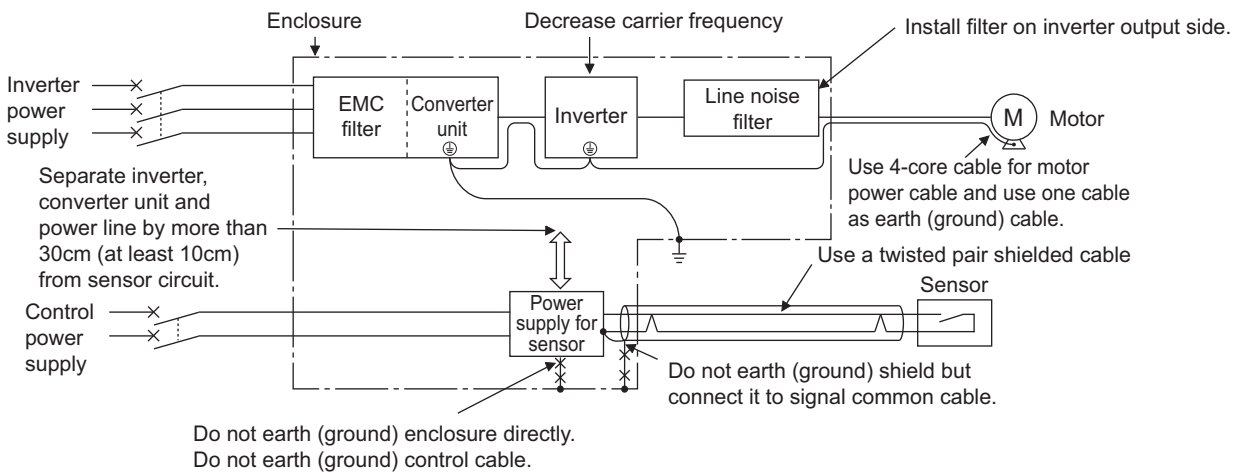

NOTE

- For compliance with the EU EMC Directive, refer to [page 131](#).

3.1.3 Converter unit (FR-CC2) built-in EMC filter

The converter unit is equipped with a built-in EMC filter (capacitive filter).

These filters are effective in reducing air-propagated noise on the input side of the converter unit.

To enable the EMC filter, set the EMC filter ON/OFF connector to the ON position.

Two female connectors are initially connected to the OFF (disabled) male connectors.

To enable the EMC filter, fit both of the EMC filter ON/OFF connectors to the "enabled" (ON) position.

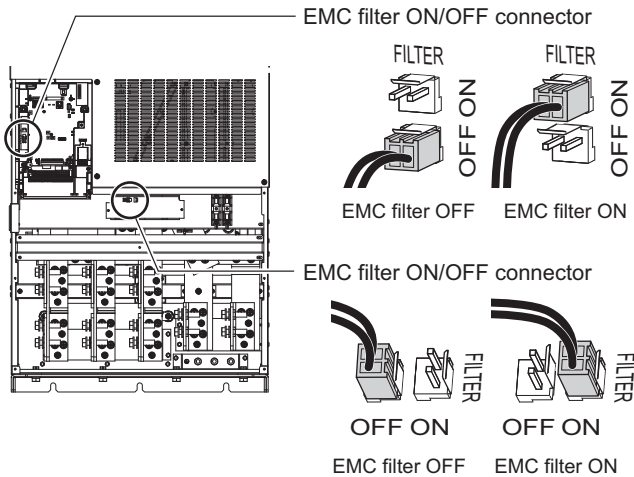

◆ How to enable or disable the filter

- Before removing a front cover, check to make sure that the indication of the inverter operation panel is OFF, wait for at least 10 minutes after the power supply has been switched OFF, and check that there is no residual voltage using a digital multimeter or the like.
- When disconnecting the connector, push the fixing tab and pull the connector straight without pulling the cable or forcibly pulling the connector with the tab fixed.

When installing the connector, also engage the fixing tab securely.

(If it is difficult to disconnect the connector, use a pair of needle-nose pliers, etc.)

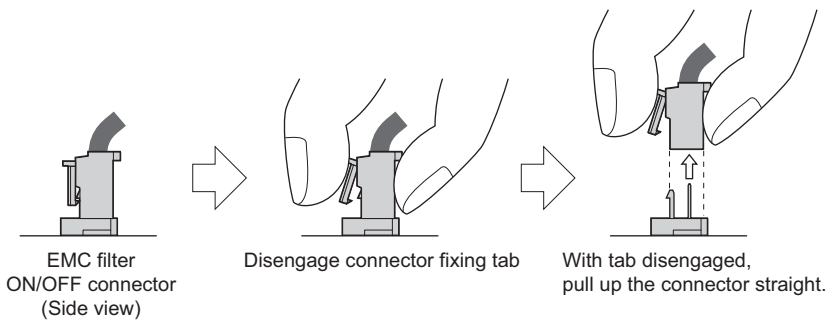

NOTE

- Fit the connector to either ON or OFF position.
- Enabling (turning ON) the EMC filter increases leakage current. (Refer to [page 81](#).)

⚠ WARNING

- While power is ON, do not open the front cover. Doing so may cause an electric shock.

3.2 Power supply harmonics

3.2.1 Power supply harmonics

The inverter may generate power supply harmonics from its converter circuit to affect the power generator, power factor correction capacitor etc. Power supply harmonics are different from noise and leakage currents in source, frequency band and transmission path. Take the following countermeasures.

- Differences between harmonics and noises

Item	Harmonics	Noise
frequency	Normally 40th to 50th degrees or less (3 kHz or less).	High frequency (several 10 kHz to 1 GHz order).
Location	To-electric channel, power impedance.	To-space, distance, wiring path.
Quantitative understanding	Theoretical calculation possible.	Random occurrence, quantitative grasping difficult.
Generated amount	Nearly proportional to the load capacity.	Changes with the current variation ratio. (Gets larger as switching speed increases.)
Affected equipment immunity	Specified by standards per equipment.	Different depending on maker's equipment specifications.
Countermeasure	Provide a reactor.	Increase distance.

- Countermeasures

The harmonic current generated from the inverter to the input side differs according to various conditions such as the wiring impedance, whether a reactor is used or not, and output frequency and output current on the load side.

For the output frequency and output current, we understand that this should be calculated in the conditions under the rated load at the maximum operating frequency.

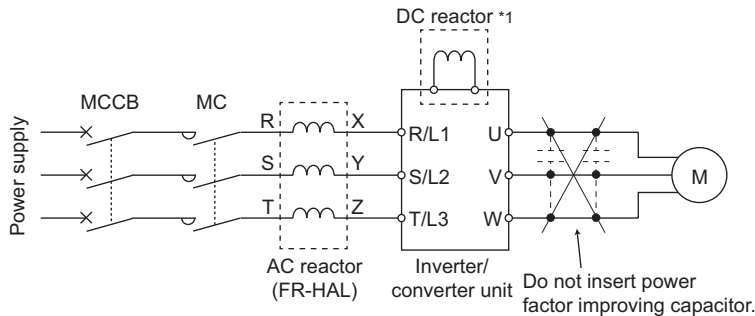

*1 The converter unit (FR-CC2) has a built-in DC reactor.

NOTE

- The power factor improving capacitor and surge suppressor on the inverter output side may be overheated or damaged by the harmonic components of the inverter output. Also, since an excessive current flows in the inverter to activate overcurrent protection, do not provide a capacitor and surge suppressor on the inverter output side when the motor is driven by the inverter. For power factor improvement, install a reactor on the inverter input side or in the DC circuit.

3.2.2 Harmonic suppression guidelines in Japan

Inverters have a converter section (rectifier circuit) and generate a harmonic current.

Harmonic currents flow from the inverter to a power receiving point via a power transformer. The Harmonic Suppression Guidelines was established to protect other consumers from these outgoing harmonic currents.

The three-phase 200 V input specifications 3.7 kW or lower were previously covered by the Harmonic Suppression Guidelines for Household Appliances and General-purpose Products and other models were covered by the Harmonic Suppression Guidelines for Consumers Who Receive High Voltage or Special High Voltage. However, the transistorized inverter has been excluded from the target products covered by the Harmonic Suppression Guidelines for Household Appliances and General-purpose Products in January 2004 and the Harmonic Suppression Guideline for Household Appliances and General-purpose Products was repealed on September 6, 2004.

All capacity and all models of general-purpose inverter used by specific consumers are now covered by the Harmonic Suppression Guidelines for Consumers Who Receive High Voltage or Special High Voltage (hereinafter referred to as the Specific Consumer Guidelines).

- Specific Consumer Guidelines

This guideline sets forth the maximum harmonic currents outgoing from a high-voltage or especially high-voltage receiving consumer who will install, add or renew harmonic generating equipment. If any of the maximum values is exceeded, this guideline requires that consumer to take certain suppression measures.

- Maximum values of outgoing harmonic currents per 1 kW contract power

Received power voltage	5th	7th	11th	13th	17th	19th	23rd	Over 23rd
6.6 kV	3.5	2.5	1.6	1.3	1.0	0.9	0.76	0.70
22 kV	1.8	1.3	0.82	0.69	0.53	0.47	0.39	0.36
33 kV	1.2	0.86	0.55	0.46	0.35	0.32	0.26	0.24

◆ Application of the specific consumer guidelines

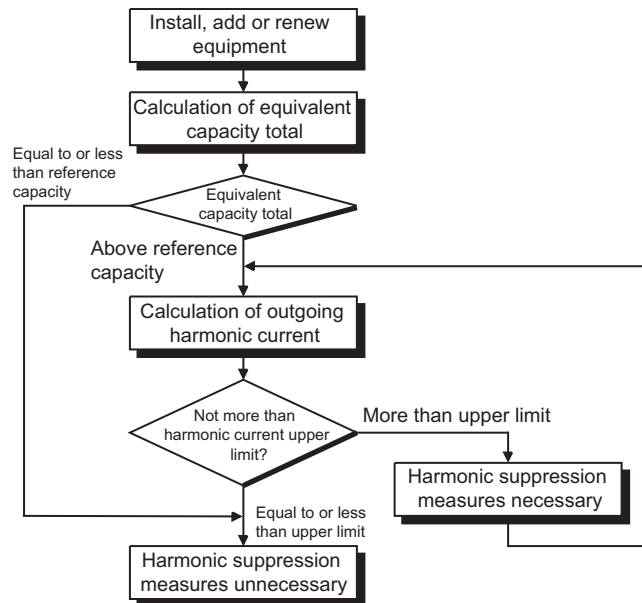

■ Conversion factor

Classification	Circuit type		Conversion factor K_i
	3	Three-phase bridge (capacitor smoothing)	
	With a reactor (on AC/DC side)		$K_{34} = 1.4$
5	Self-excitation three-phase bridge	When a high power factor converter is used	$K_5 = 0$

■ Equivalent capacity limit

Received power voltage	Reference capacity
6.6 kV	50 kVA
22/33 kV	300 kVA
66 kV or more	2000 kVA

■ Harmonic contents (values of the fundamental current is 100%)

Reactor	5th	7th	11th	13th	17th	19th	23rd	25th
Used (on DC side)	30	13	8.4	5.0	4.7	3.2	3.0	2.2
Used (on AC/DC side)	28	9.1	7.2	4.1	3.2	2.4	1.6	1.4

■ Calculation of equivalent capacity P0 of harmonic generating equipment

"Equivalent capacity" is the capacity of a 6-pulse converter converted from the capacity of consumer's harmonic generating equipment and is calculated by the following equation. If the sum of equivalent capacities is higher than the limit (refer to [page 87](#)), harmonics must be calculated by the equation in next subheading.

$$P0 = \sum (Ki \times Pi) \text{ [kVA]}$$

Ki: Conversion factor (Refer to [page 87](#).)

Pi: Rated capacity of harmonic generating equipment^{*1} [kVA]

i: Number indicating the conversion circuit type

*1 Rated capacity: Determined by the capacity of the applied motor and found in the following table. The rated capacity used here is used to calculate the generated harmonic amount and is different from the power supply capacity required for actual inverter drive.

■ Calculation of outgoing harmonic current

Outgoing harmonic currents = fundamental wave current (value converted from received power voltage) × operation ratio × harmonic contents

- Operation ratio: actual load factor × operation time ratio during 30 minutes
- Harmonic content: Refer to [page 87](#).

■ Rated capacities and outgoing harmonic currents of inverter-driven motors

Applicable motor (kW)	Rated current (A)	Fundamental wave current converted from 6.6 kV (mA)	Rated capacity (kVA)	Outgoing harmonic current converted from 6.6 kV (mA) (with a DC reactor, 100% operation ratio)							
	400 V			5th	7th	11th	13th	17th	19th	23rd	25th
75	123	7455	87.2	2237	969	626	373	350	239	224	164
90	147	8909	104	2673	1158	748	445	419	285	267	196
110	179	10848	127	3254	1410	911	542	510	347	325	239
132	216	13091	153	3927	1702	1100	655	615	419	393	288
160	258	15636	183	4691	2033	1313	782	735	500	469	344
220	355	21515	252	6455	2797	1807	1076	1011	688	645	473
250	403	24424	286	7327	3175	2052	1221	1148	782	733	537
280	450	27273	319	8182	3545	2291	1364	1282	873	818	600
315	506	30667	359	9200	3987	2576	1533	1441	981	920	675
355	571	34606	405	10382	4499	2907	1730	1627	1107	1038	761
400	643	38970	456	11691	5066	3274	1949	1832	1247	1169	857
450	723	43818	512	13146	5696	3681	2191	2060	1402	1315	964
500	804	48727	570	14618	6335	4093	2436	2290	1559	1462	1072
560	900	54545	638	16364	7091	4582	2727	2564	1746	1636	1200
630	1013	61394	718	18418	7981	5157	3070	2886	1965	1842	1351

■ Determining if a countermeasure is required

A countermeasure for harmonics is required if the following condition is satisfied: outgoing harmonic current > maximum value per 1 kW contract power × contract power.

■ Harmonic suppression techniques

No.	Item	Description
1	Reactor installation (FR-HAL)	With the DC reactor equipped on its DC side, the converter unit (FR-CC2) can suppress the outgoing harmonic current. Install an AC reactor (FR-HAL) on the AC side of the inverter to further suppress outgoing harmonic currents.
2	High power factor converter (FR-HC2)	This converter trims the current waveform to be a sine waveform by switching the rectifier circuit (converter module) with transistors. Doing so suppresses the generated harmonic amount significantly. Connect it to the DC area of an inverter. Use the high power factor converter (FR-HC2) with the accessories that come as standard.
3	Installation of power factor improving capacitor	When used with a reactor connected in series, the power factor improving correction capacitor can absorb harmonic currents.
4	Transformer multi-phase operation	Use two transformers with a phase angle difference of 30° in combinations of Δ to Δ and Δ to Δ , to provide an effect corresponding to 12 pulses, reducing low-degree harmonic currents.
5	Passive filter (AC filter)	A capacitor and a reactor are used together to reduce impedances at specific frequencies. Harmonic currents are expected to be absorbed greatly by using this technique.
6	Active filter	This filter detects the current in a circuit generating a harmonic current and generates a harmonic current equivalent to a difference between that current and a fundamental wave current to suppress the harmonic current at the detection point. Harmonic currents are expected to be absorbed greatly by using this technique.

3.3 Installation of a reactor

When the inverter is connected near a large-capacity power transformer (1000 kVA or more) or when a power factor correction capacitor is to be switched over, an excessive peak current may flow in the power input circuit, damaging the converter circuit. To prevent this, always install an AC reactor (FR-HAL), which is available as an option.

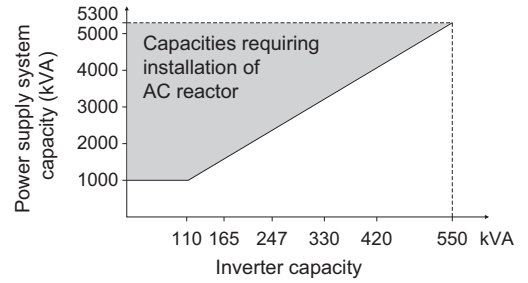
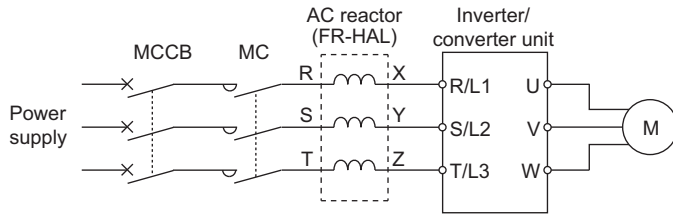

3.4 Power shutdown and magnetic contactor (MC)

◆ Converter unit input side magnetic contactor (MC)

On the converter unit input side, it is recommended to provide an MC for the following purposes.

(Refer to [page 24](#) for selection.)

- To disconnect the inverter from the power supply at activation of a protective function or at malfunctioning of the driving system (emergency stop, etc.).
- To prevent any accident due to an automatic restart at power restoration after an inverter stop made by a power failure.
- To separate the inverter from the power supply to ensure safe maintenance and inspection work.

Use the converter unit input current as a reference for selection of an MC to perform an emergency stop during operation, and select the MC conforming to JEM 1038-AC-3 class rated operational current.

NOTE

- Since repeated inrush currents at power ON will shorten the life of the converter circuit (switching life is about 1,000,000 times), frequent starts and stops of the magnetic contactor must be avoided. Turn ON or OFF the start (STF/STR) signal for the inverter start control to run or stop the inverter.

• Inverter start/stop circuit example

As shown in the following figure, always use the start signal (turn ON or OFF the STF/STR signal) to make a start or stop.

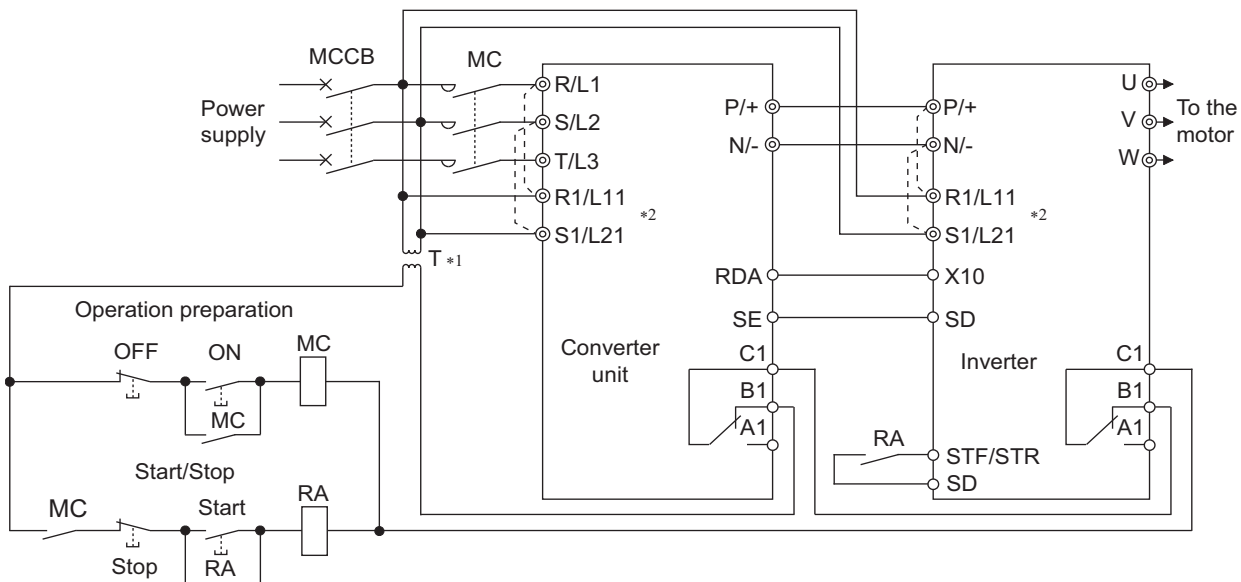

*1 When the power supply is 400 V class, install a stepdown transformer.

*2 To hold the Fault signal when the inverter's protective circuit is activated, connect the control circuit power supply terminals R1/L11 and S1/L21 to the input side of the MC. At this time, remove the jumpers connected to terminals R1/L11 and S1/L21. (Refer to [page 59](#) for removal of the jumper.)

◆ Handling of the magnetic contactor on the inverter's output side

Switch the magnetic contactor between the inverter and motor only when both the inverter and motor are at a stop. When the magnetic contactor is turned ON while the inverter is operating, overcurrent protection of the inverter and such will activate. When an MC is provided to switch to a commercial power supply, for example, it is recommended to use the commercial power supply-inverter switchover function [Pr.135 to Pr.139](#). (The commercial power supply operation is not available with Vector control dedicated motors nor with PM motors.)

◆ Handling of the manual contactor on the inverter's output side

A PM motor is a synchronous motor with high-performance magnets embedded inside. High-voltage is generated at the motor terminals while the motor is running even after the inverter power is turned OFF. In an application where the PM motor is driven by the load even after the inverter is powered OFF, a low-voltage manual contactor must be connected at the inverter's output side.

 **NOTE**

- Before wiring or inspection for a PM motor, confirm that the PM motor is stopped. In an application, such as fan and blower, where the motor is driven by the load, a low-voltage manual contactor must be connected at the inverter's output side, and wiring and inspection must be performed while the contactor is open. Otherwise you may get an electric shock.
- Do not open or close the contactor while the inverter is running (outputting).

3.5 Countermeasures against deterioration of the 400 V class motor insulation

In the PWM type inverter, a surge voltage attributable to wiring constants is generated at the motor terminals. Especially in a 400 V class motor, the surge voltage may deteriorate the insulation. When the 400 V class motor is driven by the inverter, consider the following countermeasures:

◆ Countermeasures (with induction motor)

It is recommended to take one of the following countermeasures:

■ Rectifying the motor insulation and limiting the PWM carrier frequency according to the wiring length

For the 400 V class motor, use an insulation-enhanced motor.

Specifically,

- Order a "400 V class inverter-driven insulation-enhanced motor".
- For the dedicated motor such as the constant-torque motor and low-vibration motor, use an "inverter-driven dedicated motor".
- Set **Pr.72 PWM frequency selection** as indicated below according to the wiring length.

	Wiring length	
	100 m or shorter	Longer than 100 m
Pr.72 PWM frequency selection	6 (6 kHz) or lower	4 (4 kHz) or lower

■ Suppressing the surge voltage on the inverter side

- If the motor capacity is 280 kW or lower, connect the sine wave filter (MT-BSL/BSC) to the output side.

◆ Countermeasures (with PM motor)

When the wiring length exceeds 50 m, set "9" (6 kHz) or less in **Pr.72 PWM frequency selection**.

NOTE

- When using an optional sine wave filter (MT-BSL/BSC), set "25" (2.5 kHz) in **Pr.72**.
- For details on the sine wave filter (MT-BSL/BSC), refer to the Instruction Manual of each option.
- A sine wave filter (MT-BSL/BSC) can be used under V/F control. Do not use the filters under different control methods.
- The carrier frequency is limited during PM sensorless vector control. (Refer to the FR-A800 Instruction Manual (Detailed).)

3.6 Checklist before starting operation

The FR-A800 series inverter and FR-CC2 converter unit are highly reliable products, but incorrect peripheral circuit making or operation/handling method may shorten the product life or damage the products.

Before starting operation, always recheck the following points.

Checkpoint	Countermeasure	Refer to page	Check by user
Crimp terminals are insulated.	Use crimp terminals with insulation sleeves to wire the power supply and the motor.	—	
The wiring between the power supply (terminals R/L1, S/L2, T/L3) and the motor (terminals U, V, W) is correct.	Application of power to the output terminals (U, V, W) of the inverter will damage the inverter. Never perform such wiring.	43	
No wire offcuts are left from the time of wiring.	Wire offcuts can cause a fault, failure, or malfunction. Always keep the inverter and the converter unit clean. When drilling mounting holes in an enclosure etc., take caution not to allow chips and other foreign matter to enter the inverter or the converter unit.	—	
The main circuit cable gauge is correctly selected.	Use an appropriate cable gauge to suppress the voltage drop to 2% or less. If the wiring distance is long between the inverter and motor, a voltage drop in the main circuit will cause the motor torque to decrease especially during the output of a low frequency.	44	
The total wiring length is within the specified length.	Keep the total wiring length within the specified length. In long distance wiring, charging currents due to stray capacitance in the wiring may degrade the fast-response current limit operation or cause the equipment on the inverter's output side to malfunction. Pay attention to the total wiring length.	44	
Countermeasures are taken against EMI.	The input/output (main circuit) of the inverter or the converter unit includes high frequency components, which may interfere with the communication devices (such as AM radios) used near the inverter or the converter unit. In such case, enable the EMC filter (turn ON the EMC filter ON/OFF connector) to minimize interference.	85	
On the inverter's output side, there is no power factor correction capacitor, surge suppressor, or radio noise filter installed.	Doing so will shut off the inverter output or damage the capacitor or surge suppressor. If any of the above devices is connected, immediately remove it.	—	
When performing an inspection or rewiring on the product that has been energized, the operator has waited long enough after shutting off the power supply.	For a short time after the power-OFF, a high voltage remains in the smoothing capacitor, and it is dangerous. Before performing an inspection or rewiring, wait 10 minutes or longer after the power supply turns OFF, then confirm that the voltage across the main circuit terminals P/+ and N/- of the inverter is low enough using a digital multimeter, etc.	—	
The inverter's output side has no short circuit or ground fault occurring.	<ul style="list-style-type: none"> A short circuit or ground fault on the inverter's output side may damage the inverter module. Fully check the insulation resistance of the circuit prior to inverter operation since repeated short circuits caused by peripheral circuit inadequacy or an earth (ground) fault caused by wiring inadequacy or reduced motor insulation resistance may damage the inverter module. Fully check the to-earth (ground) insulation and phase-to-phase insulation of the inverter's output side before power-ON. Especially for an old motor or use in hostile atmosphere, securely check the motor insulation resistance, etc. 	—	
The circuit is not configured to use the converter unit's input-side magnetic contactor to start/stop the inverter frequently.	Since repeated inrush currents at power ON will shorten the life of the inverter and the converter unit, frequent starts and stops of the magnetic contactor must be avoided. Turn ON or OFF the inverter's start (STF/STR) signal to run or stop the inverter.	90	
The voltage applied to the I/O signal circuits of the inverter and the converter unit are within the specifications.	Application of a voltage higher than the permissible voltage to the I/O signal circuits of the inverter or the converter unit or opposite polarity may damage the I/O devices. Especially check the wiring to prevent the speed setting potentiometer from being connected incorrectly to short circuit terminals 10E and 5.	48	

Checkpoint	Countermeasure	Refer to page	Check by user
The converter unit and the inverter are correctly connected.	<ul style="list-style-type: none"> Make sure that terminal P/+ of the converter unit and terminal P/+ of the inverter, and terminal N/- of the converter unit and terminal N- of the inverter are correctly connected. Connecting the opposite polarity of terminals N/- and P/+ will damage the inverter. Also, do not install an MCCB across terminals P/+ and N/- (across terminals P and P/+ or across N and N/-). Always connect terminal RDA of the converter unit and terminal MRS (X10) of the inverter, and terminal SE of the converter unit and terminal SD (terminal PC in the source logic) of the inverter. Not doing so may lead to damage of the converter unit. 	41	
When using the electronic bypass operation, electrical and mechanical interlocks are provided between the electronic bypass contactors MC1 and MC2.	<p>When using a switching circuit as shown below, chattering due to misconfigured sequence or arc generated at switching may allow undesirable current to flow in and damage the inverter. Miswiring may also damage the inverter. (The commercial power supply operation is not available with Vector control dedicated motors nor with PM motors.)</p> <p>If switching to the commercial power supply operation while a failure such as an output short circuit has occurred between the magnetic contactor MC2 and the motor, the damage may further spread. Therefore, make sure to take precautions against such a failure, for example, providing a protection circuit using the OH input signal.</p>	—	
A countermeasure is provided for power restoration after a power failure.	If the machine must not be restarted when power is restored after a power failure, provide an MC in the converter unit's input side and also make up a sequence which will not switch ON the start signal. If the start signal (start switch) remains ON after a power failure, the inverter will automatically restart as soon as the power is restored.	—	
For Vector control, the encoder is properly installed.	The encoder must be directly connected to a motor shaft without any backlash. (Real sensorless vector control or PM sensorless vector control do not require an encoder.)	67	
A magnetic contactor (MC) is installed on the converter unit's input side.	<p>On the converter unit's input side, connect an MC for the following purposes:</p> <ul style="list-style-type: none"> To disconnect the inverter and the converter unit from the power supply at activation of a protective function or at malfunctioning of the driving system (emergency stop, etc.). To prevent any accident due to an automatic restart at power restoration after an inverter stop made by a power failure. To separate the inverter and the converter unit from the power supply to ensure safe maintenance and inspection work. <p>Use the converter unit input current as a reference for selection of an MC to perform an emergency stop during operation, and select the MC conforming to JEM 1038-AC-3 class rated operational current.</p>	90	
The magnetic contactor on the inverter's output side is properly handled.	Switch the magnetic contactor between the inverter and motor only when both the inverter and motor are at a stop.	90	
When using a PM motor, a low-voltage manual contactor is installed on the inverter's output side.	A PM motor is a synchronous motor with high-performance magnets embedded inside. High-voltage is generated at the motor terminals while the motor is running even after the inverter power is turned OFF. In an application, such as fan and blower, where the motor is driven by the load, a low-voltage manual contactor must be connected at the inverter's output side, and wiring and inspection must be performed while the contactor is open. Otherwise you may get an electric shock.	90	
An EMI countermeasure is provided for the frequency setting signals.	<p>If electromagnetic noise generated from the inverter and the converter unit causes the frequency setting signal to fluctuate and motor rotation speed to become unstable when changing the motor speed with an analog signals, the following measures are effective.</p> <ul style="list-style-type: none"> Do not run the signal cables and power cables (inverter and converter unit I/O cables) in parallel with each other, and do not bundle them. Run the signal cables as far away as possible from the power cables (inverter and converter unit I/O cables). Use shielded cables. Install a ferrite core on the signal cable (Example: ZCAT3035-1330 TDK). 	—	

Checkpoint	Countermeasure	Refer to page	Check by user
A countermeasure is provided for an overload operation.	When performing frequent starts/stops by the inverter, rise/fall in the temperature of the transistor element of the inverter will repeat due to a repeated flow of large current, shortening the life from thermal fatigue. Since thermal fatigue is related to the amount of current, the life can be increased by reducing current at locked condition, starting current, etc. Reducing current may extend the service life but may also cause torque shortage, which leads to a start failure. Adding a margin to the current can eliminate such a condition. For an induction motor, use an inverter and a converter unit of higher capacities (up to two ranks). For a PM motor, use an inverter and a converter unit, and PM motor of higher capacities.	—	
The specifications and rating match the system requirements.	Make sure that the specifications and rating match the system requirements.	—	
Countermeasures are taken against electrical corrosion on the motor bearing.	When a motor is driven by the inverter, axial voltage is generated on the motor shaft, which may cause electrical corrosion of the bearing in rare cases depending on the wiring, load, operating conditions of the motor or specific inverter settings (high carrier frequency and EMC filter ON). Contact your sales representative to take appropriate countermeasures for the motor. The following shows examples of countermeasures for the inverter. <ul style="list-style-type: none"> • Decrease the carrier frequency. • Turn OFF the EMC filter. • Provide a common mode choke^{*1} on the output side of the inverter. (This is effective regardless of the EMC filter ON/OFF connector setting.) 	—	

*1 Our recommended common mode choke is FT-3KM F series FINEMET® common mode choke core which is manufactured by Hitachi Metals, Ltd. FINEMET is a registered trademark of Hitachi Metals, Ltd.

3.7 Failsafe system which uses the inverter

When a fault is detected by the protective function, the protective function activates and outputs the Fault signal. However, the Fault signal may not be output at an inverter's fault occurrence when the detection circuit or output circuit fails, etc. Although Mitsubishi assures the best quality products, provide an interlock which uses inverter status output signals to prevent accidents such as damage to the machine when the inverter fails for some reason. Also at the same time consider the system configuration where a failsafe from outside the inverter, without using the inverter, is enabled even if the inverter fails.

◆ Interlock method which uses the inverter status output signals

By combining the inverter output signals to provide an interlock as shown below, an inverter failure can be detected.

No.	Interlock method	Check method	Used signals
a	Inverter protective function operation	Operation check of an alarm contact. Circuit error detection by negative logic.	Fault (ALM) signal
b	Inverter operating status	Operation ready signal check.	Inverter operation ready (RY) signal
c	Inverter running status	Logic check of the start signal and running signal.	Start (STF or STR) signal Inverter running (RUN) signal
d	Inverter running status	Logic check of the start signal and output current.	Start (STF or STR) signal Output current detection (Y12) signal

- When using various signals, assign the functions to **Pr.190 to Pr.196 (Output terminal function selection)** referring to the table on the left.

Output signal	Pr.190 to Pr.196 setting	
	Positive logic	Negative logic
ALM	99	199
RY	11	111
RUN	0	100
Y12	12	112

NOTE

- Changing the terminal assignment using **Pr.190 to Pr.196 (Output terminal function selection)** may affect the other functions. Set parameters after confirming the function of each terminal.

■ Checking by using the Fault signal output from the inverter ... (a)

When the inverter's protective function activates and the inverter output is stopped, the Fault (ALM) signal is output. (The ALM signal is assigned to terminals A1, B1, and C1 in the initial setting). With this signal, check that the inverter operates properly. In addition, negative logic can be set. (ON when the inverter is normal, OFF when the fault occurs.)

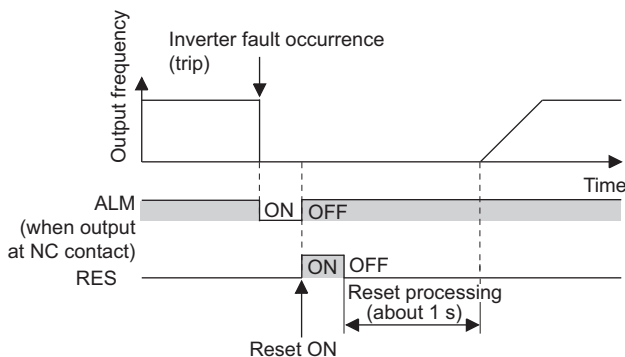

■ Checking the inverter operating status by using the Inverter operation ready signal output from the inverter ... (b)

The Inverter operation ready (RY) signal is output when the inverter power is ON and the inverter becomes operative. Check if the RY signal is output after powering ON the inverter.

■ Checking the inverter operating status by using the start signal input to the inverter and the Inverter running signal output from the inverter ... (c)

The Inverter running (RUN) signal is output when the inverter is running. (The RUN signal is assigned to terminal RUN in the initial setting.) Check if the RUN signal is output while a start signal (the STF/STR signal for forward/reverse rotation command) is input to the inverter. Even after the start signal is turned OFF, the RUN signal is kept output until the inverter makes the motor to decelerate and to stop. For the logic check, configure a sequence considering the inverter's deceleration time.

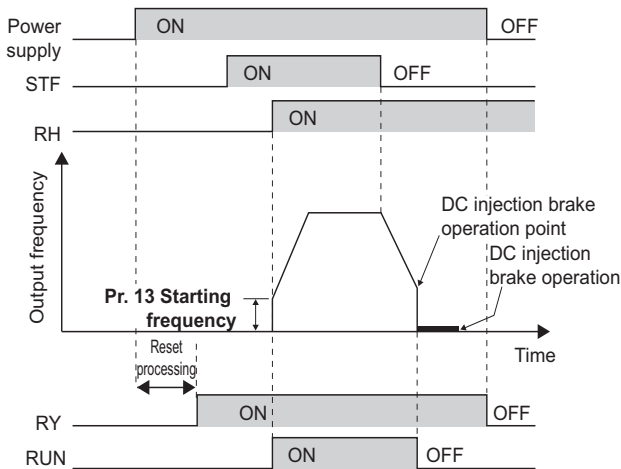

■ Checking the motor operating status by using the start signal input to the inverter and the Output current detection signal output from the inverter ... (d)

The Output current detection (Y12) signal is output when the inverter operates and currents flows into the motor.

Check if the Y12 signal is output while a start signal (the STF/STR signal for forward/reverse rotation command) is input to the inverter. The Y12 signal is initially set to be output at 150% inverter rated current. Adjust the level to around 20% using no load current of the motor as reference with **Pr.150 Output current detection level**.

Like the Inverter running (RUN) signal, even after the start signal is turned OFF, the Y12 signal is kept output until the inverter stops the output to a decelerating motor. For the logic check, configure a sequence considering the inverter's deceleration time.

◆ Backup method which does not use the inverter

Even if the interlock is provided by the inverter status signal, enough failsafe is not ensured depending on the failure status of the inverter itself. For example, if an inverter CPU fails in a system interlocked with the inverter's fault, start, and RUN signals, no fault signal will be output and the RUN signal will be kept ON because the inverter CPU is down.

Provide a speed detector to detect the motor speed and current detector to detect the motor current, and consider the backup system such as performing a check as follows according to the level of importance of the system.

■ Start signal and actual operation check

Check the motor running and motor current while the start signal is input to the inverter by comparing the start signal to the inverter and detected speed of the speed detector or detected current of the current detector. Note that the current is flowing through the motor while the motor coasts to stop, even after the inverter's start signal is turned OFF. For the logic check, configure a sequence considering the inverter's deceleration time. In addition, it is recommended to check the three-phase current when using the current detector.

■ Command speed and actual operation check

Check for a gap between the actual speed and commanded speed by comparing the inverter's speed command and the speed detected by the speed detector.

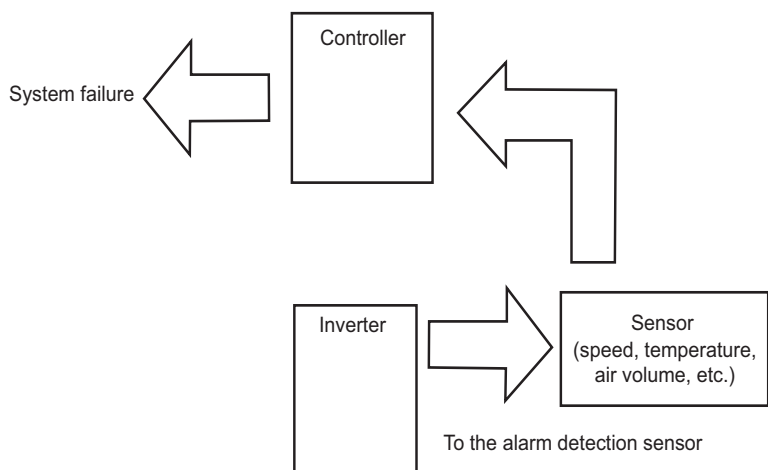

CHAPTER 4 PROTECTIVE FUNCTIONS

4.1	Inverter fault and alarm indications	100
4.2	Reset method for the protective functions	101
4.3	Check and clear of the fault history	102
4.4	List of fault displays	104

4 PROTECTIVE FUNCTIONS

This chapter explains the "PROTECTIVE FUNCTIONS" that operate in this product.

Always read the instructions before use.

4.1 Inverter fault and alarm indications

- When the inverter detects a fault, depending on the nature of the fault, the operation panel displays an error message or warning, or a protective function is activated to shut off the inverter output.
- When any fault occurs, take an appropriate corrective action, then reset the inverter, and resume the operation. Restarting the operation without a reset may break or damage the inverter.
- When a protective function is activated, note the following points.

Item	Description
Fault output signal	Opening the magnetic contactor (MC) provided on the input side of the inverter at a fault occurrence shuts off the control power to the inverter, therefore, the fault output will not be retained.
Fault indication	When the protective function is activated, the operation panel displays a fault indication.
Operation restart method	While the protective function is activated, the inverter output is kept shutoff. Reset the inverter to restart the operation.

- Inverter fault or alarm indications are categorized as follows.

Displayed item	Description
Error message	A message regarding operational fault and setting fault by the operation panel and the parameter unit. The inverter output is not shut off.
Warning	The inverter output is not shut off even when a warning is displayed. However, failure to take appropriate measures will lead to a fault.
Alarm	The inverter output is not shut off. An Alarm (LF) signal can also be output with a parameter setting.
Fault	When a protective function is activated, the inverter output is shut off and a Fault (ALM) signal is output.

NOTE

- For details on fault indications and other malfunctions, refer to the FR-A800 Instruction Manual (Detailed).
- The last eight faults can be displayed on the operation panel. (Fault history) (For operation, refer to [page 102](#).)

4.2 Reset method for the protective functions

Reset the inverter by performing any of the following operations. Note that the accumulated heat value of the electronic thermal relay function and the number of retries are cleared (erased) by resetting the inverter.

The inverter recovers about 1 second after the reset is released.

- On the operation panel, press  to reset the inverter.
(This may only be performed when a fault occurs.)

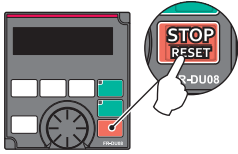

- Switch the power OFF once, then switch it ON again.

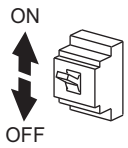

- Turn ON the Reset (RES) signal for 0.1 second or more. (If the RES signal is kept ON, "Err" appears (blinks) to indicate that the inverter is in a reset status.)

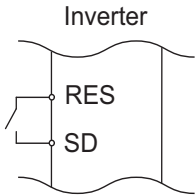

NOTE

- OFF status of the start signal must be confirmed before resetting the inverter fault. Resetting an inverter fault with the start signal ON restarts the motor suddenly.

4.3 Check and clear of the fault history

The operation panel stores the past eight fault records which appears when a protective function is activated. (Fault history)

◆ Check for the fault history

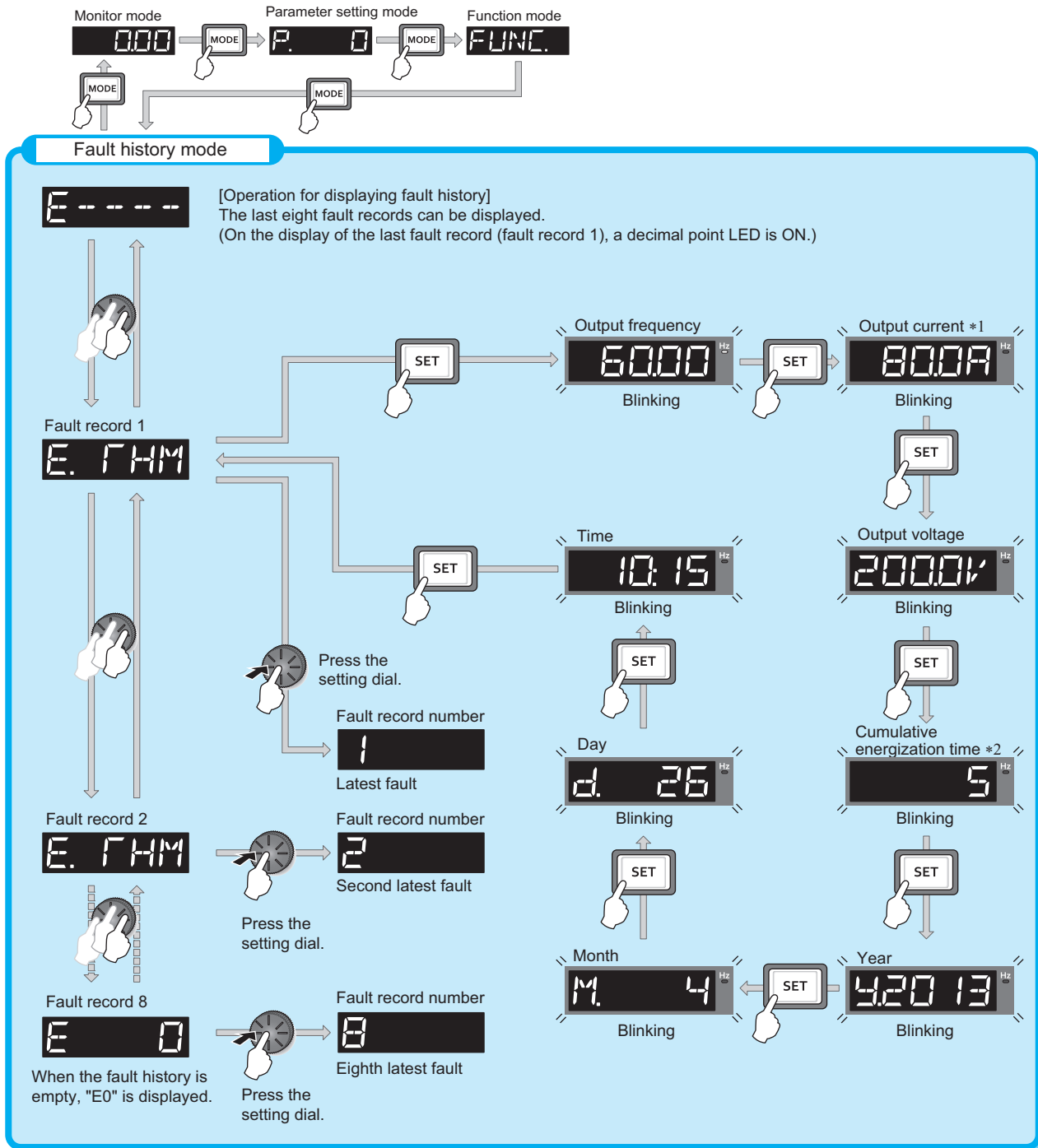

*1 When an overcurrent trip occurs by an instantaneous overcurrent, the monitored current value saved in the fault history may be lower than the actual current that has flowed.









*2 The cumulative energization time and actual operation time are accumulated from 0 to 65535 hours, then cleared, and accumulated again from 0.

◆ Fault history clearing procedure

Point

- Set Err.CL Fault history clear = "1" to clear the fault history.

Operating procedure

- 1.** Turning ON the power of the inverter
The operation panel is in the monitor mode.
- 2.** Selecting the parameter setting mode
Press  to choose the parameter setting mode. (The parameter number read previously appears.)
- 3.** Selecting the parameter number
Turn  until "Err.CL" (Fault history clear) appears. Press  to read the present set value. "0" (initial value) appears.
- 4.** Fault history clear
Turn  to change the set value to "1". Press  to start clearing.
"1" and "Err.CL" are displayed alternately after parameters are cleared.
 - Turn  to read another parameter.
 - Press  to show the setting again.
 - Press  twice to show the next parameter.

4.4 List of fault displays

For details, refer to the Instruction Manual (Detailed).

◆ Error message

- A message regarding operational fault and setting fault by the operation panel and the parameter unit is displayed. The inverter output is not shut off.

Operation panel indication		Name
HOLD	HOLD	Operation panel lock
LOCd	LOCD	Password locked
Er 1 to Er 4 Er 8	Er1 to Er4, Er8	Parameter write error
rE 1 to rE 8	rE1 to rE8	Copy operation error
Err.	Err.	Error

◆ Warning

- The inverter output is not shut off even when a warning is displayed. However, failure to take appropriate measures will lead to a fault.

Operation panel indication		Name
OL	OL	Stall prevention (overcurrent)
oL	oL	Stall prevention (overvoltage)
TH	TH	Electronic thermal relay function pre-alarm
PS	PS	PU stop
SL	SL	Speed limit indication
CF	CF	Continuous operation during communication fault
CP	CP	Parameter copy
SA	SA	Safety stop
MT 1 to MT 3	MT1 to MT3	Maintenance timer 1 to 3
UF	UF	USB host error
HP 1	HP1	Home position return setting error
HP 2	HP2	Home position return uncompleted
HP 3	HP3	Home position return parameter setting error
LdF	LDF	Load fault warning
EHR	EHR	Ethernet communication fault

◆ Alarm

- The inverter output is not shut off. An Alarm (LF) signal can also be output with a parameter setting.

Operation panel indication		Name
FN	FN	Fan alarm

◆ Fault

- When a protective function is activated, the inverter output is shut off and a Fault (ALM) signal is output.
- The data code is used for checking the fault detail via communication or with **Pr.997 Fault initiation**.

Operation panel indication		Name
E. OC 1	E.OC1	Overcurrent trip during acceleration
E. OC 2	E.OC2	Overcurrent trip during constant speed
E. OC 3	E.OC3	Overcurrent trip during deceleration or stop
E. OV 1	E.OV1	Regenerative overvoltage trip during acceleration
E. OV 2	E.OV2	Regenerative overvoltage trip during constant speed
E. OV 3	E.OV3	Regenerative overvoltage trip during deceleration or stop
E. THT	E.THT	Inverter overload trip (electronic thermal relay function)
E. THM	E.THM	Motor overload trip (electronic thermal relay function)
E. FIN	E.FIN	Heat sink overheat
E. OLT	E.OLT	Stall prevention stop
E. SOT	E.SOT	Loss of synchronism detection
E. LUP	E.LUP	Upper limit fault detection
E. LDN	E.LDN	Lower limit fault detection
E. GF	E.GF	Output side earth (ground) fault overcurrent
E. LF	E.LF	Output phase loss
E. OHT	E.OHT	External thermal relay operation
E. PTC	E.PTC	PTC thermistor operation
E. OPT	E.OPT	Option fault
E. OP 1 to OP 3	E.OP1 to E.OP3	Communication option fault
E. 16 to E. 20	E.16 to E.20	User definition error by the PLC function

Operation panel indication		Name
E. PEG	E.PE6	Internal storage device fault
E. PE	E.PE	Parameter storage device fault (control circuit board)
E. PUE	E.PUE	PU disconnection
E. RET	E.RET	Retry count excess
E. PE2	E.PE2	Parameter storage device fault (main circuit board)
E. CPU E. 5 to E. 7	E.CPU, E. 5 to E. 7	CPU fault
E. CTE	E.CTE	Operation panel power supply short circuit/RS-485 terminals power supply short circuit
E. P24	E.P24	24 VDC power fault
E. CDO	E.CDO	Abnormal output current detection
E. SER	E.SER	Communication fault (inverter)
E. EHR	E.EHR	Ethernet communication fault
E. AIE	E.AIE	Analog input fault
E. USB	E.USB	USB communication fault
E. SAF	E.SAF	Safety circuit fault
E. PBT E. 13	E.PBT, E.13	Internal circuit fault
E. OS	E.OS	Overspeed occurrence
E. ECA	E.ECA	Encoder signal loss for orientation
E. OSD	E.OSD	Speed deviation excess detection
E. ECT	E.ECT	Signal loss detection
E. Od	E.OD	Excessive position fault
E. Mb1 to E. Mb7	E.MB1 to E.MB7	Brake sequence fault
E. EP	E.EP	Encoder phase fault
E. MP	E.MP	Magnetic pole position unknown
E. EF	E.EF	External fault during output operation
E. LCI	E.LCI	4 mA input fault
E. PCH	E.PCH	Pre-charge fault
E. PID	E.PID	PID signal fault
E. 1 to E. 3	E. 1 to E. 3	Option fault
E. 11	E.11	Opposite rotation deceleration fault

◆ Others

- The fault history and the operation status of the inverter are displayed. It is not a fault indication.

Operation panel indication		Name
E - - - - -	E----	Fault history
E. 0	E.0	No fault records
EV	EV	24 V external power supply operation
Rd	RD	Backup in progress
WR	WR	Restoration in progress

If faults other than the above appear, contact your sales representative.

MEMO

CHAPTER 5 PRECAUTIONS FOR MAINTENANCE AND INSPECTION

5.1	Inspection item.....	108
5.2	Measurement of main circuit voltages, currents, and powers.....	115

5 PRECAUTIONS FOR MAINTENANCE AND INSPECTION

This chapter explains the precautions for maintenance and inspection of this product.
Always read the instructions before use.

5.1 Inspection item

The inverter is a static unit mainly consisting of semiconductor devices. Daily inspection must be performed to prevent any fault from occurring due to the adverse effects of the operating environment, such as temperature, humidity, dust, dirt and vibration, changes in the parts with time, service life, and other factors.

◆ Precautions for maintenance and inspection

When accessing the inverter for inspection, wait for at least 10 minutes after the power supply has been switched OFF. Then, make sure that the voltage across the main circuit terminals P/+ and N/- on the inverter is not more than 30 VDC using a digital multimeter, etc.

5.1.1 Daily inspection

Basically, check for the following faults during operation.

- Motor operation fault
- Improper installation environment
- Cooling system fault
- Abnormal vibration, abnormal noise
- Abnormal overheat, discoloration

5.1.2 Periodic inspection

Check the areas inaccessible during operation and requiring periodic inspection. Consult us for periodic inspection.

Check and clean the cooling system: Clean the air filter, etc.

Check the tightening and retighten: The screws and bolts may become loose due to vibration, temperature changes, etc. Check and tighten them. Tighten them according to the specified tightening torque. (Refer to [page 44.](#))

Check the conductors and insulating materials for corrosion and damage.

Measure the insulation resistance.

Check and change the cooling fan and relay.

NOTE

- Check safety sub-functions at least once per three months. Note that the safety communication option must be restarted before the operation check. For details on the operation check, refer to the Instruction Manual of the safety communication option.
-

5.1.3 Daily and periodic inspection

Area of inspection	Inspection item	Description	Inspection interval		Corrective action at fault occurrence	Check by user
			Daily	Periodic ^{*3}		
General	Surrounding environment	Check the surrounding air temperature, humidity, dirt, corrosive gas, oil mist, etc.	○		Improve the environment.	
	Overall unit	Check for unusual vibration and noise.	○		Check fault location and retighten.	
		Check for dirt, oil, and other foreign material. ^{*1}	○		Clean.	
	Power supply voltage	Check that the main circuit voltage and control circuit voltage are normal. ^{*2}	○		Inspect the power supply.	
Main circuit	General	• Check with megger (between main circuit terminals and earth (ground) terminal).		○	Contact the manufacturer.	
		• Check for loose screws and bolts.		○	Retighten.	
		• Check for overheat traces on the parts.		○	Contact the manufacturer.	
		• Check for stains.		○	Clean.	
	Conductors and cables	• Check conductors for distortion. • Check cable sheaths for breakage and deterioration (crack, discoloration, etc.).		○	Contact the manufacturer.	
	Transformer/reactor	Check for unusual odor and abnormal increase of whining sound.	○		Stop the equipment and contact the manufacturer.	
	Terminal block	Check for a damage.		○	Stop the equipment and contact the manufacturer.	
	Smoothing aluminum electrolytic capacitor	• Check for liquid leakage. • Check for safety valve projection and bulge. • Visual check		○	Contact the manufacturer.	
	Relay/contactors	Check that the operation is normal and no chattering sound is heard.		○	Contact the manufacturer.	
Control circuit, protective circuit	Operation check	• Check for an output voltage imbalance between phases while operating the inverter alone.		○	Contact the manufacturer.	
		• Check that no fault is found in protective and display circuits in a sequence protective operation test.		○	Contact the manufacturer.	
	Components check	Overall	• Check for unusual odor and discoloration. • Check for serious rust development.		○	Stop the equipment and contact the manufacturer.
Aluminum electrolytic capacitor		• Check for liquid leakage in a capacitor and deformation trace. • Visual check and judge by the life check of the control circuit capacitor (Pr.257).		○	Contact the manufacturer.	
Cooling system	Cooling fan	• Check for unusual vibration and noise. • Check for loose screws and bolts. • Check for stains.	○		Replace the fan. Fix with the fan cover fixing screws. Clean.	
	Heat sink	• Check for clogging. • Check for stains.		○	Clean. Clean.	
Display	Indication	• Check that indications are correct. • Check for stains.	○	○	Contact the manufacturer. Clean.	
	Meter/counter	Check that readouts are correct.	○		Stop the equipment and contact the manufacturer.	
Load motor	Operation check	Check for vibration and abnormal increase in operation noise.	○		Stop the equipment and contact the manufacturer.	

*1 Oil component of the heat dissipation grease used inside the inverter may leak out. The oil component, however, is not flammable, corrosive, nor conductive and is not harmful to humans. Wipe off such oil component.

*2 It is recommended to install a voltage monitoring device for checking the voltage of the power supplied to the inverter.

*3 One to two years of periodic inspection cycle is recommended. However, it differs according to the installation environment. Consult us for periodic inspection.

NOTE

- Continuous use of a leaked, deformed, or degraded smoothing aluminum electrolytic capacitor (as shown in the table above) may lead to a burst, breakage, or fire. Replace such capacitor without delay.
- For details on **Pr.257 Control circuit capacitor life display**, refer to the Instruction Manual (Detailed).

5.1.4 Checking the inverter and converter semiconductor devices

◆ Preparation

- Disconnect the external power supply cables (R/L1, S/L2, T/L3) and motor cables (U, V, W). (Measurement can be made without disconnecting the cables connecting the inverter and the converter unit (FR-CC2).)
- Prepare a continuity tester. (For the resistance measurement, use the 100 Ω range.)

◆ Checking method

Change the polarity of the tester alternately at the inverter terminals R/L1, S/L2, T/L3, U, V, W, P/+, and N/- and check the electric continuity.

NOTE

- Before measurement, check that the smoothing capacitor is discharged.
- At the time of electric discontinuity, the measured value is almost ∞. When there is an instantaneous electric continuity, due to the smoothing capacitor, the tester may not indicate ∞. At the time of electric continuity, the measured value is several Ω to several tens of Ω. When all measured values are almost the same (although values may not be constant depending on the tester type), it shows that there are no electrical paths with problems.

◆ Semiconductor device numbers and terminals to be checked

		Tester polarity		Continuity		Tester polarity		Continuity
		⊕	⊖			⊕	⊖	
Converter unit	D1	R/L1	P/+	No	D4	R/L1	N/-	Yes
		P/+	R/L1	Yes		N/-	R/L1	No
	D2	S/L2	P/+	No	D5	S/L2	N/-	Yes
		P/+	S/L2	Yes		N/-	S/L2	No
	D3	T/L3	P/+	No	D6	T/L3	N/-	Yes
		P/+	T/L3	Yes		N/-	T/L3	No
Inverter	TR1	U	P/+	No	TR4	U	N/-	Yes
		P/+	U	Yes		N/-	U	No
	TR3	V	P/+	No	TR6	V	N/-	Yes
		P/+	V	Yes		N/-	V	No
	TR5	W	P/+	No	TR2	W	N/-	Yes
		P/+	W	Yes		N/-	W	No

(Assuming that an analog meter is used.)

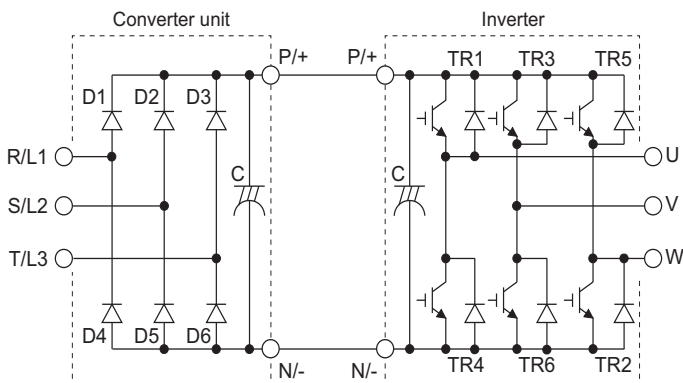

5.1.5 Cleaning

Always run the inverter in a clean status.

When cleaning the inverter, gently wipe dirty areas with a soft cloth immersed in neutral detergent or ethanol.

NOTE

- Do not use solvent, such as acetone, benzene, toluene and alcohol, as these will cause the inverter surface paint to peel off.
- The display, etc. of the operation panel and parameter unit are vulnerable to detergent and alcohol. Therefore, avoid using them for cleaning.

5.1.6 Replacement of parts

The inverter consists of many electronic parts such as semiconductor devices.

The following parts may deteriorate with age because of their structures or physical characteristics, leading to reduced performance or fault of the inverter. For preventive maintenance, the parts must be replaced periodically.

Use the life check function as a guidance of parts replacement.

Part name	Estimated lifespan ^{*1}	Description
Cooling fan	10 years	Replace (as required)
Main circuit smoothing capacitor	10 years ^{*2}	Replace (as required)
On-board smoothing capacitor	10 years ^{*2}	Replace the board (as required).
Relays	—	As required
Main circuit fuse	10 years	Replace (as required)

*1 Estimated lifespan for when the yearly average surrounding air temperature is 40°C.
(without corrosive gas, flammable gas, oil mist, dust and dirt etc.)

*2 Output current: 80% of the inverter rating

NOTE

- For parts replacement, contact the nearest Mitsubishi Electric FA center.

◆ Inverter parts life display

The inverter diagnoses the control circuit capacitor and the cooling fan by itself, and estimates their lives.

The self-diagnostic warning is output when the life span of each part is near its end. It gives an indication of replacement time.

Guideline for life judgment using the life warning output

Part	Judgment level
Control circuit capacitor	Estimated remaining life 10%
Cooling fan	Not more than the specified speed
ABC relay contact	Estimated remaining life 10%

NOTE

- Refer to the Instruction Manual (Detailed) to perform the life check of the inverter parts.

◆ Replacement procedure of the cooling fan

The replacement interval of the cooling fan used for cooling the parts generating heat such as the main circuit semiconductor is greatly affected by the surrounding air temperature. When unusual noise and/or vibration are noticed during inspection, the cooling fan must be replaced immediately.

■ Removal

1. Remove the fan cover fixing screws, and remove the fan cover.
2. Disconnect the fan connector and remove the fan block.
3. Remove the fan fixing screws, and remove the fan.

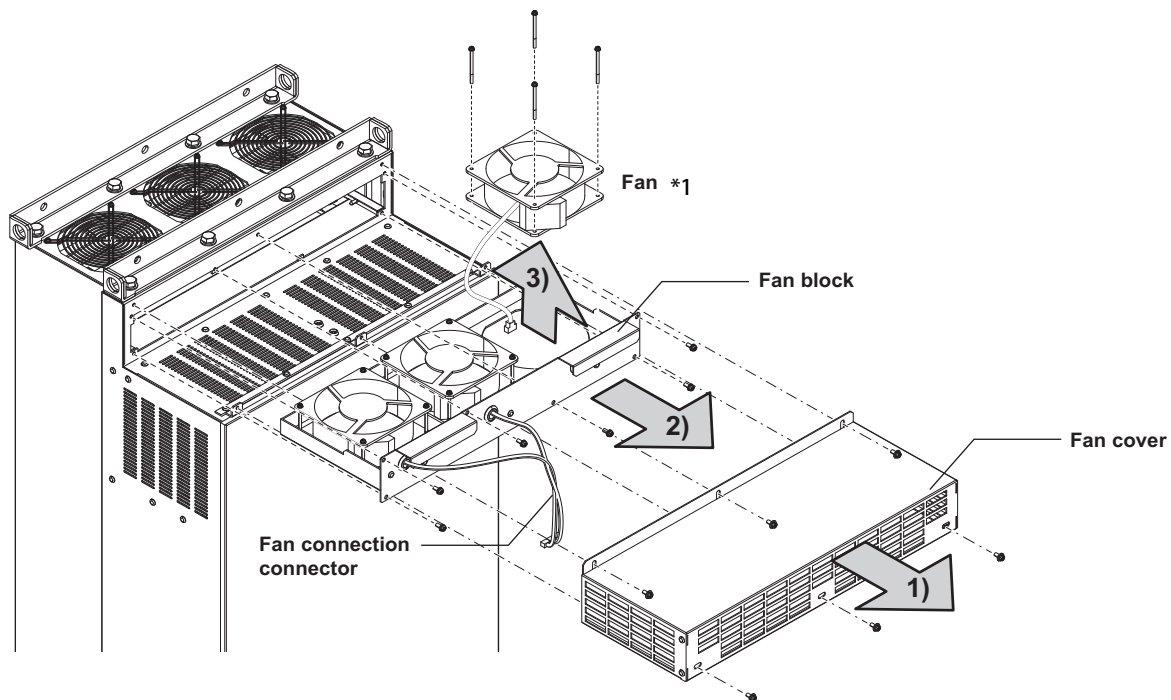

*1 The number of cooling fans differs according to the inverter capacity.

■ Reinstallation

1. After confirming the orientation of the fan, reinstall the fan so that the "AIR FLOW" faces up.

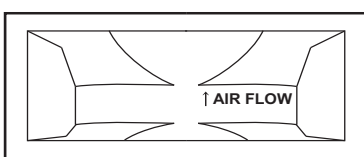

<Fan side face>

2. Install fans referring to the above figure. The tightening torque of the fan fixing screws is 0.73 N·m.

NOTE

- Installing the fan in the opposite direction of air flow may shorten the inverter life.
- Ensure that the cables are not caught when the fan is installed.
- Switch OFF the power before starting the fan replacement work. To prevent an electric shock accident, keep the inverter with its covers on during fans replacement since the inverter circuits are charged with voltage even after power OFF.

◆ Smoothing capacitors

A large-capacity aluminum electrolytic capacitor is used for smoothing in the DC section of the main circuit, and an aluminum electrolytic capacitor is used for stabilizing the control power in the control circuit. Adverse effects from ripple currents deteriorate capacitors. Replacement intervals of capacitors vary greatly with surrounding temperatures and operating conditions. Replace them roughly every 10 years when used in normal air-conditioned environments.

Inspecting the product visually:

- Case: Check that the sides and bottom of the capacitor have not ruptured.
- Rubber seal: Check for any noticeable bulging or severe cracks.
- Check for external cracks, discoloration, leakage, etc. It is assumed that the capacitor has reached the end of its life when its capacity has dropped below 80% of its rated capacity.

NOTE

- The inverter diagnoses the control circuit capacitor by itself and can estimate its remaining life. Refer to the Instruction Manual (Detailed).

5

◆ Relay output terminals

- The contacts of relays deteriorate over time. To prevent faults from occurring, relays must be replaced when they have reached the maximum number of switching operations (switching life).
- The control terminal block must be replaced in case of failure of either relay connected to the relay output terminals A1, B1, and C1, or A2, B2, and C2.

◆ Main circuit fuse

Fuses are used in some inverters. Replacement intervals of capacitors vary greatly with surrounding temperatures and operating conditions. Replace them roughly every 10 years when used in normal air-conditioned environments.

5.1.7 Removal and reinstallation of the control circuit terminal block

This product has a removable control circuit terminal block, which can be replaced with a new one or a control terminal option.

◆ Removal and reinstallation

1. Loosen the two installation screws at the both side of the control circuit terminal block. (These screws cannot be removed.)
Slide down the control circuit terminal block to remove it.

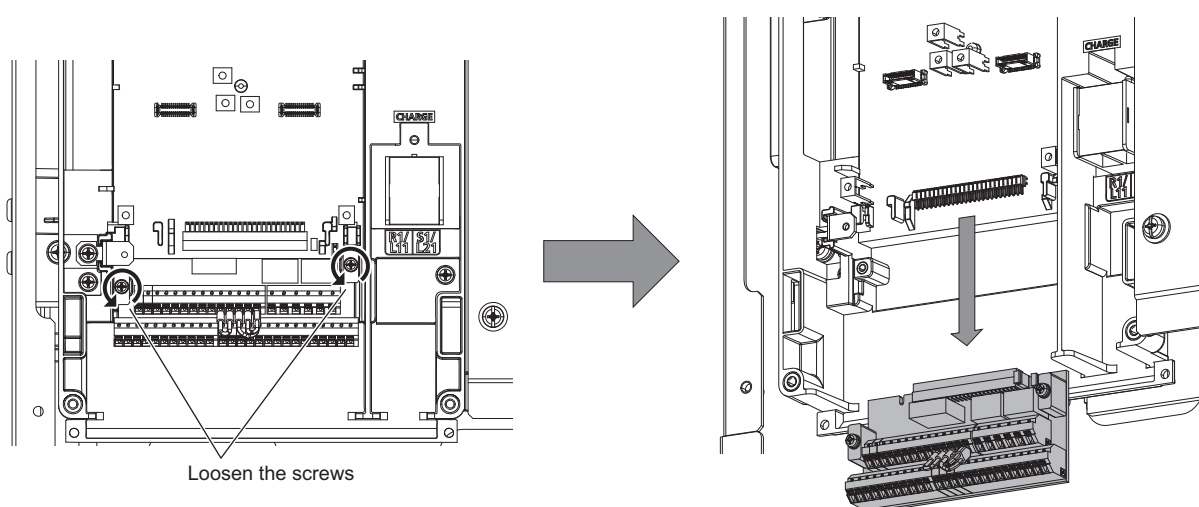

2. Be careful not to bend the pins of the inverter's control circuit connector, reinstall the control circuit terminal block and fix it with the mounting screws.

NOTE

- Before starting the replacement, power OFF the inverter, wait for at least 10 minutes, and then check that the charge lamp is OFF to ensure safety.

◆ Removal and reinstallation precautions

The following are the precautions to remove or reinstall the control circuit terminal block. Observe the following precautions and handle the inverter properly to avoid malfunctions or failures.

- To remove or reinstall the control circuit terminal block, keep it upright so that it is parallel with the inverter.
- To install the control circuit terminal block, slide it upward so that the tongues on the inverter slot into the grooves on the terminal block.
- Check that the terminal block is parallel to the inverter and the pins on the inverter control circuit connector are not bent. After checking proper connection, fix the terminal block in place with two screws.

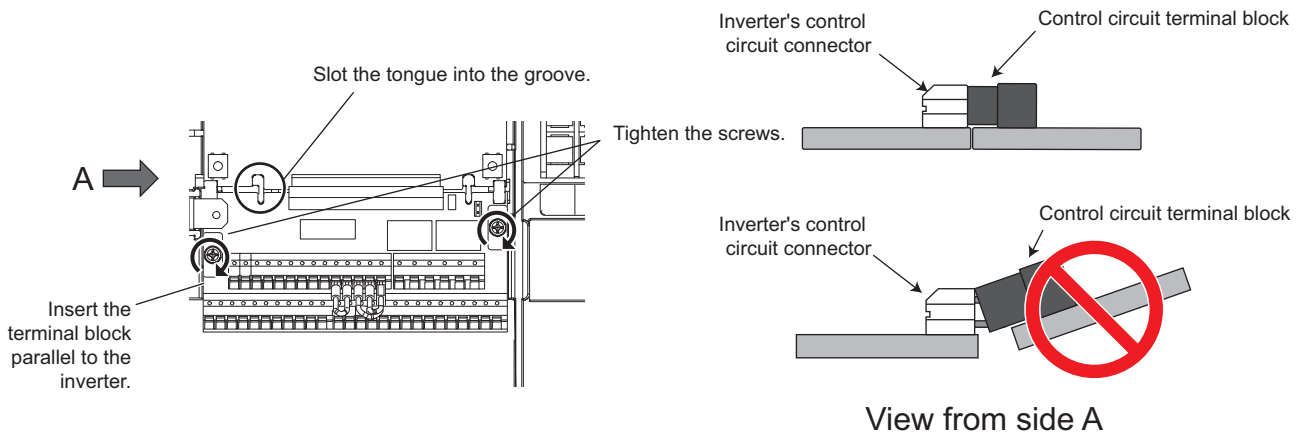

NOTE

- Do not tilt the terminal block while tightening the screws or removing it from the inverter. (Otherwise, a stress applied to the control circuit terminal block or the control circuit connector may cause damage to them.)
- After replacing the control terminal block, connect the jumper connector to the correct position in accordance with the control logic of input signals. (Refer to [page 54](#).)

5.2 Measurement of main circuit voltages, currents, and powers

Since the voltages and currents on the inverter power supply and output sides include harmonics, measurement data depends on the instruments used and circuits measured. When instruments for commercial frequency are used for measurement, measure the following circuits with the instruments given on the next page.

NOTE

- When installing meters etc. on the inverter output side
When the inverter-to-motor wiring length is long, the meters and CTs may generate heat due to line-to-line leakage current. Therefore, choose equipment which has enough capacity for the current rating.
To measure and display the output voltage and output current of the inverter, it is recommended that the terminal AM and FM/CA output functions of the inverter are used.

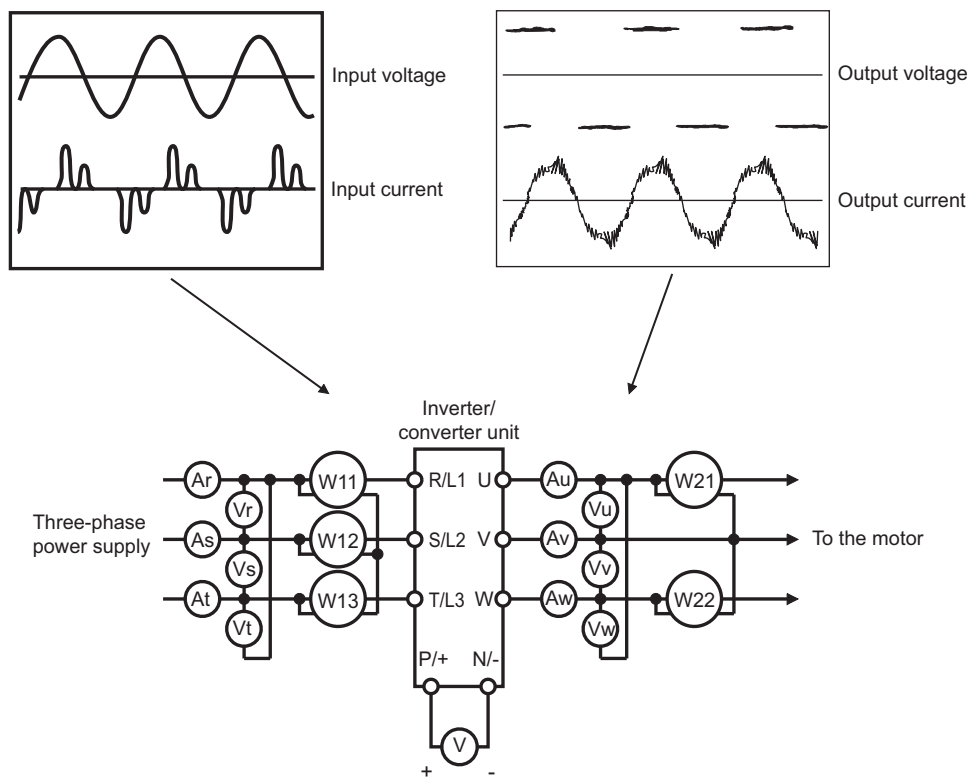

◆ Measuring points and instruments

	Item	Measuring point	Measuring instrument	Remarks (reference measured value)	
Converter unit (FR-CC2)	Power supply voltage V1	Between R/L1 and S/L2, S/L2 and T/L3, and T/L3 and R/L1	Digital power meter (designed for inverter)	Commercial power Within permissible AC voltage fluctuation. (Refer to page 122.)	
	Input current I1	Line current at R/L1, S/L2, and T/L3			
	Input power P1	At R/L1, S/L2, and T/L3, and between R/L1 and S/ L2, S/L2 and T/L3, and T/ L3 and R/L1		P1 = W11 + W12 + W13 (3-wattmeter method)	
	Input power factor Pf1	Calculate after measuring input voltage, input current and input power. $Pf_1 = \frac{P_1}{\sqrt{3}V_1 \times I_1} \times 100\%$			
	Converter output	Between P/+ and N/-	Digital multimeter or other tester	Inverter LED indication 1.35 × V1	
	Operation enable signal External thermal relay signal Reset signal	Across terminals RD1, OH, RES(+) and SD (for sink logic)	Digital multimeter or other tester, or moving-coil type instrument (internal resistance 50 kΩ or more)	Voltage when terminal is open: 20 to 30 VDC. Voltage when signal is ON: 1 V or less.	Terminal SD is a common terminal.
	Fault signal	Between A1 and C1 Between B1 and C1	Digital multimeter or other tester	Continuity check*3 [Normal] Across A1 and C1: Discontinuity Across B1 and C1: Continuity [Fault] Across A1 and C1: Continuity Across B1 and C1: Discontinuity	

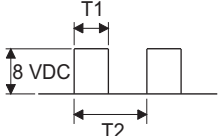
	Item	Measuring point	Measuring instrument	Remarks (reference measured value)		
Inverter	Output voltage V2	Between U and V, V and W, and W and U	Digital power meter (designed for inverter) ^{*1}	Difference between the phases must be within 1% of the maximum output voltage.		
	Output current I2	Line current at U, V, and W	Digital power meter (designed for inverter)	Difference between the phases must be within 10%.		
	Output power P2	At U, V, and W, and between U and V, and V and W		P2 = W21 + W22 2-wattmeter method (or 3-wattmeter method)		
	Output power factor Pf2	Calculate in similar manner to the input power factor. $Pf_2 = \frac{P_2}{\sqrt{3}V_2 \times I_2} \times 100\%$				
	Frequency setting signal	2, and between 4(+) and 5 Between 1(+) and 5	Digital multimeter or other tester, or moving-coil type instrument (internal resistance 50 kΩ or more)	0 to 10 VDC, 4 to 20 mA 0 to ±5 VDC and 0 to ±10 VDC	Terminal 5 is a common terminal.	
	Power supply for a frequency setting potentiometer	Between 10(+) and 5		5.2 VDC		
		Between 10E(+) and 5		10 VDC		
	Frequency meter signal	Between AM(+) and 5		Approximately 10 VDC at maximum frequency (without frequency meter)	Approximately 20 mADC at maximum frequency	Terminal SD is a common terminal.
		Between CA(+) and 5		Approximately 5 VDC at maximum frequency (without frequency meter)		
	Start signal, Select signal, Reset signal, Output stop signal	Across STF, STR, RH, RM, RL, JOG, RT, AU, STOP, CS, RES, MRS(+) and SD (for sink logic)		Between FM(+) and SD	 <p>Pulse width T1: Adjust with C0 (Pr.900). Pulse cycle T2: Set with Pr.55 (for frequency monitor only).</p>	Voltage when terminal is open: 20 to 30 VDC. Voltage when signal is ON: 1 V or less.
Fault signal		Between A1 and C1 Between B1 and C1				

*1 Use an FFT to measure the output voltage accurately. A digital multimeter or general measuring instrument cannot measure accurately.

*2 When the carrier frequency exceeds 5 kHz, do not use this instrument since using it may increase eddy current losses produced in metal parts inside the instrument, leading to burnout. In this case, use an approximate-effective value type.

*3 When the setting of **Pr.195 ABC1 terminal function selection** is the positive logic.

5.2.1 Measurement of powers

Use a digital power meter (for inverter) for the input side of the converter unit (FR-CC2) and the output side of the inverter.

5.2.2 Measurement of voltages

◆ Converter unit (FR-CC2) input side

Use a digital power meter for inverters for the input side voltage.

◆ Inverter output side

Always use a digital power meter for inverter for measurement as the output side voltage has a PWM-controlled rectangular wave.

The value displayed on the operation panel is the inverter-controlled voltage itself. Hence, that value is accurate and it is recommended to monitor values using the operation panel. Monitoring values via the operation panel or by outputting the analog signal is recommended as these values are accurate.

5.2.3 Measurement of currents

Use a digital power meter (for inverter) for the input side of the converter unit (FR-CC2) and the output side of the inverter.

Since the converter unit input current tends to be unbalanced, measurement of three phases is recommended. The correct value cannot be obtained by measuring only one or two phases. On the other hand, the unbalanced ratio of each phase of the output current should be within 10%.

The inverter output current can be monitored on the operation panel. The value displayed on the operation panel is accurate even if the output frequency varies. Hence, it is recommended to monitor values on the operation panel or by outputting the analog signal.

5.2.4 Example of measuring converter unit (FR-CC2) input power factor

Calculate the factor from the effective power and the apparent power. A power-factor meter cannot indicate an exact value.

$$\begin{aligned} \text{Total power factor of the converter unit} &= \frac{\text{Effective power}}{\text{Apparent power}} \\ &= \frac{\text{Three-phase input power found by the 3-wattmeter method}}{\sqrt{3} \times V (\text{power supply voltage}) \times I (\text{input current effective value})} \end{aligned}$$

5.2.5 Measurement of converter output voltage (between terminals P and N)

The output voltage of the converter is output across terminals P and N, and can be measured with a voltmeter such as a digital multimeter. The voltage varies according to the power supply voltage. Approximately 540 to 600 VDC is output when no load is applied. The voltage decreases when a load is applied.

When energy is regenerated from the motor during deceleration, for example, the converter output voltage rises to nearly 800 to 900 VDC maximum.

5.2.6 Measurement of inverter output frequency

In the initial setting of the FM type inverter, a pulse train proportional to the output frequency is output across the pulse train output terminals FM and SD on the inverter. This pulse train output can be counted by a frequency counter, or a digital multimeter can be used to read the mean value of the pulse train output voltage. When a digital multimeter is used to measure the output frequency, approximately 5 VDC is indicated at the maximum frequency.

For detailed specifications of the pulse train output terminal FM, refer to the Instruction Manual (Detailed).

In the initial setting of the CA type inverter, a pulse train proportional to the output frequency is output across the analog current output terminals CA and 5 on the inverter. Measure the current using a digital multimeter.

For detailed specifications of the current output terminal CA, refer to the Instruction Manual (Detailed).

5.2.7 Insulation resistance test using megger

- For the inverter and the converter unit (FR-CC2), conduct the insulation resistance test on the main circuit only as follows and do not perform the test on the control circuit. (Use a 500 VDC megger.)

NOTE

- Before performing the insulation resistance test on the external circuit, disconnect the cables from all terminals of the inverter and the converter unit so that the test voltage is not applied to the inverter and the converter unit.
- For the continuity test of the control circuit, use a tester for high resistance range and do not use the megger or buzzer.

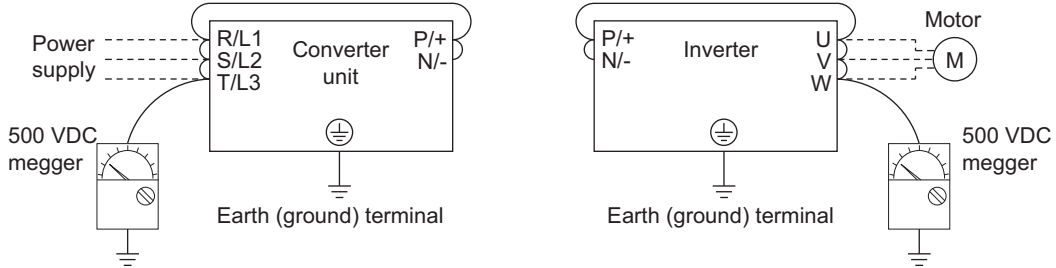

5

5.2.8 Withstand voltage test

Do not conduct a withstand voltage test. Deterioration may occur.

MEMO

CHAPTER 6 SPECIFICATIONS

6.1	Inverter rating.....	122
6.2	Common specifications.....	123
6.3	Outline dimension drawings.....	125

6 SPECIFICATIONS

This chapter explains the specifications of this product.

Always read the instructions before use.

6.1 Inverter rating

◆ 400 V class

- Inverter

Model FR-A842-[]		07700	08660	09620	10940	12120
		315K	355K	400K	450K	500K
Applicable motor capacity (kW) ^{*1}	SLD	400	450	500	560	630
	LD	355	400	450	500	560
	ND (initial setting)	315	355	400	450	500
	HD	280	315	355	400	450
Rated capacity (kVA) ^{*2}	SLD	587	660	733	834	924
	LD	521	587	660	733	834
	ND (initial setting)	465	521	587	660	733
	HD	417	465	521	587	660
Rated current (A)	SLD	770	866	962	1094	1212
	LD	683	770	866	962	1094
	ND (initial setting)	610	683	770	866	962
	HD	547	610	683	770	866
Overload current rating ^{*3}	SLD	110% 60 s, 120% 3 s (inverse-time characteristics) at surrounding air temperature of 40°C				
	LD	120% 60 s, 150% 3 s (inverse-time characteristics) at surrounding air temperature of 50°C				
	ND (initial setting)	150% 60 s, 200% 3 s (inverse-time characteristics) at surrounding air temperature of 50°C				
	HD	200% 60 s, 250% 3 s (inverse-time characteristics) at surrounding air temperature of 50°C				
Rated voltage ^{*4}		Three-phase 380 to 500 V				
Regenerative braking torque ^{*5} (when used with the converter unit (FR-CC2))	Maximum brake torque	10% torque, continuous				
Input power	Power supply voltage	430 to 780 VDC				
	Control power supply auxiliary input	Single-phase 380 to 500 V, 50/60 Hz ^{*7}				
	Permissible control power supply auxiliary input fluctuation	Frequency ±5%, voltage ±10%				
Protection rating of structure (IEC 60529) ^{*6}		Open type (IP00)				
Cooling system		Forced air				
Approx. mass (kg)		163	163	243	243	243

*1 The applicable motor capacity indicated is the maximum capacity applicable for use of the Mitsubishi Electric standard 4-pole motor.

*2 The rated output capacity is the value with respect to 440 V output voltage.

*3 The percentage of the overload current rating is the ratio of the overload current to the inverter's rated output current. For repeated duty, allow time for the inverter and motor to return to or below the temperatures under 100% load.

*4 The maximum output voltage does not exceed the power supply voltage. The maximum output voltage can be changed within the setting range.

However, the maximum point of the voltage waveform at the inverter output side is the power supply voltage multiplied by about $\sqrt{2}$.

*5 Value for the ND rating

*6 The protection rating of the FR-DU08 is IP40 (except for the PU connector).

*7 For the power voltage exceeding 480 V, set **Pr.977 Input voltage mode selection**. (For details, refer to the Instruction Manual (Detailed).)

6.2 Common specifications

Control	Control method		Soft-PWM control, high carrier frequency PWM control (selectable among V/F control, Advanced magnetic flux vector control, Real sensorless vector control), Optimum excitation control, Vector control ^{*1} , and PM sensorless vector control
	Output frequency range		0.2 to 590 Hz (The upper-limit frequency is 400 Hz under Advanced magnetic flux vector control, Real sensorless vector control, Vector control ^{*1} , and PM sensorless vector control.)
	Frequency setting resolution	Analog input	0.015 Hz/60 Hz at 0 to 10 V/12 bits (terminals 2 and 4). 0.03 Hz/60 Hz at 0 to 5 V/11 bits or 0 to 20 mA/approx. 11 bits (terminals 2 and 4), at 0 to ±10 V/12 bits (terminal 1). 0.06 Hz/60 Hz at 0 to ±5 V/11 bits (terminal 1).
		Digital input	0.01 Hz
	Frequency accuracy	Analog input	Within ±0.2% of the maximum output frequency (25°C ±10°C)
		Digital input	0.01% or less of the set output frequency
	Voltage/frequency characteristics		Base frequency can be set from 0 to 590 Hz. Constant-torque/variable-torque pattern or adjustable 5 points V/F can be selected.
	Starting torque		SLD rating: 120% 0.3 Hz, LD rating: 150% 0.3 Hz, ND rating: 200% ^{*2} 0.3 Hz, HD rating: 250% ^{*2} 0.3 Hz (under Real sensorless vector control or Vector control ^{*1})
	Torque boost		Manual torque boost
	Acceleration/deceleration time setting		0 to 3600 s (acceleration and deceleration can be set individually), linear or S-pattern acceleration/deceleration mode, backlash countermeasures acceleration/deceleration can be selected.
	DC injection brake (induction motor)		Operation frequency (0 to 120 Hz), operation time (0 to 10 s), operation voltage (0% to 30%) variable
	Stall prevention operation level		Activation range of stall prevention operation (SLD rating: 0 to 120%, LD rating: 0 to 150%, ND rating: 0 to 220%, HD rating: 0 to 280%). Whether to use the stall prevention or not can be selected (V/F control, Advanced magnetic flux vector control)
Torque limit level		Torque limit value can be set (0% to 400% variable). (Real sensorless vector control, Vector control ^{*1} , PM sensorless vector control)	
Operation	Frequency setting signal	Analog input	Terminals 2 and 4: 0 to 10 V / 0 to 5 V / 4 to 20 mA (0 to 20 mA). Terminal 1: -10 to +10 V / -5 to +5 V.
		Digital input	Input using the setting dial of the operation panel or parameter unit. Input of four-digit BCD (Binary-coded decimal) or 16-bit binary (when the option FR-A8AX is installed).
	Start signal		Forward and reverse rotation or start signal automatic self-holding input (3-wire input) can be selected.
	Input signal (12)		Low-speed operation command, Middle-speed operation command, High-speed operation command, Second function selection, Terminal 4 input selection, Jog operation selection, Selection of automatic restart after instantaneous power failure / flying start, Output stop, Start self-holding selection, Forward rotation command, Reverse rotation command, Inverter reset The signal to be input can be changed using Pr.178 to Pr.189 (Input terminal function selection) .
	Pulse train input		100k pulses/s
	Operational function		Maximum and minimum frequency settings, multi-speed operation, acceleration/deceleration pattern, thermal protection, DC injection brake, starting frequency, JOG operation, output stop (MRS), stall prevention, regeneration avoidance, increased magnetic excitation deceleration, frequency jump, rotation display, automatic restart after instantaneous power failure, electronic bypass sequence, remote setting, automatic acceleration/deceleration, retry function, carrier frequency selection, fast-response current limit, forward/reverse rotation prevention, operation mode selection, slip compensation, droop control, load torque high-speed frequency control, speed smoothing control, traverse, auto tuning, applied motor selection, gain tuning, RS-485 communication, Ethernet communication, PID control, PID pre-charge function, easy dancer control, cooling fan operation selection, stop selection (deceleration stop/coasting), power failure time deceleration-to-stop function, stop-on-contact control, PLC function, life diagnosis, maintenance timer, current average monitor, multiple rating, orientation control ^{*1} , speed control, torque control, position control, pre-excitation, torque limit, test run, 24 V power supply input for control circuit, anti-sway control
	Output signal Open collector output (5) Relay output (2)		Inverter running, Up to frequency, Overload warning, Output frequency detection, Fault The signal to be output can be changed using Pr.190 to Pr.196 (Output terminal function selection) . Fault codes (4 bits) of the inverter can be output from the open collector.
Pulse train output		50k pulses/s	

Indication	For indication on external meters	Pulse train output (FM type inverter)	Max. 2.4 kHz via one terminal (for the indication of inverter output frequency). The item for monitoring can be changed using Pr.54 FM/CA terminal function selection .
		Current output (CA type inverter)	Max. 20 mADC via one terminal (for the indication of inverter output frequency). The item for monitoring can be changed using Pr.54 FM/CA terminal function selection .
		Voltage output	Max. 10 VDC via one terminal (for the indication of inverter output frequency). The item for monitoring can be changed using Pr.158 AM terminal function selection .
	Operation panel (FR-DU08)	Status monitoring	Output frequency, output current, output voltage, and frequency setting value are monitored. The item for monitoring can be changed using Pr.52 Operation panel main monitor selection .
		Fault record	When a protective function is activated, a fault indication is displayed and the output voltage, output current, output frequency, cumulative energization time, date (year, month, day) and time at the occurrence of the fault are stored. Each fault is recorded and the last 8 records can be displayed.
Protective function	Fault	Overcurrent trip during acceleration, Overcurrent trip during constant speed, Overcurrent trip during deceleration or stop, Regenerative overvoltage trip during acceleration, Regenerative overvoltage trip during constant speed, Regenerative overvoltage trip during deceleration or stop, Inverter overload trip (electronic thermal relay function), Motor overload trip (electronic thermal relay function), Heat sink overheat, Stall prevention stop, Loss of synchronism detection ^{*5} , Upper limit fault detection, Lower limit fault detection, Output side earth (ground) fault overcurrent, Output phase loss, External thermal relay operation ^{*5} , PTC thermistor operation ^{*5} , Option fault, Communication option fault, Parameter storage device fault (control circuit board), Parameter storage device fault (main circuit board), PU disconnection, Retry count excess ^{*5} , CPU fault, Operation panel power supply short circuit/RS-485 terminals power supply short circuit, 24 VDC power fault, Abnormal output current detection, Communication fault (inverter) ^{*6} , Ethernet communication fault ^{*7} , Analog input fault, USB communication fault, Safety circuit fault, Overspeed occurrence ^{*5} , Speed deviation excess detection ^{*1*5} , Signal loss detection ^{*1*5} , Excessive position fault ^{*1*5} , Encoder signal loss for orientation ^{*1*5} , Brake sequence fault ^{*5} , Encoder phase fault ^{*1*5} , 4 mA input fault ^{*5} , Pre-charge fault ^{*5} , PID signal fault ^{*5} , Opposite rotation deceleration fault ^{*5} , Internal circuit fault, Magnetic pole position unknown ^{*1} , External fault during output operation ^{*5} , Internal storage device fault	
	Alarm, Warning, Error message	Fan alarm, Stall prevention (overcurrent), Stall prevention (overvoltage), Electronic thermal relay function pre-alarm, PU stop, Speed limit indication ^{*5} , Parameter copy, Safety stop, Maintenance signal output ^{*5} , USB host error, Home position return setting error ^{*5} , Home position return uncompleted ^{*5} , Home position return parameter setting error ^{*5} , Operation panel lock ^{*5} , Password locked ^{*5} , Parameter write error, Copy operation error, 24 V external power supply operation, Continuous operation during communication fault, Load fault warning, Ethernet communication fault ^{*5*7}	
Environment	Surrounding air temperature	-10°C to +50°C (non-freezing) (LD, ND, HD ratings) -10°C to +40°C (non-freezing) (SLD rating)	
	Surrounding air humidity	90% RH or less (non-condensing)	
	Storage temperature ^{*3}	-20°C to +65°C	
	Ambience	Indoors (free from corrosive gas, flammable gas, oil mist, dust and dirt)	
	Altitude/vibration	Maximum 2500 m ^{*4} , 2.9 m/s ² or less at 10 to 55 Hz in X, Y, and Z directions	

*1 Available when a Vector control compatible option is installed.

*2 In the initial setting, the starting torque is limited to 150% by the torque limit level.

*3 Applicable to conditions for a short time, for example, in transit.

*4 For installation at an altitude above 1000 m, consider a 3% reduction in the rated current per 500 m increase in altitude.

*5 Not activated in the inverter in the initial state.

*6 Available only for the RS-485 model.

*7 Available only for the Ethernet model.

6.3 Outline dimension drawings

FR-A842-07700(315K), FR-A842-08660(355K)

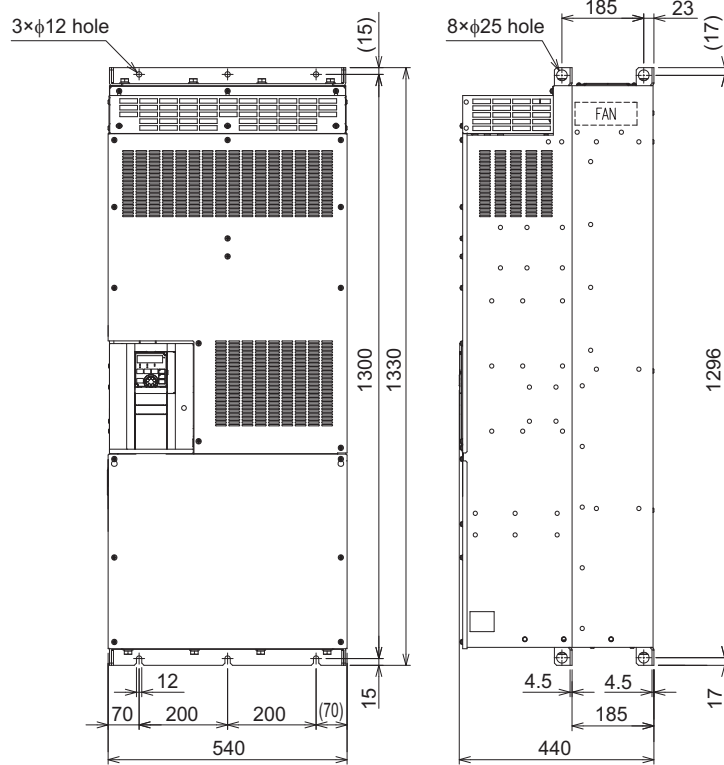

(Unit: mm)

FR-A842-09620(400K), FR-A842-10940(450K), FR-A842-12120(500K)

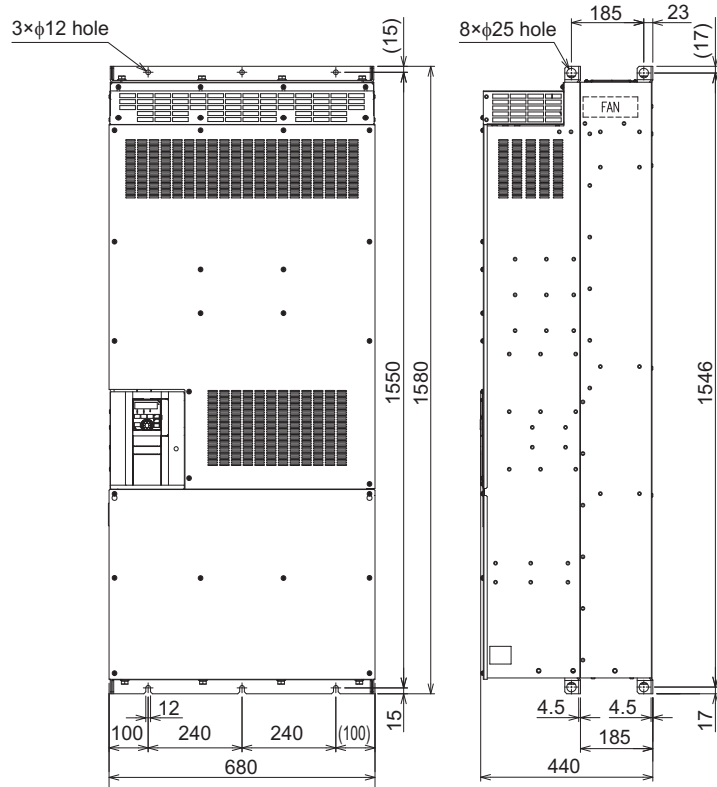

(Unit: mm)

Operation panel (FR-DU08, FR-LU08)

Outline drawing

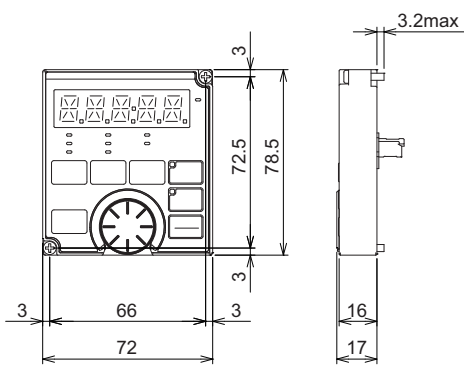

Panel cutting dimension drawing

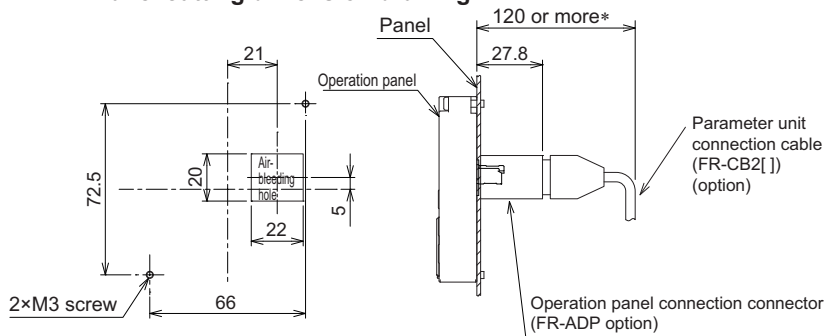

* Denotes the space required to connect an optional parameter unit connection cable (FR-CB2[]). When using another cable, leave the space required for the cable specification.

(Unit: mm)

CHAPTER 7 APPENDIX

7.1	Comparison with FR-A840.....	128
7.2	Comparison with FR-A800.....	129
7.3	Compatible plug-in option.....	130
7.4	Instructions for compliance with the EU Directives.....	131
7.5	Instructions for UL and cUL.....	134
7.6	Instructions for EAC.....	136
7.7	Restricted Use of Hazardous Substances in Electronic and Electrical Products.....	137
7.8	Referenced Standard (Requirement of Chinese standardized law).....	137
7.9	Compliance with the UK certification scheme.....	138
7.10	EU Declaration of Conformity.....	138

7 APPENDIX

APPENDIX provides the reference information for use of this product.

Refer to APPENDIX as required.

7.1 Comparison with FR-A840

The following table shows the function differences between FR-A840 (standard model) and FR-A842 (separated converter type).

Item	FR-A840	FR-A842
Pr.30 Regenerative function selection	Setting ranges: "0 to 2, 10, 11, 20, 21, 100 to 102, 110, 111, 120, 121" Initial value: "0"	Setting ranges: "2, 10, 11, 102, 110, 111" Initial value: "10"
Pr.70 Special regenerative brake duty	With the parameter	Without the parameter
Monitor function (Pr.52, Pr.54, Pr.158, Pr.774 to Pr.776, Pr.992, Pr.1027 to Pr.1034)	Regenerative brake duty: Available	Regenerative brake duty: Unavailable
Input terminal function selection (Pr.178 to Pr.189)	DC feeding operation permission (X70), DC feeding cancel (X71): Available	DC feeding operation permission (X70), DC feeding cancel (X71): Unavailable
Pr.187 MRS terminal function selection	Initial value "24" (MRS)	Initial value "10" (X10)
Output terminal function assignment selection (Pr.190 to Pr.196, Pr.313 to Pr.322)	Instantaneous power failure/undervoltage (IPF), Regenerative brake prealarm (RBP), DC current feeding (Y85), Main circuit capacitor life (Y87), Inrush current limit circuit life (Y89): Available	Instantaneous power failure/undervoltage (IPF), Regenerative brake prealarm (RBP), DC current feeding (Y85), Main circuit capacitor life (Y87), Inrush current limit circuit life (Y89): Unavailable
Pr.192 IPF terminal function selection	Initial value "2" (IPF)	Initial value "9999" (No function)
Inrush current limit circuit life display, Main circuit capacitor life display (Pr.256, Pr.258, Pr.259)	With the parameter	Without the parameter
Pr.599 X10 terminal input selection	Initial value "0" (NO contact specification)	Initial value "1" (NC contact specification)
Pr.872 Input phase loss protection selection	With the parameter	Without the parameter
Warning, protective functions	Regenerative brake prealarm (RB), Instantaneous power failure (E.IPF), Undervoltage (E.UVT), Input phase loss (E.ILF), Brake transistor alarm detection (E.BE), Inrush current limit circuit fault: Available	Regenerative brake prealarm (RB), Instantaneous power failure (E.IPF), Undervoltage (E.UVT), Input phase loss (E.ILF), Brake transistor alarm detection (E.BE), Inrush current limit circuit fault: Unavailable

7.2 Comparison with FR-A800

The following table shows the function differences between FR-A800 and FR-A800-F/G (safety communication model).

Item	FR-A800-F/G (with safety communication option installed)		FR-A800/FR-A800-E
	FR-A8NCG-S	A8SPRS	
Safety communication	CC-Link IE TSN	PROFIsafe	Not supported
Safety performance	PLe SIL3 (PLd SIL2 without the option installed)		PLe SIL3 / PLd SIL2 (depending on the SERIAL)
Functional safety	Refer to the specifications of the safety sub-functions (page 19).		STO only
Fault display without safety communication option installed	E.SAF		Not displayed
Communication option fault	E.SAF		E.OP1 to E.OP3
Terminal SO output	Disabled (always OFF)		Enabled
Plug-in option	For availability of the options, refer to page 130.	Restricted (For availability of the options, refer to page 130.)	Not restricted
Control terminal option	Available (FR-A8TP, FR-A8TR ^{*1})	Not available	Available (FR-A8TP, FR-A8TR ^{*1} , FR-A8TAT ^{*1})
SW3/SW4 (initial state)	ON/ON		OFF/OFF
Pr.359 Encoder rotation direction	Initial value	0	1
	Setting range	0, 1, 100, 101	0, 100
Pr.800 Control method selection	Setting range	0 to 6, 9 to 14, 20, 100 to 106, 109 to 114	0 to 6, 9 to 14, 20 (Fast-response operation is not available.)
Pr.862 Encoder option selection	Setting available	Setting not available	Setting available
Machine end encoder Machine end orientation Machine end simple orientation	Available ^{*2}	Not available	Available ^{*2}
Test operation	X22 signal	Invalid	Invalid ^{*3}
Control mode	First motor	Not restricted	
	Second monitor	Not restricted	Vector control is not available.

*1 Not available for the Ethernet models.

*2 A compatible encoder option is required.

*3 When the X22 signal is input during test operation, the operation is performed at the orientation speed. An orientation stop is not executed.

7.3 Compatible plug-in option

The following plug-in options are available in this product with the safety communication option is installed.

- When used with FR-A8NCG-S

Model	Specification/function
FR-A8AX	16-bit digital input
FR-A8AY	Analog output / digital output
FR-A8AR	Relay output
FR-A8AP	Orientation control / encoder feedback control / Vector control
FR-A8TP	Vector control terminal block
FR-A8AZ	Bipolar analog output / high-resolution analog input / motor thermistor interface
FR-A8APR	Resolver interface / orientation control / resolver (encoder) feedback control / Vector control
FR-A8AL	Orientation control / encoder feedback control / Vector control / position control / encoder pulse division output
FR-A8APS	EnDat interface / orientation control / encoder feedback control / Vector control / position control
FR-A8AVP	Phase-synchronized bypass switching
FR-A8APA	SinCos encoder interface / orientation control / encoder feedback control / Vector control

- When used with A8SPRS

Model	Specification/function	Availability	Restriction
FR-A8AVP	Phase-synchronized bypass switching	○	—
FR-A8AX	16-bit digital input	Δ	Max. six cables (Installing the A8SPRS reduces the wiring space.)
FR-A8AY	Analog output / digital output	Δ	
FR-A8AZ	Bipolar analog output / high-resolution analog input / motor thermistor interface	○	—

○: Available (not restricted), Δ: Available (restricted)

7.4 Instructions for compliance with the EU Directives

The EU Directives are issued to standardize different national regulations of the EU Member States and to facilitate free movement of the equipment, whose safety is ensured, in the EU territory.

Since 1996, compliance with the EMC Directive that is one of the EU Directives has been legally required. Since 1997, compliance with the Low Voltage Directive, another EU Directive, has been also legally required. When a manufacturer confirms its equipment to be compliant with the EMC Directive and the Low Voltage Directive, the manufacturer must declare the conformity and affix the CE marking.

- The authorized representative in the EU
The authorized representative in the EU is shown below.
Name: Mitsubishi Electric Europe B.V.
Address: Mitsubishi-Electric-Platz 1, 40882 Ratingen, Germany

◆ EMC Directive

We declare that this inverter conforms with the EMC Directive and affix the CE marking on the inverter.

- EMC Directive: 2014/30/EU
- Standard(s): EN 61800-3:2004+A1:2012 (Second environment / PDS Category "C3")
- This inverter is not intended to be used on a low-voltage public network which supplies domestic premises. When using the inverter in a residential area, take appropriate measures and ensure the conformity of the inverter used in the residential area.
- Radio frequency interference is expected if used on such a network.
- The installer shall provide a guide for installation and use, including recommended mitigation devices.

Note:

First environment

Environment including buildings/facilities which are directly connected to a low voltage main supply which also supplies residential buildings. Directly connected means that there is no intermediate transformer between these buildings.

Second environment

Environment including all buildings/facilities which are not directly connected to a low voltage main supply which also supplies residential buildings.

■ Note

Ensure the EMC filter is enabled, install the product as stated below, and, then carry out any wiring.

- The converter unit has a built-in EMC filter (Class C3). Enable the EMC filter. (For the details, refer to [page 85](#).)
- Connect the inverter and the converter unit to an earthed (grounded) power supply.
- Install the motor and controller cable found in the EMC Installation Manual (BCN-A21041-204) and Technical News (MF-S-113) according to the instructions.
- To make full use of the built-in EMC filter, motor cable lengths should not exceed 20 m.
- Ensure that the finalized system which includes an inverter and converter unit complies with the EMC Directive.

◆ Low Voltage Directive

We have self-confirmed our inverters as products compliant to the Low Voltage Directive and affix the CE marking on the inverters.

- Low Voltage Directive: 2014/35/EU
- Conforming standard: EN 61800-5-1:2007

■ Outline of instructions

- Do not use an earth leakage circuit breaker as an electric shock protector without connecting the equipment to the earth. Connect the equipment to the earth (ground) securely.
- Wire the earth terminal independently. (Do not connect two or more cables to one terminal.)

- Use the cable sizes on [page 44](#) under the following conditions.

- Surrounding air temperature: 40°C maximum

If conditions are different from the above, select appropriate wire according to EN 60204-1 or IEC 60364-5-52.

- Use a tinned (plating should not include zinc) crimping terminal to connect the earth (ground) cable. When tightening the screw, be careful not to damage the threads.
- For use as a product compliant with the Low Voltage Directive, use PVC cable whose size is indicated on [page 44](#).
- Use the molded case circuit breaker and magnetic contactor which conform to the EN or IEC Standard.
- DC current may flow from the inverter to a protective earth (ground) conductor. When using a residual current device (RCD) or residual current monitor (RCM), connect a type B RCD or RCM to the power supply side.
- Use the inverter under the conditions of overvoltage category II (regardless of the earth (ground) condition of the power supply), overvoltage category III (400 V class products must be used with the earth-neutral system power supply) and pollution degree 2 or lower specified in IEC 60664.
To use the inverter under the conditions of pollution degree 2, install it in the enclosure of IP2X or higher.
To use the inverter under the conditions of pollution degree 3, install it in the enclosure of IP54 or higher.
- On the input and output of the inverter and the converter unit, use cables of the size and type set forth in EN 60204-1 or IEC 60364-5-52.
- The operating capacity of the relay outputs (terminal symbols A1, B1, C1, A2, B2, C2) should be 30 VDC, 0.3 A. (Relay output has basic isolation from the internal circuit of the inverter and the converter unit.)
- Control circuit terminals on [page 36](#) are safely isolated from the main circuit.
- Environment (For the details, refer to [page 27](#).)

	During operation	In storage	During transportation
Surrounding air temperature	LD, ND (initial setting), HD: -10°C to +50°C SLD: -10°C to +40°C	-20°C to +65°C	-20°C to +65°C
Humidity	90% RH or less	90% RH or less	90% RH or less
Maximum altitude	2500 m ^{*1}	2500 m	10000 m

*1 For installation at an altitude above 1000 m, consider a 3% reduction in the rated current per 500 m increase in altitude.

■ Branch circuit protection

Provide a Class T, Class J, Class CC, or Class L fuse. (Use a product which conforms to the EN or IEC Standard.)

FR-CC2-□	H315K	H355K	H400K	H450K	H500K	H560K	H630K
Rated fuse voltage (V)	500 V or more						
Permissible fuse rating (A)	1100	1200	1350	1500	1800	1800	1800

■ Short circuit ratings

Suitable for use in a circuit capable of delivering not more than 100 kA rms symmetrical amperes, 500 V maximum.

◆ Motor overload protection

When using the electronic thermal relay function as motor overload protection, set the rated motor current in **Pr.9 Electronic thermal O/L relay**.

This function detects the overload of the motor and shut off the inverter output by stopping the operation of the transistor at the inverter output side. (The operation characteristic is shown below.)

- When using the Mitsubishi Electric constant-torque motor

1. Set "1, 13 to 16" in **Pr.71**. (This setting enables the 100% constant-torque characteristic in the low-speed range.)
2. Set the rated motor current in **Pr.9**.

Operational characteristic of the electronic thermal relay function

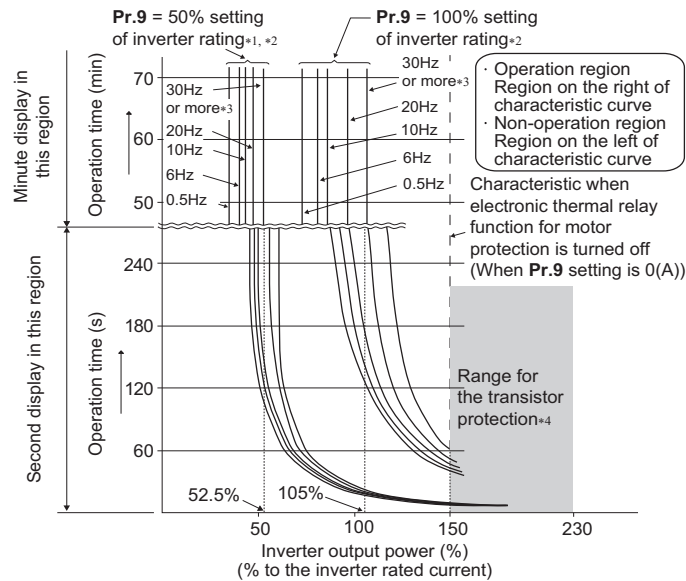

*1 When setting **Pr.9** to a value (current value) of 50% of the inverter rated output current.

*2 The % value denotes the percentage to the inverter rated current. It is not the percentage to the rated motor current.

*3 When the electronic thermal relay function dedicated to the Mitsubishi Electric constant-torque motor is set, this characteristic curve applies to operation at 6 Hz or higher.

*4 Transistor protection is activated depending on the temperature of the heat sink. The protection may be activated even with less than 150% depending on the operating conditions.

NOTE

- The internal accumulated heat value of the electronic thermal O/L relay is reset to the initial value by the inverter's power reset or reset signal input. Avoid unnecessary reset and power-OFF.
- Install an external thermal relay (OCR) between the inverter and motors to operate several motors, a multi-pole motor or a dedicated motor with one inverter. When configuring an external thermal relay, note that the current indicated on the motor rating plate is affected by the line-to-line leakage current. (Refer to the Instruction Manual (Detailed).)
- The cooling effect of the motor drops during low-speed operation. Use a thermal protector or a motor with built-in thermistor.
- When the difference between the inverter and motor capacities is large and the setting is small, the protective characteristics of the electronic thermal relay function will be deteriorated. In such case, use an external thermal relay.
- A dedicated motor cannot be protected by the electronic thermal relay. Use an external thermal relay.
- Motor over temperature sensing is not provided by the drive.
- The electronic thermal memory retention function is not provided by the drive.

◆ EU RoHS Directive

We declare that our inverters are compliant to the EU RoHS Directive (2011/65/EU) and affix the CE marking on the inverters.

7.5 Instructions for UL and cUL

(Standard to comply with: UL 508C, CSA C22.2 No.274-13)

◆ Installation

The below types of inverter have been approved as products for use in enclosure.

Design the enclosure so that the surrounding air temperature, humidity and ambience of the inverter will satisfy the specifications. (Refer to [page 27](#).)

■ Branch circuit protection

For installation in the United States, Class T, Class J, Class CC, or Class L fuses must be provided, in accordance with the National Electrical Code and any applicable local codes.

For installation in Canada, Class T, Class J, Class CC, or Class L fuses must be provided, in accordance with the Canadian Electrical Code and any applicable local codes.

FR-CC2-[]	H315K	H355K	H400K	H450K	H500K	H560K	H630K
Rated fuse voltage (V)	500 V or more						
Permissible fuse rating (A)	1100	1200	1350	1500	1800	1800	1800

◆ Wiring to the power supply and the motor

Refer to the National Electrical Code (Article 310) regarding the allowable current of the cable. Select the cable size for 125% of the rated current according to the National Electrical Code (Article 430).

For wiring the input (R/L1, S/L2, T/L3) terminals of the converter unit and output (U, V, W) terminals of the inverter, use the UL listed copper, stranded wires (rated at 75°C) and round crimp terminals. Crimp the terminals with the crimping tool recommended by the terminal manufacturer.

◆ Short circuit ratings

Suitable for use in a circuit capable of delivering not more than 100 kA rms symmetrical amperes, 500 V maximum.

◆ Motor overload protection

When using the electronic thermal relay function as motor overload protection, set the rated motor current in **Pr.9 Electronic thermal O/L relay**.

This function detects the overload (overheat) of the motor and shut off the inverter output by stopping the operation of the transistor at the inverter output side. (The operation characteristic is shown below.)

- When using the Mitsubishi Electric constant-torque motor

1. Set "1, 13 to 16" in **Pr.71**. (This setting enables the 100% constant-torque characteristic in the low-speed range.)
2. Set the rated motor current in **Pr.9**.

Operation characteristics of electronic thermal O/L relay function

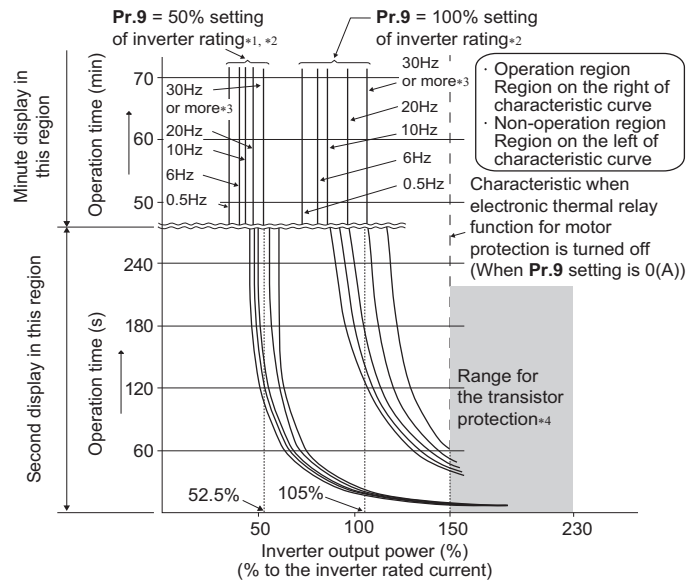

*1 When setting **Pr.9** to a value (current value) of 50% of the inverter rated output current.

*2 The % value denotes the percentage to the inverter rated current. It is not the percentage to the rated motor current.

*3 When the electronic thermal relay function dedicated to the Mitsubishi Electric constant-torque motor is set, this characteristic curve applies to operation at 6 Hz or higher.

*4 Transistor protection is activated depending on the temperature of the heat sink. The protection may be activated even with less than 150% depending on the operating conditions.

NOTE

- The internal accumulated heat value of the electronic thermal O/L relay is reset to the initial value by the inverter's power reset or reset signal input. Avoid unnecessary reset and power-OFF.
- Install an external thermal relay (OCR) between the inverter and motors to operate several motors, a multi-pole motor or a dedicated motor with one inverter. When configuring an external thermal relay, note that the current indicated on the motor rating plate is affected by the line-to-line leakage current. (Refer to the Instruction Manual (Detailed).)
- The cooling effect of the motor drops during low-speed operation. Use a thermal protector or a motor with built-in thermistor.
- When the difference between the inverter and motor capacities is large and the setting is small, the protective characteristics of the electronic thermal relay function will be deteriorated. In such case, use an external thermal relay.
- A dedicated motor cannot be protected by the electronic thermal relay. Use an external thermal relay.
- Motor over temperature sensing is not provided by the drive.

7.6 Instructions for EAC



The product certified in compliance with the Eurasian Conformity has the EAC marking.

Note: EAC marking

In 2010, three countries (Russia, Belarus, and Kazakhstan) established a Customs Union for the purposes of revitalizing the economy by forming a large economic bloc by abolishing or reducing tariffs and unifying regulatory procedures for the handling of articles.

Products to be distributed over these three countries of the Customs Union must comply with the Customs Union Technical Regulations (CU-TR), and the EAC marking must be affixed to the products.

For information on the country of origin, manufacture year and month, and authorized sales representative (importer) in the CU area of this product, refer to the following:

- Country of origin indication
Check the rating plate of the product. (Refer to [page 13](#).)
Example: MADE IN JAPAN
- Manufactured year and month
Check the SERIAL number indicated on the rating plate of the product. (Refer to [page 13](#).)
- Authorized sales representative (importer) in the CU area
The authorized sales representative (importer) in the CU area is shown below.
Name: Mitsubishi Electric Turkey A.S. Head Office
Address: Serifali Mahallesi Kale Sokak. No:41 34775 Umraniye, Istanbul, Turkey
Phone: +90-216-969-25-00
FAX: +90-216-661-44-47

7.7 Restricted Use of Hazardous Substances in Electronic and Electrical Products

The mark of restricted use of hazardous substances in electronic and electrical products is described as follows based on the "Management Methods for the Restriction of the Use of Hazardous Substances in Electrical and Electronic Products" of the People's Republic of China.

电器电子产品有害物质限制使用标识要求



本产品中所含有的有害物质的名称、含量、含有部件如下表所示。

- 产品中所含有害物质的名称及含量

部件名称 ^{*2}	有害物质 ^{*1}					
	铅 (Pb)	汞 (Hg)	镉 (Cd)	六价铬 (Cr (VI))	多溴联苯 (PBB)	多溴二苯醚 (PBDE)
电路板组件 (包括印刷电路板及其构成的零部件, 如电阻、电容、集成电路、连接器等)、电子部件	×	○	×	○	○	○
金属壳体、金属部件	×	○	○	○	○	○
树脂壳体、树脂部件	○	○	○	○	○	○
螺丝、电线	○	○	○	○	○	○

上表依据 SJ/T11364 的规定编制。

○: 表示该有害物质在该部件所有均质材料中的含量均在 GB/T26572 规定的限量要求以下。

×: 表示该有害物质在该部件的至少一种均质材料中的含量超出 GB/T26572 规定的限量要求。

*1 即使表中记载为 ×, 根据产品型号, 也可能会有有害物质的含量为限制值以下的情况。

*2 根据产品型号, 一部分部件可能不包含在产品中。

7.8 Referenced Standard (Requirement of Chinese standardized law)

This Product is designed and manufactured accordance with the following Chinese standards.

Machinery safety:	GB/T 16855.1 GB/T 12668.502 GB 28526 GB/T 12668.3
Electrical safety:	GB/T 12668.501
EMC	GB/T 12668.3

7.9 Compliance with the UK certification scheme



We declare that this product conforms with the related technical requirements under UK legislation, and affix the UKCA (UK Conformity Assessed) marking on the product.

Approval conditions are the same as those for the EU Directives. (Refer to [page 131](#).)

UKCA marking:

The UKCA marking is used for products sold in the markets of Great Britain (England, Wales, and Scotland) from January 1, 2021 after the departure of the UK from the EU on January 31, 2020.

7.10 EU Declaration of Conformity

For details, refer to Appendix in the FR-A8NCG-S Instruction Manual.

MEMO

WARRANTY

When using this product, make sure to understand the warranty described below.

1. Warranty period and coverage

We will repair any failure or defect (hereinafter referred to as "failure") in our FA equipment (hereinafter referred to as the "Product") arisen during warranty period at no charge due to causes for which we are responsible through the distributor from which you purchased the Product or our service provider. However, we will charge the actual cost of dispatching our engineer for an on-site repair work on request by customer in Japan or overseas countries. We are not responsible for any on-site readjustment and/or trial run that may be required after a defective unit are repaired or replaced.

[Term]

The term of warranty for Product is twelve months after your purchase or delivery of the Product to a place designated by you or eighteen months from the date of manufacture whichever comes first ("Warranty Period"). Warranty period for repaired Product cannot exceed beyond the original warranty period before any repair work.

[Limitations]

- (1) You are requested to conduct an initial failure diagnosis by yourself, as a general rule. It can also be carried out by us or our service company upon your request and the actual cost will be charged.
However, it will not be charged if we are responsible for the cause of the failure.
- (2) This limited warranty applies only when the condition, method, environment, etc. of use are in compliance with the terms and conditions and instructions that are set forth in the instruction manual and user manual for the Product and the caution label affixed to the Product.
- (3) Even during the term of warranty, the repair cost will be charged on you in the following cases;
 - a failure caused by your improper storing or handling, carelessness or negligence, etc., and a failure caused by your hardware or software problem
 - a failure caused by any alteration, etc. to the Product made on your side without our approval
 - a failure which may be regarded as avoidable, if your equipment in which the Product is incorporated is equipped with a safety device required by applicable laws and has any function or structure considered to be indispensable according to a common sense in the industry
 - a failure which may be regarded as avoidable if consumable parts designated in the instruction manual, etc. are duly maintained and replaced
 - any replacement of consumable parts (condenser, cooling fan, etc.)
 - a failure caused by external factors such as inevitable accidents, including without limitation fire and abnormal fluctuation of voltage, and acts of God, including without limitation earthquake, lightning and natural disasters
 - a failure generated by an unforeseeable cause with a scientific technology that was not available at the time of the shipment of the Product from our company
 - any other failures which we are not responsible for or which you acknowledge we are not responsible for

2. Term of warranty after the stop of production

- (1) We may accept the repair at charge for another seven (7) years after the production of the product is discontinued. The announcement of the stop of production for each model can be seen in our Sales and Service, etc.
- (2) Please note that the Product (including its spare parts) cannot be ordered after its stop of production.

3. Service in overseas

Our regional FA Center in overseas countries will accept the repair work of the Product; however, the terms and conditions of the repair work may differ depending on each FA Center. Please ask your local FA center for details.

4. Exclusion of loss in opportunity and secondary loss from warranty liability

Regardless of the gratis warranty term, Mitsubishi Electric shall not be liable for compensation to:

- (1) Damages caused by any cause found not to be the responsibility of Mitsubishi Electric.
- (2) Loss in opportunity, lost profits incurred to the user by Failures of Mitsubishi Electric products.
- (3) Special damages and secondary damages whether foreseeable or not, compensation for accidents, and compensation for damages to products other than Mitsubishi Electric products.
- (4) Replacement by the user, maintenance of on-site equipment, start-up test run and other tasks.

5. Change of Product specifications

Specifications listed in our catalogs, manuals or technical documents may be changed without notice.

6. Application and use of the Product

- (1) For the use of our product, its applications should be those that may not result in a serious damage even if any failure or malfunction occurs in product, and a backup or fail-safe function should operate on an external system to product when any failure or malfunction occurs.
- (2) Our product is designed and manufactured as a general purpose product for use at general industries.
Therefore, applications substantially influential on the public interest for such as atomic power plants and other power plants of electric power companies, and also which require a special quality assurance system, including applications for railway companies and government or public offices are not recommended, and we assume no responsibility for any failure caused by these applications when used.
In addition, applications which may be substantially influential to human lives or properties for such as airlines, medical treatments, railway service, incineration and fuel systems, man-operated material handling equipment, entertainment machines, safety machines, etc. are not recommended, and we assume no responsibility for any failure caused by these applications when used. We will review the acceptability of the abovementioned applications, if you agree not to require a specific quality for a specific application. Please contact us for consultation.

About the enclosed CD-ROM

The enclosed CD-ROM contains PDF files of manuals related to this product.

◆ Before using the enclosed CD-ROM

- The copyright and other rights of the enclosed CD-ROM all belong to Mitsubishi Electric Corporation.
- No part of the enclosed CD-ROM may be copied or reproduced without the permission of Mitsubishi Electric Corporation.
- Specifications of the enclosed CD-ROM are subject to change for modification without notice.
- We are not responsible for any damages and lost earnings, etc. from use of the enclosed CD-ROM.
- Warranty

We do not provide a warranty against defects in the enclosed CD-ROM and related documents.

NOTE

- This is a personal computer dedicated CD-ROM. Do not attempt to play it on ordinary audio devices. The loud volume may damage hearing and speakers.

◆ System requirements for the enclosed CD-ROM

- System for viewing PDF files is required to read instruction manuals contained in the enclosed CD-ROM.

◆ Operating method of the enclosed CD-ROM

- How to read instruction manuals

Step 1. Start the computer and place the enclosed CD-ROM in the CD-ROM drive.

Step 2. The main window will automatically open in the web browser.

Step 3. Choose your language from the language menu.

Step 4. Click the manual you want to read in the "INSTRUCTION MANUAL" list.

Step 5. The PDF manual will open.

- Manual opening of the enclosed CD-ROM

Step 1. Start the computer and place the enclosed CD-ROM in the CD-ROM drive.

Step 2. Open the "index.html" file.

Step 3. The main window will open in the web browser. Follow the previous steps from Step 3 to Step 5.

- PDF data of the instruction manual are stored in "MANUAL" folder on this CD-ROM.

REVISIONS

*The manual number is given on the bottom left of the back cover.

Revision date	*Manual number	Revision
Sep. 2023	IB(NA)-0600978ENG-A	First edition

FR-A800/A800 Plus Series

Instruction Manual Supplement

1 Instructions for UL and cUL

(Standard to comply with: UL 61800-5-1, CSA C22.2 No. 274)

◆ Applicable models

- FR-A842-07700(315K) to 12120(500K)

The above models are compliant with both UL 508C and UL 61800-5-1, CSA C22.2 No. 274.

For the instructions for UL 61800-5-1, CSA C22.2 No. 274, refer to this Instruction Manual Supplement.

For the instructions for UL 508C, refer to the FR-A802 (SEPARATED CONVERTER TYPE) INSTRUCTION MANUAL (HARDWARE)

◆ Product handling information / Informations sur la manipulation du produit

-WARNING- Operation of this product requires detailed installation and operation instructions provided in the Instruction Manual (HARDWARE) and the Instruction Manual (Detailed) intended for use with this product. Please forward relevant manuals to the end user. The manuals can also be downloaded in PDF form from the Mitsubishi Electric FA Global Website. To order manuals, please contact your sales representative.

-AVERTISSEMENT-

L'utilisation de ce produit nécessite des instructions détaillées d'installation et d'utilisation fournies dans les manuels d'instructions en anglais (Instruction Manual (HARDWARE) et Instruction Manual (Detailed)) destinés à être utilisés avec ce produit. Veuillez transmettre les manuels correspondants à l'utilisateur final. Les manuels peuvent également être téléchargés au format PDF sur Mitsubishi Electric FA Global Website. Pour commander des manuels, veuillez contacter votre représentant commercial.

◆ Precautions for compliance with CSA C22.2 No.274

Use the inverter under the conditions of overvoltage category III and pollution degree 2 or lower specified in IEC 60664.

◆ Branch circuit protection

For installation in the United States, branch circuit protection must be provided in accordance with the National Electrical Code and any applicable provincial codes.

For installation in Canada, branch circuit protection must be provided in accordance with the Canadian Electrical Code and any applicable provincial codes. Short circuit protection of the inverter cannot be used as branch circuit protection. Integral solid state short circuit protection does not provide branch circuit protection. Branch circuit protection must be provided in accordance with the National Electrical Code and any additional local code.

■ Precautions for opening the branch-circuit protective device / Précautions pour ouvrir le dispositif de protection du circuit de dérivation

-WARNING- If the fuse melts down or the breaker trips on the input side of this product, check for wiring faults (such as short circuits). Identify and remove the cause of melting down or the trip before replacing the fuse or resetting the tripped breaker (or before applying the power to the inverter again).

-AVERTISSEMENT-

Si le fusible fond ou si le disjoncteur se déclenche du côté entrée de ce produit, vérifier les défauts de câblage (tels que les courts-circuits). Identifier et éliminer la cause de la fonte ou du déclenchement avant de remplacer le fusible ou de réinitialiser le disjoncteur déclenché (ou avant de remettre sous tension l'onduleur).

■ Fuse selection

Fuses are selected based on IEC/EN/UL 61800-5-1 and CSA C22.2 No. 274.

For installation in the United States, the following semi-conductor fuses must be provided, in accordance with the National Electrical Code and any applicable local codes. For installation in Canada, the following semi-conductor fuses must be provided, in accordance with the Canada Electrical Code and any applicable provincial codes. Always install the following semiconductor fuses for branch circuit protection.

- 6-phase rectification

Converter model	Cat. No.	Manufacturer	Rating (A)
FR-CC2-H315K	PC33UD69V1250TF	Mersen	1250
FR-CC2-H355K	PC33UD69V1250TF	Mersen	1250
FR-CC2-H400K	PC33UD69V1400TF	Mersen	1400
FR-CC2-H450K	PC33UD69V1400TF	Mersen	1400
FR-CC2-H500K	PC33UD69V1400TF	Mersen	1400
FR-CC2-H560K	PC33UD69V1400TF	Mersen	1400
FR-CC2-H630K	PC33UD69V1400TF	Mersen	1400

- 12-phase rectification

Converter model	Cat. No.	Manufacturer	Rating (A)
FR-CC2-H315K	PC33UD69V900TF	Mersen	900
FR-CC2-H355K	PC33UD69V900TF	Mersen	900
FR-CC2-H400K	PC33UD69V1100TF	Mersen	1100
FR-CC2-H450K	PC33UD69V1100TF	Mersen	1100
FR-CC2-H500K	PC33UD69V1100TF	Mersen	1100
FR-CC2-H560K	PC33UD69V1100TF	Mersen	1100
FR-CC2-H630K	PC33UD69V1100TF	Mersen	1100

◆ Capacitor discharge time / Temps de décharge du condensateur

CAUTION -Risk of Electric Shock-

Before wiring or inspection, check that the LED indicator turns OFF. Any person who is involved in wiring or inspection shall wait for 10 minutes or longer after power OFF and check that there are no residual voltage using a digital multimeter or the like. The capacitor is charged with high voltage for some time after power OFF, and it is dangerous.

ATTENTION -Risque de choc électrique-

Avant le câblage ou l'inspection, vérifier que le témoin LED s'éteint. Toute personne impliquée dans le câblage ou l'inspection doit attendre 10 minutes ou plus après la mise hors tension et vérifier l'absence de tension résiduelle à l'aide d'un multimètre numérique ou similaire. Le condensateur est chargé avec une haute tension pendant un certain temps après la mise hors tension, ce qui est dangereux. Précautions pour ouvrir le dispositif de protection du circuit de dérivation.

◆ Wiring to the power supply and the motor

- Refer to the National Electrical Code (Article 310) regarding the allowable current of the cable. Select the cable size for 125% of the rated current according to the National Electrical Code (Article 430). For wiring the input (R/L1, S/L2, T/L3) and output (U, V, W) terminals of the inverter, use the UL listed copper, stranded wires (rated at 75°C) and round crimp terminals. Crimp the terminals with the crimping tool recommended by the terminal manufacturer.

◆ Short circuit ratings

- Suitable for use in a circuit capable of delivering not more than 100 kA rms symmetrical amperes, 500 V Maximum.

◆ Motor overload protection

When using the electronic thermal relay function as motor overload protection, set the rated motor current in **Pr.9**
Electronic thermal O/L relay.

Operation characteristics of electronic thermal relay function

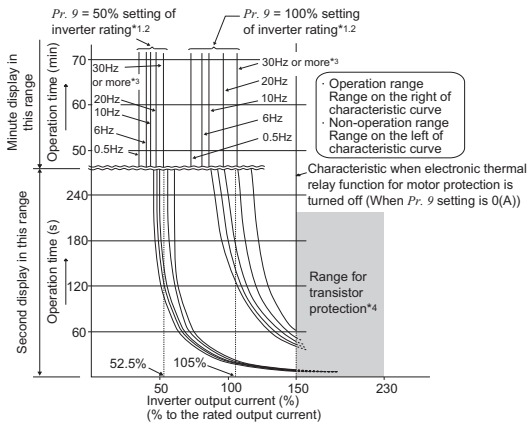

This function detects the overload (overheat) of the motor, stops the operation of the inverter's output transistor, and stops the output. (The operation characteristic is shown on the left.)

- When using the Mitsubishi Electric constant-torque motor
 - (1) Set one of "1, 13 to 16" in **Pr.71**. (This provides a 100% continuous torque characteristic in the low-speed range.)
 - (2) Set the rated current of the motor in **Pr.9**.

- *1 When a value 50% of the inverter rated output current (current value) is set in **Pr.9**
- *2 The % value denotes the percentage to the inverter rated current. It is not the percentage to the rated motor current.
- *3 When you set the electronic thermal relay function dedicated to the Mitsubishi Electric constant-torque motor, this characteristic curve applies to operation at 6 Hz or higher.
- *4 Transistor protection is activated depending on the temperature of the heat sink. The protection may be activated even with less than 150% depending on the operating conditions.

NOTE

- The internal accumulated heat value of the electronic thermal relay function is reset by inverter power reset and reset signal input. Avoid unnecessary reset and power-OFF.
- When multiple motors are driven with a single inverter or when a multi-pole motor or a special motor is driven, install an external thermal relay (OCR) between the inverter and motors. Note that the current indicated on the motor rating plate is affected by the line-to-line leakage current (details in the Instruction Manual (HARDWARE)) when selecting the setting for an external thermal relay.
- The cooling effect of the motor drops during low-speed operation. Use a thermal protector or a motor with built-in thermistor.
- When the difference between the inverter and motor capacities is large and the setting is small, the protective characteristics of the electronic thermal relay function will be deteriorated. In this case, use an external thermal relay.
- A special motor cannot be protected by the electronic thermal relay function. Use an external thermal relay.
- Motor over temperature sensing is not provided by the drive.

◆ Applicable power supply

For use at an altitude above 2000 m (maximum 2500 m), only a neutral-point earthed (grounded) power supply can be used.

MEMO

mitsubishi electric corporation

HEAD OFFICE: TOKYO BUILDING 2-7-3, MARUNOUCHI, CHIYODA-KU, TOKYO 100-8310, JAPAN