

MITSUBISHI ELECTRIC INVERTER



A800-E

FR-A870-E

INSTRUCTION MANUAL (HARDWARE)

High functionality and high performance

FR-A870-00550 to 00890, 02300, 02860-E

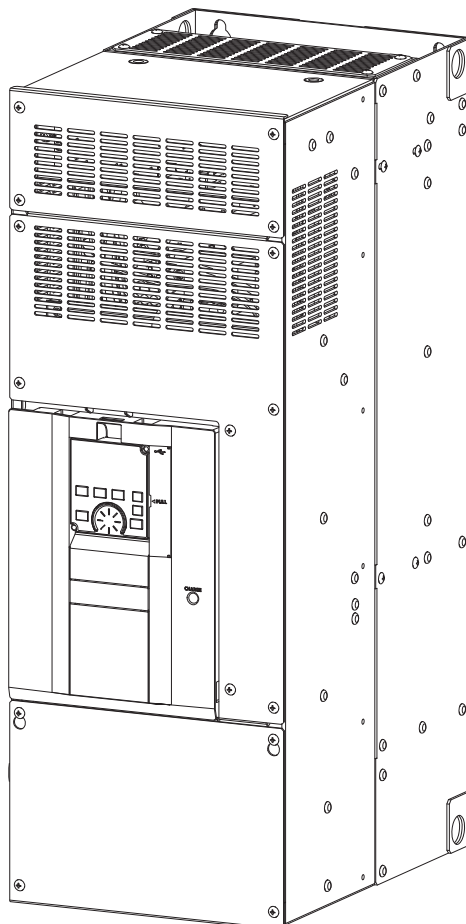

INTRODUCTION	1
INSTALLATION AND WIRING	2
PRECAUTIONS FOR USE OF THE INVERTER	3
PROTECTIVE FUNCTIONS	4
PRECAUTIONS FOR MAINTENANCE AND INSPECTION	5
SPECIFICATIONS	6

Thank you for choosing this Mitsubishi Electric inverter.

This Instruction Manual describes handling and cautions about the hardware, such as installation and wiring, for the FR-A870. Information about the software, such as basic operations and parameters, is described in the FR-A870 Instruction Manual (Function) on the CD-ROM enclosed with this product. For the details of Ethernet communication, refer to the Ethernet Function Manual on the CD-ROM. In addition to this Instruction Manual, read all relevant instruction manuals on the CD-ROM carefully. Do not use this product until you have a full knowledge of this product mechanism, safety information and instructions. Please forward this Instruction Manual to the end user.

Safety instructions

Do not attempt to install, operate, maintain or inspect this product until you have read through this Instruction Manual and supplementary documents carefully and can use the equipment correctly. Do not use this product until you have a full knowledge of this product mechanism, safety information and instructions.

Installation, operation, maintenance and inspection must be performed by qualified personnel. Here, an expert means a person who meets all the following conditions.

- A person who took a proper engineering training. Such training may be available at your local Mitsubishi Electric office. Contact your local sales office for schedules and locations.
- A person who can access operating manuals for the protective devices (e.g. light curtain) connected to the safety control system. A person who has read and familiarized himself/herself with the manuals.

In this Instruction Manual, the safety instruction levels are classified into "WARNING" and "CAUTION"



WARNING

Incorrect handling may cause hazardous conditions, resulting in death or severe injury.



CAUTION

Incorrect handling may cause hazardous conditions, resulting in medium or slight injury, or may cause only material damage.

Note that even the  level may lead to a serious consequence depending on conditions. Be sure to follow the instructions of both levels as they are critical to personal safety.

Electric shock prevention



WARNING

- Do not remove the front cover or the wiring cover while the power of this product is ON, and do not run this product with the front cover or the wiring cover removed as the exposed high voltage terminals or the charging part of the circuitry can be touched. Otherwise you may get an electric shock.
- Even if power is OFF, do not remove the front cover except for wiring or periodic inspection as the inside of this product is charged. Otherwise you may get an electric shock.
- Before wiring or inspection, check that the LED display of the operation panel is OFF. Any person who is involved in wiring or inspection shall wait for at least 10 minutes after the power supply has been cut off, and check that there are no residual voltage using a tester or the like. The capacitor is charged with high voltage for some time after power OFF, and it is dangerous.
- This product must be earthed (grounded). Earthing (grounding) must conform to the requirements of national and local safety regulations and electrical code (NEC section 250, IEC 61140 class 1 and other applicable standards).
- Any person who is involved in wiring or inspection of this product shall be fully competent to do the work.
- This product body must be installed before wiring. Otherwise you may get an electric shock or be injured.
- Do not touch the setting dial or keys with wet hands. Doing so may cause an electric shock.
- Do not subject the cables to scratches, excessive stress, heavy loads or pinching. Doing so may cause an electric shock.
- Do not change the cooling fan while power is ON as it is dangerous.
- Do not touch the printed circuit board or handle the cables with wet hands. Doing so may cause an electric shock.
- Never touch the motor terminals, etc. right after powering OFF as the DC voltage is applied to the motor for 1 second after powering OFF if the main circuit capacitor capacity is measured. Doing so may cause an electric shock.

Fire prevention



CAUTION

- This product must be installed on a nonflammable wall without holes in it so that its components cannot be touched from behind. Installing it on or near flammable material may cause a fire.
- If this product becomes faulty, the product power must be switched OFF. A continuous flow of large current may cause a fire.
- When using a brake resistor, a sequence that will turn OFF power when a fault signal is output must be configured. Otherwise the brake resistor may excessively overheat due to damage of the brake transistor and such, causing a fire.
- Do not connect a resistor directly to the DC terminals P/+ and N/. Doing so could cause a fire.
- Be sure to perform daily and periodic inspections as specified in the Instruction Manual. There is a possibility of explosion, damage, or fire if this product is used without inspection.

Injury prevention



CAUTION

- The voltage applied to each terminal must be as specified in the Instruction Manual. Otherwise burst, damage, etc. may occur.
- The cables must be connected to the correct terminals. Otherwise an explosion or damage may occur.
- The polarity (+ and -) must be correct. Otherwise an explosion or damage may occur.
- While power is ON or for some time after power-OFF, do not touch this product as it will be extremely hot. Doing so may cause burns.

Additional instructions

The following instructions must be also followed. If this product is handled incorrectly, it may cause unexpected fault, an injury, or an electric shock.



CAUTION

Transportation and installation

- To prevent injury, wear cut-resistant gloves when opening packaging with sharp tools.
- Use proper lifting techniques or a trolley when carrying products. Failure to do so may lead to injuries.
- Do not stand or place any heavy objects on this product.
- Do not stack the boxes containing this product higher than the number recommended.
- When carrying this product, do not hold it by the front cover. It may fall or break.
- During installation, caution must be taken not to drop the product as doing so may cause injuries.
- This product must be installed on a surface that withstands the weight of the product.
- Do not install this product on a hot surface.
- Ensure the mounting orientation of this product is correct.
- Ensure this product is mounted securely in its enclosure.
- Do not install or operate this product if it is damaged or has parts missing.
- Foreign conductive objects must be prevented from entering this product. That includes screws and metal fragments or other flammable substance such as oil.
- As this product is a precision instrument, do not drop or subject it to impact.
- The surrounding air temperature must be between -10 and +40°C (non-freezing). Otherwise the inverter may be damaged.
- The ambient humidity must be 95% RH or less (non-condensing). Otherwise the inverter may be damaged. (Refer to [page 17](#) for details.)

⚠ CAUTION

Transportation and installation

- The temporary storage temperature (applicable to a short limited time such as a transportation time) must be between -20 and +65°C. Otherwise this product may be damaged.
- This product must be used indoors (without corrosive gas, flammable gas, oil mist, dust and dirt etc.) Otherwise the product may be damaged.
- Do not use this product at an altitude above 4000 m. Vibration should not exceed 2.9 m/s² at 10 to 55 Hz in X, Y, and Z directions. Otherwise the product may be damaged. (For the installation at an altitude above 1000 m, consider a 3% reduction in the rated current per 500 m increase in altitude.) (Refer to page 17 for details.)
- If halogens (including fluorine, chlorine, bromine, and iodine) contained in fumigants for wood packages enter this product, the product may be damaged. Prevent the entry of fumigant residuals or use an alternative method such as heat disinfection. Note that sterilization or disinfection of wood packages should be performed before packing the product.

Wiring

- Do not install a power factor correction capacitor, surge absorber, or radio noise filter on the output side of this product. These devices may overheat or burn out.
- The output of this product (output terminals U, V, W) must be correctly connected to a motor. Otherwise the motor will rotate inversely.

Test operation

- Before starting the test operation, confirm or adjust the parameter settings. Failure to do so may cause some machines to make unexpected motions.

⚠ WARNING

Usage

- Stay away from the equipment after using the retry function in this product as the equipment will restart suddenly after the output shutoff of this product.
- Depending on the function settings of this product, the product does not stop its output even when the STOP/RESET key on the operation panel is pressed. To prepare for it, provide a separate circuit and switch (to turn OFF the power of this product, or apply a mechanical brake, etc.) for an emergency stop.
- Be sure to turn OFF the start (STF/STR) signal before clearing the fault as this product will restart the motor suddenly after a fault is cleared.
- Use only a three-phase induction motor as a load on this product. Connection of any other electrical equipment to the output of this product may damage the equipment.
- Performing pre-excitation (LX signal and X13 signal) under torque control (Real sensorless vector control) may start the motor running at a low speed even when the start command (STF or STR) is not input. This product with the start command ON may also rotate the motor at a low speed when the speed limit value is set to zero. Confirm that the motor running will not cause any safety problems before performing pre-excitation.
- Do not modify this product.
- Do not remove any part which is not instructed to be removed in the Instruction Manuals. Doing so may lead to a failure or damage of the product.

⚠ CAUTION

Usage

- The electronic thermal O/L relay function may not be enough for protection of a motor from overheating. It is recommended to install an external thermal relay or a PTC thermistor for overheat protection.
- Do not repeatedly start or stop this product with a magnetic contactor on its input side. Doing so may shorten the life of this product.
- Use a noise filter or other means to minimize the electromagnetic interference with other electronic equipment used nearby this product.
- Appropriate precautions must be taken to suppress harmonics. Otherwise harmonics in power systems generated from this product may heat/damage a power factor correction capacitor or a generator.
- For a 690 V class motor driven with this product, use an insulation-enhanced motor. Otherwise surge voltage, which is attributed to the length and thickness of wire, may occur at the motor terminals, causing the motor insulation to deteriorate.
- As all parameters return to their initial values after the Parameter clear or All parameter clear is performed, the needed parameters for this product operation must be set again before the operation is started.
- This product can be easily set for high-speed operation. Therefore, consider all things related to the operation such as the performance of a motor and equipment in a system before the setting change.
- This product's brake function cannot be used as a mechanical brake. Use a separate device instead.
- Perform an inspection and test operation of this product if it has been stored for a long period of time.
- To avoid damage to this product due to static electricity, static electricity in your body must be discharged before you touch this product.
- In order to protect this product and the system against unauthorized access by external systems via network, take security measures such as setting up a firewall.
- Depending on the network environment, this product may not operate as intended due to delays or disconnection in communication. Carefully consider what type of environment this product will be used in and any safety issues related to its use.

Emergency stop

- A safety backup such as an emergency brake must be provided for devices or equipment in a system to prevent hazardous conditions in case of failure of this product or an external device controlling this product.
- If the breaker installed on the input side of this product trips, check for wiring faults (short circuits etc.) and damage to internal parts of this product. Identify and remove the cause of the trip before resetting the tripped breaker (or before applying the power to this product again).
- When a protective function is activated, take an appropriate corrective action before resetting this product to the operation.

Maintenance, inspection and parts replacement

- Do not carry out a megger (insulation resistance) test on the control circuit of this product. Doing so will cause failure.

Disposal

- This product must be treated as industrial waste.

Application of caution labels

Caution labels are used to ensure safety during use of Mitsubishi Electric inverters.
Apply the following labels to the inverter if the "retry function" and/or "automatic restart after instantaneous power failure" have been enabled.

- For the retry function

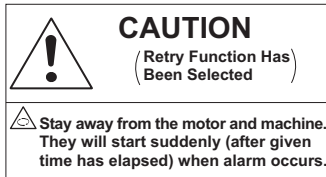

- For automatic restart after instantaneous power failure

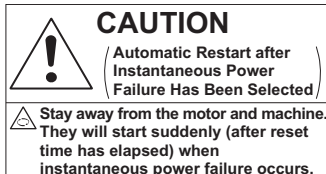

Application of motor control labels

Apply the following labels to the inverter to avoid connecting a motor different from those intended for the motor control setting.

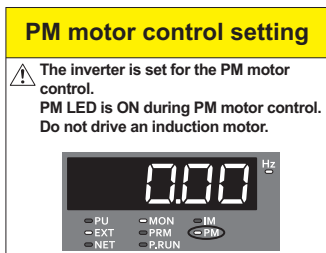
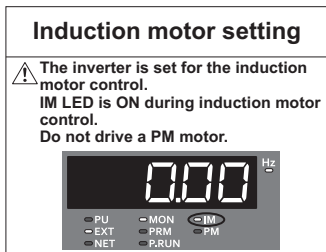

General instruction

- For clarity, illustrations in this Instruction Manual may be drawn with covers or safety guards removed. Ensure all covers and safety guards are properly installed prior to starting operation.

CONTENTS

1	INTRODUCTION	7
1.1	Product checking and accessories	8
1.2	Component names	9
1.3	About the related manuals	10
2	INSTALLATION AND WIRING	11
2.1	Peripheral devices	12
2.1.1	Inverter and peripheral devices	12
2.1.2	Peripheral devices	14
2.2	Removal and reinstallation of the operation panel or the front covers	15
2.3	Installation of the inverter and enclosure design	17
2.3.1	Inverter installation environment	17
2.3.2	Amount of heat generated by the inverter	19
2.3.3	Cooling system types for inverter enclosure	20
2.3.4	Inverter installation	21
2.4	Terminal connection diagrams	23
2.5	Main circuit terminals	27
2.5.1	Details on the main circuit terminals	27
2.5.2	Main circuit terminal layout and wiring of power supply and motor	28
2.5.3	Recommended cables and the wiring length	31
2.5.4	Earthing (grounding) precautions	33
2.6	Control circuit	34
2.6.1	Details on the control circuit terminals	34
2.6.2	Control logic (sink/source) change	38
2.6.3	Wiring of control circuit	40
2.6.4	Wiring precautions	42
2.6.5	When using separate power supplies for the control circuit and the main circuit	43
2.6.6	When supplying 24 V external power to the control circuit	44
2.6.7	Safety stop function	46
2.7	Communication connectors and terminals	48
2.7.1	PU connector	48
2.7.2	Ethernet connector	49
2.7.3	USB connector	50
2.8	Connection of motor with encoder (vector control)	52
2.9	Parameter settings for a motor with encoder	58
2.10	Connection of brake resistor	59
2.11	Installing communication option	60
3	PRECAUTIONS FOR USE OF THE INVERTER	61

3.1	Electro-magnetic interference (EMI) and leakage currents	62
3.1.1	Leakage currents and countermeasures	62
3.1.2	Countermeasures against inverter-generated EMI	63
3.1.3	Built-in EMC filter	65
3.2	Power supply harmonics	66
3.2.1	Power supply harmonics	66
3.3	Power-OFF and magnetic contactor (MC)	67
3.4	Countermeasures against deterioration of the 690 V class motor insulation	68
3.5	Checklist before starting operation	69
3.6	Failsafe system which uses the inverter	71

4 PROTECTIVE FUNCTIONS 73

4.1	Inverter fault and alarm indications	74
4.2	Reset method for the protective functions	74
4.3	Check and clear of the fault history	75
4.4	List of fault displays	77

5 PRECAUTIONS FOR MAINTENANCE AND INSPECTION 79

5.1	Inspection item	80
5.1.1	Daily inspection	80
5.1.2	Periodic inspection	80
5.1.3	Daily and periodic inspection	81
5.1.4	Checking the inverter and converter modules	83
5.1.5	Cleaning	83
5.1.6	Replacement of parts	84
5.1.7	Removal and reinstallation of the control circuit terminal block	89
5.2	Measurement of main circuit voltages, currents and powers	91
5.2.1	Measurement of powers	93
5.2.2	Measurement of voltages	93
5.2.3	Measurement of currents	93
5.2.4	Measurement of inverter input power factor	93
5.2.5	Measurement of converter output voltage (across terminals P and N)	93
5.2.6	Measurement of inverter output frequency	94
5.2.7	Insulation resistance test using megger	94
5.2.8	Withstand voltage test	94

6 SPECIFICATIONS 95

6.1	Inverter rating	96
------------	------------------------	-----------

6.2	Common specifications	98
6.3	Inverter outline dimensions	100

APPENDIX **103**

Appendix 1 Instructions for compliance with the EU Directives.....	104
Appendix 2 Instructions for UL and cUL	107
Appendix 3 Instructions for EAC.....	109
Appendix 4 Restricted Use of Hazardous Substances in Electronic and Electrical Products	110
Appendix 5 Referenced Standard (Requirement of Chinese standardized law).....	110

1 INTRODUCTION

The contents described in this chapter must be read before using this product.

Always read the instructions before use.

1.1	Product checking and accessories	8
1.2	Component names	9
1.3	About the related manuals	10

<Abbreviations>

DU	Operation panel (FR-DU08)
Operation panel	Operation panel (FR-DU08) and LCD operation panel (FR-LU08)
Parameter unit	Parameter unit (FR-PU07)
PU	Operation panel and parameter unit
Inverter	Mitsubishi Electric inverter FR-A800 series (690 V class)
Ethernet board	Ethernet communication board (FR-A8ETH)
Vector control compatible option	FR-A8AP/FR-A8AL/FR-A8APR/FR-A8APS/FR-A8APA (plug-in option)/ FR-A8TP (control terminal option)
Pr.	Parameter number (Number assigned to function)
PU operation	Operation using the PU (operation panel/parameter unit)
External operation	Operation using the control circuit signals
Combined operation	Combined operation using the PU (operation panel/parameter unit) and External operation

<Trademarks>

- All company and product names herein are the trademarks and registered trademarks of their respective owners.
- Ethernet is a registered trademark of Fuji Xerox Co., Ltd.

<Notes on descriptions in this Instruction Manual>

- Connection diagrams in this Instruction Manual appear with the control logic of the input terminals as sink logic, unless otherwise specified. (For the control logic, refer to [page 38](#).)

1.1 Product checking and accessories

Unpack the product and check the rating plate and the capacity plate of the inverter to ensure that the model agrees with the order and the product is intact.

◆ Inverter model

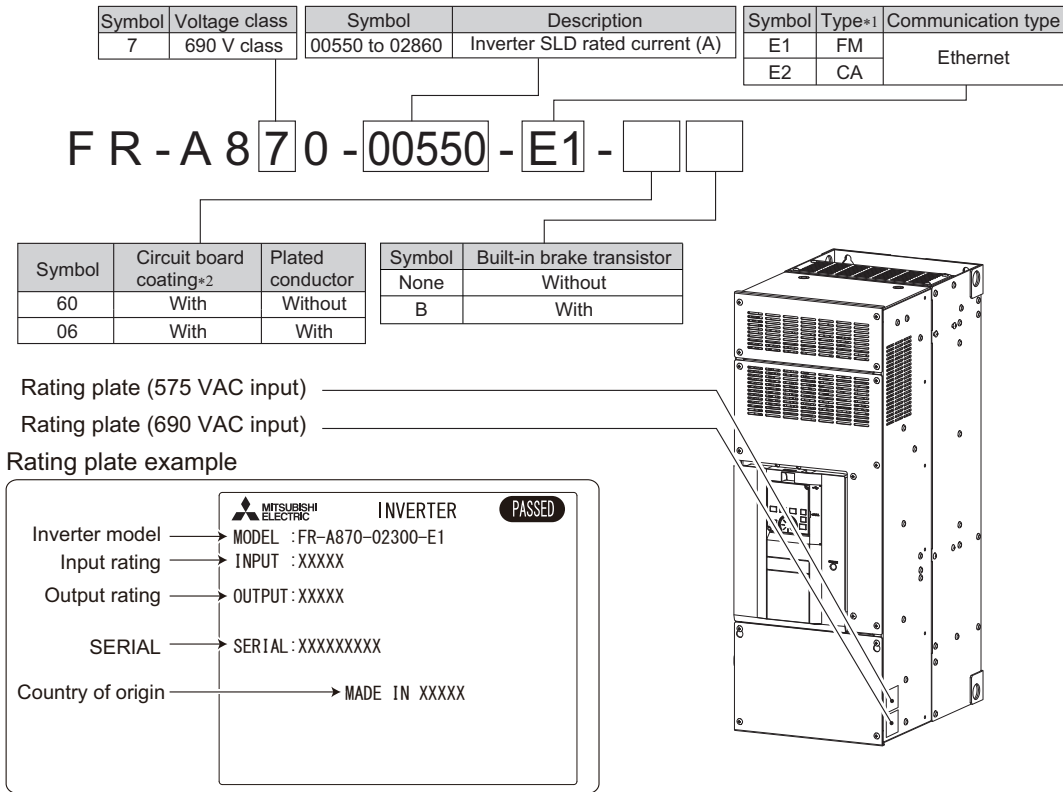

*1 Specification differs by the type. Major differences are shown in the table below.

Type	Monitor output	Initial setting			
		Built-in EMC filter	Control logic	Rated frequency	Pr.19 Base frequency voltage
FM (terminal FM equipped model)	Terminal FM (pulse train output) Terminal AM (analog voltage output (0 to ±10 VDC))	OFF	Sink logic	60 Hz	9999 (same as the power supply voltage)
CA (terminal CA equipped model)	Terminal CA (analog current output (0 to 20 mADC)) Terminal AM (analog voltage output (0 to ±10 VDC))	ON	Source logic	50 Hz	8888 (95% of the power supply voltage)

*2 Conforming to IEC 60721-3-3 3C2/3S2

◆ How to read the SERIAL number

Rating plate example

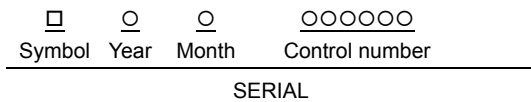

The SERIAL consists of one symbol, two characters indicating the production year and month, and six characters indicating the control number. The last digit of the production year is indicated as the Year, and the Month is indicated by 1 to 9, X (October), Y (November), or Z (December).

◆ Accessory

- Earthing (grounding) cable (1): For connection with a communication option. (Refer to [page 60](#).)
- CD-ROM (1): Including the Instruction Manual (Function) and other documents.

1.2 Component names

Component names are shown below.

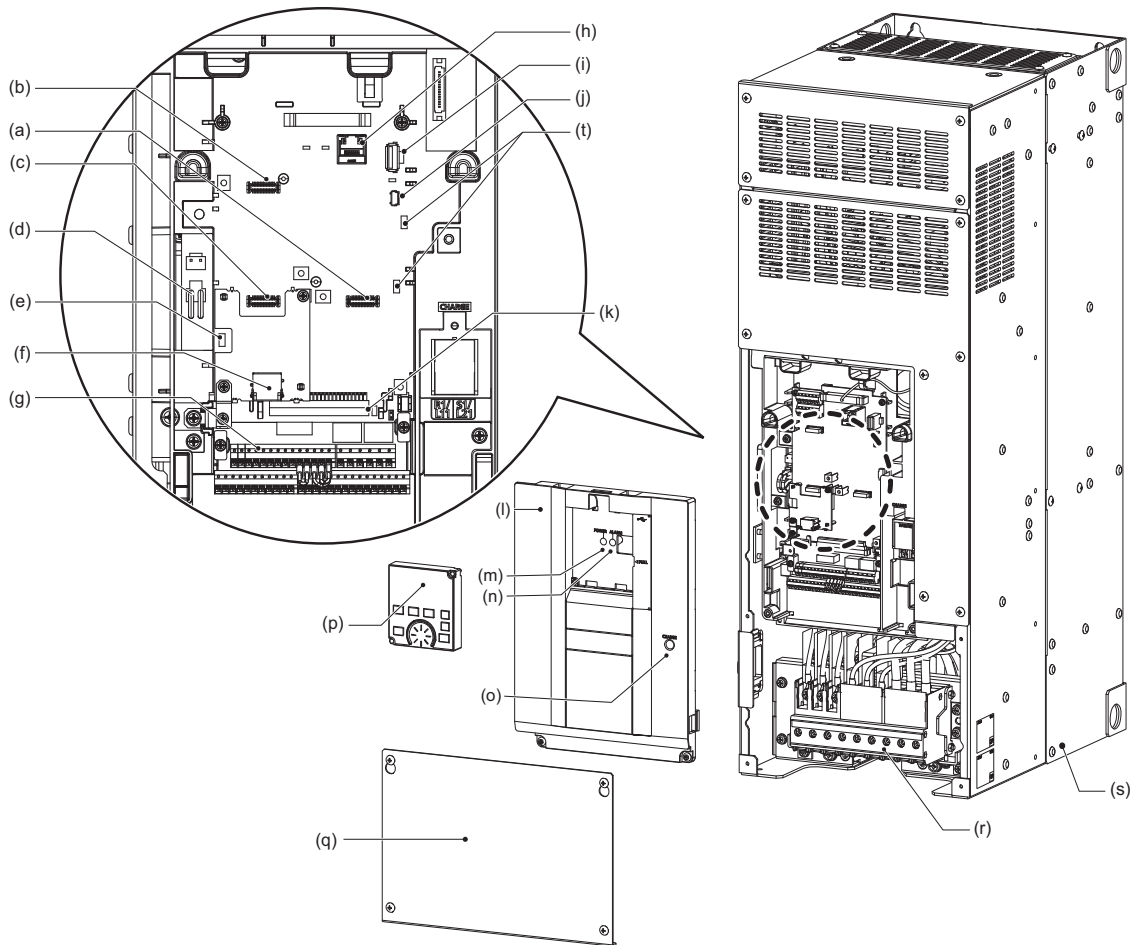

Symbol	Name	Description	Refer to page
(a)	Plug-in option connector 1	Connects a plug-in option or a communication option.	Instruction Manual of the option
(b)	Plug-in option connector 3		
(c)	Plug-in option connector 2	Connector 2 cannot be used because the Ethernet board is installed in the initial status. The Ethernet board must be removed to install a plug-in option to connector 2. (However, Ethernet communication is disabled in that case.)	49
(d)	EMC filter ON/OFF connector	Turns ON/OFF the EMC filter.	65
(e)	Voltage/current input switch (SW2)	Selects between voltage and current for the terminal 2 and 4 inputs.	*1
(f)	Ethernet communication connector	Connect the Ethernet dedicated cable for connection to the network.	49
(g)	Control circuit terminal block	Connects cables for the control circuit.	34
(h)	PU connector	Connects the operation panel or the parameter unit.	48
(i)	USB A connector	Connects a USB memory device.	50
(j)	USB mini B connector	Connects a personal computer and enables communication with FR Configurator2.	50
(k)	Control logic switchover jumper connector	Switch the control logic of input signals as necessary.	38
(l)	Upper front cover	Remove this cover for the installation of the product, installation of a plug-in (communication) option, RS-485 terminal wiring, switching of the voltage/current input switch, etc.	15
(m)	Power lamp	Stays ON while the power is supplied to the control circuit (R1/L11, S1/L21).	28
(n)	Charge lamp	Stays ON while the power is supplied to the main circuit.	28
(o)	Alarm lamp	Turns ON when the protective function of the inverter is activated.	28
(p)	Operation panel (FR-DU08)	Operates and monitors the inverter.	*1
(q)	Lower front cover	Remove this cover for wiring.	15
(r)	Main circuit terminal block	Connects cables for the main circuit.	27
(s)	Cooling fan	Cools the inverter.	85
(t)	Switches for manufacturer setting (SW3 and SW4)	Do not change the initial setting (OFF ).	—

*1 Refer to the Instruction Manual (Function).

1.3 About the related manuals

The manuals related to FR-A870 are shown below.

Manual name	Manual number
FR-A870 Instruction Manual (Function)	IB-0600616ENG
FR-A800/F800 PLC Function Programming Manual	IB-0600492ENG
Ethernet Function Manual	IB-0600628ENG
FR Configurator2 Instruction Manual	IB-0600516ENG
FR-A870 Safety Stop Function Instruction Manual	BCN-A23228-017

2 **INSTALLATION AND WIRING**

This chapter explains the installation and the wiring of this product. Always read the instructions before using the equipment.

2.1	Peripheral devices	12
2.2	Removal and reinstallation of the operation panel or the front covers	15
2.3	Installation of the inverter and enclosure design	17
2.4	Terminal connection diagrams	23
2.5	Main circuit terminals	27
2.6	Control circuit	34
2.7	Communication connectors and terminals	48
2.8	Connection of motor with encoder (vector control)	52
2.9	Parameter settings for a motor with encoder	58
2.10	Connection of brake resistor	59
2.11	Installing communication option.....	60

2.1 Peripheral devices

2.1.1 Inverter and peripheral devices

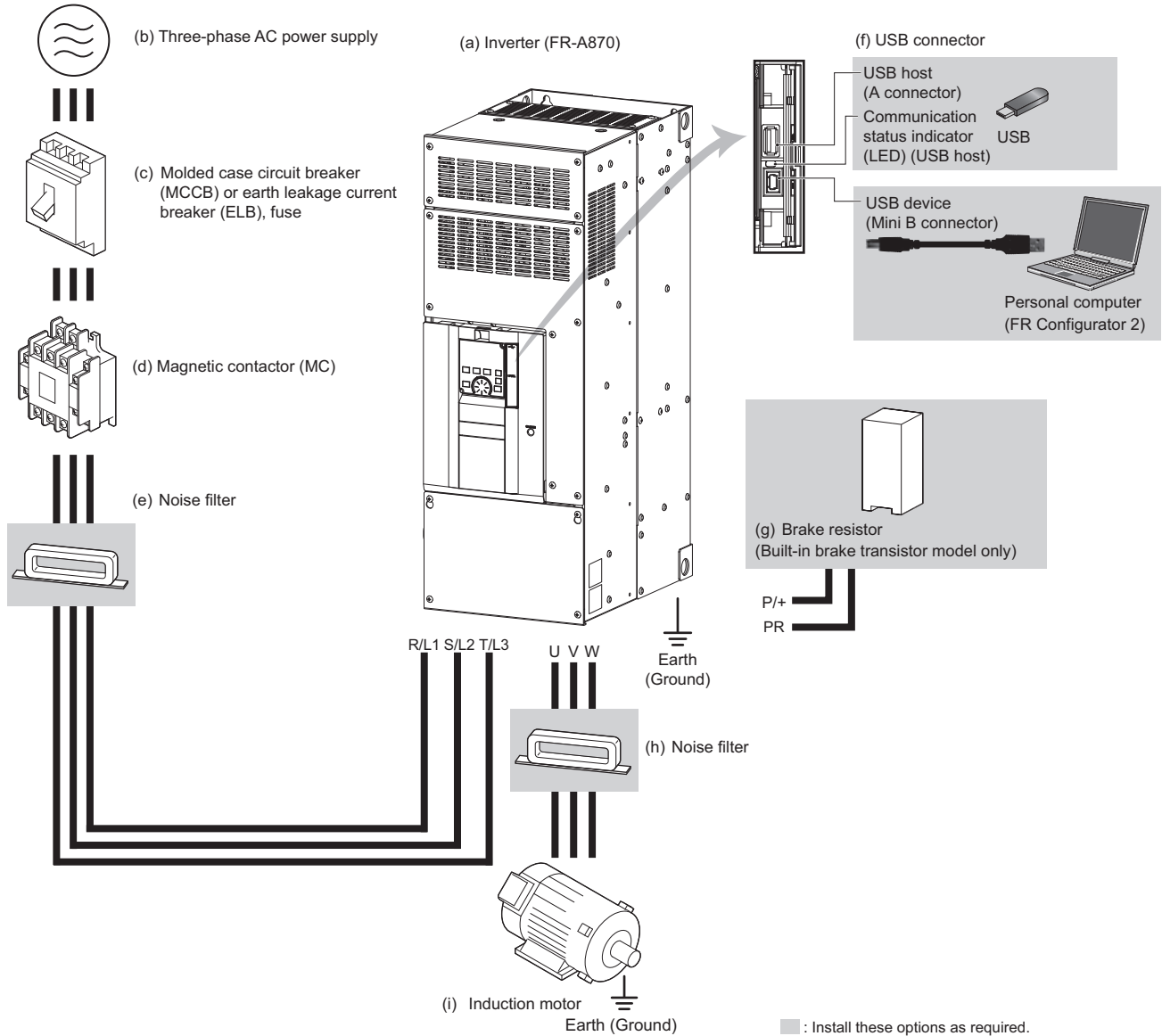

NOTE

- To prevent an electric shock, always earth (ground) the motor and inverter.
- Do not install a power factor correction capacitor or surge suppressor or capacitor type filter on the inverter's output side. Doing so will cause the inverter to trip or the capacitor and surge suppressor to be damaged. If any of the above devices is connected, immediately remove it. When installing a molded case circuit breaker on the output side of the inverter, contact the manufacturer of the molded case circuit breaker.
- Electromagnetic wave interference
The input/output (main circuit) of the inverter includes high frequency components, which may interfere with the communication devices (such as AM radios) used near the inverter. In this case, activating the EMC filter may minimize interference. (Refer to [page 65](#).)
- For details of options and peripheral devices, refer to the respective Instruction Manual.

Symbol	Name	Overview	Refer to page
(a)	Inverter (FR-A870)	The life of the inverter is influenced by the surrounding air temperature. The surrounding air temperature should be as low as possible within the permissible range. This must be noted especially when the inverter is installed in an enclosure. Incorrect wiring may lead to damage of the inverter. The control signal lines must be kept fully away from the main circuit lines to protect them from noise. The built-in EMC filter can reduce the noise.	17 23 65
(b)	Three-phase AC power supply	Must be within the permissible power supply specifications of the inverter.	96
(c)	Molded case circuit breaker (MCCB), earth leakage circuit breaker (ELB), or fuse	Must be selected carefully since an inrush current flows in the inverter at power ON.	14
(d)	Magnetic contactor (MC)	Install this to ensure safety. Do not use this to start and stop the inverter. Doing so will shorten the life of the inverter.	67
(e)	Noise filter	Suppresses the noise radiated from the power supply side of the inverter.	63
(f)	USB connection	A USB (Ver. 1.1) cable connects the inverter with a personal computer. A USB memory device enables parameter copies and the trace function.	50
(g)	Brake resistor	Connecting a brake resistor to a built-in brake transistor improves the braking capability of the inverter (built-in brake transistor model only). Select the brake resistor according to the inverter capacity. Always install a thermal relay.	59
(h)	Noise filter	Install this to reduce the electromagnetic noise generated from the inverter.	63
(i)	Induction motor	Connect a squirrel-cage induction motor.	—

2.1.2 Peripheral devices

Check the model of the inverter you purchased. Appropriate peripheral devices must be selected according to the capacity. Refer to the table below to prepare appropriate peripheral devices.

◆ND rating (Pr.570 Multiple rating setting = "2")

Motor output (kW)*1	Applicable inverter model	Molded case circuit breaker (MCCB)*2 or earth leakage circuit breaker (ELB)	Input-side magnetic contactor*3
37	FR-A870-00550	75 A	60 A
45	FR-A870-00660	75 A	60 A
55	FR-A870-00890	100 A	80 A
160	FR-A870-02300	250 A	200 A
200	FR-A870-02860	300 A	260 A

*1 Assumes the use of a 4-pole standard motor with the power supply voltage of 690 VAC 60 Hz.

*2 Select an MCCB according to the power supply capacity. Install one MCCB per inverter.

For the use in the United States or Canada, provide the appropriate UL and cUL listed fuse that is suitable for branch circuit protection. (Refer to [page 107](#).)

*3 The magnetic contactor is selected based on the AC-1 class. The electrical durability of magnetic contactor is 500,000 times. When the magnetic contactor is used for emergency stops during motor driving, the electrical durability is 25 times.

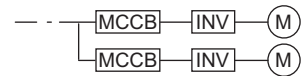

NOTE

- When the inverter capacity is larger than the motor capacity, select an MCCB and a magnetic contactor according to the inverter model, and select cables and reactors according to the motor output.
- When the breaker on the inverter's input side trips, check for the wiring fault (short circuit), damage to internal parts of the inverter etc. The cause of the trip must be identified and removed before turning ON the power of the breaker.

◆SLD rating (Pr.570 Multiple rating setting = "0")

Motor output (kW)*1	Applicable inverter model	Molded case circuit breaker (MCCB)*2 or earth leakage circuit breaker (ELB)	Input-side magnetic contactor*3
37	FR-A870-00550	75 A	60 A
45	FR-A870-00660	100 A	80 A
55	FR-A870-00890	125 A	100 A
160	FR-A870-02300-E	300 A	260 A
200	FR-A870-02860-E	350 A	350 A

*1 Assumes the use of a 4-pole standard motor with the power supply voltage of 690 VAC 60 Hz.

*2 Select an MCCB according to the power supply capacity. Install one MCCB per inverter.

For the use in the United States or Canada, provide the appropriate UL and cUL listed fuse that is suitable for branch circuit protection. (Refer to [page 107](#).)

*3 Magnetic contactor is selected based on the AC-1 class. The electrical durability of magnetic contactor is 500,000 times. When the magnetic contactor is used for emergency stops during motor driving, the electrical durability is 25 times.

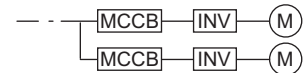

NOTE

- When the inverter capacity is larger than the motor capacity, select an MCCB and a magnetic contactor according to the inverter model, and select cables and reactors according to the motor output.
- When the breaker on the inverter's input side trips, check for the wiring fault (short circuit), damage to internal parts of the inverter etc. The cause of the trip must be identified and removed before turning ON the power of the breaker.

2.2 Removal and reinstallation of the operation panel or the front covers

◆ Removal and reinstallation of the operation panel

- Loosen the two screws on the operation panel.
(These screws cannot be removed.)
- Press the upper edge of the operation panel while pulling out the operation panel.

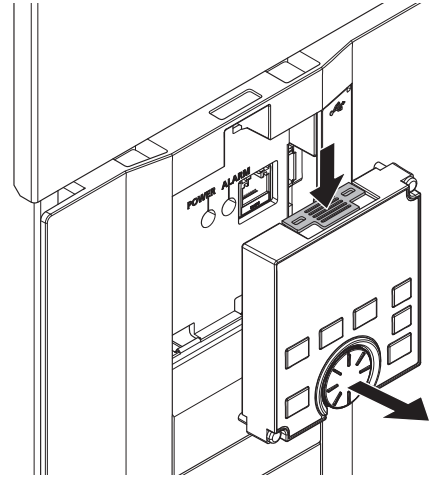
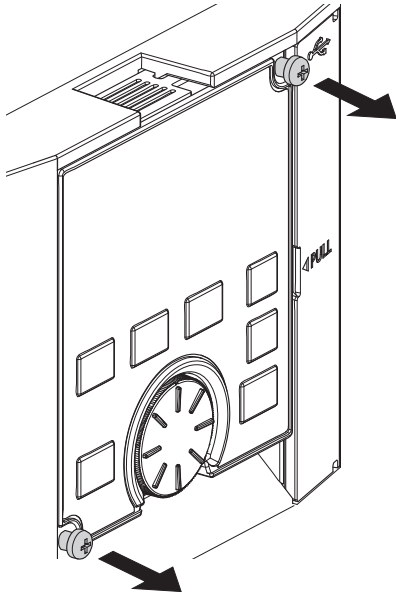

To reinstall the operation panel, align its connector on the back with the PU connector of the inverter, and insert the operation panel. After confirming that the operation panel is fit securely, tighten the screws. (Tightening torque: 0.40 to 0.45 N·m)

◆ Removal of the lower front cover

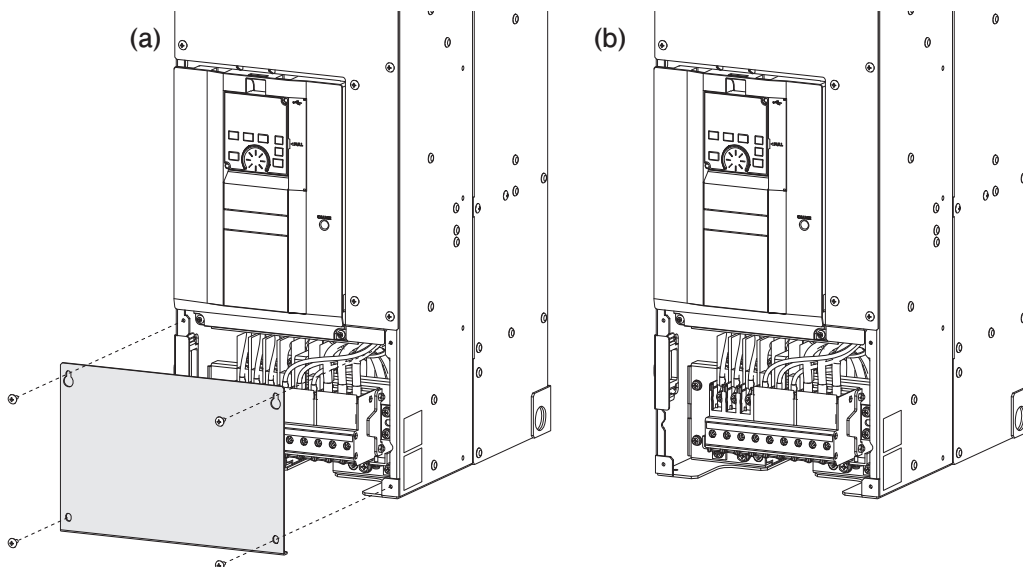

- (a) When the mounting screws are removed, the lower front cover can be removed.
 (b) With the lower front cover removed, the main circuit terminals can be wired.

◆ Removal of the upper front cover

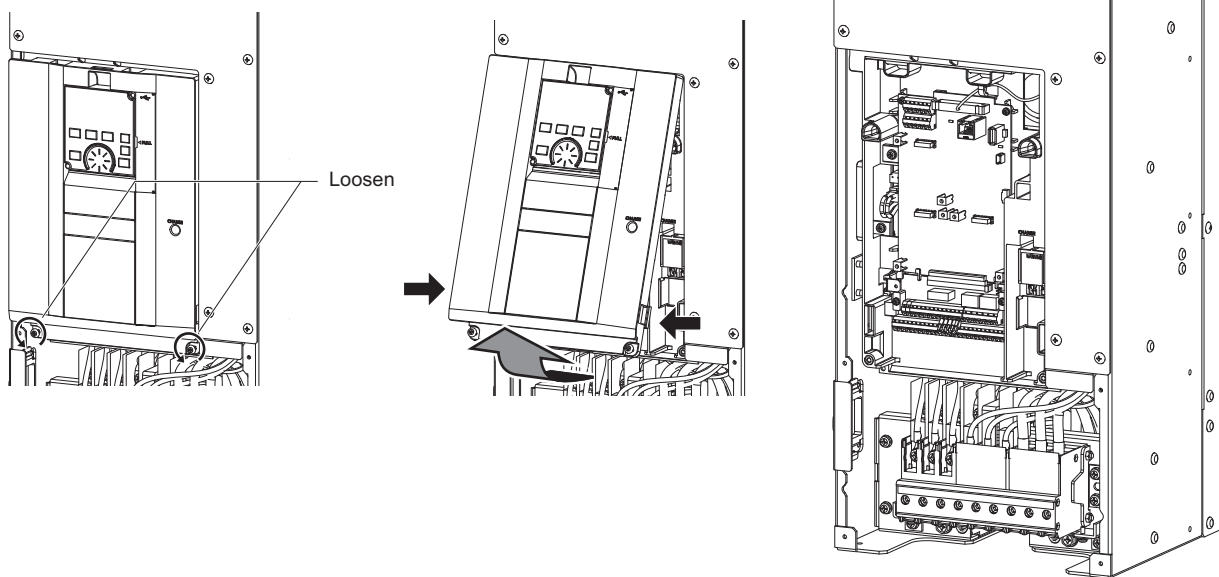

- With the lower front cover removed, loosen the screws on the upper front cover. (These screws cannot be removed.)
- Holding the areas around the installation hooks on the sides of the upper front cover, pull out the cover using its upper side as a support.
- With the upper front cover removed, the control circuit can be wired and the plug-in option can be installed.

◆ Reinstallation of the front covers

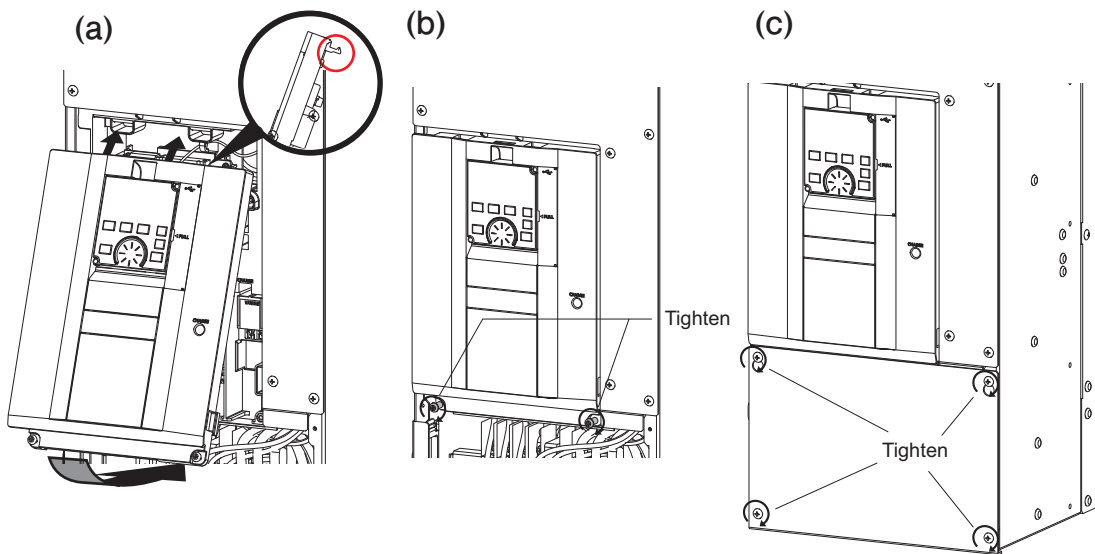

- Clip on the upper front cover as illustrated. Check that it is properly secured.
- Tighten the screws on the lower part of the upper front cover.
- Attach the lower front cover using the screws.

NOTE

- Fully make sure that the front covers are installed securely. Always tighten the mounting screws of the front covers.

2.3 Installation of the inverter and enclosure design

When designing or manufacturing an inverter enclosure, determine the structure, size, and device layout of the enclosure by fully considering the conditions such as heat generation of the contained devices and the operating environment. An inverter unit uses many semiconductor devices. To ensure higher reliability and long period of operation, operate the inverter in the ambient environment that completely satisfies the equipment specifications.

2.3.1 Inverter installation environment

The following table lists the standard specifications of the inverter installation environment. Using the inverter in an environment that does not satisfy the conditions deteriorates the performance, shortens the life, and causes a failure. Refer to the following points, and take adequate measures.

◆ Standard environmental specifications of the inverter

Item	Description
Surrounding air temperature	-10°C to +40°C (non-freezing) <div style="text-align: right; margin-top: 10px;"> </div>
Ambient humidity	With circuit board coating (conforming to IEC 60721-3-3 3C2/3S2): 95% RH or less (non-condensing), Without circuit board coating: 90% RH or less (non-condensing)
Storage temperature*1	-20°C to +65°C
Atmosphere	Indoors (free from corrosive gas, flammable gas, oil mist, dust and dirt)
Altitude	Maximum 4000 m.*2
Vibration	2.9 m/s ² or less at 10 to 55 Hz (directions of X, Y, Z axes)

*1 Temperature applicable for a short time, e.g. in transit.

*2 For the installation at an altitude above 1000 m, derate the rated current 3% per 500 m.

◆ Temperature

The permissible surrounding air temperature of the inverter is between -10°C and +40°C. Always operate the inverter within this temperature range. Operation outside this range will considerably shorten the service lives of the semiconductors, parts, capacitors and others. Take the following measures to keep the surrounding air temperature of the inverter within the specified range.

(a) Measures against high temperature

- Use a forced ventilation system or similar cooling system. (Refer to [page 20](#).)
- Install the enclosure in an air-conditioned electric chamber.
- Block direct sunlight.
- Provide a shield or similar plate to avoid direct exposure to the radiated heat and wind of a heat source.
- Ventilate the area around the enclosure well.

(b) Measures against low temperature

- Provide a space heater in the enclosure.
- Do not power OFF the inverter. (Keep the start signal of the inverter OFF.)

(c) Sudden temperature changes

- Select an installation place where temperature does not change suddenly.
- Avoid installing the inverter near the air outlet of an air conditioner.
- If temperature changes are caused by opening/closing of a door, install the inverter away from the door.

◆Humidity

Operate the inverter within the ambient air humidity of usually 45 to 90% (up to 95% with circuit board coating). Too high humidity will pose problems of reduced insulation and metal corrosion. On the other hand, too low humidity may cause a spatial electrical breakdown.

The insulation distance defined in JEM 1103 "Control Equipment Insulator" is humidity of 45 to 85%.

(a) Measures against high humidity

- Make the enclosure enclosed, and provide it with a hygroscopic agent.
- Provide dry air into the enclosure from outside.
- Provide a space heater in the enclosure.

(b) Measures against low humidity

Air with proper humidity can be blown into the enclosure from outside. Also when installing or inspecting the unit, discharge your body (static electricity) beforehand, and keep your body away from the parts and patterns.

(c) Measures against condensation

Condensation may occur if frequent operation stops change the in-enclosure temperature suddenly or if the outside air temperature changes suddenly.

Condensation causes such faults as reduced insulation and corrosion.

- Take the measures against high humidity in (a).
- Do not power OFF the inverter. (Keep the start signal of the inverter OFF.)

◆Dust, dirt, oil mist

Dust and dirt will cause such faults as poor contacts, reduced insulation and cooling effect due to the moisture-absorbed accumulated dust and dirt, and in-enclosure temperature rise due to a clogged filter. In an atmosphere where conductive powder floats, dust and dirt will cause such faults as malfunction, deteriorated insulation and short circuit in a short time. Since oil mist will cause similar conditions, it is necessary to take adequate measures.

Countermeasure

- Place the inverter in a totally enclosed enclosure.
Take measures if the in-enclosure temperature rises. (Refer to [page 20](#).)
- Purge air.
Pump clean air from outside to make the in-enclosure air pressure higher than the outside air pressure.

◆Corrosive gas, salt damage

If the inverter is exposed to corrosive gas or to salt near a beach, the printed board patterns and parts will corrode or the relays and switches will result in poor contact.

In such places, take the measures given in the previous paragraph.

◆Explosive, flammable gases

As the inverter is non-explosion proof, it must be contained in an explosion-proof enclosure. In places where explosion may be caused by explosive gas, dust or dirt, an enclosure cannot be used unless it structurally complies with the guidelines and has passed the specified tests. This makes the enclosure itself expensive (including the test charges). The best way is to avoid installation in such places and install the inverter in a non-hazardous place.

◆High altitude

Use the inverter at an altitude of within 4000 m. For the installation at an altitude above 1000 m, derate the rated current 3% per 500 m.

If it is used at a higher place, it is likely that thin air will reduce the cooling effect and low air pressure will deteriorate dielectric strength.

◆ Vibration, impact

The vibration resistance of the inverter is up to 2.9 m/s^2 at 10 to 55 Hz frequency and 1 mm amplitude for the directions of X, Y, Z axes. Subjecting the product to vibration and impacts over a long period of time may loosen the structures and cause poor contacts of connectors, even if those vibration and impacts are within the specified values.

Especially when impacts are applied repeatedly, caution must be taken because such impacts may break the installation feet.

Countermeasure

- Provide the enclosure with rubber vibration isolators.
- Strengthen the structure to prevent the enclosure from resonance.
- Install the enclosure away from the sources of the vibration.

2.3.2 Amount of heat generated by the inverter

◆ Installing the heat sink inside the enclosure

When the heat sink is installed inside the enclosure, the amount of heat generated by the inverter unit and converter unit is shown in the following tables.

Inverter FR-A870-□	Amount of heat generated (W)	
	SLD	ND
00550	850	610
00660	980	720
00890	1360	850
02300	3700	3000
02860	4600	3700

NOTE

- The amount of heat generated shown assumes that the output current is the inverter rated current, and the carrier frequency is 1 kHz.

2.3.3 Cooling system types for inverter enclosure

From the enclosure that contains the inverter, the heat of the inverter and other equipment (transformers, lamps, resistors, etc.) and the incoming heat such as direct sunlight must be dissipated to keep the in-enclosure temperature lower than the permissible temperatures of the in-enclosure equipment including the inverter.

The cooling systems are classified as follows in terms of the cooling calculation method.

- (a) Cooling by natural heat dissipation from the enclosure surface (totally enclosed type)
- (b) Cooling by heat sink (aluminum fin, etc.)
- (c) Cooling by ventilation (forced ventilation type, pipe ventilation type)
- (d) Cooling by heat exchanger or cooler (heat pipe, cooler, etc.)

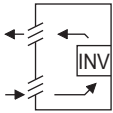
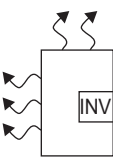
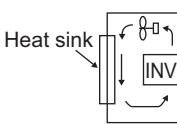
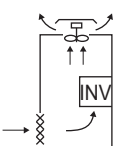
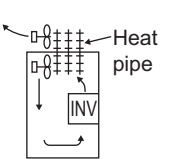
Cooling system		Enclosure structure	Comment
Natural	Natural ventilation (enclosed ventilated type)		This system is low in cost and generally used, but the enclosure size increases as the inverter capacity increases. This system is for relatively small capacities.
	Natural ventilation (totally enclosed type)		Being a totally enclosed type, this system is the most appropriate for hostile environment having dust, dirt, oil mist, etc. The enclosure size increases depending on the inverter capacity.
Forced air	Heat sink cooling		This system has restrictions on the heat sink mounting position and area. This system is for relatively small capacities.
	Forced ventilation		This system is for general indoor installation. This is appropriate for enclosure downsizing and cost reduction, and often used.
	Heat pipe		This system is a totally enclosed type, and is appropriate for enclosure downsizing.

2.3.4 Inverter installation

◆ Inverter placement

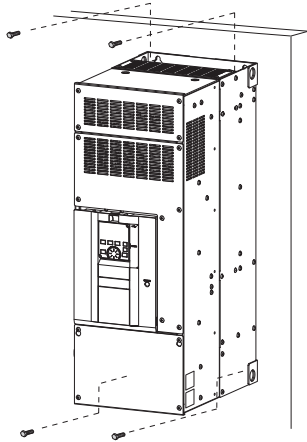

- Install the inverter on a strong surface securely with screws.
- Leave enough clearances and take cooling measures.
- Avoid places where the inverter is subjected to direct sunlight, high temperature and high humidity.
- Install the inverter on a nonflammable wall surface.
- When encasing multiple inverters, install them in parallel as a cooling measure.
- For heat dissipation and maintenance, keep clearance between the inverter and the other devices or enclosure surface. The space below the inverter is required for wiring, and the space above the inverter is required for heat dissipation.
- When designing or building an enclosure for the inverter, carefully consider influencing factors such as heat generation of the contained devices and the operating environment.

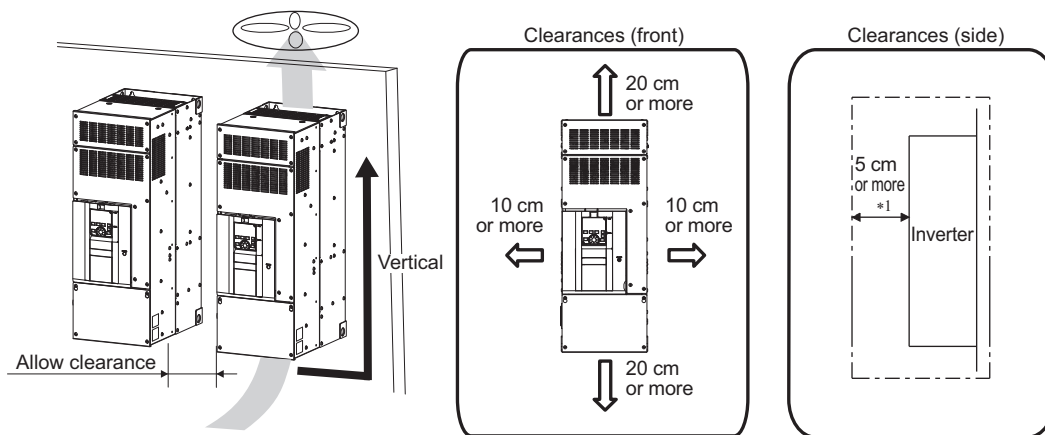

*1 There needs to be a space of at least 30 cm in front of the inverter to replace the cooling fan. Refer to [page 85](#) for fan replacement.

◆ Installation orientation of the inverter

Install the inverter on a wall as specified. Do not mount it horizontally or in any other way.

◆ Above the inverter

Heat is blown up from inside the inverter by the small fan built in the unit. Any equipment placed above the inverter should be heat resistant.

◆Arrangement of multiple inverters

When multiple inverters are placed in the same enclosure, arrange them horizontally as shown in the right figure (a). When it is inevitable to arrange them vertically to minimize space, take such measures as to provide guides since heat from the bottom inverters can increase the temperatures in the top inverters, causing inverter failures.

When mounting multiple inverters, fully take caution not to make the surrounding air temperature of the inverter higher than the permissible value by providing ventilation and increasing the enclosure size.

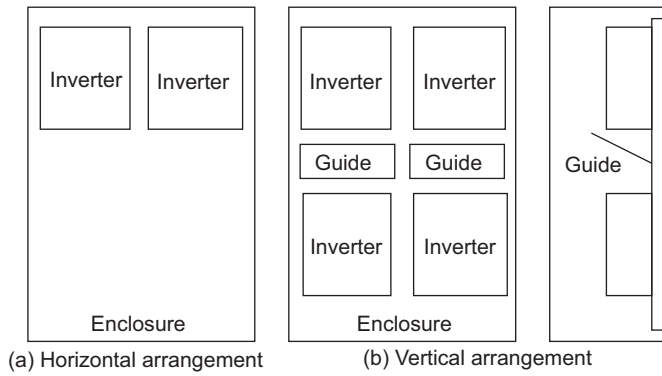

Arrangement of multiple inverters

◆Arrangement of the ventilation fan and inverter

Heat generated in the inverter is blown up from the bottom of the unit as warm air by the cooling fan. When installing a ventilation fan for that heat, determine the place of ventilation fan installation after fully considering an air flow. (Air passes through areas of low resistance. Make an airway and airflow plates to expose the inverter to cool air.)

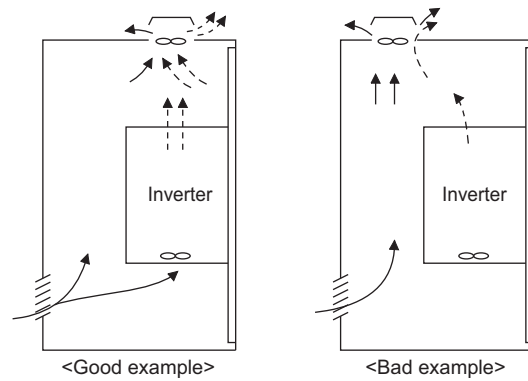

Arrangement of the ventilation fan and inverter

2.4 Terminal connection diagrams

◆ FM type

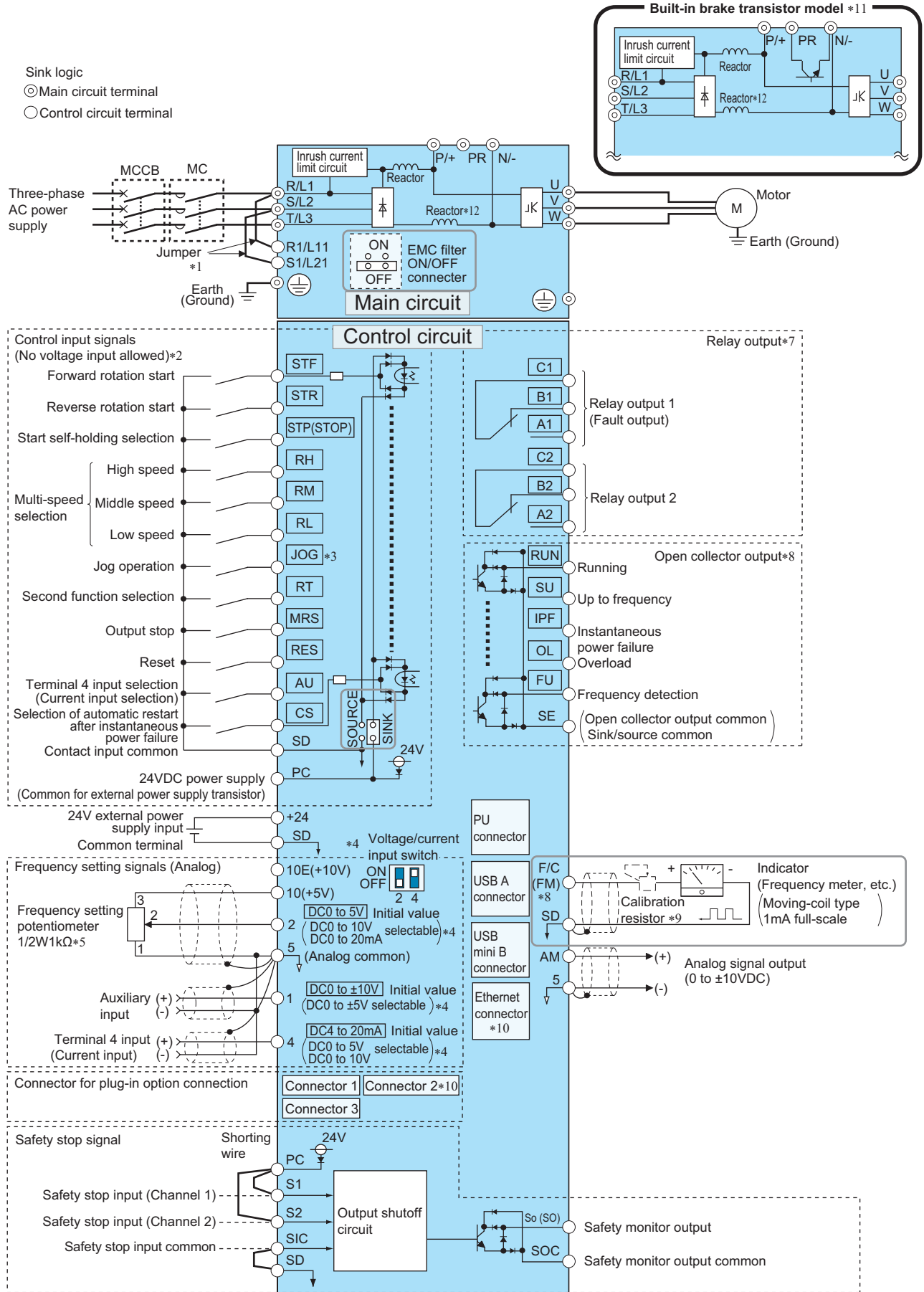

2

Terminal connection diagrams

- *1 When using separate power supply for the control circuit, remove the jumper between R1/L11 and S1/L21.
- *2 The function of these terminals can be changed with the input terminal assignment (**Pr.178 to Pr.189**).
- *3 Terminal JOG is also used as a pulse train input terminal. Use **Pr.291** to choose JOG or pulse.
- *4 Terminal input specifications can be changed by analog input specification switchover (**Pr.73, Pr.267**). To input a voltage, set the voltage/current input switch OFF. To input a current, set the voltage/current input switch ON. Terminals 10 and 2 are also used as a PTC input terminal. (**Pr.561**)
- *5 It is recommended to use 2 W 1 k Ω when the frequency setting signal is changed frequently.
- *6 The function of these terminals can be changed with the output terminal assignment (**Pr.195, Pr.196**).
- *7 The function of these terminals can be changed with the output terminal assignment (**Pr.190 to Pr.194**).
- *8 Terminal FM can be used to output pulse trains as open collector output by setting **Pr.291**.
- *9 Not required when calibrating the scale with the operation panel.
- *10 The option connector 2 cannot be used because the Ethernet board is installed in the initial status. The Ethernet board must be removed to install a plug-in option to the option connector 2. (However, Ethernet communication is disabled in that case.)
- *11 Connect a brake resistor to terminals P/+ and PR (built-in brake transistor model only). Install a thermal relay to prevent overheating and damage of the brake resistor (refer to [page 59](#)).
- *12 &&The reactor is not provided with the FR-A870-00890 or lower.

NOTE

- To prevent a malfunction due to noise, keep the signal cables 10 cm or more away from the power cables. Also, separate the main circuit cables at the input side from the main circuit cables at the output side.
- After wiring, wire offcuts must not be left in the inverter.
Wire offcuts can cause an alarm, failure or malfunction. Always keep the inverter clean.
When drilling mounting holes in an enclosure etc., take caution not to allow chips and other foreign matter to enter the inverter.
- Set the voltage/current input switch correctly. Incorrect setting may cause a fault, failure or malfunction.
- For the parameter details, refer to the Instruction Manual (Function).

◆CA type

- Source logic
- ◎ Main circuit terminal
- Control circuit terminal

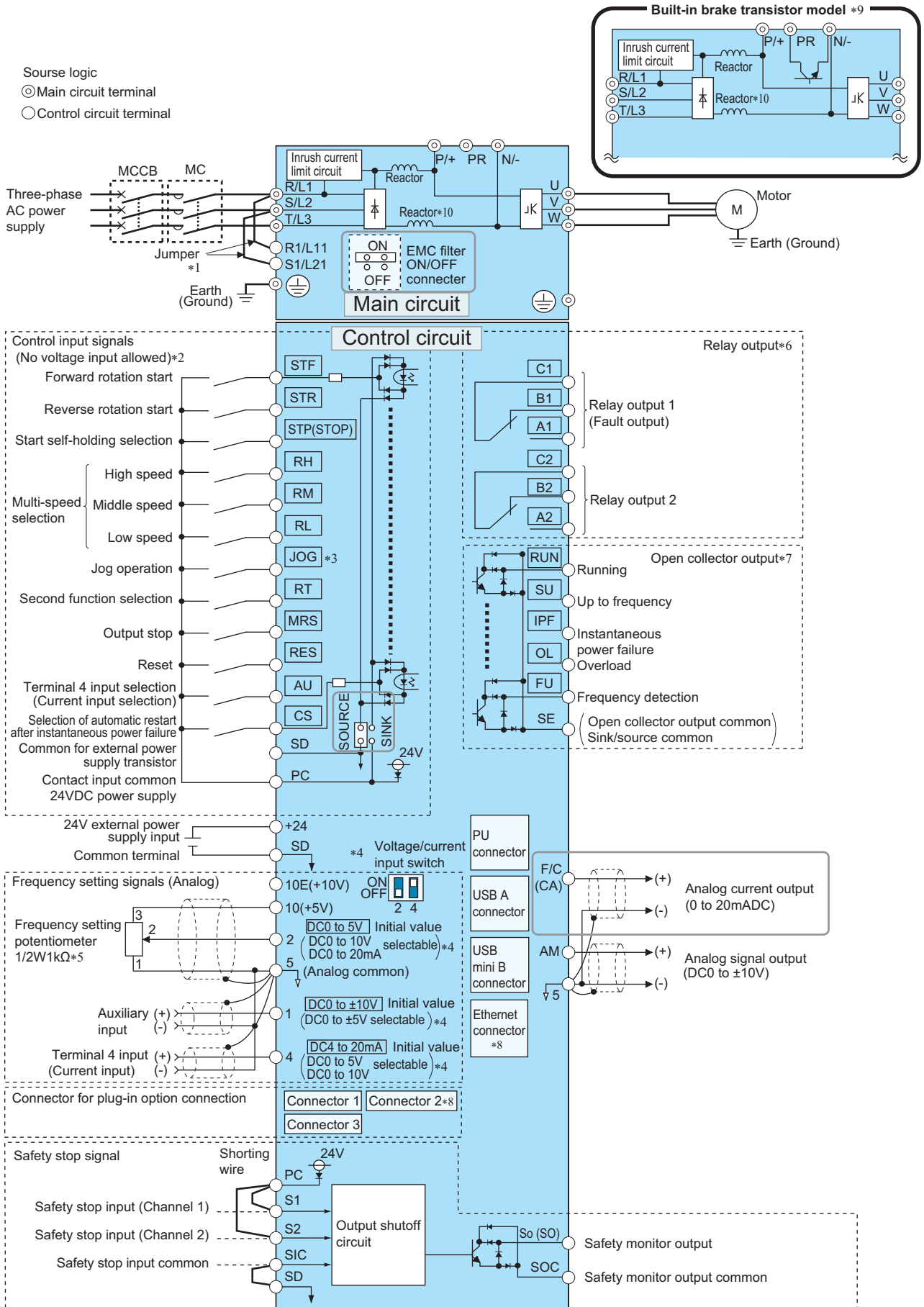

Terminal connection diagrams

- *1 When using separate power supply for the control circuit, remove the jumper between R1/L11 and S1/L21.
- *2 The function of these terminals can be changed with the input terminal assignment (**Pr.178 to Pr.189**).
- *3 Terminal JOG is also used as a pulse train input terminal. Use **Pr.291** to choose JOG or pulse.
- *4 Terminal input specifications can be changed by analog input specification switchover (**Pr.73, Pr.267**). To input a voltage, set the voltage/current input switch OFF. To input a current, set the voltage/current input switch ON. Terminals 10 and 2 are also used as a PTC input terminal. (**Pr.561**)
- *5 It is recommended to use 2 W 1 k Ω when the frequency setting signal is changed frequently.
- *6 The function of these terminals can be changed with the output terminal assignment (**Pr.195, Pr.196**).
- *7 The function of these terminals can be changed with the output terminal assignment (**Pr.190 to Pr.194**).
- *8 The option connector 2 cannot be used because the Ethernet board is installed in the initial status. The Ethernet board must be removed to install a plug-in option to the option connector 2. (However, Ethernet communication is disabled in that case.)
- *9 Connect a brake resistor to terminals P/+ and PR (built-in brake transistor model only). Install a thermal relay to prevent overheating and damage of the brake resistor (refer to [page 59](#)).
- *10 The reactor is not provided with the FR-A870-00890 or lower.

NOTE

- To prevent a malfunction due to noise, keep the signal cables 10 cm or more away from the power cables. Also, separate the main circuit cables at the input side from the main circuit cables at the output side.
- After wiring, wire offcuts must not be left in the inverter.
Wire offcuts can cause an alarm, failure or malfunction. Always keep the inverter clean.
When drilling mounting holes in an enclosure etc., take caution not to allow chips and other foreign matter to enter the inverter.
- Set the voltage/current input switch correctly. Incorrect setting may cause a fault, failure or malfunction.
- For the parameter details, refer to the Instruction Manual (Function).

2.5 Main circuit terminals

2.5.1 Details on the main circuit terminals

Terminal symbol	Terminal name	Terminal function description	Refer to page
R/L1, S/L2, T/L3	AC power input	Connect these terminals to the commercial power supply.	—
U, V, W	Inverter output	Connect these terminals to a three-phase squirrel cage motor.	—
R1/L11, S1/L21	Power supply for the control circuit	Connected to the AC power supply terminals R/L1 and S/L2. To retain the fault display and fault output, remove the jumpers across terminals R/L1 and R1/L11 and across S/L2 and S1/L21, and supply external power to these terminals. The power capacity necessary when separate power is supplied from R1/L11 and S1/L21 is 80 VA.	43
N/-	Keep them open.		
P/+, PR	Brake resistor	Connect a brake resistor to terminals P/+ and PR (built-in brake transistor model only). Connecting the brake resistor increases the regenerative braking capability. Select the brake resistor according to the inverter capacity.	59
	Earth (ground)	For earthing (grounding) the inverter chassis. This must be earthed (grounded).	33

2.5.2 Main circuit terminal layout and wiring of power supply and motor

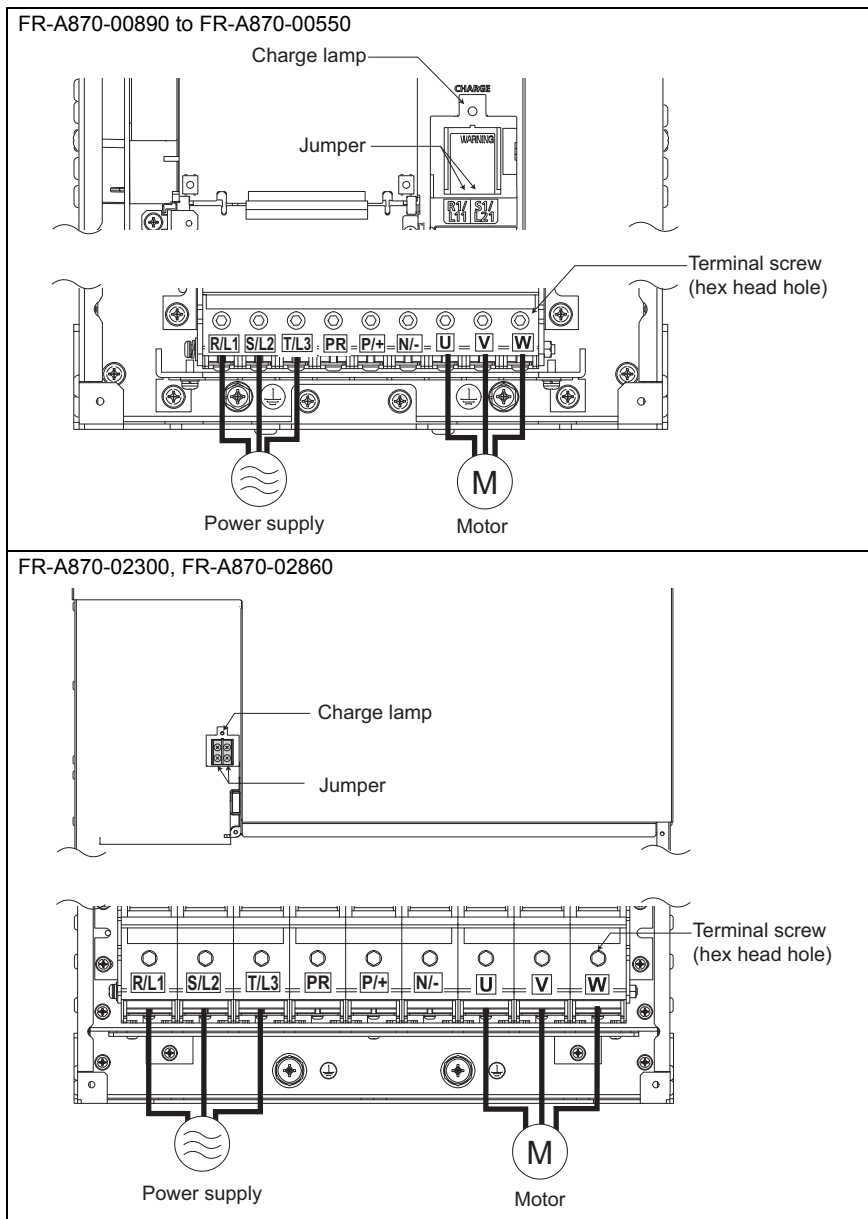

NOTE

- Make sure the power cables are connected to terminals R/L1, S/L2, and T/L3. (Phase need not be matched.) Never connect the power cable to terminals U, V, and W of the inverter. Doing so will damage the inverter.
- Connect the motor to terminals U, V, and W. The phase need to be matched.

◆ Wiring method

Before the inverter is installed inside the enclosure, terminal block covers must be removed and reinstalled for wiring as required.

(1) Loosen the screw on the terminal block cover and remove the cover.

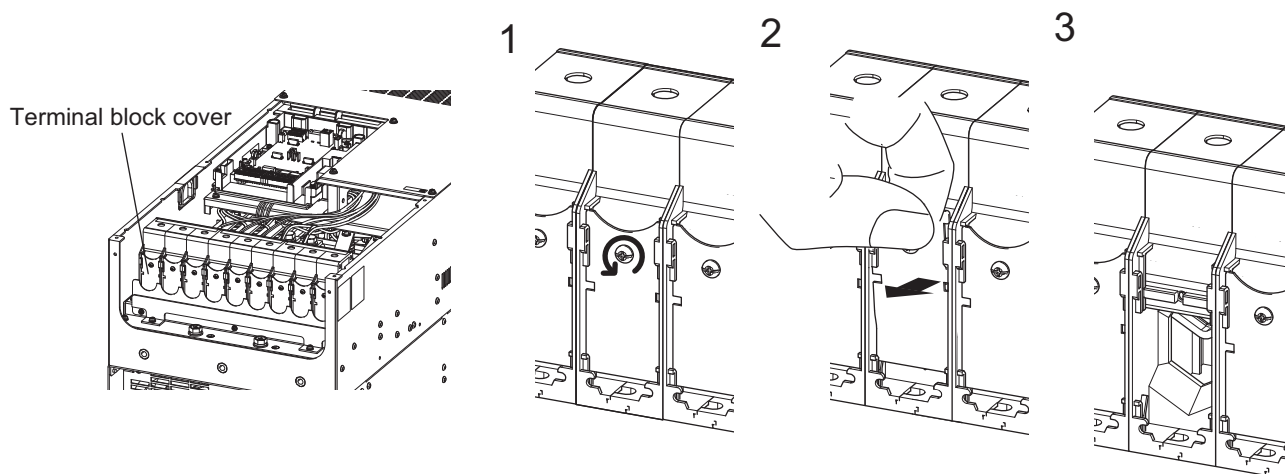

(2) Loosen the terminal screw to lower the inside clamp all the way down. Turn the terminal block cover upside down and insert it into the terminal block (the curved side is on the bottom). Fix it with the screw (tightening torque: $0.5 \pm 0.1 \text{ N} \cdot \text{m}$).

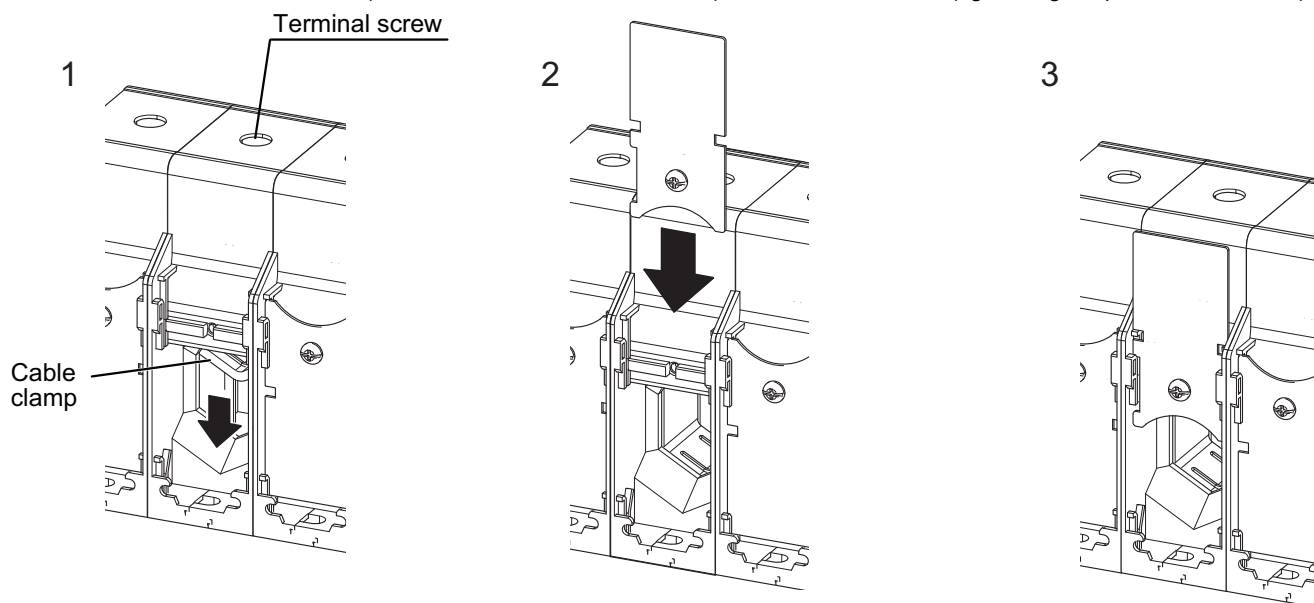

Main circuit terminals

(3) Wire connection

Select stranded wire with the sheath stripped back or flexible wire with a ferrule.

Do not use solid wire. Refer to [page 31](#) for details.

The ferrule or wire is inserted into a socket of the terminal.

Strip the wire as follows. When using flexible wire, use an appropriate ferrule.

Wire strip length

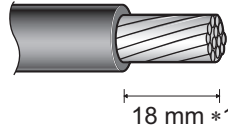

*1 &&40 mm for FR-A870-02300 to 02860.

(4) After installing the inverter, insert each wire into the terminal and tighten the terminal screw. The clamp is tightened to fix the wire.

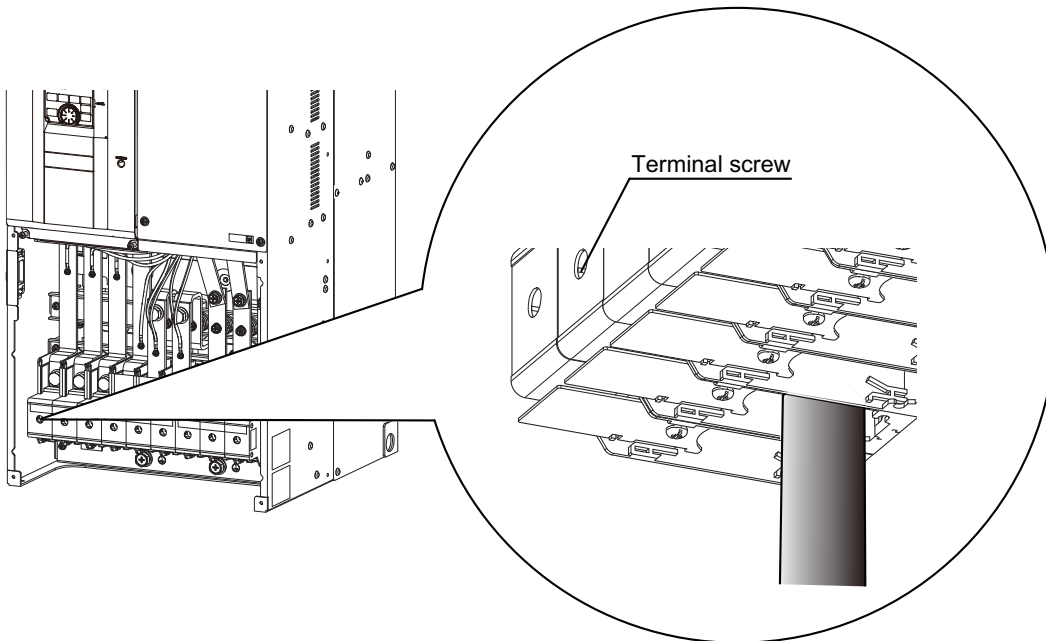

NOTE

- For terminals that are not wired, leave the covers as they are.
- Terminal block covers must be attached if the inverter is to be used under IP20 requirements.

2.5.3 Recommended cables and the wiring length

Select a recommended cable size to ensure that the voltage drop ratio is within 2%.

If the wiring distance is long between the inverter and motor, the voltage drop in the main circuit wires will cause the motor torque to decrease especially at a low speed.

The following table shows the recommended cable size for cables that are 20 m in length.

- 690 V class (690 V input power supply)

Applicable inverter model FR-A870-[]	Terminal screw size*3	Tightening torque N·m	Cable gauge*6*7							
			AWG/MCM*1			PVC cables, etc. (mm ²)*2				
			Stranded*4		Earthing (grounding) cable	Stranded*4		Flexible with ferrule *5		Earthing (grounding) cable
			R/L1, S/L2, T/L3	U, V, W		R/L1, S/L2, T/L3	U, V, W	R/L1, S/L2, T/L3	U, V, W	
00550	M6	5±0.2	6	6	6	16	16	16	16	16
00660	M6	5±0.2	4	4	4	16	16	16	16	16
00890	M6	5±0.2	4	4	4	25	25	25	25	16
02300	M10	20±2	4/0	4/0	2/0	150	150	150	150	70
02860	M10	20±2	300	300	3/0	185	185	185	185	95

*1 It is the gauge of a cable with the continuous maximum permissible temperature of 75°C (THHW cable).

It assumes a surrounding air temperature of 40°C or lower and in-enclosure wiring.

(For use in the United States or Canada, refer to [page 107](#).)

*2 It is the gauge of a cable with the continuous maximum permissible temperature of 70°C (PVC cable).

It assumes a surrounding air temperature of 40°C or lower and in-enclosure wiring.

(Selection example for use mainly in Europe.)

*3 It indicates the size of screw for terminals R/L1, S/L2, T/L3, U, V, W, P/+, N/-, and PR, and a terminal for earthing (grounding).

*4 &&When using stranded wire, strip back the sheath 18 mm for the FR-A870-00550 to 00890 or 40 mm for the A870-02300 to 02860.

*5 &&When using flexible wire, strip back the sheath 18 mm for the FR-A870-00550 to 00890 or 40 mm for the A870-02300 to 02860, and crimp the wire with a ferrule.

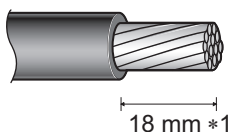

*1 &&40 mm for FR-A870-02300 to 02860.

*6 Use copper wire.

*7 Use stranded wire or flexible wire with a ferrule. Do not use solid wire nor flexible wire without a ferrule.

- Commercially available ferrules (as of July 2019)

Cable gauge (mm ²)	Ferrule part No.*2	Hand Crimping tool	Electric Crimping tool	Battery	Charger	Crimping die
6	7518V	CRIMPFOX6*1	-	-	-	-
10	7618V	K28	-	-	-	-
16	7718V		-	-	-	-
25	7818V		-	-	-	-
35	7918V		-	-	-	-
150	8440V		-	EKM6022L*2	RAL1*2	LGL1*2
185	8540V	-	-	-	-	AE22185*2

*1 Phoenix Contact Co., Ltd.

*2 Klauke

The line voltage drop can be calculated by the following formula:

$$\text{Line voltage drop [V]} = \frac{\sqrt{3} \times \text{wire resistance [m}\Omega\text{/m]} \times \text{wiring distance [m]} \times \text{current [A]}}{1000}$$

Use a larger diameter cable when the wiring distance is long or when the voltage drop (torque reduction) in the low speed range needs to be reduced.



- Tighten the terminal screw to the specified torque.

A screw that has been tightened too loosely can cause a short circuit or malfunction.

A screw that has been tightened too tightly can cause a short circuit or malfunction due to the unit breakage.

◆ Total wiring length

Connect one or more general-purpose motors within the total wiring length shown in the following table. (It must be 100 m or less under Vector control.)

Cable type	Pr.72 setting (carrier frequency)	FR-A870-00550 to 00890	FR-A870-02300, 02860
Unshielded	2 (2 kHz) or lower	500 m	500 m
	3 (3 kHz) or higher	100 m	500 m
Shielded	2 (2 kHz) or lower	100 m	500 m
	3 (3 kHz) or higher	Cannot be used.	500 m

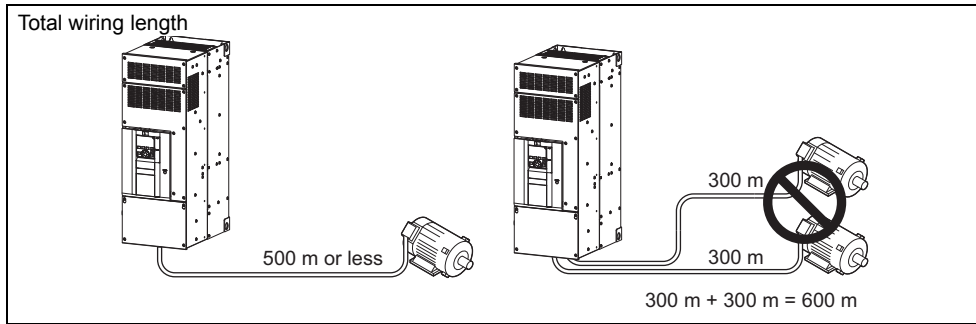

When driving a 690 V class motor by the inverter, surge voltages attributable to the wiring constants may occur at the motor terminals, deteriorating the insulation of the motor. In this case, use a 690 V class inverter-driven insulation-enhanced motor. When the wiring length exceeds 100 m, set "4" (4 kHz) or less in **Pr.72 PWM frequency selection** (carrier frequency).

NOTE

- Especially for long-distance wiring, the inverter may be affected by a charging current caused by stray capacitances of the wiring, leading to an activation of the overcurrent protection, malfunction of the fast-response current limit operation, or even to an inverter failure. It may also cause a malfunction or fault of the equipment connected ON the inverter output side. If the fast-response current limit function malfunctions, disable this function. (**Pr.156 Stall prevention operation selection**, refer to the Instruction Manual (Function)).
- For the details of **Pr.72 PWM frequency selection**, refer to the Instruction Manual (Function).
- Refer to [page 68](#) to drive a 690 V class motor by an inverter.

2.5.4 Earthing (grounding) precautions

- Always earth (ground) the motor and inverter.

◆ Purpose of earthing (grounding)

Generally, an electrical apparatus has an earth (ground) terminal, which must be connected to the ground before use. An electrical circuit is usually insulated by an insulating material and encased. However, it is impossible to manufacture an insulating material that can shut off a leakage current completely, and actually, a slight current flows into the case. The purpose of earthing (grounding) the case of an electrical apparatus is to prevent operators from getting an electric shock from this leakage current when touching it.

To avoid the influence of external noises, this earthing (grounding) is important to EMI-sensitive equipment that handle low-level signals or operate very fast such as audio equipment, sensors, computers.

◆ Earthing (grounding) system to be established

As described previously, earthing (grounding) is roughly classified into an electrical shock prevention and the prevention of malfunction due to the influence of electromagnetic noise. These two purposes should be clearly distinguished, and the appropriate earth (ground) system must be established to prevent the leakage current having the inverter's high frequency components from reversing through another earth (ground) point for malfunction prevention by following these instructions:

- Make the separate earth (ground) connection (I) for high frequency products such as the inverter from any other devices (EMI-sensitive devices described above) wherever possible.

Establishing adequate common (single-point) earth (ground) system (II) shown in the following figure is allowed only in cases where the separate earth (ground) system (I) is not feasible. Do not make inadequate common (single-point) earth (ground) connection (III).

As leakage current containing many high frequency components flows into the earthing (grounding) cables of the inverter and inverter-driven motor. They must also be earthed (grounded) separately from the EMI-sensitive devices described above. In a high building, it may be effective to use its iron structure frames as earthing (grounding) electrode for EMI prevention in order to separate from the earth (ground) system for electric shock prevention.

- Earthing (Grounding) must conform to the requirements of national and local safety regulations and electrical codes (NEC section 250, IEC 61140 class 1 and other applicable standards).
- Use the thickest possible earthing (grounding) cable. The earthing (grounding) cable should be equal to the size indicated in the table on [page 31](#).
- The earthing (grounding) point should be as close as possible to the inverter, and the earth (ground) cable length should be as short as possible.
- Run the earthing (grounding) cable as far away as possible from the I/O wiring of the EMI-sensitive devices and run them in parallel in the minimum distance.

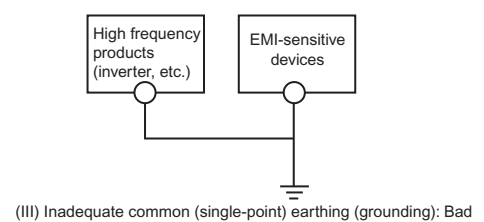
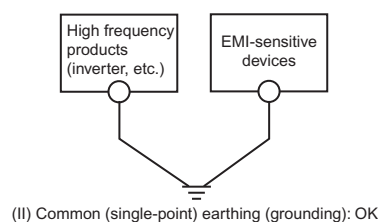
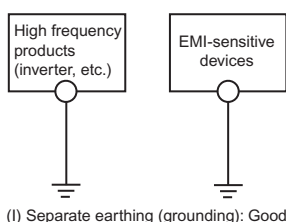

NOTE

- To be compliant with the EU Directive (Low Voltage Directive), refer to [page 104](#).

2.6 Control circuit

2.6.1 Details on the control circuit terminals

Input signal function of the terminals in can be selected by setting **Pr.178 to Pr.196 (I/O terminal function selection)**. For the parameter details, refer to the Instruction Manual (Function).

◆ Input signal

Type	Terminal symbol	Terminal name	Terminal function description		Rated specification
Contact input	STF	Forward rotation start	Turn ON the STF signal to start forward rotation and turn it OFF to stop.	When the STF and STR signals are turned ON simultaneously, the stop command is given.	Input resistance 4.7 kΩ Voltage when contacts are open: 21 to 27 VDC When contacts are short-circuited: 4 to 6 mADC
	STR	Reverse rotation start	Turn ON the STR signal to start reverse rotation and turn it OFF to stop.		
	STP (STOP)	Start self-holding selection	Turn ON the STP (STOP) signal to self-hold the start signal.		
	RH, RM, RL	Multi-speed selection	Multi-speed can be selected according to the combination of RH, RM and RL signals.		
	JOG	Jog mode selection	Turn ON the JOG signal to enable JOG operation (initial setting) and turn ON the start signal (STF or STR) to start JOG operation.		
		Pulse train input	Terminal JOG is also used as a pulse train input terminal. To use as a pulse train input terminal, change the Pr.291 setting. (Maximum input pulse: 100k pulses/s)		Input resistance 2 kΩ When contacts are short-circuited: 8 to 13 mADC
	RT	Second function selection	Turn ON the RT signal to enable the second function. When the second function such as "second torque boost" and "second V/F (base frequency)" is set, turning ON the RT signal enables the selected function.		Input resistance 4.7 kΩ Voltage when contacts are open: 21 to 27 VDC When contacts are short-circuited: 4 to 6 mADC
	MRS	Output stop	Turn ON the MRS signal (20 ms or more) to stop the inverter output. Use this signal to shut off the inverter output when stopping the motor with an electromagnetic brake.		
	RES	Reset	Use this signal to reset a fault output provided when a protective function is activated. Turn ON the RES signal for 0.1 second or longer, then turn it OFF. In the initial setting, reset is set always-enabled. Setting Pr.75 makes reset possible only after the occurrence of an inverter fault. The inverter will restart about 1 second after reset.		
	AU	Terminal 4 input selection	The terminal 4 function is available only when the AU signal is turned ON. Turning the AU signal ON makes terminal 2 invalid.		
	CS	Selection of automatic restart after instantaneous power failure	When the CS signal is left ON, the inverter restarts automatically at power restoration. Note that restart setting is necessary for this operation. In the initial setting, a restart is disabled.		
	SD	Contact input common (sink)*2	Common terminal for the contact input terminal (sink logic), terminal FM.		—
		External transistor common (source)*3	Connect this terminal to the power supply common terminal of a transistor output (open collector output) device, such as a programmable controller, in the source logic to avoid malfunction by undesirable current.		
24 VDC power supply common		Common terminal for the 24 VDC power supply (terminal PC, terminal +24) Isolated from terminals 5 and SE.			
PC	External transistor common (sink)*2	Connect this terminal to the power supply common terminal of a transistor output (open collector output) device, such as a programmable controller, in the sink logic to avoid malfunction by undesirable currents.		Power supply voltage range 19.2 to 28.8 VDC Permissible load current 100 mA	
	Contact input common (source)*3	Common terminal for contact input terminal (source logic).			
	24 VDC power supply	Can be used as a 24 VDC 0.1 A power supply.			

Type	Terminal symbol	Terminal name	Terminal function description	Rated specification
Frequency setting	10E	Frequency setting power supply	When connecting the frequency setting potentiometer at an initial status, connect it to terminal 10. Change the input specifications of terminal 2 using Pr.73 when connecting it to terminal 10E.	10 VDC ± 0.4 V Permissible load current 10 mA
	10			5 VDC ± 0.5 V Permissible load current 10 mA
	2	Frequency setting (voltage)	Inputting 0 to 5 VDC (or 0 to 10 V, 0 to 20 mA) provides the maximum output frequency at 5 V (10 V, 20 mA) and makes input and output proportional. Use Pr.73 to switch among input 0 to 5 VDC (initial setting), 0 to 10 VDC, and 0 to 20 mA. Set the voltage/current input switch in the ON position to select current input (0 to 20 mA).*1	When voltage is input: Input resistance 10 k Ω ± 1 k Ω Maximum permissible voltage 20 VDC
	4	Frequency setting (current)	Inputting 4 to 20 mADC (or 0 to 5 V, 0 to 10 V) provides the maximum output frequency at 20 mA and makes input and output proportional. This input signal is valid only when the AU signal is ON (terminal 2 input is invalid). Use Pr.267 to switch among input 4 to 20 mA (initial setting), 0 to 5 VDC, and 0 to 10 VDC. Set the voltage/current input switch in the OFF position to select voltage input (0 to 5 V/0 to 10 V).*1 Use Pr.858 to switch terminal functions.	When current is input: Input resistance 245 Ω ± 5 Ω Permissible maximum current 30 mA
	1	Frequency setting auxiliary	Inputting 0 to ± 5 VDC or 0 to ± 10 VDC adds this signal to terminal 2 or 4 frequency setting signal. Use Pr.73 to switch between input 0 to ± 5 VDC and 0 to ± 10 VDC (initial setting). Use Pr.868 to switch terminal functions.	Input resistance 10 k Ω ± 1 k Ω Permissible maximum voltage ± 20 VDC
	5	Frequency setting common	Common terminal for frequency setting signal (terminal 2, 1 or 4) and analog output terminal AM, CA. Do not earth (ground).	—
Thermistor	10 2	PTC thermistor input	For receiving PTC thermistor outputs. When PTC thermistor is valid (Pr.561 \neq "9999"), terminal 2 is not available for frequency setting.	Applicable PTC thermistor specification Overheat detection resistance: 0.5 to 30 k Ω (Set by Pr.561)
External power supply input	+24	24 V external power supply input	For connecting a 24 V external power supply. If a 24 V external power supply is connected, power is supplied to the control circuit while the main power circuit is OFF.	Input voltage 23 to 25.5 VDC Input current 1.4 A or less

- *1 Set **Pr.73**, **Pr.267**, and the voltage/current input switch correctly, then input an analog signal in accordance with the setting.
Applying a voltage with the voltage/current input switch ON (current input is selected) or a current with the switch OFF (voltage input is selected) could cause component damage of the inverter or analog circuits of output devices. (For the details, refer to the Instruction Manual (Function).)
- *2 Sink logic is initially set for the FM-type inverter.
- *3 Source logic is initially set for the CA-type inverter.

◆ Output signal

Type	Terminal symbol	Terminal name	Terminal function description		Rated specification
Relay	A1, B1, C1	Relay output 1 (fault output)	1 changeover contact output that indicates that an inverter's protective function has been activated and the outputs are stopped. Fault: discontinuity across B and C (continuity across A and C), Normal: continuity across Band C (discontinuity across A and C)		Contact capacity 230 VAC 0.3 A (power factor = 0.4) 30 VDC 0.3 A
	A2, B2, C2	Relay output 2	1 changeover contact output		
Open collector	RUN	Inverter running	Switched to LOW when the inverter output frequency is equal to or higher than the starting frequency (initial value 0.5 Hz). Switched to HIGH during stop or DC injection brake operation.		Permissible load 24 VDC (maximum 27 VDC) 0.1 A (The voltage drop is 2.8 V at maximum while the signal is ON.) LOW is when the open collector output transistor is ON (conducted). HIGH is when the transistor is OFF (not conducted).
	SU	Up to frequency	Switched to LOW when the output frequency is within the set frequency range $\pm 10\%$ (initial value). Switched to HIGH during acceleration/ deceleration and at a stop.		
	OL	Overload warning	Switched to LOW when stall prevention is activated by the stall prevention function. Switched to HIGH when stall prevention is canceled.		
	IPF	Instantaneous power failure	Switched to LOW when an instantaneous power failure occurs or when the undervoltage protection is activated.		
	FU	Frequency detection	Switched to LOW when the inverter output frequency is equal to or higher than the preset detection frequency, and to HIGH when it is less than the preset detection frequency.		
	SE	Open collector output common	Common terminal for terminals RUN, SU, OL, IPF, FU		
Pulse	FM *1	For meter	Outputs a selected monitored item (such as output frequency) among several monitored items. The signal is not output during an inverter reset.	Output item: Output frequency (initial setting)	Permissible load current 2 mA For full scale 1440 pulses/s
		NPN open collector output		This terminal can be used for open collector outputs by setting Pr.291 .	Maximum output pulse 50k pulses/s Permissible load current 80 mA
Analog	AM	Analog voltage output	The output signal is proportional to the magnitude of the corresponding monitor item. Use Pr.55 , Pr.56 , and Pr.866 to set full scales for the monitored output frequency, output current, and torque. (Refer to the Instruction Manual (Function).)	Output item: Output frequency (initial setting)	Output signal 0 to ± 10 VDC, Permissible load current 1 mA (load impedance 10 k Ω or more) Resolution 8 bits
	CA *2	Analog current output			Load impedance 200 Ω to 450 Ω Output signal 0 to 20 mADC

*1 Terminal FM is provided in the FM-type inverter.

*2 Terminal CA is provided in the CA-type inverter.

◆ Communication

Type	Terminal symbol	Terminal name	Terminal function description	
Ethernet	—	Ethernet connector	Communication can be made via Ethernet. Category: 100BASE-TX/10BASE-T Data transmission speed: 100 Mbps (100BASE-TX) / 10 Mbps (10BASE-T) Transmission method: Baseband Maximum segment length: 100 m between the hub and the inverter Number of cascade connection stages: Up to 2 (100BASE-TX) / up to 4 (10BASE-T) Interface: RJ-45 Number of interfaces available: 1 IP version: IPv4	
RS-485	—	PU connector	With the PU connector, communication can be made through RS-485. (For connection on a 1:1 basis only) Conforming standard: EIA-485 (RS-485) Transmission format: Multidrop link Communication speed: 4800 to 115200 bps Wiring length: 500 m	
USB	—	USB A connector	A connector (receptacle) A USB memory device enables parameter copies and the trace function.	Interface: Conforms to USB 1.1 (USB 2.0 full-speed compatible) Transmission speed: 12 Mbps
		USB B connector	Mini B connector (receptacle) The inverter can be connected to a personal computer via USB.	

◆ Safety stop signal

Terminal symbol	Terminal name	Terminal function description	Rated specification	Refer to page
S1	Safety stop input (Channel 1)	Terminals S1 and S2 are used for the safety stop input signal for the safety relay module. Terminals S1 and S2 are used at the same time (dual channel). Inverter output is shutoff by shortening/opening between terminals S1 and SIC, or between S2 and SIC. In the initial status, terminals S1 and S2 are shorted with terminal PC by shorting wires. Terminal SIC is shorted with terminal SD. Remove the shorting wires and connect the safety relay module when using the safety stop function.	Input resistance 4.7 k Ω Input current 4 to 6 mA DC (with 24 VDC input)	46
S2	Safety stop input (Channel 2)			
SIC	Safety stop input terminal common	Common terminal for terminals S1 and S2.	—	
So (SO)	Safety monitor output (open collector output)	Indicates the safety stop input signal status. Switched to LOW when the status is other than the internal safety circuit failure. Switched to HIGH during the internal safety circuit failure status. (LOW is when the open collector output transistor is ON (conducted). HIGH is when the transistor is OFF (not conducted).) Refer to the Safety Stop Function Instruction Manual when the signal is switched to HIGH while both terminals S1 and S2 are open. (Please contact your sales representative for the manual.)	Permissible load 24 VDC (27 VDC at maximum), 0.1 A (The voltage drop is 3.4 V at maximum while the signal is ON.)	
SOC	Safety monitor output terminal common	Common terminal for terminal So (SO).	—	

2.6.2 Control logic (sink/source) change

Change the control logic of input signals as necessary.

To change the control logic, change the jumper connector position on the control circuit board.

Connect the jumper connector to the connector pin of the desired control logic.

The control logic of input signals is initially set to the sink logic (SINK) for the FM type.

The control logic of input signals is initially set to the source logic (SOURCE) for the CA type.

(The output signals may be used in either the sink or source logic independently of the jumper connector position.)

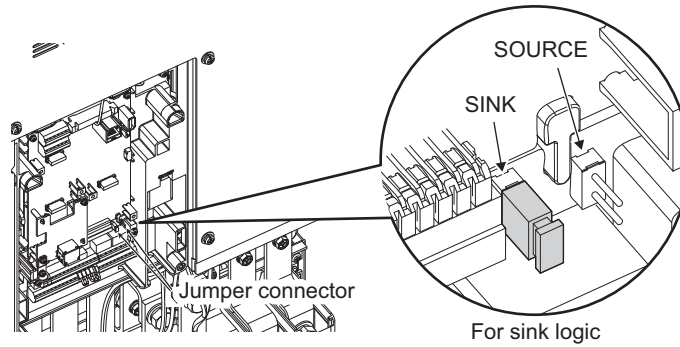

NOTE

- Make sure that the jumper connector is installed correctly.
- Never change the control logic while power is ON.

◆ Sink logic and source logic

- In the sink logic, a signal switches ON when a current flows from the corresponding signal input terminal. Terminal SD is common to the contact input signals. Terminal SE is common to the open collector output signals.
- In the source logic, a signal switches ON when a current flows into the corresponding signal input terminal. Terminal PC is common to the contact input signals. Terminal SE is common to the open collector output signals.

● Current flow concerning the input/output signal when sink logic is selected

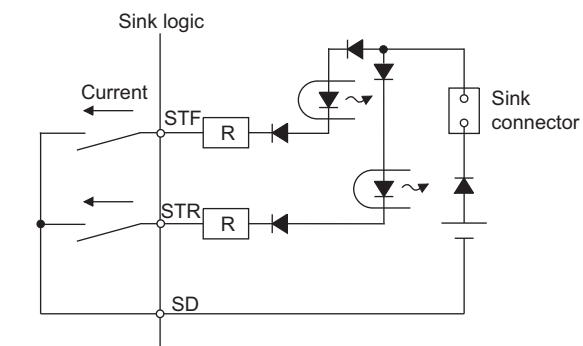

● Current flow concerning the input/output signal when source logic is selected

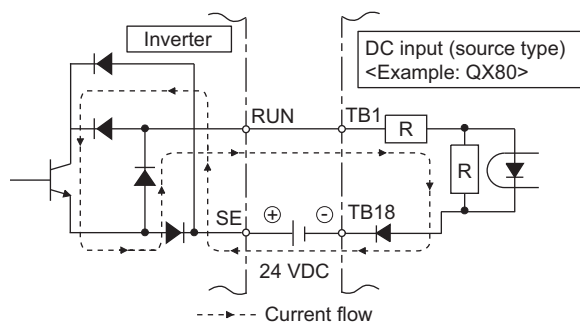
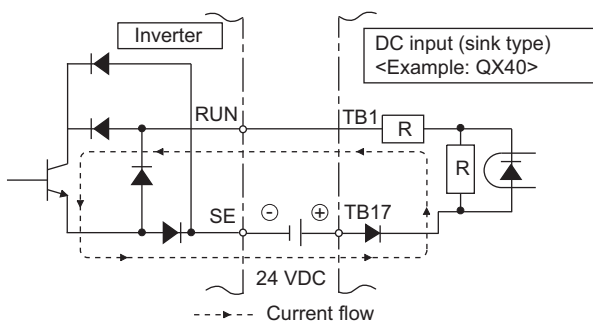
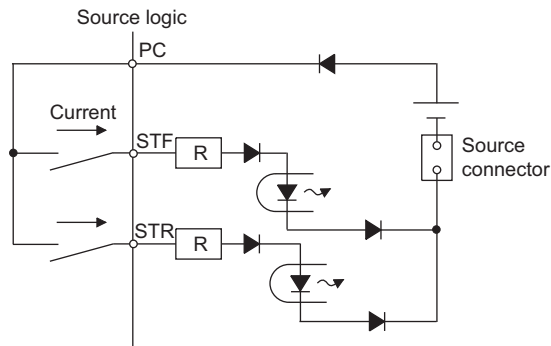

- When using an external power supply for transistor output

Sink logic

Use terminal PC as a common terminal, and perform wiring as shown below. (Do not connect terminal SD of the inverter with terminal 0 V of the external power supply. When using terminals PC-SD as a 24 VDC power supply, do not install an external power supply in parallel with the inverter. Doing so may cause a malfunction in the inverter due to undesirable currents.)

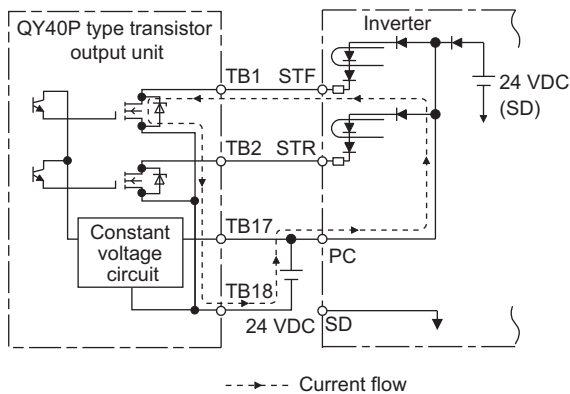

Source logic

Use terminal SD as a common terminal, and perform wiring as shown below. (Do not connect terminal PC of the inverter with terminal +24 V of the external power supply. When using terminals PC-SD as a 24 VDC power supply, do not install an external power supply in parallel with the inverter. Doing so may cause a malfunction in the inverter due to undesirable currents.)

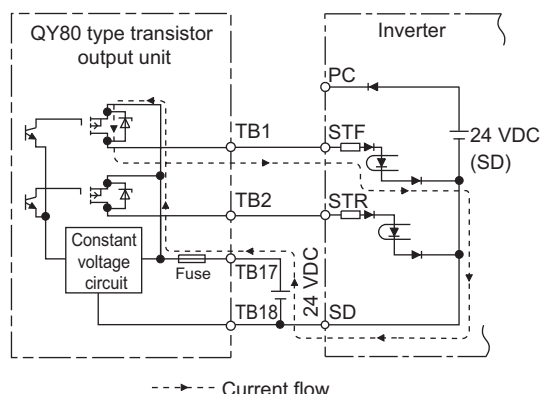

2.6.3 Wiring of control circuit

◆Control circuit terminal layout

- Recommended cable gauge: 0.3 to 0.75 mm²

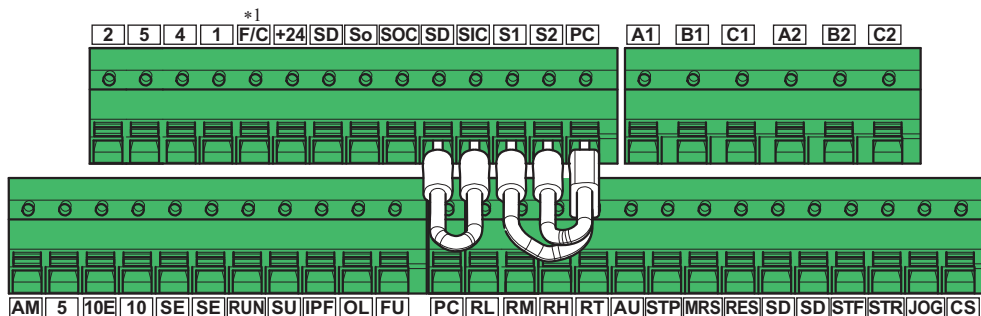

*1 This terminal operates as terminal FM for the FM type, and as terminal CA for the CA type.

◆Wiring method

- Wire insertion

Use crimp terminals and stripped wire for the control circuit wiring. For single wire, the stripped wire can be used without crimp terminal.

Connect the end of wires (crimp terminal or stranded wire) to the terminal block.

- (1) Strip the signal wires as shown below. If too much of the wire is stripped, a short circuit may occur with neighboring wires. If not enough of the wire is stripped, wires may become loose and fall out. Twist the stripped end of wires to prevent them from fraying. Do not solder it.

Wire strip length



- (2) Use appropriate crimp terminals (ferrules, blade terminals, etc.).

Insert wires to the crimp terminal, and check that the wires come out for about 0 to 0.5 mm from a sleeve.

Check the condition of the crimp terminal after crimping. Do not use the crimp terminal of which the crimping is inappropriate, or the face is damaged.

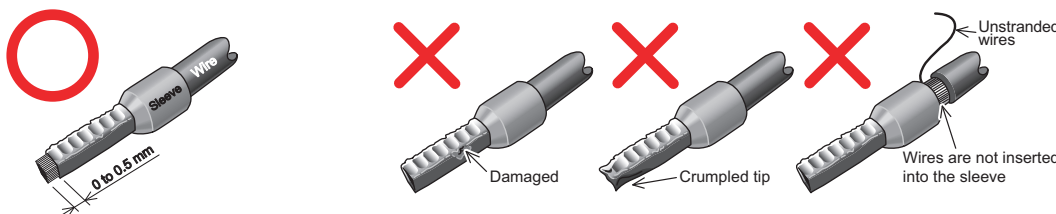

- Crimp terminals commercially available (as of January 2017)

Phoenix Contact Co., Ltd.

Wire gauge (mm ²)	Ferrule part No.			Crimping tool model No.
	With insulation sleeve	Without insulation sleeve	For UL wire*1	
0.3	AI 0,34-10TQ	—	—	CRIMPFOX 6
0.5	AI 0,5-10WH	—	AI 0,5-10WH-GB	
0.75	AI 0,75-10GY	A 0,75-10	AI 0,75-10GY-GB	
1	AI 1-10RD	A 1-10	AI 1-10RD/1000GB	
1.25, 1.5	AI 1,5-10BK	A 1,5-10	AI 1,5-10BK/1000GB*2	
0.75 (for two wires)	AI-TWIN 2 × 0,75-10GY	—	—	

*1 A ferrule terminal with an insulation sleeve compatible with the MTW wire which has a thick wire insulation.

*2 Applicable for terminals A1, B1, C1, A2, B2, and C2.

NICHIFU Co., Ltd.

Wire gauge (mm ²)	Blade terminal part No.	Insulation cap part No.	Crimping tool model No.
0.3 to 0.75	BT 0.75-11	VC 0.75	NH 69

(3) Insert each wire into the terminal.

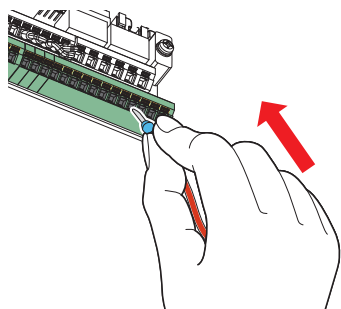

When using single wire or stranded wires without a crimp terminal, push the open/close button all the way down with a flathead screwdriver, and insert the wire.

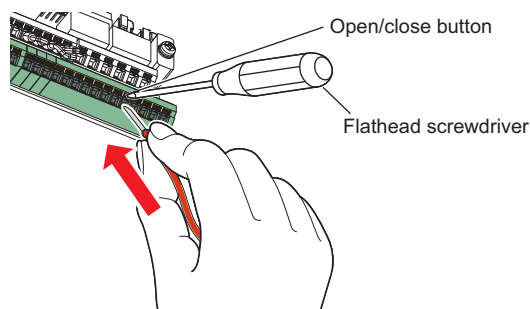

NOTE

- When using stranded wires without a crimp terminal, twist enough to avoid short circuit with neighboring terminals or wires.
- Place the flathead screwdriver vertical to the open/close button. In case the blade tip slips, it may cause an inverter damage or injury.

• Wire removal

Pull the wire while pushing the open/close button all the way down firmly with a flathead screwdriver.

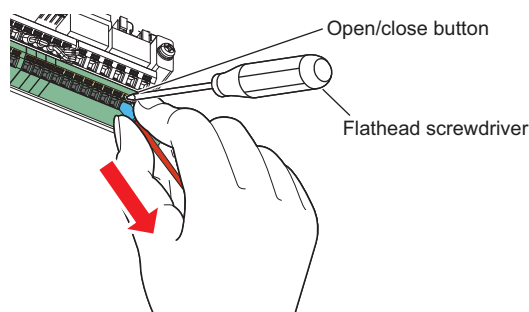

NOTE

- Pulling out the wire forcefully without pushing the open/close button all the way down may damage the terminal block.
- Use a small flathead screwdriver (tip thickness: 0.4 mm/tip width: 2.5 mm).

If a flathead screwdriver with a narrow tip is used, terminal block may be damaged.

Commercially available products (as of April 2019)

Product	Model	Manufacturer
Screwdriver	SZF 0- 0,4 × 2,5	Phoenix Contact Co., Ltd.

- Place the flathead screwdriver vertical to the open/close button. In case the blade tip slips, it may cause an inverter damage or injury.

◆ Common terminals of the control circuit (SD, PC, 5, SE)

- Terminals SD (sink logic), PC (source logic), 5, and SE are common terminals (0V) for I/O signals. (All common terminals are isolated from each other.) Do not earth (ground) these terminals. Avoid connecting terminal SD (sink logic) with 5, terminal PC (source logic) with 5, and terminal SE with 5.
- In the sink logic, terminal SD is a common terminal for the contact input terminals (STF, STR, STP (STOP), RH, RM, RL, JOG, RT, MRS, RES, AU, CS) and the pulse train output terminal (FM*1). The open collector circuit is isolated from the internal control circuit by photocoupler.
- In the source logic, terminal PC is a common terminal for the contact input terminals (STF, STR, STP (STOP), RH, RM, RL, JOG, RT, MRS, RES, AU, CS). The open collector circuit is isolated from the internal control circuit by photocoupler.
- Terminal 5 is a common terminal for the frequency setting terminals (2, 1 or 4) and the analog output terminals (AM, CA*2). It should be protected from external noise using a shielded or twisted cable.
- Terminal SE is a common terminal for the open collector output terminals (RUN, SU, OL, IPF, FU). The contact input circuit is isolated from the internal control circuit by photocoupler.

*1 Terminal FM is provided in the FM-type inverter.

*2 Terminal CA is provided in the CA-type inverter.

◆ Signal inputs by contactless switches

The contact input terminals of the inverter (STF, STR, STP (STOP), RH, RM, RL, JOG, RT, MRS, RES, AU, CS) can be controlled using a transistor instead of a contact switch as shown below.

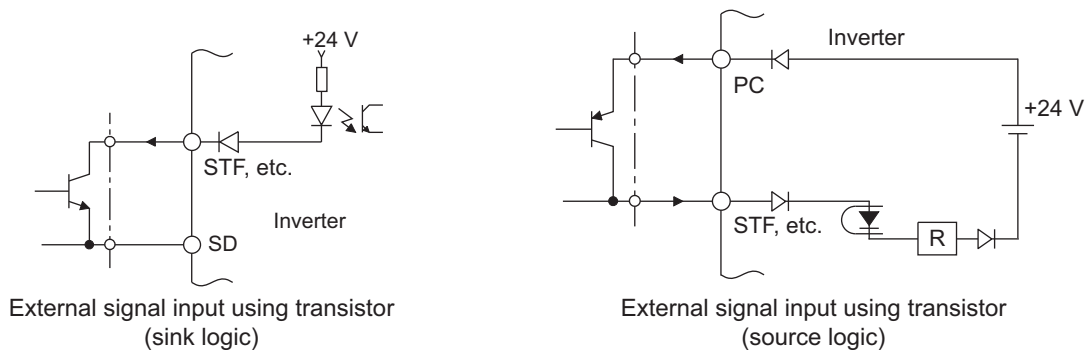

2.6.4 Wiring precautions

- It is recommended to use a cable of 0.3 to 0.75 mm² for the connection to the control circuit terminals.
- The wiring length should be 30 m (200 m for terminal FM) at the maximum.
- Use two or more parallel micro-signal contacts or twin contacts to prevent contact faults when using contact inputs since the control circuit input signals are micro-currents.
- To suppress EMI, use shielded or twisted cables for the control circuit terminals and run them away from the main and power circuits (including the 200 V relay sequence circuit). For the cables connected to the control circuit terminals, connect their shields to the common terminal of the connected control circuit terminal. When connecting an external power supply to terminal PC, however, connect the shield of the power supply cable to the negative side of the external power supply. Do not directly earth (ground) the shield to the enclosure, etc.
- Always apply a voltage to the fault output terminals (A1, B1, C1, A2, B2, C2) via a relay coil, lamp, etc.
- Separate the wiring of the control circuit away from the wiring of the main circuit.

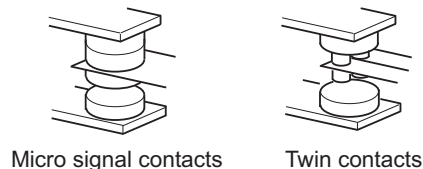

Make cuts in rubber bush of the inverter side and lead the wires through.

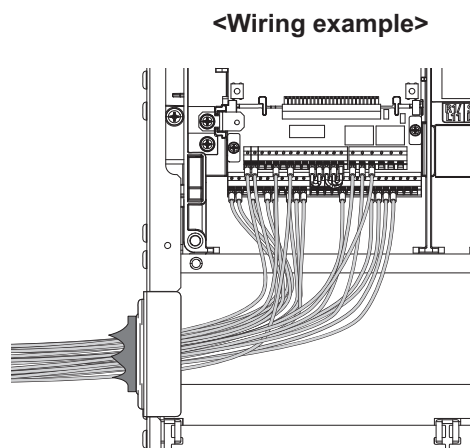
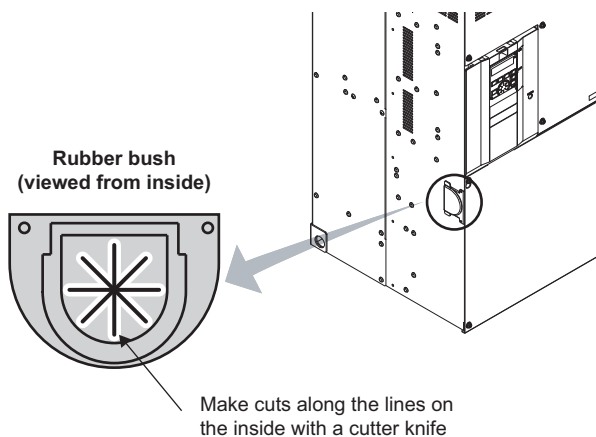

2.6.5 When using separate power supplies for the control circuit and the main circuit

◆ Cable size for the control circuit power supply (terminals R1/L11, S1/L21)

- Terminal screw size: M4
- Cable gauge: 0.75 mm² to 2 mm²
- Tightening torque: 1.5 N·m

◆ Connection method

<Connection diagram>

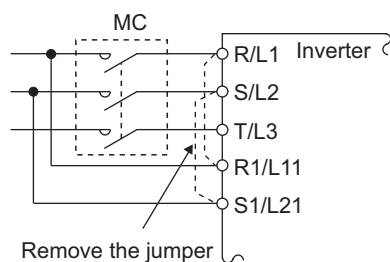

When a fault occurs, opening of the electromagnetic contactor (MC) on the inverter power supply side results in power loss in the control circuit, disabling the fault output signal retention. Terminals R1/L11 and S1/L21 are provided to hold a fault signal. In this case, connect the power supply terminals R1/L11 and S1/L21 of the control circuit to the input side of the MC.

Do not connect the power cable to incorrect terminals. Doing so may damage the inverter.

- Remove the upper screws.
- Remove the lower screws.
- Pull the jumper toward you to remove.
- Connect the separate power supply cable for the control circuit to the upper terminals (R1/L11, S1/L21).

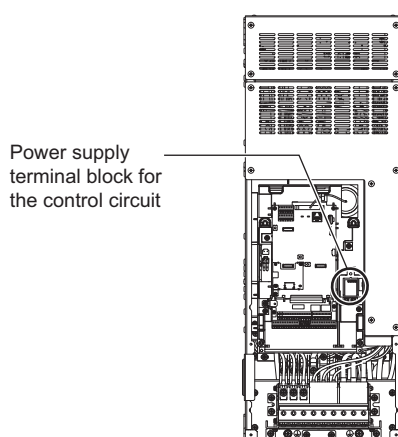
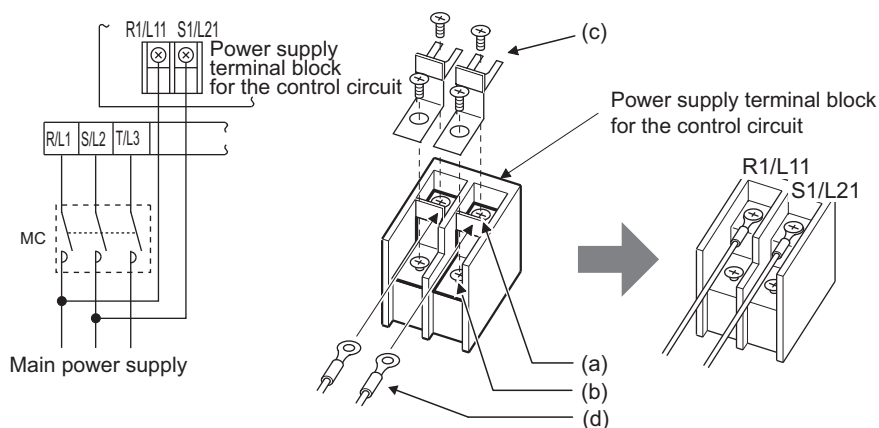

NOTE

- When using separate power supplies, always remove the jumpers across terminals R/L1 and R1/L11 and across S/L2 and S1/L21. The inverter may be damaged if the jumpers are not removed.
- The voltage should be the same as that of the main control circuit when the control circuit power is supplied from other than the input side of the MC.
- The power capacity necessary when separate power is supplied from R1/L11 and S1/L21 is 80 VA.
- If the main circuit power is switched OFF (for 0.1 second or more) then ON again, the inverter is reset and a fault output will not be held.

2.6.6 When supplying 24 V external power to the control circuit

Connect a 24 V external power supply across terminals +24 and SD. Connecting a 24 V external power supply enables I/O terminal ON/OFF operation, operation panel displays, control functions, and communication during communication operation even at power-OFF of inverter's main circuit power supply. When the main circuit power supply is turned ON, the power supply source changes from the 24 V external power supply to the main circuit power supply.

◆ Specification of the applicable 24 V external power supply

Item	Rated specification
Input voltage	23 to 25.5 VDC
Input current	1.4 A or less

Commercially available products (as of April 2019)

Model		Manufacturer
S8FS-G05024C*1	Specifications: Capacity 50 W, output voltage 24 VDC, output current 2.2 A Installation method: Direct installation, screw type terminal block with a cover Input: Single-phase 100 to 240 VAC	OMRON Corporation
S8VK-S06024*1	Specifications: Capacity 60 W, output voltage 24 VDC, output current 2.5 A Installation method: DIN rail installation, push-in (spring) type terminal block Input: Single-phase 100 to 240 VAC	
S8VK-WA24024*1	Specifications: Capacity 240 W, output voltage 24 VDC, output current 10 A Installation method: DIN rail installation, push-in (spring) type terminal block Input: Three-phase 200 to 240 VAC	

*1 For the latest information about OMRON power supply, contact OMRON corporation.

◆ Starting and stopping the 24 V external power supply operation

- Supplying 24 V external power while the main circuit power is OFF starts the 24 V external power supply operation. Likewise, turning OFF the main circuit power while supplying 24 V external power starts the 24 V external power supply operation.
- Turning ON the main circuit power stops the 24 V external power supply operation and enables the normal operation.

NOTE

- When the 24 V external power is supplied while the main circuit power supply is OFF, the inverter operation is disabled.
- In the initial setting, when the main power supply is turned ON during the 24 V external power supply operation, a reset is performed in the inverter, then the power supply changes to the main circuit power supply. (The reset can be disabled using Pr.30.)

◆ Confirming the 24 V external power supply input

- During the 24 V external power supply operation, "EV" blinks on the operation panel. The alarm lamp also blinks. Thus, the 24 V external power supply operation can be confirmed even when the operation panel is removed.

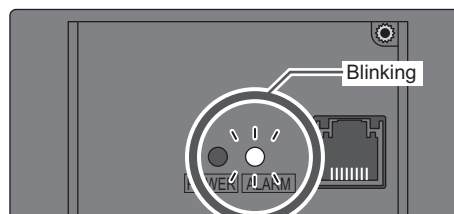
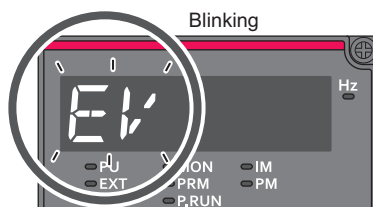

- During the 24 V external power supply operation, the 24 V external power supply operation signal (EV) is output. To use the EV signal, set "68 (positive logic) or 168 (negative logic)" in one of Pr.190 to Pr.196 (output terminal function selection) to assign function to an output terminal.

◆ Operation while the 24 V external power is supplied

- Fault history and parameters can be read and parameters can be written (when the parameter write from the operation panel is enabled) using the operation panel keys.
- The safety stop function is invalid during the 24 V external power supply operation.
- During the 24 V external power supply operation, monitored items and signals related to inputs to main circuit power supply, such as output current, converter output voltage, and IPF signal, are invalid.
- The faults, which have occurred when the main circuit power supply is ON, continue to be output after the power supply is changed to the 24 V external power supply. Perform the inverter reset or turn OFF then ON the power to reset the faults.
- If the power supply changes from the main circuit power supply to the 24 V external power supply while measuring the main circuit capacitor's life, the measurement completes after the power supply changes back to the main circuit power supply (**Pr.259** = "3").
- The output data is retained when "1 or 11" is set in **Pr.495 Remote output selection**.

NOTE

- Inrush current equal to or higher than the 24 V external power supply specification may flow at power-ON. Confirm that the power supply and other devices are not affected by the inrush current and the voltage drop caused by it. Depending on the power supply, the inrush current protection may be activated to disable the power supply. Select the power supply and capacity carefully.
- When the wiring length between the external power supply and the inverter is long, the voltage often drops. Select the appropriate wiring size and length to keep the voltage in the rated input voltage range.
- In a serial connection of several inverters, the current increases when it flows through the inverter wiring near the power supply. The increase of the current causes voltage to drop further. When connecting different inverters to different power supplies, use the inverters after confirming that the input voltage of each inverter is within the rated input voltage range. Depending on the power supply, the inrush current protection may be activated to disable the power supply. Select the power supply and capacity carefully.
- "E.SAF or E.P24" may appear when the start-up time of the 24 V power supply is too long (less than 1.5 V/s) in the 24 V external power supply operation.
- "E.P24" may appear when the 24 V external power supply input voltage is low. Check the external power supply input.
- Do not touch the control circuit terminal block (circuit board) during the 24 V power supply operation (when conducted). Otherwise you may get an electric shock or burn.

2.6.7 Safety stop function

◆Function description

The terminals related to the safety stop function are shown below.

Terminal symbol	Terminal function description	
S1*1	For input of the safety stop channel 1.	Between S1 and SIC, S2 and SIC Open: In safety stop mode Short: Other than the safety stop mode.
S2*1	For input of the safety stop channel 2.	
SIC*1	Common terminal for S1 and S2.	
So (SO)	Outputs when an alarm or failure is detected. The signal is output when no internal safety circuit failure*2 exists.	OFF: Internal safety circuit failure*2 ON: No internal safety circuit failure*2
SOC	Open collector output (terminal So (SO)) common	

*1 In the initial status, terminals S1 and PC, S2 and PC, and SIC and SD are respectively shorted with shorting wires. To use the safety stop function, remove all the shortening wires, and then connect to the safety relay module as shown in the following connection diagram.

*2 At an internal safety circuit failure, the operation panel displays one of the faults shown on the next page.

NOTE

- Use terminal So (SO) to output a fault and to prevent restarting of the inverter. The signal cannot be used as safety stop input terminal to other devices.

◆Connection diagram

To prevent automatic restart after a fault occurrence, connect the reset button of a safety relay module or a safety programmable controller across terminals So (SO) and SOC. The reset button acts as the feedback input for the safety relay module or the safety programmable controller.

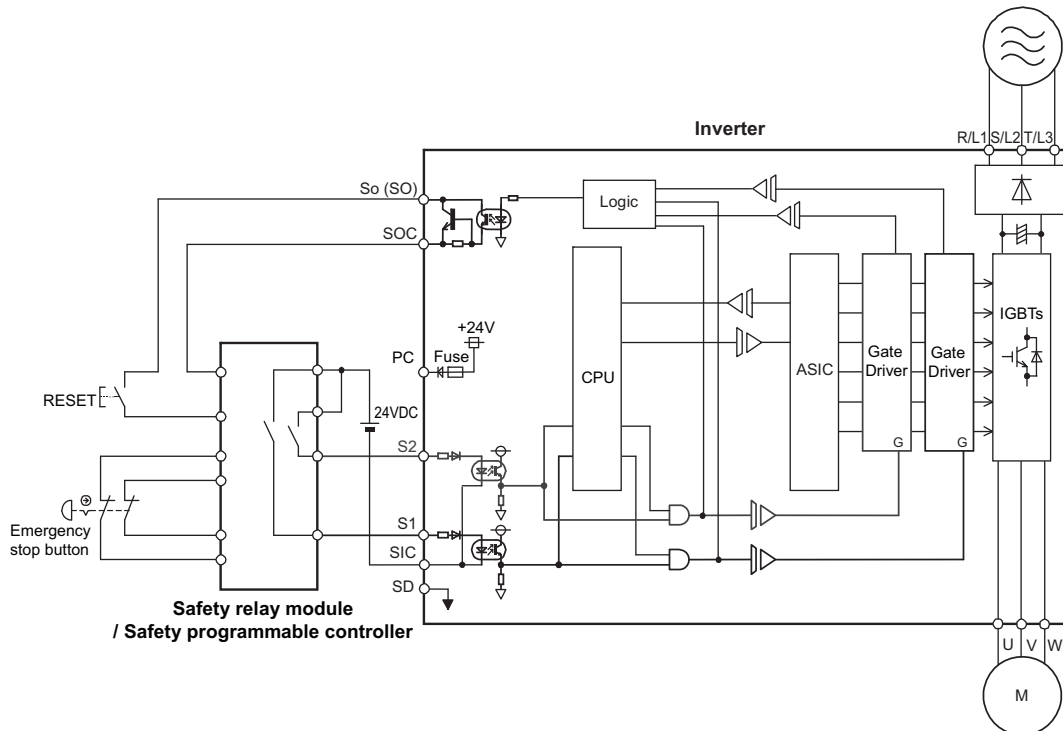

◆ Safety stop function operation

Input power	Internal safety circuit status	Input terminal *1,*2		Output terminal So (SO)	Output signal *8, *9, *10	Inverter running status	Operation panel indication	
		S1	S2				E.SAF*6	SA*7
OFF	—	—	—	OFF	OFF	Output shutoff (Safe state)	Not displayed	Not displayed
ON	Normal	ON	ON	ON*3	OFF	Drive enabled	Not displayed	Not displayed
	Normal	ON	OFF	OFF*4	OFF*4	Output shutoff (Safe state)	Displayed	Displayed
	Normal	OFF	ON	OFF*4	OFF*4	Output shutoff (Safe state)	Displayed	Displayed
	Normal	OFF	OFF	ON*3	ON*3	Output shutoff (Safe state)	Not displayed	Displayed
	Fault	ON	ON	OFF	OFF	Output shutoff (Safe state)	Displayed	Not displayed*5
	Fault	ON	OFF	OFF	OFF	Output shutoff (Safe state)	Displayed	Displayed
	Fault	OFF	ON	OFF	OFF	Output shutoff (Safe state)	Displayed	Displayed
	Fault	OFF	OFF	OFF	OFF	Output shutoff (Safe state)	Displayed	Displayed

*1 ON: The transistor is conducted. OFF: The transistor is not conducted.

*2 When not using the safety stop function, short across terminals S1 and PC, S2 and PC, and SIC and SD to use the inverter. (In the initial status, terminals S1 and PC, S2 and PC, and SIC and SD are respectively shorted with shoring wires.)

*3 If any of the protective functions shown in the following table is activated, terminal So (SO) and the SAFE signal turn OFF.

Fault record	Operation panel indication
Option fault	E.OPT
Communication option fault	E.OP1 to E.OP3
Parameter storage device fault (control circuit board)	E.PE
Retry count excess	E.RET
Parameter storage device fault (main circuit board)	E.PE2
Operation panel power supply short circuit	E.CTE
24 VDC power fault	E.P24
Safety circuit fault	E.SAF

Fault record	Operation panel indication
Overspeed occurrence	E.OS
Speed deviation excess detection	E.OSD
Signal loss detection	E.ECT
Excessive position fault	E.OD
Brake sequence fault	E.MB1 to E.MB7
Encoder phase fault	E.EP
CPU fault	E.CPU
	E.5 to E.7
Internal circuit fault	E.13

*4 If the internal safety circuit is operated normally, terminal So (SO) remains ON until E.SAF is displayed, and terminal So (SO) turns OFF when E.SAF is displayed.

*5 SA is displayed when terminals S1 and S2 are identified as OFF due to the internal safety circuit failure.

*6 If another fault occurs at the same time as E.SAF, the other fault can be displayed.

*7 If another warning occurs at the same time as SA, the other warning can be displayed.

*8 The ON/OFF state of the output signal is the one for the positive logic. The ON and OFF are reversed for the negative logic.

*9 For SAFE signal, refer to the following table and assign the function by **Pr.190 to Pr.196 (output terminal function selection)**.

Output signal	Pr.190 to Pr.196 settings	
	Positive logic	Negative logic
SAFE	80	180

*10 The use of SAFE signal has not been certified for compliance with safety standards.

For more details, refer to the Safety Stop Function Instruction Manual. Find a PDF copy of this manual in the CD-ROM enclosed with the product.

2.7 Communication connectors and terminals

2.7.1 PU connector

◆ Mounting the operation panel or the parameter unit on the enclosure surface

- Having an operation panel or a parameter unit on the enclosure surface is convenient. With a connection cable, the operation panel or the parameter unit can be mounted to the enclosure surface and connected to the inverter. Use the option FR-CB2[], or connectors and cables available on the market. (To mount the operation panel, the optional connector (FR-ADP) is required.) Securely insert one end of the connection cable until the stoppers are fixed.

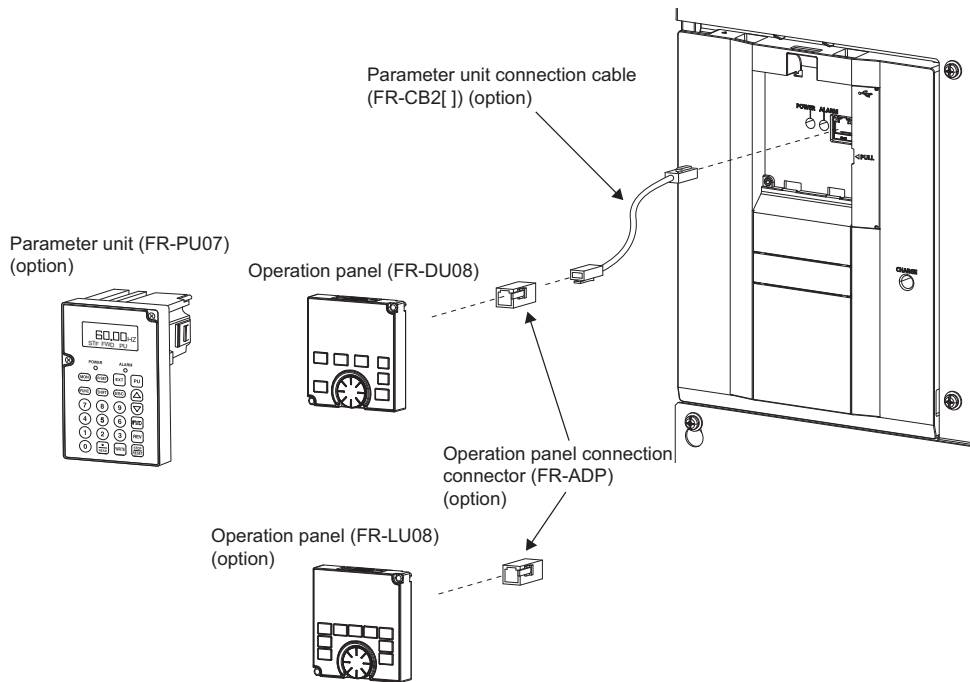

NOTE

- Refer to the following table when fabricating the cable on the user side. Keep the total cable length within 20 m.
- Commercially available products (as of February 2015)

Name	Model	Manufacturer
Communication cable	SGLPEV-T (Cat5e/300 m) 24AWG × 4P	Mitsubishi Cable Industries, Ltd.
RJ-45 connector	5-554720-3	Tyco Electronics

◆ Communication operation

- Using the PU connector enables communication operation from a personal computer, etc. When the PU connector is connected with a personal, FA or other computer by a communication cable, a user program can run to monitor the inverter or read and write parameters. Communication can be performed with the Mitsubishi inverter protocol (computer link operation). For the details, refer to the Instruction Manual (Function).

2.7.2 Ethernet connector

◆ Ethernet communication specifications

Item	Description
Category	100BASE-TX/10BASE-T
Data transmission speed	100 Mbps (100BASE-TX) / 10 Mbps (10BASE-T)
Transmission method	Baseband
Maximum segment length	100 m between the hub and the inverter
Number of cascade connection stages	Up to 2 (100BASE-TX) / up to 4 (10BASE-T)
Interface	RJ-45
Number of interfaces available	1
IP version	IPv4

◆ Connection cable

Use Ethernet cables compliant with the following standards.

Communication speed	Cable	Connector	Standard
100 Mbps	Category 5 or higher, (shielded / STP) straight cable	RJ-45 connector	100BASE-TX
10M bps	Category 3 or higher, (shielded / STP) straight cable		10BASE-T
	Category 3 or higher, (UTP) straight cable		

◆ Hub

Use a hub that supports transmission speed of the Ethernet.

2.7.3 USB connector

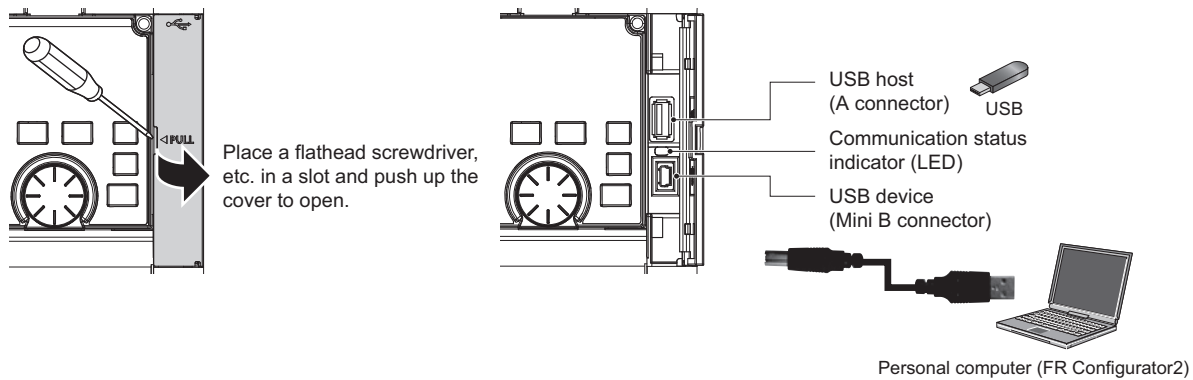

◆ USB host communication

Interface		Conforms to USB 1.1
Transmission speed		12 Mbps
Wiring length		Maximum 5 m
Connector		USB A connector (receptacle)
Compatible USB memory	Format	FAT32
	Capacity	1 GB or more (used in the recorder mode of the trace function)
	Encryption function	Not available

- Different inverter data can be saved in a USB memory device.
- The USB host communication enables the following functions.

Function	Description
Parameter copy	<ul style="list-style-type: none"> • Copies the parameter setting from the inverter to the USB memory device. A maximum of 99 parameter setting files can be saved in a USB memory device. • The parameter setting data copied in the USB memory device can be copied to other inverters. This function is useful in backing up the parameter setting or for sharing the parameter setting among multiple inverters. • The parameter setting data copied in the USB memory device can be saved in a personal computer and edited in FR Configurator 2.
Trace	<ul style="list-style-type: none"> • The monitored data and output status of the signals can be saved in a USB memory device. • The saved data can be imported to FR Configurator2 to diagnose the operating status of the inverter.
PLC function data copy	<ul style="list-style-type: none"> • This function copies the PLC function project data to a USB memory device when the PLC function is used. • The PLC function project data copied in the USB memory device can be copied to other inverters. • This function is useful in backing up the parameter setting and for allowing multiple inverters to operate by the same sequence programs.

- When the inverter recognizes the USB memory device without any problem, "USB--A" is briefly displayed on the operation panel.
- When the USB memory device is removed, "USB--" is briefly displayed on the operation panel.
- The operating status of the USB host can be checked on the LED display of the inverter.

LED display status	Operating status
OFF	No USB connection.
ON	The communication is established between the inverter and the USB device.
Blinking rapidly	The USB memory device is being accessed. (Do not remove the USB memory device.)
Blinking slowly	Error in the USB connection.

- When a device such as a USB battery charger is connected to the USB connector and an excessive current (500 mA or more) flows, USB host error "UF" (UF warning) is displayed on the operation panel.
- When the UF warning appears, the USB error can be canceled by removing the USB device and setting Pr.1049 = "1". (The UF warning can also be canceled by resetting the inverter power or resetting with the RES signal.)

NOTE

- Do not connect devices other than a USB memory device to the inverter.
- If a USB device is connected to the inverter via a USB hub, the inverter cannot recognize the USB memory device properly.
- &&For details on the applicable inverters, refer to the FR Configurator2 Instruction Manual.

◆ USB device communication

The inverter can be connected to a personal computer with a USB (Ver. 1.1) cable.
Parameter setting and monitoring can be performed by FR Configurator2.

Interface	Conforms to USB 1.1
Transmission speed	12 Mbps
Wiring length	Maximum 5 m
Connector	USB mini B connector (receptacle)
Power supply	Self-powered

NOTE

- For the details of FR Configurator2, refer to the Instruction Manual of FR Configurator2

2.8 Connection of motor with encoder (vector control)

Using encoder-equipped motors together with a vector control compatible option enables speed, torque, and positioning control operations under orientation control, encoder feedback control, and full-scale vector control.

This section explains wiring for use of the FR-A8AP.

◆ Appearance and parts name of the FR-A8AP

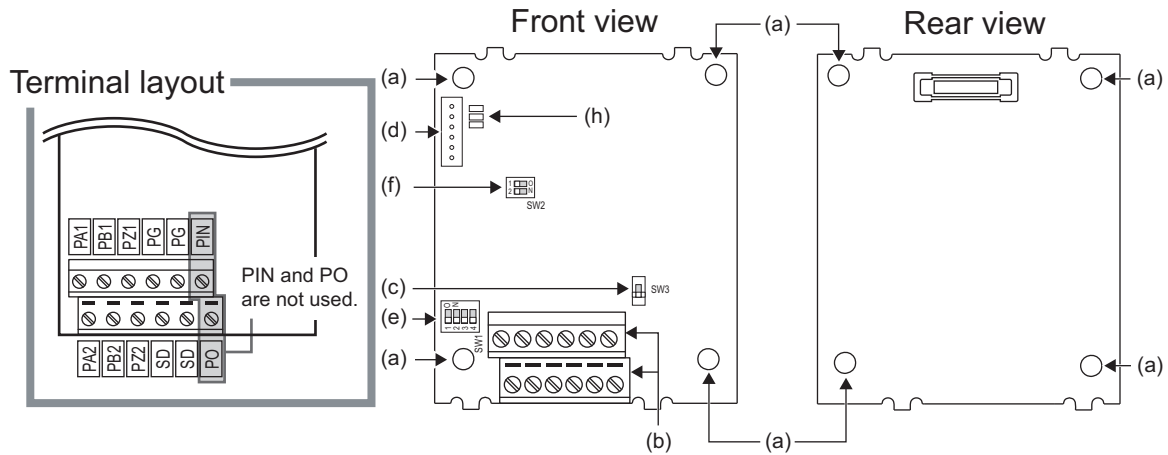

Symbol	Name	Description	Refer to page
a	Mounting hole	Used for installation to the inverter.	—
b	Terminal block	Connected with the encoder.	55
c	Encoder type selection switch (SW3)	Switches the encoder type (differential line driver/complementary).	53
d	CON2 connector	Used for extension	—
e	Terminating resistor selection switch (SW1)	Switches ON or OFF the internal terminating resistor.	53
f	Switch for manufacturer setting (SW2)	Do not change from the initially-set status. (Switches 1 and 2 are OFF .)	—
g	Connector	Connected to the option connector of the inverter.	9
h	LED for manufacturer check	Not used.	—

◆ Terminals of the FR-A8AP

Terminal symbol	Terminal name	Description
PA1	Encoder A-phase signal input terminal	A-, B- and Z-phase signals are input from the encoder.
PA2	Encoder A-phase inverse signal input terminal	
PB1	Encoder B-phase signal input terminal	
PB2	Encoder B-phase inverse signal input terminal	
PZ1	Encoder Z-phase signal input terminal	
PZ2	Encoder Z-phase inverse signal input terminal	
PG	Encoder power supply (positive side) input terminal	Input terminal for the encoder power supply. Connect the external power supply (5 V, 12 V, 15 V, 24 V) and the encoder power cable. When the encoder output is the differential line driver type, only 5 V can be input. Make the voltage of the external power supply same as the encoder output voltage. (Check the encoder specification.)
SD	Encoder power supply ground terminal	
PIN	Not used.	
PO		

NOTE

- When the encoder's output voltage differs from its input power supply voltage, the signal loss detection (E.ECT) may occur.
- Incorrect wiring or faulty setting to the encoder will cause a fault such as an overcurrent (E.OC[]) and an inverter overload (E.THT). Correctly perform the encoder wiring and setting.

◆ Switches of the FR-A8AP

- Encoder type selection switch (SW3)
Selects either the differential line driver or complementary setting.
It is initially set to the differential line driver. Switch its position according to the output circuit.

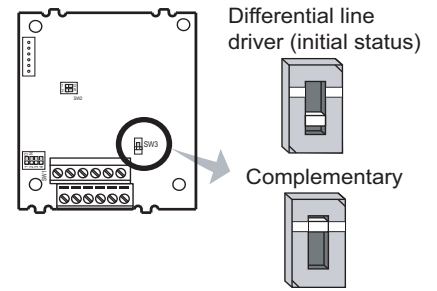

- Terminating resistor selection switch (SW1)
Selects ON/OFF of the internal terminating resistor.
Set the switch to ON (initial status) when an encoder output type is differential line driver, and set to OFF when complementary.
ON: with internal terminating resistor (initial status)
OFF: without internal terminating resistor

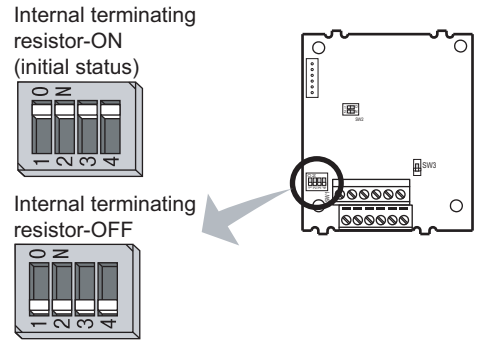

NOTE

- Set all switches to the same setting (ON/OFF).
- Set the switch "OFF" when sharing an encoder with another unit (NC (computerized numerical controller), etc.) having a terminating resistor under the differential line driver setting.
- Prepare an encoder's power supply (5 V/12 V/15 V/24 V) according to the encoder's output voltage. When the encoder output is the differential line driver type, only 5 V can be input.
- The SW2 switch is for manufacturer setting. Do not change the setting.

- Encoder specification

Item	Specification
Resolution	0 to 4096 Pulse/Rev (setting by Pr. 369)
Power supply voltage	5 V, 12 V, 15 V, 24 V
Output signal form	A, B phases (90° phase shift) Z phase: 1 pulse/rev
Output circuit	Differential line driver or complementary

◆ Encoder cable

FR-JCBL	FR-V7CBL																
<table border="1" style="margin: auto;"> <thead> <tr style="background-color: #e0f7fa;"> <th>Model</th> <th>Length L (m)</th> </tr> </thead> <tbody> <tr> <td>FR-JCBL5</td> <td>5</td> </tr> <tr> <td>FR-JCBL15</td> <td>15</td> </tr> <tr> <td>FR-JCBL30</td> <td>30</td> </tr> </tbody> </table>	Model	Length L (m)	FR-JCBL5	5	FR-JCBL15	15	FR-JCBL30	30	<p>• A P clip for earthing (grounding) a shielded cable is provided.</p> <table border="1" style="margin: auto;"> <thead> <tr style="background-color: #e0f7fa;"> <th>Model</th> <th>Length L (m)</th> </tr> </thead> <tbody> <tr> <td>FR-V7CBL5</td> <td>5</td> </tr> <tr> <td>FR-V7CBL15</td> <td>15</td> </tr> <tr> <td>FR-V7CBL30</td> <td>30</td> </tr> </tbody> </table>	Model	Length L (m)	FR-V7CBL5	5	FR-V7CBL15	15	FR-V7CBL30	30
Model	Length L (m)																
FR-JCBL5	5																
FR-JCBL15	15																
FR-JCBL30	30																
Model	Length L (m)																
FR-V7CBL5	5																
FR-V7CBL15	15																
FR-V7CBL30	30																

*1 As the terminal block of the FR-A8AP is an insertion type, cables need to be treated. (Refer to the following description.)

- When using an encoder cable (FR-JCBL, FR-V5CBL, etc.) dedicated to the conventional motor, cut the crimp terminal of the encoder cable and strip wires to make wires' ends exposed. Also, treat the shielding wires of the shielded twisted pair cable to ensure that they will not contact conductive areas. Twist the stripped end of wires to prevent them from fraying. Do not solder it.

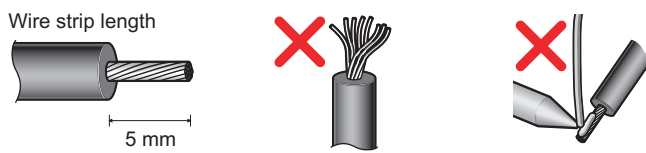

NOTE

- Information on blade terminals
Commercially available products (as of January 2017)
Phoenix Contact Co., Ltd.

Terminal screw size	Wire gauge (mm ²)	Ferrule part No.		Crimping tool model No.
		With insulation sleeve	Without insulation sleeve	
M2	0.3,	AI 0,34-6TQ	A 0,34-7	CRIMPFOX 6
	0.5	AI 0,5-6WH	A 0,5-6	

NICHIFU Co., Ltd.

Terminal screw size	Wire gauge (mm ²)	Blade terminal part No.	Insulation cap part No.	Crimping tool model No.
M2	0.3 to 0.75	BT 0.75-7	VC 0.75	NH 69

- When crimping the non-insulated crimp terminal shown above, make sure that the twisted stripped end do not come out of the terminal.

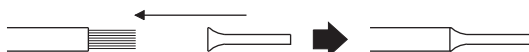

- Connection terminal compatibility table

Encoder cable	FR-V7CBL	FR-JCBL
FR-A8AP terminal	PA1	PA
	PA2	Do not connect anything to this.
	PB1	PB
	PB2	Do not connect anything to this.
	PZ1	PZ
	PZ2	Do not connect anything to this.
	PG	PG
	SD	SD
		AG2

◆ Wiring example

- Speed control

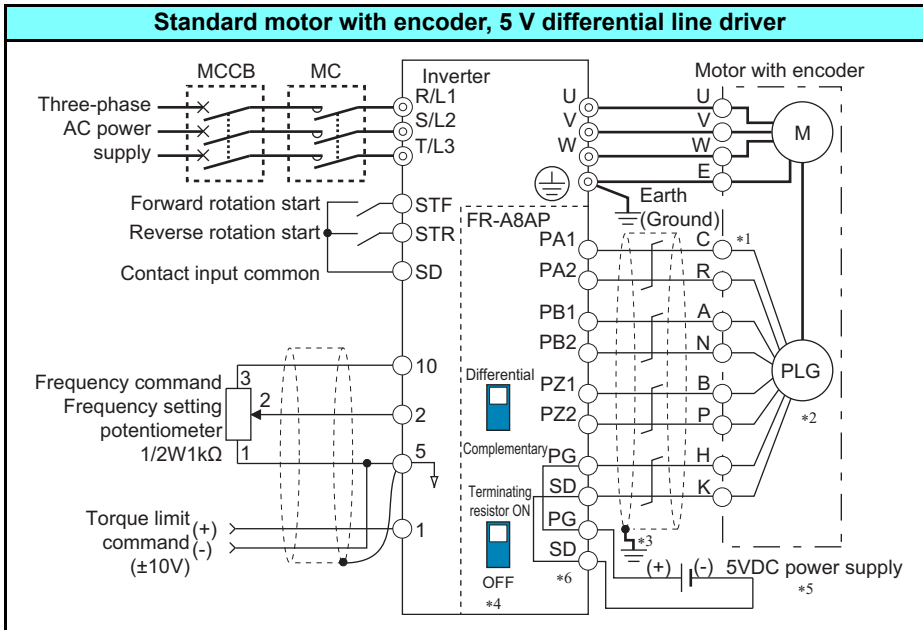

- Torque control

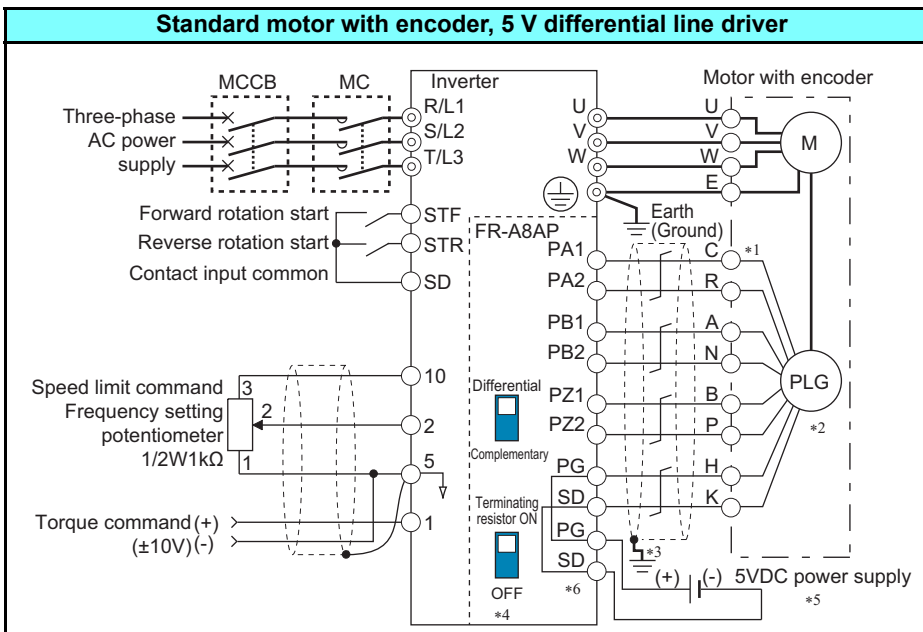

Connection of motor with encoder (vector control)

- Position control

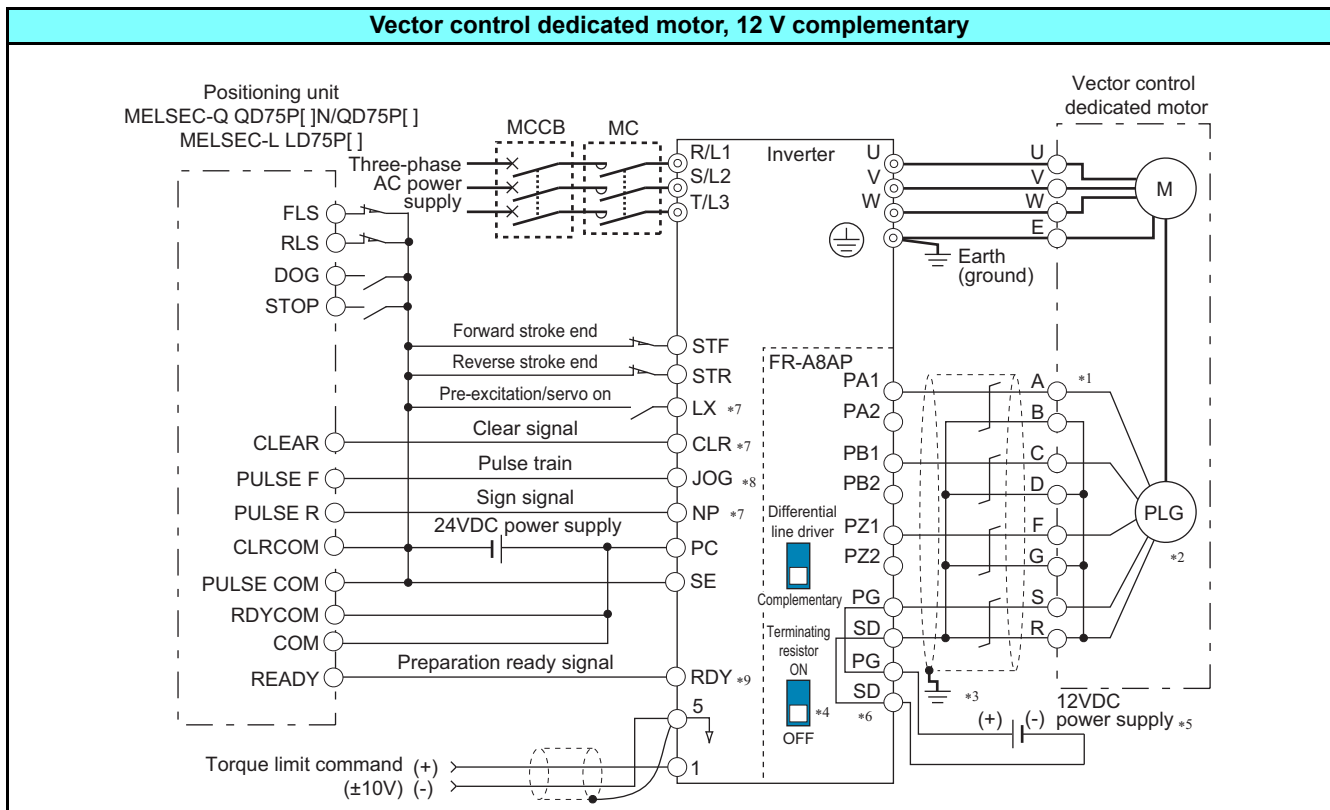

- *1 The pin number differs according to the encoder used.
Speed, control, torque control, and position control by pulse train input are available with or without the Z-phase being connected.
- *2 Connect the encoder so that there is no looseness between the motor and motor shaft. Speed ratio must be 1:1.
- *3 Earth (ground) the shield of the encoder cable to the enclosure using a tool such as a P-clip. (Refer to [page 57](#).)
- *4 For the complementary, set the terminating resistor selection switch to OFF position. (Refer to [page 53](#).)
- *5 A separate power supply of 5 V/12 V/15 V/24 V is necessary according to the encoder power specification.
When the encoder output is the differential line driver type, only 5 V can be input.
Make the voltage of the external power supply the same as the encoder output voltage, and connect the external power supply across PG and SD.
- *6 For terminal compatibility of the FR-JCBL, FR-V7CBL, and FR-A8AP, refer to [page 55](#).
- *7 Assign the function using [Pr.178 to Pr.184](#), [Pr.187 to Pr.189](#) (input terminal function selection).
- *8 When position control is selected, terminal JOG function is invalid and simple position pulse train input terminal becomes valid.
- *9 Assign the function using [Pr.190 to Pr.194](#) (output terminal function selection).

◆ Instructions for encoder cable wiring

- Use shielded twisted pair cables (0.2 mm² or larger) to connect the FR-A8AP. For the wiring to terminals PG and SD, use several cables in parallel or use a thick cable, according to the wiring length.
To protect the cables from noise, run them away from any source of noise (such as the main circuit and power supply voltage).

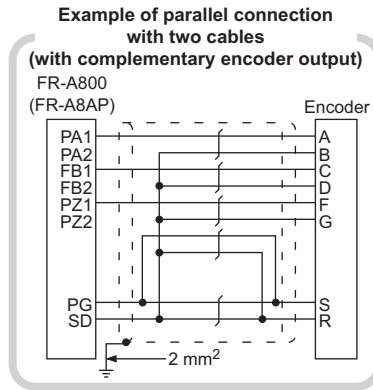

Wiring length	Parallel connection	Larger-size cable	
Within 10 m	At least two cables in parallel	Cable gauge 0.2 mm ²	
Within 20 m	At least four cables in parallel		0.4 mm ² or larger
Within 100 m	At least six cables in parallel		0.75 mm ² or larger
			1.25 mm ² or larger

*1 When differential line driver is set and a wiring length is 30 m or more.

The wiring length can be extended to 100 m by increasing the 5 V power supply (approximately to 5.5 V) while using six or more 0.2 mm² gauge cables in parallel or a 1.25 mm² or larger gauge cable. The voltage applied must be within power supply specifications of encoder.

- To reduce noise of the encoder cable, earth (ground) the encoder's shielded cable to the enclosure (as close as possible to the inverter) with a P-clip or U-clip made of metal.

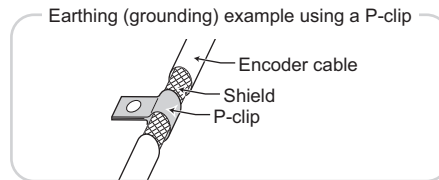

- When one encoder is shared between FR-A8AP and CNC (computerized numerical controller), its output signal should be connected as shown below. In this case, the wiring length between FR-A8AP and CNC should be as short as possible, within 5 m.

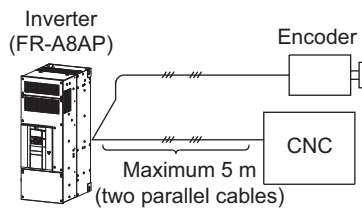



NOTE

- For the details of the optional encoder dedicated cable (FR-JCBL/FR-V7CBL), refer to [page 54](#).
- The FR-V7CBL is provided with a P-clip for earthing (grounding) shielded cables.

2.9 Parameter settings for a motor with encoder

◆ Parameter for the encoder (Pr.359, Pr.369, Pr.851, Pr.852)

- Set the encoder specifications.

Pr.	Name	Initial value	Setting range	Description		
359 C141	852 C241	Encoder rotation direction	1	0	Set when using a motor for which forward rotation (encoder) is clockwise (CW) viewed from the shaft	Set for the operation at 120 Hz or less.
				100		Set for the operation at a frequency higher than 120 Hz.
				1	Set when using a motor for which forward rotation (encoder) is counterclockwise (CCW) viewed from the shaft	Set for the operation at 120 Hz or less.
				101		Set for the operation at a frequency higher than 120 Hz.
369 C140	851 C240	Number of encoder pulses	1024	0 to 4096	Set the number of encoder pulses output. Set the number of pulses before it is multiplied by 4.	

The parameters above can be set when a vector control compatible option is installed.

- The following table shows parameters to be set according to a vector control compatible option to be used.

Item	FR-A8AP/FR-A8AL/ FR-A8APA parameter	FR-A8APR parameter	FR-A8APS parameter	FR-A8TP parameter
Encoder/Resolver rotation direction	Pr.359			Pr.852
Number of detector pulses	Pr.369	— (fixed 1024 pulses)	— (Obtained via communication from the encoder)	Pr.851

◆ Parameter settings for the motor under vector control

Motor name	Pr.9 Electronic thermal O/L relay	Pr.71 Applied motor	Pr.80 Motor capacity	Pr.81 Number of motor poles	Pr.359/Pr.852 Encoder rotation direction	Pr.369/Pr.851 Number of encoder pulses
Standard motor	Rated motor current	0 (3)*1	Motor capacity	Number of motor poles	*2	*2
Constant-torque motor	Rated motor current	1 (13)*1	Motor capacity	Number of motor poles	*2	*2

*1 Offline auto tuning is required. (Refer to the Instruction Manual (Function).)

*2 Set this parameter according to the motor.

2.10 Connection of brake resistor

When an inverter-driven motor is driven by a load or requires rapid deceleration, install an external brake resistor (built-in brake transistor model only). Connect the brake resistor to terminals P/+ and PR. (For locations of the terminals P/+ and PR, refer to the terminal block layout on [page 28](#).)

Do not use the brake resistor with a resistance smaller than the minimum resistance shown below. Also, the brake resistor must have a sufficient capacity to consume the regenerative power.

Inverter	Voltage class	Minimum resistance (Ω)	Power consumption of resistor (kW)
FR-A870-00550	575 VAC input	13	67.8
FR-A870-00660	690 VAC input		89.7
FR-A870-00890			
FR-A870-02300	575 VAC input	4	220.4
FR-A870-02860	690 VAC input		291.6

Set parameters as follows:

- **Pr.30 Regenerative function selection = "1"**
- Set **Pr.70 Special regenerative brake duty** according to the amount and frequency of the regenerative driving, and make sure that the resistor can consume the regenerative power properly.
- When the regenerative brake transistor is damaged, install a thermal relay as shown in the following sequence to prevent overheat and burnout of the brake resistor. Properly select a thermal relay according to the regenerative driving frequency or the rated power or resistance of the brake resistor.

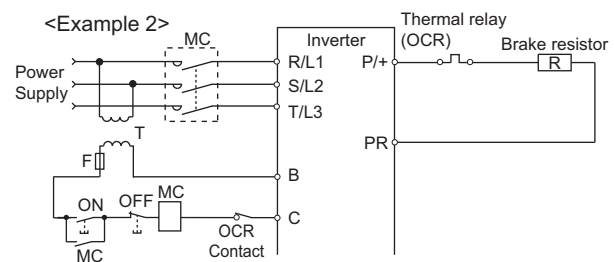
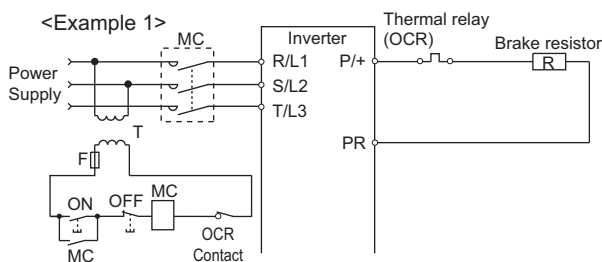

⚠ Caution

- If the resistor selection is incorrect, overcurrent may damage the inverter built-in brake transistor. Besides, the resistor may be burned due to overheat.
- If the selection of the thermal relay is incorrect, the resistor may be burned due to overheat.

NOTE

- The wiring length between the inverter and the brake resistor must be within 5 m. When using twisted pair cable, use the cable within 10 m.

2.11 Installing communication option

- To use a communication option, the enclosed earthing (grounding) cable needs to be installed. Install the cable according to the following procedure.

No.	Installation procedure
1	Insert spacers into the mounting holes that will not be tightened with the option mounting screws.
2	Fit the connector of the communication option to the guide of the connector of the inverter, and insert the option as far as it goes. (Insert it to the inverter option connector 1.)
3	Remove the mounting screw (lower) of the Ethernet board earth plate. Fit the one terminal of the earthing (grounding) cable on the Ethernet board earth plate and fix it securely to the inverter with the mounting screw (tightening torque 0.33 N·m to 0.40 N·m).
4	Fix the left part of the communication option securely with the option mounting screw, and place another terminal of the earthing (grounding) cable on the right part of the option and fix the cable terminal and the option with the option mounting screw (tightening torque 0.33 N·m to 0.40 N·m). If the screw holes do not line up, the connector may not be inserted deep enough. Check the connector.

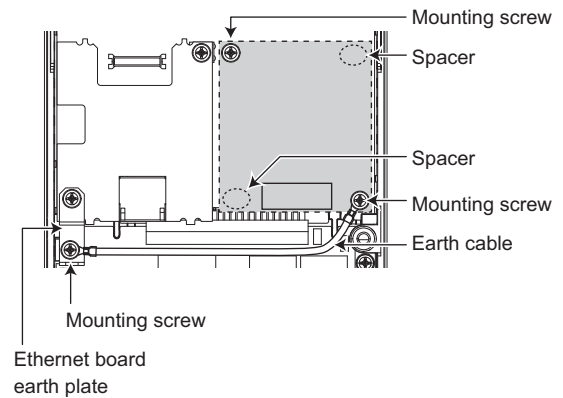
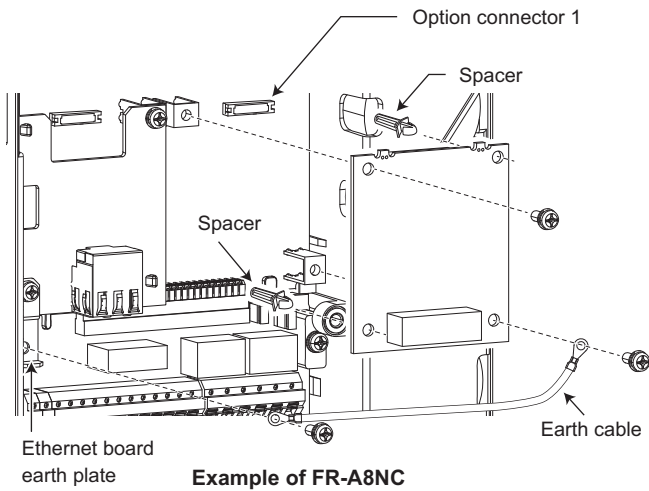

NOTE

- The number and shape of the spacers used differ depending on the communication option type. Refer to the Instruction Manual of each communication option for details.
- The earth plate enclosed with a communication option is not used.

3 PRECAUTIONS FOR USE OF THE INVERTER

This chapter explains the precautions for use of this product.
Always read the instructions before using the equipment.

3.1	Electro-magnetic interference (EMI) and leakage currents ..	62
3.2	Power supply harmonics	66
3.3	Power-OFF and magnetic contactor (MC)	67
3.4	Countermeasures against deterioration of the 690 V class motor insulation.....	68
3.5	Checklist before starting operation	69
3.6	Failsafe system which uses the inverter	71

3.1 Electro-magnetic interference (EMI) and leakage currents

3.1.1 Leakage currents and countermeasures

Capacitances exist between the inverter I/O cables, other cables and earth and in the motor, through which a leakage current flows. Since its value depends on the static capacitances, carrier frequency, etc., low acoustic noise operation at the increased carrier frequency of the inverter will increase the leakage current. Therefore, take the following countermeasures. Select the earth leakage current breaker according to its rated sensitivity current, independently of the carrier frequency setting.

◆To-earth (ground) leakage currents

Leakage currents may flow not only into the the power system of the inverter but also into the power systems through the earthing (grounding) cable, etc. These leakage currents may operate earth leakage circuit breakers and earth leakage relays unnecessarily.

●Suppression technique

- If the carrier frequency setting is high, decrease the **Pr.72 PWM frequency selection** setting.
Note that motor noise increases. Selecting **Pr.240 Soft-PWM operation selection** makes the sound inoffensive.
- By using earth leakage circuit breakers designed to suppress harmonics and surge voltage in the power system of the inverter and other devices, operation can be performed with the carrier frequency kept high (with low noise).

●To-earth (ground) leakage currents

- Take caution as long wiring will increase the leakage current. Decreasing the carrier frequency of the inverter reduces the leakage current.
- Increasing the motor capacity increases the leakage current.

◆Line-to-line leakage currents

Harmonics of leakage currents flowing in static capacitances between the inverter output cables may operate the external thermal relay unnecessarily.

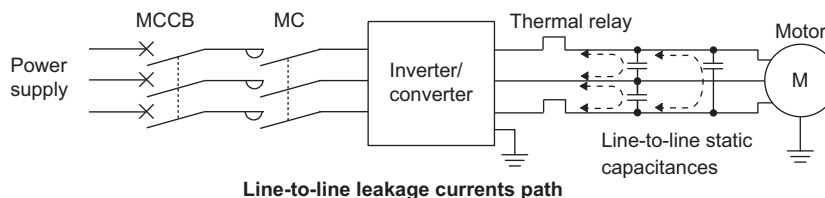

●Countermeasures

- Use **Pr.9 Electronic thermal O/L relay**.
- If the carrier frequency setting is high, decrease the **Pr.72 PWM frequency selection** setting.
Note that motor noise increases. Selecting **Pr.240 Soft-PWM operation selection** makes the sound inoffensive.
To ensure that the motor is protected against line-to-line leakage currents, it is recommended to use a temperature sensor to directly detect motor temperature.

●Installation and selection of the molded case circuit breaker

Install a molded case circuit breaker (MCCB) on the power receiving side to protect the wiring at the inverter input side. Select an MCCB according to the inverter input side power factor, which depends on the power supply voltage, output frequency and load. Especially for a completely electromagnetic MCCB, a slightly large capacity must be selected since its operation characteristic varies with harmonic currents. (Check it in the data of the corresponding breaker.) As an earth leakage current breaker, use the earth leakage current breaker designed for harmonics and surge suppression.

3.1.2 Countermeasures against inverter-generated EMI

Some electromagnetic noises enter the inverter to cause the inverter malfunction, and others are radiated by the inverter to cause the peripheral devices to malfunction. Though the inverter is designed to have high immunity performance, it handles low-level signals, so it requires the following basic techniques. Also, since the inverter chops outputs at high carrier frequency, that could generate electromagnetic noises. If these electromagnetic noises cause peripheral devices to malfunction, EMI countermeasures should be taken to suppress noises. These techniques differ slightly depending on EMI paths.

- Basic techniques
 - Do not run the power cables (I/O cables) and signal cables of the inverter in parallel with each other and do not bundle them.
 - Use shielded twisted pair cables for the detector connecting and control signal cables and connect the sheathes of the shielded cables to terminal SD.
 - Ground (Earth) the inverter, motor, etc. at one point.
- Techniques to reduce electromagnetic noises that enter and cause a malfunction of the inverter (EMI countermeasures)

When devices that generate many electromagnetic noises (which use magnetic contactors, electromagnetic brakes, many relays, for example) are installed near the inverter and the inverter may malfunction due to electromagnetic noises, the following countermeasures must be taken:

 - Provide surge suppressors for devices that generate many electromagnetic noises to suppress electromagnetic noises.
 - Install data line filters (page 64) to signal cables.
 - Ground (Earth) the shields of the detector connection and control signal cables with cable clamp metal.
- Techniques to reduce electromagnetic noises that are radiated by the inverter to cause the peripheral devices to malfunction (EMI countermeasures)

Inverter-generated noises are largely classified into those radiated by the cables connected to the inverter and inverter main circuits (I/O), those electromagnetically and electrostatically induced to the signal cables of the peripheral devices close to the main circuit power supply, and those transmitted through the power supply cables.

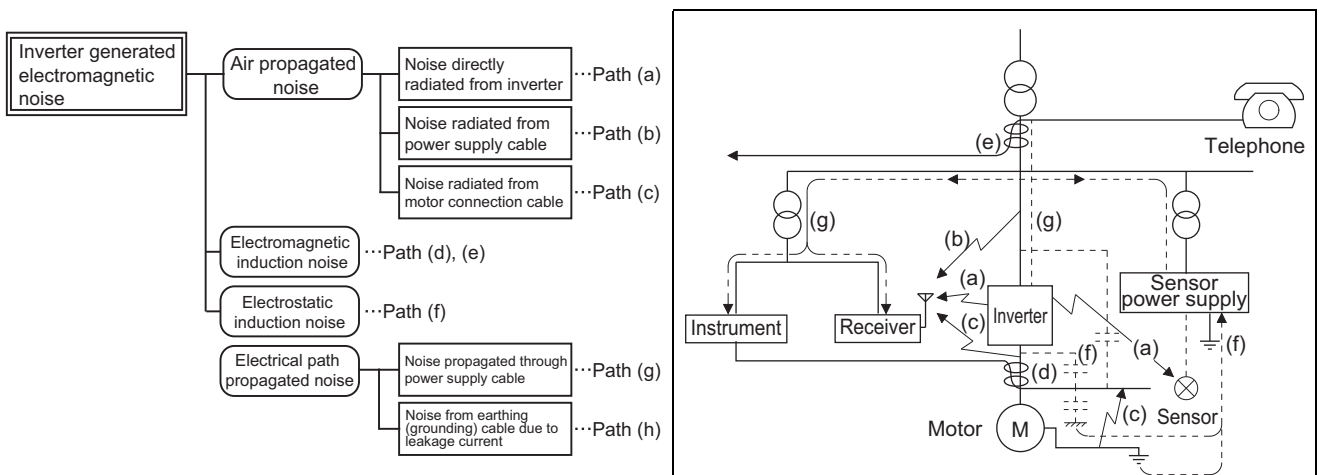

Electro-magnetic interference (EMI) and leakage currents

Noise propagation path	Countermeasure
(a)(b)(c)	<p>When devices that handle low-level signals and are liable to malfunction due to electromagnetic noises, e.g. instruments, receivers and sensors, are contained in the enclosure that contains the inverter or when their signal cables are run near the inverter, the devices may malfunction due to by air-propagated electromagnetic noises. The following countermeasures must be taken:</p> <ul style="list-style-type: none"> • Install easily affected devices as far away as possible from the inverter. • Run easily affected signal cables as far away as possible from the inverter and its I/O cables. • Do not run the signal cables and power cables (inverter I/O cables) in parallel with each other and do not bundle them. • Set the EMC filter ON/OFF connector of the inverter to the ON position. (Refer to page 65.) • Inserting a line noise filter into the output suppresses the radiated noise from the cables. • Use shielded cables as signal cables and power cables and run them in individual metal conduits to produce further effects.
(d)(e)(f)	<p>When the signal cables are run in parallel with or bundled with the power cables, magnetic and static induction noises may be propagated to the signal cables to cause malfunction of the devices and the following countermeasures must be taken:</p> <ul style="list-style-type: none"> • Install easily affected devices as far away as possible from the inverter. • Run easily affected signal cables as far away as possible from the inverter and its I/O cables. • Do not run the signal cables and power cables (inverter I/O cables) in parallel with each other and do not bundle them. • Use shielded cables as signal cables and power cables and run them in individual metal conduits to produce further effects.
(g)	<p>When the power supplies of the peripheral devices are connected to the power supply of the inverter in the same line, inverter-generated noises may flow back through the power supply cables to cause malfunction of the devices and the following countermeasures must be taken:</p> <ul style="list-style-type: none"> • Set the EMC filter ON/OFF connector of the inverter to the ON position. (Refer to page 65.) • Install the line noise filter to the power cables (output cables) of the inverter.
(h)	<p>When a closed loop circuit is formed by connecting the peripheral device wiring to the inverter, leakage currents may flow through the earthing (grounding) cable of the inverter to cause the device to malfunction. In that case, disconnecting the earthing (grounding) cable from the device may stop the malfunction of the device.</p>

●Data line filter

Data line filter is effective as an EMI countermeasure. Provide a data line filter for the detector cable, etc.

<Example> Data line filter : ZCAT3035-1330 (by TDK)
 : ESD-SR-250 (by NEC TOKIN)
 Impedance (ZCAT3035-1330)

Impedance (Ω)	
10 to 100 MHz	100 to 500 MHz
80	150

The impedance values above are reference values, and not guaranteed values.

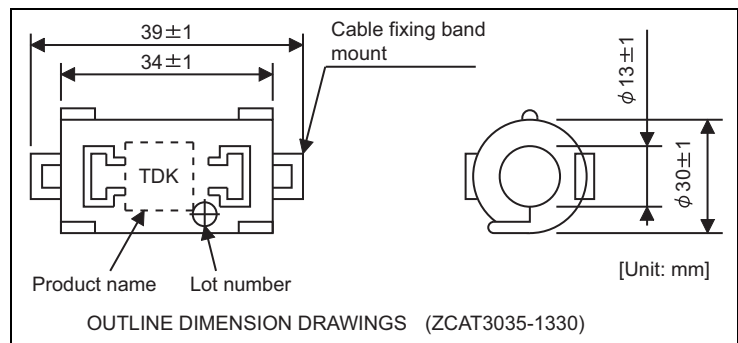

●EMI countermeasure example

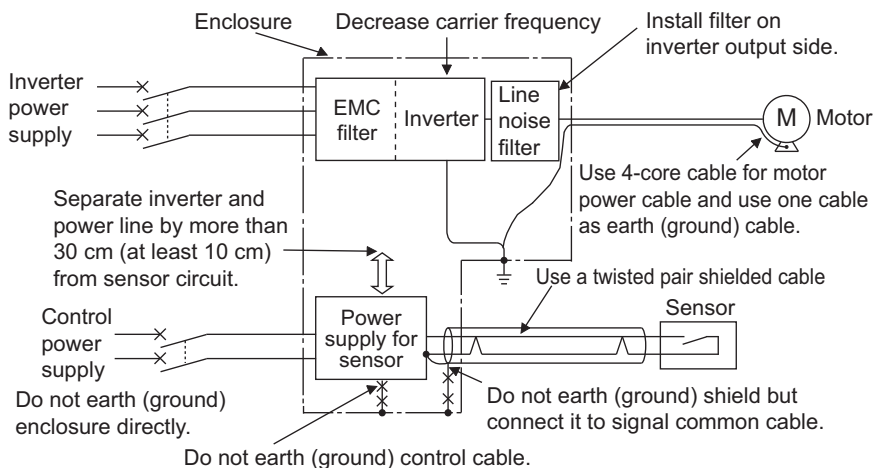

NOTE

• For compliance with the EU EMC Directive, refer to [page 104](#).

3.1.3 Built-in EMC filter

This inverter is equipped with a built-in EMC filter (capacitive filter) and a common mode choke.

These filters are effective in reducing air-propagated noise on the input side of the inverter.

To enable the EMC filter, fit the EMC filter ON/OFF connector to the ON position. The FM type is initially set to "disabled" (OFF), and the CA type to "enabled" (ON). (For the FR-A870-00550 to 00890, two EMC filter ON/OFF connectors are provided. The both connectors are initially set to the "disabled" (OFF) position.)

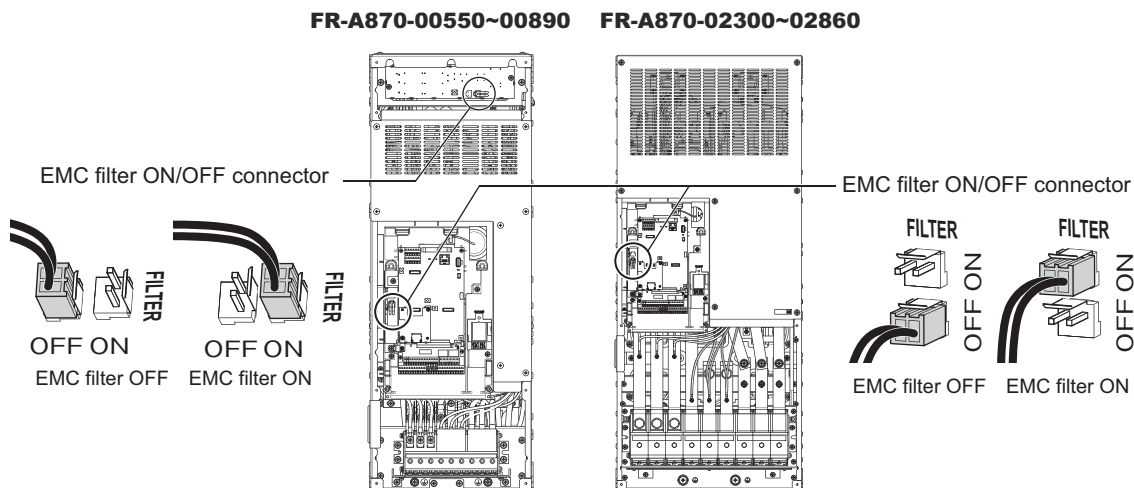

<How to enable or disable the filter>

- Before removing a front cover, check to make sure that the indication of the inverter operation panel is OFF, wait for at least 10 minutes after the power supply has been switched OFF, and check that there is no residual voltage using a tester or the like.
- When disconnecting the connector, push the fixing tab and pull the connector straight without pulling the cable or forcibly pulling the connector with the tab fixed. When installing the connector, also engage the fixing tab securely. (If it is difficult to disconnect the connector, use a pair of needle-nose pliers, etc.)

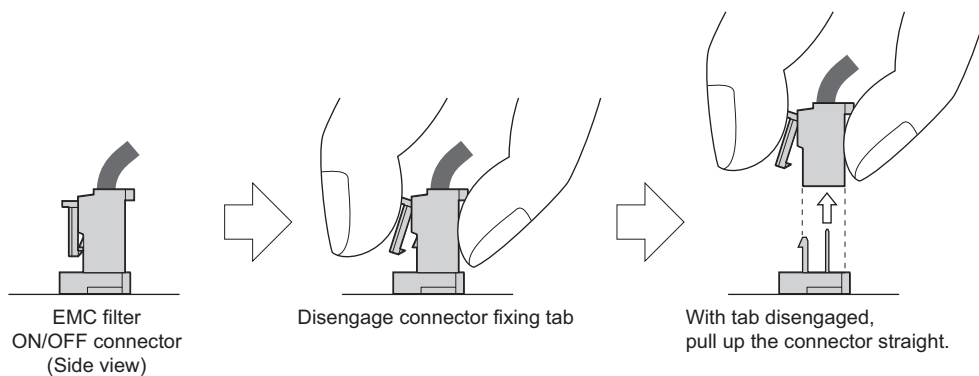

NOTE

- Fit the connector to either ON or OFF position.
- Enabling (turning ON) the EMC filter increases leakage current. (Refer to [page 63](#).)

Warning

- While power is ON or when the inverter is running, do not open the front cover. Otherwise you may get an electric shock.

3.2 Power supply harmonics

3.2.1 Power supply harmonics

The inverter may generate power supply harmonics from its converter circuit to affect the power generator, power factor correction capacitor etc. Power supply harmonics are different from noise and leakage currents in source, frequency band and transmission path. Take the following countermeasure suppression techniques.

- The differences between harmonics and noises

Item	Harmonics	Noise
Frequency	Normally 40th to 50th degrees or less (3 kHz or less).	High frequency (several 10 kHz to 1 GHz order).
Location	To-electric channel, power impedance.	To-space, distance, wiring path,
Quantitative understanding	Theoretical calculation possible.	Random occurrence, quantitative grasping difficult.
Generated amount	Nearly proportional to the load capacity.	Changes with the current variation ratio. (Gets larger as switching speed increases.)
Affected equipment immunity	Specified by standards per equipment.	Different depending on maker's equipment specifications.
Countermeasure	Provide a reactor.	Increase distance.

- Countermeasures

The harmonic current generated from the inverter to the input side differs according to various conditions such as the wiring impedance, whether a reactor is used or not, and output frequency and output current on the load side.

For the output frequency and output current, we understand that this should be calculated in the conditions under the rated load at the maximum operating frequency.

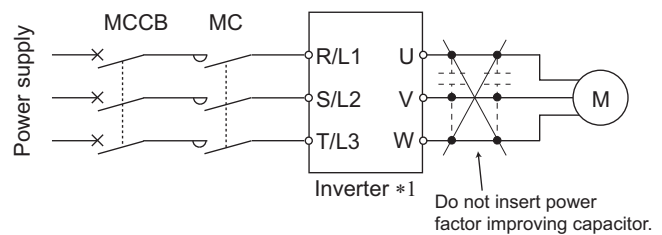

*1 The inverter has a built-in DC reactor.

3.3 Power-OFF and magnetic contactor (MC)

◆ Inverter input side magnetic contactor (MC)

On the inverter input side, it is recommended to provide an MC for the following purposes:

(Refer to [page 14](#) for selection.)

- To disconnect the inverter from the power supply at activation of a protective function or at malfunctioning of the driving system (emergency stop, etc.).
- To prevent any accident due to an automatic restart at power restoration after an inverter stop made by a power failure.
- To separate the inverter from the power supply to ensure safe maintenance and inspection work.

NOTE

- Since repeated inrush currents at power ON will shorten the life of the converter circuit (switching life is about 1,000,000 times), frequent starts and stops of the magnetic contactor must be avoided. Turn ON/OFF the inverter start controlling terminals (STF, STR) to run/stop the inverter.

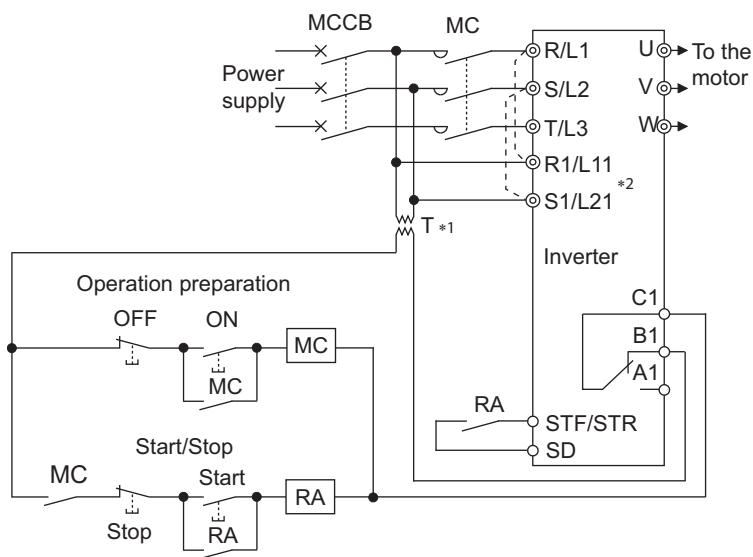

- Inverter start/stop circuit example

As shown on the left, always use the start signal (ON or OFF of STF(STR) signal) to make a start or stop.

*1 Install a stepdown transformer.

*2 Connect the power supply terminals R1/L11, S1/L21 of the control circuit to the input side of the MC to hold an alarm signal when the inverter's protective circuit is activated. At this time, remove jumpers across terminals R/L1 and R1/L11 and S/L2 and S1/L21. (Refer to [page 43](#) for removal of the jumper.)

◆ Handling of the magnetic contactor on the inverter's output side

Switch the magnetic contactor between the inverter and motor only when both the inverter and motor are at a stop. When the magnetic contactor is turned ON while the inverter is operating, overcurrent protection of the inverter and such will activate.

When an MC is provided to switch to a commercial power supply, for example, it is recommended to use the electronic bypass function of **Pr.135 to Pr.139** (refer to the Instruction Manual (Function)).

3.4 Countermeasures against deterioration of the 690 V class motor insulation

In the PWM type inverter, a surge voltage attributable to wiring constants is generated at the motor terminals. Especially in a 690 V class motor, the surge voltage may deteriorate the insulation. When the 690 V class motor is driven by the inverter, consider the following countermeasures:

- Rectifying the motor insulation and limiting the PWM carrier frequency according to the wiring length
For the 690 V class motor, use an insulation-enhanced motor.
Specifically,
 - Order a "690 V class inverter-driven insulation-enhanced motor".
 - When the wiring length exceeds 100 m, set "4" (4 kHz) or less in **Pr.72 PWM frequency selection** (carrier frequency).



- For the details of **Pr.72 PWM frequency selection**, refer to the Instruction Manual (Function).

3.5 Checklist before starting operation

The FR-A800 series inverter is a highly reliable product, but incorrect peripheral circuit making or operation/handling method may shorten the product life or damage the product.

Before starting operation, always recheck the following points.

Checkpoint	Countermeasure	Refer to page	Check by user
Crimp terminals are insulated.	Use crimp terminals with insulation sleeves to wire the power supply and the motor.	-	
The wiring between the power supply (R/L1, S/L2, T/L3) and the motor (U, V, W) is correct.	Application of power to the output terminals (U, V, W) of the inverter will damage the inverter. Never perform such wiring.	27	
No wire offcuts are left from the time of wiring.	Wire offcuts can cause an alarm, failure or malfunction. Always keep the inverter clean. When drilling mounting holes in an enclosure etc., take caution not to allow chips and other foreign matter to enter the inverter.	-	
The main circuit cable gauge is correctly selected.	Use an appropriate cable gauge to suppress the voltage drop to 2% or less. If the wiring distance is long between the inverter and motor, the voltage drop in the main circuit will cause the motor torque to decrease especially during the output of a low frequency.	31	
The total wiring length is within the specified length.	Keep the total wiring length within the specified length. In long distance wiring, charging currents due to stray capacitance in the wiring may degrade the fast-response current limit operation or cause the equipment on the inverter's output side to malfunction. Pay attention to the total wiring length.	31	
Countermeasures are taken against EMI.	The input/output (main circuit) of the inverter includes high frequency components, which may interfere with the communication devices (such as AM radios) used near the inverter. In such case, activate the EMC filter (turn ON the EMC filter ON/OFF connector) to minimize interference.	65	
Countermeasures are taken against electrical corrosion on the motor bearing.	When a motor is driven by the inverter, axial voltage is generated on the motor shaft, which may cause electrical corrosion of the bearing in rare cases depending on the wiring, load, operating conditions of the motor or specific inverter settings (high carrier frequency and EMC filter ON). Contact your sales representative to take appropriate countermeasures for the motor. The following shows examples of countermeasures for the inverter. • Decrease the carrier frequency. • Turn OFF the EMC filter. • Provide a common mode choke on the output side of the inverter. *1 (This is effective regardless of the EMC filter ON/OFF connector setting.)	-	
On the inverter's output side, there is no power factor correction capacitor, surge suppressor, or radio noise filter installed.	Such installation will cause the inverter to trip or the capacitor and surge suppressor to be damaged. If any of the above devices is connected, immediately remove it.	-	
When performing an inspection or rewiring on the product that has been energized, the operator has waited long enough after shutting off the power supply.	For a short time after the power-OFF, a high voltage remains in the smoothing capacitor, and it is dangerous. Before performing an inspection or rewiring, wait 10 minutes or longer after the power supply turns OFF, then confirm that the voltage across the main circuit terminals P/+ and N/- of the inverter is low enough using a tester, etc.	-	
The inverter's output side has no short circuit or ground fault occurring.	• A short circuit or ground fault on the inverter's output side may damage the inverter module. • Fully check the insulation resistance of the circuit prior to inverter operation since repeated short circuits caused by peripheral circuit inadequacy or a ground fault caused by wiring inadequacy or reduced motor insulation resistance may damage the inverter module. • Fully check the to-earth (ground) insulation and phase-to-phase insulation of the inverter's output side before power-ON. Especially for an old motor or use in hostile atmosphere, make sure to check the motor insulation resistance, etc.	-	
The circuit is not configured to use the inverter's input-side magnetic contactor to start/stop the inverter frequently.	Since repeated inrush currents at power ON will shorten the life of the converter circuit, frequent starts and stops of the magnetic contactor must be avoided. Turn ON/OFF the inverter's start signals (STF, STR) to run/stop the inverter.	67	

Checklist before starting operation

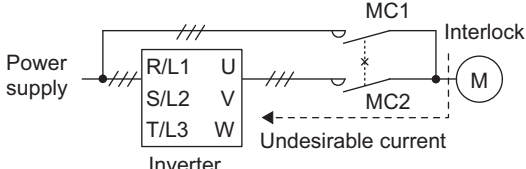
Checkpoint	Countermeasure	Refer to page	Check by user
A mechanical brake is not connected to terminals P/+ and PR.	To terminals P/+ and PR, connect only an external brake resistor.	59	
The voltage applied to the inverter I/O signal circuits is within the specifications.	Application of a voltage higher than the permissible voltage to the inverter I/O signal circuits or opposite polarity may damage the I/O devices. Especially check the wiring to prevent the speed setting potentiometer from being connected incorrectly to short circuit terminals 10E and 5.	34	
When using the electronic bypass operation, electrical and mechanical interlocks are provided between the electronic bypass contactors MC1 and MC2.	<p>When using a switching circuit as shown below, chattering due to mis-configured sequence or arc generated at switching may allow undesirable current to flow in and damage the inverter. Mis-wiring may also damage the inverter.</p>  <p>If switching to the commercial power supply operation while a failure such as an output short circuit has occurred between the magnetic contactor MC2 and the motor, the damage may further spread. If a failure has occurred between the MC2 and the motor, a protection circuit such as using the OH signal input must be provided.</p>	-	
A countermeasure is provided for power restoration after a power failure.	If the machine must not be restarted when power is restored after a power failure, provide an MC in the inverter's input side and also make up a sequence which will not switch ON the start signal. If the start signal (start switch) remains ON after a power failure, the inverter will automatically restart as soon as the power is restored.	-	
When using vector control, the encoder is properly installed.	The encoder must be directly connected to a motor shaft without any backlash. (Real sensorless vector control do not require an encoder.)	52	
A magnetic contactor (MC) is installed on the inverter's input side.	On the inverter's input side, connect an MC for the following purposes: <ul style="list-style-type: none"> • To disconnect the inverter from the power supply at activation of a protective function or at malfunctioning of the driving system (emergency stop, etc.). • To prevent any accident due to an automatic restart at power restoration after an inverter stop made by a power failure. • To separate the inverter from the power supply to ensure safe maintenance and inspection work. 	67	
The magnetic contactor on the inverter's output side is properly handled.	Switch the magnetic contactor between the inverter and motor only when both the inverter and motor are at a stop.	67	
An EMI countermeasure is provided for the frequency setting signals.	If electromagnetic noise generated from the inverter causes frequency setting signal to fluctuate and the motor rotation speed to be unstable when changing the motor speed with analog signals, the following countermeasures are effective: <ul style="list-style-type: none"> • Do not run the signal cables and power cables (inverter I/O cables) in parallel with each other and do not bundle them. • Run signal cables as far away as possible from power cables (inverter I/O cables). • Use shielded cables. • Install a ferrite core on the signal cable (Example: ZCAT3035-1330 by TDK). 	63	
A countermeasure is provided for an overload operation.	When performing frequent starts/stops by the inverter, rise/fall in the temperature of the transistor element of the inverter will repeat due to a repeated flow of large current, shortening the life from thermal fatigue. Since thermal fatigue is related to the amount of current, the life can be increased by reducing current at locked condition, starting current, etc. Reducing current may extend the service life but may also cause torque shortage, which leads to a start failure. Adding a margin to the current can eliminate such a condition. Use an inverter of a higher capacity (up to two ranks).	-	
The specifications and rating match the system requirements.	Make sure that the specifications and rating match the system requirements.	96	

*1 Recommended common mode choke: FT-3KM F series FINEMET® common mode choke cores manufactured by Hitachi Metals, Ltd. FINEMET is a registered trademark of Hitachi Metals, Ltd.

3.6 Failsafe system which uses the inverter

When a fault is detected by the protective function, the protective function activates and outputs a fault signal. However, a fault signal may not be output at an inverter's fault occurrence when the detection circuit or output circuit fails, etc. Although Mitsubishi assures the best quality products, provide an interlock which uses inverter status output signals to prevent accidents such as damage to the machine when the inverter fails for some reason. Also at the same time consider the system configuration where a failsafe from outside the inverter, without using the inverter, is enabled even if the inverter fails.

◆ Interlock method which uses the inverter status output signals

By combining the inverter output signals to provide an interlock as shown below, an inverter failure can be detected.

No.	Interlock method	Check method	Used signals
a	Inverter protective function operation	Operation check of an alarm contact. Circuit error detection by negative logic.	Fault output signal (ALM signal)
b	Inverter operating status	Operation ready signal check.	Operation ready signal (RY signal)
c	Inverter running status	Logic check of the start signal and running signal.	Start signal (STF signal, STR signal) Running signal (RUN signal)
d	Inverter running status	Logic check of the start signal and output current.	Start signal (STF signal, STR signal) Output current detection signal (Y12 signal)

(a) Checking by the output of the inverter fault signal

When the inverter's protective function activates and the inverter trips, the fault output signal (ALM signal) is output. (ALM signal is assigned to terminals A1, B1, and C1 in the initial setting).

With this signal, check that the inverter operates properly.

In addition, negative logic can be set. (ON when the inverter is normal, OFF when the fault occurs.)

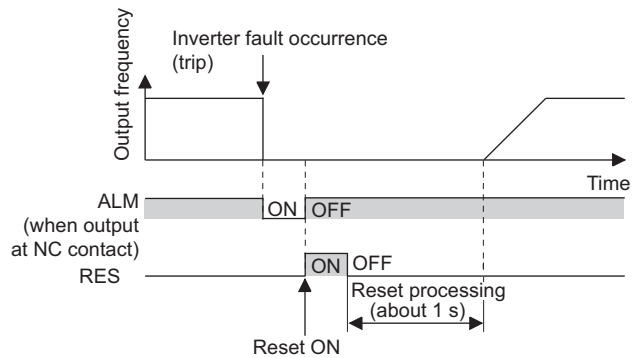

(b) Checking the inverter operating status by the inverter operation ready completion signal

Operation ready signal (RY signal) is output when the inverter power is ON and the inverter becomes operative. Check if the RY signal is output after powering ON the inverter.

(c) Checking the inverter operating status by the start signal input to the inverter and inverter running signal

The inverter running signal (RUN signal) is output when the inverter is running. (RUN signal is assigned to terminal RUN in the initial setting.)

Check if RUN signal is being output while inputting a start signal to the inverter. (STF signal is a forward rotation signal, and STR is a reverse rotation signal.) Even after the start signal is turned OFF, the RUN signal is kept output until the inverter makes the motor to decelerate and to stop. For the logic check, configure a sequence considering the inverter's deceleration time.

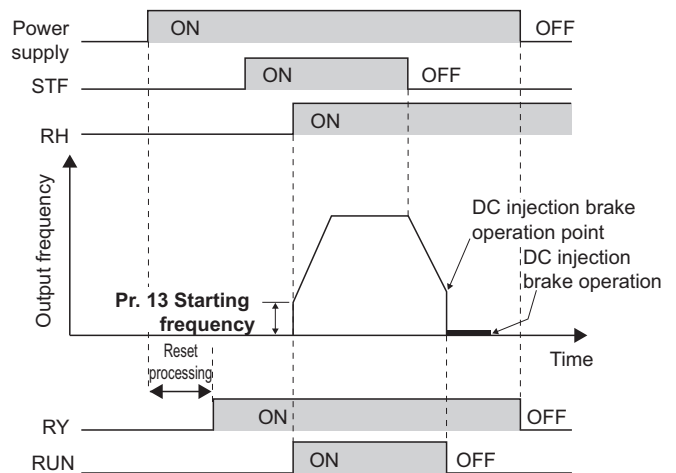

Failsafe system which uses the inverter

- (d) Checking the motor operating status by the start signal input to the inverter and inverter output current detection signal
- The output current detection signal (Y12 signal) is output when the inverter operates and currents flows into the motor. Check if Y12 signal is being output while inputting a start signal to the inverter. (STF signal is a forward rotation signal, and STR is a reverse rotation signal.) The Y12 signal is initially set to be output at 150% inverter rated current. Adjust the level to around 20% using no load current of the motor as reference with **Pr.150 Output current detection level**. Like the inverter running signal (RUN signal), even after the start signal is turned OFF, the Y12 signal is kept output until the inverter stops the output to a decelerating motor. For the logic check, configure a sequence considering the inverter's deceleration time.

Output signal	Pr.190 to Pr.196 setting	
	Positive logic	Negative logic
ALM	99	199
RY	11	111
RUN	0	100
Y12	12	112

- When using various signals, assign the functions to **Pr.190 and Pr.196 (output terminal function selection)** referring to the table on the left.

NOTE

- Changing the terminal assignment using **Pr.190 and Pr.196 (output terminal function selection)** may affect the other functions. Set parameters after confirming the function of each terminal.
- For the details on the parameters and signals, refer to the Instruction Manual (Function).

◆Backup method outside the inverter

Even if the interlock is provided by the inverter status signal, enough failsafe is not ensured depending on the failure status of the inverter itself. For example, if an inverter CPU fails in a system interlocked with the inverter's fault, start, and RUN signals, no fault signal will be output and the RUN signal will be kept ON because the inverter CPU is down.

Provide a speed detector to detect the motor speed and current detector to detect the motor current and consider the backup system such as performing a check as below according to the level of importance of the system.

- (a) Start signal and actual operation check

Check the motor running and motor current while the start signal is input to the inverter by comparing the start signal to the inverter and detected speed of the speed detector or detected current of the current detector. Note that the current is flowing through the motor while the motor coasts to stop, even after the inverter's start signal is turned OFF. For the logic check, configure a sequence considering the inverter's deceleration time. In addition, it is recommended to check the three-phase current when using the current detector.

- (b) Command speed and actual operation check

Check for a gap between the actual speed and commanded speed by comparing the inverter's speed command and the speed detected by the speed detector.

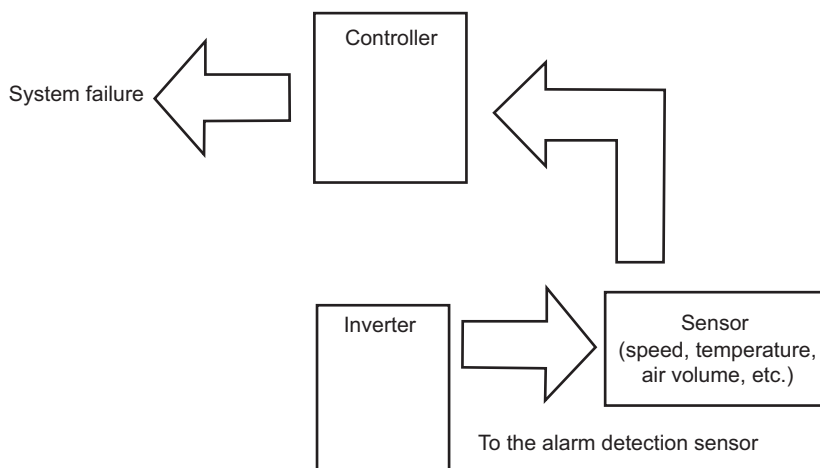

4 PROTECTIVE FUNCTIONS

This chapter explains the protective function that operates in this product. Always read the instructions before using the equipment.

4.1	Inverter fault and alarm indications	74
4.2	Reset method for the protective functions.....	74
4.3	Check and clear of the fault history	75
4.4	List of fault displays	77

4.1 Inverter fault and alarm indications

- When the inverter detects a fault, depending on the nature of the fault, the operation panel displays an error message or warning, or a protective function activates to trip the inverter.
- When any fault occurs, take an appropriate corrective action, then reset the inverter, and resume the operation. Restarting the operation without a reset may break or damage the inverter.
- When a protective function activates, note the following points.

Item	Description
Fault output signal	Opening the magnetic contactor (MC) provided on the input side of the inverter at a fault occurrence shuts off the control power to the inverter, therefore, the fault output will not be retained.
Fault or alarm indication	When a protective function activates, the operation panel displays a fault indication.
Operation restart method	While a protective function is activated, the inverter output is kept shutoff. Reset the inverter to restart the operation.

- Inverter fault or alarm indications are categorized as below.

Displayed item	Description
Error message	A message regarding an operational fault and setting fault by the operation panel (FR-DU08) and parameter unit (FR-PU07) is displayed. The inverter does not trip.
Warning	The inverter does not trip even when a warning is displayed. However, failure to take appropriate measures will lead to a fault.
Alarm	The inverter does not trip. An Alarm (LF) signal can also be output with a parameter setting.
Fault	A protective function activates to trip the inverter and output a Fault (ALM) signal.

NOTE

- For the details of fault indications and other malfunctions, refer to the FR-A870 Instruction Manual (Function).
- The past eight faults can be displayed on the operation panel. (Fault history) (For the operation, refer to [page 75](#).)

4.2 Reset method for the protective functions

Reset the inverter by performing any of the following operations. Note that the accumulated heat value of the electronic thermal relay function and the number of retries are cleared (erased) by resetting the inverter.

The inverter recovers about 1 second after the reset is released.

- On the operation panel, press  to reset the inverter.
(This may only be performed when a fault occurs.)

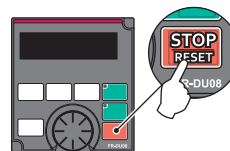

- Switch power OFF once, then switch it ON again.

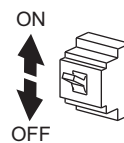

- Turn ON the Reset (RES) signal for 0.1 second or more. (If the RES signal is kept ON, "Err" appears (blinks) to indicate that the inverter is in a reset status.)

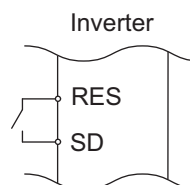

NOTE

- OFF status of the start signal must be confirmed before resetting the inverter fault. Resetting an inverter fault with the start signal ON restarts the motor suddenly.

4.3 Check and clear of the fault history

The operation panel stores the last eight fault records which appeared when the protective function was activated (fault history).

◆ Checking the fault history

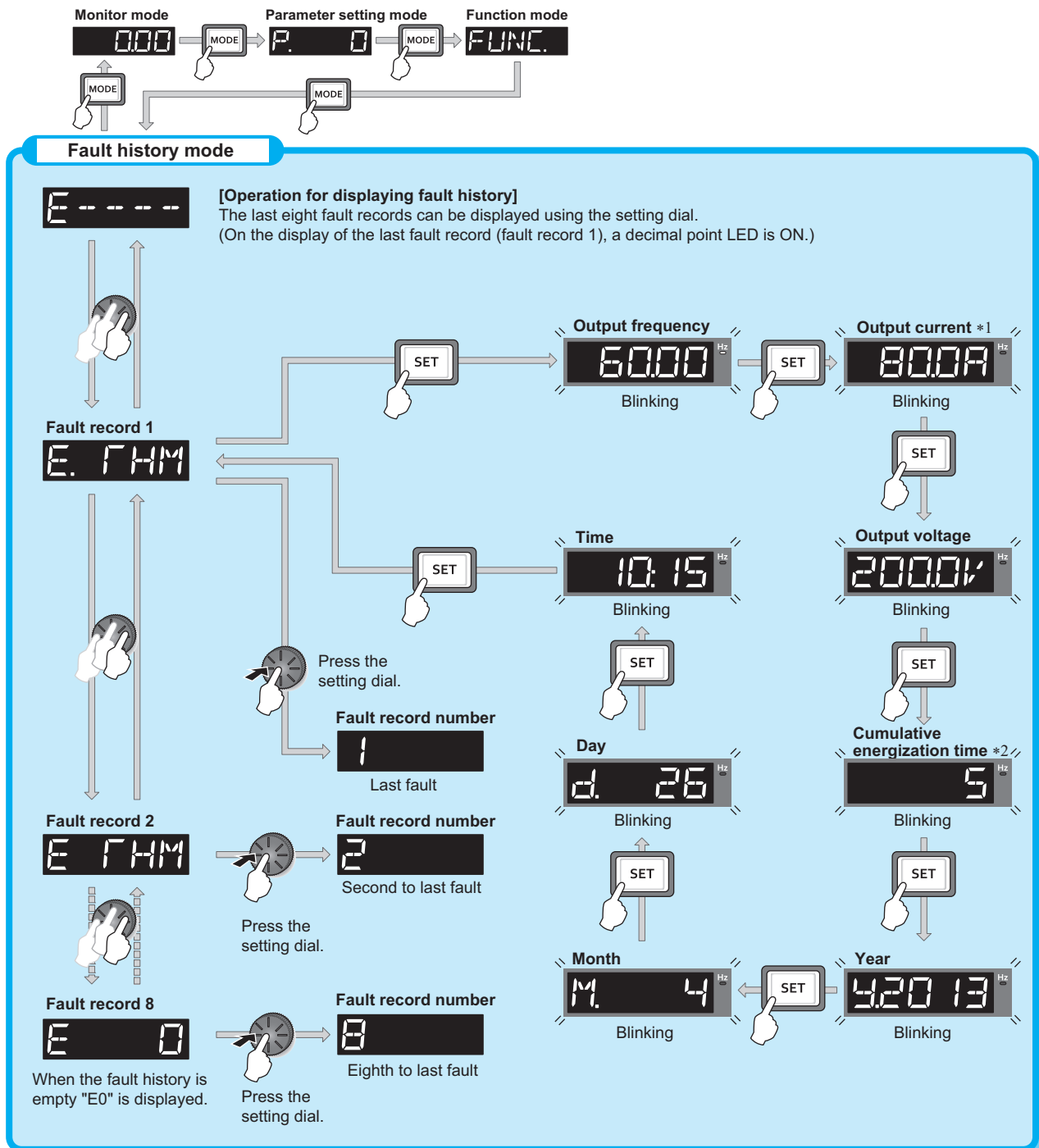









◆ Clearing fault history



- Set Err.CL Fault history clear = "1" to clear the fault history.

Operation

1.	Turning ON the power of the inverter The operation panel is in the monitor mode.
2.	Selecting the parameter setting mode Press  to choose the parameter setting mode. (The parameter number read previously appears.)
3.	Selecting the parameter number Turn  until "Err.CL" (fault history clear) appears. Press  to read the present set value. "0" (initial value) appears.
4.	Fault history clear Turn  to change the set value to "1". Press  to start clear. "1" and "Err.CL" are displayed alternately after parameters are cleared. • Turn  to read another parameter. • Press  to show the setting again. • Press  twice to show the next parameter.

4.4 List of fault displays

For the details, refer to the Instruction Manual (Function).

Operation panel indication		Name		Operation panel indication		Name	
Error message	HOLD	HOLD	Operation panel lock	E. FIN	E.FIN	Heat sink overheat	
	LOCd	LOCd	Password locked	E. IPF	E.IPF	Instantaneous power failure	
	Er 1 to Er 4 Er 8	Er1 to Er4 Er8	Parameter write error	E. UVT	E.UVT	Undervoltage	
	rE 1 to rE 4 rE 6 to rE 8	rE1 to rE4 rE6 to rE8	Copy operation error	E. ILF	E.ILF	Input phase loss	
	Err.	Err.	Error	E. OLT	E.OLT	Stall prevention stop	
				E. LUP	E.LUP	Upper limit fault detection	
				E. LDN	E.LDN	Lower limit fault detection	
Warning	OL	OL	Stall prevention (overcurrent)	E. bE	E.BE*1	Brake transistor alarm detection	
	oL	oL	Stall prevention (overvoltage)	E. GF	E.GF	Output side earth (ground) fault overcurrent	
	Rb	RB*1	Regenerative brake pre-alarm	E. LF	E.LF	Output phase loss	
	TH	TH	Electronic thermal relay function pre-alarm	E. OHT	E.OHT	External thermal relay operation	
	PS	PS	PU stop	E. PTC	E.PTC	PTC thermistor operation	
	SL	SL	Speed limit indication (output during speed limit)	E. OPT	E.OPT	Option fault	
	CF	CF	Continuous operation during communication fault	E. OP 1 to E. OP 3	E.OP1 to E.OP3	Communication option fault	
	CP	CP	Parameter copy	E. 16 to E. 20	E.16 to E.20	User definition error by the PLC function	
	SA	SA	Safety stop	E. PE	E.PE	Parameter storage device fault (control circuit board)	
	MT 1 to MT 3	MT1 to MT3	Maintenance timer 1 to 3	E. PUE	E.PUE	PU disconnection	
	UF	UF	USB host error	E. RET	E.RET	Retry count excess	
	HP 1	HP1	Home position return setting error	E. PE2	E.PE2	Parameter storage device fault (main circuit board)	
	HP 2	HP2	Home position return uncompleted	E. CPU	E.CPU	CPU fault	
	HP 3	HP3	Home position return parameter setting error	E. 5 to E. 7	E.5 to E.7	CPU fault	
	EHR	EHR*2	Ethernet communication fault	E. CTE	E.CTE	Operation panel power supply short circuit	
	Alarm	FN	FN	Fan alarm	E. P24	E.P24	24 VDC power fault
Fault	E. OC 1	E.OC1	Overcurrent trip during acceleration	E. CDO	E.CDO	Abnormal output current detection	
	E. OC 2	E.OC2	Overcurrent trip during constant speed	E. IOH	E.IOH	Inrush current limit circuit fault	
	E. OC 3	E.OC3	Overcurrent trip during deceleration or stop	E. AIE	E.AIE	Analog input fault	
	E. OV 1	E.OV1	Regenerative overvoltage trip during acceleration	E. USB	E.USB	USB communication fault	
	E. OV 2	E.OV2	Regenerative overvoltage trip during constant speed	E. SAF	E.SAF	Safety circuit fault	
	E. OV 3	E.OV3	Regenerative overvoltage trip during deceleration or stop	E. PBT	E.PBT	Internal circuit fault	
	E. THF	E.THT	Inverter overload trip (electronic thermal relay function)	E. 13	E.13	Internal circuit fault	
	E. THM	E.THM	Motor overload trip (electronic thermal relay function)	E. OS	E.OS	Overspeed occurrence	
			E. OSD	E.OSD	Speed deviation excess detection		

List of fault displays

Operation panel indication		Name	
Fault	E. ECT	E.ECT	Signal loss detection
	E. Od	E.OD	Excessive position fault
	E. Mb1 to E. Mb7	E.MB1 to E.MB7	Brake sequence fault
	E. EP	E.EP	Encoder phase fault
	E. EF	E.EF	External fault during output operation
	E. LCI	E.LCI	4 mA input fault
	E. PCH	E.PCH	Pre-charge fault
	E. PID	E.PID	PID signal fault
	E. 1 to E. 3	E. 1 to E. 3	Option fault
	E. 11	E.11	Opposite rotation deceleration fault
	E. EHR	E.EHR*2	Ethernet communication fault
Others	E-----	E----	Fault history
	E. 0	E.0	No fault history
	EV	EV	24 V external power supply operation
	Rd	RD	Backup in progress
	WR	WR	Restoration in progress

If any indication other than the above appear, contact your sales representative.

*1 The built-in brake transistor model only.

*2 For the details, refer to the Ethernet Function Manual.

5 PRECAUTIONS FOR MAINTENANCE AND INSPECTION

This chapter explains the precautions for maintenance and inspection for this product.

Always read the instructions before using the equipment.

5.1	Inspection item.....	80
5.2	Measurement of main circuit voltages, currents and powers ..	91

Inspection item

The inverter is a static unit mainly consisting of semiconductor devices. Daily inspection must be performed to prevent any fault from occurring due to the adverse effects of the operating environment, such as temperature, humidity, dust, dirt and vibration, changes in the parts with time, service life, and other factors.

•Precautions for maintenance and inspection

When accessing the inverter for inspection, wait for at least 10 minutes after the power supply has been switched OFF, and then make sure that the voltage across the main circuit terminals P/+ and N/- of the inverter is not more than 30 VDC using a tester, etc.

5.1 Inspection item

5.1.1 Daily inspection

Basically, check for the following faults during operation.

- Motor operation fault
- Improper installation environment
- Cooling system fault
- Abnormal vibration, abnormal noise
- Abnormal overheat, discoloration

5.1.2 Periodic inspection

Check the areas inaccessible during operation and requiring periodic inspection.

Consult us for periodic inspection.

- Check and clean the cooling system. Clean the air filter, etc.
- Check the tightening and retighten. The screws and bolts may become loose due to vibration, temperature changes, etc. Check and tighten them.
Tighten them according to the specified tightening torque. (Refer to [page 31.](#))
- Check the conductors and insulating materials for corrosion and damage.
- Measure the insulation resistance.
- Check and change the cooling fan and relay.

NOTE

- When using the safety stop function, periodic inspection is required to confirm that safety function of the safety system operates correctly.
For more details, refer to the Safety Stop Function Instruction Manual.

5.1.3 Daily and periodic inspection

Area of inspection	Inspection item	Description	Inspection interval		Corrective action at fault occurrence	Check by the user	
			Daily	Periodic ^{*3}			
General	Surrounding environment	Check the surrounding air temperature, humidity, dirt, corrosive gas, oil mist, etc.	○		Improve the environment.		
	Overall unit	Check for unusual vibration and noise.	○		Check fault location and retighten.		
		Check for dirt, oil, and other foreign material. ^{*1}	○		Clean.		
Power supply voltage	Check that the main circuit voltages and control voltages are normal. ^{*2}	○		Inspect the power supply.			
Main circuit	General	(1) Check with megger (across main circuit terminals and earth (ground) terminal).		○	Contact the manufacturer.		
		(2) Check for loose screws and bolts.		○	Retighten.		
		(3) Check for overheat traces on the parts.		○	Contact the manufacturer.		
		(4) Check for stain.		○	Clean.		
	Conductors, cables	(1) Check conductors for distortion.		○	Contact the manufacturer.		
		(2) Check cable sheaths for breakage and deterioration (crack, discoloration, etc.).		○	Contact the manufacturer.		
	Transformer/reactor	Check for unusual odor and abnormal increase of whining sound.	○		Stop the equipment and contact the manufacturer.		
	Terminal block	Check for a damage.		○	Stop the equipment and contact the manufacturer.		
Smoothing aluminum electrolytic capacitor	(1) Check for liquid leakage. (2) Check for safety valve projection and bulge. (3) Visual check and judge by the life check of the main circuit capacitor. (Refer to page 84.)		○ ○ ○	Contact the manufacturer. Contact the manufacturer.			
Relay/contactor	Check that the operation is normal and no chattering sound is heard.		○	Contact the manufacturer.			
Resistor	(1) Check for crack in resistor insulation.	(1)	○	Contact the manufacturer.			
	(2) Check for a break in the cable.	(2)	○	Contact the manufacturer.			
Control circuit, protective circuit	Operation check	(1) Check that the output voltages across phases are balanced while operating the inverter alone.		○	Contact the manufacturer.		
		(2) Check that no fault is found in protective and display circuits in a sequence protective operation test.		○	Contact the manufacturer.		
	Components check	Overall	(1) Check for unusual odor and discoloration.		○	Stop the equipment and contact the manufacturer.	
			(2) Check for serious rust development.		○	Contact the manufacturer.	
	Aluminum electrolytic capacitor	(1) Check for liquid leakage in a capacitor and deformation trace.		○	Contact the manufacturer.		
		(2) Visual check and judge by the life check of the control circuit capacitor. (Refer to page 84.)		○	Contact the manufacturer.		
Cooling system	Cooling fan	(1) Check for unusual vibration and noise.	○		Replace the fan.		
		(2) Check for loose screws and bolts.		○	Fix with the fan cover fixing screws		
(3) Check for stain.			○	Clean.			
	Heat sink	(1) Check for clogging.		○	Clean.		
		(2) Check for stain.		○	Clean.		

Inspection item

Area of inspection	Inspection item	Description	Inspection interval		Corrective action at fault occurrence	Check by the user
			Daily	Periodic ^{*3}		
Display	Indication	(1) Check that display is normal. (2) Check for stain.	○	○	Contact the manufacturer. Clean.	
	Meter	Check that reading is normal.	○		Stop the equipment and contact the manufacturer.	
Load motor	Operation check	Check for vibration and abnormal increase in operation noise.	○		Stop the equipment and contact the manufacturer.	

*1 Oil component of the heat dissipation grease used inside the inverter may leak out. The oil component, however, is not flammable, corrosive, nor conductive and is not harmful to humans. Wipe off such oil component.

*2 It is recommended to install a voltage monitoring device for checking the voltage of the power supplied to the inverter.

*3 One to two years of periodic inspection cycle is recommended. However, it differs according to the installation environment. Consult us for periodic inspection.

NOTE

- Continuous use of a leaked, deformed, or degraded smoothing aluminum electrolytic capacitor (as shown in the table above) may lead to a burst, breakage or fire. Replace such a capacitor without delay.

5.1.4 Checking the inverter and converter modules

◆Preparation

- Disconnect the external power supply cables (R/L1, S/L2, T/L3) and motor cables (U, V, W).
- Prepare a tester. (For the resistance measurement, use the 100 Ω range.)

◆Checking method

Change the polarity of the tester alternately at the inverter terminals R/L1, S/L2, T/L3, U, V, W, P/+, and N/- and check the electric continuity.

NOTE

- Before measurement, check that the smoothing capacitor is discharged.
- At the time of electric discontinuity, the measured value is almost ∞. When there is an instantaneous electric continuity, due to the smoothing capacitor, the tester may not indicate ∞. At the time of electric continuity, the measured value is several Ω to several tens of Ω. If all measured values are almost the same, although these values are not constant depending on the module type and tester type, the modules are without fault.

◆Module device numbers and terminals to be checked

		Tester polarity		Result			Tester polarity		Result
		⊕	⊖				⊕	⊖	
Converter module	D1	R/L1	P/+	Discontinuity	D4	R/L1	N/-	Continuity	
		P/+	R/L1	Continuity		N/-	R/L1	Discontinuity	
	D2	S/L2	P/+	Discontinuity	D5	S/L2	N/-	Continuity	
		P/+	S/L2	Discontinuity		N/-	S/L2	Discontinuity	
	D3	T/L3	P/+	Discontinuity	D6	T/L3	N/-	Continuity	
		P/+	T/L3	Discontinuity		N/-	T/L3	Discontinuity	
Inverter module	TR1	U	P/+	Discontinuity	TR4	U	N/-	Continuity	
		P/+	U	Continuity		N/-	U	Discontinuity	
	TR3	V	P/+	Discontinuity	TR6	V	N/-	Continuity	
		P/+	V	Continuity		N/-	V	Discontinuity	
	TR5	W	P/+	Discontinuity	TR2	W	N/-	Continuity	
		P/+	W	Continuity		N/-	W	Discontinuity	

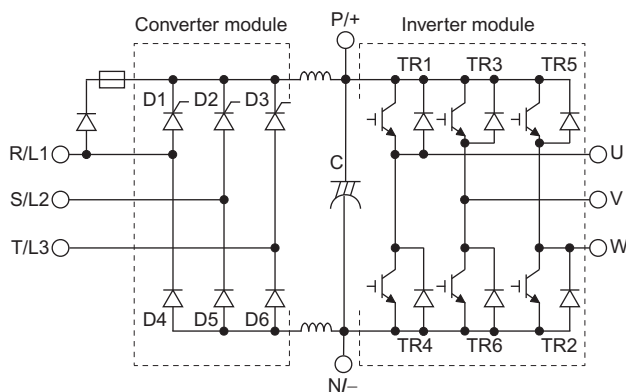

(Assumes the use of an analog meter.)

5.1.5 Cleaning

Always run the inverter in a clean status.

When cleaning the inverter, gently wipe dirty areas with a soft cloth immersed in neutral detergent or ethanol.

NOTE

- Do not use solvent, such as acetone, benzene, toluene and alcohol, as these will cause the inverter surface paint to peel off.
- The display, etc. of the operation panel (FR-DU08) and parameter unit (FR-PU07) are vulnerable to detergent and alcohol. Therefore, avoid using them for cleaning.

5.1.6 Replacement of parts

The inverter consists of many electronic parts such as semiconductor devices.

The following parts may deteriorate with age because of their structures or physical characteristics, leading to reduced performance or fault of the inverter. For preventive maintenance, the parts must be replaced periodically.

Use the life check function as a guidance of parts replacement.

Part name	Estimated lifespan*1	Description
Cooling fan	10 years	Replace (as required)
Main circuit smoothing capacitor	10 years*2	Replace (as required)
On-board smoothing capacitor	10 years*2	Replace the board (as required)
Relays	—	As required
Main circuit fuse	10 years	Replace (as required)

*1 Estimated lifespan for when the yearly average surrounding air temperature is 35°C.
(without corrosive gas, flammable gas, oil mist, dust and dirt etc.)

*2 Output current: 80% of the inverter rating

NOTE

- For parts replacement, contact the nearest Mitsubishi FA center.

◆ Displaying the life of the inverter parts

The inverter diagnoses the main circuit capacitor, control circuit capacitor, cooling fan, and inrush current limit circuit by itself and estimates their lives.

The self-diagnostic warning is output when the life span of each part is near its end. It gives an indication of replacement time.

Guideline for life judgment by the life warning output

Parts	Judgment level
Main circuit capacitor	85% of the initial capacity
Control circuit capacitor	Estimated remaining life 10%
Inrush current limit circuit	Estimated remaining life 10% (Power ON: 100,000 times left)
Cooling fan	Specified speed

NOTE

- Refer to the Instruction Manual (Function) to perform the life check of the inverter parts.

◆ Replacement procedure of the cooling fan

The replacement interval of the cooling fan used for cooling the parts generating heat such as the main circuit semiconductor is greatly affected by the surrounding air temperature. When unusual noise and/or vibration are noticed during inspection, the cooling fan must be replaced immediately.

◆ Removal (FR-A870-00550 to FR-A870-00890)

1) Disconnect the fan connector.

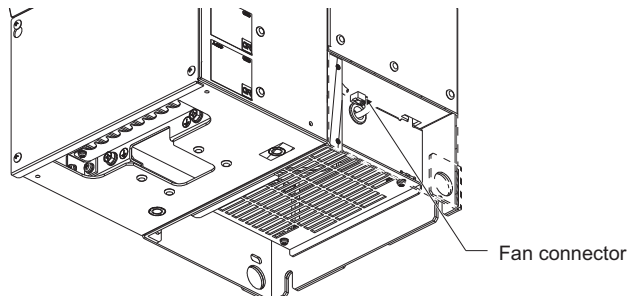

2) Remove the cover installation screws, and then remove the lower front cover.

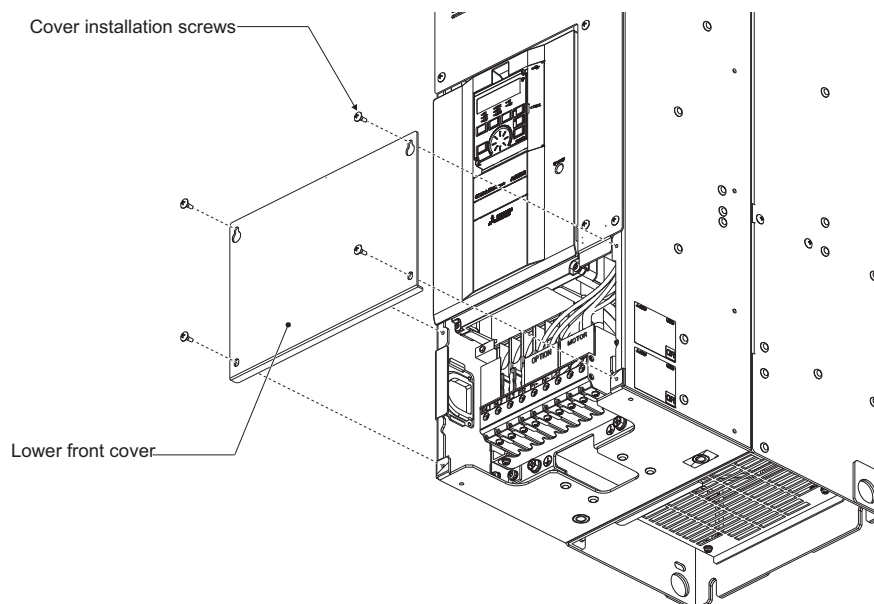

3) Remove the fan unit installation screws.

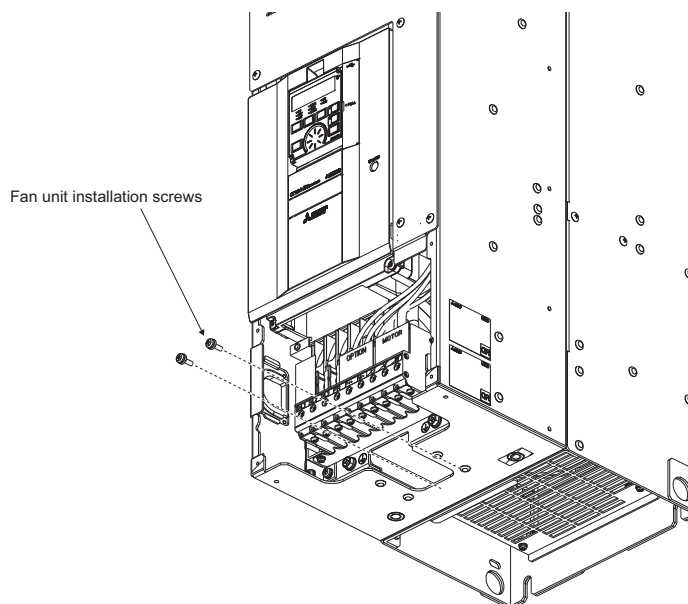

Inspection item

4) Slide the fan unit in the direction shown by the arrow in the figure.

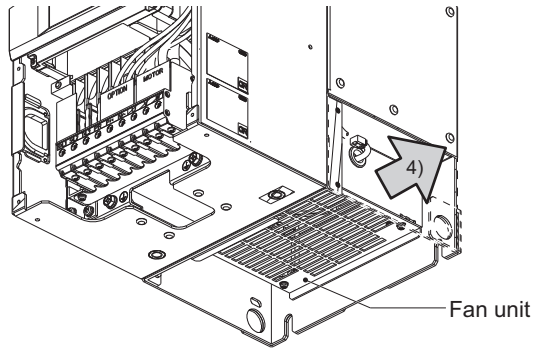

5) Remove the fan unit.

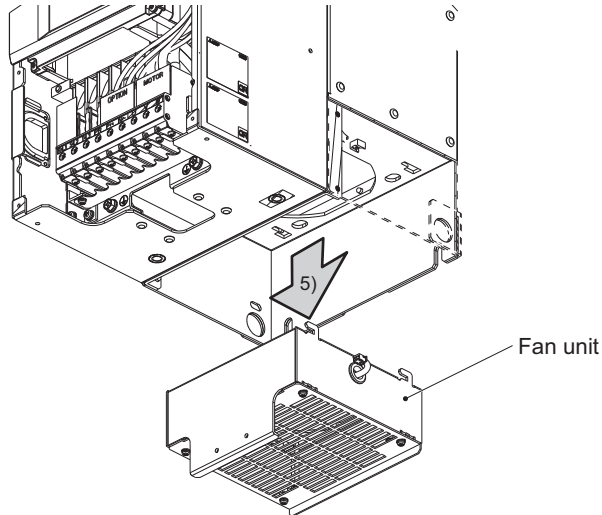

6) Remove the fan cover fixing screws, and remove the fan cover of the fan unit.

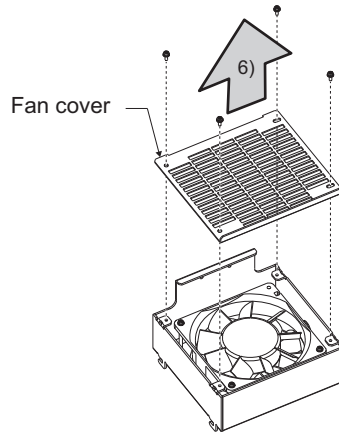

7) Remove the fan fixing screws, and remove the fan.

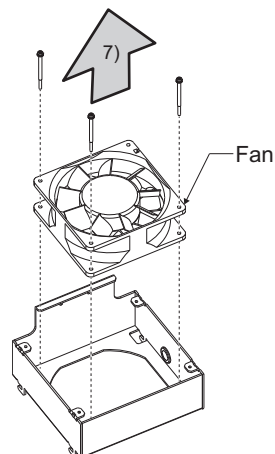

◆ Removal (FR-A870-02300, FR-A870-02860)

1) Remove the fan cover fixing screws, and remove the fan cover.

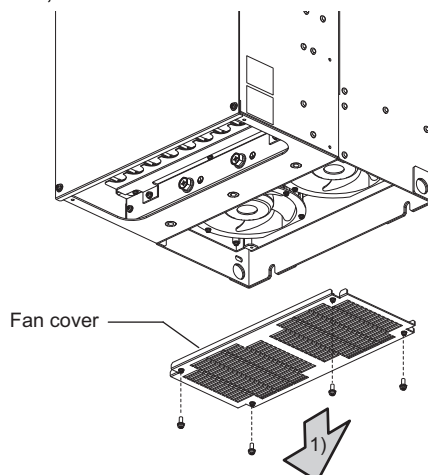

2) Disconnect the fan connector and remove the fan block.

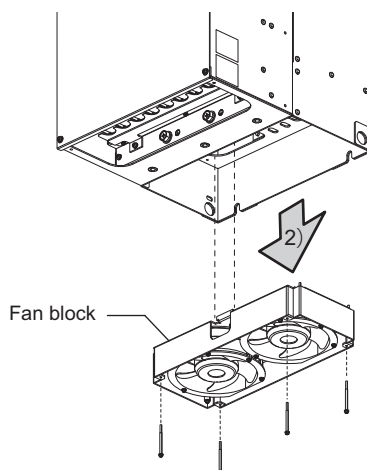

3) Remove the fan fixing screws, and remove the fan.

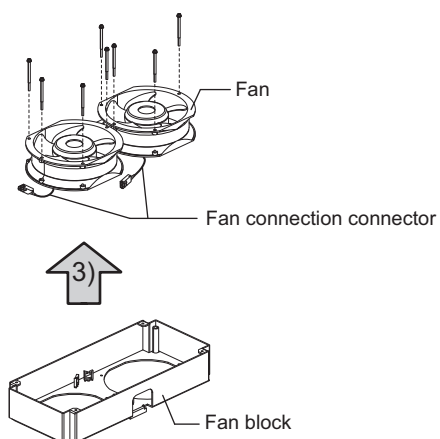

◆ Reinstallation

- 1) Check the orientation of the fan for reinstallation. The "AIR FLOW" arrow printed on the side of the fan must point upward.

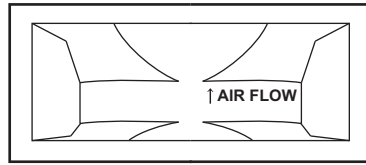

<Fan side view>

- 2) Reverse the removal procedure to reinstall the fan.

NOTE

- Installing the fan in the opposite air flow direction can cause the inverter life to be shorter.
- Prevent the cable from being caught when installing a fan.
- Switch the power OFF and remove the main circuit terminal wires before replacing the fans. Since the inverter circuits are charged with voltage even after power OFF, replace fans only when the inverter cover is on the inverter to prevent an electric shock accident.
- Be careful when removing the fan block as it is heavy.
- &&When attaching the fan block to the FR-A870-02300 or FR-A870-02860, insert the clip into the notch, position the fan block, and then fix it into place.

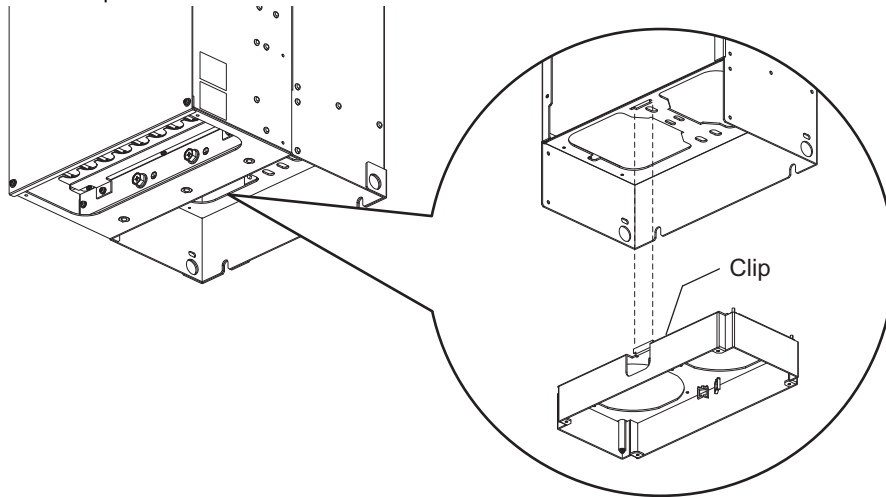

◆Smoothing capacitors

A large-capacity aluminum electrolytic capacitor is used for smoothing in the DC section of the main circuit, and an aluminum electrolytic capacitor is used for stabilizing the control power in the control circuit. Adverse effects from ripple currents deteriorate capacitors. Replacement intervals of capacitors vary greatly with surrounding temperatures and operating conditions. Replace them roughly every 10 years when used in normal air-conditioned environments.

Inspecting the product visually:

- Case: Check that the sides and bottom of the capacitor have not ruptured.
- Rubber seal: Check for any noticeable bulging or severe cracks.
- Check for external cracks discoloration, leakage, etc. It is assumed that the capacitor has reached the end of its life when its capacity has dropped below 80% of its rated capacity.

NOTE

- The inverter diagnoses the main circuit capacitor and control circuit capacitor by itself and can estimate its remaining life. (Refer to the Instruction Manual (Function).)

◆Relay output terminals

- The contacts of relays deteriorate over time. To prevent faults from occurring, relays must be replaced when they have reached the maximum number of switching operations (switching life).
- The control terminal block must be replaced in case of failure of either relay connected to the relay output terminals A1, B1, and C1, or A2, B2, and C2.

◆Main circuit fuse inside the inverter

A fuse is used inside the inverter. Replacement intervals of fuses vary with surrounding temperatures and operating conditions. Replace them roughly every 10 years when used in normal air-conditioned environments.

5.1.7 Removal and reinstallation of the control circuit terminal block

The FR-A800 series inverter has a removable control circuit terminal block, which can be replaced with a new one or a control terminal option.

◆Removal and reinstallation

- 1) Loosen the two mounting screws at the both side of the control circuit terminal block. (These screws cannot be removed.) Slide down the control circuit terminal block to remove it.

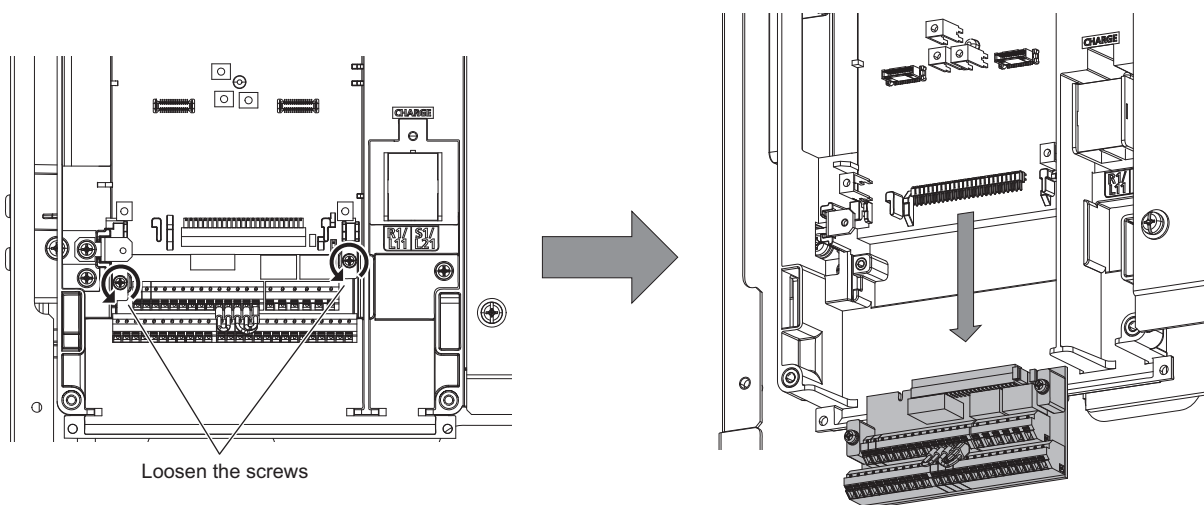

- 2) Be careful not to bend the pins of the inverter's control circuit connector, reinstall the control circuit terminal block and fix it with the mounting screws.

NOTE

- Before starting inverter replacement, switch power OFF, wait for at least 10 minutes, and then check the voltage with a tester and such to ensure safety.

◆ Removal and reinstallation precautions

Precautions to be taken when removing or reinstalling the control circuit terminal block are shown below.

Observe the following precautions and handle the inverter properly to avoid malfunctions or failures.

- To remove or reinstall the control circuit terminal block, keep it upright so that it is parallel with the inverter.
- To install the control circuit terminal block, slide it upward so that the tongues on the inverter slot into the grooves on the terminal block.
- Check that the terminal block is parallel to the inverter and the pins on the inverter control circuit connector are not bent. After checking proper connection, fix the terminal block in place with two screws.

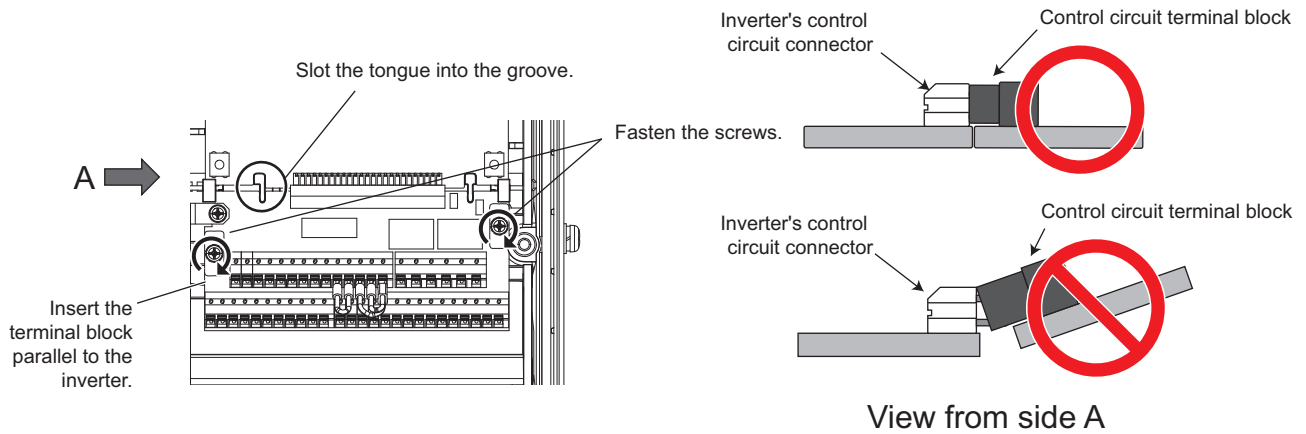

NOTE

- Do not tilt the terminal block while tightening the screws or removing it from the inverter. (Otherwise, stress applied to the control circuit terminal block or the control circuit connector may damage the pins.)
- After replacing the control terminal block, connect the jumper connector to the correct position in accordance with the control logic of input signals. (Refer to [page 38](#).)

5.2 Measurement of main circuit voltages, currents and powers

Since the voltages and currents on the inverter power supply and output sides include harmonics, measurement data depends on the instruments used and circuits measured.

When instruments for commercial frequency are used for measurement, measure the following circuits with the instruments given on the next page.

NOTE

- When installing meters etc. on the inverter output side
When the inverter-to-motor wiring length is large, the meters and CTs may generate heat due to line-to-line leakage current. Therefore, choose the equipment which has enough allowance for the current rating.
To measure and display the output voltage and output current of the inverter, it is recommended to use the terminal AM and FM/CA output functions of the inverter.

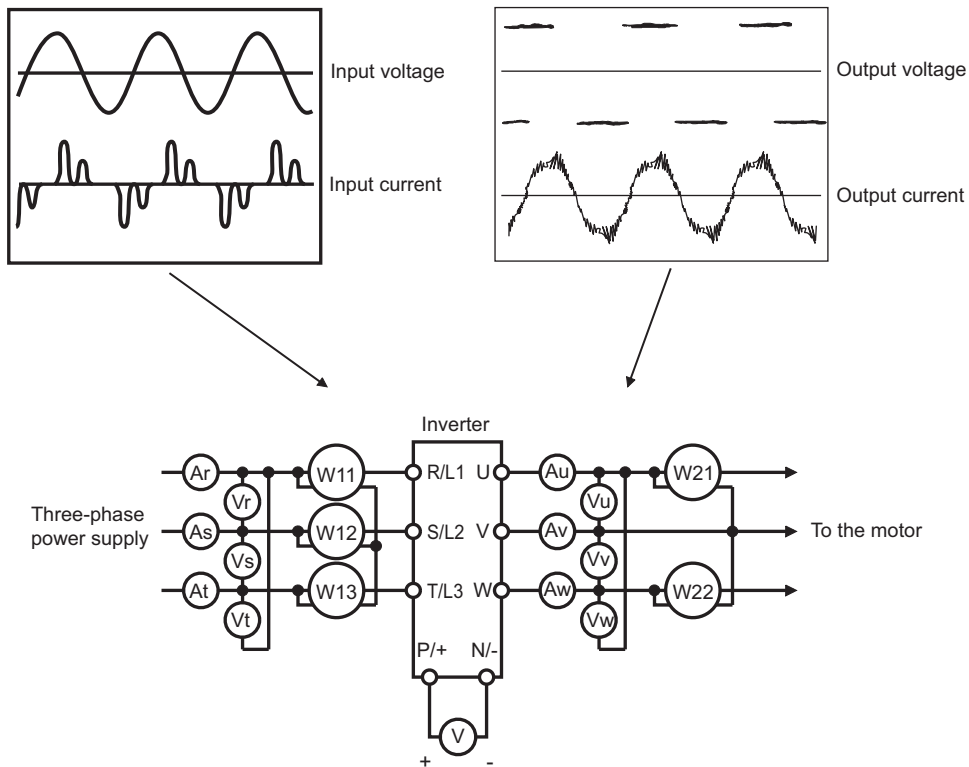

◆ Measuring points and instruments

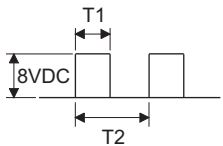
Item	Measuring point	Measuring instrument	Remarks (reference measured value)									
Power supply voltage V1	Across R/L1 and S/L2, S/L2 and T/L3, T/L3 and R/L1	Digital power meter (designed for inverter)	Commercial power supply Within permissible AC voltage fluctuation (Refer to page 96 .)									
Power supply side current I1	R/L1, S/L2, T/L3 line current											
Power supply side power P1	R/L1, S/L2, T/L3 and Across R/L1 and S/L2, S/L2 and T/L3, T/L3 and R/L1		P1 = W11 + W12 + W13 (3-wattmeter method)									
Power supply side power factor Pf1	Calculate after measuring power supply voltage, power supply side current and power supply side power. $Pf_1 = \frac{P_1}{\sqrt{3}V_1 \times I_1} \times 100\%$											
Output side voltage V2	Across U and V, V and W, and W and U	Digital power meter (designed for inverter)*1	Difference between the phases is within 1% of the maximum output voltage.									
Output side current I2	U, V and W line currents		Difference between the phases is 10% or lower of the inverter rated current.									
Output side power P2	U, V, W and across U and V, V and W	Digital power meter (designed for inverter)	P2 = W21 + W22 2-wattmeter method (or 3-wattmeter method)									
Output side power factor Pf2	Calculate in similar manner to power supply side power factor. $Pf_2 = \frac{P_2}{\sqrt{3}V_2 \times I_2} \times 100\%$											
Converter output	Across P/+ and N/-	Moving-coil type (such as tester)	Inverter LED is lit. 1.35 × V1									
Frequency setting signal	Across 2, 4(+) and 5	Digital multimeter or other tester, or moving-coil type instrument (internal resistance 50 kΩ or more)	0 to 10 VDC, 4 to 20 mA									
	Across 1(+) and 5		0 to ±5 VDC and 0 to ±10 VDC									
Frequency setting power supply	Across 10(+) and 5		5.2 VDC									
	Across 10E(+) and 5		10 VDC									
Frequency meter signal	Across AM(+) and 5		Approximately 10 VDC at maximum frequency (without frequency meter)	"5" is common.								
	Across CA(+) and 5		Approximately 20 mADC at maximum frequency									
	Across FM(+) and SD		Approximately 5 VDC at maximum frequency (without frequency meter)	"SD" is common.								
			 <p>Pulse width T1: Adjust with C0 (Pr.900). Pulse cycle T2: Set with Pr.55. (frequency monitor only)</p>									
Start signal Select signal Reset signal Output stop signal	Across STF, STR, RH, RM, RL, JOG, RT, AU, STP (STOP), CS, RES, MRS(+) and SD (for sink logic)			When open 20 to 30 VDC ON voltage: 1 V or less								
Fault signal	Across A1 and C1 Across B1 and C1		Digital multimeter or other tester	Continuity check*2 <table border="0" style="width: 100%;"> <tr> <td></td> <td style="text-align: center;">[Normal]</td> <td style="text-align: center;">[Fault]</td> </tr> <tr> <td>Across A1 and C1</td> <td style="text-align: center;">Discontinuity</td> <td style="text-align: center;">Continuity</td> </tr> <tr> <td>Across B1 and C1</td> <td style="text-align: center;">Continuity</td> <td style="text-align: center;">Discontinuity</td> </tr> </table>		[Normal]	[Fault]	Across A1 and C1	Discontinuity	Continuity	Across B1 and C1	Continuity
	[Normal]	[Fault]										
Across A1 and C1	Discontinuity	Continuity										
Across B1 and C1	Continuity	Discontinuity										

*1 Use an FFT to measure the output voltage accurately. A tester or general measuring instrument cannot measure accurately.

*2 When the setting of **Pr.195 ABC1 terminal function selection** is the positive logic

5.2.1 Measurement of powers

Use a digital power meter (for inverter) for the input side of the converter unit (FR-CC2) and the output side of the inverter.

5.2.2 Measurement of voltages

◆ Inverter input side

As the input side voltage has a sine wave and it is extremely small in distortion, accurate measurement can be made with an ordinary AC meter.

◆ Inverter output side

When using a measuring instrument, use a digital power meter for inverters as the inverter outputs PWM-controlled square wave voltage.

The value displayed on the operation panel is the inverter-controlled voltage itself. Hence, that value is accurate and it is recommended to monitor values using the operation panel.

5.2.3 Measurement of currents

Use a digital power meter (for inverter) for the input side of the converter unit (FR-CC2) and the output side of the inverter. Since the converter unit input current tends to be unbalanced, measurement of three phases is recommended. Correct value cannot be obtained by measuring only one or two phases. On the other hand, the unbalanced ratio of each phase of the output side current should be within 10%.

The inverter output current can be monitored on the operation panel. The value monitored on the operation panel is accurate if the output frequency varies, and it is recommended to monitor values (provide analog output) using the operation panel.

5.2.4 Measurement of inverter input power factor

Calculate using effective power and apparent power. A power-factor meter cannot indicate an exact value.

$$\begin{aligned} \text{Total power factor of the inverter} &= \frac{\text{Effective power}}{\text{Apparent power}} \\ &= \frac{\text{Three-phase input power found by the 3-wattmeter method}}{\sqrt{3} \times V \text{ (power supply voltage)} \times I \text{ (input current effective value)}} \end{aligned}$$

5.2.5 Measurement of converter output voltage (across terminals P and N)

The output voltage of the converter is output across terminals P and N and can be measured with a moving-coil type meter (tester). Although the voltage varies according to the power supply voltage, approximately 710 to 930 V is output when no load is connected and voltage decreases during driving load operation.

When energy is regenerated from the motor during deceleration, for example, the converter output voltage rises to nearly 1200 to 1300 V maximum.

5.2.6 Measurement of inverter output frequency

In the initial setting of the FM-type inverter, a pulse train proportional to the output frequency is output across the pulse train output terminals FM and SD of the inverter. This pulse train output can be counted by a frequency counter, or a meter (moving-coil type voltmeter) can be used to read the mean value of the pulse train output voltage. When a meter is used to measure the output frequency, approximately 5 VDC is indicated at the maximum frequency.

For detailed specifications of the pulse train output terminal FM, refer to the Instruction Manual (Function).

In the initial setting of the CA-type inverter, a pulse train proportional to the output frequency is output across the analog current output terminals CA and 5 of the inverter. Measure the current using an ammeter or tester.

For detailed specifications of the analog current output terminal CA, refer to the Instruction Manual (Function).

5.2.7 Insulation resistance test using megger

- For the inverter, conduct the insulation resistance test on the main circuit only as shown below and do not perform the test on the control circuit. (Use a 500 VDC megger.)

NOTE

- Before performing the insulation resistance test on the external circuit, disconnect the cables from all terminals of the inverter so that the test voltage is not applied to the inverter.
- For the continuity test of the control circuit, use a tester (high resistance range) and do not use the megger or buzzer.

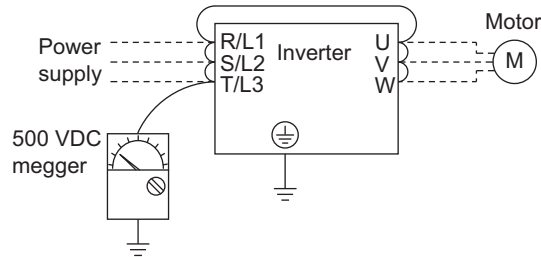

5.2.8 Withstand voltage test

Do not conduct a withstand voltage test. Deterioration may occur.

6 SPECIFICATIONS

This chapter explains the specifications of this product.
Always read the instructions before using the equipment.

6.1	Inverter rating	96
6.2	Common specifications	98
6.3	Inverter outline dimensions	100

6.1 Inverter rating

◆690 VAC power input

Model FR-A870-[]		00550	00660	00890	02300	02860	
Applicable motor capacity (kW)*1	SLD	45	55	75	200	250	
	ND (initial setting)	37	45	55	160	200	
Output	Rated capacity (kVA)*2	SLD	66	79	106	275	342
		ND (initial setting)	55	66	79	221	275
	Rated current (A)*3	SLD	55	66	89	230	286
		ND (initial setting)	46	55	66	185	230
Overload current rating*4	SLD	110% 60 s, 120% 3 s (inverse-time characteristics) at surrounding air temperature 40°C					
	ND (initial setting)	150% 60 s, 200% 3 s (inverse-time characteristics) at surrounding air temperature 40°C					
Rated voltage*5		Three-phase 600 to 690 V					
Regenerative braking*6		Brake transistor Built-in					
Power supply	Rated input AC voltage/frequency		Three-phase 600 to 690 V 50 Hz/60 Hz				
	Permissible AC voltage fluctuation		540 to 759 V 50 Hz/60 Hz				
	Permissible frequency fluctuation		±5%				
	Rated input current (A)*7	SLD	45	55	75	230	286
		ND (initial setting)	37	45	55	185	230
	Power supply capacity (kVA)*8	SLD	66	79	106	275	342
ND (initial setting)		55	66	79	221	275	
Protective structure (IEC 60529)*9		Enclosed type (IP20)					
Cooling system		Forced air cooling					
Noise level (dB)*10		65	65	65	79	79	
Approx. mass (kg)		54	56	59	120	122	

*1 Indicates the maximum capacity applicable to voltage of 690 V.

*2 The rated output capacity indicated assumes that the output voltage is 690 V.

*3 Possible output currents during continuous operation under Real sensorless vector control or Vector control are shown in the table below.

PWM carrier frequency	00550		00660		00890		02300		02860	
	SLD	ND	SLD	ND	SLD	ND	SLD	ND	SLD	ND
2 kHz	45 A	39 A	54 A	47 A	73 A	56 A	191 A	159 A	237 A	198 A
4 kHz	27 A	26 A	33 A	31 A	44 A	38 A	115 A	107 A	143 A	133 A

The PWM carrier frequency is automatically decreased to 2 kHz for heavy duty applications when operating the motor under Real sensorless vector control or Vector control with a PWM carrier frequency of 6 kHz or more (Pr.72 ≥ 6). The carrier frequency stays at 4 kHz in fast-response operation.

- *4 The % value of the overload current rating indicated is the ratio of the overload current to the inverter's rated output current. For repeated duty, allow time for the inverter and motor to return to or below the temperatures under 100% load.
- *5 The maximum output voltage does not exceed the power supply voltage. The maximum output voltage can be changed within the setting range. However, the maximum point of the voltage waveform at the inverter output side is the power supply voltage multiplied by about $\sqrt{2}$.
- *6 Built-in brake transistor model only. For the resistance, refer to [page 59](#).
- *7 The rated input current indicates a value at a rated output voltage. The impedance at the power supply side (including those of the input reactor and cables) affects the rated input current.
- *8 The power supply capacity is the value when at the rated output current. It varies by the impedance at the power supply side (including those of the input reactor and cables).
- *9 FR-DU08: IP40 (except for the PU connector section)
- *10 Values measured 1 m in front of the inverter and 1.6 m from the floor.

◆ 575 VAC power input

Model FR-A870-[]		00550	00660	00890	02300	02860	
Applicable motor capacity (kW)*1	SLD	37	45	55	132	160	
	ND (initial setting)	30	37	45	110	132	
Output	Rated capacity (kVA)*2	SLD	55	66	89	229	285
		ND (initial setting)	46	55	66	184	229
	Rated current (A)*3	SLD	55	66	89	230	286
		ND (initial setting)	46	55	66	185	230
	Overload current rating*4	SLD	110% 60 s, 120% 3 s (inverse-time characteristics) at surrounding air temperature 40°C				
		ND (initial setting)	150% 60 s, 200% 3 s (inverse-time characteristics) at surrounding air temperature 40°C				
Rated voltage*5		Three-phase 525 to 600 V					
Regenerative braking*6	Brake transistor	Built-in					
Power supply	Rated input AC voltage/frequency	Three-phase 525 to 600 V 50 Hz/60 Hz					
	Permissible AC voltage fluctuation	472 to 660 V 50 Hz/60 Hz					
	Permissible frequency fluctuation	±5%					
	Rated input current (A)*7	SLD	55	66	89	230	286
		ND (initial setting)	46	55	66	185	230
	Power supply capacity (kVA)*8	SLD	55	66	89	229	285
ND (initial setting)		46	55	66	184	229	
Protective structure (IEC 60529)*9		Enclosed type (IP20)					
Cooling system		Forced air cooling					
Noise level (dB)*10		65	65	65	79	79	
Approx. mass (kg)		54	56	59	120	122	

*1 Indicates the maximum capacity applicable to voltage of 575 V.

*2 The rated output capacity indicated assumes that the output voltage is 575 V.

*3 Possible output currents during continuous operation under Real sensorless vector control or Vector control are shown in the table below.

PWM carrier frequency	00550		00660		00890		02300		02860	
	SLD	ND	SLD	ND	SLD	ND	SLD	ND	SLD	ND
2 kHz	45 A	39 A	54 A	47 A	73 A	56 A	191 A	159 A	237 A	198 A
4 kHz	27 A	26 A	33 A	31 A	44 A	38 A	115 A	107 A	143 A	133 A

The PWM carrier frequency is automatically decreased to 2 kHz for heavy duty applications when operating the motor under Real sensorless vector control or Vector control with a PWM carrier frequency of 6 kHz or more (Pr.72 ≥ 6). The carrier frequency stays at 4 kHz in fast-response operation.

*4 The % value of the overload current rating indicated is the ratio of the overload current to the inverter's rated output current. For repeated duty, allow time for the inverter and motor to return to or below the temperatures under 100% load.

*5 The maximum output voltage does not exceed the power supply voltage. The maximum output voltage can be changed within the setting range. However, the maximum point of the voltage waveform at the inverter output side is the power supply voltage multiplied by about $\sqrt{2}$.

*6 Built-in brake transistor model only. For the resistance, refer to [page 59](#).

*7 The rated input current indicates a value at a rated output voltage. The impedance at the power supply side (including those of the input reactor and cables) affects the rated input current.

*8 The power supply capacity is the value when at the rated output current. It varies by the impedance at the power supply side (including those of the input reactor and cables).

*9 FR-DU08: IP40 (except for the PU connector section)

*10 Values measured 1 m in front of the inverter and 1.6 m from the floor.

6.2 Common specifications

Control specifications	Control method		Soft-PWM control, high carrier frequency PWM control (selectable among V/F control, Advanced magnetic flux vector control, Real sensorless vector control), vector control*1.
	Output frequency range		0.2 to 590 Hz (The upper-limit frequency is 400 Hz under Advanced magnetic flux vector control, Real sensorless vector control, vector control*1.)
	Frequency setting resolution	Analog input	0.015 Hz/60 Hz (0 to 10 V/12 bits for terminals 2 and 4) 0.03 Hz/60 Hz (0 to 5 V/11 bits or 0 to 20 mA/approx. 11 bits for terminals 2 and 4, 0 to ±10 V/12 bits for terminal 1) 0.06 Hz/60 Hz (0 to ±5 V/11 bits for terminal 1)
		Digital input	0.01 Hz
	Frequency accuracy	Analog input	Within ±0.2% of the max. output frequency (25°C ± 10°C)
		Digital input	Within 0.01% of the set output frequency
	Voltage/frequency characteristics		Base frequency can be set from 0 to 590 Hz. Constant-torque/variable-torque pattern or adjustable 5 points V/F can be selected.
	Starting torque		SLD rating: 120% 0.3 Hz, ND rating: 200%*2 0.3 Hz (under Real sensorless vector control or vector control*1)
	Torque boost		Manual torque boost
	Acceleration/deceleration time setting		0 to 3600 s (acceleration and deceleration can be set individually), linear or S-pattern acceleration/deceleration mode, backlash countermeasures acceleration/deceleration can be selected.
	DC injection brake (induction motor)		Operation frequency (0 to 120 Hz), operation time (0 to 10 s), operation voltage (0 to 30%) variable
	Stall prevention operation level		Activation range of stall prevention operation (SLD rating: 0 to 120%, ND rating: 0 to 220%). Whether to use the stall prevention or not can be selected. (V/F control, Advanced magnetic flux vector control)
	Torque limit level		Torque limit value can be set (0 to 400% variable). (Real sensorless vector control, vector control*1)
Operation specifications	Frequency setting signal	Analog input	Terminals 2 and 4: 0 to 10 V, 0 to 5 V, 4 to 20 mA (0 to 20 mA) are available. Terminal 1: -10 to +10 V, -5 to +5 V are available.
		Digital input	Input using the setting dial of the operation panel or parameter unit Four-digit BCD or 16-bit binary (when used with option FR-A8AX)
	Start signal		Forward and reverse rotation or start signal automatic self-holding input (3-wire input) can be selected.
	Input signals (twelve terminals)		Low-speed operation command, Middle-speed operation command, High-speed operation command, Second function selection, Terminal 4 input selection, Jog operation selection, Selection of automatic restart after instantaneous power failure, flying start, Output stop, Start self-holding selection, Forward rotation command, Reverse rotation command, Inverter reset The input signal can be changed using Pr.178 to Pr.189 (input terminal function selection) .
	Pulse train input		100k pulses/s
	Operational functions		Maximum and minimum frequency settings, multi-speed operation, acceleration/deceleration pattern, thermal protection, DC injection brake, starting frequency, JOG operation, output stop (MRS), stall prevention, regeneration avoidance, increased magnetic excitation deceleration, frequency jump, rotation display, automatic restart after instantaneous power failure, electronic bypass sequence, remote setting, automatic acceleration/deceleration, retry function, carrier frequency selection, fast-response current limit, forward/reverse rotation prevention, operation mode selection, slip compensation, droop control, load torque high-speed frequency control, speed smoothing control, traverse, auto tuning, applied motor selection, gain tuning, RS-485 communication, PID control, PID pre-charge function, easy dancer control, cooling fan operation selection, stop selection (deceleration stop/coasting), power-failure deceleration stop function*3, stop-on-contact control, PLC function, life diagnosis, maintenance timer, current average monitor, multiple rating, orientation control*1, speed control, torque control, position control, pre-excitation, torque limit, test run, 24 V power supply input for control circuit, safety stop function, anti-sway control
	Output signal	Open collector output (five terminals) Relay output (two terminals) Pulse train output (FM type)	
Pulse train output (FM type)		50k pulses/s	
Indication	For meter	Pulse train output (FM type)	Max. 2.4 kHz: one terminal (output frequency) The monitored item can be changed using Pr.54 FM/CA terminal function selection .
		Current output (CA type)	Max. 20 mADC: one terminal (output current) The monitored item can be changed using Pr.54 FM/CA terminal function selection .
		Voltage output	Max. 10 VDC: one terminal (output voltage) The monitored item can be changed using Pr.158 AM terminal function selection .
	Operation panel (FR-DU08)	Operating status	Output frequency, Output current, Output voltage, Frequency setting value The monitored item can be changed using Pr.52 Operation panel main monitor selection .
Fault record		Fault record is displayed when a fault occurs. Past 8 fault records and the conditions immediately before the fault (output voltage/current/frequency/cumulative energization time/year/month/date/time) are saved.	

	Protective/warning function	<p>Protective function</p> <p>Overcurrent trip during acceleration, Overcurrent trip during constant speed, Overcurrent trip during deceleration or stop, Regenerative overvoltage trip during acceleration, Regenerative overvoltage trip during constant speed, Regenerative overvoltage trip during deceleration or stop, Inverter overload trip, Motor overload trip, Heat sink overheat, Instantaneous power failure, Undervoltage, Input phase loss*3, Stall prevention stop, Brake transistor alarm detection*5, Upper limit fault detection, Lower limit fault detection, Output side earth (ground) fault overcurrent, Output short circuit, Output phase loss, External thermal relay operation*3, PTC thermistor operation*3, Option fault, Communication option fault, Parameter storage device fault (control circuit board), PU disconnection, Retry count excess*3, CPU fault, Operation panel power supply short circuit, 24 VDC power fault, Abnormal output current detection*3, Inrush current limit circuit fault, Communication fault (inverter), Analog input fault, USB communication fault, Safety circuit fault, Overspeed occurrence*3, Speed deviation excess detection*1*3, Signal loss detection*1*3, Excessive position fault*1*3, Brake sequence fault*3, Encoder phase fault*1*3, External fault during output operation, 4 mA input fault*3, Pre-charge fault*3, PID signal fault*3, Opposite rotation deceleration fault*3, Internal circuit fault, Abnormal internal temperature</p> <p>Warning function</p> <p>Fan alarm, Stall prevention (overcurrent), Stall prevention (overvoltage), Regenerative brake pre-alarm*3*5, Electronic thermal relay function pre-alarm, PU stop, Speed limit indication*3, Safety stop, Maintenance signal output*3, USB host error, Home position return setting error*3, Home position return uncompleted*3, Home position return parameter setting error*3, Operation panel lock*3, Password locked*3, Parameter write error, Copy operation error, 24 V external power supply operation, Continuous operation during communication fault, Load fault warning</p>
Environment	Surrounding air temperature	-10°C to +40°C (non-freezing)
	Surrounding air humidity	95% RH or less (non-condensing) (With circuit board coating (conforming to IEC 60721-3-3 3C2/3S2)) 90% RH or less (non-condensing) (Without circuit board coating)
	Storage temperature*4	-20°C to +65°C
	Atmosphere	Indoors (without corrosive gas, flammable gas, oil mist, dust and dirt, etc.)
	Altitude/vibration	Maximum 4000 m (For installation at an altitude above 1000 m, consider a 3% reduction in the rated current per 500 m increase in altitude.), 2.9 m/s ² or less at 10 to 55 Hz (directions of X, Y, Z axes)

- *1 Available only when a vector control compatible option is mounted.
- *2 In the initial setting, the starting torque is limited to 150% by the torque limit level.
- *3 This protective function is not available in the initial status.
- *4 Temperature applicable for a short time, e.g. in transit.
- *5 The built-in brake transistor model only.

6.3 Inverter outline dimensions

FR-A870-00550~ FR-A870-00890

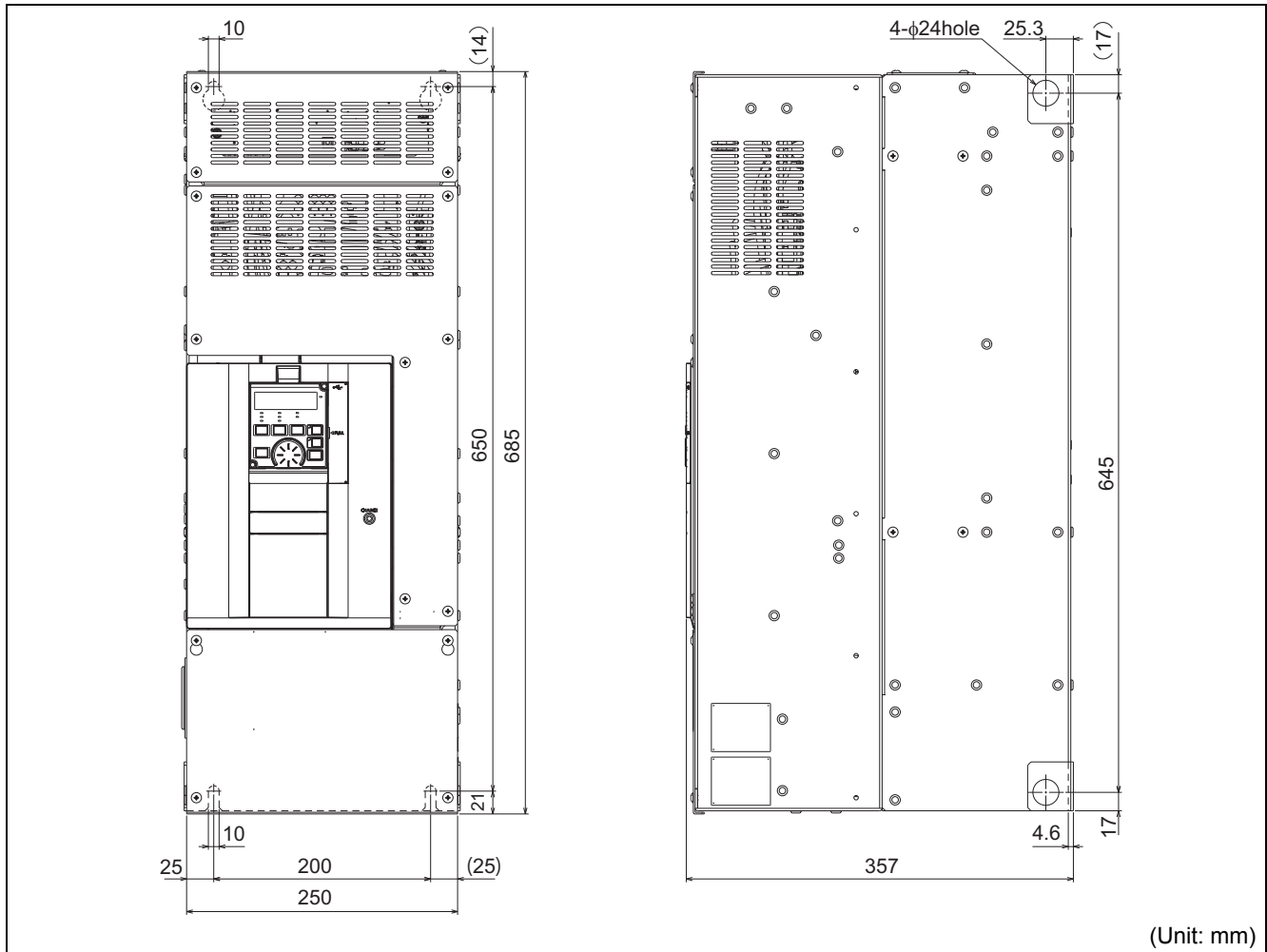

(Unit: mm)

FR-A870-02300, 02860

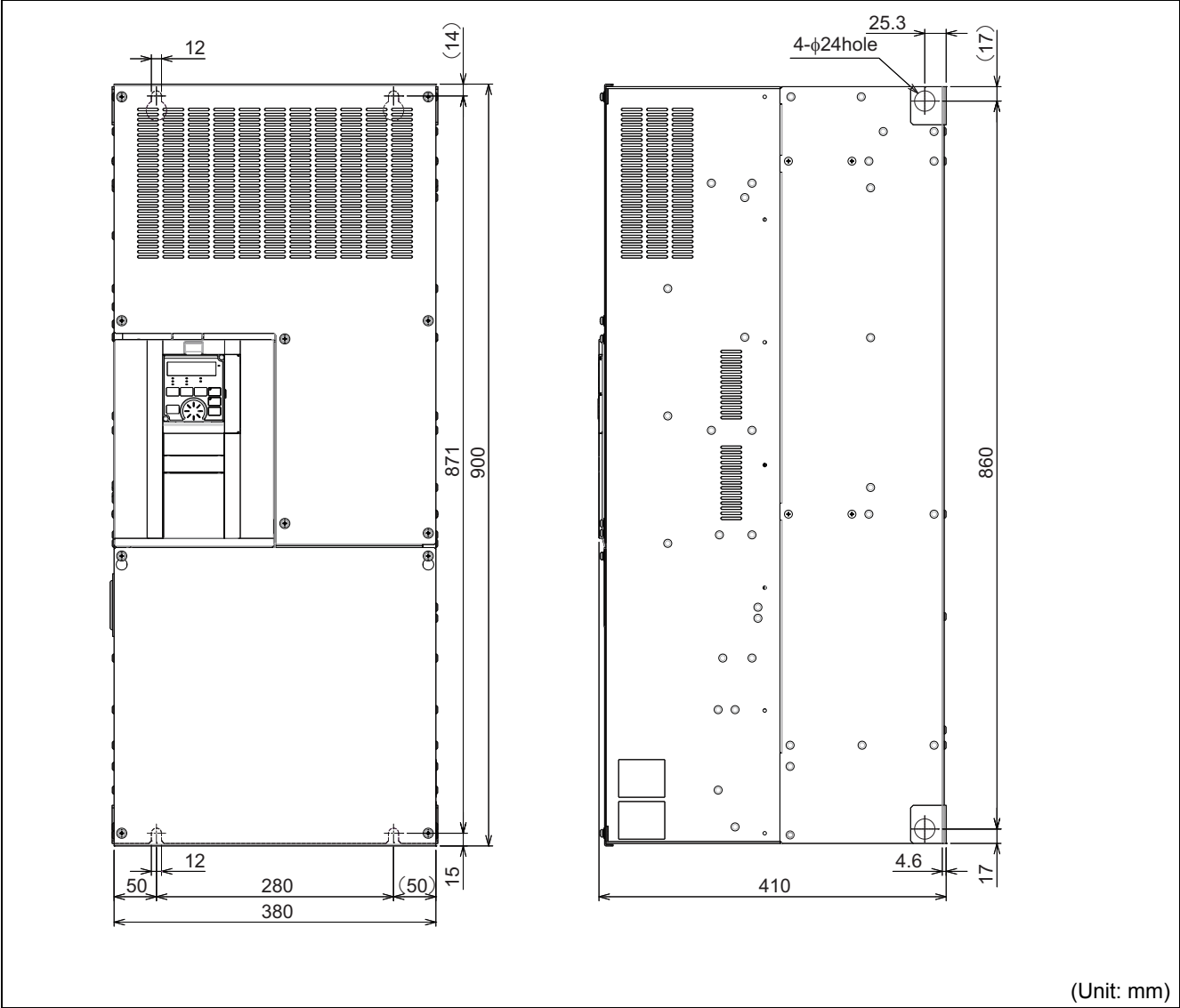

(Unit: mm)

Operation panel (FR-DU08)

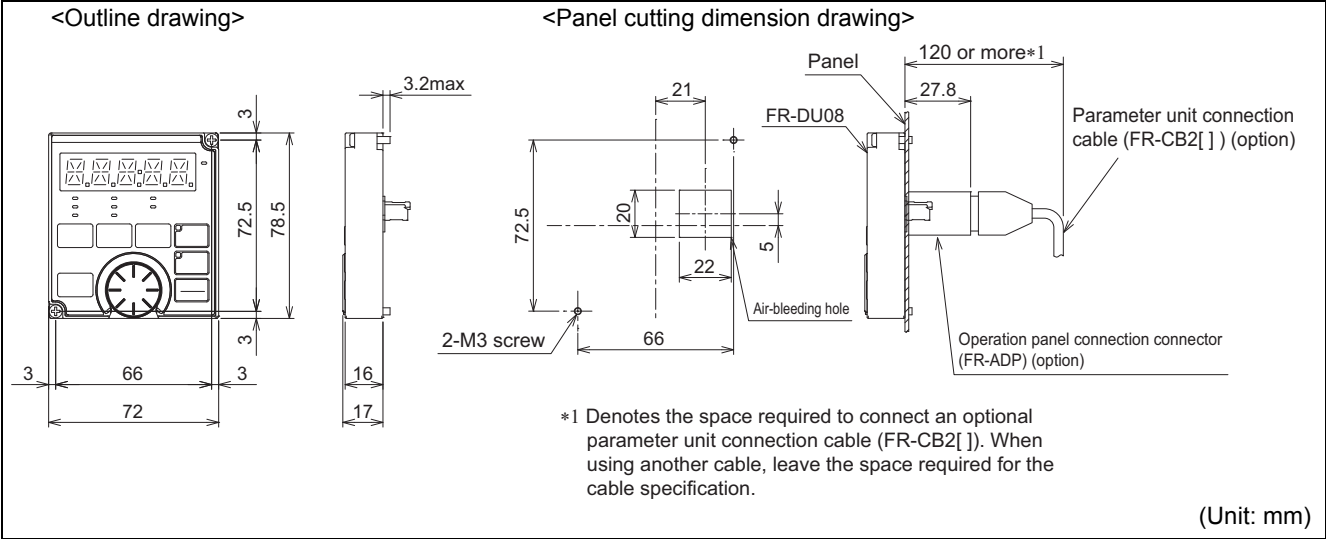

*1 Denotes the space required to connect an optional parameter unit connection cable (FR-CB2[]). When using another cable, leave the space required for the cable specification.

(Unit: mm)

MEMO



APPENDIX

APPENDIX provides the reference information for use of this product.
Refer to APPENDIX as required.

Appendix 1	Instructions for compliance with the EU Directives.....	104
Appendix 2	Instructions for UL and cUL.....	107
Appendix 3	Instructions for EAC	109
Appendix 4	Restricted Use of Hazardous Substances in Electronic and Electrical Products	110
Appendix 5	Referenced Standard (Requirement of Chinese standardized law).....	110

Appendix 1 Instructions for compliance with the EU Directives

The EU Directives are issued to standardize different national regulations of the EU Member States and to facilitate free movement of the equipment, whose safety is ensured, in the EU territory.

Since 1996, compliance with the EMC Directive that is one of the EU Directives has been legally required. Since 1997, compliance with the Low Voltage Directive, another EU Directive, has been also legally required. When a manufacturer confirms its equipment to be compliant with the EMC Directive and the Low Voltage Directive, the manufacturer must declare the conformity and affix the CE marking.

- The authorized representative in the EU
The authorized representative in the EU is shown below.
Name: Mitsubishi Electric Europe B.V.
Address: Mitsubishi-Electric-Platz 1, 40882 Ratingen, Germany

◆ EMC Directive

We declare that this inverter conforms with the EMC Directive and affix the CE marking on the inverter.

- EMC Directive: 2014/30/EU
- Standard(s): EN 61800-3:2004+A1:2012 (Second environment / PDS Category "C3")
- This inverter is not intended to be used on a low-voltage public network which supplies domestic premises. When using the inverter in a residential area, take appropriate measures and ensure the conformity of the inverter used in the residential area.
- Radio frequency interference is expected if used on such a network.
- The installer shall provide a guide for installation and use, including recommended mitigation devices.

Note:

First environment

Environment including buildings/facilities which are directly connected to a low voltage main supply which also supplies residential buildings. Directly connected means that there is no intermediate transformer between these buildings.

Second environment

Environment including all buildings/facilities which are not directly connected to a low voltage main supply which also supplies residential buildings.

◆ Note

Ensure the EMC filter is enabled, install the product as stated below, and then carry out any wiring.

- The inverter has a built-in EMC filter (Class C3). Enable the EMC filter. (For details, refer to [page 65](#).)
- Connect the inverter to an earthed (grounded) power supply.
- To make full use of the built-in EMC filter, motor cable lengths should not exceed 20 m.
- Ensure that the finalized system which includes an inverter complies with the EMC Directive.

◆ Low Voltage Directive

We have self-confirmed our inverters as products compliant to the Low Voltage Directive and affix the CE marking on the inverters.

- Low Voltage Directive: 2014/35/EU
- Conforming standard: EN 61800-5-1:2007

◆ Outline of instructions

- Do not use an earth leakage current breaker as an electric shock protector without connecting the equipment to the earth. Connect the equipment to the earth securely.
- Wire the earth terminal independently. (Do not connect two or more cables to one terminal.)
- Use the cable sizes indicated on [page 31](#) under the following conditions.
 - Surrounding air temperature: 40°C maximum

If conditions are different from above, select appropriate wire according to EN 60204 or IEC 60364-5-52.
- Use a tinned (plating should not include zinc) crimp terminal to connect the earth (ground) cable. When tightening the screw, be careful not to damage the threads.

For use as a product compliant with the Low Voltage Directive, use PVC cable whose size is indicated on [page 31](#).
- Use the moulded case circuit breaker and magnetic contactor which conform to the EN or IEC Standard.
- This product can cause a d.c. current in the protective earthing conductor. Where a residual current-operated protective (RCD) or monitoring (RCM) device is used for protection in case of direct or indirect contact, only an RCD or RCM of Type B is allowed on the supply side of this product.
- Large leakage current flows through the protective earth (ground) conductor of this product. &&The maximum leakage current from the inverter during operation is 10 mA (measured in AC/DC current as specified in IEC 60990). Do not use earth (ground) wires smaller than those specified in national and local safety regulations regarding leakage currents.
- Use the inverter under the conditions of overvoltage category II (usable regardless of the earth (ground) condition of the power supply), overvoltage category III (usable with the earthed-neutral system power supply) and pollution degree 2 or lower specified in IEC 60664.
 - To use the inverter under the conditions of pollution degree 2, install it in the enclosure of IP 2X or higher.
 - To use the inverter under the conditions of pollution degree 3, install it in the enclosure of IP54 or higher.
- On the input and output of the inverter, use cables of the type and size set forth in EN 60204.
- The operating capacity of the relay outputs (terminal symbols A1, B1, C1, A2, B2 and C2) should be 30 VDC, 0.3 A. (Relay output has basic isolation from the inverter internal circuit.)
- Control circuit terminals indicated on [page 23](#) are safely isolated from the main circuit.
- Environment (For the detail, refer to [page 17](#).)

	During operation	In storage	During transportation
Surrounding air temperature	-10 to +40°C	-20 to +65°C	-20 to +65°C
Ambient humidity	95% RH or less	95% RH or less	95% RH or less
Maximum altitude	4000 m*1	4000 m	10000 m

*1 For installation at an altitude above 1000 m, consider a 3% reduction in the rated current per 500 m increase in altitude.

◆ Wiring protection

Provide the appropriate fuse in accordance with the table below.

Inverter model	Fuse type	Model	Manufacturer	Rating
FR-A870-00550, 00660, 00890	UL Recognized High Speed	170M3015	Busmann	200 A, 700 VAC
FR-A870-02300, 02860	UL Recognized High Speed	170M4014	Busmann	500 A, 700 VAC

◆ Short circuit ratings

Suitable For Use in A Circuit Capable of Delivering Not More Than 100 kA rms Symmetrical Amperes, 690 V Maximum.

◆ Motor overload protection

When using the electronic thermal relay function as motor overload protection, set the rated motor current in **Pr.9 Electronic thermal O/L relay**.

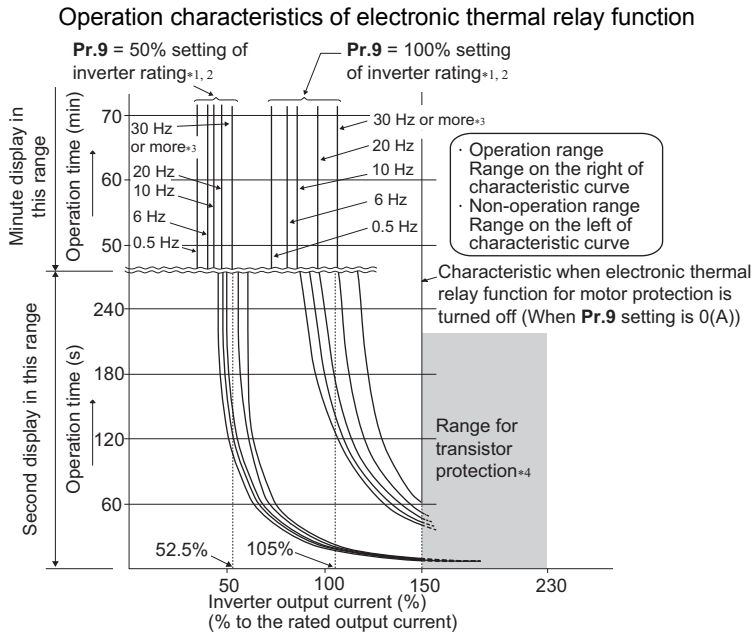

This function detects the overload of the motor, stops the operation of the inverter's output transistor, and stops the output. (The operation characteristic is shown on the left.)

- *1 When a value 50% of the inverter rated output current (current value) is set in **Pr.9**
- *2 The % value denotes the percentage to the inverter rated current. It is not the percentage to the rated motor current.
- *3 Transistor protection is activated depending on the temperature of the heat sink. The protection may be activated even with less than 150% depending on the operating conditions.

NOTE

- The internal accumulated heat value of the electronic thermal relay function is reset by inverter power reset and reset signal input. Avoid unnecessary reset and power-OFF.
- When multiple motors are driven with a single inverter or when a multi-pole motor or a special motor is driven, install an external thermal relay (OCR) between the inverter and motors. Note that the current indicated on the motor rating plate is affected by the line-to-line leakage current (refer to [page 62](#)) when selecting the setting for an external thermal relay.
- The cooling effect of the motor drops during low-speed operation. Use a thermal protector or a motor with built-in thermistor.
- When the difference between the inverter and motor capacities is large and the setting is small, the protective characteristics of the electronic thermal relay function will be deteriorated. In this case, use an external thermal relay.
- A special motor cannot be protected by the electronic thermal relay function. Use an external thermal relay.
- Motor over temperature sensing is not provided by the drive.
- Electronic thermal memory retention function is not provided by the drive.
- The electronic thermal relay function is not a speed sensing function.

Appendix 2 Instructions for UL and cUL

The FR-A800 series (690 V class) are UL certified with the maximum voltage of 600 V.
(Standard to comply with: UL 61800-5-1, CSA C22.2 No.274-13)

◆ General precaution

CAUTION - Risk of Electric Shock -

The bus capacitor discharge time is 10 minutes. Before starting wiring or inspection, switch power off, wait for more than 10 minutes, and check for residual voltage between terminal P/+ and N/- with a meter etc., to avoid a hazard of electrical shock.

ATTENTION - Risque de choc électrique -

La durée de décharge du condensateur de bus est de 10 minutes. Avant de commencer le câblage ou l'inspection, mettez l'appareil hors tension et attendez plus de 10 minutes.

◆ Installation

The below types of inverters have been approved as products for use in enclosure and approval tests were conducted under the following conditions.

Design the enclosure so that the surrounding air temperature, humidity and ambience of the inverter will satisfy the specifications. (Refer to [page 17](#).)

◆ Wiring protection

Provide the appropriate fuse in accordance with the table below.

Inverter model	Fuse type	Model	Manufacturer	Rating
FR-A870-00550, 00660, 00890	UL Recognized High Speed	170M3015	Bussmann	200 A, 700 VAC
FR-A870-02300, 02860	UL Recognized High Speed	170M4014	Bussmann	500 A, 700 VAC

◆ Important note

The operating capacity of the relay outputs (terminal symbols A1, B1, C1, A2, B2 and C2) should be 30 VDC, 0.3 A. (Relay output has basic isolation from the inverter internal circuit.)

◆ Wiring to the power supply and the motor

Refer to the National Electrical Code (Article 310) regarding the allowable current of the cable. Select the cable size for 125% of the rated current according to the National Electrical Code (Article 430).

To wire the input (R/L1, S/L2, T/L3) and output (U, V, W) terminals of the inverter, use UL approved copper wires (rated at 75°C).

◆ Short circuit ratings

Suitable For Use in A Circuit Capable of Delivering Not More Than 100 kA rms Symmetrical Amperes, 600 V Maximum.

◆ Motor overload protection

When using the electronic thermal relay function as motor overload protection, set the rated motor current in **Pr.9 Electronic thermal O/L relay**.

Operation characteristics of electronic thermal relay function

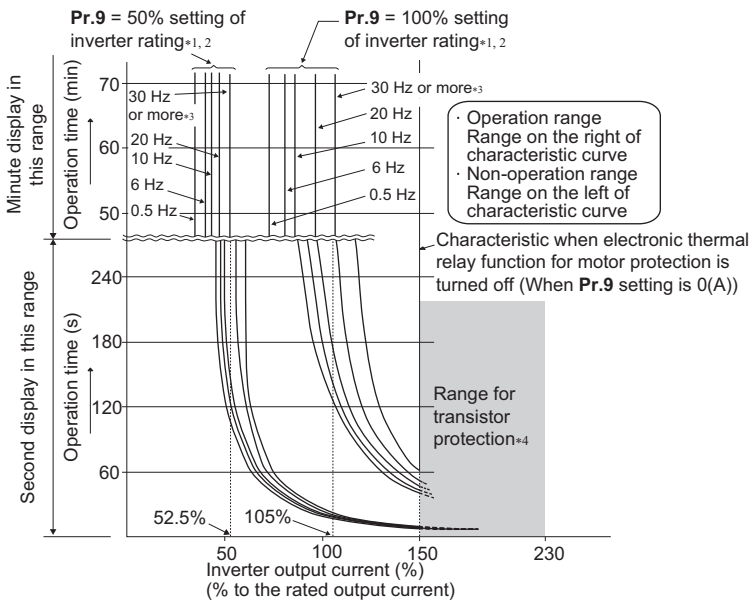

This function detects the overload (overheat) of the motor, stops the operation of the inverter's output transistor, and stops the output. (The operation characteristic is shown on the left.)

- *1 When a value 50% of the inverter rated output current (current value) is set in **Pr.9**
- *2 The % value denotes the percentage to the inverter rated current. It is not the percentage to the rated motor current.
- *3 Transistor protection is activated depending on the temperature of the heat sink. The protection may be activated even with less than 150% depending on the operating conditions.

NOTE

- The internal accumulated heat value of the electronic thermal relay function is reset by inverter power reset and reset signal input. Avoid unnecessary reset and power-OFF.
- When multiple motors are driven with a single inverter or when a multi-pole motor or a special motor is driven, install an external thermal relay (OCR) between the inverter and motors. Note that the current indicated on the motor rating plate is affected by the line-to-line leakage current (refer to [page 62](#)) when selecting the setting for an external thermal relay.
- The cooling effect of the motor drops during low-speed operation. Use a thermal protector or a motor with built-in thermistor.
- When the difference between the inverter and motor capacities is large and the setting is small, the protective characteristics of the electronic thermal relay function will be deteriorated. In this case, use an external thermal relay.
- A special motor cannot be protected by the electronic thermal relay function. Use an external thermal relay.
- Motor over temperature sensing is not provided by the drive.
- Electronic thermal memory retention function is not provided by the drive.

Appendix 3 Instructions for EAC

EAC

The product certified in compliance with the Eurasian Conformity has the EAC marking.

Note: EAC marking

In 2010, three countries (Russia, Belarus, and Kazakhstan) established a Customs Union for the purposes of revitalizing the economy by forming a large economic bloc by abolishing or reducing tariffs and unifying regulatory procedures for the handling of articles.

Products to be distributed over these three countries of the Customs Union must comply with the Customs Union Technical Regulations (CU-TR), and the EAC marking must be affixed to the products.

For information on the country of origin, manufacture year and month, and authorized sales representative (importer) in the CU area of this product, refer to the following:

- Country of origin indication
Check the rating plate of the product. (Refer to [page 8.](#))
Example: MADE IN JAPAN
- Manufactured year and month
Check the SERIAL number indicated on the rating plate of the product. (Refer to [page 8.](#))
- Authorized sales representative (importer) in the CU area
The authorized sales representative (importer) in the CU area is shown below.
Name: Mitsubishi Electric (Russia) LLC
Address: 52, bld 1 Kosmodamianskaya Nab 115054, Moscow, Russia
Phone: +7 (495) 721-2070
Fax: +7 (495) 721-2071

Appendix 4 Restricted Use of Hazardous Substances in Electronic and Electrical Products

The mark of restricted use of hazardous substances in electronic and electrical products is applied to the product as follows based on the “Management Methods for the Restriction of the Use of Hazardous Substances in Electrical and Electronic Products” of the People's Republic of China.

电器电子产品有害物质限制使用标识要求



本产品中所含有的有害物质的名称、含量、含有部件如下表所示。

- 产品中所含有害物质的名称及含量

部件名称 *2	有害物质 *1					
	铅 (Pb)	汞 (Hg)	镉 (Cd)	六价铬 (Cr (VI))	多溴联苯 (PBB)	多溴二苯醚 (PBDE)
电路板组件 (包括印刷电路板及其构成的零部件, 如电阻、电容、集成电路、连接器等)、电子部件	×	○	×	○	○	○
金属壳体、金属部件	×	○	○	○	○	○
树脂壳体、树脂部件	○	○	○	○	○	○
螺丝、电线	○	○	○	○	○	○

上表依据 SJ/T11364 的规定编制。

○: 表示该有害物质在该部件所有均质材料中的含量均在 GB/T26572 规定的限量要求以下。

×: 表示该有害物质在该部件的至少一种均质材料中的含量超出 GB/T26572 规定的限量要求。

*1 即使表中记载为 ×, 根据产品型号, 也可能会有有害物质的含量为限制值以下的情况。

*2 根据产品型号, 一部分部件可能不包含在产品中。

Appendix 5 Referenced Standard (Requirement of Chinese standardized law)

This Product is designed and manufactured accordance with following Chinese standards.

- Machinery safety: GB/T 16855.1
 GB/T 12668.502
 GB 28526
 GB/T 12668.3
 Electrical safety : GB/T 12668.501
 EMC : GB/T 12668.3

MEMO

WARRANTY

When using this product, make sure to understand the warranty described below.

1. Warranty period and coverage

We will repair any failure or defect (hereinafter referred to as "failure") in our FA equipment (hereinafter referred to as the "Product") arisen during warranty period at no charge due to causes for which we are responsible through the distributor from which you purchased the Product or our service provider. However, we will charge the actual cost of dispatching our engineer for an on-site repair work on request by customer in Japan or overseas countries. We are not responsible for any on-site readjustment and/or trial run that may be required after a defective unit are repaired or replaced.

[Term]

The term of warranty for Product is twelve months after your purchase or delivery of the Product to a place designated by you or eighteen months from the date of manufacture whichever comes first ("Warranty Period"). Warranty period for repaired Product cannot exceed beyond the original warranty period before any repair work.

[Limitations]

- (1) You are requested to conduct an initial failure diagnosis by yourself, as a general rule. It can also be carried out by us or our service company upon your request and the actual cost will be charged.
However, it will not be charged if we are responsible for the cause of the failure.
- (2) This limited warranty applies only when the condition, method, environment, etc. of use are in compliance with the terms and conditions and instructions that are set forth in the instruction manual and user manual for the Product and the caution label affixed to the Product.
- (3) Even during the term of warranty, the repair cost will be charged on you in the following cases;
 - a failure caused by your improper storing or handling, carelessness or negligence, etc., and a failure caused by your hardware or software problem
 - a failure caused by any alteration, etc. to the Product made on your side without our approval
 - a failure which may be regarded as avoidable, if your equipment in which the Product is incorporated is equipped with a safety device required by applicable laws and has any function or structure considered to be indispensable according to a common sense in the industry
 - a failure which may be regarded as avoidable if consumable parts designated in the instruction manual, etc. are duly maintained and replaced
 - any replacement of consumable parts (condenser, cooling fan, etc.)
 - a failure caused by external factors such as inevitable accidents, including without limitation fire and abnormal fluctuation of voltage, and acts of God, including without limitation earthquake, lightning and natural disasters
 - a failure generated by an unforeseeable cause with a scientific technology that was not available at the time of the shipment of the Product from our company
 - any other failures which we are not responsible for or which you acknowledge we are not responsible for

2. Term of warranty after the stop of production

- (1) We may accept the repair at charge for another seven (7) years after the production of the product is discontinued. The announcement of the stop of production for each model can be seen in our Sales and Service, etc.
- (2) Please note that the Product (including its spare parts) cannot be ordered after its stop of production.

3. Service in overseas

Our regional FA Center in overseas countries will accept the repair work of the Product; however, the terms and conditions of the repair work may differ depending on each FA Center. Please ask your local FA center for details.

4. Exclusion of loss in opportunity and secondary loss from warranty liability

Regardless of the gratis warranty term, Mitsubishi shall not be liable for compensation to:

- (1) Damages caused by any cause found not to be the responsibility of Mitsubishi.
- (2) Loss in opportunity, lost profits incurred to the user by Failures of Mitsubishi products.
- (3) Special damages and secondary damages whether foreseeable or not, compensation for accidents, and compensation for damages to products other than Mitsubishi products.
- (4) Replacement by the user, maintenance of on-site equipment, start-up test run and other tasks.

5. Change of Product specifications

Specifications listed in our catalogs, manuals or technical documents may be changed without notice.

6. Application and use of the Product

- (1) For the use of our product, its applications should be those that may not result in a serious damage even if any failure or malfunction occurs in product, and a backup or fail-safe function should operate on an external system to product when any failure or malfunction occurs.
- (2) Our product is designed and manufactured as a general purpose product for use at general industries.
Therefore, applications substantially influential on the public interest for such as atomic power plants and other power plants of electric power companies, and also which require a special quality assurance system, including applications for railway companies and government or public offices are not recommended, and we assume no responsibility for any failure caused by these applications when used.
In addition, applications which may be substantially influential to human lives or properties for such as airlines, medical treatments, railway service, incineration and fuel systems, man-operated material handling equipment, entertainment machines, safety machines, etc. are not recommended, and we assume no responsibility for any failure caused by these applications when used.
We will review the acceptability of the abovementioned applications, if you agree not to require a specific quality for a specific application. Please contact us for consultation.

◆ About the enclosed CD-ROM

- The enclosed CD-ROM contains PDF copies of the manuals related to this product.

◆ Before using the enclosed CD-ROM

- The copyright and other rights of the enclosed CD-ROM all belong to Mitsubishi Electric Corporation.
- No part of the enclosed CD-ROM may be copied or reproduced without the permission of Mitsubishi Electric Corporation.
- Specifications of the enclosed CD-ROM are subject to change for modification without notice.
- We are not responsible for any damages and lost earnings, etc. from use of the enclosed CD-ROM.
- Trademarks

Microsoft, Windows, Windows Vista, and Internet Explorer are either registered trademarks or trademarks of Microsoft Corporation in the United States and/or other countries.

Adobe and Adobe Reader are either registered trademarks or trademarks of Adobe Systems Incorporated in the United States and/or other countries.

Intel and Pentium are trademarks of Intel Corporation in the United States and/or other countries.

Other company and product names of companies herein are all trademarks or registered trademarks of those respective companies.

- Warranty

We do not provide a warranty against defects in the enclosed CD-ROM and related documents.



- This is a personal computer dedicated CD-ROM. Do not attempt to play it on ordinary audio devices. The loud volume may damage hearing and speakers.

◆ System requirements for the enclosed CD-ROM

- The following system is required to read instruction manuals contained in the enclosed CD-ROM.

Item	Specifications
OS	Microsoft® Windows® 10, Windows® 8.1, Windows® 8, Windows® 7, Windows Vista®
CPU	Intel® Pentium® or better processor
Memory	128 MB of RAM
Hard disk	90 MB of available hard-disk space
CD-ROM drive	Double speed or more (more than quadruple speed is recommended)
Monitor	800×600 dots or more
Application	Adobe® Reader® 7.0 or more Internet Explorer® 6.0 or more

◆ Operating method of the enclosed CD-ROM

- How to read instruction manuals

Step 1. Start the personal computer and place the enclosed CD-ROM in the CD-ROM drive.

Step 2. The main window will automatically open in the web browser.

Step 3. Choose your language from a language menu.

Step 4. Click the manual you want to read in the "INSTRUCTION MANUAL" list.

Step 5. The PDF manual will open.

- Manual opening of the enclosed CD-ROM

Step 1. Start the personal computer and place the enclosed CD-ROM in the CD-ROM drive.

Step 2. Open the "index.html" file.

Step 3. The main window will open in the web browser. Follow the previous steps from Step 3 to Step 5.

- PDF data of the instruction manual are stored in "MANUAL" folder on the enclosed CD-ROM.

REVISIONS

*The manual number is given on the bottom left of the back cover.

Revision date	*Manual number	Revision
Feb. 2018	IB(NA)-0600803ENG-A	First edition
Aug. 2018	IB(NA)-0600803ENG-B	Added <ul style="list-style-type: none"> • Built-in brake transistor model
Dec. 2019	IB(NA)-0600803ENG-C	Added <ul style="list-style-type: none"> • FR-A870-00550 to 00890

1 Direct multi-speed operation

When the RLF (RLR) signal is input, the operation is the same as the one when the STF (STR) signal and RL signal are input.

◆ Input terminal function assignment

- Use **Pr.178 to Pr.189** to set the functions of the input terminals.
- Refer to the following table and set the parameters.

Setting	Signal name	Function	Related parameter
128	RLF	Low-speed forward rotation command	Pr.6
129	RLR	Low-speed reverse rotation command	Pr.6

◆ Direct multi-speed setting

- While the RLF or RLR signal is input, the operation is according to **Pr.6 Multi-speed setting (low-speed)**. The rotation is forward while the RLF signal is input, and the rotation is reverse while the RLR signal is input.

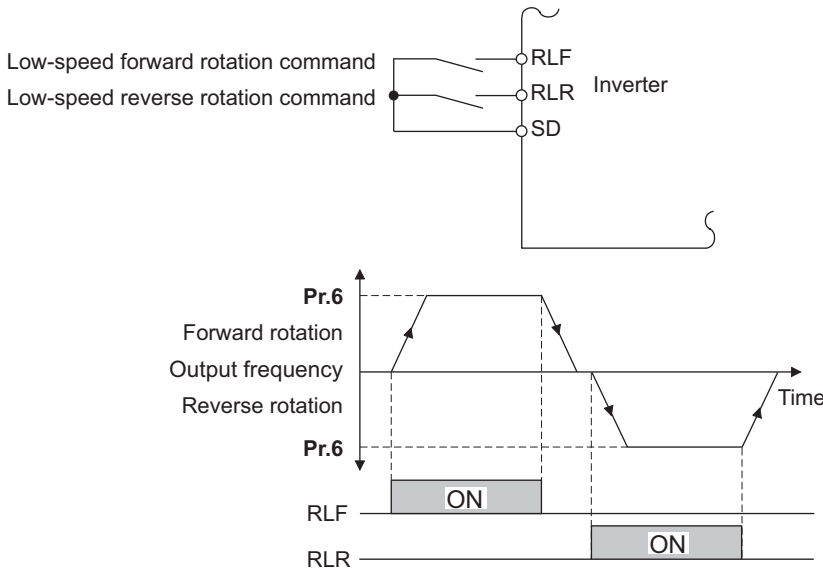

NOTE

- The **Pr.6** setting should be equal to or higher than the **Pr.13 Starting frequency** setting.
- To assign the RLF and RLR signals to input terminals, set "128 (RLF)" and "129 (RLR)" in any two parameters from **Pr.178 to Pr.189 (Input terminal function selection)**.
- The direct multi-speed operation is enabled only when the inverter operates in External operation mode.
- When the RLR or STR signal is input while the RLF signal is input, the motor is decelerated to stop.
- When the RLF or STF signal is input while the RLR signal is input, the motor is decelerated to stop.
- When **Pr.59 Remote function selection** ≠ "0", the RLF signal is used as the STF signal, and the RLR signal is used as the STR signal.
- When the stop-on-contact function is enabled, the RLF signal is used as the STF signal, and the RLR signal is used as the STR signal.
- When the RLF or RLR signal is turned ON to enable the direct multi-speed operation, the setting of **Pr.250 Stop selection** and the STP (STOP) signal are disabled.

2 Polarity of frequency command under dancer control

The inverter can be operated even when the polarity of the frequency command is negative under dancer control.

Pr.	Name	Initial value	Setting range	Description
73 T000	Analog input selection	1	0 to 7	The polarity reversible operation is disabled when the PID manipulated amount is added to the main speed command.
			10 to 17	The polarity reversible operation is enabled when the PID manipulated amount is added to the main speed command.

- Setting "10 to 17" in **Pr.73 Analog input selection** enables the polarity reversible operation of the main speed command to which PID manipulated amount added. (Polarity reversible operation of the main speed command without addition is not possible.)
- When the polarity reversible operation is enabled, the integral term cannot be limited by the maximum and minimum frequency when **Pr.1015 Integral stop selection at limited frequency** = "0 or 10".

3 Checking of current input on analog input terminal

A terminal for current input check can be selected.

Pr.	Name	Initial value	Setting range	Description
573 T052	4 mA input check selection	9999	1, 11, 21	Operation continues with output frequency before the current input loss.
			2, 12, 22	4 mA input fault (E.LCI) is activated when the current input loss is detected.
			3, 13, 23	The inverter output decelerates the motor to a stop when the current input loss is detected. After the motor is stopped, 4 mA input fault (E.LCI) is activated.
			4, 14, 24	Operation continues at the frequency set in Pr.777 .
			9999	No current input check.

◆ Selection terminal for current input check (Pr.573)

- Use **Pr.573** to select which terminal's current input is checked.

Pr.573 setting	Terminal to be checked
1 to 4	Terminals 2 and 4
11 to 14	Terminals 4
21 to 24	Terminals 2

4 Input terminal status monitor

The input states of terminals S1 and S2 can be monitored.

◆ Monitor item list (Pr.52, Pr.774 to Pr.776, Pr.992)

- Use Pr.52, Pr.774 to Pr.776, or Pr.992 to select the item to monitor on the operation panel or the parameter unit.
- Refer to the following table to find the setting value for each monitoring. The value in the Pr. setting column is set in each of the parameters for monitoring (Pr.52, Pr.774 to Pr.776, and Pr.992) to determine the monitor item. The value in the RS-485 column is used for the RS-485 communication special monitor selection. The value in the MODBUS RTU column is used for the MODBUS RTU real time monitor.

Monitor item	Increment and unit	Pr. setting	RS-485	MODBUS RTU	Description
Input terminal status	—	55*2	H0F*1	40215*1	The ON/OFF state of the input terminals on the inverter is displayed. (Refer to page 3 for details of indication on the DU.)

*1 The details of bits for the input terminal status are as follows. (1: ON state, 0: OFF state of a terminal on the inverter. "—" denotes an indefinite (null) value.)

b15													b0			
S1	S2	-	-	CS	RES	STP (STOP)	MRS	JOG	RH	RM	RL	RT	AU	STR	STF	

*2 Parameter setting is not available for setting the item as the main monitor item on the LCD operation panel (FR-LU08) or the parameter unit (FR-PU07). Use the monitor function of the FR-LU08 or the FR-PU07 for setting.

◆ Monitoring I/O terminals on the operation panel (FR-DU08) (Pr.52, Pr.774 to Pr.776, Pr.992)

- When Pr.52 (Pr.774 to Pr.776, Pr.992) = "55", the I/O terminal state can be monitored on the operation panel (FR-DU08).
- When a terminal is ON, the corresponding LED segment is ON. The center LED segments are always ON.

Pr.52, Pr.774 to Pr.776, Pr.992 setting	Monitor item	Monitor description
55	I/O terminal status	Displays the I/O terminal ON/OFF state of the inverter.

- On the I/O terminal monitor, the upper LEDs indicate the input terminal status, and the lower LEDs indicate the output terminal status.

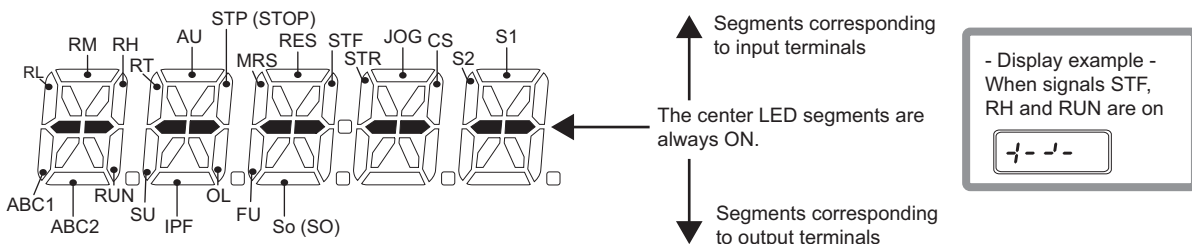

5 Main circuit capacitor life measuring

The measurement of the main circuit capacitor life can start whenever the power supply is turned OFF without setting the parameter every time.

Pr.	Name	Initial value	Setting range	Description
259 E704*1	Main circuit capacitor life measuring	0	0	No measurement
			1 (2, 3, 8, 9)	Setting "1" and turning the power supply OFF starts the measurement of the main circuit capacitor life. (Only once) If the setting value of Pr.259 becomes "3" after turning the power supply ON again, it means that the measurement is completed. The deterioration degree is read to Pr.258 .
			11 (12, 13, 18, 19)	When "11" is set, turning OFF the power supply starts the measurement of the main circuit capacitor life. If the setting value of Pr.259 becomes "13" after turning the power supply ON again, it means that the measurement is completed. The deterioration degree is read to Pr.258 .

*1 The setting is not available for the separated converter type.

◆ Life display of the main circuit capacitor (Pr.258, Pr.259) (Standard models and liquid cooled type inverters)

Point

- For accurate life measurement of the main circuit capacitor, wait three hours or longer after turning OFF. The temperature left in the main circuit capacitor affects measurement.

- The deterioration degree of the main circuit capacitor is displayed in **Pr.258**.
- With the main circuit capacitor capacity at factory shipment as 100%, the capacitor life is displayed in **Pr.258** every time measurement is made. When the measured value falls to 85% or lower, bit 1 of **Pr.255** is turned ON (set to 1) and the Y90 signal is also output as an alert.
- Measure the capacitor capacity according to the following procedure and check the deterioration degree of the capacitor capacity.

1. Check that the motor is connected and at a stop.
2. Set "1, 11" (measuring start) in **Pr.259**.
3. Switch the power OFF. The inverter applies DC voltage to the motor to measure the capacitor capacity while the inverter is OFF.
4. After confirming that the power lamp is OFF, turn ON the power again.
5. Check that "3, 13" (measurement complete) is set in **Pr.259**, read **Pr.258**, and check the deterioration degree of the main circuit capacitor.

Pr.259	Description	Remarks
0	No measurement	Initial value
1, 11	Start measurement	Measurement starts when the power supply is switched OFF. (Only once when Pr.259 = "1") When Pr.259 = "11", the measurement starts every time the power supply is turned OFF.
2, 12	During measurement	Only displayed and cannot be set. (When "11" is set in Pr.259 , "12, 13, 18, or 19" is displayed.)
3, 13	Measurement complete	
8, 18	Forced end	
9, 19	Measurement error	

NOTE

- When the main circuit capacitor life is measured under the following conditions, "forced end" (**Pr.259** = "8, 18"), or "measurement error" (**Pr.259** = "9, 19") may occur, or the status may remain in "measurement start" (**Pr.259** = "1, 11"). To perform measurement, first eliminate the following conditions. Under the following conditions, even if "measurement complete" (**Pr.259** = "3, 13") is reached, measurement cannot be performed correctly.
 - Terminals R1/L11, S1/L21 or DC power supply is connected to terminals P/+ and N/-.
 - The power supply is switched ON during measurement.
 - The motor is not connected to the inverter.
 - The motor is running (coasting).
 - The motor capacity is smaller than the inverter capacity by two ranks or more.
 - The inverter output is shut off or a fault occurred while the power was OFF.
 - The inverter output is shut off with the MRS signal.
 - The start command is given while measuring.
 - The applied motor setting is incorrect.
- Operation environment: Surrounding air temperature (annual average of 40°C (free from corrosive gas, flammable gas, oil mist, dust and dirt)).
Output current: 80% of the inverter rating
- Since repeated inrush currents at power ON will shorten the life of the converter circuit, frequent starts and stops of the magnetic contactor must be avoided.

WARNING

- When measuring the main circuit capacitor capacity (**Pr.259** = "1, 11"), the DC voltage is applied to the motor for about 1 second at power OFF. Never touch the motor terminal, etc. right after powering OFF to prevent an electric shock.

6 Load characteristics fault detection

This section describes how to set the load characteristics reference for the existing load characteristics fault detection function. The following shows the procedure to set the load characteristics reference manually.

Pr.	Name	Initial value	Setting range	Description
1481 H521	Load characteristics load reference 1	9999	0 to 400%	Set the reference value of normal load characteristics. 8888: The present load status is written as reference status. 9999: The load reference is invalid.
1482 H522	Load characteristics load reference 2	9999		
1483 H523	Load characteristics load reference 3	9999		
1484 H524	Load characteristics load reference 4	9999		
1485 H525	Load characteristics load reference 5	9999		

◆ Setting the load characteristics reference manually (Pr.1481 to Pr.1485)

- Set **Pr.1480 Load characteristics measurement mode** = "0" (initial value).
- Set **Pr.1486** and **Pr.1487** to specify the frequency band for the measurement, and calculate the frequency as the load characteristics reference (f2 to f4) using the following table.
- Start the inverter operation, and set **Pr.1481** = "8888" during operation at the frequency of the load characteristics reference 1 (f1). The load status at that point is set in **Pr.1481** (only when the set frequency is within ±2 Hz of the frequency of the measurement point, and the SU signal is ON).
- Set load references in **Pr.1482 to Pr.1485** in the same way as **Pr.1481**.

Reference	Frequency	Load reference
Load characteristics reference 1	f1: Load characteristics minimum frequency (Pr.1487)	Pr.1481
Load characteristics reference 2	f2 = (f5-f1)/4+f1	Pr.1482
Load characteristics reference 3	f3 = (f5-f1)/2+f1	Pr.1483
Load characteristics reference 4	f4 = (f5-f1)×3/4+f1	Pr.1484
Load characteristics reference 5	f5: Load characteristics maximum frequency (Pr.1486)	Pr.1485

NOTE

- When inputting values directly in **Pr.1481 to Pr.1485** under V/F control or Advanced magnetic flux vector control, input the load meter monitored values at the frequency of each load characteristics reference.
- When inputting values directly in **Pr.1481 to Pr.1485** under Real sensorless vector control or Vector control, input the load meter monitored values at the frequency of each load characteristics reference.

7 PLC function

This section describes the CC-Link I/O specifications for the PLC function. For details, refer to the PLC function programming manual.

- The signal name of the PLC function device No. Y34 differs depending on the setting of **Pr.192 IPF terminal function selection** as follows.

Pr.192 setting	Signal name
9999	Instantaneous power failure (Terminal IPF function)
Other than 9999	Overload alarm (Terminal OL function)

- The signal name of the PLC function device No. Y35 differs depending on the setting of **Pr.193 OL terminal function selection** as follows.

Pr.193 setting	Signal name
9999	Overload alarm (Terminal OL function)
Other than 9999	Instantaneous power failure (Terminal IPF function)

8 Cooling fan operation selection during the test operation

The cooling fan can be stopped during Vector control test operation.

Pr.	Name	Initial value	Setting range	Description
244	Cooling fan operation selection	1	0	Cooling fan ON/OFF control is disabled. (The cooling fan is always ON at power ON) The cooling fan operates at power ON.
			1	Cooling fan ON/OFF control is enabled. The fan is always ON while the inverter is running. During a stop, the inverter status is monitored and the fan switches ON/OFF according to the temperature.
			101 to 105	Cooling fan ON/OFF control is enabled. Set the cooling fan stop waiting time within 1 to 5 seconds.
			1000	Cooling fan ON/OFF control is disabled. (The cooling fan is always ON at power ON) The cooling fan operates at power ON.
			1001	Cooling fan ON/OFF control is enabled. The fan is always ON while the inverter is running. During a stop, the inverter status is monitored and the fan switches ON/OFF according to the temperature.
			1101 to 1105	Cooling fan ON/OFF control is enabled. Set the cooling fan stop waiting time within 1 to 5 seconds.
H100	Cooling fan operation selection	1	0	Cooling fan ON/OFF control is disabled. (The cooling fan is always ON at power ON) The cooling fan operates at power ON.
			1	Cooling fan ON/OFF control is enabled. The fan is always ON while the inverter is running. During a stop, the inverter status is monitored and the fan switches ON/OFF according to the temperature.
			101 to 105	Cooling fan ON/OFF control is enabled. Set the cooling fan stop waiting time within 1 to 5 seconds.
H106	Cooling fan operation selection during the test operation	0	0	The cooling fan operates according to the H100 setting during Vector control test operation.
			1	The cooling fan can be set to always OFF during Vector control test operation.

◆ Cooling fan operation selection during the test operation (P.H106)

- When **P.H106** = "1" or **Pr.244** = "1000, 1001, or 1101 to 1105", the cooling fan can be set to always OFF during Vector control test operation.

9 Inverter parts life display

The degree of deterioration of the control circuit capacitor, main circuit capacitor, cooling fan, inrush current limit circuit, and relay contacts of terminals A, B, and C can be diagnosed on the monitor. When the life span of each part is near its end, the self-diagnostic warning is output to prevent a fault. (Use the life check of this function as a guideline only, since the life span of each part except for the main circuit capacitor is calculated theoretically.)

Pr.	Name	Initial value	Setting range	Description
255 E700	Life alarm status display	0	(0 to 255)*1	Displays whether or not the life alarm output level is reached for the following parts: the control circuit capacitor, main circuit capacitor, cooling fan, inrush current limit circuit, and relay contacts of terminals A, B, and C. Read-only.
507 E706	Display/reset ABC1 relay contact life	100%	(0 to 100%)	Displays the degree of deterioration of the relay contacts of terminals A1, B1, and C1.
508 E707	Display/reset ABC2 relay contact life	100%	(0 to 100%)	Displays the degree of deterioration of the relay contacts of terminals A2, B2, and C2.

*1 The setting range (read-only) differs depending on the inverter model (standard model, separate converter type).

◆ Life alarm display and signal output (Y90 signal, Pr.255)

- In the life diagnosis of the main circuit capacitor, the alarm signal (Y90) is not output unless measurement by turning OFF the power supply is performed.

- Pr.255 Life alarm status display** and the Life alarm (Y90) signal can be used to check whether or not the life alarm output level is reached for the following parts: the control circuit capacitor, main circuit capacitor, cooling fan, inrush current limit circuit, or relay contacts of terminals A, B, and C.

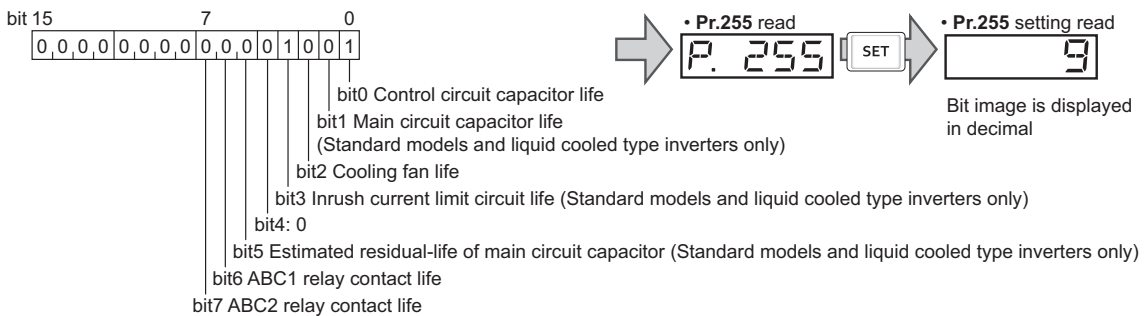

- When the parts have reached the life alarm output level, the corresponding bits of **Pr.255** turns ON. The ON/OFF state of the bits can be checked with **Pr.255**. The following table shows examples.

Pr.255		bit 7	bit 6	bit 5	bit 4	bit 3	bit 2	bit 1	bit 0	Remarks
Decimal	Binary									
239	11101111	○	○	○	×	○	○	○	○	All parts have reached alarm output level for standard structure models.
5	101	×	×	×	×	×	○	×	○	Control circuit capacitor and cooling fan have reached alarm output level.
0	0	×	×	×	×	×	×	×	×	No parts have reached alarm output level.

○: Parts reaching alarm output level ×: Parts not reaching alarm output level

- The Life alarm (Y90) signal turns ON when the life alarm output level is reached for either of the following: the control circuit capacitor life, main circuit capacitor life, cooling fan life, inrush current limit circuit life, estimated residual-life of the main circuit capacitor, ABC1 relay contact life, or ABC2 relay contact life.
- For the terminal used for the Y90 signal, set "90" (positive logic) or "190" (negative logic) in any of **Pr.190 to Pr.196 (Output terminal function selection)**.

NOTE

- When using an option (FR-A8AY, FR-A8AR, FR-A8NC, FR-A8NCE, or FR-A8NCG), warning signals can be output individually: Control circuit capacitor life (Y86) signal, Main circuit capacitor life (Y87) signal, Cooling fan life (Y88) signal, Inrush current limit circuit life (Y89) signal, Estimated residual-life of main circuit capacitor (Y248) signal, ABC1 relay contact life (Y249) signal, and ABC2 relay contact life (Y250) signal.
- Changing the terminal assignment using **Pr.190 to Pr.196 (Output terminal function selection)** may affect the other functions. Set parameters after confirming the function of each terminal.

◆ Life display of the relay contacts of terminals A, B, and C (Pr.507, Pr.508)

- The degree of deterioration of the relay contacts of terminals A1, B1, and C1 is displayed in **Pr.507**, and that for terminals A2, B2, and C2 is displayed in **Pr.508**.
- The number of times the contacts of relay turn ON is counted down from 100% (0 time) by 1% (500 times). When the counter reaches 10% (45,000 times), bit 6 or bit 7 of **Pr.255** turns ON and a warning is output by the Y90 signal.
- Any value can be set in **Pr.507** and **Pr.508**. After replacement of the control circuit terminal block or installation of a control terminal option, set **Pr.507** and **Pr.508** again.

10 For customers using communication options manufactured by HMS

◆ DriveControl writing restriction selection

- The command source to change the DriveControl settings (including Netctrl bit and Netref bit) can be selected.

Pr.	Name	Initial value	Setting range	Description
349	Communication reset selection/Ready bit status selection	0	0, 1, 100, 101, 1000, 1001, 1100, 1101, 10000, 10001, 10100, 10101, 11000, 11001, 11100, 11101	Use this parameter to select the error reset operation, Ready bit status, inverter reset operation when a fault is cleared, and DriveControl writing restriction.
N010	Communication reset selection	0	0	Error reset is enabled in any operation mode.
			1	Error reset is enabled in the Network operation mode.
N240	Ready bit status selection	0	0	The status of Ready bit in communication data can be changed when an HMS network option is installed.
			1	
N241	Reset selection after inverter faults are cleared	0	0	The inverter is reset when a fault is cleared.
			1	The inverter is not reset when a fault is cleared.
N242	DriveControl writing restriction selection	0	0	DriveControl writing is not restricted.
			1	DriveControl writing is restricted.

■ DriveControl writing restriction selection (P.N242)

- The command source to change the DriveControl settings can be restricted to only the command source selected by **Pr.550 NET mode operation command source selection**.

Setting value					Description					
Pr.349	N010	N240	N241	N242	Communication reset selection ^{*1}		Ready bit status selection ^{*2}		Reset selection after inverter faults are cleared	DriveControl writing restriction selection
					NET operation mode	Other than NET operation mode	Main circuit: power-ON	Main circuit: power-OFF ^{*3}		
0	0	0	0	0	Reset enabled	Reset enabled	Ready bit: ON	Ready bit: ON	Reset enabled	Not restricted
1	1	0	0	0	Reset enabled	Reset disabled	Ready bit: ON	Ready bit: ON	Reset enabled	Not restricted
100	0	1	0	0	Reset enabled	Reset enabled	Ready bit: ON	Ready bit: OFF	Reset enabled	Not restricted
101	1	1	0	0	Reset enabled	Reset disabled	Ready bit: ON	Ready bit: OFF	Reset enabled	Not restricted
1000	0	0	1	0	Reset enabled	Reset enabled	Ready bit: ON	Ready bit: ON	Reset disabled ^{*4}	Not restricted
1001	1	0	1	0	Reset enabled	Reset disabled	Ready bit: ON	Ready bit: ON	Reset disabled ^{*4}	Not restricted
1100	0	1	1	0	Reset enabled	Reset enabled	Ready bit: ON	Ready bit: OFF	Reset disabled ^{*4}	Not restricted
1101	1	1	1	0	Reset enabled	Reset disabled	Ready bit: ON	Ready bit: OFF	Reset disabled ^{*4}	Not restricted
10000	0	0	0	1	Reset enabled	Reset enabled	Ready bit: ON	Ready bit: ON	Reset enabled	Restricted ^{*4}
10001	1	0	0	1	Reset enabled	Reset disabled	Ready bit: ON	Ready bit: ON	Reset enabled	Restricted ^{*4}
10100	0	1	0	1	Reset enabled	Reset enabled	Ready bit: ON	Ready bit: OFF	Reset enabled	Restricted ^{*4}
10101	1	1	0	1	Reset enabled	Reset disabled	Ready bit: ON	Ready bit: OFF	Reset enabled	Restricted ^{*4}
11000	0	0	1	1	Reset enabled	Reset enabled	Ready bit: ON	Ready bit: ON	Reset disabled ^{*4}	Restricted ^{*4}
11001	1	0	1	1	Reset enabled	Reset disabled	Ready bit: ON	Ready bit: ON	Reset disabled ^{*4}	Restricted ^{*4}
11100	0	1	1	1	Reset enabled	Reset enabled	Ready bit: ON	Ready bit: OFF	Reset disabled ^{*4}	Restricted ^{*4}
11101	1	1	1	1	Reset enabled	Reset disabled	Ready bit: ON	Ready bit: OFF	Reset disabled ^{*4}	Restricted ^{*4}

*1 The operation mode affects the availability of communication reset.

*2 The ON/OFF state of the power supply affects the ON/OFF state of Ready bit.

*3 When 24 V external power is available for control circuit or power is input only to control circuit.

*4 Available when the HMS network option is installed.

◆ Inverter monitor items / command items

- The following inverter monitor items are added.

16-bit data

No.	Description	Unit	Type	Read/ write
H0024	Torque (positive polarity for driving torque / negative polarity for regenerative braking torque)	0.1%	unsigned	R

FR-A800/A800 Plus Series

Instruction Manual Supplement

1 Emergency drive



This function is used in case of emergency such as a fire to forcibly continue inverter operation to drive a motor without activating protective functions even if the inverter detects a fault. Using this function may cause damage of the motor or the inverter because driving the motor is given the highest priority. Use this function for emergency operation only. When the inverter is damaged by a fault, the motor operation can be continued by switching to the commercial power supply operation.

The emergency drive function is available only for standard structure models and IP55 compatible models.

Pr.	Name	Initial value		Setting range	Description
		FM	CA		
523 H320*1	Emergency drive mode selection	9999		100, 111, 112, 121, 122, 123, 124, 200, 211, 212, 221, 222, 223, 224, 300, 311, 312, 321, 322, 323, 324, 400, 411, 412, 421, 422, 423, 424	Select the operation mode of the emergency drive.
				9999	Emergency drive disabled.
524 H321*1*2	Emergency drive running speed	9999		0 to 590 Hz*3	Set the running frequency in the fixed frequency mode of the emergency drive (when the fixed frequency mode is selected in Pr.523)
				0% to 100%*3	Set the PID set point in the PID control mode of the emergency drive (when the PID control mode is selected in Pr.523)
				9999*3	Emergency drive disabled.
515 H322*1	Emergency drive dedicated retry count	1		1 to 200	Set the retry count during emergency drive operation.
				9999*3	Without retry count excess (no restriction on the number of retries).
1013 H323*1	Emergency drive running speed after retry reset	60 Hz	50 Hz	0 to 590 Hz	Set the frequency for operation after a retry when any of E.CPU, E.1 to E.3, and E.5 to E.7 occurs during emergency drive operation.
514 H324*1	Emergency drive dedicated waiting time	9999		0.1 to 600 s	Set the retry waiting time during emergency drive operation.
				9999	The Pr.68 setting is applied to the operation.
136 A001	MC switchover interlock time	1 s		0 to 100 s	Set the operation interlock time for MC2 and MC3.
139 A004	Automatic switchover frequency from inverter to bypass operation	9999		0 to 60 Hz	Set the frequency at which the inverter-driven operation is switched over to the commercial power supply operation when the condition for the electronic bypass is established during emergency drive operation.
				8888, 9999	Electronic bypass during emergency drive is disabled.
57 A702	Restart coasting time	9999		0	Coasting time differs according to the inverter capacity. (Refer to the description of the automatic restart after instantaneous power failure function in the Instruction Manual (Detailed) or the Instruction Manual (Function).)
				0.1 to 30 s	Set the waiting time for the inverter to perform a restart after restoring power due to an instantaneous power failure.
				9999	No restart

*1 The setting is available for the standard structure model and the IP55 compatible model.

*2 Set **Pr.524** after setting **Pr.523**.

*3 When **Pr.523** = "100, 200, 300, or 400", the emergency drive is activated regardless of the **Pr.524** setting.

◆ Connection diagram

- A connection diagram of the emergency drive (commercial mode) is as follows.

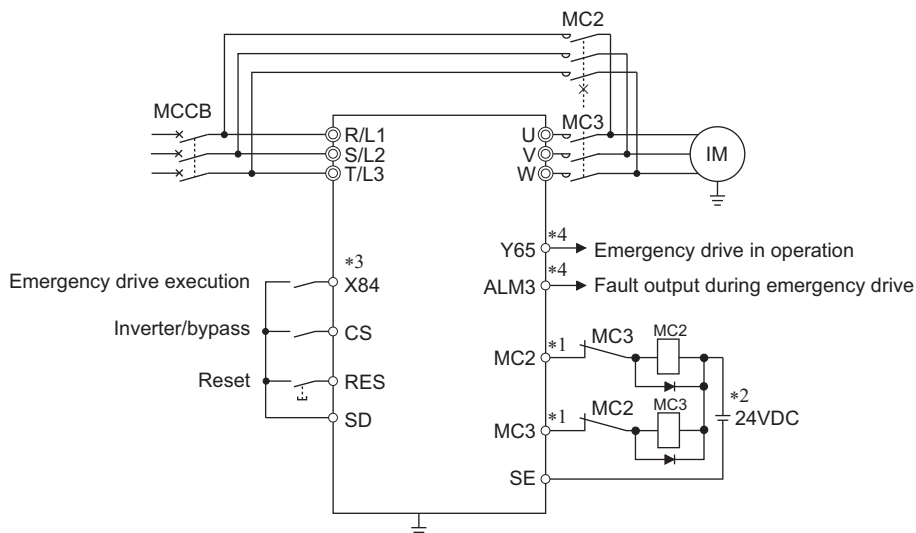

*1 Be careful of the capacity of the sequence output terminals.

The applied terminals differ by the settings of **Pr.190 to Pr.196 (Output terminal function selection)**.

Output terminal capacity	Output terminal permissible load
Open collector output of inverter (RUN, SU, IPF, OL, FU)	24 VDC 0.1 A
Inverter relay output (A1-C1, B1-C1, A2-B2, B2-C2) Relay output option (FR-A8AR)	230 VAC 0.3 A 30 VDC 0.3 A

*2 When connecting a DC power supply, insert a protective diode.

When connecting an AC power supply, use relay output terminals of the inverter or contact output terminals of the relay output option (FR-A8AR).

*3 The applied terminals differ by the settings of **Pr.180 to Pr.189 (Input terminal function selection)**

*4 The applied terminals differ by the settings of **Pr.190 to Pr.196 (Output terminal function selection)**.

NOTE

- Be sure to provide a mechanical interlock for MC2 and MC3.

◆ Emergency drive execution sequence

Point

- When the X84 signal is ON for 3 seconds, the emergency drive is activated.
- The Y65 signal turns ON during emergency drive operation.
- "ED" appears on the operation panel during emergency drive operation.
- The ALM3 signal turns ON when a fault occurs during emergency drive operation.

- To activate the emergency drive, the X84 signal needs to be ON for three seconds while all the following conditions are satisfied.

Item	Condition
Emergency drive parameter settings	Pr.523 ≠ "9999" Pr.524 ≠ "9999" (Setting is not required when Pr.523 = "100, 200, 300, or 400".)
Control method	Either of the following control methods is selected (when Pr.800 = "9, 10, 20, 109, or 110" or Pr.451 = "10, 20, 110, or 9999") <ul style="list-style-type: none"> • V/F control • Advanced magnetic flux vector control • Real sensorless vector control (speed control) • PM sensorless vector control (speed control) • PM sensorless vector control test operation
Contradictory condition	None of the following conditions are satisfied. <ul style="list-style-type: none"> • Enabling the electronic bypass sequence function • Enabling the brake sequence function • Using the FR-A8NS (option) • During offline auto tuning • Supplying power through terminals R1 and S1 • Pr.30 = "2, 102"

- When the "retry" (**Pr.523** = "2□□, 3□□") is selected, it is recommended to use the automatic restart after instantaneous power failure function at the same time.
- Parameter setting is not available during emergency drive operation.
- To return to the normal operation during emergency drive operation, do the following. (The operation will not be returned to normal only by turning OFF the X84 signal.)
Reset the inverter, or turn the power supply OFF.
Clear a fault by turning ON the X51 signal while the sequence function is enabled (when the protective function is activated).
- The operation is switched over to the commercial power supply operation in case of the following during emergency drive operation while the commercial mode or the retry / commercial mode is selected.
24 V external power supply operation, power failure status or operation with the power supplied through R1/S1 (except when the DC feeding mode 1 or 2 is selected), undervoltage
- To input the X84 signal, set "84" in any of **Pr.178 to Pr.189 (Input terminal function selection)** to assign the function.
- For the terminal used for the Y65 signal output, assign the function by setting "65 (positive logic)" or "165 (negative logic)" in any of **Pr.190 to Pr.196 (Output terminal function selection)**. For the terminal used for the ALM3 signal output, assign the function by setting "66 (positive logic)" or "166 (negative logic)" in any of **Pr.190 to Pr.196 (Output terminal function selection)**.
- The X84 signal input is valid either through the external terminal or via network regardless of the **Pr.338** and **Pr.339** settings (Selection of control source in Network operation mode).
- During emergency drive operation, the operation is performed as **Pr.502 Stop mode selection at communication error** = "0 (initial value)" and communication errors (such as E.SER) do not occur. (A protective function is performed according to its operation during emergency drive operation.)

- The following diagram shows the operation of the emergency drive function (in the retry / output shutoff mode or in the fixed frequency mode (**Pr.523** = "211")).

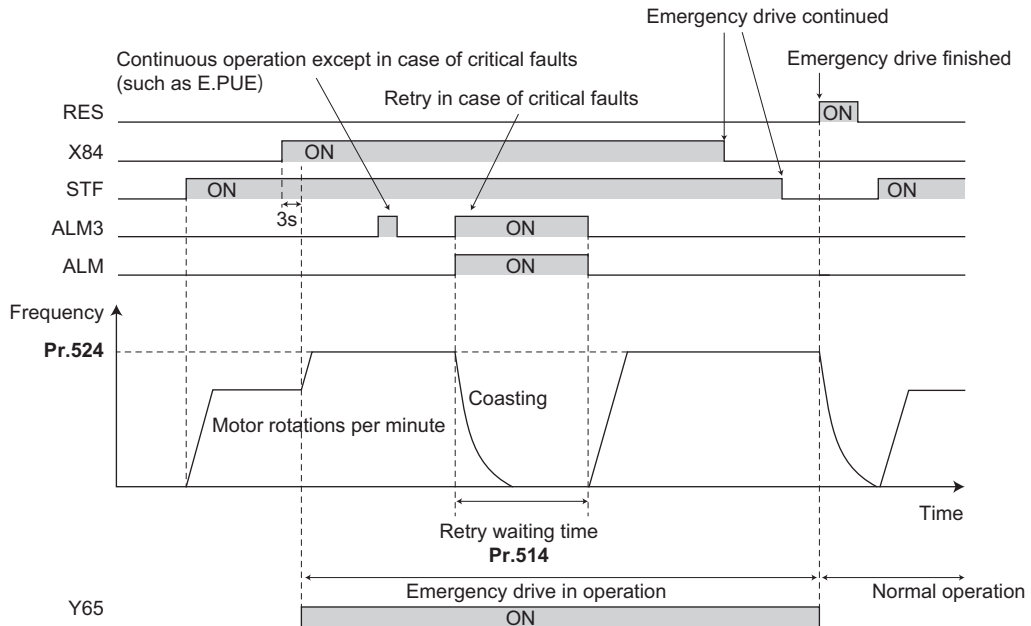

- The following diagram shows the operation of switching over to the commercial power supply operation during emergency drive operation by using the CS signal (when the electronic bypass during emergency drive operation is enabled) (in the commercial mode or in the fixed frequency mode (**Pr.523** = "411")).

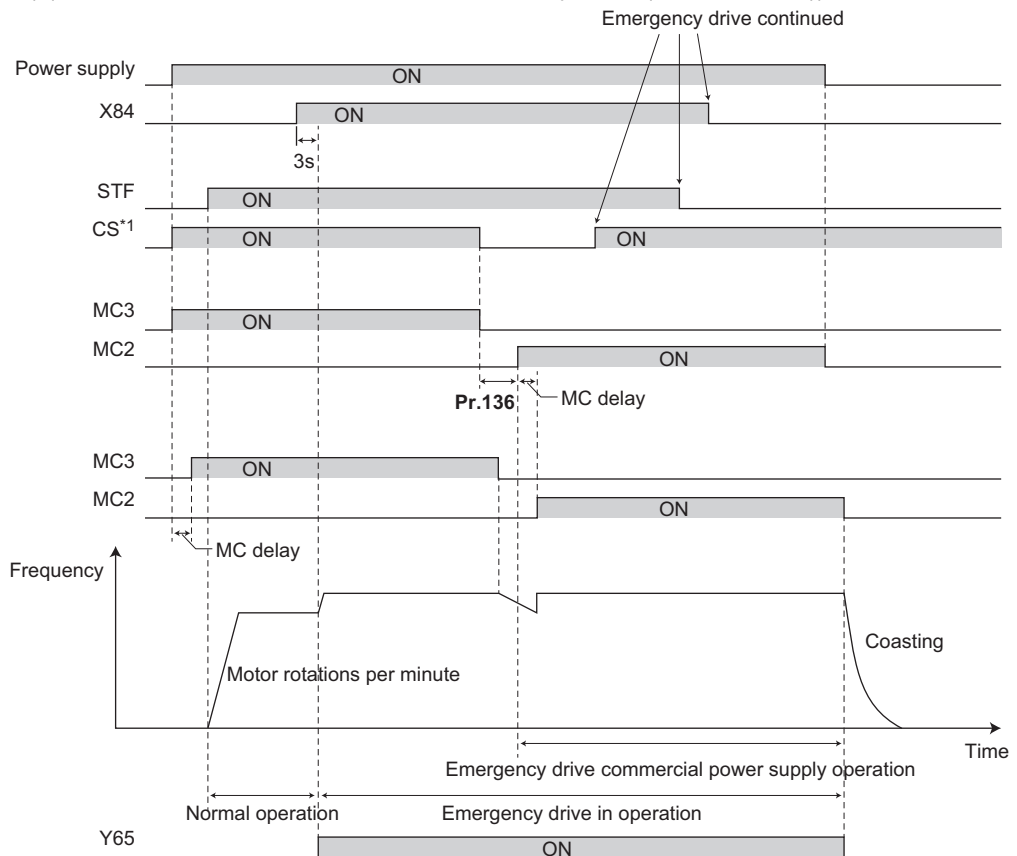

*1 Input the CS signal via an external terminal.

NOTE

- The emergency drive function is not available for the FR-A800-CRN and FR-B, B3 series inverters.

◆ Emergency drive operation selection (Pr.523, Pr.524)

- Use **Pr.523 Emergency drive mode selection** to select the emergency drive operation. Set a value in the hundreds place to select the operation when a valid protective function is activated (critical fault) during emergency drive. Set values in the ones and tens places to select the operation method.

Pr.523 setting	Emergency drive operation mode		Description
100	Output shutoff mode		Output shutoff at a critical fault occurrence.
200	Retry / output shutoff mode		Retry operation at a critical fault occurrence. (Output shutoff at the occurrence of a fault for which retry is not permitted.) The output is shut off when a critical fault for which retry is not permitted occurs, or the retry count is exceeded.
300 ^{*1}	Retry / commercial mode		Retry operation at a critical fault occurrence. (Electronic bypass at the occurrence of a critical fault for which retry is not permitted.) The operation is switched over to the commercial power supply operation when a critical fault for which retry is not permitted occurs, or the retry count is exceeded. While Pr.515 = "9999", the operation is switched over to the commercial power supply operation when the retry count reaches 200.
400 ^{*1}	Commercial mode		The operation is switched over to the commercial power supply operation when a critical fault occurs.
000	Normal operation		The operation is performed with the same set frequency and by the same starting command as those in the normal operation. Use this mode to avoid output shutoff due to a fault.
011	Fixed frequency mode	Forward rotation	The operation is forcibly performed with the frequency set in Pr.524 . Even when the motor is stopped, the operation is started by the emergency drive operation.
012		Reverse rotation	
021	PID control mode	Forward rotation	The operation is performed under PID control using the Pr.524 setting as a set point. The measured values are input in the method set in Pr.128 .
022		Reverse rotation	
023		Forward rotation (Second PID measured value input)	The operation is performed under PID control using the Pr.524 setting as a set point. The measured values are input in the method set in Pr.753 .
024		Reverse rotation (Second PID measured value input)	
9999	Emergency drive disabled.		

*1 Under PM sensorless vector control, the operation is not switched over to the commercial power supply operation and the output is shut off.

NOTE

- The operation is automatically switched from the PU operation mode or External/PU combined operation mode to the External operation mode when the emergency drive is activated in the fixed frequency mode or in the PID control mode.

◆ Retry operation during emergency drive (Pr.515, Pr.514)

- Set the retry operation during emergency drive operation. Use **Pr.515 Emergency drive dedicated retry count** to set the retry count, and use **Pr.514 Emergency drive dedicated waiting time** to set the retry waiting time.
- The ALM signal output conditions depend on the **Pr.67 Number of retries at fault occurrence** setting. (Refer to the description of the retry function in the Instruction Manual (Detailed) or the Instruction Manual (Function).)
- For the protective functions (critical faults) for which a retry is performed during emergency drive operation, refer to [page 7](#).

NOTE

- During emergency drive operation, **Pr.65 Retry selection** is not available.

◆ Electronic bypass during emergency drive (Pr.136, Pr.139, Pr.57)

- For selecting the commercial mode (Pr.523 = "3□□, 4□□"), setting is required as follows.
Set **Pr.136 MC switchover interlock time** and **Pr.139 Automatic switchover frequency from inverter to bypass operation** and assign MC2 and MC3 signals to output terminals.
When the CS signal is assigned to an input terminal, set **Pr.57 Restart coasting time** ≠ "9999" and input the CS signal through the terminal. (In the initial setting, the CS signal is assigned to the terminal CS.)
Select V/F control, Advanced magnetic flux vector control, or Real sensorless vector control. (Under PM sensorless vector control, the operation is not switched over to the commercial power supply operation the output is shut off.)
- During emergency drive operation, the operation is switched over to the commercial power supply operation when any of the following conditions is satisfied.
CS signal turns OFF.
A critical fault for which retry is not permitted occurs while **Pr.523** = "3□□".
A critical fault occurs while **Pr.523** = "4□□".
- While the motor is driven by the inverter during emergency drive operation, if a condition for electronic bypass is satisfied, the output frequency is accelerated/decelerated to the **Pr.139** setting. When the frequency reaches the set frequency, the operation is switched over to the commercial power supply operation. (The operation is immediately switched over to the commercial power supply operation during output shutoff due to a critical fault occurrence.)
- If the parameter for electronic bypass is not set while the commercial mode is set (**Pr.523** = "3□□, 4□□"), the operation is not switched over to the commercial power supply operation even when a condition for switchover is satisfied, and the output is shut off.
- To assign the MC2 and MC3 signals to output terminals, use any two of **Pr.190 to Pr.196 (Output terminal function selection)** and set "18 (positive logic)" for the MC2 signal and set "19 (positive logic)" for the MC3 signal.
- Operation of magnetic contactor (MC2, MC3)

Magnetic contactor	Installation location	Operation	
		During commercial power supply operation	During inverter operation
MC2	Between power supply and motor	Shorted	Open
MC3	Between inverter output side and motor	Open	Shorted

- The input signals are as follows.

Signal	Function	Operation	MC operation ^{*4}	
			MC2	MC3
CS ^{*1}	Inverter/bypass	ON: Inverter operation	×	○
		OFF: Emergency drive commercial power supply operation ^{*2}	○	×
X84	Emergency drive operation	ON: Emergency drive operation	—	—
		OFF: Normal operation ^{*3}	×	○
RES	Operation status reset	ON: Reset	×	No change
		OFF: Normal operation	—	—

*1 Input the CS signal via an external terminal. (Set **Pr.162** = "0 to 3, 10 to 13" or **Pr.338** = "1".)

*2 If the signal is turned ON after switchover to the emergency drive commercial power supply operation, the operation will not be returned to the inverter-driven operation.

*3 If the signal is turned OFF during the emergency drive operation, the operation will not be returned to normal.

*4 MC operation is as follows.

Notation	MC operation
○	ON
×	OFF
—	During inverter operation: MC2-OFF, MC3-ON During commercial power supply operation: MC2-ON, MC3-OFF
No change	The operation status before changing the signal state to ON or OFF is held.

NOTE

- During electronic bypass operation while the electronic bypass sequence is enabled (**Pr.135** = "1"), the emergency drive function is not available.

◆ PID control during emergency drive operation

- During emergency drive operation in the PID control mode, the operation is performed under PID control using the **Pr.524** setting as a set point. Input the measured values in the method set in **Pr.128** or **Pr.753**.
- When the PID control mode is selected for emergency drive, the PID action during emergency drive operation is as follows depending on the PID control setting.

Item	PID control action		
	Set point / measured value input setting	Deviation input setting	Without PID control setting
Measured value input selection (Pr.128, Pr.753)	Held	Terminal 4 input	Terminal 4 input
Forward action / reverse action selection (Pr.128, Pr.753)	Held	Held	Reverse action
Proportional band (Pr.129, Pr.756)	Held	Held	100% (initial value)
Integral time (Pr.130, Pr.757)	Held	Held	1 s (initial setting)
Differential time (Pr.134, Pr.758)	Held	Held	Not used (initial setting)
Applied to the frequency / calculation only (Pr.128, Pr.753)	Applied to the frequency	Applied to the frequency	Applied to the frequency
Dancer control	Invalid	Invalid	Invalid
Other PID-related settings	Held	Held	Held

- While the "retry" (**Pr.523** = "22[, 32[") is selected in the PID control mode, if a retry occurs at an occurrence of E.CPU, E.1 to E.3, or E.5 to E.7 during emergency drive operation, the operation is performed not under PID control but with the fixed frequency.

Use **Pr.1013 Emergency drive running speed after retry reset** to set the fixed frequency.

◆ Operation of protective functions during emergency drive

- Operation of protective functions during emergency drive is as follows.

Protective function	Operation during emergency drive	Protective function	Operation during emergency drive	Protective function	Operation during emergency drive
E.OC1	Retry	E.OP3	The function is disabled.	E.ECA	The function is disabled.
E.OC2	Retry	E.16	The function is disabled.	E.MB1	The function is disabled.
E.OC3	Retry	E.17	The function is disabled.	E.MB2	The function is disabled.
E.OV1	Retry	E.18	The function is disabled.	E.MB3	The function is disabled.
E.OV2	Retry	E.19	The function is disabled.	E.MB4	The function is disabled.
E.OV3	Retry	E.20	The function is disabled.	E.MB5	The function is disabled.
E.THT	Retry	E.PE	Output shutoff	E.MB6	The function is disabled.
E.THM	Retry	E.PUE	The function is disabled.	E.MB7	The function is disabled.
E.FIN	Retry	E.RET	Output shutoff	E.EP	The function is disabled.
E.IPF	The function is disabled.	E.PE2	Output shutoff	E.MP	The function is disabled.
E.UVT	The function is disabled.	E.CPU	Retry	E.EF	The function is disabled.
E.ILF	The function is disabled.	E.CTE	The function is disabled.	E.IAH	The function is disabled.
E.OLT	Retry	E.P24	The function is disabled.	E.LCI	The function is disabled.
E.SOT	Retry	E.CDO	Retry	E.PCH	The function is disabled.
E.LUP	The function is disabled.	E.IOH	Output shutoff	E.PID	The function is disabled.
E.LDN	The function is disabled.	E.SER	The function is disabled.	E.1	Retry ^{*2}
E.BE	Retry ^{*1}	E.AIE	The function is disabled.	E.2	Retry ^{*2}
E.GF	Retry	E.USB	The function is disabled.	E.3	Retry ^{*2}
E.LF	The function is disabled.	E.SAF	Retry ^{*1}	E.5	Retry ^{*2}
E.OHT	Retry	E.PBT	Retry ^{*1}	E.6	Retry ^{*1*2}
E.PTC	Retry	E.OS	The function is disabled.	E.7	Retry ^{*1*2}
E.OPT	The function is disabled.	E.OSD	The function is disabled.	E.11	The function is disabled.
E.OP1	The function is disabled.	E.ECT	The function is disabled.	E.13	Output shutoff
E.OP2	The function is disabled.	E.OD	The function is disabled.		

*1 While the switchover to the commercial power supply operation during emergency drive operation is enabled, when the same protective function is activated twice consecutively, the retry is attempted up to twice.

*2 In normal operation (**Pr.523** = "200 or 300"), the start signal is turned OFF at the same time the retry function resets the protective function. Input the start signal again to resume the operation.

- The fault output during emergency drive operation is as follows.

Signal	Pr.190 to Pr.196 setting		Description
	Positive logic	Negative logic	
ALM	99	199	Turns ON at the occurrence of a fault that causes the above-mentioned "retry" or "output shutoff" during emergency drive operation.
ALM3	66	166	Output when a fault occurs during emergency drive operation. During emergency drive operation, if a fault that does not activate any protective function occurs, the signal turns ON for 3 seconds and then turns OFF.

◆ Input signal operation

- During emergency drive operation in the fixed frequency mode or in the PID control mode, input signals unrelated to the emergency drive become invalid with some exceptions.
- The following table shows functions of the signals that do not become invalid during emergency drive operation in the fixed frequency mode or in the PID control mode.

Input signal status	Fixed frequency mode	PID control mode
Valid	OH, X31 ^{*1} , X32, X41 ^{*1} , TRG, TRC, X51, RES, X70, X71	OH, X31 ^{*1} , X32, X41 ^{*1} , TRG, TRC, X51, RES, X70, X71
Held	RT, X9, X17, X18, MC, SQ, X84	RT, X9, X17, X18, MC, SQ, X64, X65, X66, X67, X79, X84
Always-ON	—	X14, X77, X78, X80

^{*1} The signal is available only for the FR-A800-LC.

◆ Emergency drive status monitor

- Set "68" in **Pr.52, Pr.774 to Pr.776, Pr.992** to monitor the status of the emergency drive on the operation panel.
- Description of the status monitor

Operation panel indication	Description	
	Emergency drive setting	Emergency drive operating status
0	Emergency drive function setting is not available.	—
1	Electronic bypass during emergency drive operation is disabled.	During normal operation
2		Operating properly
3		A certain alarm is occurring. ^{*2}
4		Emergency drive in operation
5		A critical fault is occurring. The operation is being continued by the retry.
11	Electronic bypass during emergency drive operation is enabled.	During normal operation
12		Operating properly
13		A certain alarm is occurring. ^{*2}
14		Emergency drive in operation
15		A critical fault is occurring. The operation is being continued by the retry.
20 ^{*1}		Electronic bypass is started during emergency drive (during acceleration/ deceleration to the switchover frequency).
30 ^{*1}		During electronic bypass during emergency drive (waiting during the interlock time).
40 ^{*1}		During commercial power supply operation during emergency drive

^{*1} The first digit remains the same as the previous numerical value (fault condition).

^{*2} "A certain alarm" means a protective function disabled during emergency drive shown in the tables on [page 7](#).

⚠ CAUTION

- When the emergency drive operation is performed, the operation is continued or the retry is repeated even when a fault occurs, which may damage or burn the inverter and motor. Before restarting the normal operation after using this function, make sure that the inverter and motor have no fault. Any damage of the inverter or the motor caused by using the emergency drive function is not covered by the warranty even within the guarantee period.

2 Forward rotation output (Y30) signal and Reverse rotation output (Y31) signal

The Forward rotation output (Y30) signal and Reverse rotation output (Y31) signal become available under encoder feedback control.

- Under Vector control or encoder feedback control, the Forward rotation output (Y30) signal or the Reverse rotation output (Y31) signal is output according to the actual rotation direction of the motor.

NOTE

- For the details on the Y30 and Y31 signals, refer to the Instruction Manual (Detailed) or the Instruction Manual (Function).
-

FR-A800/A800 Plus Series

Instruction Manual Supplement

1 Internal storage device fault (E.PE6)

The operation of the storage device in the inverter can be checked.

If a data fault occurs in the storage device in the inverter, the protective function (E.PE6) is activated.

When the read value of **Pr.890** is "7" or smaller, an inverter reset after All parameter clear can return the operation to normal. (The parameters that had been changed before All parameter clear must be set again.)

Operation panel indication	E.PE6	E. PEE	FR-LU08 indication	Fault
Name	Internal storage device fault			
Description	This protective function is activated by an inverter reset if writing data fails due to power-OFF or a data fault occurs in the storage device during parameter operations ^{*1} .			
Check point	Check if the power was turned OFF during parameter operations.			
Corrective action	Check the power supply or the devices on the power system to check that the devices have no fault. <ul style="list-style-type: none"> When E.PE6 occurs due to power-OFF during parameter operations: Check the read value of Pr.890. When the value is "7" or smaller, perform All parameter clear and then an inverter reset. The parameters that had been changed before All parameter clear must be set again. When E.PE6 occurs due to other reason (such as turning OFF/ON the power or an inverter reset): Contact your sales representative. 			

*1 For example, when parameter clear, All parameter clear, Parameter copy, or offline auto tuning is performed in the inverter, or when parameter batch write is performed in FR Configurator2.

NOTE

- "E.PE6" does not activate the retry function.
- "E.PE6" outputs the Fault output 3 (Y91) signal.
- "E.PE6" turns OFF the Safety monitor output (SAFE) signal.
- "E.PE6" is not cleared by turning ON the Fault clear (X51) signal.
- "E.PE6" is not activated during emergency drive operation.
- The communication data code for "E.PE6" is 172 (HAC).

◆ Checking faulty area in the internal storage device

When E.PE6 occurs, faulty area in the internal storage device can be checked by reading **Pr.890**.

Pr.	Name	Initial value	Setting range	Description
890 H325	Internal storage device status indication	0	(0 to 9999)	A faulty area detected by self-check function can be indicated in the internal storage device.



- Use the read value of **Pr.890** to check the faulty area.
- The following table shows faulty areas indicated by the read value of **Pr.890**. Some read values indicate that there are multiple faulty areas. (For example, the read value "7" indicates that all the areas described in No. 1 to No. 3 are faulty.)

No.	Read value	Description
1	1, 3, 5, 7	Storage area other than the area for parameter settings is faulty (such as area for the set frequency). (When All parameter clear is performed, the set frequency, remotely-set frequency, host name for Ethernet communication, position pulse, multi-revolution counter, and offline auto tuning data are cleared.)
2	2, 3, 6, 7	Storage area for standard parameter settings is faulty.
3	4, 5, 6, 7	Storage area for communication parameter settings is faulty.
4	8 to 9999	Area for manufacturer setting

FR-A800/A800 Plus Series

Instruction Manual Supplement

1 Monitoring terminals S1 and S2 (FR Configurator2)

Graph display using FR Configurator2 is supported for terminals S1 and S2 (data from the high speed sampling and the USB trace file).

The state of terminals S1 and S2 can be displayed in graph form using FR Configurator2.

The FR Configurator2 version 1.28E or later supports graph display for terminals S1 and S2.

For details on FR Configurator2, refer to the FR Configurator2 Instruction Manual.

◆ Digital source (monitor item) selection

- Terminals S1 and S2 can be selected as digital sources for the trace function.
- Select the digital sources (input/output signals) to be set to **Pr.1038 to Pr.1045** from the following table. When a value other than the ones in the following table is set, "0" (OFF) is applied for indication.

Setting value	Signal name
1	STF
2	STR
3	AU
4	RT
5	RL
6	RM
7	RH
8	JOG
9	MRS
10	STP(STOP)
11	RES
12	CS
15	S2
16	S1

Setting value	Signal name
21	X0
22	X1
23	X2
24	X3
25	X4
26	X5
27	X6
28	X7
29	X8
30	X9
31	X10
32	X11
33	X12
34	X13
35	X14
36	X15
37	DY

Setting value	Signal name
101	RUN
102	SU
103	IPF
104	OL
105	FU
106	ABC1
107	ABC2
121	DO0
122	DO1
123	DO2
124	DO3
125	DO4
126	DO5
127	DO6
128	RA1
129	RA2
130	RA3

FR-A800/A800 Plus Series

Instruction Manual Supplement

1 Earth (ground) fault detection at start / restricting reset method for an earth (ground) fault

The reset method for the output side earth (ground) fault overcurrent (E.GF) can be restricted.

- Select whether to enable or disable the earth (ground) fault detection at start. When enabled, the earth (ground) fault detection is performed immediately after a start signal input to the inverter.
- Select whether to restrict the reset method for an earth (ground) fault.

Pr.	Name	Initial value	Setting range	Description	
				Earth (ground) fault	Reset method
249 H101	Earth (ground) fault detection at start	0	0	Not detected at start	Not restricted
			1	Detected at start	
			2		Restricted

◆ Selecting whether to perform the earth (ground) fault detection at start

- If an earth (ground) fault is detected at start while **Pr.249** = "1 or 2", the output side earth (ground) fault overcurrent (E.GF) is detected and output is shut off.
- Earth (ground) fault detection at start is enabled under V/F control and Advanced magnetic flux vector control.
- When the **Pr.72 PWM frequency selection** setting is high, enable the earth (ground) fault detection at start.

NOTE

- Because the detection is performed at start, output is delayed for approx. 20 ms every start.
- Use **Pr.249** to enable/disable the earth (ground) fault detection at start. During operation, earth (ground) faults are detected regardless of the **Pr.249** setting.

◆ Restricting reset method for an earth (ground) fault

- The reset method when the output is shut off due to the output side earth (ground) fault overcurrent (E.GF) can be restricted. When E.GF occurs while **Pr.249** = "2", E.GF can be reset only by turning OFF the control circuit power.
- This restriction prevents the inverter from being damaged due to repeated reset operations by the other methods such as entering the RES signal.
- When E.GF occurs while **Pr.249** = "2", the output short-circuit detection (ALM4) signal can be output.
- For the terminal used to output the ALM4 signal, set "23" (positive logic) or "123" (negative logic) in any of **Pr.190 to Pr.196 (Output terminal function selection)**.
- If **Pr.249** is set to "2" while the retry function is enabled (**Pr.67** is not set to "0"), no retry is performed even when E.GF occurs.
- If **Pr.249** is set to "2" while the automatic bypass switching after inverter fault is enabled (**Pr.138** is not set to "1"), the operation is not switched to the commercial power supply operation even when E.GF occurs.

NOTE

- Changing the terminal assignment using **Pr.190 to Pr.196 (Output terminal function selection)** may affect the other functions. Set parameters after confirming the function of each terminal.
- E.GF is not cleared by turning ON the Fault clear (X51) signal when **Pr.249** = "2".
- If E.GF occurs during emergency drive operation when **Pr.249** = "2", the output is shut off.

2 Output short-circuit fault (E.SCF)

Select the reset operation and fault indication for an output short-circuit.

Pr.	Name	Initial value	Setting range	Description	
				Operation after detection	Reset method
521 H194	Output short-circuit detection	0	0	E.OC1 to E.OC3	Not restricted
			1	E.SCF	Restricted

- The fault indication for an output short-circuit (E.OC1 to E.OC3, and E.SCF) can be changed by the **Pr.521** setting.
- When an output short-circuit is detected while **Pr.521** = "1", E.SCF is displayed and the inverter output is shut off.
- When E.SCF occurs while **Pr.521** = "1", E.SCF can be reset only by turning OFF the control circuit power. (E.OC1 to E.OC3 can be reset by any reset method.)
- This restriction prevents the inverter from being damaged due to repeated reset operations by the other methods such as entering the RES signal.
- When E.SCF occurs, the output short-circuit detection (ALM4) signal can be output.
- For the terminal used to output the ALM4 signal, set "23" (positive logic) or "123" (negative logic) in any of **Pr.190 to Pr.196 (Output terminal function selection)**.
- If the automatic bypass switching after inverter fault is enabled (**Pr.138** is not set to "1"), the operation is not switched to the commercial power supply operation even when E.SCF occurs.

Operation panel indication	E.SCF		FR-LU08 indication	Fault
Name	Output short-circuit fault			
Description	The inverter output is shut off when an output short-circuit is detected while Pr.521 = "1". When Pr.521 = "0" (initial value), E.OC1, E.OC2, or E.OC3 appears when an output short-circuit is detected.			
Check point	Check for output short-circuit.			
Corrective action	Check the wiring to make sure that any output short circuit does not occur, then turn OFF the control circuit power to reset the inverter.			

NOTE

- When short-circuit resistance is large, the current does not reach the short-circuit detection level. In such a case, an output short-circuit cannot be detected.
- Changing the terminal assignment using **Pr.190 to Pr.196 (Output terminal function selection)** may affect the other functions. Set parameters after confirming the function of each terminal.
- E.SCF does not activate the retry function.
- E.SCF is not cleared by turning ON the Fault clear (X51) signal.
- If E.SCF occurs during emergency drive operation, the output is shut off.
- The communication data code for E.SCF is 20 (H14).

3 Extended detection time of the output current and zero current

The setting range of the **Pr.151 Output current detection signal delay time** and **Pr.153 Zero current detection time** is extended.

Pr.	Name	Initial value	Setting range	Description
151 M461	Output current detection signal delay time	0 s	0 to 300 s	Set the output current detection time. Enter the time from when the output current reaches the set current or higher to when the Output current detection (Y12) signal is output.
153 M463	Zero current detection time	0.5 s	0 to 300 s	Set the time from when the output current drops to the Pr.152 setting or lower to when the Zero current detection (Y13) signal is output.

4 Selecting the command interface in the Network operation mode (Pr.338, Pr.339)

- The proximity dog (X76) signal can be input via communication.
- The following table shows the command interface for the function in the Network operation mode, determined by the parameter settings: an external terminal or a communication interface (RS-485 terminals or communication option).

Pr.338 Communication operation command source		0: NET			1: EXT		
Pr.339 Communication speed command source		0: NET	1: EXT	2: EXT	0: NET	1: EXT	2: EXT
X76	Proximity dog	Combined			EXT		

[Explanation of Terms in Table]

EXT: External terminal only

Combined: Either external terminal or communication interface

FR-A800/A800 Plus Series

Instruction Manual Supplement

1 Online L compensation

Sensorless

Under Real sensorless vector control, inductance compensation can be used to prevent degradation in control performance when magnetic saturation occurs in the motor.

Pr.	Name	Initial value	Setting range	Description
221 C161	Excitation current compensation point 1	25%	25 to 200%	Set the excitation current command value for inductance compensation.
222 C162	Inductance compensation rate 1	9999	0 to 200%	Set the inductance compensation rate.
			9999	Inductance compensation rate 1 disabled.
223 C163	Excitation current compensation point 2	50%	25 to 200%	Set the excitation current command value for inductance compensation.
224 C164	Inductance compensation rate 2	9999	0 to 200%	Set the inductance compensation rate.
			9999	Inductance compensation rate 2 disabled.
225 C165	Excitation current compensation point 3	75%	25 to 200%	Set the excitation current command value for inductance compensation.
226 C166	Inductance compensation rate 3	9999	0 to 200%	Set the inductance compensation rate.
			9999	Inductance compensation rate 3 disabled.
227 C167	Excitation current compensation point 4	125%	25 to 200%	Set the excitation current command value for inductance compensation.
228 C168	Inductance compensation rate 4	9999	0 to 200%	Set the inductance compensation rate.
			9999	Inductance compensation rate 4 disabled.
71 C100	Applied motor	0	*1	By selecting a motor, the thermal characteristic and motor constant of each motor are set.
80 C101	Motor capacity	9999	0.4 to 55 kW*2	Set the applied motor capacity.
			0 to 3600 kW*3	
			9999	V/F control
81 C102	Number of motor poles	9999	2, 4, 6, 8, 10, 12	Set the number of motor poles.
			9999	V/F control
9 C103	Electronic thermal O/L relay	Inverter rated current	0 to 500 A*2	Set the rated motor current.
			0 to 3600 A*3	
83 C104	Rated motor voltage	690 V	0 to 1000 V	Set the rated motor voltage (V).
84 C105	Rated motor frequency	9999	10 to 400 Hz	Set the rated motor frequency (Hz).
			9999	The setting value of Pr.3 Base frequency is used.
96 C110	Auto tuning setting/status	0	0	No offline auto tuning
			1	Offline auto tuning is performed without the motor rotating.
			11	Offline auto tuning is performed without the motor rotating (under V/F control).
			101	Offline auto tuning is performed with the motor rotating.
			131	Offline auto tuning is performed with the motor rotating (including magnetic saturation L tuning).

*1 For the setting range, refer to the Instruction Manual (Function).

*2 For the FR-A870-00890 or lower.

*3 For the FR-A870-02300 or higher, FR-A872-05690 to 07150, and FR-A870-03590(280K)/04560(355K)-LC.

◆ Excitation current compensation point settings (Pr.221, Pr.223, Pr.225, Pr.227)

- The excitation current compensation points 1 to 4 can be set regardless of the order of the parameters **Pr.221**, **Pr.223**, **Pr.225**, and **Pr.227**. (The **Pr.221** setting needs not be smaller than the **Pr.225** setting.) The setting values of the excitation current compensation points 1 to 4 are automatically arranged by the inverter in ascending order.
- 100% cannot be set in **Pr.221**, **Pr.223**, **Pr.225**, and **Pr.227**.
- Set different values in **Pr.221**, **Pr.223**, **Pr.225**, and **Pr.227**.
- Setting example when **Pr.221** setting < **Pr.223** setting < **Pr.225** setting < **Pr.227** setting

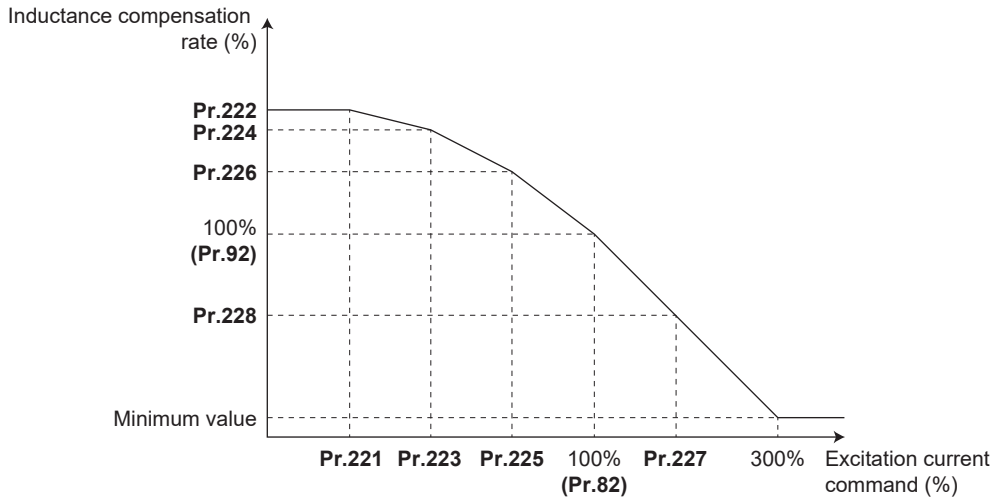

- Setting example when **Pr.225** setting < **Pr.223** setting < **Pr.221** setting < **Pr.227** setting

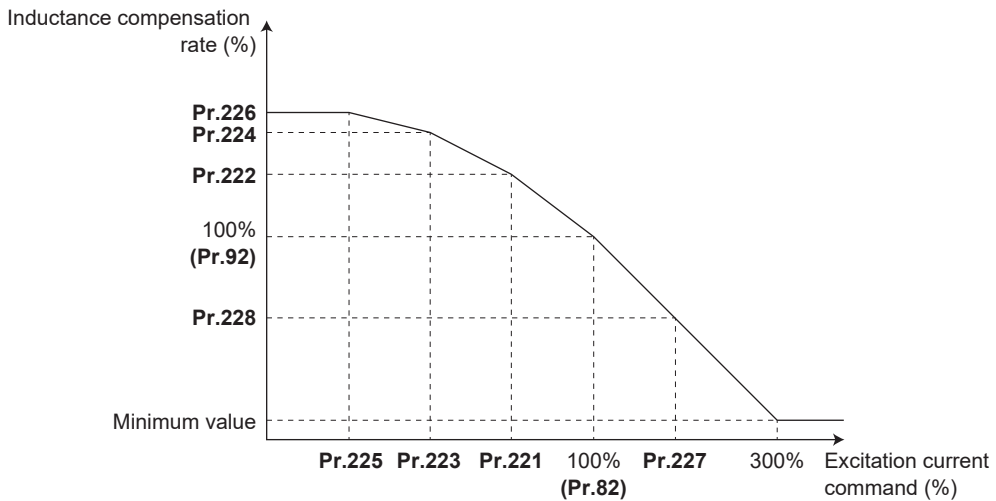

◆ Inductance compensation rate settings (Pr.222, Pr.224, Pr.226, Pr.228)

- The inductance compensation rates 1 to 4 can be automatically set by offline auto tuning.
- When "9999" is set in **Pr.222, Pr.224, Pr.226, or Pr.228**, the corresponding point is invalid.
- Setting example when "9999" is set in **Pr.224 and Pr.228**

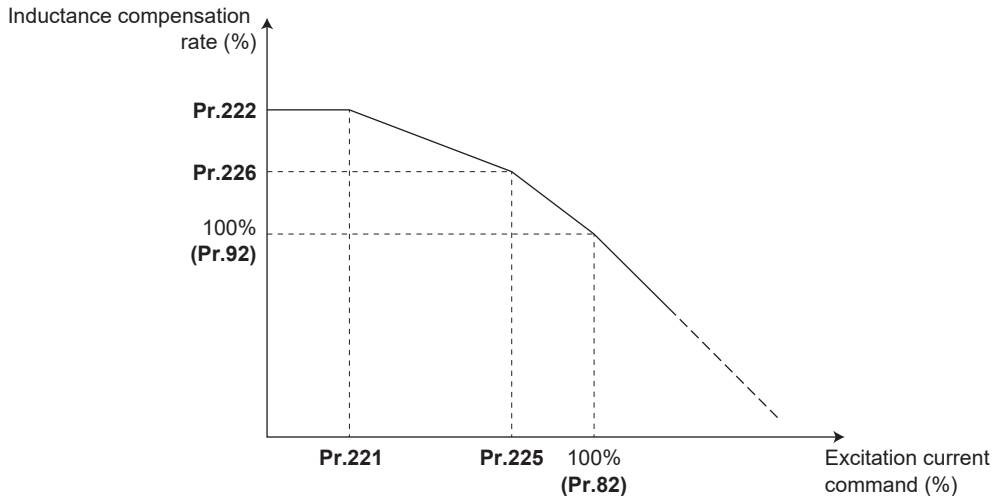

◆ Offline auto tuning (including magnetic saturation L tuning)

Point

- The following describes how to perform magnetic saturation L tuning. For other offline auto tuning, refer to the description of offline auto tuning for an induction motor in the Instruction Manual (Function).
- When offline auto tuning (including magnetic saturation L tuning) is performed, the tuning result is set in the motor constant related parameters (**Pr.82, Pr.90 to Pr.94, Pr.859, and Pr.298**). For details, refer to the description of offline auto tuning for an induction motor in the Instruction Manual (Function).

■ Before performing offline auto tuning

Check the following points before performing offline auto tuning:

- Check that a value other than "9999" is set in **Pr.80 and Pr.81**, and Real sensorless vector control is selected (with **Pr.800**).
- Check that a motor is connected. (Check that the motor is not rotated by an external force during tuning.)
- To perform magnetic saturation L tuning, remove the load and apply only the inertia load.
- Select a motor with the rated current equal to or less than the inverter rated current. (The motor capacity must be 0.4 kW or higher.) If a motor with substantially low rated current compared with the inverter rated current, however, is used, speed and torque accuracies may deteriorate due to torque ripples, etc. Set the rated motor current to about 40% or higher of the inverter rated current.
- Tuning is not available for a high-slip motor, high-speed motor, or special motor.
- The maximum frequency is 400 Hz.
- Check the following points for the offline auto tuning with motor rotation (**Pr.96 Auto tuning setting/status = "131"**).

The torque is not sufficient during tuning.

Check that the motor can be rotated up to the speed close to the rated speed.

Check that the mechanical brake is released.

■ Settings

- To perform tuning, set the following parameters about the motor.

First motor Pr.	Name	Initial value	Description
80	Motor capacity	9999 (V/F control)	Set the motor capacity (kW).
81	Number of motor poles	9999 (V/F control)	Set the number of motor poles (2 to 12).
800	Control method selection	20	Set this parameter under Real sensorless vector control.
9	Electronic thermal O/L relay	Inverter rated current	Set the rated motor current (A).
83	Rated motor voltage	690 V	Set the rated motor voltage (V) printed on the motor's rating plate.
84	Rated motor frequency	9999	Set the rated motor frequency (Hz). When the setting is "9999", the Pr.3 Base frequency setting is used.
71	Applied motor	0 (standard motor)	Set this parameter according to the motor.* ¹ Three types of motor constant setting ranges, units and tuning data can be stored according to settings.
96	Auto tuning setting/status	0	Set "131". 131: Tuning is performed with the motor rotating. The motor can rotate up to the speed near the rated motor frequency. The magnetic saturation characteristic is also tuned.

*1 Set **Pr.71 Applied motor** according to the motor to be used. (For the **Pr.71** setting values, refer to the Instruction Manual (Function).)

NOTE

- "131" cannot be set in **Pr.463 Second motor auto tuning setting/status**.
- When **Pr.11 DC injection brake operation time** = "0" or **Pr.12 DC injection brake operation voltage** = "0", offline auto tuning is performed at the initial setting of **Pr.11** or **Pr.12**.

- For tuning accuracy improvement, set the following parameters when the motor constants are known in advance.

First motor Pr.	Name	Description
707	Motor inertia (integer)	Motor inertia* ²
724	Motor inertia (exponent)	$J_m = \text{Pr.707} \times 10^{(-\text{Pr.724})} \text{ (kg}\cdot\text{m}^2\text{)}$

*2 The setting is valid only when a value other than "9999" is set in both **Pr.707** and **Pr.724**.

■ Performing tuning

Point

- Before performing tuning, check the monitor display of the operation panel or parameter unit if the inverter is in the state ready for tuning. The motor starts by turning ON the start command while tuning is unavailable.



- In the PU operation mode, press  /  on the operation panel.

For External operation, turn ON the start command (STF signal or STR signal). Tuning starts.

NOTE

- Satisfy the required inverter start conditions to start offline auto tuning. For example, stop the input of the MRS signal.
- To force tuning to end, use the MRS or RES signal or  on the operation panel.
(Turning OFF the start signal (STF signal or STR signal) also ends tuning.)
- During offline auto tuning, only the following I/O signals are valid (initial value).
Input terminals <valid signals>: STP (STOP), OH, MRS, RT, RES, STF, STR, S1, and S2
Output terminals: RUN, OL, IPF, FM/CA, AM, A1B1C1, and So (SO)
- When the rotation speed and the output frequency are selected for terminals FM/CA and AM, the progress status of offline auto tuning is output in 15 steps from FM/CA and AM.
- Do not perform ON/OFF switching of the Second function selection (RT) signal during offline auto tuning. Auto tuning will not be performed properly.
- Setting offline auto tuning (**Pr.96 Auto tuning setting/status** = "131") will make pre-excitation invalid.
- When the offline auto tuning with motor rotation is selected (**Pr.96 Auto tuning setting/status** = "131"), take caution and ensure safety against the rotation of the motor.
- When executing offline auto tuning, input the operation command after switching ON the main circuit power (R/L1, S/L2, T/L3) of the inverter.
- While **Pr.79 Operation mode selection** = "7", turn ON the PU operation external interlock (X12) signal for tuning in the PU operation mode.

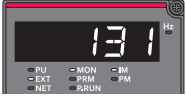
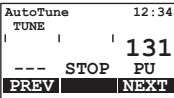
- During tuning, the monitor is displayed on the operation panel as follows.

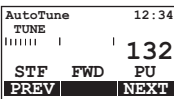
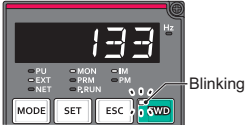
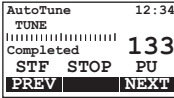
Tuning status	Operation panel (FR-DU08) display	LCD operation panel (FR-LU08) display
(1) Setting		
(2) During tuning		
(3) Normal completion		

- Note: Offline auto tuning time (with the initial setting)

Offline auto tuning setting	Time
With the motor rotating (including magnetic saturation L tuning) (Pr.96 = "131")	Approximately 140 s maximum

- When offline auto tuning ends, press  on the operation panel during PU operation. For External operation, turn OFF the start signal (STF signal or STR signal).
This operation resets the offline auto tuning, and the PU's monitor display returns to the normal indication.
(Without this operation, next operation cannot be started.)

NOTE

- The motor constants measured once during offline auto tuning are stored as parameters and their data are held until offline auto tuning is performed again. However, the tuning data is cleared when performing All parameter clear.
- Changing **Pr.71** after tuning completion will change the motor constant. For example, if "3" is set in **Pr.71** after tuning is performed with **Pr.71** = "0", the tuning data becomes invalid. To use the tuned data, set "0" again in **Pr.71**.

- If offline auto tuning has ended in error (see the following table), motor constants are not set. Perform an inverter reset and perform tuning again.

Error display	Error cause	Countermeasures
8	Forced end	Set Pr.96 = "131" and retry.
9	Inverter protective function operation	Make the setting again.
91	The current limit (stall prevention) function is activated.	Set the acceleration/deceleration time longer. Set Pr.156 Stall prevention operation selection = "1". Remove the load and apply only the inertia load, then retry.
92	The converter output voltage fell to 75% of the rated voltage.	Check for the power supply voltage fluctuation. Check the Pr.83 Rated motor voltage setting.
93	Calculation error. The motor is not connected.	Check the Pr.83 and Pr.84 settings. Check the motor wiring and make the setting again.
94	Rotation tuning frequency setting error. (The frequency command for the tuning was given to exceed the maximum frequency setting, or to be in the frequency jump range.)	Check the Pr.1 Maximum frequency and Pr.31 to Pr.36 Frequency jump settings.
95	Magnetic saturation L tuning error (The excitation current did not reach the set point within 20 s.)	Remove the load and apply only the inertia load, then retry. Reduce the range of the excitation current compensation points, and adjust the setting so that the excitation current compensation points 1 to 4 are evenly distributed, then retry.

- When tuning is ended forcibly by pressing  or turning OFF the start signal (STF or STR) during tuning, offline auto tuning does not end properly. (The motor constants have not been set.)
Perform an inverter reset and perform tuning again.

NOTE

- An instantaneous power failure occurring during tuning will result in a tuning error. After power is restored, the inverter starts normal operation. Therefore, when the STF (STR) signal is ON, the motor starts forward (reverse) rotation.
- Any fault occurring during tuning is handled as in the normal operation. However, if the retry function is set, no retry is performed.
- The set frequency monitor displayed during the offline auto tuning is 0 Hz.

CAUTION

- Note that the motor may start running suddenly.

■ Parameters updated by tuning results after tuning

The following table shows the parameters to which the offline auto tuning result is applied according to the **Pr.96** setting.

○: Applied, —: Not applied

First motor Pr.	Name	Pr.96 = 1	Pr.96 = 11	Pr.96 = 101	Pr.96 = 131
82	Motor excitation current	○	—	○	○
90	Motor constant (R1)	○	○	○	○
91	Motor constant (R2)	○	—	○	○
92	Motor constant (L1)	○	—	○	○
93	Motor constant (L2)	○	—	○	○
94	Motor constant (X)	○	—	○	○
859	Torque current	○	—	○	○
298	Frequency search gain	○	○	○	○
96	Auto tuning setting/status	○	○	○	○
222	Inductance compensation rate 1	—*1	—	—*1	○
224	Inductance compensation rate 2	—*1	—	—*1	○
226	Inductance compensation rate 3	—*1	—	—*1	○
228	Inductance compensation rate 4	—*1	—	—*1	○

*1 When offline auto tuning is performed with **Pr.96** = "1 or 101", "9999" is set.

2 Emergency drive status monitor

"10" has been added for the emergency drive status monitor display on the operation panel.

- Set "68" in **Pr.52, Pr.774 to Pr.776, Pr.992** to monitor the status of the emergency drive on the operation panel.
- Description of the status monitor

Operation panel indication	Description		
	Emergency drive setting	Emergency drive operating status	
0	Emergency drive function setting is not available.	—	
1	Electronic bypass during emergency drive operation is disabled.	During normal operation	
2		Operating properly	
3		A certain alarm is occurring.*2	
4		A fault is occurring. The operation is being continued by the retry.	
5		A fault is occurring. The continuous operation is not allowed due to output shutoff.	
10	Parameter settings for electronic bypass during emergency drive operation are enabled.	During normal operation	
11	Electronic bypass during emergency drive operation is enabled.	Emergency drive in operation	Operating properly
12			A certain alarm is occurring.*2
13			A fault is occurring. The operation is being continued by the retry.
14			A fault is occurring. The continuous operation is not allowed due to output shutoff.
15		Electronic bypass is started during emergency drive (during acceleration/ deceleration to the switchover frequency).	
2□*1		During electronic bypass during emergency drive (waiting during the interlock time).	
3□*1		During commercial power supply operation during emergency drive	
4□*1			

*1 The value in the ones place indicates the previous displayed value (the setting at a fault occurrence).

*2 "A certain alarm" means a protective function disabled during emergency drive.

NOTE

- For other information on the emergency drive function, refer to the Instruction Manual Supplement (BCN-C22005-959).

mitsubishi electric corporation

HEAD OFFICE: TOKYO BUILDING 2-7-3, MARUNOUCHI, CHIYODA-KU, TOKYO 100-8310, JAPAN