

INVERTER

Heatsink Protrusion Attachment

<FR-A7CN01 to 14>

Thank you for selecting the Mitsubishi Electric inverter option unit.

This instruction manual gives handling information and precautions for use of this equipment. Incorrect handling might cause an unexpected fault. Before using the equipment, please read this manual carefully to use the equipment to its optimum. Please forward this instruction manual to the end user.

Safety Precautions

- ⚠ While power is ON or for some time after power-OFF, do not touch the inverter (high power factor converter) and attachment as they will be extremely hot. Doing so can cause burns.
- ⚠ The product must be transported in correct method that corresponds to the weight. Failure to do so may lead to injuries. Take special care with the edge sections.
- ⚠ Do not allow conductive foreign matter such as screws, metal chips, or flammable foreign matter such as oil enter the inverter (high power factor converter).

This attachment allows approximately 70% of the heat generated by the inverter (high power factor converter) to be radiated outside the enclosure by protruding the inverter (high power factor converter) heatsink section out from the rear side of the enclosure.

1. Preparation

- 1) Confirm the attachment model.
- 2) Confirm that the following parts are enclosed with the indicated quantity.

No.	Name	Attachment Model				
		FR-A7CN01 to 03	FR-A7CN04	FR-A7CN05 to 07	FR-A7CN08, 09	FR-A7CN10 to 14
1)	Upper installation frame	1	1	1	1	1
2)	Upper cover	1	1	1	1	1
3)	Lower installation frame	1	1	*1)	*1)	*1)
4)	Frame installation screw	4 (M5)	4 (M8)	*2)	*2)	*2)
5)	Cover installation screw	2 (M4)	2 (M4)	6 (M4)	6 (M4)	6 (M4)
6)	Right installation frame	—	—	1	1	1
7)	Left installation frame	—	—	1	1	1
8)	Sticker	—	—	—	2	—

*1) For the FR-A7CN05 to 14 lower installation frame, use an inverter (high power factor converter) frame by changing its' installation position.

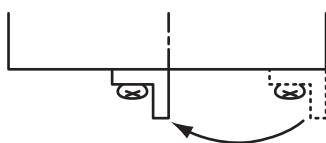

*2) Use inverter (high power factor converter) screws.

- 3) Applicable model

Applicable model	Applicable Attachment													
	FR-A7CN01	FR-A7CN02	FR-A7CN03	FR-A7CN04	FR-A7CN05	FR-A7CN06	FR-A7CN07	FR-A7CN08	FR-A7CN09	FR-A7CN10	FR-A7CN11	FR-A7CN12	FR-A7CN13	FR-A7CN14
FR-F720(P)	2.2K 3.7K 5.5K	7.5K 11K	15K	18.5K 22K 30K	37K	—	45K 55K	—	—	75K 90K 110K	—	—	—	—
FR-F740(P)	0.75K 1.5K 2.2K 3.7K 5.5K	7.5K 11K	15K 18.5K	22K 30K	—	37K	45K 55K 75K	90K	110K	132K 160K	—	—	—	—
FR-A720	1.5K 2.2K 3.7K	5.5K 7.5K	11K	15K 18.5K 22K	30K	—	37K 45K	—	—	75K 90K	55K	—	—	—
FR-A740	0.4K 0.75K 1.5K 2.2K 3.7K	5.5K 7.5K	11K 15K	18.5K 22K	—	30K	37K 45K 55K	75K	90K	110K 132K	—	—	—	—
FR-HC2	—	7.5K	H7.5K H15K	15K	30K H30K	—	—	—	75K H110K	—	—	55K	H75K	H55K

2. Installation

1) Cut the enclosure with the following dimensions according to the inverter (high power factor converter) capacity.

FR-A7CN01

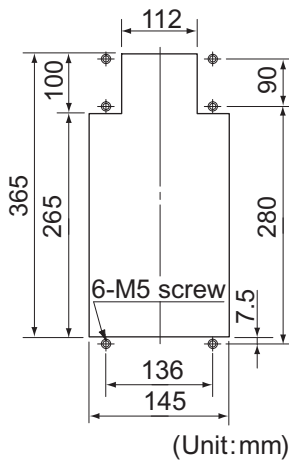

Applicable model
FR-F720(P)-2.2K to 5.5K
FR-F740(P)-0.75K to 5.5K
FR-A720-1.5K to 3.7K
FR-A740-0.4K to 3.7K

FR-A7CN02

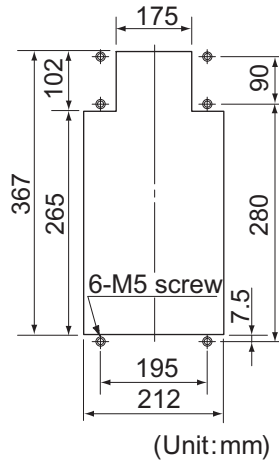

Applicable model
FR-F720(P)-7.5K, 11K
FR-F740(P)-7.5K, 11K
FR-A720-5.5K, 7.5K
FR-A740-5.5K, 7.5K
FR-HC2-7.5K

FR-A7CN03

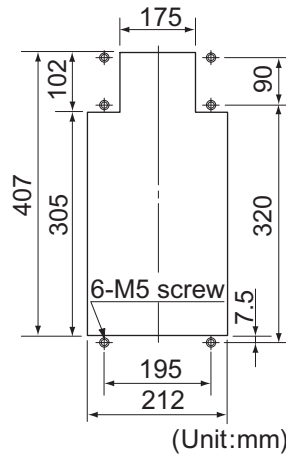

Applicable model
FR-F720(P)-15K
FR-F740(P)-15K, 18.5K
FR-A720-11K
FR-A740-11K, 15K
FR-HC2-H7.5K, H15K

FR-A7CN04

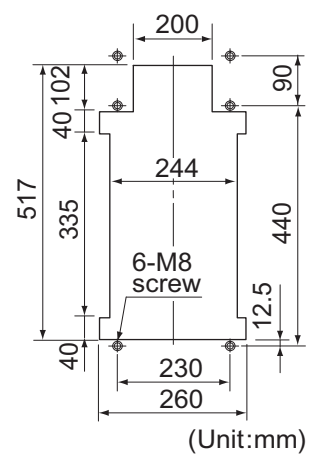

Applicable model
FR-F720(P)-18.5K to 30K
FR-F740(P)-22K, 30K
FR-A720-15K to 22K
FR-A740-18.5K, 22K
FR-HC2-15K

FR-A7CN05

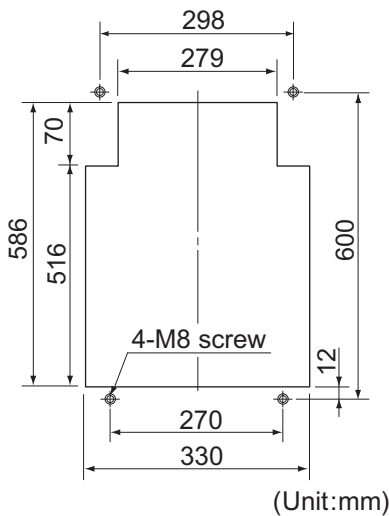

Applicable model
FR-F720(P)-37K
FR-A720-30K
FR-HC2-30K
FR-HC2-H30K

FR-A7CN06

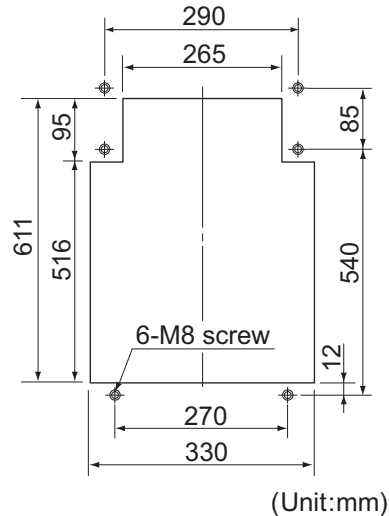

Applicable model
FR-F740(P)-37K
FR-A740-30K

FR-A7CN07

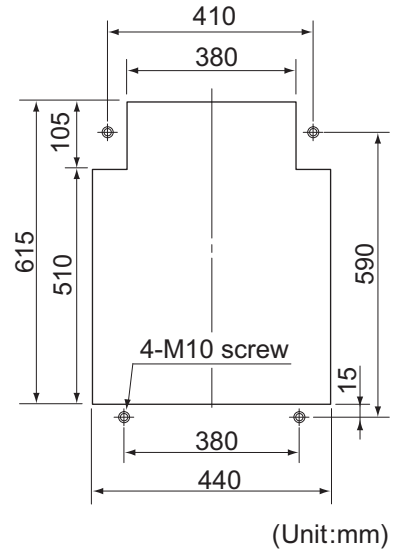

Applicable model
FR-F720(P)-45K, 55K
FR-F740(P)-45K, 55K, 75K
FR-A720-37K, 45K
FR-A740-37K, 45K, 55K

FR-A7CN08, 09

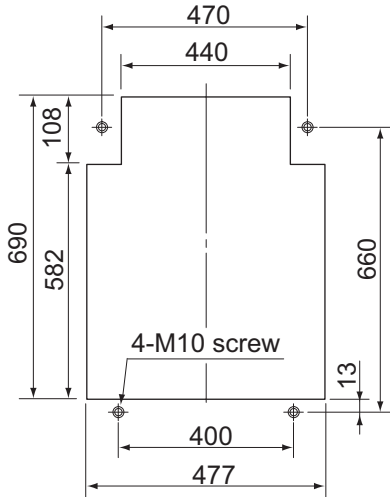

(Unit:mm)

Applicable model
FR-F740(P)-90K, 110K
FR-A740-75K, 90K
FR-HC2-75K
FR-HC2-H110K

FR-A7CN10

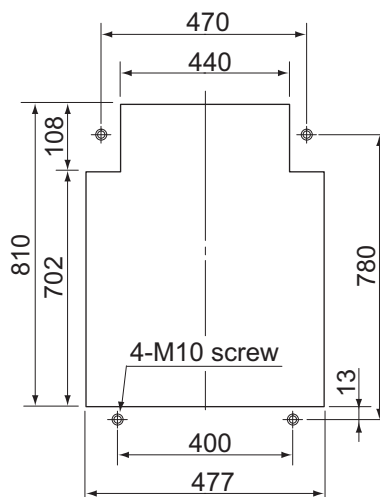

(Unit:mm)

Applicable model
FR-F720(P)-75K, 90K, 110K
FR-F740(P)-132K, 160K
FR-A720-75K, 90K
FR-A740-110K, 132K

FR-A7CN11

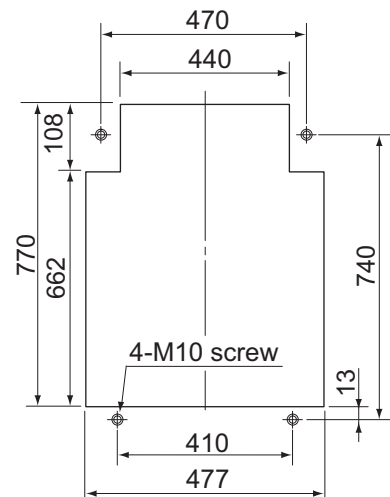

(Unit:mm)

Applicable model
FR-A720-55K

FR-A7CN12

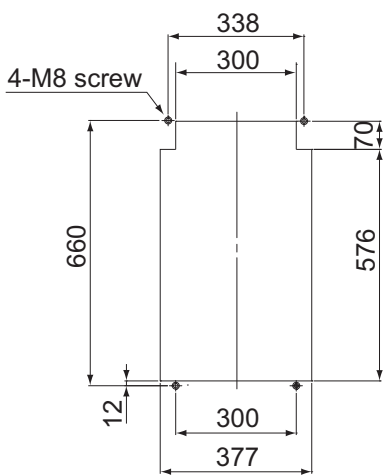

(Unit:mm)

Applicable model
FR-HC2-55K

FR-A7CN13

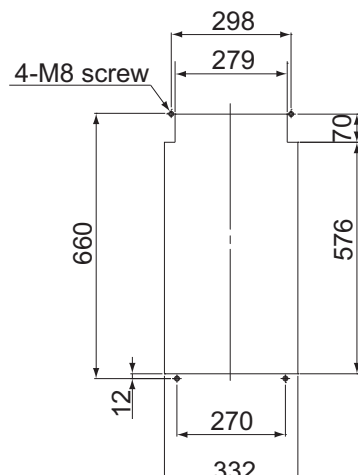

(Unit:mm)

Applicable model
FR-HC2-H75K

FR-A7CN14

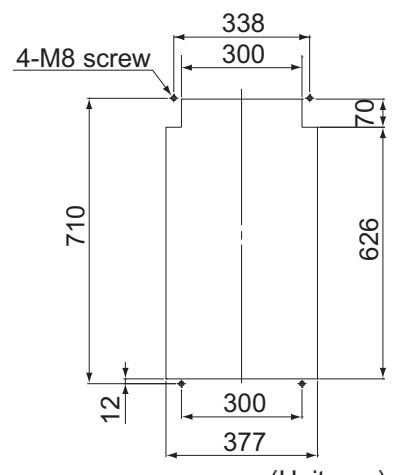

(Unit:mm)

Applicable model
FR-HC2-H55K

2) Refer to "4. Heatsink protrusion attachment and inverter (high power factor converter) assembly" to assemble. After assembly, install the inverter (high power factor converter) in the enclosure.

**NOTE**

- Having a cooling fan, the cooling section which comes out of the enclosure cannot be used in the environment of water drops, oil, mist, dust, etc.
- Be careful not to drop screws, dust etc. into the inverter (high power factor converter) and cooling fan section.
- There is 1mm of clearance between the FR-A7CN and inverter (high power factor converter). (The inverter (high power factor converter) is not in an enclosed condition)

3. Outline dimension drawings

(----- : Panel cut dimensions)

FR-A7CN01

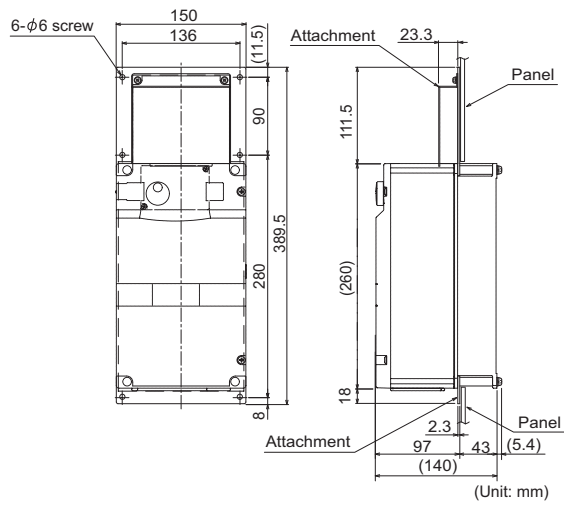

FR-A7CN02

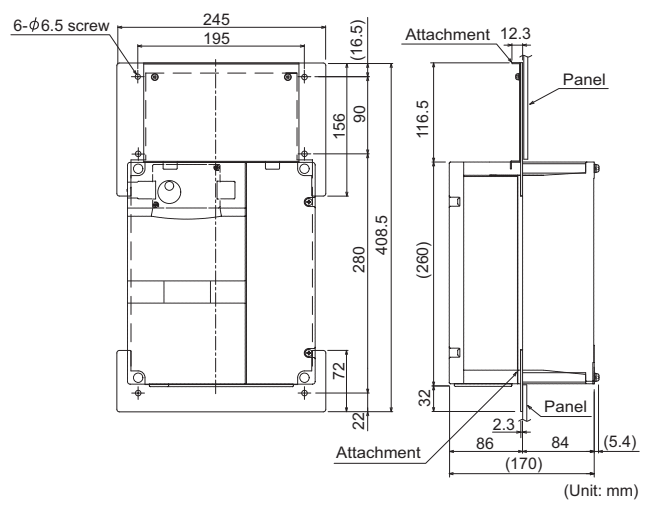

FR-A7CN03

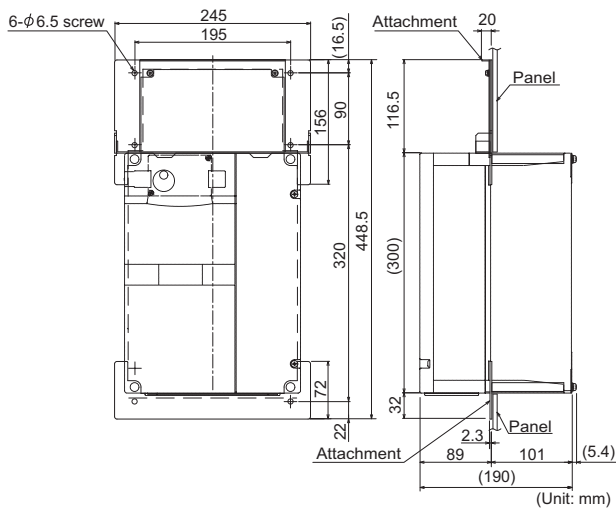

FR-A7CN04

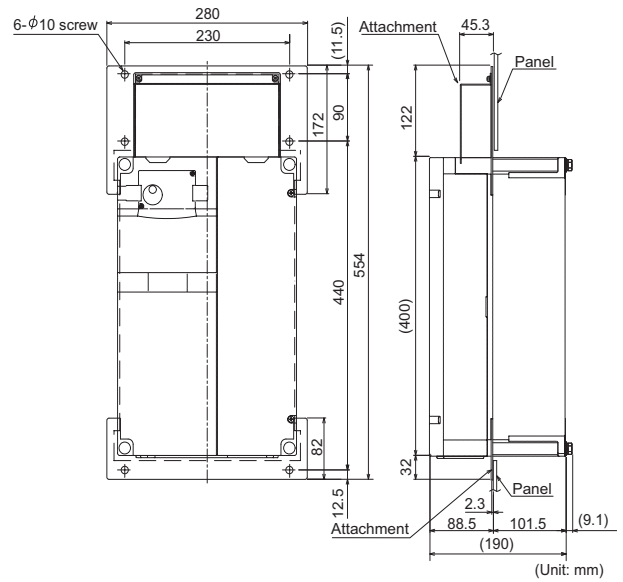

FR-A7CN05

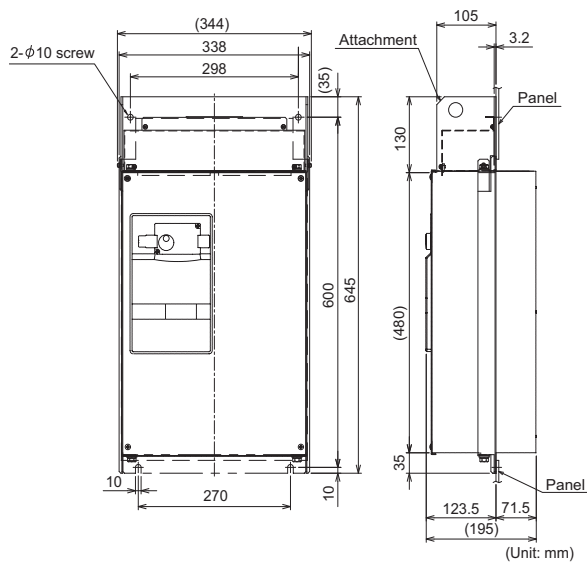

FR-A7CN06

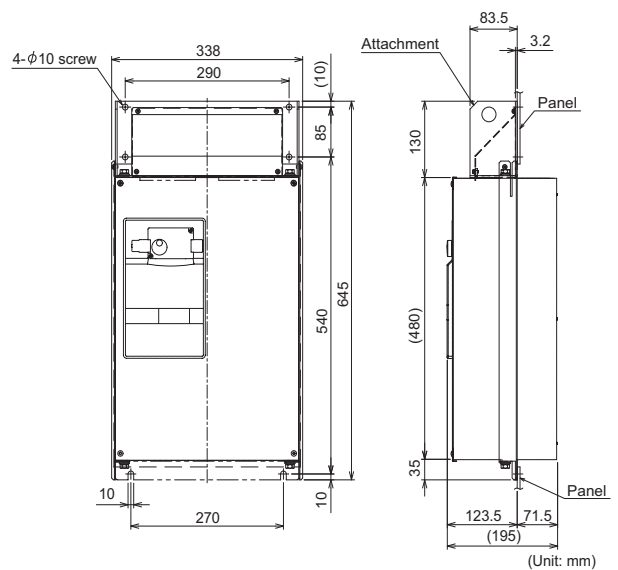

FR-A7CN07

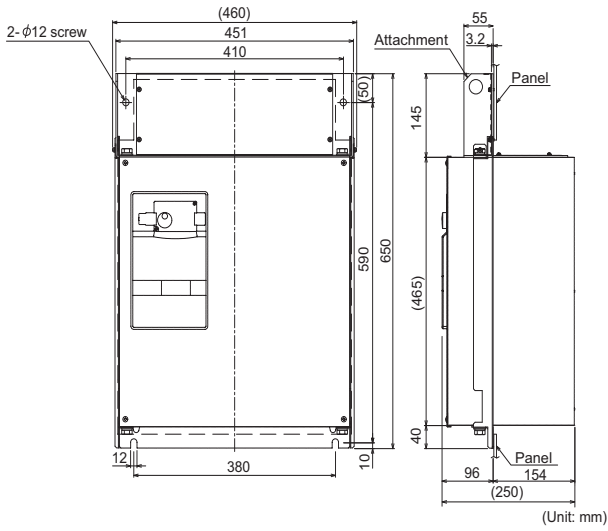

FR-A7CN08, 09

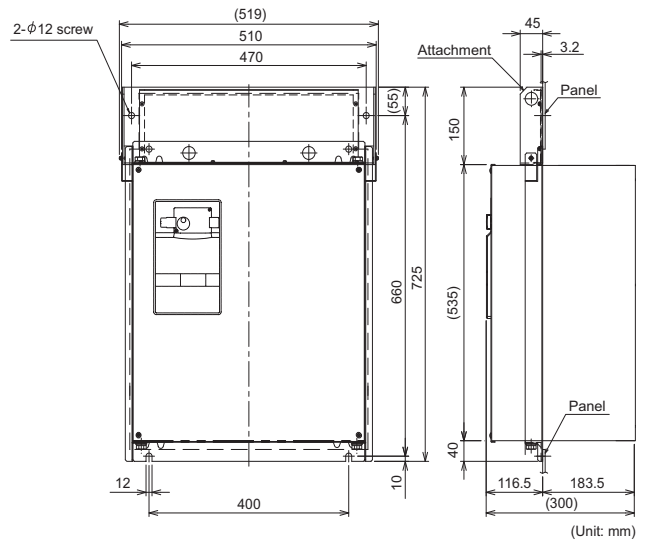

FR-A7CN10

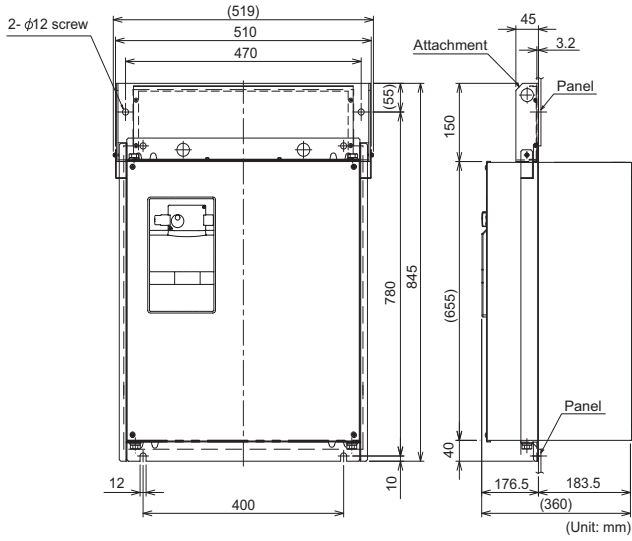

FR-A7CN11

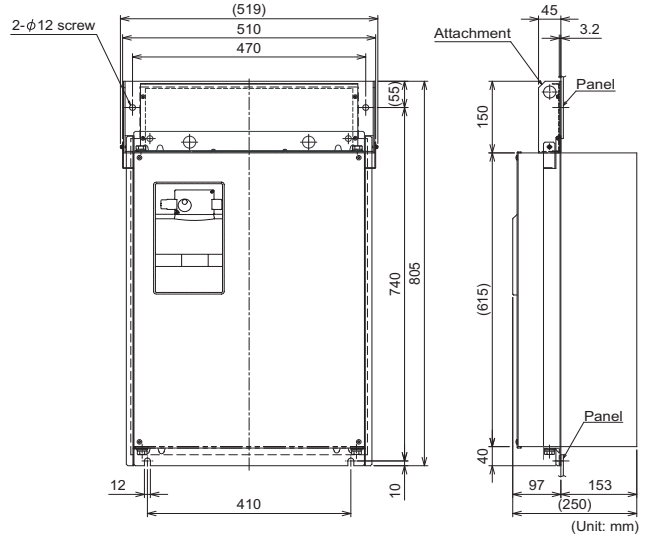

FR-A7CN12

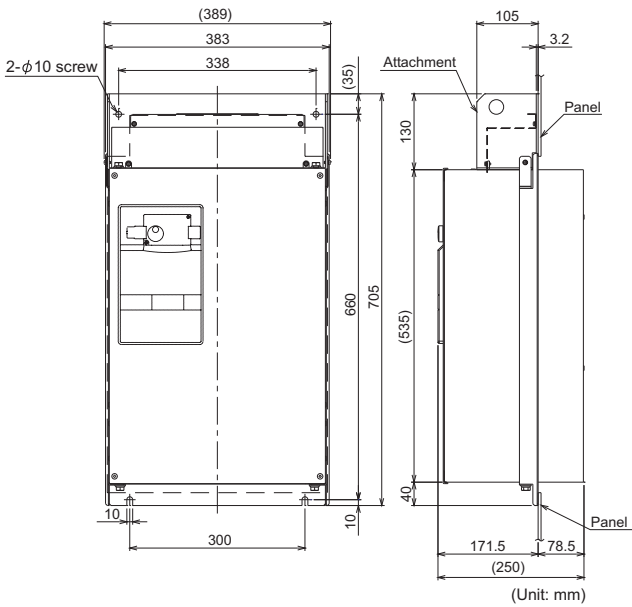

FR-A7CN13

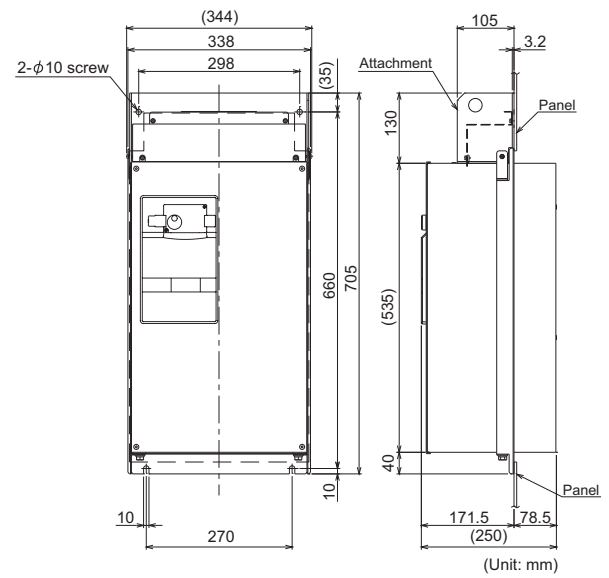

FR-A7CN14

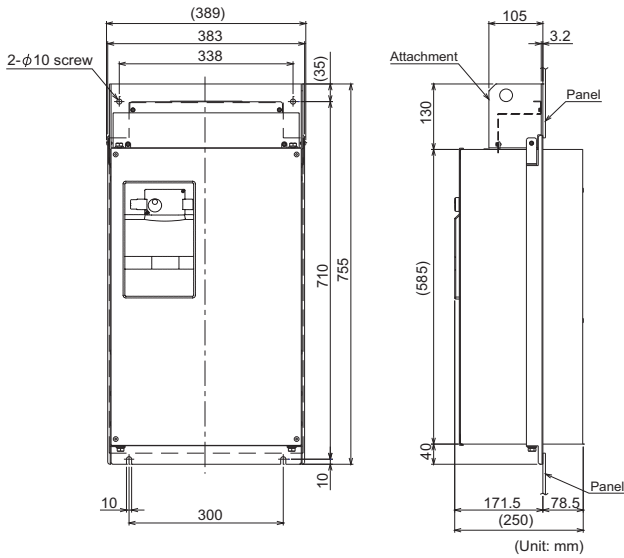

4. Heatsink protrusion attachment and inverter (high power factor converter) assembly

FR-A7CN01

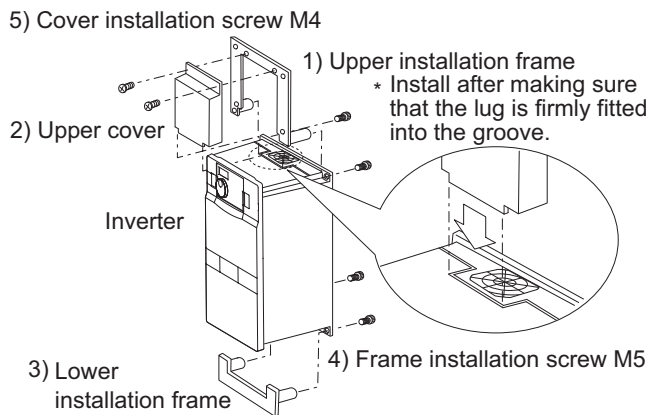

FR-A7CN02

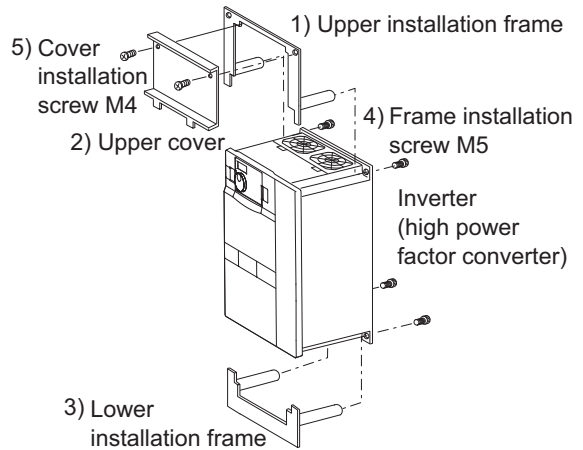

FR-A7CN03

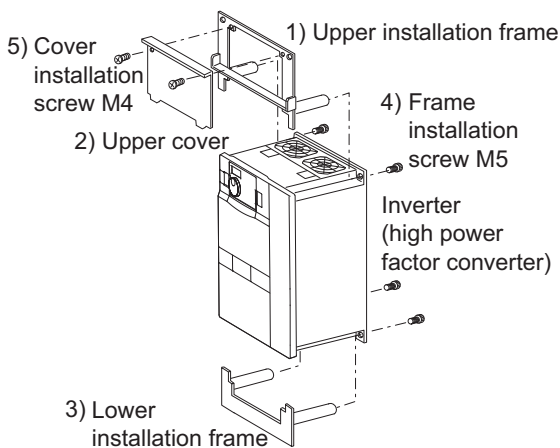

FR-A7CN04

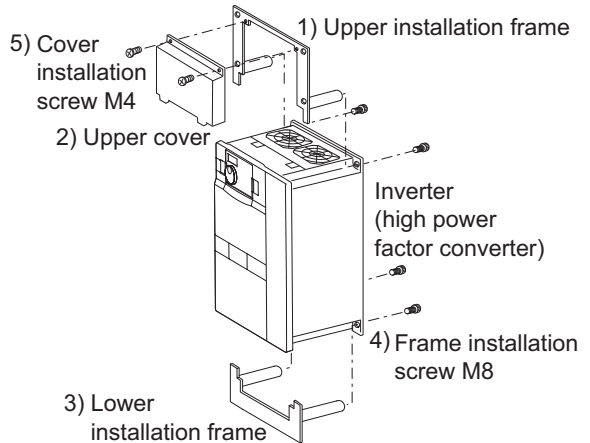

FR-A7CN05

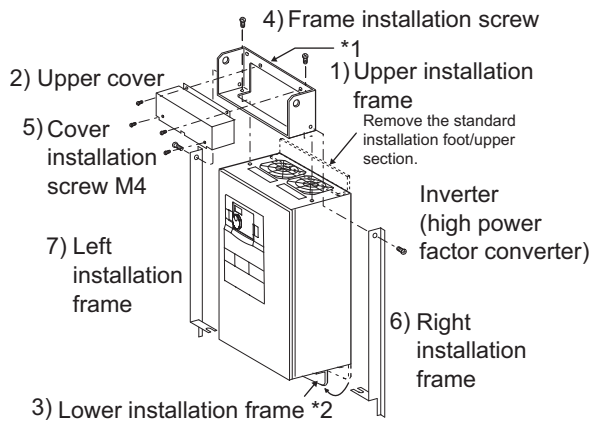

FR-A7CN06

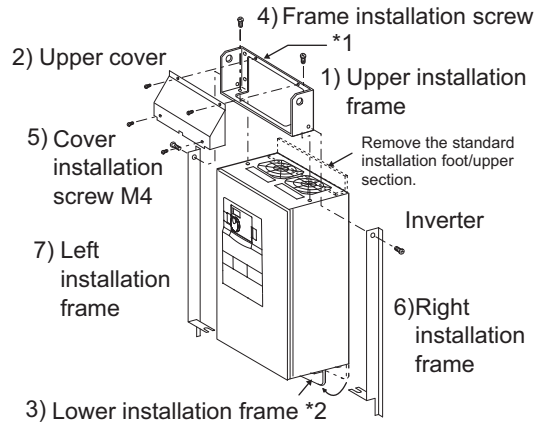

FR-A7CN07

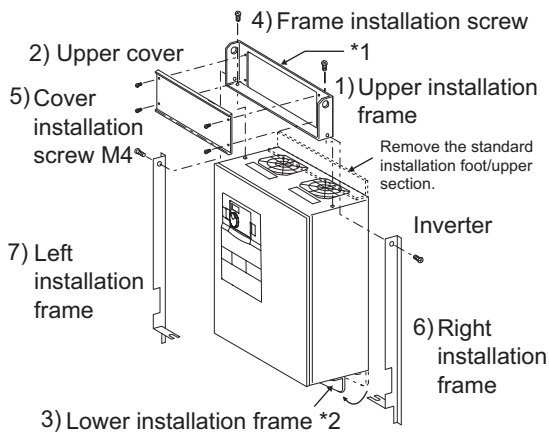

FR-A7CN08, 09

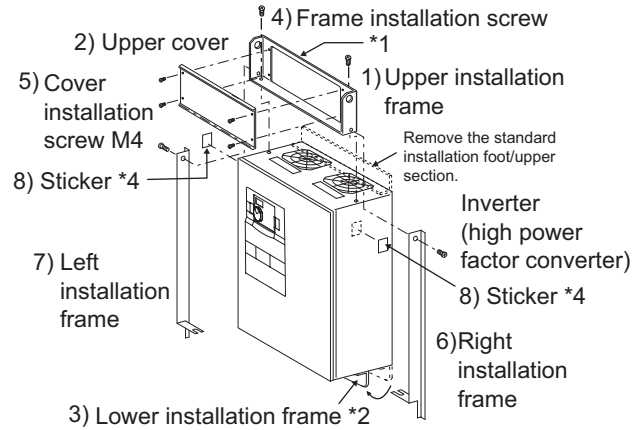

FR-A7CN10, 11

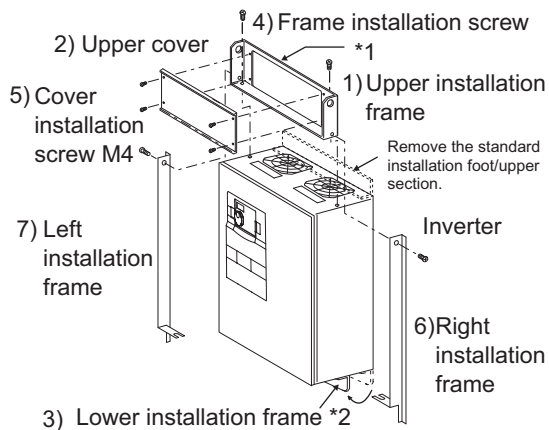

FR-A7CN12, 13, 14

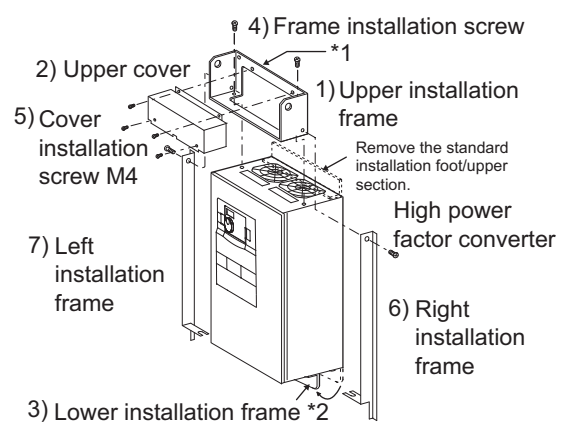

REMARKS

Replacement procedure of the cooling fan

When replacing the cooling fan, "remove the upper cover 2)" and replace the cooling fan from the opening. (Refer to the Instruction Manual of the inverter (high power factor converter) for details.)

- *1 When carrying the inverter (high power factor converter), do not hold it by the upper frame section of "1) upper installation frame". Doing so may change the frame shape.
- *2 Change the position of the "standard installation foot/lower section" (same as "3) lower installation frame") and screw up both "6) 7) left and right installation frames".
- *3 For the FR-A7CN07 to 11, fit the "2) upper cover" to the "1) upper installation frame" first, and then install the "1) upper installation frame" to the inverter (high power factor converter).
When installing an "2) upper cover" to the "1) upper installation frame", a gap may sometimes be left between the lower part of the "2) upper cover" and the "1) upper installation frame". Install the upper cover after making sure that there is no gap.

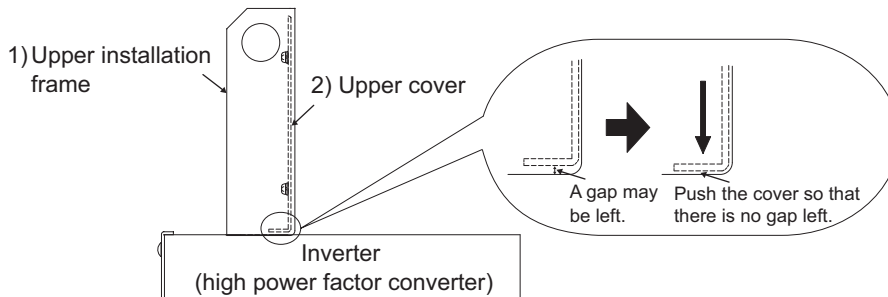

- *4 Place a "8) sticker" before installing the heatsink protrusion attachment. Slits are on the left and right sides of the inverter. Cover the slits on both sides with stickers. (Sticker placement is not necessary for the high power factor converter.)

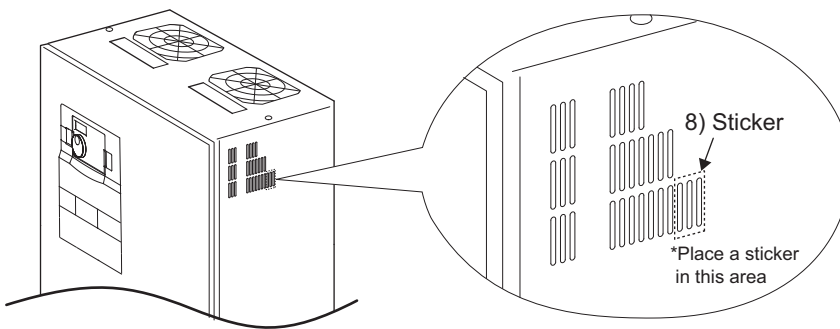

MITSUBISHI ELECTRIC CORPORATION

HEAD OFFICE: TOKYO BUILDING 2-7-3, MARUNOUCHI, CHIYODA-KU, TOKYO 100-8310, JAPAN