



INVERTER

Control terminal option

FR-E7TR

INSTRUCTION MANUAL

RS-485 2 port terminal block

PRE-OPERATION INSTRUCTIONS

1

INSTALLATION

2

WIRING

3

COMMUNICATION OPERATION
FROM RS-485 TERMINALS

4

Thank you for choosing this Mitsubishi Inverter control terminal option.

This instruction manual gives handling information and precautions for use of this equipment. Incorrect handling might cause an unexpected fault. Before using the equipment, please read this manual carefully to use the equipment to its optimum performance.

Please forward this manual to the end user.

This section is specifically about safety matters

Do not attempt to install, operate, maintain or inspect this product until you have read through this instruction manual and appended documents carefully and can use the equipment correctly. Do not use this product until you have a full knowledge of the equipment, safety information and instructions.

In this instruction manual, the safety instruction levels are classified into "WARNING" and "CAUTION".



WARNING

Assumes that incorrect handling may cause hazardous conditions, resulting in death or severe injury.



CAUTION

Assumes that incorrect handling may cause hazardous conditions, resulting in medium or slight injury, or may cause physical damage only.

Note that even the  CAUTION level may lead to a serious consequence according to conditions. Please follow the instructions of both levels because they are important to personnel safety.

Safety Precautions

1. Electric Shock Prevention

WARNING

- While power is on or when the inverter is running, do not open the front cover. Otherwise, you may get an electric shock.
- Do not run the inverter with the front cover or wiring cover removed. Otherwise, you may access the exposed high-voltage terminals and charging part and get an electric shock.
- If power is off, do not remove the front cover except for wiring or periodic inspection. You may access the charged inverter circuits and get an electric shock.
- Before starting wiring or inspection, check to make sure that the indication of the inverter operation panel is off, wait for at least 10 minutes after the power supply has been switched off, and check that there are no residual voltage using a tester or the like. The capacitor is charged with high voltage for some time after power off and it is dangerous.
- Any person who is involved in the wiring or inspection of this equipment should be fully competent to do the work.
- Always install the control terminal option before wiring. Otherwise, you may get an electric shock or be injured.
- Do not touch the control terminal option with wet hands. Otherwise, you may get an electric shock.
- Do not subject the cables to scratches, excessive stress, heavy loads or pinching. Otherwise you may get an electric shock.

2. Injury Prevention

CAUTION

- Apply only the voltage specified in the instruction manual to each terminal. Otherwise, burst, damage, etc. may occur.
- Ensure that the cables are connected to the correct terminals. Otherwise, burst, damage, etc. may occur.
- Always make sure that polarity is correct to prevent damage, etc. Otherwise, burst, damage may occur.
- While power is on or for some time after power-off, do not touch the inverter as they will be extremely hot. Doing so can cause burns.

3. Additional Instructions

Also note the following points to prevent an accidental failure, injury, electric shock, etc.

(1) Transportation and mounting

CAUTION

- Do not install or operate the terminal block option unit if it is damaged or has parts missing.
- Do not stand or rest heavy objects on the product.
- Check that the mounting orientation is correct.
- Prevent other conductive bodies such as screws and metal fragments or other flammable substance such as oil from entering the inverter.

(2) Trial run

CAUTION

- Before starting operation, confirm and adjust the parameters. A failure to do so may cause some machines to make unexpected motions.

(3) Usage

WARNING

- Do not modify the equipment.
- Do not perform parts removal which is not instructed in this manual. Doing so may lead to fault or damage of the product.

CAUTION

- When parameter clear or all parameter clear is performed, reset the required parameters before starting operations. Each parameter returns to the initial value.
- For prevention of damage due to static electricity, touch nearby metal before touching this product to eliminate static electricity from your body.

(4) Maintenance, inspection and parts replacement

CAUTION

- Do not test the equipment with a megger (measure insulation resistance).

(5) Disposal

CAUTION

- Treat as industrial waste.

(6) General instruction

All illustrations given in this manual may have been drawn with covers or safety guards removed to provide in-depth description. Before starting operation of the product, always return the covers and guards into original positions as specified and operate the equipment in accordance with the inverter manual.

— CONTENTS —

1	PRE-OPERATION INSTRUCTIONS	1
1.1	Unpacking and Product Confirmation	1
1.1.1	Packing Confirmation	1
1.1.2	Parts	2
1.1.3	Terminal layout	3
1.2	Terminal connection diagram	4
1.3	Control terminal specifications	6
1.4	Communication	12
2	INSTALLATION	13
2.1	Pre-Installation Instructions	13
2.2	Installation procedure	14
3	WIRING	17
3.1	RS-485 terminals system configuration	17
3.2	Wiring method of RS-485 terminals	19
3.3	Wiring	23
4	COMMUNICATION OPERATION FROM RS-485 TERMINALS	25
4.1	RS-485 communication related parameter	26

1 PRE-OPERATION INSTRUCTIONS



1.1 Unpacking and Product Confirmation

Take the control terminal option out of the package, check the product name on the reverse side, and confirm that the product is as you ordered and intact.

This product is a control terminal option unit dedicated for the FR-E700 series.

1.1.1 Packing Confirmation

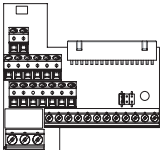
Check the enclosed items.

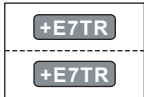
<p>Control terminal option 1</p> 	<p>Instruction manual 1</p> 	<p>Control terminal change notice sticker Two stickers (<i>refer to page 16</i>)</p> 
--	---	--

1.1.2 Parts

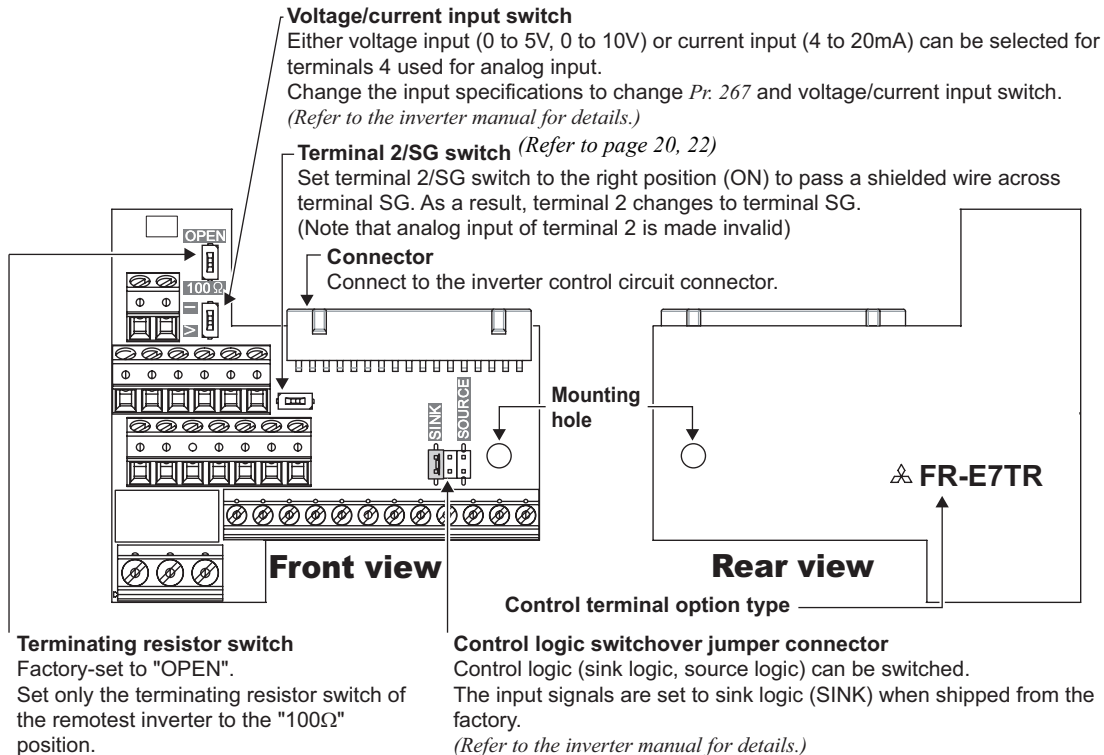



1.1.3 Terminal layout

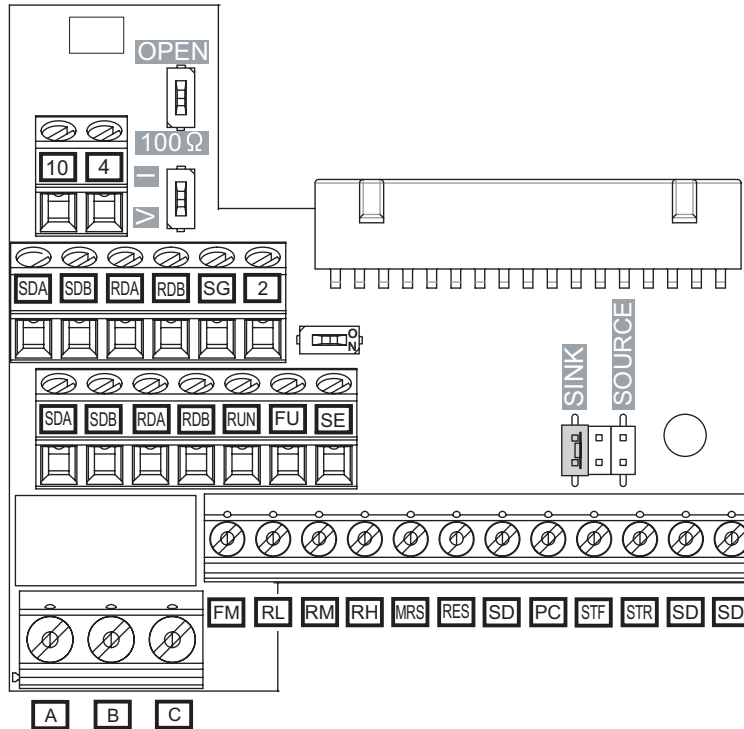

1

1.2 Terminal connection diagram

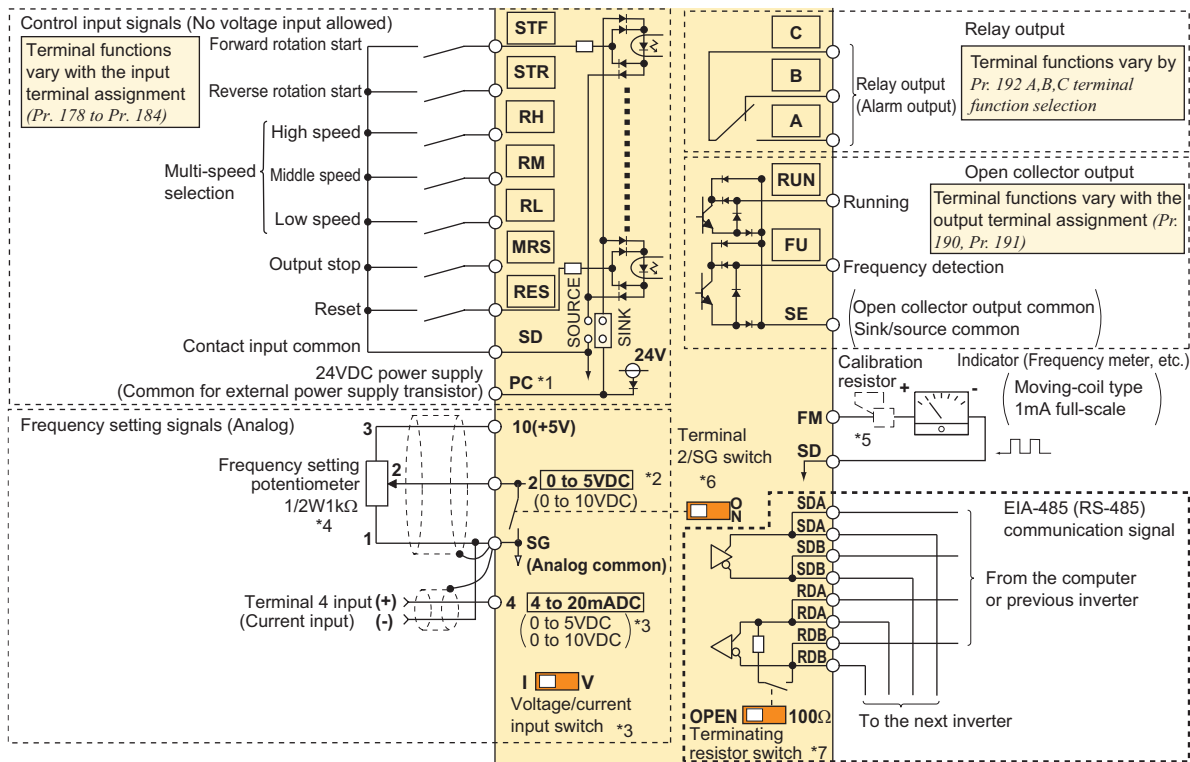



- *1 When using terminals PC-SD as a 24VDC power supply, take care not to short across terminals PC-SD.
- *2 Terminal input specifications can be changed by analog input specifications switchover (*Pr. 73*).
- *3 Terminal input specifications can be changed by analog input specifications switchover (*Pr. 267*).
Set the voltage/current input switch in the "V" position to select voltage input (0 to 5V/0 to 10V) and "I" (initial value) to select current input (4 to 20mA).
- *4 It is recommended to use 2W1k Ω when the frequency setting signal is changed frequently.
- *5 It is not necessary when calibrating the indicator from the operation panel.
- *6 Set the switch to the right (ON) position to pass a shielded wire across terminal SG.
- *7 Set only the terminating resistor switch of the remotest inverter to the "100 Ω " position.



1.3 Control terminal specifications

(1) RS-485 communication

Terminal Symbol	Terminal Name	Description
SDA (2 points)	Inverter send+	Sending signal output terminal from the inverter.
SDB (2 points)	Inverter send-	Inverse sending signal output terminal from the inverter.
RDA (2 points)	Inverter receive+	Receive signal input terminal of the inverter. Changing the terminating resistor switch to "100Ω" side connects the inverter to the 100Ω terminating resistor.
RDB (2 points)	Inverter receive-	Receive signal input terminal of the inverter. Changing the terminating resistor switch to "100Ω" side connects the inverter to the 100Ω terminating resistor.
SG	RS-485 communication common, Analog common	Common terminal of RS-485 communication and frequency setting signal (terminal 2 or terminal 4). Do not earth (ground).



(2) Frequency setting

Terminal Symbol	Terminal Name	Description	Rated Specifications
10	Frequency setting power supply	Used as power supply when connecting potentiometer for frequency setting (speed setting) from outside of the inverter.	5.2VDC \pm 0.2V Permissible load current 10mA
2	Frequency setting (voltage)/ Common terminal	Inputting 0 to 5VDC (or 0 to 10V) provides the maximum output frequency at 5V (10V) and makes input and output proportional. Use <i>Pr. 73</i> to switch between input 0 to 5VDC (initial setting) and 0 to 10VDC input. Set terminal 2/SG switch (<i>refer to page 2</i>) to the right position (ON) to change terminal 2 to terminal SG to pass a shielded wire across terminal SG during RS-485 communication. In this case, voltage at terminal 2 is 0V input.	Voltage input: Input resistance $10k\Omega \pm 1k\Omega$ Permissible maximum voltage 20VDC SG selection: Common terminal Terminal 2 (Initial status) Terminal SG 
4	Frequency setting (current)	Inputting 4 to 20mA (or 0 to 5V, 0 to 10V) provides the maximum output frequency at 20mA and makes input and output proportional. This input signal of terminal 4 is valid only when the AU signal is on (terminal 2 input is invalid). Use <i>Pr. 267</i> to switch from among input 4 to 20mA (initial setting), 0 to 5VDC and 0 to 10VDC. Set the voltage/current input switch in the "V" position to select voltage input (0 to 5V/0 to 10V).	Current input: Input resistance $233\Omega \pm 5\Omega$ Maximum permissible current 30mA. Voltage input: Input resistance $10k\Omega \pm 1k\Omega$ Permissible maximum voltage 20VDC Current input (Initial status) Voltage input 

* Refer to the inverter manual for details of *Pr. 73* and *Pr. 267*.

(3) Contact input

Terminal Symbol	Terminal Name	Description		Rated Specifications
STF*	Forward rotation start	Turn on the STF signal to start forward rotation and turn it off to stop.	When the STF and STR signals are turned on simultaneously, the stop command is given.	Input resistance 4.7kΩ Voltage at opening 21 to 26VDC When contacts are short-circuited 4 to 6mADC
STR*	Reverse rotation start	Turn on the STR signal to start reverse rotation and turn it off to stop.		
RH, RM, RL*	Multi-speed selection	Multi-speed can be selected according to the combination of RH, RM and RL signals.		
MRS*	Output stop	Turn on the MRS signal (20ms or more) to stop the inverter output. Use to shut off the inverter output when stopping the motor by electromagnetic brake.		
RES*	Reset	Used to reset fault output provided when fault occurs. Turn on the RES signal for more than 0.1s, then turn it off. By setting <i>Pr. 75</i> , reset can be set to enabled only at an inverter alarm occurrence. Recover about 1s after reset is cancelled. Refer to the inverter manual for details of <i>Pr. 75</i> .		

* Input signal functions can be selected using *Pr.178 to Pr.184 (input terminal function selection)*.
Refer to the inverter manual for details of *Pr. 178 to Pr.184* .



Terminal Symbol	Terminal Name	Description	Rated Specifications
SD	Contact input common (sink) (initial setting)	Common terminal for contact input terminal (sink logic) and terminal FM.	—
	External transistor common (source)	When connecting the transistor output (open collector output), such as a programmable controller (PLC), when source logic is selected, connect the external power supply common for transistor output to this terminal to prevent a malfunction caused by undesirable currents.	
	24VDC power supply common	Common output terminal for 24VDC 0.1A power supply (PC terminal). Isolated from terminals SG and SE.	
PC	External transistor common (sink) (initial setting)	When connecting the transistor output (open collector output), such as a programmable controller (PLC), when sink logic is selected, connect the external power supply common for transistor output to this terminal to prevent a malfunction caused by undesirable currents.	Power supply voltage range 22 to 26VDC Permissible load current 100mA
	Contact input common (source)	Common terminal for contact input terminal (source logic)	
	24VDC power supply	Can be used as 24VDC 0.1A power supply.	

(4) Output signal

Type	Terminal Symbol	Terminal Name	Description	Rated Specifications
Relay	A, B, C *1	Relay output (fault output)	1 changeover contact output indicates that the inverter protective function has activated and the output stopped. Alarm: discontinuity across B-C (continuity across A-C), Normal: continuity across B-C (discontinuity across A-C)	Contact capacity:230VAC 0.3A (power factor = 0.4) 30VDC 0.3A
Open collector	RUN *1	Inverter running	Switched low when the inverter output frequency is equal to or higher than the starting frequency (initial value 0.5Hz). Switched high during stop or DC injection brake operation. *2	Permissible load 24VDC (27VDC maximum) 0.1A (maximum voltage drop when the signal is on 3.4V)
	FU *1	Frequency detection	Switched low when the inverter output frequency is equal to or higher than the preset detected frequency and high when less than the preset detected frequency. *2	
	SE	Open collector output common	Common terminal of terminal RUN and FU.	—
Pulse	FM	For meter	Select one e.g. output frequency from monitor items. *3 The output signal is proportional to the magnitude of the corresponding monitoring item.	Output item: Output frequency (initial setting)

*1 Output signal function can be selected using Pr. 190 to Pr. 192 (output terminal function selection)
Refer to the inverter manual for details of Pr. 190 to Pr. 192.

*2 Low indicates that the open collector output transistor is on (conducts).
High indicates that the transistor is off (does not conduct).

*3 Not output during inverter reset.



CAUTION

- Terminals SD, SG and SE are common terminals for I/O signal. (All common terminals are isolated from each other.) Do not earth them.
Do not connect terminal SD-SG and terminal SE-SG.
 - Terminal SD is a common terminal for the contact input terminals (STF, STR, RH, RM, RL, MRS, RES) and frequency output signal (FM). The open collector circuit is isolated from the internal control circuit by photocoupler.
 - Terminal SG is a common terminal for the frequency setting signals (terminal 2 or 4) and RS-485 communication. It should be protected from external noise using a shielded or twisted cable.
 - Terminal SE is a common terminal for the open collector output terminal (RUN, FU). The contact input circuit is isolated from the internal control circuit by photocoupler.
-
-

1.4 Communication

Item	Description
Communication protocol	Mitsubishi inverter protocol (computer link communication), Modbus-RTU protocol
Conforming standard	EIA-485 (RS-485)
Number of connectable devices	32 units maximum
Communication speed	4800/9600/19200/38400bps
Communication method	Half-duplex system, full-duplex system
Terminating resistor	100Ω (valid/invalid can be changed with a terminating resistor switch)

2 INSTALLATION

2.1 Pre-Installation Instructions

Make sure that the input power of the inverter is off.

CAUTION

 Do not install or remove a control terminal option with the input power supply is on. Otherwise, the inverter and option may be damaged.

2.2 Installation procedure

- (1) Remove the inverter front cover.
(Refer to the inverter instruction manual for removing the front cover.)
- (2) Remove the installation screws of the standard control circuit terminal.
Pull the control circuit terminal downward.

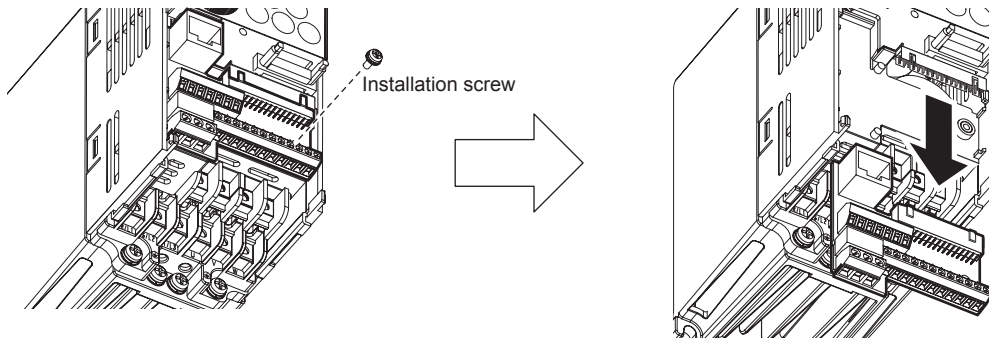

- (3) Using care not to bend the pins of the inverter's control circuit connector, reinstall the control terminal option and fix it with the mounting screws.
(Tightening torque 0.56N·m to 0.75N·m)

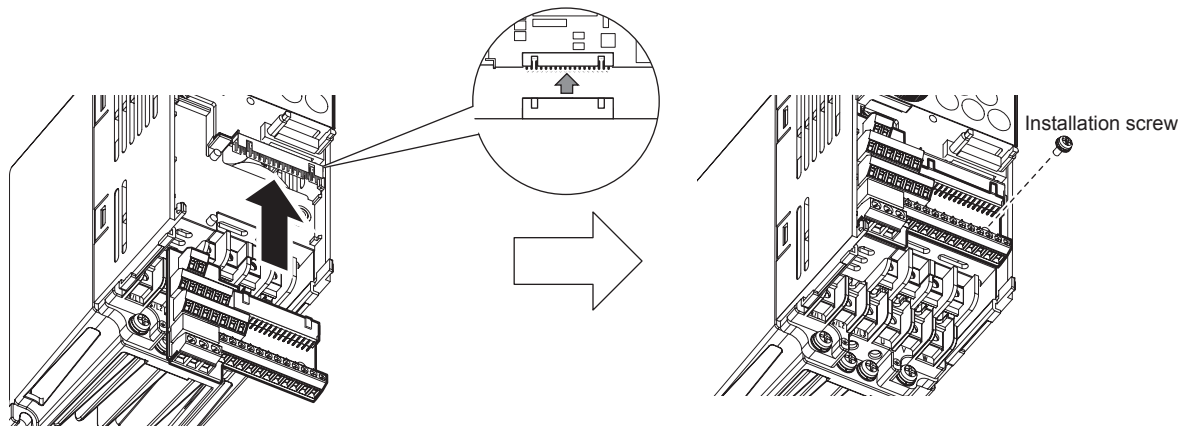

7 INSTALLATION

- (4) Install the inverter front cover.
(Refer to the inverter instruction manual for installing the front cover.)
Attach a supplied control terminal change notice sticker to the next to the model name on the front cover so that the control terminal has been replaced with the FR-E7TR. (Two control terminal change notice stickers are supplied and one of them is an extra.)

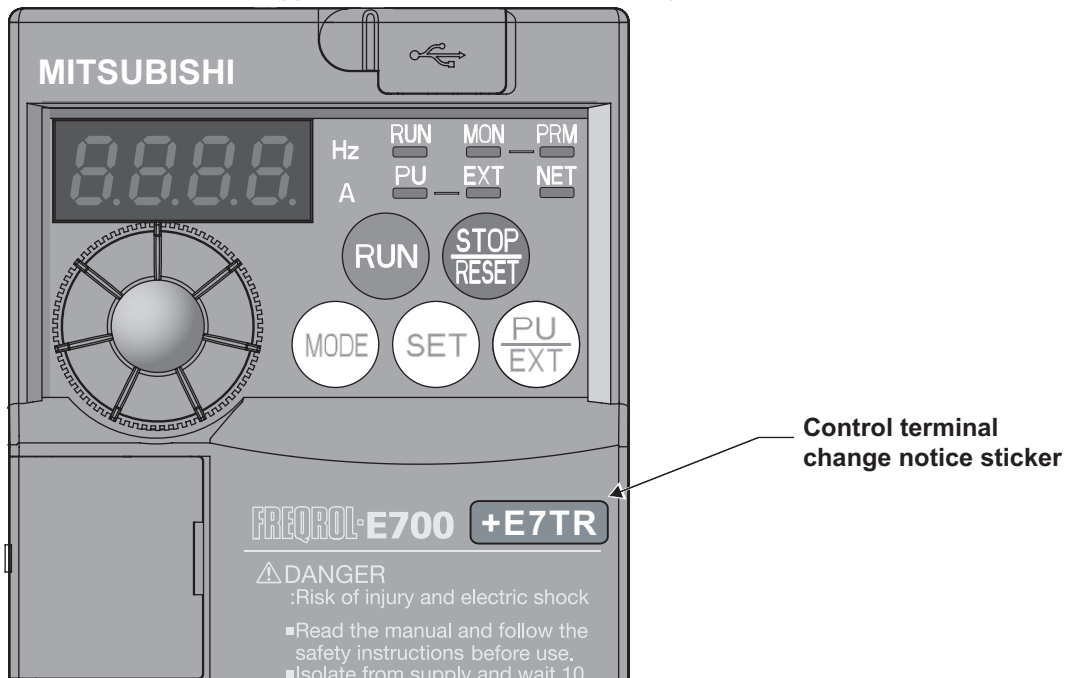

3 WIRING

3.1 RS-485 terminals system configuration

● Connection of a computer to the inverter (1:1 connection)

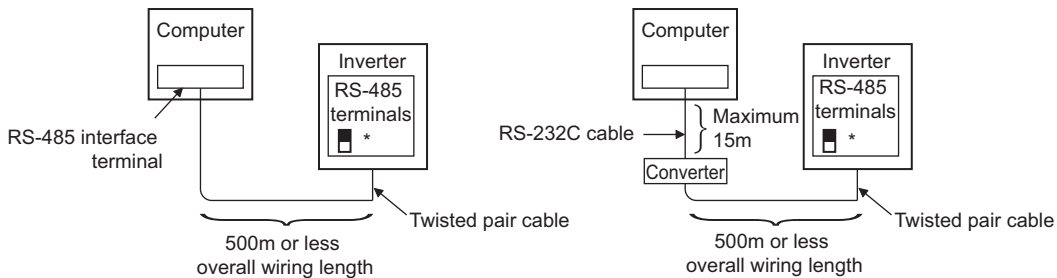

*Set the terminating resistor switch to the "100Ω" position.

● **Combination of computer and multiple inverters (1:n connection)**

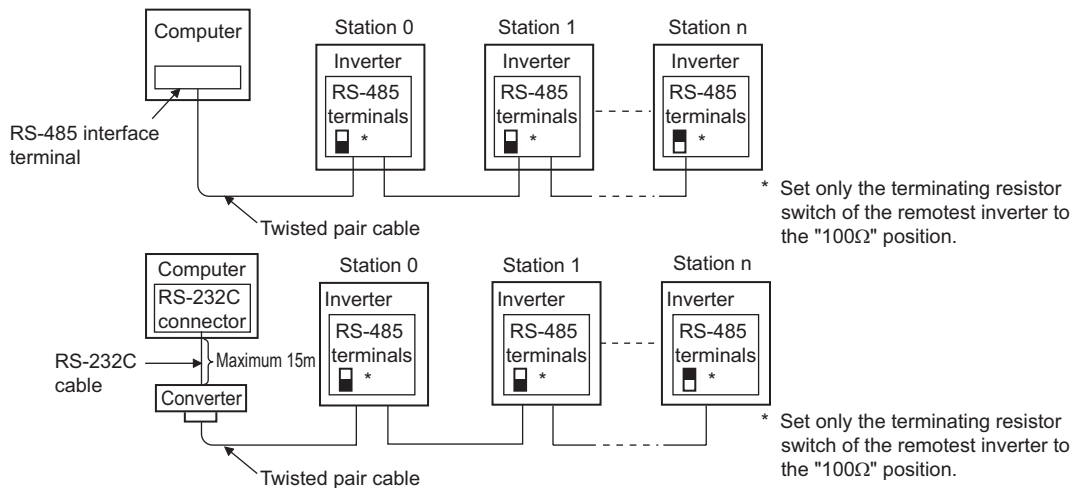

3.2 Wiring method of RS-485 terminals

(1) Four-wire type connection

●Wiring of one RS-485 computer and n inverters (several inverters)

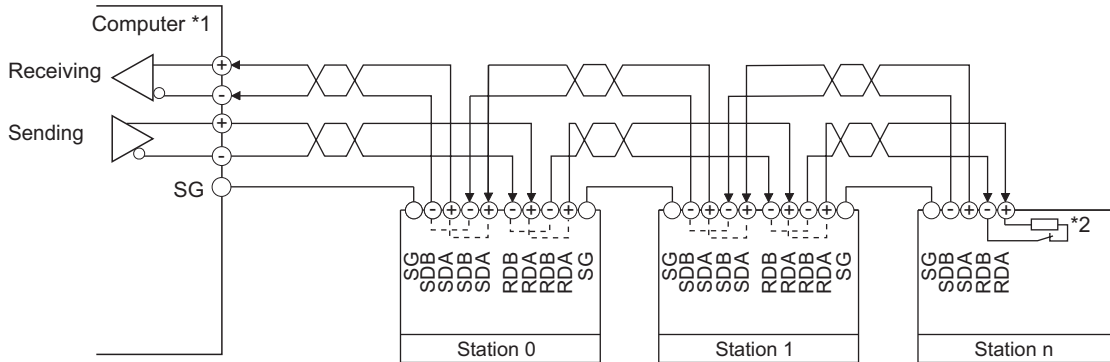

- *1 Make connections in accordance with the manual of the computer used.
Fully check the terminal numbers of the computer since they vary with the model.
- *2 For the inverter farthest from the computer, set the terminating resistor switch to ON (100Ω side).

REMARKS

Refer to the figure below for branch wiring in the case of full-duplex system.

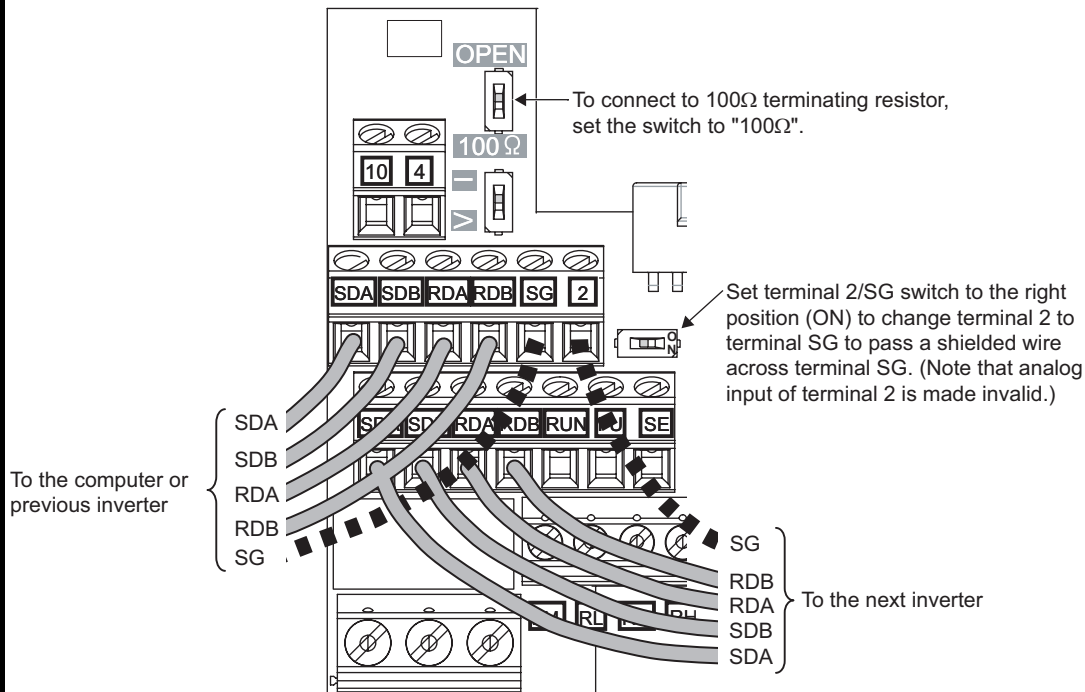

(2) Two-wire type connection

If the computer is 2-wire type, a connection from the inverter can be changed to 2-wire type by passing wires across reception terminals and transmission terminals of the RS-485 terminals.

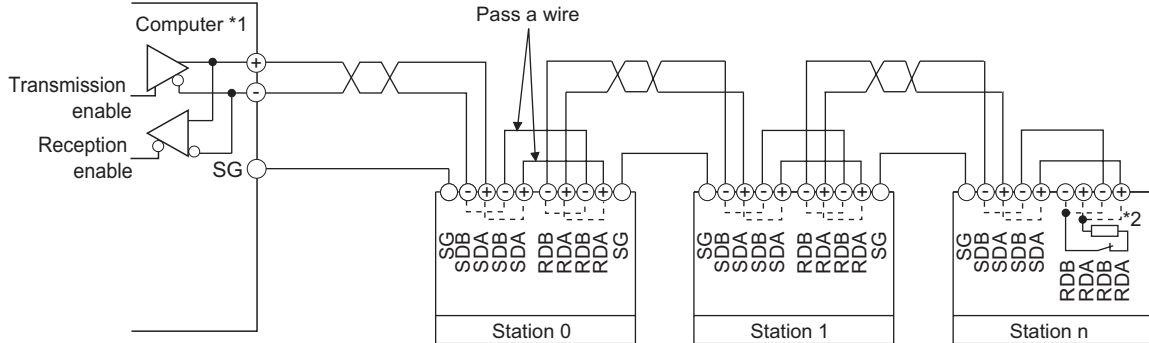

- *1 Make connections in accordance with the manual of the computer used.
Fully check the terminal numbers of the computer since they vary with the model.
- *2 For the inverter farthest from the computer, set the terminating resistor switch to ON (100Ω side).

REMARKS

Refer to the figure below for branch wiring in the case of half-duplex system.

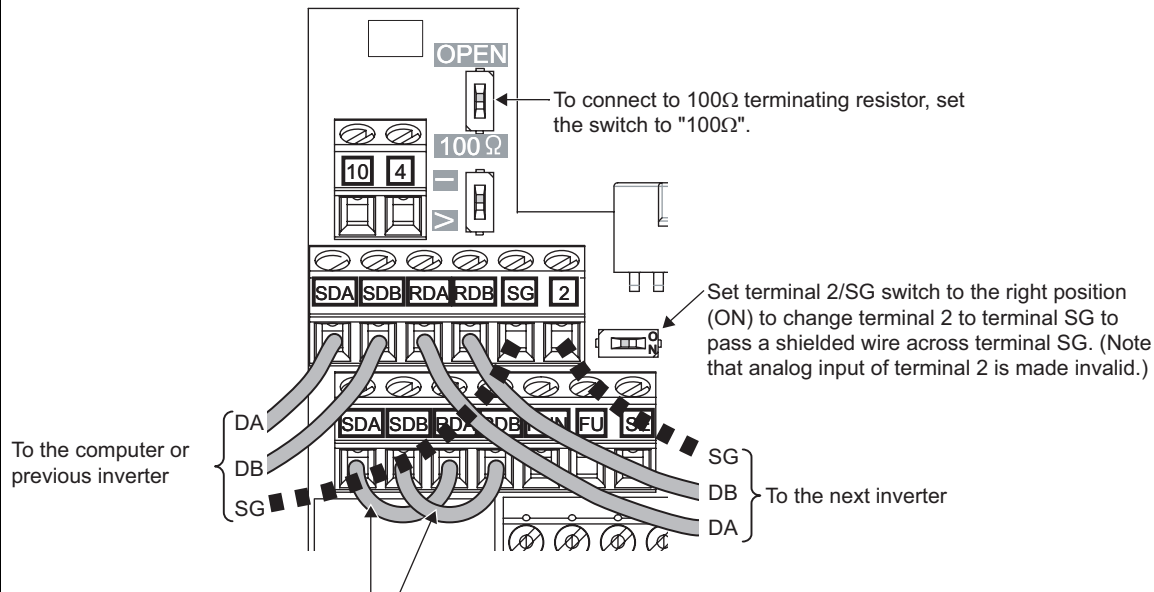

To the computer or previous inverter

Set terminal 2/SG switch to the right position (ON) to change terminal 2 to terminal SG to pass a shielded wire across terminal SG. (Note that analog input of terminal 2 is made invalid.)

To the next inverter

In the case of half duplex system, perform branch wiring.
(across SDA-RDA, across SDB-RDB)

A program should be created so that transmission is disabled (receiving state) when the computer is not sending and reception is disabled (sending state) during sending to prevent the computer from receiving its own data.

3.3 Wiring

- (1) Strip off the sheath of the cable to wire.
 Strip off the sheath about the size below. If the length of the sheath peeled is too long, a short circuit may occur among neighboring wires. If the length is too short, wires might come off.

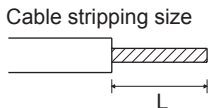

Wire the stripped cable after twisting it to prevent it from becoming loose. In addition, do not solder it. Use a bar terminal as necessary.

Terminal	L(mm)
A, B, C	6
Other than the above	5

REMARKS

Information on bar terminals
 Commercially available product examples (as of Sep., 2006)

Terminal Screw Size	Wire Size (mm ²)	Bar Terminal Model		Maker
		with insulation sleeve	without insulation sleeve	
M3 (terminal A, B, C)	0.3 to 0.5	AI 0,5-6WH	A 0,5-6	Phoenix Contact Co., Ltd.
	0.5 to 0.75	AI 0,75-6GY	A 0,75-6	
M2 (Other than the above)	0.3 to 0.5	AI 0,5-6WH	A 0,5-6	

· Bar terminal crimping tool: CRIMPFOX ZA3 (Phoenix Contact Co., Ltd.)

When using the bar terminal (without insulation sleeve), use care so that the twisted wires do not come out.

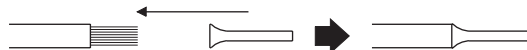

- (2) Loosen the terminal screw and insert the cable into the terminal.
- (3) Tighten the screw to the specified torque.

Undertightening can cause cable disconnection or malfunction. Overtightening can cause a short circuit or malfunction due to damage to the screw or unit.

Tightening torque: 0.5N·m to 0.6N·m (A, B, C terminals)

0.22N·m to 0.25N·m (other than the above)

* Screwdriver: Small flathead ⊖ screwdriver (Tip thickness: 0.4mm/tip width: 2.5mm)

4 COMMUNICATION OPERATION FROM RS-485 TERMINALS

Mounting a control terminal option FR-E7TR allows RS-485 communication from RS-485 terminals in place of PU connector on the standard control circuit terminal.

Set the same parameter (*refer to page 26*) as when performing RS-485 communication from PU connector. For details of initial setting and specifications when performing RS-485 communication with RS-485 terminals, refer to explanations of "RS-485 communication from PU connector" of the inverter manual.

In addition, RS-485 communication from RS-485 terminals allows communication operation and parameter setting with Mitsubishi inverter protocol (computer link communication) and Modbus-RTU communication protocol selected as same as when RS-485 communication from PU connector with a standard control circuit terminal block mounted.

For details of communication specifications and initial setting of Mitsubishi inverter protocol (computer link communication) and Modbus-RTU communication protocol, refer to "Each protocol of communication operation from PU connector" of the inverter manual.

CAUTION

Always reset the inverter after making the initial settings of the parameters. After you have changed the communication-related parameters, communication cannot be made until the inverter is reset.

4.1 RS-485 communication related parameter

For details of parameter, refer to explanations of "RS-485 communication from PU connector " and "Each protocol of communication operation from PU connector" of the inverter manual.

(1) Operation command source and speed command source during communication operation (Pr. 338, Pr. 339, Pr. 550, Pr. 551)

Parameter Number	Name	Initial Value	Setting Range	Description
338	Communication operation command source	0	0	Operation command source communication
			1	Operation command source external
339	Communication speed command source	0	0	Speed command source communication
			1	Speed command source external (Frequency setting from communication is invalid, terminal 2 setting from external is valid)
			2	Speed command source external (Frequency setting from communication is valid, terminal 2 setting from external is invalid)
550 *	NET mode operation command source selection	9999	0	Selects the communication option as NET operation mode command source.
			2	Selects RS-485 terminals as the NET operation mode command source.
			9999	Automatic communication option recognition Normally, the RS-485 terminals are valid. When a communication option is mounted, the communication option is valid.



Parameter Number	Name	Initial Value	Setting Range	Description
551 *	PU mode operation command source selection	9999	2	Selects RS-485 terminals as the NET operation mode command source.
			3	Selects the USB connector as the PU operation mode command source.
			4	Selects the operation panel as the PU operation mode command source.
			9999	USB automatic recognition Normally, operation panel is the command source. When USB is connected, USB is the command source.

The above parameters can be set when *Pr. 160 User group read selection* = "0". However, the parameters can be set whenever the communication option is connected.

* *Pr. 550 and Pr. 551* are always write-enabled.

(2) Initial settings and specifications of RS-485 communication (Pr. 117 to Pr. 120, Pr. 123, Pr. 124, Pr. 549)

Parameter Number	Name	Initial Value	Setting Range	Description	
117	PU communication station number	0	0 to 31 (0 to 247) *	Inverter station number specification Set the inverter station numbers when two or more inverters are connected to one personal computer.	
118	PU communication speed	192	48, 96, 192, 384	Communication speed The setting value × 100 equals the communication speed. Example) 19200bps if 192	
119	PU communication stop bit length	1		Stop bit length	Data length
			0	1bit	8bit
			1	2bit	
			10	1bit	7bit
11	2bit				
120	PU communication parity check	2	0	Without parity check	
			1	With odd parity check	
			2	With even parity check	
123	PU communication waiting time setting	9999	0 to 150ms	Set the waiting time between data transmission to the inverter and response.	
			9999	Set with communication data.	
124	PU communication CR/LF selection	1	0	Without CR/LF	
			1	With CR	
			2	With CR/LF	
549	Protocol selection	0	0	Mitsubishi inverter (computer link operation) protocol	
			1	Modbus-RTU protocol	

The above parameters can be set when Pr. 160 User group read selection = "0".

* When "1" (Modbus-RTU protocol) is set in Pr. 549, the setting range within parenthesis is applied.



(3) Operation selection at communication error occurrence (Pr.121, Pr.122, Pr.502)

Parameter Number	Name	Initial Value	Setting Range	Description			
121	Number of PU communication retries	1	0 to 10	Number of retries at data receive error occurrence. If the number of consecutive errors exceeds the permissible value, the inverter will come to trip (depends on Pr. 502). Valid only Mitsubishi inverter (computer link operation) protocol.			
			9999	If a communication error occurs, the inverter will not come to trip.			
122	PU communication check time interval	0	0	RS-485 communication can be made. Note that a communication fault (E.PUE) occurs as soon as the inverter is switched to the operation mode with control source.			
			0.1 to 999.8s	Communication check (signal loss detection) time interval If a no-communication state persists for longer than the permissible time, the inverter will come to trip (depends on Pr.502).			
			9999	No communication check (signal loss detection)			
502	Stop mode selection at communication error	0	0, 3	At Alarm Occurrence	Indication	Alarm Output	At Error Removal
				Coasts to stop	E.PUE	Output	Stop (E.PUE)
			1	Decelerates to stop	After stop E.PUE	Output after stop	Stop (E.PUE)
			2	Decelerates to stop	After stop E.PUE	Without output	Automatic restart functions

The above parameters can be set when Pr. 160 User group read selection = "0". However, the parameters can be set whenever the communication option is connected.

MEMO

MEMO

REVISIONS

*The manual number is given on the bottom left of the back cover.

Print Date	*Manual Number	Revision
Oct., 2007	IB-0600330ENG-A	First edition