



**MITSUBISHI  
ELECTRIC**

# VECTOR INVERTER

## INSTRUCTION MANUAL

---

PARAMETER UNIT

# FR-PU04V

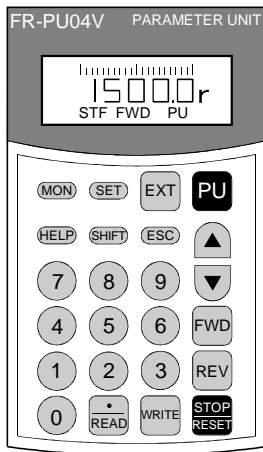

**PRE-OPERATION  
INFORMATION**

**1**

**FUNCTIONS**

**2**

**HELP**

**3**

**OPERATION**

**4**

**SPECIFICATION**

**5**

Thank you for choosing the Mitsubishi vector inverter option unit.

This instruction manual gives handling information and precautions for use of this equipment. Incorrect handling might cause an unexpected fault. Before using the equipment, please read this manual carefully to use the equipment to its optimum. Please forward this manual to the end user.

This instruction manual uses the International System of Units (SI). The measuring units in the yard and pound system are indicated in parentheses as reference values.

## **This section is specifically about safety matters.**

Do not attempt to install, operate, maintain or inspect this product until you have read through this instruction manual and appended documents carefully and can use the equipment correctly. Do not use this product until you have a full knowledge of the equipment, safety information and instructions. In this instruction manual, the safety instruction levels are classified into "WARNING" and "CAUTION".



Assumes that incorrect handling may cause hazardous conditions, resulting in death or severe injury.



Assumes that incorrect handling may cause hazardous conditions, resulting in medium or slight injury, or may cause physical damage only.

Note that the CAUTION level may lead to a serious consequence according to conditions. Please follow the instructions of both levels because they are important to personnel safety.

# SAFETY INSTRUCTIONS

## 1. Electric Shock Prevention

### WARNING

- Do not run the inverter with the front cover removed. Otherwise, you may access exposed high voltage terminals or charging devices and get an electric shock.
- Any person who is involved in the wiring or inspection of this equipment should be fully competent to do the work.
- Always install the inverter before wiring. Otherwise, you may get an electric shock or be injured.
- Operate the keys with dry hands to prevent an electric shock.

## 2. Additional Instructions

To prevent injury, damage or product failure, please note the following points.

### (1) Transportation and mounting

### CAUTION

- Do not install and operate the parameter unit (FR-PU04V) if it is damaged or has parts missing.
- Do not stand or rest heavy objects on this equipment.
- Check the inverter mounting orientation is correct.
- The parameter unit (FR-PU04V) is a precision device. Do not drop it or subject it to impact.
- Use the product under the following environmental conditions:

Environment	Ambient temperature	-10°C to +50°C (+14°F to +122°F) (non-freezing)
	Ambient humidity	90%RH or less (non-condensing)
	Storage temperature	-20°C to +65°C (-4°F to +149°F) *
	Ambience	Indoors (free from corrosive gas, flammable gas, oil mist, dust and dirt)
	Altitude, vibration	Max. 1000m (328.80feet) above sea level, 5.9m/s <sup>2</sup> or less (conforming to JIS C 0040)

\* Temperatures applicable for a short time, e.g. in transit.

## (2) Test operation and adjustment

### CAUTION

- Before starting operation, confirm and adjust the parameters. A failure to do so may cause some machines to make unexpected motions.

## (3) Usage

### WARNING

- The [STOP] key is only valid when function setting has been made. Provide an emergency stop switch separately.
- Make sure that the start signal is off before resetting the alarm. A failure to do so may restart the motor suddenly.
- Do not modify the equipment.

### CAUTION

- When parameter clear or all parameter clear is performed, each parameter returns to the factory setting. Re-set the required parameters before starting operation.

## (4) Corrective actions for alarm

### CAUTION

- Provide safety backup devices, such as an emergency brake, to protect machines and equipment from hazard if the parameter unit (FR-PU04V) becomes faulty.

## (5) Disposal

### CAUTION

- Treat as industrial waste.

## (6) General instruction

All illustrations given in this manual may have been drawn with covers or safety guards removed to provide in-depth description. Before starting operation of the product, always return the covers and guards into original positions as specified and operate the equipment in accordance with the manual.

# - CONTENTS -

<b>1 PRE-OPERATION INFORMATION</b>	<b>1</b>
1.1 Overview .....	2
1.1.1 Appearance and parts identification .....	2
1.1.2 Explanation of the keys .....	2
1.2 Installation and Removal .....	4
1.2.1 Installation .....	4
1.2.2 Removal .....	5
1.3 Parameters to Be Checked First .....	6
1.3.1 Parameter unit display language selection (Pr. 145) .....	6
1.3.2 Buzzer beep control (Pr. 990) .....	6
1.3.3 LCD contrast (Pr. 991) .....	6
<b>2 FUNCTIONS</b>	<b>7</b>
2.1 Monitoring Function .....	8
2.1.1 Display overview .....	8
2.1.2 Using the [SHIFT] key to change the main screen .....	10
2.1.3 Setting the first priority screen (first screen) .....	10
2.1.4 Using the [HELP] key to change the main screen .....	11
2.1.5 Using the "PU main display data selection parameter" to change the screen .....	12
2.2 Frequency Setting .....	13
2.2.1 Direct setting .....	13
2.2.2 Step setting .....	14
2.2.3 Precautions for speed setting .....	14
2.3 Setting and Changing the Parameter Values .....	15
2.3.1 Direct setting .....	15
2.3.2 Step setting .....	17
2.3.3 Precautions for setting write .....	18
2.4 Calibration of the Meter (Speed Meter) .....	18
2.4.1 Calibration of DA1 and DA2 terminals .....	18
2.5 Adjustment of the frequency setting signals "bias" and "gain" .....	22
2.5.1 Adjustment procedure .....	22
2.6 Copy and Verify Functions .....	25
2.6.1 Copying the parameter settings .....	25
2.6.2 Verifying the parameters .....	26

<b>3 HELP</b>	<b>27</b>
3.1 Overview of the Help Functions .....	28
3.1.1 Help function menu .....	28
3.1.2 Help function display data .....	29
3.2 Operation Procedures for the Help Functions.....	31
3.2.1 Monitor function.....	31
3.2.2 Selection of PU operation (direct input).....	33
3.2.3 Selection of the PU jog operation mode.....	34
3.2.4 Parameters.....	35
3.2.5 Parameter Clear.....	38
3.2.6 Alarm History.....	39
3.2.7 Alarm Clear .....	40
3.2.8 Inverter Reset.....	41
3.2.9 Selectop .....	42
3.2.10 Option.....	42
3.3 Other Precautions .....	43
3.3.1 Precautions for parameter unit operation .....	43
<b>4 OPERATION</b>	<b>45</b>
4.1 Operation Modes.....	46
4.1.1 How to select the operation mode.....	46
4.2 PU Operation .....	48
4.2.1 Ordinary operation.....	48
4.2.2 PU jog operation.....	49
4.3 Combined Operation (Operation using external input signals and PU) .....	50
4.3.1 Entering the start signal from outside and setting the running speed from the PU (Pr. 79=3) .....	50
4.3.2 Entering the running speed from outside and making start and stop from the PU (Pr. 79 = 4) .....	51
4.3.3 Entering the start signal and multi-speed signal from outside and setting multiple speeds from the PU .....	52
<b>5 SPECIFICATION</b>	<b>53</b>
5.1 Specifications .....	54
5.1.1 Standard specifications .....	54
5.1.2 Outline drawing .....	55
5.1.3 Panel cutting drawing.....	55



# 1

# PRE-OPERATION INFORMATION

This chapter provides the basic "pre-operation information (overview)" for use of this product.

Always read the instructions before using the equipment

1.1	Overview .....	2
1.2	Installation and Removal.....	4
1.3	Parameters to Be Checked First .....	6

1

2

3

4

5

## 1.1 Overview

### 1.1.1 Appearance and parts identification

Unpack the parameter unit from the carton, check the name plate on the back, and make sure that the product has not been damaged before using the equipment.

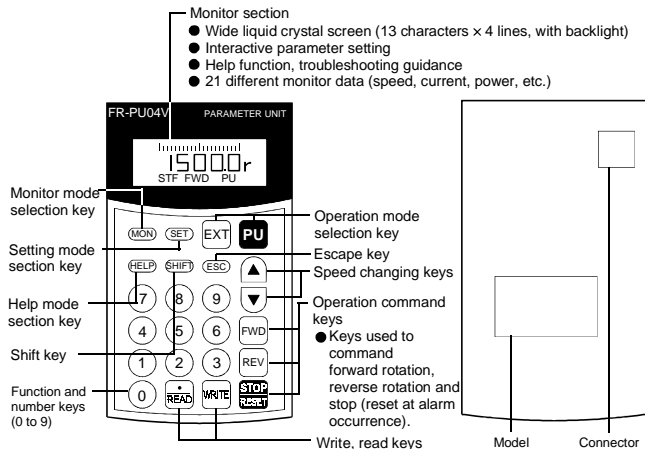

### 1.1.2 Explanation of the keys

Key	Description
(SET) Key	Used to select the parameter setting mode.
(MON) Key	Used to display the main monitor.
(ESC) Key	Operation cancel key.
(HELP) Key	Used to select the help mode.
(SHIFT) Key	Used to shift to the next item in the setting or monitoring mode.
Number keys	Used to enter a speed, parameter number or set value.
(EXT) Key	Used to select the external operation mode.
(PU) Key	Used to select the PU operation mode.



Key	Description
▲ and ▼ key	<ul style="list-style-type: none"> <li>• Used to keep on increasing or decreasing the running speed. Hold down to vary the speed.</li> <li>• Press either of these keys on the setting mode screen to change the parameter setting sequentially.</li> <li>• On the monitoring, parameter or help menu screen, these keys are used to move the cursor.</li> <li>• Hold down the (SHIFT) key and press either of these keys to advance or return the display screen one page.</li> <li>• In the parameter copy or verify mode, the ▼ key is used as a verify key.</li> </ul>
FWD key	Forward rotation command key.
REV key	Reverse rotation command key.
STOP/RESET key	<ul style="list-style-type: none"> <li>• Stop command key.</li> <li>• Used as a reset key when an alarm occurs.</li> </ul>
WRITE key	<ul style="list-style-type: none"> <li>• Used to write a set value in the setting mode.</li> <li>• Used as a clear key in the all parameter clear or alarm history clear mode.</li> </ul>
READ key	<ul style="list-style-type: none"> <li>• Used also as a decimal point key.</li> <li>• Used as a parameter number read key in the setting mode.</li> <li>• Used as an item select key on the menu screen such as parameter list or monitoring list.</li> <li>• Used as an alarm definition display key in the alarm history display mode.</li> <li>• Used as a command voltage read key in the calibration mode.</li> </ul>
Display	13 character × 4 line liquid crystal display screen shows monitoring data, such as speed, motor current and I/O terminal states, as well as troubleshooting guidance and other information.
Connector	Used for connection of the parameter unit with the inverter. You may either connect the unit directly or use the connection cable (FR-CB2□□) for connection.
Model	<div style="border: 1px solid black; padding: 10px; width: fit-content; margin: 0 auto;"> <p>FR-PU04V</p> <p> MITSUBISHI ELECTRIC CORPORATION</p> <p>MADE IN JAPAN</p> </div>

**CAUTION**

1. Do not use a sharp-pointed tool to push the keys.
2. The display is a liquid crystal display. Do not press your fingers against the display.

## **1.2 Installation and Removal**

To ensure safety, install and remove the parameter unit after switching the Inverters power off.

### **1.2.1 Installation**

(1) Installation to the inverter

1) Remove the operation panel (FR-DU04-1) and accessory cover.

(For details of the removal procedure of the control panel (FR-DU04-1), refer to the inverter instruction manual (basic).)

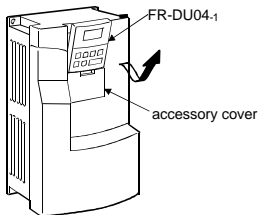

2) Insert the parameter unit straight and fit it securely.

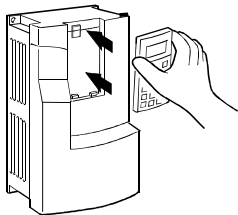

- (2) Using the connection cable (FR-CB2) for connection

**REMARKS**

For details of the connection cable (FR-CB2), refer to the connection cable (FR-CB2) instruction manual.

- 1) Remove the operation panel.
- 2) Insert the cable plugs securely into the connectors of the inverter and parameter unit (FR-PU04V) along the cable guides until the stoppers are actuated.

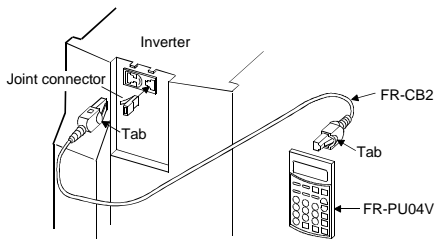

**CAUTION**

The parameter unit must be installed when the front cover is fitted on the inverter.

**1.2.2 Removal**

- (1) Removal from the inverter  
Hold down the top button of the FR-PU04V and pull the parameter unit toward you, using the catches as a support.

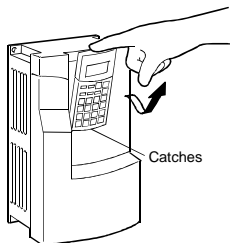

- (2) Removal when the connection cable (FR-CB2) is used  
Hold down the tab at the cable end and gently pull the plug.

1

2

3

4

5

## 1.3 Parameters to Be Checked First

Change the following parameter settings as required.  
For the changing procedures, refer to page 15.

### 1.3.1 Parameter unit display language selection (Pr. 145)

By setting the Pr. 145 "parameter unit display language selection" value, you can select the language displayed on the parameter unit.

Pr. 145 Setting	Display Language
0	Japanese (factory setting of Japanese domestic version)
1	English (factory setting of NA version)
2	German
3	French
4	Spanish
5	Italian
6	Swedish
7	Finnish

### 1.3.2 Buzzer beep control (Pr. 990)

By setting the Pr. 990 "buzzer beep control" value, you can select to either generate or mute the "beep" which sounds when you press any of the parameter unit keys.

Pr.990 Setting	Description
0	No sound
1	Sound generated (factory setting)

### 1.3.3 LCD contrast (Pr. 991)

By setting the Pr. 991 "LCD contrast" value, you can adjust the contrast of the parameter unit LCD.

Pr. 991 Setting	
0 to 63	<p>right Factory setting Dark</p>

#### CAUTION

When adjusting the contrast, change the value one by one. If you change the value greatly, the LCD of the parameter unit may become invisible.

# 2

# FUNCTIONS

This chapter describes the "functions" for use of this product. Always read the instructions before using the equipment.

2.1	Monitoring Function.....	8
2.2	Frequency Setting .....	13
2.3	Setting and Changing the Parameter Values .....	15
2.4	Calibration of the Meter (Speed Meter).....	18
2.5	Adjustment of the frequency setting signals "bias" and "gain".....	22
2.6	Copy and Verify Functions .....	25

1

2

3

4

5

# FUNCTIONS

## 2.1 Monitoring Function

### 2.1.1 Display overview

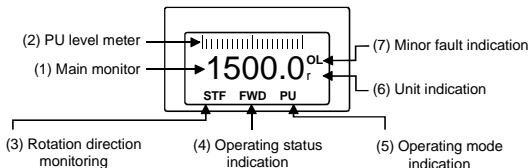

#### (1) Main monitor

Shows the output speed, output current, output voltage, alarm history and other monitor data.

- Using the **(SHIFT)** key to change to the next screen (refer to page 10)
- Using the **(HELP)** key to change to the next screen (refer to page 11)
- Using Pr. 52 "PU main display data selection" to change the main screen (refer to page 12)

#### REMARKS

For other motors, select the display from the help function monitor. (refer to page 31)

#### (2) PU level meter

Setting the Pr. 53 "PU level display data selection" displays the data selected on the 5% graduated level meter.

Refer to the inverter instruction manual (basic) for details.

#### (3) Rotation direction monitoring

Indicates the direction of rotation of the motor.

STF : Forward rotation

STR : Reverse rotation

- - - : No command or both STF and STR on

#### (4) Operating status indication

Shows the operating status of the inverter.

STOP : During stop

FWD : During forward rotation

REV : During reverse rotation

JOGf : During job forward rotation

JOGr : During jog reverse rotation

- (5) Operation mode indication  
Displays the status of the operation mode.  
EXT : External operation mode  
PU : PU operation mode  
EXTj : External jog mode  
PUj : PU jog mode  
NET : Link operation mode  
PU+E : Combined operation mode
- (6) Unit indication  
Shows the unit of the main monitor.
- (7) Minor fault display  
Displays an inverter fault as an alarm.  
- - - : Normal  
OL : Stall (current)  
oL : Stall (voltage)  
RB : Regenerative brake pre-alarm  
TH : Electronic overcurrent protection pre-alarm  
ZC : Zero current detection  
PS : PU stop  
FN : Cooling fan stop  
MT : Maintenance signal  
SL : Speed limit

1

2

3

4

5

## FUNCTIONS

### 2.1.2 Using the [SHIFT] key to change the main screen

When "0" (factory setting) is set in Pr. 52 "PU main display data selection", merely pressing the [SHIFT] key calls 6 different monitor screens in sequence.

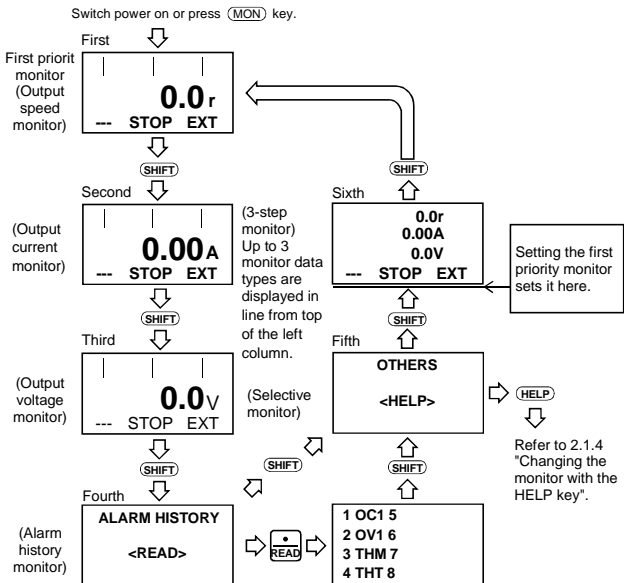

### 2.1.3 Setting the first priority screen (first screen)

Set the screen which appears first when power is switched on or the (MON) key is pressed.

- When you press the [WRITE] key with any screen other than ALARM HISTORY and OTHERS being displayed, that screen is set as the first priority screen and will be displayed first.
- You cannot set "15 I/P Signal", "16 O/P Signal" or multiple simultaneous screens as the first priority screen.



**2.1.4 Using the [HELP] key to change the main screen**

**REMARKS**

Refer to page 27 for details of the help functions.

- Example: Select the output current peak value monitor.

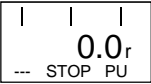
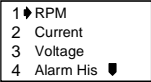
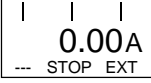
<p>1) Press the <b>[MON]</b> key. .... The parameter unit is placed in the monitoring mode.</p>	
<p>2) Press the <b>[HELP]</b> key. .... The monitoring list appears.</p>	
<p>3) Hold down the <b>[SHIFT]</b> key and press the <b>[DOWN]</b> key three times, then release the <b>[SHIFT]</b> key, and press the <b>[DOWN]</b> key twice. (Moves the cursor to 15 I/P Signal.)</p>	<p>.... Hold down <b>[SHIFT]</b> and press the <b>[DOWN]</b> or <b>[UP]</b> key to shift the screen one page.</p>
<p>4) Press the <b>[READ]</b> key. .... The screen shown on the right (CAUTION 1)</p>	
<p>5) Press the <b>[WRITE]</b> key. .... The screen in step 4) is set as the first priority screen.</p>	<p>.... Subsequently press the <b>[SHIFT]</b> key to call another monitor screen.</p>

1

2

**CAUTION**

1. The selective monitor screen is not yet the first priority screen in the above step 4) when the **[READ]** key was pressed. Hence, the selected item is erased from memory as soon as the power is switched off or another operation mode (such as external operation) is selected. In this case, the item must be selected again in the above procedure. When you press the **[WRITE]** key to select the first priority screen, the selected item is stored in memory.
2. In step 5) where the **[WRITE]** key was pressed in the above setting example, the "output current peak" selected here is first displayed with priority when the other operation peak mode is switched to the monitoring mode. To give first priority to another monitor screen, press the **[WRITE]** key with that monitor screen being displayed. (Refer to page 10.)

3

4

5

## FUNCTIONS

- When "load meter", "motor exciting current", "motor load ratio", "position pulse", "cumulative operation time", "actual operation time", "torque command", "torque current command" or "motor output" monitor screen is selected
- When the "load meter", "motor exciting current" or "motor load ratio" is selected by Pr. 52, the output current monitor screen is switched to either of these monitor screens selected. When the "position pulse", "cumulative operation time", "actual operation time", "torque command", "torque current command" or "motor output" is selected by Pr. 52, the output voltage monitor screen is switched to any of these screens selected. Therefore, when any of these nine items is selected, the output current or output voltage monitor screen cannot be used.

### 2.1.5 Using the "PU main display data selection parameter" to change the screen

By setting the Pr. 52 value, you can change the "second" and "third" screen displays from the first priority screen using the **(SHIFT)** key.

#### REMARKS

Refer to the inverter instruction manual (basic) for details of the "PU main display data selection parameter".

	Pr. 52 Setting
Output current monitor	17 (load meter)
	18 (motor exciting current)
	24 (motor load ratio)
Output voltage monitor	19 (position pulse)
	20 (cumulative operation time)
	23 (actual operation time)
	32 (torque command)
	33 (torque current command)
	34 (motor output)

When "load meter" "motor exciting current" or "motor load ratio" monitor is selected, this screen is switched to the selected screen.

When "position pulse" "cumulative operation time" "actual operation time" "torque command" "torque current command" or "motor output" monitor is selected, this screen is switched to the selected screen.

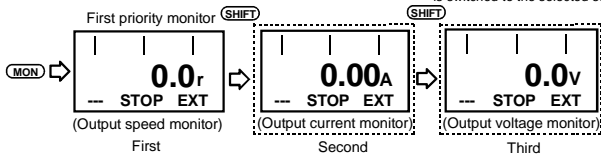

## 2.2 Frequency Setting

Make this setting in the PU operation mode.

### REMARKS

The external start signal (STF or STR) must not be ON to switch from external operation mode to PU operation mode.

### 2.2.1 Direct setting

- Operation procedure (Changing from 0r/min setting to 1500r/min setting)

1) Press the <b>PU</b> key. ....The speed setting screen appears.	<div style="border: 1px solid black; padding: 5px; text-align: center;"> <p><b>DIRECTLY</b></p> <p>Set            0.0r</p> <p>↓</p> </div>
2) Press the <b>1</b> <b>5</b> <b>0</b> <b>0</b> keys. ....Enter 1500r/min. (Remarks)	<div style="border: 1px solid black; padding: 5px; text-align: center;"> <p><b>DIRECTLY</b></p> <p>Set            0.0r</p> <p>↓                1500.0r</p> </div>
3) Press the <b>WRITE</b> key. ....Register the 1500r/min setting. (Setting complete)	<div style="border: 1px solid black; padding: 5px; text-align: center;"> <p><b>DIRECTLY</b></p> <p style="background-color: black; color: white; padding: 2px;"><b>1500.0r</b></p> <p><b>Completed</b></p> </div>

1

### REMARKS

If you entered an incorrect value, press the **ESC** key to return to the pre-entry state.

2

3

4

5

## FUNCTIONS

### 2.2.2 Step setting

1) Press the <b>PU</b> key. ....The speed setting screen appears.	<b>DIRECTLY</b> Set 0.0r ↓
2) Press the <b>▲/▼</b> key to enter any value (1500r/min). (Remarks) You can set any value between the maximum speed (Pr. 1) and minimum speed (Pr. 2).	<b>DIRECTLY</b> Set 0.0r ↓ 1500.0r
3) Press the <b>WRITE</b> key. ....Register the 1500r/min setting. (Setting complete)	<b>DIRECTLY</b> <b>1500.0r</b> Completed

#### REMARKS

During operation, you can also make the step setting to change the running speed. If you operate the **▲/▼** key in the monitor mode, however, the speed will not stop when you release the key but will further increase (or decrease). (Since the **▲/▼** key is used to vary the preset speed, the varied speed will differ from the output speed.)

### 2.2.3 Precautions for speed setting

- 1) Pr. 79 "operation mode selection" must have been set to make the "PU operation mode" valid.
- 2) In the monitor mode, you cannot make the setting directly (refer to page 13) to set the running speed. Perform the step setting (refer to page 14) and press the **WRITE** key, or press the **PU** key to deselect the monitor mode before starting frequency setting.

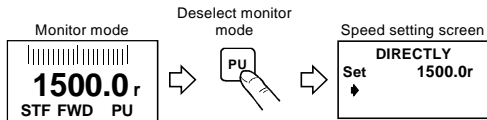

## 2.3 Setting and Changing the Parameter Values

The inverter has a number of parameters. Using the PU, you can choose parameters required for operation and set and/or change their values as appropriate according to the load and running conditions. Set "1" in Pr. 77 "parameter write inhibit selection" to inhibit write.

### REMARKS

Refer to the inverter instruction manual (basic) for details of the parameters.

### 2.3.1 Direct setting

- Operation procedure (Example: Reading and writing the Pr. 8 "deceleration time" value)

1) Press the <b>PU</b> key. ....The speed setting screen appears.	<div style="border: 1px solid black; padding: 5px; text-align: center;"> <b>DIRECTLY</b>            Set 0.0r            ↓         </div>	<b>1</b>
2) Press the <b>SET</b> key. ....The parameter unit enters the parameter setting mode.	<div style="border: 1px solid black; padding: 5px; text-align: center;"> <b>SETTING MODE</b>            Set Pr. NO.            FOR PR List            &lt;HELP&gt;         </div>	<b>2</b>
3) Press the required parameter number <b>8</b> . ....The screen on the right appears.	<div style="border: 1px solid black; padding: 5px; text-align: center;"> <b>SETTING MODE</b>            Pr. NO.            8            &lt;READ&gt;         </div>	<b>3</b>
4) Press the <b>READ</b> key. ....The current setting appears on the display.	<div style="border: 1px solid black; padding: 5px; text-align: center;">           8 Dec. T1            5.0S            ↓         </div>	<b>4</b>
5) Enter the required value ( <b>1 8 0</b> ) (Example: To set to 180 seconds) (Remarks)	<div style="border: 1px solid black; padding: 5px; text-align: center;">           8 Dec. T1            5.0S            ↓            180S         </div>	<b>5</b>
6) Press the <b>WRITE</b> key. ....The setting is stored into memory.	<div style="border: 1px solid black; padding: 5px; text-align: center;">           8 Dec. T1  <b>180.0S</b>            Completed         </div>	
7) Press the <b>SHIFT</b> key to move to the next parameter (Pr. 9) and call the current setting. Then, press the <b>SHIFT</b> key to advance to the next parameter.	<div style="border: 1px solid black; padding: 5px; text-align: center;">           9 Set THM            28.5A            ↓         </div>	

## ***FUNCTIONS***

---

### **REMARKS**

If you entered an incorrect value, press the **(ESC)** key to return to the pre-entry state.

### **POINT**

Set and/or change the parameter values in the PU operation mode. When the PU operation indication is not shown, refer to page 45 and switch to the PU operation mode. Note that the values of some parameters may be set and/or changed in the external operation and combined operation modes. For the parameters whose values can be set and changed, refer to the inverter instruction manual (basic).

In addition to the above procedure, the help function may be used to call the parameter list for setting. For more information, refer to page 27.

## 2.3.2 Step setting

The way to vary the speed continuously using the  $\blacktriangle/\blacktriangledown$  key is shown below.

You can vary the speed while you press the  $\blacktriangle/\blacktriangledown$  key. Since the speed varies slowly at first, this setting can be used for fine adjustment.

- Operation procedure (Example: Reading and writing the Pr. 8 "deceleration time" value)

1) Press the <b>PU</b> key. .... The speed setting screen appears.	<div style="border: 1px solid black; padding: 5px; text-align: center;"> <b>DIRECTLY</b>            Set            0.0r            ◆         </div>	1
2) Press the <b>SET</b> key. .... The parameter unit enters the parameter setting mode.	<div style="border: 1px solid black; padding: 5px; text-align: center;"> <b>SETTING MODE</b>            Set   Pr. NO.            FOR PR List            &lt;HELP&gt;         </div>	2
3) Press the required parameter number <b>8</b> . .... The screen on the right appears.	<div style="border: 1px solid black; padding: 5px; text-align: center;"> <b>SETTING MODE</b>            Pr. NO.                      8            &lt;READ&gt;         </div>	3
4) Press the <b>READ</b> key. .... The current setting appears on the display.	<div style="border: 1px solid black; padding: 5px; text-align: center;"> <b>8            Dec. T1</b>                      <b>5.0S</b>            ◆         </div>	4
5) Press the $\blacktriangle/\blacktriangledown$ key until the required value. (Remarks) .... A new setting appears on the display.	<div style="border: 1px solid black; padding: 5px; text-align: center;"> <b>8            Dec. T1</b>                      5.0S            ◆            <b>180S</b> </div>	5
6) Press the <b>WRITE</b> key. .... The setting is stored into memory.	<div style="border: 1px solid black; padding: 5px; text-align: center;"> <b>8            Dec. T1</b>                      <b>180.0S</b>            Completed         </div>	
7) Press the <b>SHIFT</b> key to move to the next parameter (Pr. 9) and call the current setting. Then, press the <b>SHIFT</b> key to advance to the next parameter.	<div style="border: 1px solid black; padding: 5px; text-align: center;"> <b>9            Set THM</b>                      28.5A            ◆         </div>	

### REMARKS

If you entered an incorrect value, press the **ESC** key to return to the pre-entry state.

## 2.3.3 Precautions for setting write

- Perform write when the inverter is at a stop in the PU operation mode or combined operation mode. Write cannot be performed in the external operation mode. (Read may be performed in any operation mode.) However, some parameters can be accessed for write in the external operation mode or during operation. Refer to the instruction manual (basic) of the inverter used.
- In addition to the above case, setting write cannot be performed when:
  - 1) Parameter write disable (Pr. 77) has been set;
  - 2) The parameter number selected does not exist in the parameter list; or
  - 3) The value entered is outside the setting range.
- When write cannot be performed and an error (X) appears, press the **ESC** key and make setting once more.

(Example: For Pr. 7 "Acceleration time")

7 Acc. T1 Setting Error E20000S <ESC>
--

## 2.4 Calibration of the Meter (Speed Meter)

### 2.4.1 Calibration of DA1 and DA2 terminals

#### REMARKS

Refer to the inverter instruction manual (basic) for details of the parameters and meter.

The following are the ways to calibrate the full-scale deflection of the meters connected to terminals DA1 and DA2 using the parameter unit.

#### 1) Calibration of DA1 terminal

- Connect a meter (speed meter) across terminals DA1-5 of the inverter. (Note the polarity. DA1 is positive.)
- If a calibration resistor is already connected, make adjustment to "zero" the resistance value or remove the calibration resistor.
- Set Pr. 54.

When you have selected the speed, inverter output current or like as an output signal, preset in Pr. 55 or Pr. 56 the speed or current value at which the output signal will be 1500r/min.

At this 1500r/min or the rated current, the meter normally deflects to full-scale.

#### 2) Calibration of DA2 terminal

- Connect a 0-10VDC meter (speed meter) across terminals DA2-5 of the inverter. (Note the polarity. DA2 is positive.)
- Set Pr. 158.

When you have selected the speed, inverter output current or like as an output signal, preset in Pr. 55 or Pr. 56 the speed or current value at which the output signal will be 10V.



- (1) Calibration procedure 1 (when calibration is performed at 1500r/min running speed)
- Calibration of DA1 terminal (DA2 terminal can also be calibrated in the similar manner.)

Parameters

Pr.900	"DA1 terminal calibration"
Pr.901	"DA2 terminal calibration"
Pr.54	"DA1 terminal function selection"
Pr.158	"DA2 terminal function selection"
Pr.55	"speed monitoring reference"
Pr.56	"current monitoring reference"

1) Press the <b>SET</b> key in the PU operation mode.	..... The parameter unit is placed in the parameter setting mode.	<b>SETTING MODE</b> Set Pr. NO. FOR PR. List <HELP>
2) Type <b>900</b> ( <b>901</b> ) with the number keys and press the <b>READ</b> key.	..... The preset speed is displayed.	<b>900 D/A1 Tune</b> RUN Inverter Set 0.0r PU
3) Type <b>1500</b> with the number keys and press the <b>WRITE</b> key.	..... The screen changes as shown on the right.	<b>900 D/A1 Tune</b> RUN Inverter Set 1500.0r PU
4) Press the <b>FWD</b> key to start forward rotation at 1500r/min. You need not connect the motor.		<b>900 D/A1 Tune</b> Mnt rS Inverter Set 1500.0r ⬇ ⬆ <WRITE>PU
5) Using the <b>▲/▼</b> key, adjust the meter pointer to a predetermined position.	..... The meter pointer moves. (Depending on the setting, the needle may not move immediately.)	
6) Press the <b>WRITE</b> key.	..... Calibration is complete.	<b>900 D/A1 Tune</b> Completed <MONITOR>

Press the **MON** key to return to the main monitor screen.

1

2

3

4

5

## FUNCTIONS

### (2) Calibration procedure 2 (for output current)

- Calibration of DA1 terminal (DA2 terminal can also be calibrated in the similar manner.)

To output the output current or another item which cannot easily achieve a 100% value if operation is performed, adjust the reference voltage output (when the Pr. 54 "DA1 terminal function selection" (Pr. 158 "DA2 terminal function selection" setting is "21"), then select any of the choices displayed.

Setting of reference voltage output	1) Press the <b>SET</b> key in the PU operation mode.	.....The parameter unit is placed in the parameter setting mode.	<div style="border: 1px solid black; padding: 5px;"> <b>SETTING MODE</b>            Set Pr. NO.            FOR PR. List            &lt;HELP&gt;         </div>
	2) Type <b>5</b> <b>4</b> ( <b>1</b> <b>5</b> <b>8</b> ) with the number keys and press the <b>READ</b> key.	.....The current Pr. 54 (Pr. 158) setting appears.	<div style="border: 1px solid black; padding: 5px;">           54 Set D/A1              1            ◆         </div>
	3) Type <b>2</b> <b>1</b> with the number keys and press the <b>WRITE</b> key.	.....The setting of reference voltage output is complete.	<div style="border: 1px solid black; padding: 5px;">           54 Set D/A1              1              21            ◆            Completed         </div>
	4) Press the <b>SET</b> key.	.....The parameter unit is put in the parameter setting mode.	<div style="border: 1px solid black; padding: 5px;"> <b>SETTING MODE</b>            Set Pr. NO.            FOR PR. List            &lt;HELP&gt;         </div>
	5) Type <b>9</b> <b>0</b> ( <b>0</b> ( <b>9</b> <b>0</b> <b>1</b> )) with the number keys and press the <b>READ</b> key.	.....The current Pr. 901 (Pr. 901) setting appears.	<div style="border: 1px solid black; padding: 5px;"> <b>900 D/A1 Tune</b>  <b>RUN Inverter</b>            Set 0.0r            PU         </div>

Setting of reference voltage output

6) Type <b>(1)(5)</b> <b>(0)(0)</b> with the number keys and press the <b>WRITE</b> key.	.....The setting of maximum running speed is complete.	<div style="border: 1px solid black; padding: 5px; text-align: center;"> <b>900 D/A1 Tune              RUN Inverter              Set <math>\blacktriangledown</math> 1500.0r              PU</b> </div>
7) Press the <b>FWD</b> key.	.....Forward rota- tion is per- formed at 1500r/min. You need not connect the motor to make adjustment.	
8) Using the <b>(▲)</b> or <b>(▼)</b> key, adjust the voltage across termi- nals DA1-5 and press the <b>WRITE</b> key.	.....Setting is com- plete.	<div style="border: 1px solid black; padding: 5px; text-align: center;"> <b>900 D/A1 Tune              Completed              &lt;MONITOR&gt;</b> </div>
9) Press the <b>(SET)</b> key.	.....The param- eter unit is put in the param- eter setting mode.	<div style="border: 1px solid black; padding: 5px; text-align: center;"> <b>SETTING MODE              Set Pr. NO.              FOR PR. List              &lt;HELP&gt;</b> </div>
10) Type <b>(5)(4)</b> <b>(1)(5)(8)</b> with the number keys and press the <b>READ</b> key.	.....The current Pr. 54 (Pr. 158) setting appears.	<div style="border: 1px solid black; padding: 5px; text-align: center;"> <b>54 Set D/A1              21</b>  <math>\blacktriangledown</math> </div>
11) Type <b>(2)</b> with the number keys and press the <b>WRITE</b> key.	.....The setting of output current is complete.	<div style="border: 1px solid black; padding: 5px; text-align: center;"> <b>54 Set D/A1              2</b>  <math>\blacktriangledown</math>  <b>Completed</b> </div>

Setting of output current

.....The output voltage  
 displayed is the value  
 at 100% output.  
 This voltage is not  
 stored if you do not  
 press the **WRITE** key.

1

2

3

4

5

.....The current set in Pr.  
 56 "current monitor-  
 ing reference" is at  
 100% value and the  
 output at this point is  
 the voltage.

## FUNCTIONS

### 2.5 Adjustment of the frequency setting signals "bias" and "gain"

#### REMARKS

Refer to the inverter instruction manual (basic) for details of the functions.

#### 2.5.1 Adjustment procedure

There are three ways to adjust the bias and gain of the frequency setting voltage (current).

- (1) Not adjusting bias voltage
- (2) Adjusting any point with application of voltage across terminals 2-5
- (3) Adjusting any point without application of voltage across terminals 2-5

#### Parameters

Pr.902	"speed setting No. 2 bias"
Pr.903	"speed setting No. 2 gain"
Pr.904	"torque command No. 3 bias"
Pr.905	"torque command No. 3 gain"
Pr.917	"No.1 terminal bias"
Pr.918	"No.1 terminal gain"
Pr.919	"No.1 terminal bias (torque/magnetic flux)"
Pr.920	"No.1 terminal gain (torque/magnetic flux)"

- Adjustment of Pr. 903 "speed setting No. 2 gain" (Pr. 902 to Pr. 905 can also be adjusted in the similar manner.)

- (1) Read Pr. 903 to display the currently set gain speed.

1) Press the <b>PU</b> key. .... The speed setting screen appears.	<b>DIRECTLY</b> Set 0.0r ↓
2) Press the <b>SET</b> key. .... The parameter unit is put in the parameter setting mode.	<b>SETTING MODE</b> Set Pr. NO. FOR PR. List <HELP>
3) Type <b>903</b> with the number keys.	<b>SETTING MODE</b> Pr. NO. 903 <READ>
4) Press the <b>READ</b> key. .... The current Pr. 903 setting appears.	903 Extgain2 ↓ 0r Set ↓ <WRITE> EXT ↓ <READ>

- Not adjusting bias voltage → To (2)-1)
- Adjusting any point with application of voltage across terminals 2-5 → To (2)-2)
- Adjusting any point without application of voltage across terminals 2-5 → To (2)-3)

## (2)-1) Setting of frequency setting No. 2 gain

1) Type <b>①⑦⑦⑦</b> with the number keys.	<div style="border: 1px solid black; padding: 5px;"> <b>903 Extgain2</b>            ↓ <b>1000r</b>            Set ↓ &lt;WRITE&gt;            EXT ↓ &lt;READ&gt;         </div>
2) Press the <b>WRITE</b> key. .... The set value is stored into memory and gain setting is complete.	<div style="border: 1px solid black; padding: 5px;"> <b>903 Extgain2</b>  <div style="background-color: black; color: white; display: inline-block; padding: 2px 10px;"><b>1000r</b></div>  <b>Completed</b> </div>

.....Voltage need not be applied across terminals 2-5. At this time, set the gain on the assumption that the 10V in the inverter is the set voltage.

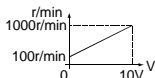

Adjustment of the speed setting No. 2 gain is completed.

## (2)-2) Adjusting any point with application of voltage across terminals 2-5

1) Press the <b>READ</b> key. .... The current Pr. 903 setting appears.	<div style="border: 1px solid black; padding: 5px;"> <b>903 Extgain2</b>            ↓ <b>1500r</b>            EXT <b>99.0%</b> </div>
2) Type <b>①⑦⑦⑦</b> with the number keys.	<div style="border: 1px solid black; padding: 5px;"> <b>903 Extgain2</b>            ↓ <b>1500r</b>            EXT <b>99.0%</b> </div>
3) Press the <b>WRITE</b> key. .... The cursor (▶) moves to the set voltage.	<div style="border: 1px solid black; padding: 5px;"> <b>903 Extgain2</b>            ↓ <b>1000r</b>            EXT <b>99.0%</b> </div>
4) Apply a 10V voltage.	<div style="border: 1px solid black; padding: 5px;"> <b>903 Extgain2</b>            ↓ <b>1000r</b>            EXT <b>99.6%</b> </div>
5) Press the <b>WRITE</b> key. .... The set value is stored into memory and gain setting is complete.	<div style="border: 1px solid black; padding: 5px;"> <b>903 Extgain2</b>            ↓ <b>1000r</b>            EXT <b>99.6%</b>  <b>Completed</b> </div>

← The previous setting is displayed.

← The current set voltage across terminals 2-5 is displayed in %. When the set voltage is changed, the % value also changes.

← Set the voltage across terminals 2-5 to achieve 100%.

.....In this example, 10V is applied as 1000r/min is set for 10V input.

← Setting is completed as shown below: The value displayed may not be just 100.0% in some cases.

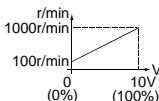

Adjustment of the speed setting No. 2 gain is completed.

1

2

3

4

5

## FUNCTIONS

### (2)-3) Adjusting any point without application of voltage across terminals 2-5

1) Press the <b>RECALL</b> key. .... The current Pr. 903 setting appears.	<div style="border: 1px solid black; padding: 5px;"> <p>903 Extgain2</p> <p>◆ 1500r</p> <p>97.1%</p> <p>EXT 99.0%</p> </div>	<p>← The previous setting is displayed.</p> <p>← The current set voltage across terminals 2-5 is displayed in %.</p> <p>When the set voltage is changed, the % value also changes.</p>
2) Type <b>1 0 0 0</b> with the number keys. .... The screen changes as shown on the right.	<div style="border: 1px solid black; padding: 5px;"> <p>903 Extgain2</p> <p>◆ 1000r</p> <p>97.1%</p> <p>EXT 99.0%</p> </div>	
3) Press the <b>WRITE</b> key. .... The cursor (◆) moves to the set voltage.	<div style="border: 1px solid black; padding: 5px;"> <p>903 Extgain2</p> <p>◆ 1000r</p> <p>97.1%</p> <p>EXT 99.0%</p> </div>	..... Voltage need not be applied across terminals 2-5.
4) Type <b>1 0 0</b> with the number keys. .... In this example, 100% is input as 1000r/min is set for 10V (100%).	<div style="border: 1px solid black; padding: 5px;"> <p>903 Extgain2</p> <p>◆ - 1000r</p> <p>100%</p> <p>EXT 99.0%</p> </div>	
5) Press the <b>WRITE</b> key. .... The set value is stored into memory and gain setting is complete.	<div style="border: 1px solid black; padding: 5px;"> <p>903 Extgain2</p> <p>1000r</p> <p>100%</p> <p>Completed</p> </div>	← Setting is completed as shown below:

Adjustment of the speed setting No. 2 gain is completed.

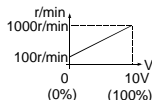

### CAUTION

1. Changing the Pr. 903 and/or Pr. 905 setting will not change the Pr. 20 "acceleration/deceleration reference speed" value.
2. If the calibration (command) value set in Pr. 902, Pr. 903, Pr. 904 or Pr. 905 is close to the corresponding value, a "command error" will occur and that value cannot be written.

## 2.6 Copy and Verify Functions

### 2.6.1 Copying the parameter settings

You can read and store parameter settings into the FR-PU04V. You can also copy the stored parameter settings to another inverter of the same series and same capacity.

<Precautions for setting>

- Select the PU operation mode.
- Use these functions after stopping the inverter.
- Parameter values cannot be copied when you have set "1" in Pr. 77 "parameter write inhibit selection" of the copy destination inverter to inhibit parameter write.
- Copy/verify cannot be performed between different inverter series.
- Reading the parameter settings.

1) Connect the FR-PU04V to the inverter. 2) Press the <b>SET</b> key. .... This selects the setting mode.	<b>SETTING MODE</b> Set Pr. NO Pr. List ↕ HELP Pr. COPY ↕ ▲	<b>1</b>
3) Press the <b>▲</b> key. .... The parameter unit enters the ROM batch mode.	<b>ALL Pr. S</b> READ ↕ <READ> WRITE ↕ <WRITE> VER ↕ ▼	
4) Press the <b>READ</b> key. .... The inverter's parameter settings are stored.	<b>ALL Pr. S</b> <b>Reading Completed</b>	<b>2</b>

- Writing the parameter settings

1) Connect the FR-PU04V to the inverter. 2) Press the <b>SET</b> key. .... This selects the setting mode.	<b>SETTING MODE</b> Set Pr. NO Pr. List ↕ HELP Pr. COPY ↕ ▲	<b>3</b>
3) Press the <b>▲</b> key. .... The parameter unit goes into the ROM batch mode.	<b>ALL Pr. S</b> READ ↕ <READ> WRITE ↕ <WRITE> VER ↕ ▼	<b>4</b>
4) Press the <b>WRITE</b> key. .... The parameter settings stored in the FR-PU04V are copied to the copy destination inverter.	<b>ALL Pr. S</b> <b>Writing Completed</b> <b>Please Reset</b>	<b>5</b>
5) Reset the inverter.		

## FUNCTIONS

### CAUTION

1. Please reset the inverter after copying the parameter.
2. Note that all data stored in the parameter unit is updated when read is performed from the inverter.
3. Write cannot be performed while the inverter is running. Read and verify can be performed during running.
4. Read and write cannot be stopped partway through the operation.
5. If power is switched off, parameter data stored in the parameter unit remains unerasd. Therefore, a backup power supply is not needed.
6. Exercise care not to switch power off while parameters are being written.

### 2.6.2 Verifying the parameters

- Verify

1) Connect the FR-PU04V to the inverter. 2) Press the <b>SET</b> key. .... This selects the setting mode.	<b>SETTING MODE</b> Set Pr. NO Pr. List $\blacktriangledown$ HELP Pr. COPY $\blacktriangledown$
3) Press the  key. .... The parameter unit enters the ROM batch mode.	<b>ALL Pr.S</b> READ $\blacktriangledown$ <READ> WRITE $\blacktriangledown$ <WRITE> VER $\blacktriangledown$
4) Press the  key. .... The parameter settings stored in the FR-PU04V are verified with those of the inverter.  (If an error is detected during verify, the corresponding Pr. is shown. However, if an incorrect value has been entered directly only "Verify Err" will be displayed.)	<b>ALL Pr. S</b>  <b>Verifying Completed</b>

Press the key when you want to continue verify with "Verify Err" displayed.



# 3

# HELP

This chapter explains the **HELP** key in the use of this product. Always read the instructions before using the equipment.

3.1	Overview of the Help Functions .....	28
3.2	Operation Procedures for the Help Functions.....	31
3.3	Other Precautions .....	43

1

2

3

4

5

## 3.1 Overview of the Help Functions

Press the (HELP) key twice in any operation mode to call the help function menu, on which you can perform various functions.

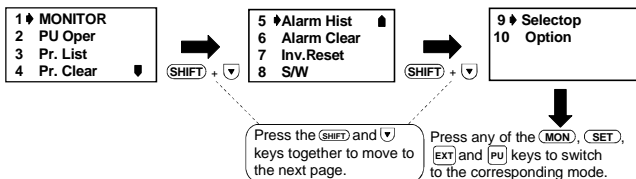

### 3.1.1 Help function menu

Help Menu	Description	Refer To
1. MONITOR	The monitor list appears, and you can change from one screen to another and set the first priority screen.	Page 31
2. PU Oper	You can select the PU operation mode via direct input (direct setting with the number keys) or select the jog operation mode from the PU, and displays how to operate the keys.	Page 33
3. Pr. List	The parameter menu appears, and you can perform "parameter setting", "list display", "change list display" and "initial value list display".	Page 35
4. Pr. Clear	The parameter clear menu appears, and you can perform "parameter clear", "all clear" and "no clear".	Page 38
5. Alarm Hist	Shows the history of past faults (alarms).	Page 39
6. Alarm Clear	Clears all the fault (alarm) history.	Page 40
7. Inv. Reset	Resets the inverter.	Page 41
8. S/W	Shows the software control number of the inverter.	--
9. Selectop	Shows the signals assigned to the I/O terminals of the control circuit and the ON-OFF states of the signals.	Page 42
10. Option	Shows the option fitting states of the option connectors 1 to 3.	Page 42

### 3.1.2 Help function display data

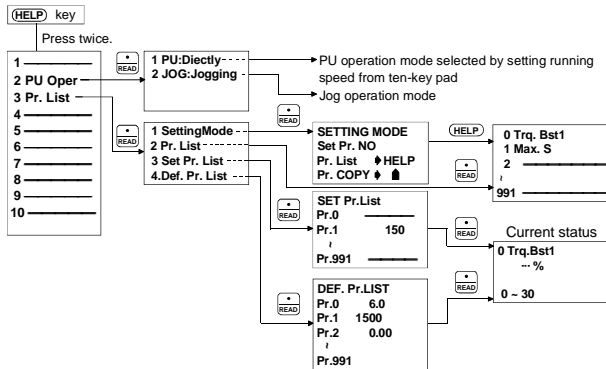
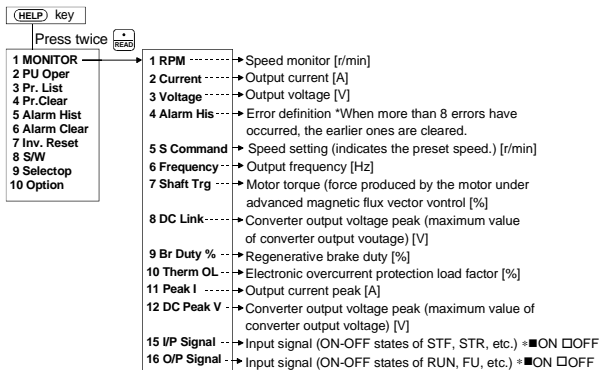

1

2

3

4

5













## 3.2 Operation Procedures for the Help Functions

### 3.2.1 Monitor function

The monitoring list appears and you can change from one monitor screen to another and set the first priority screen.

- To call the monitoring list from the help function menu

1) Press the <b>HELP</b> key twice in the monitoring mode. .... The help function menu is called.	<div style="border: 1px solid black; padding: 5px;">           1 <b>MONITOR</b>            2 PU Oper            3 Pr. List            4 Pr. Clear  </div>
2) Make sure that the cursor (  ) is located at "1 MONITOR". ....If not, move the cursor with the  /  key.	<div style="border: 1px solid black; padding: 5px;">           1 <b>MONITOR</b>            2 PU Oper            3 Pr. List            4 Pr. Clear  </div>
3) Press the <b>READ</b> key. .... The monitoring list is called.	<div style="border: 1px solid black; padding: 5px;">           1 <b>RPM</b>            2 Current            3 Voltage            4 Alarm His </div>
4) Press the  or  key to move the cursor to the required item. Note: If the required item is not found, press the <b>SHIFT</b> key and  key together to shift to the next page.	<div style="border: 1px solid black; padding: 5px;">           1 RPM            2 <b>Current</b>            3 Voltage            4 Alarm His </div>
5) Press the <b>READ</b> key. .... The monitor screen indicated by the cursor appears. Press the <b>WRITE</b> key to give the first priority to this monitor screen.	<div style="border: 1px solid black; padding: 5px; text-align: center;">                            <b>0.00A</b>            --- STOP PU         </div>

1

2



3

4

5

## HELP

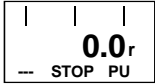
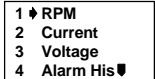
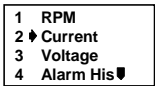
- To call the monitoring list directly in the monitoring mode

1) Press the <b>(MON)</b> key. (CAUTION) ..... The parameter unit is put in the monitoring mode.	 <p>0.0<sub>r</sub> --- STOP PU</p>
2) Press the <b>(HELP)</b> key. .... The monitoring list is called.	 <p>1 <b>↕</b> RPM 2 <b>Current</b> 3 <b>Voltage</b> 4 <b>Alarm His</b> <b>↓</b></p>
3) Press the <b>(▲)</b> or <b>(▼)</b> key to move the cursor to the required item. Note: If the required item is not found, press the <b>(SHIFT)</b> key and <b>(▼)</b> key together to shift to the next page.	 <p>1 RPM 2 <b>↕</b> <b>Current</b> 3 <b>Voltage</b> 4 <b>Alarm His</b> <b>↓</b></p>
4) Press the <b>(READ)</b> key. .... The monitor screen indicated by the cursor appears. Press the <b>(WRITE)</b> key to give the first priority to this monitor screen.	 <p>0.00<sub>A</sub> --- STOP PU</p>

### CAUTION

You need not press this key when the parameter unit is already in the monitoring mode.

### 3.2.2 Selection of PU operation (direct input)

You can select the PU operation mode via direct input (direct setting from the ten digits key pad) or select the jog operation mode from the PU and show how to operate the keys.

- Calling from the help function menu

1) Press the <b>(HELP)</b> key twice in the monitoring mode. ....The help function menu is called.	<div style="border: 1px solid black; padding: 5px;">           1 <b>MONITOR</b>            2 <b>PU Oper</b>            3 <b>Pr. List</b>            4 <b>Pr. Clear</b> ▾         </div>
2) Using the <b>(▼)</b> key, move the cursor to "2 PU Operation".	<div style="border: 1px solid black; padding: 5px;">           1 <b>MONITOR</b>            2 <b>PU Oper</b>            3 <b>Pr. List</b>            4 <b>Pr. Clear</b> ▾         </div>
3) Press the <b>(READ)</b> key. ....The menu on the right appears.	<div style="border: 1px solid black; padding: 5px;">           1 <b>PU : Directly</b>            2 <b>JOG : Jogging</b> </div>
4) Make sure that the cursor is located at "1 PU: Directly". ....If not, move the cursor with the <b>(▲/▼)</b> key.	<div style="border: 1px solid black; padding: 5px;">           1 <b>PU : Directly</b>            2 <b>JOG : Jogging</b> </div>
5) Press the <b>(READ)</b> key. ....The PU operation mode is selected and the speed setting screen appears.	<div style="border: 1px solid black; padding: 5px;"> <b>DIRECTLY</b>            Set                    0.0r            ◆         </div>
6) Press the <b>(HELP)</b> key. ....The key operation guide appears.	<div style="border: 1px solid black; padding: 5px;"> <b>KEY OPERATION</b>            Fset : 0 ~ 9            Then : WRITE            Then : FWD,REV         </div>

- To call the key operation guide directly

1) Press the <b>(PU)</b> key. ....The speed setting screen appears.	<div style="border: 1px solid black; padding: 5px;"> <b>DIRECTLY</b>  <b>SET</b>                    0.0r            ◆         </div>
2) Press the <b>(HELP)</b> key. ....The key operation guide appears.	<div style="border: 1px solid black; padding: 5px;"> <b>KEY OPERATION</b>            Fset : 0 ~ 9            Then : WRITE            Then : FWD,REV         </div>

## 3.2.3 Selection of the PU jog operation mode

### (1) Calling from the help function menu

<p>1) Press the <b>(HELP)</b> key twice in the monitoring mode. ....The help function menu is called.</p>	<pre> 1 ↕ MONITOR 2 PU Oper 3 Pr. List 4 Pr. Clear ▾                     </pre>
<p>2) Using the <b>(▼)</b> key, move the cursor to "2 PU Operation".</p>	<pre> 1 MONITOR 2 ↕ PU Oper 3 Pr. List 4 Pr. Clear ▾                     </pre>
<p>3) Press the <b>(READ)</b> key. ....The menu on the right appears.</p>	<pre> 1 ↕ PU : Directly 2 JOG : Jogging                     </pre>
<p>4) Using the <b>(▼)</b> key, move the cursor to "2 JOG: Jogging".</p>	<pre> 1 PU : Directly 2 ↕ JOG : Jogging                     </pre>
<p>5) Press the <b>(READ)</b> key. ....The PU jog operation mode is selected and the speed setting screen appears.</p>	<pre>           PU/JOG Set      500.0r ↕                     </pre>
<p>6) Press the <b>(HELP)</b> key. ....The key operation guide is displayed.</p>	<pre> KEY OPERATION Fset : 0 ~ 9 Then : WRITE Then : FWD,REV                     </pre>

### (2) Calling the key operation guide directly

<p>1) Press the <b>(PU)</b> key. ....The speed setting screen appears.</p>	<pre> DIRECTLY Set      0.0r ↕                     </pre>
<p>2) Press the <b>(SHIFT)</b> key. ....The PU jog operation mode is selected and the speed setting screen appears.</p>	<pre>           PU/JOG Set      500.0r ↕                     </pre>
<p>3) Press the <b>(HELP)</b> key. ....The key operation guide appears.</p>	<pre> KEY OPERATION Fset : 0 ~ 9 Then : WRITE Then : FWD,REV                     </pre>



### 3.2.4 Parameters

The parameter menu is displayed and you can select and perform any of the following operations:

- (1) Setting:..... Switches to the parameter setting mode.
- (2) Pr. List:..... Lists the parameters in numerical order so that you can read and write individual parameter values.
- (3) Set Pr. List:..... Lists only the parameters whose factory settings have been changed, together with their Pr. numbers. (For parameters whose factory settings remain unchanged, their Pr. numbers are only displayed.)
- (4) Def. Pr. List: ..... Lists the initial values (default factory settings) of parameters.

#### (1) Parameter "Setting"

1) Press the <b>HELP</b> key twice in the monitoring mode. ....The help function menu is called.	<div style="border: 1px solid black; padding: 5px;">             1 <b>MONITOR</b>              2 <b>PU Oper</b>              3 <b>Pr. List</b>              4 <b>Pr. Clear</b> </div>
2) Using the <b>▼</b> key, move the cursor to "3 Pr. List".	<div style="border: 1px solid black; padding: 5px;">             1 <b>MONITOR</b>              2 <b>PU Oper</b>              3 <b>Pr. List</b>              4 <b>Pr. Clear</b> </div>
3) Press the <b>READ</b> key. ....The parameter menu appears.	<div style="border: 1px solid black; padding: 5px;">             1 <b>SettingMode</b>              2 <b>Pr. List</b>              3 <b>Set Pr.List</b>              4 <b>Def. Pr. List</b> </div>
4) Press the <b>READ</b> key. ....The parameter unit switches to the setting mode. Refer to the parameter setting method on page 13.	<div style="border: 1px solid black; padding: 5px;"> <b>Setting Mode</b>  <b>Set Pr. NO</b>  <b>FOR Pr. List</b>  <b>&lt;HELP&gt;</b> </div>

1







2

3

4

5

## (2) "2 Pr. List"

1) Refer to page 35 and call the parameter menu.	<div style="border: 1px solid black; padding: 5px;"> <p>1 <b>◆</b> SettingMode                  2 Pr.List                  3 Set Pr. List                  4 Def. Pr. List</p> </div>
2) Using the  key, move the cursor to "2 Pr. List".	<div style="border: 1px solid black; padding: 5px;"> <p>1 SettingMode                  2 <b>◆</b> Pr. List                  3 Set Pr. List                  4 Def. Pr. List</p> </div>
3) Press the  key. ....The parameter list is displayed.	<div style="border: 1px solid black; padding: 5px;"> <p>0 <b>◆</b> Trq. Bst1                  1 Max. S                  2 Min. S                  3 VFbaseF1</p> </div>
4) Press the  or  key to move the cursor to the required item.	<div style="border: 1px solid black; padding: 5px;"> <p>0 <b>◆</b> Trq. Bst1                  1 Max. S                  2 Min. S                  3 VFbaseF1</p> </div>
5) If the required item is not found, press the  key and  key together to shift to the next page.	
6) Press the  key. ....The parameter indicated by the cursor is read and the parameter unit enters the parameter setting mode.	<div style="border: 1px solid black; padding: 5px;"> <p>0 Trq. Bst1                  6.0%                  ◆</p> </div>

Press the  key to move to the next parameter.

## (3) Display of "3 Set Pr. List"



- When the parameter setting has been changed from the factory setting, the new value is displayed.

"-" is displayed when the parameter setting has not been changed from the factory setting.

The parameters are displayed in numerical order, starting with No. 0.

## (4) Display of "4 Def. Pr. List"

The factory settings of the parameters are displayed.

1) Refer to page 35 and call the parameter menu.	<pre> 1 # SettingMode 2 Pr. List 3 Set Pr. List 4 Def. Pr. List           </pre>
2) Using the  key, move the cursor to "3 Set Pr. List".	<pre> 1 SettingMode 2 Pr. List 3 # Set Pr. List 4 Def. Pr. List           </pre>
3) Press the  key. ....The SET Pr. LIST appears. (CAUTION)	<pre> Set Pr. List Pr 0 # 8.0 Pr 1 - Pr 2 -           </pre>

To call the Def. Pr. List or Def. Pr. List 2, move the cursor to "4 Def. Pr. List" in above step 2.

**CAUTION**

Press the  key and  key together to move to the next page.

1

2

3

4

5

## 3.2.5 Parameter Clear

The parameter clear menu appears and you can select and perform any of the following three operations:

Switch to the PU operation mode before performing any operation.

- Clear Pr.: ..... Initializes the parameter settings to the factory settings. (Some parameters are not initialized.)
- Clear All: ..... Initializes the parameter settings and calibration values to the factory settings. (Some parameters are not initialized.)
- Clear None: ..... Does not initialize.

### CAUTION

**For details of the parameters not cleared by executing Pr. clear or All clear, refer to the inverter instruction manual (basic).**

- Parameter clear

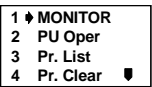
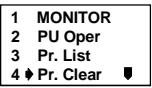
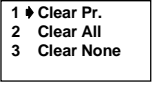
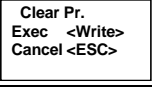
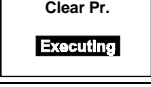
1) Press the <b>HELP</b> key twice in the operation mode. ....The help function menu is called.	
2) Using the <b>▼</b> key, move the cursor to "4 Pr. Clear".	
3) Press the <b>READ</b> key. ....The parameter clear menu appears.	
4) Press the <b>WRITE</b> key. ....The screen changes as shown on the right.	
5) Press the <b>WRITE</b> key. ....The screen changes as shown on the right and the parameters are initialized. (Note)	

To execute Clear All, move the cursor to "2 Clear All" in above step 3.

### CAUTION

**When you press the **ESC** key, the clear operation is not performed.**

### 3.2.6 Alarm History

Shows the history of eight past alarms.

1) Press the <b>HELP</b> key twice in the operation mode.	.....The help function menu is called.	<div style="border: 1px solid black; padding: 5px;">           1 <b>MONITOR</b>            2 <b>PU Oper</b>            3 <b>Pr. List</b>            4 <b>Pr. Clear</b> ▾         </div>
2) Press the <b>SHIFT</b> key and <b>▼</b> key together.	.....The screen moves to the next page.	<div style="border: 1px solid black; padding: 5px;">           5 <b>Alarm Hist</b> ▲            6 <b>AlarmClear</b>            7 <b>Inv. Reset</b>            8 <b>S/W</b> </div>
3) Make sure that the cursor is located at "5 Alarm Hist".	.....If not, move the cursor with the <b>▲/▼</b> key.	<div style="border: 1px solid black; padding: 5px;">           5 <b>Alarm Hist</b> ▲            6 <b>AlarmClear</b>            7 <b>Inv. Reset</b>            8 <b>S/W</b> </div>
4) Press the <b>READ</b> key.	.....The alarm history appears.	<div style="border: 1px solid black; padding: 5px;">           1 OV3 5 UVT            2 UVT 6            3 UVT 7            4 UVT 8         </div>
5) Press the <b>READ</b> key.	.....The running speed at alarm occurrence is displayed.	<div style="border: 1px solid black; padding: 5px;"> <b>Latest Error</b>             OV During Dec            1500r ▾         </div>
6) Press the <b>▼</b> key.	.....The voltage/current application time at alarm occurrence is displayed.	<div style="border: 1px solid black; padding: 5px;"> <b>Latest Error</b> ▲            220.0V            17.5A            6000hr         </div>

To display the second or earlier past failure monitor, press the **READ** key in step 5 above.

1

2

3

4

5

**3.2.7 Alarm Clear**

Clears all the alarm history.

<p>1) Press the <b>(HELP)</b> key twice in the operation mode. ....The help function menu is called.</p>	<div style="border: 1px solid black; padding: 5px;"> <p>1 <b>MONITOR</b>            2 <b>PU Oper</b>            3 <b>Pr. List</b>            4 <b>Pr. Clear</b> ▾</p> </div>
<p>2) Press the <b>(SHIFT)</b> key and <b>(▼)</b> key together. ....The screen moves to the next page.</p>	<div style="border: 1px solid black; padding: 5px;"> <p>5 <b>Alarm Hist</b> ▲            6 <b>AlarmClear</b>            7 <b>Inv. Reset</b>            8 <b>S/W</b></p> </div>
<p>3) Using the <b>(▼)</b> key, move the cursor to "6 Alarm Clear".</p>	<div style="border: 1px solid black; padding: 5px;"> <p>5 <b>Alarm Hist</b> ▲            6 <b>AlarmClear</b>            7 <b>Inv. Reset</b>            8 <b>S/W</b></p> </div>
<p>4) Press the <b>(READ)</b> key.</p>	<div style="border: 1px solid black; padding: 5px;"> <p><b>Alarm Clear</b>  <b>Exec &lt;WRITE&gt;</b>  <b>Cancel &lt;ESC&gt;</b></p> </div>
<p>5) Press the <b>(WRITE)</b> key. ....The screen changes as shown on the right and the alarm history is cleared.  <b>(CAUTION)</b></p>	<div style="border: 1px solid black; padding: 5px;"> <p><b>ALARM CLEAR</b></p> <p style="text-align: center;"><b>Completed</b></p> </div>

**CAUTION**

When you press the **(ESC)** key, the alarm history clear operation is not performed.

### 3.2.8 Inverter Reset

Resets the inverter.

1) Press the <b>(HELP)</b> key twice in the operation mode. ....The help function menu is called.	<div style="border: 1px solid black; padding: 5px;">           1 <b>MONITOR</b>            2 <b>PU Oper</b>            3 <b>Pr. List</b>            4 <b>Pr.Clear</b> </div>
2) Press the <b>(SHIFT)</b> key and <b>(▼)</b> key together. ....The screen moves to the next page.	<div style="border: 1px solid black; padding: 5px;">           5 <b>Alarm Hist</b>             6 <b>AlarmClear</b>            7 <b>Inv. Reset</b>            8 <b>S/W</b> </div>
3) Using the <b>(▼)</b> key, move the cursor to "7 Inv. Reset".	<div style="border: 1px solid black; padding: 5px;">           5 <b>Alarm Hist</b>             6 <b>AlarmClear</b>            7 <b>Inv.Reset</b>             8 <b>S/W</b> </div>
4) Press the <b>(READ)</b> key. ....The screen changes as shown on the right.	<div style="border: 1px solid black; padding: 5px;"> <b>Inv. RESET</b>  <b>Exec &lt;WRITE&gt;</b>  <b>Cancel &lt;ESC&gt;</b> </div>
5) Press the <b>(WRITE)</b> key. ....The inverter is reset and the parameter unit switches to the monitoring mode. (CAUTION)	<div style="border: 1px solid black; padding: 5px; text-align: center;"> </div>

#### CAUTION

When you press the **(ESC)** key, the inverter is not reset and the parameter unit switches to the monitoring mode.

A similar reset operation may also be performed by switching power "off" or by switching the RES signal on.

If the inverter's protective function is activated to bring the inverter to an alarm stop (output shutoff), the alarm stop state may be canceled by pressing the **(STOP RESET)** key without performing the above operation.

1

2

3

4

5

## 3.2.9 Selectop

Displays the signals assigned to the I/O terminals of the control circuit and their ON-OFF states.

1) Press the <b>(HELP)</b> key twice in the operation mode. .... The help function menu is called.	<b>1</b> ♦ MONITOR <b>2</b> PU Oper <b>3</b> Pr. List <b>4</b> Pr. Clear ▾
2) Press the <b>(SHIFT)</b> key and <b>(▼)</b> key together twice. .... The screen moves two pages.	<b>9</b> ♦ Selectop ⬆ <b>10</b> Option
3) Make sure that the cursor is located at "9 selectop" .....If not, move the cursor with the <b>(▲)</b> / <b>(▼)</b> key.	<b>9</b> ♦ Selectop ⬆ <b>10</b> Option
4) Press the <b>(READ)</b> key. .... The signals assigned to the control circuit terminals and their ON-OFF states are displayed. (CAUTION)	DI1 : 0 <input checked="" type="checkbox"/> DI2 : 1 <input type="checkbox"/> DI3 : 2 <input type="checkbox"/> DI4 : 3 <input type="checkbox"/> ▾

### CAUTION

The screen shows "- - -" when you set "9999" in Pr. 180 to Pr. 195.

## 3.2.10 Option

Displays what options are fitted to the option connectors 1 to 3.

1) Press the <b>(HELP)</b> key twice in the operation mode. .... The help function menu is called.	<b>1</b> ♦ MONITOR <b>2</b> PU Oper <b>3</b> Pr. List <b>4</b> Pr. Clear ▾
2) Press the <b>(SHIFT)</b> key and <b>(▼)</b> key together twice. .... The screen moves two pages.	<b>9</b> ♦ Selectop ⬆ <b>10</b> Option
3) Using the <b>(▼)</b> key, move the cursor to "11".	<b>9</b> Selectop ⬆ <b>10</b> ♦ Option
4) Press the <b>(READ)</b> key. .... What options are fitted are displayed.	<Option> OP1: ---- OP2: V5AM OP3: ----



### 3.3 Other Precautions

#### 3.3.1 Precautions for parameter unit operation

Note the following items when operating the parameter unit to prevent setting from being disabled or incorrect values from being entered.

- (1) Precautions for the digit count and decimal point of input value
  - The maximum number of input digits is 5. If you enter a value in excess of 5 digits, the most significant digit is ignored.  
12345.6 → ■2345.6  
(Input)    ↑ Ignored
- (2) Other indications
  - When the input power is switched on (or the inverter is reset), the message below will be displayed. It is displayed while the inverter and parameter unit are making communication checks mutually, and is not a fault.  
However, if that message does not disappear in about 1 minute, perform the following check.

**PU to Inverter  
comms. Error  
Inv. Reset O N**

<Check items>

- 1) Check that the reset signal (across terminals RES-SD) is not ON.
- 2) Check that the parameter unit is fitted in the connector properly.
- (3) Power-on indication
  - 1) When you connect the parameter unit and power on the inverter, the initial screen appears. (For about 3 seconds)

**MITSUBISHI**

- 2) When communication with the inverter starts, the monitor mode is established.

1

2

3

4

5

# MEMO

# 4

# OPERATION

This chapter explains the basic "operation" for use of this product. Always read the instructions before using the equipment.

4.1	Operation Modes.....	46
4.2	PU Operation .....	48

1

2

3

4

5

## OPERATION

### 4.1 Operation Modes

#### 4.1.1 How to select the operation mode

- (1) Switching from external operation mode [EXT] to PU operation mode [PU]

##### Confirmation

Make sure that the external input signal (STF, STR) is OFF.

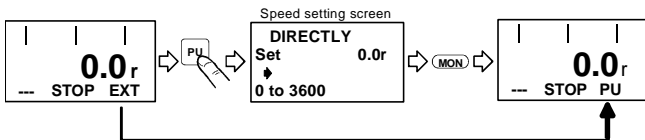

Pressing the **[PU]** key switches to the PU operation mode and changes the operation mode indication to [PU], establishing the PU operation mode.

- (2) Switching from PU operation mode [PU] to external operation mode [EXT]

##### Confirmation

Make sure that the external input signal (STF, STR) is OFF and that the operation command indication is "---".

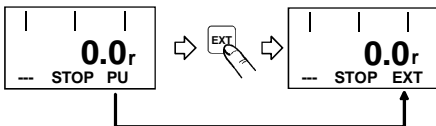

Pressing the **[EXT]** key switches to the external operation mode and changes the operation mode indication to [EXT], establishing the external operation mode.

- (3) Switching to the combined operation mode  
Change the Pr. 79 "operation mode selection" setting as indicated below.  
"PU+E" is displayed in the operation mode indication position.

#### REMARKS

Refer to the inverter instruction manual (basic) for details.

Setting	Description	
	Running frequency setting	Start signal
3	Parameter unit • Direct setting and ▲/▼ key setting External signal input • Multi-speed selection (Pr. 4 to Pr. 6, Pr. 24 to Pr. 27, Pr.232 to Pr.239)	External signal input • Terminal STF • Terminal STR
4	External signal input • 0 to 10VDC across terminal 2 - 5, 0 to ±10VDC across terminals 3(1) - 5 • Multi-speed selection (Pr. 4 to Pr. 6, Pr. 24 to Pr. 27, Pr.232 to Pr.239) • JOG speed setting (Pr. 15)	Parameter unit • <b>FWD</b> key • <b>REV</b> key

## CAUTIONS

If the operation mode cannot be switched properly, check the following:

**1. External input signal (STF or STR signal)**

Make sure that the signal is off. If it is on, the operation mode cannot be switched properly.

**2. Parameter setting**

Confirm the Pr. 79 "operation mode selection" setting. (Refer to page 46 and the inverter instruction manual (basic).)

**3. Limitation of the operation mode**

When Pr. 79 "operation mode selection" setting is other than "0", the operation mode is limited accordingly.

1

2

3

4

5

# OPERATION

## 4.2 PU Operation

### REMARKS

The functions vary with the inverter. (Refer to the inverter instruction manual (basic) for details.)

### 4.2.1 Ordinary operation

You can change speed by repeating the following steps 2 and 3 during motor operation:

Step	Operation Procedure
1	<p>Switch power on, press the <b>PU</b> key, and make sure that the speed setting screen appears on the display. (If it is not shown, switch to the PU operation mode.)</p> <div style="border: 1px solid black; padding: 5px; width: fit-content;"><p style="text-align: center;"><b>DIRECTLY</b></p><p style="text-align: center;">Set            0.0r</p><p style="text-align: center;">↓</p><p style="text-align: center;"><b>0 to 3600r</b></p></div>
2	<p>Set the running speed to 1500r/min.</p> <p>After setting the running speed in either of the following ways, press the <b>WRITE</b> key to enter the running speed:</p> <ul style="list-style-type: none"><li>• Direct setting After pressing the <b>PU</b> key, enter the speed directly with the number keys. Note that this setting is not available in the monitoring mode. In this case, press the <b>PU</b> key to leave the monitoring mode and re-set the speed.</li><li>• Step setting Press the <b>▲/▼</b> key to keep on varying the speed. Hold down the <b>▲</b> (or <b>▼</b>) key to vary the speed. At the beginning, the speed varies slowly and this feature may be used for fine adjustment. Step setting may also be made during inverter operation. However, since the <b>▲/▼</b> key is used to vary the preset speed, the varied speed will differ from the output speed in the monitor mode where the output speed is displayed.</li></ul>
3	<p>Press the <b>FWD</b> or <b>REV</b> key.</p> <p>The motor starts running. The parameter unit automatically enters the monitoring mode and shows the output speed.</p> <div style="border: 1px solid black; padding: 5px; width: fit-content;"><p style="text-align: center;">     </p><p style="text-align: center;"><b>1500.0r</b></p><p style="text-align: center;">STF FWD PU</p></div>
4	<p>Press the <b>STOP/RESET</b> key.</p> <p>The motor is decelerated to a stop.</p> <div style="text-align: center;"></div>

### REMARKS

When performing PU operation to run the motor, pressing the start key (**FWD** or **REV** key) after setting the running speed switches to monitor mode automatically.

## 4.2.2 PU jog operation

Hold down the **FWD** or **REV** key to perform operation, and release it to stop.

- Jog operation cannot be performed in the following cases:
  - During motor operation
  - The jog speed setting (Pr. 15) value is less than the starting speed (Pr. 13) value.

Step	Operation Procedure	
1	Switch to the PU operation mode. If the operation mode indication is not [PU], refer to page 46 and switch to the PU operation mode.	<p style="text-align: center;"><b>DIRECTLY</b></p> <p>Set            0.0r</p> <p>↓</p> <p><b>0 to 3600r</b></p>
2	Set "200" in Pr. 15 "jog speed setting". Pr. 16 "jog acceleration/deceleration time" can also be set. <Factory settings> Pr. 15 "jog speed setting" ..... 150r/min Pr. 16 "jog acceleration/deceleration time" can also be set. ....0.5s	
3	Press the <b>PU</b> key, then the <b>(SHIFT)</b> key. The jog operation mode is selected and the PU JOG speed setting screen appears on the display. To change the speed, enter the value and press the <b>WRITE</b> key.	<p style="text-align: center;"><b>PU/JOG</b></p> <p>Set            200.0r</p> <p>↓</p>
4	Press the <b>FWD</b> or <b>REV</b> key. The display changes to the monitor screen. Hold down the key to perform operation and release it to stop. If the motor does not run, check Pr. 13 "starting speed". If its setting is less than the starting speed, the motor will not run.	
5	Press the <b>PU</b> key. The inverter exits from the jog operation mode and returns to the ordinary PU operation mode. To return to the jog operation mode, press the <b>(SHIFT)</b> key.	<p style="text-align: center;"><b>DIRECTLY</b></p> <p>Set            0.0r</p> <p>↓</p>

### REMARKS

The jog operation mode may also be selected from the **(HELP)** key. (Refer to page 29)



## OPERATION

### 4.3 Combined Operation (Operation using external input signals and PU)

#### REMARKS

Refer to the inverter instruction manual (basic) for details.

#### 4.3.1 Entering the start signal from outside and setting the running speed from the PU (Pr. 79=3)

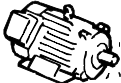

Step	Operation Procedure
1	Switch the power on.
2	Set "3" in Pr. 79 "operation mode selection". The combined operation mode is selected and the operation mode indication on the display changes to "PU+E". 
3	Set the start switch (STF or STR) to ON. Note: If the forward and reverse rotation switches are both set to ON, the inverter will not start. Also, if these switches are both set to ON during operation, the motor is decelerated to a stop. 
4	Set the running speed to 1500r/min from the parameter unit. The operation command indication changes to "STF" or "STR" and the operation status indication changes to the output (FWD or REV) indication. • Direct setting After pressing the <b>PU</b> key, enter the speed directly with the number keys. Note that this setting is not available in the monitoring mode. In this case, press the <b>WRITE</b> key to leave the monitoring mode and then re-set the speed. • Press the <b>PU</b> key to call the speed setting screen, and perform step setting. Press the <b>▲/▼</b> key to keep on varying the speed. Hold down the <b>▲</b> (or <b>▼</b> ) key to vary the speed. As the speed varies slowly at the beginning, this feature may be used for fine adjustment.
5	Set the start switch (STF or STR) to OFF. The motor stops running. 

#### CAUTIONS

1. The external speed setting signals and the PU's **FWD** and **REV** keys are not accepted.
2. The stop key is valid when Pr. 75 "PU stop selection" = "14 to 17".





### 4.3.2 Entering the running speed from outside and making start and stop from the PU (Pr. 79 = 4)

Step	Operation Procedure	
1	Switch the power on.	
2	Set "4" in Pr. 79 "operation mode selection".The combined operation mode is selected and the operation mode indication on the display changes to "PU+E".	
3	Enter the external running speed signal (select the multi-speed signal or turn the speed setting potentiometer).	
4	Press the <b>FWD</b> or <b>REV</b> key of the PU. The motor starts running. The state of the output speed is shown on the display. Note :The starting terminals (STF, STR) of the inverter are invalid. The inverter may also be started by pressing the <b>FWD</b> or <b>REV</b> key of the PU and then increasing the level of the speed setting signal.	
5	Press the <b>STOP/RESET</b> key of the PU. The motor is decelerated to a stop.	

- 1
- 2
- 3
- 4
- 5

## OPERATION

### 4.3.3 Entering the start signal and multi-speed signal from outside and setting multiple speeds from the PU

Step	Operation Procedure	
1	Switch the power on.	
2	Select the multi-speed signal required for operation (switch the RH, RM, RL or REX signal on).	
3	<p>Set the start switch (STF or STR signal) to ON. The operation command indication changes to "STF" or "STR", the operation status indication changes to the output (FWD or REV) indication, and the motor starts running. Note: If the forward and reverse rotation switches are both set to ON, the inverter will not start. Also, if these switches are both set to ON during operation, the motor is decelerated to a stop.</p>	 <p>A digital display showing a speed of 1500.0r. Below the speed, there are three indicators: STF, FWD, and EXT. STF is lit, FWD is lit, and EXT is not lit.</p>
4	<p>Change the multi-speed during running from the PU. When high speed has been selected (RH signal ON), changing the Pr. 4 "three-speed setting (high speed)" value varies the speed. Note The other multiple-speed settings not being used may also be changed during operation.</p>	 <p>An illustration of a motor with motion lines around it. A hand is shown turning a dial or knob on the side of the motor, indicating a speed change.</p>
5	<p>Switch off the multi-speed signal (RH, RM, RL or REX signal) and set the start switch (STF or STR signal) to OFF. The motor stops running.</p>	 <p>An illustration of a motor with motion lines around it. A hand is shown turning a dial or knob on the side of the motor, indicating a stop.</p>

# 5

# SPECIFICATIONS

This chapter provides the "specifications" for use of this product. Always read the instructions before using the equipment.

5.1 Specifications ..... 54

1

2

3

4

5

## **PECIFICATION**

### **5.1 Specifications**

#### **5.1.1 Standard specifications**

<b>Item</b>	<b>Specifications</b>
Ambient temperature	-10°C to +50°C (+14°F to +122°F)(non-freezing) (CAUTION 1)
Ambient humidity	90%RH or less (non-condensing)
Storage temperature	-20°C to +65°C (-4°F to +149°F) (CAUTION 4)
Ambience	Indoors (free from corrosive gas, flammable gas, oil mist, dust and dirt)
Altitude, vibration	Maximum 1000m (328.80feet) above sea level for standard operation 5.9m/s <sup>2</sup> or less (conforming to JIS C 0040)
Power supply	Power is supplied from the inverter.
Connection	Fitted to the inverter or connected to the inverter by the cable.
Display	LCD (liquid crystal display, 13 characters 4 lines)
Size	125 (H) x 70 (W) x 15 (D)
Data retention	Onboard E <sup>2</sup> PROM
Number of write times	Maximum 100,000 times

#### **CAUTIONS**

- 1. At the low temperatures of less than about 0, the liquid crystal display (LCD) may be slower in operation.  
At high temperatures, the LCD life may become shorter.**
- 2. Do not expose the liquid crystal screen to direct sunlight.**
- 3. During transportation, use care to avoid loading the liquid crystal display.**
- 4. Temperatures applicable for a short time, e.g. in transit.**

**5.1.2 Outline drawing**

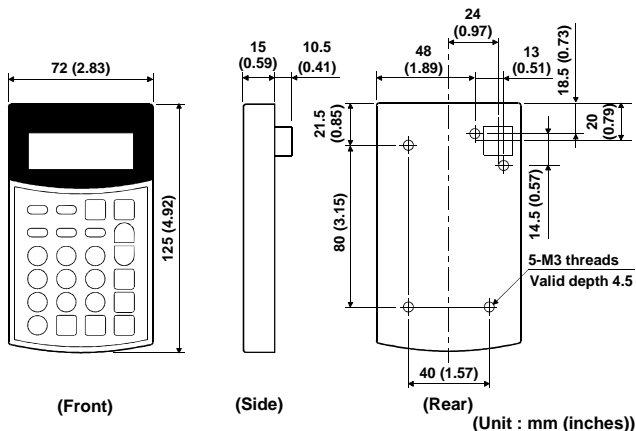

1

**5.1.3 Panel cutting drawing**

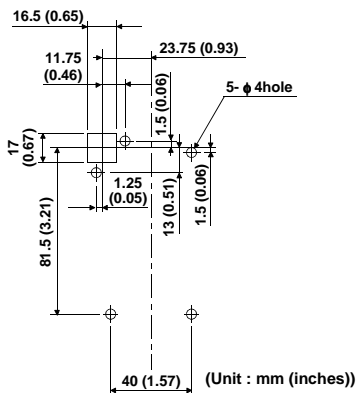

2

3

4

5

## REVISIONS

\*The manual number is given on the bottom left of the back cover.

Print Date	*Manual Number	Revision
Oct., 2001	IB(NA)-0600079-A	First edition