

RFI Filter Units for Frequency Inverters

FR-A 500/FR-F 500/FR-F 700

Short reference for RFI filter unit type FFR-A540-8A-SF100 to 180A-SF100, FFR-F740-55A-SF100 and FN 3359/250/28 to FN 3359/1600/99

Please read the following installation notes carefully to use the filter unit to its option.



CAUTION:

The RFI filter units described in this reference sheet are designed exclusively for use with Mitsubishi inverter types FR-A 500, FR-F 500 and FR-F 700. These filters are necessary to comply with limits for conducted noise voltages defined by the EN 61800-3 standard. The ≤ 180 A filter units are suitable for complying with the limits for Environment 1 (unrestricted and restricted distribution) and Environment 2. The > 180 A filter units are suitable for complying with the limits for Environment 1 (restricted distribution) and Environment 2.

It is possible to that you may experience different results in practice, particularly if you do not completely and correctly follow the accepted EMC procedures for proper installation of filters and routing the power and control lines.

These filters are NOT designed for use in IT networks. When the noise filters are operated leakage currents are discharged to earth. This can trigger upstream protective devices (as RCDs), particularly when there are unbalanced mains voltages, mains phase failures or switching activities on the input side of the filter. The values of the power loss and leakage current in the following tables are typical values in a steady and error-free state. Depending on the power supply voltage, the power supply frequency and the filter used they may vary slightly. Please note, that the appearance and wiring mechanics of the noise filters may differ from the figures shown in this short reference. Safe functioning as well as the grade of the radio frequency protection do not take affect of this.

For further details please refer to the Mitsubishi manual for Frequency Inverters and EMC, which contains detailed information about EMC conforming installation.

Mounting

Check the inverter type. The filter should be used only in combination with inverters described in the table below.

Filter	Frequency inverter performance category				
	FR-A			FR-F	
	540 EC	520	540L-G EC	540L EC	740 EC
FFR-A540-8A-SF100	0.4 k-1.5 k	0.4 k/0.75 k	—	—	00023-00052
FFR-A540-16A-SF100	2.2 k/3.7 k	1.5 k/2.2 k	—	—	00083
FFR-A540-30A-SF100	5.5 k/7.5 k	3.7 k	—	—	00126-00250
FFR-A540-50A-SF100	11 k/15 k	5.5 k	—	—	—
FFR-F740-55A-SF100	—	—	—	—	00310/00380
FFR-A540-75A-SF100	18.5 k/22 k	7.5 k/11 k	—	—	00470/00620
FFR-A540-95A-SF100	30 k	15 k	—	—	00770
FFR-A540-120A-SF100	37 k	18.5 k	—	—	00930
FFR-A540-180A-SF100	45 k/55 k	22 k/30 k	—	—	01160
FN 3359/180/28	—	37 k	75 k	75 k/90 k	01800
FN 3359/250/28	—	45 k	90 k	110 k	02160
FN 3359/400/99	—	55 k	110 k-132 k	132 k-185 k	—
FN 3359/600/99	—	—	160 k/220 k	220 k/280 k	—
FN 3359/1000/99	—	—	280 k/375 k	375 k/450 k	—
FN 3359/1600/99	—	—	450 k	530 k	—

Function

The filters described in this document are designed to reduce conducted noise voltages to comply with the limits defined for Environments 1 and 2. The FFR-A540-□□□A-SF100 and FFR-F740-55A-SF100 can provide conformity with the limits for Environment 1 (unrestricted distribution) with motor cable lengths of up to 20 m (shielded) and for Environment 1 (restricted distribution) with motor cable lengths of up to 100 m (shielded), and thus also with the 100 A limits of Environment 2 with motor cable lengths of up to 100 m.

The FN 3359/□□□ filters can provide conformity with the limits for Environment 1 (restricted distribution) with motor cable lengths of up to 100m (shielded), and thus also with the limits defined for Environment 2 up to the same motor cable length.

Mounting of filters type FFR-A540-□□□A and FFR-F740-□□□A

Fix the inverter to the top panel of the filter and secure it with the screws provided.

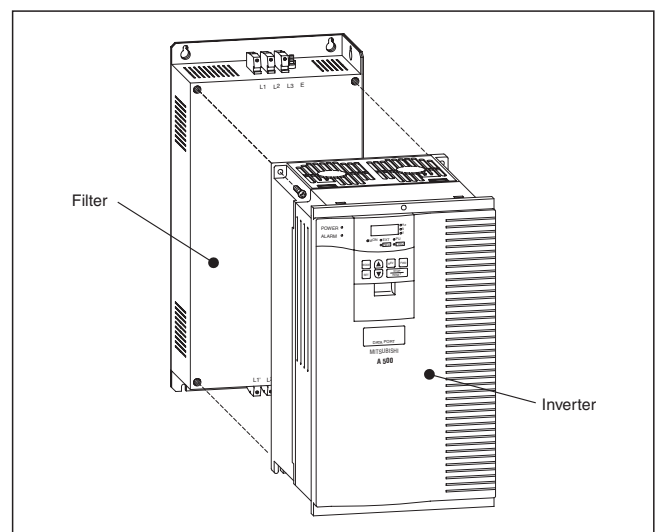

To fix the filter-inverter unit on the back of the cabinet use the mounting bolts provided with the filter. For correct filter performance the filter mounting bolts should electrically bond to the cabinet back panel which is connected to earth. If this is not possible, the paint should be removed from the cabinet directly under the filter footprint.

Mounting of filters type FN 3359/□□□

The filters type FN3359 and the according inverters are mounted side by side on the back of the cabinet. For correct filter performance the filter mounting bolts should electrically bond to the cabinet back panel which is connected to earth. If this is not possible, the paint should be removed from the cabinet directly under the filter footprint.

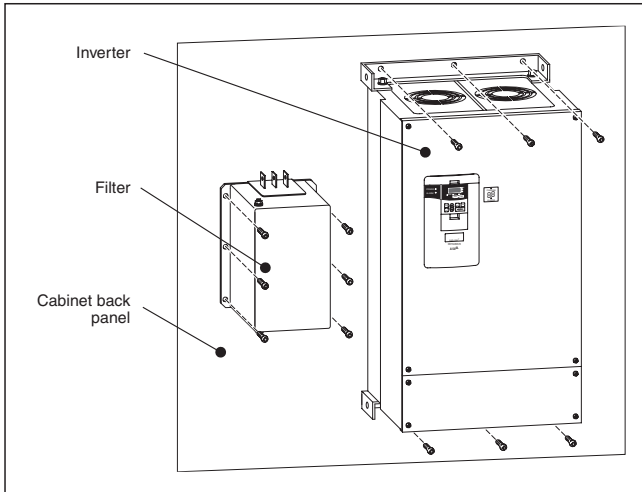

Wiring

For electrical installation follow the wiring procedure shown in the picture below. The maximum wiring length of the motor cable should be within the specified values.

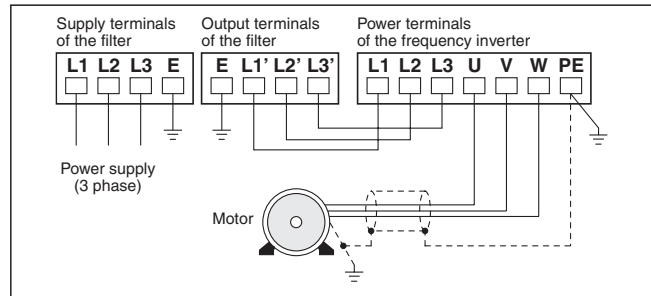

All cables must be shielded and earthed at both ends in order to reduce cable radiation. Earth motor, bond to filters.

For environmental conditions and mounting position please note the instructions in the operation manual for the frequency inverter FR-A 540(L-G) EC, FR-F 500L EC or FR-F 700 EC respectively.

Specifications

Specifications	Filter	
	FFR-A540-□□□A-SF100 and FFR-F740-□□□A-SF100	FN 3359/□□□
Rated voltage	Max. 3~ 480 V AC	Max. 3~ 500 V AC
Frequency	50 / 60 Hz	50 / 60 Hz
Rated and leakage current	See the following tables	See the following tables
Power loss	See the following tables	See the following tables
Ambient temperature range	-25-85 °C	-25-85 °C
Ambient humidity	90 %	90 %
Vibration	10-200 Hz; 1.8 g	10-200 Hz; 1.8 g

Dimensions

Filter type FFR-A540-8A-SF100 to FFR-A540-30A-SF100

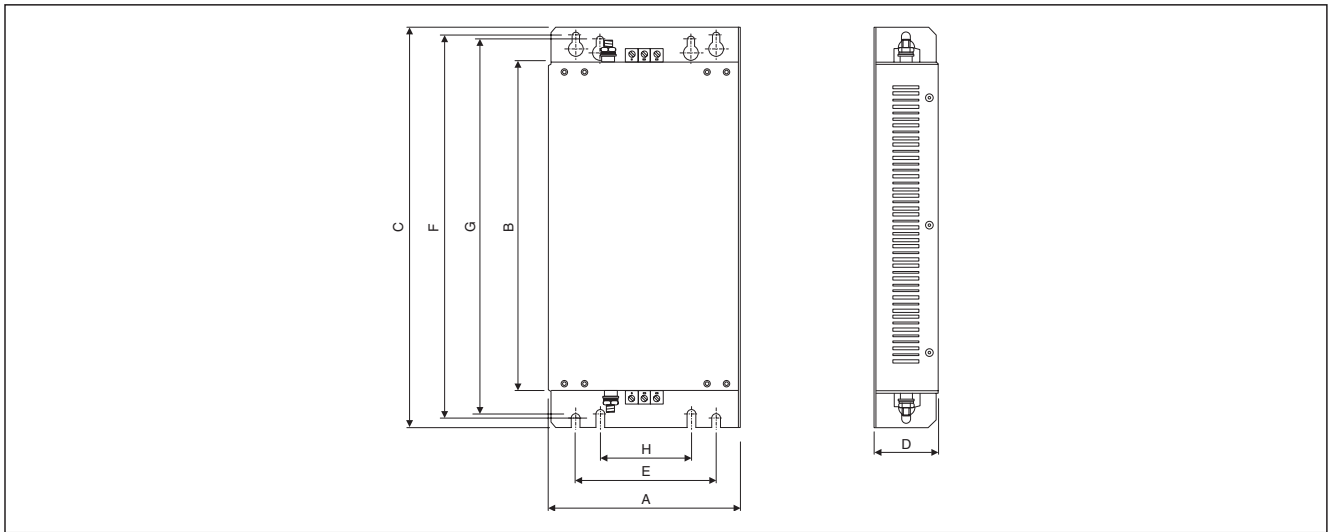

Filter type	Inverter			A	B	C	D	E	F	G	H	Mounting screws	Weight [kg]	Power loss [W]	Leakage current [mA] ^①	Rated current [A]
	FR-A 540	FR-A 520	FR-F 740													
FFR-A540-8A-SF100	0.4 k-1.5 k	0.4 k/0.75 k	00023-00052	150	260	315	50	110	300	295	70	4 × M5	1.5	5	< 30	8
FFR-A540-16A-SF100	2.2 k/3.7 k	1.5 k/2.2 k	00083	150	260	315	50	110	300	295	70	4 × M5	1.5	8	< 30	16
FFR-A540-30A-SF100	5.5 k/7.5 k	3.7 k	00126-00250	220	260	315	60	180	300	295	125	4 × M5	1.8	14	< 30	30

^① The values shown are for the leakage currents in a balanced 400V 50Hz mains network under normal conditions. Higher leakage currents can occur briefly in the event of phase failures and when systems are powered on.

Filter type FFR-A540-50A-SF100 to FFR-A540-180A-SF100 and FFR-F740-55A-SF100

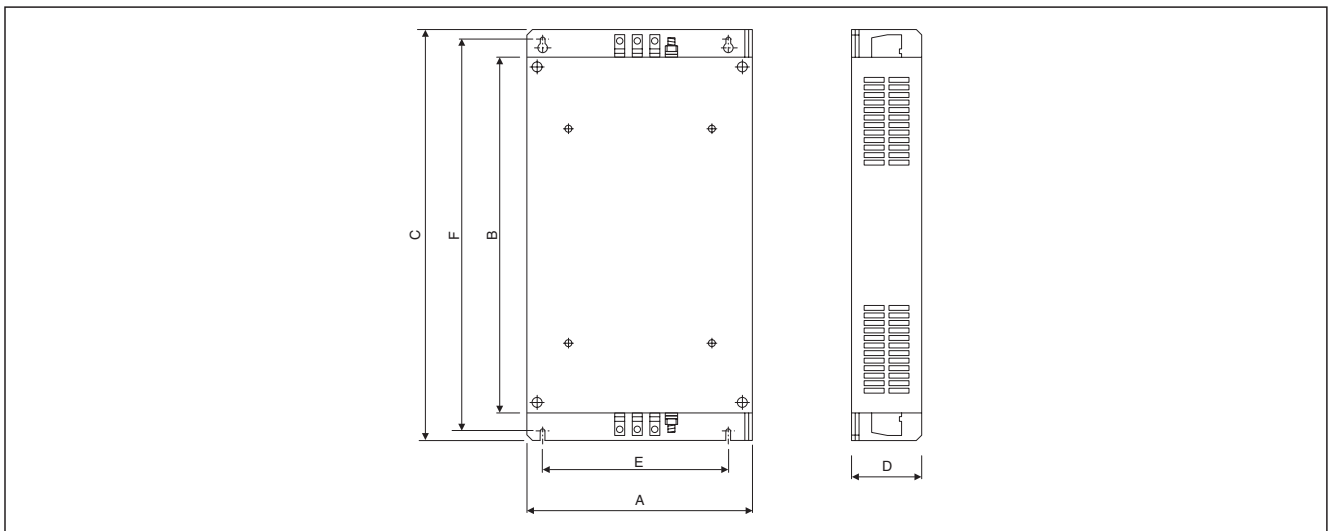

Filter type	Inverter			A	B	C	D	E	F	Mounting screws	Weight [kg]	Power loss [W]	Leakage current [mA] ^①	Rated current [A]
	FR-A 540	FR-A 520	FR-F 740											
FFR-A540-50A-SF100	11 k/15 k	5.5 k	—	251.5	400	460	80	210	445	4 × M8 (for FR-A540) 4 × M5 (for FR-A520)	3.5	25	< 30	50
FFR-F740-55A-SF100	—	—	00310/00380	221.5	300	360	80	180	345	4 × M5	3	34	< 30	55
FFR-A540-75A-SF100	18.5 k/22 k	7.5 k/11 k	00470/00620	251.5	400	476	80	210	457	4 × M8 (for FR-A540) 4 × M5 (for FR-A520)	4.1	34	< 30	75
FFR-A540-95A-SF100	30 k	15 k	00770	340	550	626	90	280	607	4 × M8	6.7	36	< 30	95
FFR-A540-120A-SF100	37 k	18.5 k	00930	450	550	636	120	380	617	4 × M10	9.7	34	< 30	120
FFR-A540-180A-SF100	45 k/55 k	22 k/30 k	01160	450	550	652	120	380	633	4 × M10	10.8	62	< 30	180

^① The values shown are for the leakage currents in a balanced 400V 50Hz mains network under normal conditions. Higher leakage currents can occur briefly in the event of phase failures and when systems are powered on.

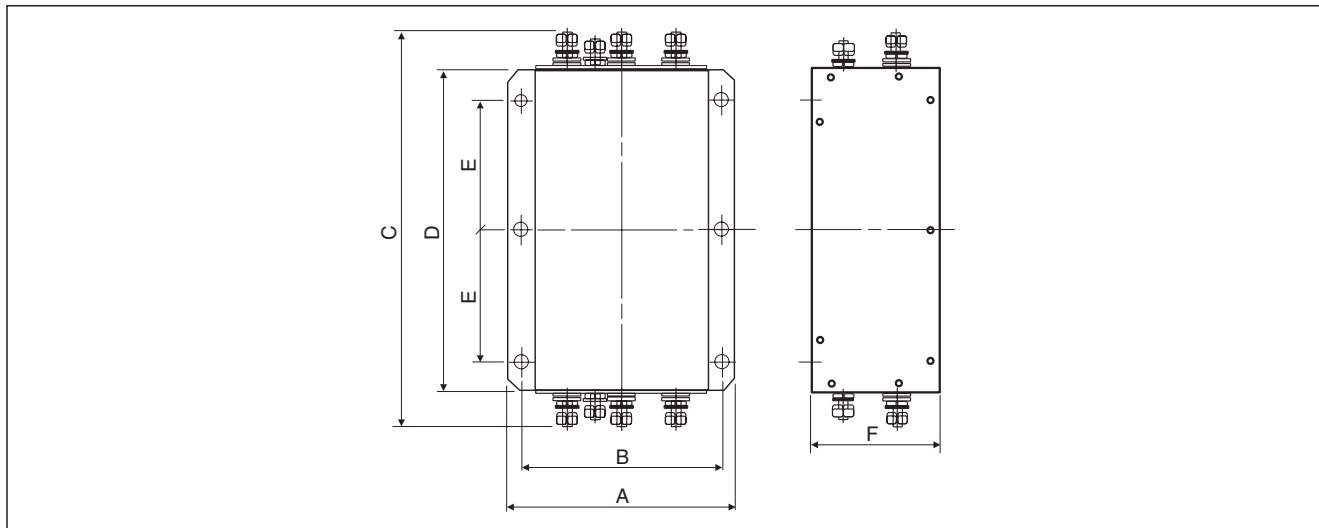
Filter type FN 3359/180/28 to FN 3359/250/99

Filter type	Inverter				A	B	C	D	E	F	Weight [kg]	Power loss [W]	Leakage current ^① [mA]	Rated current [A]
	FR-A 540L-G	FR-A 520	FR-F 540L	FR-F 740										
FN 3359/180/28	75 k	37 k	75 k/90 k	01800	210	185	360	300	120	120	6.5	34	< 6	180
FN 3359/250/28	90 k	45 k	110 k	02160	230	205	360	300	120	125	7	38	< 6	250

^① The values shown are for the leakage currents in a balanced 400V 50Hz mains network under normal conditions. Higher leakage currents can occur briefly in the event of phase failures and when systems are powered on.

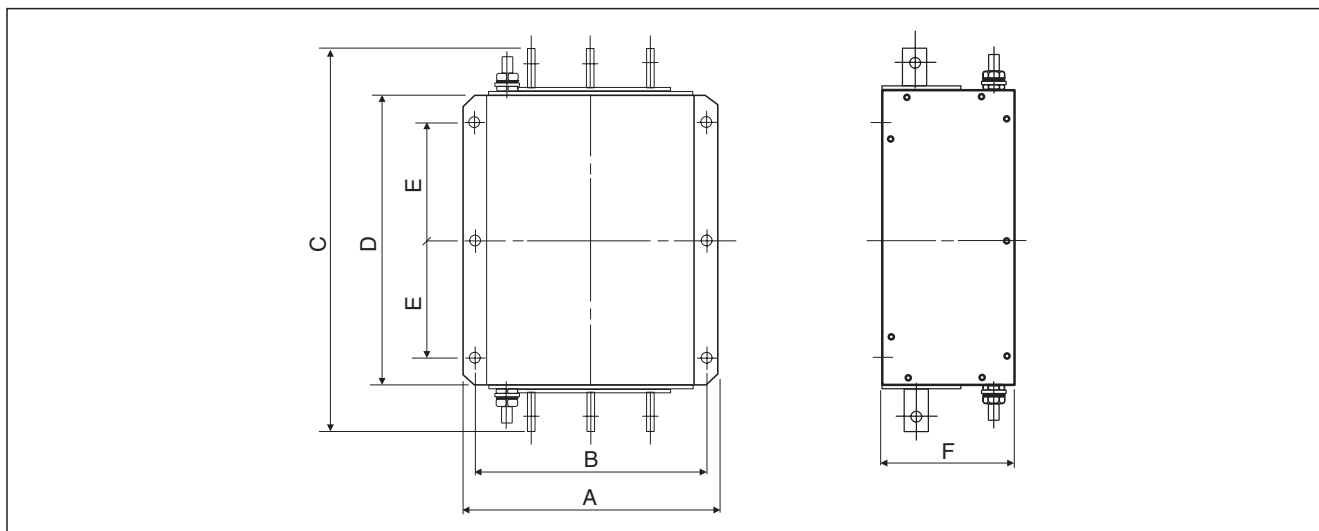
Filter type FN 3359/400/28 to FN 3359/1600/99

Filtertyp	Inverter			A	B	C	D	E	F	Weight [kg]	Power loss [W]	Leakage current ^① [mA]	Rated current [A]
	FR-A 540L-G	FR-A 520	FR-F 540L										
FN 3359/400/99	110 k–132 k	55 k	132 k–185 k	260	235	386	300	120	115	10.5	51	< 6	400
FN 3359/600/99	160 k/220 k	—	220 k/280 k	260	235	386	300	120	135	11	65	< 6	600
FN 3359/1000/99	280 k/375 k	—	375 k/450 k	280	255	456	350	145	170	18	84	< 6	1000
FN 3359/1600/99	450 k	—	530 k	300	275	586	400	170	160	27	130	< 6	1600

^① The values shown are for the leakage currents in a balanced 400V 50Hz mains network under normal conditions. Higher leakage currents can occur briefly in the event of phase failures and when systems are powered on.

Specifications subject to change without notice.

Order No.: 71063-D / 06.04