



TRANSISTORIZED INVERTER

-INSTRUCTION MANUAL-

DeviceNet CONFORMANCE TESTED COMMUNICATION OPTION

FR-A5ND

Thank you for choosing the Mitsubishi transistorized inverter option unit. This instruction manual gives handling information and precautions for use of this equipment. Incorrect handling might cause an unexpected fault. Before using the equipment, please read this manual carefully to use the equipment to its optimum.

This section is specifically about safety matters

Do not attempt to install, operate, maintain or inspect this product until you have read through this instruction manual and appended documents carefully and can use the equipment correctly. Do not use this product until you have a full knowledge of the equipment, safety information and instructions.

In this instruction manual, the safety instruction levels are classified into "WARNING" and "CAUTION".



WARNING

Assumes that incorrect handling may cause hazardous conditions, resulting in death or severe injury.



CAUTION

Assumes that incorrect handling may cause hazardous conditions, resulting in medium or slight injury, or may cause physical damage only.

Note that the CAUTION level may lead to a serious consequence according to conditions. Please follow the instructions of both levels because they are important to personnel safety.

SAFETY INSTRUCTIONS

1. Electric Shock Prevention



WARNING

- While power is on or when the inverter is running, do not open the front cover. You may get an electric shock.
- Do not run the inverter with the front cover removed. Otherwise, you may access the exposed high-voltage terminals and charging part and get an electric shock.
- Even if power is off, do not remove the front cover except for wiring or periodic inspection. You may access the charged inverter circuits and get an electric shock.
- Before starting wiring or inspection, switch power off, wait for more than 10 minutes, and check for the presence of any residual voltage with a tester, etc.



WARNING

- Any person who is involved in the wiring or inspection of this equipment should be fully competent to do the work.
- Always install the option unit before wiring. Otherwise, you may get an electric shock or be injured.
- Handle this option unit with dry hands to prevent an electric shock.
- Do not subject the cables to scratches, excessive stress, heavy loads or pinching. Otherwise, you may get an electric shock.
- While power is on, do not move the station number and baud rate setting switches. Doing so can cause an electric shock.

2. Injury Prevention



CAUTION

- Apply only the voltage specified in the instruction manual to each terminal to prevent damage, etc.
- Ensure that the cables are connected to the correct terminals. Otherwise, damage, etc. may occur.
- Always make sure that polarity is correct to prevent damage, etc.
- While power is on or for some time after power-off, do not touch the inverter as it is hot and you may get burnt.

3. Additional instructions

Also note the following points to prevent an accidental failure, injury, electric shock, etc.:

(1) Transportation and mounting



CAUTION

- Do not install or operate the option unit if it is damaged or has parts missing.
- Do not stand or rest heavy objects on the product.
- Check that the mounting orientation is correct.
- Prevent screws, metal fragments or other conductive bodies, oil or other flammable substance from entering the inverter.

(2) Test operation and adjustment



CAUTION

- Before starting operation, confirm and adjust the parameters. A failure to do so may cause some machines to make unexpected motions.

(3) Usage



WARNING

- Do not modify the equipment.



CAUTION

- When parameter clear or all parameter clear is performed, each parameter returns to the factory setting. Re-set the required parameters before starting operation.
- For prevention of damage due to static electricity, touch nearby metal before touching this product to eliminate static electricity from your body.

(4) Maintenance, inspection and parts replacement



CAUTION

- Do not test the equipment with a megger (measure insulation resistance).

(5) Disposal



CAUTION

- Treat as industrial waste.

(6) General instruction

All illustrations given in this manual may have been drawn with covers or safety guards removed to provide in-depth description. Before starting operation of the product, always return the covers and guards into original positions as specified and operate the equipment in accordance with the manual.

CONTENTS

1. INTRODUCTION	1
1.1 General	1
1.2 Product Confirmation	2
1.3 Description	3
1.4 Notes on firmware revision of the FR-A5ND	4
2. INSTALLATION	5
2.1 Pre-Installation Checks	5
2.2 Installation Procedure	6
2.3 Constructing DeviceNet Drop Cable	8
2.4 Pre Network Connection Procedure	10
2.5 Connection to Network	11
2.6 Changing Node Addresses	12
2.7 LED Status Indicator	13
3. GETTING STARTED	14
3.1 Introduction	14
3.1.1 General description	14
3.2 Basic Configuration	16
3.2.1 Set Baud Rate:	16
3.2.2 Set Node Address:	16
3.2.3 DeviceNet I/O Assembly:	16
3.2.4 Polling Rate	17
3.3 Loss of Communications	17
4. Operation	18
4.1 Operation Modes	18
4.2 Operation Mode Selection	18
4.3 Functions Available in Operation Modes	19
4.4 Input from Network to inverter	20
4.4.1 Control input commands	20
4.4.2 Output frequency/speed setting	20
4.4.3 Inverter reset	20
4.4.4 Parameter writing	20
4.5 Output from Inverter to Network	21
4.5.1 Inverter status	21
4.5.2 Inverter monitoring	21
4.5.3 Parameter Read	22
4.6 Inverter Reset	22

4.7	Setting Frequency/Speed Value.....	22
4.8	Parameter Clear (Pr Clr) Commands	22
4.9	Control Input Instruction.....	23

5. FR-A5ND SPECIFIC PARAMETERS 24

5.1	Startup Data.....	24
5.2	Other Option-Specific Parameters.....	28
5.3	Operation at Communication Error Occurrence	29
5.3.1	Operation selection at communication error occurrence (For the FR-A500/V500 series only).....	29
5.3.2	Alarm and measures.....	33
5.3.3	Inverter reset.....	34

6. OBJECT MAP DEFINITIONS 35

6.1	Response Timing.....	36
6.2	Recommendation For Software Developers.....	37
6.3	Connection with OMRON Master	37

7. OBJECT MAP—A500(L)/F500(L) SERIES 38

7.1	Class 0x01 - Identity Object.....	38
7.1.1	Class 0x01 Attributes - Instance 0	38
7.1.2	Class 0x01 Services - Instance 0	38
7.1.3	Class 0x01 - Instance 1	38
7.1.4	Class 0x01 Instance Services - Instance 1	38
7.2	Class 0x03 - DeviceNet Object.....	39
7.2.1	Class 0x03 Attributes - Instance 0	39
7.2.2	Class 0x03 Services - Instance 0	39
7.2.3	Class 0x03 - Instance 1	39
7.2.4	Class 0x03 Instance Services - Instance 1	39
7.3	Class 0x04 - Assembly Object.....	40
7.3.1	Class 0x04 - Output Instance 20 (0x14)	40
7.3.2	Class 0x04 - Output Instance 21 (0x15) Default.....	40
7.3.3	Class 0x04 - Output Instance 26 (0x1A).....	40
7.3.4	Class 0x04 - Input Instance 70 (0x46)	42
7.3.5	Class 0x04 - Input Instance 71 (0x47) Default.....	42
7.3.6	Class 0x04 - Input Instance 76 (0x4C)	42
7.4	Class 0x05 - DeviceNet Connection Object.....	44
7.4.1	Class 0x05 Attributes - Instance 0	44
7.4.2	Class 0x05 Services - Instance 0	44
7.4.3	Class 0x05 Instance 1 - Explicit Messaging	44
7.4.4	Class 0x05 Instance 2 - Polled I/O	46
7.4.5	Class 0x05 Instance 4 - Explicit Messaging	48
7.4.6	Class 0x05 Instance 5 - Explicit Messaging	49
7.4.7	Class 0x05 Instance 6 - Explicit Messaging	50
7.4.8	Class 0x05 Instance Services - Instances 1,2,4,5,6.....	51
7.5	Class 0x28 - Motor Data Object.....	51

7.5.1	Class 0x28 Attributes - Instance 0	51
7.5.2	Class 0x28 Services - Instance 0	51
7.5.3	Class 0x28 Instance 1	51
7.5.4	Class 0x28 Instance Services.....	51
7.6	Class 0x29 - Control Supervisor Object.....	52
7.6.1	Class 0x29 Attributes - Instance 0	52
7.6.2	Class 0x29 Services	52
7.6.3	Class 0x29 Instance 1	52
7.6.4	Class 0x29 Instance Services.....	53
7.7	Class 0x2A - AC Drive Object.....	54
7.7.1	Class 0x2A Attributes - Instance 0.....	54
7.7.2	Class 0x2A Services.....	54
7.7.3	Class 0x2A Instance 1	54
7.7.4	Class 0x2A Instance Services	58
7.8	Class 0x66 - Extended Object I	59
7.8.1	Class 0x66 Attributes - Instance 0	59
7.8.2	Class 0x66 Services	59
7.8.3	Class 0x66 Instance 1	59
7.8.4	Class 0x66 Instance Services.....	64
7.9	Class 0x67 - Extended Object II	65
7.9.1	Class 0x67 Attributes - Instance 0	65
7.9.2	Class 0x67 Services	65
7.9.3	Class 0x67 Instance 1	65
7.9.4	Class 0x67 Instance Services.....	67
7.10	Class 0x70 to 0x79 - Extended Object III	68

8. OBJECT MAP V500 SERIES

69

8.1	Class 0x01 - Identity Object.....	69
8.1.1	Class 0x01 Attributes - Instance 0	69
8.1.2	Class 0x01 Services - Instance 0	69
8.1.3	Class 0x01 - Instance 1	69
8.1.4	Class 0x01 Instance Services - Instance 1	69
8.2	Class 0x03 - DeviceNet Object.....	70
8.2.1	Class 0x03 Attributes - Instance 0	70
8.2.2	Class 0x03 Services - Instance 0	70
8.2.3	Class 0x03 - Instance 1	70
8.2.4	Class 0x03 Instance Services - Instance 1	70
8.3	Class 0x04 - Assembly Object.....	71
8.3.1	Class 0x04 - Output Instance 20 (0x14)	71
8.3.2	Class 0x04 - Output Instance 21 (0x15) Default.....	71
8.3.3	Class 0x04 - Output Instance 26 (0x1A).....	71
8.3.4	Class 0x04 - Input Instance 70 (0x46)	73
8.3.5	Class 0x04 - Input Instance 71 (0x47) Default.....	73
8.3.6	Class 0x04 - Input Instance 76 (0x4C)	73
8.4	Class 0x05 - DeviceNet Connection Object.....	75
8.4.1	Class 0x05 Attributes - Instance 0	75
8.4.2	Class 0x05 Services - Instance 0	75
8.4.3	Class 0x05 Instance 1 - Explicit Messaging	75
8.4.4	Class 0x05 Instance 2 - Polled I/O	77
8.4.5	Class 0x05 Instance 4 - Explicit Messaging	79

8.4.6	Class 0x05 Instance 5 - Explicit Messaging	80
8.4.7	Class 0x05 Instance 6 - Explicit Messaging	81
8.4.8	Class 0x05 Instance Services - Instances 1,2,4,5,6.....	82
8.5	Class 0x28 - Motor Data Object.....	82
8.5.1	Class 0x28 Attributes - Instance 0	82
8.5.2	Class 0x28 Services - Instance 0	82
8.5.3	Class 0x28 Instance 1	82
8.5.4	Class 0x28 Instance Services.....	82
8.6	Class 0x29 - Control Supervisor Object.....	83
8.6.1	Class 0x29 Attributes - Instance 0	83
8.6.2	Class 0x29 Services	83
8.6.3	Class 0x29 Instance 1	83
8.6.4	Class 0x29 Instance Services.....	84
8.7	Class 0x2A - AC Drive Object.....	85
8.7.1	Class 0x2A Attributes - Instance 0.....	85
8.7.2	Class 0x2A Services	85
8.7.3	Class 0x2A Instance 1	85
8.7.4	Class 0x2A Instance Services	89
8.8	Class 0x66 - Extended Object I	90
8.8.1	Class 0x66 Attributes - Instance 0	90
8.8.2	Class 0x66 Services	90
8.8.3	Class 0x66 Instance 1	90
8.8.4	Class 0x66 Instance Services.....	93
8.9	Class 0x67 - Extended Object II	94
8.9.1	Class 0x67 Attributes - Instance 0	94
8.9.2	Class 0x67 Services	94
8.9.3	Class 0x67 Instance 1	94
8.9.4	Class 0x67 Instance Services.....	95
8.10	Class 0x70 to 0x79 - Extended Object III	96

9. TROUBLESHOOTING **97**

9.1	Inspecting Display On Parameter Unit And MNS Status LED On FR-A5ND	97
-----	--	----

10. SPECIFICATIONS **98**

Appendix A. Electronic Data Sheets (EDS files) **99**

Appendix B. DeviceNet Error Code **100**

1. INTRODUCTION

1.1 General

This instruction manual provides information on connecting the Mitsubishi FR-A500(L)/F500(L)/V500 series inverter to a DeviceNet network using the FR-A5ND for sending and receiving data to and from a DeviceNet master. Read this manual completely before installing, operating or servicing the option unit.

This manual is intended for use by qualified personnel. Installation should only be performed by qualified personnel. You must be able to operate and program serial devices to use the equipment.

This option allows the inverter to be connected to a network adhering to the DeviceNet communications protocol.

Illustrations provided in this manual may have covers or safety guards removed to provide a clear view. Before starting operation of the product be sure to install covers and guards into the original position.

DeviceNet™ is a trademark of ODVA (Open DeviceNet Vendor Association, Inc.).

The following is a list of important features for the option unit

- Data Rates of 125kbps, 250kbps, and 500kbps.
- Up to 64 stations supported on a single network
- Ability to add or remove stations without disrupting network operation.
- Network access to all inverter parameters, Start/Stop commands, and monitor data.
- Passed ODVA Conformance Test in January, 1998

1.2 Product Confirmation

This product may be used with the FR-V500 series manufactured in and after May 2002 only. Check the SERIAL number indicated on the rating plate and package on the inverter.

[SERIAL]

<u>X</u>	<u>2</u>	<u>5</u>	<u>000000</u>
Symbol	Year	Month	Control number

REMARKS

Only the FR-A5ND option unit manufactured in and after May 2002 is compatible with the FR-V500 series inverter.
Do not fit the FR-A5ND option unit manufactured before May 2002 to the FR-V500 series inverter. The inverter will not function properly.

1.3 Description

The FR-A5ND option unit consists of two circuit boards as shown in Figure 1-1. The option unit must be mounted in option port #3 on the inverter unit. Two rotary switches, mounted on the top printed circuit board, are used to assign station numbers from 0 to 63. An LED status light mounted next to the DeviceNet connector provides status information on the communication link.

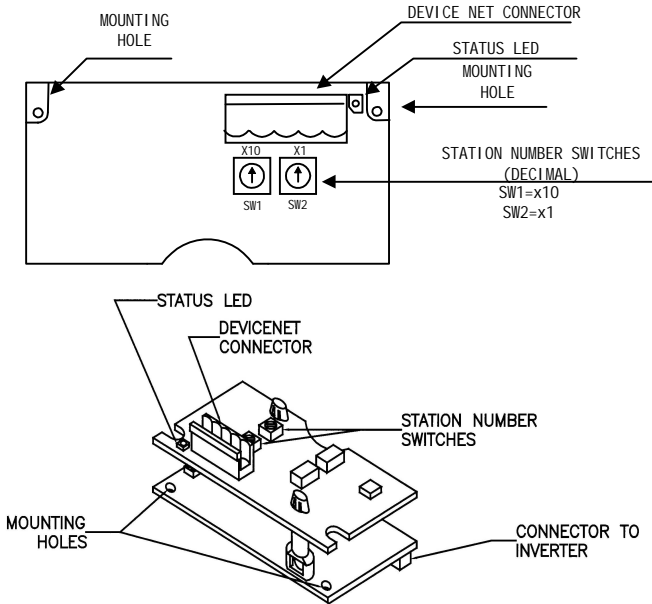

Figure 1-1: FR-A5ND Option Unit

1.4 Notes on firmware revision of the FR-A5ND

Clarifications for FR-A5ND Devicenet Option Modules containing firmware revision 7008E.

The firmware revision of the FR-A5ND Devicenet Option Module can be identified by the marking on the ROM IC on the lower circuit board.

1. When reading data via Class 0x2A, Instance 1, Attribute 29 or Class 0x29, Instance 1, Attribute 15, the value returned will be the current setting of Pr. 338 and Pr. 339 respectively. When in EXT mode or PU mode, Pr. 338 and Pr. 339 are not active and the speed reference and control commands are accepted only via the external I/O terminals or parameter unit as designated.
2. If the expected packet rate (EPR) is set to a value below the existing EPR via the Devicenet network using Class 0x05, Instance 1 or 2, Attribute 9, a communication error will occur. Correct the EPR value and restart the connection.
3. When writing a parameter value using Assembly Object Class 0x04, Output Instance 26 (byte 0, bit 7 = 1) the programmatic response via Class 0x04, Input Instance 76 will contain, in bytes 4 & 5, the data sent in bytes 2 & 3 of the original Instance 26 message. To verify that the parameter value held in the inverter is correct, the user must initiate a Get, again using Output Instance 26 (byte 0, bit 7 = 0).
4. When using the FR-A5ND Devicenet option module, the A500(L) does not execute setting "7" in Pr. 79 properly and this setting should not be used. In networked applications, Pr. 79 is typically set to either "0" or "6".
5. The A500(L) will accept a inverter Reset command via the Devicenet network when the operation mode of the inverter is in the net mode or the operation mode is switchable to the net mode.

2. INSTALLATION

The inverter top cover must be removed to install the option unit. After installation, the top cover must be reinstalled and connection to the DeviceNet bus is completed through a connector accessible through the top cover.

WARNING

 **Cover removal can expose charged components. Be sure the proper procedures are followed when removing the cover. Remove the cover following the procedure in the inverter manual.**

2.1 Pre-Installation Checks

Verify that the following included components are supplied.	<ol style="list-style-type: none">1. FR-A5ND Option Unit2. Two mounting screws M3 x 8 (VSP896M205)3. Instruction Manual
Verify the inverter type.	This option unit is designed to work with the FR-A500(L)/F500(L)/V500 series inverter. Do not attempt to use this unit with any other inverter (e.g. A100, A200, Z, F, and E Series). These models use a different option connector and if the user forces the connector, the inverter may be damaged.
Ensure that the inverter input power is turned off.	The inverter and/or the option unit may be damaged if installed with power on. The inverter performs an initialization procedure at power on that includes checking the option port. Adding the option later causes a hardware conflict which will result in the alarm "E. OP3". And may damage the inverter or option unit .

2.2 Installation Procedure

Mounting Option Unit In Inverter Option Port #3.

- (1) Verify that power has been turned off and that the inverter top cover has been removed.

CAUTION

The FR-A5ND option unit must be installed in Option Port #3 only. An attempt to install in any other port may cause the inverter or the option unit to be damaged.

- (2) Using the two mounting holes for alignment reference, carefully insert the option unit connector into the inverter connector as shown in figure 2-1 and firmly press the unit into place.
Also be sure to fit the unit into the option fixing hook (For the FR-A500/FR-F500 series, it is available in Aug., 2000.).

CAUTION

If screw holes in the option unit do not line up with the inverter mounting holes, check that the connector has been correctly fitted.

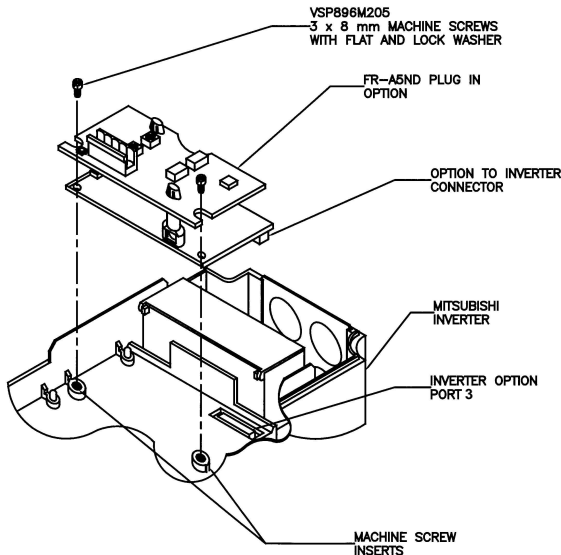

Figure 2-1 : Option Unit Aligned with Option Port #3

- (3) Secure the option unit to the inverter with the two mounting screws.

(4) Option unit is now mechanically installed as shown in figure 2-2.

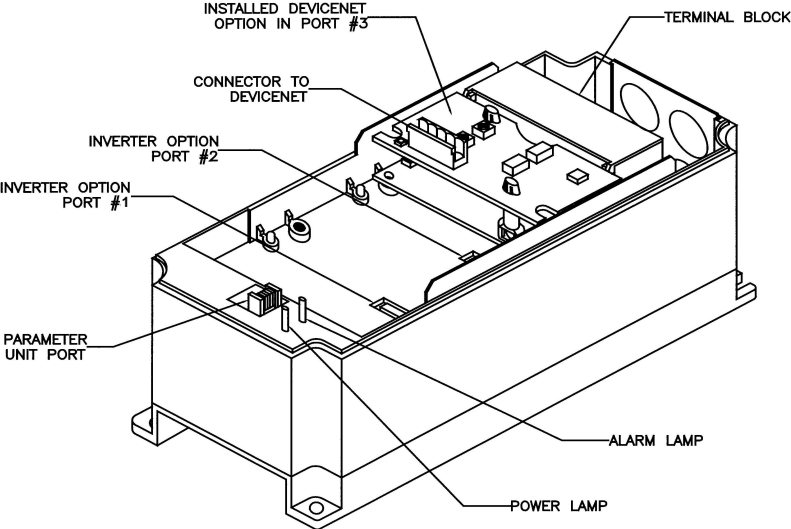

Figure 2-2: FR-A5ND Option Unit Installed in inverter

2.3 Constructing DeviceNet Drop Cable

A DeviceNet drop cable, Figure 2-3, is used to connect the FR-A5ND option unit to the DeviceNet network. The drop cable consists of an ODVA approved "thin" cable as well as an ODVA approved 5-pin connector that mates with the FR-A5ND DeviceNet Option connector. Another connector compatible with the network's trunk cable must also be selected by the user/installer. The user/installer should reference the appropriate ODVA standards and documents for further information. Recommended parts are:

DeviceNet Thin Cable: Belden part number 3084A or equivalent.

5-Pin Connector for FR-A5ND:

Phoenix Contact part number MSTBP 2.5/5-ST-5.08 AB AU SO.

Or Phoenix Contact part number MSTB 2.5/5-ST-5.08-AU.

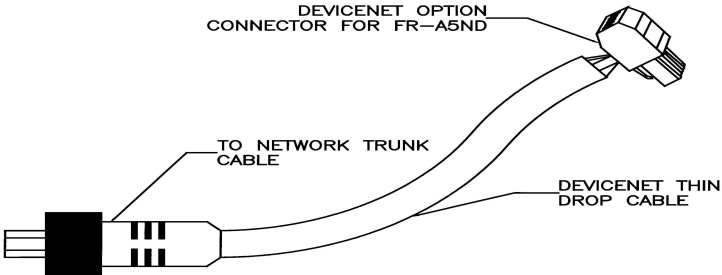

Figure 2-3 : DeviceNet Cable

CAUTION

Maximum length of drop cable must not exceed 6.1m.

The DeviceNet option connector pin out connections are shown in figure 2-4.

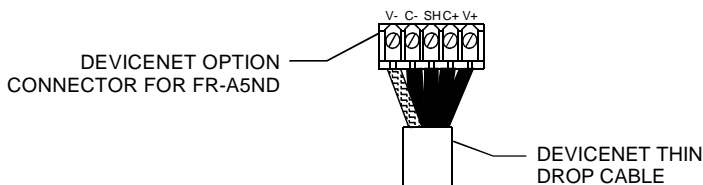

Figure 2-4 : Connector Pin Out Diagram

The function for each pin is listed in table 2-1

Pin No.	Color	Signal
1	Black	V-
2	Blue	CAN-
3	Bare	Shield
4	White	CAN+
5	Red	V+

Table 2-1 : Pin Out Functions

- (1) Strip the insulation and shielding back about 40mm on the free wire end of the drop cable to expose the four colored signal wires and the silver shield wire.
- (2) Strip the insulation back about 6mm on the signal wires.
- (3) Tin the end of the shield wire to prevent fraying.
- (4) Attach the connector to the DeviceNet cable as follows:
 - (a) Using a flathead screwdriver (3.75 mm maximum width), insert the screwdriver into the upper holes of the connector plug, Figure 2-4, turn the screw counter clockwise to open the clamps in the lower holes to allow wires to be inserted.
 - (b) Install the signal wires into the Phoenix Contact connector plug as shown in Figure 2-4. Be sure to match the wire colors to the correct pin as shown in Table 2-1.
 - (c) After all wires are properly inserted, turn the holding screws, Figure 2-4 clockwise to securely clamp the wires. When properly tightened, wires should not be able to be pulled out.

2.4 Pre Network Connection Procedure

CAUTION

Each Device on the network must be assigned a unique station number between the values of 0 to 63

- (1) Set the two station number switches , page 3 , for an address between 0 and 63. Any number out of the range of 0 to 63 is automatically changed to 63 by the option unit software.
- (2) Be sure that the FR-A5ND option unit is snugly inserted into the inverter and the option unit connector is fully and firmly seated before proceeding.
- (3) Remove the wiring cover (DATA PORT), Figure 2-5, from the inverter cover.
- (4) Reinstall the inverter cover making sure that DATA PORT opening is aligned with the DeviceNet connector.
- (5) Connect the DeviceNet thin drop cable to the inverter by inserting the 5-pin connector through the DATA PORT opening into the DeviceNet standard socket on the option unit.

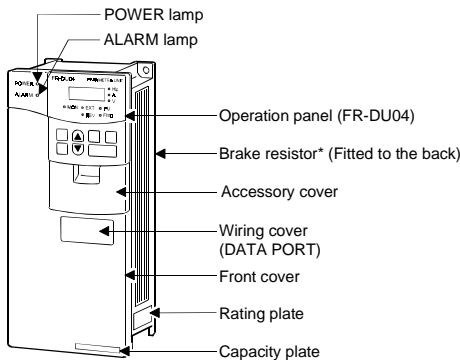

Figure 2-5 : Wiring Cover (DATA PORT)

2.5 Connection to Network

At this point the option unit should be installed in the inverter, the address switches properly set, the cable constructed, and the connector connected to the option unit through the DATA PORT.

⚠ CAUTION

⚠ Do not connect cable to the network until told to do so.

- (1) Check that power is turned off to the inverter.
- (2) Make sure that the terminating resistor is installed at each end of the trunk cable, as shown in Figure 2-6. These resistors must meet the following requirements:
 - 1) $R = 121\Omega$
 - 2) 1% metal film
 - 3) 0.25W
- (3) Connect cable to network as follows:
 - (a) If the trunk connector is a DeviceNet sanctioned pluggable or sealed connector, the connection to the active network can be made at any time whether inverter is on or off. The option unit automatically detects when the connection is completed.
 - (b) If connecting to the network with free wires, power to the network and inverter should be shut off as a safety precaution in case two or more signal wires are accidentally shorted together.
- (4) Check that all connections are completed, and all necessary wires not associated with DeviceNet are connected to the inverter unit.
- (5) It is now safe to apply power to the inverter and run it in the PU or external mode.

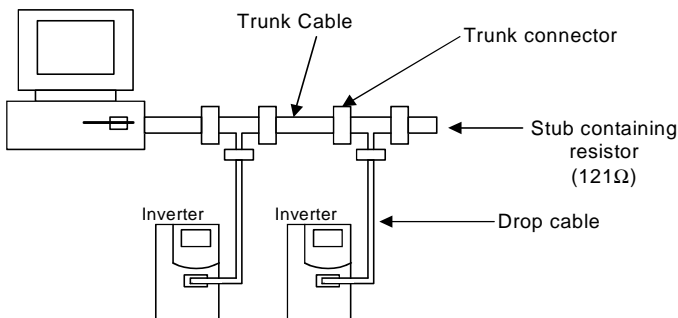

Figure 2-6 : Connection to System

2.6 Changing Node Addresses

CAUTION

The state of the address switches is sampled once at power on. Changing the address later on will have no effect and the software will keep the number read at power on.

To change the address switches, proceed as follows.

- (1) Turn power off.
- (2) Disconnect drop cable from option unit.
- (3) Remove inverter cover.
- (4) Set address switches for desired node address. Remember SW1 is high digit and SW2 is low digit. For example, to set node address 24, you have to set SW1 = 2, SW2 = 4.

REMARKS

Node Address can also be changed by Network or Parameter Unit FR- PU04(V). See page 16 and page 24.

- (5) Reinstall inverter cover.
- (6) Reconnect drop cable to inverter option unit.
- (7) Turn power on.

2.7 LED Status Indicator

The LED Status indicator labeled MNS (see page 3) provides information on the status of operation as shown in Table 2-2. The indicator has five states, Off, Blinking Green, Steady Green, Blinking Red, and Steady Red.

After connecting the drop cable to the trunk of the active network, observe the condition of the Status LED. The option unit uses the Combined Module/Network status LED scheme described in the DeviceNet communications standard.

LED CONDITION	STATE OF SYSTEM	NOTE
Off	Inverter power off	Turn inverter power on. Option unit will then complete duplicate station number test.
Blinking green	Network and inverter power on Connection not yet established by host	The option unit has powered up successfully and determined that its station number does not conflict with other stations. However, a host has not yet established a communications link.
Steady Green	Network and inverter power on, Connection established by host	A master device on the network has designated the option unit for communications. LED holds this state also during communication.
Blinking Red	Connection time-out	Master designated option unit for communication (LED green state), but then sent no messages within the time limit (*1) set in the expected packet rate. Check to see that host station has not been disconnected from the network.
Steady Red	Critical link failure	Failed communication device <ul style="list-style-type: none"> • Duplicate station number • Network power off • Cable from option unit to Network not connected or severed. • Option unit is only node on network • Network damaged • Multiple Baud Rates on same Network Must cycle power to recover from this fault.

*1 Time Limit = 4 x EPR (Expected Packet Rate)

Table 2-2.: LED Status

3. GETTING STARTED

3.1 Introduction

This section is intended to facilitate the configuration of the FR-A5ND DeviceNet Option with minimum effort. It is assumed that the factory settings specified in this section are acceptable to the user. If the user wishes to change these values, the data necessary to do so is provided later in the manual.

This section also assumes that the network cabling is complete and DeviceNet communication has been established. The status LED on the FR-A5ND option should be either blinking green or steady green as described in table on page 13.

3.1.1 General description

The FR-A5ND DeviceNet Option Unit is considered a slave device in the DeviceNet communication standard. This means that the FR-A5ND cannot initiate messages on the network. A master device must establish a connection to the Option Unit and then send commands, requests for information, etc.

The FR-A5ND Option Unit supports Group 3 Messaging as defined in the DeviceNet standard. This feature of the FR-A5ND Option Unit means that it is possible for one master to control the inverter while another reads data from the same inverter. This also means that the DeviceNet master must support the UCMM protocol for proper operation.

- (1) It is strongly recommended that the user configures the DeviceNet network using a software tool designed specifically for that purpose. The use of such a tool greatly simplifies the configuration, reduces confusion, and enhances accuracy. Additionally, the configuration tool will facilitate the elimination of conflicts between network devices and ensure consistency throughout the network.

One such tool is RSNetWorx™ as supplied by Rockwell Software. Tools are available from many other suppliers but the descriptions contained in the Getting Started section are based upon the use of RSNetWorx.

RSNetWorx™ is a trademark of Rockwell Software Inc..

- (2) When adding the FR-A5ND DeviceNet Communication Option Unit to an inverter that has previously been configured for a specific application, it may be necessary to complete a "Parameter All Clear" (PrClr) instruction in the inverter in order to remove unintentional conflicts and to allow the inverter to recognize the presence of the option card.

If this becomes necessary, you will need to record the existing configuration before issuing the PrClr command as this command will restore factory settings to all inverter parameters. Once the command is completed and the inverter has recognized the FR-A5ND Option Unit, the inverter configuration data may be re-entered either via the parameter unit or the network.

- (3) To use the RSNetWorx software, you will need to acquire the DeviceNet Electronic Data Sheet (EDS) file. The EDS file is a standard DeviceNet file which defines the configurable parameters of a field device and facilitates the network configuration software's ability to recognize a specific field device. Refer to the configuration software tool instruction manual for more information about the installation and use of EDS files.

The most up to date EDS file can be downloaded from the web site ODVA (Open DeviceNet Vendor Association, Inc.) or obtained from your sales representative. See page 99 for details on how to obtain this file.

3.2 Basic Configuration

3.2.1 Set Baud Rate:

The baud rate must be consistent throughout the network in order to establish communication and allow configuration via the network. Therefore, this step is critical to the success of the FR-A5ND Option Unit's configuration.

- (1) Upon power-up, the FR-A5ND Option Unit will default to a communication speed of 125kbps.
- (2) The baud rate may be set via the network using "Baud Rate," attribute 2 of DeviceNet Class 0x03, instance 1. See page 39 for further information.
- (3) The baud rate may be set manually via the parameter unit by changing Pr. 345. See page 24 for further information.

3.2.2 Set Node Address:

The station number assigned to the FR-A5ND Option Unit on page 10 will determine the default node address upon inverter power-up. If, upon network configuration, an address conflict is found, the Node Address may be set via the using "Node Address," attribute1 of the DeviceNet Class 0x03, instance 1. See page 39 for further information. Another way to set node address is changing Pr. 346 via FR-PU04(V). See page 24 for further information.

3.2.3 DeviceNet I/O Assembly:

Communication between a master device and a slave device on the network requires that the DeviceNet Class 0x04 - "Assembly Object" in both devices be the same.

Default I/O Assembly:

Upon power-up, the FR-A5ND Option Unit will default to Class 0x04 - Output Instance 21 and Class 0x04 - Input Instance 71. See page 40 for further information on DeviceNet Class 0x04 and changing the desired Output and Input Instances.

3.2.4 Polling Rate

Determination of the proper polling rate of the DeviceNet master device is dependent upon the characteristics of the entire network. To minimize potential conflicts and maximize system reliability, a minimum polling rate interval of 30ms is suggested. The user may, at their discretion, adjust this rate as network performance allows.

3.3 Loss of Communications

In the default polled communication mode, the FR-A5ND DeviceNet Option Unit will respond to loss of polling based upon configuration of the Watchdog Timer Action (WDA) bits of Pr. 345 as defined in section 5.1 of this manual. The factory setting of these bits is decimal 0. Such loss of polling may occur upon physical disconnection of network cabling, network power loss, failure within the master, etc.

When the WDA bits of Pr. 345 are set to decimal 0, the inverter will continue to execute the last command received until the communication time-out is reached. This time out value is equal to 4 times the Expected Packet Rate (EPR) as configured by the user. Once the FR-A5ND times out, the inverter will generate an E. OP3 error and decelerate to a stop.

When the WDA bits of Pr. 345 are set to decimal 2, the inverter will continue to execute the last command received until another command is issued. The FR-A5ND will ignore the communication loss, generate no error and automatically reset the connection when communication is restored.

4. Operation

Operation of the inverter changes slightly when the FR-A5ND is installed. These changes are described in the following paragraphs. Parameter definitions including newly created parameters, as well as operation with the FR-A5ND installed are described.

4.1 Operation Modes

PU operation mode

Control of the inverter is from the parameter unit (PU).

External operation mode

Control of the inverter is by external signals connected to the inverter's terminal block.

Network (computer link) operation mode

Control of the inverter is via commands from a DeviceNet master. However, FR-A5ND-specific Pr. 338 and Pr. 339 can be used to select external control for forward/reverse/stop and output frequency setting.

4.2 Operation Mode Selection

The following chart describes the required actions to change the operation mode.

mode change	required action
External operation → PU operation	Press PU key on parameter unit
PU operation → external operation	Press EXT key on parameter unit
External operation → network operation	Valid DeviceNet connection is completed
Network operation → external operation	All DeviceNet connections are released

For all other mode changes, consult the inverter manual.

When Pr. 79=0 (factory setting), the following conditions must also be met before a mode change can be effected:

- inverter is stopped
- Forward and reverse commands are off

Use 0 or 6 (switch over mode) value for Pr. 79.

Pr. 340 allows selection of network operation mode on power up and after a drive reset. See page 28 for further information.

4.3 Functions Available in Operation Modes

The functions of the drive depend on the mode of the drive. The following chart indicates the available commands according to the inverter operation mode.

Control type	Command type	Operation mode		
		Net mode	External mode	PU mode
DeviceNet master module	Operation command	yes*1	no	no
	Output frequency/speed setting	yes*1	no	no
	Monitor	yes	yes	yes
	Parameter write *3	—	—	—
	Parameter read *3	—	—	—
	Inverter reset	yes*2	no	no
External terminals	Operation command	yes*1	yes	no
	Output frequency/speed setting	yes*1	yes	no
	Inverter reset	yes	yes	yes

*1 Depends on value of Pr. 338 and Pr. 339

*2 Inverter can't be reset if communication line error has occurred.

*3 The following chart indicates parameter read/write validity from Network at each status of Figure 4-1.

Status	(A)	(B)	(C)	(D)	(E)
Drive Mode	External mode	PU mode	External mode	PU mode	NET mode
Connection	Not established	Not established	Established	Established	Established
LED Condition	Blinking Green	Blinking Green	Steady Green	Steady Green	Steady Green
Read	no	no	yes	yes	yes
Write	no	no	no	no	yes
Error message	no	no	yes	yes	yes

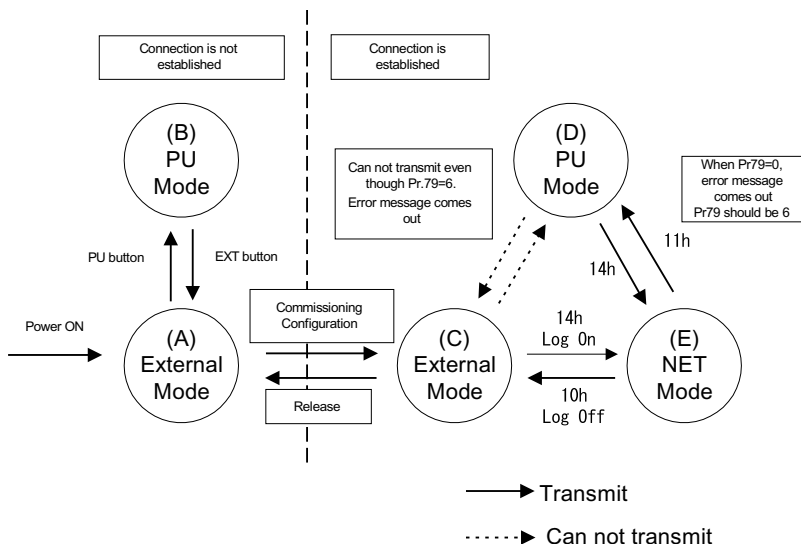

Figure 4-1 : Drive mode status

4.4 Input from Network to inverter

4.4.1 Control input commands

FR-A5ND supports STF and STR. Some other Control Input Commands are supported as well.

4.4.2 Output frequency/speed setting

Output frequency/output speed can be set. The setting range varies according to the inverter.

4.4.3 Inverter reset

Inverter can be reset via DeviceNet using Identity object reset service. Note that this reset service also performs a parameter clear, the type of which depends on the type of the identity reset service. See page 38, 52 and 54 for relevant implementations.

FR-A500(L)/F500(L) seriesrefer to pages 38, 52 and 55

FR-V500 seriesrefer to pages 69, 83 and 86

4.4.4 Parameter writing

For parameter writing, all standard parameters are supported. In addition, the parameters listed in the Option-specific Parameter section of this specification are supported.

4.5 Output from Inverter to Network

4.5.1 Inverter status

Inverter status can be monitored using class 0x2A, instance 1, attribute 114. This is a bitmapped status byte defined as follows:

bit	Definition			
	FR-A500(L)/F500(L)		FR-V500	
0	Running	(RUN)	Running	(RUN)
1	Forward running	(FWD)	Forward running	(FWD)
2	Reverse running	(REV)	Reverse running	(REV)
3	Up to frequency	(SU)	Up to speed	(SU)
4	Overload	(OL)	Overload	(OL)
5	Instantaneous power failure	(IPF)	Instantaneous power failure	(IPF)
6	Frequency detection	(FU)	Frequency detection	(FB)
7	Alarm	(ABC)	Alarm	(ABC)
8-14	(Not used)	-	(Not used)	-
15	Operation ready	(READY)	Operation ready	(READY)

FR-A500(L)/F500(L) seriesrefer to page 55

FR-V500 seriesrefer to page 86

4.5.2 Inverter monitoring

The following items can be monitored:

Inverter status can be monitored using class 0x2A, attribute 170 to 198.

FR-A500(L)/F500(L) seriesrefer to page 57

FR-V500 seriesrefer to page 88

Output frequency	Output current peak value	Cumulative energization time
Output current	Converter output voltage peak value	Orientation status (*1,2)
Output voltage	Input power (*2)	Actual operation time
Frequency setting	Output power (*2)	Motor load factor
Running speed (r/min)	Input terminal status	Cumulative power (*2)
Motor torque (*1)	Output terminal status	Torque command (*3)
Converter output voltage	Load meter	Torque current command (*3)
Regenerative brake duty (*1)	Motor excitation current (*1)	Motor output (*3)
Electronic overcurrent protection load factor	Position pulse (*1)	Feedback pulse (*3)

*1 These items can not be monitored with the FR-F500(L) series.

*2 These items can not be monitored with the FR-V500 series.

*3 These items can be monitored with the FR-V500 series only.

CAUTION

Input/Output terminal assignment functions depend on programmed functions such as brake sequence. Refer to page 54 for more details.

4.5.3 Parameter Read

For parameter reading, all standard parameters are supported. In addition, the parameters listed in the Option-specific Parameter section of this specification are supported.

Some inverter parameters require configuration to be viewed via the PU. All supported parameters are fully accessible regardless of inverter configuration in such cases.

4.6 Inverter Reset

Inverter reset behavior is as noted in page 20.

4.7 Setting Frequency/Speed Value

To change frequency/speed setting value in RAM, access it by Attr.#112 and #113 of Class 0x2A AC Drive Object.

FR-A500(L)/F500(L) seriesrefer to page 55

FR-V500 seriesrefer to page 86

4.8 Parameter Clear (Pr Clr) Commands

To access various Pr Clr Commands, use Attr.#'s 102 to 107 Of Class 0x2A ACDrive Object.

4.9 Control Input Instruction

To send any Control Input Instruction to the inverter, use Class 0x2A instance 1 attribute 114. For example, setting it with value 0x0002 (STF) will cause the inverter to run FWD.

Refer to the following bitmap tables for details:

The following items can be sent to the inverter as control input instruction.

bit	FR-A500(L)/F500(L) series	FR-V500 series
	Running command (signal name)	Running command (signal name)
0	(Blank)	(Blank)
1	Forward rotation command (STF)	Forward rotation command (STF)
2	Reverse rotation command (STR)	Reverse rotation command (STR)
3	High speed operation command (RH)	Low speed operation command (RL)
4	Middle speed operation command (RM)	Middle speed operation command (RM)
5	Low speed operation command (RL)	High speed operation command (RH)
6	JOG operation selection (JOG)	Second function selection (RT)
7	Second function selection (RT)	DI11 terminal function selection *1
8	Current input selection (AU)	DI12 terminal function selection *1
9	Automatic restart after instantaneous power failure selection (CS)	DI13 terminal function selection *1
10	Output stop (MRS)	Output stop (MRS)
11-15	(Blank)	(Blank)

*1 Functions can be assigned using Pr. 400 to Pr. 402 when the FR-A5ND is fitted.

FR-A500(L)/F500(L) seriesrefer to page 55

FR-V500 seriesrefer to page 86

5. FR-A5ND SPECIFIC PARAMETERS

There are several parameters which are used only when the FR-A5ND is installed in the inverter. The following sections describe these parameters.

5.1 Startup Data

Use Pr. 345 to Pr. 348 to set startup data of the network. They are described below. Use them to override DIP Switch settings, i.e., to do software reset of MAC ID. These are Read-Only parameters from DeviceNet.

(1) To support the FR-A5ND, new parameters were created.

Pr. No.	Function	Setting Range (Factory Setting)		Minimum Increments
		Accessed from the DU04(-1)	Accessed from the PU04(V), DeviceNet (*1)	
345	DeviceNet address startup data (low byte)	0 to 255 (63 (0x3F))	0 to 65535 (41023 (0xA03F))	1
346	DeviceNet address baud rate startup data (low byte)	0 to 255 (132 (0x84))	0 to 65535 (20612 (0x5084))	1
347	DeviceNet address startup data (high byte)	0 to 255 (160 (0xA0))	0 to 255 (160 (0xA0))	1
348	DeviceNet address baud rate startup data (high byte)	0 to 255 (80 (0x50))	0 to 255 (80 (0x50))	1

Use the hexadecimal integers in the parentheses for bit-map reference only.

REMARKS

(*1) Pr. 345 and Pr. 346 are treated as 16-bit data.

Pr. 345 and Pr. 347 are bit-mapped parameters. The definition is as follows.

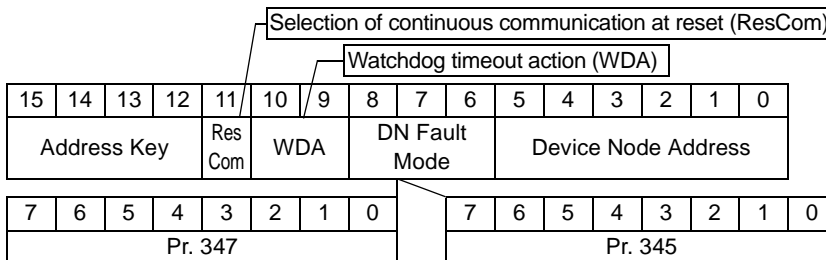

Pr. 346 and Pr. 348 are bit-mapped parameters. The definition is as follows.

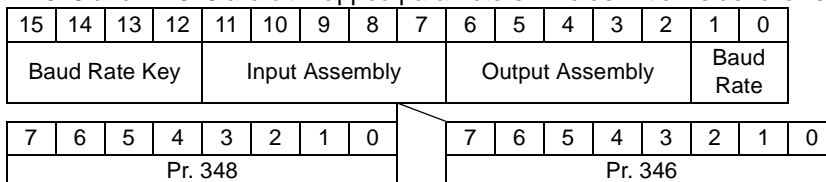

The following table defines each entry.

Name	Description	Semantics	Factory Setting
Watchdog Timeout Action (WDA)	<p>This value provides the action when no message is sent for more than (four times the EPR setting time) period.</p> <p>(Note) If the WDA is changed using the PU then the change is also modified in the E²PROM. But if the WDA is changed using DeviceNet Class5 Instance 2 Attribute 12, the change is valid until the next power cycle or system reset occurs.</p>	<p>0=transition to time out Inverter: E.OP3 LED of FR-A5ND: blinking red Network: Keep connection</p> <p>1=auto delete Inverter: E.OP3 LED of FR-A5ND: solid green Network: Polled I/O connection is disconnected</p> <p>2=auto reset, time out action is ignored Inverter: No E.OP3 LED of FR-A5ND: solid green Network: Keep connection</p>	0
Selection of continuous communication at inverter reset (ResCom) (*1)	Whether the option unit is reset or not at inverter reset can be selected.(Set "1" in Pr. 340.)	<p>0=Both the inverter and option unit are reset</p> <p>1=The option unit continues communication even if the inverter is reset. (*2)</p>	0
Input Assembly (IA) (*3)	<p>This value is used in class 0x04 input instance</p> <p>This value is changed using class 0x29 instance 1 attribute 40</p>	<p>Input instance ID</p> <p>0 = 0x46 = 70 1 = 0x47 = 71 6 = 0x4C = 76</p>	1
Output Assembly (OA) (*3)	<p>This value is used in class 0x04 output instance</p> <p>This value is changed using class 0x29 instance 1 attribute 41</p>	<p>Output instance ID</p> <p>0 = 0x14 = 20 1 = 0x15 = 21 6 = 0x1A = 26</p>	1
Baud Rate (BR)	<p>This value provides the Baud Rate.</p> <p>This value is changed using class 0x03 instance 1 attribute 2</p>	<p>0,3 = 125 kbps 1 = 250 kbps 2 = 500 kbps</p>	0

FR-A5ND SPECIFIC PARAMETERS

Name	Description	Semantics	Factory Setting
Device Address (Addr) (*4)	This value provides the Node Address(MAC ID). This value is changed using class 0x03 instance 1 attribute 1	Node address; range is 0 to 63 (same as attribute semantics)	63
Address Key (AKey)	Internal Validation	1010(Binary)-Preset; None o.w.	1010 (*5)
Baudrate Key (BKey)	Internal Validation	0101(Binary)-Preset; None o.w.	0101 (*5)

- *1 If selection of continuous communication at inverter reset is set, communication may not be reestablished depending on the master actions when connection has timed out. In this case, release connection to reestablish communication.
- *2 The inverter starts up in operation mode other than NET mode after the inverter was reset. Thus, set 1 (NET mode startup at power on or reset) in Pr. 340 "link startup mode selection" in advance when selection of continuous communication at inverter reset was selected. Communication continues only after connection is established.
- *3 Input assembly and output assembly must be matching values.
For example, if input assembly is zero, output assembly must be zero.
When the value except 0, 1 and 6 is set, 6 is automatically used.
- *4 Node Address may also be changed using Rotary Switch. The Rotary Switch setting is valid only when Pr. 345 is set to 63.
- *5 When data values other than those described as in the preset value above are entered, the FR-A5ND will use the specified factory settings of WDA, Device Node Address, Input Assy, Output Assy, and Baud Rate.

REMARKS

DN Fault Mode (DFM) Not supported. DFM should be zero.

Normally, these parameters will not be accessed via the FR-PU04(V) parameter unit. Instead, a DeviceNet user will access the various fields of these parameters via DeviceNet and set them according to the table above. However, if a DeviceNet Configuration Software tool is not used, Pr. 345 and Pr. 346 must be set manually via the FR-PU04(V). (The parameters can not be changed using the FR-DU04(-1))

(1) Setting method of Pr. 345 "DeviceNet address startup data (low byte)"
Pr. 345 Formula:

$$\text{Pr. 345} = (\text{Akey} \times 4096) + (\text{ResCom} \times 2048) + (\text{WDA} \times 512) + (\text{DFM} \times 64) + \text{Addr}$$

Name	Range	Factor	Example 1	Example 2	Example 3
Akey	10	4096	10×4096	10×4096	10×4096
ResCom	0-1	2048	0×2048	1×2048	0×2048
WDA	0-3	512	0×512	1×512	2×512
DFM	0	64	0×64	0×64	0×64
Addr	0-63	1	63×1	4×1	10×1
Sum (Pr. 345)	--	--	41023	43524	41994

Akey = 10 only

ResCom = 0

WDA = 0

DFM = 0 only

Addr = 63

$$\text{Sum} = (10 \times 4096) + (0 \times 2048) + (0 \times 512) + (0 \times 64) + (63 \times 1) = 41023$$

(2) Setting method Pr. 346 "DeviceNet baud rate startup data (low byte)"

$$\text{Pr. 346 Formula: Pr. 346} = (\text{Bkey} \times 4096) + (\text{IA} \times 128) + (\text{OA} \times 4) + \text{BR}$$

Name	Range	Factor	Example 1	Example 2	Example 3
Bkey	5	4096	5×4096	5×4096	5×4096
IA	0-6	128	1×128	0×128	6×128
OA	0-6	4	1×4	0×4	6×4
BR	0-2	1	0×1	1×1	2×1
Sum (Pr. 346)	--	--	20612	20481	21274

Bkey = 5 only

IA = 1 for Instance 71

OA = 1 for Instance 21

BR = 0 for 125kbps

$$\text{Sum} = (5 \times 4096) + (1 \times 128) + (1 \times 4) + (0 \times 1) = 20612$$

5.2 Other Option-Specific Parameters

The following table identifies option-specific parameters which are used for the FR-A5ND.

Parameter No.	Function	Setting Range	Minimum Increment	Default Setting
338	Operation control command source	0, 1	1	0
339	Speed command source	0, 1	1	0
340	Link start-up mode selection	0, 1, 2	1	0

Below is the definition for Pr. 338 and Pr. 339.

Control Source Selection		Functions													
Pr. 338 (control)	Pr. 339 (speed ref.)	STF	STR	STOP	JOG	RT	2	4	1	RH, RM, RL	AU	RES	MRS	OH	CS
0 (Device Net)	0 (Device Net)	DN	DN	—	—	DN	DN	DN	DN	DN	—	both	both	ext	ext
0 (Device Net)	1 (External terminal)	DN	DN	—	—	DN	ext	ext	ext	ext	ext	both	both	ext	ext
1 (External terminal)	0 (Device Net)	ext	ext	ext	ext	ext	DN	DN	DN	DN	—	both	ext	ext	ext
1 (External terminal)	1 (External terminal)	ext	ext	ext	ext	ext	ext	ext	ext	ext	ext	both	ext	ext	ext

ext - control is via input to external terminal

DN - control is via DeviceNet

both - control is via either external terminals or DeviceNet

'-' - control is via neither external terminals nor DeviceNet

Definition for Pr. 340:

Value	Function
0	The inverter operates in the external operation mode after power-up or inverter reset.
1	The inverter operates in the network operation mode after power-up or inverter reset.
2	The inverter operates in the network operation mode after power-up or inverter reset. However, it will resume the pre-instantaneous power failure operation mode after an instantaneous power failure occurs.

5.3 Operation at Communication Error Occurrence

5.3.1 Operation selection at communication error occurrence (For the FR-A500/V500 series only)

You can select operations at error occurrences by setting Pr. 500 to Pr. 502 under network operation.

REMARKS

For the FR-A500 series, Pr. 500 to Pr. 502 are available with an upgraded inverter. Refer to the inverter manual for the availability of the parameters.

- Parameter setting

1) Pr. 500 "communication error recognition waiting time"

You can set the waiting time from when a communication line fault occurs until it is recognized as a communication error.

Parameter Number	Setting Range	Minimum Setting Increments	Factory Setting
500	0 to 999.8s	0.1s	0

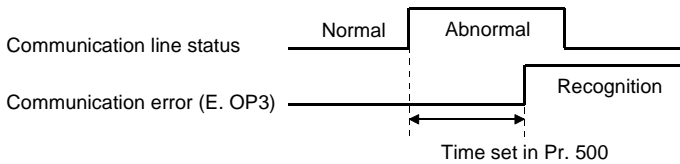

If the communication line fault still persists after the time set in Pr. 500 has elapsed, it is recognized as a communication error.

When the fault is restored to normal communication within the set time, it is not regarded as a communication error and operation continues.

FR-A5ND SPECIFIC PARAMETERS

2) Pr. 501 "communication error occurrence count display"

The cumulative number of communication error occurrences can be indicated. Write 0 to erase this cumulative count.

Parameter Number	Setting Range	Minimum Setting Increments	Factory Setting
501	0	1	0

Count timing depending on communication line status

Normal Abnormal Normal Abnormal

Incremented by 1 Incremented by 1

At the point of communication line fault occurrence, Pr. 501 "communication error occurrence count display" is incremented by 1.

CAUTION

The communication error occurrence count is stored into RAM temporarily. Since this data is stored in E²PROM at one-hour intervals, performing power-on reset or inverter reset may cause the Pr. 501 data to be the value stored in E²PROM the last time depending on the reset timing.

3) Pr. 502 "communication error-time stop mode selection"

You can select the inverter operation if a communication line fault or a fault of the option unit itself occurs.

Parameter Number	Setting Range	Minimum Setting Increments	Factory Setting
502	0, 1, 2	1	0

About setting

• At Fault Occurrence

Fault	Pr. 502 Setting	Operation	Indication	Alarm output
Communication line	0	Continued*	Normal indication*	Not provided*
	1			
	2			
Option itself	0	Coast to stop	E. 3 lit	Provided
	1, 2	Decelerated to stop	E. 3 lit after stop	Provided after stop

* If the fault status returns to the normal communication status within the time set in Pr. 500 , communication line fault (E.OP3) does not occur.

• At Fault Recognition after Elapse of Pr. 500 Time

Fault	Pr. 502 Setting	Operation	Indication	Alarm output
Communication line	0	Coast to stop	E.OP3 lit	Provided
	1	Decelerated to stop	E.OP3 lit after stop	Provided after stop
	2	Decelerated to stop	E.OP3 lit after stop	Not provided
Option itself	0	Coast to stop	E. 3 lit	Provided
	1, 2	Decelerated to stop	E. 3 lit after stop	Provided after stop

• At Fault Removal

Fault	Pr. 502 Setting	Operation	Indication	Alarm output
Communication line	0	Kept stopped	E.OP3 kept lit	Kept provided
	1			
	2	Restart	Normal indication	Not provided
Option itself	0	Kept stopped	E. 3 kept lit	Kept provided
	1, 2			

CAUTION

1. A communication line fault [E.OP3 (alarm data: HA3)] is a fault that occurs on the communication line, and a fault of the option unit itself [E. 3 (alarm data: HF3)] is a communication circuit fault in the option.
 2. The alarm output is the ABC contact output or alarm bit output.
 3. When the Pr. 502 setting is "1" or "2", the deceleration time is the ordinary deceleration time setting (e.g. Pr. 8, Pr. 44, Pr. 45).
 4. The acceleration time at a restart is the ordinary acceleration time setting (e.g. Pr. 7, Pr. 44).
 5. When the Pr. 502 setting is "2", the operation/speed command at a restart is the one given before the fault occurrence.
 6. When the setting was made to provide an alarm output, the fault definition is stored into the alarm history.
(The fault definition is written to the alarm history when an alarm output is provided.)
When no alarm output is provided, the fault definition overwrites the alarm indication of the alarm history temporarily, but is not stored.
After the fault is removed, the alarm indication is reset and returns to the ordinary monitor, and the alarm history returns to the preceding alarm indication.
 7. When a communication line fault occurs at the Pr. 502 setting of "2", removing the fault during deceleration causes acceleration to restart at that point.
(Acceleration is not restarted if the fault is that of the option unit itself.)
-
-

5.3.2 Alarm and measures

(1) The inverter operates as follows at alarm occurrences

Fault Location	Status		Operation Mode		
			PU operation	External operation	Network operation
Inverter alarm	Inverter operation		Inverter trip	Inverter trip	Inverter trip
	Data communication		Continued	Continued	Continued
Communication line alarm	Inverter operation		Continued	Continued	Inverter trip (Depends on the Pr. 502 setting)
	Data communication		Stop	Stop	Stop
Option itself	Communication option connection fault	Inverter operation	Inverter trip (Depends on the Pr. 502 setting)	Inverter trip (Depends on the Pr. 502 setting)	Inverter trip (Depends on the Pr. 502 setting)
		Data communication	Continued	Continued	Continued
	Option unit alarm	Inverter operation	Continued	Continued	Inverter trip (Depends on the Pr. 502 setting)
		Data communication	Stop	Stop	Stop

(2) Measures at alarm occurrences

Alarm Indication	Alarm Definition	Measures
E. OP3	Communication line alarm	Check the LED states of the option unit and remove the cause of the alarm. (Refer to page 13 for the LED indication status.) Check the master module.
E. 3	Option alarm	Check the connection between the inverter and option unit for poor contact, etc. and remove the cause of the alarm.

When alarms other than the above are displayed, refer to the inverter manual and remove the cause of the alarm.

5.3.3 Inverter reset

Which resetting method is allowed or not allowed in each operation mode is described below.

Resetting Method		Operation Mode		
		Network operation	External operation	PU operation
Master module	Inverter reset • Inverter reset can be made any time.	Allowed	Disallowed	Disallowed
	Error reset at inverter fault • Reset can be made only when the protective function of the inverter is activated.	Allowed	Allowed	Allowed
Connect terminals RES-SD		Allowed	Allowed	Allowed
Switch off inverter power		Allowed	Allowed	Allowed

CAUTION

1. **When a communication line fault has occurred, reset cannot be made from the master module.**
2. **The inverter is set to the external operation mode if it has been reset in the network operation mode.**
To resume the network operation, the inverter must be switched to the network operation again.
(When "1" or "2" is set in Pr. 340 "link startup mode selection", switching is not needed. Refer to page 28.)
3. **Communication stops for about 1s during inverter reset.**

6. OBJECT MAP DEFINITIONS

<Object model of DeviceNet>

For DeviceNet, each node is modeled as collections of objects (abstraction of particular functions of the products).

Each node, therefore, can draw an object model map internally from characteristic of each function. This is an object map.

The following four terms are used to describe object.

Items	Definitions
Class	Collections of all objects which have same types of functions Generalization of object
Instance	Concrete expression of object
Attribute	Expression of object characteristic
Service	Function supported by object or class

This section explains object definitions for use of the FR-A5ND DeviceNet. For details of the definitions, consult the DeviceNet documentation available from ODVA.

Class	Object Name
0x01	Identity Object
0x03	DeviceNet Object
0x04	Assembly object
0x05	DeviceNet Connection Object
0x28	Motor Data Object
0x29	Control Management Object
0x2A	AC Drive Object
0x66	Extended Object I
0x67	Extended Object II
0x70 to 0x79	Extended Object III

In the following tables, Get and Set mean:

Get :Read from inverter

Set :Write to inverter

6.1 Response Timing

Response time differs according to request types to the FR-A5ND.
The following explains response time taken to respond to each request.

(1) Polling: Reading Request

Conditions: Explicit Messaging (G2&G3)

Get: from when Attribute is executed until reading data is output

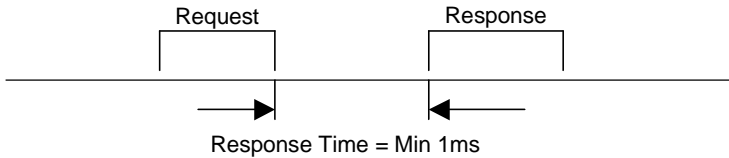

(2) Polling: Writing Request (excluding (3) below)

Conditions: Explicit Messaging (G2&G3)

Set: from when Attribute is executed until writing is completed

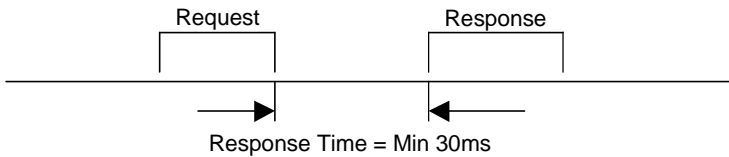

(3) PrClr, PrAllClr, PrUsrClr, PrClr(ECP), PrAllClr(ECP), PrUsrClr(ECP):

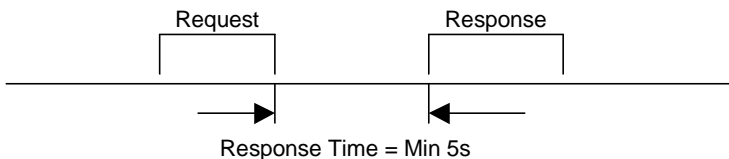

6.2 Recommendation For Software Developers

For software developers only:

- a. Make a handshake procedure, send a request, wait for response, then go to next request.
- b. Set waiting time between each message based on FR-A5ND specifications above, e.g. for reading set to 1ms each time; for writing set to 30ms each time.

6.3 Connection with OMRON Master

Make sure that you perform the master setup of either (a) or (b) before connecting the FR-A5ND to the OMRON master (C200HW-DRM21-V1, and CVM1-DRM21-V1).

- (a) Use the OMRON master in auto scan mode.
- (b) If you use the OMRON master in scan list valid mode, extend the master communication interval time to greater than 200ms. (Use the OMRON configurator for the setting up the master communication interval time.)

7. OBJECT MAP—A500(L)/F500(L) SERIES

This section describes the object definitions for the FR-A5ND DeviceNet implementation. For details of the definitions, consult the DeviceNet documentation available from ODVA.

7.1 Class 0x01 - Identity Object

7.1.1 Class 0x01 Attributes - Instance 0

#	Access	Attribute	Type	Value
1	Get	Revision	Word	1
2	Get	Maximum Instance	Word	1
6	Get	Maximum Class Attributes	Word	7
7	Get	Maximum Instance Attributes	Word	7

7.1.2 Class 0x01 Services - Instance 0

#	Service
0x0E	Get Attribute Single

7.1.3 Class 0x01 - Instance 1

Attr#	Access	Attribute	Type	Range	Value
1	Get	Vendor ID	Word	0 to 65535	82
2	Get	Product Type	Word	0 to 65535	02
3	Get	Product Code	Word	0 to 65535	500 (*1)
4	Get	Revision	Struct	0 to 0xFFFF	1. YYY (*2)
5	Get	Status	Word	0 to 0xFFFF	0000
6	Get	Serial Number	Double Word	00000000 to 0xFFFFFFFF	xxxxxxxx
7	Get	Name	5 bytes		A500 (*3)

*1 For the FR-F500 series, the value is "503".

*2 High byte means Integer and Low byte means decimal. For example, 0x010A means version 1.010.

*3 The actual data are 0x04 0x41 0x35 0x30 0x30. 0x04 means the number of bytes, 4 bytes. 0x41 0x35 0x30 0x30 means ASCII code of "A500". For the FR-F500 series, the value is "F500".

7.1.4 Class 0x01 Instance Services - Instance 1

#	Service	Description
0x05	Reset	0- Reset 1- Pr All Clr & Reset
0x0E	Get Attribute Single	

7.2 Class 0x03 - DeviceNet Object

7.2.1 Class 0x03 Attributes - Instance 0

None. Not Applicable, Not Related To FR-A500(L)/F500(L).

7.2.2 Class 0x03 Services - Instance 0

None. Not Applicable, Not Related To FR-A500(L)/F500(L).

7.2.3 Class 0x03 - Instance 1

Attr#	Access	Attribute	Range	Value
1	Get/Set	Node Address (MAC ID) (*1)	00 to 63	63
2	Get/Set	Baud Rate (*1) 00, 03 : 125kbps 01 : 250kbps 02 : 500kbps	00 to 02	00
3	Get/Set	Bus Off Interrupt(*2) 00: Hold the CAN chip in tis bus-off (reset) state upon detection of a bus-off indication. 01: If possible, fully reset the CAN chip and continue communicating upon detection of a bus-off indication	00 to 01	00
4	Get/Set	Bus Off Counter (*2) It counts number of bus-off interrupts.	00 to 255	00
5	Get	Allocation Information	00 to 0xFFFF	e.g. 0x0103
8	Get	MAC ID Switch Value	00 to 63	00

*1 See also Class 0x67, Attrs.45 and 46.

*2 Bus Off interrupt and Bus Off Counter are not supported via FR-A5ND.

REMARKS

See DeviceNet specifications Vol. I, 5-5 for detail definition.

7.2.4 Class 0x03 Instance Services - Instance 1

#	Service
0x4B	Allocate
0x4C	Release
0x0E	Get Attribute Single
0x10	Set Attribute Single

7.3 Class 0x04 - Assembly Object

7.3.1 Class 0x04 - Output Instance 20 (0x14)

Instance 20	Byte	Bit 7	Bit 6	Bit 5	Bit 4	Bit 3	Bit 2	Bit 1	Bit0
	0						Fault Reset		Run Fwd
	1	00							
	2	Speed Reference (Low Byte)							
	3	Speed Reference (High Byte)							

7.3.2 Class 0x04 - Output Instance 21 (0x15) Default

Instance 21	Byte	Bit 7	Bit 6	Bit 5	Bit 4	Bit 3	Bit 2	Bit 1	Bit0
	0		Net Ref	NetCtrl			Fault Reset	Run Rev	Run Fwd
	1	00							
	2	Speed Reference (Low Byte)							
	3	Speed Reference (High Byte)							

7.3.3 Class 0x04 - Output Instance 26 (0x1A)

Instance 26	Byte	Bit 7	Bit 6	Bit 5	Bit 4	Bit 3	Bit 2	Bit 1	Bit0
	0	Write Param	Net Ref	NetCtrl			Fault Reset	Run Rev	Run Fwd
	1	Parameter Instance No.							
	2	(Low Byte) Speed Ref or Parameter Write Data							
	3	(High Byte) Speed Ref or Parameter Write Data							
	4	Parameter Class							
	5	Parameter Attribute Number							

Output instance 26 (0x1A) provides write/read parameter access control of the parameter class, parameter instance No., and attribute No. specified by the above Byte 4 and 5. It also provides parameter data (Byte 2 and 3) write operation to the class.

Use Class 0x29 Instance 1 Attribute 41 to select Output Assembly Instance, make sure it matches Input Assembly Instance. For example, Output Instance 26 **must** be used together with Input Instance 76 in those applications requiring parameter access.

Output Instance 26 (0x1A) provides write/read parameter access control of the parameter class, the parameter attribute number of only Instance 1 of that Class, and the parameter data for a write operation.

Output Instance 26 utilizes 6 data bytes.

The Output Instance 26 bytes operates in the following manner:

Byte No.	Bit No.	Name	Definitions
0	7	Write Parameter	If Write Parameter=0, the value of Byte 2 and Byte 3 are written to the parameter as Speed Ref.
			If Write Parameter=1, the value of Byte 2 and Byte 3 are written to the parameter class and attribute indicated by Byte 4 and Byte 5 as parameter write data.
	6	NetRef	If NetRef =1, the Speed Ref is taken from Byte 2 and Byte 3.
	5	NetCtrl	If NetRef =0, Bit 2, Bit 1, and Bit 0 are ignored.
			If NetRef =1, Bit 2, Bit 1, and Bit 0 are valid.
	4		Not used.
	3		Not used.
	2	Fault Reset	If Fault Reset is set to 1, then the inverter is reset when an alarm occurs.
	1	Run Fwd	If Run Rev =1 and Run Fwd =0, the drive rotates in the reverse direction. If Run Fwd =1 and Run Rev =0, the drive spins in the forward direction.
0	Run Rev		
1		Instance No. can be specified. When 00 is specified, instance No. is regarded as 1.	
2		Low Byte of the Speed Ref or parameter write data	
3		High Byte of the Speed Ref or parameter write data	
4		Parameter Class , e.g. 0x2A, 0x66, 0x67	
5		Parameter Attribute Number, e.g. 0x0A, 0x65	

7.3.4 Class 0x04 - Input Instance 70 (0x46)

Instance 70	Byte	Bit 7	Bit 6	Bit 5	Bit 4	Bit 3	Bit 2	Bit 1	Bit0
	0						Run(1) Fwd		Faulted
	1	00							
	2	Speed Actual (Low Byte)							
	3	Speed Actual (High Byte)							

**7.3.5 Class 0x04 - Input Instance 71 (0x47)
Default**

Instance 71	Byte	Bit 7	Bit 6	Bit 5	Bit 4	Bit 3	Bit 2	Bit 1	Bit0
	0	AtRef Speed	Ref From Net	Ctrl From Net	Ready	Run(2) Rev	Run(1) Fwd		Faulted
	1	00							
	2	Speed Actual (Low Byte)							
	3	Speed Actual (High Byte)							

7.3.6 Class 0x04 - Input Instance 76 (0x4C)

Instance 76	Byte	Bit 7	Bit 6	Bit 5	Bit 4	Bit 3	Bit 2	Bit 1	Bit0
	0	AtRef Speed	Ref From Net	Ctrlol From Net	Ready	Run(2) Rev	Run(1) Fwd	Operation control mode	Faulted
	1	00							
	2	Speed Actual (Low Byte)							
	3	Speed Actual (High Byte)							
	4	Parameter Read (Low Byte)							
	5	Parameter Read (High Byte)							

Use Class0x29 Instance 1 attribute 40 to select Input Assembly Instance, make sure it matches Output Assembly Instance. For example, Input Instance 76 **must** be used together with Output Instance 26 in those applications requiring parameter access.

The Input Instance 76 (0x4C) provide 16 bits of parameter data.

Input Instance 76 utilizes 6 data bytes.

The Input Instance 76 bytes operates in the following manner:

Byte No.	Bit No.	Name	Definitions
0	7	At Ref Speed	The drive is very close to or at the Ref Speed.
	6	Ref From Net	Speed setting comes from the DeviceNet master. (This value is same as opposite value of Pr. 339)
	5	Control From Net	Fault Reset, Run Rev, Run Fwd come from the DeviceNet Master. (This value is same as opposite value of Pr. 338)
	4	Ready	The value is always "1" while communication is established.
	3	Run Rev	Drive is rotating in the reverse direction.
	2	Run Fwd	Drive is rotating in the forward direction.
	1	Operation control mode	0: Run command from the DeviceNet master is disabled. 1: Run command from the DeviceNet master is enabled. (*2)
	0		The drive is in a fault state.
1		Must be zero.	
2		Low Byte of the Speed Actual.	
3		High Byte of the Speed Actual.	
4		Low Byte of Parameter Read.(*1)	
5		High Byte of Parameter Read.(*1)	

*1 The Read data may still be the previous data immediately following Parameter Write. Allow at least 1s prior to reading parameter data after a parameter write is performed.

*2 Bit status in the run command mode is as follows. (Refer to page 28 for operation command source and speed command source.)

Inverter Status			Operation control mode bit
Current operation mode	Operation control command source (Pr. 338)	Speed control command source (Pr. 339)	
NET	0: NET	0: NET	1
	0: NET	1: EXT	0
	1: EXT	0: NET	
	1: EXT	1: EXT	
Other than NET	—	—	

7.4 Class 0x05 - DeviceNet Connection Object

FR-A5ND supports only Polled I/O and Explicit Msg, not Bit-Strobed I/O.

7.4.1 Class 0x05 Attributes - Instance 0

None. Not Applicable, Not Related To FR-A500(L)/F500(L).

7.4.2 Class 0x05 Services - Instance 0

None. Not Applicable, Not Related To FR-A500(L)/F500(L).

7.4.3 Class 0x05 Instance 1 - Explicit Messaging

Attr#	Access	Attribute	Range	Value
1	Get	State	00 to 04	00:Non-existent 01:Configuring 02:Waiting for connection ID 03:Established 04:Timed out
2	Get	Instance Type	00 to 01	00:Explicit Messaging
3	Get	Transport Trigger Class	00 to 0xFF	0x83: Server Transport Class 3
4	Get	Produced Connection ID	0 to 0xFFFF	The value to be placed in the CAN Identifier Field when this Connection transmits e.g. 0x0740: That means Group 3 Explicit response message of Slave, Source MAC ID = 0
5	Get	Consumed Connection ID	0 to 0xFFFF	This value will be specified in the CAN Identifier Field of messages that are to be consumed. e.g. 0x0780: That means Group 3 Explicit request message of Master, destination MAC ID = 0.
6	Get	Initial Comm Characteristics	0 to 0xFF	0x33: Source : Group 3 message Destination : Group 3 message

OBJECT MAP—A500(L)/F500(L) SERIES

Attr#	Access	Attribute	Range	Value
7	Get	Produced Connection Size	0 to 65535	7 : 7 bytes This value specifies the maximum number of Message Body bytes that a module is able to transmit across the connection.
8	Get	Consumed Connection Size	0 to 65535	7 : 7 bytes This value specifies the maximum number of Message Body bytes that a module is able to receive across the connection.
9	Get/Set	Expected Pack Rate (EPR) (*1)	0 to 65535	e.g. 2500 : 2500ms
12	Get/Set	Watchdog Action (WDA)	0 to 03	0 : Transition to time out 1 : Auto delete (factory setting) 2 : Auto reset 3 : Deferred delete
13	Get	Produced Connection Path Length	0 to 65535	0 Specifies the number of bytes of information within the produced_connection_path attribute.
14	Get	Produced Connection Path	variable	empty
15	Get	Consumed Connection Path Length	0 to 65535	0 Specifies the number of bytes of information within the consumed_connection_path attribute.
16	Get	Consumed Connection Path	variable	empty

*1 Get value is same as Set value.

REMARKS

Refer to Vol.1:5-4 of DeviceNet Specifications for details.

7.4.4 Class 0x05 Instance 2 - Polled I/O

Attr#	Access	Attribute	Range	Value
1	Get	State	00 to 04	See Class0x05 instance1 Attribute 1
2	Get	Instance Type	00 to 01	01 : I/O Messaging
3	Get	Transport Trigger Class	00 to 0xFF	0x82: Server Transport Class 2
4	Get	Produced Connection ID	0 to 0xFFFF	The value to be placed in the CAN Identifier Field when this Connection transmits e.g. 0x03C0: That means Group 1 Polled I/O response message of Slave, Source MAC ID = 0
5	Get	Consumed Connection ID	0 to 0xFFFF	This value will be specified in the CAN Identifier Field of messages that are to be consumed. e.g. 0x0405: That means Group 2 Polled I/O command message of Master, destination MAC ID = 0.
6	Get	Initial Comm Characteristics	0 to 0xFF	0x01: Source : Group 1 message Destination : Group 2 message
7	Get	Produced Connection Size	0 to 65535	4 : 4 bytes(*2) See Class0x05 instance1 Attribute 7
8	Get	Consumed Connection Size	0 to 65535	4 : 4 bytes(*2) See Class0x05 instance1 Attribute 8
9	Get/Set	EPR (*3)	0 to 65535	e.g. 2500 : 2500ms
12	Get/Set	Watchdog Action (WDA)	0 to 02	0 : Transition to time out 1 : Auto delete (factory setting) 2 : Auto reset
13	Get	Produced Connection Path Length	0 to 65535	3 : 3 bytes See Class0x05 instance1 Attribute 13
14	Get	Produced Connection Path (*1)	variable	0x62 0x34 0x37

OBJECT MAP—A500(L)/F500(L) SERIES

Attr#	Access	Attribute	Range	Value
15	Get	Consumed Connection Path Length	0 to 65535	3 : 3 bytes See Class0x05 instance1 Attribute 15
16	Get	Consumed Connection Path (*1)	variable	0x62 0x31 0x35

*1 Use Class 0x29 Instance 1 Attribute 40, Class 0x29 Instance 1 Attribute 41 to change I/O Assembly Instances.

The produced_connection_path and consume_connection_path attributes are made up of a byte stream which defines the Application Object(s). The format is below.

0x62 0xMM 0xNN

0x62 : Logic address

0xMM 0xNN : Application Object Data. This is ASCII Code which shows input/output instance value (HEX).

e.g. When input instance 71 and output instance 21 are used,

(a) Produced_connection_path

71 = 0x47

4 = 0x34 and 7 = 0x37 for ASCII Code

Therefore the produced_connection_path of input instance 71 = 0x62
0x34 0x37

(b) Consumed_connection_path

21 = 0x15

1 = 0x31 and 5 = 0x35 for ASCII Code

Therefore the consumed_connection_path of output instance 21 = 0x62
0x31 0x35

*2 Value dependent

When output instance 20, 21 or input instance 70, 71, the value is 4 bytes.

When output instance 26 or input instance 76, the value is 6 bytes.

*3 Get value is same as Set value.

REMARKS

Refer to Vol.I:5-4 of DeviceNet Specifications for details.

7.4.5 Class 0x05 Instance 4 - Explicit Messaging

Attr#	Access	Attribute	Range	Value
1	Get	State	00 to 04	See Class0x05 instance1 Attribute 1
2	Get	Instance Type	00 to 01	00:Explicit Messaging
3	Get	Transport Trigger Class	00 to 0xFF	0x83: Server Transport Class 3
4	Get	Produced Connection ID	0 to 0xFFFF	e.g. 0x0740: See Class0x05 instance1 Attribute 4
5	Get	Consumed Connection ID	0 to 0xFFFF	e.g. 0x0780: See Class0x05 instance1 Attribute 5
6	Get	Initial Comm Characteristics	0 to 0xFF	0x33: See Class0x05 instance1 Attribute 6
7	Get	Produced Connection Size	0 to 65535	7 : 7 bytes See Class0x05 instance1 Attribute 7
8	Get	Consumed Connection Size	0 to 65535	7 : 7 bytes See Class0x05 instance1 Attribute 8
9	Get/Set	Expected Pack Rate (EPR)	0 to 65535	e.g. 2500 : 2500ms
12	Get/Set	Watchdog Action (WDA)	0 to 03	See Class0x05 instance1 Attribute 12
13	Get	Produced Connection Path Length	0 to 65535	0 See Class0x05 instance1 Attribute 13
14	Get	Produced Connection Path	variable	empty
15	Get	Consumed Connection Path Length	0 to 65535	0 See Class0x05 instance1 Attribute 15
16	Get	Consumed Connection Path	variable	empty

REMARKS

Refer to Vol.I:5-4 of DeviceNet Specifications for details.

7.4.6 Class 0x05 Instance 5 - Explicit Messaging

Attr#	Access	Attribute	Range	Value
1	Get	State	00 to 04	See Class0x05 instance1 Attribute 1
2	Get	Instance Type	00 to 01	00:Explicit Messaging
3	Get	Transport Trigger Class	00 to 0xFF	0x83: Server Transport Class 3
4	Get	Produced Connection ID	0 to 0xFFFF	e.g. 0x0740: See Class0x05 instance1 Attribute 4
5	Get	Consumed Connection ID	0 to 0xFFFF	e.g. 0x0780: See Class0x05 instance1 Attribute 5
6	Get	Initial Comm Characteristics	0 to 0xFF	0x33: See Class0x05 instance1 Attribute 6
7	Get	Produced Connection Size	0 to 65535	7 : 7 bytes See Class0x05 instance1 Attribute 7
8	Get	Consumed Connection Size	0 to 65535	7 : 7 bytes See Class0x05 instance1 Attribute 8
9	Get	Expected Pack Rate (EPR)	0 to 65535	e.g. 2500 : 2500ms
12	Get/Set	Watchdog Action (WDA)	0 to 03	See Class0x05 instance1 Attribute 12
13	Get	Produced Connection Path Length	0 to 65535	0 See Class0x05 instance1 Attribute 13
14	Get	Produced Connection Path	variable	empty
15	Get	Consumed Connection Path Length	0 to 65535	0 See Class0x05 instance1 Attribute 15
16	Get	Consumed Connection Path	variable	empty

REMARKS

Refer to Vol.I:5-4 of DeviceNet Specifications for details.

7.4.7 Class 0x05 Instance 6 - Explicit Messaging

Attr#	Access	Attribute	Range	Value
1	Get	State	00 to 04	See Class0x05 instance1 Attribute 1
2	Get	Instance Type	00 to 01	00:Explicit Messaging
3	Get	Transport Trigger Class	00 to 0xFF	0x83: Server Transport Class 3
4	Get	Produced Connection ID	0 to 0xFFFF	e.g. 0x0740: See Class0x05 instance1 Attribute 4
5	Get	Consumed Connection ID	0 to 0xFFFF	e.g. 0x0780: See Class0x05 instance1 Attribute 5
6	Get	Initial Comm Characteristics	0 to 0xFF	0x33: See Class0x05 instance1 Attribute 6
7	Get	Produced Connection Size	0 to 65535	7 : 7 bytes See Class0x05 instance1 Attribute 7
8	Get	Consumed Connection Size	0 to 65535	7 : 7 bytes See Class0x05 instance1 Attribute 8
9	Get	Expected Pack Rate (EPR)	0 to 65535	e.g. 2500 : 2500ms
12	Get/Set	Watchdog Action (WDA)	0 to 03	See Class0x05 instance1 Attribute 12
13	Get	Produced Connection Path Length	0 to 65535	0 See Class0x05 instance1 Attribute 13
14	Get	Produced Connection Path	variable	empty
15	Get	Consumed Connection Path Length	0 to 65535	0 See Class0x05 instance1 Attribute 15
16	Get	Consumed Connection Path	variable	empty

REMARKS

Refer to Vol.I:5-4 of DeviceNet Specifications for details.

7.4.8 Class 0x05 Instance Services - Instances 1,2,4,5,6

#	Service
0x0E	Get Attribute Single
0x10	Set Attribute Single

7.5 Class 0x28 - Motor Data Object

7.5.1 Class 0x28 Attributes - Instance 0

None. Not Applicable, Not Related To FR-A500(L)/F500(L).

7.5.2 Class 0x28 Services - Instance 0

None. Not Applicable, Not Related To FR-A500(L)/F500(L).

7.5.3 Class 0x28 Instance 1

Attr#	Access	Attribute	Range	Factory Setting
3	Get/Set	Motor Type	0 to 10	7: Induction Motor
6	Get/Set	Rated Current, cf. Pr. 9 (Unit 0.01A)	0 to 65535	0x00FF (*2)
7	Get/Set	Rated Voltage, cf. Pr. 83 (Unit 0.1V) (*1)	0 to 65535	0x07D0
8	Get/Set	Rated Power, cf. Pr. 80 (Unit 0.01kW)	0 to 65535	0xFFFF
9	Get/Set	Rated Frequency, cf. Pr. 84 (Unit 0.01Hz) (*1)	0 to 65535	0x1770
12	Get/Set	Polecount, cf. Pr. 144	0 to 65535	4
15	Get/Set	Base Speed, cf. Pr. 3 (Unit r/min)	0 to 65535	0x0708

*1 Pr. 83 and Pr. 84 are linked to #'s 7 and 9 respectively only if Pr. 80 and Pr. 81 are not factory setting.

*2 The factory setting varies according to the inverter capacity.

REMARKS

Refer to Vol.II:6-28 of DeviceNet Specifications for details.

7.5.4 Class 0x28 Instance Services

#	Service
0x0E	Get Attribute Single
0x10	Set Attribute Single

7.6 Class 0x29 - Control Supervisor Object

7.6.1 Class 0x29 Attributes - Instance 0

None. Not Applicable, Not Related To FR-A500(L)/F500(L).

7.6.2 Class 0x29 Services

None. Not Applicable, Not Related To FR-A500(L)/F500(L).

7.6.3 Class 0x29 Instance 1

Attr#	Access	Attribute	Range	Factory Setting
3	Get/Set	Run1 00 : Stop 01 : Forward	00 to 01	00
4	Get/Set	Run2 00 : Stop 01 : Reverse	00 to 01	00
5	Get/Set	NetControl, cf. Pr338 (*3) 0 : Local Control 1 : Network Control The actual status of Run/Stop control is reflected in attribute 15, ControlFromNet.	00 to 01	01
6	Get	State 1 : Start up 2 : Not ready 3 : Ready 4 : Enabled 5 : Stopping 6 : Fault_Stop 7 : Faulted	0 to 7	3
7	Get	Running1 1 : (Enabled and Run1) or (Stopping and Running1) or (Fault_Stop and Running1) 0 : Other State	0 to 1	0
8	Get	Running2 1 : (Enabled and Run2) or (Stopping and Running2) or (Fault_Stop and Running2) 0 : Other State	0 to 1	0

Attr#	Access	Attribute	Range	Factory Setting
9	Get	Ready 1 : Ready or Enabled or Stopping 0 : Other State	0 to 1	1
10	Get	Faulted 1 : Fault Occurred (latched) 0 : No Fault present	0 to 1	0
12	Get/Set	FaultRst (*1) 0->1 : Fault Reset 0 : No action	0 to 1	0
15	Get	ControlFromNet (*2) 0 : Control is local 1 : Control is from Network	0 to 1	1
16	Get/Set	DNFaultMode (Action on loss of DeviceNet) 0 : Fault + Stop 1 : Ignore 2 to 0xFF : Unsupported	0 to 0xFF	0
40	Get/Set	Input Assembly	70 to 76	0x47(71)
41	Get/Set	Output Assembly	20 to 26	0x15(21)

*1 After reset with 0 ->1, This value must be set to 0 before inverter reset may be performed.

*2 This data is only updated after Inverter Reset or power cycle.

*3 The logic is opposite from Pr. 338. That means attribute 5 = 1 is same as Pr. 338 = 0

REMARKS

Refer to Vol.II:6-29 of DeviceNet Specifications for details.

7.6.4 Class 0x29 Instance Services

#	Service
0x0E	Get Attribute Single
0x10	Set Attribute Single

7.7 Class 0x2A - AC Drive Object

7.7.1 Class 0x2A Attributes - Instance 0

None. Not Applicable, Not Related To FR-A500(L)/F500(L).

7.7.2 Class 0x2A Services

None. Not Applicable, Not Related To FR-A500(L)/F500(L).

7.7.3 Class 0x2A Instance 1

AC Profile Compatibles

Attr#	Access	Attribute	Factory Setting
1	Get	Number of Attributes supported	1
3	Get	At Reference 1 : Drive actual at reference (speed) 0 : Other state	0
4	Get/Set	Net Reference, cf. Pr. 339 (*1) 0 : Set speed not DN Control 1 : Set speed at DN Control The actual status of speed reference is reflected in attribute 29, RefFromNe.	1
6	Get	Drive Mode	0
7	Get	SpeedActual (Actual Drive Speed) Unit : r/min	0
8	Get/Set	SpeedRef (Speed reference) Unit : r/min	0
9	Get	Current Actual (Actual motor phase current) Unit : 0.01A	0
15	Get	Power Actual (Actual output power) Unit : kW	0
17	Get	Output Voltage Unit : V	0
18	Get/Set	AccelerationTime, cf. Pr. 7 Unit : 0.1s	0x0032
19	Get/Set	DecelerationTime, cf. Pr. 8 Unit : 0.1s	0x0032
20	Get/Set	LowSpeedLimit, cf. Pr. 2 Unit : r/min	0
21	Get/Set	HighSpeedLimit, cf. Pr. 1 Unit : r/min	0xFFFF

Attr#	Access	Attribute	Factory Setting
29	Get	ReffFromNet (*2) Status of speed reference 0 : Local speed reference 1 : DeviceNet speed reference	1

*1 The logic is opposite from Pr. 339. That means attribute 4 = 1 is same as Pr. 339 = 0

*2 This data is updated only after Inverter Reset or power cycle.

REMARKS

Refer to Vol.II:6-30 of DeviceNet Specifications for details.

The following variables and parameters are vendor-specific, refer to inverter manual for more details:

System Environment Variables(Class 0x2A Instance 1)

Attr#	Access	Attribute	Write Value
100	Set	User Clear Value Setting	9999
101	Set	Inverter Reset (*1)	0x0000
102	Set	Parameter Clear	0x965A
103	Set	Parameter All Clear	0x99AA
104	Set	Parameter User Clear	0x5A55
105	Set	Parameter Clear (Excluding Communication Parameters) (*2)	0x5A96
106	Set	Parameter All Clear (Excluding Communication Parameters) (*2)	0xAA99
107	Set	Parameter User Clear (Excluding Communication Parameters) (*2)	0x555A
112	Get/Set	Running Frequency (RAM) (*3)	0.01Hz increments
113	Set	Running Frequency (E ² PROM) (*3)	0.01Hz increments
114	Get/Set	Inverter Status/Control Input Cmd (refer to the next page)	(*3)
120	Get/Set	(a)Operating Mode (Get) 0 : Ext mode 1 : PU mode 2 : External JOG 3 : PU JOG 4: Net mode 5: Both PU and Ext mode 6: Program mode (b)Inverter Config (Set) (*4) 0x0010 : Ext mode 0x0011 : PU mode 0x0014 : Net mode	

OBJECT MAP—A500(L)/F500(L) SERIES

- *1 When Pr. 340=0, the drive will default to External mode following a inverter reset.
- *2 Note that the FR-A5ND specific parameters of Pr. 345 to Pr. 348 are cleared.
- *3 Values written to either Pr. 112 or Pr. 113 may be read from Pr. 112.
- *4 Enter only 2 bytes data.

Bit-map for inverter status/control input instruction

Refer to the following bit-map of inverter status.

Bit	Definition	
0	Running	(RUN)
1	Forward running	(FWD)
2	Reverse running	(REV)
3	Up to frequency	(SU)
4	Overload	(OL)
5	Instantaneous power failure	(IPF)
6	Frequency detection	(FU)
7	Alarm	(ABC)
8-14	(Blank)	-
15	Operation ready completion	(READY)

Refer to the following bit-map of control input instruction.

Bit	Definition	
0	(Blank)	-
1	Forward rotation command	(STF)
2	Reverse rotation command	(STR)
3	High speed operation command (*1)	(RH)
4	Middle speed operation command (*1)	(RM)
5	Low speed operation command (*1)	(RL)
6	Jog operation selection (*1)	(JOG)
7	Second function selection (*1)	(RT)
8	Current input selection (*1)	(AU)
9	Instantaneous power failure restart selection (*1)	(CS)
10	Output stop	(MRS)
11-15	(Blank)	-

*1 Input terminal function can be assigned using Pr. 180 to Pr. 186.

Real Time Parameters(Class 0x2A Instance 1)

Attr#	Access	Attribute	Increment Value	
			A500/F500	A500L/ F500L
141	Get/Set	Alarm History 1 (*1)/ Alarm History All Clrm (*2)	—	—
142	Get	Alarm History 2 (*1)	—	—
143	Get	Alarm History 3 (*1)	—	—
144	Get	Alarm History 4 (*1)	—	—
145	Get	Alarm History 5 (*1)	—	—
146	Get	Alarm History 6 (*1)	—	—
147	Get	Alarm History 7 (*1)	—	—
148	Get	Alarm History 8 (*1)	—	—
170	Get	Output frequency	0.01Hz	0.01Hz
171	Get	Output Current	0.01A	0.1A
172	Get	Output Voltage	0.1V	0.1V
174	Get	Frequency Setting Value	0.01Hz	0.01Hz
175	Get	Running Speed	1 r/min	1 r/min
176	Get	Motor Torque	0.01%	0.01%
177	Get	Converter Output Voltage	0.1V	0.1V
178	Get	Regenerative Brake Duty	0.1%	0.1%
179	Get	Electric Over current protection Load Factor	0.1%	0.1%
180	Get	Output Current Peak Value	0.01A	0.1A
181	Get	Converter Output Voltage Peak Value	0.1V	0.1V
182	Get	Input Power	0.01kW	0.1kW
183	Get	Output Power	0.01kW	0.1kW
184	Get	Input Terminal (refer to the next page)	—	—
185	Get	Output Terminal (refer to the next page)	—	—
186	Get	Load Meter	—	—
187	Get	Motor Exciting Current	0.01A	0.1A
188	Get	Position Pulse	—	—
189	Get	Cumulative operation time	1 hour	1 hour
191	Get	Orientation Status	—	—
192	Get	Actual Operation Time	1 hour	1 hour
193	Get	Motor Load Factor	0.1%	0.1%
194	Get	Cumulative Power	1kWh	1kWh

*1 See next page for Alarm Definition vs Alarm #.

*2 Writing any value to #141 resets the alarm history.

OBJECT MAP—A500(L)/F500(L) SERIES

The following is bit-map for input terminal monitor that can be monitored using class 0x2A, attribute 184 and 185.

Bit-map for Input Terminal Monitor:

15..12	11	10	9	8	7	6	5	4	3	2	1	0
0	CS *1	RES	STOP	MRS	JOG *1	RH *1	RM *1	RL *1	RT *1	AU *1	STR	STF

Bit-map for Output Terminal Monitor:

15..6	5	4	3	2	1	0
0	A, B, C *2	FU *2	OL *2	IPF *2	SU *2	RUN *2

The bit-wise data here reflect Pr. 190 to 195, if the assignments for terminals are changed, the bit-map may not be the same.

In the above Bit-maps, 1 means the data is present, 0 means the data is absent.

*1 Use Pr. 180 to Pr. 186 to change the input terminal function.

*2 Use Pr. 190 to Pr. 195 to change the output terminal function.

Table Of Alarm # vs Alarm Definition

#	Definition	#	Definition	#	Definition	#	Definition
10	OC1	80	GF	D1	OSd	F3	E3
11	OC2	81	LF	D2	ECT	F4	E4
12	OC3	90	OHT	D3	Od	F5	E5
20	OV1	A0	OPT	D4	ECA	F6	E6
21	OV2	A1	OP1	D5	Mb1	F7	E7
22	OV3	A2	OP2	D6	Mb2	F8	E8
30	THT	A3	OP3	D7	Mb3	F9	E9
31	THM	B0	PE	D8	Mb4	FA	E10
40	FIN	B1	PUE	D9	Mb5	FB	E11
41	FAN	B2	RET	DA	Mb6	FC	E12
50	IPF	C0	CPU	DB	Mb7	FD	E13
51	UVT	C1	CTE	F0	E0	FE	E14
60	OLT	C2	P24	F1	E1	FF	E15
70	BE	D0	OS	F2	E2		

Refer to the inverter manual for details of alarm definition.

7.7.4 Class 0x2A Instance Services

#	Service
0x0E	Get Attribute Single
0x10	Set Attribute Single

7.8 Class 0x66 - Extended Object I

7.8.1 Class 0x66 Attributes - Instance 0

None. Not Applicable, Not Related To A500(L)/F500(L).

7.8.2 Class 0x66 Services

None. Not Applicable, Not Related To A500(L)/F500(L).

7.8.3 Class 0x66 Instance 1

Parameters

Parameter definition differs according to the inverter. Refer to the inverter manual for details of parameter definition, setting range, or the like.

Attr#	Access	Attribute
10	Get/Set	Pr. 0 Torque Boost (Manual)
11	Get/Set	Pr. 1 Maximum Frequency Limit
12	Get/Set	Pr. 2 Minimum Frequency Limit
13	Get/Set	Pr. 3 Base Frequency
14	Get/Set	Pr. 4 Multi Speed (Hi)
15	Get/Set	Pr. 5 Multi Speed (middle)
16	Get/Set	Pr. 6 Multi Speed (low)
17	Get/Set	Pr. 7 Acceleration Time
18	Get/Set	Pr. 8 Deceleration Time
19	Get/Set	Pr. 9 Electronic Thermal O/L Relay
20	Get/Set	Pr. 10 DC Injection Brake Operation Frequency
21	Get/Set	Pr. 11 DC Injection Brake Operation Time
22	Get/Set	Pr. 12 DC Injection Brake Voltage
23	Get/Set	Pr. 13 Starting Frequency
24	Get/Set	Pr. 14 Applied Load Selection
25	Get/Set	Pr. 15 Jog Frequency
26	Get/Set	Pr. 16 Jog Acceleration/Deceleration Time
27	Get/Set	Pr. 17 MRS input selection
28	Get/Set	Pr. 18 High Speed Maximum Frequency Limit
29	Get/Set	Pr. 19 Base Frequency Voltage
30	Get/Set	Pr. 20 Acceleration/Deceleration Ref Frequency
31	Get/Set	Pr. 21 Acceleration/Deceleration Time Increment*
32	Get/Set	Pr. 22 Stall Prevention Operation
33	Get/Set	Pr. 23 High Speed Stall Prevent
34	Get/Set	Pr. 24 Multi-Speed Setting (4th)
35	Get/Set	Pr. 25 Multi-Speed Setting (5th)

OBJECT MAP—A500(L)/F500(L) SERIES

Attr#	Access	Attribute
36	Get/Set	Pr. 26 Multi-Speed Setting (6th)
37	Get/Set	Pr. 27 Multi-Speed Setting (7th)
38	Get/Set	Pr. 28 Multi-Speed Input Compensation
39	Get/Set	Pr. 29 Acceleration/Deceleration Pattern
40	Get/Set	Pr. 30 Regenerative function selection
41	Get/Set	Pr. 31 Frequency Jump 1A
42	Get/Set	Pr. 32 Frequency Jump 1B
43	Get/Set	Pr. 33 Frequency Jump 2A
44	Get/Set	Pr. 34 Frequency Jump 2B
45	Get/Set	Pr. 35 Frequency Jump 3A
46	Get/Set	Pr. 36 Frequency Jump 3B
47	Get/Set	Pr. 37 Speed Display
51	Get/Set	Pr. 41 Up-to-Frequency Sensitivity
52	Get/Set	Pr. 42 Output Frequency Detect FWD
53	Get/Set	Pr. 43 Output Frequency Detect REV
54	Get/Set	Pr. 44 2nd Acceleration/Deceleration Time
55	Get/Set	Pr. 45 2nd Deceleration Time
56	Get/Set	Pr. 46 2nd Torque Boost
57	Get/Set	Pr. 47 2nd V/F (base frequency)
58	Get/Set	Pr. 48 2nd Stall Prevention Operation Current
59	Get/Set	Pr. 49 2nd Stall Prevention Operation Frequency
60	Get/Set	Pr. 50 2nd Output Frequency Detection
62	Get/Set	Pr. 52 PU Main Display Data Selection
63	Get/Set	Pr. 53 PU Level Display Data Selection
64	Get/Set	Pr. 54 FM Terminal Function Selection
65	Get/Set	Pr. 55 Frequency Monitoring Reference
66	Get/Set	Pr. 56 Current Monitoring Reference
67	Get/Set	Pr. 57 Restart Coasting Time
68	Get/Set	Pr. 58 Restart Cushion Time
69	Get/Set	Pr. 59 Remote Setting Function
70	Get/Set	Pr. 60 Intelligent Mode Selection
71	Get/Set	Pr. 61 Reference Current for Intelligent Mode
72	Get/Set	Pr. 62 Reference Current for Intelligent Mode Acceleration
73	Get/Set	Pr. 63 Reference Current for Intelligent Mode Deceleration
74	Get/Set	Pr. 64 Starting Frequency for Elevator
75	Get/Set	Pr. 65 Retry Selection
76	Get/Set	Pr. 66 Stall Prevention Operation Level Reduction Starting Frequency
77	Get/Set	Pr. 67 Number of Retries at Alarm

OBJECT MAP—A500(L)/F500(L) SERIES

Attr#	Access	Attribute
78	Get/Set	Pr. 68 Retry Waiting Time
79	Get/Set	Pr. 69 Retry Count Display Erase
80	Get/Set	Pr. 70 Special Regenerative Brake Duty
81	Get/Set	Pr. 71 Applied Motor
82	Get/Set	Pr. 72 PWM Frequency Selection
83	Get/Set	Pr. 73 0 to 5v, 0 to 10v Select
84	Get/Set	Pr. 74 Response Time for Analog
85	Get/Set	Pr. 75 Reset Selection
86	Get/Set	Pr. 76 Alarm Code Output Selection
87	Get	Pr. 77 Parameter Write Disable Selection
88	Get/Set	Pr. 78 Reverse Rotation Prevention
89	Get	Pr. 79 Operation Mode Selection
90	Get/Set	Pr. 80 Motor Capacity
91	Get/Set	Pr. 81 Number of Motor Poles
92	Get/Set	Pr. 82 Excitation Current
93	Get/Set	Pr. 83 Rated Motor Voltage
94	Get/Set	Pr. 84 Rated Motor Frequency
99	Get/Set	Pr. 89 Speed Gain Control
100	Get/Set	Pr. 90 Motor Constant R1
101	Get/Set	Pr. 91 Motor Constant R2
102	Get/Set	Pr. 92 Motor Constant L1
103	Get/Set	Pr. 93 Motor Constant L2
104	Get/Set	Pr. 94 Motor Constant X
105	Get/Set	Pr. 95 Online Auto Tuning
106	Get/Set	Pr. 96 Auto Tuning Setting/State
110	Get/Set	Pr. 100 V/F 1 (1st Frequency)
111	Get/Set	Pr. 101 V/F 1 (1st Frequency Voltage)
112	Get/Set	Pr. 102 V/F 2 (2nd Frequency)
113	Get/Set	Pr. 103 V/F 2 (2nd Frequency Voltage)
114	Get/Set	Pr. 104 V/F 3 (3rd Frequency)
115	Get/Set	Pr. 105 V/F 3 (3rd Frequency Voltage)
116	Get/Set	Pr. 106 V/F 4 (4th Frequency)
117	Get/Set	Pr. 107 V/F 4 (4th Frequency Voltage)
118	Get/Set	Pr. 108 V/F 5 (5th Frequency)
119	Get/Set	Pr. 109 V/F 5 (5th Frequency Voltage)
120	Get/Set	Pr. 110 3rd Acceleration/Deceleration Time
121	Get/Set	Pr. 111 3rd Deceleration Time
122	Get/Set	Pr. 112 3rd Torque Boost

OBJECT MAP—A500(L)/F500(L) SERIES

Attr#	Access	Attribute
123	Get/Set	Pr. 113 3rd V/F (Base Frequency)
124	Get/Set	Pr. 114 3rd Stall Prevention Operation Current
125	Get/Set	Pr. 115 3rd Stall Prevention Operation Frequency
126	Get/Set	Pr. 116 3rd Output Frequency Detection
127	Get/Set	Pr. 117 Station Number.
128	Get/Set	Pr. 118 Comms Speed
129	Get/Set	Pr. 119 Stop Bit Length
130	Get/Set	Pr. 120 Parity Check Presence/Absence
131	Get/Set	Pr. 121 No. Of Comms Retries
132	Get/Set	Pr. 122 Comms Check Time Interval
133	Get/Set	Pr. 123 Waiting Time Setting
134	Get/Set	Pr. 124 CR, LF Presence/Absence
138	Get/Set	Pr. 128 PID Action Selection
139	Get/Set	Pr. 129 PID Proportional Band
140	Get/Set	Pr. 130 PID Integral Time
141	Get/Set	Pr. 131 PID Upper Limit
142	Get/Set	Pr. 132 PID Lower Limit
143	Get/Set	Pr. 133 PID Action Set Point For PU Operation
144	Get/Set	Pr. 134 PID Differential Time
145	Get/Set	Pr. 135 CPS-inverter Switch-Over Sequence Output Terminal Selection
146	Get/Set	Pr. 136 MC Switch-over Interlock Time
147	Get/Set	Pr. 137 Starting Waiting Time
148	Get/Set	Pr. 138 CPS-inverter Switch-over Selection at Alarm Occur
149	Get/Set	Pr. 139 Auto inverter-CPS Switch-Over Frequency
150	Get/Set	Pr. 140 Backlash Acceleration Stopping Frequency
151	Get/Set	Pr. 141 Backlash Acceleration Stopping Time
152	Get/Set	Pr. 142 Backlash Deceleration Stopping frequency
153	Get/Set	Pr. 143 Backlash Deceleration Stopping Time
154	Get/Set	Pr. 144 Speed setting switch-over (*1)
155	Get/Set	Pr. 145 PU Language Selection
158	Get/Set	Pr. 148 Stall Prevention At 0V-Input 1.0%
159	Get/Set	Pr. 149 Stall Prevention At 10V-Input 1.0%
160	Get/Set	Pr. 150 Output Current Detection Level
161	Get/Set	Pr. 151 Output Current Detection Period
162	Get/Set	Pr. 152 Zero-Current Detection Level
163	Get/Set	Pr. 153 Zero-Current Detection Period
164	Get/Set	Pr. 154 Voltage Reduction Selection During Stall Prevention Operation

OBJECT MAP—A500(L)/F500(L) SERIES

Attr#	Access	Attribute
165	Get/Set	Pr. 155 RT Activated Condition
166	Get/Set	Pr. 156 Stall Prevention Operation Selection
167	Get/Set	Pr. 157 OL Signal Waiting Time
168	Get/Set	Pr. 158 AM Terminal Function Selection
172	Get/Set	Pr. 162 Auto Restart After IPF Selection
173	Get/Set	Pr. 163 1st Cushion Time For Restart
174	Get/Set	Pr. 164 1st Cushion Voltage For Restart
175	Get/Set	Pr. 165 Restart Stall Prevention Operation Level
180	Get/Set	Pr. 170 Watt-Hour Meter Clear
181	Get/Set	Pr. 171 Actual Operating Hour Meter Clear
183	Get	Pr. 173 User Group 1 Registration
184	Get	Pr. 174 User Group 1 Deletion
185	Get	Pr. 175 User Group 2 Registration
186	Get	Pr. 176 User Group 2 Deletion
190	Get/Set	Pr. 180 RL Terminal Function Selection
191	Get/Set	Pr. 181 RM Terminal Function Selection
192	Get/Set	Pr. 182 RH Terminal Function Selection
193	Get/Set	Pr. 183 RT Terminal Function Selection
194	Get/Set	Pr. 184 AU Terminal Function Selection
195	Get/Set	Pr. 185 JOG Terminal Function Selection
196	Get/Set	Pr. 186 CS Terminal Function Selection
200	Get/Set	Pr. 190 RUN Terminal Function Selection
201	Get/Set	Pr. 191 SU Terminal Function Selection
202	Get/Set	Pr. 192 IPF Terminal Function Selection
203	Get/Set	Pr. 193 OL Terminal Function Selection
204	Get/Set	Pr. 194 FU Terminal Function Selection
205	Get/Set	Pr. 195 ABC Terminal I Function Selection
209	Get/Set	Pr. 199 User's Initial Value Setting
212	Get/Set	Pr. 232 Multi-Speed Setting (Speed 8)
213	Get/Set	Pr. 233 Multi-Speed Setting (Speed 9)
214	Get/Set	Pr. 234 Multi-Speed Setting (Speed 10)
215	Get/Set	Pr. 235 Multi-Speed Setting (Speed 11)
216	Get/Set	Pr. 236 Multi-Speed Setting (Speed 12)
217	Get/Set	Pr. 237 Multi-Speed Setting (Speed 13)
218	Get/Set	Pr. 238 Multi-Speed Setting (Speed 14)
219	Get/Set	Pr. 239 Multi-Speed Setting (Speed 15)
220	Get/Set	Pr. 240 Soft-PWM selection
224	Get/Set	Pr. 244 Cooling Fan Operation Selection

OBJECT MAP—A500(L)/F500(L) SERIES

Attr#	Access	Attribute
230	Get/Set	Pr. 250 Stop Selection
231	Get/Set	Pr. 251 Phase Loss Detection Selection
232	Get/Set	Pr. 252 Override Bias
233	Get/Set	Pr. 253 Override Gain
241	Get/Set	Pr. 261 Power Failure Stop Function
242	Get/Set	Pr. 262 Subtraction Frequency At Deceleration Start
243	Get/Set	Pr. 263 Subtraction Starting Frequency
244	Get/Set	Pr. 264 Power Failure Deceleration Time 1
245	Get/Set	Pr. 265 Power Failure Deceleration Time 2
246	Get/Set	Pr. 266 Power Failure Deceleration Time Switch-over Frequency

*1 Pr. 144 value >100 is not supported via FR-A5ND

REMARKS

Values "8888" and "9999" displayed on the parameter unit indicate 65520 (HFFF0) and 65535 (HFFFF) respectively.

7.8.4 Class 0x66 Instance Services

#	Service
0x0E	Get Attribute Single
0x10	Set Attribute Single

7.9 Class 0x67 - Extended Object II

7.9.1 Class 0x67 Attributes - Instance 0

None. Not Applicable, Not Related To A500(L)/F500(L).

7.9.2 Class 0x67 Services

None. Not Applicable, Not Related To A500(L)/F500(L).

7.9.3 Class 0x67 Instance 1

Parameters

Parameter definition differs according to the inverter. Refer to the inverter manual for details of parameter definition, setting range, or the like.

Attr#	A500 Pr	Access	Attribute
10	Pr. 270	Get/Set	Stop-On-Contact / Load Torque Hi-Speed Control Selection
11	Pr. 271	Get/Set	Hi-Speed Setting Maximum Current
12	Pr. 272	Get/Set	Hi-Speed Setting Minimum Current
13	Pr. 273	Get/Set	Current Average Range
14	Pr. 274	Get/Set	Current Average Filter Constant
15	Pr. 275	Get/Set	Stop-On-Contact Exciting Current Low-Speed Multiplier Factor
16	Pr. 276	Get/Set	Stop-On-Contact PWM Carrier frequency
18	Pr. 278	Get/Set	Brake Opening Frequency
19	Pr. 279	Get/Set	Brake Opening Current
20	Pr. 280	Get/Set	Brake Opening Current Detection Time
21	Pr. 281	Get/Set	Brake Operating Time At Start
22	Pr. 282	Get/Set	Brake Operation Frequency
23	Pr. 283	Get/Set	Brake Operation Time At Stop
24	Pr. 284	Get/Set	Deceleration Detection Function Selection
25	Pr. 285	Get/Set	Over speed Detection Frequency
38	Pr. 338	Get/Set	Op Cmd Source
39	Pr. 339	Get/Set	Speed Cmd Source
40	Pr. 340	Get/Set	Link Startup Mode Selection
45	Pr. 345	Get	DeviceNet Address Setup Data
46	Pr. 346	Get	DeviceNet Baudrate Setup Data
67	Pr. 367	Get/Set	Speed Feedback Range
68	Pr. 368	Get/Set	Feedback Gain

OBJECT MAP—A500(L)/F500(L) SERIES

Programmed Operation

	Attr#	A500 Pr	Access	Attribute
Program Set 1	100	Pr. 200	Get/Set	Program Time Unit Selection
	101	Pr. 201 Time	Get/Set	Program Setting 1 Time
	102	Pr. 201 Dir	Get/Set	Program Setting 1 Direction
	103	Pr. 201 Freq	Get/Set	Program Setting 1 Frequency
	104	Pr. 202 Time	Get/Set	Program Setting 2 Time
	105	Pr. 202 Dir	Get/Set	Program Setting 2 Direction
	106	Pr. 202 Freq	Get/Set	Program Setting 2 Frequency
	⋮	⋮	⋮	⋮
	128	Pr. 210 Time	Get/Set	Program Setting 10 Time
	129	Pr. 210 Dir	Get/Set	Program Setting 10 Direction
Program Set 2	130	Pr. 210 Freq	Get/Set	Program Setting 10 Frequency
	131	Pr. 211 Time	Get/Set	Program Setting 11 Time
	132	Pr. 211 Dir	Get/Set	Program Setting 11 Direction
	133	Pr. 211 Freq	Get/Set	Program Setting 11 Frequency
	134	Pr. 212 Time	Get/Set	Program Setting 12 Time
	135	Pr. 212 Dir	Get/Set	Program Setting 12 Direction
	136	Pr. 212 Freq	Get/Set	Program Setting 12 Frequency
	⋮	⋮	⋮	⋮
	158	Pr. 220 Time	Get/Set	Program Setting 20 Time
	159	Pr. 220 Dir	Get/Set	Program Setting 20 Direction
Program Set 3	160	Pr. 220 Freq	Get/Set	Program Setting 20 Frequency
	161	Pr. 221 Time	Get/Set	Program Setting 21 Time
	162	Pr. 221 Dir	Get/Set	Program Setting 21 Direction
	163	Pr. 221 Freq	Get/Set	Program Setting 21 Frequency
	164	Pr. 222 Time	Get/Set	Program Setting 22 Time
	165	Pr. 222 Dir	Get/Set	Program Setting 22 Direction
	166	Pr. 222 Freq	Get/Set	Program Setting 22 Frequency
	⋮	⋮	⋮	⋮
	188	Pr. 230 Time	Get/Set	Program Setting 30 Time
	189	Pr. 230 Dir	Get/Set	Program Setting 30 Direction
190	Pr. 230 Freq	Get/Set	Program Setting 30 Frequency	
191	Pr. 231	Get/Set	Time of Day Setting	

Calibration Functions : Class 0x67 Instance 1

Attr#	A500 Pr	Access	Attribute
202	Pr. 902 Freq	Get/Set	Frequency Voltage Bias - Frequency
203	Pr. 902 %	Get/Set	Frequency Voltage Bias - Percent
204	Pr. 903 Freq	Get/Set	Frequency Voltage Gain - Frequency
205	Pr. 903 %	Get/Set	Frequency Voltage Gain - Percent
206	Pr. 904 Freq	Get/Set	Frequency Current Bias - Frequency
207	Pr. 904 %	Get/Set	Frequency Current Bias - Percent
208	Pr. 905 Freq	Get/Set	Frequency Current Gain - Frequency
209	Pr. 905 %	Get/Set	Frequency Current Gain - Percent

REMARKS

65520 (HFFF0) is displayed as "8888" and 65535 (HFFFF) as "9999" on the parameter unit.

7.9.4 Class 0x67 Instance Services

#	Service
0x0E	Get Attribute Single
0x10	Set Attribute Single

7.10 Class 0x70 to 0x79 - Extended Object III

(1) Class 0x70 to 0x79 Instance attribute

Inverter Parameter

Class	Instance No.	Attribute No.	Pr. No.	Access	Description (*1)
0x70	1	10 to 109	Pr. 0 to Pr. 99	Get/Set	
0x71	1	10 to 109	Pr. 100 to Pr. 199	Get/Set	
0x72	1	10 to 109	Pr. 200 to Pr. 299	Get/Set	Programmed operation set time etc.
	2	11 to 40	Pr. 201 to Pr. 230	Get/Set	Programmed operation set direction etc.
	3	11 to 40	Pr. 201 to Pr. 230	Get/Set	Programmed operation set frequency etc.
0x73	1	10 to 109	Pr. 300 to Pr. 399	Get/Set	
0x74	1	10 to 109	Pr. 400 to Pr. 499	Get/Set	
0x75	1	10 to 109	Pr. 500 to Pr. 599	Get/Set	
0x76	1	10 to 109	Pr. 600 to Pr. 699	Get/Set	
0x77	1	10 to 109	Pr. 700 to Pr. 799	Get/Set	
0x78	1	10 to 109	Pr. 800 to Pr. 899	Get/Set	
0x79	1	10 to 109	Pr. 900 to Pr. 999	Get/Set	Parameter offset, parameter gain, etc. for calibration
	2	10 to 49	Pr. 900 to Pr. 939	Get/Set	Parameter analog value for calibration

REMARKS

Refer to the inverter instruction manual for details of parameter definitions.

(2) Class 0x70 to 0x79 Instance service

Service code	Description
0x0E	Read attribute value
0x10	Write attribute value

8. OBJECT MAP V500 SERIES

This section describes the object definitions for the FR-A5ND DeviceNet implementation. For details of the definitions, consult the DeviceNet documentation available from ODVA.

8.1 Class 0x01 - Identity Object

8.1.1 Class 0x01 Attributes - Instance 0

#	Access	Attribute	Type	Value
1	Get	Revision	Word	1
2	Get	Maximum Instance	Word	1
6	Get	Maximum Class Attributes	Word	7
7	Get	Maximum Instance Attributes	Word	7

8.1.2 Class 0x01 Services - Instance 0

#	Service
0x0E	Get Attribute Single

8.1.3 Class 0x01 - Instance 1

Attr#	Access	Attribute	Type	Range	Value
1	Get	Vendor ID	Word	0 to 65535	82
2	Get	Product Type	Word	0 to 65535	02
3	Get	Product Code	Word	0 to 65535	502
4	Get	Revision	Struct	0 to 0xFFFF	1. YYY (*1)
5	Get	Status	Word	0 to 0xFFFF	0000
6	Get	Serial Number	Double Word	00000000 to 0xFFFFFFFF	xxxxxxx
7	Get	Name	5 bytes		V500 (*2)

*1 High byte means Integer and Low byte means decimal. For example, 0x010A means version 1.010.

*2 The actual data are 0x04 0x56 0x35 0x30 0x30. 0x04 means the number of bytes, 4 bytes. 0x56 0x35 0x30 0x30 means ASCII code of "V500".

8.1.4 Class 0x01 Instance Services - Instance 1

#	Service	Description
0x05	Reset	0- Reset 1- Pr All Clr & Reset
0x0E	Get Attribute Single	

8.2 Class 0x03 - DeviceNet Object

8.2.1 Class 0x03 Attributes - Instance 0

None. Not Applicable, Not Related To FR-V500.

8.2.2 Class 0x03 Services - Instance 0

None. Not Applicable, Not Related To FR-V500.

8.2.3 Class 0x03 - Instance 1

Attr#	Access	Attribute	Range	Value
1	Get/Set	Node Address (MAC ID) (*1)	00 to 63	63
2	Get/Set	Baud Rate (*1) 00, 03 : 125kbps 01 : 250kbps 02 : 500kbps	00 to 02	00
3	Get/Set	Bus Off Interrupt(*2) 00: Hold the CAN chip in tis bus-off (reset) state upon detection of a bus-off indication. 01: If possible, fully reset the CAN chip and continue communicating upon detection of a bus-off indication	00 to 01	00
4	Get/Set	Bus Off Counter (*2) It counts number of bus-off interrupts.	00 to 255	00
5	Get	Allocation Information	00 to 0xFFFF	e.g. 0x0103
8	Get	MAC ID Switch Value	00 to 63	00

*1 See also Class 0x67, Attrs.45 and 46.

*2 Bus Off interrupt and Bus Off Counter are not supported via FR-A5ND.

REMARKS

See DeviceNet specifications Vol. I, 5-5 for detail definition.

8.2.4 Class 0x03 Instance Services - Instance 1

#	Service
0x4B	Allocate
0x4C	Release
0x0E	Get Attribute Single
0x10	Set Attribute Single

8.3 Class 0x04 - Assembly Object

8.3.1 Class 0x04 - Output Instance 20 (0x14)

Instance 20	Byte	Bit 7	Bit 6	Bit 5	Bit 4	Bit 3	Bit 2	Bit 1	Bit0
	0						Fault Reset		Run Fwd
	1	00							
	2	Speed Reference (Low Byte)							
	3	Speed Reference (High Byte)							

8.3.2 Class 0x04 - Output Instance 21 (0x15) Default

Instance 21	Byte	Bit 7	Bit 6	Bit 5	Bit 4	Bit 3	Bit 2	Bit 1	Bit0
	0		Net Ref	NetCtrl			Fault Reset	Run Rev	Run Fwd
	1	00							
	2	Speed Reference (Low Byte)							
	3	Speed Reference (High Byte)							

8.3.3 Class 0x04 - Output Instance 26 (0x1A)

Instance 26	Byte	Bit 7	Bit 6	Bit 5	Bit 4	Bit 3	Bit 2	Bit 1	Bit0
	0	Write Param	Net Ref	NetCtrl			Fault Reset	Run Rev	Run Fwd
	1	Parameter Instance No.							
	2	(Low Byte) Speed Ref or Parameter Write Data							
	3	(High Byte) Speed Ref or Parameter Write Data							
	4	Parameter Class							
	5	Parameter Attribute Number							

Output instance 26 (0x1A) provides write/read parameter access control of the parameter class, parameter instance No., and attribute No. specified by the above Byte 4 and 5. It also provides parameter data (Byte 2 and 3) write operation to the class.

Use Class 0x29 Instance 1 Attribute 41 to select Output Assembly Instance, make sure it matches Input Assembly Instance. For example, Output Instance 26 **must** be used together with Input Instance 76 in those applications requiring parameter access.

OBJECT MAP V500 SERIES

Output Instance 26 (0x1A) provides write/read parameter access control of the parameter class, the parameter attribute number of only Instance 1 of that Class, and the parameter data for a write operation.

Output Instance 26 utilizes 6 data bytes.

The Output Instance 26 bytes operates in the following manner:

Byte No.	Bit No.	Name	Definitions
0	7	WriteParameter	If Write Parameter=0, the value of Byte 2 and Byte 3 are written to the parameter as Speed Ref.
			If Write Parameter=1, the value of Byte 2 and Byte 3 are written to the parameter class and attribute indicated by Byte 4 and Byte 5 as parameter write data.
	6	NetRef	If NetRef =1, the Speed Ref is taken from Byte 2 and Byte 3.
	5	NetCtrl	If NetRef =0, Bit 2, Bit 1, and Bit 0 are ignored.
			If NetRef =1, Bit 2, Bit 1, and Bit 0 are valid.
	4		Not used.
	3		Not used.
	2	Fault Reset	If Fault Reset is set to 1, then the inverter is reset when an alarm occurs.
	1	Run Fwd	If Run Rev =1 and Run Fwd =0, the drive rotates in the reverse direction. If Run Fwd =1 and Run Rev =0, the drive spins in the forward direction.
0	Run Rev		
1	Instance No. can be specified. When 00 is specified, instance No. is regarded as 1.		
2	Low Byte of the Speed Ref or parameter write data		
3	High Byte of the Speed Ref or parameter write data		
4	Parameter Class , e.g. 0x2A, 0x66, 0x67		
5	Parameter Attribute Number, e.g. 0x0A, 0x65		

8.3.4 Class 0x04 - Input Instance 70 (0x46)

Instance 70	Byte	Bit 7	Bit 6	Bit 5	Bit 4	Bit 3	Bit 2	Bit 1	Bit0
	0						Run(1) Fwd		Faulted
	1	00							
	2	Speed Actual (Low Byte)							
	3	Speed Actual (High Byte)							

8.3.5 Class 0x04 - Input Instance 71 (0x47) Default

Instance 71	Byte	Bit 7	Bit 6	Bit 5	Bit 4	Bit 3	Bit 2	Bit 1	Bit0
	0	AtRef Speed	Ref From Net	Ctrl From Net	Ready	Run(2) Rev	Run(1) Fwd		Faulted
	1	00							
	2	Speed Actual (Low Byte)							
	3	Speed Actual (High Byte)							

8.3.6 Class 0x04 - Input Instance 76 (0x4C)

Instance 76	Byte	Bit 7	Bit 6	Bit 5	Bit 4	Bit 3	Bit 2	Bit 1	Bit0
	0	AtRef Speed	Ref From Net	Ctrlol From Net	Ready	Run(2) Rev	Run(1) Fwd	Operation control mode	Faulted
	1	00							
	2	Speed Actual (Low Byte)							
	3	Speed Actual (High Byte)							
	4	Parameter Read (Low Byte)							
	5	Parameter Read (High Byte)							

Use Class0x29 Instance 1 attribute 40 to select Input Assembly Instance, make sure it matches Output Assembly Instance. For example, Input Instance 76 **must** be used together with Output Instance 26 in those applications requiring parameter access.

The Input Instance 76 (0x4C) provide 16 bits of parameter data.

Input Instance 76 utilizes 6 data bytes.

OBJECT MAP V500 SERIES

The Input Instance 76 bytes operates in the following manner:

Byte No.	Bit No.	Name	Definitions
0	7	At Ref Speed	The drive is very close to or at the Ref Speed.
	6	Ref From Net	Speed setting comes from the DeviceNet master. (This value is same as opposite value of Pr. 339)
	5	Control From Net	Fault Reset, Run Rev, Run Fwd come from the DeviceNet Master. (This value is same as opposite value of Pr. 338)
	4	Ready	The value is always "1" while communication is established.
	3	Run Rev	Drive is rotating in the reverse direction.
	2	Run Fwd	Drive is rotating in the forward direction.
	1	Operation control mode	0: Run command from the DeviceNet master is disabled. 1: Run command from the DeviceNet master is enabled. (*2)
	0		The drive is in a fault state.
1		Must be zero.	
2		Low Byte of the Speed Actual.	
3		High Byte of the Speed Actual.	
4		Low Byte of Parameter Read.(*1)	
5		High Byte of Parameter Read.(*1)	

*1 The Read data may still be the previous data immediately following Parameter Write. Allow at least 1s prior to reading parameter data after a parameter write is performed.

*2 Bit status in the run command mode is as follows. (Refer to page 28 for operation command source and speed command source.)

Inverter Status			Operation control mode bit
Current operation mode	Operation control command source (Pr. 338)	Speed control command source (Pr. 339)	
NET	0: NET	0: NET	1
	0: NET	1: EXT	0
	1: EXT	0: NET	
	1: EXT	1: EXT	
Other than NET	—	—	

8.4 Class 0x05 - DeviceNet Connection Object

FR-A5ND supports only Polled I/O and Explicit Msg, not Bit-Strobed I/O.

8.4.1 Class 0x05 Attributes - Instance 0

None. Not Applicable, Not Related To FR-V500.

8.4.2 Class 0x05 Services - Instance 0

None. Not Applicable, Not Related To FR-V500.

8.4.3 Class 0x05 Instance 1 - Explicit Messaging

Attr#	Access	Attribute	Range	Value
1	Get	State	00 to 04	00:Non-existent 01:Configuring 02:Waiting for connection ID 03:Established 04:Timed out
2	Get	Instance Type	00 to 01	00:Explicit Messaging
3	Get	Transport Trigger Class	00 to 0xFF	0x83: Server Transport Class 3
4	Get	Produced Connection ID	0 to 0xFFFF	The value to be placed in the CAN Identifier Field when this Connection transmits e.g. 0x0740: That means Group 3 Explicit response message of Slave, Source MAC ID = 0
5	Get	Consumed Connection ID	0 to 0xFFFF	This value will be specified in the CAN Identifier Field of messages that are to be consumed. e.g. 0x0780: That means Group 3 Explicit request message of Master, destination MAC ID = 0.
6	Get	Initial Comm Characteristics	0 to 0xFF	0x33: Source : Group 3 message Destination : Group 3 message

OBJECT MAP V500 SERIES

Attr#	Access	Attribute	Range	Value
7	Get	Produced Connection Size	0 to 65535	7 : 7 bytes This value specifies the maximum number of Message Body bytes that a module is able to transmit across the connection.
8	Get	Consumed Connection Size	0 to 65535	7 : 7 bytes This value specifies the maximum number of Message Body bytes that a module is able to receive across the connection.
9	Get/Set	Expected Pack Rate (EPR) (*1)	0 to 65535	e.g. 2500 : 2500ms
12	Get/Set	Watchdog Action (WDA)	0 to 03	0 : Transition to time out 1 : Auto delete (factory setting) 2 : Auto reset 3 : Deferred delete
13	Get	Produced Connection Path Length	0 to 65535	0 Specifies the number of bytes of information within the produced_connection_path attribute.
14	Get	Produced Connection Path	variable	empty
15	Get	Consumed Connection Path Length	0 to 65535	0 Specifies the number of bytes of information within the consumed_connection_path attribute.
16	Get	Consumed Connection Path	variable	empty

*1 Get value is same as Set value.

REMARKS

Refer to Vol.1:5-4 of DeviceNet Specifications for details.

8.4.4 Class 0x05 Instance 2 - Polled I/O

Attr#	Access	Attribute	Range	Value
1	Get	State	00 to 04	See Class0x05 instance1 Attribute 1
2	Get	Instance Type	00 to 01	01 : I/O Messaging
3	Get	Transport Trigger Class	00 to 0xFF	0x82: Server Transport Class 2
4	Get	Produced Connection ID	0 to 0xFFFF	The value to be placed in the CAN Identifier Field when this Connection transmits e.g. 0x03C0: That means Group 1 Polled I/O response message of Slave, Source MAC ID = 0
5	Get	Consumed Connection ID	0 to 0xFFFF	This value will be specified in the CAN Identifier Field of messages that are to be consumed. e.g. 0x0405: That means Group 2 Polled I/O command message of Master, destination MAC ID = 0.
6	Get	Initial Comm Characteristics	0 to 0xFF	0x01: Source : Group 1 message Destination : Group 2 message
7	Get	Produced Connection Size	0 to 65535	4 : 4 bytes(*2) See Class0x05 instance1 Attribute 7
8	Get	Consumed Connection Size	0 to 65535	4 : 4 bytes(*2) See Class0x05 instance1 Attribute 8
9	Get/Set	EPR (*3)	0 to 65535	e.g. 2500 : 2500ms
12	Get/Set	Watchdog Action (WDA)	0 to 02	0 : Transition to time out 1 : Auto delete (factory setting) 2 : Auto reset
13	Get	Produced Connection Path Length	0 to 65535	3 : 3 bytes See Class0x05 instance1 Attribute 13
14	Get	Produced Connection Path (*1)	variable	0x62 0x34 0x37

OBJECT MAP V500 SERIES

Attr#	Access	Attribute	Range	Value
15	Get	Consumed Connection Path Length	0 to 65535	3 : 3 bytes See Class0x05 instance1 Attribute 15
16	Get	Consumed Connection Path (*1)	variable	0x62 0x31 0x35

*1 Use Class 0x29 Instance 1 Attribute 40, Class 0x29 Instance 1 Attribute 41 to change I/O Assembly Instances.

The produced_connection_path and consume_connection_path attributes are made up of a byte stream which defines the Application Object(s). The format is below.

0x62 0xMM 0xNN

0x62 : Logic address

0xMM 0xNN : Application Object Data. This is ASCII Code which shows input/output instance value (HEX).

e.g. When input instance 71 and output instance 21 are used,

(a) Produced_connection_path

71 = 0x47

4 = 0x34 and 7 = 0x37 for ASCII Code

Therefore the produced_connection_path of input instance 71 = 0x62
0x34 0x37

(b) Consumed_connection_path

21 = 0x15

1 = 0x31 and 5 = 0x35 for ASCII Code

Therefore the consumed_connection_path of output instance 21 = 0x62
0x31 0x35

*2 Value dependent

When output instance 20,21 or input instance 70,71, the value is 4 bytes.

When output instance 26 or input instance 76, the value is 6 bytes.

*3 Get value is same as Set value.

REMARKS

Refer to Vol.1:5-4 of DeviceNet Specifications for details.

8.4.5 Class 0x05 Instance 4 - Explicit Messaging

Attr#	Access	Attribute	Range	Value
1	Get	State	00 to 04	See Class0x05 instance1 Attribute 1
2	Get	Instance Type	00 to 01	00:Explicit Messaging
3	Get	Transport Trigger Class	00 to 0xFF	0x83: Server Transport Class 3
4	Get	Produced Connection ID	0 to 0xFFFF	e.g. 0x0740: See Class0x05 instance1 Attribute 4
5	Get	Consumed Connection ID	0 to 0xFFFF	e.g. 0x0780: See Class0x05 instance1 Attribute 5
6	Get	Initial Comm Characteristics	0 to 0xFF	0x33: See Class0x05 instance1 Attribute 6
7	Get	Produced Connection Size	0 to 65535	7 : 7 bytes See Class0x05 instance1 Attribute 7
8	Get	Consumed Connection Size	0 to 65535	7 : 7 bytes See Class0x05 instance1 Attribute 8
9	Get/Set	Expected Pack Rate (EPR)	0 to 65535	e.g. 2500 : 2500ms
12	Get/Set	Watchdog Action (WDA)	0 to 03	See Class0x05 instance1 Attribute 12
13	Get	Produced Connection Path Length	0 to 65535	0 See Class0x05 instance1 Attribute 13
14	Get	Produced Connection Path	variable	empty
15	Get	Consumed Connection Path Length	0 to 65535	0 See Class0x05 instance1 Attribute 15
16	Get	Consumed Connection Path	variable	empty

REMARKS

Refer to Vol.I:5-4 of DeviceNet Specifications for details.

8.4.6 Class 0x05 Instance 5 - Explicit Messaging

Attr#	Access	Attribute	Range	Value
1	Get	State	00 to 04	See Class0x05 instance1 Attribute 1
2	Get	Instance Type	00 to 01	00:Explicit Messaging
3	Get	Transport Trigger Class	00 to 0xFF	0x83: Server Transport Class 3
4	Get	Produced Connection ID	0 to 0xFFFF	e.g. 0x0740: See Class0x05 instance1 Attribute 4
5	Get	Consumed Connection ID	0 to 0xFFFF	e.g. 0x0780: See Class0x05 instance1 Attribute 5
6	Get	Initial Comm Characteristics	0 to 0xFF	0x33: See Class0x05 instance1 Attribute 6
7	Get	Produced Connection Size	0 to 65535	7 : 7 bytes See Class0x05 instance1 Attribute 7
8	Get	Consumed Connection Size	0 to 65535	7 : 7 bytes See Class0x05 instance1 Attribute 8
9	Get	Expected Pack Rate (EPR)	0 to 65535	e.g. 2500 : 2500ms
12	Get/Set	Watchdog Action (WDA)	0 to 03	See Class0x05 instance1 Attribute 12
13	Get	Produced Connection Path Length	0 to 65535	0 See Class0x05 instance1 Attribute 13
14	Get	Produced Connection Path	variable	empty
15	Get	Consumed Connection Path Length	0 to 65535	0 See Class0x05 instance1 Attribute 15
16	Get	Consumed Connection Path	variable	empty

REMARKS

Refer to Vol.I:5-4 of DeviceNet Specifications for details.

8.4.7 Class 0x05 Instance 6 - Explicit Messaging

Attr#	Access	Attribute	Range	Value
1	Get	State	00 to 04	See Class0x05 instance1 Attribute 1
2	Get	Instance Type	00 to 01	00:Explicit Messaging
3	Get	Transport Trigger Class	00 to 0xFF	0x83: Server Transport Class 3
4	Get	Produced Connection ID	0 to 0xFFFF	e.g. 0x0740: See Class0x05 instance1 Attribute 4
5	Get	Consumed Connection ID	0 to 0xFFFF	e.g. 0x0780: See Class0x05 instance1 Attribute 5
6	Get	Initial Comm Characteristics	0 to 0xFF	0x33: See Class0x05 instance1 Attribute 6
7	Get	Produced Connection Size	0 to 65535	7 : 7 bytes See Class0x05 instance1 Attribute 7
8	Get	Consumed Connection Size	0 to 65535	7 : 7 bytes See Class0x05 instance1 Attribute 8
9	Get	Expected Pack Rate (EPR)	0 to 65535	e.g. 2500 : 2500ms
12	Get/Set	Watchdog Action (WDA)	0 to 03	See Class0x05 instance1 Attribute 12
13	Get	Produced Connection Path Length	0 to 65535	0 See Class0x05 instance1 Attribute 13
14	Get	Produced Connection Path	variable	empty
15	Get	Consumed Connection Path Length	0 to 65535	0 See Class0x05 instance1 Attribute 15
16	Get	Consumed Connection Path	variable	empty

REMARKS

Refer to Vol.I:5-4 of DeviceNet Specifications for details.

8.4.8 Class 0x05 Instance Services - Instances 1,2,4,5,6

#	Service
0x0E	Get Attribute Single
0x10	Set Attribute Single

8.5 Class 0x28 - Motor Data Object

8.5.1 Class 0x28 Attributes - Instance 0

None. Not Applicable, Not Related To FR-V500.

8.5.2 Class 0x28 Services - Instance 0

None. Not Applicable, Not Related To FR-V500.

8.5.3 Class 0x28 Instance 1

Attr#	Access	Attribute	Range	Factory Setting
3	Get/Set	Motor Type	0 to 10	7: Induction Motor
6	Get/Set	Rated Current, cf. Pr. 9 (Unit 0.01A)	0 to 65535	(*1)
7	Get/Set	Rated Voltage, cf. Pr. 83 (Unit 0.1V)	0 to 65535	0x07D0
8	Get/Set	Rated Power, cf. Pr. 80 (Unit 0.01kW)	0 to 65535	(*1)
9	Get/Set	Rated Frequency, cf. Pr. 84 (Unit 0.01Hz)	0 to 65535	0x1770
12	Get/Set	Polecount, cf. Pr. 144	0 to 65535	4
15	Get/Set	Base Speed, cf. Pr. 3 (Unit r/min)	0 to 65535	0x0708

*1 The factory setting varies according to the inverter capacity.

REMARKS

Refer to Vol.II:6-28 of DeviceNet Specifications for details.

8.5.4 Class 0x28 Instance Services

#	Service
0x0E	Get Attribute Single
0x10	Set Attribute Single

8.6 Class 0x29 - Control Supervisor Object

8.6.1 Class 0x29 Attributes - Instance 0

None. Not Applicable, Not Related To FR-V500.

8.6.2 Class 0x29 Services

None. Not Applicable, Not Related To FR-V500.

8.6.3 Class 0x29 Instance 1

Attr#	Access	Attribute	Range	Factory Setting
3	Get/Set	Run1 00 : Stop 01 : Forward	00 to 01	00
4	Get/Set	Run2 00 : Stop 01 : Reverse	00 to 01	00
5	Get/Set	NetControl, cf. Pr338 (*3) 0 : Local Control 1 : Network Control The actual status of Run/Stop control is reflected in attribute 15, ControlFromNet.	00 to 01	01
6	Get	State 1 : Start up 2 : Not ready 3 : Ready 4 : Enabled 5 : Stopping 6 : Fault_Stop 7 : Faulted	0 to 7	3
7	Get	Running1 1 : (Enabled and Run1) or (Stopping and Running1) or (Fault_Stop and Running1) 0 : Other State	0 to 1	0
8	Get	Running2 1 : (Enabled and Run2) or (Stopping and Running2) or (Fault_Stop and Running2) 0 : Other State	0 to 1	0

OBJECT MAP V500 SERIES

Attr#	Access	Attribute	Range	Factory Setting
9	Get	Ready 1 : Ready or Enabled or Stopping 0 : Other State	0 to 1	1
10	Get	Faulted 1 : Fault Occurred (latched) 0 : No Fault present	0 to 1	0
12	Get/Set	FaultRst (*1) 0->1 : Fault Reset 0 : No action	0 to 1	0
15	Get	ControlFromNet (*2) 0 : Control is local 1 : Control is from Network	0 to 1	1
16	Get/Set	DNFaultMode (Action on loss of DeviceNet) 0 : Fault + Stop 1 : Ignore 2 to 0xFF : Unsupported	0 to 0xFF	0
40	Get/Set	Input Assembly	70 to 76	0x47(71)
41	Get/Set	Output Assembly	20 to 26	0x15(21)

*1 After reset with 0 ->1, This value must be set to 0 before inverter reset may be performed.

*2 This data is only updated after Inverter Reset or power cycle.

*3 The logic is opposite from Pr. 338. That means attribute 5 = 1 is same as Pr. 338 = 0

REMARKS

Refer to Vol.II:6-29 of DeviceNet Specifications for details.

8.6.4 Class 0x29 Instance Services

#	Service
0x0E	Get Attribute Single
0x10	Set Attribute Single

8.7 Class 0x2A - AC Drive Object

8.7.1 Class 0x2A Attributes - Instance 0

None. Not Applicable, Not Related To FR-V500.

8.7.2 Class 0x2A Services

None. Not Applicable, Not Related To FR-V500.

8.7.3 Class 0x2A Instance 1

AC Profile Compatibles

Attr#	Access	Attribute	Factory Setting
1	Get	Number of Attributes supported	1
3	Get	At Reference 1 : Drive actual at reference (speed) 0 : Other state	0
4	Get/Set	Net Reference, cf. Pr. 339 (*1) 0 : Set speed not DN Control 1 : Set speed at DN Control The actual status of speed reference is reflected in attribute 29, RefFromNe.	1
6	Get	Drive Mode	0
7	Get	SpeedActual (Actual Drive Speed) Unit : r/min	0
8	Get/Set	SpeedRef (Speed reference) Unit : r/min	0
9	Get	Current Actual (Actual motor phase current) Unit : 0.01A	0
17	Get	Output Voltage Unit : V	0
18	Get/Set	AccelerationTime, cf. Pr. 7 Unit : 0.1s	0x0032
19	Get/Set	DecelerationTime, cf. Pr. 8 Unit : 0.1s	0x0032
20	Get/Set	LowSpeedLimit, cf. Pr. 2 Unit : r/min	0
21	Get/Set	HighSpeedLimit, cf. Pr. 1 Unit : r/min	0xFFFF
29	Get	RefFromNet (*2) Status of speed reference 0 : Local speed reference 1 : DeviceNet speed reference	1

OBJECT MAP V500 SERIES

*1 The logic is opposite from Pr. 339. That means attribute 4 = 1 is same as Pr. 339 = 0

*2 This data is updated only after INVReset or power cycle.

REMARKS

Refer to Vol.II:6-30 of DeviceNet Specifications for details.

The following variables and parameters are vendor-specific, refer to inverter manual for more details:

System Environment Variables(Class 0x2A Instance 1)

Attr#	Access	Attribute	Write Value
100	Set	User Clear Value Setting	9999
101	Set	Inverter Reset (*1)	0
102	Set	Parameter Clear	0x965A
103	Set	Parameter All Clear	0x99AA
105	Set	Parameter Clear (excluding Communication parameter) (*2)	0x5A96
106	Set	Parameter All Clear (excluding Communication parameter) (*2)	0xAA99
112	Get/Set	Running Speed (RAM) (*3, 4)	1r/min
113	Set	Running Speed (E ² PROM) (*3, 4)	1r/min
114	Get/Set	Inverter Status / Control Input Cmd (refer to the next page)	(*3)
120	Get/Set	(a) Operating Mode (Get) 0: Ext mode 1: PU mode 2: External JOG 3: PU JOG 4: Net mode 5: Both PU and Ext mode (b) Operating Mode (Set) (*5) 0x0010: Ext mode 0x0011: PU mode 0x0014: Net mode The Net mode can be changed to the PU mode only when Pr. 79=6.	

REMARKS

(*1) When Pr.340=0, the drive will default to external mode following a inverter reset.

(*2) Note that the FR-A5ND dedicated parameters of Pr. 345 to Pr. 348 are cleared.

(*3) Values written to either Pr. 112 or Pr. 113 may be read from Pr. 112.

(*4) When the option unit is fitted to the FR-V500 series inverter, attribute changes to speed setting (1r/min). Depend on the Pr.144 and Pr.37 settings, it changes to speed increments (1r/min), frequency increments (0.01Hz) or machine speed increments (1r/min). Note that when Pr.37≠0 or Pr.144=0, attribute changes to machine speed for Get and speed setting for Set.

(*5) Enter only 2 bytes data.

Bit-map for inverter status/control input instruction

Refer to the following bit-map of inverter status.

Bit	Definition	
0	Running	(RUN)
1	Forward running	(FWD)
2	Reverse running	(REV)
3	Up to speed	(SU)
4	Overload	(OL)
5	Instantaneous power failure	(IPF)
6	Frequency detection	(FB)
7	Alarm	(ABC)
8-14	(Blank)	-
15	Operation ready completion	(READY)

Refer to the following bit-map of control input instruction.

Bit	Definition	
0	(Blank)	-
1	Forward rotation command	(STF)
2	Reverse rotation command (*1)	(STR)
3	Low speed operation command (*1)	(RL)
4	Middle speed operation command (*1)	(RM)
5	High speed operation command (*1)	(RH)
6	Second function selection (*1)	(RT)
7	DI11 terminal function selection (*2)	-
8	DI12 terminal function selection (*2)	-
9	DI13 terminal function selection (*2)	-
10	Output stop(*3)	(MRS)
11-15	(Blank)	-

*1 Input terminal function can be assigned using Pr. 180 to Pr. 183 (DI1 to DI4) and Pr. 187 (STR).

*2 Input terminal function can be assigned using Pr. 400 to Pr. 402 (DI11 to DI13). Setting of Pr. 400 to Pr. 402 is enabled when the FR-A5ND is fitted.

*3 MRS can be used in combination with another MRS whose function was assigned by another input terminal function. However, the signal functions according to the OR operation result.

Real Time Parameters

Attr#	Access	Attribute	Increment Value
141	Get/Set	Alarm History 1 (*1)/ Alarm History All Clrm (*2)	—
142	Get	Alarm History 2 (*1)	—
143	Get	Alarm History 3 (*1)	—
144	Get	Alarm History 4 (*1)	—
145	Get	Alarm History 5 (*1)	—
146	Get	Alarm History 6 (*1)	—
147	Get	Alarm History 7 (*1)	—
148	Get	Alarm History 8 (*1)	—
170	Get	Output frequency (*3)	0.01Hz
171	Get	Output Current	0.01A
172	Get	Output Voltage	0.1V
174	Get	Speed Setting (*4)	0.01Hz
175	Get	Running Speed (*4)	1 r/min
176	Get	Motor Torque	0.01%
177	Get	Converter Output Voltage	0.1V
178	Get	Regenerative Brake Duty	0.1%
179	Get	Electric Over current Protection Load Factor	0.1%
180	Get	Output Current Peak Value	0.01A
181	Get	Converter Output Voltage Peak Value	0.1V
184	Get	Input Terminal (refer to the next page)	—
185	Get	Output Terminal (refer to the next page)	—
186	Get	Load Meter	—
187	Get	Motor Exciting Current	0.01A
188	Get	Position Pulse	—
189	Get	Cumulative operation time	1 hour
192	Get	Actual Operation Time	1 hour
193	Get	Motor Load Factor	0.1%
195	Get	Torque Command	0.1%
196	Get	Torque Current Command	0.1%
197	Get	Motor Output	0.01kW
198	Get	Feed Back Pulse	—

REMARKS

- (*1) See the following table for Alarm # vs Alarm Definition.
- (*2) Writing any value to #141 resets the alarm history.
- (*3) A standard of frequency display changes according to Pr.81, Pr.144 and Pr.454 attribute (polarity setting).
- (*4) The attributes change to speed increments (1r/min), frequency increments (0.01Hz), machine speed increments (1r/min) according to Pr.144, and Pr.37 attribute

(1) Bit-map for Input Terminal Status Monitor:

15..12	11	10	9	8	7	6	5	4	3	2	1	0
0	0	0	0	0	RES	OH	DI4 *1	DI3 *1	DI2 *1	DI1 *1	STR *1	STF

(2) Bit-map for Output Terminal Status Monitor:

15..7	6	5	4	3	2	1	0
0	DO13 *2	DO12 *2	DO11 *2	ABC *2	DO3 *2	DO2 *2	DO1 *2

REMARKS

The bit pattern above reflects Pr. 180 to Pr. 195 (I/O terminal assignment). If the assignments for terminals are changed, the above bit-map is automatically changed. In the above bit-maps, 1 means the data is present, 0 means the data is absent.

(*1) Input terminal function can be assigned using Pr. 180 to Pr. 183, and Pr. 187.

(*2) Output terminal function can be assigned using Pr. 190 to Pr. 192 (DO1 to DO3), and Pr. 195 (ABC), Pr. 410 to Pr. 412 (DO11 to DO13).

FR-V500 Table of Alarm # vs Alarm Definition

#	Definition	#	Definition	#	Definition
0x00	No Fault	0x90	OHT	0xD4	ECA
0x10	OC1	0xA0	OPT	0xD5	MB1
0x11	OC2	0xA1	OP1	0xD6	MB2
0x12	OC3	0xA2	OP2	0xD7	MB3
0x20	OV1	0xA3	OP3	0xD8	MB4
0x21	OV2	0xB0	PE	0xD9	MB5
0x22	OV3	0xB1	PUE	0xDA	MB6
0x30	THT	0xB2	RET	0xDB	MB7
0x31	THM	0xC0	CPU	0xDC	EP
0x40	FIN	0xC1	CTE	0xF1	E.1
0x50	IPF	0xC2	P24	0xF2	E.2
0x51	UVT	0xC3	P12	0xF3	E.3
0x60	OLT	0xD0	OS	0xF6	E.6
0x70	BE	0xD1	OSD	0xF7	E.7
0x80	GF	0xD2	ECT		
0x81	LF	0xD3	OD		

REMARKS

Refer to the FR-V500 series instruction manual for explanation of Alarm Codes.

8.7.4 Class 0x2A Instance Services

#	Service
0x0E	Get Attribute Single
0x10	Set Attribute Single

8.8 Class 0x66 - Extended Object I**8.8.1 Class 0x66 Attributes - Instance 0**

None. Not Applicable, Not Related To V500.

8.8.2 Class 0x66 Services

None. Not Applicable, Not Related To V500.

8.8.3 Class 0x66 Instance 1**Parameters**

Refer to the inverter manual for details of parameter definition, setting range, or the like.

Attr#	Access	Attribute
10	Get/Set	Pr. 0 Torque Boost (Manual)
11	Get/Set	Pr. 1 Maximum Speed
12	Get/Set	Pr. 2 Minimum Speed
13	Get/Set	Pr. 3 Base Frequency
14	Get/Set	Pr. 4 Multi Speed (Hi)
15	Get/Set	Pr. 5 Multi Speed (middle)
16	Get/Set	Pr. 6 Multi Speed (low)
17	Get/Set	Pr. 7 Acceleration Time
18	Get/Set	Pr. 8 Deceleration Time
19	Get/Set	Pr. 9 Electronic Thermal O/L Relay
20	Get/Set	Pr. 10 DC Injection Brake Operation Speed
21	Get/Set	Pr. 11 DC Injection Brake Operation Time
22	Get/Set	Pr. 12 DC Injection Brake Voltage
23	Get/Set	Pr. 13 Starting Frequency
25	Get/Set	Pr. 15 Jog Speed Setting
26	Get/Set	Pr. 16 Jog Acceleration/Deceleration Time
27	Get/Set	Pr. 17 MRS input selection
28	Get/Set	Pr. 18 High Speed Maximum Frequency Limit
29	Get/Set	Pr. 19 Base Frequency Voltage
30	Get/Set	Pr. 20 Acceleration/Deceleration Ref Speed
31	Get/Set	Pr. 21 Acceleration/Deceleration Time Increment*
32	Get/Set	Pr. 22 Torque Restriction Level
34	Get/Set	Pr. 24 Multi-Speed Setting (4th)
35	Get/Set	Pr. 25 Multi-Speed Setting (5th)
36	Get/Set	Pr. 26 Multi-Speed Setting (6th)
37	Get/Set	Pr. 27 Multi-Speed Setting (7th)
38	Get/Set	Pr. 28 Multi-Speed Input Compensation
39	Get/Set	Pr. 29 Acceleration/Deceleration Pattern
40	Get/Set	Pr. 30 Regenerative function selection

Attr#	Access	Attribute
41	Get/Set	Pr. 31 Speed Jump 1A
42	Get/Set	Pr. 32 Speed Jump 1B
43	Get/Set	Pr. 33 Speed Jump 2A
44	Get/Set	Pr. 34 Speed Jump 2B
45	Get/Set	Pr. 35 Speed Jump 3A
46	Get/Set	Pr. 36 Speed Jump 3B
47	Get/Set	Pr. 37 Speed Display
51	Get/Set	Pr. 41 Up-to-Frequency Sensitivity
52	Get/Set	Pr. 42 Speed Detection
53	Get/Set	Pr. 43 Speed Detection for Reverse Rotation
54	Get/Set	Pr. 44 2nd Acceleration/Deceleration Time
55	Get/Set	Pr. 45 2nd Deceleration Time
60	Get/Set	Pr. 50 2nd Speed Detection
62	Get/Set	Pr. 52 PU Main Display Data Selection
63	Get/Set	Pr. 53 PU Level Display Data Selection
64	Get/Set	Pr. 54 DA1 Terminal Function Selection
65	Get/Set	Pr. 55 Speed Monitoring Reference
66	Get/Set	Pr. 56 Current Monitoring Reference
67	Get/Set	Pr. 57 Restart Coasting Time
68	Get/Set	Pr. 58 Restart Cushion Time
69	Get/Set	Pr. 59 Remote Setting Function Selection
70	Get/Set	Pr. 60 Intelligent Mode Selection
75	Get/Set	Pr. 65 Retry Selection
77	Get/Set	Pr. 67 Number of Retries at Alarm
78	Get/Set	Pr. 68 Retry Waiting Time
79	Get/Set	Pr. 69 Retry Count Display Erase
80	Get/Set	Pr. 70 Special Regenerative Brake Duty
81	Get/Set	Pr. 71 Applied Motor
82	Get/Set	Pr. 72 PWM Frequency Selection
83	Get/Set	Pr. 73 Speed Setting Signal
85	Get/Set	Pr. 75 Reset Selection
86	Get/Set	Pr. 76 Alarm Code Output Selection
87	Get	Pr. 77 Parameter Write Disable Selection
88	Get/Set	Pr. 78 Reverse Rotation Prevention Selection
89	Get	Pr. 79 Operation Mode Selection
90	Get/Set	Pr. 80 Motor Capacity
91	Get/Set	Pr. 81 Number of Motor Poles
92	Get/Set	Pr. 82 Motor Excitation Current
93	Get/Set	Pr. 83 Rated Motor Voltage
94	Get/Set	Pr. 84 Rated Motor Frequency
100	Get/Set	Pr. 90 Motor Constant R1
101	Get/Set	Pr. 91 Motor Constant R2

OBJECT MAP V500 SERIES

Attr#	Access	Attribute
102	Get/Set	Pr. 92 Motor Constant L1
103	Get/Set	Pr. 93 Motor Constant L2
104	Get/Set	Pr. 94 Motor Constant X
105	Get/Set	Pr. 95 Online Auto Tuning Selection
106	Get/Set	Pr. 96 Auto Tuning Setting/State
120	Get/Set	Pr. 110 3rd Acceleration/Deceleration Time
121	Get/Set	Pr. 111 3rd Deceleration Time
126	Get/Set	Pr. 116 3rd Speed Detection
127	Get/Set	Pr. 117 Communication Station Number
128	Get/Set	Pr. 118 Communication Speed
129	Get/Set	Pr. 119 Stop Bit Length/Data Length
130	Get/Set	Pr. 120 Parity Check Presence/Absence
131	Get/Set	Pr. 121 No. Of Communication Retries
132	Get/Set	Pr. 122 Communication Check Time Interval
133	Get/Set	Pr. 123 Waiting Time Setting
134	Get/Set	Pr. 124 CR, LF Presence/Absence Selection
138	Get/Set	Pr. 128 PID Action Selection
139	Get/Set	Pr. 129 PID Proportional Band
140	Get/Set	Pr. 130 PID Integral Time
141	Get/Set	Pr. 131 PID Upper Limit
142	Get/Set	Pr. 132 PID Lower Limit
143	Get/Set	Pr. 133 PID Action Set Point For PU Operation
144	Get/Set	Pr. 134 PID Differential Time
150	Get/Set	Pr. 140 Backlash Acceleration Stopping Speed
151	Get/Set	Pr. 141 Backlash Acceleration Stopping Time
152	Get/Set	Pr. 142 Backlash Deceleration Stopping Speed
153	Get/Set	Pr. 143 Backlash Deceleration Stopping Time
154	Get/Set	Pr. 144 Speed setting switch-over (*1)
155	Get/Set	Pr. 145 PU Language Selection
160	Get/Set	Pr. 150 Output Current Detection Level
161	Get/Set	Pr. 151 Output Current Detection Period
162	Get/Set	Pr. 152 Zero-Current Detection Level
163	Get/Set	Pr. 153 Zero-Current Detection Period
166	Get/Set	Pr. 156 Stall Prevention Operation Selection
167	Get/Set	Pr. 157 OL Signal Output Time
168	Get/Set	Pr. 158 DA2 Terminal Function Selection
172	Get/Set	Pr. 162 Auto Restart After IPF Selection
173	Get/Set	Pr. 163 1st Cushion Time For Restart
174	Get/Set	Pr. 164 1st Cushion Voltage For Restart
175	Get/Set	Pr. 165 Restart Current Restriction Level
181	Get/Set	Pr. 171 Actual Operating Hour Meter Clear
190	Get/Set	Pr. 180 DI1 Terminal Function Selection

Attr#	Access	Attribute
191	Get/Set	Pr. 181 DI2 Terminal Function Selection
192	Get/Set	Pr. 182 DI3 Terminal Function Selection
193	Get/Set	Pr. 183 DI4 Terminal Function Selection
200	Get/Set	Pr. 190 DO1 Terminal Function Selection
201	Get/Set	Pr. 191 DO2 Terminal Function Selection
202	Get/Set	Pr. 192 DO3 Terminal Function Selection
205	Get/Set	Pr. 195 ABC Terminal I Function Selection
212	Get/Set	Pr. 232 Multi-Speed Setting (Speed 8)
213	Get/Set	Pr. 233 Multi-Speed Setting (Speed 9)
214	Get/Set	Pr. 234 Multi-Speed Setting (Speed 10)
215	Get/Set	Pr. 235 Multi-Speed Setting (Speed 11)
216	Get/Set	Pr. 236 Multi-Speed Setting (Speed 12)
217	Get/Set	Pr. 237 Multi-Speed Setting (Speed 13)
218	Get/Set	Pr. 238 Multi-Speed Setting (Speed 14)
219	Get/Set	Pr. 239 Multi-Speed Setting (Speed 15)
220	Get/Set	Pr. 240 Soft-PWM selection
224	Get/Set	Pr. 244 Cooling Fan Operation Slection
230	Get/Set	Pr. 250 Stop Selection
231	Get/Set	Pr. 251 Output Phase Failure Protection Selection
232	Get/Set	Pr. 252 Override Bias
233	Get/Set	Pr. 253 Override Gain
241	Get/Set	Pr. 261 Power Failure Stop Function
242	Get/Set	Pr. 262 Subtraction Speed At Deceleration Start
243	Get/Set	Pr. 263 Subtraction Starting Speed
244	Get/Set	Pr. 264 Power Failure Deceleration Time 1
245	Get/Set	Pr. 265 Power Failure Deceleration Time 2
246	Get/Set	Pr. 266 Power Failure Deceleration Time Switch-over Speed

*1 Pr. 144 value >100 is not supported via FR-A5ND

REMARKS

65520 (HFFF0) is displayed as "8888" and 65535 (HFFFF) as "9999" on the parameter unit.

8.8.4 Class 0x66 Instance Services

#	Service
0x0E	Get Attribute Single
0x10	Set Attribute Single

8.9 Class 0x67 - Extended Object II

8.9.1 Class 0x67 Attributes - Instance 0

None. Not Applicable, Not Related To FR-V500.

8.9.2 Class 0x67 Services

None. Not Applicable, Not Related To FR-V500.

8.9.3 Class 0x67 Instance 1

Parameters

Refer to the inverter manual for details of parameter definition, setting range, or the like.

Attr#	Parameter	Access	Attribute
18	Pr. 278	Get/Set	Brake Opening Speed
19	Pr. 279	Get/Set	Brake Opening Current
20	Pr. 280	Get/Set	Brake Opening Current Detection Time
21	Pr. 281	Get/Set	Brake Operating Time At Start
22	Pr. 282	Get/Set	Brake Operation Speed
23	Pr. 283	Get/Set	Brake Operation Time At Stop
24	Pr. 284	Get/Set	Deceleration Detection Function Selection
25	Pr. 285	Get/Set	Over Detection Speed
38	Pr. 338	Get/Set	Op Cmd Source
39	Pr. 339	Get/Set	Speed Cmd Source
40	Pr. 340	Get/Set	Link Startup Mode Selection
45	Pr. 345	Get	DeviceNet Address Setup Data
46	Pr. 346	Get	DeviceNet Baudrate Setup Data

Calibration Functions : Class 0x67 Instance 1

Attr#	Parameter	Access	Description
202	Pr. 902 Speed	Get/Set	Speed Setting No. 2 Bias - Speed
203	Pr. 902 %	Get/Set	Speed Setting No. 2 Bias - %
204	Pr. 903 Speed	Get/Set	Speed Setting No. 2 Gain - Speed
205	Pr. 903 %	Get/Set	Speed Setting No. 2 Gain - %
206	Pr. 904 Torque	Get/Set	Torque Command No. 3 Bias - Torque
207	Pr. 904 %	Get/Set	Torque Command No. 3 Bias - %
208	Pr. 905 Torque	Get/Set	Torque Command No. 3 Gain - Torque
209	Pr. 905 %	Get/Set	Torque Command No. 3 Gain - %

REMARKS

65520 (HFFF0) is displayed as "8888" and 65535 (HFFFF) as "9999" on the parameter unit.

8.9.4 Class 0x67 Instance Services

#	Service
0x0E	Get Attribute Single
0x10	Set Attribute Single

8.10 Class 0x70 to 0x79 - Extended Object III

(1) Class 0x70 to 0x79 Instance attribute

Inverter Parameter

Class	Instance No.	Attribute No.	Pr. No.	Access	Description (*1)
0x70	1	10 to 109	Pr.0 to Pr.99	Get/Set	
0x71	1	10 to 109	Pr.100 to Pr.199	Get/Set	
0x72	1	10 to 109	Pr.200 to Pr.299	Get/Set	
0x73	1	10 to 109	Pr.300 to Pr.399	Get/Set	
0x74	1	10 to 109	Pr.400 to Pr.499	Get/Set	
0x75	1	10 to 109	Pr.500 to Pr.599	Get/Set	
0x76	1	10 to 109	Pr.600 to Pr.699	Get/Set	
0x77	1	10 to 109	Pr.700 to Pr.799	Get/Set	
0x78	1	10 to 109	Pr.800 to Pr.899	Get/Set	
0x79	1	10 to 109	Pr.900 to Pr.999	Get/Set	Parameter offset, parameter gain, etc. for calibration
	2	10 to 49	Pr.900 to Pr.939	Get/Set	Parameter analog value for calibration

Refer to the inverter instruction manual for details of parameter definitions.

(2) Class 0x70 to 0x79 Instance service

Service code	Description
0x0E	Read attribute value
0x10	Write attribute value

9. TROUBLESHOOTING

If a fault occurs and the inverter fails to operate properly, locate the cause of the fault and take proper corrective action by referring to the troubleshooting below. If the corresponding information is not found in the table, the inverter has problem, or the component parts are damaged, contact the nearest service representative.

9.1 Inspecting Display On Parameter Unit And MNS Status LED On FR-A5ND

In response to the occurrence of a fault, the display unit of the inverter automatically displays the code of the detected fault and MNS Status LED on FR-A5ND shows the status of the detected fault.

Display		Possible Causes	Check	Corrective Action
Operation panel of inverter	LED On FR-A5ND			
E.OP3	Blinking Red	Connection time-out, Master designated FR-A5ND for communication, but sent no msgs within time limit = 4*EPR.	Host station has not been disconnected from network.	Reset the inverter, Reconnect the network, Master is up and running, Master sends msgs within time limit.
0.00	Off	No good contact between inverter and FR-A5ND.	FR-A5ND was not plugged in firmly.	Follow the instruction in Section 2, plug in FR-A5ND firmly, Restart the network.
0.00	Red	Duplicate station number; Network power off; Network cable offline; FR-A5ND is only node, not even a Master is present; Network damaged.	No duplicate station numbers; Network power on; All cables are in proper connection; Master is on network. No damage to network;	Check required items at left box, Reset the inverter, Restart the network.

10.SPECIFICATIONS

- | | |
|---|--|
| 1) Communication power supply input voltage | • 11 to 28 V dc |
| 2) Communication power supply consumption current | • 90mA maximum @24Vdc input |
| 3) Standard | <ul style="list-style-type: none"> • conforms to ODVA DeviceNet Specification Release 2.0 (independently tested by University of Michigan test lab, January, 1998); supports UCMM |
| 4) Network topology | <ul style="list-style-type: none"> • DeviceNet (linear bus with drop lines) |
| 5) Transmission Media | <ul style="list-style-type: none"> • DeviceNet standard thick or thin cable |
| 6) Maximum cable distance | <ul style="list-style-type: none"> • 500m at 125kbps with thick cable (see DeviceNet specification for details on maximum cable distance for different baud rates) |
| 7) Transmission speed | <ul style="list-style-type: none"> • 125kbps, 250kbps, 500kbps |
| 8) Number of inverters connectable | <ul style="list-style-type: none"> • 62 inverters with minimum of one node as a master and plus repeater |
| 9) Supported inverters | <ul style="list-style-type: none"> • FR-A500(L)/F500(L)/V500 |
| 10) Dimension | <ul style="list-style-type: none"> • 96 x 49 x 33 mm |

11) Environmental

Ambient temperature	-10 to 50°C (non-condensing)
Ambient humidity	90% or less (non-condensing)
Vibration	5.9m/s ² or less, conforming to JIS-C0912
Protective structure	Open type (IP00), JEM1030

Appendix A. Electronic Data Sheets (EDS files)

The EDS file of the A500(L)/F500(L)/V500 series can be downloaded from the web site.

Download free of charge from the Open DeviceNet Vendors Association web site at <http://www.odva.org>

Contact your sales representative for details.

REMARKS

The EDS file has been constructed to ODVA standards. Consult your DeviceNet configuration software instruction manual for the proper installation of the EDS file.

Appendix B. DeviceNet Error Code

The following table lists the Error Codes that may be present in the General Error Code field of an Error Response message.

Error Code	Name	Description
0x00	Success	Service was successfully performed by the object specified.
0x02	Resource unavailable	Resources needed for the object to perform the requested service were unavailable.
0x04	Path segment error	The path segment identifier or the segment syntax was not understood by the processing node.
0x05	Path destination unknown	The path is referencing an object class, instance or structure element that is not known or is not contained in the processing node.
0x07	Connection lost	The messaging connection was lost
0x08	Service not supported	The requested service was not implemented or was not defined for this Object Class/Instance.
0x09	Invalid attribute value	Invalid attribute data detected
0x0A	Attribute list error	An attribute in the Get_Attribute_List or Set_Attribute_List response has a non-zero status.
0x0B	Already in requested mode/state	The object is already in the mode/state being requested by service.
0x0C	Object state conflict	The object cannot perform the requested service in its current mode/state.
0x0D	Object already exist	The requested instance of object to be created already exists.
0x0E	Attribute not settable	A request to modify a non-modifiable attribute was received.
0x0F	Privilege violation	A permission /privilege check failed
0x10	Device state conflict	The device's current mode/state prohibits the execution of the requested service.
0x11	Reply data too large	The data to be transmitted in the response buffer is larger than the allocated response buffer.
0x13	Not enough data	The service did not supply enough data to perform the specified.

Error Code	Name	Description
0x14	Attribute not supported	The attribute specified in the request is not supported.
0x15	Too much data	The service supplied more data than was expected.
0x16	Object does not exist	The object specified does not exist in the device.
0x18	No stored attribute data	The attribute data of this object was not saved prior to the requested service.
0x19	Store operation failure	The attribute data of this object was not saved due to a failure during the attempt.
0x1C	Missing attribute list entry data	The service did not supply an attribute in a list of attributes that was needed by service to perform the requested behaviour.
0x1D	Invalid attribute value list	The service is returning the list of attributes supplied with status information for those attributes that was invalid.
0x1F	Vender specific error	A vender specific error has been encountered.
0x20	Invalid parameter	A parameter associated with the request was invalid.
0x27	Unexpected attribute in list	An attempt was made to set an attribute that is not able to be set at this time.
0x28	Invalid Member ID	The Member ID specified in the request does not exist in the specified Class/ Instance/Attribute.
0x29	Member not settable	A request to modify a non-modifiable member was received.
0x2A	Group 2 only server general failure	This error code may only be reported by group 2 only servers with 4K or less code space and only in place of Service not supported, Attribute not supported and Attribute not settable .

REVISIONS

*The manual number is given on the bottom left of the back cover.

Print Date	*Manual Number	Revision
Mar., 2003	IB(NA)-0600147E-A	First edition