

mitsubishi

LARGE CAPACITY INVERTER

FR-A500L



**HIGH PERFORMANCE
&
HIGH-FUNCTIONS**

FR-A560L-375K~900K-NA

- INSTRUCTION MANUAL -

 **MITSUBISHI
ELECTRIC**

Thank you for choosing this Mitsubishi Large Capacity Inverter.

This instruction manual gives handling information and precautions for use of this equipment.

Incorrect handling might cause an unexpected fault. Before using the inverter, please read this manual carefully to use the equipment to its optimum.

This manual describes the parts which are different from the FR-A500L chassis drive, up to 280kw. Please refer to the FR-A500L instruction manual for further details.

This section is specifically about safety matters

Do not attempt to install, operate, maintain or inspect the inverter until you have read through this instruction manual and appended documents carefully and can use the equipment correctly.

Do not use the inverter until you have a full knowledge of the equipment, safety information and instructions. In this instruction manual, the safety instruction levels are classified into "WARNING" and "CAUTION".



Assumes that incorrect handling may cause hazardous conditions, resulting in death or severe injury.



Assumes that incorrect handling may cause hazardous conditions, resulting in medium or slight injury, or may cause physical damage only.

Note that the CAUTION level may lead to a serious consequence according to conditions. Please follow the instructions of both levels because they are important to personnel safety.

SAFETY INSTRUCTIONS

1. Electric Shock Prevention



WARNING

- While power is on or when the inverter is running, do not open the front door. You may get an electric shock.
- Do not run the inverter with the front door opened. Contact with the exposed high-voltage terminals or charging part of circuitry will cause an electric shock.
- If power is off, do not open the front door except for wiring or periodic inspection. You may access the charged inverter circuits and get an electric shock.
- Before starting wiring or inspection, switch power off, wait for more at least 10 minutes and check for the presence of any residual voltage with meter (see chapter 2 for-further details.) etc.
- Any person who is involved in the wiring or inspection of this equipment should be fully competent to do the work.
- Always install the inverter before wiring. Otherwise, you may get an electric shock or be injured.
- Operate the switches with dry hands to prevent an electric shock.
- Do not subject the cables to scratches, excessive stress, heavy loads or pinching. Otherwise, you may get an electric shock.

2. Fire Prevention



CAUTION

- Install the inverter on an incombustible cubicle. Installing the inverter directly on or near a combustible surface could lead to a fire.
- If the inverter has become faulty, switch off the inverter power. A continuous flow of large current could cause a fire.
- Do not connect the resistor directly to the DC terminals +(P), -(N). This could cause a fire.

3. Injury Prevention



CAUTION

- Apply only the voltage specified in the instruction manual to each terminal to prevent damage, etc.
- Ensure that the cables are connected to the correct terminals. Otherwise, damage, etc. may occur.
- Always make sure that polarity is correct to prevent damage, etc.
- After the inverter has been operating for a relatively long period of time, do not touch the inverter as it may be hot and you may get burnt.

4. Additional instructions

Also note the following points to prevent an accidental failure, injury, electric shock, etc.:

(1) Transportation and installation

CAUTION

- When carrying products, use correct lifting gear to prevent injury.
- Ensure that installation position and material can withstand the weight of the inverter. Install according to the information in the Instruction Manual.
- Do not operate if the inverter is damaged or has parts missing.
- Do not stand or rest heavy objects on the inverter.
- Check the inverter mounting orientation is correct.
- Prevent screws, wire fragments, conductive bodies, oil or other flammable substances from entering the inverter.
- Do not drop the inverter, or subject it to impact.
- Use the inverter under the following environmental conditions:

Ambient temperature	-10°C to +40°C (14°F to 104°F) (non-freezing) for 530K-900K -10°C to +40°C (14°F to 104°F) (non-freezing) at VT rating for 375K, 450K -10°C to +50°C (14°F to 122°F) (non-freezing) at CT rating for 375K, 450K
Ambient humidity	90%RH or less (non-condensing)
Storage temperature	-20°C to +65°C (-4°F to 149°F)
Ambience	Indoors (free from corrosive gas, flammable gas, oil mist, dust and dirt)
Altitude, vibration	Maximum 1000m (3280.80feet.) above sea level for standard operation. After 1000 derate by 3% for every extra 500m up to 2500m (91%).

* For transportation

Temperature	-20°C to 65°C (-4°F to 149°F)
Relative humidity	90% or less
Air pressure	70kPa to 106kPa

(2) Wiring

CAUTION

- Do not fit capacitive equipment such as power factor correction capacitor, noise filter or surge suppressor to the output of the inverter.
- The connection orientation of the output cables U, V, W to the motor will affect the direction of rotation of the motor.

(3) Trial run

CAUTION

- Check all parameters, and ensure that the machine will not be damaged by sudden start-up.

(4) Operation

CAUTION

- When you have chosen the retry function, stay away from the equipment as it will restart suddenly after an alarm stop.
- The [STOP] key is valid only when the appropriate function setting has been made. Prepare an emergency stop switch separately.
- Make sure that the start signal is off before resetting the inverter alarm. A failure to do so may restart the motor suddenly.
- The load used should be a three-phase induction motor only. Connection of any other electrical equipment to the inverter output may damage the equipment.
- The electronic overcurrent protection does not guarantee protection of the motor from overheat.
- Do not use a magnetic contactor on the inverter input for frequent starting/stopping of the inverter.
- Use a noise filter to reduce the effect of electromagnetic interference. Otherwise nearby electronic equipment may be affected.
- Take measures to suppress harmonics. Otherwise power harmonics from the inverter may heat/damage the power capacitor and generator.
- When an over 400V class motor is inverter-driven, it should be insulation-enhanced or surge voltages suppressed. Surge voltages attributable to the wiring constants may occur at motor terminals, deteriorating the insulation of the motor.
- When parameter clear or all clear is performed, each parameter returns to the factory setting. Re-set the required parameters before starting operation.
- The inverter can be easily set for high-speed operation. Before changing its setting, fully examine the performances of the motor and machine.
- In addition to the inverter's holding function, install a holding device (e. g. mechanical brake) to ensure safety.
- Before running the inverter which had been stored for a long period, always perform inspection and test operation.

(5) Emergency stop

CAUTION

- Provide a safety backup such as an emergency brake which will prevent the machine and equipment from hazardous conditions if the inverter fails.

(6) Maintenance, inspection and parts replacement

CAUTION

- Do not carry out a megger (insulation resistance) test on the control circuit of the inverter.

(7) Disposing of the inverter

CAUTION

- Treat as industrial waste.

(8) General instructions

Many of the diagrams and drawings in this instruction manual show the inverter without a cover, or partially open. NEVER run the inverter like this. Always replace the cover and follow this instruction manual when operating the inverter.

CONTENTS

1 OUTLINE	1
1.1 Pre-Operation Information	1
1.1.1 Precautions for operation	1
1.2 Basic Configuration.....	2
1.2.1 Basic configuration.....	2
2 INSTALLATION AND WIRING	3
2.1 Installation.....	3
2.1.1 Instructions for installation	3
2.2 Wiring	5
2.2.1 Terminal connection diagram	5
2.2.2 Wiring of the main circuit	8
2.2.3 Wiring of the control circuit	12
2.2.4 Connection to the PU connector	16
2.2.5 Design information.....	17
3 OPERATION.....	17
4 PARAMETER	18
4.1. Parameter list.....	18
5 PROTECTIVE FUNCTIONS.....	24
5.1 Errors (Alarms)	24
5.1.1 Error (alarm) definitions	24
5.1.2 Correspondences between digital and actual characters	28
5.1.3 Alarm code output.....	29
5.1.4 Resetting the inverter	29
5.2 Troubleshooting.....	30
5.2.1 Checking the operation panel display at alarm stop	30
5.2.2 Faults and check points	32
5.3 Precautions for Maintenance and Inspection	34
5.3.1 Precautions for maintenance and inspection.....	34
5.3.2 Check items	34
5.3.3 Periodic inspection.....	34
5.3.4 Insulation resistance test using megger	35
5.3.5 Dielectric strength test	35
5.3.6 Replacement of parts.....	38
5.3.7 Measurement of main circuit voltages, currents and power	39
6 SPECIFICATIONS.....	41
6.1 Standard Specifications	41
6.1.1 Model specifications.....	41
6.1.2 Common specifications.....	42
6.1.3 Outline drawings	44
APPENDICES.....	45
Appendix3.....	47
Appendix4.....	49
Appendix5.....	50

CHAPTER 1

OUTLINE

This chapter gives information on the basic "outline" of this product.

Always read the instructions in this chapter before using the equipment.

1.1 Pre-Operation Information..... 1
 1.2 Basic Configuration 2

<Abbreviations>

- DU
Operation panel (FR-DU04)
- PU
Operation panel (FR-DU04) and parameter unit (FR-PU04)
- Inverter
Mitsubishi Large Capacity inverter FR-A500L series
- FR-A500L
Mitsubishi Large Capacity inverter FR-A500L series
- Pr.
Parameter number
- PU operation
Operation using the PU (FR-DU04/FR-PU04)
- External operation
Operation using the control circuit signals
- Combined operation
Operation using both the PU (FR-DU04/FR-PU04) and external operation
- MT-A100E
Mitsubishi large capacity inverter MT-A100 series
<EXCELLENT> series

CHAPTER 1	OUTLINE
CHAPTER 2	INSTALLATION AND WIRING
CHAPTER 3	OPERATION
CHAPTER 4	PARAMETERS
CHAPTER 5	PROTECTIVE FUNCTIONS
CHAPTER 6	SPECIFICATIONS
APPENDICES	

1.1 Pre-Operation Information

1.1.1 Precautions for operation

Incorrect handling might cause the inverter to operate improperly, its life to be reduced considerably, or at the worst, the inverter to be damaged. Handle the inverter properly in accordance with the information in each section as well as the precautions and instructions of this manual to use it correctly.

This manual is written for the FR-A500L series large capacity inverters.

For handling information on the parameter unit (FR-PU04), inboard options, stand-alone options, etc., refer to the corresponding manuals.

(1) Unpacking and product check

Unpack the inverter and check the capacity plate on the front cover and the rating plate on the inverter side face to ensure that the product agrees with your order and the inverter is intact

1) Inverter type

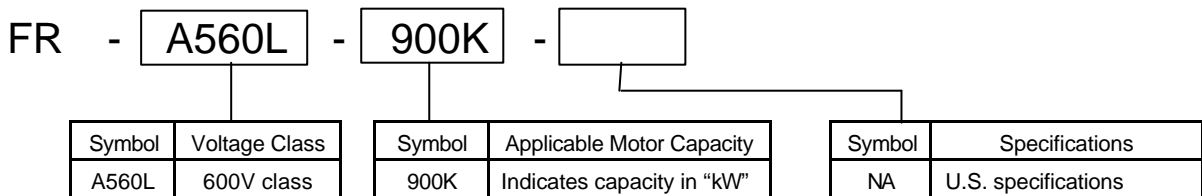

2) Accessory

Instruction manual

If you have found any discrepancy, damage, etc., please contact your sales representative.

(2) Preparations of instruments and parts required for operation

Instruments and parts to be prepared depend on how the inverter is operated. Prepare equipment and parts as necessary.

(3) Installation

To operate the inverter with high performance for a long time, install the inverter in a proper place, in a correct direction, and with proper clearances.

(4) Wiring

Connect the power supply, motor and operation signals (control signals) to the terminal block. Note that incorrect connection may damage the inverter and peripheral devices. (See page 8.)

1.2 Basic Configuration

1.2.1 Basic configuration

The following devices are required to operate the inverter. Proper peripheral devices must be selected and correct connections made to ensure proper operation. Incorrect system configuration and connections can cause the inverter to operate improperly, its life to be reduced considerably, and in the worst case, the inverter to be damaged.

Please handle the inverter properly in accordance with the information in each section as well as the precautions and instructions of this manual. (For connections of the peripheral devices, refer to the corresponding manuals.)

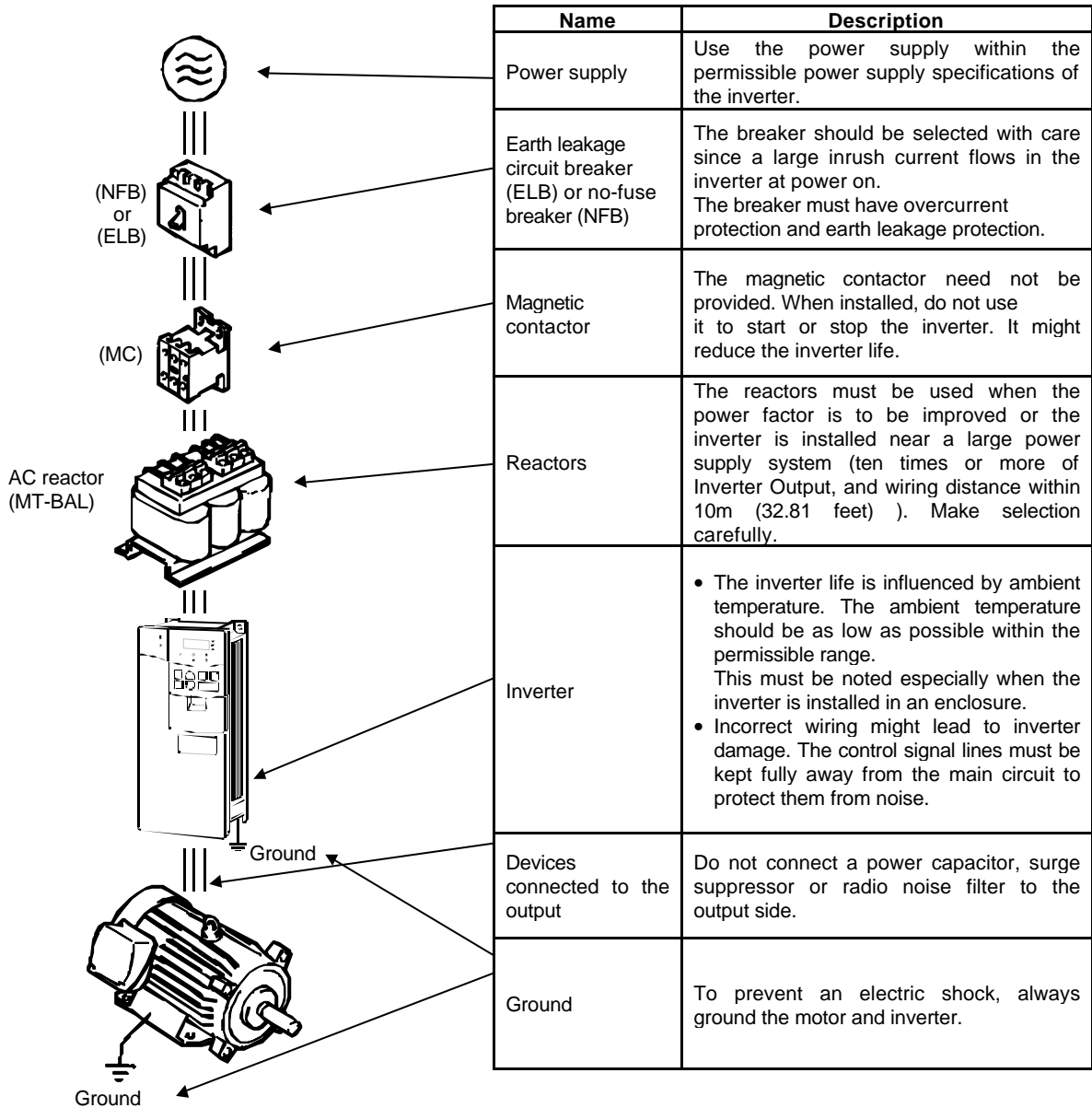

CHAPTER 2

INSTALLATION AND WIRING

This chapter gives information on the basic "installation and wiring" of this product.

Always read the instructions in this chapter before using the equipment.

2.1 Installation	3
2.2 Wiring	5

CHAPTER 1	OUTLINE
CHAPTER 2	INSTALLATION AND WIRING
CHAPTER 3	OPERATION
CHAPTER 4	PARAMETERS
CHAPTER 5	PROTECTIVE FUNCTIONS
CHAPTER 6	SPECIFICATIONS
APPENDICES	

2.1 Installation

2.1.1 Instructions for installation

- 1) Handle the unit carefully.

The inverter uses plastic parts. Handle it gently to protect it from damage. Also, hold the unit with even strength and do not apply too much strength to the front cover alone.

- 2) Install the inverter where it is not subjected to vibration.

Note the vibration of a cart, press, etc.

- 3) Note on ambient temperature

The inverter life is under great influence of ambient temperature. In the place of installation, ambient temperature must be within the permissible range (-10°C to $+40^{\circ}\text{C}$ (14°F to 104°F)). Check that the ambient temperature is within that range in the positions shown in figure 3).

*For FR-A560L-375, 450K at constant torque (CT) rating maximum ambient temperature can be 50°C (122°F).

- 4) Install the inverter on a non-combustible surface.

The inverter will be very hot (maximum. about 150°C (302°F)). Install it on a non-combustible surface (e.g. metal). Also leave sufficient clearances around the inverter.

- 5) Avoid high temperature and high humidity.

Avoid places where the inverter is subjected to direct sunlight, high temperature and high humidity.

Note: The cooling section outside the enclosure has the cooling fan. Do not use the inverter in any environment where it is exposed to waterdrops, oil mist, dust, etc.

- 6) Avoid places where the inverter is exposed to oil mist, flammable gases, fluff, dust, dirt, etc.

Install the inverter in a clean place or inside a "totally enclosed" panel which does not accept any suspended matter.

- 7) Note the cooling method when the inverter is installed in an enclosure.

When an inverter is mounted in an enclosure, the ventilation fans of the inverter and enclosure must be carefully positioned to keep the ambient temperature of the inverter below the permissible value. If they are installed in improper positions, the rise in ambient temperature will result in reduced performance of the inverter.

- 8) Secure the inverter vertically, with bolts.

Install the inverter on an installation surface securely and vertically with screws or bolts.

3) Note on ambient temperatures

FR-A560L-530 ~ 900K

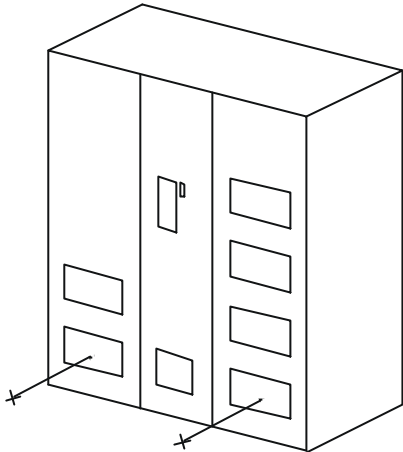

40°C at 5cm (1.97 inch)

FR-A560L-375, 450K

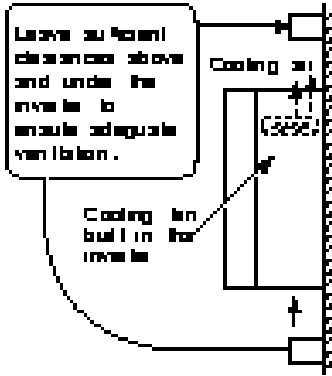
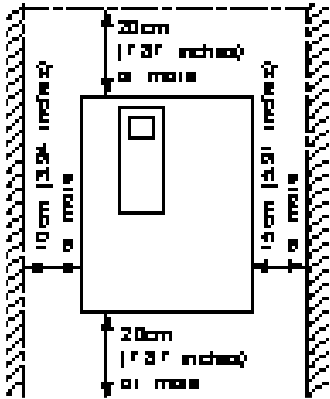

2.2 Wiring

INSTALLATION AND WIRING

2.2.1 Terminal connection diagram

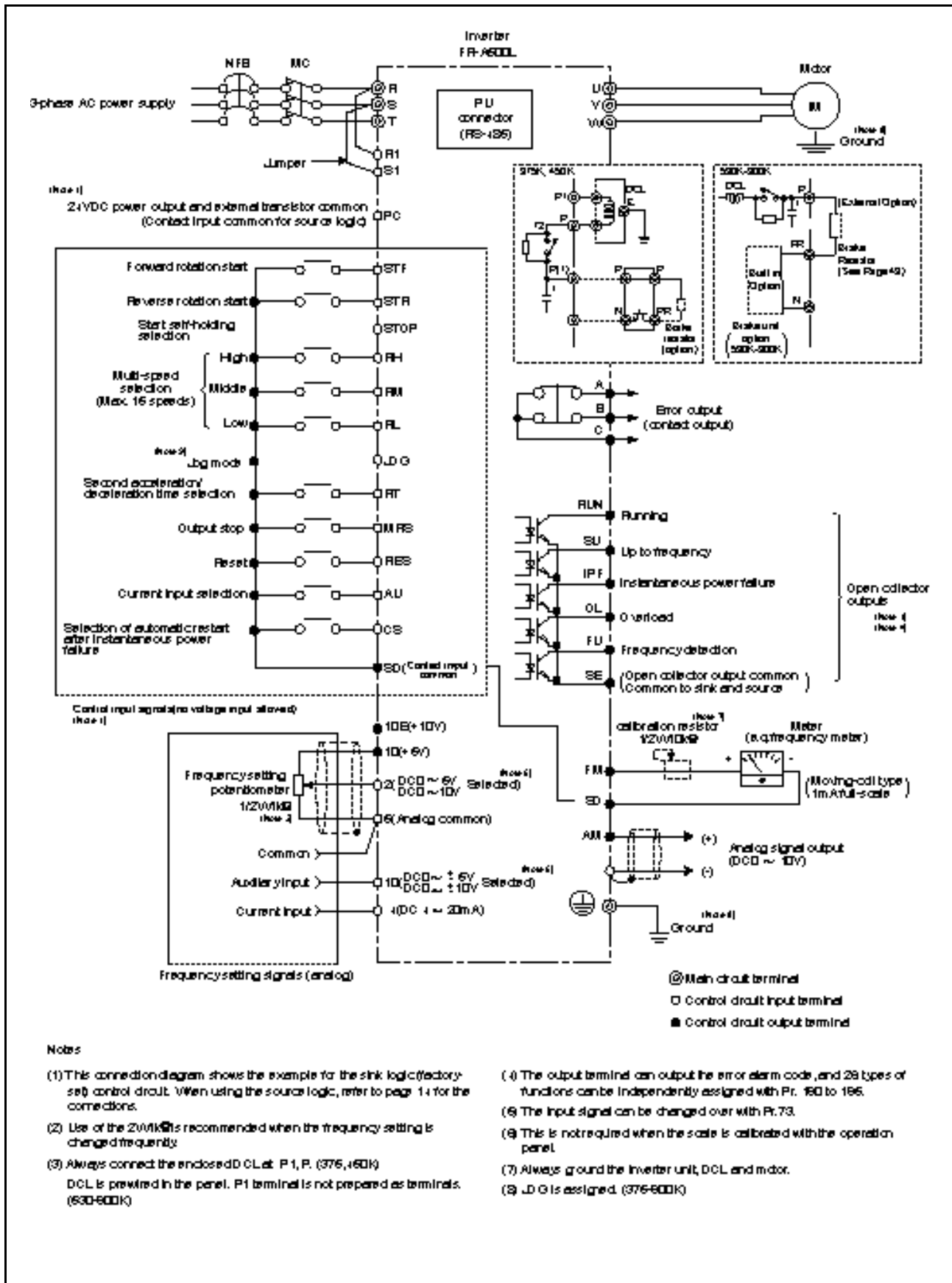

(1) Description of main circuit terminals

Type	Symbol	Terminal Name	Description
Main circuit	R, S, T <L ₁ , L ₂ , L ₃ >	AC power input	Connect to the commercial power supply. Keep these terminals unconnected when using the high power factor converter (MT-HC).
	U, V, W	Inverter output	Connect a three-phase squirrel-cage motor.
	R1, S1 <L ₁₁ , L ₂₁ >	Power supply for control circuit	Connected to the AC power supply terminals R and S. To retain the alarm display and alarm output or when using the high power factor converter (MT-HC), remove the jumpers from terminals R-R1 and S-S1 and apply external power to these terminals.
	P, N <+, ->	Optional converter connection	Connect the optional power return converter (MT-RC) or high power factor converter (MT-HC).
	P, P1	DC reactor connection	Connect the enclosed DC reactor. (375, 450K) DC reactor is prewired in 530-900K sizes.
	P, PR <+, PR>	Brake resistor connection	Connect the optional FR-BR5 brake resistor.
		Ground	For grounding the inverter chassis. Must be earthed.

Note: < > Terminal names in parentheses are those of the EC version.

(2) Description of control circuit terminals

Type	Symbol	Terminal Name	Description	
Input signals Contacts, e.g. start, function setting	STF	Forward rotation start	Turn on the STF signal to start forward rotation and turn it off to stop. Acts as a programmed operation start signal in the programmed operation mode. (Turn on to start and turn off to stop.)	When the STF and STR signals are turned on simultaneously, the stop command is given.
	STR	Reverse rotation start	Turn on the STR signal to start reverse rotation and turn it off to stop.	
	STOP	Start self-holding selection	Turn on the STOP signal to select the self-holding of the start signal.	
	RH, RM, RL	Multi-speed selection	Use the RH, RM and RL signals as appropriate to select multiple speeds.	Input terminal function selection (Pr. 180 to Pr. 186) change terminal functions.
	(JOG)	JOG mode selection	This terminal connected internally, can not be used by the customer. (530-900KW:this signal is assigned in Factory.)	
	RT	Second acceleration/ deceleration time selection	Turn on the RT signal to select the second acceleration/ deceleration time. When the second functions such as "second torque boost" and "second V/F (base frequency)" functions have been set, these functions can also be selected by turning on the RT signal.	
	MRS	Output stop	Turn on the MRS signal (20ms or longer) to stop the inverter output. Used to shut off the inverter output to bring the motor to a stop by the magnetic brake.	
	RES	Reset	Used to reset the protective circuit activated. Turn on the RES signal for more than 0.1 sec, then turn it off.	
	AU	Current input selection	Only when the AU signal is turned on, the inverter can be operated with the 4-20mADC frequency setting signal.	Input terminal function selection (Pr. 180 to Pr. 186) change terminal functions.
	CS	Automatic restart after instantaneous power failure selection	With the CS signal on, restart can be made automatically when the power is restored after an instantaneous power failure. Note that this operation requires restart parameters to be set. When the inverter is shipped from the factory, it is set to disallow restart.	
	SD	Contact input common (sink)	Common terminal for the terminal FM. Common output terminal for 24VDC 0.1A power (PC terminal).	
PC	24VDC power and external transistor common Contact input common (source)	When transistor output (open collector output), such as a programmable controller, is connected, connect the external power supply common for transistor output to this terminal to prevent a fault caused by leakage current. This terminal can be used as a 24VDC, 0.1A power output. When source logic has been selected, this terminal serves as a contact input common.		

INSTALLATION AND WIRING

Type	Symbol	Terminal Name	Description			
Input signals	Analog frequency setting	10E	Frequency setting power supply	10VDC, permissible load current 10mA	When the frequency setting potentiometer is connected in the factory-set state, connect it to terminal 10. When it is connected to terminal 10E, change the input specifications of terminal 2.	
		10		5VDC, permissible load current 10mA		
		2	Frequency setting (voltage)	By entering 0 to 5VDC (0 to 10VDC), the maximum output frequency is reached at 5V (or 10V) and I/O are proportional. Switch between input 0 to 5VDC (factory setting) and 0 to 10VDC from operation terminal. Input resistance 10kΩ. Maximum permissible voltage 20V.		
		4	Frequency setting (current)	By entering 4 to 20mADC, the maximum output frequency is reached at 20mA and I/O are proportional. This input signal is valid only when the AU signal is on. Input resistance 250Ω. Maximum permissible current 30mA.		
		1	Auxiliary frequency setting	By entering 0 to ±5VDC 0 to ±10VDC, this signal is added to the frequency setting signal of terminal 2 or 4. Switch between input 0 to ±5VDC and 0 to ±10VDC (factory setting) from operation terminal. Input resistance 10kΩ. Maximum permissible voltage ±20V.		
		5	Frequency setting input common	Common to the frequency setting signal (terminal 2, 1 or 4) and analog output terminal AM. Do not earth.		
Output signals	Open collector	Contact	A , B , C	Alarm output	Change-over contact output indicating that the output has been stopped by the inverter protective function activated. 200VAC 0.3A, 30VDC 0.3A. Alarm: discontinuity across B-C (continuity across A-C), normal: continuity across B-C (discontinuity across A-C).	Output terminal function selection (Pr. 190 to Pr. 195) change terminal functions.
			RUN	Inverter running	Switched low when the inverter output frequency is equal to or higher than the starting frequency (factory set to 0.5Hz, variable). Switched high during stop or DC dynamic brake operation ^(note1) . Permissible load 24VDC 0.1A.	
			SU	Up to frequency	Switched low when the output frequency has reached within ±10% of the set frequency (factory setting, variable). Switched high during acceleration, deceleration or stop ^(note 1) . Permissible load 24VDC 0.1A.	
			OL	Overload alarm	Switched low when the stall prevention function has caused stall prevention to be activated. Switched high when stall prevention is reset ^(note 1) . Permissible load 24VDC 0.1A.	
			IPF	Instantaneous power failure	Switched low when instantaneous power failure or undervoltage protection is activated ^(note 1) . Permissible load 24VDC 0.1A.	
			FU	Frequency detection	Switched low when the output frequency has reached or exceeded the detection frequency set as appropriate. Switched high when below the detection frequency ^(note 1) . Permissible load 24VDC 0.1A.	
			SE	Open collector output common	Common to the RUN, SU, OL, IPF and FU terminals.	
	Pulse	Analog	FM	For meter	One selected from 16 monitoring items, such as output frequency, is output ^(note 2) .	Factory setting of output item: Frequency Permissible load current 1mA 1440 pulses/second. at 60Hz
			AM	Analog signal output	The output signal is proportional to the magnitude of each monitoring item.	Factory setting of output item: Frequency Output signal 0 to 10VDC Permissible load current 1mA
	Communication	RS485	—	PU connector	With the operation panel connector, communication can be made through RS-485. <ul style="list-style-type: none"> • Conforming Standard : EIA Standard RS-485 • Transmission format : Multi-drop link • Communication speed : Maximum 19200 baud rates • Overall length : 500m 	

Note1: Low indicates that the open collector outputting transistor is on (conducts). High indicates that the transistor is off (does not conduct).

Note2: Not output while the inverter is reset.

2.2.2 Wiring of the main circuit

(1) Wiring instructions

- 1) Power must not be applied to the output terminals (U, V, W) of the inverter. Otherwise the inverter will be damaged.
- 2) After wiring, wire off-cuts must not be left in the inverter.
Wire off-cuts can cause an alarm, failure or malfunction. Always keep the inverter clean.
- 3) Use thick cables to make a voltage drop of 2% or less.
If the wiring distance is long between the inverter and motor, a main circuit cable voltage drop will cause the motor torque to decrease especially at the output of a low frequency.
- 4) Electromagnetic wave interference
The input/output (main circuit) of the inverter includes harmonic components, which may interfere with the communication devices (such as AM radios) used near the inverter. In this case, use shielded wire cables as the power cable.
- 5) Do not install a power capacitor, surge suppressor or radio noise filter (FR-BIF option) in the output side of the inverter.
This will cause the inverter to trip or the capacitor and surge suppressor to be damaged. If any of the above devices are installed, immediately remove them.
- 6) When rewiring after operation, make sure that the POWER lamp has gone off, and when more than 10minutes have elapsed after power-off, check with a tester that the DC bus voltage is zero. After that, start rewiring work. For some time after power-off, there is a dangerous voltage in the capacitor.
- 7) Top attachments should be removed before operating because of Air exhaust. Side attachments can be used for fixing the unit. (See page 44)

Notes on Grounding

- Leakage currents flow in the inverter. To prevent an electric shock, the inverter and motor must be grounded (grounding resistance: 10Ω or less.)
- Use the dedicated ground terminal to ground the inverter. (Do not use the screw in the case, chassis, etc.)
- The ground cable should have a thickness of 38mm², or more, and be as short as possible. The grounding point should be as close to the inverter as possible.

(2) Terminal block layout

In the main circuit of the inverter, the terminals are arranged as shown below:

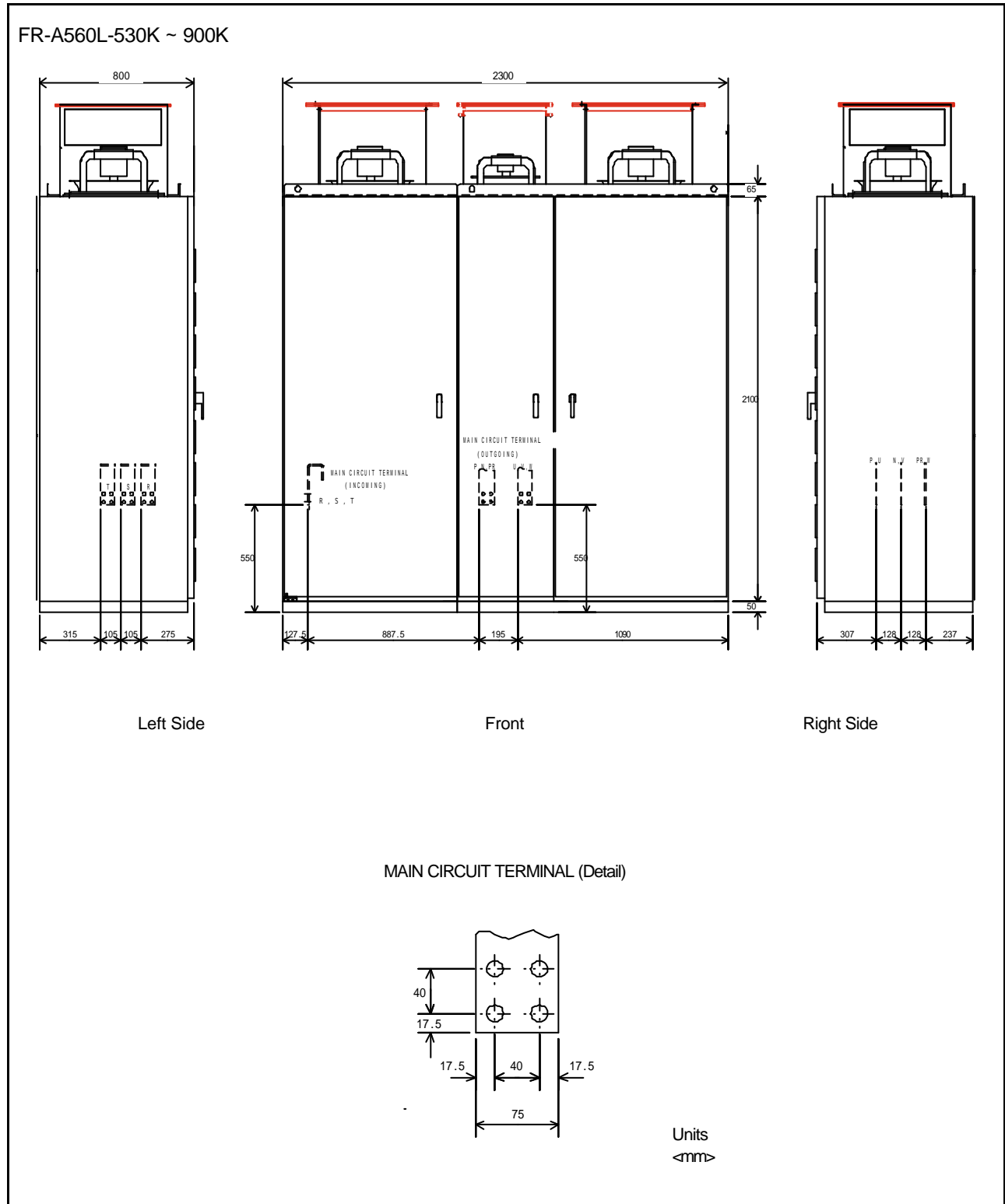

FR-A560L-375K, 450K

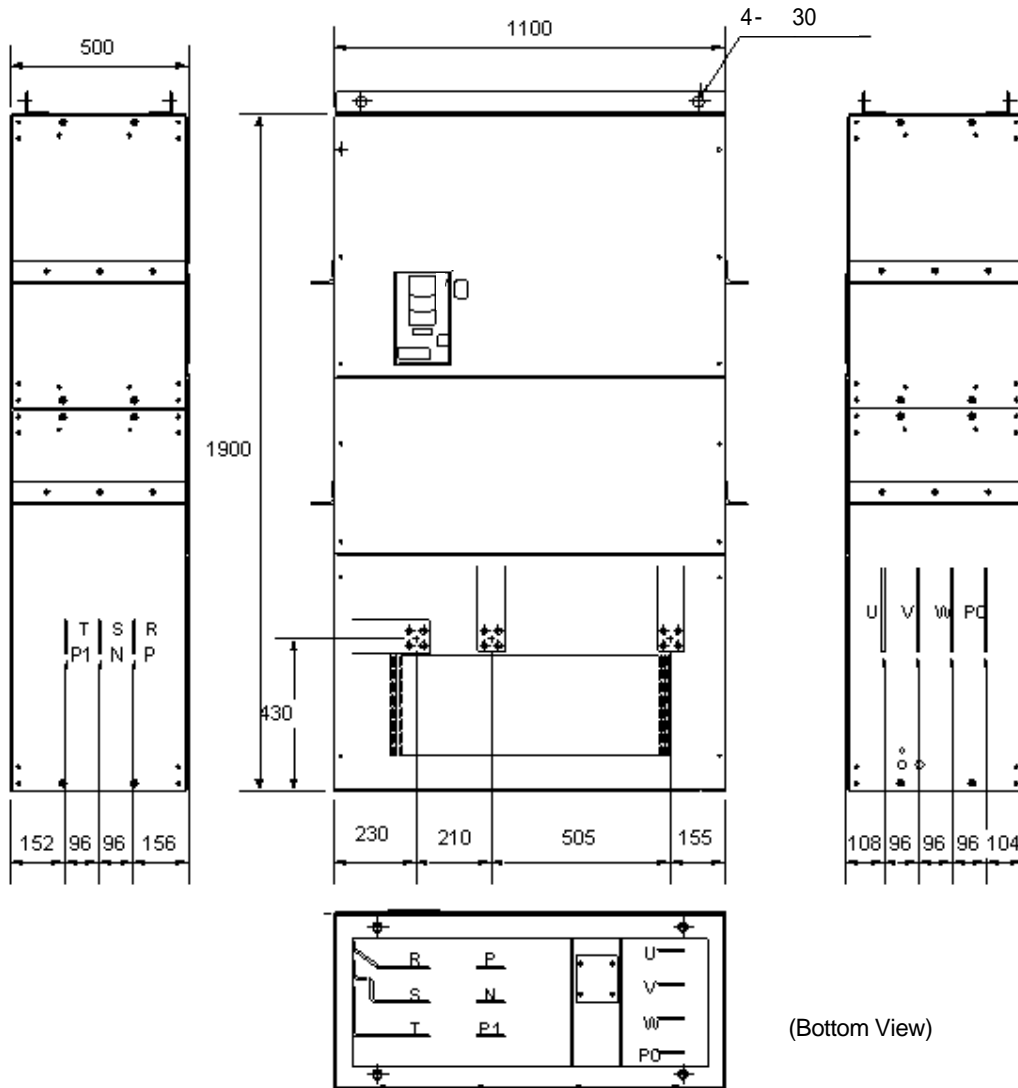

(Bottom View)

R, S, T
TERMINAL (Detail)

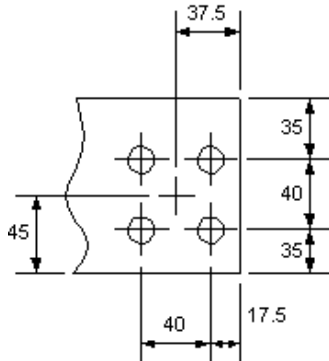

U, V, W, PO
P1, P, N

TERMINAL (Detail)

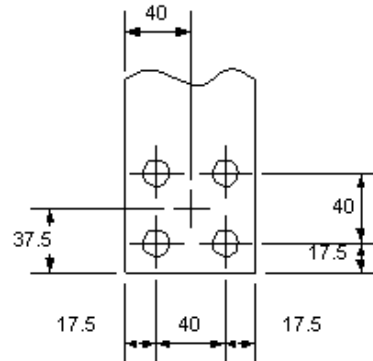

Units < mm >

(3) Connection of the power supply and motor

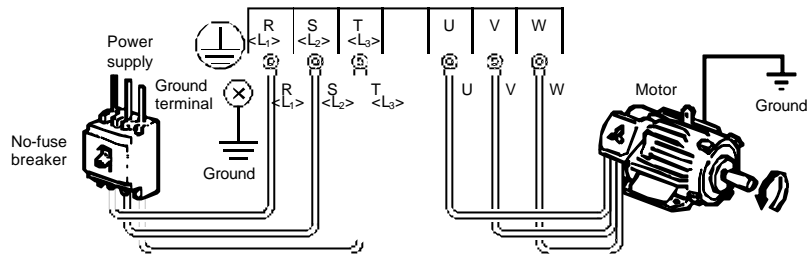

The power supply cables must be connected to R, S, T<L1, L2, L3>. If they are connected to U, V, W, the inverter will be damaged.

Connect the motor to U, V, W.
In the above connection, turning on the forward rotation switch (signal) rotates the motor in the counterclockwise (arrow) direction when viewed from the load shaft.

(4) Connecting the control circuit to a power supply separately from the main circuit

If the magnetic contactor (MC) in the inverter power supply is opened when the protective circuit is operated, the inverter control circuit power is lost and the alarm output signal cannot be kept on. To keep the alarm signal on terminals R1 and S1 are available. In this case, connect the power supply terminals R1 and S1 <L11 and L21> of the control circuit to the primary side of the MC.

<Connection procedure>

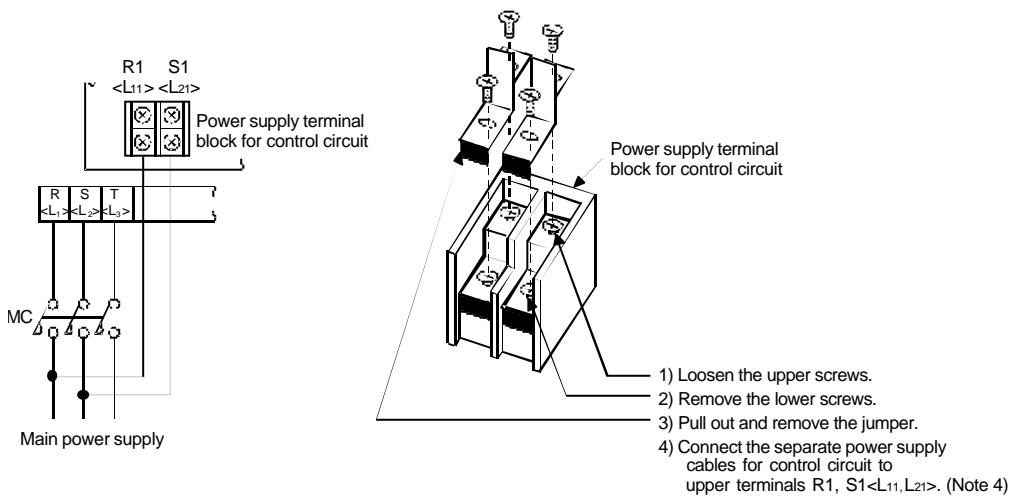

- Note:
1. When the main circuit power (R, S, T) <L1, L2, L3> is on, do not switch off the control power (terminals R1, S1<L11, L21>). Otherwise the inverter may be damaged.
 2. When using a separate power supply, the jumpers across R-R1 and S-S1 <L1-L11 and L2-L21> must be removed. Otherwise the inverter may be damaged.
 3. For a different power supply system which takes the power of the control circuit from other than the primary side of the MC, the voltage should be equal to the main circuit voltage.
 4. The power supply cables must not be connected to the lower terminals. If connected, the inverter may be damaged.

2.2.3 Wiring of the control circuit

(1) Wiring instructions

- 1) Terminals SD, SE and 5 are common to the I/O signals and isolated from each other. These common terminals must not be connected to each other or earthed.
- 2) Use shielded or twisted cables for connection to the control circuit terminals and run them away from the main and power circuits (including the 200V relay sequence circuit).
- 3) The frequency input signals to the control circuit are micro currents. When contacts are required, use two or more parallel micro signal contacts or a twin contact to prevent a contact fault.
- 4) It is recommended to use the cables of 0.75mm² gauge for connection to the control circuit terminals.
If the cable gauge used is 1.25mm² or more, the front cover may be lifted when there are many cables running or the cables are run improperly, resulting in an operation panel or parameter unit contact fault.

(2) Terminal block layout

● NA version (OR Version)

In the control circuit of the inverter, the terminals are arranged as shown below:

Terminal screw size: M3.5

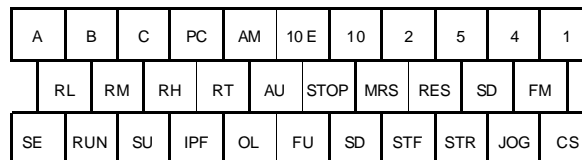

● EC version

Terminal screw size : M3

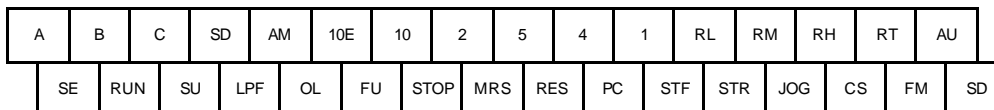

<Wiring procedure>

- 1) For the wiring of the control circuit, strip the sheaths of the cables and use them as they are.
Strip the sheath to the following dimension. If too much is stripped this may cause a short circuit with the neighboring cable. If too little stripped this may cause cable disconnection.

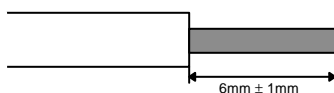

- 2) Loosen the terminal screw and insert the cable into the terminal.
- 3) Tighten the screw to the specified torque.
Undertightening can cause cable disconnection or malfunction. Overtightening can cause a short circuit or malfunction due to the screw or unit damaged.

Tightening torque : 5 to 6 kgf·cm

Note : Wire the stripped cable by twisting it to prevent it from becoming loose. (Do not plate the cable with solder.)

Note : 1. Use a NFB (No fuse breakers) or fuse on the inverter input (primary) side.

2. Make sure that the control circuit terminal wiring does not touch power circuit terminals (or screws) or conducting power circuit.

(3) Changing the control logic

The input signals are set to sink logic for the NA version, and to source logic for the EC version.

To change the control logic, the connector on the back of the control circuit terminal block must be moved to the other position.

(The output signals may be used in either the sink or source logic independently of the connector position.)

- 1) Loosen the two mounting screws in both ends of the control circuit terminal block. (The screws cannot be removed.)

With both hands, pull down the terminal block from the back of the control circuit terminals.

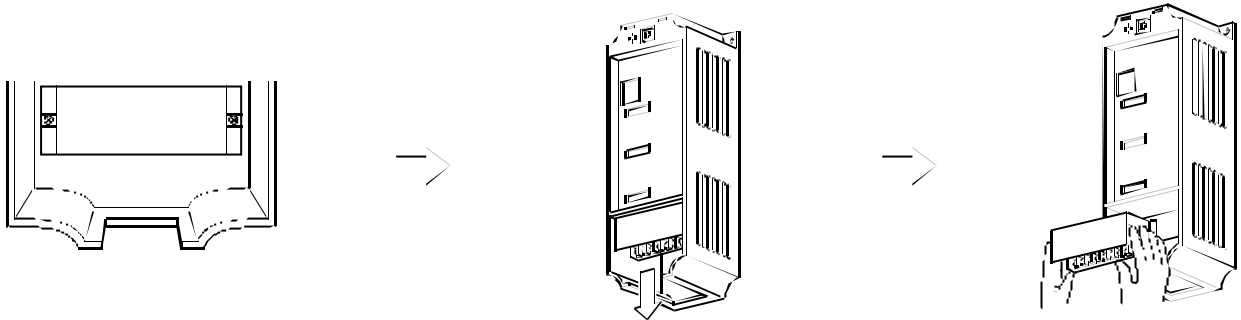

- 2) Remove the connector in the sink logic position on the back surface of the control circuit terminal block and fit it to the source logic position.

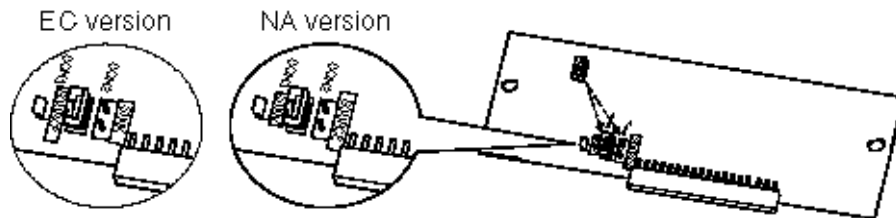

- 3) Using care not to bend the pins of the control circuit connector, reinstall the control circuit terminal block and fix it with the mounting screws.

Note: 1. Make sure that the control circuit connector is fitted correctly.
 2. While power is on, never disconnect the control circuit terminal block.
 3. The sink-source logic change-over connector must be fitted in only one of those positions. If it is fitted in both positions at the same time, the inverter may be damaged.

4) Sink logic type

- In this logic, a signal switches on when a current flows out of the corresponding signal input terminal. Terminal SD is common to the contact input signals. Terminal SE is common to the open collector output signals.

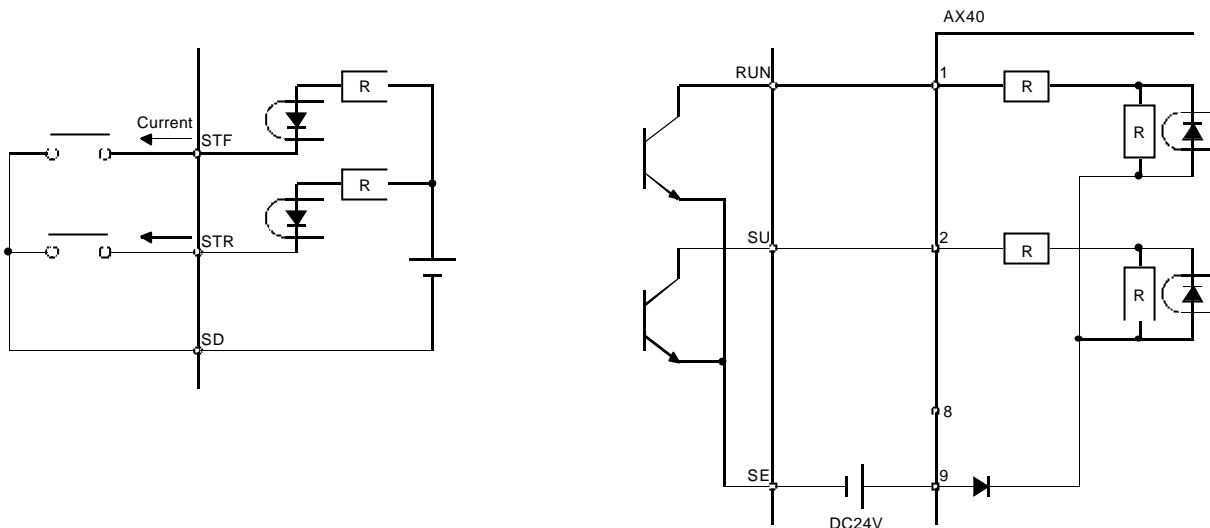

- When using an external power supply for transistor output, use terminal PC as a common to prevent misoperation caused by leakage current. (Do not connect terminal SD of the inverter with terminal 0V of the external power supply.)

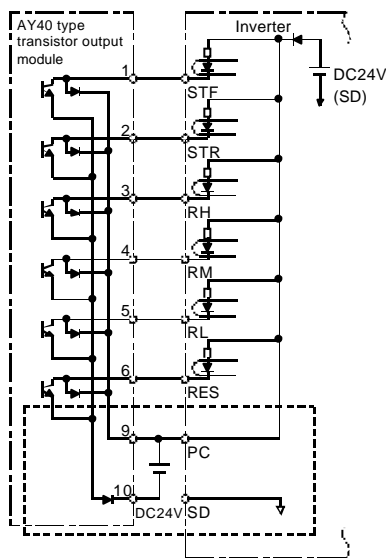

5) Source logic type

- In this logic, a signal switches on when a current flows into the corresponding signal input terminal. Terminal PC is common to the contact input signals. Terminal SE is common to the open collector output signals.

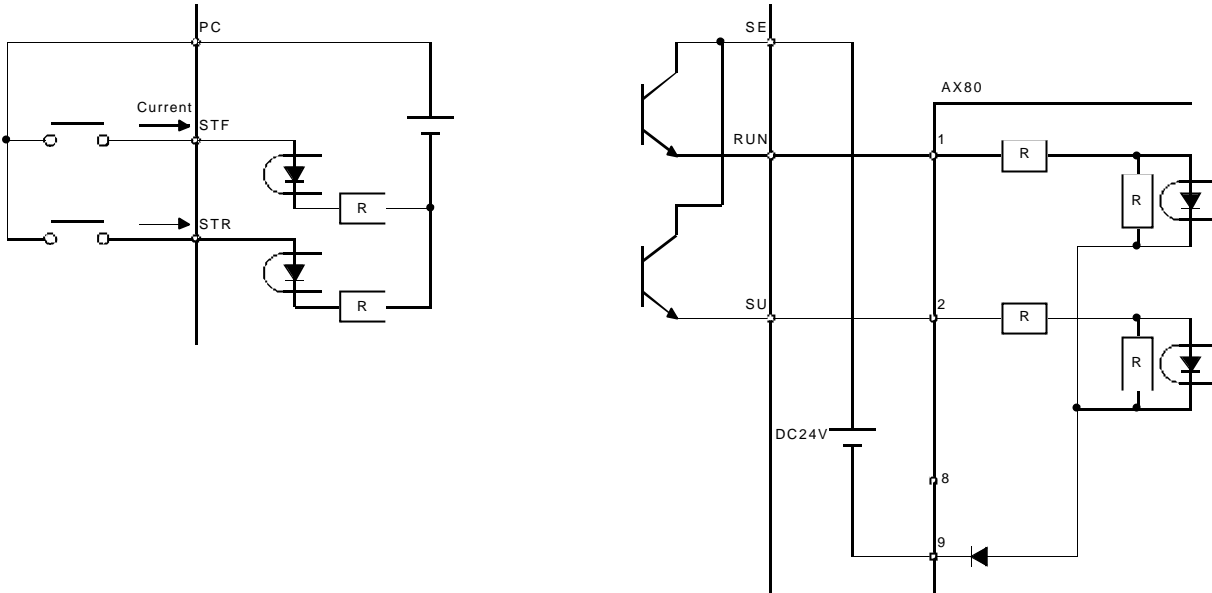

- When using an external power supply for transistor output, use terminal SD as a common to prevent misoperation caused by leakage current.

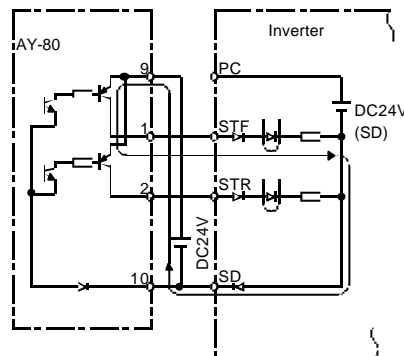

(4) How to use terminals “STOP”, “CS” and “PC”

1) Using the “STOP” terminal

A connection example (for sink logic) for self-holding the start signal (forward rotation, reverse rotation) is shown on the right.

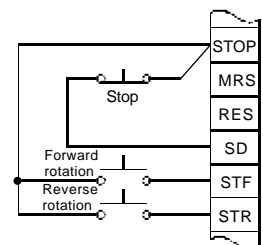

2) Using the “CS” terminal

This terminal is used to perform automatic restart after instantaneous power failure and commercial power supply-inverter switch-over operation.

<Example: Automatic restart after instantaneous power failure in sink logic>

Connect terminals CS-SD and set a value other than “9999” in Pr. 57 “coasting time for automatic restart after instantaneous power failure”.



3) Using the “PC” terminal

This terminal can be used as 24VDC power output using SD as a common terminal.

Specifications: 18V to 26VDC, 0.1A permissible current

Note that the wiring length should be within 30m.

Do not short terminals PC-SD.

When terminal PC is used as a 24V power supply, leakage current from transistor output cannot be prevented.

2.2.4 Connection to the PU connector

(1) When connecting the operation panel or parameter unit using a connection cable

<Recommended cable connector>

- Parameter unit connection cable (FR-CB2) (option) or the following connector and cable.
- Connector: RJ45 connector
Example: 5-554720-3, Nippon AMP
- Cable: Cable conforming to EIA568 (e.g. 10BASE-T cable)
Example: SGLPEV 0.5mm x 4P, MITSUBISHI CABLE INDUSTRIES, LTD.

Note: The maximum wiring length is 20m (65.62 feet).

(2) For RS-485 communication

With the operation panel disconnected, the PU connector can be used for communication operation from a personal computer etc.

<PU connector pin-outs>

Viewed from the inverter (receptacle side) front

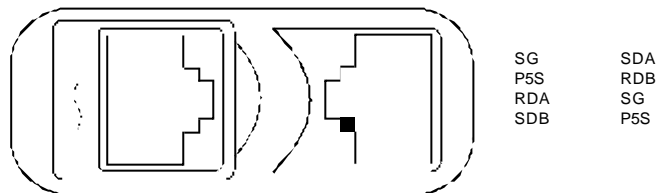

- Note: 1. Do not connect the PU connector to the computer's LAN board, FAX modem socket or telephone modular connector. Otherwise, the product may be damaged due to electrical specification differences.
2. Pins 2 and 8 (P5S) provide power to the operation unit or parameter unit. Do not use these pins for RS-485 communication.

Use the connector and cable as detailed below.

- Connector: RJ45 connector
Example: 5-554720-3, Nippon AMP
- Cable: Cable conforming to EIA568 (e.g. 10BASE-T cable)
Example: SGLPEV 0.5mm x 4P, MITSUBISHI CABLE INDUSTRIES, LTD.

☆When the communication board of the personal computer has the RS-232C specifications, prepare an RS-485, RS-232C converter.

Example of converter.

1) Model: FA-T-RS40

Converter

Industrial Systems Division Mitsubishi Electric Engineering Co., Ltd.

2) Model: DINV-485CAB

Interface built-in cable

Dia Trend Co., Ltd.

2.2.5 Design information

- 1) For commercial power supply-inverter switch-over operation, provide electrical and mechanical interlocks for MC1 and MC2 designed for commercial power supply-inverter switch-over.
When there is a commercial power supply-inverter switch-over circuit as shown below, the inverter will be damaged by leakage current from the power supply due to arcs generated at the time of switch-over or chattering caused by a sequence error.
- 2) If the machine must not be restarted when power is restored after a power failure, provide a magnetic contactor in the inverter's primary circuit and also make up a sequence which will not switch on the start signal.
If the start signal (start switch) remains on after a power failure, the inverter will automatically restart as soon as the power is restored.
- 3) When the power supply used with the control circuit is different from the one used with the main circuit, make up a circuit which will switch off the main circuit power supply terminals R, S, T <L₁, L₂, L₃> when the power supply terminals , R1, S1 <L₁₁, L₂₁> for the control circuit are switched off.
- 4) Since the input signals to the control circuit are on a low level, use two parallel micro signal contacts or a twin contact for contact inputs to prevent a contact fault.
- 5) Do not apply a large voltage to the contact input terminals (e.g. STF) of the control circuit.
- 6) Do not apply a voltage directly to the alarm output signal terminals (A, B, C).
Always apply a voltage to these terminals via a relay coil, lamp, etc.
- 7) Make sure that the specifications and rating match the system requirements.

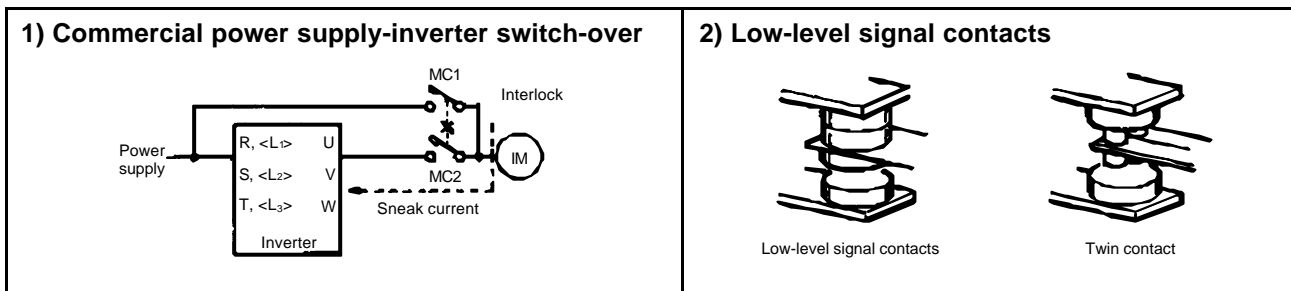

CHAPTER 3

OPERATION

This chapter provides the basic "operation" information for use of this product.

Always read this chapter before using the equipment.

- 3.1 Pre-Operation Information..... Refer to FR-A540L/A560L
- 3.2 Operation Refer to FR-A540L/A560L

CHAPTER 1	OUTLINE
CHAPTER 2	INSTALLATION AND WIRING
CHAPTER 3	OPERATION
CHAPTER 4	PARAMETERS
CHAPTER 5	PROTECTIVE FUNCTIONS
CHAPTER 6	SPECIFICATIONS
APPENDICES	

CHAPTER 4

PARAMETERS

This chapter explains the "parameters" of this product.
Always read the instructions before using the equipment.

- 4.1 Parameter List.....18
- 4.2 Parameter Function Details..... Refer to FR-A540L/A560L

Note: By making parameter settings, you can change the functions of contact input terminals RL, RM, RH, RT, AU, CS and open collector output terminals RUN, SU, IPF, OL, FU. Therefore, signal names corresponding to the functions are used in the description of this chapter (except in the wiring examples). Note that they are not terminal names.
The setting in brackets refer to the "EC" versions default settings.

CHAPTER 1	OUTLINE
CHAPTER 2	INSTALLATION AND WIRING
CHAPTER 3	OPERATION
CHAPTER 4	PARAMETERS
CHAPTER 5	PROTECTIVE FUNCTIONS
CHAPTER 6	SPECIFICATIONS
APPENDICES	

4.1 Parameter List

PARAMETERS

Function	Parameter Number	Name	Setting Range	Minimum Setting Increments	Factory Setting	Refer To Page: <Notes>
Basic functions	0	Torque boost (Note 1)	0 to 30%	0.1%	1%	48
	1	Maximum frequency	0 to 60Hz	0.01Hz	60Hz	49
	2	Minimum frequency	0 to 120Hz	0.01Hz	0Hz	49
	3	Base frequency	0 to 400Hz	0.01Hz	60Hz<50Hz>	50
	4	Multi-speed setting (high speed)	0 to 400Hz	0.01Hz	60Hz	51
	5	Multi-speed setting (middle speed)	0 to 400Hz	0.01Hz	30Hz	51
	6	Multi-speed setting (low speed)	0 to 400Hz	0.01Hz	10Hz	51
	7	Acceleration time	0 to 3600 sec/ 0 to 360 sec	0.1 sec/ 0.01 sec	15 sec	52
	8	Deceleration time	0 to 3600 sec/ 0 to 360 sec	0.1 sec/ 0.01 sec	15 sec	52
	9	Electronic thermal O/L relay	0 to 3600A	0.1A	Rated output current	52
Standard operation functions	10	DC injection brake operation frequency	0 to 120Hz, 9999	0.01Hz	3Hz	54
	11	DC injection brake operation time	0 to 10 sec, 8888	0.1 sec	0.5 sec	54
	12	DC injection brake voltage	0 to 30%	0.1%	1%	54
	13	Starting frequency	0 to 60Hz	0.01Hz	0.5Hz	55
	14	Load pattern selection (Note 1)	0 to 5	1	0	55
	15	Jog frequency	0 to 400Hz	0.01Hz	5Hz	56
	16	Jog acceleration/deceleration time	0 to 3600 sec/ 0 to 360 sec	0.1 sec/ 0.01 sec	0.5 sec	56
	17	MRS input selection	0,2	1	0	57
	18	High-speed maximum frequency	0 to 400Hz	0.01Hz	60Hz	57
	19	Base frequency voltage (Note 1)	0 to 1000V, 8888, 9999	0.1V	9999<8888>	57
	20	Acceleration/deceleration reference frequency	1 to 400Hz	0.01Hz	60Hz<50Hz>	57
	21	Acceleration/deceleration time increments	0,1	1	0	57
	*22	Stall prevention operation level	0 to 150%, 9999	0.1%	150%	58
	*23	Stall prevention operation level at double speed	0 to 150%, 9999	0.1%	9999	58
	24	Multi-speed setting (speed 4)	0 to 400Hz, 9999	0.01Hz	9999	59
	25	Multi-speed setting (speed 5)	0 to 400Hz, 9999	0.01Hz	9999	59
	26	Multi-speed setting (speed 6)	0 to 400Hz, 9999	0.01Hz	9999	59
	27	Multi-speed setting (speed 7)	0 to 400Hz, 9999	0.01Hz	9999	59
	28	Multi-speed input compensation	0, 1	1	0	59
	29	Acceleration/deceleration pattern	0, 1, 2, 3	1	0	60
30	Regenerative function selection	0, 1, 2	1	0	61	
31	Frequency jump 1A	0 to 400Hz, 9999	0.01Hz	9999	62	
32	Frequency jump 1B	0 to 400Hz, 9999	0.01Hz	9999	62	
33	Frequency jump 2A	0 to 400Hz, 9999	0.01Hz	9999	62	
34	Frequency jump 2B	0 to 400Hz, 9999	0.01Hz	9999	62	
35	Frequency jump 3A	0 to 400Hz, 9999	0.01Hz	9999	62	
36	Frequency jump 3B	0 to 400Hz, 9999	0.01Hz	9999	62	
37	Speed display	0,1 to 9998	1	0	63	
Output terminal functions	41	Up-to-frequency sensitivity	0 to 100%	0.1%	10%	64
	42	Output frequency detection	0 to 400Hz	0.01Hz	6Hz	64
	43	Output frequency detection for reverse rotation	0 to 400Hz, 9999	0.01Hz	9999	64
Second functions	44	Second acceleration/deceleration time	0 to 3600 sec/ 0 to 360 sec	0.1 sec/ 0.01 sec	5 sec	65
	45	Second deceleration time	0 to 3600 sec/ 0 to 360 sec, 9999	0.1 sec/ 0.01 sec	9999	65
	46	Second torque boost (Note 1)	0 to 30%, 9999	0.1%	9999	65
	47	Second V/F (base frequency) (Note 1)	0 to 400Hz, 9999	0.01Hz	9999	65
	*48	Second stall prevention operation current	0 to 150%	0.1%	150%	65
	49	Second stall prevention operation frequency	0 to 400Hz, 9999	0.01Hz	0	65
	50	Second output frequency detection	0 to 400Hz	0.01Hz	30Hz	64

PARAMETERS

Function	Parameter Number	Name	Setting Range	Minimum Setting Increments	Factory Setting	Refer To Page: <Notes>	
Display functions	52	DU/PU main display data selection	0, 5 to 14, 17, 18, 20, 23, 24, 25, 100	1	0	67	
	53	PU level display data selection	0 to 3, 5 to 14, 17, 18	1	1	67	
	54	FM terminal function selection	1 to 3, 5 to 14, 17, 18, 21	1	1	67	
	55	Frequency monitoring reference	0 to 400Hz	0.01Hz	60Hz<50Hz>	69	
	56	Current monitoring reference	0 to 3600A	0.1A	Rated output current	69	
Automatic restart functions	57	Restart coasting time	0 to 30 sec, 9999	0.1 sec	9999	70	
	58	Restart cushion time	0 to 60 sec	0.1 sec	1.0 sec	70	
Additional function	59	Remote setting function selection	0, 1, 2	1	0	72	
Operation selection functions	60	Intelligent mode selection	0 to 8	1	0	73	
	61	Reference I for intelligent mode	0 to 3600A, 9999	0.1A	9999	75	
	*62	Ref. I for intelligent mode accel.	0 to 150%, 9999	0.1%	9999	75	
	*63	Ref. I for intelligent mode decel.	0 to 150%, 9999	0.1%	9999	75	
	64	Starting frequency for elevator mode	0 to 10Hz, 9999	0.01Hz	9999	75	
	65	Retry selection	0 to 5	1	0	76	
	66	Stall prevention operation level reduction starting frequency	0 to 400Hz	0.01Hz	60Hz<50Hz>	77	
	67	Number of retries at alarm occurrence	0 to 10,101 to 110	1	0	76	
	68	Retry waiting time	0 to 10 sec	0.1 sec	1 sec	76	
	69	Retry count display erasure	0	—	0	76	
	70	Special regenerative brake duty	0 to 100%	0.1%	0%	77	
	71	Applied motor	0 to 8, 13 to 18	1	0	78	
	72	PWM frequency selection	0, 1, 2	1	1	79	
	73	0-5V/0-10V selection	0 to 5, 10 to 15	1	1	80	
	74	Filter time constant	0 to 8	1	1	81	
	75	Reset selection/disconnected PU detection/PU stop selection	0 to 3, 14 to 17	1	14	81	
	76	Alarm code output selection	0, 1, 2, 3	1	0	83	
	77	Parameter write disable selection	0, 1, 2	1	0	84	
	78	Reverse rotation prevention selection	0, 1, 2	1	0	85	
79	Operation mode selection	0 to 8	1	0	86		
Motor constants	80	Motor capacity	0 to 3600kW, 9999	0.1kW	9999	89	
	81	Number of motor poles	2, 4, 6, 12, 14, 16, 9999	1	9999	89	
	82	Motor exciting current (Note 6)	0 to , 9999	1	9999	90	
	*83	Rated motor voltage	0 to 1000V	0.1V	575V	90	
	84	Rated motor frequency	50 to 120Hz	0.01Hz	60Hz<50Hz>	90	
	89	Speed control gain	0 to 200%	0.1%	100%	89	
	90	Motor constant (R1) (Note 6)	(Note 6)	(Note 6)	9999	90	
	91	Motor constant (R2) (Note 6)	(Note 6)	(Note 6)	9999	90	
	92	Motor constant (L1) (Note 6)	(Note 6)	(Note 6)	9999	90	
	93	Motor constant (L2) (Note 6)	(Note 6)	(Note 6)	9999	90	
	94	Motor constant (X) (Note 6)	(Note 6)	(Note 6)	9999	90	
	95	Online auto tuning selection	0, 1	1	0	96	
	96	Auto tuning setting/status	0, 1, 101	1	0	90	
	5-point flexible V/F characteristics	100	V/F1 (first frequency) (Note 1)	0 to 400Hz, 9999	0.01Hz	9999	98
		101	V/F1 (first frequency voltage) (Note 1)	0 to 1000V	0.1V	0	98
		102	V/F2 (second frequency) (Note 1)	0 to 400Hz, 9999	0.01Hz	9999	98
		103	V/F2 (second frequency voltage) (Note 1)	0 to 1000V	0.1V	0	98
104		V/F3 (third frequency) (Note 1)	0 to 400Hz, 9999	0.01Hz	9999	98	
105		V/F3 (third frequency voltage) (Note 1)	0 to 1000V	0.1V	0	98	
106	V/F4 (fourth frequency) (Note 1)	0 to 400Hz, 9999	0.01Hz	9999	98		

PARAMETERS

Function	Parameter Number	Name	Setting Range	Minimum Setting Increments	Factory Setting	Refer To Page: <Notes>
5-point flexible V/F characteristics	107	V/F4 (fourth frequency voltage) (Note 1)	0 to 1000V	0.1V	0	98
	108	V/F5 (fifth frequency) (Note 1)	0 to 400Hz, 9999	0.01Hz	9999	98
	109	V/F5 (fifth frequency voltage) (Note 1)	0 to 1000V	0.1V	0	98
Third functions	110	Third acceleration/deceleration time	0 to 3600 sec/ 0 to 360 sec, 9999	0.1 sec/ 0.01 sec	9999	99
	111	Third deceleration time	0 to 3600 sec/ 0 to 360 sec, 9999	0.1 sec/ 0.01 sec	9999	99
	112	Third torque boost (Note 1)	0 to 30.0%, 9999	0.1%	9999	99
	113	Third V/F (base frequency) (Note 1)	0 to 400Hz, 9999	0.01Hz	9999	99
	*114	Third stall prevention operation current	0 to 150%	0.1%	150%	99
	115	Third stall prevention operation frequency	0 to 400Hz	0.01Hz	0	99
Communication functions	116	Third output frequency detection	0 to 400Hz, 9999	0.01Hz	9999	99
	117	Station number	0 to 31	1	0	99
	118	Communication speed	48, 96, 192	1	192	99
	119	Stop bit length/data length	0, 1 (data length 8) 10, 11 (data length 7)	1	1	99
	120	Parity check presence/absence	0, 1, 2	1	2	99
	121	Number of communication retries	0 to 10, 9999	1	1	99
	122	Communication check time interval	0, 0.1 to 999.8 sec, 9999	0.1	0<9999>	99
	123	Waiting time setting	0 to 150ms, 9999	10ms	9999	99
PID control	124	CR, LF presence/absence selection	0,1,2	1	1	99
	128	PID action selection	10, 11, 20, 21	1	10	109
	129	PID proportional band	0.1 to 1000%, 9999	0.1%	100%	109
	130	PID integral time	0.1 to 3600 sec, 9999	0.1 sec	1 sec	109
	131	Upper limit	0 to 100%, 9999	0.1%	9999	109
	132	Lower limit	0 to 100%, 9999	0.1%	9999	109
	133	PID action set point for PU operation	0 to 100%	0.01%	0%	109
Commercial power supply-inverter switch-over	134	PID differential time	0.01 to 10.00 sec, 9999	0.01 sec	9999	109
	135	Commercial power supply-inverter switch-over sequence output terminal selection	0, 1, 2	1	0	116
	136	MC switch-over interlock time	0 to 100.0 sec	0.1 sec	1.0 sec	116
	137	Start waiting time	0 to 100.0 sec	0.1 sec	0.5 sec	116
	138	Commercial power supply-inverter switch-over selection at alarm occurrence	0, 1	1	0	116
Backlash	139	Automatic inverter-commercial power supply switch-over frequency	0 to 60.00Hz, 9999	0.01Hz	9999	116
	140	Backlash acceleration stopping frequency (Note 7)	0 to 400Hz	0.01Hz	1.00Hz	119
	141	Backlash acceleration stopping time (Note 7)	0 to 360 sec	0.1 sec	0.5 sec	119
	142	Backlash deceleration stopping frequency (Note 7)	0 to 400Hz	0.01Hz	1.00Hz	119
Display	143	Backlash deceleration stopping time (Note 7)	0 to 360 sec	0.1 sec	0.5 sec	119
	144	Speed setting switch-over	0, 2, 4, 6, 8, 10, 102, 104, 106, 108, 110	1	4	119
Additional functions	*148	Stall prevention level at 0V input	0 to 150%	0.1%	120%	58
	*149	Stall prevention level at 10V input	0 to 150%	0.1%	150%	58

PARAMETERS

Function	Parameter Number	Name	Setting Range	Minimum Setting Increments	Factory Setting	Refer To Page: <Notes>
Current detection	150	Output current detection level	0 to 200%	0.1%	150%	120
	151	Output current detection period	0 to 10 sec	0.1 sec	0	120
	152	Zero current detection level	0 to 200%	0.1%	5.0%	121
	153	Zero current detection period	0 to 1 sec	0.01 sec	0.5 sec	121
Sub functions	154	Voltage reduction selection during stall prevention operation	0, 1	1	1	121
	155	RT activated condition	0, 10	1	0	122
	*156	Stall prevention operation selection	0 to 31 (Odd), 100	1	0	122
	157	OL signal waiting time	0 to 25 sec, 9999	0.1 sec	0	124
	158	AM terminal function selection	1 to 3, 5 to 14, 17, 18, 21	1	1	124
Additional function	160	User group read selection	0, 1, 10, 11	1	0	125
Automatic restart after instantaneous power failure	162	Automatic restart after instantaneous power failure selection	0, 1, 2	1	0	125
	163	First cushion time for restart	0 to 20 sec	0.1 sec	0 sec	125
	164	First cushion voltage for restart	0 to 100%	0.1%	0%	125
	*165	Restart stall prevention operation level	0 to 150%	0.1%	150%	125
Initial monitor	170	Watt-hour meter clear	0	—	0	126
	171	Actual operation hour meter clear	0	—	0	126
User functions	173	User group 1 registration	0 to 999	1	0	125
	174	User group 1 deletion	0 to 999, 9999	1	0	125
	175	User group 2 registration	0 to 999	1	0	125
	176	User group 2 deletion	0 to 999, 9999	1	0	125
Terminal assignment functions	180	RL terminal function selection	0 to 99, 9999	1	0	126
	181	RM terminal function selection	0 to 99, 9999	1	1	126
	182	RH terminal function selection	0 to 99, 9999	1	2	126
	183	RT terminal function selection	0 to 99, 9999	1	3	126
	184	AU terminal function selection	0 to 99, 9999	1	4	126
	*185	JOG terminal function selection	Already Assigned			126
	186	CS terminal function selection	0 to 99, 9999	1	6	126
	190	RUN terminal function selection	0 to 199, 9999	1	0	128
	191	SU terminal function selection	0 to 199, 9999	1	1	128
	192	IPF terminal function selection	0 to 199, 9999	1	2	128
	193	OL terminal function selection	0 to 199, 9999	1	3	128
194	FU terminal function selection	0 to 199, 9999	1	4	128	
195	A, B, C terminal function selection	0 to 199, 9999	1	99	128	
Additional function	199	User's initial value setting	0 to 999, 9999	1	0	130

* Pr.185 : This terminal is already assigned in Factory. User can not use.

PARAMETERS

Function	Parameter Number	Name	Setting Range	Minimum Setting Increments	Factory Setting	Refer To Page: <Note5>
Programmed operation	200	Programmed operation minute/second selection	0 to 3	1	0	131
	201	Program set 1 1 to 10	0 to 2: Rotation direction 0 to 400, 9999:Frequency 0 to 99.59: Time	1 0.1Hz Minute or second	0 9999 0	131
	211	Program set 2 11 to 20	0 to 2: Rotation direction 0 to 400, 9999:Frequency 0 to 99.59: Time	1 0.1Hz Minute or second	0 9999 0	131
	221	Program set 3 21 to 30	0 to 2: Rotation direction 0 to 400, 9999:Frequency 0 to 99.59: Time	1 0.1Hz Minute or second	0 9999 0	131
	231	Timer setting	0 to 99.59	—	0	131
Multi-speed operation	232	Multi-speed setting (speed 8)	0 to 400Hz, 9999	0.01Hz	9999	135
	233	Multi-speed setting (speed 9)	0 to 400Hz, 9999	0.01Hz	9999	135
	234	Multi-speed setting (speed 10)	0 to 400Hz, 9999	0.01Hz	9999	135
	235	Multi-speed setting (speed 11)	0 to 400Hz, 9999	0.01Hz	9999	135
	236	Multi-speed setting (speed 12)	0 to 400Hz, 9999	0.01Hz	9999	135
	237	Multi-speed setting (speed 13)	0 to 400Hz, 9999	0.01Hz	9999	135
	238	Multi-speed setting (speed 14)	0 to 400Hz, 9999	0.01Hz	9999	135
	239	Multi-speed setting (speed 15)	0 to 400Hz, 9999	0.01Hz	9999	135
Sub functions	240	Soft-PWM setting	0, 1	1	1	135
	244	Cooling fan operation selection	0, 1	1	0	135
Stop selection function	250	Stop selection	0 to 100 sec, 9999	0.1 sec	9999	135
Sub functions	251	Start holding time	0 to 10 sec, 9999	0.1 sec	9999	136
Power failure stop function	261	Power failure stop selection	0, 1	1	0	137
	262	Subtracted frequency at deceleration start	0 to 20Hz	0.01Hz	3Hz	137
	263	Subtraction starting frequency	0 to 120Hz, 9999	0.01Hz	60Hz<50Hz>	137
	264	Power-failure deceleration time 1	0 to 3600/ 0 to 360 sec	0.1 sec/ 0.01 sec	5 sec	137
	265	Power-failure deceleration time 2	0 to 3600/ 0 to 360 sec, 9999	0.1 sec/ 0.01 sec	9999	137
	266	Power-failure deceleration time switch-over frequency	0 to 400Hz	0.01Hz	60Hz	137
Selection function	270	Stop-on-contact/load torque high-speed frequency control selection	0, 1, 2, 3	1	0	139
High-speed frequency control	271	High-speed setting maximum current	0 to 200%	0.1%	50%	140
	272	Mid-speed setting minimum current	0 to 200%	0.1%	100%	140
	273	Current averaging range	0 to 400Hz, 9999	0.01Hz	9999	140
	274	Current averaging filter constant	1 to 4000	1	16	140
Stop on contact	275	Stop-on-contact exciting current low-speed multiplying factor (Note 5)	0 to 1000%, 9999	1%	9999	143
	276	Stop-on-contact PWM carrier frequency (Note 5)	0, 1, 2, 9999	1	9999	143

PARAMETERS

Function	Parameter Number	Name	Setting Range	Minimum Setting Increments	Factory Setting	Refer To Page: <Note>		
Brake sequence functions	278	Brake opening frequency (Note 3)	0 to 30Hz	0.01Hz	3Hz	142		
	279	Brake opening current (Note 3)	0 to 200%	0.1%	130%	142		
	280	Brake opening current detection time (Note 3)	0 to 2 sec	0.1 sec	0.3 sec	142		
	281	Brake operation time at start (Note 3)	0 to 5 sec	0.1 sec	0.3 sec	142		
	282	Brake operation frequency (Note 3)	0 to 30Hz	0.01Hz	6Hz	142		
	283	Brake operation time at stop (Note 3)	0 to 5 sec	0.1 sec	0.3 sec	142		
	284	Deceleration detection function selection (Note 3)	0, 1	1	0	142		
	285	Overspeed detection frequency	0 to 30Hz, 9999	0.01Hz	9999	142		
	*570	CT/VT Selection	0, 1	1	0	151		
Calibration functions	900	FM terminal calibration	—	—	—	152		
	901	AM terminal calibration	—	—	—	152		
	902	Frequency setting voltage bias	0 to 10V	0 to 60Hz	0.01Hz	0V	0Hz	154
	903	Frequency setting voltage gain	0 to 10V	1 to 400Hz	0.01Hz	5V	60Hz <50Hz>	154
	904	Frequency setting current bias	0 to 20mA	0 to 60Hz	0.01Hz	4mA	0Hz	154
	905	Frequency setting current gain	0 to 20mA	1 to 400Hz	0.01Hz	20mA	60Hz <50Hz>	154
Additional function	990	Buzzer control	0, 1	1	1	156		
	991	Parameter unit parameters	Refer to the parameter unit instruction manual for details.					

- Note: 1. Indicates the parameter settings which are ignored when the advanced magnetic flux vector control mode is selected.
2. The half-tone screened parameters allow their settings to be changed during operation if 0 (factory setting) has been set in Pr. 77. (Note that the Pr. 72 and Pr. 240 settings cannot be changed during external operation.)
3. Can be set when Pr. 80, 81 \neq 9999, Pr. 60 = 7 or 8.
4. Can be accessed when Pr. 80, 81 \neq 9999, Pr. 77 = 801.
5. Can be accessed when Pr. 270 = 1 or 3, Pr. 80, 81 \neq 9999.
6. The setting range and min. setting unit will differ according to the Pr. 71 "applied motor" setting value.
7. Can be accessed when Pr. 29 = 3.
8. Parameters marked asterisk (*) on top are different setting range, factory setting or function from FR-A540L.
9. Page numbers correspond to A540/A560L instruction manual, IB07401-0x.

CHAPTER 5

PROTECTIVE FUNCTIONS

This chapter explains the "protective functions" of this product.

Always read the instructions before using the equipment.

5.1 Errors (Alarms)	24
5.2 Troubleshooting	30
5.3 Precautions for Maintenance and Inspection ...	34

CHAPTER 1	OUTLINE
CHAPTER 2	INSTALLATION AND WIRING
CHAPTER 3	OPERATION
CHAPTER 4	PARAMETERS
CHAPTER 5	PROTECTIVE FUNCTIONS
CHAPTER 6	SPECIFICATIONS
APPENDICES	

5.1 Errors (Alarms)

PROTECTIVE FUNCTIONS

If any fault has occurred in the inverter, the corresponding protective function is activated and the error (alarm) indication appears automatically on the PU display. When the protective function is activated, refer to "5.2 Troubleshooting" and clear up the cause by taking proper action. If an alarm stop has occurred, the inverter must be reset to restart it.

5.1.1 Error (alarm) definitions

Operation Panel Display (FR-DU04)	Parameter Unit (FR-PU04)	Name		Description
E.OC1	OC During Acc	During acceleration	Overcurrent shut-off	When the inverter output current reaches or exceeds approx. 200% of the rated current, the protective circuit is activated to stop the inverter output.
E.OC2	Stedy Spd OC	During constant speed		
E.OC3	OC During Dec	During deceleration During stop		
E.OV1	OV During Acc	During acceleration	Regenerative overvoltage shut-off	If regenerative energy from the running motor causes the inverter's internal main circuit DC voltage to reach or exceed the specified value, the protective circuit is activated to stop the inverter output. This may also be activated by a surge voltage generated in the power supply system.
E.OV2	Stedy Spd OV	During constant speed		
E.OV3	OV During Dec	During deceleration During stop		
E.THM	Motor Overload	Overload shut-off (electronic overcurrent protection)	Motor	The electronic overcurrent protection in the inverter detects motor overheat due to overload or cooling capability reduced during constant-speed operation. When 85% of the preset value is reached, pre-alarm (TH indication) occurs. When the specified value is reached, the protective circuit is activated to stop the inverter output. When a special motor such as a multi-pole motor or more than one motor is run, the motor cannot be protected by the electronic overcurrent protection. Provide a thermal relay in the inverter output circuit.
E.THT	Inv. Overload		Inverter	If a current not less than 150% of the rated output current flows and overcurrent shut-off (OC) does not occur (200% or less), inverse-time characteristics cause the electronic overcurrent protection to be activated to stop the inverter output. (Overload immunity: 150%, 60 sec) At low-speed regions, the operation time may be short.
E.IPF	Inst.Pwr. Loss	Instantaneous power failure protection		If a power failure has occurred in excess of 15msec (this applies also to inverter input shut-off), this function is activated to stop the inverter output to prevent the control circuit from misoperation. At this time, the alarm output contacts are opened (across B-C) and closed (across A-C). (Note 1) If a power failure persists for more than 100ms, the alarm output is not provided, and if the start signal is on at the time of power restoration, the inverter will restart. (If a power failure is instantaneous within 15msec, the control circuit operates properly.)
E.UVT	Under Voltage	Undervoltage protection		If the inverter power supply voltage drops, the control circuit will not operate properly. Furthermore, the motor torque could drop and the heat generated may increase. The inverter output will be stopped if the power supply voltage drops to 150V (approx. 300V for 400V class) or less. The undervoltage protection function will activate if the DC reactor accessory is not used.
E.FIN	H/Sink O/Temp	Fin overheat		If the cooling fin overheats, the temperature sensor is activated to stop the inverter output.

PROTECTIVE FUNCTIONS

Operation Panel Display (FR-DU04)	Parameter Unit (FR-PU04)	Name	Description
E. GF	Ground Fault	Output side ground fault overcurrent protection	This function stops the inverter output if a ground fault occurs in the inverter's output (load) side and a ground fault current flows. A ground fault occurring at low ground resistance may activate the overcurrent protection (OC1 to OC3).
E.OHT	OH Fault	External thermal relay operation (Note 3)	If the external thermal relay designed for motor overheat protection or the internally mounted temperature relay in the motor switches on (relay contacts "open"), the inverter output can be stopped if those contacts had been entered into the inverter. If the relay contacts are reset automatically, the inverter will not restart unless it is reset.
E.OLT (When stall prevention operation has reduced the running frequency to 0. OL during stall prevention operation)	Still Prev STP (OL shown during stall prevention operation)	During acceleration	If a current not less than 150% (Note 4) of the rated inverter current flows in the motor, this function lowers the frequency until the load current reduces to prevent the inverter from resulting in overcurrent shut-off. When the load current has reduced below 150%, this function increases the frequency again to accelerate and operate the inverter up to the set frequency.
		During constant-speed operation	If a current not less than 150% (Note 4) of the rated inverter current flows in the motor, this function lowers the frequency until the load current reduces to prevent overcurrent shut-off. When the load current has reduced below 150%, this function increases the frequency up to the set value.
		During deceleration	If the regenerative energy of the motor has increased above the brake capability, this function increases the frequency to prevent overvoltage shut-off. If a current not less than 150% (Note 4) of the rated inverter current flows in the motor, this function increases the frequency until the load current reduces to prevent the inverter from resulting in overcurrent shut-off. When the load current has reduced below 150%, this function decreases the frequency again.
E.OPT	Option Fault	Option alarm	<ul style="list-style-type: none"> • Stops the inverter output if the dedicated inboard option used in the inverter results in setting error or connection (connector) fault. • When the high power factor converter connection is selected, this alarm is displayed if AC power is connected to R, S, T.
E.OP1 to OP3	Option slot alarm 1 to 3	Option slot alarm	Stops the inverter output if a functional fault (such as communication error of the communication option) occurs in the inboard option loaded in any slot.
E. PE	Corrupt Memry	Parameter error	Stops the output if a fault occurs in E ² PROM which stores parameter settings.
E.PUE	PU Leave Out	PU disconnection occurrence	This function stops the inverter output if communication between inverter and PU is suspended, e.g. the operation panel or parameter unit is disconnected, when "2", "3", "16" or "17" is set in Pr. 75 "reset selection/PU disconnection detection/PU stop selection". This function stops the inverter output if the number of successive communication errors is greater than the number of permissible retries when Pr. 121 value is "9999" for RS-485 communication from PU connector. This function stops the inverter output if communication is broken for a period of time set in Pr. 122.
E.RET	Retry No Over	Retry count exceeded	If operation cannot be resumed within the number of retries set, this function stops the inverter output.
E.LF	—	Open output phase protection	This function stops the inverter output when any of the three phases (U, V, W) on the inverter's output side (load side) opens.
E.CPU	CPU Fault	CPU error	If the arithmetic operation of the built-in CPU does not end within a predetermined period, the inverter self-determines it has an alarm and stops the output.
E.P24	—	24VDC power output short circuit	When 24VDC power output from the PC terminal is shorted, this function shuts off the power output. At this time, all external contact inputs switch off. The inverter cannot be reset by entering the RES signal. To reset, use the operation panel or switch power off, then on again.

PROTECTIVE FUNCTIONS

Operation Panel Display (FR-DU04)	Parameter Unit (FR-PU04)	Name	Description
E.CTE	—	Operation panel power short circuit	When the operation panel power (P5S of the PU connector) is shorted, this function shuts off the power output. At this time, the operation panel (parameter unit) cannot be used and RS-485 communication from the PU connector cannot be made. To reset, enter the RES signal or switch power off, then on again.
—	—	Brake resistor overheat protection	Inverters of 7.5K or less contains a brake resistor. When the regenerative brake duty from the motor has reached 85% of the specified value, pre-alarm (RB indication) occurs. If the specified value is exceeded, the brake circuit operation is stopped temporarily to protect the brake resistor from overheating. (If the brake is operated in this state, regenerative overvoltage shut-off will occur.) When the brake resistor has cooled, the brake operation is resumed.
E.MB1 to MB7	—	Brake sequence error	This function stops the inverter output if a sequence error occurs during the use of the brake sequence function (Pr. 278 to Pr. 285).
E.14	E.14	DC fuse blown	The inverter output will stop if the DC fuse blows.
E.15	E.15	Main circuit error	Brake unit cooling fin overheat, control board ambient temperature error, output overcurrent, cooling fan power supply error, capacitor overcurrent, cooling fin overheat, gate power supply error. Refer to the next page (page 27) for details.

Note: 1. If Pr. 195 (A, B, C terminal function selection) is as set in the factory.
 2. The terminals used must be allocated using Pr. 190 to Pr. 195.
 3. External thermal relay operation is only activated when "OH" is set in any of Pr. 180 to Pr. 186 (input terminal function selection).
 4. Indicates that the stall prevention operation level has been set to 150% (factory setting). If this value is changed, stall prevention is operated at the new value.
 5. Resetting method
 When the protective function is activated and the inverter stops its output (the motor is coasted to a stop), the inverter is kept stopped. Unless reset, the inverter cannot restart. To reset the inverter, use any of the following methods: switch power off once, then on again; short reset terminal RES-SD for more than 0.1 seconds, then open; press the [RESET] key of the parameter unit (use the help function of the parameter unit). If RES-SD is kept shorted, the operation panel will show "Err." or the parameter unit will show that the inverter is being reset.

Main circuit error [E,15] details

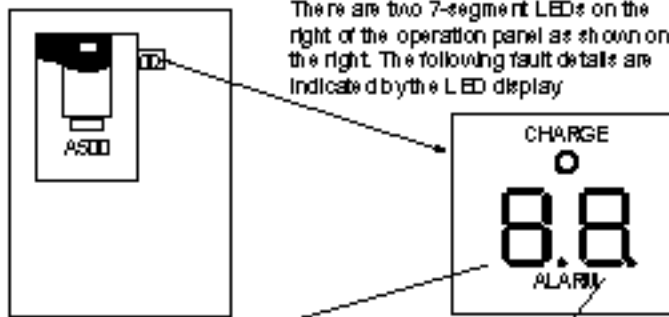

Left LED	Brake unit cooling fin overheating	Control board ambient temperature error	Output overcurrent
0			○
1		○	
2		○	○
3			○
4		○	○
5	○		○
6	○		○
7	○	○	
8	○	○	○
9	○		○
A	○	○	
B	○	○	○

Right LED	Cooling fan power supply error	Capacitor overcurrent	Cooling fin overheating	Gate power supply error
0				○
1			○	
2			○	○
3		○		
4		○		○
5		○	○	○
6	○			○
7	○		○	
8	○		○	○
9	○	○		○
A	○	○	○	
B	○	○	○	○

* For example, if the display is **15**, the output overcurrent, capacitor overcurrent and gate power supply error have occurred.

Name	Details
Brake unit cooling fin overheating	The inverter output will stop if the brake unit's cooling fin temperature rises above the specified value.
Control board ambient temperature error	The inverter output will stop if the ambient temperature of the control board rises above the specified value.
Output overcurrent	The inverter output will stop if the inverter's output current flows above the specified value.
Cooling fan power supply error	The inverter output will stop if the cooling fan's power drops below the specified value.
Capacitor overcurrent	The inverter will stop if a current exceeding the specified value flows to the main circuit smoothing capacitor.
Cooling fin overheating	The inverter output will stop if the cooling fin's temperature rises above the specified value.
Gate power supply error	The inverter output will stop if the gate power supply voltage drops below the specified value.

To know the operating status at the occurrence of alarm

When any alarm has occurred, the display automatically switches to the indication of the corresponding protective function (error). By pressing the [MODE] key at this point without resetting the inverter, the display shows the output frequency. In this way, it is possible to know the running frequency at the occurrence of the alarm. It is also possible to know the current in the same manner. However, these values are not stored in memory and are erased when the inverter is reset.

5.1.2 Correspondences between digital and actual characters

There are the following correspondences between the actual alphanumeric characters and the digital characters displayed on the operation panel:

Actual	Digital
0	0
1	1
2	2
3	3
4	4
5	5
6	6
7	7
8	8
9	9

Actual	Digital
A	A
B	b
C	C
E	E
F	F
G	G
H	H
I	I
J	J
L	L

Actual	Digital
M	m
N	n
O	O
o	o
P	P
T	T
U	U
V	V
r	r
-	-

5.1.3 Alarm code output

By setting Pr. 76 "alarm code output selection", an alarm definition can be output as a 4-bit digital signal. This signal is output from the open collector output terminals equipped as standard on the inverter. Correlations between alarm definitions and alarm codes are as follows.

Operation Panel Display (FR-DU04)	Output Terminal Signal On-Off				Alarm Code	Alarm Output (across B-C)
	SU	IPF	OL	FU		
E.OC1	0	0	0	1	1	Provided (Open)
E.OC2	0	0	1	0	2	
E.OC3	0	0	1	1	3	
E.OV1	0	1	0	0	4	Provided (Open)
E.OV2						
E.OV3						
E.THM	0	1	0	1	5	Provided (Open)
E.THT	0	1	1	0	6	
E.IPF	0	1	1	1	7	Provided (Open)
E.UVT	1	0	0	0	8	Provided (Open)
E.FIN	1	0	0	1	9	Provided (Open)
E. 15	1	0	1	0	A	Provided (Open)
E. GF	1	0	1	1	B	Provided (Open)
E.OHT	1	1	0	0	C	Provided (Open)
E.OLT	1	1	0	1	D	Not provided (Provided when OLT is displayed) (Open)
E.OPT	1	1	1	0	E	Provided (Open)
E.OP1 to E.OP3	1	1	1	0	E	Provided (Open)
E. PE	1	1	1	1	F	Provided (Open)
E.PUE						Provided (Open)
E.RET						Provided (Open)
E.LF						Provided (Open)
E.CPU						Provided (Open)
E.14						Provided (Open)

(Note) 0: Output transistor OFF, 1: Output transistor ON (common terminal SE)
The alarm output assumes that Pr. 195 setting is "99" (factory setting).

5.1.4 Resetting the inverter

The inverter can be reset by performing any of the following operations. Note that the electronic overcurrent protection's internal heat calculation value and the number of retries are cleared (erased) by resetting the inverter.

- Operation 1: Using the operation panel (FR-DU04), press the [RESET] key to reset the inverter.
- Operation 2: Switch power off once, then switch it on again.
- Operation 3: Switch on the reset signal (RES).

5.2 Troubleshooting

PROTECTIVE FUNCTIONS

If any function of the inverter is lost due to occurrence of a fault, clear up the cause and make correction in accordance with the following procedure. Contact your sales representative if the corresponding fault is not found below, the inverter has failed, parts have been damaged, or any other fault has occurred.

5.2.1 Checking the operation panel display at alarm stop

The alarm code is displayed on the operation panel to indicate the cause of a faulty operation. Clear up the cause and take proper action in accordance with the following table:

Operation Panel Display	Check Point	Remedy
E.OC1	Acceleration too fast? Check for output short circuit or ground fault.	Increase acceleration time.
E.OC2	Sudden load change? Check for output short circuit or ground fault.	Keep load stable.
E.OC3	Deceleration too fast? Check for output short circuit or ground fault. Mechanical brake of motor operating too fast?	Increase deceleration time. Check brake operation.
E.OV1	Acceleration too fast?	Increase acceleration time.
E.OV2	Sudden load change?	Keep load stable.
E.OV3	Deceleration too fast?	Increase deceleration time. (Set deceleration time which matches load GD^2 .) Reduce braking duty.
E.THM	Motor used under overload?	Reduce load.
E.THT		Increase motor and inverter capacities.
E.IPF	Check the cause of instantaneous power failure.	Restore power.
E.UVT	Large-capacity motor started? Jumper or DC reactor connected across terminals P-P1?	Check power system equipment such as power supply. Connect jumper or DC reactor across terminals P-P1.
E.FIN	Ambient temperature too high?	Set ambient temperature within specifications.
E.GF	Check motor and cables for ground fault.	Resolve ground faults.
E.OHT	Check motor for overheat.	Reduce load and frequency of operation.
E.OLT	Motor used under overload?	Reduce load. Increase motor and inverter capacities.
E.OPT	Check for loose connectors.	Connect securely
E.OP1 to E.OP3	Option function setting or operation proper? (1 to 3 indicate the option slot numbers.)	Check the option function setting, etc.
E.PE	Number of parameter write times too many?	Control card
E.PUE	DU or PU fitted securely?	Fit DU or PU securely.
E.RET	Check cause of alarm.	
E.LF	Check for open output phase.	Repair open phase.
E.CPU	Check for loose connectors.	Change inverter. Connect securely.
E.P24	Check PC terminal output for short.	Repair short.
E.CTE	Check PU connector cable for short.	Check PU and cable.
E.MB1 to MB7	Check brake sequence.	
PS	STOP key of operation panel pressed during external operation to stop?	Check load status. Refer to Pr.75.
RB	Brake resistor used too often?	Increase deceleration time.
TH	Load too large? Sudden acceleration?	Reduce load amount or frequency of running.
OL	Motor used under overload? Sudden deceleration? oL: Overvoltage stall OL: Overcurrent stall	Lighten load. Reduce frequency of braking.
E.14(DC fuse)	Is the DC circuit short circuited?	Repair the short-circuited section, and replace the DC fuse.

PROTECTIVE FUNCTIONS

Operation Panel Display	Check Point		Remedy
E.15	Brake unit cooling fin overheating	Is the usage frequency of the brake unit appropriate? Are the cooling fins clogged? Is there any error in the inverter unit cooling fan?	Reduce the load GD ² . Reduce the braking frequency. Clean the cooling fins. Replace the cooling fan.
	Control board ambient temperature error	Is there an error in the cooling fan? Is the ambient temperature too high?	Replace the cooling fan. Keep the ambient temperature within the specifications.
	Output over current	Is there an output short circuit or ground fault? (Check the motor winding and insulation resistance.) Was rapid acceleration attempted? Did the load fluctuate suddenly? Was rapid deceleration attempted? Were the motor's mechanical brakes applied too quickly?	Repair the output short circuit and ground fault. (Repair or replace the motor.) Lengthen the deceleration time. Eliminate the sudden fluctuate in the load. Lengthen the deceleration time. Investigate the braking operation.
	Cooling fan power supply error	Is the cooling fan's power supply output short circuited? Is the cooling fan's power supply abnormal? Is the fuse blown?	Repair the short-circuited section. Replace the cooling fan power supply. Replace the fuse.
	Capacitor overcurrent	Is the DC circuit short circuited? Is there an output short circuit or ground fault? (Check the motor winding and insulation resistance.)	Repair the short-circuited section, and replace the DC fuse. Repair the output short circuit and ground fault. (Repair or replace the motor.)
	Cooling fin overheat	Is there an error in the cooling fan? Are the cooling fins clogged? Is the ambient temperature too high?	Replace the cooling fan. Clean the cooling fins. Keep the ambient temperature within the specifications.
	Gate power supply error	Is the gate output short circuited? Is there an error in the control power supply board?	Repair the short-circuited section. Replace the control power supply board.

- When the protective function is activated, take proper corrective action, reset the inverter, then resume operation.

5.2.2 Faults and check points

POINT: Check the corresponding areas. If the cause is still unknown, it is recommended to initialize the parameters (return to factory settings), re-set the required parameter values, and check again.

(1) Motor remains stopped.

- 1) Check the main circuit
 - Check that a proper power supply voltage is applied (operation panel display is provided).
 - Check that the motor is connected properly.
- 2) Check the input signals
 - Check that the start signal is input.
 - Check that both the forward and reverse rotation start signals are not input.
 - Check that the frequency setting signal is not zero.
 - Check that the AU signal is on when the frequency setting signal is 4 to 20mA.
 - Check that the output stop signal (MRS) or reset signal (RES) is not on.
 - Check that the CS signal is not off when automatic restart after instantaneous power failure is selected (Pr. 57 = other than "9999").
- 3) Check the parameter settings
 - Check that the reverse rotation prevention (Pr. 78) is not selected.
 - Check that the operation mode (Pr. 79) setting is correct.
 - Check that the bias and gain (Pr. 902 to Pr. 905) settings are correct.
 - Check that the starting frequency (Pr. 13) setting is not greater than the running frequency.
 - Check that various operational functions (such as three-speed operation), especially the maximum frequency (Pr. 1), are not zero.
- 4) Check the load
 - Check that the load is not too heavy.
 - Check that the shaft is not locked.
- 5) Others
 - Check that the ALARM lamp is not lit.
 - Check that the Pr. 15 "jog frequency" setting is not lower than the Pr. 13 "starting frequency" value.

(2) Motor rotates in opposite direction.

- Check that the phase sequence of output terminals U, V and W is correct.
- Check that the start signals (forward rotation, reverse rotation) are connected properly.

(3) Speed greatly differs from the setting.

- Check that the frequency setting signal is correct. (Measure the input signal level.)
- Check that the following parameter settings are proper: Pr. 1, Pr. 2, Pr. 902 to Pr. 905, Pr. 19.
- Check that the input signal lines are not affected by external noise. (Use shielded cables)
- Check that the load is not too heavy.

(4) Acceleration/deceleration is not smooth.

- Check that the acceleration and deceleration time settings are not too short.
- Check that the load is not too heavy.
- Check that the torque boost (Pr. 0, Pr. 46, Pr. 112) setting is not too large to activate the stall function.

(5) Motor current is large.

- Check that the load is not too heavy.
- Check that the torque boost (Pr. 0, Pr. 46, Pr. 112) setting is not too large.

(6) Speed does not increase.

- Check that the maximum frequency (Pr. 1) setting is correct.
- Check that the load is not too heavy. (In agitators, etc., load may become heavy in winter.)
- Check that the torque boost (Pr. 0, Pr. 46, Pr. 112) setting is not too large to activate the stall prevention function.

(7) Speed varies during operation.

During operation under advanced magnetic flux vector control, the output frequency varies with load fluctuation between 0 and 2Hz. This is a normal operation and is not a fault.

- 1) Inspection of load
 - Check that the load is not varying.
- 2) Inspection of input signal
 - Check that the frequency setting signal is not varying.
 - Check that the frequency setting signal is not affected by induced noise.
- 3) Others
 - Check that the settings of the applied motor capacity (Pr. 80) and the number of applied motor poles (Pr. 81) are correct for the inverter and motor capacities in advanced magnetic flux vector control.
 - Check that the wiring length is within 30m in advanced magnetic flux vector control.
 - Check that the wiring length is correct in V/F control.

(8) Operation mode is not changed properly.

If the operation mode is not changed properly, check the following:

1. External input signal ······ Check that the STF or STR signal is off.
When it is on, the operation mode cannot be changed.
2. Parameter setting ········ Check the Pr. 79 setting.
When the setting of Pr. 79 "operation mode selection" is "0" (factory setting), switching input power on places the inverter in the external operation mode. Press the operation panel's [MODE] key three times and press the [UP] key (press the [PU] key for the parameter unit (FR-PU04)). This changes the external operation mode into the PU operation mode. For any other setting (1 to 8), the operation mode is limited according to the setting.

(9) Operation panel (FR-DU04) display is not provided.

- Make sure that the operation panel is connected securely with the inverter.

(10) POWER lamp is not lit.

- Make sure that the wiring and installation are correct.

5.3 Precautions for Maintenance and Inspection

PROTECTIVE FUNCTIONS

The transistorized inverter is a static unit mainly consisting of semiconductor devices. Daily inspection must be performed to prevent any fault from occurring due to adverse influence by the operating environment, such as temperature, humidity, dust, dirt and vibration, changes in the parts with time, service life, and other factors.

5.3.1 Precautions for maintenance and inspection

For some short time after the power is switched off, a high voltage remains in the smoothing capacitor. When accessing the inverter for inspection, switch power off. When more than 10 minutes have elapsed, make sure that the voltage across the main circuit terminals P-N of the inverter is 30VDC or less using a tester, etc.

5.3.2 Check items

(1) Daily inspections

- Check the following:
 - 1) Motor operation fault
 - 2) Improper installation environment
 - 3) Cooling system fault
 - 4) Unusual vibration and noise
 - 5) Unusual overheating and discoloration
- During operation, check the inverter input voltages using a tester.

(2) Cleaning

Always run the inverter in a clean state.

When cleaning the inverter, gently wipe dirty areas with a soft cloth immersed in neutral detergent or ethanol.

Note: Do not use solvent, such as acetone, benzene, toluene and alcohol, as they will cause the inverter surface paint to peel off.

Do not use detergent or alcohol to clean the display and other sections of the operation panel (FR-DU04) or parameter unit (FR-PU04) as these sections will deform.

5.3.3 Periodic inspection

Check the areas inaccessible during operation and requiring periodic inspection. For periodic inspection, consult us.

- 1) Cooling system:····· Clean the air filter, etc.
- 2) Screws and bolts:····· These parts may become loose due to vibration, temperature changes, etc.
Check that they are tightened securely and retighten as necessary.
- 3) Conductors and insulating materials: Check for corrosion and damage.
- 4) Insulation resistance: Measure.
- 5) Cooling fan, smoothing capacitor, relay: Check and change if necessary.

5.3.4 Insulation resistance test using megger

- 1) Before performing the insulation resistance test using a megger on the external circuit, disconnect the cables from all terminals of the inverter so that the test voltage is not applied to the inverter.
- 2) For the continuity test of the control circuit, use a tester (high resistance range) and do not use the megger or buzzer.
- 3) For the inverter, conduct the insulation resistance test on the main circuit only as shown below and do not perform the test on the control circuit. (Use a 500VDC megger.)

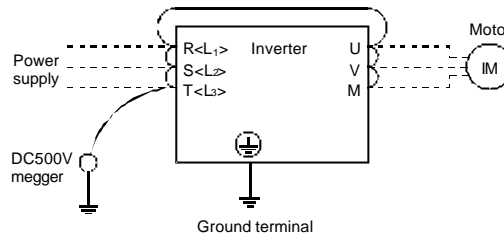

5.3.5 Dielectric strength test

Do not conduct a dielectric strength test. The inverter's main circuit uses semiconductors, which may be deteriorated if a pressure test is made.

Daily and Periodic Inspection

Area of Inspection	Inspection Item	Description	Interval			Method	Criterion	Instrument
			Daily	Periodic				
				1 year	2 years			
General	Surrounding environment	Check ambient temperature, humidity, dust, dirt, etc.	○			(Refer to page 3)	Ambient temperature: -10°C to +40°C, non-freezing. Ambient humidity: 90% or less, non-condensing.	Thermometer, hygrometer, recorder
	Overall unit	Check for unusual vibration and noise.	○			Visual and auditory checks.	No fault.	
	Power supply voltage	Check that main circuit voltage is normal.	○			Measure voltage across inverter terminals R-S-T <L ₁ -L ₂ -L ₃ >.	Within permissible AC voltage fluctuation (Refer to page 40)	Tester, digital multimeter
Main circuit	General	(1) Check with megger (across main circuit terminals and ground terminal). (2) Check for loose screws and bolts. (3) Check for overheating of each part. (4) Clean.		○	○	(1) Disconnect all cables from inverter and measure across terminals R, S, T, U, V, W <L ₁ , L ₂ , L ₃ , U, V, W>, and ground terminal with megger. (2) Re-tighten. (3) Visual check.	(1) 5M Ω or more. (2), (3) No fault.	500VDC class megger
	Conductors, cables	(1) Check conductors for distortion. (2) Check cable sheaths for breakage.		○	○	(1), (2) Visual check.	(1), (2) No fault.	
	Terminal block	Check for damage.		○		Visual check.	No fault	

PROTECTIVE FUNCTIONS

Daily and Periodic Inspection

Area of Inspection	Inspection Item	Description	Interval		Method	Criterion	Instrument	
			Daily	Periodic				
				1 year				2 years
Main circuit	Inverter module, Converter module	Check resistance across terminals.			○	Disconnect cables from inverter and measure across terminals R, S, T, P, N and U, V, W, P, N <L ₁ , L ₂ , L ₃ , +, -, and U, V, W, +, -> with tester range of 100Ω.	(See the following pages)	Analog tester
	Smoothing capacitor	(1) Check for liquid leakage. (2) Check for safety valve projection and bulge. (3) Measure electrostatic capacity.	○ ○		○	(1), (2) Visual check. (3) Measure with capacity meter.	(1), (2) No fault. (3) 85% or more of rated capacity.	Capacity meter
	Relay	(1) Check for chatter during operation. (2) Check for rough surface on contacts.		○ ○		(1) Auditory check. (2) Visual check.	(1) No fault. (2) No fault.	
	Resistor	(1) Check for crack in resistor insulation. (2) Check for open cable.		○ ○		(1) Visual check. Cement resistor, wire-wound resistor. (2) Disconnect one end and measure with tester.	(1) No fault. (2) Error should be within ±10% of indicated resistance value.	Tester, digital multimeter
Control circuit Protective circuit	Operation check	(1) Check balance of output voltages across phases with inverter operated independently. (2) Perform sequence protective operation test to make sure of no fault in protective and display circuits.		○ ○		(1) Measure voltage across inverter output terminals U-V-W. (2) Simulatively connect or disconnect inverter protective circuit output terminals.	(1) Phase-to-phase voltage balance within 8V for 400V. (2) Fault must occur because of sequence.	Digital multimeter, rectifier type voltmeter
Cooling system	Cooling fan	(1) Check for unusual vibration and noise. (2) Check for loose connection.	○		○	(1) Turn by hand with power off. (2) Re-tighten	(1) Smooth rotation. (2) No fault.	
	Cooling fan power supply	Is the power supply's output voltage correct?		○		Measure with a tester.	24V ± 2.4V	Tester
Display	Display	(1) Check if LED lamp is blown. (2) Clean.	○		○	(1) Light indicator lamps on panel. (2) Clean with rag.	(1) Check that lamps are lit.	
	Meter	Check that reading is normal.	○			Check reading of meters on panel.	Must satisfy specified and management values.	Voltmeter, ammeter, etc.
Motor	General	(1) Check for unusual vibration and noise. (2) Check for unusual odor.	○ ○			(1) Auditory, sensory, visual checks. (2) Check for unusual odor due to overheating, damage, etc.	(1), (2) No fault.	
	Insulation resistance	(1) Check with megger (across terminals and ground terminal).			○	(1) Disconnect cables from U, V, W, including motor cables.	(1) 5M Ω or more	500V megger

● **Checking the inverter and converter modules**

<Preparation>

- (1) Disconnect the external power supply cables (R, S, T) <L₁, L₂, L₃> and motor cables (U, V, W).
- (2) Prepare a tester. (Use 100Ω range.)

<Checking method>

Change the polarity of the tester alternately at the inverter terminals R, S, T, U, V, W, P and N <L₁, L₂, L₃, U, V, W, + and ->, and check for continuity.

Note: 1. Before measurement, check that the smoothing capacitor is discharged.
 2. At the time of continuity, the measured value is several to several ten's-of ohms depending on the module type, circuit tester type, etc. If all measured values are almost the same, the modules are without fault.

<Module device numbers and terminals to be checked>

	Tester Polarity		Measured Value	Tester Polarity		Measured Value		
	⊕	⊖		⊕	⊖			
Converter module	D1	R<L ₁ >	P<+>	Discontinuity	D4	R<L ₁ >	N<->	Continuity
		P<+>	R<L ₁ >	Continuity		N<->	R<L ₁ >	Discontinuity
	D2	S<L ₂ >	P<+>	Discontinuity	D5	S<L ₂ >	N<->	Continuity
		P<+>	S<L ₂ >	Continuity		N<->	S<L ₂ >	Discontinuity
	D3	T<L ₃ >	P<+>	Discontinuity	D6	T<L ₃ >	N<->	Continuity
		P<+>	T<L ₃ >	Continuity		N<->	T<L ₃ >	Discontinuity
Inverter module	TR1	U	P<+>	Discontinuity	TR4	U	N<->	Continuity
		P<+>	U	Continuity		N<->	U	Discontinuity
	TR2	V	P<+>	Discontinuity	TR6	V	N<->	Continuity
		P<+>	V	Continuity		N<->	V	Discontinuity
	TR5	W	P<+>	Discontinuity	TR2	W	N<->	Continuity
		P<+>	W	Continuity		N<->	W	Discontinuity

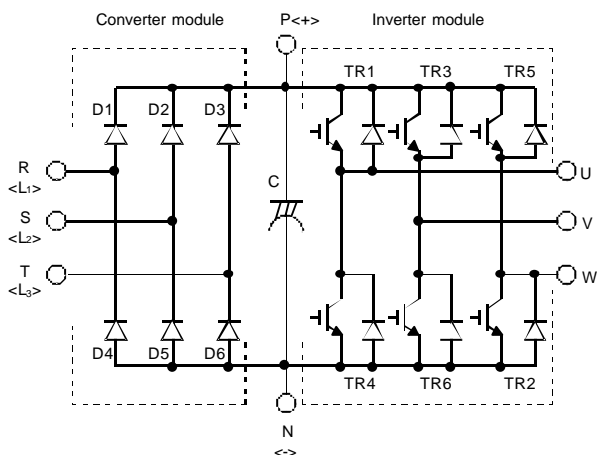

5.3.6 Replacement of parts

The inverter consists of many electronic parts such as semiconductor devices.

The following parts may deteriorate with age because of their structures or physical characteristics, leading to reduced performance or failure of the inverter. For preventive maintenance, the parts must be changed periodically.

(1) Cooling fan

The cooling fan cools heat-generating parts such as the main circuit semiconductor devices. The life of the cooling fan bearing is usually 10,000 to 35,000 hours. Hence, the cooling fan must be changed every 2 to 3 years if the inverter is run continuously. When unusual noise and/or vibration is noticed during inspection, the cooling fan must be changed immediately.

(2) Smoothing capacitors

A large-capacity aluminum electrolytic capacitor is used for smoothing the DC in the main circuit, and an aluminum electrolytic capacitor is also used for stabilizing the control power in the control circuit. Their characteristics are adversely affected by ripple current, etc. When the inverter is operated in an ordinary, air-conditioned environment, change the capacitors about every 5 years. When 5 years have elapsed, the capacitors will deteriorate more rapidly.

Check the capacitors at least every year (less than six months if their life will be expired soon).

Check the following:

- 1) Case (side faces and bottom face for expansion)
- 2) Sealing plate (for remarkable warping and extreme cracks)
- 3) Explosion-proof valve (for excessive valve expansion and operation)
- 4) Appearance, external cracks, discoloration, leakage. When the measured capacitance of the capacitor has reduced below 85% of the rating, change the capacitor.

(3) Relays

To prevent a contact fault, etc., relays must be changed according to the number of accumulative switching times (switching life).

See the following table for the inverter parts replacement guide. Lamps and other short-life parts must also be changed during periodic inspection.

Replacement Parts of the Inverter

Part Name	Standard Replacement Interval	Description
Cooling fan	5 years	Change (as required)
Smoothing capacitor in main circuit	5 years	Change (as required)
Smoothing capacitor on control board	5 years	Change the board (as required)
Smoothing capacitor on cooling fan power supply	5 years	Change the power supply (as required)
Relays	————	Change as required

5.3.7 Measurement of main circuit voltages, currents and power

Measurement of voltages and currents

Since the voltages and currents on the inverter power supply and output sides include harmonics, accurate measurement depends on the instruments used and circuits measured.

When instruments for commercial frequency are used for measurement, measure the following circuits using the instruments given on the next page.

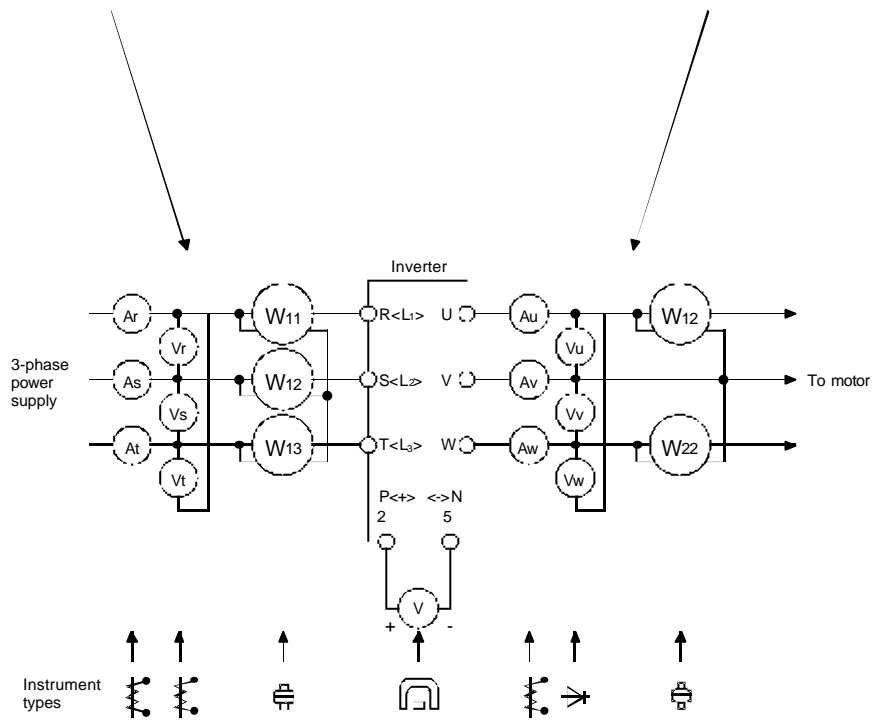
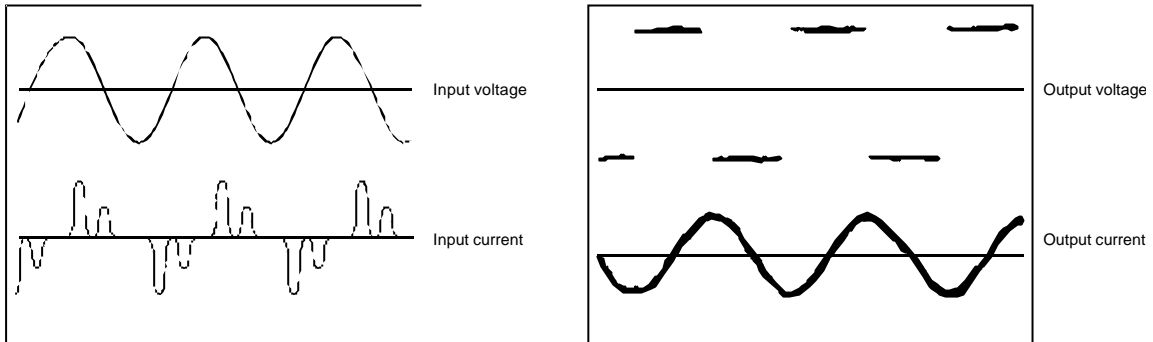

Typical Measuring Points and Instruments

Note: Use an FFT to measure the output voltage accurately. Accurate measurement cannot be made if you use a tester or general measuring instruments.

Measuring Points and Instruments

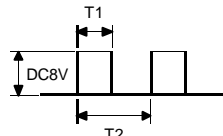
Item	Measuring Point	Measuring Instrument	Remarks (Reference Measured Value) *
Power supply voltage V_1	Across R-S, S-T and T-R <Across L_1 - L_2 , L_2 - L_3 and L_3 - L_1 >	Moving-iron type AC voltmeter	Commercial power supply Within permissible AC voltage fluctuation (Refer to Page 40)
Power supply side current I_1	R, S and T line currents < L_1 , L_2 , and L_3 line currents>	Moving-iron type AC ammeter	
Power supply side power P_1	At R, S and T, and across R-S, S-T and T-R <At L_1 , L_2 and L_3 , and across L_1 - L_2 , L_2 - L_3 and L_3 - L_1 >	Electrodynamic type single-phase wattmeter	$P_1 = W_{11} + W_{12} + W_{13}$ (3-wattmeter method)
Power supply side power factor Pf_1	Calculate after measuring power supply voltage, power supply side current and power supply side power. $Pf_1 = \frac{P_1}{\sqrt{3} V_1 \cdot I_1} \times 100\%$		
Output side voltage V_2	Across U-V, V-W and W-U	Rectifier type AC voltmeter (Note 1) (Not moving-iron type)	Difference between phases is within $\pm 1\%$ of maximum output voltage.
Output side current I_2	U, V and W line currents	Moving-iron type AC ammeter	Current should be equal to or less than rated inverter current. Difference between phases is 10% or lower.
Output side power P_2	At U, V and W, and across U-V and V-W	Electrodynamic type single-phase wattmeter	$P_2 = W_{21} + W_{22}$ 2-wattmeter method (or 3-wattmeter method)
Output side power factor Pf_2	Calculate in similar manner to power supply side power factor. $Pf_2 = \frac{P_2}{\sqrt{3} V_2 \cdot I_2} \times 100\%$		
Converter output	Across P-N< Across + and - >	Moving-coil type (such as tester)	POWER lamp lit $1.35 \times V_1$ Maximum 760V during regenerative operation
Frequency setting signal	Across 2 (+) -5 Across 1 (+) -5 Across 4 (+) -5	Moving-coil type (Tester, etc. may be used) (Internal resistance: 50k Ω or larger)	0 to 5V/0 to 10VDC
Frequency setting power supply	Across 10 (+) -5 Across 10E (+) -5		0 to $\pm 5V/0$ to $\pm 10VDC$
			4 to 20mADC
			5VDC
			10VDC
Frequency meter signal	Across FM (+) -SD		Approximately. 5VDC at maximum frequency (without frequency meter)
			
			Pulse width T1: Adjusted by Pr.900
			Pulse cycle T2: Set by Pr.55 (Valid for frequency monitoring only)
	Across AM (+) -5		Approximately 10VDC at maximum frequency (without frequency meter)
Start signal Select signal	Across STF, STR, RH, RM, RL, RT, AU, STOP, CS (+) -SD		20 to 30VDC when open. ON voltage: 1V or less
Reset	Across RES (+) -SD		
Output stop	Across MRS (+) -SD		
Alarm signal	Across A-C Across B-C	Moving-coil type (such as tester)	Continuity check (Note 2) <At OFF> <At ON> Across A-C: Discontinuity Continuity Across B-C: Continuity Discontinuity

- Note
1. Accurate data will not be obtained by a tester.
 2. When Pr. 195 "A, B, C terminal function selection" setting is positive logic.

CHAPTER 6

SPECIFICATIONS

This chapter provides the "specifications" of this product.
Always read the instructions before using the equipment.

6.1 Standard Specifications 41

CHAPTER 1	OUTLINE
CHAPTER 2	INSTALLATION AND WIRING
CHAPTER 3	OPERATION
CHAPTER 4	PARAMETERS
CHAPTER 5	PROTECTIVE FUNCTIONS
CHAPTER 6	SPECIFICATIONS
APPENDICES	

6.1 Standard specification

SPECIFICATIONS

6.1.1 Model specifications

Model FR-A560L-		K-NA	375	450	530	600	670	750	800	900K
Applicable motor capacity (kW) ^(Note 1)	Constant torque		375	450	530	600	670	750	800	900
	Variable torque		450	530	600	670	750	800	900	950
Rated capacity (HP) ^(Note 2)	Constant torque		550	650	750	800	900	1000	1100	1200
	Variable torque		650	750	800	900	1000	1100	1200	1300
Rated current (A)	Constant torque		552	663	773	800	880	990	1100	1210
	Variable torque		663	773	800	880	990	1100	1210	1320
Overload capacity	Constant torque		150% 60 sec., 200% 0.5 sec (inverse-time characteristics)		150% 60 sec. (inverse-time characteristics)					
	Variable torque		120% 60 sec., 150% 0.5 sec (inverse-time characteristics)		120% 60 sec. (inverse-time characteristics)					
Voltage		Three phase, 575V 50 / 60Hz								
Rated input AC voltage, frequency		Three phase, 575V 50 / 60Hz								
Tolerable AC voltage fluctuation		488 to 632V 50 / 60Hz								
Tolerable frequency fluctuation		± 5%								
Power facility capacity (kVA)	Constant torque		550	660	770	797	896	986	1095	1205
	Variable torque		660	770	797	896	986	1095	1205	1315
Protective structure (JEM 1030)			Open type (IP00)			Open type (IP20)				
Ambient temperature			-10°C to 40°C (14°F to 104°F) at VT -10°C to 50°C (14°F to 122°F) at CT			-10°C to 40°C (14°F to 104°F)				
Cooling method		Forced air cooling								
Approx. weight (kg (lb))			490 (1078)	500 (1100)	1060 (2332)	1060 (2332)	1100 (2420)	1100 (2420)	1200 (2640)	1200 (2640)

- Note: 1. The applicable motor capacity indicated is the maximum capacity applicable when Mitsubishi 4-pole standard motor is used For A540K. (When National Electric Code based motor is used for A560L)
2. The rated output capacity indicated is based on National Electric Code for 460V for A540L. (575V for A560L)
3. The overload capacity indicated in % is the ratio of the overload current to the inverter's rated current. For repeated duty, allow time for the inverter and motor to return to or below the temperatures under 100% load.
4. The maximum output voltage cannot exceed the power supply voltage. The maximum output voltage may be set as desired below the power supply voltage.
5. The power supply capacity changes with the values of the power supply side inverter impedance (including those of the input reactor and cables).
6. For use in Variable torque mode, refer to Pr. 570.
7. For inverter environmental conditions (including ambient temperature) please check page A-3.

6.1.2 Common specifications

Control specifications	Control system		Soft-PWM control/high carrier frequency PWM control (V/F control or advanced magnetic flux vector control can be selected)
	Output frequency range		0.2 to 400Hz
	Frequency setting resolution	Analog input	0.015Hz/60Hz (terminal 2 input: 12 bits/0 to 10V, 11 bits/0 to 5V, terminal 1 input: 12 bits/-10 to +10V, 11 bits/-5 to +5V)
		Digital input	0.01Hz
	Frequency accuracy		Within $\pm 0.2\%$ of maximum output frequency ($25^{\circ}\text{C} \pm 10^{\circ}\text{C}$) for analog input, within 0.01% of set output frequency for digital input
	Voltage/frequency characteristic		Base frequency set as required between 0 and 400Hz. Constant torque or variable torque pattern can be selected.
	Starting torque		150%: At 0.5Hz (for advanced magnetic flux vector control)
	Torque boost		Manual torque boost
	Acceleration/deceleration time setting		0 to 3600 sec (acceleration and deceleration can be set individually), linear or S-pattern acceleration/deceleration mode can be selected.
	DC dynamic brake		Operation frequency (0 to 120Hz), operation time (0 to 10 sec), voltage (0 to 30%) variable
Stall prevention operation level		Operation current level can be set (0 to 150% variable), presence or absence can be selected.	
Operational specifications	Frequency setting signal	Analog input	0 to 5VDC, 0 to 10VDC, 0 to ± 10 VDC, 4 to 20mADC
		Digital input	3-digit BCD or 12-bit binary using operation panel or parameter unit (when the FR-A5AX option is used)
	Start signal		Forward and reverse rotation, start signal automatic self-holding input (3-wire input) can be selected.
	Input signals	Multi-speed selection	Up to 15 speeds can be selected. (Each speed can be selected in the range of 0 to 400Hz. The operation speed can be changed from the operation panel or parameter unit during operation.)
		Second, third acceleration/deceleration time selection	0 to 3600 sec (up to three different accelerations and decelerations can be set individually.)
		Current input selection	Input of frequency setting signal 4 to 20mADC (terminal 4) is selected.
		Output stop	Instantaneous shut-off of inverter output (frequency, voltage)
		Alarm reset	Alarm retained at the activation of protective function is reset.
	Operation functions		Maximum/minimum frequency setting, frequency jump operation, external thermal relay input selection, polarity reversible operation, automatic restart operation after instantaneous power failure, commercial power supply-inverter switch-over operation, forward/reverse rotation prevention, slip compensation, operation mode selection, offline auto tuning function, online auto tuning function, PID control, programmed operation, computer link operation (RS-485)
	Output signals	Operating status	5 different signals can be selected from inverter running, up to frequency, instantaneous power failure (undervoltage), frequency detection, second frequency detection, third frequency detection, during program mode operation, during PU operation, overload alarm, regenerative brake pre-alarm, electronic overcurrent protection pre-alarm, zero current detection, output current detection, PID lower limit, PID upper limit, PID forward/reverse rotation, commercial power supply-inverter switch-over MC1, 2, 3, operation ready, brake release request, fan fault and fin overheat pre-alarm minor fault. Open collector output.
		Alarm (inverter trip)	Contact output...change-over contact (230VAC 0.3A, 30VDC 0.3A) Open collector...alarm code (4 bit) output
		For meter	1 signal can be selected from output frequency, motor current (steady or peak value), output voltage, frequency setting, running speed, motor torque, converter output voltage (steady or peak value), regenerative brake duty, electronic overcurrent protection load factor, input power, output power, load meter, and motor exciting current. Pulse train output (1440 pulses/sec./full scale) and analog output (0 to 10VDC).

SPECIFICATIONS

Display	Display on operation panel FR-DUO4 or parameter unit FR-PU04	Operating status	Selection can be made from output frequency, motor current (steady or peak value), output voltage, frequency setting, running speed, motor torque, converter output voltage (steady or peak value), electronic overcurrent protection load factor, input power, output power, load meter, motor exciting current, cumulative energization time, actual operation time, watt-hour meter, regenerative brake duty and motor load factor.
		Alarm definition	Alarm definition is displayed when protective function is activated. 8 alarm definitions are stored. (Four alarm definitions are only displayed on the operation panel.)
	Additional display on parameter unit (FR-PU04) only	Operating status	Input terminal signal states, output terminal signal states, option fitting status, terminal assignment status
		Alarm definition	Output voltage/current/frequency/cumulative energization time immediately before protective function is activated
		Interactive guidance	Operation guide and troubleshooting by help function
	Protective/alarm functions		Overcurrent shut-off (during acceleration deceleration, constant speed) regenerative overvoltage shut-off, undervoltage, instantaneous power failure, overload shut-off (electronic overcurrent protection), ground fault overcurrent, stall prevention, overload warning, fin overheat, option error, parameter error, PU disconnection, No. of retries over, output open phase, CPU error, 24VDC power supply output short circuit, operation panel power supply short circuit, main circuit error
Environment	Ambient temperature ⁽¹⁾	-10°C to +40°C (non-freezing)	
	Ambient humidity	90%RH or less (non-condensing)	
	Storage temperature ⁽²⁾	-20°C to +65°C	
	Ambience	Indoors. (No corrosive and flammable gases, oil mist, dust and dirt.)	
	Altitude, vibration	Max. 1000m (3280.80 feet) above sea level, 5.9m/s ² {0.6G} or less (conforms to JIS C 0911)	

Note: 1. For FR-A560L-375K, 450K at constant torque (CT) rating maximum ambient temperature can be 50°C (122°F).
2. Temperature applicable for a short period in transit, etc.

6.1.3 Outline drawings

● **FR-A560L-450K, 375K**

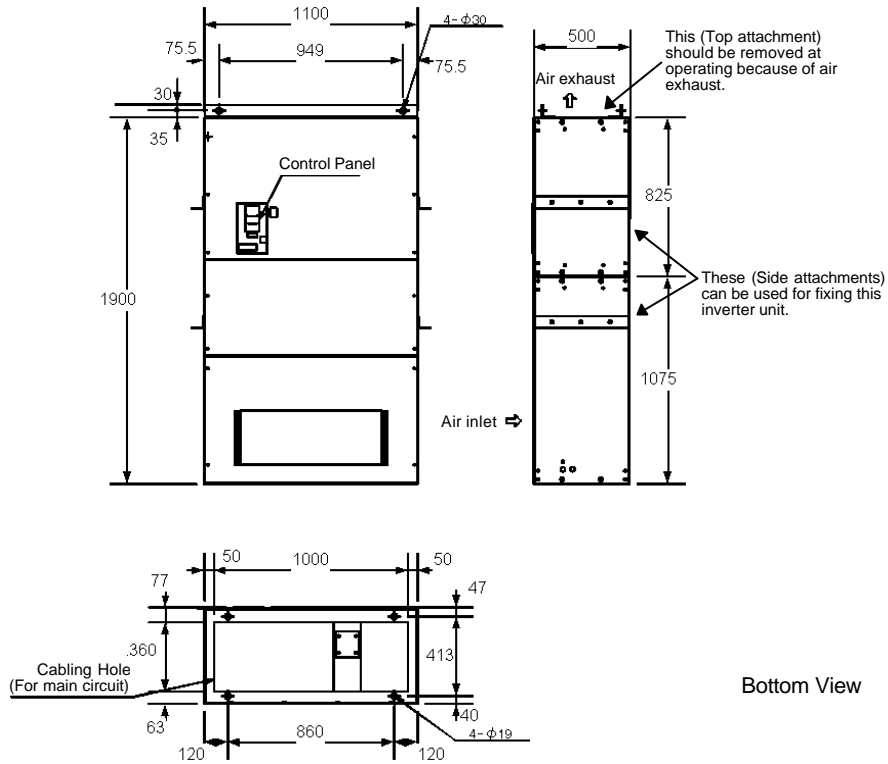

Bottom View

● **Accessory**
DC REACTOR (for FR-A560L-450K, 375K)

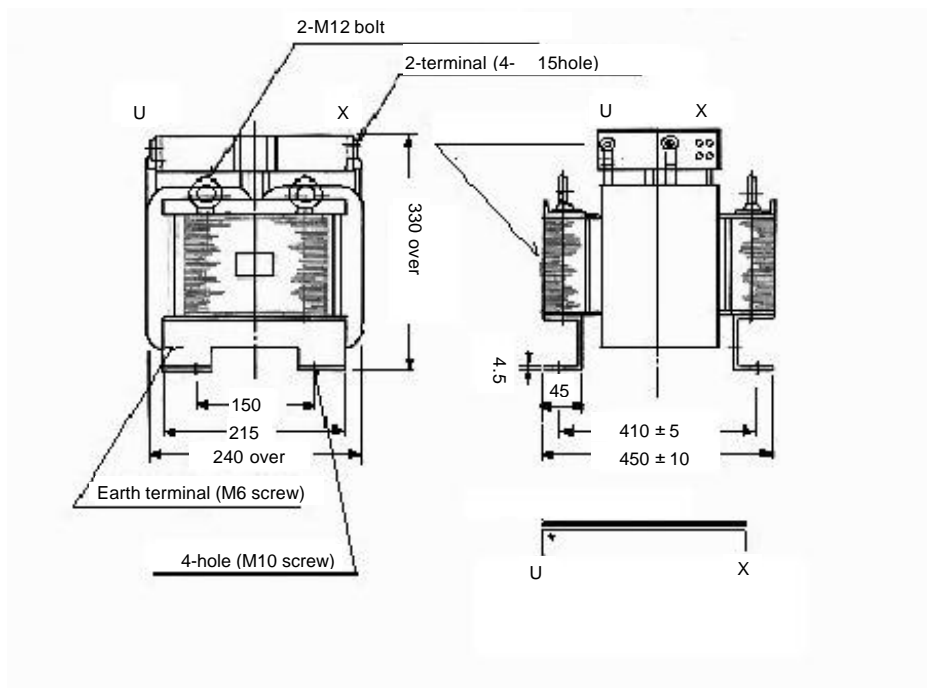

● FR-A560L-530K ~ 900K

DC reactor is internally mounted and wired.

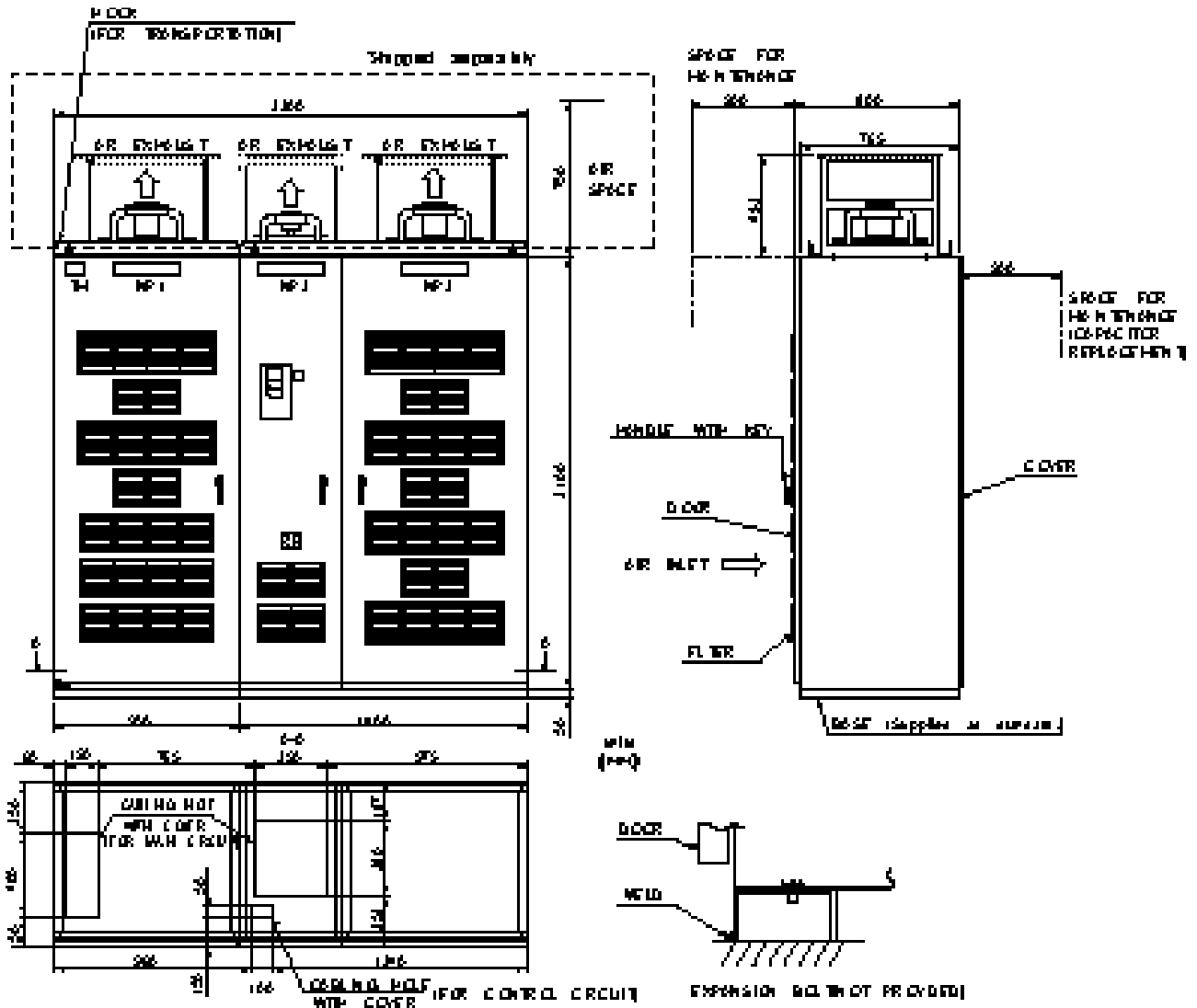

■ Operation panel
FR-DU04

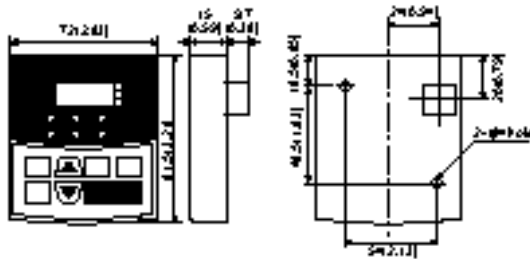

■ Parameter unit (option)
FR-PU04

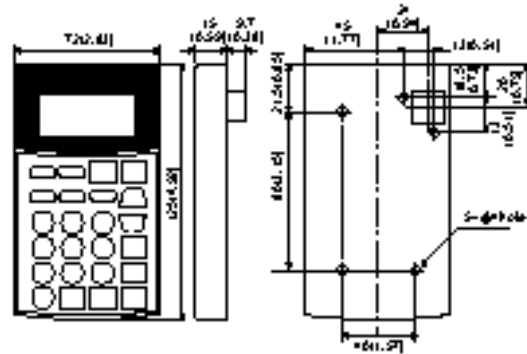

● Panel cut diagram

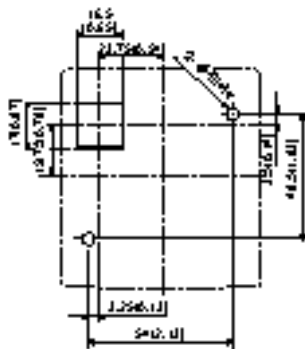

● Panel cut diagram

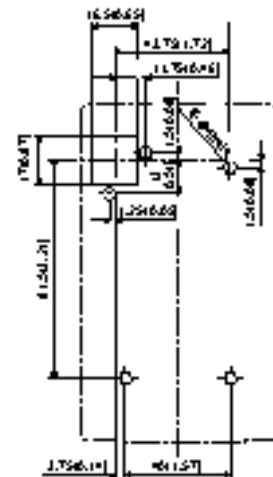

PU connector pin layout
(Looking from front of Inverter unit "receptacle side")

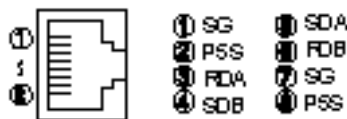

(Unit : mm (Inches))

Note) 1. Do not connect to the computer's LAN board, FAX/modem socket or telephone modular connector. The electrical specifications differ, so the product could be damaged if connected.

2. The No.2 and 8 pins (PSS) are the power supply for the parameter unit. Do not use these when carrying out RS-485 communication.

Appendix 3

Installation procedure for cooling fan (FR-A560L-530K ~ 900K)

1. Install and fix bolts and screws.

- Step1** Put cooling fans and fan covers.
- Step2** Fix cooling fans and fan covers by M12 bolts.
- Step3** Put cooling fan ceilings and fix by M4 screws.

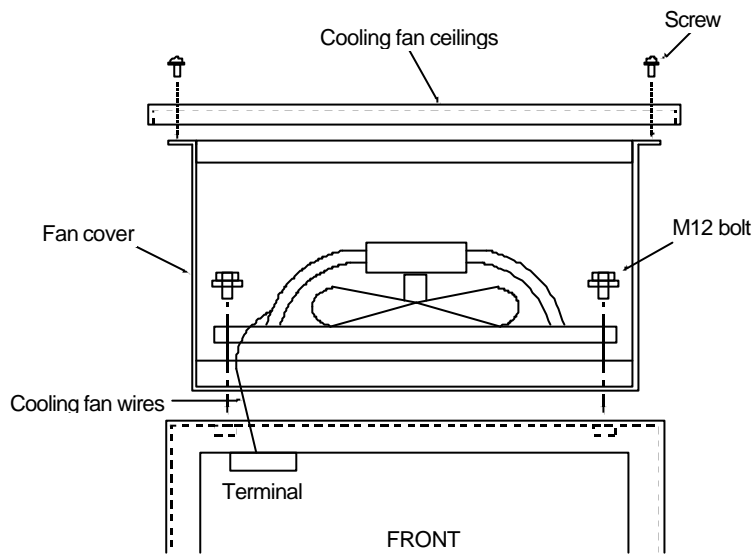

2. Wiring between cooling fan and terminals is as follows;

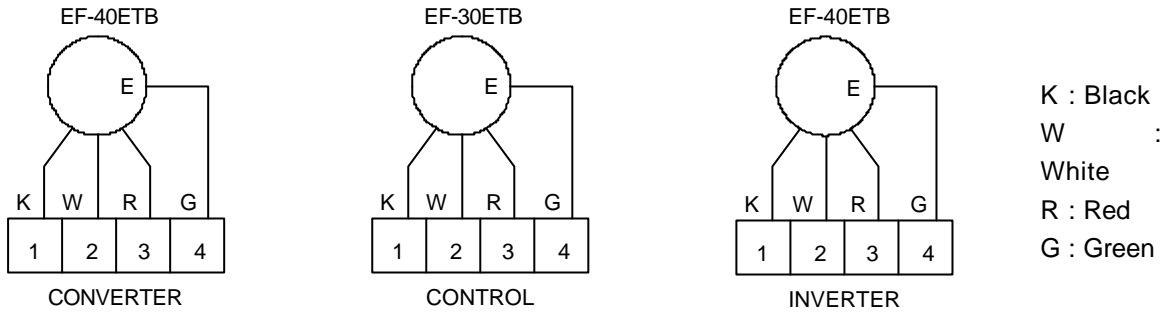

Step 4 Connect cooling fan wires as above drawing.

3. Check the air flow direction

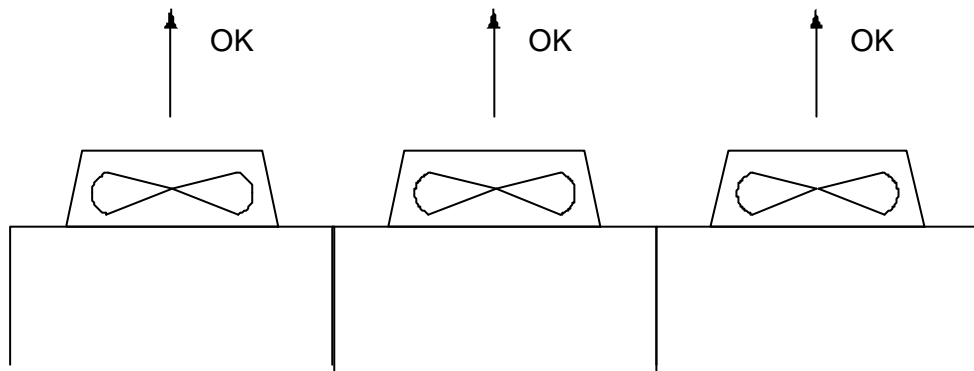

Appendix 4

Installation procedure for brake unit (option) (FR-A560L-530K ~ 900K)

Step1 Connect wires as the next drawing.

Wiring between FR-A500L and MT-BR5 (option)

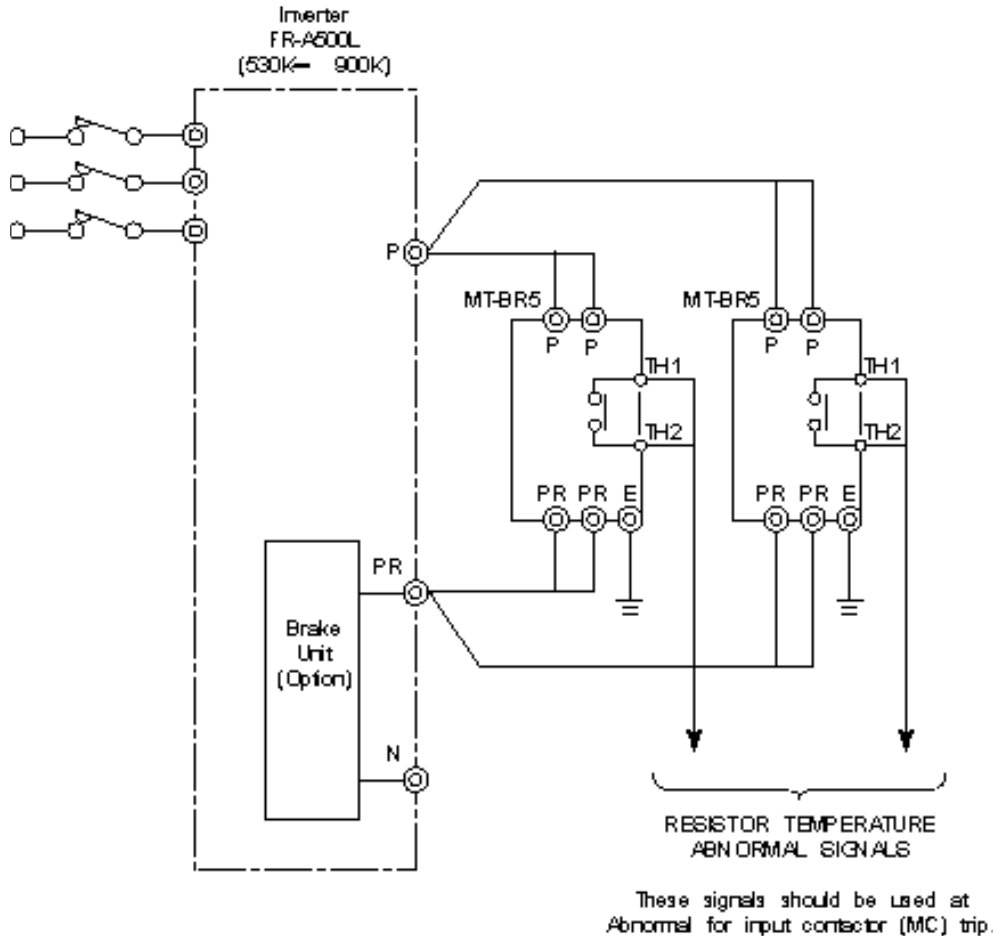

Step2 Set parameter 30 : when brake unit is used, set to 1.

Step3 Set parameter 70 : when brake unit is used, set to 10%.
This brake unit and brake resistor are designed at 10%.

Appendix 5

Appendix 5

Shipment case example

