

RFI Filter Units for Frequency Inverters FR-E 500 EC

Short reference for RFI filter unit types FFR-E520S-14A-SC1 to 26A-SC1 and FFR-E540-4.5A-SF1 to 27A-SF1

Please read the following installation notes carefully to ensure a proper usage.



CAUTION:

The RFI filter units described in this reference sheet are designed exclusively for use with the Mitsubishi inverter type FR-E 500. These filters are necessary to comply with limits for conducted noise voltages defined by the EN 61800-3 standard.

It is possible to that you may experience different results in practice, particularly if you do not completely and correctly follow the accepted EMC procedures for proper installation of filters and routing the power and control lines.

These filters are NOT designed for use in IT networks. When the noise filters are operated leakage currents are discharged to earth. This can trigger upstream protective devices (as RCDs), particularly when there are unbalanced mains voltages, mains phase failures or switching activities on the input side of the filter. The values of the power loss and leakage current in the following tables are typical values in a steady and error-free state. Depending on the power supply voltage, the power supply frequency and the filter used they may vary slightly. Please note, that the appearance and wiring mechanics of the noise filters may differ from the figures shown in this short reference. Safe functioning as well as the grade of the radio frequency protection do not take affect of this.

For further details please refer to the Mitsubishi manual for Frequency Inverters and EMC, which contains detailed information about EMC conforming installation.

Mounting

Check the inverter type. The filter should be used only in combination with inverters described in the table below.

Frequency inverter		Filter
FR-E 520S EC	0.4 k bis 0.75 k	FFR-E520S-14A-SC1
	1.5 k bis 2.2 k	FFR-E520S-26A-SC1
FR-E 540 EC	0.4 k bis 0.75 k	FFR-E540-4.5A-SF1
	1.5 k bis 3.7 k	FFR-E540-15A-SF1
	5.5 k bis 7.5 k	FFR-E540-27A-SF1

Function

The filters described in this document are designed to reduce conducted noise voltages to comply with the limits defined for Environments 1 and 2.

The filters provide conformity with the limits for Environment 1 (unrestricted distribution) with motor cable lengths of up to 20 m (shielded) and for Environment 1 (restricted distribution) with motor cable lengths of up to 100 m (shielded), and thus also with the 100 A limits of Environment 2 with motor cable lengths of up to 100 m.

Mounting of built-on filters

The filters FFR-E520S-□A-SC1 are flush fitting filters. Set the filter in the sparing of the inverter and secure it with the screws provided.

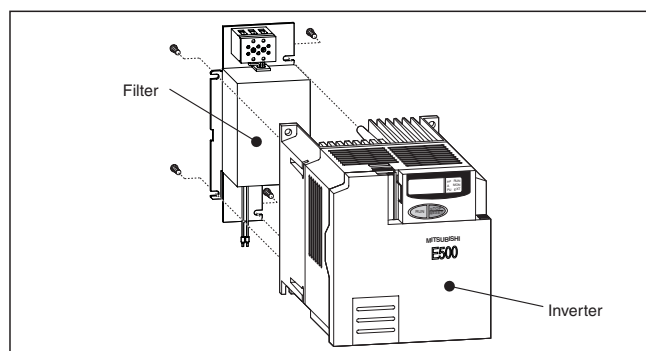

Mounting of footprint filters

Fix the inverter to the top panel of the filter and secure it with the screws provided.

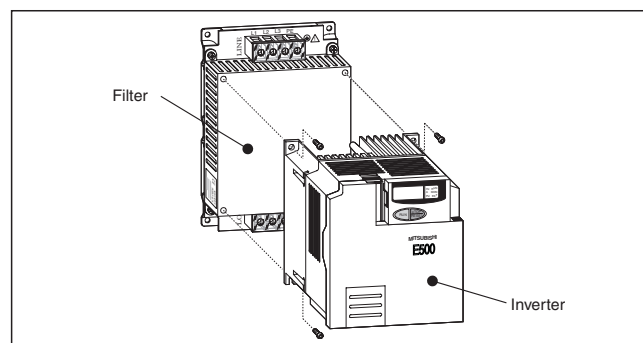

Installation in a cabinet

Fix the filter-inverter unit on the back of the cabinet. For correct filter performance the filter mounting bolts should electrically bond to the cabinet back panel which is connected to earth. If this is not possible, the paint should be removed from the cabinet directly under the filter footprint.

Wiring

For electrical installation follow the wiring procedure shown in the picture below. The maximum wiring length of the motor cable should be within the specified values. The connection of the inverters FR-E 520S EC is single-phase, the connection of the inverters FR-E 540 EC is three-phase.

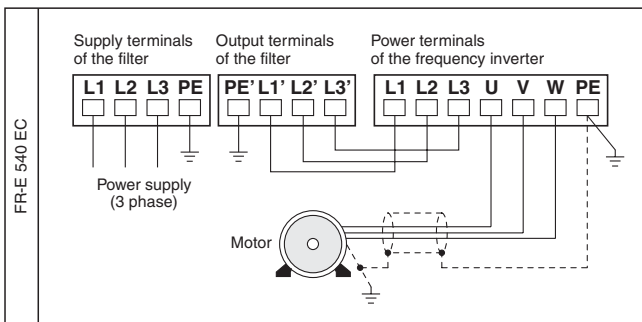
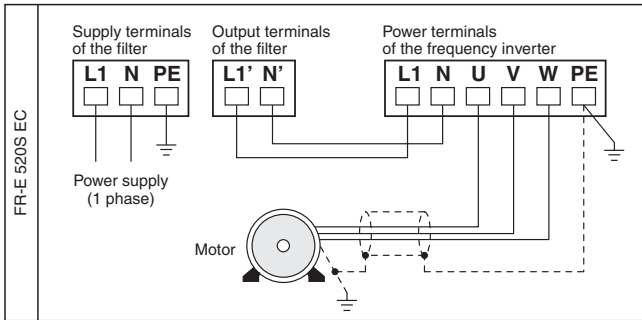

All cables especially the line between inverter and motor must be shielded to reduce cable radiation. The shield of the motor line must be connected on both the motor and inverter side. Earth motor and filter.

The outputs of the filters are equipped with coloured wires. The combination of the wires and the inverter terminals is listed in the following table.

Filter	Filter side	Inverter side
FFR-E520S-□A-SC1	Brown	L1
	Blue	N
FFR-E540-□A-SF1	Black	L1, L2, L3
	Yellow/green	PE

For environmental conditions and mounting position please note the instructions in the operation manual for the frequency inverter FR-E 500 EC.

Specifications

Specifications	Filter	
	FFR-E520S-□A-SC1	FFR-E540-□A-SF1
Rated voltage	Max. 1~ 250V AC	Max. 3~ 480V AC
Frequency	50 / 60Hz	
Rated and leakage current	See the following tables	
Power loss	See the following tables	
Ambient temperature range	-25~100°C	-25~85°C
Ambient humidity	90%	
Vibration	10~200Hz; 1.8g	

Dimensions

FFR-E520S-14A-SC1 to FFR-E520S-26A-SC1

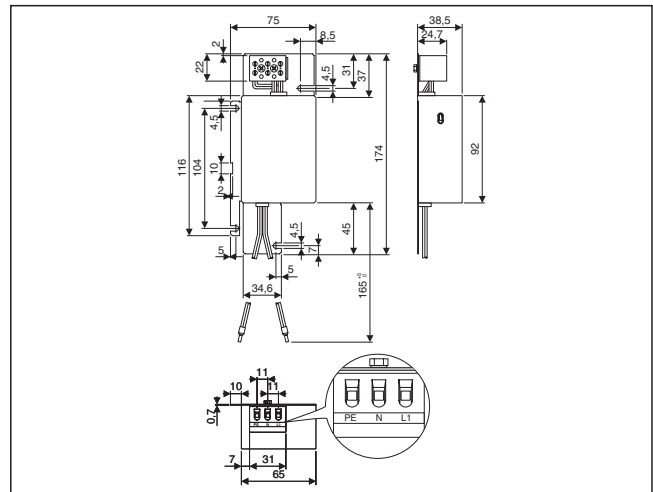

Inverter FR-E 520S EC	0.4 k/0.75 k	1.5 k~2.2 k
Filter FFR-E520S	14A-SC1	26A-SC1
Mounting screws	4 × M4	4 × M4
Weight [kg]	0.47	0.5
Power loss [W]	5.3	11
Leakage current [mA]	< 30.3	< 30.3
Rated current [A]	14	26

Filter type FFR-E540-4.5A-SF1 to FFR-E540-27A-SF1

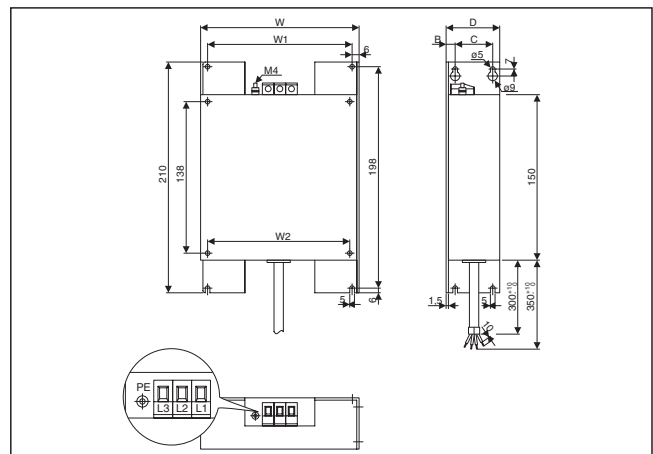

Inverter FR-E 540 EC	0.4 k/0.75 k	1.5 k~3.7 k	5.5 k/7.5 k
Filter FFR-E540	4.5A-SF1	15A-SF1	27A-SF1
W	140	140	220
A	8	8	12.5
B	46	46	55
W1, W2	128	128	208
Mounting screws	4 × M4	4 × M4	4 × M4
Weight [kg]	1.3	1.45	1.7
Power loss [W]	4	12	25
Leakage current [mA]	< 30	< 30	< 30
Rated current [A]	4.5	15	27