

CL1PAD1 Power Adapter Model

Thank you very much for purchasing this product.

Please read this manual thoroughly before starting to use the product and handle the product properly.

User's Manual

MODEL	CL1PAD1
MANUAL Number	JY997D04601H
Date	November 2021

SAFETY PRECAUTIONS

(Read these precautions before using)

Please read this manual carefully and pay special attention to safety in order to handle this product properly. Also pay careful attention to safety and handle the module properly.

These precautions apply only to Mitsubishi equipment. Refer to the user's manual of the CPU module to use for a description of the PLC system safety precautions.

These SAFETY PRECAUTIONS classify the safety precautions into two categories: "WARNING" and "CAUTION".

WARNING Procedures which may lead to a dangerous condition and cause death or serious injury if not carried out properly.

CAUTION Procedures which may lead to a dangerous condition and cause superficial to medium injury, or physical damage only, if not carried out properly.

Depending on circumstances, procedures indicated by **CAUTION** may also be linked to serious results. In any case, it is important to follow the directions for usage. Store this manual in a safe place so that you can take it out and read it whenever necessary. Always forward it to the end user.

DESIGN PRECAUTIONS

WARNING

Depending on a failure in the remote I/O module, the output may become the ON or OFF status. For output signals which can lead to a severe accident, install a circuit monitoring them outside the module.

CAUTION

Do not bind the control cable and the flat cable dedicated to CC-Link/LT together with the main circuit and the power cable. Keep such cables far from the main circuit and the power cable. Assume a distance of 100mm (3.94") or more. Otherwise, malfunction may be caused by noise. Use the power adapter without applying any force on the connector for CC-Link/LT interface and the flat cable dedicated to CC-Link/LT. Otherwise, such cables may be broken or fail.

INSTALLATION PRECAUTIONS

CAUTION

Use the power adapter within an environment described by the general specifications in this manual. If the power adapter is used in any environment outside the range for the general specifications, electrical shock, fire, malfunction, product damage or product deterioration may occur. Do not directly touch the conductive area of the power adapter. Malfunction or damage of the power adapter may be caused by such touching. Securely fix the power adapter with DIN rail or mounting screws. Securely tighten the mounting screws within the specified torque range. If the screws are insufficiently tightened, the power adapter may drop, short-circuit or malfunction. If the screws are excessively tightened, the screws may be damaged, and the power adapter may drop or short-circuit. Install the power adapter on to a flat surface. If the mounting surface is concave and/or convex, and if excessive force is applied on the PC board, nonconformity may occur.

WIRING PRECAUTIONS

WARNING

Make sure to shut down all phases of the power supply outside the module before starting the installation or wiring work. If all phases are not shut down, electrical shock or product damage may be caused.

CAUTION

Confirm the rated voltage and the terminal arrangement of the power adapter, then correctly wire the power adapter. If a power supply not conforming to the specification rating is connected or the power adapter is wired incorrectly, fire, failure or malfunction may occur. Tighten the terminal screws within the specified torque range. If the terminal screws are insufficiently tightened, fire or malfunction may occur. If the terminal screws are excessively tightened, the screws may be damaged, and the module may short-circuit, equipment failures, or malfunction. Make sure that foreign objects such as cutting and wire chips do not enter the power adapter. Fire, failure or malfunction may be caused by the foreign objects. Attach a warning label (hazard symbol 417-IEC-5036) concerning electric shock to the panel.

STARTING AND MAINTENANCE PRECAUTIONS

WARNING

Do not touch the terminals while the power is being supplied. Electrical shock or malfunction may be caused by such touching. Shut down all phases of the power supply outside the power adapter before cleaning or tightening the terminal screws. If all phases are not shut down, the power adapter may fail or malfunction.

CAUTION

Do not disassemble or modify the power adapter. Failure, malfunction, injury or fire may be caused by disassembly or modification. The power adapter case is made of resin. Do not drop it. Do not apply strong impact to it. The power adapter may be damaged by dropping or strong impact. Shut down all phases of the power supply outside the power adapter before attaching or removing the power adapter to/from the panel. If all phases are not shut down, the power adapter may fail or malfunction.

DISPOSAL PRECAUTIONS

CAUTION

When disposing of the product, treat it as an industrial waste.

TRANSPORTATION AND MAINTENANCE PRECAUTIONS

CAUTION

During transportation avoid any impact as the module is a precision instrument. Doing so could cause trouble in the module. If it is necessary to check the operation of module after transportation, in case of any impact damage.

Compliance with EC directive (CE marking)

This notification does not guarantee that an entire mechanical module produced in accordance with the contents of the notification comply with the following standards. Compliance to EMC directive of the entire mechanical module should be checked by the user / manufacturer.

Attention

This product is designed for use in industrial applications.

Standards with which this product complies

Type : Programmable Controller (Open Type Equipment)

Models : Products manufactured from November 1st, 2002 to April 30th, 2006 are compliant with EN61000-6-4 and EN61131-2:1994+A11:1996+A12:2000 after May 1st, 2006 are compliant with EN61131-2:2007

Electromagnetic Compatibility Directive (EMC)	Remark
EN61000-6-4:2007 Electromagnetic compatibility - Generic standards - Emission standard for Industrial environment	Compliance with all relevant aspects of the standard. (Radiated Emissions and Mains Terminal Voltage Emissions)
EN61131-2:1994/A11:1996/A12:2000 Programmable controllers - Equipment requirements and tests	Compliance with all relevant aspects of the standard. • Radiated electromagnetic field • Fast transient burst • Electrostatic discharge • Damped oscillatory wave
EN61131-2:2007 Programmable controllers - Equipment requirements and tests	Compliance with all relevant aspects of the standard. EMI • Radiated Emission • Conducted Emission EMS • Radiated electromagnetic field • Fast transient burst • Electrostatic discharge • High-energy surge • Voltage drops and interruptions • Conducted RF • Power frequency magnetic field

Notes For compliance to EMC directive

It is necessary to install the CL1 series module in a shielded metal control panel. For more details, please contact the local Mitsubishi Electric sales site.

Use this product in Zone A^{*1} as defined in EN61131-2.

*1 Zone defined in EN61131-2
Separation defined in EN61131-2 for EMC LVD regulation decided depending on condition in industrial setting.

Zone C = Factory mains which is isolated from public mains by dedicated transformers.

Zone B = Dedicated power distribution which is protected by secondary surge protection. (300V or less in the rated voltage is assumed.)

Zone A = Local power distribution which is isolated from dedicated power distribution by AC/DC converters, isolation transformers, etc. (120V or less in the rated voltage is assumed.)

When the following models use the CC-Link/LT power adapter model (CL1PAD1), a power line connecting to the external power supply terminal of the CL1PAD1 must be 30m(98'5") or less.

- CL2AD4-B
- CL2DA2-B

Compliance with UKCA marking

The requirements for compliance with UKCA marking are the same as that with EC directive (CE marking).

1. Outline of Product

This product is a power adapter connected to CC-Link/LT. This product supplies 24V DC power from an external power supply to the CC-Link/LT system. At least one power adapter is required per CC-Link/LT system.

2. Name of Each Part

2.1 Name of each part and assignment

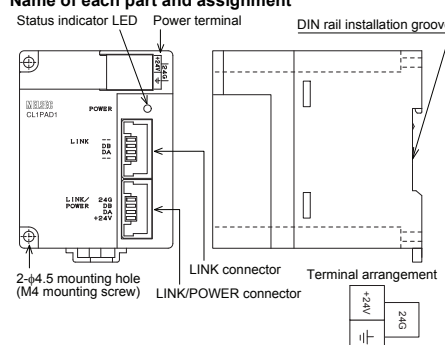

Name	Description
Status indicator LED	POWER Lit while the power is supplied
Interface	LINK connector DB For communication
	24G Power supply for communication (-)
	LINK/POWER connector DB For communication
Power terminal	DA For communication
	+24V Power supply for communication (+)
	24G Input voltage: 28.8V DC or less (depending on connected model) Rated input current: 5.0 A (Use a proper external power supply under consideration of initial current of remote I/O modules.)

*4 This index indicates the degree of generation of conductive substances in the environment in which the module is used. The degree of contamination 2 indicates that contamination is caused by generation of only non-conductive substances. In this degree, however, temporary conduction may be caused by accidental condensation.

2) Performance specifications

Item	Specification
Voltage input range	Depends on the connected model (28.8V DC max.).
Max. rated current	5.0A [Use the power adapter in the range in which the total current consumption of each unit does not exceed the maximum rated current while the power is supplied (except the period immediately after the power is turned on).]
Insulation resistance	10MΩ between the external terminals as a whole and the ground terminal by 500V DC insulation resistance tester
External connection method	Supplies power from outside to power adapter: 3 points (M3 screws) on terminal block Communication line/module power supply module Compatible with flat cable dedicated to CC-Link/LT Connector (with 4 pins) dedicated to CC-Link/LT x 2

4. Construction Cautions

At least one power adapter is required per CC-Link/LT system. When constructing the system using only one power adapter, the following three conditions should be satisfied.

- If the following two conditions are not satisfied, use of two or more power adapters in constructing the system.
- The current capacity of the power adapter is 5A, therefore, total current consumption should be an equivalent to or less than 5 A.
- In order to operate the system in stable status, the voltage drop should be equivalent to or less than 3.6 V.
- The minimum operating voltage of each module connected to the power adapter is 20.4 V, therefore, supply voltage subtracted by the voltage drop should be equivalent to or more than 20.4 V.

4.1 System power calculation method

4.1.1 Current consumption calculation

$$\text{Current consumption in CC-Link/LT system} = \text{Total current consumption of each module in CC-Link/LT system} + \text{Total current consumption of I/O equipment (such as sensors) (to which power is supplied via communication cable)*1} \leq 5A$$

*5 Some remote I/O modules for CC-Link/LT supply the power for I/O via the flat cable dedicated to CC-Link/LT. For the details, refer to the instruction manual of each remote I/O module.

4.1.2 Voltage drop

Calculate the voltage drop based on the simplified graph or the calculation formula. (supply voltage: 24V DC, ambient temperature: 20°C)

1) Selection based on the simplified graph

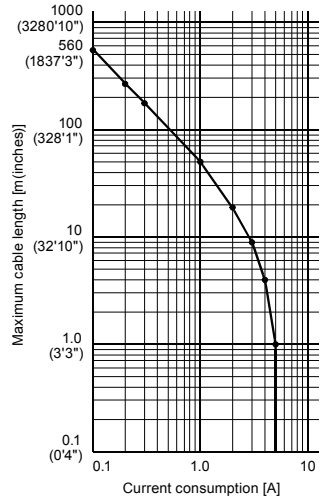

One power adapter is allowed within the range shown in the graph above.

2) Selection based on the calculation formula

$$\text{Voltage drop (V)} = \frac{\text{Maximum distance (m)}}{\text{Constant: 11}} \times \text{Constant: 0.06} \times \text{Total current consumption (A)} \leq 3.6V$$

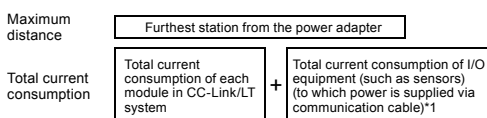

*1 Some remote I/O modules for CC-Link/LT supply the power for I/O via the flat cable dedicated to CC-Link/LT. For the details, refer to the instruction manual of each remote I/O module.

The simplified graph and the calculation formula concerning voltage drop calculations may not be accurate depending on the ambient temperature and the number of used connectors dedicated to CC-Link/LT. If the driving voltage (20.4V) cannot be assured in a used remote I/O module, add another power adapter.

5. Installation

The power adapter can be installed to a DIN rail or directly installed with screws. Each installation procedure is described below.

5.1 Installation direction

Do not install the power adapter on the floor surface, the ceiling surface or in the vertical direction. If the power adapter is installed on such a surface or in such a direction, its temperature may rise. Make sure to install the power adapter on the wall horizontally.

5.2 Installation to DIN rail

Align the upper DIN rail installation groove in the power adapter with the DIN rail 1), and press the power adapter in that status 2). When removing the power adapter, pull downward the hook for installation to DIN rail 3), then remove the power adapter 4).

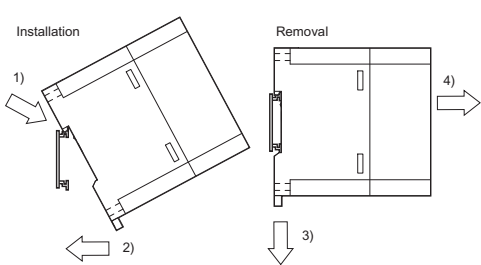

Applicable DIN rail TH35-7.5Fe and TH35-7.5Al

5.3 Direct installation

Screw-tighten the power adapter by tightening M4 screws to the upper and lower mounting holes (two holes in all) provided in the power adapter. Install the module so that the clearance of 1 to 2mm (0.04" to 0.08") is assured for each module.

Applicable screw M4 x 0.7mm(0.03") x 16mm(0.63") or more (Tightening torque range: 0.78 to 1.08 N·m)

5.4 Crimp-style terminal

For the I/O wiring, use crimp-style terminals of the following dimensions.

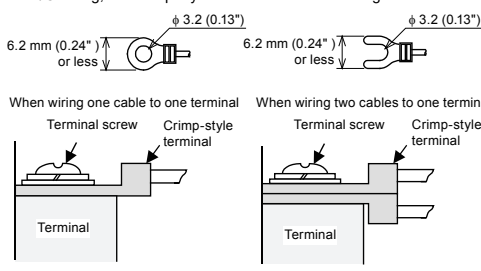

Tighten the terminal screws (M3 screws) on the terminal block with a tightening torque of 0.42 to 0.58 N·m. Do not tighten terminal screws with a torque outside the above-mentioned range. Failure to do so may cause short circuit, equipment failures, or malfunctions.

Applicable crimp-style terminal	• RAV1.25-3 • V1.25-3 (manufactured by JST Mfg. Co., Ltd.) • 1.25-3 and TG1.25-3 (manufactured by NICHIFU Co., Ltd.)
Applicable wire size	0.3 to 1.25 mm ²

6. Power Wiring

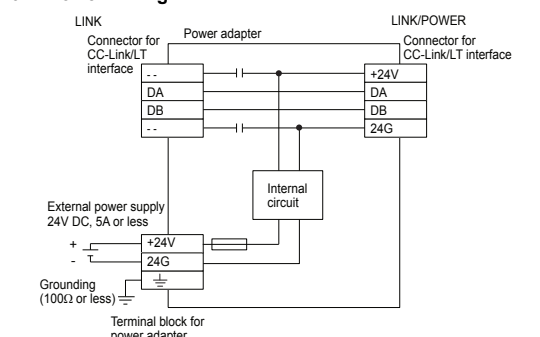

- The external power supply is to be provided by the user.
- Use a proper external power supply with consideration for total current consumption and total initial current of remote I/O modules and I/O equipment (such as sensors) connected to the power adapter.

7. Outside Dimensions

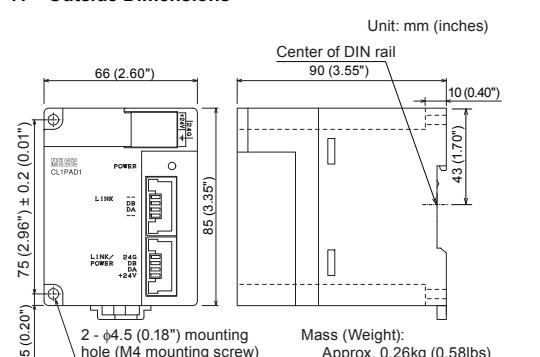

Mass (Weight): Approx. 0.26kg (0.58lbs)

2.2 Handling of LINK connector and LINK/POWER connector

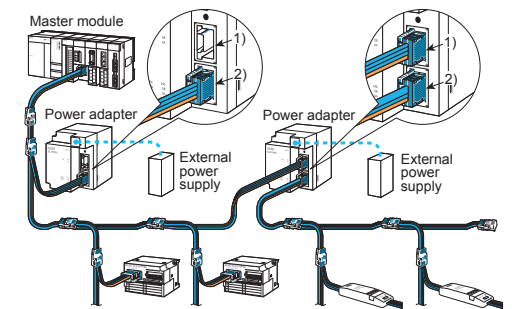

- LINK connector
- LINK/POWER connector

LINK connector:
Executes only communication (does not supply power). Used when two or more power adapters are used in the CC-Link/LT system.

LINK/POWER connector:
Executes communication, and supplies the power to the CC-Link/LT system.

3. Specifications

1) General specifications

Item	Specification		
Ambient working temperature	0 to 55°C (32 to 131°F)		
Ambient storage temperature	-25 to 75°C (-13 to 167°F)		
Ambient operating humidity	5 to 95%RH: Dew condensation shall not be allowed.		
Ambient storage humidity	5 to 95%RH: Dew condensation shall not be allowed.		
Vibration resistance (*1)	Intermittent vibration is present	Number of sweep times	
	Frequency: 10 to 57Hz	Acceleration: -	Half amplitude: 0.075mm
	Frequency: 57 to 150Hz	Acceleration: 9.8m/s ²	Half amplitude: -
Vibration resistance (*1)	Continuous vibration is present	Number of sweep times	
	Frequency: 10 to 57Hz	Acceleration: -	Half amplitude: 0.035mm
	Frequency: 57 to 150Hz	Acceleration: 4.9m/s ²	Half amplitude: -
Impact resistance (*1)	147 m/s ² , 3 times in each of X, Y and Z directions		
Operating atmosphere	Corrosive gas should not be present.		
Operating altitude	2,000m(6561'8") or less (*2)		
Installation place	Inside control panel		
Over-voltage category	II or less (*3)		
Degree of contamination	2 or less (*4)		

- *1 The criterion is shown in IEC61131-2.
- *2 The module cannot be used in an environment pressurized above the atmospheric pressure which can be generated around the altitude of 0 m. If the module is used in such an environment, it may fail.
- *3 It indicates in which wiring area from the public wiring net to the mechanical module inside the site the equipment is assumed to be connected. The category II applies, for example, to equipment whose power is supplied from a fixed facility. The surge-resistant voltage of equipment whose rating is up to 300V is 2,500V.

「电器电子产品有害物质限制使用标识要求」的表示方式

含有害6物质的名称, 含有量, 含有部品
本产品中所含有的有害6物质的名称, 含有量, 含有部品如下表所示。

部件名称	有害物质					
	铅 (Pb)	汞 (Hg)	镉 (Cd)	六价铬 (Cr (VI))	多溴联苯 (PBB)	多溴二苯醚 (PBDE)
可编程序控制器	○	○	○	○	○	○
印刷基板	×	○	○	○	○	○

本表格依据SJ/T 11364的规定编制。

○: 表示该有害物质在该部件所有均质材料中的含量均在GB/T 26572规定的限量要求以下。
×: 表示该有害物质至少在该部件的某一均质材料中的含量超出GB/T 26572规定的限量要求。

基于中国标准法的参考规格: GB/T15969.2

This manual confers no industrial property rights or any rights of any other kind, nor does it confer any patent licenses. Mitsubishi Electric Corporation cannot be held responsible for any problems involving industrial property rights which may occur as a result of using the contents noted in this manual.

Warranty
Exclusion of loss in opportunity and secondary loss from warranty liability
Regardless of the gratis warranty term, Mitsubishi shall not be liable for compensation to:
(1) Damages caused by any cause found not to be the responsibility of Mitsubishi.
(2) Loss in opportunity, lost profits incurred to the user by Failures of Mitsubishi products.
(3) Special damages and secondary damages whether foreseeable or not, compensation for accidents, and compensation for damages to products other than Mitsubishi products.
(4) Replacement by the user, maintenance of on-site equipment, start-up test run and other tasks.

For safe use
This product has been manufactured as a general-purpose part for general industries, and has not been designed or manufactured to be incorporated in a device or system used in purposes related to human life.
Before using the product for special purposes such as nuclear power, electric power, aerospace, medicine or passenger movement vehicles, consult with Mitsubishi Electric.
This product has been manufactured under strict quality control. However when installing the product where major accidents or losses could occur if the product fails, install appropriate backup or failsafe functions in the system.

Country/Region	Sales office/Tel	Country/Region	Sales office/Tel
USA	MITSUBISHI ELECTRIC AUTOMATION, INC. 500 Corporate Woods Parkway, Vernon Hills, IL 60061, U.S.A. Tel: +1-847-478-2100/+1-847-478-2500 (NC) MITSUBISHI ELECTRIC DO BRASIL COMERCIO E SERVICOS LTDA. Avenida Adelfino Cardana, 293, 21 andar: Bela Vista, Baurista, São Paulo Tel: +55-11-4688-3000	Russia	Mitsubishi Electric (Russia) LLC 2, bld. 1, Leninskoyevaya str., 115064 Moscow, Russia Tel: +7-495-721-2070
Brazil	MITSUBISHI ELECTRIC EUROPE B.V. - German Branch Mitsubishi-Electric-Platz 1, 40882 Ratingen, Germany Tel: +49-2102-486-0 MITSUBISHI ELECTRIC EUROPE BV (UK Branch) Travelers Lane, Hatfield, Hertfordshire, AL10 8XB, UK Tel: +44-1707-28-8780	China	MITSUBISHI ELECTRIC AUTOMATION (CHINA) LTD. No. 1386 Hongqiao Road, Mitsubishi Electric Automation Center, Changning District, Shanghai, China Tel: +86-21-2322-3030 SETSUYO ENTERPRISE CO., LTD. 6F, No. 105, Wugong 3rd Road, Wugu District, New Taipei City 24889, Taiwan, R.O.C. Tel: +886-2-259-2469
Germany	MITSUBISHI ELECTRIC EUROPE B.V. - Italian Branch Centro Direzionale Colonna - Palazzo Sirio, Viale Colonna 7, 20964 Agrate Branzia (MI), Italy Tel: +39-039-605311/+39-039-6053-3421 (NC) MITSUBISHI ELECTRIC EUROPE B.V. - Spanish Branch Carretera de Rubí 75-80-AC-420, E-08190 Sant Cugat del Valles (Barcelona), Spain Tel: +34-093-65-3131/+34-093-65-2258 (NC)	Taiwan	MITSUBISHI ELECTRIC AUTOMATION KOREA CO., LTD. 7F-9F, Gangseo Hangang 30-tower A, 401, Yangcheon-gu, Gyeonggi-do, Seoul, 07528, Korea Tel: +82-2-669-9530
UK	MITSUBISHI ELECTRIC EUROPE B.V. - Polish Branch Mitsubishi Electric Europe B.V. Polish Branch ul. Krakowska 48, 32-063 Balice, Poland Tel: +48-12-347-65-00	Korea	MITSUBISHI ELECTRIC ASIA PTE. LTD. 387 Alexandra Road, Mitsubishi Electric Building, Singapore 159943 Tel: +65-6473-2308
Italy	MITSUBISHI ELECTRIC EUROPE B.V. - Czech Branch Prague Office Pekárska 62/17, 150 00 Praha 5, Czech Republic Tel: +420-255-719-200	Singapore	MITSUBISHI ELECTRIC ASIA PTE. LTD. 387 Alexandra Road, Mitsubishi Electric Building, Singapore 159943 Tel: +65-6473-2308
Spain	MITSUBISHI ELECTRIC EUROPE B.V. - French Branch 25, Boulevard des Bouvettes, F-92741 Nanterre Cedex, France Tel: +33-1-45-85-85-88	Thailand	Mitsubishi Electric Factory Automation (Thailand) Co., Ltd. 12th Floor, SV City Building, Office Tower 1, No. 888/19 and 20 Rama 3 Road, Keweenaw Bangkokpang, Khai Yunnanaw, Bangkok 10110, Thailand Tel: +66-2682-6522-31
France	MITSUBISHI ELECTRIC EUROPE B.V. - Indonesian Branch Gedung Jina 9th Floor, Jl. MH Thamrin No. 12, Jakarta Pusat 10340, Indonesia Tel: +62-21-3192-6469	India	Mitsubishi Electric India Pvt. Ltd. Gurgaon Branch 2nd Floor, Tower A & B, Cyber Greens, DLF Cyber City, DLF Phase - II, Gurgaon - 122002, Haryana, India Tel: +91-124-6630300
Czech Republic	MITSUBISHI ELECTRIC EUROPE B.V. - Australian Branch Mitsubishi Electric Australia Pty. Ltd. 348 Victoria Road PO BOX111, Rydalmere, N.S.W 2116, Australia Tel: +61-2-9684-7777	Indonesia	MITSUBISHI ELECTRIC AUSTRALIA PTY. LTD. 348 Victoria Road PO BOX111, Rydalmere, N.S.W 2116, Australia Tel: +61-2-9684-7777

MITSUBISHI ELECTRIC CORPORATION
HEAD OFFICE: TOKYO BUILDING, 2-7-3 MARUNOUCHI, CHYUO-KU, TOKYO 100-8310, JAPAN

When exported from Japan,