

CL2Y8-TPE1S2

CC-Link/LT Remote I/O Module

Thank you very much for purchasing this product.

Please read this manual thoroughly before starting to use the product and handle the product properly.

User's Manual

MODEL	CL2Y8-TPE1S2-U
MODEL CODE	13JP74
IB(NA)-0800318-E(1806)MEE	

© 2005 MITSUBISHI ELECTRIC CORPORATION

SAFETY PRECAUTIONS

(Read these precautions before using.)

Please read this manual carefully and pay special attention to safety in order to handle this product properly. Also pay careful attention to safety and handle the module properly.

These precautions apply only to Mitsubishi equipment. Refer to the user's manual of the CPU module to use for a description of the programmable controller system safety precautions. In this manual, the safety precautions are classified into two levels: " ⚠ WARNING " and " ⚠ CAUTION ".

⚠ WARNING	Indicates that incorrect handling may cause hazardous conditions, resulting in death or severe injury.
------------------	--

⚠ CAUTION	Indicates that incorrect handling may cause hazardous conditions, resulting in minor or moderate injury or property damage.
------------------	---

Under some circumstances, failure to observe the precautions given under " ⚠ CAUTION " may lead to serious consequences.

Observe the precautions of both levels because they are important for personal and system safety.

Make sure that the end users read this manual and then keep the manual in a safe place for future reference.

[DESIGN PRECAUTIONS]

⚠ WARNING

- Configure an interlock circuit in a sequence program so that the system operates on the safety side using the communication status information in the event the data link falls into a communication problem. Otherwise, erroneous output and malfunction may result in accidents.
- Output could be switched on or off when a problem occurs in the remote I/O modules. So build an external monitoring circuit that will monitor any output signals that could cause a serious accident.

[DESIGN PRECAUTIONS]

⚠ CAUTION

- Do not have control cables and communication cables bundled with or placed near by the main circuit and/or power cables. Wire those cables at least 100mm(3.94 inch) away from the main circuit and/or power cables. It may cause malfunction due to noise interference.

[INSTALLATION PRECAUTIONS]

⚠ CAUTION

- Use the module in an environment that meets the general specifications contained in this manual. Using this module in an environment outside the range of the general specifications could result in electric shock, fire, erroneous operation, and damage to or deterioration of the product.
- Do not directly touch the module's conductive parts. Doing so could cause malfunction or trouble in the module.
- Tighten the module securely using DIN rail or installation screws within the specified torque range. If the screws are too loose, the module may drop from its installation position, short circuit, or malfunction. If the screws are too tight, the screws may be damaged, which may cause the module to drop from its installation position or short circuit.

[WIRING PRECAUTIONS]

⚠ WARNING

- Completely turn off the externally supplied power used in the system when installing or placing wiring. Not completely turning off all power could result in electric shock or damage to the product.

[WIRING PRECAUTIONS]

⚠ CAUTION

- Terminal screws which are not to be used must be tightened always. Otherwise there will be a danger of short circuit against the bare solderless terminals.

[WIRING PRECAUTIONS]

⚠ CAUTION

- Perform correct wiring for the module according to the product's rated voltage and terminal arrangement. Connecting to a power supply different from rating or missing-wiring may cause fire and/or product failure.
- Fix terminal screws securely within the regulated torque. Loose terminal screws may cause fire and/or malfunction. If the terminal screws are too tight, it may cause short circuit or erroneous operation due to damage of the screws.
- Make sure foreign objects do not get inside the module, such as dirt and wire chips. It may cause fire, product failure or malfunction.

[STARTING AND MAINTENANCE PRECAUTIONS]

⚠ WARNING

- Do not touch terminals when the power is on. Doing so could cause an electric shock.
- Switch off all phases of the externally supplied power used in the system when cleaning the module or retightening the terminal or module mounting screws. Not doing so could result in electric shock.

[STARTING AND MAINTENANCE PRECAUTIONS]

⚠ CAUTION

- Do not disassemble or modify the module. Doing so may cause failure, malfunction, injury, or fire.
- Do not drop or apply any strong impact to the module. Doing so may damage the module.
- Completely turn off the externally supplied power used in the system before mounting or removing the module. Not doing so could result in damage to the product.
- Before touching the module, always touch grounded metal, etc. to discharge static electricity from the human body, etc. Not doing so can cause the module to fail or malfunction.

[DISPOSAL PRECAUTIONS]

⚠ CAUTION

- When disposing of this product, treat it as industrial waste.

PRÉCAUTIONS DE SÉCURITÉ

(Lire ces précautions avant usage.)

Prière de lire attentivement ce manuel. Prêter une attention particulière à tout ce qui a trait à la sécurité pour utiliser le produit correctement.

Ces précautions ne concernent que l'équipement Mitsubishi. Dans le manuel de l'utilisateur du module CPU correspondant, voir l'exposé des précautions de sécurité concernant le système de l'automate programmable.

Dans ce manuel, les précautions de sécurité sont classées en deux niveaux, à savoir : " ⚠ AVERTISSEMENT " et " ⚠ ATTENTION ".

⚠ AVERTISSEMENT	Attire l'attention sur le fait qu'une négligence peut créer une situation de danger avec risque de mort ou de blessures graves.
------------------------	---

⚠ ATTENTION	Attire l'attention sur le fait qu'une négligence peut créer une situation de danger avec risque de blessures légères ou de gravité moyennes ou risque de dégâts matériels.
--------------------	--

Dans certaines circonstances, le non-respect d'une précaution de sécurité introduite sous le titre " ⚠ ATTENTION " peut avoir des conséquences graves.

Les précautions de ces deux niveaux doivent être observées dans leur intégralité car elles ont trait à la sécurité des personnes et aussi du système.

Veiller à ce que les utilisateurs finaux lisent ce manuel qui doit être conservé soigneusement à portée de main pour s'y référer autant que de besoin.

[PRÉCAUTIONS DE CONCEPTION]

⚠ AVERTISSEMENT

- Prévoir dans le programme séquentiel un circuit de verrouillage sur la base des informations d'état de la communication, de façon à maintenir la sécurité de fonctionnement du système dans l'éventualité d'un problème de communication affectant la liaison de données. Faute de quoi, une sortie erronée ou un dysfonctionnement pourrait être à l'origine d'accidents.
- La sortie pourrait se trouver activée ou désactivée à la survenance d'un problème dans le module E/S distant. On constituera donc un circuit de surveillance externe couvrant tous les signaux de sortie qui pourraient être à l'origine d'un accident grave.

[PRÉCAUTIONS DE CONCEPTION]

⚠ ATTENTION

- Ne pas grouper ni placer à proximité les câbles de commande ou câbles de communication avec les câbles des circuits principaux et/ou d'alimentation. Câbler en plaçant ces câbles à une distance d'au moins 100mm (3 94 pouces) des câbles des circuits principaux ou de l'alimentation. Cela pourrait être à l'origine d'un bruit parasite entraînant des dysfonctionnements.

[PRÉCAUTIONS D'INSTALLATION]

⚠ ATTENTION

- Utiliser le module dans un environnement conforme aux spécifications générales présentées dans ce manuel. L'utilisation de ce module dans un environnement autre que celui prévu dans les spécifications générales peut être à l'origine d'un choc électrique, d'un départ de feu ou d'un dysfonctionnement, ou peut endommager ou détériorer le produit.

[PRÉCAUTIONS D'INSTALLATION]

⚠ ATTENTION

- Éviter tout contact direct avec les parties conductrices du module. Cela pourrait être à l'origine de dysfonctionnements ou autres problèmes avec le module.
- Serrer le module fermement avec un rail DIN ou avec des vis de fixation serrées dans les limites du couple de serrage prescrit. Si le serrage des vis est insuffisant, il y a risque de chute du module, de court-circuit ou de dysfonctionnement. Un serrage excessif peut endommager les vis et il y a risque de détachement du module et de court-circuit.

[PRÉCAUTIONS DE CÂBLAGE]

⚠ AVERTISSEMENT

- Couper complètement l'alimentation externe utilisée par le système avant de mettre avant le câblage ou le raccordement de câbles. Ne pas couper complètement toutes les alimentations expose au risque de chocs électriques et d'endommagement du produit.

[PRÉCAUTIONS DE CÂBLAGE]

⚠ ATTENTION

- Les vis des bornes qui restent inutilisées doivent toujours être serrées. Faute de quoi, il y a danger de court-circuit par contact avec les bornes-barres sans soudure.
- Effectuer le câblage du module correctement, compte tenu de la tension nominale du produit et en respectant l'affectation des bornes. Le raccordement d'une alimentation de tension nominale différente ou une erreur de câblage peuvent être à l'origine d'un départ de feu et/ou d'une panne du produit.
- Fixer les vis de borne fermement en serrant au couple prescrit. Des vis de bornes desserrées peuvent être à l'origine d'un départ de feu et/ou de dysfonctionnements. Si serrage excessif des vis de bornes peut les endommager et être à l'origine d'un court-circuit ou un fonctionnement erratique.
- Veiller à éviter toute pénétration d'impuretés, copeaux de câblage ou autre corps étranger dans le module. Cela pourrait être à l'origine d'un départ de feu, ou du panne ou d'un dysfonctionnement du produit.

[PRÉCAUTIONS DE DÉMARRAGE ET DE MAINTENANCE]

⚠ AVERTISSEMENT

- Ne pas toucher aux bornes quand l'appareil est sous tension. Cela pourrait être à l'origine d'un choc électrique.
- Avant le nettoyage du module ou le reserrage des vis de borne ou des vis de fixation du module, couper les alimentations externes utilisées par le système sur toutes les phases. Faute de quoi, il y a risque de choc électrique.

[PRÉCAUTIONS DE DÉMARRAGE ET DE MAINTENANCE]

⚠ ATTENTION

- Ne pas démonter ni modifier le module. Cela pourrait être à l'origine de pannes, de dysfonctionnements, de blessures ou d'un départ de feu.
- Ne pas faire tomber le module, ni le soumettre à de forts chocs. Cela risquerait d'endommager le module.
- Couper complètement l'alimentation externe utilisée par le système avant de mettre en place ou de retirer le module. Faute de quoi, il y a risque d'endommagement du produit.
- Avant de toucher au module, se débarrasser de la charge électrostatique qu'accumule le corps humain en touchant un objet métallique raccordé à la terre. Le non-respect de cette précaution peut être à l'origine de pannes ou de dysfonctionnements du module.

[PRÉCAUTIONS DE MISE AU REBUT]

⚠ ATTENTION

- Lors de sa mise au rebut, ce produit doit être traité comme un déchet industriel.

CONDITIONS OF USE FOR THE PRODUCT

- Mitsubishi programmable controller ("the PRODUCT") shall be used in conditions;
 - where any problem, fault or failure occurring in the PRODUCT, if any, shall not lead to any major or serious accident; and
 - where the backup and fail-safe function are systematically or automatically provided outside of the PRODUCT for the case of any problem, fault or failure occurring in the PRODUCT.
- The PRODUCT has been designed and manufactured for the purpose of being used in general industries.

MITSUBISHI SHALL HAVE NO RESPONSIBILITY OR LIABILITY (INCLUDING, BUT NOT LIMITED TO ANY AND ALL RESPONSIBILITY OR LIABILITY BASED ON CONTRACT, WARRANTY, TORT, PRODUCT LIABILITY) FOR ANY INJURY OR DEATH TO PERSONS OR LOSS OR DAMAGE TO PROPERTY CAUSED BY THE PRODUCT THAT ARE OPERATED OR USED IN APPLICATION NOT INTENDED OR EXCLUDED BY INSTRUCTIONS, PRECAUTIONS, OR WARNING CONTAINED IN MITSUBISHI'S USER, INSTRUCTION AND/OR SAFETY MANUALS, TECHNICAL BULLETINS AND GUIDELINES FOR THE PRODUCT. ("Prohibited Application")

Prohibited Applications include, but not limited to, the use of the PRODUCT in;

 - Nuclear Power Plants and any other power plants operated by Power companies, and/or any other cases in which the public could be affected if any problem or fault occurs in the PRODUCT.
 - Railway companies or Public service purposes, and/or any other cases in which establishment of a special quality assurance system is required by the Purchaser or End User.

Item	Type	CL2Y8-TPE1S2
Max. inrush current		0.7A 10ms or lower
Leakage current at OFF		0.1mA or lower
Voltage drop at ON		0.1V or lower (TYP) 0.1A, 0.2V or lower (MAX.) 0.1A
Output method		Source type
Protect function		Overload protection function, Overheat protection function
Response time	OFF → ON	1.0ms or lower
	ON → OFF	1.0ms or lower (Resistive load)
Surge suppression		Zener diode
Common wiring method		8 points/1 common (terminal block 2-wire type)
Number of stations occupied	In 4-point mode:	Occupies 2 stations
	In 8 or 16-point mode:	Occupies 1 station
External power supply of the output part	Voltage	10.2 to 28.8V DC (ripple ratio : within 5%)
	Current consumption	10mA or lower (24V DC, when all points are ON) Not including external load current
	Module power supply	
Module power supply	Voltage	24V DC (-15 to +20%) (ripple ratio : within 5%)
	Current consumption	40mA or lower (When 24V DC and all point is on)
	Current on startup	90mA or lower (24V DC)
Noise durability		DC type noise voltage 500Vp-p, noise width 1µs, noise carrier frequency 25 to 60kHz (noise simulator condition) First transient/noise burst IEC 61000-4-4 : 1kV
Withstand voltage		500V AC for 1 minute between primary (external DC terminal) and secondary (internal circuit)
Insulation resistance		10MΩ or more between primary (external DC terminal) and secondary (internal circuit) when measured with a 500V DC insulation resistance tester
Protection class		IP2X
Weight		0.13kg
I/O part connection method		2-piece 20-point spring clamp terminal block
Module installation method		DIN rail installation, mounted by screws of type M4 × 0.7 mm × 16 mm or larger Can be installed in 3 directions
Applicable wire size		0.3 to 1.5mm ² (AWG22 to 16)

3. Part Names

This section explains the names of the components for the remote I/O module.

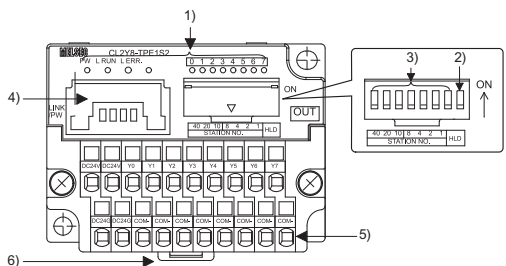

[Pin numbers and signal names]	Pin No.	Signal name	[Terminal numbers and signal names]
1	+24V	1 3 5 7 9 11 13 15 17 19	DA
2	DA	DC24V DC24V Y0 Y1 Y2 Y3 Y4 Y5 Y6 Y7	DB
3	DB	2 4 6 8 10 12 14 16 18 20	24G
4	24G	COM. COM. COM. COM. COM. COM. COM. COM. COM. COM. COM. COM. COM. COM.	

[Numéros de broche et noms des signaux]	Broc he N°	Nom de signal	[Numéros de borne et noms des signaux]
1	+24V	1 3 5 7 9 11 13 15 17 19	DA
2	DA	DC24V DC24V Y0 Y1 Y2 Y3 Y4 Y5 Y6 Y7	DB
3	DB	2 4 6 8 10 12 14 16 18 20	24G
4	24G	COM. COM. COM. COM. COM. COM. COM. COM. COM. COM. COM. COM. COM. COM.	

No.	Item	Description																		
1)	Operating status indicator LEDs	<p>LED name Confirmation details</p> <p>PW On: Power supply on. Off: The power supply is turned off or the voltage drop is too large.</p> <p>L RUN On: Normal communication. Off: Communication cutoff (time expiration error).</p> <p>L ERR. On: Indicates that a communication data error has occurred or the setting switch is outside the allowable range. Flicker at regular intervals: Indicates that the setting switch has been changed while current is being conducted. (The module continues to operate even while the LED is flickering. The changed settings will be reflected when the power has been restored.) Flicker at irregular intervals: Indicates that the terminal resistor is left unconnected or that the module or connection cable are affected by noise. Off: Normal communication.</p> <p>0 to 7 Displays the ON/OFF status of the output (turned on in the ON status and turned off in the OFF status).</p>																		
2)	Output hold setting switch (SW8)	Specifies whether to maintain or turn off the output of the remote I/O module in case the communication stops. The switch is set to OFF at shipment from the factory. ON: Maintain output OFF: Turn output off																		
3)	Station number setting switches (SW1 to 7)	Select "10", "20" or "40" to set the ten's place of the station number. Select "1", "2", "4" or "8" to set the one's place of the station number. All switches are set to OFF at shipment from the factory. Always set the station number within the range of 1 to 64. A setting error occurs and "L ERR." LED flickers if the value outside the range 1 to 64 is set. (Example) Set the switches as below when setting the station number to 32: <table border="1" style="margin-left: 20px;"> <thead> <tr> <th>Station number</th> <th>Ten's place</th> <th>One's place</th> </tr> </thead> <tbody> <tr> <td>40</td> <td>20</td> <td>10</td> </tr> <tr> <td>20</td> <td>10</td> <td>8</td> </tr> <tr> <td>10</td> <td>8</td> <td>4</td> </tr> <tr> <td>8</td> <td>4</td> <td>2</td> </tr> <tr> <td>4</td> <td>2</td> <td>1</td> </tr> </tbody> </table>	Station number	Ten's place	One's place	40	20	10	20	10	8	10	8	4	8	4	2	4	2	1
Station number	Ten's place	One's place																		
40	20	10																		
20	10	8																		
10	8	4																		
8	4	2																		
4	2	1																		
4)	Connector for CC-Link/LT interface	Connector for CC-Link/LT communication line and module power supply.																		
5)	Terminal block for I/O interface	Spring clamp terminal block for connecting output signal, load power supply, and external power supply of the output part. <i>Bornier à étrier pour raccordement du signal de sortie, de l'alimentation de charge et de l'alimentation externe de la partie sortie.</i> <i>Bornier pour interface E/S</i>																		
6)	Hook for DIN rail	Hook for installing the module on a DIN rail.																		

4. Handling Precautions

- Tighten the terminal screws for the module to the specified torque shown below. Insufficient tightening torque could result in shorts, failures or malfunction.

Screw location	Clamping torque range
Module mounting screw (M4 screw)	0.78 to 1.08 N·m
Terminal block mounting screw (M3 screw)	0.42 to 0.58 N·m

- Serrer les vis de borne du module dans les limites du couple de serrage prescrit. Un couple de serrage insuffisant peut être à l'origine de court-circuits, pannes ou dysfonctionnements.

Emplacement des vis	Force de serrissage admissible
Vis de fixation du module (Vis M4)	0,78 à 1,08 N·m
Vis de fixation de bornier (vis M3)	0,42 à 0,58 N·m

- When using a DIN rail, attach the DIN rail after taking the following items into consideration:
 - Applicable DIN rail types (conform to JIS C 2812) TH35-7.5F TH35-7.5A

- Interval between the DIN rail's installation screws
- Tighten the screws using a pitch of 20mm (7.87in.) or less when attaching a DIN rail.

- To attach the remote I/O module to the DIN rail, press the centerline area of the DIN rail hook beneath the module until a click is heard.

- Maintain some distance between the module and other components and parts, 10 mm from the top and 50mm (1.97in.) from the bottom of the module, in order to improve ventilation and to make replacement of the module easy if a remote I/O module is installed on a board.

- Install the remote I/O module on a level surface. If the surface is uneven, unnecessary force is applied to the printed circuit board, causing malfunctions.

5. Wiring

5. Câblage

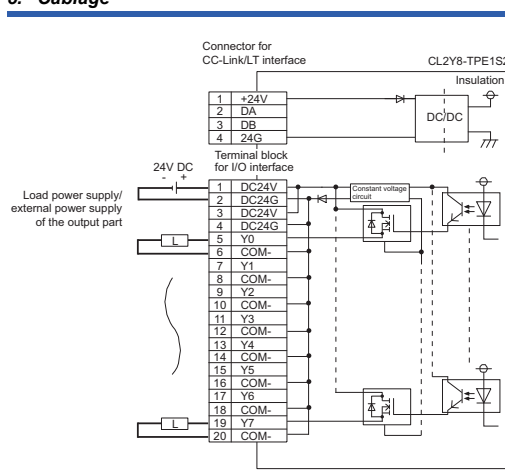

All COM- and DC24G terminals are connected within the module (common). The power to the module is supplied via the power adapter.
Toutes les bornes COM- et DC24G sont connectées à l'intérieur du module (commun). L'alimentation du module se fait via l'adaptateur d'alimentation.

6. External Dimensions

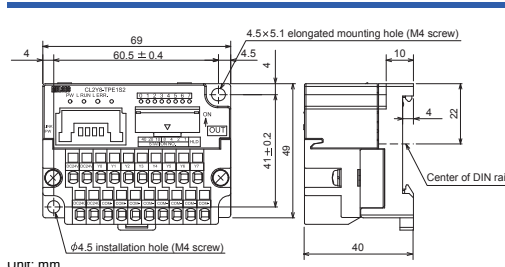

Unit: mm

7. Cable Installation Procedure

Precaution for installing or removing cables

- Insert only one wire into the circular shaped hole of the spring clamp terminal block. Inserting two or more wires may result in a poor contact to the terminal part.
- Strip the wire according to the specification. If the wire strip length is too long, the exposed conductive part may cause electric shock or short circuit. If the wire strip length is too short, it may result in a poor contact to the spring clamp terminal part.
- When using a spring clamp terminal block tool, follow the instruction below. Failure to do so may cause damage of the spring clamp terminal part or the terminal block resin part.
 - Use a dedicated tool for a spring clamp terminal block.
 - Do not insert the wire or the bar solderless terminal before inserting the tool into the square shaped hole.
 - Insert the tool vertically into the hole.

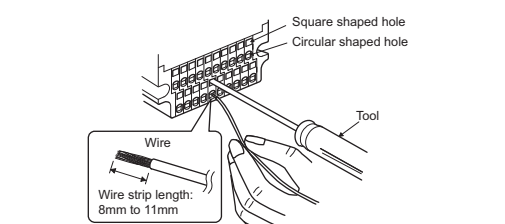

- Aircraft or Aerospace, Medical applications, Train equipment, transport equipment such as Elevator and Escalator, Incineration and Fuel devices, Vehicles, Manned transportation, Equipment for Recreation and Amusement, and Safety devices, handling of Nuclear or Hazardous Materials or Chemicals, Mining and Drilling, and/or other applications where there is a significant risk of injury to the public or property.

Notwithstanding the above, restrictions Mitsubishi may in its sole discretion, authorize use of the PRODUCT in one or more of the Prohibited Applications, provided that the usage of the PRODUCT is limited only for the specific applications agreed to by Mitsubishi and provided further that no special quality assurance or fail-safe, redundant or other safety features which exceed the general specifications of the PRODUCTS are required. For details, please contact the Mitsubishi representative in your region.

1. Overview

This user's manual explains specifications and names of individual parts of the CL2Y8-TPE1S2 type CC-Link/LT remote I/O module (hereinafter abbreviated as remote I/O module).

2. Specifications

2.1 General Specifications

The General specifications for the remote I/O module are shown in the following table.

Item	Specifications			
Operating ambient temperature	0 to 55°C 0 to 55 °C			
Temperature e ambiante de fonctionne ment				
Storage ambient temperature	-25 to 75°C			
Operating ambient humidity	5 to 95%RH, non-condensing			
Storage ambient humidity				
Vibration resistance	Compliant with JIS B 3502 and IEC 61131-2			
	Frequency	Constant acceleration	Half amplitude	Sweep count
Shock resistance	Compliant with JIS B 3502 and IEC 61131-2 (147 m/s ² , 3 times each in 3 directions X, Y, Z)			
	Operating atmosphere	No corrosive gases		
Operating altitude	0 to 2000m			
Installation location	Inside a control panel ¹⁾			
Overvoltage category	II or less			
Pollution degree ²⁾	2 or less			