

CL2X8-D1S2

CC-Link/LT Remote I/O Module

Thank you very much for purchasing this product.

Please read this manual thoroughly before starting to use the product and handle the product properly.

User's Manual

MODEL	CL2X8-D1S2-U
MODEL CODE	13JP23
IB(NA)-0800256-F(1806)MEE	

© 2003 MITSUBISHI ELECTRIC CORPORATION

SAFETY PRECAUTIONS

(Read these precautions before using.)

Please read this manual carefully and pay special attention to safety in order to handle this product properly. Also pay careful attention to safety and handle the module properly.

These precautions apply only to Mitsubishi equipment. Refer to the user's manual of the CPU module to use for a description of the programmable controller system safety precautions.

Before using this product, please read this manual and the relevant manuals carefully and pay full attention to safety to handle the product correctly. In this manual, the safety precautions are classified into two levels: "▲ WARNING" and "▲ CAUTION".

▲ WARNING	Indicates that incorrect handling may cause hazardous conditions, resulting in death or severe injury.
------------------	--------------------------------------------------------------------------------------------------------

▲ CAUTION	Indicates that incorrect handling may cause hazardous conditions, resulting in minor or moderate injury or property damage.
------------------	-----------------------------------------------------------------------------------------------------------------------------

Under some circumstances, failure to observe the precautions given under "▲ CAUTION" may lead to serious consequences. Observe the precautions of both levels because they are important for personal and system safety.

Make sure that the end users read this manual and then keep the manual in a safe place for future reference.

[DESIGN PRECAUTIONS]

▲ WARNING

- Configure an interlock circuit in a sequence program so that the system operates on the safety side using the communication status information in the event the data link fails into a communication problem. Otherwise, erroneous output and malfunction may result in accidents.
- Input could be switched on or off when a problem occurs in the remote I/O modules. So build an external monitoring circuit that will monitor any input signals that could cause a serious accident.

[DESIGN PRECAUTIONS]

▲ CAUTION

- Do not have control cables and communication cables bundled with or placed near by the main circuit and/or power cables. Wire those cables at least 100mm(3.94 inch) away from the main circuit and/or power cables. It may cause malfunction due to noise interference.

[INSTALLATION PRECAUTIONS]

▲ CAUTION

- Use the module in an environment that meets the general specifications contained in this manual. Using this module in an environment outside the range of the general specifications could result in electric shock, fire, erroneous operation, and damage to or deterioration of the product.
- Do not directly touch the module's conductive parts. Doing so could cause malfunction or trouble in the module.
- Tighten the module securely using DIN rail or installation screws within the specified torque range. If the screws are too loose, the module may drop from its installation position, short circuit, or malfunction. If the screws are too tight, the screws may be damaged, which may cause the module to drop from its installation position or short circuit.

[WIRING PRECAUTIONS]

▲ WARNING

- Completely turn off the externally supplied power used in the system when installing or placing wiring. Not completely turning off all power could result in electric shock or damage to the product.

[WIRING PRECAUTIONS]

▲ CAUTION

- Terminal screws which are not to be used must be tightened always. Otherwise there will be a danger of short circuit against the bare solderless terminals.

[WIRING PRECAUTIONS]

▲ CAUTION

- Perform correct wiring for the module according to the product's rated voltage and terminal arrangement. Connecting to a power supply different from rating or missing-wiring may cause fire and/or product failure.
- Fix terminal screws securely within the regulated torque. Loose terminal screws may cause fire and/or malfunction. If the terminal screws are too tight, it may cause short circuit or erroneous operation due to damage of the screws.
- Make sure foreign objects do not get inside the module, such as dirt and wire chips. It may cause fire, product failure or malfunction.

[STARTING AND MAINTENANCE PRECAUTIONS]

▲ WARNING

- Do not touch terminals when the power is on. Doing so could cause an electric shock.
- Switch off all phases of the externally supplied power used in the system when cleaning the module or retightening the terminal or module mounting screws. Not doing so could result in electric shock.

[STARTING AND MAINTENANCE PRECAUTIONS]

▲ CAUTION

- Do not disassemble or modify the module. Doing so may cause failure, malfunction, injury, or fire.
- Do not drop or apply any strong impact to the module. Doing so may damage the module.
- Completely turn off the externally supplied power used in the system before mounting or removing the module. Not doing so could result in damage to the product.
- Before touching the module, always touch grounded metal, etc. to discharge static electricity from the human body, etc. Not doing so can cause the module to fail or malfunction.

[DISPOSAL PRECAUTIONS]

▲ CAUTION

- When disposing of this product, treat it as industrial waste.

PRÉCAUTIONS DE SÉCURITÉ

(Lire ces précautions avant usage.)

Préparez de lire attentivement ce manuel. Prêter une attention particulière à tout ce qui a trait à la sécurité pour utiliser le produit correctement. Ces précautions ne concernent que l'équipement Mitsubishi. Dans le manuel de l'utilisateur du module CPU correspondant, voir l'exposé des précautions de sécurité concernant le système de l'automate programmable. Avant d'utiliser ce produit, lire attentivement ce manuel ainsi que les manuels auxquels il renvoie, et toujours considérer la sécurité comme de la plus haute importance en manipulant le produit correctement. Dans ce manuel, les précautions de sécurité sont classées en deux niveaux, à savoir : "▲ AVERTISSEMENT" et "▲ ATTENTION".

▲ AVERTISSEMENT	Attire l'attention sur le fait qu'une négligence peut créer une situation de danger avec risque de mort ou de blessures graves.
------------------------	---------------------------------------------------------------------------------------------------------------------------------

▲ ATTENTION	Attire l'attention sur le fait qu'une négligence peut créer une situation de danger avec risque de blessures légères ou de gravité moyennes ou risque de dégâts matériels.
--------------------	----------------------------------------------------------------------------------------------------------------------------------------------------------------------------

Dans certaines circonstances, le non-respect d'une précaution de sécurité introduite sous le titre "▲ ATTENTION" peut avoir des conséquences graves. Les précautions de ces deux niveaux doivent être observées dans leur intégralité car elles ont trait à la sécurité des personnes et aussi du système. Veiller à ce que les utilisateurs finaux lisent ce manuel qui doit être conservé soigneusement à portée de main pour s'y référer autant que de besoin.

[PRÉCAUTIONS DE CONCEPTION]

▲ AVERTISSEMENT

- Prévoir dans le programme séquentiel un circuit de verrouillage sur la base des informations d'état de la communication, de façon à maintenir la sécurité de fonctionnement du système dans l'éventualité d'un problème de communication affectant la liaison de données. Faute de quoi, une sortie erronée ou un dysfonctionnement pourrait être à l'origine d'accidents.
- L'entrée peut être activée ou désactivée à la survenance d'un problème dans les modules E/S distants. On constituera donc un circuit de surveillance externe couvrant tous les signaux d'entrée qui pourraient être à l'origine d'un accident grave.

[PRÉCAUTIONS DE CONCEPTION]

▲ ATTENTION

- Ne pas grouper ni placer à proximité les câbles de commande ou câbles de communication avec les câbles des circuits principaux et/ou d'alimentation. Câbler en plaçant ces câbles à une distance d'au moins 100mm (3,94 pouces) des câbles des circuits principaux ou de l'alimentation. Cela pourrait être à l'origine d'un bruit parasite entraînant des dysfonctionnements.

[PRÉCAUTIONS D'INSTALLATION]

▲ ATTENTION

- Utiliser le module dans un environnement conforme aux spécifications générales présentées dans ce manuel. L'utilisation de ce module dans un environnement autre que celui prévu dans les spécifications générales peut être à l'origine d'un choc électrique, d'un départ de feu ou d'un dysfonctionnement, ou peut endommager ou détériorer le produit.
- Éviter tout contact direct avec les parties conductrices du module. Cela pourrait être à l'origine de dysfonctionnements ou autres problèmes avec le module.
- Serrer le module fermement avec un rail DIN ou avec des vis de fixation serties dans les limites du couple de serrage prescrit. Si le serrage des vis est insuffisant, il y a risque de chute du module, de court-circuit ou de dysfonctionnement. Un serrage excessif peut endommager les vis et il y a risque de détachement du module et de court-circuit.

[PRÉCAUTIONS DE CÂBLAGE]

▲ AVERTISSEMENT

- Couper complètement l'alimentation externe utilisé par le système avant de mettre en place le câblage ou le raccordement de câbles. Ne pas couper complètement toutes les alimentations exposées au risque de chocs électriques et d'endommagement du produit.

[PRÉCAUTIONS DE CÂBLAGE]

▲ ATTENTION

- Mis vis des bornes qui restent inutilisées doivent toujours être serrées. Faute de quoi, il y a danger de court-circuit par contact avec les bornes-barrés sans soudure.
- Effectuer le câblage du module correctement, compte tenu de la tension nominale du produit et en respectant l'affectation des bornes. Le raccordement d'une alimentation de tension nominale différente ou une erreur de câblage peuvent être à l'origine d'un départ de feu et/ou d'une panne du produit.
- Fixer les vis de borne fermement en serrant au couple prescrit. Des vis de bornes desserrées peuvent être à l'origine d'un départ de feu et/ou de dysfonctionnements. Si serrage excessif des vis de bornes peut les endommager et être à l'origine d'un court-circuit ou d'un fonctionnement erratique.
- Veiller à éviter toute pénétration d'impuretés, copeaux de câblage ou autre corps étranger dans le module. Cela pourrait être à l'origine d'un départ de feu, ou du panne ou d'un dysfonctionnement du produit.

[PRÉCAUTIONS DE DÉMARRAGE ET DE MAINTENANCE]

▲ AVERTISSEMENT

- Ne pas toucher aux bornes quand l'appareil est sous tension. Cela pourrait être à l'origine d'un choc électrique.
- Avant le nettoyage du module ou le resserrage des vis de borne ou des vis de fixation du module, couper les alimentations externes utilisées par le système sur toutes les phases. Faute de quoi, il y a risque de choc électrique.

[PRÉCAUTIONS DE DÉMARRAGE ET DE MAINTENANCE]

▲ ATTENTION

- Ne pas démonter ni modifier le module. Cela pourrait être à l'origine de pannes, de dysfonctionnements, de blessures ou d'un départ de feu.
- Ne pas faire tomber le module, ni le soumettre à de forts chocs. Cela risquerait d'endommager le module.
- Couper complètement l'alimentation externe utilisé par le système avant de mettre en place ou de retirer le module. Faute de quoi, il y a risque d'endommagement du produit.
- Avant de toucher au module, se débarrasser de la charge électrostatique qu'accumule le corps humain en touchant un objet métallique raccordé à la terre. Le non-respect de cette précaution peut être à l'origine de pannes ou de dysfonctionnements du module.

[PRÉCAUTIONS DE MISE AU REBUT]

▲ ATTENTION

- Lors de sa mise au rebut, ce produit doit être traité comme un déchet industriel.

CONDITIONS OF USE FOR THE PRODUCT

- Mitsubishi programmable controller ("the PRODUCT") shall be used in conditions;
 - where any problem, fault or failure occurring in the PRODUCT, if any, shall not lead to any major or serious accident; and
 - where the backup and fail-safe function are systematically or automatically provided outside of the PRODUCT for the case of any problem, fault or failure occurring in the PRODUCT.
- The PRODUCT has been designed and manufactured for the purpose of being used in general industries. MITSUBISHI SHALL HAVE NO RESPONSIBILITY OR LIABILITY (INCLUDING, BUT NOT LIMITED TO ANY AND ALL RESPONSIBILITY OR LIABILITY BASED ON CONTRACT, WARRANTY, TORT, PRODUCT LIABILITY) FOR ANY INJURY OR DEATH TO PERSONS OR LOSS OR DAMAGE TO PROPERTY CAUSED BY THE PRODUCT THAT ARE OPERATED OR USED IN APPLICATION NOT INTENDED OR EXCLUDED BY INSTRUCTIONS, PRECAUTIONS, OR WARNING CONTAINED IN MITSUBISHI'S USER, INSTRUCTION AND/OR SAFETY MANUALS, TECHNICAL BULLETINS AND GUIDELINES FOR THE PRODUCT.

Item	Type	CL2X8-D1S2
Isolation method		Photocoupler isolation
Rated load voltage		24V DC
Rated input current		Approx. 4mA
Max. simultaneous ON input points		100%
ON voltage/ON current		19V or higher/3mA or higher
OFF voltage/OFF current		11V or lower/1.7mA or lower
Input resistance		5.6kΩ
Response time	Response time setting	0.5ms (High speed response type)
	OFF→ON	TYP. 0.05 ms
	MAX.	0.1 ms
	ON→OFF	TYP. 0.2 ms
	MAX.	0.5 ms
Common wiring method		8 points/1 common (terminal block 2-wire type)
Input method		Positive common/negative common shared type
Number of stations occupied		In 4-point mode: Occupies 2 stations In 8 or 16-point mode: Occupies 1 station
Module power supply	Voltage	24V DC (-15 to +20%) (ripple ratio : within 5%)
	Current consumption	40mA or lower (When 24V DC and all point is on)
	Current on startup	90mA or lower (24V DC)
Noise durability		DC type noise voltage 500Vp-p, noise width 1μs, noise carrier frequency 25 to 60kHz (noise simulator condition) First transient/noise burst IEC 61000-4-4 : 1kV
Withstand voltage		500V AC for 1 minute between primary (external DC terminal) and secondary (internal circuit)
Insulation resistance		10MΩ or more between primary (external DC terminal) and secondary (internal circuit) when measured with a 500V DC insulation resistance tester
Protection class		IP2X
Weight		0.12kg
I/O part connection method Méthode de raccordement de la partie E/S		2-piece 20-point spring clamp terminal block Bornier à étier 2-pièces 20-points
Module installation method		DIN rail installation, mounted by screws of type M4×0.7 mm×16 mm or larger. Can be installed in six directions
Applicable wire size Taille du fil à utiliser		0.3 to 1.5mm ² (AWG22 to 16) 0.3 à 1,5 mm ² (22 à 16 AWG)

3. Part Names

This section explains the names of the components for the remote I/O module.

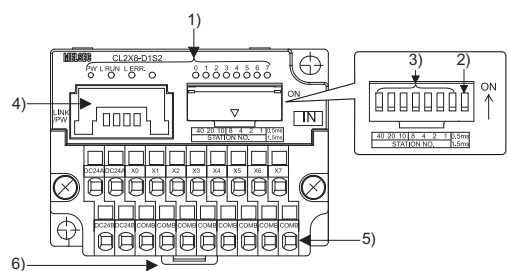

[Pin numbers and signal names]	Pin No.	Signal name	[Terminal numbers and signal names]
	1	+24V	1 +24V
	2	DA	2 DA
	3	DB	3 DB
	4	24G	4 24G

[Numéros de broche et noms des signaux]	Broche N°	Signal name	[Numéros de borne et noms des signaux]
	1	+24V	1 +24V
	2	DA	2 DA
	3	DB	3 DB
	4	24G	4 24G

No.	Item	Description									
1)	Operating status indicator LEDs	LED name PW On: Power supply is on. Off: The power supply is turned off or the voltage drop is too large. L.RUN On: Normal communication. Off: Communication cutoff (time expiration error). L.ERR. On: Indicates that a communication data error has occurred or the setting switch is outside the allowable range. Flicker at regular intervals: Indicates that the setting switch has been changed while current is being conducted. (The module continues to operate even while the LED is flickering. The changed settings will be reflected when the power has been restored.) Flicker at irregular intervals: Indicates that the terminal resistor is left unconnected or that the module or connection cable are affected by noise. Off: Normal communication.									
2)	Response time setting switch (SW)	Set the response time (OFF→ON/ON→OFF time) of the remote I/O module. OFF is set as default (factory-set). Noise may be taken in as input, if high speed response type is set. Be sure to set response time in consideration of the environment. ON: 0.5ms (High speed response type) OFF: 1.5ms (Standard type)									
3)	Station number setting switches (SW1 to 7)	Select "10", "20" or "40" to set the ten's place of the station number. Select "1", "2", "4" or "8" to set the one's place of the station number. All switches are set to OFF at shipment from the factory. Always set the station number within the range of 1 to 64. A setting error occurs and "L.ERR." LED flickers if the value outside the range 1 to 64 is set. (Example) Set the switches as below when setting the station number to 32: <table border="1"><tr><td>Station number</td><td>Ten's place</td><td>One's place</td></tr><tr><td>40</td><td>20</td><td>10</td></tr><tr><td>32</td><td>OFF</td><td>ON</td></tr></table>	Station number	Ten's place	One's place	40	20	10	32	OFF	ON
Station number	Ten's place	One's place									
40	20	10									
32	OFF	ON									
4)	Connector for CC-Link/LT interface	Connector for CC-Link/LT communication line and module power supply.									
5)	Terminal block for I/O interface	Terminal block for connecting input signals and external power supply of the input part.									
6)	Hook for DIN rail	Hook for installing the module on a DIN rail.									

4. Handling Precautions

- Tighten the terminal screws for the module to the specified torque shown below. Insufficient tightening torque could result in shorts, failures or malfunction.

Screw location	Clamping torque range
Module mounting screw (M4 screw)	0.78 to 1.08 N*m
Terminal block mounting screw (M3 screw)	0.42 to 0.58 N*m
- When using a DIN rail, attach the DIN rail after taking the following items into consideration:
 - Applicable DIN rail types (conform to JIS C 2812) TH35-7.5F TH35-7.5A
 - Interval between the DIN rail's installation screws
 - Tighten the screws using a pitch of 200mm (7.87in.) or less when attaching a DIN rail.
 - To attach the remote I/O module to the DIN rail, press the centerline area of the DIN rail hook beneath the module until a click is heard.
- Maintain some distance between the module and other components and parts, 10 mm from the top and 50mm (1.97in.) from the bottom of the module, in order to improve ventilation and to make replacement of the module easy if a remote I/O module is installed on a board.
- Install the remote I/O module on a level surface. If the surface is uneven, unnecessary force is applied to the printed circuit board, causing malfunctions.

5. Wiring

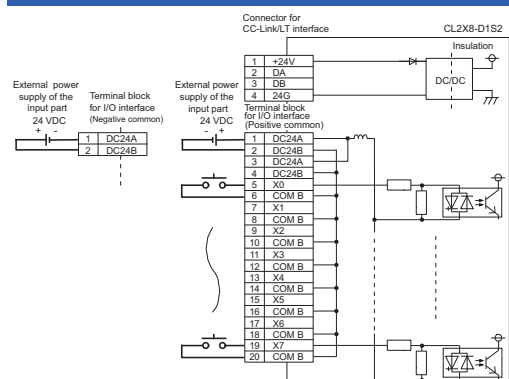

All COM B and DC24B terminals are connected within the module (common). The power to the module is supplied via the power adapter. Toutes les bornes COM B et DC24B sont connectées à l'intérieur du module (commun). L'alimentation du module se fait via l'adaptateur d'alimentation.

English	French
External power supply of the input part 24 VDC	Alimentation externe de la partie entrée 24Vcc
Terminal block for I/O interface (Negative common)	Bornier pour interface E/S (commun négatif)
Connector for CC-Link/LT interface	Connecteur pour interface CC-Link/LT
Terminal block for I/O interface (Positive common)	Bornier pour interface E/S (commun positif)
Insulation	Isolation

6. External Dimensions

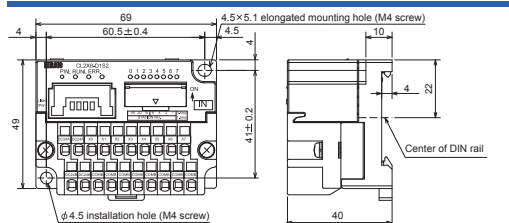

Unit: mm

7. Cable Installation Procedure

Precaution for installing or removing cables

- Insert only one wire into the circular shaped hole of the spring clamp terminal block. Inserting two or more wires may result in a poor contact to the terminal part.
- Strip the wire according to the specification. If the wire strip length is too long, the exposed conductive part may cause electric shock or short circuit. If the wire strip length is too short, it may result in a poor contact to the spring clamp terminal part.
- When using a spring clamp terminal block tool, follow the instruction below. Failure to do so may cause damage of the spring clamp terminal part or the terminal block resin part.
 - Use a dedicated tool for a spring clamp terminal block.
 - Do not insert the wire or the bar solderless terminal before inserting the tool into the square shaped hole.
 - Insert the tool vertically into the hole.

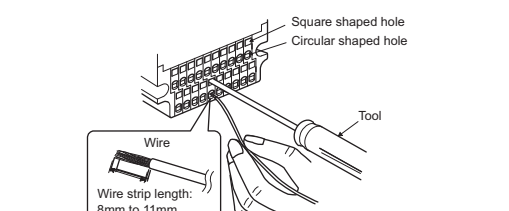

("Prohibited Application")

- Prohibited Applications include, but not limited to, the use of the PRODUCT in;
- Nuclear Power Plants and any other power plants operated by Power companies, and/or any other cases in which the public could be affected if any problem or fault occurs in the PRODUCT.
 - Railway companies or Public service purposes, and/or any other cases in which establishment of a special quality assurance system is required by the Purchaser or End User.
 - Aircraft or Aerospace, Medical applications, Train equipment, transport equipment such as Elevator and Escalator, Incineration and Fuel devices, Vehicles, Manned transportation, Equipment for Recreation and Amusement, and Safety devices; handling of Nuclear or Hazardous Materials or Chemicals, Mining and Drilling, and/or other applications where there is a significant risk of injury to the public or property.

Notwithstanding the above, restrictions Mitsubishi may in its sole discretion, authorize use of the PRODUCT in one or more of the Prohibited Applications, provided that the usage of the PRODUCT is limited only for the specific applications agreed to by Mitsubishi and provided further that no special quality assurance or fail-safe, redundant or other safety features which exceed the general specifications of the PRODUCTS are required. For details, please contact the Mitsubishi representative in your region.

1. Overview

This user's manual explains specifications and names of individual parts of the CL2X8-D1S2 type CC-Link/LT remote I/O module (hereinafter abbreviated as remote I/O module).

2. Specifications

2.1 General Specifications

The General specifications for the remote I/O module are shown in the following table.

Item	Specifications				
Operating ambient temperature	0 to 55°C 0 à 55 °C				
Temperature	Température ambiante de fonctionnement				
Storage ambient temperature	-25 to 75°C				
Operating ambient humidity	5 to 95%RH, non-condensing				
Storage ambient humidity					
Vibration resistance	Compliant with JIS B 3502 and IEC 61131-2				
Shock resistance	Frequency	Constant acceleration	Half amplitude	Sweep count	
	Under intermittent vibration	5 to 8.4Hz 1.8 to 150Hz	9.8m/s ²	3.5mm	10 times each in X, Y, Z directions
Shock resistance	Under continuous vibration	5 to 8.4Hz 8.4 to 150Hz	4.9m/s ²	1.75mm	-
	Compliant with JIS B 3502 and IEC 61131-2 (147 m/s ² , 3 times each in 3 directions X, Y, Z)				
Operating atmosphere	No corrosive gases				
Operating altitude	0 to 2000m				
Installation location	Inside a control panel ¹³				
Overvoltage category	II or less				
Pollution degree	2 or less				

- This indicates the section of the power supply to which the equipment is assumed to be connected between the public electrical power distribution network and the machinery within premises. Category II applies to equipment for which electrical power is supplied from fixed facilities. The surge voltage withstand level for up to the rated voltage of 300V is 2500V.
- This index indicates the degree to which conductive material is generated in terms of the environment in which the equipment is used. Pollution level 2 is when only non-conductive pollution occurs. A temporary conductivity caused by condensing must be expected occasionally.
- It can also be used in an environment other than on the control panel if the conditions such as usage ambient temperature and humidity are satisfied.

2.2 Performance specifications

The performance specifications for the remote I/O module are shown in the following table.

Item	Type	CL2X8-D1S2
Number of inputs		8 points

Cable Installation

- Insert the tool vertically all the way inside the square shaped hole of the remote I/O module.
- Insert the wire or the bar solderless terminal into the circular shaped hole, and remove the tool from the hole.
- Check that the wire or the bar solderless terminal is firmly clamped by pulling it lightly.

Cable removal

- Insert the tool vertically all the way inside the square shaped hole of the remote I/O module.
- Pull the wire or the bar solderless terminal out of the hole.

WARRANTY

Mitsubishi will not be held liable for damage caused by factors found not to be the cause of Mitsubishi; machine damage or lost profits caused by faults in the Mitsubishi products; damage, secondary damage, accident compensation caused by special factors unpredictable by Mitsubishi; damages to products other than Mitsubishi products; and to other duties.

Country/Region	Sales office/Tel
USA	MITSUBISHI ELECTRIC AUTOMATION, INC. 500 Corporate Woods Parkway, Vernon Hills, IL 60061, U.S.A. Tel : +1-847-478-2100
Mexico	MITSUBISHI ELECTRIC AUTOMATION, INC. Mexico Branch Carretera México-Querétaro, Col. Zona Industrial, Tlalpanpantla Edo. Mexico, C.P. 54030 Tel : +52-55-3067-7500
Brazil	MITSUBISHI ELECTRIC DO BRASIL COMÉRCIO E SERVIÇOS LTDA. Avenida Adelson Cardana, 293, 21 andar, Bethaville, Barueri SP, Brazil Tel : +55-11-4689-3000
Germany	MITSUBISHI ELECTRIC EUROPE B.V. German Branch Mitsubishi-Electric-Platz 1, 40882 Ratingen, Germany Tel : +49-2102-486-0
UK	MITSUBISHI ELECTRIC EUROPE B.V. UK Branch Travellers Lane, Hatfield, Hertfordshire, AL10 8XB, U.K. Tel : +44-107-28-8780
Ireland	MITSUBISHI ELECTRIC EUROPE B.V. Irish Branch Westgate Business Park, Ballymount, Dublin 24, Ireland Tel : +353-1-498000
Italy	MITSUBISHI ELECTRIC EUROPE B.V. Italian Branch Centro Direzionale Colonna-Palazzo Sirio Viale Colonna 7, 20864 Agrate Brienza(Milano) Italy Tel : +39-039-60531
Spain	MITSUBISHI ELECTRIC EUROPE, B.V. Spanish Branch Carretera de Rubí, 76-80-Adpo. 420, 08190 Sant Cugat del Vallés (Barcelona), Spain Tel : +34-935-65-3131
France	MITSUBISHI ELECTRIC EUROPE B.V. French Branch 25, Boulevard des Bouyets, 92741 Nanterre Cedex, France Tel : +33-1-55-88-55-88
Czech Republic	MITSUBISHI ELECTRIC EUROPE B.V. Czech Branch Avenir Business Park, Radlicka 751/113e, 158 00 Praha5, Czech Republic Tel : +42-0-251-551-670
Poland	MITSUBISHI ELECTRIC EUROPE B.V. Polish Branch ul. Krakowska 50, 32-083 Balice, Poland Tel : +48-12-347-65-00
Sweden	MITSUBISHI ELECT