

# CL1Y4-R1B1

## CC-Link/LT Remote I/O Module

### User's Manual

MODEL	CL1Y4-R1B1
MANUAL Number	JY997D05501J
Date	July 2018

CC-link/LT

#### ●SAFETY PRECAUTIONS●

(Read these precautions before using)

Please read this manual carefully and pay special attention to safety in order to handle this product properly. Also pay careful attention to safety and handle the module properly.

These precautions apply only to Mitsubishi equipment. Refer to the user's manual of the CPU module to use for a description of the PLC system safety precautions.

If the equipment is used in a manner not specified by the manufacturer, the protection provided by the equipment may be impaired. These ●SAFETY PRECAUTIONS● classify the safety precautions into two categories: "WARNING" and "CAUTION".

**WARNING** Procedures which may lead to a dangerous condition and cause death or serious injury if not carried out properly.

**CAUTION** Procedures which may lead to a dangerous condition and cause superficial to medium injury, or physical damage only, if not carried out properly.

Depending on circumstances, procedures indicated by **CAUTION** may also be linked to serious results.

In any case, it is important to follow the directions for usage.

Store this manual in a safe place so that you can take it out and read it whenever necessary. Always forward it to the end user.

#### [DESIGN PRECAUTIONS]

##### WARNING

- Configure an interlock circuit in a sequence program so that the system operates on the safety side using the communication status information in the event the data link falls into a communication problem. Otherwise, erroneous output and malfunction may result in accidents.
- Remote input and output can not be switched ON or OFF when a problem occurs in the remote I/O modules. Therefore build an external monitoring circuit that will monitor any input signals that could cause a serious accident.

##### CAUTION

- Do not have control cables and communication cables bundled with or placed near by the main circuit and/or power cables. Wire those cables at least 100mm(3.94 inch) away from the main circuit and/or power cables. It may cause malfunction due to noise interference.
- Use the module and the flat cable dedicated to CC-Link/LT without applying any force on them. Otherwise, such cables may be broken or fail.

#### [INSTALLATION PRECAUTIONS]

##### CAUTION

- Use the module in an environment that meets the general specifications contained in this manual. Using this module in an environment outside the range of the general specifications could result in electric shock, fire, erroneous operation, and damage to or deterioration of the product.
- Do not directly touch the module's conductive parts. Doing so could cause malfunction or trouble in the module.
- Tighten the module securely using DIN rail or installation screws within the specified torque range.
- If the screws are too loose, the module may drop from its installation position, short circuit, or malfunction. If the screws are too tight, the screws may be damaged, which may cause the module to drop from its installation position or short circuit.
- Install the module on a flat surface.
- If the mounting surface has concave and/or convex, an excessive force may be applied on the module, and nonconformity may be caused.

#### [WIRING PRECAUTIONS]

##### WARNING

- Perform installation and wiring after disconnecting the power supply at all phases externally. If the power is not disconnected at all phases an electric shock or product damage may result.
- The temperature rating of the cable should be 80°C or more.

##### CAUTION

- Terminal screws which are not to be used must be tightened always. Otherwise there will be a danger of short circuit against the bare solderless terminals.
- Do not perform wiring to an idle terminal "NC" outside the product. The product may be damaged by such external wiring.
- Perform correct wiring for the module according to the product's rated voltage and terminal arrangement. Connecting to a power supply different from rating or miss-wiring may cause fire, product failure or malfunction.
- Fix terminal screws securely within the regulated torque. Loose terminal screws may cause fire and/or malfunction.
- If the terminal screws are too tight, it may cause short circuit, equipment failures, or erroneous operation due to damage of the screws.
- Make sure foreign objects do not get inside the module, such as dirt and wire chips. It may cause fire, product failure or malfunction.
- Attach a warning label (hazard symbol 417-IEC-5036) concerning the electric shock to the location.

#### [STARTING AND MAINTENANCE PRECAUTIONS]

##### WARNING

- Do not touch the terminals when the power is ON. It may cause an electric shock or malfunction.
- Perform cleaning the module or retightening of terminal screws after turning OFF the all external power supply for sure. Failure to do so may cause failure or malfunction of the modules.
- For cleaning, perform dry wiping without using chemicals.
- If there is the possibility of touching the PLC inside a control panel in maintenance, make sure to discharge to avoid the influence of static electricity.

##### CAUTION

- Do not disassemble or modify the module. Doing so may cause failure, malfunction, injury, or fire.
- The module case is made of resin; do not drop it or subject it to strong shock. A module damage may result.
- Make sure to switch all phases of the external power supply OFF before installing or removing the module to/from the panel. Failure to do so may cause failure or malfunction of the modules.

#### [DISPOSAL PRECAUTIONS]

##### CAUTION

- When disposing of this product, treat it as industrial waste.

#### [TRANSPORTATION AND MAINTENANCE PRECAUTIONS]

##### CAUTION

- During transportation avoid any impact as the module is a precision instrument. Doing so could cause trouble in the module.
- If it is necessary to check the operation of module after transportation, in case of any impact damage.

#### ●Notification of CE marking●

This notification does not guarantee that an entire mechanical module produced in accordance with the contents of the notification comply with the following standards. Compliance to EMC standards of the entire mechanical module should be checked by the user / manufacturer. Compliance to LVD standards of the entire mechanical module should be checked by the user / manufacturer.

**Attention**  
This product is designed for use in industrial applications.

#### Standards with which this product complies

Type : Programmable Controller (Open Type Equipment) Remote I/O module  
Electromagnetic Compatibility Standards (EMC):

Models : Products manufactured:  
from February 1st, 2003 to April 30th, 2006 are compliant with EN61000-6-4 and EN61131-2:1994+A11:1996+A12:2000 after May 1st, 2006 are compliant with EN61131-2:2007.

Low Voltage Stanadards (LVD):

Models : Products manufactured:  
from November 1st,2002 to April 30th,2006 are compliant with EN61000-6-4 and EN61131-2:1994+A11:1996+A12:2000 from May 1st,2006 to February 28th,2018 are compliant with EN61131-2:2007 after March 1st,2018 are compliant with EN61010-2-201:2013<sup>1</sup>.

<sup>1</sup> For products manufactured after January 1 2018, there may be compliant cases.

Electromagnetic Compatibility Standards (EMC)	Remark
EN61000-6-4:2001 Electromagnetic compatibility -Generic standards - Emission standard for Industrial environment	Compliance with all relevant aspects of the standard. (Radiated Emissions and Mains Terminal Voltage Emissions)
EN61131-2:1994/A11:1996/A12:2000 Programmable controllers -Equipment requirements and tests	Compliance with all relevant aspects of the standard. • Radiated electromagnetic field • Fast transient burst • Electrostatic discharge • Damped oscillatory wave
EN61131-2: 2007 Programmable controllers -Equipment requirements and tests	Compliance with all relevant aspects of the standard. <b>EMI</b> • Radiated Emission • Conducted Emission <b>EMS</b> • Radiated electromagnetic field • Fast transient burst • Electrostatic discharge • High-energy surge • Voltage drops and interruptions • Conducted RF • Power frequency magnetic field

Low Voltage Standards (LVD)	Remark
EN61131-2:1994/A11:1996 /A12:2000 :2007 Programmable controllers -Equipment requirements and tests	The equipment has been assessed as a component for fitting in a suitable control box which meets the requirements of EN61131-2:1994 + A11:1996 + A12:2000, :2007
EN61010-2-201:2013 Safety of electrical equipment for measurement, control, and test	The equipment has been assessed as a component for fitting in a suitable control box which meets the requirements of EN61010-2-201:2013

For more details please contact the local Mitsubishi Electric sales site.

- Notes For compliance to EMC LVD regulation.  
It is necessary to install the CL1 series module in a shielded metal control panel.
- Use this product in Zone A<sup>2</sup> as defined in EN61131-2.  
The terminal and the wiring for the output signals and load power supply can be used in zone B<sup>2</sup>.
- <sup>2</sup> Zone defined in EN61131-2  
Separation defined in EN61131-2 for EMC LVD regulation decided depending on condition in industrial setting.  
Zone C = Factory mains which is isolated from public mains by dedicated transformers.  
Zone B = Dedicated power distribution which is protected by secondary surge protection. (300V or less in the rated voltage is assumed.)  
Zone A = Local power distribution which is isolated from dedicated power distribution by AC/DC converters, isolation transformers, etc. (120V or less in the rated voltage is assumed.)
- For the control panel, use the product having sufficient strength, fire protectiveness and shielding property to an installation environment.
- To an external connection port other than AC power supply terminal and AC output terminal, connect the circuit separated from a dangerous voltage by a double/reinforced insulation.
- For crimp terminals to be used for the wiring applied with 30 V AC or higher, use the products with insulating sleeves.
- Cutoff device such as a breaker or a circuit protector should be installed in accordance with the following precautions.  
- Use EN60947-1 or EN60947-3 standards.  
- Place the cutoff device so that it can be operated easily.  
- Specify that the cutoff device is for this equipment.

#### 1. Outline of Product

This product is a terminal block type output module connected to CC-Link/LT. This product has four output points (relay output).

#### 2. Name and Setting of Each Part and Terminal Arrangement

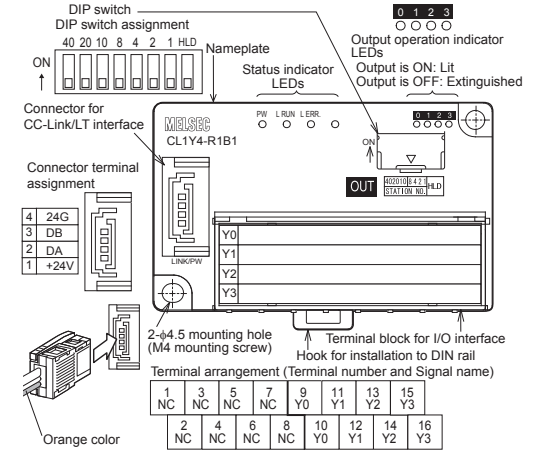

Name	Description																
Status indicator LED	PW ON while the power is supplied.																
	L RUN ON while normal operation is executed.																
Output operation indicator LEDs	ON: When a communication error or DIP switch setting error occurred Fllickering at a constant interval: When the setting of the DIP switch was changed while the power was supplied (even while the LED is flickering, the operation continues. The new setting becomes valid when the power is turned OFF once, then ON again.) Fllickering at an intermittent interval: When a terminal resistor is not attached or when the module or a connection cable is affected by noise																
	OFF: When the output is ON. Extinguished while the output is OFF.																
Interface	Connector for CC-Link/LT communication line/module power supply (24G/DB/DA/+24V)																
Terminal block for I/O interface	Terminal block to connect output signals and load power supply																
DIP switch	Set the 10's digit of the station No. using "STATION NO. 10", "STATION NO. 20" and "STATION NO. 40". Set the 1's digit of the station No. using "STATION NO. 1", "STATION NO. 2", "STATION NO. 4" and "STATION NO. 8". Factory default = All bits are OFF. Make sure to set the station No. in the range from 1 to 64. If any station No. outside the range from 1 to 64 is set, it is regarded as an error and the L ERR. LED lights.  Example: When setting the station No. to "32", set the DIP switch as follows. <table border="1" style="margin-left: auto; margin-right: auto;"> <tr> <td>Station No.</td> <td>40</td> <td>20</td> <td>10</td> <td>8</td> <td>4</td> <td>2</td> <td>1</td> </tr> <tr> <td></td> <td>32</td> <td>OFF</td> <td>ON</td> <td>OFF</td> <td>OFF</td> <td>ON</td> <td>OFF</td> </tr> </table>	Station No.	40	20	10	8	4	2	1		32	OFF	ON	OFF	OFF	ON	OFF
Station No.	40	20	10	8	4	2	1										
	32	OFF	ON	OFF	OFF	ON	OFF										
HLD	Holds the output (when an error has occurred). ON: Holds the output. OFF: Clears the output.																
Nameplate printing	△ is a mark that instructs to use the cable with an appropriate temperature rating (80°C or more) for wiring.																

#### 3. Installation

The CL1Y4-R1B1 can be installed to DIN rail or directly installed using mounting screws.

Each installation procedure is described below.

### 3.1 Installation to DIN rail

Align the upper DIN rail installation groove in the module with the DIN rail (1), and press the module in that status (2). When removing the module, pull the hook downward for installation to DIN rail (3), then remove the module (4).

#### DIN rail mounting screw pitch

When installing the module to the DIN rail, tighten the mounting screws at the pitch of 200mm(7.87") or less.

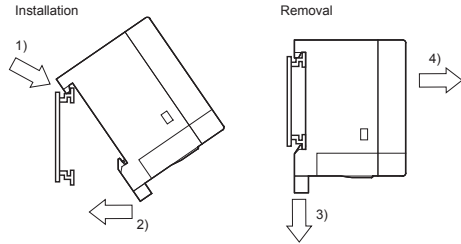

Applicable DIN rail | TH35-7.5Fe and TH35-7.5Al

### 3.2 Direct installation

Screw-tighten the module by attaching M4 screws to the upper and lower mounting holes (two holes in all) provided in the module. Install the module so that the clearance of 1 to 2mm (0.04" to 0.08") is assured for each module.

Applicable screw | M4 × 0.7mm(0.03") × 16mm(0.63") or more  
(Tightening torque range: 0.78 to 1.08 N·m)

## 4. Wiring

### 4.1 External wiring

The output terminals of the CL1Y4-R1B1 can be used with either AC or DC load voltage.

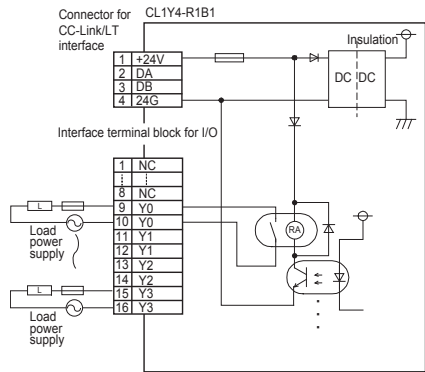

Wire nothing to the NC terminal (idle terminal).

### 4.2 Crimp-style terminal

For I/O wiring, use crimp-style terminals of the following dimensions.

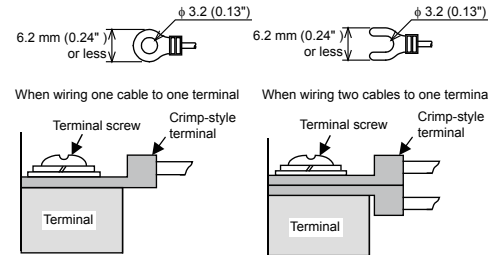

Applicable crimp-style terminal

- RAV1.25-3
- V1.25-3 (manufactured by JST Mfg. Co., Ltd.)
- 1.25-3 and TG1.25-3 (manufactured by NICHIFU Co., Ltd.)

Applicable wire size | 0.3 to 1.25 mm<sup>2</sup>

Use a crimp-style terminal in a status in which no force is applied on the cable.

### 4.3 Module terminal screw

Tighten the terminal screws (M3 screws) on the terminal block with a tightening torque of 0.42 to 0.58 N·m. Do not tighten terminal screws exceeding the specified torque. Failure to do so may cause short circuit, equipment failures, or malfunctions.

## 5. Specifications

### 5.1 General specifications

Item	Specification			
Operating ambient temperature	0 to 55°C (32 to 131°F)			
Storage ambient temperature	-25 to 75°C (-13 to 167°F)			
Operating ambient humidity	5 to 95%RH: Dew condensation shall not be considered.			
Storage ambient humidity	5 to 95%RH: Dew condensation shall not be considered.			
Vibration resistance (*1)	When intermittent vibration is present		Number of times of sweep 10 times in each of X, Y and Z directions (for 80 min)	
	Frequency	Acceleration		Half amplitude
	10 to 57Hz	-		0.075mm
	57 to 150Hz	9.8m/s <sup>2</sup>		-
	When continuous vibration is present			
Frequency	Acceleration	Half amplitude		
10 to 57Hz	-	0.035mm		
57 to 150Hz	4.9m/s <sup>2</sup>	-		
Shock resistance (*1)	147 m/s <sup>2</sup> , 3 times in each of X, Y and Z directions			
Operating ambience	Corrosive gas shall not be present.			
Operating altitude	2,000m(6561'8") or less (*2)			
Installation location	Inside control panel (*3)			
Overvoltage category	II or less (*4)			
Pollution level	2 or less (*5)			

Notes:

- \*1 The criterion is shown in IEC61131-2.
- \*2 The module cannot be used in an environment pressurized above the atmospheric pressure which can be generated around the altitude of 0 m. If the module is used in such an environment, it may fail.
- \*3 CC-Link/LT system is assumed to be installed in an environment equivalent to indoor.
- \*4 This indicates the section of the power supply to which the equipment is assumed to be connected between the public electrical power distribution network and the machinery within premises. Category II applies to equipment for which electrical power is supplied from fixed facilities. The surge voltage withstand level for up to the rated voltage of 300V is 2500V.
- \*5 This index indicates the degree of conductive generating substances in the environment in which the module is used. The degree of contamination 2 indicates that contamination is caused by generation of only non-conductive substances. In this degree, however, temporary conduction may be caused by accidental condensation.

### 5.2 Output specifications

Item	Specification
Output method	Relay output
Number of outputs	4 points
Insulation method	Mechanical insulation
Rated load voltage	240V AC/30V DC or less (250V AC or less when the unit does not comply with UL or cUL standards)
Max. load current	2A/point 2A/1common
Response time	OFF→ON ON→OFF Approx. 10ms or less Approx. 10ms or less
Common wiring method	1point/1common (Mutually exclusive outputs) (terminal block one-wire type)
Internal protection for outputs	Internal protection circuit none Please connect the fuse in the connected load outside.

### 5.3 Performance specifications

Item	Specification	
Module power supply	Voltage	20.4 to 28.8V DC (24V DC -15% to +20%) Ripple ratio: Within 5%
	Current consumption	65mA (when all points are ON)
	Initial current	70mA
	Max. allowable momentary power failure period	PS1:1ms
Number of stations occupied	4-, 8- or 16-point mode: 1 station	
Noise durability	DC type: 500 Vp-p AC type: 1,000 Vp-p Noise width: 1 μs Cycle: 25 to 60 Hz (by noise simulator)	
Withstand voltage	AC type: 1,500V AC for 1 min DC type: 500V AC for 1 min	
Isolation resistance	10 MΩ or higher between primary area (external DC terminal) and secondary area (internal circuit) by 500V DC insulation resistance tester	
Protection grade	IP1X	
I/O area connection method	Connection with terminal block	
Module installation method	DIN rail installation, mounted by screws of type M4 × 0.7mm(0.03") × 16mm(0.63") or larger Can be installed in six directions	
Mass (weight)	0.11kg (0.24lbs)	
Contact life	200V AC - 1.5 A, 240V AC - 1 A (COSφ = 0.7): 100,000 times or more	
	200V AC - 1 A, 240V AC - 0.1 A (COSφ = 0.35): 100,000 times or more	
	24V DC - 1 A, 100V DC - 0.1 A (L/R = 7 ms): 100,000 times or more	

## 6. Outside Dimensions

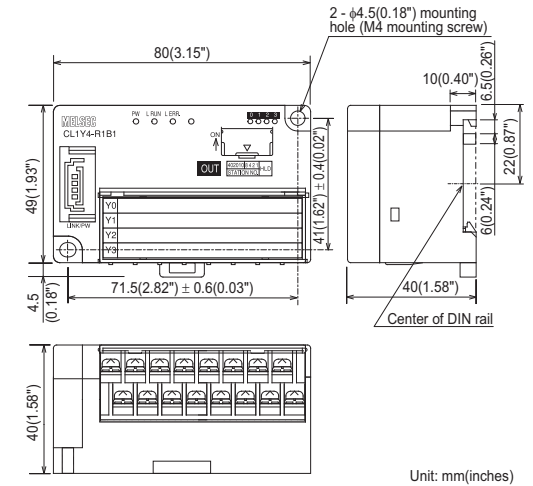

Unit: mm(inches)

「电器电子产品有害物质限制使用标识要求」的表示方式



Note: This symbol mark is for China only.

含有有害6物质的名称, 含有量, 含有部品  
本产品中所含有的有害6物质的名称, 含有量, 含有部品如下表所示。

产品中有害物质的名称及含量

部件名称	有害物质					
	铅 (Pb)	汞 (Hg)	镉 (Cd)	六价铬 (Cr (VI))	多溴联苯 (PBB)	多溴二苯醚 (PBDE)
可编程外壳	○	○	○	○	○	○
控制器印刷基板	×	○	○	○	○	○

本表格依据SJ/T 11364的规定编制。

○: 表示该有害物质在该部件所有均质材料中的含量均在GB/T 26572规定的限量要求以下。  
×: 表示该有害物质至少在该部件的某一均质材料中的含量超出GB/T 26572规定的限量要求。

基于中国标准法的参考规格: GB/T15969.2

This manual confers no industrial property rights or any rights of any other kind, nor does it confer any patent licenses. Mitsubishi Electric Corporation cannot be held responsible for any problems involving industrial property rights which may occur as a result of using the contents noted in this manual.

### Warranty

Exclusion of loss in opportunity and secondary loss from warranty liability  
Regardless of the gratis warranty term, Mitsubishi shall not be liable for compensation to:  
(1) Damages caused by any cause found not to be the responsibility of Mitsubishi.  
(2) Loss in opportunity, lost profits incurred to the user by Failures of Mitsubishi products.  
(3) Special damages and secondary damages whether foreseeable or not, compensation for accidents, and compensation for damages to products other than Mitsubishi products.  
(4) Replacement by the user, maintenance of on-site equipment, start-up test run and other tasks.



- For safe use
- This product has been manufactured as a general-purpose part for general industries, and has not been designed or manufactured to be incorporated in a device or system used in purposes related to human life.
  - Before using the product for special purposes such as nuclear power, electric power, aerospace, medicine or passenger movement vehicles, consult with Mitsubishi Electric.
  - This product has been manufactured under strict quality control. However when installing the product where major accidents or losses could occur if the product fails, install appropriate backup or failsafe functions in the system.

Country/Region	Sales office/Tel	Mitsubishi Electric (Russia) LLC
USA	MITSUBISHI ELECTRIC AUTOMATION, INC. 500 Corporate Woods Parkway, Vernon Hills, IL 60061, U.S.A. Tel: +1-847-478-2100/+1-847-478-2500 (NC) Tel: +1-469-721-2070	52, bld. 1, Kosmodamianskaya emb., 115054 Moscow, Russia Tel: +7-495-721-2070
Brazil	MITSUBISHI ELECTRIC DO BRASIL COMERCIO E SERVICOS LTDA. Avenida Adelaide Cardina, 293, 21 andar, Bethaville, Barueri SP, Brazil Tel: +55-11-4688-3000	China MITSUBISHI ELECTRIC AUTOMATION (CHINA) LTD. Mitsubishi Electric Automation Center, No.1386 Hongqiao Road, Shanghai, China Tel: +86-21-2322-3030
Germany	MITSUBISHI ELECTRIC EUROPE B.V. - German Branch Mitsubishi-Electric-Platz 1, 40882 Ratingen, Germany Tel: +49-2102-488-0	Taiwan SETSUYO ENTERPRISE CO., LTD. New Taipei City 24888, Taiwan, R.O.C. Tel: +886-2-2269-2489
UK	MITSUBISHI ELECTRIC EUROPE BV, UK Branch Travellers Lane, Hatfield, Hertfordshire, AL10 8XB, UK Tel: +44-1707-28-8780	Korea MITSUBISHI ELECTRIC AUTOMATION KOREA CO., LTD. 7F-9F, Gangseo Hangang Xi-tower A, 401, Yangcheon-ro Gangseo-Gu, Seoul, 07528, Korea Tel: +82-2-3960-8500
Italy	MITSUBISHI ELECTRIC EUROPE B.V. - Italian Branch Centro Direzionale Colosani - Palazzo Siro, Viale Colosani 7, 20864 Agrate Branzi (MB), Italy Tel: +39-039-60531/+39-039-6053-342	Singapore MITSUBISHI ELECTRIC ASIA PTE. LTD. 307 Alexandra Road, Mitsubishi Electric Building, Singapore 119943 Tel: +65-6473-2308
Spain	MITSUBISHI ELECTRIC EUROPE, B.V. - Spanish Branch Carretera de Rubi 76-80-AC, 420, E-08190 Sant Cugat del Valles (Barcelona), Spain Tel: +34-935-65-3131/+34-935-65-2236	Thailand Mitsubishi Electric Factory Automation (Thailand) Co., Ltd. 12th Floor, SV City Building, Office Tower 1, No. 896/19 and 20 Rama 3 Road, Kwang Bangsonggang, Khet Yankawa, Bangkok 10120, Thailand Tel: +66-2862-6522-31
France	MITSUBISHI ELECTRIC EUROPE B.V. - French Branch 25, Boulevard des Bouvets, 92741 Nanterre Cedex, France Tel: +33-1-55-68-65-68	Indonesia PT. Mitsubishi Electric Indonesia Gedung Jaya 11th Floor, Jl. MH. Thamrin No. 12, Jakarta Pusat 10340, Indonesia Tel: +62-21-3192-9461
Czech Republic	MITSUBISHI ELECTRIC EUROPE B.V. - Czech Branch Avent Business Park, Radicka 751/1136, 158 00 Praha8, Czech Republic Tel: +420-251-551-470	India Mitsubishi Electric India Pvt. Ltd. Gurgaon Head Office 2nd Floor, Tower A & B, Cyber Greens, DLF Cyber City, DLF Phase - III, Gurgaon - 122002, Haryana, India Tel: +91-124-4630300
Poland	Mitsubishi Electric Europe B.V. Polish Branch ul. Krakowska 50, 32-083 Balice, Poland Tel: +48-12-347-65-00	Australia MITSUBISHI ELECTRIC AUSTRALIA PTY. LTD. 348 Victoria Road PO BOX111, Rydalmere, N.S.W. 2116, Australia Tel: + 61-2-9684-7777

## MITSUBISHI ELECTRIC CORPORATION

HEAD OFFICE : TOKYO BUILDING, 2-7-3 MARUNOUCHI, CHiyODA-KU, TOKYO 100-8310, JAPAN

When exported from Japan, this manual does not require application to the Ministry of Economy, Trade and Industry for service transaction permission.

Specifications subject to change without notice.

