

**MITSUBISHI ELECTRIC**

**GOT2000 Series**  
**USB Environmental Protection Cover**

**User's Manual**

**GT25-UCOV**  
**GT21-WUCOV**  
**GT25-05UCOV**

Thank you for purchasing Mitsubishi Electric Graphic Operation Terminal.

**Prior to use, please read both this manual and detailed manual thoroughly to fully understand the product.**

MODEL	GT25-UCOV-U-JE
MODEL CODE	1D7MI2
IB(NA)-0800501-F(2104)MEE	

© 2013 MITSUBISHI ELECTRIC CORPORATION

**SAFETY PRECAUTIONS**  
 (Always read these precautions before using this equipment.)

Before using this product, please read this manual and the relevant manuals introduced in this manual carefully and pay full attention to safety to handle the product correctly.

The precautions given in this manual are concerned with this product. In this manual, the safety precautions are ranked as "WARNING" and "CAUTION".

**WARNING** Indicates that incorrect handling may cause hazardous conditions, resulting in death or severe injury.

**CAUTION** Indicates that incorrect handling may cause hazardous conditions, resulting in medium or slight personal injury or physical damage.

Note that the CAUTION level may lead to a serious accident according to the circumstances. Always follow the precautions of both levels because they are important to personal safety. Please save this manual to make it accessible when required and always forward it to the end user.

**INSTALLATION PRECAUTIONS**

**CAUTION**

- Make sure to securely fix the USB environmental protection cover onto the GOT using fixing screws and tighten the screws in the specified torque of 0.36 N·m to 0.48 N·m. Loose tightening may cause the USB environmental protection cover to drop off and/or the GOT to fail or malfunction. Overtightening may damage and drop screws and/or the USB environmental protection cover.
- When closing the USB environmental protection cover, fix the cover to the GOT by pushing the [PUSH] or [USB] mark on the latch firmly to comply with the protective structure.

**4. INSTALLATION AND REMOVAL**

**4.1 Installing the USB Environmental Protection Cover**

**4.1.1 GT25-UCOV, GT25-05UCOV**

The installation procedure for the USB environmental protection cover is explained using GT2712.

1) Get up the hinge of the USB environmental protection cover.

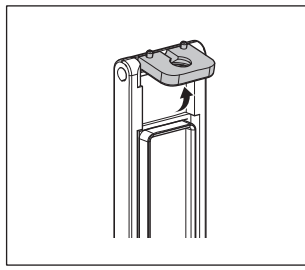

2) Align the hinge projection of the USB environmental protection cover on the guiding hole of the GOT. Put a supplied fixing screw through the hinge hole of the USB environmental protection cover.

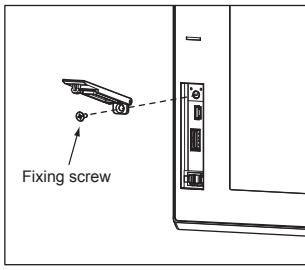

3) Tighten the fixing screw in the specified torque range (0.36 N·m to 0.48 N·m) to fix the cover to the GOT.

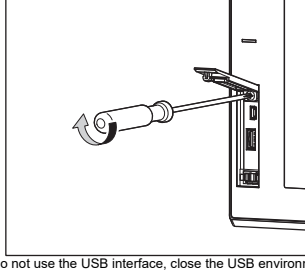

4) When you do not use the USB interface, close the USB environmental protection cover by pushing in the [PUSH] mark on the cover firmly.

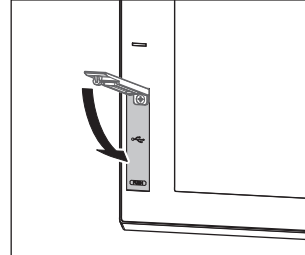

**[DISPOSAL PRECAUTIONS]**

**CAUTION**

- Dispose of this product as industrial waste.

**[TRANSPORTATION PRECAUTIONS]**

**CAUTION**

- When fumigants that contain halogen materials such as fluorine, chlorine, bromine, and iodine are used for disinfecting and protecting wooden packaging from insects, they cause malfunction when entering our products. Please take necessary precautions to ensure that remaining materials from fumigant do not enter our products, or treat packaging with methods other than fumigation (heat method). Additionally, disinfect and protect wood from insects before packing products.

**Manuals**

The following shows manuals relevant to this product.

Manual name	Manual number (Model code)
GOT2000 Series User's Manual (Hardware)	SH-081194ENG (1D7MJ5)

For detailed manuals and relevant manuals, refer to the e-Manual or PDF manuals stored in the DVD-ROM for the screen design software used.

The latest manuals are also available from MITSUBISHI ELECTRIC FA Global Website (www.MitsubishiElectric.com/fa).

**Referenced Standard: GB/T15969.2 (Requirement of Chinese standardized law)**

**Packing List**  
 After unpacking the box, check that the following products are included.

Model	Product	Quantity
GT25-UCOV	GOT2000 series USB environmental protection cover	1
GT21-WUCOV	Fixing screw (M3 x 6)	1
GT25-05UCOV	GOT2000 Series USB Environmental Protection Cover User's Manual (This manual)	1

**1. OVERVIEW**

This user's manual describes the USB environmental protection cover of the GOT2000 series (hereinafter referred to as the USB environmental protection cover). The USB environmental protection cover is for protection of the USB interface.

The following table shows the USB environmental protection cover models and applicable GOTs.

Model	Screen sizes for the applicable GOTs
GT25-UCOV	The following GOTs with the USB interface on their front faces - 15" models - 12.1" models - 10.4" models - 8.4" models
GT21-WUCOV	The following GOTs with the USB interface on their front faces - 12.1" wide models - 10.1" wide models - 7" wide models - GT2505-VTBD
GT25-05UCOV	GT2705-VTBD

The USB environmental protection cover is used to make the USB interface compliant with the protective structure IP67F.

\*1: The suffix "F" of IP67F is a symbol that indicates protection rate against oil. It is described in the Appendix of JIS C 0920 of the Japanese Industrial Standards.

**2. SPECIFICATIONS**

The following shows the performance specifications of the USB environmental protection cover.  
 The general specifications of the USB environmental protection cover are the same as those of the GOT.  
 For the general specifications of the GOT, refer to the GOT2000 Series User's Manual (Hardware).

Item	Description
Protective structure*1	IP67F
Weight	0.005 kg

\*1: The USB interface is IP67F-rated when the USB environmental protection cover is installed to the GOT.  
 To conform to IP67F, close the USB environmental protection cover by pushing in the [PUSH] mark or [USB] mark firmly to lock the cover.  
 (The USB interface is IP2X-rated when the USB environmental protection cover is open.)

**3. EXTERNAL DIMENSIONS**

**3.1 GT25-UCOV**

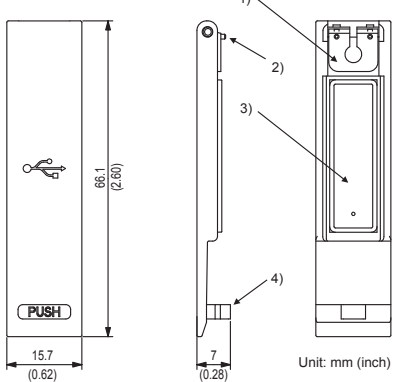

Unit: mm (inch)

No.	Name	Description
1)	Hinge	Hinge for opening or closing the USB environmental protection cover
2)	Hinge projection	Hinge projection to be fitted in the GOT guiding hole
3)	Packing	Packing for protecting the USB interface
4)	Latch	Latch for fixing or opening the USB environmental protection cover

**3.2 GT21-WUCOV**

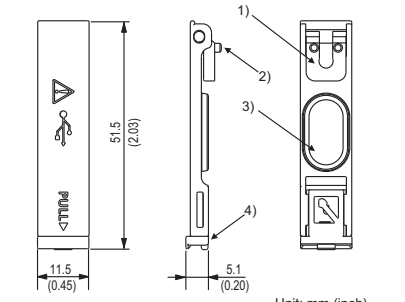

Unit: mm (inch)

No.	Name	Description
1)	Hinge	Hinge for opening or closing the USB environmental protection cover
2)	Hinge projection	Hinge projection to be fitted in the GOT guiding hole
3)	Packing	Packing for protecting the USB interface
4)	Latch	For locking or unlocking the USB environmental protection cover

**3.3 GT25-05UCOV**

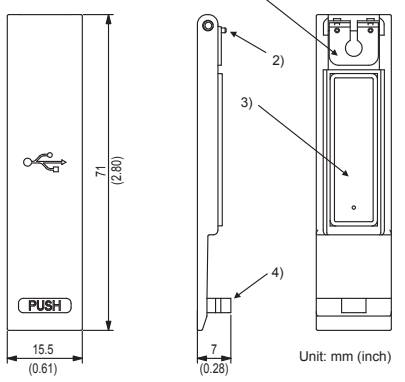

Unit: mm (inch)

No.	Name	Description
1)	Hinge	Hinge for opening or closing the USB environmental protection cover
2)	Hinge projection	Hinge projection to be fitted in the GOT guiding hole
3)	Packing	Packing for protecting the USB interface
4)	Latch	Latch for fixing or opening the USB environmental protection cover

5) To use the USB interface, open the USB environmental protection cover by pushing the [PUSH] mark on the cover.

**4.1.2 GT21-WUCOV**

The installation procedure for the USB environmental protection cover is explained using GT2510-WX.

1) Get up the hinge of the USB environmental protection cover.

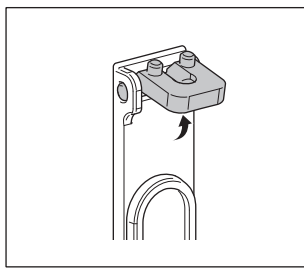

2) Align the hinge projection of the USB environmental protection cover on the guiding hole of the GOT. Put a supplied fixing screw through the hinge hole of the USB environmental protection cover.

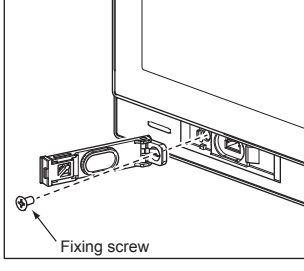

3) Tighten the fixing screw in the specified torque range (0.36 N·m to 0.48 N·m) to fix the cover to the GOT.

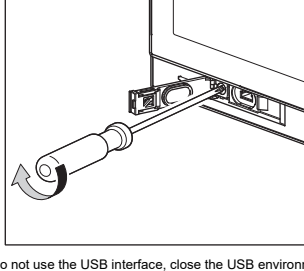

4) When you do not use the USB interface, close the USB environmental protection cover by pushing in the [USB] mark on the cover firmly. When you close the USB environmental protection cover, make sure that the latch is fully retracted into the cover body. Otherwise, the USB environmental protection cover may get damaged.

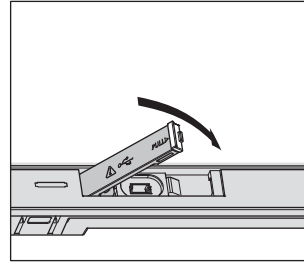

5) To use the USB interface, unlock the USB environmental protection cover by sliding its latch and then open the cover.

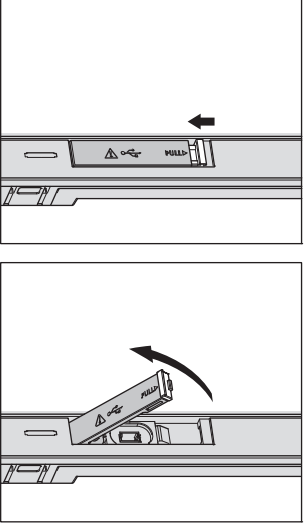

**4.2 Removing the USB Environmental Protection Cover**

Perform the reverse procedure of installation for removing the USB environmental protection cover.

**5. PRECAUTIONS FOR USE**

- When the USB environmental protection cover is closed, the USB interface is IP67F-rated. In this case, the USB environmental protection cover must be locked into position by pushing in the [PUSH] mark or [USB] mark firmly.
- The USB environmental protection cover is a consumable product. Check the cover periodically. When the cover has damage, heavy soil, and others, replace the cover.

**Warranty**  
 Mitsubishi Electric will not be held liable for damage caused by factors found not to be the cause of Mitsubishi Electric; machine damage or lost profits caused by faults in the Mitsubishi Electric products; damage, secondary damage, accident compensation caused by special factors unpredictable by Mitsubishi Electric; damages to products other than Mitsubishi Electric products; and to other duties.

**For safe use**  
 This product has been manufactured as a general-purpose part for general industries, and has not been designed or manufactured to be incorporated in a device or system used in purposes related to human life.  
 Before using the product for special purposes such as nuclear power, electric power, aerospace, medicine or passenger movement vehicles, consult with Mitsubishi Electric.  
 This product has been manufactured under strict quality control. However, when installing the product where major accidents or losses could occur if the product fails, install appropriate backup or failsafe functions in the system.

Country/Region	Sales office/Tel
USA	Mitsubishi Electric Automation, Inc. 500 Corporate Woods Parkway, Vernon Hills, IL 60061, U.S.A. Tel: +1-847-478-2100
Brazil	Mitsubishi Electric do Brasil Comercio e Servicos Ltda. Avenida Adalino Cardana, 293, 21 andar, Bethaville, Barueri SP, Brazil Tel: +55-11-4689-3000
Mexico	Mitsubishi Electric Automation, Inc. Mexico Branch Boulevard Miguel de Cervantes Saavedra 301, Torre Norte Piso 5, Ampliacion Granada, Miguel Hidalgo, Ciudad de Mexico, Mexico, C.P.11520 Tel: +52-55-3601-7912
Germany	Mitsubishi Electric Europe B.V. German Branch Mitsubishi-Electric-Platz 1, 40882 Ratingen, Germany Tel: +49-2102-488-0
UK	Mitsubishi Electric Europe B.V. UK Branch Travelers Lane, UK-Hatfield, Hertfordshire, AL10 8XB, U.K. Tel: +44-1477-28-8780
Italy	Mitsubishi Electric Europe B.V. Italian Branch Centro Direzionale Colleoni - Palazzo Sirtio, Viale Colleoni 7, 20964 Agrate Brianza (MB), Italy Tel: +39-039-60531
Spain	Mitsubishi Electric Europe B.V. Spanish Branch Carretera de Rubi, 78-80-Appdo. 420, E-08190 Sant Cugat del Valles (Barcelona), Spain Tel: +34-935-65-3131
France	Mitsubishi Electric Europe B.V. French Branch 25, Boulevard des Bouvets, 92741 Nanterre Cedex, France Tel: +33-1-55-68-55-68
Czech	Mitsubishi Electric Europe B.V. Czech Branch Pekarska 62/17, 155 00 Praha 5, Czech Republic Tel: +420-255 719 200
Turkey	Mitsubishi Electric Turkey A.S. Umraniyeh Branch Serifali Mahallesi Nispetiye Sokak No:5, TR-34775 Umraniyeh / Istanbul, Turkey Tel: +90-216-528-3990
Poland	Mitsubishi Electric Europe B.V. Polish Branch ul. Krakowska 48, 32-063 Balice, Poland Tel: +48-12-347-65-00
Russia	Mitsubishi Electric (Russia) LLC St. Petersburg Branch Pskarskiy pr. 2, bld 2, R "Sch", BC "Benua", office 720, 195027 St. Petersburg, Russia Tel: +7-812-633-3461
South Africa	Adroit Technologies 20 Waterford Office Park, 189 Witkoppen Road, Fourways, South Africa Tel: +27-11-658-8100
China	Mitsubishi Electric Automation (China) Ltd. Mitsubishi Electric Automation Center, No.1386 Hongqiao Road, Shanghai, China Tel: +86-21-2322-3030
Taiwan	SETSUYO ENTERPRISE CO., LTD. 6F, No.105, Wugong 3rd Road, Wugu District, New Taipei City 24889, Taiwan Tel: +886-2-2299-2499
Korea	Mitsubishi Electric Automation Korea Co., Ltd. 7F to 9F, Gangseo Hangang Xi-tower A, 401, Yangcheon-ro, Gangseo-Gu, Seoul 07528, Korea Tel: +82-2-3660-9569
Singapore	Mitsubishi Electric Asia Pte. Ltd. 307 Alexandra Road, Mitsubishi Electric Building, Singapore 159943 Tel: +65-6473-2308
Thailand	Mitsubishi Electric Factory Automation (Thailand) Co., Ltd. 12th Floor, Siv City Building, Office Tower 1, No. 99/19 and 20 Rama 3 Road, Kwaeng Bangpongngang, Khet Yannawa, Bangkok 10120, Thailand Tel: +66-2882-6522 to 31
Indonesia	PT. Mitsubishi Electric Indonesia Gedung Jaya 8th Floor, Jl. MH. Thamrin No.12, Jakarta Pusat 10340, Indonesia Tel: +62-21-3192-6461
Vietnam	Mitsubishi Electric Vietnam Company Limited 11th & 12th Floor, Viettel Tower B, 285 Cach Mang Thang 8 Street, Ward 12, District 10, Ho Chi Minh City, Vietnam. Tel: +84-28-3910-5945
India	Mitsubishi Electric India Pvt. Ltd. Pune Branch Emerald House, EL-3, J Block, M.I.D.C., Bhosari, Pune - 411026, Maharashtra, India Tel: +91-20-2710-2000
Australia	MITSUBISHI ELECTRIC AUSTRALIA PTY. LTD. 348 Victoria Road, P.O. Box 11, Rydalmere, N.S.W 2116, Australia Tel: +61-2-9684-7777

**MITSUBISHI ELECTRIC CORPORATION**  
 HEAD OFFICE: TOKYO BUILDING, 2-7-3 MARUNOUCHI, CHIYODA-KU, TOKYO 100-8310, JAPAN  
 NAGOYA WORKS: 1-14, YADA-MINAMI 5-CHOME, HIGASHI-KU, NAGOYA, JAPAN

When exported from Japan, this manual does not require application to the Ministry of Economy, Trade and Industry for service transaction permission.

Specifications subject to change without notice.  
 Printed in Japan, April 2021.