

---

# **GT15 MELSECNET/10**

## **communication unit**

---

### User's Manual

#### **GT15-75J71LP23-Z**

Set of A9GT-QJ71LP23 and GT15-75IF900

#### **GT15-75J71BR13-Z**

Set of A9GT-QJ71BR13 and GT15-75IF900

Thank you for purchasing the GOT1000 Series.

Prior to use, please read both this manual and detailed manual thoroughly to fully understand the product.

MODEL	GT15-75J71LP23-Z-U
MODEL CODE	1D7M30
IB(NA)-0800315-D(2011)MEE	

GRAPHIC OPERATION TERMINAL

# **GOT1000**

## ●SAFETY PRECAUTIONS●

(Always read these precautions before using this equipment.)

Before using this product, please read this manual and the relevant manuals introduced in this manual carefully and pay full attention to safety to handle the product correctly.

The precautions given in this manual are concerned with this product. In this manual, the safety precautions are ranked as "WARNING" and "CAUTION".



Indicates that incorrect handling may cause hazardous conditions, resulting in death or severe injury.



Indicates that incorrect handling may cause hazardous conditions, resulting in medium or slight personal injury or physical damage.

Note that the  CAUTION level may lead to a serious accident according to the circumstances.

Always follow the precautions of both levels because they are important to personal safety.

Please save this manual to make it accessible when required and always forward it to the end user.

## [DESIGN PRECAUTIONS]

### **WARNING**

- If a communication fails in data link, the faulty station holds the data link data generated before the communication error. Create an interlock circuit in the sequence program using the communication status information in order that the system will operate safely.  
Check the faulty station and the operation status during communication error by referring to the relevant manuals.
- Some failures of cable or communication unit may cause the GOT to keep the outputs on or off.  
Create an external circuit for monitoring output signals that may lead to serious accidents.  
Failure to do so may cause mis-outputs or malfunctions, resulting in accidents.
- If a communication error (including cable disconnection) occurs during monitoring, the communication between the GOT and PLC CPU may be interrupted and the GOT may be inoperative.  
For bus connection : The PLC CPU is down and the GOT is inoperative.  
For other than above: The GOT is inoperative.  
When configuring a system including the GOT, the possibility of GOT communication error must be considered; make sure the operation significant for the system will be performed by switches on devices other than the GOT.  
Failure to do so may cause mis-outputs or malfunctions, resulting in accidents.
- To maintain the security (confidentiality, integrity, and availability) of the GOT and the system against unauthorized access, DoS<sup>\*1</sup> attacks, computer viruses, and other cyberattacks from unreliable networks and devices via network, take appropriate measures such as firewalls, virtual private networks (VPNs), and antivirus solutions.  
Mitsubishi Electric shall have no responsibility or liability for any problems involving GOT trouble and system trouble by unauthorized access, DoS attacks, computer viruses, and other cyberattacks.  
<sup>\*1</sup> DoS: A denial-of-service (DoS) attack disrupts services by overloading systems or exploiting vulnerabilities, resulting in a denial-of-service (DoS) state.

## [DESIGN PRECAUTIONS]

### CAUTION

- Do not install the communication cables together with the main circuit or power lines, or bring them close to each other. The distance of 100mm (3.9inch) or more should be ensured. Failure to do so may cause malfunctions due to noise.

## [INSTALLATION PRECAUTIONS]

### WARNING

- Be sure to shut off all phases of the external power supply used by the system before mounting or removing this unit to/from the GOT.  
Not doing so can cause a unit failure or malfunction.

### CAUTION

- Use this unit in the environment given in the general specifications of the GT15 User's Manual.  
Not doing so can cause an electric shock, fire, malfunction or product damage or deterioration.
- When installing this unit to the GOT, fit it to the connection interface of the GOT and tighten the mounting screws in the specified torque range.  
Undertightening can cause a drop, failure or malfunction.  
Overtightening can cause a drop, failure or malfunction due to screw or unit damage.
- Do not directly touch the conductive part or electronic components of the unit.  
This may cause the unit to fail or malfunction.

## [WIRING PRECAUTIONS]

### **WARNING**

- Be sure to shut off all phases of the external power supply used by the system before wiring.  
Failure to do so may cause electric shock, product damage or malfunctions.

### **CAUTION**

- Be careful not to let foreign matter such as dust or wire chips get inside the unit. This may cause a fire, failure or malfunctions.
- Make sure to securely connect the cable to the connector of unit.  
Incorrect connection may cause malfunctions.
- Make sure to fix communication cables and power cables to the unit by ducts or clamps. Failure to do so may cause damage of the unit or the cables due to accidental pull or unintentional shifting of the cables, or malfunctions due to poor contact of the cables.
- Do not hold the cable by hand and pull it out from the unit.  
When removing the cable from the unit, make sure to hold the connector by hand and pull it.  
Failure to do so may cause malfunctions or damage to the unit or cable.
- Solder the coaxial cable connector correctly.  
Incomplete soldering may cause a malfunction.

## [STARTUP AND MAINTENANCE PRECAUTIONS]

### **WARNING**

- Do not touch the connector while power is on.  
Failure to do so may cause electric shock or malfunctions.
- Before starting cleaning, always shut off GOT power externally in all phases.  
Not doing so can cause a unit failure or malfunction.

## [STARTUP AND MAINTENANCE PRECAUTIONS]

### CAUTION

- Do not disassemble or modify any unit.  
This will cause failure, malfunction, injuries, or fire.
- Do not touch the conductive areas and electronic parts of this unit directly.  
Doing so can cause a unit malfunction or failure.
- Do not change the switch settings while power is on.  
This may cause failures or malfunctions.
- Make sure to externally shut off all phases of the power supply before cleaning the unit and retightening unit mounting screws.  
Failure to do so may cause the unit to fail or malfunction.  
Loose tightening may cause a fall of the unit, short circuits, or malfunctions.  
Overtightening may damage the screws and/or the unit, resulting in a fall of the unit, short circuits or malfunctions.
- Always make sure to touch the grounded metal to discharge the electricity charged in the body, etc., before touching the unit.  
Failure to do so may cause a failure or malfunctions of the unit.

## [DISPOSAL PRECAUTIONS]

### CAUTION

- Dispose of this product as industrial waste.

## [TRANSPORTATION PRECAUTIONS]

### CAUTION

- Make sure to transport the GOT main unit and/or relevant unit(s) in the manner they will not be exposed to the impact exceeding the impact resistance described in the general specifications of the GT15 User's Manual, as they are precision devices.  
Failure to do so may cause the unit to fail.  
Check if the unit operates correctly after transportation.

## REVISIONS

\*The manual number is noted at the lower right of the top cover.

Print Date	*Manual Number	Revision
Jan., 2005	IB(NA)-0800315-A	First edition
Dec., 2005	IB(NA)-0800315-B	Description of the front cover is reviewed.
Mar., 2006	IB(NA)-0800315-C	Partial corrections Chapter 1, 2, 7
Nov., 2020	IB(NA)-0800315-D	Partial corrections SAFETY PRECAUTIONS

This manual confers no industrial property rights or any rights of any other kind, nor does it confer any patent licenses. Mitsubishi Electric Corporation cannot be held responsible for any problems involving industrial property rights which may occur as a result of using the contents noted in this manual.

---

---

## CONTENTS

---

---

1. Overview .....	1
2. Performance Specifications .....	2
3. Part Names and the Settings .....	4
4. Installation Procedure .....	9
5. Precautions for Laying Cables .....	11
5.1 Precautions for cable connection (A9GT-QJ71LP23) .....	11
5.2 Precautions for cable connection (A9GT-QJ71BR13) .....	12
6. Wiring Method .....	15
7. External Dimensions .....	16



## Manuals

The following shows manuals relevant to this product.

### Detailed Manual

Manual name	Manual number (Type code)
GT15 User's Manual (Option)	SH-080528ENG (1D7M23)
GOT1000 Connection Manual (Option)	SH-080532ENG (1D7M26)

### Relevant Manuals

For relevant manuals, refer to the PDF manual stored within the drawing software used.

---

---

## 1. Overview

---

---

This manual explains the GT15 MELSECNET/10 communication unit (hereinafter referred to as GT15-75J71LP23-Z/GT15-75J71BR13-Z), i.e., the specifications, switch settings and how to mount onto the GOT.

The GT15-75J71LP23-Z and GT15-75J71BR13-Z allow the GOT 1000 series to function as a normal station (MELSECNET/10 connection) in the MELSECNET/10 network system (PLC to PLC network).

After unpacking each product package, check if the following items are contained.

### <GT15-75J71LP23-Z>

Product name	Model name	Quantity
A9GT-QJ71LP23 network unit (for optical loop network connection; normal station only)	(A9GT-QJ71LP23)	1
Interface converter unit	(GT15-75IF900)	1
Communication unit fixing bracket	-	3

### <GT15-75J71BR13-Z>

Product name	Model name	Quantity
A9GT-QJ71BR13 network unit*1 (for coaxial bus network connection; normal station only)	(A9GT-QJ71BR13)	1
F-type connector	(A6RCON-F)	1
Interface converter unit	(GT15-75IF900)	1
Communication unit fixing bracket	-	3

\*1 : In the case of coaxial-type network system, terminal resistors must be attached to both terminal stations of the network. The A9GT-QJ71BR13 does not include terminal resistors (A6RCON-R75:75Ω). Therefore, they should be prepared by the user.

A network unit (A9GT-QJ71LP23 or A9GT-QJ71BR13) can be connected to the GOT with the GT15-75IF900, which can perform monitoring as a normal station in the MELSECNET/10 network system (PLC to PLC network).

For system configuration when connecting the GOT to MELSECNET/10, refer to GOT1000 Series Connection Manual.
--

## 2. Performance Specifications

The following is the performance specification of MELSECNET/10 communication unit.

For the general specifications of MELSECNET/10 communication unit, refer to the GT15 User's Manual <sup>\*1</sup>.

Item	A9GT-QJ71LP23	A9GT-QJ71BR13	
Maximum number of link points per network	LX/LY	8192 points	
	LB	8192 points	
	LW	8192 points	
Maximum number of link points per station	$\{(B+Y)/8+(2 \times W)\} \leq 2000$ bytes		
Communication speed	10Mbps (20 Mbps : multiples transmission)	10Mbps	
Communication method	Token ring method	Token bus method	
Synchronous method	Frame synchronous		
Type of transmission channel	Double loop (Optical fiber cable)	Coaxial single bus	
Overall distance (Distance between stations) <sup>2</sup>	30km SI optical cable inter station 500m H-PCF optical cable inter station 1km Broad-band H-PCF optical canle inter station 1km QSI optical cable inter station 1km	3C-2V	300m (0.19 mil) (Distance between stations: 300m (0.19 mil))
		5C-2V	500m (0.31 mil) (Distance between stations: 500m (0.31 mil))
		Repeater module (A6BR10, A6BR10-DC) Maximum expansion is 2.5km	
Accessible network range	Same network only		
Maximum number of groups	9		
Number of stations connected to a network	63 stations	31 stations	
RAS functions	<ul style="list-style-type: none"> <li>• Loopback in case of error detection or cable disconnection (Specific to A9GT-QJ71LP23)</li> <li>• Link channel check for the host station</li> <li>• Abnormality detection by link special relay, resistor</li> <li>• Various diagnostic functions</li> </ul>		
Transient transmission	• N:N communication		
Cable	Optical fiber cable (Arranged by user <sup>*3</sup> )	3C-3V 5C-2V or equivalent	

Item	A9GT-QJ71LP23	A9GT-QJ71BR13
Applicable connectors	2-core optical connector plug (Arranged by user <sup>*3</sup> )	BNC-P-3-NiCAu (For 3C-2V) BNC-P-5-NiCAu (For 5C-2V) Equivalent goods (manufactured by DDK Electronics., LTD.)
Internal current consumption	0.52A in total with GT15-75IF900	
Weight	0.5kg (1.1lb) in total with GT15-75IF900	

\*1 : The vibration resistance of the MELSECNET/10 communication unit is as follows. (Differs with the GT15.)

Item	Specifications					
Vibration resistance	Conforming to JIS B 3502, IEC 61131-2	Under intermittent vibration	10 to 57Hz	---	0.075mm (0.003inch)	10 times each in X, Y, Z directions (for 80 minch)
			57 to 150Hz	9.8m/s <sup>2</sup>	---	
		Under continuous vibration	10 to 57Hz	---	0.035mm (0.001inch)	
			57 to 150Hz	4.9m/s <sup>2</sup>	---	

\*2 : In the case of coaxial bus system, the cable length between stations may be restricted, depending on the number of connected stations. (Refer to Section 5.2 (1).)

\*3 : Please note that use of optical fiber cable requires the expertise, special tools and dedicated connector for connection. Please contact your local Mitsubishi Electric System Service or representative, for the purchase of the required items.

### 3. Part Names and the Settings

The following indicates part names and the setting of each part of A9GT-QJ71LP23, A9GT-QJ71BR13 and GT15-75IF900.

A9GT-QJ71LP23

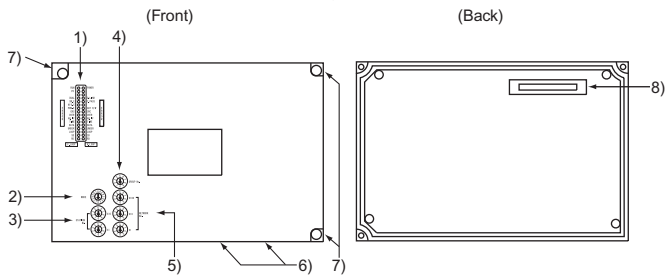

A9GT-QJ71BR13

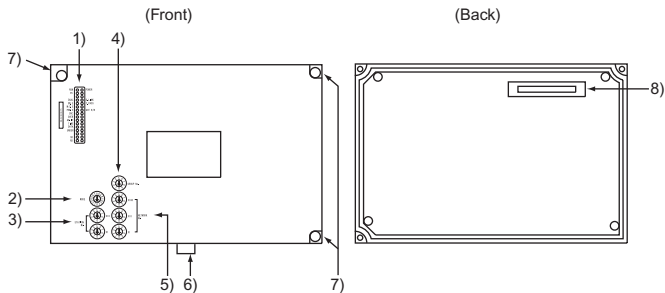

GT15-75IF900

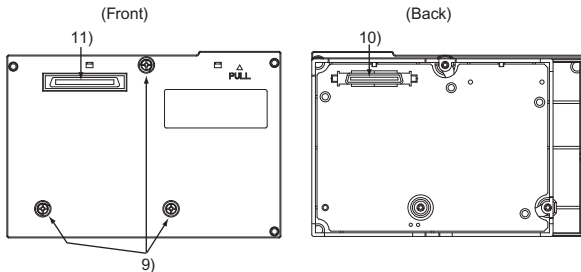

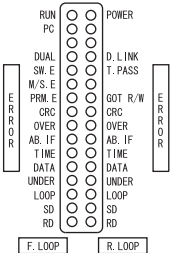
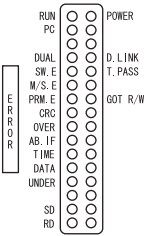
No.	Name	Details	
1)	<p data-bbox="129 109 170 131"><b>LED</b></p> <p data-bbox="129 203 290 225"><b>A9GT-QJ71LP23</b></p> 	Name	Details
	RUN	On : Normal operation Off : The WDT error has Toccured.	
	PC	On : Set to the PLC to PLC network (Always ON)	
	DUAL	On : Multiple transmission is being executed. Off : Multiple transmission is not being executed.	
	SW.E	On : No.2 to 5 switch settings are incorrect. Off : Normal	
	M/S.E	On : Station No. settings are overlapped on the same network. Off : Normal	
	PRM.E	On : An error has occurred because common parameters are inconsistent with station- specific parameters, i.e., parameters received from sub-control station are different from those of host station (received from control station). Off : Normal	
	POWER	On : Power is supplied. Off : Power is not supplied.	
	D.LINK	On : Data link is being executed. Off : Data link is not being executed.	
	T.PASS	On : Participating in the button passing. Off : Not participating in the button passing.	
	GOT R/W	On : Communicating with GOT Off : Not communicating with GOT	
	CRC	On : An error has occurred, i.e., an error code is detected in the received data. <Cause> The timing when the station that sends data to the corresponding station is disconnected, H/W failure, cable failure, noise, etc. Off : Normal	
	OVER	On : An error has occurred, i.e., the received data processing is delayed. <Cause> H/W failure, cable failure, noise, etc. Off : Normal	
	<p data-bbox="129 655 295 677"><b>A9GT-QJ71BR13</b></p> 	POWER	On : Power is supplied. Off : Power is not supplied.
D.LINK	On : Data link is being executed. Off : Data link is not being executed.		
T.PASS	On : Participating in the button passing. Off : Not participating in the button passing.		
GOT R/W	On : Communicating with GOT Off : Not communicating with GOT		
CRC	On : An error has occurred, i.e., an error code is detected in the received data. <Cause> The timing when the station that sends data to the corresponding station is disconnected, H/W failure, cable failure, noise, etc. Off : Normal		
OVER	On : An error has occurred, i.e., the received data processing is delayed. <Cause> H/W failure, cable failure, noise, etc. Off : Normal		

No.	Name	Details	
1)	LED	AB.IF	<p>On : An error has occurred, i.e., "1" is continuously received more than specified times, or the received data length is too short.            &lt;Cause&gt; The timing when the station that sends data to the corresponding station is disconnected, H/W failure, cable failure, noise, etc.            Off : Normal</p>
		TIME	<p>On : When the baton has not been passed to the host station within the monitor time.            &lt;Cause&gt; Short monitor time, cable failure, noise, etc.            Off : Normal</p>
		DATA	<p>On : An error has occurred, i.e., an error code is received.            &lt;Cause&gt; Cable failure, noise, etc.            Off : Normal</p>
		UNDER	<p>On : An error has occurred, i.e., the internal processing of the data to be sent is not executed at constant intervals.            &lt;Cause&gt; H/W failure.            Off : Normal</p>
		LOOP	<p>On : An error has occurred in forward loop/ reverse loop.            &lt;Cause&gt; The adjacent station power is off, cable is disconnected/unconnected.            (Specific to A9GT-QJ71LP23)            Off : Normal</p>
		SD	Barely on : Data transmitting
		RD	Barely on : Data transmitting <sup>*2</sup>

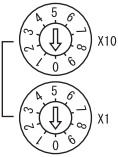
No.	Name	Details																																																			
2) *3	Mode setting switch 	Setting of mode (Factory setting at time of shipping: 0) <table border="1" data-bbox="368 136 932 918"> <thead> <tr> <th data-bbox="368 136 474 168">Mode</th> <th data-bbox="474 136 621 168">Name</th> <th data-bbox="621 136 932 168">Contents</th> </tr> </thead> <tbody> <tr> <td data-bbox="368 168 474 278">0</td> <td data-bbox="474 168 621 278">On-line (automatic double line existent)</td> <td data-bbox="621 168 932 278">Data link (automatic double line existent)</td> </tr> <tr> <td data-bbox="368 278 474 310">1</td> <td colspan="2" data-bbox="474 278 932 310">Use not possible</td> </tr> <tr> <td data-bbox="368 310 474 371">2</td> <td data-bbox="474 310 621 371">Off-line</td> <td data-bbox="621 310 932 371">Placing local station in parallel condition</td> </tr> <tr> <td data-bbox="368 371 474 403">3</td> <td data-bbox="474 371 621 403">-</td> <td data-bbox="621 371 932 403">Unusable</td> </tr> <tr> <td data-bbox="368 403 474 435">4</td> <td data-bbox="474 403 621 435">-</td> <td data-bbox="621 403 932 435">Unusable</td> </tr> <tr> <td data-bbox="368 435 474 467">5</td> <td data-bbox="474 435 621 467">-</td> <td data-bbox="621 435 932 467">Unusable</td> </tr> <tr> <td data-bbox="368 467 474 528">6</td> <td data-bbox="474 467 621 528">Test mode 4</td> <td data-bbox="621 467 932 528">Station-to station test (Slave station)</td> </tr> <tr> <td data-bbox="368 528 474 560">7</td> <td data-bbox="474 528 621 560">Test mode 5</td> <td data-bbox="621 528 932 560">Self- loopback test</td> </tr> <tr> <td data-bbox="368 560 474 592">8</td> <td data-bbox="474 560 621 592">Test mode 6</td> <td data-bbox="621 560 932 592">Internal self- loopback test</td> </tr> <tr> <td data-bbox="368 592 474 624">9</td> <td data-bbox="474 592 621 624">Test mode 7</td> <td data-bbox="621 592 932 624">Hardware test</td> </tr> <tr> <td data-bbox="368 624 474 656">A</td> <td data-bbox="474 624 621 656">-</td> <td data-bbox="621 624 932 656">Unusable</td> </tr> <tr> <td data-bbox="368 656 474 688">B</td> <td data-bbox="474 656 621 688">-</td> <td data-bbox="621 656 932 688">Unusable</td> </tr> <tr> <td data-bbox="368 688 474 720">C</td> <td data-bbox="474 688 621 720">-</td> <td data-bbox="621 688 932 720">Unusable</td> </tr> <tr> <td data-bbox="368 720 474 781">D</td> <td data-bbox="474 720 621 781">Test mode 8</td> <td data-bbox="621 720 932 781">Network number confirmation (LED indication)</td> </tr> <tr> <td data-bbox="368 781 474 843">E</td> <td data-bbox="474 781 621 843">Test mode 9</td> <td data-bbox="621 781 932 843">Group number confirmation (LED indication)</td> </tr> <tr> <td data-bbox="368 843 474 918">F</td> <td data-bbox="474 843 621 918">Test mode 10</td> <td data-bbox="621 843 932 918">Station number confirmation (LED indication)</td> </tr> </tbody> </table>	Mode	Name	Contents	0	On-line (automatic double line existent)	Data link (automatic double line existent)	1	Use not possible		2	Off-line	Placing local station in parallel condition	3	-	Unusable	4	-	Unusable	5	-	Unusable	6	Test mode 4	Station-to station test (Slave station)	7	Test mode 5	Self- loopback test	8	Test mode 6	Internal self- loopback test	9	Test mode 7	Hardware test	A	-	Unusable	B	-	Unusable	C	-	Unusable	D	Test mode 8	Network number confirmation (LED indication)	E	Test mode 9	Group number confirmation (LED indication)	F	Test mode 10	Station number confirmation (LED indication)
		Mode	Name	Contents																																																	
		0	On-line (automatic double line existent)	Data link (automatic double line existent)																																																	
		1	Use not possible																																																		
		2	Off-line	Placing local station in parallel condition																																																	
		3	-	Unusable																																																	
		4	-	Unusable																																																	
		5	-	Unusable																																																	
		6	Test mode 4	Station-to station test (Slave station)																																																	
		7	Test mode 5	Self- loopback test																																																	
		8	Test mode 6	Internal self- loopback test																																																	
		9	Test mode 7	Hardware test																																																	
		A	-	Unusable																																																	
		B	-	Unusable																																																	
		C	-	Unusable																																																	
		D	Test mode 8	Network number confirmation (LED indication)																																																	
E	Test mode 9	Group number confirmation (LED indication)																																																			
F	Test mode 10	Station number confirmation (LED indication)																																																			
3) *3	Station number setting switch 	Station number setting (factory setting at time of shipping: 1) <Setting range> 1 to 64 : station number Other than 1 to 64 : setting error (SW.E LED lamp is lit)																																																			

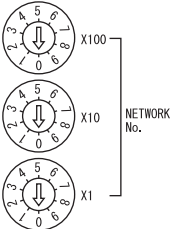

No.	Name	Details
4) *3	Group number setting Switch 	Group number setting (factory setting at time of shipping: 0) <Setting range> 0 : No group setting (Fixed)*4
5) *3	Network number setting switch 	Network number setting (factory setting at time of shipping: 1) <Setting range> 1 to 239 : Network number Other than 1 to 239: Setting error (SW.E LED lamp is lit)
6)	Connector	A9GT-QJ71LP23 : Connect the optical fiber cable A9GT-QJ71BR13 : Connect the F-type connector
7)	Mounting screw	Screw for mounting to the GT15-75IF900
8)	Connector	Connector for connection to the GT15-75IF900
9)	Mounting screw	Mounting screw to be fixed with the GOT main unit
10)	Interface connector	Connector connecting to GOT
11)	Extension connector	Connector connecting with A9GT-QJ71LP23/ A9GT-QJ71BR13

\*1 : Even if the station No. settings are overlapped, the M/S.E. LED may not be on, depending on the line status or cable connection status. It is recommended to confirm the settings by performing a visual check and executing a confirmation test.

\*2 : If no terminal resistors are attached, this may be always on.  
(This is not a network error (specific to A9GT-QJ71BR13.))

\*3 : Make sure to reset the GOT after changing the settings. However, this does not apply when 2) mode setting switch is changed to any of "D" to "F".

\*4 : The GOT does not use a group number. Set as 0 (No group designation).

---

## 4. Installation Procedure

---

- (1) Power off the GOT.
- (2) Remove the two extension unit covers of the GOT.

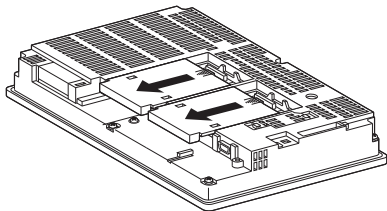

- (3) Fit the GT15-75IF900 along the groove of the GOT case.

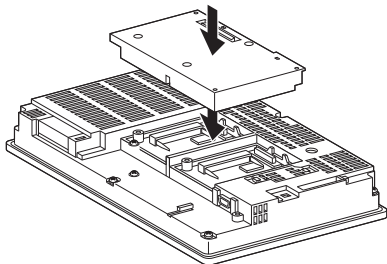

- (4) Fasten the GT15-75IF900 by tightening its mounting screws (3 places) with tightening torque 0.36 to 0.48 N·m.

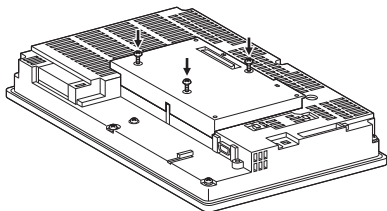

- (5) Attach the communication unit fixing brackets (3 places) to GT15-75IF900, then fasten them with tightening torque of 0.36 to 0.48 N•m.

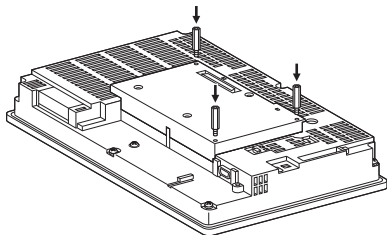

- (6) Mount the network unit (A9GT-QJ71LP23 or A9GT-QJ71BR13) to GT15-75IF900.

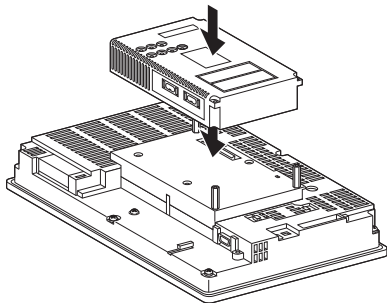

- (7) Fasten the unit fixing brackets (3 places) with tightening torque of 0.36 to 0.48N•m.

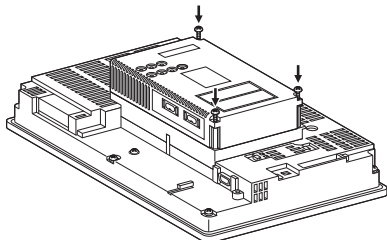

---

---

## 5. Precautions for Laying Cables

---

---

### 5.1 Precautions for cable connection (A9GT-QJ71LP23)

- (1) The distance between stations varies depending on the type of optical fiber cable used.

Type		Distance between stations [m (ft.)]
SI optical fiber cable (Old type: A-2P-□)	L type	500 (1640.5)
	H type	300 (984.3)
SI optical fiber cable		500 (1640.5)
H-PCF optical fiber cable		1000 (3281)
Broad-band H-PCF optical fiber cable		1000 (3281)
QSI optical fiber cable		1000 (3281)

- (2) When connecting an optical fiber cable, the following restrictions on the bending radius must be observed.  
For further details, please ask the supplier where you purchase the cable.
- (3) When laying the optical fiber cable, do not touch the fiber core of the cable connector or module connector, or let dirt or dust collect on it. If oil from the hands, dirt or dust should adhere to the core, the transmission loss will increase, causing a malfunction in the data link.
- (4) When attaching or detaching the optical-fiber cable to/from the module, hold the cable connector securely with the hands.
- (5) Connect the cable connector and module connector securely until you hear a "click" sound.
- (6) Please wire IN/OUT of the connector for the cable correctly.  
After wiring, perform a loop test or station-to-station test or others to confirm if the setting and wiring of A9GT-QJ71LP23 have been done properly.  
For testing methods, refer to the following manuals.
- Type MELSECNET/10 Network system (PLC to PLC network) Reference Manual
  - For QnA/Q4AR MELSECNET/10 Network System Reference Manual
  - Q Corresponding MELSECNET/H Network System Reference Manual (PLC to PLC network)

It might be generated that a baton abnormal passing cannot be generated when miswiring and the downed bureau which cannot do the loopback of an arbitrary bureau do the row again even by the reclosing of the power supply.

## 5.2 Precautions for cable connection (A9GT-QJ71BR13)

### (1) Restrictions on the cable length between stations

- (a) When connecting between the network modules, the cable lengths indicated in the table below should be used according to the number of stations connected.

A communication error may occur if a cable length other than the lengths indicated in the table is used.

Station-to-station cable length	Number of stations connected		Number of stations connected	
	2 to 9 stations		10 to 33 stations	
Cable type	3C-2V	5C-2V	3C-2V	5C-2V
0 to 1 m (3.28 ft.)	× (cable less than 1m (3.28 ft.) in length cannot be used.)			
1 (3.28 ft.) to 5 m (16.4 ft.)	○	○	○	○
5 (16.4 ft.) to 13 m (42.65 ft.)	○	○	×	×
13 (42.65 ft.) to 17 m (55.78 ft.)	○	○	○	○
17 (55.78 ft.) to 25 m (175.63 ft.)	○	○	×	×
25 (175.63 ft.) to 300 m (98.43 ft.)	○	○	○	○
300 (98.43 ft.) to 500 m (1640.5 ft.)	×	○	×	○

○ : Allowed    × : Not allowed

- (b) If there is the possibility of an increase in the number of stations due to system expansion, install the cables with advance consideration of the restrictions.
- (c) When using a repeater module (models A6BR10 or A6BR10-DC), use the station-to-station cable length indicated by "10 to 33" stations, regardless of the number of stations connected or the number of repeater modules.

(2) Precautions for laying cable

- (a) Coaxial cables must be laid 100mm or more apart from power cables and control cables.
- (b) Consider wiring using double-shielded coaxial cable in places that are subject to large amounts of noise.

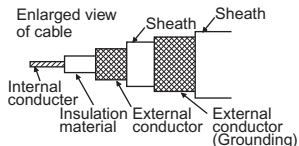
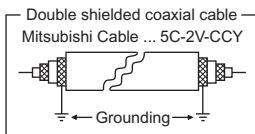

The 5C-2V connector plug is applicable to double-shielded coaxial cable.

Connect the 5C-2V connector plug to the coaxial cable inside a double-shielded coaxial cable. Ground the shielded part outside a double-shielded coaxial cable as shown in the above figure.

- (3) Double shielded coaxial cables have the following restrictions on the bending radius.

Cable type	Allowable bending radius $r$ [mm](in.)	Connector A[mm](in.)
3C-2V	23 (0.91)	50 (1.97)
5C-2V	30 (1.18)	

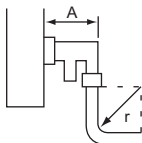

- (4) Do not pull any of the connected coaxial cables.  
This will cause a faulty contact, cable disconnection, or damage to the unit.
- (5) Make sure to connect a terminal resistor to both terminal stations of the coaxial bus type network system.
- (6) The F type connector has the possibility to extract a white oxide according to the use environment.  
However, there is no problem on the function because the oxide is not generated in connected part.

(7) Please wire the cable correctly.

After wiring, perform a station-to-station test or others to confirm if the setting and wiring of A9GT-QJ71BR13 have been done properly. For testing methods, please refer to following manuals.

- Type MELSECNET/10 Network system (PLC to PLC network) Reference Manual
- For QnA/Q4AR MELSECNET/10 Network System Reference Manual
- Q Corresponding MELSECNET/H Network System Reference Manual (PLC to PLC network)

It might be generated that a baton abnormal passing cannot be generated when miswiring and the downed bureau cannot do the row again even by the reclosing of the power supply.

(8) There are integral type and separate type F-shaped connectors. In the case of the separate type F-shaped connector, tighten the ring of the connector until the ring is tight before connecting the connector to the network module.

If the ring is loose, a communication error may occur.

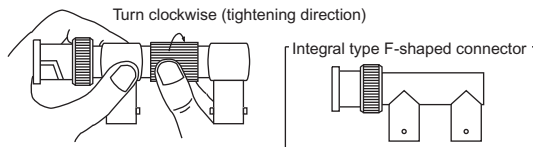

After connecting the F-shaped connector to the network module, retighten its ring periodically.

Retighten it with both hands as shown below.

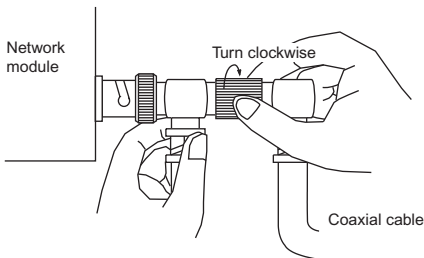

---

---

## 6. Wiring Method

---

---

### (1) A9GT-QJ71LP23

The optical fiber cable is wired in the following manner.

There is no problem even if not wiring in order of the station number.

Define a control station number and a normal station number according to the system specifications.

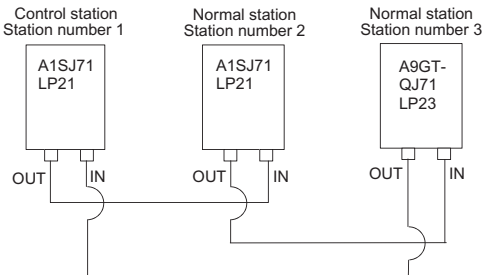

### (2) A9GT-QJ71BR13

The coaxial cable is wired in the following manner.

There is no program even if not wiring in order of the station number.

Define a control station number and a normal station number according to the system specifications.

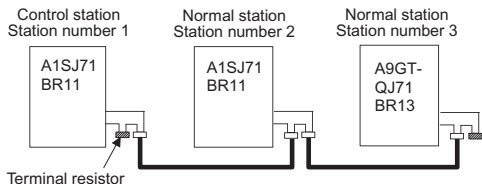



---

---

## 7. External Dimensions

---

---

(1) GT15-75IF900

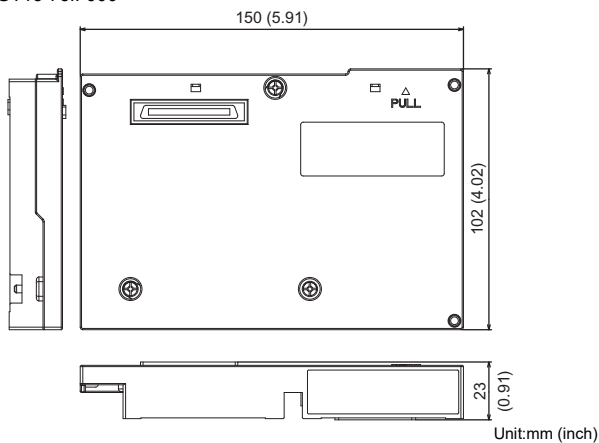



(3) A9GT-QJ71BR13

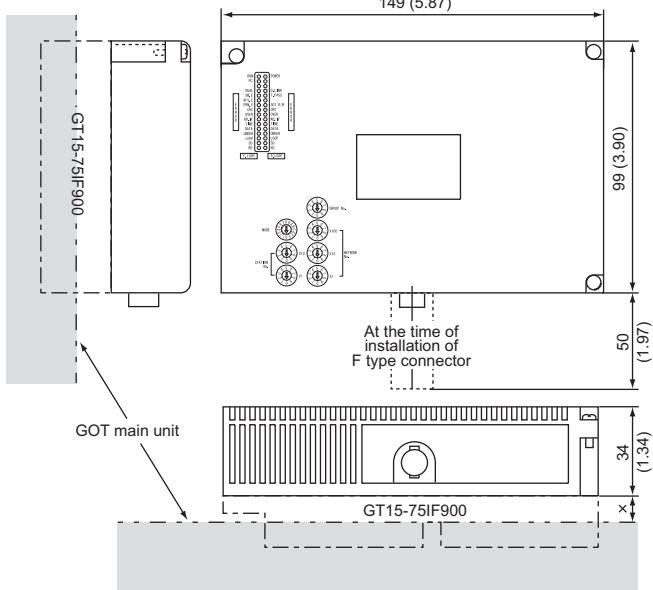

Dimensions of X when mounted to the GOT.

15", 12.1", 10.4"	13.5 (0.53)
8.4"	15.5 (0.61)

Unit:mm (inch)





## Warranty

Mitsubishi will not be held liable for damage caused by factors found not to be the cause of Mitsubishi; machine damage or lost profits caused by faults in the Mitsubishi products; damage, secondary damage, accident compensation caused by special factors unpredictable by Mitsubishi; damages to products other than Mitsubishi products; and to other duties.

### For safe use

- This product has been manufactured as a general-purpose part for general industries, and has not been designed or manufactured to be incorporated in a device or system used in purposes related to human life.
- Before using the product for special purposes such as nuclear power, electric power, aerospace, medicine or passenger movement vehicles, consult with Mitsubishi.
- This product has been manufactured under strict quality control. However, when installing the product where major accidents or losses could occur if the product fails, install appropriate backup or failsafe functions in the system.

Country/Region	Sales office/Tel	Country/Region	Sales office/Tel
USA	Mitsubishi Electric Automation, Inc. 500 Corporate Woods Parkway, Vernon Hills, IL 60061, U.S.A. Tel: +1-847-478-2100	South Africa	Adroit Technologies 20 Waterford Office Park, 189 Witkoppen Road, Fourways, South Africa Tel: +27-11-658-8100
Brazil	Mitsubishi Electric do Brasil Comercio e Servicos Ltda. Avenida Adelino Cardana, 293, 21 andar, Bethaville, Barueri SP, Brazil Tel: +55-11-4689-3000	China	Mitsubishi Electric Automation (China) Ltd. Mitsubishi Electric Automation Center, No.1386 Honggiao Road, Shanghai, China Tel: +86-21-2322-3030
Mexico	Mitsubishi Electric Automation, Inc. Mexico Branch Boulevard Miguel de Cervantes Saavedra 301, Torre Norte Piso 5, Ampliacion Granada, Miguel Hidalgo, Ciudad de Mexico, Mexico, C.P.11520 Tel: +52-55-3067-7512	Taiwan	SETSUYO ENTERPRISE CO., LTD. 6F, No.105, Wugong 3rd Road, Wugu District, New Taipei City 24889, Taiwan Tel: +886-2-2299-2499
Germany	Mitsubishi Electric Europe B.V. German Branch Mitsubishi-Electric-Platz 1, 40882 Ratingen, Germany Tel: +49-2102-486-0	Korea	Mitsubishi Electric Automation Korea Co., Ltd. 7F to 9F, Gangseo Hangang Xi-tower A, 401, Yangcheon-ro, Gangseo-Gu, Seoul 07528, Korea Tel: +82-2-3660-9569
UK	Mitsubishi Electric Europe B.V. UK Branch Travellers Lane, UK-Hatfield, Hertfordshire, AL10 8XB, U.K. Tel: +44-1707-28-8780	Singapore	Mitsubishi Electric Asia Pte. Ltd. 307 Alexandra Road, Mitsubishi Electric Building, Singapore 159943 Tel: +65-6473-2308
Italy	Mitsubishi Electric Europe B.V. Italian Branch Centro Direzionale Colleoni - Palazzo Sirio, Viale Colleoni 7, 20864 Agrate Brianza (MB), Italy Tel: +39-039-60531	Thailand	Mitsubishi Electric Factory Automation (Thailand) Co., Ltd. 12th Floor, SV.City Building, Office Tower 1, No. 896/19 and 20 Rama 3 Road, Kwaeng Bangpongpan, Khet Yannawa, Bangkok 10120, Thailand Tel: +66-2682-8522 to 31
Spain	Mitsubishi Electric Europe B.V. Spanish Branch Carretera de Rubi, 76-80-Apdo. 420, E-08190 Sant Cugat del Valles (Barcelona), Spain Tel: +34-935-65-3131	Indonesia	PT. Mitsubishi Electric Indonesia Gedung Jaya 8th Floor, J.L. MH. Thamrin No.12, Jakarta Pusat 10340, Indonesia Tel: +62-21 3192-6461
France	Mitsubishi Electric Europe B.V. French Branch 25, Boulevard des Bouvets, 92741 Nanterre Cedex, France Tel: +33-1-55-68-55-68	Vietnam	Mitsubishi Electric Vietnam Company Limited 11th & 12th Floor, Viettel Tower B, 285 Cach Mang Thang 8 Street, Ward 12, District 10, Ho Chi Minh City, Vietnam. Tel: +84-28-3910-5945
Czech	Mitsubishi Electric Europe B.V. Czech Branch Pekarska 621/7, 155 00 Praha 5, Czech Republic Tel: +420-255 719 200	India	Mitsubishi Electric India Pvt. Ltd. Pune Branch Emerald House, EL-3, J Block, M.I.D.C., Bhosari, Pune - 411026, Maharashtra, India Tel: +91-20-2710-2000
Turkey	Mitsubishi Electric Turkey A.S. Umraniye Branch Serifali Mahallesi Nutuk Sokak No:5, TR-34775 Umraniye / Istanbul, Turkey Tel: +90-216-526-3990	Australia	MITSUBISHI ELECTRIC AUSTRALIA PTY. LTD. 348 Victoria Road, P.O. Box 11, Rydalmere, N.S.W 2116, Australia Tel: +61-2-9684-7777
Poland	Mitsubishi Electric Europe B.V. Polish Branch ul. Krakowska 48, 32-083 Balice, Poland Tel: +48-12-347-65-00		
Russia	Mitsubishi Electric (Russia) LLC St. Petersburg Branch Piskarevsky pr. 2, bld 2, lit "Sch", BC "Benua", office 720, 195027, St. Petersburg, Russia Tel: +7-812-633-3497		

## MITSUBISHI ELECTRIC CORPORATION

HEAD OFFICE : TOKYO BUILDING, 2-7-3 MARINOUCHI, CHYODA-KU, TOKYO 100-8310, JAPAN  
NAGOYA WORKS : 1-14, YADA-MINAMI 5-CHOME, HIGASHI-KU, NAGOYA, JAPAN

When exported from Japan, this manual does not require application to the Ministry of Economy,  
Trade and Industry for service transaction permission.

Specifications subject to change without notice. Printed in Japan, November 2020.