

# MITSUBISHI

---

# Model A9GT-70LTTBW

# Back Light

---

## User's Manual

Thank you for purchasing the MELSEC-GOT Series.

To ensure correct use of this equipment, please carefully read this manual prior to use.



MODEL	A9GT-70LTT-BW-U
MODEL CODE	1DM194
IB(NA)-0800281-A(0401)MEE	

# ● SAFETY PRECAUTIONS ●

(Always read before starting use)

Before using this product, please read this manual and the relevant manuals introduced in this manual carefully and pay full attention to safety to handle the product correctly.

The precautions given in this manual are concerned with this product. For the safety precautions of the programmable controller system, please read the CPU module user's manual.

In this manual, the safety precautions are ranked as "DANGER" and "CAUTION".



**DANGER**

Indicates that incorrect handling may cause hazardous conditions, resulting in death or severe injury.



**CAUTION**

Indicates that incorrect handling may cause hazardous conditions, resulting in medium or slight personal injury or physical damage.

Note that the  **CAUTION** level may lead to a serious consequence according to the circumstances.

Always follow the precautions of both levels because they are important to personal safety.

Please save this manual to make it accessible when required and always forward it to the end user.

## [HANDING PRECAUTIONS]

### **DANGER**

- Before changing the backlight, always switch off the GOT power externally in all phases (when the GOT is connected to the bus, the PLC CPU power must also be switched off externally in all phases) and remove the GOT main unit from the enclosure.

Not switching the power off in all phases may cause an electric shock.

Not removing the unit from the enclosure can cause injury due to a drop.

### **CAUTION**

- While changing the backlight, do not touch the circuit boards and electronic parts of the GOT.

Doing so can cause a failure or malfunction.

- When changing the backlight, always note the following.

- Wear gloves or fingerstalls before starting the replacement of the backlight. Not doing so can cause injury.

- Start changing the backlight more than 5 minutes after switching the GOT power off.

Not doing so can cause a burn due to the heat of the backlight.

## [DISPOSAL PRECAUTIONS]

### CAUTION

- When disposing, treat this product as industrial waste.

### Related Manuals

The following manuals are available for this equipment.

Detailed Manual

Manual name	Manual No. (Model code)
A985GOT/A975GOT/A970GOT/A960GOT User's Manual (Available as option)	SH-4005 (13JL70)

# 1. Overview

This user's manual explains the model A9GT-70LTTBW backlight (Referred to as backlight, hereafter).

# 2. Performance

The table below lists the performance specifications of the back lights.

Item	Specifications
Applicable models *1	A975GOT-TBA-B, A975GOT-TBD-B, A970GOT-TBA-B, A970GOT-TBD-B
Kind	Cold cathode tube back light
Life	43,000 h

\*1: Indicates models of function version B (manufactured in January, 2004) or later.

### <Checking function version>

GOT function version can be checked from the rating plate, which is situated on the backside of the GOT.

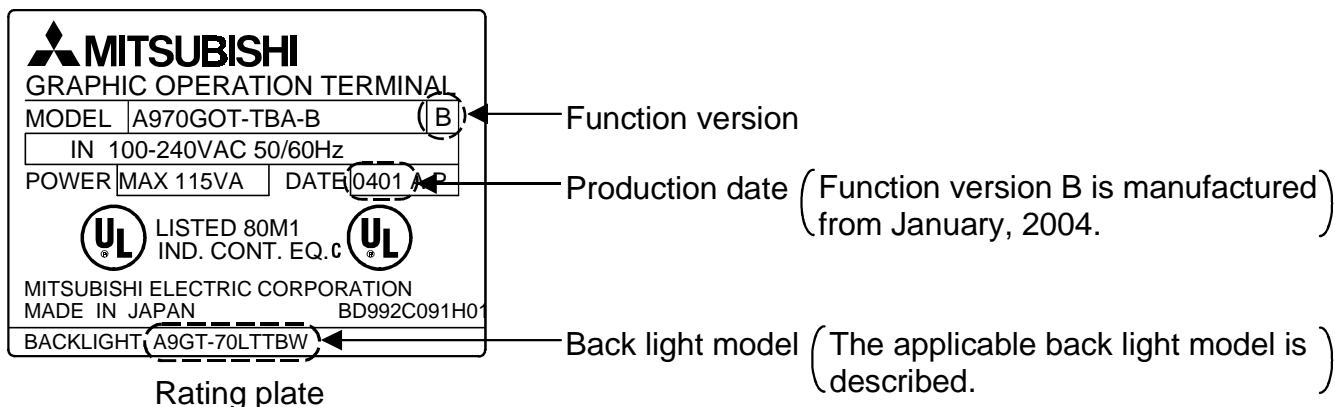

### <Back light description>

For the purpose of quick confirmation, the model name is described on the back light.

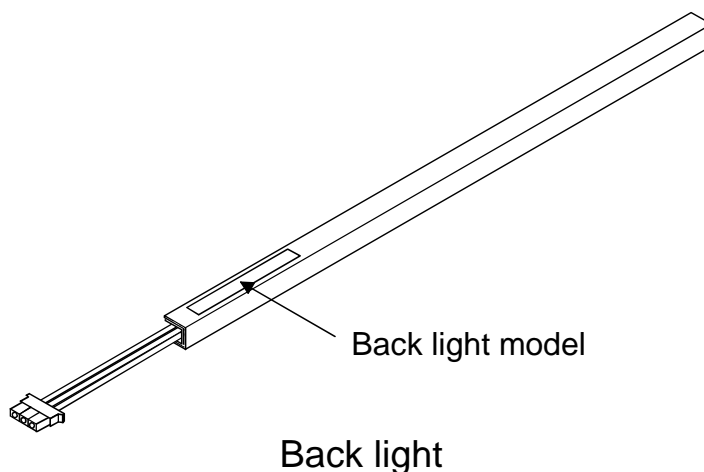

### 3. How to Change the Backlight for Liquid Crystal

In GOT, back lights are incorporated for the indicator LCD. These back lights lose the luminance as they are used. Replace the back lights if the luminance lowers further than that affects the performance of the indicator screen.

The back light replacement procedure is described below.

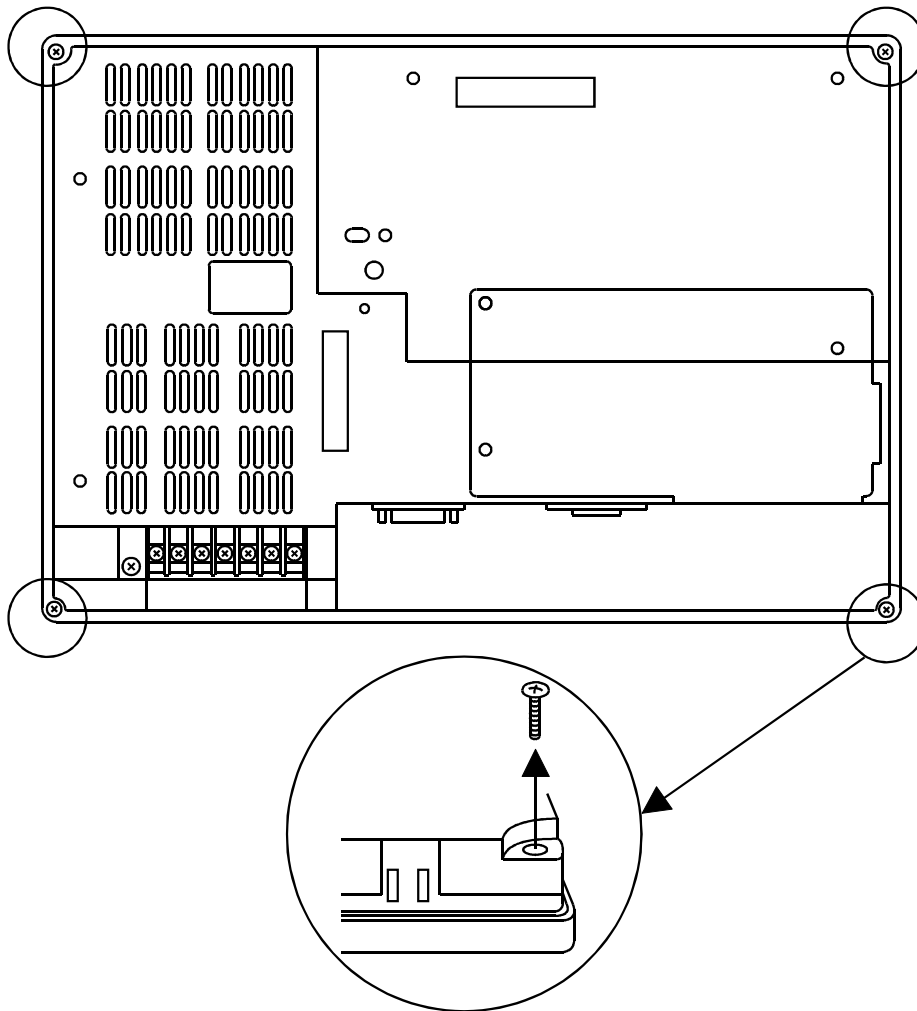

- 1) Turn off the GOT power supply. Remove the wire from the power terminal. Then remove the communications cable.
- 2) Loosen the metal fitting on GOT to remove GOT from the cabinet.
- 3) Use a screw driver and remove four fastening screws on the back of GOT.

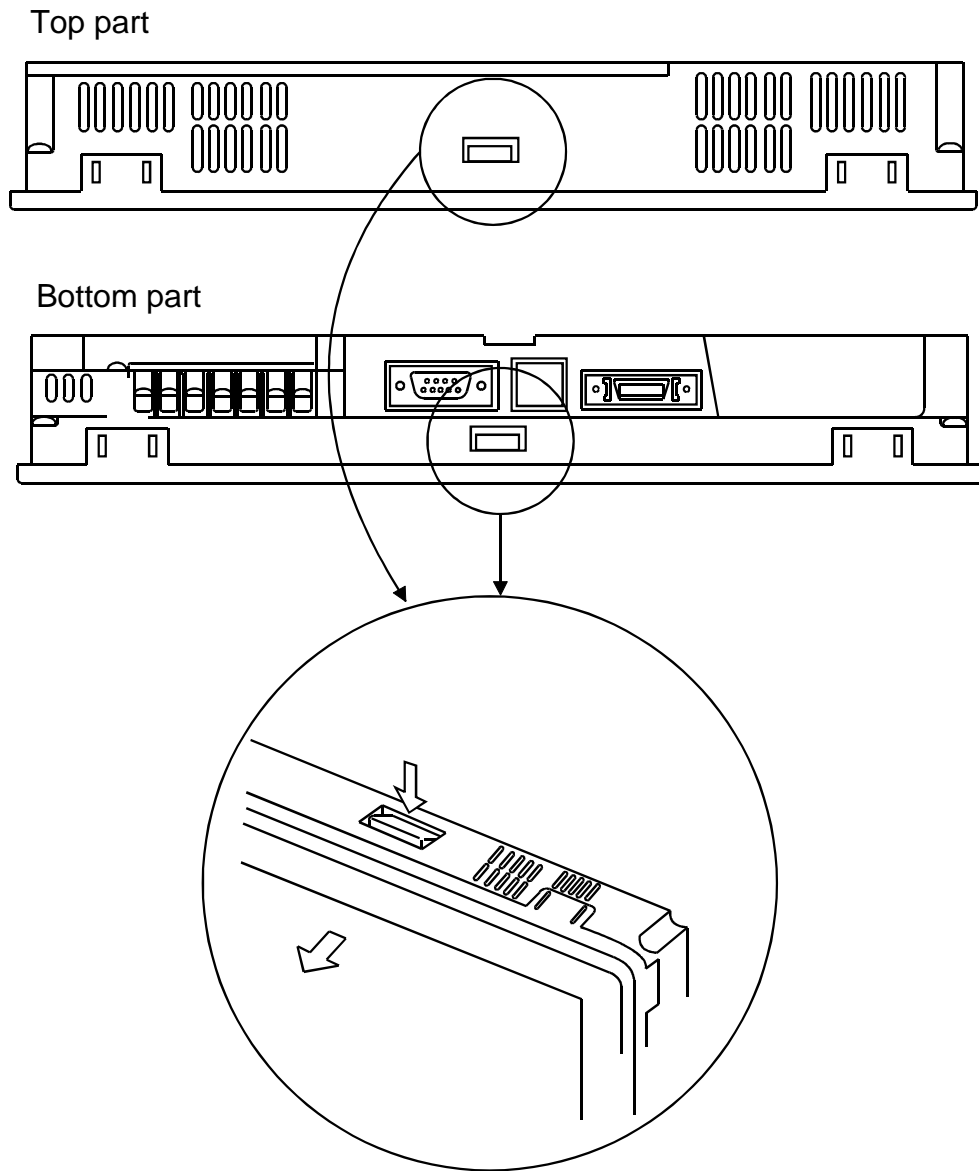

4) After removing the fastening screws, remove the indicator cover from GOT, while pressing two fastening hooks.

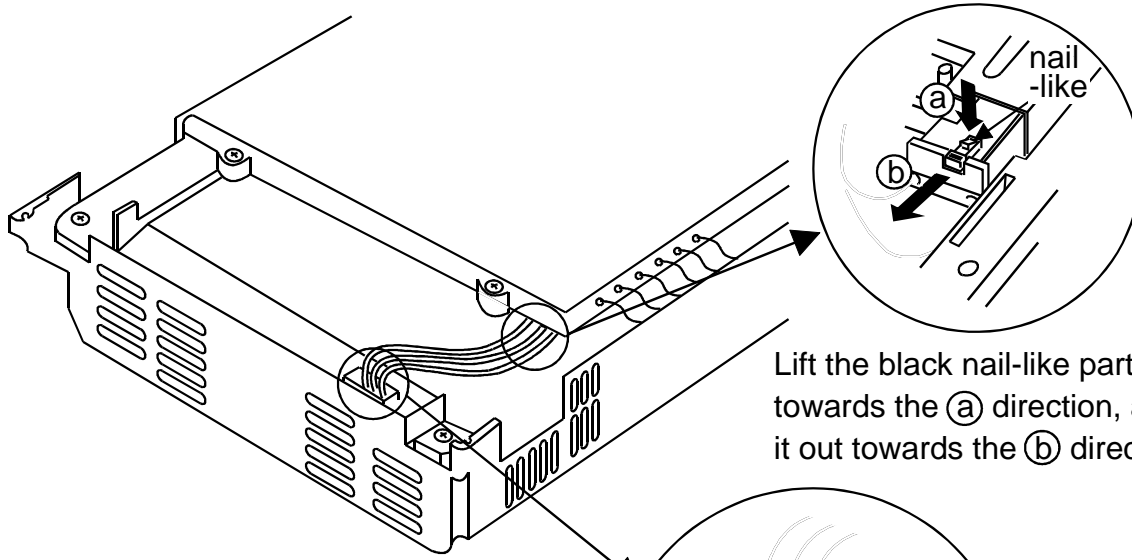

Lift the black nail-like part (black) towards the (a) direction, and pull it out towards the (b) direction.

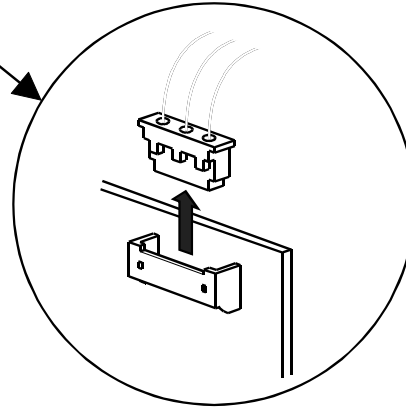

Remove the cable connector on the back lights from the indicator connector.

- 5) Show the front face of GOT, and remove the cable connector that is fitted to the upper one of the back lights from the indicator connector.
- 6) Pull out the upper one of the back lights from the indicator.
- 7) To install new back lights, follow the procedure opposite to that of removing. Similarly, follow the opposite procedure for installing the indicator. Make sure to securely install the indicator and apply a torque within the specified range to the fastening screws for GOT.  
36 to 48N•cm (3.2 to 4.2lb•inch)

## Warranty

Mitsubishi will not be held liable for damage caused by factors found not to be the cause of Mitsubishi; machine damage or lost profits caused by faults in the Mitsubishi products; damage, secondary damage, accident compensation caused by special factors unpredictable by Mitsubishi; damages to products other than Mitsubishi products; and to other duties.

### ⚠ For safe use

- This product has been manufactured as a general-purpose part for general industries, and has not been designed or manufactured to be incorporated in a device or system used in purposes related to human life.
- Before using the product for special purposes such as nuclear power, electric power, aerospace, medicine or passenger movement vehicles, consult with Mitsubishi.
- This product has been manufactured under strict quality control. However, when installing the product where major accidents or losses could occur if the product fails, install appropriate backup or failsafe functions in the system.

Country/Region	Sales office/Tel	Country/Region	Sales office/Tel
U.S.A	Mitsubishi Electric Automation Inc. 500 Corporate Woods Parkway Vernon Hills, IL 60061 Tel : +1-847-478-2100	Hong Kong	Ryoden Automation Ltd. 10th Floor, Manulife Tower, 169 Electric Road, North Point, HongKong Tel : +852-2887-8870
Brazil	MELCO-TEC Rep. Com.e Assessoria Tecnica Ltda. AV. Paulista 1471, Conj. 308, Sao Paulo City, Sao Paulo State, Brazil Tel : +55-11-283-2423	China	Ryoden Automation Shanghai Ltd. 3F Block5 Building Automation Instrumentation Plaza 103 Cao Bao Rd. Shanghai 200233 China Tel : +86-21-6475-3228
Germany	Mitsubishi Electric Europe B.V. German Branch Gothaer Strasse 8 D-40880 Ratingen, GERMANY Tel : +49-2102-486-0	Taiwan	Setsuyo Enterprise Co., Ltd. 6F., No.105 Wu-Kung 3rd.RD, Wu-Ku Hsiang, Taipei Hsine, Taiwan Tel : +886-2-2299-2499
U.K	Mitsubishi Electric Europe B.V. UK Branch Travellers Lane, Hatfield, Herts., AL10 8XB,UK Tel : +44-1707-276100	Korea	HAN NEUNG TECHNO CO.,LTD. 1F Dong Seo Game Channel Bldg., 660-11, Deungchon-dong Kangsec-ku, Seoul, Korea Tel : +82-2-3660-9552
Italy	Mitsubishi Electric Europe B.V. Italian Branch Centro Dir. Colleoni, Pal. Perseo-Ingr.2 Via Paracelso 12, 20041 Agrate B., Milano, Italy Tel : +39-039-6053344	Singapore	Mitsubishi Electric Asia Pte, Ltd. 307 ALEXANDRA ROAD #05-01/02, MITSUBISHI ELECTRIC BUILDING SINGAPORE 159943 Tel : +65-6473-2308
Spain	Mitsubishi Electric Europe B.V. Spanish Branch Carretera de Rubi 76-80 08190 - Sant Cugat del Valles, Barcelona, Spain Tel : +34-93-565-3131	Thailand	F. A. Tech Co.,Ltd. 898/28,29,30 S.V.City Building,Office Tower 2,Floor 17-18 Rama 3 Road, Bangkokpong, Yannawa, Bangkok 10120 Tel : +66-2-682-6522
France	Mitsubishi Electric Europe B.V. French Branch 25 Boulevard des Bouvets, F-92741 Nanterre Cedex, France TEL: +33-1-5568-5568	Indonesia	P.T. Autoteknindo SUMBER MAKMUR Jl. Muara Karang Selatan Block A Utara No.1 Kav. No.11 Kawasan Industri/ Pergudangan Jakarta - Utara 14440 Tel : +62-21-663-0833
South Africa	Circuit Breaker Industries LTD. Tripswitch Drive, Elandsfontein Gauteng, South Africa Tel : +27-11-928-2000	India	Messung Systems Put,Ltd. Electronic Sadan NO:111 Unit No15, M.I.D.C BHOSARI,PUNE-411026 Tel : +91-20-712-2807
		Australia	Mitsubishi Electric Australia Pty. Ltd. 348 Victoria Road, PostalBag, No 2, Rydalmere, N.S.W 2116, Australia Tel : +61-2-9684-7777

## MITSUBISHI ELECTRIC CORPORATION

HEAD OFFICE : 1-8-12, OFFICE TOWER Z 14F HARUMI CHUO-KU 104-6212, JAPAN  
NAGOYA WORKS : 1-14, YADA-MINAMI 5-CHOME, HIGASHI-KU, NAGOYA, JAPAN

When exported from Japan, this manual does not require application to the Ministry of Economy, Trade and Industry for service transaction permission.

Specifications subject to change without notice.  
Printed in Japan on recycled paper.