

When considering to use this module for an atomic power, aerospace, medical fields or passenger use mobile, please contact to a sales representative beforehand.

## Programmable Controller MELSEC iQ-R Series Energy Measuring Module Model RE81WH User's Manual (Hardware)

Before using this module, please read both this manual and Details carefully and pay full attention to safety to handle this module correctly. Make sure that the end users read this manual and then keep the manual in a safe place for future reference. The following manuals are also related to this module. Order each manual as needed, referring to the following list.

Manual name	Manual number (Model code)
Energy Measuring module Model RE81WH User's Manual (Details)	IB63D82 (19W851)
MELSEC iQ-R Module Configuration Manual	SH-081262ENG

### COMPLIANCE WITH THE EMC AND LOW VOLTAGE DIRECTIVES

(1) For programmable controller system  
To configure a system meeting the requirements of the EMC and Low Voltage Directives when incorporating the Mitsubishi programmable controller (EMC and Low Voltage Directives compliant) into other machinery or equipment, refer to the MELSEC iQ-R Module Configuration Manual "EMC and Low Voltage Directive".  
The CE mark, indicating compliance with the EMC and Low Voltage Directives, is printed on the rating plate of the programmable controller.  
(2) For this module  
For the compliance of this module with the EMC and Low Voltage Directives, refer to the User's Manual (Details).

#### 1. Features

(1) This Energy Measuring module can measure various types of electric quantity just ONE module.  
This Energy Measuring module can measure electric energy, reactive energy, current, voltage, electric power, power factor, frequency, harmonic current and harmonic voltage. Both consumption and regeneration of the electric energy can be measured.  
(2) Extensive monitoring functions  
In addition to memorizing the maximum and minimum values, two types of alarm monitoring for upper and lower limit can be performed.  
(3) It also can measure the electric energy for a certain period.  
It can measure the electric energy for the duration of time for which the output device is on. This feature enables to acquire the electric energy needed during device operation or energy per fact.

#### 2. Checking packaged contents

The following items for this module are included in the package. Check that no items are missing.  
• Energy Measuring module x 1 • User's Manual (Hardware) x 1

#### 3. Safety Precautions

**3.1 Precautions for Operating Environment and Conditions**  
This module is premised on being used in pollution degree 2<sup>(EN61010-1)</sup> environment. When used in higher pollution degree, protect the module from the pollution on another device side to be incorporated.  
Overvoltage category of measuring circuit in this module is CAT III<sup>(EN61010-1)</sup>.  
Do not use this product in the places listed below. Failure to follow the instruction may cause malfunctions and a life decrease of product.  
• Places the ambient temperature exceeds the range 0 ~ 55°C.  
• Places the average daily temperature exceeds +35°C  
• Places the relative humidity exceeds the range 5 ~ 95% or places with dewfall.  
• Altitude exceeds 2000 m.  
• Places exposed to rain or water drop.  
• Dust, corrosive gas, saline and oil smoke exist.  
• Places in strong electromagnetic field or places large amounts of external noise exist.  
• Vibration and impact exceed the specifications.  
• Installed excluding the control panel.  
This module is the open type device, which are designed to be housed within another device for prevention of electric shock. House the module within the device such as the control panel before use. (Indoor use)  
(Note 1) For the definition of the pollution degree and the over voltage category, refer to EN61010-1/2010.

#### 3.2 Matters concerning the preparation before use

• Use the module in the specified usage environment and conditions.  
• The setting of this module (phase system, primary voltage, primary current) is necessary before using it.  
Refer to the User's Manual (Details) about each setting method.

## 6. How to wire

### 6.1 Wiring

Depending on the phase/wire system of the circuit, follow the wiring diagrams as below.  
For connecting the current circuit, make sure to use the module in combination with the dedicated current sensor (Refer to 6.3 Current sensor).  
For attaching method of the current sensor and detailed specifications, refer to the User's Manual (Details).

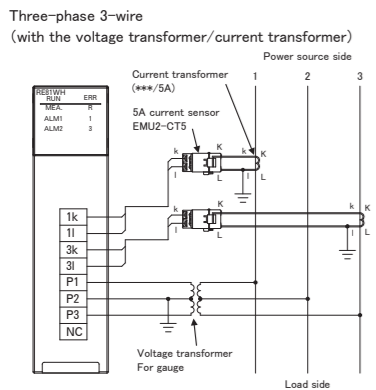
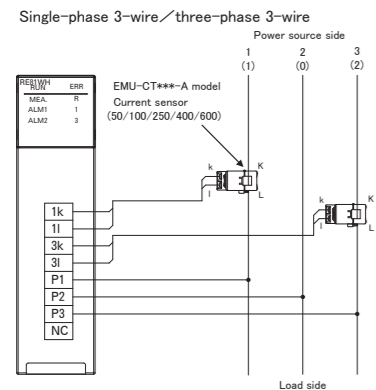

\*For a low voltage circuit, grounding of the secondary sides of VT and CT is not necessary.

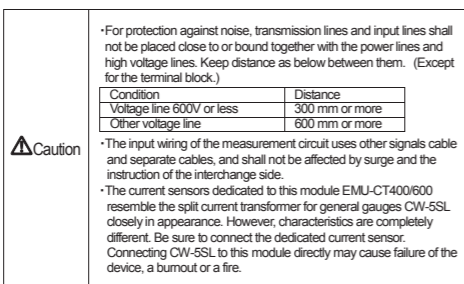
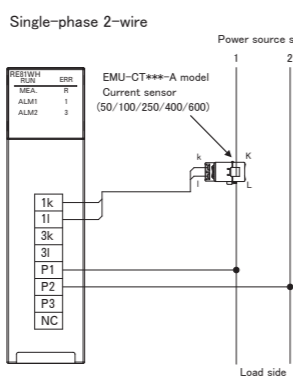

• Maximum voltage of the circuit connected to this module is 260V. For the circuit over this voltage, use the transformer. Using the transformer, primary voltage is configurable up to 6600V. Secondary voltage is fixed to 110 or 220V. (Special primary voltage of VT can be set up to 6600V in any, and special secondary voltage of VT can be set up to 220V in any.)  
• Make sure that before connecting the cable, the orientation of the current sensor is correct for attachment. K to L is the correct direction. K: power source side, L: load side.  
• Current sensor(excluding EMU2-CT5) is extendable up to 50 m.  
• EMU2-CT5 is extendable up to 10 m, using together with an extension cable. To extend the wire further, use the current transformer CW-SSL for split-type instrument in combination, extending the secondary wiring on CW-SSL(L) side.

### 3.3 Installation and Wiring Precautions

Make sure to use the module by following cautions of this section. Improper use may impair protection provided by this module.

**Danger**  
• Shut off the external power supply for the module in all phases before installing or wiring. Failure to do so may cause an electric shock or a damage of the module.  
• Shut off the power supply for the module in all phases before installing or wiring. Failure to do so may cause an electric shock or a damage, a fire on the module.

• Any person who is involved in the installation and the wiring of this Programmable Controller should be fully competent to do the work.  
• Secure the spatial distance more than 100 mm in all directions (other than back).  
• Use the programmable controller in an environment that meets the general specifications in the MELSEC iQ-R Module Configuration Manual. Failure to do so may result in electric shock, fire, malfunction, or damage to or deterioration of the product.  
• After mounting the module, ensure that the module fixing hook is securely applied on the base unit and the module is surely mounted. Incorrect mounting may cause malfunctions, a failure or a drop of the module.  
When using the Programmable Controller in an environment of frequent vibrations, fix the module with a screw.  
• Tighten the screw within the specified torque range. Loose tightening can cause drop of the screw, short circuit or malfunction. Over tightening can damage the screw and/or module, resulting in drop, short circuit, or malfunction.  
• Do not directly touch any conductive part of the module. Doing so can cause malfunctions or a failure of the module.  
• When using this module, make sure to use it in combination with the dedicated current sensor. Do not exceed the rating of the module for input of the current sensor. A secondary side (5A) of transformer cannot directly input to this module. For further details, refer to the manuals for the current sensor to maintain the functionalities and the accuracy of the module.  
• The dedicated current sensor is used only for low voltage circuit. It cannot be used for a high voltage circuit. EMU2-CT5 and EMU2-CT5-A should be used with secondary side (5A) of transformer transfixed. If it is connected with a high voltage circuit by mistake, it may cause a burnout of the device and a fire. It is critically dangerous. For the allowance maximum voltage of current sensor, refer to the User's Manual (Details).  
• The dedicated current sensor has a polarity (directionality). Be careful of it when installing the module.  
• Take care not entering any foreign objects such as strips and wire pieces into the module. It may cause a fire, a failure or a malfunction.  
• In order to prevent the module from incoming foreign objects such as wire pieces during wiring work, a foreign-object preventive label is placed on the module. While a wiring work is performed, keep the label on the module. Before operating the system, peel off the label for heat release. If the foreign-object preventive label is not peeled off and the system is in use, residual heat inside the module may reduce the product life.  
• The wires to be connected to the module shall be placed in a duct or fixed together by clamping. If the electric wires are not placed in the duct or clamped together, kosen wires or their movement or careless stretch may cause a breakage of the module or wire or a malfunction due to poor contact of electric wires.  
• Use appropriate size of electric wires. If inappropriate size of electric wire is used, it may cause a fire due to generated heat.  
• In case using stranded wire, take measures so that the filament should not vary by using a bar terminal or by processing the point twisted. Use the bar terminal appropriated for the size of electric wires. If inappropriate bar terminal is used, a wire breakage or a contact failure may occur, which may cause a device malfunction, a failure, a burnout or a fire.  
• After inserting the electric wire or a bar terminal, make sure that no missing insertion is existing. Missing insertion may cause a malfunction, a fire, or an electric shock on the device.  
• If the wires connected to the module are strongly pulled off, it may cause a malfunction or a breakage to the module or the wire.  
• Ensure the wiring to the module properly after checking the rated voltage and current of the product and the terminal pin assignment. If the input voltage exceeds the rated voltage or the wiring is improper, it may cause a fire or a breakage.  
• Do not exceed the specified voltage when doing an insulation resistance test and a commercial frequency withstand voltage test.  
• To prevent persons with little knowledge about electric equipment from electric shock, panel must be taken either following measure.  
Lock the panel so that only those who get an education about electrical equipment and have sufficient knowledge can unlock, or shut off power supply automatically upon opening the panel. Cover the dangerous voltage part of the module.

### Caution

### 3.4 Precautions for Start-up and Maintenance

This module is not compliant for dealing / proving electric energy specified in a measurement law.

**Caution**  
• Use the product within the ratings specified in this manual. If it is used outside the ratings, it may cause not only a malfunction or a failure but also a fire or a burnout.  
• Before operating the product, check that active bare wire etc. does not exist around the product. If any bare wire is found, stop the operation immediately, and take an appropriate action such as isolation protection.  
• Do not disassemble or modify the module. It may cause a failure, a malfunction, an injury or a fire.  
• Attaching and detaching the module must be performed after the power source is shut off for all outside phases. If all phases are not shut off, it may cause an electric shock, a failure or a malfunction of the module.  
• Do not touch powered wires. It may cause a malfunction.  
• Tightening mounting screws and cleaning module must be performed after the power source is shut off for all outside phases. If all phases are not shut off, it may cause an electric shock, a failure or a malfunction of the module.  
• Use a soft dry cloth to clean off dirt of the module surface.  
• Do not let a chemical cloth remain on the surface for an extended period of time nor wipe the surface with thinner or benzene.  
• Check for the following items to use this module properly for a long time.  
-Daily maintenance-  
<(1) No damage on this module (2) No abnormality with LED indicators (3) No abnormal noise, smell or heat.  
<Periodical maintenance (Once every 6 months to 1 year) >  
(4) No looseness with installation, wire connection to terminal blocks, and connector connection.  
(Check these items under the electric outage condition).

### 3.5 Storage Precautions

To store the module, turn off the power and remove wires, and put it in a plastic bag.  
For long-time storage, avoid the following places. Failure to follow the instruction may cause a failure and reduced life of the module.  
• Places the ambient temperature exceeds the range -25 ~ +75 °C. • Places the average daily temperature exceeds 35 °C.  
• Places the relative humidity exceeds the range 5 ~ 95% or places with dewfall. • Vibration and impact exceed the specifications.  
• Places with metal fragments or conductive substance are flying. • Places exposed to rain, water drops or direct sunlight.  
• Dust, corrosive gas, saline and oil smoke exist.

### 3.6 Disposal Precautions

When disposing of this module, treat it as industrial waste.

### 3.7 Packaging materials and this manual

For reduction of environmental load, packaging materials are produced with cardboard, and this manual is printed on recycled paper.

## 4. Name and function of each part

4.1 Names and functions of parts of RE81WH are provided below.

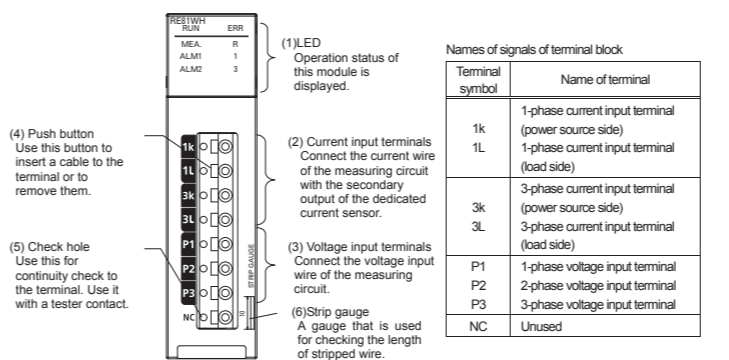

✓ **Supplementary**  
Check the stripping length using the strip gauge of this module.

## 7. Dimensions

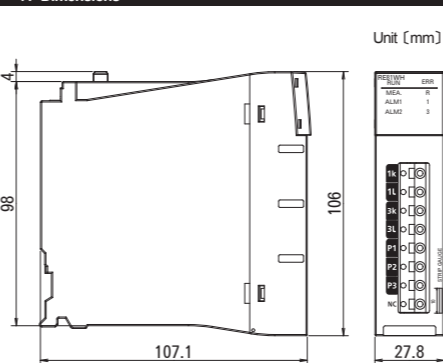

## 8. Specifications

Item	Specifications	
Model	RE81WH	
Phase-wire system	Single-phase 2-wire / single-phase 3-wire / three-phase 3-wire	
Voltage circuit	Single-phase 2-wire, three-phase 3-wire	
	Single-phase 3-wire	
Rating	110V, 220V AC	
	110V AC (b/w 1- and 2-side, 2- and 3-side) 220V AC (b/w 1- and 3-side)	
	5A, 50A, 100A, 250A, 400A, 600AAC (The dedicated split type current sensor is used. Each value refers to the current at the primary side of the current sensor.) Configurable primary current when using 5A sensor: 5A - 6000A Secondary current maximum 66.66mA	
Frequency	50/60Hz (Frequency automatically recognized) Current: ±1.0% (100% of the rating) Voltage: ±1.0% (100% of the rating) Electric power: ±1.0% (100% of the rating) Reactive energy: ±1.0% (100% of the rating) Apparent power: ±1.0% (100% of the rating) Harmonic current: ±2.5% (100% of the rating) Harmonic voltage: ±2.5% (100% of the rating) Frequency: ±1.0% (45 - 65Hz range of the rating) Power factor: ±3.0% (against the electric angle 90°) Electric energy: ±2.0% (5 - 100% range of the rating, power factor = 1) Reactive energy: ±2.5% (10 - 100% range of the rating, power factor = 0)	
Allowable tolerance of module (excluding the current sensor)		
Transient overvoltage	Measurement circuit: CAT III	
Measuring circuit count	1 circuit	
Operating environment	Operating temperature	0 ~ +55°C (Average daily temperature 35°C or below) (Note 1)
	Operating humidity	5 - 95%RH (No condensation)
	Storage temperature	-25 ~ +75°C
	Operating altitude	2000 m or below
	Commercial frequency withstand voltage	Between voltage/current input terminals - programmable controller power source and GND terminals: 2210V AC 5sec
Standard	EMC:	EN61131-2:2007 EN61326-1:2006
	Safety standard:	EN61131-2:2007 EN61010-1:2010 UL61010-1:3rd Edition
Installation area	Inside a control panel (Note 1) : 0 ~ +50°C (complies with UL standard)	

## 9. Warranty

In case you have any questions or the product may have a failure, make an inquiry to your nearest MITSUBISHI ELECTRIC CORPORATION office.  
• The charge-free warranty period of the product shall be 36 months from the date of your purchase or the date the product is delivered to your specified delivery location. However, the maximum limit of the charge-free warranty period shall be set to 42 months from the time of manufacture by defining the longest distribution period of the product as 6 months after the product is shipped from our manufacturing factory. Also, the charge-free warranty period for the replacement product shall not be extended exceeding the charge-free warranty period for the original product.

• Our company shall not be liable to compensate for any loss arising from events not attributable to our company, opportunity loss and lost earning of the customer due to failure of the product, and loss, secondary loss, accident compensation, damage to other products besides our products and other operations caused by a special reason regardless of our company's predictability in both within and beyond the charge-free warranty period.

**Caution** If an abnormal sound, bad-smelling, smoke, or heat breaks out of this module, switch it off promptly, and do not use it.

## 10. Content Poisonous Substance

(1) 电子信息产品污染控制标识  
根据《电子信息产品有害物质限制使用管理办法》，该标识适用于在中国销售的电子信息产品，其中的数字为产品的环保使用期限。只要遵守本产品在安全和使用方面的注意事项，从生产日算起的环保使用期限内不会造成环境污染或对人体、财产产生深刻的影响。  
注) 产品正常使用废弃后，应按照国家及地方的法律法规完成该电子信息产品的回收和再利用。

(2) 产品中有害物质的名称及含量  
本产品中所含有的6种有害物质的名称、含有信息及含有部件如下表所示。

部件名称	有害物质					
	铅 (Pb)	汞 (Hg)	镉 (Cd)	六价铬 (Cr(VI))	多溴联苯 (PBB)	多溴二苯醚 (PBDE)
基板	×	○	○	○	○	○
箱子	○	○	○	○	○	○
铭牌	○	○	○	○	○	○

本表格依据 JIS T1364 的规定编制。  
○: 表示该有害物质在该部件所有均质材料中的含量均在 GB/T 26572 规定的限量要求以下。  
×: 表示该有害物质至少在该部件的某一均质材料中的含量超出 GB/T 26572 规定的限量要求。  
且虽然自然界没有成熟的替代方案，但是符合欧盟 RoHS 指令要求。

## 11. Handling precautions

Precautionary note written in Korean  
사용자안내문 A급 기기 (업무용 방송통신기자재)  
이 기기는 업무용(A급) 전자파적합기기로서 판매자 또는 사용자는 이 점을 주의하시기 바라며, 가정외의 지역에서 사용하는 것을 목적으로 합니다.

## 12. Customer Service

**MITSUBISHI ELECTRIC CORPORATION**  
HEAD OFFICE: TOKYO BUILDING, 2-7-3, MARUNOUCHI, CHIYODA-KU, TOKYO 100-8310, Japan

Please refer to "catalog" or "user's manual (Details)" for more detail.