

Programmable Controller

MELSEC iQ-R
series

MELSEC iQ-R Series Energy Measuring Module
User's Manual (Details)

RE81WH

INTRODUCTION

(Read these precautions before using this product.)

This manual contains important instructions for MELSEC iQ-R series RE81WH.

Before using this module, please read this manual and the relevant manuals carefully and pay full attention to safety to handle the product correctly.

The precautions given in this manual are concerned with this module only. For the safety precautions of the programmable controller system, refer to the "MELSEC iQ-R Module Configuration Manual".

Make sure that end users read this manual and then keep the manual in a safe place for future reference.

■ Notations in this manual

Use the following marks in this manual.

Mark	Meaning of the mark
⚠Danger	Indicates that incorrect handling by ignoring this mark may result in death or severe injury.
⚠Caution	Indicates that incorrect handling by ignoring this mark may result in injury or property damage.
✓Supplement	Indicates precautions to avoid malfunction, to work the module properly.

Depending on circumstances, failure to follow the precautions given under "⚠Caution" may lead to further serious consequences.

Please follow the precautions with full care because they are critical for personal and system safety.

The "n" used in this manual (for example: Xn0, Yn0, Un\G0, etc.) indicates the Start I/O No. of this module.

■ Relevant manuals

The following manuals are also related to this module. You can download each manuals from the following web site.

<http://www.mitsubishielectric.com/fa/>

Title	Document number
MITSUBISHI Programmable Controller MELSEC iQ-R Series Energy Measuring Module Model RE81WH User's Manual (Hardware)	IB63D83
MELSEC iQ-R Module Configuration Manual	SH-081262ENG
GX Works3 Operating Manual	SH-081215ENG

■ Checking package contents

This following items for this device and included in package. Check that no items are missing.

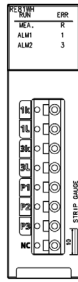

Energy Measuring Module (RE81WH) x1

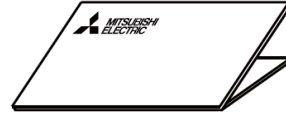

User's Manual (Hardware) x1

This module is not compliant for dealing / proving electric energy specified in a measurement law. Please use the certified watt-hour meter to be used for deal and proof of electric energy measurement stipulated. When considering to use this module for an atomic power, aerospace, medical fields or passenger use mobile, please contact to a sales representative beforehand.

FEATURES

- (1) This Energy Measuring Module can measure various types of electric quantity just ONE module.
This Energy Measuring module can measure electric energy, reactive energy, current, voltage, electric power, power factor, frequency, harmonic current and harmonic voltage.
Both consumption and regeneration of the electric energy can be measured.
- (2) Extensive monitoring functions.
In addition to memorizing the maximum and minimum values, two types of alarm monitoring for upper and lower limit can be performed.
Since the alarm setting is stored in the buffer memory, there is no need to complicated programs.
- (3) It also can measure the electric energy for a certain period.
It can measure the electric energy for the duration of time for which the output device is on.
This feature enables to acquire the electric energy needed during device operation or energy per tact.
- (4) It can acquire waveform data of current and voltage.
It can acquire waveform data of the measured current and voltage.
Thus, it is able to monitor / indicate using waveform data.

Revision history

* Manual Number is provided at the bottom of the cover page.

Revision data	Manual number *	Revision
Mar, 2018	IB63D82	First edition
Nov, 2018	IB63D82A	<ul style="list-style-type: none"> ■ Modification, addition for the description of the version related to RE81WH Section 2.2, 6.4 ■ Modification for the errors and other description Section 4.2, 5.1, 5.5 and 8.1

This manual does not guarantee to protect or does not give permission to any industrial property and any related rights. Also, our company shall not be held any responsible for any issues related to industrial properties due to product usage described in this manual.

CONTENTS

INTRODUCTION	1
FEATURES	3
CONTENTS	5
Section 1 SAFETY PRECAUTIONS	7
1.1 Precautions for Operating Environment and Conditions	7
1.2 Matters concerning the preparation before use	7
1.3 Installation and Wiring Precautions	8
1.4 Precautions for Start-up and Maintenance	10
1.5 Storage Precautions	10
1.6 Disposal Precautions	10
1.7 Packaging materials and this manual	10
Section 2 SYSTEM CONFIGURATION.....	11
2.1 Precautions for system configuration	11
2.2 Applicable system.....	11
Section 3 NAME AND FUNCTION OF EACH PART	14
3.1 Name of each part	14
3.2 Indication and function of LEDs.....	15
3.3 List of functions.....	16
3.4 Functions in detail.....	17
Section 4 I/O SIGNALS TO CPU MODULE	38
4.1 List of I/O signals	38
4.2 Details of I/O signals.....	39
Section 5 BUFFER MEMORY	51
5.1 Buffer memory assignment	51
5.2 Configurable sections (Un\G0 - Un\G99)	60
5.3 Measurement sections (Un\G100 - Un\G2999).....	70
5.4 Common sections (Un\G3000 - Un\G4999)	91
5.5 Waveform data sections (Un\G10000 - Un\G22013)	94
Section 6 SETTING AND PROCEDURE FOR OPERATION.....	98
6.1 Procedure for operation.....	98
6.2 Mounting and removing the module	99
6.3 Wiring.....	101
6.4 Parameter setting	112
Section 7 PROGRAMMING	126
7.1 Programming procedure.....	126
7.2 System configuration and usage conditions for sample program	127
7.3 Sample programming	129
Section 8 TROUBLESHOOTING	135
8.1 List of error codes.....	135
8.2 Troubleshooting.....	137
8.3 Q&A	140

Section 9	REQUIREMENT FOR THE COMPLIANCE WITH EMC AND LOW VOLTAGE DIRECTIVES	143
Section 10	SPECIFICATION	144
10.1	General specifications	144
10.2	Electrical and mechanical specifications	146
10.3	External dimensions	147
10.4	Optional devices	148
APPENDIX	153
INDEX	154
WARRANTY	156

Section 1 SAFETY PRECAUTIONS

1.1 Precautions for Operating Environment and Conditions

This module is premised on being used in pollution degree 2 ^(Note1) environment. When used in higher pollution degree, protect the module from the pollution on another device side to be incorporated.

Overvoltage category of measuring circuit in this module is CAT III ^(Note 1).

Do not use this product in the places listed below. Failure to follow the instruction may cause malfunctions and a life decrease of product.

- Places the ambient temperature exceeds the range 0 – 55°C.
- Places the average daily temperature exceeds +35°C
- Places the relative humidity exceeds the range 5 – 95% or places with dewfall.
- Altitude exceeds 2000 m.
- Places metal fragments or conductive substance are flying.
- Places exposed to direct sunlight.
- Dust, corrosive gas, saline and oil smoke exist.
- Places exposed to rain or water drop.
- Places in strong electromagnetic field or places large amounts of external noise exist.
- Vibration and impact exceed the specifications.
- Installed places excluding the control panel.

This module is the open type device, which are designed to be housed within another device for prevention of electric shock. House the module within the device such as the control panel before use. (Indoor use)

(Note 1) For the definition of the pollution degree and the over voltage category, refer to EN61010-1/2010.

1.2 Matters concerning the preparation before use

Use the module in the specified usage environment and conditions.

The setting of this module (phase wire system, primary voltage, primary current) is necessary before using it.

*Refer to "5.2 Configurable sections (Un\G0 - Un\G99)" about each setting method.

 **Danger**

- Do not write data into "System Area" in the buffer memory of the intelligent function module.
Also, do not output (turn ON) the "use prohibited" signal in the output signal sent from the sequencer CPU to the intelligent function module.
Doing so may cause a malfunction to the sequencer system.

1.3 Installation and Wiring Precautions

Make sure to use the module by following cautions of this section. Improper use may impair protection provided by this module.

Danger

- Shut off the external power supply for the module in all phases before installing or wiring. Failure to do so may cause an electric shock or a damage of the module.
- Shut off the power supply for the module in all phases before installing or wiring. Failure to do so may cause an electric shock or a damage, a fire on the module.

Caution

<Precautions for Electric work>

- Any person who is involved in the installation and the wiring of this Programmable Controller should be fully competent to do the work.
- Use the programmable controller in an environment that meets the general specifications in the “MELSEC iQ-R Module Configuration Manual”. Failure to do so may result in electric shock, fire, malfunction, or damage to or deterioration of the product.
- After mounting the module, ensure that the module fixing hook is securely applied on the base unit and the module is surely mounted. Incorrect mounting may cause malfunctions, a failure or a drop of the module. When using the Programmable Controller in an environment of frequent vibrations, fix the module with a screw.
- Tighten the screw within the specified torque range. Loose tightening can cause drop of the screw, short circuit or malfunction. Over tightening can damage the screw and/or module, resulting in drop, short circuit, or malfunction.
- Do not directly touch any conductive part of the module. Doing so can cause malfunctions or a failure of the module.
- Take care not entering any foreign objects such as strips and wire pieces into the module. It may cause a fire, a failure or a malfunction.
- In order to prevent the module from incoming foreign objects such as wire pieces during wiring work, a foreign-object preventive label is placed on the module. While a wiring work is performed, keep the label on the module. Before operating the system, peel off the label for heat release. If the foreign-object preventive label is not peeled off and the system is in use, residual heat inside the module may reduce the product life.
- After inserting the electric wire or a bar terminal, make sure that no missing insertion is existing. Missing insertion may cause a malfunction, a fire, or an electric shock on the device.
- Ensure the wiring to the module properly after checking the rated voltage and current of the product and the terminal pin assignment. If the input voltage exceeds the rated voltage or the wiring is improper, it may cause a fire or a breakage.
- The wires to be connected to the module shall be placed in a duct or fixed together by clamping. If the electric wires are not placed in the duct or clamped together, loosen wires or their movement or careless stretch may cause a breakage of the module or wire or a malfunction due to poor contact of electric wires.
- For protection against noise, transmission lines and input lines shall not be placed close to or bound together with the power lines and high voltage lines. Keep distance as below between them. (Except for the terminal block.)

Condition	Distance
High-voltage line 600V or less	300mm or more
Other high-voltage line	600mm or more

 **Caution**

<Connection of terminal block>

- In case using stranded wire, take measures so that the filament should not vary by using a bar terminal or by processing the point twisted. Use the bar terminal appropriated for the size of electric wires. If inappropriate bar terminal is used, a wire breakage or a contact failure may occur, which may cause a device malfunction, a failure, a burnout or a fire.
- Use appropriate size of electric wires. If inappropriate size of electric wire is used, it may cause a fire due to generated heat.

<Connection with the current sensor>

- When using this module, make sure to use it in combination with the dedicated current sensor. Do not exceed the rating of the module for input of the current sensor. A secondary side (5A) of transformer cannot directly input tot this module. For further details, refer the manuals for the current sensor to maintain the functionalities and the accuracy of the module.
- The dedicated current sensor (excludes EMU2-CT5 and EMU-CT5-A) is used only for low voltage circuit. It cannot be used for a high voltage circuit. EMU2-CT5 and EMU-CT5-A should be used with secondary side (5A) of transformer transixed. If it is connected with a high voltage circuit by mistake, it may cause a burnout of the device and a fire. It is critically dangerous. For the allowance maximum voltage of current sensor, refer to “10.4.1” in this manual.
- The dedicated current sensor has a polarity (directionality). Be careful about it when installing the module.
- If the wires connected to the module are strongly pulled off, it may cause a malfunction or a breakage to the module or the wire.

<Connection of ground>

- Do not exceed the specified voltage when doing an insulation resistance test and a commercial frequency withstand voltage test.
- To prevent persons with little knowledge about electric equipment from electric shock, panel must be taken either following measure.
 - Lock the panel so that only those who get an education about electrical equipment and have sufficient knowledge can unlock, or shut off power supply automatically upon opening the panel.
 - Cover the dangerous voltage part of the module.

1.4 Precautions for Start-up and Maintenance

Caution

- Use the product within the ratings specified in this manual. If it is used outside the ratings, it may cause not only a malfunction or a failure but also a fire or a burnout.
- Before operating the product, check that active bare wire etc. does not exist around the product. If any bare wire is found, stop the operation immediately, and take an appropriate action such as isolation protection.
- Do not disassemble or modify the module. It may cause a failure, a malfunction, an injury or a fire.
- Attaching and detaching the module must be performed after the power source is shut off for all outside phases. If all phases are not shut off, it may cause an electric shock, a failure or a malfunction of the module.
- Do not touch powered wires. It may cause a malfunction.
- Tightening mounting screws and cleaning module must be performed after the power source is shut off for all outside phases. If all phases are not shut off, it may cause an electric shock, a failure or a malfunction of the module.
- Use a soft dry cloth to clean off dirt of the module surface.
- Do not let a chemical cloth remain on the surface for an extended period of time nor wipe the surface with thinner or benzene.
- Check for the following items to use this module properly for a long time.
 - <Daily maintenance>
 - (1) No damage on this module.
 - (2) No abnormality with LED indicators.
 - (3) No abnormal noise, smell or heat.
 - <Periodical maintenance (Once every 6 months to 1 year) >
 - (4) No looseness with installation, wire connection to terminal blocks, and connector connection.
(Check these items under the electric outage condition.)

1.5 Storage Precautions

To store the module, turn off the power and remove wires, and put it in a plastic bag.

For long-time storage, avoid the following places. Failure to follow the instruction may cause a failure and reduced life of the module.

- Places the ambient temperature exceeds the range -25 - +75 °C.
- Places the average daily temperature exceeds 35 °C.
- Places the relative humidity exceeds the range 5 - 95% or places with dewfall.
- Vibration and impact exceed the specifications.
- Places with metal fragments or conductive substance are flying.
- Places exposed to rain, water drops or direct sunlight.
- Dust, corrosive gas, saline and oil smoke exist.

1.6 Disposal Precautions

When disposing of this module, treat it as industrial waste.

1.7 Packaging materials and this manual

For reduction of environmental load, packaging materials are produced with cardboard, and this manual is printed on recycled paper.

Section 2 SYSTEM CONFIGURATION

2.1 Precautions for system configuration

Attention to the following when configuring the system.

- Please install each modules so that the total number of occupied I/O points of these modules is equal to or less than the number of I/O points of the CPU module used.
- Depending on the rated output current of the power supply used, mounting of the maximum number of modules may not be possible. Consider the current consumption of each module to configure the system.

2.2 Applicable system

2.2.1 Applicable module

(1) CPU module

The CPU module that can install RE81WH is shown below.

For the number of mountable modules, refer to the "MELSEC iQ-R Module Configuration Manual".

RE81WH supports multiple CPU system.

Attachable CPU Module	
CPU Type	CPU Model
Programmable controller CPU	R00CPU
	R01CPU
	R02CPU
	R04CPU
	R08CPU
	R16CPU
	R32CPU
	R120CPU
	R04ENCPU
	R08ENCPU
	R16ENCPU
	R32ENCPU
R120ENCPU	

Attachable CPU Module	
CPU Type	CPU Model
Process CPU	R08PCPU
	R16PCPU
	R32PCPU
	R120PCPU
Safety CPU	R08SF CPU
	R16SF CPU
	R32SF CPU
	R120SF CPU
C Controller module	R12CCPU-V

(2) Base unit

The Base unit that can install RE81WH is shown below.

RE81WH can be installed to any I/O slot *1*2.

*1 In case of Process CPU that operates in redundant mode, it can only be mounted with the extension base unit. It is not allowed to be mounted with the main base unit.

*2 Limited within the range of I/O points for the CPU module.

Mountable Base unit	
Type	Model
Main base	R35B
	R38B
	R312B
	R310B
	R310B-HT
	R38RB-HT
Extension base	R65B
	R68B
	R612B
	R610RB
	R610B-HT
	R68RB-HT

(3) Applicable software package

Software packages applicable to this module as follows.

Refer to the next page for the version of this module.

Product name	Model name	Remarks	RE81WH version
GX Works3 Version1	SW1DND-GXW3-J	1.040S or later	A
		1.050C or later	B

2.2.2 How to confirm the version of RE81WH

Confirm the version of RE81WH as below:

Refer to previous page for the software package corresponding to the each version.

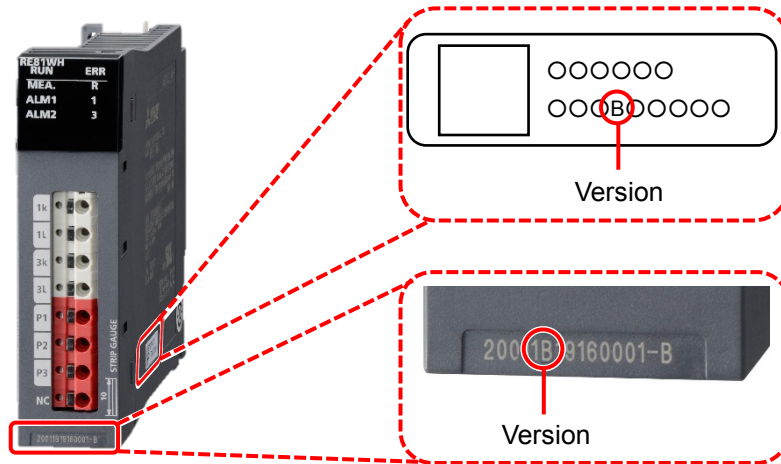

Changes for version of RE81WH

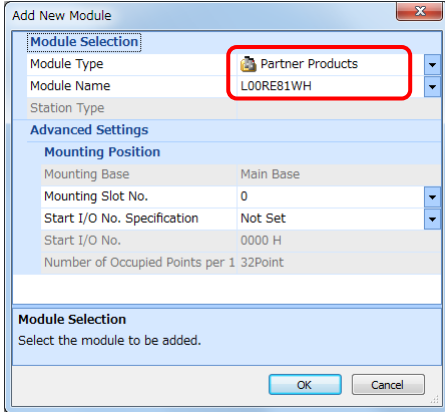
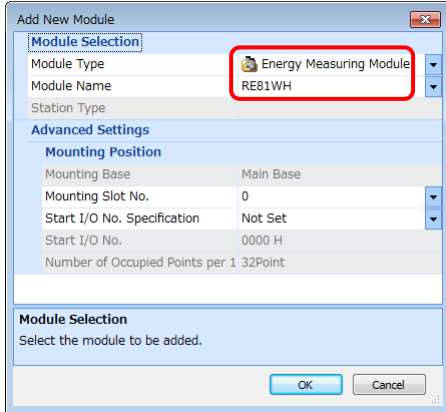
Version (Shipment start date)	Before	After
A	-	-
B (Nov, 2018)	 <p>Profile registration needed* Version : A</p>	 <p>Profile registration unneeded Version : B</p>

* When using version A on GX Works3, Profile (for MELSEC iQ-R series Energy Measuring Module (RE81WH) profile) registration is needed

Refer to “GX Works3 operating manual” for registration of profile.

You can download the profile from the web site. (<http://www.mitsubishielectric.com/fa/>)

When using version B, Profile registration unneeded.

Section 3 NAME AND FUNCTION OF EACH PART

3.1 Name of each part

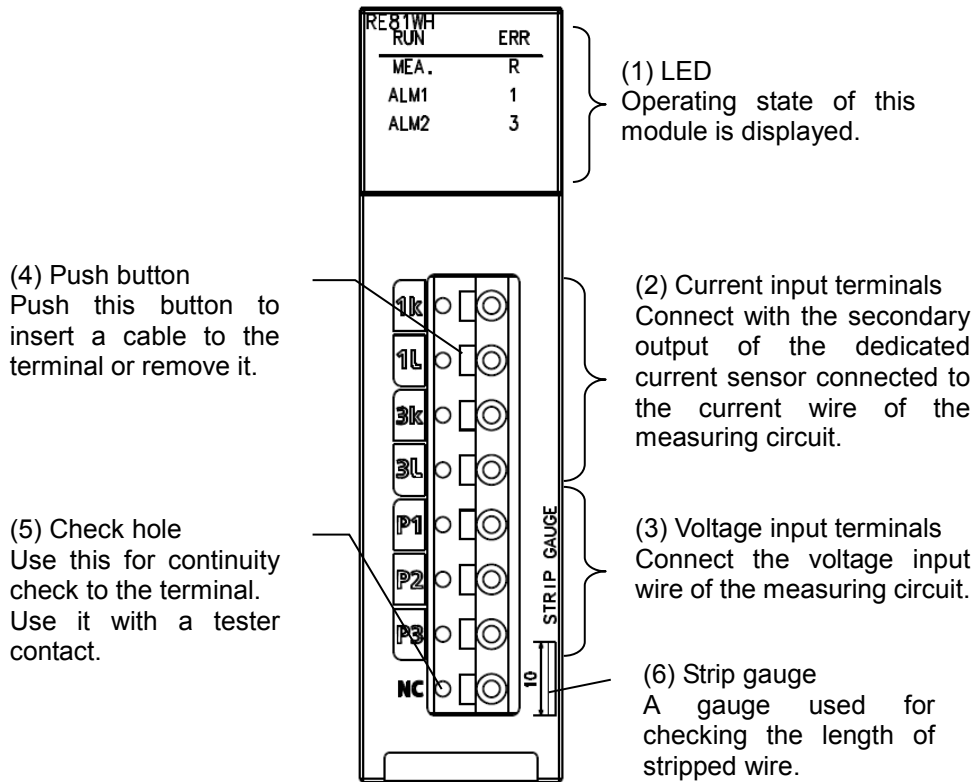

Figure 3.1-1 Appearance of the module

Table 3.1-1 The names and operations of terminal block

Terminal symbol	Name of terminal
1k	1-phase current input terminal (power source side)
1L	1-phase current input terminal (load side)
3k	3-phase current input terminal (power source side)
3L	3-phase current input terminal (load side)
P1	1-phase voltage input terminal
P2	2-phase voltage input terminal
P3	3-phase voltage input terminal
NC	Unused

3.2 Indication and function of LEDs

The following describes names and functions of LEDs.

Table 3.2-1 Names and functions of LEDs

Name	Color	Role	Indicator condition
RUN LED	Green	Displays the operation status of this module.	ON: Normal operation OFF: Internal power supply is off, error is in occurrence in hardware. *1
MEA LED *2	Green	Displays measuring status of this module.	ON: Measuring electric energy (consumption or regeneration) OFF: No measuring electric energy (no measurement)
ALM1 LED	Red	Displays alarm 1 occurrence status.	Flashing: Alarm 1 occurring ON: Alarm 1 occurring → Not occurring (In the case of alarm 1 reset method = Self-retention) OFF: Alarm 1 not occurring
ALM2 LED	Red	Displays alarm 2 occurrence status.	Flashing: Alarm 2 occurring ON: Alarm 2 occurring → Not occurring (In the case of alarm 2 reset method = Self-retention) OFF: Alarm 2 not occurring
ERR LED	Red	Displays error and the status of this module.	Flashing: Error in out of range of setting values *1 ON: Error in occurrence in hardware *1 OFF: Normal operation
R LED *2	Green	Displays the status of measurement (regeneration) of this module.	ON: Measuring electric energy (regeneration) OFF: Other than the above
1 LED *2	Green	Displays the status of measurement (regeneration) at side 1 of this module.	ON: Measuring 1-phase electric energy (regeneration) OFF: Other than the above
3 LED *2	Green	Displays the status of measurement (regeneration) at side 3 of this module.	ON: Measuring 3-phase electric energy (regeneration) OFF: Other than the above

*1: For details, refer to “8.1 List of error codes” in this manual.

*2: When calculated value is low, “MEA”LED, “R”LED, “1”LED and “3”LED are looked like flashing. Comparing to the last value per measuring cycle, LEDs light while calculating, then LEDs light off upon no changes. Since measuring cycle is shortest as 10ms, short period setting seems like flashing.

3.3 List of functions

Functions of RE81WH are provided in "Table 3.3-1 List of Functions".

Table 3.3-1 List of Functions

No.	Function	Descriptions	Reference section
1	Measurement	It measures current, current demand, voltage, electric power, electric power demand, Reactive power, apparent power, power factor, frequency, effective energy (consumption, regeneration), reactive energy (consumption lag), harmonic current, current harmonic distortion, harmonic voltage, voltage harmonic distortion, and sequentially stores the records into a buffer memory.	3.4.1
2	Periodic electric energy	The electric energy only for a period of time when a certain output signal is ON will be stored in the buffer memory. Periodic energy 1 and 2 can be measured independently.	3.4.2
3	Hold max./min. values	For current demand, voltage, electric power demand, and power factor, each maximum/minimum values and date/time of occurrence are stored.	3.4.3
4	Upper/lower limit alarm monitoring	Among current demand, voltage, electric power demand, and power factor, you can select two measuring items for which their upper/lower limit can be monitored. If it exceeds the upper limit or goes below the lower limit, the specified input signal is turned on.	3.4.4
5	Test	Parameter setting enables pseudo-storage of the specified value into the buffer memory, even with non-existence of input from voltage and current (sensor). Using this module, you can create a sequence, etc.	3.4.5
6	Integrated value set	Set the integrated value (electric energy (consumption, regeneration), reactive energy (consumption lag)) to an arbitrary value. It is used to clear integrated value.	3.4.6
7	Output of waveform data	Stores waveform data of current / voltage of the measured circuit into the buffer memory.	3.4.7

3.4 Functions in detail

3.4.1 Measuring function

(1) Measured items

Measured items and measured ranges are described as follows.

Each measured item is stored in the buffer memory at every measuring cycle.

Refer to "5.2.12" for measuring cycle, and refer to "4.2.1(7)" for measuring cycle of harmonic current and harmonic voltage.

Table 3.4.1-1 List of Measured items (1/2)

Measured items	
	Details
Current	Phase 1 current
	Phase 2 current ^{*1}
	Phase 3 current ^{*1}
	Average current
Current demand * The average of fluctuation for the set period of current demand time is indicated.	Phase 1 current demand
	Phase 2 current demand ^{*1}
	Phase 3 current demand ^{*1}
	Max. value
	Min. value
	Date of max. value occurrence
	Date of min. value occurrence
Harmonic current ^{*2}	Phase 1 harmonic current (n th)
	Phase 1 harmonic current (Total)
	Phase 3 harmonic current (n th) ^{*1}
	Phase 3 harmonic current (Total) ^{*1}
	Phase 1 current harmonic distortion (n th)
	Phase 1 current harmonic distortion (Total)
	Phase 3 current harmonic distortion (n th) ^{*1}
	Phase 3 current harmonic distortion (Total) ^{*1}

*1: If phase wire system is set to single-phase 2-wire, measurement will not be taken.

*2: The order of harmonic as follows.

RMS: 1st, 3rd, 5th, 7th, 9th, 11th, 13th, 15th, 17th, 19th

Distortion: 3rd, 5th, 7th, 9th, 11th, 13th, 15th, 17th, 19th

Table 3.4.1-1 List of Measured items (2/2)

Measured items	
	Details
Voltage	1-2 voltage (voltage V12)
	2-3 voltage ^{*1} (voltage V23)
	3-1 voltage ^{*1} (voltage V31)
	Average voltage
	Max. value
	Min. value
	Date/time of max. value occurrence
	Date/time of min. value occurrence
Harmonic voltage ^{*2}	1-2 harmonic voltage (n th)
	1-2 harmonic voltage (Total)
	2-3 harmonic voltage (n th) ^{*1}
	2-3 harmonic voltage (Total) ^{*1}
	1-2 voltage harmonic distortion (n th)
	1-2 voltage harmonic distortion (Total)
	2-3 voltage harmonic distortion (n th) ^{*1}
	2-3 voltage harmonic distortion (Total) ^{*1}
Electric power	Present value
Electric power demand * The average of fluctuation for the set period of electric power demand time is indicated.	Present value
	Max. value
	Min. value
	Date/time of max. value occurrence
	Date/time of min. value occurrence
Reactive power	Reactive power
Apparent power	Apparent power
Power factor	Present value
	Max. value
	Min. value
	Date/time of max. value occurrence
	Date/time of min. value occurrence
Frequency	Present value
Electric energy	Electric energy (consumption)
	Electric energy (regeneration)
Reactive energy	Reactive energy (consumption lag)
Periodic electric energy	Periodic electric energy 1
	Periodic electric energy 2

*1: If phase wire system is set to single-phase 2-wire, measurement will not be taken.

*2: The order of harmonic as follows.

RMS: 1st, 3rd, 5th, 7th, 9th, 11th, 13th, 15th, 17th, 19th

Distortion: 3rd, 5th, 7th, 9th, 11th, 13th, 15th, 17th, 19th

(2) Total, maximum, and minimum values

The following describes how to calculate the maximum, minimum, and total values.

Table 3.4.1-2 How to calculate the maximum, minimum and average values

Item	Phase wire system	Formula
Average current	single-phase 2-wire	Average current = 1-phase current
	single-phase 3-wire three-phase 3-wire	Average current = (1-phase current + 3-phase current) / 2
Average voltage	single-phase 2-wire	Average voltage = voltage V12
	single-phase 3-wire three-phase 3-wire	Average voltage = (voltage V12 + voltage V23) / 2
Maximum current demand	single-phase 2-wire	Maximum value of 1-phase current demand (The highest value after the max./min. value was reset.)
	single-phase 3-wire	Highest value of either 1-phase current demand or 3-phase current demand (The highest value after the max./min. value was reset.)
	three-phase 3-wire	Highest value among 1-phase current demand, 2-phase current demand, or 3-phase current demand (The highest value after the max./min. value was reset.)
Minimum current demand	single-phase 2-wire	Minimum value of 1-phase current demand (The lowest value after the max./min. value was reset.)
	single-phase 3-wire	Lowest value of either 1-phase current demand or 3-phase current demand (The lowest value after the max./min. value was reset.)
	three-phase 3-wire	Lowest value among 1-phase current demand, 2-phase current demand, or 3-phase current demand (The lowest value after the max./min. value was reset.)
Maximum voltage	single-phase 2-wire	Highest value of the 1 - 2 line voltage (The highest value after the max./min. value was reset.)
	single-phase 3-wire	Highest value of either the 1 - 2 line voltage or the 2 - 3 line voltage (The highest value after the max./min. value was reset.)
	three-phase 3-wire	Highest value among the 1 - 2 line voltage, the 2 - 3 line voltage, or 3 - 1 line voltage (The highest value after the max./min. value was reset.)
Minimum voltage	single-phase 2-wire	Lowest value of the 1 - 2 line voltage (The lowest value after the max./min. value was reset.)
	single-phase 3-wire	Lowest value of either the 1 - 2 line voltage or the 2 - 3 line voltage (The lowest value after the max./min. value was reset.)
	three-phase 3-wire	Lowest value among the 1 - 2 line voltage, the 2 - 3 line voltage, or 3 - 1 line voltage (The lowest value after the max./min. value was reset.)

(3) Resolution of measured data

Resolution of measured data according to the rating (phase wire system, primary voltage setting, and primary current setting) is described as follows.

(a) Current, current demand

Primary current setting PA ^{*1}	Multiplying factor	Resolution ^{*2}	
PA < 40 A	-3	2 digits after the decimal point	0.01 A
40 A ≤ PA < 400 A	-3	1 digit after the decimal point	0.1 A
400 A ≤ PA < 4000 A	-3	Integer	1 A
4000 A ≤ PA	-3	x10	10 A

*1: Case of setting value of the primary current (Un\G2) is "0", the primary current (PA) is value of primary current of CT (Un\G7).

In other cases, the primary current (PA) is the value of primary current (Un\G2).

*2: Digits lower than the resolution are fixed to 0.

(b) Voltage

Primary voltage setting PV ^{*1}	Multiplying factor	Resolution ^{*2}	
PV < 330 V	-3	1 digit after the decimal point	0.1 V
330 V ≤ PV < 3300 V	-3	Integer	1 V
3300 V ≤ PV	-3	x10	10 V

*1: Case of setting value of the primary voltage (Un\G1) is "0", the primary voltage (PV) is value of primary voltage of VT (Un\G5).

In other cases, the primary voltage (PV) is the value of primary voltage (Un\G1).

*2: Digits lower than the resolution are fixed to 0.

(c) Electric power, electric power demand, Reactive power, Apparent power

Full load power W ^{*1}		Multiplying factor	Resolution ^{*2 *3}	
I	W < 12 kW	-3	3 digits after the decimal point	0.001 kW
II	12 kW ≤ W < 120 kW	-3	2 digits after the decimal point	0.01 kW
III	120 kW ≤ W < 1200 kW	-3	1 digit after the decimal point	0.1 kW
IV	1200 kW ≤ W < 12000 kW	-3	Integer	1 kW
V	12000 kW ≤ W < 120000 kW	-3	x10	10 kW

*1: Full load power (W) can be calculated by the following formula.

For calculating full load power W, refer to "Table 3.4.1-3 How to calculate full load power".

Full load power W(kW) = $\alpha \times$ Primary voltage (V) \times Primary current (A) / 1000

Case of single-phase 2-wire: $\alpha = 1$

Case of single-phase 3-wire: $\alpha = 2$

Case of three-phase 3-wire: $\alpha = \sqrt{3}$

*2: Digits lower than the resolution are fixed to 0.

*3: The module is kvar for reactive power and kVA for apparent power.

(d) Power factor

Power factor	Multiplying factor	Resolution*1	
All setting ranges	-3	1 digit after the decimal point	0.1 %

*1: Digits lower than the resolution are fixed to 0.

(e) Frequency

Frequency	Multiplying factor	Resolution*1	
All setting ranges	-3	1 digit after the decimal point	0.1 Hz

*1: Digits lower than the resolution are fixed to 0.

(f) Electric energy, reactive energy, periodic electric energy

	Full load power W*1	Multiplying factor	Resolution*2 *3	
I	$W < 12 \text{ kW}$	-5	5 digits after the decimal point	0.00001 kWh
II	$12 \text{ kW} \leq W < 120 \text{ kW}$	-4	4 digits after the decimal point	0.0001 kWh
III	$120 \text{ kW} \leq W < 1200 \text{ kW}$	-3	3 digits after the decimal point	0.001 kWh
IV	$1200 \text{ kW} \leq W < 12000 \text{ kW}$	-2	2 digits after the decimal point	0.01 kWh
V	$12000 \text{ kW} \leq W < 120000 \text{ kW}$	-1	1 digit after the decimal point	0.1 kWh

*1: Refer to "(c) *1" about how to calculate Full load power (W).

For calculating full load power W, refer to "Table 3.4.1-3 How to calculate full load power".

*2: Because the higher resolution than a typical watt-hour meter, the minimum digit values will change more than 2 at once update in accordance with setting value of input voltage, primary current, primary voltage of VT, secondary voltage of VT, primary current of CT and the condition of load.

*3: In the case of reactive energy, the unit will be kvarh.

Table 3.4.1-3 How to calculate full load power
Single-phase 2 wire system

		Primary voltage [V]							
		110	220	440	690	1100	2200	3300	6600
Primary current [A]	5								
	6								
	7.5		I						
	8								
	10		W < 12 kW						
	12								
	15								
	20								
	25								
	30								
	40								
	50				II				
	60								
	75								
	80								
	100								
	120								
	150								
	200								
	250					III			
	300								
	400								
	500								
	600								
	750								
	800								
	1000							IV	
	1200								
1500									
1600									
2000									
2500									
3000								V	
4000									
5000									
6000									

W < 12 kW

12 kW ≤ W < 120 kW

120 kW ≤ W < 1200 kW

1200 kW ≤ W < 12000 kW

12000 kW ≤ W < 120000 kW

Single-phase 3-wire system

		Primary voltage [V]	
		110	
Primary current [A]	5	I $W < 12 \text{ kW}$	
	6		
	7.5		
	8		
	10		
	12		
	15		
	20		
	25		
	30		
	40		
	50		
	60		
	75		II $12 \text{ kW} \leq W < 120 \text{ kW}$
	80		
	100		
	120		
	150		
	200		
	250		
	300		
	400		
	500		
	600	III $120 \text{ kW} \leq W < 1200 \text{ kW}$	
	750		
	800		
	1000		
	1200		
	1500		
	1600		
2000			
2500			
3000			
4000	IV $1200 \text{ kW} \leq W < 12000 \text{ kW}$		
5000			
6000			
6000			

Three-phase 3-wire system

		Primary voltage [V]							
		110	220	440	690	1100	2200	3300	6600
Primary current [A]	5								
	6								
	7.5		I						
	8								
	10		W < 12 kW						
	12								
	15								
	20								
	25								
	30				II				
	40								
	50								
	60								
	75								
	80								
	100								
	120								
	150								
	200					III			
	250								
	300								
	400								
	500								
	600								
	750								
	800								
	1000								
	1200								
	1500								
	1600								
2000									
2500									
3000									
4000									
5000									
6000									

W < 12 kW

12 kW ≤ W < 120 kW

120 kW ≤ W < 1200 kW

1200 kW ≤ W < 12000 kW

12000 kW ≤ W < 120000 kW

(4) Restrictions for measuring data

- Measurement cannot be performed immediately after the power loading to the sequencer system (Module ready signal is under the OFF condition).

After checking that Module ready (Xn0) is ON, obtain measuring data.

- Measurement cannot be performed immediately after operating conditions are set up to the module. After checking that Operating condition setting completion flag (Xn9) becomes ON, obtain measuring data.

- Behaviors during operation are as follows.

Measuring item	Behavior of the module
Current	When the input current is less than 0.4% of the rating current, it becomes 0A.
Current demand	Current demand is obtained by current moving average. Therefore, even if the current is 0A, current demand may not be 0A.
Harmonic current	Current condition: Indicate "0 A" at each phase if current is 0A.
	Voltage condition: Indicate "0 A" if 1-2 line voltage is 0V.
	Frequency condition: Indicate "0 A" at all phase if frequency is under 44.5Hz.
Current harmonic distortion	Harmonic current condition: Indicate "0 %" at each phase if harmonic current (Harmonic current (1st)) is 0A.
	Voltage condition: Indicate "0 %" if 1-2 line voltage is 0V.
	Frequency condition: Indicate "0 %" at all phase if frequency is under 44.5Hz.
Voltage	Indicate "0 V" if RMS value is under 11V. (*1)
Harmonic voltage	Voltage condition: Indicate "0 V" at each inter-wire if voltage is 0V. Indicate "0 V" if 1-2 line voltage is 0V.
	Frequency condition: When it is less than 44.5Hz, it becomes 0V.
Voltage harmonic distortion	Voltage condition: Indicate "0 %" at each inter-wire if voltage is 0V. Indicate "0 %" if 1-2 line voltage is 0V.
	Frequency condition: When it is less than 44.5Hz, it becomes 0V.
Electric power, Reactive power, Apparent power	When current is 0A (at all phases are 0A) or when voltage is 0V (all in-between wires are 0V), it becomes 0kW. * The unit is kvar for reactive power and kVA for apparent power.
Electric power demand	Electric power demand is obtained by electric power moving average. Therefore, even if electric power is 0kW, electric power demand may not be 0kW.
Electric energy	The electric energy is measured with a load that is about 0.4% or more of all load power. Even if the indicated value is "0", measurement value will increase.
Power factor	When current is 0A (at all phases are 0A) or when voltage is 0V (all in-between wires are 0V), it becomes 100%
Frequency	Voltage condition Indicate "0 Hz" if 1-2 line voltage is 0 V.
	Frequency condition When it is less than 44.5Hz, it is fixed to 44.5Hz.

*1: In 1-phase three-wire system, indicate "0 V" if RMS value is under 22V.

3.4.2 Measuring function for periodic electric energy

This function is to measure electric energy (consumption) for a certain period, and stores it into the buffer memory. It can be used to measure electric energy for a certain fact or energy (standby power) when the facility or equipment is not in operation.

(1) Overview

- (a) It can measure two periodic electric energy at maximum (periodic electric energy 1, periodic electric energy 2). Each of these can be measured independently.
- (b) While the time when Periodic electric energy 1 measurement flag (Yn1)/ Periodic electric energy 2 measurement flag (Yn2) is ON, periodic electric energy can be measured.
- (c) Since Periodic electric energy is stored in the nonvolatile memory, it can be retained even when a power source reset.
- (d) I/O signals and buffer memory corresponding to each of periodic electric energy 1 and 2 are shown below.

	Buffer memory (Double words)	Periodic electric energy measurement flag	Periodic electric energy data completion flag	Periodic electric energy reset request	Periodic electric energy reset completion flag
Periodic electric energy 1	Un\G114,115	Yn1	Xn1	Yn3	Xn3
Periodic electric energy 2	Un\G116,117	Yn2	Xn2	Yn4	Xn4

✓ Supplement

Quantity survey of periodic electric energy is performed every measuring cycle. Therefore, if the time for turning ON Periodic electric energy 1 measurement flag (Yn1) and Periodic electric energy 2 measurement flag (Yn2) is set to measuring cycle or less, measurement may not be performed. For the measuring cycle, refer to "5.2.12".

(2) Basic procedure

(a) Measuring periodic electric energy

- (i) Check that Periodic electric energy measurement flag (Yn1/Yn2) is OFF.
- (ii) Check periodic electric energy (Un\G114, 115/Un\G116, 117).
- (iii) When starting measurement, set Periodic electric energy measurement flag (Yn1/Yn2) to ON.
This module starts measuring specified periodic electric energy, and Periodic electric energy data completion flag (Xn1/Xn2) will be turned OFF.
- (iv) When stopping measurement, set Periodic electric energy measurement flag (Yn1/Yn2) to OFF.
This module stops measuring the specified periodic electric energy, and Periodic electric energy data completion flag (Xn1/Xn2) will be turned ON.
- (v) Check that Periodic electric energy data completion flag (Xn1/Xn2) becomes ON, and obtain the value of periodic electric energy.

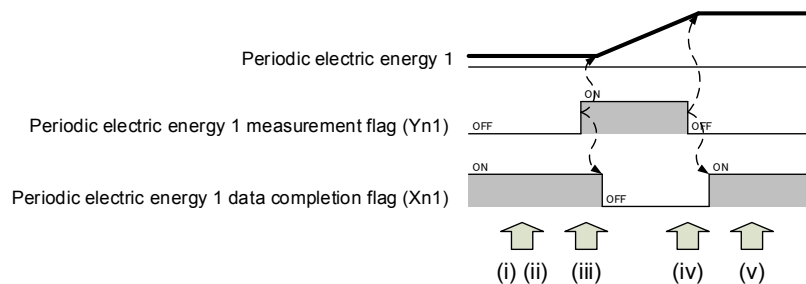

Figure 3.4.2-1 Basic procedure of measuring the periodic electric energy 1

(b) Resetting periodic electric power

- (i) Check that Periodic electric energy measurement flag (Yn1/Yn2) is OFF and Periodic electric energy reset request (Yn3/Yn4) is OFF.
- (ii) Set Periodic electric energy reset request (Yn3/Yn4) to ON. The specified periodic electric energy is reset to 0 kWh, and Periodic electric energy reset completion flag (Xn3/Xn4) will be turned to ON.
- (iii) Check the Periodic electric energy reset completion flag (Xn3/Xn4) has become ON, then set Periodic electric energy reset request (Yn3/Yn4) to OFF.
Periodic electric energy reset completion flag (Xn3/Xn4) will be turned OFF.

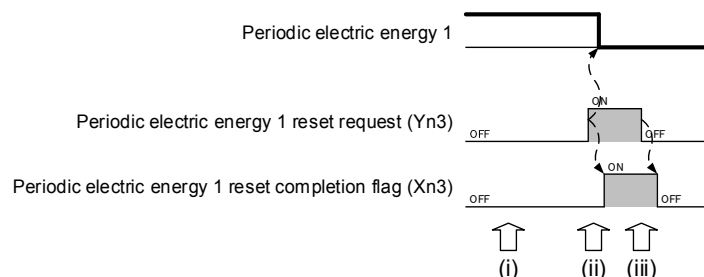

Figure 3.4.2-2 How to reset the periodic electric energy 1

(3) Example of use

(a) Procedure for continuously measuring periodic electric energy

If you turn Periodic electric energy measurement flag (Yn1/Yn2) to ON only while measurement is needed, this module accumulates the power starting at the previously measured amount. Usage procedure is the same as (a) in (2).

An example is shown below.

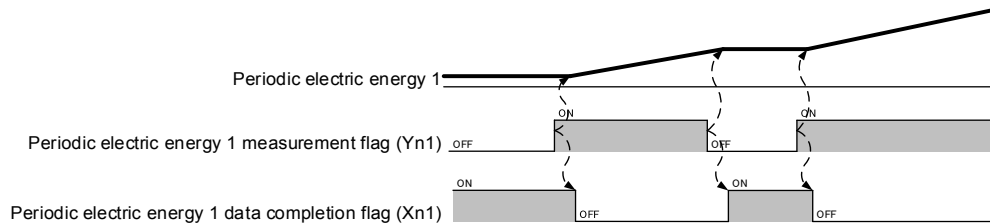

Figure 3.4.2-3 Example of continuous measurement of periodic electric energy 1

(b) Procedure for measuring periodic electric energy at every reset

By the following usage procedure, this module accumulates electric energy every time after resetting periodic electric energy.

- (i) Check that Periodic electric energy measurement flag (Yn1/Yn2) is OFF and Periodic electric energy reset request (Yn3/Yn4) is OFF.
- (ii) Set Periodic electric energy reset request (Yn3/Yn4) to ON.
The specified periodic electric energy is reset to 0 kWh, and Periodic electric energy reset completion flag (Xn3/Xn4) will be turned ON.
- (iii) Check that Periodic electric energy reset completion flag (Xn3/Xn4) has become ON, and then set Periodic electric energy reset request (Yn3/Yn4) to OFF.
Periodic electric energy reset completion flag (Xn3/Xn4) will be turned OFF.
- (iv) When starting measurement, set Periodic electric energy measurement flag (Yn1/Yn2) to ON.
This module starts measuring the specified periodic electric energy, and Periodic electric energy data completion flag (Xn1/Xn2) will be turned OFF.
- (v) When stopping measurement, set Periodic electric energy measurement flag (Yn1/Yn2) to OFF.
This module stops measuring the specified periodic electric energy, and Periodic electric energy data completion flag (Xn1/Xn2) will be turned ON.
- (vi) Check that Periodic electric energy data completion flag (Xn1/Xn2) becomes ON, and obtain the value of periodic electric energy.

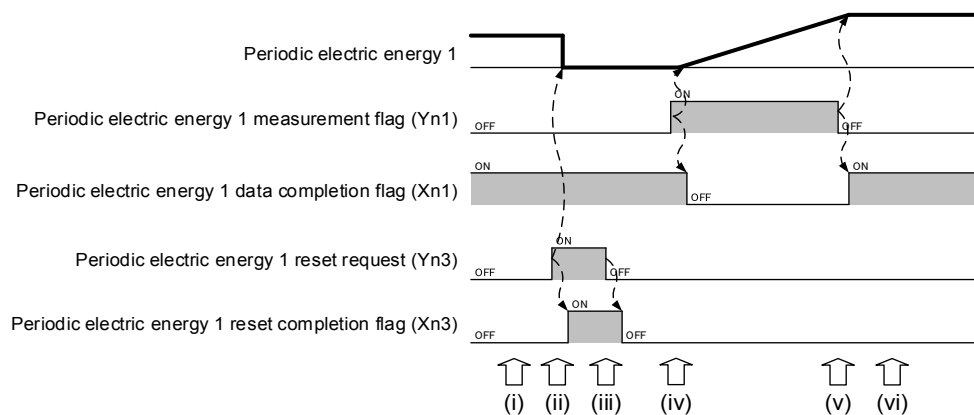

Figure 3.4.2-4 Example of measurement of periodic electric energy 1 every time after resetting

3.4.3 Max./min. value hold function

It memorizes the max./min. value for each measuring item, and retains them until the max./min. value clear are performed.

(1) Max./min. value memory

It memorizes the max. and min. values, and the time of occurrence (year/month/day/hour/minute/second/day of the week/millisecond) values for the following measuring item.

* The max. and min. values and the date of occurrence are stored in the nonvolatile memory, so that these values can be retained even when a power source reset.

- Current demand
- Voltage
- Electric power demand
- Power factor

(2) How to clear the max. and min. values

You can use the I/O signal to clear the max. and min. values that specified by max./min. values clear target (Un\G56).

The max. and min. values immediately after the clear becomes the present values and the date of occurrence will be the present date and time.

The following describes how to clear the max. and min. values.

- (a) Check that Max./min. values clear request (YnD) is OFF.
- (b) Set the max./min. values clear target(Un\G56).

The setting range is shown below.

Setting value	Description
11	Current demand
12	Voltage
13	Electric power demand
14	Power factor
19	All of the above
Others	Do not clear

- (c) Set Max./min. values clear request (YnD) to ON.

This module clears the max./min. values set by (b), and the date of occurrence, and set Max./min. values clear completion flag (XnD) to ON.

- (d) Check that Max./min. values clear completion flag (XnD) is ON, and then set Max./min. values clear request (YnD) to OFF.

Max./min. values clear completion flag (XnD) will be turned OFF.

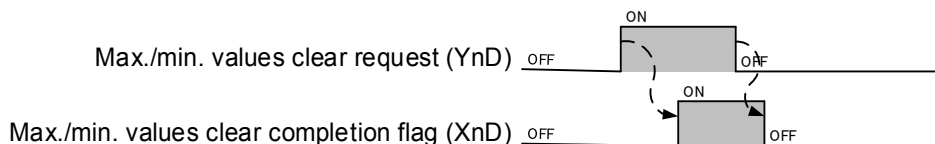

Figure 3.4.3-1 Procedure for clearing max./min. value

3.4.4 Upper/lower limit alarm monitoring function

You can set an upper and lower limit alarm for maximum two points and implement a monitoring function for them.

During the alarm monitoring, you can check the alarm occurrence by the input signal.

(1) Setting items of the upper/lower limit alarm monitoring

Setting items and setting range for the alarm monitoring are described below.

Items set in the buffer memory (Alarm 1 / Alarm 2)	Setting range	Description
Alarm monitoring factor (Un\G11 / Un\G21)	0: No monitoring 1: Current demand upper limit 2: Current demand lower limit 3: Voltage upper limit 4: Voltage lower limit 5: Power demand upper limit 6: Power demand lower limit 7: Power factor upper limit 8: Power factor lower limit	For respective alarm 1 and alarm 2, set the monitoring item either the upper / lower limit or measuring factor.
Alarm monitoring value (Un\G12,13 / Un\G22,23)	-2147483648 – 2147483647 [Unit] Current demand : $\times 10^{-3}$ A Voltage : $\times 10^{-3}$ V Electric Power demand : $\times 10^{-3}$ kW Power factor : $\times 10^{-3}$ %	The value to be monitored for the alarm. Set the value according to the unit of the measuring item that is set as an alarm monitoring factor. (Double words)
Alarm reset method (Un\G14 / Un\G24)	0: Self-retention 1: Self-reset	Set whether or not the alarm-occurrence condition should be retained if the value goes below the upper limit alarm value or goes over the lower limit alarm value after the upper/lower limit alarm occurred.
Alarm delay time (Un\G15 / Un\G25)	0 – 300 [Unit] second	Only when the state that it exceeds the upper limit alarm monitoring value or it goes below the lower limit alarm monitoring value continues for the period of alarm delay time, it is considered as an alarm occurrence.

* Each item of the alarm monitoring is stored in the nonvolatile memory, so that values can be retained even when a power source reset.

(2) How to set the upper/lower limit alarm monitoring

Setting procedures are as following.

- (a) Check that Operating condition setting request (Yn9) is OFF.
- (b) Set the alarm item in the buffer memory (Un\G11 / Un\G21), alarm value (Un\G12, 13 / Un\G22, 23), alarm reset method (Un\G14 / Un\G24), and alarm delay time (Un\G15 / Un\G25).
- (c) Set Operating condition setting request (Yn9) to ON.
Operation starts at each set value, and then, Operating condition setting completion flag (Xn9) is turned ON.
- (d) Check that Operating condition setting completion flag (Xn9) becomes ON, and then set Operating condition setting request (Yn9) to OFF.
Operating condition setting completion flag (Xn9) will be turned OFF.

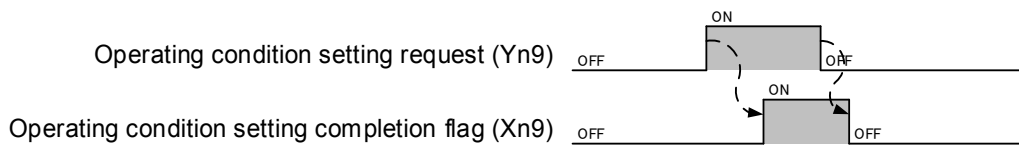

Figure 3.4.4-1 Time chart of alarm monitoring setting

(3) Behavior of the upper/lower limit alarm

- (a) When the alarm reset method is in the “0: Self-retention” setting (example of an upper limit monitoring at alarm 1)
 - (i) If the measured value that was set with the alarm 1 monitoring item exceeds the upper limit and the situation continues and remains for the alarm 1 delay time, Alarm 1 flag (XnA) will be turned ON.
At the same time, ALM1 LED flashes.
 - (ii) Even if the measured value goes below the upper limit, Alarm 1 flag (XnA) retains an ON status (Self-retention).
During the self-retention, ALM1 LED is turned on.
 - (iii) By turning Alarm 1 reset request (YnA) to ON, Alarm 1 flag (XnA) will be turned OFF.
At this time, ALM1 LED is turned off.
 - (iv) Check that Alarm 1 flag (XnA) becomes OFF, and then set Alarm 1 reset request (YnA) to OFF.

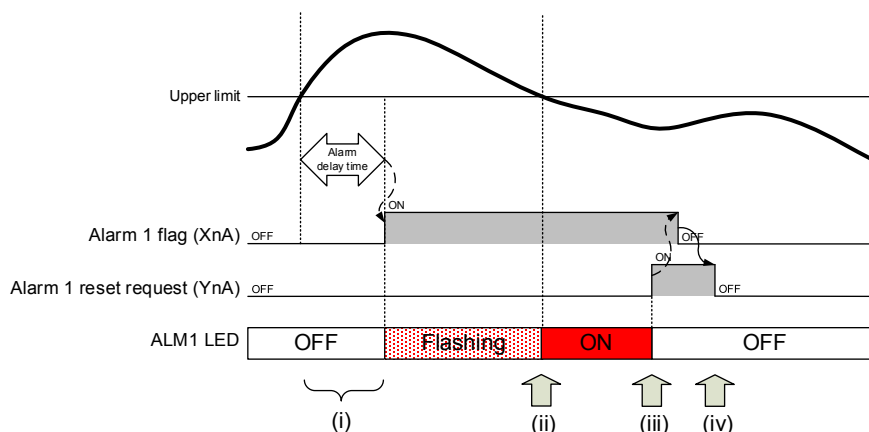

Figure 3.4.4-2 Time chart of the upper/lower limit alarm (alarm reset method = “Self-retention”)

- (b) When the alarm reset method is in the “1: Self-reset” setting (example of an upper limit monitoring at alarm 1)
- (i) If the measured value that was set with the alarm 1 monitoring factor exceeds the upper limit and the situation continues and remains for the alarm 1 delay time, Alarm 1 flag (XnA) will be turned ON. At the same time, ALM1 LED flashes.
 - (ii) If the measured value goes below the upper limit, Alarm 1 flag (XnA) will be turned OFF. At this time, ALM1 LED is turned off.
 - (iii) When the measured value that was set with the alarm 1 monitoring item goes below the upper limit within the alarm 1 delay time even though the measured value exceeds the upper limit, the alarm 1 flag (XnA) will remain in OFF status.

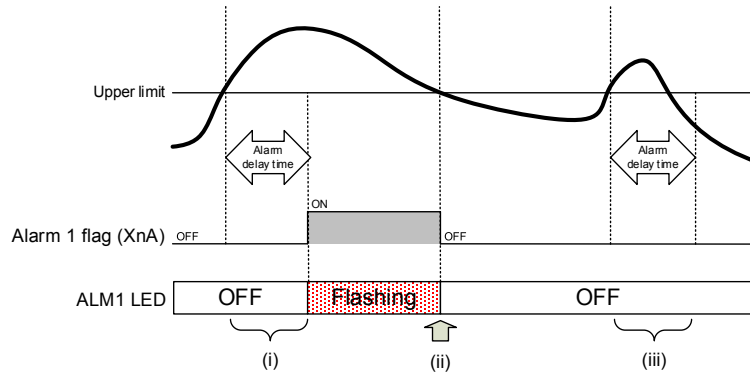

Figure 3.4.4-3 Time chart of the upper/lower limit alarm (alarm reset method = “Self-reset”)

- (c) When the alarm reset method is in the “Self-reset” setting (Example of a lower limit monitoring at alarm 2)
- (i) If the measured value that was set with the alarm 2 monitoring factor goes below the lower limit and the situation continues and remains for the alarm 2 delay time, Alarm 2 flag (XnB) will turn ON. At the same time, ALM2 LED flashes.
 - (ii) If the measured value exceeds the lower limit, Alarm 2 flag (XnB) will turn OFF. At this time, ALM2 LED is turned off.
 - (iii) When the measured value that was set with the alarm 2 monitoring item exceeds the lower limit within the alarm 2 delay time even though the measured value goes below the lower limit, the Alarm 2 flag (XnB) will remain in OFF status.

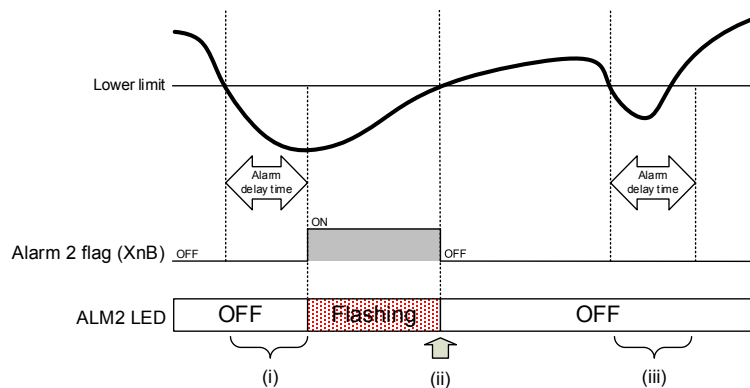

Figure 3.4.4-4 Time chart of the upper/lower limit alarm (alarm reset method = “Self-reset”)

(4) How to reset Alarm flag

When Alarm flag is ON during the alarm occurrence or the self-retention (in the case of the alarm reset method = "Self-retention"), Alarm flag can be reset (turned OFF) using Alarm reset request.

(a) How to reset Alarm flag during alarm occurrence (example of the upper limit alarm monitoring with the alarm 1)

- (i) If the measured value that was set with the alarm 1 monitoring factor exceeds the upper limit, Alarm 1 flag (XnA) will turn ON.
At the same time, ALM1 LED flashes.
- (ii) By turning Alarm 1 reset request (YnA) to ON, Alarm 1 flag (XnA) will turn OFF.
At this time, ALM1 LED will remain flashing (because ALM1 LED is synchronized with the alarm status, it will not turn off).
- (iii) Check that Alarm 1 flag (XnA) becomes OFF, and then set Alarm 1 reset request (YnA) to OFF.
- (iv) If the measured value goes below the upper limit, ALM1 LED will turn off.
- (v) After that, if the measured value exceeds the upper limit, Alarm 1 flag (XnA) will turn ON again. At the same time, ALM1 LED flashes.

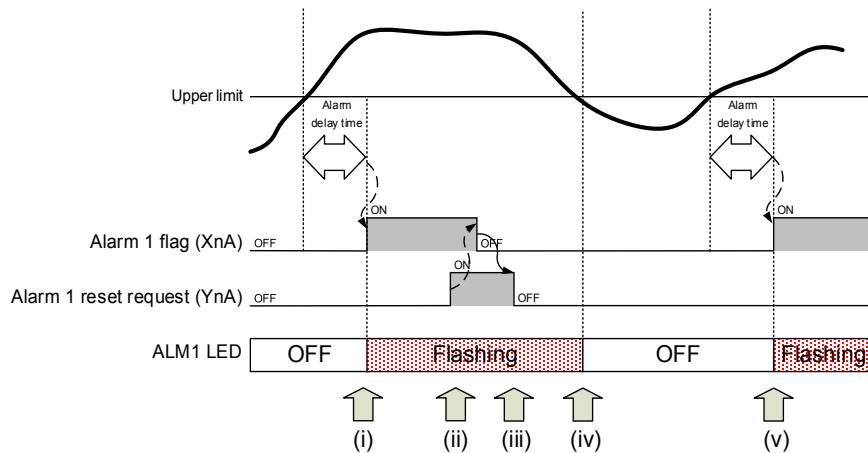

Figure 3.4.4-5 Procedure for resetting Alarm 1 flag (alarm reset method = "Self-reset")

(b) How to reset Alarm flag during self-retention (only in the case the alarm reset method = "Self-retention")
Refer to the procedure described in (3)(a).

(5) Precautions during the alarm monitoring

When current demand time and electric power demand time are set to anytime other than 0 second, current demand value and electric power demand value become lower than the actual values (closer to 0) immediately after the power source ON and the CPU reset.

When current demand value and electric power demand value are being monitored for their lower limit alarm, the alarm occurrence flag may turn ON. Thus, to avoid this, follow the procedure below.

- (a) Set the alarm monitoring target to "no monitoring" immediately after the power source ON and the CPU reset.
- (b) After passing for a 3-times longer period than the demand time, set the alarm monitoring target again, and start the alarm monitoring.

3.4.5 Test function

This function is to output pseudo-fixed value to a buffer memory for debugging sequence program. The value can be output to the buffer memory without input of voltage and current.

 Caution
--

- | |
|---|
| <ul style="list-style-type: none">● Because fixed-value is output to the buffer memory, separate the actual device to avoid unexpected operation before running the sequence program. |
|---|

(1) How to use the test function

Using the parameter setting, you can start the test mode to output the fixed value.

Refer to "6.4.2" for procedure of the parameter setting, refer to "6.4.5" for start or end the test mode.

(2) Content of pseudo-output

For the value to be output to the buffer memory, refer to Table 5.1-1 to 5.1-3 in "5.1 Buffer memory assignment".

(3) LED display when using the test function

All LED ON.

(4) I/O signals when using the test function

Unit READY (Xn0) only ON.

Other input and output signals are all OFF.

3.4.6 Integrated value set function

This is a function that can set the integrated value (electric energy (consumption, regeneration), reactive energy (consumption lag)) to an arbitrary value.

It is used to clear integrated value.

(1) Setting procedure

Setting procedures are as follows.

- (a) Set the integrated value setting target (Un\G51) in the buffer memory.

Setting range is as follows.

Setting value	Description
0	No set
1	Electric energy (consumption)
2	Electric energy (regeneration)
3	Reactive energy (consumption lag)

- (b) Set the integrated value setting value (Un\G52, 53) in the buffer memory.

- Configurable range: 0 to 999999999

- The unit used for the setting value is the same as that used for the electric energy and reactive energy output to the buffer memory.

For details, refer to "5.3.2".

- (c) Turn Integrated value set request (YnC) from OFF to ON to enable the setting.

Integrated value set completion flag (XnC) turns ON after Integrated value set request (YnC) is set OFF to ON.

- (d) After checking that integrated value set completion flag (XnC) turns ON and setting is completed, set the integrated value set request (YnC) to OFF.

After detected that the integrated value set request (YnC) turns OFF, the integrated value set completion flag (XnC) turns OFF.

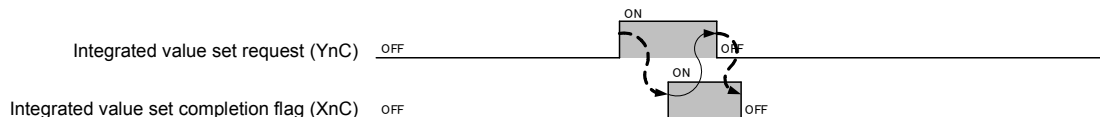

Figure 3.4.6 Integrated value setting procedure

(2) Default value

Integrated value setting target (Un\G51) is set to 0 (No set).

Integrated value setting value (Un\G52, 53) is set to 0.

3.4.7 Waveform data output function

Waveform data is sampling data of current / voltage waveform of the measured circuit. Using this data, it is possible to display the waveform, obtain changes of waveform. (Each data is converted value as unit V, A)

Waveform data is stored into the buffer memory in two methods as below.

* Waveform data to be measured is same, whereas buffer memory for storing data different.

- (1) Waveform data sampled during period of measured data acquisition clock is stored into the buffer memory.

The waveform data is stored into the buffer memory per period of measured data acquisition clock.

The buffer memory for storing multiple waveform data is secured. Waveform data sampled per sampling period (254 μ s) during period of measured data acquisition clock is collectively stored into the buffer memory. This method is used for acquiring waveform data synchronized with period of measured data acquisition clock.

Refer to "4.2.1(8)" for synchronizing method.

(a) Measuring items

Measured items	Details
	waveform data of voltage waveform data of 1-2 line voltage waveform data of 2-3 line voltage* ¹
waveform data of current waveform data of 1-phase current waveform data of 3-phase current* ¹	

(b) Number of waveform data

The number of each waveform data to be stored is the number of sampling during period of measured data acquisition clock.

Since the sampling period is not synchronized with the period of measured data acquisition clock, the number of waveform data may be different even in the same period of measured data acquisition clock.

Thus, the number of each waveform data is stored into the buffer memory separately from the waveform data.

(c) Restrictions for waveform data:

- It is impossible to obtain waveform data immediately after applying power to programmable controller system. (Module ready OFF state)

Obtain waveform data after confirming "Module ready ON state".

- It is impossible to obtain waveform data immediately after setting operating condition of this device.

Obtain waveform data after confirming "operating condition setting completed flag" is ON.

- Set the period of measured data acquisition clock below 50ms.

Where the period is larger than 50ms, waveform data is not stored into the buffer memory.

- It is possible to occur communication error inside the RE81WH due to disturbance noise (parallel noise to CT line). When a communication error is occurred (when a communication error flag indicates error), waveform data during the period of measured data acquisition clock is not stored into the buffer memory. Instead "0" is stored into the buffer memory.

(2) The waveform data is stored into the buffer memory per sampling period.

The waveform data is stored into the buffer memory per sampling period (μs) of the waveform data.

This method is used for acquiring the waveform data synchronized with sampling period.

Refer to "4.2.1(6)" for synchronizing method.

(a) Measured items

Measured items	Details
Continuous waveform data of voltage and current	waveform data of 1-2 line voltage
	waveform data of 2-3 line voltage* ¹
	waveform data of 1-phase current
	waveform data of 3-phase current* ¹

*1: When setting single phase 2-wire system for phase wire system, no measuring is performed.

(b) Number of waveform data

The number of each waveform data to be stored into buffer memory at once is one.

(c) Restrictions for waveform data

- It is impossible to obtain waveform data immediately after applying power to programmable controller system. (Module ready OFF state)
Obtain waveform data after confirming "Module ready ON state".
- It is impossible to obtain waveform data immediately after setting operating condition of this device.
Obtain waveform data after confirming "operating condition setting completed flag" is ON.
- It is possible to occur communication error inside the RE81WH due to disturbance noise (parallel noise to CT line). When a communication error is occurred (when a communication error flag indicates error), waveform data during the period of measured data acquisition clock is not stored into the buffer memory. (In this case, the last waveform data is stored into the buffer memory)

Section 4 I/O SIGNALS TO CPU MODULE

4.1 List of I/O signals

I/O signals of RE81WH are listed in Table 4.1-1.

Table 4.1-1 List of I/O signals

Input signal (signal direction from RE81WH to CPU module)		Output signal (signal direction from CPU module to RE81WH)	
Device No.	Signal name	Device No.	Signal name
Xn0	Module ready	Yn0	Use prohibited *1
Xn1	Periodic electric energy 1 data completion flag	Yn1	Periodic electric energy 1 measurement flag
Xn2	Periodic electric energy 2 data completion flag	Yn2	Periodic electric energy 2 measurement flag
Xn3	Periodic electric energy 1 reset completion flag	Yn3	Periodic electric energy 1 reset request
Xn4	Periodic electric energy 2 reset completion flag	Yn4	Periodic electric energy 2 reset request
Xn5	Use prohibited *1	Yn5	Use prohibited *1
Xn6	Waveform data acquisition clock	Yn6	Use prohibited *1
Xn7	Measured harmonics data acquisition clock	Yn7	Use prohibited *1
Xn8	Measured data acquisition clock	Yn8	Use prohibited *1
Xn9	Operating condition setting completion flag	Yn9	Operating condition setting request
XnA	Alarm 1 flag	YnA	Alarm 1 reset request
XnB	Alarm 2 flag	YnB	Alarm 2 reset request
XnC	Integrated value set completion flag	YnC	Integrated value set request
XnD	Max./min. values clear completion flag	YnD	Max./min. values clear request
XnE	Use prohibited *1	YnE	Use prohibited *1
XnF	Error flag	YnF	Error clear request
Xn10	Use prohibited *1	Yn10	Use prohibited *1
Xn11	Use prohibited *1	Yn11	Use prohibited *1
Xn12	Use prohibited *1	Yn12	Use prohibited *1
Xn13	Use prohibited *1	Yn13	Use prohibited *1
Xn14	Use prohibited *1	Yn14	Use prohibited *1
Xn15	Use prohibited *1	Yn15	Use prohibited *1
Xn16	Use prohibited *1	Yn16	Use prohibited *1
Xn17	Use prohibited *1	Yn17	Use prohibited *1
Xn18	Use prohibited *1	Yn18	Use prohibited *1
Xn19	Use prohibited *1	Yn19	Use prohibited *1
Xn1A	Use prohibited *1	Yn1A	Use prohibited *1
Xn1B	Use prohibited *1	Yn1B	Use prohibited *1
Xn1C	Use prohibited *1	Yn1C	Use prohibited *1
Xn1D	Use prohibited *1	Yn1D	Use prohibited *1
Xn1E	Use prohibited *1	Yn1E	Use prohibited *1
Xn1F	Use prohibited *1	Yn1F	Use prohibited *1

*1: These signals cannot be used by the user since they are for system use only.

4.2 Details of I/O signals

Detailed explanation about I/O signals of RE81WH is shown as follows

4.2.1 Input signals

(1) Module ready (Xn0)

After the power of CPU module is turned on or the CPU module reset is performed, it will turn ON upon the measurement is ready.

This signal (Xn0) is turned OFF when energy measuring module displays a hardware error, then RUN LED is turned off.

(2) Periodic electric energy 1 data completion flag (Xn1)

When Periodic electric energy 1 measurement flag (Yn1) is turned OFF and measuring of the periodic electric energy 1 is stopped, then this signal (Xn1) turns ON.

When Periodic electric energy 1 (Yn1) is turned ON and measuring of the periodic electric energy 1 is started, then this signal (Xn1) turns OFF.

Where you obtain data in a state where Periodic electric energy 1 is settled, obtain the data while this signal (Xn1) is ON.

* For specific usage procedures, refer to "3.4.2".

(3) Periodic electric energy 2 data completion flag (Xn2)

The usage procedure is the same as Periodic electric energy 1 data completion flag (Xn1).

Refer to (2).

(4) Periodic electric energy 1 reset completion flag (Xn3)

When Periodic electric energy 1 reset request (Yn3) is turned ON, and the periodic electric energy 1 stored in the buffer memory is reset, then this signal (Xn3) turns ON.

When Periodic electric energy 1 reset request (Yn3) is turned off, the signal (Xn3) turns OFF.

* For specific usage procedures, refer to "3.4.2".

(5) Periodic electric energy 2 reset completion flag (Xn4)

The usage procedure is the same as Periodic electric energy 1 reset completion flag (Xn3).

Refer to (4).

(6) Waveform data acquisition clock (Xn6)

The clock is to acquire the waveform data by synchronizing with this module.

This signal (Xn6) detects switching of OFF to ON so that it is able to acquire waveform data by synchronizing.

*When acquiring waveform data per period of measured data acquisition clock, refer to “5.2.12”.

(a) Clock operation

After power ON of the CPU module, it starts clock operation with this signal (6) ON immediately after first computing.

When the setting of phase wire system, primary voltage, primary current primary voltage of VT, secondary voltage of VT, primary current of CT and period of measured data acquisition clock is changed, it starts clock operation with the signal immediately after setting change.

Below diagram indicates ON time and OFF time of this signal.

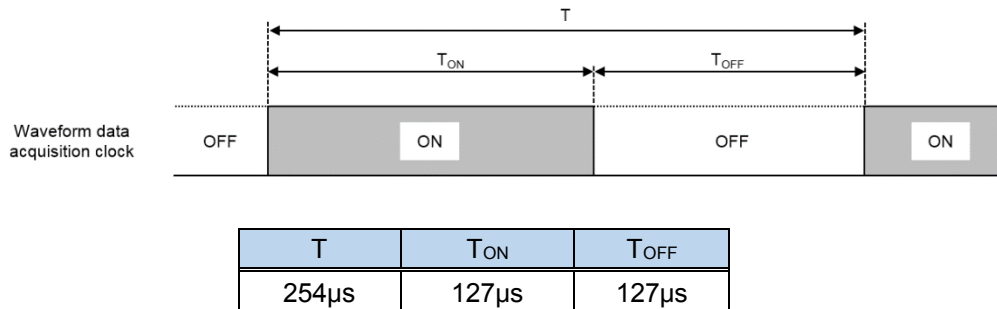

(b) Measured items which update data

Measured items		Buffer memory
Voltage and current continuous waveform data	1-2 voltage waveform data	Un\G22002, 22003
	2-3 voltage waveform data	Un\G 22004, 22005
	Phase 1 current waveform data	Un\G 22008, 22009
	Phase 3 current waveform data	Un\G 22012, 22013

(c) Synchronizing method

Please note as below in order to acquire waveform data by synchronizing with this module.

(i) The program is configured to set the scan time of ladder program will be less than 127μs. The scan time should be shorter than ON time and OFF time in order to detect “OFF → ON” of the signal (Xn6).

(ii) Acquire data by detecting “OFF → ON” of the signal (Xn6). Waveform data is updated immediately before the signal (Xn6) is ON. Since the last value and latest value are mixed while updating, it is able to acquire waveform data at a timing as below.

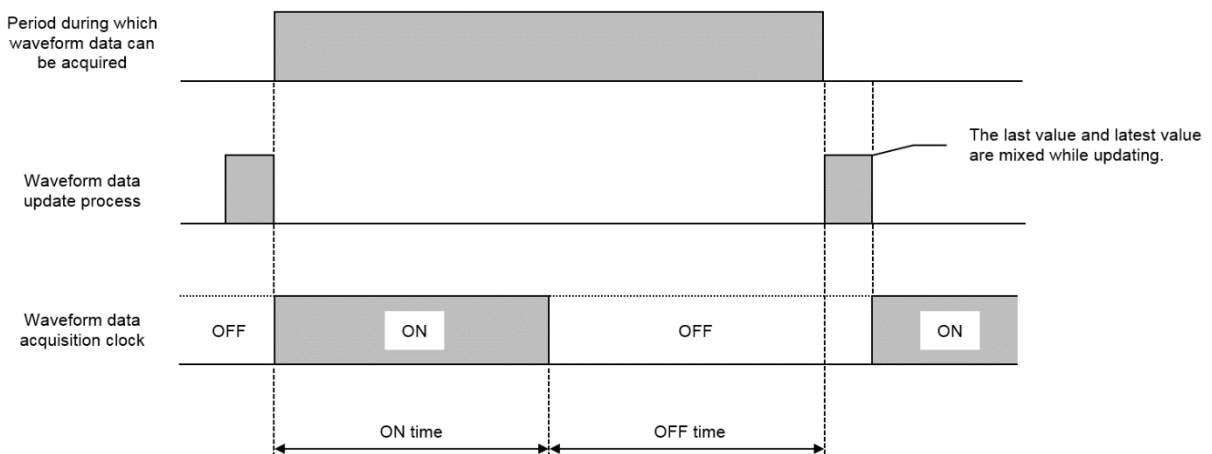

(7) Measured harmonics data acquisition clock (Xn7)

The clock is to acquire measured harmonics data by synchronizing with this module.

If the signal (Xn7) detects switching from OFF to ON, it is possible to obtain measured harmonics data in synchronization with this module.

(a) Clock operation

After the power is supplied to the CPU module and immediately after the initial computation is performed, this signal (Xn7) is turned ON and measured harmonics data acquisition clock is started.

If the settings of the phase wire system, primary voltage, primary current, primary voltage of VT, secondary voltage of VT, primary current of CT and period of measured data acquisition clock are changed, this signal turns ON immediately after the change of the settings and measured harmonics data acquisition clock is started.

Below diagram indicates ON time and OFF time of this signal.

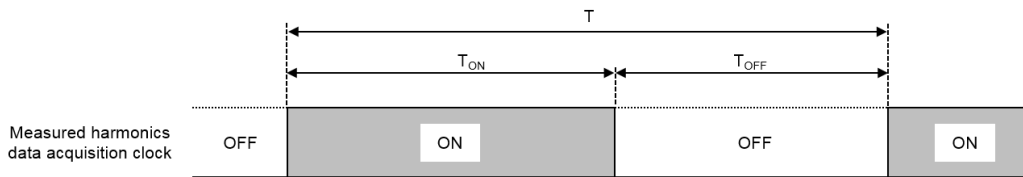

T	T _{ON}	T _{OFF}
1 sec	500 ms	500 ms

(b) Measured items which update data

The measured items to be updated the data in the period of this signal (Xn7) are shown below.

Measured items		Buffer memory
Harmonic voltage	1-2 harmonic voltage (n th)	Un\G1002 - Un\G 1021
	1-2 harmonic voltage (Total)	Un\G1022, 1023
	2-3 harmonic voltage (n th)	Un\G1030 - Un\G 1049
	2-3 harmonic voltage (Total)	Un\G1050, 1051
Harmonic current	Phase 1 harmonic current (n th)	Un\G1202 - Un\G1221
	Phase 1 harmonic current (Total)	Un\G1222, 1223
	Phase 3 harmonic current (n th)	Un\G1260 - Un\G1279
	Phase 3 harmonic current (Total)	Un\G1280, 1281
Voltage harmonic distortion	1-2 voltage harmonic distortion (n th)	Un\G1402 - Un\G1410
	1-2 voltage harmonic distortion (Total)	Un\G1411
	2-3 voltage harmonic distortion (n th)	Un\G1420 - Un\G1428
	2-3 voltage harmonic distortion (Total)	Un\G1429
Current harmonic distortion	Phase 1 current harmonic distortion (n th)	Un\G1602 - Un\G1610
	Phase 1 current harmonic distortion (Total)	Un\G1611
	Phase 3 current harmonic distortion (n th)	Un\G1640 - Un\G1648
	Phase 3 current harmonic distortion (Total)	Un\G1649

* The order of harmonic as follows.

RMS: 1st, 3rd, 5th, 7th, 9th, 11th, 13th, 15th, 17th, 19th

Distortion: 3rd, 5th, 7th, 9th, 11th, 13th, 15th, 17th, 19th

(c) Synchronizing method

Please note as below in order to acquire measured harmonics data by synchronizing with this module.

(i) The program is configured to set the scan time of ladder program will be less than 500ms.
The scan time should be shorter than ON time and OFF time in order to detect "OFF → ON" of the signal (Xn7).

(ii) Acquire data by detecting "OFF → ON" of the signal (Xn7).

Measured harmonics data is updated immediately before the signal (Xn7) is ON. Since the last value and latest value are mixed while updating, it is able to acquire measured harmonics data at a timing as below.

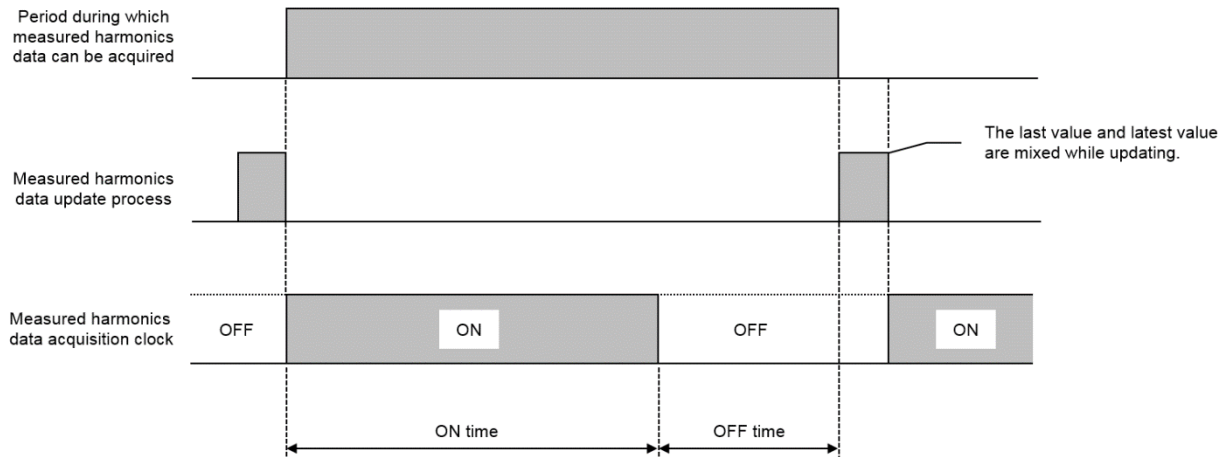

(8) Measured data acquisition clock (Xn8)

The clock is to acquire measured data by synchronizing with this module.

If it is able to detect switching from ON to OFF (or OFF to ON) of the signal (Xn8), it is possible to obtain measured data in synchronization with this module.

(a) Clock operation

After the power is supplied to the CPU module and immediately after the initial computation is performed, this signal (Xn8) is turned ON and clock operation is started. After that, this signal turns ON at the timing when the measurement data is completely written into the buffer memory after the elapse of the period of measured data acquisition clock.

If the settings of the phase wire system, primary voltage, primary current, primary voltage of VT, secondary voltage of VT, primary current of CT and period of measured data acquisition clock are changed, this signal turns ON immediately after the change of the settings and clock operation is started.

Below diagram indicates ON time and OFF time of this signal (Xn8).

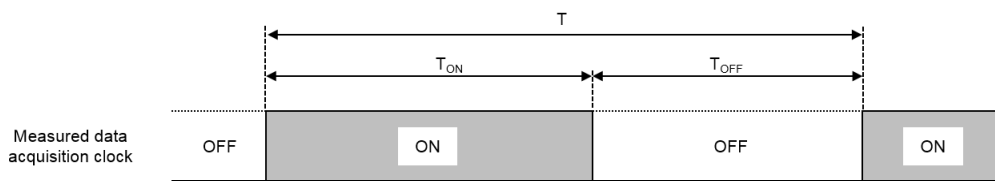

Period of measured data acquisition clock	T	T _{ON}	T _{OFF}
10ms	6 to 10ms	4ms	2 to 6ms
20 to 10000ms	4/5 to 1 of the period of measured data acquisition clock	2/5 of the measured data acquisition clock	2/5 to 3/5 of the period of measured data acquisition clock

(b) Measured items which update data

The measured items to update the data in the period of this signal (Xn8) are shown below.

Measured items		Buffer memory
Electric energy	Electric energy (consumption)	Un\G102, 103
	Electric energy (regeneration)	Un\G104, 105
	Reactive energy (consumption lag)	Un\G106, 107
	Periodic electric energy 1	Un\G114, 115
	Periodic electric energy 2	Un\G116, 117
Current	1 - phase current	Un\G202, 203
	2 - phase current	Un\G204, 205
	3 - phase current	Un\G206, 207
	1 - phase current demand	Un\G210, 211
	2 - phase current demand	Un\G212, 213
	3 - phase current demand	Un\G214, 215
	Average current	Un\G218, 219
Voltage	1 - 2 line voltage	Un\G302, 303
	2 - 3 line voltage	Un\G304, 305
	3 - 1 line voltage	Un\G306, 307
	Average voltage	Un\G314, 315
Electric power	Electric power	Un\G402, 403
	Electric power demand	Un\G404, 405
Reactive power	Reactive power	Un\G502, 503
Apparent power	Apparent power	Un\G602, 603
Power factor	Power factor	Un\G702, 703
Frequency	Frequency	Un\G802, 803
Waveform data ^{*2}	1-2 voltage waveform data 1 to 300 ^{*1}	Un\G10004 - Un\G10603
	2-3 voltage waveform data 1 to 300 ^{*1}	Un\G12004 - Un\G12603
	Phase 1 current waveform data 1 to 300 ^{*1}	Un\G16004 - Un\G16603
	Phase 3 current waveform data 1 to 300 ^{*1}	Un\G20004 - Un\G20603

*1. Since the number of waveform data varies according to the period of measured data acquisition clock, it is different from the actual range for storing data.

*2. It stores data when the period of measured data acquisition clock is 10 to 50ms.

It does not store the waveform data into the buffer memory when the period of measured data acquisition clock is over 50ms.

(c) Synchronizing method

Please note as below in order to acquire measured data by synchronizing with this module.

- (i) The program is configured to set the scan time of ladder program will be within below range.
The scan time should be shorter than ON time and OFF time in order to detect "OFF → ON" of the signal (Xn8).

Period of measured data acquisition clock	Scan time of ladder program
10ms	Less than 2ms
20ms to 10000ms	2/5 of the period of measured data acquisition clock

- (ii) Acquire data by detecting "OFF → ON" of the signal (Xn8).
Measured data is updated immediately before the signal (Xn8) is ON. Since the last value and latest value are mixed while updating, it is able to acquire measured data at a timing as below.

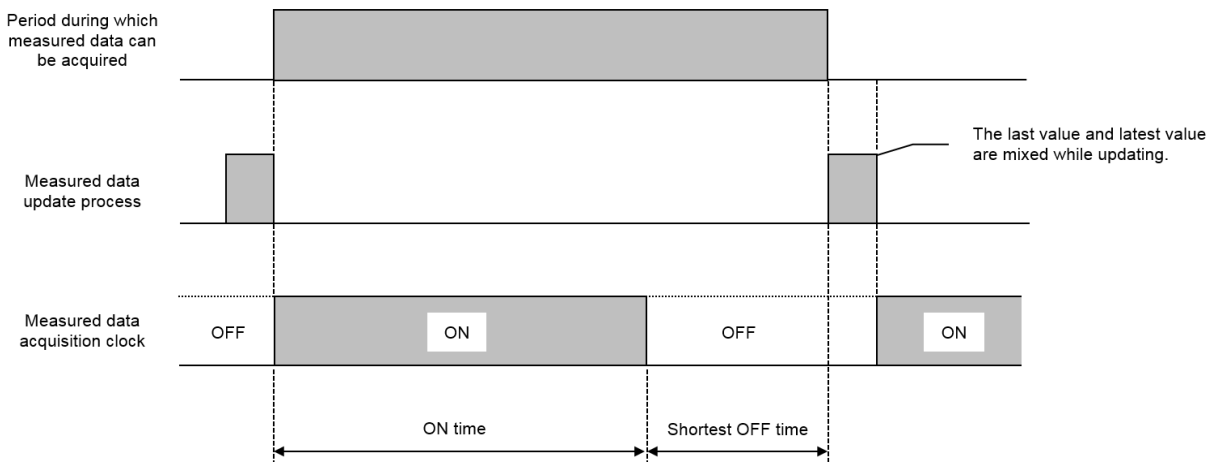

(9) Operating condition setting completion flag (Xn9)

When turning Operating condition setting request (Yn9) to ON and changing the following settings, this signal (Xn9) turns ON.

- Phase wire system (Un\G0)
- Primary voltage (Un\G1)
- Primary current (Un\G2)
- Current demand time (Un\G3)
- Electric power demand time (Un\G4)
- Primary voltage of VT (Un\G5)
- Secondary voltage of VT (Un\G6)
- Primary current of CT (Un\G7)
- Alarm 1 monitoring factor (Un\G11)
- Alarm 1 monitoring value (Un\G12, 13)
- Alarm 1 reset method (Un\G14)
- Alarm 1 delay time (Un\G15)
- Alarm 2 monitoring factor (Un\G21)
- Alarm 2 monitoring value (Un\G22, 23)
- Alarm 2 reset method (Un\G24)
- Alarm 2 delay time (Un\G25)
- Period of measured data acquisition clock (Un\G60, 61)

When operating condition setting request (Yn9) is OFF, this signal (Xn9) turns OFF.

(10) Alarm 1 flag (XnA)

If the measured value of the alarm 1 monitoring factor (Un\G11) exceeds the upper limit (in the case of the lower alarm, it goes under the lower limit), and if the situation continues and passes the alarm 1 delay time (Un\G15), then this signal (XnA) turns ON.

Operations after this signal (XnA) is turned ON are different depending on the setting of the alarm 1 reset method (Un\G14).

(a) When the alarm 1 reset method (Un\G14) is "0: Self-retention"

If the measured value of the alarm 1 monitoring target becomes below the upper limit (in the case of lower limit alarm, it exceeds the lower limit), then this signal (XnA) retains ON.

When the alarm 1 reset request (YnA) is set to ON, this signal (XnA) turns OFF.

(b) When the alarm 1 reset method (Un\G14) is "1: Self-reset"

Even if the measured value of the alarm 1 monitoring target becomes below the upper limit (in the case of lower limit alarm, it exceeds the lower limit), this signal (XnA) turns OFF.

When the measured value of the alarm 1 monitoring target is set to "not monitoring", this signal (XnA) turns OFF.

* For the actual behavior of alarm monitoring, refer to "3.4.4".

(11) Alarm 2 flag (XnB)

The usage procedure is the same as Alarm 1 flag (XnA).

Refer to (10).

(12) Integrated value set completion flag (XnC)

When Integrated value set request (YnC) is turned ON, and preset of each integrated value such as electric energy (consumption), electric energy (regeneration), reactive energy (consumption delay) is completed, this signal (XnC) turns ON.

When integrated value set request (YnC) is turned OFF, this signal (XnC) turns OFF.

(13) Max./min. values clear completion flag (XnD)

When Max./min. values clear request (YnD) is turned ON and the data of max./min. value (maximum value, minimum value and their date and time of occurrence) are cleared, this signal (XnD) turns ON.

When Max./min. values clear request (YnD) is turned OFF, this signal (XnD) turns OFF.

(14) Error flag (XnF)

If an outside-set-value error occurs, and if a hardware error occurs, this signal (XnF) turns ON.

The description of the occurred error can be checked with a latest error code (Un\G3000).

If an outside-set-value error occurs, this signal (XnF) is turned OFF by setting a value within the range again.

* For description of error codes, refer to "8.1 List of error codes".

4.2.2 Output signals

(1) Periodic electric energy 1 measurement flag (Yn1)

While switching this signal (Yn1) from the ON status to the OFF status, the periodic electric energy 1 is measured, and will be stored into the buffer memory.

When this signal (Yn1) is turned OFF, Periodic electric energy 1 data completion flag (Xn1) is turns ON at the time when the periodic electric energy 1 is settled for that period, and then the periodic electric energy 1 is retained.

In order to read the settled data of the periodic electric energy 1 by using the sequence program, use Periodic electric energy 1 data completion flag (Xn1) as the interlock condition.

* For specific usage procedures, refer to "3.4.2".

(2) Periodic electric energy 2 measurement flag (Yn2)

The usage procedure is the same as that of Periodic electric energy 1 measurement flag (Yn1).

Refer to (1).

(3) Periodic electric energy 1 reset request (Yn3)

When this request (Yn3) is turned ON from the OFF status, Periodic electric energy 1 reset completion flag (Xn3) turns ON, and the periodic electric energy 1 that has been stored in the buffer memory is reset to "0". Regardless of the status of Periodic electric energy 1 measurement flag (Yn1), either OFF or ON, the periodic electric energy can be reset using this request (Yn3). When Periodic electric energy 1 measurement flag (Yn1) is ON, and the measurement is taking place, the measurement will resume immediately after the reset.

When this request (Yn3) is set to OFF, Periodic electric energy 1 reset completion flag (Xn3) turns OFF.

*For specific usage procedures, refer to "3.4.2".

(4) Periodic electric energy 2 reset request (Yn4)

The usage procedure is the same as that of Periodic electric energy 1 reset request (Yn3).

Refer to (3).

(5) Operating condition setting request (Yn9)

When switching this request (Yn9) from the OFF status to the ON status, the following operating conditions will be set.

- Phase wire system (Un\G0)
- Primary voltage (Un\G1)
- Primary current (Un\G2)
- Current demand time (Un\G3)
- Electric power demand time (Un\G4)
- Primary voltage of VT (Un\G5)
- Secondary voltage of VT (Un\G6)
- Primary current of CT (Un\G7)
- Alarm 1 monitoring factor (Un\G11)
- Alarm 1 monitoring value (Un\G12, 13)
- Alarm 1 reset method (Un\G14)
- Alarm 1 delay time (Un\G15)
- Alarm 2 monitoring factor (Un\G21)
- Alarm 2 monitoring value (Un\G22, 23)
- Alarm 2 reset method (Un\G24)
- Alarm 2 delay time (Un\G25)
- Period of measured data acquisition clock (Un\G60, 61)

When the setting for operating condition is completed, Operating condition setting completion flag (Xn9) turns ON.

When this request (Yn9) is turned OFF, Operating condition setting completion flag (Xn9) turns OFF.

(6) Alarm 1 reset request (YnA)

When Alarm 1 flag (XnA) is reset, this request (YnA) turns ON.

When this request (YnA) is switched from the OFF status to the ON status, Alarm 1 flag (XnA) will forcibly be turned OFF regardless of the present alarm occurrence status.

Make sure that Alarm 1 flag (XnA) is turned OFF, then turn this request (YnA) OFF.

(7) Alarm 2 reset request (YnB)

The usage procedure is the same as that of Alarm 1 reset request (YnA).

Refer to (6).

(8) Integrated value set request (YnC)

If you want to set the energy (consumption and regeneration) and the reactive energy to an arbitrary value, use this signal (YnC). After writing Integrated value setting target (Un\G51) and Integrated value setting value (Un\G52, 53) into it, and after that, turn this request (YnC) into ON.

When switching this request (YnC) from the OFF status to the ON status, setting of the integrated value will be performed. When the integrated value setting is completed, integrated value set completion flag (XnC) turns ON.

When this request (YnC) is set to OFF, Integrated value set completion flag (XnC) turns OFF.

(9) Max./min. values clear request (YnD)

When the max./min. value data (max./min. value and their date/time of occurrence) is reset, this request (YnD) turns ON.

When switching this request (YnD) from the OFF status to the ON status after max./min. values clear target (Un\G56) is setting, the max./min. value data corresponding to the setting contents will be cleared. When clearing the max./min. data is completed, Max./min. values clear completion flag (XnD) turns ON.

(10) Error clear request (YnF)

When switching this request (YnF) from the OFF status to the ON status while an outside-set-value error is present, Error flag (XnF) turns OFF, and the latest error code in the buffer memory (Un\G3000) and time of error occurrence (Un\G3001 - Un\G3005) will be cleared.

At the same time as clearing the error above, the value that was set in the buffer memory below will be returned to the previously set value, and Integrated value setting target (Un\G51) and Integrated value setting value (Un\G52, 53) will be changed to 0.

[Set value to be replaced with the previously set value]

- Phase wire system (Un\G0)
- Primary voltage (Un\G1)
- Primary current (Un\G2)
- Current demand time (Un\G3)
- Electric power demand time (Un\G4)
- Primary voltage of VT (Un\G5)
- Secondary voltage of VT (Un\G6)
- Primary current of CT (Un\G7)
- Alarm 1 monitoring factor (Un\G11)
- Alarm 1 monitoring value (Un\G12, 13)
- Alarm 1 reset method (Un\G14)
- Alarm 1 delay time (Un\G15)
- Alarm 2 monitoring factor (Un\G21)
- Alarm 2 monitoring value (Un\G22, 23)
- Alarm 2 reset method (Un\G24)
- Alarm 2 delay time (Un\G25)
- Period of measured data acquisition clock (Un\G60, 61)

While a hardware error is occurred (error code: 0001H to 0FFFH), it will not be cleared even though this signal (YnF) turns ON.

Section 5 BUFFER MEMORY

5.1 Buffer memory assignment

The following describes buffer memory assignment.

 **Caution**

- In the buffer memory, do not write data to the "system area" or area where data writing is not impossible from sequence programs.
Data writing to those area may cause malfunction.

(1) Configurable sections (Un\G0 to Un\G99)

Table 5.1-1 Configurable sections (Un\G0 to Un\G99)

Item	Address (Decimal)	Description	Default value	R/W	Back up ^{*1}	Output value during the test mode ^{*2}
Setting value	0	Phase wire system	3	R/W	○	3
	1	Primary voltage	2	R/W	○	2
	2	Primary current	2	R/W	○	2
	3	Current demand time	120	R/W	○	120
	4	Electric power demand time	120	R/W	○	120
	5	Primary voltage of VT	0	R/W	○	0
	6	Secondary voltage of VT	0	R/W	○	0
	7	Primary current of CT	0	R/W	○	0
	8 - 10	System area	-	-	-	-
	11	Alarm 1 monitoring factor	0	R/W	○	5
	12	Alarm 1 monitoring value	0	R/W	○	1000
	13					
	14	Alarm 1 reset method	0	R/W	○	0
	15	Alarm 1 delay time	0	R/W	○	5
	16 - 20	System area	-	-	-	-
	21	Alarm 2 monitoring factor	0	R/W	○	6
	22	Alarm 2 monitoring value	0	R/W	○	-1000
	23					
	24	Alarm 2 reset method	0	R/W	○	1
	25	Alarm 2 delay time	0	R/W	○	300
	26 - 50	System area	-	-	-	-
	51	Integrated value setting target	0	W	×	0
	52	Integrated value setting value	0	W	×	0
	53					
	54	System area	-	-	-	-
	55					
	56	Max./min. values clear target	0	W	×	11
	57 - 59	System area	-	-	-	-
	60	Period of measured data acquisition clock	10	R/W	○	10
	61					
62 - 99	System area	-	-	-	-	

*1: Even if the power failure is restored, data is held because data is backed up by the nonvolatile memory.

*2: For the procedure for using the test mode, refer to "3.4.5".

(2) Measurement sections (Un\G100 to Un\G2999)

Table 5.1-2 Measurement sections (Un\G100 to Un\G2999) (1/6)

Item	Address (Decimal)	Description	Default value	R/W	Back up ^{*1}	Output value during the test mode ^{*2}
Electric energy	100	Multiplying factor of electric energy and reactive energy	-	R	×	-4
	101	System area	-	-	-	-
	102	Electric energy (consumption)	-	R	○	123456789
	103		-	R	○	234567890
	104	Electric energy (regeneration)	-	R	○	345678901
	105		-	R	○	456789012
	106	Reactive energy (consumption lag)	-	R	○	567890123
	107		-	R	○	678901234
	108 - 113	System area	-	-	-	-
	114	Periodic electric energy 1	-	R	○	789012345
	115		-	R	○	890123456
	116	Periodic electric energy 2	-	R	○	901234567
	117		-	R	○	012345678
118 - 199	System area	-	-	-	-	
Current	200	Multiplying factor of current	-3	R	×	-3
	201	System area	-	-	-	-
	202	Phase 1 current	-	R	×	10100
	203		-	R	×	10200
	204	Phase 2 current	-	R	×	10300
	205		-	R	×	10400
	206	Phase 3 current	-	R	×	10500
	207		-	R	×	10600
	208	System area	-	-	-	-
	209		-	-	-	-
	210	Phase 1 current demand	-	R	×	11100
	211		-	R	×	11200
	212	Phase 2 current demand	-	R	×	11300
	213		-	R	×	11400
	214	Phase 3 current demand	-	R	×	11500
	215		-	R	×	11600
	216	System area	-	-	-	-
	217		-	-	-	-
	218	Average current	-	R	×	10400
	219		-	R	×	10500
	220	Maximum current demand	-	R	○	10500
	221		-	R	○	2011h
	222	Year of time of max. current demand	-	R	○	0102h
	223	Month and day of time of max. current demand	-	R	○	0304h
	224	Hour and minute of time of max. current demand	-	R	○	0501h
	225	Second and day of the week of time of max. current demand	-	R	○	0500h
	226	Millisecond of time of max. current demand	-	R	○	-
	227	System area	-	-	-	-
	228	Minimum current demand	-	R	○	20600
	229		-	R	○	2014h
	230	Year of time of min. current demand	-	R	○	0405h
	231	Month and day of time of min. current demand	-	R	○	0607h
232	Hour and minute of time of min. current demand	-	R	○	0804h	
233	Second and day of the week of time of min. current demand	-	R	○	0600h	
234	Millisecond of time of min. current demand	-	R	○	-	
235 - 299	System area	-	-	-	-	

*1: Even if the power failure is restored, data is held because data is backed up by the nonvolatile memory.

*2: For the procedure for using the test mode, refer to "3.4.5".

Table 5.1-2 Measurement sections (Un\G100 to Un\G2999) (2/6)

Item	Address (Decimal)	Description	Default value	R/W	Back up ^{*1}	Output value during the test mode ^{*2}	
Voltage	300	Multiplying factor of voltage	-3	R	×	-3	
	301	System area	-	-	-	-	
	302	1-2 voltage	-	R	×	20100	
	303						
	304	2-3 voltage	-	R	×	20200	
	305						
	306	3-1 voltage	-	R	×	20300	
	307						
	308 - 313	System area	-	-	-	-	
	314	Average voltage	-	R	×	20400	
	315						
	316 - 319	System area	-	-	-	-	
	320	Maximum voltage	-	R	○	20500	
	321						
	322	Year of time of max. voltage	-	R	○	2013h	
	323	Month and day of time of max. voltage	-	R	○	0304h	
	324	Hour and minute of time of max. voltage	-	R	○	0506h	
	325	Second and day of the week of time of max. voltage	-	R	○	0703h	
	326	Millisecond of time of max. voltage	-	R	○	0700h	
	327	System area	-	-	-	-	
	328	Minimum voltage	-	R	○	20600	
	329						
	330	Year of time of min. voltage	-	R	○	2014h	
	331	Month and day of time of min. voltage	-	R	○	0405h	
	332	Hour and minute of time of min. voltage	-	R	○	0607h	
	333	Second and day of the week of time of min. voltage	-	R	○	0804h	
	334	Millisecond of time of min. voltage	-	R	○	0800h	
	335 - 399	System area	-	-	-	-	
	Electric power	400	Multiplying factor of electric power	-3	R	×	-3
		401	System area	-	-	-	-
		402	Electric power	-	R	×	30100
		403					
		404	Electric power demand	-	R	×	30200
405							
406 - 419		System area	-	-	-	-	
420		Maximum electric power demand	-	R	○	30300	
421							
422		Year of time of max. electric power demand	-	R	○	2015h	
423		Month and day of time of max. electric power demand	-	R	○	0506h	
424		Hour and minute of time of max. electric power demand	-	R	○	0708h	
425		Second and day of the week of time of max. electric power demand	-	R	○	0905h	
426		Millisecond of time of max. electric power demand	-	R	○	0321h	
427		System area	-	-	-	-	
428		Minimum electric power demand	-	R	○	30400	
429							
430		Year of time of min. electric power demand	-	R	○	2016h	
431		Month and day of time of min. electric power demand	-	R	○	0607h	
432		Hour and minute of time of min. electric power demand	-	R	○	0809h	
433		Second and day of the week of time of min. electric power demand	-	R	○	1005h	
434		Millisecond of time of min. electric power demand	-	R	○	0654h	
435 - 499		System area	-	-	-	-	

*1: Even if the power failure is restored, data is held because data is backed up by the nonvolatile memory.

*2: For the procedure for using the test mode, refer to "3.4.5".

Table 5.1-2 Measurement sections (Un\G100 to Un\G2999) (3/6)

Item	Address (Decimal)	Description	Default value	R/W	Back up ^{*1}	Output value during the test mode ^{*2}
Reactive power	500	Multiplying factor of reactive power	-3	R	×	-3
	501	System area	-	-	-	-
	502	Reactive power	-	R	×	40100
	503					
	504 - 599	System area	-	-	-	-
Apparent power	600	Multiplying factor of Apparent power	-3	R	×	-3
	601	System area	-	-	-	-
	602	Apparent power	-	R	×	40200
	603					
	604 - 699	System area	-	-	-	-
Power factor	700	Multiplying factor of power factor	-3	R	×	-3
	701	System area	-	-	-	-
	702	Power factor	-	R	×	50100
	703					
	704 - 719	System area	-	-	-	-
	720	Maximum power factor	-	R	○	50200
	721					
	722	Year of time of max. power factor	-	R	○	2017h
	723	Month and day of time of max. power factor	-	R	○	0708h
	724	Hour and minute of time of max. power factor	-	R	○	0910h
	725	Second and day of the week of time of max. power factor	-	R	○	1106h
	726	Millisecond of time of max. power factor	-	R	○	0987h
	727	System area	-	-	-	-
	728	Minimum power factor	-	R	○	50300
	729					
	730	Year of time of min. power factor	-	R	○	2018h
	731	Month and day of time of min. power factor	-	R	○	0809h
	732	Hour and minute of time of min. power factor	-	R	○	1011h
	733	Second and day of the week of time of min. power factor	-	R	○	1200h
	734	Millisecond of time of min. power factor	-	R	○	0111h
735 - 799	System area	-	-	-	-	
Frequency	800	Multiplying factor of frequency	-3	R	×	-3
	801	System area	-	-	-	-
	802	Frequency	-	R	×	60100
	803					
	804 - 999	System area	-	-	-	-

*1: Even if the power failure is restored, data is held because data is backed up by the nonvolatile memory.

*2: For the procedure for using the test mode, refer to "3.4.5".

Table 5.1-2 Measurement sections (Un\G100 to Un\G2999) (4/6)

Item	Address (Decimal)	Description	Default value	R/W	Back up ^{*1}	Output value during the test mode ^{*2}
Harmonic voltage	1000	Multiplying factor of harmonic voltage	-3	R	×	-3
	1001	System area	-	-	-	-
	1002	1-2 harmonic voltage (1st)	-	R	×	101
	1003					
	1004	1-2 harmonic voltage (3rd)	-	R	×	103
	1005					
	1006	1-2 harmonic voltage (5th)	-	R	×	105
	1007					
	1008	1-2 harmonic voltage (7th)	-	R	×	107
	1009					
	1010	1-2 harmonic voltage (9th)	-	R	×	109
	1011					
	1012	1-2 harmonic voltage (11th)	-	R	×	111
	1013					
	1014	1-2 harmonic voltage (13th)	--	R	×	113
	1015					
	1016	1-2 harmonic voltage (15th)	-	R	×	115
	1017					
	1018	1-2 harmonic voltage (17th)	-	R	×	117
	1019					
	1020	1-2 harmonic voltage (19th)	-	R	×	119
	1021					
	1022	1-2 harmonic voltage (Total)	-	R	×	120
	1023					
	1024 - 1029	System area	-	-	-	-
	1030	2-3 harmonic voltage (1st)	-	R	×	201
	1031					
	1032	2-3 harmonic voltage (3rd)	-	R	×	203
	1033					
	1034	2-3 harmonic voltage (5th)	-	R	×	205
	1035					
	1036	2-3 harmonic voltage (7th)	-	R	×	207
	1037					
	1038	2-3 harmonic voltage (9th)	-	R	×	209
	1039					
	1040	2-3 harmonic voltage (11th)	-	R	×	211
	1041					
	1042	2-3 harmonic voltage (13th)	-	R	×	213
	1043					
	1044	2-3 harmonic voltage (15th)	-	R	×	215
	1045					
	1046	2-3 harmonic voltage (17th)	-	R	×	217
	1047					
	1048	2-3 harmonic voltage (19th)	-	R	×	219
	1049					
	1050	2-3 harmonic voltage (Total)	-	R	×	220
	1051					
	1052 - 1199	System area	-	-	-	-

*1: Even if the power failure is restored, data is held because data is backed up by the nonvolatile memory.

*2: For the procedure for using the test mode, refer to "3.4.5".

Table 5.1-2 Measurement sections (Un\G100 to Un\G2999) (5/6)

Item	Address (Decimal)	Description	Default value	R/W	Back up ^{*1}	Output value during the test mode ^{*2}
Harmonic current	1200	Multiplying factor of harmonic current	-3	R	×	-3
	1201	System area	-	-	-	-
	1202	Phase 1 harmonic current (1st)	-	R	×	2101
	1203					
	1204	Phase 1 harmonic current (3rd)	-	R	×	2103
	1205					
	1206	Phase 1 harmonic current (5th)	-	R	×	2105
	1207					
	1208	Phase 1 harmonic current (7th)	-	R	×	2107
	1209					
	1210	Phase 1 harmonic current (9th)	-	R	×	2109
	1211					
	1212	Phase 1 harmonic current (11th)	-	R	×	2111
	1213					
	1214	Phase 1 harmonic current (13th)	-	R	×	2113
	1215					
	1216	Phase 1 harmonic current (15th)	-	R	×	2115
	1217					
	1218	Phase 1 harmonic current (17th)	-	R	×	2117
	1219					
	1220	Phase 1 harmonic current (19th)	-	R	×	2119
	1221					
	1222	Phase 1 harmonic current (Total)	-	R	×	2120
	1223					
	1224 - 1259	System area	-	-	-	-
	1260	Phase 3 harmonic current (1st)	-	R	×	2201
	1261					
	1262	Phase 3 harmonic current (3rd)	-	R	×	2203
	1263					
	1264	Phase 3 harmonic current (5th)	-	R	×	2205
	1265					
	1266	Phase 3 harmonic current (7th)	-	R	×	2207
	1267					
	1268	Phase 3 harmonic current (9th)	-	R	×	2209
	1269					
	1270	Phase 3 harmonic current (11th)	-	R	×	2211
	1271					
	1272	Phase 3 harmonic current (13th)	-	R	×	2213
	1273					
	1274	Phase 3 harmonic current (15th)	-	R	×	2215
	1275					
	1276	Phase 3 harmonic current (17th)	-	R	×	2217
	1277					
	1278	Phase 3 harmonic current (19th)	-	R	×	2219
	1279					
	1280	Phase 3 harmonic current (Total)	-	R	×	2220
	1281					
1282 - 1399	System area	-	-	-	-	

*1: Even if the power failure is restored, data is held because data is backed up by the nonvolatile memory.

*2: For the procedure for using the test mode, refer to "3.4.5".

Table 5.1-2 Measurement sections (Un\G100 to Un\G2999) (6/6)

Item	Address (Decimal)	Description	Default value	R/W	Back up ^{*1}	Output value during the test mode ^{*2}	
Voltage harmonic distortion	1400	Multiplying factor of voltage harmonic distortion	-1	R	×	-1	
	1401	System area	-	-	-	-	
	1402	1-2 voltage harmonic distortion (3rd)	-	R	×	4103	
	1403	1-2 voltage harmonic distortion (5th)	-	R	×	4105	
	1404	1-2 voltage harmonic distortion (7th)	-	R	×	4107	
	1405	1-2 voltage harmonic distortion (9th)	-	R	×	4109	
	1406	1-2 voltage harmonic distortion (11th)	-	R	×	4111	
	1407	1-2 voltage harmonic distortion (13th)	-	R	×	4113	
	1408	1-2 voltage harmonic distortion (15th)	-	R	×	4115	
	1409	1-2 voltage harmonic distortion (17th)	-	R	×	4117	
	1410	1-2 voltage harmonic distortion (19th)	-	R	×	4119	
	1411	1-2 voltage harmonic distortion (Total)	-	R	×	4120	
	1412 - 1419	System area	-	-	-	-	
	1420	2-3 voltage harmonic distortion (3rd)	-	R	×	4203	
	1421	2-3 voltage harmonic distortion (5th)	-	R	×	4205	
	1422	2-3 voltage harmonic distortion (7th)	-	R	×	4207	
	1423	2-3 voltage harmonic distortion (9th)	-	R	×	4209	
	1424	2-3 voltage harmonic distortion (11th)	-	R	×	4211	
	1425	2-3 voltage harmonic distortion (13th)	-	R	×	4213	
	1426	2-3 voltage harmonic distortion (15th)	-	R	×	4215	
	1427	2-3 voltage harmonic distortion (17th)	-	R	×	4217	
	1428	2-3 voltage harmonic distortion (19th)	-	R	×	4219	
	1429	2-3 voltage harmonic distortion (Total)	-	R	×	4220	
	1430 - 1599	System area	-	-	-	-	
	Current harmonic distortion	1600	Multiplying factor of current harmonic distortion	-1	R	×	-1
		1601	System area	-	-	-	-
		1602	Phase 1 current harmonic distortion (3rd)	-	R	×	6103
1603		Phase 1 current harmonic distortion (5th)	-	R	×	6105	
1604		Phase 1 current harmonic distortion (7th)	-	R	×	6107	
1605		Phase 1 current harmonic distortion (9th)	-	R	×	6109	
1606		Phase 1 current harmonic distortion (11th)	-	R	×	6111	
1607		Phase 1 current harmonic distortion (13th)	-	R	×	6113	
1608		Phase 1 current harmonic distortion (15th)	-	R	×	6115	
1609		Phase 1 current harmonic distortion (17th)	-	R	×	6117	
1610		Phase 1 current harmonic distortion (19th)	-	R	×	6119	
1611		Phase 1 current harmonic distortion (Total)	-	R	×	6120	
1612 - 1639		System area	-	-	-	-	
1640		Phase 3 current harmonic distortion (3rd)	-	R	×	6203	
1641		Phase 3 current harmonic distortion (5th)	-	R	×	6205	
1642		Phase 3 current harmonic distortion (7th)	-	R	×	6207	
1643		Phase 3 current harmonic distortion (9th)	-	R	×	6209	
1644		Phase 3 current harmonic distortion (11th)	-	R	×	6211	
1645		Phase 3 current harmonic distortion (13th)	-	R	×	6213	
1646		Phase 3 current harmonic distortion (15th)	-	R	×	6215	
1647		Phase 3 current harmonic distortion (17th)	-	R	×	6217	
1648		Phase 3 current harmonic distortion (19th)	-	R	×	6219	
1649		Phase 3 current harmonic distortion (Total)	-	R	×	6220	
1650 - 2999		System area	-	-	-	-	

*1: Even if the power failure is restored, data is held because data is backed up by the nonvolatile memory.

*2: For the procedure for using the test mode, refer to "3.4.5".

(3) Common sections (Un\G3000 to Un\G4999)

Table 5.1-3 Common sections (Un\G3000 to Un\G4999)

Item	Address (Decimal)	Description	Default value	R/W	Back up ^{*1}	Output value during the test mode ^{*2}
Error	3000	Latest error code	-	R	-	3001h
	3001	Year of time of error	-	R	-	2019h
	3002	Month and day of time of error	-	R	-	0910h
	3003	Hour and minute of time of error	-	R	-	1112h
	3004	Second and day of the week of time of error	-	R	-	1301h
	3005	Millisecond of time of error	-	R	x	0111h
LED	3006 - 3099	System area	-	-	-	-
	3100	Status of LEDs	-	R	x	1111h
	3101					
3102 - 4999	System area	-	-	-	-	

*1: Even if the power failure is restored, data is held because data is backed up by the nonvolatile memory.

*2: For the procedure for using the test mode, refer to "3.4.5".

(4) Waveform data sections (Un\G10000 to Un\G22013)

Table 5.1-4 Waveform data sections (Un\G10000 to Un\G22013) (1/2)

Item	Address (Decimal)	Description	Default value	R/W	Back up ^{*1}	Output value during the test mode ^{*2}	
Voltage waveform data	10000	Multiplying factor of voltage waveform data	-3	R	-	-3	
	10001	Number of the waveform data of voltage	0	R	-	40	
	10002	Communication error flag	0	R	-	0	
	10003	System area	-	-	-	-	
	10004	1-2 voltage waveform data 1 ^{*3}	0	R	-	1	
	10005						
	10006	1-2 voltage waveform data 2 ^{*3}	0	R	-	2	
	10007						
	⋮						
	10602	1-2 voltage waveform data 300 ^{*3}	0	R	-	998	
	10603						
	10604	System area	-	-	-	-	
	12003						
	12004	2-3 voltage waveform data 1 ^{*3}	0	R	-	1001	
	12005						
	12006	2-3 voltage waveform data 2 ^{*3}	0	R	-	1002	
	12007						
	⋮						
	12602	2-3 voltage waveform data 300 ^{*3}	0	R	-	1998	
	12603						
12604	System area	-	-	-	-		
15999							

*1: Even if the power failure is restored, data is held because data is backed up by the nonvolatile memory.

*2: For the procedure for using the test mode, refer to "3.4.5".

*3: Storage addresses for each 300 waveform data are allocated to the buffer memory. Practically, waveform data being sampled during period of measured data acquisition clock is stored, 0 is stored to the remaining address.

Table 5.1-4 Waveform data sections (Un\G10000 to Un\G22013) (2/2)

Item	Address (Decimal)	Description	Default value	R/W	Back up ^{*1}	Output value during the test mode ^{*2}	
Current waveform data	16000	Multiplying factor of current waveform data	-3	R	-	-3	
	16001	Number of the waveform data of current	0	R	-	40	
	16002	Communication error flag	0	R	-	0	
	16003	System area	-	-	-	-	
	16004	Phase 1 current waveform data 1 ^{*3}	0	R	-	3001	
	16005						
	16006	Phase 1 current waveform data 2 ^{*3}	0	R	-	3002	
	16007						
	⋮						
	16602	Phase 1 current waveform data 300 ^{*3}	0	R	-	3998	
	16603						
	16604 , 20003	System area	-	-	-	-	
	20004	Phase 3 current waveform data 1 ^{*3}	0	R	-	5001	
	20005						
	20006	Phase 3 current waveform data 2 ^{*3}	0	R	-	5002	
	20007						
	⋮						
	20602	Phase 3 current waveform data 300 ^{*3}	0	R	-	5998	
	20603						
	20604 , 21999	System area	-	-	-	-	
Voltage and current continuous waveform data	22000	Multiplying factor of voltage and current waveform data	-3	R	-	-3	
	22001	Communication error flag	0	R	-	0	
	22002	1-2 voltage waveform data	0	R	-	1	
	22003						
	22004	2-3 voltage waveform data	0	R	-	2	
	22005						
	22006	System area	-	-	-	-	
	22007	Phase 1 current waveform data	0	R	-	4	
	22008						
	22009	System area	-	-	-	-	
	22010						
	22011	Phase 3 current waveform data	0	R	-	6	
	22012						
22013							

*1: Even if the power failure is restored, data is held because data is backed up by the nonvolatile memory.

*2: For the procedure for using the test mode, refer to "3.4.5".

*3: Storage addresses for each 300 waveform data are allocated to the buffer memory. Practically, waveform data being sampled during period of measured data acquisition clock is stored, 0 is stored to the remaining address.

5.2 Configurable sections (Un\G0 - Un\G99)

5.2.1 Phase wire system (Un\G0)

Phase wire system for target electric circuits is configured below.

(1) Setting procedure

- (a) Set the phase wire in the buffer memory. Setting range is as follows.

Setting value	Description
1	single-phase 2-wire
2	single-phase 3-wire
3	three-phase 3-wire

- (b) Turn Operating condition setting request (Yn9) from OFF to ON to enable the setting.
(Refer to “4.2.2(5)”.)

(2) Default value

It is set to [3: three-phase 3-wire].

5.2.2 Primary voltage (Un\G1), Primary voltage of VT (Un\G5), Secondary voltage of VT (Un\G6)

Primary voltage (Un\G1):

Set the primary voltage of the target electric circuit.

Primary voltage of VT (Un\G5):

When using a voltage transformer that is not in the primary voltage (Un\G1) setting, set the voltage of the primary side of voltage transformer.

Secondary voltage of VT (Un\G6):

When using a voltage transformer that is not in the primary voltage (Un\G1) setting, set the voltage of the secondary side of voltage transformer.

(1) Setting procedure

- (a) Set the primary voltage, primary voltage of VT and secondary voltage of VT in the buffer memory.
Setting range is as follows.

When setting the value of primary voltage other than "1, 2, 4 to 10", set to "0: Any voltage" this setting, and set primary / secondary voltage of VT (Un\G5 / Un\G6).

When the value of this setup is set as "1, 2, 4 to 10", primary/ secondary voltage of VT are disabled.

Primary voltage (Un\G1)		Primary voltage of VT (Un\G5)	Secondary voltage of VT (Un\G6)
Setting value	Description		
0	Any voltage	1 - 6600	1 - 220
1	110 V (Direct connection) *1	0 - 6600 (However, this setting is disabled)	0 - 220 (However, this setting is disabled)
2	220 V (Direct connection)		
4	220/110 V		
5	440/110 V		
6	690/110 V		
7	1100/110 V		
8	2200/110 V		
9	3300/110 V		
10	6600/110 V		

*1: When the wiring system is single-phase 3-wire, you can only set "1: 110V (Direct connection)" for the primary voltage (Un\G1).

- (b) Turn Operating condition setting request (Yn9) from OFF to ON to enable the setting. (Refer to “4.2.2(5)”.)

(2) Default value

Primary voltage (Un\G1) is set to [2: 220 V (Direct connection)].

Primary voltage of VT (Un\G5) is set to [0].

Secondary voltage of VT (Un\G6) is set to [0].

5.2.3 Primary current (Un\G2), Primary current of CT (Un\G7)

Primary current (Un\G2) set the primary current of the target electric circuit.

Primary current of CT (Un\G7) set the current of the primary side of current transformer When using primary current of current transformer that is not in the primary current (Un\G2). Secondary current of CT cannot be set, since secondary current of CT is fixed to 5A.

(1) Setting procedure

- (a) Set the primary current and primary current of CT in the buffer memory.

Setting range is as follows: Please choose the settings to match the current sensor to be used.

When set other than "1 to 5, 501 to 536, 1001 to 1003, 1501 to 1536" the value of the primary current, set to "0: Any current (EMU-CT5-A)" or "1000: Any current (EMU2-CT5)" primary current (Un\G2), and set primary current of CT (Un\G7).

When the value of primary current (Un\G2) setup is set as "1 to 5, 501 to 536, 1001 to 1003, 1501 to 1536", primary current of CT is disabled.

Table 5.2.3-1 Setting value of Primary current and primary current of CT (1/2)

Primary current (Un\G2)		Primary current of CT (Un\G7)	Current sensor	Primary current (Un\G2)		Primary current of CT (Un\G7)	Current sensor
Setting value	Description			Setting value	Description		
0	Any current	1~6000	EMU-CT5-A	516	100/5A	0~6000 (However, this setting is disabled)	EMU-CT5-A
1	50A	0~6000 (However, this setting is disabled)	EMU-CT50-A	517	120/5A		
2	100A		EMU-CT100-A	518	150/5A		
3	250A		EMU-CT250-A	519	200/5A		
4	400A		EMU-CT400-A	520	250/5A		
5	600A		EMU-CT600-A	521	300/5A		
501	5/5A		0~6000 (However, this setting is disabled)	EMU-CT5-A	522		
502	6/5A	523			500/5A		
503	7.5/5A	524			600/5A		
504	8/5A	525			750/5A		
505	10/5A	526			800/5A		
506	12/5A	527			1000/5A		
507	15/5A	528			1200/5A		
508	20/5A	529			1500/5A		
509	25/5A	530			1600/5A		
510	30/5A	531			2000/5A		
511	40/5A	532			2500/5A		
512	50/5A	533			3000/5A		
513	60/5A	534			4000/5A		
514	75/5A	535			5000/5A		
515	80/5A	536			6000/5A		

Table 5.2.3-1 Setting value of Primary current and primary current of CT (2/2)

Primary current (Un\G2)		Primary current of CT (Un\G7)	Current sensor
Setting value	Description		
1000	Any current	1~6000	EMU2-CT5
1001	50A	0~6000 (However, this setting is disabled)	EMU-CT50
1002	100A		EMU-CT100
1003	250A		EMU-CT250
1501	5/5A		EMU2-CT5
1502	6/5A		
1503	7.5/5A		
1504	8/5A		
1505	10/5A		
1506	12/5A		
1507	15/5A		
1508	20/5A		
1509	25/5A		
1510	30/5A		
1511	40/5A		
1512	50/5A		
1513	60/5A		
1514	75/5A		
1515	80/5A		

Primary current (Un\G2)		Primary current of CT (Un\G7)	Current sensor
Setting value	Description		
1516	100/5A	0~6000 (However, this setting is disabled)	EMU2-CT5
1517	120/5A		
1518	150/5A		
1519	200/5A		
1520	250/5A		
1521	300/5A		
1522	400/5A		
1523	500/5A		
1524	600/5A		
1525	750/5A		
1526	800/5A		
1527	1000/5A		
1528	1200/5A		
1529	1500/5A		
1530	1600/5A		
1531	2000/5A		
1532	2500/5A		
1533	3000/5A		
1534	4000/5A		
1535	5000/5A		
1536	6000/5A		

(b) Operating condition setting request (Yn9) from OFF to ON to enable the setting.
(Refer to "4.2.2(5)")

(2) Default value

Primary current (Un\G2) is set to "2: 100 A".

Primary current of CT (Un\G7) is set to "0".

5.2.4 Current demand time (Un\G3)

Set a time duration for which the moving average of current demand value is calculated from the measured current value.

If current demand time is set short, the response to change of current will be quick; however, the fluctuation range may be too large. Adjust the duration according to the load and purposes.

(1) Setting procedure

(a) Set current demand time in the buffer memory

- Configurable range: 0 to 1800 (seconds)
- Set the value in seconds.
- If this setting is set to 0 second, the current demand will be the same value as the current.

(b) Operating condition setting request (Yn9) from OFF to ON to enable the setting.

(Refer to “4.2.2(5)”.)

(2) Default value

It is set to [120 seconds].

5.2.5 Electric power demand time (Un\G4)

Set a time duration for which the moving average of electric power demand value is calculated from the measured electric power value.

If electric power demand time is set short, the response to change of power will be quick; however, the fluctuation range may be too large. Adjust the duration according to the load and purposes.

(1) Setting procedure

(a) Set electric power demand time in the buffer memory.

- Configurable range: 0 to 1800 (seconds)
- Set the value in seconds.
- If this setting is set to 0 second, the electric power demand will be the same value as the electric power demand.

(b) Operating condition setting request (Yn9) from OFF to ON to enable the setting.

(Refer to “4.2.2(5)”.)

(2) Default value

It is set to [120 seconds].

5.2.6 Alarm 1 monitoring factor (Un\G11), alarm 2 monitoring factor (Un\G21)

Set which measuring item will be monitored for the upper/lower limit alarm.

Alarm 1 and 2 operate independently.

(1) Setting procedure

(a) Set the item for alarm 1 and 2 in the buffer memory. Setting range is as follows.

Setting value	Description
0	No monitoring
1	Current demand upper limit
2	Current demand lower limit
3	Voltage upper limit
4	Voltage lower limit
5	Electric power demand upper limit
6	Electric power demand lower limit
7	Power factor upper limit
8	Power factor lower limit

(b) Measuring items for the monitoring target are as follows.

Description	Measuring item of monitoring target		
	single-phase 2-wire	single-phase 3-wire	three-phase 3-wire
Current demand upper limit Current demand lower limit	1-phase current demand	1-phase current demand 3-phase current demand *1	1-phase current demand 2-phase current demand 3-phase current demand *1
Voltage upper limit Voltage lower limit	1 - 2 line voltage	1 - 2 line voltage 2 - 3 line voltage *1	1 - 2 line voltage 2 - 3 line voltage 3 - 1 line voltage *1
Electric power demand upper limit Electric power demand lower limit	Electric power demand		
Power factor upper limit Power factor lower limit	Power factor *2		

*1: When multiple number of measuring items are targeted for monitoring, the alarm judgment condition will be as following.

Upper/lower limits	Alarm judgment conditions	
	Condition for occurrence	Condition for non-occurrence
Current demand upper limit Voltage upper limit	Any one of alarm monitoring factor exceeds the alarm monitoring value.	All alarm item go below the alarm monitoring value.
Current demand lower limit Voltage lower limit	Any one of alarm monitoring factor go below the alarm monitoring value.	All alarm item exceeds the alarm monitoring value.

*2: The idea of upper and lower for PF upper / lower limit judgment is shown below.

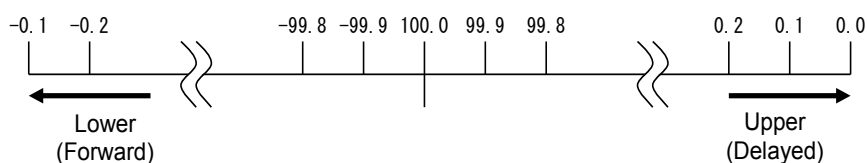

- (c) Operating condition setting request (Yn9) from OFF to ON to enable the setting.
(Refer to “4.2.2(5)”.)

(2) Default value

It is set to [0: not monitoring].

5.2.7 Alarm 1 monitoring value (Un\G12, 13), alarm 2 monitoring value (Un\G22, 23)

Set the upper/lower limit monitoring value for the target that was set in alarm 1 monitoring factor and alarm 2 monitoring factor.

(1) Setting procedure

- (a) Set the monitoring values for alarm 1 and 2 in the buffer memory.

Configurable range: -2147483648 to 2147483647

* The unit of the setting value is the same as below which was used for the measuring value of the monitored target configured in alarm 1 monitoring factor and alarm 2 monitoring factor.

Alarm 1 monitoring factor Alarm 2 monitoring factor	Unit of alarm 1 monitoring value and alarm 2 monitoring value
Current demand upper limit Current demand lower limit	$\times 10^{-3}\text{A}$
Voltage upper limit Voltage lower limit	$\times 10^{-3}\text{V}$
Electric power demand upper limit Electric power demand lower limit	W ($\times 10^{-3}\text{kW}$)
Power factor upper limit Power factor lower limit	$\times 10^{-3}\%$

- (b) Operating condition setting request (Yn9) from OFF to ON to enable the setting.
(Refer to “4.2.2(5)”.)

(2) Default value

It is set to [0].

5.2.8 Alarm 1 reset method (Un\G14), Alarm 2 reset method (Un\G24)

Set the reset method of the alarm1 and alarm 2.

For differences in behavior of alarm monitoring for different reset methods, refer to “3.4.4(3)”.

(1) Setting procedure

- (a) Set the reset method for alarm 1 and 2 in the buffer memory. Setting range is as follows.

Setting value	Description
0	Self-retention
1	Self-reset

- (b) Operating condition setting request (Yn9) from OFF to ON to enable the setting.
(Refer to “4.2.2(5)”.)

(2) Default value

It is set to [0: Self-retention].

5.2.9 Alarm 1 delay time (Un\G15), alarm 2 delay time (Un\G25)

Set the alarm delay time for the alarm 1 and alarm 2.

In a state that the delay time is set as any value other than “0” second, if a state where the value exceeds alarm monitoring value continues longer than the delay time, no alarm will be generated. (In a state that the delay time is set as any value other than “0” second, if a state where the value exceeds alarm monitoring value continues shorter than the delay time, no alarm will be generated.)

For detailed behavior, refer to “3.4.4(3)”.

(1) Setting procedure

- (a) Set the delay time for alarm 1 and alarm 2 in the buffer memory.

- Setting range: 0 to 300 (seconds)
- Set the value in seconds.

- If this setting is set to 0 second, Alarm occurrence when measured value exceeds or goes under the alarm 1 monitoring value or alarm 2 monitoring value.

- (b) Operating condition setting request (Yn9) from OFF to ON to and enable the setting.
(Refer to “4.2.2(5)”.)

(2) Default value

It is set to [0 seconds].

5.2.10 Integrated value setting target (Un\G51), Integrated value setting value (Un\G52, 53)
Set any value to the integrated value.

(1) Setting procedure

(a) Set the integrated value setting target (Un\G51) in the buffer memory. Setting range is as follows.

Setting value	Description
0	No set
1	Electric energy (consumption)
2	Electric energy (regeneration)
3	Reactive energy (consumption lag)

(b) Set the integrated value setting value in the buffer memory.

•Setting range: 0 to 999999999

* The unit used for the setting value is the same as that used for the electric energy and reactive energy that are output to the buffer memory.

For details, refer to “5.3.2”.

(c) Turn Integrated value set request (YnC) from OFF to ON to enable the setting.

(d) After checking that integrated value set completion flag (XnC) turns ON and setting is completed, set the integrated value set request (YnC) to OFF.

After detected that the integrated value set request (YnC) turns OFF, the integrated value set completion flag (XnC) turns OFF.



Figure 5.2.10 Setting procedure for integrated value

(2) Default value

Integrated value setting target (Un\G51) is set to [0: No set].

Integrated value setting value (Un\G52, 53) is set to [0].

5.2.11 Max./min. values clear target (Un\G56)

Set to clear the data by max./min. clear request.

(1) Setting procedure

- (a) Set the max./min. values clear target(Un\G56) in the buffer memory. Setting range is as follows.

Setting value	Description
11	Current demand
12	Voltage
13	Electric power demand
14	Power factor
19	All of the above
Others	Do not clear

- (b) Turn Max./min. values clear request (YnD) from OFF to ON to enable the setting.

- (c) After checking that Max./min. values clear completion flag (XnD) turns ON and clear is completed, set the Max./min. values clear request (YnD) to OFF.

When detecting that the Max./min. values clear request (YnD) turns OFF, the Max./min. values clear completion flag (XnD) turns OFF.



Figure 5.2.11 Max./min. values clear procedure

(2) Default value

It is set to "0: Do not clear".

5.2.12 Period of measured data acquisition clock (Un\G60, 61)

Set a data update period.

Period of measured data acquisition clock (Xn8) is the data update period.

If period of measured data acquisition clock is 10ms, measured data acquisition clock (Xn8) operates at a cycle of 10ms.

* For Measured data acquisition clock (Xn8), refer to “4.2.1(8)”.

(1) Setting procedure

(a) Set period of measured data acquisition clock (Un\G60, 61) in the buffer memory.

•Setting range: 10 to 10000 (ms)

•Can be set in 10ms increments. (If a value that is not divisible by 10 is set, the first digit is rounded up.)

<Example> When the period of measured data acquisition clock is 123 ms:

Period of measured data acquisition clock = $123 \text{ ms} / 10 \text{ ms} = \text{quotient } 12 + \text{remainder } 3 \text{ ms}$

Thus, because it is not divisible by 10, the first digit is rounded up and 130 is set.

(b) Turn Operating condition setting request (Yn9) from OFF to ON to enable the setting.

(Refer to “4.2.2(5)”.)

(2) Precautions for setting

The scan time should be less than OFF time of the measured data acquisition clock (Xn8) in order to detect “OFF → ON” of the measured data acquisition clock.

Since the OFF time varies according to the period of measured data acquisition clock, pay attention to set the scan time of ladder program as below.

Period of measured data acquisition clock	Scan time of ladder program
10ms	Less than 2ms
20ms to 10000ms	2/5 of the period of measured data acquisition clock

Refer to “” for details.

(3) Default value

It is set to “10ms”.

5.3 Measurement sections (Un\G100 - Un\G2999)

This product divides the measuring data into the “Data” and “Multiplying factor”, and output them to Buffer memory.

Actual measuring data is obtained by the following formula.

$$\text{Measuring data} = \text{Data} \times 10^n \text{ (Multiplying factor is } n\text{).}$$

(Example) Average current

The values output to the Buffer memory are as follows when average current is measured 123.456A.

Data (Un\G218, 219): 123456

Multiplying factor (Un\G200): -3

The actual measuring data is obtained from the value of Buffer memory as follows.

$$\begin{aligned} \text{Measuring data} &= \text{Data} \times 10^{-3} \\ &= 123.456\text{A} \end{aligned}$$

5.3.1 Multiplying factor of electric energy and reactive energy (Un\G100)

Multiplying factor of electric energy and reactive energy are stored.

How to determine the multiplying factor, refer to “3.4.1(3)”.

(1) Details of stored data

(a) Storage format

Data is stored as 16-bit signed binary in the buffer memory.

•Data range: -5 to -1

(b) Update timing

It will be updated when phase wire system (Un\G0), primary voltage (Un\G1), and primary current (Un\G2), primary voltage of VT (Un\G5), secondary voltage of VT (Un\G6), primary current of CT (Un\G7) are set.

5.3.2 Electric energy (consumption) (Un\G102, 103), electric energy (regeneration) (Un\G104, 105)
Stores the electric energy of the consumption side and the regeneration side will be stored.

(1) Details of stored data

(a) Storage format

Data is stored as double-word 32-bit unsigned binary in the buffer memory.

• Data range: 0 to 999999999

* When the stored data exceeds 999999999, stored data turns to 0 and continues measuring.

* Restrictions for measured data including resolution and measuring range, refer to “3.4.1”.

(b) Unit

Unit can be determined by multiplying factor of electric energy and reactive energy (Un\G100), as shown below.

Multiplying factor of electric energy and reactive energy (Un\G100)	Unit
-5	$\times 10^{-5}$ kWh
-4	$\times 10^{-4}$ kWh
-3	$\times 10^{-3}$ kWh
-2	$\times 10^{-2}$ kWh
-1	$\times 10^{-1}$ kWh

(c) Update timing

It will be updated every measuring cycle. For measuring cycle, refer to “5.2.12”.

5.3.3 Reactive energy (consumption lag) (Un\G106, 107)

Delayed consumption of the reactive energy is stored.

(1) Details of stored data

(a) Storage format

Data is stored as double-word 32-bit unsigned binary in the buffer memory.

• Data range: 0 to 999999999

* When the stored data exceeds 999999999, stored data turns to 0 and continues measuring.

* Restrictions for measured data including resolution and measuring range, refer to “3.4.1”.

(b) Unit

Unit can be determined by the multiplying factor of electric energy and reactive energy (Un\G100), as shown below.

Multiplying factor of electric energy and reactive energy (Un\G100)	Unit
-5	$\times 10^{-5}$ kvarh
-4	$\times 10^{-4}$ kvarh
-3	$\times 10^{-3}$ kvarh
-2	$\times 10^{-2}$ kvarh
-1	$\times 10^{-1}$ kvarh

(c) Update timing

It will be updated every measuring cycle. For measuring cycle, refer to “5.2.12”.

5.3.4 Periodic electric energy 1 (Un\G114, 115), periodic electric energy 2 (Un\G116, 117)

Stores the periodic electric energy 1 and periodic electric energy 2. The periodic electric energy of the consumption side is measured.

For specific usage procedures for the periodic electric energy, refer to “3.4.2”.

(1) Details of stored data

(a) Storage format

Data is stored as double-word 32-bit unsigned binary in the buffer memory.

• Data range: 0 to 999999999

* When the stored data exceeds 999999999, stored data turns to 0 and continues measuring.

* Restrictions for measured data including resolution and measuring range, refer to “3.4.1”.

(b) Unit

Unit can be determined by the multiplying factor of electric energy and reactive energy (Un\G100), as shown below.

Multiplying factor of electric energy and reactive energy (Un\G100)	Unit
-5	$\times 10^{-5}\text{kWh}$
-4	$\times 10^{-4}\text{kWh}$
-3	$\times 10^{-3}\text{kWh}$
-2	$\times 10^{-2}\text{kWh}$
-1	$\times 10^{-1}\text{kWh}$

(c) Update timing

It will be updated every measuring cycle. For measuring cycle, refer to “5.2.12”.

5.3.5 Multiplying factor of current (Un\G200)

The multiplying factor of the electric current is stored.

(1) Details of stored data

(a) Storage format

Data is stored as 16-bit signed binary in the buffer memory.

• Data range: -3 (fixed)

(b) Update timing

Because it is fixed at -3, there is no update.

5.3.6 Phase 1 current (Un\G202, 203), Phase 2 current (Un\G204, 205),
Phase 3 current (Un\G206, 207)

The electric current (present value) of each phase is stored.

(1) Details of stored data

(a) Storage format

Data is stored as double-word 32-bit unsigned binary in the buffer memory.

• Data range: 0 to 999999990 (0 to 99999.990 A)

* Restrictions for measured data including resolution and measuring range, refer to "3.4.1".

(b) Unit

× 10⁻³A *Unit is fixed.

(c) Update timing

It will be updated every measuring cycle. For measuring cycle, refer to "5.2.12".

5.3.7 Phase 1 current demand (Un\G210, 211), Phase 2 current demand (Un\G212, 213),
Phase 3 current demand (Un\G214, 215)

Stores the electric current (present value) at each phase that is measured based on the moving average for the duration of time configured in the electric current demand time (Un\G3).

(1) Details of stored data

(a) Storage format

Data is stored as double-word 32-bit unsigned binary in the buffer memory.

• Data range: 0 to 999999990 (0 to 99999.990 A)

* Restrictions for measured data including resolution and measuring range, refer to "3.4.1".

(b) Unit

× 10⁻³A *Unit is fixed.

(c) Update timing

It will be updated every measuring cycle. For measuring cycle, refer to "5.2.12".

5.3.8 Average current (Un\G218, 219)

Stores the Average current.

For procedure for storing the Average current using phase wire system, refer to "3.4.1(2)".

(1) Details of stored data

(a) Storage format

Data is stored as double-word 32-bit unsigned binary in the buffer memory.

• Data range: 0 to 999999990 (0 to 99999.990 A)

* Restrictions for measured data including resolution and measuring range, refer to "3.4.1".

(b) Unit

× 10⁻³A *Unit is fixed.

(c) Update timing

It will be updated every measuring cycle. For measuring cycle, refer to "5.2.12".

- 5.3.9 Maximum current demand (Un\G220, 221),
minimum current demand (Un\G228, 229)

Stores the max./min. values of the electric current demand among phases.

For procedure for storing the max./min. the electric current demand using phase wire system, refer to "3.4.1(2)".

(1) Details of stored data

(a) Storage format

Data is stored as double-word 32-bit unsigned binary in the buffer memory.

• Data range: 0 to 999999990 (0 to 99999.990 A)

* Restrictions for measured data including resolution and measuring range, refer to "3.4.1".

(b) Unit

$\times 10^{-3}\text{A}$ *Unit is fixed.

(c) Update timing

It will be updated every measuring cycle if it exceeds the current demand max. value or goes under the current demand min. value.

For measuring cycle, refer to "5.2.12".

- 5.3.10 Year of time of max. current demand (Un\G222),
month and day of time of max. current demand (Un\G223),
hour and minute of time of max. current demand (Un\G224),
second and day of the week of time of max. current demand (Un\G225),
millisecond of time of max. current demand (Un\G226),
year of time of min. current demand (Un\G230),
month and day of time of min. current demand (Un\G231),
hour and minute of time of min. current demand (Un\G232),
second and day of the week of time of min. current demand (Un\G233)
millisecond of time of min. current demand (Un\G234)

Stores year, month, day, hour, minute, second, day of the week and millisecond of time of maximum value of electric current demand (Un\G220, 221) and minimum value of electric current demand (Un\G228, 229) were updated.

(1) Details of stored data

(a) Storage format

As indicated below, Data is stored as BCD code in the buffer memory.

Buffer memory address	Storage format																
Un\G222 /Un\G230	<p>e.g.) Year 2010 2010h</p>																
Un\G223 /Un\G231	<p>e.g.) July 30 0730h</p>																
Un\G224 /Un\G232	<p>e.g.) 10:35 1035h</p>																
Un\G225 /Un\G233	<p>e.g.) 48 sec Friday 4805h</p> <table border="1" style="margin-left: 20px;"> <thead> <tr> <th colspan="2">Day of the week</th> </tr> </thead> <tbody> <tr> <td>0</td> <td>Sunday</td> </tr> <tr> <td>1</td> <td>Monday</td> </tr> <tr> <td>2</td> <td>Tuesday</td> </tr> <tr> <td>3</td> <td>Wednesday</td> </tr> <tr> <td>4</td> <td>Thursday</td> </tr> <tr> <td>5</td> <td>Friday</td> </tr> <tr> <td>6</td> <td>Saturday</td> </tr> </tbody> </table>	Day of the week		0	Sunday	1	Monday	2	Tuesday	3	Wednesday	4	Thursday	5	Friday	6	Saturday
Day of the week																	
0	Sunday																
1	Monday																
2	Tuesday																
3	Wednesday																
4	Thursday																
5	Friday																
6	Saturday																
Un\G226 /Un\G234	<p>e.g.) 172 millisecond 172h</p>																

(b) Update timing

It will be updated every measuring cycle if it exceeds the current demand max. value or goes under the current demand min. value.

For measuring cycle, refer to "5.2.12".

5.3.11 Multiplying factor of voltage (Un\G300)

The multiplying factor of the electric voltage is stored.

(1) Details of stored data

(a) Storage format

Data is stored as 16-bit signed binary in the buffer memory.

• Data range: -3 (fixed)

(b) Update timing

Because it is fixed at -3, there is no update.

5.3.12 1-2 voltage (Un\G302, 303), 2-3 voltage (Un\G304, 305), 3-1 voltage (Un\G306, 307)

The electric voltage between every combination of wires (present value) is stored.

(1) Details of stored data

(a) Storage format

Data is stored as double-word 32-bit unsigned binary in the buffer memory.

• Data range: 0 to 99999900 (0 to 99,999.900 V)

* Restrictions for measured data including resolution and measuring range, refer to "3.4.1".

(b) Unit

$\times 10^{-3}V$ *Unit is fixed.

(c) Update timing

It will be updated every measuring cycle. For measuring cycle, refer to "5.2.12".

5.3.13 Average voltage (Un\G314, 315)

Stores the Average voltage.

For procedure for storing the Average voltage using phase wire system, refer to "3.4.1(2)".

(1) Details of stored data

(a) Storage format

Data is stored as double-word 32-bit unsigned binary in the buffer memory.

• Data range: 0 to 99999900 (0 to 99,999.900 V)

* Restrictions for measured data including resolution and measuring range, refer to "3.4.1".

(b) Unit

$\times 10^{-3}V$ *Unit is fixed.

(c) Update timing

It will be updated every measuring cycle. For measuring cycle, refer to "5.2.12".

5.3.14 Maximum voltage (Un\G320, 321), minimum voltage (Un\G328, 329)

Stores the max./min. values of the voltage among in-between wires.

For procedure for storing the max./min. voltage using phase wire system, refer to "3.4.1(2)".

(1) Details of stored data

(a) Storage format

Data is stored as double-word 32-bit unsigned binary in the buffer memory.

• Data range: 0 to 99999900 (0 to 99,999.900 V)

* Restrictions for measured data including resolution and measuring range, refer to "3.4.1".

(b) Unit

$\times 10^{-3}V$ *Unit is fixed.

(c) Update timing

It will be updated every measuring cycle if it exceeds the voltage max. value or goes under the voltage min. value.

For measuring cycle, refer to "5.2.12".

5.3.15 Year of time of max. voltage (Un\G322), month and day of time of max. voltage (Un\G323), hour and minute of time of max. voltage (Un\G324), second and day of the week of time of max. voltage (Un\G325), millisecond of time of max. voltage (Un\G326), year of time of min. voltage (Un\G330), month and day of time of min. voltage (Un\G331), hour and minute of time of min. voltage (Un\G332), second and day of the week of time of min. voltage (Un\G333), millisecond of time of min. voltage (Un\G334)

Stores year, month, day, hour, minute, second, day of the week and millisecond of time of maximum voltage (Un\G320, 321) and minimum voltage (Un\G328, 329) were updated.

(1) Details of stored data

(a) Storage format

As indicated below, Data is stored as BCD code in the buffer memory.

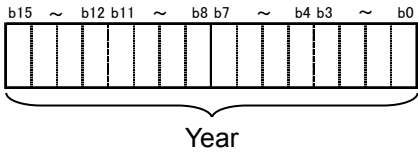
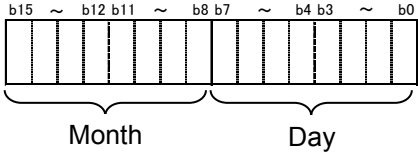
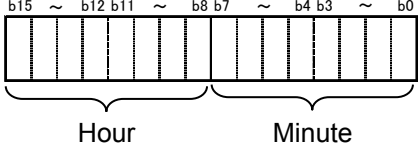
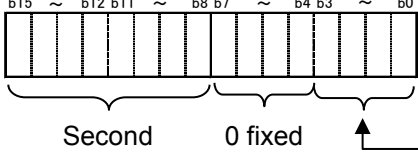
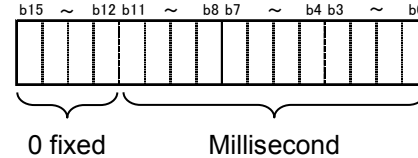
Buffer memory address	Storage format																
Un\G322 /Un\G330	 <p>e.g.) Year 2010 2010h</p>																
Un\G323 /Un\G331	 <p>e.g.) July 30 0730h</p>																
Un\G324 /Un\G332	 <p>e.g.) 10:35 1035h</p>																
Un\G325 /Un\G333	 <p>e.g.) 48 sec Friday 4805h</p> <table border="1" data-bbox="970 1077 1158 1301"> <thead> <tr> <th colspan="2">Day of the week</th> </tr> </thead> <tbody> <tr> <td>0</td> <td>Sunday</td> </tr> <tr> <td>1</td> <td>Monday</td> </tr> <tr> <td>2</td> <td>Tuesday</td> </tr> <tr> <td>3</td> <td>Wednesday</td> </tr> <tr> <td>4</td> <td>Thursday</td> </tr> <tr> <td>5</td> <td>Friday</td> </tr> <tr> <td>6</td> <td>Saturday</td> </tr> </tbody> </table>	Day of the week		0	Sunday	1	Monday	2	Tuesday	3	Wednesday	4	Thursday	5	Friday	6	Saturday
Day of the week																	
0	Sunday																
1	Monday																
2	Tuesday																
3	Wednesday																
4	Thursday																
5	Friday																
6	Saturday																
Un\G326 /Un\G334	 <p>e.g.) 172 millisecond 172h</p>																

(b) Update timing

It will be updated every measuring cycle if it exceeds the voltage max. value or goes under the voltage min. value.

For measuring cycle, refer to "5.2.12".

5.3.16 Multiplying factor of electric power (Un\G400)

The multiplying factor of electric power is stored.

(1) Details of stored data

(a) Storage format

Data is stored as 16-bit signed binary in the buffer memory.

• Data range: -3 (fixed)

(b) Update timing

Because it is fixed at -3, there is no update.

5.3.17 Electric power (Un\G402, 403)

The electric power (present value) is stored.

(1) Details of stored data

(a) Storage format

Data is stored as double-word 32-bit signed binary in the buffer memory.

If the power is negative, represents the regenerative power.

• Data range: -999999999 to 999999999 (-999999.999 to 999999.999 kW)

* Restrictions for measured data including resolution and measuring range, refer to "3.4.1".

* The sign of the data is as shown in the following figure.

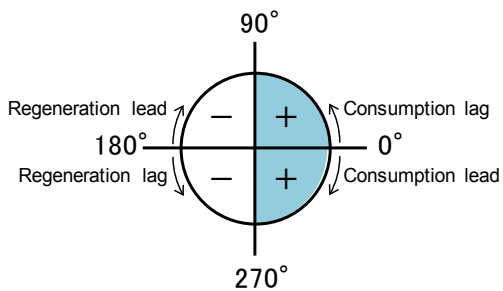

(b) Unit

$\times 10^{-3}\text{kW}$ *Unit is fixed.

(c) Update timing

It will be updated every measuring cycle. For measuring cycle, refer to "5.2.12".

5.3.18 Electric power demand (Un\G404, 405)

Stores the electric power that is measured based on the moving average for the duration of time configured in the electric power demand time (Un\G4).

(1) Details of stored data

(a) Storage format

Data is stored as double-word 32-bit signed binary in the buffer memory.

If the power is negative, represents the regenerative power.

• Data range: -999999999 to 999999999 (-999999.999 to 999999.999 kW)

* Restrictions for measured data including resolution and measuring range, refer to "3.4.1".

(b) Unit

× 10⁻³kW *Unit is fixed.

(c) Update timing

It will be updated every measuring cycle. For measuring cycle, refer to "5.2.12".

5.3.19 Maximum electric power demand (Un\G420, 421),
minimum electric power demand (Un\G428, 429)

Stores the max./min. values of the electric power demand.

(1) Details of stored data

(a) Storage format

Data is stored as double-word 32-bit signed binary in the buffer memory.

If the power is negative, represents the regenerative power.

• Data range: -999999999 to 999999999 (-999999.999 to 999999.999 kW)

* Restrictions for measured data including resolution and measuring range, refer to "3.4.1".

(b) Unit

× 10⁻³kW *Unit is fixed.

(c) Update timing

It will be updated every measuring cycle if it exceeds the electric power demand max. value or goes under the electric power demand min. value.

For measuring cycle, refer to "5.2.12".

5.3.20 Year of time of max. electric power demand (Un\G422),
month and day of time of max. electric power demand (Un\G423),
hour and minute of time of max. electric power demand (Un\G424),
second and day of the week of time of max. electric power demand (Un\G425),
millisecond of time of max. electric power demand (Un\G426),
year of time of min. electric power demand (Un\G430),
month and day of time of min. electric power demand (Un\G431),
hour and minute of time of min. electric power demand (Un\G432),
second and day of the week of time of min. electric power demand (Un\G433),
millisecond of time of min. electric power demand (Un\G434)

Stores year, month, day, hour, minute, second, day of the week and millisecond of time of maximum value of electric power demand (Un\G420, 421) and minimum value of electric power demand (Un\G428, 429) were updated.

(1) Details of stored data

(a) Storage format

As indicated below, Data is stored as BCD code in the buffer memory.

Buffer memory address	Storage format																
Un\G422 /Un\G430	<p>e.g.) Year 2010 2010h</p>																
Un\G423 /Un\G431	<p>e.g.) July 30 0730h</p>																
Un\G424 /Un\G432	<p>e.g.) 10:35 1035h</p>																
Un\G425 /Un\G433	<p>e.g.) 48 sec Friday 4805h</p> <table border="1" style="margin-left: 20px;"> <thead> <tr> <th colspan="2">Day of the week</th> </tr> </thead> <tbody> <tr><td>0</td><td>Sunday</td></tr> <tr><td>1</td><td>Monday</td></tr> <tr><td>2</td><td>Tuesday</td></tr> <tr><td>3</td><td>Wednesday</td></tr> <tr><td>4</td><td>Thursday</td></tr> <tr><td>5</td><td>Friday</td></tr> <tr><td>6</td><td>Saturday</td></tr> </tbody> </table>	Day of the week		0	Sunday	1	Monday	2	Tuesday	3	Wednesday	4	Thursday	5	Friday	6	Saturday
Day of the week																	
0	Sunday																
1	Monday																
2	Tuesday																
3	Wednesday																
4	Thursday																
5	Friday																
6	Saturday																
Un\G426 /Un\G434	<p>e.g.) 172 millisecond 172h</p>																

(b) Update timing

It will be updated every measuring cycle if it exceeds the electric power demand max. value or goes under the electric power demand min. value.

For measuring cycle, refer to "5.2.12".

5.3.21 Multiplying factor of reactive power (Un\G500)

The multiplying factor of reactive power is stored.

(1) Details of stored data

(a) Storage format

Data is stored as 16-bit signed binary in the buffer memory.

• Data range: -3 (fixed)

(b) Update timing

Because it is fixed at -3, there is no update.

5.3.22 Reactive power (Un\G502, 503)

The reactive power is stored.

(1) Details of stored data

(a) Storage format

Data is stored as double-word 32-bit signed binary in the buffer memory.

• Data range: -999999999 to 999999999 (-999999.999 to 999999.999 kvar)

* Restrictions for measured data including resolution and measuring range, refer to “3.4.1”.

* The sign of the data is as shown in the following figure.

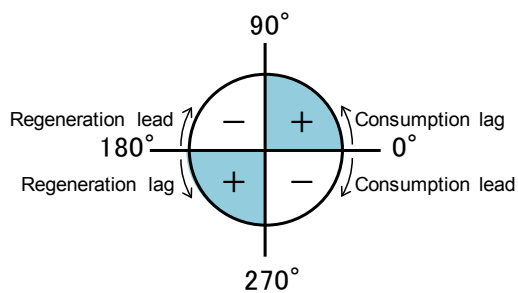

(b) Unit

$\times 10^{-3}$ kvar *Unit is fixed.

(c) Update timing

It will be updated every measuring cycle. For measuring cycle, refer to “5.2.12”.

5.3.23 Multiplying factor of apparent power (Un\G600)

The multiplying factor of apparent power is stored.

(1) Details of stored data

(a) Storage format

Data is stored as 16-bit signed binary in the buffer memory.

• Data range: -3 (fixed)

(b) Update timing

Because it is fixed at -3, there is no update.

5.3.24 Apparent power (Un\G602, 603)

The apparent power is stored.

(1) Details of stored data

(a) Storage format

Data is stored as double-word 32-bit unsigned binary in the buffer memory.

• Data range: 0 to 999999999 (0.000 to 999999.999 kVA)

* Restrictions for measured data including resolution and measuring range, refer to “3.4.1”.

(b) Unit

× 10⁻³kVA *Unit is fixed.

(c) Update timing

It will be updated every measuring cycle. For measuring cycle, refer to “5.2.12”.

5.3.25 Multiplying factor of power factor (Un\G700)

The multiplying factor of the power factor is stored.

(1) Details of stored data

(a) Storage format

Data is stored as 16-bit signed binary in the buffer memory.

• Data range: -3 (fixed)

(b) Update timing

Because it is fixed at -3, there is no update.

5.3.26 Power factor (Un\G702, 703)

Stores the power factor.

(1) Details of stored data

(a) Storage format

Data is stored as double-word 32-bit signed binary in the buffer memory.

• Data range: -100000 to 100000 (-100.000 to 100.000%)

* Restrictions for measured data including resolution and measuring range, refer to “3.4.1”.

* The sign of the data is as shown in the following figure.

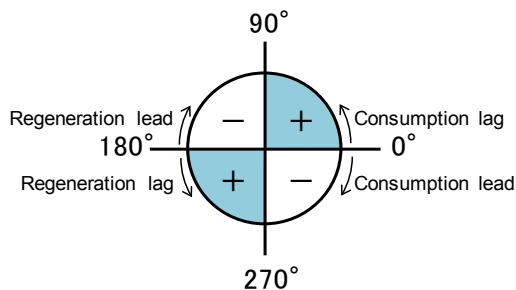

(b) Unit

× 10⁻³% *Unit is fixed.

(c) Update timing

It will be updated every measuring cycle. For measuring cycle, refer to “5.2.12”.

5.3.27 Maximum power factor (Un\G720, 721), minimum power factor (Un\G728, 729)
The max./min. power factors are stored.

(1) Details of stored data

(a) Storage format

Data is stored as double-word 32-bit signed binary in the buffer memory.

• Data range: -100000 to 100000 (-100.000 to 100.000%)

* For the resolution, refer to "3.4.1".

(b) Unit

× 10⁻³% *Unit is fixed.

(c) Update timing

It will be updated every measuring cycle if it exceeds the power factor max. value or goes under the power factor min. value.

For measuring cycle, refer to "5.2.12".

5.3.28 Year of time of max. power factor (Un\G722),
month and day of time of max. power factor (Un\G723),
hour and minute of time of max. power factor (Un\G724),
second and day of the week of time of max. power factor (Un\G725),
millisecond of time of max. power factor (Un\G726),
year of time of min. power factor (Un\G730),
month and day of time of min. power factor (Un\G731),
hour and minute of time of min. power factor (Un\G732),
second and day of the week of time of min. power factor (Un\G733),
millisecond of time of min. power factor (Un\G734)

Stores year, month, day, hour, minute, second, day of the week and millisecond of time of maximum power factor (Un\G720, 721) and minimum power factor (Un\G728, 729) were updated.

(1) Details of stored data

(a) Storage format

As indicated below, Data is stored as BCD code in the buffer memory.

Buffer memory address	Storage format																
Un\G722 /Un\G730	<p>e.g.) Year 2010 2010h</p>																
Un\G723 /Un\G731	<p>e.g.) July 30 0730h</p>																
Un\G724 /Un\G732	<p>e.g.) 10:35 1035h</p>																
Un\G725 /Un\G733	<p>e.g.) 48 sec Friday 4805h</p> <table border="1" style="margin-left: auto; margin-right: auto;"> <thead> <tr> <th colspan="2">Day of the week</th> </tr> </thead> <tbody> <tr><td>0</td><td>Sunday</td></tr> <tr><td>1</td><td>Monday</td></tr> <tr><td>2</td><td>Tuesday</td></tr> <tr><td>3</td><td>Wednesday</td></tr> <tr><td>4</td><td>Thursday</td></tr> <tr><td>5</td><td>Friday</td></tr> <tr><td>6</td><td>Saturday</td></tr> </tbody> </table>	Day of the week		0	Sunday	1	Monday	2	Tuesday	3	Wednesday	4	Thursday	5	Friday	6	Saturday
Day of the week																	
0	Sunday																
1	Monday																
2	Tuesday																
3	Wednesday																
4	Thursday																
5	Friday																
6	Saturday																
Un\G726 /Un\G734	<p>e.g.) 172 millisecond 172h</p>																

(b) Update timing

It will be updated every measuring cycle if it exceeds the power factor max. value or goes under the power factor min. value.

For measuring cycle, refer to "5.2.12".

5.3.29 Multiplying factor of frequency (Un\G800)

The multiplying factor of the frequency is stored.

(1) Details of stored data

(a) Storage format

Data is stored as 16-bit signed binary in the buffer memory.

• Data range: -3 (fixed)

(b) Update timing

Because it is fixed at -3, there is no update.

5.3.30 Frequency (Un\G802, 803)

Stores the frequency.

(1) Details of stored data

(a) Storage format

Data is stored as double-word 32-bit unsigned binary in the buffer memory.

• Data range: 0 to 999900 (0 to 999.900 Hz)

* Restrictions for measured data including resolution and measuring range, refer to “3.4.1”.

(b) Unit

× 10⁻³Hz *Unit is fixed.

(c) Update timing

It will be updated every measuring cycle. For measuring cycle, refer to “5.2.12”.

5.3.31 Multiplying factor of harmonic voltage (Un\G1000)

The multiplying factor of the harmonic voltage is stored.

(1) Details of stored data

(a) Storage format

Data is stored as 16-bit signed binary in the buffer memory.

• Data range: -3 (fixed)

(b) Update timing

Because it is fixed at -3, there is no update.

- 5.3.32 1-2 harmonic voltage (Un\G1002 - Un\G1021),
2-3 harmonic voltage (Un\G1030 - Un\G1049)

Stores the harmonic voltage RMS between each line. (1st, 3rd, 5th, 7th, 9th, 11th, 13th, 15th, 17th, and 19th are stored.)

(1) Details of stored data

(a) Storage format

Data is stored as double-word 32-bit unsigned binary in the buffer memory.

•Data range: 0 to 99999999 (0 to 99999.999 V)

* Restrictions for measured data including resolution and measuring range, refer to "3.4.1".

(b) Unit

$\times 10^{-3}\text{V}$ *Unit is fixed.

(c) Update timing

It will be update about every second. For details, refer to "4.2.1(7)".

- 5.3.33 1-2 harmonic voltage (Total) (Un\G1022, 1023),
2-3 harmonic voltage (Total) (Un\G1050, 1051)

Stores the harmonic total voltage RMS between each line.

(1) Details of stored data

(a) Storage format

Data is stored as double-word 32-bit signed binary in the buffer memory.

•Data range: 0 to 99999999 (0 to 99999.999 V)

* Restrictions for measured data including resolution and measuring range, refer to "3.4.1".

(b) Unit

$\times 10^{-3}\text{V}$ *Unit is fixed.

(c) Update timing

It will be update about every second. For details, refer to "4.2.1(7)".

- 5.3.34 Multiplying factor of harmonic current (Un\G1200)

The multiplying factor of the harmonic current is stored.

(1) Details of stored data

(a) Storage format

Data is stored as 16-bit signed binary in the buffer memory.

•Data range: -3 (fixed)

(b) Update timing

Because it is fixed at -3, there is no update.

5.3.35 Phase 1 harmonic current (Un\G1202 - Un\G1221),
Phase 3 harmonic current (Un\G1260 - Un\G1279)

Stores the harmonic current RMS between each phase. (1st, 3rd, 5th, 7th, 9th, 11th, 13th, 15th, 17th, and 19th are stored.)

(1) Details of stored data

(a) Storage format

Data is stored as double-word 32-bit unsigned binary in the buffer memory.

•Data range: 0 to 99999999 (0 to 99999.999 A)

* Restrictions for measured data including resolution and measuring range, refer to "3.4.1".

(b) Unit

$\times 10^{-3}\text{A}$ *Unit is fixed.

(c) Update timing

It will be update about every second. For details, refer to "4.2.1(7)".

5.3.36 Phase 1 harmonic current (Total) (Un\G1222, 1223),
phase 3 harmonic current (Total) (Un\G1280, 1281)

Stores the harmonic total current RMS between each phase.

(1) Details of stored data

(a) Storage format

Data is stored as double-word 32-bit unsigned binary in the buffer memory.

•Data range: 0 to 99999999 (0 to 99999.999 A)

* Restrictions for measured data including resolution and measuring range, refer to "3.4.1".

(b) Unit

$\times 10^{-3}\text{A}$ *Unit is fixed.

(c) Update timing

It will be update about every second. For details, refer to "4.2.1(7)".

5.3.37 Multiplying factor of voltage harmonic distortion (Un\G1400)

The multiplying factor of the harmonic voltage distortion ratio is stored.

(1) Details of stored data

(a) Storage format

Data is stored as 16-bit signed binary in the buffer memory.

•Data range: -1 (fixed)

(b) Update timing

Because it is fixed at -1, there is no update.

- 5.3.38 1-2 voltage harmonic distortion (Un\G1402 - Un\G1410),
2-3 voltage harmonic distortion (Un\G1420 - Un\G1428)

Stores the harmonic voltage distortion ratio between each line. (3rd, 5th, 7th, 9th, 11th, 13th, 15th, 17th, and 19th are stored.)

(1) Details of stored data

(a) Storage format

Data is stored as 16-bit unsigned binary in the buffer memory.

•Data range: 0 to 9999 (0 to 999.9 %)

* Restrictions for measured data including resolution and measuring range, refer to "3.4.1".

(b) Unit

× 10⁻¹% *Unit is fixed.

(c) Update timing

It will be update about every second. For details, refer to "4.2.1(7)".

- 5.3.39 1-2 voltage harmonic distortion (Total) (Un\G1411),
2-3 voltage harmonic distortion (Total) (Un\G1429)

Stores the harmonic total voltage distortion ratio between each line.

(1) Details of stored data

(a) Storage format

Data is stored as 16-bit unsigned binary in the buffer memory.

•Data range: 0 to 9999 (0 to 999.9 %)

* Restrictions for measured data including resolution and measuring range, refer to "3.4.1".

(b) Unit

× 10⁻¹% *Unit is fixed.

(c) Update timing

It will be update about every second. For details, refer to "4.2.1(7)".

- 5.3.40 Multiplying factor of current harmonic distortion (Un\G1600)

The multiplying factor of the harmonic current distortion ratio is stored.

(1) Details of stored data

(a) Storage format

Data is stored as 16-bit signed binary in the buffer memory.

•Data range: -1 (fixed)

(b) Update timing

Because it is fixed at -1, there is no update.

5.3.41 Phase 1 current harmonic distortion (Un\G1602 - Un\G1610),
phase 3 current harmonic distortion (Un\G1640 - Un\G1648)

Stores the harmonic current distortion ratio between each phase. (3rd, 5th, 7th, 9th, 11th, 13th, 15th, 17th, and 19th are stored.)

(1) Details of stored data

(a) Storage format

Data is stored as 16-bit unsigned binary in the buffer memory.

• Data range: 0 to 9999 (0 to 999.9 %)

* Restrictions for measured data including resolution and measuring range, refer to "3.4.1".

(b) Unit

× 10⁻¹% *Unit is fixed.

(c) Update timing

It will be update about every second. For details, refer to "4.2.1(7)".

5.3.42 Phase 1 current harmonic distortion (Total) (Un\G1611),
phase 3 current harmonic distortion (Total) (Un\G1649)

Stores the harmonic total current distortion ratio between each phase.

(1) Details of stored data

(a) Storage format

Data is stored as 16-bit unsigned binary in the buffer memory.

• Data range: 0 to 9999 (0 to 999.9 %)

* Restrictions for measured data including resolution and measuring range, refer to "3.4.1".

(b) Unit

× 10⁻¹% *Unit is fixed.

(c) Update timing

It will be update about every second. For details, refer to "4.2.1(7)".

5.4 Common sections (Un\G3000 - Un\G4999)

5.4.1 Latest error code (Un\G3000)

The latest error code that is detected with this module will be stored.

For the list of error codes, refer to “8.1 List of error codes”.

(1) Details of stored data

(a) Storage format

Data is stored as 16-bit unsigned binary in the buffer memory.

•Data range: 0000h (normal), 0001h to FFFFh (error code)

(b) Update timing

It will be updated at the time of error occurrence and error recovery.

- 5.4.2 Year of time of the error (Un\G3001),
- month and day of time of error (Un\G3002),
- hour and minute of time of error (Un\G3003),
- second and day of the week of time of error (Un\G3004),
- millisecond of time of error (Un\G3005)

The year, month, day, hour, minute, second, day of the week and millisecond of time of the error will be stored.

(1) Details of stored data

(a) Storage format

As indicated below, Data is stored as BCD code in the buffer memory.

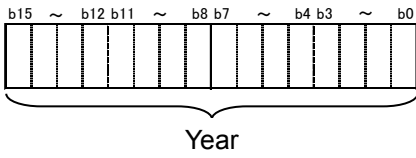
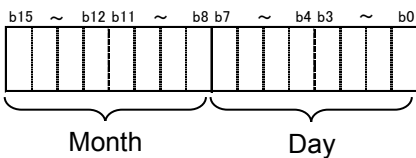
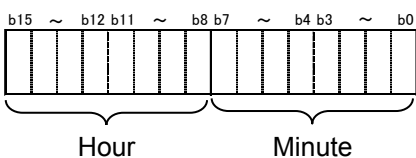
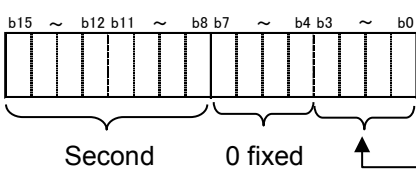
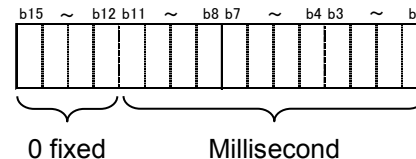
Buffer memory address	Storage format																
Un\G3001	 <p style="text-align: right;">e.g.) Year 2010 2010h</p>																
Un\G3002	 <p style="text-align: right;">e.g.) July 30 0730h</p>																
Un\G3003	 <p style="text-align: right;">e.g.) 10:35 1035h</p>																
Un\G3004	 <p style="text-align: right;">e.g.) 48 sec Friday 4805h</p> <table border="1" style="margin-left: auto; margin-right: 0;"> <thead> <tr> <th colspan="2">Day of the week</th> </tr> </thead> <tbody> <tr><td>0</td><td>Sunday</td></tr> <tr><td>1</td><td>Monday</td></tr> <tr><td>2</td><td>Tuesday</td></tr> <tr><td>3</td><td>Wednesday</td></tr> <tr><td>4</td><td>Thursday</td></tr> <tr><td>5</td><td>Friday</td></tr> <tr><td>6</td><td>Saturday</td></tr> </tbody> </table>	Day of the week		0	Sunday	1	Monday	2	Tuesday	3	Wednesday	4	Thursday	5	Friday	6	Saturday
Day of the week																	
0	Sunday																
1	Monday																
2	Tuesday																
3	Wednesday																
4	Thursday																
5	Friday																
6	Saturday																
Un\G3005	 <p style="text-align: right;">e.g.) 172 millisecond 172h</p>																

(b) Update timing

It will be updated at the time of error occurrence and error recovery.

5.4.3 Status of LEDs (Un\G3100, 3101)

The status of LEDs will be stored.

(1) Details of stored data

(a) Storage format

As indicated below, Data is stored in the buffer memory.

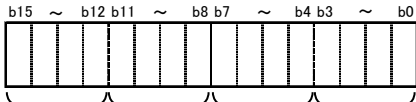
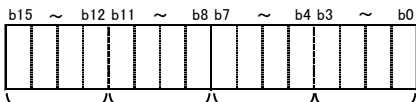
Buffer memory address	Storage format
Un\G3100	 <p style="text-align: right;"> RUN LED MEA. LED ALM1 LED ALM2 LED </p> <p> RUN LED, MEA. LED ALM1 LED, ALM2 LED 0: OFF 0: OFF 1: ON 1: ON 2: Flashing </p>
Un\G3101	 <p style="text-align: right;"> ERR LED R LED 1 LED 3 LED </p> <p> R LED, 1. LED, 3 LED ERR LED 0: OFF 0: OFF 1: ON 1: ON 2: Flashing </p>

* When calculated value is low, "MEA"LED, "R"LED, "1"LED and "3"LED are looked like flashing. Comparing to the last value per measuring cycle, LEDs light while calculating, then LEDs light off upon no changes. Since measuring cycle is shortest as 10ms, short period setting seems like flashing.

(b) Update timing

It will be update at the status of LED is change.

5.5 Waveform data sections (Un\G10000 - Un\G22013)

5.5.1 Multiplying factor of voltage waveform data (Un\G10000)

The multiplying factor of waveform data of voltage is stored.

(1) Details of stored data

(a) Storage format

Data is stored as 16-bit signed binary in the buffer memory.

•Data range: -3 (fixed)

(b) Update timing

Because it is fixed at -3, there is no update.

5.5.2 Number of the waveform data of voltage (Un\G10001)

The number of the waveform data during a period of measured data acquisition clock is stored.

(1) Details of stored data

(a) Storage format

Data is stored as 16-bit signed binary in the buffer memory.

•Data range: 0 to 300

(b) Update timing

It will be updated every measuring cycle. For measuring cycle, refer to "5.2.12".

5.5.3 Communication error flag (Un\G10002)

Result of internal communication of RE81WH is stored.

(1) Details of stored data

(a) Storage format

Data is stored as 16-bit signed binary in the buffer memory.

•Data range: 0, 1 (0: no error, 1: error)

(b) Update timing

It will be updated every measuring cycle. For measuring cycle, refer to "5.2.12".

(2) Precautions

Where the data is "1: error", the waveform data of voltage of the period of measured data acquisition clock is not stored into the buffer memory.

- 5.5.4 1-2 voltage waveform data 1 to 300 (Un\G10004 - Un\G10603),
2-3 voltage waveform data 1 to 300 (Un\G12004 - Un\G12603)

Waveform data of each inter-wire voltage is stored.

Stores data of the number of the waveform data of voltage (Un\G10001) from waveform data 1.

(1) Details of stored data

(a) Storage format

Data is stored as double-word 32-bit signed binary in the buffer memory.

•Data range: -999999999 to 999999999 (-999999.999 to 99999.999 V)

(b) Storage range

The range differs according to the period of measured data acquisition clock.

Refer to "" as to details.

(c) Unit

$\times 10^{-3}V$ *Unit is fixed.

(d) Update timing

It will be updated every measuring cycle. For measuring cycle, refer to "5.2.12".

5.5.5 Multiplying factor of current waveform data (Un\G16000)

The multiplying factor of waveform data of current is stored.

(1) Details of stored data

(a) Storage format

Data is stored as 16-bit signed binary in the buffer memory.

•Data range: -3 (fixed)

(b) Update timing

Because it is fixed at -3, there is no update.

5.5.6 Number of the waveform data of current (Un\G16001)

The number of the waveform data during a period of measured data acquisition clock is stored.

(1) Details of stored data

(a) Storage format

Data is stored as 16-bit signed binary in the buffer memory.

•Data range: 0 to 300

(b) Update timing

It will be updated every measuring cycle. For measuring cycle, refer to "5.2.12".

5.5.7 Communication error flag (Un\G16002)

Result of internal communication of RE81WH is stored.

(1) Details of stored data

(a) Storage format

Data is stored as 16-bit signed binary in the buffer memory.

•Data range: 0, 1 (0: no error, 1: error)

(b) Update timing

It will be updated every measuring cycle. For measuring cycle, refer to "5.2.12".

(2) Precautions

Where the data is "1: error", the waveform data of voltage of the period of measured data acquisition clock is not stored into the buffer memory.

5.5.8 Phase 1 current waveform data 1 to 300 (Un\G16004 - Un\G16603), phase 3 current waveform data 1 to 300 (Un\G20004 - Un\G20603)

Waveform data of each phase current is stored.

Stores data of the number of the waveform data of current (Un\G16001) from waveform data 1.

(1) Details of stored data

(a) Storage format

Data is stored as double-word 32-bit signed binary in the buffer memory.

•Data range: -999999999 to 999999999 (-999999.999 to 99999.999 A)

(b) Storage range

The range differs according to the period of measured data acquisition clock.

Refer to "" as to details.

(c) Unit

$\times 10^{-3}A$ *Unit is fixed.

(d) Update timing

It will be updated every measuring cycle. For measuring cycle, refer to "5.2.12".

5.5.9 Multiplying factor of voltage and current waveform data (Un\G22000)

The multiplying factor of waveform data of voltage and current is stored.

(1) Details of stored data

(a) Storage format

Data is stored as 16-bit signed binary in the buffer memory.

•Data range: -3 (fixed)

(b) Update timing

Because it is fixed at -3, there is no update.

5.5.10 Communication error flag (Un\G22001)

Result of internal communication of RE81WH is stored.

(1) Details of stored data

(a) Storage format

Data is stored as 16-bit signed binary in the buffer memory.

•Data range: 0, 1 (0: no error, 1: error)

(b) Update timing

It will be updated every measuring cycle. For measuring cycle, refer to "5.2.12".

(2) Precautions

Where the data is "1: error", the waveform data of voltage and current of sampling period is not stored into the buffer memory.

5.5.11 1-2 voltage waveform data (Un\G22002, 22003),
2-3 voltage waveform data (Un\G22004, 22005)

Waveform data of each inter-wire voltage is stored.

(1) Details of stored data

(a) Storage format

Data is stored as double-word 32-bit signed binary in the buffer memory.

•Data range: -999999999 to 999999999 (-99999.999 to 99999.999 V)

(b) Unit

$\times 10^{-3}V$ *Unit is fixed.

(c) Update timing

It will be updated every measuring cycle. For measuring cycle, refer to "4.2.1(6)".

5.5.12 Phase 1 current waveform data (Un\G22008, 22009),
phase 3 current waveform data (Un\G22012, 22013)

Waveform data of each phase current is stored.

(1) Details of stored data

(a) Storage format

Data is stored as double-word 32-bit signed binary in the buffer memory.

•Data range: -999999999 to 999999999 (-99999.999 to 99999.999 A)

(b) Unit

$\times 10^{-3}A$ *Unit is fixed.

(c) Update timing

It will be updated every measuring cycle. For measuring cycle, refer to "4.2.1(6)".

Section 6 SETTING AND PROCEDURE FOR OPERATION

6.1 Procedure for operation

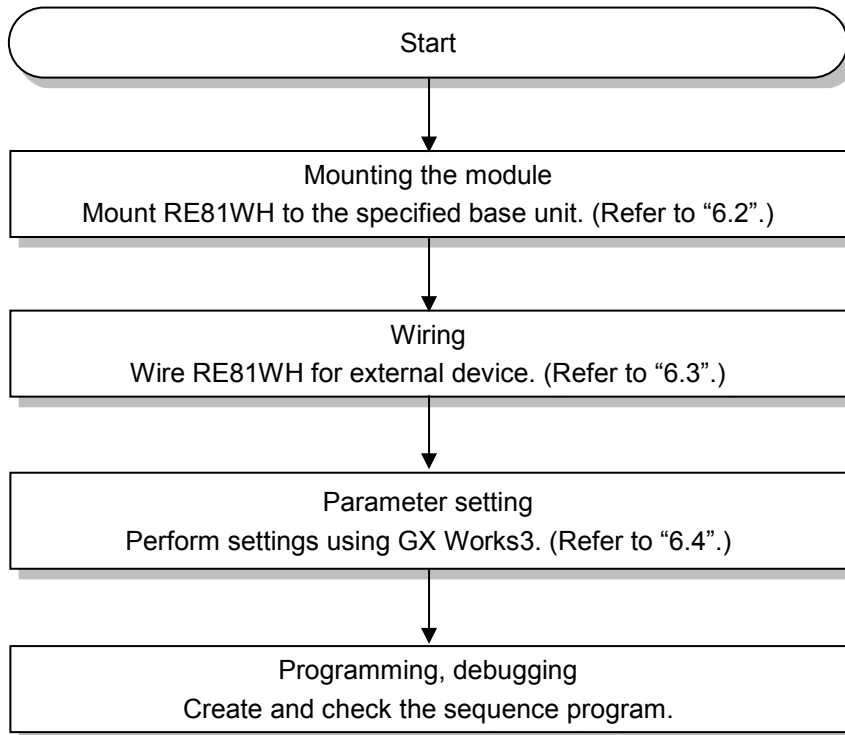
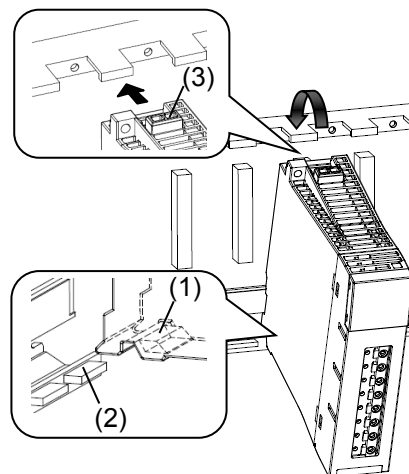

Figure 6.1-1 Procedure for operation

6.2 Mounting and removing the module

6.2.1 How to mount to the base unit

1. When a cap is attached to the module connector of the base unit, remove it.
2. Place the concave part (1) of the module on to the guide (2) of the base unit.
3. Push in the module until the module fixing hook (3) snaps into place.
4. Check that the module fixing hook (3) hangs the base unit and the module is mounted on the base unit securely.



Caution

- Mount to the base of MELSEC iQ-R series.
- When mounting the module, make sure to insert the protruding portions for fixing the module into the holes on the base unit. In those case, insert it securely so that the protruding portion of the module does not come off of the holes. Do not forcibly mount the module, otherwise the module may be damaged.
- When installing the module at a vibrating area with strong impact, tighten the module to the base unit using screws.

Module-fixing screws: M3 x 12mm (Prepare them by yourself)

Screw size	Tightening torque range
Module-fixing screws (M3 x 12mm)	0.36 – 0.48 N·m

- Mounting and detaching the module and the base unit should be performed 50 times or less (to conform to JIS B3502). If the count exceeds 50 times, it may cause a malfunction.

6.2.2 How to detach it from the base unit

1. Support the module with both hands and securely press the module fixing hook (1) with your finger.
2. Pull the module straight supporting it at its bottom while pressing the module fixing hook (1).
3. While lifting the module, remove the concave part (2) from the guide (3) of the base unit.

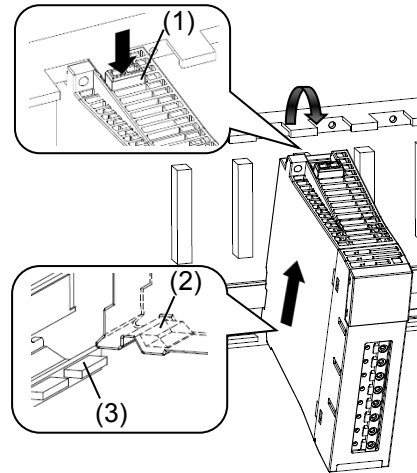

 **Caution**

- When module-fixing screws are used, make sure to remove the screws for detaching the module first, and then remove the protruding portion for fixing the module from the holes. If you remove the module forcibly, it may break the protruding portions for fixing the module.

6.3 Wiring

6.3.1 Precautions for wiring

Caution

- For protection against noise, input lines shall not be placed close to or bound together with the power lines and high-voltage lines. Keep distance as below between them. (except for the terminal block)

Condition	Distance
High-voltage line 600V or less	300mm or more
Other high-voltage line	600mm or more

- (1) Maximum voltage of the circuit connected to RE81WH is 260V. For the circuit over this voltage, surely use the transformer. When using the transformer, primary voltage is configurable up to 6600V. Secondary voltage can be setup to 110V or 220V. (Primary voltage of VT can be set up to 6600V, and secondary voltage of VT can be set up to 220V as optional setting.)
- (2) Before connecting the cable, make sure that the orientation of the current sensor is correct for attachment. K to L is the correct direction. K: power source side, L: load side.
- (3) Use insulation wire rather than basic insulation for the primary side cable of current sensor.
- (4) Do not ground the secondary side of the current sensor.
- (5) Dedicated current sensor (excludes EMU2-CT5) is extendable up to 50m.
- (6) EMU2-CT5 is extendable up to 11m, using together with an extension cable. To extend the wire further, use the current transformer CW-5S(L) for split-type instrument in combination, extending the secondary wiring on CW-5S(L) side.
- (7) The available transformer ratio is 220/110 V to 6600/110 V. For connection to P1 to P3 terminals on this module, connect the secondary of transformer. Make sure that terminal symbols are correct.
- (8) Dedicated current sensor (excludes EMU2-CT5 and EMU-CT5-A) is used only for low voltage circuit. It cannot be used for a high voltage circuit. EMU2-CT5 and EMU-CT5-A should be used with the secondary side (5A) of transformer transfixed. If they are used for the circuit directly, they should be used under 200V.
- (9) For input wiring of the measurement circuit, use separate cables from other external signals in order to prevent from AC surge and induction.
- (10) Keep any object off the cables.
- (11) Protect cable coating from scratch.
- (12) Cable length should be routed in length with a margin, please take care to avoid causing stress to pull the terminal block. (Tensile load: less than 22N)
- (13) Please do not connect two or more cables to one terminal hole of the current input terminal block. If the engagement of the terminal becomes weak, cable may fall out.

6.3.2 How to connect wires

(1) Follow the "6.3.3 How to wire" for external connection to RE81WH.

(2) Use applicable wire as described below.

At the connection between the secondary terminal of the dedicated current sensor (excludes EMU2-CT5) and current input terminals, use twisted pair cable.

Applicable wire (Usable electric wire)	Single wire: AWG24 - AWG16 ($\phi 0.52 - 1.29\text{mm}$) Stranded wire: AWG20 - AWG16 ($0.52 - 1.30\text{mm}^2$)
---	---

(3) Stripping length of the used wire in use has to be 10 to 11mm. Check the stripping length using the gauge of RE81WH main module.

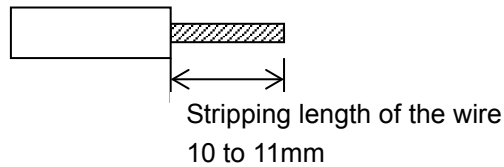

(4) When stranded wire is used, a bar terminal must be used.

Recommended bar terminal	TGV TC-1.25-11T (Made by Nichifu) or equivalent
--------------------------	---

(5) When inserting and detaching cables to/from the terminal, use the push button. Check that the wire is securely inserted.

(6) Insert a wire to the terminal all the way until it touches the end.

6.3.3 How to wire

Follow the wiring diagram (Figure 6.3.3-1 ~ 6.3.3-5) for external connection of RE81WH.

(1) In the case using 5A current sensor.

(a) Case of using EMU2-CT5

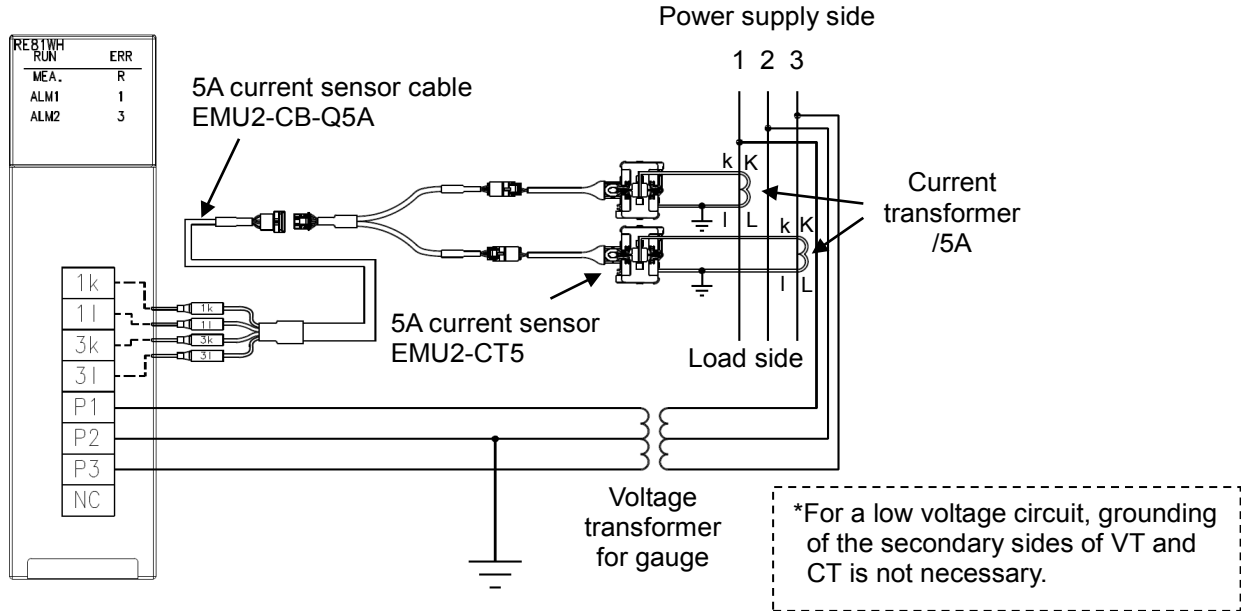

Figure 6.3.3-1 In the case of Three-phase 3-wire system (with the voltage transformer for gauge/current transformer)

(b) Case of using EMU-CT5-A

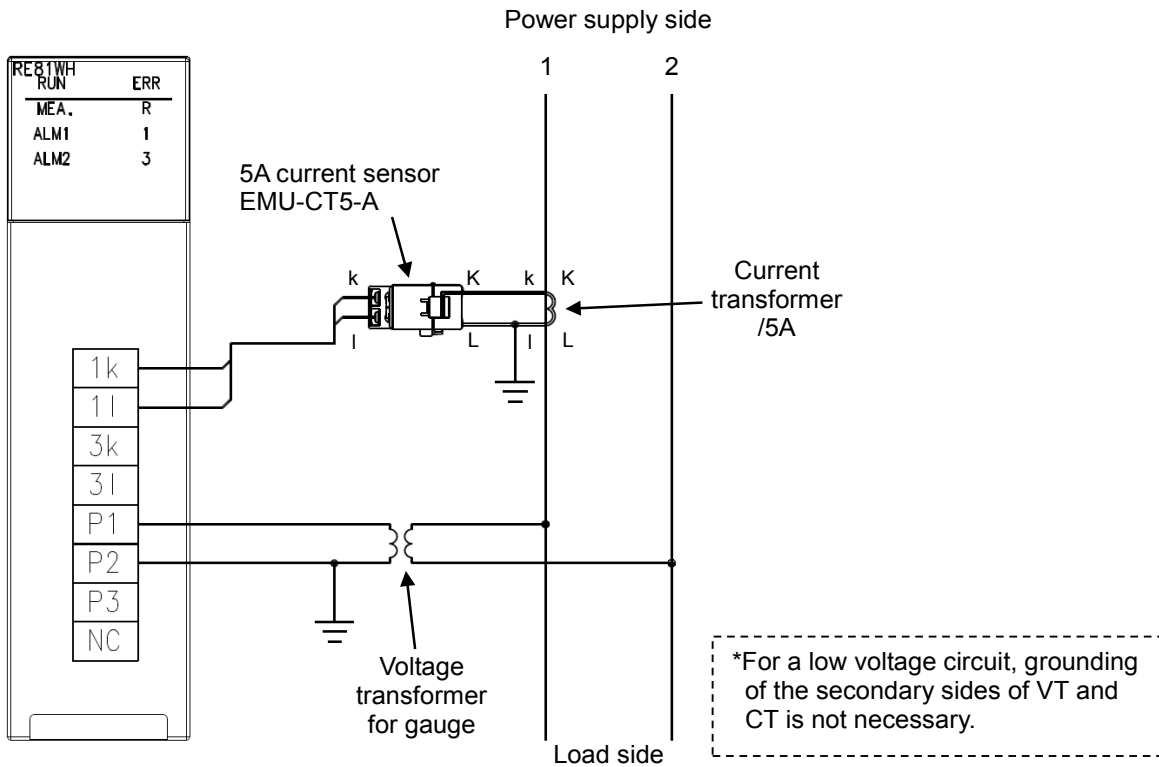

Figure 6.3.3-2 In the case of Single-phase 2-wire system (with the voltage transformer for gauge/current transformer)

- (2) In the case using split-type current sensor
 - (a) Case of Three-phase 3-wire system

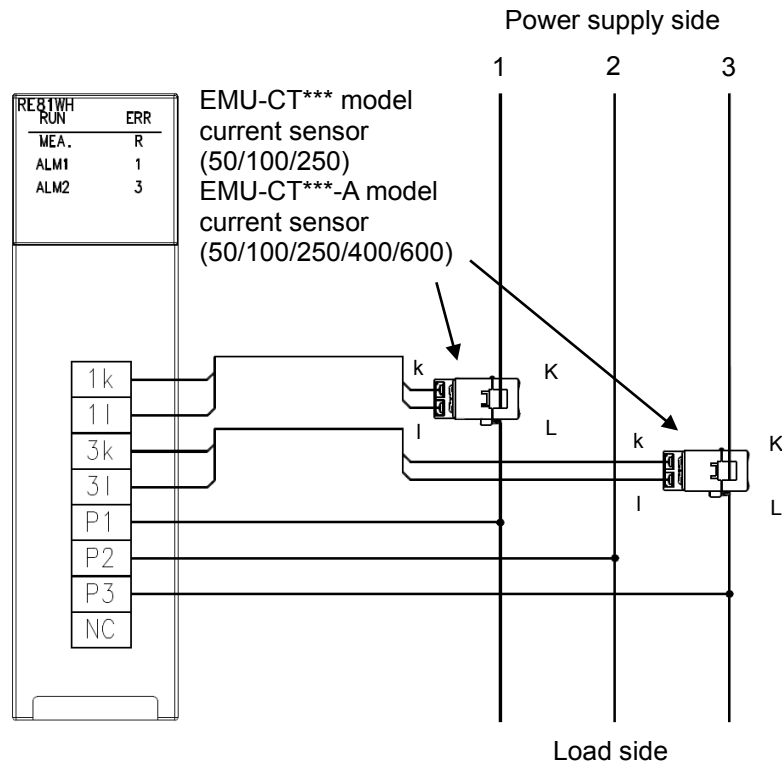

Figure 6.3.3-3 In the case of Three-phase 3-wire system

- (b) Case of Single-phase 2-wire system

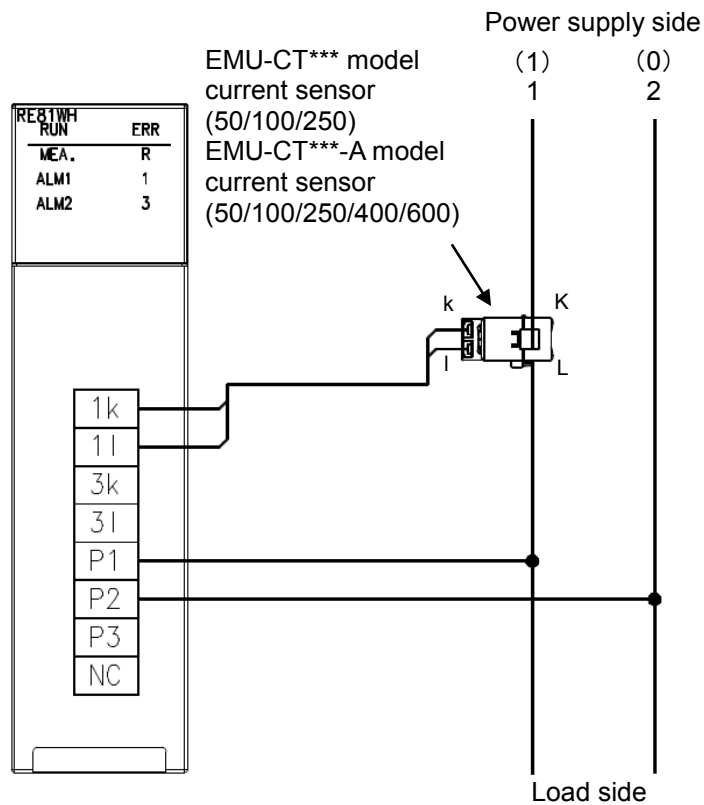

Figure 6.3.3-4 In the case of Single-phase 2-wire system

(c) Case of Single-phase 3-wire system

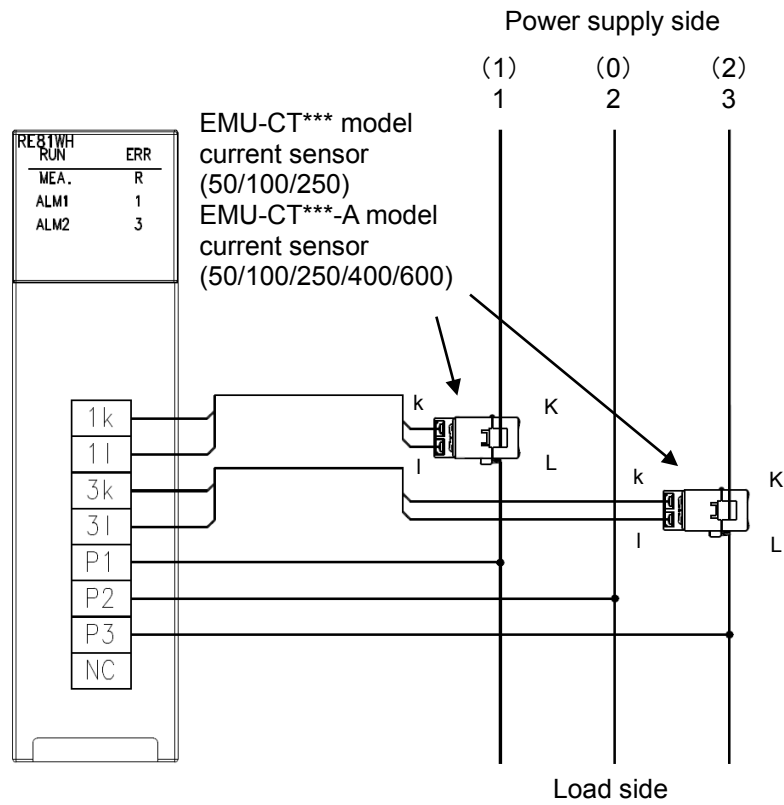

Figure 6.3.3-5 In the case of Single-phase 3-wire

6.3.4 Current circuit connection

A dedicated current sensor is required to connect the current circuit.

■ How to attach EMU-CT5/CT50/CT100/CT250-A

- (1) Press the locking claw of the moving core, please open the moving core by removing the engagement (Figure 1). Before inserting the cable, check the symbols K and L to fit the current sensor in the correct direction. (The direction from the power supply side to the load side is indicated with →. (Figure 3))
- (2) After checking that the core parting faces are free from dirt, close the moving core. Push down the moving core until the stoppers are securely locked. (Locking claw of the moving core is applied to the stopper, you hear click.) (Figure 2)
- (3) Pass the tying bands into the current sensor locking holes to secure the sensor with the cable. (Figure 3)

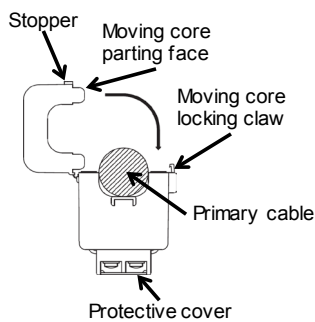

(Figure 1)

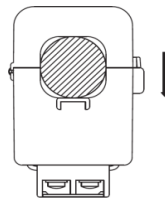

(Figure 2)

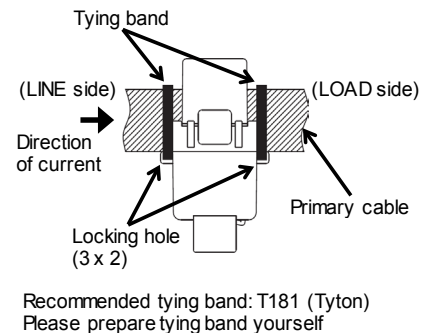

Recommended tying band: T181 (Tyton)
Please prepare tying band yourself

(Figure 3)

⚠ Caution

- Make sure that before connecting the cable, the orientation of the current sensor is correct for attachment. K to L is the correct direction. K: power source side, L: load side.
- Do not bend the moving core in a direction other than the operation direction (shown in Fig. 1). The current sensor may be damaged.

		EMU-CT5-A	EMU-CT50-A	EMU-CT100-A	EMU-CT250-A
Usable wires size (reference)	IV cable	38 mm ² or less	38 mm ² or less	60 mm ² or less	200 mm ² or less
	CV cable	22 mm ² or less	22 mm ² or less	60 mm ² or less	150 mm ² or less

* Size of electric wires conforms to description in the catalog of general PVC insulated wires. Thickness of external PVC insulation is different according to the wire. Check with the external dimension diagram of this product and make sure the wire can go through the given space.

- Use insulation wire rather than basic insulation for the primary side cable of current sensor.
- Do not ground the secondary side of the current sensor.

■ How to attach EMU-CT400/CT600-A

- (1) Press the locking claw of the moving core, please open the moving core by removing the engagement (Figure 1). At this time, the hinge cover opens automatically. Before inserting the cable, check the symbols K and L to fit the current sensor in the correct direction. (The direction from the power supply side to the load side is indicated with →. (Figure 3))
- (2) After checking that the core parting faces are free from dirt, close the moving core. Push down the moving core until the stoppers are securely locked. (Locking claw of the moving core is applied to the stopper, you hear click.) After the stopper is securely locked, close the hinge cover. (Figure 2)
- (3) Pass the tying bands into the current sensor locking holes to secure the sensor with the cable. (Figure 3)

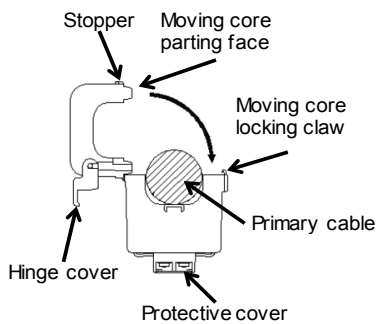

(Figure 1)

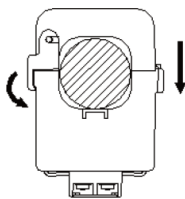

(Figure 2)

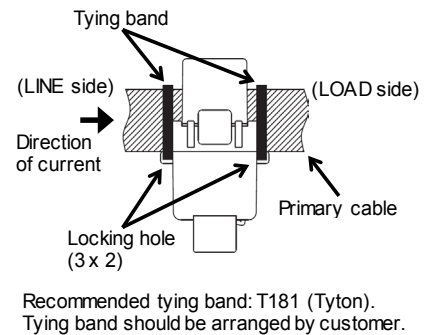

(Figure 3)

⚠ Caution

- Make sure that before connecting the cable, the orientation of the current sensor is correct for attachment. K to L is the correct direction. K: power source side, L: load side.
- Do not bend the moving core in a direction other than the operation direction (shown in Fig. 1). The current sensor may be damaged.

		EMU-CT400-A	EMU-CT600-A
Usable wires size (reference)	IV cable	500 mm ² or less	500 mm ² or less
	CV cable	400 mm ² or less	400 mm ² or less

* Size of electric wires conforms to description in the catalog of general PVC insulated wires. Thickness of external PVC insulation is different according to the wire. Check with the external dimension diagram of this product and make sure the wire can go through the given space.

- Use insulation wire rather than basic insulation for the primary side cable of current sensor.
- Do not ground the secondary side of the current sensor.

■ How to attach EMU-CT50/CT100/CT250

Follow the procedure below to attach to the cable of the target circuit.

- (1) Open the movable core, as shown in the figure on the right.
Lift slowly the hooks located on both sides of the movable core, and detach them from the stopper. Do not force to open it. You may break the hook.
- (2) Do not let the cable touch on the core-split surface. Thus, carefully pass the cable from underneath. Before passing the cable, check the direction symbols of K and L, in order to attach the sensor in the correct orientation. (Direction from power source side (K) to load side (L) is indicated with the arrow.)

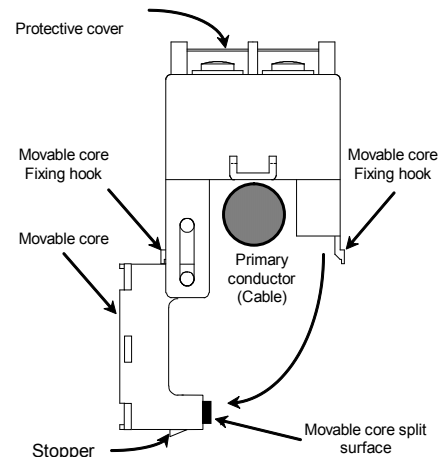
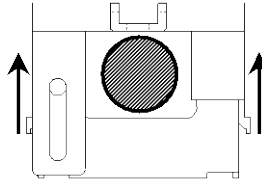

- (3) Make sure no dust or foreign object is attached on the split-core surface, and after that, close the movable core. Lift the movable core until the stoppers are firmly locked. (When the hooks on both side of movable core are locked to the stoppers, you will hear click sound twice.)
- (4) Put a binding cable through a hole for fixing the current sensor, and then tie it with the cable. Do not tie it too tightly. (Holes for fixing the current sensor are located on both side of the current sensor.)
- (5) Cut off the extra portion of binding cable, using a nipper, etc, to avoid interference of the cable.
- (6) Lift a protective cover of the secondary terminal, by holding the center portion of the protective cover, and remove it. And then, connect the given sensor cable. Check the terminal symbols printed on the secondary terminal surface, so that connection is performed correctly.

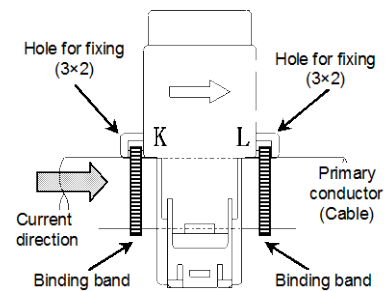

⚠ Caution

- When opening the movable core on current sensor, do not widen the hook for fixing the movable core too much. It may break the hook.
- Refer to the table below for appropriate size of electric wires.

		EMU-CT50	EMU-CT100	EMU-CT250
Usable wires size (reference)	IV cable	60 mm ² or less	60 mm ² or less	150 mm ² or less
	CV cable	38 mm ² or less	38 mm ² or less	150 mm ² or less (Note 1)

Note 1: The recommendation is 100mm².

* Size of electric wires conforms to description in the catalog of general PVC insulated wires. Thickness of external PVC insulation is different according to the wire. Check with the external dimension diagram of this product and make sure the wire can go through the given space.

- Use insulation wire rather than basic insulation for the primary side cable of current sensor.
- Do not ground the secondary side of the current sensor.

■ How to attach EMU2-CT5

Transfix EMU2-CT5 current sensor cable to the secondary-side wire of current transformer (/5A rated). Make sure to use it in a correct combination with 5A current sensor conversion cable: EMU2-CB-Q5A
 EMU2-CT5 has polarities. Make sure to connect to the right symbol on the terminal. Power source side: (k side), load side: (l side).

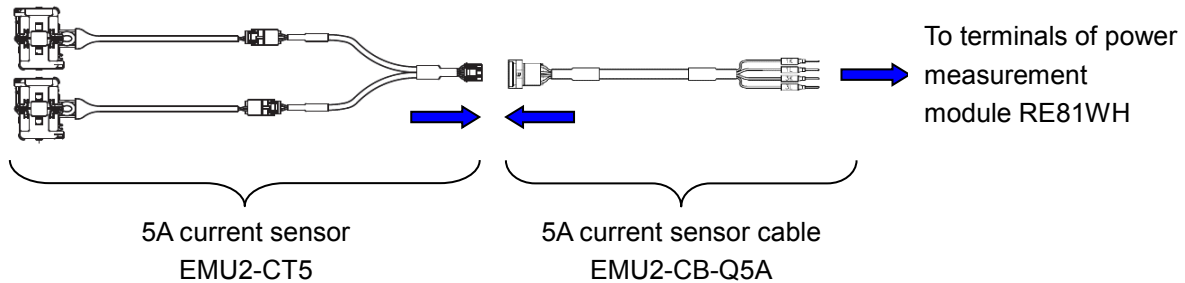

Follow the procedure below to attach the cable to the target circuit.

- (1) Slide the lock pin to the arrow direction.
- (2) Put the electric wire through the clamp, and close the clamp again.
- (3) Use your finger to hold the clamp in the full close position, and push the lock pin until it locks.

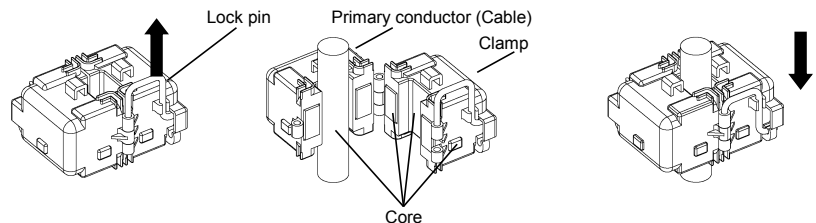

⚠ Caution

- The lock pin is made of metal. If you let it touch electrically charged portions, it may cause electric shock or device failure or fire. Be careful handling the lock pin.
- Physical impact to the core may cause breakage. It may directly influence the performance. Be careful handling the core.
- The mating surface on the core is very sensitive. Even a small foreign object on the surface may affect the measurement performance.
- Excessive force to the core during the clamp opened may cause breakage. Incorrect direction may cause inaccurate measurement.
- Use insulation wire rather than basic insulation for the primary side cable of current sensor.
- Do not ground the secondary side of the current sensor.
- For both the transfixing wire and the binding band for fixing the sensor, use the size of $W=2.6$ mm or less. To fix them together put a binding band through a hole for fixing the current sensor, and tie it with the cable. Do not tie it too tightly.
 (Total four holes for fixing the current sensor exist on both sides of the current sensor).

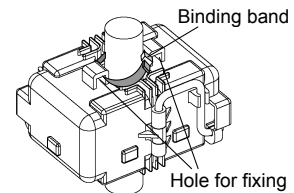

■ When wiring single-phase 2-wire circuit

5A current sensor is not used L3. As shown below, L3 remove connector, and connector with insulating tape.

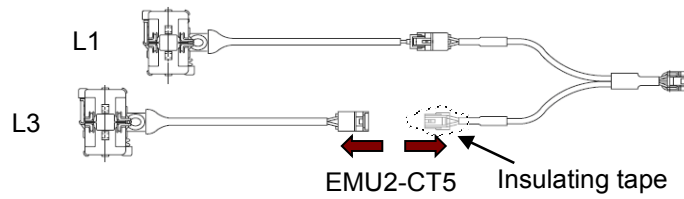

■ Extending the cable of 5 A current sensor

If the cable from current sensor is too short, you can extend it by using an extension cable as shown below.

Extension cable (standard)

Model name	EMU2-CB-T1M	EMU2-CB-T5M	EMU2-CB-T10M
Cable length	1 m	5 m	10 m

Extension cable (separate)

Model name	EMU2-CB-T1MS	EMU2-CB-T5MS	EMU2-CB-T10MS
Cable length	1m	5m	10m

Follow the procedure below to extend for cable of EMU2-CT5.

(1) Connecting 5 A current sensor and extension cable (standard)

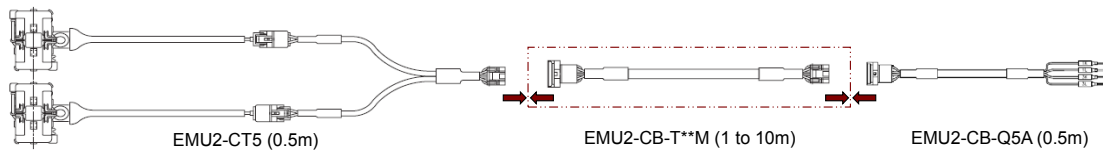

(2) Connecting 5 A current sensor and extension cable (separate)

(a) Remove the connectors.

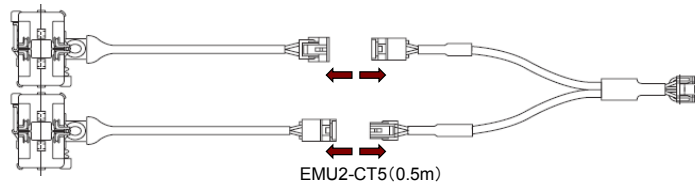

(b) Connecting the extension cable.

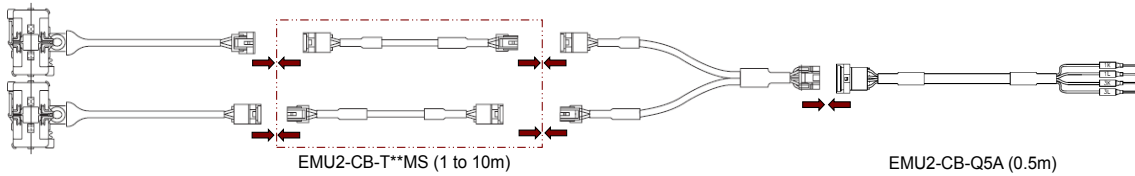

✓ Supplement

Cable extension for EMU2-CT5 is 10 m max. (Total cable length is 11m max.)
 Use extension cable (separate) when 1-phase and 3-phase are set apart.

6.3.5 Voltage circuit connection

If a 220 V or higher circuit is used, use a transformer.

The transformer which has primary voltage of VT less than 6600V and secondary voltage of VT not more than 220V can be used. For connection to P1 to P3 terminals on RE81WH, connect the secondary of transformer. Make sure that terminal symbols are correct.

In order to perform maintenance work such as changing the wire layout and replacing equipment, we recommend that you connect protective device (breaker) for the voltage input circuit (P1, P2, and P3 terminals).

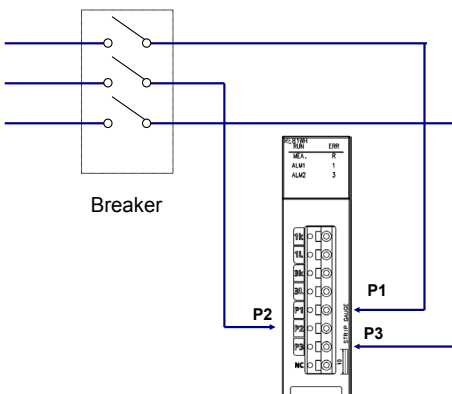

6.4 Parameter setting

This section explains setting from GX Works3 necessary to use RE81WH. Before performing this setting, install GX Works3 and connect the Management CPU with the PC using a USB cable. For details, refer to the “manual of CPU module”. For operation the GX works3, refer to “GX Works3 Operating Manual”.

* For the screen and operation, description using an example of RE81WH(version B).

✓ Supplement

To addition the module, parameter setting and auto refresh, write the settings to the CPU module, and operation the following.

Settings	Operation
Addition the module	Reset the CPU module (OFF → ON) or power on the programmable controller again.
Auto refresh	
Parameter setting	(1) Reset the CPU module (OFF → ON) or power on the programmable controller again. (2) Operate the CPU module “STOP → RUN”. (3) Operate the operating condition setting request (Yn9) “ON → OFF”.

6.4.1 Addition the module

Add the model name of the energy measuring module to use the project.

* When adding the module, it is necessary to add the module to system parameter in addition to the operation of this procedure.

Refer to “GX Works3 Operating Manual” as to method for adding the module to system parameter.

(1) Addition procedure

Open the “New Module” window.

Select “Parameter” → “Module Information” in “Navigation” window, and right-click and select [Add New Module...] from the shortcut menu.

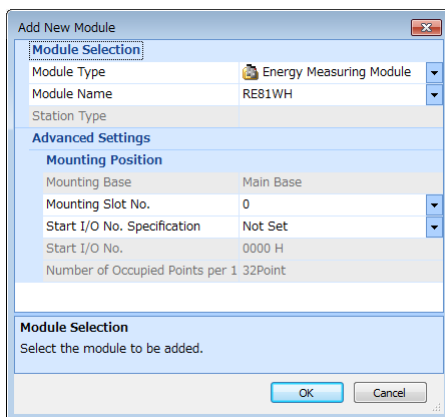

Item		Description
Module Selection	Module Type*	Set “Energy Measuring Module”.
	Module Name*	Set “RE81WH”.
Advanced Settings	Mounting Slot No.	Set the slot No. where the module is mounted.
	Start I/O No. Specification	If you will be set start I/O No., setting to “Set”.
	Start I/O No.	The start I/O number (hexadecimal) of the target module is set, according to the mounted slot No. Any start I/O number can be set.

* When the version of RE81WH is “A”, select as below:

Module Type: Partner Products

Module Name: L00RE81WH

6.4.2 Parameter setting

Set the parameters.

Setting parameters on the screen omits the parameter setting in a program.

(1) Setting procedure

Below diagrams are examples of setting the RE81WH as “Mounting slot No.: 0”, “Start I/O No.: 0000”.
The start I/O No. varies depending on the mounting slot No.

(a) Open the “Parameter editor”.

Double-click “Parameter” → “Module Information” → “n:RE81WH” in “Navigation” window and “Module Parameter” is opened.

(The “n” is start I/O No. of target module.)

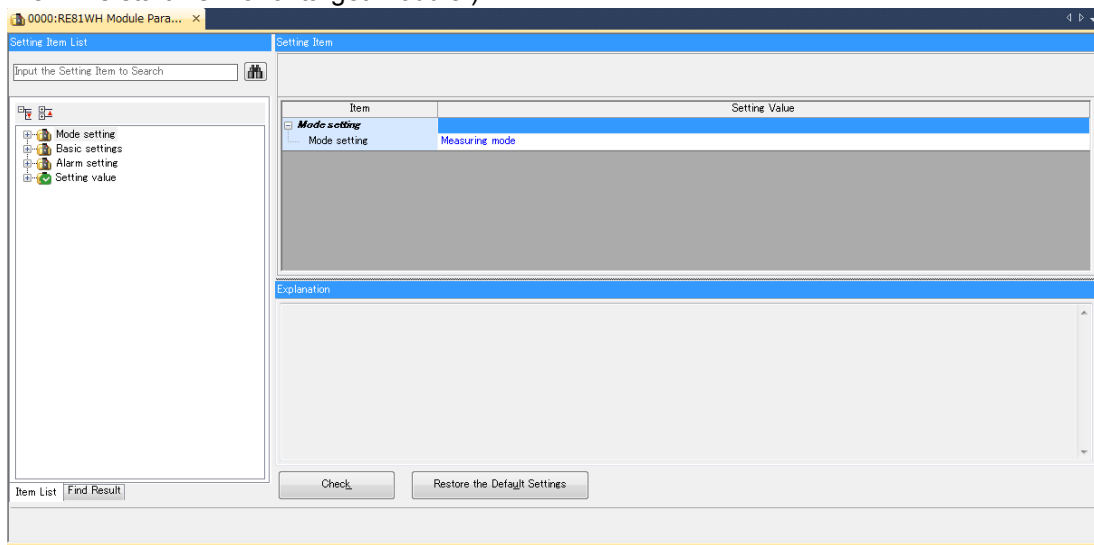

(b) Select the items from [Setting Item List] and [Setting Item], and select from pull-down list or input from text box the setting value.

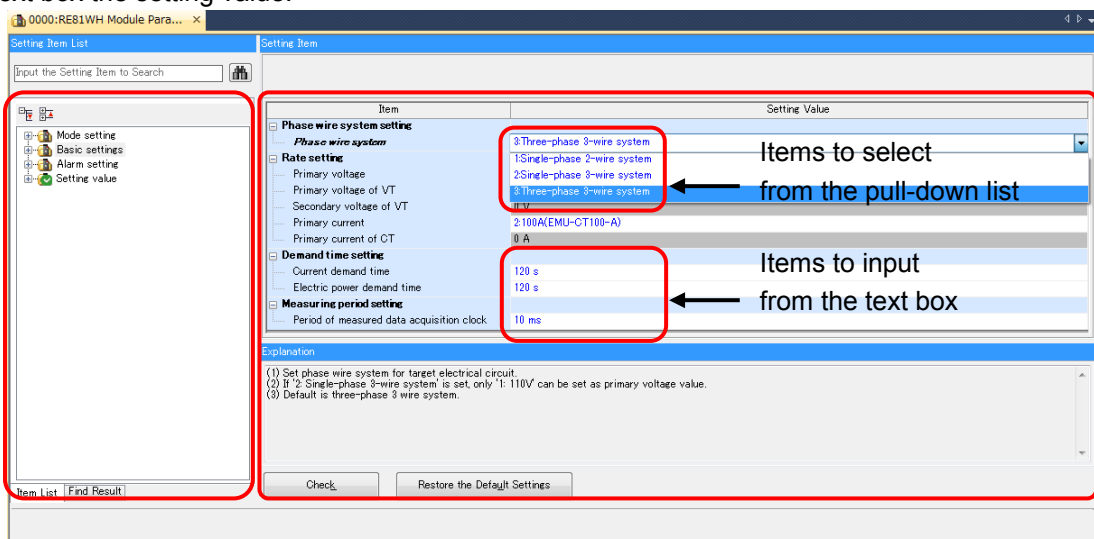

(i) Items to select from the pull-down list

When select the item to set, displayed the triangle (▼) at the right in cell.
Click the triangle (▼), and select a setting value from pull-down list.

(ii) Items to input from the text box

Double-click the item to set, and input the setting value.

- (c) Select [Write to PLC] in [Online] menu, and “Online Data Operation” window will be displayed. Please write to PLC according to your environment.

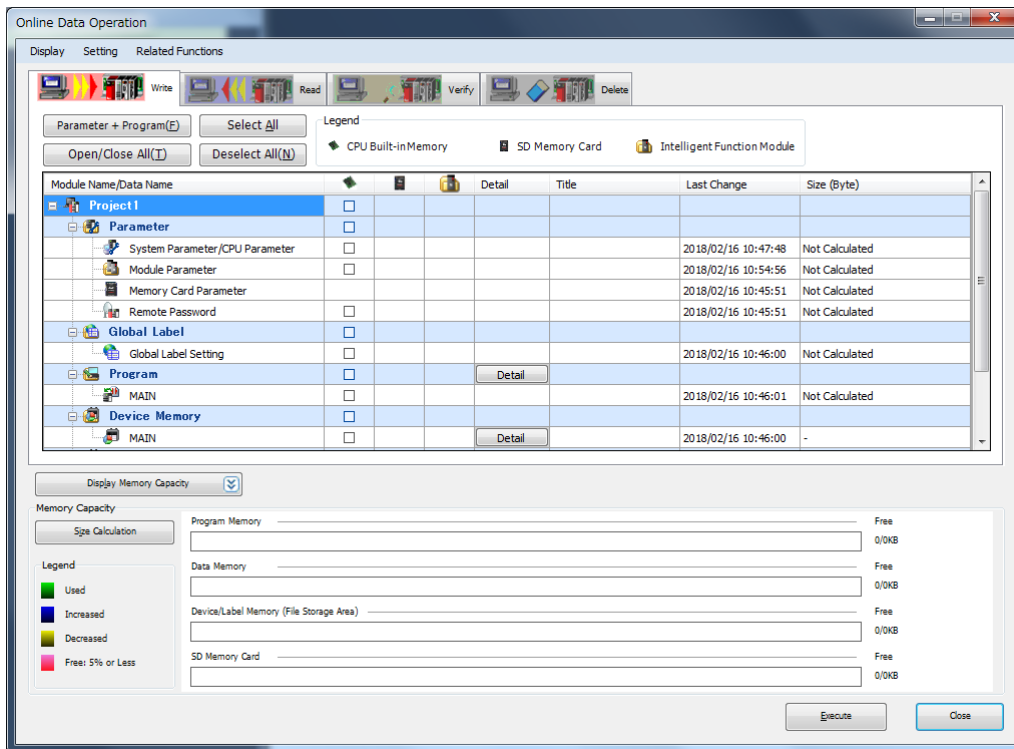

(Example) When write to CPU built in memory:

Click the check box of “(Project Name)” → “Parameter” → “Module Parameter”, and click “Execute” button.

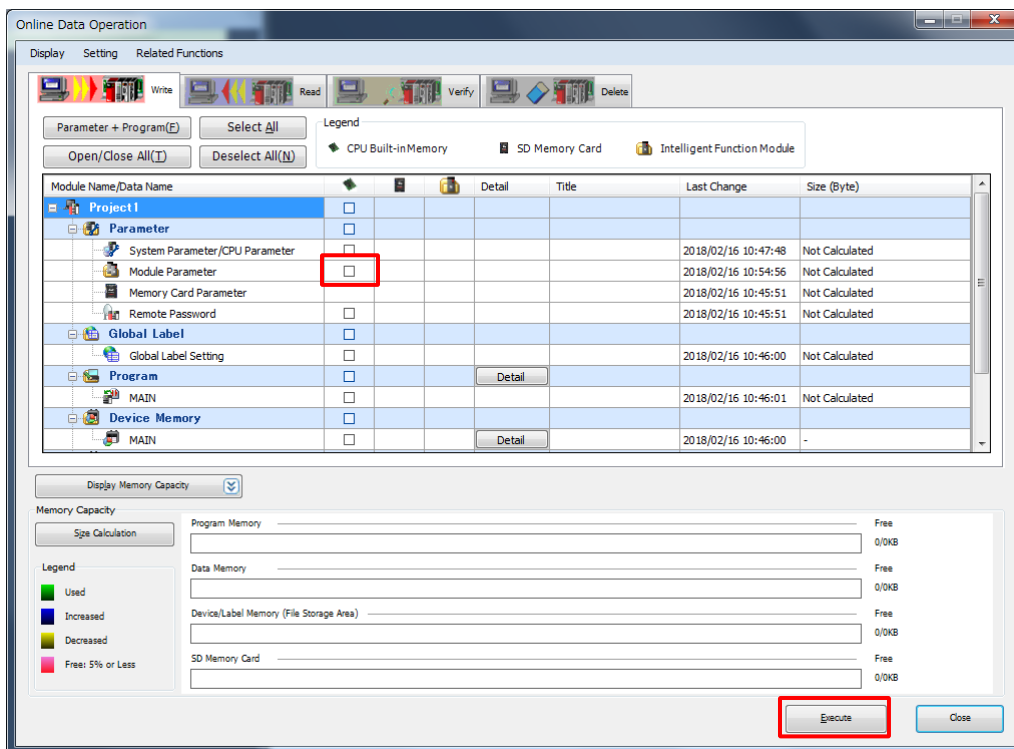

- (d) Reset the CPU module (OFF → ON) or power on the programmable controller again.
- (e) Operate the CPU module “STOP → RUN”.
- (f) Open the “Device/Buffer Memory Batch Monitor”.
Select [Online] → [Monitor] → [Device/Buffer Memory Batch Monitor].

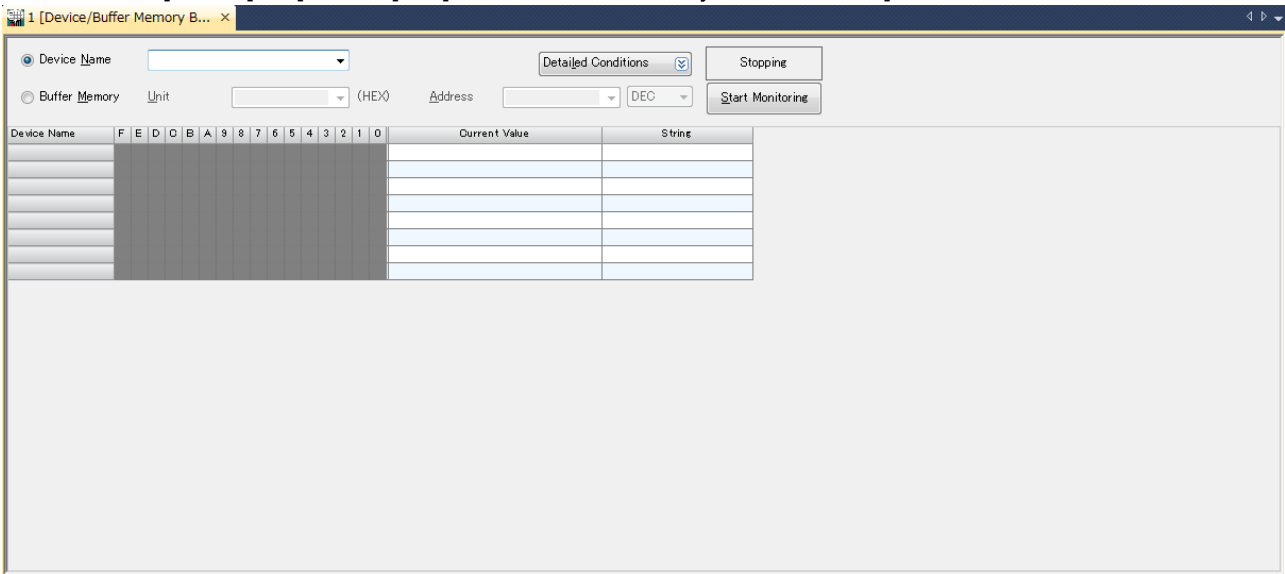

- (g) Input “Yn9” in device name, and press [Enter] key.
Right-click on “0” column of “Yn9” row, and click [Modify Value].
The value changes from “0” to “1”.
(The “n” is the Start I/O No. of the unit)

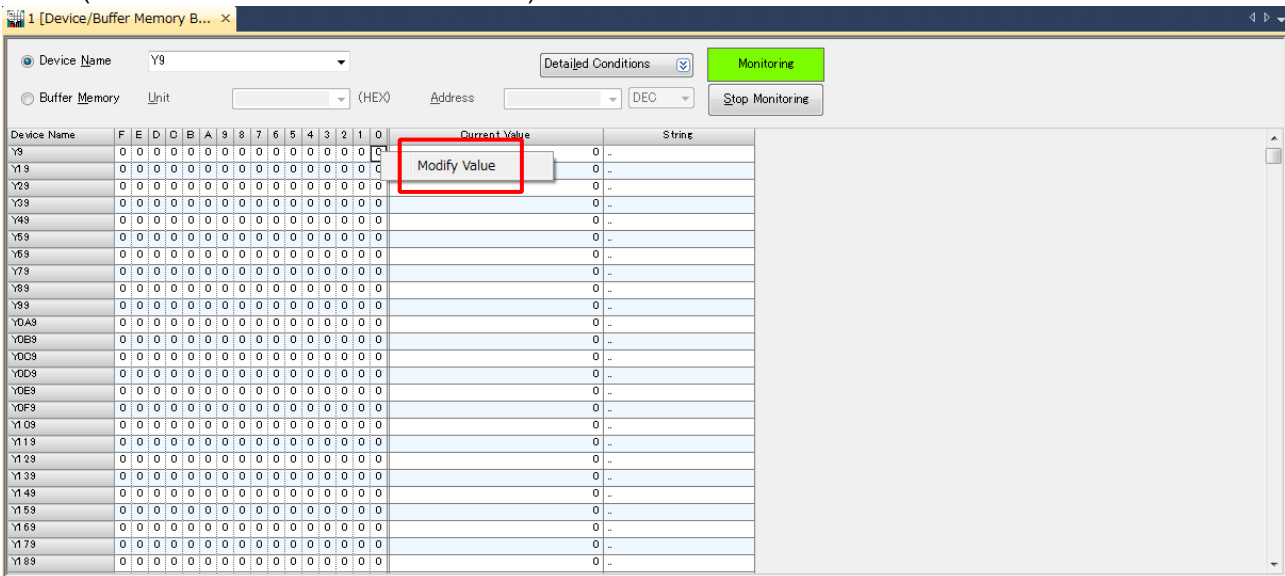

Example: When start I/O No. is 0040,
Input the “Y49” in device name.

- (h) Input “Xn9” as device name, then press [Enter] key.
Where setting contents set in the parameter are applied, [0] column of [Xn9] row is changed to “1”.
After confirming the value is “1”, then change [0] column of [Xn9] row from “1” to “0” according to procedure (g).

(2) Setting items

The data can be setup is showed below. Bold text is default setting value.

(a) Mode setting

Set the operation mode.

Item	Setting value	Reference
Mode setting	Measuring mode	3.4.5
	Test mode	

(b) Basic settings

Make necessary settings for energy measurement.

Item	Setting value	Reference
Phase wire system	single-phase 2-wire single-phase 3-wire three-phase 3-wire	5.2.1
Primary voltage *1	Any voltage 110V 220V 220/110V 440/110V 690/110V 1100/110V 2200/110V 3300/110V 6600/110V	5.2.2
Primary voltage of VT	0 - 6600 (0)	5.2.2
Secondary voltage of VT	0 - 220 (0)	5.2.2

*1: When the wiring system is single-phase 3-wire, you can only set "1: 110V" for the primary voltage.

Item	Setting value	Reference	
Primary current	Any current (EMU-CT5-A) 50A (EMU-CT50-A) 100A (EMU-CT100-A) 250A (EMU-CT250-A) 400A (EMU-CT400-A) 600A (EMU-CT600-A) 5/5A (EMU-CT5-A) 6/5A (EMU-CT5-A) 7.5/5A (EMU-CT5-A) 8/5A (EMU-CT5-A) 10/5A (EMU-CT5-A) 12/5A (EMU-CT5-A) 15/5A (EMU-CT5-A) 20/5A (EMU-CT5-A) 25/5A (EMU-CT5-A) 30/5A (EMU-CT5-A) 40/5A (EMU-CT5-A) 50/5A (EMU-CT5-A) 60/5A (EMU-CT5-A) 75/5A (EMU-CT5-A) 80/5A (EMU-CT5-A) 100/5A (EMU-CT5-A) 120/5A (EMU-CT5-A) 150/5A (EMU-CT5-A) 200/5A (EMU-CT5-A) 250/5A (EMU-CT5-A) 300/5A (EMU-CT5-A) 400/5A (EMU-CT5-A) 500/5A (EMU-CT5-A) 600/5A (EMU-CT5-A) 750/5A (EMU-CT5-A) 800/5A (EMU-CT5-A) 1000/5A (EMU-CT5-A) 1200/5A (EMU-CT5-A) 1500/5A (EMU-CT5-A) 1600/5A (EMU-CT5-A) 2000/5A (EMU-CT5-A) 2500/5A (EMU-CT5-A) 3000/5A (EMU-CT5-A) 4000/5A (EMU-CT5-A) 5000/5A (EMU-CT5-A) 6000/5A (EMU-CT5-A)	Any current (EMU2-CT5) 50A (EMU-CT50) 100A (EMU-CT100) 250A (EMU-CT250) 5/5A (EMU2-CT5) 6/5A (EMU2-CT5) 7.5/5A (EMU2-CT5) 8/5A (EMU2-CT5) 10/5A (EMU2-CT5) 12/5A (EMU2-CT5) 15/5A (EMU2-CT5) 20/5A (EMU2-CT5) 25/5A (EMU2-CT5) 30/5A (EMU2-CT5) 40/5A (EMU2-CT5) 50/5A (EMU2-CT5) 60/5A (EMU2-CT5) 75/5A (EMU2-CT5) 80/5A (EMU2-CT5) 100/5A (EMU2-CT5) 120/5A (EMU2-CT5) 150/5A (EMU2-CT5) 200/5A (EMU2-CT5) 250/5A (EMU2-CT5) 300/5A (EMU2-CT5) 400/5A (EMU2-CT5) 500/5A (EMU2-CT5) 600/5A (EMU2-CT5) 750/5A (EMU2-CT5) 800/5A (EMU2-CT5) 1000/5A (EMU2-CT5) 1200/5A (EMU2-CT5) 1500/5A (EMU2-CT5) 1600/5A (EMU2-CT5) 2000/5A (EMU2-CT5) 2500/5A (EMU2-CT5) 3000/5A (EMU2-CT5) 4000/5A (EMU2-CT5) 5000/5A (EMU2-CT5) 6000/5A (EMU2-CT5)	5.2.3
Primary current of CT	0 - 6000 (0)	5.2.3	
Current demand time	0 - 1800 (120)	5.2.4	
Electric power demand time	0 - 1800 (120)	5.2.5	
Period of measured data acquisition clock	10 - 10000 (10)	5.2.12	

*1: When the wiring system is single-phase 3-wire, you can only set "1: 110V" for the primary voltage.

(c) Alarm setting

Setting the upper/lower limit alarm.

Item	Setting value	Reference
Alarm 1 monitoring factor	<u>No monitoring</u> Current demand upper limit Current demand lower limit Voltage upper limit Voltage lower limit Electric power demand upper limit Electric power demand lower limit Power factor upper limit Power factor lower limit	5.2.6
Alarm 1 monitoring value	-2147483648 - 2147483647 (<u>0</u>)	5.2.7
Alarm 1 reset method	<u>Self-retention</u> Self-reset	5.2.8
Alarm 1 delay time	0 - 300 (<u>0</u>)	5.2.9
Alarm 2 monitoring factor	<u>No monitoring</u> Current demand upper limit Current demand lower limit Voltage upper limit Voltage lower limit Electric power demand upper limit Electric power demand lower limit Power factor upper limit Power factor lower limit	5.2.6
Alarm 2 monitoring value	-2147483648 ~ 2147483647 (<u>0</u>)	5.2.7
Alarm 2 reset method	<u>Self-retention</u> Self-reset	5.2.8
Alarm 2 delay time	0 - 300 (<u>0</u>)	5.2.9

(d) Setting value

Setting for the auto refresh.

For details, refer to "6.4.3".

6.4.3 Auto Refresh

This function transfers data in the buffer memory to specified devices.

Programming of reading/writing data is unnecessary.

(1) Setting procedure

Below diagrams are examples of setting the RE81WH as “Mounting slot No.: 0”, “Start I/O No.: 0000”.

The start I/O No. varies depending on the mounting slot No.

(a) Open the “Parameter editor”.

Double-click “Parameter” → “Module Information” → “n:RE81WH” in “Navigation” window and “Module Parameter” is opened.

(The “n” is start I/O No. of target module.)

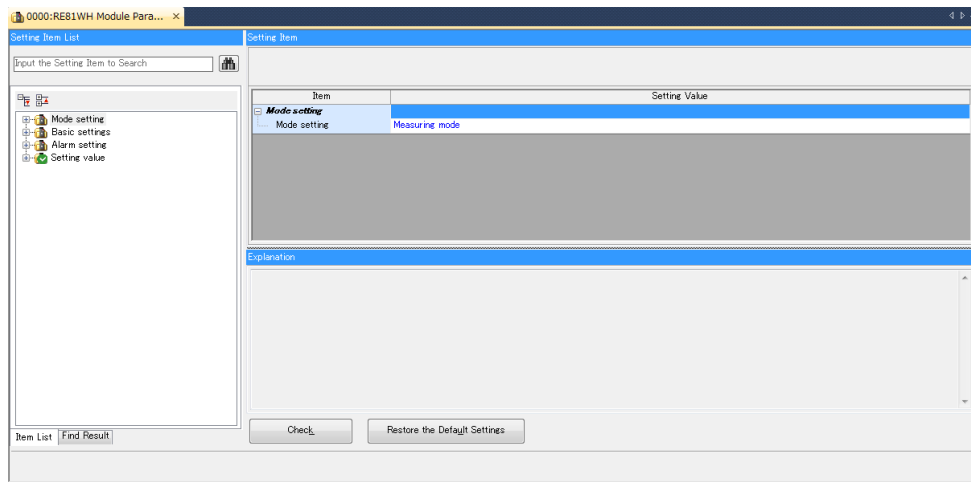

(b) Select the [Setting value] in [Setting Item List].

(c) Double-click the item to set. And select from pull-down list or input from text box the setting value.

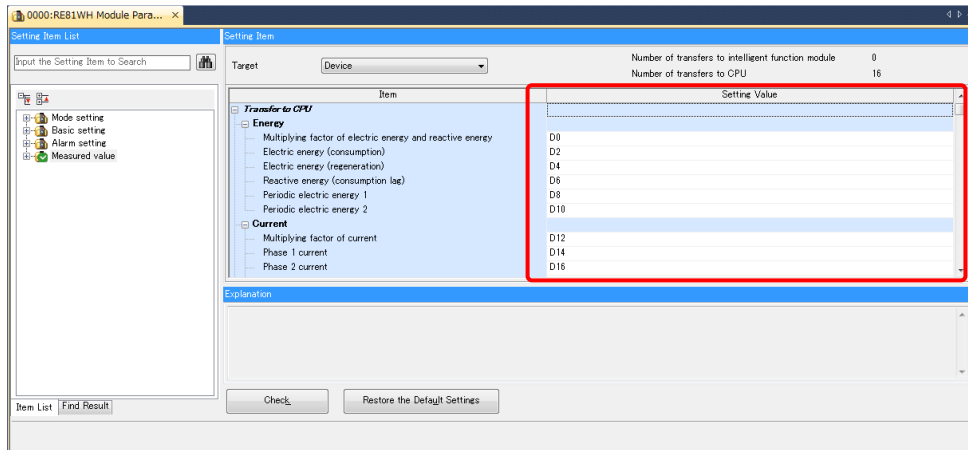

✓ Supplement

Available devices are X, Y, M, L, B, T, C, ST, D, W, R, and ZR.

When a bit device X, Y, M, L, or B is used, set a number that is divisible by 32 points (example: X20, Y120, M32).

Data in the buffer memory are stored in 32 points of devices starting from the set device No. (Example: When X10 is set, the Data is stored in X10 to X2F).

- (d) Select [Write to PLC] in [Online] menu, and “Online Data Operation” window will be displayed. Please write to PLC according to your environment.

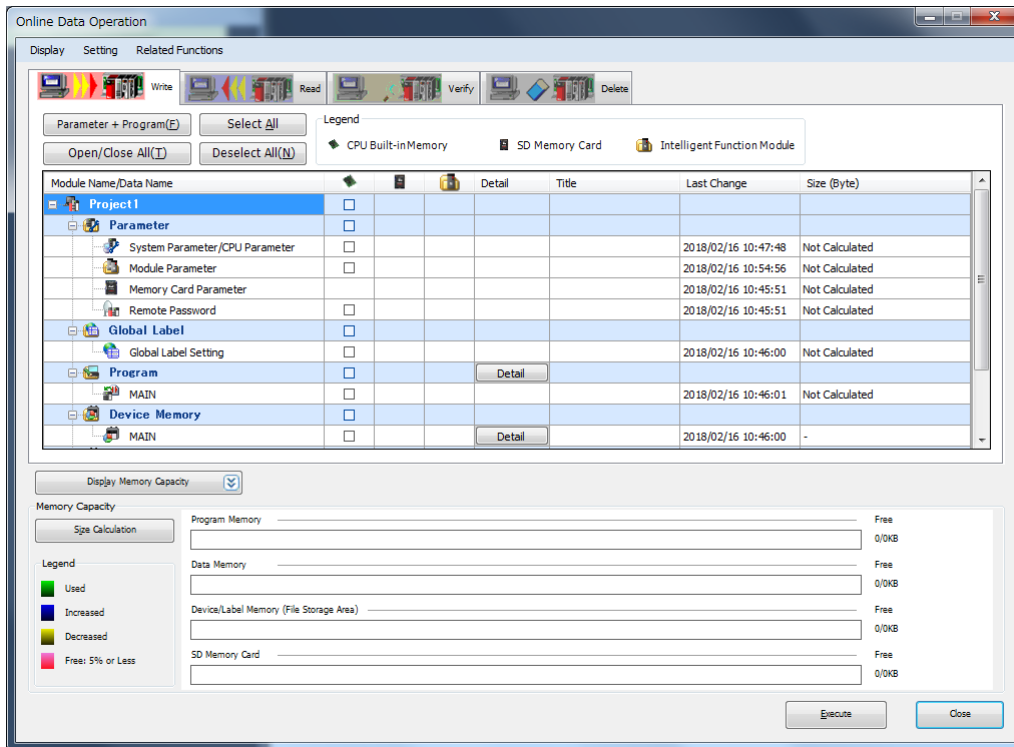

(Example) When write to CPU built in memory:

Click the check box of “(Project Name)” → “Parameter” → “Module Parameter”, and click “Execute” button.

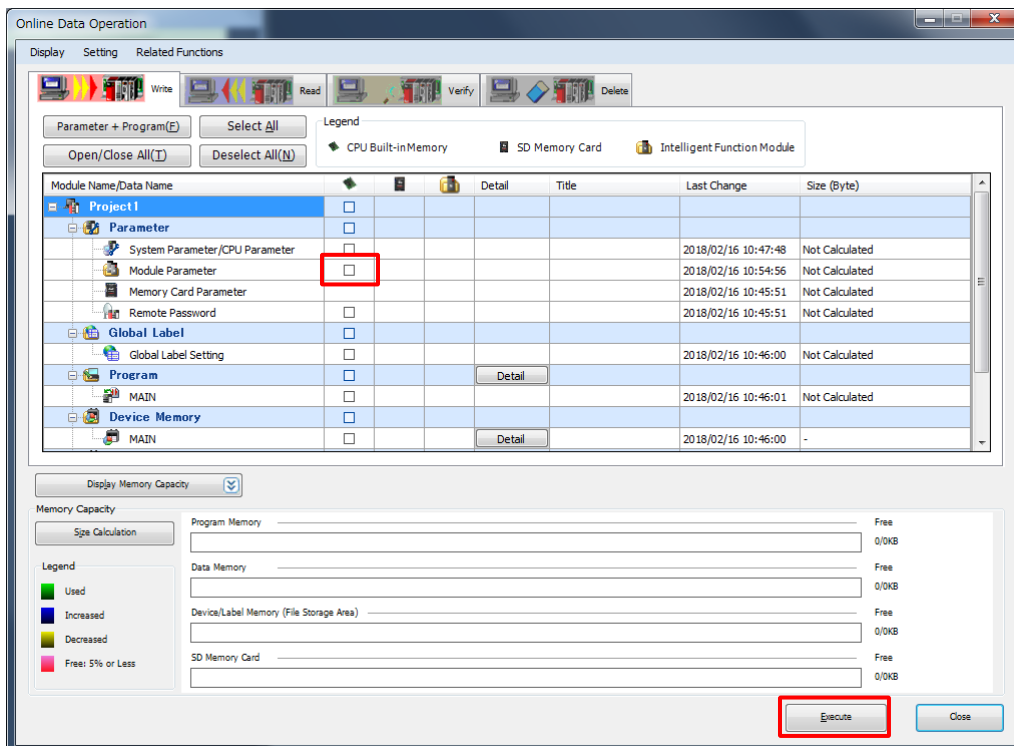

- (e) Reset the CPU module (OFF → ON) or power on the programmable controller again.

(2) Setting items

The data can be setup is showed below. Bold text is default setting value.

(a) Transfer to CPU

Specify the refresh destination for measurement section and waveform data section of buffer memory.

(b) Refresh timing

Set the refresh timing of the specified refresh destination.

Item	Setting value	Description
Refresh Timing	<u>At the Execution Time of END Instruction</u>	The refresh is performed when the END instruction of the CPU module is executed.
	At the Execution Time of Specified Program	The refresh is performed when the program specified in "Group [n]" is executed.
Refresh Group [n](n: 1-64)	1~64 (1)	Specify the group number of refresh group setting of CPU parameter.

6.4.4 Integrated value set function

This function is to set integrated value (electric energy (consumption, regeneration) and reactive energy (consumption lag)) to any value. If you want to clear integrated value, set it to 0.

(1) Setting procedure

Below diagrams are examples of setting the RE81WH as “Mounting slot No.: 0”, “Start I/O No.: 0000”. The start I/O No. varies depending on the mounting slot No..

(a) Open the “Watch” window.

Select [View] → [Docking Window] → [Watch 1].

(b) Input “Un\G51”, “Un\G52”, “YnC” and “XnC” for column of [Name].

(The “n” is start I/O No. of target module.)

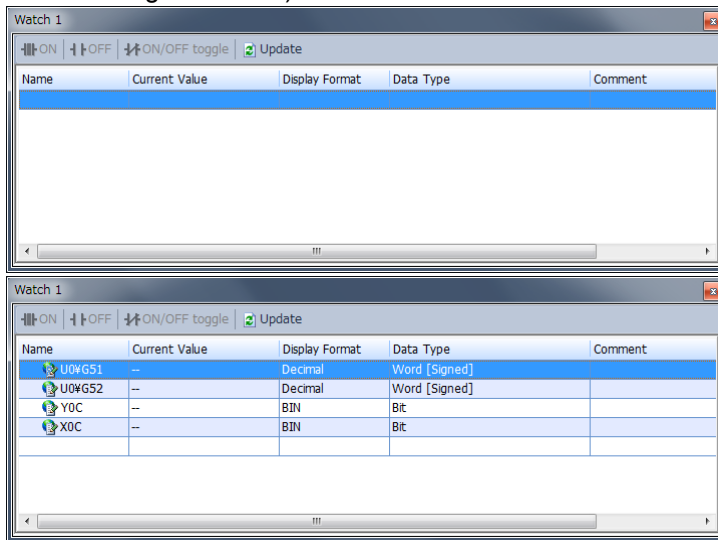

Example: When start I/O No. is 0040,
Input “Y49” in device name.

(c) Change the [Data Type] of [Un\G52].

Double-click the [Data Type] column of [Yn9] row, and select the “Double Word [Unsigned]/Bit String [32-bit]” from pull-down list.

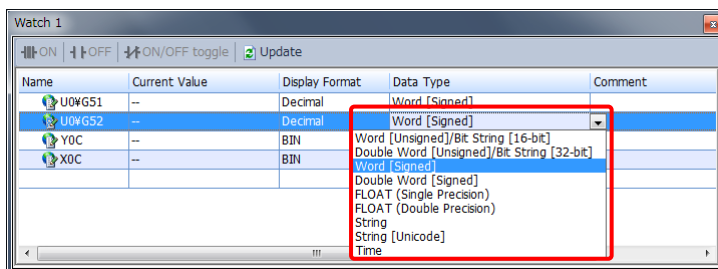

(d) Right-click on the [watch 1] window → select [Start Watching] from the shortcut menu.

Display the value of programmable controller.

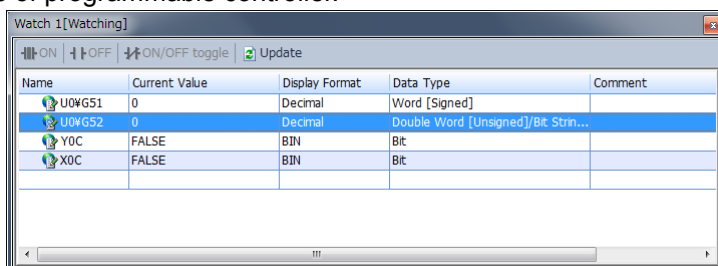

- (e) Setting the [Integrated value setting target] (Un\G51) and [Integrated value setting value] (Un\G52, 53).

Setting range is as follows.

- (i) Integrated value setting target (Un\G51)

Setting value	Description
0	No set
1	Electric energy (consumption)
2	Electric energy (regeneration)
3	Reactive energy (consumption lag)

- (ii) Integrated value setting value (Un\G52, 53)

Setting range: 0 to 99999999

* The unit used for the setting value is the same as that used for the electric energy and reactive energy that are output to the buffer memory.

- (f) Select [YnC] and click the [ON/OFF toggle] button.

[YnC] changes for "TRUE".

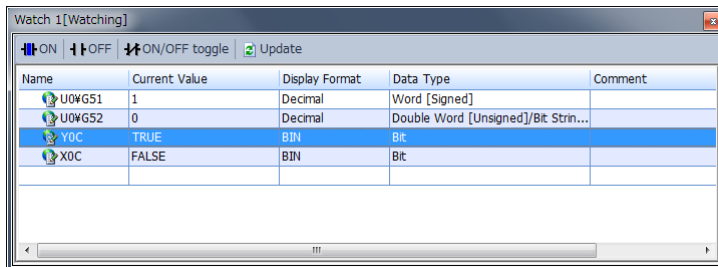

- (g) When the settings of [Integrated value setting target] (Un\G51) and [Integrated value setting value] (Un\G52, 53) are reflected, [XnC] changes for "TRUE".

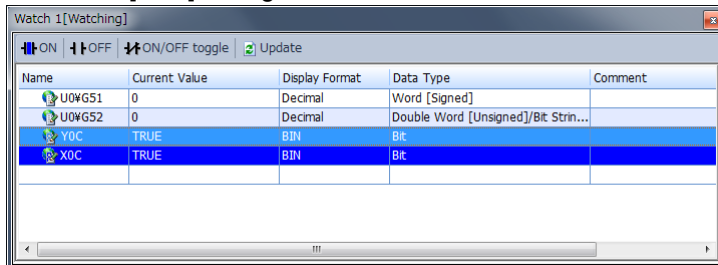

- (h) After confirming that [XnC] changes for "TRUE", click [ON/OFF toggle] button to change the [YnC] for "FALSE".

When detect the [YnC] changes for "FALSE", [XnC] changes for "FALSE".

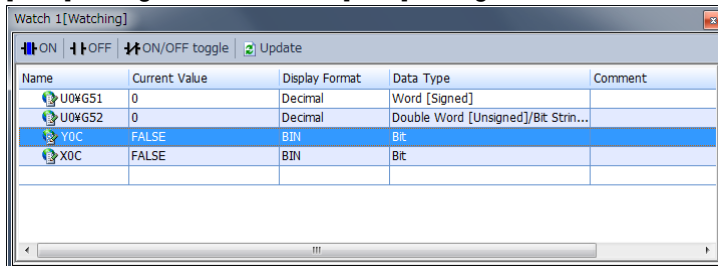

6.4.5 Debugging program

RE81WH provides a test function so that you can debug a program with no input of voltage or current. Pseudo-value can be stored into the buffer memory. For detailed explanation for the test function, refer to “3.4.5”.

 **Caution**

- Test function stores pseudo-values for setting value and error information as well as measured value. If you use these data to control the sequence program that controls external devices, there is a chance that erroneous control may occur. For safety of external devices, use this function after disconnecting the device.

(1) Starting the test mode

- (a) Configure the Parameter setting as shown below. (Refer to “6.4.2”.)

Item	Setting value
Mode setting	Test mode

- (b) Execute the writing to PLC parameter.

After resetting the CPU module, the setting value will become effective.

- (c) RE81WH start up in test mode after restart the CPU module.

At this time, All LEDs are turned on, and pseudo-values are stored in the buffer memory.

(2) Finish the test mode (Move back to the measuring mode)

- (a) Configure the Parameter setting as shown below. (Refer to “6.4.2”.)

Item	Setting value
Mode setting	Measuring mode

- (b) Execute the writing to PLC parameter.

After resetting the CPU module, the setting value will become effective.

- (c) RE81WH start up in measuring mode after restart the CPU module.

At this time, setting values, integrated values and periodic electric energy are the value before starting test mode.

Section 7 PROGRAMMING

This chapter explains about programming for RE81WH.

When you apply sample programs introduced in this chapter into the actual system, make sure to verify in advance that there is no problem with the target system control.

Follow the procedure in Figure 7.1-1 to create a sample program using RE81WH.

The default setting allows you to use either GX Works3 (refer to “6.4 Parameter setting”) or the sequence program to make setting; however, if the setting is made for the first time by using GX Works3, the program for initial setting can be eliminated, which will reduce time for scanning.

7.1 Programming procedure

Follow the procedure in Figure 7.1-1 to create a program for acquiring the measured data, alarm monitoring, calculating periodical electricity amount using RE81WH.

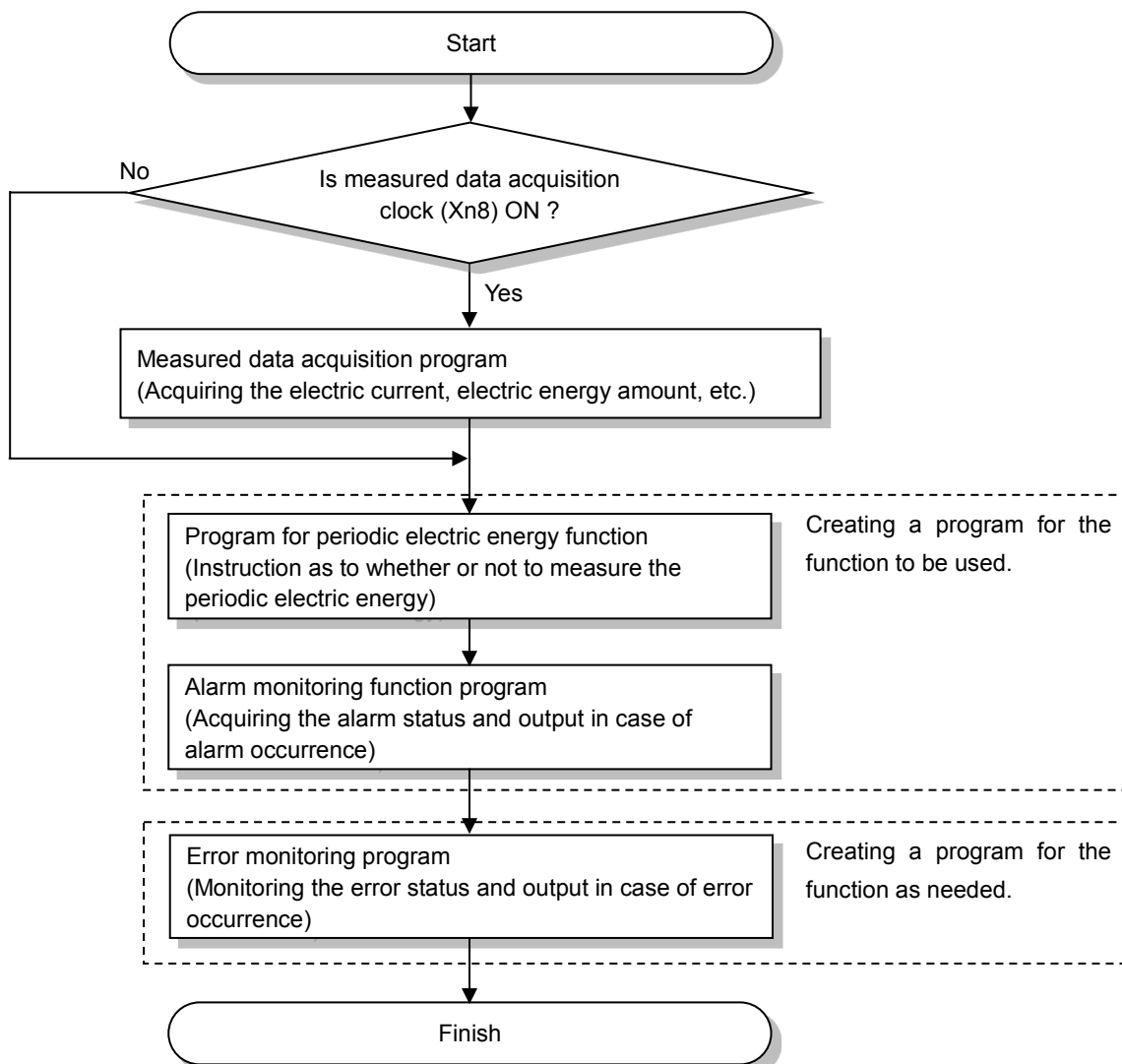

Figure 7.1-1 Programming chart

7.2 System configuration and usage conditions for sample program

A sample program under the following system and the usage condition is shown below.

7.2.1 System configuration

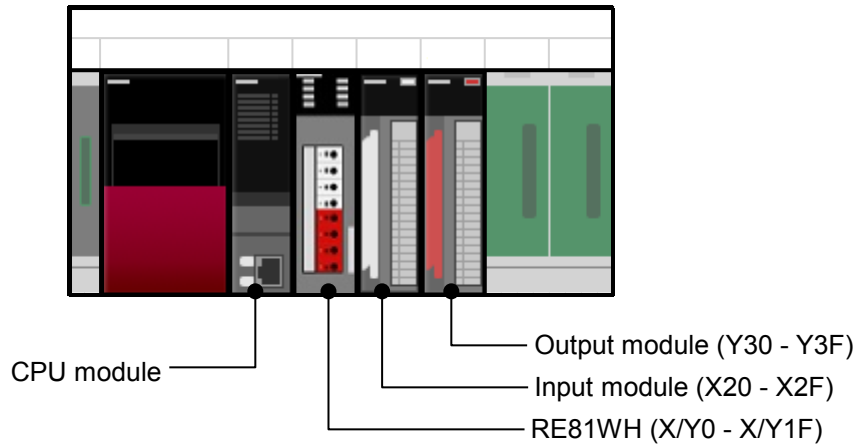

Figure 7.2.1-1 Sample system configuration using a sample program

7.2.2 Setting conditions for parameter setting

Setting is as follows.

For setting procedure, refer to "6.4.2".

Item		Setting value
Mode setting		Measuring mode
Basic settings	Phase wire system	Three-phase 3-wire
	Primary voltage	220 V
	Primary current	250 A (EMU-CT250-A)
	Current demand time	30 sec
	Electric power demand time	30 sec
	Primary voltage of VT	0
	Secondary voltage of VT	0
	Primary current of CT	0
Measured data acquisition clock	1000 (1 sec)	
Alarm setting	Alarm 1 monitoring factor	Current demand upper limit
	Alarm 1 monitoring value	100000 (100 A)
	Alarm 1 reset method	Self-reset
	Alarm 1 delay time	5 sec
	Alarm 2 monitoring factor	Current demand upper limit
	Alarm 2 monitoring value	120000 (120 A)
	Alarm 2 reset method	Self-reset
	Alarm 2 delay time	5 sec

Before creating a program, mount RE81WH to the base unit, and connect it to external devices.

<Example> Electric current sensor: EMU-CT250-A

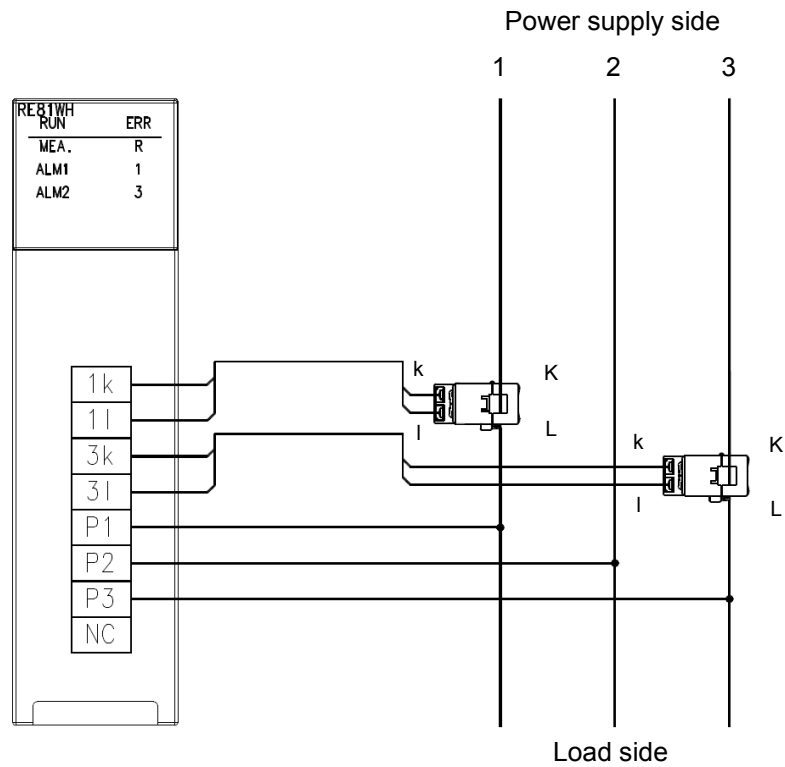

Figure 7.2.3-1 Example of wiring using a sample program

7.3 Sample programming

7.3.1 Sample program when performing the initial setting using GX Works3.

(1) List of devices

Table 7.3.1-1 List of devices

Device	Module	Function
D20	CPU module	Device that stores latest error code
X0	RE81WH (X/Y0 - X/Y1F)	Module ready
XA		Alarm 1 flag
XB		Alarm 2 flag
XF		Error flag
Y1		Periodic electric energy 1 measurement flag
Y2		Periodic electric energy 2 measurement flag
X20		Input module (X20 - X2F)
Y30	Output module (Y30 - Y3F)	Device that turns ON to send an output to the external device when the alarm 1 occurs
Y31		Device that turns ON to send an output to the external device when the alarm 2 occurs
Y32		Device that turns ON to send an output to the external device in the case of an error

(2) List of buffer memories to be used

Table 7.3.1-2 List of buffer memories to be used

Buffer memory	Description	Setting value	Remarks
U0\G3000	Latest error code	-	Stores latest error code

(3) Sample program

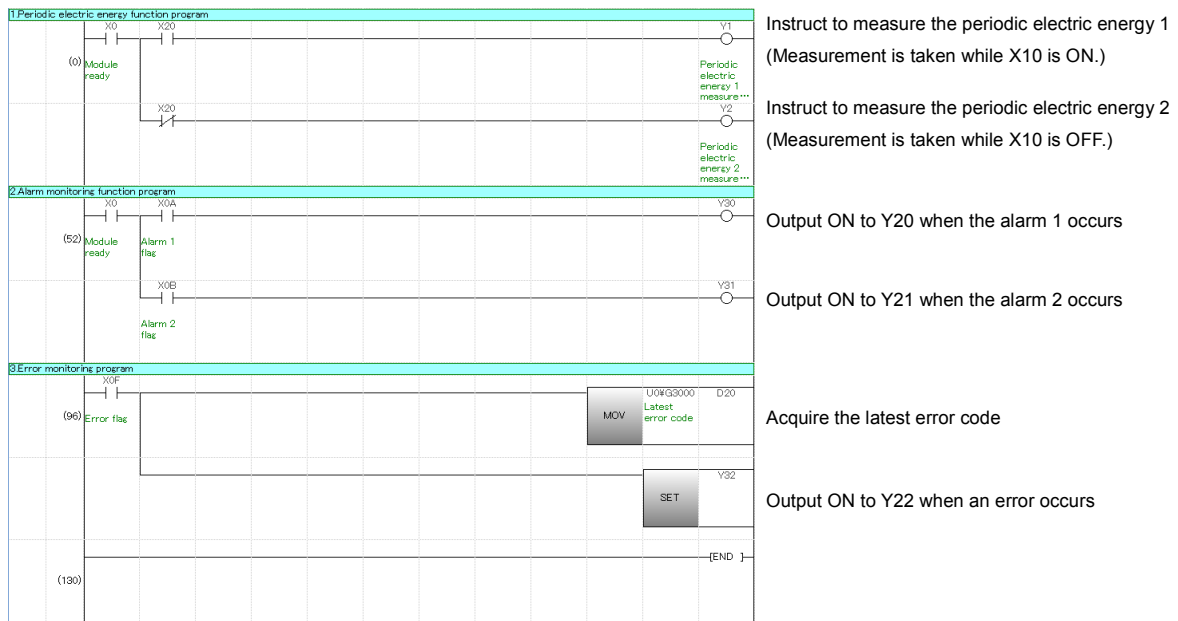

Figure 7.3.1-1 Example of sample program

7.3.2 Sample program when make the initial setting using sequence program.

(1) List of devices

Table 7.3.2-1 List of device

Device	Module	Function
D0	CPU module	Device that stores multiplying factor of electric energy and reactive energy
D2,D3		Device that stores electric energy (consumption)
D4,D5		Device that stores Average current
D6,D7		Device that stores Average voltage
D8,D9		Device that stores electric power
D10,D11		Device that stores reactive power
D12,D13		Device that stores power factor
D14,D15		Device that stores frequency
D16,D17		Device that stores 1-2 harmonic voltage (Total)
D18,D19		Device that stores phase 1 harmonic current (Total)
D20,D21		Device that stores 1-2 voltage harmonic distortion (Total)
D22,D23		Device that stores phase 1 current harmonic distortion (Total)
D20		Device that stores latest error code
X0		RE81WH (X/Y0 - X/Y1F)
X7	Measured harmonics data acquisition clock	
X8	Measured data acquisition clock	
X9	Operating condition setting completion flag	
XA	Alarm 1 flag	
XB	Alarm 2 flag	
XF	Error flag	
Y1	Periodic electric energy 1 measurement flag	
Y2	Periodic electric energy 2 measurement flag	
Y9	Operating condition setting request	
X20	Input module (X20 - X2F)	Device that the user will turn ON in order to support measurement of periodic electric energy
Y30	Output module (Y30 - Y3F)	Device that turns On to send an output to the external device when the alarm 1 occurs
Y31		Device that turns On to send an output to the external device when the alarm 2 occurs
Y32		Device that turns ON to send an output to the external device in the case of an error

(2) List of buffer memories to be used

Table 7.3.2-2 List of buffer memories to be used

Buffer memory	Description	Setting value	Remarks
U0\G0	Phase wire system	3	Three-phase 3-wire
U0\G1	Primary voltage	2	220 V
U0\G2	Primary current	3	250 A (EMU-CT250-A)
U0\G3	Current demand time	30	30 sec
U0\G4	Electric power demand time	30	30 sec
U0\G5	Primary voltage of VT	0	When Primary voltage (U0\G1) is except 0
U0\G6	Secondary voltage of VT	0	When Primary voltage (U0\G1) is except 0
U0\G7	Primary current of CT	0	When Primary current (U0\G2) is except 0
U0\G11	Alarm 1 monitoring factor	1	Current demand upper limit
U0\G12, 13	Alarm 1 monitoring value	100000	100 A
U0\G14	Alarm 1 reset method	1	Self-reset
U0\G15	Alarm 1 delay time	5	5 sec
U0\G21	Alarm 2 monitoring factor	1	Current demand upper limit
U0\G22, 23	Alarm 2 monitoring value	120000	120 A
U0\G24	Alarm 2 reset method	0	Self-retention
U0\G25	Alarm 2 delay time	5	5 sec
U0\G60, 61	Period of measured data acquisition clock	1000	1 sec
U0\G100	Multiplying factor of electric energy	—	Stores multiplying factor of electric energy
U0\G102, 103	Electric energy (consumption)	—	Stores electric energy
U0\G218, 219	Average current	—	Stores Average current
U0\G314, 315	Average voltage	—	Stores Average voltage
U0\G402, 403	Electric power	—	Stores active energy
U0\G502, 503	Reactive power	—	Stores reactive energy
U0\G702, 703	Power factor	—	Stores power factor
U0\G802, 803	Frequency	—	Stores frequency
U0\G1022, 1023	1-2 harmonic voltage (Total)	—	Stores 1-2 harmonic voltage (Total)
U0\G1222, 1223	Phase 1 harmonic current (Total)	—	Stores phase 1 harmonic current (Total)
U0\G1411	1-2 voltage harmonic distortion (Total)	—	Stores 1-2 voltage harmonic distortion (Total)
U0\G1611	Phase 1 current harmonic distortion (Total)	—	Stores phase 1 current harmonic distortion (Total)
U0\G3000	Latest error code	—	Stores latest error code

(3) Sample program

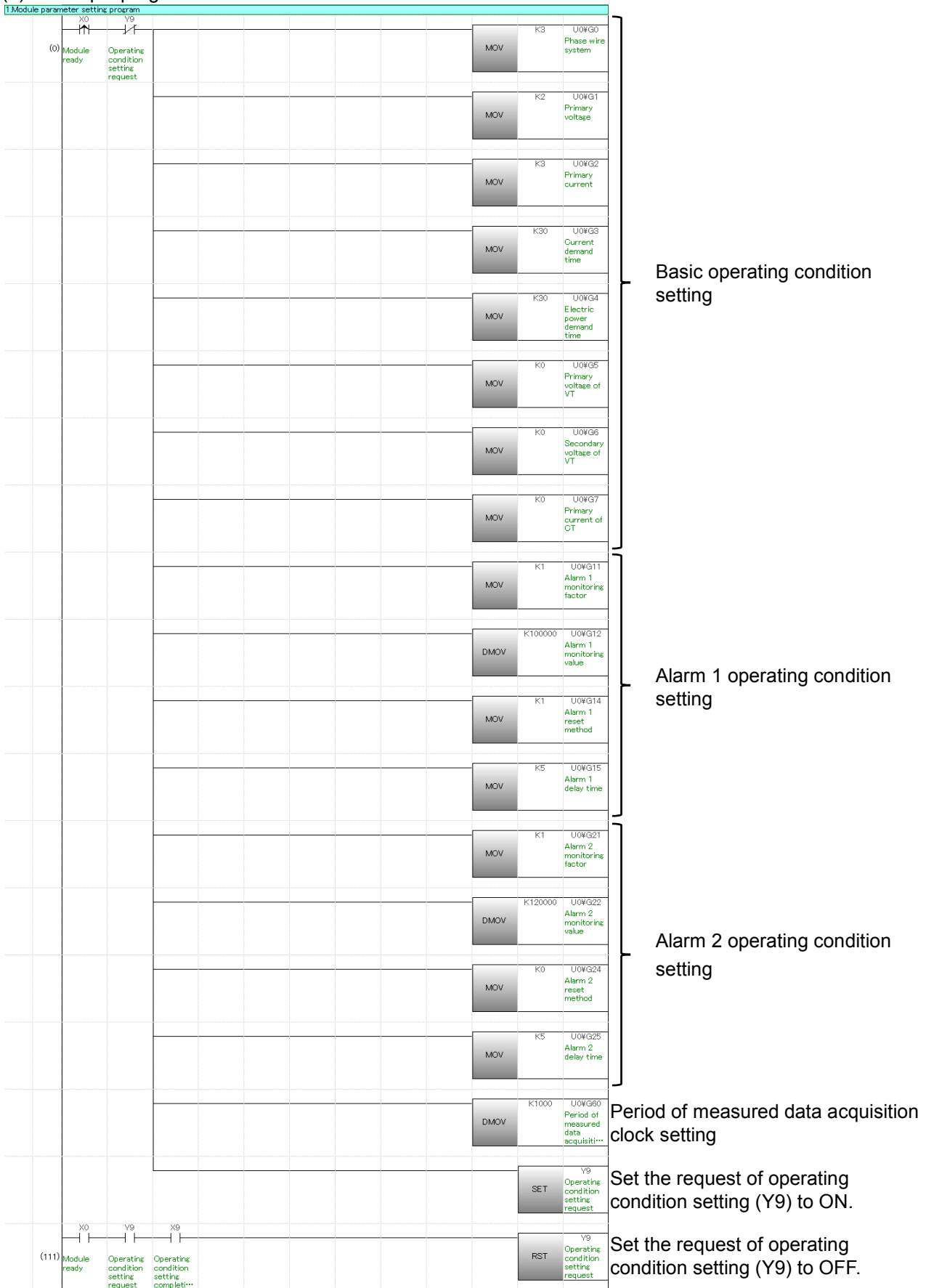
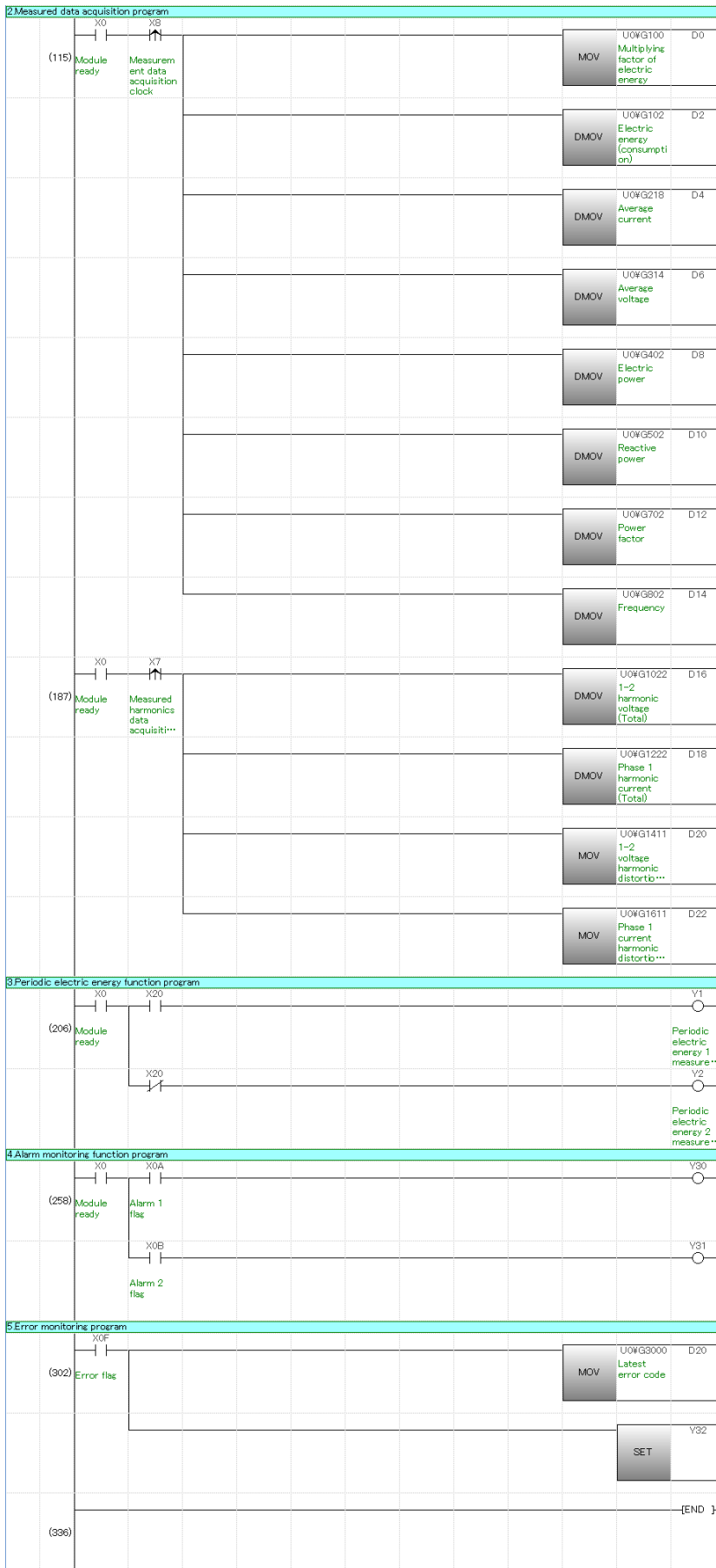

Figure 7.3.2-1 Example of sample program (1/2)



Acquire each type of the measured values

Instruct to measure the periodic electric energy 1 (Measurement is taken when X20 is ON.)

Instruct to measure the periodic electric energy 2 (Measurement is taken when X20 is OFF.)

Output ON to Y30 when the alarm 1 occurs

Output ON to Y31 when the alarm 2 occurs

Acquire the latest error code

Output ON to Y32 when an error occurs

Figure 7.3.2-2 Example of sample program (2/2)

Section 8 TROUBLESHOOTING

Caution

- If an abnormal sound, bad-smelling smoke, fever break out from this module, switch it off immediately and don't use it.

8.1 List of error codes

When the Data is written to the CPU module from this module or when a reading error occurs, error codes will be stored into the following buffer memory.

Table 8.1-1 Latest error code, storage destination upon error occurrence

Latest error code	Time of error occurrence
Un\G3000	Un\G3001 to Un\G3005

Table below shows error codes.

Table 8.1-2 List of error codes (1/2)

Error code (HEX)	Error level	Descriptions	Action	Reference
3001h 3002h 3003h	Mid	Hardware error with the module.	Turn the power OFF/ON. If the error recurs, the module may have a failure. Consult with a nearest sales agent or our company branch for the symptom of the failure.	-
1801h	Low	Phase wire method (Un\G0) is set out of range.	Check phase wire method, and set it within 1-3.	5.2.1
1802h	Low	Primary voltage (Un\G1) is set out of range.	Set it within 0 to 2, 4 to 10 according to the primary voltage.	5.2.2
1803h	Low	Primary current (Un\G2) is set out of range.	Set it within the range* of 0 to 5, 501 to 536, 1000 to 1003, 1501 to 1536 according to the primary current.	5.2.3
1804h	Low	Current demand time (Un\G3) is set out of range.	Set current demand time within the range* of 0 to 1800 (seconds).	5.2.4
1805h	Low	Electric power demand time (Un\G4) is set out of range.	Set electric power demand time within the range* of 0 to 1800 (seconds).	5.2.5
1806h	Low	Alarm 1 monitoring factor (Un\G11) is set out of range.	Set alarm 1 monitoring factor within 0 to 8.	5.2.6
1807h	Low	Alarm 2 monitoring factor (Un\G21) is set out of range.	Set alarm 2 monitoring factor within 0 to 8.	5.2.6
1808h	Low	Alarm 1 reset method (Un\G14) is set out of range.	Set alarm 1 reset method within 0 to 1.	5.2.8
1809h	Low	Alarm 2 reset method (Un\G24) is set out of range.	Set alarm 2 reset method within 0 to 1.	5.2.8

* Also check that it is set in decimal.

Table 8.1-2 List of error codes (2/2)

Error code (HEX)	Error level	Descriptions	Action	Reference
180Ah	Low	Alarm 1 delay time (Un\G15) is set out of range.	Set alarm 1 delay time within the range* of 0 to 300 (seconds).	5.2.9
180Bh	Low	Alarm 2 delay time (Un\G25) is set out of range.	Set alarm 2 delay time within the range* of 0 to 300 (seconds).	5.2.9
180Ch	Low	Integrated value setting value (Un\G52, 53) is set out of range.	Set electric energy preset value within the range* of 0 to 999999999 in the double word format (32-bit integer).	5.2.10
180Dh	Low	Primary voltage of VT is set out of range.	Set primary voltage of VT within the range* of 0 to 6600 (V). However, this setting cannot set 0 (Any voltage) when primary voltage (Un\G1) is 0.	5.2.2
180Eh	Low	Secondary voltage of VT is set out of range.	Set secondary voltage of VT within the range* of 0 to 220 (V). However, this setting cannot set 0 (Any voltage) when primary voltage (Un\G1) is 0.	5.2.2
180Fh	Low	Primary current of CT is set out of range.	Set primary current of CT within the range* of 0 to 6000 (A). However, this setting cannot set 0 (Any current (EMU-CT5-A)) or 1000 (Any current (EMU2-CT5)) when primary current (Un\G2) is 0.	5.2.3
1841h	Low	Period of measured data acquisition clock is set out of range.	Set period of measured data acquisition clock within the range* of 10 to 10000 (ms).	5.2.12
0000h	-	Normal	-	-

* Also check that it is set in decimal.

8.2 Troubleshooting

8.2.1 When "RUN" LED is turned off

Table 8.2.1-1 When "RUN" LED is turned off

Check item	Action	Reference
Is power source is supplied?	Check that supply voltage of the power source is within the rating.	—
Is capacity of the power source module sufficient?	Calculate the consumption current of CPU module, I/O module, and intelligent function module attached to the base unit, and check that the power capacity is sufficient.	—
Is the watchdog time an error?	Reset CPU module, and check whether it is turned on. If RUN LED is not turned on even after doing the above, the module may have a failure. Consult with a nearest sales agent or our company branch for the symptom of the failure.	—
Is the module properly attached to the base unit?	Check the module attachment status.	6.2
Is the slot type set to "empty" in the I/O assignment setting of the PC parameter?	Set the slot type to "Intelligent".	6.4.1

8.2.2 When "ERR" LED is turned on or flashing

(1) If it is ON

Table 8.2.2-1 When "ERR" LED is turned on

Check item	Action	Reference
Did any error occur?	Check latest error code (Un\G3000), and take a corrective action as described in "8.1 List of error codes". After that, reset CPU module, and check whether it is turned on. If "ERR." LED is turned on even after doing the above, the module may have a failure. Consult with a nearest sales agent or our company branch for the symptom of the failure.	8.1

(2) If it is flashing

Table 8.2.2-2 When "ERR" LED is flashing

Check item	Action	Reference
Did any error occur?	The set value may be out of range. Check that the operating condition settings and the integrated value are correct. Correct configuration or changing the request for error clear (YF*) to ON will recover the error. When the error is cleared using the error clear request (YF*), the operation continues with the previous setting. * In the case where the initial I/O number of this module is 0.	4.2.2 Section 5 6.4.2

8.2.3 If electric energy cannot be measured

The following check has to be performed while current is flowing from the power source side to the load side.

Table 8.2.3-1 If electric energy cannot be measured

Check item			Action	Reference
"MEA." LED	"R" LED	"1" "3" LED		
OFF	OFF	Both "1" and "3" LED are OFF.	The type of current sensor may be incorrect. In addition, if the rating of the used sensor is different from the primary current, measurement cannot be taken correctly.	6.3
			Wiring is not done or may be wrong. Refer to "6.3 Wiring" to check the wiring.	
			Voltage wiring may be incorrect. Check connection of P1, P2, and P3.	
ON	ON	Both "1" and "3" LED are ON.	Current sensors on both 1 side and 3 side may be installed in the reverse direction. Check the connection.	
			Voltage wiring may be incorrect. Check connection of P1, P2, and P3.	
	OFF or ON	Only "1" LED is ON.	Current sensor on side 1 may be installed in the reverse order or current sensors on side 1 and side 3 may be swapped. Check the connection.	
			Connection between P1 and P2 or P1 and P3 may be reserved. Check the connection.	
		Only "3" LED is ON.	Current sensor on side 3 may be installed in the reverse order or current sensors on side 1 and side 3 may be swapped. Check the connection.	
			Connection between P2 and P3 or P1 and P3 may be reserved. Check the connection.	
OFF	OFF	Both "1" and "3" LED are OFF.	Measurement is taken normally. Check for the correct buffer memory address and data format (double word: 32-bit integer).	

- 8.2.4 If the electric current and voltage that are measured using this module do not match with the ones measured with other gauge

Table 8.2.4-1 If current and voltage that are measured using this module do not match with the ones measured with other gauge

Check item	Action	Reference
Are phase wire method, primary current, and primary voltage correct?	Check the value in the buffer memory for checking the phase wire method, primary current and primary voltage. When the value in the buffer memory is changed, you need to turn the request for operating condition setting into ON. Otherwise, it will not be applied to the measurement.	5.1
Does the compared gauge measure the effective value correctly?	This module stores the effective value into the buffer memory. If the compared device uses the average value instead of the effective value, the resulted value may largely differ when there is current distortion in the measurement circuit.	—
Is the secondary of current sensor short-circuited?	Make sure that the secondary of current sensor is not short-circuited. If it is connected to Mitsubishi's current transformer CW-5S (L), check that the secondary switch is not short-circuited.	—
Are you using other current sensor than recommended ones?	Only the dedicated current sensors can be connected to this module. Check that other company's sensor is not being used.	—

8.3 Q&A

8.3.1 General

Q	To what degree is the module durable against overvoltage and over current? Is external protective circuit required?
A	<p>Momentary* : Up to 2 times as high as rated voltage and 20 times as high as rated current.</p> <p>Continuous : Up to 1.1 times as high as rated voltage and rated current.</p> <p>* Momentary means: Energizing 9 times for 0.5 seconds at 1-minute intervals, and then 1 time for 5 seconds. External protective circuit is not required.</p>
Q	Can the module be used as an electric energy meter?
A	<p>This module can be used to measure the electric energy and to manage the use of electric energy.</p> <p>However, it cannot be used for deal and proof of electric energy measurement stipulated in the measurement law.</p>
Q	Are errors in wiring verifiable easily?
A	They are verifiable by the illuminating condition of "MEA.", "R," "1," and "3" LEDs on the front of the module. Refer to "8.2.3" for details.
Q	Is it OK to open the secondary terminals of the current sensor?
A	The secondary side of the dedicated current sensor is equipped with the protective circuit against opening of secondary terminals. Opening them during the wiring work causes no problems. However, for safety, please do not continuously energize the module with the terminals open.
Q	Is measurement of inverter circuit possible?
A	<p>Measuring the secondary side of the inverter is impossible due to the large fluctuation of frequency.</p> <p>Make measurement on the primary side of the inverter. However, since a current waveform on the primary side of the inverter has a distortion containing the harmonic components, a slight difference may occur.</p>
Q	Obtained values may be different from other measuring instruments. Why is it so?
A	<p>There are various possible causes. Check the following first, please:</p> <p>[1] Check for wiring errors (polarity of current sensors, connections of current circuits, and connections of voltage circuits, in particular).</p> <p>[2] On the split-type current sensor, check for the poor engagement or separation of fitting surfaces.</p> <p>[3] On the split-type current sensor, check for pinching of foreign object between fitting surfaces.</p> <p>[4] Check that the measuring instrument used for comparison indicates a correct RMS value.</p> <p>[5] If the measuring instrument used for comparison measures an average value instead of RMS value, distortion in the current of the circuit to be measured causes a significant difference of values. This module measures an RMS value.</p> <p>[6] Check for the short-circuit on the secondary side of the current transformer (CT).</p> <p>[7] Only a dedicated current sensor is connectable to module. Check that the proper current sensor is connected or not.</p>

8.3.2 Q&A about Specifications

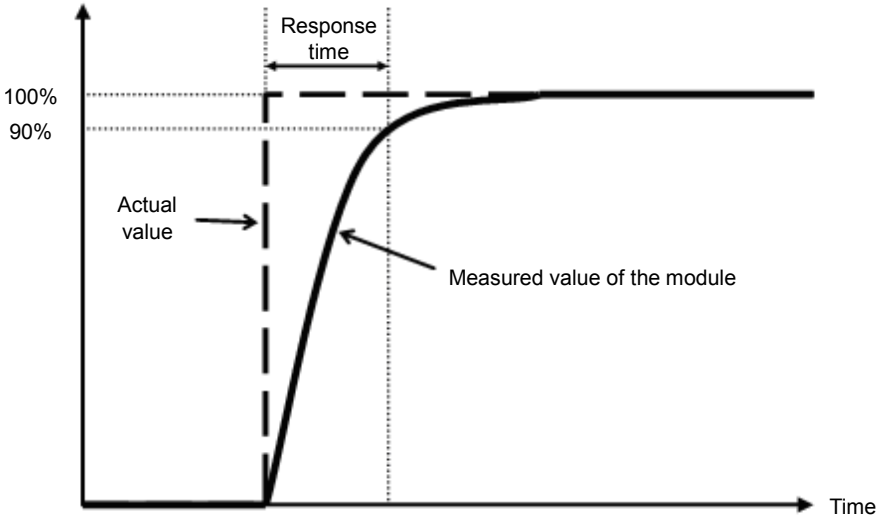
Q	What accuracy does “measuring accuracy” mean?
A	In terms of the amount of electricity, it means a range of tolerances in reading values. For example, when the reading value is “10 kWh,” a tolerance is ± 0.2 kWh. In terms of measuring items other than the amount of electricity, it means tolerance for the rated input. As to the current, when a rated current is set to 250 A, $\pm 1\%$ of 250 A is a tolerance.
Q	Is accuracy of a current sensor included?
A	Accuracy of a current sensor is not included in accuracy of the module. A maximum value of tolerance is obtained by summing tolerance of the module and that of a current sensor.
Q	To what degree an area of micro current is measured?
A	A current value is measured from the area exceeding 0.4% of the rated current. In an area below 0.4%, measurement result is indicated as “0” (zero). However, the amount of electricity is still being measured in that case. Even if the indicated value is “0,” measurement value will increase in continuing measurement for a long time. The amount of electricity is measured with a load that is about 0.4% or more of all load power.
Q	What kind of time is “response time”?
A	<p>“Response time” is a period of time between a point of sudden change of voltage or current input and a point that an output (computation result) follows up to within $\pm 10\%$ of input.</p> 
Q	When the “MEA” LED flashes?
A	When calculated value is low, “MEA”LED, “R”LED, “1”LED and “3”LED are looked like flashing. Comparing to the last value per measuring cycle, LEDs light while calculating, then LEDs light off upon no changes. Since measuring cycle is shortest as 10ms, short period setting seems like flashing.

8.3.3 Q&A about Installing

Q	What is wire diameter that allows installing a current sensor?
A	The nominal cross-sectional areas of the conductor of 600-V vinyl coated wires that can penetrate (values for reference), refer to "6.3.4" The above shows the standard nominal cross-sectional areas. Due to the outer difference of finished vinyl insulation and deformation (bending) depending on manufacturers, a wire may not penetrate. Make verification on site.
Q	What are the points when installing a current sensor?
A	Dedicated current sensor is split-type. If split surfaces are not engaged sufficiently or a foreign object exists between the split surfaces, adequate performances are not obtained. Pay attention for installation.

8.3.4 Q&A about Connection

Q	Does polarity exist in connection between a current sensor and the module?
A	Yes, it does. Make connections so that secondary terminals of current sensor (k, l) and terminal symbols of module conform with each other. If polarity is incorrect, the current value is measurable, but the electric power and the electrical energy can not be measured correctly.
Q	Are there any key points in avoiding errors in wiring?
A	Check polarity of current sensor on the primary current side. Power supply side of the circuit is indicated as "K," and the load is indicated as "L." An arrow indicates the direction from K to L. For a 3-wire circuit, check that the current sensor and the module are connected correctly for the 1-side circuit and 3-side circuit. Besides, check that voltage inputs are connected correctly among P1, P2, and P3.
Q	How do wires extend between a current sensor and the module?
A	Dedicated current sensor (excludes EMU2-CT5) is extendable up to 50 m. Model EMU2-CT5 is extendable up to 11 m, using together with extension cable. To extend the wire further, use the current transformer CW-5S(L) for split-type instrument in combination, extending the secondary wiring on CW-5S(L) side.

8.3.5 Q&A about Setting

Q	Is the setting required?
A	At least, settings of phase wires, primary current and primary voltage are required. Perform settings in accordance with a circuit to be connected.
Q	If a primary current setting value is different from that of rated current on a connected current sensor, does it cause a breakdown?
A	It does not cause breakdown or burning. However, measurement values will be totally incorrect.

Section 9 REQUIREMENT FOR THE COMPLIANCE WITH EMC AND LOW VOLTAGE DIRECTIVES

(1) For programmable controller system

To configure a system meeting the requirements of the EMC and Low Voltage Directives when incorporating the Mitsubishi programmable controller (EMC and Low Voltage Directives compliant) into other machinery or equipment, refer to “MELSEC iQ-R Module Configuration Manual”.

The CE mark, indicating compliance with the EMC and Low Voltage Directives, is printed on the rating plate of the programmable controller.

(2) For the module

For the compliance of this module with the EMC and Low Voltage Directives, refer to “6.3 Wiring”.

(3) CE marking conformity combination module

This module conforms to CE marking standard in a condition to make combination use with following current sensor and cable.

Current sensor	EMU-CT50, EMU-CT100, EMU-CT250, EMU-CT400-A, EMU-CT600-A	EMU2-CT5
Cable or current sensor cable	CE marking cable (twisted pair cable) Single wire : AWG24 - 16 (ϕ 0.52 - 1.29mm) Stranded wire : AWG20 - 16 (0.52 - 1.30mm ²)	EMU2-CB-Q5A, EMU2-T1M, EMU2-T5M, EMU2-T10M, EMU2-T1MS, EMU2-T5MS, EMU2-T10MS
Max. cable length	50m	11m

Section 10 SPECIFICATION

10.1 General specifications

Item		Specifications	
Phase wire system		single-phase 2-wire / single-phase 3-wire / three-phase 3-wire	
Rating	Voltage circuit *1	single-phase 2-wire, three-phase 3-wire	110 V , 220 V AC
		single-phase 3-wire	110V AC (1 - 2 line, 2 - 3 line) 220 V (1 - 3 line)
	Current circuit		5A, 50 A, 100 A, 250 A, 400 A, 600 A AC (Current sensor is used. Each value refers to the current at the primary side of current sensor. When current sensor is used together with current transformer (CT), the primary-side current is configurable up to 6000 A.) *2
	Frequency		50/60 Hz
Allowable tolerance of main module (excluding current sensor) *3		Current : ±1.0% (100% of the rating) Current demand *4 : ±1.0% (100% of the rating) Voltage : ±1.0% (100% of the rating) Electric power : ±1.0% (100% of the rating) Electric power demand *4 : ±1.0% (100% of the rating) Reactive power : ±1.0% (100% of the rating) Apparent power : ±1.0% (100% of the rating) Harmonic current : ±2.5% (100% of the rating) Harmonic voltage : ±2.5% (100% of the rating) Frequency : ±1.0% (45 – 65 Hz range of the rating) Power factor : ±3.0% (against the electric angle 90°) Electric energy : ±2.0% (5 – 100% range of the rating, power factor = 1) Reactive energy : ±2.5% (10 – 100% range of the rating, power factor = 0)	
Measurable circuit count		1 circuit	
Data update cycle		10 to 10000ms (It can be set in increments of 10ms) *5	
Response time		100 ms or less	
Backup for electric blackout		Backup is made using nonvolatile memory. (Stored items: settings, the max./min. values and time of occurrence, electric energy (consumption, regenerated), reactive energy (consumption lag), and periodic electric energy)	
I/O occupation		32 points	

*1: 110 V, 220V AC direct connection is possible. For the circuit over this voltage, an external transformer (VT) is necessary (Primary voltage of VT can be set up to 6600V, and secondary voltage of VT can be set up to 220V as optional setting). Star – delta connection and delta – star connection transformer instead of VT cannot measure definitely to be out of phase. Please use a transformer of the same connection.

- *2: 5 A primary current can be set when using the current sensor is as follows.
5A, 6A, 7.5A, 8A, 10A, 12A, 15A, 20A, 25A, 30A, 40A, 50A, 60A, 75A, 80A, 100A, 120A, 150A, 200A, 250A, 300A, 400A, 500A, 600A, 750A , 800A, 1000A, 1200A, 1500A, 1600A, 2000A, 2500A, 3000A, 4000A, 5000A, 6000A (Primary current of CT can be set up to 6000A in any . However, secondary current of CT can not be set to other than 5A).
- *3: Please refer to “10.4.1” as for the ratio error of the current sensor.
- *4: Demand shows the moving average of a set period.
- *5: As to measuring cycle, refer to “4.2.1(8)”.

10.2 Electrical and mechanical specifications

Item		Specifications			
Consumed VA	Voltage circuit	Each phase 0.1 VA (at 110 V AC), Each phase 0.2 VA (at 220 V AC)			
	Current circuit	Each phase 0.1 VA (secondary side of current sensor)			
Internal current consumption (5 V DC)	0.45 A				
Operating temperature *1*2	0 – 55°C (Average daily temperature 35°C or below)				
Operating humidity	5 – 95% RH (No condensation)				
Storage temperature	-25° – +75°C				
Storage humidity	5 – 95% RH (No condensation)				
Operating altitude	2000m or below				
Installation area	Inside a control panel				
Operating environment	No corrosive gas				
Vibration resistance	Conforms to JIS B 3502, IEC 61131-2	Frequency	Constant acceleration	Half amplitude	Sweep time
		5 – 8.4Hz	-	3.5 mm	XYZ each direction 10 times
		8.4 – 150 Hz	9.8 m/s ²	-	
Impact resistance	Conforms to JIS B 3502, IEC 61131-2 (147m/s ² , XYZ each direction 3 times)				
Over voltage category	III or less				
Pollution degree	2 or less				
Equipment category	Class I				
Applicable wire (Usable electric wire)	Single wire	AWG24 – AWG16 (φ0.52 - 1.29 mm)			
	Stranded wire *3*4	AWG20 – AWG16 (0.52 - 1.30 mm ²)			
Tightening torque	Module-fixing screws (M3 screw) *5	0.36 – 0.48 N·m			
Commercial frequency withstand voltage	Between voltage/current input terminals - sequencer power source and GND terminals 2210 V AC 5 sec				
Insulation resistance	5 MΩ or more (500 V DC) at locations above				
Standard *6	EMC: EN61131-2:2007, EN61326-1:2013 LVD: EN61131-2:2007, EN61010-1:2010 UL61010-1:3 rd Edition				
Dimensions	27.8 mm (W) x 106 mm (H) x 107.1 mm (D) excluding protruding portions				
Mass	0.2 kg				

*1: 0 - +50°C (complies with UL standard)

*2: If this modules mounted on the extended temperature range base unit, the same performance as the used in an operating temperature of 0 to 55 is provided even in an operating temperature of 0 to 60.

*3: At the connection between the secondary terminal of current sensor (k, l) and the main module terminal (1k, 1l, 3k, 3l), use twisted pair cable.

*4: If stranded wire is used, a bar terminal must be used.
Recommended bar terminal: TGV TC-1.25-11T (Made by Nichifu)

*5: The module can be fixed easily to the base unit, using the hook on top of the module. However, if it is used under a vibrating environment, we strongly recommend that the module be fixed with screws.

*6: When combine this module with a CT (Model: EMU2-CT5, EMU-CT50, EMU-CT100, EMU-CT250, EMU-CT400-A, EMU-CT600-A), it becomes UL standard.

10.3 External dimensions

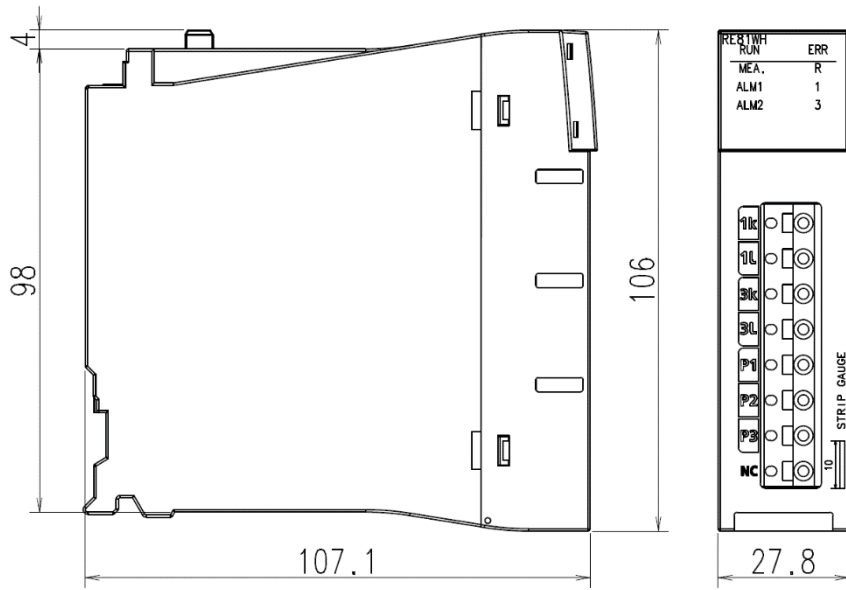

Unit [mm]

10.4 Optional devices

10.4.1 Specifications

■ Split type current sensor

Item	Specifications		
Model	EMU-CT50	EMU-CT100	EMU-CT250
Rated primary current	50A AC	100A AC	250A AC
Rated secondary current	16.66 mA	33.33 mA	66.66 mA
Rated burden	0.1 VA		
Maximum voltage (voltage to ground / line voltage)	460V AC		
Ratio error	±1% (5% to 100% of rating, RL ≤ 10 Ω)		
Phase displacement	±0.9 c rad (5% to 100% of rating, RL ≤ 10 Ω)		
Measurement (installation) category	III		
Pollution degree	2		
Working temperature range	-5 to +55°C (daily mean temperature: 35 or less)		
Working humidity range	5 to 95%RH (no condensation)		
CE marking conformity standard	EN61010-2-32		
CE marking conformity standard Maximum voltage (voltage to ground / line voltage)	460V AC		
Weight (per one)	0.1kg		

* Use an electric wire of the size of penetrating this current sensor for a primary side cable, do not use a non-insulation electric wire or a metal for a primary cable.

* Use insulation wire rather than basic insulation for the primary side cable of current sensor.

* Do not ground the secondary side of the current sensor.

Item	Specifications				
Model	EMU-CT50-A	EMU-CT100-A	EMU-CT250-A	EMU-CT400-A	EMU-CT600-A
Rated primary current	50A AC	100A AC	250A AC	400A AC	600A AC
Rated secondary current	16.66mA	33.33mA	66.66mA	66.66mA	66.66mA
Rated burden	0.1VA				
Maximum voltage (voltage to ground / line voltage)	460V AC				
Ratio error	±1% (5% to 100% of rating, RL ≤ 10Ω)				
Phase displacement	±1.3 c rad (10% to 100% of rating, RL = 10Ω) ±1.8 c rad (5% of rating, RL = 10Ω)	±1.2 c rad (5% to 100% of rating, RL = 10Ω)	±1.2 c rad (5% to 100% of rating, RL ≤ 10Ω)		
Measurement (installation) category	-			III	
Pollution degree	-			2	
Working temperature range	-5 to +55°C (daily mean temperature: 35°C or less)				
Working humidity range	30% to 85%RH (no condensation)				
CE marking conformity standard	-			EN61010-2-32	
CE marking conformity standard Maximum voltage (voltage to ground / line voltage)	-			460V AC	
Weight (per one)	0.05kg	0.1kg	0.2kg	0.3kg	0.4kg

* Use an electric wire of the size of penetrating this current sensor for a primary side cable, do not use a non-insulation electric wire or a metal for a primary cable.

* Use insulation wire rather than basic insulation for the primary side cable of current sensor.

* Do not ground the secondary side of the current sensor.

■ 5A current sensor

Item	Specifications	
	EMU2-CT5	EMU-CT5-A
Model	EMU2-CT5	EMU-CT5-A
Rated primary current	5A AC	
Rated secondary current	1.66mA	
Rated burden	0.1VA	
Maximum voltage (voltage to ground / line voltage)	260V AC	460V AC
Ratio error	±1% (5% to 100% of rating, $R_L \leq 10 \Omega$)	±1% (5% to 100% of rating, $R_L \leq 10 \Omega$)
Phase displacement	±0.9 c rad (5% to 100% of rating, $R_L \leq 10 \Omega$)	±1.3 c rad (10% to 100% of rating, $R_L \leq 10 \Omega$) ±1.8 c rad (5% of rating, $R_L = 10 \Omega$)
Measurement (installation) category	III	-
Pollution degree	2	-
Working temperature range	-5 to +55°C (daily mean temperature: 35°C or less)	-5 to +55°C (daily mean temperature: 35°C or less)
Working humidity range	5% to 95%RH (no condensation)	30% to 85%RH (co condensation)
CE marking conformity standard	EN61010-2-32	-
CE marking conformity standard Maximum voltage	260V AC	-
Weight (per one)	0.1kg	0.05kg

* Use an electric wire of the size of penetrating this current sensor for a primary side cable, do not use a non-insulation electric wire or a metal for a primary cable.

* Use insulation wire rather than basic insulation for the primary side cable of current sensor.

* Do not ground the secondary side of the current sensor.

10.4.2 External dimensions

■ Current sensor

◆ EMU-CT50, EMU-CT100, EMU-CT250

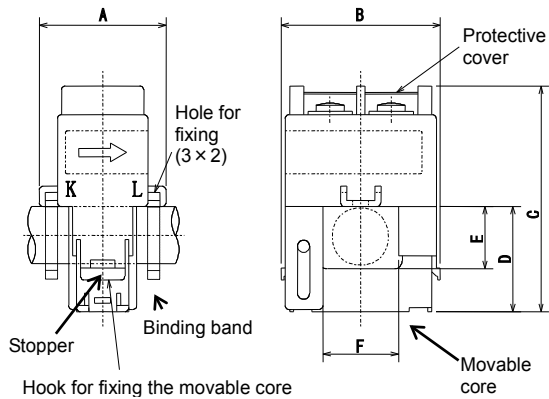

Unit [mm]

Model	A	B	C	D	E	F
EMU-CT50	31.5	39.6	55.2	25.7	15.2	18.8
EMU-CT100	31.5	39.6	55.2	25.7	15.2	18.8
EMU-CT250	36.5	44.8	66	32.5	22	24

◆ EMU-CT5-A, EMU-CT50-A, EMU-CT100-A

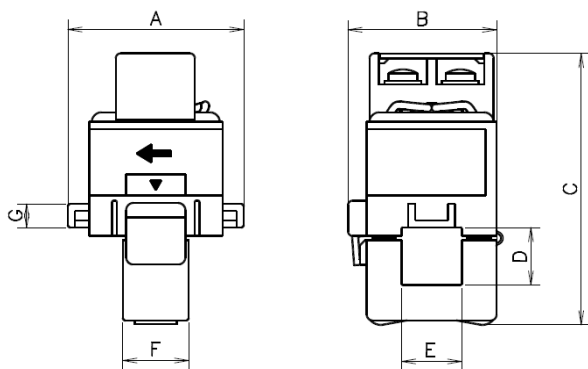

Unit [mm]

Model	A	B	C	D	E	F	G
EMU-CT5-A	37.4	31.6	57.5	12.2	12.8	14	5
EMU-CT50-A	37.4	31.6	57.5	12.2	12.8	14	5
EMU-CT100-A	43.6	33.6	65	16.2	16.2	19	5

◆ EMU-CT250-A, EMU-CT400-A, EMU-CT600-A

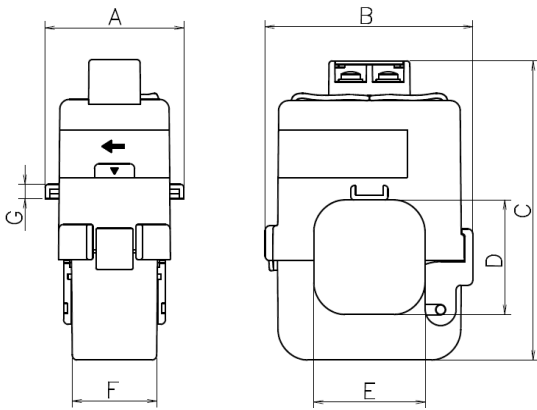

Unit [mm]

Model	A	B	C	D	E	F	G
EMU-CT250-A	42.6	49.4	74.5	24	24	25.2	4.5
EMU-CT400-A	44.9	67.2	94	36	36	27	4.5
EMU-CT600-A							

◆ EMU2-CT5

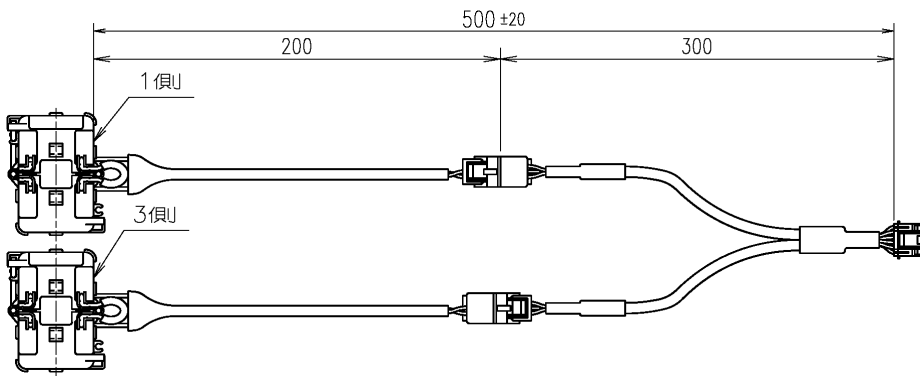

Unit [mm]

Sensor in detail

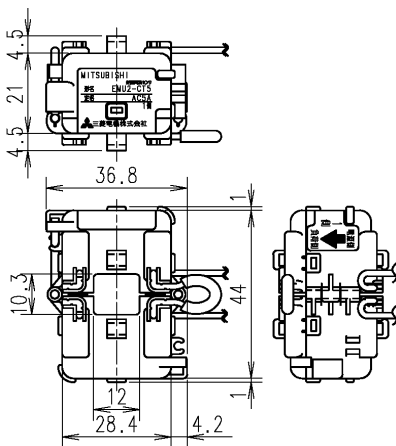

Unit [mm]

■ Dedicated cable

◆ 5A current sensor cable EMU2-CB-Q5A

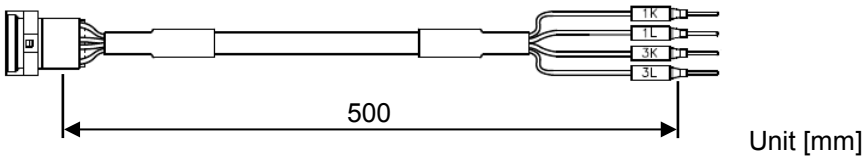

◆ Extension cable (standard) EMU2-CB-T**M

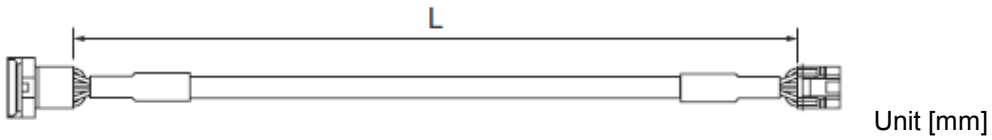

Model	EMU2-CB-T1M	EMU2-CB-T5M	EMU2-CB-T10M
Length	1000	5000	10000

◆ Extension cable (separate) EMU2-CB-T**MS

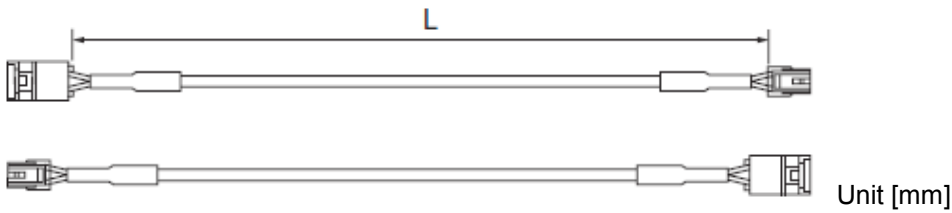

Model	EMU2-CB-T1MS	EMU2-CB-T5MS	EMU2-CB-T10MS
Length	1000	5000	10000

APPENDIX

Calculation methods of measured items is shown below.

Items	formula
Current for phase p	$I_p = \sqrt{\frac{\sum_{k=0}^{N-1} i_{pk}^2}{N}}$
Lp - Lg voltage	$V_{pg} = \sqrt{\frac{\sum_{k=0}^{N-1} (V_{gN_k} - V_{pN_k})^2}{N}}$
Electric power for phase p	$P_p = \frac{1}{N} \cdot \sum_{k=0}^{N-1} (V_{pN_k} \times i_{pk})$
Reactive power for phase p	$Q_p = \frac{1}{N} \cdot \sum_{k=0}^{N-1} (V_{pN_k} \times i_{90_pk})$
Apparent power for phase p	$S_p = V_{pN} \times i_p$
Total electric power	$P = P_1 + P_2 + P_3$
Total reactive power	$Q = Q_1 + Q_2 + Q_3$
Total apparent power	$S = S_1 + S_2 + S_3$
Power factor	$PF = \frac{P}{S}$

INDEX

[A]		[L]	
Alarm delay time	30	List of functions	16
Alarm flag (XnA/XnB).....	31, 32, 46	List of I/O signals	38
Alarm monitoring factor.....	30		
Alarm reset method	30	[M]	
Alarm reset request (YnA/YnB)	31, 49	Max./min. value hold function	29
Applicable wire.....	102	Max./min. values	
Average current	19	clear completion flag (XnD).....	29, 47
Average voltage	19	Max./min. values clear request (YnD).....	29, 50
		Max./min. values clear target.....	29, 68
[B]		Measured data acquisition clock (Xn8).....	43
Bar terminal	102	Measured harmonics	
		data acquisition clock (Xn7)	41
[C]		Measured items	17
Current demand time	33, 63	Module ready (Xn0)	39
Current sensor cable	109, 152		
		[N]	
[D]		Name of each part	14
Demand	19		
		[O]	
[E]		Operating condition setting	
Electric energy	18, 21	completion flag (Xn9)	46
Electric power demand	33, 63	Operating condition setting request (Yn9)	49
EMU2-CT5.....	109, 149		
EMU-CT5/50/100/250/400/600-A	106, 148	[P]	
EMU-CT50/100/250.....	108	Periodic electric energy.....	18, 26
Error clear request (YnF).....	50	Periodic electric energy data	
Error flag (XnF)	47	completion flag (Xn1/Xn2).....	27, 39
External dimensions	147	Periodic electric energy	
		measurement flag (Yn1/Yn2)	27, 48
[F]		Periodic electric energy reset	
Full load power	20	completion flag (Xn3/Xn4).....	27, 39
		Periodic electric energy	
[G]		reset request (Yn3/Yn4)	27, 48
GX Works3.....	112	Phase wire system.....	60, 144
		Primary current setting.....	20
[H]		Primary voltage setting	20
Harmonic current	41, 87, 89	Programming	126
Harmonic voltage.....	41, 86, 88		
		[S]	
[I]		Split type current sensor	148
Integrated value set	35, 123		
Integrated value set completion flag (XnC)	35, 47		
Integrated value set request (YnC).....	35, 49		

[T]

Test function.....34, 125
Troubleshooting 135

[U]

Upper/lower limit alarm monitoring function30

[W]

Waveform data.....36, 40, 44
Waveform data acquisition clock (Xn6)40
Wiring.....101

WARRANTY

For using this product, please thoroughly read the following product warranty descriptions.

1. Gratis Warranty Period and Gratis Warranty Coverage

If any failure or defect (hereinafter collectively called "failures") for which our company is held responsible occurs on the product during the gratis warranty period, our company shall replace the product for free through the distributor at which you purchased the product or our service company.

However, if an international travel is required for replacement, or a travel to an isolated island or equivalent remote location is required for replacement, the actual cost incurred to send an engineer(s) shall be charged.

[Gratis Warranty Period]

The gratis warranty term of the product shall be for one year after the date of purchase or delivery to a designated place.

Note that after manufacture and shipment from Mitsubishi, the maximum distribution period shall be six (6) months, and the longest gratis warranty term after manufacturing shall be eighteen (18) months. The gratis warranty term of repair parts shall not exceed the gratis warranty term before repairs.

[Gratis Warranty Coverage]

- (1) The gratis warranty shall apply only if the product is being used properly in the conditions, with the methods and under the environments in accordance with the terms and precautions described in the instruction manual, user's manual and caution label on the product, etc.
- (2) Replacement shall be charged for the following cases even during the gratis warranty period.
 1. Failures occurring due to your improper storage or handling, carelessness or fault, and failures arising from the design contents of hardware or software you use.
 2. Failures arising from modification you performed on the product without prior consent of our company.
 3. Failures occurring in the event that the product is assembled into the device you use and that are acknowledged as avoidable if the device is equipped with a safety mechanism that comply with the legal regulations applicable to the device or with functions/architecture which are considered as necessary to be equipped under conventions of the industry.
 4. Failures due to accidental force such as a fire, abnormal voltage, etc. and force majeure such as an earthquake, thunderstorm, wind, flood, etc.
 5. Failures due to matters unpredictable based on the level of science technology at the time of product
 6. Other failures which are beyond responsibility of our company or which you admit that our company is not held responsible for.

2. Fare-Paying Repair Period after Production Discontinued

- (1) The period our company may accept product replacement with charge shall be seven (7) years after production of the product is discontinued.

Production stoppage shall be announced in the technical news, etc. of our company.

- (2) The product (including spare) cannot be supplied after production is discontinued.

3. Exemption of Compensation Liability for Opportunity Loss, Secondary Loss, etc.

Our company shall not be liable to compensate for any loss arising from events not attributable to our company, opportunity loss and lost earning of the customer due to failure of the product, and loss, secondary loss, accident compensation, damage to other products besides our products and other operations caused by a special reason regardless of our company's predictability in both within and beyond the gratis warranty period.

4. Change of Product Specifications

Please be advised in advance that the specifications described in catalogs, manuals or technical materials are subject to change without notice.

5. Application of Products

- (1) For use of our general-purpose sequencer MELSEC-iQ-R series and Energy Measuring Unit RE81WH, they shall be used for a purpose which shall not lead to a material accident even when a failure or malfunction of the sequencer occurs, and a backup or fail-safe function shall be implemented systematically at external of the device in the event of a failure or malfunction.
- (2) Our general-purpose sequencers are designed and manufactured as general-purpose products which are targeted for general industry applications. Therefore, use of the sequencer for purposes in nuclear power plants and other power plants of each electric power company which greatly affect public, or for purposes in each JR company and the Defense Agency requiring a special quality assurance system shall be excluded from its applications.
 Provided that, the sequencer may be used for such purposes if the customer acknowledges that it should be used for limited purpose only and agrees not to require special quality.
 Additionally, if you are considering to use this device for purposes that are expected to greatly affect human life or property and require high reliability especially in safety or control system such as aviation, medical care, railroad, combustion/fuel device, manned carrier device, entertainment machine, safety equipment, please consult with our service representative to exchange necessary specifications.

= End of page =

Energy Measuring Module

Service Network

Country/Region	Corporation Name	Address	Telephone
Australia	Mitsubishi Electric Australia Pty. Ltd.	348 Victoria Road, Rydalmere, N.S.W. 2116, Australia	+61-2-9684-7777
Bangladesh	PROGRESSIVE TRADING CORPORATION	HAQUE TOWER,2ND FLOOR,610/11,JUBILEE ROAD, CHITTAGONG, BANGLADESH	+880-31-624307
	ELECTRO MECH AUTOMATION& ENGINEERING LTD.	SHATABDI CENTER, 12TH FLOOR, SUITES: 12-B, 292, INNER CIRCULAR ROAD, FAKIRA POOL, MOTIJHEEL, DHAKA-1000, BANGLADESH	+88-02-7192826
Belarus	Tehnikon	Oktyabrskaya 19, Of. 705, BY-220030 Minsk, Belarus	+375 (0)17 / 210 46 26
Belgium	Koning & Hartman B.V.	Woluwelaan 31, BE-1800 Vilvoorde, Belgium	+32 (0)2 / 2570240
Brazil	Mitsubishi Electric Do Brasil Comercio E Servicos Ltda.	Av. Adelino Cardana, 293 -21 and. - Bethaville, 06401-147, Barueri/SP - Brasil	+55-11-4689-3000
Cambodia	DHINIMEX CO.,LTD	#245, St. Tep Phan, Phnom Penh, Cambodia	+855-23-997-725
Chile	Rhona S.A.	Vte. Agua Santa 4211 Casilla 30-D (P.O. Box) Vina del Mar, Chile	+56-32-2-320-600
China	Mitsubishi Electric Automation (China) Ltd.	Mitsubishi Electric Automation Building, No.1386 Hongqiao Road, Shanghai,200336	+86-21-2322-3030
	Mitsubishi Electric Automation (China) Ltd. North China Branch	9/F, Office Tower1 Henderson Centre 18 Jianguomennei Dajie DongCheng district Beijing 100005	+86-10-6518-8830
	Mitsubishi Electric Automation (China) Ltd. NorthEast China Branch	Room 2302,President Building Tower C,No.69 Heping North Avenue, Heping District,Shenyang,110003	+86-24-2259-8830
	Mitsubishi Electric Automation (China) Ltd. South China Branch	Room 2512-2516, Great China International Exchange Square, Jintian Rd.S., Futian District, Shenzhen, 518034	+86-755-2399-8272
	Mitsubishi Electric Automation (China) Ltd. South China Branch	Room 1809, North Tower, The Hub Center, No.1068, Xing Gang East Road, Haizhu District, GuangZhou, China 510335	+86-20-8923-6730
	Mitsubishi Electric Automation (China) Ltd. SouthWest China Branch	1501,1502,1503,15F,Guang-hua Centre,Block C,NO.98 Guang Hua North 3th Road Chengdu,610000	+86-28-8446-8030
	Mitsubishi Electric Automation (Hong Kong) Ltd.	20/F, Cityplaza One, 1111 king's Road, TaiKoo shing, Hong Kong	+852-2510-0555
Colombia	Proelectrico Representaciones S.A.	Carrera 42 # 75-367 Bod 109 Itagui Colombia	+57-4-4441284
Czech Republic	AUTOCONT CONTROL SYSTEMS S.R.O	Technologická 374/6, CZ-708 00 Ostrava - Pustkovec	+420 595 691 150
Denmark	BEIJER ELECTRONICS A/S	LYKKEGARDSVEJ 17, DK-4000 ROSKILDE	+45 (0)46/ 75 76 66
Egypt	Cairo Electrical Group	9, Rostoum St. Garden City P.O. Box 165-11516 Maglis El-Shaab,Cairo - Egypt	+20-2-27961337
France	Mitsubishi Electric Europe B.V.	25, Boulevard des Bouvets, F-92741 Nanterre Cedex	+33 (0) 1 / 55 68 55 68
Germany	Mitsubishi Electric Europe B.V.	Mitsubishi-Electric-Platz 1, 40882 Ratingen, Germany	+49 (2102) 4860
Greece	KALAMARAKIS - SAPOUNAS S.A.	IONIAS & NEROMILOU STR., CHAMOMILOU ACHARNES, ATHENS, 13678 Greece	+30-2102 406000
	UTEKO	5, MAVROGENOUS STR., 18542 PIRAEUS, Greece	+30-211-1206-900
Hungary	Meltrade Ltd.	Fertő utca 14. HU-1107 Budapest, Hungary	+36 (0)1-431-9726
India	Mitsubishi Electric India Private Limited	2nd Floor, Tower A&B, Cyber Greens, DLF Cyber City, DLF Phase-III, Gurgaon - 122 022 Haryana, India	+91-124-4630300
Indonesia	PT.Mitsubishi Electric Indonesia	Gedung Jaya 8th floor, J.L.MH. Thamrin No.12 Jakarta Pusat 10340, Indonesia	+62-21-3192-6461
	P. T. Sahabat Indonesia	P.O.Box 5045 Kawasan Industri Pergudangan, Jakarta, Indonesia	+62-(0)21-6610651-9
Ireland	Mitsubishi Electric Europe B.V.	Westgate Business Park, Ballymount, IRL-Dublin 24, Ireland	+353 (0)1-4198800
Israel	Gino Industries Ltd.	26, Ophir Street IL-32235 Haifa, Israel	+972 (0)4-867-0656
Italy	Mitsubishi Electric Europe B.V.	Viale Colleoni 7, I-20041 Agrate Brianza (MI), Italy	+39 039-60531
Kazakhstan	Kazpromavtomatika	ul. Zhambyla 28, KAZ - 100017 Karaganda	+7-7212-501000
Korea	Mitsubishi Electric Automation Korea Co., Ltd	9F Gangseo Hangang xi-tower, 401 Yangcheon-ro, Gangseo-gu, Seoul 07528 Korea	+82-2-3660-9572
Laos	AROUNKIT CORPORATION IMPORT-EXPORT SOLE CO.,LTD	SAPHANMO VILLAGE. SAYSETHA DISTRICT, VIENTIANE CAPITAL, LAOS	+856-20-415899
Lebanon	Comptoir d'Electricite Generale-Liban	Cebaco Center - Block A Autostrade Dora, P.O. Box 11-2597 Beirut - Lebanon	+961-1-240445
Lithuania	Rifas UAB	Tinklu 29A, LT-5300 Panevezys, Lithuania	+370 (0)45-582-728
Malaysia	Mitric Sdn Bhd	No. 5 Jalan Pemberita U1/49, Temasya Industrial Park, Glenmarie 40150 Shah Alam,Selangor, Malaysia	+603-5569-3748
Malta	ALFATRADE LTD	99 PAOLA HILL, PAOLA PLA 1702, Malta	+356 (0)21-697-816
Maroco	SCHIELE MAROC	KM 7,2 NOUVELLE ROUTE DE RABAT AIN SEBAA, 20600 Casablanca, Maroco	+212 661 45 15 96
Mexico	Mitsubishi Electric Automation, Inc.	Mariano Escobedo 69, Col. Zona Industrial, Tlalnepantla, MEX - 54030 - MX	+55-3067-7500
Myanmar	Peace Myanmar Electric Co.,Ltd.	NO137/139 Botahtaung Pagoda Road, Botahtaung Town Ship 11161, Yangon, Myanmar	+95-(0)1-202589
Nepal	Watt&Volt House	KHA 2-65,Volt House Dilibazar Post Box:2108,Kathmandu,Nepal	+977-1-4411330
Netherlands	Imtech Marine & Offshore B.V.	Sluisjesdijk 155, NL-3087 AG Rotterdam, Netherlands	+31 (0)10-487-19 11
North America	Mitsubishi Electric Automation, Inc.	500 Corporate Woods Parkway, Vernon Hills, IL 60061 USA	+847-478-2100
Norway	Scanelec AS	Leivikasen 43B, NO-5179 Godvik, Norway	+47 (0)55-506000
Middle East Arab Countries & Cyprus	Comptoir d'Electricite Generale-International-S.A.L.	Cebaco Center - Block A Autostrade Dora P.O. Box 11-1314 Beirut - Lebanon	+961-1-240430
Pakistan	Prince Electric Co.	2-P GULBERG II, LAHORE, 54600, PAKISTAN	+92-42-575232, 5753373
	AL-KAMAL GROUP	OFFICE NO.7&8, 1ST FLOOR, BARKAT ALI KHAN CENTER, 101, CIRCULAR ROAD, LAHORE. PAKISTAN	+92-42-37631632
Philippines	Edison Electric Integrated, Inc.	24th Fl. Galleria Corporate Center, Edsa Cr. Origas Ave., Quezon City Metro Manila, Philippines	+63-(0)2-634-8691
Poland	Mitsubishi Electric Europe B.V. Polish Branch	Krakowska 50, 32-083 Balice, Poland	+48 (0) 12 630 47 00
Republic of Moldova	Intehsis SRL	bld. Traian 23/1, MD-2060 Kishinev, Moldova	+373 (0)22-66-4242
Romania	Sirius Trading & Services SRL	RO-060841 Bucuresti, Sector 6 Aleea Lacul Morii Nr. 3	+40-(0)21-430-40-06
Russia	Mitsubishi Electric Europe B.V. Moscow Branch	52, bld. 3 Kosmodamienskaya Nab. 115054, Moscow, Russia	+7 495 721-2070
Saudi Arabia	Center of Electrical Goods	Al-Shuwayer St. Side way of Salahuddin Al-Ayoubi St. P.O. Box 15955 Riyadh 11454 - Saudi Arabia	+966-1-4770149
Singapore	Mitsubishi Electric Asia Pte. Ltd.	307 Alexandra Road, Mitsubishi Electric Building, Singapore 159943	+65-6473-2308
Slovakia	PROCONT, Presov	Kupelna 1/, SK - 08001 Presov, Slovakia	+421 (0)51 - 7580 611
	SIMAP	Jana Derku 1671, SK - 91101 Trencin, Slovakia	+ 421 (0)32 743 04 72
Slovenia	Inea RBT d.o.o.	Stegne 11, SI-1000 Ljubljana, Slovenia	+386 (0)1-513-8116
South Africa	CBI-electric: low voltage	Private Bag 2016, ZA-1600 Isando Gauteng, South Africa	+27-(0)11-9282000
Spain	Mitsubishi Electric Europe B.V. Spanish Branch	Carretera de Rubi 76-80, E-08190 Sant Cugat del Vallés (Barcelona), Spain	+34 (0)93-565-3131
Sweden	Euro Energy Components AB	Järnvägsgatan 36, S-434 24 Kungälv, Sweden	+46 (0)300-690040
Switzerland	TriElec AG	Muehlentalstrasse 136, CH-8201 Schaffhausen	+41-(0)52-6258425
Taiwan	Setsuyo Enterprise Co., Ltd	5th Fl., No.105, Wu Kung 3rd, Wu-Ku Hsiang, Taipei, Taiwan, R.O.C.	+886-(0)2-2298-8889
Thailand	United Trading & Import Co., Ltd.	77/12 Bamrungmuang Road,Klong Mahanak Pomprab Bangkok Thailand	+66-223-4220-3
Tunisia	MOTRA Electric	3, Résidence Imen, Avenue des Martyrs Mourouj III, 2074 - El Mourouj III Ben Arous, Tunisia	+216-71 474 599
Turkey	GTS	Bayraktar Bulvarı Nutuk Sok. No:5, Posta Kutusu34384, TR-34775 Yukan Dudullu-Uemraniye, Istanbul, Turkey	+90 (0)216 526 3990
United Kingdom	Mitsubishi Electric Europe B.V.	Travellers Lane, UK-Hatfield, Herts. AL10 8XB, United Kingdom	+44 (0)1707-276100
Uruguay	Fierro Vignoli S.A.	Avda. Uruguay 1274 Montevideo Uruguay	+598-2-902-0808
Venezuela	Adesco S.A.	Calle 7 La Urbina Edificio Los Robles Locales C y D Planta Baja, Caracas - Venezuela	+58-212-241-9952
Vietnam	Mitsubishi Electric Vietnam Co.,Ltd. Head Office	Unit01-04, 10th Floor, Vincom Center, 72 Le Thanh Ton Street, District 1, Ho Chi Minh City, Vietnam	+84-8-3910-5945
	Mitsubishi Electric Vietnam Co.,Ltd. Hanoi Branch	6th Floor, Detech Tower, 8 Ton That Thuyet Street, My Dinh 2 Ward, Nam Tu Liem District, Hanoi City, Vietnam	+84-4-3937-8075

MITSUBISHI ELECTRIC CORPORATION

HEAD OFFICE: TOKYO BUILDING, 2-7-3, MARUNOUCHI, CHIYODA-KU, TOKYO 100-8310, JAPAN