

Programmable Controller

MELSEC iQ-R
series

MELSEC iQ-R CC-Link System
Master/Local Module
User's Manual (Application)

-RJ61BT11

SAFETY PRECAUTIONS



(Read these precautions before using this product.)

Before using this product, please read this manual and the relevant manuals carefully and pay full attention to safety to handle the product correctly.

If products are used in a different way from that specified by manufacturers, the protection function of the products may not work properly.

The precautions given in this manual are concerned with this product only. For the safety precautions of the programmable controller system, refer to the MELSEC iQ-R Module Configuration Manual.

In this manual, the safety precautions are classified into two levels: "⚠️ WARNING" and "⚠️ CAUTION".

 WARNING	Indicates that incorrect handling may cause hazardous conditions, resulting in death or severe injury.
 CAUTION	Indicates that incorrect handling may cause hazardous conditions, resulting in minor or moderate injury or property damage.

Under some circumstances, failure to observe the precautions given under "⚠️ CAUTION" may lead to serious consequences.

Observe the precautions of both levels because they are important for personal and system safety.

Make sure that the end users read this manual and then keep the manual in a safe place for future reference.

[Design Precautions]

WARNING

- Configure safety circuits external to the programmable controller to ensure that the entire system operates safely even when a fault occurs in the external power supply or the programmable controller. Failure to do so may result in an accident due to an incorrect output or malfunction.
 - (1) Emergency stop circuits, protection circuits, and protective interlock circuits for conflicting operations (such as forward/reverse rotations or upper/lower limit positioning) must be configured external to the programmable controller.
 - (2) When the programmable controller detects an abnormal condition, it stops the operation and all outputs are:
 - Turned off if the overcurrent or overvoltage protection of the power supply module is activated.
 - Held or turned off according to the parameter setting if the self-diagnostic function of the CPU module detects an error such as a watchdog timer error.
 - (3) All outputs may be turned on if an error occurs in a part, such as an I/O control part, where the CPU module cannot detect any error. To ensure safety operation in such a case, provide a safety mechanism or a fail-safe circuit external to the programmable controller. For a fail-safe circuit example, refer to "General Safety Requirements" in the MELSEC iQ-R Module Configuration Manual.
 - (4) Outputs may remain on or off due to a failure of a component such as a relay and transistor in an output circuit. Configure an external circuit for monitoring output signals that could cause a serious accident.
 - In an output circuit, when a load current exceeding the rated current or an overcurrent caused by a load short-circuit flows for a long time, it may cause smoke and fire. To prevent this, configure an external safety circuit, such as a fuse.
 - Configure a circuit so that the programmable controller is turned on first and then the external power supply. If the external power supply is turned on first, an accident may occur due to an incorrect output or malfunction.
 - Configure a circuit so that the external power supply is turned off first and then the programmable controller. If the programmable controller is turned off first, an accident may occur due to an incorrect output or malfunction.
 - For the operating status of each station after a communication failure, refer to manuals for the network used. For the manuals, please consult your local Mitsubishi representative. Incorrect output or malfunction due to a communication failure may result in an accident.
 - When connecting an external device with a CPU module or intelligent function module to modify data of a running programmable controller, configure an interlock circuit in the program to ensure that the entire system will always operate safely. For other forms of control (such as program modification, parameter change, forced output, or operating status change) of a running programmable controller, read the relevant manuals carefully and ensure that the operation is safe before proceeding. Improper operation may damage machines or cause accidents. When a Safety CPU is used, data cannot be modified while the Safety CPU is in SAFETY MODE.
-

[Design Precautions]

WARNING

- Especially, when a remote programmable controller is controlled by an external device, immediate action cannot be taken if a problem occurs in the programmable controller due to a communication failure. To prevent this, configure an interlock circuit in the program, and determine corrective actions to be taken between the external device and CPU module in case of a communication failure.
 - Do not write any data to the "system area" and "write-protect area" of the buffer memory in the module. Also, do not use any "use prohibited" signals as an output signal from the CPU module to each module. Doing so may cause malfunction of the programmable controller system. For the "system area", "write-protect area", and the "use prohibited" signals, refer to the user's manual for the module used. For areas used for safety communications, they are protected from being written by users, and thus safety communications failure caused by data writing does not occur.
 - If a communication cable is disconnected, the network may be unstable, resulting in a communication failure of multiple stations. Configure an interlock circuit in the program to ensure that the entire system will always operate safely even if communications fail. Failure to do so may result in an accident due to an incorrect output or malfunction. When safety communications are used, an interlock by the safety station interlock function protects the system from an incorrect output or malfunction.
 - To set a refresh device in the module parameters, select the device Y for the remote output (RY) refresh device. If a device other than Y, such as M and L, is selected, the CPU module holds the device status even after its status is changed to STOP. For how to stop data link, refer to the troubleshooting in this manual.
-

[Design Precautions]

CAUTION

- Do not install the control lines or communication cables together with the main circuit lines or power cables. Doing so may result in malfunction due to electromagnetic interference. Keep a distance of 100mm or more between those cables.
 - During control of an inductive load such as a lamp, heater, or solenoid valve, a large current (approximately ten times greater than normal) may flow when the output is turned from off to on. Therefore, use a module that has a sufficient current rating.
 - After the CPU module is powered on or is reset, the time taken to enter the RUN status varies depending on the system configuration, parameter settings, and/or program size. Design circuits so that the entire system will always operate safely, regardless of the time.
 - Do not power off the programmable controller or reset the CPU module while the settings are being written. Doing so will make the data in the flash ROM and SD memory card undefined. The values need to be set in the buffer memory and written to the flash ROM and SD memory card again. Doing so also may cause malfunction or failure of the module.
 - When changing the operating status of the CPU module from external devices (such as the remote RUN/STOP functions), select "Do Not Open by Program" for "Opening Method" of "Module Parameter". If "Open by Program" is selected, an execution of the remote STOP function causes the communication line to close. Consequently, the CPU module cannot reopen the line, and external devices cannot execute the remote RUN function.
-

[Security Precautions]

WARNING

- To maintain the security (confidentiality, integrity, and availability) of the programmable controller and the system against unauthorized access, denial-of-service (DoS) attacks, computer viruses, and other cyberattacks from external devices via the network, take appropriate measures such as firewalls, virtual private networks (VPNs), and antivirus solutions.
-

[Installation Precautions]

WARNING

- Shut off the external power supply (all phases) used in the system before mounting or removing the module. Failure to do so may result in electric shock or cause the module to fail or malfunction.
-

[Installation Precautions]

CAUTION

- Use the programmable controller in an environment that meets the general specifications in the MELSEC iQ-R Module Configuration Manual. Failure to do so may result in electric shock, fire, malfunction, or damage to or deterioration of the product.
 - To mount a module, place the concave part(s) located at the bottom onto the guide(s) of the base unit, and push in the module until the hook(s) located at the top snaps into place. Incorrect interconnection may cause malfunction, failure, or drop of the module.
 - To mount a module with no module fixing hook, place the concave part(s) located at the bottom onto the guide(s) of the base unit, push in the module, and fix it with screw(s). Incorrect interconnection may cause malfunction, failure, or drop of the module.
 - When using the programmable controller in an environment of frequent vibrations, fix the module with a screw.
 - Tighten the screws within the specified torque range. Undertightening can cause drop of the component or wire, short circuit, or malfunction. Overtightening can damage the screw and/or module, resulting in drop, short circuit, or malfunction. For the specified torque range, refer to the MELSEC iQ-R CC-Link System Master/Local Module User's Manual (Startup).
 - When using an extension cable, connect it to the extension cable connector of the base unit securely. Check the connection for looseness. Poor contact may cause malfunction.
 - When using an SD memory card, fully insert it into the SD memory card slot. Check that it is inserted completely. Poor contact may cause malfunction.
 - Securely insert an extended SRAM cassette or a battery-less option cassette into the cassette connector of the CPU module. After insertion, close the cassette cover and check that the cassette is inserted completely. Poor contact may cause malfunction.
 - Beware that the module could be very hot while power is on and immediately after power-off.
 - Do not directly touch any conductive parts and electronic components of the module, SD memory card, extended SRAM cassette, battery-less option cassette, or connector. Doing so can cause malfunction or failure of the module.
-

[Wiring Precautions]

WARNING

- Shut off the external power supply (all phases) used in the system before installation and wiring. Failure to do so may result in electric shock or cause the module to fail or malfunction.
- After installation and wiring, attach a blank cover module (RG60) to each empty slot before powering on the system for operation. Also, attach an extension connector protective cover^{*1} to each unused extension cable connector as necessary. Directly touching any conductive parts of the connectors while power is on may result in electric shock.

*1 For details, please consult your local Mitsubishi Electric representative.

[Wiring Precautions]

CAUTION

- Individually ground the FG and LG terminals of the programmable controller with a ground resistance of 100 ohms or less. Failure to do so may result in electric shock or malfunction.
 - Use applicable solderless terminals and tighten them within the specified torque range. If any spade solderless terminal is used, it may be disconnected when the terminal screw comes loose, resulting in failure.
 - Check the rated voltage and signal layout before wiring to the module, and connect the cables correctly. Connecting a power supply with a different voltage rating or incorrect wiring may cause fire or failure.
 - Connectors for external devices must be crimped or pressed with the tool specified by the manufacturer, or must be correctly soldered. Incomplete connections may cause short circuit, fire, or malfunction.
 - Securely connect the connector to the module. Poor contact may cause malfunction.
 - Do not install the control lines or communication cables together with the main circuit lines or power cables. Doing so may result in malfunction due to noise. Keep a distance of 100mm or more between those cables.
 - Place the cables in a duct or clamp them. If not, dangling cables may swing or inadvertently be pulled, resulting in malfunction or damage to modules or cables.
In addition, the weight of the cables may put stress on modules in an environment of strong vibrations and shocks.
Do not clamp the extension cables with the jacket stripped. Doing so may change the characteristics of the cables, resulting in malfunction.
 - Check the interface type and correctly connect the cable. Incorrect wiring (connecting the cable to an incorrect interface) may cause failure of the module and external device.
 - Tighten the terminal screws or connector screws within the specified torque range. Undertightening can cause drop of the screw, short circuit, fire, or malfunction. Overtightening can damage the screw and/or module, resulting in drop, short circuit, fire, or malfunction.
 - When disconnecting the cable from the module, do not pull the cable by the cable part. For the cable with connector, hold the connector part of the cable. For the cable connected to the terminal block, loosen the terminal screw. Pulling the cable connected to the module may result in malfunction or damage to the module or cable.
 - Prevent foreign matter such as dust or wire chips from entering the module. Such foreign matter can cause a fire, failure, or malfunction.
 - When a protective film is attached to the top of the module, remove it before system operation. If not, inadequate heat dissipation of the module may cause a fire, failure, or malfunction.
 - Programmable controllers must be installed in control panels. Connect the main power supply to the power supply module in the control panel through a relay terminal block. Wiring and replacement of a power supply module must be performed by qualified maintenance personnel with knowledge of protection against electric shock. For wiring, refer to the MELSEC iQ-R Module Configuration Manual.
-

[Wiring Precautions]

CAUTION

- For Ethernet cables to be used in the system, select the ones that meet the specifications in the user's manual for the module used. If not, normal data transmission is not guaranteed.
 - Use Ver.1.10-compatible CC-Link dedicated cables in a CC-Link system.
If not, the performance of the CC-Link system is not guaranteed.
For maximum overall cable length and station-to-station cable length, select the one that meet the specifications in this manual. If not, normal data transmission is not guaranteed.
-

[Startup and Maintenance Precautions]

WARNING

- Do not touch any terminal while power is on. Doing so will cause electric shock or malfunction.
 - Correctly connect the battery connector. Do not charge, disassemble, heat, short-circuit, solder, or throw the battery into the fire. Also, do not expose it to liquid or strong shock. Doing so will cause the battery to produce heat, explode, ignite, or leak, resulting in injury and fire.
 - Shut off the external power supply (all phases) used in the system before cleaning the module or retightening the terminal screws, connector screws, or module fixing screws. Failure to do so may result in electric shock.
-

[Startup and Maintenance Precautions]

CAUTION

- When connecting an external device with a CPU module or intelligent function module to modify data of a running programmable controller, configure an interlock circuit in the program to ensure that the entire system will always operate safely. For other forms of control (such as program modification, parameter change, forced output, or operating status change) of a running programmable controller, read the relevant manuals carefully and ensure that the operation is safe before proceeding. Improper operation may damage machines or cause accidents.
 - Especially, when a remote programmable controller is controlled by an external device, immediate action cannot be taken if a problem occurs in the programmable controller due to a communication failure. To prevent this, configure an interlock circuit in the program, and determine corrective actions to be taken between the external device and CPU module in case of a communication failure.
 - Do not disassemble or modify the modules. Doing so may cause failure, malfunction, injury, or a fire.
 - Use any radio communication device such as a cellular phone or PHS (Personal Handy-phone System) more than 25cm away in all directions from the programmable controller. Failure to do so may cause malfunction.
 - Shut off the external power supply (all phases) used in the system before mounting or removing the module. Failure to do so may cause the module to fail or malfunction.
 - Tighten the screws within the specified torque range. Undertightening can cause drop of the component or wire, short circuit, or malfunction. Overtightening can damage the screw and/or module, resulting in drop, short circuit, or malfunction.
 - After the first use of the product, do not perform each of the following operations more than 50 times (IEC 61131-2/JIS B 3502 compliant).
Exceeding the limit may cause malfunction.
 - Mounting/removing the module to/from the base unit
 - Inserting/removing the extended SRAM cassette or battery-less option cassette to/from the CPU module
 - Mounting/removing the terminal block to/from the module
 - Connecting/disconnecting the extension cable to/from the base unit
 - After the first use of the product, do not insert/remove the SD memory card to/from the CPU module more than 500 times. Exceeding the limit may cause malfunction.
 - Do not touch the metal terminals on the back side of the SD memory card. Doing so may cause malfunction or failure of the module.
 - Do not touch the integrated circuits on the circuit board of an extended SRAM cassette or a battery-less option cassette. Doing so may cause malfunction or failure of the module.
 - Do not drop or apply shock to the battery to be installed in the module. Doing so may damage the battery, causing the battery fluid to leak inside the battery. If the battery is dropped or any shock is applied to it, dispose of it without using.
 - Startup and maintenance of a control panel must be performed by qualified maintenance personnel with knowledge of protection against electric shock. Lock the control panel so that only qualified maintenance personnel can operate it.
 - Before handling the module, touch a conducting object such as a grounded metal to discharge the static electricity from the human body. Wearing a grounded antistatic wrist strap is recommended. Failure to discharge the static electricity may cause the module to fail or malfunction.
-

[Startup and Maintenance Precautions]

CAUTION

- After unpacking, eliminate static electricity from the module to prevent electrostatic discharge from affecting the module. If an electrostatically charged module comes in contact with a grounded metal object, a sudden electrostatic discharge of the module may cause failure. For details on how to eliminate static electricity from the module, refer to the following.
Antistatic Precautions Before Using MELSEC iQ-R Series Products (FA-A-0368)
 - Use a clean and dry cloth to wipe off dirt on the module.
-

[Operating Precautions]

CAUTION

- When changing data and operating status, and modifying program of the running programmable controller from an external device such as a personal computer connected to an intelligent function module, read relevant manuals carefully and ensure the safety before operation. Incorrect change or modification may cause system malfunction, damage to the machines, or accidents.
 - Do not power off the programmable controller or reset the CPU module while the setting values in the buffer memory are being written to the flash ROM in the module. Doing so will make the data in the flash ROM and SD memory card undefined. The values need to be set in the buffer memory and written to the flash ROM and SD memory card again. Doing so can cause malfunction or failure of the module.
-

[Disposal Precautions]

CAUTION

- When disposing of this product, treat it as industrial waste.
 - When disposing of batteries, separate them from other wastes according to the local regulations. For details on battery regulations in EU member states, refer to the MELSEC iQ-R Module Configuration Manual.
-

[Transportation Precautions]

CAUTION

- When transporting lithium batteries, follow the transportation regulations. For details on the regulated models, refer to the MELSEC iQ-R Module Configuration Manual.
 - The halogens (such as fluorine, chlorine, bromine, and iodine), which are contained in a fumigant used for disinfection and pest control of wood packaging materials, may cause failure of the product. Prevent the entry of fumigant residues into the product or consider other methods (such as heat treatment) instead of fumigation. The disinfection and pest control measures must be applied to unprocessed raw wood.
-

CONDITIONS OF USE FOR THE PRODUCT

- (1) MELSEC programmable controller ("the PRODUCT") shall be used in conditions;
- i) where any problem, fault or failure occurring in the PRODUCT, if any, shall not lead to any major or serious accident; and
 - ii) where the backup and fail-safe function are systematically or automatically provided outside of the PRODUCT for the case of any problem, fault or failure occurring in the PRODUCT.
- (2) The PRODUCT has been designed and manufactured for the purpose of being used in general industries. MITSUBISHI ELECTRIC SHALL HAVE NO RESPONSIBILITY OR LIABILITY (INCLUDING, BUT NOT LIMITED TO ANY AND ALL RESPONSIBILITY OR LIABILITY BASED ON CONTRACT, WARRANTY, TORT, PRODUCT LIABILITY) FOR ANY INJURY OR DEATH TO PERSONS OR LOSS OR DAMAGE TO PROPERTY CAUSED BY the PRODUCT THAT ARE OPERATED OR USED IN APPLICATION NOT INTENDED OR EXCLUDED BY INSTRUCTIONS, PRECAUTIONS, OR WARNING CONTAINED IN MITSUBISHI ELECTRIC USER'S, INSTRUCTION AND/OR SAFETY MANUALS, TECHNICAL BULLETINS AND GUIDELINES FOR the PRODUCT.
- ("Prohibited Application")
- Prohibited Applications include, but not limited to, the use of the PRODUCT in;
- Nuclear Power Plants and any other power plants operated by Power companies, and/or any other cases in which the public could be affected if any problem or fault occurs in the PRODUCT.
 - Railway companies or Public service purposes, and/or any other cases in which establishment of a special quality assurance system is required by the Purchaser or End User.
 - Aircraft or Aerospace, Medical applications, Train equipment, transport equipment such as Elevator and Escalator, Incineration and Fuel devices, Vehicles, Manned transportation, Equipment for Recreation and Amusement, and Safety devices, handling of Nuclear or Hazardous Materials or Chemicals, Mining and Drilling, and/or other applications where there is a significant risk of injury to the public or property.
- Notwithstanding the above restrictions, Mitsubishi Electric may in its sole discretion, authorize use of the PRODUCT in one or more of the Prohibited Applications, provided that the usage of the PRODUCT is limited only for the specific applications agreed to by Mitsubishi Electric and provided further that no special quality assurance or fail-safe, redundant or other safety features which exceed the general specifications of the PRODUCTS are required. For details, please contact the Mitsubishi Electric representative in your region.
- (3) Mitsubishi Electric shall have no responsibility or liability for any problems involving programmable controller trouble and system trouble caused by DoS attacks, unauthorized access, computer viruses, and other cyberattacks.

INTRODUCTION

Thank you for purchasing the Mitsubishi Electric MELSEC iQ-R series programmable controllers.

This manual describes the functions, programming, and troubleshooting of the relevant product listed below.

Before using this product, please read this manual and the relevant manuals carefully and develop familiarity with the functions and performance of the MELSEC iQ-R series programmable controller to handle the product correctly.

When applying the program examples provided in this manual to an actual system, ensure the applicability and confirm that it will not cause system control problems.

Please make sure that the end users read this manual.

Relevant product

RJ61BT11

CONTENTS

SAFETY PRECAUTIONS	1
CONDITIONS OF USE FOR THE PRODUCT	10
INTRODUCTION	10
RELEVANT MANUALS	14
TERMS	15
GENERIC TERMS AND ABBREVIATIONS	17
CHAPTER 1 FUNCTIONS	18
1.1 Cyclic Transmission	18
Data flow and link device assignment	18
Mode	20
Link refresh	30
Cyclic data integrity assurance	32
Sequence scan synchronization specification	34
Input and output settings when failure occurs	37
Output data setting in case of CPU STOP	41
Data link stop and restart	42
Remote I/O station points setting	42
1.2 Transient Transmission	44
1.3 Standby Master Function	45
1.4 Remote Device Station Initial Setting Procedure Registration Function	53
1.5 Interrupt Setting Function	56
1.6 Master Station Duplication Error Canceling Function	56
CHAPTER 2 PARAMETER SETTINGS	57
2.1 Setting Parameters	57
2.2 Required Settings	58
Station Type	59
Mode	59
Station Number	60
Transmission Speed	61
Parameter Setting Method	61
2.3 Basic Settings	62
Own Station Setting	62
Network Configuration Settings	63
Link Refresh Settings	65
Initial Settings	68
2.4 Application Settings	71
Supplementary Cyclic Settings	72
Interrupt Settings	73
Parameter Name	74
CHAPTER 3 PROGRAMMING	75
3.1 Precautions for Programming	75
3.2 Example of Communications Between a Master Station and a Local Station	76
System configuration example	76
Setting in the master station	79
Setting in the local station	82

Checking the data link status	84
Program examples	85
3.3 Communication Example Using the Standby Master Function	89
System configuration example	89
Setting in the master station	90
Settings for a standby master station	93
Program example	95
CHAPTER 4 TROUBLESHOOTING	99
<hr/>	
4.1 Checking with LED	99
4.2 Checking the Module Status	101
4.3 Checking the System Status	103
4.4 Hardware Test	115
4.5 Troubleshooting by Symptom	116
When cyclic transmission cannot be performed	116
When transient transmission cannot be performed	119
When a slave station is disconnected	120
When operation error occurs on the master station	125
4.6 List of Error Codes	126
4.7 List of Event History	136
APPENDICES	137
<hr/>	
Appendix 1 Module Labels	137
Appendix 2 I/O Signals	138
List of I/O signals	138
Details of I/O signals	139
Appendix 3 Buffer Memory	140
List of buffer memory addresses	140
Details of buffer memory addresses	143
Appendix 4 List of Link Special Relay (SB) Areas	156
Appendix 5 List of Link Special Register (SW) Areas	162
Appendix 6 Dedicated Instruction	172
List of dedicated instructions	172
Appendix 7 Processing Time	173
Link scan time	173
Cyclic transmission delay time	176
Appendix 8 How to Use Standby Master Function in Redundant System	181
System configuration	181
Setting method	181
System switching operation	182
Communication examples	183
Appendix 9 Mounting the Module with a Remote Head Module	193
Restrictions on functions and specifications	193
Communication example	194
Appendix 10 Using the Module in the Redundant System with Redundant Extension Base Unit	208
Restrictions on functions and specifications	208
Precautions	208
Appendix 11 Added and Enhanced Functions	209

INDEX

210

REVISIONS	212
WARRANTY	213
TRADEMARKS	214
COPYRIGHTS	214

RELEVANT MANUALS

Manual name [manual number]	Description	Available form
MELSEC iQ-R CC-Link System Master/Local Module User's Manual (Application) [SH-081270ENG] (this manual)	Functions, parameter settings, programming, troubleshooting, I/O signals, and buffer memory of the CC-Link system master/local module	Print book e-Manual PDF
MELSEC iQ-R Module Configuration Manual [SH-081262ENG]	The combination of the MELSEC iQ-R series modules, common information on the installation/wiring in the system, and specifications of the power supply module, base unit, SD memory card, and battery	Print book e-Manual PDF
MELSEC iQ-R CC-Link System Master/Local Module User's Manual (Startup) [SH-081269ENG]	Specifications, procedures before operation, system configuration, wiring, and communication examples of the CC-Link system master/local module	Print book e-Manual PDF
MELSEC iQ-R Programming Manual (Module Dedicated Instructions) [SH-081976ENG]	Dedicated instructions of the intelligent function module	e-Manual PDF
MELSEC iQ-R CC-Link System Master/Local Module Function Block Reference [BCN-P5999-0380]	Function blocks used for the CC-Link system master/local module	e-Manual PDF
GX Works3 Operating Manual [SH-081215ENG]	System configuration, parameter settings, and online operations of GX Works3	e-Manual PDF
iQ Sensor Solution Reference Manual [SH-081133ENG]	Operation methods of the online functions for iQ Sensor Solution	Print book e-Manual PDF



e-Manual refers to the Mitsubishi Electric FA electronic book manuals that can be browsed using a dedicated tool.

e-Manual has the following features:

- Required information can be cross-searched in multiple manuals.
- Other manuals can be accessed from the links in the manual.
- The hardware specifications of each part can be found from the product figures.
- Pages that users often browse can be bookmarked.
- Sample programs can be copied to an engineering tool.

TERMS

Unless otherwise specified, this manual uses the following terms.

Term	Description
Buffer memory	Memory in an intelligent function module to store data such as setting values and monitor values. For CPU modules, it refers to memory to store data such as setting values and monitor values of the Ethernet function, or data used for data communication of the multiple CPU system function.
Control system	A system that controls a redundant system and performs network communications in a redundant system
Cyclic transmission	A function by which data are periodically exchanged between the master station and other stations on the same system using link devices.
Dedicated instruction	An instruction that simplifies programming for using functions of intelligent function modules
Device	A memory of a CPU module to store data. Devices such as X, Y, M, D, and others are provided depending on the intended use.
Engineering tool	A tool used for setting up programmable controllers, programming, debugging, and maintenance
Global label	A label that is valid for all the program data when multiple program data are created in the project. There are two types of global label: a module specific label (module label), which is generated automatically by GX Works3, and an optional label, which can be created for any specified device.
Intelligent device station	A station that exchanges I/O signals (bit data) and I/O data (word data) with the master station by cyclic transmission. This station responds to a transient transmission request from another station and also issues a transient transmission request to another station.
Intelligent function module	A module that has functions other than input and output, such as an A/D converter module and D/A converter module
Link device	A device (RX, RY, RWr, RWw, SB, or SW) in a CC-Link module
Link scan (link scan time)	Time required for all the stations on the network to transmit data. The link scan time depends on data volume and the number of transient transmission requests.
Local station	A station that performs cyclic transmission and transient transmission with the master station and other local stations.
Master station	A station that controls the entire system. This station can perform cyclic transmission and transient transmission with all stations. Only one master station can be used in a system.
Message transmission	A function to communicate data between a master station and slave stations when the model names of slave stations are read or the dedicated instructions are requested
Module label	A label that represents one of memory areas (I/O signals and buffer memory areas) specific to each module in a given character string. For the module used, GX Works3 automatically generates this label, which can be used as a global label.
New control system	A system that has switched to control system from standby system after system switching
New standby system	A system that has switched to standby system from control system after system switching
Process CPU (redundant mode)	A Process CPU operating in redundant mode. A redundant system is configured with this CPU module. Process control function blocks and the online module change function can be used even in this mode.
Redundant function module	A module to configure a redundant system by using it in combination with a process CPU (redundant mode).
Redundant system	A system consisting of two systems that have same configuration (CPU module, power supply module, network module, and other modules). Even after an error occurs in one of the two system, the other system takes over the control of the entire system.
Redundant system with redundant extension base unit	A redundant system that is configured using extension base unit(s)
Remote device net Ver.1 mode	A mode used to configure a system only with a master station and Ver.1-compatible remote stations.
Remote device net Ver.2 mode	A mode used to configure a system only with remote stations containing master stations and Ver.2-compatible slave stations or to add Ver.2-compatible slave stations in future (a system only with master stations and Ver.1-compatible remote stations).
Remote device station	A station that exchanges I/O signals (bit data) and I/O data (word data) with another station by cyclic transmission. This station cannot perform transient transmission.
Remote I/O net mode	A mode used to perform high-speed communications in a system consisting of a master station and remote I/O station(s) only
Remote I/O station	A station that exchanges I/O signals (bit data) with the master station by cyclic transmission This station cannot perform transient transmission.
Remote net mode	A mode used to communicate data with all stations (remote I/O station, remote device station, local station, intelligent device station, and standby master station) in a CC-Link system. There are two modes: remote net Ver.1 mode and remote net Ver.2 mode.

Term	Description
Remote net Ver.1 mode	A mode used to configure a system only with a master station and Ver.1-compatible slave station. Data can be communicated with all stations (remote I/O station, remote device station, local station, intelligent device station, and standby master station) in a CC-Link system.
Remote net Ver.2 mode	A mode used to configure a system containing master stations and Ver.2-compatible slave stations or to add Ver.2-compatible slave stations in future. Data can be communicated with all stations (remote I/O station, remote device station, local station, intelligent device station, and standby master station) in a CC-Link system. Compared to the remote net Ver.1 mode, the number of cyclic points per station is increased from 128 to 896 for RX/RV, and from 16 to 128 for RWr/RVw.
Standby system	A backup system in a redundant system
System A	A system that is set as system A to distinguish two systems in a redundant system. It is used to distinguish connected two systems (system A and system B).
System B	A system that is set as system B to distinguish two systems in a redundant system. It is used to distinguish connected two systems (system A and system B).
System switching	A function which switches the systems between the control system and the standby system to continue operation of the redundant system when a failure or an error occurs in the control system
Tracking cable	An optical fiber cable used to connect two redundant function modules in a redundant system
Transient transmission	A function of communication with another station, which is used when requested by a dedicated instruction or the engineering tool
Ver.1-compatible slave station	A slave station that supports the remote net Ver.1 mode or remote device net Ver.1 mode
Ver.2-compatible slave station	A slave station that supports the remote net Ver.2 mode or remote device net Ver.2 mode

GENERIC TERMS AND ABBREVIATIONS

Unless otherwise specified, this manual uses the following generic terms and abbreviations.

Generic term/abbreviation	Description
AJ65BT-R2N	An abbreviation for the AJ65BT-R2N CC-Link system RS-232 interface module
CPU module	A generic term for the MELSEC iQ-R series CPU modules
Data link	A generic term for cyclic transmission and transient transmission
Device supporting iQSS	A generic term for a device which supports iQ Sensor Solution. For iQ Sensor Solution, refer to the following.  iQ Sensor Solution Reference Manual
Master/local module	An abbreviation for the RJ61BT11 CC-Link system master/local module
Process CPU	A generic term for the R08PCPU, R16PCPU, R32PCPU, and R120PCPU
RDMSG	A generic term for the G.RDMSG and GP.RDMSG
Remote device net mode	A generic term for a remote device net Ver.1 mode and a remote device net Ver.2 mode
Remote head module	An abbreviation for the RJ72GF15-T2 CC-Link IE Field Network remote head module
Remote station	A generic term for a remote I/O station and a remote device station
RIFR	A generic term for the G.RIFR and GP.RIFR
RIRCV	A generic term for the G.RIRCV and GP.RIRCV
RIRD	A generic term for the G.RIRD and GP.RIRD
RISEND	A generic term for the G.RISEND and GP.RISEND
RITO	A generic term for the G.RITO and GP.RITO
RIWT	A generic term for the G.RIWT and GP.RIWT
RLPASET	A generic term for the G.RLPASET and GP.RLPASET
RWr	An abbreviation for a remote register. Word data input from a slave station to the master station (For some areas in a local station, data are input in the opposite direction.)
RWw	An abbreviation for a remote register. Word data output from the master station to a slave station (For some areas in a local station, data are output in the opposite direction.)
RX	An abbreviation for remote input. Bit data input from a slave station to the master station (For some areas in a local station, data are input in the opposite direction.)
RY	An abbreviation for remote output. Bit data output from the master station to a slave station (For some areas in a local station, data are output in the opposite direction.)
SB	An abbreviation for a link special relay. Bit data that indicates the operating status and data link status of modules on the master and local stations
Slave station	A generic term for a remote I/O station, remote device station, local station, intelligent device station, and standby master station
SW	An abbreviation for a link special register. Word data that indicates the operating status and data link status of modules on the master and local stations

1 FUNCTIONS

1.1 Cyclic Transmission

This function allows data to be periodically exchanged between the master station and other stations on the same system using link devices.

Data flow and link device assignment

Overview of communications

In CC-Link, communications are performed between the master station and slave stations using RX, RY, RWr, and RWw. Data in RX, RY, RWr, and RWw of the master/local module are stored in the buffer memory.

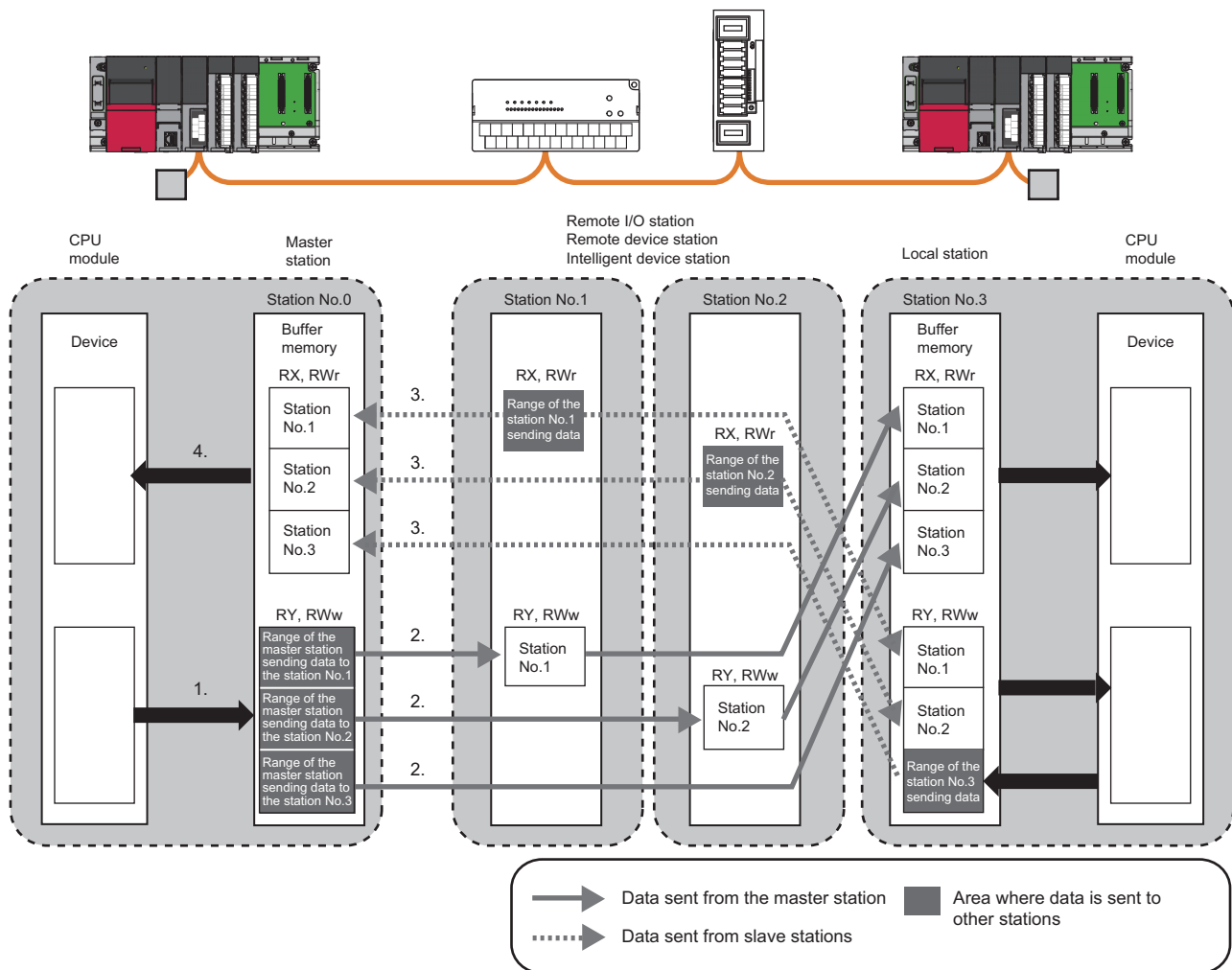

■Input and output of the master station

Data can be input to and output from all slave stations. Areas are assigned in the order of station number.

- For input to the master station, data in RX and RWr of all slave stations are stored into RX and RWr of the master station. In a local station, however, data in RY and RWw of a local station are stored into RX and RWr of the master station.
- For output from the master station, data stored in RY and RWw of the master station are output to RY and RWw of all slave stations. In a local station, however, data are stored into RX and RWr.

■Input and output of a local station

Data can be input from all slave stations. Data can be output from a local station only to the master station. Areas are assigned in the order of station number.

- For input to local stations, data in RY and RWw of other stations are stored into RX and RWr of local stations. Data in RX and RWr of other slave stations are stored into RY and RWw of local stations.
- For output from local stations, data stored in RY and RWw (own station send range) are stored into RX and RWr of the master station.

How to start communications

Power on the slave station, then master station to start data link.

When the module parameter settings are reflected, the master/local module starts data link automatically.

- When the settings are configured using an engineering tool, resetting the CPU module or powering off and on the system reflects the settings.
- When the settings are configured using dedicated instructions, executing the dedicated instructions reflects the settings.

Note that the master station sends data only to a station where data link has been started. The master station does not send data to a station where data link is not being performed.

Mode

Combination of the modes of a master/local module

The following table lists the combination of the modes of the master station and local station in a master/local module.

○: Data link can be performed. ×: Data link cannot be performed.

Mode of the master station	"Version" of "Network Configuration Settings" in "Basic Settings"	Mode of a local station		Mode of the standby master station ^{*1}	
		Remote net Ver.1 mode	Remote net Ver.2 mode	Remote net Ver.1 mode	Remote net Ver.2 mode
Remote Net Ver.1 Mode	Ver.1	○	×	○	×
Remote Net Ver.2 Mode	Ver.1	○ ^{*2}	×	—	—
	Ver.2	×	○	×	○

*1 In a standby master station, data link can be performed only when the mode is the same as that of the master station.

*2 Although a local station in the remote net Ver.1 mode cannot perform data link with a Ver.2-compatible slave station, the status of the Ver.2-compatible slave station is stored in 'Data link status of other stations' (SW0080 to SW0083) for the local station as well as that for the master station. (When the master station is normally performing data link with the Ver.2-compatible slave station, 'Data link status of other stations' (SW0080 to SW0083) for the local station indicates "0: Normal".)

Note that cyclic data in the Ver.2-compatible slave station will become "0" in the local station in the remote net Ver.1 mode. Transient transmission cannot be performed due to an error such as a timeout error.

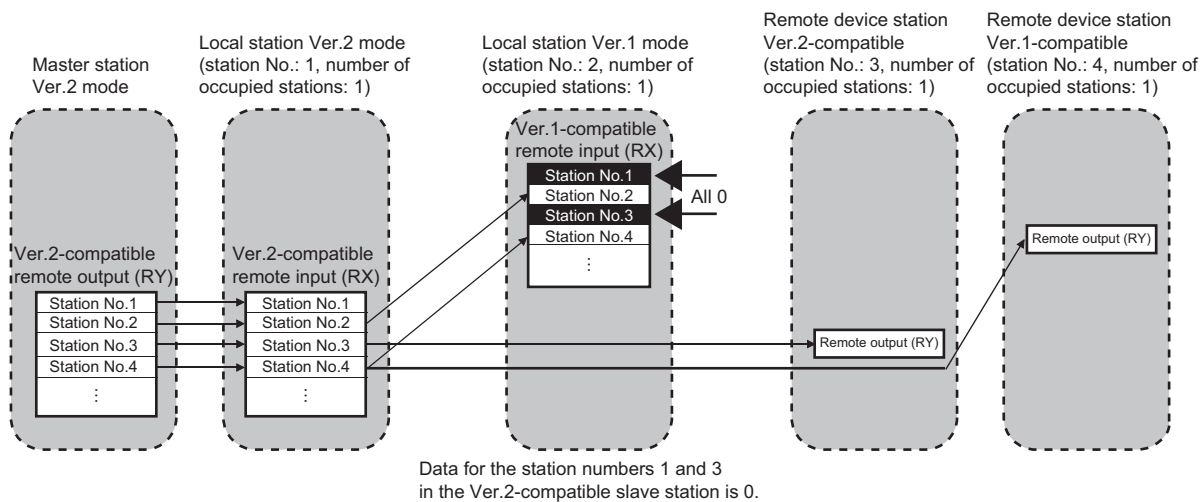

Differences in functions between the modes of a master/local module

The following table lists differences in functions between the modes of a master/local module.

Item	Mode of a master/local module		
	Remote net Ver.1 mode, Remote device net Ver.1 mode	Remote net Ver.2 mode, Remote device net Ver.2 mode	Remote I/O net mode
Storage locations of RX, RY, RWr, and RWw	Ver.1-compatible area	Ver.2-compatible area	Ver.1-compatible area
Reserved/Error invalid station	Available	Available	Not available
Zero points setting for a reserved station	Not available	Available	Not available
RWr and RWw of a remote I/O station	4 points fixed per station	0 points (RWr and RWw move over forward.)	—
Remote I/O station points setting	32 points fixed	Available ^{*1}	32 points fixed

*1 Selectable from 8 points, 8 points + empty 8 points, 16 points, and 32 points.

Setting method

Set the mode in "Mode" under "Required Settings". (☞ Page 59 Mode)

Remote net Ver.1 mode

The remote net Ver.1 mode is selected when a system is configured only with the master station and Ver.1-compatible slave stations.

When the system includes a Ver.2-compatible slave station, select the remote net Ver.2 mode.

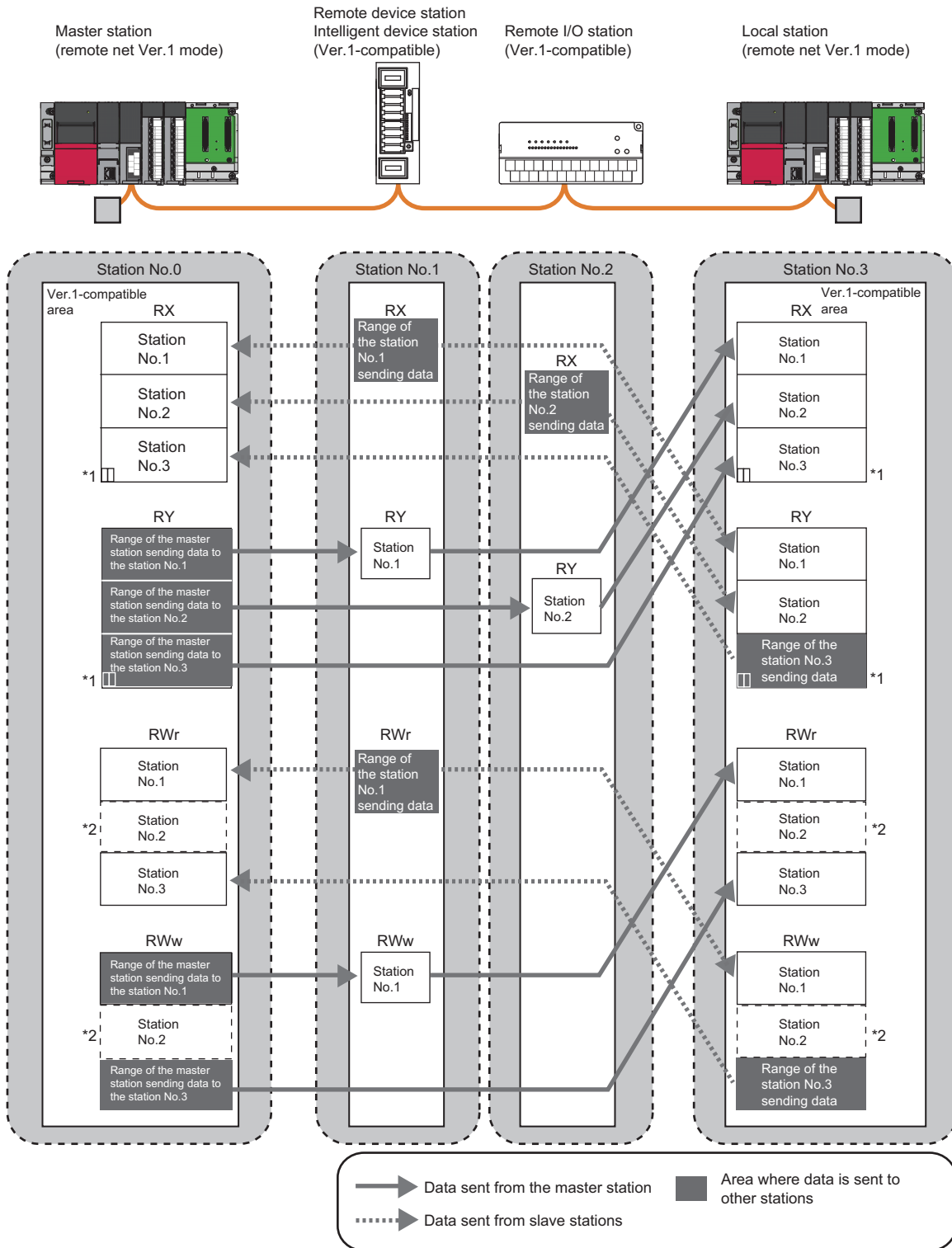

*1 The last two bits in RX and RY cannot be used for communications between the master station and a local station.
 *2 However, areas in RWr and RWw of the master station and a local station are occupied for the number of points of a remote I/O station. When areas in RWr and RWw should not be occupied, use the remote net Ver.2 mode. (Page 59 Mode)

■Points per module and per system

For the points, refer to the table of the performance specifications in the following manual.

 MELSEC iQ-R CC-Link System Master/Local Module User's Manual (Startup)

In CC-Link, increasing the number of occupied stations can increase the number of points per module. The number of occupied stations is set for each slave station.

Item	Description
Number of Occupied Stations	The number of points is increased by increasing the station numbers occupied per module. Note that the number of slave stations that can be connected to a CC-Link system is decreased because one module occupies the station numbers for multiple modules.

■Data transfer between RX, RY, RWr, and RWw and a device in a CPU module

To perform auto transfer using the module parameters in an engineering tool, setting a refresh device in "Link Refresh Settings" under "Basic Settings" can automatically transfer data between RX, RY, RWr, and RWw in a master/local module and a device in a CPU module.

To perform transfer using a program, use a module access device (Un\G□) and FROM/TO instructions to transfer data between the buffer memory areas in a master/local module and a device in a CPU module.

Address		Item	Reference
Hexadecimal	Decimal		
E0H to 15FH	224 to 351	Remote input (RX)	Page 146 Remote input (RX) and remote output (RY)
160H to 1DFH	352 to 479	Remote output (RY)	
1E0H to 2DFH	480 to 735	Remote register (RWw)	Page 148 Remote register (RWw) and remote register (RWr)
2E0H to 3DFH	736 to 991	Remote register (RWr)	

■Storage locations of RX, RY, RWr, and RWw

Areas are assigned by 32 points in the order of station number to the remote input (RX) and remote output (RY). ( Page 146 Remote input (RX) and remote output (RY))

To the remote register (RWr and RWw), areas are assigned by four points in the order of station number. (( Page 148 Remote register (RWw) and remote register (RWr)))

Remote net Ver.2 mode

The remote net Ver.2 mode is selected when a system is configured with the master station and Ver.2-compatible slave stations or when Ver.2-compatible slave stations will be added to the system in future.

In this mode, more points can be used than in the remote net Ver.1 mode.

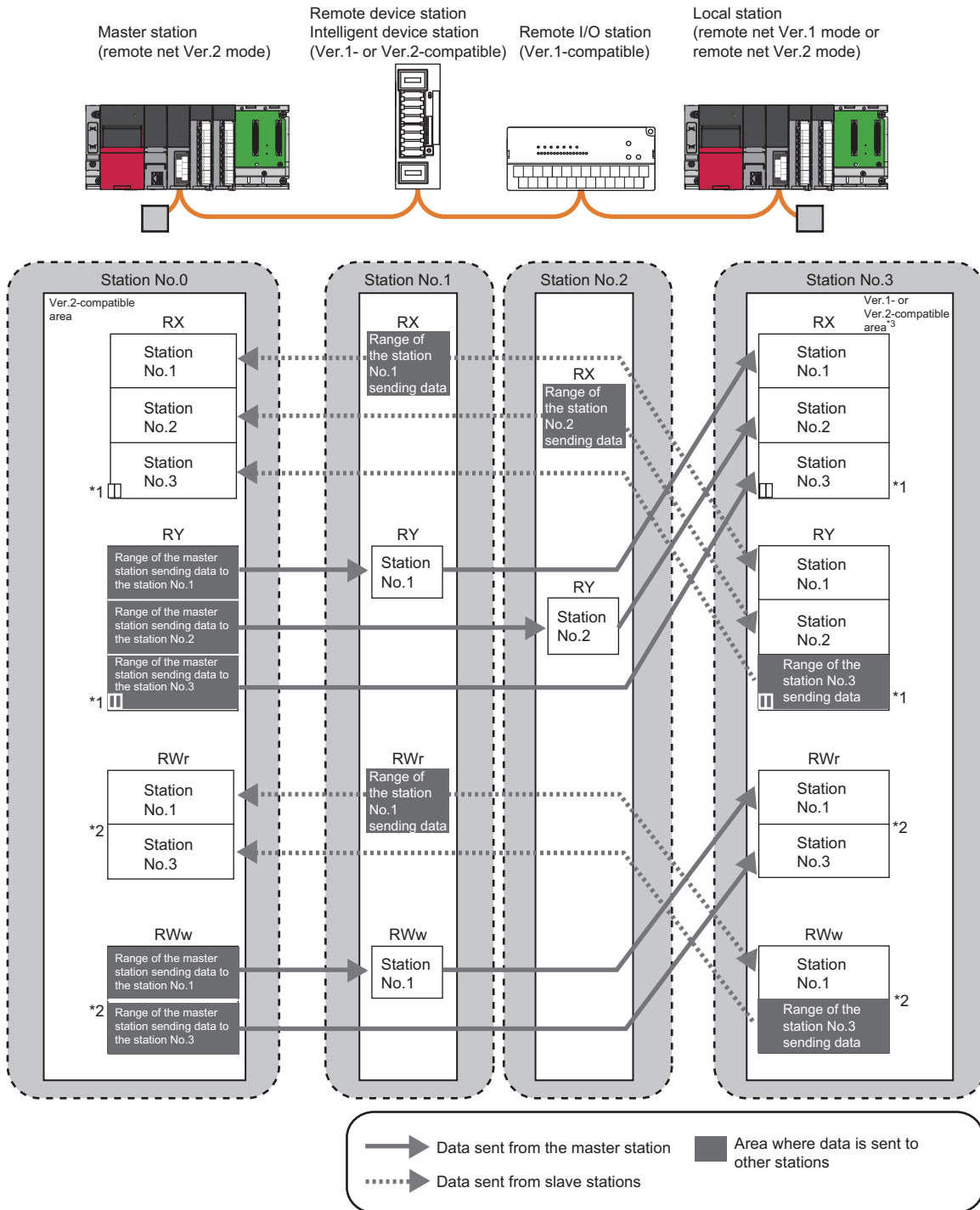

- *1 The last two bits in RX and RY cannot be used for communications between the master station and a local station.
- *2 In the master station and a local station, 0 points are assigned to RWr and RWw in a remote I/O station. (RWr and RWw move over forward.)
Note that buffer memory areas for RWr and RWw in a local station do not move over when the local station is in the remote net Ver.1 mode.
- *3 When a local station is in the remote net Ver.1 mode, data are stored in the Ver.1-compatible area. When a local station is in the remote net Ver.2 mode, data are stored in the Ver.2-compatible area.

■Points per module and per system

For the points, refer to the table of the performance specifications in the following manual.

 MELSEC iQ-R CC-Link System Master/Local Module User's Manual (Startup)

In CC-Link, increasing the number of occupied stations and extended cyclic settings can increase points per module. Set the number of occupied stations and extended cyclic settings for each slave station.

Item	Description
Number of Occupied Stations	The number of points is increased by increasing the station numbers occupied per module. Note that the number of slave stations that can be connected to a CC-Link system is decreased because one module occupies the station numbers for multiple modules.
Extended Cyclic Setting	The station numbers occupied by one module are not changed, and only the number of points are increased. Unlike "Number of Occupied Stations", the number of slave stations connected to a CC-Link system is not decreased. Note, however, that the transmission delay time is extended compared to that of when the number of points is increased in "Number of Occupied Stations".

■Data transfer between RX, RY, RWr, and RWw and a device in a CPU module

To perform auto transfer using the module parameters in an engineering tool, setting a refresh device in "Link Refresh Settings" under "Basic Settings" can automatically transfer data between RX, RY, RWr, and RWw in a master/local module and a device in a CPU module.

To perform transfer using a program, use a module access device (Un\G□) and FROM/TO instructions to transfer data between the buffer memory areas in a master/local module and a device in a CPU module.

Address		Item	Reference
Hexadecimal	Decimal		
4000H to 41FFH	16384 to 16895	Ver.2-compatible remote input (RX)	Page 153 Ver.2-compatible remote input (RX) and Ver.2-compatible remote output (RY)
4200H to 43FFH	16896 to 17407	Ver.2-compatible remote output (RY)	
4400H to 4BFFH	17408 to 19455	Ver.2-compatible remote register (RWw)	Page 154 Ver.2-compatible remote register (RWw) and Ver.2-compatible remote register (RWr)
4C00H to 53FFH	19456 to 21503	Ver.2-compatible remote register (RWr)	

■Storage locations of RX, RY, RWr, and RWw

The storage locations change depending on the number of occupied stations and extended cyclic settings in slave stations.

The storage locations for each station can be checked using Slave station offset, size information (Un\G992 to Un\G1503).

( Page 150 Slave station offset, size information)

Point

- Data stored in RX, RY, RWr, and RWw in the local station side are stored in a remote net Ver.1 mode area when the master station is in the remote net Ver.2 mode and the local station is in the remote net Ver.1 mode. Four points are occupied per station for RWr and RWw in a remote I/O station. ( Page 22 Data transfer between RX, RY, RWr, and RWw and a device in a CPU module)
- When the mode is changed from the remote net Ver.1 mode, in the remote net Ver.2 mode, RWr and RWw in a remote I/O station move over and assigned with 0 points. The assignment of the station numbers for stations after the remote I/O station changes; therefore, change the program if required.

Remote device net Ver.1 mode

The remote device net Ver.1 mode is selected when a system is configured only with the master station and Ver.1-compatible remote stations. In this mode, more remote device stations can be used than in the remote net Ver.1 mode.

When the system includes a Ver.2-compatible remote station, select the remote device net Ver.2 mode.

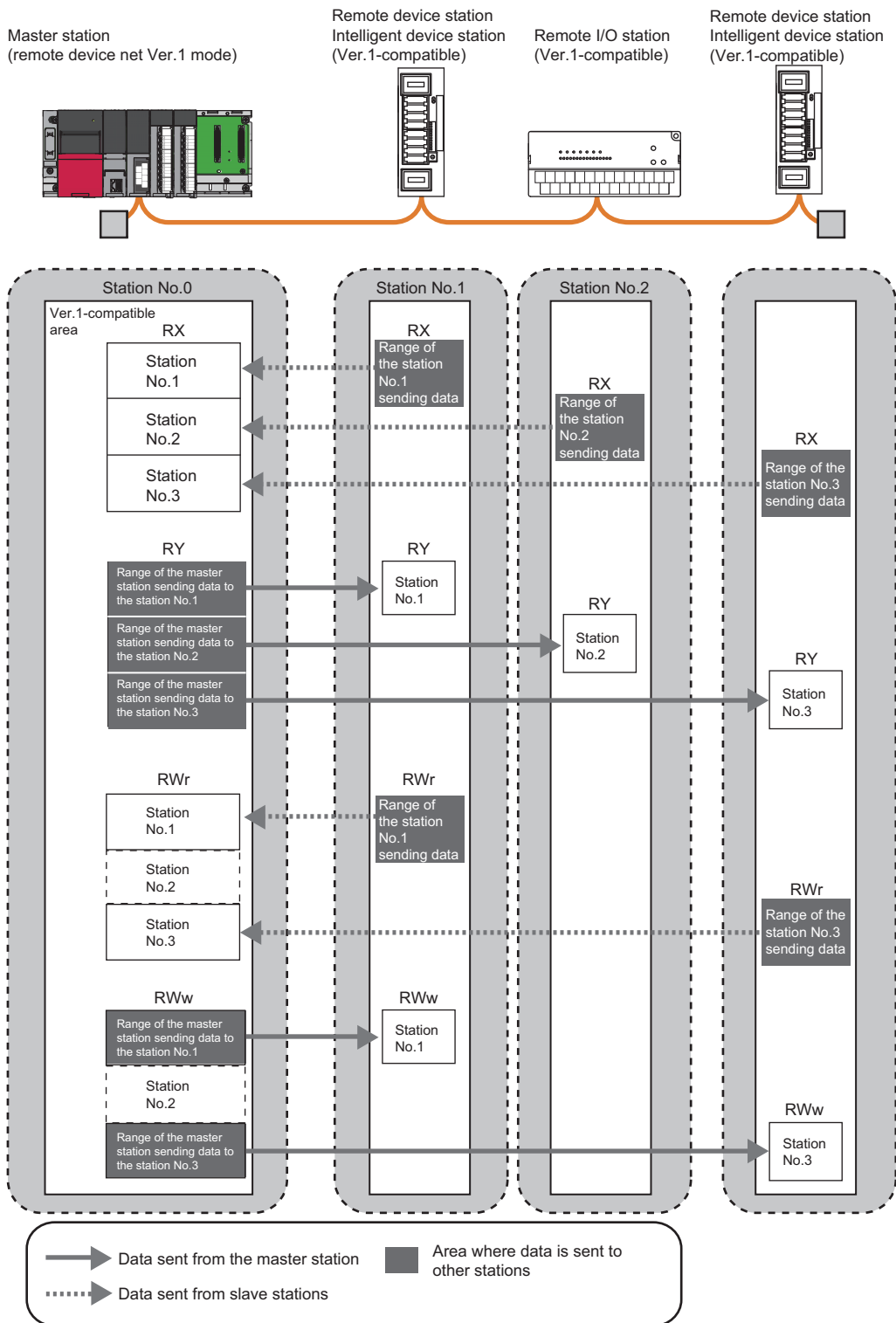

■Points per module and per system

For the points, refer to the table of the performance specifications in the following manual.

 MELSEC iQ-R CC-Link System Master/Local Module User's Manual (Startup)

In CC-Link, increasing the number of occupied stations can increase the number of points per module. The number of occupied stations is set for each slave station.

Item	Description
Number of Occupied Stations	The number of points is increased by increasing the station numbers occupied per module. Note that the number of slave stations that can be connected to a CC-Link system is decreased because one module occupies the station numbers for multiple modules.

■Data transfer between RX, RY, RWr, and RWw and a device in a CPU module

To perform auto transfer using the module parameters in an engineering tool, setting a refresh device in "Link Refresh Settings" under "Basic Settings" can automatically transfer data between RX, RY, RWr, and RWw in a master/local module and a device in a CPU module.

To perform transfer using a program, use a module access device (Un\G□) and FROM/TO instructions to transfer data between the buffer memory areas in a master/local module and a device in a CPU module.

Address		Item	Reference
Hexadecimal	Decimal		
E0H to 15FH	224 to 351	Remote input (RX)	Page 146 Remote input (RX) and remote output (RY)
160H to 1DFH	352 to 479	Remote output (RY)	
1E0H to 2DFH	480 to 735	Remote register (RWw)	Page 148 Remote register (RWw) and remote register (RWr)
2E0H to 3DFH	736 to 991	Remote register (RWr)	

■Storage locations of RX, RY, RWr, and RWw

Areas are assigned by 32 points in the order of station number to the remote input (RX) and remote output (RY) ( Page 146 Remote input (RX) and remote output (RY)).

To the remote register (RWr and RWw), areas are assigned by four points in the order of station number. ( Page 148 Remote register (RWw) and remote register (RWr))

Remote device net Ver.2 mode

The remote device net Ver.2 mode is selected when a system is configured only with the master station and remote stations including Ver.2-compatible ones or when the system includes only the master station and Ver.1-compatible remote stations but Ver.2-compatible ones will be added to the system in future.

In this mode, more points can be used than in the remote device net Ver.1 mode.

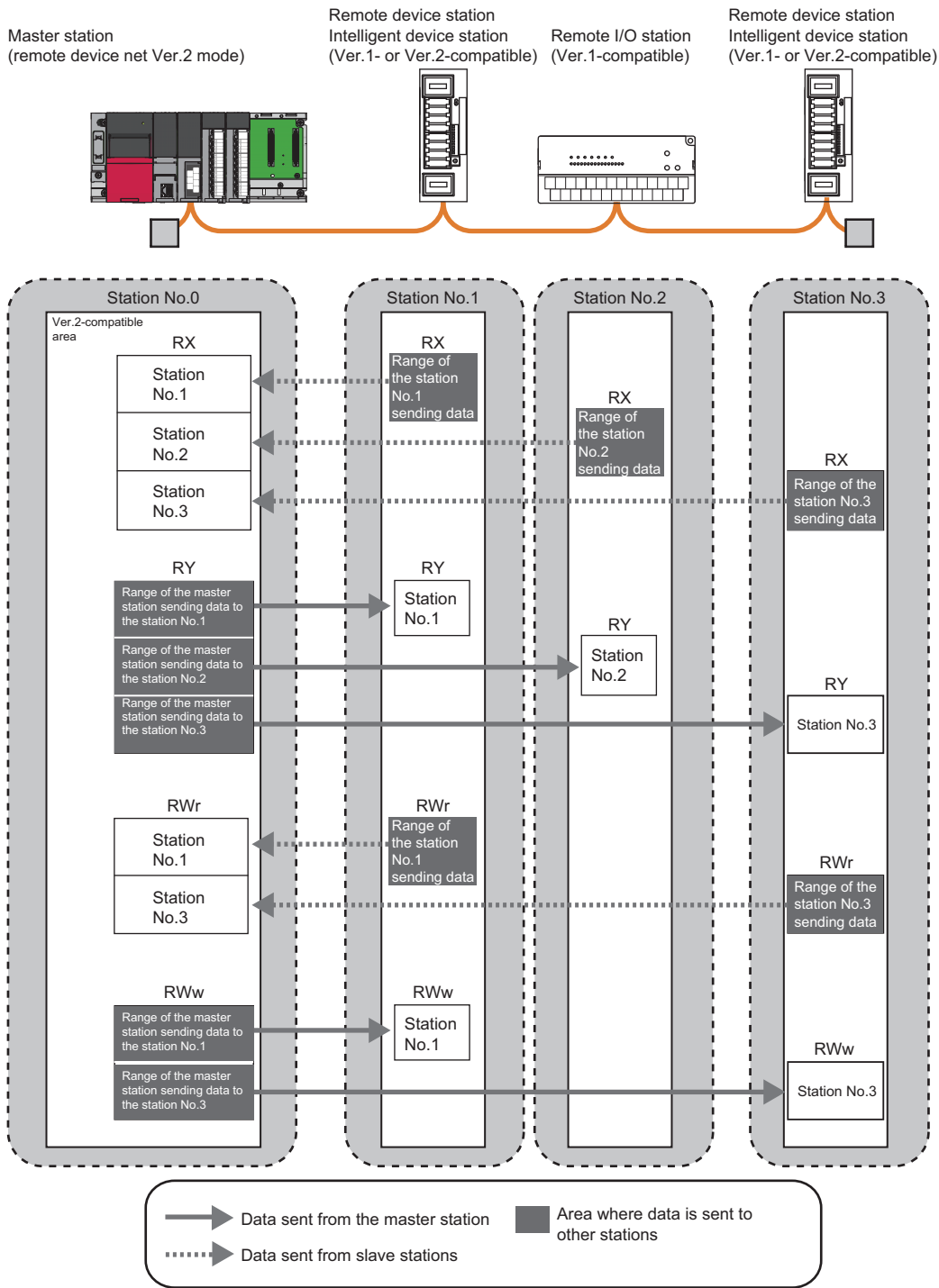

■Points per module and per system

For the points, refer to the table of the performance specifications in the following manual.

 MELSEC iQ-R CC-Link System Master/Local Module User's Manual (Startup)

In CC-Link, increasing the number of occupied stations and extended cyclic settings can increase points per module. Set the number of occupied stations and extended cyclic settings for each slave station.

Item	Description
Number of Occupied Stations	The number of points is increased by increasing the station numbers occupied per module. Note that the number of slave stations that can be connected to a CC-Link system is decreased because one module occupies the station numbers for multiple modules.
Extended Cyclic Setting	The station numbers occupied by one module are not changed, and only the number of points are increased. Unlike "Number of Occupied Stations", the number of slave stations connected to a CC-Link system is not decreased. Note, however, that the transmission delay time is extended compared to that of when the number of points is increased in "Number of Occupied Stations".

■Data transfer between RX, RY, RWr, and RWw and a device in a CPU module

To perform auto transfer using the module parameters in an engineering tool, setting a refresh device in "Link Refresh Settings" under "Basic Settings" can automatically transfer data between RX, RY, RWr, and RWw in a master/local module and a device in a CPU module.

To perform transfer using a program, use a module access device (Un\G□) and FROM/TO instructions to transfer data between the buffer memory areas in a master/local module and a device in a CPU module.

Address		Item	Reference
Hexadecimal	Decimal		
4000H to 41FFH	16384 to 16895	Ver.2-compatible remote input (RX)	Page 153 Ver.2-compatible remote input (RX) and Ver.2-compatible remote output (RY)
4200H to 43FFH	16896 to 17407	Ver.2-compatible remote output (RY)	
4400H to 4BFFH	17408 to 19455	Ver.2-compatible remote register (RWw)	Page 154 Ver.2-compatible remote register (RWw) and Ver.2-compatible remote register (RWr)
4C00H to 53FFH	19456 to 21503	Ver.2-compatible remote register (RWr)	

■Storage locations of RX, RY, RWr, and RWw

The storage locations change depending on the number of occupied stations and extended cyclic settings in slave stations.

The storage locations for each station can be checked using Slave station offset, size information (Un\G992 to Un\G1503).

( Page 150 Slave station offset, size information)

Point

When the mode is changed from the remote device net Ver.1 mode, in the remote device net Ver.2 mode, RWr and RWw in a remote I/O station move over and assigned with 0 points. The assignment of the station numbers for stations after the remote I/O station changes; therefore, change the program if required.

Remote I/O net mode

The remote I/O net mode is selected when slave stations are remote I/O stations only. Compared to other modes, transmission delay time of cyclic transmission can be shortened. In addition, modules can be operated with less settings.

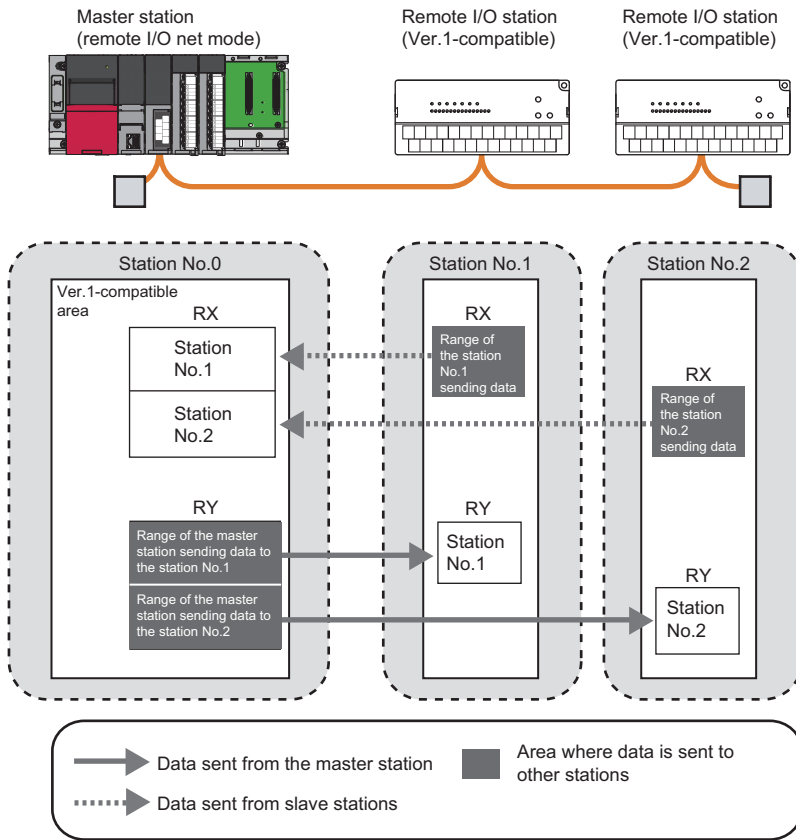

The following table lists the differences of link scan time from other modes. (Rough indication)
(When transmission speed is 10Mbps)

Number of stations	Remote I/O net mode	Remote net Ver.1 mode
		Remote net Ver.2 mode Remote device net Ver.1 mode Remote device net Ver.2 mode
8	0.61ms	1.20ms
16	0.94ms	1.57ms
32	1.61ms	2.32ms
64	2.94ms	3.81ms

Points per module and per system

For the points, refer to the table of the performance specifications in the following manual.

📖 MELSEC iQ-R CC-Link System Master/Local Module User's Manual (Startup)

■Data transfer between RX and RY and a device in a CPU module

To perform auto transfer using the module parameters in an engineering tool, setting a refresh device in "Link Refresh Settings" under "Basic Settings" transfer data between RX and RY in a master/local module and a device in a CPU module.

(☞ Page 65 Link Refresh Settings)

To perform transfer using a program, use a module access device (Un\G□) and FROM/TO instructions to transfer data between the buffer memory areas in a master/local module and a device in a CPU module.

Address		Item	Reference
Hexadecimal	Decimal		
E0H to 15FH	224 to 351	Remote input (RX)	Page 146 Remote input (RX) and remote output (RY)
160H to 1DFH	352 to 479	Remote output (RY)	

■Storage locations of RX and RY

Areas are assigned by 32 points in the order of station number to the remote input (RX) and remote output (RY). (Page 150 Slave station offset, size information)

Link refresh

This function automatically transfers data between the link device of the master/local module and the device of the CPU module or between the link devices (RX, RY, RWr, RWw, SB, and SW) of the master/local module and the devices of the CPU module or between the link devices (SB and SW) of the master/local module and the module label of the CPU module.

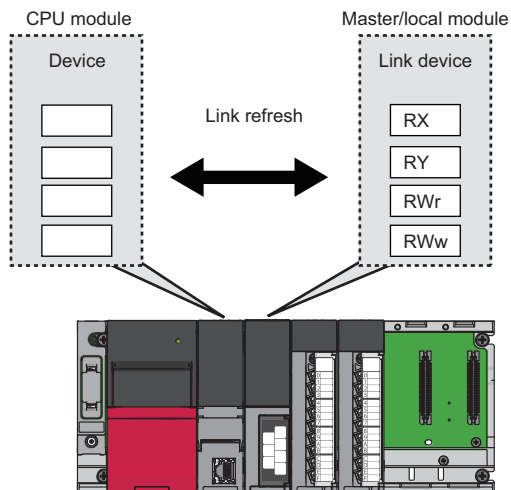

Concept of the link refresh range (number of points)

The link refresh is performed to the area set in "Link Refresh Settings" under "Basic Settings".

(1) Range set in "Link Refresh Settings" under "Basic Settings"

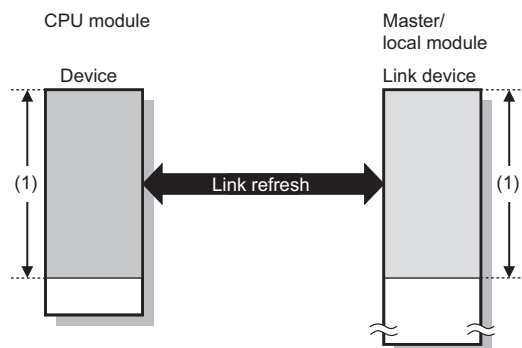

Shortening the link refresh time and transmission delay time

The link refresh time and transmission delay time can be shortened by reducing the number of link refresh points to the CPU module. The following methods can be used to reduce the number of the link refresh points.

- In "Link Refresh Settings" under "Basic Settings", set only the link devices used in the CPU module as the link refresh range. (📖 Page 65 Link Refresh Settings)
- Directly access infrequently used link devices through module access devices from the program, and remove the corresponding settings from the link refresh range.

Setting method

The link refresh is assigned in "Link Refresh Settings" under "Basic Settings". (📖 Page 65 Link Refresh Settings)

Precautions

■ Latched devices of the CPU module

Even if latched device (listed in "Devices of the CPU module" in the table below) data are cleared to 0 using a program when the CPU module is reset or powered off and on, the latched data may be output depending on the timing of a link scan and link refresh.

For how to prevent output of latched device data, perform actions listed in "How to disable the setting" in the table below.

Devices of the CPU module	How to disable the setting
Latch relay (L)	Clear the value of the device to 0 using the initial device value.*1
File register (R, ZR)	
Extended data register (D)	Delete all latch range settings.
Extended link register (W)	
Device in the latch range	

*1 For the initial device value setting of the CPU module, refer to the following.

📖 GX Works3 Operating Manual

Cyclic data integrity assurance

This function prevents read/write data from being separated between new and old data.

This function assures the cyclic data integrity in units of 32 bits or station-based units.

32-bit data integrity assurance

This function prevents read/write data in 32-bit increments from being separated between new and old data.

The data in the remote register (RWr and RWw) between a CPU module, master station, and local station are assured in units of 32 bits.

32-bit data integrity assurance is automatically performed when the following conditions are satisfied.

- The first address of the remote register (RWr and RWw) has an even number.
- When accessing the remote register (RWr/RWw) using a program, access them with an even number of devices.

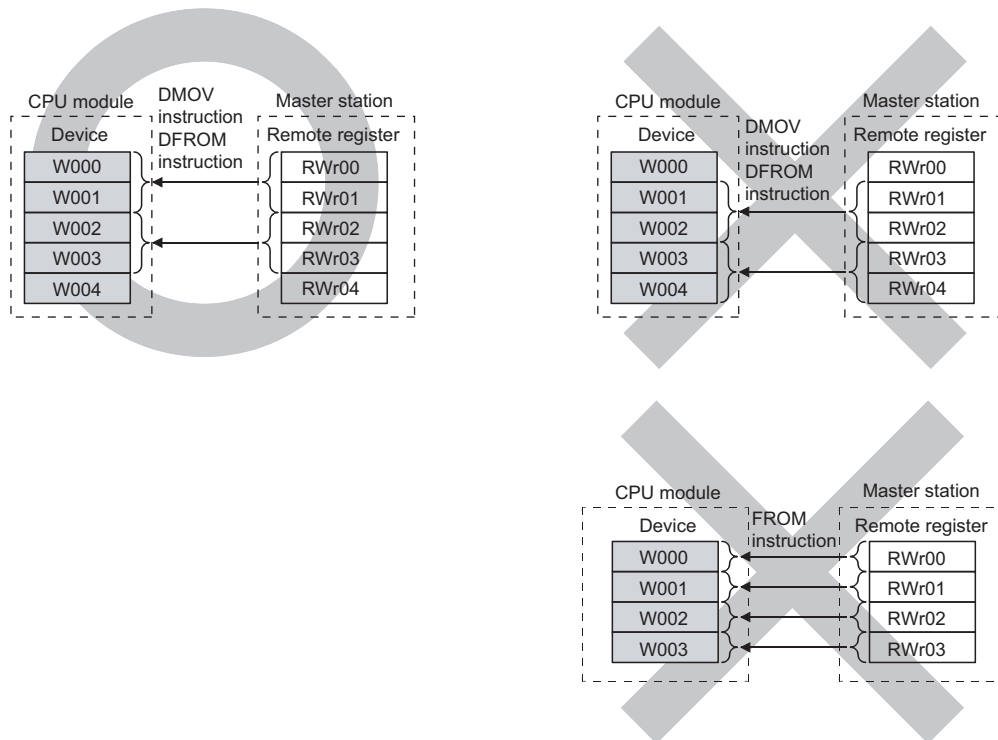

Station-based block data assurance

Cyclic data may be separated between new and old data depending on the timing of the link refresh. This function prevents read/write data per slave station from being separated between new and old data. Because module parameters are configured only on an engineering tool, a program to prevent data separation is not required.

For each slave station, data assurance is provided to data in RX, RY, RWr, and RWw that are automatically transferred to a CPU module by setting the refresh device of the module parameter.

Setting

Set station-based block data assurance under "Supplementary Cyclic Settings" in "Application Settings". (📖 Page 72 Supplementary Cyclic Settings)

Configure the setting in the master station, local station, and standby master station where data needs to be assured.

■ Operation of a data assurance

Identity of data per slave station is assured as follows.

Ex.

To assure data of the remote stations with the number of occupied stations of 3 and 1

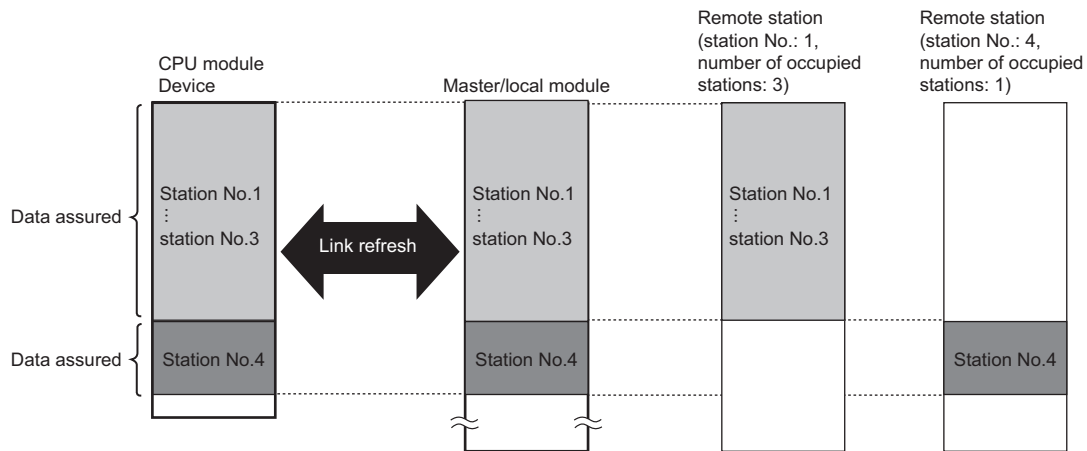

■ Precautions

- When using station-based block data assurance, set the refresh devices in the module parameter. If the refresh devices are not set, the remote input (RX), remote output (RY), and remote register (RWr, RWw) of the buffer memory may not be refreshed.
- When station-based block data assurance is used, transmission delay time and link refresh time become longer than those of when station-based block data assurance is not used. When designing a system based on an existing system, check the transmission delay time and link refresh time at startup of the system. (📖 Page 173 Processing Time)

Point

Integrity of 32-bit data in remote register (RWr and RWw) is assured even if station-based block data assurance is not set. (Assurance of 32-bit data) (📖 Page 32 32-bit data integrity assurance)

Sequence scan synchronization specification

Whether to synchronize the link scan with the sequence scan of a CPU module or not can be selected.

Difference between asynchronous and synchronous settings

■Asynchronous setting

Link scan is performed asynchronously with the sequence scan of the CPU module. Select this item to shorten input transmission delay time when sequence scan takes much more time than link scan. Note that output transmission delay time will become longer.

■Synchronous setting

Data link is performed with a scan synchronizing a program. (The sequence scan and link scan start simultaneously.) Select this item to shorten output transmission delay time. Note, however, that the input transmission delay time becomes longer if a sequence scan takes much longer than a link scan.

Because of the synchronization, extended sequence scan time increases link scan time.



When a link scan is synchronized with a sequence scan, the L RUN LED may turn on dimly.

Setting method

Set sequence scan synchronization under "Supplementary Cyclic Settings" in "Application Settings". (Page 72 Supplementary Cyclic Settings)

Data flow

Data flows in the asynchronous mode and synchronous mode are explained below using examples of communications between a master station and remote I/O station.

■Data flow asynchronous with a sequence scan

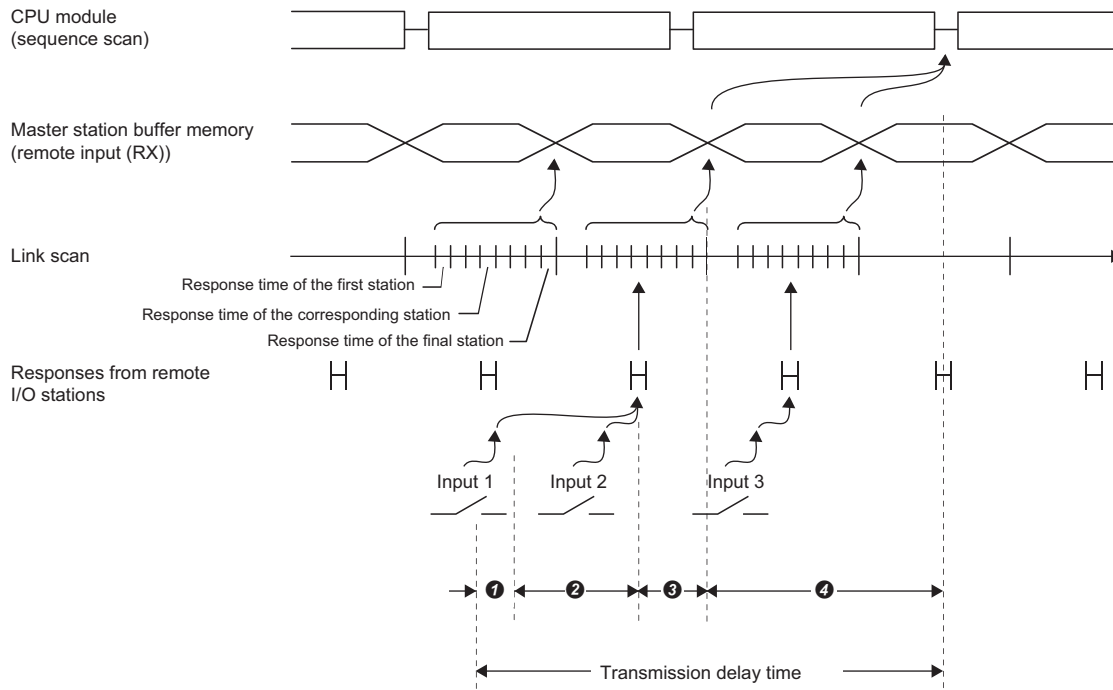

- ① Delay time due to response delay of the remote I/O station
- ② Delay time of transmission from the remote I/O station to the master station
- ③ Delay time between the master station receiving data and the data being stored into the buffer memory
- ④ Delay time until information of the master station is refreshed in the CPU module

■ Data flow synchronous with a sequence scan

Sequence scan \geq Link scan

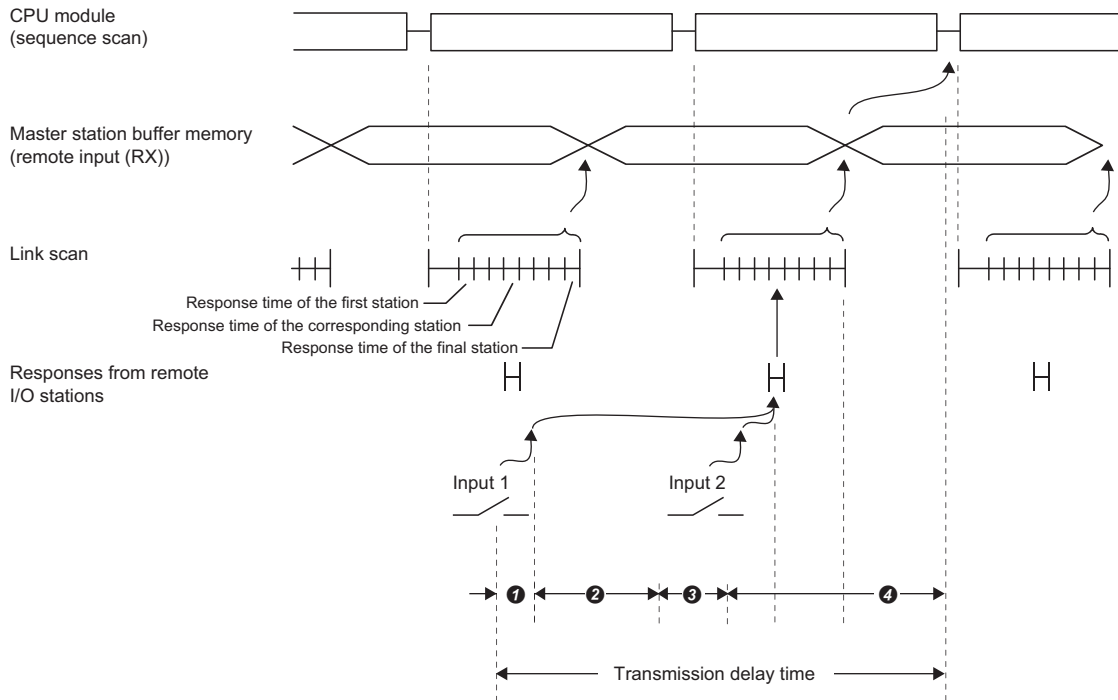

- ❶ Delay time due to response delay of the remote I/O station
- ❷ Delay time of transmission from the remote I/O station to the master station
- ❸ Delay time between the master station receiving data and the data being stored into the buffer memory
- ❹ Delay time until information of the master station is refreshed in the CPU module

■ Data flow synchronous with a sequence scan

Sequence scan < Link scan

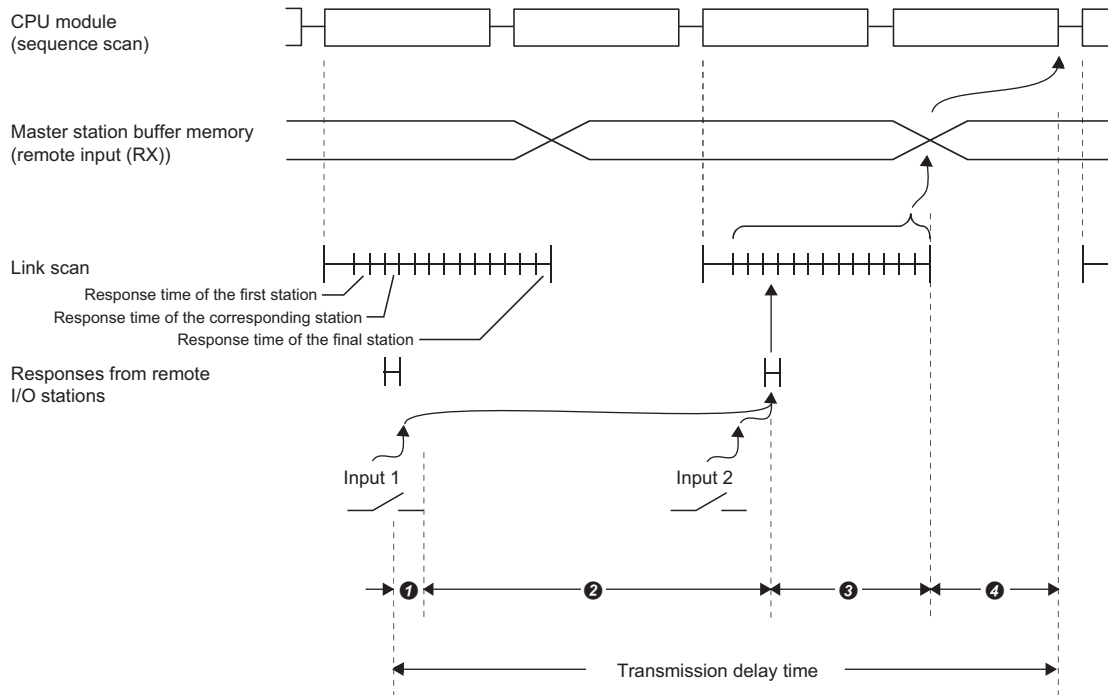

- ① Delay time due to response delay of the remote I/O station
- ② Delay time of transmission from the remote I/O station to the master station
- ③ Delay time between the master station receiving data and the data being stored into the buffer memory
- ④ Delay time until information of the master station is refreshed in the CPU module

Precautions

■ Sequence scan time when the synchronous setting is used

Do not exceed the following time. If the time exceeds the one listed below, a timeout error occurs in each station.

Transmission speed	Sequence scan time
10Mbps	50ms
5Mbps	50ms
2.5Mbps	100ms
625kbps	400ms
156kbps	800ms

Input and output settings when failure occurs

A master/local module allows for the following settings.

Setting	Range where the settings are enabled
Input Data from Data Link Faulty Station	Whether to clear or hold the following RX and RY input data from other stations can be selected. <ul style="list-style-type: none"> • Master station RX • Local station RX and RY The RWr and RWw input data from other stations are held regardless of the setting. <ul style="list-style-type: none"> • Master station RWr • Local station RWr and RWw
Data Link Setting at CPU Failure	Whether to stop or continue data link when a stop error occurs in the CPU module of a master station can be selected.

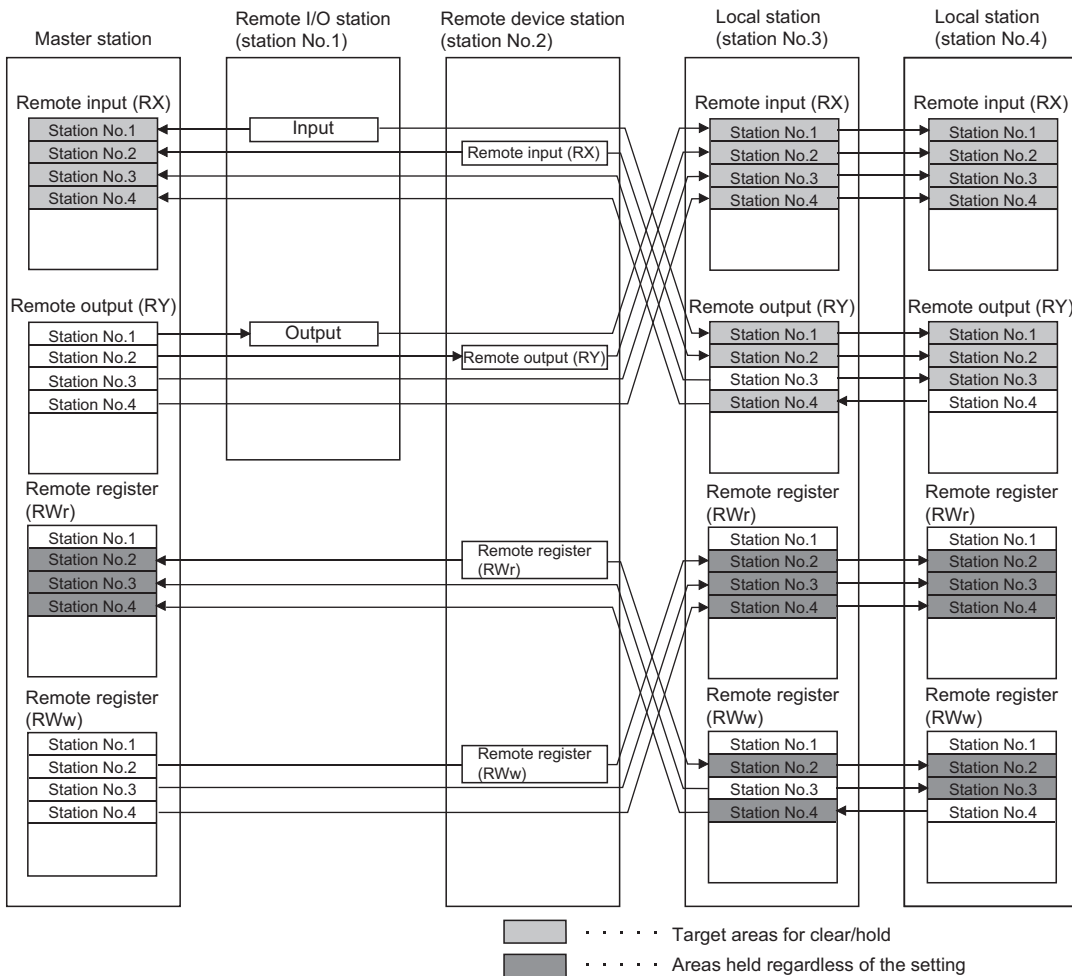

Setting method

■Setting of the input data from a data link faulty station

Select the input data setting under "Supplementary Cyclic Settings" in "Application Settings". (📖 Page 72 Supplementary Cyclic Settings)

■Data link setting at CPU failure

Select the data link setting under "Supplementary Cyclic Settings" in "Application Settings". (📖 Page 72 Supplementary Cyclic Settings)

Status difference between a master station and a slave station at an error

The station status at an error varies depending on the combination of "Input Data from Data Link Faulty Station", "Output Mode upon CPU STOP", and "Data Link Setting at CPU Failure" under "Supplementary Cyclic Settings" in "Application Settings". When configuring the settings, consider the station status at errors listed below.

■ Status of a master station, standby master station (when operating as a master station), and remote I/O station

Data link status			Master station, standby master station (operating as a master station)				Remote I/O station	
			Remote input (RX)	Remote output (RY)	Remote register (RWw)	Remote register (RWr)	Input	Output
When the CPU module of the master station is set to STOP at an error ("Data Link Setting at CPU Failure" = "Continue the Data Link")			Continue	*1	Continue	Hold	Continue	*1
When the CPU module of the local station is set to STOP at an error ("Data Link Setting at CPU Failure" = "Continue the Data Link")			*2	Continue	Continue	Continue	Continue	Continue
When data link for the entire system is stopped	"Input Data from Data Link Faulty Station" (setting in the master station)	Clear	Clear	Continue	Continue	Hold	By external signals	All points off
		Hold	Hold					
When a communication failure (such as power off) occurs in a remote I/O station	"Input Data from Data Link Faulty Station" (setting in the master station)	Clear	Clears the receive area from the remote I/O station having a communication failure.	Continue	Continue	Continue	By external signals	All points off
		Hold	Holds the receive area from the remote I/O station having a communication failure.					
When a communication failure (such as power off) occurs in a remote device station	"Input Data from Data Link Faulty Station" (setting in the master station)	Clear	Clears the receive area from the remote device station having a communication failure.	Continue	Continue	Holds the receive area from the remote device station having a communication failure.	Continue (Not affected by the communication status of the remote device station.)	Continue (Not affected by the communication status of the remote device station.)
		Hold	Holds the receive area from the remote device station having a communication failure.					
When a communication failure (such as power off) occurs in a local station	"Input Data from Data Link Faulty Station" (setting in the master station)	Clear	Clears the receive area from the local station having a communication failure.	Continue	Continue	Holds the receive area from the local station having a communication failure.	Continue (Not affected by the communication status of the local station.)	Continue (Not affected by the communication status of the local station.)
		Hold	Holds the receive area from the local station having a communication failure.					

- *1 If parameter settings have been configured using dedicated instructions, the data is held. If parameter settings have been configured using an engineering tool, the data is cleared when Y is set to the refresh device of the remote output (RY). The data is held or cleared according to "Output Mode upon CPU STOP" when the device other than Y is set.
- *2 When Y is set to the refresh device of the remote output (RY) in the local station that has stopped, only the remote output (RY) in the stopped local station is cleared. The data is held or cleared according to "Output Mode upon CPU STOP" when the device other than Y is set. Data link is continued for the other local stations.

■ Status of a remote device station, intelligent device station, local station, and standby master station (when operating as a local station)

Data link status			Remote device station, intelligent device station				Local station, standby master station (operating as a local station)			
			Remote input (RX)	Remote output (RY)	Remote register (RWw)	Remote register (RWr)	Remote input (RX)	Remote output (RY)	Remote register (RWw)	Remote register (RWr)
When the CPU module of the master station is set to STOP at an error ("Data Link Setting at CPU Failure" = "Continue the Data Link")			Continue	*1	Continue	Continue	Clear	Continue	Continue	Continue
When the CPU module of the local station is set to STOP at an error			Continue	Continue	Continue	Continue	Continue	*2	Continue	Continue
When data link for the entire system is stopped	"Input Data from Data Link Faulty Station" (for master station setting)	Clear	By external signals	All points off	Hold	By external signals	Clear	Clears the receive areas from other stations.	Holds the receive areas from other stations.	Hold
		Hold					Hold			
When a communication failure (such as power off) occurs in a remote I/O station	"Input Data from Data Link Faulty Station" (for master station setting)	Clear	Continue	Continue	Continue	Continue	Continue	Clears the receive area from the remote I/O station having a communication failure.	Continue	Continue
		Hold								
When a communication failure (such as power off) occurs in a remote device station	"Input Data from Data Link Faulty Station" (for master station setting)	Clear	By external signals	All points off	Hold	By external signals	Continue	Clears the receive area from the remote device station having a communication failure.	Holds the receive area from the remote device station having a communication failure.	Continue
		Hold								

Data link status			Remote device station, intelligent device station				Local station, standby master station (operating as a local station)			
			Remote input (RX)	Remote output (RY)	Remote register (RWw)	Remote register (RWr)	Remote input (RX)	Remote output (RY)	Remote register (RWw)	Remote register (RWr)
When a communication failure (such as power off) occurs in a local station	"Input Data from Data Link Faulty Station" (for master station setting)	Clear	Continue	Continue	Continue	Continue	Clears the receive area from the local station having a communication failure.	Holds the receive area from the local station having a communication failure.	Continue	
		Hold					Holds the receive area from the local station having a communication failure.			

- *1 If parameter settings have been configured using dedicated instructions, the data is held. If parameter settings have been configured using an engineering tool, the data is cleared when Y is set to the refresh device of the remote output (RY). The data is held or cleared according to "Output Mode upon CPU STOP" when the device other than Y is set.
- *2 When Y is set to the refresh device of the remote output (RY) in the local station that has stopped, only the remote output (RY) in the stopped local station is cleared. The data is held or cleared according to "Output Mode upon CPU STOP" when the device other than Y is set. Data link is continued for the other local stations.

Precautions

■When an error invalid station is set

If a data link error occurs in a station set as an error invalid station, input data (remote input (RX)) from that station is held regardless of the setting.

■When a standby master station is set

When a standby master station is set, the standby master station starts to take in control without data link of the master station continued even if "Data Link Setting at CPU Failure" is set to "Continue the Data Link". (Use of the standby master function is prioritized.)

Output data setting in case of CPU STOP

Whether to refresh or compulsorily clear remote output (RY) when the switch on a CPU module is set to STOP can be selected. How the remote output (RY) should be handled can be selected according to the system used. (Page 38 Status difference between a master station and a slave station at an error)

Only remote output (RY) is refreshed or compulsorily cleared according to the setting.

Remote input (RX) and remote register (RW_r and RW_w) are refreshed even if the switches on the CPU modules of the master station and local stations are set to STOP, regardless of the setting.

Point

- If the CPU module that has been set to the compulsory clear is set to STOP, compulsory output to a slave station cannot be performed by an engineering tool. (by using a device test or other methods)
- The setting is enabled even if RY is refreshed using a module access device (Un\G□) or TO instructions.

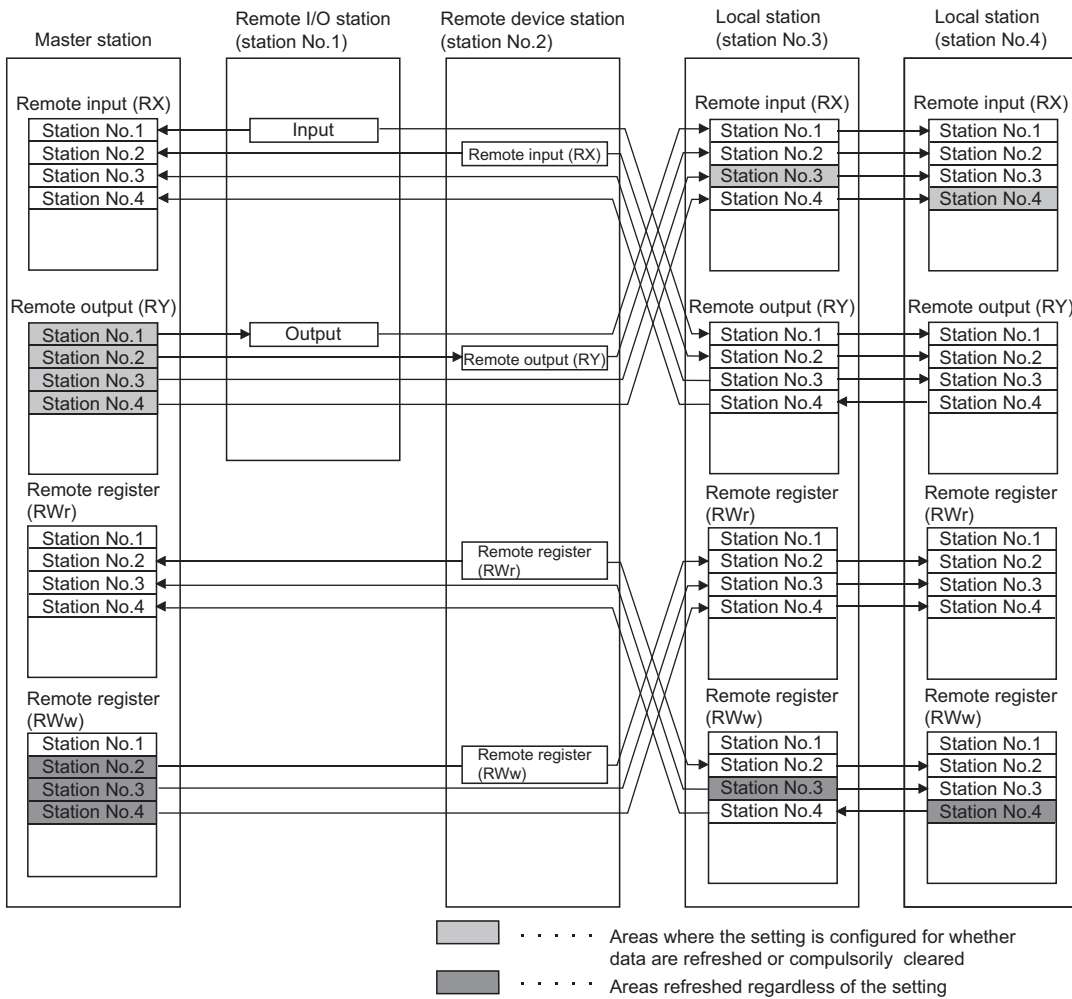

Setting method

Configure the output data setting in case of CPU STOP under "Supplementary Cyclic Settings" in "Application Settings". (Page 72 Supplementary Cyclic Settings)

Precautions

■ Device to be set in the refresh device setting

Whether remote output (RY) is refreshed or compulsorily cleared varies depending on the refresh device set for the remote output (RY) in "Link Refresh Settings" under "Basic Settings" as described below:

- When Y is set, remote output (RY) is compulsorily cleared regardless of the module parameter.
- When a device other than Y, such as M and L, is selected, remote output (RY) is refreshed or compulsorily cleared according to the setting.

Data link stop and restart

Data link can be stopped during debugging and other operations. Also, the stopped data link can be restarted.

If data link of a master station is stopped, data link is stopped in the entire system. (☞ Page 113 Stopping and restarting data link)

Remote I/O station points setting

When the master station is in the remote net Ver.2 mode or remote device net Ver.2 mode, the number of refresh points with a remote I/O station can be selected from 8 points, 16 points, and 32 points. Changing the number of points can save the areas of the refresh device in a CPU module. (In modes other than the remote net Ver.2 mode and remote device net Ver.2 mode, only 32 points per station can be selected.)

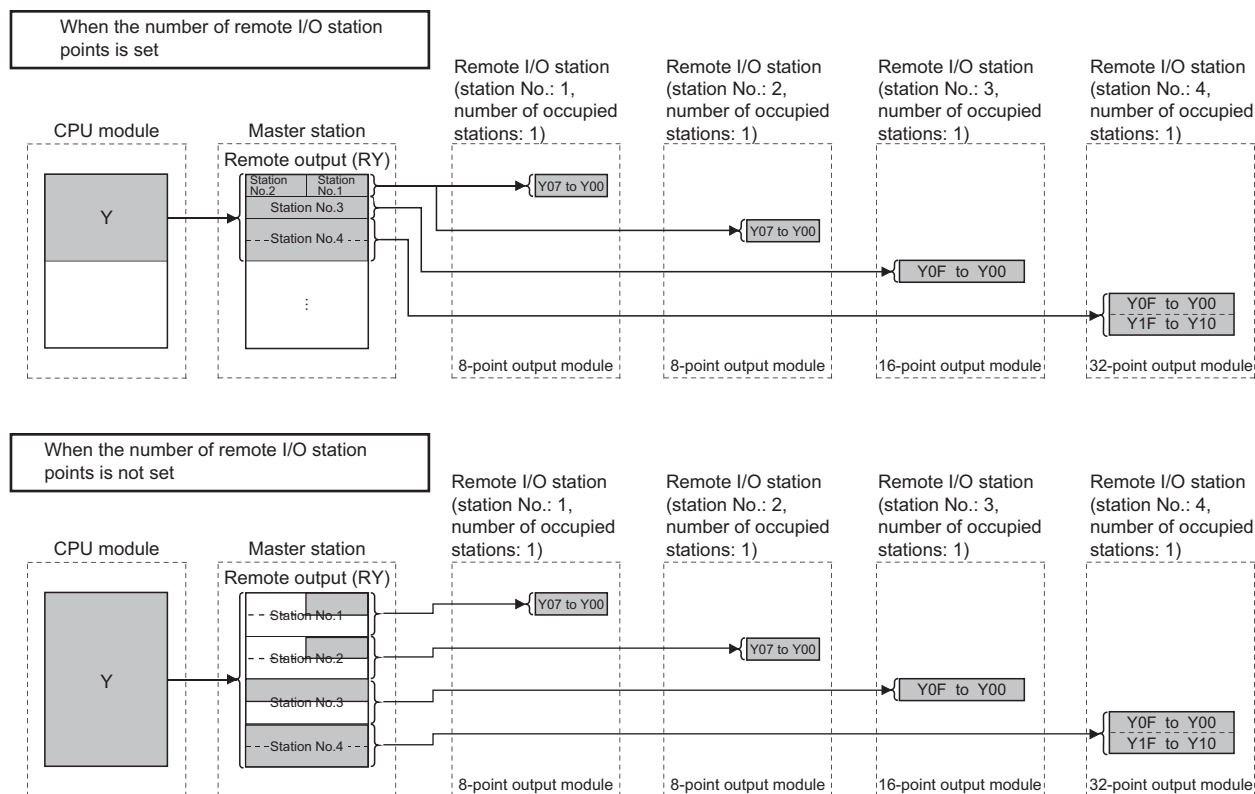

Setting method

Configure the remote I/O station points setting in "Network Configuration Settings" under "Basic Settings". (Page 63 Network Configuration Settings)

1

Point

When setting eight-point remote I/O stations, set an even number of stations consecutively. When setting an odd number of eight-point remote I/O stations, select "8 Points + Empty 8 Points" from "Remote Station Points" for the last of consecutive remote I/O stations.

The following figure shows an example of when three output modules with eight points are connected.

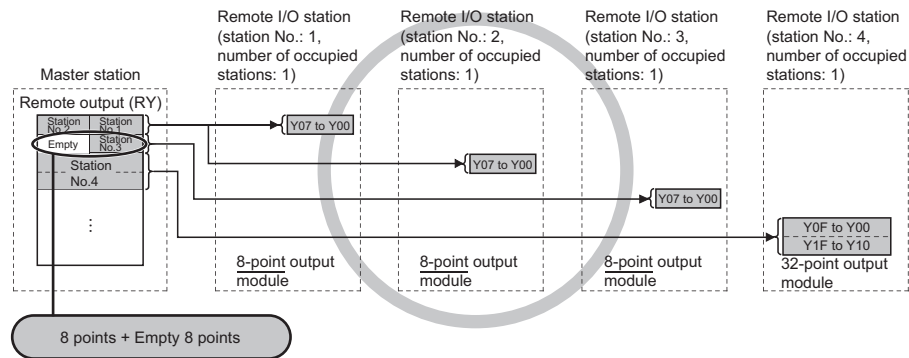

When the number of remote I/O stations is odd, eight points cannot be set in the remote station points.

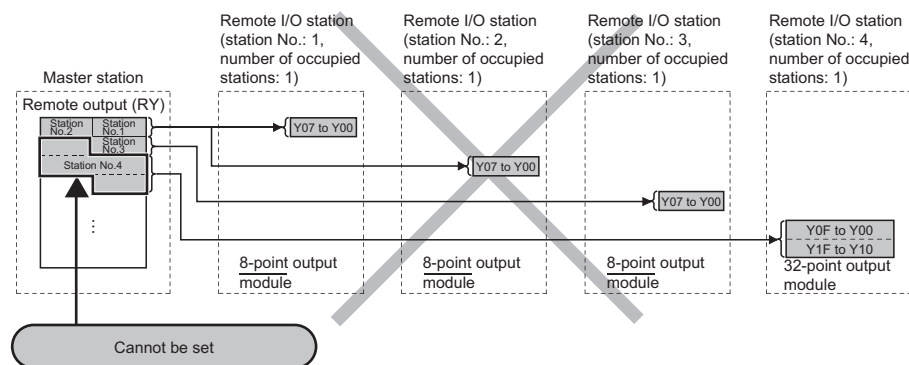

This parameter cannot be set using dedicated instructions. Therefore, read or write data from/to the device in a CPU module according to the number of I/O points of each station using a program. Consequently, the areas in refresh devices can be saved.

- Reading/writing data using a module access device (Un\G□)
- Reading/writing data using the FROM/TO instructions

Precautions

Set the number of points greater than the I/O points of a remote I/O station connected. If the smaller number of points is set in a station, data cannot be normally input to or output from stations after that.

1.2 Transient Transmission

Data can be communicated when a request is issued unlike cyclic transmission. Direct access to buffer memory areas and devices in other stations can be performed in transient transmission.

Communications using a dedicated instruction

Unlike cyclic transmission, a large capacity of data can be communicated at any timing using dedicated instructions. For details on dedicated instructions, refer to the following.

📖 MELSEC iQ-R Programming Manual (Module Dedicated Instructions)

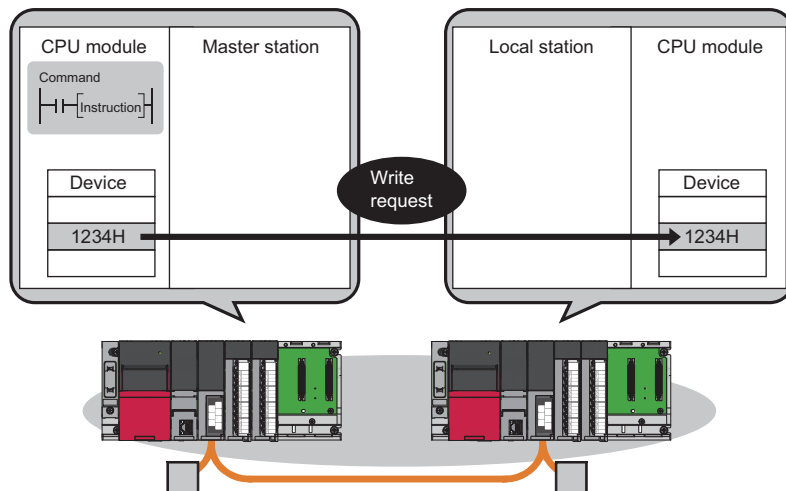

Access from other stations using an engineering tool

Seamless access to the following networks can be performed using an engineering tool.

- Ethernet
- CC-Link IE Controller Network
- CC-Link IE Field Network
- MELSECNET/H
- MELSECNET/10

Point

Access to other networks can be performed using an engineering tool only when the master/local module is connected to the end network. The master/local module cannot be used as a relay station.

1.3 Standby Master Function

If the master station goes down due to an error in a CPU module, power supply, or others, switching the control to the standby master station (a backup station for the master station) can continue data link. This function is used not to stop the entire system even if the master station goes down.

Type

The standby master function can be categorized into three types as listed below.

○: Enabled, ×: Disabled

Function	When the master station goes down, the standby master station continues data link.	When a failed master station becomes normal again, it returns in case of the standby master station going down.	When only a standby master station is started up, it starts data link.	"Station Type" in "Required Settings"	
				Master station	Standby master station
Master station switching function	○	×	× ^{*1}	Master Station	Standby Master Station
Master station duplex function	○	○	× ^{*1}	Master Station (Duplex Function)	Standby Master Station
Data link startup function using a standby master station ^{*2}	○	○	○	Master Station (Duplex Function)	Master Station (Duplex Function)

*1 A standby master station does not start data link until the master station starts up.

*2 Configure the same system for the master station and standby master station (same modules connected, module parameters, and program).

Operation

The following are the operations of the master station and standby master station of when the master station goes down. The following figure shows the operation from when the master station goes down and the standby master station continues data link to when the failed master station goes back to normal.

Controlling: Controlling the data link of the CC-Link system

Standby status: Standing by in case the station controlling the data link of the CC-Link system becomes faulty.

Data link control by the master station

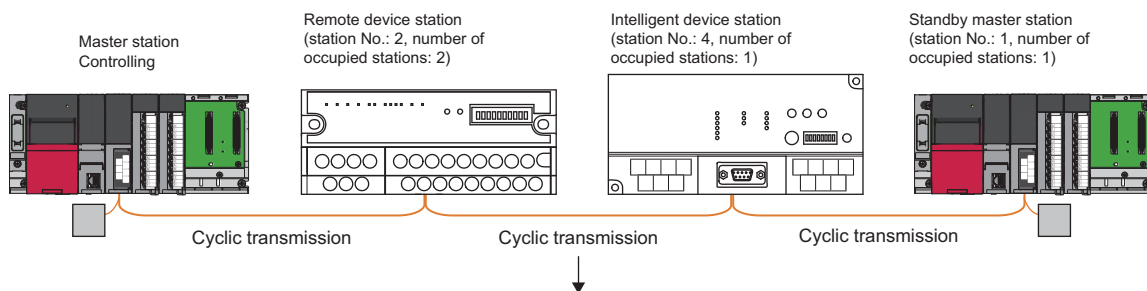

Master station is down → Data link control by the standby master station

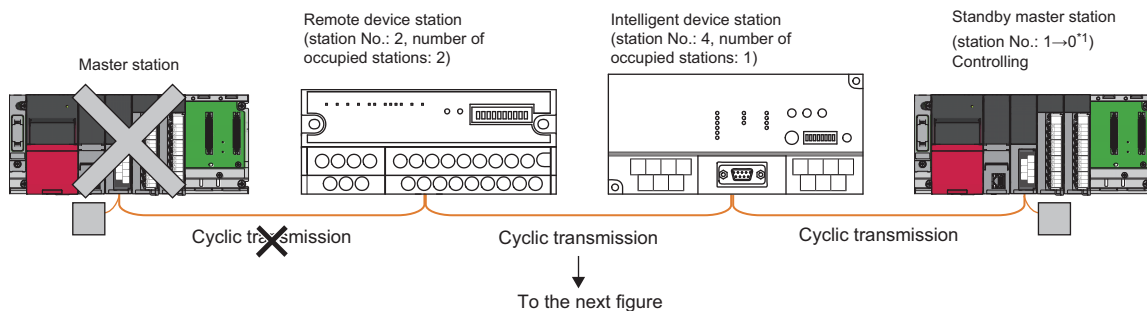

*1 The dot matrix LED indicates the station number set in the module instead of "0". The MST LED turns on and the S MST LED turns off.

Continued from the previous figure

The master station in the normal state returns to the system operation. → The master station is on standby in case of the standby master station failure.

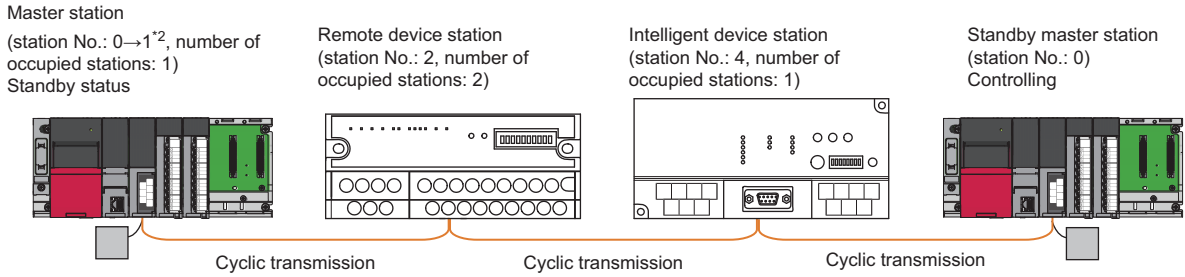

An error has occurred in the standby master station. → Data link is controlled by the master station.

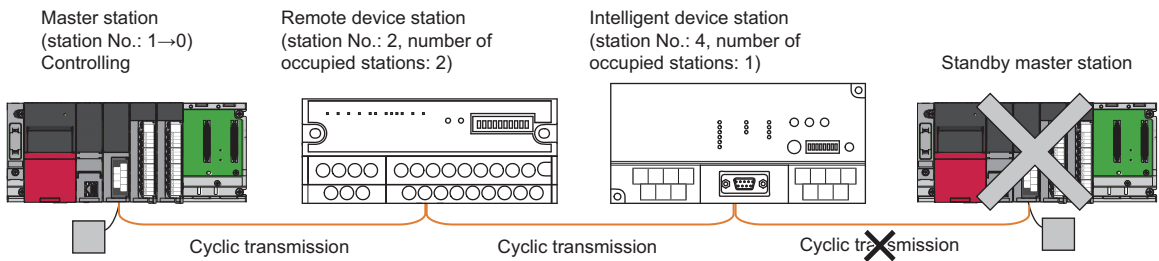

The standby master station in the normal state returns to the system operation. → The standby master station is on standby in case of the master station failure.

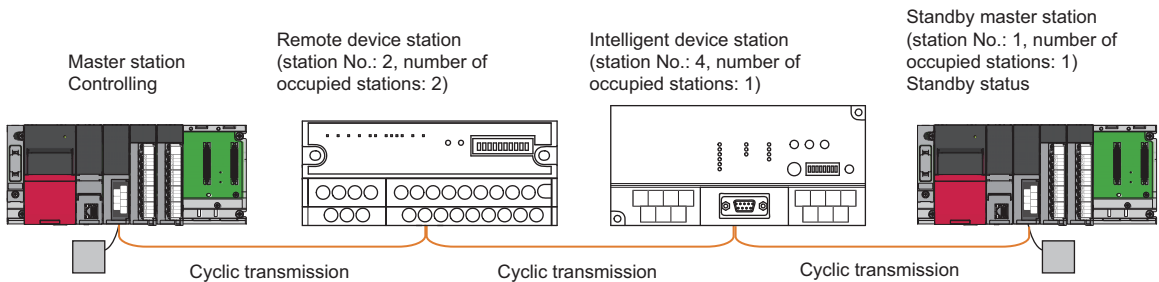

*2 When the master station returns, it operates with the station number of the standby master station, but the dot matrix LED indicates the station number set in the module ("0" for the master station). The MST LED turns off and the S MST LED turns on.

Overview of data transmission

The following is an overview of data transmission of when the standby master function is used.

1

■When data link is controlled by the master station

(Output from the master station)

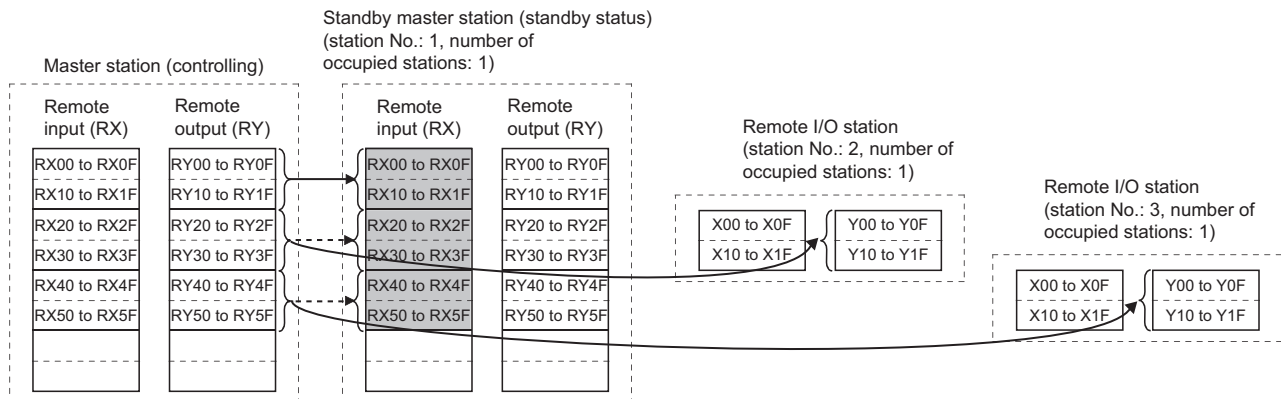

Outputs (RY and RWw) from the master station are stored in inputs (RX and RWr) of the standby master station. (Shaded areas in the figure above)

(Input of the master station)

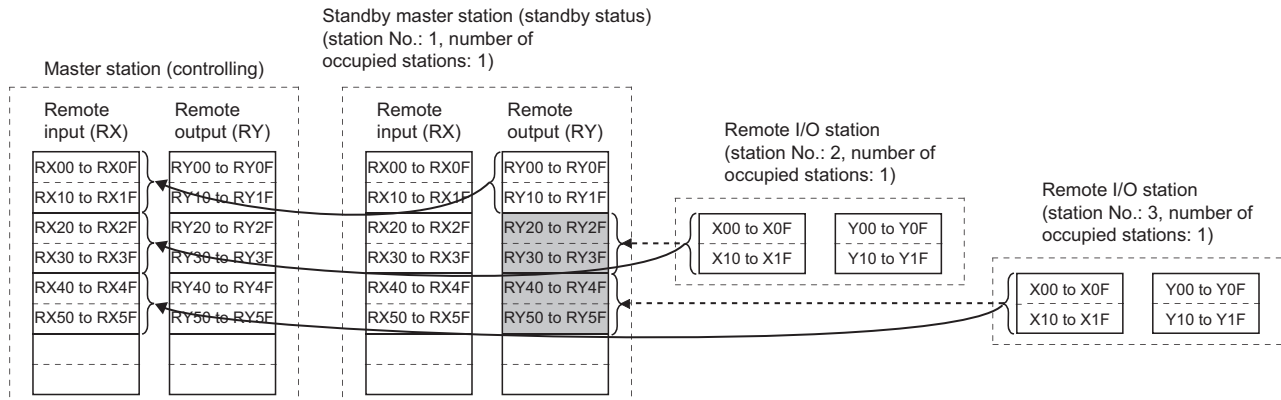

Inputs (RX and RWr) from slave stations to the master station are stored in outputs (RY and RWw) of the standby master station. (Shaded areas in the figure above)

■Operation between the master station going down and the standby master station controlling data link

If the master station goes down, the standby master station takes over the control of data link.

(Output from the standby master station)

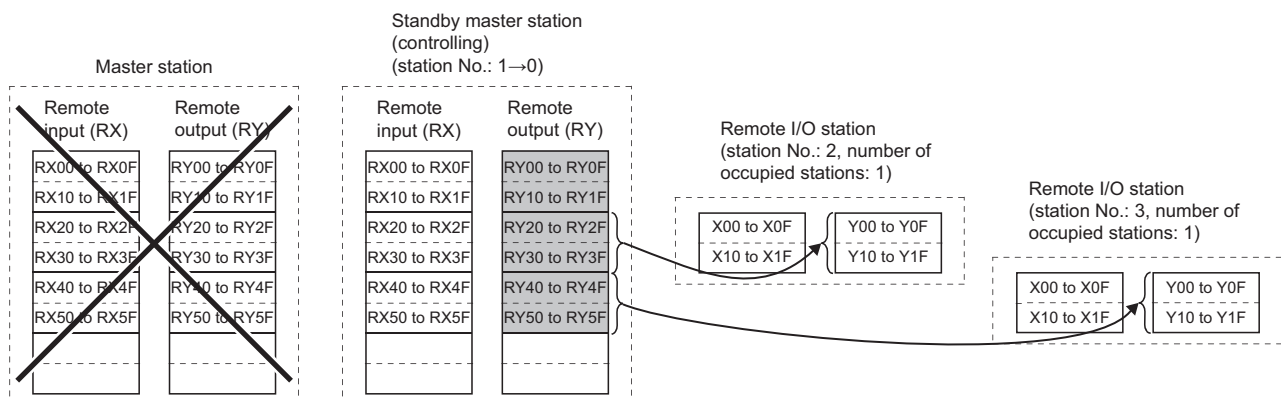

Outputs (RY and RWw) of the master station are stored in inputs (RX and RWr) of the standby master station. By transferring the inputs (RX and RWr) of the standby master station to the outputs (RY and RWw), outputs to the slave stations are continued. (Shaded areas in the figure above) (Page 89 Communication Example Using the Standby Master Function)

(Input of the standby master station)

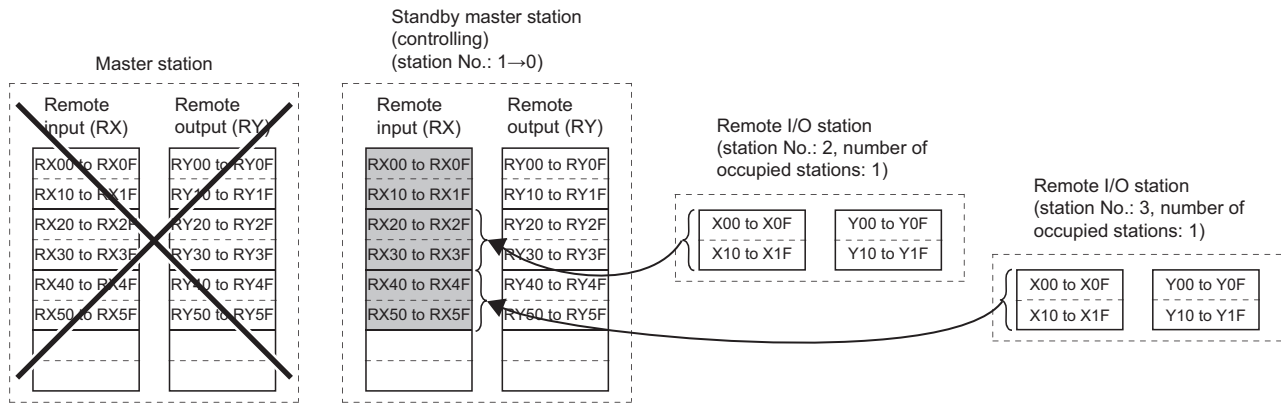

Inputs (RX and RW_r) of the master station are stored in the outputs (RY and RW_w) of the standby master station. By transferring the outputs (RY and RW_w) of the standby master station to the inputs (RX and RW_r), inputs from the slave stations are continued. (Shaded areas in the figure above) (Page 89 Communication Example Using the Standby Master Function)

Operation between the master station returning and the standby master station controlling data link

(Output from the standby master station)

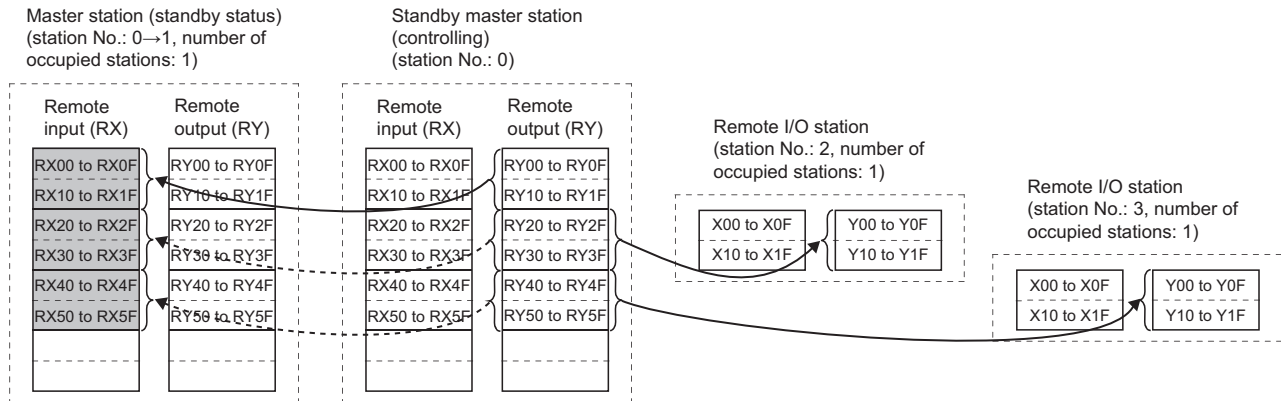

Outputs (RY and RW_w) from the standby master station are stored in inputs (RX and RW_r) of the master station. (Shaded areas in the figure above)

(Input of the standby master station)

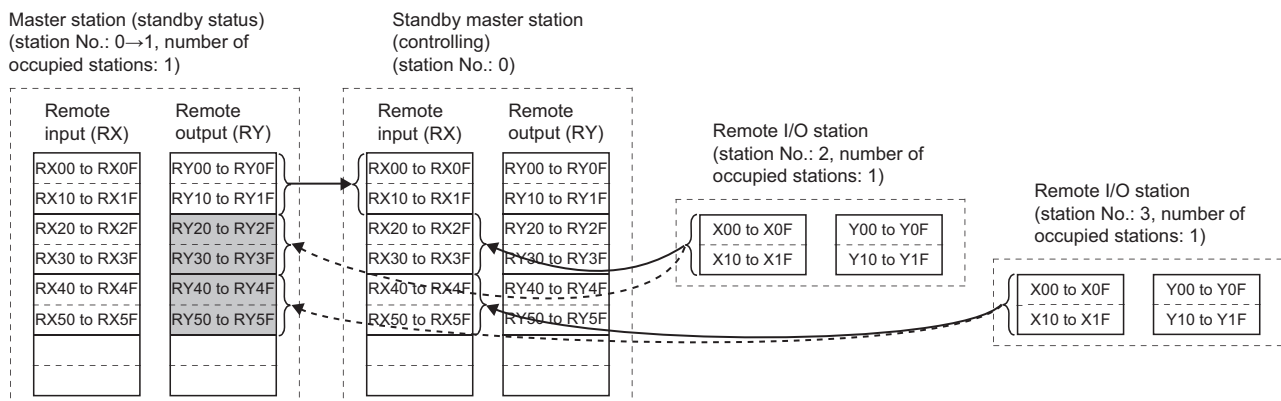

Inputs (RX and RW_r) from slave stations to the standby master station are stored in outputs (RY and RW_w) of the master station. (Shaded areas in the figure above)

■ Operation between the standby master station going down and the master station controlling data link

If the standby master station goes down, the master station takes over the control of data link.

(Output from the master station)

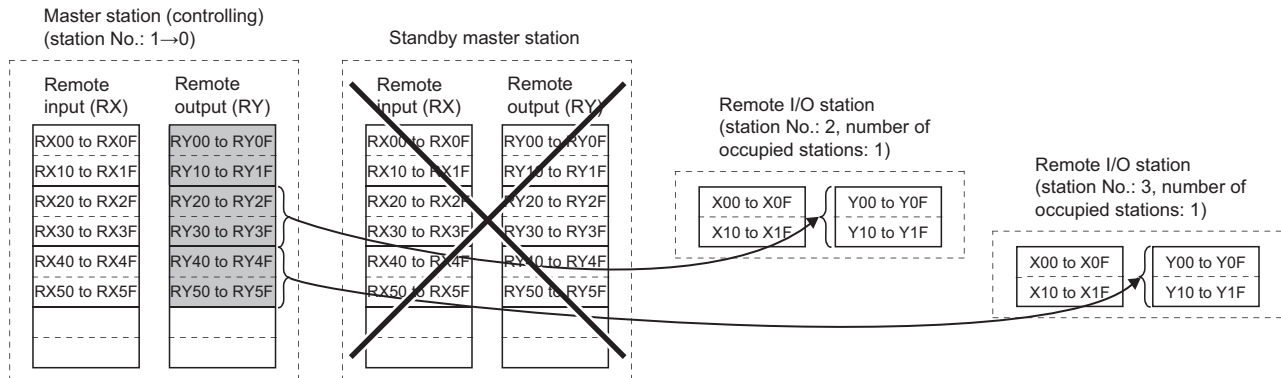

Outputs (RY and RWw) of the standby master station are stored in inputs (RX and RWr) of the master station. By transferring the inputs (RX and RWr) of the master station to the outputs (RY and RWw), outputs to the slave stations are continued.

(Shaded areas in the figure above) (☞ Page 89 Communication Example Using the Standby Master Function)

(Input of the master station)

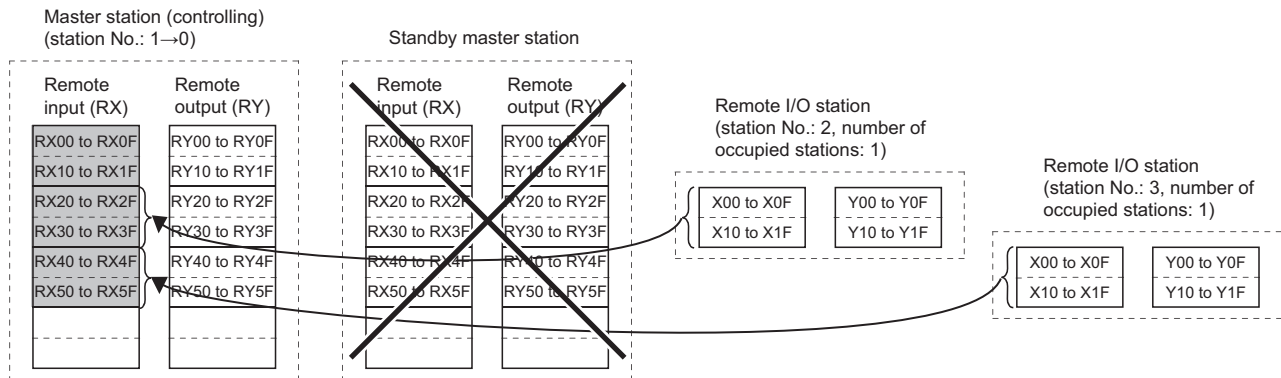

Inputs (RX and RWr) of the standby master station are stored in the outputs (RY and RWw) of the master station. By transferring the outputs (RY and RWw) of the master station to the inputs (RX and RWr), inputs from the slave stations are continued. (Shaded areas in the figure above) (☞ Page 89 Communication Example Using the Standby Master Function)

Setting method

Set the standby master station in the "Add New Module" window or "Station Type" in "Required Settings". (☞ Page 59 Station Type)

Precautions

■The number of standby master stations

One standby master station can be connected in one system.

■Data link control of a standby master station

When a master station goes down, data link control is automatically switched to a standby master station. Note that an instruction to refresh cyclic data is not issued. Use a link special relay (SB) and link special register (SW) to issue a refresh instruction. (☞ Page 52 Link special relay (SB) areas and link special register (SW) areas)

After the instruction is issued, information before a master station error is detected is output to each station.

■Change in the module parameter settings of the master station

While data link is performed by a standby master station, the module parameter settings of the master station cannot be changed.

■Station number setting for a standby master station

If the station number of the standby master station differs from that is set in "Network Configuration Settings" under "Basic Settings" of the master station, an error (error code: B39A) occurs in the standby master station. If an error has occurred, reset the CPU module of the standby master station after changing the module parameter settings of the master station or changing the station number of the standby master station.

■If the terminal block of a master station is removed while the master station is controlling data link

If the terminal block of a master station is removed without powering off the master station and reconnected, both of the master station and standby master station will perform master operation because the right of controlling data link is transferred to the standby master station; therefore, communications cannot be normally performed.

By powering off the master station and reconnecting the terminal block and powering on the master station, the master station is reconnected as standby master station operation; therefore, communications can be normally performed.

■The status of an LED when data link control is switched to a standby master station

When the master station goes down and the standby master station starts to take in control of data link, the ERR. LED on the standby master station flashes. The station number of the standby master station is changed from the one set in the module parameters to the station number 0, and the standby master station is regarded that it is not connected. Data link is normally performed.

To prevent this situation, set the standby master station as an error invalid station.

■Number of points and range of devices to save data using a program

The points and range of devices where data from a master station (station operating as a master station) to a standby master station (station operating as a standby master station) are saved using a program vary depending on the system.

■If an error is detected in the master station in the initial status (before data link is started)

Data link control is not transferred to the standby master station and data link is not started. (This applies only to the master station switching function and master station duplex function.)

■When the data link startup function by standby master station is used

- Parameters and program set in the master station and standby master station

Set the same module parameters and program in the master station and standby master station. If not, the operation is not guaranteed.

- Line test

When the data link start function by a standby master station is used, a line test cannot be executed using the mode setting. Use an engineering tool to execute a line test. (☞ Page 109 Line test)

■ Processing that sets the link devices saved at master switching and refresh instruction at standby master switching

After saving the link devices, wait a fixed number of scans and execute the processing that sets the link devices saved at master switching and 'Refresh instruction at standby master switching' (SB0001).

Number of scans for waiting after saving the link devices differs depending on the mode setting. Use the following values.

Mode setting	Number of scans for waiting	Remark
<ul style="list-style-type: none"> • Remote Net Ver.1 Mode • Remote Device Net Ver.1 Mode • Remote I/O Net Mode 	Fixed to 0	—
<ul style="list-style-type: none"> • Remote Net Ver.2 Mode • Remote Device Net Ver.2 Mode 	$(\text{Link scan time} \div \text{Sequence scan time})$ (Rounded up to the nearest integer) $\times 4$	<ul style="list-style-type: none"> • For link scan time, use the maximum value after master switching. • For sequence scan time, use the minimum value after master switching.

Link special relay (SB) areas and link special register (SW) areas

Link special relay (SB) areas and link special register (SW) areas related to the standby master function are listed below.

■Link special relay (SB) areas

Link special relay (SB) areas related to the standby master function are listed below.

- 'Refresh instruction at standby master switching' (SB0001)
- 'Forced master switching' (SB000C)
- 'Refresh instruction acceptance status at standby master switching' (SB0042)
- 'Refresh instruction completion status at standby master switching' (SB0043)
- 'Forced master switching enable status' (SB0046)
- 'Master switching request acceptance' (SB005A)
- 'Master switching request completion' (SB005B)
- 'Forced master switching request acceptance' (SB005C)
- 'Forced master switching request completion' (SB005D)
- 'Standby master station setting status of own station' (SB0062)
- 'Master station information' (SB0070)
- 'Standby master station information' (SB0071)
- 'Master station return specification information' (SB0079)
- 'Master/standby master operation status of own station' (SB007B)

■Link special register (SW) areas

Link special register (SW) areas related to the standby master function are listed below.

- 'Refresh instruction at standby master switching result' (SW0043)
- 'Forced master switching instruction result' (SW005D)
- 'Standby master station number' (SW0073)

■ON/OFF timing of link special relay (SB) areas

The following figure shows the ON/OFF timing of link special relay (SB) areas related to the standby master function.

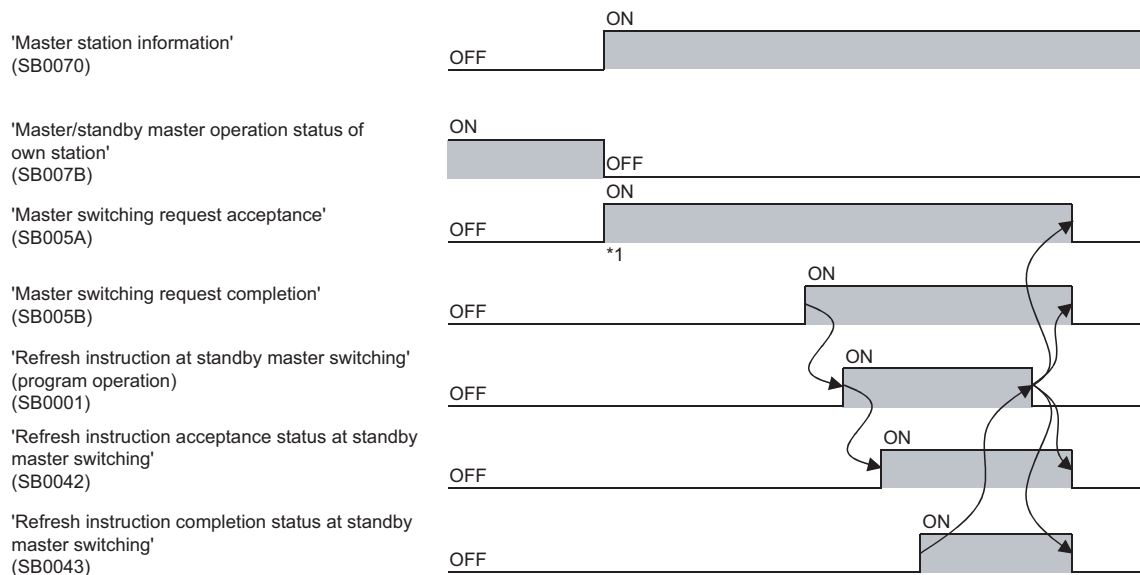

*1 When turning on 'Master switching request acceptance' (SB005A), save data stored in RX, RY, RWr, and RWw to the devices and set data stored in RX to RY, data stored in RY to RX, data stored in RWr to RWw, and data stored in RWw to RWr using a program. In addition, turn on 'Refresh instruction at standby master switching' (SB0001).

After saving data stored in RX, RY, RWr, and RWw to the devices, wait a fixed number of scans and execute the processing that sets data stored in RX to RY, data stored in RY to RX, data stored in RWr to RWw, and data stored in RWw to RWr using a program and the processing that turns on the 'Refresh instruction at standby master switching' (SB0001).

For details, refer to Page 50 Precautions.

1.4 Remote Device Station Initial Setting Procedure Registration Function

The initial setting of a remote device station which is performed on a program can be registered in advance using an engineering tool and can be saved by turning on the link special relay (SB). A program for the initial setting is not required.

Number of initial settings registered

■Number of remote device stations

The initial settings of up to 64 remote device stations can be registered in one master/local module.

■Number of initial settings registered per remote device station

Up to 32 items of the initial settings can be registered per remote device station. An engineering tool and program cannot be used together for the initial setting in one remote device station. If they are used together, a remote device station may malfunction.

■If the processing has stopped

Information about an initial setting in progress is stored in 'Remote device station initialization procedure registration execution individual information' (buffer memory addresses: Un\G23680 to Un\G23743) of the master/local module. If the processing has stopped halfway, information such as the number of the procedure that has stopped and the target station number can be checked.

Setting method

Configure the setting of the remote device station initial setting procedure registration function in "Initial Settings" under "Basic Settings". Then use 'Remote device station initialization procedure registration instruction' (SB000D) to reflect the initial settings to the remote device station. (☞ Page 68 Initial Settings)

Specification of remote device station to be initialized

Specification of remote device station to be initialized is a procedure for initial processing only in a specified station. When a remote device station in operation has been replaced due to failure, the initial processing can be performed only in a specified remote device station that has been replaced. Remote device stations other than a specified station continue to operate.

The following figure shows an example of specifying the remote device station (station number 3) to be initialized.

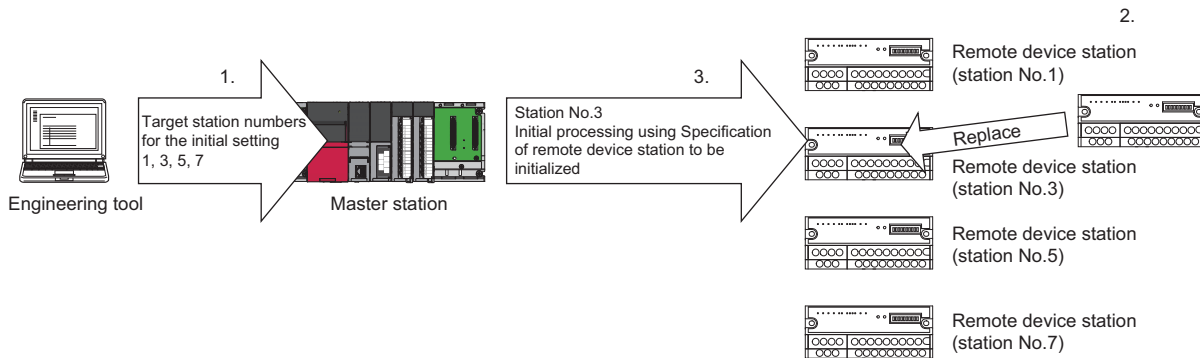

1. Replace the failed remote device station (station number 3).
2. Use 'Specification of remote device station to be initialized' (SW0014 to SW0017) to specify the station number 3. Turn on the applicable bit (only the bit of the start station number) in SW0014 to SW0017.

	b15	b14	b13	b12	b11	b10	b9	b8	b7	b6	b5	b4	b3	b2	b1	b0
SW0014	16	15	14	13	12	11	10	9	8	7	6	5	4	3	2	1
SW0015	32	31	30	29	28	27	26	25	24	23	22	21	20	19	18	17
SW0016	48	47	46	45	44	43	42	41	40	39	38	37	36	35	34	33
SW0017	64	63	62	61	60	59	58	57	56	55	54	53	52	51	50	49

1 to 64 in the table indicate station numbers.

Point

When all bits are off, an initial processing is performed in all the stations set in "Initial Settings" under "Basic Settings".

3. Configure the initialization procedure registration by turning on 'Remote device station initialization procedure registration instruction' (SB000D).

During the initial processing in the station number 3, other stations (station numbers 1, 5, and 7) continue the control.

Precautions

■Reflection of the settings

The initial settings registered using an engineering tool are reflected to a remote device station by writing the settings to a CPU module and turning on 'Remote device station initialization procedure registration instruction' (SB000D).

■Processing time

Because one step is executed per link scan, more setting items extend the processing time further than that of when a program is used.

■While 'Remote device station initialization procedure registration instruction' (SB000D) is on
Data in the remote I/O (RX, RY) and remote register (RWr, RWw) stops being refreshed.

■Handling of signals that are required to be always on (such as CH.□ Conversion enable flag of an AJ65BT-64RD3/4)

Turning off 'Remote device station initialization procedure registration instruction' (SB000D) after the initial processing is completed turns off all the RY signals that have turned on while the initial procedure registration is performed. To prevent this, use a program to turn on signals that are required to be always on.

■Turning on 'Completion status of remote device station initialization procedure' (SB005F)

When 'Specification of remote device station to be initialized' (SW0014 to SW0017) is selected, 'Completion status of remote device station initialization procedure' (SB005F) does not turn on until the procedure registration is normally completed in all the stations. If a faulty station exists, turn off 'Remote device station initialization procedure registration instruction' (SB000D) depending on the completion status of other stations.

■Initialization procedure registration for a standby master station

The initial setting cannot be configured in a standby master station. When replacing a remote device station while a standby master station is operating as a master station, configure the initial setting on a program.

■When the instruction is not required

The initialization procedure registration instruction may not be required under some situations, such as when the remote input (RX) is set as a condition device.

Link special relay (SB) areas and link special register (SW) areas

■Link special relay (SB) areas

Link special relay (SB) areas related to the remote device station initialization procedure registration are listed below.

- 'Remote device station initialization procedure registration instruction' (SB000D)
- 'Execution status of remote device station initialization procedure' (SB005E)
- 'Completion status of remote device station initialization procedure' (SB005F)

■Link special register (SW) areas

- 'Specification of remote device station to be initialized' (SW0014 to SW0017)
- 'Remote device station initialization procedure registration instruction result' (SW005F)
- 'Remote device station initialization procedure registration completion status' (SW0164 to SW0167)

Buffer memory

Buffer memory areas related to the remote device station initialization procedure registration are listed below.

- 'Remote device station initialization procedure registration execution individual information' (Buffer memory address: Un\G23680 to Un\G23743)

1.5 Interrupt Setting Function

An interrupt request is issued to a CPU module when the interrupt conditions that have been set using an engineering tool are satisfied, and the interrupt program can be executed. This function is used to stop the control and execute an interrupt program upon an error or for other purposes.

Because the conditions are set using an engineering tool, the number of steps in a program is reduced, shortening the scan time.

An interrupt request can be issued to all stations.

Setting method

Set the interrupt setting function under "Interrupt Settings" in "Application Settings". (📖 Page 73 Interrupt Settings)

1.6 Master Station Duplication Error Canceling Function

When a master station duplication error has been detected, the error can be cleared without resetting the CPU module or powering off and on the system.

How to cancel the error

1. Eliminate the cause of a master station duplication error.

Another master station may exist on the same line, or the line may be being influenced by noise.

2. Turn on 'Master station duplication error cancel request' (SB0007).

Link special relay (SB) areas and link special register (SW) areas

Link special relay (SB) areas and a link special register (SW) areas related to the master station duplication error canceling function are listed below.

- 'Master station duplication error cancel request' (SB0007)
- 'Master station duplication error cancel acceptance' (SB0057)
- 'Master station duplication error cancel completion' (SB0058)
- 'Master station duplication error cancel result' (SW0057)

Timing chart

The following figure shows the timing chart of the link special relay (SB) areas and link special register(SW) areas.

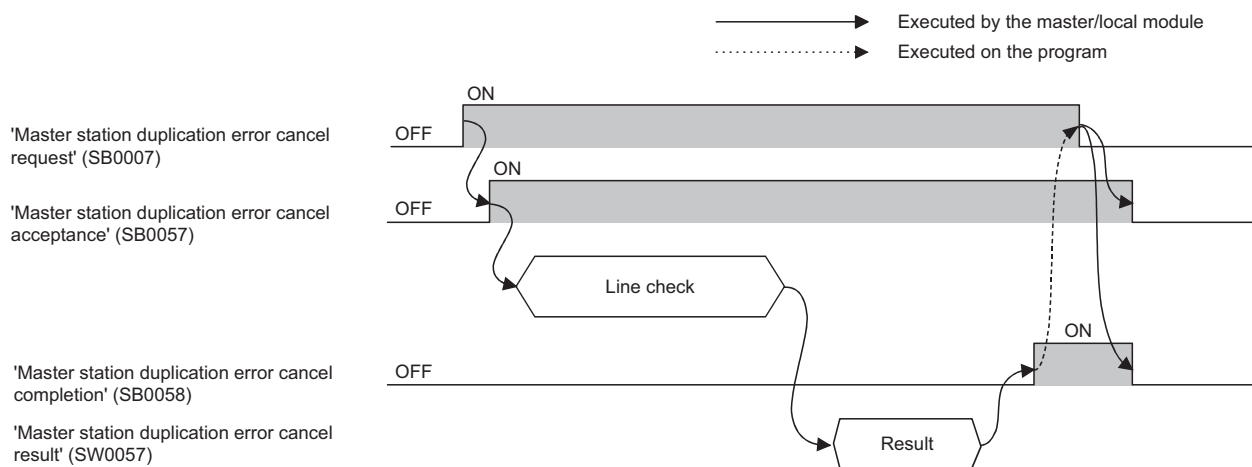

2 PARAMETER SETTINGS

This chapter describes the parameter settings required for the master/local module.

2.1 Setting Parameters

2

1. Add the master/local module in the engineering tool.

 [Navigation window] ⇒ [Parameter] ⇒ [Module Information] ⇒ Right-click ⇒ [Add New Module]

2. The required setting, basic setting, and application setting are included in the parameter settings. Select one of the settings from the tree structure on the window shown below and set parameters.

 [Navigation window] ⇒ [Parameter] ⇒ [Module Information] ⇒ [RJ61BT11]

3. After setting parameters, click the [Apply] button.

4. Write the settings to the CPU module using the engineering tool.

 [Online] ⇒ [Write to PLC]

5. The settings are reflected by resetting the CPU module or remote head module, or powering off and on the system.

2.2 Required Settings

Set the station type or mode of the master/local module.

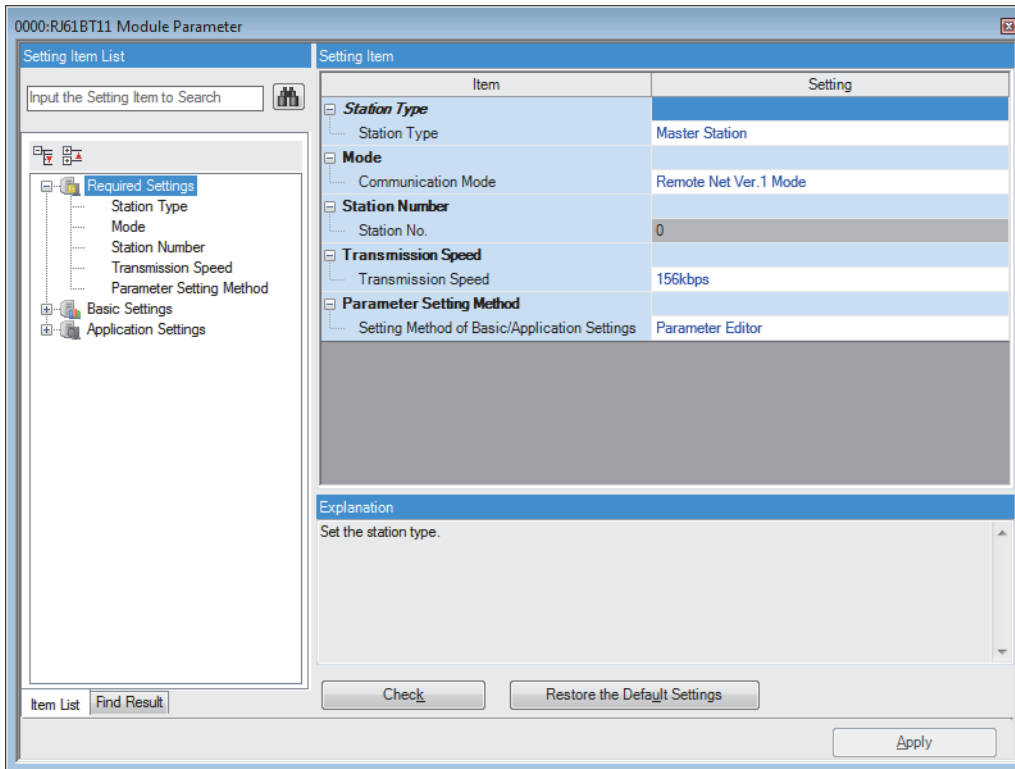

○: Can be set, ×: Cannot be set

Item	Availability			Reference
	Master station	Master station (duplex function)	Local station/standby master station	
Station Type	○	○	○	Page 59 Station Type
Mode	○	○	○	Page 59 Mode
Station Number	×	○*1	○	Page 60 Station Number
Transmission Speed	○	○	○	Page 61 Transmission Speed
Parameter Setting Method	○	×	×	Page 61 Parameter Setting Method

*1 Set the station number in "Network Configuration Settings" under "Basic Settings". ( Page 63 Network Configuration Settings)

Station Type

Set the station type of the master/local module.

Item	Description	Setting range ^{*1}
Station Type	Set the station type of the master/local module. <ul style="list-style-type: none"> To use this module as a standby master station, select "Master Station (Duplex Function)" or "Standby Master Station". When "Master Station (Duplex Function)" is set, the master station returns as a standby master operating station while data link is performed by a standby master station. To mount this module on the main base unit in a redundant system with redundant extension base unit, select "Master Station (Duplex Function)". To mount this module on the extension base unit in a redundant system with redundant extension base unit, select "Master Station". 	<ul style="list-style-type: none"> Master Station Master Station (Duplex Function) Standby Master Station Local Station (Default: Master Station)

*1 When "Setting Method of Basic/Application Settings" in "Parameter Setting Method" is set to "Program", the setting range is fixed to "Master Station".

Point 

To use the modules in a redundant system, refer to the following.

 Page 181 Setting method

Mode

Set the mode of the master/local module.

Item	Description	Setting range ^{*1}		
		Master station ^{*1}	Master station (duplex function)	Standby master station, local station
Communication Mode	Set the mode of the master/local module.	<ul style="list-style-type: none"> Remote Net Ver.1 Mode Remote Net Ver.2 Mode Remote Device Net Ver.1 Mode Remote Device Net Ver.2 Mode Remote I/O Net Mode Offline Line Test Hardware Test (Default: Remote Net Ver.1 Mode)	<ul style="list-style-type: none"> Remote Net Ver.1 Mode Remote Net Ver.2 Mode Offline Line Test Hardware Test (Default: Remote Net Ver.1 Mode)	<ul style="list-style-type: none"> Remote Net Ver.1 Mode Remote Net Ver.2 Mode Offline Hardware Test (Default: Remote Net Ver.1 Mode)

*1 When "Setting Method of Basic/Application Settings" in "Parameter Setting Method" is set to "Program", "Remote I/O Net Mode" cannot be set.

Station Number

Set the station number of the master/local module.

Item	Description	Setting range		
		Master station	Master station (duplex function)	Standby master station, local station
Station No.	Set the station number of the master/local module.	Fixed to 0* ¹ (Default: 0)	0 to 64* ² (Default: 0)	1 to 64 (Default: Blank)

*1 When "Mode" is set to "Line Test", the setting range is 0 to 64.

*2 Set the station number in "Network Configuration Settings" under "Basic Settings". (Page 63 Network Configuration Settings)

Point

To use the modules in a redundant system, refer to the following.

Page 181 Setting method

Precautions

Station number setting for CC-Link

For CC-Link, follow the rules below to set the station numbers.

- Set the station numbers not used for other stations. If a station number already in use is set, an error occurs.
- Set consecutive station numbers for stations in the same system. To set empty station numbers for future use, set the stations as reserved stations. Setting the stations as reserved stations prevents the stations from being detected as a faulty station. Set reserved stations in "Network Configuration Settings" under "Basic Settings". (Page 63 Network Configuration Settings)
- If an empty station number is set without setting a reserved station, the station is detected as a faulty station in 'Data link status of other stations' (SW0080 to SW0083).
- The station numbers need to be consecutive, but wiring does not need to be performed in the order of station number.
- Set the start station number when the number of occupied stations is two or more.

Station number duplication

If a station number other than the start station number is already in use in the master/local module, it is detected.

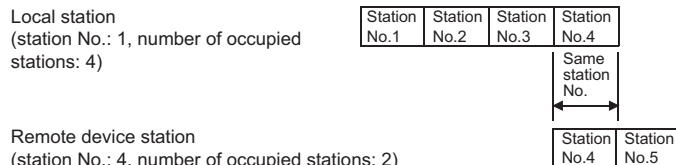

If a start station number is in use, it is not detected. (The station number 0 of the master station is detected if it is in use.)

Check whether the station number of the station where a data link error has occurred is not already used for other stations using 'Data link status of other stations' (SW0080 to SW0083).

Ex.

For the following case (a local station (station No.1 with the number of occupied stations of 4) and a remote device station (station No.1 with the number of occupied stations of 2)), the station number duplication is not detected.

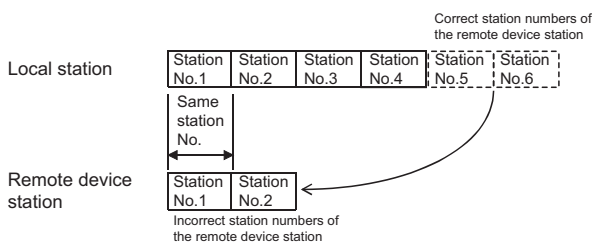

Transmission Speed

Set the transmission speed of the master/local module.

Item	Description	Setting range	
		Master station, master station (duplex function)	Standby master station, local station
Transmission Speed	Set the transmission speed of the master/local module.	<ul style="list-style-type: none"> • 156kbps • 625kbps • 2.5Mbps • 5Mbps • 10Mbps (Default: 156kbps)	<ul style="list-style-type: none"> • 156kbps • 625kbps • 2.5Mbps • 5Mbps • 10Mbps • Auto-tracking (Default: Auto-tracking)

Precautions

- When "Transmission Speed" is set to "Auto-tracking", it takes approximately five seconds for the transmission speed to be established with auto-tracking after the power-on. When a station returns after disconnection, it also takes approximately five seconds for the transmission speed to be established with auto-tracking. When the terminal block is installed or removed or line status becomes unstable during the power-on, it may takes five seconds or longer for the transmission speed to be established.
- Set the same transmission speed in all the stations in the CC-Link system. Data link cannot be performed with a slave station where the different transmission speed from the master station is set.
- The transmission speed that can be set varies depending on the overall distance of Ver.1.10-compatible CC-Link dedicated cable. (📖 MELSEC iQ-R CC-Link System Master/Local Module User's Manual (Startup))
- Check whether the same transmission speed are set for both the master station and slave stations by obtaining (checking) the transmission speed setting using the operation test of CC-Link diagnostics. (🔍 Page 111 Checking the transmission speed setting)

Parameter Setting Method

Select whether to set parameters of the master/local module with the engineering tool or with a program.

Item	Description	Setting range	
		Master station	Master station (duplex function), standby master station, local station
Setting Method of Basic/Application Settings	<p>■Parameter Editor*1 Select this item to set the parameter using the engineering tool. The following are advantages.</p> <ul style="list-style-type: none"> • Parameters can be easily set in the window without creating a program for setting. • The data will be automatically transferred between the devices of the CPU module and the link special relay (SB), link special register (SW), and link devices of the master/local module, or between the module label of the CPU module and the link special relay (SB) and link special register (SW) of the master/local module. <p>■Program*2 Select this item to set the parameter using the dedicated instruction (RLPASET instruction). The following are advantages.</p> <ul style="list-style-type: none"> • Parameters can be changed without resetting the CPU module. • More master/local modules than the number of modules that can be set using the engineering tool can be mounted. 	<ul style="list-style-type: none"> • Parameter Editor • Program (Default: Parameter Editor)	Parameter Editor (fixed)

*1 In a redundant system with redundant extension base unit, set "Parameter Editor" when the master/local module is mounted on an extension base unit. If "Program" is set, an error occurs and data link does not start.

*2 Set the mode and transmission speed using the engineering tool even if "Program" is selected.

2.3 Basic Settings

Set the network configuration, link refresh settings, or other parameters for the master/local module.

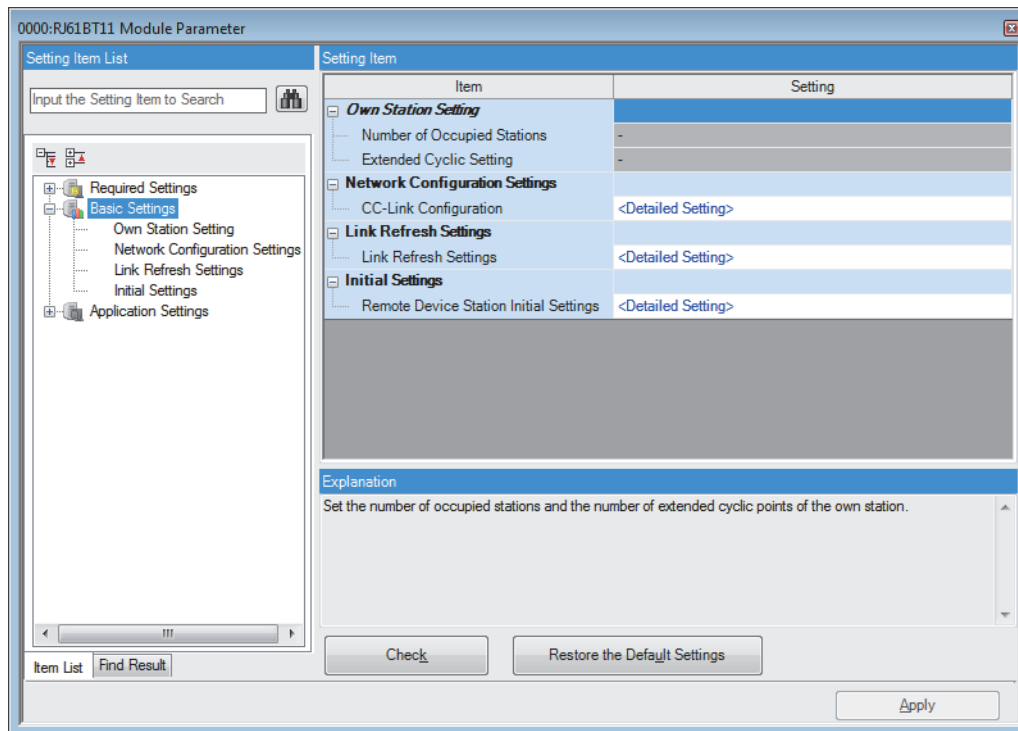

○: Can be set, △: Can be set partly, ×: Cannot be set

Item	Availability ^{*1}			Reference
	Master station	Master station (duplex function)	Local station/standby master station	
Own Station Setting	×	×	○	Page 62 Own Station Setting
Network Configuration Settings	○	○	×	Page 63 Network Configuration Settings
Link Refresh Settings	○	○ ^{*2}	○	Page 65 Link Refresh Settings
Initial Settings	○	○	×	Page 68 Initial Settings

*1 When "Setting Method of Basic/Application Settings" under "Parameter Setting Method" in "Required Settings" is set to "Program", "Basic Settings" cannot be set.

*2 To use the link refresh settings in a redundant system, refer to the following.

☞ Page 67 Use in a redundant system

Own Station Setting

Set the number of occupied stations or expanded cyclic setting for the master/local module.

Item	Description	Setting range
Number of Occupied Stations	Set the number of occupied stations of a local station or the standby master station.	<ul style="list-style-type: none"> • 1 Station Occupied • 2 Stations Occupied • 3 Stations Occupied • 4 Stations Occupied (Default: 1 Station Occupied)
Extended Cyclic Setting	Set the extended cyclic setting of a local station or the standby master station. This item can be set only when "Mode" under "Required Settings" is set to "Remote Net Ver.2 Mode".	<ul style="list-style-type: none"> • Single • Double • Quadruple • Octuple (Default: Single)

Network Configuration Settings

Set the information of slave stations connected to the master station.

Setting method

The procedure for the network configuration settings is shown below.

1. Select the module in "Module List" and drag it to "List of stations" or "Network map".

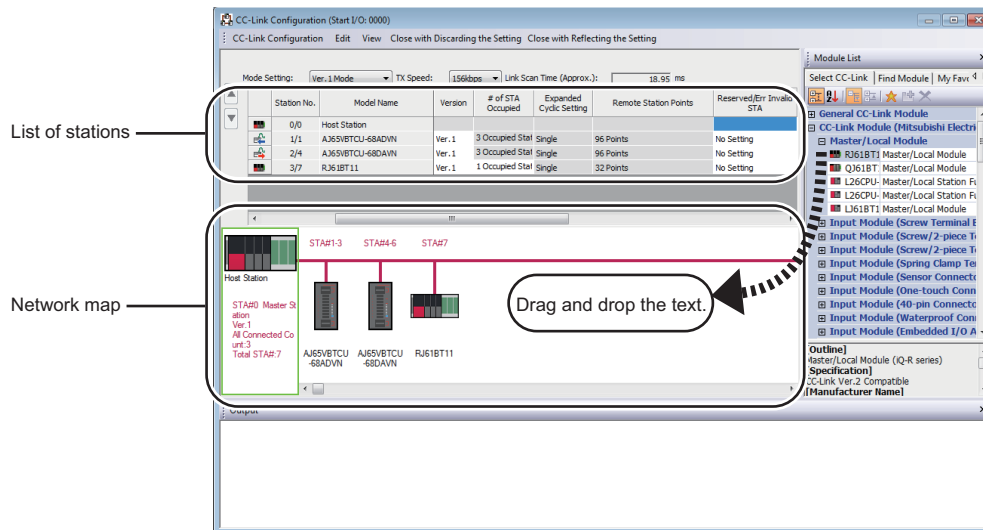

2. Set the required items.

3. Check the system configuration.

[CC-Link Configuration] ⇒ [Check] ⇒ [System Configuration]

When an error or a warning message appears on the output window, refer to the following.

MELSOFT Navigator MessageNo.

4. Select [Close with Reflecting the Setting] to finish the network configuration settings.

Point

Set the station type of the own station to "Master Station (Duplex Function)" to be used in a redundant system. For standby master station, select "General Local Station" from the "Module List" and set "Station Type" to "Local Station (Standby Master Station)". The system B operates with the station number of the standby master.

Setting items

Item	Description	Setting range
Mode Setting	Set the mode of the master station.	<ul style="list-style-type: none"> • Ver.1 Mode • Ver.2 Mode • Ver.1 Mode (Remote Device Net) • Ver.2 Mode (Remote Device Net) • Remote I/O Mode (Default: Mode set in "Mode" under "Required Settings")
TX Speed	Set the transmission speed of the master station.	<ul style="list-style-type: none"> • 156kbps • 625kbps • 2.5Mbps • 5Mbps • 10Mbps (Default: Value set in "Transmission Speed" under "Required Settings")
Link Scan Time (Approx.)	The estimate value of link scan time is displayed. For the estimate value of link scan time, refer to following. Page 173 Link scan time	—

Item	Description	Setting range
Station No.	<ul style="list-style-type: none"> ■ For the master station <ul style="list-style-type: none"> • 0/0 is displayed. ■ For a slave station <ul style="list-style-type: none"> • The order of the slave station is displayed before the slash. • The start station number of the slave station is displayed after the slash. 	—
Model Name	The module model name is displayed. If the module information cannot be found, "Module with No Profile Found" is displayed.	—
Station Type	Select the station type. Set the same type of the slave station actually connected.	The setting varies depending on the set module.
Version	<p>Set CC-Link version of the slave station.</p> <p>Select the mode of the master/local module if the slave station is a master/local module.</p> <p>Select the same CC-Link version as the version of the slave station actually connected. If not, data link cannot be performed.</p>	The setting varies depending on the set module.
# of STA Occupied	Set the number of occupied stations of the slave station. Set it to increase the number of link points per slave station.	The setting varies depending on the set module.
Expanded Cyclic Setting	<p>Set the extended cyclic setting for the slave station. Set it to increase the number of link points per slave station.</p> <p>Set it only when the mode of the slave station is remote net Ver.2 mode.</p>	The setting varies depending on the set module.
Remote Station Points	<p>Set the number of points of remote I/O (RX, RY) occupied by the slave station. Set it to save the devices of the CPU module that are set for the link refresh targets.</p> <p>Set it only when the mode of the master station is remote net Ver.2 mode, or when the mode of the master station is remote device net Ver.2 mode and the slave station is the remote I/O station.</p>	The setting varies depending on the set module.
Reserved/Err Invalid STA	<p>Set it to reserve the slave station or to set the slave station as an error invalid station.</p> <ul style="list-style-type: none"> • For slave stations that will be connected in future, set them as reserved stations. • To prevent slave stations from being detected as faulty stations at the data link error, set them as error invalid stations. • When the master station is remote net Ver.2 mode or remote device net Ver.2 mode, the number of points of a reserved station can be set to zero. Set zero points for a reserved station using the engineering tool. • When a slave station that has been set as an error invalid station is specified as a reserved station, reserved station selection is prioritized. • If an error has occurred in all the slave stations set as an error invalid station, the ERR. LED turns on. 	<ul style="list-style-type: none"> • No Setting • Reserved Station • Error Invalid Station (Default: No Setting)
Intelligent Buffer Selection (word)	<p>Set the size of buffer memory used to perform transient transmission with dedicated instructions. This item can be set only when a slave station is a local station, intelligent device station, or standby master station.</p> <p>■ Send Set the size of send buffer to send data using the RIWT instruction. This item must be set when modules on the standby master station are not MELSEC iQ-R series modules.</p> <p>■ Receive Set the size of receive buffer to receive data using the RIRD instruction. This item must be set when modules on the standby master station are not MELSEC iQ-R series modules.</p> <p>■ Auto Set the size of automatic update buffer to communicate with an intelligent device station using automatic update buffer. Set the size required for each intelligent device station.</p>	<p>Send: 0, 64 to 4096 Note that the total buffer size of "Send" and "Receive" for all slave stations must be 4096 or less. (Default: 64)</p> <p>Receive: 0, 64 to 4096 Note that the total buffer size of "Send" and "Receive" for all slave stations must be 4096 or less. (Default: 64)</p> <p>Auto: 0, 128 to 4096 Note that the total buffer size of "Auto" for all slave stations must be 4096 or less. (Default: 128)</p>
Station-specific mode setting	Set the station-specific mode for the slave station. This item can be set only when the slave station supports the station-specific mode.	The setting varies depending on the set module.
Properties	<p>Right-click the module in "Network map" and select "Properties".</p> <p>The model name or manufacturer is displayed.</p>	The setting varies depending on the set module.

Link Refresh Settings

Set the link refresh ranges between the link devices of the master/local module and the devices of the CPU module or between the link devices of the master/local module and the module label of the CPU module.

Setting method

The procedure for the link refresh settings is shown below.

1. Set the required items.

No.	Link Side					CPU Side				
	Device Name	Points	Start	End		Target	Device Name	Points	Start	End
-	SB	512	00000	001FF	↔	Module Label				
-	SW	512	00000	001FF	↔	Module Label				
1					↔					
2					↔					
3					↔					
4					↔					
5					↔					
6					↔					
7					↔					
8					↔					
9					↔					
10					↔					
11					↔					

2. Click the [Apply] button to finish the link refresh settings.

Setting items

Item	Description	Setting range
Device Assignment Method	<p>Right-click in the setting window and select a link device assignment method from the "Device Assignment Method" menu.</p> <ul style="list-style-type: none"> Start/End: Enter the start and end numbers of link devices. Points/Start: Enter the points and start numbers of link devices. 	<ul style="list-style-type: none"> Start/End Points/Start (Default: Start/End)
—	<p>Link Side</p> <p>Set the link refresh ranges of SB and SW. One range can be set for each SB and SW. (☞ Page 30 Link refresh)</p> <p>Ex.</p> <p>Master/local module</p> <p>CPU module</p>	<p>Device Name</p> <ul style="list-style-type: none"> SB SW <p>Points</p> <ul style="list-style-type: none"> SB: 16 to 512 (Set it in increments of 16 points.) SW: 1 to 512 (Default: Blank (512 points when the refresh target is the module label)) <p>Start</p> <ul style="list-style-type: none"> SB: 00000H to 001F0H (Set a multiple of 16 including 0.) SW: 00000H to 001FFH (Default: Blank (fixed to 0 when the refresh target is the module label)) <p>End</p> <ul style="list-style-type: none"> SB: 0000FH to 001FFH (Set a multiple of 16 -1.) SW: 00000H to 001FFH (Default: Blank (fixed to 1FFH when the refresh target is the module label))
—	<p>CPU Side</p>	<p>Target</p> <ul style="list-style-type: none"> Module Label Specify Device (Default: Module Label) <p>Device Name</p> <ul style="list-style-type: none"> Module Label: — Specify Device (when link side is fixed to SB): SB, M, L, B, D, W, R, ZR, RD (only SB, W, and RD for remote head module) Specify Device (when link side is fixed to SW): SW, M, L, B, D, W, R, ZR, RD (only SW, W, and RD for remote head module) (Default: Blank (cannot be set when the refresh target is the module label)) <p>Points, Start, End</p> <ul style="list-style-type: none"> Range of the device in the CPU module (Default: Blank (cannot be set when the refresh target is the module label))

Item	Description	Setting range																																																												
1 to 256	<p>Link Side</p> <p>Set the link refresh ranges of RX, RY, RWr, and RWw. Up to 256 ranges can be set. (☞ Page 30 Link refresh)</p> <p>Ex.</p> <table border="1"> <thead> <tr> <th colspan="5">Link Side</th> <th colspan="5">CPU Side</th> </tr> <tr> <th>No.</th> <th>Device Name</th> <th>Points</th> <th>Start</th> <th>End</th> <th>Target</th> <th>Device Name</th> <th>Points</th> <th>Start</th> <th>End</th> </tr> </thead> <tbody> <tr> <td>1</td> <td>RX</td> <td>256</td> <td>00000</td> <td>000FF</td> <td>Specify Device</td> <td>X</td> <td>256</td> <td>01000</td> <td>010FF</td> </tr> <tr> <td>2</td> <td>RY</td> <td>256</td> <td>00000</td> <td>000FF</td> <td>Specify Device</td> <td>Y</td> <td>256</td> <td>01000</td> <td>010FF</td> </tr> <tr> <td>3</td> <td>RWr</td> <td>256</td> <td>00000</td> <td>000FF</td> <td>Specify Device</td> <td>W</td> <td>256</td> <td>00000</td> <td>000FF</td> </tr> <tr> <td>4</td> <td>RWw</td> <td>256</td> <td>00000</td> <td>000FF</td> <td>Specify Device</td> <td>W</td> <td>256</td> <td>01000</td> <td>010FF</td> </tr> </tbody> </table> <p>CPU Side</p>	Link Side					CPU Side					No.	Device Name	Points	Start	End	Target	Device Name	Points	Start	End	1	RX	256	00000	000FF	Specify Device	X	256	01000	010FF	2	RY	256	00000	000FF	Specify Device	Y	256	01000	010FF	3	RWr	256	00000	000FF	Specify Device	W	256	00000	000FF	4	RWw	256	00000	000FF	Specify Device	W	256	01000	010FF	<p>Device Name</p> <ul style="list-style-type: none"> • RX, RY, RWr, RWw <p>(Default: Blank)</p> <p>Points</p> <ul style="list-style-type: none"> • RX, RY: 16 to 8192 (Set it in increments of 16 points.) • RWr, RWw: 4 to 2048 (Set it in increments of 4 points) <p>(Default: Blank)</p> <p>Start</p> <ul style="list-style-type: none"> • RX, RY: 00000H to 01FF0H (Set a multiple of 16 including 0.) • RWr, RWw: 00000H to 007FCH (Set a multiple of 4 including 0.) <p>(Default: Blank)</p> <p>End</p> <ul style="list-style-type: none"> • RX, RY: 0000FH to 01FFFH (Set a multiple of 16 - 1.) • RWr, RWw: 00003H to 007FFH (Set a multiple of 4 - 1.) <p>(Default: Blank)</p> <hr/> <p>Target</p> <ul style="list-style-type: none"> • Specify Device <p>Device Name</p> <ul style="list-style-type: none"> • Specify Device (when link side is RX): X, M, L, B, D, W, R, ZR, RD (only X, W, and RD for remote head module) • Specify Device (when link side is RY): Y, M, L, B, D, W, R, ZR, RD (only Y, W, and RD for remote head module) • Specify Device (when link side is RWr): M, L, B, D, W, R, ZR, RD (only W and RD for remote head module) • Specify Device (when link side is RWw): M, L, B, D, W, R, ZR, RD (only W and RD for remote head module) <p>(Default: Blank)</p> <p>Points, Start, End</p> <ul style="list-style-type: none"> • Range of the device in the CPU module <p>(Default: Blank)</p>
Link Side					CPU Side																																																									
No.	Device Name	Points	Start	End	Target	Device Name	Points	Start	End																																																					
1	RX	256	00000	000FF	Specify Device	X	256	01000	010FF																																																					
2	RY	256	00000	000FF	Specify Device	Y	256	01000	010FF																																																					
3	RWr	256	00000	000FF	Specify Device	W	256	00000	000FF																																																					
4	RWw	256	00000	000FF	Specify Device	W	256	01000	010FF																																																					

Precautions

■ Device set to "CPU Side"

Set parameters that differ from the following:

- "Link Refresh Settings" in "Basic Settings" of a CC-Link master/local module
- "Refresh Setting" of other network modules
- I/O numbers used for I/O modules and intelligent function modules
- "Refresh Setting" of intelligent function modules
- "Refresh Setting between Multiple CPU" of "CPU Parameter" for a multiple CPU system

■ Use in a redundant system

Do not set a link device other than the link special relay (SB) or link special register (SW) to "Link Side". Setting a link device other than the link special relay (SB) or link special register (SW) will not result in a refresh.

Initial Settings

Set the procedure for the initial settings when registering the initial settings of a remote device station using an engineering tool. The initial settings are reflected to the remote device station by turning on 'Remote device station initialization procedure registration instruction' (SB000D)

Setting method

The procedure for the initial settings is shown below.

1. Set "Target Station No." in the "Remote Device Initial Setting Target Station No. Setting" window.

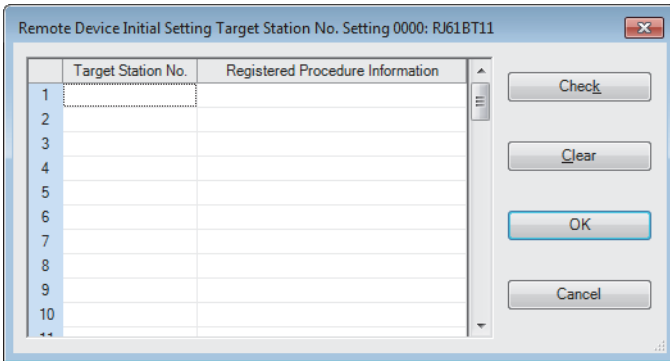

2. Double-click the number of registered procedures displayed on the right side of the set target station number, and set each item in the "Remote Device Initial Setting Procedure Registration" window.

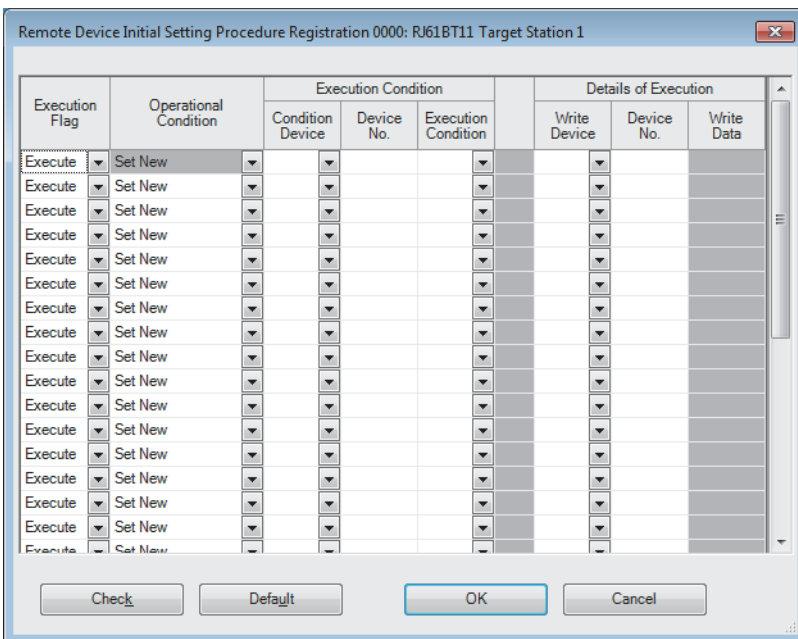

3. Click the [OK] button to finish the remote device initial setting.
4. When the initial settings are completed, write the settings to the CPU module using the engineering tool.
5. Start the initial settings by turning on 'Remote device station initialization procedure registration instruction' (SB000D). While the initial settings are being executed, 'Execution status of remote device station initialization procedure' (SB005E) is on.

Also, the execution procedure number and the target station number for the procedure registration are stored in 'Remote device station initialization procedure registration execution individual information' (buffer memory address: Un\G23680 to Un\G23743).

6. When the initial settings are completed for all the set stations, 'Completion status of remote device station initialization procedure' (SB005F) is turned on.

The stations where the initial settings are completed can be checked with 'Remote device station initialization procedure registration completion status' (SW0164 to SW0167). (☞ Page 162 List of link special register (SW) areas)

Also, the execution results are stored in 'Remote device station initialization procedure registration instruction result' (SW005F). The data stored in 'Remote device station initialization procedure registration execution individual information' (buffer memory address: Un\G23680 to Un\G23743) become FF□□H. (□□ indicates the target station number for the initial settings.)

7. Turn off 'Remote device station initialization procedure registration instruction' (SB000D).

'Remote device station initialization procedure registration instruction result' (SW005F) and 'Remote device station initialization procedure registration execution individual information' (buffer memory address: Un\G23680 to Un\G23743) are cleared.

■Timing chart

The following figure shows the operations of a link special relay (SB) and link special register (SW) when the remote device station initialization procedure registration is performed.

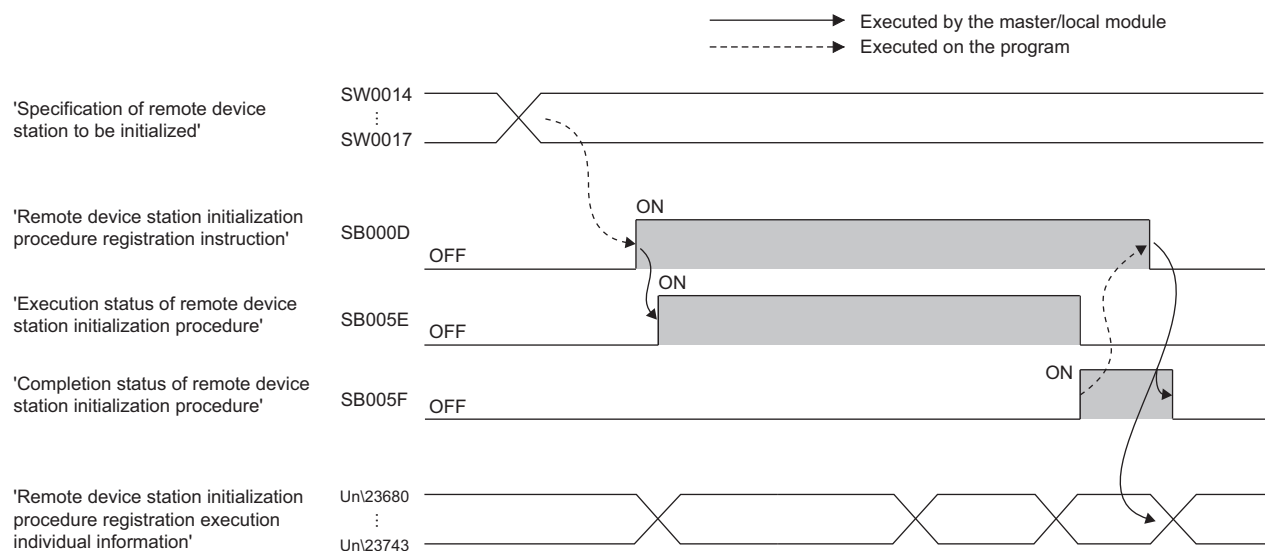

Setting items

■Remote Device Initial Setting Target Station No. Setting

Item	Description	Setting range
Target Station No.	Set the target station number of the remote device initial setting.	1 to 64 (Default: Blank)
Registered Procedure Information	The number of registered procedures in the remote device initial setting is stored.	— (Default: Blank)

■Remote Device Initial Setting Procedure Registration

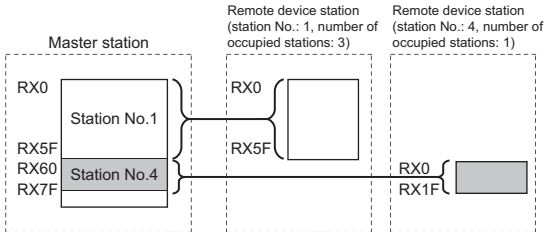
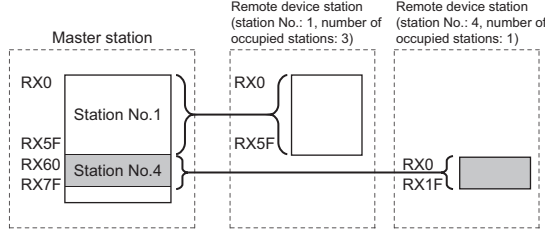
Item	Description	Setting range																														
Input Format	Right-click in the "Remote Device Initial Setting Procedure Registration" window and select an input type of "Write Data" from the "Input Format" menu.	<ul style="list-style-type: none"> Decimal Hexadecimal (Default: Decimal)																														
Execution Flag	Select whether to actually execute the registered procedure or not. Click it to change the setting. Select "Set Only" to use the setting only as a reference when inputting similar setting items.	<ul style="list-style-type: none"> Execute Set Only (Default: Execute)																														
Operational Condition	Select whether to newly set the condition for the initial settings or use the same condition as the above line. <table border="1" style="width: 100%; border-collapse: collapse; text-align: center;"> <thead> <tr> <th rowspan="2">Execution Flag</th> <th rowspan="2">Operational Condition</th> <th colspan="3">Execution Condition</th> <th colspan="3">Details of Execution</th> </tr> <tr> <th>Condition Device</th> <th>Device No.</th> <th>Execution Condition</th> <th>Write Device</th> <th>Device No.</th> <th>Write Data</th> </tr> </thead> <tbody> <tr> <td>Execute</td> <td>Set New</td> <td>RX</td> <td>1</td> <td>ON</td> <td>RY</td> <td>3</td> <td>ON</td> </tr> <tr> <td>Execute</td> <td>Same as Prev. Set</td> <td>RX</td> <td>1</td> <td>ON</td> <td>RWw</td> <td>2</td> <td>15</td> </tr> </tbody> </table>	Execution Flag	Operational Condition	Execution Condition			Details of Execution			Condition Device	Device No.	Execution Condition	Write Device	Device No.	Write Data	Execute	Set New	RX	1	ON	RY	3	ON	Execute	Same as Prev. Set	RX	1	ON	RWw	2	15	<ul style="list-style-type: none"> Set New Same as Prev. Set (Default: Set New)
Execution Flag	Operational Condition			Execution Condition			Details of Execution																									
		Condition Device	Device No.	Execution Condition	Write Device	Device No.	Write Data																									
Execute	Set New	RX	1	ON	RY	3	ON																									
Execute	Same as Prev. Set	RX	1	ON	RWw	2	15																									
Execution Condition	Condition Device	Set the device to execute the initial settings.	<ul style="list-style-type: none"> RX SB (Default: Blank)																													
	Device No.	Set the device number of the device set to "Condition Device". Set the number as the first device of each station is 0. For instance, 0 to 1F are set to the device number for the station No.4 in the following case. 	<ul style="list-style-type: none"> For RX: 0H to 37FH For SB: 0H to 1FFH (Default: Blank)																													
	Execution Condition	Set whether to execute the initial settings with ON of the condition device or with OFF of the condition device.	<ul style="list-style-type: none"> ON OFF (Default: Blank)																													
Details of Execution	Write Device	Set the device where the initial settings are written.	<ul style="list-style-type: none"> RY RWw (Default: Blank)																													
	Device No.	Set the device number of the device set in "Write Device". Set the number as the first device of each station is 0. For instance, 0 to 1F are set to the device number for the station No.4 in the following case. 	<ul style="list-style-type: none"> For RY: 0H to 37FH For RWw: 0H to 7FH (Default: Blank)																													
	Write Data	Set the data for the initial settings. (The data to be written to the device set to "Write Device" and "Device No.")	<ul style="list-style-type: none"> For RY: ON or OFF For RWw: 0H to FFFFH (Default: Blank)																													

2.4 Application Settings

Set the supplementary cyclic settings, interrupt settings, or other parameters for the master/local module.

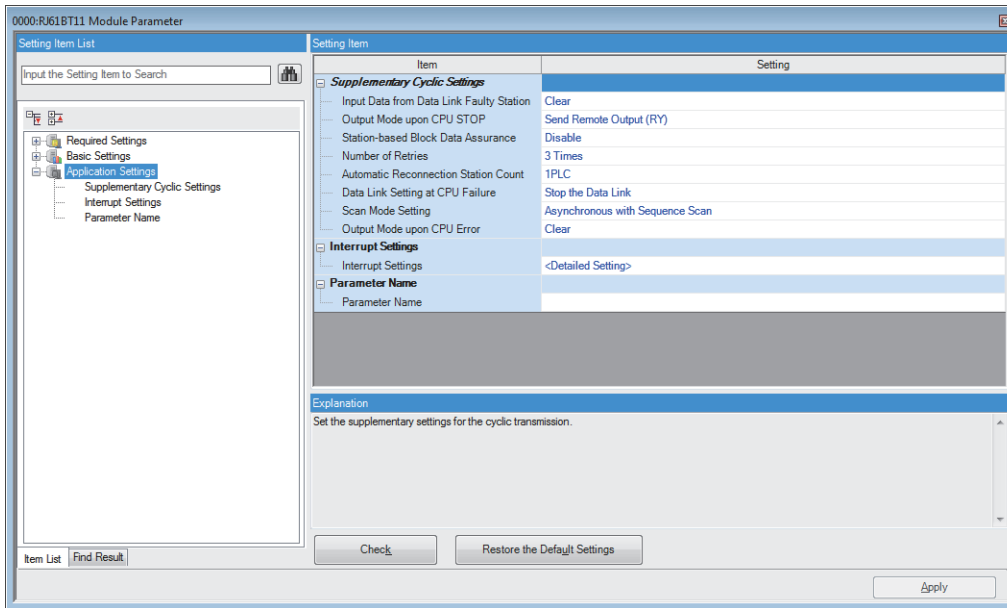

○: Can be set, △: Can be set partly, ×: Cannot be set

Item	Availability*1			Reference
	Master station	Master station (duplex function)	Local station/standby master station	
Supplementary Cyclic Settings	○	△*2	△*3	Page 72 Supplementary Cyclic Settings
Interrupt Settings	○	○	○	Page 73 Interrupt Settings
Parameter Name	○	○	○	Page 74 Parameter Name

*1 When "Setting Method of Basic/Application Settings" under "Parameter Setting Method" in "Required Settings" is set to "Program", "Application Settings" cannot be set.

*2 "Data Link Setting at CPU Failure" cannot be set.

*3 "Number of Retries", "Automatic Reconnection Station Count", "Data Link Setting at CPU Failure", and "Scan Mode Setting" cannot be set.

Supplementary Cyclic Settings

Set the station-based block data assurance, scan mode setting, or other parameters.

Item	Description	Setting range
Input Data from Data Link Faulty Station	Set whether to clear or hold data input/output from a data link faulty station. ■Master station The targets are remote input (RX) from the remote station and local station. ■Local station The targets are remote input (RX) from the master station and remote output (RY) from the remote station and local station.	<ul style="list-style-type: none"> • Clear • Hold (Default: Clear)
Output Mode upon CPU STOP	Select whether remote output (RY) is refreshed (held at the value before STOP) or cleared to zero (0) when the CPU module is set to STOP. ■Master station The target is remote output (RY) to the slave station. ■Local station The target is remote output (RY) to the master station.	<ul style="list-style-type: none"> • Send Remote Output (RY) • Send 0 data (Default: Send Remote Output (RY))
Station-based Block Data Assurance	Set whether to ensure a data integrity of the data blocks being refreshed between the master/local module and the CPU module. (☞ Page 32 Station-based block data assurance) To use this module in a redundant system, set "Station-based Block Data Assurance" to "Disable". Even if "Station-based Block Data Assurance" is set to "Enable", any data will not be assured for each station.	<ul style="list-style-type: none"> • Disable • Enable (Default: Disable)
Number of Retries	Set the number of retries for when a communication failure occurs.	1 to 7 Times (Default: 3 Times)
Automatic Reconnection Station Count	Set the number of slave stations that return to the system operation by a single link scan after the stations are disconnected due to a communication failure. Setting a larger number extends link scan time of when the station returns.	1 to 10 PLC (Default: 1 PLC)
Data Link Setting at CPU Failure	Set whether to stop or continue data link if a stop error occurs in a CPU module. Note that this item cannot be used when the standby master function is used.	<ul style="list-style-type: none"> • Stop the Data Link • Continue the Data Link (Default: Stop the Data Link)
Scan Mode Setting	Set the mode of the link scan. ■Asynchronous with Sequence Scan Link scan is performed asynchronously with the sequence scan of the CPU module. Select this item to shorten input transmission delay time when sequence scan takes much more time than link scan. Note that output transmission delay time will become longer. ■Synchronous with Sequence Scan Link scan is performed synchronously with the sequence scan of the CPU module. Select this item in the following cases: <ul style="list-style-type: none"> • To shorten the output transmission delay time*¹ • To keep transmission delay time constant*² 	<ul style="list-style-type: none"> • Asynchronous with Sequence Scan • Synchronous with Sequence Scan (Default: Asynchronous with Sequence Scan)
Output Mode upon CPU Error	Set whether to hold or clear the output in the master/local module when the CPU module is in a stop error. Select "Hold" to hold the output in the master/local module when the CPU module is in a stop error.	<ul style="list-style-type: none"> • Clear • Hold (Default: Clear)

*1 When sequence scan takes more time than link scan, input transmission delay time becomes longer.

*2 The sequence scan must be constant as well. Set "Constant Scan Setting" in "RAS Setting" of "CPU Parameter".

Interrupt Settings

Set conditions for sending an interrupt request to the CPU module.

Setting method

1. Set an interrupt condition device.

Up to 16 interrupt conditions can be set.

No.	Device/ Reception Channel	Device No.	Detection Method	Condition Type	Condition Value	Interrupt Pointer	Comment
SI 00							
SI 01							
SI 02							
SI 03							
SI 04							
SI 05							
SI 06							
SI 07							
SI 08							
SI 09							
SI 10							
SI 11							
SI 12							

2. Click the [Apply] button to finish the interrupt settings.

Setting items

Item	Description	Setting range
Word Device Setting Value Input Format	Right click in the setting window and select from the "Word Device Setting Value Input Format" menu.	<ul style="list-style-type: none"> Decimal Hexadecimal (Default: Decimal)
Device/Reception Channel	Set the device for the interrupt conditions.	Refer to the following table.
Device No.		
Detection Method	Set the detection timing of an interrupt generated by the device set in "Device/Reception Channel" and "Device No."	
Condition Type		
Condition Value	When "RWw", "RWr", or "SW" is selected in "Device/Reception Channel", enter a word device value that triggers an interrupt.	
Interrupt Pointer	Set an interrupt pointer (I) to be used for an interrupt program. A device can be used for the interrupt pointer.	
Comment	Set a comment for the interrupt pointer used.	—

(Setting range)

Device/ Reception Channel	Device No.	Detection Method	Condition Type	Condition Value	Interrupt Pointer
RX	0H to 1FFFH	Level + ON: Interrupt occurs by turning on the device.		—	Device: I0 to I15, I50 to I1023
RY	0H to 1FFFH	Level + OFF: Interrupt occurs by turning off the device.			
SB	0H to 1FFH	Edge + ON: Interrupt occurs at the rising edge of the device. Edge + OFF: Interrupt occurs at the falling edge of the device.			
RWr	0H to 7FFH	Level + Values Match: Interrupt occurs when values match.	0 to 65535 (0H to FFFFH)		
RWw	0H to 7FFH	Level + Values Mismatch: Interrupt occurs when values do not match.			
SW	0H to 1FFH	Edge + Values Match: Interrupt occurs when values match (first time only). Edge + Values Mismatch: Interrupt occurs when values do not match (first time only).			
Scan Completed	—	—		—	



If the interrupt condition is established upon the completion of a link scan, the interrupt is issued. If "Scan Completed" is set to "Device/Reception Channel", the interrupt is issued without condition upon the completion of a link scan.

Precautions

■When "Detection Method" is set to "Level" and the interrupt condition is always met

If the sequence scan takes much longer than the link scan, since interrupt processing is activated in each link scan, sequence scan time may greatly increase, resulting in a watchdog timer error of the CPU module.

When "Detection Method" is set to "Level" and the interrupt condition is always met, do not use interrupt settings and correct the interrupt condition in the program.

■Before executing an interrupt program

Execute the EI instruction in a main routine program and enable an interrupt. (📖 MELSEC iQ-R CPU Module User's Manual (Application))

■When multiple interrupts have simultaneously occurred

The operation may delay.

■Mode of a master/local module

The interrupt to the CPU module can be performed when the master/local module is in online mode. The interrupt cannot be performed when the master/local module is in hardware test or offline mode.

■Starting an interrupt program by the rising/falling edge of the specified device

Do not start an interrupt program using instructions, such as PLS and PLF, that depend on the rising/falling edge of the specified devices because changes in devices might not be read.

Ex.

A request for the interrupt is issued by turning on RX10.

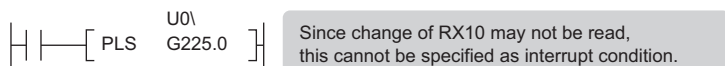

■An interrupt cannot be generated

Changes in the interrupt condition device cannot be detected if the change is shorter than the transmission delay time.

■Using cyclic data in an interrupt program

When an interrupt program is executed, RX, RY, RWr, and RWw are not link refreshed to CPU module devices. Therefore, directly access to the buffer memory of a master/local module by using Module access device (Un\G□).

■At data link error

When data link is faulty, a request for the interrupt to a CPU module is not issued.

Parameter Name

Item	Description	Setting range
Parameter Name	Set a name for the module parameter if desired.	Up to 8 one-byte or two-byte characters (Default: Blank)

3 PROGRAMMING

This chapter describes programming and start-up examples of the master/local module.

3.1 Precautions for Programming

This section describes precautions to create master/local module programs.

Interlock program

For a cyclic transmission program, interlock with 'Data link status of other stations' (SW0080 to SW0083).

Ex.

Interlock example

Classification	Label name	Description	Device
Module label	BT11_1.bnSts_DataLinkError_Other[1]	Data link status of other stations (station No.1)	SW0080.0
	BT11_1.bnSts_DataLinkError_Other[2]	Data link status of other stations (station No.2)	SW0080.1

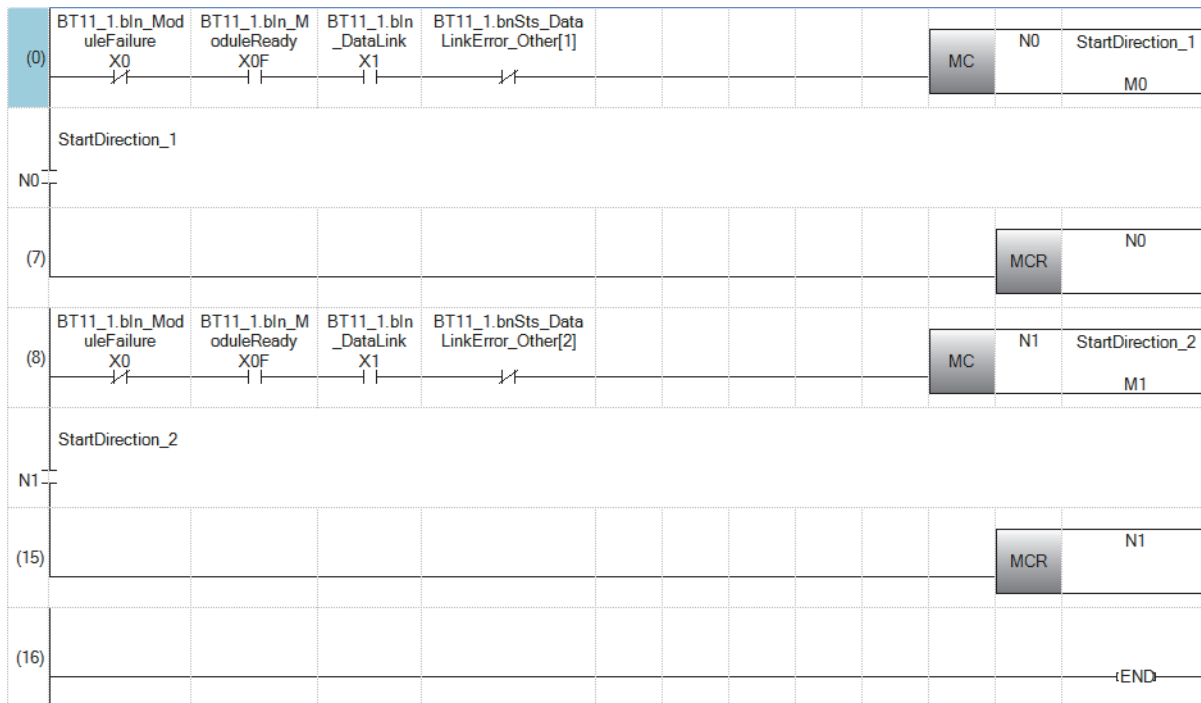

(7) Create the communication program with station No.1 within the control range of N0.

(15) Create the communication program with station No.2 within the control range of N1.

3.2 Example of Communications Between a Master Station and a Local Station

This section describes communications between the master station and local station.

System configuration example

The following system configuration is used to explain communication between the master station and local station.

System configuration

The same system is used for the master station and local station.

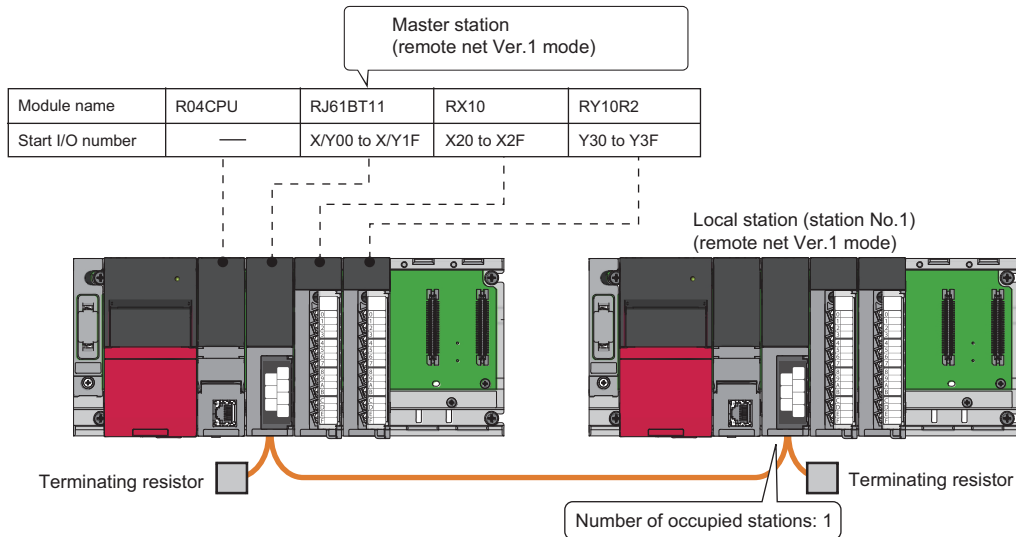

Link device assignment

This section describes the RX, RY, RWr, or RWw assignment of program examples.

Point

Remote net Ver.1 mode is used in this program examples. When the remote net Ver.2 mode or remote device net Ver.2 mode is used, the buffer memory addresses of storage locations vary. (Page 21 Remote net Ver.1 mode)

■RX/RX assignment

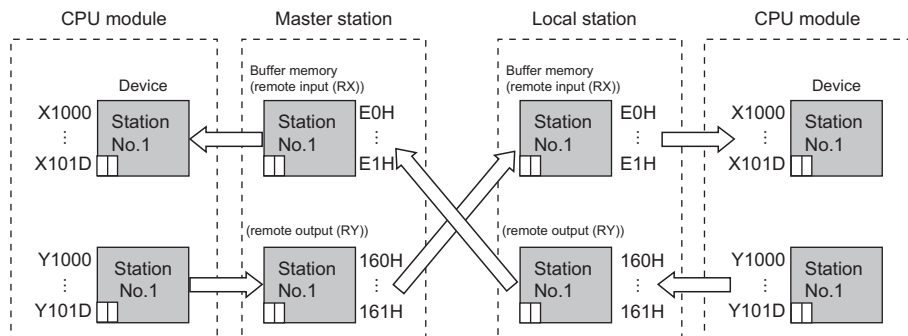

CPU module	Master station		Slave station		
	Buffer memory address		Station number	Module name	RX, RY
Device	Hexadecimal	Decimal			
X1000 to X100F	E0H	224	1	RJ61BT11	RY0 to RYF
X1010 to X101D	E1H	225			RY10 to RY1D
Y1000 to Y100F	160H	352			RX0 to RXF
Y1010 to Y101D	161H	353			RX10 to RX1D

Point

The last two bits in RX and RY cannot be used for communications between a master station and a local station.

■RWr/RWw assignment

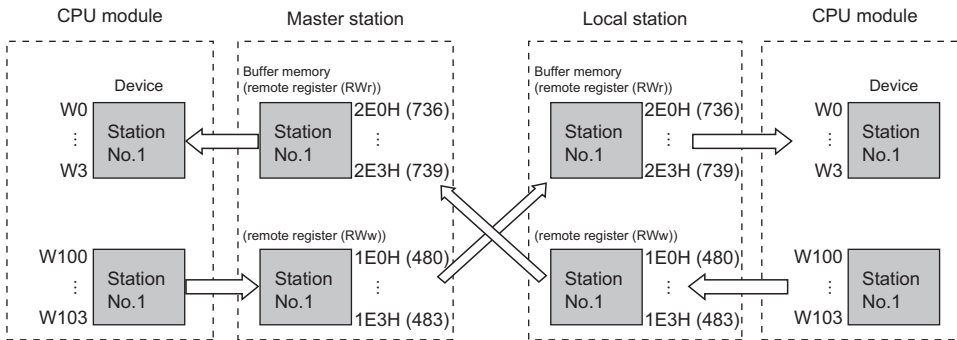

CPU module	Master station		Slave station		
	Buffer memory address		Station number	Module name	RWr, RWw
	Hexadecimal	Decimal			
W0	2E0H	736	1	RJ61BT11	RWw0
W1	2E1H	737			RWw1
W2	2E2H	738			RWw2
W3	2E3H	739			RWw3
W100	1E0H	480			RWr0
W101	1E1H	481			RWr1
W102	1E2H	482			RWr2
W103	1E3H	483			RWr3

Setting in the master station

Connect the engineering tool to the CPU module on the master station and set the parameters.

1. Set the CPU module as follows.

 [Project] ⇒ [New]

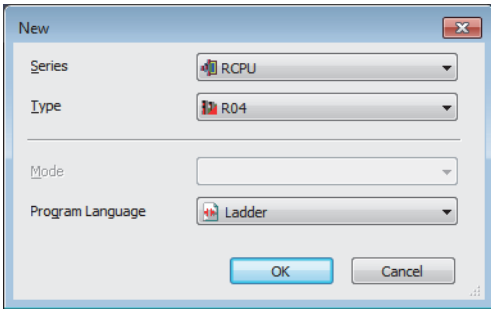

2. Click the [Setting Change] button and set the module label to [Use].

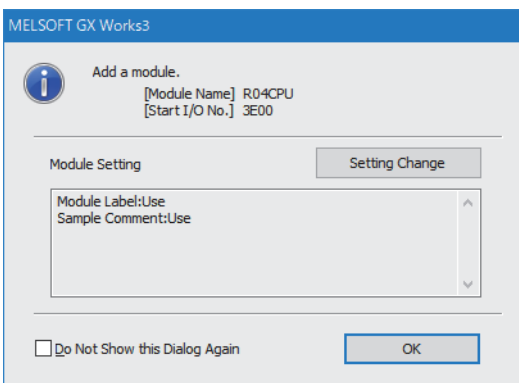

3. Set the master/local module as follows.

 [Navigation window] ⇒ [Parameter] ⇒ [Module Information] ⇒ Right-click ⇒ [Add New Module]

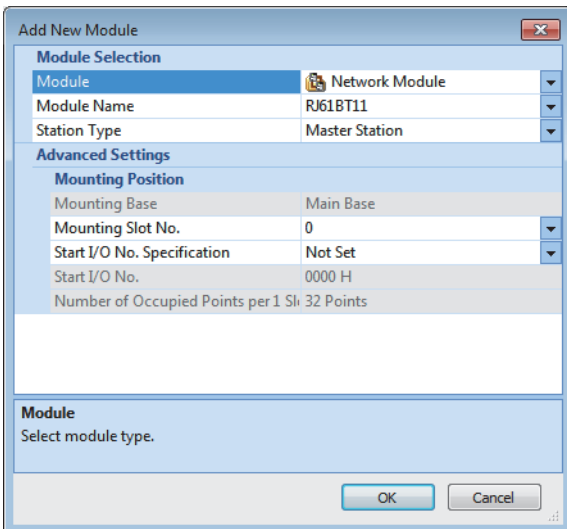

4. Click the [OK] button to add the module labels of the master/local module.

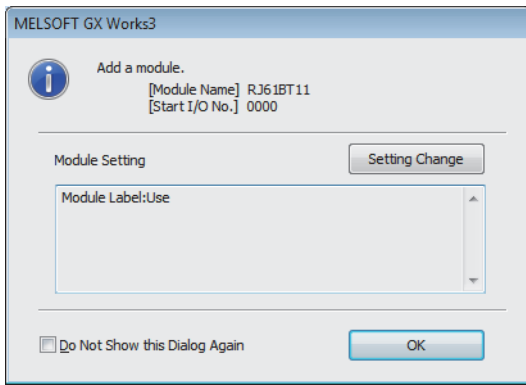

5. Set the items in "Required Settings" as follows.

[Navigation window] ⇒ [Parameter] ⇒ [Module Information] ⇒ [RJ61BT11] ⇒ [Required settings]

Setting Item	Item	Setting
Station Type	Station Type	Master Station
	Mode	Remote Net Ver.1 Mode
Station Number	Communication Mode	Remote Net Ver.1 Mode
	Station No.	0
Transmission Speed	Transmission Speed	156kbps
	Parameter Setting Method	Parameter Editor
	Setting Method of Basic/Application Settings	Parameter Editor

6. Set the network configuration as follows.

[Navigation window] ⇒ [Parameter] ⇒ [Module Information] ⇒ [RJ61BT11] ⇒ [Basic Settings] ⇒ [Network Configuration Settings]

Station No.	Model Name	Station Type	Version	# of STA Occupied	Expanded Cyclic Setting	Remote Station Points	Reserved/Err Invalid STA	Intelligent Buffer Selection(word)			Station-specific mode setting
								Send	Receive	Auto	
0/0	Host Station	Master Station									
1/1	RJ61BT11	Local Station	Ver. 1	1 Occupied Sta	Single	32 Points	No Setting	64	64	128	

7. Set the link refresh settings as follows.

[Navigation window] ⇒ [Parameter] ⇒ [Module Information] ⇒ [RJ61BT11] ⇒ [Basic Settings] ⇒ [Link Refresh Settings]

No.	Link Side					CPU Side				
	Device Name	Points	Start	End		Target	Device Name	Points	Start	End
-	SB	512	00000	001FF	↔	Module Label				
-	SW	512	00000	001FF	↔	Module Label				
1	RX	32	00000	0001F	↔	Specify Device	X	32	01000	0101F
2	RY	32	00000	0001F	↔	Specify Device	Y	32	01000	0101F
3	RWr	4	00000	00003	↔	Specify Device	W	4	00000	00003
4	RWw	4	00000	00003	↔	Specify Device	W	4	00100	00103
5					↔					

8. Set the supplementary cyclic settings as follows.

 [Navigation window] ⇒ [Parameter] ⇒ [Module Information] ⇒ [RJ61BT11] ⇒ [Application Settings] ⇒ [Supplementary Cyclic Settings]

Item	Setting
Supplementary Cyclic Settings	
Input Data from Data Link Faulty Station	Clear
Output Mode upon CPU STOP	Send Remote Output (RY)
Station-based Block Data Assurance	Enable
Number of Retries	3 Times
Automatic Reconnection Station Count	1PLC
Data Link Setting at CPU Failure	Stop the Data Link
Scan Mode Setting	Asynchronous with Sequence Scan
Output Mode upon CPU Error	Clear
Interrupt Settings	
Interrupt Settings	<Detailed Setting>
Parameter Name	
Parameter Name	

9. Write the set parameters to the CPU module on the master station. Then reset the CPU module or power off and on the system.

 [Online] ⇒ [Write to PLC]

Point 

In this example, default values are used for parameters that are not shown above. For the parameter setting, refer to the chapter explaining the parameters in this manual. ( Page 57 PARAMETER SETTINGS)

Setting in the local station

Connect the engineering tool to the CPU module on the local station and set the parameters.

1. Set the CPU module and add the module labels of the CPU module. The setting method of the CPU module and addition method of the module label are the same as those of the master station. (Page 79 Setting in the master station)
2. Set the master/local module as follows.

[Navigation window] ⇒ [Parameter] ⇒ [Module Information] ⇒ Right-click ⇒ [Add New Module]

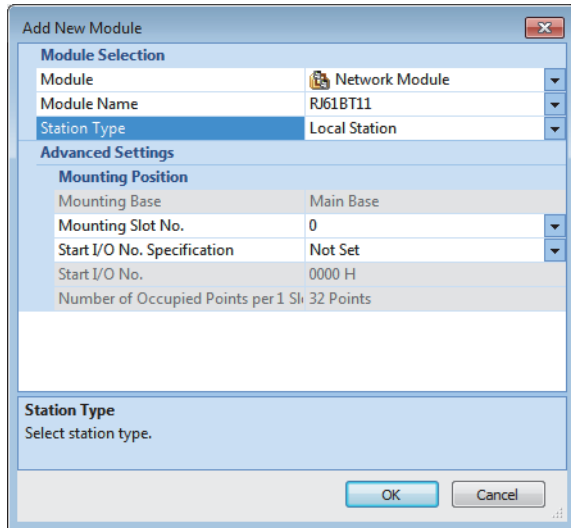

3. Add the module labels of the master/local module. The addition method of the module label is the same as that of the master station. (Page 79 Setting in the master station)
4. Set the items in "Required Settings" as follows.

[Navigation window] ⇒ [Parameter] ⇒ [Module Information] ⇒ [RJ61BT11] ⇒ [Required settings]

Setting Item	
Item	Setting
Station Type	
Station Type	Local Station
Mode	
Communication Mode	Remote Net Ver.1 Mode
Station Number	
Station No.	1
Transmission Speed	
Transmission Speed	Auto-tracking
Parameter Setting Method	
Setting Method of Basic/Application Settings	Parameter Editor

5. Set the own station setting as follows.

[Navigation window] ⇒ [Parameter] ⇒ [Module Information] ⇒ [RJ61BT11] ⇒ [Basic Settings] ⇒ [Own station Settings]

Setting Item	
Item	Setting
Own Station Setting	
Number of Occupied Stations	1 Station Occupied
Extended Cyclic Setting	Single
Network Configuration Settings	
CC-Link Configuration	<Detailed Setting>
Link Refresh Settings	
Link Refresh Settings	<Detailed Setting>
Initial Settings	
Remote Device Station Initial Settings	<Detailed Setting>

6. Set the link refresh settings as follows.

[Navigation window] ⇒ [Parameter] ⇒ [Module Information] ⇒ [RJ61BT11] ⇒ [Basic Settings] ⇒ [Link Refresh Settings]

No.	Link Side						CPU Side				
	Device Name	Points	Start	End	Target		Device Name	Points	Start	End	
-	SB	512	00000	001FF	Module Label						
-	SW	512	00000	001FF	Module Label						
1	RX	32	00000	0001F	Specify Device	X	32	01000	0101F		
2	RY	32	00000	0001F	Specify Device	Y	32	01000	0101F		
3	RWr	4	00000	00003	Specify Device	W	4	00000	00003		
4	RWw	4	00000	00003	Specify Device	W	4	00100	00103		
5											

7. Set the supplementary cyclic settings as follows.

[Navigation window] ⇒ [Parameter] ⇒ [Module Information] ⇒ [RJ61BT11] ⇒ [Application Settings] ⇒ [Supplementary Cyclic Settings]

Item	Setting
Supplementary Cyclic Settings	
Input Data from Data Link Faulty Station	Clear
Output Mode upon CPU STOP	Send Remote Output (RY)
Station-based Block Data Assurance	Enable
Number of Retries	3 Times
Automatic Reconnection Station Count	1PLC
Data Link Setting at CPU Failure	Stop the Data Link
Scan Mode Setting	Asynchronous with Sequence Scan
Output Mode upon CPU Error	Clear
Interrupt Settings	
Interrupt Settings	<Detailed Setting>
Parameter Name	
Parameter Name	

8. Write the set parameters to the CPU module on the local station. Then reset the CPU module or power off and on the system.

[Online] ⇒ [Write to PLC]

Point

In this example, default values are used for parameters that are not shown above. For the parameter setting, refer to the chapter explaining the parameters in this manual. (☞ Page 57 PARAMETER SETTINGS)

Checking the data link status

Check whether data link is normally performed between the master station and local station after setting parameters for both of the stations.

1. Power on the local station, then master station to start data link.
2. When the LEDs are in the following states, data link is being performed normally.
 - LEDs on the master station

LED	Status
RUN	On
ERR.	Off
MST	On
S MST	Off
156K	On
625K	Off
2.5M	
5M	
10M	
L RUN	On
L ERR.	Off
SD	Flashing ^{*1}
RD	

*1 The LEDs may look dimly lit or off depending on the communication status.

- LEDs on the local station

LED	Status
RUN	On
ERR.	Off
MST	
S MST	
156K	On
625K	Off
2.5M	
5M	
10M	
L RUN	On
L ERR.	Off
SD	Flashing ^{*1}
RD	

*1 The LEDs may look dimly lit or off depending on the communication status.

Program examples

- Sending station: Master station (station No.0)

Classification	Label name	Description	Device																				
Module label	BT11_1.blIn_ModuleFailure	Module failure	X0																				
	BT11_1.blIn_DataLink	Own station data link status	X1																				
	BT11_1.blIn_ModuleReady	Module ready	XF																				
	BT11_1.blInSts_DataLinkError_Other[1]	Data link status of other stations (station No.1)	SW0080.0																				
Label to be defined	Define global labels as shown below:																						
	<table border="1"> <thead> <tr> <th>Label Name</th> <th>Data Type</th> <th>Class</th> <th>Assign (Device/Label)</th> </tr> </thead> <tbody> <tr> <td>StartDirection</td> <td>Bit</td> <td>VAR_GLOBAL</td> <td>M100</td> </tr> <tr> <td>DataSend</td> <td>Bit</td> <td>VAR_GLOBAL</td> <td>X20</td> </tr> <tr> <td>DataRecv</td> <td>Bit</td> <td>VAR_GLOBAL</td> <td>Y31</td> </tr> <tr> <td>DataLinkError</td> <td>Bit</td> <td>VAR_GLOBAL</td> <td>Y3F</td> </tr> </tbody> </table>			Label Name	Data Type	Class	Assign (Device/Label)	StartDirection	Bit	VAR_GLOBAL	M100	DataSend	Bit	VAR_GLOBAL	X20	DataRecv	Bit	VAR_GLOBAL	Y31	DataLinkError	Bit	VAR_GLOBAL	Y3F
Label Name	Data Type	Class	Assign (Device/Label)																				
StartDirection	Bit	VAR_GLOBAL	M100																				
DataSend	Bit	VAR_GLOBAL	X20																				
DataRecv	Bit	VAR_GLOBAL	Y31																				
DataLinkError	Bit	VAR_GLOBAL	Y3F																				

Device	Description	Module
X1000 to X101D	Remote input (RX0 to RX1D)	RJ61BT11 (local station)
Y1000 to Y101D	Remote output (RY0 to RY1D)	
W0 to W3	Remote register (RWr0 to RWr3)	
W100 to W103	Remote register (RWw0 to RWw3)	

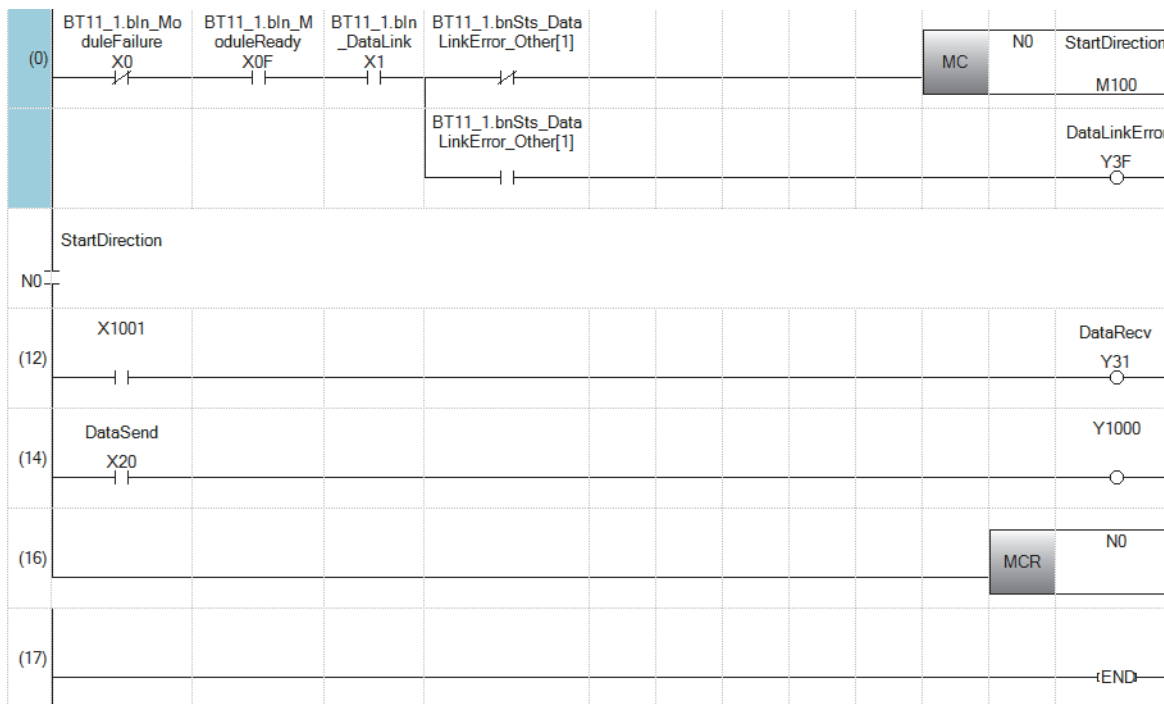

- (0) The data link status is checked.
- (12)Control program using receive data from a local station
- (14)Program to create send data to a local station

- Receiving station: Local station (station No.1)

Classification	Label name	Description	Device	
Module label	BT11_1.blIn_ModuleFailure	Module failure	X0	
	BT11_1.blIn_DataLink	Own station data link status	X1	
	BT11_1.blIn_ModuleReady	Module ready	XF	
Label to be defined	Define global labels as shown below:			
	Label Name	Data Type	Class	Assign (Device/Label)
	StartDirection	Bit	VAR_GLOBAL	M100
	DataSend	Bit	VAR_GLOBAL	X21
	DataRecv	Bit	VAR_GLOBAL	Y30

Device	Description	Module
X1000 to X101D	Remote input (RX0 to RX1D)	RJ61BT11 (master station)
Y1000 to Y101D	Remote output (RY0 to RY1D)	
W0 to W3	Remote register (RW0 to RW3)	
W100 to W103	Remote register (RW0 to RW3)	

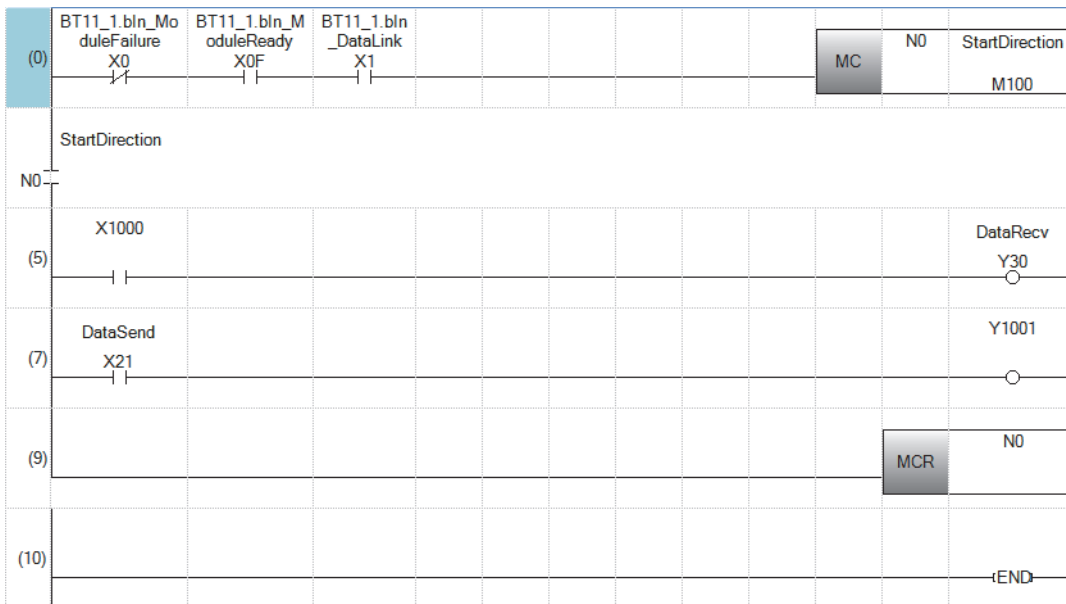

- (0) The data link status is checked.
- (5) Control program using receive data from the master station
- (7) Program to create send data to the master station

• Program flow

- 1 Master station (14): When 'DataSend' (X20) in the master station is turned on, Y1000 in the master station turns on and X1000 in the local station turns on.
- 2 Local station (5): When X1000 in the local station turns on, 'DataRecv' (Y30) in the local station turns on.
- 3 Local station (7): When 'DataSend' (X21) in the local station is turned on, Y1001 in the local station turns on and X1001 in the master station turns on.
- 4 Master station (12): When X1001 in the master station turns on, 'DataRecv' (Y31) in the master station turns on.

To assure the integrity of cyclic data in each slave station

One of the following actions assures the integrity of cyclic data in each slave station.

Note that data integrity is not assured across slave stations.

■Using the engineering tool

Set "Station-based Block Data Assurance" under "Supplementary Cyclic Settings" in "Application Settings" to "Enable". (Page 72 Supplementary Cyclic Settings)

■Using a program

Interlock with RX and RY.

- Master station (station No.0)

Label Name	Data Type	Class	Assign (Device/Label)
ReqSend	Bit	VAR_GLOBAL	M0
SendData	Word [Unsigned]/Bit String [16-bit]	VAR_GLOBAL	D0

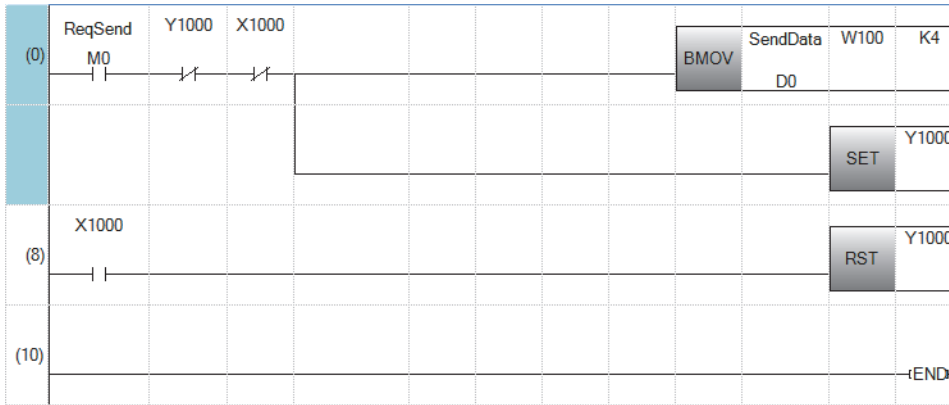

• Local station (station No.1)

Label Name	Data Type	Class	Assign (Device/Label)
ReqRecv	Bit	VAR_GLOBAL	M0
RecvData	Word [Unsigned]/Bit String [16-bit]	VAR_GLOBAL	D100

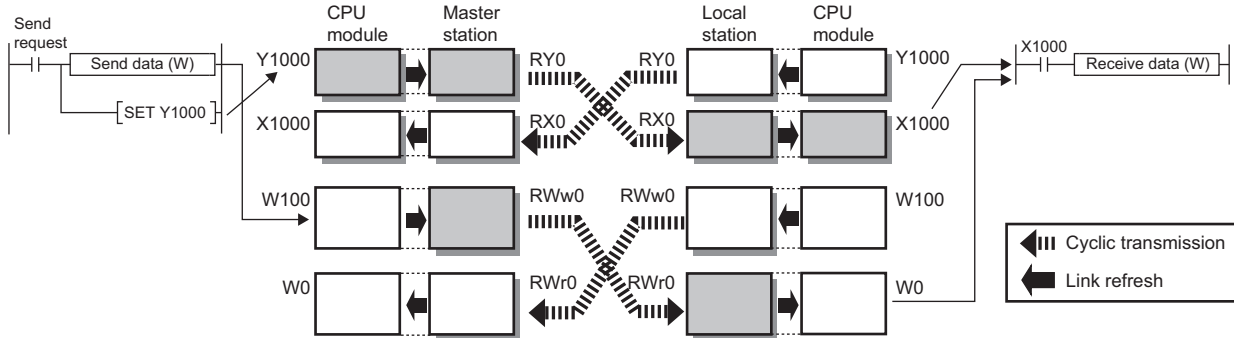
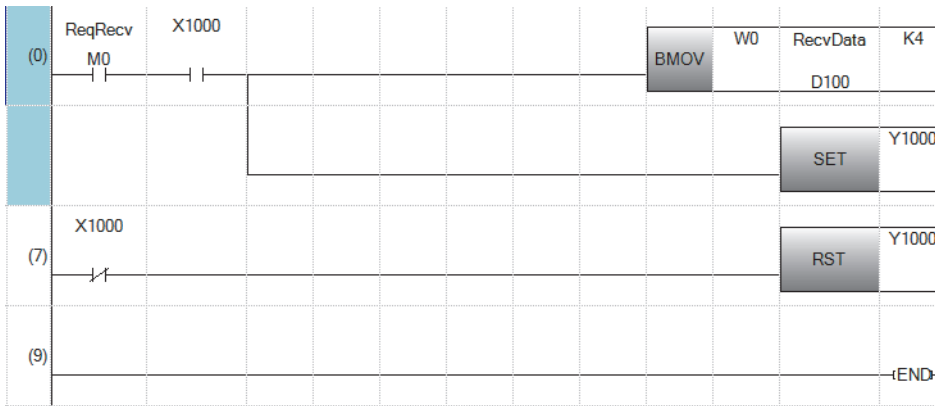

• Program flow

- ① Master station (0): Turn on 'ReqSend' (M0) in the master station.
- ② Local station (0): Turn on 'ReqRecv' (M0) in the local station.
- ③ Master station (0): Information in 'SendData' (D0 to D3) is transferred to W100 to W103 (RWw0 to RWw3).
- ④ Master station (0): After the information is stored in W100 to W103, turn on Y1000 for a handshake in the master station.*1
- ⑤ Local station (0): Data in RWw is sent before data in RY is sent by cyclic transmission. Then X1000 in the local station turns on.
- ⑥ Local station (0): Information in W0 to W3 is stored in 'RecvData' (D100 to D103).
- ⑦ Local station (0): After the information is stored in 'RecvData' (D100 to D103), turn on Y1000 for a handshake in the local station.
- ⑧ Master station (8): Turning on Y1000 in the local station turns off Y1000 in the master station.
- ⑨ Local station (7): Turning off Y1000 in the master station turns off Y1000 in the local station.

*1 If a handshake is performed in one bit of the remote I/O (RX, RY) in a station with the number of occupied stations of two or more, the integrity of cyclic data is assured per slave station. An interlock for the number of occupied stations (in units of four words) is not required.

3.3 Communication Example Using the Standby Master Function

This section describes communications using the master station duplex function of the standby master function.

System configuration example

The following system configuration is used to explain communications using the master station duplex function.

System configuration

The same system is used for the master station and standby master station.

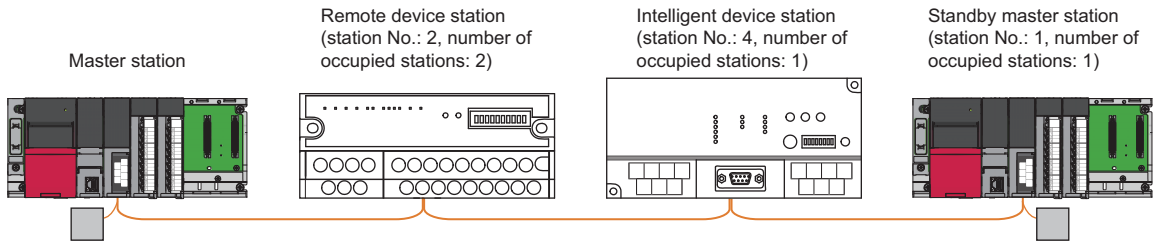

Setting in the master station

Connect the engineering tool to the CPU module on the master station and set the parameters.

1. Set the CPU module as follows.

 [Project] ⇒ [New]

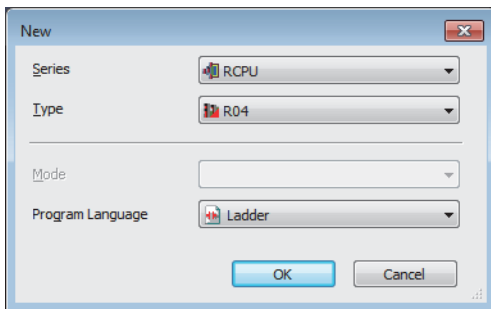

2. Click the [Setting Change] button and set the module label to [Use].

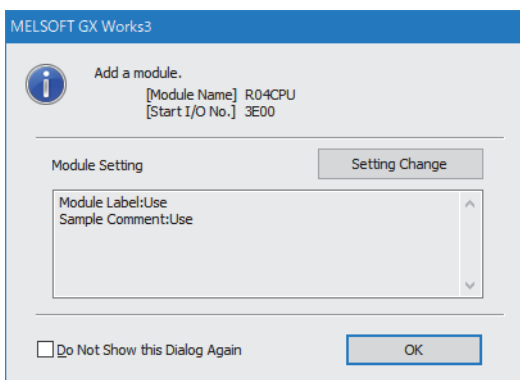

3. Set the master/local module as follows.

 [Navigation window] ⇒ [Parameter] ⇒ [Module Information] ⇒ Right-click ⇒ [Add New Module]

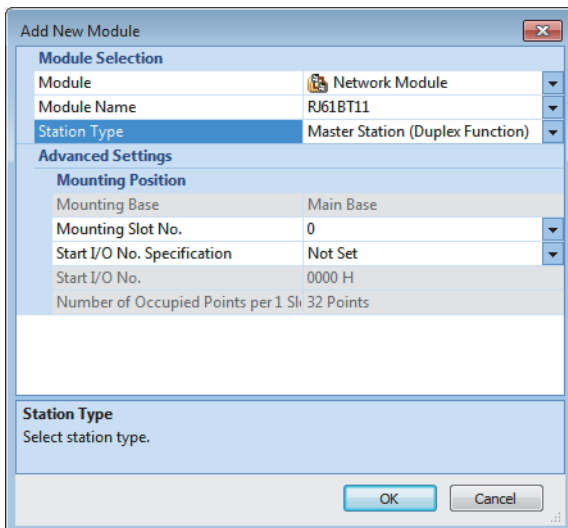

4. Click the [OK] button to add the module labels of the master/local module.

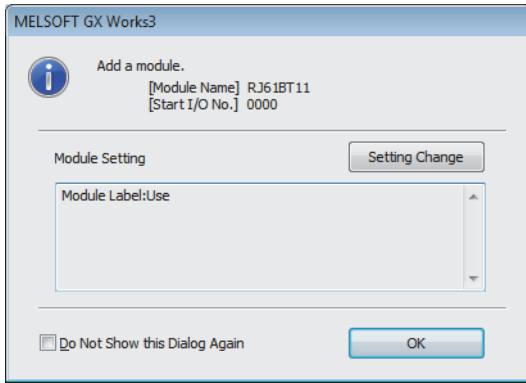

5. Set the items in "Required Settings" as follows.

[Navigation window] ⇒ [Parameter] ⇒ [Module Information] ⇒ [RJ61BT11] ⇒ [Required settings]

Setting Item	Item	Setting
Station Type	Station Type	Master Station (Duplex Function)
	Mode	Remote Net Ver.1 Mode
Station Number	Communication Mode	Remote Net Ver.1 Mode
	Station No.	0
Transmission Speed	Transmission Speed	156kbps
	Parameter Setting Method	Parameter Editor
Setting Method of Basic/Application Settings		Parameter Editor

6. Set the network configuration as follows.

[Navigation window] ⇒ [Parameter] ⇒ [Module Information] ⇒ [RJ61BT11] ⇒ [Basic Settings] ⇒ [Network Configuration Settings]

Station No.	Model Name	Station Type	Version	# of STA Occupied	Expanded Cyclic Setting	Remote Station Points	Reserved/Err Inval STA	Intelligent Buffer Selection(word)			Station-specific mode setting
								Send	Receive	Auto	
0/0	Host Station	Master Station (Duplex Function)	Ver. 1	1 Occupied STA	Single	32 Points	No Setting	64	64	128	
1/1	RJ61BT11	Standby Master Station	Ver. 1	2 Occupied STA	Single	64 Points	No Setting				
2/2	General Remote Device Station	Remote Device Station	Ver. 1	1 Occupied STA	Single	32 Points	No Setting	64	64	128	
3/4	Gen. Intelligent Device Station	Intelligent Device Station	Ver. 1	1 Occupied STA	Single	32 Points	No Setting				

7. Set the link refresh settings as follows.

[Navigation window] ⇒ [Parameter] ⇒ [Module Information] ⇒ [RJ61BT11] ⇒ [Basic Settings] ⇒ [Link Refresh Settings]

No.	Link Side					CPU Side				
	Device Name	Points	Start	End		Target	Device Name	Points	Start	End
-	SB	512	00000	001FF	↔	Module Label				
-	SW	512	00000	001FF	↔	Module Label				
1	RX	128	00000	0007F	↔	Specify Device	X	128	01000	0107F
2	RY	128	00000	0007F	↔	Specify Device	Y	128	01000	0107F
3	RWr	16	00000	0000F	↔	Specify Device	W	16	00000	0000F
4	RWw	16	00000	0000F	↔	Specify Device	W	16	00100	0010F
5					↔					

8. Set the supplementary cyclic settings as follows.

 [Navigation window] ⇒ [Parameter] ⇒ [Module Information] ⇒ [RJ61BT11] ⇒ [Application Settings] ⇒ [Supplementary Cyclic Settings]

Setting Item	Item	Setting
	Supplementary Cyclic Settings	
	Input Data from Data Link Faulty Station	Clear
	Output Mode upon CPU STOP	Send Remote Output (RY)
	Station-based Block Data Assurance	Enable
	Number of Retries	3 Times
	Automatic Reconnection Station Count	1PLC
	Data Link Setting at CPU Failure	Stop the Data Link
	Scan Mode Setting	Asynchronous with Sequence Scan
	Output Mode upon CPU Error	Clear
	Interrupt Settings	
	Interrupt Settings	<Detailed Setting>
	Parameter Name	
	Parameter Name	

9. Write the set parameters to the CPU module on the master station. Then reset the CPU module or power off and on the system.

 [Online] ⇒ [Write to PLC]

Point 

In this example, default values are used for parameters that are not shown above. For the parameter setting, refer to the chapter explaining the parameters in this manual. ( Page 57 PARAMETER SETTINGS)

Settings for a standby master station

Connect the engineering tool to the CPU module on the standby master station and set the parameters.

1. Set the CPU module and add the module labels of the CPU module. The setting method of the CPU module and addition method of the module label are the same as those of the master station. (☞ Page 90 Setting in the master station)
2. Set the master/local module as follows.

☞ [Navigation window] ⇒ [Parameter] ⇒ [Module Information] ⇒ Right-click ⇒ [Add New Module]

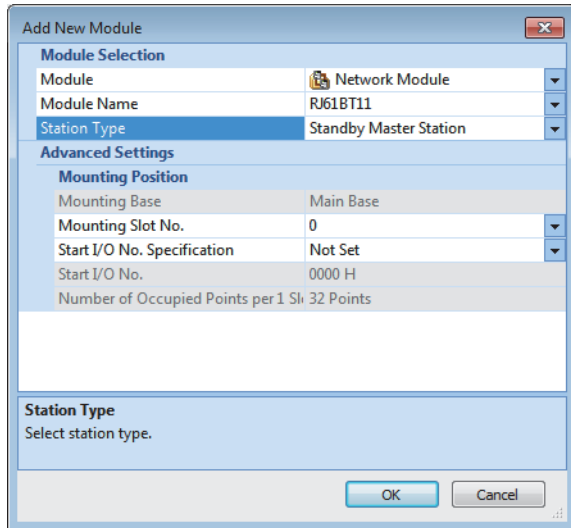

3. Add the module labels of the master/local module. The addition method of the module label is the same as that of the master station. (☞ Page 90 Setting in the master station)
4. Set the items in "Required Settings" as follows.

☞ [Navigation window] ⇒ [Parameter] ⇒ [Module Information] ⇒ [RJ61BT11] ⇒ [Required settings]

Setting Item	Item	Setting
Station Type	Station Type	Standby Master Station
Mode	Communication Mode	Remote Net Ver.1 Mode
Station Number	Station No.	1
Transmission Speed	Transmission Speed	Auto-tracking
Parameter Setting Method	Setting Method of Basic/Application Settings	Parameter Editor

5. Set the own station setting as follows.

☞ [Navigation window] ⇒ [Parameter] ⇒ [Module Information] ⇒ [RJ61BT11] ⇒ [Basic Settings] ⇒ [Own station Settings]

Setting Item	Item	Setting
Own Station Setting	Number of Occupied Stations	1 Station Occupied
	Extended Cyclic Setting	Single
Network Configuration Settings	CC-Link Configuration	<Detailed Setting>
Link Refresh Settings	Link Refresh Settings	<Detailed Setting>
Initial Settings	Remote Device Station Initial Settings	<Detailed Setting>

6. Set the link refresh settings as follows.

[Navigation window] ⇒ [Parameter] ⇒ [Module Information] ⇒ [RJ61BT11] ⇒ [Basic Settings] ⇒ [Link Refresh Settings]

No.	Link Side					CPU Side				
	Device Name	Points	Start	End		Target	Device Name	Points	Start	End
-	SB	512	00000	001FF	↔	Module Label				
-	SW	512	00000	001FF	↔	Module Label				
1	RX	128	00000	0007F	↔	Specify Device	X	128	01000	0107F
2	RY	128	00000	0007F	↔	Specify Device	Y	128	01000	0107F
3	RWr	16	00000	0000F	↔	Specify Device	W	16	00000	0000F
4	RWw	16	00000	0000F	↔	Specify Device	W	16	00100	0010F
5					↔					

7. Set the supplementary cyclic settings as follows.

[Navigation window] ⇒ [Parameter] ⇒ [Module Information] ⇒ [RJ61BT11] ⇒ [Application Settings] ⇒ [Supplementary Cyclic Settings]

Setting Item	
Item	Setting
Supplementary Cyclic Settings	
Input Data from Data Link Faulty Station	Clear
Output Mode upon CPU STOP	Send Remote Output (RY)
Station-based Block Data Assurance	Enable
Number of Retries	3 Times
Automatic Reconnection Station Count	1PLC
Data Link Setting at CPU Failure	Stop the Data Link
Scan Mode Setting	Asynchronous with Sequence Scan
Output Mode upon CPU Error	Clear
Interrupt Settings	
Interrupt Settings	<Detailed Setting>
Parameter Name	
Parameter Name	

8. Write the set parameters to the CPU module on the standby master station. Then reset the CPU module or power off and on the system.

[Online] ⇒ [Write to PLC]

Point

In this example, default values are used for parameters that are not shown above. For the parameter setting, refer to the chapter explaining the parameters in this manual. (☞ Page 57 PARAMETER SETTINGS)

Program example

- Master station, standby master station

Classification	Label name	Description	Device	
Module label	RCPU.stSM.bAlways_ON	Always on	SM400	
	RCPU.stSM.bAfter_RUN1_Scan_ON	Turning on for one scan after RUN	SM402	
	RCPU.stSM.b1sClock	One second clock	SM412	
	BT11_1.bIn_ModuleFailure	Module failure	X0	
	BT11_1.bIn_DataLink	Own station data link status	X1	
	BT11_1.bIn_ModuleReady	Module ready	XF	
	BT11_1.bReq_Refresh_StandbyMasterSwitching	Refresh instruction at standby master switching	SB0001	
	BT11_1.bReq_ForcedMasterSwitching	Forced master switching	SB000C	
	BT11_1.bAcpt_Refresh_StandbyMasterSwitching	Refresh instruction acceptance status at standby master switching	SB0042	
	BT11_1.bCompl_Refresh_StandbyMasterSwitching	Refresh instruction completion status at standby master switching	SB0043	
	BT11_1.bSts_ForcedMasterSwitchingExecutable	Forced master switching enable status	SB0046	
	BT11_1.bAcpt_MasterSwitching	Master switching request acceptance	SB005A	
	BT11_1.bCompl_MasterSwitching	Master switching request completion	SB005B	
	BT11_1.bCompl_ForcedMasterSwitching	Forced master switching request completion	SB005D	
	BT11_1.bOpe_StandbyMaster	Master/standby master operation status of own station	SB007B	
BT11_1.uRslt_Refresh_StandbyMasterSwitching	Refresh instruction at standby master switching result	SW0043		
Label to be defined	Define global labels as shown below:			
	Label Name	Data Type	Class	Assign (Device/Label)
	StartDitection_OperateMasterStation	Bit	VAR_GLOBAL	M0
	StartDitection_OperateStandbyMasterStation	Bit	VAR_GLOBAL	M1
	ControlStart_OperateMasterStation	Bit	VAR_GLOBAL	M10
	ControlStart_OperateStandbyMasterStation	Bit	VAR_GLOBAL	M11
	Compl_ScanWaitAfterBackUpLinkDevice	Bit	VAR_GLOBAL	M103
	ReqForcedMasterStationSwitching	Bit	VAR_GLOBAL	M200
	NumberOfScansAfterBackUpLinkDevice	Word [Unsigned]/Bit String [16-bit]	VAR_GLOBAL	D0
	BackUpRX	Word [Unsigned]/Bit String [16-bit](0..7)	VAR_GLOBAL	W1000
	BackUpRY	Word [Unsigned]/Bit String [16-bit](0..7)	VAR_GLOBAL	W1100
	BackUpRWw	Word [Unsigned]/Bit String [16-bit](0..15)	VAR_GLOBAL	W1500
	BackUpRWw	Word [Unsigned]/Bit String [16-bit](0..15)	VAR_GLOBAL	W1600

(0)	RCPU.stSM.bAfter_RUN1_Sca n_ON SM402									SET	ControlStart_OperateMaster Station M10
										SET	ControlStart_OperateStandb yMasterStation M11
(3)	BT11_1.bn_ModuleFailure X0	BT11_1.bn_DataLink X1	BT11_1.bn_ModuleRea dy X0F	BT11_1.bOpe_Standby Master					MC	N0	StartDitection_OperateMaste rStation M0
											StartDitection_OperateMasterS tation N0
(10)	StartDitection_OperateMasterS tation M0									RST	Compl_ScanWaitAfterBackU pLinkDevice M103
									MOV	K0	NumberOfScansAfterBackUp LinkDevice D0
(15)	BT11_1.bAcpt_MasterSwitchin g	Compl_ScanWaitAfterBackUp LinkDevice M103								INC	NumberOfScansAfterBackUp LinkDevice D0
										SET	Compl_ScanWaitAfterBackU pLinkDevice M103
(24)	BT11_1.bAcpt_MasterSwitchin g								BMOV	K4X1000	BackUpRX W1000
									BMOV	K4Y1000	BackUpRY W1100
									BMOV	W0	BackUpRWw W1500
									BMOV	W100	BackUpRWw W1600
(46)	BT11_1.bCompl_MasterSwitch ing	Compl_ScanWaitAfterBackUp LinkDevice M103							BMOV	BackUpRX W1000	K4Y1000
									BMOV	BackUpRY W1100	U0G224
									BMOV	BackUpRWw W1500	W100
									BMOV	BackUpRWw W1600	U0G736
(71)	BT11_1.bAcpt_MasterSwitchin g	BT11_1.bCompl_MasterSwitc hing	Compl_ScanWaitAfterBa ckUpLinkDevice M103							SET	BT11_1.bReq_Refresh_Sta ndbyMasterSwitching
										RST	Compl_ScanWaitAfterBackU pLinkDevice M103
(79)	BT11_1.bAcpt_Refresh_Stand byMasterSwitching	BT11_1.bCompl_Refresh_Sta ndbyMasterSwitching								RST	BT11_1.bReq_Refresh_Sta ndbyMasterSwitching
										SET	ControlStart_OperateMaster Station M10
(90)	ControlStart_OperateMasterSt ation M10	RCPU.stSM.bIsClock SM412								INCP	K4Y1020
(95)										MCR	N0
(96)	BT11_1.bn_ModuleFailure X0	BT11_1.bn_DataLink X1	BT11_1.bn_ModuleRea dy X0F	BT11_1.bOpe_Standby Master					MC	N1	StartDitection_OperateStand byMasterStation M1
											StartDitection_OperateStandb yMasterStation N1
(103)	ControlStart_OperateStandby MasterStation M11	RCPU.stSM.bIsClock SM412								INCP	K4Y1000
(108)	RCPU.stSM.bAlways_ON SM400									RST	ControlStart_OperateMaster Station M10
(110)										MCR	N1
(111)											{END}

- (0) Set the control start relay when the master station or standby master station is operating.
- (10) Turn off 'Compl_ScanWaitAfterBackUpLinkDevice' (M103). Also, clear 'NumberOfScansAfterBackUpLinkDevice' (D0).
- (15) After saving the RX, RY, RWr, RWw data to devices and wait a fixed number of scans, turn on 'Compl_ScanWaitAfterBackUpLinkDevice' (M103).
 After saving the link devices, wait a fixed number of scans and execute the processing that sets the link devices saved at master switching and 'Refresh instruction at standby master switching' (SB0001). (In the program example, wait for the number of scans for the value entered in the position "K0".)
 For details, refer to precautions of the standby master function. (Page 50 Precautions)
- (24) When 'Master switching request acceptance' (SB005A) turns on, data in RX, RY, RWr, and RWw are saved in 'BackUpRX' (W1000), 'BackUpRY' (W1100), 'BackUpRWr' (W1500), and 'BackUpRWw' (W1600).
- (46) When 'Master switching request completion' (SB005B) turns on and 'Compl_ScanWaitAfterBackUpLinkDevice' (M103) turns on, data saved in 'BackUpRX' (W1000), 'BackUpRY' (W1100), 'BackUpRWr' (W1500), and 'BackUpRWw' (W1600) are stored in RX, RY, RWr, and RWw.
- (71) Turn on 'Refresh instruction at standby master switching' (SB0001).
- (79) Turn off 'Refresh instruction at standby master switching' (SB0001).
- (90) Control program when the master station is operating
- (103) Control program when the standby master station (local station) is operating

To switch the data link control from the standby master station to the master station

To switch the data link control forcibly from the standby master station to the master station, change (90) and (103) in the program as shown below: (☞ Page 95 Program example)

■Program for (90)

(90)	ControlStart_OperateMasterStation M10	RCPUsiSM_b1sClock SM412								INCP	K4Y1020
		ReqForcedMasterStationSwitching M200	BT11_1_bSis_ForcedMasterSwitchingExecutable							SET	BT11_1_bReq_ForcedMasterSwitching

■Program for (103)

(103)	ControlStart_OperateStandbyMasterStation M11	RCPUsiSM_b1sClock SM412								INCP	K4Y1000
		BT11_1_bCompL_ForcedMasterSwitching								RST	BT11_1_bReq_ForcedMasterSwitching

4 TROUBLESHOOTING

This chapter describes how to identify and remove the cause of an error in the master/local module.

4.1 Checking with LED

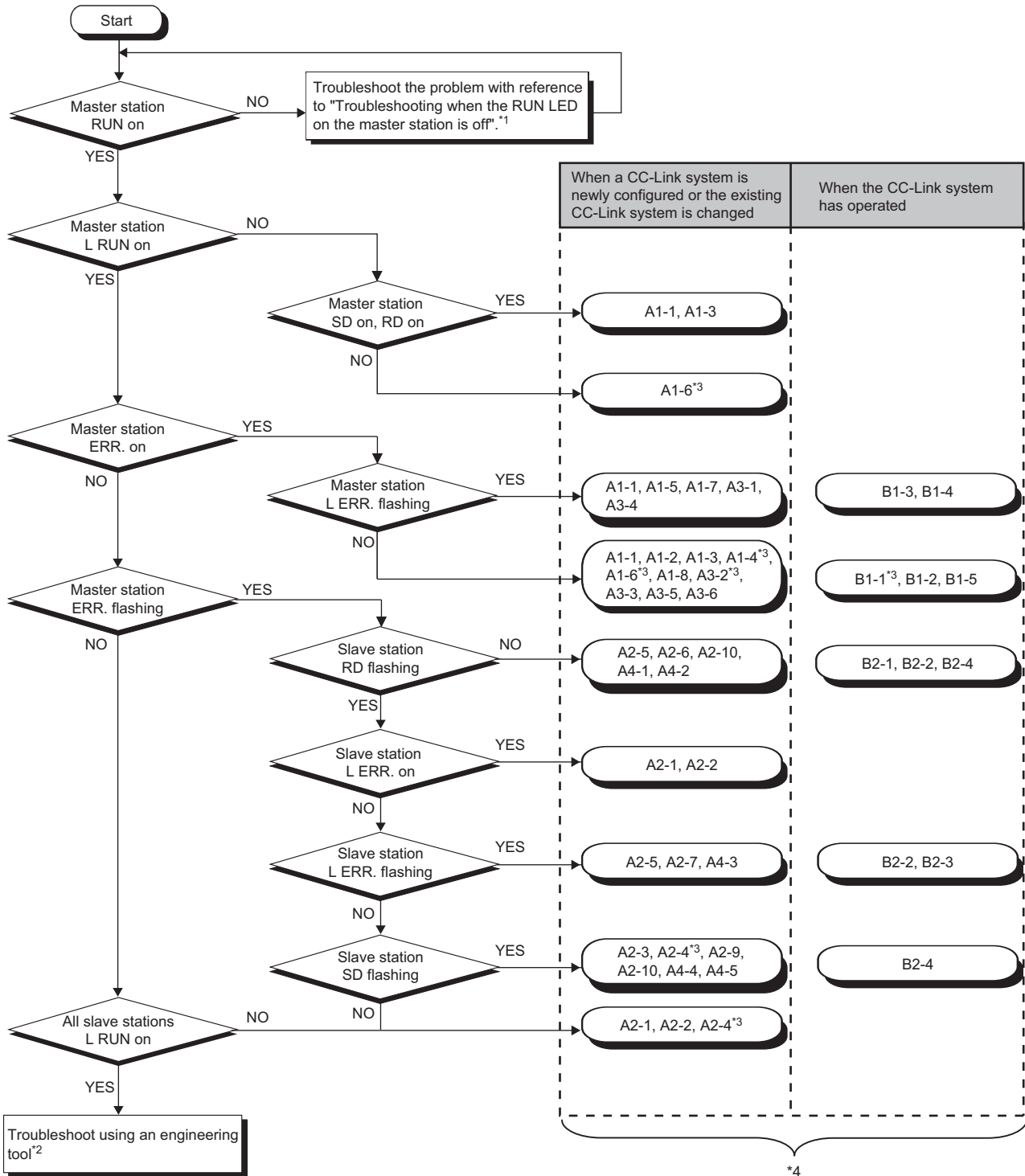

*1 Page 100 When the RUN LED of the master station turns off

*2 Page 101 Checking the Module Status

*3 An engineering tool is required to check the error details.

*4 The item corresponds to the number of the check item for when a slave station is disconnected. Refer to the corresponding check item and take the action. (Page 120 When a slave station is disconnected)

When the RUN LED of the master station turns off

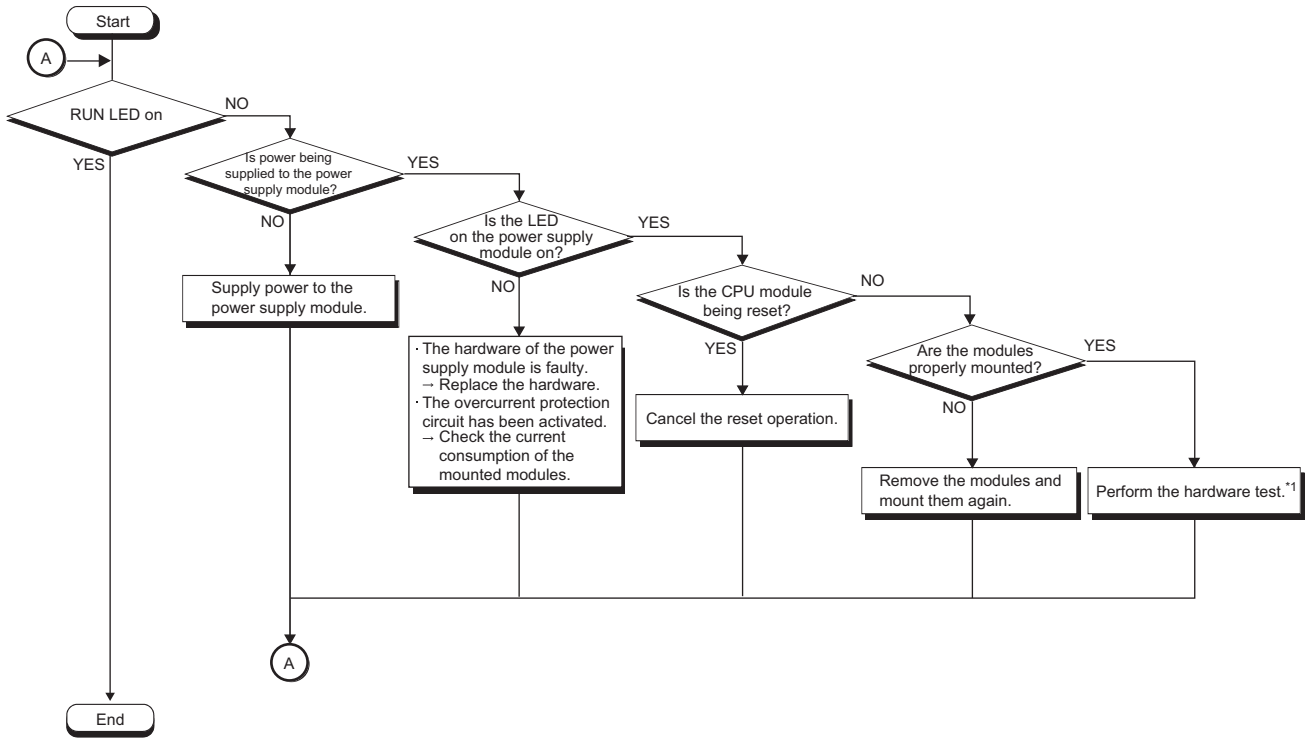

*1 Page 115 Hardware Test

4.2 Checking the Module Status

The following items can be checked in the "Module Diagnostics" window for the master/local module.

Item		Description
Error Information		Displays the details of the errors currently occurring. Click the [Event History] button to check the history of errors that have occurred on the CC-Link system, errors detected for each module, and operations that have been executed.
Module Information List		Displays various status information of the master/local module.
Supplementary Function	CC-Link Diagnostics	Enables checking the cause to resolve the problem when an error occurs in the CC-Link system. ( Page 103)

4

Error Information

Check the details of the error currently occurring and action to remove the error.

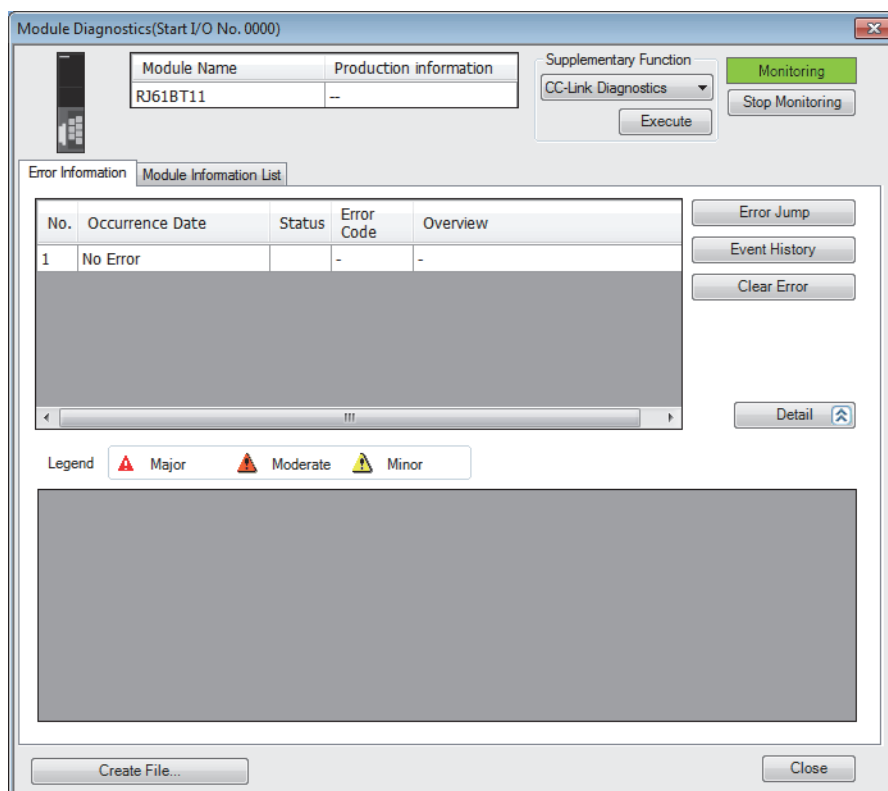

Item	Description
Detailed Information	Displays detailed information about each error (maximum of 3 pieces).
Cause	Displays the detailed error causes.
Corrective Action	Displays the actions to eliminate the error causes.

Module Information List

Switch to the [Module Information List] tab to check various status information of the master/local module.

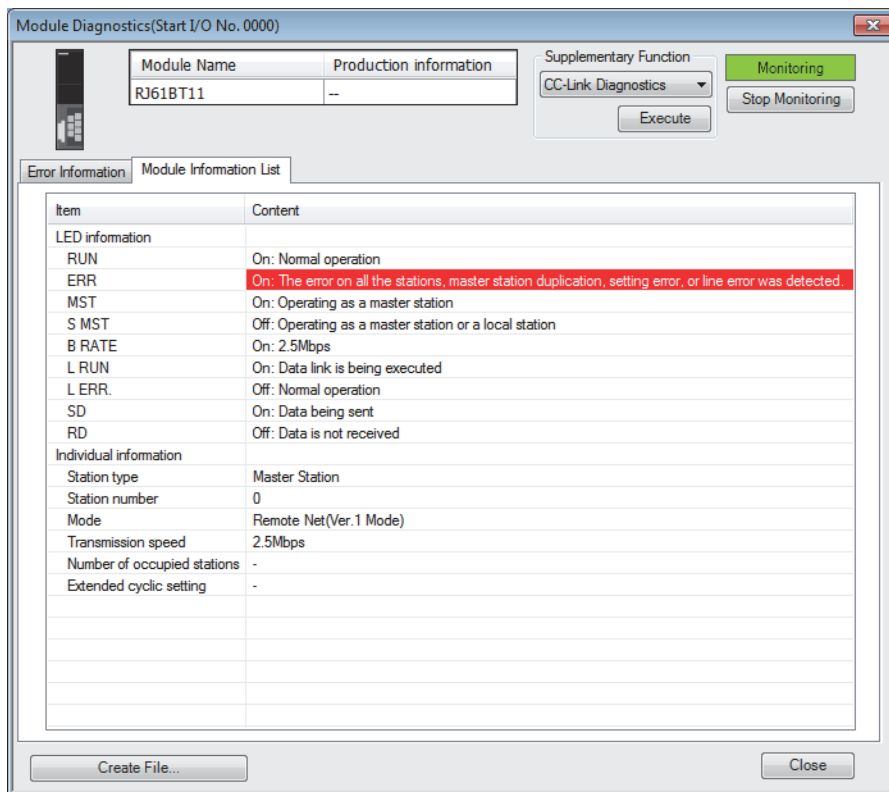

Item	Description	
LED information	Displays the LED status of the master/local module.	
Individual information	Station type	Displays the station type set for the module selected.
	Station number	Displays the station number set for the module selected.
	Mode	Displays the mode setting set for the module selected.
	Transmission speed	Displays the transmission speed set for the module selected.
	Number of occupied stations ^{*1}	Displays the number of occupied stations set for the module selected.
	Extended cyclic setting ^{*1}	Displays the extended cyclic setting set for the module selected.

*1 When the "Station type" is "Master Station" or "Master Station (Duplex Function)", "—" is displayed.

4.3 Checking the System Status

Perform the CC-Link diagnostics to check the system status and error details or to perform a line test for troubleshooting.

 [Diagnostics] ⇒ [CC-Link Diagnostics]

Point

- In a redundant system configuration of the remote head module, the CC-Link diagnostics cannot be started when the engineering tool is connected to the remote head module of the standby system. Connect it to the remote head module of the control system, and start the system.
 - In a redundant system configuration, the CC-Link diagnostics cannot be started if the system A/system B display is switched on the main base information of the system monitor.
-

The following figure shows how to perform troubleshooting using CC-Link diagnostics.

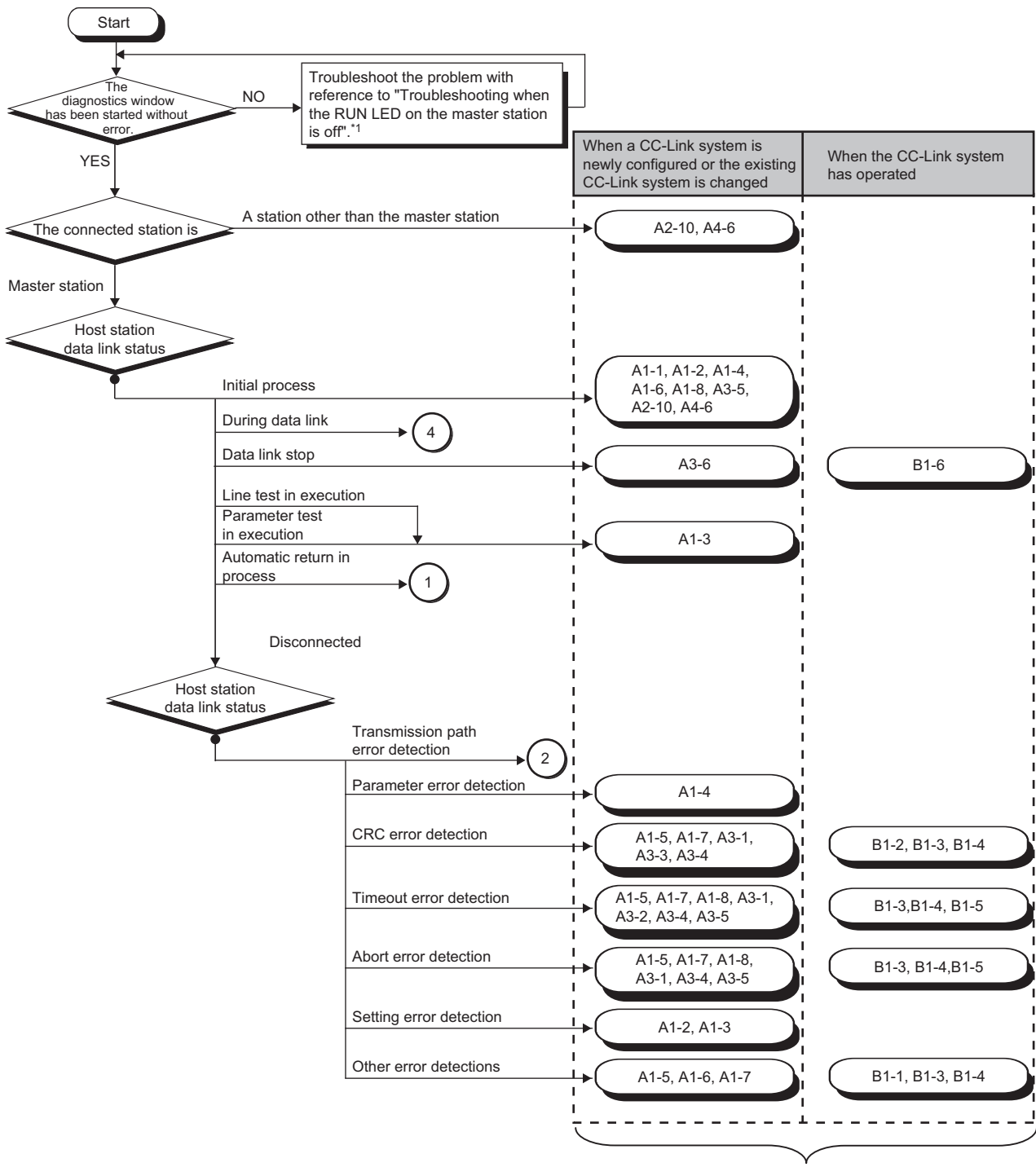

*1 Page 100 When the RUN LED of the master station turns off

*2 The item corresponds to the number of the check item for when a slave station is disconnected. Refer to the corresponding check item and take the action. (Page 120 When a slave station is disconnected)

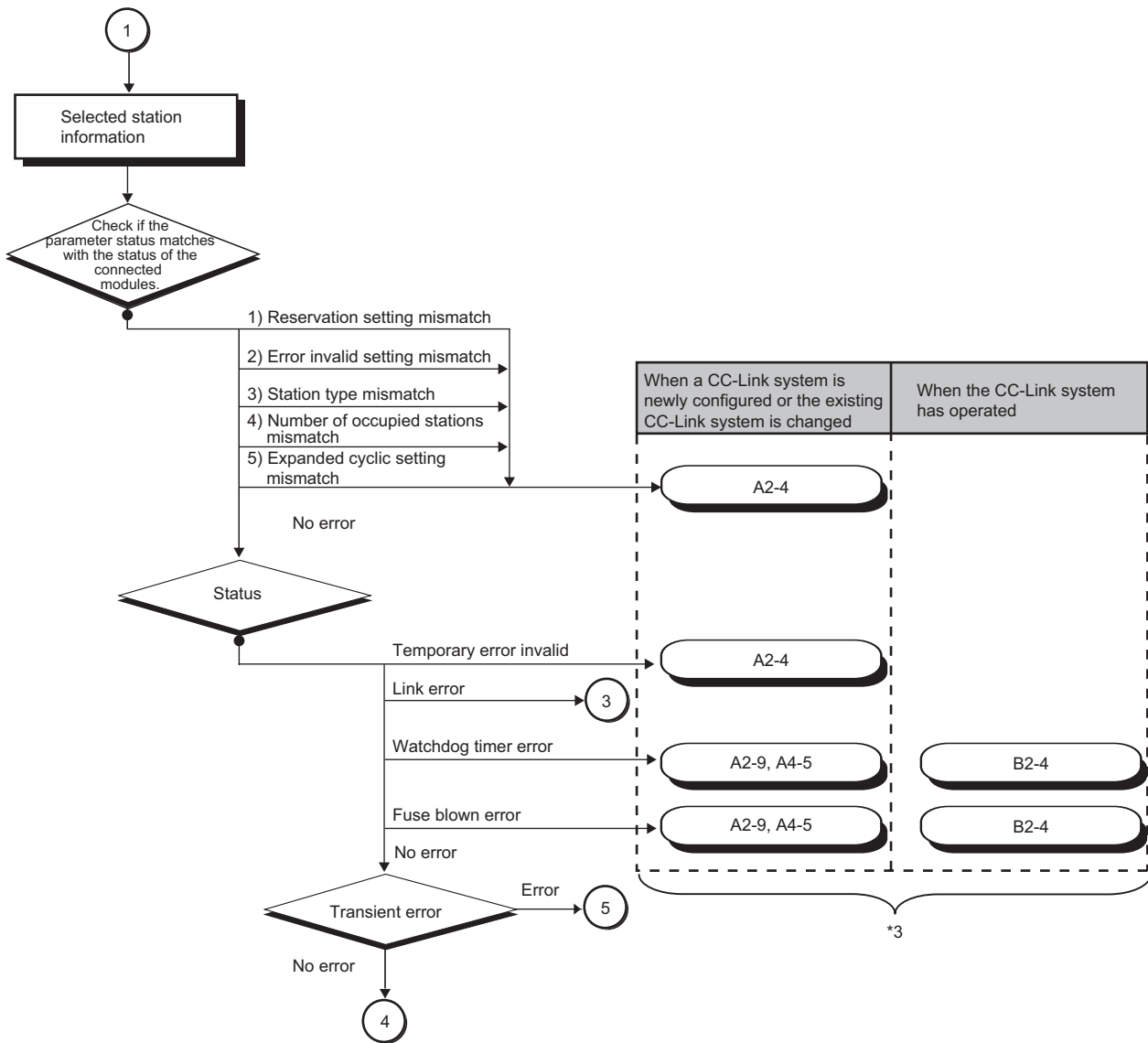

*3 The item corresponds to the number of the check item for when a slave station is disconnected. Refer to the corresponding check item and take the action. (👉 Page 120 When a slave station is disconnected)

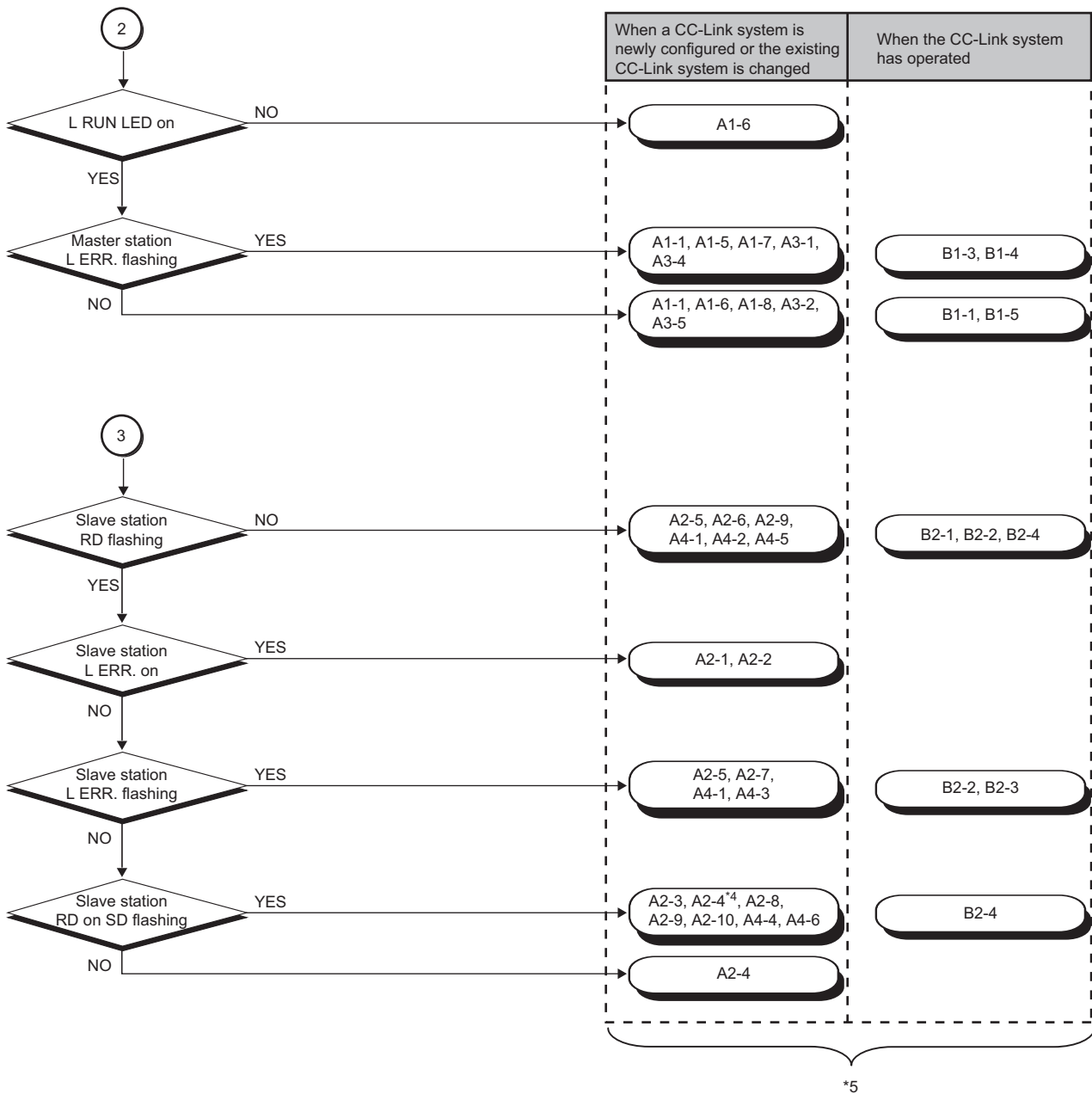

*4 An engineering tool is required to check the error details.

*5 The item corresponds to the number of the check item for when a slave station is disconnected. Refer to the corresponding check item and take the action. (☞ Page 120 When a slave station is disconnected)

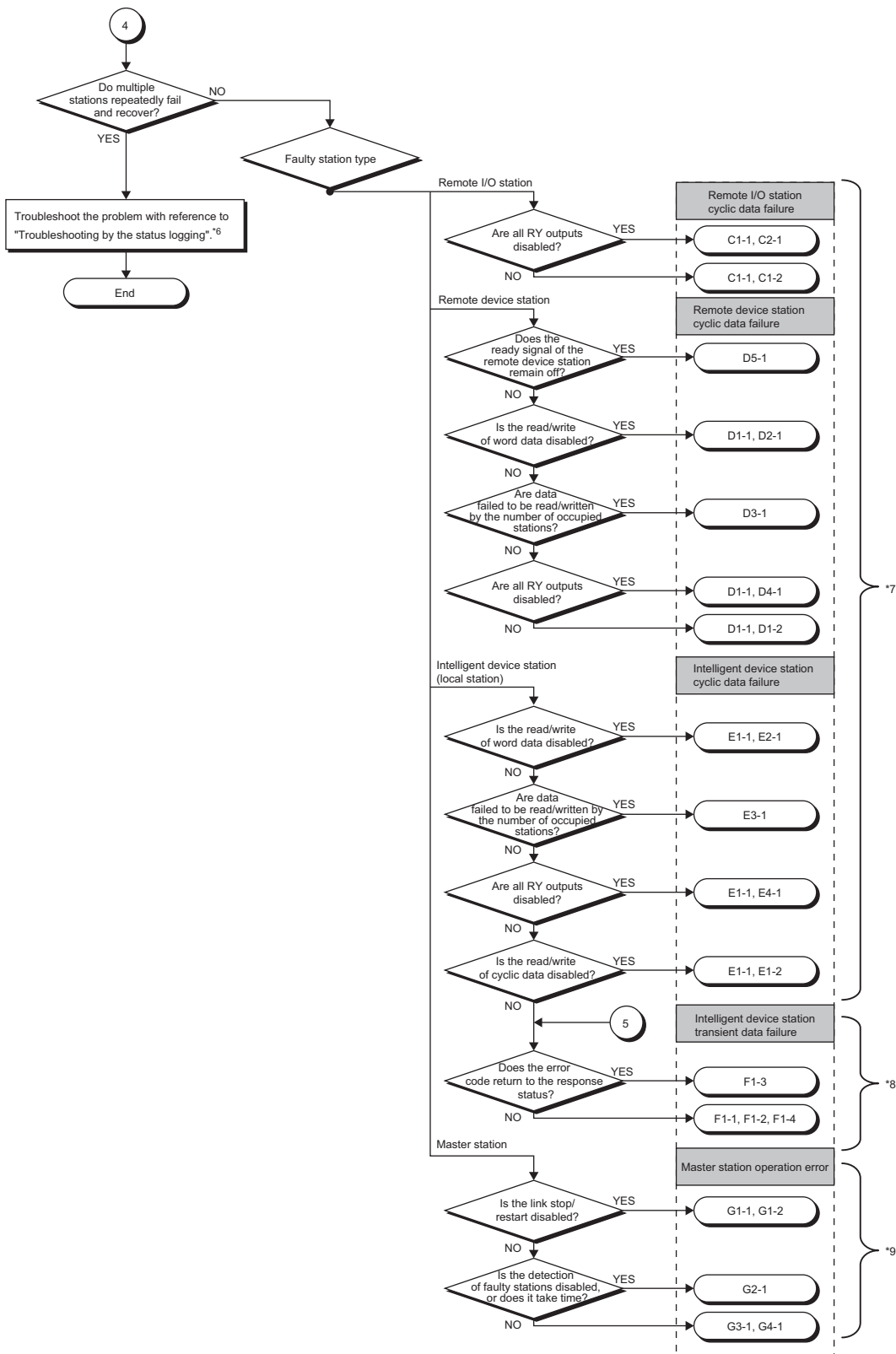

*6 Page 111 Status logging

*7 The item corresponds to the number of the check item for when cyclic transmission cannot be performed. Refer to the corresponding check item and take the action. (Page 116 When cyclic transmission cannot be performed)

*8 The item corresponds to the number of the check item for when transient transmission cannot be performed. Refer to the corresponding check item and take the action. (Page 119 When transient transmission cannot be performed)

*9 The item corresponds to the number of the check item for when operation error occurs on the master station. Refer to the corresponding check item and take the action. (Page 125 When operation error occurs on the master station)

Diagnostics window

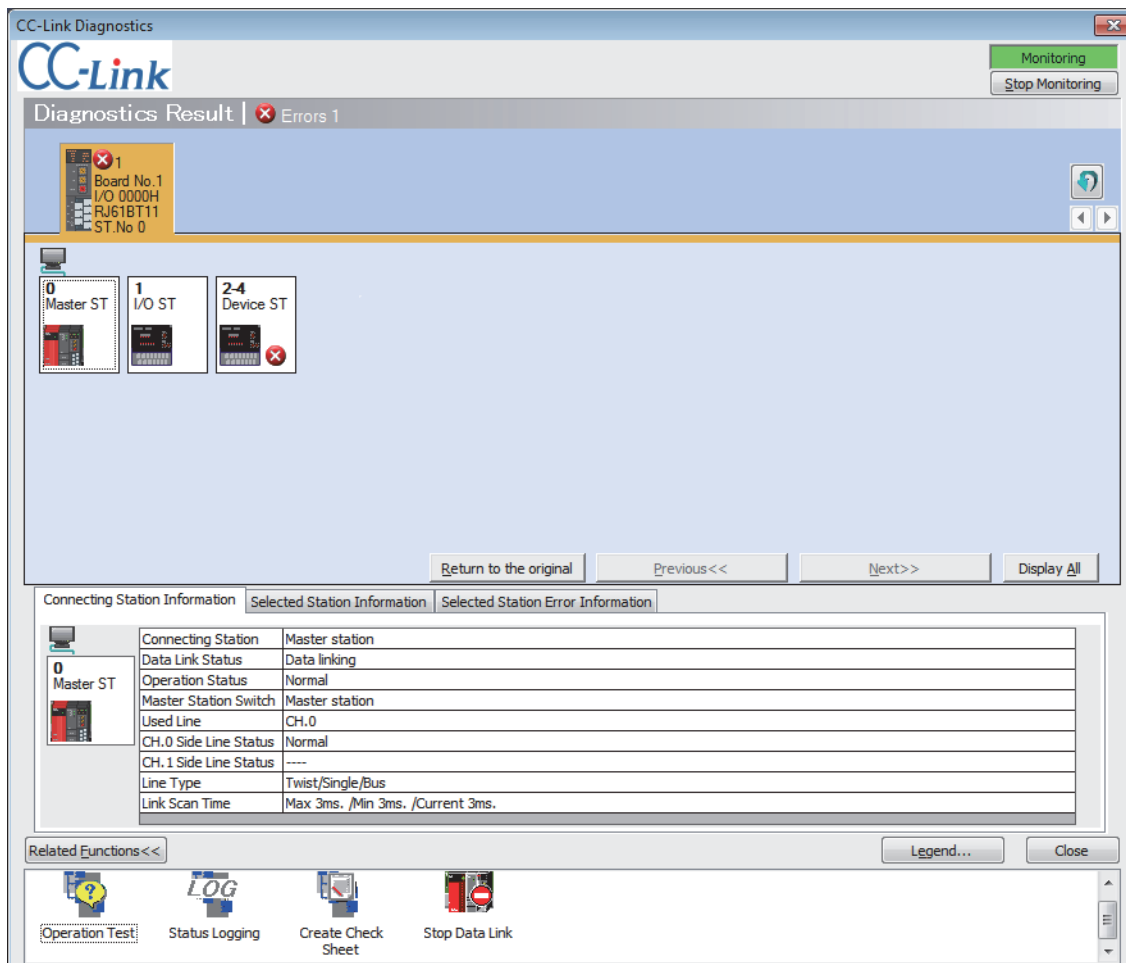

Item	Description
Diagnostics Result	Displays the number of errors and warnings that have occurred on the master/local module.
Module list/diagnostics target selection area	Displays master/local modules. The number of errors (errors and warnings) that have occurred is also displayed. The diagnostics target can be changed by clicking a module icon.
Station list	Displays stations in the CC-Link system using icons. In the "Detail Display" mode, the 24th or later stations are displayed by clicking the [Next] button. Display is switched using the [Display All] button or [Detail Display] button. In the "Display All" mode, information on all stations can be viewed in one window. The icons can be freely arranged by drag-and-drop. To display the icons in the order of station number, click the [Return to the original] button.
Connected Station Information	Displays the station number of the connected station (own station).
Selected Station Information	Displays the information, such as a station number, of the station selected in the station list area (other station).
Selected Station Error Information	Displays error information of the station selected in the station list area.
Related Functions	Switches whether to display or hide the related function icons. For details on the related functions, refer to the following. <ul style="list-style-type: none"> • Operation Test (☞ Page 109 Line test, Page 111 Checking the transmission speed setting) • Status Logging (☞ Page 111 Status logging) • Create Check Sheet (☞ Page 113 Creating a check sheet) • Start Data Link/Stop Data Link (☞ Page 113 Stopping and restarting data link)
Legend	Displays the explanation of icons on the diagnostics window.

Point

Update of the number of errors/warnings in "Diagnostics Result"

Only the number of errors/warnings that occur in the system of the module selected in "Module list/diagnostics target selection area" is updated during monitoring.

To update to the latest number of errors/warnings of other modules, update the module list.

Line test

Check whether a Ver.1.10-compatible CC-Link dedicated cable is properly connected and data link can be performed with slave stations.

Execute the test from the master station.

■Procedure

1. Open the "CC-Link Diagnostics" window.

 [Diagnostics] ⇒ [CC-Link Diagnostics]

2. Double-click "Operation Test" in "Related Functions".

3. Select "Loop test" under "Test Type".

4. Select the slave station where the line test is performed under "Test Target".

- Select "All stations (Station 1-64)" to perform the test for all stations connected.
- Select "Specified station" to perform the test for the station specified. Specify the start station number when the number of occupied stations is two or more.

5. Click the [Execute] button to start the line test. After the line test is completed, the result is displayed on the right side of the window.

- Do not write data to the buffer memory areas (buffer memory address: 5E0H and 608H) during line test.
- Do not perform a line test using a program and other peripherals at the same time. The line test may not be normally performed.

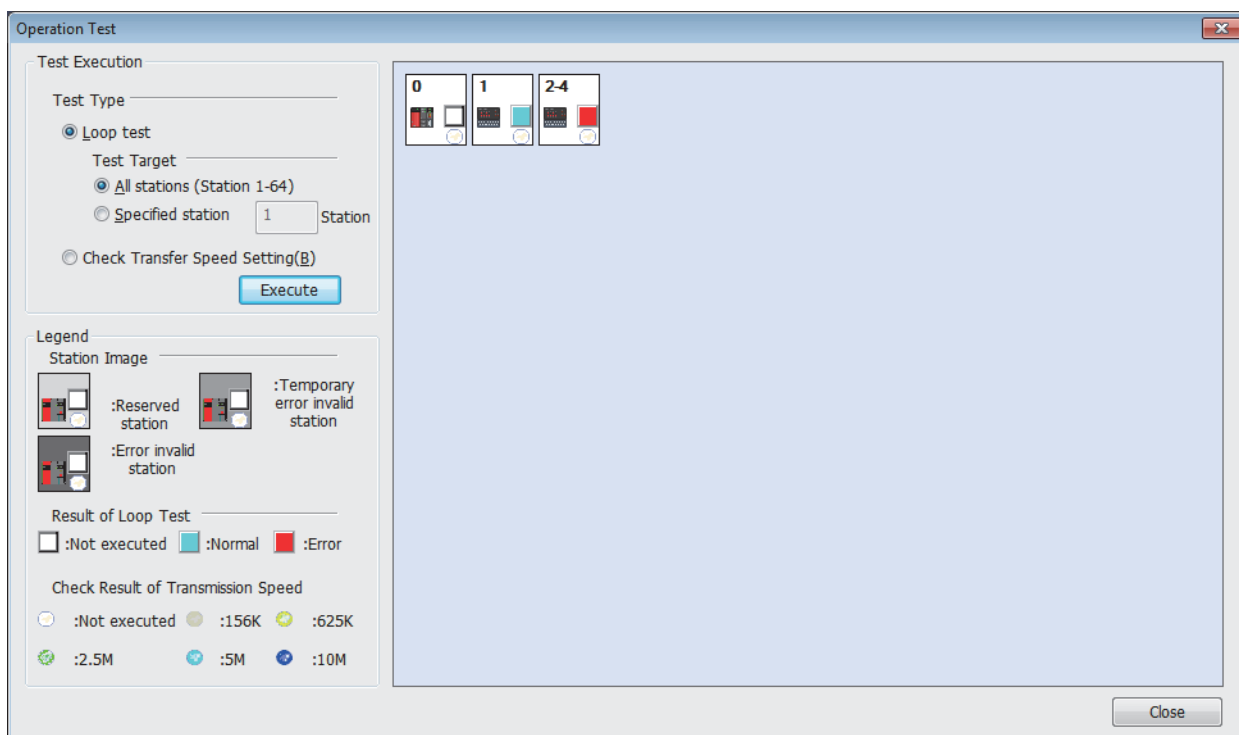

Point

When performing a line test, do not set the transmission speed of slave stations to auto-tracking. Set the transmission speed of slave stations to the same as that of the master station. An error may occur during the line test for slave stations whose transmission speed is set only to auto-tracking. If occurred, check the cable connection status and the network line status by following the troubleshooting procedure.

■ Performing the test using parameter settings

Line test can be performed using parameter settings in addition to CC-Link diagnostics.

This section describes the procedure for performing using parameter settings.

1. Check that the RUN/STOP/RESET switch of the CPU module is set to STOP.
2. Set "Required Settings" of the master/local module as follows using the engineering tool.

 [Navigation window] ⇒ [Parameter] ⇒ [RJ61BT11] ⇒ [Module Parameter] ⇒ [Required Settings]

Item	Setting
Station Type	"Master Station" or "Master Station (Duplex Function)"
Mode	Line Test
Station Number	0
Transmission Speed	Set the same as while system is running.

3. Write the module parameters to the CPU module.
4. Power off and on or reset the CPU module to start the line test.
5. Check the test result with the dot matrix LED of the master/local module.

Test results	Dot matrix LED indication	Description
Normal completion	L.T. (flashes for at least 5 seconds)	Test results are stored in 'Line test 1 result' (SW00B4 to SW00B7). The line test is performed for all the 64 stations regardless of whether it is connected or not. Ignore test results for the slave stations not connected and stations whose transmission speed is set to auto-tracking. For standby master station, the test result is stored only in 'Standby master station test result' (SB00B4). If the test has completed successfully, operations of step 6 to 9 are not required.
Abnormal end	ERR	Test results are stored in 'Line test 2 result' (SW00B8). If the test has ended abnormally, perform the line test for the slave station where an error has occurred by following the step 6 to 9.

6. Using the engineering tool, change the following setting to the station number of the slave station where an error has occurred. Specify the start station number when the number of occupied stations is two or more.

 [Navigation window] ⇒ [Parameter] ⇒ [RJ61BT11] ⇒ [Module Parameter] ⇒ [Required Settings] ⇒ [Station Number]

7. Write the module parameters to the CPU module.
8. Power off and on or reset the CPU module to start the line test.
9. Check the test result with the dot matrix LED of the master/local module.

Test results	Dot matrix LED indication	Description
Normal completion	L.T. (flashes for at least 5 seconds)	—
Abnormal end	ERR	Test results are stored in 'Line test 2 result' (SW00B8).

Point

- To perform a line test (step 7) for the standby master station, specify the station number of standby master station set in "Network Configuration Settings" under "Basic Settings".
- When the data link startup by standby master station is executed, line test using parameter setting cannot be performed. Perform the line test using the engineering tool.

Checking the transmission speed setting

Check that the transmission speed setting of the slave station is the same as that of the master station.

The station number of the slave station having a different transmission speed setting can be also checked; therefore action to remove a transmission error can be easily taken.

■ Procedure

1. Open the "CC-Link Diagnostics" window.

 [Diagnostics] ⇒ [CC-Link Diagnostics]

2. Double-click "Operation Test" in "Related Functions".

3. Select "Check Transfer Speed Setting" under "Test Type".

4. Click the [Execute] button to start checking of the transmission speed setting. After checking of the transmission speed is completed, the transmission speed of each station is displayed on the right side of the window.

- Do not write to the buffer memory areas (buffer memory addresses: 5E0H, 5E4H, 5F8H, 641H, 645H, 783H to 787H).
- Do not check the transmission speed setting using a program or other peripherals at the same time. If executed at the same time, checking of transmission speed setting may fail.
- In addition, do not check the transmission speed setting using the "Create Check Sheet" wizard at the same time.

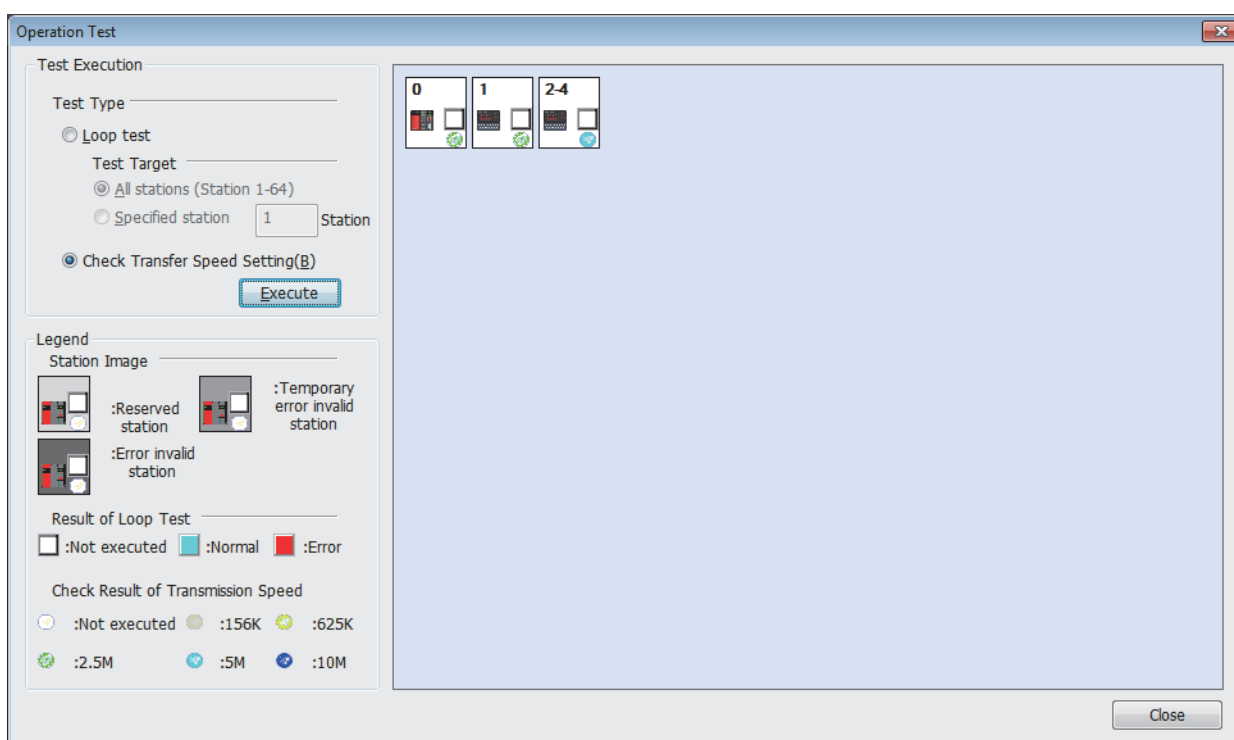

Status logging

Data link status of all stations is logged. When multiple stations repeatedly fail and recover or stations after a specific station do so, the location of the error cause, such as poor cable connection and noise, can be easily identified.

With "RAM + Flash ROM" selected, the first 45 logs after logging start are stored on the flash ROM. Logs stored on the flash ROM can be checked even after the system is powered off and on or the programmable controller CPU module is reset.

Point

In a redundant system, the status logging cannot be used when a system has been specified by "Specify Redundant CPU" of "Target System" in the "Specify Connection Destination Connection" window. Directly connect the engineering tool to the station that performs logging, specify the own remote head module (set "Not Specified" in "Specify Redundant CPU"), and execute the operation.

■ Procedure

1. Open the "CC-Link Diagnostics" window.

[Diagnostics] ⇒ [CC-Link Diagnostics]

2. Double-click "Status Logging" in "Related Functions".

3. Set "Time of Logging Acquisition".

Enter the period for which logging is being executed.

When 0 seconds is set, logging will be continued until the [Stop Logging] button is clicked or the number of logs reaches 5000.

4. Select either "RAM" or "RAM + Flash ROM" in "Log Storage Area in CC-Link Module".

- If the engineering tool cannot be connected at all times, select "RAM + Flash ROM". After logs are collected, connect the engineering tool to check the log (maximum 45 items) stored in the Flash ROM.
- If the engineering tool can be connected at all times, up to 5000 logs can be stored regardless of the selected option ("RAM" or "RAM + Flash ROM").

5. Click the [Start Logging] button.

Logging will be executed for the specified period.

Logging will stop when the [Stop Logging] button is clicked, or the number of logs reaches 5000.

6. Select the item in the "Log List" to display its status in the log display part.

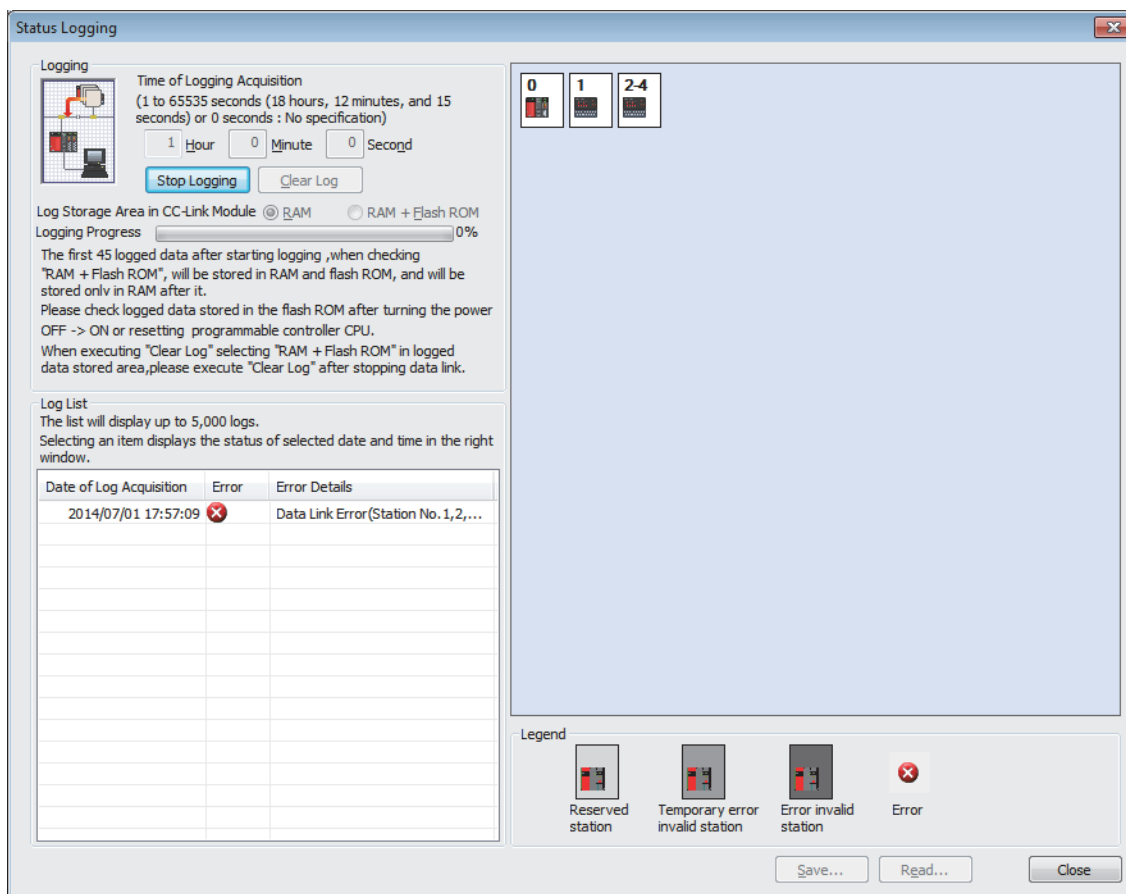

■ Saving logs in a CSV file and reading the saved logs

Click the [Save] button to save the information displayed under "Log List" to a CSV file.

Click the [Read] button to read the saved CSV log file and display the contents under "Log List".

■Deleting logs

Click the [Clear Log] button to delete logs in a master/local module

If the [Clear Log] button is clicked with "RAM + Flash ROM" selected, the logs stored in the flash ROM will also be deleted.

While the logs on the flash ROM are being deleted, do not power off the master/local module.

■Precautions

- Logging will not start in the following cases.

Item
Logs stored on the flash ROM have not yet been fully deleted.
"RAM + Flash ROM" has been selected and 45 logs have already been stored in the flash ROM.
The cumulative number of times that logs are stored in the flash ROM has exceeded 100000 times.

- The log storage areas listed below are available. To store 96 or more items (maximum 5000 items), keep the engineering tool connected even after logging is started. If the number of logs stored in the RAM area has exceeded 95 without connecting the engineering tool, the stored log will be overwritten, starting with the oldest one.

Log storage area	Number of logs stored
RAM area (equipped in a module)	95 logs maximum
Flash ROM area (equipped in a module)	45 logs maximum
Hard disk of the engineering tool (personal computer)	5000 logs maximum

Creating a check sheet

A check sheet, which is useful for performing troubleshooting, is created through a wizard and with reference to the Open Field Network CC-Link Troubleshooting Guide.

■Procedure

1. Open the "CC-Link Diagnostics" window.

 [Diagnostics] ⇒ [CC-Link Diagnostics]

2. Double-click "Create Check Sheet" in "Related Functions".

3. Configure settings with answering a series of questions displayed on the windows.

The created check sheet is saved in Excel format.

Point

Do not check the transmission speed setting using a program or other peripherals at the same time. If executed at the same time, checking of transmission speed setting may fail.

Stopping and restarting data link

Data link of a master/local module is stopped and restarted.

During a debugging, the master/local module does not receive data from other stations and does not send data of the own station.

■Procedure

1. Open the "CC-Link Diagnostics" window.

 [Diagnostics] ⇒ [CC-Link Diagnostics]

2. Select the icon for a master/local module where data link is to be stopped and restarted.

3. Double-click "Stop Data Link" in "Related Functions".

4. When step 3 is performed while the data link of the selected module has been stopped, the data link will restart.

Point

When stopping or restarting data link, do not write data to the buffer memory area (buffer memory address: 5E0H).

Setting and canceling a temporary error invalid station

Even if a data link error occurs in a slave station, the station is not detected as a faulty station in the master station and local station. This can be set even during data link, unlike the error invalid station setting function.

This function is used to exchange slave stations for maintenance or for other purposes during data link.

■ Procedure

1. Open the "CC-Link Diagnostics" window.

 [Diagnostics] ⇒ [CC-Link Diagnostics]

2. Right-click the target slave station icon of the temporary error invalid station setting and select "Enable/Disable Ignore Station Errors".

The selected station will be a temporary error invalid station.

3. When the step 2 is performed while the selected station has been set as a temporary error invalid station, the temporary error invalid station setting is canceled.

Point

When setting a temporary error invalid station, do not write data to the buffer memory areas (buffer memory address: 5E0H and 603H to 607H).

4.4 Hardware Test

A master/local module is individually tested to check whether it normally operates.

Procedure

1. Connect the terminating resistor provided with the module between the DA and DB terminals on the terminal block of the master/local module.
2. Check the following before powering on.
 - Module mounting status
 - Input power supply voltage
 - The CPU module is set to STOP.
3. Set the following item to "Hardware Test".
 [Navigation window] ⇒ [Parameter] ⇒ [Module Information] ⇒ [RJ61BT11] ⇒ [Required settings] ⇒ [Mode]
4. Write the module parameters to the CPU module.
5. Power off and on or reset the CPU module to start the hardware test.

Point

Do not perform a hardware test while connected to another station. Doing so may result in a failure of the test.

Checking the status and result of hardware test

The test status and result can be checked with LED indication of the module.

Test status	LED indication
Test in progress	The dot matrix LED indicates "H.T."
Normal completion	The dot matrix LED indicates "OK".
Abnormal end	The dot matrix LED indicates "ERR".

If the test fails, check if the terminating resistor provided with the master/local module is connected between the DA and DB terminals. If the terminating resistor is connected, the possible cause is a hardware failure. Replace the master/local module.

4.5 Troubleshooting by Symptom

This section describes troubleshooting method by symptom. If an error has occurred in the master/local module, identify the error cause using the engineering tool. (☞ Page 101 Checking the Module Status)

When cyclic transmission cannot be performed

Remote I/O station					
Problem	Check item	Description	Check method	Action	
Cyclic data cannot be read/written.	C1-1	Refresh data area	Have refresh devices been correctly set in the module parameters? (RX, RY, SB, SW)	Check if the refresh devices have been set within the range. Check if no device overlaps with ones used in programs or in other networks. Note that the number of points of 8-point or 16-point I/O modules per station is 32 points (fixed) (excluding number of points set for the remote I/O station).	Correct the refresh device setting. Set the devices so that they do not overlap with ones used in programs and in other networks.
			Are the link refresh to refresh devices using the module parameters and refresh using a program (Un\G□ or FROM/TO instructions) being performed at the same time?	<ul style="list-style-type: none"> Check the program. Check the refresh devices set in the module parameters. 	Execute only one of the refresh processes; either link refresh to refresh devices using the module parameters or refresh using a program (Un\G□ or FROM/TO instructions)
			Is the correct buffer memory area being read from/written to? (RX, RY, SB, SW)	Check the program. Note that the number of points of 8-point or 16-point I/O modules per station is 32 points (fixed) (excluding number of points set for the remote I/O station).	<ul style="list-style-type: none"> Access the correct buffer memory area in the corresponding station. Set the devices so that they do not overlap with ones used in programs and in other networks.
			Is any of refresh devices (RX, RY) of the module parameters set for the redundant system?	Check if any of refresh devices (RX, RY) is set by mistake for the redundant system.	<ul style="list-style-type: none"> Avoid any refresh devices (RX, RY) setting for the redundant system. Use program (Un\G□) to make a refresh.
	C1-2	Parameter setting	Is a station to which reading/writing cannot be performed specified as a reserved station?	Check if the bit corresponding to the faulty station is not "1" in 'Reserved station specification status' (SW0074 to SW0077).	Cancel the reserved station setting.
Data cannot be output from RY.	C2-1	Refresh instruction	Is the refresh instruction executed after changing parameters by the dedicated instruction?	Check if 'Refresh instruction when changing parameters by the dedicated instruction' (SB0003) is turned on.	Turn on 'Refresh instruction when changing parameters by the dedicated instruction' (SB0003).

Remote device station

Problem	Check item	Description	Check method	Action	
Cyclic data cannot be read/written.	D1-1	Refresh data area	Has the link refresh been correctly set? (RX, RY, RWw, RWr, SB, SW)	Check if no device overlaps with ones used in programs or in other networks.	Set the devices so that they do not overlap with ones used in programs and in other networks.
			Is the buffer memory area accessed correctly? (RX, RY, RWw, RWr, SB, SW)	Check if no device overlaps with ones used in programs or in other networks.	<ul style="list-style-type: none"> Access the correct buffer memory area in the corresponding station. Set the devices so that they do not overlap with ones used in programs.
			Is any of refresh devices (RX, RY, RWw, RWr) of the module parameters set for the redundant system?	Check if any of refresh devices (RX, RY, RWw, RWr) is set by mistake for the redundant system.	<ul style="list-style-type: none"> Avoid any refresh devices (RX, RY, RWw, RWr) setting for the redundant system. Use program (Un\G□) to make a refresh.
	D1-2	Parameter setting	Is a station to which reading/writing cannot be performed specified as a reserved station?	Check if the bit corresponding to the faulty station is not "1" in 'Reserved station specification status' (SW0074 to SW0077).	Cancel the reserved station setting.
Word data cannot be read/written.	D2-1	Parameter setting	Do the parameter settings match with the status of the connected modules?	Check if a remote I/O station is connected to the corresponding station number.	Match the model set by the parameter with that of the connected module.
Cyclic data (lower area) cannot be read/written.	D3-1	Parameter setting	Do the parameter settings match with the status of the connected modules?	Check if a module with the small number of occupied stations is not connected to the corresponding station number.	Match the number of occupied stations set by the parameter with that of the connected module.
Data cannot be output from RY.	D4-1	Refresh instruction	Is the refresh instruction executed after changing parameters by the dedicated instruction?	Check if 'Refresh instruction when changing parameters by the dedicated instruction' (SB0003) is turned on.	Turn on 'Refresh instruction when changing parameters by the dedicated instruction' (SB0003).
A remote device station does not become ready (RXn1B remains off).	D5-1	Initial setting	Has the initial setting completed?	Were RYn18 (Initial data processing completion flag) and RYn19 (Initial data setting request flag) turned on and off?	Perform the initial data processing.
			Has the remote device station initialization procedure registration completed?	<ul style="list-style-type: none"> Check if 'Remote device station initialization procedure registration instruction' (SB000D) is turned off. Check 'Remote device station initialization procedure registration instruction result' (SW005F). 	Change the registration.
			Is the initial setting for the remote device station correct?	<ul style="list-style-type: none"> Check the parameters. Check the program. 	Correct the remote device station initial setting.
			Has the initialize setting been enabled?	Check if 'Remote device station initialization procedure registration instruction' (SB000D) has been turned on using a program.	Turn on 'Remote device station initialization procedure registration instruction' (SB000D) using a program and check that the initialize setting is enabled.

Intelligent device station (local station)

Problem	Check item	Description	Check method	Action	
Cyclic data cannot be read/written.	E1-1	Refresh data area	Has the link refresh been correctly set? (RX, RY, RWw, RWr, SB, SW)	Check if no device overlaps with ones used in programs or in other networks.	Set the devices so that they do not overlap with ones used in programs and in other networks.
			Is the buffer memory area accessed correctly? (RX, RY, RWw, RWr, SB, SW)	Check if no device in the master station overlaps with ones used in programs or in other networks.	<ul style="list-style-type: none"> Access the correct buffer memory area in the master station. Set the devices so that they do not overlap with ones used in programs.
			Is any of refresh devices (RX, RY, RWw, RWr) of the module parameters set for the redundant system?	Check if no device in the local station overlaps with ones used in programs or in other networks.	<ul style="list-style-type: none"> Access the correct buffer memory area in the local station. Set the devices so that they do not overlap with ones used in programs.
		Is any of refresh devices (RX, RY, RWw, RWr) of the module parameters set for the redundant system?	Check if any of refresh devices (RX, RY, RWw, RWr) is set by mistake for the redundant system.	<ul style="list-style-type: none"> Avoid any refresh devices (RX, RY, RWw, RWr) setting for the redundant system. Use program (Un\G□) to make a refresh. 	
	E1-2	Parameter setting	Is a station to which reading/writing cannot be performed specified as a reserved station?	Check if the bit corresponding to the faulty station is not "1" in 'Reserved station specification status' (SW0074 to SW0077).	Cancel the reserved station setting.
Word data cannot be read/written.	E2-1	Parameter setting	Do the parameter settings match with the status of the connected modules?	Check if a remote I/O station is connected to the corresponding station number.	Match the model set by the parameter with that of the connected module.
Cyclic data (lower area) cannot be read/written.	E3-1	Parameter setting	Do the parameter settings match with the status of the connected modules?	Check if a module with the small number of occupied stations is not connected to the corresponding station number.	Match the number of occupied stations set by the parameter with that of the connected module.
Data cannot be output from RY.	E4-1	Refresh instruction	Is the refresh instruction executed after changing parameters by the dedicated instruction?	Check if 'Refresh instruction when changing parameters by the dedicated instruction' (SB0003) is turned on.	Turn on 'Refresh instruction when changing parameters by the dedicated instruction' (SB0003).

When transient transmission cannot be performed

Intelligent device station (local station)

Problem	Check item		Description	Check method	Action
Transient error	F1-1	Refresh data area	Is the transient transmission (dedicated instruction) correctly performed?	Check if the correct destination is accessed.	Access the correct buffer memory area in the corresponding station.
	F1-2	Parameter setting	Do the parameter settings match with the status of the connected modules?	Check if a remote I/O station or remote device station is not connected.	Match the model set by the parameter with that of the connected module.
	F1-3	Response status	Error code B404H (response timeout)	Check if a response is received from the request destination station within the monitoring time.	Increase the monitoring time value. If the error occurs again, check the modules and cables at the destination.
			Is the transient transmission (dedicated instruction) correctly performed?	Check the error code stored in completion status when the dedicated instruction was executed.	Take action according to the error code.
			Do the master station and the intelligent device station have no error?	<ul style="list-style-type: none"> • Check the error code of the CPU module. • Check the error code of the master station. • Check the operating status of the master station and the target intelligent device station. 	Take action according to the error code.
F1-4	Target station number	Is the target station number correct?	Check if transient transmission is not being executed for the same station number at the same time.	Correct the station number setting. If executing for the same station number, shift the execution timing.	

When a slave station is disconnected

When a system is newly configured or the system is changed

Problem	Check item		Description	Check method	Action
Data link cannot be performed in the entire system.	A1-1	Station number	Is the station number correctly set for the faulty station?	Check the station number setting.	Correct the station number setting.
	A1-2	Transmission speed	Are the transmission speed values set within the range, and same between the master station and slave stations?	Check the transmission speed settings of all stations.	Correct the transmission speed setting.
	A1-3	Mode	Is the online mode set to the master station?	Check the mode setting of the master station.	Set the online mode.
	A1-4	Parameter setting	<ul style="list-style-type: none"> Are the module parameters, such as number of stations and station information, correctly set? Does the master station have no error? Module parameters in the engineering tool. 	Check the parameters of the CPU module on the master station using the engineering tool.	<ul style="list-style-type: none"> Correct the module parameters. Format the CPU module memory then write the module parameters.
				Check 'Station number of own station' (SW0061) and 'Mode setting status' (SW0060).	
				Check SW0068, SW0069, SW0070, SW0071, SW0072, SW0074 to SW0077, SW0098 to SW009B, SW009C to SW009F, SW0144 to SW0147.	
	A1-5	Cable or other parts	<p>Are there no disconnection, short circuit, incorrect wiring, poor connection, and coexistence of different cables? Do a transmission distance, station-to-station distance, transmission cable, and FG terminal grounding meet the specifications?</p> <p>Are terminating resistors connected?</p>	Check if cables between the master station and slave stations are not disconnected.	Correct the wiring.
Check if terminating resistors are connected to the both ends in the CC-Link system.				Connect terminating resistors to the both ends in the CC-Link system.	
Check if a station with built-in terminating resistor is connected other than at both ends in the CC-Link system.					
A1-6	CPU module	Does the CPU module on the master station have no error?	Check the error code of the CPU module.	Remove the CPU module error. (MELSEC iQ-R CPU Module User's Manual (Application))	
			Check if the module has been identified.	Take action so that the CPU module may identify the master/local module. (MELSEC iQ-R CPU Module User's Manual (Application))	
			Is the sequence scan long? (Synchronous mode)	Check if the sequence scan time is within the range. 10Mbps: 50ms 5Mbps: 50ms 2.5Mbps: 100ms 625kbps: 400ms 156kbps: 800ms	Set the asynchronous mode or reduce the transmission speed.
A1-7	Noise	Is the transmission cable free from noise?	Check if the transmission cable is away from the power cable.	Keep the transmission cable away from the power cable. (Keep a distance of 100mm or more is recommended)	
			Check if the FG terminal is grounded separated from the GND terminal of the power system.	Ground the terminals separately.	
			Reduce the transmission speed and check if the frequency of occurrence of noise is reduced.	<ul style="list-style-type: none"> Take measures to reduce noise. Reduce the transmission speed. 	

Problem	Check item		Description	Check method	Action
Data link cannot be performed in the entire system.	A1-8	Failure of the master station	Do modules on the master station normally operate?	Replace the modules and check if the station normally operates.	Repair or replace the module on the master station.
A station cannot perform data link.	A2-1	Station number	Is the station number correctly set for the faulty station?	Check the station number setting.	Correct the station number setting.
	A2-2	Transmission speed	Is the transmission speed setting correctly set for the faulty station?	Check the transmission speed.	Set the same transmission speed as that set for other stations.
	A2-3	Online status (slave station)	Is the CC-Link interface of the faulty station online?	Check the status of the faulty station.	Set it online.
	A2-4	Parameter setting	<ul style="list-style-type: none"> Are the module parameters, such as number of stations and station information, correctly set? Does the master station have no error? Module parameters in the engineering tool. 	Check the module parameters of the CPU module on the master station using the engineering tool. Check SW0068, SW0069, SW0070, SW0071, SW0072, SW0074 to SW0077, SW0098 to SW009B, SW009C to SW009F, SW0144 to SW0147.	<ul style="list-style-type: none"> Correct the module parameters. Format the CPU module memory then write the module parameters.
	A2-5	Cable or other parts	Are there no disconnection, short circuit, incorrect wiring, poor connection, and coexistence of different cables? Do a transmission distance, station-to-station distance, transmission cable, and FG terminal grounding meet the specifications?	Check if the SD LED and RD LED on the faulty station are flashing.	Correct the wiring.
				When faulty stations occur sequentially to one end on the transmission path, check cables connected to faulty stations close to the master station. (Multiple stations)	Correct the wiring.
			Are terminating resistors connected?	Check if terminating resistors are connected to the both ends in the CC-Link system. Check if a station with built-in terminating resistor is connected other than at both ends in the CC-Link system.	Connect terminating resistors to the both ends in the CC-Link system.
	A2-6	Power supply (for communications)	Is the power on, and is the applied voltage within the specified range?	Check if the modules on the faulty station are powered on.	Power on the module.
				Check if the applied voltage is within the specified range.	Apply the voltage within the specified range.
	A2-7	Noise	Is the transmission cable free from noise?	Check if the transmission cable is away from the power cable.	Keep the transmission cable away from the power cable. (Keep a distance of 100mm or more is recommended)
Check if the FG terminal is grounded separated from the GND terminal of the power system.				Ground the terminals separately.	
Reduce the transmission speed and check if the frequency of occurrence of noise is reduced.				Take measures to reduce noise. Reduce the transmission speed.	
A2-9	Failure of a slave station	Do slave stations normally operate?	Replace modules on the faulty station and check if the station normally operates.	Repair or replace the module on the faulty station.	
A2-10	Standby master station	Is the standby master station controlling the data link?	Check if the standby master station is not set as a station controlling the data link by the CC-Link diagnostics of the master station.	Restart the system so that the master station will control the data link.	

Problem	Check item		Description	Check method	Action
Data link cannot be performed in the entire system occasionally.	A3-1	Cable or other parts	Are cables and connectors securely connected and do they meet specifications?	Check cables between the master station and slave stations.	Correct the wiring.
	A3-2	Parameter setting	Is the sequence scan long? (Synchronous mode)	Check if the sequence scan time is within the range. 10Mbps: 50ms 5Mbps: 50ms 2.5Mbps: 100ms 625kbps: 400ms 156kbps: 800ms	Set the asynchronous mode or reduce the transmission speed.
	A3-3	Power supply (for communications)	Is the power on, and is the applied voltage within the specified range?	Check power supplied to the master station and all slave stations.	Apply the voltage within the specified range.
	A3-4	Noise	Is the transmission cable free from noise?	Check if the transmission cable is away from the power cable.	Keep the transmission cable away from the power cable. (Keep a distance of 100mm or more is recommended)
				Check if the FG terminal is grounded separated from the GND terminal of the power system.	Ground the terminals separately.
				Reduce the transmission speed and check if the frequency of occurrence of noise is reduced.	<ul style="list-style-type: none"> Take measures to reduce noise. Reduce the transmission speed.
A3-5	Failure of the master station	Do modules on the master station normally operate?	Replace the modules and check if the station normally operates.	Repair or replace the module on the master station.	
A3-6	Link stop	Is the data link stop instruction correctly executed?	Check if 'Data link stop' (SB0002) is turned off.	<ul style="list-style-type: none"> Do not turn on 'Data link stop' (SB0002). Do not write to the refresh source device of 'Data link stop' (SB0002) from multiple locations. 	

Problem	Check item	Description	Check method	Action	
A station cannot perform data link occasionally.	A4-1	Cable or other parts	Are there no disconnection, short circuit, incorrect wiring, poor connection, and coexistence of different cables? Do a transmission distance, station-to-station distance, transmission cable, and FG terminal grounding meet the specifications?	Check cables connected to the faulty station. When faulty stations occur sequentially to one end on the transmission path, check cables connected to faulty stations close to the master station. (Multiple stations)	Correct the wiring.
			Are terminating resistors connected?	Check if terminating resistors are connected to the both ends in the CC-Link system. Check if a station with built-in terminating resistor is connected other than at both ends in the CC-Link system.	
		A4-2	Power supply (for communications)	Is the power on, and is the applied voltage within the specified range?	Check power supplied to the faulty station.
	A4-3	Noise	Is the transmission cable free from noise?	Check if the transmission cable is away from the power cable.	Keep the transmission cable away from the power cable.
				Check if the FG terminal is grounded separated from the GND terminal of the power system.	Ground the terminals separately.
				Reduce the transmission speed and check if the frequency of occurrence of noise is reduced.	<ul style="list-style-type: none"> • Take measures to reduce noise. • Reduce the transmission speed.
A4-4	Start-up	Has the faulty station started with the correct procedure?	Check if the faulty station normally starts with a different procedure.	Start the faulty station by following the procedure described in the manual for the station.	
A4-5	Failure of a slave station	Do slave stations normally operate?	Replace modules on the faulty station and check if the station normally operates.	Repair or replace the module on the faulty station.	
A4-6	Standby master station	Is the standby master station controlling the data link?	Check if the standby master station is not set as a station controlling the data link by the CC-Link diagnostics of the master station.	Restart the system so that the master station will control the data link.	

When the system has already operated

Problem	Check item	Description	Check method	Action	
Data link cannot be performed in the entire system.	B1-1	CPU module	Does the CPU module on the master station have no error?	Check the error code of the CPU module.	Remove the CPU module error. (MELSEC iQ-R CPU Module User's Manual (Application))
				Check if the module has been identified.	Take action so that the CPU module may identify the master/local module. (MELSEC iQ-R CPU Module User's Manual (Application))
	B1-2	Power supply (for communications)	Is a voltage low?	Check power supplied to the master station and all slave stations.	Apply the voltage within the specified range.
	B1-3	Cable or other parts	Are there no disconnection, short circuit, and poor connection?	Check if cables between the master station and slave stations are not disconnected.	Correct the wiring.
	B1-4	Noise	Is the transmission cable free from noise?	Check if the transmission cable is away from the power cable.	Keep the transmission cable away from the power cable. (Keep a distance of 100mm or more is recommended)
				Check if the FG terminal is grounded separated from the GND terminal of the power system.	Ground the terminals separately.
Reduce the transmission speed and check if the frequency of occurrence of noise is reduced.				<ul style="list-style-type: none"> Take measures to reduce noise. Reduce the transmission speed. 	
B1-5	Failure of the master station	Do modules on the master station normally operate?	Replace the modules and check if the station normally operates.	Repair or replace the module on the master station.	
B1-6	Link stop	Is the data link stop instruction correctly executed?	Check if 'Data link stop' (SB0002) is turned off.	<ul style="list-style-type: none"> Do not turn on 'Data link stop' (SB0002). Do not write to the refresh source device of 'Data link stop' (SB0002) from multiple locations. 	
A station cannot perform data link occasionally.	B2-1	Power supply (for communications)	Is a voltage low?	Check power supplied to the faulty station.	Apply the voltage within the specified range.
	B2-2	Cable or other parts	Are cables and connectors securely connected and do they meet specifications?	Check cables connected to the faulty station.	Correct the wiring.
				When faulty stations occur sequentially to one end on the transmission path, check cables connected to faulty stations close to the master station.	
	B2-3	Noise	Is the transmission cable free from noise?	Check if the transmission cable is away from the power cable.	Keep the transmission cable away from the power cable. (Keep a distance of 100mm or more is recommended)
Check if the FG terminal is grounded separated from the GND terminal of the power system.				Ground the terminals separately.	
Reduce the transmission speed and check if the frequency of occurrence of noise is reduced.				<ul style="list-style-type: none"> Take measures to reduce noise. Reduce the transmission speed. 	
B2-4	Failure of a slave station	Do slave stations normally operate?	Replace modules on the faulty station and check if the station normally operates.	Repair or replace the module on the faulty station.	

When operation error occurs on the master station

Problem	Check item	Description	Check method	Action	
Data link cannot be stopped/ restarted.	G1-1	Data link stop	Is 'Data link stop' (SB0002) turned on?	<ul style="list-style-type: none"> Check the program. Check the refresh devices set in the module parameters. 	<ul style="list-style-type: none"> Correctly set the SB area. Turn on 'Data link stop' (SB0002).
		Does no error occur?	Check 'Data link stop result' (SW0045).	Take action according to the error code.	
	G1-2	Data link restart	Is 'Data link restart' (SB0000) turned on?	<ul style="list-style-type: none"> Check the program. Check the refresh devices set in the module parameters. 	<ul style="list-style-type: none"> Correctly set the SB area. Turn on 'Data link restart' (SB0000).
		Does no error occur?	Check 'Data link restart result' (SW0041).	Take action according to the error code.	
		Is the corresponding station disconnected?	<ul style="list-style-type: none"> Check cable status visually or by the line test using the engineering tool. Check the parameters. (Local station) Check the operating status of the CPU module on the corresponding station. 	Correct the cables and settings of the corresponding station, and start the system.	
	A faulty station cannot be detected.	G2-1	Is the station set as an error invalid station?	Is the station set as an error invalid station?	Check 'Error invalid station specification status' (SW0078 to SW007B).
Check 'Temporary error invalid status' (SW007C to SW007F).				Cancel the temporary error invalid station setting.	
Are station numbers unique?		Are station numbers unique?	Check the station number setting.	Correct the station number setting.	
A station becomes faulty at a certain transmission speed.	G3-1	<ul style="list-style-type: none"> Can a faulty station be identified with 'Data link status of other stations' (SW0080 to SW0083)? Are communications normal if the transmission speed is slow such as 156kbps? Are communications normal if the transmission speed is slow such as 156kbps? 	Can a faulty station be identified with 'Data link status of other stations' (SW0080 to SW0083)?	Check transmission speed of the faulty station.	Set the same transmission speed as that set for the master station.
			Are communications normal if the transmission speed is slow such as 156kbps?	Check if the cables are properly wired.	Correct the wiring.
			Are communications normal if the transmission speed is slow such as 156kbps?	Check if the cables are grounded by the shielded part.	Ground the shielded part.
			Are communications normal if the transmission speed is slow such as 156kbps?	Check if terminating resistors are connected to the both ends in the CC-Link system.	Connect terminating resistors to both ends in the CC-Link system.
			Are communications normal if the transmission speed is slow such as 156kbps?	Check if a station with built-in terminating resistor is connected other than at both ends in the CC-Link system.	
When multiple remote stations are simultaneously powered off at a speed of 156kbps, the L RUN LED turns off temporarily.	G4-1	Number of retries setting	Number of retries setting	Check the number of retries.	<ul style="list-style-type: none"> Increase the transmission speed. Reduce the number of retries.

4.6 List of Error Codes

This section lists the error codes, error details and causes, and action for the errors occur in the processings for data communication between master/local module and slave stations or caused by processing requests from the CPU module on the own station.

Error codes can be checked in the [Error Information] tab of the "Module Diagnostics" window for the master/local module.

( Page 101 Error Information)

Error code	Error details and causes	Action	Detailed information
1080H	The number of writes to the flash ROM has exceeded 100000. (Number of writes > 100000 times)	Replace the module.	—
1810H	The hardware has failed.	<ul style="list-style-type: none"> The possible cause is a malfunction due to noise. Check the wire and cable distances and ground condition of each device, and take measures to reduce noise. Perform a hardware test. If the error occurs again, the possible cause is a hardware failure of the module. Please consult your local Mitsubishi representative. 	—
20E0H	The module cannot communicate with the CPU module.	The hardware failure of the CPU module may have been occurred. Please consult your local Mitsubishi representative.	—
24C0H	The hardware has failed.	<ul style="list-style-type: none"> The possible cause is a malfunction due to noise. Check the wire and cable distances and ground condition of each device, and take measures to reduce noise. Perform a hardware test. If the error occurs again, the possible cause is a hardware failure of the module. Please consult your local Mitsubishi representative. 	Parameter information <ul style="list-style-type: none"> I/O No. Base No. Slot No. CPU No.
24C1H to 24C3H	The bus communication has failed.	<ul style="list-style-type: none"> The possible cause is a malfunction due to noise. Check the wire and cable distances and ground condition of each device, and take measures to reduce noise. Perform a hardware test. If the error occurs again, the possible cause is a hardware failure of the module. Please consult your local Mitsubishi representative. 	Parameter information <ul style="list-style-type: none"> I/O No. Base No. Slot No. CPU No.
24C6H	The bus communication has failed.	<ul style="list-style-type: none"> The possible cause is a malfunction due to noise. Check the wire and cable distances and ground condition of each device, and take measures to reduce noise. Perform a hardware test. If the error occurs again, the possible cause is a hardware failure of the module. Please consult your local Mitsubishi representative. 	—
3C00H	A hardware failure has been detected.	<ul style="list-style-type: none"> The possible cause is a malfunction due to noise. Check the wire and cable distances and ground condition of each device, and take measures to reduce noise. Perform a hardware test. If the error occurs again, the possible cause is a hardware failure of the module. Please consult your local Mitsubishi representative. 	—
3C02H	A bus error has been detected.	<ul style="list-style-type: none"> The possible cause is a malfunction due to noise. Check the wire and cable distances and ground condition of each device, and take measures to reduce noise. Perform a hardware test. If the error occurs again, the possible cause is a hardware failure of the module. Please consult your local Mitsubishi representative. 	—
3C10H	A hardware failure has been detected.	<ul style="list-style-type: none"> Take measures to reduce noise. Reset the CPU module, and run it again. If the same error code is displayed again, the possible cause is a hardware failure of the error module. Please consult your local Mitsubishi representative. 	—
3C14H	A bus error has been detected.	Reset the CPU module, and run it again. If the same error code is displayed again, the possible cause is a hardware failure of the error module or CPU module. Please consult your local Mitsubishi representative.	—
B002H	System error	Please consult your local Mitsubishi representative.	—
B101H to B106H	System error	Please consult your local Mitsubishi representative.	—
B109H	System error	Please consult your local Mitsubishi representative.	—

Error code	Error details and causes	Action	Detailed information
B10AH	A data link error has occurred on the target station specified for the message transmission function.	Check the operation of the target station.	—
B10CH	The message transmission function is executed to a target station that is not available for the message transmission function.	Check the station number of the target station. Or, check whether the target station supports the message transmission function.	—
B110H to B112H	A line error has occurred.	Check and correct the wiring.	—
B113H	A line error has occurred. Or a momentary power failure has occurred in the sending station.	Modify the line, or check the power supply module and power supplied to the sending station.	—
B115H	A line error has occurred.	Check and correct the wiring.	—
B116H	A line error has occurred.	Check and correct the wiring.	—
B120H	With the remote device station initialization procedure registration function, the remote device station initialization procedure registration instruction was turned off before all procedures are completed.	Complete all the procedures before turning off the remote device station initialization procedure registration instruction.	—
B122H	System error	Please consult your local Mitsubishi representative.	—
B123H	System error	Please consult your local Mitsubishi representative.	—
B124H	The remote device station initialization procedure registration instruction was turned on in a station other than the master station.	Turn on the remote device station initialization procedure registration instruction in the master station (station No.0).	—
B125H	<ul style="list-style-type: none"> The remote device station initialization procedure registration instruction was turned on without setting the remote device station initialization procedure registration. A bit other than the one corresponding to the start station number was turned on in 'Specification of remote device station to be initialized' (SW0014 to SW0017) to instruct the remote device station initialization procedure registration. 	<ul style="list-style-type: none"> Set the remote device station initialization procedure registration before turning on the remote device station initialization procedure registration instruction. Turn on only the bit corresponding to the start station number in 'Specification of remote device station to be initialized' (SW0014 to SW0017). 	—
B201H	A data link error has occurred in the corresponding station during transient transmission.	Check the communication status of other stations, if a temporary error invalid station is present, or if the corresponding station is stopped.	—
B202H	System error	Please consult your local Mitsubishi representative.	—
B203H	System error	Please consult your local Mitsubishi representative.	—
B204H	Too many transient requests were sent to the corresponding station.	Wait for a while and send the request again.	—
B205H	A transient request was issued to a station other than an intelligent device station.	Check the target station.	—
B301H	A line test request was issued during link stop.	Perform a line test while data link is being performed.	—
B302H	The specified station number for a line test request, temporary error invalid request, or temporary error invalid canceling request is greater than the maximum station number that can communicate.	Specify a station number smaller than or equal to the maximum communication station number.	—
B303H	Target station number is not set for temporary error invalid request or temporary error invalid cancellation request.	Set the station number. (SW0003, SW0004 to SW0007)	—
B304H	When a line test was executed, an error has been detected in a remote station, intelligent device station, or standby master station.	Check if the remote station, intelligent device station, or standby master station have been started, and that the cables are not disconnected.	—
B305H	System error	Please consult your local Mitsubishi representative.	—
B306H	A station number other than the start station number has been specified in the temporary error invalid request or temporary error invalid canceling request.	Specify the start station for the temporary error invalid request or temporary error invalid cancellation request.	—
B307H	When one of the following requests is issued, a data link error has occurred in all stations. <ul style="list-style-type: none"> 'Data link restart' (SB0000) 'Data link stop' (SB0002) 	Issue the request again after the data link returns to normal.	—
B308H	A slave station number is not within 1 to 64.	Set the station number for the slave station within 1 to 64.	—
B309H	The station number of the connected module is duplicated (including the number of occupied stations). However, excluding duplication of the start station number.	Check the station number of the module.	—

Error code	Error details and causes	Action	Detailed information
B30AH	<ul style="list-style-type: none"> The station type differs between the mounted modules and parameter settings. The mode setting is invalid in the master station, local station, or standby master station. The mode of the master station differs from that of the standby master station. 	<ul style="list-style-type: none"> Correct the parameter. Set the parameters of the master station, local station, or standby master station again, and reset the CPU module. 	—
B30BH	The module parameter details do not match the installation status.	Correct the installation status or module parameters so that both are matched.	—
B30CH	The master station switching was instructed to a station other than the standby master station.	Specify the standby master station number.	—
B30DH	A request, such as the temporary error invalid station specification, line test request, or data link stop/restart request, was issued before data link is started.	Issue the request after the data link is started.	—
B30EH	Execution of a function that is started using SB, SW and executable only on the master station was attempted on a local station.	Execute the corresponding function from the master station.	—
B30FH	System error	Please consult your local Mitsubishi representative.	—
B310H	'Data link restart' (SB0000) was turned on specifying the station that was performing data link.	Turn on 'Data link restart' (SB0000) specifying the station where data link has been stopped using 'Data link stop' (SB0002).	—
B311H	'Data link stop' (SB0002) was turned on specifying the station where data link had been stopped.	Turn on 'Data link stop' (SB0002) specifying the station performing data link.	—
B312H	'Forced master switching' (SB000C) was turned on in a system where no standby master station exists or the standby master station was down.	Start the data link of the standby master station then turn on 'Forced master switching' (SB000C).	—
B313H	'Forced master switching' (SB000C) was turned on in a system where all stations were faulty.	Start the data link of the standby master station then turn on 'Forced master switching' (SB000C).	—
B314H	'Forced master switching' (SB000C) was turned on for a station other than the master station.	Turn on 'Forced master switching' (SB000C) in the master station.	—
B315H	While the master station was being switched to the standby master station, 'Forced master switching' (SB000C) was turned on again.	Correct the status of 'Forced master switching' (SB000C).	—
B316H	System error	Please consult your local Mitsubishi representative.	—
B317H	<ul style="list-style-type: none"> The RLPASET instruction was executed to a module where parameters had been set using the engineering tool. The parameter setting was changed without powering off and on the programmable controller system or resetting the CPU module. 	Clear parameters for the target module using the engineering tool then set the parameters using the RLPASET instruction.	—
B31AH	The master station duplication error canceling instruction was executed while data link had already been started.	Do not execute the master station duplication error cancellation instruction during data link.	—
B31BH	The transmission speed test was performed during data link.	Turn on 'Transmission speed test request' (SB000B) after turning on 'Data link stop' (SB0002).	—
B31CH	System error	Please consult your local Mitsubishi representative.	—
B31DH	System error	Please consult your local Mitsubishi representative.	—
B31EH	Logging was started while logs were being deleted.	Delete the logs then start logging.	—
B31FH	Logs were deleted during logging.	Stop the logging then delete the logs.	—
B320H	Logging was executed or logs were deleted in the remote I/O net mode.	Set the remote net mode then start the logging or delete the logs.	—
B321H	System error	Please consult your local Mitsubishi representative.	—
B322H	The logs were deleted during data link with "RAM + Flash ROM" selected.	Terminate the data link then delete the logs.	—
B323H	Although the logs had been set to be deleted with "RAM + Flash ROM" selected, logging was started before deletion of logs was complete.	Delete the logs again with "RAM + Flash ROM" selected.	—
B324H	Storing logs to the flash ROM was attempted when the flash ROM was not ready for storage.	Delete the logs with "RAM + Flash ROM" selected then start logging, or start logging with "RAM" selected.	—
B325H	The cumulative number of times that logs are stored on the flash ROM has exceeded 100000 times.	Start logging with "RAM" selected. To execute logging with "RAM + Flash ROM" selected, replace the module.	—
B326H	System error	Please consult your local Mitsubishi representative.	—

Error code	Error details and causes	Action	Detailed information
B384H	In the station information parameter, a number other than 1H to 40H is set for a station number (including the number of occupied stations).	Set the number within the range of 1H to 40H.	—
B385H	The total number of occupied stations set in the station information parameter exceeded 64.	Set the value to 64 or less.	—
B386H	In the station information parameter, all the number of occupied stations is set to 0.	Set the value within the range of 1 to 4.	—
B388H	The station type in the station information parameter is out of the range in the remote net Ver.1 mode.	Set a value within 0 to 2 in the remote net Ver.1 mode.	—
B38AH	System error	Please consult your local Mitsubishi representative.	—
B38BH	More than 42 remote device stations are set in the station information parameter.	Set the number of remote device stations to 42 or less. Set the stations to remote device net mode.	—
B38CH	More than 26 intelligent device stations (including local stations) are set in the station information parameter.	Set the number of intelligent device stations to 26 or less.	—
B38DH	In the invalid station specification parameter, a station number other than the start station number of the module or a station number not set in the parameter is set. [Example of when a station number other than the start station number is set] For a module that occupies 4 stations (station No.5 to No.8), a bit corresponding to a station number other than the station No.5 is on.	Set the start station number of the module. Do not set a station number not set in the parameter.	—
B38FH	The total size of the automatic update buffer set in the station information parameter exceeded 4K words.	Set the total size of the automatic update buffer within 4K words.	—
B390H	A value other than 1 to 64 is set in the standby master station specification parameter.	Set the value within the range of 1 to 64.	—
B391H	A value other than 1 to 7 is set in the number of retries parameter.	Set the value within the range of 1 to 7.	—
B392H	A value other than 0 or 1 is set in the parameter of data link setting at CPU failure.	Set 0 or 1.	—
B393H	A value other than 0 or 1 is set in the scan mode setting parameter.	Set 0 or 1.	—
B394H	A value other than 1 to 10 is set in the number of automatic return stations parameter.	Set the value within the range of 1 to 10.	—
B395H	System error	Please consult your local Mitsubishi representative.	—
B396H	The station number is already in use in the station information parameter.	Set a unique number.	—
B397H	The station information parameter setting does not meet the following condition: $(16 \times A) + (54 \times B) + (88 \times C) \leq 2304$ A: The number of remote I/O stations B: The number of remote device stations C: The number of intelligent device stations (including local stations)	Set parameters so that the conditions described in the left are satisfied.	—
B398H	A value other than 1 to 4 is set as the number of occupied stations in the station information parameter.	Set the value within the range of 1 to 4.	—
B399H	A value other than 1 to 64 is set in the number of connected modules parameter.	Set the value within the range of 1 to 64.	—
B39AH	The station number set using the station number setting of the standby master station differs from the one set in "Network Configuration Settings" under "Basic Settings" of the master station. Or the station set in "Network Configuration Settings" under "Basic Settings" of the master station is a local station.	Change the parameter for the master station, or change the station number setting of the local station or standby master station. Then reset the CPU module on the local station or standby master station.	—
B39BH	All stations are set as a reserved station.	Correct the reserved station specification.	—
B39CH	<ul style="list-style-type: none"> A station type other than "Standby Master Station" is set for the station set as the standby master station in "Network Configuration Settings" under "Basic Settings" of the master station. The mode setting of the master station differs from that of the standby master station. 	<ul style="list-style-type: none"> Set the standby master station type to "Standby Master Station". Set the same mode for the master station and the standby master station. 	—

Error code	Error details and causes	Action	Detailed information
B39DH	Zero points are set for a station other than a reserved station.	Set zero points for a reserved station.	—
B39EH	<ul style="list-style-type: none"> • 8 points or 16 points are set for a station other than a remote I/O station. • 8 points and 16 points are set for the same remote I/O station. 	<ul style="list-style-type: none"> • 8 points and 16 points are set for the same remote I/O station. • Set either 8 points or 16 points for the remote I/O station. 	—
B3A0H	<p>The mode setting is invalid in the master station, local station, or standby master station.</p> <ul style="list-style-type: none"> • The mode of the master station differs from that of the standby master station. • The local station is in the remote net Ver.2 mode, and the master station is in the remote net Ver.1 mode. 	Correct the mode setting of the master station, local station, or standby master station again, and reset the CPU module.	—
B3A2H	In the remote I/O net mode, a station other than a remote I/O station is set in the station type parameter using the dedicated instruction.	Set all stations as a remote I/O station.	—
B3A3H	In the remote net Ver.2 mode, the total number of remote points in station information exceeded 8192, the maximum number of points.	Change the number of remote station points set in the station information settings.	—
B3A4H	While the standby master station was operating as a master station by the master station duplex function, the network parameter setting of the faulty master station was changed.	Undo the module parameters of the master station.	—
B3A6H	In the remote device net mode, a station type other than a remote I/O station or remote device station is set in the station type parameter using the dedicated instruction.	Set all stations as a remote device station.	—
B3F1H to B3F3H	System error	Please consult your local Mitsubishi representative.	—
B401H	The parameter setting was changed during transient request.	Change the parameters after all transient requests are completed or before the request is issued.	—
B404H	A response is not received from the request destination station within the monitoring time.	Increase the monitoring time value. If the error occurs again, check the modules and cables at the destination.	—
B405H	A transient request was issued to a remote I/O station or a remote device station. Or too many transient requests were sent to the corresponding station.	Set a local station or an intelligent device station as the target station or wait for a while and send the request again. (Transient overload state)	—
B407H	System error	Please consult your local Mitsubishi representative.	—
B409H	System error	Please consult your local Mitsubishi representative.	—
B411H	The number of read/write points in the control data of the dedicated instruction is out of the range.	Set a number of read points or write points within range.	—
B412H	The station number in the control data of the dedicated instruction is out of the range.	Set the station number within range.	—
B413H	Multiple dedicated instructions were executed to the same station.	Review the program.	—
B414H	The value set in the interlock signal storage device of the RIRCV instruction or RISEND instruction is out of range.	Set the interlock signal storage device value within range.	—
B415H	The dedicated instruction which is executable only on the master station was attempted to be executed on a station other than the master station.	Check if the own station type is a master station.	—
B416H	System error	Please consult your local Mitsubishi representative.	—
B417H	System error	Please consult your local Mitsubishi representative.	—
B418H	With the message transmission function, an abnormal data was received.	Set the receivable data size to a value larger than the receive data size.	—
B419H	System error	Please consult your local Mitsubishi representative.	—
B41AH	System error	Please consult your local Mitsubishi representative.	—
B601H	An unsupported request was received.	Check and correct the request data or the target station number.	—
B602H	Too many transient requests were sent to the corresponding station.	Wait for a while and send the request again.	—
B603H	Too many transient requests were sent to the corresponding station.	Wait for a while and send the request again.	—
B604H	Transient transmission was performed during a line test.	Wait for a while and send the request again.	—

Error code	Error details and causes	Action	Detailed information
B605H	The transient storage buffer data was failed to be obtained.	Wait for a while and send the request again.	—
B606H	System error	Please consult your local Mitsubishi representative.	—
B607H	The CPU module on the target station is in error.	Check the CPU module of the target station.	—
B608H	Transient transmission was performed to the AJ61BT11 or A1SJ61BT11 in the I/O mode.	Set the target station to intelligent mode.	—
B60CH	System error	Please consult your local Mitsubishi representative.	—
B700H	System error	Please consult your local Mitsubishi representative.	—
B701H to B704H	Transient transmission failed.	<ul style="list-style-type: none"> • Reduce the load placed on the transient transmission and perform the transmission again. • If the error occurs again even after taking the above, please consult your local Mitsubishi representative. 	—
B705H	System error	Please consult your local Mitsubishi representative.	—
B706H	System error	Please consult your local Mitsubishi representative.	—
B771H	Too many transient requests were sent to the corresponding station.	Wait for a while and send the request again.	—
B772H	System error	Please consult your local Mitsubishi representative.	—
B773H	System error	Please consult your local Mitsubishi representative.	—
B774H	The target station was not an intelligent device station.	Check if the target station is an intelligent device station.	—
B775H to B777H	Unsupported transient data was received.	Check the application on the source that issued the request.	—
B778H	A response is not received from the request destination.	Check the modules and cables at the request destination.	—
B779H	System error	Please consult your local Mitsubishi representative.	—
B780H	Transient transmission was performed although the target station was set to I/O mode.	Set the target station to intelligent mode.	—
B781H	System error	Please consult your local Mitsubishi representative.	—
B782H	When connection to another station is set, the sending destination station and the sending source station are the same.	Check the station number of the destination or change the setting to connection to the own station.	—
B783H	When data larger than 1K was being sent in transient transmission, an error has occurred in the transient storage buffer.	Wait for a while and send the request again.	—
B801H	A non-existing access code or attribute is set.	Set the correct access code or attribute.	—
B802H	A non-existing access code was used.	Use the correct access code.	—
B803H	The number of data points is out of the range.	Set the number of data points within 1 to 960 bytes.	—
B804H	<ul style="list-style-type: none"> • The attribute definition is invalid. • A transient transmission was performed although the target station does not support transient transmission. 	<ul style="list-style-type: none"> • Correct the attributes definition. • Correct the target station number setting. • Correct the function version of the target local station and software version. 	—
B805H	The number of data is out of the range.	Set a value within 1 to 100 for writing and within 1 to 160 for reading.	—
B807H	<ul style="list-style-type: none"> • The start device number is out of the range. • The address was not a multiple of 16 when the bit device was accessed. 	<ul style="list-style-type: none"> • Set the start device number within the range. • Set the address in multiples of 16 when the bit device is accessed. 	—
B80AH	System error	Please consult your local Mitsubishi representative.	—
B80DH	The set combination (address and number of points) exceeded the processable range.	Set the number of points to be processed within the device range.	—
B80FH to B812H	System error	Please consult your local Mitsubishi representative.	—
B814H	The file register capacity is not set.	Set the file register capacity.	—
B815H	Transient transmission was performed although the target station was set to I/O mode.	Set the target station to intelligent mode.	—
B817H	System error	Please consult your local Mitsubishi representative.	—
B821H	System error	Please consult your local Mitsubishi representative.	—
B822H	System error	Please consult your local Mitsubishi representative.	—
B823H	The mode setting of the remote control is not correct.	Correct the mode specification.	—
B824H	System error	Please consult your local Mitsubishi representative.	—
B826H	System error	Please consult your local Mitsubishi representative.	—

Error code	Error details and causes	Action	Detailed information
B830H	System error	Please consult your local Mitsubishi representative.	—
B903H	A transient request was issued to a station that had not secured a communication buffer.	Secure a communication buffer area using the parameter.	—
B981H to B987H	System error	Please consult your local Mitsubishi representative.	—
B988H	An error has been detected in the CPU module.	Check the error of the CPU module and take action using the module diagnostics.	—
	A hardware failure has been detected.	Please consult your local Mitsubishi representative.	—
B989H	An error has been detected in the CPU module.	Check the error of the CPU module and take action using the module diagnostics.	—
	A hardware failure has been detected.	Please consult your local Mitsubishi representative.	—
B9FFH	An error has been detected in the CPU module.	Check the error of the CPU module and take action using the module diagnostics.	—
	A hardware failure has been detected.	Please consult your local Mitsubishi representative.	—
BA01H	A hardware failure has been detected.	Please consult your local Mitsubishi representative.	—
BA02H	System error	Please consult your local Mitsubishi representative.	—
BA05H	System error	Please consult your local Mitsubishi representative.	—
BA06H to BA13H	A hardware failure has been detected.	Please consult your local Mitsubishi representative.	—
BA14H	A hardware (communication circuit) failure has been detected.	<ul style="list-style-type: none"> • Check that the terminating resistor provided with the master/local module is connected between the DA and DB terminals, and execute the hardware test again. • If the error occurs again even after taking the above, please consult your local Mitsubishi representative. 	—
BA15H	A hardware failure has been detected.	Please consult your local Mitsubishi representative.	—
BA16H	A hardware (communication circuit) failure has been detected.	<ul style="list-style-type: none"> • Check that the terminating resistor provided with the master/local module is connected between the DA and DB terminals, and execute the hardware test again. • If the error occurs again even after taking the above, please consult your local Mitsubishi representative. 	—
BA17H	A hardware (communication circuit) failure has been detected.	<ul style="list-style-type: none"> • Check that the terminating resistor provided with the master/local module is connected between the DA and DB terminals, and execute the hardware test again. • If the error occurs again even after taking the above, please consult your local Mitsubishi representative. 	—
BA19H	The target station of the line test 2 cannot be communicated.	Check the cables and the target station.	—
BA1BH	A communication failure has occurred in all stations during execution of the line test 1.	Check the cables.	—
BA1FH to BA21H	A hardware failure has been detected.	Please consult your local Mitsubishi representative.	—
BB01H	Execution of some of the following was attempted at the same time on the same station (Including the same request). <ul style="list-style-type: none"> • Remote device station initialization procedure registration function • RISEND or RIRCV instruction • Access from a peripheral to a remote device station 	Execute after other processing is completed.	—
BBC0H	<ul style="list-style-type: none"> • While this module is mounted on the main base unit in a redundant system, the station type of the own station has been set to other than "Master Station (Duplex Function)". • While this module is mounted on the extension base unit in a redundant system, the station type of the own station has been set to other than "Master Station". 	<ul style="list-style-type: none"> • Set the station type of the own station to "Master Station (Duplex Function)" when this module is mounted on the main base unit in a redundant system. • Set the station type of the own station to "Master Station" when this module is mounted on the extension base unit in a redundant system. 	—
BBC1H to BBC3H	System error	Please consult your local Mitsubishi representative.	—
BBC5H	<ul style="list-style-type: none"> • Multiple master stations exist on the same line. • Noise has been detected on the line at power-on. 	<ul style="list-style-type: none"> • Reduce the number of master stations on the same line to one. • When the data link starts by turning on 'Master station duplication error cancel request' (SB0007), check the line status. 	—

Error code	Error details and causes	Action	Detailed information
BBC7H	System error	Please consult your local Mitsubishi representative.	—
BBC8H	System error	Please consult your local Mitsubishi representative.	—
BBCAH	Multiple standby master stations exist on the same line.	<ul style="list-style-type: none"> • Reduce the number of standby master stations on the same line to one. • Check the line status. 	—
BBCBH	System error	Please consult your local Mitsubishi representative.	—
BBCCH	While this module is mounted on the extension base unit in a redundant system, the parameter setting method has been set to "Program".	Set the parameter setting method to "Parameter Editor" when this module is mounted on the extension base unit in a redundant system.	—
BBD1H	System error	Please consult your local Mitsubishi representative.	—
BBD3H	System error	Please consult your local Mitsubishi representative.	—
BC01H	A data link error has occurred on all stations during a message transmission.	Issue the request after the data link is started.	—
BC02H	System error	Please consult your local Mitsubishi representative.	—
BC03H	<p>The target station specified for the message transmission function is in any of the following status.</p> <ul style="list-style-type: none"> • No network parameter is set. • The specified station number is not the start station number. • The station is set as a reserved station. • A data link error has occurred (including error on all stations). 	Check the parameters or operation on the target station.	—
BC04H	The message transmission was performed to a station other than a remote device station or intelligent device station.	Check the target station.	—
BC05H	The target station number specified for message transmission function is not within 1 to 64.	Check the specified station number.	—
BC06H	The message transmission function was attempted to be executed on a station other than the master station.	Execute the message transmission function on the master station.	—
BC07H	The transmission data size was out of the range when message transmission function was executed.	Set the transmission data size within the range.	—
BC08H, BC09H	System error	Please consult your local Mitsubishi representative.	—
BC33H to BC39H	System error	Please consult your local Mitsubishi representative.	—
BC50H	With the message transmission function, an abnormal data was received.	Check the program to see if any prohibited remote output (RY) has not been accessed. If the error occurs again even after checking the above, the possible cause is a failure of a master/local module or remote device station. Please consult your local Mitsubishi representative.	—
BC51H	<ul style="list-style-type: none"> • During execution of message transmission function, a data link error has occurred on the corresponding station. • During execution of message transmission, some parameters were changed. • With the message transmission function, an abnormal data was received. 	<ul style="list-style-type: none"> • Check the operation of the target remote device station. • Stop the data link then change the parameters. • Check the program to see if any prohibited remote output (RY) has not been accessed. If the error occurs again even after checking the above, the possible cause is a failure of a master/local module or remote device station. Please consult your local Mitsubishi representative. 	—
BC52H	<ul style="list-style-type: none"> • With the message transmission function, a communication timeout has occurred. • 'Data link stop' (SB0002) was turned on during message transmission. • With the message transmission function, a stop error in the CPU module was detected. 	<ul style="list-style-type: none"> • Set a larger value in 'Monitoring time setting' (SW0009) If the error occurs again, check the modules and cables at the destination. • Stop data link after completion of message transmission. • To execute message transmission while there is a stop error in the CPU module, set "Data Link Setting at CPU Failure" under "Supplementary Cyclic Settings" in "Application Settings" to "Continue the Data Link". 	—

Error code	Error details and causes	Action	Detailed information
BC53H	<ul style="list-style-type: none"> With the message transmission function, a communication timeout has occurred. 'Data link stop' (SB0002) was turned on during message transmission. With the message transmission function, a stop error in the CPU module was detected. 	<ul style="list-style-type: none"> Set a larger value in 'Monitoring time setting' (SW0009) If the error occurs again, check the modules and cables at the destination. Stop data link after completion of message transmission. To execute message transmission while there is a stop error in the CPU module, set "Data Link Setting at CPU Failure" under "Supplementary Cyclic Settings" in "Application Settings" to "Continue the Data Link". 	—
BC54H	With the message transmission function, an abnormal data was received.	Execute the message transmission function again. If the error occurs again, the possible cause is a failure of a master/local module or remote device station. Please consult your local Mitsubishi representative.	—
BC55H	With the message transmission function, an abnormal data was received.	Execute the message transmission function again. If the error occurs again, the possible cause is a failure of a master/local module or remote device station. Please consult your local Mitsubishi representative.	—
BC57H	Multiple peripherals tried to access the same remote device station at the same time.	Execute after other processing is completed.	—
BC58H	With the message transmission function, an abnormal data was received.	Execute the message transmission function again. If the error occurs again, the possible cause is a failure of a master/local module or remote device station. Please consult your local Mitsubishi representative.	—
BC59H	With the message transmission function, an abnormal data was received.	Execute the message transmission function again. If the error occurs again, the possible cause is a failure of a master/local module or remote device station. Please consult your local Mitsubishi representative.	—
BC5AH	System error	Please consult your local Mitsubishi representative.	—
BC5BH	With the message transmission function, an abnormal response was received.	Check the operation of the target remote device station.	—
BC5CH to BC5FH	With the message transmission function, an abnormal data was received.	Execute the message transmission function again. If the error occurs again, the possible cause is a failure of a master/local module or remote device station. Please consult your local Mitsubishi representative.	—
BC60H	<ul style="list-style-type: none"> The message transmission function was executed simultaneously for five or more remote device stations. The message transmission function was executed simultaneously for five or more intelligent device stations. 	Reduce the number for simultaneous execution to four or less.	—
BC70H	The peripherals sent requests to the remote device station exceeding the number of concurrent execution.	Reduce the number for simultaneous execution to four or less.	—
BC71H	The remote device station access function was attempted to be performed from a station other than the master station.	Execute the function from the master station.	—
BC72H	<p>The remote device station to be accessed from the peripherals is in any of the following.</p> <ul style="list-style-type: none"> The station is not set in the network parameter. The specified station number is not the start station number. The station is set as a reserved station. A data link error has occurred (including error on all stations). 	Check the parameters or operation on the target station.	—
BC73H	The remote device station to be accessed from the peripherals is a remote I/O station.	Check the station number and station type of the specified target station.	—
BC74H	The specified device (RX, RY, RWw, or RWr) number is out of the valid device range for the connected target station.	Check the parameters and the device range of the target station.	—
BC75H	A data link error has occurred in all stations during access from the peripherals to the remote device station.	Issue the request after the data link is started.	—
BC76H	Time check over has occurred during access from the peripherals to the remote device station.	Increase the time check time in the application of the request source, or check the operation of the target slave station.	—
BC81H	System error	Please consult your local Mitsubishi representative.	—
BC90H	The message transmission result read request was received from the station with an unacceptable target station number.	Correct the target station number at the request source and retry the operation.	—

Error code	Error details and causes	Action	Detailed information
BC91H	Timeout has occurred in receiving response data of message transmission.	Set a larger value in 'Monitoring time setting' (SW0009) for execution. If the error occurs again, check the modules and cables at the destination.	—
BD83H	System error	Please consult your local Mitsubishi representative.	—
BD84H	System error	Please consult your local Mitsubishi representative.	—
BD85H	An error has been detected in the CPU module.	Check the error of the CPU module and take action using the module diagnostics.	—
	A hardware failure has been detected.	Please consult your local Mitsubishi representative.	—
BD86H	System error	Please consult your local Mitsubishi representative.	—
BD87H	System error	Please consult your local Mitsubishi representative.	—
BF11H to BF1CH	System error	Please consult your local Mitsubishi representative.	—
BF20H	System error	Please consult your local Mitsubishi representative.	—
BF30H to BF37H	System error	Please consult your local Mitsubishi representative.	—
BF38H	An error has been detected in reading the execution result in access from the peripherals to the remote device station.	<ul style="list-style-type: none"> • Check the application on the source that issued the request. • Check if another peripheral is accessing the remote device station. 	—
BF39H	An error has been detected in the request procedure in access from the peripherals to the remote device station.	<ul style="list-style-type: none"> • Check the application on the source that issued the request. • Check if multiple peripherals are accessing the remote device station. • Check if a value is written in the system area in the buffer memory. 	—
BF40H to BF42H	System error	Please consult your local Mitsubishi representative.	—
BF43H	The station type of the target station for message transmission is neither a remote device station nor intelligent device station.	Correct the target station at the request source and retry the operation.	—
BF44H	System error	Please consult your local Mitsubishi representative.	—
BF50H	System error	Please consult your local Mitsubishi representative.	—
BFFAH	The message transmission function was executed simultaneously for five or more intelligent device stations.	Reduce the number for simultaneous execution to four or less.	—
BFFBH	Too many transient requests were sent from the engineering tool or GOT.	Wait for a while and send the request again.	—

4.7 List of Event History

This section lists the events saved by the master/local modules.

Event code	Event type	Description	Cause
00510	System	<<Own station>> Data link start	Data link of the own station was started.
00511		<<Another station>> Data link start	Data link of another station was started.
00512		<<Own station>> Data link startup execution	Data link of the own station has been started in accordance with the data link restart instruction.
00513		<<Own station>> Data link stop execution	Data link of the own station has been stopped in accordance with the data link stop instruction.
00520		Temporary error invalid station setting execution	Temporary error invalid station setting was executed. Station number information shows the target station by the bit pattern in units of 16 stations. (The setting can be simultaneously executed for multiple stations.) For station No.1, b0 of the station number information (1 to 16) is turned on. For station No.64, b15 of the station number information (49 to 64) is turned on.
00521		Temporary error invalid station setting cancel execution	Temporary error invalid station cancel setting was executed. Station number information shows the target station by the bit pattern in units of 16 stations. (The setting can be simultaneously executed for multiple stations.) For station No.1, b0 of the station number information (1 to 16) is turned on. For station No.64, b15 of the station number information (49 to 64) is turned on.
00530		Master station duplication error cancel execution	The master station duplication error cancel instruction was executed
00531		Number of retries clear execution	The number of retries clear was executed.
00600		<<Own station>> Master/standby master switching occurrence	Master station was down, or manual switching of the master and standby master station has occurred.
00601		Refresh execution at standby master station switching	Refresh was started after standby master station switching.
00C00		<<Own station>> Data link stop	Data link of the own station was stopped.
00C01		<<Another station>> Data link stop	Data link of another station was stopped.
00C02		<<Another station>> WDT error occurrence	A WDT error has occurred in another station.
00C03		<<Another station>> Fuse blown occurrence	A fuse blown error has occurred in another station.
00C04		<<Another station>> Switch change occurrence	While data link was being performed, the station number switch or transmission speed switch was changed.
00C05	<<Another station>> Station number already in use	Station number overlap of the slave station has occurred. Station number information (1 to 4) shows the overlapped station number by the bit pattern in units of 16 stations. (The overlap may be simultaneously occurred in multiple stations.) For station No.2, b1 of the station number information 1 is turned on. For station No.64, b15 of the station number information 4 is turned on.	
00C06	<<Another station>> The loading and parameter do not match.	For loading and parameter consistency status, any of the following cases has occurred. <ul style="list-style-type: none"> • The station types do not match. • The number of occupied stations does not match. • The extended cyclic settings do not match. • The CC-Link compatible versions do not match. Station number information (1 to 4) shows the station number where an inconsistency has occurred by the bit pattern in units of 16 stations. (The inconsistency may be simultaneously occurred in multiple stations.) For station No.1, b0 of the station number information 1 is turned on. For station No.64, b15 of the station number information 4 is turned on.	
24100	Operation	<<Own station>> Parameter change occurrence	The parameter setting was changed.

APPENDICES

Appendix 1 Module Labels

I/O signals, buffer memory, link special relay (SB), and link special register areas (SW) of a master/local module can be set using module labels.

Structure of a module label

A module label consists of the following names.

"Instance name"_"Module number"."Label name"

"Instance name"_"Module number"."Label name"_D

Ex.

BT11_1.bIn_ModuleReady

■ Instance name

The instance name of a master/local module is as follows.

Module model name	Instance name
RJ61BT11	BT11

■ Module number

A module number is assigned to distinguish the modules having the same instance name, counting from "1".

■ Label name

A label name is a module-specific name.

■ _D

This symbol indicates that the module label is for direct access. A label without this symbol is for refresh. The following table lists the differences between refresh and direct access.

Type	Description	Access timing
Refresh	The values read from/written to the module label are collectively reflected to the module when refresh is executed. The time required for the execution of a program can be shortened.	When refresh is executed
Direct access	The value read from/written to the module label is reflected to the module immediately. Although the execution time of the program is longer than the one at refresh, the responsiveness is improved. For the instruction processing time, refer to the following.  MELSEC iQ-R Programming Manual (CPU Module Instructions, Standard Functions/Function Blocks)	When a value is read from/written to the module label

A

Appendix 2 I/O Signals

This section describes the I/O signals for the CPU module. The I/O signal assignment of when the start I/O number of the master/local module is "0" is listed below.

List of I/O signals

The following table lists I/O signals. The device X is an input signal from the master/local module to the CPU module. The device Y is an output signal from the CPU module to the master/local module.

Input signals

Device No.	Signal name
X0	Module failure
X1	Own station data link status
X2	Use prohibited
X3	Data link status of other stations
X4 to XE	Use prohibited
XF	Module ready
X10 to X1F	Use prohibited

Output signals

Device No.	Signal name
Y0 to Y1F	Use prohibited

Point

Do not use (turn on) any "use prohibited" signals as an input or output signal to the CPU module. Doing so may cause malfunction of the programmable controller system.

Details of I/O signals

This appendix describes on/off timing and conditions of I/O signals.

Module failure: X0

This signal indicates whether the module is normal or faulty.

Off: Module normal

On: Module failure

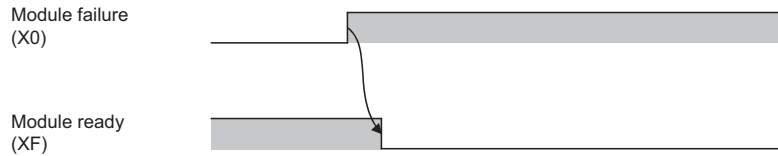

Own station data link status: X1

This signal indicates the data link status of the own station.

'Operation status of own station' (SB006E) has the same functionality. Use either of X1 or 'Operation status of own station' (SB006E) for programming.

Note that the on/off conditions of X1 are the opposite to those of 'Operation status of own station' (SB006E). The conditions of X1 are as follows:

Off: Data link stop

On: Data link in progress

Data link status of other stations: X3

This signal indicates the data link status of other stations (remote station, local station, intelligent device station, and standby master station).

'Data link status of other stations' (SB0080) has the same functionality. Use either of X3 or 'Data link status of other stations' (SB0080) for programming.

Off: All stations normal

On: Faulty station found (The status of the faulty station is stored in 'Data link status of other stations' (SW0080 to SW0083).)

A

Point

It takes maximum of six seconds for 'Data link status of other stations' (X3) to turn on after a slave station connected to the master station or local station becomes faulty. The time until this signal turns on differs depending on the system configuration and error status.

Module ready: XF

This signal indicates whether the module is ready for operation. When the module becomes ready, this signal turns on.

When the module is in the following state, this signal turns off.

- When Module failure (X0) turns on

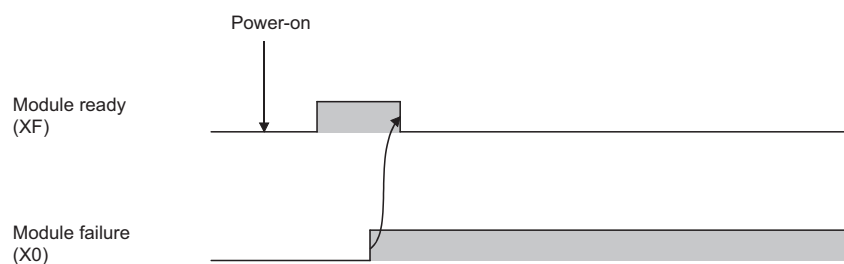

Appendix 3 Buffer Memory

The buffer memory is used to exchange data between the master/local module and the CPU module. Buffer memory values are reset to default when the CPU module is reset or the system is powered off.

List of buffer memory addresses

When a standby master station is used, refer to the respective columns under "Availability" in the table as explained below.

- When a standby master station is operating as a master station: "Master station" column
- When a standby master station is operating as a standby master station: "Local station" column

○: Available, —: Not available

Address		Name	Description	Read/write	Availability		Reference
Hexadecimal	Decimal				Master station	Local station	
0H to DFH	0 to 223	Parameter information area	Stores parameter settings.	Read	○ ^{*1}	—	Page 143 Parameter information area
E0H to 15FH	224 to 351	Remote input (RX) ^{*2}	■Master station Stores the data input from slave stations.	Read	○	—	Page 146 Remote input (RX)
			■Local station Stores the data input from the master station.		—	○	Page 146 Remote input (RX)
160H to 1DFH	352 to 479	Remote output (RY) ^{*2}	■Master station Stores the data output to slave stations.	Read, write	○	—	Page 147 Remote output (RY)
			■Local station Stores the data output to the master station. Data input from other slave stations are also stored.		—	○	Page 147 Remote output (RY)
1E0H to 2DFH	480 to 735	Remote register (RWw) ^{*2}	■Master station Stores the send data to slave stations.	Read, write	○	—	Page 149 Remote register (RWw)
			■Local station Stores the send data to the master station and other slave stations. Data received from other slave stations are also stored.		—	○	Page 149 Remote register (RWw)
2E0H to 3DFH	736 to 991	Remote register (RWr) ^{*2}	■Master station Stores the data received from slave stations.	Read	○	—	Page 148 Remote register (RWr)
			■Local station Stores the data received from the master station.		—	○	Page 149 Remote register (RWw)
3E0H to 5DFH	992 to 1503	Slave station offset, size information (512 words)	Stores the offset and size of RX, RY, RWw, and RWr in each slave station.	Read	○	○	Page 150 Slave station offset, size information
5E0H to 5FFH	1504 to 1535	Link special relay (SB)	Stores the data link status.	Read, write (Data can be written only to areas with the first 32 addresses.)	○	○	Page 152 Link special relay (SB)
600H to 7FFH	1536 to 2047	Link special register (SW)	Stores the data link status.				Page 152 Link special register (SW)
800H to 9FFH	2048 to 2559	System area	—	—	—	—	—
A00H to FFFH	2560 to 4095	Random access buffer	Stores any data and is used for transient transmission.	Read, write	○	○	Page 152 Random access buffer
1000H to 1FFFH	4096 to 8191	System area	—	—	—	—	—

Address		Name	Description	Read/write	Availability		Reference
Hexadecimal	Decimal				Master station	Local station	
2000H to 2FFFH	8192 to 12287	Automatic update buffer	Stores data automatically updated when transient transmission (communications using the automatic update buffer) is performed with an intelligent device station.	Read, write	○	—	Page 153 Automatic update buffer
3000H to 3FFFH	12288 to 16383	System area	—	—	—	—	—
4000H to 41FFH	16384 to 16895	Ver.2-compatible remote input (RX) ^{*3}	■Master station Stores the data input from slave stations.	Read	○	—	Page 153 Ver.2-compatible remote input (RX) and Ver.2-compatible remote output (RY)
			■Local station Stores the data input from the master station.		—	○	Page 153 Ver.2-compatible remote input (RX) and Ver.2-compatible remote output (RY)
4200H to 43FFH	16896 to 17407	Ver.2-compatible remote output (RY) ^{*3}	■Master station Stores the data output to slave stations.	Read, write	○	—	Page 153 Ver.2-compatible remote input (RX) and Ver.2-compatible remote output (RY)
			■Local station Stores the data output to the master station. Data input from other slave stations are also stored.		—	○	Page 153 Ver.2-compatible remote input (RX) and Ver.2-compatible remote output (RY)
4400H to 4BFFH	17408 to 19455	Ver.2-compatible remote register (RWw) ^{*3}	■Master station Stores the send data to slave stations.	Read, write	○	—	Page 154 Ver.2-compatible remote register (RWw) and Ver.2-compatible remote register (RWr)
			■Local station Stores the send data to the master station and other slave stations. Data received from other slave stations are also stored.		—	○	Page 154 Ver.2-compatible remote register (RWw) and Ver.2-compatible remote register (RWr)
4C00H to 53FFH	19456 to 21503	Ver.2-compatible remote register (RWr) ^{*3}	■Master station Stores the data received from slave stations.	Read	○	—	Page 154 Ver.2-compatible remote register (RWw) and Ver.2-compatible remote register (RWr)
			■Local station Stores the data received from the master station.		—	○	Page 154 Ver.2-compatible remote register (RWw) and Ver.2-compatible remote register (RWr)
5400H to 5C7FH	21504 to 23679	System area	—	—	—	—	—
5C80H to 5CBFH	23680 to 23743	Remote device station initialization procedure registration execution individual information	Stores the execution progress of the remote device station initial setting procedure registration function.	Read	○	—	Page 155 Remote device station initialization procedure registration execution individual info.
5CC0H to 7FFFH	23744 to 32767	System area	—	—	—	—	—

*1 Not available when a standby master station is controlling the system.

*2 This buffer memory area is used when the remote net Ver.1 mode, remote device net Ver.1 mode, or remote I/O net mode is selected.

*3 This buffer memory area is used when the remote net Ver.2 mode or remote device net Ver.2 mode is selected.

Point 

Do not write data to "System area".
Doing so may cause malfunction of the programmable controller system.

Details of buffer memory addresses

This appendix describes buffer memory areas.

Parameter information area

This area stores parameter settings.

Do not write data in this area. Doing so may cause an error.

Address		Item	Description																																																		
Hexadecimal	Decimal																																																				
0H	0	(Use prohibited)	—																																																		
1H	1	Total number of connected stations	Stores the number of slave stations (including a reserved station) connected to the master station. Default: 64 (stations) Range: 1 to 64 (station)																																																		
2H	2	Number of retries	Stores the number of retries to a station where a communication failure has occurred. Default: 3 (times) Range: 1 to 7 (time)																																																		
3H	3	Number of automatic return stations	Stores the number of slave stations that return to system operation by one link scan. Default: 1 (time) Range: 1 to 10 (time)																																																		
4H	4	Standby master station specification	Stores the standby master station number. Default: 0 (0: no standby master station specified) Range: 0 to 64 (0: no standby master station specified, 1 to 64: station number of the corresponding station)																																																		
5H	5	(Use prohibited)	—																																																		
6H	6	Data link setting at CPU failure	Stores the specified data link status if a programmable controller CPU error occurs in the mater station. Default: 0 (Data link stopped) Range: 0 (Data link stopped), 1 (Data link continued)																																																		
7H	7	Scan mode setting	Stores whether to synchronize a link scan with a sequence scan. Default: 0 (Asynchronous with a sequence scan) Range: 0 (Asynchronous with a sequence scan), 1 (Synchronous with a sequence scan)																																																		
8H to FH	8 to 15	(Use prohibited)	—																																																		
10H to 13H	16 to 19	Reserved station setting	Stores the reserved station specification status. Only the bit corresponding to the start station number turns on. Default: 0 (Not set) Range: The bit corresponding to the station number turns on. <table border="1" style="margin-left: auto; margin-right: auto;"> <thead> <tr> <th></th> <th>b15</th> <th>b14</th> <th>b13</th> <th>b12</th> <th>to</th> <th>b3</th> <th>b2</th> <th>b1</th> <th>b0</th> </tr> </thead> <tbody> <tr> <td>10H (16)</td> <td>16</td> <td>15</td> <td>14</td> <td>13</td> <td>to</td> <td>4</td> <td>3</td> <td>2</td> <td>1</td> </tr> <tr> <td>11H (17)</td> <td>32</td> <td>31</td> <td>30</td> <td>29</td> <td>to</td> <td>20</td> <td>19</td> <td>18</td> <td>17</td> </tr> <tr> <td>12H (18)</td> <td>48</td> <td>47</td> <td>46</td> <td>45</td> <td>to</td> <td>36</td> <td>35</td> <td>34</td> <td>33</td> </tr> <tr> <td>13H (19)</td> <td>64</td> <td>63</td> <td>62</td> <td>61</td> <td>to</td> <td>52</td> <td>51</td> <td>50</td> <td>49</td> </tr> </tbody> </table> 1 to 64 in the table indicate station numbers.		b15	b14	b13	b12	to	b3	b2	b1	b0	10H (16)	16	15	14	13	to	4	3	2	1	11H (17)	32	31	30	29	to	20	19	18	17	12H (18)	48	47	46	45	to	36	35	34	33	13H (19)	64	63	62	61	to	52	51	50	49
	b15	b14	b13	b12	to	b3	b2	b1	b0																																												
10H (16)	16	15	14	13	to	4	3	2	1																																												
11H (17)	32	31	30	29	to	20	19	18	17																																												
12H (18)	48	47	46	45	to	36	35	34	33																																												
13H (19)	64	63	62	61	to	52	51	50	49																																												
14H to 17H	20 to 23	Error invalid station setting	Stores the error invalid station specification status. Only the bit corresponding to the start station number turns on. Default: 0 (Not set) Range: The bit corresponding to the station number turns on. <table border="1" style="margin-left: auto; margin-right: auto;"> <thead> <tr> <th></th> <th>b15</th> <th>b14</th> <th>b13</th> <th>b12</th> <th>to</th> <th>b3</th> <th>b2</th> <th>b1</th> <th>b0</th> </tr> </thead> <tbody> <tr> <td>14H (20)</td> <td>16</td> <td>15</td> <td>14</td> <td>13</td> <td>to</td> <td>4</td> <td>3</td> <td>2</td> <td>1</td> </tr> <tr> <td>15H (21)</td> <td>32</td> <td>31</td> <td>30</td> <td>29</td> <td>to</td> <td>20</td> <td>19</td> <td>18</td> <td>17</td> </tr> <tr> <td>16H (22)</td> <td>48</td> <td>47</td> <td>46</td> <td>45</td> <td>to</td> <td>36</td> <td>35</td> <td>34</td> <td>33</td> </tr> <tr> <td>17H (23)</td> <td>64</td> <td>63</td> <td>62</td> <td>61</td> <td>to</td> <td>52</td> <td>51</td> <td>50</td> <td>49</td> </tr> </tbody> </table> 1 to 64 in the table indicate station numbers.		b15	b14	b13	b12	to	b3	b2	b1	b0	14H (20)	16	15	14	13	to	4	3	2	1	15H (21)	32	31	30	29	to	20	19	18	17	16H (22)	48	47	46	45	to	36	35	34	33	17H (23)	64	63	62	61	to	52	51	50	49
	b15	b14	b13	b12	to	b3	b2	b1	b0																																												
14H (20)	16	15	14	13	to	4	3	2	1																																												
15H (21)	32	31	30	29	to	20	19	18	17																																												
16H (22)	48	47	46	45	to	36	35	34	33																																												
17H (23)	64	63	62	61	to	52	51	50	49																																												
18H to 1FH	24 to 31	(Use prohibited)	—																																																		



Address		Item	Description																																																		
Hexadecimal	Decimal																																																				
20H (1st station) to 5FH (64th station)	32 (1st station) to 95 (64th station)	Station information	<p>Stores the status of the station type, the number of occupied stations, and the extended cyclic settings specified in the module parameters for slave stations.</p> <p>Default: 0101H (Ver.1-compatible remote I/O station, one station occupied, and station number 1) : 0140H (Ver.1-compatible remote I/O station, one station occupied, and station number 64)</p> <p>Range: Refer to the following.</p> <div style="text-align: center;"> <table border="1" style="margin: auto;"> <tr> <td style="text-align: center;">b15</td> <td style="text-align: center;">to</td> <td style="text-align: center;">b12</td> <td style="text-align: center;">b11</td> <td style="text-align: center;">to</td> <td style="text-align: center;">b8</td> <td style="text-align: center;">b7</td> <td style="text-align: center;">to</td> <td style="text-align: center;">b0</td> </tr> <tr> <td colspan="3" style="text-align: center;">Station type</td> <td colspan="2" style="text-align: center;">Number of occupied stations</td> <td colspan="4" style="text-align: center;">Station No.</td> </tr> </table> <p style="text-align: right; margin-right: 100px;">1 to 64 (01H to 40H)</p> <p style="margin-left: 100px;">1H: Number of occupied stations: 1 2H: Number of occupied stations: 2 3H: Number of occupied stations: 3 4H: Number of occupied stations: 4</p> <p>0H: Ver.1-compatible remote I/O station 1H: Ver.1-compatible remote device station 2H: Ver.1-compatible intelligent device station 5H: Ver.2-compatible remote device station (single) 6H: Ver.2-compatible intelligent device station (single) 8H: Ver.2-compatible remote device station (double) 9H: Ver.2-compatible intelligent device station (double) BH: Ver.2-compatible remote device station (quadruple) CH: Ver.2-compatible intelligent device station (quadruple) EH: Ver.2-compatible remote device station (octuple) FH: Ver.2-compatible intelligent device station (octuple)</p> </div>	b15	to	b12	b11	to	b8	b7	to	b0	Station type			Number of occupied stations		Station No.																																			
b15	to	b12	b11	to	b8	b7	to	b0																																													
Station type			Number of occupied stations		Station No.																																																
60H to 7FH	96 to 127	(Use prohibited)	—																																																		
80H to CDH	128 to 205	Automatic update buffer assignment	<p>Stores the buffer memory sizes assigned for a local station, intelligent device station, and standby master station during transient transmission.</p> <p>Default: 128 words Range: 0 (word) (not set) or 128 (word) to 4096 (word) Note that the total size must be within 4096 (word).</p> <p>■1st station</p> <ul style="list-style-type: none"> • 80H (128): Use prohibited • 81H (129): Use prohibited • 82H (130): Automatic update buffer size only for intelligent device stations : <p>■26th station</p> <ul style="list-style-type: none"> • CBH (203): Use prohibited • CCH (204): Use prohibited • CDH (205): Automatic update buffer size only for intelligent device stations 																																																		
CEH, CFH	206, 207	(Use prohibited)	—																																																		
D0H to D3H	208 to 211	8-point remote I/O station setting	<p>Stores the station number of the remote I/O station where 8 points have been set in the remote I/O station points setting.</p> <p>When "8 Points + Empty 8 Points" has been set, the station number is stored in both 8-point remote I/O station setting and 16-point remote I/O station setting.</p> <p>Default: 0 (Not set) Range: The bit corresponding to the station number turns on.</p> <table border="1" style="margin: auto;"> <thead> <tr> <th></th> <th>b15</th> <th>b14</th> <th>b13</th> <th>b12</th> <th>to</th> <th>b3</th> <th>b2</th> <th>b1</th> <th>b0</th> </tr> </thead> <tbody> <tr> <td>D0H (208)</td> <td>16</td> <td>15</td> <td>14</td> <td>13</td> <td>to</td> <td>4</td> <td>3</td> <td>2</td> <td>1</td> </tr> <tr> <td>D1H (209)</td> <td>32</td> <td>31</td> <td>30</td> <td>29</td> <td>to</td> <td>20</td> <td>19</td> <td>18</td> <td>17</td> </tr> <tr> <td>D2H (210)</td> <td>48</td> <td>47</td> <td>46</td> <td>45</td> <td>to</td> <td>36</td> <td>35</td> <td>34</td> <td>33</td> </tr> <tr> <td>D3H (211)</td> <td>64</td> <td>63</td> <td>62</td> <td>61</td> <td>to</td> <td>52</td> <td>51</td> <td>50</td> <td>49</td> </tr> </tbody> </table> <p style="text-align: center;">1 to 64 in the table indicate station numbers.</p>		b15	b14	b13	b12	to	b3	b2	b1	b0	D0H (208)	16	15	14	13	to	4	3	2	1	D1H (209)	32	31	30	29	to	20	19	18	17	D2H (210)	48	47	46	45	to	36	35	34	33	D3H (211)	64	63	62	61	to	52	51	50	49
	b15	b14	b13	b12	to	b3	b2	b1	b0																																												
D0H (208)	16	15	14	13	to	4	3	2	1																																												
D1H (209)	32	31	30	29	to	20	19	18	17																																												
D2H (210)	48	47	46	45	to	36	35	34	33																																												
D3H (211)	64	63	62	61	to	52	51	50	49																																												

Address		Item	Description																																																		
Hexadecimal	Decimal																																																				
D4H to D7H	212 to 215	16-point remote I/O station setting	<p>Stores the station number of the remote I/O station where 16 points have been set in the remote I/O station points setting.</p> <p>When "8 Points + Empty 8 Points" has been set, the station number is stored in both 8-point remote I/O station setting and 16-point remote I/O station setting.</p> <p>Default: 0 (Not set)</p> <p>Range: The bit corresponding to the station number turns on.</p> <table border="1"> <thead> <tr> <th></th> <th>b15</th> <th>b14</th> <th>b13</th> <th>b12</th> <th>to</th> <th>b3</th> <th>b2</th> <th>b1</th> <th>b0</th> </tr> </thead> <tbody> <tr> <td>D4H (212)</td> <td>16</td> <td>15</td> <td>14</td> <td>13</td> <td>to</td> <td>4</td> <td>3</td> <td>2</td> <td>1</td> </tr> <tr> <td>D5H (213)</td> <td>32</td> <td>31</td> <td>30</td> <td>29</td> <td>to</td> <td>20</td> <td>19</td> <td>18</td> <td>17</td> </tr> <tr> <td>D6H (214)</td> <td>48</td> <td>47</td> <td>46</td> <td>45</td> <td>to</td> <td>36</td> <td>35</td> <td>34</td> <td>33</td> </tr> <tr> <td>D7H (215)</td> <td>64</td> <td>63</td> <td>62</td> <td>61</td> <td>to</td> <td>52</td> <td>51</td> <td>50</td> <td>49</td> </tr> </tbody> </table> <p>1 to 64 in the table indicate station numbers.</p>		b15	b14	b13	b12	to	b3	b2	b1	b0	D4H (212)	16	15	14	13	to	4	3	2	1	D5H (213)	32	31	30	29	to	20	19	18	17	D6H (214)	48	47	46	45	to	36	35	34	33	D7H (215)	64	63	62	61	to	52	51	50	49
	b15	b14	b13	b12	to	b3	b2	b1	b0																																												
D4H (212)	16	15	14	13	to	4	3	2	1																																												
D5H (213)	32	31	30	29	to	20	19	18	17																																												
D6H (214)	48	47	46	45	to	36	35	34	33																																												
D7H (215)	64	63	62	61	to	52	51	50	49																																												
D8H to DBH	216 to 219	0-point reserved station specification	<p>Stores the station number of the reserved station where 0 points have been set.</p> <p>Default: 0 (Not set)</p> <p>Range: The bit corresponding to the station number turns on.</p> <table border="1"> <thead> <tr> <th></th> <th>b15</th> <th>b14</th> <th>b13</th> <th>b12</th> <th>to</th> <th>b3</th> <th>b2</th> <th>b1</th> <th>b0</th> </tr> </thead> <tbody> <tr> <td>D8H (216)</td> <td>16</td> <td>15</td> <td>14</td> <td>13</td> <td>to</td> <td>4</td> <td>3</td> <td>2</td> <td>1</td> </tr> <tr> <td>D9H (217)</td> <td>32</td> <td>31</td> <td>30</td> <td>29</td> <td>to</td> <td>20</td> <td>19</td> <td>18</td> <td>17</td> </tr> <tr> <td>DAH (218)</td> <td>48</td> <td>47</td> <td>46</td> <td>45</td> <td>to</td> <td>36</td> <td>35</td> <td>34</td> <td>33</td> </tr> <tr> <td>DBH (219)</td> <td>64</td> <td>63</td> <td>62</td> <td>61</td> <td>to</td> <td>52</td> <td>51</td> <td>50</td> <td>49</td> </tr> </tbody> </table> <p>1 to 64 in the table indicate station numbers.</p>		b15	b14	b13	b12	to	b3	b2	b1	b0	D8H (216)	16	15	14	13	to	4	3	2	1	D9H (217)	32	31	30	29	to	20	19	18	17	DAH (218)	48	47	46	45	to	36	35	34	33	DBH (219)	64	63	62	61	to	52	51	50	49
	b15	b14	b13	b12	to	b3	b2	b1	b0																																												
D8H (216)	16	15	14	13	to	4	3	2	1																																												
D9H (217)	32	31	30	29	to	20	19	18	17																																												
DAH (218)	48	47	46	45	to	36	35	34	33																																												
DBH (219)	64	63	62	61	to	52	51	50	49																																												
DCH to DFH	220 to 223	(Use prohibited)	—																																																		



Remote input (RX) and remote output (RY)

This buffer memory area is used when the remote net Ver.1 mode, remote device net Ver.1 mode, or remote I/O net mode is selected.

- In the remote net Ver.1 mode, remote device net Ver.1 mode, or remote I/O net mode, data are stored in the remote input (RX) and remote output (RY). ( Page 21 Remote net Ver.1 mode, Page 25 Remote device net Ver.1 mode, Page 29 Remote I/O net mode)

■Remote input (RX)

For the master station, data input from slave stations are stored.

For local stations, data input from the master station are stored.

Station number	Buffer memory address	Station number	Buffer memory address	Station number	Buffer memory address	Station number	Buffer memory address	Station number	Buffer memory address
1	E0H and E1H (224 and 225)	14	FAH and FBH (250 and 251)	27	114H and 115H (276 and 277)	40	12EH and 12FH (302 and 303)	53	148H and 149H (328 and 329)
2	E2H and E3H (226 and 227)	15	FCH and FDH (252 and 253)	28	116H and 117H (278 and 279)	41	130H and 131H (304 and 305)	54	14AH and 14BH (330 and 331)
3	E4H and E5H (228 and 229)	16	FEH and FFH (254 and 255)	29	118H and 119H (280 and 281)	42	132H and 133H (306 and 307)	55	14CH and 14DH (332 and 333)
4	E6H and E7H (230 and 231)	17	100H and 101H (256 and 257)	30	11AH and 11BH (282 and 283)	43	134H and 135H (308 and 309)	56	14EH and 14FH (334 and 335)
5	E8H and E9H (232 and 233)	18	102H and 103H (258 and 259)	31	11CH and 11DH (284 and 285)	44	136H and 137H (310 and 311)	57	150H and 151H (336 and 337)
6	EAH and EBH (234 and 235)	19	104H and 105H (260 and 261)	32	11EH and 11FH (286 and 287)	45	138H and 139H (312 and 313)	58	152H and 153H (338 and 339)
7	ECH and EDH (236 and 237)	20	106H and 107H (262 and 263)	33	120H and 121H (288 and 289)	46	13AH and 13BH (314 and 315)	59	154H and 155H (340 and 341)
8	EEH and EFH (238 and 239)	21	108H and 109H (264 and 265)	34	122H and 123H (290 and 291)	47	13CH and 13DH (316 and 317)	60	156H and 157H (342 and 343)
9	F0H and F1H (240 and 241)	22	10AH and 10BH (266 and 267)	35	124H and 125H (292 and 293)	48	13EH and 13FH (318 and 319)	61	158H and 159H (344 and 345)
10	F2H and F3H (242 and 243)	23	10CH and 10DH (268 and 269)	36	126H and 127H (294 and 295)	49	140H and 141H (320 and 321)	62	15AH and 15BH (346 and 347)
11	F4H and F5H (244 and 245)	24	10EH and 10FH (270 and 271)	37	128H and 129H (296 and 297)	50	142H and 143H (322 and 323)	63	15CH and 15DH (348 and 349)
12	F6H and F7H (246 and 247)	25	110H and 111H (272 and 273)	38	12AH and 12BH (298 and 299)	51	144H and 145H (324 and 325)	64	15EH and 15FH (350 and 351)
13	F8H and F9H (248 and 249)	26	112H and 113H (274 and 275)	39	12CH and 12DH (300 and 301)	52	146H and 147H (326 and 327)	—	—

■ Remote output (RY)

For the master station, data output to slave stations are stored.

For local stations, data output to the master station are stored. Data input from slave stations are also stored.

Station number	Buffer memory address	Station number	Buffer memory address	Station number	Buffer memory address	Station number	Buffer memory address	Station number	Buffer memory address
1	160H and 161H (352 and 353)	14	17AH and 17BH (378 and 379)	27	194H and 195H (404 and 405)	40	1AEH and 1AFH (430 and 431)	53	1C8H and 1C9H (456 and 457)
2	162H and 163H (354 and 355)	15	17CH and 17DH (380 and 381)	28	196H and 197H (406 and 407)	41	1B0H and 1B1H (432 and 433)	54	1CAH and 1CBH (458 and 459)
3	164H and 165H (356 and 357)	16	17EH and 17FH (382 and 383)	29	198H and 199H (408 and 409)	42	1B2H and 1B3H (434 and 435)	55	1CCH and 1CDH (460 and 461)
4	166H and 167H (358 and 359)	17	180H and 181H (384 and 385)	30	19AH and 19BH (410 and 411)	43	1B4H and 1B5H (436 and 437)	56	1CEH and 1CFH (462 and 463)
5	168H and 169H (360 and 361)	18	182H and 183H (386 and 387)	31	19CH and 19DH (412 and 413)	44	1B6H and 1B7H (438 and 439)	57	1DOH and 1D1H (464 and 465)
6	16AH and 16BH (362 and 363)	19	184H and 185H (388 and 389)	32	19EH and 19FH (414 and 415)	45	1B8H and 1B9H (440 and 441)	58	1D2H and 1D3H (466 and 467)
7	16CH and 16DH (364 and 365)	20	186H and 187H (390 and 391)	33	1A0H and 1A1H (416 and 417)	46	1BAH and 1BBH (442 and 443)	59	1D4H and 1D5H (468 and 469)
8	16EH and 16FH (366 and 367)	21	188H and 189H (392 and 393)	34	1A2H and 1A3H (418 and 419)	47	1BCH and 1BDH (444 and 445)	60	1D6H and 1D7H (470 and 471)
9	170H and 171H (368 and 369)	22	18AH and 18BH (394 and 395)	35	1A4H and 1A5H (420 and 421)	48	1BEH and 1BFH (446 and 447)	61	1D8H and 1D9H (472 and 473)
10	172H and 173H (370 and 371)	23	18CH and 18DH (396 and 397)	36	1A6H and 1A7H (422 and 423)	49	1C0H and 1C1H (448 and 449)	62	1DAH and 1DBH (474 and 475)
11	174H and 175H (372 and 373)	24	18EH and 18FH (398 and 399)	37	1A8H and 1A9H (424 and 425)	50	1C2H and 1C3H (450 and 451)	63	1DCH and 1DDH (476 and 477)
12	176H and 177H (374 and 375)	25	190H and 191H (400 and 401)	38	1AAH and 1ABH (426 and 427)	51	1C4H and 1C5H (452 and 453)	64	1DEH and 1DFH (478 and 479)
13	178H and 179H (376 and 377)	26	192H and 193H (402 and 403)	39	1ACH and 1ADH (428 and 429)	52	1C6H and 1C7H (454 and 455)	—	—

Remote register (RWw) and remote register (RWr)

This buffer memory area is used when the remote net Ver.1 mode or remote device net Ver.1 mode is selected.

- In the remote net Ver.1 mode and remote device net Ver.1 mode, data are stored in the remote register (RWr and RWw).

(☞ Page 21 Remote net Ver.1 mode, Page 25 Remote device net Ver.1 mode)

■Remote register (RWr)

For the master station, data received from slave stations are stored.

For local stations, data received from the master station are stored.

Station number	Buffer memory address	Station number	Buffer memory address	Station number	Buffer memory address	Station number	Buffer memory address	Station number	Buffer memory address
1	2E0H to 2E3H (736 to 739)	14	314H to 317H (788 to 791)	27	348H to 34BH (840 to 843)	40	37CH to 37FH (892 to 895)	53	3B0H to 3B3H (944 to 947)
2	2E4H to 2E7H (740 to 743)	15	318H to 31BH (792 to 795)	28	34CH to 34FH (844 to 847)	41	380H to 383H (896 to 899)	54	3B4H to 3B7H (948 to 951)
3	2E8H to 2EBH (744 to 747)	16	31CH to 31FH (796 to 799)	29	350H to 353H (848 to 851)	42	384H to 387H (900 to 903)	55	3B8H to 3BBH (952 to 955)
4	2ECH to 2EFH (748 to 751)	17	320H to 323H (800 to 803)	30	354H to 357H (852 to 855)	43	388H to 38BH (904 to 907)	56	3BCH to 3BFH (956 to 959)
5	2F0H to 2F3H (752 to 755)	18	324H to 327H (804 to 807)	31	358H to 35BH (856 to 859)	44	38CH to 38FH (908 to 911)	57	3C0H to 3C3H (960 to 963)
6	2F4H to 2F7H (756 to 759)	19	328H to 32BH (808 to 811)	32	35CH to 35FH (860 to 863)	45	390H to 393H (912 to 915)	58	3C4H to 3C7H (964 to 967)
7	2F8H to 2FBH (760 to 763)	20	32CH to 32FH (812 to 815)	33	360H to 363H (864 to 867)	46	394H to 397H (916 to 919)	59	3C8H to 3CBH (968 to 971)
8	2FCH to 2FFH (764 to 767)	21	330H to 333H (816 to 819)	34	364H to 367H (868 to 871)	47	398H to 39BH (920 to 923)	60	3CCH to 3CFH (972 to 975)
9	300H to 303H (768 to 771)	22	334H to 337H (820 to 823)	35	368H to 36BH (872 to 875)	48	39CH to 39FH (924 to 927)	61	3D0H to 3D3H (976 to 979)
10	304H to 307H (772 to 775)	23	338H to 33BH (824 to 827)	36	36CH to 36FH (876 to 879)	49	3A0H to 3A3H (928 to 931)	62	3D4H to 3D7H (980 to 983)
11	308H to 30BH (776 to 779)	24	33CH to 33FH (828 to 831)	37	370H to 373H (880 to 883)	50	3A4H to 3A7H (932 to 935)	63	3D8H to 3DBH (984 to 987)
12	30CH to 30FH (780 to 783)	25	340H to 343H (832 to 835)	38	374H to 377H (884 to 887)	51	3A8H to 3ABH (936 to 939)	64	3DCH to 3DFH (988 to 991)
13	310H to 313H (784 to 787)	26	344H to 347H (836 to 839)	39	378H to 37BH (888 to 891)	52	3ACH to 3AFH (940 to 943)	—	—

■ Remote register (RWw)

For the master station, data sent to slave stations are stored.

For local stations, data sent to the master station are stored. Data received from slave stations are also stored.

Station number	Buffer memory address	Station number	Buffer memory address	Station number	Buffer memory address	Station number	Buffer memory address	Station number	Buffer memory address
1	1E0H to 1E3H (480 to 483)	14	214H to 217H (532 to 535)	27	248H to 24BH (584 to 587)	40	27CH to 27FH (636 to 639)	53	2B0H to 2B3H (688 to 691)
2	1E4H to 1E7H (484 to 487)	15	218H to 21BH (536 to 539)	28	24CH to 24FH (588 to 591)	41	280H to 283H (640 to 643)	54	2B4H to 2B7H (692 to 695)
3	1E8H to 1EBH (488 to 491)	16	21CH to 21FH (540 to 543)	29	250H to 253H (592 to 595)	42	284H to 287H (644 to 647)	55	2B8H to 2BBH (696 to 699)
4	1ECH to 1EFH (492 to 495)	17	220H to 223H (544 to 547)	30	254H to 257H (596 to 599)	43	288H to 28BH (648 to 651)	56	2BCH to 2BFH (700 to 703)
5	1F0H to 1F3H (496 to 499)	18	224H to 227H (548 to 551)	31	258H to 25BH (600 to 603)	44	28CH to 28FH (652 to 655)	57	2C0H to 2C3H (704 to 707)
6	1F4H to 1F7H (500 to 503)	19	228H to 22BH (552 to 555)	32	25CH to 25FH (604 to 607)	45	290H to 293H (656 to 659)	58	2C4H to 2C7H (708 to 711)
7	1F8H to 1FBH (504 to 507)	20	22CH to 22FH (556 to 559)	33	260H to 263H (608 to 611)	46	294H to 297H (660 to 663)	59	2C8H to 2CBH (712 to 715)
8	1FCH to 1FFH (508 to 511)	21	230H to 233H (560 to 563)	34	264H to 267H (612 to 615)	47	298H to 29BH (664 to 667)	60	2CCH to 2CFH (716 to 719)
9	200H to 203H (512 to 515)	22	234H to 237H (564 to 567)	35	268H to 26BH (616 to 619)	48	29CH to 29FH (668 to 671)	61	2D0H to 2D3H (720 to 723)
10	204H to 207H (516 to 519)	23	238H to 23BH (568 to 571)	36	26CH to 26FH (620 to 623)	49	2A0H to 2A3H (672 to 675)	62	2D4H to 2D7H (724 to 727)
11	208H to 20BH (520 to 523)	24	23CH to 23FH (572 to 575)	37	270H to 273H (624 to 627)	50	2A4H to 2A7H (676 to 679)	63	2D8H to 2DBH (728 to 731)
12	20CH to 20FH (524 to 527)	25	240H to 243H (576 to 579)	38	274H to 277H (628 to 631)	51	2A8H to 2ABH (680 to 683)	64	2DCH to 2DFH (732 to 735)
13	210H to 213H (528 to 531)	26	244H to 247H (580 to 583)	39	278H to 27BH (632 to 635)	52	2ACH to 2AFH (684 to 687)	—	—

Slave station offset, size information

In the remote net Ver.2 mode and remote device net Ver.2 mode, the assignment of RX, RY, RWw, and RWr for each station differs depending on the extended cyclic settings and the remote I/O station points setting.

■Offset

This area stores the start buffer memory addresses of RX, RY, RWw, and RWr assigned for each station.

When two or more stations are occupied, a value is stored only in the start buffer memory address of the first station. For example, when the station number 1 occupies two stations, values are stored only in the RX, RY, RWw, RWr offset, and size information of the station number 1 and those for the station number 2 remain the default.

■Size

This area stores the sizes of RX, RY, RWw, and RWr assigned for each station (unit: word).

When the size is less than one word, the storage value is rounded up; therefore, 1 is stored.

When eight points are set in the remote I/O station points setting, 1 is stored. For the remote I/O station points setting, refer to the following.

-  Page 42 Remote I/O station points setting

If the target station is a reserved station, 0000H is stored.

The following table lists the relationship between RX/RY/RWw/RWr offset/size information and buffer memory addresses for each station.

Buffer memory address		Item	Default (hexadecimal)
Hexadecimal	Decimal		
3E0H	992	Station No.1 RX offset	0000H
3E1H	993	Station No.1 RX size	0000H
⋮	⋮	⋮	—
45EH	1118	Station No.64 RX offset	0000H
45FH	1119	Station No.64 RX size	0000H
460H	1120	Station No.1 RY offset	0000H
461H	1121	Station No.1 RY size	0000H
⋮	⋮	⋮	—
4DEH	1246	Station No.64 RY offset	0000H
4DFH	1247	Station No.64 RY size	0000H
4E0H	1248	Station No.1 RWw offset	0000H
4E1H	1249	Station No.1 RWw size	0000H
⋮	⋮	⋮	—
55EH	1374	Station No.64 RWw offset	0000H
55FH	1375	Station No.64 RWw size	0000H
560H	1376	Station No.1 RWr offset	0000H
561H	1377	Station No.1 RWr size	0000H
⋮	⋮	⋮	—
5DEH	1502	Station No.64 RWr offset	0000H
5DFH	1503	Station No.64 RWr size	0000H

The following figure shows an example of connecting the local station with the extended cyclic settings and remote I/O stations with the remote I/O station points setting.

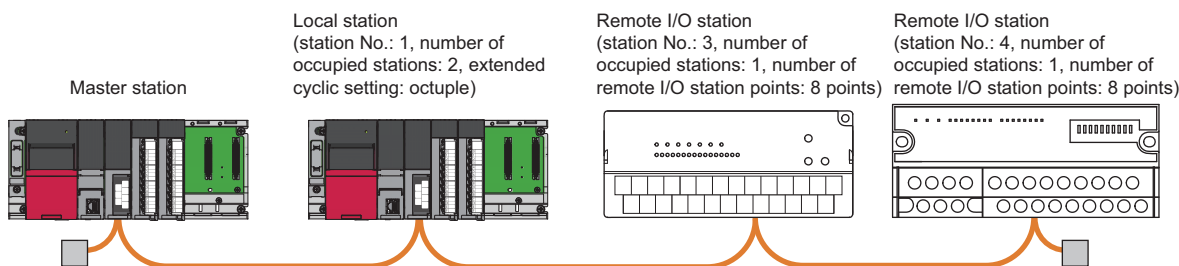

Buffer memory area	Value	Description
Station No.1 RX offset	4000H	Start buffer memory address of RX in the station number 1
Station No.1 RX size	24 (18H)	$384 \text{ (number of points of RX)} \div 16 = 24 \text{ words}$
Station No.2 RX offset	4000H	Because the station occupies two stations, check the area in the station number 1.
Station No.2 RX size	0 (Default)	Because the station occupies two stations, check the area in the station number 1.
Station No.3 RX offset	4018H	Start buffer memory address of RX in the station number 3
Station No.3 RX size	1 (1H)	The lower eight bits of the area (buffer memory address: 4018H) are the corresponding size of RX in the station number 3; however, 1 is stored, because a value less than one word is rounded up.
Station No.4 RX offset	4018H	Start buffer memory address of RX in the station number 4
Station No.4 RX size	1 (1H)	The upper eight bits of the area (buffer memory address: 4018H) are the corresponding size of RX in the station number 4; however, 1 is stored, because a value less than one word is rounded up.
Station No.1 RY offset	4200H	Start buffer memory address of RY in the station number 1
Station No.1 RY size	24 (18H)	$384 \text{ (number of points of RY)} \div 16 = 24 \text{ words}$
Station No.2 RY offset	4200H	Because the station occupies two stations, check the area in the station number 1.
Station No.2 RY size	0 (Default)	Because the station occupies two stations, check the area in the station number 1.
Station No.3 RY offset	4218H	Start buffer memory address of RY in the station number 3
Station No.3 RY size	1 (1H)	The lower eight bits of the area (buffer memory address: 4018H) are the corresponding size of RY in the station number 3; however, 1 is stored, because a value less than one word is rounded up.
Station No.4 RY offset	4218H	Start buffer memory address of RY in the station number 4
Station No.4 RY size	1 (1H)	The upper eight bits of the area (buffer memory address: 4018H) are the corresponding size of RY in the station number 4; however, 1 is stored, because a value less than one word is rounded up.
Station No.1 RWw offset	4400H	Start buffer memory address of RWw in the station number 1
Station No.1 RWw size	64 (40H)	$2 \text{ (number of occupied stations)} \times 32 \text{ (extended cyclic settings)} = 64$
Station No.2 RWw offset	4400H	Because the station occupies two stations, check the area in the station number 1.
Station No.2 RWw size	0 (Default)	Because the station occupies two stations, check the area in the station number 1.
Station No.3 RWw offset	4400H	Start buffer memory address of RWw in the station number 3
Station No.3 RWw size	0 (Default)	Buffer memory area size of RWw in the station number 3
Station No.4 RWw offset	4400H	Start buffer memory address of RWw in the station number 4
Station No.4 RWw size	0 (Default)	Buffer memory area size of RWw in the station number 4
Station No.1 RWr offset	4C00H	Start buffer memory address of RWr in the station number 1
Station No.1 RWr size	64 (40H)	$2 \text{ (number of occupied stations)} \times 32 \text{ (extended cyclic settings)} = 64$
Station No.2 RWr offset	4C00H	Because the station occupies two stations, check the area in the station number 1.
Station No.2 RWr size	0 (Default)	Because the station occupies two stations, check the area in the station number 1.
Station No.3 RWr offset	4C40H	Start buffer memory address of RWr in the station number 3
Station No.3 RWr size	0 (Default)	Buffer memory area size of RWr in the station number 3
Station No.4 RWr offset	4C40H	Start buffer memory address of RWr in the station number 4
Station No.4 RWr size	0 (Default)	Buffer memory area size of RWr in the station number 4

A

Link special relay (SB)

This area stores bit (on/off) data indicating the data link status.

Buffer memory addresses 5E0H to 5FFH correspond to link special relay areas SB0000 to SB01FF.

The following table lists the relationship between buffer memory addresses 5E0H to 5FFH and link special relay areas SB0000 to SB01FF.

Address	b15	b14	b13	b12	b11	b10	b9	b8	b7	b6	b5	b4	b3	b2	b1	b0
5E0H (1504)	F	E	D	C	B	A	9	8	7	6	5	4	3	2	1	0
5E1H (1505)	1F	1E	1D	1C	1B	1A	19	18	17	16	15	14	13	12	11	10
5E2H (1506)	2F	2E	2D	2C	2B	2A	29	28	27	26	25	24	23	22	21	20
5E3H (1507)	3F	3E	3D	3C	3B	3A	39	38	37	36	35	34	33	32	31	30
5E4H (1508)	4F	4E	4D	4C	4B	4A	49	48	47	46	45	44	43	42	41	40
5E5H (1509)	5F	5E	5D	5C	5B	5A	59	58	57	56	55	54	53	52	51	50
5E6H (1510)	6F	6E	6D	6C	6B	6A	69	68	67	66	65	64	63	62	61	60
5E7H (1511)	7F	7E	7D	7C	7B	7A	79	78	77	76	75	74	73	72	71	70
5E8H (1512)	8F	8E	8D	8C	8B	8A	89	88	87	86	85	84	83	82	81	80
5E9H (1513)	9F	9E	9D	9C	9B	9A	99	98	97	96	95	94	93	92	91	90
5EAH (1514)	AF	AE	AD	AC	AB	AA	A9	A8	A7	A6	A5	A4	A3	A2	A1	A0
5EBH (1515)	BF	BE	BD	BC	BB	BA	B9	B8	B7	B6	B5	B4	B3	B2	B1	B0
5ECH (1516)	CF	CE	CD	CC	CB	CA	C9	C8	C7	C6	C5	C4	C3	C2	C1	C0
5EDH (1517)	DF	DE	DD	DC	DB	DA	D9	D8	D7	D6	D5	D4	D3	D2	D1	D0
5EEH (1518)	EF	EE	ED	EC	EB	EA	E9	E8	E7	E6	E5	E4	E3	E2	E1	E0
5EFH (1519)	FF	FE	FD	FC	FB	FA	F9	F8	F7	F6	F5	F4	F3	F2	F1	F0
5F0H (1520)	10F	10E	10D	10C	10B	10A	109	108	107	106	105	104	103	102	101	100
5F1H (1521)	11F	11E	11D	11C	11B	11A	119	118	117	116	115	114	113	112	111	110
5F2H (1522)	12F	12E	12D	12C	12B	12A	129	128	127	126	125	124	123	122	121	120
5F3H (1523)	13F	13E	13D	13C	13B	13A	139	138	137	136	135	134	133	132	131	130
5F4H (1524)	14F	14E	14D	14C	14B	14A	149	148	147	146	145	144	143	142	141	140
5F5H (1525)	15F	15E	15D	15C	15B	15A	159	158	157	156	155	154	153	152	151	150
5F6H (1526)	16F	16E	16D	16C	16B	16A	169	168	167	166	165	164	163	162	161	160
5F7H (1527)	17F	17E	17D	17C	17B	17A	179	178	177	176	175	174	173	172	171	170
5F8H (1528)	18F	18E	18D	18C	18B	18A	189	188	187	186	185	184	183	182	181	180
5F9H (1529)	19F	19E	19D	19C	19B	19A	199	198	197	196	195	194	193	192	191	190
5FAH (1530)	1AF	1AE	1AD	1AC	1AB	1AA	1A9	1A8	1A7	1A6	1A5	1A4	1A3	1A2	1A1	1A0
5FBH (1531)	1BF	1BE	1BD	1BC	1BB	1BA	1B9	1B8	1B7	1B6	1B5	1B4	1B3	1B2	1B1	1B0
5FCH (1532)	1CF	1CE	1CD	1CC	1CB	1CA	1C9	1C8	1C7	1C6	1C5	1C4	1C3	1C2	1C1	1C0
5FDH (1533)	1DF	1DE	1DD	1DC	1DB	1DA	1D9	1D8	1D7	1D6	1D5	1D4	1D3	1D2	1D1	1D0
5FEH (1534)	1EF	1EE	1ED	1EC	1EB	1EA	1E9	1E8	1E7	1E6	1E5	1E4	1E3	1E2	1E1	1E0
5FFH (1535)	1FF	1FE	1FD	1FC	1FB	1FA	1F9	1F8	1F7	1F6	1F5	1F4	1F3	1F2	1F1	1F0

Link special register (SW)

This area stores word data indicating the data link status.

Buffer memory addresses 600H to 7FFH correspond to link special register areas SW0000 to SW01FF.

Random access buffer

This area stores data to be sent to other stations. The data are read and written by transient transmission.

Automatic update buffer

This area stores data automatically updated when transient transmission (communications using the automatic update buffer) is performed with an intelligent device station. The automatic update buffer size of intelligent device stations is set in "Network Configuration Settings" under "Basic Settings". (☞ Page 63 Network Configuration Settings)

The following figure shows an example of communications using the automatic update buffer.

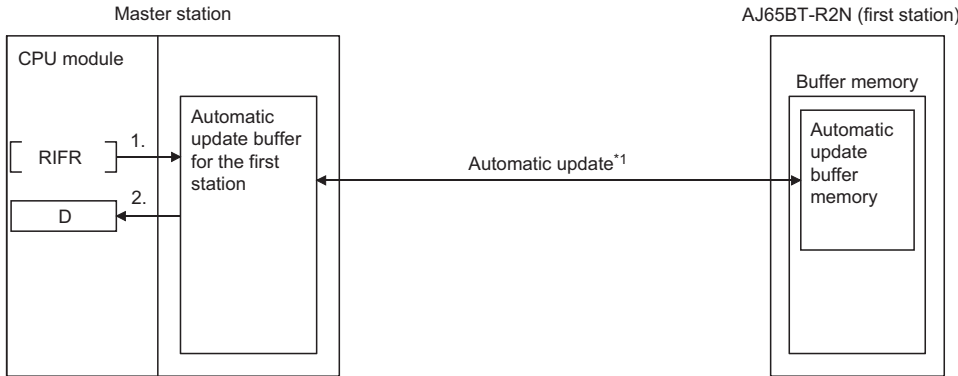

1. The automatic update buffer for the first station is accessed.
2. The data specified in the control data is stored in the device of the CPU module.

*1 For timing of the automatic update, refer to the manual for the AJ65BT-R2N. (☞ CC-Link System RS-232 Interface Module User's Manual (Nonprocedural Protocol Mode))

Ver.2-compatible remote input (RX) and Ver.2-compatible remote output (RY)

This buffer memory area is used when the remote net Ver.2 mode or remote device net Ver.2 mode is selected.

In the remote net Ver.2 mode, data are stored in the remote input (RX) and remote output (RY) in all slave stations (including Ver.1-compatible slave stations).

☞ Page 23 Remote net Ver.2 mode

☞ Page 27 Remote device net Ver.2 mode

For the master station, data input from slave stations are stored.

For local stations, data input from the master station are stored.

Storage location for each station

The storage locations change depending on the number of occupied stations and extended cyclic settings in slave stations.

The storage locations for each station can be checked using Slave station offset, size information (Un\G992 to Un\G1503).

☞ Page 150 Slave station offset, size information

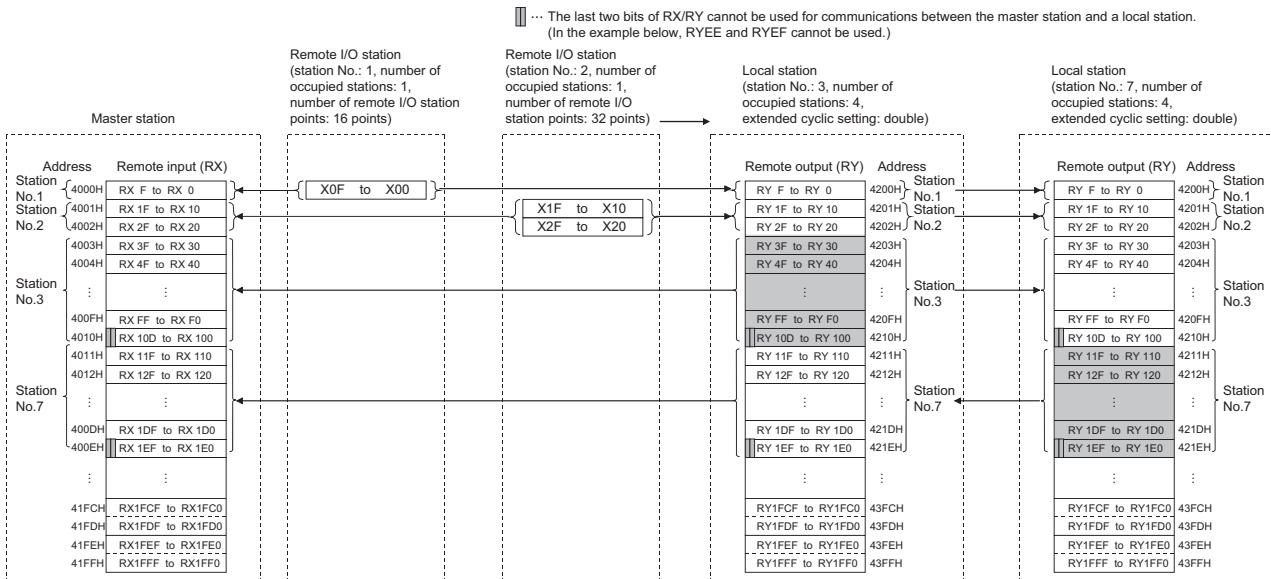

Ver.2-compatible remote register (RWw) and Ver.2-compatible remote register (RWr)

This buffer memory area is used when the remote net Ver.2 mode or remote device net Ver.2 mode is selected.

In the remote net Ver.2 mode or remote device net Ver.2 mode, data are stored in the remote register (RWr/RWw) of all slave stations (including Ver.1-compatible slave stations).

☞ Page 23 Remote net Ver.2 mode

☞ Page 27 Remote device net Ver.2 mode

Storage location for each station

The storage locations change depending on the number of occupied stations and extended cyclic settings in slave stations.

The storage locations for each station can be checked using Slave station offset, size information (Un\G992 to Un\G1503).

☞ Page 150 Slave station offset, size information

Ex.

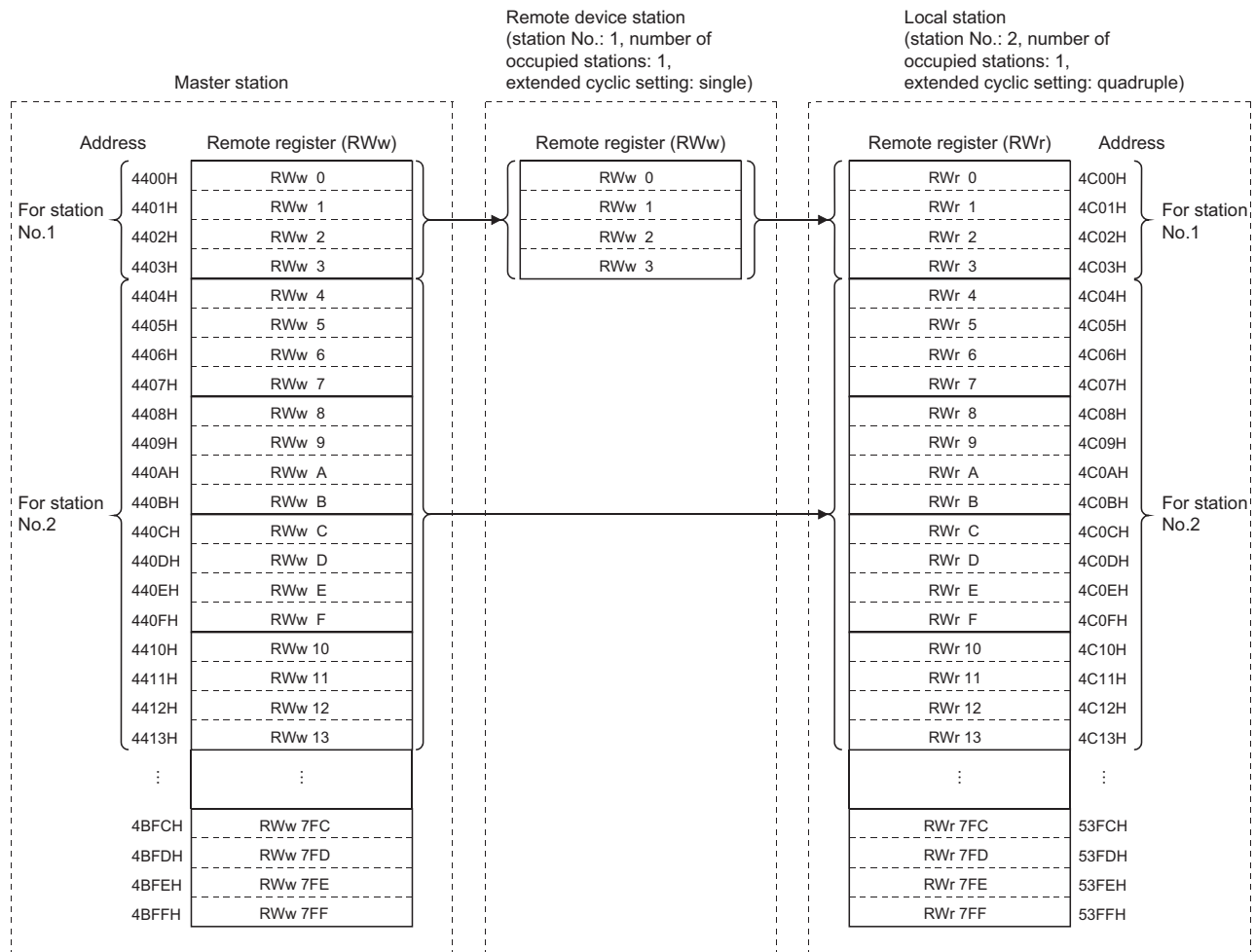

Remote device station initialization procedure registration execution individual info.

This area stores the execution progress of the remote device station initial setting procedure registration function.

Address	Remote device station initialization procedure registration execution individual information
5C80H	Remote device station initialization procedure registration execution individual information (station number 1)
5C81H	Remote device station initialization procedure registration execution individual information (station number 2)
⋮	
5CBEH	Remote device station initialization procedure registration execution individual information (station number 63)
5CBFH	Remote device station initialization procedure registration execution individual information (station number 64)

The following values are stored in the bits of Remote device station initialization procedure registration execution individual information.

Bit	Description	Value
b15 to b8	Stores the next execution procedure number.	<ul style="list-style-type: none">• 1 to 32 (In process)• FFH (Completed) (Default: 0)
b7 to b0	Stores the station number.	1 to 64 (01H to 40H) (Default: 0)

Appendix 4 List of Link Special Relay (SB) Areas

The link special relay (SB) is turned on/off depending on various factors during data link. Any error status of the data link can be checked by using and monitoring it in the program.

Application of the link special relay (SB)

By using the link special relay (SB), the status of CC-Link system can be checked from HMI (Human Machine Interfaces) as well as the engineering tool.

Refresh of the link special relay (SB)

To use the link special relay (SB), set them in "Link Refresh Settings" in "Basic Settings" so that they are refreshed to the devices or labels of the CPU module. (🔗 Page 65 Link Refresh Settings)

Ranges turned on/off by users and by the system

The following ranges correspond to when the link special relay (SB) areas are assigned from SB0000 to SB01FF.

- Turned on/off by users: SB0000 to SB001F
- Turned on/off by the system: SB0020 to SB01FF

List of link special relay (SB) areas

The following table lists the link special relay (SB) areas when they are assigned from SB0000 to SB01FF.

When a standby master station is used, refer to the respective columns under "Availability" in the table as explained below.

- When a standby master station is operating as a master station: "Master station" column
- When a standby master station is operating as a standby master station: "Local station" column

Point

Do not turn on or off areas whose numbers are not on the following list or ranges turned on/off by the system. Doing so may cause malfunction of the programmable controller system.

No.	Name	Description	Availability (○: Available, ×: Not available)		
			Online		Offline
			Master station	Local station	
SB0000	Data link restart	Restarts the data link that has been stopped by SB0002. Off: Not instructed On: Instructed	○	○	×
SB0001	Refresh instruction at standby master switching	Refreshes cyclic data after data link control is transferred to the standby master station. Off: Not instructed On: Instructed	○	×	×
SB0002	Data link stop	Stops the data link of the own station. Note that if this relay is instructed to the master station, the entire system will stop. Off: Not instructed On: Instructed	○	○	×
SB0003	Refresh instruction when changing parameters by the dedicated instruction	Refreshes cyclic data after parameter setting is changed by the RLPASET instruction. Off: Not instructed (refresh stopped) On: Instructed (refresh started/continued)	○	×	×
SB0004	Temporary error invalid request	Determines the stations specified by SW0003 to SW0007 as a temporary error invalid station. Off: Not requested On: Requested	○	×	×
SB0005	Temporary error invalid cancel request	Cancels the temporary error invalid station setting configured for the stations specified by SW0003 to SW0007. Off: Not requested On: Requested	○	×	×

No.	Name	Description	Availability (○: Available, ×: Not available)		
			Online		Offline
			Master station	Local station	
SB0007	Master station duplication error cancel request	Clears a master station duplication error. Off: Not instructed On: Instructed	○ ^{*1}	×	×
SB0008	Line test request	Executes a line test to the station specified by SW0008. Off: Not requested On: Requested	○	×	×
SB000B	Transmission speed test request	Executes a transmission speed test. Off: Not requested On: Requested	○ ^{*1}	×	×
SB000C	Forced master switching	Forcibly transfers data link control from the standby master station during data link control to the master station that stands by for system down of the standby master station. Off: Not requested On: Requested	○	×	×
SB000D	Remote device station initialization procedure registration instruction	Performs an initial processing using the information registered by the initialization procedure registration using an engineering tool. While SB000D is on, the remote I/O and remote register are stopped to be refreshed. Off: Not instructed On: Instructed	○	×	×
SB0020	Module status	Stores the communication status between the master/local module and CPU module. Off: Normal On: Error	○	○	○
SB0040	Data link restart acceptance	Stores whether the data link restart instruction has been accepted. Off: Not accepted On: Accepted	○	○	×
SB0041	Data link restart completion	Stores whether the data link restart instruction has been completed. Off: Not completed On: Started	○	○	×
SB0042	Refresh instruction acceptance status at standby master switching	Stores whether the refresh instruction at standby master switching has been accepted. Off: Not executed On: Accepted	○	×	×
SB0043	Refresh instruction completion status at standby master switching	Stores whether the refresh instruction at standby master switching has been completed. Off: Not executed On: Switched	○	×	×
SB0044	Data link stop acceptance	Stores whether the data link stop instruction has been accepted. Off: Not accepted On: Accepted	○	○	×
SB0045	Data link stop completion	Stores whether the data link stop instruction has been completed. Off: Not completed On: Stopped	○	○	×
SB0046	Forced master switching enable status	Stores whether 'Forced master switching' (SB000C) can be executed. Off: Cannot be executed On: Can be executed	○ ^{*2}	×	×
SB0048	Temporary error invalid acceptance status	Stores whether the remote station temporary error invalid instruction has been accepted. Off: Not executed On: Accepted	○	×	×
SB0049	Temporary error invalid completion status	Stores whether the remote station temporary error invalid instruction has been completed. Off: Not executed On: A temporary error invalid station determined	○	×	×
SB004A	Temporary error invalid cancel acceptance status	Stores whether the remote station temporary error invalid cancel instruction has been accepted. Off: Not executed On: Accepted	○	×	×

No.	Name	Description	Availability (○: Available, ×: Not available)		
			Online		Offline
			Master station	Local station	
SB004B	Temporary error invalid cancel completion status	Stores whether the remote station temporary error invalid cancel instruction has been completed. Off: Not executed On: Temporary error invalid station setting canceled	○	×	×
SB004C	Line test acceptance status	Stores whether a line test request has been accepted. Off: Not executed On: Accepted	○	×	×
SB004D	Line test completion status	Stores whether a line test has been completed. Off: Not executed On: Completed	○	×	×
SB0050	Offline test status	Stores whether an offline test is being executed. Off: Not executed On: In process	×	×	○
SB0057	Master station duplication error cancel acceptance	Stores whether a master station duplication error cancel request has been accepted. Off: Not accepted On: Accepted	○	×	×
SB0058	Master station duplication error cancel completion	Stores whether a master station duplication error cancel request has been completed. Off: Not completed On: Completed	○	×	×
SB005A	Master switching request acceptance	Stores whether the standby master station has detected the system down of the master station and has accepted a request of switching from standby master operation to master operation. Off: Not accepted On: Accepted	×	○ ^{*2}	×
SB005B	Master switching request completion	Stores whether the standby master station has been switched as a master station. Off: Not completed On: Completed	×	○ ^{*2}	×
SB005C	Forced master switching request acceptance	Stores whether a forced master switching request has been accepted. Off: Not accepted On: Accepted	○	×	×
SB005D	Forced master switching request completion	Stores whether a forced master switching request has been completed. Off: Not completed On: Completed	○	○	×
SB005E	Execution status of remote device station initialization procedure	Stores whether the initialization procedure is being performed. Off: Not executed On: In process	○	×	×
SB005F	Completion status of remote device station initialization procedure	Stores whether the initialization procedure has been completed. Off: Not completed On: Completed	○	×	×
SB0060	Mode of own station	Stores the mode setting status of the own station. Off: Online On: Mode other than online	○	○	○
SB0061	Type of own station	Stores the station type of the own station. Off: Master station (station number: 0) On: Local station (station number: 1 to 64)	○	○	×
SB0062	Standby master station setting status of own station	Stores whether the own station has been set as a standby master station. Off: Not set On: Set	○	○	○
SB0065	Input data status of own data link faulty station	Stores the setting status of "Input Data from Data Link Faulty Station" under "Supplementary Cyclic Settings" in "Application Settings" of the own station. Off: Clear On: Hold	○	○	×

No.	Name	Description	Availability (○: Available, ×: Not available)		
			Online		Offline
			Master station	Local station	
SB0066	Number of own station occupied stations	Stores the number of occupied stations of the own station.	×	○	×
SB0067		<ul style="list-style-type: none"> ■1 station occupied <ul style="list-style-type: none"> • SB0066: Off • SB0067: Off ■2 stations occupied <ul style="list-style-type: none"> • SB0066: Off • SB0067: On ■3 stations occupied <ul style="list-style-type: none"> • SB0066: On • SB0067: On ■4 stations occupied <ul style="list-style-type: none"> • SB0066: On • SB0067: Off 			
SB006D	Parameter setting status	Stores whether the parameters have been correctly set. Off: Normal On: Setting incorrect (An error code is stored in SW0068.)	○*1	×	×
SB006E	Operation status of own station	Stores whether data link with other stations is being performed. Off: In process On: Not performed	○	○	×
SB006F	Setting status of block guarantee of cyclic data per station	Stores whether the block guarantee of cyclic data per station has been set to the own station. Off: Not set On: Set	○	○	×
SB0070	Master station information	Stores the data link status. Off: Data link control by the master station On: Data link control by the standby master station	○	○	×
SB0071	Standby master station information	Stores whether a standby master station exists. Off: Absent On: Present	○	○	×
SB0072	Scan mode setting information	Stores the setting status of the scan mode. Off: Link scan is performed asynchronously with a sequence scan. On: Link scan is performed synchronously with a sequence scan.	○	×	×
SB0073	Data link setting at CPU failure	Indicates the data link status specified by the parameter when CPU is down. Off: Data link stopped On: Data link continued	○	○	×
SB0074	Reserved station specification status	Stores whether a reserved station has been specified by the parameter. Off: Not specified On: Specified (The set station number is stored in SW0074 to SW0077.) Depending on the link refresh timing, SB0074 may be updated with the time difference of one sequence scan from the update of 'Reserved station specification status' (SW0074 to SW0077).	○	○	×
SB0075	Error invalid station specification status	Stores whether an error invalid station has been specified using the parameter. Off: Not specified On: Specified (The set station number is stored in SW0078 to SW007B.) Depending on the link refresh timing, SB0075 may be updated with the time difference of one sequence scan from the update of 'Error invalid station specification status' (SW0078 to SW007B).	○	○	×
SB0076	Temporary error invalid station setting information	Stores whether a temporary error invalid station has been set. Off: Not set On: Set (The set station number is stored in SW007C to SW007F.) Depending on the link refresh timing, SB0076 may be updated with the time difference of one sequence scan from the update of 'Temporary error invalid status' (SW007C to SW007F).	○	○	×
SB0077	Parameter receive status	Stores whether parameters have been received from the master station. Off: Received On: Not received	×	○	×
SB0079	Master station return specification information	Stores whether "Master Station" or "Master Station (Duplex Function)" has been set in "Station Type" under "Required Settings". Off: Master station On: Master station (duplex function)	○	×	×



No.	Name	Description	Availability (○: Available, ×: Not available)		
			Online		Offline
			Master station	Local station	
SB007A	Standby master station operation history of own station	Stores whether the own station has ever operated as a standby master station. Off: Has no history of operating as a standby master station On: Has a history of operating as a standby master station	○	×	×
SB007B	Master/standby master operation status of own station	Stores whether the own station is operating as a master station or standby master station. Off: The own station is operating as a master station. On: The own station is operating as a standby master station.	○	○	×
SB007C	Slave station refresh/ compulsory clear setting status in case of programmable controller CPU STOP	Stores the parameter setting status of output data at CPU STOP. Off: Receives remote output (RY). On: Sends 0 data.	○	○	×
SB0080	Data link status of other stations	Stores the communication status with slave stations. Off: All stations normal On: Faulty station found (The faulty station number is stored in SW0080 to SW0083.) It takes maximum of six seconds for 'Data link status of other stations' (SB0080) to turn on after a slave station connected to the master station or local station becomes faulty.	○	○	×
SB0081	Watchdog timer error status of other stations	Stores whether a watchdog timer error has occurred in other stations. Off: No error On: Error Depending on the link refresh timing, SB0081 may be updated with the time difference of one sequence scan from the update of 'Watchdog timer error occurrence status of other stations' (SW0084 to SW0087).	○	○	×
SB0082	Fuse blown status of other stations	Stores whether a fuse blown error has occurred in other stations. (SW0088 to SW008B) Off: No error On: Error Depending on the link refresh timing, SB0082 may be updated with the time difference of one sequence scan from the update of 'Fuse blown status of other stations' (SW0088 to SW008B).	○	○	×
SB0083	Switch change status of other stations	Detects whether the setting of setting switches of other stations during data link has been changed. Off: No change On: Changed Depending on the link refresh timing, SB0083 may be updated with the time difference of one sequence scan from the update of 'Switch change status of other stations' (SW008C to SW008F).	○	○	×
SB0090	Line status of own station	Stores whether the line to the own station is normally operating. Off: Normal On: Error (disconnected)	×	○	×
SB0094	Transient transmission status	Stores whether a transient transmission error has occurred. Off: No error On: Error	○	○	×
SB0095	Master stations transient transmission status	Stores whether the master station is normally performing transient transmission. Off: Normal On: Error	×	○	×
SB00B4	Standby master station test result	Stores the result of the line test 1. Off: Normal On: Error	○	×	○
SB0160	Remote register use prohibited status	Stores whether the use of the remote register is prohibited. Off: Available On: Use prohibited	○	×	×
SB0184	Transmission speed test result of standby master station	Stores the result of the transmission speed test to the standby master station. Off: Normal (same transmission speed as the master station) or no response from the module On: Error (different transmission speed from the master station)	○	×	×

No.	Name	Description	Availability (○: Available, ×: Not available)		
			Online		Offline
			Master station	Local station	
SB0185	Transmission speed test acceptance status	Stores whether 'Transmission speed test request' (SB000B) has been accepted. Off: Not accepted On: Accepted	○	×	×
SB0186	Transmission speed test completion status	Stores whether a transmission speed test has been completed. Off: Not completed On: Completed	○	×	×

*1 Available for stations with the station number 0 only.

*2 Available for the standby master station only.

Appendix 5 List of Link Special Register (SW) Areas

The link special register (SW) stores the information during data link. Error locations and causes can be checked by using and monitoring the link special register (SW) in programs.

Application of the link special register (SW)

By using the link special register (SW), the status of CC-Link system can be checked from HMI (Human Machine Interfaces) as well as the engineering tool.

Refresh of the link special register (SW)

To use the link special register (SW), set them in "Link Refresh Settings" under "Basic Settings" so that they are refreshed to the devices or labels of the CPU module. ( Page 65 Link Refresh Settings)

Range where data are stored by users and range where data are stored by the system

The following ranges correspond to when the link special register (SW) areas are assigned from SW0000 to SW01FF.

- Stored by users: SW0000 to SW001F
- Stored by the system: SW0020 to SW01FF

List of link special register (SW) areas

The following table lists the link special register (SW) when they are assigned from SW0000 to SW01FF.

When a standby master station is used, refer to the respective columns under "Availability" in the table as explained below.

- When a standby master station is operating as a master station: "Master station" column
- When a standby master station is operating as a standby master station: "Local station" column

Point

Do not write any data to an area whose number is not on the following list or ranges where data are stored by the system. Doing so may cause malfunction of the programmable controller system.

No.	Name	Description	Availability (○: Available, ×: Not available)																																																				
			Online		Offline																																																		
			Master station	Local station																																																			
SW0003	Multiple temporary error invalid station specification	Selects whether to specify multiple temporary error invalid stations. 00: Multiple stations set in SW0004 to SW0007 specified 01 to 64: A single station specified from 1 to 64 (The number represents the station number to be set as a temporary error invalid station.)	○	×	×																																																		
SW0004 to SW0007	Temporary error invalid station specification	Specifies a temporary error invalid station. 0: Temporary error invalid station not specified 1: Temporary error invalid station specified <table border="1" style="margin-left: auto; margin-right: auto;"> <thead> <tr> <th></th> <th>b15</th> <th>b14</th> <th>b13</th> <th>b12</th> <th>to</th> <th>b3</th> <th>b2</th> <th>b1</th> <th>b0</th> </tr> </thead> <tbody> <tr> <td>SW0004</td> <td>16</td> <td>15</td> <td>14</td> <td>13</td> <td>to</td> <td>4</td> <td>3</td> <td>2</td> <td>1</td> </tr> <tr> <td>SW0005</td> <td>32</td> <td>31</td> <td>30</td> <td>29</td> <td>to</td> <td>20</td> <td>19</td> <td>18</td> <td>17</td> </tr> <tr> <td>SW0006</td> <td>48</td> <td>47</td> <td>46</td> <td>45</td> <td>to</td> <td>36</td> <td>35</td> <td>34</td> <td>33</td> </tr> <tr> <td>SW0007</td> <td>64</td> <td>63</td> <td>62</td> <td>61</td> <td>to</td> <td>52</td> <td>51</td> <td>50</td> <td>49</td> </tr> </tbody> </table> 1 to 64 in the table indicate station numbers. The stations need not be set by the number of occupied stations. Error invalid stations, reserved stations, station with the end station number, and stations later than that are excepted.		b15	b14	b13	b12	to	b3	b2	b1	b0	SW0004	16	15	14	13	to	4	3	2	1	SW0005	32	31	30	29	to	20	19	18	17	SW0006	48	47	46	45	to	36	35	34	33	SW0007	64	63	62	61	to	52	51	50	49	○	×	×
	b15	b14	b13	b12	to	b3	b2	b1	b0																																														
SW0004	16	15	14	13	to	4	3	2	1																																														
SW0005	32	31	30	29	to	20	19	18	17																																														
SW0006	48	47	46	45	to	36	35	34	33																																														
SW0007	64	63	62	61	to	52	51	50	49																																														
SW0008	Line test station setting	Sets a station number where the line test is executed. 0: Entire system (executed to all stations) 01 to 64: Specified station Default: 0	○	×	×																																																		

No.	Name	Description	Availability (○: Available, ×: Not available)																																																				
			Online		Offline																																																		
			Master station	Local station																																																			
SW0009	Monitoring time setting	Sets monitoring time when dedicated instructions are used. Default: 10 (seconds) (value = 0) Setting range: 1 to 360 (seconds) If a value outside the range is set, the monitoring time will be 360 seconds. When SW000B is set, the time until a dedicated instruction fails is as follows: (Number of retries + 1) × monitoring time	○	○	×																																																		
SW000A	CPU monitoring time setting	Sets the monitoring time of CPU response when the CPU module is accessed through transient transmission. Default: 90 (seconds) (value = 0) Setting range: 1 to 3600 (seconds) If a value outside the range is set, the monitoring time will be 3600 seconds.	○	○	×																																																		
SW000B	Dedicated instruction retry count setting	Sets the number of retries of when dedicated instructions are used. Default: 0 (No retry) Setting range: 0 to 7 (time) If a value outside the range is set, the number of times will be 7.	○	○	×																																																		
SW0014 to SW0017	Specification of remote device station to be initialized	Specifies a station where an initial processing is performed using the information registered by the initialization procedure registration using an engineering tool. 0: Initial processing not performed 1: Initial processing performed <table border="1" style="margin-left: auto; margin-right: auto;"> <thead> <tr> <th></th> <th>b15</th> <th>b14</th> <th>b13</th> <th>b12</th> <th>to</th> <th>b3</th> <th>b2</th> <th>b1</th> <th>b0</th> </tr> </thead> <tbody> <tr> <td>SW0014</td> <td>16</td> <td>15</td> <td>14</td> <td>13</td> <td>to</td> <td>4</td> <td>3</td> <td>2</td> <td>1</td> </tr> <tr> <td>SW0015</td> <td>32</td> <td>31</td> <td>30</td> <td>29</td> <td>to</td> <td>20</td> <td>19</td> <td>18</td> <td>17</td> </tr> <tr> <td>SW0016</td> <td>48</td> <td>47</td> <td>46</td> <td>45</td> <td>to</td> <td>36</td> <td>35</td> <td>34</td> <td>33</td> </tr> <tr> <td>SW0017</td> <td>64</td> <td>63</td> <td>62</td> <td>61</td> <td>to</td> <td>52</td> <td>51</td> <td>50</td> <td>49</td> </tr> </tbody> </table> 1 to 64 in the table indicate station numbers. The stations need not be set by the number of occupied stations. Error invalid stations, reserved stations, station with the end station number, and stations later than that are excepted.		b15	b14	b13	b12	to	b3	b2	b1	b0	SW0014	16	15	14	13	to	4	3	2	1	SW0015	32	31	30	29	to	20	19	18	17	SW0016	48	47	46	45	to	36	35	34	33	SW0017	64	63	62	61	to	52	51	50	49	○	×	×
	b15	b14	b13	b12	to	b3	b2	b1	b0																																														
SW0014	16	15	14	13	to	4	3	2	1																																														
SW0015	32	31	30	29	to	20	19	18	17																																														
SW0016	48	47	46	45	to	36	35	34	33																																														
SW0017	64	63	62	61	to	52	51	50	49																																														
SW0020	Module status	Stores the communication status between the master/local module and CPU module. 0: Normal Values other than 0:Error code (📖 User's manual for the CPU module used)	○	○	○																																																		
SW0041	Data link restart result	Stores whether the data link restart instruction using SB0000 has been normally completed. 0: Normal Values other than 0:Error code (📖 Page 126 List of Error Codes)	○	○	×																																																		
SW0043	Refresh instruction at standby master switching result	Stores whether the refresh instruction at standby master switching has been normally completed. 0: Normal Values other than 0:Error code (📖 Page 126 List of Error Codes)	○	×	×																																																		
SW0045	Data link stop result	Stores whether the data link stop instruction using SB0002 has been normally completed. 0: Normal Values other than 0:Error code (📖 Page 126 List of Error Codes)	○	○	×																																																		
SW0049	Temporary error invalid station specification result	Stores whether the temporary error invalid station specification has been normally completed. 0: Normal Values other than 0:Error code (📖 Page 126 List of Error Codes)	○	×	×																																																		
SW004B	Temporary error invalid station specification cancel result	Stores whether the temporary error invalid station setting has been normally canceled. 0: Normal Values other than 0:Error code (📖 Page 126 List of Error Codes)	○	×	×																																																		
SW004D	Line test result	Stores the result of a line test. 0: Normal Values other than 0:Error code (📖 Page 126 List of Error Codes)	○	×	×																																																		
SW0057	Master station duplication error cancel result	Stores whether a master station duplication error cancel request has been normally completed. 0: Normal completion Values other than 0:Error code (📖 Page 126 List of Error Codes)	○	×	×																																																		

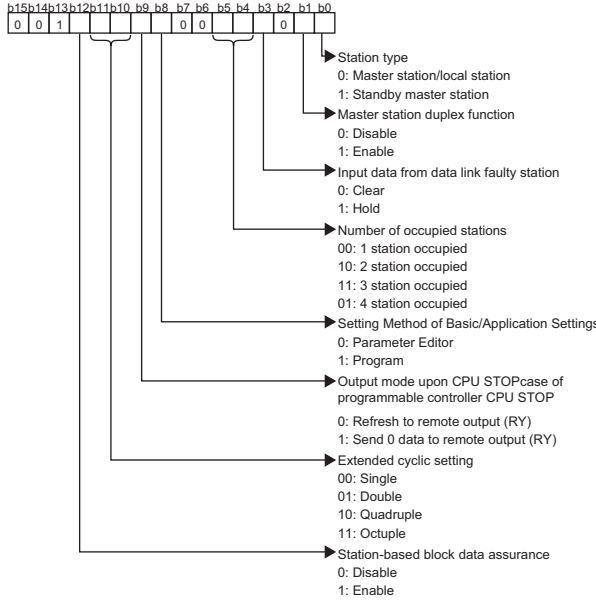

No.	Name	Description	Availability (○: Available, ×: Not available)		
			Online		Offline
			Master station	Local station	
SW0058	Detailed LED display status	<p>Stores the details of the LED indication status.</p> <p>0: Off 1: On</p> <p> ▶ LINE (ERROR): A cable is disconnected or the transmission path has been affected by noise. ▶ TIME (ERROR): Responses cannot be received from any station due to the cable being disconnected or the transmission path being affected by noise. ▶ PRM (ERROR): Invalid parameter value ▶ M/S (ERROR): Multiple master stations exist on the same line. ▶ SW (ERROR): Error in switch settings ▶ S MST: The station is operating as a standby master station. ▶ MST: The station is operating as a master station. ▶ ERR.: Error ▶ RUN: The module is operating normally. </p> <ul style="list-style-type: none"> • The use of b11 is prohibited. • The ERR. LED on the master/local module turns on when a bit among b4 to b8 and b14 is on. 	○	○	○
SW0059	Transmission speed setting	<p>Stores the transmission speed setting status. Auto-tracking (b15) is enabled only at local stations.</p> <p>0: Not set 1: Set</p> <p> ▶ 10Mbps ▶ 5Mbps ▶ 2.5Mbps ▶ 625kbps ▶ 156kbps ▶ Auto-tracking </p>	○	○	○
SW005B	Transmission speed operation status	<p>Stores the transmission speed operation status. The bit "During auto-tracking" (b15) is enabled only at local stations.</p> <p>0: Not in operation 1: In operation</p> <p> ▶ 10Mbps ▶ 5Mbps ▶ 2.5Mbps ▶ 625kbps ▶ 156kbps ▶ During auto-tracking </p>	○	○	○
SW005C	Detailed LED display status (2)	<p>Stores the detailed display status of the module LED.</p> <p>0: Off 1: On</p> <p> ▶ Transmission speed setting 156kbps ▶ Transmission speed setting 625kbps ▶ Transmission speed setting 2.5Mbps ▶ Transmission speed setting 5Mbps ▶ Transmission speed setting 10Mbps </p> <ul style="list-style-type: none"> • The use of b0 to b6 is prohibited. 	○	○	○

No.	Name	Description	Availability (○: Available, ×: Not available)		
			Online		Offline
			Master station	Local station	
SW005D	Forced master switching instruction result	Stores whether the forced master switching instruction using SB000C has been normally completed. 0: Normal Values other than 0:Error code (☞ Page 126 List of Error Codes)	○	×	×
SW005F	Remote device station initialization procedure registration instruction result	Stores whether the initialization procedure registration instruction using SB000D has been normally completed. 0: Normal Values other than 0:Error code (☞ Page 126 List of Error Codes)	○	×	×
SW0060	Mode setting status	Stores the mode setting status. 0: Online (remote net mode) 1: Online (remote I/O net mode) 2: Offline 3: Line test 1 4: Line test 2 6: Hardware test C: Online (remote device net mode)	○	○	○
SW0061	Station number of own station	Stores the current own station's station number. 0: Master station 1 to 64:Local station	○	○	○
SW0062	Module operating status	Stores the module operation setting configured using the parameter. 	○	○	○
SW0064	Number of retries information	Stores the set number of retries upon an abnormal response. 1 to 7 (time)	○	×	×
SW0065	Number of automatic return stations	Stores the set number of automatic return stations in one link scan. 1 to 10 (station)	○	×	×
SW0067	Parameter information	Stores the information of "Setting Method of Basic/Application Settings" under "Parameter Setting Method" in "Required Settings". 0H:Parameter editor 3H:Program	○	×	○
SW0068	Parameter status of own station	Stores whether the parameters have been correctly set. 0: Normal Values other than 0:Error code (☞ Page 126 List of Error Codes)	○	×	×



No.	Name	Description	Availability (○: Available, ×: Not available)																																																				
			Online		Offline																																																		
			Master station	Local station																																																			
SW0069	Installation status	Stores whether unique station numbers have been assigned for modules and whether parameter settings match with connected module status. 0: Normal Values other than 0: Error code (☞ Page 126 List of Error Codes) Error details are stored in SW0098 to SW009B and SW009C to SW009F. This item is checked, and the result is stored only at link startup.	○	×	×																																																		
SW006D	Maximum link scan time	Stores the maximum link scan time. (unit: 1ms)	○	○	×																																																		
SW006E	Current link scan time	Stores the current link scan time. (unit: 1ms)	○	○	×																																																		
SW006F	Minimum link scan time	Stores the minimum link scan time. (unit: 1ms)	○	○	×																																																		
SW0070	Total number of stations	Stores the end station number set using the parameter. 1 to 64 (station)	○	×	×																																																		
SW0071	Maximum communication station number	Stores the maximum station number during data link (station number set using the station number setting switches). 1 to 64 (station) Reserved stations are excepted.	○	×	×																																																		
SW0072	Number of connected modules	Stores the number of modules performing data link. Reserved stations are excepted.	○	×	×																																																		
SW0073	Standby master station number	Stores the standby master station number. 1 to 64 (station)	○	○	×																																																		
SW0074 to SW0077	Reserved station specification status	Stores whether a station has been set as a reserved station. 0: A station other than a reserved station 1: Reserved station <table border="1" style="margin-left: auto; margin-right: auto;"> <thead> <tr> <th></th> <th>b15</th> <th>b14</th> <th>b13</th> <th>b12</th> <th>to</th> <th>b3</th> <th>b2</th> <th>b1</th> <th>b0</th> </tr> </thead> <tbody> <tr> <td>SW0074</td> <td>16</td> <td>15</td> <td>14</td> <td>13</td> <td>to</td> <td>4</td> <td>3</td> <td>2</td> <td>1</td> </tr> <tr> <td>SW0075</td> <td>32</td> <td>31</td> <td>30</td> <td>29</td> <td>to</td> <td>20</td> <td>19</td> <td>18</td> <td>17</td> </tr> <tr> <td>SW0076</td> <td>48</td> <td>47</td> <td>46</td> <td>45</td> <td>to</td> <td>36</td> <td>35</td> <td>34</td> <td>33</td> </tr> <tr> <td>SW0077</td> <td>64</td> <td>63</td> <td>62</td> <td>61</td> <td>to</td> <td>52</td> <td>51</td> <td>50</td> <td>49</td> </tr> </tbody> </table> <p style="text-align: center;">1 to 64 in the table indicate station numbers.</p> Only the bit corresponding to the start station number turns on. The station with the end station number and stations later than that are excepted.		b15	b14	b13	b12	to	b3	b2	b1	b0	SW0074	16	15	14	13	to	4	3	2	1	SW0075	32	31	30	29	to	20	19	18	17	SW0076	48	47	46	45	to	36	35	34	33	SW0077	64	63	62	61	to	52	51	50	49	○	○	×
	b15	b14	b13	b12	to	b3	b2	b1	b0																																														
SW0074	16	15	14	13	to	4	3	2	1																																														
SW0075	32	31	30	29	to	20	19	18	17																																														
SW0076	48	47	46	45	to	36	35	34	33																																														
SW0077	64	63	62	61	to	52	51	50	49																																														
SW0078 to SW007B	Error invalid station specification status	Stores whether a station has been set as an error invalid station. 0: A station other than an error invalid station 1: Error invalid station <table border="1" style="margin-left: auto; margin-right: auto;"> <thead> <tr> <th></th> <th>b15</th> <th>b14</th> <th>b13</th> <th>b12</th> <th>to</th> <th>b3</th> <th>b2</th> <th>b1</th> <th>b0</th> </tr> </thead> <tbody> <tr> <td>SW0078</td> <td>16</td> <td>15</td> <td>14</td> <td>13</td> <td>to</td> <td>4</td> <td>3</td> <td>2</td> <td>1</td> </tr> <tr> <td>SW0079</td> <td>32</td> <td>31</td> <td>30</td> <td>29</td> <td>to</td> <td>20</td> <td>19</td> <td>18</td> <td>17</td> </tr> <tr> <td>SW007A</td> <td>48</td> <td>47</td> <td>46</td> <td>45</td> <td>to</td> <td>36</td> <td>35</td> <td>34</td> <td>33</td> </tr> <tr> <td>SW007B</td> <td>64</td> <td>63</td> <td>62</td> <td>61</td> <td>to</td> <td>52</td> <td>51</td> <td>50</td> <td>49</td> </tr> </tbody> </table> <p style="text-align: center;">1 to 64 in the table indicate station numbers.</p> Only the bit corresponding to the start station number turns on. Reserved stations, station with the end station number, and stations later than that are excepted.		b15	b14	b13	b12	to	b3	b2	b1	b0	SW0078	16	15	14	13	to	4	3	2	1	SW0079	32	31	30	29	to	20	19	18	17	SW007A	48	47	46	45	to	36	35	34	33	SW007B	64	63	62	61	to	52	51	50	49	○	○	×
	b15	b14	b13	b12	to	b3	b2	b1	b0																																														
SW0078	16	15	14	13	to	4	3	2	1																																														
SW0079	32	31	30	29	to	20	19	18	17																																														
SW007A	48	47	46	45	to	36	35	34	33																																														
SW007B	64	63	62	61	to	52	51	50	49																																														

No.	Name	Description	Availability (○: Available, ×: Not available)																																																				
			Online		Offline																																																		
			Master station	Local station																																																			
SW007C to SW007F	Temporary error invalid status	<p>Stores whether a station is in the temporary error invalid status.</p> <p>0: Normal 1: Temporary error invalid status</p> <table border="1"> <thead> <tr> <th></th> <th>b15</th> <th>b14</th> <th>b13</th> <th>b12</th> <th>to</th> <th>b3</th> <th>b2</th> <th>b1</th> <th>b0</th> </tr> </thead> <tbody> <tr> <td>SW007C</td> <td>16</td> <td>15</td> <td>14</td> <td>13</td> <td>to</td> <td>4</td> <td>3</td> <td>2</td> <td>1</td> </tr> <tr> <td>SW007D</td> <td>32</td> <td>31</td> <td>30</td> <td>29</td> <td>to</td> <td>20</td> <td>19</td> <td>18</td> <td>17</td> </tr> <tr> <td>SW007E</td> <td>48</td> <td>47</td> <td>46</td> <td>45</td> <td>to</td> <td>36</td> <td>35</td> <td>34</td> <td>33</td> </tr> <tr> <td>SW007F</td> <td>64</td> <td>63</td> <td>62</td> <td>61</td> <td>to</td> <td>52</td> <td>51</td> <td>50</td> <td>49</td> </tr> </tbody> </table> <p>1 to 64 in the table indicate station numbers.</p> <p>The bits turn on by the number of occupied stations. Error invalid stations, reserved stations, station with the end station number, and stations later than that are excepted.</p>		b15	b14	b13	b12	to	b3	b2	b1	b0	SW007C	16	15	14	13	to	4	3	2	1	SW007D	32	31	30	29	to	20	19	18	17	SW007E	48	47	46	45	to	36	35	34	33	SW007F	64	63	62	61	to	52	51	50	49	○	○	×
	b15	b14	b13	b12	to	b3	b2	b1	b0																																														
SW007C	16	15	14	13	to	4	3	2	1																																														
SW007D	32	31	30	29	to	20	19	18	17																																														
SW007E	48	47	46	45	to	36	35	34	33																																														
SW007F	64	63	62	61	to	52	51	50	49																																														
SW0080 to SW0083	Data link status of other stations	<p>Stores the data link status of each station.</p> <p>0: Normal 1: Data link error</p> <table border="1"> <thead> <tr> <th></th> <th>b15</th> <th>b14</th> <th>b13</th> <th>b12</th> <th>to</th> <th>b3</th> <th>b2</th> <th>b1</th> <th>b0</th> </tr> </thead> <tbody> <tr> <td>SW0080</td> <td>16</td> <td>15</td> <td>14</td> <td>13</td> <td>to</td> <td>4</td> <td>3</td> <td>2</td> <td>1</td> </tr> <tr> <td>SW0081</td> <td>32</td> <td>31</td> <td>30</td> <td>29</td> <td>to</td> <td>20</td> <td>19</td> <td>18</td> <td>17</td> </tr> <tr> <td>SW0082</td> <td>48</td> <td>47</td> <td>46</td> <td>45</td> <td>to</td> <td>36</td> <td>35</td> <td>34</td> <td>33</td> </tr> <tr> <td>SW0083</td> <td>64</td> <td>63</td> <td>62</td> <td>61</td> <td>to</td> <td>52</td> <td>51</td> <td>50</td> <td>49</td> </tr> </tbody> </table> <p>1 to 64 in the table indicate station numbers.</p> <p>The bits turn on by the number of occupied stations. It takes maximum of six seconds for this register to turn on after a slave station connected to the master station or local station becomes faulty. The time until this signal turns on differs depending on the system configuration and error status. Temporary error invalid stations, error invalid stations, reserved stations, station with the end station number, and stations later than that are excepted.</p>		b15	b14	b13	b12	to	b3	b2	b1	b0	SW0080	16	15	14	13	to	4	3	2	1	SW0081	32	31	30	29	to	20	19	18	17	SW0082	48	47	46	45	to	36	35	34	33	SW0083	64	63	62	61	to	52	51	50	49	○	○	×
	b15	b14	b13	b12	to	b3	b2	b1	b0																																														
SW0080	16	15	14	13	to	4	3	2	1																																														
SW0081	32	31	30	29	to	20	19	18	17																																														
SW0082	48	47	46	45	to	36	35	34	33																																														
SW0083	64	63	62	61	to	52	51	50	49																																														
SW0084 to SW0087	Watchdog timer error occurrence status of other stations	<p>Stores whether a watchdog timer error has occurred.</p> <p>0: No watchdog timer error 1: Watchdog timer error</p> <table border="1"> <thead> <tr> <th></th> <th>b15</th> <th>b14</th> <th>b13</th> <th>b12</th> <th>to</th> <th>b3</th> <th>b2</th> <th>b1</th> <th>b0</th> </tr> </thead> <tbody> <tr> <td>SW0084</td> <td>16</td> <td>15</td> <td>14</td> <td>13</td> <td>to</td> <td>4</td> <td>3</td> <td>2</td> <td>1</td> </tr> <tr> <td>SW0085</td> <td>32</td> <td>31</td> <td>30</td> <td>29</td> <td>to</td> <td>20</td> <td>19</td> <td>18</td> <td>17</td> </tr> <tr> <td>SW0086</td> <td>48</td> <td>47</td> <td>46</td> <td>45</td> <td>to</td> <td>36</td> <td>35</td> <td>34</td> <td>33</td> </tr> <tr> <td>SW0087</td> <td>64</td> <td>63</td> <td>62</td> <td>61</td> <td>to</td> <td>52</td> <td>51</td> <td>50</td> <td>49</td> </tr> </tbody> </table> <p>1 to 64 in the table indicate station numbers.</p> <p>Only the bit corresponding to the start station number turns on. Reserved stations, station with the end station number, and stations later than that are excepted.</p>		b15	b14	b13	b12	to	b3	b2	b1	b0	SW0084	16	15	14	13	to	4	3	2	1	SW0085	32	31	30	29	to	20	19	18	17	SW0086	48	47	46	45	to	36	35	34	33	SW0087	64	63	62	61	to	52	51	50	49	○	○	×
	b15	b14	b13	b12	to	b3	b2	b1	b0																																														
SW0084	16	15	14	13	to	4	3	2	1																																														
SW0085	32	31	30	29	to	20	19	18	17																																														
SW0086	48	47	46	45	to	36	35	34	33																																														
SW0087	64	63	62	61	to	52	51	50	49																																														
SW0088 to SW008B	Fuse blown status of other stations	<p>Stores whether a fuse blown error has occurred.</p> <p>0: Normal 1: Fuse blown</p> <table border="1"> <thead> <tr> <th></th> <th>b15</th> <th>b14</th> <th>b13</th> <th>b12</th> <th>to</th> <th>b3</th> <th>b2</th> <th>b1</th> <th>b0</th> </tr> </thead> <tbody> <tr> <td>SW0088</td> <td>16</td> <td>15</td> <td>14</td> <td>13</td> <td>to</td> <td>4</td> <td>3</td> <td>2</td> <td>1</td> </tr> <tr> <td>SW0089</td> <td>32</td> <td>31</td> <td>30</td> <td>29</td> <td>to</td> <td>20</td> <td>19</td> <td>18</td> <td>17</td> </tr> <tr> <td>SW008A</td> <td>48</td> <td>47</td> <td>46</td> <td>45</td> <td>to</td> <td>36</td> <td>35</td> <td>34</td> <td>33</td> </tr> <tr> <td>SW008B</td> <td>64</td> <td>63</td> <td>62</td> <td>61</td> <td>to</td> <td>52</td> <td>51</td> <td>50</td> <td>49</td> </tr> </tbody> </table> <p>1 to 64 in the table indicate station numbers.</p> <p>The bits turn on by the number of occupied stations. Reserved stations, station with the end station number, and stations later than that are excepted.</p>		b15	b14	b13	b12	to	b3	b2	b1	b0	SW0088	16	15	14	13	to	4	3	2	1	SW0089	32	31	30	29	to	20	19	18	17	SW008A	48	47	46	45	to	36	35	34	33	SW008B	64	63	62	61	to	52	51	50	49	○	○	×
	b15	b14	b13	b12	to	b3	b2	b1	b0																																														
SW0088	16	15	14	13	to	4	3	2	1																																														
SW0089	32	31	30	29	to	20	19	18	17																																														
SW008A	48	47	46	45	to	36	35	34	33																																														
SW008B	64	63	62	61	to	52	51	50	49																																														



No.	Name	Description	Availability (○: Available, ×: Not available)																																																				
			Online		Offline																																																		
			Master station	Local station																																																			
SW008C to SW008F	Switch change status of other stations	<p>Stores whether the setting of switches of other stations during data link has been changed.</p> <p>0: No change 1: Changed</p> <table border="1"> <thead> <tr> <th></th> <th>b15</th> <th>b14</th> <th>b13</th> <th>b12</th> <th>to</th> <th>b3</th> <th>b2</th> <th>b1</th> <th>b0</th> </tr> </thead> <tbody> <tr> <td>SW008C</td> <td>16</td> <td>15</td> <td>14</td> <td>13</td> <td>to</td> <td>4</td> <td>3</td> <td>2</td> <td>1</td> </tr> <tr> <td>SW008D</td> <td>32</td> <td>31</td> <td>30</td> <td>29</td> <td>to</td> <td>20</td> <td>19</td> <td>18</td> <td>17</td> </tr> <tr> <td>SW008E</td> <td>48</td> <td>47</td> <td>46</td> <td>45</td> <td>to</td> <td>36</td> <td>35</td> <td>34</td> <td>33</td> </tr> <tr> <td>SW008F</td> <td>64</td> <td>63</td> <td>62</td> <td>61</td> <td>to</td> <td>52</td> <td>51</td> <td>50</td> <td>49</td> </tr> </tbody> </table> <p>1 to 64 in the table indicate station numbers.</p> <p>Only the bit corresponding to the start station number turns on. Reserved stations, station with the end station number, and stations later than that are excepted.</p>		b15	b14	b13	b12	to	b3	b2	b1	b0	SW008C	16	15	14	13	to	4	3	2	1	SW008D	32	31	30	29	to	20	19	18	17	SW008E	48	47	46	45	to	36	35	34	33	SW008F	64	63	62	61	to	52	51	50	49	○	○	×
	b15	b14	b13	b12	to	b3	b2	b1	b0																																														
SW008C	16	15	14	13	to	4	3	2	1																																														
SW008D	32	31	30	29	to	20	19	18	17																																														
SW008E	48	47	46	45	to	36	35	34	33																																														
SW008F	64	63	62	61	to	52	51	50	49																																														
SW0090	Line status	<p>Stores the line status.</p> <p>0: Normal 1: Data link disabled (disconnected)</p>	×	○	×																																																		
SW0094 to SW0097	Transient transmission status	<p>Stores whether a transient transmission error has occurred.</p> <p>0: No transient transmission error 1: Transient transmission error</p> <table border="1"> <thead> <tr> <th></th> <th>b15</th> <th>b14</th> <th>b13</th> <th>b12</th> <th>to</th> <th>b3</th> <th>b2</th> <th>b1</th> <th>b0</th> </tr> </thead> <tbody> <tr> <td>SW0094</td> <td>16</td> <td>15</td> <td>14</td> <td>13</td> <td>to</td> <td>4</td> <td>3</td> <td>2</td> <td>1</td> </tr> <tr> <td>SW0095</td> <td>32</td> <td>31</td> <td>30</td> <td>29</td> <td>to</td> <td>20</td> <td>19</td> <td>18</td> <td>17</td> </tr> <tr> <td>SW0096</td> <td>48</td> <td>47</td> <td>46</td> <td>45</td> <td>to</td> <td>36</td> <td>35</td> <td>34</td> <td>33</td> </tr> <tr> <td>SW0097</td> <td>64</td> <td>63</td> <td>62</td> <td>61</td> <td>to</td> <td>52</td> <td>51</td> <td>50</td> <td>49</td> </tr> </tbody> </table> <p>1 to 64 in the table indicate station numbers.</p> <p>Only the bit corresponding to the start station number turns on. Reserved stations, station with the end station number, and stations later than that are excepted.</p>		b15	b14	b13	b12	to	b3	b2	b1	b0	SW0094	16	15	14	13	to	4	3	2	1	SW0095	32	31	30	29	to	20	19	18	17	SW0096	48	47	46	45	to	36	35	34	33	SW0097	64	63	62	61	to	52	51	50	49	○	○	×
	b15	b14	b13	b12	to	b3	b2	b1	b0																																														
SW0094	16	15	14	13	to	4	3	2	1																																														
SW0095	32	31	30	29	to	20	19	18	17																																														
SW0096	48	47	46	45	to	36	35	34	33																																														
SW0097	64	63	62	61	to	52	51	50	49																																														
SW0098 to SW009B	Station number overlap status	<p>Stores whether station numbers are unique when the start station numbers of modules are different.</p> <p>0: Normal 1: Station number in use (start station number only)</p> <table border="1"> <thead> <tr> <th></th> <th>b15</th> <th>b14</th> <th>b13</th> <th>b12</th> <th>to</th> <th>b3</th> <th>b2</th> <th>b1</th> <th>b0</th> </tr> </thead> <tbody> <tr> <td>SW0098</td> <td>16</td> <td>15</td> <td>14</td> <td>13</td> <td>to</td> <td>4</td> <td>3</td> <td>2</td> <td>1</td> </tr> <tr> <td>SW0099</td> <td>32</td> <td>31</td> <td>30</td> <td>29</td> <td>to</td> <td>20</td> <td>19</td> <td>18</td> <td>17</td> </tr> <tr> <td>SW009A</td> <td>48</td> <td>47</td> <td>46</td> <td>45</td> <td>to</td> <td>36</td> <td>35</td> <td>34</td> <td>33</td> </tr> <tr> <td>SW009B</td> <td>64</td> <td>63</td> <td>62</td> <td>61</td> <td>to</td> <td>52</td> <td>51</td> <td>50</td> <td>49</td> </tr> </tbody> </table> <p>1 to 64 in the table indicate station numbers.</p> <p>Reserved stations, station with the end station number, and stations later than that are excepted.</p> <p>Only the bit corresponding to the start station number turns on. This item is checked, and the result is stored only upon data link start and the change of a parameter.</p> <p>For a slave station with the transmission speed auto-tracking setting, whether the station number is already used for other stations may not be detected.</p> <p>When the station number of a station is the same as that of the standby master station, the status cannot be detected.</p>		b15	b14	b13	b12	to	b3	b2	b1	b0	SW0098	16	15	14	13	to	4	3	2	1	SW0099	32	31	30	29	to	20	19	18	17	SW009A	48	47	46	45	to	36	35	34	33	SW009B	64	63	62	61	to	52	51	50	49	○	×	×
	b15	b14	b13	b12	to	b3	b2	b1	b0																																														
SW0098	16	15	14	13	to	4	3	2	1																																														
SW0099	32	31	30	29	to	20	19	18	17																																														
SW009A	48	47	46	45	to	36	35	34	33																																														
SW009B	64	63	62	61	to	52	51	50	49																																														

No.	Name	Description	Availability (○: Available, ×: Not available)																																																											
			Online		Offline																																																									
			Master station	Local station																																																										
SW009C to SW009F	Installation/parameter matching status	<p>Stores the matching statuses such as the matching of CC-Link versions between the parameter settings and the modules on slave stations.</p> <p>■ The station types do not match. (This mismatch occurs in the following combinations of station types.)</p> <table border="1"> <tr> <td>Installation</td> <td>Parameter</td> </tr> <tr> <td>Remote device station</td> <td>Remote I/O station</td> </tr> <tr> <td rowspan="2">Intelligent device station</td> <td>Remote I/O station</td> </tr> <tr> <td>Remote device station</td> </tr> </table> <p>■ The number of occupied stations do not match (installation > parameter). ■ The extended cyclic settings do not match. ■ The remote station versions do not match between the parameter settings and installed modules.</p> <p>0: Normal 1: Mismatch error</p> <table border="1"> <thead> <tr> <th></th> <th>b15</th> <th>b14</th> <th>b13</th> <th>b12</th> <th>to</th> <th>b3</th> <th>b2</th> <th>b1</th> <th>b0</th> </tr> </thead> <tbody> <tr> <td>SW009C</td> <td>16</td> <td>15</td> <td>14</td> <td>13</td> <td>to</td> <td>4</td> <td>3</td> <td>2</td> <td>1</td> </tr> <tr> <td>SW009D</td> <td>32</td> <td>31</td> <td>30</td> <td>29</td> <td>to</td> <td>20</td> <td>19</td> <td>18</td> <td>17</td> </tr> <tr> <td>SW009E</td> <td>48</td> <td>47</td> <td>46</td> <td>45</td> <td>to</td> <td>36</td> <td>35</td> <td>34</td> <td>33</td> </tr> <tr> <td>SW009F</td> <td>64</td> <td>63</td> <td>62</td> <td>61</td> <td>to</td> <td>52</td> <td>51</td> <td>50</td> <td>49</td> </tr> </tbody> </table> <p>1 to 64 in the table indicate station numbers.</p> <p>Reserved stations, station with the end station number, and stations later than that are excepted.</p> <p>Only the bit corresponding to the start station number turns on. This item is checked, and the result is stored only upon data link start and the change of a parameter.</p>	Installation	Parameter	Remote device station	Remote I/O station	Intelligent device station	Remote I/O station	Remote device station		b15	b14	b13	b12	to	b3	b2	b1	b0	SW009C	16	15	14	13	to	4	3	2	1	SW009D	32	31	30	29	to	20	19	18	17	SW009E	48	47	46	45	to	36	35	34	33	SW009F	64	63	62	61	to	52	51	50	49	○	×	×
Installation	Parameter																																																													
Remote device station	Remote I/O station																																																													
Intelligent device station	Remote I/O station																																																													
	Remote device station																																																													
	b15	b14	b13	b12	to	b3	b2	b1	b0																																																					
SW009C	16	15	14	13	to	4	3	2	1																																																					
SW009D	32	31	30	29	to	20	19	18	17																																																					
SW009E	48	47	46	45	to	36	35	34	33																																																					
SW009F	64	63	62	61	to	52	51	50	49																																																					
SW00B4 to SW00B7	Line test 1 result	<p>Stores the result of the line test 1.</p> <p>0: Normal 1: Error</p> <table border="1"> <thead> <tr> <th></th> <th>b15</th> <th>b14</th> <th>b13</th> <th>b12</th> <th>to</th> <th>b3</th> <th>b2</th> <th>b1</th> <th>b0</th> </tr> </thead> <tbody> <tr> <td>SW00B4</td> <td>16</td> <td>15</td> <td>14</td> <td>13</td> <td>to</td> <td>4</td> <td>3</td> <td>2</td> <td>1</td> </tr> <tr> <td>SW00B5</td> <td>32</td> <td>31</td> <td>30</td> <td>29</td> <td>to</td> <td>20</td> <td>19</td> <td>18</td> <td>17</td> </tr> <tr> <td>SW00B6</td> <td>48</td> <td>47</td> <td>46</td> <td>45</td> <td>to</td> <td>36</td> <td>35</td> <td>34</td> <td>33</td> </tr> <tr> <td>SW00B7</td> <td>64</td> <td>63</td> <td>62</td> <td>61</td> <td>to</td> <td>52</td> <td>51</td> <td>50</td> <td>49</td> </tr> </tbody> </table> <p>1 to 64 in the table indicate station numbers.</p> <p>The bits turn on by the number of occupied stations.</p>		b15	b14	b13	b12	to	b3	b2	b1	b0	SW00B4	16	15	14	13	to	4	3	2	1	SW00B5	32	31	30	29	to	20	19	18	17	SW00B6	48	47	46	45	to	36	35	34	33	SW00B7	64	63	62	61	to	52	51	50	49	○	×	×							
	b15	b14	b13	b12	to	b3	b2	b1	b0																																																					
SW00B4	16	15	14	13	to	4	3	2	1																																																					
SW00B5	32	31	30	29	to	20	19	18	17																																																					
SW00B6	48	47	46	45	to	36	35	34	33																																																					
SW00B7	64	63	62	61	to	52	51	50	49																																																					
SW00B8	Line test 2 result	<p>Stores the result of a line test.</p> <p>0: Normal Values other than 0: Error code (☞ Page 126 List of Error Codes)</p>	○	×	×																																																									
SW0140 to SW0143	Compatible CC-Link Ver. information	<p>Stores a slave station that supports the CC-Link Ver.2 mode.</p> <p>0: Ver.1-compatible slave station 1: Ver.2-compatible slave station</p> <table border="1"> <thead> <tr> <th></th> <th>b15</th> <th>b14</th> <th>b13</th> <th>b12</th> <th>to</th> <th>b3</th> <th>b2</th> <th>b1</th> <th>b0</th> </tr> </thead> <tbody> <tr> <td>SW0140</td> <td>16</td> <td>15</td> <td>14</td> <td>13</td> <td>to</td> <td>4</td> <td>3</td> <td>2</td> <td>1</td> </tr> <tr> <td>SW0141</td> <td>32</td> <td>31</td> <td>30</td> <td>29</td> <td>to</td> <td>20</td> <td>19</td> <td>18</td> <td>17</td> </tr> <tr> <td>SW0142</td> <td>48</td> <td>47</td> <td>46</td> <td>45</td> <td>to</td> <td>36</td> <td>35</td> <td>34</td> <td>33</td> </tr> <tr> <td>SW0143</td> <td>64</td> <td>63</td> <td>62</td> <td>61</td> <td>to</td> <td>52</td> <td>51</td> <td>50</td> <td>49</td> </tr> </tbody> </table> <p>1 to 64 in the table indicate station numbers.</p> <p>The bits turn on by the number of occupied stations.</p> <p>Reserved stations, station with the end station number, and stations later than that are excepted.</p>		b15	b14	b13	b12	to	b3	b2	b1	b0	SW0140	16	15	14	13	to	4	3	2	1	SW0141	32	31	30	29	to	20	19	18	17	SW0142	48	47	46	45	to	36	35	34	33	SW0143	64	63	62	61	to	52	51	50	49	○	×	×							
	b15	b14	b13	b12	to	b3	b2	b1	b0																																																					
SW0140	16	15	14	13	to	4	3	2	1																																																					
SW0141	32	31	30	29	to	20	19	18	17																																																					
SW0142	48	47	46	45	to	36	35	34	33																																																					
SW0143	64	63	62	61	to	52	51	50	49																																																					



No.	Name	Description	Availability (○: Available, ×: Not available)																																																										
			Online		Offline																																																								
			Master station	Local station																																																									
SW0144 to SW0147	CC-Link Ver. installation/parameter matching status	<p>Stores whether a CC-Link version matches between the parameter settings and the modules on slave stations.</p> <p>0: Normal 1: Mismatch error</p> <table border="1"> <thead> <tr> <th></th> <th>b15</th> <th>b14</th> <th>b13</th> <th>b12</th> <th>to</th> <th>b3</th> <th>b2</th> <th>b1</th> <th>b0</th> </tr> </thead> <tbody> <tr> <td>SW0144</td> <td>16</td> <td>15</td> <td>14</td> <td>13</td> <td>to</td> <td>4</td> <td>3</td> <td>2</td> <td>1</td> </tr> <tr> <td>SW0145</td> <td>32</td> <td>31</td> <td>30</td> <td>29</td> <td>to</td> <td>20</td> <td>19</td> <td>18</td> <td>17</td> </tr> <tr> <td>SW0146</td> <td>48</td> <td>47</td> <td>46</td> <td>45</td> <td>to</td> <td>36</td> <td>35</td> <td>34</td> <td>33</td> </tr> <tr> <td>SW0147</td> <td>64</td> <td>63</td> <td>62</td> <td>61</td> <td>to</td> <td>52</td> <td>51</td> <td>50</td> <td>49</td> </tr> </tbody> </table> <p>1 to 64 in the table indicate station numbers.</p> <p>■Example of a mismatch error</p> <table border="1"> <thead> <tr> <th>Installation</th> <th>Parameter</th> </tr> </thead> <tbody> <tr> <td>Ver.2-compatible remote device station</td> <td>Ver.1-compatible remote device station</td> </tr> <tr> <td>Ver.1-compatible remote device station</td> <td>Ver.2-compatible remote device station</td> </tr> </tbody> </table> <p>The bits corresponding to the start station number and the number of occupied stations turn on. Reserved stations, station with the end station number, and stations later than that are excepted.</p>		b15	b14	b13	b12	to	b3	b2	b1	b0	SW0144	16	15	14	13	to	4	3	2	1	SW0145	32	31	30	29	to	20	19	18	17	SW0146	48	47	46	45	to	36	35	34	33	SW0147	64	63	62	61	to	52	51	50	49	Installation	Parameter	Ver.2-compatible remote device station	Ver.1-compatible remote device station	Ver.1-compatible remote device station	Ver.2-compatible remote device station	○	×	×
	b15	b14	b13	b12	to	b3	b2	b1	b0																																																				
SW0144	16	15	14	13	to	4	3	2	1																																																				
SW0145	32	31	30	29	to	20	19	18	17																																																				
SW0146	48	47	46	45	to	36	35	34	33																																																				
SW0147	64	63	62	61	to	52	51	50	49																																																				
Installation	Parameter																																																												
Ver.2-compatible remote device station	Ver.1-compatible remote device station																																																												
Ver.1-compatible remote device station	Ver.2-compatible remote device station																																																												
SW0148	Parameter mode	<p>Stores the mode set to a system.</p> <p>0: Remote net Ver.1 mode, Remote device net Ver.1 mode, Remote I/O net mode 2: Remote net Ver.2 mode, Remote device net Ver.2 mode</p>	○	○	×																																																								
SW0149	Parameter mode of own station	<p>Stores the mode set to the own station.</p> <p>0: Remote net Ver.1 mode, Remote device net Ver.1 mode, Remote I/O net mode 2: Remote net Ver.2 mode, Remote device net Ver.2 mode</p>	○	○	×																																																								
SW0152	Maximum communication station number	<p>Stores the maximum station number during data link in real time (1 to 64: station number in the station number setting). Reserved stations, error invalid stations, and temporary error invalid stations are excepted.</p>	○	×	×																																																								
SW0153	Number of connected modules involved in communication	<p>Stores the number of modules performing data link in real time. Reserved stations, error invalid stations, and temporary error invalid stations are excepted.</p>	○	×	×																																																								
SW0160 to SW0163	Remote register use prohibited status	<p>Stores whether the use of the remote register is prohibited.</p> <p>0: Available 1: Use prohibited</p> <table border="1"> <thead> <tr> <th></th> <th>b15</th> <th>b14</th> <th>b13</th> <th>b12</th> <th>to</th> <th>b3</th> <th>b2</th> <th>b1</th> <th>b0</th> </tr> </thead> <tbody> <tr> <td>SW0160</td> <td>16</td> <td>15</td> <td>14</td> <td>13</td> <td>to</td> <td>4</td> <td>3</td> <td>2</td> <td>1</td> </tr> <tr> <td>SW0161</td> <td>32</td> <td>31</td> <td>30</td> <td>29</td> <td>to</td> <td>20</td> <td>19</td> <td>18</td> <td>17</td> </tr> <tr> <td>SW0162</td> <td>48</td> <td>47</td> <td>46</td> <td>45</td> <td>to</td> <td>36</td> <td>35</td> <td>34</td> <td>33</td> </tr> <tr> <td>SW0163</td> <td>64</td> <td>63</td> <td>62</td> <td>61</td> <td>to</td> <td>52</td> <td>51</td> <td>50</td> <td>49</td> </tr> </tbody> </table> <p>1 to 64 in the table indicate station numbers.</p> <p>Only the bit corresponding to the start station number turns on. Error invalid stations, reserved stations, station with the maximum station number, and stations later than that are excepted.</p>		b15	b14	b13	b12	to	b3	b2	b1	b0	SW0160	16	15	14	13	to	4	3	2	1	SW0161	32	31	30	29	to	20	19	18	17	SW0162	48	47	46	45	to	36	35	34	33	SW0163	64	63	62	61	to	52	51	50	49	○	×	×						
	b15	b14	b13	b12	to	b3	b2	b1	b0																																																				
SW0160	16	15	14	13	to	4	3	2	1																																																				
SW0161	32	31	30	29	to	20	19	18	17																																																				
SW0162	48	47	46	45	to	36	35	34	33																																																				
SW0163	64	63	62	61	to	52	51	50	49																																																				

No.	Name	Description	Availability (○: Available, ×: Not available)																																																				
			Online		Offline																																																		
			Master station	Local station																																																			
SW0164 to SW0167	Remote device station initialization procedure registration completion status	Stores whether the remote device station initialization procedure registration has been completed. 0: Not completed 1: Completed <table border="1"> <thead> <tr> <th></th> <th>b15</th> <th>b14</th> <th>b13</th> <th>b12</th> <th>to</th> <th>b3</th> <th>b2</th> <th>b1</th> <th>b0</th> </tr> </thead> <tbody> <tr> <td>SW0164</td> <td>16</td> <td>15</td> <td>14</td> <td>13</td> <td>to</td> <td>4</td> <td>3</td> <td>2</td> <td>1</td> </tr> <tr> <td>SW0165</td> <td>32</td> <td>31</td> <td>30</td> <td>29</td> <td>to</td> <td>20</td> <td>19</td> <td>18</td> <td>17</td> </tr> <tr> <td>SW0166</td> <td>48</td> <td>47</td> <td>46</td> <td>45</td> <td>to</td> <td>36</td> <td>35</td> <td>34</td> <td>33</td> </tr> <tr> <td>SW0167</td> <td>64</td> <td>63</td> <td>62</td> <td>61</td> <td>to</td> <td>52</td> <td>51</td> <td>50</td> <td>49</td> </tr> </tbody> </table> <p>1 to 64 in the table indicate station numbers.</p> <p>Only the bit corresponding to the start station number turns on.</p>		b15	b14	b13	b12	to	b3	b2	b1	b0	SW0164	16	15	14	13	to	4	3	2	1	SW0165	32	31	30	29	to	20	19	18	17	SW0166	48	47	46	45	to	36	35	34	33	SW0167	64	63	62	61	to	52	51	50	49	○	×	×
	b15	b14	b13	b12	to	b3	b2	b1	b0																																														
SW0164	16	15	14	13	to	4	3	2	1																																														
SW0165	32	31	30	29	to	20	19	18	17																																														
SW0166	48	47	46	45	to	36	35	34	33																																														
SW0167	64	63	62	61	to	52	51	50	49																																														
SW0183	Transmission speed test result	Stores the result of a transmission speed test. 0: Normal Values other than 0: Error code (☞ Page 126 List of Error Codes)	○	○	×																																																		
SW0184 to SW0187	Transmission speed test result of each station	Stores the result of the transmission speed test for each station. 0: Normal (same transmission speed as the master station) or no response from the module 1: Error (different transmission speed from the master station) <table border="1"> <thead> <tr> <th></th> <th>b15</th> <th>b14</th> <th>b13</th> <th>b12</th> <th>to</th> <th>b3</th> <th>b2</th> <th>b1</th> <th>b0</th> </tr> </thead> <tbody> <tr> <td>SW0184</td> <td>16</td> <td>15</td> <td>14</td> <td>13</td> <td>to</td> <td>4</td> <td>3</td> <td>2</td> <td>1</td> </tr> <tr> <td>SW0185</td> <td>32</td> <td>31</td> <td>30</td> <td>29</td> <td>to</td> <td>20</td> <td>19</td> <td>18</td> <td>17</td> </tr> <tr> <td>SW0186</td> <td>48</td> <td>47</td> <td>46</td> <td>45</td> <td>to</td> <td>36</td> <td>35</td> <td>34</td> <td>33</td> </tr> <tr> <td>SW0187</td> <td>64</td> <td>63</td> <td>62</td> <td>61</td> <td>to</td> <td>52</td> <td>51</td> <td>50</td> <td>49</td> </tr> </tbody> </table> <p>1 to 64 in the table indicate station numbers.</p> <p>Only the bit corresponding to the start station number turns on.</p>		b15	b14	b13	b12	to	b3	b2	b1	b0	SW0184	16	15	14	13	to	4	3	2	1	SW0185	32	31	30	29	to	20	19	18	17	SW0186	48	47	46	45	to	36	35	34	33	SW0187	64	63	62	61	to	52	51	50	49	○	×	×
	b15	b14	b13	b12	to	b3	b2	b1	b0																																														
SW0184	16	15	14	13	to	4	3	2	1																																														
SW0185	32	31	30	29	to	20	19	18	17																																														
SW0186	48	47	46	45	to	36	35	34	33																																														
SW0187	64	63	62	61	to	52	51	50	49																																														

The timing of when data in link special register (SW) area are updated differs depending on the link special register number. The following table lists the update timing.

Link special register	Data update timing	Link special register	Data update timing
SW0041	Updated regardless of the SB status	SW0071	Updated regardless of the SB status (Updated after each station becomes stable.)
SW0045		SW0072	
SW0060	When the SB0060 status is changed	SW0074 to SW0077	When the SB0074 status is changed
SW0061	When the SB0061 status is changed	SW0078 to SW007B	When the SB0075 status is changed
SW0062	Updated regardless of the SB status	SW0080 to SW0083	When the SB0080 status is changed
SW0067		SW0088 to SW008B	Updated regardless of the SB status
SW0068		SW0090	When the SB0090 status is changed
SW0069		SW0098 to SW009B	Updated regardless of the SB status
SW006A		SW009C to SW009	
SW006D		SW00B4 to SW00B7	
SW006E		SW00B8	
SW006F			
SW0070			

Appendix 6 Dedicated Instruction

Dedicated instructions facilitate programming for using intelligent function modules.

A master/local module can perform the following operations by using dedicated instructions.

- Transient transmission to a master station, local station, and intelligent device station
- Module parameter settings for a master station

List of dedicated instructions

For details on dedicated instructions, refer to the following.

 MELSEC iQ-R Programming Manual (Module Dedicated Instructions)

Target station	Instruction	Description
Master station Local station Intelligent device station	RIRD	Reads the specified points of data from the buffer memory or the device in the CPU module of the target station.
	RIWT	Writes the specified points of data to the buffer memory areas of the target station or the device in the CPU module of the target station.
Intelligent device station	RIRCV	Automatically performs handshaking with the intelligent device station and reads data from the buffer memory areas of the specified intelligent device station. Available for communication with modules that have signals for the handshake, such as AJ65BT-R2N.
	RISEND	Automatically performs handshaking with the intelligent device station and writes data to the buffer memory areas of the specified intelligent device station. Available for communication with modules that have signals for the handshake, such as AJ65BT-R2N.
	RIFR	Reads data from the automatic update buffer of the intelligent device station or the random access buffer. Available for communication with modules that have the automatic update buffer, such as AJ65BT-R2N.
	RITO	Writes data to the automatic update buffer of the intelligent device station or the random access buffer. Available for communication with modules that have the automatic update buffer, such as AJ65BT-R2N.
Remote device station	RDMSG	Reads/writes parameters from/to the remote device station and reads the status of the remote device station. Available for communication with the remote device station that supports the message transmission function, such as NZ2AW1C2AL.
Master station	RLPASET	Sets the module parameters to the master station and starts up the data link.

Appendix 7 Processing Time

This appendix describes data link processing time such as link scan time and transmission delay time.

When all the stations in a CC-Link system are normally performing data link, the retry processing time (RT) and return processing time (F) that are included in the formulas are not required to be added.

Link scan time

This section describes the scan time of a CC-Link system. How to calculate the link scan time of when a master/local module is in the remote net mode, remote device net mode, and remote I/O net mode is explained.

In the remote net mode

$$LS = BT \times \{(27 + (NI \times 4.8) + (NW \times 9.6) + (N \times 30) + (ni \times 4.8) + (nw \times 9.6) + TR)\} + ST + EX + (RT + F) [\mu s]$$

BT: Constant (transmission speed)

Transmission speed	156kbps	625kbps	2.5Mbps	5Mbps	10Mbps
BT	51.2	12.8	3.2	1.6	0.8

NI: Last station number in A, B, and C (The number of occupied stations included, but a reserved station excluded. The value should be multiples of 8.)

- A: Last station number in a remote I/O station
- B: Last station number in a remote device station (The number of occupied stations is included.)
- C: Last station number in local stations, standby master stations, and intelligent device stations (The number of occupied stations is included.)

NW: Last station number in B and C (The number of occupied stations included, but a reserved station excluded. The value should be multiples of 8.)

Last station No.	1 to 8	9 to 16	17 to 24	25 to 32	33 to 40	41 to 48	49 to 56	57 to 64
NI, NW	8	16	24	32	40	48	56	64

N: Number of connected modules (A reserved station is excluded.)

ni: a + b + c (A reserved station is excluded.)

- a: Total number of stations occupied by a remote I/O station
- b: Total number of stations occupied by a remote device station
- c: Total number of stations occupied by local stations, standby master stations, and intelligent device stations

nw: b + c (A reserved station is excluded.)

ST: Constant (The largest value in the results of ❶ to ❸. When B is 0, the result of ❷ is ignored. When C is 0, the result of ❸ is ignored.)

❶ $800 + (A \times 15)$

❷ $900 + (B \times 50)$

❸ $C \leq 26: 1200 + (C \times 100), C > 26: 3700 + \{(C - 26) \times 25\}$

EX: Constant (Add 50 to the sum in the table below when the remote net Ver.2 mode is used.)

Extended cyclic setting	Number of occupied stations			
	1 station occupied	2 stations occupied	3 stations occupied	4 stations occupied
Single	0	0	0	0
Double	$70 \times \text{number of stations}$	$80 \times \text{number of stations}$	$90 \times \text{number of stations}$	$100 \times \text{number of stations}$
Quadruple	$90 \times \text{number of stations}$	$110 \times \text{number of stations}$	$130 \times \text{number of stations}$	$150 \times \text{number of stations}$
Octuple	$110 \times \text{number of stations}$	$160 \times \text{number of stations}$	$210 \times \text{number of stations}$	$260 \times \text{number of stations}$

TR: Transient processing time (added only when a transient request processing is executed)

- When a master station issues a transient request: 180
- When a local station issues a transient request: $40.8 \times \text{number of stations that issued a transient request}$



RT: Retry processing time (Only the link scan with a faulty slave station where data link is being performed is added.)

$\alpha + \beta \times (\text{number of detected faulty stations} - 1)$

- α : Retry processing time of the first station

$BT \times \{(200 + R) \times \text{retry count setting value} + 178.5\}$

When a transient request is issued: $R: 13.2 + (NI \times 4.8) + (NW \times 9.6) + 180$

When a transient request is not issued: $R: 13.2 + (NI \times 4.8) + (NW \times 9.6)$

- β : Retry processing time of the second and subsequent stations

$BT \times \{(200 + P) \times \text{retry count setting value} + 178.5\}$

P: 10.8

F: Return processing time (added only when there is a faulty station)

- $BT \times \{243.1 + 210.8 \times (\text{number of automatic return stations} - 1)\} + ST$

In the remote device net mode

$LS = BT \times (27 + (NI \times 4.8) + (NW \times 9.6) + (N \times 30) + (ni \times 4.8) + (nw \times 9.6)) + ST + EX + (RT + F) [\mu s]$

BT: Constant (transmission speed)

Transmission speed	156kbps	625kbps	2.5Mbps	5Mbps	10Mbps
BT	51.2	12.8	3.2	1.6	0.8

NI: Last station number in A and B (The number of occupied stations included, but a reserved station excluded. The value should be multiples of 8.)

- A: Last station number in a remote I/O station

- B: Last station number in a remote device station (The number of occupied stations is included.)

NW: Last station number in B (The number of occupied stations included, but a reserved station excluded. The value should be multiples of 8.)

Last station No.	1 to 8	9 to 16	17 to 24	25 to 32	33 to 40	41 to 48	49 to 56	57 to 64
NI, NW	8	16	24	32	40	48	56	64

N: Number of connected modules (A reserved station is excluded.)

ni: $a + b$ (A reserved station is excluded.)

- a: Total number of stations occupied by a remote I/O station

- b: Total number of stations occupied by a remote device station

nw: b (A reserved station is excluded.)

ST: Constant (The largest value in the results of ❶ and ❷. When B is 0, the result of ❷ is ignored.)

❶ $800 + (A \times 15)$

❷ $900 + (B \times 50)$

EX: Constant (Add 50 to the sum in the table below when the remote net Ver.2 mode is used.)

Extended cyclic setting	Number of occupied stations			
	1 station occupied	2 stations occupied	3 stations occupied	4 stations occupied
Single	0	0	0	0
Double	$70 \times \text{number of stations}$	$80 \times \text{number of stations}$	$90 \times \text{number of stations}$	$100 \times \text{number of stations}$
Quadruple	$90 \times \text{number of stations}$	$110 \times \text{number of stations}$	$130 \times \text{number of stations}$	$150 \times \text{number of stations}$
Octuple	$110 \times \text{number of stations}$	$160 \times \text{number of stations}$	$210 \times \text{number of stations}$	$260 \times \text{number of stations}$

RT: Retry processing time (Only the link scan with a faulty slave station where data link is being performed is added.)

F: Return processing time (added only when there is a faulty station)

- $BT \times \{243.1 + 210.8 \times (\text{number of automatic return stations} - 1)\} + ST$

In the remote I/O net mode

$$LS = BT \{27 + (NI \times 4.8) + (N \times 30) + (ni \times 4.8)\} + ST + RT + F \text{ [\mu s]}$$

BT: Constant (transmission speed)

Transmission speed	156kbps	625kbps	2.5Mbps	5Mbps	10Mbps
BT	51.2	12.8	3.2	1.6	0.8

NI: Last station number (The value should be multiples of 8.)

Last station No.	1 to 8	9 to 16	17 to 24	25 to 32	33 to 40	41 to 48	49 to 56	57 to 64
NI	8	16	24	32	40	48	56	64

N: Number of connected modules (A reserved station is excluded.)

ni: Total number of occupied stations (A reserved station is excluded.)

ST: Constant

- $250 + (ni \times 10)$

RT: Retry processing time (Only the link scan with a faulty slave station where data link is being performed is added.)

$$\alpha + \beta \times (\text{number of detected faulty stations} - 1)$$

- α : Retry processing time of the first station

$$BT \times \{(200 + R) \times \text{retry count setting value} + 178.5\}$$

$$R: 13.2 + (NI \times 4.8) + (NW \times 9.6)$$

- β : Retry processing time of the second and subsequent stations

$$BT \times \{(200 + P) \times \text{retry count setting value} + 178.5\}$$

$$P: 10.8$$

F: Return processing time (added only when there is a faulty station)

- $BT \times 243.1 + ST$

Cyclic transmission delay time

This section describes transmission delay time (time until data is transmitted).

Master station ↔ remote I/O station

■ Master station (RX) ← remote I/O station (input)

This is the time between a signal input to a remote I/O station and the device of a CPU module turning on (off).

The following table lists the calculation formulas.

Calculation value	Station-based block data assurance used		Station-based block data assurance not used	
	Asynchronous with sequence scan	Synchronous with sequence scan	Asynchronous with sequence scan	Synchronous with sequence scan
Normal value	$(SM \times n) + (LS \times 1) + Rio$	$\{(SM \times n) \times 1\} + Rio$	$SM + (LS \times 1) + Rio$	$\{(SM \times n) \times 1\} + Rio$
Max. value	$(SM \times n) + (LS \times 2) + Rio$	$\{(SM \times n) \times 2\} + Rio$	$SM + (LS \times 2) + Rio$	$\{(SM \times n) \times 2\} + Rio$

The letters in the table mean as follows.

SM: Master station sequence scan time

LS: Link scan time

n: $LS \div SM$ (The decimal point is rounded up.)

Rio: Remote I/O response time

■ Master station (RY) → remote I/O station (output)

This is the time between the device of a CPU module turning on (off) and the output of a remote I/O station turning on (off).

The following table lists the calculation formulas.

Calculation value	Station-based block data assurance used		Station-based block data assurance not used	
	Asynchronous with sequence scan	Synchronous with sequence scan	Asynchronous with sequence scan	Synchronous with sequence scan
Normal value	$(SM \times n) + (LS \times 1) + Rio$	$(SM \times n) + (LS \times 1) + Rio$	$SM + (LS \times 1) + Rio$	$(SM \times n) + (LS \times 1) + Rio$
Max. value	$(SM \times n) + (LS \times 2) + Rio$	$(SM \times n) + (LS \times 2) + Rio$	$SM + (LS \times 2) + Rio$	$(SM \times n) + (LS \times 2) + Rio$

The letters in the table mean as follows.

SM: Master station sequence scan time

LS: Link scan time

n: $LS \div SM$ (The decimal point is rounded up.)

Rio: Remote I/O response time

Master station ↔ remote device station (Ver.1-compatible slave station)

■ Master station (RX) (RWr) ← remote device station (RX) (RWr)

This is the time between a signal input to a remote device station and the device of a CPU module turning on (off) or the time until the data in the device of a CPU module is changed.

The following table lists the calculation formulas.

Calculation value	Station-based block data assurance used		Station-based block data assurance not used	
	Asynchronous with sequence scan	Synchronous with sequence scan	Asynchronous with sequence scan	Synchronous with sequence scan
Normal value	$(SM \times n) + (LS \times 1) + Rd$	$\{(SM \times n) \times 1\} + Rd$	$SM + (LS \times 1) + Rd$	$\{(SM \times n) \times 1\} + Rd$
Max. value	$(SM \times n) + (LS \times 2) + Rd$	$\{(SM \times n) \times 2\} + Rd$	$SM + (LS \times 2) + Rd$	$\{(SM \times n) \times 2\} + Rd$

The letters in the table mean as follows.

SM: Master station sequence scan time

LS: Link scan time

n: $LS \div SM$ (The decimal point is rounded up.)

Rd: Remote device station processing time

■ Master station (RY) (RWw) → remote device station (RY) (RWw)

This is the time between the device of a CPU module turning on (off) and the output of a remote device station turning on (off) or between data set in the device of a CPU module and the data in a remote device station changed.

The following table lists the calculation formulas.

Calculation value	Station-based block data assurance used		Station-based block data assurance not used	
	Asynchronous with sequence scan	Synchronous with sequence scan	Asynchronous with sequence scan	Synchronous with sequence scan
Normal value	$(SM \times n) + (LS \times 1) + Rd$	$(SM \times n) + (LS \times 1) + Rd$	$SM + (LS \times 1) + Rd$	$(SM \times n) + (LS \times 1) + Rd$
Max. value	$(SM \times n) + (LS \times 2) + Rd$	$(SM \times n) + (LS \times 2) + Rd$	$SM + (LS \times 2) + Rd$	$(SM \times n) + (LS \times 2) + Rd$

The letters in the table mean as follows.

SM: Master station sequence scan time

LS: Link scan time

n: $LS \div SM$ (The decimal point is rounded up.)

Rd: Remote device station processing time

Master station ↔ remote device station (Ver.2-compatible slave station)

■ Master station (RX) (RWr) ← remote device station (RX) (RWr)

This is the time between a signal input to a remote device station and the device of a CPU module turning on (off) or the time until the data in the device of a CPU module is changed.

The following table lists the calculation formulas.

Calculation value	Station-based block data assurance used		Station-based block data assurance not used	
	Asynchronous with sequence scan	Synchronous with sequence scan	Asynchronous with sequence scan	Synchronous with sequence scan
Normal value	$(SM \times n) + (LS \times 1 \times m) + Rd$	$\{(SM \times t) \times 1\} + Rd$	$SM + (LS \times 1 \times m) + Rd$	$\{(SM \times t) \times 1\} + Rd$
Max. value	$(SM \times n) + (LS \times 2 \times m) + Rd$	$\{(SM \times t) \times 2\} + Rd$	$SM + (LS \times 2 \times m) + Rd$	$\{(SM \times t) \times 2\} + Rd$

The letters in the table mean as follows.

SM: Master station sequence scan time

LS: Link scan time

n: $LS \div SM$ (The decimal point is rounded up.)

t: $LS \times m \div SM$ (The decimal point is rounded up.)

Rd: Remote device station processing time

m: Constant according to the extended cyclic setting

Extended cyclic setting	Single	Double	Quadruple	Octuple
m	1	3	7	15

■ Master station (RY) (RWw) → remote device station (RY) (RWw)

This is the time between the device of a CPU module turning on (off) and the output of a remote device station turning on (off) or between data set in the device of a CPU module and the data in a remote device station changed.

The following table lists the calculation formulas.

Calculation value	Station-based block data assurance used		Station-based block data assurance not used	
	Asynchronous with sequence scan	Synchronous with sequence scan	Asynchronous with sequence scan	Synchronous with sequence scan
Normal value	$(SM \times n) + [LS \times \{(1 \times m) + 1\}] + Rd$	$(SM \times t) + (LS \times m) + Rd$	$(SM \times n) + [LS \times \{(1 \times m) + 1\}] + Rd$	$(SM \times t) + (LS \times m) + Rd$
Max. value	$(SM \times n) + [LS \times \{(2 \times m) + 1\}] + Rd$	$(SM \times t) + (LS \times m) + Rd$	$(SM \times n) + [LS \times \{(2 \times m) + 1\}] + Rd$	$(SM \times t) + (LS \times m) + Rd$

The letters in the table mean as follows.

SM: Master station sequence scan time

LS: Link scan time

n: $LS \div SM$ (The decimal point is rounded up.)

t: $LS \times m \div SM$ (The decimal point is rounded up.)

Rd: Remote device station processing time

m: Constant according to the extended cyclic setting

Extended cyclic setting	Single	Double	Quadruple	Octuple
m	1	3	7	15

Master station ↔ local station (Ver.1-compatible slave station)

■ Master station (RX) (RWr) ← local station (RY) (RWw)

This is the time between the device of the CPU module in a local station turning on (off) and the device of the CPU module in a master station turning on (off).

This is also the time between data set in the device of the CPU module in a local station and the data stored into the device of the CPU module in a master station.

The following table lists the calculation formulas.

Calculation value	Station-based block data assurance used		Station-based block data assurance not used	
	Asynchronous with sequence scan	Synchronous with sequence scan	Asynchronous with sequence scan	Synchronous with sequence scan
Normal value	$(SM \times n) + (LS \times 2) + \{SL \times (k + 1)\}$	$\{(SM \times n) \times 2\} + LS + \{SL \times (k + 1)\}$	$SM + (LS \times 2) + SL$	$\{(SM \times n) \times 2\} + LS + SL$
Max. value	$(SM \times n) + (LS \times 3) + \{SL \times (k + 1)\}$	$\{(SM \times n) \times 3\} + LS + \{SL \times (k + 1)\}$	$SM + (LS \times 3) + SL$	$\{(SM \times n) \times 3\} + LS + SL$

The letters in the table mean as follows.

SM: Master station sequence scan time

LS: Link scan time

SL: Local station sequence scan time

n: $LS \div SM$ (The decimal point is rounded up.)

k: $LS \div SL$ (The decimal point is rounded up.)

■ Master station (RY) (RWw) → local station (RX) (RWr)

This is the time between the device of the CPU module in a master station turning on (off) and the device of the CPU module in a local station turning on (off).

This is also the time between data set in the device of the CPU module in a master station and the data stored into the device of the CPU module in a local station.

The following table lists the calculation formulas.

Calculation value	Station-based block data assurance used		Station-based block data assurance not used	
	Asynchronous with sequence scan	Synchronous with sequence scan	Asynchronous with sequence scan	Synchronous with sequence scan
Normal value	$(SM \times n) + (LS \times 2) + \{SL \times (k + 1)\}$	$(SM \times n) + (LS \times 2) + \{SL \times (k + 1)\}$	$SM + (LS \times 2) + SL$	$(SM \times n) + (LS \times 2) + SL$
Max. value	$(SM \times n) + (LS \times 3) + \{SL \times (k + 1)\}$	$(SM \times n) + (LS \times 2) + \{SL \times (k + 1)\}$	$SM + (LS \times 3) + SL$	$(SM \times n) + (LS \times 2) + SL$

The letters in the table mean as follows.

SM: Master station sequence scan time

LS: Link scan time

SL: Local station sequence scan time

n: $LS \div SM$ (The decimal point is rounded up.)

k: $LS \div SL$ (The decimal point is rounded up.)

Master station ↔ local station (Ver.2-compatible slave station)

■ Master station (RX) (RW_r) ← local station (RY) (RW_w)

This is the time between the device of the CPU module in a local station turning on (off) and the device of the CPU module in a master station turning on (off).

This is also the time between data set in the device of the CPU module in a local station and the data stored into the device of the CPU module in a master station.

The following table lists the calculation formulas.

Calculation value	Station-based block data assurance used		Station-based block data assurance not used	
	Asynchronous with sequence scan	Synchronous with sequence scan	Asynchronous with sequence scan	Synchronous with sequence scan
Normal value	$SM \times n + [LS \times \{(1 \times m) + 1\}] + \{SL \times (k + 1)\}$	$\{(SM \times t) \times 2\} + \{SL \times (k + 1)\}$	$SM + [LS \times \{(1 \times m) + 1\}] + SL$	$(SM \times t) \times 2$
Max. value	$(SM \times n) + [LS \times \{(2 \times m) + 1\}] + \{SL \times (k + 1)\}$	$\{(SM \times t) \times 3\} + \{SL \times (k + 1)\}$	$SM + [LS \times \{(2 \times m) + 1\}] + SL$	$(SM \times t) \times 3$

The letters in the table mean as follows.

SM: Master station sequence scan time

LS: Link scan time

SL: Local station sequence scan time

n: $LS \div SM$ (The decimal point is rounded up.)

t: $LS \times m \div SM$ (The decimal point is rounded up.)

k: $LS \div SL$ (The decimal point is rounded up.)

m: Constant according to the extended cyclic setting

Extended cyclic setting	Single	Double	Quadruple	Octuple
m	1	3	7	15

■ Master station (RY) (RW_w) → local station (RX) (RW_r)

This is the time between the device of the CPU module in a master station turning on (off) and the device of the CPU module in a local station turning on (off).

This is also the time between data set in the device of the CPU module in a master station and the data stored into the device of the CPU module in a local station.

The following table lists the calculation formulas.

Calculation value	Station-based block data assurance used		Station-based block data assurance not used	
	Asynchronous with sequence scan	Synchronous with sequence scan	Asynchronous with sequence scan	Synchronous with sequence scan
Normal value	$(SM \times n) + [LS \times \{(1 \times m) + 1\}] + \{SL \times (k + 1)\}$	$\{(SM \times t) \times 1\} + \{SL \times (k + 1)\}$	$SM + [LS \times \{(1 \times m) + 1\}] + SL$	$\{(SM \times t) \times 1\} + SL$
Max. value	$(SM \times n) + [LS \times \{(2 \times m) + 1\}] + \{SL \times (k + 1)\}$	$\{(SM \times t) \times 2\} + \{SL \times (k + 1)\}$	$SM + [LS \times \{(2 \times m) + 1\}] + SL$	$\{(SM \times t) \times 2\} + SL$

The letters in the table mean as follows.

SM: Master station sequence scan time

LS: Link scan time

SL: Local station sequence scan time

n: $LS \div SM$ (The decimal point is rounded up.)

t: $LS \times m \div SM$ (The decimal point is rounded up.)

k: $LS \div SL$ (The decimal point is rounded up.)

m: Constant according to the extended cyclic setting

Extended cyclic setting	Single	Double	Quadruple	Octuple
m	1	3	7	15

Master station ↔ intelligent device station

Transmission delay time between a master station and an intelligent device station varies depending on the intelligent device station.

Refer to the user's manual for the intelligent device module used.

Appendix 8 How to Use Standby Master Function in Redundant System

This section describes how to use CC-Link in a redundant system of the CPU module.

The standby master function allows for continuous CC-Link communications by switching the master operating station with the program even if system switching occurs in a redundant system.

When the master/local module is mounted on an extension base unit in a redundant system with redundant extension base unit, refer to the following.

☞ Page 208 Using the Module in the Redundant System with Redundant Extension Base Unit

Restriction

Use the following modules in a redundant system.

- Process CPU
- Redundant function module
- The RJ61BT11 with a firmware version of "04" or later

Check the versions of the Process CPU and engineering tool in a redundant system. (📖 MELSEC iQ-R CPU Module User's Manual (Application))

System configuration

This section describes the configuration of a redundant system on CC-Link.

Master/local modules are mounted on the base units of both systems of a redundant system.

A redundant system is configured by connecting the master/local modules in both systems together using Ver.1.10-compatible CC-Link dedicated cables.

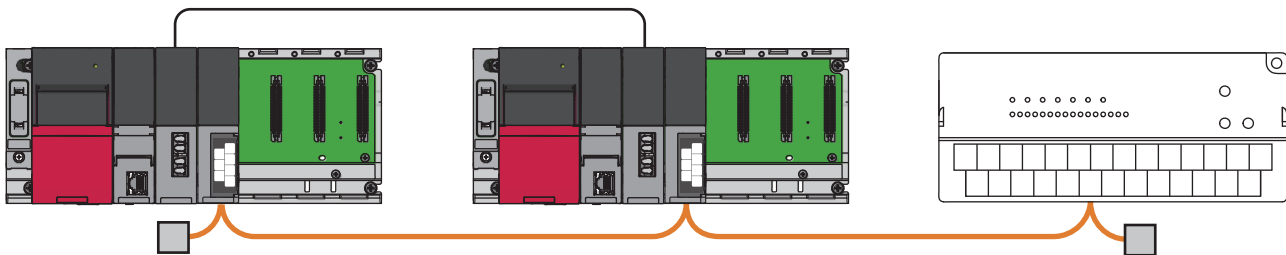

A

Setting method

This section describes how to use module parameters in a redundant system.

Use a master station (system A) to set the module parameters.

Required Settings

■ Station Type

Set the station type to "Master Station (Duplex Function)".

■ Station Number

Enter a station number of system A. This item is not required for system B because the station number for it is set in "Network Configuration Settings" under "Basic Settings".

Basic Settings

■ Network Configuration Settings

Set the stations of system A and system B as follows:

System A/system B	Station type	Model	Station number
System A	Master Station (Duplex Function)	—	—
System B	Local Station (Standby Master Station)	General Local Station	Other than 0

■Link Refresh Settings

Do not set a link device other than the link special relay (SB) or link special register (SW) to "Link Side". Setting a link device other than the link special relay (SB) or link special register (SW) will not result in a refresh.

Application Settings

■Supplementary Cyclic Settings

Station-based block data is not assured. Even if "Station-based Block Data Assurance" is set to "Enable", any data will not be assured for each station.

System switching operation

This section describes system switching operation when CC-Link is used in a redundant system.

When system switching can be followed

When the control system power supply module fails or a stop error occurs in the CPU module, the system and master operating station are switched to continue controlling the slave station.

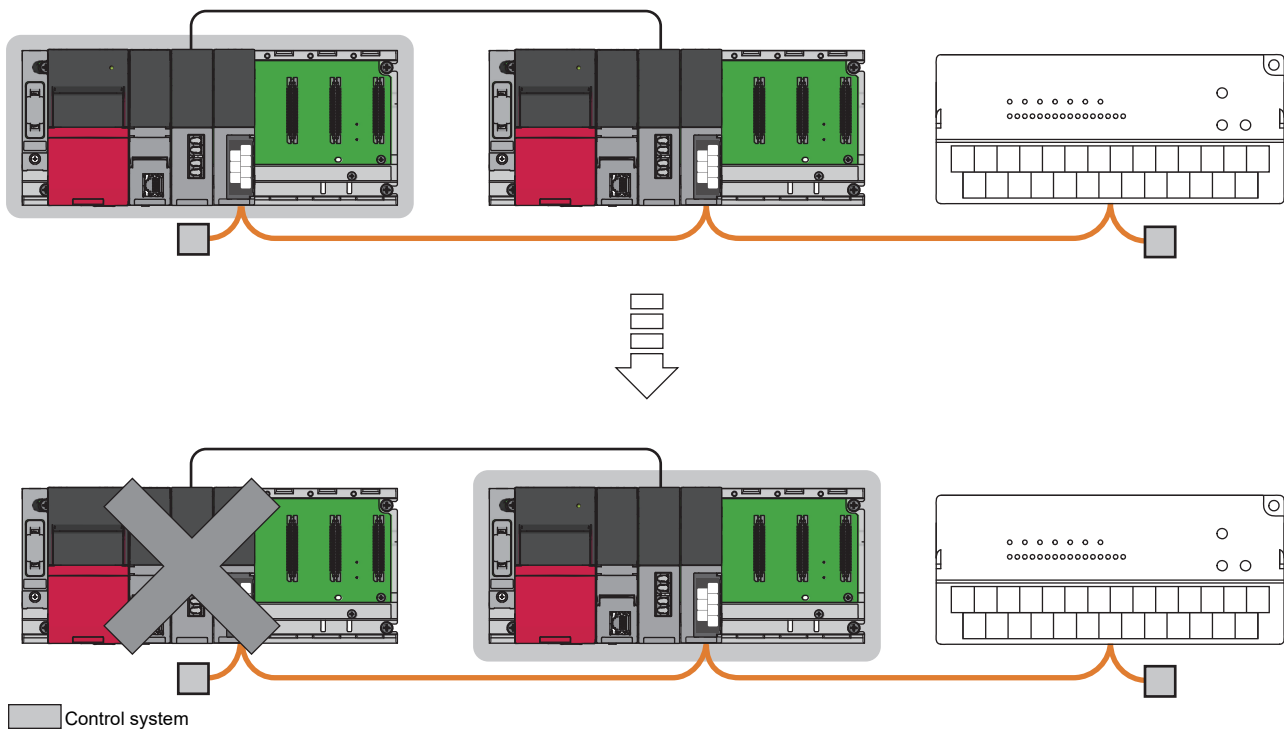

When system switching cannot be followed

When a system switching occurs due to the following system switching cause, the master station as a new standby system still can make normal communications with the remote station and no switching to the standby master station will occur. Because the standby master station of the new control system remains a standby master station, it cannot control the remote station as a master station and therefore CC-Link cannot be controlled by the new control system.

The data link control must be switched from the standby master station to the master station using the new standby system program.

For details on the program, refer to the communication example. (☞ Page 183 Communication examples)

- Execution of the system switching instruction
- System switching operation from the engineering tool
- System switching request from another network module

Precautions

- When the master/local modules are simultaneously powered on in both systems, the system A (control system) will start as a master operating station. When a master/local module is powered on in a single system, a system which is powered on will start as a master operating station. To power on a single system, start up the system so that the system of the master operating station becomes a control system.
- When the both systems are simultaneously powered on in the redundant system with redundant extension base units, the system B (standby system) may start as a master operating station. In this case, switch the system of the master operating station to the system A (control system) by the program. (☞ Page 192 Programs when starting in a redundant system with redundant extension base unit).
- Do not start up a system with a master/local module mounted by configuring the system B as a control system even if the previous control system was system B.
- To check the status of standby system master/local module with an engineering tool connected to a control system, use 'Data link status of other stations' (SW0080 to SW0083). If the data link status of the standby system remains in the normal state (in 'Data link status of other stations' (SW0080 to SW0083) and a bit corresponding to a standby master station is off) for two seconds or more, the master/local module of the standby system has been started normally.
- Do not set tracking for the link special relay areas (SB0020 to SB01FF), which are turned on/off by the system, or the link special register areas (SW0020 to SW01FF), where data is stored by the system.
- The remote output (RY) and remote register (RWw) are held until the master operating station switch is completed with the switching and program.

Point

For details on tracking, refer to the following.

📖 MELSEC iQ-R CPU Module User's Manual (Application)

Communication examples

This section describes communication examples using the standby master function in a redundant system.

A

System configuration example

The following system configuration is used to explain the communication examples using the standby master function in a redundant system.

A same configuration should be used for the control system and standby system of the redundant system.

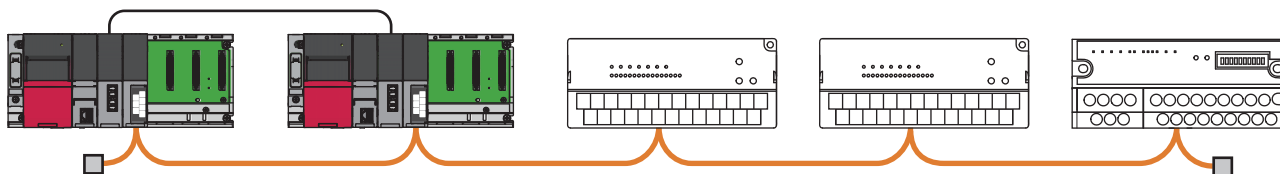

Master station (control system): Station No.0

Standby master station (standby system): Station No.5

Remote I/O station: Station No.1

Remote I/O station: Station No.2

Remote device station: Station No.3

Point

The program example uses a setting of 80H for the start I/O number of the redundant function module and 40H for the start I/O number of the master/local module.

Settings for a master station and standby master station

Connect the engineering tool to the CPU module on the control system and set the parameters.

In a redundant system, the same program and parameter are written to both systems. A new project does not need to be created for the standby system.

1. Set the CPU module as follows.

 [Project] ⇒ [New]

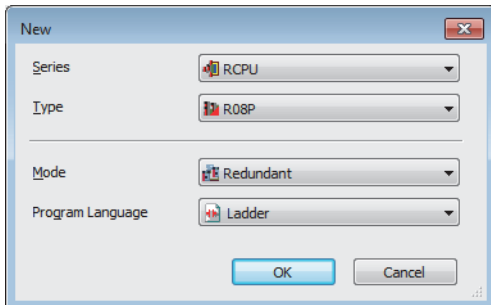

2. Click the [Setting Change] button and set the module label to [Use].

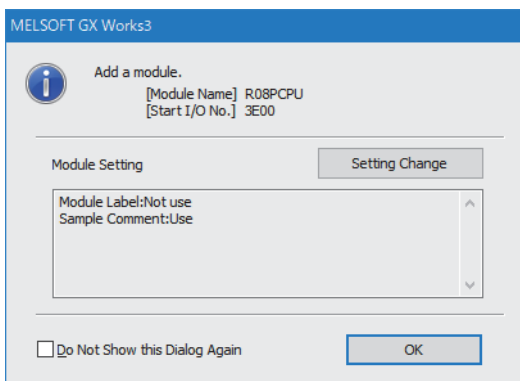

3. In the I/O assignment setting, set the redundant function module for slot No.0.

 [Navigation window] ⇒ [Parameter] ⇒ [System Parameter] ⇒ [I/O Assignment] tab ⇒ [I/O Assignment Setting]

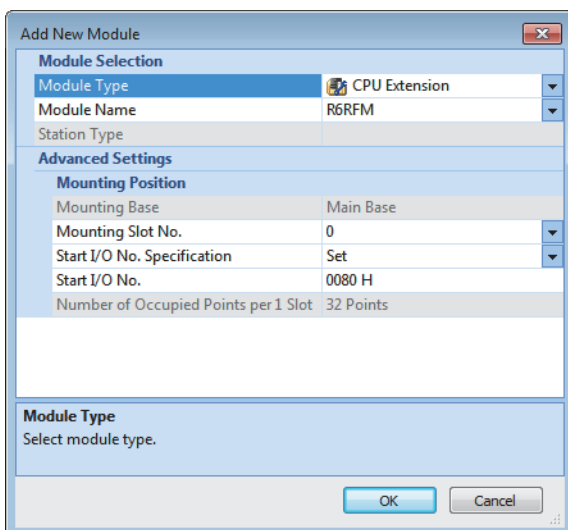

4. Set the master/local module for the slot No.1.

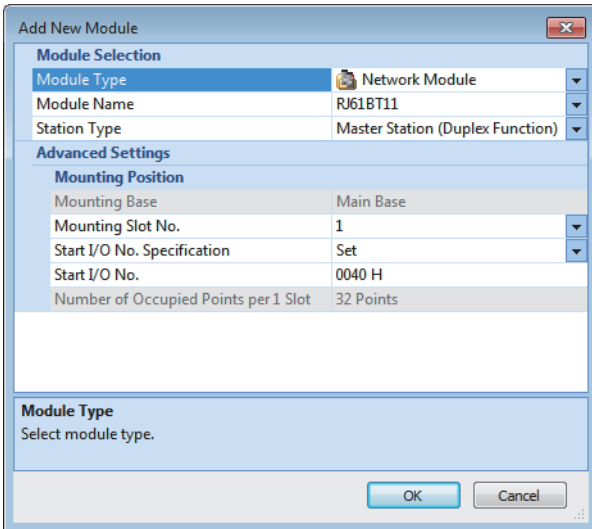

5. Click the [OK] button to add the module labels of the master/local module.

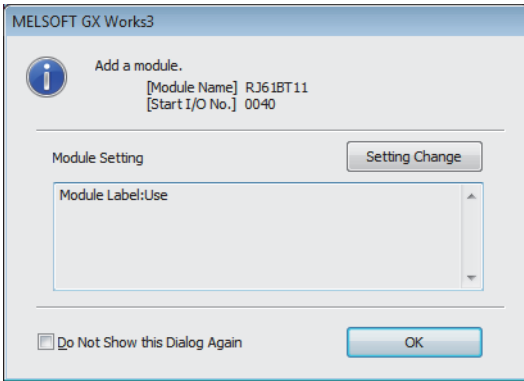

6. Set the items in "Required Settings" as follows.

[Navigation window] ⇒ [Parameter] ⇒ [Module Information] ⇒ [RJ61BT11] ⇒ [Required setting]

Item	Setting
Station Type	
Station Type	Master Station (Duplex Function)
Mode	
Communication Mode	Remote Net Ver.1 Mode
Station Number	
Station No.	0
Transmission Speed	
Transmission Speed	10Mbps
Parameter Setting Method	
Setting Method of Basic/Application Settings	Parameter Editor



7. Set the network configuration as follows.

[Navigation window] ⇒ [Parameter] ⇒ [Module Information] ⇒ [RJ61BT11] ⇒ [Basic Settings] ⇒ [Network Configuration Settings]

Station No.	Model Name	Station Type	Version	# of STA Occupied	Expanded Cyclic Setting	Remote Station Points	Reserved/Err Invalid STA	Intelligent Buffer Selection(word)			Station-specific mode setting
								Send	Receive	Auto	
0/0	Host Station	Master Station (Duplex Function)									
1/1	General Remote I/O Station	Remote I/O Station	Ver. 1	1 Occupied Station	Single	32 Points	No Setting				
2/2	General Remote I/O Station	Remote I/O Station	Ver. 1	1 Occupied Station	Single	32 Points	No Setting				
3/3	General Remote Device Station	Remote Device Station	Ver. 1	2 Occupied Station	Single	64 Points	No Setting				
4/5	General Local Station	Local Station	Ver. 1	1 Occupied Station	Single	32 Points	No Setting	64	64	128	

The diagram below the table shows a network topology with a central bus and five stations: STA#0 (Master Station), STA#1 (General Remote I/O Station), STA#2 (General Remote I/O Station), STA#3-4 (General Remote Device Station), and STA#5 (General Local Station).

8. Set the redundant function module of the own system as the system A in the "System A/B Setting" window, and reset the CPU modules of both systems or power off and on the both systems.

[Online] ⇒ [Redundant PLC Operation] ⇒ [System A/B Setting]

The dialog box contains the following fields and controls:

- System Status:**
 - Connective System: System Unknown
 - Other System: System Unknown
- Set the Connective System:**
 - Dropdown menu: System A
- Buttons: Execute, Close

9. Write the set parameters to the system A CPU module.

[Online] ⇒ [Write to PLC]

10. Click the [Yes] button to write to the CPU modules of both systems.

The dialog box contains the following text:

Write to both systems.
Are you sure you want to continue?

Please do not change the operation mode while it is running.

Buttons: Yes, No

11. Either reset the CPU modules of both systems or power off and on both systems.

Point In this example, default values are used for parameters that are not shown above. For the parameter setting, refer to the chapter explaining the parameters in this manual. (Page 57 PARAMETER SETTINGS)

Program example

Use the following program to follow the CC-Link control and system switching:

Program	Execution type	Both systems program executions setting ^{*1}
System switching following program for the standby system	Scan	Both Systems Executions
System switching following program for the control system	Scan	Control System Execution
Control processing program for CC-Link	Scan	Control System Execution

*1 Set this item in "Program Setting" of "CPU Parameter". Follow the order of the procedure above to set the program setting. (📖 MELSEC iQ-R CPU Module User's Manual (Application))



Some of program conversions may generate a CheckWarning showing that a dual coil is detected but there is no problem in the program operation.

Classification	Label name	Description	Device	
Module label	RCPU.stSM.bAfter_RUN1_Scan_ON	After RUN, On for one scan only	SM402	
	RCPU.stSM.bAfter_System_Switching_One_SCAN_ON_Standby_System_To_Control_System	ON for only one scan after system switching (standby system to control system)	SM1643	
	RCPU.stSM.bAfter_System_Switching_One_SCAN_ON_Control_System_To_Standby_System	ON for only one scan after system switching (control system to standby system)	SM1644	
	BT11_1.bReq_Refresh_StandbyMasterSwitching	Refresh instruction at standby master switching	SB0001	
	BT11_1.bReq_ForcedMasterSwitching	Forced master switching	SB000C	
	BT11_1.bAcpt_Refresh_StandbyMasterSwitching	Refresh instruction acceptance status at standby master switching	SB0042	
	BT11_1.bCompl_Refresh_StandbyMasterSwitching	Refresh instruction completion status at standby master switching	SB0043	
	BT11_1.bAcpt_MasterSwitching	Master switching request acceptance	SB005A	
	BT11_1.bCompl_MasterSwitching	Master switching request completion	SB005B	
	BT11_1.bOpe_StandbyMaster	Master/standby master operation status of own station	SB007B	
	BT11_1.uRslt_Refresh_StandbyMasterSwitching	Refresh instruction at standby master switching result	SW0043	
	BT11_1.bIn_ModuleFailure	Module failure	X40	
	BT11_1.bIn_DataLink	Own station data link status	X41	
	BT11_1.bIn_ModuleReady	Module ready	X4F	
Label to be defined	Define global labels as shown below:			
	Label Name	Data Type	Class	Assign (Device/Label)
	NumberOfScansAfterBackUpLinkDevice	Word [Unsigned]/Bit String [16-bit]	VAR_GLOBAL	D0
	EnableControlProgramExecution	Bit	VAR_GLOBAL	M100
	Compl_ScanWaitAfterBackUpLinkDevice	Bit	VAR_GLOBAL	M103
	DuringDataLinkExecution	Bit	VAR_GLOBAL	M4531
	ControlProgramNotExecutedPointer	Pointer	VAR_GLOBAL	P1
	BackUpRY	Word [Unsigned]/Bit String [16-bit](0..7)	VAR_GLOBAL	W1200
	BackUpRX	Word [Unsigned]/Bit String [16-bit](0..7)	VAR_GLOBAL	W1300
	BackUpRWw	Word [Unsigned]/Bit String [16-bit](0..15)	VAR_GLOBAL	W1400
	BackUpRWr	Word [Unsigned]/Bit String [16-bit](0..15)	VAR_GLOBAL	W1500

Refresh device

Redundant system uses a program to refresh the remote input (RX), remote output (RY), and remote register (RW_r, RW_w). Use module parameters to make refresh settings for the link special relay (SB) and link special register (SW).

Refresh device and refresh range of CC-Link used by the system (five stations are used) of this example are as follows. Change the transfer range of the CC-Link device and range of the CPU device depending on the number of systems and module type to be used.

Device	Description		
	Link device	Start address of buffer memory	Number of transfers (word)
X1000 to X109F ^{*1}	Remote input (RX00 to RX9F)	224 (E0H)	10
Y1000 to Y109F ^{*1}	Remote output (RY00 to RY9F)	352 (160H)	10
W1100 to W1113 ^{*1}	Remote register (RW _w 00 to RW _w 13)	480 (1E0H)	20
W1000 to W1013 ^{*1}	Remote register (RW _r 00 to RW _r 13)	736 (2E0H)	20
BT11_1 (module label)	Link special relay (SB0000 to SB01FF)	1504 (5E0H)	— ^{*2}
	Link special register (SW0000 to SW01FF)	1536 (600H)	

*1 Labels can be also used.

*2 Link refresh allows for auto transfer.

System switching following program for the standby system

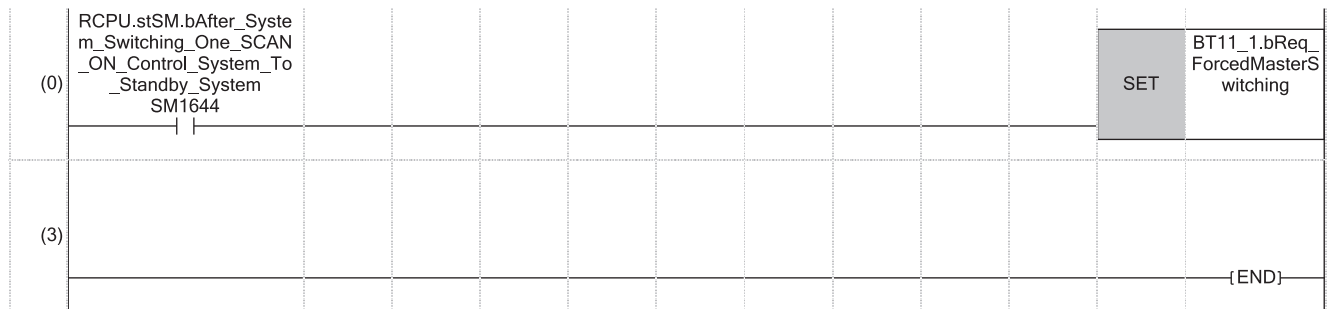

(0) When the system is switched from control system to standby system by redundant system switching, turn on 'Forced master switching' (SB000C).

System switching following program for the control system

(0)	RCPU.stSM.bAfter_System_Switching_One_SCANN_ON_Standby_System_To_Control_System SM1643						RST	BT11_1.bReq_ForcedMasterSwitching
							RST	EnableControlProgramExecution
								M100
							RST	Compl_ScanWaitAfterBackupLinkDevice
								M103
							MOV	NumberOfScansAfterBackupLinkDevice
								D0
(7)	BT11_1.bAcpt_MasterSwitching	Compl_ScanWaitAfterBackupLinkDevice M103					INC_U	NumberOfScansAfterBackupLinkDevice
								D0
			>_U	NumberOfScansAfterBackupLinkDevice D0	K0		SET	Compl_ScanWaitAfterBackupLinkDevice
								M103
(16)	BT11_1.bAcpt_MasterSwitching						BMOV	U4\G352 BackUp RY
								W1200
							BMOV	U4\G224 BackUp RX
								W1300
							BMOV	U4\G480 BackUp RWw
								W1400
							BMOV	U4\G736 BackUp RWr
								W1500
(42)	BT11_1.bCompl_MasterSwitching	Compl_ScanWaitAfterBackupLinkDevice M103					BMOV	BackUp RX U4\G352
								W1300
							BMOV	BackUp RY U4\G224
								W1200
							BMOV	BackUp RWr U4\G480
								W1500
							BMOV	BackUp RWw U4\G736
								W1400



(69)	BT11_1.bAcpt_MasterSwitching	BT11_1.bComp_MasterSwitching	CompL_ScanWaitAfterBackupLinkDevice M103							SET	BT11_1.bReq_Refresh_StandbyMasterSwitching
										RST	CompL_ScanWaitAfterBackupLinkDevice M103
(77)	BT11_1.bAcpt_Refresh_StandbyMasterSwitching	BT11_1.bComp_Refresh_StandbyMasterSwitching								RST	BT11_1.bReq_Refresh_StandbyMasterSwitching
			=_U	K0	BT11_1.uRsIt_Refresh_StandbyMasterSwitching					SET	EnableControlProgramExecution M100
(88)	EnableControlProgramExecution M100							BMOV	K4Y1000	U4\G352	K10
								BMOV	U4\G224	K4X1000	K10
								BMOV	W1100	U4\G480	K20
								BMOV	U4\G736	W1000	K20
(109)											{END}

- (0) When the system is switched from standby system to control system by redundant system switching, turn off 'Forced master switching' (SB000C), 'EnableControlProgramExecution' (M100), and 'CompL_ScanWaitAfterBackupLinkDevice' (M103). Also, clear 'NumberOfScansAfterBackupLinkDevice' (D0).
- (7) After saving the RX, RY, RWr, RWw data to devices and wait a fixed number of scans, turn on 'CompL_ScanWaitAfterBackupLinkDevice' (M103). After saving the link devices, wait a fixed number of scans and execute the processing that sets the link devices saved at master switching and 'Refresh instruction at standby master switching' (SB0001). (In the program example, wait for the number of scans for the value entered in the position "K0".) For details, refer to precautions of the standby master function. (Page 50 Precautions)
- (16)When 'Master switching request acceptance' (SB005A) is turned on, the data in RX, RY, RWr and RWw will be saved in 'BackupRX' (W1300), 'BackupRY' (W1200), 'BackupRWr' (W1500), and 'BackupRWw' (W1400).
- (42)When 'Master switching request completion' (SB005B) and 'CompL_ScanWaitAfterBackupLinkDevice' (M103) are turned on, the data saved in the 'BackupRX' (W1300), 'BackupRY' (W1200), 'BackupRWr' (W1500), and 'BackupRWw' (W1400) will be stored in RY, RX, RWw and RWr.
- (69)Turn on 'Refresh instruction at standby master switching' (SB0001).
- (77)Turn off 'Refresh instruction at standby master switching' (SB0001).
- (88)Execute refresh for link devices (RX, RY, RWr, and RWw).

■Control processing program for CC-Link

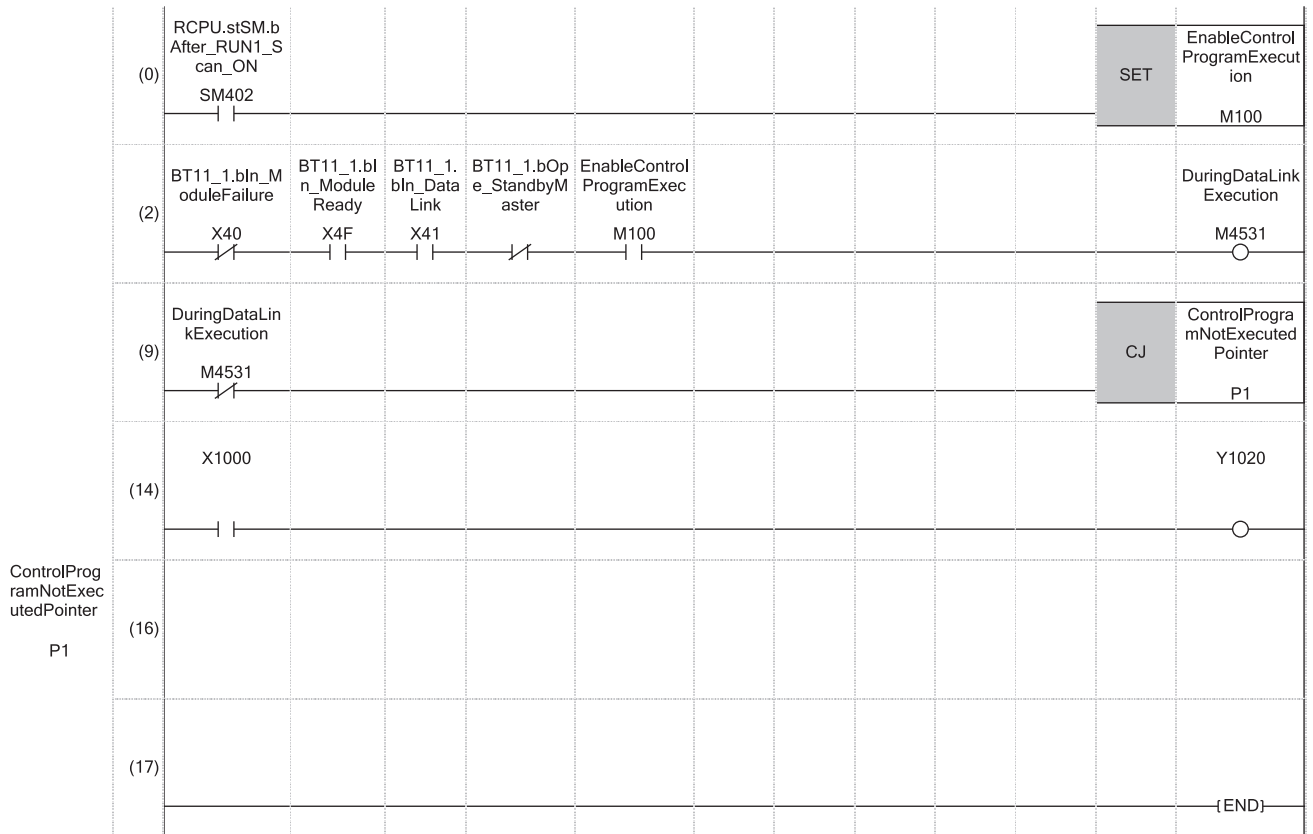

(14)Control program for CC-Link



Programs when starting in a redundant system with redundant extension base unit

In a redundant system with redundant extension base unit, set the parameters and add the programs when a system with the master/local module on the main base unit is started up.

Parameter settings

Program	Execution type	Both systems program executions setting ^{*1}
Initial processing program in a redundant system with redundant extension base unit	Scan	Both Systems Executions
System switching following program for the standby system	☞ Page 187 Program example	
System switching following program for the control system		
Control processing program for CC-Link		

*1 Set this item in "Program Setting" of "CPU Parameter". Follow the order of the procedure above to set the program setting. (☞ MELSEC iQ-R CPU Module User's Manual (Application))

Classification	Label name	Description	Device
Module label	RCPU.stSM.bSystem_A_Identification_Flag	System A identification flag	SM1632
	RCPU.stSM.bSystem_B_Identification_Flag	System B identification flag	SM1633
	RCPU.stSM.bControl_System_Identification_Flag	Control system identification flag	SM1634
	RCPU.stSM.bStandby_System_Identification_Flag	Standby system identification flag	SM1635
	BT11_1.bReq_ForcedMasterSwitching	Forced master switching	SB000C
	BT11_1.bOpe_StandbyMaster	Master/standby master operation status of own station	SB007B
	BT11_1.bnSts_DataLinkError_Other	Data link status of other stations	SW0080
	BT11_1.bIn_DataLink	Own station data link status	X41

Label to be defined Define global labels as shown below:

Label Name	Data Type	Class	Assign (Device/Label)
Compl_InitialProgramExecution	Bit	VAR_GLOBAL	M300

Initial processing program in a redundant system with redundant extension base unit

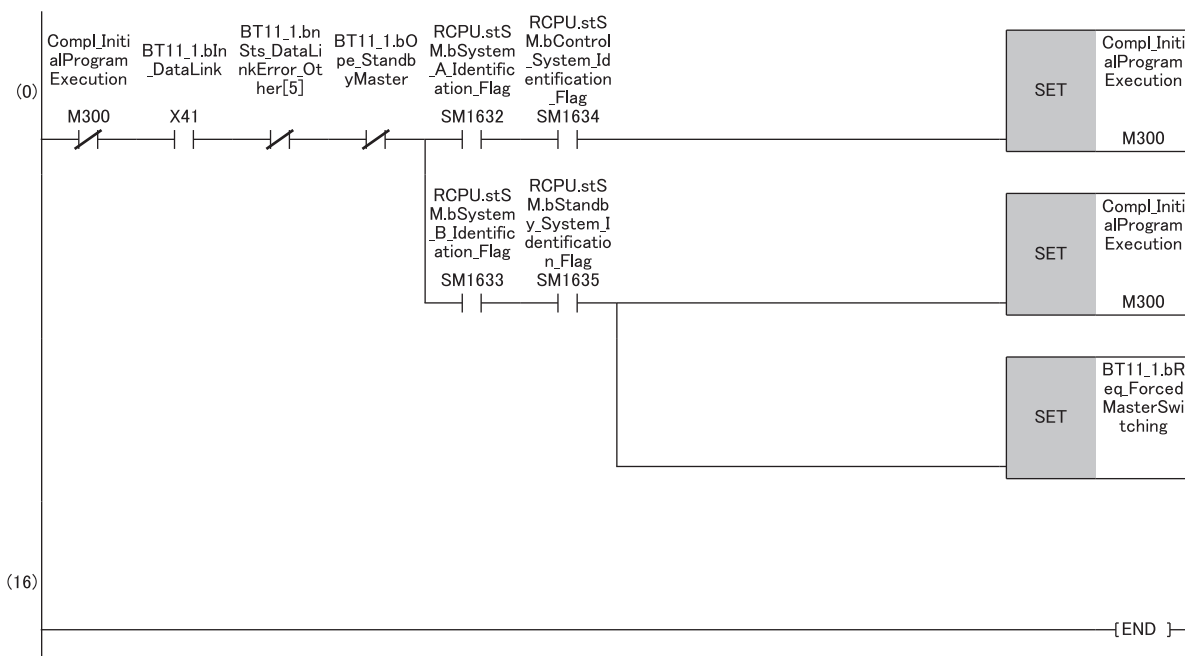

(0)Specify a bit corresponding to the station number of the standby master station for 'Data link status of other stations' (SB0080). (The program example above shows when the standby master station is station number 5.)

Appendix 9 Mounting the Module with a Remote Head Module

This chapter describes the restrictions, precautions, and communication example for when mounting the master/local module with a remote head module.

Restrictions on functions and specifications

Function

■Cyclic transmission

Function	Restrictions
Sequence scan synchronization specification	This function cannot be used.

■Transient transmission

Function	Restrictions
Dedicated instruction	This function cannot be used.

■Diagnostics

Function	Restrictions
CC-Link diagnostics	When the device data of the master station on CC-Link IE Field Network are transferred to the link special relay (SB) and link special register (SW) of the master/local module by data transfer between devices of the remote head module, the following functions cannot be used. <ul style="list-style-type: none">• Stopping and restarting data link• Line test• Checking the transmission speed setting• Temporary error invalid station setting function• Status logging

■Others

Function	Restrictions
Interrupt setting function	This function cannot be used.

Module parameter

The device that can be set to the refresh target in "Link Refresh Settings" under "Basic Settings" differs from when connecting the module to the CPU module. (☞ Page 65 Link Refresh Settings)

A

Communication example

This section describes the communication example for when connecting the master/local module to a remote head module.

System configuration example

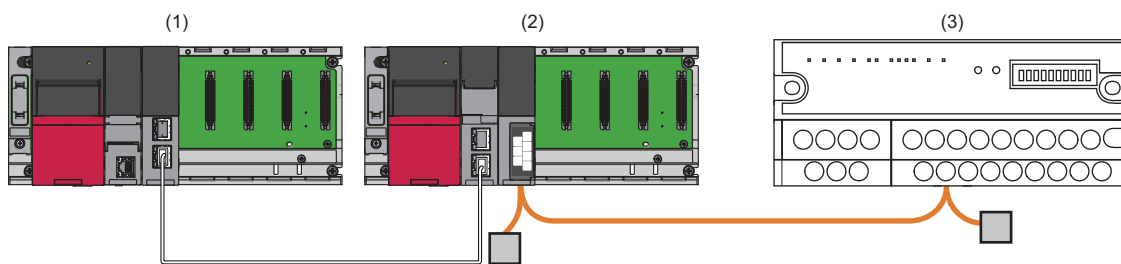

No.	Model	Network	Station type	Start I/O No.	Station No.	Number of occupied stations
(1)	R04CPU	—				
	RJ71GF11-T2	CC-Link IE Field Network	Master station	X/Y00 to X/Y1F	0	—
(2)	RJ72GF15-T2		Intelligent device station	—	1	—
	RJ61BT11	CC-Link	Master station	X/Y00 to X/Y1F	0	—
(3)	AJ65SBT-64AD		Remote device station	—	1	1

Link device assignment

This section describes the RX, RY, RWr, or RWw assignment of program examples.

Point

- Remote net Ver.1 mode is used in this program examples. When the remote net Ver.2 mode or remote device net Ver.2 mode is used, the buffer memory addresses of storage locations vary. For the modes, refer to the MELSEC iQ-R CC-Link System Master/Local Module User's Manual (Startup).
- For details on the signals of the RX/RX and RWr/RWw of the AJ65SBT-64AD, refer to the manual for the AJ65SBT-64AD.

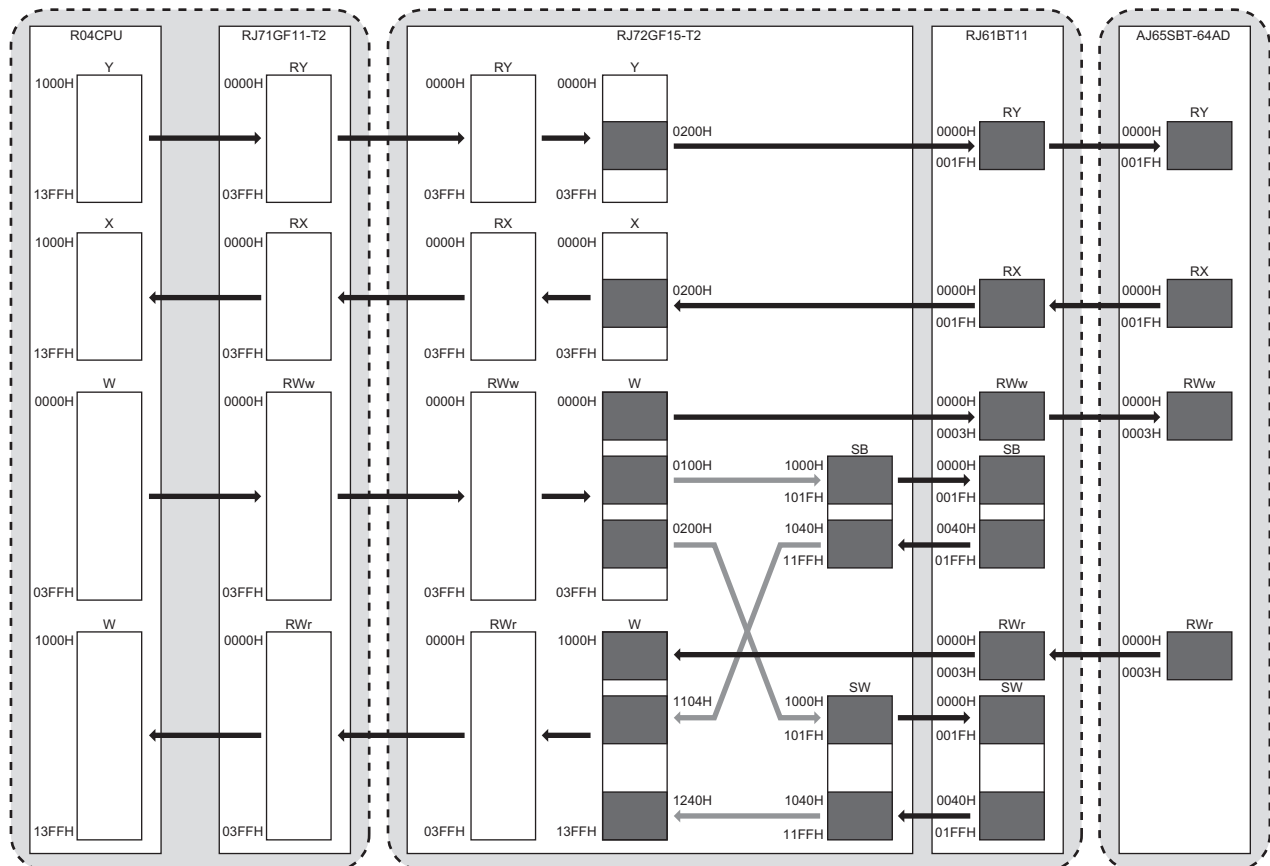

■RX/RX assignment

R04CPU	CC-Link IE Field Network			CC-Link					
	RJ71GF11-T2		RJ72GF15-T2		RJ61BT11		AJ65SBT-64AD		RX, RY
	Device	Buffer memory address Hexadecimal	Decimal	Station No.	Device	Buffer memory address Hexadecimal	Decimal	Station No.	
X1000 to X11FF	0H to 1FH	0 to 31	1	RX0 to RX1FF	X0 to X1FF	—	—	—	—
X1200 to X121F	20H to 21H	32 to 33		RX200 to RX21F	X200 to X21F	E0H to E1H	224 to 225	1	RX0 to RX1F
X1220 to X13FF	22H to 3FH	34 to 63		RX220 to RX3FF	X220 to X3FF	—	—	—	—
Y1000 to Y11FF	400H to 41FH	1024 to 1055		RY0 to RY1FF	Y0 to Y1FF	—	—	—	—
Y1200 to Y121F	420H to 421H	1056 to 1057		RY200 to RY21F	Y200 to Y21F	160H to 161H	352 to 353	1	RY0 to RY1F
Y1220 to Y13FF	422H to 43FH	1058 to 1087		RY220 to RY3FF	Y220 to Y3FF	—	—	—	—

■RWr/RWw assignment

R04CPU	CC-Link IE Field Network					CC-Link			
	RJ71GF11-T2		RJ72GF15-T2			RJ61BT11		AJ65SBT-64AD	
	Buffer memory address		Station No.	RWr, RWw	Device ^{*1}	Buffer memory address		Station No.	RWr, RWw or SB, SW
Hexadecimal	Decimal	Hexadecimal				Decimal			
W0 to W3	800H to 803H	2048 to 2051	1	RWw0 to RWw3	W0 to W3	1E0H to 1E3H	480 to 483	1	RWw0 to RWw3
W4 to WFF	804H to 8FFH	2052 to 2303		RWw4 to RWwFF	W4 to WFF	—	—	—	—
W100 to W101	900H to 901H	2304 to 2305		RWw100 to RWw101	W100 to W101 (SB1000 to SB101F)	—	—	—	SB0000 to SB001F
W102 to W1FF	902H to 9FFH	2306 to 2559		RWw102 to RWw1FF	W102 to W1FF	—	—	—	—
W200 to W21F	A00H to A1FH	2560 to 2591		RWw200 to RWw21F	W200 to W21F(SW1000 to SW101F)	—	—	—	SW0000 to SW001F
W220 to W3FF	A20H to BFFH	2592 to 3071		RWw220 to RWw3FF	W220 to W3FF	—	—	—	—
W1000 to W1003	2800H to 2803H	10240 to 10243		RWr0 to RWr3	W1000 to W1003	2E0H to 2E3H	736 to 739	1	RWr0 to RWr3
W1004 to W1103	2804H to 2903H	10244 to 10499		RWr4 to RWr103	W1004 to W1103	—	—	—	—
W1104 to W111F	2904H to 291FH	10500 to 10527		RWr104 to RWr11F	W1104 to W111F (SB1040 to SB11FF)	—	—	—	SB0040 to SB01FF
W1120 to W123F	2920H to 2A3FH	10528 to 10815		RWr120 to RWr23F	W1120 to W123F	—	—	—	—
W1240 to W13FF	2A40H to 2BFFH	10816 to 11263		RWr240 to RWr3FF	W1240 to W13FF (SW1040 to SW11FF)	—	—	—	SW0040 to SW01FF

*1 The SB and SW numbers indicates the devices set in the transfer setting between devices.

Setting in the master station on CC-Link IE Field Network

Connect the engineering tool to the CPU module of the master station on CC-Link IE Field Network and set parameters.

1. Set the CPU module as follows.

 [Project] ⇒ [New]

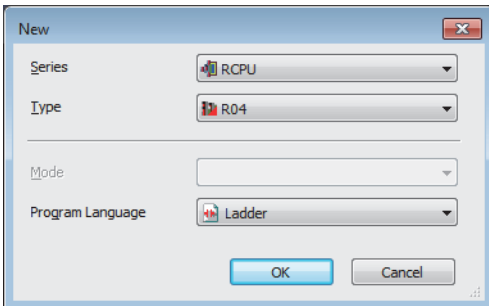

2. Click the [Setting Change] button and set the module label to [Use].

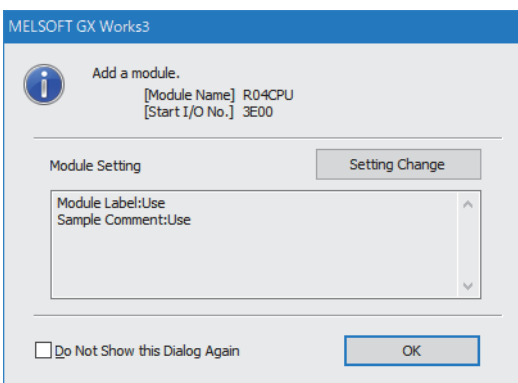

3. Set the CC-Link IE Field Network master/local module as follows.

 [Navigation window] ⇒ [Parameter] ⇒ [Module Information] ⇒ Right click ⇒ [Add New Module]

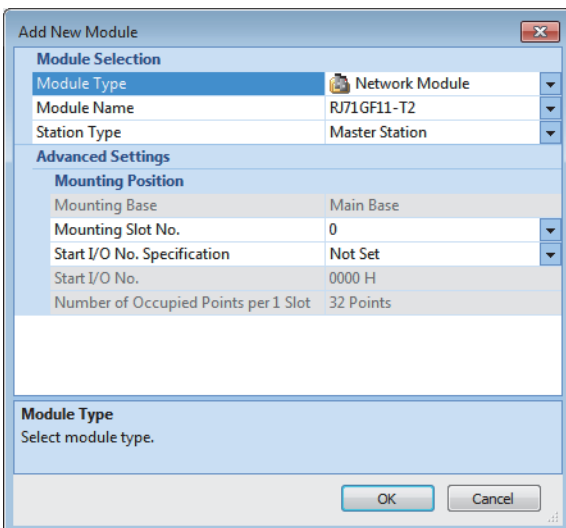

A

- Click the [OK] button to add the module labels of the CC-Link IE Field Network master/local module.

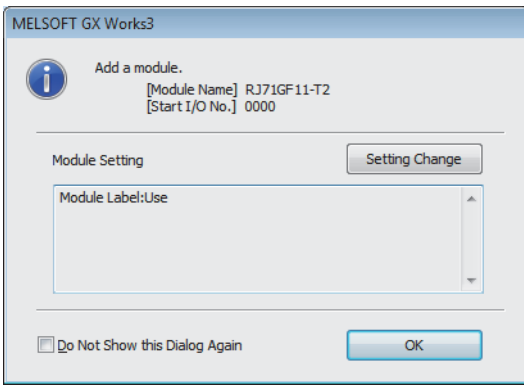

- Set the items in "Required Settings" of "Module Parameter" as follows.

[Navigation window] ⇒ [Parameter] ⇒ [Module Information] ⇒ [RJ71GF11-T2] ⇒ [Required settings]

Setting Item	Item	Setting
Station Type	Station Type	Master Station
	Network Number	1
Station Number	Setting Method	Parameter Editor
	Station No.	0
Parameter Setting Method	Setting Method of Basic/Application Settings	Parameter Editor

- Set the network configuration as follows.

[Navigation window] ⇒ [Parameter] ⇒ [Module Information] ⇒ [RJ71GF11-T2] ⇒ [Basic Settings] ⇒ [Network Configuration Settings]

No.	Model Name	STA#	Station Type	RX/Ry Setting			RWw/RWr Setting			Reserved/Error Invalid Station/System Switching Monitoring Target Station
				Points	Start	End	Points	Start	End	
0	Host Station	0	Master Station							
1	RJ72GF15-T2	1	Intelligent Device Station	1024	0000	03FF	1024	0000	03FF	No Setting

7. Set the refresh settings as follows.

 [Navigation window] ⇒ [Parameter] ⇒ [Module Information] ⇒ [RJ71GF11-T2] ⇒ [Basic Settings] ⇒ [Refresh Settings]

No.	Link Side						CPU Side				
	Device Name	Points	Start	End	Target		Device Name	Points	Start	End	
-	SB	512	00000	001FF		Module Label					
-	SW	512	00000	001FF		Module Label					
1	RX	1024	00000	003FF		Specify Device	X	1024	01000	013FF	
2	RY	1024	00000	003FF		Specify Device	Y	1024	01000	013FF	
3	RWw	1024	00000	003FF		Specify Device	W	1024	00000	003FF	
4	RWr	1024	00000	003FF		Specify Device	W	1024	01000	013FF	
5											

8. Write the set parameters to the CPU module of the master station on CC-Link IE Field Network. Then, reset the CPU module or power off and on the system.

 [Online] ⇒ [Write to PLC]

Point 

In this example, default values are used for parameters that are not shown above. For the parameters, refer to the following.

 MELSEC iQ-R CC-Link IE Field Network User's Manual (Application)

Setting in the intelligent device station on CC-Link IE Field Network

Connect the engineering tool to the remote head module of the intelligent device station on CC-Link IE Field Network and set the parameters.

1. Set the remote head module as follows.

[Project] ⇒ [New]

2. Set the items in "Network Required Setting" of "CPU Parameter" as follows.

[Navigation window] ⇒ [Parameter] ⇒ [RJ72GF15-T2] ⇒ [CPU Parameter] ⇒ [Network Required Setting]

Setting Item	
Item	Setting
Network Number	
Network Number	1
Station Number	
Station No.	1

3. Set the transfer setting between devices as follows.

[Navigation window] ⇒ [Parameter] ⇒ [RJ72GF15-T2] ⇒ [CPU Parameter] ⇒ [Network Application Setting] ⇒ [Transfer Setting between Devices]

No.	Source				Destination			
	Device Name	Points	Start	End	Device Name	Points	Start	End
1	W	2	00100	00101	SB	32	01000	0101F
2	W	32	00200	0021F	SW	32	01000	0101F
3	SB	448	01040	011FF	W	28	01104	0111F
4	SW	448	01040	011FF	W	448	01240	013FF
5								

4. Set the master/local module as follows.

[Navigation window] ⇒ [Parameter] ⇒ [Module Information] ⇒ Right click ⇒ [Add New Module]

5. Click the [OK] button.

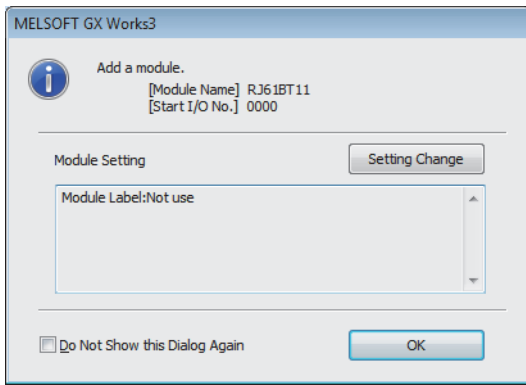

6. Set the items in "Required Settings" of "Module Parameter" as follows.

[Navigation window] ⇒ [Parameter] ⇒ [Module Information] ⇒ [RJ61BT11] ⇒ [Module Parameter] ⇒ [Required Settings]

Item	Setting
Station Type	
Station Type	Master Station
Mode	
Communication Mode	Remote Net Ver.1 Mode
Station Number	
Station No.	0
Transmission Speed	
Transmission Speed	156kbps
Parameter Setting Method	
Setting Method of Basic/Application Settings	Parameter Editor

7. Set the network configuration as follows.

[Navigation window] ⇒ [Parameter] ⇒ [Module Information] ⇒ [RJ61BT11] ⇒ [Basic Settings] ⇒ [Network Configuration Settings]

Station No.	Model Name	Station Type	Version	# of STA Occupied	Expanded Cyclic Setting	Remote Station Points	Reserved/Err Invalid STA	Intelligent Buffer Selection(word)			Station-specific mode setting
								Send	Receive	Auto	
0/0	Host Station	Master Station									
1/1	AJ65SBT-64AD	Remote Device Station	Ver.1	1 Occupied Sta	Single	32 Points	No Setting				

The network diagram shows a '自局' (Local) area with a 'STA#0 Master Station Ver.1 All Connected Count:1 Total STA#:1' and a 'STA#1' connected to it. The STA#1 is identified as 'AJ65SBT-64AD'.



8. Set the link refresh settings as follows.

[Navigation window] ⇒ [Parameter] ⇒ [Module Information] ⇒ [RJ61BT11] ⇒ [Basic Settings] ⇒ [Link Refresh Settings]

No.	Link Side						CPU Side				
	Device Name	Points	Start	End	Target		Device Name	Points	Start	End	
-	SB	512	00000	001FF	Specify Device	SB	512	01000	011FF		
-	SW	512	00000	001FF	Specify Device	SW	512	01000	011FF		
1	RX	32	00000	0001F	Specify Device	X	32	00200	0021F		
2	RY	32	00000	0001F	Specify Device	Y	32	00200	0021F		
3	RWw	4	00000	00003	Specify Device	W	4	00000	00003		
4	RWr	4	00000	00003	Specify Device	W	4	01000	01003		
5											

9. Set the target station number of the remote device initial setting as follows.

[Navigation window] ⇒ [Parameter] ⇒ [Module Information] ⇒ [RJ61BT11] ⇒ [Basic Settings] ⇒ [Initial Settings]

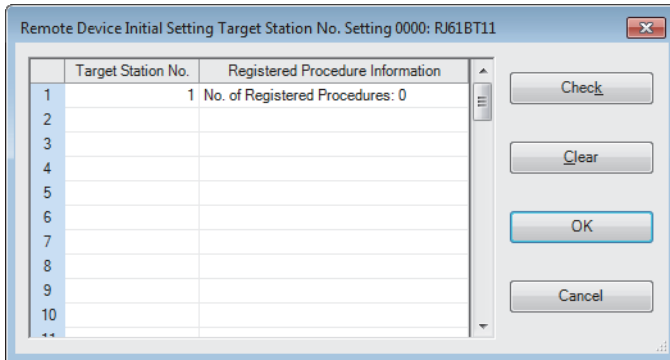

10. Double-click "No. of Registered Procedures" to open the "Remote Device Initial Setting Procedure Registration" window.

11. In "Remote Device Initial Setting Procedure Registration" window, right-click the icon and click "Hexadecimal" of the "Input Format". Set the items in the initial settings as follows.

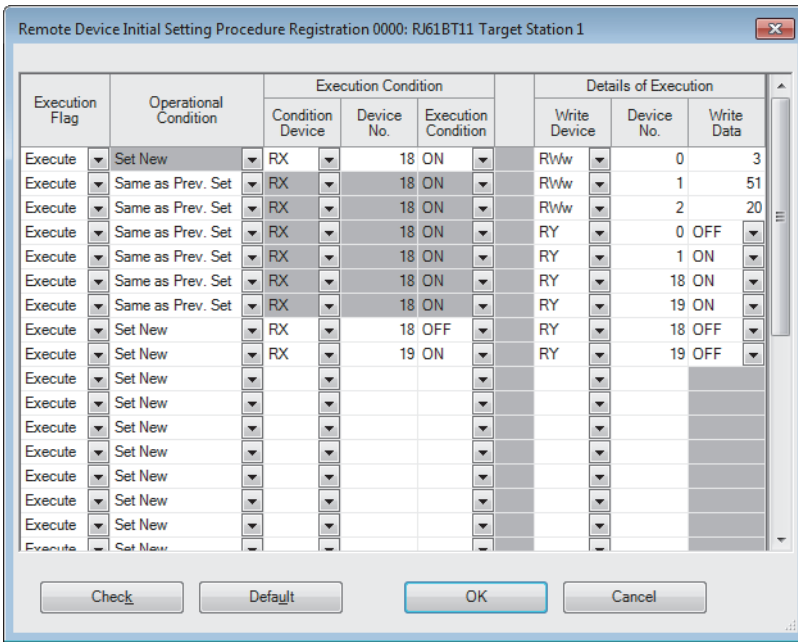

Setting the initial setting executes the following processing from the first condition.

Condition	Description
1st	The CH.1 and CH.2 are set to the A/D conversion enable.
2nd	An input range is set. • CH.1: 0 to 5V • CH.2: User range setting 1 (-10 to +10V)
3rd	The number of moving average processing counts is set. • CH.1: 4 times • CH.2: 16 times
4th	CH.1 A/D conversion method is set to the sampling processing.
5th	CH.2 A/D conversion method is set to the moving average processing.
6th	Initial data processing completion flag is turned on.
7th	Initial data setting request flag is turned on.
8th	Initial data processing completion flag is turned off.
9th	Initial data setting request flag is turned off.

12. Write the set parameters to the remote head module of the intelligent device station on CC-Link IE Field Network. Then, reset the remote head module or power the system off and on.

[Online] ⇄ [Write to PLC]

A

Point

In this example, default values are used for parameters that are not shown above. For the parameters, refer to the following.

- MELSEC iQ-R CC-Link IE Field Network Remote Head Module User's Manual (Application)
- Page 57 PARAMETER SETTINGS

Setting in the CC-Link remote device station

Set the station number and transmission speed using the switches on the remote device station as follows.

- Station number setting switch: Turning on only STATION NO.1 (station No.1)
- Transmission speed setting switch: All off (156kbps)

STATION NO.							B LATE		
40	20	10	8	4	2	1	4	2	1
OFF	OFF	OFF	OFF	OFF	OFF	ON	OFF	OFF	OFF

Checking the system status

After setting parameters, power on the system in order of the CC-Link remote device station, remote head module, and CPU module, and check the data link status of each network.

■Checking CC-Link IE Field Network

1. Connect the engineering tool to the CPU module on the master station.
2. Start the CC-Link IE Field Network diagnostics.

 [Diagnostics] ⇒ [CC-Link IE Field Diagnostics]

For information on the CC-Link IE Field Network diagnostics from the master station, refer to the following.

 MELSEC iQ-R CC-Link IE Field Network User's Manual (Application)

■Checking CC-Link

When the LEDs are in the following states, data link is being performed normally.

- Remote head module

LED	Status
RUN	On
ERR	Off
BUS RUN	On ^{*1}
CTRL	Off
SBY	Off
D LINK	On
SD/RD	On
L ERR	Off

*1 When the remote head module is in the STOP state, the LED turns off.

- Master/local module

LED	Status
RUN	On
ERR.	Off
MST	On
S MST	Off
156K	On
625K	Off
2.5M	
5M	
10M	
L RUN	On
L ERR.	Off
SD	Flashing ^{*2}
RD	

*2 The LEDs may look dimly lit or off depending on the communication status.

- AJ65SBT-64AD

LED	Status
PW	On
RUN	On
L RUN	On
L ERR.	Off

Program example

This program uses the module labels of the CC-Link IE Field Network master/local module.

Write the program to the CPU module on the master station.

Classification	Label name	Description	Device
Module label	GF11_1.bSts_DataLinkError	Data link error status of own station	SB0049
	GF11_1.bnSts_DataLinkError_Station[1]	Data link status of each station (station No.1)	SW00B0.0

Label Name	Data Type	Class	Assign (Device/Label)
bStartDirection_1	Bit	VAR_GLOBAL	M1
bSts_64AD_DataLink	Bit	VAR_GLOBAL	M10
bChangeInitialSetting	Bit	VAR_GLOBAL	M100
b64AD_DataLinkError	Bit	VAR_GLOBAL	M110
bCH1_RangeError	Bit	VAR_GLOBAL	M111
bCH2_RangeError	Bit	VAR_GLOBAL	M112
bCH3_RangeError	Bit	VAR_GLOBAL	M113
bCH4_RangeError	Bit	VAR_GLOBAL	M114
bEEPROM_WriteError	Bit	VAR_GLOBAL	M115
bErrorReset	Bit	VAR_GLOBAL	M120
bStartDirection_2	Bit	VAR_GLOBAL	M200
bCCL_UnitError	Bit	VAR_GLOBAL	X1000
bCCL_DataLink	Bit	VAR_GLOBAL	X1001
bCCL_UnitReady	Bit	VAR_GLOBAL	X100F
bCH1_AD_ConversionComp	Bit	VAR_GLOBAL	X1200
bCH2_AD_ConversionComp	Bit	VAR_GLOBAL	X1201
bCH1_RangeErrorFlag	Bit	VAR_GLOBAL	X1204
bCH2_RangeErrorFlag	Bit	VAR_GLOBAL	X1205
bCH3_RangeErrorFlag	Bit	VAR_GLOBAL	X1206
bCH4_RangeErrorFlag	Bit	VAR_GLOBAL	X1207
bEEPROM_WriteErrorFlag	Bit	VAR_GLOBAL	X120C
bInitialDataProcReqFlag	Bit	VAR_GLOBAL	X1218
bInitialDataSetCompFlag	Bit	VAR_GLOBAL	X1219
bErrorStsFlag	Bit	VAR_GLOBAL	X121A
bRemoteReady	Bit	VAR_GLOBAL	X121B
bCH1_MovingAveSpecifying	Bit	VAR_GLOBAL	Y1200
bCH2_MovingAveSpecifying	Bit	VAR_GLOBAL	Y1201
bInitialDataSetReqFlag	Bit	VAR_GLOBAL	Y1219
bErrorResetReqFlag	Bit	VAR_GLOBAL	Y121A
bReqInitialization	Bit	VAR_GLOBAL	W100.D
bCompInitialization	Bit	VAR_GLOBAL	W1105.F
wCH1_Value	Word [Signed]	VAR_GLOBAL	D0
wCH2_Value	Word [Signed]	VAR_GLOBAL	D1
wAD_Conv_EnableProhibit	Word [Unsigned]/Bit String [16-bit]	VAR_GLOBAL	W0
wInputRange	Word [Unsigned]/Bit String [16-bit]	VAR_GLOBAL	W1
wMovingAveCountSetting	Word [Unsigned]/Bit String [16-bit]	VAR_GLOBAL	W2
wCH1_DigitalOutputVal	Word [Signed]	VAR_GLOBAL	W1000
wCH2_DigitalOutputVal	Word [Signed]	VAR_GLOBAL	W1001
w64AD_DataLink	Word [Unsigned]/Bit String [16-bit]	VAR_GLOBAL	W1280

(0)	GF11_1.bSts_DataLinkError	GF11_1.bnSts_DataLinkError_Station[1]				MC	N1	bStartDirection_1 M1
bStartDirection_1 N1 — M1								
(6)	bCCL_UnitError X1000	bCCL_UnitReading X100F	bCCL_DataLink X1001			MOV	w64AD_DataLink W1280	K1M10
bSts_64AD_DataLink M10								
bSts_64AD_DataLink M10								
bStartDirection_2 N0 — M200								
(44)	bCompInitialization W1105.F					RST	bReqInitialization W100.D	
(46)	bInitialDataProcReqFlag X1218					SET	bReqInitialization W100.D	
(48)	bChangeInitialSetting M100					MOVP	H3 wAD_Conv_EnableProhibit W0	
MOVP								
MOVP								
RST								
SET								
SET								

(159)	bInitialData SetCompFlag X1219 						RST	bInitialDataSetReqFlag Y1219	
(161)	bRemoteReady X121B 	bCH1_AD_ConversionComp X1200 					MOV	wCH1_DigitalOutputVal W1000	wCH1_Value D0
		bCH2_AD_ConversionComp X1201 					MOV	wCH2_DigitalOutputVal W1001	wCH2_Value D1
(220)	bErrorStsFlag X121A 	bCH1_RangeErrorFlag X1204 						bCH1_RangeError M111 ○	
		bCH2_RangeErrorFlag X1205 						bCH2_RangeError M112 ○	
		bCH3_RangeErrorFlag X1206 						bCH3_RangeError M113 ○	
		bCH4_RangeErrorFlag X1207 						bCH4_RangeError M114 ○	
		bEEPROM_WriteErrorFlag X120C 						bEEPROM_WriteError M115 ○	
		bErrorReset M120 					SET	bErrorResetReqFlag Y121A	
(326)	bErrorResetReqFlag Y121A 	bErrorStsFlag X121A /					RST	bErrorResetReqFlag Y121A	
(344)							MCR	N0	
(345)							MCR	N1	
(346)								[END]	

- (0) Check the data link status of CC-Link IE Field Network.
- (6) Check the data link status of CC-Link.
- (44), (46) Perform the CC-Link remote device station initial setting.
- (48), (159) Change the CC-Link remote device station initial setting.
- (161) Read the digital output value.
- (220), (326) Perform the processing when an error occurs.

Appendix 10 Using the Module in the Redundant System with Redundant Extension Base Unit

This chapter describes restrictions and precautions for using the master/local module that is mounted on the extension base unit in the redundant system.

Restrictions on functions and specifications

Function

Function	Restriction
Interrupt setting function	This function cannot be used.

Dedicated instructions

Any dedicated instructions of the master/local modules cannot be used.

To execute those dedicated instructions, mount the modules on the main base unit.

Module FBs

Any module FBs of the master/local modules cannot be used.

Module parameters

■Required Settings

- Set "Station Type" to "Master Station".
- Set "Setting Method of Basic/Application Settings" to "Parameter Editor" in "Parameter Setting Method".

■Application Settings

- Do not set "Interrupt Settings".

Precautions

- If the system switching occurs while the module is received the dedicated instruction or accessed from another station, a communication timeout may occur. Retry the operation as necessary.

Appendix 11 Added and Enhanced Functions

The following table lists the added and enhanced functions in the master/local module.

Added and enhanced function	Firmware version
<ul style="list-style-type: none">• Communications in a redundant system using the standby master function*1• Redundant system of the remote head module	"04" or later
<ul style="list-style-type: none">• Automatic detection of connected device• iQ Sensor Solution data backup/restoration function	Refer to the following.  iQ Sensor Solution Reference Manual
Extension base unit in a redundant system with redundant extension base unit*1	"07" or later

*1 There are restrictions on the CPU module to be used. For details, refer to the following.

 MELSEC iQ-R CPU Module User's Manual (Application)

INDEX

0 to 9

32-bit data integrity assurance 32

A

A faulty station cannot be detected 125
Automatic update buffer 153
Auto-tracking setting of transmission speed 61

C

CC-Link diagnostics 103
CC-Link Ver. installation/parameter matching
status 170
Checking the transmission speed setting 111
Compatible CC-Link Ver. information 169
Completion status of remote device station
initialization procedure 158
Control system 15
CPU monitoring time setting 163
Current link scan time 166
Cyclic transmission 15

D

Data link restart 156
Data link restart acceptance 157
Data link restart completion 157
Data link restart result 163
Data link setting at CPU failure 37,159
Data link status of other stations 160,167
Data link stop 156
Data link stop acceptance 157
Data link stop completion 157
Data link stop result 163
Detailed LED display status 164

E

Error codes 126
Error invalid station specification status 159,166
Execution status of remote device station
initialization procedure 158
Extended cyclic setting 62

F

Forced master switching 157
Forced master switching instruction result 165
Forced master switching request acceptance 158
Forced master switching request completion 158
Functions 18
Fuse blown status of other stations 160

I

Input data from data link faulty station 37
Input data status of own data link faulty station 158
Installation status 166
Installation/parameter matching status 169
Intelligent device station 15

Intelligent function module 15

L

Line status of own station 160
Line test 109
Line test 1 result 169
Line test 2 result 169
Line test acceptance status 158
Line test completion status 158
Line test request 157
Line test result 163
Line test station setting 162
Link special register (SW) 152,162
Link special relay (SB) 152,156
Local station 15

M

Master station 15
Master station information 159
Master station return specification information 159
Master stations transient transmission status 160
Master switching request acceptance 158
Master switching request completion 158
Master/local module 17
Master/standby master operation status of own
station 160
Maximum communication station number 166
Maximum link scan time 166
Minimum link scan time 166
Mode of own station 158
Mode setting status 165
Module operating status 165
Module status 157,163
Monitoring time setting 163
Multiple temporary error invalid station
specification 162

N

New control system 15
New standby system 15
Number of automatic return stations 165
Number of connected modules 166
Number of occupied stations 62
Number of own station occupied stations 159
Number of retries information 165

O

Offline test status 158
Operation status of own station 159

P

Parameter information 165
Parameter receive status 159
Parameter setting status 159
Parameter status of own station 165
Process CPU 17

R

Random access buffer	152
RDMSG	17,172
Redundant function module	15
Redundant system	15
Refresh instruction acceptance status at standby master switching	157
Refresh instruction at standby master switching	156
Refresh instruction at standby master switching result	163
Refresh instruction completion status at standby master switching	157
Refresh instruction when changing parameters by the dedicated instruction	156
Remote device net mode	17
Remote device net Ver.1 mode	15,25
Remote device net Ver.2 mode	15,27
Remote device station	15
Remote device station initialization procedure registration execution individual information	155
Remote device station initialization procedure registration instruction	157
Remote head module	17,193
Remote I/O net mode	15,29
Remote I/O station	15
Remote net mode	15
Remote net Ver.1 mode	16,21
Remote net Ver.2 mode	16,23
Remote station	17
Reserved station specification status	159,166
Reserved/err invalid STA	64
RIFR	17,172
RIRCV	17,172
RIRD	17,172
RISEND	17,172
RITO	17,172
RIWT	17,172
RLPASET	17,172
RWr	17
RWw	17
RX	17
RY	17

S

SB	17,156
Scan mode setting information	159
Setting status of block guarantee of cyclic data per station	159
Slave station offset, size information	150
Standby master station information	159
Standby master station number	166
Standby master station setting status of own station	158
Standby system	16
Station number of own station	165
Station number overlap status	168
Station-based block data assurance	32
Status difference between a master station and a slave station at an error	38
Status logging	111
SW	17,162
Switch change status of other stations	160,168
System switching	16

T

Temporary error invalid acceptance status	157
Temporary error invalid cancel acceptance status	157
Temporary error invalid cancel completion status	158
Temporary error invalid cancel request	156
Temporary error invalid completion status	157
Temporary error invalid request	156
Temporary error invalid station setting information	159
Temporary error invalid station specification	162
Temporary error invalid station specification cancel result	163
Temporary error invalid station specification result	163
Temporary error invalid status	167
Total number of stations	166
Tracking cable	16
Transient transmission	16
Transient transmission status	160,168
Transmission speed setting	164
Transmission speed test acceptance status	161
Transmission speed test completion status	161
Transmission speed test request	157
Transmission speed test result	171
Transmission speed test result of each station	171
Transmission speed test result of standby master station	160
Type of own station	158

V

Ver.1-compatible slave station	16
Ver.2-compatible remote input (RX)	153
Ver.2-compatible remote output (RY)	153
Ver.2-compatible remote register (RWr)	154
Ver.2-compatible remote register (RWw)	154
Ver.2-compatible slave station	16

W

Watchdog timer error occurrence status of other stations	167
Watchdog timer error status of other stations	160

REVISIONS

*The manual number is given on the bottom left of the back cover.

Revision date	*Manual number	Description
June 2014	SH(NA)-081270ENG-A	First edition
April 2015	SH(NA)-081270ENG-B	■Added or modified parts TERMS, Section 1.3, 3.3, 4.1, 4.3, 4.5, 4.6, Appendix 6
May 2016	SH(NA)-081270ENG-C	■Added function Redundant system using the standby master function ■Added or modified parts RELEVANT MANUALS, TERMS, Section 1.1, 2.2, 2.3, 2.4, 3.2, 3.3, 4.3, 4.5, 4.6, Appendix 7, 8, 9
August 2016	SH(NA)-081270ENG-D	Error correction
April 2018	SH(NA)-081270ENG-E	■Added functions Automatic detection of connected device, iQ Sensor Solution data backup/restoration function ■Added or modified parts SAFETY PRECAUTIONS, RELEVANT MANUALS, Section 1.2, 2.1, 3.1, 3.2, 3.3, 4.4, 4.6, Appendix 5, 6, 7, 8, 9, 10
October 2020	SH(NA)-081270ENG-F	■Added function Extension base unit in the redundant system configuration ■Added or modified parts SAFETY PRECAUTIONS, CONDITIONS OF USE FOR THE PRODUCT, RELEVANT MANUALS, TERMS, GENERIC TERMS AND ABBREVIATIONS, Section 2.2, 2.4, 4.3, 4.6, Appendix 8, 9, 10
March 2021	SH(NA)-081270ENG-G	■Added or modified parts SAFETY PRECAUTIONS, CONDITIONS OF USE FOR THE PRODUCT
December 2022	SH(NA)-081270ENG-H	■Added or modified parts SAFETY PRECAUTIONS, TERMS, Section 2.3, Appendix 1, 8, COPYRIGHTS

Japanese manual number: SH-081268-G

This manual confers no industrial property rights or any rights of any other kind, nor does it confer any patent licenses. Mitsubishi Electric Corporation cannot be held responsible for any problems involving industrial property rights which may occur as a result of using the contents noted in this manual.

© 2014 MITSUBISHI ELECTRIC CORPORATION

WARRANTY

Please confirm the following product warranty details before using this product.

1. Gratis Warranty Term and Gratis Warranty Range

If any faults or defects (hereinafter "Failure") found to be the responsibility of Mitsubishi occurs during use of the product within the gratis warranty term, the product shall be repaired at no cost via the sales representative or Mitsubishi Service Company.

However, if repairs are required onsite at domestic or overseas location, expenses to send an engineer will be solely at the customer's discretion. Mitsubishi shall not be held responsible for any re-commissioning, maintenance, or testing on-site that involves replacement of the failed module.

[Gratis Warranty Term]

The gratis warranty term of the product shall be for one year after the date of purchase or delivery to a designated place. Note that after manufacture and shipment from Mitsubishi, the maximum distribution period shall be six (6) months, and the longest gratis warranty term after manufacturing shall be eighteen (18) months. The gratis warranty term of repair parts shall not exceed the gratis warranty term before repairs.

[Gratis Warranty Range]

- (1) The range shall be limited to normal use within the usage state, usage methods and usage environment, etc., which follow the conditions and precautions, etc., given in the instruction manual, user's manual and caution labels on the product.
- (2) Even within the gratis warranty term, repairs shall be charged for in the following cases.
 1. Failure occurring from inappropriate storage or handling, carelessness or negligence by the user. Failure caused by the user's hardware or software design.
 2. Failure caused by unapproved modifications, etc., to the product by the user.
 3. When the Mitsubishi product is assembled into a user's device, Failure that could have been avoided if functions or structures, judged as necessary in the legal safety measures the user's device is subject to or as necessary by industry standards, had been provided.
 4. Failure that could have been avoided if consumable parts (battery, backlight, fuse, etc.) designated in the instruction manual had been correctly serviced or replaced.
 5. Failure caused by external irresistible forces such as fires or abnormal voltages, and Failure caused by force majeure such as earthquakes, lightning, wind and water damage.
 6. Failure caused by reasons unpredictable by scientific technology standards at time of shipment from Mitsubishi.
 7. Any other failure found not to be the responsibility of Mitsubishi or that admitted not to be so by the user.

2. Onerous repair term after discontinuation of production

- (1) Mitsubishi shall accept onerous product repairs for seven (7) years after production of the product is discontinued. Discontinuation of production shall be notified with Mitsubishi Technical Bulletins, etc.
- (2) Product supply (including repair parts) is not available after production is discontinued.

3. Overseas service

Overseas, repairs shall be accepted by Mitsubishi's local overseas FA Center. Note that the repair conditions at each FA Center may differ.

4. Exclusion of loss in opportunity and secondary loss from warranty liability

Regardless of the gratis warranty term, Mitsubishi shall not be liable for compensation to:

- (1) Damages caused by any cause found not to be the responsibility of Mitsubishi.
- (2) Loss in opportunity, lost profits incurred to the user by Failures of Mitsubishi products.
- (3) Special damages and secondary damages whether foreseeable or not, compensation for accidents, and compensation for damages to products other than Mitsubishi products.
- (4) Replacement by the user, maintenance of on-site equipment, start-up test run and other tasks.

5. Changes in product specifications

The specifications given in the catalogs, manuals or technical documents are subject to change without prior notice.

TRADEMARKS

The company names, system names and product names mentioned in this manual are either registered trademarks or trademarks of their respective companies.

In some cases, trademark symbols such as [™] or [®] are not specified in this manual.

This Product uses the Source Code of μ T-Kernel under μ T-License granted by the T-Engine Forum (www.t-engine.org).

COPYRIGHTS

This Product uses the Source Code of μ T-Kernel under μ T-License granted by the T-Engine Forum (www.t-engine.org).

SH(NA)-081270ENG-H(2212)MEE

MODEL: RJ61BT11-U-OU-E

MODEL CODE: 13JX19

MITSUBISHI ELECTRIC CORPORATION

HEAD OFFICE: TOKYO BLDG., 2-7-3, MARUNOUCHI, CHIYODA-KU, TOKYO 100-8310, JAPAN
NAGOYA WORKS: 1-14, YADA-MINAMI 5-CHOME, HIGASHI-KU, NAGOYA 461-8670, JAPAN

When exported from Japan, this manual does not require application to the
Ministry of Economy, Trade and Industry for service transaction permission.

Specifications subject to change without notice.