

Model QE83WH4W

User's Manual (Hardware)

Before using this module, please read both the manual and Details carefully and pay full attention to safety to handle this module correctly.
Make sure that the end users read this manual and then keep the manual in a safe place for future reference.

ABOUT MANUALS

The following manuals are also related to this module.
Order each manual as needed, referring to the following list.

Manual name	Manual number(model code)
Energy Measuring Module User's Manual (Details) QE83WH4W	IB63722(19H466)

COMPLIANCE WITH THE EMC AND LOW VOLTAGE DIRECTIVES

(1) For programmable controller system
To configure a system meeting the requirements of the EMC and Low Voltage Directives when incorporating the Mitsubishi programmable controller (EMC and Low Voltage Directives compliant) into other machinery or equipment, refer to Chapter 9 "EMC AND LOW VOLTAGE DIRECTIVES" of the CPU's User's Manual (Hardware Design, Maintenance and Inspection).
The CE mark, indicating compliance with the EMC and Low Voltage Directives, is printed on the rating plate of the programmable controller.

(2) For this module
For the compliance of this module with the EMC and Low Voltage Directives, refer to Section 6.1 Wiring.

1. Features

- (1) This Energy Measuring Module can measure three channels of various types of electric quantity.
It can measure three channels of electric energy, reactive energy, current, voltage, electric power, reactive power, apparent power, power factor, and frequency.
Both consumption and regeneration of the electric energy can be measured.
- (2) Extensive monitoring functions
In addition to memorizing the maximum and minimum values, two types of alarm monitoring for upper and lower limit can be performed for each channel.
- (3) It also can measure the electric energy for a certain period.
It can measure the electric energy for the duration of time for which the output device is on.
- (4) Equipped with the current measuring mode where eight channels of current can be measured.
By selecting the current measuring mode using the intelligent function module switch, you can measure only the current through eight channels.

Note that the input/output signals and buffer memory to be used in the current measuring mode are different from those used in the regular operation mode. For details, refer to "User's Manual (Details)".

2. Checking packaged contents

The following items for this device are included in the package. Check that no items are missing.

- Energy Measuring Module x 1
- Voltage input terminal block x 1
- User's Manual (Hardware) x 1

3. Safety Precautions

3.1 Precautions for Operating Environment and Conditions

- Do not use this product in the places listed below. Failure to follow the instruction may cause malfunctions and a life decrease of product.
 - Places the Ambient temperature exceeds the range 0 ~ 55°C.
 - Places the Relative humidity exceeds the range 5 ~ 95% or places with dewfall.
 - Altitude exceeds 2000 m.
 - Places exposed to rain or water drip.
 - Dust, corrosive gas, saline and oil smoke exist.
 - Vibration and impact exceed the specifications.
 - Installed excluding the control panel.

6. How to wire

6.1 Wiring

Follow the wiring diagram for external connection of QE83WH4W.
Current sensor (EMU-CT590CT100CT250CT400CT600, EMU2-CT5-4W) is necessary for the connection of the current circuit.
Voltage transform unit (QE83WH4VT) is necessary for the connection of the voltage circuit. In addition, up to five QE83WH4W modules can be connected to one voltage transform unit.
Please refer to the User's Manual (Details) of this module, and the installation method and the detailed specifications of the current sensor and the voltage transform unit.

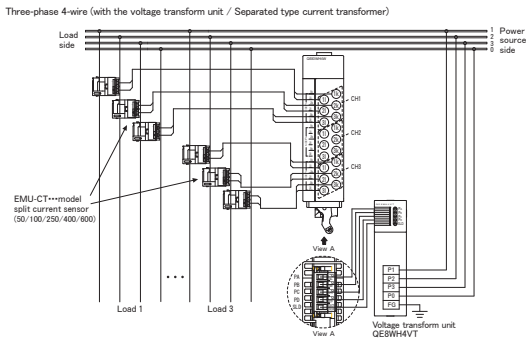

3.2 Matters concerning the preparation before use

- Use the module in the specified usage environment and conditions.
- The setting of this module (primary voltage, primary current, necessary before using it.
- Please refer to "User's Manual (Details)" about each setting method.

3.3 Installation and Wiring Precautions

- Danger**
 - Shut off the external power supply for the module in all phases before installing or wiring. Failure to do so may cause an electric shock or damage of the module.
- Any person who is involved in the installation and the wiring of this Sequencer should be fully competent to do the work. The programmable controller in an environment that meets the general specifications in the User's Manual for the CPU module used. Failure to do so may result in electric shock, fire, malfunction, or damage to or deterioration of the module.
- To mount the module, while pressing the module-mounting lever located in the lower part of the module, fully insert the module fixing projection(s) into the hole(s) in the base unit and press the module unit. Snaps into place. Incorrect mounting may cause malfunction, failure or break of the module.
- When using the Sequencer in an environment of frequent vibrations, fix the module with a screw.
- Tighten the screw within the specified torque range. Under tightening can cause drop of the screw, short circuit or malfunction. Over tightening can damage the screw and/or module, resulting in drop, short circuit, or malfunction.
- Shut off the external power supply for the system in all phases before mounting or removing the module. Failure to do so may result in damage to the product.
- Do not directly touch any conductive part of the module. Doing so can cause malfunction or failure of the module.
- R3 terminal must be grounded according to the D-type ground (Type 3) dedicated for sequencer. Failure to do so may result in an electric shock or a malfunction.
- When using this product, make sure to use it in combination with current sensor (EMU-CT series or EMU2-CT5-4W). Please note to exceed the rating of this product for output of current sensor. For further details, please refer to current sensor manual to maintain the functionality and the accuracy of this product.
- The dedicated current sensor (EMU-CT590CT100CT250CT400CT600) is used only for low voltage circuit. It cannot be used with a high voltage circuit. Also, EMU2-CT5-4W should be used with the secondary side (S) A of transformer loadtest. If it is connected with a high-voltage circuit by mistake, it may cause a burnout of the device and a fire. It is critically dangerous.
- Measurement circuit voltage cannot be input directly into the module. Please enter the output voltage of the voltage transform unit (QE83WH4VT).
- The dedicated current sensor has a polarity (directionality). Be careful about it when installing the module.
- Take care not entering any foreign objects such as ships and wires pieces into the module. It may cause a fire, a failure or a malfunction.
- In order to prevent the module from incoming foreign objects such as wires pieces during wiring work, a foreign-object preventive label is placed on the module. While a wiring work is performed, keep the label on the module. Before operating the system, peel off the label for heat release. If the foreign-object preventive label is not peeled and the system is in use, residual heat inside the module may reduce the product life.
- The wires to be connected to the module shall be placed in a duct or fixed together by clamping. If the electric wires are not placed in the duct or clamped together, loosen wires or their movement or careless stretch may cause a breakage of the module or wire or a malfunction due to poor contact of electric wires.
- Use appropriate size of electric wires. If inappropriate size of electric wire is used, it may cause a fire due to generated heat.
- Use the applicable solderless terminals (R1.25-3) for current input terminals. If inappropriate solderless terminal is used, a wire breakage or a contact failure may occur, which may cause a device malfunction, a failure, a burnout, or a fire.
- When using stranded wires for the voltage input terminals, strand the wire edges to prevent thin wires from loosening.
- After inserting the electric wire or a solderless terminal, make sure that no missing insertion is existing. Missing insertion may cause a device malfunction, a fire, or an electric shock.
- If the wires connected to the module are strongly pulled off, it may cause a malfunction or a breakage to the module or the wire.
- Ensure the wiring to the module properly, checking the rated voltage and current of the product and the terminal pin assignment. If the input voltage exceed the rated voltage or the wiring is improper, it may cause a fire or a breakage. (Tensile load: 22N ± 2N)
- Do not exceed the specified voltage when doing an insulation resistance test and a commercial frequency withstand voltage test.
- To protect persons who do not have adequate knowledge of electric equipment from electric shocks, any of the following measures should be taken for the panel.
 - (a) To lock the panel so that only trained persons having adequate knowledge of electric equipment can open it.
 - (b) To design the structure so that the power is automatically interrupted upon opening of the panel.
- The protection class of the panel should be IP2X or higher.

Caution

- (1)LED Operating status of this module is displayed.
- (2)Current input terminals Connect the current wire of the measuring circuit with the secondary output of the dedicated current sensor.
- (3)Voltage input terminals Connect the voltage input wire of the measuring circuit.

3.4 Precautions for Start-up and Maintenance

- Use the product within the ratings specified in this manual. If it is used outside the ratings, it may cause not only malfunction or failure but also fire or burnout.
- Before operating the product, check that active bare wire, etc. does not exist around the product. If any bare wire is found, stop the operation immediately, and take an appropriate action such as isolation protection.
- Do not disassemble or modify the module. It may cause failure, malfunction, injury or fire.
- Attaching and detaching the module must be performed after the power source is shut off for all outside phases. If all phases are not shut off, it may cause electric shock, failure or malfunction of the module.
- Do not touch powered wires. It may cause malfunction.
- Tighten mounting screws and cleaning module must be performed after the power source is shut off for all outside phases. If all phases are not shut off, it may cause electric shock, failure or malfunction of the module.
- Use a soft dry cloth to clean off dirt of the module surface.
- Do not let a chemical cloth remain on the surface for an extended period of time nor wipe the surface with thinner or benzene.
- Check for the following items to use this module properly for long time.
 - Daily maintenance
 - (1) No damage on this module (2) No abnormality with LED indicators (3) No abnormal noise, smell or heat.
 - Periodical maintenance (Once every 6 months to 1 year)
 - (4) No looseness with installation, wire connection to terminal blocks, and connector connection. (Check these items under the electric outage condition.)

3.5 Disposal Precautions

- When disposing of this module, treat it as industrial waste.

4. Name and function of each part

4.1 Names and functions of parts of QE83WH4W are provided below.

Names of signals of terminal block	
Terminal symbol	Name of terminal
CH1	1k 1-phase current input terminal (power source side)
	2k 2-phase current input terminal (power source side)
	3k 3-phase current input terminal (load side)
CH2	1k 1-phase current input terminal (power source side)
	2k 2-phase current input terminal (power source side)
	3k 3-phase current input terminal (load side)
CH3	1k 1-phase current input terminal (power source side)
	2k 2-phase current input terminal (power source side)
	3k 3-phase current input terminal (load side)
PA, PB, PC, PD	Terminal for connecting the secondary terminal block of the voltage transform unit
SLD	Shield connection terminal

4.2 Names and functions of LEDs

The following describes names and functions of LEDs.

Name	Color	Role	Indicator condition
0 LED	Green	Displays the operation status of this module.	ON: Normal operation OFF: Internal power shut-off, hardware error *1
1 LED	Green	Displays CH1 measurement status of this module.	ON: Measuring electric energy (consumption) Flashing: Measuring electric energy (regeneration)
2 LED	Green	Displays CH2 measurement status of this module.	ON: Measuring electric energy (consumption) Flashing: Measuring electric energy (regeneration)
3 LED	Green	Displays CH3 measurement status of this module.	ON: Measuring electric energy (consumption) Flashing: Measuring electric energy (regeneration)
4 LED	Green	Displays CH1 1-side measurement status (regeneration) of this module.	ON: Measuring electric energy (regeneration) on side 1 OFF: Other than the above
5 LED	Green	Displays CH2 1-side measurement status (regeneration) of this module.	ON: Measuring electric energy (regeneration) on side 1 OFF: Other than the above
6 LED	Green	Displays CH3 1-side measurement status (regeneration) of this module.	ON: Measuring electric energy (regeneration) on side 1 OFF: Other than the above
7 LED	-	-	Always OFF.
8 LED	Red	Displays errors and conditions of this module.	Flashing: Out-of-range error ON: Hardware error OFF: Normal operation
9 LED	Green	Displays CH1 2-side measurement status (regeneration) of this module.	ON: Measuring electric energy (regeneration) on side 2 OFF: Other than the above
A LED	Green	Displays CH2 2-side measurement status (regeneration) of this module.	ON: Measuring electric energy (regeneration) on side 2 OFF: Other than the above
B LED	Green	Displays CH3 2-side measurement status (regeneration) of this module.	ON: Measuring electric energy (regeneration) on side 2 OFF: Other than the above
C LED	Green	Displays CH1 3-side measurement status (regeneration) of this module.	ON: Measuring electric energy (regeneration) on side 3 OFF: Other than the above
D LED	Green	Displays CH2 3-side measurement status (regeneration) of this module.	ON: Measuring electric energy (regeneration) on side 3 OFF: Other than the above
E LED	Green	Displays CH3 3-side measurement status (regeneration) of this module.	ON: Measuring electric energy (regeneration) on side 3 OFF: Other than the above
F LED	-	-	Always OFF.

*1: For details, check with the list of error codes. (Refer to section 8.1)

5. Attaching and removing the module

5.1 How to attach to the base unit

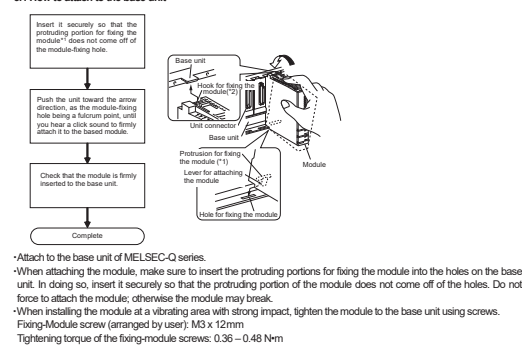

- Attach to the base unit of MELSEC-Q series.
- When attaching the module, make sure to insert the protruding portions for fixing the module into the holes on the base unit. In doing so, insert it securely so that the protruding portion of the module does not come off of the holes. Do not force to attach the module, otherwise the module may break.
- When installing the module at a vibrating area with strong impact, tighten the module to the base unit using screws.
- Fixing-Module screw (arranged by user), M3 x 12 mm
- Tightening torque of the fixing-module screws: 0.36 ~ 0.48 N·m

7. Dimensions

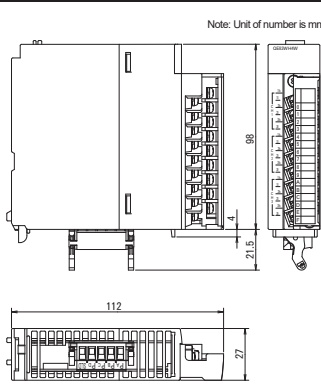

8. Specifications

Item	Specifications
Model	QE83WH4W
Phase-wire system	Three-phase 4-wire
Voltage circuit	63.5/70 ~ 27/480 V AC (Selected from: 63.5/110V, 100/173V, 105/182V, 110/190V, 115/199V, 120/208V, 127/220V, 200/346V, 220/380V, 230/400V, 240/415V, 242/420V, 250/430V, 254/440V, 265/480V, 277/480V Each value refers to the primary voltage of voltage transform unit (QE83WH4VT). If more than 27/480 V AC, use a transformer (VT). Primary voltage of VT can be set up to 6000V.)
	Rating
Current circuit	5A AC (The dedicated split type current sensor is used. 5 A current sensor is used together with the current transformer (CT), and the primary-side current is configurable up to 6000 A.)
Frequency	50Hz-60Hz Current, current demand: ±1.0% (100% of the rating) Voltage: ±1.0% (100% of the rating) Electric power, electric power demand: ±1.0% (100% of the rating) Reactive power: ±1.0% (100% of the rating) Apparent power: ±1.0% (100% of the rating) Frequency: ±1.0% (45 ~ 65 Hz range of the rating) Power factor: ±0.0% (against the electric angle 90°) Electric energy: ±2.0% Reactive energy: ±2.5% (5 ~ 100% range of the rating, power factor = 1) (10 ~ 100% range of the rating, power factor = 0)
Measurable circuit count	3 circuits under the same voltage system (3 channels), or 8 circuits (8 channels) in the current measuring mode
Operating temperature	0 ~ 55°C (Average daily temperature: 35°C or below)
Operating humidity	5 ~ 95% RH (No condensation)
Storage temperature	-25 ~ +75°C
Operating altitude	2000 m or below Between voltage/current input terminals - SLD terminal: 2210 V AC 5 sec Between voltage/current input terminals - sequencer power source and GND terminals: 2210 V AC 5 sec
Commercial frequency withstand voltage	Standard EMC EN61131-2:2007, EN61326-1:2006, EN61131-2:2007, EN61010-1:2010 LVD EN61131-2:2007, EN61010-1:2010
Installation area	Inside a control panel

9. Warranty

- The charge-free warranty period for the product shall be 1 year from the date of your purchase or the date the product is delivered your specified delivery location. However, the maximum limit of the charge-free warranty period shall be set to 18 months from the time of manufacture by defining the longest distribution period of the product as 6 months after the product is shipped from our manufacturing factory. Also, the charge-free warranty period for the replacement product shall not be extended exceeding the charge-free warranty period for the original product.
- Our company shall not be liable to compensate for any loss arising from events not attributable to our company, opportunity loss and lost earning of the customer due to failure of the product, and loss, secondary loss, accident compensation, damage to other products besides our products and other operations caused by a special reason regardless of our company's predictability in both within and beyond the charge-free warranty period.

Caution If an abnormal sound, bad-smelling smoke, fever break out from this module, I switch it off promptly, and don't use it.

KCC-REI-MEK-19H013
Applicant: MITSUBISHI ELECTRIC AUTOMATION KOREA CO.Ltd
Equipment Name: Energy Measuring Module
Model: QE83WH4W
Made in: JAPAN
Manufacturer: MITSUBISHI ELECTRIC CORPORATION FUKUYAMA WORKS

사용자안내문 A급 기기 (업무용 방송통신기자재)
이 기기는 업무용(A급) 전자파적합기기로서 판매자 또는 사용자는 이 점을 주의하시기 바랍니다. 가정외의 지역에서 사용하는 것을 목적으로 합니다.

10. Customer Service

MITSUBISHI ELECTRIC CORPORATION
HEAD OFFICE: TOKYO BUILDING, 2-7-1, MARUNOUCHI, CHYODOKU, TOKYO 100-8510, Japan
Please refer to "catalog" or "user's manual (Details)" for more detail.

- Caution**
 - Input signal wire shall not be bound together with or placed close to the main circuit and power line. Keep 300 mm or longer distance between them.(Except for the terminal input section) It may cause malfunction due to noise.
 - The input wiring of the measurement circuit uses separate cables which is different from other signal cables, and do not be affected by surge and the insulation of the interchange side.
 - In actual use, connect the SLD terminal to a shield.

- Make sure that before connecting the cable, the direction of the current sensor is correct for attachment. K to L is the correct direction. K: power source side, L: load side.
- The available range of the voltage transform unit is from 55/95V AC to 227/480V AC. When this product is used in a circuit more than 227/480V AC, voltage transformer is required.
- The available phase voltage of the transformer is up to 660V. Connect the secondary side of the transformer to the terminal (P1, P2, P3, P0) of the Voltage transform unit. Make sure that terminal symbols are correct. This product cannot connect with the secondary side of the transformer directly.

6.2 How to connect wires

- Use appropriate electric wires and tighten a screw by appropriate torque as described right.
- <Voltage input terminals>
- Insert a wire to the terminal all the way until it touches the end.
- Stripping length of the used wire is up to 7mm.
- When using a stranded wire, strand the wire edges to prevent thin wires from loosening.

- <Current input terminals>
- Use an applicable solderless terminals. No solderless terminal with insulation sleeve can be used on the terminal block. It is recommended to cover the solderless terminals connecting electric cables with a mark tube or insulating tube.
- Applicable solderless terminals for current input terminals
- R1.25-3 (No solderless terminal with insulation sleeve can be used).
- <Applicable wire(Usable electric wire)>

	Voltage input terminals	Current input terminals
Single wire	AWG24-16	-
Stranded wire	AWG20-16	AWG20-18
Tightening torque [N·m]	0.4-0.5	0.42-0.58

* To comply with UL/UL standards, use the wires meeting the following requirements.
The rated temperature of the copper conductor should be 60°C/75°C.
< Cable applicable (Fil électrique utilisable)>

	Terminals de tension d'entrée	Terminals de courant d'entrée
Cable simple	AWG24-16	-
Cable brin	AWG20-16	AWG20-18
Couple de serrage [N·m]	0.4-0.5	0.42-0.58

* Pour être conforme à UL/UL standard, utilisez le fil électrique selon les conditions suivantes.
La température classée du conduit en cuivre doit être à 60°C/75°C.