

Mitsubishi Programmable Controller

MELSEC **Q** series

Insulation Monitoring Module User's Manual (Details)

QE82LG

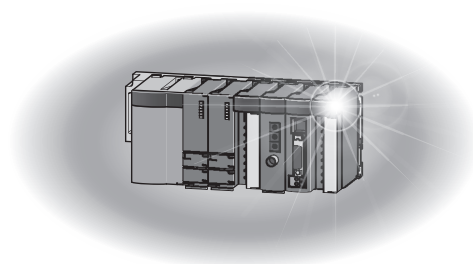

● SAFETY PRECAUTIONS ●

(Read these precautions before using this product.)

This manual contains important instructions for MELSEC-Q series QE82LG.

Before using this product, please read this manual and the relevant manuals carefully and pay full attention to safety to handle the product correctly.

The precautions given in this manual are concerned with this product only. For the safety precautions of the programmable controller system, refer to the user's manual of the CPU module used.

In this manual, the safety precautions are classified into two levels: "DANGER" and "CAUTION".



Indicates that incorrect handling may cause hazardous conditions, resulting in death or severe injury.



Indicates that incorrect handling may cause hazardous conditions, resulting in medium or slight personal injury or physical damage.

Under some circumstances, failure to observe the precautions given under “ CAUTION” may lead to serious consequences.

Observe the precautions of both levels because they are important for personal and system safety.

Keep this manual in an accessible place for future reference whenever needed, and make sure it is delivered to the end user.

[Precautions for Operating Environment and Conditions]

Caution

- Do not use this product in the places listed below. Failure to follow the instruction may cause malfunctions or decrease of product-life.
 - Places the Ambient temperature exceeds the range 0 - 55°C.
 - Places the Relative humidity exceeds the range 5 - 95% or condensation is observed.
 - Altitude exceeds 2000 m.
 - Places exposed to rain or water drop.
 - Dust, corrosive gas, saline and oil smoke exist.
 - Vibration and impact exceed the specifications.
 - Installation on excluding the control board

[Design Precautions]

Danger

- Do not write data into “System Area” in the buffer memory of the intelligent function module. Also, do not output (turn ON) the “use prohibited” signal in the output signal sent from the sequencer CPU to the intelligent function module. Doing so may cause a malfunction to the sequencer system.

Caution

- Do not install the input signal wire together with the main circuit lines or power cables. Keep a distance of 300 mm or more between them. (Except for the terminal input part) Failure to do so may result in malfunction due to noise.
- This module can not be used as an Electric Leakage Relay.

[Installation Precautions]

Caution

- Any person who is involved in the installation and the wiring of this Sequencer should be fully competent to do the work.
- Use the programmable controller in an environment that meets the general specifications in the User’s manual of the CPU module used.
Failure to do so may result in electric shock, fire, malfunction, or damage to or deterioration of the product.
- To mount the module, while pressing the module-mounting lever located in the lower part of the module, fully insert the module fixing projection(s) into the hole(s) in the base unit and press the module until it snaps into place.
Incorrect mounting may cause a malfunction, failure or a fall of the module.
When using the Sequencer in an environment of frequent vibrations, fix the module with a screw.
- Tighten the screws within the specified torque range.
Fixing-Module screw (arranged by user): M3 x 12mm
Tightening torque of the fixing-module screws 0.36 - 0.48 N•m
When the screw tightening is loose, it causes a fall, short-circuit, and a malfunction.
Over-tightening can damage the screws and the module, and it may cause a fall, short-circuit, or a malfunction.
- Shut off the external power supply for the system in all phases before mounting or removing the module. Failure to do so may result in damage to the product.
- Do not touch directly any conductive parts and electronic parts of the module.
Doing so can cause a malfunction or failure of the module.

[Wiring Precautions]

Danger

- For installation and wiring works, make sure that the power source is shut off for all outside phases. If all phases are not turned off, it may cause an electric shock or product damages.

Caution

- FG terminal must be grounded according to the D-type ground (Type 3) dedicated for sequencer. Failure to do so may result in electric shock or malfunction.
- When using this product, make sure to use it in combination with Mitsubishi's zero-phase current transformer (ZCT). Please not to exceed the ratings of this product for input of zero phase transformer. For further details, please refer to zero phase transformer manual to maintain the functionality and the accuracy of this product .

Split-type ZCT	CZ-22S , CZ-30S , CZ-55S CZ-77S , CZ-112S
Through-type ZCT	ZT15B, ZT30B , ZT40B , ZT60B , ZT80B , ZT100B , ZTA600A , ZTA1200A , ZTA2000A

- This module and the zero-phase current transformer are used for less than 600V circuit only. They are not used with exceeding 600V circuit.
- Do not open the secondary side of the zero-phase current transformer.
- Take care not entering any foreign objects such as chips and wire pieces into the module. It may cause a fire, failure or a malfunction.
- In order to prevent the module from incoming foreign objects such as wire pieces during wiring work, a foreign-object preventive label is placed on the module. While a wiring work is performed, keep the label on the module. Before operating the system, peel off the label for heat release. If the foreign-object preventive label is not peeled and the system is in use, residual heat inside the module may reduce the product life.
- The wires to be connected to the module shall be put in a duct or fixed together by clamp. If not, the loosing and unstable wire or careless stretching results in poor contact of electric wires. That may cause a breakage of the module or wire or a malfunction.
- Use appropriate size of electric wires. If inappropriate size of electric wire is used, it may cause a fire due to generated heat. For appropriate size of electric wires, refer to 7.5.2 How to connect wires.
- In case using stranded wire, take measures so that the filament should not vary by using a bar terminal or by processing the point twisted. Use the bar terminal appropriated for the size of electric wires. If using inappropriate bar terminals, a wire breakage or a contact failure may cause a device malfunction, failure, a burnout or a fire.
- After wiring, confirm whether there is a wiring forgetting or a faulty wiring. They may cause a device malfunction, a fire, or an electric shock.
- When removing the wires connected to the module, do not pull wires as holding on their electric wire portions. Push the buttons on the terminal, and then remove the wire.
- If the wires connected to the module are strongly pulled off, it may cause a malfunction or a breakage to the module or the wire. (Tensile load: 22N or less)
- Ensure the wiring to the module properly, checking the rated voltage and current of the product and the terminal pin assignment. If the input voltage exceed the rated voltage or the wiring is improper, it may cause a fire or a breakage.
- Do not exceed the specified voltage when doing an insulation resistance test and a commercial frequency withstand voltage test.

[Start-up Precautions]

Caution

- Use the product within the ratings specified in this manual. When using it outside the ratings, it not only causes a malfunction or failure but also there is a fear of igniting and damaging by a fire.
- Before operating the product, check that active bare wire and so on does not exist around the product. If any bare wire exists, stop the operation immediately, and take an appropriate action such as isolation protection.
- Do not disassemble or modify the module. It may cause failure, a malfunction, an injury or a fire.
- Attaching and detaching the module must be performed after the power source is shut off for all outside phases. If not all phases are shut off, it may cause failure or a malfunction of the module.
- Do not touch the live terminal. It may cause a malfunction.

[Maintenance Precautions]

Caution

- Cleaning and additional tightening of module-fixing screws must be performed after the input power source is shut off for all outside phases. If not all phases are shut off, it may cause failure or a malfunction of the module.
- Use a soft dry cloth to clean off dirt of the module surface.
- Do not let a chemical cloth remain on the surface for an extended period nor wipe the surface with thinner or benzene.

Check for the following items for using this product properly for long time.

<Daily maintenance>

(1) No damage on this product (2) No abnormality with LED indicators (3) No abnormal noise, smell or heat.

<Periodical maintenance> (Once every 6 months to 1 year)

(4) Confirm there is loosening in installation, wire connection to terminal blocks, and the connection of the connectors. (Check these items under the power failure condition.)

[Storage Precautions]

Caution

- To store this product, turn off the power and remove wires, and put it in a plastic bag.
For long-time storage, avoid the following places. Failure to follow the instruction may cause a failure and reduced life of the product.
 - Places the Ambient temperature exceeds the range -25 to +75°C.
 - Places the Relative humidity exceeds the range 5 - 95% or condensation is observed.
 - Dust, corrosive gas, saline and oil smoke exist, and vibration and frequent physical impact occur.
 - Places exposed to rain or water drop.

[Disposal Precautions]

Caution

- Dispose of the product as an industrial waste.

Revision history

* Manual number is provided at the bottom of the cover page.

Printed date	* Manual number	Revision history
Jan, 2011	IB-63564	First edition
Sep, 2011	IB-63564-A	<u>Correction</u> SAFETY PRECAUTIONS, Section 4.2, Section 8.1, Section 8.3 <u>Addition</u> SAFETY PRECAUTIONS, Section 2.1, Section 3.2, Section 7.4, Section 9.3
Aug. 2012	IB-63564-B	<u>Correction</u> Section 2.3, Section 7.6, Section 9.1
Jul. 2013	IB-63564-C	<u>Correction</u> Section 2.3, Section 7.6, Section 7.7, Section 8.2, Section 9.3 <u>Addition</u> Section 1.1, Section 3.1, Section 4.2, Section 6.1, Section 6.3
Nov. 2013	IB-63564-D	<u>Correction</u> Section 4.1, Section 4.2.5, Section 6.1, Section 6.2.2, Section 6.2.3, Section 6.3.1, Section 6.3.2, Section 6.3.4, Section 6.3.5, Section 6.4.1, Section 7.6.2, Section 7.6.4, Section 8.2, Section 9.1 <u>Addition</u> Section 6.1, Section 6.4.3, Appendix 3
Jan. 2016	IB63564E	<u>Correction</u> Cover, Back cover
Jul, 2017	IB63564F	<u>Correction</u> Compliance with the EMC and Low Voltage Directives, Section 2.1, Section 3.2, Section 6.2, Section 6.3, Section 6.4, Section 7.2, Section 7.5, Section 7.6, Section 8, Section 9.2, Appendix 2, Appendix 3, Back cover
Jan, 2021	IB63564G	<u>Correction</u> Compliance with the EMC and Low Voltage Directives, Section 3.2, Back cover

This manual does not guarantee to protect or does not give a permission to any industrial property and any related rights. Also, our company shall not be held any responsible for any issues related to industrial properties due to product usage described in this manual.

Table of Content

SAFETY PRECAUTIONS	A-1
Revision history	A-5
Table of content	A-6
Compliance with the EMC and Low Voltage Directives	A-8
Names, abbreviations, terminology	A-9
Product configuration	A-9
Chapter 1: Overview	1-1
1.1 Features	1-1
Chapter 2: System Configuration	2-1 - 2-4
2.1 Applicable system	2-1
2.2 Precautions for system configuration	2-3
2.3 How to check the function version, serial number, and module version	2-3
Chapter 3: Specifications	3-1 - 3-2
3.1 General specifications	3-1
3.2 Electrical and mechanical specifications	3-2
Chapter 4: Functions	4-1 - 4-11
4.1 List of functions	4-1
4.2 Functions in detail	4-2
Chapter 5: I/O signal to CPU module	5-1 - 5-7
5.1 List of I/O signals	5-1
5.2 Details of I/O signals	5-2
Chapter 6: Buffer memory	6-1 - 6-13
6.1 Buffer memory assignment	6-1
6.2 Configurable sections (Un\G0 to Un\G1100, Un\G2000 to Un\G2100)	6-4
6.3 Measurable sections (Un\G1100 to Un\G1999, Un\G2100 to Un\G2999)	6-6
6.4 Common sections (Un\G3000 to Un\G4999)	6-12
Chapter 7: Setting and procedure for operation	7-1 - 7-24
7.1 Precautions for handling	7-1
7.2 Procedure for operation	7-2
7.3 Name and function of each part	7-3
7.4 Attaching and removing the module	7-5
7.5 Connecting wires, wiring	7-7
7.6 Setting from GX Works2	7-14
7.7 Setting from GX Developer	7-20

Chapter 8: Programming	8-1 - 8-8
------------------------	-----------

8.1 Programming procedure	8-1
8.2 System configuration and usage conditions for sample program	8-2
8.3 Sample programming	8-4

Chapter 9: Troubleshooting	9-1 - 9-8
----------------------------	-----------

9.1 List of error codes	9-1
9.2 Troubleshooting	9-4
9.3 Q&A.....	9-7

Appendix	Appendix 1 - 7
----------	----------------

Appendix 1: External dimensions	Appendix-1
Appendix 2: Optional devices.....	Appendix-2
Appendix 3: Addition or change of functions	Appendix-7

Index	Index 1
-------	---------

Compliance with the EMC and Low Voltage Directives

(1) For programmable controller system

To configure a system meeting the requirements of the EMC and Low Voltage Directives when incorporating the Mitsubishi programmable controller (EMC and Low Voltage Directives compliant) into other machinery or equipment, refer to QCPU User's Manual (Hardware Design, Maintenance and Inspection).

The CE mark, indicating compliance with the EMC and Low Voltage Directives, is printed on the rating plate of the programmable controller.

(2) For the product

For the compliance of this product with the EMC and Low Voltage Directives, refer to Section 7.5 Wiring.

In addition, attach ferrite cores to power line of power supply module.

Ferrite cores used in our testing is below.

KITAGAWA INDUSTRIES CO.,LTD., RFC-10

(3) CE marking conformity combination module

This module conforms to CE marking standard in a condition to make combination use with following zero-phase current transformer (ZCT) and cable.

Split-type ZCT	CZ-22S , CZ-30S , CZ-55S CZ-77S , CZ-112S
Through-type ZCT	ZT15B, ZT30B , ZT40B , ZT60B , ZT80B , ZT100B , ZTA600A , ZTA1200A , ZTA2000A
cable	CE marking cable (twisted pair cable) Single wire: AWG24 – AWG18 (φ0.5 - 1.0mm) Stranded wire: AWG22 – AWG18 (0.3 – 0.8 mm ²)
Max. cable length	50m

Names, abbreviations, terminology

In this manual, the following names, abbreviations, and terminology are used to explain the insulation monitoring module, unless otherwise specified.

Names, abbreviations, terminology	Descriptions of names, abbreviations, terminology
Io1	Abbreviation for CH1 leak current.
Ior1	Abbreviation for CH1 leak current for resistance.
Io2	Abbreviation for CH2 leak current.
Ior2	Abbreviation for CH2 leak current for resistance.
CH1 Alarm	Collective term for Io1 1-step alarm, Io1 2-step alarm, Ior1 1-step alarm, and Ior1 2-step alarm.
CH2 Alarm	Collective term for Io2 1-step alarm, Io2 2-step alarm, Ior2 1-step alarm, and Ior2 2-step alarm.
CH1 max. value	Collective term for Io1 max. value and its date/time of occurrence, and Ior1 max. value and its date/time of occurrence.
CH2 max. value	Collective term for Io2 max. value and its date/time of occurrence, and Ior2 max. value and its date/time of occurrence.
Date/time of occurrence	Collective term for the year of max. value occurrence, month and day of max. value occurrence, hour and minute of max. value occurrence, and second and day of the week of max. value occurrence.
CH1 Alarm occurrence count	Collective term for Io1 1-step alarm occurrence count, Io1 2-step alarm occurrence count, Ior1 1-step alarm occurrence count, and Ior1 2-step alarm occurrence count.
CH2 Alarm occurrence count	Collective term for Io2 1-step alarm occurrence count, Io2 2-step alarm occurrence count, Ior2 1-step alarm occurrence count, and Ior2 2-step alarm occurrence count.
ZCT	Abbreviation for zero-phase current transformer

Product configuration

The following describes the product configuration.

Model name	Product name	Quantity
QE82LG	Insulation monitoring Module	1

Chapter 1: Overview

This manual explains specifications, handling methods, and programming of Insulation Monitoring Module QE82LG (hereinafter, abbreviated as QE82LG) supporting MELSEC-Q series.

1.1 Features

- (1) This enables to measure leak current for safety actions.
By monitoring leak current (I_o), risk for electric shock can be detected.
- (2) This enables constant monitoring of insulation for equipment.
By monitoring leak current for resistance (I_{or}), deterioration of equipment insulation can be tracked.
- (3) This enables 2-level alarm monitoring during monitoring for each measuring element.
For each leak current (I_o) and leak current for resistance (I_{or}), 2-level alarm monitoring can be performed without a sequence.
- (4) This enables to measure two circuits, using one device.
At the power source with the same-phase wire system, a single device can measure two circuits.
- (5) This enables to measure sensitive.
By changing setting to high sensitivity mode, this enables to measure from 0.01mA.

Chapter 2: System Configuration

2.1 Applicable system

The following describes applicable systems.

(1) Applicable module and the quantity of attachable pieces

(a) When mounted with CPU module

CPU module to which QE82LG can be attached and the number of attachable pieces are shown below.

Depending on the combination of the attached module and the number of attached pieces, lack of power capacity may occur.

When attaching the module, please consider the power capacity.

If the power capacity is insufficient, reconsider the combination of modules to be attached.

Since the number of attachable modules are limited by the power module which used, please refer to the notes on the 2.2 precautions for system configuration.

Attachable CPU Module		Attachable quantity.	Remarks
CPU Type	CPU Model		
Programmable controller CPU	Basic model QCPU	Q00JCPU	16
		Q00CPU	24
		Q01CPU	
	High performance model QCPU	Q02CPU	64
		Q02HCPU	
		Q06HCPU	
		Q12HCPU	
		Q25HCPU	
	Process CPU	Q02PHCPU	64
		Q06PHCPU	
		Q12PHCPU	
		Q25PHCPU	
	Redundant CPU	Q12PRHCPU	53
		Q25PRHCPU	
	Universal model QCPU	Q00UJCPU	16
		Q00UCPU	24
		Q01UCPU	36
		Q02UCPU	
		Q03UDCPU	
		Q04UDHCPU	64
		Q06UDHCPU	
		Q10UDHCPU	
		Q13UDHCPU	
Q20UDHCPU			
Q26UDHCPU			
Q03UDECPU			
Q04UDEHCPU			
Q06UDEHCPU			
Q10UDEHCPU			
Q13UDEHCPU			
Q20UDEHCPU			
Q26UDEHCPU			
Q50UDEHCPU			
Q100UDEHCPU			

Attachable CPU Module		Attachable quantity.	Remarks	
CPU Type	CPU Model			
Programmable controller CPU	High-Speed Universal model QCPU	64		
				Q03UDVCPU
				Q04UDVCPU
				Q06UDVCPU
				Q13UDVCPU
				Q26UDVCPU
				Q04UDPVCPU
				Q06UDPVCPU
				Q13UDPVCPU
C Controller module		64		
				Q06CCPU-V
				Q06CCPU-V-B
				Q12DCCPU-V
				Q24DHCCPU-LS
				Q26DHCCPU-LS

(b) When mounted with MELSECNET/H remote I/O station

The table below shows the network modules applicable to the QE82LG and the number of network modules to be mounted.

Depending on the combination with other modules or the number of mounted modules, power supply capacity may be insufficient.

Pay attention to the power supply capacity before mounting modules, and if the power supply capacity is insufficient, change the combination of the modules.

Applicable Network Module	Number of modules	Remarks
QJ72LP25-25	64	
QJ72LP25G		
QJ72BR15		

(c) The base unit can be mounted

QE82LG can be installed to any I/O slot of main base unit and extension base unit.

*1 In case of redundant CPU, can be mounted to the extension base unit only.

Mounted to the main base unit is not allowed.

*2 Limited within the range of I/O points for the CPU module.

(2) For multiple CPU system

The function version of the first released CT input module is C, and the CT input module supports multiple CPU systems.

When using the CT input module in a multiple CPU system, refer to the following.

*QCPU User's Manual (Multiple CPU system)

- (3) Applicable software package
 QE82LG supported software packages are as follows:
 (a) Software package for sequencer

Product name	Model name	Remarks
GX Works2	SWnDNC-GXW2	iQ Platform compatible programmable controller engineering software
GX Developer	SWnD5C-GPPW	MELSEC sequencer programming software. "n" in the model name is 4 or larger.

2.2 Precautions for system configuration

- (1) When attaching it to an expansion base without a power module
 If QE82LG is attached to an expansion base without a power module, refer to the user's manual of the sequencer CPU to be used in order to select the power module and expansion cable.

2.3 How to check the function version, serial number, and module version

- (1) How to check the serial number and module version
 It can be checked with the serial number label (placed on the right side of QE82LG).

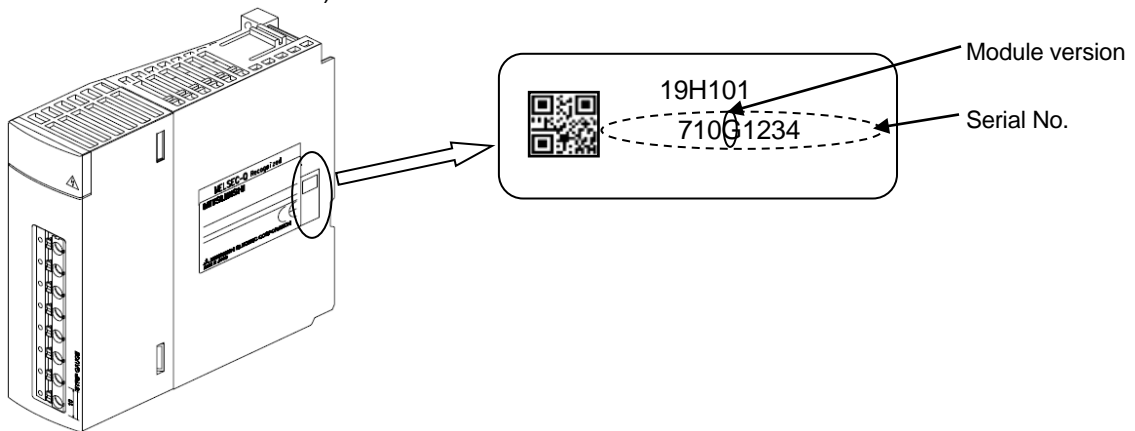

(2) How to check the function version and serial number

(a) Checking on the front of the module.

The serial number and function version on the rating plate is shown on the front (at the bottom) of the module.

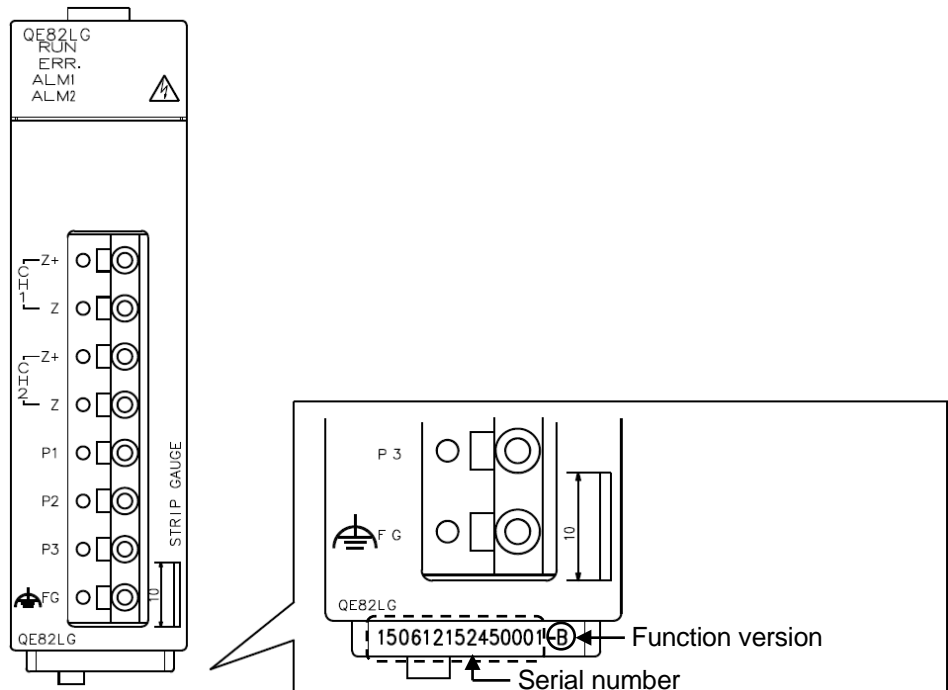

(b) Checking on the System monitor dialog box (Product Information List)

To display the system monitor, select [Diagnostics] → [System monitor] and click the **Product Information List** button of GX Developer.

Slot	Type	Series	Model name	Points	I/O No.	Master PLC	Serial No	Ver.	Product No.
PLC	PLC	Q	Q00UJCPU	-	-	-	1310200000000000	B	140115140218032-B
0-0	Intelli.	Q	QE82LG	16pt	0000	-	1506200000000000	B	-
0-1	-	-	None	-	-	-	-	-	-
0-2	-	-	None	-	-	-	-	-	-
0-3	-	-	None	-	-	-	-	-	-

Point

The serial number displayed on the Product Information List dialog box of GX Developer may differ from that on the rating plate and on the front of the module.

- The serial number on the rating plate and front part of the module indicates the management information of the product.
- The serial number displayed on the Product Information List dialog box of GX Developer indicates the function information of the product.

The function information of the product is updated when a new function is added.

Chapter 3: Specifications

3.1 General specifications

Item		Specifications	
Phase-wire system		single-phase 2-wire / single-phase 3-wire / three-phase 3-wire	
Ratings	Voltage circuit *1,*2	single-phase 2-wire, three-phase 3-wire	110 V , 220 V AC
		single-phase 3-wire	110V AC (1 - 2 line, 2 - 3 line) 220 V (1 - 3 line)
	Leak current circuit	1 A AC (Zero-phase current transformer (ZCT) is used. It indicates the primary current value of ZCT.)	
	Frequency	50-60 Hz	
Measuring range		Low sensitivity mode	: 0-1000mA
		High sensitivity mode	: 0.00-100.00mA
Resolution		Low sensitivity mode	: 1mA
		High sensitivity mode	: 0.01mA
Allowable tolerance of module (excluding ZCT)		Low sensitivity mode	: Leak current : $\pm 2.5\%$ (10 – 100% range of Ratings) : $\pm 2.5\text{mA}$ (0 – 10% range of Ratings) : Leak current for resistance : $\pm 2.5\%$ (10 – 100% range of Ratings) : $\pm 2.5\text{mA}$ (0 – 10% range of Ratings)
		High sensitivity mode	: Leak current : $\pm 2.5\text{mA}$: Leak current for resistance : $\pm 2.5\text{mA}$
Measurable circuit count		2 circuits* ³	
Data update cycle		Leak current	: 2 seconds or less
		Leak current for resistance	: 10 seconds or less
Backup for electric blackout		Nonvolatile memory is used. (Items: Settings, Max. value and date/time of occurrence, Alarm occurrence count)	
I/O occupation		16 points (I/O assignment: intelligence 16 points)	

* 1:110 V, 220V direct connection is possible. Above 440V voltage transformer outside (VT) is required.

* 2:In case of measuring leakage current for resistance, it is possible on single-phase 2-wire, single-phase 3-wire, three-phase 3-wire delta circuit.

* 3:The measurement of two circuits is possible at one module in the same system in the same trans.

3.2 Electrical and mechanical specifications

Item		Specifications					
Consumption VA	Voltage circuit	Each phase 0.1 VA (at 110 V AC), Each phase 0.2 VA (at 220 V AC)					
Internal current consumption (5 V DC)		0.17 A					
Operating temperature		0 – 55°C (Average daily temperature 35°C or below)					
Operating humidity		5 – 95% RH (No condensation)					
Storage temperature		-25° – +75°C					
Storage humidity		5 – 95% RH (No condensation)					
Operating altitude		2000m or below					
Installation area		Inside a control panel					
Operating environment		No corrosive gas					
Vibration resistance		Conforms to JIS B 3502, IEC 61131-2	Frequency	Constant acceleration	Half amplitude	Sweep time	
			Intermittent vibration	5 – 8.4 Hz	-	3.5 mm	XYZ each direction 10 times
				8.4 – 150 Hz	9.8 m/s ²	-	
			Continuous vibration	5 – 8.4 Hz	-	1.75 mm	-
8.4 – 150 Hz	4.9 m/s ²	-					
Impact resistance		Conforms to JIS B 3502, IEC 61131-2 (147 m/s ² , XYZ each direction 3 times)					
Over voltage category *1		II or less					
Pollution degree *2		2 or less					
Equipment category		Class I					
Applicable wire (Usable electric wire)	ZCT Input terminal (Z+, Z terminal) ³	Single wire	AWG24 – AWG18 (φ0.5 - 1.0mm)				
		Stranded wire ⁴	AWG22 – AWG18 (0.3 – 0.8 mm ²)				
	Voltage input terminal	Single wire	AWG24 – AWG18 (φ0.5 - 1.0mm)				
		Stranded wire ⁴	AWG22 – AWG18 (0.3 – 0.8 mm ²)				
Tightening torque		Module-fixing screws (M3 screw) ⁵ 0.36 – 0.48 N·m					
Commercial frequency withstand voltage		Between voltage/leak current input terminals – FG terminal				2210 V AC 5 sec	
		Between voltage/leak current input terminals – sequencer power source and GND terminal				2210 V AC 5 sec	
Insulation resistance		5 MΩ or more (500 V DC) at locations above					
Standard		EMC: EN61131-2:2007, EN61326-1:2013 LVD: EN61131-2:2007, EN61010-1:2010					
External dimensions		27.4 mm (W) x 98 mm (H) x 90 mm (D), excluding protruding portions					
Mass		0.1 kg					
Product life expectancy		10 years (used under the average daily temperature 35°C or less)					

*1. This indicates the assumed area of electric distribution to which the device is connected, the area ranging from public distribution to factory machinery. The category II applies to the device power-supplied from fixed facility. The surge voltage of this product is 2500 V up to the rated voltage of 300 V.

*2. The index indicates the level of conductive substance at the device's operating environment. Contamination level 2 means only non-conductive substance. However, occasional condensation may lead to temporary conduction.

*3. At the connection between ZCT secondary terminal and this module terminal (Z+, Z), each wire has to be twisted for usage.

*4. If stranded wire is used, a bar terminal must be used.
Recommended bar terminal: TGV TC-1.25-11T (Made by Nichifu)

*5. The module can be fixed easily to the base unit, using the hook on top of the module. However, if it is used under a vibrating environment, we strongly recommend that the module be fixed with screws.

Chapter 4: Functions

4.1 List of functions

Functions of QE82LG are provided in Table 4.1-1.

Table 4.1-1 List of functions

No.	Function	Descriptions	Reference section
1	Measurement	It enable measures Io1, Ior1, Io2, and Ior2, and stores the records into a buffer memory as needed.	Section 4.2.1
		It changes a low sensitivity mode (0-1000mA) and high sensitivity mode (0.00-100.00mA) and can measure an leak current. *1	Section 7.6.2 7.7.2
2	Hold max. values	For Io1, Ior1, Io2, and Ior2, each maximum values and date of occurrence are stored in the buffer memory as needed. Even if the power source reset occurs, maximum values and date of occurrence are retained.	Section 4.2.2
3	Alarm monitoring	It can monitor the upper limit for Io1, Ior1, Io2, and Ior2. In addition, you can set 2 steps of alarm values for each monitored element, and they can be used in such way to release cautious alarm and real alarm. When the value exceeds and continues to be over the monitoring value for alarm delay time, a specified input signal is turned on.	Section 4.2.3
4	Alarm occurrence count	For each alarm monitored element, it counts the frequency of the alarms, which will be stored in the buffer memory as needed. It can count up to 9999 times of Alarm occurrence count. If the count exceeds 9999 times, Alarm occurrence count remains 9999 times. Even if the power source reset occurs, the count of alarm occurrence is retained.	Section 4.2.4
5	Test	The intelligent function module switch enables pseudo-storage of the specified value into the buffer memory, even with non-existence of voltage and current (sensor) input. Using this module, you can create a sequence, etc.	Section 4.2.5

*1: High sensitivity mode can be used QE82LG whose serial number (upper six digits, shown on the front (at the bottom) of the module) is 150612 or later.

4.2 Functions in detail

4.2.1 Measuring functions

(1) Measured items

Measured items and measured ranges are described as follows:

Measured items	
	Details
CH1 leak current	Present value (Un\G1100)
	Max. value (Un\G1101)
	Date/time of occurrence (Un\G1102 to Un\G1105)
CH1 leak current for resistance	Present value (Un\G1150)
	Max. value (Un\G1151)
	Date/time of occurrence (Un\G1152 to Un\G1155)
CH2 leak current	Present value (Un\G2100)
	Max. value (Un\G2101)
	Date/time of occurrence (Un\G2102 to Un\G2105)
CH2 leak current for resistance	Present value (Un\G2150)
	Max. value (Un\G2151)
	Date/time of occurrence (Un\G2152 to Un\G2155)

(2) Resolution of measured data

Resolution of measured data is described as follows:

- Leak current, leak current for resistance

Measured items	Mode	Resolution		Measuring range
Io1 Ior1	Low sensitivity mode	Integer	1 mA	0-1000mA
Io2 Ior2	High sensitivity mode	Two decimal places	0.01mA	0.00-100.00mA

(3) Restrictions for measuring data

- Measurement cannot be performed immediately after the power loading to the sequencer system (while Module ready (Xn0) is under the OFF condition). After checking that Module ready (Xn0) is ON, obtain measuring data.
- Measurement cannot be performed immediately after operating conditions are set up to this module. After checking that Operating condition setting completion flag (Xn9) becomes ON, obtain measuring data.
- Behaviors during operation are as follows:

Measured items	Behavior of this module
Io1 Ior1 Io2 Ior2	When the input current is less than 1 mA in low sensitivity mode or 0.01mA in high sensitivity mode, it becomes 0 mA. When the input current is less than 80 V, it becomes 0 mA. In the case of abnormal frequency (when it is less than 44.5 Hz or over 66.5 Hz), it becomes 0 mA.

4.2.2 Max. values hold function

It memorizes the max. value for each measured element, and retains it until the max. value is cleared.

(1) Max. value memory

- 1) It memorizes the max. value for the following measured element.
 - CH1 leak current
 - CH1 leak current for resistance
 - CH2 leak current
 - CH2 leak current for resistance
- 2) It memorizes the date and time of occurrence (year/month/day/hour/minute/second/day of the week) together with the max. value.
- 3) The max. value and the date and time of occurrence are stored in the nonvolatile memory, so that these max. values can be retained even at a power source reset.

(2) How to clear the max. value

- 1) You can use the I/O signal to clear the max. value.
- 2) The max. value immediately after clearing will be the present value and the date of occurrence will be the present date and time.
- 3) The following data can be cleared upon CH1 max. value clear request (YnA). However, the following data cannot be cleared individually.
 - Io1 max. value (Un\G1101)
 - Io1 date and time of occurrence (Un\G1102 to Un\G1105)
 - Ior1 max. value (Un\G1151)
 - Ior1 date and time of occurrence (Un\G1152 to Un\G1105)
- 4) The following data can be cleared upon CH2 max. value clear request (YnC). However, the following data cannot be cleared individually.
 - Io2 max. value (Un\G2101)
 - Io2 date and time and time of occurrence (Un\G2102 to Un\G2105)
 - Ior2 max. value (Un\G2151)
 - Ior2 date and time of occurrence (Un\G2152 to Un\G2105)
- 5) The following describes how to clear CH1 max. value. (CH2 max. value follows the same procedure using CH2 max. value clear request (YnC).)
 - (i) Check that CH1 max. value clear request (YnA) is OFF.
 - (ii) Set CH1 max. value clear request (YnA) to ON.

Max. values and dates and times of occurrence of CH1 leak current and CH1 leak current for resistance are cleared, and then CH1 max. value clear completion flag (XnA) is turned ON.
 - (iii) Check that CH1 max. value clear completion flag (XnA) is ON, and then set CH1 max. value clear request (YnA) to OFF.

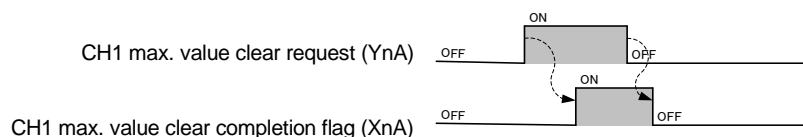

Figure 4.2.2-1 Procedure for clearing max. value

4.2.3 Alarm monitoring function

For monitoring each measured item, you can set max. 2 points of upper limit alarm to perform monitoring. During the alarm monitoring, the module can monitor the input signal to check for the occurrence.

(1) Setting the alarm monitoring

1) Setting items and setting range for the alarm monitoring are described below.

Setting item	Setting range	Description
Alarm value	Low sensitivity mode 1 to 1000 (mA) High sensitivity mode 0.01-100.00 (mA) 0: No monitoring	The value is for monitoring the target measured element. Alarm is released when the present value exceeds alarm value and the situation continues for alarm delay time. Also, in the case of 2-step monitoring, the 1-step and secondary alarm values can be configured regardless of their size.
Alarm reset method	0: Self-retention 1: Auto reset	You can set whether or not the alarm-occurrence condition should be retained if the value goes back to the alarm value after the alarm is released.
Alarm delay time	0 to 300 (seconds)	Alarm is released when the present value exceeds the alarm value and the situation continues for alarm delay time.

2) Setting procedures are as follows:

- (i) Check that Operating condition setting request (Yn9) is OFF.
- (ii) Set alarm value, alarm reset method, and alarm delay time. For the address of buffer memory corresponding to each measured element, refer to Chapter 6.
- (iii) Set Operating condition setting request (Yn9) to ON. Operation starts at each set value, and then Operating condition setting completion flag (Xn9) is turned OFF.
- (iv) Check that Operating condition setting completion flag (Xn9) becomes OFF, and then set Operating condition setting request (Yn9) to OFF.

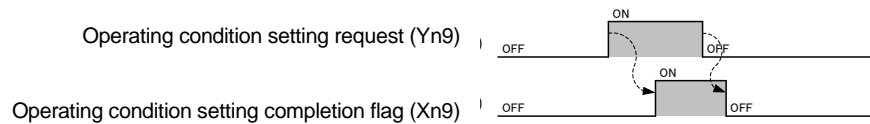

Figure 4.2.3-1 Time chart of alarm monitoring setting

3) Each item of the alarm monitoring is stored in the nonvolatile memory, so that set values can be retained even at a power source reset.

(2) Alarm flag (Xn1 to Xn8) and behavior of ALM1 LED and ALM2 LED

1) There are 4 statuses of alarm for each alarm monitoring element.

(a) Alarm non-occurrence status

The present value is under alarm value or the present value exceeds alarm value but the situation continues for less than alarm delay time.

(b) Alarm occurrence status

The present value exceeds alarm value and the situation exceeds alarm delay time.

(c) Self-retention status (Only when the alarm reset method is set to “self-retention”)

The present value has changed from the alarm occurrence status to be under alarm value.

(d) Alarm reset status

Alarm reset request (Yn1, Yn5) is released under the alarm occurrence status, and the present value is still over alarm value.

* In order to state the alarm, alarm monitoring must be less than the value once during the alarm reset state.

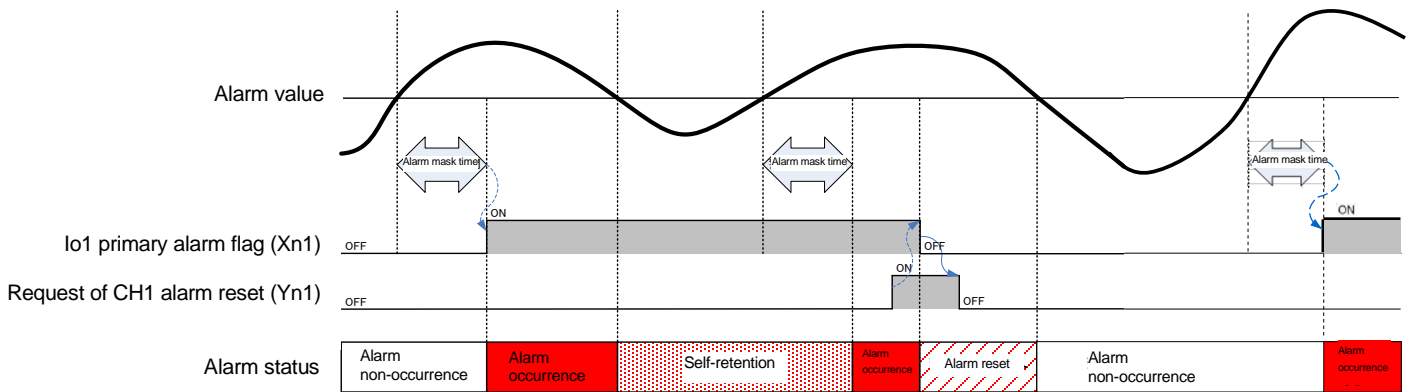

Figure 4.2.3-2 Example of alarm status (alarm reset method = “self-retention”)

2) Relationship between the alarm status and Alarm flag (Xn1 to Xn8)

(a) Alarm non-occurrence status

Under the alarm non-occurrence status, Alarm flag (Xn1 to Xn8) is OFF.

(b) Alarm occurrence status

Under the alarm occurrence status, Alarm flag (Xn1 to Xn8) is ON.

(c) Self-retention status

Under the self-retention status, Alarm flag (Xn1 to Xn8) is ON.

(d) Alarm reset status

Under the alarm reset status, Alarm flag (Xn1 to Xn8) is OFF.

- 3) Behaviors of ALM1 LED and ALM2 LED
- (a) The indication of ALM1 LED changes according to status of CH1 Alarm.
 - lo1 primary alarm flag (Xn1)
 - lo1 secondary alarm flag (Xn2)
 - lor1 primary alarm flag (Xn3)
 - lor1 secondary alarm flag (Xn4)

 - (b) The indication of ALM2 LED changes according to status of CH2 Alarm.
 - lo2 primary alarm flag (Xn5)
 - lo2 secondary alarm flag (Xn6)
 - lor2 primary alarm flag (Xn7)
 - lor2 secondary alarm flag (Xn8)

 - (c) ALM1 LED and ALM2 LED display the following 3 indications according to the alarm status of the alarm occurrence flag.
 - Flashing
Of the alarm occurrence flags, one or more flags are in the alarm occurrence status or in the alarm reset status (regardless of the status of the remaining alarm occurrence flags).
 - ON
Of the alarm occurrence flags, one or more flags are in the self-retention status and the remaining flags of alarm occurrence are in the alarm non-occurrence status.
 - OFF
Flags of alarm occurrence are all in the alarm non-occurrence status.

(3) Behavior of alarms

- 1) When the alarm reset method is in the “auto reset” setting (Example of lo1 primary alarm monitoring):
 - (a) If the present value lo1 exceeds alarm value and the situation continues for alarm delay time, lo1 primary alarm flag (Xn1) will be turned ON. At the same time, ALM1 LED flashes.
 - (b) If the present value goes below the upper limit, lo1 primary alarm flag (Xn1) will be turned OFF. At this time, ALM1 LED is turned off.
 - (c) Even if the present value lo1 exceeds alarm value, if the value goes under alarm value within alarm delay time, lo1 primary alarm flag (Xn1) will remain OFF.

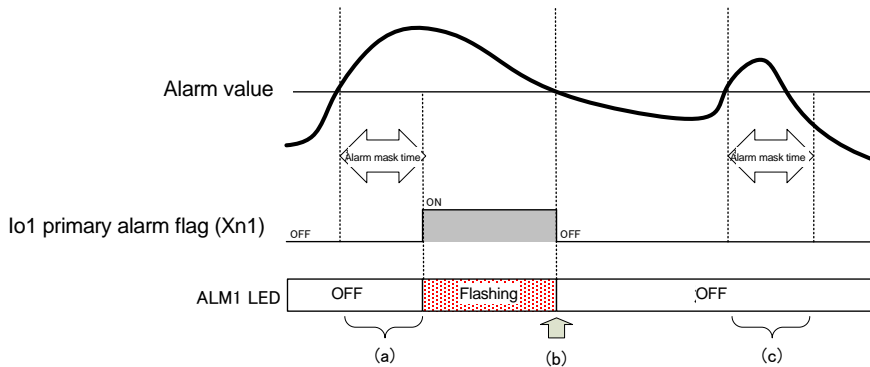

Figure 4.2.3-3 Time chart of the secondary alarm (alarm reset method = “auto-reset”)

- 2) When alarm reset method is set to “self-retention” (Example of lo1 primary alarm monitoring)
 - (a) If the present value lo1 exceeds alarm value and the situation continues for alarm delay time, lo1 primary alarm flag (Xn1) will be turned ON. At the same time, ALM1 LED flashes.
 - (b) If the present value lo1 goes below the upper limit, lo1 primary alarm flag (Xn1) remains ON (self-retention). During the self-retention, ALM1 LED is turned on.
 - (c) By turning CH1 alarm reset request (Yn1) to ON, lo1 primary alarm flag (Xn1) will be turned OFF. At this time, ALM1 LED is turned off.
 - (d) Check that lo1 primary alarm flag (Xn1) becomes OFF, and then set CH1 alarm reset request (Yn1) to OFF.

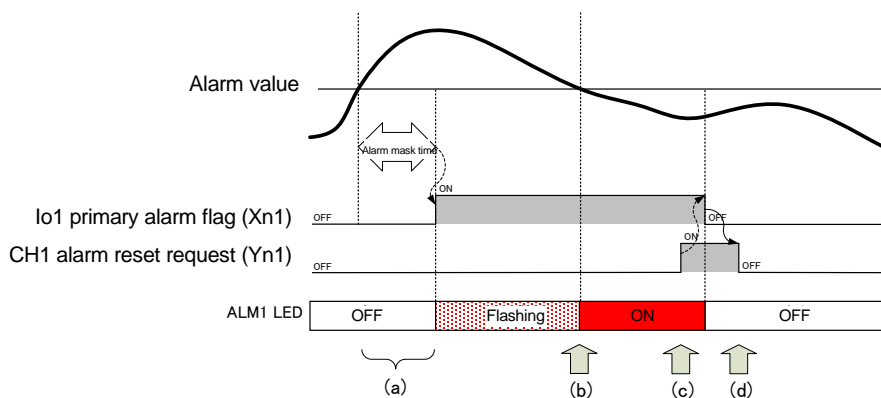

Figure 4.2.3-4 Time chart of the secondary alarm (alarm reset method = “self-retention”)

- 3) An example of lo1 primary alarm monitoring is indicated in 1) and 2) above. Other alarm monitoring will be in accordance with the same behavior.

For the setting items for the buffer memory that corresponds to the alarm monitoring and the I/O signals, refer to Chapters 5 and 6.

(3) How to reset Alarm flag

- 1) If Alarm flag is ON during the alarm occurrence or the self-retention (in the case of the alarm reset method = "self-retention"), Alarm flag can be reset (turned OFF) using Alarm reset request.

- 2) CH1 alarm clear request (Yn1) will clear the following data. However, the following data cannot be cleared individually.
 - lo1 primary alarm flag (Xn1)
 - lo1 secondary alarm flag (Xn2)
 - lor1 primary alarm flag (Xn3)
 - lor1 secondary alarm flag (Xn4)

- 3) The following data can be cleared upon CH2 alarm reset request (Yn5). However, the following data cannot be cleared individually.
 - lo2 primary alarm flag (Xn5)
 - lo2 secondary alarm flag (Xn6)
 - lor2 primary alarm flag (Xn7)
 - lor2 secondary alarm flag (Xn8)

- 4) How to reset Alarm flag during alarm occurrence (Example of lo1 primary alarm monitoring)
 - (a) If the present value lo1 exceeds alarm value, lo1 primary alarm flag (Xn1) will be turned ON. At the same time, ALM1 LED flashes.
 - (b) By turning CH1 alarm reset request (Yn1) to ON, lo1 primary alarm flag (Xn1) will be turned OFF. At this time, ALM1 LED will remain flashing (because ALM1 LED is synchronized with the alarm status, it will not turn off).
 - (c) Check that lo1 primary alarm flag (Xn1) becomes OFF, and then set CH1 alarm reset request (Yn1) to OFF.
 - (d) If the present value lo1 goes under alarm value, ALM1 LED will be turned off.
 - (e) After that, if the present value lo1 exceeds alarm value, lo1 primary alarm flag (Xn1) will be turned ON again. At the same time, ALM1 LED flashes.

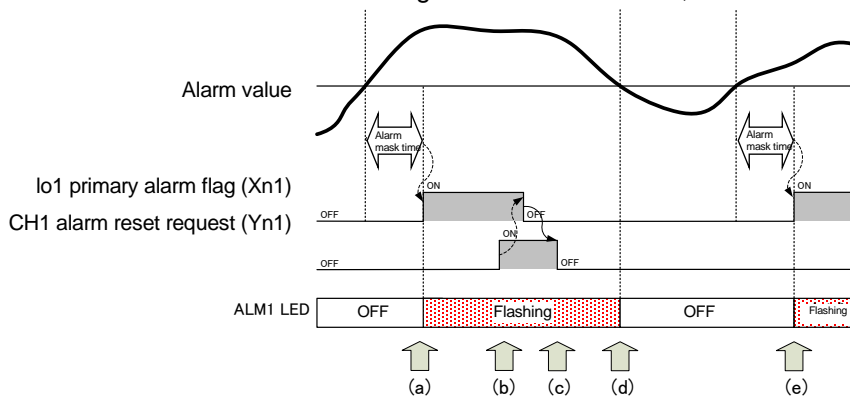

Figure 4.2.3-5 Procedure for resetting lo1 primary alarm flag (alarm reset method = “auto-reset”)

- 5) How to reset Alarm flag during self-retention (in the case the alarm reset method = “self-retention” only)

Refer to the procedure described in (2) 2).

4.2.4 Alarm occurrence count function

It memorizes the count of alarm occurrence for each alarm monitoring element, and retains it until the count of alarm occurrence is performed.

(1) Memory of Alarm occurrence count

- 1) It memorizes each alarm occurrence count for the following element.
 - lo1 primary alarm
 - lo1 secondary alarm
 - lor1 primary alarm
 - lor1 secondary alarm
 - lo2 primary alarm
 - lo2 secondary alarm
 - lor2 primary alarm
 - lor2 secondary alarm
- 2) Alarm occurrence count is stored in the nonvolatile memory, so that it can be retained even at a power source reset.

(2) How to clear Alarm occurrence count

- 1) You can use I/O signal to clear the count of alarm occurrence.
- 2) The count of alarm occurrence immediately after the clear will be "0".
- 3) The following data can be cleared upon CH1 alarm occurrence count clear request (YnB). However, the following data cannot be cleared individually.
 - lo1 primary alarm occurrence count (Un\G1200)
 - lo1 secondary alarm occurrence count (Un\G1201)
 - lor1 primary alarm occurrence count (Un\G1250)
 - lor1 secondary alarm occurrence count (Un\G1251)
- 4) The following data can be cleared upon CH2 alarm occurrence count clear request (YnD). However, the following data cannot be cleared individually.
 - lo2 primary alarm occurrence count (Un\G2200)
 - lo2 secondary alarm occurrence count (Un\G2201)
 - lor2 primary alarm occurrence count (Un\G2250)
 - lor2 secondary alarm occurrence count (Un\G2251)
- 5) The following describes how to clear CH1 alarm occurrence count. (CH2 alarm occurrence count follows the same procedure using CH2 alarm occurrence count clear request (YnD).)
 - (i) Check that CH1 alarm occurrence count clear request (YnB) is OFF.
 - (ii) Set CH1 alarm occurrence count clear request (YnB) to ON.

CH1 alarm occurrence count is cleared, and then CH1 alarm occurrence count clear completion flag (XnB) is turned ON.
 - (iii) Check that CH1 alarm occurrence count clear completion flag (XnB) is ON, and then set CH1 alarm occurrence count clear request (YnB) to OFF.

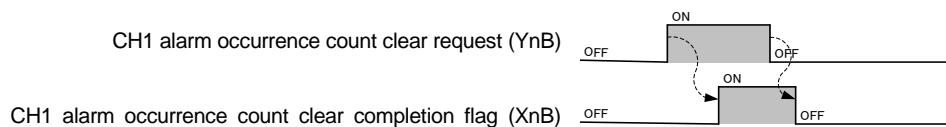

Figure 4.2.3-6 Procedure for clearing Alarm occurrence count

4.2.5 Test function

This function is to output pseudo-fixed value to a buffer memory for debugging sequence program. The value can be output to the buffer memory without input of voltage and current.

(1) How to use the test function

- 1) Using the intelligent function switch settings, you can start the test mode to output the fixed value.
- 2) For procedure for setting the intelligent function switch, refer to 7.5.2.
- 3) To finish the test mode, the set value is returned by the intelligent function switch setting, and after that, it starts a measuring mode (low sensitivity mode or high sensitivity mode) by resetting it.
(It resumes with the previous set value and accumulated electric energy as well as periodic electric energy.)

(2) Content of pseudo-output

For the value to be output to the buffer memory, refer to Tables 6.1-1 to 6.1-3 in 6.1 Buffer memory assignment.

(3) Precautions for using the test function

- 1) Because pseudo-fixed value is output to the buffer memory, isolate the actual device to avoid unexpected operation before running the sequence program.

Chapter 5: I/O signal to CPU module

5.1 List of I/O signals

I/O signals of QE82LG are listed in Table 5.1-1.

The “n” that is used in this and later chapters (for example: Xn0, Yn0, Un\G0, etc.) refers to the number that appears at the beginning of QE82LG.

Table 5.1-1 List of I/O signals

Input signal (signal direction from QE82LG to CPU module)		Output signal(signal direction from CPU module to QE82LG)	
Device #	Signal name	Device #	Signal name
Xn0	Module ready	Yn0	Use prohibited *1
Xn1	lo1 primary alarm flag	Yn1	CH1 alarm reset request
Xn2	lo1 secondary alarm flag	Yn2	Use prohibited *1
Xn3	lor1 primary alarm flag	Yn3	Use prohibited *1
Xn4	lor1 secondary alarm flag	Yn4	Use prohibited *1
Xn5	lo2 primary alarm flag	Yn5	CH2 alarm reset request
Xn6	lo2 secondary alarm flag	Yn6	Use prohibited *1
Xn7	lor2 primary alarm flag	Yn7	Use prohibited *1
Xn8	lor2 secondary alarm flag	Yn8	Use prohibited *1
Xn9	Operating condition setting completion flag	Yn9	Operating condition setting request
XnA	CH1 max. value clear completion flag	YnA	CH1 max. value clear request
XnB	CH1 alarm occurrence count clear completion flag	YnB	CH1 alarm occurrence count clear request
XnC	CH2 max. value clear completion flag	YnC	CH2 max. value clear request
XnD	CH2 alarm occurrence count clear completion flag	YnD	CH2 alarm occurrence count clear request
XnE	Use prohibited *1	YnE	Use prohibited *1
XnF	Error flag	YnF	Error clear request

Point

*1 These signals cannot be used by the user since they are for system use only. If these are set to on or off by the sequence program, the performance of the QE82LG cannot be guaranteed.

5.2 Details of I/O signals

Detailed explanation about I/O signals of QE82LG is provided as follows:

5.2.1 Input signals

(1) Module ready (Xn0)

- (a) When the power of CPU module is turned on or the CPU module reset is performed, it will turn ON as soon as the measurement is ready.
- (b) Module ready is turned OFF when the insulation monitoring module displays a hardware error, and RUN LED is turned off.

(2) Io1 primary alarm flag (Xn1)

- (a) When the present value Io1 exceeds Io1 primary alarm value (Un\G1000) and the situation continues for Io1 primary alarm delay time (Un\G1002), this signal (Xn1) turns ON.
- (b) Operations after this signal (Xn1) is turned ON will be different depending on the setting of Io1 primary alarm reset method (Un\G1001) below.

[When Io1 primary alarm reset method (Un\G1001) is “self-retention”]

Even if the present value Io1 goes under Io1 primary alarm value (Un\G1000), this signal (Xn1) remains ON. Then, when CH1 alarm reset request (Yn1) is turned to ON, this signal (Xn1) turns OFF.

[When Io1 primary alarm reset method (Un\G1001) is “auto reset”]

If the present value Io1 goes under Io1 primary alarm value (Un\G1000), this signal (Xn1) turns OFF.

- (c) When Io1 primary alarm value (Un\G1000) is set to “0 (not monitoring)”, this signal (Xn1) is always OFF.

*For the actual behavior of alarm monitoring, refer to 4.2.4.

(3) Io1 secondary alarm flag (Xn2)

The usage procedure is the same as Io1 primary alarm flag (Xn1). Refer to (2).

(4) Ior1 primary alarm flag (Xn3)

The usage procedure is the same as Io1 primary alarm flag (Xn1). Refer to (2).

(5) Ior1 secondary alarm flag (Xn4)

The usage procedure is the same as Io1 primary alarm flag (Xn1). Refer to (2).

- (6) lo2 primary alarm flag (Xn5)
The usage procedure is the same as lo1 primary alarm flag (Xn1). Refer to (2).
- (7) lo2 secondary alarm flag (Xn6)
The usage procedure is the same as lo1 primary alarm flag (Xn1). Refer to (2).
- (8) lor2 primary alarm flag (Xn7)
The usage procedure is the same as lo1 primary alarm flag (Xn1). Refer to (2).
- (9) lor2 secondary alarm flag (Xn8)
The usage procedure is the same as lo1 primary alarm flag (Xn1). Refer to (2).
- (10) Operating condition setting completion flag (Xn9)
- (a) When turning Operating condition setting request (Yn9) to ON and changing the following settings, this signal (Xn9) turns ON.
- Phase wire system (Un\G0)
 - lo1 primary alarm value (Un\G1000)
 - lo1 primary alarm reset method (Un\G1001)
 - lo1 primary alarm delay time (Un\G1002)
 - lo1 secondary alarm value (Un\G1003)
 - lo1 secondary alarm reset method (Un\G1004)
 - lo1 secondary alarm delay time (Un\G1005)
 - lor1 primary alarm value (Un\G1050)
 - lor1 primary alarm reset method (Un\G1051)
 - lor1 primary alarm delay time (Un\G1052)
 - lor1 secondary alarm value (Un\G1053)
 - lor1 secondary alarm reset method (Un\G1054)
 - lor1 secondary alarm delay time (Un\G1055)
 - lo2 primary alarm value (Un\G2000)
 - lo2 primary alarm reset method (Un\G2001)
 - lo2 primary alarm delay time (Un\G2002)
 - lo2 secondary alarm value (Un\G2003)
 - lo2 secondary alarm reset method (Un\G2004)
 - lo2 secondary alarm delay time (Un\G2005)
 - lor2 primary alarm value (Un\G2050)
 - lor2 primary alarm reset method (Un\G2051)
 - lor2 primary alarm delay time (Un\G2052)
 - lor2 secondary alarm value (Un\G2053)
 - lor2 secondary alarm reset method (Un\G2054)
 - lor2 secondary alarm delay time (Un\G2055)
- (b) When Operating condition setting request (Yn9) is OFF, this signal (Xn9) turns OFF.

(11) CH1 max. value clear completion flag (XnA)

(a) When CH1 max. value clear request (YnA) is turned ON and the following max. value data are cleared, this signal (XnA) turns ON.

- lo1 max. value (Un\G1101)
- lo1 date/time of occurrence (Un\G1102 to Un\G1105)
- lor1 max. value (Un\G1151)
- lor1 date/time of occurrence (Un\G1152 to Un\G1155)

(b) When CH1 max. value clear request (YnA) is turned OFF, this signal (XnA) turns OFF.

(12) CH1 alarm occurrence count clear completion flag (XnB)

(a) When CH1 alarm occurrence count clear request (YnB) is turned ON and the following alarm occurrence count data are cleared, this signal (XnB) turns ON.

- lo1 primary alarm occurrence count (Un\G1200)
- lo1 secondary alarm occurrence count (Un\G1201)
- lor1 primary alarm occurrence count (Un\G1250)
- lor1 secondary alarm occurrence count (Un\G1251)

(b) When CH1 alarm occurrence count clear request (YnB) is turned OFF, this signal (XnB) turns OFF.

(13) CH2 max. value clear completion flag (XnC)

The usage procedure is the same as CH1 max. value clear completion flag (XnA). Refer to (11).

(14) CH2 alarm occurrence count clear completion flag (XnD)

The usage procedure is the same as CH1 alarm occurrence count clear completion flag (XnB). Refer to (12).

(15) Error flag (XnF)

(a) If an outside-set-value error occurs, and if a hardware error occurs, this signal (XnF) turns ON.

(b) The description of the error occurred can be checked with latest error code (Un\G3000).

*For description of error codes, refer to section 9.1.

(c) If an outside-set-value error occurs, this signal (XnF) is turned OFF by setting a value within the range again.

5.2.2 Output signals

(1) CH1 alarm reset request (Yn1)

(a) When resetting the following flags for alarm occurrence, this signal (Yn1) turns ON.

- lo1 primary alarm flag (Xn1)
- lo1 secondary alarm flag (Xn2)
- lor1 primary alarm flag (Xn3)
- lor1 secondary alarm flag (Xn4)

(b) When this signal (Yn1) is switched from the OFF status to the ON status, above alarm flag will forcibly be turned OFF regardless of alarm flag status.

(2) CH2 alarm reset request (Yn5)

(a) When resetting the following flags for alarm occurrence, this signal (Yn5) turns ON.

- lo2 primary alarm flag (Xn5)
- lo2 secondary alarm flag (Xn6)
- lor2 primary alarm flag (Xn7)
- lor2 secondary alarm flag (Xn8)

(b) When this signal (Yn5) is switched from the OFF status to the ON status, above alarm flag will forcibly be turned OFF regardless of alarm flag status.

(3) Operating condition setting request (Yn9)

(a) When switching this signal (Yn9) from the OFF status to the ON status, the following operating conditions will be set.

- Phase wire system (Un\G0)
- lo1 primary alarm value (Un\G1000)
- lo1 primary alarm reset method (Un\G1001)
- lo1 primary alarm delay time (Un\G1002)
- lo1 secondary alarm value (Un\G1003)
- lo1 secondary alarm reset method (Un\G1004)
- lo1 secondary alarm delay time (Un\G1005)
- lor1 primary alarm value (Un\G1050)
- lor1 primary alarm reset method (Un\G1051)
- lor1 primary alarm delay time (Un\G1052)
- lor1 secondary alarm value (Un\G1053)
- lor1 secondary alarm reset method (Un\G1054)
- lor1 secondary alarm delay time (Un\G1055)
- lo2 primary alarm value (Un\G2000)
- lo2 primary alarm reset method (Un\G2001)
- lo2 primary alarm delay time (Un\G2002)
- lo2 secondary alarm value (Un\G2003)
- lo2 secondary alarm reset method (Un\G2004)
- lo2 secondary alarm delay time (Un\G2005)
- lor2 primary alarm value (Un\G2050)
- lor2 primary alarm reset method (Un\G2051)
- lor2 primary alarm delay time (Un\G2052)
- lor2 secondary alarm value (Un\G2053)
- lor2 secondary alarm reset method (Un\G2054)
- lor2 secondary alarm delay time (Un\G2055)

- (b) When the operating condition setting is completed, Operating condition setting completion flag (Xn9) turns ON.
 - (c) When this signal (Yn9) is turned OFF, Operating condition setting completion flag (Xn9) turns OFF.
- (4) CH1 max. value clear request (YnA)
- (a) When switching this signal (YnA) from the OFF status to the ON status, the following max. value data will be cleared.
 - lo1 max. value (Un\G1101)
 - lo1 date/time of occurrence (Un\G1102 to Un\G1105)
 - lor1 max. value (Un\G1151)
 - lor1 date/time of occurrence (Un\G1152 to Un\G1155)
 - (b) When clearing the max. data above is completed, CH1 max. value clear completion flag (XnA) turns ON.
 - (c) When this signal (YnA) is turned OFF, CH1 max. value clear completion flag (XnA) is turned OFF.
- (5) CH1 alarm occurrence count clear request (YnB)
- (a) When switching this signal (YnB) from the OFF status to the ON status, the following max. value data will be cleared.
 - lo1 primary alarm occurrence count (Un\G1200)
 - lo1 secondary alarm occurrence count (Un\G1201)
 - lor1 primary alarm occurrence count (Un\G1250)
 - lor1 secondary alarm occurrence count (Un\G1251)
 - (b) When clearing the max. data above is completed, CH1 alarm occurrence count clear completion flag (XnB) turns ON.
 - (c) When this signal (YnB) is turned OFF, CH1 alarm occurrence count clear completion flag (XnB) turns OFF.
- (6) CH2 max. value clear request (YnC)
- (a) When switching this signal (YnC) from the OFF status to the ON status, the following max. value data will be cleared.
 - lo2 max. value (Un\G2101)
 - lo2 date/time of occurrence (Un\G2102 to Un\G2105)
 - lor2 max. value (Un\G2151)
 - lor2 date/time of occurrence (Un\G2152 to Un\G2155)
 - (b) When clearing the max. data above is completed, CH2 max. value clear completion flag (XnC) turns ON.
 - (c) When this signal (YnC) is turned OFF, CH2 max. value clear completion flag (XnC) turns OFF.

- (7) CH2 alarm occurrence count clear request (YnD)
- (a) When switching this signal (YnD) from the OFF status to the ON status, the following max. value data will be cleared.
 - lo2 primary alarm occurrence count (Un\G2200)
 - lo2 secondary alarm occurrence count (Un\G2201)
 - lor2 primary alarm occurrence count (Un\G2250)
 - lor2 secondary alarm occurrence count (Un\G2251)
 - (b) When clearing the max. data above is completed, CH2 alarm occurrence count clear completion flag (XnD) turns ON.
 - (c) When this signal (YnD) is turned OFF, CH2 alarm occurrence count clear completion flag (XnD) turns OFF.
- (8) Error clear request (YnF)
- (a) When switching this signal from the OFF status to the ON status while an outside-set-value error occurs, Error flag (XnF) will be turned OFF and latest error code (Un\G3000) will be cleared.
 - (b) At the same time as the clearing error above, the value set in the buffer memory below will be replaced with the previously set value.
[Values that are to be replaced with the previously set value]
 - Phase wire system (Un\G0)
 - lo1 primary alarm value (Un\G1000)
 - lo1 primary alarm reset method (Un\G1001)
 - lo1 primary alarm delay time (Un\G1002)
 - lo1 secondary alarm value (Un\G1003)
 - lo1 secondary alarm reset method (Un\G1004)
 - lo1 secondary alarm delay time (Un\G1005)
 - lor1 primary alarm value (Un\G1050)
 - lor1 primary alarm reset method (Un\G1051)
 - lor1 primary alarm delay time (Un\G1052)
 - lor1 secondary alarm value (Un\G1053)
 - lor1 secondary alarm reset method (Un\G1054)
 - lor1 secondary alarm delay time (Un\G1055)
 - lo2 primary alarm value (Un\G2000)
 - lo2 primary alarm reset method (Un\G2001)
 - lo2 primary alarm delay time (Un\G2002)
 - lo2 secondary alarm value (Un\G2003)
 - lo2 secondary alarm reset method (Un\G2004)
 - lo2 secondary alarm delay time (Un\G2005)
 - lor2 primary alarm value (Un\G2050)
 - lor2 primary alarm reset method (Un\G2051)
 - lor2 primary alarm delay time (Un\G2052)
 - lor2 secondary alarm value (Un\G2053)
 - lor2 secondary alarm reset method (Un\G2054)
 - lor2 secondary alarm delay time (Un\G2055)
 - (c) While a hardware error is present (error code: 0000H to 0FFFH), it will not be cleared even if this signal (YnF) turns ON.

Chapter 6: Buffer memory

6.1 Buffer memory assignment

The following describes buffer memory assignment.

Point	Do not write data into the prohibited area in the buffer memory from system area and sequence program. If data are written into these areas, it may cause malfunction.
-------	--

(1) Configurable sections (Un\G0 to Un\G1100, Un\G2000 to Un\G2100)

Table 6.1-1 Configurable sections (Un\G0 to Un\G1100, Un\G2000 to Un\G2100)

Item	Address (decimal)		Data type ^{*1}	Description	Default value	R/W ^{*2}	Backup ^{*3}	Value during the test mode ^{*4}		
	CH1	CH2						CH1	CH2	
Configurable section	0		Pr	Phase wire system	3	R/W	○	3		
	1-99		-	System area	-	-	-	0		
	100		Md	Leak current, Leak current for resistance multiplying factor (x 10 ⁿ)	0	R	○	-2		
	1000	2000	Pr	Leak current	primary alarm value	0	R/W	○	0	0
	1001	2001	Pr		primary alarm reset method	0	R/W	○	0	0
	1002	2002	Pr		primary alarm delay time	0	R/W	○	0	0
	1003	2003	Pr		secondary alarm value	0	R/W	○	0	0
	1004	2004	Pr		secondary alarm reset method	0	R/W	○	0	0
	1005	2005	Pr		secondary alarm delay time	0	R/W	○	0	0
	1006-1049	2006-2049	-		System area	-	-	-	-	-
	1050	2050	Pr	Leak current for resistance	primary alarm value	0	R/W	○	0	0
	1051	2051	Pr		primary alarm reset method	0	R/W	○	0	0
	1052	2052	Pr		primary alarm delay time	0	R/W	○	0	0
	1053	2053	Pr		secondary alarm value	0	R/W	○	0	0
	1054	2054	Pr		secondary alarm reset method	0	R/W	○	0	0
	1055	2055	Pr		secondary alarm delay time	0	R/W	○	0	0
	1056-1100	2056-2100	-	System area	-	-	-	-	-	

*1: Pr indicates setting data, and Md indicates monitoring data.

*2: It indicates readable / writable status from the sequence program.

R: Readable

W: Writable

*3: Even if the power failure is restored, data is held because data is backed up by the nonvolatile memory.

*4: For the procedure for using the test mode, refer to section 4.2.5.

(2) Measurable sections (Un\G1100 to Un\G1999, Un\G2100 to Un\G2999)

Table 6.1-2 Measurable sections (Un\G1100 to Un\G1999, Un\G2100 to Un\G2999)

Item	Address (decimal)		Data type ^{*1}	Description	Default value	R/W ^{*2}	Backup ^{*3}	Value during the test mode ^{*4}		
	CH1	CH2						CH1	CH2	
Measurable section	1100	2100	Md	Leak current	Present value	0	R	-	1001	2001
	1101	2101	Md		Max. value	0	R	○	1002	2002
	1102	2102	Md		Year of time of max. value	0000h	R	○	2010h	2020h
	1103	2103	Md		Month and day of time of max. value	0000h	R	○	0903h	1004h
	1104	2104	Md		Hour and minute of time of max. value	0000h	R	○	0102h	0203h
	1105	2105	Md		Second and day of the week of time of max. value	0000h	R	○	0304h	0405h
	1106-1149	2106-2149	-	System area		-	-	-	-	-
	1150	2150	Md	Leak current for resistance	Present value	0	R	-	1011	2011
	1151	2151	Md		Max. value	0	R	○	1012	2012
	1152	2152	Md		Year of time of max. value	0000h	R	○	2011h	2021h
	1153	2153	Md		Month and day of time of max. value	0000h	R	○	0102h	0203h
	1154	2154	Md		Hour and minute of time of max. value	0000h	R	○	0304h	0405h
	1155	2155	Md		Second and day of the week of time of max. value	0000h	R	○	0506h	0600h
	1156-1199	2156-2199	-	System area		-	-	-	-	-
	1200	2200	Md	Leak current	primary alarm occurrence count	0	R	○	1021	2021
	1201	2201	Md		secondary alarm occurrence count	0	R	○	1022	2022
	1202-1249	2202-2249	-	System area		-	-	-	-	-
	1250	2250	Md	Leak current for resistance	primary alarm occurrence count	0	R	○	1031	2031
	1251	2251	Md		secondary alarm occurrence count	0	R	○	1032	2032
	1252-1999	2252-2999	-	System area		-	-	-	-	-

*1: Pr indicates setting data, and Md indicates monitoring data.

*2: It indicates readable / writable status from the sequence program.

R: Readable

W: Writable

*3: Even if the power failure is restored, data is held because data is backed up by the nonvolatile memory.

*4: For the procedure for using the test mode, refer to section 4.2.5.

(3) Common sections (Un\G3000 to Un\G4999)

Table 6.1-3 Latest error sections (Un\G3000 to Un\G4999)

Item	Address (decimal)	Data type ¹	Description	Default value	R/W ²	Backup ³	Value during the test mode ⁴
Common sections	3000	Md	Latest error code	0000h	R	-	0001h
	3001	Md	Year of time of error	0000h	R	-	2019h
	3002	Md	Month and day of time of error	0000h	R	-	0910h
	3003	Md	Hour and minute of time of error	0000h	R	-	1112h
	3004	Md	Month and day of time of error	0000h	R	-	1301h
	3005-3499	-	System area	-	-	-	-
	3500	Md	Measuring mode	0000h	R	-	0001h
	3501-4999	-	System area	-	-	-	-

*1: Pr indicates setting data, and Md indicates monitoring data.

*2: It indicates readable / writable status from the sequence program.

R: Readable

W: Writable

*3: Even if the power failure is restored, data is held because data is backed up by the nonvolatile memory.

*4: For the procedure for using the test mode, refer to section 4.2.5.

6.2 Configurable sections (Un\G0 to Un\G1100, Un\G2000 to Un\G2100)

6.2.1 Phase wire system (Un\G0)

Phase wire system for target electric circuits is configured.
It is common for both CH1 and CH2.

(1) Setting procedure

(a) Set the phase wire in the buffer memory. Setting range is as follows:

Setting value	Description
1	Single-phase 2-wire
2	Single-phase 3-wire
3	Three-phase 3-wire

(b) Turn Operating condition setting request (Yn9) from OFF to ON to enable the setting. (Refer to 5.2.2(5).)

(2) Default value

It is set to 3 (Three-phase 3-wire).

6.2.2 Leak current, Leak current for resistance multiplying factor (Un\G100)

Stores the measured value of multiplying factor for leak current and leak current for resistance.

(1) Details of stored data

(a) It depends on the measuring mode (low sensitivity mode and high sensitivity mode).
For the setting of Measuring mode, refer to section 7.6.2 or 7.7.2.

(2) Default value

It is set to 0. (Low sensitivity mode: 10^0)

6.2.3 Io1 primary alarm value (Un\G1000)

Set the monitoring level of CH1 leak current.
For the buffer memory address of other monitoring value, refer to section 6.1(1).

(1) Setting procedure

(a) Set the monitoring value in the buffer memory. Setting range is as follows:

Setting range	Description
0	No monitoring
Low sensitivity mode: 1 to 1000 (mA) High sensitivity mode: 1 to 10000 ($\times 10^{-2}$ mA)	Monitors with the set value

(b) Turn Operating condition setting request (Yn9) from OFF to ON to enable the setting. (Refer to 5.2.2(5).)

(2) Default value

All monitoring values are set to 0 (no monitoring).

6.2.4 Io1 primary alarm reset method (Un\G1001)

Set alarm reset method of CH1 leak current.

For differences in behavior of alarm monitoring for different reset methods, refer to 4.2.4(2).

For the buffer memory address of other reset methods, refer to section 6.1(1).

(1) Setting procedure

(a) Set the reset method in the buffer memory. Setting range is as follows:

Setting value	Description
0	Self-retention
1	Auto reset

(b) Turn Operating condition setting request (Yn9) from OFF to ON to enable the setting. (Refer to 5.2.2(5).)

(2) Default value

All reset methods are set to 0 (self-retention).

6.2.5 Io1 primary alarm delay time (Un\G1002)

Set alarm delay time of CH1 leak current.

Alarm delay time means a grace period of time that starts from the moment when it exceeds the upper limit of monitoring value until the alarm occurrence flag is turned ON. For detailed behavior, refer to 4.2.4(2).

For the buffer memory address of other alarm delay time, refer to section 6.1(1).

(1) Setting procedure

(a) Set alarm delay time in the buffer memory.

- Configurable range: 0 to 300 (seconds)
- Set the value in seconds.

(b) Turn Operating condition setting request (Yn9) from OFF to O to enable the setting. (Refer to 5.2.2(5).)

(2) Default value

All alarm delay time is set to 0 (seconds).

6.3 Measurable sections (Un\G1100 to Un\G1999, Un\G2100 to Un\G2999)

This product divides the measuring data into the Data and Multiplier, and output them to Buffer memory. Actual measuring data is obtained by the following formula.

$$\text{Measuring data} = \text{Data} \times 10^n \text{ (Multiplier is } n\text{).}$$

(Example)

The values output to the Buffer memory are as follows when I_o present value is measured 123.45mA.

Data (Un\G1100): 12345

Multiplier (Un\G100): -2 (High sensitive mode)

The actual measuring data is obtained from the value of Buffer memory as follows.

$$\begin{aligned} \text{Measuring data} &= 12345 \times 10^{-2} \\ &= 123.45\text{mA} \end{aligned}$$

6.3.1 I_{o1} present value (Un\G1100)

Stores the measured value of CH1 leak current.

For the buffer memory address of CH2, refer to section 6.1(2).

(1) Details of stored data

(a) Storage format

Data are stored as 16-bit unsigned binary in the buffer memory.

- Data range: Low sensitivity mode: 0 to 9999 (mA), High sensitivity mode: 0 to 65535(x 10⁻²mA)

*Restrictions for measured data including resolution and measuring range, refer to section 4.2.1.

(b) Unit

It is decided by leak current, leak current for resistance multiplying factor. (Un\G100)

Leak current, Leak current for resistance multiplying factor (Un\G100)	Unit
-2	x10 ⁻² mA
0	x10 ⁰ mA

(c) Data update cycle

It will be updated approximately every 2 seconds.

6.3.2 Io1 max. value (Un\G1101)

Stores the max. value of Io1 present value.

For the buffer memory address of CH2, refer to section 6.1(2).

(1) Details of stored data

(a) Storage format

Data are stored as 16-bit unsigned binary in the buffer memory.

- Data range: Low sensitivity mode: 0 to 9999 (mA), High sensitivity mode: 0 to 65535($\times 10^{-2}$ mA)

*Restrictions for measured data including resolution and measuring range, refer to section 4.2.1.

(b) Data update cycle

It will be updated according to the update cycle of Io1 present value (Un\G1100).

(2) How to clear the stored data

To clear all of CH1 max. values, perform the following operations.

- Change CH1 max. value clear request (YnA) from OFF to ON.

After stored data are cleared, the max. values that have been obtained since all data were cleared will be stored for every CH1 max. value.

*To clear CH2 max. values, follow the same procedure using CH2 max. value clear request (YnC).

- 6.3.3 Year of time of Io1 max. value (Un\G1102), Month and day of time of Io1 max. value (Un\G1103), Hour and minute of time of Io1 max. value (Un\G1104), Second and day of the week of time of Io1 max. value (Un\G1105)

Stores the occurrence date/time such as year, month, day, hour, minute, second, and day of the week of Io1 max. value (Un\G1101).

For the buffer memory address of CH2, refer to section 6.1(2).

(1) Details of stored data

(a) Storage format

As indicated below, data are stored as BCD code in the buffer memory.

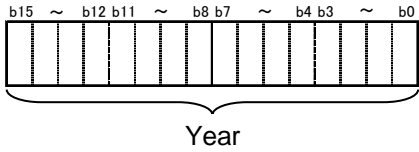
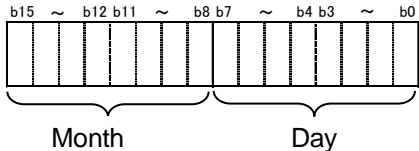
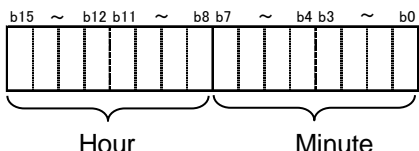
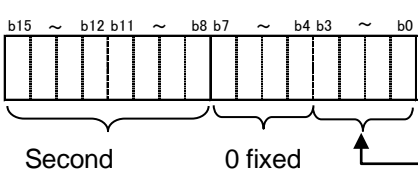
Buffer memory address	Storage format																
Un\G1102	 <p>e.g.) Year 2011 2011h</p>																
Un\G1103	 <p>e.g.) Jan 21 0121h</p>																
Un\G1104	 <p>e.g.) 10:35 1035h</p>																
Un\G1105	 <p>e.g.) 48sec Friday 4805h</p> <table border="1" data-bbox="1198 1411 1422 1594"> <thead> <tr> <th colspan="2">Day of the week</th> </tr> </thead> <tbody> <tr><td>0</td><td>Sunday</td></tr> <tr><td>1</td><td>Monday</td></tr> <tr><td>2</td><td>Tuesday</td></tr> <tr><td>3</td><td>Wednesday</td></tr> <tr><td>4</td><td>Thursday</td></tr> <tr><td>5</td><td>Friday</td></tr> <tr><td>6</td><td>Saturday</td></tr> </tbody> </table>	Day of the week		0	Sunday	1	Monday	2	Tuesday	3	Wednesday	4	Thursday	5	Friday	6	Saturday
Day of the week																	
0	Sunday																
1	Monday																
2	Tuesday																
3	Wednesday																
4	Thursday																
5	Friday																
6	Saturday																

(b) Data update cycle

It will be updated according to the update cycle of Io1 present value (Un\G1100).

(2) How to clear the stored data

To clear all of CH1 max. value occurrence dates, perform the following operations.

- Change CH1 max. value clear request (YnA) from OFF to ON.

After stored data are cleared, the max. value occurrence dates that have been obtained since all data were cleared will be stored for every CH1 max. value occurrence date.

*To clear CH2 max. values, follow the same procedure using CH2 max. value clear request (YnC).

6.3.4 Ior1 present value (Un\G1150)

Stores the measured value of CH1 leak current for resistance.
For the buffer memory address of CH2, refer to section 6.1(2).

(1) Details of stored data

(a) Storage format

Data are stored as 16-bit unsigned binary in the buffer memory.

- Data range: Low sensitivity mode: 0 to 9999 (mA), High sensitivity mode; 0 to 65535 ($\times 10^{-2}$ mA)

*Restrictions for measured data including resolution and measuring range, refer to section 4.2.1.

(b) Data update cycle

It will be updated approximately every 10 seconds.

6.3.5 Ior1 max. value (Un\G1151)

Stores the max. value of Ior1 present value.
For the buffer memory address of CH2, refer to section 6.1(2).

(1) Details of stored data

(a) Storage format

Data are stored as 16-bit unsigned binary in the buffer memory.

- Data range: Low sensitivity mode: 0 to 9999 (mA), High sensitivity mode; 0 to 65535 ($\times 10^{-2}$ mA)

*Restrictions for measured data including resolution and measuring range, refer to section 4.2.1.

(b) Data update cycle

It will be updated according to the update cycle of Ior1 present value (Un\G1150).

(2) How to clear the stored data

To clear all of CH1 max. values, perform the following operations.

- Change CH1 max. value clear request (YnA) from OFF to ON.

After stored data are cleared, the max. values that have been obtained since all data were cleared will be stored for every CH1 max. value.

*To clear CH2 max. values, follow the same procedure using CH2 max. value clear request (YnC).

- 6.3.6 Year of time of lor1 max. value (Un\G1152), Month and day of time of lor1 max. value (Un\G1153), Hour and minute of time of lor1 max. value (Un\G1154), Second and day of the week of time of lor1 max. value (Un\G1155)

Stores the occurrence date/time such as year, month, day, hour, minute, second, and day of the week of lor1 max. value (Un\G1151).

For the buffer memory address of CH2, refer to section 6.1(2).

(1) Details of stored data

(a) Storage format

As indicated below, data are stored as BCD code in the buffer memory.

Buffer memory address	Storage format																
Un\G1152	<p>e.g.) Year 2011 2011h</p>																
Un\G1153	<p>e.g.) Jan 21 0121h</p>																
Un\G1154	<p>e.g.) 10:35 1035h</p>																
Un\G1155	<p>e.g.) 48sec Friday 4805h</p> <table border="1" style="margin-left: 20px;"> <thead> <tr> <th colspan="2">Day of the week</th> </tr> </thead> <tbody> <tr><td>0</td><td>Sunday</td></tr> <tr><td>1</td><td>Monday</td></tr> <tr><td>2</td><td>Tuesday</td></tr> <tr><td>3</td><td>Wednesday</td></tr> <tr><td>4</td><td>Thursday</td></tr> <tr><td>5</td><td>Friday</td></tr> <tr><td>6</td><td>Saturday</td></tr> </tbody> </table>	Day of the week		0	Sunday	1	Monday	2	Tuesday	3	Wednesday	4	Thursday	5	Friday	6	Saturday
Day of the week																	
0	Sunday																
1	Monday																
2	Tuesday																
3	Wednesday																
4	Thursday																
5	Friday																
6	Saturday																

(b) Data update cycle

It will be updated according to the update cycle of lor1 present value (Un\G1150).

(2) How to clear the stored data

To clear all of CH1 max. value occurrence dates, perform the following operations.

- Change CH1 max. value clear request (YnA) from OFF to ON.

After stored data are cleared, the max. value occurrence dates that have been obtained since all data were cleared will be stored for every CH1 max. value occurrence date.

*To clear CH2 max. values, follow the same procedure using CH2 max. value clear request (YnC).

6.3.7 Io1 primary alarm occurrence count (Un\G1200)

Stores the count of alarms that occurred with Io1 primary alarm (how many times Io1 primary alarm flag (Xn1) has been turned ON).

For the buffer memory address of other alarm occurrence count, refer to section 6.1(2).

(1) Details of stored data

(a) Storage format

Data are stored as 16-bit signed binary in the buffer memory.

- Data range: 0 to 9999 (times)

(b) Data update cycle

It will be updated according to the update cycle of Io1 present value (Un\G1100).

(2) How to clear the stored data

To clear all of CH1 alarm occurrence count, perform the following operations.

- Change CH1 alarm occurrence count clear request (YnB) from OFF to ON.

After stored data are cleared, "0" will be stored for all CH1 alarm occurrence counts.

*To clear CH2 alarm occurrence count, follow the same procedure using CH2 alarm occurrence count clear request (YnD).

6.4 Common sections (Un\G3000 to Un\G4999)

6.4.1 Latest error code (Un\G3000)

*For the list of error codes, refer to section 9.1.

(1) Details of stored data

(a) Storage format

Data are stored as 16-bit unsigned binary in the buffer memory.

- Data range: 0000h (normal), 0001h to FFFFh (error code)

(b) Data update cycle

It will be updated at the time of error occurrence and error recovery.

- 6.4.2 Year of time of error (Un\G3001), Month and day of time of error (Un\G3002), Hour and minute of time of error (Un\G3003), Second and day of the week of time of error (Un\G3004)

Stores the occurrence date/time such as year, month, day, hour, minute, second, and day of the week of the error.

(1) Details of stored data

(a) Storage format

As indicated below, data are stored as BCD code in the buffer memory.

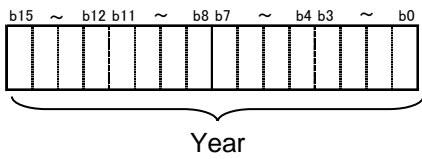
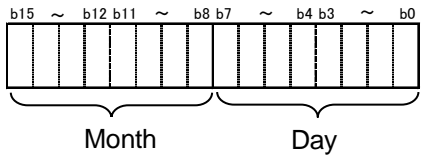
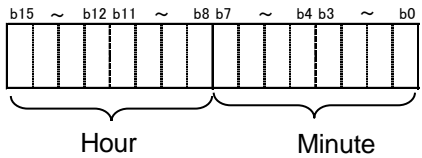
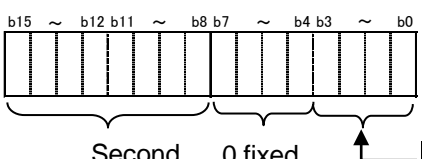
Buffer memory address	Storage format																
Un\G3001	 <p>e.g.) Year 2011 2011h</p>																
Un\G3002	 <p>e.g.) Jan 21 0121h</p>																
Un\G3003	 <p>e.g.) 10:35 1035h</p>																
Un\G3004	 <p>e.g.) 48 sec Friday 4805h</p> <table border="1" data-bbox="1201 1332 1422 1516"> <thead> <tr> <th colspan="2">Day of the week</th> </tr> </thead> <tbody> <tr><td>0</td><td>Sunday</td></tr> <tr><td>1</td><td>Monday</td></tr> <tr><td>2</td><td>Tuesday</td></tr> <tr><td>3</td><td>Wednesday</td></tr> <tr><td>4</td><td>Thursday</td></tr> <tr><td>5</td><td>Friday</td></tr> <tr><td>6</td><td>Saturday</td></tr> </tbody> </table>	Day of the week		0	Sunday	1	Monday	2	Tuesday	3	Wednesday	4	Thursday	5	Friday	6	Saturday
Day of the week																	
0	Sunday																
1	Monday																
2	Tuesday																
3	Wednesday																
4	Thursday																
5	Friday																
6	Saturday																

(b) Data update cycle

It will be updated at the time of error occurrence and error recovery.

6.4.3 Measuring mode (Un\G3500)

The setting content for measuring mode can be checked.

For the setting of Measuring mode, refer to section 7.6.2 or 7.7.2.

Measuring mode	Measuring mode(Un\G3500)
Low sensitivity mode	0
High sensitivity mode	1

Chapter 7: Setting and procedure for operation

7.1 Precautions for handling

- (1) Do not drop the case of this module or give a strong impact.
- (2) Do not remove the printed circuit board of the module from the case.
It may cause failure.
- (3) Prevent the inside of the module from any foreign objects such as chips and wire pieces.
It may cause fire, failure or malfunction.
- (4) In order to prevent the module from incoming foreign objects such as wire pieces during wiring work, a foreign-object preventive label is placed on the module.
While a wiring work is performed, keep the label on the module.
Before operating the system, peel off the label for heat release.
- (5) Module fixing screws must be tightened within the specified range as described below.
Loose screws may cause short-circuit, failure, or malfunction.
*1 The module can be fixed easily to the base unit, using the hook on top of the module. However, if it is used under a vibrating environment, we strongly recommend that the module be fixed with screws.

Table 7.1-1 Tightening torque

Locations of screws	Torque range
Module-fixing screws (M3 screw) *1	0.36 - 0.48 N•m

- (6) To attach the module to the base unit, firmly insert the protruding portions for fixing the module into the holes on the base unit, and make sure the module is securely attached to the module holes as fulcrum points.
Insecure attachment of the module may case malfunction, failure, and a falling.
- (7) Before touching the module, make sure that you need to discharge static electricity on your body by touching a metal that is grounded.
Otherwise, it may cause failure or malfunction to the module.

7.2 Procedure for operation

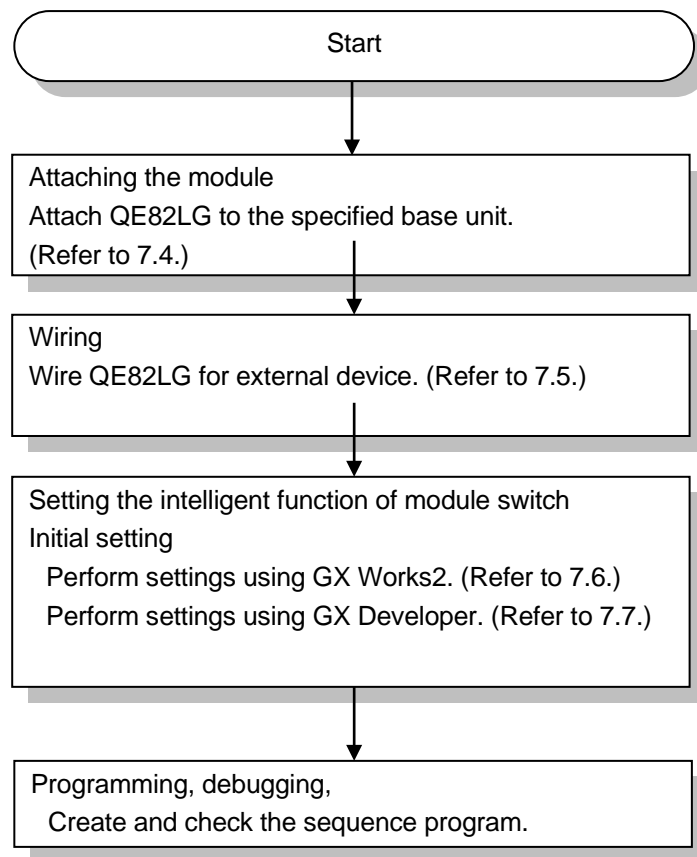

Figure 7.2-1 Procedure for operation

7.3 Name and function of each part

Names and functions of parts of QE82LG are provided below.

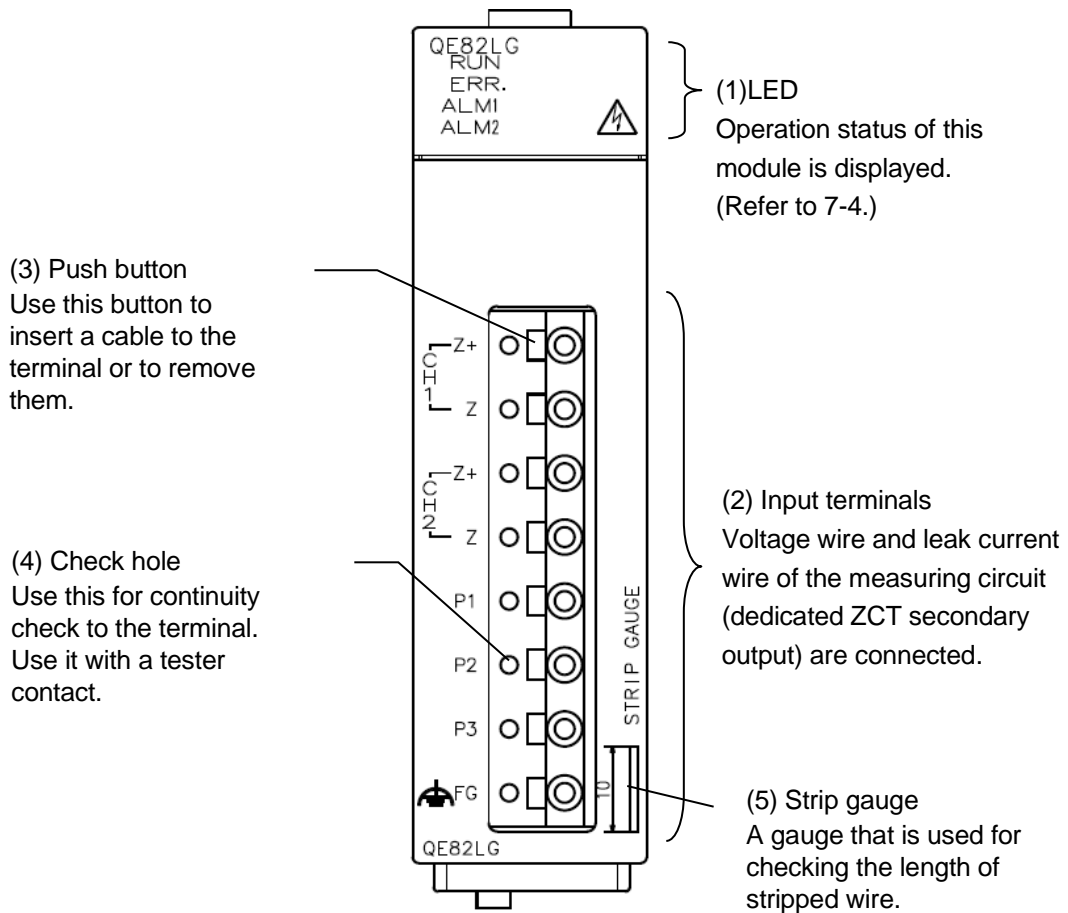

Figure 7.3-1 Appearance of the module

(1) Names and functions of LEDs

The following describes names and functions of LEDs.

Table 7.3-1 Names and functions of LEDs

Name	Color	Role	ON/OFF condition
RUN LED	Green	Displays the operation status of this module.	ON: Normal operation OFF: 5V power discontinuity, watch dog timer error
ERR. LED	Red	Displays errors and conditions of this module.	ON: Hardware error *1 Flashing: Out-of-range error *1 OFF: Normal operation
ALM1 LED	Red	Displays alarm occurrence status of CH1.	Refer to 4.2.3 (2) 3).
ALM2 LED	Red	Displays alarm occurrence status of CH2.	Refer to 4.2.3 (2) 3).

Note: During the test (debug), all LEDs will be turned ON.

*1 For details, check with the list of error codes. (Refer to section 9.1.)

(2) Names of signals of terminal block

The following describes names of signals of terminal block.

Table 7.3-2 Names of signals of terminal block

Name of terminal	Description
CH1 Z+, Z	Leak current input terminal (CH1)
CH1 Z+, Z	Leak current input terminal (CH2)
P1	1-phase voltage input terminal
P2	2-phase voltage input terminal
P3	3-phase voltage input terminal
FG	Frame GND terminal

7.4 Attaching and removing the module

7.4.1 How to attach to the base unit

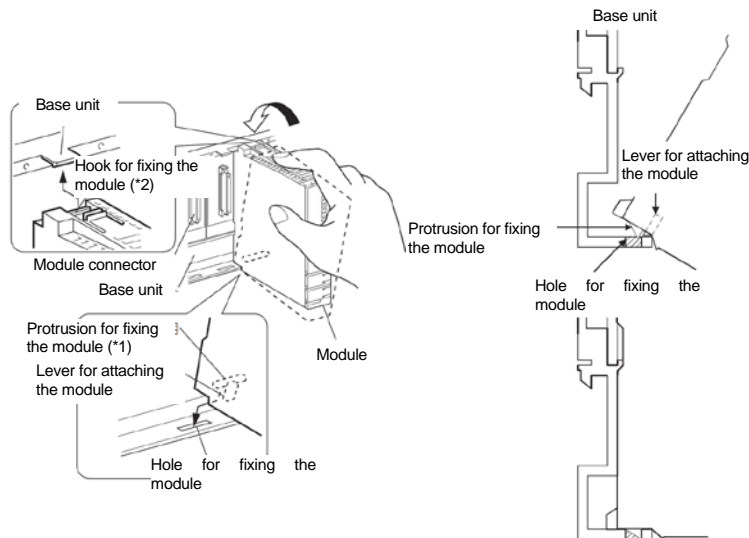
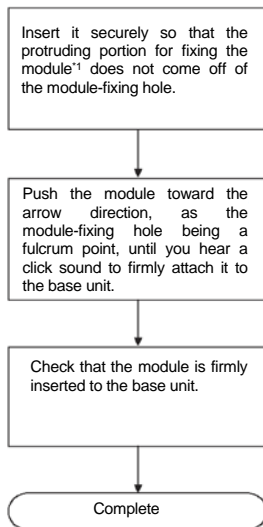

! Caution

- Attach to the base of MELSEC-Q series.
- When attaching the module, make sure to insert the protruding portions for fixing the module into the holes on the base unit. In doing so, insert it securely so that the protruding portion of the module does not come off of the holes. Do not force to attach the module; otherwise the module may break.
- When installing the module at a vibrating area with strong impact, tighten the module to the base unit using screws. Module-fixing screws: M3 x 12 (Prepare them yourself.)

Locations of screws	Torque range
Module-fixing screws (M3 screw) *1	0.36 - 0.48 N•m

- Attaching and detaching the module and the base unit should be performed 50 times or less (to conform to JIS B3502). If the count exceeds 50 times, it may cause a malfunction.

7.4.2 How to detach the base unit

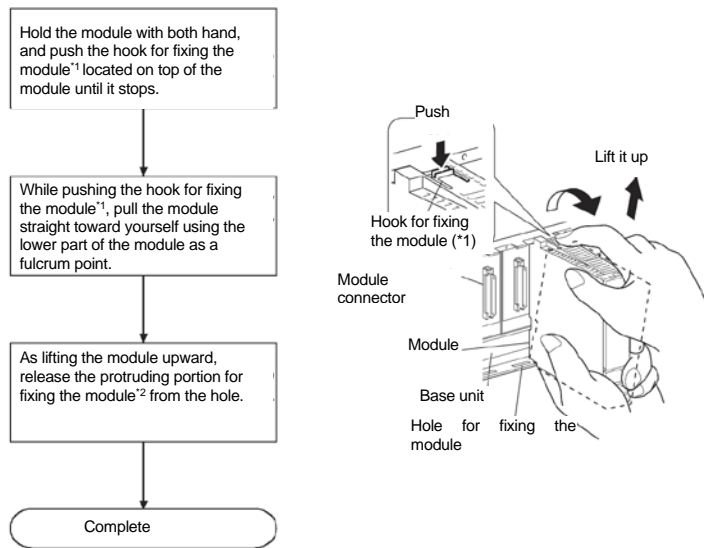

- When module-fixing screws are used, make sure to remove the screws for detaching the module first, and then remove the protruding portion for fixing the module from the holes. Do no force to remove the module; it may break the protruding portions for fixing the module.

7.5 Connecting wires, wiring

7.5.1 Precautions for wiring

- (1) Connect cables. For connecting voltage transformer and ZCT, refer to the wiring diagram.
- (2) For wiring, check with the wiring diagram and check the phase wire system for the connecting circuit.
- (3) For the leak current input, Mitsubishi's ZCT is required. (Refer to section 7.5.3.)
- (4) If a current sensor is located in a strong magnetic field such area nearby a transformer or high-current cable bus bar, the voltage circuit input may be influenced, which in turn affects the measured value. Thus, please ensure sufficient distance between devices.
- (5) For wiring voltage circuit and ZCT secondary, use separate cables from other external signals in order to prevent from AC surge and induction.
- (6) Keep any object off the cables.
- (7) Protect cable coating from scratch.
- (8) Cable length should be routed in length with a margin, please take care to avoid causing stress to pull the terminal block. (Tensile load: less than 22N)
- (9) Please do not connect two or more cables to one terminal hole of the current input terminal block. The engagement of the terminal becomes weak, and cable may fall out.
- (10) For the actual usage, connect the FG terminal to ground. (D-type ground: Type 3) Connect it directly to the ground terminal.

7.5.2 How to connect wires

(1) Follow the wiring diagram for external connection to QE82LG.

(2) Use appropriate electric wires as described below.

Appropriate wires for voltage input circuit (acceptable electric wires)

Voltage input terminal P1, P2, P3, FG	Single wire: AWG24 – AWG18 ($\phi 0.5 - 1.0\text{mm}$) Stranded wire: AWG22 – AWG18 ($0.3 - 0.8 \text{ mm}^2$)
--	---

Appropriate wires for leak current input (acceptable electric wires)

Leak current input terminal Z+, Z	Single wire: AWG24 – AWG18 ($0.5 - 1.0 \text{ mm}^2$) Stranded wire: AWG22 – AWG18 ($0.3 - 0.8 \text{ mm}^2$)
--------------------------------------	--

(3) Stripping length of the wire in use has to be 10 to 11 mm. Check the stripping length using the strip gauge of this module.

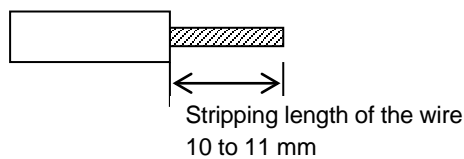

(4) When using stranded wire, make sure to use a bar terminal or treat the wire edge by stripping in order to keep thin lines from loosening.

Recommended bar terminal	TGV TC-1.25-11T (Made by Nichifu) or equivalent
--------------------------	---

* Stranded wire

(5) When attaching and detaching cables to/from the terminal, use the push button. Check that the wire is securely inserted.

(6) Insert a wire to the terminal all the way until it touches the end.

7.5.3 Connection diagram

For external connection to QE82LG, follow the phase method and the connection diagram.

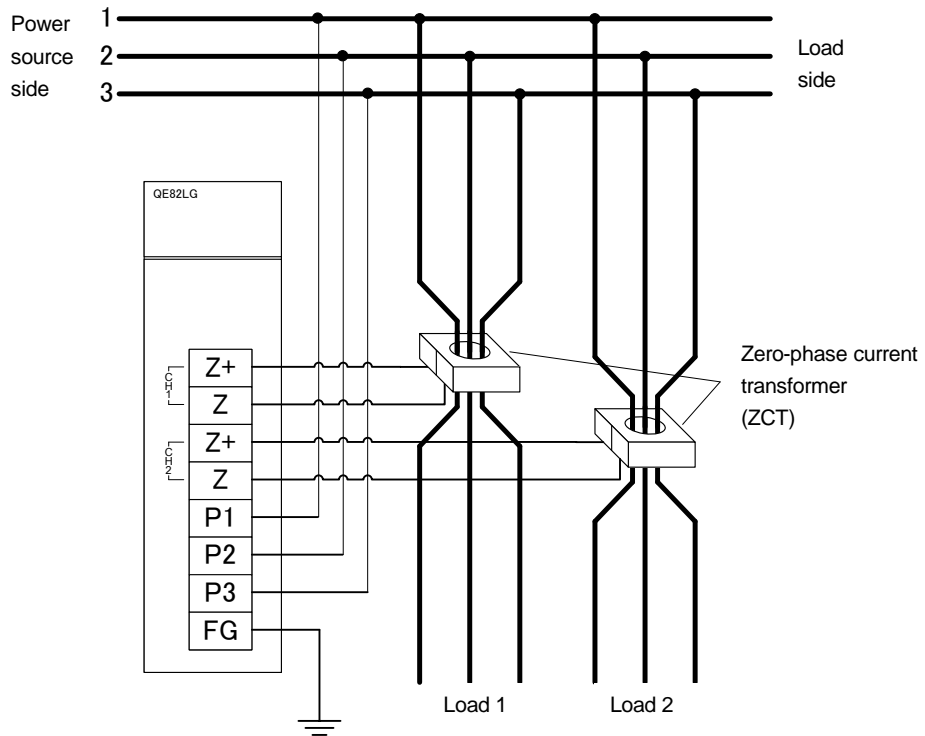

Figure 7.5.3-1 In the case of Three-phase 3-wire

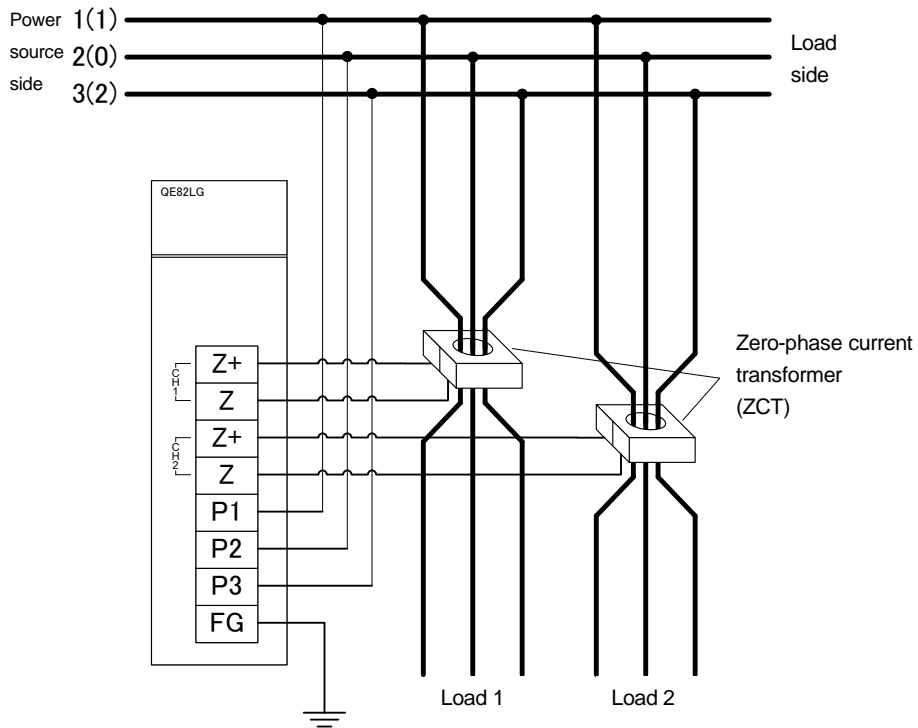

Figure 7.5.3-2 In the case of Single-phase 3-wire

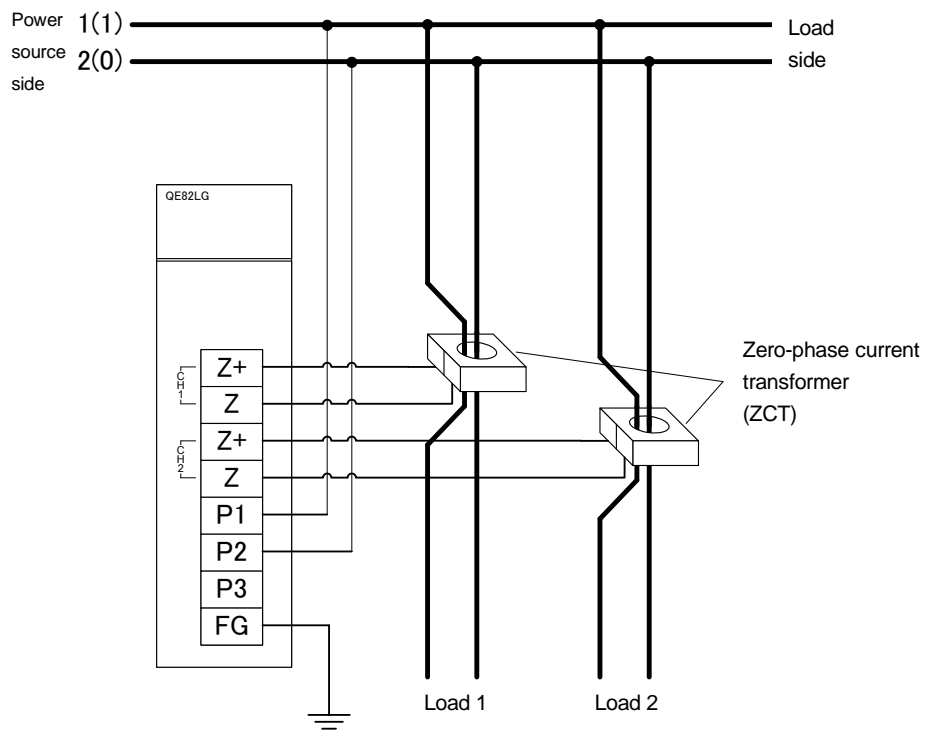

Figure 7.5.3-3 In the case of Single-phase 2-wire

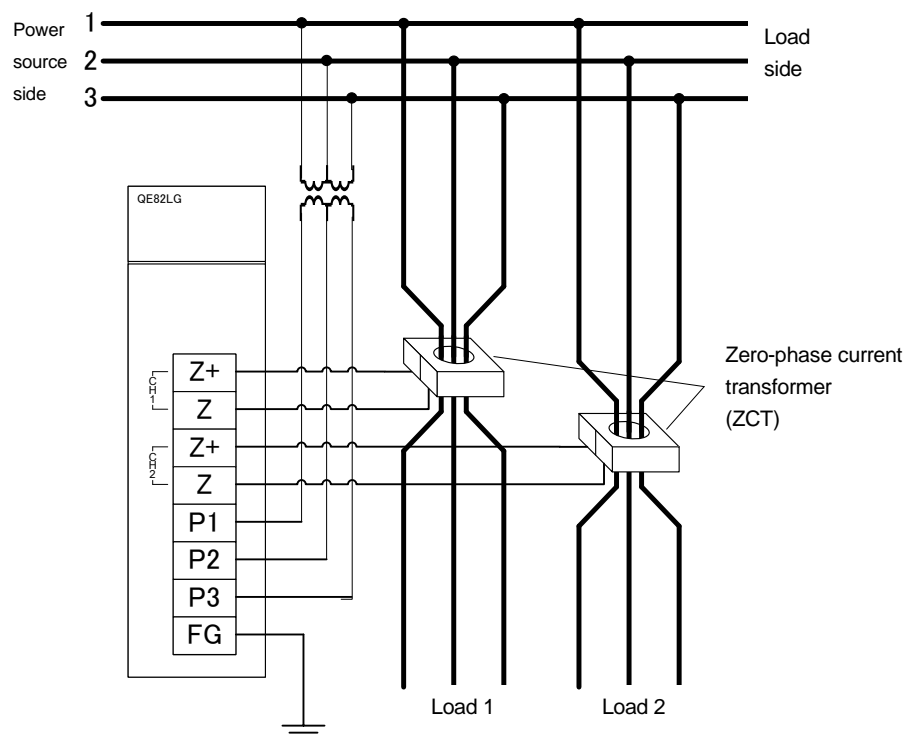

Figure 7.5.3-3 In the case of Single-phase 2-wire (with the voltage transformer for gauge/current transformer)

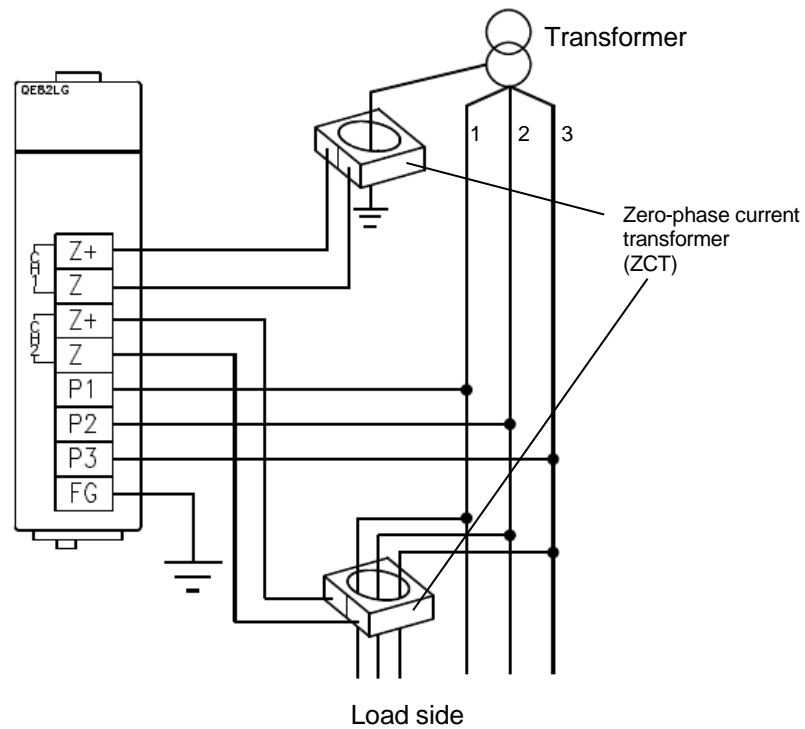

Figure 7.5.3-5 Measuring with the transformer secondary side ground line

- ZCT (CZ, ZT series) do not have a secondary output polarity.
- ZCT (CZ, ZT series) are dedicated for low voltage circuits. It cannot be used for high voltage circuits. Connecting to a high voltage circuit by mistake can cause burning of equipment and fire, which is extremely dangerous.
- In the absence of voltage input, correct measurement cannot be performed, so be sure to connect the voltage input terminal.
- Two circuits can be measured by one module at same line and same phase wire system.
(ex. It cannot be measured when CH1: three-phase 3-wire, CH2: single-phase 3-wire)
- Measuring of the leakage current for resistance can be measured with single-phase 2-wire, single-phase 3-wire, three-phase 3-wire delta circuit.
- Measuring of the leakage current (I_o) can be measured with three-phase 3-wire star circuit and special grounding circuit such as high resistance grounding circuit and capacitor grounding circuit..

7.5.3.1 Connection to leak current circuit (Z+, Z terminal)

For wiring the leak current circuit, use Mitsubishi's zero-phase current transformer (ZCT).

*Using other company's zero-phase current transformer (ZCT) is not allowed.

(1) Combination of zero-phase current transformers (ZCT)

For ZCT combination, use Mitsubishi's device as described below.

	Mitsubishi ZCT
Split-type ZCT	CZ-22S, CZ-30S, CZ-55S, CZ-77S, CZ-112S
Through-type ZCT	ZT15B, ZT30B, ZT40B, ZT60B, ZT80B, ZT100B
ZCT with primary conductor	ZTA600A, ZTA1200A, ZTA2000A

(2) Length of wire between ZCT and this module is max. 50 m (when used with the appropriate cable in section 7.5.2).

(3) ZCT output wire from Z+ and Z terminal has to be stranded at 40 times/m.

Supplemental: ZCT connection

(1) Precautions for passing a conductor through the ZCT

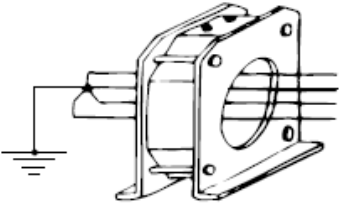
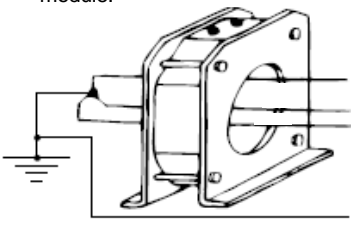
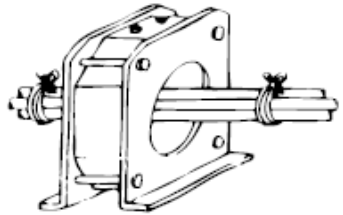
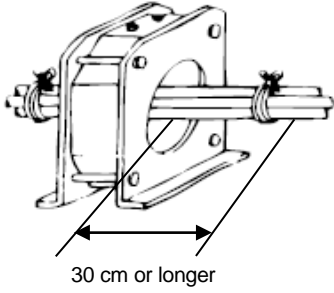
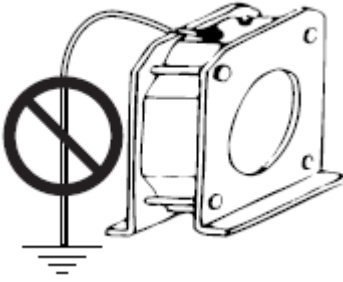
<p>1. In the case of the Single-phase 3-wire type, make sure to pass all three wires, including a neutral wire, through ZCT.</p> <p>Neutral conductor to ZCT</p> 	<p>2. If a ground line is connected to the cable run, do not let it go through the ZCT. (If load current flow is not intended, do not use the wire for passing through ZCT.)</p> <p>Do not pass a dedicated ground line through the module.</p> 	<p>3. If an accident such as short circuit occurs, and large current that exceeds the rating flows through the wire, it may cause mechanical stress to the ZCT. Thus, tie the wires together using a tightening band, etc.</p> 
<p>4. Do not bend the passing wire near ZCT. If you use a primary conductor over 300 A, keep one side of the wire at 30 cm or longer.</p> 	<p>5. Do not use a ZCT lead wire for ground.</p> 	

7 Setting and procedure for operation

QE82LG

(2) Zero phase current transformer (CZ, ZT series) is affected by the external magnetic field generated by current when ZCT is installed in the vicinity of the trunk line where large current flows as a result, an error occurs in the measured value. Please install the distance as shown in the below table with the trunk line.

Split type zero-phase current transformer

		CZ-22S	CZ-30S	CZ-55S	CZ-77S	CZ-112S
Current	100A	100mm	100mm	150mm	100mm	100mm
	300A	150mm	250mm			
	500A					
	700A			250mm		
	1000A					
	2000A	250mm	450mm	450mm		

Through type zero-phase current transformer

		ZT15B	ZT30B	ZT40B	ZT60B	ZT80B	ZT100B
Current	100A	100mm					
	300A						
	500A						
	700A						
	1000A						
	2000A						

7.5.3.2 Voltage circuit connection

- (1) When 220 V or higher is loaded to the voltage circuit, use a transformer for gauge.
- (2) For connection to P1 to P3 terminals on QE82LG, connect the specified voltage according to the phase wire system. Make sure that terminal symbols are correct. If phase wires are connected incorrectly, accurate measurement cannot be performed.
- (3) In order to perform maintenance work such as changing the wire layout and replacing equipment, we recommend that you connect protective device (breaker) for the voltage input circuit (P1, P2, and P3 terminals).

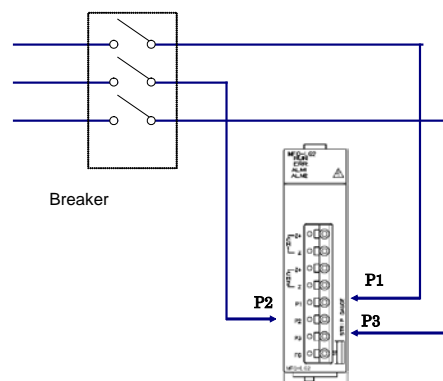

7.5.3.3 FG terminal connection

- For the actual usage, connect the FG terminal to ground. (D-type ground: Type 3)
- Do not connect to FG terminal during the insulation resistance test and pressure test.

7.6 Setting from GX Works2

This section explains setting from GX Works2 necessary to use QE82LG. Before performing this setting, install GX Works2 and connect the Management CPU with the PC using a USB cable. For details, refer to the manual of CPU module.

Point	To addition the unit, enable the switch setting, parameter setting and auto refresh, write the settings to the CPU module, and reset the CPU module or power on the programmable controller again.
-------	--

7.6.1 Addition the unit

Add the model name of the energy measuring module to use the project.

(1) Addition procedure

Open the “New Module” window.

Project window→[intelligent Function Module]→Right-click→[New Module...]

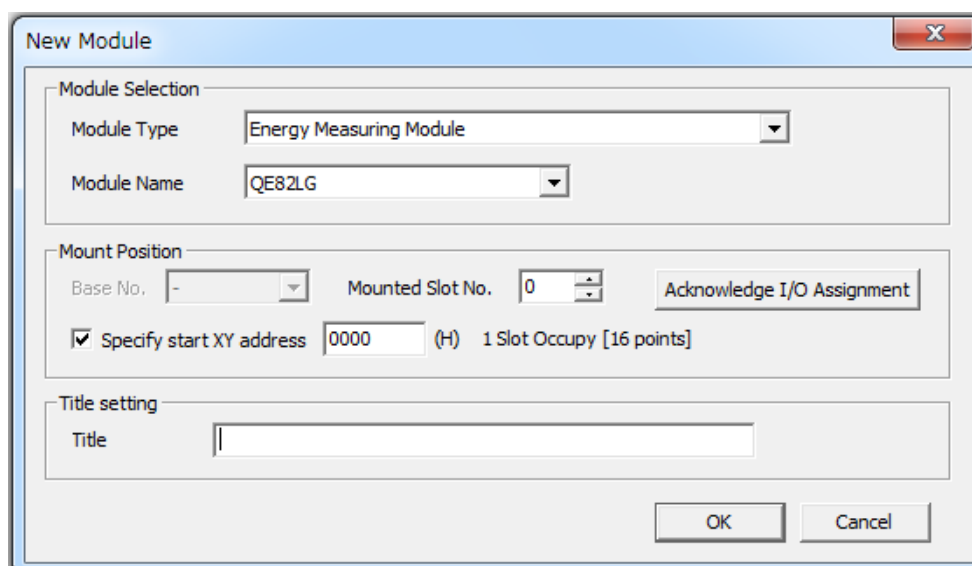

Figure 7.6.1-1 Dialog box of “I/O assignment”

Table 7.6.1-1 Setting items on the “I/O assignment” tab

Item		Description
Module Selection	Module Type	Set [Energy Measuring module].
	Module Name	Set the name of the module to mount.
Mount Position	Base No.	Set the base No. where the module is mounted.
	Mounted Slot No.	Set the slot No. where the module is mounted.
	Specify start XY address	The start I/O number (hexadecimal) of the target module is set, according to the mounted slot No. Any start I/O number can be set.
Title Setting	Title	Set any title.

7.6.2 Setting the intelligent function of the module switch

Set the operation mode.

(1)Setting procedure

Open the "Switch Setting" window.

Project window→[intelligent Function Module]→Module name→[Switch Setting]

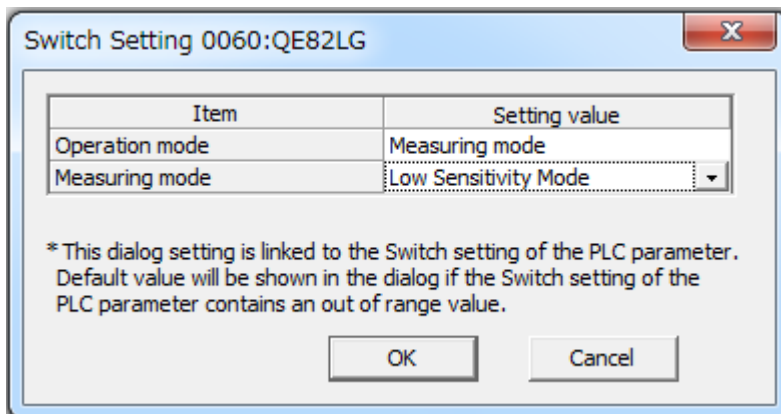

Figure 7.6.2-1 Dialog box to set the intelligent function of the module switch

Table 7.6.2-1 Setting the intelligent function of the module switch

Item	Description	Setting value
Operation mode	Measurement Mode and test mode are changed.	Measuring mode (default) Test mode
Measuring mode	When set measuring mode above setting, set the kind of measuring mode. When set test mode above setting, this setting disable.	Regular operating mode(default) Current measuring mode

7.6.3 Parameter Setting

Set the parameters.

Setting parameters on the screen omits the parameter setting in a program.

(1) Setting procedure

Open the "Parameter" window.

Project window → [intelligent Function Module] → Module name → [Parameter]

Display Filter:

Item	CH1	CH2
Common setting	Set common setting.	
Phase wire system	3: Three-phase 3-wire system	
Leak current (Io) Primary alarm monitoring function	Set Leak current (Io) Primary alarm monitoring function.	
Primary alarm value	0 mA	0 mA
Primary alarm reset method	0: Self-retention	0: Self-retention
Primary alarm delay time	0 Seconds	0 Seconds
Leak current (Io) Secondary alarm monitoring function	Set Leak current (Io) Secondary alarm monitoring function.	
Secondary alarm value	0 mA	0 mA
Secondary alarm reset method	0: Self-retention	0: Self-retention
Secondary alarm delay time	0 Seconds	0 Seconds
Leak current for resistance (Ior) Primary alarm monitoring function	Set Leak current for resistance (Ior) Primary alarm monitoring function.	
Primary alarm value	0 mA	0 mA
Primary alarm reset method	0: Self-retention	0: Self-retention
Primary alarm delay time	0 Seconds	0 Seconds
Leak current for resistance (Ior) Secondary alarm monitoring function	Set Leak current for resistance (Ior) Secondary alarm monitoring function.	
Secondary alarm value	0 mA	0 mA
Secondary alarm reset method	0: Self-retention	0: Self-retention
Secondary alarm delay time	0 Seconds	0 Seconds

(1) Set the primary alarm delay time of leak current for resistance (Ior).
 (2) The time is the one until giving an alarm after measured value of primary alarm monitoring item exceeds primary alarm monitoring value.
 (3) To validate the setting, ON/OFF the Operating condition setting request is required.
 (4) Settable range is from 0 to 300 seconds. Default value is 0.
 (5) Primary alarm flag will be turned to ON when the present value exceeds the primary alarm monitoring value and elapses the primary alarm delay time.

Figure 7.6.3-1 Dialog box to monitor all buffer memories (a case where the module is attached to the slot 0)

(2) Double-click the item to change the setting, and input the setting value.

- Items to input from the pull-down list
Double-click the item to set to display the pull-down list. Select the item.
- Items to input from the text box
Double-click the item to set, and input the setting value.

(3) Setup of CH2 to CH4 is performed by operation of Procedure (2).

Item	Setting value		Reference
Common setting	Phase wire system	1:Single-phase 2-wire 2:Single-phase 3-wire 3:Three-phase 3-wire	Section 6.2.1
Leak current (I _o) Primary alarm monitoring function	Primary alarm value	0 : No monitoring 【Low sensitivity mode】 1 to 1000mA : Monitors with the set value 【High sensitivity mode】 1 to 10000 (×10 ⁻²) mA : Monitors with the set value	Section 6.2.3
	Primary alarm reset method	0:Self-retention 1:Auto reset	Section 6.2.4
	Primary alarm delay time	0~300seconds	Section 6.2.5
Leak current (I _o) Secondary alarm monitoring function	Secondary alarm value	0 : No monitoring 【Low sensitivity mode】 1 to 1000mA : Monitors with the set value 【High sensitivity mode】 1 to 10000 (×10 ⁻²) mA : Monitors with the set value	Section 6.2.3
	Secondary alarm reset method	0:Self-retention 1:Auto reset	Section 6.2.4
	Secondary alarm delay time	0~300seconds	Section 6.2.5
Leak current for resistance (I _{or}) Primary alarm monitoring function	Primary alarm value	0 : No monitoring 【Low sensitivity mode】 1 to 1000mA : Monitors with the set value 【High sensitivity mode】 1 to 10000 (×10 ⁻²) mA : Monitors with the set value	Section 6.2.3
	Primary alarm reset method	0:Self-retention 1:Auto reset	Section 6.2.4
	Primary alarm delay time	0~300seconds	Section 6.2.5
Leak current for resistance (I _{or}) Secondary alarm monitoring function	Secondary alarm value	0 : No monitoring 【Low sensitivity mode】 1 to 1000mA : Monitors with the set value 【High sensitivity mode】 1 to 10000 (×10 ⁻²) mA : Monitors with the set value	Section 6.2.3
	Secondary alarm reset method	0:Self-retention 1:Auto reset	Section 6.2.4
	Secondary alarm delay time	0~300seconds	Section 6.2.5

7.6.4 Auto Refresh

This function transfers data in the buffer memory to specified devices. Programming of reading/writing data is unnecessary.

(1) Setting procedure

- 1) Start "Auto Refresh" .
Project window→[intelligent Function Module]→Module name→[Auto Refresh]
- 2) Start "Auto Refresh" .
Click the item to set, and input the destination device for auto refresh.

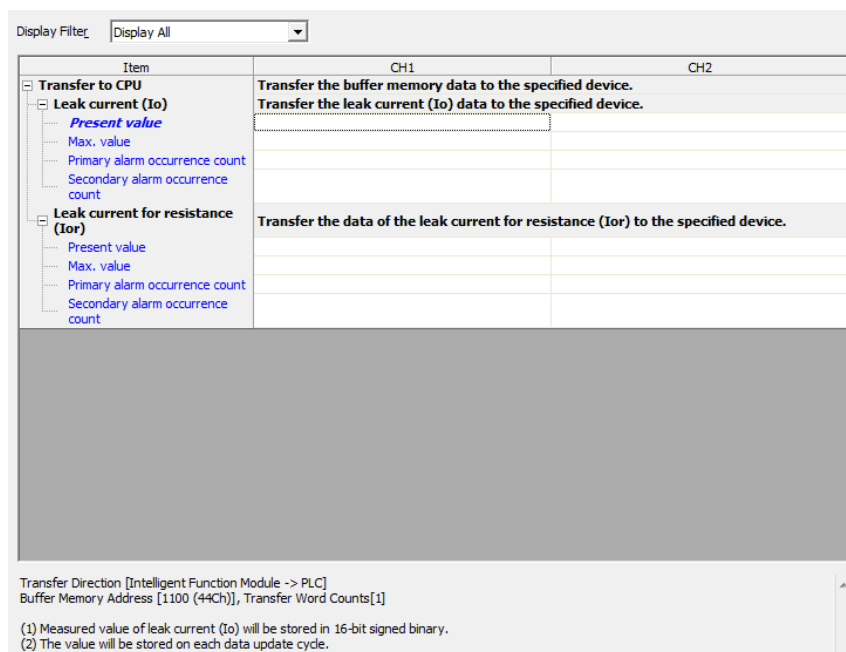

Point
<p>Available devices are X, Y, M, L, B, T, C, ST, D, W, R, and ZR.</p> <p>When a bit device X, Y, M, L, or B is used, set a number that is divisible by 16 points (example: X10, Y120, M16).</p> <p>Data in the buffer memory are stored in 16 points of devices starting from the set device No. (Example: When X10 is set, the data are stored in X10 to X1F).</p>

7.6.5 Debugging program

QE81WH provides a test function so that you can debug a program with no input of voltage or current. Pseudo-value can be stored into the buffer memory. For detailed explanation for the test function, refer to 4.2.5.

**Caution**

Test function stores pseudo-values for setting value and error information as well as measured value. If you use these data to control the sequence program that controls external devices, there is a chance that erroneous control may occur. For safety of external devices, use this function after disconnecting the device.

- (1) Setting intelligent function of the module switch
 - 1) Configure the operation mode in switch setting as shown below. (Refer to 7.6.2)
Test mode transition : Test mode
 - 2) From the "Online" menu, select "Write to PLC" to display the dialog box of Write to PLC, and then execute the writing to PLC parameter. After resetting the CPU module, the value will become effective.

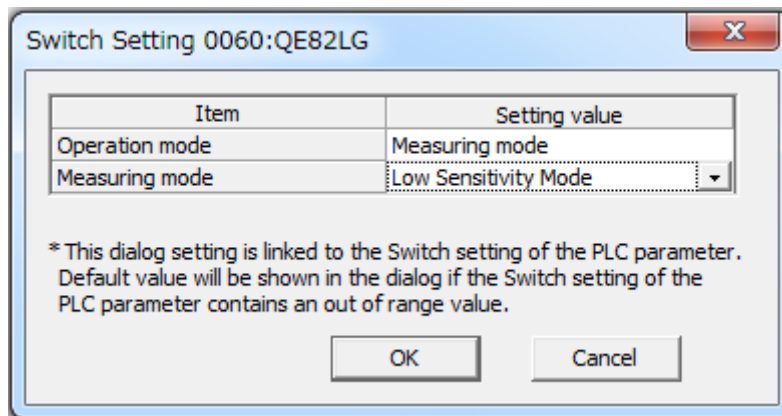

- (2) Starting the test function
 - 1) Reset the CPU module.
 - 2) QE84WH starts in the test function mode. All LEDs are turned on. Pseudo-values are stored in the buffer memory.
- (3) Finishing the test function (Move back to the measuring mode)
 - 1) Following 1) in step (1), Configure the operation mode in switch setting as shown below.
Test mode transition : Test mode
 - 2) Following 2) in step (1), write the data into PLC.
 - 3) Reset the CPU module, then the operation goes back to the measuring mode.

7.7 Setting from GX Developer

This section explains setting from GX Developer necessary to use QE82LG. Before performing this setting, install the GX Developer and connect the Management CPU with the PC using a USB cable. For details, refer to the manual of CPU module.

7.7.1 I/O assignment setting

- (1) Double-click the dialog box of "PLC Parameter in the GX Developer Project.
- (2) Click "I/O assignment".
- (3) Set the following item to the slot*1 to which QE82LG has been attached.

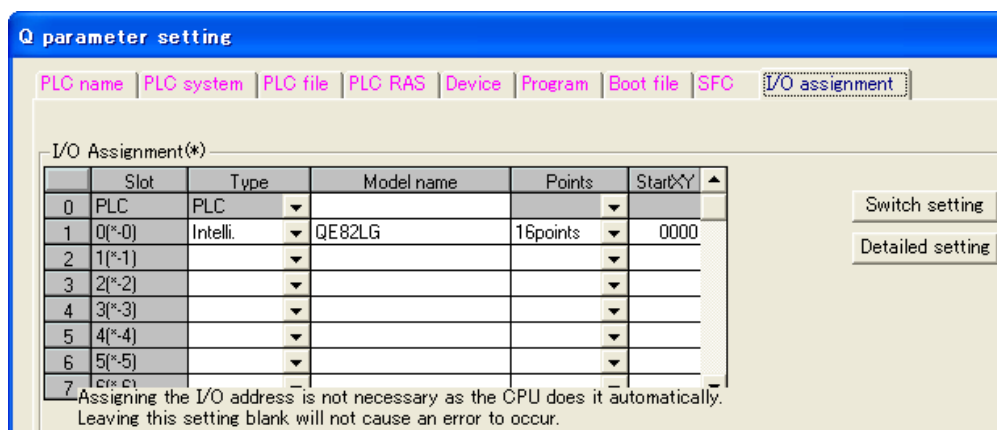

Figure 7.7.1-1 Dialog box of "I/O assignment"

Table 7.7.1-1 Setting items on the "I/O assignment" tab

Item	Descriptions
Type	Select "Intelli."
Model name	Enter the model name of the module.
Points	Select 16 points.
Start XY	Enter the initial I/O number of QE82LG.

*1 is a case where QE82LG is attached to the slot 0.

7.7.2 Setting the intelligent function of the module switch

- (1) In the "I/O assignment setting" of 7.7.1, click the **Switch setting** button to display the dialog box of "I/O module, intelligent function module switch setting".
- (2) The intelligent function module switch setting displays switches 1 to 5; however, only the switch 5 is used for this purpose. Switch setting is configured using 16-bit data. Settings are as shown in Table 7.7.2-1.

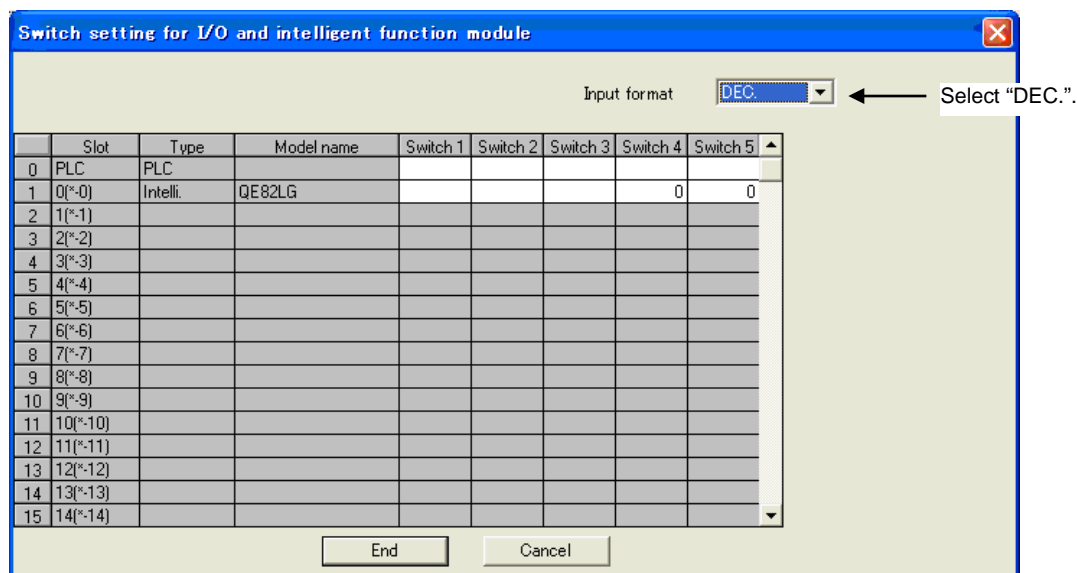

Figure 7.7.2-1 Dialog box to set the intelligent function of the module switch

Table 7.7.2-1 Setting the intelligent function of the module switch

Switch No.	Switch name	Description
1	Not used	-
2	Not used	-
3	Not used	-
4	Measuring mode*1	0: Low sensitivity mode 1: High sensitivity mode
5	Operating mode	0: Measuring mode (Even if it is not set, measuring mode is performed.) 1: Test mode*2

*1: When Operating mode (Switch No.5) is set to Test mode(1), the setting of Measuring mode is ignored.

*2: For details of the test mode, refer to 4.2.5.

- (3) When the setting is completed, click the Complete setting button.
- (4) From the "Online" menu, select "Write to PLC" to display the dialog box of Write to PLC, and then execute the writing to PLC parameter. After resetting the CPU module, the value will become effective.

7.7.3 Initial setting

This section explains the setting of the operating condition for phase wire systems that are required for measurement. Once each value is set, these values will be stored in the nonvolatile memory of this module, so that reconfiguration is not needed. You can also perform the setting using sequence program. In this case, you need to create a program, as referring to Chapter 8.

Follow the procedure below for each setting.

- (1) Check the current setting
 - (2) Set the buffer memory
-
- (1) Check the current setting
 - 1) From the "Online" menu, select "Monitor" – "Buffer memory all". The dialog box to monitor all buffer memories is displayed. After setting the address as shown below, click the **Start monitoring** button to check the current buffer memory status.
 - Module initial address: Set the initial address of this module.
 - Buffer memory address: 0
(Display: 16-bit integer, numerical value: check the number in decimal)
 - 2) Check each item. The following shows items for operating condition settings. For specific setting value, see the provided references.

Table 7.7.3-1 List of setting items

Buffer memory address	Item	Reference
Un\G0	Phase wire	Section 6.2.1

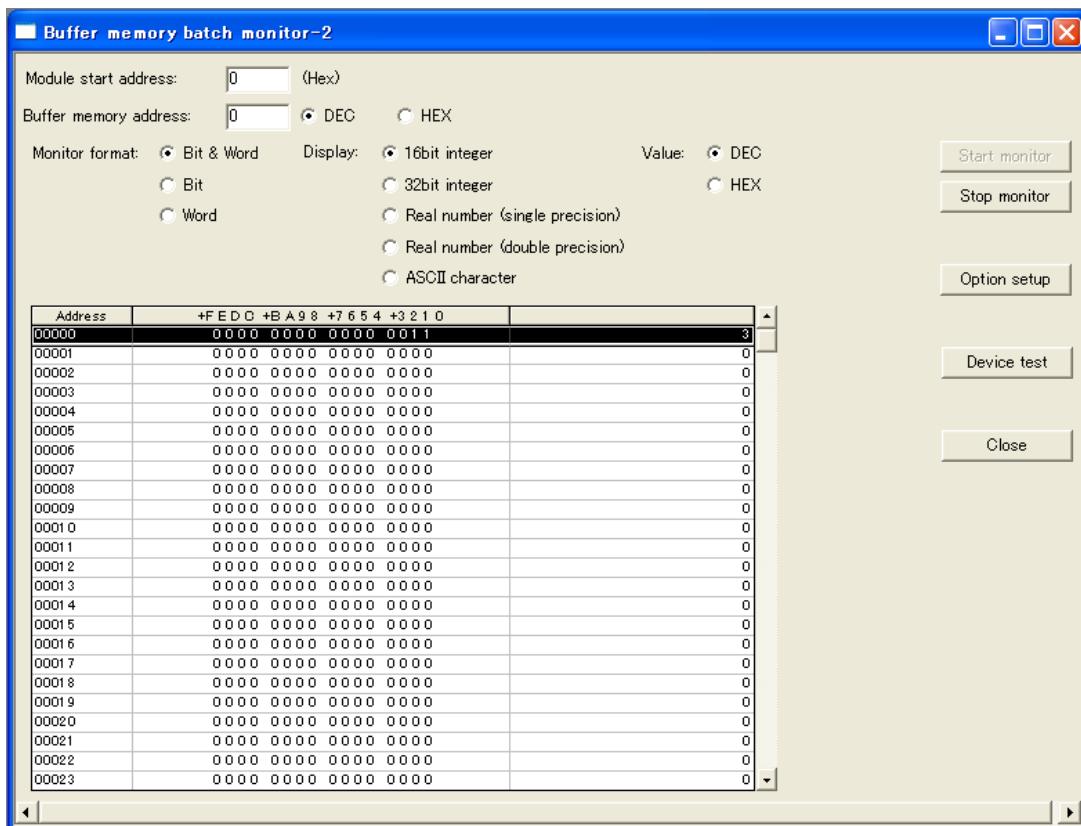

Figure 7.7.3-1 Dialog box to monitor all buffer memories (a case where the module is attached to the slot 0)

- (2) Set the buffer memory
 - 1) In the dialog box to monitor all buffer memories, click the **Device test** button to display the Device test dialog box.
 - 2) In the Word device / buffer memory, specify the module initial address and buffer address, and click the **Set** button to apply the setting.

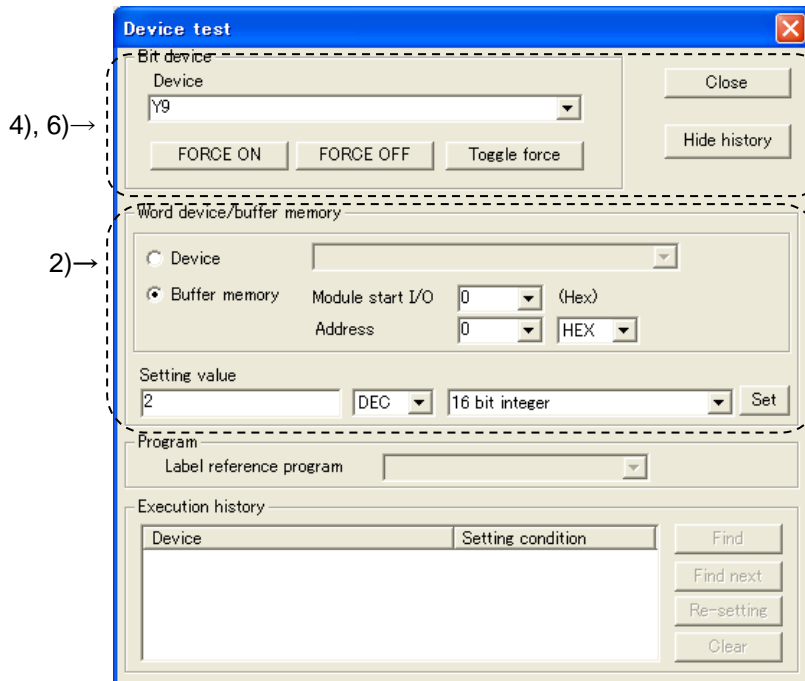

Figure 7.7.3-2 Device test dialog box (a case where the module is attached to the slot 0)

- 3) Change the setting in 2).
- 4) In the section of bit device setting in the device test dialog box, select "Y9"* and click the **Force ON** button.
- 5) When the setting is completed without any problem, the Device "X9"* changes to ON. Check this using the procedure as follows:
 - (a) From the "Online" menu, select "Monitor" – "Device all". The dialog box to monitor all devices is displayed.
 - (b) Set "X0"* to the device, and click "Start monitoring"
 - (c) Check that Device "X9"* is in the ON status.

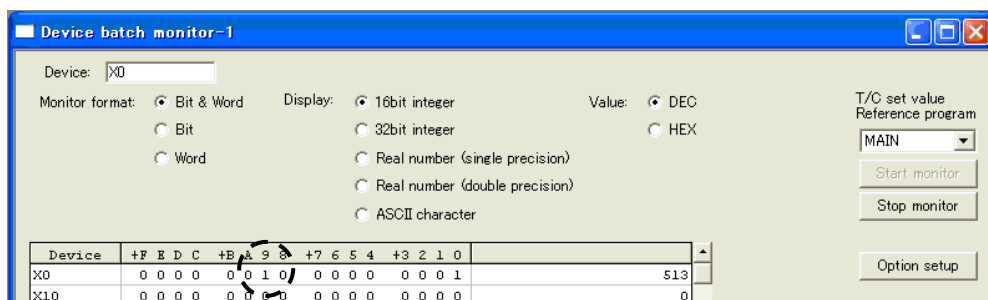

Figure 7.7.3-3 Checking the device "X9"* in the dialog box to monitor all devices

- 6) After checking that the device "X9"* is in the ON status, select "Device: "Y9"* in the dialog box of device test, and then click the **Force OFF** button. Setting is completed.
- 7) If the Device "X9"* is not in the ON status, this means an error because the set value is out of range (ERR.LED is flashing). Modify the setting, and change the device "Y9" to the OFF status, then change it back to the ON status.

* Indicates a number in the case where the initial I/O number (initial XY) is set to 0.

7.7.4 Debugging program (optional)

QE82LG provides a test function so that you can debug a program with no input of voltage or current. Pseudo-value can be stored into the buffer memory. For detailed explanation for the test function, refer to 4.2.5.

⚠ Caution

Test function stores pseudo-values for setting value and error information as well as measured value. If you use these data to control the sequence program that controls external devices, there is a chance that erroneous control may occur. For safety of external devices, use this function after disconnecting the device.

(1) Setting intelligent function of the module switch

- 1) In the "I/O assignment setting" of 7.7.1, click the **Switch setting** button to display the dialog box of "I/O module, intelligent function module switch setting". (Refer to 7.7.2)
- 2) The intelligent function module switch setting displays switches 1 to 5; however, only the switch 5 is used for this purpose. Switch setting is configured using 16-bit data.

Setting is as follows:

Switch 5: "1" (set in decimal)

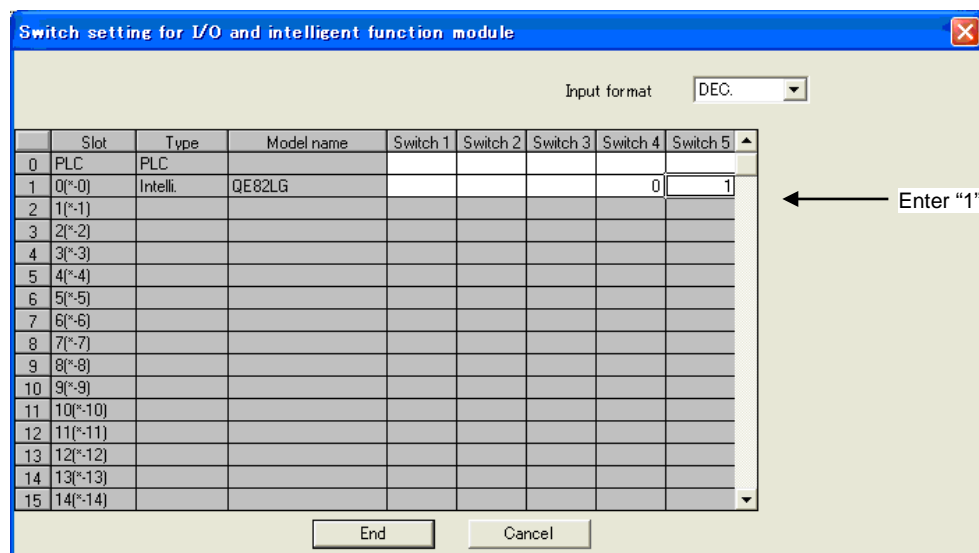

Figure 7.7.4-1 Dialog box to set the intelligent function of the module switch

- 3) When the setting is completed, click the **Complete setting** button.
- 4) From the "Online" menu, select "Write to PLC" to display the dialog box of Write to PLC, and then execute the writing to PLC parameter.
- 5) After resetting the CPU module, the value will become effective.

(2) Starting the test function

- 1) Reset the CPU module.
- 2) QE82LG starts in the test function mode. All LEDs are turned on. Pseudo-values are set effective in the buffer memory.

(3) Finishing the test function (Move back to the measuring mode)

- 1) Following 1) and 2) in step (1), configure the intelligent function switch setting as shown below.
 - Switch 5: "0" (set in decimal)
 - Switch 4: "0" or "1" (Low or high sensitivity mode)
- 2) Following 3) and 4) in step (1), complete the setting and write the data into PLC.
- 3) Reset the CPU module, then the operation goes back to the measuring mode (Low or high sensitivity mode).

Chapter 8: Programming

This chapter explains programming for QE82LG.

When you apply sample programs introduced in this chapter into the actual system, make sure to verify in advance that there is no problem with the target system control.

Follow the procedure in Figure 8.1-1 to create a sample program using QE82LG.

The default setting allows you to use either GX Works2 (refer to 7.6), GX Developer (refer to 7.7) or the sequence program to make settings; however, if the setting is made for the first time by using GX Works2 or GX Developer, the program for initial setting can be eliminated, which will reduce time for scanning.

8.1 Programming procedure

Follow the procedure in Figure 8.1-1 to create a program for acquiring the measured data, alarm monitoring using QE82LG.

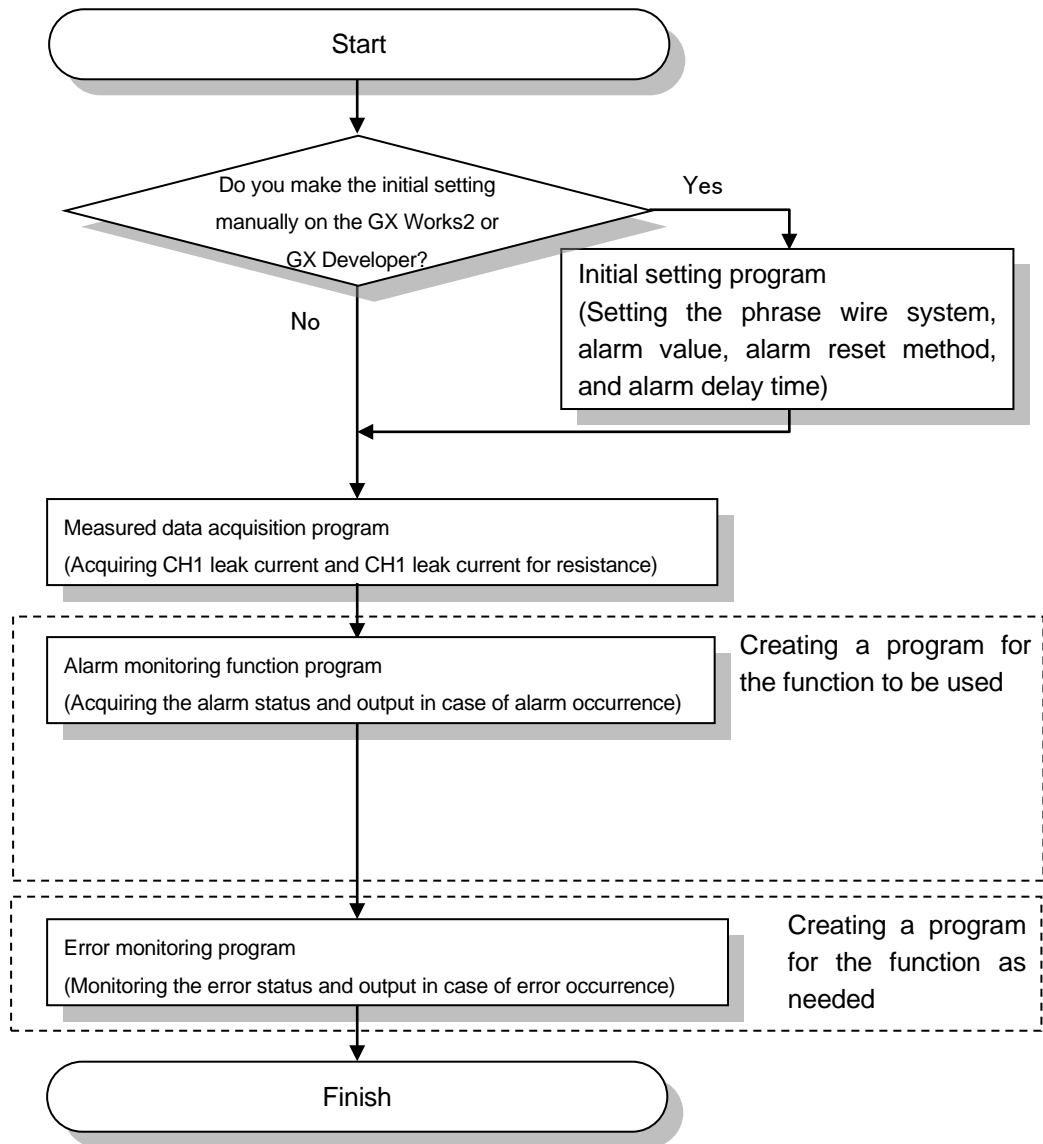

Figure 8.1-1 Programming chart

8.2 System configuration and usage conditions for sample program

A sample program is shown below based on the following system and the usage condition.

(1) System configuration

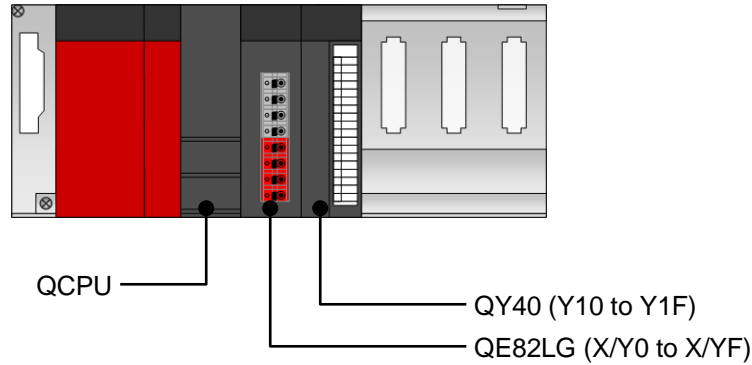

Figure 8.2-1 Sample system configuration using a sample program

(2) Setting conditions for the intelligent function of the module switch

Setting is as follows:

Table 8.2-1 Setting the intelligent function of the module switch

Switch No.	Switch name	Description
1	Not used	-
2	Not used	-
3	Not used	-
4	Measuring mode	0 (Low sensitivity mode)
5	Operating mode	0 (measuring mode)

(3) Programming conditions

(a) Setting the operating conditions

- Phase wire system: Three-phase 3-wire

(b) Alarm monitoring setting

- lo1 primary alarm value : 300 (mA)
- lo1 primary alarm reset method : Auto reset
- lo1 primary alarm delay time : 10 sec
- lo1 secondary alarm value : 500 (mA)
- lo1 secondary alarm reset method : Self-retention
- lo1 secondary alarm delay time : 0 sec
- lor1 primary alarm value : 100 (mA)
- lor1 primary alarm reset method : Auto reset
- lor1 primary alarm delay time : 30 sec
- lor1 secondary alarm value : 200 (mA)
- lor1 secondary alarm reset method : Self-retention
- lor1 secondary alarm delay time : 15 sec

(4) Before creating a program

Before creating a program, attach QE82LG to the base unit, and connect it to external devices.

Connected device: ZCT Input (+Z, Z, CH1, CH2), voltage input (P1, P2, P3)

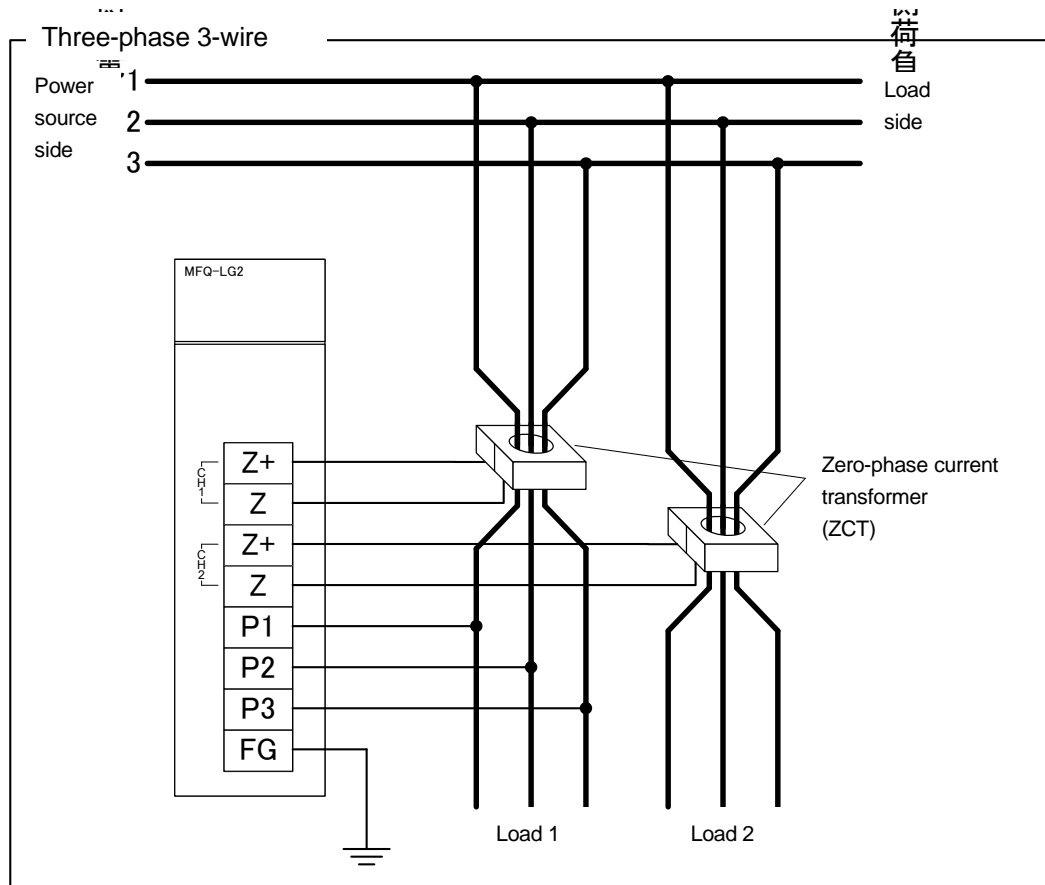

Figure 8.2-2 Example of wiring using a sample program

8.3 Sample programming

(1) List of devices

Table 8.3-1 List of devices

Device	Function	
D0	Device that stores lo1 present value	
D1	Device that stores lo1 max. value	
D2	Device that stores year of time of lo1 max. value	
D3	Device that stores month and day of time of lo1 max. value	
D4	Device that stores hour and minute of time of lo1 max. value	
D5	Device that stores second and day of the week of time of lo1 max. value	
D6	Device that stores lor1 present value	
D7	Device that stores lor1 max. value	
D8	Device that stores year of time of lor1 max. value	
D9	Device that stores month and day of time of lor1 max. value	
D10	Device that stores hour and minute of time of lor1 max. value	
D11	Device that stores second and day of the week of time of lor1 max. value	
D20	Device that stores latest error code	
X0	Module ready	QE82LG (X/Y0 to X/YF)
X1	lo1 primary alarm flag	
X2	lo1 secondary alarm flag	
X3	lor1 primary alarm flag	
X4	lor1 secondary alarm flag	
X9	Operating condition setting completion flag	
XF	Error flag	
Y9	Operating condition setting request	
Y10	Device that turns ON to send an output to the external device in the case that lo1 primary alarm flag (X1) is observed	
Y11	Device that turns ON to send an output to the external device in the case that lo1 secondary alarm flag (X2) is observed	
Y12	Device that turns ON to send an output to the external device in the case that lor1 primary alarm flag (X3) is observed	
Y13	Device that turns ON to send an output to the external device in the case that lor1 secondary alarm flag (X4) is observed	
Y14	Device that turns ON to send an output to the external device in the case of an error	

(2) List of buffer memories to be used

Table 8.3-2 List of buffer memories to be used

Device	Description	Setting value	Remarks
U0\G0	Phase wire system	3	Three-phase 3-wire
U0\G1000	lo1 primary alarm value	300	300 mA
U0\G1001	lo1 primary alarm reset method	1	Auto reset
U0\G1002	lo1 primary alarm delay time	10	10 sec
U0\G1003	lo1 secondary alarm value	500	500 mA
U0\G1004	lo1 secondary alarm reset method	0	Self-retention
U0\G1005	lo1 secondary alarm delay time	0	0 sec
U0\G1050	lor1 primary alarm value	100	100 mA
U0\G1051	lor1 primary alarm reset method	1	Auto reset
U0\G1052	lor1 primary alarm delay time	30	30 sec
U0\G1053	lor1 secondary alarm value	200	200 mA
U0\G1054	lor1 secondary alarm reset method	0	Self-retention
U0\G1055	lor1 secondary alarm delay time	15	15 sec
U0\G1100	lo1 present value	-	Stores lo1 present value
U0\G1101	lo1 max. value	-	Stores lo1 max. value
U0\G1102	Year of time of lo1 max. value	-	Stores year of time of lo1 max. value
U0\G1103	Month and day of time of lo1 max. value	-	Stores month and day of time of lo1 max. value
U0\G1104	Hour and minute of time of lo1 max. value	-	Stores hour and minute of time of lo1 max. value
U0\G1105	Second and day of the week of time of lo1 max. value	-	Stores second and day of the week of time of lo1 max. value
U0\G1150	lor1 present value	-	Stores lor1 present value
U0\G1151	lor1 max. value	-	Stores lor1 max. value
U0\G1152	Year of time of lor1 max. value	-	Stores year of time of lor1 max. value
U0\G1153	Month and day of time of lor1 max. value	-	Stores month and day of time of lor1 max. value
U0\G1154	Hour and minute of time of lor1 max. value	-	Stores hour and minute of time of lor1 max. value
U0\G1155	Second and day of the week of time of lor1 max. value	-	Stores second and day of the week of time of lor1 max. value
U0\G3000	Latest error code	-	Stores latest error code

(3) Sample program

1. Initial setting program for QE82LG

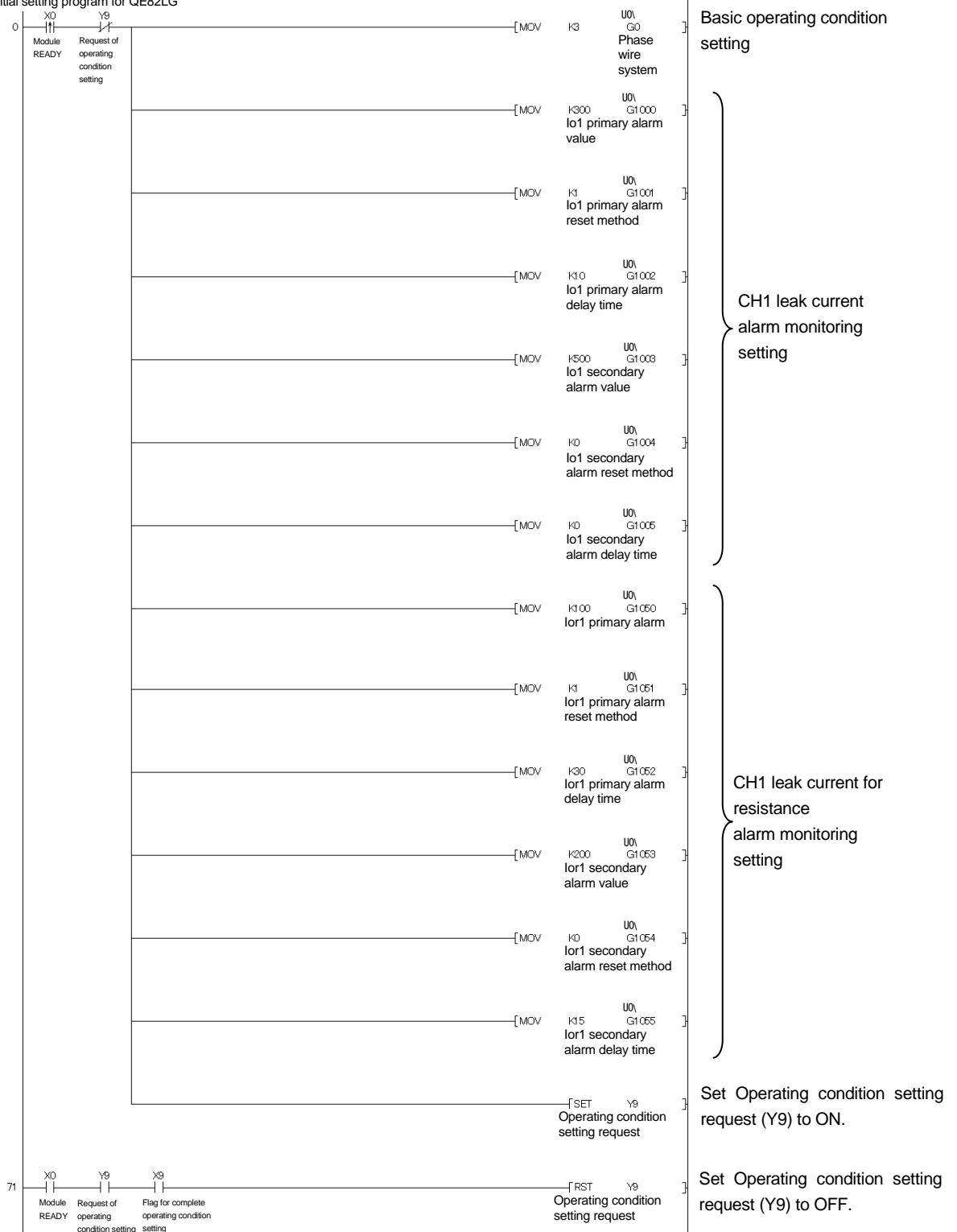

Figure 8.3-1 Example of a sample program

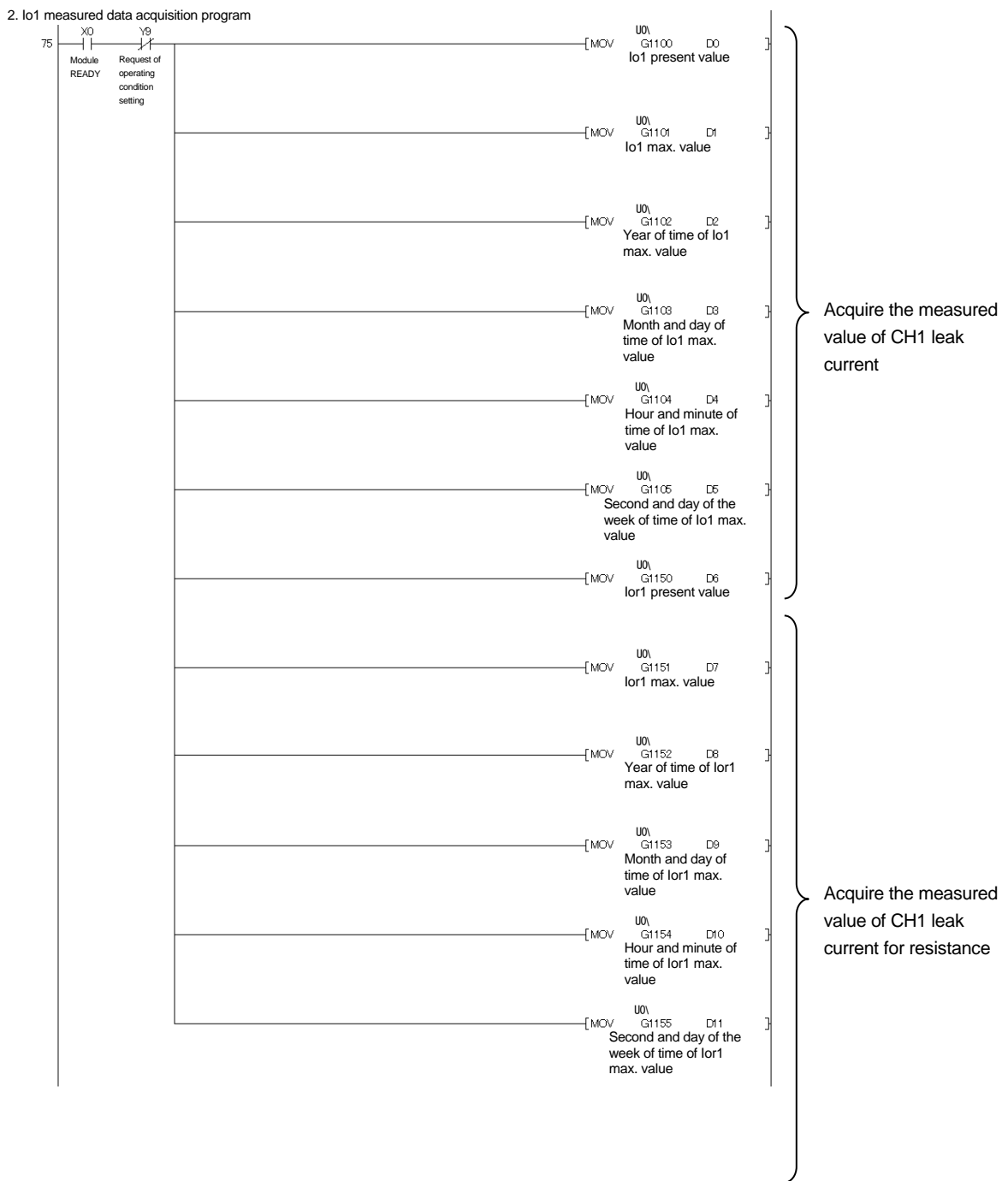

Figure 8.3-2 Example of a sample program (continued)

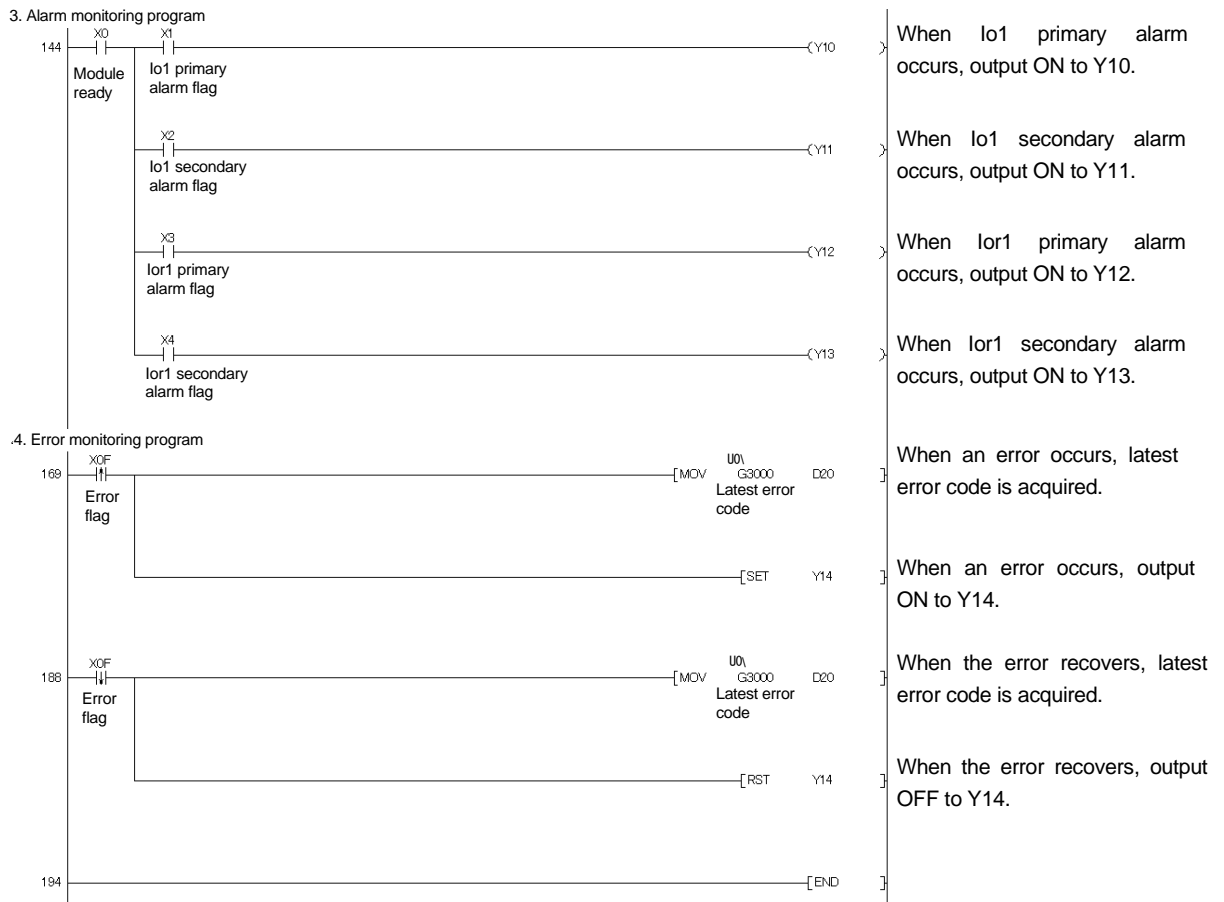

Figure 8.3-3 Example of a sample program (continued)

Chapter 9: Troubleshooting

9.1 List of error codes

When the data are written to the CPU module from this module or when a reading error occurs, error codes will be stored into the following buffer memory.

Table 9.1-1 Latest error code, storage destination upon error occurrence

Latest error code	Time of error occurrence
Un\G3000	Un\G3001 to Un\G3004

Table below shows error codes.

Table 9.1-2 List of error codes

Error code (HEX)	Error level	Descriptions	Action	Reference
0001h	Mid	In test mode, "0001h" stores.	It returns from test mode to the measuring mode.	Section 4.2.5
		Except in test mode, hardware error with the module.	Turn the power OFF/ON. If the error recurs, the module may have a failure. Consult with a nearest sales agent or our company branch for the symptom of the failure.	-
0002h 0003h	Mid	Hardware error with the module.		
1001h	Low	Phase wire system (Un\G0) is set out of range.	Check the setting value, and set it within 1 to 3.	Section 6.2.1
1002h	Low	lo1 primary alarm value (Un\G1000) is set out of range.	Check the setting value, and set it within following values. Low sensitivity mode: 0 to 1000mA High sensitivity mode: 0.00 to 100.00mA	Section 6.2.2
1003h	Low	lo1 primary alarm reset method value (Un\G1001) is set out of range.	Check the setting value, and set it within 0 to 1.	Section 6.2.3
1004h	Low	lo1 primary alarm delay time value (Un\G1002) is set out of range.	Check the setting value, and set it within 0 to 300.	Section 6.2.4
1005h	Low	lo1 secondary alarm value (Un\G1003) is set out of range.	Check the setting value, and set it within following values. Low sensitivity mode: 0 to 1000mA High sensitivity mode: 0.00 to 100.00mA	Section 6.2.2
1006h	Low	lo1 secondary alarm reset method (Un\G1004) is set out of range.	Check the setting value, and set it within 0 to 1.	Section 6.2.3

* Also check that it is set in decimal.

Table 9.1-2 List of error codes

Error code (HEX)	Error level	Descriptions	Action	Reference
1007h	Low	lo1 secondary alarm delay time value (Un\G1005) is set out of range.	Check the setting value, and set it within 0 to 300.	Section 6.2.4
1008h	Low	lor1 primary alarm value (Un\G1050) is set out of range.	Check the setting value, and set it within following values. Low sensitivity mode: 0 to 1000mA High sensitivity mode: 0.00 to 100.00mA	Section 6.2.2
1009h	Low	lor1 primary alarm reset method value (Un\G1051) is set out of range.	Check the setting value, and set it within 0 to 1.	Section 6.2.3
100Ah	Low	lor1 primary alarm delay time value (Un\G1052) is set out of range.	Check the setting value, and set it within 0 to 300.	Section 6.2.4
100Bh	Low	lor1 secondary alarm value (Un\G1053) is set out of range.	Check the setting value, and set it within following values. Low sensitivity mode: 0 to 1000mA High sensitivity mode: 0.00 to 100.00mA	Section 6.2.2
100Ch	Low	lor1 secondary alarm reset method (Un\G1054) is set out of range.	Check the setting value, and set it within 0 to 1.	Section 6.2.3
100Dh	Low	lor1 secondary alarm delay time value (Un\G1055) is set out of range.	Check the setting value, and set it within 0 to 300.	Section 6.2.4
100Eh	Low	lo2 primary alarm value (Un\G2000) is set out of range.	Check the setting value, and set it within following values. Low sensitivity mode: 0 to 1000mA High sensitivity mode: 0.00 to 100.00mA	Section 6.2.2
100Fh	Low	lo2 primary alarm reset method value (Un\G2001) is set out of range.	Check the setting value, and set it within 0 to 1.	Section 6.2.3
1010h	Low	lo2 primary alarm delay time value (Un\G2002) is set out of range.	Check the setting value, and set it within 0 to 300.	Section 6.2.4
1011h	Low	lo2 secondary alarm value (Un\G2003) is set out of range.	Check the setting value, and set it within following values. Low sensitivity mode: 0 to 1000mA High sensitivity mode: 0.00 to 100.00mA	Section 6.2.2
1012h	Low	lo2 secondary alarm reset method value (Un\G2004) is set out of range.	Check the setting value, and set it within 0 to 1.	Section 6.2.3
1013h	Low	lo2 secondary alarm delay time value (Un\G2005) is set out of range.	Check the setting value, and set it within 0 to 300.	Section 6.2.4

* Also check that it is set in decimal.

Table 9.1-2 List of error codes

Error code (HEX)	Error level	Descriptions	Action	Reference
1014h	Low	lor2 primary alarm value (Un\G2050) is set out of range.	Check the setting value, and set it within following values. Low sensitivity mode: 0 to 1000mA High sensitivity mode: 0.00 to 100.00mA	Section 6.2.2
1015h	Low	lor2 primary alarm reset method value (Un\G2051) is set out of range.	Check the setting value, and set it within 0 to 1.	Section 6.2.3
1016h	Low	lor2 primary alarm delay time value (Un\G2052) is set out of range.	Check the setting value, and set it within 0 to 300.	Section 6.2.4
1017h	Low	lor2 secondary alarm value (Un\G2053) is set out of range.	Check the setting value, and set it within following values. Low sensitivity mode: 0 to 1000mA High sensitivity mode: 0.00 to 100.00mA	Section 6.2.2
1018h	Low	lor2 secondary alarm reset method value (Un\G2054) is set out of range.	Check the setting value, and set it within 0 to 1.	Section 6.2.3
1019h	Low	lor2 secondary alarm delay time value (Un\G2055) is set out of range.	Check the setting value, and set it within 0 to 300.	Section 6.2.4
0000h	—	Normal	-	-

* Also check that it is set in decimal.

9.2 Troubleshooting

9.2.1 When “RUN” LED is turned off

Table 9.2.1-1 When “RUN” LED is turned off

Check item	Action	Reference
Is power source is supplied?	Check that supply voltage of the power source is within the rating.	Section 3.1
Is capacity of the power source module sufficient?	Calculate the consumption current of the CPU module, I/O module, and intelligent function module attached to the base unit, and check that the power capacity is sufficient.	-
Is the watchdog time an error?	Reset the CPU module, and check whether it is turned on. If RUN LED is not turned on even after doing the above, the module may have a failure. Consult with a nearest sales agent or our company branch for the symptom of the failure.	-
Is the module properly attached to the base unit?	Check the module attachment status.	-
Is the slot type set to “empty” in the I/O assignment setting of the PC parameter at GX Developer?	Set the slot type to “Intelligent”.	Section 7.7

9.2.2 When "ERR" LED is turned on or flashing

(1) If it is ON

Table 9.2.2-1 When "ERR" LED is turned on

Check item	Action	Reference
Did any error occur?	Check the latest error code (Un\G3000), and take a corrective action as described in section 9.1. After that, reset the CPU module, and check whether it is turned on. If "ERR." LED is turned on even after doing the above, the module may have a failure. Consult with a nearest sales agent or our company branch for the symptom of the failure.	Section 9.1

(2) If it is flashing

Table 9.2.2-2 When "ERR" LED is flashing

Check item	Action	Reference
Did any error occur?	The set value may be out of range. Check that the operating condition settings are correct. Correct configuration or changing Error clear request (YnF) to ON will recover the error. When the error is cleared using Error clear request (YnF), the operation continues with the previous setting.	Section 5.2.2 Chapter 6 Section 7.6.3

9.2.3 If the leak current value that is measured using this module does not match with the one measured with other gauge

Table 9.2.3-1 If the leak current value that is measured using this module does not match with the one measured with other gauge

Check item	Action	Reference
Is phase wire system correct?	Check the value in the buffer memory for checking the phase wire system. When the value in the buffer memory is changed, you need to turn the request for operating condition setting into ON. Otherwise, it will not be applied to the measurement.	Section 6.1 Section 7.5.3
Does the compared gauge measure the effective value correctly?	This module stores the effective value into the buffer memory. If the compared device uses the average value instead of the effective value, the resulted value may largely differ when there is current distortion in the measurement circuit.	-
Is the secondary of ZCT short-circuited?	Make sure that the secondary of ZCT is not short-circuited.	-
Is the secondary of ZCT open-circuited?	Make sure that the secondary of ZCT is not open-circuited.	-
Are you using other ZCT than recommended ones?	ZCTs that can be connected to this module is limited to only Mitsubishi's ZCT. Check that other company's ZCT is not being used. (Refer to section 7.5.3.1.)	-

9.3 Q&A

9.3.1 General

Q	To what degree is the module durable against overvoltage and overcurrent? Is external protective circuit required?
A	<p>Momentary* : Up to 2 times as high as rated voltage and 20 times as high as rated current. Continuous : Up to 1.1 times as high as rated voltage and rated current.</p> <p>* Momentary means: Energizing 9 times for 0.5 seconds at 1-minute intervals, and then 1 time for 5 seconds. External protective circuit is not required.</p>
Q	Is it OK to open secondary output terminal of zero-phase current transformer (ZCT)?
A	<p>Do not open the secondary output terminals (k, l) of ZCT. Opening the secondary output terminals may affect characteristics of ZCT. In addition, do not short-circuit or ground the test terminals (kt, lt) of ZCT. Otherwise, the leak current may not be detected correctly.</p>
Q	Is measurement of inverter circuit possible?
A	<p>Measuring the secondary side of the inverter is impossible due to the large fluctuation of frequency. Make measurement on the primary side of the inverter. However, since a current waveform on the primary side of the inverter has a distortion containing the harmonic components, a slight error occurs.</p>
Q	Obtained values may be different from other measuring instruments. Why is it so?
A	<p>There are various possible causes. Check the following first, please: [1] Check for wiring errors (connections of voltage circuits, in particular). [2] Check for the short-circuit on the secondary side of ZCT. [3] ZCT connectable to the module is the dedicated ZCT manufactured by Mitsubishi Electric only. Check that the proper ZCT is connected. [4] On the split-type ZCT, check for the poor engagement or separation of fitting surfaces. [5] On the split-type ZCT, check for the pinching of foreign object between fitting surfaces. [6] Check that the measuring instrument used for comparison indicates the correct RMS value. [7] If the measuring instrument used for comparison measures an average value instead of rms value, distortion in the current of the circuit to be measured causes a significant difference of values. This module measures an rms value.</p>

9.3.2 Q&A about Specifications

Q	What does “the module tolerance” against?
A	<p>It means tolerance against the input leak current. In case of low sensitivity mode, both of the leak current (I_o) and resistance leak current (I_{or}) have a rated leak current of 1000 mA. Therefore, within the range of the input leak current from 100 to 1000 mA, a tolerance is $\pm 2.5\%$ of input leak current. On the other hand, within the range of the input leak current below 100 mA, a tolerance is ± 2.5 mA. In case of high sensitivity mode, a tolerance is ± 2.5 mA because leak current rating is 100mA.</p>
Q	Is tolerance of zero-phase current transformer (ZCT) included?
A	<p>Tolerance of the module does not include a tolerance of zero-phase current transformer (ZCT). A maximum value of tolerance is obtained by summing tolerance of the module and that of zero-phase current transformer (ZCT).</p>
Q	To what degree an area of microcurrent is measured?
A	<p>A leak current is measured from the area exceeding 1 mA. In an area lower than 1 mA, a measurement result is indicated as “0” (zero).</p>
Q	Is measurement of leak current (I_o) possible without applying a voltage?
A	<p>Measurement of leak current (I_o) is impossible without applying a voltage. When an input voltage is lower than 80 V or when a frequency is inappropriate (below 44.5 Hz or over 66.5 Hz), the measurement result is 0 mA.</p>

Q	Is measurement of leak current possible without applying a voltage?
A	Measurement of leak current is impossible without applying a voltage. Be sure to connect a voltage.

Q	What kind of time is “response time”?
A	<p>“Response time” is a period of time between a point of sudden change of voltage or current input and a point that an output (computation result) follows up to within $\pm 10\%$ of input.</p>

Q	Hardware error “0001h” occurred.
A	<p>Check whether the module is in the test mode. In the test mode, a pseudo value “0001h” is stored as the latest error code to allow debugging of a ladder program. By returning from test mode to measuring mode, the error code becomes “0000h.” (Refer to Section 4.2.5.)</p> <p>If the module is not in the test mode, it means a hardware error. Take actions in Section 9.1.</p>

9.3.3 Q&A about Installing

Q	What wire diameter can penetrate zero-phase current transformer (ZCT)?
A	Refer to “Appendix 2 Option Device (1) Specifications.”

9.3.4 Q&A about Connection

Q	Does polarity exist in connection between zero-phase current transformer (ZCT) and insulation monitor module?
A	No it doesn't.

Q	Are there any key points in avoiding errors in wiring?
A	When making measurement for two circuits, pay attention not to connect zero-phase current transformer (ZCT) to the incorrect channel (CH1 or CH2). Pay attention not to make errors in connecting voltage inputs among P1, P2, and P3.

9.3.5 Q&A about Setting

Q	Is the setting required?
A	At least, phase wire setting is required. Specify settings in accordance with a circuit to be connected.

Appendix

Appendix 1: External dimensions

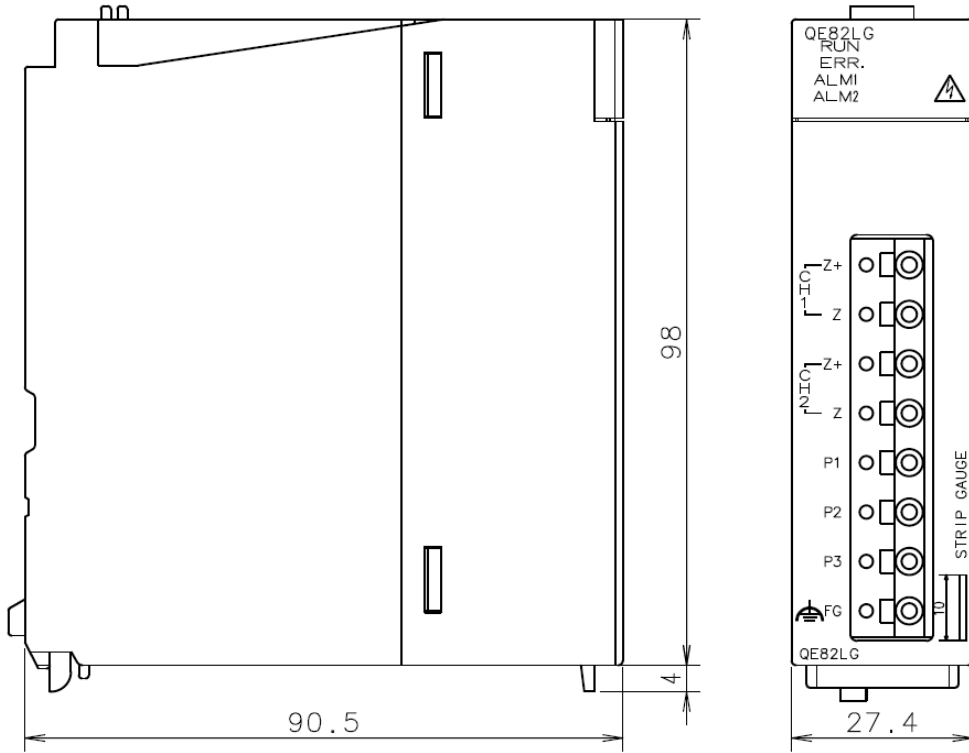

Unit: mm

Appendix 2: Optional devices

(1) Split-type zero-phase current transformer (ZCT)

(a) Specification

Item	Specifications				
Model	CZ-22S	CZ-30S	CZ-55S	CZ-77S	CZ-112S
Hole diameter(mm)	φ22	φ30	φ55	φ77	φ112
Primary current	AC 50A	AC 100A	AC 300A	AC 600A	AC 1000A
Maximum operating voltage	AC 600V				
Rated frequency	50/60Hz				
Rated current in short time (Peak value)	50kA (100kA)				
Category of measuring	Ⅲ				
Pollution degree	2				
Regulatory Compliance	EN61010-2-032				
Combined equipment	Using with fit QE82LG				
Mass	0.5kg	0.6kg	1.8kg	2.8kg	6.0kg

(b) Hole diameter of split-type zero-phase current transformer (ZCT) and Maximum wire radius penetrable and allowable current

Wiring method			Maximum wire radius penetrable (mm ²) (Allowable current(A))				
Wiring	Wire number	Type of wire	CZ-22S	CZ-30S	CZ-55S	CZ-77S	CZ-112S
Single-phase 2-wire	2	600V vinyl wire (IV wire)	22 (115)	60 (217)	250 (556)	500 (842)	—*1
		600V cross polyethylene Isolation wire (CV wire)	22 (130)	38 (190)	200 (545)	500 (920)	1000 (1470)
Single-phase 3-wire Three-phase 3-wire	3	600V vinyl wire (IV wire)	22 (115)	38 (162)	200 (469)	500 (842)	—*1
		600V cross polyethylene Isolation wire (CV wire)	14 (100)	38 (190)	150 (455)	400 (815)	1000 (1470)

Note:

(1) The thickness of the wire is different from maker.

(2) IV wire shows that an insulator.

(3) CV line is as culvert laying showed deference value and Compressed stranded wire.

(more than 600mm² cable is showed as reference value.)

*1. Use the electric wire of penetrable size. And, satisfy the allowable current of the electric wire which an electric current flowing through the point targeted for a measurement uses.

(c) External dimensions

(CZ-22S, CZ-30S, CZ-55S, CZ-77S)

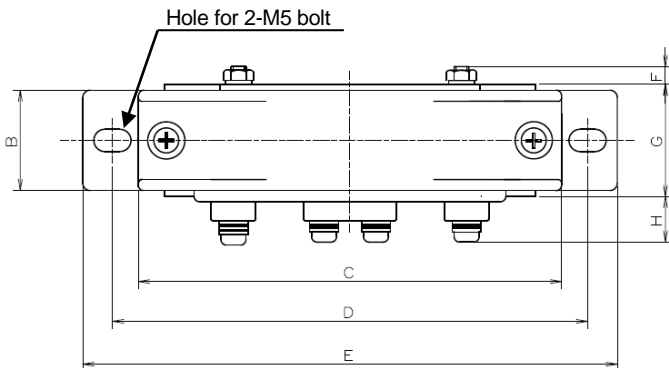

(CZ-112S)

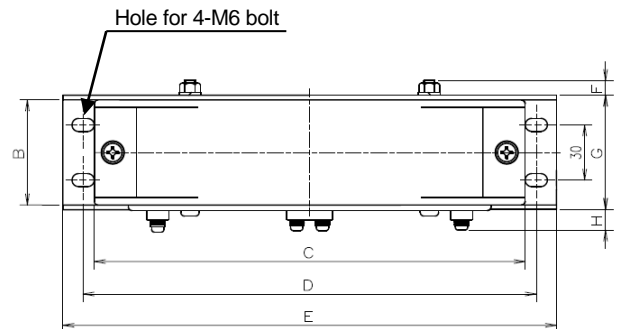

CZ-55S

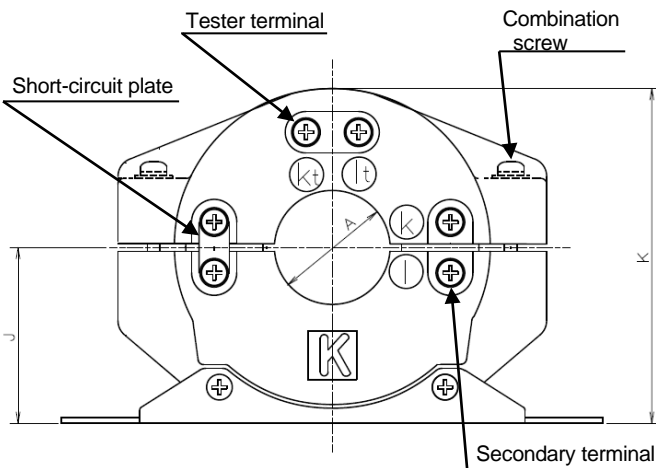

Dimension table

	CZ-22S	CZ-30S	CZ-55S	CZ-77S	CZ-112S
A	$\phi 22$	$\phi 30$	$\phi 55$	$\phi 77$	$\phi 112$
B	27	27	32	41	57
C	100	114	148	198	234
D	112	130	160	210	246
E	128	144	177	232	268
F	5	5	7	10	8
G	30	30	36	45	62
H	12	12	12	12	12
J	41	47	66	90	109
K	77	89	124	171	207

Unit[mm]

(2) Through-type zero-phase current transformer

(a) Specification

Item	Specifications					
Model	ZT15B	ZT30B	ZT40B	ZT60B	ZT80B	ZT100B
Hole diameter(mm)	φ15	φ30	φ40	φ60	φ80	φ100
Maximum operating voltage	AC 600V					
Rated frequency	50/60Hz					
Rated current in short time	50kA (100kA)					
Mass	0.2kg	0.4kg	0.6kg	2.0kg	2.6kg	3.3kg

(b) Hole diameter of through-type zero-phase current transfer (ZCT) and Maximum wire radius penetrable and allowable current

Wiring method			Maximum wire radius penetrable (mm ²) (Allowable current(A))					
Wiring	Wire number	Type of wire	ZT15B	ZT30B	ZT40B	ZT60B	ZT80B	ZT100B
Single-phase 2-wire	2	600V vinyl wire (IV wire)	8 (61)	60 (217)	100 (298)	325 (650)	—*1	—*1
		600V cross polyethylene Isolation wire (CV wire)	3.5 (44)	38 (190)	100 (355)	250 (620)	500 (920)	800 (1285)
Single-phase 3-wire Three-phase 3-wire	3	600V vinyl wire (IV wire)	8 (61)	38 (162)	100 (298)	250 (556)	500 (842)	—*1
		600V cross polyethylene Isolation wire (CV wire)	2 (31)	38 (190)	60 (255)	200 (545)	400 (815)	600 (1005)

Note

(1) The thickness of the wire is different from maker.

(2) IV wire shows that an insulator.

(3) CV line is as culvert laying showed deference value and Compressed stranded wire.
(more than 600mm² cable is showed as reference value.)

*1. Use the electric wire of penetrable size. And, satisfy the allowable current of the electric wire which an electric current flowing through the point targeted for a measurement uses.

(c) External dimensions

ZT15B, 30B, 40B models

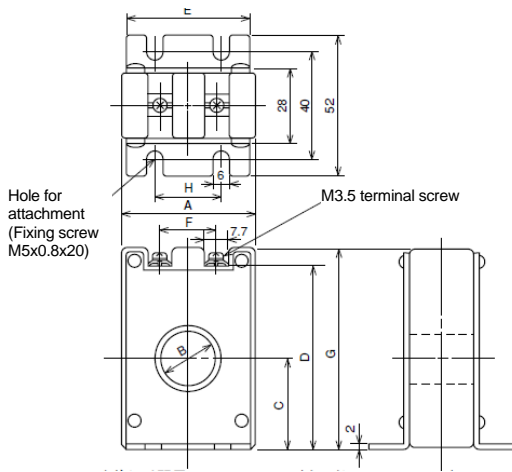

Dimension table for ZT15B, 30B, 40B models

	ZT15B	ZT30B	ZT40B
A	48	68	85
B	15	30	40
C	29	37	43
D	62	82	92
E	46	66	81
F	15	30	40
G	70	90	100
H	25	50	50

Dimension table for ZT60B, 80B, 100B models

	ZT60B	ZT80B	ZT100B
A	140	160	185
B	60	80	100
C	73	82	93
D	150	169	190
E	46	48	50

ZT60B, 80B, 100B models

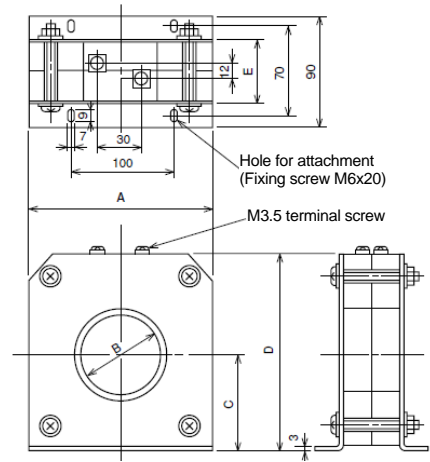

Unit [mm]

(3) Zero-phase current transformer with primary conductor
 (a) Specification

Item	Specification		
Model	ZTA600A	ZTA1200A	ZTA2000A
Allowable current	600A	1200A	2000A
Number of poles	3		
Maximum operating voltage	AC 600V		
Rated current in short time	100kA (peak value)		
Mass	6.5kg	11kg	27kg

◆ Zero-phase current transformer with primary conductor (ZTA600A, ZTA1200A, ZTA2000A)

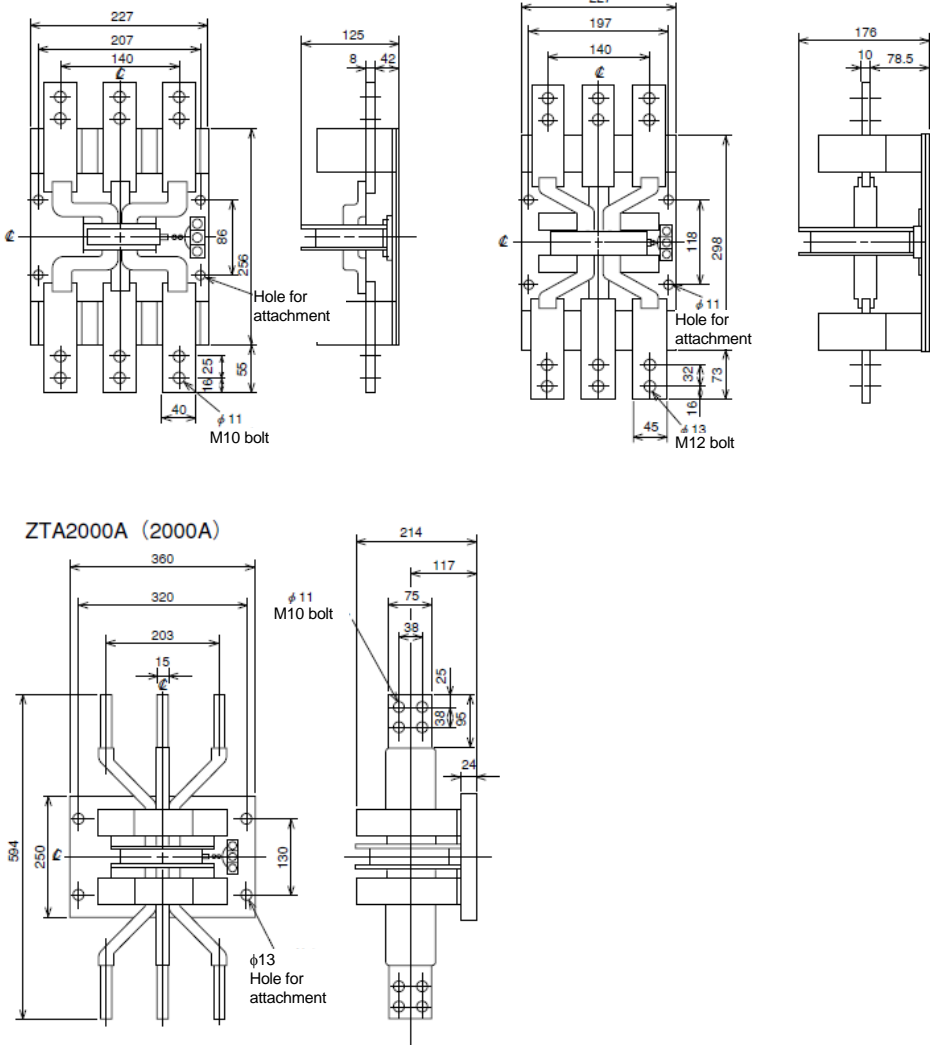

Appendix 3: Addition or change of functions

The following table lists functions added or changed to the QE82LG and GX Works2, serial number of compatible QE82LG, and software version of compatible GX Works2.

Added or changed contents	serial number with the QE82LG*1	Software version with the GX Works2	Reference
Support with GX Works2	Upper 6 digits is 120911 or later	1.90U or later	-
High sensitivity mode	Upper 6 digits is 150612 or later	1.501X or later	Section 4.2.1 Section 7.6.2

*1: Shown on the front (at the bottom) of the module. When a serial number is not displayed on the front of module, the module does not support added or changed contents.

Index

[A]

Alarm delay time 4-4
Alarm flag (Xn1 - Xn8) 4-5, 5-2
Alarm monitoring function 4-4
Alarm non-occurrence status 4-5
Alarm occurrence count clear completion
flag (XnB,XnD) 4-10, 5-4
Alarm occurrence count clear request
(YnB,YnD) 4-10, 5-6
Alarm occurrence count function 4-10
Alarm occurrence status 4-5
Alarm reset method 4-7
Alarm reset request (Yn1,Yn5) 5-5
Alarm reset status 4-5
Alarm value 4-4
ALM1 LED, ALM2 LED 4-5
Appropriate wire 7-7
Auto reset 4-7

[B]

Bar terminal 7-7

[C]

CH1 Alarm, CH2 Alarm A-9, 4-6
CH1 alarm occurrence count,
CH2 alarm occurrence count A-9, 4-10
CH1 max. value, CH2 max. value A-9, 4-3

[E]

ERR. LED 7-4
Error clear request (YnF) 5-7
Error code 9-1
Error flag (XnF) 5-4

[G]

GX Developer 7-20
GX Works2 7-14

[I]

Io1, Ior1, Io2, Ior2 A-9, 4-2

[L]

Latest error code 6-12

[M]

Max. value 4-2, 6-7
Max. value clear completion flag (XnA,XnC) 5-4
Max. value clear request (YnA,YnC) 4-3, 5-6
Max. values hold function 4-3
Measured value of leak current 6-6
Measuring function 4-2
Module ready (Xn0) 5-2

[N]

Name of each part 7-3

[O]

Operating condition setting completion
flag (Xn9) 5-3
Operating condition setting request (Yn9) 5-5

[P]

Phase wire system 6-4

[S]

Self-retention 4-7
Self-retention status 4-5
Serial number 2-3

[T]

Test function 4-11
Time of error 6-13
Time of max. value 6-8, 6-10

[Z]

ZCT A-9, 7-8, 7-11
Zero-phase current transformer A-9, 7-8, 7-11

Warranty

For using this product, please thoroughly read the following product warranty descriptions.

1. Gratis Warranty Period and Gratis Warranty Coverage

If any failure or defect (hereinafter collectively called "failures") for which our company is held responsible occurs on the product during the gratis warranty period, our company shall replace the product for free through the distributor at which you purchased the product or our service company.

However, if an international travel is required for replacement, or a travel to an isolated island or remote location equivalent is required for replacement, the actual cost incurred to send an engineer(s) shall be charged.

[Gratis Warranty Period]

The gratis warranty term of the product shall be for one year after the date of purchase or delivery to a designated place.

Note that after manufacture and shipment from Mitsubishi, the maximum distribution period shall be six (6) months, and the longest gratis warranty term after manufacturing shall be eighteen (18) months. The gratis warranty term of repair parts shall not exceed the gratis warranty term before repairs.

[Gratis Warranty Coverage]

- (1) The gratis warranty shall apply only if the product is being used properly in the conditions, with the methods and under the environments in accordance with the terms and precautions described in the instruction manual, user's manual, caution label on the product, etc.
- (2) Replacement shall be charged for the following cases even during the gratis warranty period.
 - 1) Failures occurring due to your improper storage or handling, carelessness or fault, and failures arising from the design contents of hardware or software you use.
 - 2) Failures arising from modification you performed on the product without prior consent of our company.
 - 3) Failures occurring in the event that the product is assembled into the device you use and that are acknowledged as avoidable if the device is equipped with a safety mechanism that comply with the legal regulations applicable to the device or with functions/architecture which are considered as necessary to be equipped under conventions of the industry.
 - 4) Failures due to accidental force such as a fire, abnormal voltage, etc. and force majeure such as an earthquake, thunderstorm, wind, flood, etc.
 - 5) Failures due to matters unpredictable based on the level of science technology at the time of product
 - 6) Other failures which are beyond responsibility of our company or which you admit that our company is not held responsible for.

2. Fare-Paying Repair Period after Production Discontinued

- (1) The period our company may accept product replacement with charge shall be seven (7) years after production of the product is discontinued.

Production stoppage shall be announced in the technical news, etc. of our company.
- (2) The product (including spare) cannot be supplied after production is discontinued.

3. Exemption of Compensation Liability for Opportunity Loss, Secondary Loss, etc.

Our company shall not be liable to compensate for any loss arising from events not attributable to our company, opportunity loss and lost earning of the customer due to failure of the product, and loss, secondary loss, accident compensation, damage to other products besides our products and other operations caused by a special reason regardless of our company's predictability in both within and beyond the gratis warranty period.

4. Change of Product Specifications

Please be advised in advance that the specifications described in catalogs, manuals or technical materials are subject to change without notice.

5. Application of Products

- (1) For use of our general-purpose sequencer MELSEC-Q series and Insulation Monitoring Module QE82LG, they shall be used for a purpose which shall not lead to a material accident even when a failure or malfunction of the sequencer occurs, and a backup or fail-safe function shall be implemented systematically at external of the device in the event of a failure or malfunction.
- (2) Our general-purpose sequencers are designed and manufactured as general-purpose products which are targeted for general industry applications. Therefore, use of the sequencer for purposes in nuclear power plants and other power plants of each electric power company which greatly affect public, or for purposes in each JR company and the Defense Agency requiring a special quality assurance system shall be excluded from its applications.

However, the sequencer may be used for such purposes if the customer acknowledges that it should be used for limited purpose only and agrees not to require special quality.

Also, if you are considering to use this device for purposes that are expected to greatly affect human life or property and require high reliability especially in safety or control system such as aviation, medical care, railroad, combustion/fuel device, manned carrier device, entertainment machine, safety equipment, please consult with our service representative to exchange necessary specifications.

Energy Measuring Module

Service Network

Country/Region	Corporation Name	Address	Telephone
Australia	Mitsubishi Electric Australia Pty. Ltd.	348 Victoria Road, Rydalmere, N.S.W. 2116, Australia	+61-2-9684-7777
Algeria	Mec Casa	Rue i N 125 Hay-Es-Salem, 02000, W-Chlef, Algeria	+213-27798069
Bangladesh	PROGRESSIVE TRADING CORPORATION	HAQUE TOWER,2ND FLOOR,610/11,JUBILEE ROAD, CHITTAGONG, BANGLADESH	+880-31-624307
	ELECTRO MECH AUTOMATION& ENGINEERING LTD.	SHATABDI CENTER, 12TH FLOOR, SUITES-12-B, 292, INNER CIRCULAR ROAD, FAKIRA POOL, MOTIJHEEL, DHAKA-1000, BANGLADESH	+88-02-7192826
Belarus	Tehnikon	Oktyabrskaya 19, Off. 705, BY-220030 Minsk, Belarus	+375 (0)17 / 210 46 26
Belgium	Koning & Hartman B.V.	Woluweleen 31, BE-1800 Vilvoorde, Belgium	+32 (0)2 / 2570240
Brazil	Mitsubishi Electric do Brasil Comércio e Serviços Ltda.	Avenida Adelino Cardana, 293 – 21º Andar, Bethaville, Barueri, SP, Brasil, CEP 06401-147	+55-11-4689-3000
Cambodia	DHINIMEX CO.,LTD	#245, St. Tep Phan, Phnom Penh, Cambodia	+855-23-997-725
Central America	Automation International LLC	7050 W. Palmetto Park Road Suite #15 PMB #555, Boca Raton, FL 33433	+1-561-237-5228
Chile	Rhona S.A. (Main office)	Vte. Agua Santa 4211 Casilla 30-D (P.O. Box) Vina del Mar, Chile	+56-32-2-320-600
China	Mitsubishi Electric Automation (China) Ltd.	Mitsubishi Electric Automation Building, No.1386 Hongqiao Road, Shanghai, China 200336	+86-21-2322-3030
	Mitsubishi Electric Automation (China) Ltd. Beijing	5/F, ONE INDIGO,20 Jiuxianqiao Road Chaoyang District, Beijing, China 100016	+86-10-6518-8830
	Mitsubishi Electric Automation (China) Ltd. ShenZhen	Level 8, Galaxy World Tower B, 1 Yabao Road, Longgang District, Shenzhen, China 518129	+86-755-2399-8272
	Mitsubishi Electric Automation (China) Ltd. GuangZhou	Rm.1006, A1 Times E-Park, No.276-282, Hanxi Road East, Zhongcun Street, Panyu Distric, Guangzhou, China 510030	+86-20-8923-6730
	Mitsubishi Electric Automation (China) Ltd. ChengDu	1501-1503,15F, Guang-hua Centre Building-C, No.98 North Guang Hua 3th Rd Chengdu, China 610000	+86-28-8446-8030
	Mitsubishi Electric Automation (Hong Kong) Ltd.	20/F., Cityplaza One, 1111 King's Road, Taikoo shing, Hong Kong	+852-2510-0555
Colombia	Proelectrico Representaciones S.A.	Carrera 42 N° 75 – 367 Bodega 109, Itagüí, Medellín, Antioquia, Colombia	+57-4-4441284
Czech Republic	AUTOCONT CONTROL SYSTEMS S.R.O	Technologická 374/6, CZ-708 00 Ostrava - Pustkovec	+420 595 691 150
Denmark	BEIJER ELECTRONICS A/S	LYKKEGARDSVEJ 17, DK-4000 ROSKILDE, Denmark	+45 (0)46/ 75 76 66
Egypt	Cairo Electrical Group	9, Rostoum St. Garden City P.O. Box 165-11516 Maglis El-Shaab,Cairo - Egypt	+20-2-27961337
France	Mitsubishi Electric Europe B.V. French Branch	FR-92741 Nanterre Cedex	+33 (0)1 55 68 57 01
Germany	Mitsubishi Electric Europe B.V.	Mitsubishi-Electric-Platz 1, 40882 Ratingen, Germany	+49 (0) 2102 4860
Greece	KALAMARAKIS - SAPOUNAS S.A.	IONIAS & NEROMILOU STR., CHAMOILIOS ACHARNES, ATHENS, 13678 Greece	+30-2102 406000
	UTECO	5, MAVROGENOUS STR., 18542 PIRAEUS, Greece	+30-211-1206-900
Hungary	Meltrade Ltd.	Fertő utca 14, HU-1107 Budapest, Hungary	+36 (0)1-431-9726
India	Mitsubishi Electric India Private Limited	2nd Floor, Tower A&B, Cyber Greens, DLF Cyber City, DLF Phase-III, Gurgaon - 122 022 Haryana, India	+91-124-4630300
	Mitsubishi Electric India Private Limited Pune Sales Office	ICC-Devi Gaurav Technology Park, Unit no. 402, Fourth Floor, Survey no. 191-192 (P), Opp. Vallabh Nagar Bus Depot, Pune – 411018, Maharashtra, India	+91-20-68192100
	Mitsubishi Electric India Private Limited FA Center	204-209, 2nd Floor, 31FIVE, Corporate Road, Prahladnagar, Ahmedabad 380015,Gujarat, India	+91-79677-77888
Indonesia	PT.Mitsubishi Electric Indonesia	Gedung Jaya 8th floor, J.L. MH. Thamrin No.12 Jakarta Pusat 10340, Indonesia	+62-21-3192-6461
	P.T. Sahabat Indonesia	P.O.Box 5045 Kawasan Industri Perjudangan, Jakarta, Indonesia	+62(0)21-6610651-9
Ireland	Mitsubishi Electric Europe B.V.	Westgate Business Park, Ballymount, IRL-Dublin 24, Ireland	+353 (0)1-4198800
Israel	Gino Industries Ltd.	26, Ophir Street IL-32235 Haifa, Israel	+972 (0)4-867-0656
Italy	Mitsubishi Electric Europe B.V.	Viale Colleoni 7, I-20041 Agrate Brianza (MI), Italy	+39 039-60531
Kazakhstan	Kazpromavtomatika	Ul. Zhambyla 28, KAZ - 100017 Karaganda	+7-7212-501000
Korea	Mitsubishi Electric Automation Korea Co., Ltd	9F Gangseo Hangang xi-tower A, 401 Yangcheon-ro, Gangseo-gu, Seoul 07528 Korea	+82-2-3660-9573
Laos	AROUNKIT CORPORATION IMPORT-EXPORT SOLE CO.,LTD	SAPHANMO VILLAGE. SAYSETHA DISTRICT, VIENTIANE CAPITAL, LAOS	+856-20-415899
Lebanon	Comptoir d'Electricite Generale-Liban	Cebaco Center - Block A Autostrade Dora, P.O. Box 11-2597 Beirut - Lebanon	+961-1-240445
Lithuania	Rifas UAB	Tinklu 29A, LT-5300 Panevezys, Lithuania	+370 (0)45-582-728
Malaysia	Mitric Sdn Bhd	No. 5 Jalan Pemberita U1/49, Temasya Industrial Park, Glenmarie 40150 Shah Alam,Selangor, Malaysia	+603-5669-3748
	Flexible Automation System Sdn Bhd	60, Jalan USJ 10/1B,UEP Subang Jaya,47620 Selangor Darul Ehsan,Malaysia	+603-5633-1280
Malta	ALFATRADE LTD	99 PAOLA HILL, PAOLA PLA 1702, Malta	+356 (0)21-697-816
Marocco	SCHIELE MAROC	KM 7.2 NOUVELLE ROUTE DE RABAT AIN SEBAA, 20600 Casablanca, Maroco	+212 661 45 15 96
Myanmar	Peace Myanmar Electric Co.,Ltd.	NO137/139 Botahtaung Pagoda Road, Botahtaung Town Ship 11161,Yangon,Myanmar	+95-(0)1-202589
Nepal	Watt&Volt House	KHA 2-65, Volt House Dillibazar Post Box:2108,Kathmandu, Nepal	+977-1-4411330
Netherlands	Imtech Marine & Offshore B.V.	Sluisjesdijk 155, NL-3087 AG Rotterdam, Netherlands	+31 (0)10-487-19 11
North America	Mitsubishi Electric Automation, Inc.	500 Corporate Woods Parkway, Vernon Hills, IL 60061 USA	+847-478-2100
Norway	Scanelec AS	Leirvikasen 43B, NO-5179 Godvik, Norway	+47 (0)55-506000
Mexico	Mitsubishi Electric Automation, Inc. Mexico Branch	Bldv. Miguel de Cervantes Saavedra 301, Torre Norte Piso 5, Col. Ampliación Granada, Miguel Hidalgo, Ciudad de México, CP 11520, México	+52-55-3067-7511
Middle East Arab Countries & Cyprus	Comptoir d'Electricite Generale-International-S.A.L.	Cebaco Center - Block A Autostrade Dora P.O. Box 11-1314 Beirut - Lebanon	+961-1-240430
Pakistan	Prince Electric Co.	2-P GULBERG II, LAHORE, 54600, PAKISTAN	+92-42-575232, 5753373
Peru	Rhona S.A. (Branch office)	Avenida Argentina 2201, Cercado de Lima	+51-1-464-4459
Philippines	MELCO Factory Automation Philippines Inc.	128 Lopez Rizal St., Brgy. Highway Hills, Mandaluyong City, Metro Manila, Philippines	+63-(0)2-256-8042
	Edison Electric Integrated, Inc.	24th Fl. Galleria Corporate Center, Edsa Cr. Ortigas Ave., Quezon City Metro Manila, Philippines	+63-(0)2-634-8691
Poland	Mitsubishi Electric Europe B.V. Polish Branch	Krakowska 48, 32-083 Balice, Poland	+48 12 347 65 00
Republic of Moldova	Intehsis SRL	bld. Traian 23/1, MD-2060 Kishinev, Moldova	+373 (0)22-66-4242
Romania	Sirius Trading & Services SRL	RO-060841 Bucuresti, Sector 6 Aleea Lacul Morii Nr. 3	+40-(0)21-430-40-06
Russia	Mitsubishi Electric (Russia) LLC	2 bld.1, Letnikovskaya street, Moscow, 115114, Russia	+7 495 721-2070
Saudi Arabia	Center of Electrical Goods	Al-Shuwayer St. Side way of Salahuddin Al-Ayoubi St. P.O. Box 15955 Riyadh 11454 - Saudi Arabia	+966-1-4770149
Singapore	Mitsubishi Electric Asia Pte. Ltd.	307 Alexandra Road, Mitsubishi Electric Building, Singapore 159943	+65-6473-2308
Slovakia	PROCONT, Presov	Kupelna 1/, SK - 08001 Presov, Slovakia	+421 (0)51 - 7580 611
	SIMAP	Jana Derku 1671, SK - 91101 Trenčín, Slovakia	+421 (0)32 743 04 72
Slovenia	Inea RBT d.o.o.	Stegne 11, SI-1000 Ljubljana, Slovenia	+386 (0)1-513-8116
South Africa	CBI-electric: low voltage	Private Bag 2016, ZA-1600 Isando Gauteng, South Africa	+27-(0)11-9282000
Spain	Mitsubishi Electric Europe B.V. Spanish Branch	Carretera de Rubí 76-80, E-08190 Sant Cugat del Vallés (Barcelona), Spain	+34 (0)93-565-3131
Sweden	Mitsubishi Electric Europe B.V. (Scandinavia)	Hedvig Möllers gata 6, 223 55 Lund, Sweden	+46 (0)8-625-10-00
	Euro Energy Components AB	Järnvägsgatan 36, S-434 24 Kungälv, Sweden	+46 (0)300-690040
Switzerland	TriElec AG	Muehentalstrasse 136, CH-8201 Schaffhausen, Switzerland	+41-(0)52-6258425
Taiwan	Setsuyo Enterprise Co., Ltd	5th Fl., No.105, Wu Kung 3rd, Wu-Ku Hsiang, Taipei, Taiwan, R.O.C.	+886-(0)2-2298-8889
	United Trading & Import Co., Ltd.	77/12 Bamrungmuang Road,Klong Mahanak Pomprab Bangkok Thailand	+66-223-4220-3
Thailand	MITSUBISHI ELECTRIC FACTORY AUTOMATION (THAILAND) CO.,LTD	101, True Digital Park Office, 5th Floor, Sukhumvit Road, Bangchak, Phara Khanong, Bangkok, 10260 Thailand	+662-092-8600
Tunisia	MOTRA Electric	3, Résidence Imen, Avenue des Martyrs Mourouj III, 2074 - El Mourouj III Ben Arous, Tunisia	+216-71 474 599
Turkey	Mitsubishi Electric Turkey A.Ş.	Şerifali Mahallesi Kale Sokak No: 41, 34775 Ümraniye, Istanbul, Turkey	+90-216-969-2666
United Kingdom	Mitsubishi Electric Europe B.V.	Travellers Lane, UK-Hatfield, Herts. AL10 8XB, United Kingdom	+44 (0)1707-276100
Uruguay	Fierro Vignoli S.A.	Avda. Uruguay 1274 Montevideo Uruguay	+598-2-902-0808
Vietnam	Mitsubishi Electric Vietnam Co.,Ltd. Head Office	11th & 12th Floor, Viettel Tower B, 285 Cach Mang Thang 8 Street, Ward 12, District 10, Ho Chi Minh City, Vietnam	+84-28-3910-5945
	Mitsubishi Electric Vietnam Co.,Ltd. Hanoi Branch	24th Floor, Handico Tower, Pham Hung Road, khu do thi moi Me Tri Ha, Nam Tu Liem District, Hanoi City, Vietnam	+84-24-3937-8075

MITSUBISHI ELECTRIC CORPORATION
HEAD OFFICE: TOKYO BUILDING, 2-7-3, MARUNOUCHI, CHIYODA-KU, TOKYO 100-8310, JAPAN