



Programmable Controller

MELSEC **Q** series

MELSEC-Q
QD77GF Simple Motion Module
User's Manual (Network)

-QD77GF4
-QD77GF8
-QD77GF16

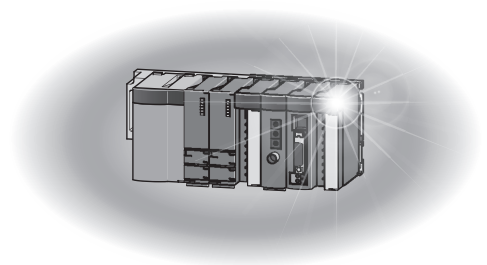

● SAFETY PRECAUTIONS ●

(Please read these instructions before using this equipment.)

Before using this product, please read this manual and the relevant manuals introduced in this manual carefully and pay full attention to safety to handle the product correctly.

The precautions given in this manual are concerned with this product only. Refer to the user's manual of the CPU module to use for a description of the PLC system safety precautions.

In this manual, the safety instructions are ranked as "DANGER" and "CAUTION".

 **DANGER**

Indicates that incorrect handling may cause hazardous conditions, resulting in death or severe injury.

 **CAUTION**

Indicates that incorrect handling may cause hazardous conditions, resulting in medium or slight personal injury or physical damage.

Depending on circumstances, procedures indicated by  CAUTION may also be linked to serious results.

In any case, it is important to follow the directions for usage.

Please save this manual to make it accessible when required and always forward it to the end user.

For Safe Operations

1. Prevention of electric shocks

DANGER

- Never open the front case or terminal covers while the power is ON or the unit is running, as this may lead to electric shocks.
- Never run the unit with the front case or terminal cover removed. The high voltage terminal and charged sections will be exposed and may lead to electric shocks.
- Never open the front case or terminal cover at times other than wiring work or periodic inspections even if the power is OFF. The insides of the module and servo amplifier are charged and may lead to electric shocks.
- Completely turn off the externally supplied power used in the system before mounting or removing the module, performing wiring work, or inspections. Failing to do so may lead to electric shocks.
- When performing wiring work or inspections, turn the power OFF, wait at least ten minutes, and then check the voltage with a tester, etc. Failing to do so may lead to electric shocks.
- Be sure to ground the module, servo amplifier and servomotor (Ground resistance: 100 Ω or less). Do not ground commonly with other devices.
- The wiring work and inspections must be done by a qualified technician.
- Wire the units after installing the module, servo amplifier and servomotor. Failing to do so may lead to electric shocks or damage.
- Never operate the switches with wet hands, as this may lead to electric shocks.
- Do not damage, apply excessive stress, place heavy things on or sandwich the cables, as this may lead to electric shocks.
- Do not touch the module, servo amplifier, servomotor connector or terminal blocks while the power is ON, as this may lead to electric shocks.
- Do not touch the built-in power supply, built-in grounding or signal wires of the module and servo amplifier, as this may lead to electric shocks.

2. For fire prevention

CAUTION

- Install the module, servo amplifier, servomotor and regenerative resistor on incombustible. Installing them directly or close to combustibles will lead to fire.
- If a fault occurs in the module or servo amplifier, shut the power OFF at the servo amplifier's power source. If a large current continues to flow, fire may occur.
- When using a regenerative resistor, shut the power OFF with an error signal. The regenerative resistor may abnormally overheat due to a fault in the regenerative transistor, etc., and may lead to fire.
- Always take heat measures such as flame proofing for the inside of the control panel where the servo amplifier or regenerative resistor is installed and for the wires used. Failing to do so may lead to fire.
- Do not damage, apply excessive stress, place heavy things on or sandwich the cables, as this may lead to fire.

3. For injury prevention

CAUTION

- Do not apply a voltage other than that specified in the instruction manual on any terminal. Doing so may lead to destruction or damage.
- Do not mistake the terminal connections, as this may lead to destruction or damage.
- Do not mistake the polarity (+/-), as this may lead to destruction or damage.
- Do not touch the heat radiating fins of module or servo amplifier, regenerative resistor and servomotor, etc., while the power is ON and for a short time after the power is turned OFF. In this timing, these parts become very hot and may lead to burns.
- Always turn the power OFF before touching the servomotor shaft or coupled machines, as these parts may lead to injuries.
- Do not go near the machine during test operations or during operations such as teaching. Doing so may lead to injuries.

4. Various precautions

Strictly observe the following precautions. Mistaken handling of the unit may lead to faults, injuries or electric shocks.

(1) System structure

CAUTION

- Always install a leakage breaker on the module and servo amplifier power source.
- If installation of an electromagnetic contactor for power shut off during an error, etc., is specified in the instruction manual for the servo amplifier, etc., always install the electromagnetic contactor.
- Install the emergency stop circuit externally so that the operation can be stopped immediately and the power shut off.
- Use the module, servo amplifier, servomotor and regenerative resistor with the correct combinations listed in the instruction manual. Other combinations may lead to fire or faults.
- Use the CPU module, base unit, and Simple Motion module with the correct combinations listed in the instruction manual. Other combinations may lead to faults.
- If safety standards (ex., robot safety rules, etc.) apply to the system using the module, servo amplifier and servomotor, make sure that the safety standards are satisfied.
- Construct a safety circuit externally of the module or servo amplifier if the abnormal operation of the module or servo amplifier differ from the safety directive operation in the system.
- In systems where coasting of the servomotor will be a problem during the forced stop, emergency stop, servo OFF or power supply OFF, use dynamic brakes.
- Make sure that the system considers the coasting amount even when using dynamic brakes.
- In systems where perpendicular shaft dropping may be a problem during the forced stop, emergency stop, servo OFF or power supply OFF, use both dynamic brakes and electromagnetic brakes.
- The dynamic brakes must be used only on errors that cause the forced stop, emergency stop, or servo OFF. These brakes must not be used for normal braking.
- The brakes (electromagnetic brakes) assembled into the servomotor are for holding applications, and must not be used for normal braking.

CAUTION

- The system must have a mechanical allowance so that the machine itself can stop even if the stroke limits switch is passed through at the max. speed.
- Use wires and cables that have a wire diameter, heat resistance and bending resistance compatible with the system.
- Use wires and cables within the length of the range described in the instruction manual.
- The ratings and characteristics of the parts (other than module, servo amplifier and servomotor) used in a system must be compatible with the module, servo amplifier and servomotor.
- Install a cover on the shaft so that the rotary parts of the servomotor are not touched during operation.
- There may be some cases where holding by the electromagnetic brakes is not possible due to the life or mechanical structure (when the ball screw and servomotor are connected with a timing belt, etc.). Install a stopping device to ensure safety on the machine side.

(2) Parameter settings and programming

DANGER

- Set the parameter values to those that are compatible with the module, servo amplifier, servomotor and regenerative resistor model and the system application. The protective functions may not function if the settings are incorrect.
- The regenerative resistor model and capacity parameters must be set to values that conform to the operation mode and servo amplifier. The protective functions may not function if the settings are incorrect.
- Set the mechanical brake output and dynamic brake output validity parameters to values that are compatible with the system application. The protective functions may not function if the settings are incorrect.
- Set the stroke limit input validity parameter to a value that is compatible with the system application. The protective functions may not function if the setting is incorrect.
- Set the servomotor encoder type (increment, absolute position type, etc.) parameter to a value that is compatible with the system application. The protective functions may not function if the setting is incorrect.
- Use the program commands for the program with the conditions specified in the instruction manual.
- Set the sequence function program capacity setting, device capacity, latch validity range, I/O assignment setting, and validity of continuous operation during error detection to values that are compatible with the system application. The protective functions may not function if the settings are incorrect.

DANGER

- The input devices and data registers assigned to the link will hold the data previous to when communication is terminated by an error, etc. Thus, an error correspondence interlock program specified in the instruction manual must be used.
- Use the interlock program specified in the intelligent function module's instruction manual for the program corresponding to the intelligent function module.
- When connecting GX Works2 with the CPU module or connecting a personal computer with an intelligent function module to modify data of a running programmable controller, configure an interlock circuit in the program to ensure that the entire system will always operate safely. For other forms of control (such as program modification or operating status change) of a running programmable controller, read the relevant manuals carefully and ensure that the operation is safe before proceeding. Especially, when a remote programmable controller is controlled by an external device, immediate action cannot be taken if a problem occurs in the programmable controller due to a communication failure. To prevent this, configure an interlock circuit in the program, and determine corrective actions to be taken between the external device and CPU module in case of a communication failure.
- For the operating status of each station after a communication failure, refer to Section 8.1.7 in this manual. Incorrect output or malfunction due to a communication failure may result in an accident.
- Do not write any data to the "system area" of the buffer memory in the intelligent function module. Also, do not use any "use prohibited" signals as an output signal from the CPU module to the intelligent function module.
Doing so may cause malfunction of the programmable controller system.
- To set a refresh device in the network parameter, select the device Y for the remote output (RY) refresh device. If a device other than Y, such as M and L, is selected, the CPU module holds the device status even after its status is changed to STOP.
- If a communication cable is disconnected, the network may be unstable, resulting in a communication failure of multiple stations. Configure an interlock circuit in the program to ensure that the entire system will always operate safely even if communications fail.
Failure to do so may result in an accident due to an incorrect output or malfunction.

(3) Transportation and installation

DANGER

- Shut off the external power supply (all phases) used in the system before mounting or removing a module. Failure to do so may result in electric shock or cause the module to fail or malfunction.

⚠ CAUTION

- Transport the product with the correct method according to the mass.
- Use the servomotor suspension bolts only for the transportation of the servomotor. Do not transport the servomotor with machine installed on it.
- Do not stack products past the limit.
- When transporting the module or servo amplifier, never hold the connected wires or cables.
- When transporting the servomotor, never hold the cables, shaft or detector.
- When transporting the module or servo amplifier, never hold the front case as it may fall off.
- When transporting, installing or removing the module or servo amplifier, never hold the edges.
- Install the unit according to the instruction manual in a place where the mass can be withstood.
- Do not get on or place heavy objects on the product.
- Always observe the installation direction.
- Keep the designated clearance between the module or servo amplifier and control panel inner surface or the module and servo amplifier, module or servo amplifier and other devices.
- Do not install or operate modules, servo amplifiers or servomotors that are damaged or that have missing parts.
- Do not block the intake/outtake ports of the servo amplifier and servomotor with cooling fan.
- Do not allow conductive matter such as screw or cutting chips or combustible matter such as oil enter the module, servo amplifier or servomotor.
- The module, servo amplifier and servomotor are precision machines, so do not drop or apply strong impacts on them.
- Securely fix the module, servo amplifier and servomotor to the machine according to the instruction manual. If the fixing is insufficient, these may come off during operation.
- Always install the servomotor with reduction gears in the designated direction. Failing to do so may lead to oil leaks.
- Store and use the unit in the following environmental conditions.

Environment	Conditions	
	Module/Servo amplifier	Servomotor
Ambient temperature	According to each instruction manual.	0°C to +40°C (With no freezing)
Ambient humidity	According to each instruction manual.	80% RH or less (With no dew condensation)
Storage temperature	According to each instruction manual.	-20°C to +65°C
Atmosphere	Indoors (where not subject to direct sunlight). No corrosive gases, flammable gases, oil mist or dust must exist	
Altitude	According to each instruction manual	
Vibration	According to each instruction manual	

- When coupling with the servomotor shaft end, do not apply impact such as by hitting with a hammer. Doing so may lead to detector damage.
- Do not apply a load larger than the tolerable load onto the servomotor shaft. Doing so may lead to shaft breakage.

CAUTION

- When not using the module for a long time, disconnect the power line from the module or servo amplifier.
- Place the module and servo amplifier in static electricity preventing vinyl bags and store.
- When storing for a long time, please contact with our sales representative.
Also, execute a trial operation.
- Make sure that the connectors for the servo amplifier and peripheral devices have been securely installed until a click is heard.
Not doing so could lead to a poor connection, resulting in erroneous input and output.
- Use the programmable controller in an environment that meets the general specifications in the user's manual for the CPU module used. Failure to do so may result in electric shock, fire, malfunction, or damage to or deterioration of the product.
- To mount the module, while pressing the module mounting lever located in the lower part of the module, fully insert the module fixing projection(s) into the hole(s) in the base unit and press the module until it snaps into place. Incorrect mounting may cause malfunction, failure or drop of the module.
When using the programmable controller in an environment of frequent vibrations, fix the module with a screw.
- Tighten the screws within the specified torque range. Undertightening can cause drop of the screw, short circuit or malfunction. Overtightening can damage the screw and/or module, resulting in drop, short circuit, or malfunction.
- Do not directly touch any conductive parts and electronic components of the module. Doing so can cause malfunction or failure of the module.
- When fumigants that contain halogen materials such as fluorine, chlorine, bromine, and iodine are used for disinfecting and protecting wooden packaging from insects, they cause malfunction when entering our products.
Please take necessary precautions to ensure that remaining materials from fumigant do not enter our products, or treat packaging with methods other than fumigation (heat method). Additionally, disinfect and protect wood from insects before packing products.
- The module and the servo amplifier must not be used with parts which contain halogen-series flame retardant materials (such as bromine) under coexisting conditions.

(4) Wiring

⚠ DANGER

- Shut off the external power supply (all phases) used in the system before wiring. Failure to do so may result in electric shock or cause the module to fail or malfunction.

⚠ CAUTION

- Correctly and securely wire the wires. Reconfirm the connections for mistakes and the terminal screws for tightness after wiring. Failing to do so may lead to run away of the servomotor.
- After wiring, install the protective covers such as the terminal covers to the original positions.
- Do not install a phase advancing capacitor, surge absorber or radio noise filter (option FR-BIF) on the output side of the servo amplifier.
- Correctly connect the output side (terminal U, V, W). Incorrect connections will lead the servomotor to operate abnormally.
- Do not connect a commercial power supply to the servomotor, as this may lead to trouble.
- Do not mistake the direction of the surge absorbing diode installed on the DC relay for the control signal output of brake signals, etc. Incorrect installation may lead to signals not being output when trouble occurs or the protective functions not functioning.

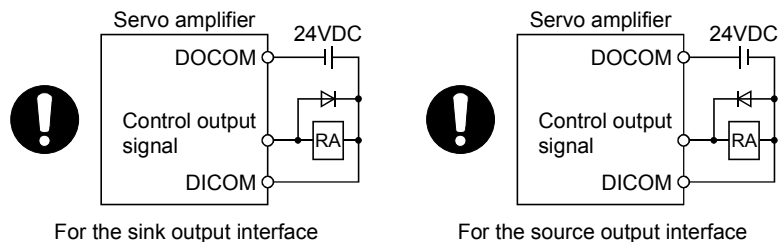

- Do not connect or disconnect the connection cables between each unit, the encoder cable or PLC expansion cable while the power is ON.
- Securely tighten the cable connector fixing screws and fixing mechanisms. Insufficient fixing may lead to the cables coming off during operation.
- Do not bundle the power line or cables.
- Use applicable solderless terminals and tighten them with the specified torque. If any solderless spade terminal is used, it may be disconnected when the terminal screw comes loose, resulting in failure.
- Do not install the control lines or communication cables together with the main circuit lines or power cables. Keep a distance of 100mm or more between them. Failure to do so may result in malfunction due to noise.
- Prevent foreign matter such as dust or wire chips from entering the module. Such foreign matter can cause a fire, failure, or malfunction.
- A protective film is attached to the top of the module to prevent foreign matter, such as wire chips, from entering the module during wiring. Do not remove the film during wiring. Remove it for heat dissipation before system operation.

CAUTION

- Place the cables in a duct or clamp them. If not, dangling cable may swing or inadvertently be pulled, resulting in damage to the module or cables or malfunction due to poor contact. Do not clamp the extension cables with the jacket stripped. Doing so may change the characteristics of the cables, resulting in malfunction.
- When disconnecting the cable from the module, do not pull the cable by the cable part. For the cable with connector, hold the connector part of the cable. Pulling the cable connected to the module may result in malfunction or damage to the module or cable.
- Use 1000BASE-T-compliant Ethernet cables for Ethernet connection. For the maximum station-to-station distance and the overall cable distance, follow the specifications in this manual. If not, normal data transmission is not guaranteed.

(5) Trial operation and adjustment

CAUTION

- Confirm and adjust the program and each parameter before operation. Unpredictable movements may occur depending on the machine.
- Extreme adjustments and changes may lead to unstable operation, so never make them.
- When using the absolute position system function, on starting up, and when the module or absolute position motor has been replaced, always perform a home position return.
- Before starting test operation, set the parameter speed limit value to the slowest value, and make sure that operation can be stopped immediately by the forced stop, etc. if a hazardous state occurs.
- Before starting the operation, confirm the brake function.

(6) Usage methods

CAUTION

- Immediately turn OFF the power if smoke, abnormal sounds or odors are emitted from the module, servo amplifier or servomotor.
- Always execute a test operation before starting actual operations after the program or parameters have been changed or after maintenance and inspection.
- Do not attempt to disassemble and repair the units excluding a qualified technician whom our company recognized.
- Do not make any modifications to the unit.
- Keep the effect or electromagnetic obstacles to a minimum by installing a noise filter or by using wire shields, etc.
Electromagnetic obstacles may affect the electronic devices used near the module or servo amplifier.
- When using the CE Mark-compliant equipment design, refer to the "EMC Installation Guidelines" (data number IB(NA)-67339) and refer to the corresponding EMC guideline information for the servo amplifiers and other equipment.

⚠ CAUTION

- Note that when the reference axis speed is designated for interpolation operation, the speed of the partner axis (2nd axis, 3rd axis and 4th axis) may be larger than the set speed (larger than the speed limit value).
- Use the units with the following conditions.

Item	Conditions
Input power	According to each instruction manual.
Input frequency	According to each instruction manual.
Tolerable momentary power failure	According to each instruction manual.

(7) Corrective actions for errors

⚠ CAUTION

- If an error occurs in the self diagnosis of the module or servo amplifier, confirm the check details according to the instruction manual, and restore the operation.
- If a dangerous state is predicted in case of a power failure or product failure, use a servomotor with electromagnetic brakes or install a brake mechanism externally.
- Use a double circuit construction so that the electromagnetic brake operation circuit can be operated by emergency stop signals set externally.

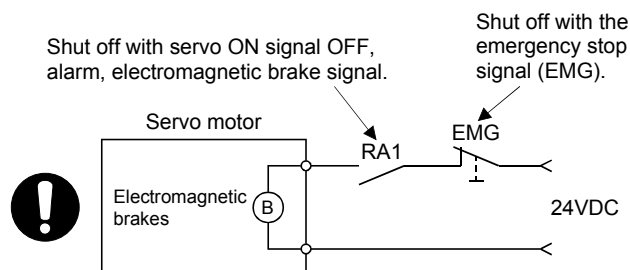

- If an error occurs, remove the cause, secure the safety and then resume operation after alarm release.
- The unit may suddenly resume operation after a power failure is restored, so do not go near the machine. (Design the machine so that personal safety can be ensured even if the machine restarts suddenly.)

(8) Maintenance, inspection and part replacement

DANGER

- Do not touch any terminal while power is on. Doing so will cause electric shock or malfunction.
- Shut off the external power supply (all phases) used in the system before cleaning the module or retightening the module fixing screw. Failure to do so may result in electric shock.

CAUTION

- Before performing online operations (especially, program modification, forced output, and operating status change) for the running CPU module on another station from GX Works2 over CC-Link IE Field Network, read relevant manuals carefully and ensure the safety. Improper operation may damage machines or cause accidents.
- Do not disassemble or modify the modules. Doing so may cause failure, malfunction, injury, or a fire.
- Use any radio communication device such as a cellular phone or PHS (Personal Handy-phone System) more than 25cm away in all directions from the programmable controller. Failure to do so may cause malfunction.
- Shut off the external power supply (all phases) used in the system before mounting or removing a module. Failure to do so may cause the module to fail or malfunction.
- Tighten the screw within the specified torque range. Undertightening can cause drop of the screw, short circuit or malfunction. Overtightening can damage the screw and/or module, resulting in drop, short circuit, or malfunction.
- Perform the daily and periodic inspections according to the instruction manual.
- Perform maintenance and inspection after backing up the program and parameters for the module and servo amplifier.
- Do not place fingers or hands in the clearance when opening or closing any opening.
- Periodically replace consumable parts such as batteries according to the instruction manual.
- Do not touch the lead sections such as ICs or the connector contacts.
- Before touching the module, always touch grounded metal, etc. to discharge static electricity from human body. Failure to do so may cause the module to fail or malfunction.
- Do not directly touch the module's conductive parts and electronic components. Touching them could cause an operation failure or give damage to the module.
- Do not place the module or servo amplifier on metal that may cause a power leakage or wood, plastic or vinyl that may cause static electricity buildup.
- Do not perform a megger test (insulation resistance measurement) during inspection.
- When replacing the module or servo amplifier, always set the new module settings correctly.

⚠ CAUTION

- When the module or absolute position motor has been replaced, carry out a home position return operation using the following method, otherwise position displacement could occur.
 - After writing the servo data to the Simple Motion module using programming software, switch on the power again, then perform a home position return operation.
- After maintenance and inspections are completed, confirm that the position detection of the absolute position detector function is correct.
- Do not drop or impact the battery installed to the module.
Doing so may damage the battery, causing battery liquid to leak in the battery. Do not use the dropped or impacted battery, but dispose of it.
- Do not short circuit, charge, overheat, incinerate or disassemble the batteries.
- The electrolytic capacitor will generate gas during a fault, so do not place your face near the module or servo amplifier.
- The electrolytic capacitor and fan will deteriorate. Periodically replace these to prevent secondary damage from faults. Please contact with our sales representative.
- Lock the control panel and prevent access to those who are not certified to handle or install electric equipment.
- Do not mount/remove the module and base or terminal block more than 50 times (IEC61131-2-compliant), after the first use of the product. Failure to do so may cause malfunction.
- Do not burn or break a module and servo amplifier. Doing so may cause a toxic gas.

(9) About processing of waste

When you discard module, servo amplifier, a battery (primary battery) and other option articles, please follow the law of each country (area).

⚠ CAUTION

- This product is not designed or manufactured to be used in equipment or systems in situations that can affect or endanger human life.
- When considering this product for operation in special applications such as machinery or systems used in passenger transportation, medical, aerospace, atomic power, electric power, or submarine repeating applications, please contact your nearest Mitsubishi sales representative.
- Although this product was manufactured under conditions of strict quality control, you are strongly advised to install safety devices to forestall serious accidents when it is used in facilities where a breakdown in the product is likely to cause a serious accident.

(10) General cautions

⚠ CAUTION

- All drawings provided in the instruction manual show the state with the covers and safety partitions removed to explain detailed sections. When operating the product, always return the covers and partitions to the designated positions, and operate according to the instruction manual.

● CONDITIONS OF USE FOR THE PRODUCT ●

- (1) Mitsubishi programmable controller ("the PRODUCT") shall be used in conditions;
 - i) where any problem, fault or failure occurring in the PRODUCT, if any, shall not lead to any major or serious accident; and
 - ii) where the backup and fail-safe function are systematically or automatically provided outside of the PRODUCT for the case of any problem, fault or failure occurring in the PRODUCT.
- (2) The PRODUCT has been designed and manufactured for the purpose of being used in general industries. MITSUBISHI SHALL HAVE NO RESPONSIBILITY OR LIABILITY (INCLUDING, BUT NOT LIMITED TO ANY AND ALL RESPONSIBILITY OR LIABILITY BASED ON CONTRACT, WARRANTY, TORT, PRODUCT LIABILITY) FOR ANY INJURY OR DEATH TO PERSONS OR LOSS OR DAMAGE TO PROPERTY CAUSED BY the PRODUCT THAT ARE OPERATED OR USED IN APPLICATION NOT INTENDED OR EXCLUDED BY INSTRUCTIONS, PRECAUTIONS, OR WARNING CONTAINED IN MITSUBISHI'S USER, INSTRUCTION AND/OR SAFETY MANUALS, TECHNICAL BULLETINS AND GUIDELINES FOR the PRODUCT.

("Prohibited Application")

Prohibited Applications include, but not limited to, the use of the PRODUCT in;

- Nuclear Power Plants and any other power plants operated by Power companies, and/or any other cases in which the public could be affected if any problem or fault occurs in the PRODUCT.
- Railway companies or Public service purposes, and/or any other cases in which establishment of a special quality assurance system is required by the Purchaser or End User.
- Aircraft or Aerospace, Medical applications, Train equipment, transport equipment such as Elevator and Escalator, Incineration and Fuel devices, Vehicles, Manned transportation, Equipment for Recreation and Amusement, and Safety devices, handling of Nuclear or Hazardous Materials or Chemicals, Mining and Drilling, and/or other applications where there is a significant risk of injury to the public or property.

Notwithstanding the above, restrictions Mitsubishi may in its sole discretion, authorize use of the PRODUCT in one or more of the Prohibited Applications, provided that the usage of the PRODUCT is limited only for the specific applications agreed to by Mitsubishi and provided further that no special quality assurance or fail-safe, redundant or other safety features which exceed the general specifications of the PRODUCTS are required. For details, please contact the Mitsubishi representative in your region.

INTRODUCTION

Thank you for purchasing the Mitsubishi Electric MELSEC-Q series programmable controllers. This manual describes the overview of the CC-Link IE Field Network, and operating procedure, system configuration, parameter setting, functions, programming, and troubleshooting of the QD77GF, CC-Link IE Field Network Simple Motion module (hereafter abbreviated as master/local module).

Before using this product, please read this manual and the relevant manuals carefully and develop familiarity with the functions and performance of the MELSEC-Q series programmable controller to handle the product correctly.

When applying the program examples introduced in this manual to the actual system, ensure the applicability and confirm that it will not cause system control problems.

Please make sure that the end users read this manual.

REMARK

- Unless otherwise specified, this manual describes the program examples in which the I/O numbers of X/Y00 to X/Y1F are assigned for a Q series Simple Motion module. I/O number assignment is required for using the program examples described in the manual.
For I/O number assignment, refer to the following.
QnUCPU User's Manual (Function Explanation, Program Fundamentals)
- Operating procedures are explained using GX Works2.

REVISIONS

* The manual number is given on the bottom left of the back cover.

Print Date	* Manual Number	Revision
Mar., 2013	IB(NA)-0300203-A	First edition
Feb., 2014	IB(NA)-0300203-B	[Additional function] CC IE Field configuration window, Remote operation (RESET operation only) [Additional correction/partial correction] SAFETY PRECAUTIONS, RELEVANT MANUALS
Sep., 2014	IB(NA)-0300203-C	[Additional correction/partial correction] Appendix 4.5
Apr., 2016	IB(NA)-0300203-D	[Additional model] QD77GF4/QD77GF8 [Additional function] Communication mode switching [Additional correction/partial correction] SAFETY PRECAUTIONS, RELEVANT MANUALS, MANUAL PAGE ORGANIZATION, TERMS, Section 3.2, Section 9.3, Appendix 4, Appendix 5, WARRANTY
Sep., 2017	IB(NA)-0300203-E	[Additional correction/partial correction] SAFETY PRECAUTIONS, Section 7.7, Section 8.3, Section 9.3, Section 10.1, Section 10.9, Appendix 2, Appendix 3, WARRANTY

Japanese Manual Version IB-0300201

This manual confers no industrial property rights of any other kind, nor does it confer any patent licenses. Mitsubishi Electric Corporation cannot be held responsible for any problems involving industrial property rights which may occur as a result of using the contents noted in this manual.

© 2013 MITSUBISHI ELECTRIC CORPORATION

CONTENTS

SAFETY PRECAUTIONS.....	A- 1
CONDITIONS OF USE FOR THE PRODUCT	A-13
INTRODUCTION.....	A-14
REVISIONS	A-15
CONTENTS.....	A-16
COMPLIANCE WITH THE EMC AND LOW VOLTAGE DIRECTIVES.....	A-19
RELEVANT MANUALS	A-20
MANUAL PAGE ORGANIZATION	A-22
TERMS	A-23
PACKING LIST.....	A-26

1. CC-LINK IE FIELD NETWORK	1- 1 to 1- 8
1.1 CC-Link IE Field Network	1- 2
1.2 Simple Motion Modules.....	1- 4
2. NAMES OF EACH PART	2- 1 to 2- 4
2.1 Names of Each Part.....	2- 2
3. SPECIFICATIONS	3- 1 to 3- 8
3.1 General Specifications	3- 2
3.2 Performance Specifications	3- 2
3.3 Function List	3- 3
3.4 Specifications of Input/Output Signals with CPU Module.....	3- 5
3.4.1 List of input/output signals with CPU module.....	3- 5
3.4.2 Details of input signals (Simple Motion module → CPU module).....	3- 6
3.5 Buffer Memory (Network Function)	3- 7
4. PROCEDURES BEFORE OPERATION	4- 1 to 4- 2
4.1 Procedures Before Operation.....	4- 2
5. SYSTEM CONFIGURATION	5- 1 to 5- 8
5.1 CC-Link IE Field Network Configuration	5- 2
5.1.1 Single network system	5- 2
5.1.2 Precautions.....	5- 4
5.2 Network Components	5- 7
5.2.1 Cables.....	5- 7
5.2.2 Hubs.....	5- 7
5.3 Applicable Systems.....	5- 8

6. INSTALLATION AND WIRING	6- 1 to 6- 2
-----------------------------------	---------------------

6.1 Installation and Wiring.....6- 2

7. PARAMETER SETTING	7- 1 to 7-30
-----------------------------	---------------------

7.1 Parameter and Backup7- 2

7.2 Parameter List7- 3

7.3 Network Settings7- 5

7.4 Network Configuration Settings7- 8

7.5 Network Operation Settings7-20

7.6 Refresh Parameters7-21

7.7 Interrupt Settings7-25

8. FUNCTIONS	8- 1 to 8-24
---------------------	---------------------

8.1 Fixed Cycle Communication8- 2

8.2 Synchronous Communication Function8- 2

8.3 Cyclic Transmission8- 4

8.3.1 Data flow and link device assignment8- 4

8.3.2 Link refresh8- 6

8.3.3 Direct access to link devices8- 8

8.3.4 Assurance of cyclic data integrity8-12

8.3.5 Input and output status settings in case of failure8-17

8.3.6 Output status setting for CPU module STOP8-19

8.3.7 Cyclic transmission stop and restart8-20

8.4 Transient Transmission8-21

8.4.1 Communications within the same network8-21

8.5 Reserved Station Specification and Temporary Cancel of Reserved Station Setting8-22

8.6 Interrupt Request to the CPU Module8-23

9. CC-LINK IE FIELD NETWORK DIAGNOSTICS	9- 1 to 9-26
--	---------------------

9.1 Diagnostic Items9- 2

9.2 Starting Diagnostics9- 4

9.3 Diagnostic Window9- 8

9.4 Link Start/Stop9-15

9.5 Network Event History9-18

9.6 Reserved Station Function Enable9-21

9.7 Remote Operation9-25

10. DEDICATED INSTRUCTIONS	10- 1 to 10-48
-----------------------------------	-----------------------

10.1 List of Dedicated Instructions10- 2

10.2 Precautions for Dedicated Instructions10- 4

10.2.1 Precautions for dedicated instructions (common)10- 4

10.2.2 Precautions for link dedicated instructions10- 5

10.3 How to Read Detailed Page on Dedicated Instructions10- 6

10.4 JP/GP.READ (Reading Data from Another Station)10- 8

10.5 JP/GP.SREAD (Reading Data from Another Station)10-16

10.6 JP/GP.WRITE (Writing Data to Another Station).....	10-22
10.7 JP/GP.SWRITE (Writing Data to Another Station)	10-32
10.8 ZP.REMFR (Reading Data from the Intelligent Device Station/Remote Device Station)	10-38
10.9 ZP.REMTO (Writing Data to the Intelligent Device Station/Remote Device Station).....	10-43

11. PROGRAMMING	11- 1 to 11-24
------------------------	-----------------------

11.1 Precautions for Programming.....	11- 2
11.2 Example of Communications Between the Master Station and a Head Module.....	11- 3
11.2.1 System configuration example	11- 3
11.2.2 Setting in the master station	11- 5
11.2.3 Setting in the head module	11- 7
11.2.4 Checking the network status.....	11-10
11.2.5 Program example.....	11-11
11.3 Using Link Special Relay (SB) and Link Special Register (SW).....	11-15

12. TROUBLESHOOTING	12- 1 to 12-26
----------------------------	-----------------------

12.1 Before Troubleshooting	12- 2
12.2 Troubleshooting Procedure	12- 2
12.3 Checking the LEDs	12- 7
12.4 Troubleshooting by Symptom.....	12- 9
12.4.1 Cyclic transmission cannot be performed	12- 9
12.4.2 Transient transmission cannot be performed.....	12-10
12.4.3 Station is disconnected from the network	12-10
12.4.4 Station is repeatedly disconnected and reconnected	12-10
12.4.5 Communication is unstable.....	12-10
12.5 Error Code List (D000H to DFFFH).....	12-11
12.6 Checking the Status by System Monitor	12-25

Appendices	Appendix- 1 to Appendix-36
-------------------	-----------------------------------

Appendix 1 Details of Buffer Memory Addresses	Appendix- 2
Appendix 1.1 Link device area (Un\G59392 to Un\G63007)	Appendix- 2
Appendix 1.2 RX offset/size information (Un\G63152 to Un\G63359).....	Appendix- 4
Appendix 1.3 RY offset/size information (Un\G63360 to Un\G63567).....	Appendix- 4
Appendix 1.4 RWw offset/size information (Un\G63568 to Un\G63775)	Appendix- 5
Appendix 1.5 RWr offset/size information (Un\G63776 to Un\G63983).....	Appendix- 5
Appendix 1.6 Station information (Un\G64016 to Un\G64041)	Appendix- 6
Appendix 2 Link Special Relay (SB) List.....	Appendix- 8
Appendix 3 Link Special Register (SW) List.....	Appendix-16
Appendix 4 Processing Time	Appendix-28
Appendix 4.1 Link refresh time	Appendix-29
Appendix 4.2 Link scan time	Appendix-30
Appendix 4.3 Cyclic transmission delay time	Appendix-31
Appendix 4.4 Transmission delay time of dedicated instructions	Appendix-32
Appendix 4.5 Calculation formula for operation cycle.....	Appendix-32
Appendix 5 Comparison of QJ71GF11-T2.....	Appendix-33

COMPLIANCE WITH THE EMC AND LOW VOLTAGE DIRECTIVES

(1) Method of ensuring compliance

To ensure that Mitsubishi programmable controllers maintain EMC and Low Voltage Directives when incorporated into other machinery or equipment, certain measures may be necessary. Please refer to one of the following manuals.

- QCPU User's Manual (Hardware Design, Maintenance and Inspection)
- Safety Guidelines

(This manual is included with the CPU module or base unit.)

The CE mark on the side of the programmable controller indicates compliance with EMC and Low Voltage Directives.

(2) For the product

To ensure that this product maintains EMC and Low Voltage Directives, please refer to the "MELSEC-Q QD77GF Simple Motion Module User's Manual (Positioning Control)".

RELEVANT MANUALS

(1) Simple Motion module

Manual Name <Manual number (model code)>	Description
MELSEC-Q QD77GF Simple Motion Module User's Manual (Positioning Control) <IB-0300202, 1XB956>	Specifications of the QD77GF and information on how to establish a system, maintenance and inspection, and troubleshooting Functions, programming and buffer memory for the positioning control of the QD77GF
MELSEC-Q/L QD77MS/QD77GF/LD77MS/LD77MH Simple Motion Module User's Manual (Synchronous Control) <IB-0300174, 1XB943>	Functions, programming and buffer memory for the synchronous control of the Simple Motion module
MELSEC-Q QD77GF Simple Motion Module User's Manual (Network) <IB-0300203, 1XB957>	Overview of CC-Link IE Field Network, and specifications, procedures before operation, system configuration, installation, wiring, settings, functions, programming, and troubleshooting of the MELSEC-Q series Simple Motion module

(2) CC-Link IE Field Network

Manual name <manual number (model code)>	Description
MELSEC-Q CC-Link IE Field Network Master/Local Module User's Manual <SH-080917ENG, 13JZ47>	Overview of CC-Link IE Field Network, and specifications, procedures before operation, system configuration, installation, wiring, settings, functions, programming, and troubleshooting of the MELSEC-Q series master/local module
MELSEC-QS CC-Link IE Field Network Master/Local Module User's Manual <SH-080969ENG, 13JZ53>	Overview of CC-Link IE Field Network, and specifications, procedures before operation, system configuration, installation, wiring, settings, functions, programming, and troubleshooting of the MELSEC-QS series master/local module
MELSEC-L CC-Link IE Field Network Head Module User's Manual <SH-080919ENG, 13JZ48>	Specifications, procedures before operation, system configuration, installation, wiring, settings, and troubleshooting of the head module
CC-Link IE Field Network Ethernet Adapter Module User's Manual <SH-080939ENG, 13JZ50>	Specifications, procedures before operation, system configuration, installation, wiring, settings, and troubleshooting of the Ethernet adapter module
CC-Link IE Field Network Interface Board User's Manual (For SW1DNC-CCIEF-B) <SH-080980ENG, 13JZ58>	Specifications, procedures before operation, system configuration, settings, functions, programming, and troubleshooting of the CC-Link IE Field Network interface board

(3) CPU module

Manual name <manual number (model code)>	Description
QCPU User's Manual (Hardware Design, Maintenance and Inspection) <SH-080483ENG, 13JR73>	Specifications of the hardware (CPU modules, power supply modules, base units, batteries, and memory cards), system maintenance and inspection, and troubleshooting
QnUCPU User's Manual (Function Explanation, Program Fundamentals) <SH-080807ENG, 13JZ27>	Functions and devices of the CPU module, and programming

(4) Programming tool

Manual name <manual number (model code)>	Description
GX Works2 Version1 Operating Manual (Common) <SH-080779ENG, 13JU63>	System configuration, parameter settings, and online operations (common to Simple project and Structured project) of GX Works2
GX Works2 Version1 Operating Manual (Intelligent Function Module) <SH-080921ENG, 13JU69>	Parameter settings, monitoring, and operations of the predefined protocol support function of intelligent function modules, using GX Works2

(5) Servo amplifier

Manual Name <Manual number (model code)>	Description
CC-Link IE Field Network Interface with Motion MR-J4-_B-RJ010/MR-J4-_B4-RJ010/MR-J3-T10 Servo Amplifier Instruction Manual <SH-030117, 1CW810>	I/O signals, parts names, parameters, start-up procedure and others for CC-Link IE Field Network interface AC servo amplifier with Motion MR-J4-_B-RJ010/ MR-J4-_B4-RJ010 and CC-Link IE Field Network interface unit MR-J3-T10
CC-Link IE Field Network Interface MR-J4-_GF_(-RJ) Servo Amplifier Instruction Manual (Motion Mode) <SH-030218, 1CW861>	I/O signals, parts names, parameters, start-up procedure and others for CC-Link IE Field Network interface AC servo amplifier with MR-J4-_GF_(-RJ)
CC-Link IE Field Network Interface MR-J4-_GF_(-RJ) Servo Amplifier Instruction Manual (I/O Mode) <SH-030221, 1CW863>	Parameters for point table operation, start-up procedure and others for CC-Link IE Field Network interface AC servo amplifier with MR-J4-_GF_(-RJ)

MANUAL PAGE ORGANIZATION

■ The symbols used in this manual are shown below.

- A serial No. is inserted in the "*" mark.

Symbol	Description
[Md. *]	Symbol that indicates monitor data item.
[RJ010 mode]	Symbol that indicates specifications during the communication mode compatible with MR-J4-B-RJ010. This mode corresponds to the MR-J4-_B_-RJ010+MR-J3-T10 servo amplifier. When using the virtual servo amplifier function, it operates in MR-J4-B-RJ010 communication mode regardless of the communication mode setting.
[CiA402 mode]	Symbol that indicates specifications during the communication mode compatible with CiA402. This mode corresponds to the MR-J4-_GF_(-RJ) servo amplifier and others.

■ Representation of numerical values used in this manual.

- Error codes, X/Y devices and link devices are represented in hexadecimal.
- Buffer memory addresses and setting data are represented in decimal or hexadecimal. Data ended by "H" or "h" is represented in hexadecimal.

(Example) 10.....Decimal

10H.....Hexadecimal

TERMS

Unless otherwise specified, this manual uses the following terms.

Term	Description
QCPU	Another term for the MELSEC-Q series CPU module
LCPU	Another term for the MELSEC-L series CPU module
QSCPU	Another term for the MELSEC-QS series CPU module
QnACPU	Another term for the MELSEC-QnA series CPU module
Control CPU	A CPU module that controls connected I/O modules and intelligent function modules. In a multiple CPU system, there are multiple CPU modules and each connected module can be controlled by a different CPU module.
GX Works2	The product name of the software package for the MELSEC programmable controllers
CC-Link IE Field Network	A high-speed and large-capacity open field network that is based on Ethernet (1000BASE-T)
CC-Link	A field network system where data processing for control and information can be simultaneously performed at high speed.
Simple Motion module	The abbreviation for the QD77GF CC-Link IE Field Network Simple Motion module
Head module	The abbreviation for the LJ72GF15-T2 CC-Link IE Field Network head module
Network module	A generic term for the following modules: <ul style="list-style-type: none"> • CC-Link IE Field Network module • CC-Link IE Controller Network module • Ethernet interface module • MELSECNET/H module • MELSECNET/10 module
Intelligent function module	A MELSEC-Q/L series module that has functions other than input and output, such as an A/D converter module and D/A converter module
Ethernet device	A generic term for devices, such as personal computers, that support IP (Internet Protocol) communications
Master station	A station that controls the entire network. This station can perform cyclic transmission and transient transmission with all stations. Only one master station can be used in a network.
Remote I/O station	A station that exchanges I/O signals (bit data) with the master station by cyclic transmission
Remote device station	A station that exchanges I/O signals (bit data) and I/O data (word data) with another station by cyclic transmission. This station responds to a transient transmission request from another station.
Intelligent device station	A station that exchanges I/O signals (bit data) and I/O data (word data) with another station by cyclic transmission. This station responds to a transient transmission request from another station and also issues a transient transmission request to another station.
Servo amplifier	Generic term for a drive unit. Unless specified in particular, indicates the motor driver unit of the sequential command method which is controlled by the Simple Motion module (belonging to own station).
Axis	Another term for a servo amplifier.
Slave station	A generic term for remote I/O station, remote device station, and intelligent device station
Synchronous communication device	A generic term for a servo amplifier and a slave station set to synchronous communication mode.
Asynchronous communication device	A generic term for a slave station set to other than synchronous communication mode.

Term	Description
Reserved station	A station reserved for future use. This station is not actually connected, but counted as a connected station.
Cyclic transmission	A function by which data are periodically exchanged among stations on the same network using link devices (RX, RY, RWw, and RWr)
Transient transmission	A function of communication with another station, which is used when requested by a dedicated instruction or GX Works2
Data link	Generic term for cyclic transmission and transient transmission
Dedicated instruction	An instruction that simplifies programming for using functions of intelligent function modules
Link dedicated instruction	A dedicated instruction used for transient transmission with another station. This instruction allows a master/local module to communicate with programmable controllers on the same network (CC-Link IE Field Network) and on other networks (Ethernet, CC-Link IE Controller Network, and MELSECNET/H).
Return	Process of restarting data link when a station recovers from an error
Disconnection	A process of stopping data link if a data link error occurs
Device	A device (X, Y, M, D, or others) in a CPU module
Link device	A device (RX, RY, RWr, or RWw) in a module on CC-Link IE Field Network
Remote input (RX)	Bit data input from a slave station to the master station. Refer to Section 8.3.1.
Remote output (RY)	Bit data output from the master station to a slave station. Refer to Section 8.3.1.
Remote register (RWr)	Word data input from a slave station to the master station. Refer to Section 8.3.1.
Remote register (RWw)	Word data output from the master station to a slave station. Refer to Section 8.3.1.
Link special relay (SB)	Bit data that indicates the operating status and data link status of a module on CC-Link IE Field Network
Link special register (SW)	Word data that indicates the operating status and data link status of a module on CC-Link IE Field Network
Link scan (Link scan time)	Time required for all the stations on the network to transmit data. The link scan time depends on data volume and the number of transient transmission requests.
Link refresh	Data transfer between a link device in a module on CC-Link IE Field Network and a device in a CPU module. Link refresh is performed in the END processing of the CPU module's sequence scan.
Baton pass	A token to send data over a network
Buffer memory	A memory in an intelligent function module, where data (such as setting values and monitoring values) exchanged with a CPU module are stored
Buffer memory address	An address that indicates the storage location of data assigned to the buffer memory in an intelligent function module
RAS	The abbreviation for Reliability, Availability, and Serviceability. This term refers to usability of automated equipment.

Term	Description
READ	The abbreviation for JP.READ and GP.READ
SREAD	The abbreviation for JP.SREAD and GP.SREAD
WRITE	The abbreviation for JP.WRITE and GP.WRITE
SWRITE	The abbreviation for JP.SWRITE and GP.SWRITE
REMFR	The abbreviation for ZP.REMFR
REMTO	The abbreviation for ZP.REMTO

PACKING LIST

The following items are included in the package of this product. Before use, check that all the items are included.

(1) QD77GF4

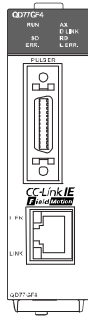

QD77GF4

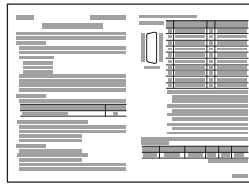

Before Using the Product

(2) QD77GF8

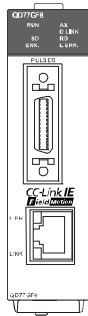

QD77GF8



Before Using the Product

(3) QD77GF16

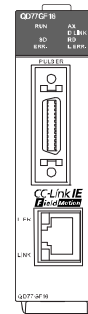

QD77GF16

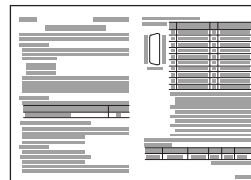

Before Using the Product

Chapter 1 CC-LINK IE FIELD NETWORK

1.1 CC-Link IE Field Network.....	1- 2
1.2 Simple Motion Modules	1- 4

1.1 CC-Link IE Field Network

CC-Link IE Field Network is a high-speed and large-capacity open field network that is based on Ethernet technology (1000BASE-T).

(1) Data communication

High-speed and large-capacity data communication is available between a master station and slave stations on CC-Link IE Field Network.

(a) Periodic communication (cyclic transmission)

Data is periodically communicated among stations within the same network.
(Refer to Section 8.3.)

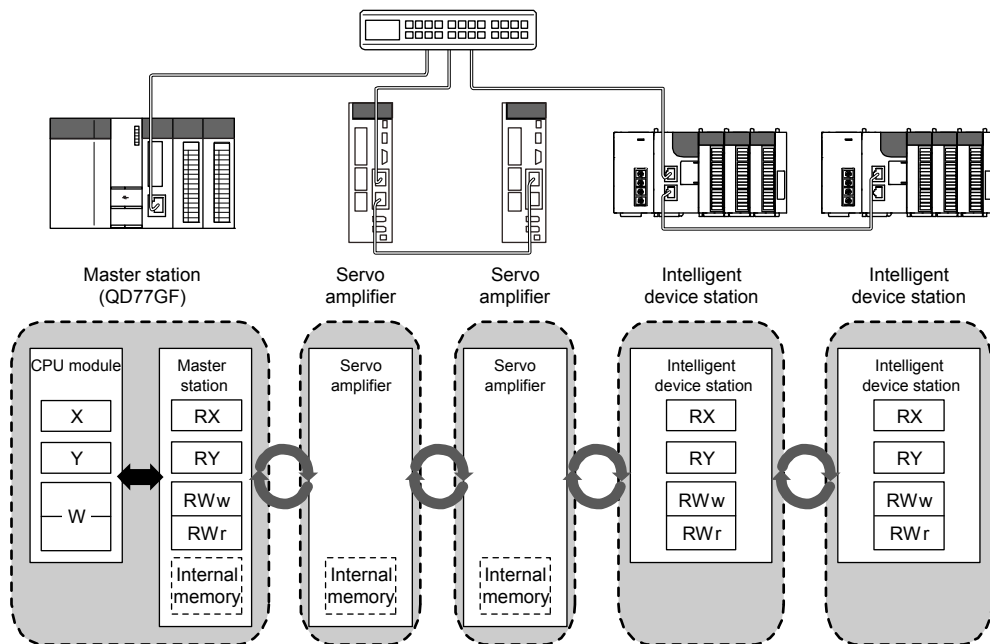

(b) Irregular communications (transient transmission)

Data is communicated upon request. (Refer to Section 8.4.)

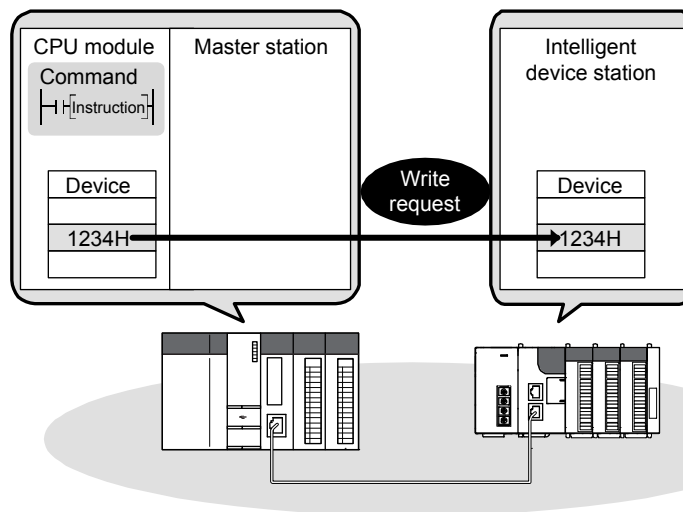

(2) 1Gbps communication speed

1Gbps communication speed allows high-speed communication. Also, the cycle time can be reduced due to the improved performance of communication response.

(3) Use of Ethernet cable

A 1000BASE-T-compliant Ethernet is used for the connection interface. The wiring cost can be reduced because 1000BASE-T-compliant Ethernet cables are commercially available. (Refer to Section 5.2.)

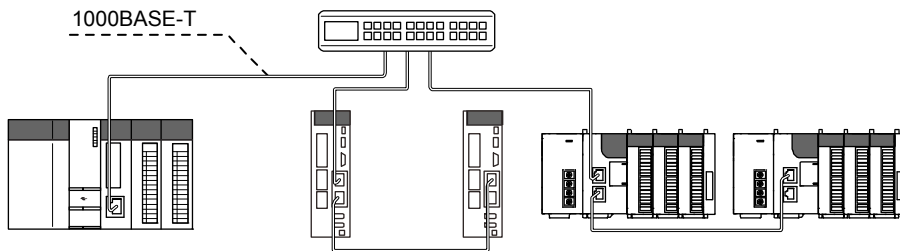

(4) Flexible wiring for system arrangements

The network can be wired into star topology and line topology. (Refer to Section 5.1.1.) For star topology, a 1000BASE-T compliant switching hub can be used. (Refer to Section 5.2.2.)

Wiring is highly flexible because a network can consist of a combination of star and line topologies. For example, the control panels can be connected through a star topology and the production lines through a line topology.

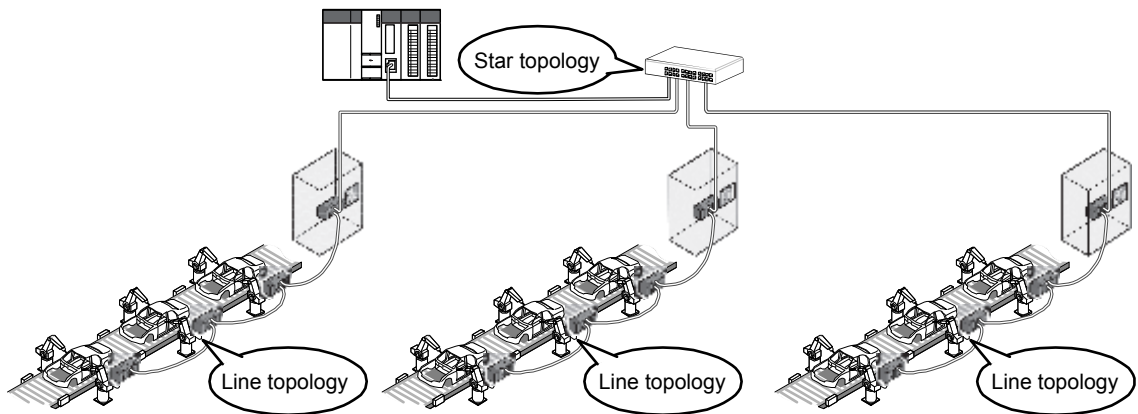

1.2 Simple Motion Modules

A Simple Motion module is used to connect a servo amplifier or a MELSEC-Q series programmable controller to CC-Link IE Field Network.

The module works as a master station on CC-Link IE Field Network.

(1) Synchronous communication function

A slave station which supports the synchronous communication function operates synchronously with the operation cycle of Simple Motion module. The operation timing of multiple slave stations can be synchronized. (A slave station which synchronizes with a Simple Motion module supports the synchronous communication function. A slave module which does not support the synchronous communication function is also connectable.)

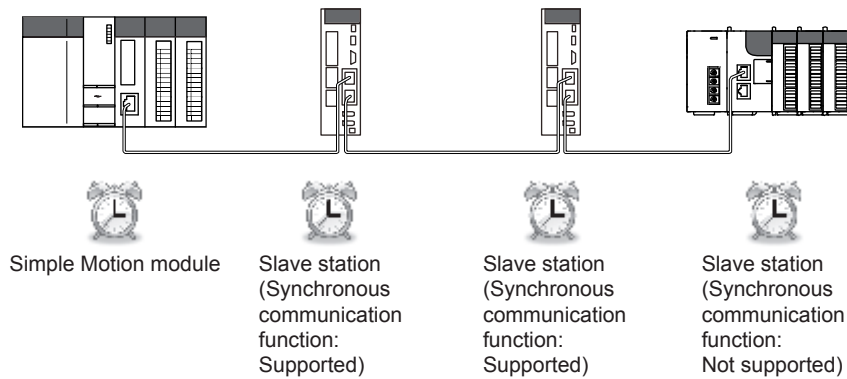

(2) Coexistence system of I/O module and driver

The coexistence system of servo amplifiers and I/O modules can be configured. The network between drivers and I/O modules can be wired by a single line, and it enables wire saving.

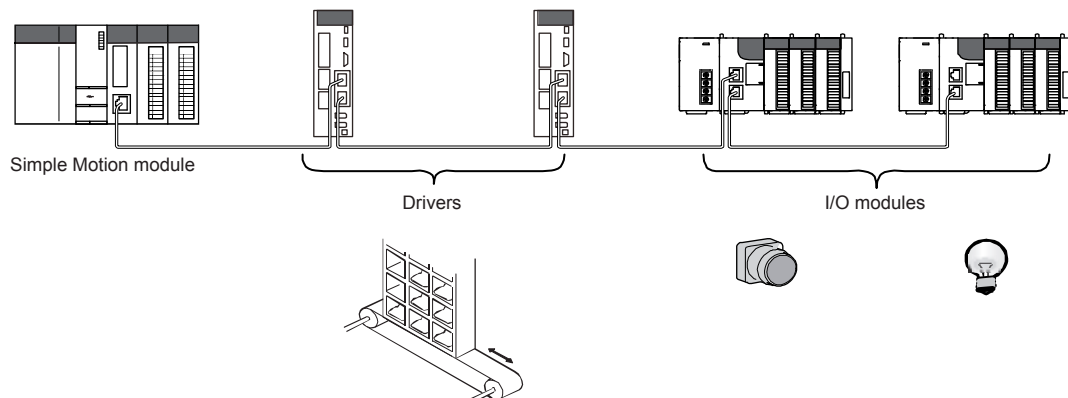

(3) Multiple axes system configuration

The servo amplifiers can be controlled up to 16 axes ^(Note-1). By connecting slave stations excluding servo amplifiers the system can be configured up to 120 axes (the number of axes that can be controlled +104 axes).

(Note-1): The 4-axis module can be controlled up to 4 axes, and the 8-axis module can be controlled up to 8 axes.

(4) High-speed periodic communication (cyclic transmission)

Since transmission delay time is short, delay caused during communication does not need to be considered (if the link scan time of each Simple Motion module is shorter than the scan time of the CPU module).

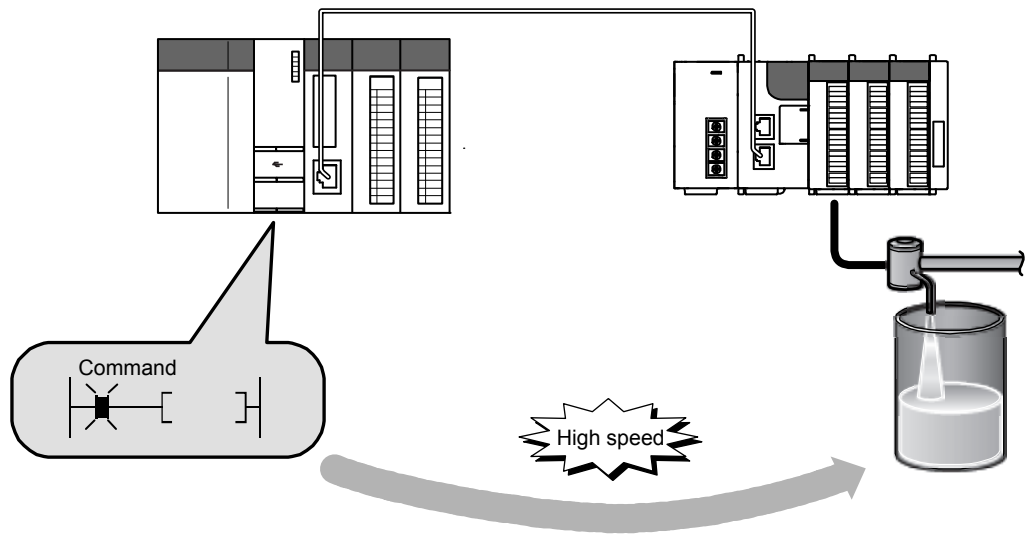

POINT

Simple Motion modules can perform cyclic transmissions in combination with the following functions:

(Refer to Section 3.3.)

- Auto transfer of data between the link devices in the Simple Motion module and the devices in the CPU module
- Direct access to the link devices in the Simple Motion module by a program
- Cyclic data assurance in units of 32 bits or per station
- Status setting (hold or clear) of input data from a slave station where a cyclic error has occurred
- Station reservation for future connection, and others

- (5) Irregular communications with another station (transient transmission)
- (a) Reading or writing data
 A Simple Motion module can access other stations by dedicated instructions.
 (Refer to Section 10.1.)

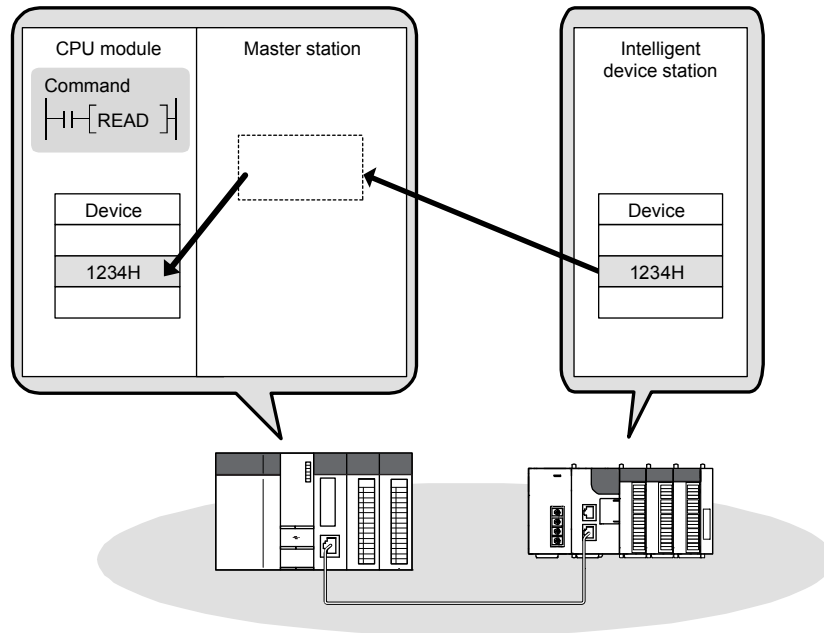

- (6) Settings and diagnostics by GX Works2
- (a) Setting parameters
 Parameters for Simple Motion modules can be set using GX Works2. Creating parameter setting programs is not necessary. (Refer to Chapter 7.)

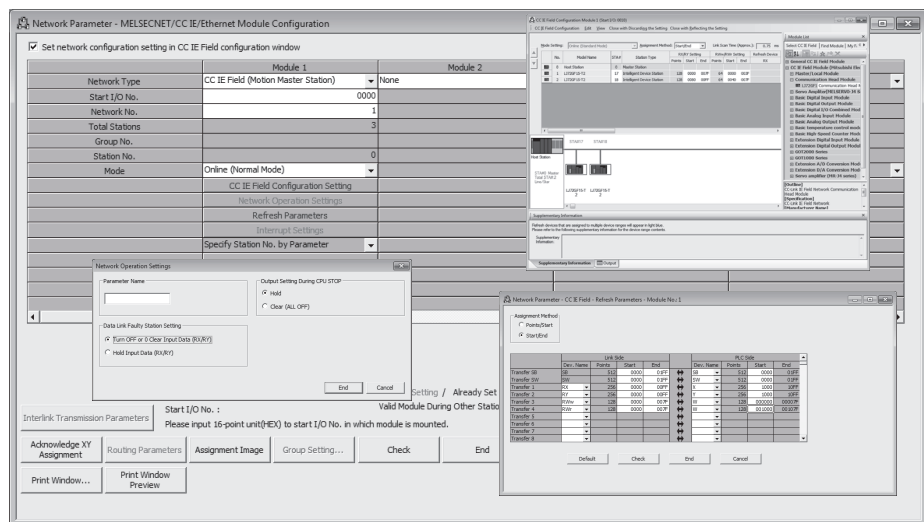

- (b) Checking CC-Link IE Field Network status graphically
 The CC-Link IE Field Network status can be checked using GX Works2. Error locations, error causes, and event history are displayed on the window. This allows the system to quickly recover from errors.
 (Refer to Chapter 9.)

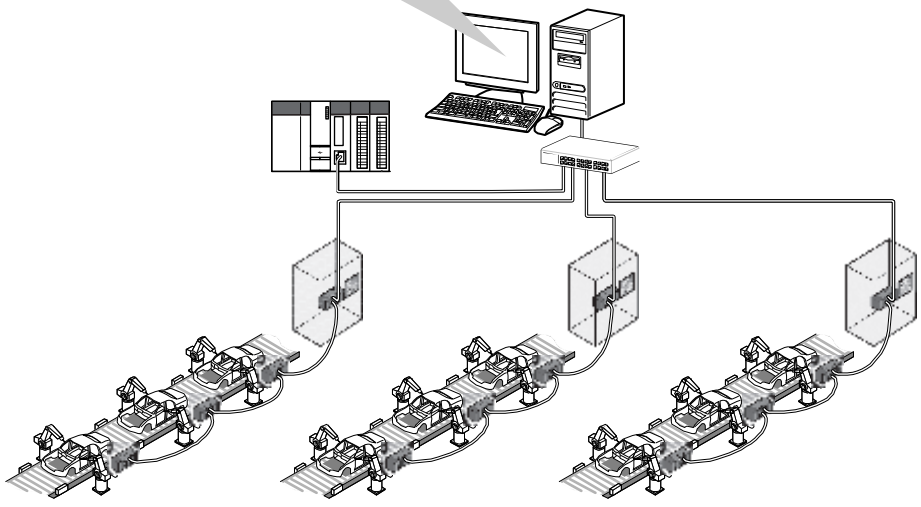
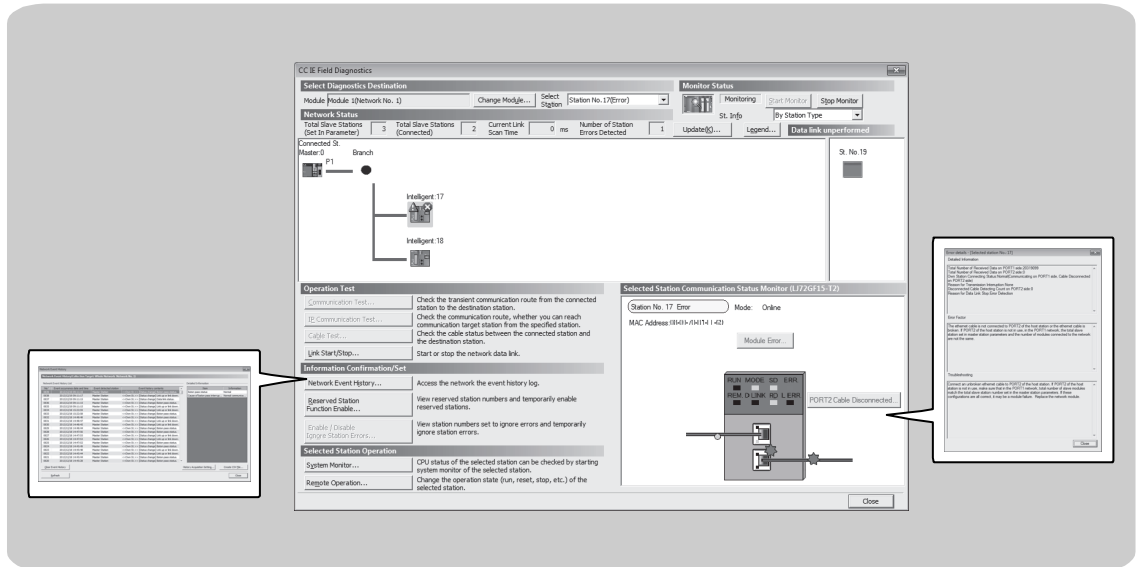

(7) Adding CC-Link IE Field Network devices without stopping the system

(a) Adding CC-Link IE Field Network devices

CC-Link IE Field Network devices whose parameters have not been set can be added without powering off the system. (Refer to the user's Manual of the head module.)

Connection of an added module can be recognized, and setting a station No. on the window allows tentative operation.

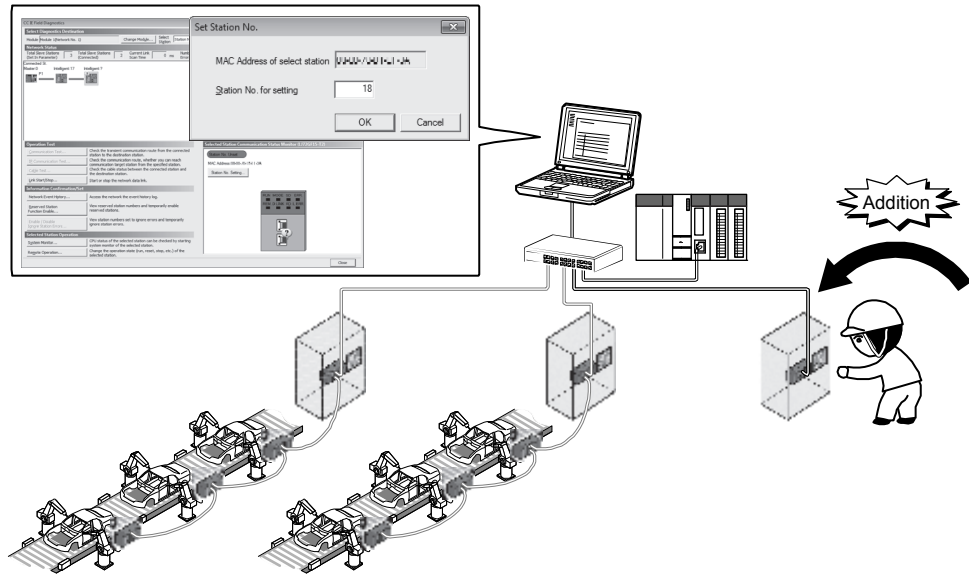

Chapter 2 NAMES OF EACH PART

2.1 Names of Each Part 2- 2

2.1 Names of Each Part

This chapter describes the names of each part of the Simple Motion module.

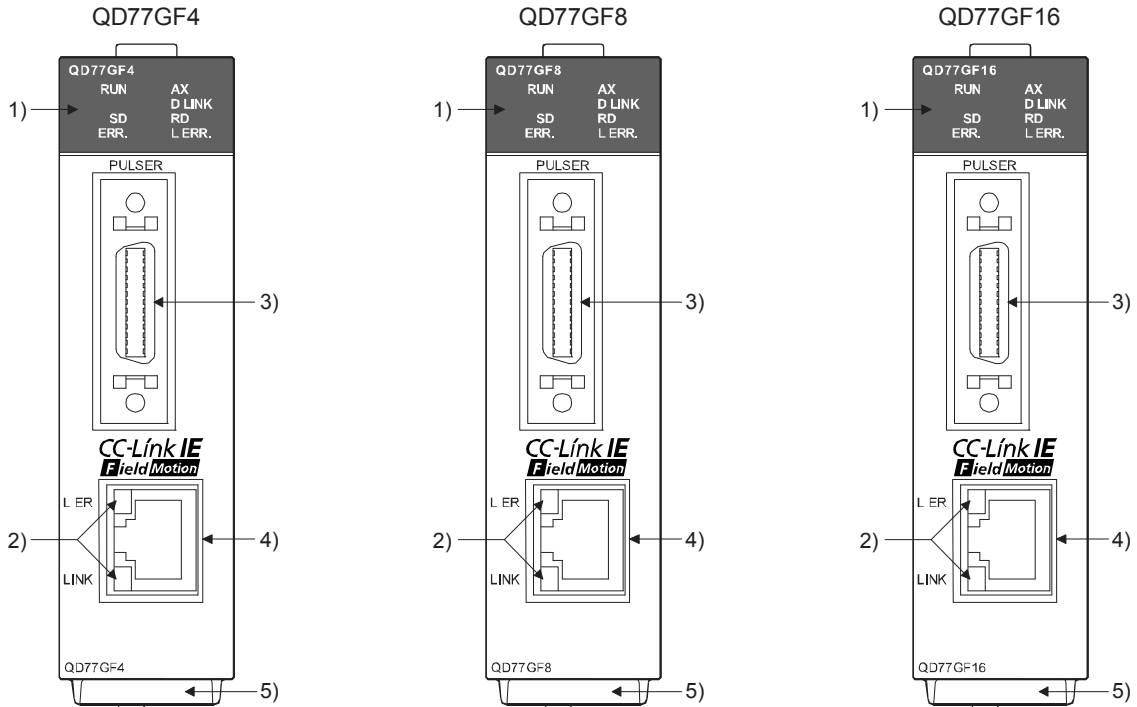

No.	Name	Description
1)	LED (upper part on the front)	Refer to this section (1).
2)	LED (CC-Link IE Field connector section)	Refer to this section (2).
3)	External input connection connector	Connector to connect the mechanical system input, manual pulse generator/incremental synchronous encoder, or forced stop input. (26-pin connector) Refer to the "MELSEC-Q QD77GF Simple Motion Module User's Manual (Positioning Control)" for details.
4)	CC-Link IE Field Network cable connector	Connector to connect the servo amplifier.
5)	Serial number plate	Shows the serial number printed on the rating plate.

(1) LED (upper part on the front)

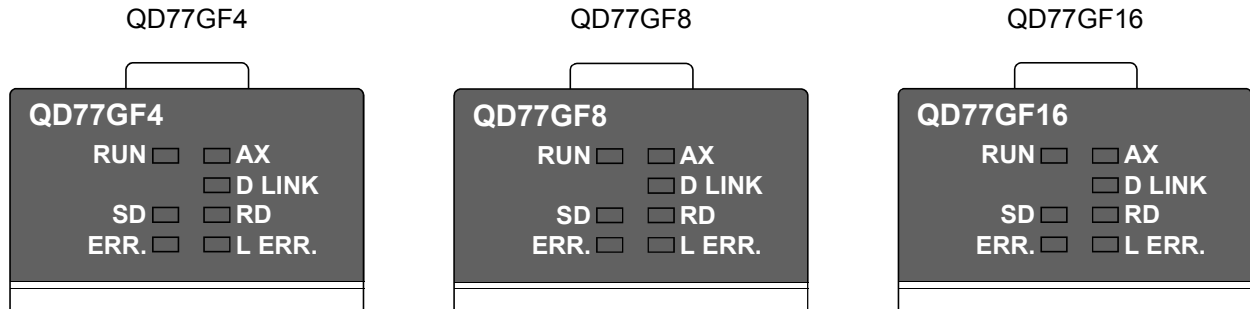

LED Display		Description
RUN LED is OFF.	RUN <input type="checkbox"/> AX <input type="checkbox"/> SD <input type="checkbox"/> D LINK <input type="checkbox"/> ERR. <input type="checkbox"/> RD <input type="checkbox"/> L ERR. <input type="checkbox"/>	Hardware failure, watch dog timer error
RUN LED is ON. ERR. LED is OFF.	RUN <input checked="" type="checkbox"/> AX <input type="checkbox"/> SD <input type="checkbox"/> D LINK <input type="checkbox"/> ERR. <input type="checkbox"/> RD <input type="checkbox"/> L ERR. <input type="checkbox"/>	Operates normally.
ERR. LED is flashing. AX LED is OFF.	RUN <input checked="" type="checkbox"/> AX <input type="checkbox"/> SD <input type="checkbox"/> D LINK <input type="checkbox"/> ERR. <input checked="" type="checkbox"/> RD <input type="checkbox"/> L ERR. <input type="checkbox"/>	Token pass not executed for some stations
ERR. LED is flashing. AX LED is flashing.	RUN <input checked="" type="checkbox"/> AX <input checked="" type="checkbox"/> SD <input type="checkbox"/> D LINK <input type="checkbox"/> ERR. <input checked="" type="checkbox"/> RD <input type="checkbox"/> L ERR. <input type="checkbox"/>	Axis error
ERR. LED is ON.	RUN <input checked="" type="checkbox"/> AX <input type="checkbox"/> SD <input type="checkbox"/> D LINK <input type="checkbox"/> ERR. <input checked="" type="checkbox"/> RD <input type="checkbox"/> L ERR. <input type="checkbox"/>	System error, CPU stop error, error in all stations, station number duplication, invalid network parameter
AX LED is ON.	RUN <input checked="" type="checkbox"/> AX <input checked="" type="checkbox"/> SD <input type="checkbox"/> D LINK <input type="checkbox"/> ERR. <input type="checkbox"/> RD <input type="checkbox"/> L ERR. <input type="checkbox"/>	Axis operation in progress
AX LED is OFF.	RUN <input checked="" type="checkbox"/> AX <input type="checkbox"/> SD <input type="checkbox"/> D LINK <input type="checkbox"/> ERR. <input type="checkbox"/> RD <input type="checkbox"/> L ERR. <input type="checkbox"/>	An axis stops or is on standby.

LED Display		Description
SD LED is ON.	RUN <input checked="" type="checkbox"/> AX <input type="checkbox"/> SD <input checked="" type="checkbox"/> D LINK <input type="checkbox"/> ERR. <input type="checkbox"/> RD <input type="checkbox"/> L ERR. <input type="checkbox"/>	Sending data.
SD LED is OFF.	RUN <input checked="" type="checkbox"/> AX <input type="checkbox"/> SD <input type="checkbox"/> D LINK <input type="checkbox"/> ERR. <input type="checkbox"/> RD <input type="checkbox"/> L ERR. <input type="checkbox"/>	Data not sent
D LINK LED is ON.	RUN <input checked="" type="checkbox"/> AX <input type="checkbox"/> SD <input type="checkbox"/> D LINK <input checked="" type="checkbox"/> ERR. <input type="checkbox"/> RD <input type="checkbox"/> L ERR. <input type="checkbox"/>	Data link in operation (cyclic transmission in progress)
D LINK LED is flashing.	RUN <input checked="" type="checkbox"/> AX <input type="checkbox"/> SD <input type="checkbox"/> D LINK <input checked="" type="checkbox"/> ERR. <input type="checkbox"/> RD <input type="checkbox"/> L ERR. <input type="checkbox"/>	Data link in operation (cyclic transmission stopped)
D LINK LED is OFF.	RUN <input checked="" type="checkbox"/> AX <input type="checkbox"/> SD <input type="checkbox"/> D LINK <input type="checkbox"/> ERR. <input type="checkbox"/> RD <input type="checkbox"/> L ERR. <input type="checkbox"/>	Data link not performed (disconnected)
RD LED is ON.	RUN <input checked="" type="checkbox"/> AX <input type="checkbox"/> SD <input type="checkbox"/> D LINK <input type="checkbox"/> ERR. <input type="checkbox"/> RD <input checked="" type="checkbox"/> L ERR. <input type="checkbox"/>	Receiving data.
RD LED is OFF.	RUN <input checked="" type="checkbox"/> AX <input type="checkbox"/> SD <input type="checkbox"/> D LINK <input type="checkbox"/> ERR. <input type="checkbox"/> RD <input type="checkbox"/> L ERR. <input type="checkbox"/>	Data not received
L ERR. LED is ON.	RUN <input checked="" type="checkbox"/> AX <input type="checkbox"/> SD <input type="checkbox"/> D LINK <input type="checkbox"/> ERR. <input type="checkbox"/> RD <input type="checkbox"/> L ERR. <input checked="" type="checkbox"/>	Frame error detection
L ERR. LED is OFF.	RUN <input checked="" type="checkbox"/> AX <input type="checkbox"/> SD <input type="checkbox"/> D LINK <input type="checkbox"/> ERR. <input type="checkbox"/> RD <input type="checkbox"/> L ERR. <input type="checkbox"/>	Frame error not detected

■: ON, ◆: Flashing, □: OFF

(2) CC-Link IE Field Network connector section

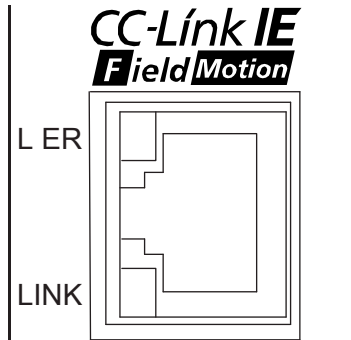

LED Display		Description
L ER LED is ON.	L ER <input checked="" type="checkbox"/> LINK <input type="checkbox"/>	Receive data error
L ER LED is OFF.	L ER <input type="checkbox"/> LINK <input type="checkbox"/>	Receive data operates normally.
LINK LED is ON.	L ER <input type="checkbox"/> LINK <input checked="" type="checkbox"/>	Linkup in progress.
LINK LED is OFF.	L ER <input type="checkbox"/> LINK <input type="checkbox"/>	Linkdown in progress.

■:ON, □: OFF

Chapter 3 SPECIFICATIONS

- 3.1 General Specifications 3- 2
- 3.2 Performance Specifications 3- 2
- 3.3 Function List 3- 3
- 3.4 Specifications of Input/Output Signals with CPU Module 3- 5
 - 3.4.1 List of input/output signals with CPU module 3- 5
 - 3.4.2 Details of input signals (Simple Motion module → CPU module) 3- 6
- 3.5 Buffer Memory (Network Function) 3- 7

This chapter describes the specifications, function list, I/O signal, and buffer memory of the Simple Motion module.

3.1 General Specifications

For the general specifications of the Simple Motion module, refer to "MELSEC-Q QD77GF Simple Motion Module User's Manual (Positioning Control)".

3.2 Performance Specifications

Performance specifications for the network function are shown below.

Item		Specifications
Operation cycle		[RJ010 mode] 0.88ms/1.77ms/3.55ms, [CiA402 mode] 1.00ms/2.00ms/4.00ms
Maximum link points per network (excluding a servo amplifier)	RWw	1024 points, 2KB
	RWr	1024 points, 2KB
	RX	8192 points, 1KB
	RY	8192 points, 1KB
Maximum link points per station	RWw	1024 points, 2KB
	RWr	1024 points, 2KB
	RX	8192 points, 1KB
	RY	8192 points, 1KB
Maximum number of send points per station	RWw	1024 points, 2KB
	RY	8192 points, 1KB
Ethernet part	Communication speed	1Gbps
	Network topology	Line topology and star topology (Coexistence of line topology and star topology is possible.)
	Connection cable	An Ethernet cable that meets the 1000BASE-T standard: Category 5e or higher, double shielded, STP, straight cable (Refer to Section 5.2.1.)
	Maximum station-to-station distance	100m max. (Compliant with ANSI/TIA/EIA-568-B (Category 5e)) (Refer to "MELSEC-Q QD77GF Simple Motion Module User's Manual (Positioning Control)".)
	Overall cable distance	Line topology: 12000m (when cables are connected to one master station and 120 slave stations) Star topology: Depends on the system configuration.
	Number of cascade connections	Up to 4 (follows hub performance)
Number of connectable stations per network	Servo amplifier	QD77GF4 : 4 modules QD77GF8 : 8 modules QD77GF16: 16 modules
	Slave station excluding a servo amplifier	104 modules
Connected stations type	Intelligent device station	Available
	Remote device station	Available
	Remote I/O station	Available
Maximum number of networks		239
Communication method		Token passing method
Number of occupied I/O points		32 points (I/O assignment: Intelligent 32 points)

3.3 Function List

Lists of network functions are shown below.

(1) Basic functions

Function	Description	Reference
Fixed cycle communication	The slave device is communicated in the fixed cycle. The communication cycle is the same as an operation cycle of the Simple Motion module.	Section 8.1
Synchronous communication	The processing cycles of the Simple Motion module and each slave station are synchronized.	Section 8.2

(2) Cyclic transmission

Function	Description	Reference	
Communications with other stations	Communications using RX and RY	The master station communicates I/O data in units of bits with other stations.	Section 7.4 Section 8.3.1
	Communications using RWr and RWw	The master station communicates I/O data in units of words with other stations.	
Access to devices and link devices	Link refresh	Transfer between the link device of the Simple Motion module and the device of the CPU module mounted with a Simple Motion module is performed automatically.	Section 7.6 Section 8.3.2
	Direct access to link devices	The program accesses the link devices (RX, RY, RWr, RWw, SB or SW) of the Simple Motion module directly.	Section 8.3.3
Assurance of cyclic data integrity	The cyclic data integrity is assured in units of 32 bits or station-based units.	Section 8.3.4	
Input status setting for data link faulty station	Whether input data from another station where a data link error occurs is cleared or held is selected.	Section 8.3.5	
Output status setting for CPU STOP	When the CPU module mounted with a Simple Motion module is set to STOP, whether cyclic data output is held or cleared can be selected.	Section 8.3.6	
Output status setting for CPU stop error	When a stop error occurs in the CPU module where a Simple Motion module is mounted, whether cyclic transmission output is held or cleared can be selected.	Section 8.3.5	
Cyclic transmission stop and restart	During debugging and other operations, cyclic transmission is stopped. (Data reception from a slave station and data sending from the own station are stopped.) Also, the stopped cyclic transmission is restarted. Transient transmission does not stop.	Section 8.3.7 Section 9.4	

(3) Transient transmission

Function	Description	Reference
Communications within the same network	Transient transmission is performed to other stations using dedicated instructions and GX Works2.	Chapter 10

(4) Diagnostic functions

Function	Description	Reference
CC-Link IE Field Network diagnostics	The status of CC-Link IE Field Network can be checked using GX Works2. The error locations, error causes, corrective actions, and event history can be checked in GX Works2.	Chapter 9
Module error collection function	The error information occurred in the Simple Motion module is notified and accumulated. Then, the confirmation of error information and troubleshooting can be executed using GX Works2.	Section 12.2

(5) Other functions

Function	Description	Reference
Reserved station specification	The reserved stations are included in the number of stations that will be connected to the network in the future without actually connecting them. Reserved stations are not detected as faulty stations even though they are not actually connected.	Section 8.5 Section 9.6
Temporary cancel of the reserved station setting	Reserved station specification can be temporarily cancelled without changing the parameters.	
Interrupt request to a CPU module	Interrupt conditions are checked every link scan, and if the interrupt conditions are met, an interrupt request is made to the CPU module to start the interrupt program.	Section 7.7 Section 8.6

3.4 Specifications of Input/Output Signals with CPU Module

3.4.1 List of input/output signals with CPU module

The Simple Motion module uses 32 input points and 32 output points for exchanging data with the CPU module.

The input/output signals when the head I/O number of Simple Motion module is set to "0H" are shown below.

If it is set to other than "0H", change the I/O number according to setting of head I/O number.

Device X refers to the signals input from the Simple Motion module to the CPU module, and device Y refers to the signals output from the CPU module to the Simple Motion module.

Signal direction: Simple Motion module → CPU module			Signal direction: CPU module → Simple Motion module						
Device No.	Signal name		Device No.	Signal name					
X0	READY		Y0	PLC READY					
X1	Synchronization flag		Y1	All axis servo ON					
X2	Use prohibited		Y2	Use prohibited					
X3									
X4									
X5									
X6									
X7									
X8									
X9									
XA									
XB									
XC									
XD									
XE									
XF			Module READY			YF			
X10			Axis 1			BUSY	Y10	Axis 1	Positioning start
X11	Axis 2	Y11	Axis 2						
X12	Axis 3	Y12	Axis 3						
X13	Axis 4	Y13	Axis 4						
X14	Axis 5	Y14	Axis 5						
X15	Axis 6	Y15	Axis 6						
X16	Axis 7	Y16	Axis 7						
X17	Axis 8	Y17	Axis 8						
X18	Axis 9	Y18	Axis 9						
X19	Axis 10	Y19	Axis 10						
X1A	Axis 11	Y1A	Axis 11						
X1B	Axis 12	Y1B	Axis 12						
X1C	Axis 13	Y1C	Axis 13						
X1D	Axis 14	Y1D	Axis 14						
X1E	Axis 15	Y1E	Axis 15						
X1F	Axis 16	Y1F	Axis 16						

Important
 [Y2 to YF] and [X2 to XE] are used by the system, and cannot be used by the user.
 If these devices are used, the operation of the Simple Motion module will not be guaranteed.

3.4.2 Details of input signals (Simple Motion module → CPU module)

The ON/OFF timing and conditions of the input signals are shown below.
 Refer to the "MELSEC-Q QD77GF Simple Motion Module User's Manual (Positioning Control)" for signals not listed in the table below.

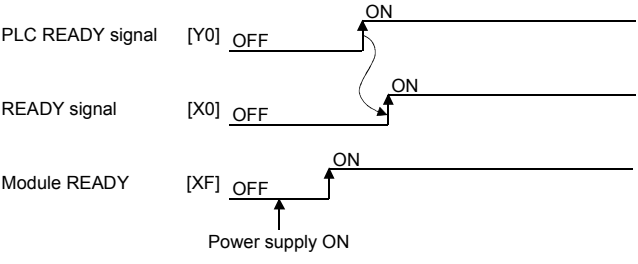
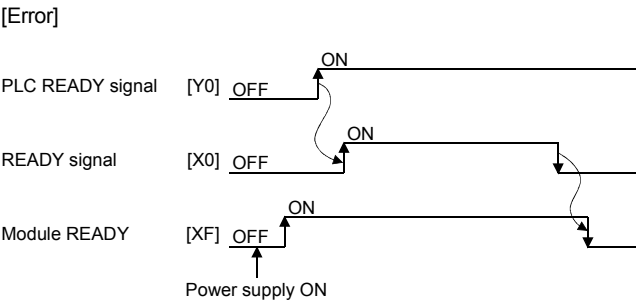
Device No.	Signal name	Signal description	Details
XF	Module READY	OFF: Module operation disabled ON: Module operation enabled	<ul style="list-style-type: none"> The signal to confirm the module operation ready status. After the power is turned from OFF to ON, this signal turns from OFF to ON when the module is normal. If the module is in error, this signal turns from ON to OFF. <p>[Normal]</p>  <p>[Error]</p> 

3.5 Buffer Memory (Network Function)

The buffer memory is used to exchange data between the Simple Motion module and the CPU module.

Following buffer memory values are defaulted when the CPU module is reset or the system is powered off. Buffer memories for the network function are shown below.

Address (Decimal (Hexadecimal))	Name	Initial value	Read, write	Refer to	
59392 to 59903 (E800H to E9FFH)	Link device area	0	Read	Appendix 1.1	
59904 to 60415 (EA00H to EBFFH)			Remote output (RY)		Read, write
60416 to 61439 (EC00H to EFFFH)			Remote register (RWw)		
61440 to 62463 (F000H to F3FFH)			Remote register (RWr)		Read
62464 to 62495 (F400H to F41FH)			Link special relay (SB)		<ul style="list-style-type: none"> • 62464 to 62465 for read and write • 62466 to 62495 for read only
62496 to 63007 (F420H to F61FH)			Link special register (SW)		<ul style="list-style-type: none"> • 62496 to 62527 for read and write • 62528 to 63007 for read only
63008 to 63151 (F620H to F6AFH)	System area			—	
63152 (F6B0H)	RX offset/size information	0	Read	Appendix 1.2	
63153 (F6B1H)					Station No.17 RX offset
to					Station No.17 RX size
63358 (F77EH)					Station No.120 RX offset
63359 (F77FH)					Station No.120 RX size
63360 (F780H)	RY offset/size information	0	Read	Appendix 1.3	
63361 (F781H)					Station No.17 RY offset
to					Station No.17 RY size
63566 (F84EH)					Station No.120 RY offset
63567 (F84FH)					Station No.120 RY size

Address (Decimal (Hexadecimal))	Name		Initial value	Read, write	Refer to
63568 (F850H)	RWw offset/size information	Station No.17 RWw offset	0	Read	Appendix 1.4
63569 (F851H)		Station No.17 RWw size			
to		to			
63774 (F91EH)		Station No.120 RWw offset			
63775 (F91FH)		Station No.120 RWw size			
63776 (F920H)		Station No.17 RWr offset			
63777 (F921H)	Station No.17 RWr size				
to	to				
63982 (F9EFH)	Station No.120 RWr offset				
63983 (F9F0H)	Station No.120 RWr size				
64016 (FA10H)	Station number		0	Read and write	Appendix 1.6
64017 (FA11H)	Station (network card) information	Manufacturer code	Own station information	Read	
64018 (FA12H)		Model type			
64019 (FA13H)		Model code			
64020 (FA14H)		Version			
64021 to 64024 (FA15H to FA18H)	System area				-
64025 (FA19H)	Station (controller) information	Controller information valid/invalid flag	Own station information	Read	Appendix 1.6
64026 (FA1AH)		Manufacturer code			
64027 (FA1BH)		Model type			
64028 (FA1CH)		Model code			
64029 (FA1DH)		Version			
64030 to 64039 (FA1EH to FA27H)		Model name string			
64040 to 64041 (FA28H to FA29H)		Vendor-specific device information			
64042 to 64047 (FA2AH to FA2FH)		System area			

Chapter 4 PROCEDURES BEFORE OPERATION

4.1 Procedures Before Operation 4- 2

4.1 Procedures Before Operation

For the procedures before operation of the Simple Motion module, refer to "MELSEC-Q QD77GF Simple Motion Module User's Manual (Positioning Control)".

Chapter 5 SYSTEM CONFIGURATION

5.1 CC-Link IE Field Network Configuration	5- 2
5.1.1 Single network system	5- 2
5.1.2 Precautions	5- 4
5.2 Network Components.....	5- 7
5.2.1 Cables	5- 7
5.2.2 Hubs.....	5- 7
5.3 Applicable Systems	5- 8

5.1 CC-Link IE Field Network Configuration

This section describes CC-Link IE Field Network configurations.

5.1.1 Single network system

(1) Overall system configuration

A single network system is a system in which a Simple Motion module (master station) and slave stations are connected using Ethernet cables as shown below. The Simple Motion module can be connected with servo amplifiers and slave stations excluding servo amplifiers. (Up to 120 slave stations and one master station can be connected.) Also, the devices which the synchronous communication function is supported/unsupported can be coexisted.

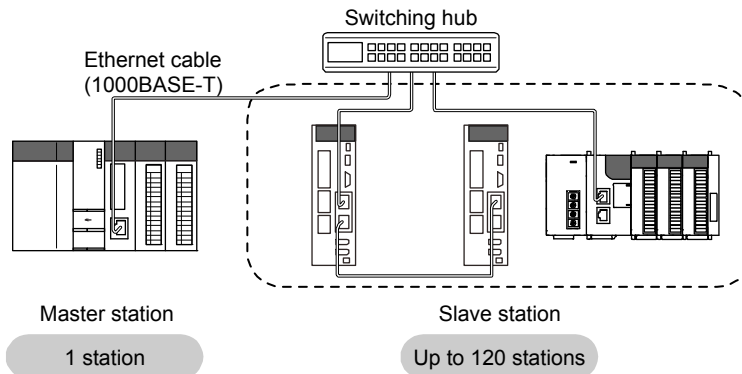

Set the station No. as shown below depending on the connected device to the Simple Motion module.

Station No.	Connected device
1 to 16 (Note-1)	Servo amplifier
17 to 120	Slave station excluding a servo amplifier

(Note-1): The range from the station No.1 to 4 is valid in the 4-axis module, and the range from the station No.1 to 8 is valid in the 8-axis module.

(2) Network configuration

(a) Network topology

The network can be wired into star topology or line topology.

A network can consist of a combination of star and line topologies. The Simple Motion module does not support the ring topology.

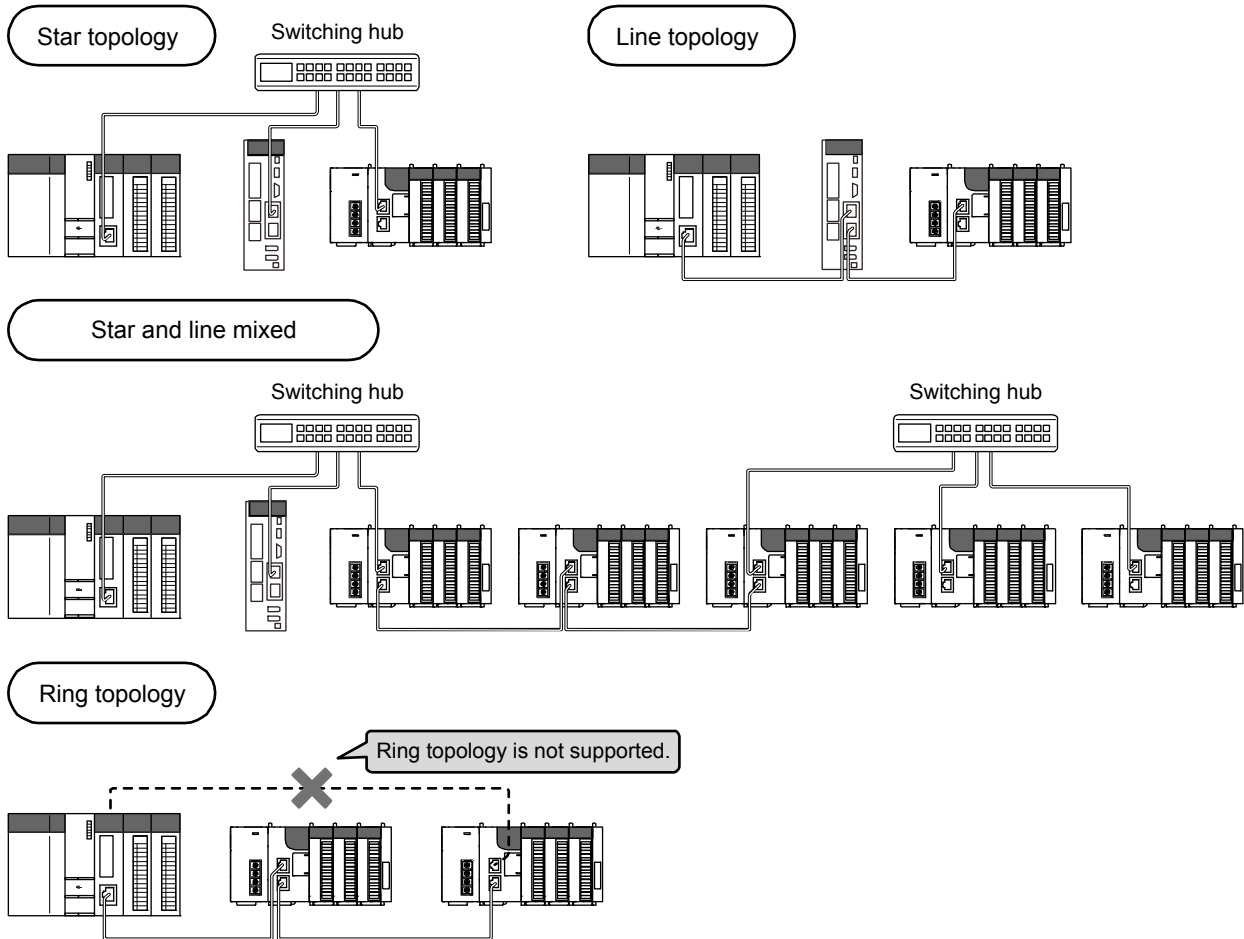

Item	Description
Star topology	The network is configured into a star using a switching hub and Ethernet cables. Slave stations can be easily added to the network using this topology. Data link continues with the stations that are operating normally. (Note-1) Use the recommended product for the switching hub.
Line topology	The network is configured into a line by connecting the modules with Ethernet cables, but without a switching hub. If an error occurs, stations after the faulty station will be disconnected. (Note-1) <div style="text-align: center;"> <p>Line topology</p> <p>Master station (Station No.0)</p> <p>Fault</p> <p>Stations after the faulty station are disconnected.</p> </div>

(Note-1): Add slave stations one by one. If multiple slave stations are added at a time, all stations on the network will be reconnected, and an error may momentarily occur in all the stations.

- (b) Station number and connection position
 Modules can be connected in any order regardless of the station number.
 When the device transmits data, delay time will occur. Therefore, it is recommended to connect servo amplifiers adjacently.

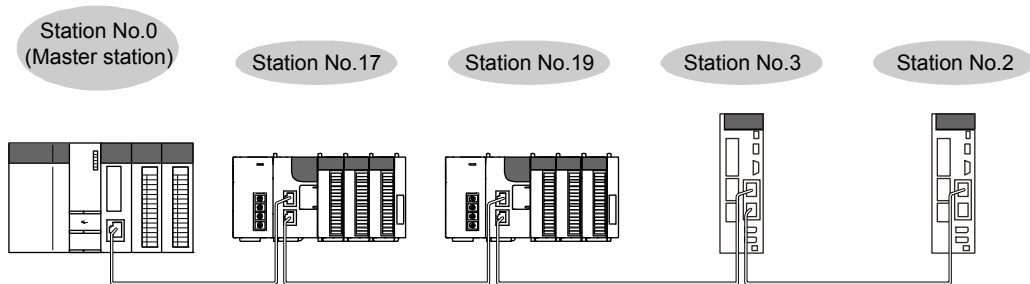

- (c) Cascade connection
 Up to 4-layer connection is available for the cascade connection.
 However, it depends on the switching hub specification.

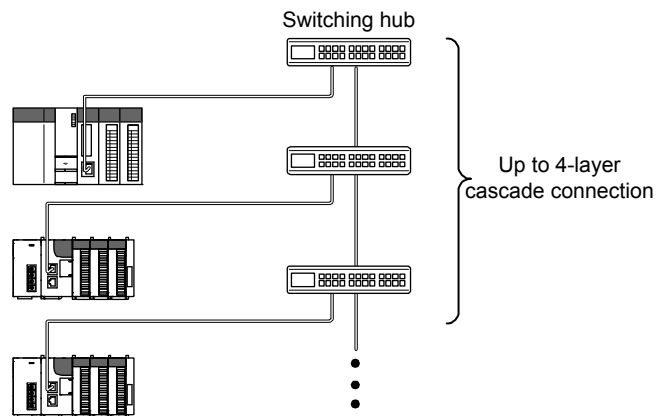

REMARK

For wiring method, refer to the "MELSEC-Q QD77GF Simple Motion Module User's Manual (Positioning Control)".

5.1.2 Precautions

- (1) Adding slave stations
 Do not connect slave stations more than the number of stations that can be controlled.
 If a slave station is added to a system having the maximum number of stations that can be controlled, all stations will fail and data link cannot be performed.
- (2) Connecting devices to the same network
 Do not connect an Ethernet device (e.g. personal computer) other than CC-Link IE Field Network device to the switching hub used on CC-Link IE Field Network. Doing so will cause timeout in the master station, resulting in disconnection of all the stations.

(3) Connecting/disconnecting a cable and powering off/on a device

When the operations listed below are performed, a data link error may momentarily occur in all the stations and outputs of the connected slave stations may turn off since all stations on the network will be reconnected. Set output data if needed. (Refer to Section 5.1.2 (4).)

Network configuration	Operation
Star topology	<ul style="list-style-type: none"> • Powering a slave station or switching hub off and on • Connecting/disconnecting an Ethernet cable connected to the switching hub • Disconnecting an Ethernet cable from a slave station and connecting it to another slave station or the switching hub • Disconnecting more than nine stations, or half the number of slave stations or more in the system • Changing the network topology when adding a slave station
Line topology	<ul style="list-style-type: none"> • Simultaneously powering off/on systems on multiple stations • Simultaneously connecting/disconnecting Ethernet cables to/from multiple stations (When a data link faulty station returns, a data link error will occur in all the stations.) • Disconnecting more than nine stations, or half the number of slave stations or more in the system • Changing the network topology when adding a slave station

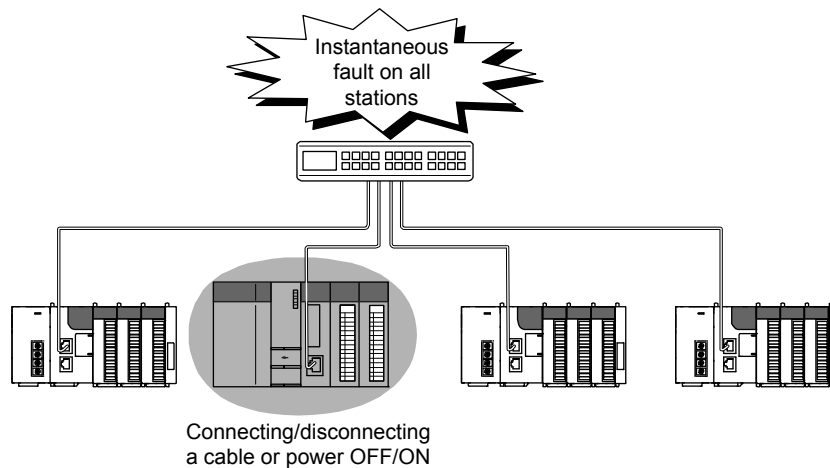

(4) Output hold when a data link error occurs

To hold the outputs when a data link error occurs, configure the following settings:

- Simple Motion module

Set that the input data from the data link faulty station is held.

Project window → [Parameter] → [Network Parameter] → [Ethernet/CC IE/MELSECNET] → [Network Operation Settings] button

- For a head module whose serial number (first five digits) is "12071" or earlier

Set that the output data when a data link error occurs is held.

Project window → [Parameter] → [PLC Parameter] → "I/O Assignment" → [Detailed Setting] button → "Error Time Output Mode"

(This setting is not required for a head module whose serial number (first five digits) is "12072" or later.)

(5) Connected station numbers

Do not duplicate station numbers. Data link may be stopped when the station number is duplicated.

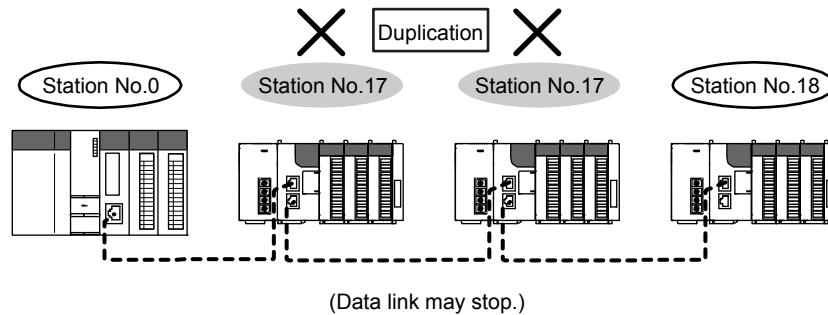

(6) Power-on order

To avoid incorrect input from slave stations, power on slave stations before the master station.

(7) Writing and resetting network parameters

When writing and resetting network parameters to the CPU module, the communication with slave devices stops temporary. Therefore, a synchronous communication error may occur in the slave device. When the error occurs in the slave device, turn the power on again.

5.2 Network Components

CC-Link IE Field Network consists of components such as cables and hubs.

5.2.1 Cables

For wiring the CC-Link IE Field Network cable, use the 1000BASE-T compliant Ethernet cables.

Ethernet cable	Connector	Type
Category 5e or higher, Double shielded/STP, Straight cable	RJ-45 connector	The following conditioning cables: <ul style="list-style-type: none"> • IEEE802.3 (1000BASE-T) • ANSI/TIA/EIA-568-B (Category 5e)

POINT

- For CC-Link IE Field Network wiring, use the recommended wiring components by CC-Link Partner Association.
- Cables for CC-Link IE Controller Network cannot be used for CC-Link IE Field Network.

(1) Product

Cables for CC-Link IE Field Network are available from Mitsubishi Electric System & Service Co., Ltd. (Catalogs for cable are also available.)

Also, the connector processing of cable length is available for your preference. Please consult your local Mitsubishi Electric System & Service Co., Ltd.

Type	Model (manufacturer)
CC-Link IE Field Network cable	SC-E5EW series (Mitsubishi Electric System & Service Co., Ltd.)

REMARK

• Cable types

The following cable types are available depending on the operating environment:

- Standard type: Cables for inside the control panel and indoor connection
- L type : Cables for outdoor connection

Cables and relay adapters of flame retardant or waterproof type are also available.

Please contact your Mitsubishi Electric System & Service Co., Ltd.

5.2.2 Hubs

Use the recommended product shown below. Operation is not guaranteed if the hubs other than the recommended product are used.

Type	Model name (manufacturer)	Number of maximum extension
CC-Link IE Field Network synchronous communication switching hub	DT135TX (Mitsubishi Electric System & Service Co., Ltd.)	4 layers

5.3 Applicable Systems

For the MELSEC-Q series systems that include the Simple Motion module, refer to "MELSEC-Q QD77GF Simple Motion Module User's Manual (Positioning Control)".

Chapter 6 INSTALLATION AND WIRING

6.1 Installation and Wiring 6- 2

6.1 Installation and Wiring

For the installation and wiring of the Simple Motion module refer to the "MELSEC-Q QD77GF Simple Motion Module User's Manual (Positioning Control)".

Chapter 7 PARAMETER SETTING

7.1 Parameter and Backup	7- 2
7.2 Parameter List	7- 3
7.3 Network Settings	7- 5
7.4 Network Configuration Settings	7- 8
7.5 Network Operation Settings	7-20
7.6 Refresh Parameters	7-21
7.7 Interrupt Settings	7-25

This chapter describes CC-Link IE Field Network parameters.

The CC-Link IE Field Network parameters are set for either the master station or slave stations.

This manual describes network parameters for Simple Motion modules. For slave station settings, refer to the manuals for the slave stations used.

7.1 Parameter and Backup

GX Works2 and Simple Motion Module Setting Tool of GX Works2 are used for each parameter setting of the Simple Motion module.

Set the required parameter based on the target station No.

Since the modules which save each parameter setting are different, when the CPU module or Simple Motion module is exchanged, rewrite the parameter to the exchanged module.

A programming tool used for each parameter setting and modules which backup each parameter setting are shown below.

Item	Target station No.		Programming tool		Backup module	
	1 to 16 (Note-4)	17 to 120	GX Works2	GX Works2 (Simple Motion Module Setting Tool)	CPU module	Simple Motion module
Parameters used for network function	○	○	○	—	○	—
Parameters used for positioning control (Note-1)	○	—	—	○ (Note-3)	—	○
Parameters used for synchronous control (Note-2)	○	—	—	○ (Note-3)	—	○

○ : Valid
— : Invalid

(Note-1): For details of parameters, refer to the "MELSEC-Q QD77GF Simple Motion Module User's Manual (Positioning Control)".

(Note-2): For details of parameters, refer to the "MELSEC-Q/L QD77MS/QD77GF/LD77MS/LD77MH Simple Motion Module User's Manual (Synchronous Control)".

(Note-3): Parameters can be also set by a sequence program.

(Note-4): The range from the station No.1 to 4 is valid in the 4-axis module, and the range from the station No.1 to 8 is valid in the 8-axis module.

7.2 Parameter List

The following table lists CC-Link IE Field Network parameters.

(1) Parameters set for a Simple Motion module

When setting the parameters for the Simple Motion module, select "CC IE Field (Motion Master Station)" in Network Type using GX Works2.

The parameters for the function not supported by the Simple Motion module are disabled.

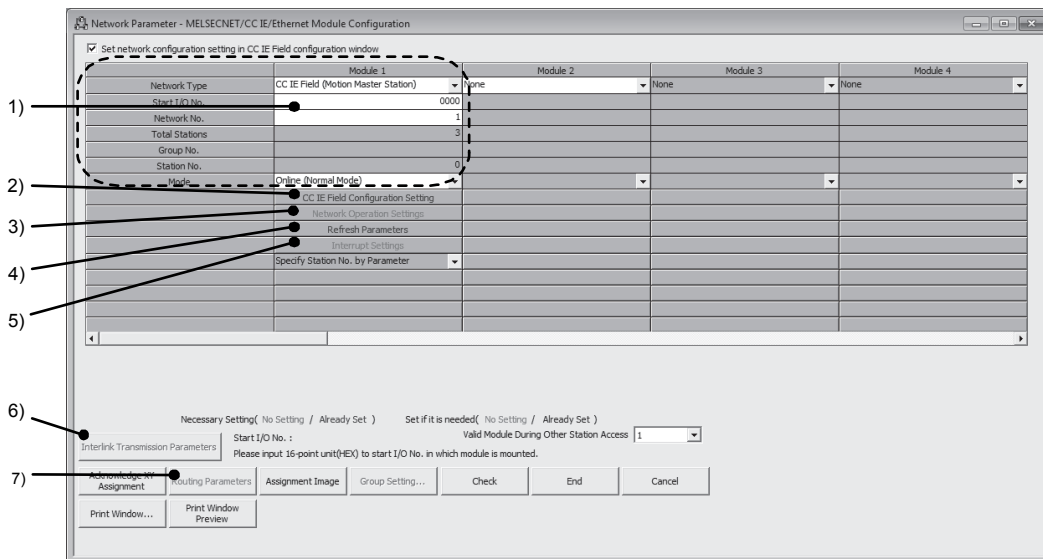

Item		Necessity of setting	Reference	
1) Network setting	Network Type	○	Section 7.3	
	Start I/O No.			
	Network No.			
	Total Stations			
	Station No.	-		
	Mode	○		
2) CC IE Field Configuration Settings	Assignment Method	○	Section 7.4	
	Station No.			
	Station Type			
	RX/RX Setting			
	RWw/RWr Setting			
	Refresh Device	-		
	Reserved/Error Invalid Station	○		
	Alias	-		
	Comment			
	Supplementary setting	Link Scan Mode Setting		-
		Loopback Function Setting		
Block Data Assurance per Station		△		
Operation Setting for Returning		-		
Equal Assignment	○			
Identical Point Assignment				
3) Network Operation Settings	Parameter Name	△	Section 7.5	
	Data Link Faulty Station Setting			
	Output Setting During CPU STOP			
	Set IP address	-		
4) Refresh Parameters		○	Section 7.6	
5) Interrupt Settings		△	Section 7.7	
6) Interlink Transmission		-	-	
7) Routing Parameters				

- : Always
- △ : When required
- : Cannot be set

POINT
<ul style="list-style-type: none"> • When parameters are not set The Simple Motion module operates as the master station in network number 1. In this case, only transient transmission is performed. (Cyclic transmission is not performed.)

- (2) Parameters set for slave stations (other than Simple Motion modules)
For the settings of a slave station, refer to the manual for the slave station used.

7.3 Network Settings

Set the network number, station number, and other parameters for the Simple Motion module.

(1) Setting procedure

- 1) Open the setting window.
Project window → [Parameter] → [Network Parameter] → [Ethernet/CC IE/MELSECNET]
- 2) Set parameters in the window.
- 3) Click the [End] button.

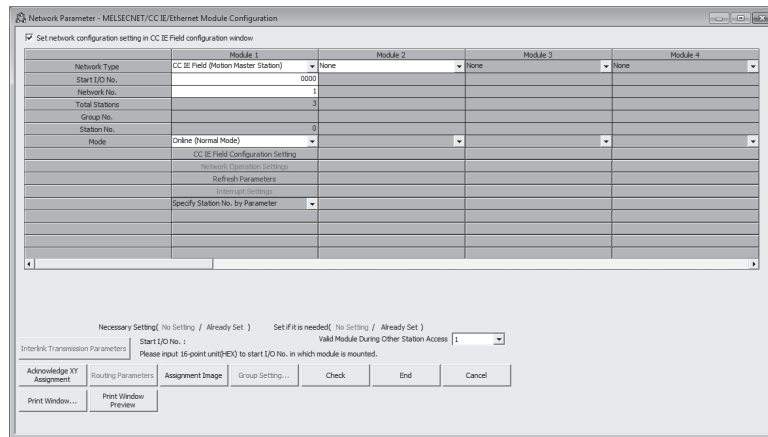

Item	Description	Setting range	Remark
Set the network configuration setting in the CC IE Field configuration window	Select the checkbox to set the network configuration setting graphically. The setting can be easily configured by selecting the module from the module list. (Refer to Section 7.4 (1).)	<ul style="list-style-type: none"> • Do not use the CC IE Field configuration window to set the network configuration setting. (Default: The checkbox is not checked.) • Use the CC IE Field configuration window to set the network configuration setting. (The checkbox is checked.) 	-
Network Type	One master station can be set in a network.	CC IE Field (Motion Master Station) (Default: Blank)	•If the value outside the setting range is set, "Parameter error (error code: D302H)" will occur, and the Simple Motion module will start in offline mode.

Item	Description	Setting range	Remark						
Start I/O No.	Enter the start I/O number of the Simple Motion module in increments of 16 points.	Within the number of I/O points of the CPU module (Default: Blank)	-						
Network No.	Enter the network number of the Simple Motion module. • One master station can be set.	1 to 239 (Default: Blank)	-						
Total Stations	Set the total number of stations in a network (excluding the master station). • If any reserved station is required, include the number of reserved stations. The number can be set when "CC IE Field (Motion Master Station)" is selected in "Network Type". When the checkbox next to "Set the network configuration setting in the CC IE Field configuration window" is selected, the setting value in the CC IE Field configuration window is displayed.	• Master station: 1 to 120 (Default: Blank)	-						
Station No.	Enter the station number of the Simple Motion module. Set a station number different from those used in the same network. The station number of the master station is fixed to "0".	Master station: Fixed to "0"	-						
Mode	• For the master station Set a master station mode.	• Online (Normal Mode) • Offline (Default: Online (Normal Mode))	•If the value outside the setting range is set, "Parameter error (error code: D303H)" will occur, and the Simple Motion module will start in offline mode.						
	<table border="1"> <thead> <tr> <th>Mode</th> <th>Description</th> </tr> </thead> <tbody> <tr> <td>Online (Normal Mode)</td> <td>This mode performs cyclic transmission and transient transmission without losing their inherent speed performance. This mode is suitable for a system that performs I/O control and analog control, and transmits large amount of data for management, monitoring, and diagnostics by transient transmission. Use this mode for general applications.</td> </tr> <tr> <td>Offline</td> <td>Select this mode to disconnect the Simple Motion module from the network for stopping data link with other stations.</td> </tr> </tbody> </table>			Mode	Description	Online (Normal Mode)	This mode performs cyclic transmission and transient transmission without losing their inherent speed performance. This mode is suitable for a system that performs I/O control and analog control, and transmits large amount of data for management, monitoring, and diagnostics by transient transmission. Use this mode for general applications.	Offline	Select this mode to disconnect the Simple Motion module from the network for stopping data link with other stations.
	Mode			Description					
Online (Normal Mode)	This mode performs cyclic transmission and transient transmission without losing their inherent speed performance. This mode is suitable for a system that performs I/O control and analog control, and transmits large amount of data for management, monitoring, and diagnostics by transient transmission. Use this mode for general applications.								
Offline	Select this mode to disconnect the Simple Motion module from the network for stopping data link with other stations.								

Item	Description	Setting range	Remark
[Network Configuration Settings] button	Set parameters of slave stations (the number of points and assignment of link devices) in the master station. When the checkbox next to "Set the network configuration setting in the CC IE Field configuration window" is checked, the button will be changed to [CC IE Field Configuration Setting]. In this manual, the operation with the checkbox checked is described for explanation purpose.	Refer to Section 7.4.	-
[Network Operation Settings] button	Set the operating status of a network if a data link error occurs or the CPU module is set to STOP.	Refer to Section 7.5.	-
[Refresh Parameters] button	Set link refresh ranges between the link devices of the Simple Motion module and the devices of the CPU module.	Refer to Section 7.6.	-
[Interrupt Settings] button	Set conditions for sending an interrupt request to the CPU module.	Refer to Section 7.7.	-

(2) Setting example

For setting examples, refer to Chapter 11.

7.4 Network Configuration Settings

Set parameters of slave stations (the number of points and assignment of link devices) in the master station. Set a link scan mode and block data assurance per station as well.

Two methods are available for the network configuration settings as listed in the following table.

Item	Description
Setting on the graphical window (CC IE Field configuration window)	<p>The network configuration can be set while checking the CC-Link IE Field Network configuration graphically.</p> <p>Slave stations are added by selecting the model name displayed on the window; therefore, a setting error in the station type can be prevented.</p> <ul style="list-style-type: none"> • Change transmission path method (Refer to Section 7.4 (1) (b).) <p>Unlike the setting on the window in the table format, the following processes can be performed.</p> <ul style="list-style-type: none"> • Change transmission path method (Refer to Section 7.4 (1) (b).) • Parameter processing of a slave station (Refer to Section 7.4 (1) (e).) • Command execution of a slave station (Refer to Section 7.4 (1) (f).)
Setting on the window in the table format	<p>The CC-Link IE Field Network configuration is set manually. (The station type is also set manually.)</p> <p>Unlike the setting on the graphical window (CC IE Field configuration window), the network configuration is not displayed graphically. (Refer to Section 7.4 (2).)</p>

(Note-1): The network configuration settings can be set only for the master station.

(1) Setting on the graphical window (CC IE Field configuration window)

- 1) Select the checkbox next to "Set the network configuration setting in the CC IE Field configuration window". (Refer to Section 7.2.)
- 2) Configure the network setting. (Refer to Section 7.3.)
- 3) Open the setting window.

Project window → [Parameter] → [Network Parameter] → [Ethernet/CC IE/MELSECNET] → [CC IE Field Configuration Setting] button

- 4) Select the module under "Module List" and drag and drop it to the station list area or the device map area.

The slave station is added to the station list area. The added module is displayed in the device map area.

- 5) Configure the remaining settings.
- 6) After the setting is completed, close the window.

[CC IE Field Configuration] → [Close with Reflecting the Setting]

REMARK

For how to operate the setting window, refer to the following.
GX Works2 Version1 Operating Manual (Common)

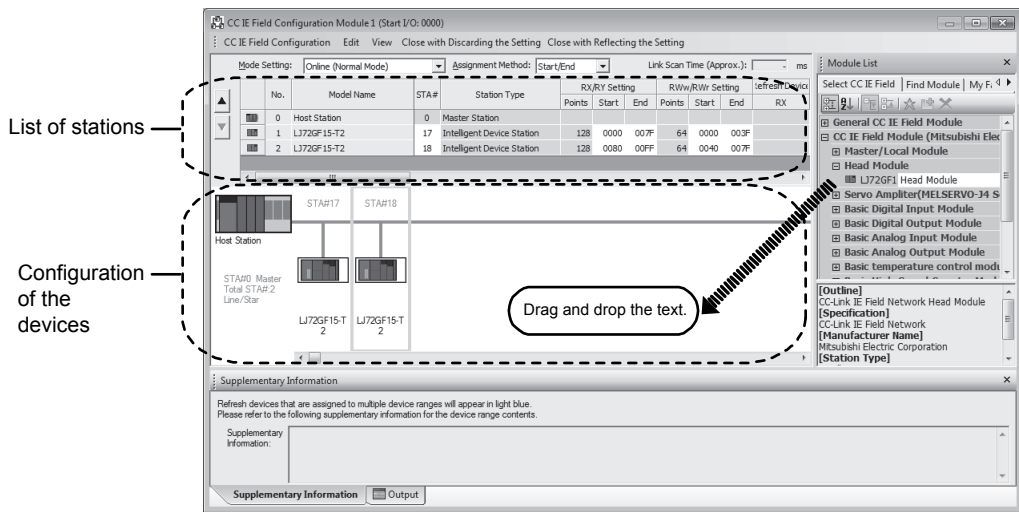

(a) Setting the configuration of the slave station in the master station

Item	Description	Setting range	Remark
Mode Setting	Set the mode of the master station. (Refer to Section 7.3 (1).)	<ul style="list-style-type: none"> • Online (Normal Mode) • Offline (Default: Online (Normal Mode))	<ul style="list-style-type: none"> •If the value outside the setting range is set, "Parameter error (error code: D303H)" will occur and the master station will start with offline mode.
Assignment Method	Select a link device assignment method. <ul style="list-style-type: none"> • Point/Start: Enter the points and start numbers of link devices. • Start/End: Enter the start and end numbers of link devices. 	<ul style="list-style-type: none"> • Point/Start • Start/End (Default: Start/End)	-
Link Scan Time (Approx.)	Displays the approximate link scan time.	-	-
No.	The total number of slave stations set in the CC IE Field configuration window is displayed.	-	-
Model Name	The module model name is displayed. If a module where the profile is not registered is set, the message "Module without profile" is displayed. Register the profile before setting the model name. For how to register a profile, refer to the "GX Works2 Version1 Operating Manual (Common)".	-	-
STA#	Enter the station number of each slave station connected to the network. Station numbers do not need to be set consecutively, but must be unique. The station number of the master station is fixed at "0".	1 to 120 (Default: Blank)	-
Station Type	Select the station type (excluding the master station). Select the station type same as that of the modules connected to the network.	(1) Station No.1 to 16 (Note-1) <ul style="list-style-type: none"> • Intelligent Device Station • Remote Device Station (2) Station No.17 to 120 <ul style="list-style-type: none"> • Intelligent Device Station • Remote Device Station • Remote I/O Station (Default: Intelligent Device Station)	<ul style="list-style-type: none"> •If the value outside the setting range is set, "Parameter error (error code: D628H)" will occur.

(Note-1): The range from the station No.1 to 4 is valid in the 4-axis module, and the range from the station No.1 to 8 is valid in the 8-axis module.

Item	Description	Setting range	Remark
RX/RV Setting	<p>Assign RX/RV points to the station No.17 to 120. (Refer to Section 8.3.1.) Points can be assigned in increments of 16 (Start: <input type="checkbox"/><input type="checkbox"/> 0H, End: <input type="checkbox"/><input type="checkbox"/><input type="checkbox"/>FH).</p> <p>To assign points equally or the same points, go to [Equal Assignment] or [Identical Point Assignment] under [CC IE Field Configuration]. (Refer to Section 7.4 (1) (d).)</p>	<ul style="list-style-type: none"> • Points: Intelligent Device Station: 16 to 2048 Remote Device Station: 16 to 128 Remote I/O Station: 16 to 64 • Device number: 0 to 1FFFH (Default: varies depending on the set module) 	<ul style="list-style-type: none"> •If the value outside the setting range is set, one of the "Parameter error (error code: D615H to D618H)" will occur. •Assigning RX/RV points to the station No.1 to 16 (Note-1) are all invalid. (If the value within the setting range is set, an error will not occur.)
RWw/RVr Setting	<p>Assign RWw/RVr points to the station No.17 to 120 in increments of 4. (Refer to Section 8.3.1.)</p> <p>To assign points equally or the same points, go to [Equal Assignment] or [Identical Point Assignment] under [CC IE Field Configuration]. (Refer to Section 7.4 (1) (d).)</p>	<ul style="list-style-type: none"> • Points: Intelligent Device Station: 4 to 1024 Remote Device Station: 4 to 64 Remote I/O Station: Cannot be set. • Device number: 0 to 3FFFH (Default: varies depending on the set module) 	<ul style="list-style-type: none"> •If the value outside the setting range is set, one of the "Parameter error (error code: D611H to D614H)" will occur. •Assigning RWw/RVr points to the station No.1 to 16 (Note-1) are all invalid. (If the value within the setting range is set, an error will not occur.)
Refresh Device	<p>Link refresh target devices in the CPU module are displayed for each link device of the Simple Motion module.</p> <p>Target devices are displayed when refresh parameters have been set. (Refer to Section 7.6.)</p>	-	-

(Note-1): The range from the station No.1 to 4 is valid in the 4-axis module, and the range from the station No.1 to 8 is valid in the 8-axis module.

Item	Description	Setting range	Remark
Reserved/Error Invalid Station	<p>Set this item to reserve the slave station from the station No.17 to 120. (Refer to Section 8.5.)</p> <ul style="list-style-type: none"> • No Setting The slave station is connected to the network. • Reserved Station The slave station is reserved for future expansion. By reserving a slave station, link device assignment will not change even if the slave station is added or the reservation is cancelled. Therefore, the program needs not to be modified. Physical connection of the slave station is not required. • Error Invalid Station This item cannot be set for the Simple Motion module. 	<ul style="list-style-type: none"> • No Setting • Reserved Station (Default: No Setting) 	<ul style="list-style-type: none"> •If the invalid station is set, "Parameter error (error code: D301H)" will occur. •All invalid for the station No.1 to 16 (Note-1).
Alias	This item cannot be set for the Simple Motion module.	All invalid.	–
Comment	This item cannot be set for the Simple Motion module.	All invalid.	–
Station-specific mode setting	Set the station-specific mode of the slave station. This setting is available only when the slave station supports the station-specific mode.	The setting varies depending on the set module.	–
Module List	The slave stations are listed. Drag and drop the modules from "Module List" to the station list area or the device map area to set the information of the slave stations into the master station.	–	–

(Note-1): The range from the station No.1 to 4 is valid in the 4-axis module, and the range from the station No.1 to 8 is valid in the 8-axis module.

(b) Change Transmission Path Method

[CC IE Field Configuration] → [Change Transmission Path Method]

Item	Description	Setting range
Change Transmission Path Method	The transmission path method cannot be changed. The ring connection is not supported.	<ul style="list-style-type: none"> • Line/Star (Default: Line/Star)

(c) Supplementary Setting
 [CC IE Field Configuration] → [Supplementary Setting]

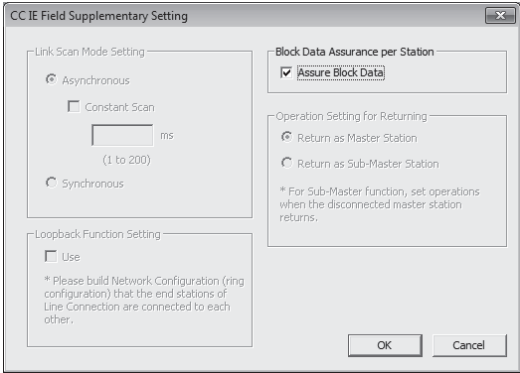
Item	Description	Setting range	Remark
<p>Supplementary Setting</p>	<p>Set "Link Scan Mode Setting", "Loopback Function Setting", "Block Data Assurance per Station", and "Operation Setting for Returning".</p>  <p>(1) Link Scan Mode Setting This item cannot be set for the Simple Motion module.</p> <p>(2) Loopback Function Setting This item cannot be set for the Simple Motion module.</p> <p>(3) Block Data Assurance per Station Select whether to assure data integrity on a station basis in link refresh between the CPU module and the Simple Motion module. (Refer to Section 8.3.4.)</p> <p>(4) Operation Setting for Returning This item cannot be set for the Simple Motion module.</p>	<ul style="list-style-type: none"> • Link Scan Mode Setting: All invalid. • Loopback Function Setting: All invalid. • Block Data Assurance per Station: Selected (Assure Block Data)/ not selected (Default: Selected (Assure Block Data)) • Operation Setting for Returning: All invalid. 	<ul style="list-style-type: none"> • "Block Data Assurance per Station" is a function for the station No.17 to 120.

(d) Equal assignment and identical point assignment of link points
 [CC IE Field Configuration] → [Equal Assignment] or [Identical Point Assignment]

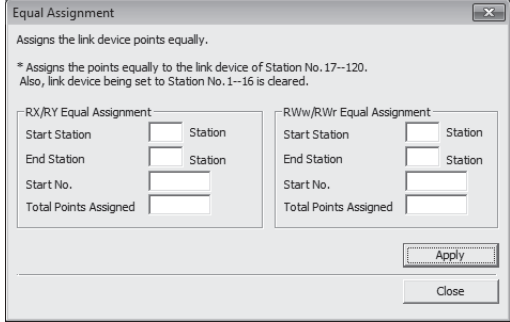
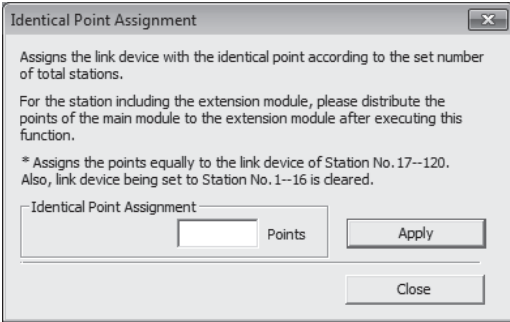
Item	Description	Setting range	Remark
Equal Assignment	<p>Equally assign link devices to stations with preset conditions.</p>  <p>(1) Start Station Enter the start station number of stations for which link devices are equally assigned.</p> <p>(2) End Station Enter the end station number of stations for which link devices are equally assigned.</p> <p>(3) Start No. Enter the start number of link devices to be equally assigned.</p> <p>(4) Total Points Assigned Enter the total points of link devices to be equally assigned.</p>	<ul style="list-style-type: none"> • Start Station: 0 to the end station number • End Station: "Start Station" to the end station number • Start No.: Same values set in "RX/Ry Setting" and "RWw/RWr Setting" • Total Points Assigned: Same values set in "RX/Ry Setting" and "RWw/RWr Setting" (Default: Blank) 	-
Identical Point Assignment	<p>Assign the same link device points to all stations.</p>  <p>Points entered in this field will be reflected to the "Points" of "RX/Ry Setting".</p> <p>Half of the points entered in this field will be reflected to the "Points" of "RWw/RWr Setting".</p>	-	-

(e) Parameter processing of a slave station

[CC IE Field Configuration] after selecting the module in the station list area →
[Parameter Processing of Slave Station]

The parameters of a slave station can be set or read. This can be performed when the slave station supports the parameter process.

The setting range varies depending on the target module. For details, refer to the manual for the slave station used.

(f) Command execution of a slave station

[CC IE Field Configuration] after selecting the module in the station list area →
[Command Execution of Slave Station]

The command of a slave station is executed. This can be performed when the slave station supports the command execution.

The setting range varies depending on the target module. For details, refer to the manual for the slave station used.

(2) Setting on the window in the table format

- 1) Set network setting parameters. (Refer to Section 7.3.)
- 2) Open the setting window.
 Project window → [Parameter] → [Network Parameter] →
 [Ethernet/CC IE/MELSECNET] → [Network Configuration Settings] button
- 3) Set parameters in the window.
- 4) Click the [End] button.

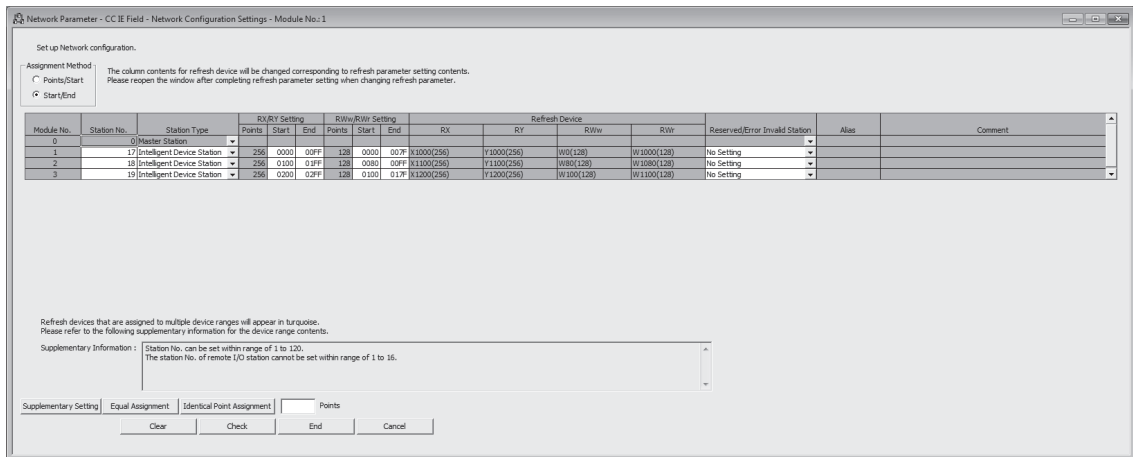

Item	Description	Setting range	Remark
Assignment Method	Select a link device assignment method. • Points/Start: Enter the points and start numbers of link devices. • Start/End: Enter the start and end numbers of link devices.	• Points/Start • Start/End (Default: Start/End)	—
Number of PLCs	The number of stations set in "Total Stations" of the network settings is displayed.	—	—
Station No.	Enter the station number of each slave station connected to the network. Station numbers do not need to be set consecutively, but must be unique. The station number of the master station is fixed at "0".	1 to 120 (Default: Consecutively numbered)	—
Station Type	Select the type of stations (excluding the master station). Select the station type of modules actually connected to the network.	(1) Station No.1 to 16 (Note-1) • Intelligent Device Station • Remote Device Station (2) Station No.17 to 120 • Intelligent Device Station • Remote Device Station • Remote I/O Station (Default: Intelligent Device Station)	If the value outside the setting range is set, "Parameter error (error code: D628H)" will occur.



(Note-1): The range from the station No.1 to 4 is valid in the 4-axis module, and the range from the station No.1 to 8 is valid in the 8-axis module.

Item	Description	Setting range	Remark
RX/RV Setting	Assign RX/RV points to the station No.17 to 120. (Refer to Section 8.3.1.) Points can be assigned in increments of 16 (Start: <input type="checkbox"/> <input type="checkbox"/> 0H, End: <input type="checkbox"/> <input type="checkbox"/> <input type="checkbox"/> FH).	<ul style="list-style-type: none"> • Points: Intelligent Device Station: 16 to 2048 Remote Device Station: 16 to 128 Remote I/O Station: 16 to 64 • Device number: 0 to 1FFFH (Default: Blank) 	<ul style="list-style-type: none"> •If the value outside the setting range is set, one of the "Parameter error (error code: D615H to D618H)" will occur. •Assigning RX/RV points to the station No.1 to 16 (Note-1) are all invalid. (If the value within the setting range is set, an error will not occur.)
RWw/RVr Setting	Assign RWw/RVr points in increments of 4 to the station No.17 to 120. (Refer to Section 8.3.1.)	<ul style="list-style-type: none"> • Points: Intelligent Device Station: 4 to 1024 Remote Device Station: 4 to 84 Remote I/O Station: Cannot be set. • Device number: 0 to 3FFFH (Default: Blank) 	<ul style="list-style-type: none"> •If the value outside the setting range is set, one of the "Parameter error (error code: D611H to D614H)" will occur. •Assigning RWw/RVr points to the station No.1 to 16 (Note-1) are all invalid. (If the value within the setting range is set, an error will not occur.)
Refresh Device	Link refresh target devices in the CPU module are displayed for each link device of the Simple Motion module. Target devices are displayed when refresh parameters have been set. (Refer to Section 7.6.)	-	-

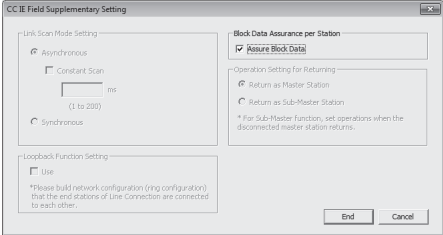
(Note-1): The range from the station No.1 to 4 is valid in the 4-axis module, and the range from the station No.1 to 8 is valid in the 8-axis module.

Item	Description	Setting range	Remark
Reserved/Error Invalid Station	<p>Set this item to reserve the slave station from the station No.17 to 120. (Refer to Section 8.5.)</p> <ul style="list-style-type: none"> • No Setting The slave station is connected to the network. • Reserved Station The slave station is reserved for future expansion. By reserving a slave station, link device assignment will not change even if the slave station is added or the reservation is cancelled. Therefore, the program needs not to be modified. Physical connection of the slave station is not required. • Error Invalid Station This item cannot be set for the Simple Motion module. 	<ul style="list-style-type: none"> • No Setting • Reserved Station (Default: Blank) 	<ul style="list-style-type: none"> •If the error invalid station is set, "Parameter error (error code: D301H)" will occur. •All invalid for the station No.1 to 16 (Note-1).
Alias	These items cannot be set for the Simple Motion module.	All invalid.	-
[Supplementary Setting] button	<p>Set "Link Scan Mode Setting", "Loopback Function Setting", "Block Data Assurance per Station", and "Operation Setting for Returning".</p>  <ol style="list-style-type: none"> (1) Link Scan Mode Setting This item cannot be set for the Simple Motion module. (2) Loopback Function Setting This item cannot be set for the Simple Motion module. (3) Block Data Assurance per Station Select whether to assure data integrity on a station basis in link refresh between the CPU module and the Simple Motion module. (Refer to Section 8.3.4.) (4) Operation Setting for Returning This item cannot be set for the Simple Motion module. 	<ul style="list-style-type: none"> • Link Scan Mode Setting: All invalid. • Loopback Function Setting: All invalid. • Block Data Assurance per Station: Selected (Assure Block Data)/not selected (Default: Selected) • Operation Setting for Returning All invalid. 	<ul style="list-style-type: none"> •"Block Data Assurance per Station" is a function for the station No.17 to 120.

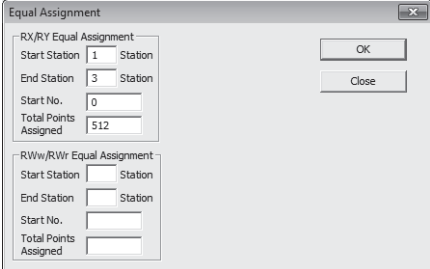
(Note-1): The range from the station No.1 to 4 is valid in the 4-axis module, and the range from the station No.1 to 8 is valid in the 8-axis module.

Item	Description	Setting range	Remark
<p>[Equal Assignment] button</p>	<p>Equally assign link devices to stations with preset conditions.</p>  <p>(1) Start Station Enter the start station number of stations for which link devices are equally assigned.</p> <p>(2) End Station Enter the end station number of stations for which link devices are equally assigned.</p> <p>(3) Start No. Enter the start number of link devices to be equally assigned.</p> <p>(4) Total Points Assigned Enter the total points of link devices to be equally assigned.</p>	<ul style="list-style-type: none"> • Start Station: 1 to the end station number • End Station: Number set to "Start Station" to the end station number • Start No.: Same values set in "RX/Ry Setting" and "RWw/RWr Setting" • Total Points Assigned: Same values set in "RX/Ry Setting" and "RWw/RWr Setting" (Default: Blank) 	<p>—</p>
<p>[Identical Point Assignment] button</p>	<p>Assign the same link device points to all stations. Enter the points in the field right next to the [Identical Point Assignment] button.</p>  <p>Points entered in this field will be reflected to the "Points" of "RX/Ry Setting". Half of the points entered in this field will be reflected to the "Points" of "RWw/RWr Setting".</p>	<p>Set in increments of 16 points.</p>	<p>—</p>

(3) Setting example

For setting examples, refer to Chapter 11.

7.5 Network Operation Settings

Set operating status of a network if a data link error occurs or the CPU module is set to STOP.

- 1) Set network setting parameters. (Refer to Section 7.3.)
- 2) Open the setting window.
Project window → [Parameter] → [Network Parameter] → [Ethernet/CC IE/MELSECNET] → [Network Operation Settings] button
- 3) Set parameters in the window.

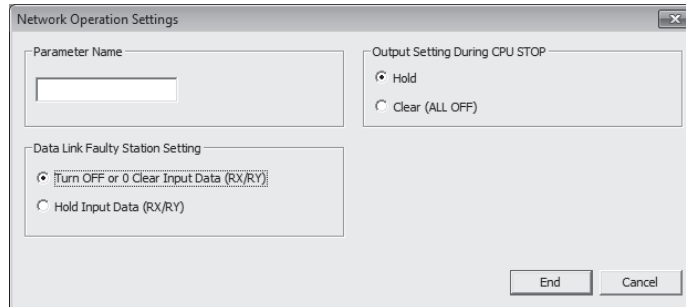

Item	Description	Setting range	Remark
Parameter Name	Enter the name of network operation setting parameters if desired.	Up to 8 characters	–
Data Link Faulty Station Setting	Select whether to hold or clear data input from the slave station No.17 to 120 where a data link error has occurred. (Refer to Section 8.3.5.)	<ul style="list-style-type: none"> • Turn OFF or 0 Clear Input Data (RX/RX) • Hold Input Data (Default: Turn OFF or 0 Clear Input Data (RX/RX)) 	All invalid for the station No.1 to 16 (Note-1).
Output Setting During CPU STOP	Select whether to hold or clear cyclic data output by the station No.17 to 120 when the CPU module mounted with the Simple Motion module is set to STOP. (Refer to Section 8.3.6.)	<ul style="list-style-type: none"> • Hold • Clear (ALL OFF) (Default: Hold) 	All invalid for the station No.1 to 16 (Note-1).

(Note-1): The range from the station No.1 to 4 is valid in the 4-axis module, and the range from the station No.1 to 8 is valid in the 8-axis module.

7.6 Refresh Parameters



Set link refresh ranges between the link devices of the Simple Motion module and the devices of the CPU module.

(1) Setting procedure

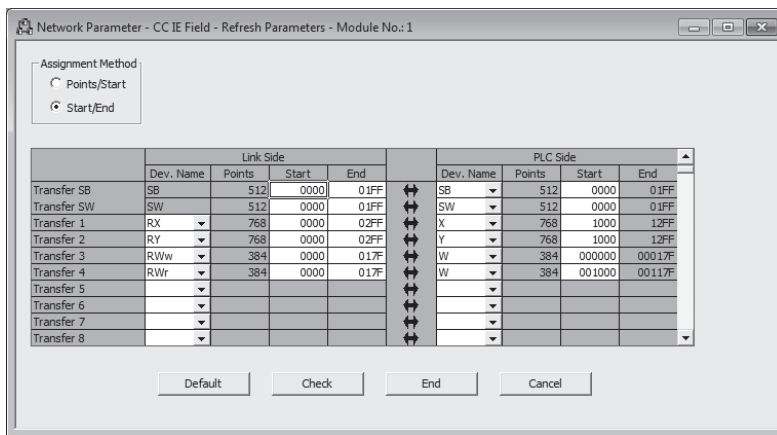
- 1) Set network setting parameters. (Refer to Section 7.3.)
- 2) Open the setting window.
Project window → [Parameter] → [Network Parameter] → [Ethernet/CC IE/MELSECNET] → [Refresh Parameters] button
- 3) Set parameters in the window.
- 4) Click the [End] button.

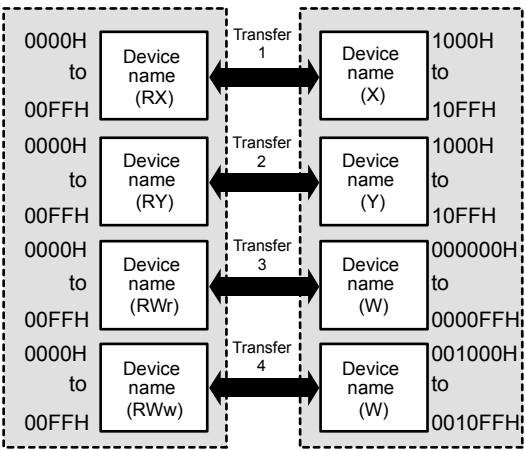

Item	Description	Setting range	Remark
Assignment Method	Select a link device assignment method. • Points/Start: Enter the points and start numbers of link devices. • Start/End: Enter the start and end numbers of link devices.	• Points/Start • Start/End (Default: Start/End)	—
Transfer SB Transfer SW	Set the link refresh ranges of SB and SW. One range can be set for each SB and SW. (Refer to Section 8.3.2.) (Example) 	(1) Transfer SB • Link Side: Fixed at "SB". • PLC Side: M, L, B, D, W, R, SB, ZR (2) Transfer SW • Link Side: Fixed at "SW". • PLC Side: M, L, B, D, W, R, SW, ZR (Default: Blank)	—
	Points, Start, End	• Link Side: 0 to 1FFH • PLC Side: Within device range of CPU module (Default: Blank) Set bit devices in increments of 16 points and word devices in increments of 4 points.	—

Item	Description	Setting range	Remark																																																																				
<p>Transfer 1 to 256</p> <p>Dev. Name</p> <p>Points, Start, End</p>	<p>Set the link refresh ranges of RX, RY, RWr, and RWw. Up to 256 ranges can be set. (Refer to Section 8.3.2.)</p> <p>(Example)</p> <table border="1" data-bbox="403 566 1045 689"> <thead> <tr> <th colspan="4">Link Side</th> <th colspan="4">PLC Side</th> </tr> <tr> <th>Transfer</th> <th>Dev. Name</th> <th>Points</th> <th>Start</th> <th>End</th> <th>Transfer</th> <th>Dev. Name</th> <th>Points</th> <th>Start</th> <th>End</th> </tr> </thead> <tbody> <tr> <td>Transfer 1</td> <td>RX</td> <td>256</td> <td>0000</td> <td>00FF</td> <td>1</td> <td>X</td> <td>256</td> <td>1000</td> <td>10FF</td> </tr> <tr> <td>Transfer 2</td> <td>RY</td> <td>256</td> <td>0000</td> <td>00FF</td> <td>2</td> <td>Y</td> <td>256</td> <td>1000</td> <td>10FF</td> </tr> <tr> <td>Transfer 3</td> <td>RWr</td> <td>256</td> <td>0000</td> <td>00FF</td> <td>3</td> <td>W</td> <td>256</td> <td>000000</td> <td>0000FF</td> </tr> <tr> <td>Transfer 4</td> <td>RWw</td> <td>256</td> <td>0000</td> <td>00FF</td> <td>4</td> <td>w</td> <td>256</td> <td>001000</td> <td>0010FF</td> </tr> <tr> <td>Transfer 5</td> <td></td> <td></td> <td></td> <td></td> <td></td> <td></td> <td></td> <td></td> <td></td> </tr> </tbody> </table>  	Link Side				PLC Side				Transfer	Dev. Name	Points	Start	End	Transfer	Dev. Name	Points	Start	End	Transfer 1	RX	256	0000	00FF	1	X	256	1000	10FF	Transfer 2	RY	256	0000	00FF	2	Y	256	1000	10FF	Transfer 3	RWr	256	0000	00FF	3	W	256	000000	0000FF	Transfer 4	RWw	256	0000	00FF	4	w	256	001000	0010FF	Transfer 5										<ul style="list-style-type: none"> • Link Side: RX, RY, RWr, RWw • PLC Side: <ul style="list-style-type: none"> When RX is set to "Link Side": X, M, L, B, D, W, R, ZR When RY is set to "Link Side": Y, M, L, B, T, C, ST, D, W, R, ZR When RWr is set to "Link Side": M, L, B, D, W, R, ZR When RWw is set to "Link Side": M, L, B, T, C, ST, D, W, R, ZR (Default: Blank) 	<p>–</p> <p>If the value outside the setting range is set on the link side, the setting will be invalid. (An error will not occur.)</p>
Link Side				PLC Side																																																																			
Transfer	Dev. Name	Points	Start	End	Transfer	Dev. Name	Points	Start	End																																																														
Transfer 1	RX	256	0000	00FF	1	X	256	1000	10FF																																																														
Transfer 2	RY	256	0000	00FF	2	Y	256	1000	10FF																																																														
Transfer 3	RWr	256	0000	00FF	3	W	256	000000	0000FF																																																														
Transfer 4	RWw	256	0000	00FF	4	w	256	001000	0010FF																																																														
Transfer 5																																																																							
<p>[Default] button</p>	<p>Reset refresh parameters to default.</p>	<p>–</p>	<p>–</p>																																																																				

(2) Checking method

- 1) Click the [Assignment Image] button in the "Network Parameter - MELSECNET/CC IE/Ethernet Module Configuration" window to open the "Assignment Image" window. (Refer to Section 7.3.)
- 2) Select the devices to be checked and the magnification ratio in the window.

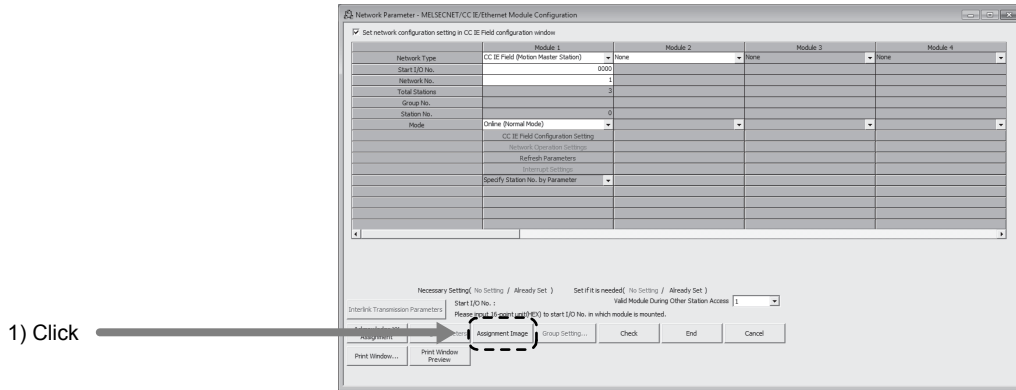

- 2) Set
 "Device (PLC side)",
 "Device (Link side)", and
 "Display magnification".

3) The assignment image is displayed.

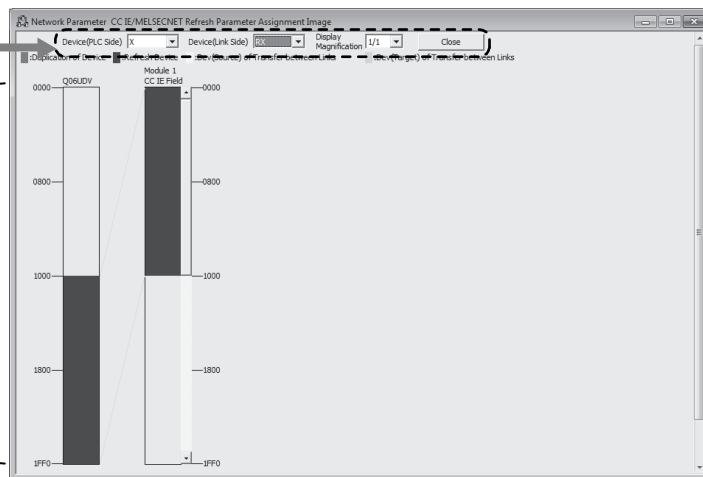

- 3) A red part in the device of the CPU module indicates that the device range overlaps with the device range set for other refresh parameters. Correct the refresh parameters.

POINT

The link devices of the Simple Motion module can be accessed from a program. (Refer to Section 8.3.3.)

(3) Precautions

(a) Device set to "Device (PLC Side)"

Set a device range that differs from the one used for the following:

- Refresh parameters for other network modules
- Auto refresh parameters for CC-Link master/local module
- I/O numbers used for I/O modules and intelligent function modules
- Auto refresh setting for intelligent function modules
- Auto refresh using the CPU shared memory in a multiple CPU system

(b) Link refresh range

Set only link devices used in the CPU module for link refresh range. Doing so will reduce link refresh points, resulting in a shorter link refresh time.

(c) Changing link device assignment in the "Network Configuration Settings" window
Correct the link refresh ranges of refresh parameters.

(d) Setting an extended data register (D) or extended link register (W) as a link refresh device

Set the link refresh range properly so that it does not cross over the boundary between the internal user device and the extended data register (D) or extended link register (W). (Refer to the user's Manual (Function Explanation, Program Fundamentals) for the CPU module used.)

(4) Setting example

For setting examples, refer to Chapter 11.

7.7 Interrupt Settings

Set conditions for sending an interrupt request to the CPU module.

(1) Setting procedure

- 1) Set network setting parameters. (Refer to Section 7.3.)
- 2) Open the setting window.
Project window → [Parameter] → [Network Parameter] → [Ethernet/CC IE/MELSECNET] → [Interrupt Settings] button
- 3) Set parameters in the window.
Up to 16 interrupt conditions can be set.
- 4) Click the [End] button.

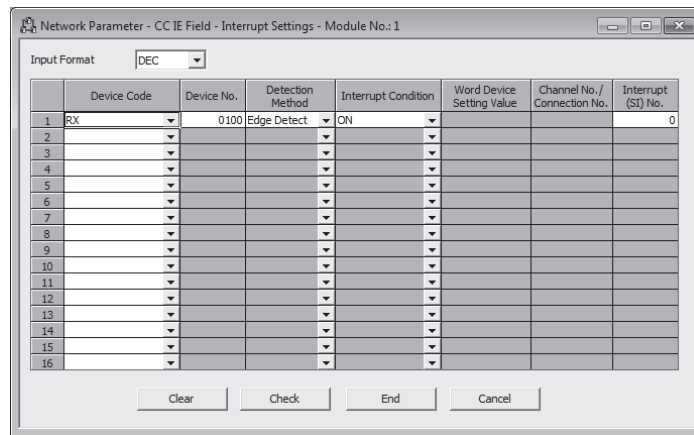

Item	Description	Setting range	Remark
Input Format	Select the input format of the "Word Device Setting Value" field.	DEC, HEX (Default: DEC)	-
Device Code	Set an interrupt condition device.	Refer to the next table.	
Device No.			
Detection Method	Select the detection timing of an interrupt generated by the device set in "Device Code" and "Device No."		
Interrupt Condition			
Word Device Setting Value	When "RWw", "RWr", or "SW" is selected in "Device Code", enter a word device value that triggers an interrupt.		
Channel No./Connection No.	This item cannot be set for the Simple Motion module.		
Interrupt (SI) No.	Enter an interrupt (SI) number used in "Interrupt Pointer Setting" of the PLC parameter window. (Refer to Section 7.7 (3).) An interrupt (SI) number is a management number assigned to each Simple Motion module. This number is required when the Simple Motion module sends an interrupt request to the CPU module.		

(Setting range)

Device Code	Device No.	Detection Method	Interrupt Condition	Word Device Setting Value	Channel No./ Connection No.	Interrupt (SI) No.
RX	0H to 1FFFH	Level Detect and ON	Interrupt occurs by turning on the device.	-	-	0 to 15
RY	0H to 1FFFH	Level Detect and OFF	Interrupt occurs by turning off the device.			
SB	0H to 1FFH	Edge Detect and ON	Interrupt occurs at the rising edge of the device. Edge Detect and OFF: Interrupt occurs at the falling edge of the device.			
RWr	0H to 3FFH	Level Detect and Equal	Interrupt occurs when values match.	0 to 65535 (0H to FFFFH)	-	0 to 15
RWw	0H to 3FFH	Level Detect and Unequal	Interrupt occurs when values do not match.			
SW	0H to 1FFH	Edge Detect and Equal	Interrupt occurs when values match (first time only). Edge Detect and Unequal: Interrupt occurs when values do not match (first time only).			
RECVS Instruction	-	This item cannot be set for the Simple Motion module.				

(Note-1): If the value outside the setting range is set, "Parameter error (error code: D62CH)" will occur, and the corresponding interrupt setting will be invalid.

- 5) After the parameters are set, open the "Intelligent Function Module Interrupt Pointer Setting" window.
Link the interrupt (SI) number assigned for the Simple Motion module to the interrupt pointer of the CPU module.
Project window → [Parameter] → [PLC Parameter] → [PLC System] → [Interrupt Pointer Setting] button

6) Click the [End] button.

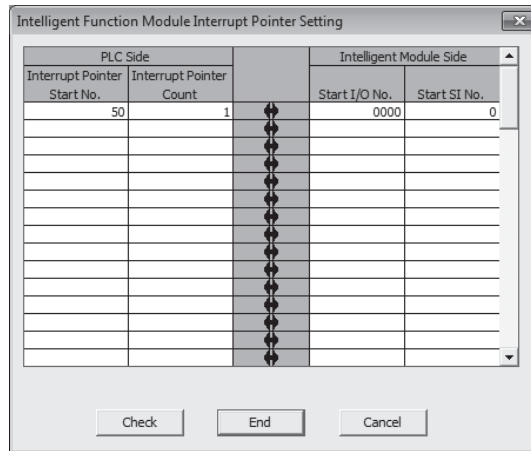

Item		Description	Setting range
PLC Side	Interrupt Pointer Start No.	Enter the start number of an interrupt program (I□□).	50 to 255 (Default: Blank)
	Interrupt Pointer Count	Enter the number of interrupt conditions.	1 to 16 (Default: Blank)
Intelligent Module Side	Start I/O No.	Enter the start I/O number of the Simple Motion module.	0000H to 0FE0H (Default: Blank)
	Start SI No.	Enter the start interrupt (SI) number of the Simple Motion module.	0 to 15 (Default: Blank)

POINT

Using an interrupt program will eliminate the need for describing a start condition in a program. This leads to reduction in the number of steps and sequence scan time.

(2) Precautions

- (a) When "Level Detect" is set for "Detection Method" and the interrupt condition is always met
 If the sequence scan takes much longer than the link scan, since interrupt processing is activated in each link scan, sequence scan time may greatly increase, resulting in a watchdog timer error of the CPU module.
 When "Level Detect" is set for "Detection Method" and the interrupt condition is always met, do not use interrupt settings and correct the interrupt condition in the program.

- (b) Before executing an interrupt program
Execute the EI instruction in a main routine program and enable an interrupt.
(Refer to the user's Manual (Function Explanation, Program Fundamentals) for the CPU module used.)

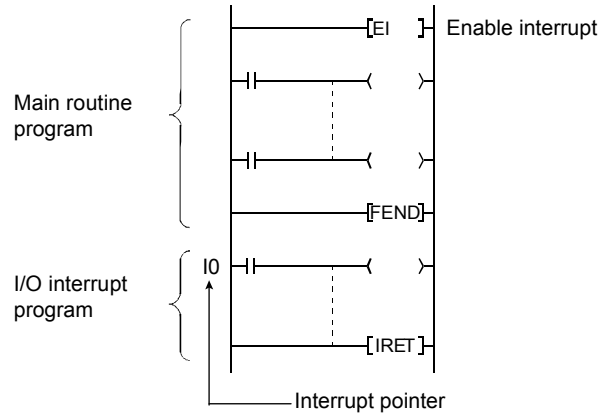

- (c) When multiple interrupts simultaneously occur
The operation may delay.
- (d) When the Simple Motion module is in offline mode
The Simple Motion module can send an interrupt request to the CPU module in online mode (cannot send the request in offline mode).
- (e) Starting an interrupt program by the rising/falling edge of the specified device
Do not start an interrupt program using instructions, such as PLS and PLF, that depend on the rising/falling edge of the specified devices because changes in devices might not be read.

(Example) Sending an interrupt request by turning on RX100 in a station in network number 7

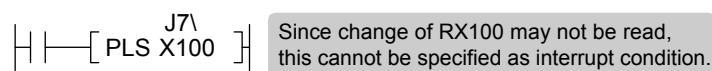

- (f) An interrupt cannot be generated
Changes in the interrupt condition device cannot be detected if the change is shorter than the transmission delay time.
- (g) Using cyclic data in an interrupt program
When an interrupt program is executed, link refresh is not performed to CPU module devices. Directly access the link devices of the Simple Motion module by direct access.

(3) Setting example

- (a) Starting the interrupt program of the master station (station number 0) when RX100 turns on

The following is a setting example to execute the interrupt program corresponding to the interrupt pointer I50 when RX100 turns on by turning on the corresponding switch on the slave station side.

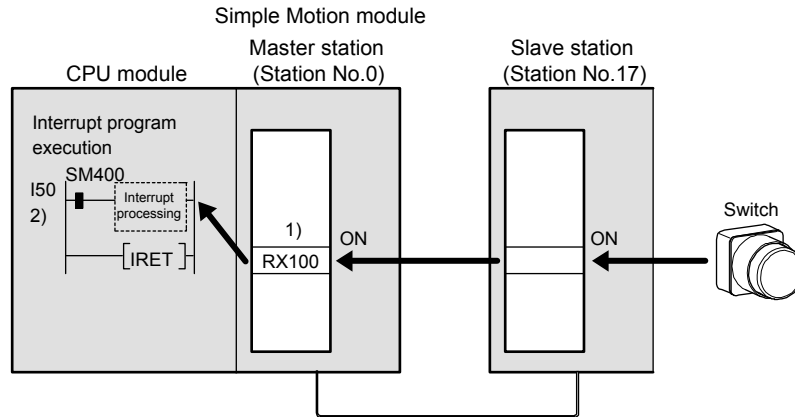

- 1) Set the interrupt setting parameters for the Simple Motion module (station number 0) in the "Interrupt Settings" window as shown below.

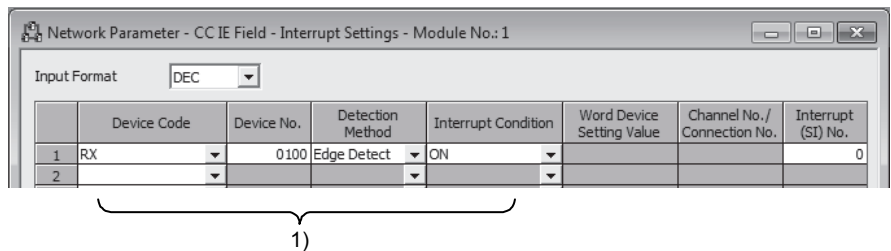

- 2) Set the parameters in the "Intelligent Function Module Interrupt Pointer Setting" window as shown below.

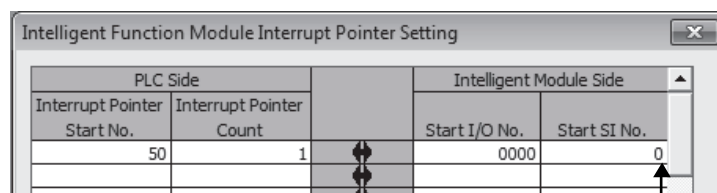

2) Set the same SI No. as the interrupt setting.

POINT

By using link special relay (SB) and link special register (SW) as an interrupt condition device, an interrupt program can be started in case of data link error. (Refer to Appendix 2, Refer to Appendix 3.)

- (b) Starting the interrupt program by an interrupt request to the CPU module in every operation cycle
 An interrupt request to the CPU module can be executed in every operation cycle by using Operation cycle interrupt request (SB000C) of link special relay (SB).

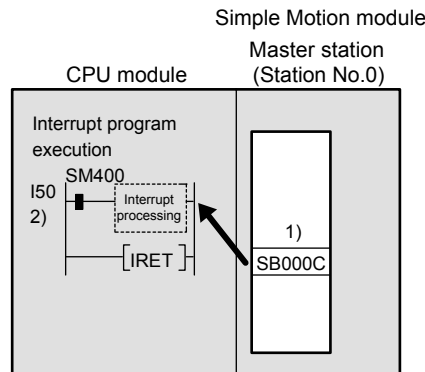

- 1) Set the interrupt setting parameters for the Simple Motion module (station number 0) in the "Interrupt Settings" window as shown below.

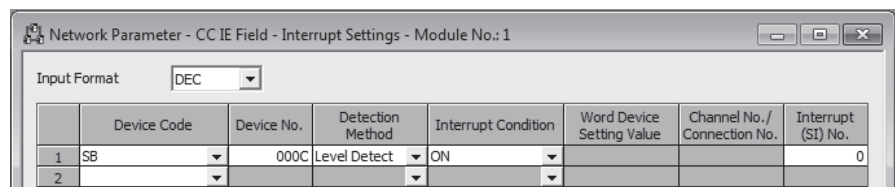

1)

- 2) Set the parameters in the "Intelligent Function Module Interrupt Pointer Setting" window as shown below.

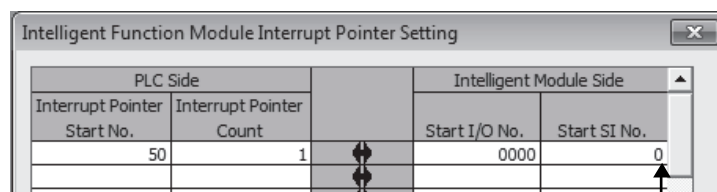

2)

Set the same SI No. as the interrupt setting.

POINT

- The interrupt request to the CPU module is executed when cyclic transmission is completed. If cyclic transmission is not performed, the interrupt request to the CPU module will not be executed.
- Run the interrupt program at the status that the operation cycle over of the Simple Motion module does not occur. The operation cycle over of the Simple Motion module is determined with ON/OFF of "[Md.133] Operation cycle over flag". When the operation cycle over occurs, the interrupt program cannot start at the normal timing.
- Complete the interrupt processing in the interrupt cycle.

Chapter 8 FUNCTIONS

8.1 Fixed Cycle Communication	8- 2
8.2 Synchronous Communication Function.....	8- 2
8.3 Cyclic Transmission	8- 4
8.3.1 Data flow and link device assignment.....	8- 4
8.3.2 Link refresh	8- 6
8.3.3 Direct access to link devices	8- 8
8.3.4 Assurance of cyclic data integrity.....	8-12
8.3.5 Input and output status settings in case of failure	8-17
8.3.6 Output status setting for CPU module STOP	8-19
8.3.7 Cyclic transmission stop and restart	8-20
8.4 Transient Transmission.....	8-21
8.4.1 Communications within the same network	8-21
8.5 Reserved Station Specification and Temporary Cancel of Reserved Station Setting	8-22
8.6 Interrupt Request to the CPU Module	8-23

This chapter explains the network functions of the Simple Motion module.

8.1 Fixed Cycle Communication

The communication cycle of the Simple Motion module is fixed cycle. The communication is performed with slave modules in a cycle set in the operation cycle setting.

8.2 Synchronous Communication Function

A slave module which supports the synchronous communication function operates synchronously with the operation cycle of the Simple Motion module (the communication cycle of CC-Link IE Field Network). Therefore, the operation timing between the Simple Motion module and each slave module can be synchronized.

A slave module which does not support the synchronous communication function is also connectable. However, the operation is not synchronized with the operation cycle of the Simple Motion module. Therefore, the operation timing of the slave module is not synchronized with the Simple Motion module.

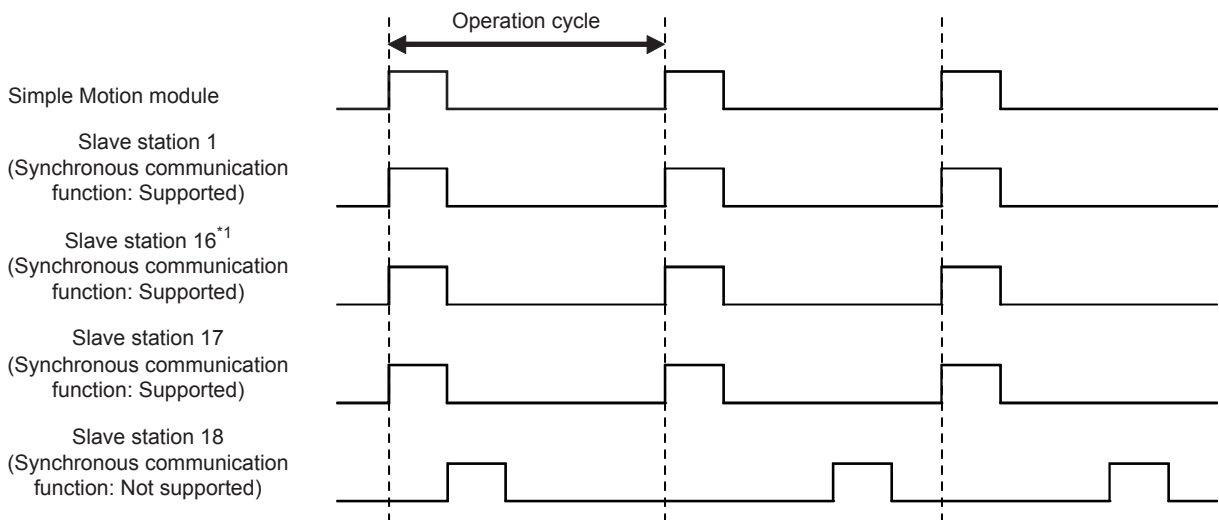
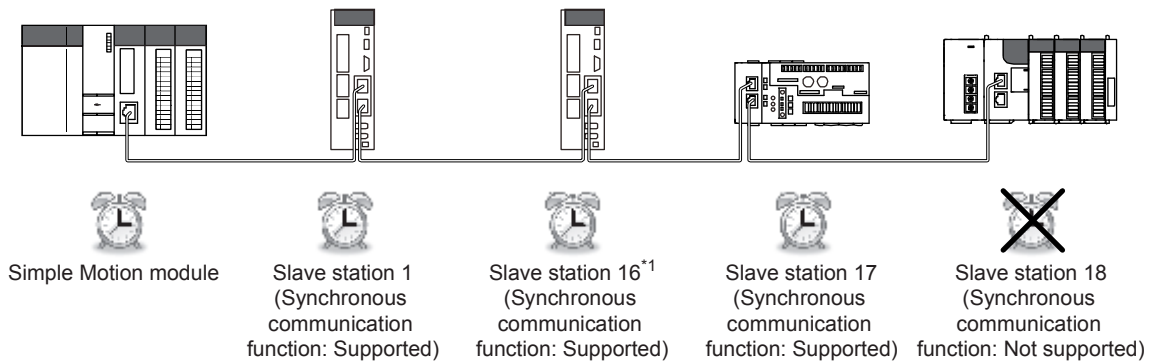

*1: The range from the station No.1 to 4 is valid in the 4-axis module, and the range from the station No.1 to 8 is valid in the 8-axis module.

POINT						
The synchronous communication function with slave modules excluding servo amplifiers is supported from the version shown below.						
<table border="1"> <thead> <tr> <th>First five digits of SERIAL No. (Note-1)</th> <th>Operation</th> </tr> </thead> <tbody> <tr> <td>Before 15092</td> <td>Slave modules operate in the normal mode (asynchronous communication mode).</td> </tr> <tr> <td>15092 or later</td> <td>Slave modules operate following the setting.</td> </tr> </tbody> </table>	First five digits of SERIAL No. (Note-1)	Operation	Before 15092	Slave modules operate in the normal mode (asynchronous communication mode).	15092 or later	Slave modules operate following the setting.
First five digits of SERIAL No. (Note-1)	Operation					
Before 15092	Slave modules operate in the normal mode (asynchronous communication mode).					
15092 or later	Slave modules operate following the setting.					
(Note-1): The serial number can be checked on the "Product Information List" screen in GX Works2.						

The link special registers (SW) for synchronous communication function are shown below.

Number	Name	Description																																																																																																																																																										
SW01C0 to SW01C7	Synchronous communication function information (each station)	<p>Stores the setting information of synchronous/asynchronous communication of the synchronous communication function for each station.</p> <p>0: Asynchronous communication mode 1: Synchronous communication mode</p> <table border="1"> <thead> <tr> <th></th> <th>b15</th><th>b14</th><th>b13</th><th>b12</th><th>b11</th><th>b10</th><th>b9</th><th>b8</th><th>b7</th><th>b6</th><th>b5</th><th>b4</th><th>b3</th><th>b2</th><th>b1</th><th>b0</th> </tr> </thead> <tbody> <tr> <td>SW01C0</td> <td>16</td><td>15</td><td>14</td><td>13</td><td>12</td><td>11</td><td>10</td><td>9</td><td>8</td><td>7</td><td>6</td><td>5</td><td>4</td><td>3</td><td>2</td><td>1</td> </tr> <tr> <td>SW01C1</td> <td>32</td><td>31</td><td>30</td><td>29</td><td>28</td><td>27</td><td>26</td><td>25</td><td>24</td><td>23</td><td>22</td><td>21</td><td>20</td><td>19</td><td>18</td><td>17</td> </tr> <tr> <td>SW01C2</td> <td>48</td><td>47</td><td>46</td><td>45</td><td>44</td><td>43</td><td>42</td><td>41</td><td>40</td><td>39</td><td>38</td><td>37</td><td>36</td><td>35</td><td>34</td><td>33</td> </tr> <tr> <td>SW01C3</td> <td>64</td><td>63</td><td>62</td><td>61</td><td>60</td><td>59</td><td>58</td><td>57</td><td>56</td><td>55</td><td>54</td><td>53</td><td>52</td><td>51</td><td>50</td><td>49</td> </tr> <tr> <td>SW01C4</td> <td>80</td><td>79</td><td>78</td><td>77</td><td>76</td><td>75</td><td>74</td><td>73</td><td>72</td><td>71</td><td>70</td><td>69</td><td>68</td><td>67</td><td>66</td><td>65</td> </tr> <tr> <td>SW01C5</td> <td>96</td><td>95</td><td>94</td><td>93</td><td>92</td><td>91</td><td>90</td><td>89</td><td>88</td><td>87</td><td>86</td><td>85</td><td>84</td><td>83</td><td>82</td><td>81</td> </tr> <tr> <td>SW01C6</td> <td>112</td><td>111</td><td>110</td><td>109</td><td>108</td><td>107</td><td>106</td><td>105</td><td>104</td><td>103</td><td>102</td><td>101</td><td>100</td><td>99</td><td>98</td><td>97</td> </tr> <tr> <td>SW01C7</td> <td>—</td><td>—</td><td>—</td><td>—</td><td>—</td><td>—</td><td>—</td><td>—</td><td>—</td><td>120</td><td>119</td><td>118</td><td>117</td><td>116</td><td>115</td><td>114</td><td>113</td> </tr> </tbody> </table> <p>Each number in the table represents a station No. — is fixed to 0.</p>		b15	b14	b13	b12	b11	b10	b9	b8	b7	b6	b5	b4	b3	b2	b1	b0	SW01C0	16	15	14	13	12	11	10	9	8	7	6	5	4	3	2	1	SW01C1	32	31	30	29	28	27	26	25	24	23	22	21	20	19	18	17	SW01C2	48	47	46	45	44	43	42	41	40	39	38	37	36	35	34	33	SW01C3	64	63	62	61	60	59	58	57	56	55	54	53	52	51	50	49	SW01C4	80	79	78	77	76	75	74	73	72	71	70	69	68	67	66	65	SW01C5	96	95	94	93	92	91	90	89	88	87	86	85	84	83	82	81	SW01C6	112	111	110	109	108	107	106	105	104	103	102	101	100	99	98	97	SW01C7	—	—	—	—	—	—	—	—	—	120	119	118	117	116	115	114	113
	b15	b14	b13	b12	b11	b10	b9	b8	b7	b6	b5	b4	b3	b2	b1	b0																																																																																																																																												
SW01C0	16	15	14	13	12	11	10	9	8	7	6	5	4	3	2	1																																																																																																																																												
SW01C1	32	31	30	29	28	27	26	25	24	23	22	21	20	19	18	17																																																																																																																																												
SW01C2	48	47	46	45	44	43	42	41	40	39	38	37	36	35	34	33																																																																																																																																												
SW01C3	64	63	62	61	60	59	58	57	56	55	54	53	52	51	50	49																																																																																																																																												
SW01C4	80	79	78	77	76	75	74	73	72	71	70	69	68	67	66	65																																																																																																																																												
SW01C5	96	95	94	93	92	91	90	89	88	87	86	85	84	83	82	81																																																																																																																																												
SW01C6	112	111	110	109	108	107	106	105	104	103	102	101	100	99	98	97																																																																																																																																												
SW01C7	—	—	—	—	—	—	—	—	—	120	119	118	117	116	115	114	113																																																																																																																																											
SW01C8 to SW01CF	Synchronous/asynchronous operation status information (each station)	<p>Stores the synchronous/asynchronous communication operation status for each station.</p> <p>0: Asynchronous 1: Synchronous</p> <table border="1"> <thead> <tr> <th></th> <th>b15</th><th>b14</th><th>b13</th><th>b12</th><th>b11</th><th>b10</th><th>b9</th><th>b8</th><th>b7</th><th>b6</th><th>b5</th><th>b4</th><th>b3</th><th>b2</th><th>b1</th><th>b0</th> </tr> </thead> <tbody> <tr> <td>SW01C8</td> <td>16</td><td>15</td><td>14</td><td>13</td><td>12</td><td>11</td><td>10</td><td>9</td><td>8</td><td>7</td><td>6</td><td>5</td><td>4</td><td>3</td><td>2</td><td>1</td> </tr> <tr> <td>SW01C9</td> <td>32</td><td>31</td><td>30</td><td>29</td><td>28</td><td>27</td><td>26</td><td>25</td><td>24</td><td>23</td><td>22</td><td>21</td><td>20</td><td>19</td><td>18</td><td>17</td> </tr> <tr> <td>SW01CA</td> <td>48</td><td>47</td><td>46</td><td>45</td><td>44</td><td>43</td><td>42</td><td>41</td><td>40</td><td>39</td><td>38</td><td>37</td><td>36</td><td>35</td><td>34</td><td>33</td> </tr> <tr> <td>SW01CB</td> <td>64</td><td>63</td><td>62</td><td>61</td><td>60</td><td>59</td><td>58</td><td>57</td><td>56</td><td>55</td><td>54</td><td>53</td><td>52</td><td>51</td><td>50</td><td>49</td> </tr> <tr> <td>SW01CC</td> <td>80</td><td>79</td><td>78</td><td>77</td><td>76</td><td>75</td><td>74</td><td>73</td><td>72</td><td>71</td><td>70</td><td>69</td><td>68</td><td>67</td><td>66</td><td>65</td> </tr> <tr> <td>SW01CD</td> <td>96</td><td>95</td><td>94</td><td>93</td><td>92</td><td>91</td><td>90</td><td>89</td><td>88</td><td>87</td><td>86</td><td>85</td><td>84</td><td>83</td><td>82</td><td>81</td> </tr> <tr> <td>SW01CE</td> <td>112</td><td>111</td><td>110</td><td>109</td><td>108</td><td>107</td><td>106</td><td>105</td><td>104</td><td>103</td><td>102</td><td>101</td><td>100</td><td>99</td><td>98</td><td>97</td> </tr> <tr> <td>SW01CF</td> <td>—</td><td>—</td><td>—</td><td>—</td><td>—</td><td>—</td><td>—</td><td>—</td><td>—</td><td>120</td><td>119</td><td>118</td><td>117</td><td>116</td><td>115</td><td>114</td><td>113</td> </tr> </tbody> </table> <p>Each number in the table represents a station No. — is fixed to 0.</p>		b15	b14	b13	b12	b11	b10	b9	b8	b7	b6	b5	b4	b3	b2	b1	b0	SW01C8	16	15	14	13	12	11	10	9	8	7	6	5	4	3	2	1	SW01C9	32	31	30	29	28	27	26	25	24	23	22	21	20	19	18	17	SW01CA	48	47	46	45	44	43	42	41	40	39	38	37	36	35	34	33	SW01CB	64	63	62	61	60	59	58	57	56	55	54	53	52	51	50	49	SW01CC	80	79	78	77	76	75	74	73	72	71	70	69	68	67	66	65	SW01CD	96	95	94	93	92	91	90	89	88	87	86	85	84	83	82	81	SW01CE	112	111	110	109	108	107	106	105	104	103	102	101	100	99	98	97	SW01CF	—	—	—	—	—	—	—	—	—	120	119	118	117	116	115	114	113
	b15	b14	b13	b12	b11	b10	b9	b8	b7	b6	b5	b4	b3	b2	b1	b0																																																																																																																																												
SW01C8	16	15	14	13	12	11	10	9	8	7	6	5	4	3	2	1																																																																																																																																												
SW01C9	32	31	30	29	28	27	26	25	24	23	22	21	20	19	18	17																																																																																																																																												
SW01CA	48	47	46	45	44	43	42	41	40	39	38	37	36	35	34	33																																																																																																																																												
SW01CB	64	63	62	61	60	59	58	57	56	55	54	53	52	51	50	49																																																																																																																																												
SW01CC	80	79	78	77	76	75	74	73	72	71	70	69	68	67	66	65																																																																																																																																												
SW01CD	96	95	94	93	92	91	90	89	88	87	86	85	84	83	82	81																																																																																																																																												
SW01CE	112	111	110	109	108	107	106	105	104	103	102	101	100	99	98	97																																																																																																																																												
SW01CF	—	—	—	—	—	—	—	—	—	120	119	118	117	116	115	114	113																																																																																																																																											

8.3 Cyclic Transmission

Data communication is available periodically among stations on the same network. Link devices (RX, RY, RWr, and RWw) are used.

8.3.1 Data flow and link device assignment

One-to-one communication is possible between the Simple Motion module (master station) and the connected device of the station No.17 to 120.

The status information of the link devices (RY and RWw) of the master station is output to the connected device of the station No.17 to 120, and the input status information from the connected device of the station No.17 to 120 is stored in the link devices (RX and RWr) of the master station.

The connected devices of the station No.1 to 16 ^(Note-1) are controlled by the Simple Motion module. It cannot communicate with the link devices of the Simple Motion module.

(Note-1): The range from the station No.1 to 4 is valid in the 4-axis module, and the range from the station No.1 to 8 is valid in the 8-axis module.

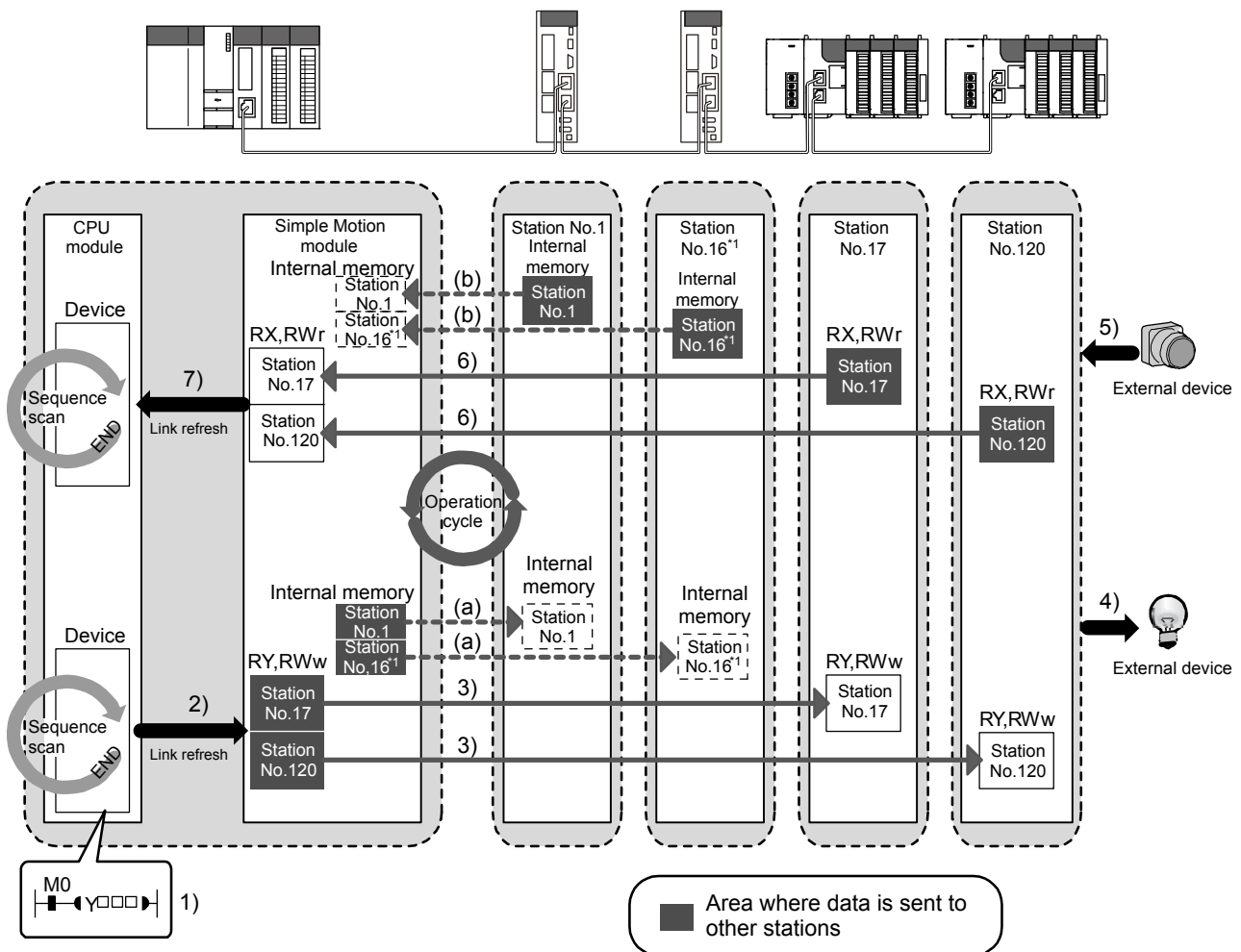

*1: The range from the station No.1 to 4 is valid in the 4-axis module, and the range from the station No.1 to 8 is valid in the 8-axis module.

(1) Station No.1 to 16 ^(Note-1)

• Output from the master station

- (a) The sending data calculated in the Simple Motion module is stored in the internal memory of the slave station in each communication cycle. The sending data to the slave stations are not stored in the link devices (RY and RWw).

• Input from the slave station

- (b) The received data from the slave station is stored in the internal memory of the Simple Motion module in each communication cycle. The received data from the slave stations are not stored in the link devices (RX and RWr).

(Note-1): The range from the station No.1 to 4 is valid in the 4-axis module, and the range from the station No.1 to 8 is valid in the 8-axis module.

(2) Station No.17 to 120

• Output from the master station

- 1) The device of the CPU module turns on.
- 2) The device status data of the CPU module are stored in the link devices (RY and RWw) of the master station by link refresh.
- 3) The status data of the link devices (RY and RWw) of the master station are stored in the link devices (RY and RWw) of each slave station by link scan.
- 4) The status data of the link devices (RY and RWw) of the slave station are output to the external device.

• Input from the slave station

- 5) The status data of the external device are stored in the link devices (RX and RWr) of the slave station.
- 6) The status data of the link devices (RX and RWr) of the slave station are stored in the link devices (RX and RWr) of the master station by link scan.
- 7) The status data of the link devices (RX and RWr) of the master station are stored in the devices of the CPU module by link refresh.

(3) Setting method

The link devices can be assigned in the network configuration settings. (Refer to Section 7.4.)

The link refresh is assigned by the Refresh Parameters. (Refer to Section 7.6.)

8.3.2 Link refresh

Data can be automatically transferred between the link devices of the Simple Motion module and the devices of the CPU module.

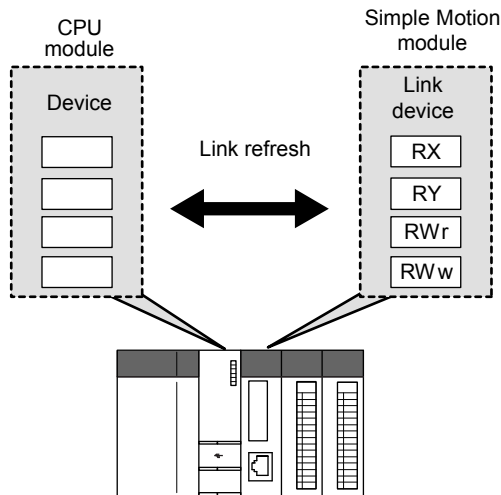

(1) Concept of the link refresh range

The area range set with the refresh parameters and also specified in the network configuration settings is executed by link refresh.

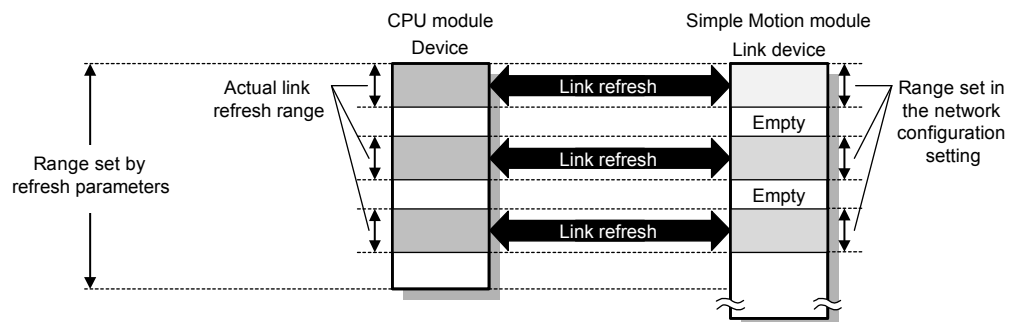

(2) Shortening the link refresh time and transmission delay time

Use the following methods to shorten time mentioned above by reducing the number of link refresh points of the CPU module.

- In the refresh parameters setting, set only the link devices used in the CPU module as the link refresh range. (Refer to Section 7.6.)
- Directly access infrequently used link devices from the program, and remove the corresponding settings from the link refresh range. (Refer to Section 8.3.3.)

(3) Setting method

The link refresh is assigned by the Refresh Parameters. (Refer to Section 7.6.)

(4) Precautions

For cyclic data assurance of more than 32 bits, use the following method.

- Enable the Block Data Assurance per Station setting. (Refer to Section 7.4, Refer to Section 8.3.4.)

POINT	
<p>When the CPU module is turned off and on or reset, data in latched devices (the devices listed in the "CPU module device" column in the table below) may be output depending on the timing of the link scan and link refresh even if the data are cleared to zero on a sequence program.</p> <p>Execute the actions listed in the "How to disable the setting" column in the table below not to output the data in the latched devices.</p>	
CPU module device	How to disable the setting
Latch relay (L), file register (R, ZR)	Use the initial device value to clear the device to 0. (Note-1)
Extended data register (D), extended link register (W), device within the latch range	Delete all the latch range settings.
<p>(Note-1): For the initial device value setting, refer to the user's manual (Function Explanation, Program Fundamentals) for the CPU module used.</p>	

8.3.3 Direct access to link devices

Direct access to each link device (RX, RY, RWr, RWw, SB, or SW) of the Simple Motion module is possible from the program. Specify a link device as the link direct device (J□\□) for direct access.

(1) Specification method

Specify the network No. and the link device of the Simple Motion module for reading or writing. Do not access outside the device range that is described below.

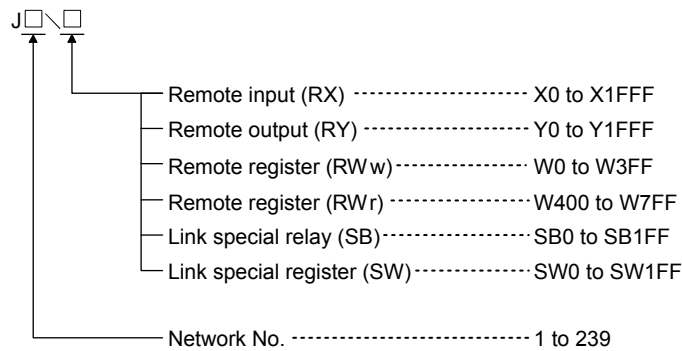

(Example)

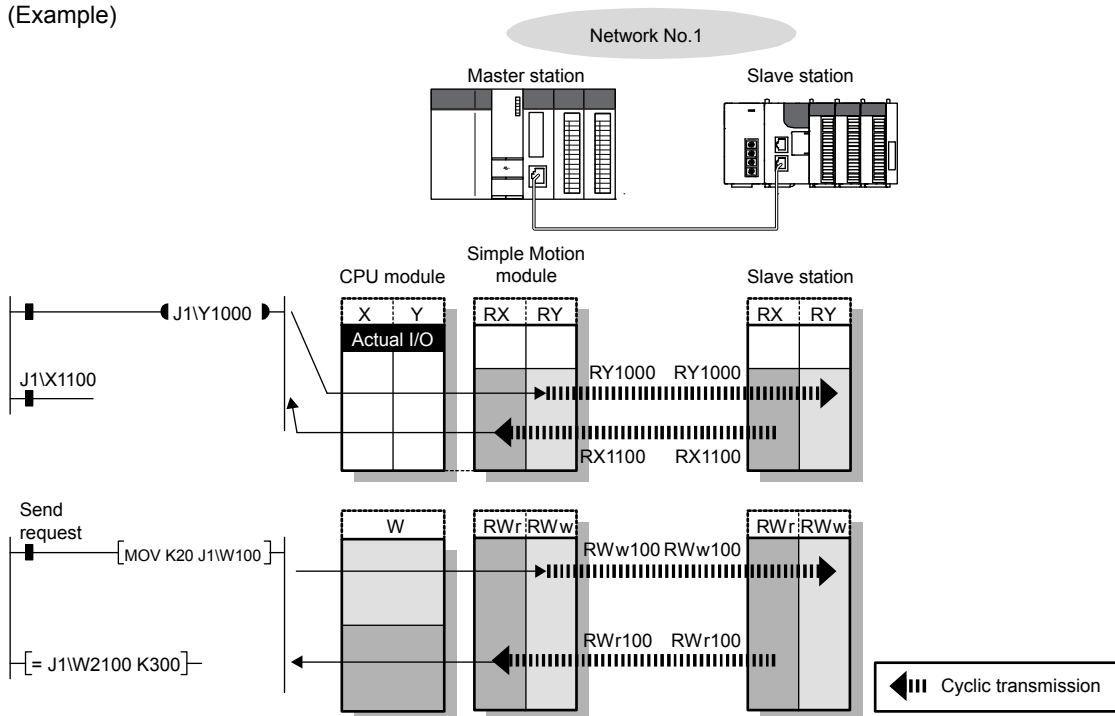

(2) Readable and writable range

Data can be read or written between the Simple Motion module and CPU module mounted on the same base unit.

(a) Read

All link devices of the Simple Motion module can be specified. (Refer to Section 8.3.3 (1).)

(b) Write

The range that satisfies all of the following conditions can be specified.

- Area where data is sent to other stations and outside the link refresh range (Refer to Section 8.3.1.)
- Within the link device range of the Simple Motion module (Refer to Section 8.3.3 (1).)

(Example)

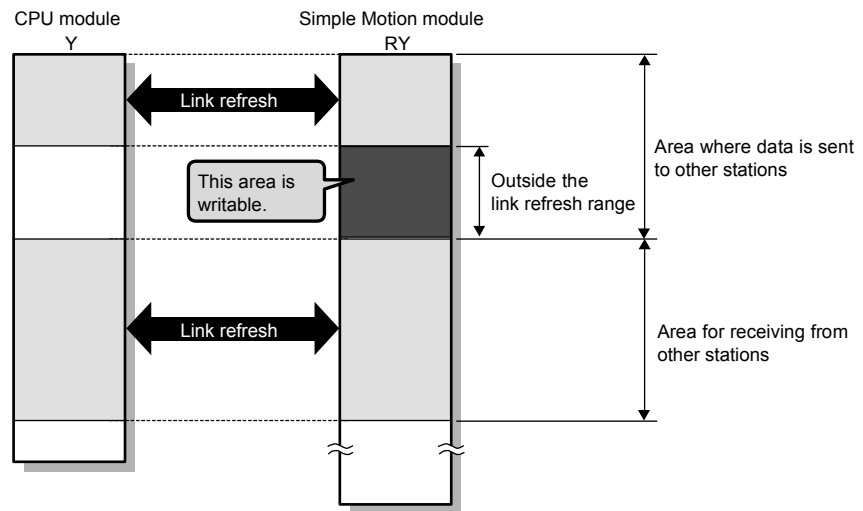

POINT

When writing data to the area in the link refresh range, directly access the link device and write the same data in the device of the CPU module.

Bad example (Only direct access to the link refresh target)

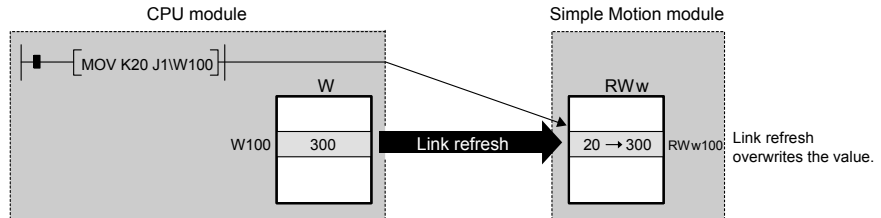

Good example (In addition to direct access, writing the same data to the CPU module device)

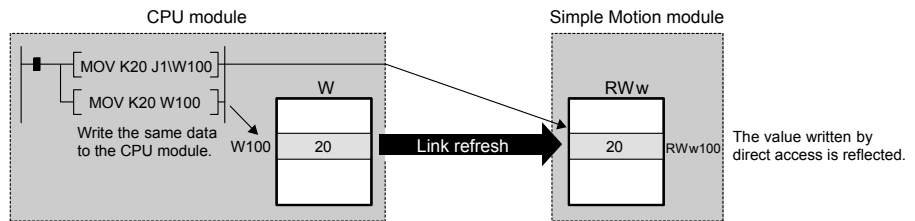

(3) Differences from link refresh

Item	Access method	
	Link refresh	Direct access
Number of steps	1 step	2 steps
Processing speed (LD B0  (Note-1))	High speed (0.0095µs)	Low speed (10 to 100µs)
Data reliability	Station-based or 32-bit units (Note-2) (Note-3)	—

(Note-1): The given value is for the Q06UDEHCPU.

(Note-2): When "Block Data Assurance per Station" is enabled (Refer to Section 8.3.4.)

(Note-3): When the conditions for the secured 32-bit data are satisfied (Refer to Section 8.3.4.)

(4) Shortening the link refresh time and transmission delay time

(a) Shortening the link refresh time

Remove infrequently used link devices from the link refresh range, and directly read or write the corresponding data using link direct devices. This reduces the number of the link refresh points to the CPU module, resulting in a shorter link refresh time. (Refer to Section 8.3.2.)

(b) Shortening the transmission delay time

Because the link direct device allows direct reading or writing of data to the link devices of the Simple Motion module at the time of the instruction execution, the transmission delay time can be shortened.

REMARK

Link refresh is executed in END processing of the sequence scan of the CPU module.

(5) Precautions

For cyclic data assurance of more than 32 bits, refer to Section 8.3.4.

8.3.4 Assurance of cyclic data integrity

The cyclic data integrity can be assured in 32-bit units or for each station.

Method	Description	Assurance		
		Link refresh	Direct access to link devices	Access to buffer memories
32-bit data assurance	Assures data in 32-bit units. Data is automatically assured by satisfying assignment conditions of link devices.	○	○	○
Block Data Assurance per Station	Assures data in station-based units. Data is assured by enabling the station-based block data assurance in the parameter setting.	○	×	×

○ : Assured
× : Not assured

(1) 32-bit data assurance

The RWr and RWw data can be assured in 32-bit units.

To enable 32-bit data assurance, disable block data assurance per station.

Project window → [Parameter] → [Network Parameter] → [Ethernet/CC IE/MELSECNET] → [CC IE Field Configuration Setting] button → [CC IE Field Configuration] → [Supplementary Setting]

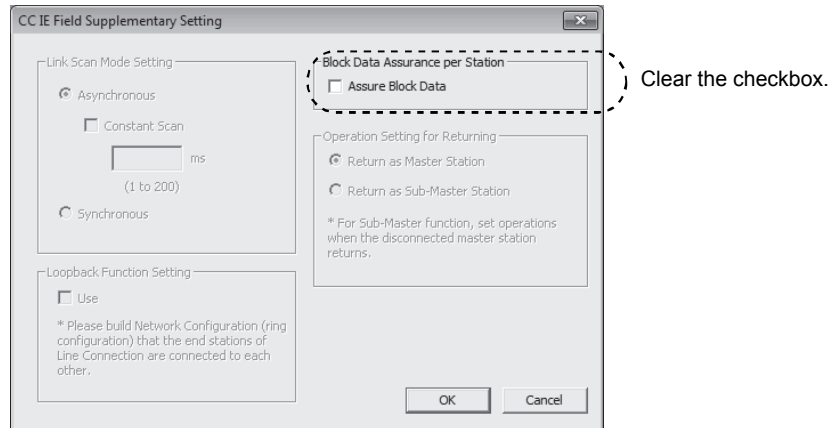
**POINT**

When there is a remote device station in the network, enable block data assurance per station.

Caution

When first five digits of SERIAL No. (Note-1) of the Simple Motion module is before 19072, refer to the following.

When the scan time of the CPU module is longer, the data communication between the Simple Motion module and the slave stations may not be able to be kept constant. If a synchronous communication error occurs at connecting the Simple Motion module and the slave stations, take measures shown below.

- Lengthen the operation cycle of the Simple Motion module.
- Shorten the scan time of the programmable controller. For how to shorten the scan time, refer to the user's manual for the CPU module used.

(Note-1): The serial number can be checked on the "Product Information List" screen in GX Works2.

(a) Access to cyclic data

When link devices are accessed, the integrity of 32-bit data can be assured by satisfying the following conditions.

- When directly accessing link devices:
 The start device number of RWr/RWw is multiples of 2.
 The number of points assigned to RWr/RWw is multiples of 2.

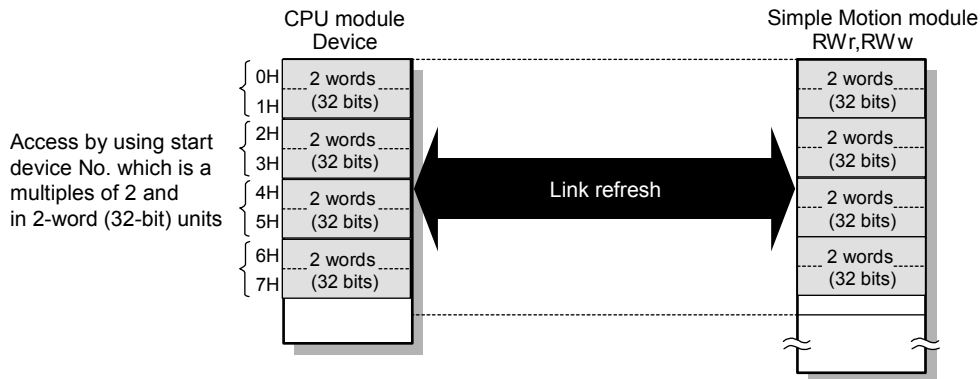

- When accessing buffer memories:
 Access using the DMOV instruction
 The start address of the buffer memory is multiples of 2.

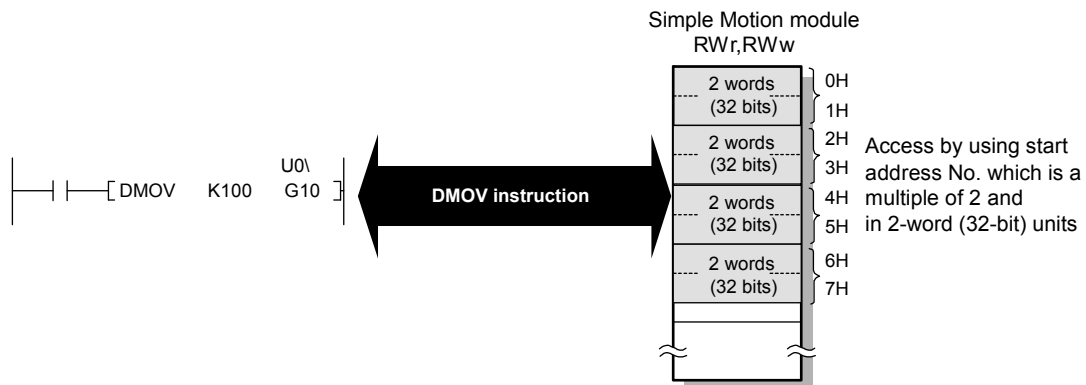

POINT
 For data assurance of more than 32 bits, use the block data assurance per station.

Caution
 When first five digits of SERIAL No. (Note-1) of the Simple Motion module is before 19072, refer to the following.
 When the scan time of the CPU module is longer, the data communication between the Simple Motion module and the slave stations may not be able to be kept constant. If a synchronous communication error occurs at connecting the Simple Motion module and the slave stations, take measures shown below.

- Lengthen the operation cycle of the Simple Motion module.
- Shorten the scan time of the programmable controller. For how to shorten the scan time, refer to the user's manual for the CPU module used.

(Note-1): The serial number can be checked on the "Product Information List" screen in GX Works2.

(2) Block data assurance per station

Integrity of the cyclic data is assured for each station by handshake between the CPU module and Simple Motion module for a link refresh.

(a) Setting

Enable "Block Data Assurance per Station" in "Network Configuration Settings" of the master station. (Refer to Section 7.4.)

Once this setting is enabled on the master station, integrity of the data for all stations is assured for each station.

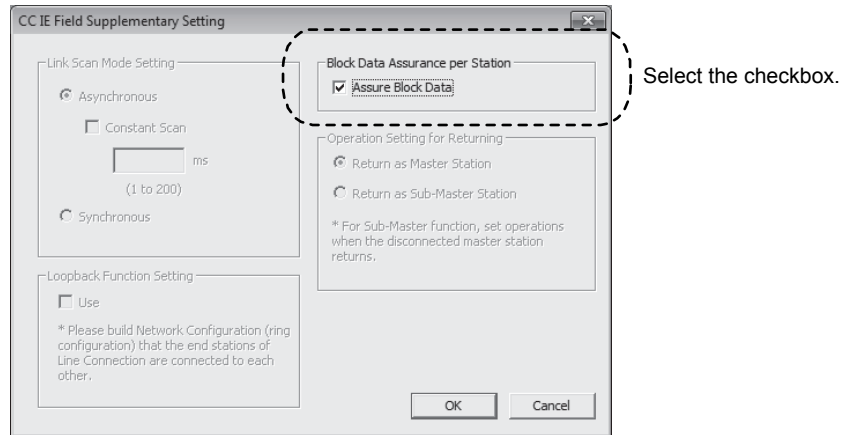
**POINT**

When there is a remote device station in the network, enable block data assurance per station.

Caution

When first five digits of SERIAL No. (Note-1) of the Simple Motion module is before 19072, refer to the following.

When the scan time of the CPU module is longer, the data communication between the Simple Motion module and the slave stations may not be able to be kept constant. If a synchronous communication error occurs at connecting the Simple Motion module and the slave station, take measures shown below.

- Lengthen the operation cycle of the Simple Motion module.
- Shorten the scan time of the programmable controller. For how to shorten the scan time, refer to the user's manual for the CPU module used.

(Note-1): The serial number can be checked on the "Product Information List" screen in GX Works2.

(b) Access to link devices

During a link refresh, data are assured for each station as shown below.

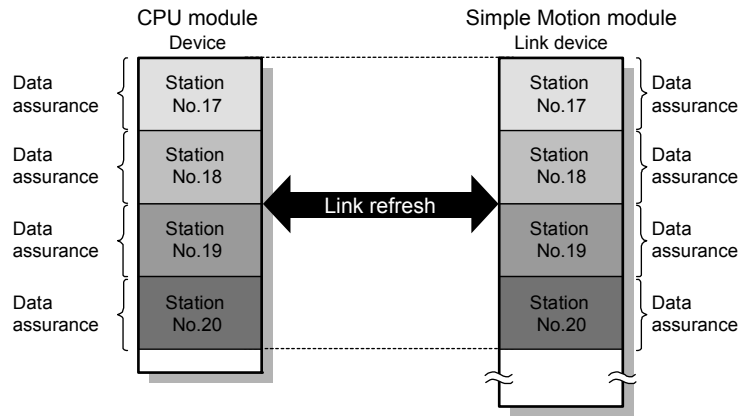

8.3.5 Input and output status settings in case of failure

For the Simple Motion module, status of input from a data link faulty station and output status of cyclic data if a stop error occurs in the CPU module can be set.

Status	Range where the settings are enabled
Input status of data link faulty station	Clearing or holding the following RX input data can be selected. • Master station RX Even if "Clear" is set, input data will be held for two seconds after disconnection. The RWr input data is held regardless of any setting. • Master station RWr
Cyclic data output when a stop error occurs in the CPU module	Clearing or holding the RY data (only the output data from the own station) of the master station can be selected.

- Area for which "Clear" or "Hold" can be selected in the data link faulty station input status setting
- Area for which "Clear" or "Hold" can be selected in the cyclic output setting for a stop error of the CPU module
- Area where data are held regardless of the setting
- Area that is dependent on the setting of the intelligent device station

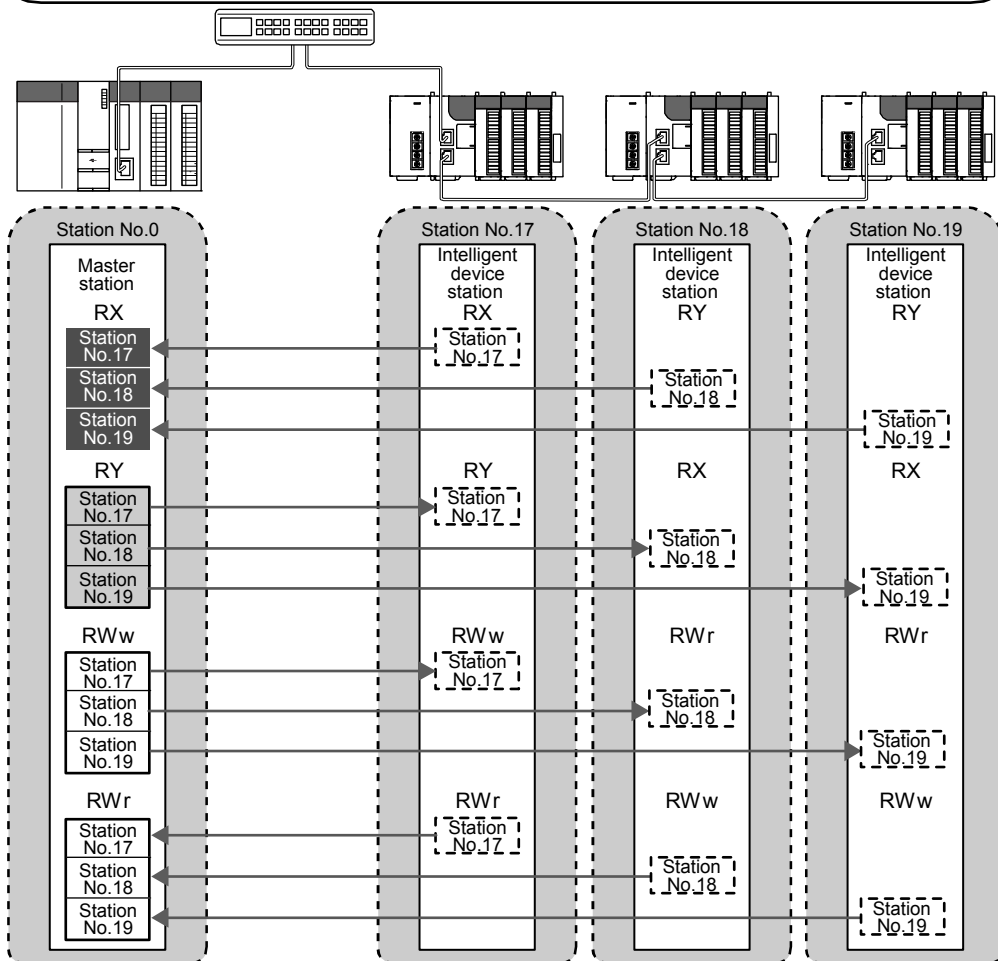

(1) Setting method

(a) Input status of data link faulty station

Set this item in the "Network Operation Settings" window. (Refer to Section 7.5.)

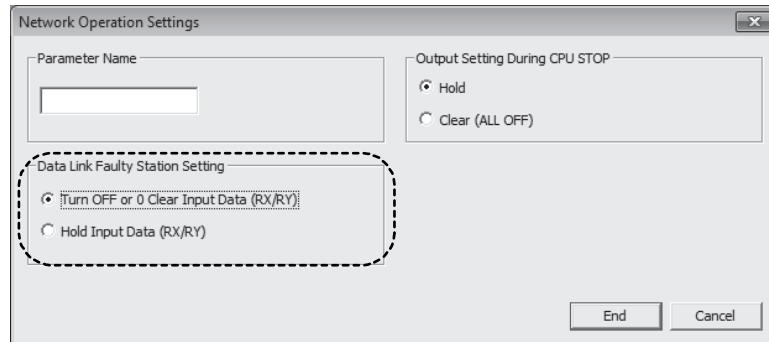

(b) Cyclic data output when a stop error occurs in the CPU module

Select "PLC Parameter" and set it in "Intelligent Function Module Detailed Setting".

[Project Window] → [Parameter] → [PLC Parameter] → "I/O Assignment" tab
→ [Detailed Setting] button → "Error Time Output Mode"

	Slot	Type	Model Name	Error Time Output Mode	PLC Operation Mode at H/W Error	I/O Response Time	Control PLC(*1)
0	PLC	PLC					
1	0(*-0)	Intelligent		Clear	Stop		
2	1(*-1)			Clear			
3	2(*-2)			Hold			

(2) Precautions

(a) When data link is stopped by users

When cyclic transmission is stopped using one of the following methods, the input status of the faulty station is held.

- CC-Link IE Field Network diagnostics (Refer to Section 9.4.)
- Link special relay (SB), link special register (SW) (Refer to Section 11.3.)

(b) Setting on a station with a data link error

When the following settings are set to "Hold" on the station where a data link error has occurred, the input status of the own station upon error is held, regardless of setting.

- "Network Operating Setting" → "Output Setting During CPU STOP" (Refer to Section 8.3.6 (2).)
- "PLC Parameter" → "Intelligent Function Module Detailed Setting" → "Error Time Output Mode" (Refer to Section 8.3.5 (1) (b).)

8.3.6 Output status setting for CPU module STOP

When the CPU module mounted with a Simple Motion module is set to STOP, whether cyclic data output is held or cleared can be selected.

(1) Range where the setting becomes enabled

The setting is fixed to hold or clear depending on devices set to link refresh, regardless of the output setting during CPU STOP.

The following table shows the relationship between the output status of the device set to link refresh and output setting during CPU STOP.

Link refresh device		Output setting during CPU STOP	
		Hold	Clear (ALL OFF)
RY	Y	Clear	Clear
	Other devices	Hold	Clear
RWw	All devices where the output setting during CPU STOP can be set	Hold	Hold

(2) Setting method

Set the output status for the case where the CPU module switch is set to STOP. Select hold or clear in the "Network Operation Settings" window. (Refer to Section 7.5.)

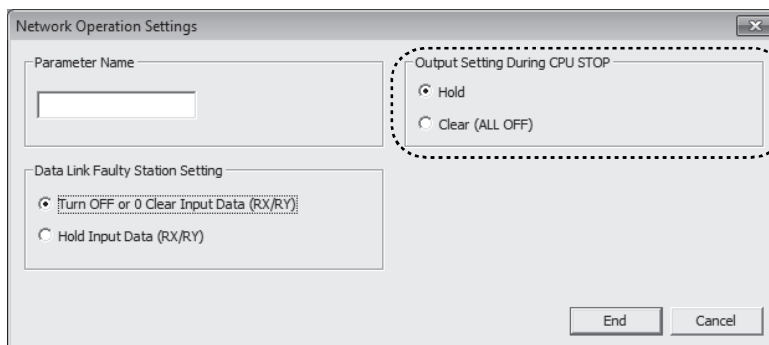

(3) Precautions

- (a) When the output setting during CPU STOP is set to clear
When the CPU module is in the STOP status, the forced output to slave stations cannot be executed using GX Works2.
- (b) When refreshing data by a link direct device
The output status of when the CPU module is set to STOP is the status set for the network operation settings.

8.3.7 Cyclic transmission stop and restart

During debugging and other operations, cyclic transmission is stopped. (Data reception from a slave station and data sending from the own station are stopped.) Also, the stopped cyclic transmission is restarted.

Transient transmission does not stop. (Refer to Section 9.4.)

The devices which can stop/restart cyclic transmission are the asynchronous communication devices. The cyclic transmission with the synchronous communication devices cannot be stopped/restarted.

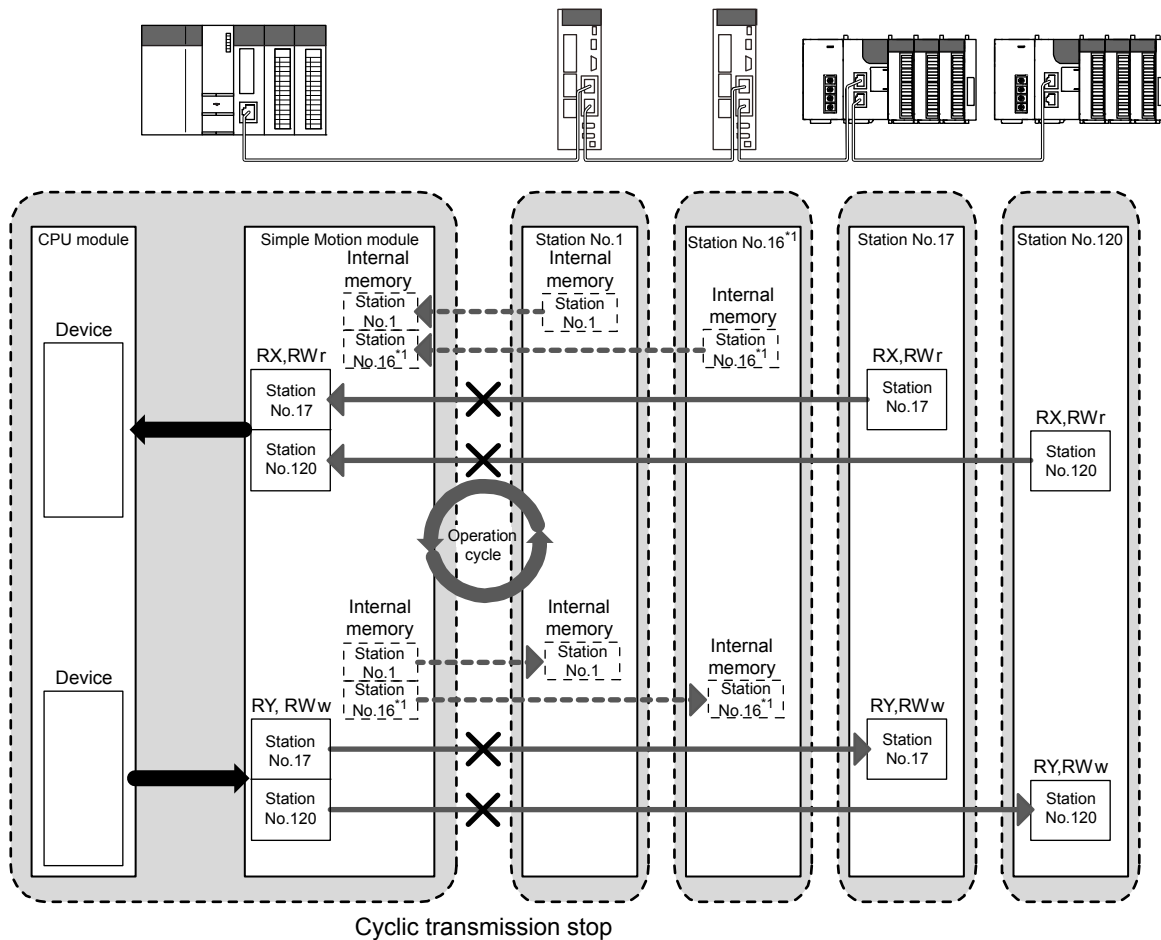

*1: The range from the station No.1 to 4 is valid in the 4-axis module, and the range from the station No.1 to 8 is valid in the 8-axis module.

8.4 Transient Transmission

This function allows communication with other stations when a request is made by a method such as a dedicated instruction.

8.4.1 Communications within the same network

Transient transmission can be performed to other stations through dedicated instructions or GX Works2. (Refer to Chapter 10.)

(Example) With a dedicated instruction (READ), accessing another station

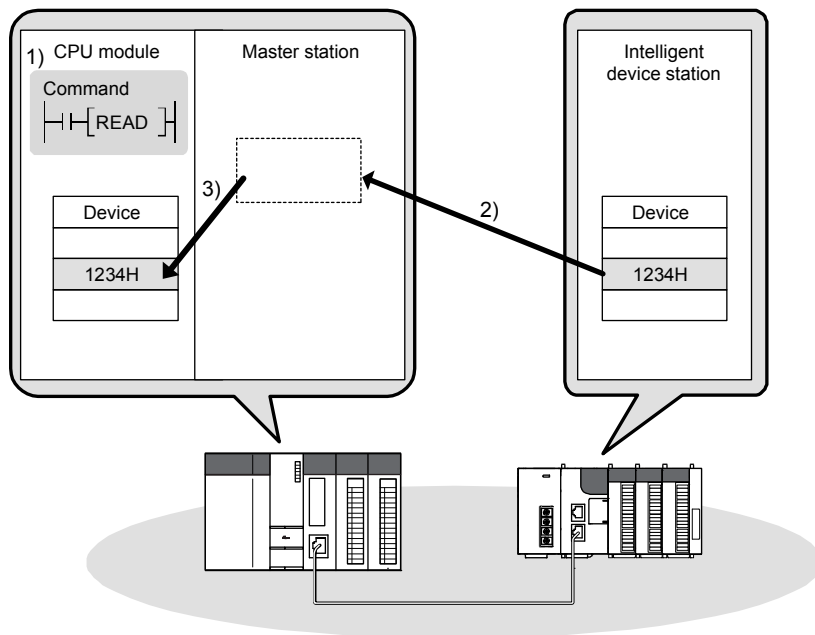

8.5 Reserved Station Specification and Temporary Cancel of Reserved Station Setting

Reserved station specification allows setting of a station that is not actually connected at present but will be connected to the network in the future (must be included in the total number of stations on the network). Reserved stations are not detected as faulty stations even though they are not actually connected.

When the reserved station function is disabled, a slave station specified as a reserved station can be canceled temporarily without changing the GX Works2 setting.

The devices which can specify reserved station specification and temporary cancel of reserved station setting are the asynchronous communication devices. The synchronous communication devices cannot specify reserved station specification or temporary cancel of reserved station setting.

(1) Reserved station specification

A slave station can be set as a reserved station in "Network Configuration Settings". (Refer to Section 7.4.)

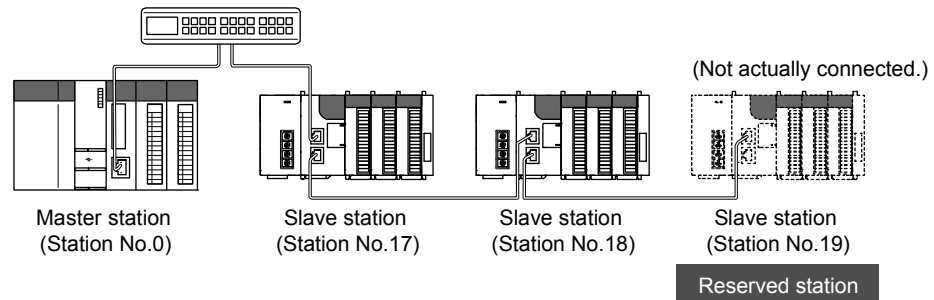

Network Configuration Setting

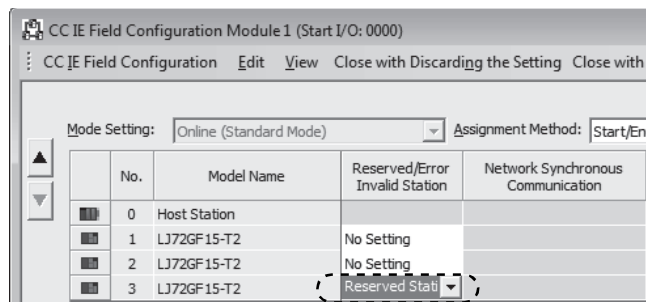

Select "Reserved Station".

(2) Temporary canceling/restoring the reserved station setting

Use this setting when connecting a reserved slave station to the network. For details on how to temporarily cancel the reserved station setting, refer to Section 9.6.

8.6 Interrupt Request to the CPU Module

Interrupt conditions are checked every link scan, and if the interrupt conditions are met, an interrupt request is made to the CPU module to start the interrupt program.

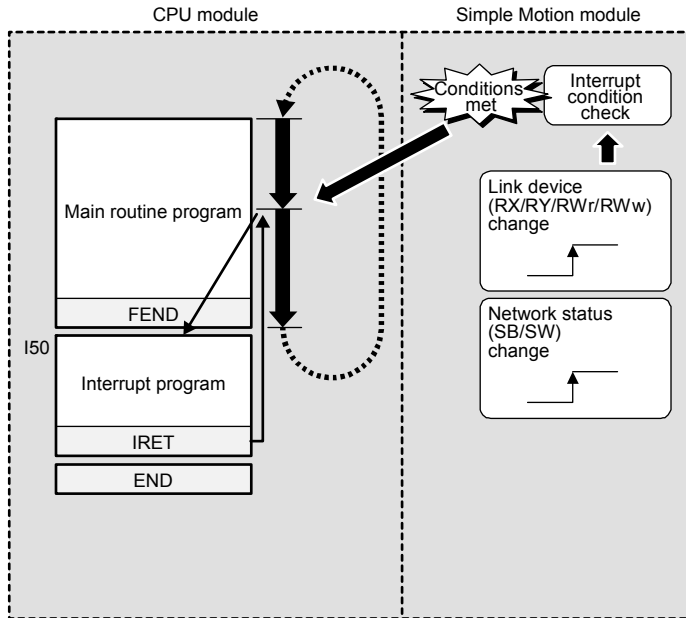

Interrupt program events by the Simple Motion module are shown below.

Device	Detection Method	Interrupt Condition	Word Device Setting Value	Channel No.	Interrupt (SI) No.
RX0 to RX1FFF	Check detection methods and interrupt conditions in every link scan. • Level Detect and ON, Level Detect and OFF • Edge Detect and ON, Edge Detect and OFF		-	-	0 to 15
RY0 to RY1FFF				-	
SB0 to SB1FF				-	
RWw0 to RWw3FF	Check detection methods and interrupt conditions in every link scan. • Level Detect and Equal, Level Detect and Unequal • Edge Detect and Equal, Edge Detect and Unequal		0 to 65535	-	
RWr0 to RWr3FF				-	
SW0 to SW1FF				-	

(1) Setting method

Set the interrupt request in the interrupt settings. (Refer to Section 7.7.)

Chapter 9 CC-LINK IE FIELD NETWORK DIAGNOSTICS

9.1 Diagnostic Items	9- 2
9.2 Starting Diagnostics	9- 4
9.3 Diagnostic Window	9- 8
9.4 Link Start/Stop	9-15
9.5 Network Event History	9-18
9.6 Reserved Station Function Enable	9-21
9.7 Remote Operation	9-25

This chapter describes how to check error locations, error causes, and event history using the CC-Link IE Field Network diagnostic function of GX Works2. With this function, the status of other stations can also be monitored.

9.1 Diagnostic Items

The following table lists items that can be diagnosed by the CC-Link IE Field Network diagnostics when GX Works2 is connected to the Simple Motion module. The diagnostic items differ depending on the station to which GX Works2 is connected.

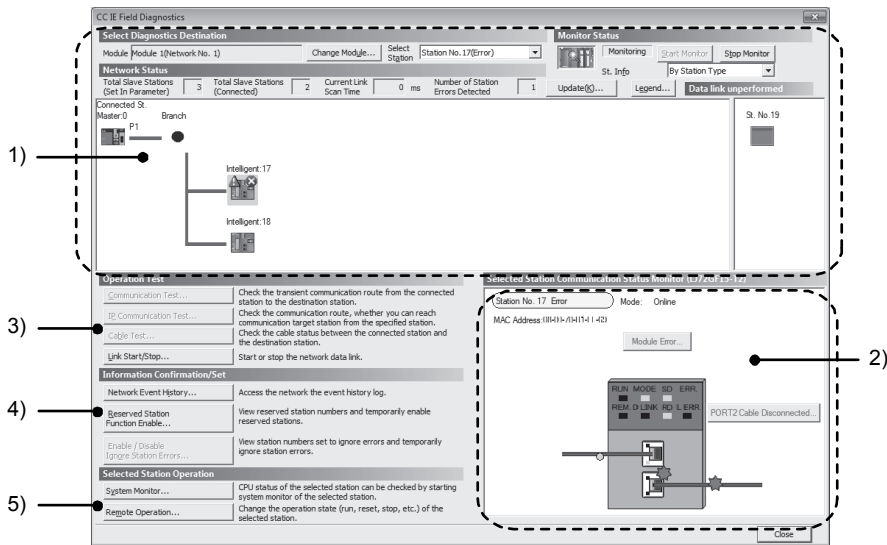

Item		Available/Not available	Restrictions	Reference
1)	Display of network map and error status	△	The icon of the servo amplifier displays "Other Modules".	Section 9.3
	Display of disconnected cable and disconnected station	○	—	
2)	Display of selected station status and error details	△	This item is not displayed when the selected module does not support "Selected Station Communication Status Monitor" of GX Works2.	Section 9.3
	Slave station number setting	○	—	
3)	Communication Test	×	Invalid because the communication test is not supported.	—
	IP Communication Test	×	Invalid because the IP communication test is not supported.	—
	Cable Test	×	Invalid because the cable test is not supported.	—
	Link Start/Stop	△	Invalid because the station No.1 to 16 ^(Note-1) cannot start/stop data link.	Section 9.4
4)	Network Event History	○	—	Section 9.5
	Reserved Station Function Enable	△	Invalid because the station No.1 to 16 ^(Note-1) cannot set reserved stations.	Section 9.6
	Enable/Disable Ignore Station Errors	×	The operation of setting/canceling is invalid.	—
5)	System Monitor	○	—	Section 12.2
	Remote Operation	△	Only "RESET" operation is supported.	Section 9.7

- : Diagnosed
- △ : Diagnosed with restrictions
- × : Not diagnosed

(Note-1): The range from the station No.1 to 4 is valid in the 4-axis module, and the range from the station No.1 to 8 is valid in the 8-axis module.

9.2 Starting Diagnostics

This section describes how to use the CC-Link IE Field Network diagnostics.

(1) Procedure

- 1) Connect GX Works2 to the CPU module.
If a slave station cannot be monitored due to an error such as cable disconnection, directly connect the supported programming tool to the slave station.
- 2) Start the CC-Link IE Field Network diagnostics from the menu.
[Diagnostics] → [CC IE Field Diagnostics]

POINT

- When another station has been specified as a connected station
The CC-Link IE Field Network diagnostics cannot be started when another station has been specified in "Other Station Setting" of the "Transfer Setup" window. Directly connect the supported programming tool to the slave station to be diagnosed, and start the CC-Link IE Field Network diagnostics.
- Starting diagnostics from the "System Monitor" window
The CC-Link IE Field Network diagnostics can also be started from the "System Monitor" window.

Click the Simple Motion module. Click the button.





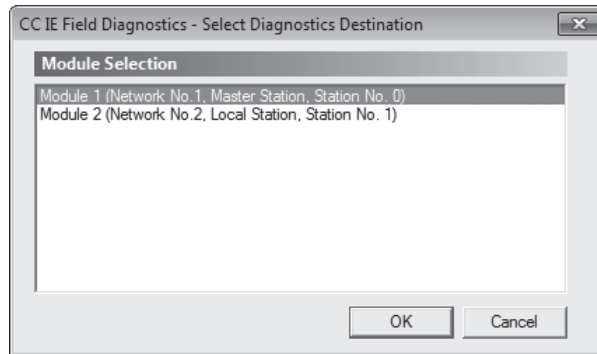

Status	Base-Slot	Series	Model Name	Point	Parameter Type	Point	I/O Address	Network No. Station No.	Master PLC
-	-	-	Power	-	Power	-	-	-	-
-	-	-	CPU	Q	Q03UDVCPU	-	-	-	-
-	0-0	Q	QD77GF16	32Point	Intelli.	32Point	0000	1-0	-
-	0-1	-	Empty	-	Empty	16Point	0020	-	-
-	0-2	-	Empty	-	Empty	16Point	0030	-	-
-	0-3	-	Empty	-	Empty	16Point	0040	-	-
-	0-4	-	Empty	-	Empty	16Point	0050	-	-
-	0-5	-	Empty	-	Empty	16Point	0060	-	-
-	0-6	-	Empty	-	Empty	16Point	0070	-	-
-	0-7	-	Empty	-	Empty	16Point	0080	-	-

- 3) When the following window opens, select the Simple Motion module to be diagnosed and click the [OK] button to start the CC-Link IE Field Network diagnostics.
 Modules are listed in the order configured in network settings. (Refer to Section 7.3.)



POINT

When multiple Simple Motion modules of the same network number are mounted on the same base unit, the module with the smallest start I/O number is always diagnosed, regardless of setting.

- 4) Select the station to be diagnosed from "Select Station" or "Network Status".
- , , or  is displayed on the module icon of the station where an error occurs.
 - A disconnected station that had performed data link is indicated with the  icon in the network map.
 A disconnected station that has been set in the network configuration settings but has not yet performed data link is displayed on the right end of the area.
 However, even if a disconnected station had performed data link, it is displayed on the right end of the area in the following cases.
 - A station that was reconnected to a network after cable disconnection/insertion or power-off and power-on of the system and remains disconnected
 - A disconnected station with the station icon deleted in the network map by clicking the [Update...] button
 -  is displayed on the icon of a cable where a communication error occurs. To check the details of the communication error, click the neighboring stations of .
 -  is displayed if the network is configured in ring topology.

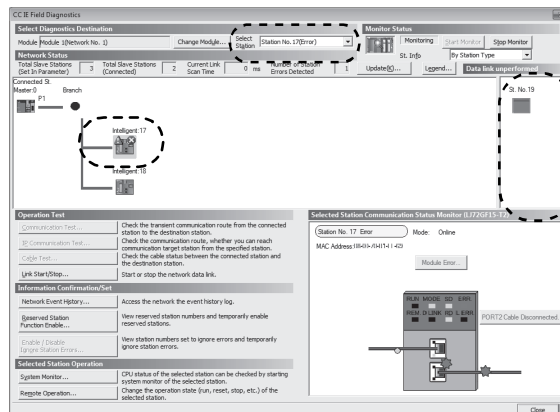

Disconnected station

POINT

- Descriptions of icons
Click the [Legend...] button. A brief description of the icon is displayed.

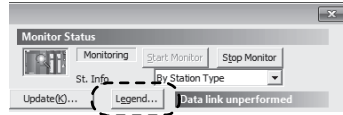

- When multiple Simple Motion modules are mounted on the same base unit
Clicking the [Change Module...] button will change the target module.

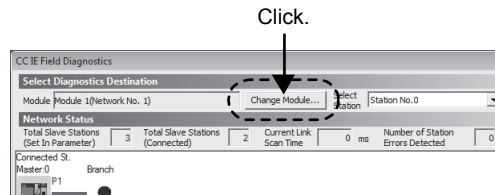

- Stations that cannot be selected as a diagnostic target
In the following cases, the status of the corresponding station cannot be checked using the CC-Link IE Field Network diagnostics.

- The network number of the station differs from those of other stations.
- More than one master station exists in the network.
- The station numbers are overlapped.

Check the error details by directly connecting the supported programming tool to the slave station in error and opening the "System Monitor" window. (Refer to Section 12.6.)

- 5) Status of a station selected in "Network Status" is displayed in "Selected Station Communication Status Monitor". (Refer to Section 9.3.)

If "Other Modules" is selected, "Selected Station Communication Status Monitor" cannot be used.

If an error occurs, a button indicating the error (e.g. [PORT2 Communication Error...]) button is displayed. Clicking the button allows checking of error details and corrective actions.

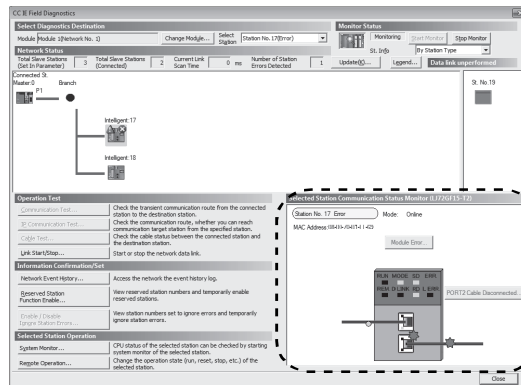

← The selected station status is displayed.

← Click.

- 6) If an error occurs in the CPU module, click the [System Monitor...] button to check the error details and corrective actions.
- 7) Various operations can be executed using the buttons under "Operation Test", "Information Confirmation/Set", and "Selected Station Operation" on the bottom left of the window. (Refer to Section 9.4 to Refer to Section 9.7.)

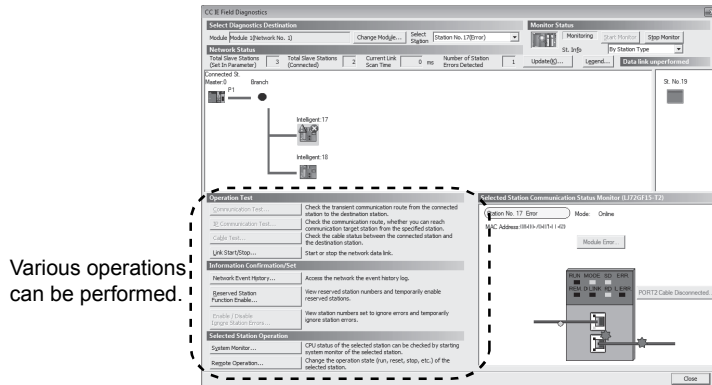

← Various operations can be performed.

(2) Measures if  is displayed in "Network Status"

- The network is configured in ring topology.

Take the following measures:

- 1) Disconnect one Ethernet cable connected to the switching hub and power off and then on the hub. (Repeat this operation until data link starts over the network.)
- 2) When data link starts across the entire network, check the network map using the CC-Link IE Field Network diagnostics. (Refer to Chapter 9.)

9.3 Diagnostic Window





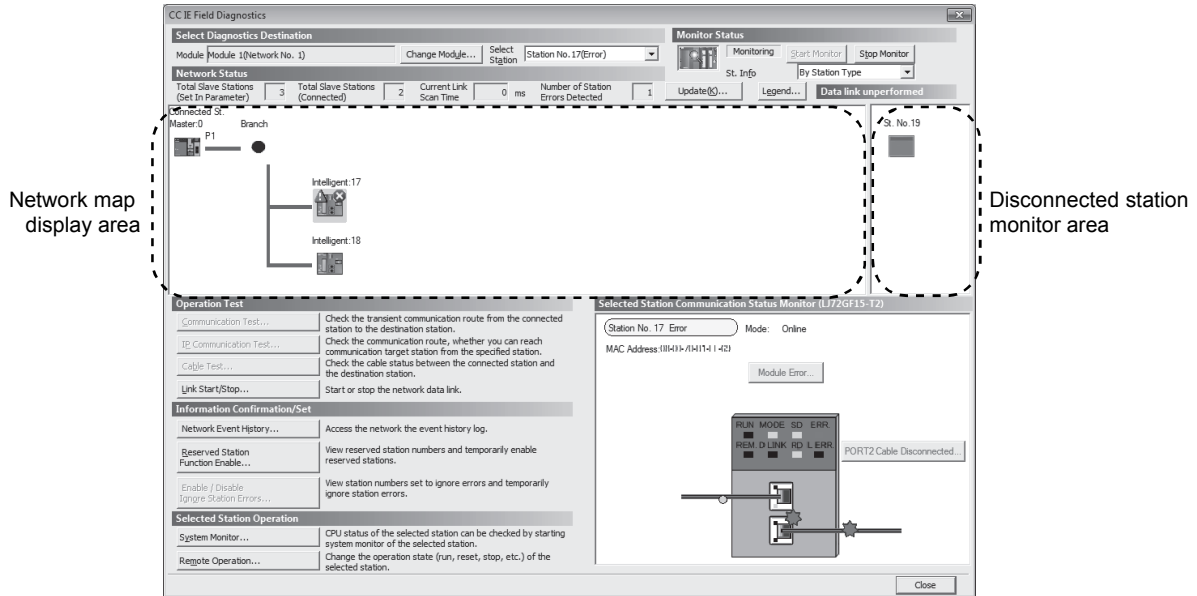

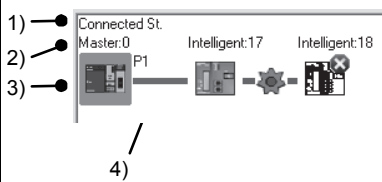

This section describes items displayed in the "CC IE Field Diagnostics" window.

(1) Displayed items





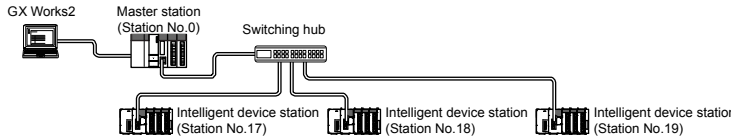
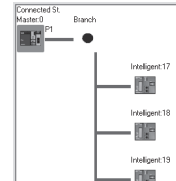

Item	Description	
Select Diagnostics Destination	Module	Displays the Simple Motion module being diagnosed.
	[Change Module...] button	When multiple Simple Motion modules are mounted, the target module can be changed. When multiple Simple Motion modules of the same network number are mounted on the same base unit, the module with the smallest start I/O number is always diagnosed, regardless of setting.
	Select Station	Select a station to be diagnosed. If an error occurs in the selected station, "(Error)" is displayed after the station number. A station to be diagnosed can be selected by clicking the module icon displayed in the network map.
Monitor Status	[Start Monitor] button	Starts monitoring of the CC-Link IE Field Network diagnostics.
	[Stop Monitor] button	Stops monitoring of the CC-Link IE Field Network diagnostics.
[Update...] button	Deletes a disconnected station displayed in the network map. The deleted station is displayed in the "disconnected station monitor area".	

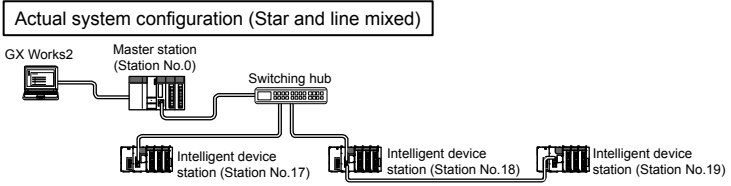
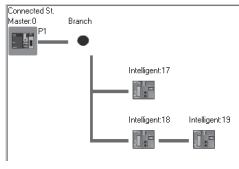
Item	Description								
<p>[Legend...] button</p>	<p>Displays the meaning of icons displayed in the "CC IE Field Diagnostics" window.</p> 								
<p>St. Info</p>	<p>The display name of the slave station can be selected from "By Device Name" and "By Station Type". When "By Device Name" is selected, the information entered in the device name of the network configuration settings is displayed.</p> <p>Note the following point for the display in "By Device Name".</p> <ul style="list-style-type: none"> • When the name of a device is not entered in the network configuration setting, the station type is displayed. <p>However, the Simple Motion module does not support "By Device Name".</p>								
<p>Network Status</p>	<table border="1"> <tr> <td data-bbox="331 1182 523 1243">Total Slave Stations (Set In Parameter)</td> <td data-bbox="523 1182 1441 1243">Displays the total number of slave stations set by parameter.</td> </tr> <tr> <td data-bbox="331 1243 523 1303">Total Slave Stations (Connected)</td> <td data-bbox="523 1243 1441 1303">Displays the total number of slave stations during data link on CC-Link IE Field Network.</td> </tr> <tr> <td data-bbox="331 1303 523 1373">Current Link Scan Time</td> <td data-bbox="523 1303 1441 1373">Displays 0.</td> </tr> <tr> <td data-bbox="331 1373 523 1438">Number of Station Errors Detected</td> <td data-bbox="523 1373 1441 1438">Displays the number of error stations in the displayed network.</td> </tr> </table>	Total Slave Stations (Set In Parameter)	Displays the total number of slave stations set by parameter.	Total Slave Stations (Connected)	Displays the total number of slave stations during data link on CC-Link IE Field Network.	Current Link Scan Time	Displays 0.	Number of Station Errors Detected	Displays the number of error stations in the displayed network.
Total Slave Stations (Set In Parameter)	Displays the total number of slave stations set by parameter.								
Total Slave Stations (Connected)	Displays the total number of slave stations during data link on CC-Link IE Field Network.								
Current Link Scan Time	Displays 0.								
Number of Station Errors Detected	Displays the number of error stations in the displayed network.								

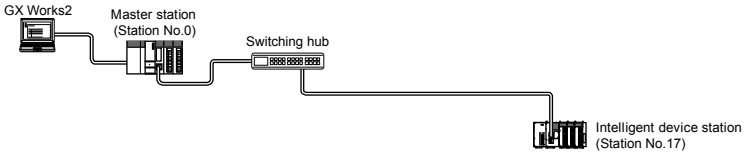
Item	Description
<p>Network Status</p> <p>Network map</p>	<p>Displays the network map of CC-Link IE Field Network and the status of each station.</p> <p>If the status is not displayed, check that there is only one master station in the system and no station number is overlapped.</p> <p>(1) Icon</p> <p>The module type and station number are displayed with an icon.</p>  <ul style="list-style-type: none"> • Click : Selection • Double-click : Displays the "System Monitor" window. • Right-click : Executes debugging. •     keys on the keyboard : Move the focus to the module to be diagnosed, and determine it with the  key.
	<p>1) Indicates the station (own station) where GX Works2 is connected.</p>
	<p>2) Displays the network type and station number. "?" is displayed when a station number has not been set. When the text's background is colored, the relevant station may have been configured as a reserved station or an error invalid station. Click the [Legend...] button to check the meaning of the background colors.</p>
	<p>3) Shows module status. Click the [Legend...] button to check the meaning of the icon.</p>
	<p>4) Displays a port to which an Ethernet cable is connected.</p>
	<p>(2) Scaling</p> <p>If all stations are not displayed in the network map, enlarge or reduce the area by pressing the  key and scrolling the wheel of a mouse. The current zoom size is displayed by placing the mouse pointer on the network map.</p> <p>(3) Network map</p> <p>A network map is displayed according to the connection status.</p> <p>Actual system configuration (Star topology)</p>  <p>Network map</p>  <p>Actual system configuration (Line topology)</p>  <p>Network map</p> 

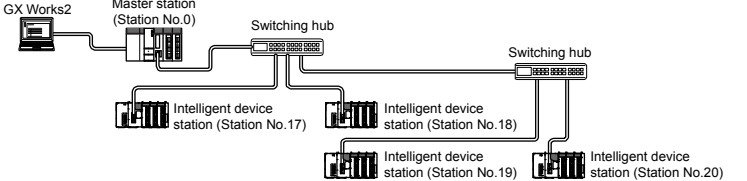
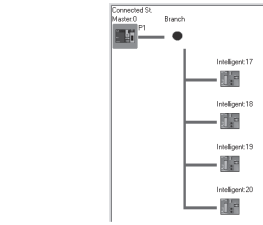
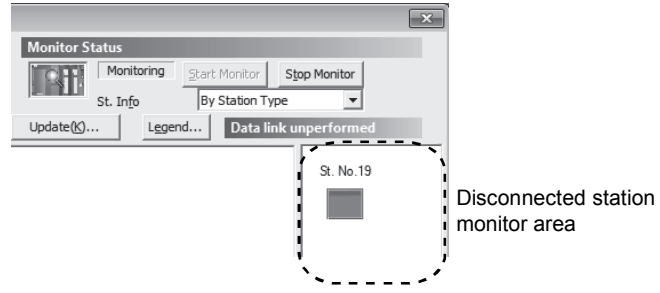
Item	Description
<p>Network Status</p> <p>Network map</p>	<p>Actual system configuration (Star and line mixed)</p>  <p>Network map</p> 

Item	Description
<p>Network map</p>	<p>Note that, in the following cases, the network map that is different from the actual system configuration is displayed.</p> <ul style="list-style-type: none"> • Two stations are connected through a switching hub. Branches are not displayed in the network map. <div data-bbox="534 448 1284 683"> <p>Actual system configuration</p>  <p>Network map</p>  </div> <ul style="list-style-type: none"> • Switching hubs are in cascade connection. Only one branch is displayed. <div data-bbox="534 884 1284 1153"> <p>Actual system configuration</p>  <p>Network map</p>  </div>
<p>Network Status</p>	<p>Displays a disconnected station that has been set in the network configuration settings but has not yet performed data link. However, even if a disconnected station had performed data link, it is displayed in this area in the following cases.</p> <ul style="list-style-type: none"> • A station that was reconnected to a network after cable disconnection/insertion or power-off and power-on of the system and remains disconnected • A disconnected station with the station icon deleted in the network map by clicking the [Update...] button <div data-bbox="534 1624 1197 1915">  </div> <p>The  icon indicates a station that has not yet performed data link. Icons other than  indicate stations that had performed data link before disconnection.</p>

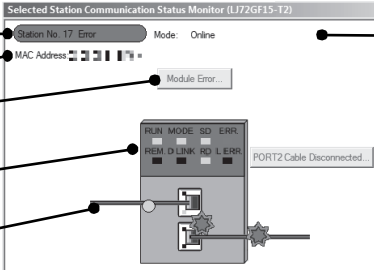
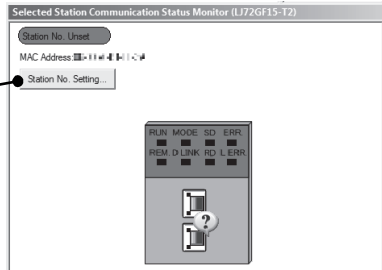
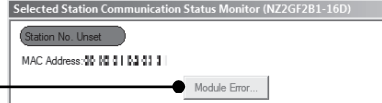
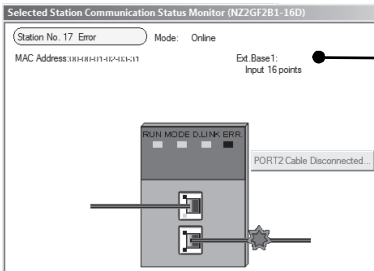
Item	Description
<p>Selected Station Communication Status Monitor</p>	<p>Displays status of the station selected in "Network Status".</p> <p>When a station where an error has occurred is selected</p>  <p>When a station with no station No. setting is selected</p>   <p>When a remote device station is selected</p> 
	<p>Displays operating status.</p> <p>1) Station No. 17 No Error : Normal operation Station No. 17 Error : Error (Data link is continued.) (yellow) Station No. 17 Error : Error (Data link is stopped.) (red)</p>
	<p>2) Displays a mode.</p> <p>3) Displays a MAC address.</p>

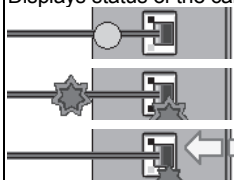
Item		Description
Selected Station Communication Status Monitor	4)	<p>Sets a station number for a slave station to which a station number has not been set. This button is displayed only when a slave station meeting the following conditions has been selected in "Network Status".</p> <ul style="list-style-type: none"> • The slave station supports station number setting from the master station. • A station number has not been set to the slave station. (Note-1) <p>When a station set in "Network Configuration Settings" is added, the external device connected to the slave station outputs data input from the master station, simultaneously with configuration of the station number setting. Therefore, set the CPU module to STOP or check that outputs from the external device will not cause a problem beforehand.</p>
	5)	Click this button to check error details. Take corrective actions, following description displayed in "Error Factor" and "Troubleshooting".
	6)	Displays the LED status of a module and communication status of PORT1 and PORT2. (Refer to Chapter 2.)
	7)	<p>Displays status of the cables connected to PORT1 and PORT2.</p>  <p>: Properly connected</p> <p>: Error (cable disconnection)</p> <p>: Error (other than cable disconnection)</p>
	8)	Displays the information of the extension module connected to the remote device station. (Note-2)
	(Note-1): For how to clear the station number set for a slave station in the CC-Link IE Field Network diagnostics, refer to the manuals for modules used on slave stations. (Note-2): To display the information of an extension module, a Simple Motion module with a serial number (first five digits) of "15092" or later is required.	
Operation Test	[Communication Test...] button	This item cannot be set for the Simple Motion module.
	[IP Communication Test...] button	This item cannot be set for the Simple Motion module.
	[Cable Test...] button	This item cannot be set for the Simple Motion module.
	[Link Start/Stop...] button	Starts or stops cyclic transmission. (Refer to Section 9.4.)
Information Confirmation/Set	[Network Event History...] button	Displays event history of a network. (Refer to Section 9.5.)
	[Reserved Station Function Enable...] button	Temporarily cancels a reservation for a slave station or reserves the slave station again. (Refer to Section 9.6.)
	[Enable/Disable Ignore Station Errors...] button	This item cannot be set for the Simple Motion module.
Selected Station Operation	[System Monitor...] button	Displays the System Monitor window. (Refer to Section 12.2.)
	[Remote Operation...] button	Performs the remote operations (RESET operation only) to the CPU module. (Refer to Section 9.7.)

9.4 Link Start/Stop

This function stops or restarts cyclic transmission of the Simple Motion module. Data reception from slave stations and data transmission of the own station are disabled during debugging. The stopped cyclic transmission can be restarted.

This function does not stop or restart transient transmission.

This function can stop and restart the cyclic transmission of an asynchronous communication device. It cannot stop or restart the cyclic transmission of a synchronous communication device. When link start/stop is executed for the synchronous communication device and the Simple Motion module, "Not support function execution error (error code: D300H)" occurs. Also, when link start/stop is executed for the multiple stations including the asynchronous communication devices and synchronous communication devices at the same time, only link start/stop is executed for the asynchronous communication devices.

The operation for the synchronous communication devices is saved as history.

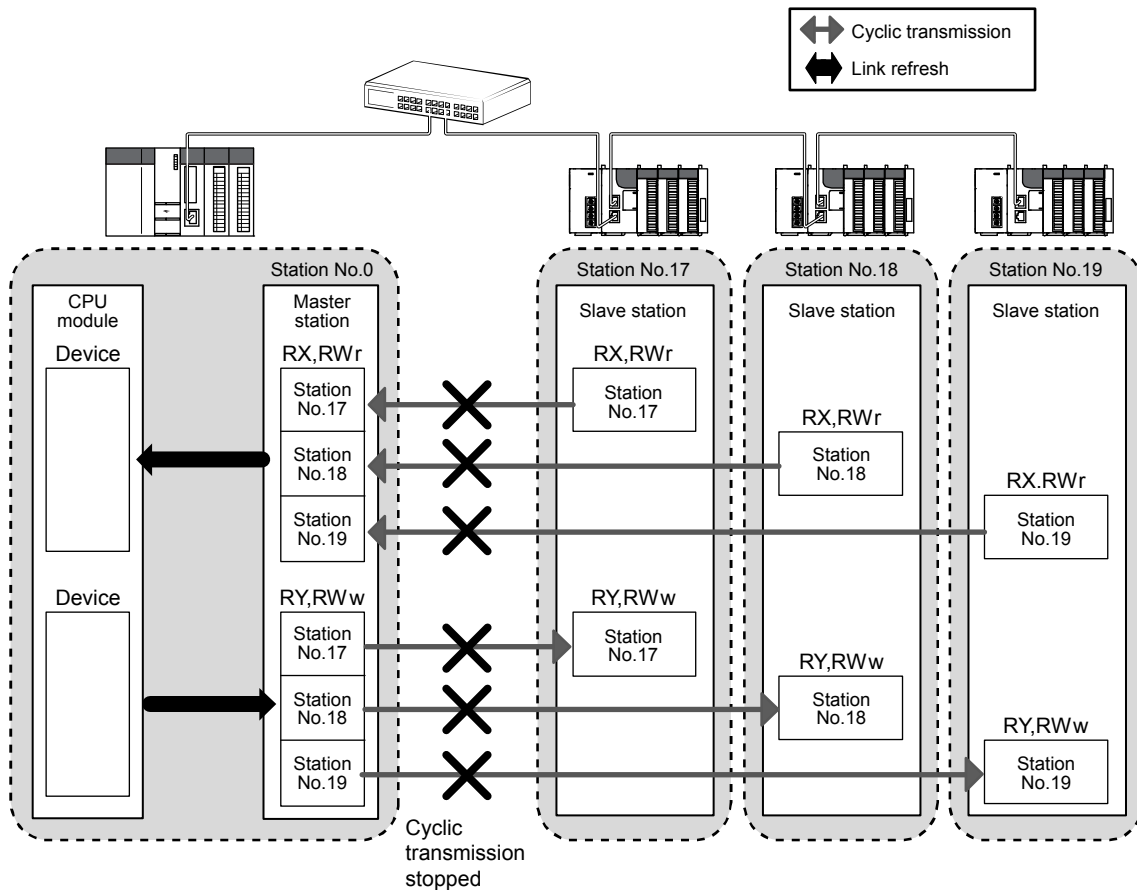

- 1) Connect GX Works2 to the CPU module.
- 2) Start the CC-Link IE Field Network diagnostics from the menu.
[Diagnostics] → [CC IE Field Diagnostics]
- 3) Click the [Link Start/Stop...] button in the "CC IE Field Diagnostics" window.
Or right-click a module icon in "Network Status", and click [Link Start/Stop].
The "Link Start/Stop" window opens.

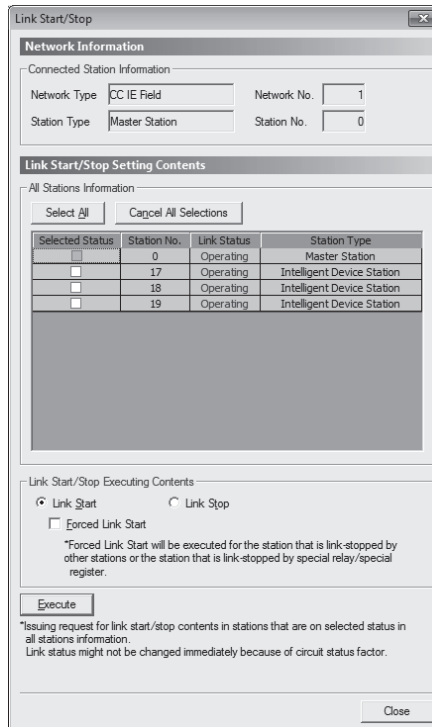

- 4) Select a station for starting or stopping cyclic transmission in "Selected Status".
- 5) Select whether to start or stop cyclic transmission in "Link Start/Stop Executing Contents".
 Selecting "Forced Link Start" will forcibly start cyclic transmission of the station where cyclic transmission was stopped by a command from another station or by link special relay (SB) or link special register (SW).
- 6) Click the [Execute] button.
 The execution status of cyclic transmission can be checked in "Link Status".

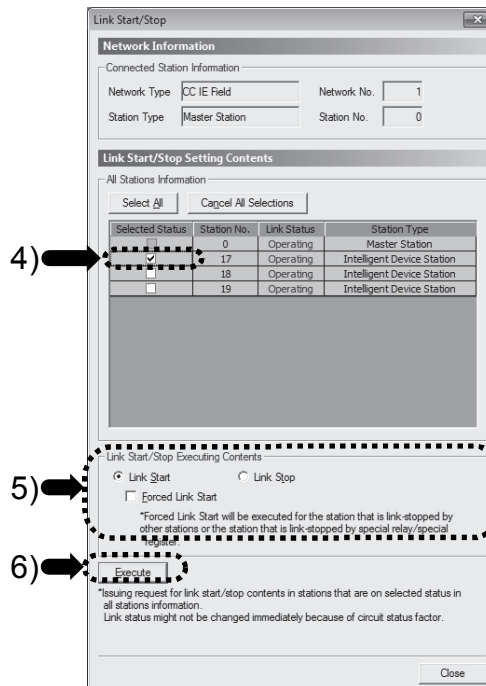

POINT
<ul style="list-style-type: none"> • When the CPU module is reset or the system is powered off and on Even if cyclic transmission has been stopped by this function, it will restart. • Stations to which the link start cannot be executed The link start cannot be executed to the following stations. <ul style="list-style-type: none"> • Station where cyclic transmission was stopped due to an error • Station where link was stopped by a command from another station (Note-1) • Station where link was stopped by link special relay (SB) or link special register (SW) (Note-1) <p>(Note-1): Selecting "Forced Link Start" will start the link.</p>

REMARK

Cyclic transmission can be started and stopped using link special relays (SBs) and link special registers (SWs). (Refer to Section 11.3.)

9.5 Network Event History

The history of events occurred in the own station and in the network can be displayed. When the master station is the target module, event history of the entire network can be displayed. The history data are useful for troubleshooting at the start of the network system.

(1) Displaying event history

- 1) Connect GX Works2 to the CPU module.
- 2) Start the CC-Link IE Field Network diagnostics from the menu.
[Diagnostics] → [CC IE Field Diagnostics]
- 3) Click the [Network Event History...] button in the "CC IE Field Diagnostics" window. Or right-click a module icon in "Network Status", and click [Network Event History]. The "Network Event History" window opens.

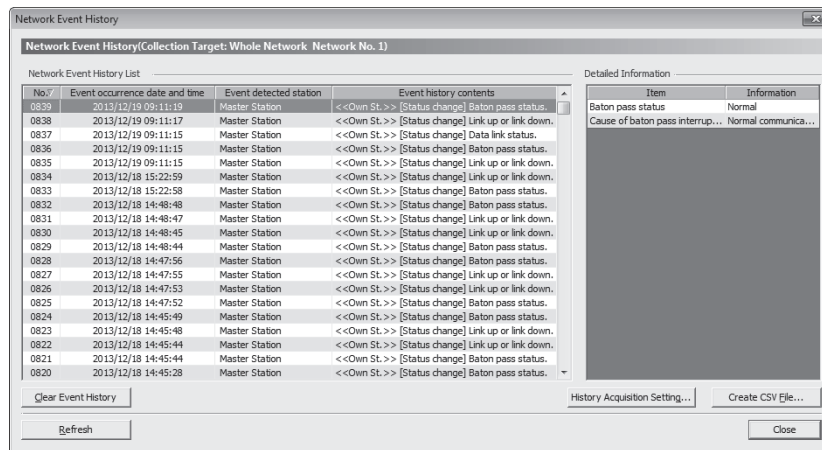

- 4) Click the [History Acquisition Setting...] button to select the events to be collected.

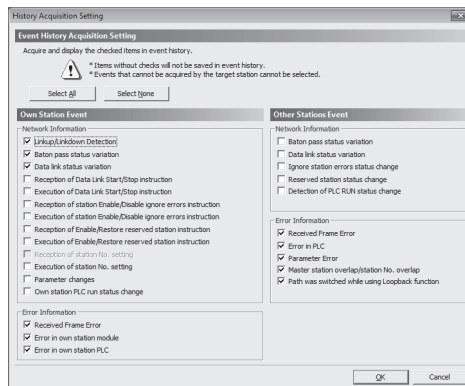
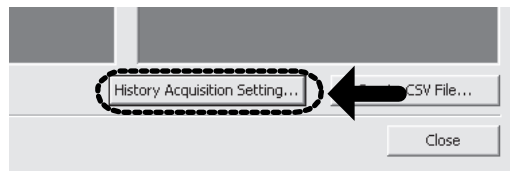

- 5) Select events to be collected and click the [OK] button.
Events that can be collected depend on the station type (master station).
- 6) Click each title to sort the events.

Network Event History(Collection Target: Whole Network Network No. 1)

No.	Event occurrence date and time	Event detected station	Event history contents
0838	2013/12/19 09:11:17	Master Station	<<Own St.>> [Status change] Link up or link down.
0837	2013/12/19 09:11:15	Master Station	<<Own St.>> [Status change] Data link status.

POINT

- The number of displayed events
Up to 1000 events can be displayed. When the maximum is reached, the events will be erased in sequence starting from the oldest one and the latest events will be displayed.
- Incorrect display of error occurrence time and date
If an error occurs during initial processing of the CPU module, "0000/00/00 00:00:00" will be displayed.

(2) Clearing event history

- 1) Click the [Clear Event History] button in the "Network Event History" window.

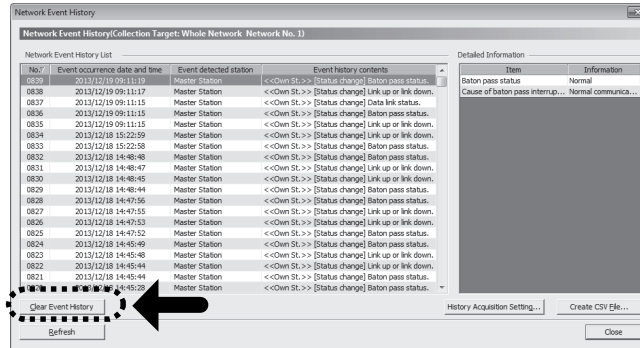

(3) Storing event history data

- (a) Auto-save feature

Event history data is automatically saved on the flash ROM. For this reason, the saved event history data will not be erased by resetting the CPU module or powering off and on the system.

REMARK

- Auto-save may fail if performed between the time that the CPU module is reset or the system is powered off and on and initial processing is completed. If failed, the event, "Invalid event history data." is displayed in "Event history contents".
- Events that have occurred during one second before the CPU module is reset or the system is powered off are not saved to event history.

- (b) Storing event history data in a CSV file

Event history data can be stored in a CSV file.

- 1) Click the [Create CSV File...] button in the "Network Event History" window and save the event history data in a CSV file

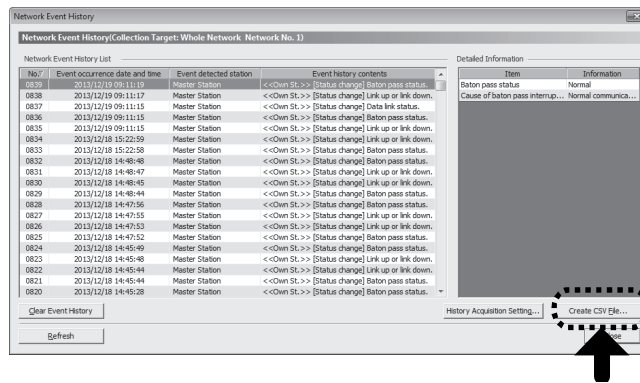

9.6 Reserved Station Function Enable

This function temporarily cancels a reservation for a slave station. Use this function to cancel the reservation of a slave station when it is connected to the network, or to reset it as a reserved station.

This function can specify or temporarily cancel a reserved station of an asynchronous communication device. It cannot specify or temporarily cancel a reserved station of a synchronous communication device. When the operation of "reserved station function enable" is executed for the synchronous communication device, "Not support function execution error (error code: D300H)" occurs. When the reserved stations are set for the synchronous communication device and asynchronous communication device at the same time, the operation of "reserved station function enable" is executed for the asynchronous communication device only. Reserved station setting is invalid for the synchronous communication device. Therefore, the operation of "reserved station function enable" cannot be executed.

(1) Selecting the target module in "Network Status"

(a) Temporarily canceling a reservation

- 1) Connect a slave station specified as a reserved station to the network.
- 2) Connect GX Works2 to the CPU module.
- 3) Start the CC-Link IE Field Network diagnostics from the menu.
[Diagnostics] → [CC IE Field Diagnostics]
- 4) In "Network Status", right-click the icon of the station for which reservation is to be cancelled. Click [Reserved Station Function Disable In Selected Station]. The text background turns orange. The reservation for the slave station is temporarily cancelled.
- 5) Debug the slave station that has been added.

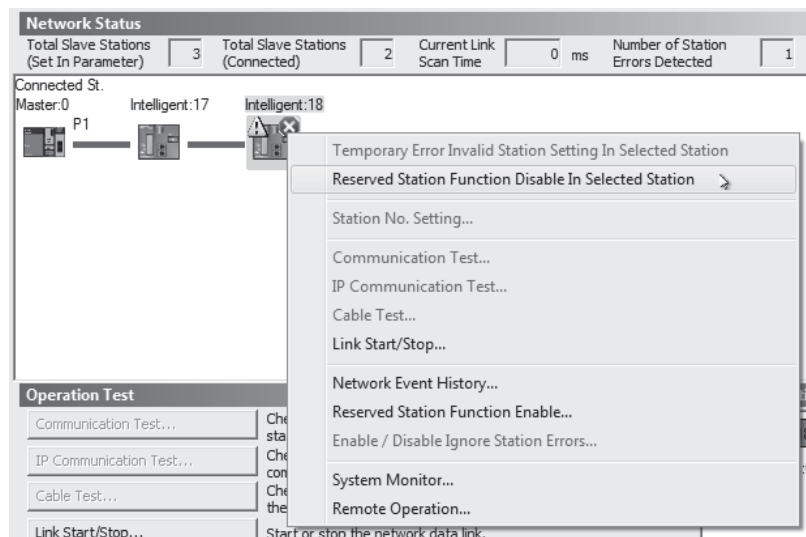

- (b) Reserving the slave station again
- 1) In "Network Status", right-click the icon of the station to be reserved again. Click [Reserved Station Function Disable In Selected Station]. The text background turns light blue. The slave station is reserved again.

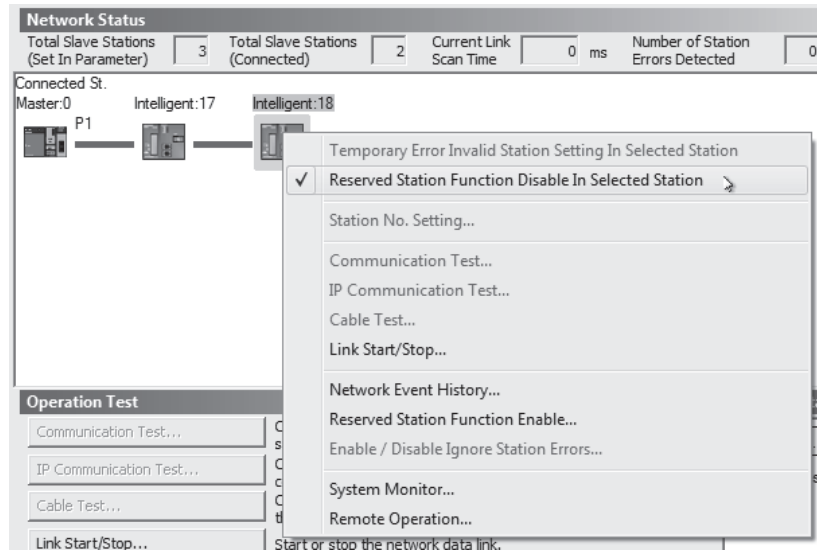

POINT

- Parameter setting
The network parameter does not reflect the temporary cancellation of reserved station specification.
- When the master station is reset or the system is powered off
The disabled reserved station setting is ignored, and the slave station returns to the status set by the network parameter of the master station.
- Checking the station number of a reserved station
The station number of a reserved station can be checked in the "Reserved Station Function Enable" window. (Refer to Section 9.6 (2).)

REMARK

The reserved station setting can also be temporarily disabled/enabled using link special relays (SBs) and link special registers (SWs) of the master station. (Refer to Section 11.3.)

(2) Selecting the target module in the "Reserved Station Function Enable" window

Reservation of multiple slave stations can be temporarily cancelled through the "Reserved Station Function Enable" window all at once.

(a) Temporarily canceling a reservation

- 1) Connect a slave station specified as a reserved station to the network.
- 2) Connect GX Works2 to the CPU module.
- 3) Start the CC-Link IE Field Network diagnostics from the menu.
[Diagnostics] → [CC IE Field Diagnostics]
- 4) Click the [Reserved Station Function Enable...] button in the "CC IE Field Diagnostics" window.

The "Reserved Station Function Enable" window opens.

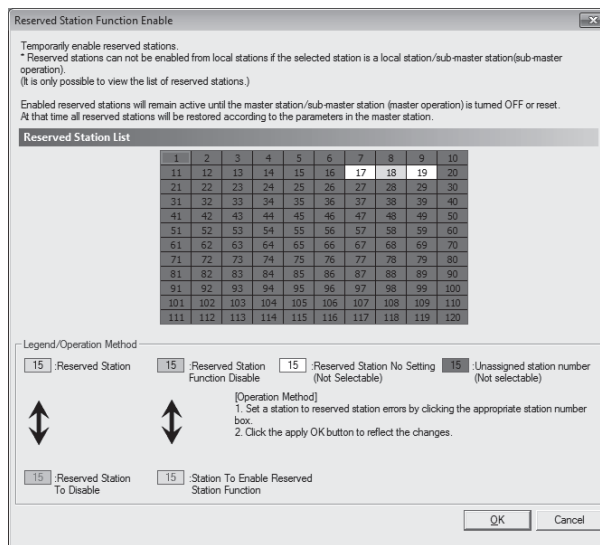

- 5) In "Reserved Station List", click the number of the target station. The text turns red and the background turns orange. Only reserved stations can be selected. The background of a reserved station number is displayed in light blue.

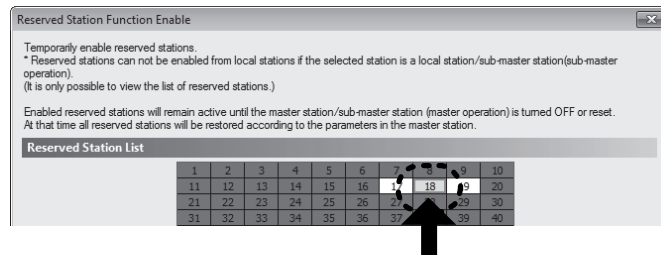

- 6) Clicking the [OK] button will temporarily cancel the reservation.

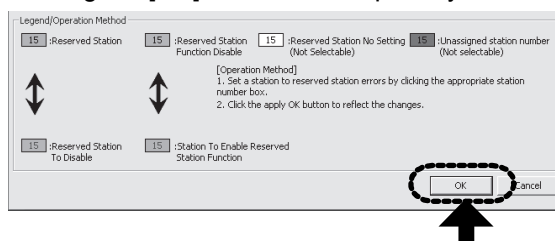

- 7) Debug the slave station that has been added.

POINT

- Parameter setting
The network parameter does not reflect the temporary cancellation of reserved station specification.
- When the master station is reset or the system is powered off
The disabled reserved station setting is ignored, and the slave station returns to the status set by the network parameter of the master station.

REMARK

The reserved station setting can also be temporarily disabled/enabled using link special relays (SBs) and link special registers (SWs) of the master station. (Refer to Section 11.3.)

- (b) Setting a station as a reserved station again
- 1) Open the "Reserved Station Function Enable" window in the same way as described in (2) (a).
 - 2) In "Reserved Station List", click the number of the target station. The text turns red and the background turns light blue. Only stations not specified as a reserved station can be selected. The background of available modules is orange.

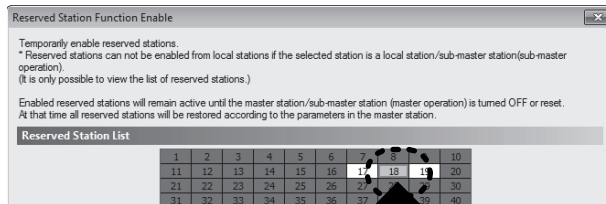

- 3) Click the [OK] button.

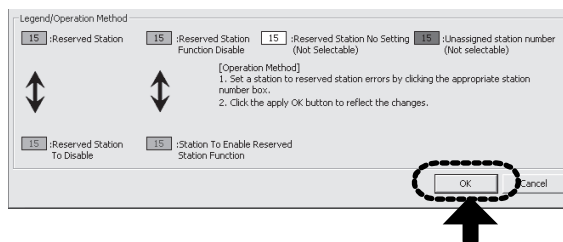

9.7 Remote Operation

Remote operation (RESET operation) can be executed with GX Works2 for the station selected on the "CC IE Field Diagnostics" window.

The displayed window varies depending on the station selected. For the operation with a module other than a Simple Motion module selected, refer to the manual for the module used. The remote operation supports "RESET" operation only. When the operation other than the remote operation is executed, "Not support function execution error (error code: D300H)" occurs. When "RESET" operation is executed, the operation cycle may be over, the connected slave stations may be disconnected momentarily, or a synchronous communication error may occur. Power on the system again if it happens.

POINT
For details of the remote operation, refer to the user's manual for the CPU module used.

Chapter 10 DEDICATED INSTRUCTIONS

10.1 List of Dedicated Instructions.....	10- 2
10.2 Precautions for Dedicated Instructions.....	10- 4
10.2.1 Precautions for dedicated instructions (common).....	10- 4
10.2.2 Precautions for link dedicated instructions	10- 5
10.3 How to Read Detailed Page on Dedicated Instructions.....	10- 6
10.4 JP/GP.READ (Reading Data from Another Station).....	10- 8
10.5 JP/GP.SREAD (Reading Data from Another Station).....	10-16
10.6 JP/GP.WRITE (Writing Data to Another Station).....	10-22
10.7 JP/GP.SWRITE (Writing Data to Another Station).....	10-32
10.8 ZP.REMFR (Reading Data from the Intelligent Device Station/Remote Device Station)	10-38
10.9 ZP.REMTO (Writing Data to the Intelligent Device Station/Remote Device Station).....	10-43

Dedicated instructions facilitate programming for using intelligent function modules.
 This chapter describes dedicated instructions that can be used in the Simple Motion modules.

10.1 List of Dedicated Instructions

The following describes dedicated instructions that can be used in the Simple Motion modules and their transmission range.

(1) Link dedicated instructions

These instructions are used for transient transmission to or from other stations.

(a) List of dedicated instructions

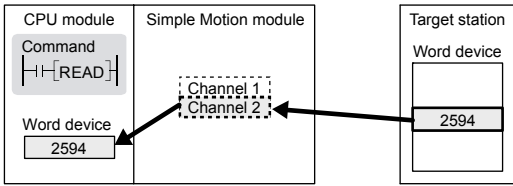
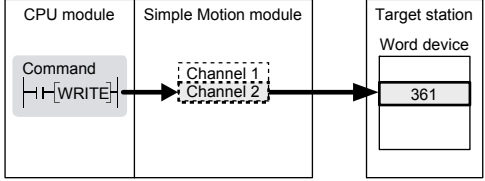
Instruction	Description	Target station (other station)	
		Target network	Target station type
READ SREAD	Reads data from the device of another station. (In units of words) For the SREAD instruction, when data read is completed, the device on the other station is turned on. Data reading from the other station by the SREAD instruction can be checked. 	CC-Link IE Field Network	Intelligent device station
WRITE SWRITE	Writes data in the device of another station. (In units of words) For the SWRITE instruction, when data write is completed, the other station's device is turned on. It can be confirmed that data was written to the other station by the SWRITE instruction. 		

Instruction	Description	Target station (other station)	
		Target network	Target station type
REMFR (Note-1)	<p>Reads data from the buffer memory in the target station. (In units of words)</p> <p>The diagram illustrates the REMFR instruction. On the left, the 'CPU module' contains a 'Command' box with 'REMFR' and a 'Word device' box with '2594'. In the middle, the 'Simple Motion module' contains a dashed box with 'Channel 1', 'Channel 2', 'Channel 3', and 'Channel 32'. On the right, the 'Target station' contains a 'Buffer memory' box with '2594'. Arrows show data being read from the 'Buffer memory' in the 'Target station' and sent to the 'Word device' in the 'CPU module'.</p>	CC-Link IE Field Network	Intelligent device station
REMTO (Note-1)	<p>Writes data to the buffer memory in the target station. (In units of words)</p> <p>The diagram illustrates the REMTO instruction. On the left, the 'CPU module' contains a 'Command' box with 'REMTO'. In the middle, the 'Simple Motion module' contains a dashed box with 'Channel 1', 'Channel 2', 'Channel 3', and 'Channel 32'. On the right, the 'Target station' contains a 'Buffer memory' box with '361'. An arrow shows data being written from the 'Simple Motion module' in the 'CPU module' to the 'Buffer memory' in the 'Target station'.</p>		

(Note-1): Execute it on the master station.

- (b) Transient transmission range of the link dedicated instruction
 - Single network system
 - It is possible to communicate with all stations on the network.

10.2 Precautions for Dedicated Instructions

10.2.1 Precautions for dedicated instructions (common)

The following describes precautions when using dedicated instructions.

- (1) **When changing data specified by dedicated instructions**
Do not change any data (e.g. control data) until execution of the dedicated instruction is completed.
- (2) **When the dedicated instruction is not completed**
Check whether the mode of the Simple Motion module is online.
A dedicated instruction cannot be executed when the mode is offline.
- (3) **When accessing another station by a dedicated instruction during CC-Link IE Field Network diagnostics**
Execution of a dedicated instruction may take some time. To reduce the waiting time, perform the CC-Link IE Field Network diagnostics using the following methods and then execute the dedicated instruction.
 - (a) **Using the COM instruction**
After communication with GX Works2 using the COM instruction, execute the dedicated instruction.
 - 1) Store 0 in the Selection of refresh processing during COM instruction execution (SD778).
 - 2) Turn on the Selection of link refresh processing during COM instruction execution (SM775).
 - 3) When the COM instruction is executed, communication with GX Works2 is executed.
 - 4) Use a dedicated instruction to access another station.

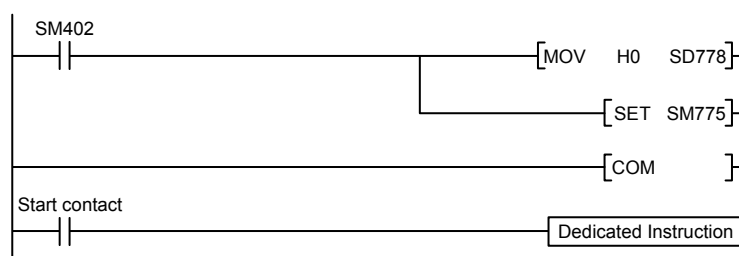

- (b) **Using the service processing setting**
In the service processing setting of PLC Parameter (PLC System) of GX Works2, secure 2 or 3 ms for the service processing time.

REMARK

For details on the COM instruction, refer to the following.
MELSEC-Q/L Programming Manual (Common Instruction)

10.2.2 Precautions for link dedicated instructions

The following describes precautions when using link dedicated instructions.

(1) Executing multiple link dedicated instructions simultaneously

When executing multiple link dedicated instructions simultaneously, make sure that the channels for the instructions are not duplicated. Link dedicated instructions with the same channel cannot be executed simultaneously. To use the same channel for multiple link dedicated instructions, execute one after completion of another. The completion status of the dedicated instruction can be checked by the completion device of the dedicated instruction.

(a) Channel

A channel is an area of a network module where data handled by a link dedicated instruction is stored. By using multiple channels, it is possible to simultaneously access from the own station to other stations or concurrently read from and write to the same network module.

(b) Number of channels

The Simple Motion module has 2 channels that can be used for link dedicated instructions. By using 2 channels simultaneously, two instructions can be executed at the same time. ^(Note-1)

(Note-1): For the REMFR/REMTO instruction, up to 32 channels can be used.

(c) Number of link dedicated instructions that can be simultaneously executed

Even when channels are not duplicated, do not simultaneously execute link dedicated instructions exceeding 34.

If the number of instructions exceeds 34, execute the instructions one by one.

(d) Application example of channels

- Simultaneous access to other stations from the own station

Use a different own station channel for each request destination.

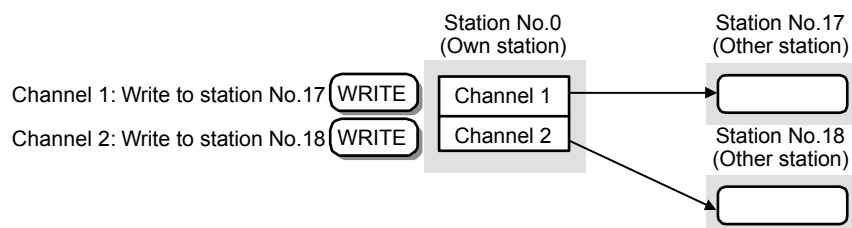

(2) Executing link dedicated instructions to AnUCPU stations

(a) Executing an instruction to AnUCPU stations

Never execute a Simple Motion module dedicated instruction to AnUCPU stations. Doing so will cause "MAIN CPU DOWN" or "WDT ERROR", and may result in an operation stop in the AnUCPU.

10.3 How to Read Detailed Page on Dedicated Instructions

This section describes the page organization and specifications for details on the dedicated instructions described in next section or later.

The following page illustration is for explanation purpose only, and should not be referred to as an actual documentation.

Instruction name

Chapter 10 DEDICATED INSTRUCTIONS

10.4 JP/GP READ (Reading Data from Another Station)

This instruction reads data from the device of the programmable controller on another station. (In units of words)

Execution condition of the instruction

Structure of the instruction in the ladder mode

A device with O is applicable to the instruction.

Setting data (9/16-1)	Internal device (System_user)		File register	Link direct device		Intelligent function module device U□□□□	Index register Zn	Constant			Others
	Bit	Word		Bit	Word			K	H	S	
(S1)	○	○									
(S2)	○	○									
(D1)		○									
(D2)		○									

(Note-1) Local devices and file registers set for each program cannot be used.
 (Note-2) T, C, D, W, ST, SD, and SW can be used.
 (Note-3) When the target station is a Basic model QCPU, a Universal model QCPU, or an LCPU, a digit-specified bit device can be used.
 (Example) K4M16

To use digit specification, the following conditions must be satisfied:
 • The device number should be multiples of 16 (16H).
 • The number of digits should be 4 (K4).

Descriptions of setting data and data type

(1) Setting data

Setting data	Description	Set by	Data type
Jn	Own station's network No. (1 to 239, 254) 254: Network specified in Valid Module During Other Station Access	User	16-bit binary
Un	Start I/O number of the Simple Motion module of the own station (00 to FEH; Upper 2 digits of the I/O number expressed in 3 digits)		
(S1)	Start device of the own station where control data is stored (Refer to Section 10.4 (1) (g)).	System	Device name
(S2)	Start device of the target station where data to be read is stored (Refer to Section 10.4 (1) (b)).		
(D1)	Start device of the own station where read data is stored. A continuous area for the read data length is required (Refer to Section 10.4 (1) (c)).		
(D2)	Device of the own station, which is turned on for 1 scan upon completion of the instruction. (D2)=1 is turned on as well when the instruction fails.		





Handling of the device to use for setting data and control data

- User: Data is set by the user before each instruction is executed.
- System: Execution result of each instruction is stored by the CPU module.

10 - 13

(1) Execution condition

Instruction execution conditions include the following types:

Any time	During on	On the rising edge	During off	On the falling edge
No symbol				

(2) Applicable devices

The following types of devices are used for the dedicated instructions on CC-Link IE Field Network:

Internal device		File register	Constant	
Bit (Note-1)	Word		K, H	\$
X, Y, M, L, F, V, B	T, ST, C, D, W	R, ZR	k□, H□	\$□

(Note-1): For bit data, a bit-specified word device can be used. For example, is used for the bit specification of a word device. (The bit number is specified in hexadecimal.)
 For example, bit 10 of D0 is specified by .
 However, bit specification cannot be used for timer (T), retentive timer (ST), and counter (C).

For details on each device, refer to the following.

User's Manual for the CPU module used (Function Explanation, Program Fundamentals)

(3) Data types

The following data types are available:

Data type	Description
Bit	Bit data or the start number of bit data
BIN 16-bit	16-bit binary data or the start number of word device
BIN 32-bit	32-bit binary data or the start number of double-word device
BCD 4-digit	Four-digit binary-coded decimal data
BCD 8-digit	Eight-digit binary-coded decimal data
Real number	Floating-point data
Character string	Character string data
Device name	Device name data

10.4 JP/GP.READ (Reading Data from Another Station)

This instruction reads data from the device on another station. (In units of words)

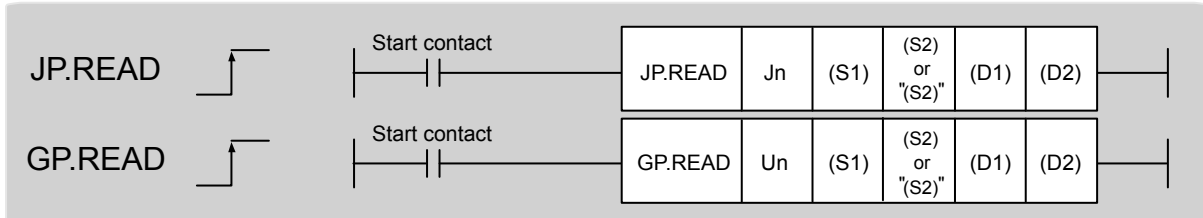

Setting data (Note-1)	Available devices										
	Internal device (System, user)		File register R, ZR	Link direct device J□\□		Intelligent function module device U□\G□	Index register Zn	Constant			Others
	Bit	Word		Bit	Word			K, H	\$		
(S1)	-	○					-				
(S2)	○ (Note-3)	○ (Note-2)	○				-				
(D1)	-	○					-				
(D2)		○					-				

(Note-1): Local devices and file registers set for each program cannot be used.

(Note-2): T, C, D, W, ST, SD, and SW can be used.

(Note-3): When the target station is a Basic model QCPU, a Universal model QCPU, or an LCPU, a digit-specified bit device can be used.

((Example) K4M16)

To use digit specification, the following conditions must be satisfied:

- The device number should be multiples of 16 (10H).
- The number of digits should be 4 (K4).

(1) Setting data

Setting data	Description	Set by	Data type
Jn	Own station's network No. (1 to 239, 254) 254: Network specified in Valid Module During Other Station Access	User	16-bit binary
Un	Start I/O number of the Simple Motion module of the own station (00 to FEH: Upper 2 digits of the I/O number expressed in 3 digits)		
(S1)	Start device of the own station where control data is stored (Refer to Section 10.4 (1) (a).)		
(S2)	Start device of the target station where data to be read is stored (Refer to Section 10.4 (1) (b).)	System	Device name
(D1)	Start device of the own station where read data is stored A continuous area for the read data length is required (Refer to Section 10.4 (1) (c).)		
(D2)	Device of the own station, which is turned on for 1 scan upon completion of the instruction. (D2)+1 is turned on as well when the instruction fails.		

(a) Control data

Device	Item	Setting data	Setting range	Set by										
(S1)+0	Abnormal end type	<div style="text-align: center;"> <table border="1" style="margin: auto;"> <tr> <td style="padding: 2px;">b15</td> <td style="padding: 2px;">to</td> <td style="padding: 2px;">b7</td> <td style="padding: 2px;">to</td> <td style="padding: 2px;">b0</td> </tr> <tr> <td style="padding: 2px;">0</td> <td></td> <td style="padding: 2px;">1</td> <td></td> <td style="padding: 2px;">1</td> </tr> </table> </div> <p>1) Abnormal end type (bit 7) Specify the set status of data in case of abnormal end. 0: After (S1)+11, no data is set for abnormal end. 1: After (S1)+11, data is set for abnormal end.</p>	b15	to	b7	to	b0	0		1		1	0001H 0081H	User
b15	to	b7	to	b0										
0		1		1										
(S1)+1	Completion status	The status of the instruction completion is stored. 0: Normal Other than 0: Error (Refer to Section 12.5.)	–	System										
(S1)+2	Channels used by own station	Specify the channels to be used by the own station. (Refer to Section 10.2.2.)	1 to 2	User										
(S1)+3	Target station's CPU type	Specify the CPU module on the target station to be accessed. 0000H: Control CPU (The access destination is the same as that of when 03FFH is selected.) 03FFH: Control CPU If the above error occurs and the instruction fails, execute the instruction again.	0000H 03FFH	User										
(S1)+4	Target station's network No.	Specify the network No. of the target station. 1 to 239: Network No. 254: Specify this when 254 is set for Jn.	1 to 239 254	User										
(S1)+5	Target station number	Specify the target station number. Master station: 125 (7DH) Intelligent device station: 1 to 120 When 125 (7DH) is set, the module always accesses the master station (station number 0).	125 (7DH) 1 to 120	User										
(S1)+6	–	Unused	0	User										
(S1)+7	Number of resends	During instruction execution For the case where the instruction is not completed within the monitoring time specified by (S1)+8, specify the number of times the instruction is resent.	0 to 15	User										
		When the instruction is completed The number of resends (result) is stored.	–	System										
(S1)+8	Arrival monitoring time	Specify the monitoring time until instruction completion. If the instruction is not completed within the specified time, the instruction is resent for the number of resends specified by (S1)+7. 0: 10 seconds 1 to 32767: 1 to 32767 seconds	0 to 32767	User										

Device	Item	Setting data	Setting range	Set by																																			
(S1)+9	Read data length	Specify the number of words to be read.	1 to 960 From QnACPU: 1 to 480 words	User																																			
(S1)+10	–	Unused	0	User																																			
(S1)+11	Clock set flag	The valid or invalid status of data after (S1)+12 is stored. (Data is stored when "1: Data at the time of abnormal end is set in the area starting from (S1)+11." is set in the abnormal end type in (S1)+0.) The stored data is not cleared even if the dedicated instruction is normally completed. 0: Invalid 1: Valid	–	System																																			
(S1)+12 to (S1)+15	Clock data of abnormal end	Clock data of abnormal end are stored in BCD format. (Data is stored when "1: Data at the time of abnormal end is set in the area starting from (S1)+11." is set in the abnormal end type in (S1)+0.) The stored data is not cleared even if the dedicated instruction is normally completed. <table border="1" style="margin-left: auto; margin-right: auto;"> <tr> <td style="text-align: right;">b15</td> <td style="text-align: center;">~</td> <td style="text-align: left;">b8</td> <td style="text-align: center;">~</td> <td style="text-align: left;">b7</td> <td style="text-align: center;">~</td> <td style="text-align: left;">b0</td> </tr> <tr> <td>(S1)+12</td> <td>Month (01H to 12H)</td> <td>Year (00H to 99H), last 2 digits</td> <td colspan="4"></td> </tr> <tr> <td>(S1)+13</td> <td>Hour (00H to 23H)</td> <td>Day (01H to 31H)</td> <td colspan="4"></td> </tr> <tr> <td>(S1)+14</td> <td>Second (00H to 59H)</td> <td>Minute (00H to 59H)</td> <td colspan="4"></td> </tr> <tr> <td>(S1)+15</td> <td>Year (00H to 99H), first 2 digits</td> <td>Day of week (00H to 06H)</td> <td colspan="4"></td> </tr> </table> <p style="text-align: center;">00H (Sun.) to 06H (Sat.)</p> When the target station is QnACPU, 00H is stored in the year (the first two digits of the year).	b15	~	b8	~	b7	~	b0	(S1)+12	Month (01H to 12H)	Year (00H to 99H), last 2 digits					(S1)+13	Hour (00H to 23H)	Day (01H to 31H)					(S1)+14	Second (00H to 59H)	Minute (00H to 59H)					(S1)+15	Year (00H to 99H), first 2 digits	Day of week (00H to 06H)					–	System
b15	~	b8	~	b7	~	b0																																	
(S1)+12	Month (01H to 12H)	Year (00H to 99H), last 2 digits																																					
(S1)+13	Hour (00H to 23H)	Day (01H to 31H)																																					
(S1)+14	Second (00H to 59H)	Minute (00H to 59H)																																					
(S1)+15	Year (00H to 99H), first 2 digits	Day of week (00H to 06H)																																					
(S1)+16	Error-detected station's network No. (Note-1)	The network No. of the station in which an error was detected is stored. (Data is stored when "1: Data at the time of abnormal end is set in the area starting from (S1)+11." is set in the abnormal end type in (S1)+0.) The stored data is not cleared even if the dedicated instruction is normally completed. 1 to 239: Network No.	–	System																																			
(S1)+17	Error-detected station number (Note-1)	The station number of the station in which an error was detected is stored. (Data is stored when "1: Data at the time of abnormal end is set in the area starting from (S1)+11." is set in the abnormal end type in (S1)+0.) The stored data is not cleared even if the dedicated instruction is normally completed. Master station: 125 (7DH) Intelligent device station: 1 to 120	–	System																																			

(Note-1): If Completion status ((S1)+1) is "Channel in use (error codes: D25AH and D25BH)", data is not stored.

- (b) Start device of the target station where data to be read is stored
If the device setting in PLC Parameter is different between the own and target stations, use "(S2)" (with double-quotation marks) to specify.
- (c) Start device of the own station where read data is stored
Specify the own station's start device (D1), within the available range so that the read data can be stored.
(Example) When the area addressed D150 or higher of the own station CPU is already used

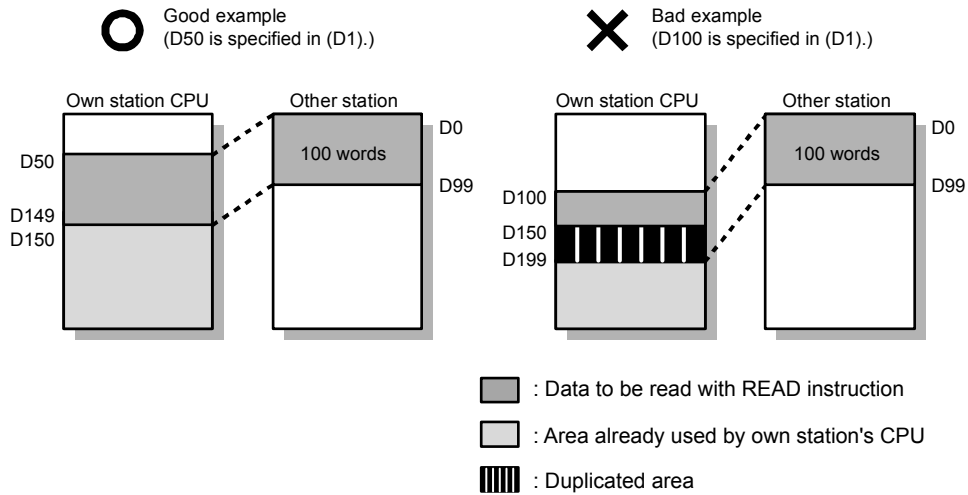

(2) Function

(a) READ instruction overview

The instruction reads data by the specified number of words (control data ((S1)+9)) from the target station start device (S2) into the own station word devices (after (D1)).

Specify the target stations in control data ((S1)+4 and (S1)+5).

When the reading from devices of the target station is completed, the completion device (D2) turns on.

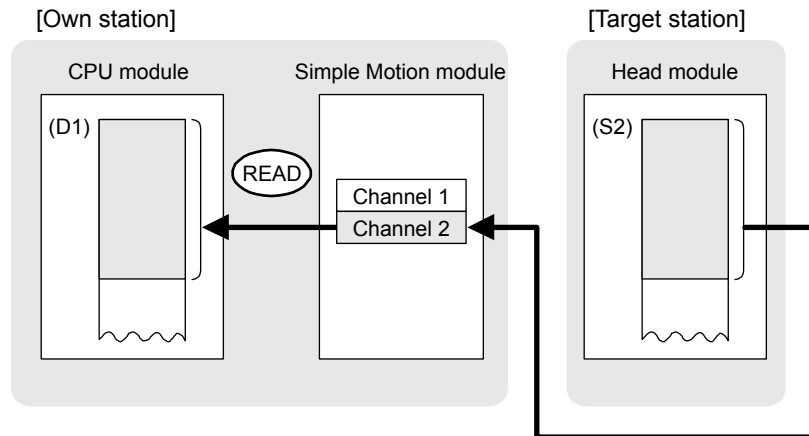

(b) Target stations which can be specified

For details on target stations which can be specified, refer to the following. Refer to Section 10.1 (1).

(c) Checking the execution status of the READ instruction

The execution status (completion or error) of the READ instruction can be checked using the following device specified for the setting data.

- Completion device (D2)

It is turned on in the END processing of the scan after completion of the READ instruction, and is turned off in the next END processing.

- Completion status indication device ((D2)+1)

It is turned on in the END processing of the scan after completion of the READ instruction, and is turned off in the next END processing only if the READ instruction fails.

(d) READ instruction execution timing

- When completed

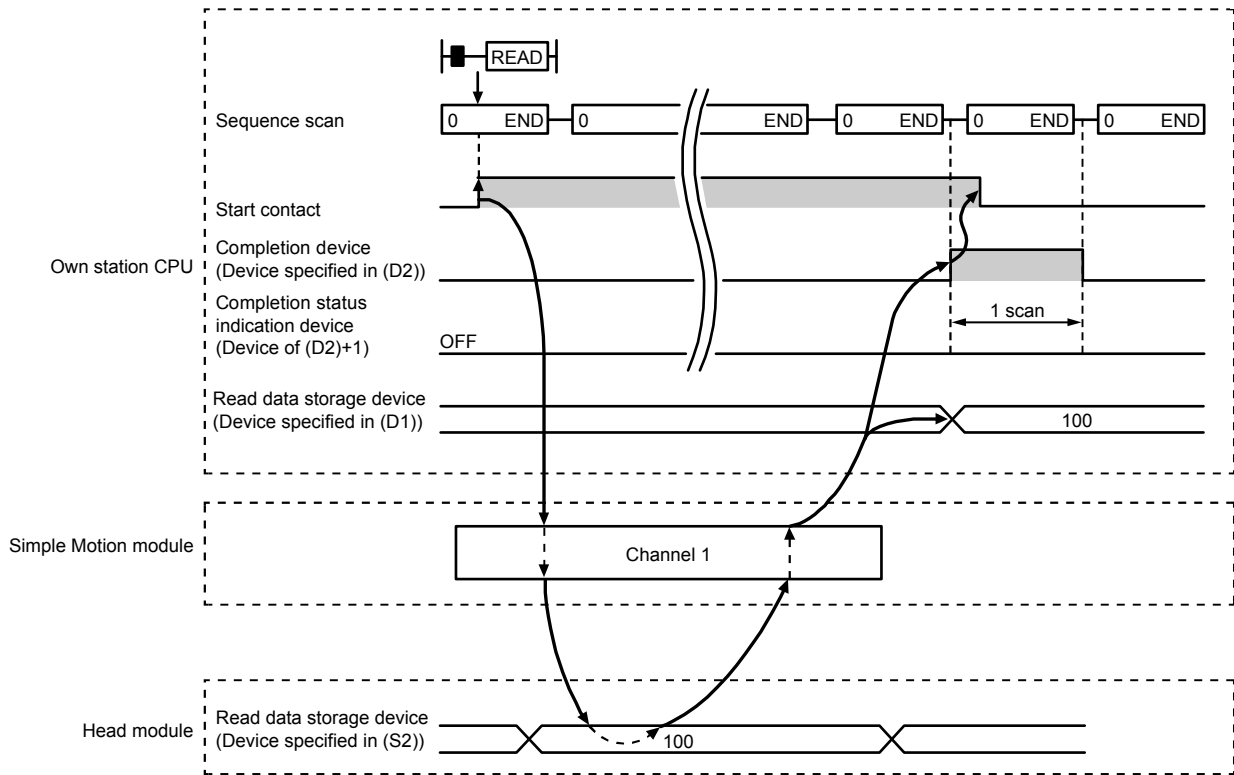

- When failed

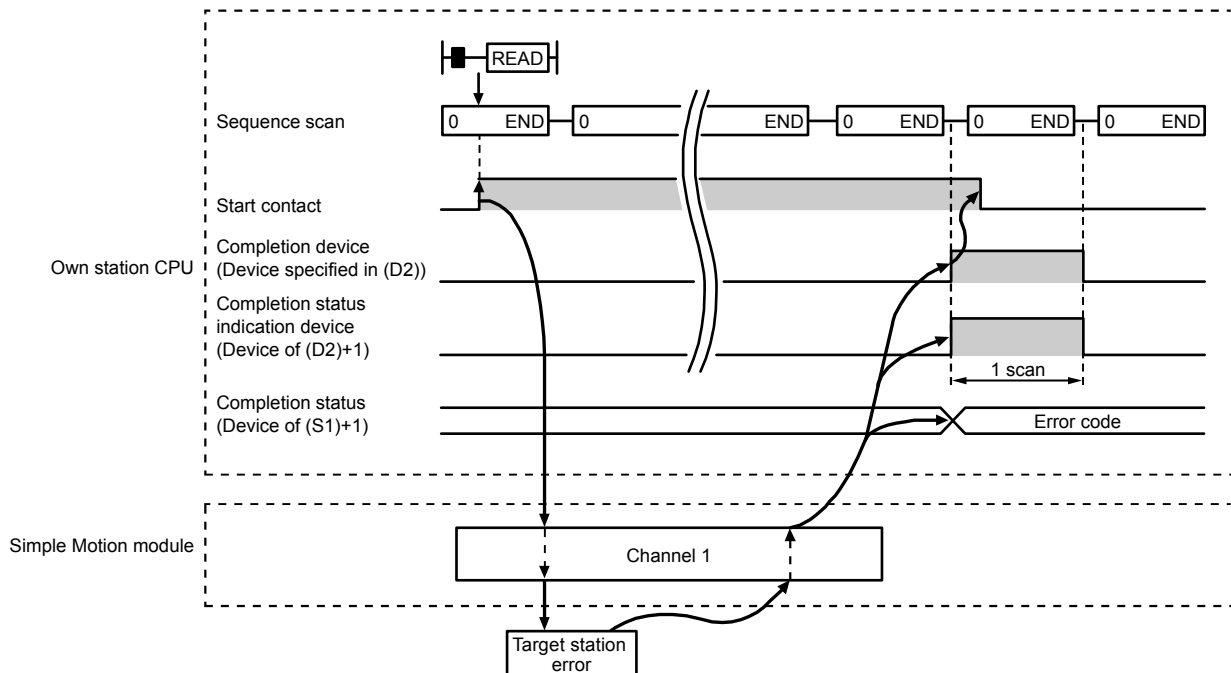

(3) Error

When the dedicated instruction fails, error details can be checked by any of the following methods:

(a) In GX Works2

Error details can be checked using CC-Link IE Field Network diagnostics. (Refer to Chapter 9.)

(b) By devices

Completion status indication device ((D2)+1) is turned on and an error code is stored in Completion status ((S1)+1) of the control data.

According to the error code, check the error details and take a corrective action. (Refer to Section 12.5.)

(4) Program example

The following program is for reading data of W250 to W254 of station No.17 (target station) into D700 to D704 of station No. 0 (own station) when M101 is turned on.

(a) System configuration

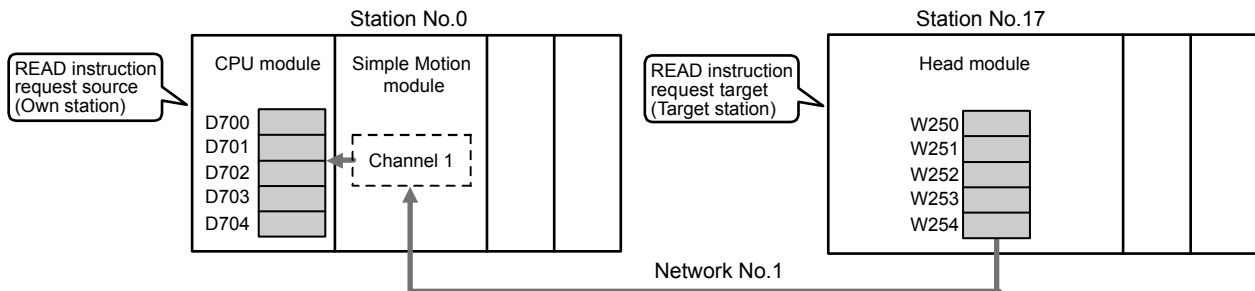

(b) Devices used in the program example

- Link special relay (SB), link special register (SW)

Device	Description	Device	Description
SB0047	Baton pass status (own station)	SW00A1.0	Baton pass status (each station) of station No.17

- Devices used by the user

Device	Description	Device	Description
M100	Control data setting command	D200 to D217	Control data
M101	Start contact	D700 to D704	Read data storage device (station No.0)
M105	Completion device		
M106	Completion status indication device		-

REMARK

For details on link special relay (SB) and link special register (SW), refer to Appendix 2 and Appendix 3.

(c) READ instruction setting

The setting of READ instruction control data is as follows.

Device		Item	Set value
(S1)+0	D200	Abnormal end type	0081H (Sets data for abnormal end)
(S1)+1	D201	Completion status	(Setting is not required because it is set by the system)
(S1)+2	D202	Channels used by own station	1
(S1)+3	D203	Target station's CPU type	0000H (control CPU)
(S1)+4	D204	Target station's network No.	1
(S1)+5	D205	Target station number	17
(S1)+6	D206	(Unused)	0
(S1)+7	D207	Number of resends	5 times
(S1)+8	D208	Arrival monitoring time	0 (10 seconds)
(S1)+9	D209	Read data length	5 words
(S1)+10	D210	(Unused)	0
(S1)+11	D211	Clock set flag	(Setting is not required because it is set by the system)
(S1)+12 to (S1)+15	D212 to D215	Clock data of abnormal end	
(S1)+16	D216	Error-detected station's network No.	
(S1)+17	D217	Error-detected station number	

(d) Program example

The following program is written to the CPU module of station No.0.

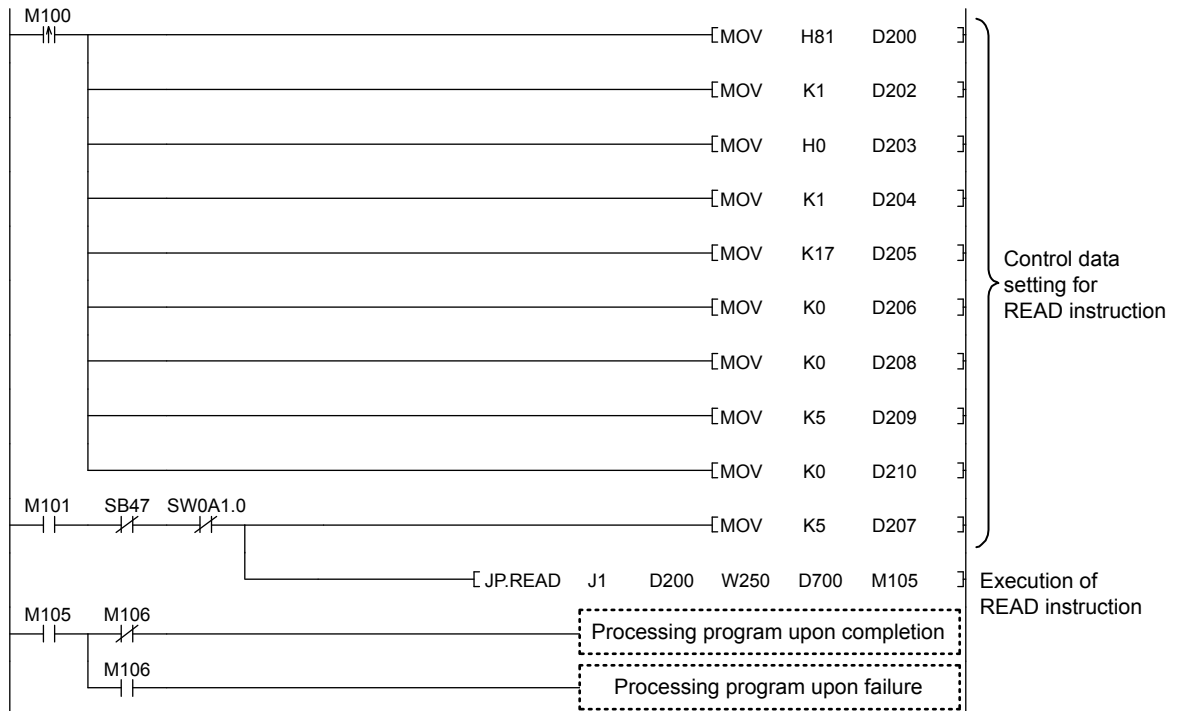

10.5 JP/GP.SREAD (Reading Data from Another Station)

This instruction reads data from the device of another station. (In units of words)
 With the SREAD instruction, when data read is completed, the device of the other station is turned on. Data reading with the SREAD instruction can be confirmed by this.

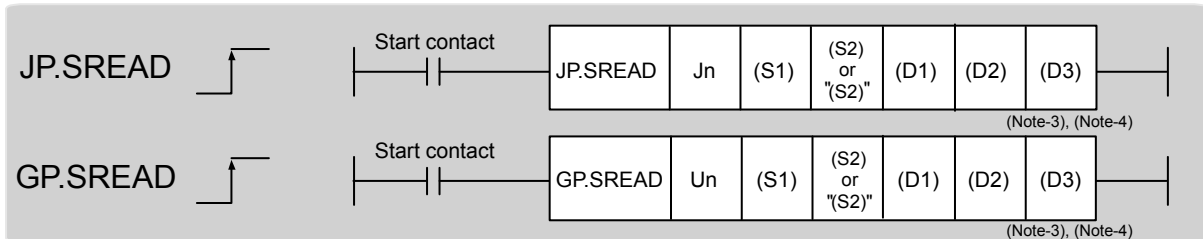

Setting data (Note-1)	Available devices									
	Internal device (System, user)		File register R, ZR	Link direct device J□\□		Intelligent function module device U□\G□	Index register Zn	Constant		Others
	Bit	Word		Bit	Word			K, H	\$	
(S1)	–	○								
(S2)	○ (Note-5)	○ (Note-2)	○							
(D1)	–	○								
(D2)		○								
(D3)		○								

(Note-1): Local devices and file registers set for each program cannot be used.

(Note-2): T, C, D, W, ST, SD, and SW can be used.

(Note-3): For the SREAD instruction, the read notification device (D3) can be omitted in the programming.

However, the operation is the same as the READ instruction.

The SREAD instruction can operate differently depending on whether read notification device (D3) is omitted or not.

(Note-4): When the target station is a Basic model QCPU or a QSCPU, the data set in the read notification device (D3) is ignored.

(Operation is the same as the READ instruction.)

(Note-5): When the target station is a Basic model QCPU, a Universal model QCPU, or an LCPU, a digit-specified bit device can be used.

((Example) K4M16)

To use digit specification, the following conditions must be satisfied:

- The device number should be multiples of 16 (10H).
- The number of digits should be 4 (K4).

(1) Setting data

Setting data	Description	Set by	Data type
Jn	Own station's network No. (1 to 239, 254) 254: Network specified in Valid Module During Other Station Access	User	16-bit binary
Un	Start I/O number of the Simple Motion module of the own station (00 to FEH: Upper 2 digits of the I/O number expressed in 3 digits)		
(S1)	Start device of the own station where control data is stored		
(S2)	Start device of the target station where data to be read is stored	System	Device name
(D1)	Start device of the own station where read data is stored A continuous area for the read data length is required.		
(D2)	Device of the own station, which is turned on for 1 scan upon completion of the instruction. (D2)+1 is turned on as well when the instruction fails.		Bit
(D3)	Device of the target station, which is turned on for 1 scan upon completion of the instruction. Data reading from another station can be confirmed.		

- (a) Control data
The SREAD instruction control data is the same as that of the READ instruction. (Refer to Section 10.4.)
- (b) Start device of the target station where data to be read is stored
The target station's start device where data to be read by the SREAD instruction is stored is the same as that of the READ instruction. (Refer to Section 10.4.)
- (c) Start device of the own station where read data is stored
The start device of the own station where data read by the SREAD instruction is stored is the same as that of the READ instruction. (Refer to Section 10.4.)

(2) Function

(a) SREAD instruction overview

The instruction reads data by the specified number of words (control data ((S1)+9)) from the target station start device (S2) into the own station word devices (after (D1)).

Specify the target stations in control data ((S1)+4 and (S1)+5).

When the reading of the data specified in (S2) is completed, the following devices are turned on.

- Own station: Completion device (D2)
- Target station: Read notification device (D3)

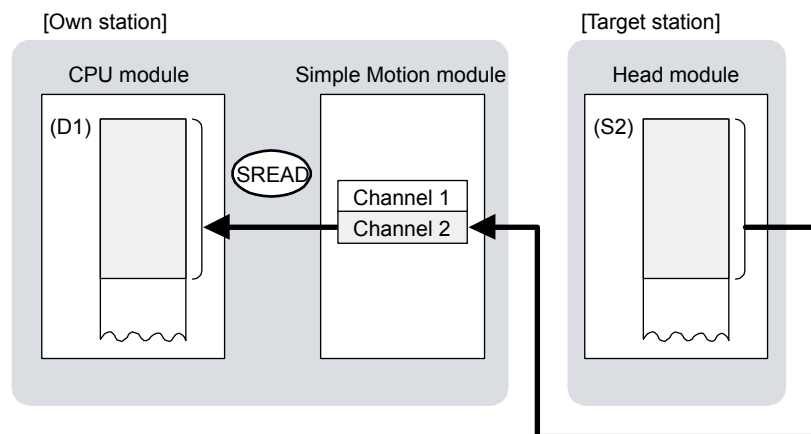

(b) Target stations which can be specified

For details on target stations which can be specified, refer to the following. Refer to Section 10.1 (1).

(c) Checking the execution status of the SREAD instruction

The execution status (completion or error) of the SREAD instruction can be checked using the following device specified for the setting data.

- Completion device (D2)

It is turned on in the END processing of the scan after completion of the SREAD instruction, and is turned off in the next END processing.
- Completion status indication device ((D2)+1)

It is turned on in the END processing of the scan after completion of the SREAD instruction, and is turned off in the next END processing only if the SREAD instruction fails.

(d) SREAD instruction execution timing

- When completed

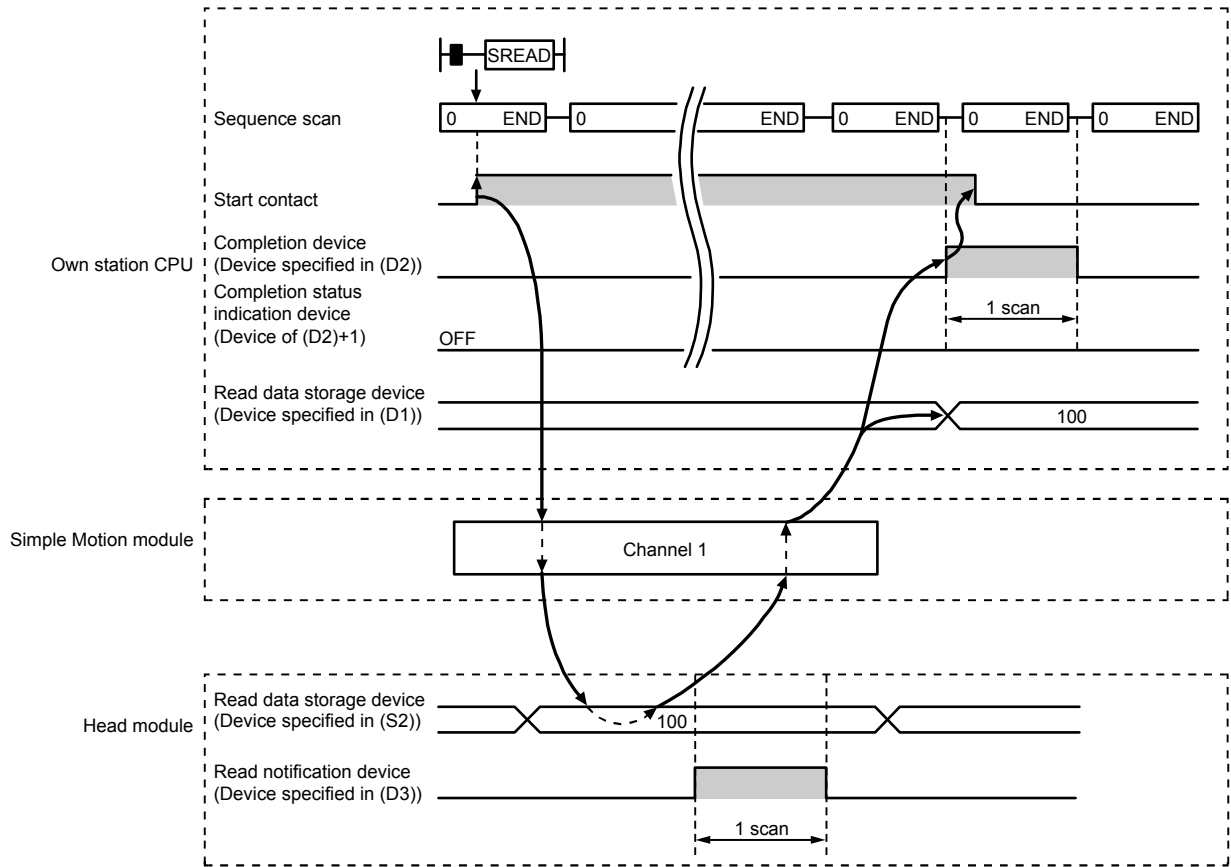

- When failed

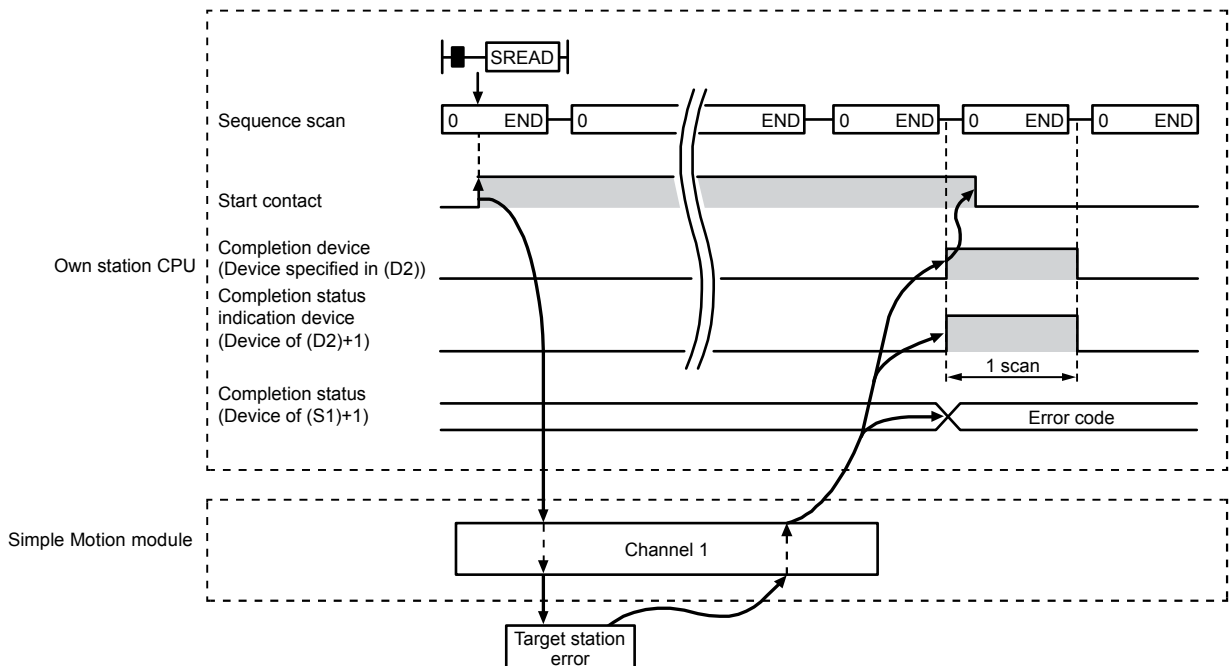

(3) Error

When the dedicated instruction fails, error details can be checked by any of the following methods:

(a) In GX Works2

Error details can be checked using CC-Link IE Field Network diagnostics. (Refer to Chapter 9.)

(b) By devices

Completion status indication device ((D2)+1) is turned on and an error code is stored in Completion status ((S1)+1) of the control data.

According to the error code, check the error details and take a corrective action. (Refer to Section 12.5.)

(4) Program example

Just like the READ instruction program example, this program example is for reading data of W250 to W254 of station No.17 (target station) into D700 to D704 of station No.0 (own station) when M101 is turned on.

Furthermore, when the read notification device (D3) of the target station is turned on, Y60 of the target station is turned on.

REMARK

Compared to the READ instruction program example, the SREAD instruction program example has a different section where the read notification device (D3) is specified at the end of the arguments. (Refer to Section 10.4 (4).)

(a) System configuration

Same as the READ instruction program example.

(b) Devices used in the program example

- Link special relay (SB), link special register (SW)
Same as the READ instruction program example.

- Devices used by users

The devices used in the SREAD instruction request source (station No.0) are the same as those in the READ instruction program example.

Devices used in the SREAD instruction request destination (station No.17)

Device	Description	Device	Description
Y107	Read notification device	Y60	Read completion device

(c) SREAD instruction setting

Same as the READ instruction program example.

(d) Program example

- Program example in SREAD instruction request source (station No.0)

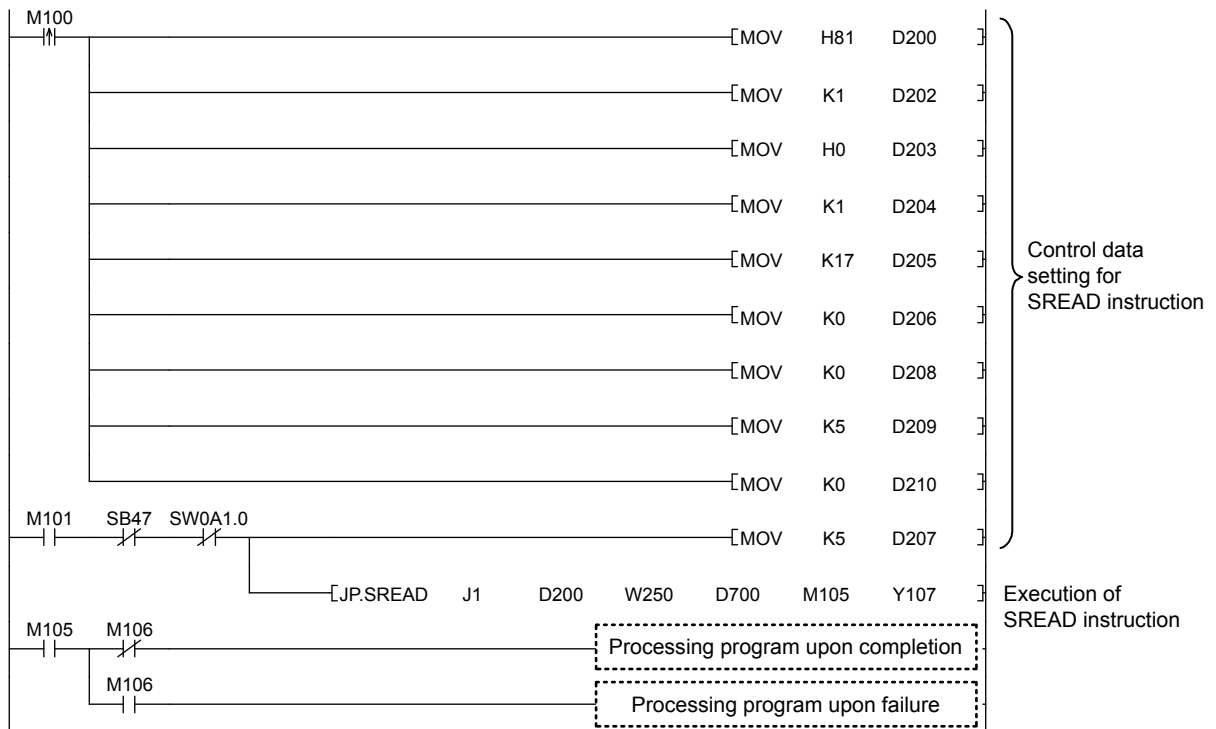

10.6 JP/GP.WRITE (Writing Data to Another Station)

This instruction writes data to the device of another station. (In units of words)

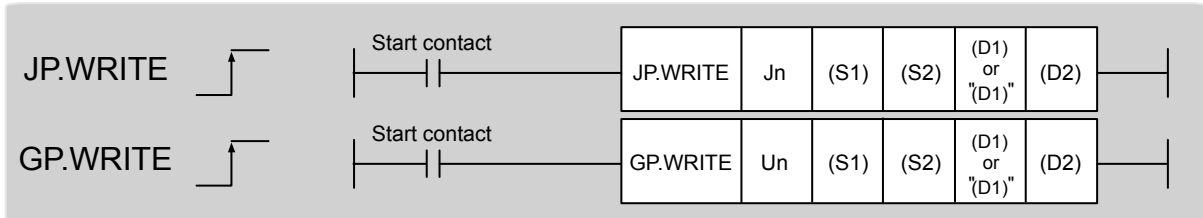

Setting data (Note-1)	Available devices									
	Internal device (System, user)		File register R, ZR	Link direct device J□\□		Intelligent function module device U□\G□	Index register Zn	Constant		Others
	Bit	Word		Bit	Word			K, H	\$	
(S1)	–	○					–			
(S2)	○ (Note-3)	○					–			
(D1)	–	○ (Note-2)	○				–			
(D2)		○					–			

(Note-1): Local devices and file registers set for each program cannot be used.

(Note-2): T, C, D, W, ST, SD, and SW can be used.

When specifying SD/SW, data can be written in the range that the user can set.

For details on SD/SW, refer to the following.

Manuals for the CPU module and network module of the target station

(Note-3): When the target station is a Basic model QCPU, a Universal model QCPU, or an LCPU, a digit-specified bit device can be used.

(Example: K4M16)

To use digit specification, the following conditions must be satisfied:

- The device number should be multiples of 16 (10H).
- The number of digits should be 4 (K4).

(1) Setting data

Setting data	Description	Set by	Data type
Jn	Own station's network No. (1 to 239, 254) 254: Network specified in Valid Module During Other Station Access	User	16-bit binary
Un	Start I/O number of the Simple Motion module of the own station (00 to FEH: Upper 2 digits of the I/O number expressed in 3 digits)		
(S1)	Start device of the own station where control data is stored		
(S2)	Start device of the own station where data to be written is stored	System	Device name
(D1)	Start device of the target station where data is to be written (A continuous area with the write data length is required.)		
(D2)	Device of the own station, which is turned on for 1 scan upon completion of the instruction. (D2)+1 is turned on as well when the instruction fails.		Bit

(a) Control data

Device	Item	Setting data	Setting range	Set by										
(S1)+0	Execution/ abnormal end type	<div style="text-align: center;"> <table border="1" style="margin: auto;"> <tr> <td style="text-align: center;">b15</td> <td style="text-align: center;">to</td> <td style="text-align: center;">b7</td> <td style="text-align: center;">to</td> <td style="text-align: center;">b0</td> </tr> <tr> <td style="text-align: center;">0</td> <td></td> <td style="text-align: center;">2)</td> <td></td> <td style="text-align: center;">1)</td> </tr> </table> </div> <p>1) Execution type (bit 0)</p> <p>0: Without arrival confirmation</p> <ul style="list-style-type: none"> When the target station is on the same network The process is completed when data is sent from the own station. <div style="text-align: center;"> </div> <p>1: With arrival confirmation</p> <p>The process is completed when data is written in the target station.</p> <div style="text-align: center;"> </div> <p>When "0: Without arrival confirmation" is specified, the result is regarded as normal on the own station even if the writing to the target station fails, as follows.</p> <ul style="list-style-type: none"> When communication ends normally even though sent data are abnormal <p>2) Abnormal end type (bit 7)</p> <p>Specify the data set status in case of abnormal end.</p> <p>0: After (S1)+11, no data is set for abnormal end.</p> <p>1: After (S1)+11, data for abnormal end is set.</p>	b15	to	b7	to	b0	0		2)		1)	0000H 0001H 0080H 0081H	User
b15	to	b7	to	b0										
0		2)		1)										
(S1)+1	Completion status	The status of the instruction completion is stored.	–	System										
		0: Normal Other than 0: Error (Refer to Section 12.5.)												

Device	Item	Setting data	Setting range	Set by
(S1)+2	Channels used by own station	Specify the channels to be used by the own station. (Refer to Section 10.2.2 (1).)	1 to 2	User
(S1)+3	Target station's CPU type	Specify the CPU module on the target station to be accessed. 0000H: Control CPU (The access destination is the same as that of when 03FFH is selected.) 03FFH: Control CPU If the above error occurs and the instruction fails, execute the instruction again.	0000H 03FFH	User
(S1)+4	Target station's network No.	Specify the network No. of the target station. 1 to 239: Network No. 254: Specify this when 254 is set for Jn.	1 to 239 254	User
(S1)+5	Target station number	Specify the target station number. (1) Station number specification Master station: 125 (7DH) Intelligent device station: 1 to 120 When 125 (7DH) is set, the module always accesses the master station (station number 0). In order to increase data reliability, it is recommended to execute the instruction after setting "1: With arrival confirmation" to the execution type specified by (S1)+0. (2) All stations specification FFH: All stations on the target station's network No. (excluding the own station) (It can be set when the execution type set for (S1)+0 is "0: Without arrival confirmation".) When using all stations specification • Specify "03FFH" for the target station's CPU type ((S1)+3) • Writing of the data cannot be confirmed on the target station. For whether data was written normally, check the device of the write target station. • Data cannot be written to the station with the station number already in use or the station with no station number setting. Correct the error then execute the instruction.	125 (7DH) 1 to 120 FFH	User
(S1)+6	–	Unused	0	User
(S1)+7	Number of resends	During instruction execution For the case where the instruction is not completed within the monitoring time specified by (S1)+8, specify the number of times the instruction is resent. (It can be set when the execution type set by (S1)+0 is "1: With arrival confirmation".)	0 to 15	User
		When the instruction is completed The number of resends (result) is stored. (Valid when the execution type set by (S1)+0 is "1: With arrival confirmation".)	–	System

Device	Item	Setting data	Setting range	Set by																									
(S1)+8	Arrival monitoring time	Specify the monitoring time until instruction completion. (It can be set when the execution type set by (S1)+0 is "1: With arrival confirmation".) If the instruction is not completed within the specified time, the instruction is resent for the number of resends specified by (S1)+7. 0: 10 seconds 1 to 32767: 1 to 32767 seconds	0 to 32767	User																									
(S1)+9	Write data length	Specify the number of words to be written.	1 to 960 To QnACPU: 1 to 480 words	User																									
(S1)+10	–	Unused	0	User																									
(S1)+11	Clock set flag	The valid or invalid status of data after (S1)+12 is stored. (Data is stored when "1: Data at the time of abnormal end is set in the area starting from (S1)+11." is set in the abnormal end type in (S1)+0.) The stored data is not cleared even if the dedicated instruction is normally completed. 0: Invalid 1: Valid	–	System																									
(S1)+12 to (S1)+15	Clock data of abnormal end	Clock data of abnormal end is stored in BCD format. (Data is stored when "1: Data at the time of abnormal end is set in the area starting from (S1)+11." is set in the abnormal end type in (S1)+0.) The stored data is not cleared even if the dedicated instruction is normally completed. <table border="1" style="margin-left: auto; margin-right: auto;"> <tr> <td style="text-align: center;">b15</td> <td style="text-align: center;">~</td> <td style="text-align: center;">b8 b7</td> <td style="text-align: center;">~</td> <td style="text-align: center;">b0</td> </tr> <tr> <td>(S1)+12</td> <td>Month (01H to 12H)</td> <td colspan="3">Year (00H to 99H), last 2 digits</td> </tr> <tr> <td>(S1)+13</td> <td>Hour (00H to 23H)</td> <td colspan="3">Day (01H to 31H)</td> </tr> <tr> <td>(S1)+14</td> <td>Second (00H to 59H)</td> <td colspan="3">Minute (00H to 59H)</td> </tr> <tr> <td>(S1)+15</td> <td>Year (00H to 99H), first 2 digits</td> <td colspan="3">Day of week (00H to 06H)</td> </tr> </table> <p style="text-align: center;">00H (Sun.) to 06H (Sat.)</p> When the target station is QnACPU, 00H is stored in the year (the first two digits of the year).	b15	~	b8 b7	~	b0	(S1)+12	Month (01H to 12H)	Year (00H to 99H), last 2 digits			(S1)+13	Hour (00H to 23H)	Day (01H to 31H)			(S1)+14	Second (00H to 59H)	Minute (00H to 59H)			(S1)+15	Year (00H to 99H), first 2 digits	Day of week (00H to 06H)			–	System
b15	~	b8 b7	~	b0																									
(S1)+12	Month (01H to 12H)	Year (00H to 99H), last 2 digits																											
(S1)+13	Hour (00H to 23H)	Day (01H to 31H)																											
(S1)+14	Second (00H to 59H)	Minute (00H to 59H)																											
(S1)+15	Year (00H to 99H), first 2 digits	Day of week (00H to 06H)																											
(S1)+16	Error-detected station's network No. (Note-1)	The network No. of the station in which an error was detected is stored. (Data is stored when "1: Data at the time of abnormal end is set in the area starting from (S1)+11." is set in the abnormal end type in (S1)+0.) The stored data is not cleared even if the dedicated instruction is normally completed. 1 to 239: Network No.	–	System																									
(S1)+17	Error-detected station number (Note-1)	The station number of the station in which an error was detected is stored. (Data is stored when "1: Data at the time of abnormal end is set in the area starting from (S1)+11." is set in the abnormal end type in (S1)+0.) The stored data is not cleared even if the dedicated instruction is normally completed. Master station: 125 (7DH) Intelligent device station: 1 to 120	–	System																									

(Note-1): If Completion status ((S1)+1) is "Channel in use (error codes: D25AH and D25BH)", data is not stored.

- (b) Start device of the own station where data to be written is stored
Specify the start device of the own station that stores data to be written.
- (c) Start device of the target station where data is to be written
If the device setting in PLC Parameter is different between the own and target stations, use "(D1)" (with double-quotation marks) to specify.
Specify the start device (D1) of the target station, within the available range so that the write data can be stored.
(Example) When the area addressed D150 or higher of the target station is already used

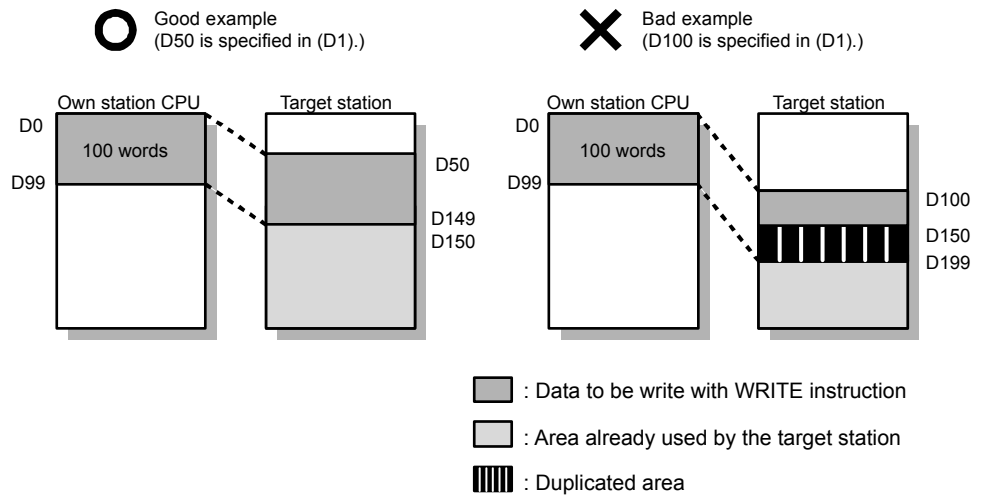

(2) Function

(a) WRITE instruction overview

The instruction writes data by the specified number of words (control data ((S1)+9)) from the own station start device (S2) into the target station word devices (after (D1)).

Specify the target stations in control data ((S1)+4 and (S1)+5).

When the writing to devices of the target station is completed, the completion device (D2) turns on.

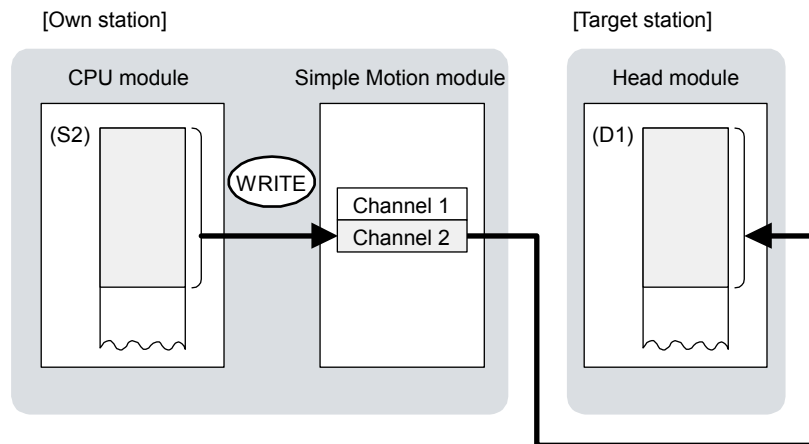

(b) Target stations which can be specified

For details on target stations which can be specified, refer to the following. Refer to Section 10.1 (1).

(c) Checking the execution status of the WRITE instruction

The execution status (completion or error) of the WRITE instruction can be checked using the following device specified by the setting data.

- Completion device (D2)
It is turned on in the END processing of the scan after completion of the WRITE instruction, and is turned off in the next END processing.
- Completion status indication device ((D2)+1)
It is turned on in the END processing of the scan after completion of the WRITE instruction, and is turned off in the next END processing only if the WRITE instruction fails.

(d) WRITE instruction execution timing

- When completed

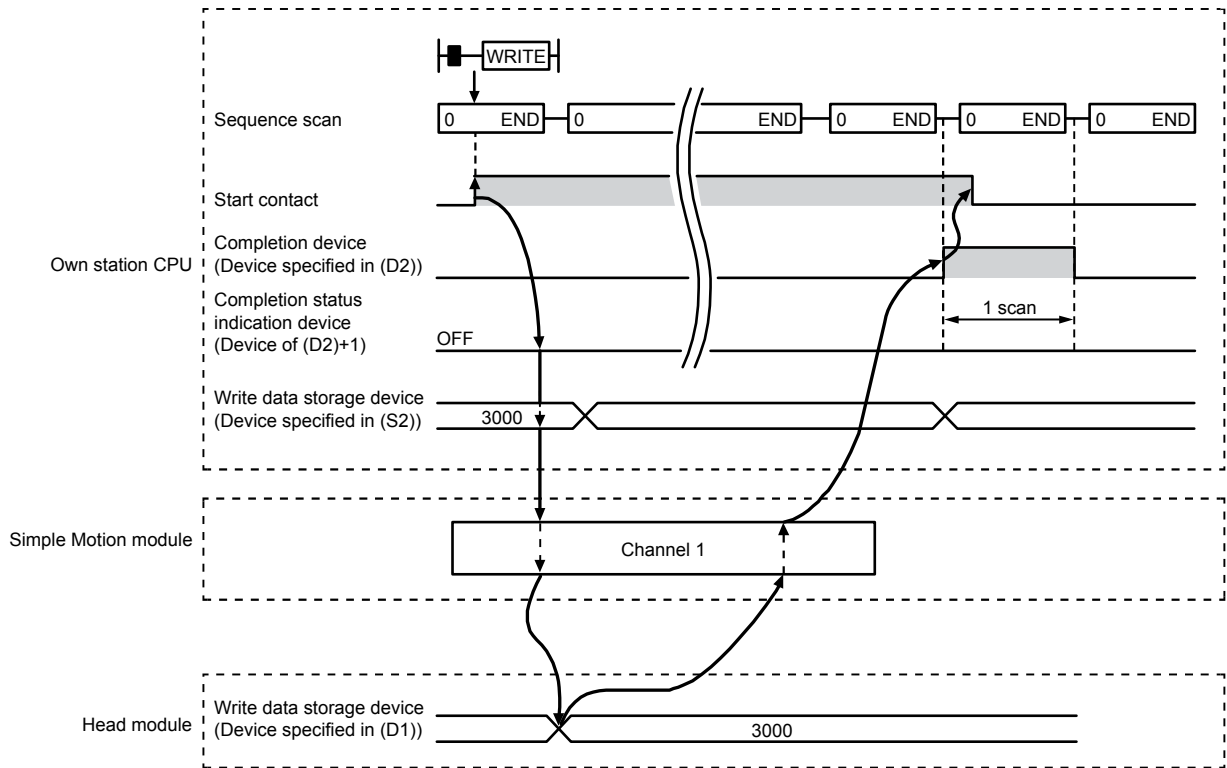

- When failed

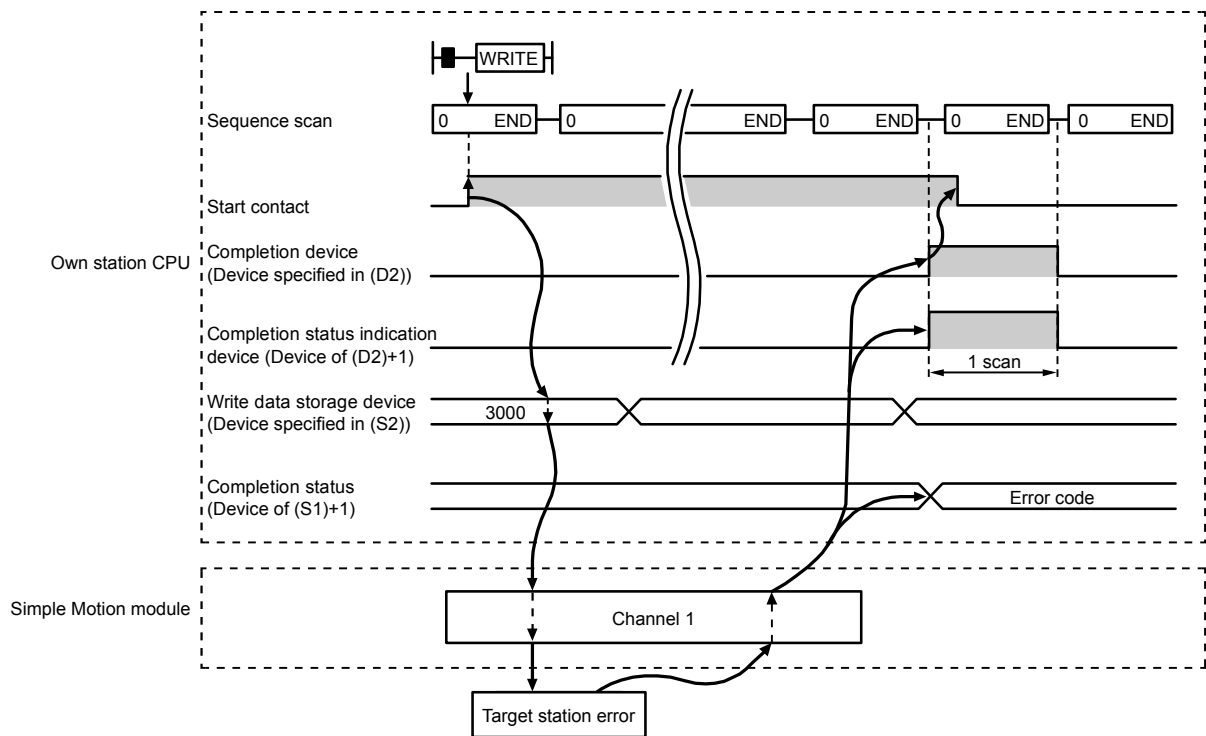

(3) Error

When the dedicated instruction fails, error details can be checked by any of the following methods:

(a) In GX Works2

Error details can be checked using CC-Link IE Field Network diagnostics. (Refer to Chapter 9.)

(b) By devices

Completion status indication device ((D2)+1) is turned on and an error code is stored in Completion status ((S1)+1) of the control data.

According to the error code, check the error details and take a corrective action. (Refer to Section 12.5.)

(4) Program example

The following program is for writing data of D750 to D753 of station No.0 (own station) into W300 to W303 of station No.18 (target station) when M112 is turned on.

(a) System configuration

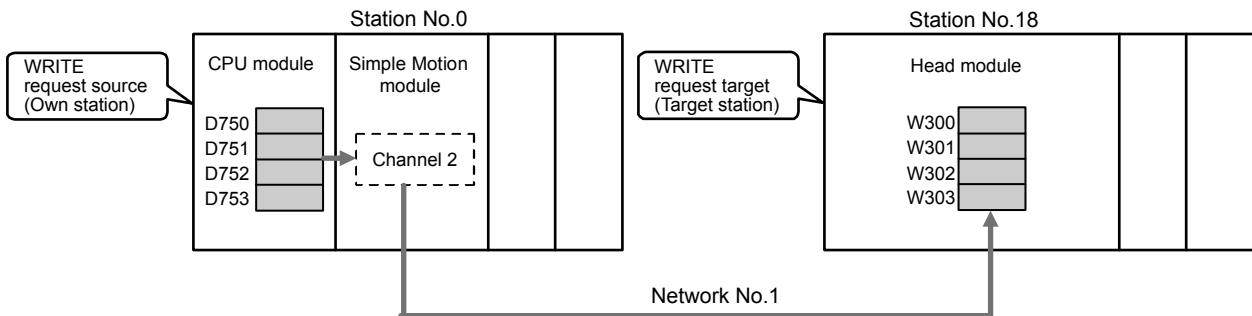

(b) Devices used in the program example

- Link special relay (SB), link special register (SW)

Device	Description	Device	Description
SB0047	Baton pass status (own station)	SW00A1.1	Baton pass status (each station) of station No.18

- Devices used by the user

Device	Description	Device	Description
M110	Control data setting command	M116	Completion status indication device
M111	White data setting command	D220 to D237	Control data
M112	Start contact	D750 to D753	Write data storage device (station No.0)
M115	Completion device		-

REMARK

For details on link special relay (SB) and link special register (SW), refer to Appendix 2 and Appendix 3.

(c) WRITE instruction setting

The setting of WRITE instruction control data is as follows.

Device		Item	Set value
(S1)+0	D220	Execution/abnormal end type	0081H. (With arrival confirmation, sets data for abnormal end)
(S1)+1	D221	Completion status	– (Setting is not required because it is set by the system)
(S1)+2	D222	Channels used by own station	2
(S1)+3	D223	Target station's CPU type	0000H (control CPU)
(S1)+4	D224	Target station's network No.	1
(S1)+5	D225	Target station number	18
(S1)+6	D226	(Unused)	0
(S1)+7	D227	Number of resends	5 times
(S1)+8	D228	Arrival monitoring time	0 (10 seconds)
(S1)+9	D229	Write data length	4 words
(S1)+10	D230	(Unused)	0
(S1)+11	D231	Clock set flag	– (Setting is not required because it is set by the system)
(S1)+12 to (S1)+15	D232 to D235	Clock data of abnormal end	
(S1)+16	D236	Error-detected station's network No.	
(S1)+17	D237	Error-detected station number	

(d) Program example

The following program is written to the CPU module of station No.0.

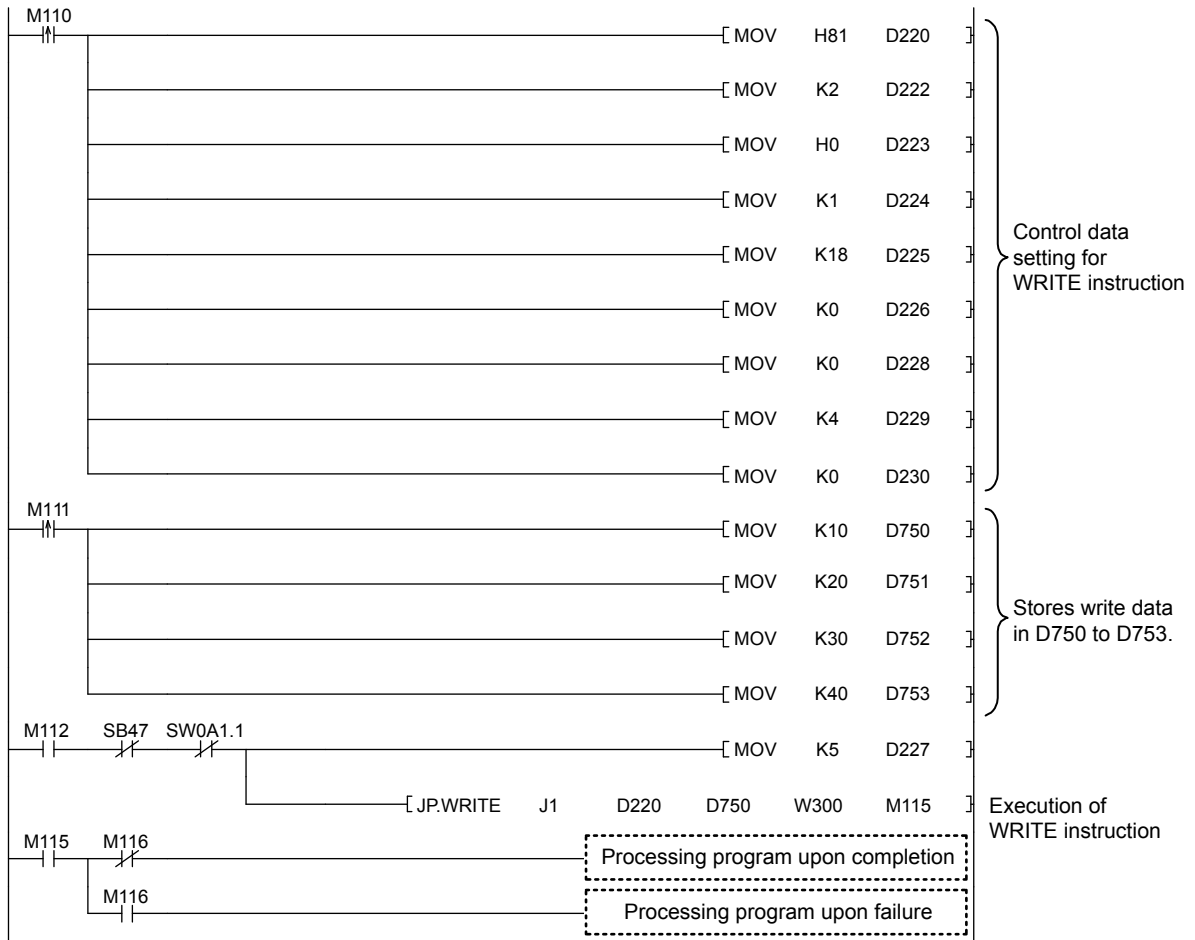

10.7 JP/GP.SWRITE (Writing Data to Another Station)

This instruction writes data to the device of another station. (In units of words)
 With the SWRITE instruction, the device of the other station is turned on when data writing is completed. Data writing with the SWRITE instruction can be confirmed by this.

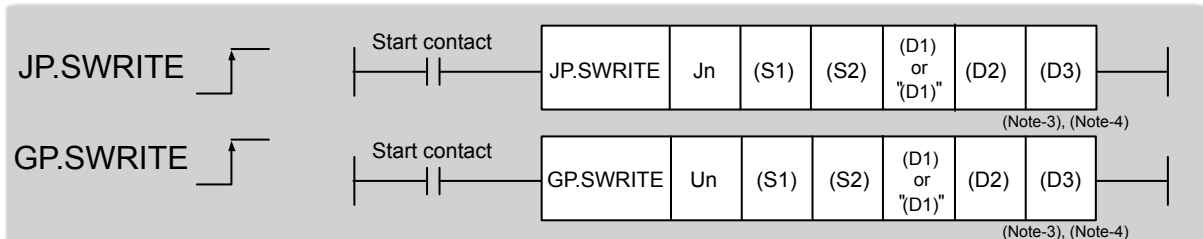

Setting data (Note-1)	Available devices									
	Internal device (System, user)		File register R, ZR	Link direct device J□\□		Intelligent function module device U□\G□	Index register Zn	Constant		Others
	Bit	Word		Bit	Word			K, H	\$	
(S1)	–	○								
(S2)	○ (Note-5)	○								
(D1)	–	○ (Note-2)	○							
(D2)		○								
(D3)		○								

(Note-1): Local devices and file registers set for each program cannot be used.

(Note-2): T, C, D, W, ST, SD, and SW can be used.

When specifying SD/SW, it can be written in the range that the user can set.

For details on SD/SW, refer to the following.

Manuals for the CPU module and network module of the target station

(Note-3): For the SWRITE instruction, the write notification device (D3) can be omitted in the programming.

However, the operation is the same as the WRITE instruction.

The SWRITE instruction can operate differently depending on whether the write notification device (D3) is omitted or not.

(Note-4): When the target station is a Basic model QCPU, the data set in the write notification device (D3) is ignored. (Operation is the same as the WRITE instruction.)

(Note-5): When the target station is a Basic model QCPU, a Universal model QCPU, or an LCPU, a digit-specified bit device can be used.

((Example) K4M16)

To use digit specification, the following conditions must be satisfied:

- The device number should be multiples of 16 (10H).
- The number of digits should be 4 (K4).

(1) Setting data

Setting data	Description	Set by	Data type
Jn	Own station's network No. (1 to 239, 254) 254: Network specified in Valid Module During Other Station Access	User	16-bit binary
Un	Start I/O number of the Simple Motion module of the own station (00 to FEH: Upper 2 digits of the I/O number expressed in 3 digits)		
(S1)	Start device of the own station where control data is stored		
(S2)	Start device of the own station where data to be written is stored	System	Device name
(D1)	Start device of the target station where data is to be written (A continuous area with the write data length is required.)		
(D2)	Device of the own station, which is turned on for 1 scan upon completion of the instruction. (D2)+1 is turned on as well when the instruction fails.		Bit
(D3)	Device of the target station, which is turned on for 1 scan upon completion of the instruction. (Data writing from another station can be confirmed.)		

- (a) Control data
The control data of the SWRITE instruction control data is the same as that of the WRITE instruction. (Refer to Section 10.6.)
- (b) Start device of the own station where data to be written is stored
The start device of the own station where data to be written by the SWRITE instruction is stored is the same as that of the WRITE instruction. (Refer to Section 10.6.)
- (c) Start device of the target station where data is to be written
The start device of the target station where data is to be written by the SWRITE instruction is the same as that of the WRITE instruction. (Refer to Section 10.6.)

(2) Function

(a) SWRITE instruction overview

The instruction writes data by the specified number of words (control data $((S1)+9)$) from the own station start device (S2) into the target station word devices (after (D1)).

Specify the target stations in control data $((S1)+4$ and $(S1)+5$).

When the writing of the data specified by (S2) is completed, the following devices are turned on.

- Own station: Completion device (D2)
- Target station: Write notification device (D3)

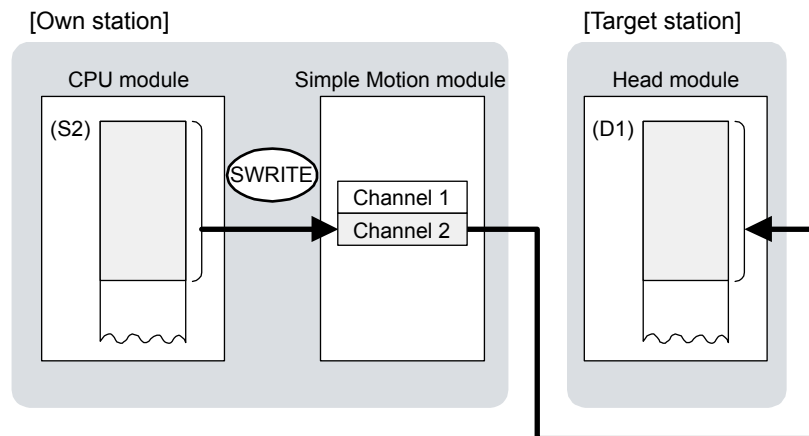

(b) Target stations which can be specified

For details on target stations which can be specified, refer to the following. Refer to Section 10.1 (1).

(c) Checking the execution status of the SWRITE instruction

The execution status (completion or error) of the SWRITE instruction can be checked using the following device specified for the setting data.

- Completion device (D2)
 - It is turned on in the END processing of the scan after completion of the SWRITE instruction, and is turned off in the next END processing.
- Completion status indication device $((D2)+1)$
 - It is turned on in the END processing of the scan after completion of the SWRITE instruction, and is turned off in the next END processing only if the SWRITE instruction fails.

(d) SWRITE instruction execution timing

- When completed

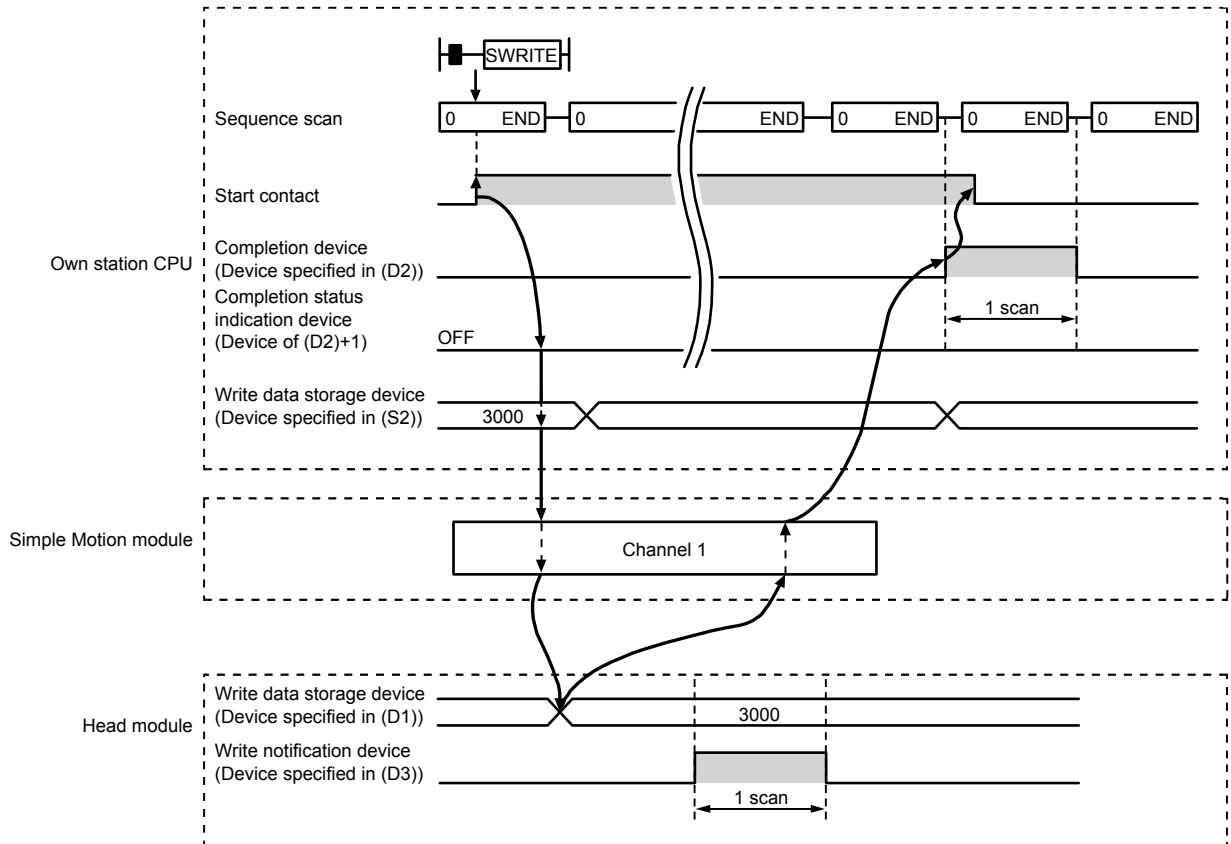

- When failed

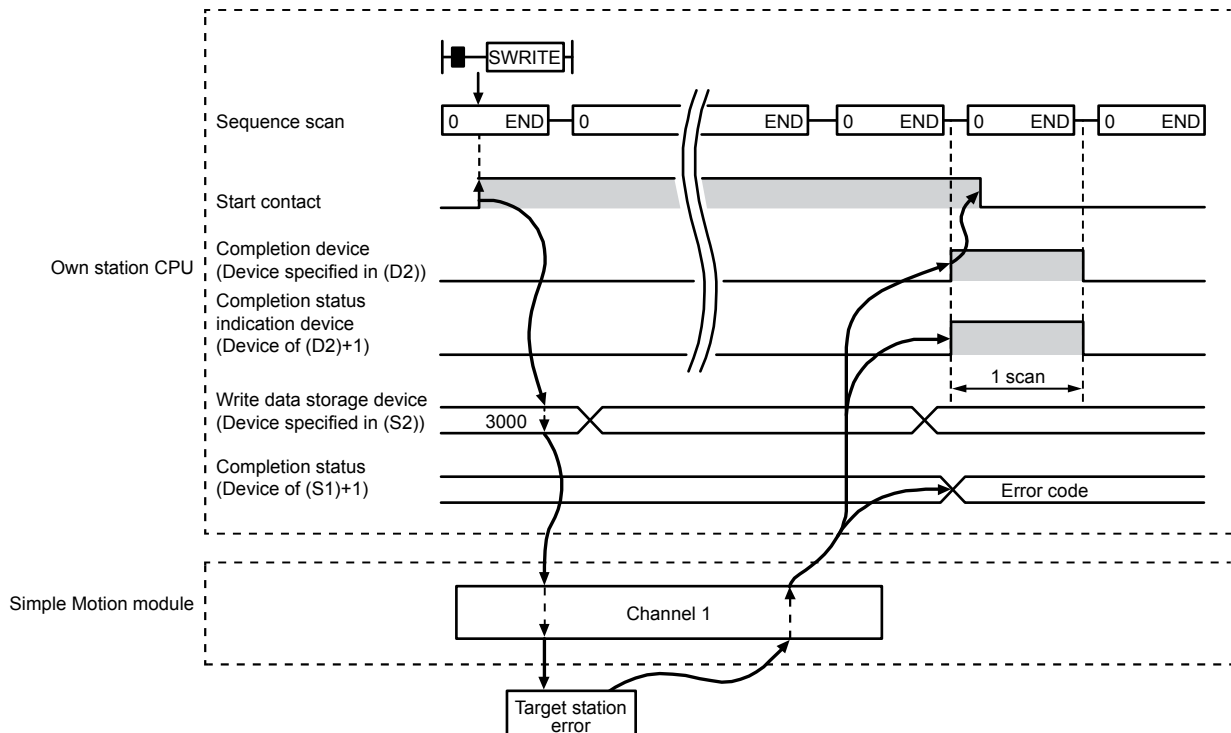

(3) Error

When the dedicated instruction fails, error details can be checked by any of the following methods:

(a) In GX Works2

Error details can be checked using CC-Link IE Field Network diagnostics. (Refer to Chapter 9.)

(b) By devices

Completion status indication device ((D2)+1) is turned on and an error code is stored in Completion status ((S1)+1) of the control data.

According to the error code, check the error details and take a corrective action. (Refer to Section 12.5.)

(4) Program example

Just like the WRITE instruction program example, this program example is for writing data of D750 to D753 of station No.0 (own station) into W300 to W303 of station No.18 (target station) when M112 is turned on.

Furthermore, when the write notification device (D3) of the target station is turned on, the data of W300 to W303 are stored in D500 to D503.

REMARK

Compared to the WRITE instruction program example, the SWRITE instruction program example has a different section where the write notification device (D3) is specified at the end of the arguments. (Refer to Section 10.6 (4).)

(a) System configuration

Same as the WRITE instruction program example.

(b) Devices used in the program example

- Link special relay (SB), link special register (SW)
Same as the WRITE instruction program example.
- Devices used by users

The devices used in the SWRITE instruction request source (station No.0) are the same as those in WRITE instruction program example.

Device used in the SWRITE instruction request destination (station No.18)

Device	Description	Device	Description
Y117	Write notification device	D500 to D503	Devices that store the data of W300 to W303

(c) SWRITE instruction setting

Same as the WRITE instruction program example.

(d) Program example

- Program example in SWRITE instruction request source (station No.0)

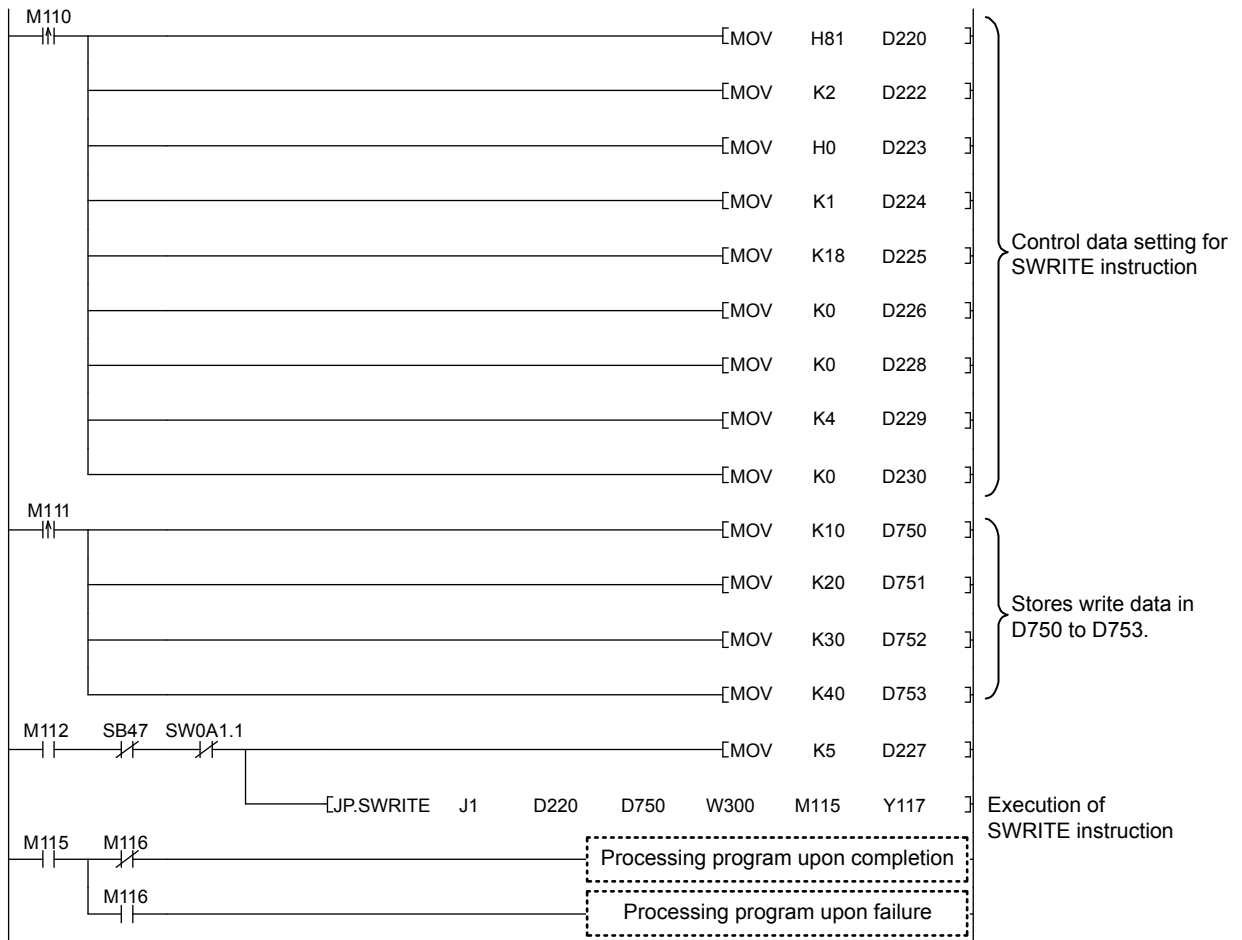

10.8 ZP.REMFR (Reading Data from the Intelligent Device Station/Remote Device Station)

This instruction reads data from the buffer memory of the intelligent device station/remote device station. (In units of words)

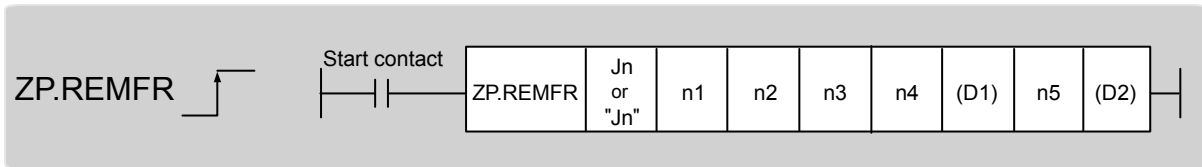

Setting data (Note-1)	Available devices									
	Internal device (System, user)		File register R, ZR	Link direct device J□\□		Intelligent function module device U□\G□	Index register Zn	Constant		Others
	Bit	Word		Bit	Word			K, H	\$	
n1	–	○			–		○	–	–	
n2	–	○			–		○	–	–	
n3	–	○			–		○	–	–	
n4	–	○			–		○	–	–	
(D1)	–	○			–		–	–	–	
n5	–	○			–		○	–	–	
(D2)		○			–		–	–	–	

(Note-1): Local devices and file registers set for each program cannot be used.

(1) Setting data

Setting data	Description	Set by	Data type
"Jn"/Jn	Target network No. (1 to 239)	User	String/16-bit binary
n1	Channels used by the own station (1 to 32)		
n2	Target station No. (1 to 120)		
n3	<ul style="list-style-type: none"> •Head module The start I/O number of the intelligent function module (00 to FEH: Upper two digits of the I/O number expressed in three digits) •Module other than a head module Fixed to 00 		16-bit binary
n4	The start address of the buffer memory of the intelligent device station/remote device station where data to be read is stored		
(D1)	Start device of the own station where read data is stored A continuous area for the read data length is required.	System	Device name
n5	Number of read points (1 to 240 words)	User	16-bit binary
(D2)	Device of the own station turned on for 1 scan upon completion of the instruction (D2)+1 is turned on as well when the instruction fails.	System	Bit

(2) Function

(a) REMFR instruction overview

The instruction reads data by the specified number of words (n5) from the start address (n4) of the buffer memory of the intelligent device station/remote device station into the own station word devices (after D1)).

Specify the target stations in setting data ("Jn"/Jn), (n2), and (n3).

When the reading of data is completed, the completion device (D2) turns on.

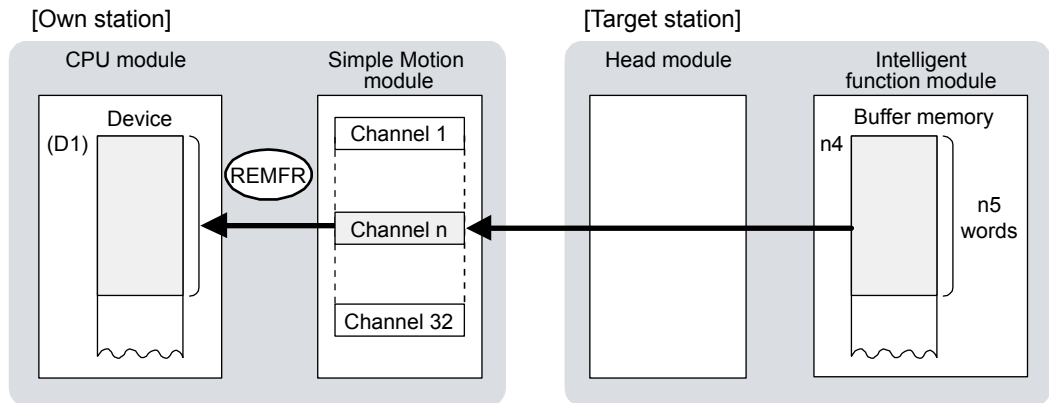

(b) Target stations which can be specified

For details on target stations which can be specified, refer to the following. Refer to Section 10.1 (1).

(c) Checking the execution status of an REMFR instruction

The execution status (completion or error) of the REMFR instruction can be checked using the following device specified for the setting data.

- Completion device (D2)
It is turned on in the END processing of the scan after completion of the REMFR instruction, and is turned off in the next END processing.
- Completion status indication device ((D2)+1)
It is turned on in the END processing of the scan after completion of the REMFR instruction, and is turned off in the next END processing only if the REMFR instruction fails.

(d) REMFR instruction execution timing

- When completed

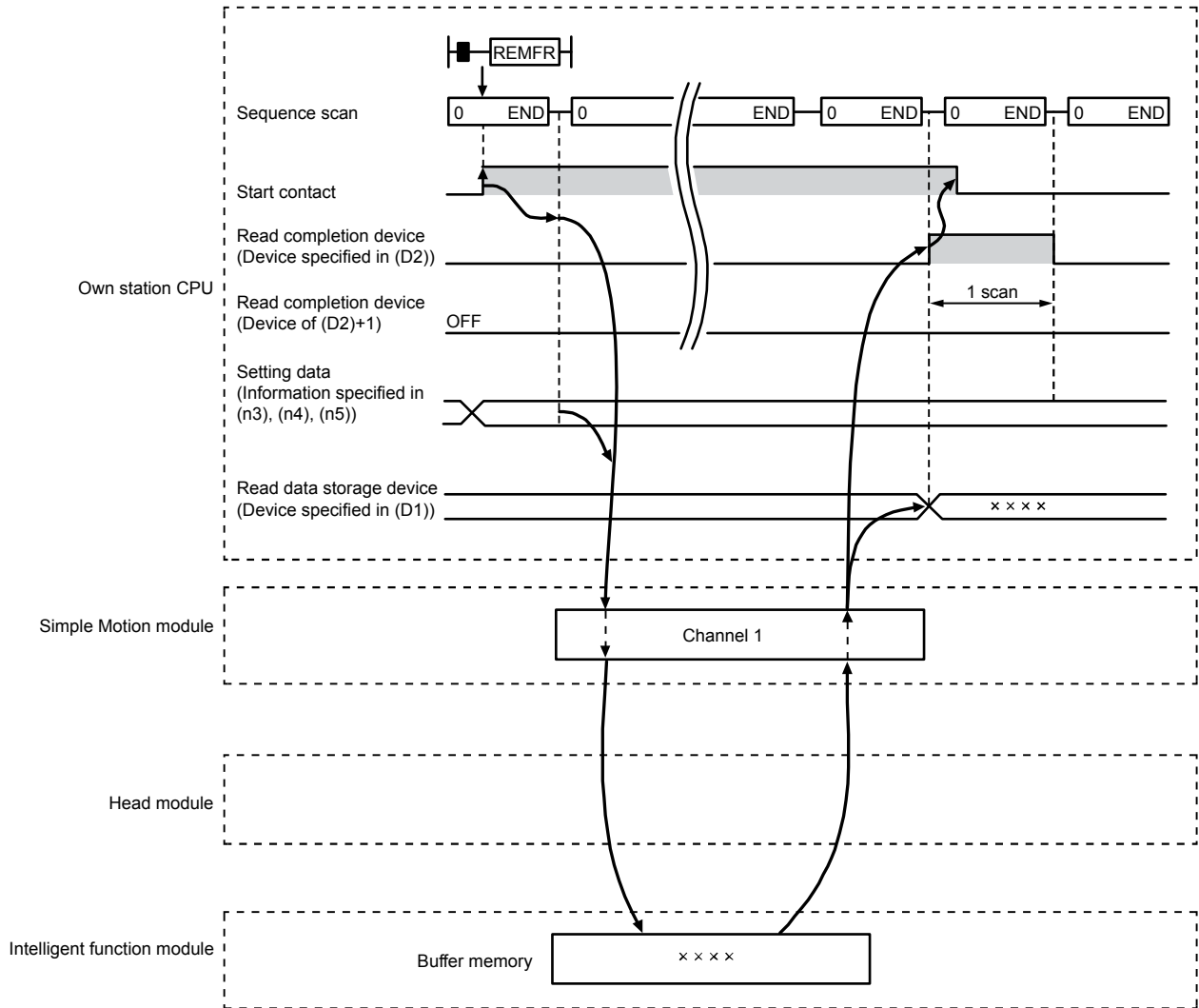

• When failed

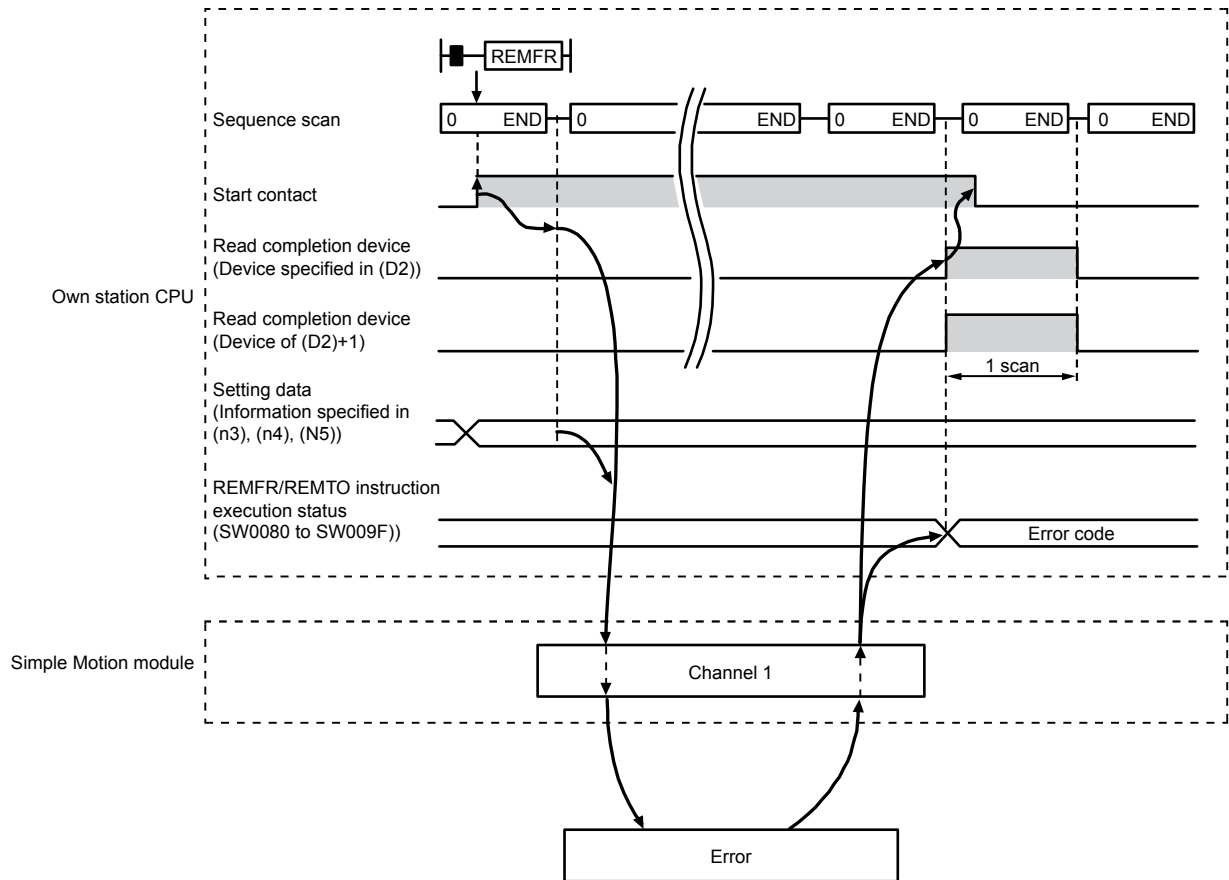

(3) Error

When a dedicated instruction fails, error details can be checked by any of the following methods:

(a) In GX Works2

Error details can be checked using CC-Link IE Field Network diagnostics. (Refer to Chapter 9.)

(b) By devices

Completion status indication device ((D2)+1) is turned on and an error code is stored in Execution status (REMFR/REMTO) (SW0080 to SW009F).

According to the error code, check the error details and take a corrective action. (Refer to Section 12.5.)

(4) Program example

The following program is for reading the data in the buffer memory (address: 256 to 355) of the intelligent function module of the station No.17 (target station) to D750 to D849 of the station No.0 (own station) when M111 is turned on.

(a) System configuration

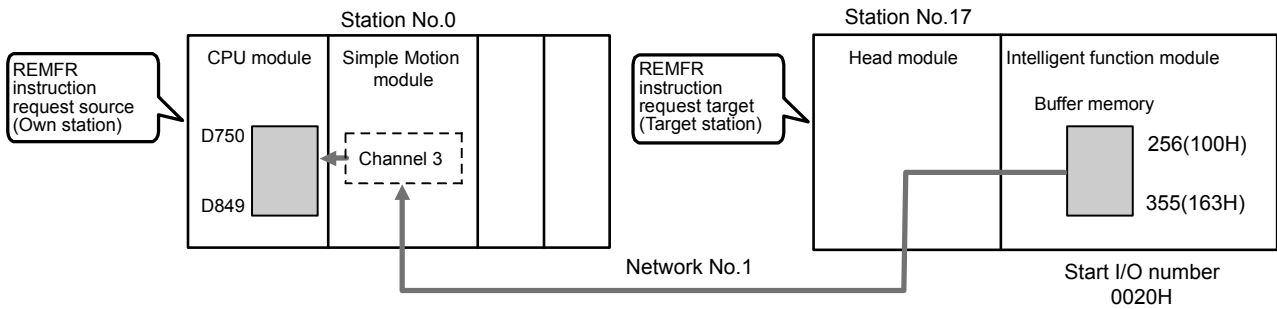

(b) Devices used in the program example

- Link special relay (SB), link special register (SW)

Device	Description	Device	Description
SB0047	Baton pass status (own station)	SW00A1.0	Baton pass status (each station) of station No. 17

- Devices used by users

Device	Description	Device	Description
M111	Start contact	M113	Completion status indication device
M112	Completion device	D750 to D849	Read data storage device

REMARK

For details on link special relay (SB) and link special register (SW), refer to Appendix 2 and Appendix 3.

(c) Program example

The following program is written to the CPU module of station No.0.

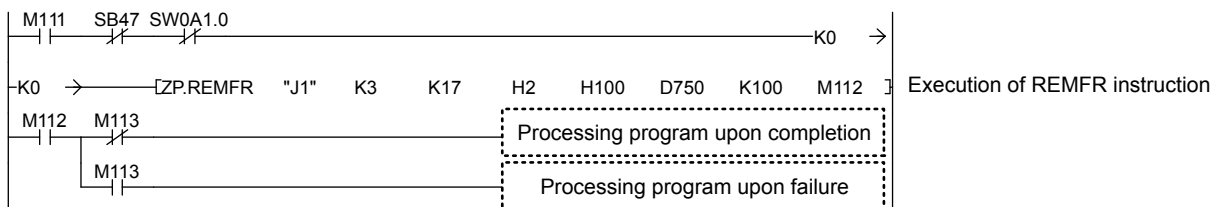

10.9 ZP.REMTO (Writing Data to the Intelligent Device Station/Remote Device Station)

This instruction writes data to the buffer memory of the intelligent device station/remote device station. (In units of words)

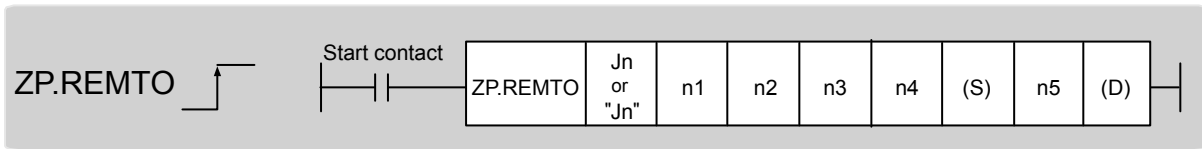

Setting data (Note-1)	Available devices									
	Internal device (System, user)		File register R, ZR	Link direct device J□\□		Intelligent function module device U□\G□	Index register Zn	Constant		Others
	Bit	Word		Bit	Word			K, H	\$	
n1	-	○					○	-	-	
n2	-	○					○	-	-	
n3	-	○					○	-	-	
n4	-	○					○	-	-	
(S)	-	○					-	-	-	
n5	-	○					○	-	-	
D		○					-		-	

(Note-1): Local devices and file registers set for each program cannot be used.

(1) Setting data

Setting data	Description	Set by	Data type	
"Jn"/Jn	Target network No. (1 to 239)	User	String/16-bit binary	
n1	Channels used by own station (1 to 32)		16-bit binary	
n2	Target station No. (1 to 120)			
n3	<ul style="list-style-type: none"> •Head module The start I/O number of the intelligent function module (00 to FEH: Upper two digits of the I/O number expressed in three digits) •Module other than a head module Fixed to 00 			
n4	The start address of the buffer memory of the intelligent device station/remote device station where data is written			
S	Start device of the own station where data to be written is stored			Device name
n5	Number of write points (1 to 240 words)			16-bit binary
D	Device of the own station, which is turned on for 1 scan upon completion of the instruction (D)+1 is turned on as well when the instruction fails.	System		Bit

(2) Function

(a) REMTO instruction overview

The instruction writes data by the specified number of words (n5) from the own station start device (S) into the buffer memory (after (n4)) of the intelligent device station/remote device station.

Specify the target stations in setting data ("Jn"/Jn), (n2), and (n3).

When the writing of data is completed, the completion device (D) turns on.

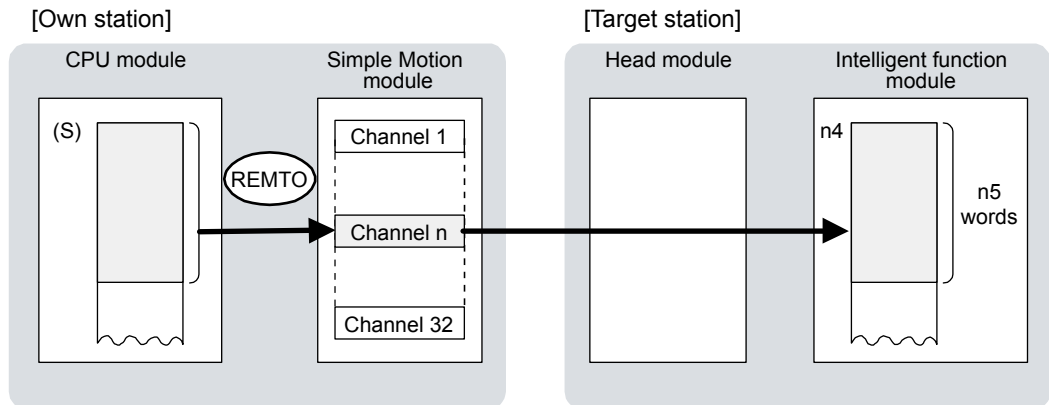

(b) Target stations which can be specified

For details on target stations which can be specified, refer to the following.
Refer to Section 10.1 (1).

(c) Checking the execution status of the REMTO instruction

The execution status (completion or error) of the REMTO instruction can be checked using the following device specified for the setting data.

- Completion device (D)

It is turned on in the END processing of the scan after completion of the REMTO instruction, and is turned off in the next END processing.

- Completion status indication device ((D)+1)

It is turned on in the END processing of the scan after completion of the REMTO instruction, and is turned off in the next END processing only if the REMTO instruction fails.

(d) REMTO instruction execution timing

- When completed

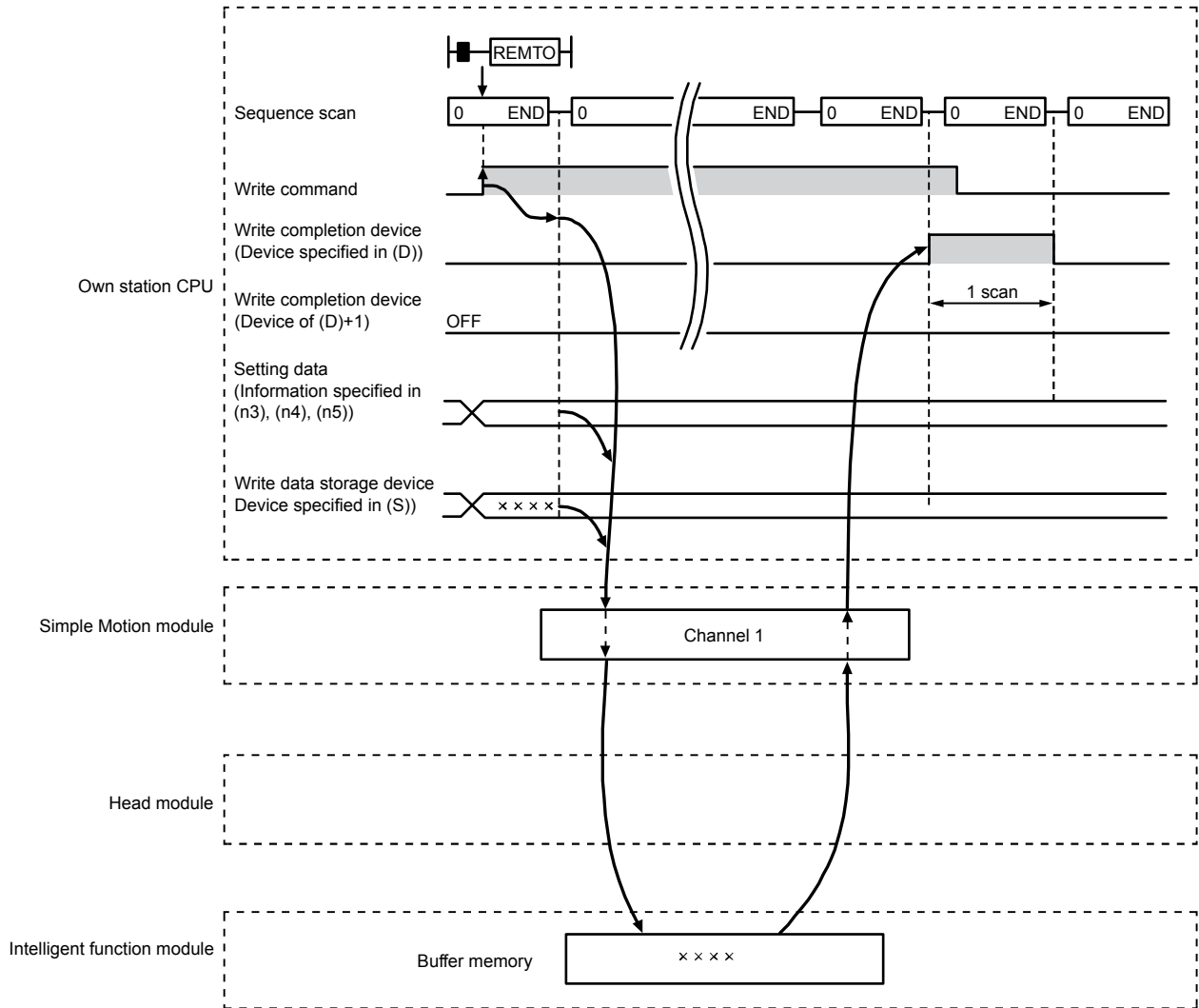

• When failed

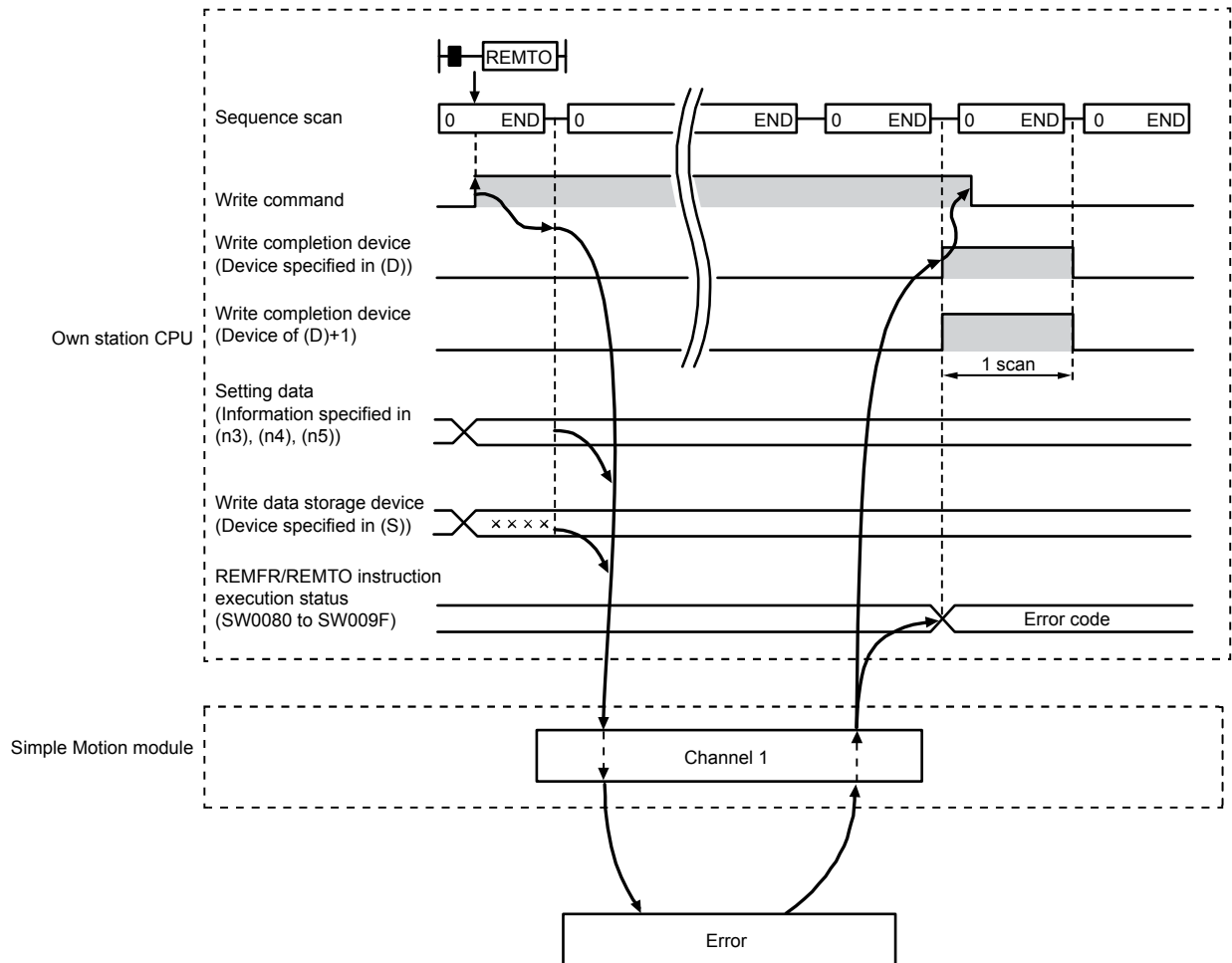

(3) Error

When the dedicated instruction fails, error details can be checked by any of the following methods:

(a) In GX Works2

Error details can be checked using CC-Link IE Field Network diagnostics. (Refer to Chapter 9.)

(b) By devices

Completion status indication device ((D)+1) is turned on, and an error code is stored in execution status (REMFR/REMTO) (SW0080 to SW009F).

According to the error code, check the error details and take a corrective action. (Refer to Section 12.5.)

(4) Program example

The following program is for writing data of D850 to D949 of station No.0 (own station) into buffer memory (address: 0 to 99) of station No.17 (target station) when M115 is turned on.

(a) System configuration

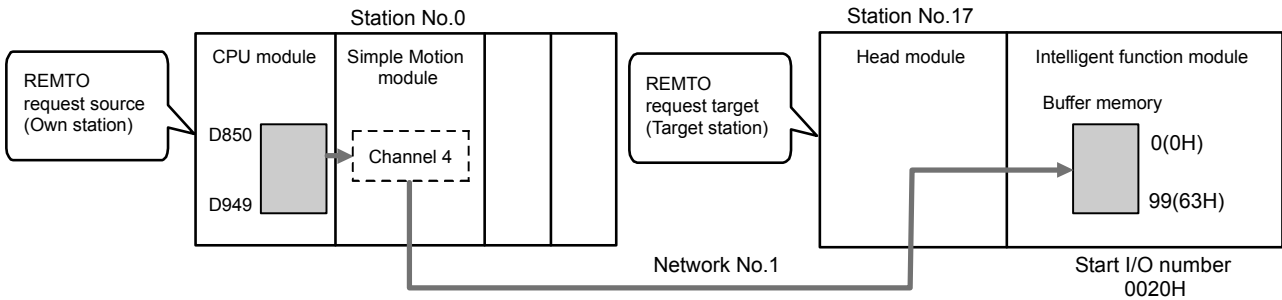

(b) Devices used in the program example

- Link special relay (SB), link special register (SW)

Device	Description	Device	Description
SB0047	Baton pass status (own station)	SW00A1.0	Baton pass status (each station) of station No. 17

- Devices used by users

Device	Description	Device	Description
M115	Start contact	M117	Completion status indication device
M116	Completion device	D850 to D949	Write data storage device

REMARK

For details on link special relay (SB) and link special register (SW), refer to Appendix 2 and Appendix 3.

(c) Program example

The following program is written in the CPU module of station No.0.

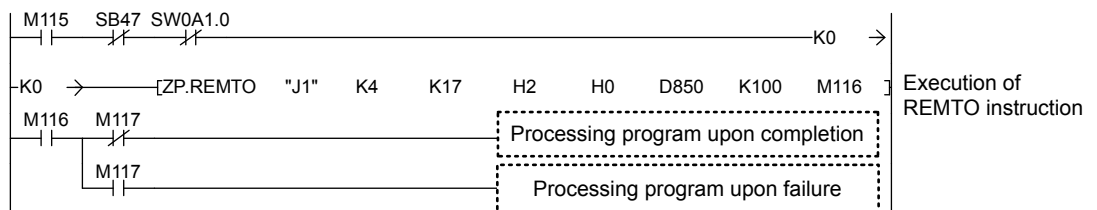

Chapter 11 PROGRAMMING

11.1 Precautions for Programming	11- 2
11.2 Example of Communications Between the Master Station and a Head Module	11- 3
11.2.1 System configuration example	11- 3
11.2.2 Setting in the master station	11- 5
11.2.3 Setting in the head module.....	11- 7
11.2.4 Checking the network status	11-10
11.2.5 Program example	11-11
11.3 Using Link Special Relay (SB) and Link Special Register (SW)	11-15

This chapter describes programming and startup examples of CC-Link IE Field Network.

REMARK

This chapter describes communications between the master station and a head module.

For other communications, refer to the manual for the slave station used.

11.1 Precautions for Programming

This section describes precautions to create CC-Link IE Field Network programs.

(1) Cyclic transmission program

For a cyclic transmission program, interlock with the following link special relay (SB) and link special register (SW). (Refer to Appendix 2 and Appendix 3.)

- Data link status (own station) (SB0049)
- Data link status (each station) (SW00B0 to SW00B7)

(Example) Interlock example

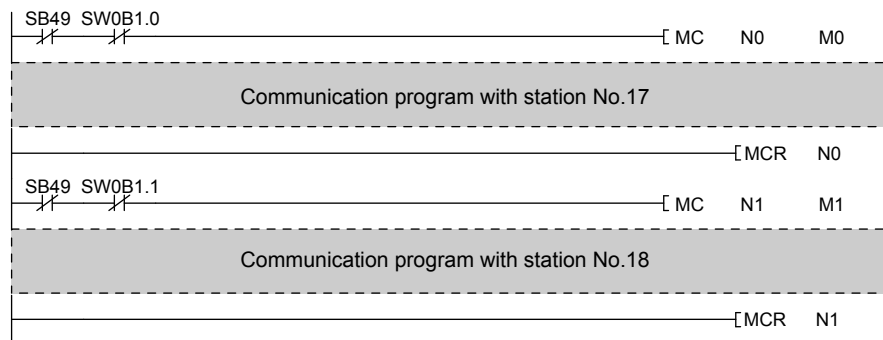

(2) Transient transmission program

For a transient transmission program, interlock with the following link special relay (SB) and link special register (SW). (Refer to Appendix 2 and Appendix 3.)

- Baton pass status (own station) (SB0047)
- Baton pass status (each station) (SW00A0 to SW00A7)

(Example) Interlock example



11.2 Example of Communications Between the Master Station and a Head Module

This section describes an example of communications where D/A conversion in CH1 and CH2 of a D/A converter module (L60DA4) are enabled and analog values are output from the channels.

If an error occurs while a digital value is written, the output module (QY10) mounted to the master station will display an error code in BCD format.

Set a scaling value only for CH1 and configure the warning output setting only for CH2.

11.2.1 System configuration example

The following system configuration is used to explain communications between the master station and a head module.

(1) System configuration

- Power supply module (Q62P)
- CPU module (Q10UDHCPU)
- Simple Motion module (QD77GF)
- Input module (QX10)
- Output module (QY10)

- Power supply module (L61P)
- Head module (LJ72GF15-T2)
- D/A converter module (L60DA4)
- Input module (LX40C6)
- Output module (LY10R2)
- END cover (L6EC)

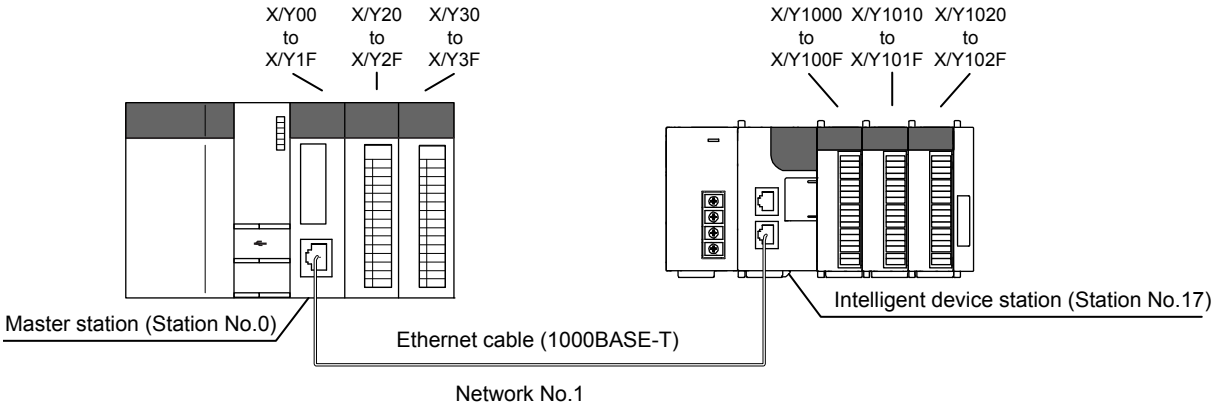

(2) Link device assignment
 (a) RX and RY assignment

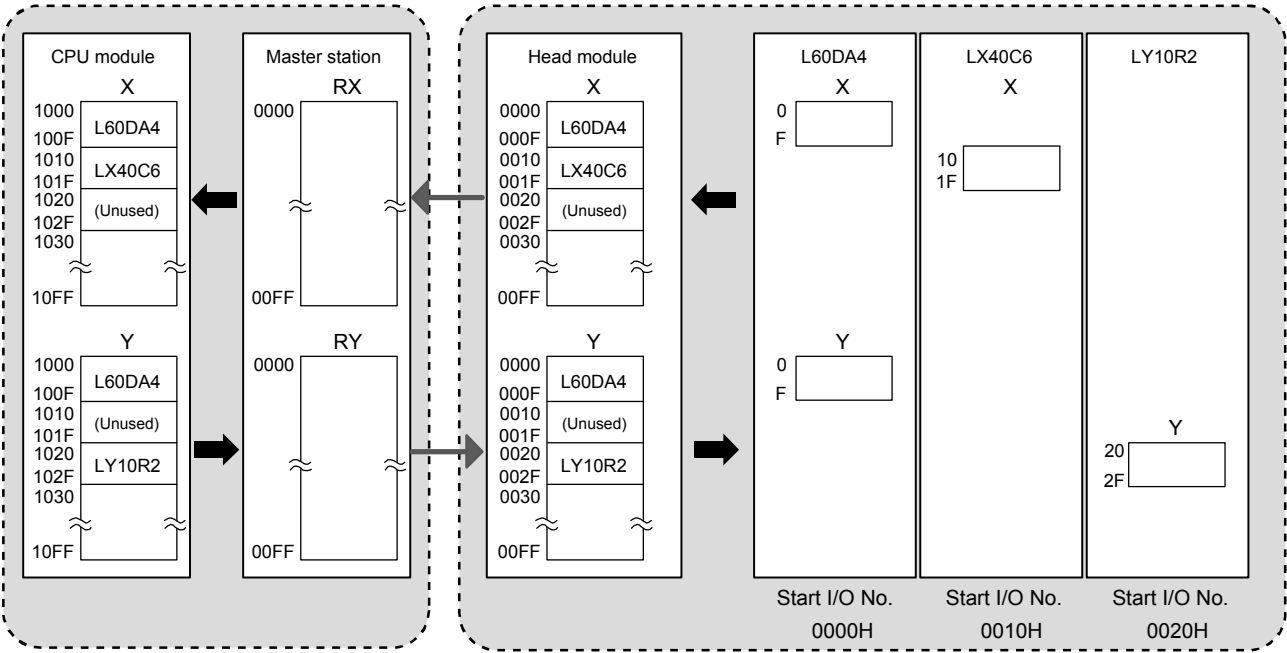

(b) RWr and RWw assignment

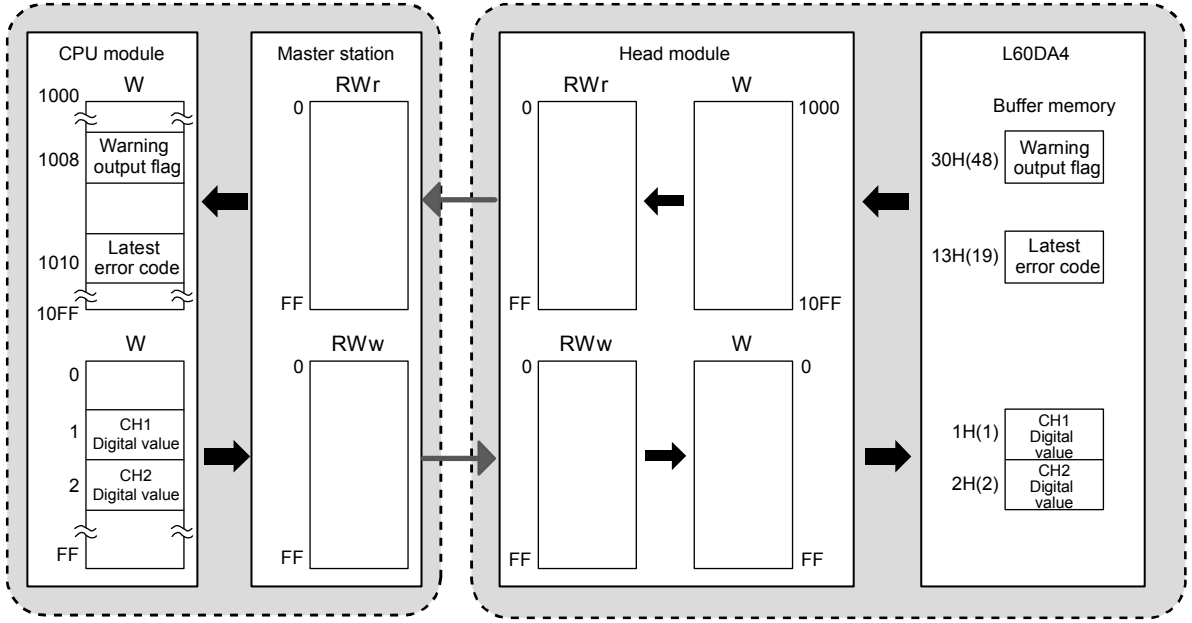

11.2.2 Setting in the master station

Connect GX Works2 to the master station and set parameters.

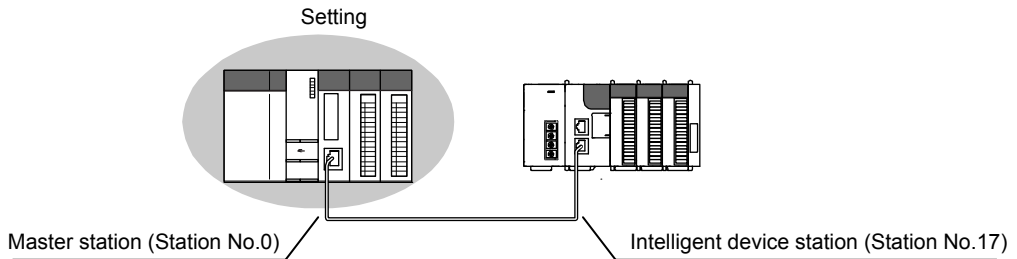

- 1) Create a project using GX Works2.
 Select "QCPU (Q mode)" in "Series" and "Q10UDH" in "Module".
 [Project] → [New]

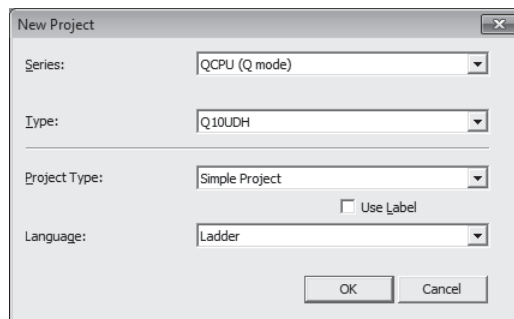

- 2) Open the network parameter window and set parameters as follows.
 Project window → [Parameter] → [Network Parameter] → [Ethernet/CC IE/MELSECNET]

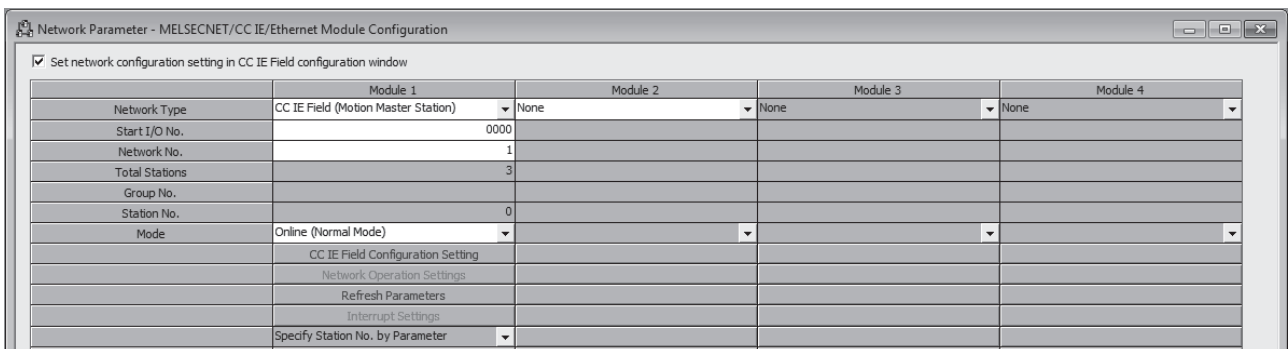

- Open the network configuration setting window and set parameters as follows.
 Project window → [Parameter] → [Network Parameter] →
 [Ethernet/CC IE/MELSECNET] → [CC IE Field Configuration Setting] button

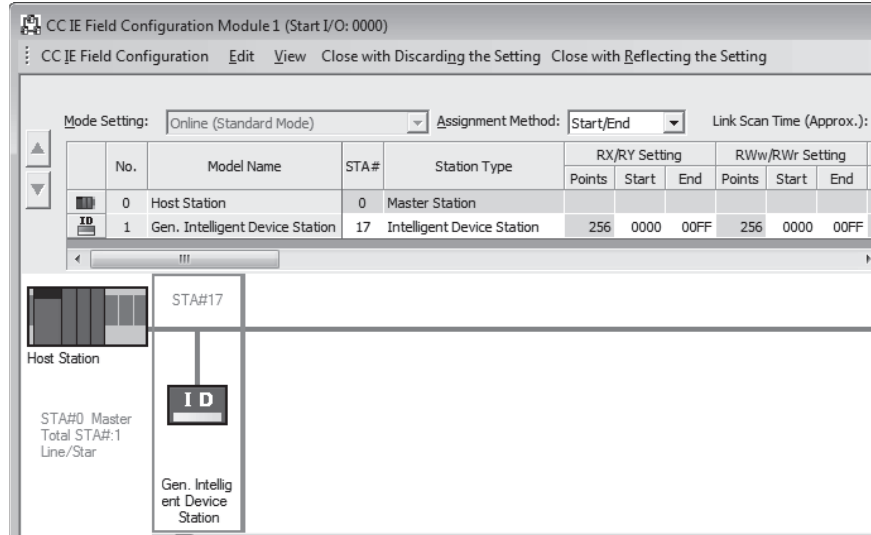

- Open the refresh parameter window and set parameters as follows.
 Project window → [Parameter] → [Network Parameter] →
 [Ethernet/CC IE/MELSECNET] → [Refresh Parameters] button

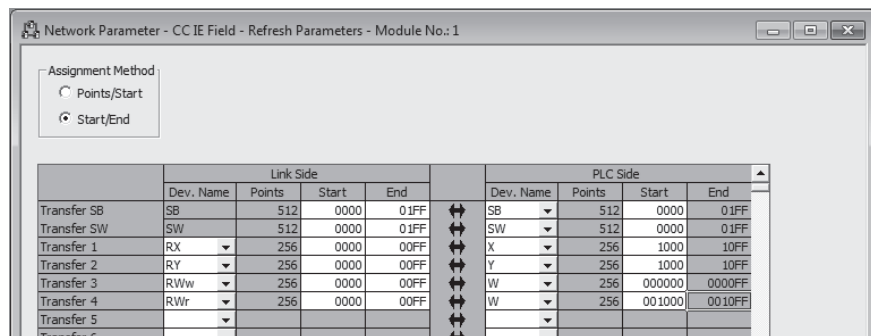

- Write the parameters to the CPU module on the master station. Then reset the CPU module or turn off and on the power.
 [Online] → [Write to PLC]

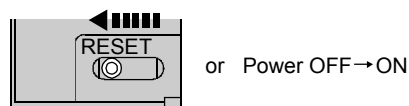

POINT

In this example, default values were used for parameters that are not shown above. For parameter setting, refer to the following. (Refer to Chapter 7.)

11.2.3 Setting in the head module

Connect GX Works2 to the head module and set parameters.

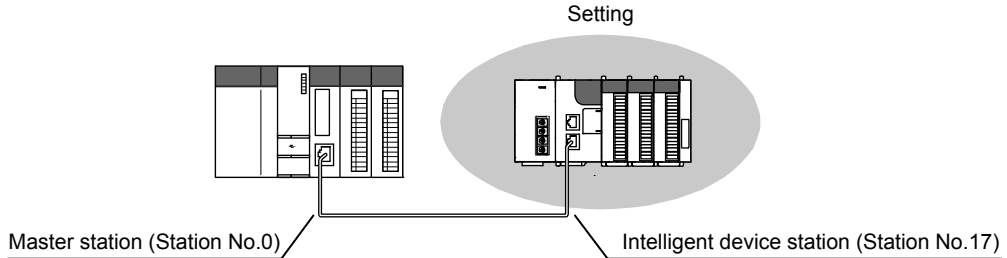

- 1) Create a project.
 Select "LCPU" in "Series" and "LJ72GF15-T2" in "Module".
 [Project] → [New]

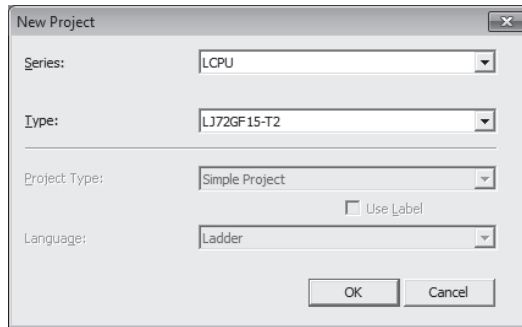

- 2) Open the PLC parameter window and set parameters as follows.
 Project window → [Parameter] → [PLC Parameter] → "Communication Head Setting"

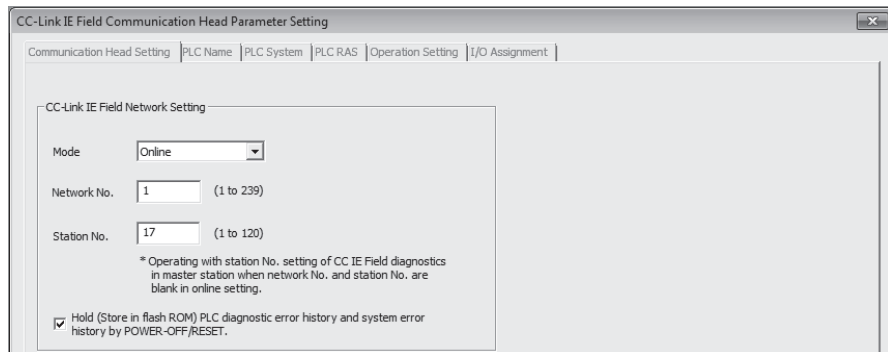

- 3) Add the D/A converter module (L60DA4) to the project.
 Project window → [Intelligent Function Module] → right-click → [New Module]

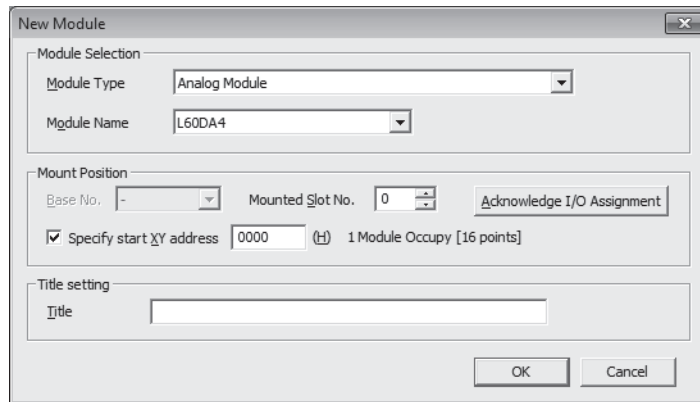

- 4) Open the switch setting window for the D/A converter module (L60DA4) and set parameters as follows.
 Project window → [Intelligent Function Module] → [L60DA4] → [Switch Setting]

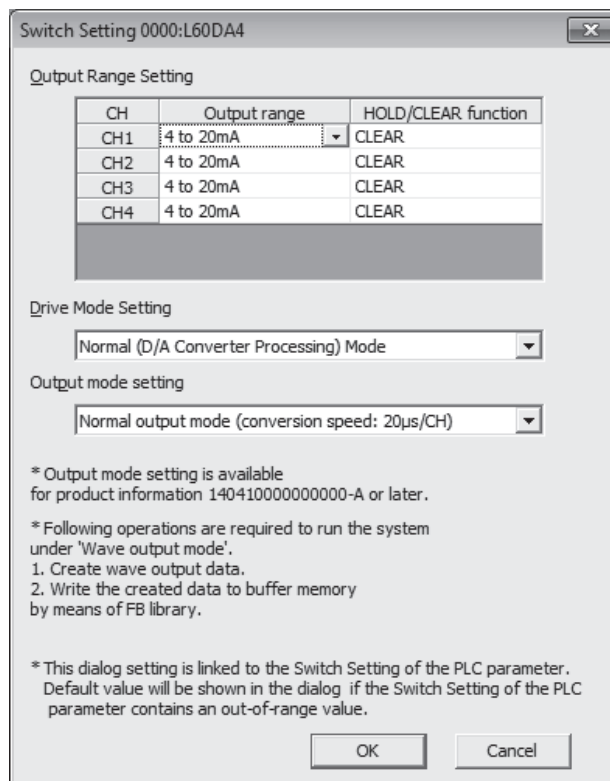

- 5) Open the initial setting window for the D/A converter module (L60DA4) and set parameters as follows.

Project window → [Intelligent Function Module] → [L60DA4] → [Parameter]

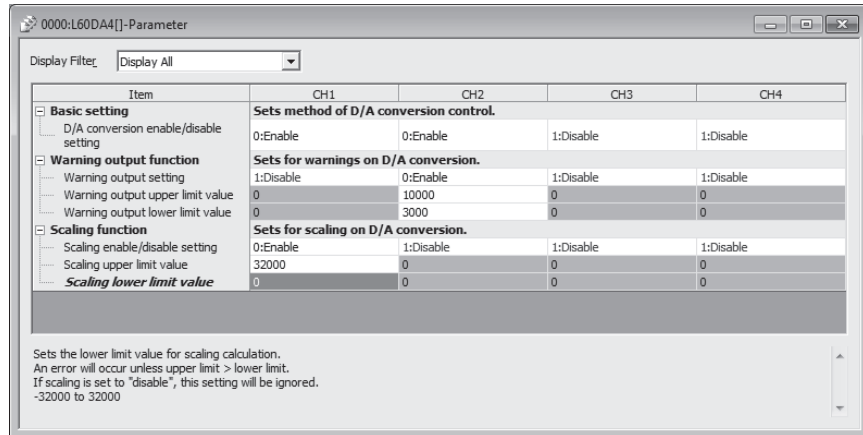

- 6) Open the auto refresh window for the D/A converter module (L60DA4) and set parameters as follows.

Project window → [Intelligent Function Module] → [L60DA4] → [Auto Refresh]

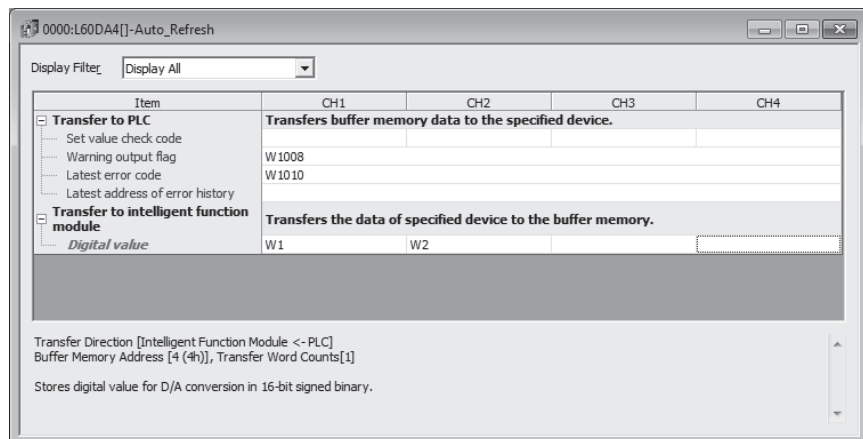

- 7) Write the parameters to the head module. Then reset the head module or turn off and on the power.

[Online] → [Write to PLC]

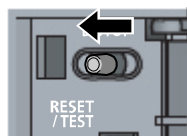

or Power OFF → ON

POINT

In this setting example, default settings are used for the parameters other than those described. For the parameter setting, refer to the following.



- User's manual for the head module
- User's manual for the intelligent function module

11.2.4 Checking the network status

Once parameters are set for the master station and head module, the CC-Link IE Field Network diagnostics of GX Works2 can be used to check whether data link is normally operating.

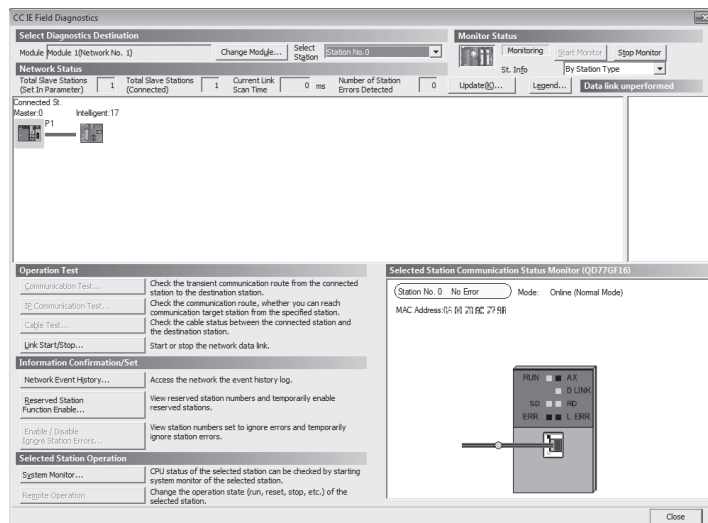
- 1) Connect GX Works2 to the master station.
 - 2) Start the CC-Link IE Field Network diagnostics from the menu.
[Diagnostics] → [CC-Link IE Field Diagnostics]
- If the following display appears, data link is normal.



If a mark, such as , , and , is displayed in "Network Status", an error has occurred. Use the CC-Link IE Field Network diagnostics to identify the cause of the error and take actions. (Refer to Section 9.2.)

(Example) If an error has occurred in a head module, the window appears as follows.

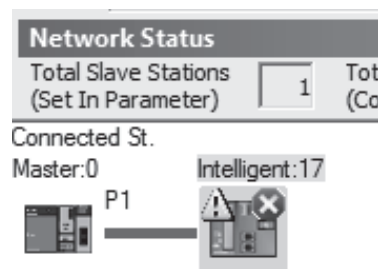

11.2.5 Program example

The following is an example of the program to be written to a CPU module on the master station.

(1) Program example of L60DA4

(a) I/O signals of D/A converter module (L60DA4)

Device	Description	Device	Description
X1000	Module READY	Y1001	CH1 Output enable/disable flag
X1007	External power supply READY flag	Y1002	CH2 Output enable/disable flag
X100E	Warning output signal	Y100E	Warning output clear request
X100F	Error occurrence flag	Y100F	Error clear request

(b) Link special relay (SB), link special register (SW)

Device	Description	Device	Description
SB0049	Data link status (own station)	SW00B1.0	Data link status (each station) (station No.17)

(c) Devices used by the user

Device	Description	Remarks
W1	CH1 Digital value	-
W2	CH2 Digital value	
W1008	Warning output flag	
W1010	Latest error code	
N0	Nesting (station No.17)	
M0	Communication condition establishment flag (station No.17)	
M20 to M27	Warning output flag	QX10 (X20 to X2F)
X21	Batch output enable signal	
X22	Digital value command to write input signal	
X24	Warning output reset signal	
X25	Error reset signal	QY10 (Y30 to Y3F)
Y30 to Y3F	Error code display (BCD 4 digits)	

(d) Program example

1) Create the following program in the project for the master station using GX Works2.

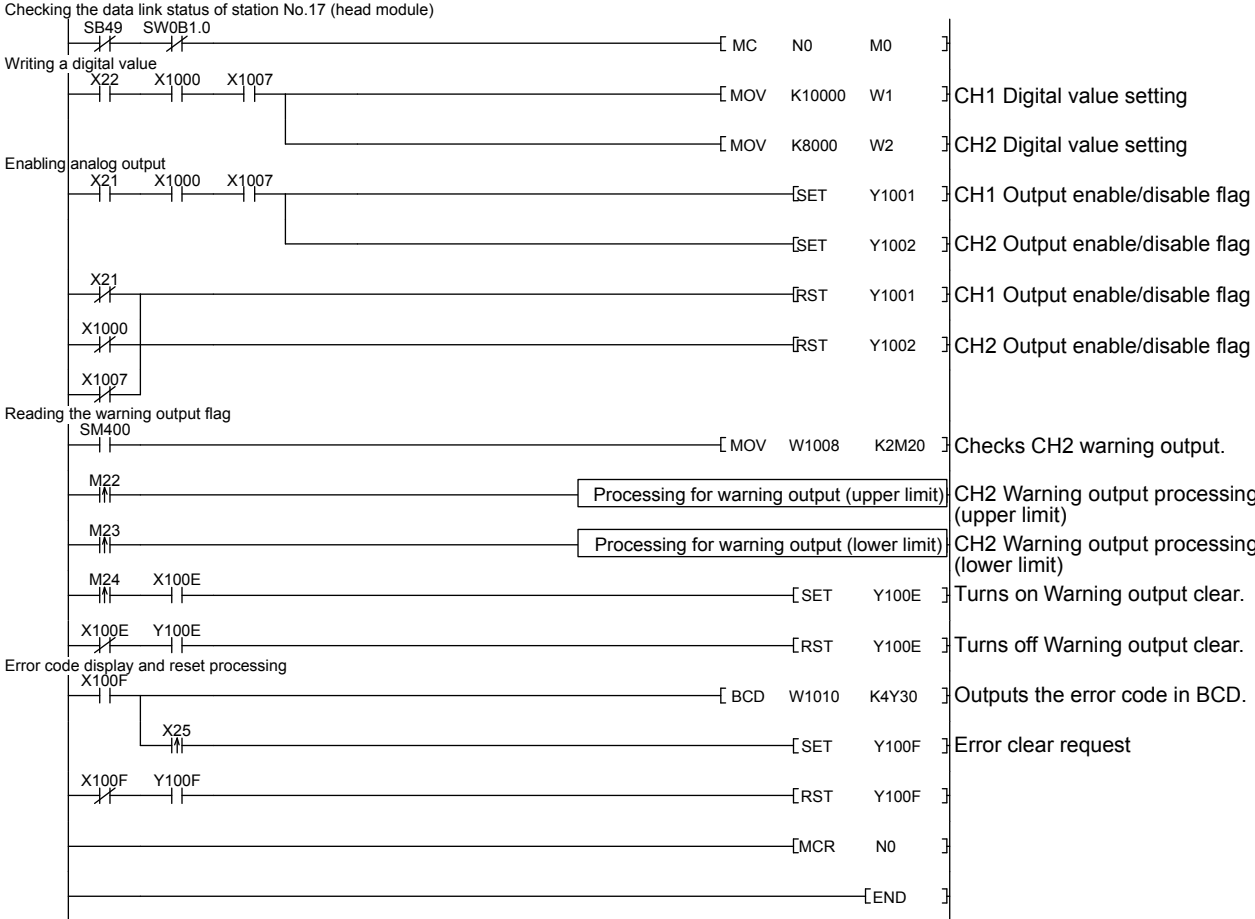

POINT

- If a response is not received for several link scans, the station is determined as a cyclic transmission faulty station, and the status is stored in Data link status (each station) (SW00B0 to SW00B7).

2) Write the program to the CPU module on the master station. Then reset the CPU module or turn off and on the power.
 [Online] → [Write to PLC]

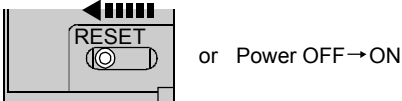

3) Set the CPU module on the master station to RUN.

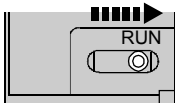

- 4) Set the switch on the head module to RUN.
When the head module switch is set to RUN, the head module starts data link.

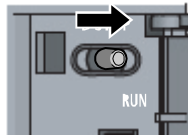

- 5) When the following are operated on the master station, an analog value is output from the D/A converter module (L60DA4).
When X22 is turned on, a digital value is set in CH1 and CH2 of the D/A converter module (L60DA4).
When X21 is turned on, an analog value is output from the D/A converter module (L60DA4).
When X24 is turned on, the warning output is cleared.
When an error occurs in the D/A converter module (L60DA4), an error code is output in BCD notation from the output module (QY10) of the master station.
When X25 is turned on, an error clear request is sent to the D/A converter module (L60DA4).

(2) Program example of station error detection

A stop error in the head module does not cause a stop error in the master station's CPU module.

If a stop error occurs in the head module, the master station is notified when the bit that corresponds to the head module's station number turns on in Operation status (each station) (SW0100 to SW0117) of the master station.

To stop the entire system, create a program as follows and set the master station's CPU module to STOP.

(a) Link special relay (SB), link special register (SW)

Device	Description	Device	Description
SB0049	Data link status (own station)	SW00B1.0	Data link status (each station) (station No.17)
	–	SW0101.0	Operation status (each station) (1) (station No.17)

(b) Devices used by the user

Device	Description
N0	Nesting (station No.17)
M0	Communication condition establishment flag (station No.17)
F0	Annunciator when an error occurs in the head module (station No.17)

(c) Program example

This program detects a stop error in station No.17 and sets the master station's CPU module STOP.

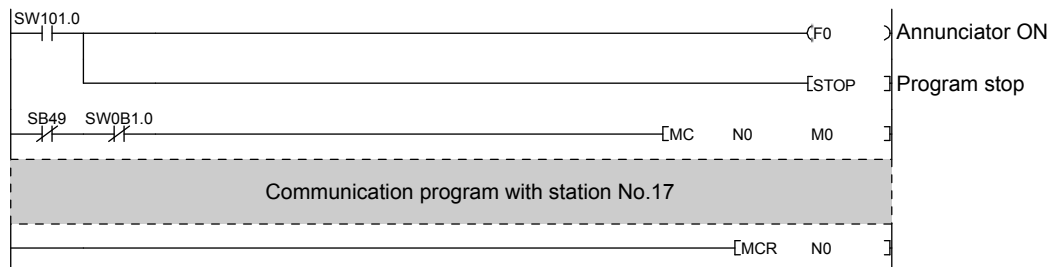

11.3 Using Link Special Relay (SB) and Link Special Register (SW)

This section describes how to use link special relays (SBs) and link special registers (SWs).

REMARK

For details on link special relay (SB) and link special register (SW), refer to Appendix 2 and Appendix 3.

(1) Stop and restart of cyclic transmission

Stop and restart of cyclic transmission are executed using the CC-Link IE Field Network diagnostics as well as link special relays (SBs) and link special registers (SWs).

However, stop and restart of cyclic transmission cannot be executed for the station No.1 to 16 ^(Note-1). (Refer to Section 9.4.)

(Note-1): The range from the station No.1 to 4 is valid in the 4-axis module, and the range from the station No.1 to 8 is valid in the 8-axis module.

(a) Stop and restart of cyclic transmission (other stations)

(Cyclic transmission stop)

- 1) Specify the station to stop cyclic transmission in the following link special registers (SWs).
 - Specifying a target station
Link stop/start direction (SW0000)
 - Specifying a station number
Link stop/start direction (SW0002 to SW0008)
- 2) Turn on System link stop (SB0003).
- 3) When the Simple Motion module accepts the request, System link stop request accept status (SB0056) turns on.
- 4) When cyclic transmission stop is completed, System link stop completion status (SB0057) turns on.
- 5) Station number of the station that sent the cyclic transmission stop request is stored in Data link stop request station (SW004A). (It is stored in the station that received the stop request.)
- 6) If cyclic transmission is stopped with error, an error code will be stored in Data link stop status (entire system) (SW0053).
- 7) Turn off System link stop (SB0003).

(Cyclic transmission restart)

- 8) Specify the station to restart cyclic transmission in the following link special registers (SWs).
 - Specifying a target station
Link stop/start direction (SW0000)
 - Specifying a station number
Link stop/start direction (SW0002 to SW0008)
- 9) Turn on System link start (SB0002).
- 10) When the Simple Motion module accepts the request, System link start request accept status (SB0054) turns on.
- 11) When cyclic transmission restart is completed, System link start completion status (SB0055) turns on.
- 12) If cyclic transmission is restarted with error, an error code will be stored in Data link start status (entire system) (SW0052).
- 13) Turn off System link start (SB0002).

Number	Description	Number	Description
SB0002	System link start	SW0000	Link stop/start direction
SB0003	System link stop	SW0002 to SW0008	Link stop/start direction
SB0054	System link start request accept status	SW004A	Data link stop request station
SB0055	System link start completion status	SW0052	Data link start status (entire system)
SB0056	System link stop request accept status	SW0053	Data link stop status (entire system)
SB0057	System link stop completion status		–

(2) Checking data link status

Data link status is checked using the CC-Link IE Field Network diagnostics as well as link special relays (SBs) and link special registers (SWs). (Refer to Chapter 9.)

(a) Checking the data link status (other stations)

- 1) Link scan time can be checked using SW005A, SW005B, "[Md.134] Operation time", and "[Md.135] Maximum operation time".
- 2) If an error occurs in data link, one of the following link special relays (SBs) turns on.
 - Baton pass status (each station) (SB00A0)
 - Baton pass status (master station) (SB00A1)
 - Data link status (each station) (SB00B0)
 - Data link status (master station) (SB00B1)
- 3) When Baton pass status (each station) (SB00A0) turns on, the station number where an error has occurred is stored in Baton pass status (each station) (SW00A0 to SW00A7).
When Data link status (each station) (SB00B0) turns on, the station number where an error has occurred is stored in Data link status (each station) (SW00B0 to SW00B7).

Details on the causes of error can be checked using link special relays (SBs) and link special registers (SWs) corresponding to the station number where the error has occurred. (Refer to Section 11.3 (2) (b).)

Number	Description	Number	Description
	-	SW005A	Maximum baton pass station
		SW005B	Maximum cyclic transmission station
SB00A0	Baton pass status (each station)	SW00A0 to SW00A7	Baton pass status (each station)
SB00A1	Baton pass status (master station)		-
SB00B0	Data link status (each station)	SW00B0 to SW00B7	Data link status (each station)
SB00B1	Data link status (master station)		-

REMARK

If the master station is powered on before slave stations, data link may be reconfigured. During the reconfiguration (maximum 13 seconds), an error is detected using SB00B0.

- (b) Checking data link status (own station)
- 1) Link scan time can be checked using "[Md.134] Operation time" and "[Md.135] Maximum operation time".
 - 2) If an error occurs in data link, one of the following link special relays (SBs) will turn on.
 - Baton pass status (own station) (SB0047)
 - Data link status (own station) (SB0049)
 - 3) The cause of error will be stored in the following link special registers (SWs).
 - Baton pass status (own station) (SW0047)
 - Cause of baton pass interruption (SW0048)
 - Cause of data link stop (SW0049)

Number	Description	Number	Description
SB0047	Baton pass status (own station)	SW0047	Baton pass status (own station)
	-	SW0048	Cause of baton pass interruption
SB0049	Data link status (own station)	SW0049	Cause of data link stop

(3) Detecting line errors

Line errors are detected using the CC-Link IE Field Network diagnostics as well as link special relays (SBs) and link special registers (SWs). (Refer to Chapter 9.)

- (a) Checking line errors on other stations
- 1) If other stations receive an error frame due to a line error, one of the following link special relays (SBs) will turn on.
 - PORT1 error frame reception status (each station) (SB0120)
 - PORT1 error frame reception status (master station) (SB0121)
 - PORT2 error frame reception status (each station) (SB0130)
 - PORT1 error frame detection (each station) (SB0140)
 - PORT1 error frame detection (master station) (SB0141)
 - PORT2 error frame detection (each station) (SB0150)
 - 2) When one of the link special relays (SBs) listed above turns on, the station number that received an error frame can be checked using link special registers (SWs) of the same number (other than SB0121 and SB0141).

Details on the causes of error can be checked using link special relays (SBs) and link special registers (SWs) corresponding to the station number where the error has occurred. (Refer to Section 11.3 (3) (b).)

Number	Description	Number	Description
SB0120	PORT1 error frame reception status (each station)	SW0120 to SW0127	PORT1 error frame reception status (each station)
SB0121	PORT1 error frame reception status (master station)	-	
SB0130	PORT2 error frame reception status (each station)	SW0130 to SW0137	PORT2 error frame reception status (each station)
SB0140	PORT1 error frame detection (each station)	SW0140 to SW0147	PORT1 error frame detection (each station)
SB0141	PORT1 error frame detection (master station)	-	
SB0150	PORT2 error frame detection (each station)	SW0150 to SW0157	PORT2 error frame detection (each station)

(b) Checking the line status (own station)

- 1) If there is a line error in the own station, one of SB006A, SB006C, and SB006E will turn on.
- 2) The line status can be checked using SW0064, SW0068, and SW0069.

Number	Description	Number	Description
SB006A	PORT1 linkup status (own station)	SW0064	Connection status (own station)
SB006C	PORT1 error frame reception status (own station)	SW0068	PORT1 line error occurrence rate (max.)
SB006E	PORT1 error frame detection (own station)	SW0069	PORT1 line error occurrence rate (present)

(4) Detecting cable disconnections

Cable disconnection is detected using the CC-Link IE Field Network diagnostics as well as link special relays (SBs) and link special registers (SWs). (Refer to Chapter 9.)

- 1) If a cable is disconnected, a baton pass error causes Baton pass status (own station) (SB0047) to turn on.
- 2) 30H is stored in Cause of baton pass interruption (SW0048).

Details on the causes of error can be checked using link special relays (SBs) and link special registers (SWs) corresponding to the station number where the error has occurred.

Number	Description	Number	Description
SB0047	Baton pass status (own station)	SW0048	Cause of baton pass interruption

(5) Checking communication error and network event history

Communication errors and network events are detected using the CC-Link IE Field Network diagnostics as well as link special relays (SBs) and link special registers (SWs). (Refer to Chapter 9.)

- 1) The number of communication errors is stored in SW0074 to SW0077. The number can be cleared by Clear communication error count (SB0006).
- 2) When network event history occurs, Event history status (SB007A) is turned on. Number of network event history items is stored in Event history cumulative count (SW007A). The number can be cleared by Event history count clear (SB0009).

Number	Description	Number	Description
SB0006	Clear communication error count		
SB0009	Event count clear		
		SW0074	PORT1 cable disconnection detection count
		SW0075	PORT1 receive error detection count
		SW0076	PORT1 total no. of received data (lower 1 word)
		SW0077	PORT1 total no. of received data (upper 1 word)
SB007A	Event history status	SW007A	Event count

(6) Checking parameter status

The reflection status and setting contents of parameters can be checked using link special relays (SBs) and link special registers (SWs).

(a) Checking the parameter status (other stations)

- 1) When a station on the network has a parameter error, Parameter error status (each station) (SB0170) is turned on.
- 2) The station number where the parameter error occurs is stored in Parameter error status (each station) (SW0170 to SW0177).
- 3) Details on the parameters on each station can be checked using link special relays (SBs) and link special registers (SWs) on each station.

Number	Description	Number	Description
SB0170	Parameter error status (each station)	SW0170 to SW0177	Parameter error status (each station)

(b) Checking the parameter status (own station)

- 1) When a parameter has an error, Received parameter error (SB004D) turns on and the error code is stored in Parameter setting status (SW004C).

Number	Description	Number	Description
SB004D	Received parameter error	SW004C	Parameter setting status

- 2) When the parameter is set in the Simple Motion module, contents of the parameter are stored in the following link special relays (SBs) and link special registers (SWs).

Number	Description	Number	Description
SB0040	Network type (own station)	SW0040	Network No.
		SW0042	Station No.
SB0043	Mode (own station)	SW0043	Mode status
SB0044	Station setting (own station) (1)		–
	–	SW0046	Module type
		SW0058	Number of total slave stations (setting)
		SW0059	Number of total slave stations (current value)
SB0074	Reserved station specification status		–
SB007B	Input data status of data link faulty station		
SB007D	Hold/clear status setting for CPU STOP		
SB00C0	Reserved station setting status	SW00C1 to SW00C7	Reserved station setting status

(7) Checking CPU module status

The CPU module status is checked using the CC-Link IE Field Network diagnostics as well as link special relays (SBs) and link special registers (SWs). (Refer to Chapter 9.)

(a) Checking the CPU module status (other stations)

- 1) Whether the CPU module is in RUN or STOP can be checked using the following link special relays (SBs) and link special registers (SWs).
 - CPU RUN status (master station) (SB00F1)
 - When CPU RUN status (each station) (SB00F0) is turned on, check the station number using CPU RUN status (each station) (SW00F0 to SW00F7).
- 2) A continuation error in the CPU module can be checked using the following link special relays (SBs) and link special registers (SWs).
 - CPU operation status (master station) (2) (SB0111)
 - When CPU operation status (each station) (2) (SB0110) is turned on, check the station number using Operation status (each station) (2) (SW0110 to SW0117).
- 3) A stop error in the CPU module can be checked using the following link special relays (SBs) and link special registers (SWs).
 - CPU operation status (master station) (1) (SB0101)
 - When CPU operation status (each station) (1) (SB0100) is turned on, check the station number using Operation status (each station) (1) (SW0100 to SW0107).

Number	Description	Number	Description
SB00F0	CPU RUN status (each station)	SW00F0 to SW00F7	CPU RUN status (each station)
SB00F1	CPU RUN status (master station)		–
SB0100	CPU operation status (each station) (1)	SW0100 to SW0107	Operation status (each station) (1)
SB0101	CPU operation status (master station) (1)		–
SB0110	CPU operation status (each station) (2)	SW0110 to SW0117	Operation status (each station) (2)
SB0111	CPU operation status (master station) (2)		–

(b) Checking CPU module status (own station)

- 1) Whether the CPU module is in RUN or STOP can be checked using CPU RUN status (own station) (SB004C).
- 2) If a continuation error occurs in the CPU module, Own station's CPU status (1) (SB004A) turns on.
If a stop error occurs in the CPU module, Own station's CPU status (2) (SB004B) turns on.
- 3) The CPU module status can be checked using Own station's CPU status (SW004B).

Number	Description	Number	Description
SB004A	Own station's CPU status (1)		–
SB004B	Own station's CPU status (2)	SW004B	Own station's CPU status
SB004C	CPU RUN status (own station)		–

(8) Dedicated instructions

The following link special relays (SBs) and link special registers (SWs) are used for dedicated instructions. (Refer to Chapter 10.)

- (a) REMFR/REMT0 instruction (Refer to Section 10.8, Refer to Section 10.9.)
 - 1) Set the following registers before executing the REMFR/REMT0 instructions:
 - Number of resends (REMFR/REMT0) (SW001A)
 - Response wait timer (REMFR/REMT0) (SW001B)
 - 2) When the REMFR/REMT0 instruction is executed, the execution status is stored in Execution status (REMFR/REMT0) (SW0080 to SW009F).

Number	Description	Number	Description
-		SW001A	Number of resends (REMFR/REMT0)
		SW001B	Response wait timer (REMFR/REMT0)
		SW0080 to SW009F	Execution status (REMFR/REMT0)

- (b) Common link dedicated instructions (except the REMFR and REMT0 instructions)

Processing results of link dedicated instructions can be checked using Send/receive instruction (1) processing result (SW0030) for channel 1 and Send/receive instruction (2) processing result (SW0031) for channel 2.

Number	Description	Number	Description
-		SW0030	Send/receive instruction (1) processing result
		SW0031	Send/receive instruction (2) processing result

(9) Canceling/restoring reserved station setting

Canceling/restoring reserved station setting is executed using the CC-Link IE Field Network diagnostics as well as link special relays (SBs) and link special registers (SWs). However, the station No.1 to 16 ^(Note-1) cannot be specified as a reserved station.

(Refer to Section 9.6.)

(Note-1): The range from the station No.1 to 4 is valid in the 4-axis module, and the range from the station No.1 to 8 is valid in the 8-axis module.

(a) Canceling reserved station setting

- 1) Specify the station number to cancel reserved station setting in Reserved station function disable setting (SW0011 to SW0017).
- 2) Turn on Reserved station function disable request (SB0012).
- 3) Reserved station function disable request accept status (SB005C) is turned on.
- 4) When reserved station setting is cancelled, Reserved station function disable completion status (SB005D) turns on.
- 5) Reserved station function disable status (SB0180) is turned on and the station number of the station in reserved station function disable status is stored in Reserved station cancel setting status (SW0181 to SW0187).
- 6) When the reserved station setting is cancelled with error, an error code will be stored in Result of reserved station function disable (SW0056).
- 7) Turn off Reserved station function disable request (SB0012).

Number	Description	Number	Description
SB0012	Reserved station function disable request	SW0011 to SW0017	Reserved station function disable setting
SB005C	Reserved station function disable request accept status	SW0056	Result of reserved station function disable
SB005D	Reserved station function disable completion status		-
SB0180	Reserved station function disable status	SW0181 to SW0187	Reserved station cancel setting status

- (b) Restoring reserved station setting
- 1) Specify the station number to restore reserved station setting in Reserved station function disable setting (SW0011 to SW0017),
 - 2) Turn on Reserved station specification enable request (SB0013).
 - 3) Reserved station specification enable request accept status (SB005E) is turned on.
 - 4) When cancellation of the reserved station specification is completed, Reserved station specification enabled status (SB005F) is turned on.
 - 5) Use Reserved station cancel setting status (SW0181 to SW0187) to check whether the station returned to the reserved station. When the station specified as Reserved station disable status is not found on the network, reserved station function disable status (SB0180) is turned off.
 - 6) When the reserved station setting is restored with error, an error code will be stored in Result of reserved station function enable (SW0057).
 - 7) Turn off Reserved station specification enable request (SB0013).

Number	Description	Number	Description
SB0013	Reserved station specification enable request	SW0011 to SW0017	Reserved station function disable setting
SB005E	Reserved station specification enable request accept status	SW0057	Result of reserved station function enable
SB005F	Reserved station specification enabled status		—
SB0180	Reserved station function disable status	SW0181 to SW0187	Reserved station cancel setting status

Chapter 12 TROUBLESHOOTING

12.1 Before Troubleshooting.....	12- 2
12.2 Troubleshooting Procedure.....	12- 2
12.3 Checking the LEDs.....	12- 7
12.4 Troubleshooting by Symptom.....	12- 9
12.4.1 Cyclic transmission cannot be performed.....	12- 9
12.4.2 Transient transmission cannot be performed.....	12-10
12.4.3 Station is disconnected from the network.....	12-10
12.4.4 Station is repeatedly disconnected and reconnected.....	12-10
12.4.5 Communication is unstable.....	12-10
12.5 Error Code List (D000H to DFFFH).....	12-11
12.6 Checking the Status by System Monitor.....	12-25

This chapter describes errors that may occur on CC-Link IE Field Network, causes of the errors, and corrective actions.

12.1 Before Troubleshooting

Check that the POWER LED of the power supply module and the MODE LED of the CPU module are on. If either or both are off, troubleshoot the CPU module. (Refer to the "User's Manual (Hardware Design, Maintenance and Inspection)" of the CPU module in use.)

12.2 Troubleshooting Procedure

The procedure for identifying the cause of the problem and taking action is explained below. For identifying the cause of the problem and taking action, use GX Works2. If a slave station cannot be monitored due to an error such as cable disconnection, directly connect the supported programming tool to the slave station.

(1) Procedure

- 1) Connect GX Works2 to the CPU module, and open the "System Monitor" window. [Diagnostics] → [System Monitor]

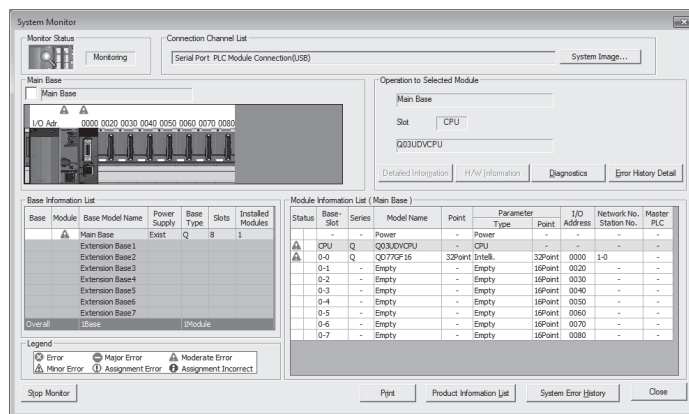

- 2) Select the module in which an error has occurred.
 - When a module other than a Simple Motion module is selected Refer to (a).
 - When the selected module is the Simple Motion module Refer to (b).

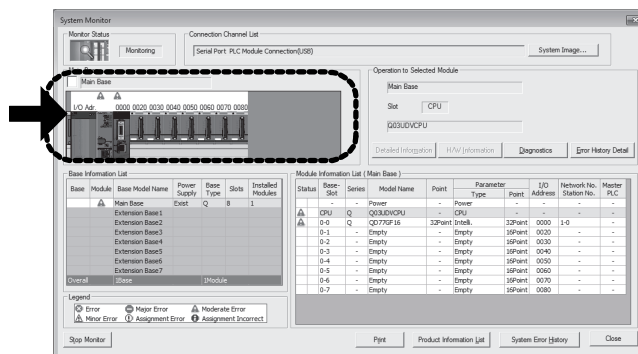

POINT

If data link cannot be performed even though no error is indicated in the "System Monitor" window, select the Simple Motion module, and click the [Diagnostics] button. (Refer to (b).)

- (a) Checking for error in modules other than the Simple Motion module
 - 1) Select a module other than the Simple Motion module in the "System Monitor" window, and click the [Diagnostics] button.

The window corresponding to the module will open. (The CPU module is selected in the illustration below.)

If the [Diagnostics] button is not supported by the module, click the [Detailed Information] button.

When data link cannot be performed even though no failure is shown in "System Monitor", select the Simple Motion module and click the [Diagnostics] button.

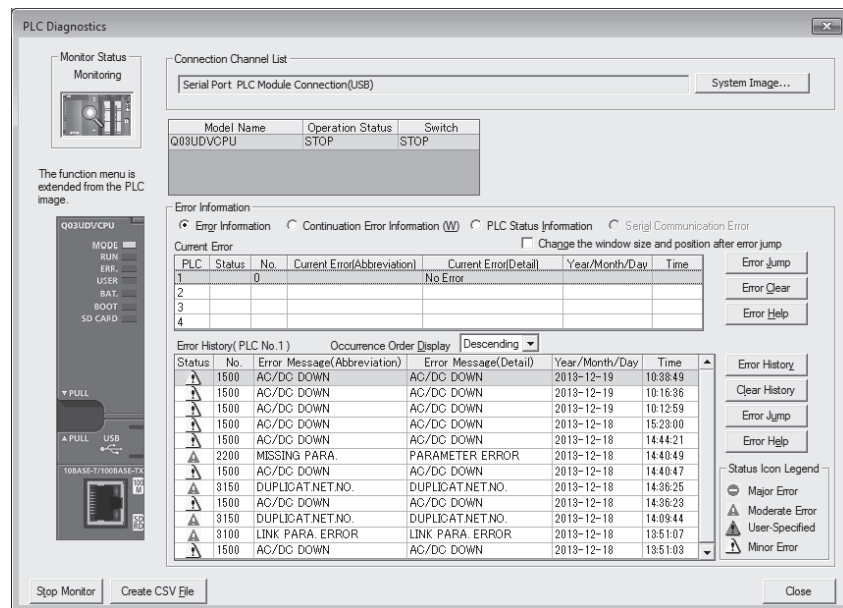

- 2) CPU resets and errors occurred before power-off are recorded in the "Error History" window.

[Diagnostics] → [System Monitor] → [System Error History] button

In the single "Error History" window, the error history of CPU modules and intelligent function modules (including the Simple Motion module) can be viewed.

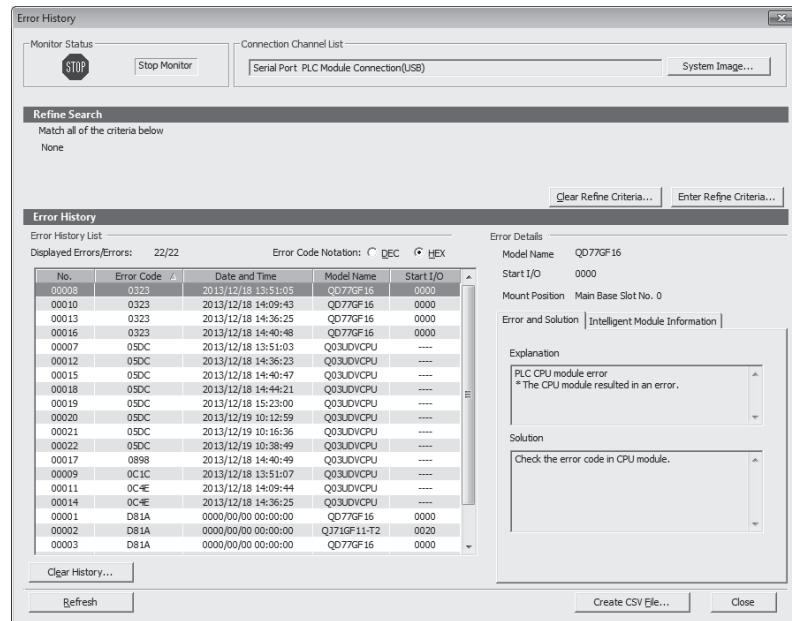

- 3) If data link cannot be performed even after the above operation is performed, perform the following:

- Checking for error using CC-Link IE Field Network diagnostics (Refer to Chapter 9.)
- Checking the LEDs (Refer to Section 12.3.)
- Troubleshooting by symptom (Refer to Section 12.4.)

- (b) Checking for error in the Simple Motion module
- 1) Select the Simple Motion module in the "System Monitor" window, and click the [Diagnostics] button. The "CC IE Field Diagnostics" window will open. Identify the cause of the error and take action.
(Refer to Chapter 9.)

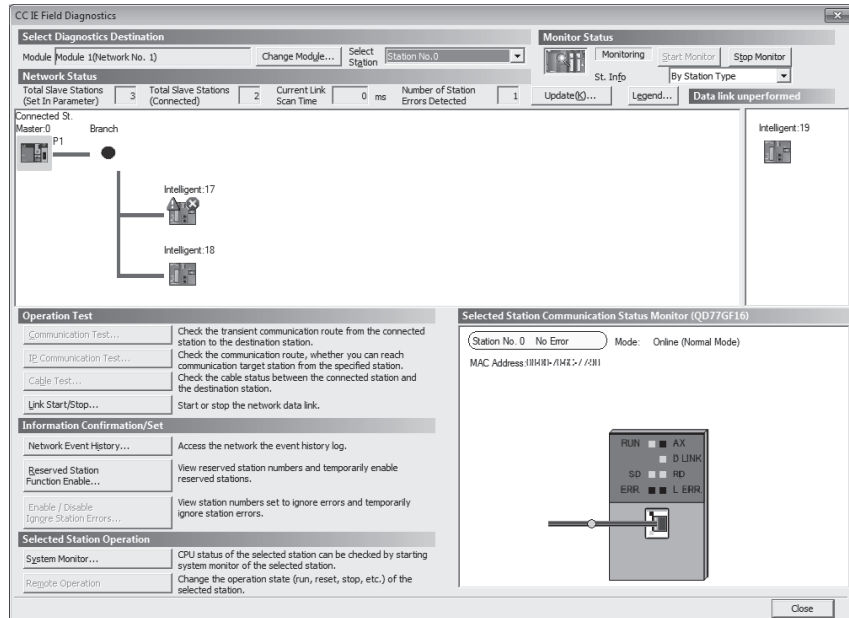

- 2) CPU resets and errors occurred before power-off are recorded in the "Error History" window.
[Diagnostics] → [System Monitor] → [System Error History] button

In the single "Error History" window, the error history of CPU modules and intelligent function modules (including the Simple Motion module) can be viewed.

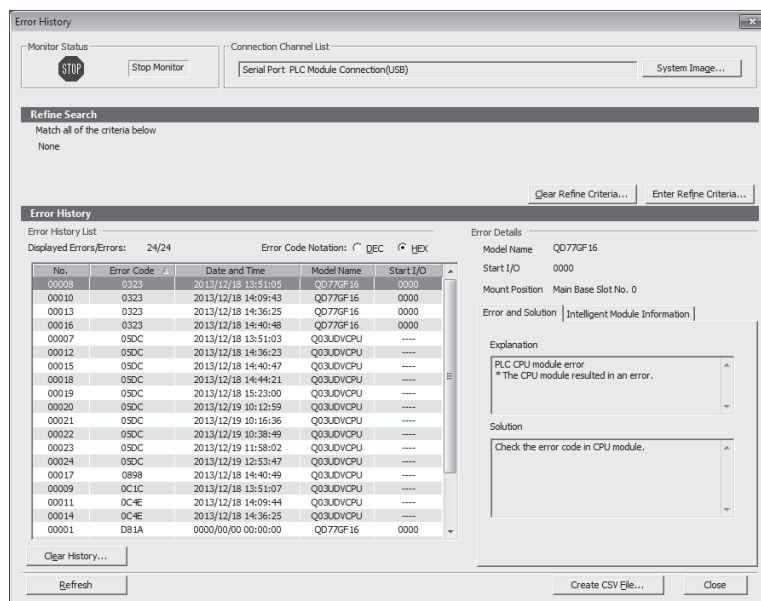

3) If data link cannot be performed even after the above operation is performed, perform the following:

- Checking the LEDs (Refer to Section 12.3.)
- Troubleshooting by symptom (Refer to Section 12.4.)

(2) Precautions on the "Error History" window

The following explains the Simple Motion module errors that may be shown in the "Error History" window.

For errors of the modules other than the Simple Motion module and functionality of the error history, refer to the manual for the relevant CPU module. (Refer to the "User's Manual (Function Explanation, Program Fundamentals)" of the CPU module in use.)

(a) No error history is displayed.

In "PLC RAS" of PLC Parameter, check if the "Module Error History Collection (Intelligent Function Module)" is selected.

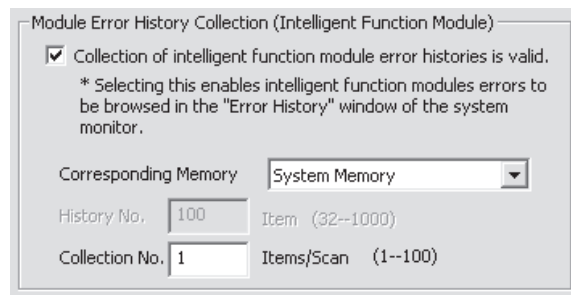

(b) The time and date of the error is not correctly displayed.

If an error occurred during initial processing of the CPU module, "0000/00/00 00:00:00" is displayed.

(c) The error code is not correctly displayed.

Instead of an error code, "*HST.LOSS*" may be displayed in the "Error Code" column if errors occurred at frequent intervals in the Simple Motion module.

No. ▾	Error Code	Date and Time	Model Name	Start I/O
00093	*HST.LOSS*	2013/12/19 20:45:54	QD77GF16	0000
00092	0385	2013/12/19 20:45:54	QD77GF16	0000

If "*HST.LOSS*" frequently appears, increase the number of collected errors per scan in "PLC RAS" of the PLC parameter window. (Refer to the "User's Manual (Function Explanation, Program Fundamentals)" of the CPU module in use.)

(d) The same error code is not displayed again.

If the same error continuously occurred, only the first error is displayed in the "Error History" window.

12.3 Checking the LEDs

The following explains how to troubleshoot the system by the LEDs.
Refer to the "MELSEC-Q QD77GF Simple Motion Module User's Manual (Positioning Control)" together.

(1) The D LINK LED turns off or is flashing

Check item	Action
Is the master station connected to the network and operating normally?	<ul style="list-style-type: none"> • If an error has occurred in the CPU module of the master station, remove the cause of the CPU module error. (Refer to Section 12.2.) • Connect GX Works2 to the master station. Check if the master station is performing data link using CC-Link IE Field Network diagnostics, and take action. (Refer to Chapter 9.)
Are 1000BASE-T-compliant Ethernet cables used?	Replace the cables with 1000BASE-T-compliant Ethernet cables. (Refer to Section 5.2.1.)
Is the station-to-station distance 100m or less?	Change the station-to-station distance to 100m or less.
Does the cabling condition (bend radius) meet the specification?	Refer to the manual for the Ethernet cable, and correct the bend radius.
Is any Ethernet cable disconnected?	Replace the Ethernet cable.
Are slave stations more than the number of stations that can be controlled connected?	Change the connection of the slave stations to the number of connectable stations per network.
Are other stations connected to the Simple Motion module operating normally?	Power on the other stations.
Is the switching hub operating normally?	<ul style="list-style-type: none"> • Check if a 1000BASE-T-compliant switching hub is used. (Refer to Section 5.2.2.) • Power off and then on the switching hub.
Check that the cables are not connected as described below. <ul style="list-style-type: none"> • The network is configured in ring topology. 	<ul style="list-style-type: none"> • Correct the wiring. (Refer to Section 5.1.1.) • If the system contains a switching hub. <ol style="list-style-type: none"> 1. Disconnect one Ethernet cable connected to the switching hub and power off and then on the hub. (Repeat this operation until data link starts over the network.) 2. When data link starts over the network, check the network configuration by CC-Link IE Field Network diagnostics. (Refer to Chapter 9.)
Is the station number of the Simple Motion module duplicated with any of the other stations?	Change the duplicated station number.

(2) The ERR. LED turns on

Check item	Action
Is there a CPU stop error?	Connect GX Works2 to the CPU module mounted with the Simple Motion module whose ERR. LED is on, identify the cause of the error, and take action. (Refer to Section 12.2.)
Is there an error in all stations?	
Is the station No. duplicated?	
Is the network parameter incorrect?	

(3) The ERR. LED is flashing

Check item	Action
Is the disconnected station displayed in the network map of the CC-Link IE Field Network diagnostics?	Perform the troubleshooting shown in "When the D LINK LED turned off or is flashing". (Refer to (1).)

If the above action does not solve the problem, "Total Stations" set in the Network Parameter window for the master station differs from the number of slave stations on the network. Correct the parameter.

(4) The L ERR. LED turns on

Check item	Action
Are the Ethernet cables operating normally?	<ul style="list-style-type: none"> • Check if 1000BASE-T-compliant Ethernet cables are used. (Refer to Section 3.2.) • Check if the station-to-station distance is 100m or less. (Refer to the "MELSEC-Q QD77GF Simple Motion Module User's Manual (Positioning Control)".) • Check if the Ethernet cables are not disconnected.
Is the switching hub operating normally?	<ul style="list-style-type: none"> • Check if a 1000BASE-T-compliant switching hub is used. (Refer to Section 5.2.2.) • Check if the switching hub is on.
Are other stations connected to the Simple Motion module operating normally?	Check if the systems on other stations are on.
Is the master station set to online mode?	Change the mode of the module to Online. (Refer to Section 7.3.)
Is there any noise affecting the system?	Check the wiring condition.

If the above actions do not solve the problem, follow the directions shown in "Communication is unstable". (Refer to Section 12.4.5.)

(5) The LINK LED turns off

Check item	Action
Are 1000BASE-T-compliant Ethernet cables used?	Replace the cables with 1000BASE-T-compliant Ethernet cables. (Refer to Section 5.2.1.)
Is the station-to-station distance 100m or less?	Change the station-to-station distance to 100m or less.
Does the cabling condition (bend radius) meet the specification?	Refer to the manual for the Ethernet cable, and correct the bend radius.
Is any Ethernet cable disconnected?	Replace the Ethernet cable.
Are the switching hub and other stations connected to the Simple Motion module normal?	Power on the switching hub and the other stations.

12.4 Troubleshooting by Symptom

Troubleshooting methods are described by symptom. Perform these troubleshooting if data link cannot be performed even though no error is detected in the Simple Motion module. If an error has occurred in the Simple Motion module, identify the error cause using GX Works2.
(Refer to Section 12.2.)

12.4.1 Cyclic transmission cannot be performed

The following lists the actions to be taken if cyclic data are not delivered to the master or a slave station.

Check item	Action
Is the D LINK LED of the master or slave station on?	If the D LINK LED is flashing or off, perform troubleshooting. (Refer to Section 12.3 (1).)
In "Network Configuration Settings" of the master station, is a slave station specified as a reserved station?	Cancel the reserved station setting. (Refer to Section 7.4.)
In "Network Configuration Settings" of the master station, is "RX/Ry Setting" or "RWw/RWr Setting" for slave stations configured?	Set RX/Ry or RWw/RWr data for each slave station within the allowable range. (Refer to Section 7.4.)
Do the station numbers set in "Network Configuration Settings" of the master station match those set for corresponding slave stations?	Correct station number (s).
Do the station types set in "Network Configuration Settings" of the master station match those set for the connected slave stations?	Check the station types set in "Network Configuration Settings" of the master station.
Are the refresh parameters set within correct ranges?	Correct the refresh parameters. Link devices and link refresh assignment can be confirmed in either of the following. <ul style="list-style-type: none"> • "Network Configuration Settings" window (Refer to Section 7.4.) • "Assignment Image" window (Refer to Section 7.6 (2).)
Is any refresh target device in the refresh parameter window overlapped with that of another network module?	Correct the refresh parameters. Overlap of a refresh target device can be checked in the "Assignment Image" window through GX Works2. (Refer to Section 7.6 (2).)
Is the station number of the Simple Motion module duplicated with any of the other stations?	Change the duplicated station number.

12.4.2 Transient transmission cannot be performed

The following lists the actions to be taken if transient transmission cannot be performed with the target station, and GX Works2 cannot perform monitoring.

Check item	Action
Is the D LINK LED of the master or slave station on or flashing?	If the D LINK LED is off, perform troubleshooting. (Refer to Section 12.3 (1).)
Is the baton pass status of the destination normal?	In the CC-Link IE Field Network diagnostics, identify the cause of the error and take action. (Refer to Chapter 9.)
Are the following control data of the dedicated instruction correct? • Target station's CPU type • Target station's network number • Target station number	Correct the control data of the dedicated instruction.
Is the station number of the Simple Motion module duplicated with any of the other stations?	Change the duplicated station number.

12.4.3 Station is disconnected from the network

The following is the troubleshooting action to be taken when a station in data link is disconnected.

Check item	Action
Is the ambient temperature for the module within the specified range?	Keep the ambient temperature within the specified range by taking action such as removing heat source.

12.4.4 Station is repeatedly disconnected and reconnected

The following lists the troubleshooting actions to be taken when a station in data link is repeatedly disconnected and reconnected.

Check item	Action
Are 1000BASE-T-compliant Ethernet cables used?	Replace the cables with 1000BASE-T-compliant Ethernet cables. (Refer to Section 5.2.1.)
Is the station-to-station distance 100m or less?	Change the station-to-station distance to 100m or less.
Does the cabling condition (bend radius) meet the specification?	Refer to the manual for the Ethernet cable, and correct the bend radius.
Is any Ethernet cable disconnected?	Replace the Ethernet cable.
Is the switching hub normal?	Power on the switching hub.

12.4.5 Communication is unstable

The following lists the troubleshooting actions to be taken when link scan time or transmission delay time is long or when a transient transmission timeout occurred.

Check item	Action
Is the L ERR. LED of the master or slave station off?	If the L ERR. LED is on or flashing, perform troubleshooting. (Refer to Section 12.3 (4).)
Is the ambient temperature for the module outside the specified range?	Keep the ambient temperature within the specified range by taking action such as removing heat source.
Is there any noise affecting the system?	Check the wiring condition.

12.5 Error Code List (D000H to DFFFH)

Error codes of the Simple Motion module are listed below.

Error code	Error	Action
D000H to D007H	Network module failure	<ul style="list-style-type: none"> • A malfunction may have occurred due to noise. Check the wire and cable distances and grounding condition of each device, and take measures against noise. • The hardware of the Simple Motion module may be faulty. Please consult your local Mitsubishi service center or representative.
D00FH	Network module failure	<ul style="list-style-type: none"> • A malfunction may have occurred due to noise. Check the wire and cable distances and grounding condition of each device, and take measures against noise. • The hardware of the Simple Motion module may be faulty. Please consult your local Mitsubishi service center or representative.
D010H	Parameter error (RX size over)	Correct the points assigned to the RX devices.
D011H	Parameter error (RY size over)	Correct the points assigned to the RY devices.
D012H	Parameter error (RWw size over)	Correct the points assigned to the RWw devices.
D013H	Parameter error (RWr size over)	Correct the points assigned to the RWr devices.
D014H to D016H	Network module failure	<ul style="list-style-type: none"> • A malfunction may have occurred due to noise. Check the wire and cable distances and grounding condition of each device, and take measures against noise. • The hardware of the Simple Motion module may be faulty. Please consult your local Mitsubishi service center or representative.
D019H to D01AH	Network module failure	<ul style="list-style-type: none"> • A malfunction may have occurred due to noise. Check the wire and cable distances and grounding condition of each device, and take measures against noise. • The hardware of the Simple Motion module may be faulty. Please consult your local Mitsubishi service center or representative.
D020H	Network module failure	<ul style="list-style-type: none"> • A malfunction may have occurred due to noise. Check the wire and cable distances and grounding condition of each device, and take measures against noise. • The hardware of the Simple Motion module may be faulty. Please consult your local Mitsubishi service center or representative.
D030H to D033H	Connection failure	Correct the wiring
D035H	Connection failure	Correct the wiring
D036H	Network module failure	<ul style="list-style-type: none"> • A malfunction may have occurred due to noise. Check the wire and cable distances and grounding condition of each device, and take measures against noise. • The hardware of the Simple Motion module may be faulty. Please consult your local Mitsubishi service center or representative.
D037H	Incorrect number of stations	<ul style="list-style-type: none"> • Check the network status using the CC-Link IE Field Network diagnostics of the programming tool. • If the number of slave stations per network is more than the number of connectable stations, reduce it to the number of connectable stations or less.
D03AH	SLMP function non-correspondence	Check the first five digits of the serial number of the station which becomes the next course of the error detection. If the module does not support the used function, replace it with the module with the latest version.
D040H	Network module failure	<ul style="list-style-type: none"> • A malfunction may have occurred due to noise. Check the wire and cable distances and grounding condition of each device, and take measures against noise. • The hardware of the Simple Motion module may be faulty. Please consult your local Mitsubishi service center or representative.

Error code	Error	Action
D041H	Incorrect number of stations	<ul style="list-style-type: none"> • Check the network status using the CC-Link IE Field Network diagnostics of the programming tool. • If the number of slave stations per network is more than the number of connectable stations, reduce it to the number of connectable stations or less.
D080H to D084H	Network module failure	<ul style="list-style-type: none"> • A malfunction may have occurred due to noise. Check the wire and cable distances and grounding condition of each device, and take measures against noise. • The hardware of the Simple Motion module may be faulty. Please consult your local Mitsubishi service center or representative.
D0A0H	Transient data transmission response wait timeout	<ul style="list-style-type: none"> • If the own station, or target station is disconnected from the network, identify the cause of the disconnection and take action. • When the target station is overloaded and cannot receive transient data, reduce the frequency of transient transmission and retry the operation.
D0A1H	Transient data transmission completion wait timeout	<ul style="list-style-type: none"> • Check if the cables and the switching hub are connected properly. • Reduce the frequency of transient transmission, and retry the operation. • The hardware of the Simple Motion module may be faulty. Please consult your local Mitsubishi service center or representative.
D0A2H	Transient data transmission processing wait timeout	<ul style="list-style-type: none"> • Reduce the frequency of transient transmission, and retry the operation. • Check if the switching hub and the cables at the request source are connected properly.
D0A3H	Transient data transmission error	<ul style="list-style-type: none"> • If the own station, or target station is disconnected from the network, identify the cause of the disconnection and take action. • Correct the number of the station for which transient data is to be sent, and retry the operation.
D0A4H to D0A6H	Transient transmission failed	<ul style="list-style-type: none"> • Check if the cables and the switching hub are connected properly. • Reduce the frequency of transient transmission, and retry the operation. • The hardware of the Simple Motion module may be faulty. Please consult your local Mitsubishi service center or representative.
D0A7H	Transient reception failed	<ul style="list-style-type: none"> • Check if the cables and the switching hub are connected properly. • Reduce the frequency of transient transmission, and retry the operation. • The hardware of the Simple Motion module may be faulty. Please consult your local Mitsubishi service center or representative.
D0C0H	Reserved station specification failed (another process in progress)	Wait for a while, and reserve the station again.
D0C1H	Reserved station cancellation failed (another process in progress)	Wait for a while, and cancel the reserved station setting again.
D0C2H	Data link stop failed (another process in progress)	Wait for a while, and instruct the data link stop again.
D0C3H	Data link start failed (another process in progress)	Wait for a while, and instruct the data link start again.
D0C6H	Another station number change failed (another process in progress)	Wait for a while, and set the station number of another station.
D0D0H	Another station number setting failed (another process in progress)	Wait for a while, and set the station number of another station.
D0E4H	Multiple master stations (including own station)	<ul style="list-style-type: none"> • Check the network status using the CC-Link IE Field Network diagnostics of the programming tool. • Check if the cables and the switching hub are connected properly. • After taking the above actions, power off and on all the stations that detected this error, or reset them.

Error code	Error	Action
D100H	Network module failure	<ul style="list-style-type: none"> • A malfunction may have occurred due to noise. Check the wire and cable distances and grounding condition of each device, and take measures against noise. • The hardware of the Simple Motion module may be faulty. Please consult your local Mitsubishi service center or representative.
D101H	Network module failure	<ul style="list-style-type: none"> • A malfunction may have occurred due to noise. Check the wire and cable distances and grounding condition of each device, and take measures against noise. • The hardware of the Simple Motion module may be faulty. Please consult your local Mitsubishi service center or representative.
D110H to D113H	Network module failure	<ul style="list-style-type: none"> • A malfunction may have occurred due to noise. Check the wire and cable distances and grounding condition of each device, and take measures against noise. • The hardware of the Simple Motion module may be faulty. Please consult your local Mitsubishi service center or representative.
D200H	Transient data received twice	<ul style="list-style-type: none"> • Check the network status using the CC-Link IE Field Network diagnostics of the programming tool. • Check if the cables and the switching hub are connected properly.
D201H	Header information error in transient transmission	Correct the header information at the request source, and retry the operation.
D202H	Send buffer full	<ul style="list-style-type: none"> • Reduce the frequency of transient transmission, and retry the operation. • Check if the cables and the switching hub are connected properly.
D203H	Read/write address error in transient transmission	Correct the read/write address at the request source, and retry the operation.
D204H	Network No. error in transient transmission	Correct the network number at the request source, and retry the operation.
D205H	Target station No. error in transient transmission	Correct the target station number at the request source, and retry the operation.
D206H	Network No. error in transient transmission	Correct the network number at the request source, and retry the operation.
D208H	Network No. error in transient transmission	Correct the network number at the request source, and retry the operation.
D209H to D20AH	Target station No. error in transient transmission	Correct the target station number at the request source, and retry the operation.
D20BH	Specified master station No. error in transient transmission	
D20CH	Current master station No. error in transient transmission	
D20DH	Transient data transmission completion wait timeout	<ul style="list-style-type: none"> • Check the network status using the CC-Link IE Field Network diagnostics of the programming tool. • When the own station, or target station detected an error, identify the cause of the error and take action. • Reduce the frequency of transient transmission, and retry the operation. • Check if the switching hub and the cables at the request source are connected properly.
D20EH	Header information error in transient transmission	Correct the header information at the request source, and retry the operation.
D20FH	Target station No. error in transient transmission	Check that the command can be requested to all or a group of stations at the request source, and retry the operation.
D210H	Target station No. error in transient transmission	Correct the header information at the request source, and retry the operation.

Error code	Error	Action
D211H	Own station No. not set (dedicated instruction)	Set the station number in the parameter setting, and retry the operation.
D212H	Transient transmission failed	<ul style="list-style-type: none"> • Check if the switching hub and the cables at the request source are connected properly. • Reduce the frequency of transient transmission, and retry the operation.
D213H	Transient data command error	Correct the request command at the request source, and retry the operation.
D214H	Transient data length error	Correct the data length at the request source, and retry the operation.
D215H	Transient data request error	Change the mode to Online, and retry the operation.
D216H to D217H	Transient data command error	Correct the request command at the request source, and retry the operation.
D218H	Incorrect number of read/write transient data	Correct the number of read/write device data at the request source, and retry the operation.
D219H	Transient data attribute code error	Correct the attribute code at the request source, and retry the operation.
D21AH	Transient data access code error	Correct the access code at the request source, and retry the operation.
D21BH to D21CH	Transient data request error	<ul style="list-style-type: none"> • Abnormal transient data were issued from the CPU module. • Replace the CPU module and retry the operation. • If this error persists, please consult your local Mitsubishi service center or representative.
D222H	Transient data command error	Correct the request command at the request source, and retry the operation.
D223H	Transient error	<ul style="list-style-type: none"> • Check the network status using the CC-Link IE Field Network diagnostics of the programming tool. • Check if the cables and the switching hub are connected properly. • If this error persists, please consult your local Mitsubishi service center or representative.
D22EH	Station No. setting not available for the target station	<ul style="list-style-type: none"> • Although change of the target station number was attempted online from the master station, the target station does not have the online station number setting function. • Check the manual for the target station if the station number setting function is available. • If the function is supported by the model, please consult your local Mitsubishi service center or representative.
D22FH	No baton pass executed in the target station	Check the communication status of the station whose station number is to be changed.
D230H	Invalid station No. setting	<ul style="list-style-type: none"> • The station number change was attempted for the own station. • Check that no station number is set for the target station.
D231H	Station No. already set in the target station	<ul style="list-style-type: none"> • The station number has been already set for the target station. • Check that no station number is set for the target station.
D232H	Station No. setting target not exist	<ul style="list-style-type: none"> • The station where the station number change was attempted does not exist. • Check that no station number is set for the target station.
D233H	Station No. setting out of range	Set the station number within 1 to 120, and retry the operation.
D234H	No baton pass executed	Check the communication status.
D235H	Transient error	<ul style="list-style-type: none"> • Check the network status using the CC-Link IE Field Network diagnostics of the programming tool. • Check if the cables and the switching hub are connected properly. • If this error persists, please consult your local Mitsubishi service center or representative.

Error code	Error	Action
D239H	SLMP transmission failed	<ul style="list-style-type: none"> • Retry the operation after a while. • If this error persists, please consult your local Mitsubishi service center or representative.
D23AH	Subheader error in SLMP transmission	Correct the subheader information at the request source, and retry the operation.
D23BH	Network No. error in SLMP transmission	Correct the network number information at the request source, and retry the operation.
D23CH	Station No. error in SLMP transmission	Correct the station number information at the request source, and retry the operation.
D23DH to D23EH	Request data error in SLMP transmission	The slave information acquisition request by the CC-Link IE Field configuration setting of the programming tool is incorrect. Close the "CC IE Field Configuration Setting" window, and request it again.
D240H	Target network No. error (dedicated instruction)	Correct the network number at the request source of the dedicated instruction, and retry the operation.
D241H	Target station No. error (dedicated instruction)	Correct the target station number at the request source of the dedicated instruction, and retry the operation.
D242H	Command code error (dedicated instruction)	Correct the command code at the request source of the dedicated instruction, and retry the operation.
D243H	Used channel error (dedicated instruction)	Set the used channel within the allowable range at the request source of the dedicated instruction, and retry the operation.
D244H	Incorrect transient data	<ul style="list-style-type: none"> • Correct the transient data at the request source, and retry the operation. • If this error persists, please consult your local Mitsubishi service center or representative.
D245H	Target station No. error (dedicated instruction)	Correct the target station number at the request source of the dedicated instruction, and retry the operation.
D246H	Incorrect transient data	<ul style="list-style-type: none"> • Correct the transient data at the request source, and retry the operation. • If this error persists, please consult your local Mitsubishi service center or representative.
D247H	Dedicated instruction received twice	<ul style="list-style-type: none"> • Check the network status using the CC-Link IE Field Network diagnostics of the programming tool. • Check if the switching hub and the cables at the request source are connected properly.
D248H	Incorrect transient data	<ul style="list-style-type: none"> • Correct the transient data at the request source, and retry the operation. • If this error persists, please consult your local Mitsubishi service center or representative.
D249H	Target station's CPU type error (dedicated instruction)	Correct the target station's CPU type at the request source of the dedicated instruction, and retry the operation.
D24AH	Arrival monitoring time error (dedicated instruction)	<ul style="list-style-type: none"> • Correct the arrival monitoring time at the request source of the dedicated instruction, and retry the operation. • When the own station, or target station detected an error, identify the cause of the error and take action. • Reduce the frequency of transient transmission, and retry the operation. • Check if the switching hub and the cables at the request source are connected properly.
D24BH	Number of resends error (dedicated instruction)	<ul style="list-style-type: none"> • Correct the number of resends at the request source of the dedicated instruction, and retry the operation. • When the own station, or target station detected an error, identify the cause of the error and take action. • Reduce the frequency of transient transmission, and retry the operation. • Check if the switching hub and the cables at the request source are connected properly.

Error code	Error	Action
D24CH	Target network No. error (dedicated instruction)	Correct the network number at the request source of the dedicated instruction, and retry the operation.
D24DH	Used channel error (dedicated instruction)	When executing the REMFR/REMTO instruction, set any of 1 to 32 for the channel No.
D24EH	Target station setting error (dedicated instruction)	<ul style="list-style-type: none"> • A value set for the control block of the dedicated instruction is out of range. Correct the value, and retry the operation. • If this error persists, please consult your local Mitsubishi service center or representative.
D24FH	Own station No. not set (dedicated instruction)	<ul style="list-style-type: none"> • Set the station number in the network parameter dialog box, and retry the operation. • If this error persists, please consult your local Mitsubishi service center or representative.
D250H	Flash ROM failure	<ul style="list-style-type: none"> • The flash ROM may be faulty. Check the wire and cable distances and grounding condition of each device, and take measures against noise. • The hardware of the Simple Motion module may be faulty. Please consult your local Mitsubishi service center or representative.
D251H	Arrival check error (dedicated instruction)	<ul style="list-style-type: none"> • Increase the number of resends at the request source of the dedicated instruction, and retry the operation. • When the own station, or target station detected an error, identify the cause of the error and take action. • Reduce the frequency of transient transmission, and retry the operation. • Check if the switching hub and the cables at the request source are connected properly.
D252H	Transmission completion wait timeout (dedicated instruction)	<ul style="list-style-type: none"> • Check the network status using the CC-Link IE Field Network diagnostics of the programming tool. • Increase the number of resends at the request source of the dedicated instruction, and retry the operation. • Reduce the frequency of transient transmission, and retry the operation. • Correct the number of link dedicated instructions that is simultaneously executed within the range. (Refer to Section 10.2.2 (1) (c).) • If this error persists, please consult your local Mitsubishi service center or representative.
D253H	Response timer timeout (dedicated instruction)	<ul style="list-style-type: none"> • Check the network status using the CC-Link IE Field Network diagnostics of the programming tool. • Increase the number of resends at the request source of the dedicated instruction, and retry the operation. • Reduce the frequency of transient transmission, and retry the operation. • Correct the number of link dedicated instructions that is simultaneously executed within the range. (Refer to Section 10.2.2 (1) (c).) • If this error persists, please consult your local Mitsubishi service center or representative.
D255H	Target station No. error (dedicated instruction)	<ul style="list-style-type: none"> • Correct the value in Target station number (control data), and retry the operation. • If this error persists, please consult your local Mitsubishi service center or representative.
D256H	Execution/abnormal end type error (dedicated instruction)	<ul style="list-style-type: none"> • Correct the value in Execution/abnormal end type (control data), and retry the operation. • If this error persists, please consult your local Mitsubishi service center or representative.
D258H	Specified/current control station not exist (dedicated instruction)	<ul style="list-style-type: none"> • Correct the value in Target station number (control data), and retry the operation. • If this error persists, please consult your local Mitsubishi service center or representative.

Error code	Error	Action
D25AH	Channel in use (dedicated instruction)	<ul style="list-style-type: none"> • Retry the operation after a while. • Change the value in Channels used by own station or Target station's channel (control data).
D25BH	Channel in use (dedicated instruction)	Change the value in Channels used by own station or Target station's channel (control data).
D25CH	Invalid function version (dedicated instruction)	<ul style="list-style-type: none"> • A value set for the control block of the dedicated instruction is out of range. Correct the value, and retry the operation. • If this error persists, please consult your local Mitsubishi service center or representative.
D25DH	Incorrect transient data	<ul style="list-style-type: none"> • Correct the transient data at the request source, and retry the operation. • If this error persists, please consult your local Mitsubishi service center or representative.
D269H	Target station type error (REMFR/REMTO)	Set the target station number specified by the REMFR/REMTO instruction to the station number of the intelligent device station or remote device station.
D26AH	Target station No. error (REMFR/REMTO)	Return the target station of the REMFR/REMTO instruction.
D273H	Request data size error	<ul style="list-style-type: none"> • Correct the request command at the request source, and retry the operation. • If this error persists, please consult your local Mitsubishi service center or representative.
D274H	Relay station No. error	<ul style="list-style-type: none"> • Correct the network number at the request source, and retry the operation. • If the request source is in another network, check the routing parameters are set correctly.
D275H	Dedicated instruction in use	<ul style="list-style-type: none"> • Dedicated instruction is in execution. Retry the operation after a while. • If this error persists, please consult your local Mitsubishi service center or representative.
D276H	Target station type error (dedicated instruction)	<ul style="list-style-type: none"> • Correct the target station type at the request source of the dedicated instruction, and retry the operation. • If this error persists, please consult your local Mitsubishi service center or representative.
D280H	Transient data request error	Correct the request command at the request source, and retry the operation.
D281H	Transient reception failed	<ul style="list-style-type: none"> • Check the network status using the CC-Link IE Field Network diagnostics of the programming tool. • When the target station is overloaded and cannot receive transient data, send the data to the target/relay station after the load on the station is reduced.
D282H	Receive queue full	<ul style="list-style-type: none"> • Once pausing the transient transmission, and retry the operation. • Reduce the frequency of transient transmission, and retry the operation. • Use the COM instruction to increase the frequency of transient transmission. • If this error persists, please consult your local Mitsubishi service center or representative.
D283H	Transient transmission failed	<ul style="list-style-type: none"> • Check the network status using the CC-Link IE Field Network diagnostics of the programming tool. • Reduce the frequency of transient transmission, and retry the operation.
D284H	Execution module error	Correct the execution module at the SLMP header, and retry the operation.

Error code	Error	Action
D2A0H	Receive buffer full	<ul style="list-style-type: none"> • Check the network status using the CC-Link IE Field Network diagnostics of the programming tool. • When the target station is overloaded and cannot receive transient data, send the data to the target/relay station after the load on the station is reduced.
D2A1H	Send buffer full	<ul style="list-style-type: none"> • Reduce the frequency of transient transmission, and retry the operation. • Check if the switching hub and the cables at the request source are connected properly.
D2A2H	Transmission completion wait timer timeout	<ul style="list-style-type: none"> • Reduce the frequency of transient transmission, and retry the operation. • Check if the switching hub and the cables at the request source are connected properly. • Correct the number of link dedicated instructions that is simultaneously executed within the range. (Refer to Section 10.2.2 (1) (c).)
D2A3H	Transient data length error	Correct the number of data (frame length) at the request source, and retry the operation.
D2A4H	Header information error in transient transmission	Correct the header information at the request source, and retry the operation.
D2A5H	Target station No. error in transient transmission	Correct the target station number at the request source, and retry the operation.
D2A6H	Transient data request source No. error	Correct the request source number at the request source, and retry the operation.
D2A7H to D2A8H	Header information error in transient transmission	Correct the header information at the request source, and retry the operation.
D2A9H	Target network No. error in transient transmission	Correct the target network number at the request source, and retry the operation.
D2AAH	Target station No. error in transient transmission	Correct the target station number at the request source, and retry the operation.
D2ABH	Request source network No. error in transient transmission	Correct the network number of the request source at the request source, and retry the operation.
D2ACH	Transient data request source No. error	Correct the station number of the request source at the request source, and retry the operation.
D2ADH	Transient data length error	Correct the number of data (frame length) at the request source, and retry the operation.
D2AFH	Target station No. error in transient transmission	Transient data transmission addressed to the own station was requested. Check the network number and target station number, and retry the operation.
D2B0H	Transient transmission failed	<ul style="list-style-type: none"> • Check if the switching hub and the cables at the request source are connected properly. • Reduce the frequency of transient transmission, and retry the operation.
D300H	Not support function execution error	Not support function is executed in the CC-Link IE Field network diagnostics. Check the support functions of the simple motion module.

Error code	Error	Action
D301H	Parameter error (temporary error invalid station setting error)	<ul style="list-style-type: none"> • Write the network parameters to the CPU module again. • In "Network Configuration Setting", cancel the temporary error invalid station setting. • If this error persists, please consult your local Mitsubishi service center or representative.
D302H	Parameter error (network type error)	<ul style="list-style-type: none"> • Write the network parameters to the CPU module again. • Correct the network type, and retry the operation. • If this error persists, please consult your local Mitsubishi service center or representative.
D303H	Parameter error (mode error)	<ul style="list-style-type: none"> • Write the network parameters to the CPU module again. • Correct the mode, and retry the operation. • If this error persists, please consult your local Mitsubishi service center or representative.
D304H	Synchronous communication error	<ul style="list-style-type: none"> • Change the operation cycle setting to a value longer than the current set value. • Check if the cables and the switching hub are connected properly. • After taking the above action, switch the power on again or resetting the CPU module. • If block data assurance per station is valid, shorten the scan time of the programmable controller. For how to shorten the scan time, refer to the user's manual for the CPU module used. • If the synchronization is not required in the system, do not use block data assurance per station.
D602H to D607H	Parameter error	<ul style="list-style-type: none"> • Write the network parameters to the CPU module again. • If this error persists, please consult your local Mitsubishi service center or representative.
D608H to D609H	Parameter error	<ul style="list-style-type: none"> • Write the network parameters to the CPU module again. • If this error persists, please consult your local Mitsubishi service center or representative.
D60DH to D610H	Network module failure	<ul style="list-style-type: none"> • A malfunction may have occurred due to noise. Check the wire and cable distances and grounding condition of each device, and take measures against noise. • The hardware of the Simple Motion module may be faulty. Please consult your local Mitsubishi service center or representative.
D611H	Parameter error (device range assignment error (RWw))	<ul style="list-style-type: none"> • Write the network parameters to the CPU module again. • Correct the value in the size of the link device in the slave station(s) (setting data), and retry the operation. • If this error persists, please consult your local Mitsubishi service center or representative.
D612H	Parameter error (device range assignment error (RWw))	<ul style="list-style-type: none"> • Write the network parameters to the CPU module again. • Correct the value in the offset of the link device in the slave station(s) (setting data), and retry the operation. • If this error persists, please consult your local Mitsubishi service center or representative.
D613H	Parameter error (device range assignment error (RWr))	<ul style="list-style-type: none"> • Write the network parameters to the CPU module again. • Correct the value in the size of the link device in the slave station(s) (setting data), and retry the operation. • If this error persists, please consult your local Mitsubishi service center or representative.
D614H	Parameter error (device range assignment error (RWr))	<ul style="list-style-type: none"> • Write the network parameters to the CPU module again. • Correct the value in the offset of the link device in the slave station(s) (setting data), and retry the operation. • If this error persists, please consult your local Mitsubishi service center or representative.

Error code	Error	Action
D615H	Parameter error (device range assignment error (RY))	<ul style="list-style-type: none"> • Write the network parameters to the CPU module again. • Correct the value in the size of the link device in the slave station(s) (setting data), and retry the operation. • If this error persists, please consult your local Mitsubishi service center or representative.
D616H	Parameter error (device range assignment error (RY))	<ul style="list-style-type: none"> • Write the network parameters to the CPU module again. • Correct the value in the offset of the link device in the slave station(s) (setting data), and retry the operation. • If this error persists, please consult your local Mitsubishi service center or representative.
D617H	Parameter error (device range assignment error (RX))	<ul style="list-style-type: none"> • Write the network parameters to the CPU module again. • Correct the value in the size of the link device in the slave station(s) (setting data), and retry the operation. • If this error persists, please consult your local Mitsubishi service center or representative.
D618H	Parameter error (device range assignment error (RX))	<ul style="list-style-type: none"> • Write the network parameters to the CPU module again. • Correct the value in the offset of the link device in the slave station(s) (setting data), and retry the operation. • If this error persists, please consult your local Mitsubishi service center or representative.
D619H to D61AH	Parameter error	<ul style="list-style-type: none"> • Write the network parameters to the CPU module again. • If this error persists, please consult your local Mitsubishi service center or representative.
D61BH	Parameter error (device duplication (RWw))	<ul style="list-style-type: none"> • Write the network parameters to the CPU module again. • Correct the value in the offset or the size of the link device in the slave station(s) (setting data), and retry the operation. • If this error persists, please consult your local Mitsubishi service center or representative.
D61CH	Parameter error (device duplication (RWr))	
D61DH	Parameter error (device duplication (RY))	
D61EH	Parameter error (device duplication (RX))	
D620H	Incorrect transient data	<ul style="list-style-type: none"> • Check the transient data at the request source, and retry the operation. • If this error persists, please consult your local Mitsubishi service center or representative.
D621H	Parameter error	<ul style="list-style-type: none"> • Write the network parameters to the CPU module again. • If this error persists, please consult your local Mitsubishi service center or representative.
D622H	Parameter error (total number of slave stations error)	<ul style="list-style-type: none"> • Write the network parameters to the CPU module again. • Correct the total number of slave stations, and retry the operation. • If this error persists, please consult your local Mitsubishi service center or representative.
D625H	Parameter error (block data assurance per station setting error)	<ul style="list-style-type: none"> • Write the network parameters to the CPU module again. • Correct the setting in "Block Data Assurance per Station", and retry the operation. • If this error persists, please consult your local Mitsubishi service center or representative.
D627H	Parameter error (slave station setting information error)	<ul style="list-style-type: none"> • Write the network parameters to the CPU module again. • Correct the value in the slave station setting information (setting data), and retry the operation. • If this error persists, please consult your local Mitsubishi service center or representative.

Error code	Error	Action
D628H	Parameter error (station type error)	<ul style="list-style-type: none"> • Write the network parameters to the CPU module again. • Correct the value in the station type (setting data), and retry the operation. • If this error persists, please consult your local Mitsubishi service center or representative.
D629H	Parameter error (station No. range error)	<ul style="list-style-type: none"> • Write the network parameters to the CPU module again. • Correct the value in the station No. (setting data) within 1 to 120, and retry the operation. • If this error persists, please consult your local Mitsubishi service center or representative.
D62AH	Parameter error (data link faulty station setting error)	<ul style="list-style-type: none"> • Write the network parameters to the CPU module again. • Correct the data link faulty station setting, and retry the operation. • If this error persists, please consult your local Mitsubishi service center or representative.
D62BH	Parameter error (output status setting for CPU STOP error)	<ul style="list-style-type: none"> • Write the network parameters to the CPU module again. • Correct the output status setting for CPU STOP, and retry the operation. • If this error persists, please consult your local Mitsubishi service center or representative.
D62CH	Parameter error (interrupt setting error)	<ul style="list-style-type: none"> • Write the network parameters to the CPU module again. • Correct the interrupt settings and retry the operation. • If this error persists, please consult your local Mitsubishi service center or representative.
D62DH	Data link start failed	<p>Data link start failed due to any of the following causes. Remove the error cause, and retry the operation.</p> <ul style="list-style-type: none"> • CPU module error on the own station • Master station duplication • Parameter error • Parameter communication in progress • Parameters not received (no slave station exists)
D642H	Parameter error (network parameter mismatch)	<ul style="list-style-type: none"> • Write the network parameters to the CPU module again. • If this error persists, please consult your local Mitsubishi service center or representative.
D643H	Parameter error (network configuration setting mismatch)	<ul style="list-style-type: none"> • Write the network parameters to the CPU module again. • If this error persists, please consult your local Mitsubishi service center or representative.
D644H	Parameter error (supplementary setting mismatch)	<ul style="list-style-type: none"> • Write the network parameters to the CPU module again. • If this error persists, please consult your local Mitsubishi service center or representative.
D645H	Parameter error (mode setting mismatch)	<ul style="list-style-type: none"> • Write the network parameters to the CPU module again. • If this error persists, please consult your local Mitsubishi service center or representative.
D646H	Parameter error (operation setting)	<ul style="list-style-type: none"> • Write the network parameters to the CPU module again. • If this error persists, please consult your local Mitsubishi service center or representative.
D701H	Temporary reserved station cancel setting not set	Set the target station(s) in Reserved station function disable setting (SW0011 to SW0017), and retry the operation.
D70BH	Request error of reserved station cancel/restoration (when different settings are simultaneously performed)	<ul style="list-style-type: none"> • Reserved station cancel/restoration using SB0012 and SB0013 cannot be simultaneously executed. • Retry the operation so that only one bit in SB0012 to SB0013 may turn on after all bits in them are turned off.

Error code	Error	Action
D720H	Data link start/stop instruction out of range	Check the setting, and stop or start data link.
D721H	Data link start/stop retry error (another station)	Retry the operation after the stop or restart of data link is completed.
D722H	Data link start/stop retry error (own station)	Retry the operation after the stop or restart of data link is completed.
D723H	Data link start/stop retry error (entire system)	Retry the operation after the stop or restart of data link is completed.
D724H	Data link start/stop station error	Check the setting, and stop or start data link.
D726H	Transient data request command error	Correct the request command at the request station, and retry the operation.
D727H	Data link start/stop command-instructing stations different	<ul style="list-style-type: none"> Data link start was instructed from a station different from the one that had instructed the data link stop. Instruct data link start and data link stop from the same station. The method of the data link start differs from that of the data link stop. Instruct the data link start using the same method as the data link stop (ex. Data link is stopped using the CC-Link IE Field Network diagnostics, and the data link is started using a program). Data link start failed. Forcibly restart the data link.
D728H	Data link start/stop command-instructing stations different	Data link start was instructed during execution of data link. Instruct data link stop then data link start.
D780H	History acquisition setting data full	The area for writing history acquisition setting data for network event history is insufficient. Reset or power off and on the CPU module.
D781H	Network module failure	<ul style="list-style-type: none"> A malfunction may have occurred due to noise. Check the wire and cable distances and grounding condition of each device, and take measures against noise. The hardware of the Simple Motion module may be faulty. Please consult your local Mitsubishi service center or representative.
D782H	History acquisition setting data error	The previous history acquisition setting data for network event history were not written successfully. Reset or power off and on the CPU module.
D783H to D784H	Transient data request error	<ul style="list-style-type: none"> The read request by the CC-Link IE Field Network diagnostics of the programming tool is incorrect. Close the "CC IE Field Diagnostics" window, and request it again. Check the read request data at the request station, and retry the operation.
D785H	Flash ROM failure	The maximum number of writes to the flash ROM is exceeded. Replace the Simple Motion module.
D786H	Flash ROM failure	The flash ROM may be faulty. Please consult your local Mitsubishi service center or representative.
D800H	Network module failure	<ul style="list-style-type: none"> A malfunction may have occurred due to noise. Check the wire and cable distances and grounding condition of each device, and take measures against noise. The hardware of the Simple Motion module may be faulty. Please consult your local Mitsubishi service center or representative.
D803H to D805H	Network module failure	<ul style="list-style-type: none"> A malfunction may have occurred due to noise. Check the wire and cable distances and grounding condition of each device, and take measures against noise. The hardware of the Simple Motion module may be faulty. Please consult your local Mitsubishi service center or representative.
D806H	Receive queue full	<ul style="list-style-type: none"> Reduce the frequency of transient transmission, and retry the operation. Check if the cables and the switching hub are connected properly. Use the COM instruction to increase the frequency of transient transmission.

Error code	Error	Action
D807H	Network module failure	<ul style="list-style-type: none"> • A malfunction may have occurred due to noise. Check the wire and cable distances and grounding condition of each device, and take measures against noise. • The hardware of the Simple Motion module may be faulty. Please consult your local Mitsubishi service center or representative.
D80AH to D80FH	Parameter error	<ul style="list-style-type: none"> • Write the network parameters to the CPU module again. • If this error persists, please consult your local Mitsubishi service center or representative.
D812H to D813H	Parameter error	<ul style="list-style-type: none"> • Write the network parameters to the CPU module again. • If this error persists, please consult your local Mitsubishi service center or representative.
D814H	Network module failure	<ul style="list-style-type: none"> • A malfunction may have occurred due to noise. Check the wire and cable distances and grounding condition of each device, and take measures against noise. • The hardware of the Simple Motion module may be faulty. Please consult your local Mitsubishi service center or representative.
D816H	Network module failure	<ul style="list-style-type: none"> • A malfunction may have occurred due to noise. Check the wire and cable distances and grounding condition of each device, and take measures against noise. • The hardware of the Simple Motion module may be faulty. Please consult your local Mitsubishi service center or representative.
D819H	CPU module failure	<ul style="list-style-type: none"> • Replace the CPU module. • If this error persists, please consult your local Mitsubishi service center or representative.
D81AH	CPU module stop error	Check the error in the "PLC Diagnostics" window of the programming tool.
D81BH	Programmable controller power failure	The power is off. Turn it on.
D826H	Flash ROM failure	<ul style="list-style-type: none"> • The maximum number of writes to the flash ROM is exceeded. • Reset the CPU module. If a failure occurs again, the hardware of the Simple Motion module may be faulty. Please consult your local Mitsubishi service center or representative.
D827H	Communication RAM failure	<ul style="list-style-type: none"> • A malfunction may have occurred due to noise. Check the wire and cable distances and grounding condition of each device, and take measures against noise. • The hardware of the Simple Motion module may be faulty. Please consult your local Mitsubishi service center or representative.
DA00H to DA01H	Network module failure	<ul style="list-style-type: none"> • A malfunction may have occurred due to noise. Check the wire and cable distances and grounding condition of each device, and take measures against noise. • The hardware of the Simple Motion module may be faulty. Please consult your local Mitsubishi service center or representative.
DA10H to DA18H	Network module failure	<ul style="list-style-type: none"> • A malfunction may have occurred due to noise. Check the wire and cable distances and grounding condition of each device, and take measures against noise. • The hardware of the Simple Motion module may be faulty. Please consult your local Mitsubishi service center or representative.
DAD0H to DAD4H	Network module failure	<ul style="list-style-type: none"> • A malfunction may have occurred due to noise. Check the wire and cable distances and grounding condition of each device, and take measures against noise. • The hardware of the Simple Motion module may be faulty. Please consult your local Mitsubishi service center or representative.

Error code	Error	Action
DAE0H to DAE3H	Network module failure	<ul style="list-style-type: none"> • A malfunction may have occurred due to noise. Check the wire and cable distances and grounding condition of each device, and take measures against noise. • The hardware of the Simple Motion module may be faulty. Please consult your local Mitsubishi service center or representative.
DAE4H	CPU module failure	<ul style="list-style-type: none"> • Please consult your local Mitsubishi service center or representative.
DAE5H	Network module failure	<ul style="list-style-type: none"> • A malfunction may have occurred due to noise. Check the wire and cable distances and grounding condition of each device, and take measures against noise. • The hardware of the Simple Motion module may be faulty. Please consult your local Mitsubishi service center or representative.
DAE6H	CC-Link IE Field not supported by the CPU	<ul style="list-style-type: none"> • Use a CPU module compatible with the Simple Motion module. • If this error persists, please consult your local Mitsubishi service center or representative.
DAE7H	Network module failure	<ul style="list-style-type: none"> • A malfunction may have occurred due to noise. Check the wire and cable distances and grounding condition of each device, and take measures against noise. • The hardware of the Simple Motion module may be faulty. Please consult your local Mitsubishi service center or representative.
DAE8H	Switch setting information error	<ul style="list-style-type: none"> • Do not set the intelligent function module switch setting. • If this error persists, please consult your local Mitsubishi service center or representative.
DAF1H	Network module failure	<ul style="list-style-type: none"> • A malfunction may have occurred due to noise. Check the wire and cable distances and grounding condition of each device, and take measures against noise. • The hardware of the Simple Motion module may be faulty. Please consult your local Mitsubishi service center or representative.
DAF2H	Flash ROM failure	<ul style="list-style-type: none"> • The flash ROM may be faulty. Check the wire and cable distances and grounding condition of each device, and take measures against noise. • The hardware of the Simple Motion module may be faulty. Please consult your local Mitsubishi service center or representative.
DAF3H	Flash ROM failure	<ul style="list-style-type: none"> • The flash ROM may be faulty. Check the wire and cable distances and grounding condition of each device, and take measures against noise. • The hardware of the Simple Motion module may be faulty. Please consult your local Mitsubishi service center or representative.
DAF5H to DAF7H	Network module failure	<ul style="list-style-type: none"> • A malfunction may have occurred due to noise. Check the wire and cable distances and grounding condition of each device, and take measures against noise. • The hardware of the Simple Motion module may be faulty. Please consult your local Mitsubishi service center or representative.
DAF8H to DAF9H	Flash ROM failure	The flash ROM may be faulty. Please consult your local Mitsubishi service center or representative.

12.6 Checking the Status by System Monitor

In the "System Monitor" window of GX Works2, the LED status of the Simple Motion module and the intelligent function module switch settings can be checked.

- 1) Open the "System Monitor" window.
[Diagnostics] → [System Monitor]
- 2) In the upper left "Main Base" area, select a module to be diagnosed, and click the [H/W Information] button.

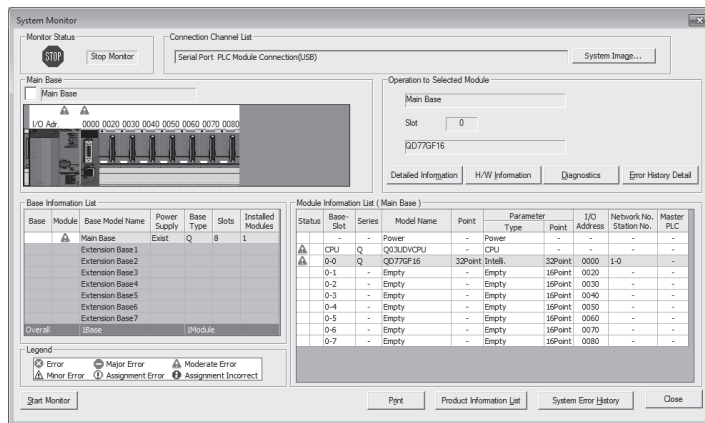

- 3) The "H/W Information" window opens.

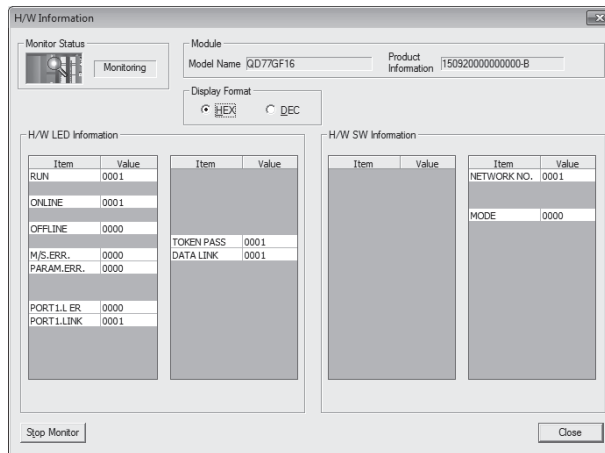

Item	Description
Display Format	Switches the display format of "H/W LED Information" and "H/W Switch Information".

Item	Description
H/W LED Information	RUN Shows the condition of the RUN LED. 0000: OFF 0001: ON
	ONLINE Shows whether the Simple Motion module is in online mode. 0000: Other than online mode 0001: Online mode
	OFFLINE Shows whether the Simple Motion module is in offline mode. 0000: Other than offline mode 0001: Offline mode
	M/S. ERR. Indicates whether the master station is duplicated or station number is overlapped. 0000: No duplication 0001: Duplicated
	PARAM.ERR. Shows the parameter error status. 0000: No error 0001: Error
	PORT1.L ER Shows the L ER LED status of PORT1. 0000: OFF 0001: ON
	PORT1.LINK Shows the LINK LED status of PORT1. 0000: OFF 0001: ON
	TOKEN PASS Shows the baton pass status of the Simple Motion module. 0000: No baton (token) passing 0001: Baton (token) passing
	DATA LINK Shows the data link status of the Simple Motion module. 0000: No data link 0001: Data link in execution
H/W SW Information	NETWORK NO. Displays the network number.
	MODE Shows the mode of the Simple Motion module. 0000: Online (Normal Mode) 0002: Offline

Appendices

Appendix 1 Details of Buffer Memory Addresses	Appendix- 2
Appendix 1.1 Link device area (Un\G59392 to Un\G63007)	Appendix- 2
Appendix 1.2 RX offset/size information (Un\G63152 to Un\G63359)	Appendix- 4
Appendix 1.3 RY offset/size information (Un\G63360 to Un\G63567)	Appendix- 4
Appendix 1.4 RWw offset/size information (Un\G63568 to Un\G63775) ...	Appendix- 5
Appendix 1.5 RWr offset/size information (Un\G63776 to Un\G63983)	Appendix- 5
Appendix 1.6 Station information (Un\G64016 to Un\G64041).....	Appendix- 6
Appendix 2 Link Special Relay (SB) List	Appendix- 8
Appendix 3 Link Special Register (SW) List	Appendix-16
Appendix 4 Processing Time	Appendix-28
Appendix 4.1 Link refresh time	Appendix-29
Appendix 4.2 Link scan time	Appendix-30
Appendix 4.3 Cyclic transmission delay time.....	Appendix-31
Appendix 4.4 Transmission delay time of dedicated instructions	Appendix-32
Appendix 4.5 Calculation formula for operation cycle	Appendix-32
Appendix 5 Comparison of QJ71GF11-T2	Appendix-33

Appendix 1 Details of Buffer Memory Addresses

This section describes the buffer memory of the Simple Motion module.

Appendix 1.1 Link device area (Un\G59392 to Un\G63007)

This buffer memory stores the RX, RY, RWw, and RWr values.

(1) Remote input (RX) (Un\G59392 to Un\G59903)

This buffer memory stores the RX value. The RX start number and number of points for each station No. can be checked by the RX offset/size information (Un\G63152 to Un\G63359). (Refer to Appendix 1.2.)

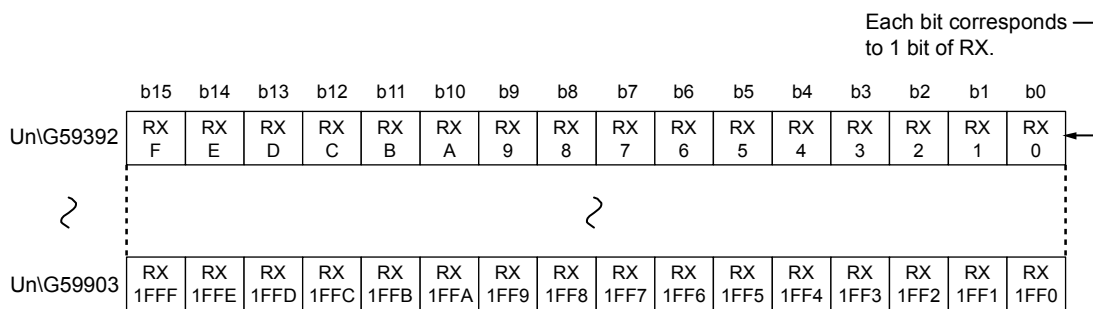

(2) Remote output (RY) (Un\G59904 to Un\G60415)

This buffer memory stores the RY value. The RY start number and number of points for each station No. can be checked by the RY offset/size information (Un\G63360 to Un\G63567). (Refer to Appendix 1.3.)

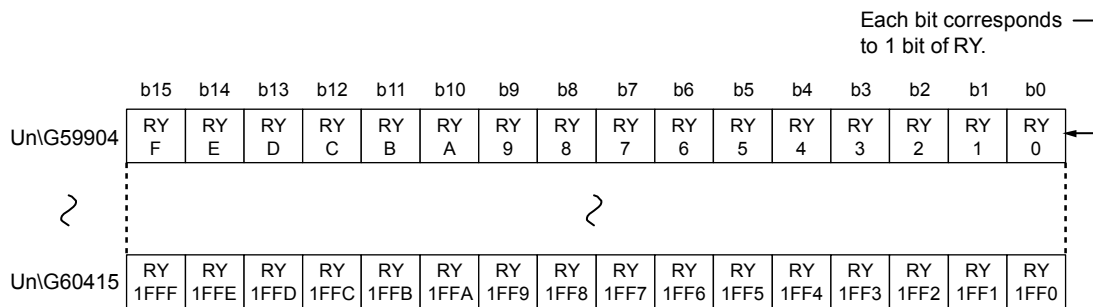

(3) Remote register (RWw) (Un\G60416 to Un\G61439)

This buffer memory stores the RWw value. The RWw start number and number of points for each station No. can be checked by the RWw offset/size information (Un\G63568 to Un\G63775). (Refer to Appendix 1.4.)

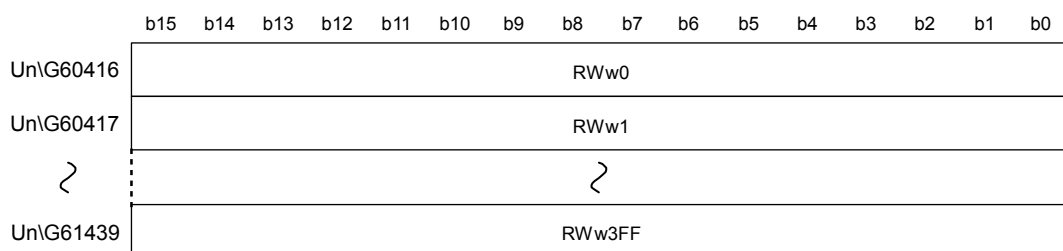

(4) Remote register (RWr) (Un\G61440 to Un\G62463)

This buffer memory stores the RWr value. The RWr start number and number of points for each station No. can be checked by the RWr offset/size information (Un\G63776 to Un\G63983). (Refer to Appendix 1.5.)



(5) Link special relay (SB) (Un\G62464 to Un\G62495)

This buffer memory stores the SB value.

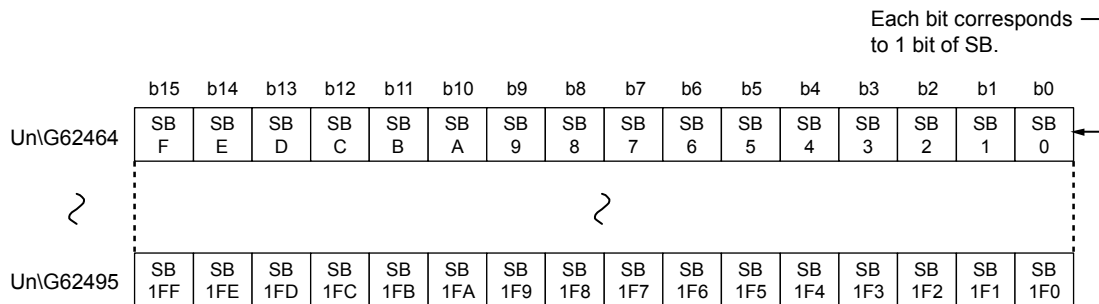

(6) Link special register (SW) (Un\G62496 to Un\G63007)

This buffer memory stores the SW value.

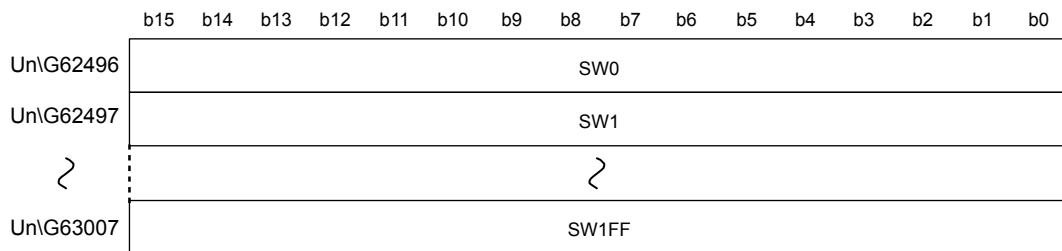

Appendix 1.2 RX offset/size information (Un\G63152 to Un\G63359)

This buffer memory stores the start number and the number of points of RX for each station.

Un\G63152	Station No.17	Offset
Un\G63153	Station No.17	Size (in units of words)
Un\G63154	Station No.18	Offset
Un\G63155	Station No.18	Size (in units of words)
⋮		
⋮		
Un\G63358	Station No.120	Offset
Un\G63359	Station No.120	Size (in units of words)

The offset and size of buffer memory areas for each station number can be calculated using the following formulas:

- Offset buffer memory address = $63152 + (\text{station No.17}) \times 2$
- Size buffer memory address = $63153 + (\text{station No.17}) \times 2$

Appendix 1.3 RY offset/size information (Un\G63360 to Un\G63567)

This buffer memory stores the start number and the number of points of RY for each station.

Un\G63360	Station No.17	Offset
Un\G63361	Station No.17	Size (in units of words)
Un\G63362	Station No.18	Offset
Un\G63363	Station No.18	Size (in units of words)
⋮		
⋮		
Un\G63566	Station No.120	Offset
Un\G63567	Station No.120	Size (in units of words)

The offset and size of buffer memory areas for each station number can be calculated using the following formulas:

- Offset buffer memory address = $63360 + (\text{station No.17}) \times 2$
- Size buffer memory address = $63361 + (\text{station No.17}) \times 2$

Appendix 1.4 RWw offset/size information (Un\G63568 to Un\G63775)

This buffer memory stores the start number and the number of points of RWw for each station.

Un\G63568	Station No.17	Offset
Un\G63569	Station No.17	Size (in units of words)
Un\G63570	Station No.18	Offset
Un\G63571	Station No.18	Size (in units of words)
⋮		⋮
Un\G63774	Station No.120	Offset
Un\G63775	Station No.120	Size (in units of words)

The offset and size of buffer memory areas for each station number can be calculated using the following formulas:

- Offset buffer memory address = $63568 + (\text{station No.17}) \times 2$
- Size buffer memory address = $63569 + (\text{station No.17}) \times 2$

Appendix 1.5 RWr offset/size information (Un\G63776 to Un\G63983)

This buffer memory stores the start number and the number of points of RWr for each station.

Un\G63776	Station No.17	Offset
Un\G63777	Station No.17	Size (in units of words)
Un\G63778	Station No.18	Offset
Un\G63779	Station No.18	Size (in units of words)
⋮		⋮
Un\G63982	Station No.120	Offset
Un\G63983	Station No.120	Size (in units of words)

The offset and size of buffer memory areas for each station number can be calculated using the following formulas:

- Offset buffer memory address = $63776 + (\text{station No.17}) \times 2$
- Size buffer memory address = $63777 + (\text{station No.17}) \times 2$

Appendix 1.6 Station information (Un\G64016 to Un\G64041)

This buffer memory stores the station's information on the network.

(1) Station number (Un\G64016)

Address	Name	Description
Un\G64016	Station number	This buffer memory sets the station number. The station information set in the station number is stored in the station information area. 0: Own station (Simple Motion module) 1 to 120: Slave station Other than 0 to 120: Stores 0 in all station information area.

(2) Station (network card) information (Un\G64017 to Un\G 64020)

Address	Name	Description
Un\G64017	Manufacturer code	This buffer memory stores the station information set in the station number.
Un\G64018	Model type	
Un\G64019	Model code	
Un\G64020	Version	

(3) Station (controller) information (Un\G64025 to Un\G64041)

Address	Name	Description
Un\G64025	Controller information valid/invalid flag	This buffer memory stores whether the value stored in the station (controller) information set in the station number is valid or invalid. 0: Invalid 1: Valid
Un\G64026	Manufacturer code	This buffer memory stores the station information set in the station number.
Un\G64027	Model type	
Un\G64028	Model code	
Un\G64029	Version	
Un\G64030 to Un\G64039	Model name string	
Un\G64040 to Un\G64041	Vendor-specific device information	

(Example) When the head module LJ72GF15-T2 (Station No.17) is connected

Address (Decimal (Hexadecimal))	Name		Value
64016 (FA10H)	Station number		17
64017 (FA11H)	Station information (Network card information)	Manufacturer code	0
64018 (FA12H)		Model type	31
64019 (FA13H)		Model code	2
64020 (FA14H)		Version	Displays the product version.
64021 to 64024 (FA15H to FA18H)	System area		Displays 0 in all addresses.
64025 (FA19H)	Station information (Controller information)	Controller information valid/invalid flag	0
64026 (FA1AH)		Manufacturer code	0
64027 (FA1BH)		Model type	0
64028 (FA1CH)		Model code	0
64029 (FA1DH)		Version	0
64030 to 64039 (FA1EH to FA27H)		Model name string	Displays 0 in all addresses.
64040 to 64041 (FA28H to FA29H)		Vendor-specific device information	Displays 0 in all addresses.
64042 to 64047 (FA2AH to FA2FH)	System area		Displays 0 in all addresses.

Appendix 2 Link Special Relay (SB) List

The link special relay (SB) is turned on/off depending on various factors at data link. Any error status of the data link can be confirmed by using and monitoring it in the program.

(1) Application of the link special relay (SB)

By using link special relays (SB), the status of CC-Link IE Field Network can be checked from HMI (Human Machine Interfaces) as well as GX Works2.

(2) Refresh of the link special relay (SB)

The link special relay (SB) uses "Transfer SB" of the refresh parameters to refresh the device of the CPU module. (Refer to Section 7.6.)

(3) Ranges that is turned on/off by users and by the system

The following ranges correspond to when the link special relays (SB) are assigned from SB0002 to SB01FF.

- Turned on/off by users: SB0002 to SB001F
- Turned on/off by the system: SB0020 to SB01FF

(4) Link special relay (SB) list

The following table shows the link special relays (SB) when they are assigned from SB0002 to SB01FF.

POINT
<ul style="list-style-type: none"> • Do not turn on or off areas whose Nos. are not on the following list or ranges turned on/off by the system. Doing so may cause malfunction of the programmable controller system. • For the usage of the link special relay (SB), refer to the following. Refer to Section 11.3.

Number	Name	Description
SB0002	System link start	<p>Cyclic transmission of the entire system is restarted. The station where cyclic transmission is restarted is specified by the Link stop/start direction (SW0002 to SW0008).</p> <p>OFF: No start direction ON : Start direction (enabled during start-up)</p> <p>(Conditions)</p> <ul style="list-style-type: none"> • This is enabled when Baton pass status (own station) (SB0047) is off. • For SB0002 and SB0003, this is enabled when only one of them is turned on.
SB0003	System link stop	<p>Cyclic transmission of the entire system is stopped. The station where cyclic transmission is stopped is specified by the Link stop/start direction (SW0002 to SW0008).</p> <p>OFF: No stop direction ON : Stop direction (enabled during start-up)</p> <p>(Conditions)</p> <ul style="list-style-type: none"> • This is enabled when Baton pass status (own station) (SB0047) is off. • For SB0002 and SB0003, this is enabled when only one of them is turned on.
SB0006	Clear communication error count	<p>Clears the link special registers for the communication error (SW0068, SW0069, SW0074 to SW0077, SW0120 to SW0127, SW0130 to SW0137, SW0140 to SW0147, and SW0150 to SW0157).</p> <p>OFF: No clear direction ON : Clear direction (valid while this relay is on)</p>
SB0009	Event count clear	<p>This clears the Event history status (SB007A) and Event count (SW007A).</p> <p>OFF: No clear direction ON : Clear direction (Errors are not counted while this is ON.)</p>
SB000C	Operation cycle interrupt request	<p>Used as the condition for the interrupt setting to execute an interrupt request to the CPU module in every operation cycle.</p>
SB0012	Reserved station function disable request	<p>Stations specified in Reserved station function disable setting (SW0011 to SW0017) are temporarily canceled from reserved stations.</p> <p>OFF: No request ON : Request issued</p>
SB0013	Reserved station specification enable request	<p>Stations specified in Reserved station function disable setting (SW0011 to SW0017) are returned to reserved stations. Only stations that were temporarily canceled can be returned to reserved stations.</p> <p>OFF: No request ON : Request issued</p>
SB0040	Network type (own station)	<p>Stores the network type of own station.</p> <p>ON: Field network</p>
SB0043	Mode (own station)	<p>Stores the mode of own station.</p> <p>OFF: Online ON : Not online</p>
SB0044	Station setting (own station) (1)	<p>This stores if the own station is a master station or not.</p> <p>OFF: Not master station ON : Master station</p>
SB0047	Baton pass status (own station)	<p>Stores the baton pass status for the own station (transient transmission possible).</p> <p>OFF: Normal ON : Error</p> <p>If an error occurs, the cause of the error can be checked by the Baton pass status (own station) (SW0047) and Cause of baton pass interruption (SW0048). Depending on the timing of the link refresh, the update of Baton pass status (own station) (SW0047) and Cause of baton pass interruption (SW0048) may be offset by one sequence scan.</p>

Number	Name	Description
SB0049	Data link status (own station)	Stores the own station's data link status. OFF: Normal ON : Error If an error occurs, the cause of the error can be checked by Cause of data link stop (SW0049). Depending on the timing of the link refresh, the update of Cause of data link stop (SW0049) may be offset by one sequence scan. (Conditions) • This is enabled when Baton pass status (own station) (SB0047) is OFF.
SB004A	Own station's CPU status (1)	Stores the continuation error status of the own station's CPU module. OFF: Normal ON : Continuation error
SB004B	Own station's CPU status (2)	Stores the stop error status of the own station's CPU module. OFF: Normal ON : Stop error
SB004C	CPU RUN status (own station)	Stores the RUN status of the own station's CPU module. OFF: RUN, STEP-RUN ON : STOP, PAUSE, or CPU module stopped due to error
SB004D	Received parameter error	Stores the status of the received parameter. (own parameter status during master station) OFF: Parameter normal ON : Parameter error
SB0054	System link start request accept status	Turns on when a cyclic transmission start request by System link start (SB0002) is accepted. OFF: Not accepted (SB0002 is off.) ON : Start accepted (SB0002 is on.) (Condition) • This is enabled when Baton pass status (own station) (SB0047) is off.
SB0055	System link start completion status	Turns on when System link start request accept status (SB0054) turns on, and cyclic transmission start is completed. OFF: Start not completed (SB0002 is off.) ON : Start completed (SB0002 is on.) (Condition) • This is enabled when Baton pass status (own station) (SB0047) is off.
SB0056	System link stop request accept status	Turns on when a cyclic transmission stop request by System link stop (SB0003) is accepted. OFF: Not accepted (SB0003 is off.) ON : Stop accepted (SB0003 is on.) (Condition) • This is enabled when Baton pass status (own station) (SB0047) is off.
SB0057	System link stop completion status	Turns on when System link stop accept status (SB0056) turns on, and cyclic transmission stop is completed. OFF: Stop not completed (SB0003 is off.) ON : Stop completed (SB0003 is on.) (Condition) • This is enabled when Baton pass status (own station) (SB0047) is off.
SB005C	Reserved station function disable request accept status	Turns on when Reserved station function disable request (SB0012) is accepted. OFF: Not accepted ON : Cancel accepted

Number	Name	Description
SB005D	Reserved station function disable completion status	Turns on when Reserved station function disable request accept status (SB005C) is turned on and disabling the reserved station function is completed. OFF: Not completed ON : Completed or error completion
SB005E	Reserved station specification enable request accept status	Turns on when Reserved station specification enable request (SB0013) is accepted. OFF: Not accepted ON : Enable accepted
SB005F	Reserved station specification enabled status	Turns on when Reserved station specification enable request accept status (SB005E) is turned on and the reserved station specification enable processing is completed. OFF: Not completed ON : Completed or error completion
SB006A	PORT1 linkup status (own station)	Stores the linkup status of PORT1 (own station). OFF: Linkup in progress ON : Linkdown in progress The time that the linkup starts after power-on or Ethernet cable connection may vary. Normally, it takes a few seconds. Depending on device status on the line, a linkup process is repeated, resulting in the increase in the time.
SB006C	PORT1 error frame reception status (own station)	Stores if an error frame is received at the own station's PORT1. OFF: An error frame has not yet been received ON : An error frame has been received
SB006E	PORT1 error frame detection (own station)	Stores if an error frame was received from power-on until the present at the own station's PORT1. OFF: An error frame has not yet been received ON : An error frame has been received
SB0074	Reserved station specification status	Stores the reserved station specification status due to parameters. The reserved station number can be checked using Reserved station setting status (SW00C1 to SW00C7). OFF: Not specified ON : Specified
SB007A	Event history status	Stores the network event history occurrence. OFF: No event history ON : Event history found If the event history is found, the cumulative number of network event history can be checked by the Event count (SW007A). Depending on the timing of the link refresh, the update of Event count (SW007A) may be offset by one sequence scan. This area is cleared when Event count clear (SB0009) is turned on.
SB007B	Input data status of data link faulty station	Stores the own station's setting status for "Data Link Disorder Station Setting". OFF: OFF or cleared to 0 ON : Hold
SB007D	Hold/clear status setting for CPU STOP	Stores the own station's setting status for "Output Setting during CPU STOP". OFF: Hold ON : Clear (ALL OFF)

Number	Name	Description
SB00A0	Baton pass status (each station)	<p>Stores the baton pass status for each station. OFF: All stations normal ON : Faulty station found</p> <p>If a faulty station is found, the status of each station can be checked by Baton pass status (each station) (SW00A0 to SW00A7).</p> <p>Depending on the timing of the link refresh, the update of Baton pass status (each station) (SW00A0 to SW00A7) may be offset by one sequence scan.</p> <p>(Conditions)</p> <ul style="list-style-type: none"> • This is enabled when Baton pass status (own station) (SB0047) is off. • Reserved stations and stations higher than the maximum station No. are ignored.
SB00A1	Baton pass status (master station)	<p>Stores the baton pass status of the master station (master operating station). OFF: Normal ON : Error</p> <p>(Condition)</p> <ul style="list-style-type: none"> • This is enabled when Baton pass status (own station) (SB0047) is off.
SB00B0	Data link status (each station)	<p>Stores the cyclic transmission status for each station. OFF: Cyclic transmission for all stations in progress ON : Cyclic transmission not executed for some stations</p> <p>If cyclic transmission are not executed for some stations, the status of each station can be checked by Data link status (each station) (SW00B0 to SW00B7).</p> <p>Depending on the timing of the link refresh, the update of Data link status (each station) (SW00B0 to SW00B7) may be offset by one sequence scan.</p> <p>(Conditions)</p> <ul style="list-style-type: none"> • This is enabled when Baton pass status (own station) (SB0047) is off. • Reserved stations and stations higher than the maximum station No. are ignored.
SB00B1	Data link status (master station)	<p>Stores the data link status of the master station (master operating station). OFF: Normal ON : Error</p> <p>(Condition)</p> <ul style="list-style-type: none"> • This is enabled when Baton pass status (own station) (SB0047) is off.
SB00C0	Reserved station setting status	<p>Stores if a reserved station has been set. OFF: No setting ON : Set</p> <p>When a reserved station has been set, each station status can be checked using Reserved station setting status (SW00C1 to SW00C7).</p> <p>Depending on the timing of the link refresh, the update of Reserved station setting status (SW00C1 to SW00C7) may be offset by one sequence scan.</p> <p>(Condition)</p> <ul style="list-style-type: none"> • This is enabled when Baton pass status (own station) (SB0047) is off.

Number	Name	Description
SB00F0	CPU RUN status (each station)	<p>Stores the RUN status of each station's CPU module. OFF: All stations are in RUN or STEP-RUN status ON: Station in STOP or PAUSE status found If a station in STOP or PAUSE status is found, the status of each station can be checked by the CPU RUN status (each station) (SW00F0 to SW00F7). Depending on the timing of the link refresh, the update of CPU RUN status (each station) (SW00F0 to SW00F7) may be offset by one sequence scan.</p> <p>(Condition) • This is enabled when Baton pass status (own station) (SB0047) is off.</p>
SB00F1	CPU RUN status (master station)	<p>Stores the RUN status of the master station's CPU module. OFF: RUN or STEP-RUN status ON : STOP or PAUSE status</p> <p>(Condition) • This is enabled when Baton pass status (own station) (SB0047) is off.</p>
SB0100	CPU operation status (each station) (1)	<p>Stores the moderate/major error or stop error status of each station. OFF: No station with a moderate/major error (stop error) found ON : Station with a moderate/major error (stop error) found If a station with a moderate/major error (stop error) is found, the status of each station can be checked by the Operation status (each station) (1) (SW0100 to SW0107). Depending on the timing of the link refresh, the update of Operation status (each station) (1) (SW0100 to SW0107) may be offset by one sequence scan.</p> <p>(Condition) • This is enabled when Baton pass status (own station) (SB0047) is off.</p>
SB0101	CPU operation status (master station) (1)	<p>Stores the stop error status of the master station's CPU module. OFF: Normal ON : Stop error occurred</p> <p>(Condition) • This is enabled when Baton pass status (own station) (SB0047) is off.</p>
SB0110	CPU operation status (each station) (2)	<p>Stores the minor error or continuation error status of each station. OFF: All stations normal or a station with a moderate/major error (stop error) found ON : Station with a minor error (continuation error) found If a station with a minor error (continuation error) is found, the status of each station can be checked by the Operation status (each station) (2) (SW0110 to SW0117). Depending on the timing of the link refresh, the update of Operation status (each station) (2) (SW0110 to SW0117) may be offset by one sequence scan.</p> <p>(Condition) • This is enabled when Baton pass status (own station) (SB0047) is off.</p>
SB0111	CPU operation status (master station) (2)	<p>Stores the continuation error status of the master station's CPU module. OFF: Normal ON : Continuation error occurred</p> <p>(Condition) • This is enabled when Baton pass status (own station) (SB0047) is off.</p>

Number	Name	Description
SB0120	PORT1 error frame reception status (each station)	<p>Stores if an error frame is received at each station's PORT1.</p> <p>OFF: An error frame has not yet been received at any stations. ON : An error frame has been received at one or more stations.</p> <p>If an error frame has been received, the status of each station can be checked by the PORT1 error frame reception status (each station) (SW0120 to SW0127).</p> <p>Depending on the timing of the link refresh, the update of PORT1 error frame reception status (each station) (SW0120 to SW0127) may be offset by one sequence scan.</p> <p>(Condition)</p> <ul style="list-style-type: none"> • This is enabled when Baton pass status (own station) (SB0047) is off.
SB0121	PORT1 error frame reception status (master station)	<p>Stores if an error frame is received at the master station's PORT1.</p> <p>OFF: An error frame has not yet been received ON : An error frame has been received</p> <p>(Condition)</p> <ul style="list-style-type: none"> • This is enabled when Baton pass status (own station) (SB0047) is off.
SB0130	PORT2 error frame reception status (each station)	<p>Stores if an error frame is received at each station's PORT2.</p> <p>OFF: An error frame has not yet been received at any stations. ON : An error frame has been received at one or more stations.</p> <p>If an error frame has been received, the status of each station can be checked by the PORT2 error frame reception status (each station) (SW0130 to SW0137).</p> <p>Depending on the timing of the link refresh, the update of PORT2 error frame reception status (each station) (SW0130 to SW0137) may be offset by one sequence scan.</p> <p>(Condition)</p> <ul style="list-style-type: none"> • This is enabled when Baton pass status (own station) (SB0047) is off.
SB0140	PORT1 error frame detection (each station)	<p>Stores if an error frame was received from power-on until the present at each station's PORT1.</p> <p>OFF: An error frame has not been received at any stations ON : An error frame has been received at one or more stations</p> <p>If an error frame has been received, the status of each station can be checked by the PORT1 error frame detection (each station) (SW0140 to SW0147).</p> <p>Depending on the timing of the link refresh, the update of PORT1 error frame detection (each station) (SW0140 to SW0147) may be offset by one sequence scan.</p> <p>(Condition)</p> <ul style="list-style-type: none"> • This is enabled when Baton pass status (own station) (SB0047) is off.
SB0141	PORT1 error frame detection (master station)	<p>Stores if an error frame was received from power-on until the present at the master station's PORT1.</p> <p>OFF: An error frame has not yet been received ON : An error frame has been received at least once</p> <p>(Condition)</p> <ul style="list-style-type: none"> • This is enabled when Baton pass status (own station) (SB0047) is off.

Number	Name	Description
SB0150	PORT2 error frame detection (each station)	<p>Stores if an error frame was received from power-on until the present at each station's PORT2.</p> <p>OFF: An error frame has not been received at any stations ON : An error frame has been received at one or more stations</p> <p>If an error frame has been received, the status of each station can be checked by the PORT2 error frame detection (each station) (SW0150 to SW0157).</p> <p>Depending on the timing of the link refresh, the update of PORT2 error frame detection (each station) (SW0150 to SW0157) may be offset by one sequence scan.</p> <p>(Condition)</p> <ul style="list-style-type: none"> • This is enabled when Baton pass status (own station) (SB0047) is off.
SB0170	Parameter error status (each station)	<p>Stores the parameter status for each station.</p> <p>OFF: No parameter errors for any stations ON : Parameter error detected at one or more stations</p> <p>If a parameter error occurs, the status of each station can be checked by the Parameter error status (each station) (SW0170 to SW0177).</p> <p>Depending on the timing of the link refresh, the update of Parameter error status (each station) (SW0170 to SW0177) may be offset by one sequence scan.</p> <p>(Conditions)</p> <ul style="list-style-type: none"> • This is enabled when Baton pass status (own station) (SB0047) is off. • Reserved stations and stations higher than the maximum station No. are ignored.
SB0180	Reserved station function disable status	<p>This stores if a reserved station function is disabled.</p> <p>OFF: No disabled reserved station function ON : Disabled reserved station function found</p> <p>If a reserved station function is disabled, the status of each station can be checked by the Reserved station cancel setting status (SW0181 to SW0187).</p> <p>Depending on the timing of the link refresh, the update of Reserved station cancel setting status (SW0181 to SW0187) may be offset by one sequence scan.</p> <p>(Condition)</p> <ul style="list-style-type: none"> • This is enabled when Baton pass status (own station) (SB0047) is off.

Appendix 3 Link Special Register (SW) List

The link special register (SW) stores the information during data link as a numerical value. Error locations and causes can be checked by the using and monitoring the link special register (SW) in programs.

(1) **Application of link special registers (SW)**

By using link special registers (SW), the status of CC-Link IE Field Network can be checked from HMI (Human Machine Interfaces) as well as GX Works2.

(2) **Link special register (SW) refresh**

The link special register (SW) uses "Transfer SW" of the refresh parameters to refresh the device of the CPU module. (Refer to Section 7.6.)

(3) **Ranges to which data are stored by users and by the system**

The following ranges correspond to when the link special registers (SW) are assigned from SW0000 to SW01FF.

- Stored by users: SW0000 to SW001F
- Stored by the system: SW0020 to SW01FF

(4) **Link special register (SW) list**

The following table shows the link special registers (SW) when they are assigned from SW0000 to SW01FF.

POINT
<ul style="list-style-type: none"> • Do not turn on or off areas whose Nos. are not on the following list or ranges turned on/off by the system. Doing so may cause malfunction of the programmable controller system. • For the usage of the link special register (SW), refer to Section 11.3.

Number	Name	Description																																																																																																																																								
SW0000	Link stop/start direction	<p>Sets the station where cyclic transmission is stopped or started.</p> <p>02H: Specified station 82H: Specified station (Forced link start)</p> <ul style="list-style-type: none"> Stopping/starting of cyclic transmission is performed by System link start (SB0002) or System link stop (SB0003). When Specified station (02H or 82H) is selected, the own station is not included. 																																																																																																																																								
SW0002 to SW0008		<p>When setting 02H or 82H by the Link stop/start direction (SW0000), this sets the station No. that stops or starts cyclic transmission.</p> <p>0: No direction issued for stop or start 1: Direction issued for stop or start</p> <table border="1"> <thead> <tr> <th></th> <th>b15</th> <th>b14</th> <th>b13</th> <th>b12</th> <th>b11</th> <th>b10</th> <th>b9</th> <th>b8</th> <th>b7</th> <th>b6</th> <th>b5</th> <th>b4</th> <th>b3</th> <th>b2</th> <th>b1</th> <th>b0</th> </tr> </thead> <tbody> <tr> <td>SW0002</td> <td>32</td> <td>31</td> <td>30</td> <td>29</td> <td>28</td> <td>27</td> <td>26</td> <td>25</td> <td>24</td> <td>23</td> <td>22</td> <td>21</td> <td>20</td> <td>19</td> <td>18</td> <td>17</td> </tr> <tr> <td>SW0003</td> <td>48</td> <td>47</td> <td>46</td> <td>45</td> <td>44</td> <td>43</td> <td>42</td> <td>41</td> <td>40</td> <td>39</td> <td>38</td> <td>37</td> <td>36</td> <td>35</td> <td>34</td> <td>33</td> </tr> <tr> <td>SW0004</td> <td>64</td> <td>63</td> <td>62</td> <td>61</td> <td>60</td> <td>59</td> <td>58</td> <td>57</td> <td>56</td> <td>55</td> <td>54</td> <td>53</td> <td>52</td> <td>51</td> <td>50</td> <td>49</td> </tr> <tr> <td>SW0005</td> <td>80</td> <td>79</td> <td>78</td> <td>77</td> <td>76</td> <td>75</td> <td>74</td> <td>73</td> <td>72</td> <td>71</td> <td>70</td> <td>69</td> <td>68</td> <td>67</td> <td>66</td> <td>65</td> </tr> <tr> <td>SW0006</td> <td>96</td> <td>95</td> <td>94</td> <td>93</td> <td>92</td> <td>91</td> <td>90</td> <td>89</td> <td>88</td> <td>87</td> <td>86</td> <td>85</td> <td>84</td> <td>83</td> <td>82</td> <td>81</td> </tr> <tr> <td>SW0007</td> <td>112</td> <td>111</td> <td>110</td> <td>109</td> <td>108</td> <td>107</td> <td>106</td> <td>105</td> <td>104</td> <td>103</td> <td>102</td> <td>101</td> <td>100</td> <td>99</td> <td>98</td> <td>97</td> </tr> <tr> <td>SW0008</td> <td>—</td> <td>—</td> <td>—</td> <td>—</td> <td>—</td> <td>—</td> <td>—</td> <td>—</td> <td>120</td> <td>119</td> <td>118</td> <td>117</td> <td>116</td> <td>115</td> <td>114</td> <td>113</td> </tr> </tbody> </table> <p>Each number in the table represents station No.</p>		b15	b14	b13	b12	b11	b10	b9	b8	b7	b6	b5	b4	b3	b2	b1	b0	SW0002	32	31	30	29	28	27	26	25	24	23	22	21	20	19	18	17	SW0003	48	47	46	45	44	43	42	41	40	39	38	37	36	35	34	33	SW0004	64	63	62	61	60	59	58	57	56	55	54	53	52	51	50	49	SW0005	80	79	78	77	76	75	74	73	72	71	70	69	68	67	66	65	SW0006	96	95	94	93	92	91	90	89	88	87	86	85	84	83	82	81	SW0007	112	111	110	109	108	107	106	105	104	103	102	101	100	99	98	97	SW0008	—	—	—	—	—	—	—	—	120	119	118	117	116	115	114	113
	b15	b14	b13	b12	b11	b10	b9	b8	b7	b6	b5	b4	b3	b2	b1	b0																																																																																																																										
SW0002	32	31	30	29	28	27	26	25	24	23	22	21	20	19	18	17																																																																																																																										
SW0003	48	47	46	45	44	43	42	41	40	39	38	37	36	35	34	33																																																																																																																										
SW0004	64	63	62	61	60	59	58	57	56	55	54	53	52	51	50	49																																																																																																																										
SW0005	80	79	78	77	76	75	74	73	72	71	70	69	68	67	66	65																																																																																																																										
SW0006	96	95	94	93	92	91	90	89	88	87	86	85	84	83	82	81																																																																																																																										
SW0007	112	111	110	109	108	107	106	105	104	103	102	101	100	99	98	97																																																																																																																										
SW0008	—	—	—	—	—	—	—	—	120	119	118	117	116	115	114	113																																																																																																																										
SW0011 to SW0017	Reserved station function disable setting	<p>Specify the slave station for which the reserved station setting is to be temporary canceled/restored.</p> <p>0: Not specified 1: Specified</p> <table border="1"> <thead> <tr> <th></th> <th>b15</th> <th>b14</th> <th>b13</th> <th>b12</th> <th>b11</th> <th>b10</th> <th>b9</th> <th>b8</th> <th>b7</th> <th>b6</th> <th>b5</th> <th>b4</th> <th>b3</th> <th>b2</th> <th>b1</th> <th>b0</th> </tr> </thead> <tbody> <tr> <td>SW0011</td> <td>32</td> <td>31</td> <td>30</td> <td>29</td> <td>28</td> <td>27</td> <td>26</td> <td>25</td> <td>24</td> <td>23</td> <td>22</td> <td>21</td> <td>20</td> <td>19</td> <td>18</td> <td>17</td> </tr> <tr> <td>SW0012</td> <td>48</td> <td>47</td> <td>46</td> <td>45</td> <td>44</td> <td>43</td> <td>42</td> <td>41</td> <td>40</td> <td>39</td> <td>38</td> <td>37</td> <td>36</td> <td>35</td> <td>34</td> <td>33</td> </tr> <tr> <td>SW0013</td> <td>64</td> <td>63</td> <td>62</td> <td>61</td> <td>60</td> <td>59</td> <td>58</td> <td>57</td> <td>56</td> <td>55</td> <td>54</td> <td>53</td> <td>52</td> <td>51</td> <td>50</td> <td>49</td> </tr> <tr> <td>SW0014</td> <td>80</td> <td>79</td> <td>78</td> <td>77</td> <td>76</td> <td>75</td> <td>74</td> <td>73</td> <td>72</td> <td>71</td> <td>70</td> <td>69</td> <td>68</td> <td>67</td> <td>66</td> <td>65</td> </tr> <tr> <td>SW0015</td> <td>96</td> <td>95</td> <td>94</td> <td>93</td> <td>92</td> <td>91</td> <td>90</td> <td>89</td> <td>88</td> <td>87</td> <td>86</td> <td>85</td> <td>84</td> <td>83</td> <td>82</td> <td>81</td> </tr> <tr> <td>SW0016</td> <td>112</td> <td>111</td> <td>110</td> <td>109</td> <td>108</td> <td>107</td> <td>106</td> <td>105</td> <td>104</td> <td>103</td> <td>102</td> <td>101</td> <td>100</td> <td>99</td> <td>98</td> <td>97</td> </tr> <tr> <td>SW0017</td> <td>—</td> <td>—</td> <td>—</td> <td>—</td> <td>—</td> <td>—</td> <td>—</td> <td>—</td> <td>120</td> <td>119</td> <td>118</td> <td>117</td> <td>116</td> <td>115</td> <td>114</td> <td>113</td> </tr> </tbody> </table> <p>Each number in the table represents station No.</p> <p>(Conditions)</p> <ul style="list-style-type: none"> For some stations, reserved station setting cannot be temporarily canceled/restored. (Refer to Section 9.6.) Stations higher than the maximum station No. are ignored. 		b15	b14	b13	b12	b11	b10	b9	b8	b7	b6	b5	b4	b3	b2	b1	b0	SW0011	32	31	30	29	28	27	26	25	24	23	22	21	20	19	18	17	SW0012	48	47	46	45	44	43	42	41	40	39	38	37	36	35	34	33	SW0013	64	63	62	61	60	59	58	57	56	55	54	53	52	51	50	49	SW0014	80	79	78	77	76	75	74	73	72	71	70	69	68	67	66	65	SW0015	96	95	94	93	92	91	90	89	88	87	86	85	84	83	82	81	SW0016	112	111	110	109	108	107	106	105	104	103	102	101	100	99	98	97	SW0017	—	—	—	—	—	—	—	—	120	119	118	117	116	115	114	113
	b15	b14	b13	b12	b11	b10	b9	b8	b7	b6	b5	b4	b3	b2	b1	b0																																																																																																																										
SW0011	32	31	30	29	28	27	26	25	24	23	22	21	20	19	18	17																																																																																																																										
SW0012	48	47	46	45	44	43	42	41	40	39	38	37	36	35	34	33																																																																																																																										
SW0013	64	63	62	61	60	59	58	57	56	55	54	53	52	51	50	49																																																																																																																										
SW0014	80	79	78	77	76	75	74	73	72	71	70	69	68	67	66	65																																																																																																																										
SW0015	96	95	94	93	92	91	90	89	88	87	86	85	84	83	82	81																																																																																																																										
SW0016	112	111	110	109	108	107	106	105	104	103	102	101	100	99	98	97																																																																																																																										
SW0017	—	—	—	—	—	—	—	—	120	119	118	117	116	115	114	113																																																																																																																										
SW001A	Number of resends (REMF/REMTO)	<p>Specifies the number of resends for the REMFR/REMTO instruction.</p> <p>0: 0 times (default) Outside the above: Number of times that is set</p> <p>(Condition)</p> <ul style="list-style-type: none"> This is enabled when Baton pass status (own station) (SB0047) is off. 																																																																																																																																								
SW001B	Response wait timer (REMF/REMTO)	<p>Specifies the response wait time for the REMFR/REMTO instruction.</p> <p>0: 10 seconds (default) Outside the above: Number of seconds that is set</p> <p>(Condition)</p> <ul style="list-style-type: none"> This is enabled when Baton pass status (own station) (SB0047) is off. 																																																																																																																																								

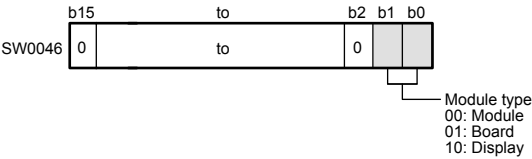
Number	Name	Description
SW0030	Send/receive instruction (1) processing result	Stores the processing results of the link dedicated instruction that used the own station's channel 1. 0: Normal completion 1 or higher: Abnormal completion (Refer to Section 12.5.)
SW0031	Send/receive instruction (2) processing result	Stores the processing results of the link dedicated instruction that used the own station's channel 2. 0: Normal completion 1 or higher: Abnormal completion (Refer to Section 12.5.)
SW0040	Network No.	Stores the network number of own station. Range: 1 to 239
SW0042	Station No.	Stores the station number of own station. Range: 1 to 120 (master station: 125), FFH (the station number not set)
SW0043	Mode status	Stores the mode of own station. 0: Online (Normal Mode) 2: Offline
SW0046	Module type	Stores the own station's hardware status. 
SW0047	Baton pass status (own station)	Stores the baton pass status for the own station (transient transmission possible). 0: Data link in progress 2: Baton pass in progress 3: Baton pass stopped 5: Offline
SW0048	Cause of baton pass interruption	Stores the cause of interruption in the communication (baton pass) of own station. 00H: At normal communication or power-on 30H: Cable disconnection 33H: Disconnection or reconnection in progress 40H: Offline mode
SW0049	Cause of data link stop	Stores the cause which stopped the data link of own station. 00H: At normal communication or power-on 02H: Monitoring timeout 05H: No slave stations (master station only) 14H: Master station duplication 18H: Parameter error 19H: Parameter communication in progress 20H: CPU module stop error 60H: Ring topology configuration (master station only)
SW004A	Data link stop request station	Stores the station No. of the station that performed the cyclic transmission stop request for the own station. Range: 1 to 120, 125 (master station) The cyclic transmission stop request is performed by System link stop (SB0003). (Condition) • This is enabled when Baton pass status (own station) (SB0047) is off.

Number	Name	Description
SW004B	Own station's CPU status	<p>Stores the own station's status.</p> <p>00H: No module mounted 01H: STOP (Normal) 02H: STOP (Stop error occurring) 03H: STOP (Continuation error occurring) 04H: RUN (Normal) 05H: RUN (Continuation error occurring) 06H: STEP-RUN 07H: PAUSE 0EH: Reset in progress 0FH: Initial processing</p>
SW004C	Parameter setting status	<p>Stores the parameter status.</p> <p>0: Normal 1 or higher: Abnormal (Refer to Section 12.5.)</p> <p>(Condition) • This is enabled when the Received parameter error (SB004D) is on.</p>
SW0052	Data link start status (entire system)	<p>Stores the results when cyclic transmission is started by System link start (SB0002).</p> <p>0: Normal 1 or higher: Error definition in own station (Refer to Section 12.5.)</p> <p>When System link start (SB0002) is turned off, the stored error definition is cleared.</p> <p>(Condition) • This is enabled when Baton pass status (own station) (SB0047) is off.</p>
SW0053	Data link stop status (entire system)	<p>Stores the results when cyclic transmission is stopped by System link stop (SB0003).</p> <p>0: Normal 1 or higher: Error definition in own station (Refer to Section 12.5.)</p> <p>When System link stop (SB0003) is turned off, the stored error definition is cleared.</p> <p>(Condition) • This is enabled when Baton pass status (own station) (SB0047) is off.</p>
SW0056	Result of reserved station function disable	<p>Stores the result when disabling reserved station function.</p> <p>0: Normal 1 or higher: Abnormal (Refer to Section 12.5.)</p> <p>When Reserved station function disable request (SB0012) is turned off, the stored error definition is cleared.</p>
SW0057	Result of reserved station function enable	<p>Stores the result when reserved station function disable is undone</p> <p>0: Normal 1 or higher: Abnormal (Refer to Section 12.5.)</p> <p>When Reserved station specification enable request (SB0013) is turned off, the stored error definition is cleared.</p>
SW0058	Number of total slave stations (setting)	<p>Stores the number of total slave stations that are set by the parameters.</p> <p>Range: 1 to 120</p>

Number	Name	Description
SW0059	Number of total slave stations (current value)	Stores the number of total slave stations that are actually connected by data link in CC-Link IE Field Network. Range: 1 to 120 (0 when own station is disconnected)
SW005A	Maximum baton pass station	Stores the maximum station No. of the stations where the baton pass is performed. Range: 1 to 120 (0 when own station is disconnected) (Condition) • This is enabled when Baton pass status (own station) (SB0047) is off.
SW005B	Maximum cyclic transmission station	Stores the maximum station No. of the station where the cyclic transmission is performed. Range: 1 to 120 (0 when own station is disconnected) (Condition) • This is enabled when Data link status (own station) (SB0049) is off.
SW0064	Connection status (own station)	Stores the connection status of own station. 08H: Normal (communication in progress on PORT1, no PORT2) 18H: Disconnecting (cable disconnected on PORT1, no PORT2) 28H: Disconnecting (establishing line on PORT1, no PORT2)
SW0068	PORT1 line error occurrence rate (max.)	Stores the occurrence rate (maximum value) of received error frames at the own station's PORT1. (Unit: %) When Clear communication error count (SB0006) is turned on, the stored occurrence rate is cleared.
SW0069	PORT1 line error occurrence rate (present)	Stores the occurrence rate (current value) of received error frames at the own station's PORT1. (Unit: %) When Clear communication error count (SB0006) is turned on, the stored occurrence rate is cleared.
SW0074	PORT1 cable disconnection detection count	Stores the (cumulative) count that was detected for cable disconnections at the PORT1. When Clear communication error count (SB0006) is turned on, the stored count is cleared. When FFFFH is counted, the value returns to 0 and the module continues to count.
SW0075	PORT1 receive error detection count	Stores the (cumulative) count that error data was received at the PORT1. The count stores only error data that is not transmitted to all stations. When Clear communication error count (SB0006) is turned on, the stored occurrence rate is cleared. When FFFFH is counted, counting stops.
SW0076	PORT1 total no. of received data (lower 1 word)	Stores the (cumulative) count that data was received at the PORT1. When Clear communication error count (SB0006) is turned on, the stored occurrence rate is cleared. When FFFFFFFFH is counted, counting stops.
SW0077	PORT1 total no. of received data (upper 1 word)	
SW007A	Event count	Stores the count of the network event history. This stored count is cleared when Event count clear (SB0009) is turned on. When FFFFH is counted, counting stops.

Number	Name	Description																																																																																																																																																									
SW0080 to SW009F	Execution status (REMFR/REMTO)	<p>Stores the REMFR/REMTO execution status for each channel.</p> <p>0: Normal completion 1 or higher: Abnormal completion (Refer to Section 12.5.)</p> <table border="0"> <tr> <td>SW0080: Channel 1</td> <td>SW0090: Channel 17</td> </tr> <tr> <td>SW0081: Channel 2</td> <td>SW0091: Channel 18</td> </tr> <tr> <td>SW0082: Channel 3</td> <td>SW0092: Channel 19</td> </tr> <tr> <td>SW0083: Channel 4</td> <td>SW0093: Channel 20</td> </tr> <tr> <td>SW0084: Channel 5</td> <td>SW0094: Channel 21</td> </tr> <tr> <td>SW0085: Channel 6</td> <td>SW0095: Channel 22</td> </tr> <tr> <td>SW0086: Channel 7</td> <td>SW0096: Channel 23</td> </tr> <tr> <td>SW0087: Channel 8</td> <td>SW0097: Channel 24</td> </tr> <tr> <td>SW0088: Channel 9</td> <td>SW0098: Channel 25</td> </tr> <tr> <td>SW0089: Channel 10</td> <td>SW0099: Channel 26</td> </tr> <tr> <td>SW008A: Channel 11</td> <td>SW009A: Channel 27</td> </tr> <tr> <td>SW008B: Channel 12</td> <td>SW009B: Channel 28</td> </tr> <tr> <td>SW008C: Channel 13</td> <td>SW009C: Channel 29</td> </tr> <tr> <td>SW008D: Channel 14</td> <td>SW009D: Channel 30</td> </tr> <tr> <td>SW008E: Channel 15</td> <td>SW009E: Channel 31</td> </tr> <tr> <td>SW008F: Channel 16</td> <td>SW009F: Channel 32</td> </tr> </table>	SW0080: Channel 1	SW0090: Channel 17	SW0081: Channel 2	SW0091: Channel 18	SW0082: Channel 3	SW0092: Channel 19	SW0083: Channel 4	SW0093: Channel 20	SW0084: Channel 5	SW0094: Channel 21	SW0085: Channel 6	SW0095: Channel 22	SW0086: Channel 7	SW0096: Channel 23	SW0087: Channel 8	SW0097: Channel 24	SW0088: Channel 9	SW0098: Channel 25	SW0089: Channel 10	SW0099: Channel 26	SW008A: Channel 11	SW009A: Channel 27	SW008B: Channel 12	SW009B: Channel 28	SW008C: Channel 13	SW009C: Channel 29	SW008D: Channel 14	SW009D: Channel 30	SW008E: Channel 15	SW009E: Channel 31	SW008F: Channel 16	SW009F: Channel 32																																																																																																																									
SW0080: Channel 1	SW0090: Channel 17																																																																																																																																																										
SW0081: Channel 2	SW0091: Channel 18																																																																																																																																																										
SW0082: Channel 3	SW0092: Channel 19																																																																																																																																																										
SW0083: Channel 4	SW0093: Channel 20																																																																																																																																																										
SW0084: Channel 5	SW0094: Channel 21																																																																																																																																																										
SW0085: Channel 6	SW0095: Channel 22																																																																																																																																																										
SW0086: Channel 7	SW0096: Channel 23																																																																																																																																																										
SW0087: Channel 8	SW0097: Channel 24																																																																																																																																																										
SW0088: Channel 9	SW0098: Channel 25																																																																																																																																																										
SW0089: Channel 10	SW0099: Channel 26																																																																																																																																																										
SW008A: Channel 11	SW009A: Channel 27																																																																																																																																																										
SW008B: Channel 12	SW009B: Channel 28																																																																																																																																																										
SW008C: Channel 13	SW009C: Channel 29																																																																																																																																																										
SW008D: Channel 14	SW009D: Channel 30																																																																																																																																																										
SW008E: Channel 15	SW009E: Channel 31																																																																																																																																																										
SW008F: Channel 16	SW009F: Channel 32																																																																																																																																																										
SW00A0 to SW00A7	Baton pass status (each station)	<p>Stores the baton pass status for each station.</p> <p>0: Baton pass normal station 1: Baton pass faulty station</p> <ul style="list-style-type: none"> If multiple stations change from faulty to normal, because they are reconnected to the network one by one per link scan, the time until the status changes to "0: Baton pass normal station" may vary by several seconds. If cables are connected/disconnected or the module is reset in line topology, the token may be lost or a reconstruction may occur, causing the baton pass status to detect an error in the first link scan. <table border="1"> <thead> <tr> <th></th> <th>b15</th> <th>b14</th> <th>b13</th> <th>b12</th> <th>b11</th> <th>b10</th> <th>b9</th> <th>b8</th> <th>b7</th> <th>b6</th> <th>b5</th> <th>b4</th> <th>b3</th> <th>b2</th> <th>b1</th> <th>b0</th> </tr> </thead> <tbody> <tr> <td>SW00A0</td> <td>16</td> <td>15</td> <td>14</td> <td>13</td> <td>12</td> <td>11</td> <td>10</td> <td>9</td> <td>8</td> <td>7</td> <td>6</td> <td>5</td> <td>4</td> <td>3</td> <td>2</td> <td>1</td> </tr> <tr> <td>SW00A1</td> <td>32</td> <td>31</td> <td>30</td> <td>29</td> <td>28</td> <td>27</td> <td>26</td> <td>25</td> <td>24</td> <td>23</td> <td>22</td> <td>21</td> <td>20</td> <td>19</td> <td>18</td> <td>17</td> </tr> <tr> <td>SW00A2</td> <td>48</td> <td>47</td> <td>46</td> <td>45</td> <td>44</td> <td>43</td> <td>42</td> <td>41</td> <td>40</td> <td>39</td> <td>38</td> <td>37</td> <td>36</td> <td>35</td> <td>34</td> <td>33</td> </tr> <tr> <td>SW00A3</td> <td>64</td> <td>63</td> <td>62</td> <td>61</td> <td>60</td> <td>59</td> <td>58</td> <td>57</td> <td>56</td> <td>55</td> <td>54</td> <td>53</td> <td>52</td> <td>51</td> <td>50</td> <td>49</td> </tr> <tr> <td>SW00A4</td> <td>80</td> <td>79</td> <td>78</td> <td>77</td> <td>76</td> <td>75</td> <td>74</td> <td>73</td> <td>72</td> <td>71</td> <td>70</td> <td>69</td> <td>68</td> <td>67</td> <td>66</td> <td>65</td> </tr> <tr> <td>SW00A5</td> <td>96</td> <td>95</td> <td>94</td> <td>93</td> <td>92</td> <td>91</td> <td>90</td> <td>89</td> <td>88</td> <td>87</td> <td>86</td> <td>85</td> <td>84</td> <td>83</td> <td>82</td> <td>81</td> </tr> <tr> <td>SW00A6</td> <td>112</td> <td>111</td> <td>110</td> <td>109</td> <td>108</td> <td>107</td> <td>106</td> <td>105</td> <td>104</td> <td>103</td> <td>102</td> <td>101</td> <td>100</td> <td>99</td> <td>98</td> <td>97</td> </tr> <tr> <td>SW00A7</td> <td>—</td> <td>—</td> <td>—</td> <td>—</td> <td>—</td> <td>—</td> <td>—</td> <td>—</td> <td>120</td> <td>119</td> <td>118</td> <td>117</td> <td>116</td> <td>115</td> <td>114</td> <td>113</td> </tr> </tbody> </table> <p>Each number in the table represents a station No. — is fixed to 0.</p> <p>(Conditions)</p> <ul style="list-style-type: none"> This is enabled when Baton pass status (own station) (SB0047) is off. Reserved stations and stations higher than the maximum station No. are ignored. 		b15	b14	b13	b12	b11	b10	b9	b8	b7	b6	b5	b4	b3	b2	b1	b0	SW00A0	16	15	14	13	12	11	10	9	8	7	6	5	4	3	2	1	SW00A1	32	31	30	29	28	27	26	25	24	23	22	21	20	19	18	17	SW00A2	48	47	46	45	44	43	42	41	40	39	38	37	36	35	34	33	SW00A3	64	63	62	61	60	59	58	57	56	55	54	53	52	51	50	49	SW00A4	80	79	78	77	76	75	74	73	72	71	70	69	68	67	66	65	SW00A5	96	95	94	93	92	91	90	89	88	87	86	85	84	83	82	81	SW00A6	112	111	110	109	108	107	106	105	104	103	102	101	100	99	98	97	SW00A7	—	—	—	—	—	—	—	—	120	119	118	117	116	115	114	113
	b15	b14	b13	b12	b11	b10	b9	b8	b7	b6	b5	b4	b3	b2	b1	b0																																																																																																																																											
SW00A0	16	15	14	13	12	11	10	9	8	7	6	5	4	3	2	1																																																																																																																																											
SW00A1	32	31	30	29	28	27	26	25	24	23	22	21	20	19	18	17																																																																																																																																											
SW00A2	48	47	46	45	44	43	42	41	40	39	38	37	36	35	34	33																																																																																																																																											
SW00A3	64	63	62	61	60	59	58	57	56	55	54	53	52	51	50	49																																																																																																																																											
SW00A4	80	79	78	77	76	75	74	73	72	71	70	69	68	67	66	65																																																																																																																																											
SW00A5	96	95	94	93	92	91	90	89	88	87	86	85	84	83	82	81																																																																																																																																											
SW00A6	112	111	110	109	108	107	106	105	104	103	102	101	100	99	98	97																																																																																																																																											
SW00A7	—	—	—	—	—	—	—	—	120	119	118	117	116	115	114	113																																																																																																																																											

Number	Name	Description																																																																																																																																																									
SW00B0 to SW00B7	Data link status (each station)	<p>Stores the cyclic transmission status for each station.</p> <p>0: Cyclic transmission normal station 1: Cyclic transmission faulty station</p> <ul style="list-style-type: none"> If multiple stations change from faulty to normal, because they are reconnected to the network one by one per link scan, the time until the status changes to "0: Cyclic transmission normal station" may vary by several seconds. If no response is received for several link scans, the station is determined to be a cyclic transmission faulty station. <table border="1" data-bbox="603 645 1169 925"> <thead> <tr> <th></th> <th>b15</th><th>b14</th><th>b13</th><th>b12</th><th>b11</th><th>b10</th><th>b9</th><th>b8</th><th>b7</th><th>b6</th><th>b5</th><th>b4</th><th>b3</th><th>b2</th><th>b1</th><th>b0</th> </tr> </thead> <tbody> <tr> <td>SW00B0</td> <td>16</td><td>15</td><td>14</td><td>13</td><td>12</td><td>11</td><td>10</td><td>9</td><td>8</td><td>7</td><td>6</td><td>5</td><td>4</td><td>3</td><td>2</td><td>1</td> </tr> <tr> <td>SW00B1</td> <td>32</td><td>31</td><td>30</td><td>29</td><td>28</td><td>27</td><td>26</td><td>25</td><td>24</td><td>23</td><td>22</td><td>21</td><td>20</td><td>19</td><td>18</td><td>17</td> </tr> <tr> <td>SW00B2</td> <td>48</td><td>47</td><td>46</td><td>45</td><td>44</td><td>43</td><td>42</td><td>41</td><td>40</td><td>39</td><td>38</td><td>37</td><td>36</td><td>35</td><td>34</td><td>33</td> </tr> <tr> <td>SW00B3</td> <td>64</td><td>63</td><td>62</td><td>61</td><td>60</td><td>59</td><td>58</td><td>57</td><td>56</td><td>55</td><td>54</td><td>53</td><td>52</td><td>51</td><td>50</td><td>49</td> </tr> <tr> <td>SW00B4</td> <td>80</td><td>79</td><td>78</td><td>77</td><td>76</td><td>75</td><td>74</td><td>73</td><td>72</td><td>71</td><td>70</td><td>69</td><td>68</td><td>67</td><td>66</td><td>65</td> </tr> <tr> <td>SW00B5</td> <td>96</td><td>95</td><td>94</td><td>93</td><td>92</td><td>91</td><td>90</td><td>89</td><td>88</td><td>87</td><td>86</td><td>85</td><td>84</td><td>83</td><td>82</td><td>81</td> </tr> <tr> <td>SW00B6</td> <td>112</td><td>111</td><td>110</td><td>109</td><td>108</td><td>107</td><td>106</td><td>105</td><td>104</td><td>103</td><td>102</td><td>101</td><td>100</td><td>99</td><td>98</td><td>97</td> </tr> <tr> <td>SW00B7</td> <td>—</td><td>—</td><td>—</td><td>—</td><td>—</td><td>—</td><td>—</td><td>—</td><td>120</td><td>119</td><td>118</td><td>117</td><td>116</td><td>115</td><td>114</td><td>113</td> </tr> </tbody> </table> <p>Each number in the table represents a station No. — is fixed to 0.</p> <p>(Conditions)</p> <ul style="list-style-type: none"> This is enabled when Baton pass status (own station) (SB0047) is off. Reserved stations and stations higher than the maximum station No. are ignored. 		b15	b14	b13	b12	b11	b10	b9	b8	b7	b6	b5	b4	b3	b2	b1	b0	SW00B0	16	15	14	13	12	11	10	9	8	7	6	5	4	3	2	1	SW00B1	32	31	30	29	28	27	26	25	24	23	22	21	20	19	18	17	SW00B2	48	47	46	45	44	43	42	41	40	39	38	37	36	35	34	33	SW00B3	64	63	62	61	60	59	58	57	56	55	54	53	52	51	50	49	SW00B4	80	79	78	77	76	75	74	73	72	71	70	69	68	67	66	65	SW00B5	96	95	94	93	92	91	90	89	88	87	86	85	84	83	82	81	SW00B6	112	111	110	109	108	107	106	105	104	103	102	101	100	99	98	97	SW00B7	—	—	—	—	—	—	—	—	120	119	118	117	116	115	114	113
	b15	b14	b13	b12	b11	b10	b9	b8	b7	b6	b5	b4	b3	b2	b1	b0																																																																																																																																											
SW00B0	16	15	14	13	12	11	10	9	8	7	6	5	4	3	2	1																																																																																																																																											
SW00B1	32	31	30	29	28	27	26	25	24	23	22	21	20	19	18	17																																																																																																																																											
SW00B2	48	47	46	45	44	43	42	41	40	39	38	37	36	35	34	33																																																																																																																																											
SW00B3	64	63	62	61	60	59	58	57	56	55	54	53	52	51	50	49																																																																																																																																											
SW00B4	80	79	78	77	76	75	74	73	72	71	70	69	68	67	66	65																																																																																																																																											
SW00B5	96	95	94	93	92	91	90	89	88	87	86	85	84	83	82	81																																																																																																																																											
SW00B6	112	111	110	109	108	107	106	105	104	103	102	101	100	99	98	97																																																																																																																																											
SW00B7	—	—	—	—	—	—	—	—	120	119	118	117	116	115	114	113																																																																																																																																											
SW00C1 to SW00C7	Reserved station setting status	<p>Stores the setting status of the reserved station.</p> <p>0: Other than reserved station (also includes stations specified as reserved station disable status) 1: Reserved station</p> <table border="1" data-bbox="603 1261 1169 1507"> <thead> <tr> <th></th> <th>b15</th><th>b14</th><th>b13</th><th>b12</th><th>b11</th><th>b10</th><th>b9</th><th>b8</th><th>b7</th><th>b6</th><th>b5</th><th>b4</th><th>b3</th><th>b2</th><th>b1</th><th>b0</th> </tr> </thead> <tbody> <tr> <td>SW00C1</td> <td>32</td><td>31</td><td>30</td><td>29</td><td>28</td><td>27</td><td>26</td><td>25</td><td>24</td><td>23</td><td>22</td><td>21</td><td>20</td><td>19</td><td>18</td><td>17</td> </tr> <tr> <td>SW00C2</td> <td>48</td><td>47</td><td>46</td><td>45</td><td>44</td><td>43</td><td>42</td><td>41</td><td>40</td><td>39</td><td>38</td><td>37</td><td>36</td><td>35</td><td>34</td><td>33</td> </tr> <tr> <td>SW00C3</td> <td>64</td><td>63</td><td>62</td><td>61</td><td>60</td><td>59</td><td>58</td><td>57</td><td>56</td><td>55</td><td>54</td><td>53</td><td>52</td><td>51</td><td>50</td><td>49</td> </tr> <tr> <td>SW00C4</td> <td>80</td><td>79</td><td>78</td><td>77</td><td>76</td><td>75</td><td>74</td><td>73</td><td>72</td><td>71</td><td>70</td><td>69</td><td>68</td><td>67</td><td>66</td><td>65</td> </tr> <tr> <td>SW00C5</td> <td>96</td><td>95</td><td>94</td><td>93</td><td>92</td><td>91</td><td>90</td><td>89</td><td>88</td><td>87</td><td>86</td><td>85</td><td>84</td><td>83</td><td>82</td><td>81</td> </tr> <tr> <td>SW00C6</td> <td>112</td><td>111</td><td>110</td><td>109</td><td>108</td><td>107</td><td>106</td><td>105</td><td>104</td><td>103</td><td>102</td><td>101</td><td>100</td><td>99</td><td>98</td><td>97</td> </tr> <tr> <td>SW00C7</td> <td>—</td><td>—</td><td>—</td><td>—</td><td>—</td><td>—</td><td>—</td><td>—</td><td>120</td><td>119</td><td>118</td><td>117</td><td>116</td><td>115</td><td>114</td><td>113</td> </tr> </tbody> </table> <p>Each number in the table represents a station No. — is fixed to 0.</p> <p>(Conditions)</p> <ul style="list-style-type: none"> This is enabled when Baton pass status (own station) (SB0047) is off. Holds the data immediately before the error. This is enabled only for normal stations in Baton pass status (each station) (SW00A0 to SW00A7). Stations higher than the maximum station No. are ignored. 		b15	b14	b13	b12	b11	b10	b9	b8	b7	b6	b5	b4	b3	b2	b1	b0	SW00C1	32	31	30	29	28	27	26	25	24	23	22	21	20	19	18	17	SW00C2	48	47	46	45	44	43	42	41	40	39	38	37	36	35	34	33	SW00C3	64	63	62	61	60	59	58	57	56	55	54	53	52	51	50	49	SW00C4	80	79	78	77	76	75	74	73	72	71	70	69	68	67	66	65	SW00C5	96	95	94	93	92	91	90	89	88	87	86	85	84	83	82	81	SW00C6	112	111	110	109	108	107	106	105	104	103	102	101	100	99	98	97	SW00C7	—	—	—	—	—	—	—	—	120	119	118	117	116	115	114	113																	
	b15	b14	b13	b12	b11	b10	b9	b8	b7	b6	b5	b4	b3	b2	b1	b0																																																																																																																																											
SW00C1	32	31	30	29	28	27	26	25	24	23	22	21	20	19	18	17																																																																																																																																											
SW00C2	48	47	46	45	44	43	42	41	40	39	38	37	36	35	34	33																																																																																																																																											
SW00C3	64	63	62	61	60	59	58	57	56	55	54	53	52	51	50	49																																																																																																																																											
SW00C4	80	79	78	77	76	75	74	73	72	71	70	69	68	67	66	65																																																																																																																																											
SW00C5	96	95	94	93	92	91	90	89	88	87	86	85	84	83	82	81																																																																																																																																											
SW00C6	112	111	110	109	108	107	106	105	104	103	102	101	100	99	98	97																																																																																																																																											
SW00C7	—	—	—	—	—	—	—	—	120	119	118	117	116	115	114	113																																																																																																																																											

Number	Name	Description																																																																																																																																																									
SW00F0 to SW00F7	CPU RUN status (each station)	<p>Stores the RUN status of each station. 0: RUN, STEP-RUN 1: STOP, PAUSE, stop error</p> <table border="1" data-bbox="603 456 1169 734"> <thead> <tr> <th></th> <th>b15</th> <th>b14</th> <th>b13</th> <th>b12</th> <th>b11</th> <th>b10</th> <th>b9</th> <th>b8</th> <th>b7</th> <th>b6</th> <th>b5</th> <th>b4</th> <th>b3</th> <th>b2</th> <th>b1</th> <th>b0</th> </tr> </thead> <tbody> <tr> <td>SW00F0</td> <td>16</td> <td>15</td> <td>14</td> <td>13</td> <td>12</td> <td>11</td> <td>10</td> <td>9</td> <td>8</td> <td>7</td> <td>6</td> <td>5</td> <td>4</td> <td>3</td> <td>2</td> <td>1</td> </tr> <tr> <td>SW00F1</td> <td>32</td> <td>31</td> <td>30</td> <td>29</td> <td>28</td> <td>27</td> <td>26</td> <td>25</td> <td>24</td> <td>23</td> <td>22</td> <td>21</td> <td>20</td> <td>19</td> <td>18</td> <td>17</td> </tr> <tr> <td>SW00F2</td> <td>48</td> <td>47</td> <td>46</td> <td>45</td> <td>44</td> <td>43</td> <td>42</td> <td>41</td> <td>40</td> <td>39</td> <td>38</td> <td>37</td> <td>36</td> <td>35</td> <td>34</td> <td>33</td> </tr> <tr> <td>SW00F3</td> <td>64</td> <td>63</td> <td>62</td> <td>61</td> <td>60</td> <td>59</td> <td>58</td> <td>57</td> <td>56</td> <td>55</td> <td>54</td> <td>53</td> <td>52</td> <td>51</td> <td>50</td> <td>49</td> </tr> <tr> <td>SW00F4</td> <td>80</td> <td>79</td> <td>78</td> <td>77</td> <td>76</td> <td>75</td> <td>74</td> <td>73</td> <td>72</td> <td>71</td> <td>70</td> <td>69</td> <td>68</td> <td>67</td> <td>66</td> <td>65</td> </tr> <tr> <td>SW00F5</td> <td>96</td> <td>95</td> <td>94</td> <td>93</td> <td>92</td> <td>91</td> <td>90</td> <td>89</td> <td>88</td> <td>87</td> <td>86</td> <td>85</td> <td>84</td> <td>83</td> <td>82</td> <td>81</td> </tr> <tr> <td>SW00F6</td> <td>112</td> <td>111</td> <td>110</td> <td>109</td> <td>108</td> <td>107</td> <td>106</td> <td>105</td> <td>104</td> <td>103</td> <td>102</td> <td>101</td> <td>100</td> <td>99</td> <td>98</td> <td>97</td> </tr> <tr> <td>SW00F7</td> <td>—</td> <td>—</td> <td>—</td> <td>—</td> <td>—</td> <td>—</td> <td>—</td> <td>—</td> <td>120</td> <td>119</td> <td>118</td> <td>117</td> <td>116</td> <td>115</td> <td>114</td> <td>113</td> </tr> </tbody> </table> <p>Each number in the table represents a station No. — is fixed to 0.</p> <p>(Conditions)</p> <ul style="list-style-type: none"> • This is enabled when Baton pass status (own station) (SB0047) is off. • Holds the data immediately before the error. • This is enabled only for normal stations in Baton pass status (each station) (SW00A0 to SW00A7). • Reserved stations and stations higher than the maximum station No. are ignored. 		b15	b14	b13	b12	b11	b10	b9	b8	b7	b6	b5	b4	b3	b2	b1	b0	SW00F0	16	15	14	13	12	11	10	9	8	7	6	5	4	3	2	1	SW00F1	32	31	30	29	28	27	26	25	24	23	22	21	20	19	18	17	SW00F2	48	47	46	45	44	43	42	41	40	39	38	37	36	35	34	33	SW00F3	64	63	62	61	60	59	58	57	56	55	54	53	52	51	50	49	SW00F4	80	79	78	77	76	75	74	73	72	71	70	69	68	67	66	65	SW00F5	96	95	94	93	92	91	90	89	88	87	86	85	84	83	82	81	SW00F6	112	111	110	109	108	107	106	105	104	103	102	101	100	99	98	97	SW00F7	—	—	—	—	—	—	—	—	120	119	118	117	116	115	114	113
	b15	b14	b13	b12	b11	b10	b9	b8	b7	b6	b5	b4	b3	b2	b1	b0																																																																																																																																											
SW00F0	16	15	14	13	12	11	10	9	8	7	6	5	4	3	2	1																																																																																																																																											
SW00F1	32	31	30	29	28	27	26	25	24	23	22	21	20	19	18	17																																																																																																																																											
SW00F2	48	47	46	45	44	43	42	41	40	39	38	37	36	35	34	33																																																																																																																																											
SW00F3	64	63	62	61	60	59	58	57	56	55	54	53	52	51	50	49																																																																																																																																											
SW00F4	80	79	78	77	76	75	74	73	72	71	70	69	68	67	66	65																																																																																																																																											
SW00F5	96	95	94	93	92	91	90	89	88	87	86	85	84	83	82	81																																																																																																																																											
SW00F6	112	111	110	109	108	107	106	105	104	103	102	101	100	99	98	97																																																																																																																																											
SW00F7	—	—	—	—	—	—	—	—	120	119	118	117	116	115	114	113																																																																																																																																											
SW0100 to SW0107	Operation status (each station) (1)	<p>Stores the moderate/major error or stop error status of each station. 0: No moderate/major error (stop error) 1: Moderate/major error (stop error)</p> <table border="1" data-bbox="603 1128 1169 1406"> <thead> <tr> <th></th> <th>b15</th> <th>b14</th> <th>b13</th> <th>b12</th> <th>b11</th> <th>b10</th> <th>b9</th> <th>b8</th> <th>b7</th> <th>b6</th> <th>b5</th> <th>b4</th> <th>b3</th> <th>b2</th> <th>b1</th> <th>b0</th> </tr> </thead> <tbody> <tr> <td>SW0100</td> <td>16</td> <td>15</td> <td>14</td> <td>13</td> <td>12</td> <td>11</td> <td>10</td> <td>9</td> <td>8</td> <td>7</td> <td>6</td> <td>5</td> <td>4</td> <td>3</td> <td>2</td> <td>1</td> </tr> <tr> <td>SW0101</td> <td>32</td> <td>31</td> <td>30</td> <td>29</td> <td>28</td> <td>27</td> <td>26</td> <td>25</td> <td>24</td> <td>23</td> <td>22</td> <td>21</td> <td>20</td> <td>19</td> <td>18</td> <td>17</td> </tr> <tr> <td>SW0102</td> <td>48</td> <td>47</td> <td>46</td> <td>45</td> <td>44</td> <td>43</td> <td>42</td> <td>41</td> <td>40</td> <td>39</td> <td>38</td> <td>37</td> <td>36</td> <td>35</td> <td>34</td> <td>33</td> </tr> <tr> <td>SW0103</td> <td>64</td> <td>63</td> <td>62</td> <td>61</td> <td>60</td> <td>59</td> <td>58</td> <td>57</td> <td>56</td> <td>55</td> <td>54</td> <td>53</td> <td>52</td> <td>51</td> <td>50</td> <td>49</td> </tr> <tr> <td>SW0104</td> <td>80</td> <td>79</td> <td>78</td> <td>77</td> <td>76</td> <td>75</td> <td>74</td> <td>73</td> <td>72</td> <td>71</td> <td>70</td> <td>69</td> <td>68</td> <td>67</td> <td>66</td> <td>65</td> </tr> <tr> <td>SW0105</td> <td>96</td> <td>95</td> <td>94</td> <td>93</td> <td>92</td> <td>91</td> <td>90</td> <td>89</td> <td>88</td> <td>87</td> <td>86</td> <td>85</td> <td>84</td> <td>83</td> <td>82</td> <td>81</td> </tr> <tr> <td>SW0106</td> <td>112</td> <td>111</td> <td>110</td> <td>109</td> <td>108</td> <td>107</td> <td>106</td> <td>105</td> <td>104</td> <td>103</td> <td>102</td> <td>101</td> <td>100</td> <td>99</td> <td>98</td> <td>97</td> </tr> <tr> <td>SW0107</td> <td>—</td> <td>—</td> <td>—</td> <td>—</td> <td>—</td> <td>—</td> <td>—</td> <td>—</td> <td>120</td> <td>119</td> <td>118</td> <td>117</td> <td>116</td> <td>115</td> <td>114</td> <td>113</td> </tr> </tbody> </table> <p>Each number in the table represents a station No. — is fixed to 0.</p> <p>(Conditions)</p> <ul style="list-style-type: none"> • This is enabled when Baton pass status (own station) (SB0047) is off. • Holds the data immediately before the error. • This is enabled only for normal stations in Baton pass status (each station) (SW00A0 to SW00A7). • Reserved stations and stations higher than the maximum station No. are ignored. 		b15	b14	b13	b12	b11	b10	b9	b8	b7	b6	b5	b4	b3	b2	b1	b0	SW0100	16	15	14	13	12	11	10	9	8	7	6	5	4	3	2	1	SW0101	32	31	30	29	28	27	26	25	24	23	22	21	20	19	18	17	SW0102	48	47	46	45	44	43	42	41	40	39	38	37	36	35	34	33	SW0103	64	63	62	61	60	59	58	57	56	55	54	53	52	51	50	49	SW0104	80	79	78	77	76	75	74	73	72	71	70	69	68	67	66	65	SW0105	96	95	94	93	92	91	90	89	88	87	86	85	84	83	82	81	SW0106	112	111	110	109	108	107	106	105	104	103	102	101	100	99	98	97	SW0107	—	—	—	—	—	—	—	—	120	119	118	117	116	115	114	113
	b15	b14	b13	b12	b11	b10	b9	b8	b7	b6	b5	b4	b3	b2	b1	b0																																																																																																																																											
SW0100	16	15	14	13	12	11	10	9	8	7	6	5	4	3	2	1																																																																																																																																											
SW0101	32	31	30	29	28	27	26	25	24	23	22	21	20	19	18	17																																																																																																																																											
SW0102	48	47	46	45	44	43	42	41	40	39	38	37	36	35	34	33																																																																																																																																											
SW0103	64	63	62	61	60	59	58	57	56	55	54	53	52	51	50	49																																																																																																																																											
SW0104	80	79	78	77	76	75	74	73	72	71	70	69	68	67	66	65																																																																																																																																											
SW0105	96	95	94	93	92	91	90	89	88	87	86	85	84	83	82	81																																																																																																																																											
SW0106	112	111	110	109	108	107	106	105	104	103	102	101	100	99	98	97																																																																																																																																											
SW0107	—	—	—	—	—	—	—	—	120	119	118	117	116	115	114	113																																																																																																																																											

Number	Name	Description																																																																																																																																																									
SW0110 to SW0117	Operation status (each station) (2)	<p>Stores the minor error or continuation error status of each station.</p> <p>0: Normal or moderate/major error (stop error) occurring 1: Minor error (continuation error) occurring</p> <table border="1" data-bbox="603 456 1169 734"> <thead> <tr> <th></th> <th>b15</th><th>b14</th><th>b13</th><th>b12</th><th>b11</th><th>b10</th><th>b9</th><th>b8</th><th>b7</th><th>b6</th><th>b5</th><th>b4</th><th>b3</th><th>b2</th><th>b1</th><th>b0</th> </tr> </thead> <tbody> <tr><td>SW0110</td><td>16</td><td>15</td><td>14</td><td>13</td><td>12</td><td>11</td><td>10</td><td>9</td><td>8</td><td>7</td><td>6</td><td>5</td><td>4</td><td>3</td><td>2</td><td>1</td></tr> <tr><td>SW0111</td><td>32</td><td>31</td><td>30</td><td>29</td><td>28</td><td>27</td><td>26</td><td>25</td><td>24</td><td>23</td><td>22</td><td>21</td><td>20</td><td>19</td><td>18</td><td>17</td></tr> <tr><td>SW0112</td><td>48</td><td>47</td><td>46</td><td>45</td><td>44</td><td>43</td><td>42</td><td>41</td><td>40</td><td>39</td><td>38</td><td>37</td><td>36</td><td>35</td><td>34</td><td>33</td></tr> <tr><td>SW0113</td><td>64</td><td>63</td><td>62</td><td>61</td><td>60</td><td>59</td><td>58</td><td>57</td><td>56</td><td>55</td><td>54</td><td>53</td><td>52</td><td>51</td><td>50</td><td>49</td></tr> <tr><td>SW0114</td><td>80</td><td>79</td><td>78</td><td>77</td><td>76</td><td>75</td><td>74</td><td>73</td><td>72</td><td>71</td><td>70</td><td>69</td><td>68</td><td>67</td><td>66</td><td>65</td></tr> <tr><td>SW0115</td><td>96</td><td>95</td><td>94</td><td>93</td><td>92</td><td>91</td><td>90</td><td>89</td><td>88</td><td>87</td><td>86</td><td>85</td><td>84</td><td>83</td><td>82</td><td>81</td></tr> <tr><td>SW0116</td><td>112</td><td>111</td><td>110</td><td>109</td><td>108</td><td>107</td><td>106</td><td>105</td><td>104</td><td>103</td><td>102</td><td>101</td><td>100</td><td>99</td><td>98</td><td>97</td></tr> <tr><td>SW0117</td><td>—</td><td>—</td><td>—</td><td>—</td><td>—</td><td>—</td><td>—</td><td>—</td><td>120</td><td>119</td><td>118</td><td>117</td><td>116</td><td>115</td><td>114</td><td>113</td></tr> </tbody> </table> <p>Each number in the table represents a station No. — is fixed to 0.</p> <p>(Conditions)</p> <ul style="list-style-type: none"> • This is enabled when Baton pass status (own station) (SB0047) is off. • Holds the data immediately before the error. • This is enabled only for normal stations in Baton pass status (each station) (SW00A0 to SW00A7). • Reserved stations and stations higher than the maximum station No. are ignored. 		b15	b14	b13	b12	b11	b10	b9	b8	b7	b6	b5	b4	b3	b2	b1	b0	SW0110	16	15	14	13	12	11	10	9	8	7	6	5	4	3	2	1	SW0111	32	31	30	29	28	27	26	25	24	23	22	21	20	19	18	17	SW0112	48	47	46	45	44	43	42	41	40	39	38	37	36	35	34	33	SW0113	64	63	62	61	60	59	58	57	56	55	54	53	52	51	50	49	SW0114	80	79	78	77	76	75	74	73	72	71	70	69	68	67	66	65	SW0115	96	95	94	93	92	91	90	89	88	87	86	85	84	83	82	81	SW0116	112	111	110	109	108	107	106	105	104	103	102	101	100	99	98	97	SW0117	—	—	—	—	—	—	—	—	120	119	118	117	116	115	114	113
	b15	b14	b13	b12	b11	b10	b9	b8	b7	b6	b5	b4	b3	b2	b1	b0																																																																																																																																											
SW0110	16	15	14	13	12	11	10	9	8	7	6	5	4	3	2	1																																																																																																																																											
SW0111	32	31	30	29	28	27	26	25	24	23	22	21	20	19	18	17																																																																																																																																											
SW0112	48	47	46	45	44	43	42	41	40	39	38	37	36	35	34	33																																																																																																																																											
SW0113	64	63	62	61	60	59	58	57	56	55	54	53	52	51	50	49																																																																																																																																											
SW0114	80	79	78	77	76	75	74	73	72	71	70	69	68	67	66	65																																																																																																																																											
SW0115	96	95	94	93	92	91	90	89	88	87	86	85	84	83	82	81																																																																																																																																											
SW0116	112	111	110	109	108	107	106	105	104	103	102	101	100	99	98	97																																																																																																																																											
SW0117	—	—	—	—	—	—	—	—	120	119	118	117	116	115	114	113																																																																																																																																											
SW0120 to SW0127	PORT1 error frame reception status (each station)	<p>Stores the station number receiving an error frame on the transmission path at each station's PORT1.</p> <p>0: A line error has not yet occurred on the transmission path of each station's PORT1. 1: A line error has occurred on the transmission path of each station's PORT1.</p> <p>When Clear communication error count (SB0006) is turned on, the stored status is cleared.</p> <table border="1" data-bbox="603 1214 1169 1491"> <thead> <tr> <th></th> <th>b15</th><th>b14</th><th>b13</th><th>b12</th><th>b11</th><th>b10</th><th>b9</th><th>b8</th><th>b7</th><th>b6</th><th>b5</th><th>b4</th><th>b3</th><th>b2</th><th>b1</th><th>b0</th> </tr> </thead> <tbody> <tr><td>SW0120</td><td>16</td><td>15</td><td>14</td><td>13</td><td>12</td><td>11</td><td>10</td><td>9</td><td>8</td><td>7</td><td>6</td><td>5</td><td>4</td><td>3</td><td>2</td><td>1</td></tr> <tr><td>SW0121</td><td>32</td><td>31</td><td>30</td><td>29</td><td>28</td><td>27</td><td>26</td><td>25</td><td>24</td><td>23</td><td>22</td><td>21</td><td>20</td><td>19</td><td>18</td><td>17</td></tr> <tr><td>SW0122</td><td>48</td><td>47</td><td>46</td><td>45</td><td>44</td><td>43</td><td>42</td><td>41</td><td>40</td><td>39</td><td>38</td><td>37</td><td>36</td><td>35</td><td>34</td><td>33</td></tr> <tr><td>SW0123</td><td>64</td><td>63</td><td>62</td><td>61</td><td>60</td><td>59</td><td>58</td><td>57</td><td>56</td><td>55</td><td>54</td><td>53</td><td>52</td><td>51</td><td>50</td><td>49</td></tr> <tr><td>SW0124</td><td>80</td><td>79</td><td>78</td><td>77</td><td>76</td><td>75</td><td>74</td><td>73</td><td>72</td><td>71</td><td>70</td><td>69</td><td>68</td><td>67</td><td>66</td><td>65</td></tr> <tr><td>SW0125</td><td>96</td><td>95</td><td>94</td><td>93</td><td>92</td><td>91</td><td>90</td><td>89</td><td>88</td><td>87</td><td>86</td><td>85</td><td>84</td><td>83</td><td>82</td><td>81</td></tr> <tr><td>SW0126</td><td>112</td><td>111</td><td>110</td><td>109</td><td>108</td><td>107</td><td>106</td><td>105</td><td>104</td><td>103</td><td>102</td><td>101</td><td>100</td><td>99</td><td>98</td><td>97</td></tr> <tr><td>SW0127</td><td>—</td><td>—</td><td>—</td><td>—</td><td>—</td><td>—</td><td>—</td><td>—</td><td>120</td><td>119</td><td>118</td><td>117</td><td>116</td><td>115</td><td>114</td><td>113</td></tr> </tbody> </table> <p>Each number in the table represents a station No. — is fixed to 0.</p> <p>(Conditions)</p> <ul style="list-style-type: none"> • This is enabled when Baton pass status (own station) (SB0047) is off. • Holds the data immediately before the error. • This is enabled only for normal stations in Baton pass status (each station) (SW00A0 to SW00A7). 		b15	b14	b13	b12	b11	b10	b9	b8	b7	b6	b5	b4	b3	b2	b1	b0	SW0120	16	15	14	13	12	11	10	9	8	7	6	5	4	3	2	1	SW0121	32	31	30	29	28	27	26	25	24	23	22	21	20	19	18	17	SW0122	48	47	46	45	44	43	42	41	40	39	38	37	36	35	34	33	SW0123	64	63	62	61	60	59	58	57	56	55	54	53	52	51	50	49	SW0124	80	79	78	77	76	75	74	73	72	71	70	69	68	67	66	65	SW0125	96	95	94	93	92	91	90	89	88	87	86	85	84	83	82	81	SW0126	112	111	110	109	108	107	106	105	104	103	102	101	100	99	98	97	SW0127	—	—	—	—	—	—	—	—	120	119	118	117	116	115	114	113
	b15	b14	b13	b12	b11	b10	b9	b8	b7	b6	b5	b4	b3	b2	b1	b0																																																																																																																																											
SW0120	16	15	14	13	12	11	10	9	8	7	6	5	4	3	2	1																																																																																																																																											
SW0121	32	31	30	29	28	27	26	25	24	23	22	21	20	19	18	17																																																																																																																																											
SW0122	48	47	46	45	44	43	42	41	40	39	38	37	36	35	34	33																																																																																																																																											
SW0123	64	63	62	61	60	59	58	57	56	55	54	53	52	51	50	49																																																																																																																																											
SW0124	80	79	78	77	76	75	74	73	72	71	70	69	68	67	66	65																																																																																																																																											
SW0125	96	95	94	93	92	91	90	89	88	87	86	85	84	83	82	81																																																																																																																																											
SW0126	112	111	110	109	108	107	106	105	104	103	102	101	100	99	98	97																																																																																																																																											
SW0127	—	—	—	—	—	—	—	—	120	119	118	117	116	115	114	113																																																																																																																																											

Number	Name	Description																																																																																																																																																									
SW0130 to SW0137	PORT2 error frame reception status (each station)	<p>Stores the station number receiving an error frame on the transmission path at each station's PORT2.</p> <p>0: A line error has not yet occurred on the transmission path of each station's PORT2. 1: A line error has occurred on the transmission path of each station's PORT2.</p> <p>When Clear communication error count (SB0006) is turned on, the stored status is cleared.</p> <table border="1" data-bbox="523 555 1169 831"> <thead> <tr> <th></th> <th>b15</th><th>b14</th><th>b13</th><th>b12</th><th>b11</th><th>b10</th><th>b9</th><th>b8</th><th>b7</th><th>b6</th><th>b5</th><th>b4</th><th>b3</th><th>b2</th><th>b1</th><th>b0</th> </tr> </thead> <tbody> <tr> <td>SW0130</td> <td>16</td><td>15</td><td>14</td><td>13</td><td>12</td><td>11</td><td>10</td><td>9</td><td>8</td><td>7</td><td>6</td><td>5</td><td>4</td><td>3</td><td>2</td><td>1</td> </tr> <tr> <td>SW0131</td> <td>32</td><td>31</td><td>30</td><td>29</td><td>28</td><td>27</td><td>26</td><td>25</td><td>24</td><td>23</td><td>22</td><td>21</td><td>20</td><td>19</td><td>18</td><td>17</td> </tr> <tr> <td>SW0132</td> <td>48</td><td>47</td><td>46</td><td>45</td><td>44</td><td>43</td><td>42</td><td>41</td><td>40</td><td>39</td><td>38</td><td>37</td><td>36</td><td>35</td><td>34</td><td>33</td> </tr> <tr> <td>SW0133</td> <td>64</td><td>63</td><td>62</td><td>61</td><td>60</td><td>59</td><td>58</td><td>57</td><td>56</td><td>55</td><td>54</td><td>53</td><td>52</td><td>51</td><td>50</td><td>49</td> </tr> <tr> <td>SW0134</td> <td>80</td><td>79</td><td>78</td><td>77</td><td>76</td><td>75</td><td>74</td><td>73</td><td>72</td><td>71</td><td>70</td><td>69</td><td>68</td><td>67</td><td>66</td><td>65</td> </tr> <tr> <td>SW0135</td> <td>96</td><td>95</td><td>94</td><td>93</td><td>92</td><td>91</td><td>90</td><td>89</td><td>88</td><td>87</td><td>86</td><td>85</td><td>84</td><td>83</td><td>82</td><td>81</td> </tr> <tr> <td>SW0136</td> <td>112</td><td>111</td><td>110</td><td>109</td><td>108</td><td>107</td><td>106</td><td>105</td><td>104</td><td>103</td><td>102</td><td>101</td><td>100</td><td>99</td><td>98</td><td>97</td> </tr> <tr> <td>SW0137</td> <td>—</td><td>—</td><td>—</td><td>—</td><td>—</td><td>—</td><td>—</td><td>—</td><td>120</td><td>119</td><td>118</td><td>117</td><td>116</td><td>115</td><td>114</td><td>113</td> </tr> </tbody> </table> <p>Each number in the table represents a station No. — is fixed to 0.</p> <p>(Conditions)</p> <ul style="list-style-type: none"> • This is enabled when Baton pass status (own station) (SB0047) is off. • Holds the data immediately before the error. • This is enabled only for normal stations in Baton pass status (each station) (SW00A0 to SW00A7). 		b15	b14	b13	b12	b11	b10	b9	b8	b7	b6	b5	b4	b3	b2	b1	b0	SW0130	16	15	14	13	12	11	10	9	8	7	6	5	4	3	2	1	SW0131	32	31	30	29	28	27	26	25	24	23	22	21	20	19	18	17	SW0132	48	47	46	45	44	43	42	41	40	39	38	37	36	35	34	33	SW0133	64	63	62	61	60	59	58	57	56	55	54	53	52	51	50	49	SW0134	80	79	78	77	76	75	74	73	72	71	70	69	68	67	66	65	SW0135	96	95	94	93	92	91	90	89	88	87	86	85	84	83	82	81	SW0136	112	111	110	109	108	107	106	105	104	103	102	101	100	99	98	97	SW0137	—	—	—	—	—	—	—	—	120	119	118	117	116	115	114	113
	b15	b14	b13	b12	b11	b10	b9	b8	b7	b6	b5	b4	b3	b2	b1	b0																																																																																																																																											
SW0130	16	15	14	13	12	11	10	9	8	7	6	5	4	3	2	1																																																																																																																																											
SW0131	32	31	30	29	28	27	26	25	24	23	22	21	20	19	18	17																																																																																																																																											
SW0132	48	47	46	45	44	43	42	41	40	39	38	37	36	35	34	33																																																																																																																																											
SW0133	64	63	62	61	60	59	58	57	56	55	54	53	52	51	50	49																																																																																																																																											
SW0134	80	79	78	77	76	75	74	73	72	71	70	69	68	67	66	65																																																																																																																																											
SW0135	96	95	94	93	92	91	90	89	88	87	86	85	84	83	82	81																																																																																																																																											
SW0136	112	111	110	109	108	107	106	105	104	103	102	101	100	99	98	97																																																																																																																																											
SW0137	—	—	—	—	—	—	—	—	120	119	118	117	116	115	114	113																																																																																																																																											
SW0140 to SW0147	PORT1 error frame detection (each station)	<p>Stores the station number that has received an error frame from power-on until the present on the transmission path at each station's PORT1.</p> <p>0: A line error is not currently occurred on the transmission path of each station's PORT1. 1: A line error is currently occurred on the transmission path of each station's PORT1.</p> <p>When Clear communication error count (SB0006) is turned on, the stored status is cleared.</p> <table border="1" data-bbox="523 1330 1169 1606"> <thead> <tr> <th></th> <th>b15</th><th>b14</th><th>b13</th><th>b12</th><th>b11</th><th>b10</th><th>b9</th><th>b8</th><th>b7</th><th>b6</th><th>b5</th><th>b4</th><th>b3</th><th>b2</th><th>b1</th><th>b0</th> </tr> </thead> <tbody> <tr> <td>SW0140</td> <td>16</td><td>15</td><td>14</td><td>13</td><td>12</td><td>11</td><td>10</td><td>9</td><td>8</td><td>7</td><td>6</td><td>5</td><td>4</td><td>3</td><td>2</td><td>1</td> </tr> <tr> <td>SW0141</td> <td>32</td><td>31</td><td>30</td><td>29</td><td>28</td><td>27</td><td>26</td><td>25</td><td>24</td><td>23</td><td>22</td><td>21</td><td>20</td><td>19</td><td>18</td><td>17</td> </tr> <tr> <td>SW0142</td> <td>48</td><td>47</td><td>46</td><td>45</td><td>44</td><td>43</td><td>42</td><td>41</td><td>40</td><td>39</td><td>38</td><td>37</td><td>36</td><td>35</td><td>34</td><td>33</td> </tr> <tr> <td>SW0143</td> <td>64</td><td>63</td><td>62</td><td>61</td><td>60</td><td>59</td><td>58</td><td>57</td><td>56</td><td>55</td><td>54</td><td>53</td><td>52</td><td>51</td><td>50</td><td>49</td> </tr> <tr> <td>SW0144</td> <td>80</td><td>79</td><td>78</td><td>77</td><td>76</td><td>75</td><td>74</td><td>73</td><td>72</td><td>71</td><td>70</td><td>69</td><td>68</td><td>67</td><td>66</td><td>65</td> </tr> <tr> <td>SW0145</td> <td>96</td><td>95</td><td>94</td><td>93</td><td>92</td><td>91</td><td>90</td><td>89</td><td>88</td><td>87</td><td>86</td><td>85</td><td>84</td><td>83</td><td>82</td><td>81</td> </tr> <tr> <td>SW0146</td> <td>112</td><td>111</td><td>110</td><td>109</td><td>108</td><td>107</td><td>106</td><td>105</td><td>104</td><td>103</td><td>102</td><td>101</td><td>100</td><td>99</td><td>98</td><td>97</td> </tr> <tr> <td>SW0147</td> <td>—</td><td>—</td><td>—</td><td>—</td><td>—</td><td>—</td><td>—</td><td>—</td><td>120</td><td>119</td><td>118</td><td>117</td><td>116</td><td>115</td><td>114</td><td>113</td> </tr> </tbody> </table> <p>Each number in the table represents a station No. — is fixed to 0.</p> <p>(Conditions)</p> <ul style="list-style-type: none"> • This is enabled when Baton pass status (own station) (SB0047) is off. • Holds the data immediately before the error. • This is enabled only for normal stations in Baton pass status (each station) (SW00A0 to SW00A7). 		b15	b14	b13	b12	b11	b10	b9	b8	b7	b6	b5	b4	b3	b2	b1	b0	SW0140	16	15	14	13	12	11	10	9	8	7	6	5	4	3	2	1	SW0141	32	31	30	29	28	27	26	25	24	23	22	21	20	19	18	17	SW0142	48	47	46	45	44	43	42	41	40	39	38	37	36	35	34	33	SW0143	64	63	62	61	60	59	58	57	56	55	54	53	52	51	50	49	SW0144	80	79	78	77	76	75	74	73	72	71	70	69	68	67	66	65	SW0145	96	95	94	93	92	91	90	89	88	87	86	85	84	83	82	81	SW0146	112	111	110	109	108	107	106	105	104	103	102	101	100	99	98	97	SW0147	—	—	—	—	—	—	—	—	120	119	118	117	116	115	114	113
	b15	b14	b13	b12	b11	b10	b9	b8	b7	b6	b5	b4	b3	b2	b1	b0																																																																																																																																											
SW0140	16	15	14	13	12	11	10	9	8	7	6	5	4	3	2	1																																																																																																																																											
SW0141	32	31	30	29	28	27	26	25	24	23	22	21	20	19	18	17																																																																																																																																											
SW0142	48	47	46	45	44	43	42	41	40	39	38	37	36	35	34	33																																																																																																																																											
SW0143	64	63	62	61	60	59	58	57	56	55	54	53	52	51	50	49																																																																																																																																											
SW0144	80	79	78	77	76	75	74	73	72	71	70	69	68	67	66	65																																																																																																																																											
SW0145	96	95	94	93	92	91	90	89	88	87	86	85	84	83	82	81																																																																																																																																											
SW0146	112	111	110	109	108	107	106	105	104	103	102	101	100	99	98	97																																																																																																																																											
SW0147	—	—	—	—	—	—	—	—	120	119	118	117	116	115	114	113																																																																																																																																											

Number	Name	Description																																																																																																																																																									
SW0150 to SW0157	PORT2 error frame detection (each station)	<p>Stores the station number that has received an error frame from power-on until the present on the transmission path at each station's PORT2.</p> <p>0: A line error is not currently occurred on the transmission path of each station's PORT2.</p> <p>1: A line error is currently occurred on the transmission path of each station's PORT2.</p> <p>When Clear communication error count (SB0006) is turned on, the stored status is cleared.</p> <table border="1" data-bbox="603 584 1169 862"> <thead> <tr> <th></th> <th>b15</th><th>b14</th><th>b13</th><th>b12</th><th>b11</th><th>b10</th><th>b9</th><th>b8</th><th>b7</th><th>b6</th><th>b5</th><th>b4</th><th>b3</th><th>b2</th><th>b1</th><th>b0</th> </tr> </thead> <tbody> <tr> <td>SW0150</td> <td>16</td><td>15</td><td>14</td><td>13</td><td>12</td><td>11</td><td>10</td><td>9</td><td>8</td><td>7</td><td>6</td><td>5</td><td>4</td><td>3</td><td>2</td><td>1</td> </tr> <tr> <td>SW0151</td> <td>32</td><td>31</td><td>30</td><td>29</td><td>28</td><td>27</td><td>26</td><td>25</td><td>24</td><td>23</td><td>22</td><td>21</td><td>20</td><td>19</td><td>18</td><td>17</td> </tr> <tr> <td>SW0152</td> <td>48</td><td>47</td><td>46</td><td>45</td><td>44</td><td>43</td><td>42</td><td>41</td><td>40</td><td>39</td><td>38</td><td>37</td><td>36</td><td>35</td><td>34</td><td>33</td> </tr> <tr> <td>SW0153</td> <td>64</td><td>63</td><td>62</td><td>61</td><td>60</td><td>59</td><td>58</td><td>57</td><td>56</td><td>55</td><td>54</td><td>53</td><td>52</td><td>51</td><td>50</td><td>49</td> </tr> <tr> <td>SW0154</td> <td>80</td><td>79</td><td>78</td><td>77</td><td>76</td><td>75</td><td>74</td><td>73</td><td>72</td><td>71</td><td>70</td><td>69</td><td>68</td><td>67</td><td>66</td><td>65</td> </tr> <tr> <td>SW0155</td> <td>96</td><td>95</td><td>94</td><td>93</td><td>92</td><td>91</td><td>90</td><td>89</td><td>88</td><td>87</td><td>86</td><td>85</td><td>84</td><td>83</td><td>82</td><td>81</td> </tr> <tr> <td>SW0156</td> <td>112</td><td>111</td><td>110</td><td>109</td><td>108</td><td>107</td><td>106</td><td>105</td><td>104</td><td>103</td><td>102</td><td>101</td><td>100</td><td>99</td><td>98</td><td>97</td> </tr> <tr> <td>SW0157</td> <td>—</td><td>—</td><td>—</td><td>—</td><td>—</td><td>—</td><td>—</td><td>—</td><td>120</td><td>119</td><td>118</td><td>117</td><td>116</td><td>115</td><td>114</td><td>113</td> </tr> </tbody> </table> <p>Each number in the table represents a station No. — is fixed to 0.</p> <p>(Conditions)</p> <ul style="list-style-type: none"> • This is enabled when Baton pass status (own station) (SB0047) is off. • Holds the data immediately before the error. • This is enabled only for normal stations in Baton pass status (each station) (SW00A0 to SW00A7). 		b15	b14	b13	b12	b11	b10	b9	b8	b7	b6	b5	b4	b3	b2	b1	b0	SW0150	16	15	14	13	12	11	10	9	8	7	6	5	4	3	2	1	SW0151	32	31	30	29	28	27	26	25	24	23	22	21	20	19	18	17	SW0152	48	47	46	45	44	43	42	41	40	39	38	37	36	35	34	33	SW0153	64	63	62	61	60	59	58	57	56	55	54	53	52	51	50	49	SW0154	80	79	78	77	76	75	74	73	72	71	70	69	68	67	66	65	SW0155	96	95	94	93	92	91	90	89	88	87	86	85	84	83	82	81	SW0156	112	111	110	109	108	107	106	105	104	103	102	101	100	99	98	97	SW0157	—	—	—	—	—	—	—	—	120	119	118	117	116	115	114	113
	b15	b14	b13	b12	b11	b10	b9	b8	b7	b6	b5	b4	b3	b2	b1	b0																																																																																																																																											
SW0150	16	15	14	13	12	11	10	9	8	7	6	5	4	3	2	1																																																																																																																																											
SW0151	32	31	30	29	28	27	26	25	24	23	22	21	20	19	18	17																																																																																																																																											
SW0152	48	47	46	45	44	43	42	41	40	39	38	37	36	35	34	33																																																																																																																																											
SW0153	64	63	62	61	60	59	58	57	56	55	54	53	52	51	50	49																																																																																																																																											
SW0154	80	79	78	77	76	75	74	73	72	71	70	69	68	67	66	65																																																																																																																																											
SW0155	96	95	94	93	92	91	90	89	88	87	86	85	84	83	82	81																																																																																																																																											
SW0156	112	111	110	109	108	107	106	105	104	103	102	101	100	99	98	97																																																																																																																																											
SW0157	—	—	—	—	—	—	—	—	120	119	118	117	116	115	114	113																																																																																																																																											
SW0170 to SW0177	Parameter error status (each station)	<p>Stores the parameter status for each station.</p> <p>0: No parameter error</p> <p>1: Parameter error found</p> <table border="1" data-bbox="603 1216 1169 1494"> <thead> <tr> <th></th> <th>b15</th><th>b14</th><th>b13</th><th>b12</th><th>b11</th><th>b10</th><th>b9</th><th>b8</th><th>b7</th><th>b6</th><th>b5</th><th>b4</th><th>b3</th><th>b2</th><th>b1</th><th>b0</th> </tr> </thead> <tbody> <tr> <td>SW0170</td> <td>16</td><td>15</td><td>14</td><td>13</td><td>12</td><td>11</td><td>10</td><td>9</td><td>8</td><td>7</td><td>6</td><td>5</td><td>4</td><td>3</td><td>2</td><td>1</td> </tr> <tr> <td>SW0171</td> <td>32</td><td>31</td><td>30</td><td>29</td><td>28</td><td>27</td><td>26</td><td>25</td><td>24</td><td>23</td><td>22</td><td>21</td><td>20</td><td>19</td><td>18</td><td>17</td> </tr> <tr> <td>SW0172</td> <td>48</td><td>47</td><td>46</td><td>45</td><td>44</td><td>43</td><td>42</td><td>41</td><td>40</td><td>39</td><td>38</td><td>37</td><td>36</td><td>35</td><td>34</td><td>33</td> </tr> <tr> <td>SW0173</td> <td>64</td><td>63</td><td>62</td><td>61</td><td>60</td><td>59</td><td>58</td><td>57</td><td>56</td><td>55</td><td>54</td><td>53</td><td>52</td><td>51</td><td>50</td><td>49</td> </tr> <tr> <td>SW0174</td> <td>80</td><td>79</td><td>78</td><td>77</td><td>76</td><td>75</td><td>74</td><td>73</td><td>72</td><td>71</td><td>70</td><td>69</td><td>68</td><td>67</td><td>66</td><td>65</td> </tr> <tr> <td>SW0175</td> <td>96</td><td>95</td><td>94</td><td>93</td><td>92</td><td>91</td><td>90</td><td>89</td><td>88</td><td>87</td><td>86</td><td>85</td><td>84</td><td>83</td><td>82</td><td>81</td> </tr> <tr> <td>SW0176</td> <td>112</td><td>111</td><td>110</td><td>109</td><td>108</td><td>107</td><td>106</td><td>105</td><td>104</td><td>103</td><td>102</td><td>101</td><td>100</td><td>99</td><td>98</td><td>97</td> </tr> <tr> <td>SW0177</td> <td>—</td><td>—</td><td>—</td><td>—</td><td>—</td><td>—</td><td>—</td><td>—</td><td>120</td><td>119</td><td>118</td><td>117</td><td>116</td><td>115</td><td>114</td><td>113</td> </tr> </tbody> </table> <p>Each number in the table represents a station No. — is fixed to 0.</p> <p>(Conditions)</p> <ul style="list-style-type: none"> • This is enabled when Baton pass status (own station) (SB0047) is off. • Holds the data immediately before the error. • This is enabled only for normal stations in Baton pass status (each station) (SW00A0 to SW00A7). • Reserved stations and stations higher than the maximum station No. are ignored. 		b15	b14	b13	b12	b11	b10	b9	b8	b7	b6	b5	b4	b3	b2	b1	b0	SW0170	16	15	14	13	12	11	10	9	8	7	6	5	4	3	2	1	SW0171	32	31	30	29	28	27	26	25	24	23	22	21	20	19	18	17	SW0172	48	47	46	45	44	43	42	41	40	39	38	37	36	35	34	33	SW0173	64	63	62	61	60	59	58	57	56	55	54	53	52	51	50	49	SW0174	80	79	78	77	76	75	74	73	72	71	70	69	68	67	66	65	SW0175	96	95	94	93	92	91	90	89	88	87	86	85	84	83	82	81	SW0176	112	111	110	109	108	107	106	105	104	103	102	101	100	99	98	97	SW0177	—	—	—	—	—	—	—	—	120	119	118	117	116	115	114	113
	b15	b14	b13	b12	b11	b10	b9	b8	b7	b6	b5	b4	b3	b2	b1	b0																																																																																																																																											
SW0170	16	15	14	13	12	11	10	9	8	7	6	5	4	3	2	1																																																																																																																																											
SW0171	32	31	30	29	28	27	26	25	24	23	22	21	20	19	18	17																																																																																																																																											
SW0172	48	47	46	45	44	43	42	41	40	39	38	37	36	35	34	33																																																																																																																																											
SW0173	64	63	62	61	60	59	58	57	56	55	54	53	52	51	50	49																																																																																																																																											
SW0174	80	79	78	77	76	75	74	73	72	71	70	69	68	67	66	65																																																																																																																																											
SW0175	96	95	94	93	92	91	90	89	88	87	86	85	84	83	82	81																																																																																																																																											
SW0176	112	111	110	109	108	107	106	105	104	103	102	101	100	99	98	97																																																																																																																																											
SW0177	—	—	—	—	—	—	—	—	120	119	118	117	116	115	114	113																																																																																																																																											

Number	Name	Description																																																																																																																																																									
SW0181 to SW0187	Reserved station cancel setting status	<p>Stores if a reserved station setting is temporarily canceled.</p> <p>0: No reserved station setting cancel 1: Reserved station function disable in progress</p> <table border="1"> <thead> <tr> <th></th> <th>b15</th> <th>b14</th> <th>b13</th> <th>b12</th> <th>b11</th> <th>b10</th> <th>b9</th> <th>b8</th> <th>b7</th> <th>b6</th> <th>b5</th> <th>b4</th> <th>b3</th> <th>b2</th> <th>b1</th> <th>b0</th> </tr> </thead> <tbody> <tr> <td>SW0181</td> <td>32</td> <td>31</td> <td>30</td> <td>29</td> <td>28</td> <td>27</td> <td>26</td> <td>25</td> <td>24</td> <td>23</td> <td>22</td> <td>21</td> <td>20</td> <td>19</td> <td>18</td> <td>17</td> </tr> <tr> <td>SW0182</td> <td>48</td> <td>47</td> <td>46</td> <td>45</td> <td>44</td> <td>43</td> <td>42</td> <td>41</td> <td>40</td> <td>39</td> <td>38</td> <td>37</td> <td>36</td> <td>35</td> <td>34</td> <td>33</td> </tr> <tr> <td>SW0183</td> <td>64</td> <td>63</td> <td>62</td> <td>61</td> <td>60</td> <td>59</td> <td>58</td> <td>57</td> <td>56</td> <td>55</td> <td>54</td> <td>53</td> <td>52</td> <td>51</td> <td>50</td> <td>49</td> </tr> <tr> <td>SW0184</td> <td>80</td> <td>79</td> <td>78</td> <td>77</td> <td>76</td> <td>75</td> <td>74</td> <td>73</td> <td>72</td> <td>71</td> <td>70</td> <td>69</td> <td>68</td> <td>67</td> <td>66</td> <td>65</td> </tr> <tr> <td>SW0185</td> <td>96</td> <td>95</td> <td>94</td> <td>93</td> <td>92</td> <td>91</td> <td>90</td> <td>89</td> <td>88</td> <td>87</td> <td>86</td> <td>85</td> <td>84</td> <td>83</td> <td>82</td> <td>81</td> </tr> <tr> <td>SW0186</td> <td>112</td> <td>111</td> <td>110</td> <td>109</td> <td>108</td> <td>107</td> <td>106</td> <td>105</td> <td>104</td> <td>103</td> <td>102</td> <td>101</td> <td>100</td> <td>99</td> <td>98</td> <td>97</td> </tr> <tr> <td>SW0187</td> <td>—</td> <td>—</td> <td>—</td> <td>—</td> <td>—</td> <td>—</td> <td>—</td> <td>—</td> <td>120</td> <td>119</td> <td>118</td> <td>117</td> <td>116</td> <td>115</td> <td>114</td> <td>113</td> </tr> </tbody> </table> <p>Each number in the table represents a station No. — is fixed to 0.</p> <p>(Conditions)</p> <ul style="list-style-type: none"> • This is enabled when Baton pass status (own station) (SB0047) is off. • Holds the data immediately before the error. • This is enabled only for normal stations in Baton pass status (each station) (SW00A0 to SW00A7). • Stations higher than the maximum station No. are ignored. 		b15	b14	b13	b12	b11	b10	b9	b8	b7	b6	b5	b4	b3	b2	b1	b0	SW0181	32	31	30	29	28	27	26	25	24	23	22	21	20	19	18	17	SW0182	48	47	46	45	44	43	42	41	40	39	38	37	36	35	34	33	SW0183	64	63	62	61	60	59	58	57	56	55	54	53	52	51	50	49	SW0184	80	79	78	77	76	75	74	73	72	71	70	69	68	67	66	65	SW0185	96	95	94	93	92	91	90	89	88	87	86	85	84	83	82	81	SW0186	112	111	110	109	108	107	106	105	104	103	102	101	100	99	98	97	SW0187	—	—	—	—	—	—	—	—	120	119	118	117	116	115	114	113																	
	b15	b14	b13	b12	b11	b10	b9	b8	b7	b6	b5	b4	b3	b2	b1	b0																																																																																																																																											
SW0181	32	31	30	29	28	27	26	25	24	23	22	21	20	19	18	17																																																																																																																																											
SW0182	48	47	46	45	44	43	42	41	40	39	38	37	36	35	34	33																																																																																																																																											
SW0183	64	63	62	61	60	59	58	57	56	55	54	53	52	51	50	49																																																																																																																																											
SW0184	80	79	78	77	76	75	74	73	72	71	70	69	68	67	66	65																																																																																																																																											
SW0185	96	95	94	93	92	91	90	89	88	87	86	85	84	83	82	81																																																																																																																																											
SW0186	112	111	110	109	108	107	106	105	104	103	102	101	100	99	98	97																																																																																																																																											
SW0187	—	—	—	—	—	—	—	—	120	119	118	117	116	115	114	113																																																																																																																																											
SW01C0 to SW01C7	Synchronous communication function information (each station)	<p>Stores the setting information of synchronous/asynchronous communication of the synchronous communication function for each station.</p> <p>0: Asynchronous communication mode 1: Synchronous communication mode</p> <table border="1"> <thead> <tr> <th></th> <th>b15</th> <th>b14</th> <th>b13</th> <th>b12</th> <th>b11</th> <th>b10</th> <th>b9</th> <th>b8</th> <th>b7</th> <th>b6</th> <th>b5</th> <th>b4</th> <th>b3</th> <th>b2</th> <th>b1</th> <th>b0</th> </tr> </thead> <tbody> <tr> <td>SW01C0</td> <td>16</td> <td>15</td> <td>14</td> <td>13</td> <td>12</td> <td>11</td> <td>10</td> <td>9</td> <td>8</td> <td>7</td> <td>6</td> <td>5</td> <td>4</td> <td>3</td> <td>2</td> <td>1</td> </tr> <tr> <td>SW01C1</td> <td>32</td> <td>31</td> <td>30</td> <td>29</td> <td>28</td> <td>27</td> <td>26</td> <td>25</td> <td>24</td> <td>23</td> <td>22</td> <td>21</td> <td>20</td> <td>19</td> <td>18</td> <td>17</td> </tr> <tr> <td>SW01C2</td> <td>48</td> <td>47</td> <td>46</td> <td>45</td> <td>44</td> <td>43</td> <td>42</td> <td>41</td> <td>40</td> <td>39</td> <td>38</td> <td>37</td> <td>36</td> <td>35</td> <td>34</td> <td>33</td> </tr> <tr> <td>SW01C3</td> <td>64</td> <td>63</td> <td>62</td> <td>61</td> <td>60</td> <td>59</td> <td>58</td> <td>57</td> <td>56</td> <td>55</td> <td>54</td> <td>53</td> <td>52</td> <td>51</td> <td>50</td> <td>49</td> </tr> <tr> <td>SW01C4</td> <td>80</td> <td>79</td> <td>78</td> <td>77</td> <td>76</td> <td>75</td> <td>74</td> <td>73</td> <td>72</td> <td>71</td> <td>70</td> <td>69</td> <td>68</td> <td>67</td> <td>66</td> <td>65</td> </tr> <tr> <td>SW01C5</td> <td>96</td> <td>95</td> <td>94</td> <td>93</td> <td>92</td> <td>91</td> <td>90</td> <td>89</td> <td>88</td> <td>87</td> <td>86</td> <td>85</td> <td>84</td> <td>83</td> <td>82</td> <td>81</td> </tr> <tr> <td>SW01C6</td> <td>112</td> <td>111</td> <td>110</td> <td>109</td> <td>108</td> <td>107</td> <td>106</td> <td>105</td> <td>104</td> <td>103</td> <td>102</td> <td>101</td> <td>100</td> <td>99</td> <td>98</td> <td>97</td> </tr> <tr> <td>SW01C7</td> <td>—</td> <td>—</td> <td>—</td> <td>—</td> <td>—</td> <td>—</td> <td>—</td> <td>—</td> <td>120</td> <td>119</td> <td>118</td> <td>117</td> <td>116</td> <td>115</td> <td>114</td> <td>113</td> </tr> </tbody> </table> <p>Each number in the table represents a station No. — is fixed to 0.</p>		b15	b14	b13	b12	b11	b10	b9	b8	b7	b6	b5	b4	b3	b2	b1	b0	SW01C0	16	15	14	13	12	11	10	9	8	7	6	5	4	3	2	1	SW01C1	32	31	30	29	28	27	26	25	24	23	22	21	20	19	18	17	SW01C2	48	47	46	45	44	43	42	41	40	39	38	37	36	35	34	33	SW01C3	64	63	62	61	60	59	58	57	56	55	54	53	52	51	50	49	SW01C4	80	79	78	77	76	75	74	73	72	71	70	69	68	67	66	65	SW01C5	96	95	94	93	92	91	90	89	88	87	86	85	84	83	82	81	SW01C6	112	111	110	109	108	107	106	105	104	103	102	101	100	99	98	97	SW01C7	—	—	—	—	—	—	—	—	120	119	118	117	116	115	114	113
	b15	b14	b13	b12	b11	b10	b9	b8	b7	b6	b5	b4	b3	b2	b1	b0																																																																																																																																											
SW01C0	16	15	14	13	12	11	10	9	8	7	6	5	4	3	2	1																																																																																																																																											
SW01C1	32	31	30	29	28	27	26	25	24	23	22	21	20	19	18	17																																																																																																																																											
SW01C2	48	47	46	45	44	43	42	41	40	39	38	37	36	35	34	33																																																																																																																																											
SW01C3	64	63	62	61	60	59	58	57	56	55	54	53	52	51	50	49																																																																																																																																											
SW01C4	80	79	78	77	76	75	74	73	72	71	70	69	68	67	66	65																																																																																																																																											
SW01C5	96	95	94	93	92	91	90	89	88	87	86	85	84	83	82	81																																																																																																																																											
SW01C6	112	111	110	109	108	107	106	105	104	103	102	101	100	99	98	97																																																																																																																																											
SW01C7	—	—	—	—	—	—	—	—	120	119	118	117	116	115	114	113																																																																																																																																											
SW01C8 to SW01CF	Synchronous/asynchronous operation status information (each station)	<p>Stores the synchronous/asynchronous communication operation status for each station.</p> <p>0: Asynchronous 1: Synchronous</p> <table border="1"> <thead> <tr> <th></th> <th>b15</th> <th>b14</th> <th>b13</th> <th>b12</th> <th>b11</th> <th>b10</th> <th>b9</th> <th>b8</th> <th>b7</th> <th>b6</th> <th>b5</th> <th>b4</th> <th>b3</th> <th>b2</th> <th>b1</th> <th>b0</th> </tr> </thead> <tbody> <tr> <td>SW01C8</td> <td>16</td> <td>15</td> <td>14</td> <td>13</td> <td>12</td> <td>11</td> <td>10</td> <td>9</td> <td>8</td> <td>7</td> <td>6</td> <td>5</td> <td>4</td> <td>3</td> <td>2</td> <td>1</td> </tr> <tr> <td>SW01C9</td> <td>32</td> <td>31</td> <td>30</td> <td>29</td> <td>28</td> <td>27</td> <td>26</td> <td>25</td> <td>24</td> <td>23</td> <td>22</td> <td>21</td> <td>20</td> <td>19</td> <td>18</td> <td>17</td> </tr> <tr> <td>SW01CA</td> <td>48</td> <td>47</td> <td>46</td> <td>45</td> <td>44</td> <td>43</td> <td>42</td> <td>41</td> <td>40</td> <td>39</td> <td>38</td> <td>37</td> <td>36</td> <td>35</td> <td>34</td> <td>33</td> </tr> <tr> <td>SW01CB</td> <td>64</td> <td>63</td> <td>62</td> <td>61</td> <td>60</td> <td>59</td> <td>58</td> <td>57</td> <td>56</td> <td>55</td> <td>54</td> <td>53</td> <td>52</td> <td>51</td> <td>50</td> <td>49</td> </tr> <tr> <td>SW01CC</td> <td>80</td> <td>79</td> <td>78</td> <td>77</td> <td>76</td> <td>75</td> <td>74</td> <td>73</td> <td>72</td> <td>71</td> <td>70</td> <td>69</td> <td>68</td> <td>67</td> <td>66</td> <td>65</td> </tr> <tr> <td>SW01CD</td> <td>96</td> <td>95</td> <td>94</td> <td>93</td> <td>92</td> <td>91</td> <td>90</td> <td>89</td> <td>88</td> <td>87</td> <td>86</td> <td>85</td> <td>84</td> <td>83</td> <td>82</td> <td>81</td> </tr> <tr> <td>SW01CE</td> <td>112</td> <td>111</td> <td>110</td> <td>109</td> <td>108</td> <td>107</td> <td>106</td> <td>105</td> <td>104</td> <td>103</td> <td>102</td> <td>101</td> <td>100</td> <td>99</td> <td>98</td> <td>97</td> </tr> <tr> <td>SW01CF</td> <td>—</td> <td>—</td> <td>—</td> <td>—</td> <td>—</td> <td>—</td> <td>—</td> <td>—</td> <td>120</td> <td>119</td> <td>118</td> <td>117</td> <td>116</td> <td>115</td> <td>114</td> <td>113</td> </tr> </tbody> </table> <p>Each number in the table represents a station No. — is fixed to 0.</p>		b15	b14	b13	b12	b11	b10	b9	b8	b7	b6	b5	b4	b3	b2	b1	b0	SW01C8	16	15	14	13	12	11	10	9	8	7	6	5	4	3	2	1	SW01C9	32	31	30	29	28	27	26	25	24	23	22	21	20	19	18	17	SW01CA	48	47	46	45	44	43	42	41	40	39	38	37	36	35	34	33	SW01CB	64	63	62	61	60	59	58	57	56	55	54	53	52	51	50	49	SW01CC	80	79	78	77	76	75	74	73	72	71	70	69	68	67	66	65	SW01CD	96	95	94	93	92	91	90	89	88	87	86	85	84	83	82	81	SW01CE	112	111	110	109	108	107	106	105	104	103	102	101	100	99	98	97	SW01CF	—	—	—	—	—	—	—	—	120	119	118	117	116	115	114	113
	b15	b14	b13	b12	b11	b10	b9	b8	b7	b6	b5	b4	b3	b2	b1	b0																																																																																																																																											
SW01C8	16	15	14	13	12	11	10	9	8	7	6	5	4	3	2	1																																																																																																																																											
SW01C9	32	31	30	29	28	27	26	25	24	23	22	21	20	19	18	17																																																																																																																																											
SW01CA	48	47	46	45	44	43	42	41	40	39	38	37	36	35	34	33																																																																																																																																											
SW01CB	64	63	62	61	60	59	58	57	56	55	54	53	52	51	50	49																																																																																																																																											
SW01CC	80	79	78	77	76	75	74	73	72	71	70	69	68	67	66	65																																																																																																																																											
SW01CD	96	95	94	93	92	91	90	89	88	87	86	85	84	83	82	81																																																																																																																																											
SW01CE	112	111	110	109	108	107	106	105	104	103	102	101	100	99	98	97																																																																																																																																											
SW01CF	—	—	—	—	—	—	—	—	120	119	118	117	116	115	114	113																																																																																																																																											

Appendix 4 Processing Time

The processing time of CC-Link IE Field Network consists of the time components below.

Sequence scan + Link refresh time + Link scan time + Slave station processing time
= Transmission delay time

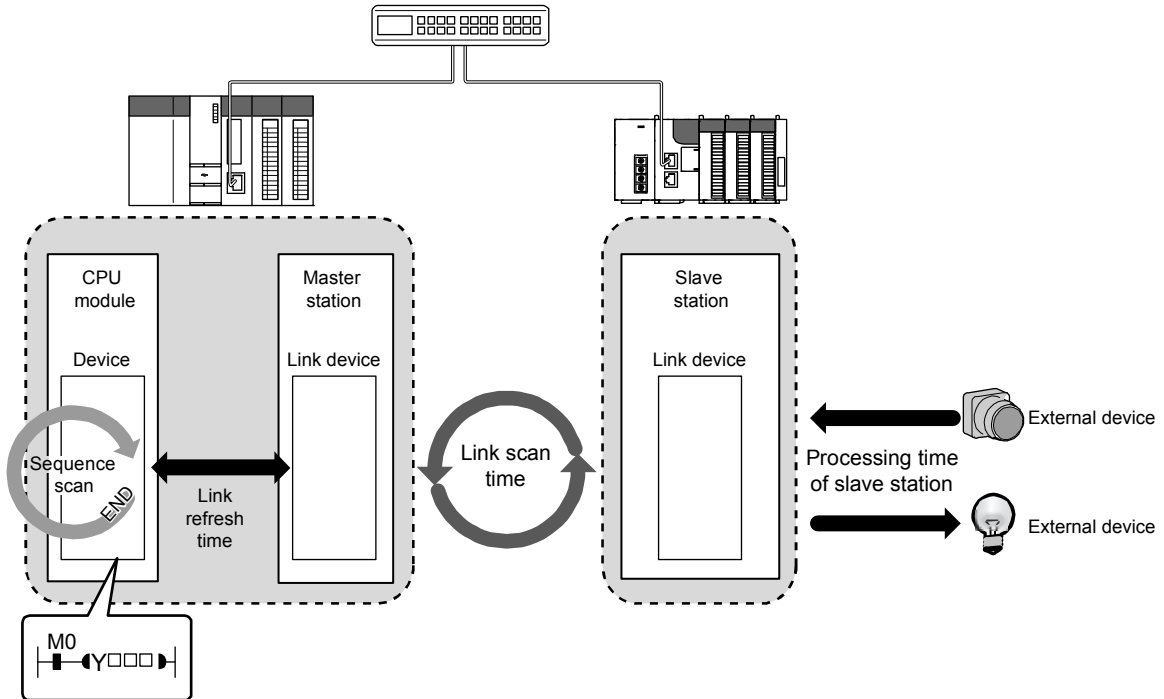

- Sequence scan: Refer to the user's manual for the CPU module used.
- Link refresh time: Refer to Appendix 4.1.
- Link scan time: Refer to Appendix 4.2.
- Slave station processing time: Refer to the manual for the slave station used.
- Transmission delay time: Refer to Appendix 4.3.

Appendix 4.1 Link refresh time

The following are formulas to calculate the link refresh time.

(1) Calculation formula

$$\alpha_T, \alpha_R = KM1 + KM2 \times \left[\frac{RX+RY+SB}{16} + RW_r + RW_w + SW \right] + \alpha_E \text{ [ms]}$$

$$\alpha_E = KM3 \times \left[\frac{RX+RY}{16} + RW_r + RW_w \right] \text{ [ms]}$$

- α_T : Sending-side link refresh time
- α_R : Receiving-side link refresh time
- RX : Total number of RX points that are actually being link-refreshed (Note-1)
- RY : Total number of RY points that are actually being link-refreshed (Note-1)
- RW_r : Total number of RW_r points that are actually being link-refreshed (Note-1)
- RW_w : Total number of RW_w points that are actually being link-refreshed (Note-1)
- SB : Number of SB points
- SW : Number of SW points
- α_E : Memory card file register (R, ZR), extended data register (D), and extended link register (W) transfer time

KM1, KM2, KM3: Constant

(Note-1): Total number of link device points for the range set by the refresh parameters and set in the network configuration settings. Note that the points assigned to reserved stations are excluded.

REMARK

Add α_E only when refreshing the data to the memory card file register. Addition is not required when refreshing the data to the standard RAM and extended SRAM cassette file registers.

• When Simple Motion module is mounted in the main base unit

CPU type		KM1 ($\times 10^{-3}$)	KM2 ($\times 10^{-3}$)	KM3 ($\times 10^{-3}$)
Universal model QCPU	Q00UJ/Q00U/Q01U/Q02UCPU	160	0.41	0.39 (Note-1)
	Q03UD/Q03UDECPU	90	0.41	0.39
	Q04UDH/Q04UDEH/Q06UDH/ Q06UDEH/Q10UDH/Q10UDEH/ Q13UDH/Q13UDEH/Q20UDH/ Q20UDEH/Q26UDH/Q26UDEH/ Q50UDEH/Q100UDEHCPU	90	0.41	0.33
	Q03UDV/Q04UDV/Q04UDPV/ Q06UDV/Q06UDPV/Q13UDV/ Q13UDPV/Q26UDV/Q26UDPVCPU	45	0.41	-

(Note-1): Only the Q02UCPU is acceptable.

- When Simple Motion module is mounted in the extension base unit

CPU type		KM1 ($\times 10^{-3}$)	KM2 ($\times 10^{-3}$)	KM3 ($\times 10^{-3}$)
Universal model QCPU	Q00UJ/Q00U/Q01U/Q02UCPU	160	1.06	0.39 (Note-1)
	Q03UD/Q03UDECPU	90	0.97	0.39
	Q04UDH/Q04UDEH/Q06UDH/ Q06UDEH/Q10UDH/Q10UDEH/ Q13UDH/Q13UDEH/Q20UDH/ Q20UDEH/Q26UDH/Q26UDEH/ Q50UDEH/Q100UDEHCPU	90	0.97	0.33
	Q03UDV/Q04UDV/Q04UDPV/ Q06UDV/Q06UDPV/Q13UDV/ Q13UDPV/Q26UDV/Q26UDPVCPU	45	0.97	-

(Note-1): Only the Q02UCPU is acceptable.

Appendix 4.2 Link scan time

Link scan time is equivalent to the operation cycle of the Simple Motion module.

Appendix 4.3 Cyclic transmission delay time

The following is the formula to calculate cyclic transmission delay time.

(1) Between the master station and an intelligent device station/remote device station

(a) Master station (RX/RWr) ← Intelligent device station/remote device station (input)

The following time is shown:

- The time from when a signal is input to the intelligent device station/remote device station until the CPU module device of the master station is turned on or off
- The time from when data are input to the intelligent device station/remote device station until the data are stored in the CPU module device of the master station

Calculation value	With block data assurance per station	Without block data assurance per station
Normal value	$(SM \times 1) + (CT \times n1) + Rio$	$(SM \times 1) + (CT \times 1) + Rio$
Maximum value	$(SM \times 1) + \{CT \times (n1 + 1)\} + Rio$	$(SM \times 1) + (CT \times 2) + Rio$

SM : Master station sequence scan time

CT : Operation cycle

n1 : $SM \div CT$ (Round up the calculated value to the nearest integer.)

Rio : Intelligent device station/remote device station processing time (Refer to the manual of the intelligent device station/remote device station used.)

(b) Master station (RY/RWw) → Intelligent device station/remote device station (output)

The following time is shown:

- The time from when the CPU module device of the master station is turned on or off until the output of the intelligent device station/remote device station is turned on or off
- The time from when data are set to the CPU module device of the master station until the data are output to the intelligent device station/remote device station

Calculation value	With block data assurance per station	Without block data assurance per station
Normal value	$(SM \times n2) + (CT \times 1) + Rio$	$(SM \times 1) + (CT \times 1) + Rio$
Maximum value	$(SM \times n2) + (CT \times 2) + Rio$	$(SM \times 2) + (CT \times 2) + Rio$

SM : Master station sequence scan time

CT : Operation cycle

n2 : $CT \div SM$ (Round up the calculated value to the nearest integer.)

Rio : Intelligent device station/remote device station processing time (Refer to the manual of the intelligent device station/remote device station used.)

Appendix 4.4 Transmission delay time of dedicated instructions

The following is the formula to calculate the transmission delay time of dedicated instructions (time after a dedicated instruction is issued until the execution of the instruction is completed).

(1) Between the master station and an intelligent device station/remote device station

(a) Master station → Intelligent device station/remote device station

$$\text{TD1: } 0.5 + \text{CT} \times 12 \times m + \text{Rio} + \text{SM} \text{ [ms]}$$

CT: Operation cycle

Rio: Intelligent device station/remote device station processing time

SM: Master station sequence scan time

m: Number of divided sending = Value that "Data length ÷ 480" is rounded up to the nearest integer

Appendix 4.5 Calculation formula for operation cycle

The following is the formula to calculate the operation cycle.

Note: The calculation result by this formula is a measure value. Check the actual operation cycle by parameters and control details to be used.

$$\text{Operation cycle } [\mu\text{sec}] = (7 \times \text{Ns}) + (0.50 \times \text{Sr}) + (32 \times \text{Na}) + 600 + \alpha p$$

Ns: Number of slave stations excluding servo amplifiers

Na: Number of servo amplifiers

Sr: Data size that is actually being link-refreshed [byte]

αp: Positioning operation cycle [μsec]

Appendix 5 Comparison of QJ71GF11-T2

This chapter describes the differences in the specifications for master/local module QJ71GF11-T2 and Simple Motion module QD77GF.

(1) Differences of mode

Model	Simple Motion module QD77GF	Master/local module QJ71GF11-T2
Mode	Online	Online (Normal Mode)
Communication cycle	Fixed cycle ([RJ010 mode] 0.88ms/1.77ms/3.55ms, [CiA402 mode] 1.00ms/2.00ms/4.00ms)	Not fixed cycle (Fastest cycle)
Maximum number of transients per link scan (1 operation cycle)	4	4 + Slave station × 1.5

(2) Differences of performance specifications

Item		Specifications	
		Simple Motion module QD77GF	Master/local module QJ71GF11-T2
Maximum link points per network	RWw	1024 points	8192 points
	RWr	1024 points	8192 points
	RX	8192 points	16384 points
	RY	8192 points	16384 points
Maximum number of send points per station	RWw	1024 points	8192 points
	RY	8192 points	16384 points
Transmission specifications	Network topology	Line topology and star topology (Coexistence of line topology and star topology is possible.)	Line topology, star topology (Coexistence of line topology and star topology is possible.), ring topology
Number of connected stations in one network	Servo amplifier	QD77GF4: 4 stations QD77GF8: 8 stations QD77GF16: 16 stations	-
	Slave station excluding a servo amplifier	104 stations	120 stations
Station type		Master station	Master station, local station
Connected station type		Intelligent device station, Remote device station, Remote I/O station	Local Station, Intelligent device station, Remote device station, Remote I/O station

(3) Functional comparison

(a) Added functions

The followings are the functions added in the Simple Motion module QD77GF.

Function	Description	Reference
Fixed cycle communication	The slave device is communicated in the fixed cycle. The communication cycle is the same as an operation cycle of the Simple Motion module.	Section 8.1
Synchronous communication	The processing cycles of the Simple Motion module and each slave station are synchronized.	Section 8.2

(b) Modified functions

The followings are the functions modified in the Simple Motion module QD77GF. For details of incompatible functions, refer to the "MELSEC-Q CC-Link IE Field Network Master/Local Module User's Manual".

1) Cyclic transmission

Function		Description	Specifications		Reference
			Simple Motion module QD77GF	Master/local module QJ71GF11-T2	
Communications with other stations	Communications using RX and RY	Communicating station	Station No.17 to 120	Station No.1 to 120	Section 8.3.1
	Communications using RWr and RWw	Communicating station	Station No.17 to 120	Station No.1 to 120	Section 8.3.1
Access to devices and link devices	Link refresh	Link device range	RX: 0 to 1FFFH RY: 0 to 1FFFH RWw: 0 to 3FFH RWr: 0 to 3FFH SB: 0 to 1FFH SW: 0 to 1FFH	RX: 0 to 3FFFH RY: 0 to 3FFFH RWw: 0 to 1FFFH RWr: 0 to 1FFFH SB: 0 to 1FFH SW: 0 to 1FFH	Section 8.3.2 Section 8.3.3
	Direct access to link devices	Link device range	RX: J□\X0 to J□\X1FFF RY: J□\Y0 to J□\Y1FFF RWw: J□\W0 to J□\W3FF RWr: J□\W400 to J□\W7FF SB: J□\SB0 to J□\SB1FF SW: J□\SW0 to J□\SW1FF □: indicates the network No.	RX: J□\X0 to J□\X3FFF RY: J□\Y0 to J□\Y3FFF RWw: J□\W0 to J□\W1FFF RWr: J□\W2000 to J□\W3FFF SB: J□\SB0 to J□\SB1FF SW: J□\SW0 to J□\SW1FF □: indicates the network No.	Section 8.3.3
Interlink transmission		-	Not supported	Supported	-
Mode selection for cyclic transmission		Mode	Online (Normal Mode)	Online (Normal Mode) Online (High Speed Mode)	Section 7.3
Scan synchronization specification		-	Not supported	Supported	-
Cyclic transmission stop and restart		Target station	Station No.17 to 120	Station No.1 to 120	Section 8.3.7

2) Transient transmission

Function	Description	Specifications		Reference
		Simple Motion module QD77GF	Master/local module QJ71GF11-T2	
Communications within the same network	Dedicated instruction	READ, SREAD, WRITE, SWRITE, REMFR, REMTO	READ, SREAD, WRITE, SWRITE, SEND, RECV, RECVS, REQ, REMFR, REMTO, RIRD, RIWT, CCPASET	Chapter10
Communications with different networks	-	Not supported	Supported	-

3) RAS functions

Function	Description	Specifications		Reference
		Simple Motion module QD77GF	Master/local module QJ71GF11-T2	
Loopback function	-	Not supported	Supported	-
Submaster function	-	Not supported	Supported	-

4) Diagnostic function

Function	Description	Specifications		Reference	
		Simple Motion module QD77GF	Master/local module QJ71GF11-T2		
Diagnostics of module alone	Hardware test	-	Not supported	Supported	-
	Self-loopback test	-	Not supported	Supported	-
Own network diagnostics	Loop test	-	Not supported	Supported	-
	Cable test	-	Not supported	Supported	-
Other network diagnostics	Communication test	-	Not supported	Supported	-
	IP communication test	-	Not supported	Supported	-

5) Other functions

Function	Description	Specifications		Reference
		Simple Motion module QD77GF	Master/local module QJ71GF11-T2	
Reserved station specification	Target station	Station No.17 to 120	Station No.1 to 120	Section 8.5
Temporary cancel of the reserved station setting	Target station	Station No.17 to 120	Station No.1 to 120	Section 8.5
Error invalid station and temporary error invalid station setting	-	Not supported	Supported	-
Interrupt request to a CPU module	Device code, Device No.	RX:0 to 1FFFH RY:0 to 1FFFH RWw:0 to 3FFH RWr:0 to 3FFH SB:0 to 1FF SW:0 to 1FF	RX:0 to 3FFFH RY:0 to 3FFFH RWw:0 to 1FFFH RWr:0 to 1FFFH SB:0 to 1FF SW:0 to 1FF RECVS instruction	Section 8.5
IP packet transfer function	-	Not supported	Supported	-

MEMO

WARRANTY

Please confirm the following product warranty details before using this product.

1. Gratis Warranty Term and Gratis Warranty Range

If any faults or defects (hereinafter "Failure") found to be the responsibility of Mitsubishi occurs during use of the product within the gratis warranty term, the product shall be repaired at no cost via the sales representative or Mitsubishi Service Company.

However, if repairs are required onsite at domestic or overseas location, expenses to send an engineer will be solely at the customer's discretion. Mitsubishi shall not be held responsible for any re-commissioning, maintenance, or testing on-site that involves replacement of the failed module.

[Gratis Warranty Term]

The gratis warranty term of the product shall be for one year after the date of purchase or delivery to a designated place. Note that after manufacture and shipment from Mitsubishi, the maximum distribution period shall be six (6) months, and the longest gratis warranty term after manufacturing shall be eighteen (18) months. The gratis warranty term of repair parts shall not exceed the gratis warranty term before repairs.

[Gratis Warranty Range]

- (1) The range shall be limited to normal use within the usage state, usage methods and usage environment, etc., which follow the conditions and precautions, etc., given in the instruction manual, user's manual and caution labels on the product.
- (2) Even within the gratis warranty term, repairs shall be charged for in the following cases.
 1. Failure occurring from inappropriate storage or handling, carelessness or negligence by the user. Failure caused by the user's hardware or software design.
 2. Failure caused by unapproved modifications, etc., to the product by the user.
 3. When the Mitsubishi product is assembled into a user's device, Failure that could have been avoided if functions or structures, judged as necessary in the legal safety measures the user's device is subject to or as necessary by industry standards, had been provided.
 4. Failure that could have been avoided if consumable parts (battery, backlight, fuse, etc.) designated in the instruction manual had been correctly serviced or replaced.
 5. Failure caused by external irresistible forces such as fires or abnormal voltages, and Failure caused by force majeure such as earthquakes, lightning, wind and water damage.
 6. Failure caused by reasons unpredictable by scientific technology standards at time of shipment from Mitsubishi.
 7. Any other failure found not to be the responsibility of Mitsubishi or that admitted not to be so by the user.

2. Onerous repair term after discontinuation of production

- (1) Mitsubishi shall accept onerous product repairs for seven (7) years after production of the product is discontinued. Discontinuation of production shall be notified with Mitsubishi Technical Bulletins, etc.
- (2) Product supply (including repair parts) is not available after production is discontinued.

3. Overseas service

Overseas, repairs shall be accepted by Mitsubishi's local overseas FA Center. Note that the repair conditions at each FA Center may differ.

4. Exclusion of loss in opportunity and secondary loss from warranty liability

Regardless of the gratis warranty term, Mitsubishi shall not be liable for compensation to:

- (1) Damages caused by any cause found not to be the responsibility of Mitsubishi.
- (2) Loss in opportunity, lost profits incurred to the user by Failures of Mitsubishi products.
- (3) Special damages and secondary damages whether foreseeable or not, compensation for accidents, and compensation for damages to products other than Mitsubishi products.
- (4) Replacement by the user, maintenance of on-site equipment, start-up test run and other tasks.

5. Changes in product specifications

The specifications given in the catalogs, manuals or technical documents are subject to change without prior notice.

TRADEMARKS

Ethernet is a registered trademark of Fuji Xerox Co., Ltd. in Japan.

Microsoft and Windows are either registered trademarks or trademarks of Microsoft Corporation in the United States and/or other countries.

The company names, system names and product names mentioned in this manual are either registered trademarks or trademarks of their respective companies.

In some cases, trademark symbols such as [™] or [®] are not specified in this manual.

IB(NA)-0300203-E(1709)MEE

MODEL: QD77GF-U-SN-E

MODEL CODE: 1XB957

mitsubishi electric corporation

HEAD OFFICE : TOKYO BUILDING, 2-7-3 MARUNOUCHI, CHIYODA-KU, TOKYO 100-8310, JAPAN
NAGOYA WORKS : 1-14, YADA-MINAMI 5-CHOME, HIGASHI-KU, NAGOYA, JAPAN

When exported from Japan, this manual does not require application to the
Ministry of Economy, Trade and Industry for service transaction permission.

Specifications subject to change without notice.