



Motion Controller

MELSEC **Q** series

Q173D(S)CPU/Q172D(S)CPU
Motion Controller
User's Manual

- Q172DCPU
- Q173DCPU
- Q172DCPU-S1
- Q173DCPU-S1
- Q172DSCPU
- Q173DSCPU

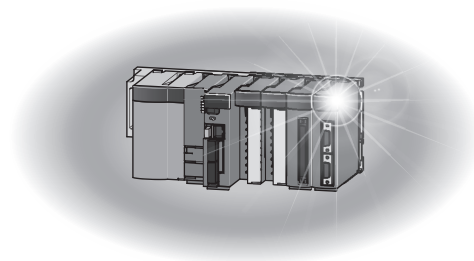

● SAFETY PRECAUTIONS ●

(Please read these instructions before using this equipment.)

Before using this product, please read this manual and the relevant manuals introduced in this manual carefully and pay full attention to safety to handle the product correctly.

These precautions apply only to this product. Refer to the Q173D(S)CPU/Q172D(S)CPU Users manual for a description of the Motion controller safety precautions.

In this manual, the safety instructions are ranked as "DANGER" and "CAUTION".

 **DANGER**

Indicates that incorrect handling may cause hazardous conditions, resulting in death or severe injury.

 **CAUTION**

Indicates that incorrect handling may cause hazardous conditions, resulting in medium or slight personal injury or physical damage.

Depending on circumstances, procedures indicated by  CAUTION may also be linked to serious results.

In any case, it is important to follow the directions for usage.

Please save this manual to make it accessible when required and always forward it to the end user.

For Safe Operations

1. Prevention of electric shocks

DANGER

- Never open the front case or terminal covers while the power is ON or the unit is running, as this may lead to electric shocks.
- Never run the unit with the front case or terminal cover removed. The high voltage terminal and charged sections will be exposed and may lead to electric shocks.
- Never open the front case or terminal cover at times other than wiring work or periodic inspections even if the power is OFF. The insides of the Motion controller and servo amplifier are charged and may lead to electric shocks.
- Completely turn off the externally supplied power used in the system before mounting or removing the module, performing wiring work, or inspections. Failing to do so may lead to electric shocks.
- When performing wiring work or inspections, turn the power OFF, wait at least ten minutes, and then check the voltage with a tester, etc. Failing to do so may lead to electric shocks.
- Be sure to ground the Motion controller, servo amplifier and servo motor. (Ground resistance : 100 Ω or less) Do not ground commonly with other devices.
- The wiring work and inspections must be done by a qualified technician.
- Wire the units after installing the Motion controller, servo amplifier and servo motor. Failing to do so may lead to electric shocks or damage.
- Never operate the switches with wet hands, as this may lead to electric shocks.
- Do not damage, apply excessive stress, place heavy things on or sandwich the cables, as this may lead to electric shocks.
- Do not touch the Motion controller, servo amplifier or servo motor terminal blocks while the power is ON, as this may lead to electric shocks.
- Do not touch the built-in power supply, built-in grounding or signal wires of the Motion controller and servo amplifier, as this may lead to electric shocks.

2. For fire prevention

CAUTION

- Install the Motion controller, servo amplifier, servo motor and regenerative resistor on incombustible. Installing them directly or close to combustibles will lead to fire.
- If a fault occurs in the Motion controller or servo amplifier, shut the power OFF at the servo amplifier's power source. If a large current continues to flow, fire may occur.
- When using a regenerative resistor, shut the power OFF with an error signal. The regenerative resistor may abnormally overheat due to a fault in the regenerative transistor, etc., and may lead to fire.
- Always take heat measures such as flame proofing for the inside of the control panel where the servo amplifier or regenerative resistor is installed and for the wires used. Failing to do so may lead to fire.
- Do not damage, apply excessive stress, place heavy things on or sandwich the cables, as this may lead to fire.

3. For injury prevention

CAUTION

- Do not apply a voltage other than that specified in the instruction manual on any terminal. Doing so may lead to destruction or damage.
- Do not mistake the terminal connections, as this may lead to destruction or damage.
- Do not mistake the polarity (+ / -), as this may lead to destruction or damage.
- Do not touch the heat radiating fins of controller or servo amplifier, regenerative resistor and servo motor, etc., while the power is ON and for a short time after the power is turned OFF. In this timing, these parts become very hot and may lead to burns.
- Always turn the power OFF before touching the servo motor shaft or coupled machines, as these parts may lead to injuries.
- Do not go near the machine during test operations or during operations such as teaching. Doing so may lead to injuries.

4. Various precautions

Strictly observe the following precautions.

Mistaken handling of the unit may lead to faults, injuries or electric shocks.

(1) System structure

CAUTION

- Always install a leakage breaker on the Motion controller and servo amplifier power source.
- If installation of an electromagnetic contactor for power shut off during an error, etc., is specified in the instruction manual for the servo amplifier, etc., always install the electromagnetic contactor.
- Install the emergency stop circuit externally so that the operation can be stopped immediately and the power shut off.
- Use the Motion controller, servo amplifier, servo motor and regenerative resistor with the correct combinations listed in the instruction manual. Other combinations may lead to fire or faults.
- Use the Motion controller, base unit and motion module with the correct combinations listed in the instruction manual. Other combinations may lead to faults.
- If safety standards (ex., robot safety rules, etc.,) apply to the system using the Motion controller, servo amplifier and servo motor, make sure that the safety standards are satisfied.
- Construct a safety circuit externally of the Motion controller or servo amplifier if the abnormal operation of the Motion controller or servo amplifier differ from the safety directive operation in the system.
- In systems where coasting of the servo motor will be a problem during the forced stop, emergency stop, servo OFF or power supply OFF, use dynamic brakes.
- Make sure that the system considers the coasting amount even when using dynamic brakes.
- In systems where perpendicular shaft dropping may be a problem during the forced stop, emergency stop, servo OFF or power supply OFF, use both dynamic brakes and electromagnetic brakes.

CAUTION

- The dynamic brakes must be used only on errors that cause the forced stop, emergency stop, or servo OFF. These brakes must not be used for normal braking.
- The brakes (electromagnetic brakes) assembled into the servo motor are for holding applications, and must not be used for normal braking.
- The system must have a mechanical allowance so that the machine itself can stop even if the stroke limits switch is passed through at the max. speed.
- Use wires and cables that have a wire diameter, heat resistance and bending resistance compatible with the system.
- Use wires and cables within the length of the range described in the instruction manual.
- The ratings and characteristics of the parts (other than Motion controller, servo amplifier and servo motor) used in a system must be compatible with the Motion controller, servo amplifier and servo motor.
- Install a cover on the shaft so that the rotary parts of the servo motor are not touched during operation.
- There may be some cases where holding by the electromagnetic brakes is not possible due to the life or mechanical structure (when the ball screw and servo motor are connected with a timing belt, etc.). Install a stopping device to ensure safety on the machine side.

(2) Security

CAUTION

- To maintain the security (confidentiality, integrity, and availability) of the programmable controller and the system against unauthorized access, denial-of-service (DoS) attacks, computer viruses, and other cyberattacks from external devices via the network, take appropriate measures such as firewalls, virtual private networks (VPNs), and antivirus solutions.

(3) Parameter settings and programming

CAUTION

- Set the parameter values to those that are compatible with the Motion controller, servo amplifier, servo motor and regenerative resistor model and the system application. The protective functions may not function if the settings are incorrect.
- The regenerative resistor model and capacity parameters must be set to values that conform to the operation mode, servo amplifier and servo power supply module. The protective functions may not function if the settings are incorrect.
- Set the mechanical brake output and dynamic brake output validity parameters to values that are compatible with the system application. The protective functions may not function if the settings are incorrect.
- Set the stroke limit input validity parameter to a value that is compatible with the system application. The protective functions may not function if the setting is incorrect.

CAUTION

- Set the servo motor encoder type (increment, absolute position type, etc.) parameter to a value that is compatible with the system application. The protective functions may not function if the setting is incorrect.
- Set the servo motor capacity and type (standard, low-inertia, flat, etc.) parameter to values that are compatible with the system application. The protective functions may not function if the settings are incorrect.
- Set the servo amplifier capacity and type parameters to values that are compatible with the system application. The protective functions may not function if the settings are incorrect.
- Use the program commands for the program with the conditions specified in the instruction manual.
- Set the sequence function program capacity setting, device capacity, latch validity range, I/O assignment setting, and validity of continuous operation during error detection to values that are compatible with the system application. The protective functions may not function if the settings are incorrect.
- Some devices used in the program have fixed applications, so use these with the conditions specified in the instruction manual.
- The input devices and data registers assigned to the link will hold the data previous to when communication is terminated by an error, etc. Thus, an error correspondence interlock program specified in the instruction manual must be used.
- Use the interlock program specified in the intelligent function module's instruction manual for the program corresponding to the intelligent function module.

(4) Transportation and installation

CAUTION

- Transport the product with the correct method according to the mass.
- Use the servo motor suspension bolts only for the transportation of the servo motor. Do not transport the servo motor with machine installed on it.
- Do not stack products past the limit.
- When transporting the Motion controller or servo amplifier, never hold the connected wires or cables.
- When transporting the servo motor, never hold the cables, shaft or detector.
- When transporting the Motion controller or servo amplifier, never hold the front case as it may fall off.
- When transporting, installing or removing the Motion controller or servo amplifier, never hold the edges.
- Install the unit according to the instruction manual in a place where the mass can be withstood.
- Do not get on or place heavy objects on the product.
- Always observe the installation direction.
- Keep the designated clearance between the Motion controller or servo amplifier and control panel inner surface or the Motion controller and servo amplifier, Motion controller or servo amplifier and other devices.

⚠ CAUTION

- Do not install or operate Motion controller, servo amplifiers or servo motors that are damaged or that have missing parts.
- Do not block the intake/outtake ports of the Motion controller, servo amplifier and servo motor with cooling fan.
- Do not allow conductive matter such as screw or cutting chips or combustible matter such as oil enter the Motion controller, servo amplifier or servo motor.
- The Motion controller, servo amplifier and servo motor are precision machines, so do not drop or apply strong impacts on them.
- Securely fix the Motion controller, servo amplifier and servo motor to the machine according to the instruction manual. If the fixing is insufficient, these may come off during operation.
- Always install the servo motor with reduction gears in the designated direction. Failing to do so may lead to oil leaks.
- Store and use the unit in the following environmental conditions.

Environment	Conditions	
	Motion controller/Servo amplifier	Servo motor
Ambient temperature	According to each instruction manual.	0°C to +40°C (With no freezing) (32°F to +104°F)
Ambient humidity	According to each instruction manual.	80% RH or less (With no dew condensation)
Storage temperature	According to each instruction manual.	-20°C to +65°C (-4°F to +149°F)
Atmosphere	Indoors (where not subject to direct sunlight). No corrosive gases, flammable gases, oil mist or dust must exist	
Altitude	According to each instruction manual	
Vibration	According to each instruction manual	

- When coupling with the synchronous encoder or servo motor shaft end, do not apply impact such as by hitting with a hammer. Doing so may lead to detector damage.
- Do not apply a load larger than the tolerable load onto the synchronous encoder and servo motor shaft. Doing so may lead to shaft breakage.
- When not using the module for a long time, disconnect the power line from the Motion controller or servo amplifier.
- Place the Motion controller and servo amplifier in static electricity preventing vinyl bags and store.
- When storing for a long time, please contact with our sales representative.
Also, execute a trial operation.
- When fumigants that contain halogen materials such as fluorine, chlorine, bromine, and iodine are used for disinfecting and protecting wooden packaging from insects, they cause malfunction when entering our products.
Please take necessary precautions to ensure that remaining materials from fumigant do not enter our products, or treat packaging with methods other than fumigation (heat method).
Additionally, disinfect and protect wood from insects before packing products.

(5) Wiring

⚠ CAUTION

- Correctly and securely wire the wires. Reconfirm the connections for mistakes and the terminal screws for tightness after wiring. Failing to do so may lead to run away of the servo motor.
- After wiring, install the protective covers such as the terminal covers to the original positions.
- Do not install a phase advancing capacitor, surge absorber or radio noise filter (option FR-BIF) on the output side of the servo amplifier.
- Correctly connect the output side (terminal U, V, W) and ground. Incorrect connections will lead the servo motor to operate abnormally.
- Do not connect a commercial power supply to the servo motor, as this may lead to trouble.
- Do not mistake the direction of the surge absorbing diode installed on the DC relay for the control signal output of brake signals, etc. Incorrect installation may lead to signals not being output when trouble occurs or the protective functions not functioning.

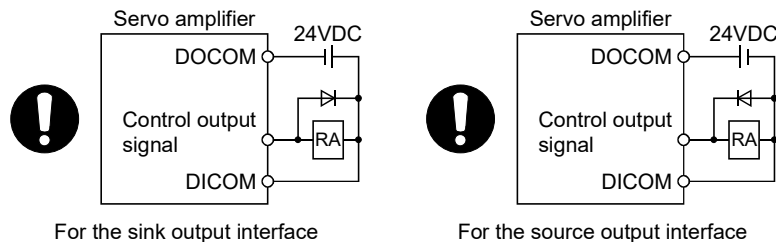

- Do not connect or disconnect the connection cables between each unit, the encoder cable or PLC expansion cable while the power is ON.
- Securely tighten the cable connector fixing screws and fixing mechanisms. Insufficient fixing may lead to the cables coming off during operation.
- Do not bundle the power line or cables.

(6) Trial operation and adjustment

⚠ CAUTION

- Confirm and adjust the program and each parameter before operation. Unpredictable movements may occur depending on the machine.
- Extreme adjustments and changes may lead to unstable operation, so never make them.
- When using the absolute position system function, on starting up, and when the Motion controller or absolute position motor has been replaced, always perform a home position return.
- Before starting test operation, set the parameter speed limit value to the slowest value, and make sure that operation can be stopped immediately by the forced stop, etc. if a hazardous state occurs.

(7) Usage methods

⚠ CAUTION

- Immediately turn OFF the power if smoke, abnormal sounds or odors are emitted from the Motion controller, servo amplifier or servo motor.
- Always execute a test operation before starting actual operations after the program or parameters have been changed or after maintenance and inspection.
- Do not attempt to disassemble and repair the units excluding a qualified technician whom our company recognized.
- Do not make any modifications to the unit.
- Keep the effect or electromagnetic obstacles to a minimum by installing a noise filter or by using wire shields, etc. Electromagnetic obstacles may affect the electronic devices used near the Motion controller or servo amplifier.
- When using the CE Mark-compliant equipment, refer to the User's manual for the Motion controllers and refer to the corresponding EMC guideline information for the servo amplifiers, inverters and other equipment.
- Use the units with the following conditions.

Item	Conditions
Input power	According to each instruction manual.
Input frequency	According to each instruction manual.
Tolerable momentary power failure	According to each instruction manual.

(8) Corrective actions for errors

⚠ CAUTION

- If an error occurs in the self diagnosis of the Motion controller or servo amplifier, confirm the check details according to the instruction manual, and restore the operation.
- If a dangerous state is predicted in case of a power failure or product failure, use a servo motor with electromagnetic brakes or install a brake mechanism externally.
- Use a double circuit construction so that the electromagnetic brake operation circuit can be operated by emergency stop signals set externally.

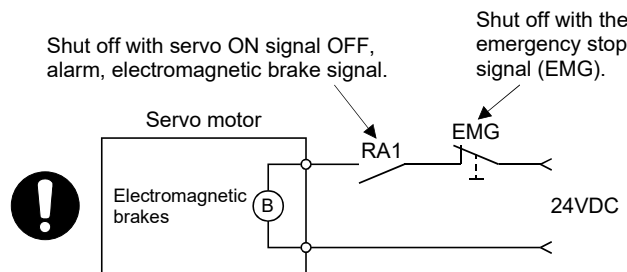

- If an error occurs, remove the cause, secure the safety and then resume operation after alarm release.
- The unit may suddenly resume operation after a power failure is restored, so do not go near the machine. (Design the machine so that personal safety can be ensured even if the machine restarts suddenly.)

(9) Maintenance, inspection and part replacement

CAUTION

- Perform the daily and periodic inspections according to the instruction manual.
- Perform maintenance and inspection after backing up the program and parameters for the Motion controller and servo amplifier.
- Do not place fingers or hands in the clearance when opening or closing any opening.
- Periodically replace consumable parts such as batteries according to the instruction manual.
- Do not touch the lead sections such as ICs or the connector contacts.
- Before touching the module, always touch grounded metal, etc. to discharge static electricity from human body. Failure to do so may cause the module to fail or malfunction.
- Do not directly touch the module's conductive parts and electronic components. Touching them could cause an operation failure or give damage to the module.
- Do not place the Motion controller or servo amplifier on metal that may cause a power leakage or wood, plastic or vinyl that may cause static electricity buildup.
- Do not perform a megger test (insulation resistance measurement) during inspection.
- When replacing the Motion controller or servo amplifier, always set the new module settings correctly.
- When the Motion controller or absolute value motor has been replaced, carry out a home position return operation using one of the following methods, otherwise position displacement could occur.
 - 1) After writing the servo data to the Motion controller using programming software, switch on the power again, then perform a home position return operation.
 - 2) Using the backup function of the programming software, load the data backed up before replacement.
- After maintenance and inspections are completed, confirm that the position detection of the absolute position detector function is correct.
- Do not drop or impact the battery installed to the module. Doing so may damage the battery, causing battery liquid to leak in the battery. Do not use the dropped or impacted battery, but dispose of it.
- Do not short circuit, charge, overheat, incinerate or disassemble the batteries.
- The electrolytic capacitor will generate gas during a fault, so do not place your face near the Motion controller or servo amplifier.
- The electrolytic capacitor and fan will deteriorate. Periodically replace these to prevent secondary damage from faults. Replacements can be made by our sales representative.
- Lock the control panel and prevent access to those who are not certified to handle or install electric equipment.
- Do not burn or break a module and servo amplifier. Doing so may cause a toxic gas.

(10) About processing of waste

When you discard Motion controller, servo amplifier, a battery (primary battery) and other option articles, please follow the law of each country (area).

CAUTION

- This product is not designed or manufactured to be used in equipment or systems in situations that can affect or endanger human life.
- When considering this product for operation in special applications such as machinery or systems used in passenger transportation, medical, aerospace, atomic power, electric power, or submarine repeating applications, please contact your nearest Mitsubishi Electric sales representative.
- Although this product was manufactured under conditions of strict quality control, you are strongly advised to install safety devices to forestall serious accidents when it is used in facilities where a breakdown in the product is likely to cause a serious accident.

(11) General cautions

- All drawings provided in the instruction manual show the state with the covers and safety partitions removed to explain detailed sections. When operating the product, always return the covers and partitions to the designated positions, and operate according to the instruction manual.

REVISIONS

* The manual number is given on the bottom left of the back cover.

Print Date	* Manual Number	Revision
Jan., 2008	IB(NA)-0300133-A	First edition
Feb., 2009	IB(NA)-0300133-B	[Additional model] MELSOFT MT Works2, MT Developer2, Software for SV43, Q10UDH/ Q13UDH/Q20UDH/Q26UDH/Q03UDE/Q04UDEH/Q06UDEH/ Q10UDEH/Q13UDEH/Q20UDEH/Q26UDEH, Q17DCCPU-V, QX40-S1/QX41-S1/QX42-S1/QX82-S1, MR-J3-□-RJ004, MR-J3-□-RJ080, MR-J3W-B [Additional correction/partial correction] Safety precautions, About Manuals, Checking serial number and operating system software version, Connector for forced stop input cable Q170DEMICOM, Exterior dimensions (Motion CPU module, Motion module), Warranty
Sep., 2010	IB(NA)-0300133-C	[Additional model] QX40H, QX70H, QH80H, QX90H, MR-J3-□BS [Additional correction/partial correction] Safety precautions, About Manuals, Restrictions by the software's version, Battery transportation, Symbol for the new EU battery directive, EMC directive
Sep., 2011	IB(NA)-0300133-D	[Additional model] Q173DCPU-S1, Q172DCPU-S1, Q35DB, Q64PN, Q50UDEHCPU, Q100UDEHCPU, GX Works2, MR Configurator2 [Additional correction/partial correction] Safety precautions, About Manuals, Restrictions by the software's version, Sample system circuit design for motion control
Dec., 2011	IB(NA)-0300133-E	[Partial correction] Section 4.2.1 Partial change of sentence
Mar., 2012	IB(NA)-0300133-F	[Additional model] Q173DSCPU, Q172DSCPU, Q173DSXY, Q171ENC-W8, MR-J4-□B, MR-J4W-□B [Additional correction/partial correction] About Manuals, Manual Page Organization, Restrictions by the software's version, Programming software version, Internal I/F connector set Q170DSIOCON, Internal I/F connector specifications, RIO cable Q173DSXYCBL□M, General specifications, Sample system circuit design for Motion control, Mounting of battery, Battery replacement procedure, Internal input circuit troubleshooting, Exterior dimensions (Serial absolute synchronous encoder)
Sep., 2012	IB(NA)-0300133-G	[Additional correction/partial correction] About Manuals, Restrictions by the software's version, Programming software version, Start-up adjustment procedure, Operating system software installation procedure
Apr., 2013	IB(NA)-0300133-H	[Additional model] Q03UDVCPU, Q04UDVCPU, Q06UDVCPU, Q13UDVCPU, Q26UDVCPU, Q24DHCCPU-V, MR-J4-□B-RJ, LJ72MS15 [Additional correction/partial correction] Safety precautions, About Manuals, Restrictions by the software's version, PLC module which can be controlled by Motion CPU, Start-up adjustment procedure, Electronic circuit symbols changed (compliant with new JIS symbols)

Print Date	* Manual Number	Revision
Nov., 2013	IB(NA)-0300133-J	[Additional model] Q24DHCCPU-LS [Additional correction/partial correction] Safety precautions, Restrictions by the software's version, Serial absolute synchronous encoder cable Q170ENCCBL□M-A, Serial absolute synchronous encoder cable connector set MR-J3CN2
Dec., 2015	IB(NA)-0300133-K	[Additional model] MR-MV200 [Additional correction/partial correction] Restrictions by the software's version, Other restrictions, General specifications, Specifications of manual pulse generator/incremental synchronous encoder, Connection examples of manual pulse generator/incremental synchronous encoder, Transportation precaution for customers, Safety circuit design, Start-up adjustment procedure, Resuming operation after storing the Motion controller, Battery replacement procedure, Warranty
Mar., 2017	IB(NA)-0300133-L	[Additional correction/partial correction] Safety precautions, Restrictions by the software's version, Other restrictions, SSCNETⅢ(/H) compatible equipment, 7-segment LED display, Troubleshooting, Internal I/F connector cable, Warranty
Dec., 2019	IB(NA)-0300133-M	[Additional model] Q26DHCCPU-LS, Q61P-D, Q52B, Q55B [Additional correction/partial correction] Discontinued models, Equipment configuration in system, PLC module which can be controlled by Motion CPU, Q173DSXY performance specifications, Battery specifications
Apr., 2022	IB(NA)-0300133-N	[Additional model] MR-J5-□B, MR-J5W-□B [Additional correction/partial correction] Safety precautions, About Manuals, Discontinued Models, Restrictions by the software's version, Equipment configuration in system, System overall configuration, Other restrictions, SSCNETⅢ(/H) compatible equipment, Internal I/F connector, Warranty

Japanese Manual Number IB(NA)-0300125

This manual confers no industrial property rights or any rights of any other kind, nor does it confer any patent licenses. Mitsubishi Electric Corporation cannot be held responsible for any problems involving industrial property rights which may occur as a result of using the contents noted in this manual.

INTRODUCTION

Thank you for choosing the Mitsubishi Electric Motion controller Q173D(S)CPU/Q172D(S)CPU.
Before using the equipment, please read this manual carefully to develop full familiarity with the functions and performance of the Motion controller you have purchased, so as to ensure correct use.

CONTENTS

Safety Precautions	A- 1
Revisions	A-11
Contents	A-13
About Manuals	A-16
Manual Page Organization	A-19
Discontinued Models.....	A-19

1. OVERVIEW	1- 1 to 1-12
--------------------	---------------------

1.1 Overview.....	1- 1
1.2 Differences between Q173D(S)CPU/Q172D(S)CPU and Q173HCPU/Q172HCPU	1- 4
1.3 Restrictions by the Software's Version.....	1- 6
1.4 Programming Software Version.....	1-12

2. SYSTEM CONFIGURATION	2- 1 to 2-102
--------------------------------	----------------------

2.1 Motion System Configuration	2- 1
2.1.1 Q173DSCPU/Q172DSCPU System overall configuration	2- 4
2.1.2 Q173DCPU(-S1)/Q172DCPU(-S1) System overall configuration.....	2- 6
2.1.3 Function explanation of the Motion CPU modules.....	2- 7
2.1.4 Restrictions on Motion systems.....	2- 8
2.2 Checking Serial Number and Operating System Software Version.....	2-13
2.2.1 Checking serial number	2-13
2.2.2 Checking operating system software version.....	2-16
2.3 System Configuration Equipment.....	2-18
2.4 General Specifications	2-25
2.5 Specifications of Equipment and Settings.....	2-26
2.5.1 Name of parts for CPU module	2-26
2.5.2 Power supply module.....	2-46
2.5.3 Base unit and extension cable.....	2-54
2.5.4 Q172DLX Servo external signals interface module	2-58
2.5.5 Q172DEX Synchronous encoder interface module	2-63
2.5.6 Q173DPX Manual pulse generator interface module	2-72
2.5.7 Q173DSXY Safety signal module.....	2-80
2.5.8 Manual pulse generator/Serial absolute synchronous encoder	2-90
2.5.9 SSCNET III cables	2-92
2.5.10 Battery	2-98
2.5.11 Forced stop input terminal	2-102

3. DESIGN	3- 1 to 3-16
------------------	---------------------

3.1 System Designing Procedure	3- 1
3.2 External Circuit Design	3- 4
3.2.1 Power supply circuit design	3- 8
3.2.2 Safety circuit design	3- 9
3.3 Layout Design within the Control Panel	3-11
3.3.1 Mounting environment.....	3-11
3.3.2 Calculating heat generation by Motion controller.....	3-12
3.4 Design Checklist	3-15

4. INSTALLATION AND WIRING	4- 1 to 4-28
-----------------------------------	---------------------

4.1 Module Installation	4- 1
4.1.1 Instructions for handling.....	4- 1
4.1.2 Instructions for mounting the base unit	4- 4
4.1.3 Installation and removal of module.....	4- 7
4.1.4 Instructions for mounting of the battery holder unit.....	4-10
4.2 Connection and Disconnection of Cable	4-11
4.2.1 SSCNETIII cable	4-11
4.2.2 Battery cable.....	4-17
4.2.3 Forced stop input cable.....	4-19
4.2.4 Internal I/F connector cable	4-20
4.3 Mounting of Battery	4-21
4.4 Mounting of Serial Absolute Synchronous Encoder	4-23
4.5 Wiring.....	4-24
4.5.1 Instructions for wiring	4-24
4.5.2 Connecting to the power supply module	4-27

5. START-UP PROCEDURES	5- 1 to 5-10
-------------------------------	---------------------

5.1 Check Items Before Start-up	5- 1
5.2 Start-up Adjustment Procedure	5- 3
5.3 Operating System Software Installation Procedure	5- 7
5.4 Trial Operation and Adjustment Checklist.....	5- 9

6. INSPECTION AND MAINTENANCE	6- 1 to 6-32
--------------------------------------	---------------------

6.1 Maintenance Works	6- 2
6.1.1 Instruction of inspection works.....	6- 2
6.2 Daily Inspection	6- 4
6.3 Periodic Inspection	6- 5
6.4 Life	6- 6
6.5 Battery	6- 7
6.5.1 Battery life.....	6- 8
6.5.2 Battery replacement procedure	6-10
6.5.3 Resuming operation after storing the Motion controller	6-14
6.5.4 Symbol for the new EU battery directive	6-14

6.6 Troubleshooting	6-15
6.6.1 Troubleshooting basics	6-15
6.6.2 Troubleshooting of Motion CPU module	6-16
6.6.3 Confirming error code	6-29
6.6.4 Internal input circuit troubleshooting	6-30

7. EMC DIRECTIVES	7- 1 to 7-10
--------------------------	---------------------

7.1 Requirements for Compliance with the EMC Directive.....	7- 1
7.1.1 Standards relevant to the EMC directive.....	7- 2
7.1.2 Installation instructions for EMC directive	7- 3
7.1.3 Parts of measure against noise	7- 6
7.1.4 Example of measure against noise	7- 8

APPENDICES	App- 1 to App-30
-------------------	-------------------------

APPENDIX 1 Cables.....	App- 1
APPENDIX 1.1 SSCNET III cables.....	App- 1
APPENDIX 1.2 Serial absolute synchronous encoder cable.....	App- 4
APPENDIX 1.3 Battery cable.....	App- 7
APPENDIX 1.4 Forced stop input cable.....	App- 8
APPENDIX 1.5 Internal I/F connector cable.....	App- 9
APPENDIX 1.6 RIO cable.....	App-14
APPENDIX 1.7 SSCNET III cables (SC-J3BUS□M-C) manufactured by Mitsubishi Electric System & Service Co., Ltd.	App-15
APPENDIX 2 Exterior Dimensions	App-16
APPENDIX 2.1 Motion CPU module	App-16
APPENDIX 2.2 Servo external signals interface module (Q172DLX).....	App-19
APPENDIX 2.3 Synchronous encoder interface module (Q172DEX).....	App-19
APPENDIX 2.4 Manual pulse generator interface module (Q173DPX).....	App-20
APPENDIX 2.5 Safety signal module (Q173DSXY)	App-20
APPENDIX 2.6 Power supply module	App-21
APPENDIX 2.7 Battery holder unit (Q170DBATC)	App-23
APPENDIX 2.8 Connector	App-24
APPENDIX 2.9 Manual pulse generator (MR-HDP01).....	App-29
APPENDIX 2.10 Serial absolute synchronous encoder	App-30

About Manuals

The following manuals are also related to this product.

When necessary, order them by quoting the details in the tables below.

Related Manuals

(1) Motion controller

Manual Name	Manual Number (Model Code)
Q173D(S)CPU/Q172D(S)CPU Motion controller User's Manual This manual explains specifications of the Motion CPU modules, Q172DLX Servo external signal interface module, Q172DEX Synchronous encoder interface module, Q173DPX Manual pulse generator interface module, Power supply modules, Servo amplifiers, SSCNETIII cables and Synchronous encoder, and the maintenance/inspection for the system, trouble shooting and others.	IB-0300133 (1XB927)
Q173D(S)CPU/Q172D(S)CPU Motion controller Programming Manual (COMMON) This manual explains the Multiple CPU system configuration, performance specifications, common parameters, auxiliary/applied functions, error lists and others.	IB-0300134 (1XB928)
Q173D(S)CPU/Q172D(S)CPU Motion controller (SV13/SV22) Programming Manual (Motion SFC) This manual explains the functions, programming, debugging, error lists for Motion SFC and others.	IB-0300135 (1XB929)
Q173D(S)CPU/Q172D(S)CPU Motion controller (SV13/SV22) Programming Manual (REAL MODE) This manual explains the servo parameters, positioning instructions, device lists, error lists and others.	IB-0300136 (1XB930)
Q173D(S)CPU/Q172D(S)CPU Motion controller (SV22) Programming Manual (VIRTUAL MODE) This manual explains the dedicated instructions to use the synchronous control by virtual main shaft, mechanical system program create mechanical module, servo parameters, positioning instructions, device lists, error lists and others.	IB-0300137 (1XB931)
Q173DSCPU/Q172DSCPU Motion controller (SV22) Programming Manual (Advanced Synchronous Control) This manual explains the dedicated instructions to use the synchronous control by synchronous control parameters, device lists, error lists and others.	IB-0300198 (1XB953)
Q173D(S)CPU/Q172D(S)CPU Motion controller Programming Manual (Safety Observation) This manual explains the details, safety parameters, safety sequence program instructions, device lists and error lists and others for safety observation function by Motion controller.	IB-0300183 (1XB945)
Motion controller Setup Guidance (MT Developer2 Version1) This manual explains the items related to the setup of the Motion controller programming software MT Developer2.	IB-0300142 (—)

(2) PLC

Manual Name	Manual Number (Model Code)
<p>QCPU User's Manual (Hardware Design, Maintenance and Inspection)</p> <p>This manual explains the specifications of the QCPU modules, power supply modules, base units, extension cables, memory card battery, and the maintenance/inspection for the system, trouble shooting, error codes and others.</p>	SH-080483ENG (13JR73)
<p>QnUCPU User's Manual (Function Explanation, Program Fundamentals)</p> <p>This manual explains the functions, programming methods and devices and others to create programs with the QCPU.</p>	SH-080807ENG (13JZ27)
<p>QCPU User's Manual (Multiple CPU System)</p> <p>This manual explains the Multiple CPU system overview, system configuration, I/O modules, communication between CPU modules and communication with the I/O modules or intelligent function modules.</p>	SH-080485ENG (13JR75)
<p>QnUCPU User's Manual (Communication via Built-in Ethernet Port)</p> <p>This manual explains functions for the communication via built-in Ethernet port of the CPU module.</p>	SH-080811ENG (13JZ29)
<p>MELSEC-Q/L Programming Manual (Common Instruction)</p> <p>This manual explains how to use the sequence instructions, basic instructions, application instructions and micro computer program.</p>	SH-080809ENG (13JW10)
<p>MELSEC-Q/L/QnA Programming Manual (PID Control Instructions)</p> <p>This manual explains the dedicated instructions used to exercise PID control.</p>	SH-080040 (13JF59)
<p>MELSEC-Q/L/QnA Programming Manual (SFC)</p> <p>This manual explains the system configuration, performance specifications, functions, programming, debugging, error codes and others of MELSAP3.</p>	SH-080041 (13JF60)
<p>I/O Module Type Building Block User's Manual</p> <p>This manual explains the specifications of the I/O modules, connector, connector/terminal block conversion modules and others.</p>	SH-080042 (13JL99)
<p>MELSEC-L SSCNETⅢ/H Head Module User's Manual</p> <p>This manual explains specifications of the head module, procedures before operation, system configuration, installation, wiring, settings, and troubleshooting.</p>	SH-081152ENG (13JZ78)



(3) Servo amplifier

Manual Name	Manual Number (Model Code)
MR-J5-B/MR-J5W-B User's Manual (Introduction) This manual explains the specifications, functions, start-up procedure and others for AC Servo MR-J5-B/ MR-J5W-B Servo amplifier.	IB-0300578ENG (—)
MR-J5 User's Manual (Hardware) This manual explains the installation, wiring, use option and others for AC Servo MR-J5-B/MR-J5W-B Servo amplifier.	SH-030298ENG (—)
MR-J5 User's Manual (Function) This manual explains how to use each function required to operate the AC Servo MR-J5-B/MR-J5W-B Servo amplifier.	SH-030300ENG (—)
MR-J5 User's Manual (Adjustment) This manual explains the operation status adjustment procedure, adjustment method and others for AC Servo MR-J5-B/MR-J5W-B Servo amplifier.	SH-030306ENG (—)
MR-J5 User's Manual (Troubleshooting) This manual explains the causes of alarms, and warnings, etc. for AC Servo MR-J5-B/MR-J5W-B Servo amplifier.	SH-030312ENG (—)
MR-J5-B/MR-J5W-B User's Manual (Parameters) This manual explains the parameters for AC Servo MR-J5-B/MR-J5W-B Servo amplifier.	IB-0300581ENG (—)
SSCNETⅢ/H Interface AC Servo MR-J4- <u> </u> B-(-RJ) Servo amplifier Instruction Manual This manual explains the I/O signals, parts names, parameters, start-up procedure and others for AC Servo MR-J4- <u> </u> B-(-RJ) Servo amplifier.	SH-030106 (1CW805)
SSCNETⅢ/H Interface Multi-axis AC Servo MR-J4W2- <u> </u> B/MR-J4W3- <u> </u> B/MR-J4W2-0303B6 Servo amplifier Instruction Manual This manual explains the I/O signals, parts names, parameters, start-up procedure and others for Multi- axis AC Servo MR-J4W2- <u> </u> B/MR-J4W3- <u> </u> B/MR-J4W2-0303B6 Servo amplifier.	SH-030105 (1CW806)
SSCNETⅢ interface MR-J3-□B Servo amplifier Instruction Manual This manual explains the I/O signals, parts names, parameters, start-up procedure and others for MR-J3-□B Servo amplifier.	SH-030051 (1CW202)
SSCNETⅢ interface 2-axis AC Servo Amplifier MR-J3W-0303BN6/MR-J3W-□B Servo amplifier Instruction Manual This manual explains the I/O signals, parts names, parameters, start-up procedure and others for 2-axis AC Servo Amplifier MR-J3W-0303BN6/MR-J3W-□B Servo amplifier.	SH-030073 (1CW604)
SSCNETⅢ Compatible Linear Servo MR-J3-□B-RJ004U□ Instruction Manual This manual explains the I/O signals, parts names, parameters, start-up procedure and others for Linear Servo MR-J3-□B-RJ004U□ Servo amplifier.	SH-030054 (1CW943)
SSCNETⅢ Compatible Fully Closed Loop Control MR-J3-□B-RJ006 Servo amplifier Instruction Manual This manual explains the I/O signals, parts names, parameters, start-up procedure and others for Fully Closed Loop Control MR-J3-□B-RJ006 Servo amplifier.	SH-030056 (1CW304)
SSCNETⅢ Interface Direct Drive Servo MR-J3-□B-RJ080W Instruction Manual This manual explains the I/O signals, parts names, parameters, start-up procedure and others for Direct Drive Servo MR-J3-□B-RJ080W Servo amplifier.	SH-030079 (1CW601)

Manual Name	Manual Number (Model Code)
SSCNETⅢ interface Drive Safety integrated MR-J3-□B Safety Servo amplifier Instruction Manual This manual explains the I/O signals, parts names, parameters, start-up procedure and others for safety integrated MR-J3-□B Safety Servo amplifier.	SH-030084 (1CW205)

Manual Page Organization

The symbols used in this manual are shown below.

Symbol	Description
	Symbol that indicates correspondence to only Q173DSCPU/Q172DSCPU.
	Symbol that indicates correspondence to only Q173DCPU(-S1)/Q172DCPU(-S1).

Discontinued Models

The following models are described in this manual, but are no longer produced.

For the onerous repair term after discontinuation of production, refer to "WARRANTY".

Model	Production discontinuation
Q61P-A1	March 2009
Q61P-A2	March 2009
Q64P	February 2010
SW6RNC-GSVPRO	September 2014
QD75MH1	September 2018
QD75MH2	September 2018
QD75MH4	September 2018
MR-J3-□B	May 2019
MR-J3W-□B	May 2019
MR-J3-□B-RJ006	May 2019
MR-J3-□B-RJ004	May 2019
MR-J3-□B-RJ080W	May 2019
MR-J3-□BS	May 2019
Q170ENC	June 2021
QD75P1	September 2021
QD75P2	September 2021
QD75P4	September 2021
QD75D1	September 2021
QD75D2	September 2021
QD75D4	September 2021

MEMO

1. OVERVIEW

1.1 Overview

This User's Manual describes the hardware specifications and handling methods of the Motion Controller for the Q series PLC Multiple CPU system.

The Manual also describes those items related to the specifications of the option module for the Motion controller, Manual pulse generator, Synchronous encoder and cables.

In this manual, the following abbreviations are used.

Generic term/Abbreviation	Description
Q173D(S)CPU/Q172D(S)CPU or Motion CPU (module)	Q173DSCPU/Q172DSCPU/Q173DCPU/Q172DCPU/Q173DCPU-S1/ Q172DCPU-S1 Motion CPU module
Q172DLX/Q172DEX/Q173DPX/ Q173DSXY or Motion module	Q172DLX Servo external signals interface module/ Q172DEX Synchronous encoder interface module ^(Note-1) / Q173DPX Manual pulse generator interface module/ Q173DSXY Safety signal module
MR-J5(W)-□B	Servo amplifier model MR-J5-□B/MR-J5W-□B
MR-J4(W)-□B	Servo amplifier model MR-J4-□B/MR-J4W-□B
MR-J3(W)-□B	Servo amplifier model MR-J3-□B/MR-J3W-□B
AMP or Servo amplifier	General name for "Servo amplifier model MR-J5-□B/MR-J5W-□B/MR-J4-□B/ MR-J4W-□B/MR-J3-□B/MR-J3W-□B"
QCPU, PLC CPU or PLC CPU module	QnUD(E)(H)CPU/QnUDVCPU
Multiple CPU system or Motion system	Abbreviation for "Multiple PLC system of the Q series"
CPU _n	Abbreviation for "CPU No.n (n= 1 to 4) of the CPU module for the Multiple CPU system"
Operating system software	General name for "SW7DNC-SV□□□/SW8DNC-SV□□□"
SV13	Operating system software for conveyor assembly use (Motion SFC) : SW8DNC-SV13□□
SV22	Operating system software for automatic machinery use (Motion SFC) : SW8DNC-SV22□□
SV43	Operating system software for machine tool peripheral use : SW7DNC-SV43□□
Programming software package	General name for MT Developer2/GX Works2/GX Developer/MR Configurator□
MELSOFT MT Works2	Abbreviation for "Motion controller engineering environment MELSOFT MT Works2"
MT Developer2 ^(Note-2)	Abbreviation for "Motion controller programming software MT Developer2 (Version 1.00A or later)"
GX Works2	Abbreviation for "Programmable controller engineering software MELSOFT GX Works2 (Version 1.15R or later)"
GX Developer	Abbreviation for "MELSEC PLC programming software package GX Developer (Version 8.48A or later)"
MR Configurator□ ^(Note-2)	General name for "MR Configurator/MR Configurator2"
MR Configurator	Abbreviation for "Servo setup software package MR Configurator (Version C0 or later)"
MR Configurator2	Abbreviation for "Servo setup software package MR Configurator2 (Version 1.01B or later)"
Manual pulse generator or MR-HDP01	Abbreviation for "Manual pulse generator (MR-HDP01)"

1 OVERVIEW

Generic term/Abbreviation	Description
Serial absolute synchronous encoder or Q171ENC-W8/Q170ENC	Abbreviation for "Serial absolute synchronous encoder (Q171ENC-W8/Q170ENC)"
SSCNET III/H ^(Note-3)	High speed synchronous network between Motion controller and servo amplifier
SSCNET III ^(Note-3)	
SSCNET III(H) ^(Note-3)	
Absolute position system	General name for "system using the servo motor and servo amplifier for absolute position"
Battery holder unit	Battery holder unit (Q170DBATC)
Intelligent function module	General name for module that has a function other than input or output such as A/D converter module and D/A converter module.
SSCNET III/H head module	Abbreviation for "MELSEC-L series SSCNET III/H head module (LJ72MS15)"
Optical hub unit or MR-MV200	Abbreviation for "SSCNET III/H compatible optical hub unit (MR-MV200)"

(Note-1): Q172DEX can be used in SV22.

(Note-2): This software is included in Motion controller engineering environment "MELSOFT MT Works2".

(Note-3): SSCNET: Servo System Controller NETwork

REMARK

For information about each module, design method for program and parameter, refer to the following manuals relevant to each module.

Item	Reference Manual
PLC CPU, peripheral devices for sequence program design, I/O modules and intelligent function module	Manual relevant to each module
Operation method for MT Developer2	Help of each software
SV13/SV22/ SV43	<ul style="list-style-type: none"> • Multiple CPU system configuration • Performance specification • Design method for common parameter • Auxiliary and applied functions (common) Q173D(S)CPU/Q172D(S)CPU Motion controller Programming Manual (COMMON)
SV13/SV22	<ul style="list-style-type: none"> • Design method for Motion SFC program • Design method for Motion SFC parameter • Motion dedicated PLC instruction Q173D(S)CPU/Q172D(S)CPU Motion controller (SV13/SV22) Programming Manual (Motion SFC)
	<ul style="list-style-type: none"> • Design method for positioning control program in the real mode • Design method for positioning control parameter Q173D(S)CPU/Q172D(S)CPU Motion controller (SV13/SV22) Programming Manual (REAL MODE)
	<ul style="list-style-type: none"> • Design method for safety observation parameter • Design method for user made safety sequence program Q173D(S)CPU/Q172D(S)CPU Motion controller Programming Manual (Safety Observation)
SV22 (Virtual mode)	<ul style="list-style-type: none"> • Design method for mechanical system program Q173D(S)CPU/Q172D(S)CPU Motion controller (SV22) Programming Manual (VIRTUAL MODE)
SV22 (Advanced synchronous control)	<ul style="list-style-type: none"> • Design method for synchronous control parameter Q173DSCPU/Q172DSCPU Motion controller (SV22) Programming Manual (Advanced Synchronous Control)

1 OVERVIEW

1.2 Differences between Q173D(S)CPU/Q172D(S)CPU and Q173HCPU/Q172HCPU

Item		Q173DSCPU	Q172DSCPU	Q173DCPU(-S1)	Q172DCPU(-S1)
Operation cycle (default)	SV13	0.22ms/ 1 to 4 axes 0.44ms/ 5 to 10 axes 0.88ms/11 to 24 axes 1.77ms/25 to 32 axes	0.22ms/ 1 to 4 axes 0.44ms/ 5 to 10 axes 0.88ms/11 to 16 axes	0.44ms/ 1 to 6 axes 0.88ms/ 7 to 18 axes 1.77ms/19 to 32 axes	0.44ms/ 1 to 6 axes 0.88ms/ 7 to 8 axes
	SV22	0.44ms/ 1 to 6 axes 0.88ms/ 7 to 16 axes 1.77ms/17 to 32 axes	0.44ms/ 1 to 6 axes 0.88ms/ 7 to 16 axes	0.44ms/ 1 to 4 axes 0.88ms/ 5 to 12 axes 1.77ms/13 to 28 axes	0.44ms/ 1 to 4 axes 0.88ms/ 5 to 8 axes
	SV43	—	—	3.55ms/29 to 32 axes	
Model name of operating system software		SW□DNC-SV□□□			
Peripheral I/F		USB/RS-232/Ethernet (via PLC CPU) PERIPHERAL I/F (Motion CPU)		USB/RS-232/Ethernet (via PLC CPU) PERIPHERAL I/F (Motion CPU) (Note-1)	
Main base unit		Multiple CPU high speed main base unit (Q35DB/Q38DB/Q312DB)			
Color of base cover		Gray			
Mounting on panel		Be sure to mount the unit by unit fixing screws.			
DIN rail		Unusable			
CPU module No.1		Universal model (QnUD(E)(H)CPU/QnUDVCPU)			
Installation orders CPU No.2 or later		No restriction			
CPU empty slot		Settable between CPU modules			
PLC CPU module		Universal model (QnUD(E)(H)CPU/QnUDVCPU)			
Motion CPU module		Q173DSCPU/Q172DSCPU		Q173DCPU(-S1)/Q172DCPU(-S1)	
Combination of Motion CPU modules		Combination with Q173DCPU(-S1)/Q172DCPU(-S1)		Combination with Q173DSCPU/Q172DSCPU	
Installation on main base unit		Be sure to install Motion CPU modules by unit fixing screws.			
Function select switch		Rotary switch 1, Rotary switch 2			
RESET/L.CLR switch		None			
LED indication		7-segment LED display			
Battery		Demand			
Battery holder unit		—		Q170DBATC	
Forced stop input		<ul style="list-style-type: none"> • Use EMI connector of Motion CPU module • Use device set by forced stop input setting in the system setting. 			
Cable for forced stop input		Demand			
Motion module		Q172DLX/Q172DEX/Q173DPX/Q173DSXY		Q172DLX/Q172DEX/Q173DPX/Q173DSXY (Note-1)	
Installation on main base unit		Q172DLX/Q172DEX/Q173DPX: Impossible to install on I/O slots of 0 to 2			
Multiple CPU high speed transmission memory for data transfer between CPU modules		Included			

1 OVERVIEW

	Q173HCPU	Q172HCPU
	0.44ms/ 1 to 3 axes 0.88ms/ 4 to 10 axes 1.77ms/11 to 20 axes 3.55ms/21 to 32 axes	0.44ms/ 1 to 3 axes 0.88ms/ 4 to 8 axes
	0.88ms/ 1 to 5 axes 1.77ms/ 6 to 14 axes 3.55ms/15 to 28 axes 7.11ms/29 to 32 axes	0.88ms/ 1 to 5 axes 1.77ms/ 6 to 8 axes
	SW□RN-SV□□□	
	USB/SSCNET	
	Main base unit (Q33B/Q35B/Q38B/Q312B)	
	Clear	
	Mount the unit by unit fixing screws when using system in a place where the vibration or impact is large.	
	Usable	
	High performance model (Qn(H)CPU)	
	Install Motion CPU modules on the right-hand side of PLC CPU module.	
	Not settable between CPU modules	
	High performance model (Qn(H)CPU)	
	Q173HCPU(-T)/Q172HCPU(-T)	
	Combination with Q173CPUN(T)/Q172CPUN(-T)	
	Install Motion CPU modules by unit fixing screws when using them in a place where the vibration or impact is large.	
	Dip switch 1 to 5	
	Provided	
	Each LED of MODE, RUN, ERR, M.RUN, BAT and BOOT	
	Add Q6BAT at continuous power failure for 1 month or more	
	Q170HBATC	
	• Use device set by forced stop input setting in the system setting.	
	—	
	Q172LX/Q172EX/Q173PX	
	No restriction	
	—	

(Note-1) : Q173DCPU-S1/Q172DCPU-S1 only

1 OVERVIEW

1.3 Restrictions by the Software's Version

There are restrictions in the function that can be used by the version of the operating system software and programming software.

The combination of each version and a function is shown in Table1.1.

Table 1.1 Restrictions by the Software's Version

Function	Operating system software version (Note-1), (Note-2)		
	Q173DSCPU/Q172DSCPU	Q173DCPU(-S1)/Q172DCPU(-S1)	
	SV13/SV22	SV13/SV22	SV43
Checking Motion controller's serial number and operating system software version in GX Developer	—	00D	—
Advanced S-curve acceleration/deceleration (Except constant-speed control (CPSTART) of servo program.)	—	00H	/
Direct drive servo MR-J3-□B-RJ080W	—	00H	00B
Servo amplifier display servo error code (#8008+20n)	—	00H	00B
0.44ms fixed-cycle event task	—	00H	/
444μs coasting timer (SD720, SD721)	—	00H	00B
Synchronous encoder current value monitor in real mode	—	00H	/
Display of the past ten times history in current value history monitor	—	00H	00C
Amplifier-less operation	—	00H	/
Servo instruction (Home position return (ZERO), high speed oscillation (OSC)) and manual pulse generator operation in mixed function of virtual mode/real mode	—	00H	/
Advanced S-curve acceleration/deceleration in constant-speed control (CPSTART) of servo program.	—	00K	/
External input signal (DOG) of servo amplifier in home position return of count method and speed-position switching control	—	00G	00B
Communication via PERIPHERAL I/F	—	00H	00C
Motion SFC operation control instruction Type conversion (DFLT, SFLT)	—	00L	—
Vision system dedicated function (MVOPEN, MVLOAD, MVTRG, MVPST, MVIN, MVFIN, MVCLOSE, MVCOM)	—	00L	/
Home position return of scale home position signal detection method	—	00L	00C
Real time display function in digital oscilloscope function	—	00N	Not support
Rapid stop deceleration time setting error invalid function	—	00S	/

1 OVERVIEW

	Programming software version					Section of reference
	MELSOFT MT Works2 (MT Developer2)			MR Configurator2	MR Configurator	
	Q173DSCPU/Q172DSCPU	Q173DCPU(-S1)/Q172DCPU(-S1)				
	SV13/SV22	SV13/SV22	SV43			
—	—	—	—	—	—	Section 2.2
1.39R	1.06G	/	—	—	—	(Note-5)
1.39R	1.06G	1.06G	1.01B	C2	/	
—	—	—	—	—	—	(Note-5), (Note-6)
1.39R	1.06G	/	—	—	—	(Note-4)
—	—	—	—	—	—	(Note-3)
—	—	/	—	—	—	(Note-6)
1.39R	1.06G	1.39R	—	—	—	(Note-3)
—	—	/	—	—	—	(Note-3)
1.39R	1.09K	/	—	—	—	(Note-6)
1.39R	1.09K	/	—	—	—	(Note-5)
1.39R	1.15R	Not support	—	—	—	/
1.39R	1.15R	1.39R	—	—	—	(Note-3)
1.39R	1.15R	—	—	—	—	(Note-4)
1.39R	1.15R	/	—	—	—	(Note-4)
1.39R	1.15R	1.39R	—	—	—	(Note-5)
1.39R	1.17T	1.39R	—	—	—	/
—	—	/	—	—	—	(Note-5)

—: There is no restriction by the version.

(Note-1): SV13/SV22 is the completely same version.

(Note-2): The operating system software version can be confirmed in the operating system software (CD-ROM), MT Developer2 or GX Works2/GX Developer. (Refer to "Q173D(S)CPU/Q172D(S)CPU Motion controller Programming Manual (COMMON) Section 1.3, 1.4".)

(Note-3): Q173D(S)CPU/Q172D(S)CPU Motion controller Programming Manual (COMMON)

(Note-4): Q173D(S)CPU/Q172D(S)CPU Motion controller (SV13/SV22) Programming Manual (Motion SFC)

(Note-5): Q173D(S)CPU/Q172D(S)CPU Motion controller (SV13/SV22) Programming Manual (REAL MODE)

(Note-6): Q173D(S)CPU/Q172D(S)CPU Motion controller (SV22) Programming Manual (VIRTUAL MODE)

(Note-7): Q173D(S)CPU/Q172D(S)CPU Motion controller Programming Manual (Safety Observation)

(Note-8): Q173DSCPU/Q172DSCPU Motion controller (SV22) Programming Manual (Advanced Synchronous Control)

1 OVERVIEW

Table 1.1 Restrictions by the Software's Version (continued)

Function	Operating system software version (Note-1), (Note-2)		
	Q173DSCPU/Q172DSCPU	Q173DCPU(-S1)/Q172DCPU(-S1)	
	SV13/SV22	SV13/SV22	SV43
Vision system dedicated function (MVOOUT)	—	00S	
Motion SFC operation control instruction Program control (IF - ELSE - IEND, SELECT -CASE - SEND, FOR -NEXT, BREAK)	—	00R	
Display format depending on the error setting data information of motion error history device (#8640 to #8735)	—	00S	
Product information list device (#8736 to #8751)	—	00S	
Safety observation function	—	00S	
Feed current value update command (M3212+20n) valid in speed control (I)	00B	Not support	
External forced stop input ON latch (SM506)	00B	00S	
Operation method (SD560)	00B	Not support	
Advanced synchronous control	00B	Not support	
Limit switch output function expansion	00B	Not support	
Driver communication function (SSCNETⅢ)	00C	Not support	
Intelligent function module support	00C	Not support	
SSCNETⅢ/H head module connection	00C	Not support	
Cam auto-generation (CAMMK) easy stroke ratio cam	00C	Not support	
Acceleration/deceleration time change function	00C	Not support	
Home position return of dogless home position signal reference method	00C	Not support	
Setting range expansion of backlash compensation amount	00C	Not support	
Multiple CPU synchronous control	00C	Not support	
Cam axis length per cycle change during synchronous control	00C	Not support	
Servo driver VCⅡ series manufactured by CKD Nikki Denso Co., Ltd.	SSCNETⅢ	—	00L
	SSCNETⅢ/H	00D	Not support
Inverter FR-A700 series	—	—	
Synchronous encoder via servo amplifier	00D	Not support	
Driver communication function (SSCNETⅢ/H)	00D	Not support	
Optical hub unit connection	00F	Not support	
Home position return of driver home position return method	00H	Not support	
Stepping motor module AlphaStep/5-phase manufactured by ORIENTAL MOTOR Co., Ltd.	00H	Not support	
Servo driver VPH series manufactured by CKD Nikki Denso Co., Ltd.	00H	Not support	
IAI electric actuator controller manufactured by IAI Corporation	00H	Not support	
Inverter FR-A800 series	00J	Not support	

1 OVERVIEW

	Programming software version			MR Configurator2	MR Configurator	Section of reference
	MELSOFT MT Works2 (MT Developer2)					
	Q173DSCPU/Q172DSCPU	Q173DCPU(-S1)/Q172DCPU(-S1)				
	SV13/SV22	SV13/SV22	SV43			
1.39R	1.39R		—	—	(Note-4)	
1.39R	1.39R		—	—	(Note-4)	
—	—		—	—	(Note-4)	
—	—		—	—	(Note-5), (Note-6)	
1.39R	1.39R		—	—	(Note-7)	
—	Not support		—	—	(Note-5)	
—	—		—	—	(Note-3)	
—	Not support		—	—	(Note-3)	
1.47Z	Not support		—	—	(Note-8)	
1.47Z	Not support		—	—	(Note-3)	
—	Not support		—	—	(Note-3)	
1.56J	Not support		—	—	(Note-3)	
1.56J	Not support		—	—	(Note-3)	
1.56J	Not support		—	—	(Note-4)	
1.56J	Not support		—	—	(Note-5)	
1.56J	Not support		—	—	(Note-5)	
1.56J	Not support		—	—	(Note-5)	
1.56J	Not support		—	—	(Note-8)	
1.56J	Not support		—	—	(Note-8)	
1.34L	1.15R		—	—	(Note-5)	
1.56J	Not support		—	—	(Note-5)	
1.34L	1.15R		—	—	(Note-5)	
1.68W	Not support		1.23Z	Not support	(Note-8)	
1.68W	Not support		1.23Z	Not support	(Note-3)	
—	Not support		—	—	(Note-5)	
1.118Y	Not support		—	—	(Note-5)	
1.118Y	Not support		—	—	(Note-5)	
1.118Y	Not support		—	—	(Note-5)	
1.118Y	Not support		—	—	(Note-5)	
1.120A	Not support		—	—	(Note-5)	

—: There is no restriction by the version.

(Note-1): SV13/SV22 is the completely same version.

(Note-2): The operating system software version can be confirmed in the operating system software (CD-ROM), MT Developer2 or GX Works2/ GX Developer. (Refer to "Q173D(S)CPU/Q172D(S)CPU Motion controller Programming Manual (COMMON) Section 1.3, 1.4".)

(Note-3): Q173D(S)CPU/Q172D(S)CPU Motion controller Programming Manual (COMMON)

(Note-4): Q173D(S)CPU/Q172D(S)CPU Motion controller (SV13/SV22) Programming Manual (Motion SFC)

(Note-5): Q173D(S)CPU/Q172D(S)CPU Motion controller (SV13/SV22) Programming Manual (REAL MODE)

(Note-6): Q173D(S)CPU/Q172D(S)CPU Motion controller (SV22) Programming Manual (VIRTUAL MODE)

(Note-7): Q173D(S)CPU/Q172D(S)CPU Motion controller Programming Manual (Safety Observation)

(Note-8): Q173DSCPU/Q172DSCPU Motion controller (SV22) Programming Manual (Advanced Synchronous Control)

1 OVERVIEW

Table 1.1 Restrictions by the Software's Version (continued)

Function	Operating system software version (Note-1), (Note-2)		
	Q173DSCPU/Q172DSCPU	Q173DCPU(-S1)/Q172DCPU(-S1)	
	SV13/SV22	SV13/SV22	SV43
Improvement of absolute positioning operation for servo driver VCI/VPH series manufactured by CKD Nikki Denso Co., Ltd., and stepping motor module AlphaStep/5-phase manufactured by ORIENTAL MOTOR Co., Ltd.	00L	Not support	
Servo amplifier MR-J5(W)-□B support	00Y	Not support	
DOG/CHANGE signal input method support	00Y	Not support	

1 OVERVIEW

	Programming software version			MR Configurator2	MR Configurator	Section of reference
	MELSOFT MT Works2 (MT Developer2)					
	Q173DSCPU/Q172DSCPU	Q173DCPU(-S1)/Q172DCPU(-S1)				
	SV13/SV22	SV13/SV22	SV43			
	—	—	/	—	—	(Note-5)
	1.170C	Not support	/	1.130L	Not support	/
	1.170C	Not support	/	—	—	(Note-3)

—: There is no restriction by the version.

(Note-1): SV13/SV22 is the completely same version.

(Note-2): The operating system software version can be confirmed in the operating system software (CD-ROM), MT Developer2 or GX Works2/GX Developer. (Refer to "Q173D(S)CPU/Q172D(S)CPU Motion controller Programming Manual (COMMON) Section 1.3, 1.4".)

(Note-3): Q173D(S)CPU/Q172D(S)CPU Motion controller Programming Manual (COMMON)

(Note-4): Q173D(S)CPU/Q172D(S)CPU Motion controller (SV13/SV22) Programming Manual (Motion SFC)

(Note-5): Q173D(S)CPU/Q172D(S)CPU Motion controller (SV13/SV22) Programming Manual (REAL MODE)

(Note-6): Q173D(S)CPU/Q172D(S)CPU Motion controller (SV22) Programming Manual (VIRTUAL MODE)

(Note-7): Q173D(S)CPU/Q172D(S)CPU Motion controller Programming Manual (Safety Observation)

(Note-8): Q173DSCPU/Q172DSCPU Motion controller (SV22) Programming Manual (Advanced Synchronous Control)

1 OVERVIEW

1.4 Programming Software Version

The programming software versions that support Motion CPU are shown below.

Motion CPU	MELSOFT MT Works2 (MT Developer2)		MR Configurator2	MR Configurator
	SV13/SV22	SV43		
Q173DSCPU	1.39R (Note-1)		1.10L	Not support
Q172DSCPU	1.39R (Note-1)		1.10L	Not support
Q173DCPU-S1	1.00A (Note-2)	1.03D (Note-3)	1.00A	C0 (Note-4)
Q172DCPU-S1	1.00A (Note-2)	1.03D (Note-3)	1.00A	C0 (Note-4)
Q173DCPU	1.00A	1.03D	1.00A	C0 (Note-4)
Q172DCPU	1.00A	1.03D	1.00A	C0 (Note-4)

(Note-1): Use version 1.47Z or later to use advanced synchronous control method.

(Note-2): Use version 1.12N or later to communicate via PERIPHERAL I/F.

(Note-3): Use version 1.23Z or later to communicate via PERIPHERAL I/F.

(Note-4): Use version C1 or later to use MR Configurator combination with MT Developer2.

2. SYSTEM CONFIGURATION

This section describes the Motion controller system configuration, precautions on use of system and configured equipment.

2.1 Motion System Configuration

(1) Equipment configuration in system
(a) Q173DSCPU/Q172DSCPU

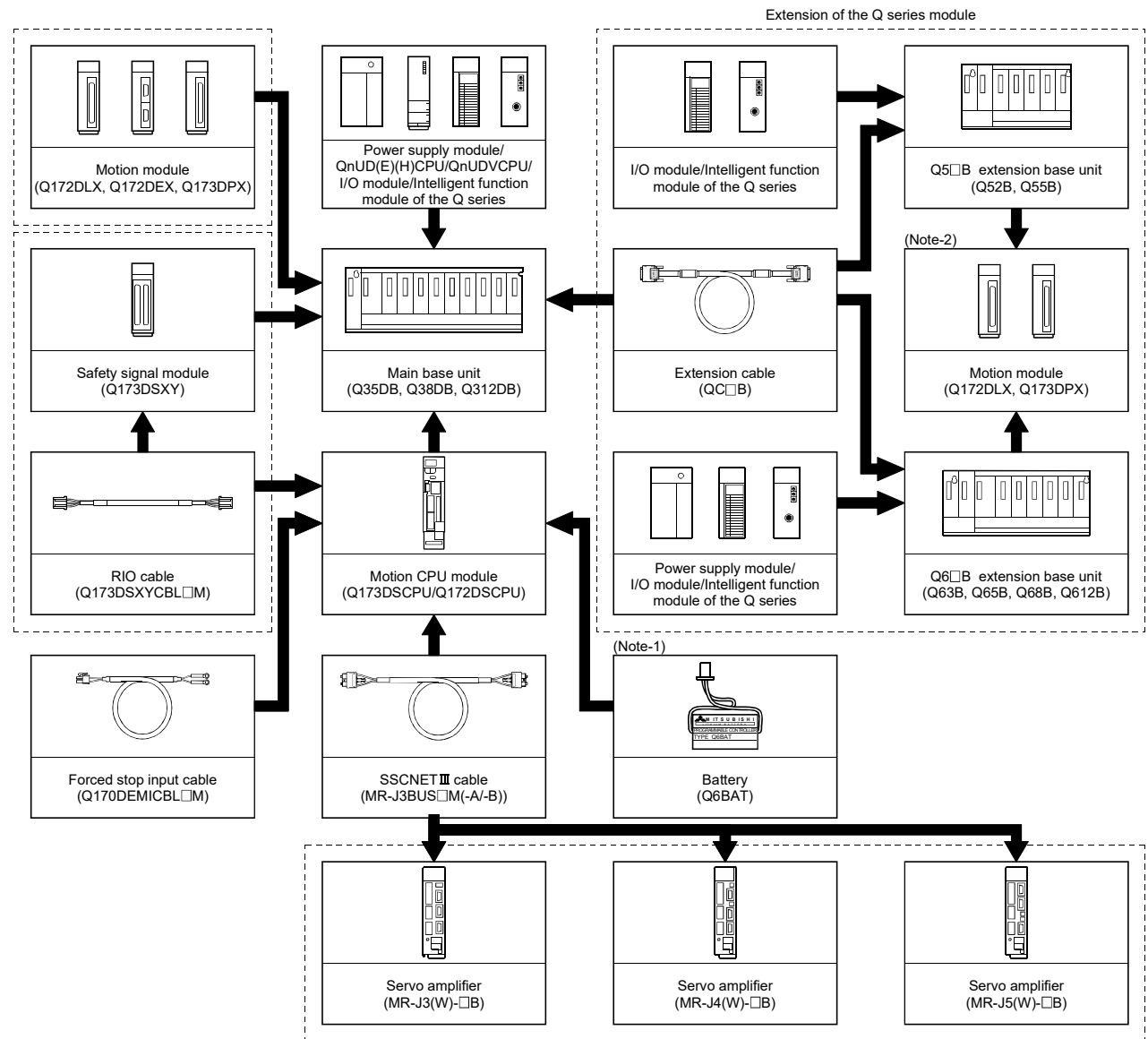

□ It is possible to select the best according to the system.

- (Note-1): Be sure to install the Battery (Q6BAT).
It is packed together with Q173DSCPU/Q172DSCPU.
- (Note-2): Q172DEX cannot be used in the extension base unit.
Install it to the main base unit.

2 SYSTEM CONFIGURATION

(b) Q173DCPU(-S1)/Q172DCPU(-S1)

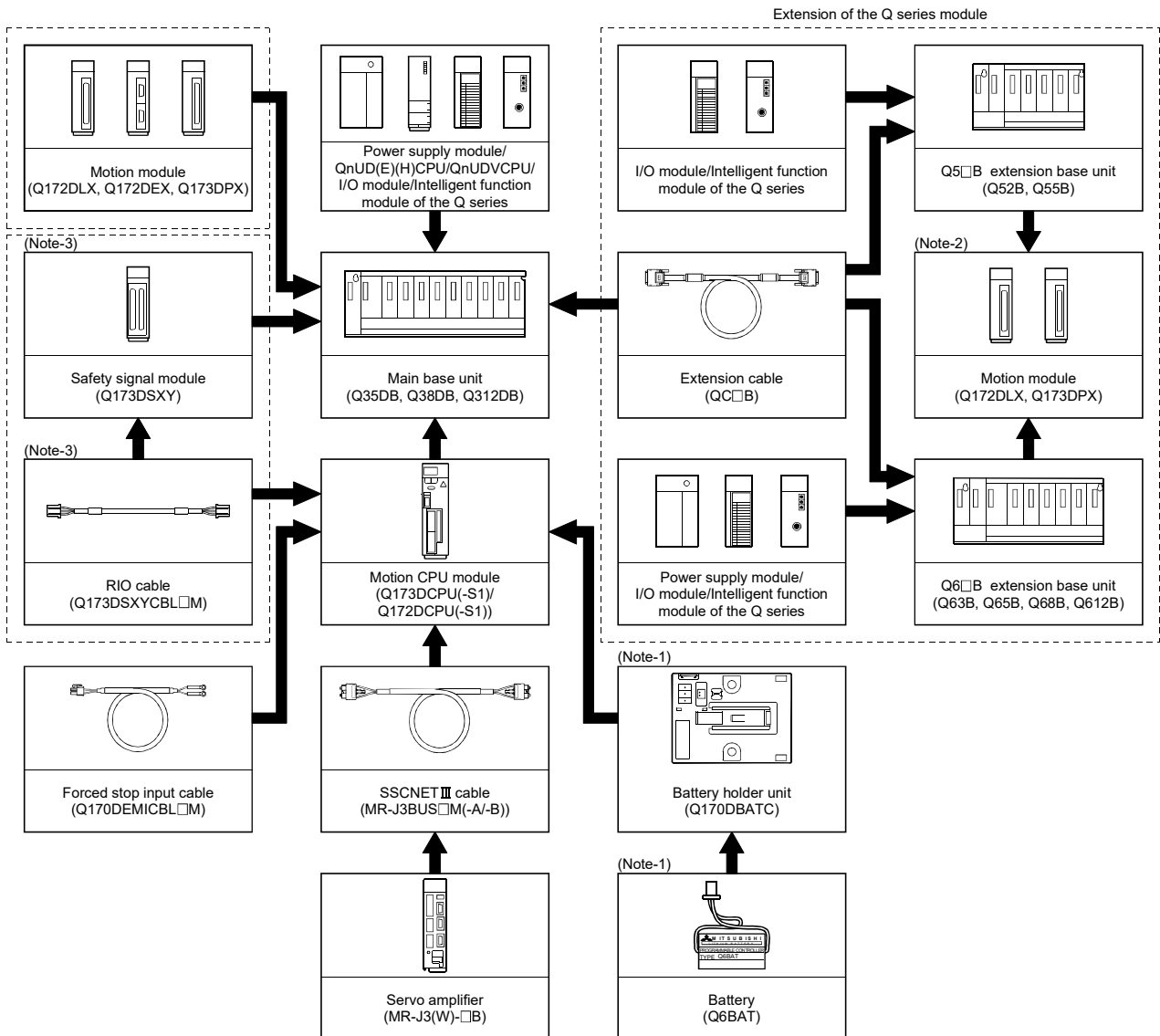

□ It is possible to select the best according to the system.

(Note-1): Be sure to install the Battery (Q6BAT) to the Battery holder unit (Q170DBATC).

It is packed together with Q173DCPU(-S1)/Q172DCPU(-S1).

(Note-2): Q172DEX cannot be used in the extension base unit.

Install it to the main base unit.

(Note-3): Q173DCPU-S1/Q172DCPU-S1 only.

2 SYSTEM CONFIGURATION

(2) Peripheral device configuration for the Q173D(S)CPU/ Q172D(S)CPU

The following (a)(b)(c) can be used.

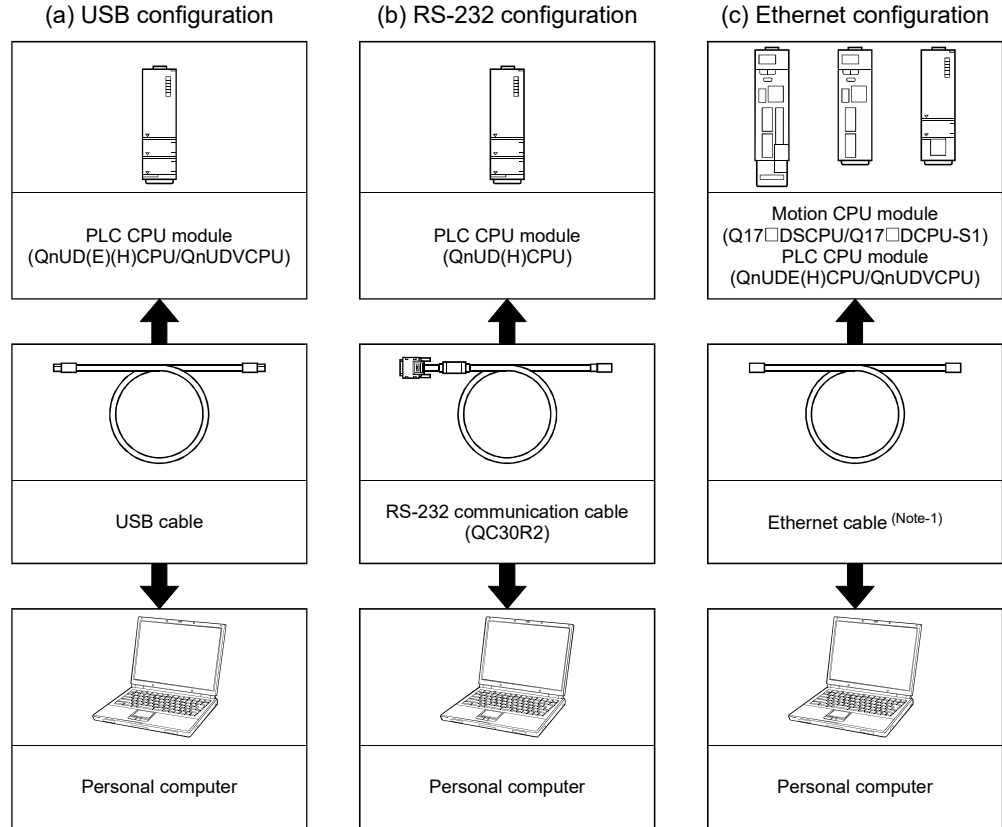

(Note-1): Corresponding Ethernet cables

1) Connecting to Motion CPU module

Part name	Connection type	Cable type	Ethernet standard	Specification
Ethernet cable	Connection with HUB	Straight cable	10BASE-T	Compliant with Ethernet standards, category 5 or higher. • Shielded twisted pair cable (STP cable)
			100BASE-TX	
	Direct connection	Crossover cable	10BASE-T	
			100BASE-TX	

[Selection criterion of cable]

- Category : 5 or higher
- Diameter of lead : AWG26 or higher
- Shield : Copper braid shield and drain wire
Copper braid shield and aluminium layered type shield

2) Connecting to PLC CPU module

Refer to the "QnUCPU User's Manual (Communication via Built-in Ethernet Port)".

2 SYSTEM CONFIGURATION

2.1.1 Q173DSCPU/Q172DSCPU System overall configuration

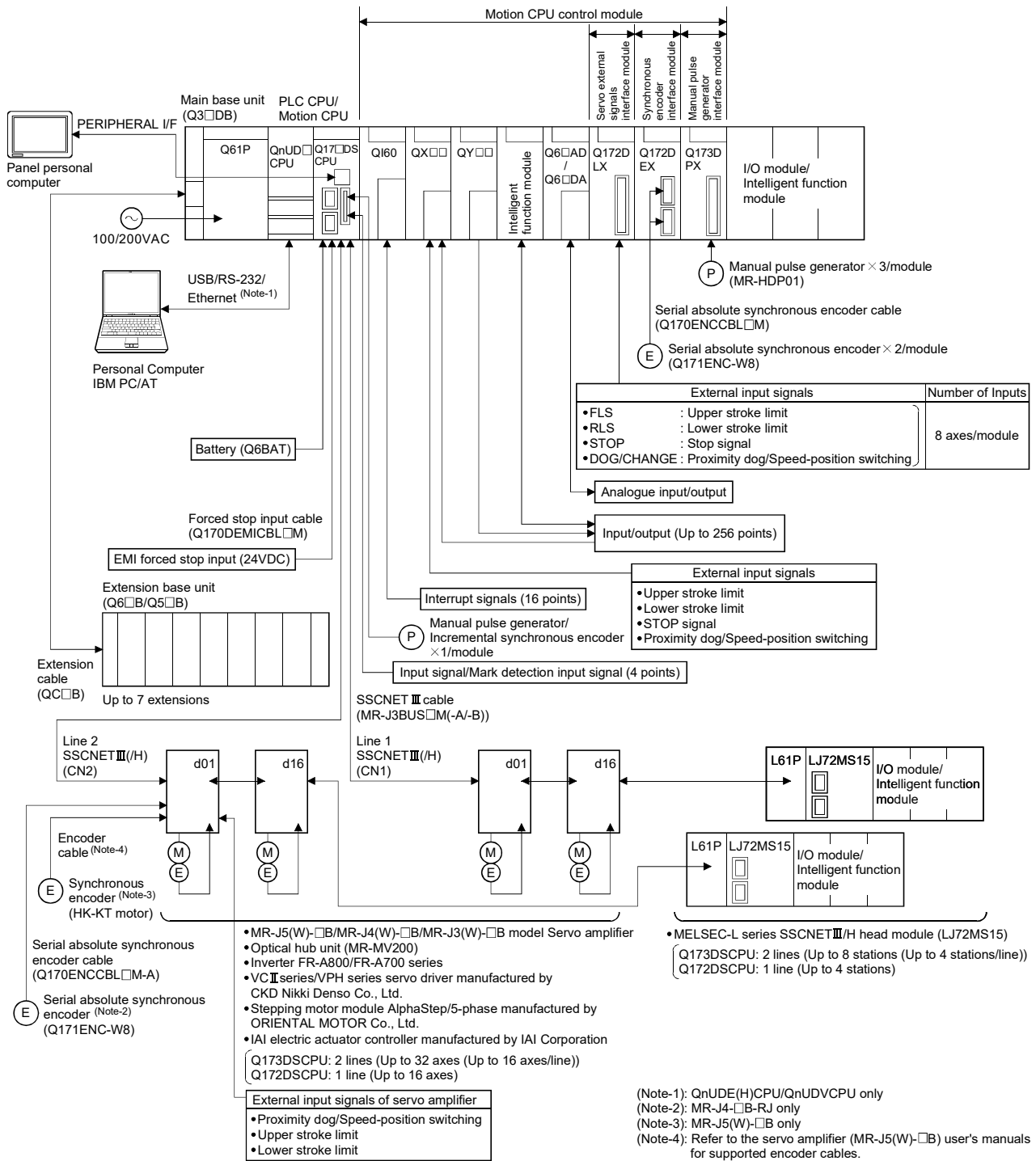

CAUTION

- Construct a safety circuit externally of the Motion controller or servo amplifier if the abnormal operation of the Motion controller or servo amplifier differ from the safety directive operation in the system.
- The ratings and characteristics of the parts (other than Motion controller, servo amplifier and servo motor) used in a system must be compatible with the Motion controller, servo amplifier and servo motor.
- Set the parameter values to those that are compatible with the Motion controller, servo amplifier, servo motor and regenerative resistor model and the system application. The protective functions may not function if the settings are incorrect.

2 SYSTEM CONFIGURATION

2.1.2 Q173DCPU(-S1)/Q172DCPU(-S1) System overall configuration

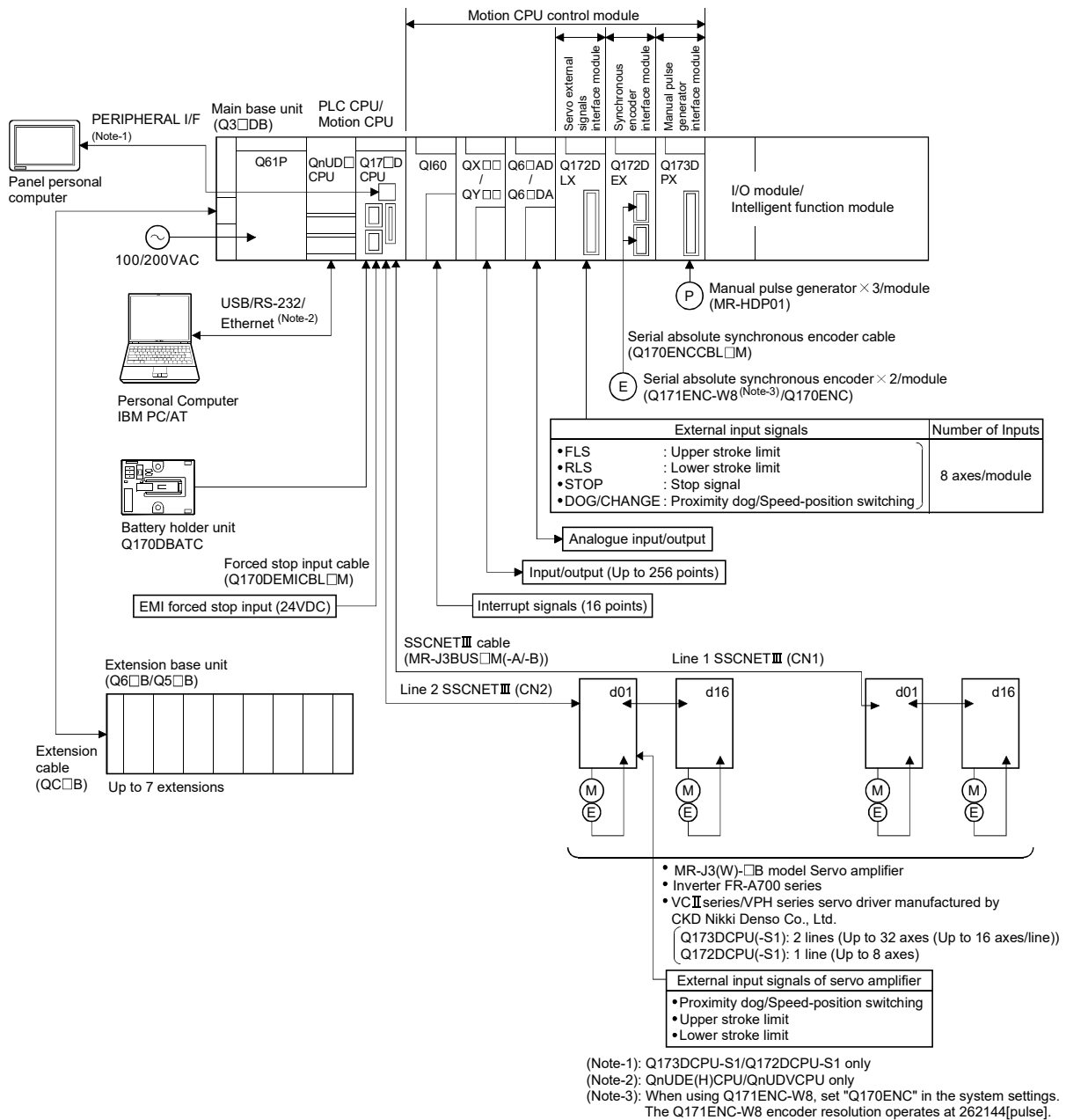

CAUTION

- Construct a safety circuit externally of the Motion controller or servo amplifier if the abnormal operation of the Motion controller or servo amplifier differ from the safety directive operation in the system.
- The ratings and characteristics of the parts (other than Motion controller, servo amplifier and servo motor) used in a system must be compatible with the Motion controller, servo amplifier and servo motor.
- Set the parameter values to those that are compatible with the Motion controller, servo amplifier, servo motor and regenerative resistor model and the system application. The protective functions may not function if the settings are incorrect.

2.1.3 Function explanation of the Motion CPU modules

- (1) The following servo amplifiers can be controlled in Motion CPU module.
 - Q173DSCPU/Q173DCPU(-S1) : Up to 32 axes per 2 lines (up to 16 axes per 1 line)
 - Q172DSCPU : Up to 16 axes per 1 line
 - Q172DCPU(-S1) : Up to 8 axes per 1 line
- (2) It is possible to set the program which synchronized with the motion operation cycle and executed at fixed cycle (Min. 0.22ms: Q173DSCPU/Q172DSCPU use).
- (3) It is possible to execute a download of servo parameters to servo amplifier, servo ON/OFF to servo amplifier and position commands, etc. by connecting between the Motion CPU module and servo amplifier with SSCNET^{III} cable.
- (4) It is possible to select the servo control functions/programming languages by installing the corresponding operating system software in the Motion CPU module.
- (5) Motion modules (Q172DLX/Q172DEX/Q173DPX) are controlled with the Motion CPU module, and the signals such as stroke limit signals connected to Motion modules and synchronous encoder can be used as motion control.
- (6) I/O modules and intelligent function modules (excluding some modules) can be controlled with the Motion CPU module.
(Refer to Section 2.3 (2) for modules that can be controlled with Motion CPU module.)
- (7) Data exchange between CPU modules is possible by Multiple CPU high speed transmission memory or automatic refresh in the Multiple CPU system.
- (8) Wiring is reduced by issuing the external signal (upper/lower stroke limit signal, proximity dog signal) via the servo amplifier.

2.1.4 Restrictions on Motion systems

- (1) Combination of Multiple CPU system
 - (a) Motion CPU module cannot be used as standalone module.
Be sure to install the universal model PLC CPU module to CPU No.1.
For Universal model PLC CPU module, "Multiple CPU high speed transmission function" must be set in the Multiple CPU settings.
 - (b) Only Multiple CPU high speed main base unit (Q35DB/Q38DB/Q312DB) can be used.
 - (c) The combination of Q173DSCPU/Q172DSCPU/Q173DCPU(-S1)/Q172DCPU(-S1) and Q173HCPU(-T)/Q172HCPU(-T)/Q173CPUN(-T)/Q172CPUN(-T) cannot be used.
The combination of Q173DSCPU/Q172DSCPU/Q173DCPU(-S1)/Q172DCPU(-S1) can be used.
 - (d) Up to four modules of universal model PLC CPU modules/Motion CPU modules can be installed from the CPU slot (the slot on the right side of power supply module) to slot 2 of the main base unit. CPU modules called as CPU No.1 to CPU No.4 from the left sequentially.
There is no restriction on the installation order of CPU No.2 to No.4.
For CPU module except CPU No.1, an empty slot can be reserved for addition of CPU module. An empty slot can be set between CPU modules.
However, the installation condition when combining with the High performance PLC CPU module/Process CPU module/PC CPU module/C controller module is different depending on the specification of CPU modules, refer to the Manuals of each CPU modules.
 - (e) It takes about 10 seconds to startup (state that can be controlled) of Motion CPU. Make a Multiple CPU synchronous startup setting suitable for the system.
 - (f) Execute the automatic refresh of the Motion CPU modules and universal model PLC CPU modules by using the automatic refresh of Multiple CPU high speed transmission area setting.
When the High performance PLC CPU module/Process CPU module/PC CPU module/C controller module is installed in the combination of Multiple CPU system, the Motion CPU module cannot execute the automatic refresh with these modules.
 - (g) Use the Motion dedicated PLC instructions that starts by "D(P)". The Motion dedicated PLC instructions that starts by "S(P)." cannot be used. When the High performance PLC CPU module/Process CPU module/PC CPU module/C controller module is installed in the combination of Multiple CPU system, the Motion dedicated PLC instruction from these modules cannot be executed.

(2) Motion modules

- (a) Installation position of Q172DEX^(Note-1) and Q173DSXY is only the main base unit.
It cannot be used on the extension base unit.
- (b) Q172DLX/Q173DPX can be installed on any of the main base unit/
extension base unit.
- (c) Q172DLX/Q172DEX^(Note-1)/Q173DPX cannot be installed in CPU slot and I/O
slot 0 to 2 of the main base unit. Wrong installation might damage the main
base unit.
- (d) Q173DSXY cannot be used in Q173DCPU/Q172DCPU.
- (e) Q172EX(-S1/-S2/-S3)/Q172LX/Q173PX(-S1) for Q173HCPU(-T)/
Q172HCPU(-T)/Q173CPUN(-T)/Q172CPUN(-T)/Q173CPU/Q172CPU
cannot be used.
- (f) Be sure to use the Motion CPU as the control CPU of Motion modules
(Q172DLX, Q172DEX^(Note-1), Q173DPX, etc.) for Motion CPU. They will not
operate correctly if PLC CPU is set and installed as the control CPU by
mistake. Motion CPU is treated as a 32-point intelligent module by PLC CPU
of other CPU.
- (g) Q173DSXY is managed with PLC CPU.
The Motion CPU to connect Q173DSXY is only CPU No.2 in the Multiple
CPU system. Q173DSXY cannot be used for the CPU No. 3 or 4.

(Note-1): Q172DEX can be used in SV22. It cannot be used in SV13/SV43.

















(3) Other restrictions

- (a) Motion CPU module cannot be set as the control CPU of intelligent function
module (excluding some modules) or Graphic Operation Terminal(GOT).
- (b) Be sure to use the battery.
- (c) There are following methods to execute the forced stop input.
 - Use an EMI connector of Motion CPU module
 - Use a device set in the forced stop input setting of system setting
- (d) Forced stop input for EMI connector of Motion CPU module cannot be
invalidated by the parameter.
When the device set in the forced stop input setting is used without use of
EMI connector of Motion CPU module, apply 24VDC voltage on EMI
connector and invalidate the forced stop input of EMI connector.
- (e) Be sure to use the cable for forced stop input (sold separately). The forced
stop cannot be released without using it.

2 SYSTEM CONFIGURATION

- (f) Set "SSCNET III/H" or "SSCNET III" for every line in the SSCNET setting of system setting to communicate with the servo amplifiers and SSCNET III/(H) compatible equipment.

The following shows the servo amplifiers and SSCNET III/(H) compatible equipment that can be used when "SSCNET III/H" and "SSCNET III" are set.

Servo amplifier/SSCNET III/(H) compatible equipment		SSCNET setting	
		SSCNET III/H 	SSCNET III
Servo amplifier	MR-J5(W)-□B  	○	×
	MR-J4(W)-□B 	○	○ (Note-1)
	MR-J3(W)-□B	×	○
Inverter	FR-A800 series  	○	○
	FR-A700 series 	×	○
SSCNET III/H head module	LJ72MS15  	○	×
Servo driver manufactured by CKD Nikki Denso Co., Ltd	VCII series 	○	○
	VPH series  	○	○
Stepping motor module AlphaStep/5-phase manufactured by ORIENTAL MOTOR Co., Ltd.  		○	×
IAI electric actuator controller manufactured by IAI Corporation  		○	×

○: Usable

×: Unusable

(Note-1): Operated in J3 compatibility mode



POINTS

It is possible to use different servo amplifiers on the same SSCNET III/H line, but when high accuracy synchronization on the load side is needed for multiple axes such as for interpolation control or synchronous control, build a system using servo amplifiers of the same servo series.

: Refer to Section 1.3 for the software version that supports this function.

2 SYSTEM CONFIGURATION

(g) The following are restrictions for the communication type depending on the operation cycle.

Operation cycle	Communication type	
	SSCNET III/H 	SSCNET III
0.22ms 	<ul style="list-style-type: none"> MR-J4W3-□B (software version A2 or earlier) cannot be used. ^(Note-1) One SSCNET III/H head module per line can be set. AlphaStep/5-phase cannot be used. ^(Note-2) Up to 2 axes per IAI electric actuator controller can be set. ^(Note-4) 	<ul style="list-style-type: none"> The maximum number of control axes per line is four axes. Set the axis select rotary switch of the servo amplifier to "0 to 3". If the axis select rotary switch of servo amplifier is set to "4 to F", the servo amplifiers are not recognized. MR-J4W3-□B (software version A2 or earlier) cannot be used. ^(Note-1) MR-J3W-□B cannot be used. FR-A700 series, VCI series, and VPH series cannot be used. ^(Note-3)
0.44ms	<ul style="list-style-type: none"> Two SSCNET III/H head modules per line can be set. Up to 4 axes per IAI electric actuator controller can be set. ^(Note-4) 	<ul style="list-style-type: none"> The maximum number of control axes per line is eight axes. Set the axis select rotary switch of the servo amplifier to "0 to 7". If the axis select rotary switch of servo amplifier is set to "8 to F", the servo amplifiers are not recognized.
0.88ms or more	—	—

—: No restriction

(Note-1): MR-J4W3-□B (Software version A3 or later) supports operation cycle 0.22ms. However, when using operation cycle 0.22ms, some functions are restricted. Refer to the servo amplifier instruction manual for details.

(Note-2): When AlphaStep/5-phase is set in system settings, operation is carried out with operation cycle at 0.44ms.

(Note-3): When FR-A700 series, VCI series, or VPH series is set in system settings, operation is carried out with operation cycle at 0.44ms.

(Note-4): When the setting exceeds the number of control axes per controller, a major error (error code: 1350) occurs. Set the operation cycle as follows according to the number of control axes per controller.

Number of control axes per controller	Operation cycle
1 to 2 axes	0.22ms or more
3 to 4 axes	0.44ms or more
5 axes or more	0.88ms or more

(h) If there is an axis which is not set at least 1 axis by system setting in applicable servo amplifier at MR-J5W-□B or MR-J4W-□B use, all axes connected to applicable servo amplifier and subsequent servo amplifiers cannot be connected. Set "Not used" to the applicable axis with a dip switch for the axis which is not used by MR-J5W-□B or MR-J4W-□B. 

2 SYSTEM CONFIGURATION

- (i) When a Multiple CPU system is configured, make sure to configure the modules so that the total current consumption of individual modules on the main base does not exceed the 5VDC output capacity of power supply module.
(Refer to Section 2.5.2 (3) "Selection of the power supply module".)
- (j) It is impossible to mount the main base unit by DIN rail when using the Motion CPU module.
Doing so could result in vibration that may cause erroneous operation.
- (k) The module name displayed by "System monitor" - "Product information list" of GX Works2/GX Developer is different depending on the function version of Motion modules (Q172DLX, Q172DEX, Q173DPX).
(Note): Even if the function version "C" is displayed, it does not correspond to the online module change.

Module name	Model display	
	Function version "B"	Function version "C"
Q172DLX	Q172LX	Q172DLX
Q172DEX	MOTION-UNIT	Q172DEX
Q173DPX	MOTION-UNIT	Q173DPX

- (l) Use the Graphic Operation Terminal (GOT) that supports Motion CPU (Q173D(S)CPU/Q172D(S)CPU).

2 SYSTEM CONFIGURATION

2.2 Checking Serial Number and Operating System Software Version

Checking for the serial number of Motion CPU module and Motion module, and the operating system software version is described below.

2.2.1 Checking serial number

(1) Motion CPU module (Q173DSCPU/Q172DSCPU)

(a) Rating plate

The rating plate is situated on the side face of the Motion CPU module.
The SERIAL line displays the Motion CPU module serial No.

(b) Front of Motion CPU module

The serial number is displayed on the battery cover situated on the lower front side of the Motion CPU module.

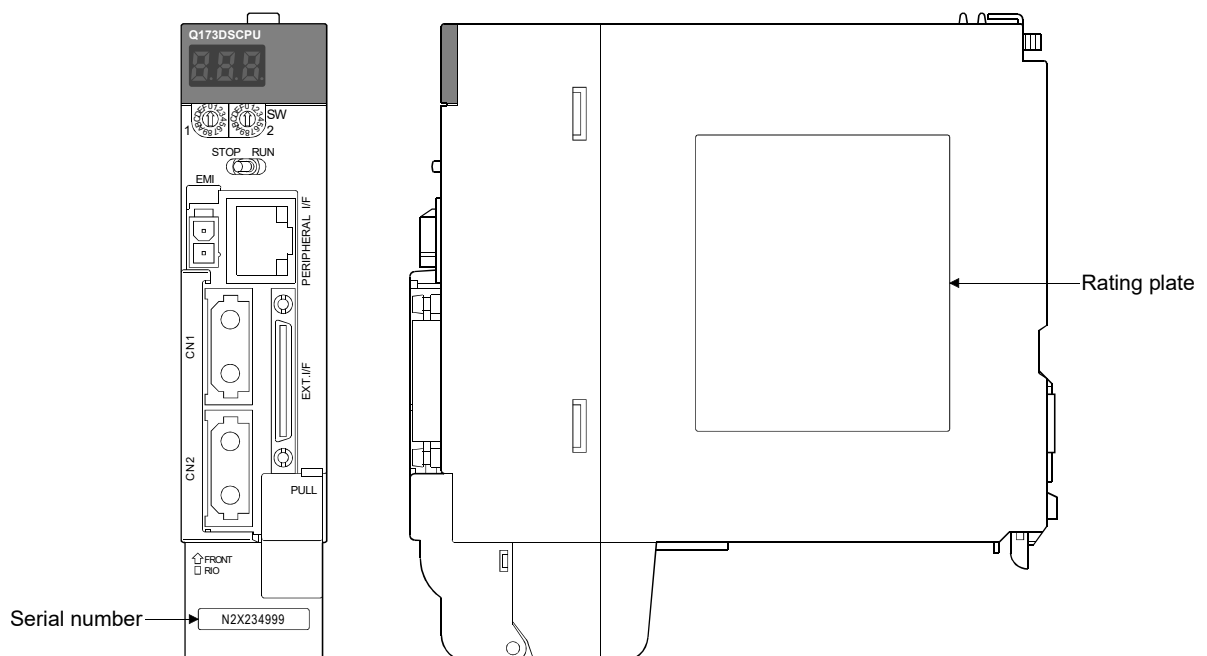

(c) System monitor (product information list)

The serial number can be checked on the system monitor screen in GX Works2/GX Developer. (Refer to Section 2.2.2.)

2 SYSTEM CONFIGURATION

(2) Motion CPU module (Q173DCPU(-S1)/Q172DCPU(-S1))

(a) Rating plate

The rating plate is situated on the side face of the Motion CPU module.
The SERIAL line displays the Motion CPU module serial No.

(b) Front of Motion CPU module

The serial number is displayed on the protruding portion situated on the lower front side of the Motion CPU module.

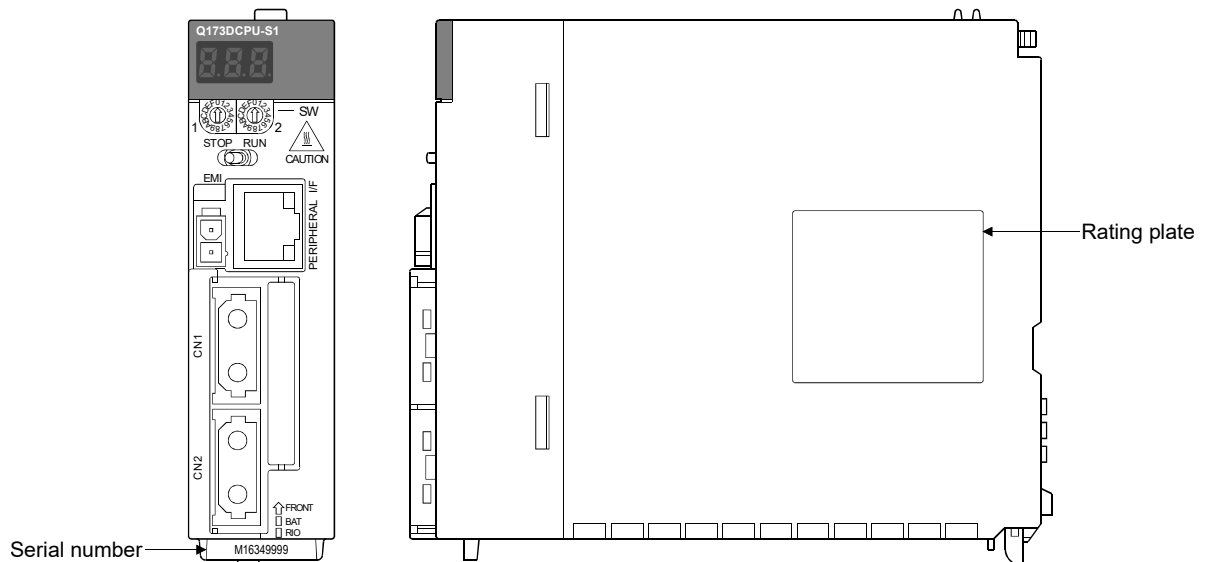

(c) System monitor (product information list)

The serial number can be checked on the system monitor screen in GX Works2/GX Developer. (Refer to Section 2.2.2.)

REMARK

The serial number display was corresponded from the Motion CPU modules manufactured in early October 2007.

(3) Motion module (Q172DLX/Q172DEX/Q173DPX/Q173DSXY)

(a) Rating plate

The rating plate is situated on the side face of the Motion module.
The SERIAL line displays the Motion CPU module serial No.

(b) Front of Motion module

The serial No. is displayed on the protruding portion situated on the lower front side of the Motion module.

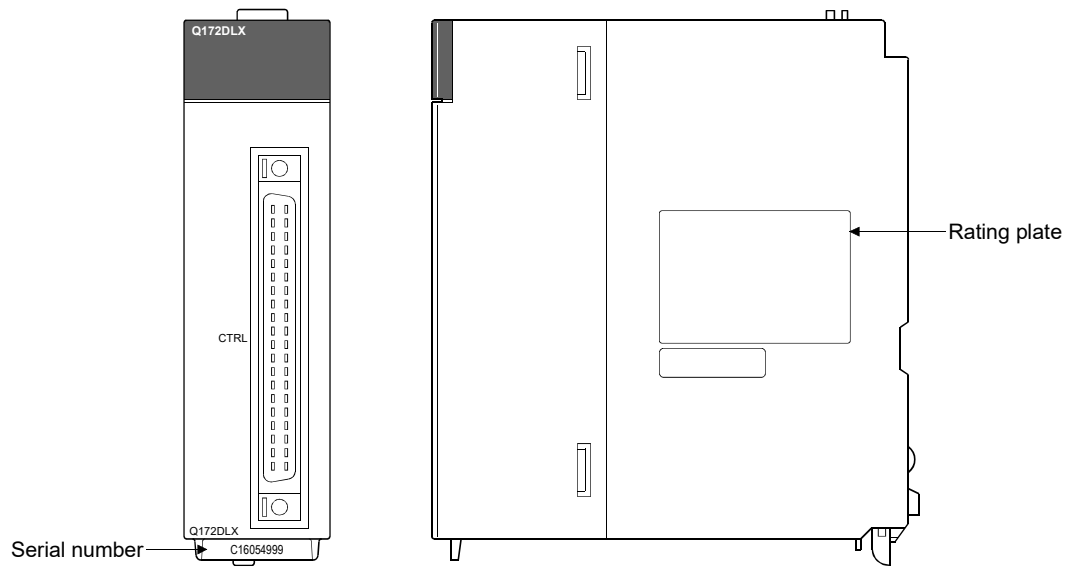

REMARK

The serial number display was corresponded from the Motion modules manufactured in early April 2008.

2 SYSTEM CONFIGURATION

2.2.2 Checking operating system software version **Ver.!**

The operating system software version can be checked on the system monitor screen in GX Works2/GX Developer.

Select [Product Information List] button on the system monitor screen displayed on [Diagnostics] – [System monitor] of GX Works2/GX Developer to check on the product information list.

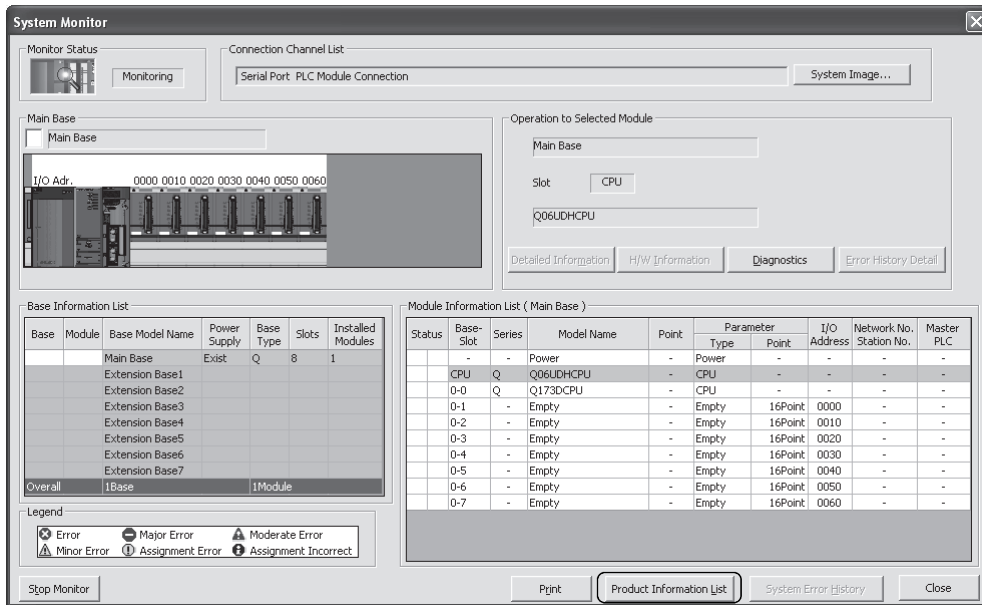

Serial number of Motion CPU module

Operating system software version

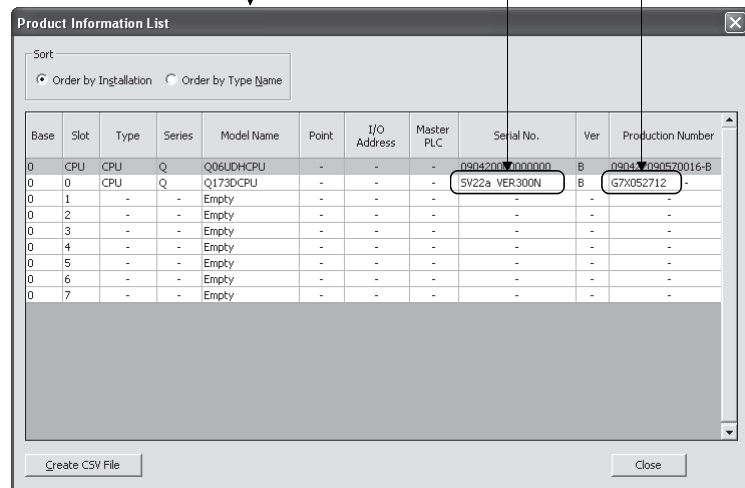

<Screen: GX Works2>

Ver.!: Refer to Section 1.3 for the software version that supports this function.

REMARK

- (1) "Serial number of Motion CPU module" and "Operating system software version" on the system monitor (Product Information List) screen of GX Works2/GX Developer was corresponded from the Motion CPU modules manufactured in early October 2007.
- (2) The operating system software version can also be checked on the system monitor screen in CD-ROM of operating system software or MT Developer2. Refer to Section 1.3.4 of the "Q173D(S)CPU/Q172D(S)CPU Motion controller Programming Manual (COMMON)" for details.

2 SYSTEM CONFIGURATION

2.3 System Configuration Equipment

(1) Motion controller related module

Part name	Model name (Note-1)	Description	Current consumption 5VDC[A]	Remark
Motion CPU module	Q173DSCPU	Up to 32 axes control, Operation cycle 0.22ms or more, Built-in Ethernet, Built-in interface in Motion CPU (Incremental synchronous encoder interface 1ch, Input signal/Mark detection input signal 4 points) (Attachment battery (Q6BAT))	1.75 (Note-2)	
	Q172DSCPU	Up to 16 axes control, Operation cycle 0.22ms or more, Built-in Ethernet, Built-in interface in Motion CPU (Incremental synchronous encoder interface 1ch, Input signal/Mark detection input signal 4 points) (Attachment battery (Q6BAT))	1.44 (Note-2)	
	Q173DCPU	Up to 32 axes control, Operation cycle 0.44ms or more (Attachment battery holder unit and battery (Q6BAT))	1.25	
	Q173DCPU-S1	Up to 32 axes control, Operation cycle 0.44ms or more, Built-in Ethernet (Attachment battery holder unit and battery (Q6BAT))	1.30	
	Q172DCPU	Up to 8 axes control, Operation cycle 0.44ms or more (Attachment battery holder unit and battery (Q6BAT))	1.25	
	Q172DCPU-S1	Up to 8 axes control, Operation cycle 0.44ms or more, Built-in Ethernet (Attachment battery holder unit and battery (Q6BAT))	1.30	
Servo external signals interface module	Q172DLX	Servo external signal input 8 axes (FLS, RLS, STOP, DOG/CHANGE ×8)	0.06	
Synchronous encoder interface module	Q172DEX	Serial absolute synchronous encoder Q171ENC-W8/Q170ENC interface ×2, Tracking input 2 points, with A6BAT	0.19	
Manual pulse generator interface module	Q173DPX	Manual pulse generator MR-HDP01/Incremental synchronous encoder interface ×3, Tracking input 3 points	0.38	
Safety signal module	Q173DSXY	Input 20 points (2 paths), Output 12 points (2 paths)	0.20	
PLC CPU module (Note-3)	Q03UDCPU	Program capacity 30k steps, LD instruction processing speed 0.02μs	0.33	
	Q04UDHCPU	Program capacity 40k steps, LD instruction processing speed 0.0095μs	0.39	
	Q06UDHCPU	Program capacity 60k steps, LD instruction processing speed 0.0095μs	0.39	
	Q10UDHCPU	Program capacity 100k steps, LD instruction processing speed 0.0095μs	0.39	
	Q13UDHCPU	Program capacity 130k steps, LD instruction processing speed 0.0095μs	0.39	
	Q20UDHCPU	Program capacity 200k steps, LD instruction processing speed 0.0095μs	0.39	
	Q26UDHCPU	Program capacity 260k steps, LD instruction processing speed 0.0095μs	0.39	
	Q03UDECPU	Program capacity 30k steps, LD instruction processing speed 0.02μs, Built-in Ethernet port	0.46	
	Q04UDEHCPU	Program capacity 40k steps, LD instruction processing speed 0.0095μs, Built-in Ethernet port	0.49	
	Q06UDEHCPU	Program capacity 60k steps, LD instruction processing speed 0.0095μs, Built-in Ethernet port	0.49	
	Q10UDEHCPU	Program capacity 100k steps, LD instruction processing speed 0.0095μs, Built-in Ethernet port	0.49	
	Q13UDEHCPU	Program capacity 130k steps, LD instruction processing speed 0.0095μs, Built-in Ethernet port	0.49	

2 SYSTEM CONFIGURATION

Motion controller related module (continued)

Part name	Model name (Note-1)	Description	Current consumption 5VDC[A]	Remark
PLC CPU module (Note-3)	Q20UDEHCPU	Program capacity 200k steps, LD instruction processing speed 0.0095μs, Built-in Ethernet port	0.49	
	Q26UDEHCPU	Program capacity 260k steps, LD instruction processing speed 0.0095μs, Built-in Ethernet port	0.49	
	Q50UDEHCPU	Program capacity 500k steps, LD instruction processing speed 0.0095μs, Built-in Ethernet port	0.50	
	Q100UDEHCPU	Program capacity 1000k steps, LD instruction processing speed 0.0095μs, Built-in Ethernet port	0.50	
	Q03UDVCPU	Program capacity 30k steps, LD instruction processing speed 0.0019μs, High-speed type	0.58	
	Q04UDVCPU	Program capacity 40k steps, LD instruction processing speed 0.0019μs, High-speed type	0.58	
	Q06UDVCPU	Program capacity 60k steps, LD instruction processing speed 0.0019μs, High-speed type	0.58	
	Q13UDVCPU	Program capacity 130k steps, LD instruction processing speed 0.0019μs, High-speed type	0.58	
	Q26UDVCPU	Program capacity 260k steps, LD instruction processing speed 0.0019μs, High-speed type	0.58	
C Controller module (Note-3)	Q12DCCPU-V	CPU: SH4A, Endian format: Little endian, OS: VxWorks®6.4	0.97	
	Q24DHCCPU-V	CPU: SH4A, Endian format: Little endian, OS: VxWorks®6.8.1	2.80	
	Q24DHCCPU-LS	CPU: SH4A, Endian format: Little endian, OS: No pre-installed operating system (Operating system installed by user)	2.80	
	Q26DHCCPU-LS	CPU: SH4A, Endian format: Little endian, OS: No pre-installed operating system (Operating system installed by user)	2.80	
Power supply module (Note-4)	Q61P-A1	100 to 120VAC input, 5VDC 6A output	—	
	Q61P-A2	200 to 240VAC input, 5VDC 6A output		
	Q61P	100 to 240VAC input, 5VDC 6A output		
	Q61P-D	100 to 240VAC input, 5VDC 6A output, life detection power supply		
	Q62P	100 to 240VAC input, 5VDC 3A/24VDC 0.6A output		
	Q63P	24VDC input, 5VDC 6A output		
	Q64P	100 to 120VAC/200 to 240VAC input, 5VDC 8.5A output		
	Q64PN	100 to 240VAC input, 5VDC 8.5A output		
Main base unit (Note-3)	Q35DB	Multiple CPU high speed bus (4 slots), Number of I/O modules : 5 slots	0.23	
	Q38DB	Multiple CPU high speed bus (4 slots), Number of I/O modules : 8 slots	0.23	
	Q312DB	Multiple CPU high speed bus (4 slots), Number of I/O modules : 12 slots	0.24	
Extension base unit (Note-3)	Q63B	Number of I/O modules installed 3 slots, type requiring power supply	0.11	
	Q65B	Number of I/O modules installed 5 slots, type requiring power supply	0.11	
	Q68B	Number of I/O modules installed 8 slots, type requiring power supply	0.12	
	Q612B	Number of I/O modules installed 12 slots, type requiring power supply	0.13	
	Q52B	Number of I/O modules installed 2 slots, type not requiring power supply	0.08	
	Q55B	Number of I/O modules installed 5 slots, type not requiring power supply	0.10	
Extension cable	QC05B	Length 0.45m(1.48ft.)	—	
	QC06B	Length 0.6m(1.97ft.)		
	QC12B	Length 1.2m(3.94ft.)		
	QC30B	Length 3m(9.84ft.)		
	QC50B	Length 5m(16.40ft.)		
	QC100B	Length 10m(32.81ft.)		

2 SYSTEM CONFIGURATION

Motion controller related module (continued)

Part name	Model name (Note-1)	Description	Current consumption 5VDC[A]	Remark
Serial absolute synchronous encoder	Q171ENC-W8	Resolution: 4194304pulse/rev Permitted axial loads Radial load: Up to 19.6N, Thrust load: Up to 9.8N Permitted speed: 3600r/min	0.25	
	Q170ENC	Resolution: 262144pulse/rev Permitted axial loads Radial load: Up to 19.6N Thrust load: Up to 9.8N Permitted speed: 3600r/min	0.20	
Serial absolute synchronous encoder cable	Q170ENCCBL□M	Serial absolute synchronous encoder Q171ENC-W8/Q170ENC ↔ Q172DEX 2m(6.56ft.), 5m(16.40ft.), 10m(32.81ft.), 20m(65.62ft.), 30m(98.43ft.), 50m(164.04ft.)	—	
	Q170ENCCBL□M-A	Serial absolute synchronous encoder Q171ENC-W8 ↔ MR-J4-□B-RJ 2m(6.56ft.), 5m(16.40ft.), 10m(32.81ft.), 20m(65.62ft.), 30m(98.43ft.), 50m(164.04ft.)	—	
Connector set for serial absolute synchronous encoder cable	Q170ENCCNS	Q172DEX side connector Connector :10120-3000PE Connector case : 10320-52F0-008 Q171ENC-W8/Q170ENC side connector Plug : D/MS3106B22-14S Cable clamp : D/MS3057-12A	—	
	MR-J3CN2	MR-J4-□B-RJ side connector Plug : 36210-0100PL Shell : 36310-3200-008 Q171ENC-W8 side connector Plug : D/MS3106B22-14S Cable clamp : D/MS3057-12A	—	
Internal I/F connector set	Q170DSIOCON	Incremental synchronous encoder/Mark detection signal interface connector With ferrite core	—	
Manual pulse generator	MR-HDP01	Pulse resolution: 25pulse/rev(100pulse/rev after magnification by 4) Permitted axial loads Radial load: Up to 19.6N Thrust load: Up to 9.8N Permitted speed: 200r/min(Normal rotation), Voltage-output	0.06	
Battery holder unit (Note-5)	Q170DBATC	Battery holder for Q6BAT (Attachment battery cable)	—	
Battery	Q6BAT	For data backup of SRAM built-in Motion CPU (Programs, Parameters, Motion devices(#), Devices of latch range, Absolute position data)	—	
	A6BAT	For data backup of Q171ENC-W8/Q170ENC	—	
Cable for forced stop input (Note-6)	Q170DEMICBL□M	Length 0.5m(1.64ft), 1m(3.28ft), 3m(9.84ft), 5m(16.40ft), 10m(32.81ft), 15m(49.21ft), 20m(65.62ft), 25m(82.02ft), 30m(98.43ft)	—	
Connector for forced stop input cable	Q170DEMICON	Connector for forced stop input cable production	—	
Connector/terminal block conversion module (Note-7)	A6TBXY36	For positive common sink type input module, sink type output module (standard type)	—	
	A6TBXY54	For positive common sink type input module, sink type output module (2-wire type)	—	
	A6TBX70	For positive common sink type input module (3-wire type)	—	

2 SYSTEM CONFIGURATION

Motion controller related module (continued)

Part name	Model name (Note-1)	Description	Current consumption 5VDC[A]	Remark
Cable for connector/ terminal block conversion module	AC05TB	Length 0.5m (1.64ft.)	—	
	AC10TB	Length 1m (3.28ft.)	—	
	AC20TB	Length 2m (6.56ft.)	—	
	AC30TB	Length 3m (9.84ft.)	—	
	AC50TB	Length 5m (16.40ft.)	—	
	AC80TB	Length 8m (26.25ft.)	—	
	AC100TB	Length 10m (32.81ft.)	—	
SSCNET III cable	MR-J3BUS□M	<ul style="list-style-type: none"> • Q173DSCPU/Q172DSCPU ↔ MR-J5(W)-□B, MR-J5(W)-□B ↔ MR-J5(W)-□B, MR-J5(W)-□B ↔ LJ72MS15 • Q173DSCPU/Q172DSCPU ↔ MR-J4(W)-□B, MR-J4(W)-□B ↔ MR-J4(W)-□B, MR-J4(W)-□B ↔ LJ72MS15 • Q173D(S)CPU/Q172D(S)CPU ↔ MR-J3(W)-□B, MR-J3(W)-□B ↔ MR-J3(W)-□B • Standard cord for inside panel 0.15m(0.49ft.), 0.3m(0.98ft.), 0.5m(1.64ft.), 1m(3.28ft.), 3m(9.84ft.) 	—	
	MR-J3BUS□M-A	<ul style="list-style-type: none"> • Q173DSCPU/Q172DSCPU ↔ MR-J5(W)-□B, MR-J5(W)-□B ↔ MR-J5(W)-□B, MR-J5(W)-□B ↔ LJ72MS15 • Q173DSCPU/Q172DSCPU ↔ MR-J4(W)-□B, MR-J4(W)-□B ↔ MR-J4(W)-□B, MR-J4(W)-□B ↔ LJ72MS15 • Q173D(S)CPU/Q172D(S)CPU ↔ MR-J3(W)-□B, MR-J3(W)-□B ↔ MR-J3(W)-□B • Standard cable for outside panel 5m(16.40ft.), 10m(32.81ft.), 20m(65.62ft.) 	—	
	MR-J3BUS□M-B (Note-8)	<ul style="list-style-type: none"> • Q173DSCPU/Q172DSCPU ↔ MR-J5(W)-□B, MR-J5(W)-□B ↔ MR-J5(W)-□B, MR-J5(W)-□B ↔ LJ72MS15 • Q173DSCPU/Q172DSCPU ↔ MR-J4(W)-□B, MR-J4(W)-□B ↔ MR-J4(W)-□B, MR-J4(W)-□B ↔ LJ72MS15 • Q173D(S)CPU/Q172D(S)CPU ↔ MR-J3(W)-□B, MR-J3(W)-□B ↔ MR-J3(W)-□B • Long distance cable 30m(98.43ft.), 40m(131.23ft.), 50m(164.04ft.) 	—	
RIO cable	Q173DSXYCBL01M	Length 0.1m (0.33ft.)	—	
	Q173DSXYCBL05M	Length 0.5m (1.64ft.)	—	

(Note-1): □=Cable length (015: 0.15m(0.49ft.), 03: 0.3m(0.98ft.), 05: 0.5m(1.64ft.), 1: 1m(3.28ft.), 2: 2m(6.56ft.), 3: 3m(9.84ft.), 5: 5m(16.40ft.), 10: 10m(32.81ft.), 20: 20m(65.62ft.), 25: 25m(82.02ft.), 30: 30m(98.43ft.), 40: 40m(131.23ft.), 50:50m(164.04ft.)

(Note-2): The manual pulse generator or incremental synchronous encoder that consumes less than 0.2[A] of current can be connected to the internal I/F connector.

(Note-3): 5VDC internal current consumption of shared equipment with PLC might be changed.
Be sure to refer to the MELSEC-Q series PLC Manuals.

(Note-4): Be sure to use the power supply module within the range of power supply capacity.

(Note-5): Battery Q6BAT is not attached to Battery holder unit Q170DBATC. Please purchase it separately.

(Note-6): Be sure to use the cable for forced stop input (sold separately). The forced stop cannot be released without using it.

Cable for forced stop input is not attached to the Motion CPU module. Please purchase the cable for length according to system separately.

(Note-7): These modules can be used in Q172DLX. It cannot be controlled using Q173DPX.

(Note-8): Please contact your nearest Mitsubishi Electric sales representative for the cable of less than 30m(98.43ft.).

2 SYSTEM CONFIGURATION

(2) PLC module which can be controlled by Motion CPU

Part name		Model name	Current consumption 5VDC[A] (Note-1)	Remark
Input module	AC	QX10	0.05 (TYP, All points ON)	Refer to the MELSEC-Q series PLC Manuals.
		QX10-TS	0.05 (TYP, All points ON)	
		QX28	0.05 (TYP, All points ON)	
	DC (Positive common)	QX40	0.05 (TYP, All points ON)	
		QX40-TS	0.05 (TYP, All points ON)	
		QX40-S1	0.06 (TYP, All points ON)	
		QX40H	0.08 (TYP, All points ON)	
		QX41	0.075 (TYP, All points ON)	
		QX41-S1	0.075 (TYP, All points ON)	
		QX41-S2	0.075 (TYP, All points ON)	
		QX42	0.09 (TYP, All points ON)	
		QX42-S1	0.09 (TYP, All points ON)	
		DC/AC	QX50	
	DC sensor	QX70	0.055 (TYP, All points ON)	
		QX70H	0.08 (TYP, All points ON)	
		QX71	0.07 (TYP, All points ON)	
		QX72	0.085 (TYP, All points ON)	
	DC (Negative common)	QX80	0.05 (TYP, All points ON)	
		QX80-TS	0.05 (TYP, All points ON)	
		QX80H	0.08 (TYP, All points ON)	
		QX81	0.075 (TYP, All points ON)	
QX81-S2		0.075 (TYP, All points ON)		
QX82		0.09 (TYP, All points ON)		
QX82-S1		0.09 (TYP, All points ON)		
QX90H		0.08 (TYP, All points ON)		
Output module	Relay	QY10	0.43 (TYP, All points ON)	
		QY10-TS	0.43 (TYP, All points ON)	
		QY18A	0.24 (TYP, All points ON)	
	Triac	QY22	0.25 (TYP, All points ON)	
	Transistor	Sink Type	QY40P	0.065 (TYP, All points ON)
			QY40P-TS	0.065 (TYP, All points ON)
			QY41P	0.105 (TYP, All points ON)
			QY41H	0.37 (TYP, All points ON)
			QY42P	0.15 (TYP, All points ON)
		Independent	QY50	0.08 (TYP, All points ON)
		Source Type	QY68A	0.11 (TYP, All points ON)
			QY80	0.08 (TYP, All points ON)
			QY80-TS	0.08 (TYP, All points ON)
			QY81P	0.095 (TYP, All points ON)
	TTL•CMOS (Sink)	QY82P	0.16 (TYP, All points ON)	
		QY70	0.095 (TYP, All points ON)	
QY71		0.15 (TYP, All points ON)		
Input/Output composite module	DC Input/ Transistor output	QH42P	0.13 (TYP, All points ON)	
		QX48Y57	0.08 (TYP, All points ON)	
		QX41Y41P	0.13 (TYP, All points ON)	
Interrupt module		QI60	0.06 (TYP, All points ON)	

2 SYSTEM CONFIGURATION

PLC module which can be controlled by Motion CPU (continued)

Part name		Model name	Current consumption 5VDC[A] (Note-1)	Remark
Analogue input module	Voltage input	Q68ADV	0.64	Refer to the MELSEC-Q series PLC Manuals.
	Current input	Q62AD-DGH	0.33	
		Q66AD-DG	0.42	
		Q68ADI	0.64	
	Voltage/current input	Q64AD	0.63	
		Q64AD-GH	0.89	
Q68AD-G		0.46		
Analogue output module	Voltage output	Q68DAVN	0.38	
	Current output	Q68DAIN	0.38	
	Voltage/current output	Q62DAN	0.33	
		Q62DA-FG	0.37	
		Q64DAN	0.34	
	Q66DA-G	0.62		
Analogue input/output module		Q64AD2DA	0.17	
High-speed counter module	Differential input	QD62D	0.38	
	5/12/24VDC input/ Differential input	QD65PD2	0.23	
Positioning module	Open collector output	QD75P1	0.40	
		QD75P2	0.46	
		QD75P4	0.58	
	Differential output	QD75D1	0.52	
		QD75D2	0.56	
		QD75D4	0.82	
	SSCNET III compatible	QD75MH1	0.15	
		QD75MH2	0.15	
QD75MH4		0.16		
Simple Motion module	SSCNET III/H compatible	QD77MS2	0.60	
		QD77MS4	0.60	
		QD77MS16	0.75	
Control unit of displacement sensor		UQ1-01	0.50	
		UQ1-02	0.50	

(Note-1): 5VDC internal current consumption of shared equipment with PLC might be changed.
Be sure to refer to the manuals for each module.

(3) SSCNET III(/H) compatible equipment

(a) SSCNET III/H compatible equipment

Part name	Model name	Description	Remarks
MR-J5 series servo amplifier	MR-J5-□B		Refer to the servo amplifier (MR-J5(W)-□B) user's manuals.
	MR-J5-□B-RJ		
	MR-J5W2-□B	For 2-axis type	
	MR-J5W3-□B	For 3-axis type	
MR-J4 series servo amplifier	MR-J4-□B		Refer to the servo amplifier (MR-J4(W)-□B) instruction manuals.
	MR-J4-□B-RJ		
	MR-J4W2-□B	For 2-axis type	
	MR-J4W3-□B	For 3-axis type	
SSCNET III/H head module	LJ72MS15	Maximum link points: Input 64 bytes, Output 64 bytes Transmission cycle: 0.222ms, 0.444ms, 0.888ms	Refer to the MELSEC-L series PLC manuals.
Optical hub unit	MR-MV200	3 branches, 1 unit, 24VDC power supply connector is attached	

2 SYSTEM CONFIGURATION

(b) SSCNET III compatible equipment

Part name	Model name	Description	Remarks
MR-J3 series servo amplifier	MR-J3-□B		Refer to the servo amplifier (MR-J3(W)-□B) instruction manuals.
	MR-J3W-□B	For 2-axis type	
	MR-J3-□B-RJ006	For fully closed control	
	MR-J3-□B-RJ004	For linear servo motor	
	MR-J3-□B-RJ080W	For direct drive motor	
	MR-J3-□B Safety	For drive safety servo	

(4) Operating system software

Application	Software package			
	Q173DSCPU (Note-1)	Q172DSCPU (Note-1)	Q173DCPU(-S1)	Q172DCPU(-S1)
Conveyor assembly use SV13	SW8DNC-SV13QJ	SW8DNC-SV13QL	SW8DNC-SV13QB	SW8DNC-SV13QD
Automatic machinery use SV22	SW8DNC-SV22QJ	SW8DNC-SV22QL	SW8DNC-SV22QA	SW8DNC-SV22QC
Machine tool peripheral use SV43	—	—	SW7DNC-SV43QA	SW7DNC-SV43QC

(Note-1): The operating system software (SV22 (Virtual mode switching method)) is installed at the time of product purchases.

(5) Programming software packages

(a) Motion controller engineering environment

Part name	Model name
MELSOFT MT Works2 (MT Developer2 (Note-1))	SW1DND-MTW2-E

(Note-1): This software is included in Motion controller engineering environment "MELSOFT MT Works2".

(6) Related software packages

(a) PLC software package

Model name	Software package
GX Works2	SW1DND-GXW2-E
GX Developer	SW8D5C-GPPW-E

(b) Servo set up software package

Model name	Software package
MR Configurator2	SW1DNC-MRC2-E
MR Configurator (Note-1)	MRZJW3-SETUP221E

(Note-1): Q173DSCPU/Q172DSCPU is not supported.

POINTS

When the operation of Windows® is unclear in the operation of this software, refer to the official Windows® manual or a guidebook from another supplier.

2 SYSTEM CONFIGURATION

2.4 General Specifications

General specifications of the Motion controller are shown below.

Item	Specification					
Operating ambient temperature	0 to 55°C (32 to 131°F)					
Storage ambient temperature	-25 to 75°C (-13 to 167°F)					
Operating ambient humidity	5 to 95% RH, non-condensing					
Storage ambient humidity	5 to 95% RH, non-condensing					
Vibration resistance	Compliant with JIS B 3502 and IEC 61131-2	Under intermittent vibration	Frequency	Constant acceleration	Half amplitude	Sweep count
			5 to 8.4Hz	—	3.5mm (0.14inch)	
		Under continuous vibration	8.4 to 150Hz	9.8m/s ²	—	10 times each in X, Y, Z directions
			5 to 8.4Hz	—	1.75mm (0.07inch)	
			8.4 to 150Hz	4.9m/s ²	—	—
Shock resistance	Compliant with JIS B 3502 and IEC 61131-2 (147m/s ² , 3 times in each of 3 directions X, Y, Z)					
Operating ambience	No corrosive gases					
Operating altitude (Note-1)	2000m(6561.68ft.) or less					
Mounting location	Inside control panel					
Overvoltage category (Note-2)	II or less					
Pollution level (Note-3)	2 or less					

(Note-1): Do not use or store the Motion controller under pressure higher than the atmospheric pressure of altitude 0m. Doing so can cause an operation failure. When using the Motion controller under pressure, please contact with our sales representative.

(Note-2): This indicates the section of the power supply to which the equipment is assumed to be connected between the public electrical power distribution network and the machinery within premises.

Category II applies to equipment for which electrical power is supplied from fixed facilities.

The surge voltage withstand level for up to the rated voltage of 300V is 2500V.

(Note-3): This index indicates the degree to which conductive material is generated in terms of the environment in which the equipment is used.

Pollution level 2 is when only non-conductive pollution occurs. A temporary conductivity caused by condensing must be expected occasionally.

CAUTION

- The Motion controller must be stored and used under the conditions listed in the table of specifications above.
- When not using the module for a long time, disconnect the power line from the Motion controller or servo amplifier.
- Place the Motion controller and servo amplifier in static electricity preventing vinyl bags and store.
- When storing for a long time, please contact with our sales representative.
Also, execute a trial operation.

2 SYSTEM CONFIGURATION

2.5 Specifications of Equipment and Settings

2.5.1 Name of parts for CPU module

This section explains the names and setting of the module.

(1) Name of parts

(a) Q173DSCPU/Q172DSCPU

With battery cover open

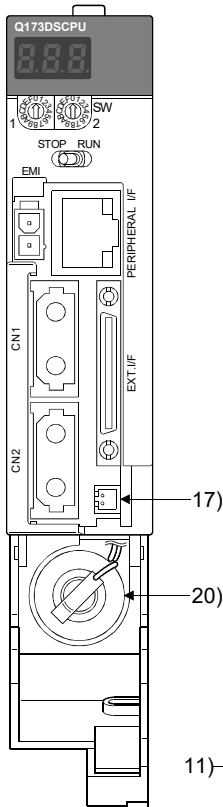

Front face of Q172DSCPU

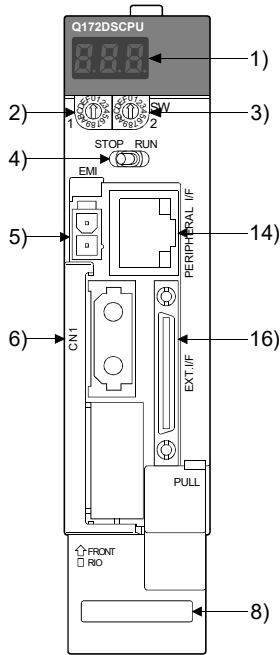

Front face of Q173DSCPU

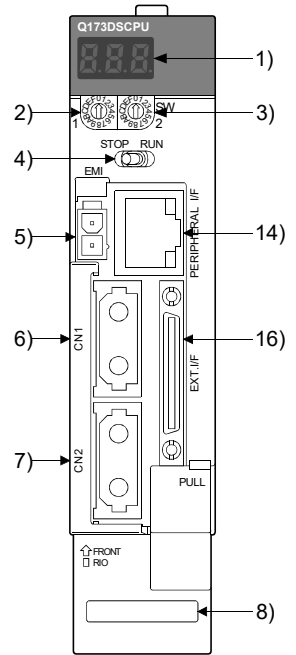

Side face

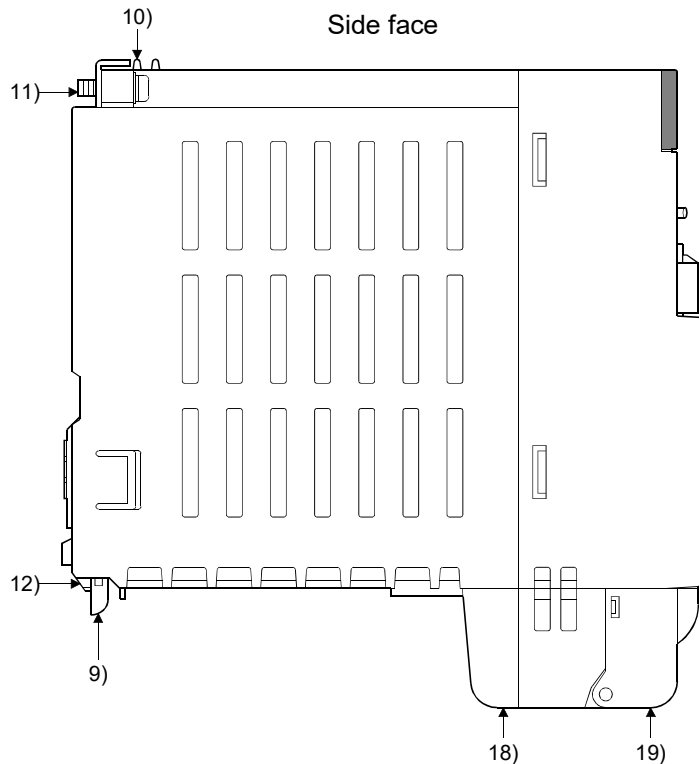

Bottom

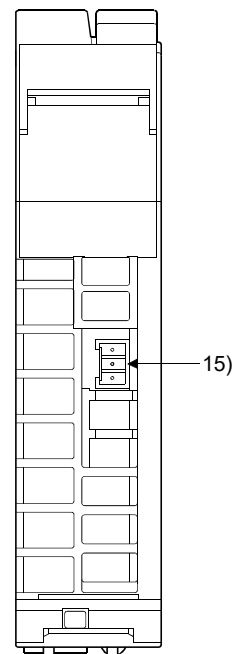

2 SYSTEM CONFIGURATION

(b) Q173DCPU(-S1)/Q172DCPU(-S1)

Front face of Q172DCPU(-S1)

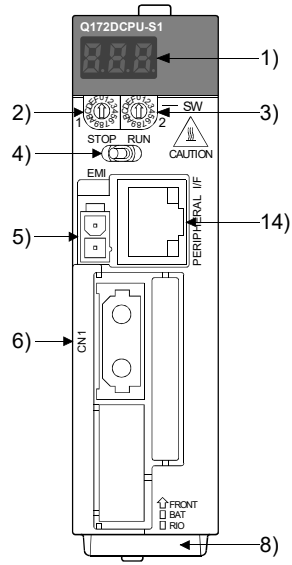

Front face of Q173DCPU(-S1)

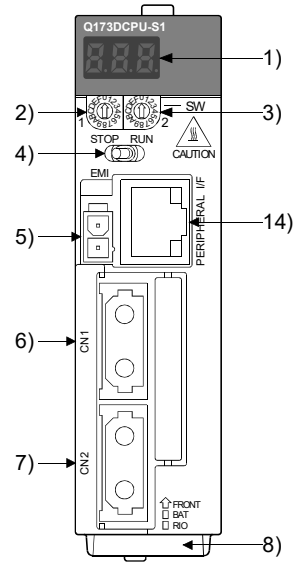

Side face

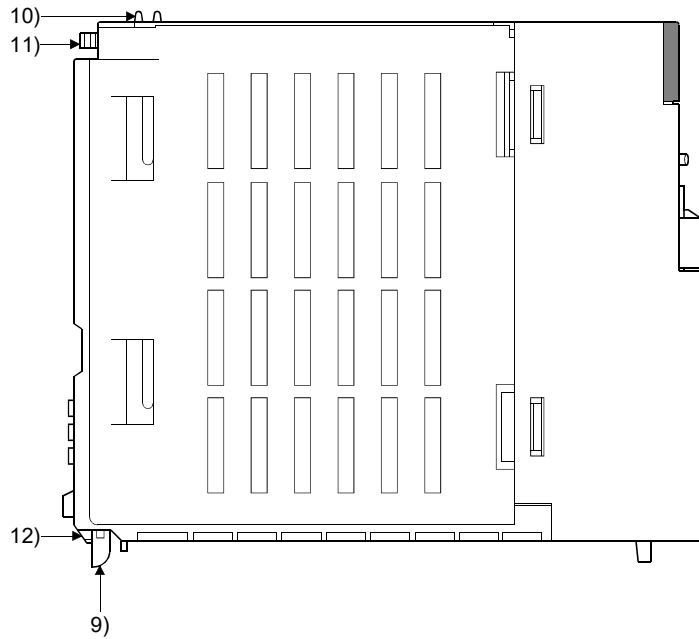

Bottom

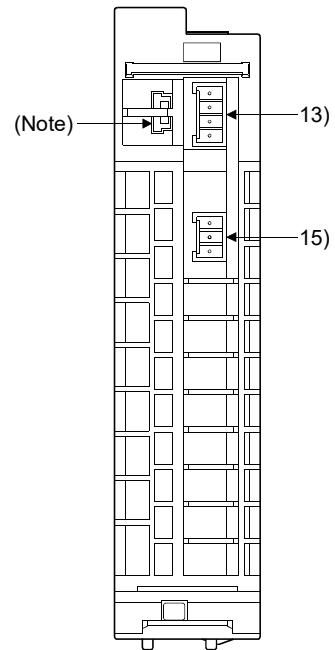

(Note): Unusable
(Under manufacturer test)

2 SYSTEM CONFIGURATION

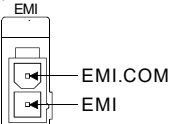
No.	Name	Application												
1)	7-segment LED	Indicates the operating status and error information.												
2)	Rotary function select 1 switch (SW1)	<ul style="list-style-type: none"> Set the operation mode. (Normal operation mode, Installation mode, Mode operated by ROM, etc) Each switch setting is 0 to F. (Note): Switch setting of factory default <ul style="list-style-type: none"> Q173DSCPU/Q172DSCPU : SW1 "0", SW2 "0" position Q173DCPU(-S1)/Q172DCPU(-S1): SW1 "A", SW2 "0" position 												
3)	Rotary function select 2 switch (SW2)													
4)	RUN/STOP switch	Move RUN/STOP to change the operating state of the Motion CPU module. RUN : Motion SFC program (SV13/SV22)/Motion program (SV43) is started. STOP : Motion SFC program (SV13/SV22)/Motion program (SV43) is stopped.												
5)	Forced stop input connector (EMI) (Note-1) 	Input to stop all axes of servo amplifier in a lump. EMI ON (opened) : Forced stop EMI OFF (24VDC input) : Forced stop release												
6)	SSCNETⅢ CN1 connector (Note-2)	Connector to connect the servo amplifier of line 1 (up to 16 axes).												
7)	SSCNETⅢ CN2 connector (Note-2), (Note-3)	Connector to connect the servo amplifier of line 2 (up to 16 axes).												
8)	Serial number display	Displays the serial number described on the rating plate.												
9)	Module mounting lever	Used to install the module to the base unit.												
10)	Module fixing hook (Note-4)	Hook used to fix the module to the base unit. (Auxiliary use for installation)												
11)	Module fixing screw	Screw used to fix to the base unit. (M3×13)												
12)	Module fixing projection	Hook used to fix to the base unit.												
13)	Battery connector (BAT) (Note-5)	Connector to connect the battery holder unit Q170DBATC.												
14)	PERIPHERAL I/F connector (Note-6)	For communication I/F with peripheral devices. <ul style="list-style-type: none"> Lower LED Remains flashing: It communicates with the peripheral devices. ON : It does not communicate with the peripheral devices. Upper LED Data transmission speed ON : 100Mbps OFF : 10Mbps <table border="1" data-bbox="590 1590 1324 1792"> <thead> <tr> <th colspan="2">Item</th> <th>Specification</th> </tr> </thead> <tbody> <tr> <td rowspan="4">Transmission</td> <td>Data transmission speed</td> <td>100Mbps/10Mbps</td> </tr> <tr> <td>Communication mode</td> <td>Full-duplex/Half-duplex</td> </tr> <tr> <td>Transmission method</td> <td>Base band</td> </tr> <tr> <td>Cable length [m(ft.)]</td> <td>Up to 30 (98.43)</td> </tr> </tbody> </table>	Item		Specification	Transmission	Data transmission speed	100Mbps/10Mbps	Communication mode	Full-duplex/Half-duplex	Transmission method	Base band	Cable length [m(ft.)]	Up to 30 (98.43)
Item		Specification												
Transmission	Data transmission speed	100Mbps/10Mbps												
	Communication mode	Full-duplex/Half-duplex												
	Transmission method	Base band												
	Cable length [m(ft.)]	Up to 30 (98.43)												
15)	RIO connector (Note-6)	Connector to connect the safety signal module (Q173DSXY).												
16)	Internal I/F connector	Connector to connect the manual pulse generator/incremental synchronous encoder, or to input the input signal/mark detection input signal. (Voltage-output/open-collector type, Differential-output type)												
17)	Battery connector	Connector to connect the battery (Q6BAT).												

2 SYSTEM CONFIGURATION

No.	Name	Application
18)	Battery holder	Holder to support the battery (Q6BAT).
19)	Battery cover	Cover for battery (Q6BAT).
20)	Battery (Note-5)	Battery for backup of program, parameters, motion devices (#), devices of latch data and absolute position data.

(Note-1): Be sure to use the cable for forced stop input (sold separately). The forced stop cannot be released without using it. If the cable for forced stop input is fabricated on the customer side, make it within 30m(98.43ft.).

(Note-2): Put the SSCNET cable in the duct or fix the cable at the closest part to the Motion CPU module with bundle material in order to prevent SSCNET cable from putting its own weight on SSCNET connector.

(Note-3): Q173DSCPU/Q173DCPU(-S1) only







(Note-4): This screw is auxiliary use for module installation to the main base unit. Be sure to fix modules to the main base unit using supplied fixing screws.

(Note-5): Be sure to use the battery. The programs, parameters, motion devices(#), devices of latch data and absolute position data of SRAM built-in Motion CPU module are not backed up if the battery is not set correctly.

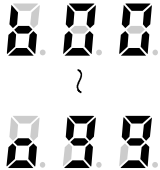
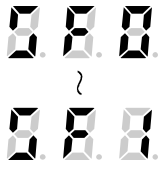





(Note-6): Q173DSCPU/Q172DSCPU/Q173DCPU-S1/Q172DCPU-S1 only

(2) 7-segment LED display

The LED displays/flashes in the combination with errors.

Item	7-segment LED	Remark
Start	 Initializing	It takes about 10 seconds to initialize (RUN/STOP display). Execute the power cycle of the Multiple CPU system if the operation stops at initializing for several minutes. It may be Motion controller's hardware fault when it is not improved. Explain the error symptom (LED display) and get advice from our sales representative for the modules with failure.
	 Initializing (Safety observation function use)	Initialization and self-diagnosis of safety observation function is executed at power supply ON. It takes about 15 seconds to execute initialization and self-diagnosis of safety observation function.
	 "E□□" display	Hardware error or software error during initializing. □ indicates the error code. Explain the error symptom (LED display) and get advice from our sales representative for the modules with failure.
Normal	 " * " remains flashing	Normal operation.
Installation mode	 Steady "INS" display, " * " remains flashing	Mode to install the operating system software via personal computer.
Operation mode	Mode operated by RAM  " * " remains flashing	Mode to operate based on the user programs and parameters stored in the SRAM built-in Motion CPU module.
	Mode operated by ROM  Steady " ." display, " * " remains flashing	Mode to operate after the user programs and parameters stored in the FLASH ROM built-in Motion CPU are read to the SRAM built-in Motion CPU.

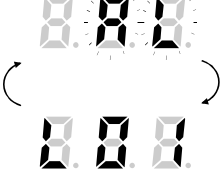
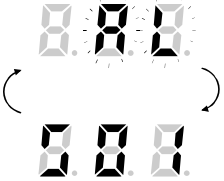
2 SYSTEM CONFIGURATION

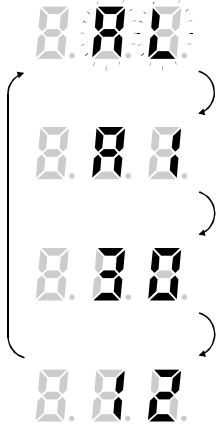
Item		7-segment LED		Remark
STOP			Steady "STP" display	Stopped the Motion SFC program (SV13/SV22)/ Motion program (SV43) with the PLC READY flag (M2000) OFF.
RUN			Steady "RUN" display	Executed the Motion SFC program (SV13/SV22)/ Motion program (SV43) with the PLC READY flag (M2000) ON.
Battery error	Early stage warning (2.7V or less)		Steady "BT1" display	Displayed at battery voltage 2.7V or less. Refer to Section "6.5 Battery".
	Final stage warning (2.5V or less)		Steady "BT2" display	Displayed at battery voltage 2.5V or less. Refer to Section "6.5 Battery".
Operating system software not installed			"A00" remains flashing	It becomes the status of installation mode when the operating system software is not installed.
System setting error			"AL" flashes 3 times ↓ Steady "L01" display	System setting error of the Motion CPU Refer to the "Q173D(S)CPU/Q172D(S)CPU Motion controller Programming Manual (COMMON)" for details.
Servo error			"AL" flashes 3 times ↓ Steady "S01" display	Servo error of the Motion CPU Refer to the Programming Manual of the operating system software used for details.
WDT error			Steady "... " display	Hardware fault or software fault Refer to the Programming Manual of the operating system software used for details.
Self-diagnostic error (Error related for Multiple CPU)			"AL" flashes 3 times ↓ Steady "A1" display (Self-diagnosis error) ↓ 4-digits error code is displayed in two sequential flashes of 2-digits each. (ex. error code [3012])	Setting error of the Multiple CPU system Refer to the "Q173D(S)CPU/Q172D(S)CPU Motion controller Programming Manual (COMMON)" for details.

POINTS

- (1) An error is displayed at the 7-segment LED, confirm the error code etc. using MT Developer2.
- (2) Refer to the Motion CPU error batch monitor of MT Developer2 or error list of Programming Manual for error details.

2 SYSTEM CONFIGURATION

(3) Rotary switch assignment

(a) Rotary function select 1 switch (SW1)

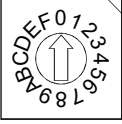
Rotary switch	Setting ^(Note)	Mode	Description
	0	Normal mode	Normal operation mode
	A	Installation mode	Installed the operating system software using MT Developer2

(Note): Do not set other than the above setting.

(b) Rotary function select 2 switch (SW2)

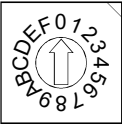
Rotary switch	Setting ^(Note)	Mode	Description
	0	Mode operated by RAM	Normal operation mode (Operation by the setting data and parameters stored in the SRAM built-in Motion CPU module.)
	6	Mode operated by ROM	Mode to operate based on the setting data and parameters wrote to the FLASH ROM built-in Motion CPU module.
	8	Ethernet IP address display mode	Mode to display the Ethernet IP address.
	C	SRAM clear	SRAM "0" clear

(Note): Do not set other than the above setting.

⚠ CAUTION

- Be sure to turn OFF the Multiple system power supply before the rotary switch setting change.

(4) Operation mode

(a) Rotary switch setting and operation mode

Rotary switch setting ^(Note-1)		Operation mode
SW1	SW2	
A	Any setting (Except C)	Installation mode
0	0	Mode operated by RAM
0	6	Mode operated by ROM
0	8	Ethernet IP address display mode
Any setting	C	SRAM clear ^(Note-2)

(Note-1): Do not set other than the above setting.

(Note-2): The programs, parameters, motion devices(#), devices of latch data and absolute position data of SRAM built-in Motion CPU module are cleared.

2 SYSTEM CONFIGURATION

(b) Operation mode overview

Operation mode	7-segment LED	Operation overview
Installation mode		<ul style="list-style-type: none"> Steady "INS" display at the 7-segment LED. Operating system software can be installed. It is STOP status regardless of the RUN/STOP switch position at the front side of Motion CPU module. The stop error "MULTI CPU DOWN (error code: 7000)" will occur at the other CPU.
Mode operated by RAM		<ul style="list-style-type: none"> " . " remains flashing in the first digit of 7-segment LED. It operates based on the user programs and parameters stored in the SRAM built-in Motion CPU module. The user programs and parameters for the ROM operation can be written to the FLASH ROM built-in Motion CPU.
Mode operated by ROM		<ul style="list-style-type: none"> " . " remains flashing in the first digit and steady " . " display in the second digit of 7-segment LED. Operation starts after the user programs and parameters stored in the FLASH ROM built-in Motion CPU module are read to the SRAM built-in Motion CPU module at power supply on or reset of the Multiple CPU system. If the ROM writing is not executed, even if the user programs and parameters are changed using the MT Developer2 during mode operated by ROM, operation starts with the contents of the FLASH ROM built-in Motion CPU module at next power supply on or reset. Also, If the ROM writing is not executed, even if the auto tuning data are reflected on the servo parameter of Motion CPU by operation in the auto-tuning setting, operation starts with the contents of the FLASH ROM built-in Motion CPU module at next power supply on or reset.
Ethernet IP address display mode	Refer to next page (c)	<ul style="list-style-type: none"> Refer to next page "(c) Ethernet IP address display mode overview". It is STOP status regardless of the RUN/STOP switch position on the front side of Motion CPU module. The stop error "MULTI CPU DOWN (error code: 7000)" will occur at the other CPU.
SRAM clear		<ul style="list-style-type: none"> " . " remains flashing in the first digit of 7-segment LED. The programs, parameters, motion devices(#), devices of latch data and absolute position data of SRAM built-in Motion CPU module are cleared by turning ON the Multiple CPU system's power supply after the rotary switch 2 is set to "C".

POINTS

- Be sure to turn OFF the Multiple CPU system's power supply before the rotary switch setting change.
- It is recommended to shift to the mode operated by ROM after the programs and parameters are fixed. The erasing of the programs and parameters can be avoided even if the battery decrease. (The ROM writing cannot be executed for the current position of the servo motor in the absolute position system, home position and latch device. Back up them beforehand using MT Developer2.)
Refer to Section 4.4 of the "Q173D(S)CPU/Q172D(S)CPU Motion controller Programming Manual (COMMON)" for details of the ROM operation.

2 SYSTEM CONFIGURATION

(c) Ethernet IP address display mode overview

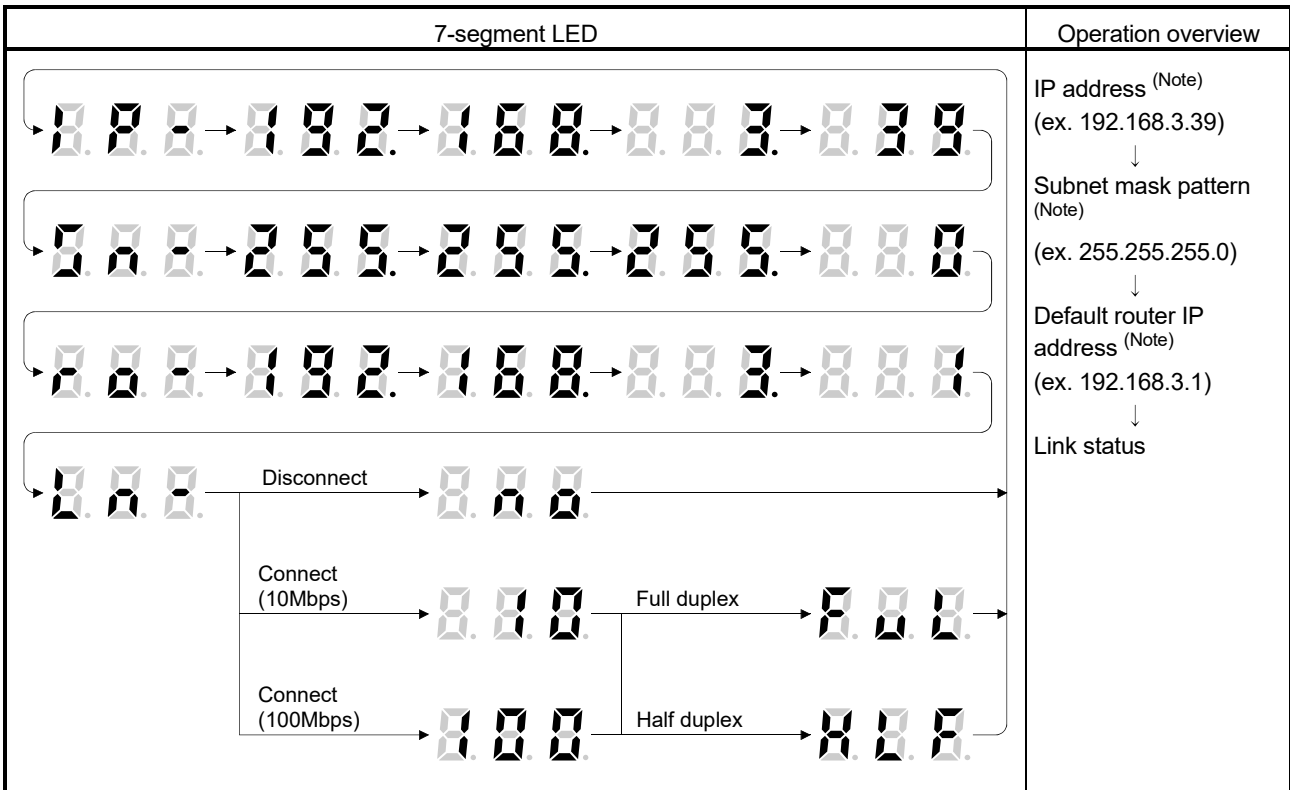

(Note): When the Ethernet parameters are not written in the Motion CPU, the addresses are displayed as follows.

- IP address : 192.168.3.39
- Subnet mask pattern : 255.255.255.0
- Default router IP address : 192.168.3.1

(5) Basic specifications of Q173D(S)CPU/Q172D(S)CPU

(a) Module specifications

Item	Q173DSCPU	Q172DSCPU	Q173DCPU	Q173DCPU-S1	Q172DCPU	Q172DCPU-S1
Internal current consumption (5VDC) [A]	1.75 (Note-1)	1.44 (Note-1)	1.25	1.30	1.25	1.30
Mass [kg]	0.38		0.33			
Exterior dimensions [mm(inch)]	120.5 (4.74)(H) × 27.4 (1.08)(W) × 120.3 (4.74)(D)		98 (3.85)(H) × 27.4 (1.08)(W) × 119.3 (4.70)(D)			

(Note-1): The current consumption (0.2[A]) of manual pulse generator/incremental synchronous encoder connected to the internal I/F connector is not included.

2 SYSTEM CONFIGURATION

(6) SV13/SV22 Motion control specifications/performance specifications

(a) Motion control specifications

Item	Q173DSCPU	Q172DSCPU	Q173DCPU(-S1)	Q172DCPU(-S1)
Number of control axes	Up to 32 axes	Up to 16 axes	Up to 32 axes	Up to 8 axes
Operation cycle (default)	SV13 0.22ms/ 1 to 4 axes 0.44ms/ 5 to 10 axes 0.88ms/ 11 to 24 axes 1.77ms/25 to 32 axes	0.22ms/ 1 to 4 axes 0.44ms/ 5 to 10 axes 0.88ms/ 11 to 16 axes	0.44ms/ 1 to 6 axes 0.88ms/ 7 to 18 axes 1.77ms/19 to 32 axes	0.44ms/ 1 to 6 axes 0.88ms/ 7 to 8 axes
	SV22 0.44ms/ 1 to 6 axes 0.88ms/ 7 to 16 axes 1.77ms/17 to 32 axes	0.44ms/ 1 to 6 axes 0.88ms/ 7 to 16 axes	0.44ms/ 1 to 4 axes 0.88ms/ 5 to 12 axes 1.77ms/13 to 28 axes 3.55ms/29 to 32 axes	0.44ms/ 1 to 4 axes 0.88ms/ 5 to 8 axes
Interpolation functions	Linear interpolation (Up to 4 axes), Circular interpolation (2 axes), Helical interpolation (3 axes)			
Control modes	PTP(Point to Point) control, Speed control, Speed-position switching control, Fixed-pitch feed, Constant speed control, Position follow-up control, Speed control with fixed position stop, Speed switching control, High-speed oscillation control, Speed-torque control, Synchronous control (SV22 (Virtual mode switching method/Advanced synchronous control method))		PTP(Point to Point) control, Speed control, Speed-position switching control, Fixed-pitch feed, Constant speed control, Position follow-up control, Speed control with fixed position stop, Speed switching control, High-speed oscillation control, Synchronous control (SV22)	
Acceleration/ deceleration control	Trapezoidal acceleration/deceleration, S-curve acceleration/deceleration, Advanced S-curve acceleration/deceleration			
Compensation	Backlash compensation, Electronic gear, Phase compensation (SV22)			
Programming language	Motion SFC, Dedicated instruction, Mechanical support language (SV22) ^(Note-1)		Motion SFC, Dedicated instruction, Mechanical support language (SV22)	
Servo program capacity	16k steps			
Number of positioning points	3200 points (Positioning data can be designated indirectly)			
Peripheral I/F	USB/RS-232/Ethernet (Via PLC CPU) PERIPHERAL I/F (Motion CPU)		USB/RS-232/Ethernet (Via PLC CPU) PERIPHERAL I/F (Motion CPU) ^(Note-2)	
Home position return function	Proximity dog method (2 types), Count method (3 types), Data set method (2 types), Dog cradle method, Stopper method (2 types), Limit switch combined method, Scale home position signal detection method, Dogless home position signal reference method, Driver home position return method		Proximity dog method (2 types), Count method (3 types), Data set method (2 types), Dog cradle method, Stopper method (2 types), Limit switch combined method, Scale home position signal detection method	
	Home position return re-try function provided, home position shift function provided			
JOG operation function	Provided			
Manual pulse generator operation function	Possible to connect 3 modules (Q173DPX use) Possible to connect 1 module (Built-in interface in Motion CPU use) ^(Note-3)		Possible to connect 3 modules (Q173DPX use)	
Synchronous encoder operation function ^(Note-4)	Possible to connect 12 modules (SV22 use) (Q172DEX + Q173DPX + Built-in interface in Motion CPU + Via device ^(Note-5) + Via servo amplifier ^(Note-5) , ^(Note-6) + Multiple CPU synchronous control ^(Note-5))		Possible to connect 12 modules (SV22 use) (Q172DEX + Q173DPX)	Possible to connect 8 modules (SV22 use) (Q172DEX + Q173DPX)
M-code function	M-code output function provided, M-code completion wait function provided			

2 SYSTEM CONFIGURATION

Motion control specifications (continued)

Item		Q173DSCPU	Q172DSCPU	Q173DCPU(-S1)	Q172DCPU(-S1)
Limit switch output function	SV13	Number of output points 32 points Watch data: Motion control data/Word device			
	SV22	Virtual mode switching method: Number of output points 32 points Advanced synchronous control method: Number of output points 64 points × 2 settings Output timing compensation Watch data: Motion control data/Word device		Number of output points 32 points Watch data: Motion control data/Word device	
ROM operation function		Provided			
Multiple CPU synchronous control (Note-5)		Provided		None	
External input signal		Q172DLX, External input signals (FLS/RLS/DOG) of servo amplifier, Built-in interface in Motion CPU (DI), Bit device		Q172DLX or External input signals (FLS/RLS/DOG) of servo amplifier	
High-speed reading function (Note-7)		Provided (Via built-in interface in Motion CPU, Via input module, Via tracking of Q172DEX/Q173DPX)		Provided (Via input module, Via tracking of Q172DEX/Q173DPX)	
Forced stop		Motion controller forced stop (EMI connector, System setting), Forced stop terminal of servo amplifier			
Number of I/O points		Total 256 points (Built-in interface in Motion CPU (Input 4 points) + I/O module + Intelligent function module)		Total 256 points (I/O module)	
Mark detection function	Mark detection mode setting	Continuous detection mode, Specified number of detection mode, Ring buffer mode		None	
	Mark detection signal	Built-in interface in Motion CPU (4 points), Bit device, DOG/CHANGE signal of Q172DLX			
	Mark detection setting	32 settings			
Clock function		Provided			
Security function		Provided (Protection by software security key or password)		Provided (Protection by password)	
All clear function		Provided			
Remote operation		Remote RUN/STOP, Remote latch clear			
Optional data monitor function	SSCNETⅢ/H	Up to 6 data/axis (Communication data: Up to 6 points/axis)		None	
	SSCNETⅢ	Up to 3 data/axis (Communication data: Up to 3 points/axis)			
Digital oscilloscope function		Motion buffering method (Real-time waveform can be displayed) Sampling data: Word 16CH, Bit 16CH		Motion buffering method (Real-time waveform can be displayed) Sampling data: Word 4CH, Bit 8CH	
Absolute position system		Made compatible by setting battery to servo amplifier. (No battery required when a servo motor with a batteryless absolute position encoder is used) (Possible to select the absolute data method or incremental method for each axis)			
SSCNET communication (Note-8)	Communication type	SSCNETⅢ/H, SSCNETⅢ		SSCNETⅢ	
	Number of lines	2 lines (Note-9)	1 line (Note-9)	2 lines	1 line
Driver communication function (Note-10)		Provided		None	

2 SYSTEM CONFIGURATION

Motion control specifications (continued)

Item		Q173DSCPU	Q172DSCPU	Q173DCPU(-S1)	Q172DCPU(-S1)
Number of Motion related modules	Q172DLX	4 modules usable	2 modules usable	4 modules usable	1 module usable
	Q172DEX	6 modules usable			4 modules usable
	Q173DPX	4 modules usable (Note-11)			3 modules usable (Note-11)
Number of SSCNETⅢ/H head module connection stations		Up to 8 stations usable (Up to 4 stations/line)	Up to 4 stations usable	Unusable	
Number of optical hub unit connections		Up to 32 units usable (Up to 16 units/line)	Up to 16 units usable	Unusable	

(Note-1): SV22 virtual mode only

(Note-2): Q173DCPU-S1/Q172DCPU-S1 only

(Note-3): When the manual pulse generator is used via the built-in interface in Motion CPU, the Q173DPX cannot be used.

(Note-4): Any incremental synchronous encoder connected to the built-in interface in Motion CPU will automatically be assigned an Axis No. one integer greater than the number of encoders connected to any Q172DEX modules and Q173DPX modules.

(Note-5): SV22 advanced synchronous control only

(Note-6): Servo amplifier (MR-J5(W)-□B/MR-J4(W)-□B) only.

Refer to "Q173DSCPU/Q172DSCPU Motion controller Programming Manual (Advanced Synchronous Control)" for details on devices that can be used as a synchronous encoder axis.

(Note-7): This cannot be used in SV22 advanced synchronous control.

(Note-8): The servo amplifiers for SSCNET cannot be used.

(Note-9): SSCNETⅢ and SSCNETⅢ/H cannot be combined in the same line.

For Q173DSCPU, SSCNETⅢ or SSCNETⅢ/H can be set every line.

(Note-10): Servo amplifier (MR-J5-□B/MR-J4-□B/MR-J3-□B) only.

(Note-11): When using the incremental synchronous encoder (SV22 use), you can use above number of modules.

When connecting the manual pulse generator, you can use only 1 module.

2 SYSTEM CONFIGURATION

(b) Motion SFC performance specifications

Item		Q173DSCPU/Q172DSCPU	Q173DCPU(-S1)/Q172DCPU(-S1)		
Motion SFC program capacity	Code total (Motion SFC chart + Operation control + Transition)	652k bytes	543k bytes		
	Text total (Operation control + Transition)	668k bytes	484k bytes		
Motion SFC program	Number of Motion SFC programs	256 (No.0 to 255)			
	Motion SFC chart size/program	Up to 64k bytes (Included Motion SFC chart comments)			
	Number of Motion SFC steps/program	Up to 4094 steps			
	Number of selective branches/branch	255			
	Number of parallel branches/branch	255			
	Parallel branch nesting	Up to 4 levels			
Operation control program (F/FS) / Transition program (G)	Number of operation control programs	4096 with F(Once execution type) and FS(Scan execution type) combined. (F/FS0 to F/FS4095)			
	Number of transition programs	4096(G0 to G4095)			
	Code size/program	Up to approx. 64k bytes (32766 steps)			
	Number of blocks(line)/program	Up to 8192 blocks (in the case of 4 steps(min)/blocks)			
	Number of characters/block	Up to 128 (comment included)			
	Number of operand/block	Up to 64 (operand: constants, word device, bit devices)			
	() nesting/block	Up to 32 levels			
Descriptive expression	Operation control program	Calculation expression, bit conditional expression, branch/repetition processing	Calculation expression, bit conditional expression		
	Transition program	Calculation expression/bit conditional expression/ comparison conditional expression			
Execute specification	Number of multi execute programs		Up to 256		
	Number of multi active steps		Up to 256 steps/all programs		
	Executed task	Normal task		Execute in main cycle of Motion CPU	
		Event task (Execution can be masked.)	Fixed cycle	Execute in fixed cycle (0.22ms, 0.44ms, 0.88ms, 1.77ms, 3.55ms, 7.11ms, 14.2ms)	Execute in fixed cycle (0.44ms, 0.88ms, 1.77ms, 3.55ms, 7.11ms, 14.2ms)
			External interrupt	Executes when the input set to the event task factor in the input module controlled by the Motion CPU (16 points) turns ON.	
			PLC interrupt	Execute with interrupt instruction (D(P).GINT) from PLC CPU.	
		NMI task		Executes when the input set to the NMI task factor in the input module controlled by the Motion CPU (16 points) turns ON.	
Number of I/O points (X/Y)		8192 points			
Number of real I/O points (PX/PY)		256 points (Built-in interface in Motion CPU (Input 4 points) + I/O module + Intelligent function module)	256 points (I/O module)		

2 SYSTEM CONFIGURATION

(7) SV43 Motion control specifications/performance specifications

(a) Motion control specifications

Item		Q173DCPU(-S1)	Q172DCPU(-S1)
Number of control axes		Up to 32 axes	
Operation cycle (default)		0.44ms/ 1 to 4 axes 0.88ms/ 5 to 12 axes 1.77ms/13 to 28 axes 3.55ms/29 to 32 axes	0.44ms/ 1 to 4 axes 0.88ms/ 5 to 8 axes
Interpolation functions		Linear interpolation (Up to 4 axes), Circular interpolation (2 axes), Helical interpolation (3 axes)	
Control modes		PTP (Point to Point) control, Constant speed positioning, High-speed oscillation control	
Acceleration/deceleration control		Trapezoidal acceleration/deceleration, S-curve acceleration/deceleration	
Compensation		Backlash compensation, Electronic gear	
Programming language		Dedicated instruction (EIA language)	
Motion program capacity		504k bytes	
Number of programs		1024	
Number of simultaneous start programs		Axis designation program : 32 Control program : 16	Axis designation program : 8 Control program : 16
Number of positioning points		Approx. 10600 points (Positioning data can be designated indirectly)	
Peripheral I/F		USB/RS-232/Ethernet (Via PLC CPU), PERIPHERAL I/F (Motion CPU) (Note-1)	
Home position return function		Proximity dog method (2 types), Count method (3 types), Data set method (2 types), Dog cradle method, Stopper method (2 types), Limit switch combined method, Scale home position signal detection method ----- Home position return re-try function provided, home position shift function provided	
JOG operation function		Provided	
Manual pulse generator operation function		Possible to connect 3 modules (Q173DPX use)	
M-code function		M-code output function provided, M-code completion wait function provided	
Limit switch output function		Number of output points 32 points Watch data: Motion control data/Word device	
Skip function		Provided	
Override ratio setting function		Override ratio setting : -100 to 100[%]	
ROM operation function		Provided	
External input signal		Q172DLX or External input signals (FLS/RLS/DOG) of servo amplifier	
High-speed reading function		Provided (Via input module, Via tracking of Q173DPX)	
Forced stop		Motion controller forced stop (EMI connector, System setting), Forced stop terminal of servo amplifier	
Number of I/O points		Total 256 points (I/O module)	
Clock function		Provided	
Security function		Provided (Protection by password)	
All clear function		Provided	
Remote operation		Remote RUN/STOP, Remote latch clear	
Digital oscilloscope function		Provided	
Absolute position system		Made compatible by setting battery to servo amplifier. (Possible to select the absolute data method or incremental method for each axis)	
SSCNET communication (Note-2)	Communication type	SSCNETⅢ	
	Number of lines	2 lines	1 line
Number of Motion related modules	Q172DLX	4 modules usable	1 module usable
	Q173DPX	1 modules usable	

(Note-1): Q173DCPU-S1/Q172DCPU-S1 only

(Note-2): The servo amplifiers for SSCNET cannot be used.

2 SYSTEM CONFIGURATION

(b) Motion program performance specifications

Item		Q173DCPU(-S1)/Q172DCPU(-S1)
Program capacity	Total of program files	504k bytes
	Number of programs	Up to 1024 (No. 1 to 1024)
Operation controls	Arithmetic operation	Unary operation, Addition and subtraction operation, Multiplication and division operation, Remainder operation
	Comparison operation	Equal to, Not equal to
	Logical operation	Logical shift operation, Logical negation, Logical AND, Logical OR, Exclusive OR
G-codes	Positioning command	G00, G01, G02, G03, G04, G09, G12, G13, G23, G24, G25, G26, G28, G30, G32, G43, G44, G49, G53, G54, G55, G56, G57, G58, G59, G61, G64, G90, G91, G92, G98, G99, G100, G101
M-codes	Output command to data register	M****
Special M-codes	Program control command	M00, M01, M02, M30, M98, M99, M100
Variable	Device variable	X, Y, M, B, F, D, W, #, U□\G
Functions	Trigonometric function	SIN, COS, TAN, ASIN, ACOS, ATAN
	Numerical function	ABS, SQR, BIN, LN, EXP, BCD, RND, FIX, FUP, INT, FLT, DFLT, SFLT
Instructions	Start/end	CALL, CLEAR
	Home position return	CHGA
	Speed/torque setting	CHGV, CHGT, TL
	Motion control	WAITON, WAITOFF, EXEON, EXEOFF
	Jump/repetition processing	CALL, GOSUB, GOSUBE, IF...GOTO, IF...THEN...ELSE IF...ELSE...END, WHILE...DO...BREAK...CONTINUE...END
	Data operation	BMOV, BDMOV, FMOV, BSET, BRST, SET, RST, MULTW, MULTR, TO, FROM, ON, OFF, IF...THEN...SET/RST/OUT, PB
Number of controls	Program calls (GOSUB/GOSUBE)	Up to 8
	Program calls (M98)	Up to 8

(8) Selection of Q172DEX, Q173DPX

Item	Synchronous encoder		Manual pulse generator
	Serial absolute	Incremental	
Q173DSCPU	12 modules		3 modules
Q172DSCPU			
Q173DCPU(-S1)			
Q172DCPU(-S1)	8 modules		
Module selection	Q172DEX	Q173DPX	

2 SYSTEM CONFIGURATION

(9) Internal I/F connector

(a) The pin layout of the internal I/F connector

Use the internal I/F connector on the front of the Motion CPU to connect to manual pulse signals and incremental synchronous encoder signals.

The following is the pin layout of the internal I/F connector as viewed from the front.

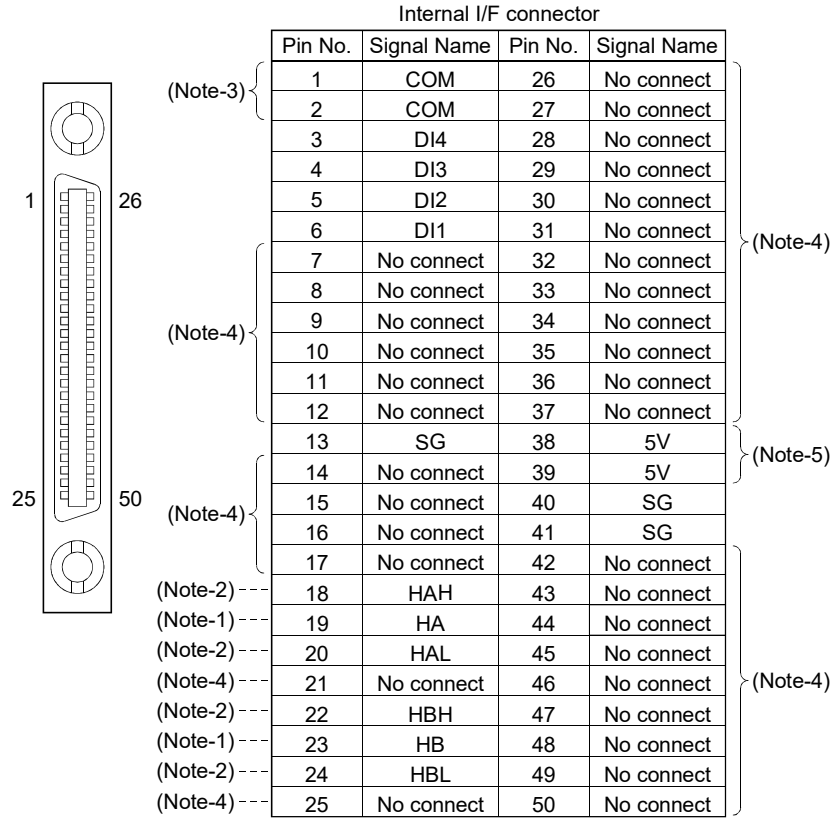

Applicable connector model name

HDR type connector (HONDA TSUSHIN KOGYO CO., LTD.)

HDR-E50MSG1+ connector

HDR-E50LPHP+ connector case

(Note-1): Voltage-output/open-collector type

Connect the A-phase signal to HA, and the B-phase signal to HB.

(Note-2): Differential-output type

Connect the A-phase signal to HAH, and the A-phase inverse signal to HAL.

Connect the B-phase signal to HBH, and the B-phase inverse signal to HBL.

(Note-3): "COM" is the common terminal of DI1, DI2, DI3 and DI4.

(Note-4): Do not connect to any of the terminal is explained as "No connect".

(Note-5): Do not use the 5V terminals for applications other than power supply for manual pulse generator/incremental synchronous encoder.

2 SYSTEM CONFIGURATION

(b) Input signal/Mark detection

1) Specifications of input signal/mark detection input signal

Item		Specifications
Number of input points		4 points
Input method		Positive common/Negative common shared
Common terminal arrangement		4 points/common (Common contact: COM)
Isolation method		Photocoupler
Rated input voltage		24VDC
Rated input current (I _{IN})		Approx. 5mA
Operating voltage range		21.6 to 26.4VDC (24VDC ±10%, ripple ratio 5% or less)
ON voltage/current		17.5VDC or more/3.5mA or more
OFF voltage/current		5VDC or less/0.9mA or less
Input resistance		Approx. 5.6kΩ
Response time	OFF to ON	1ms
	ON to OFF	

2) Interface between input signal/mark detection input signal

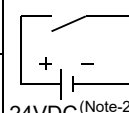
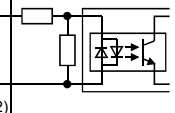
Input or output	Signal name		Pin No.				Wiring example	Internal circuit	Description
			1	2	3	4			
Input	Input/ Mark detection signal input	DI□(Note-1)	6	5	4	3	 24VDC (Note-2)		Signal input, Mark detection signal input
		COM	1 2						

(Note-1): □=1 to 4

(Note-2): As for the 24VDC sign, both "+" and "-" are possible.

2 SYSTEM CONFIGURATION

- (c) Manual pulse generator/Incremental synchronous encoder input
 1) Specifications of manual pulse generator/incremental synchronous encoder

Item		Specifications
Signal input form		Phase A/Phase B
Differential-output type (26LS31 or equivalent)	Maximum input pulse frequency ^(Note-1)	1Mpps (After magnification by 4, up to 4Mpps)
	Pulse width	1 μ s or more
	Leading edge/trailing edge time	0.25 μ s or less
	Phase difference	0.25 μ s or more
	High-voltage	2.0 to 5.25VDC
	Low-voltage	0 to 0.8VDC
	Differential voltage	\pm 0.2V
	Cable length	Up to 30m (98.43ft.)
Example of waveform (For 1Mpps)	<p>(Note): Duty ratio 50%</p>	
Voltage-output/ Open-collector type	Maximum input pulse frequency ^(Note-1)	200kpps (After magnification by 4, up to 800kpps)
	Pulse width	5 μ s or more
	Leading edge/trailing edge time	1.2 μ s or less
	Phase difference	1.2 μ s or more
	High-voltage	3.0 to 5.25 VDC
	Low-voltage	0 to 1.0VDC
	Cable length	Up to 10m (32.81ft.)
	Example of waveform (For 200kpps)	<p>(Note): Duty ratio 50%</p>

(Note-1): The maximum input pulse frequency is influenced by the leading/trailing edge time of the input waveform. Countable frequencies are shown below.

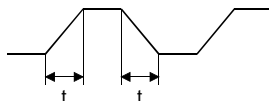

Maximum input pulse frequency	Up to 1Mpps	Up to 500kpps	Up to 200kpps	Up to 100kpps
Leading/trailing edge time (t) (A-phase, B-phase input common shared)	0.25 μ s or less	0.5 μ s or less	1.25 μ s or less	2.5 μ s or less

2 SYSTEM CONFIGURATION

POINT

Use a manual pulse generator or an incremental synchronous encoder that consumes less than 0.2[A] of current.

2) Interface between manual pulse generator (differential-output type)/ incremental synchronous encoder

Input or Output	Signal name	Pin No.	Wiring example	Internal circuit	Specification	Description	
Input	Manual pulse generator, phase A	A+ HAH	18			<ul style="list-style-type: none"> Rated input voltage 5.5VDC or less HIGH level 2.0 to 5.25VDC LOW level 0.8VDC or less 26LS31 or equivalent 	<p>For connection manual pulse generator/ incremental synchronous encoder Phases A, B</p> <ul style="list-style-type: none"> Pulse width $1\mu\text{s}$ or more Leading edge, Trailing edge time $0.5\mu\text{s}$ or more (Duty ratio: 50%) Phase difference $0.25\mu\text{s}$ or more <p>(1) Positioning address increases if Phase A leads Phase B. (2) Positioning address decreases if Phase B leads Phase A.</p>
		A- HAL	20				
	Manual pulse generator, phase B	B+ HBH	22				
		B- HBL	24				
Power supply	5V(Note-1)	38 39			<p>Power supply 5VDC</p>		
	SG	13 40 41					

(Note-1): The 5V(P5)DC power supply of system must not be used if a separate power supply is applied to the manual pulse generator/incremental synchronous encoder. If a separate power supply is used, be sure it is 5V voltage. Anything else may cause a failure.

3) Interface between manual pulse generator (voltage-output/open-collector type)/incremental synchronous encoder

Input or Output	Signal name	Pin No.	Wiring example	Internal circuit	Specification	Description
Input	Manual pulse generator, phase A HA	19			<ul style="list-style-type: none"> Rated input voltage 5.5VDC or less HIGH level 3 to 5.25VDC/ 2mA or less LOW level 1VDC or less/ 5mA or more 	<p>For connection manual pulse generator/ incremental synchronous encoder Phases A, B</p> <ul style="list-style-type: none"> Pulse width $5\mu\text{s}$ or more Leading edge, Trailing edge time $2.5\mu\text{s}$ or more (Duty ratio: 50%) Phase difference $1.2\mu\text{s}$ or more <p>(1) Positioning address increases if Phase A leads Phase B. (2) Positioning address decreases if Phase B leads Phase A.</p>
	Manual pulse generator, phase B HB	23				
Power supply	5V(Note-1)	38 39			<p>Power supply 5VDC</p>	
	SG	13 40 41				

(Note-1): The 5V(P5)DC power supply of system must not be used if a separate power supply is applied to the manual pulse generator/incremental synchronous encoder. If a separate power supply is used, be sure it is 5V voltage. Anything else may cause a failure.

2 SYSTEM CONFIGURATION

4) Connection examples of manual pulse generator/incremental synchronous encoder

• Differential-output type

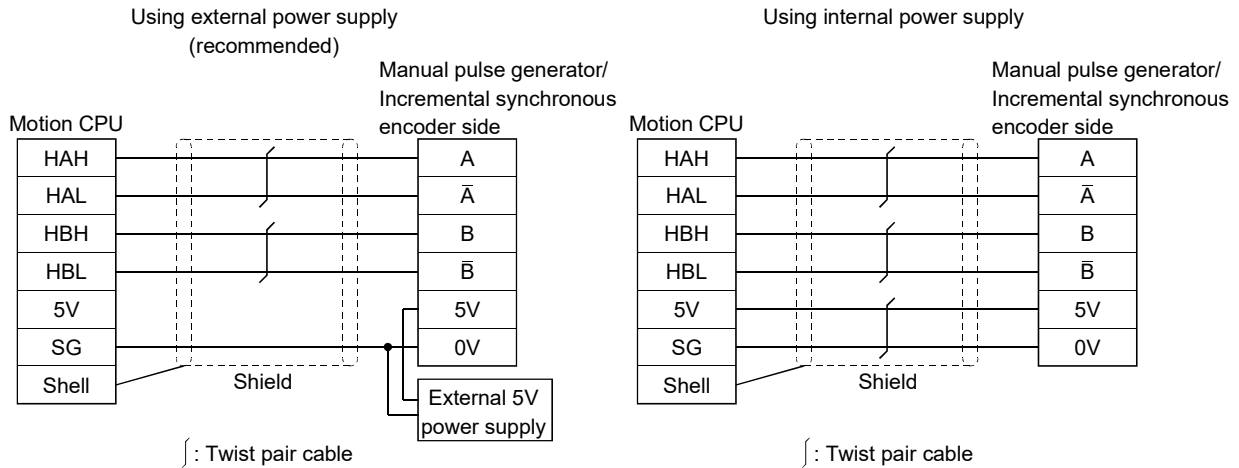

• Voltage-output type/open-collector type

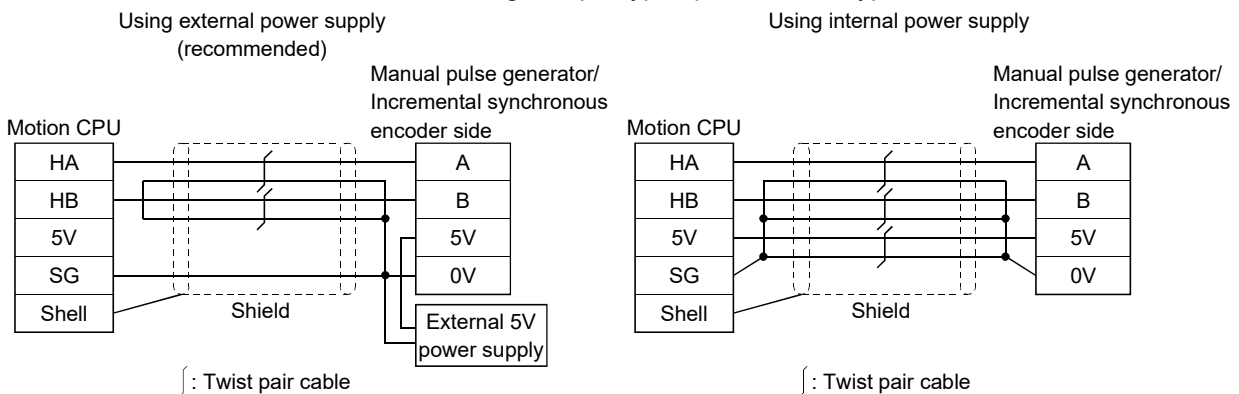

⚠ CAUTION

- If a separate power supply is applied to the manual pulse generator/incremental synchronous encoder, be sure it is 5V voltage. Anything else may cause a failure.
- Always wire the cables when power is off. Not doing so may damage the circuit of modules.
- Wire the cable correctly. Wrong wiring may damage the internal circuit.
- 5V terminal is the power supply for the manual pulse generator/incremental synchronous encoder. Do not apply a voltage and do not use it for other purposes.

(d) Connection of manual pulse generator/incremental synchronous encoder
Manual pulse generators/incremental synchronous encoders of the voltage-output/open-collector type and differential-output type can be connected. Both connection methods are different. (Refer to this section (9)(a).)

Motion CPU module	Connectable manual pulse generator/ incremental synchronous encoder
Q173DSCPU (Built-in interface in Motion CPU)	Up to 1 module
Q172DSCPU (Built-in interface in Motion CPU)	

2 SYSTEM CONFIGURATION

(e) Axis No. of manual pulse generator/synchronous encoder

The axis No. of synchronous encoder built-in interface in Motion CPU is set depending on the axis No. assigned to Q172DEX and Q173DPX.

- 1) Any built-in interface in Motion CPU will automatically be assigned an axis No. one integer greater than the number of encoders connected to any Q172DEX and Q173DPX.
- 2) Motion module installed to the smallest slot number of the Main base unit is the 1st.
- 3) Axis No. P1 to P12 of the synchronous encoder can be used.
- 4) Axis No. P1 to P3 of the manual pulse generator can be used.

When the manual pulse generator is used with the built-in interface in Motion CPU, Q173DPX cannot be used.

The setting example for the axis No. of manual pulse generator/synchronous encoder is shown below.

(Example) Q173DSCPU use (Q172DEX: 2 modules, Q173DPX: 2 modules)

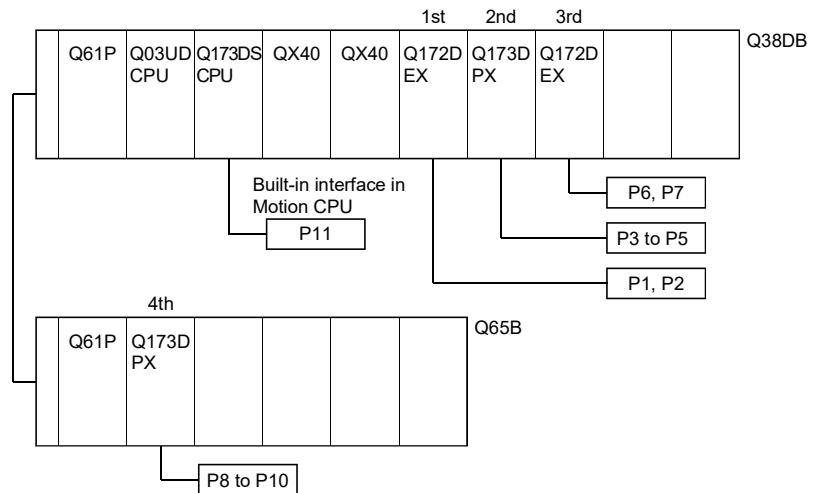

POINTS

For advanced synchronous control method, set the axis No. of synchronous encoder in the synchronous encoder axis parameter.

Refer to the "Q173DSCPU/Q172DSCPU Motion controller Programming Manual (Advanced Synchronous Control)" for details.

2 SYSTEM CONFIGURATION

2.5.2 Power supply module

(1) Power supply module specifications

Power supply modules specifications (Q61P-A1, Q61P-A2, Q61P, Q62P)

Item		Q61P-A1	Q61P-A2	Q61P	Q62P
Base loading position		Q series power supply module loading slot			
Applicable base unit		Q35DB, Q38DB, Q312DB, Q63B, Q65B, Q68B, Q612B			
Input power supply		100 to 120VAC (+10%/-15%) (85 to 132VAC)	200 to 240VAC (+10%/-15%) (170 to 264VAC)	100 to 240VAC (+10%/-15%) (85 to 264VAC)	
Input frequency		50/60Hz ±5%			
Input voltage distortion factor		5% or less			
Max. input apparent power		105VA		130VA	105VA
Inrush current		20A 8ms or less (Note-4)			
Rated output current	5VDC	6A			3A
	24VDC	—			0.6A
External output voltage		—			24VDC±10%
Overcurrent protection (Note-1)	5VDC	6.6A or more			3.3A or more
	24VDC	—			0.66A or more
Overvoltage protection (Note-2)	5VDC	5.5 to 6.5V			
Efficiency		70% or more			65% or more
Allowable momentary power failure time (Note-3)		20ms or less			
Dielectric withstand voltage		2300VAC per minute (Altitude 0 to 2000m (0 to 6561.68ft.)) Across inputs/LG and outputs/FG			
Insulation resistance		Across inputs/LG and outputs/FG, across inputs and LG, across outputs and FG 10MΩ or more by insulation resistance tester (500VDC)			
Noise durability		<ul style="list-style-type: none"> • By noise simulator of 1500Vp-p noise voltage, 1μs noise width and 25 to 60Hz noise frequency • Noise voltage IEC 61000-4-4, 2kV 			
Operation indication		LED indication (Normal : ON (Green), Error : OFF)			
Fuse		Built-in (Unchangeable by user)			
Contact output section	Application	ERR. contact			
	Rated switching voltage/current	24VDC, 0.5A			
	Minimum switching load	5VDC, 1mA			
	Response time	OFF to ON: 10ms or less, ON to OFF: 12ms or less			
	Life time	Mechanical : 20 million times or more Electrical : 100 thousand times or more at rated switching voltage/current			
	Surge suppressor	None			
	Fuse	None			
Terminal screw size		M3.5 screw			
Applicable wire size		0.75 to 2mm ²			
Applicable solderless terminal		RAV1.25 to 3.5, RAV2 to 3.5, thickness of 0.8mm or less. Two solderless terminals can be connected to one terminal.			
Applicable tightening torque		0.66 to 0.89 N•m			
Exterior dimensions[mm(inch)]		98(H) × 55.2(W) × 90(D) (3.86(H) × 2.17(W) × 3.54(D))			
Mass [kg]		0.31		0.40	0.39

2 SYSTEM CONFIGURATION

Power supply modules specifications (Q63P, Q64P, Q64PN, Q61P-D)

Item		Q63P	Q64P	Q64PN	Q61P-D
Base loading position		Q series power supply module loading slot			
Applicable base unit		Q35DB, Q38DB, Q312DB, Q63B, Q65B, Q68B, Q612B			
Input power supply		24VDC (+30%/-35%) (15.6 to 31.2VDC)	100 to 120VAC/200 to 240VAC (+10%/-15%) (85 to 132VAC/170 to 264VAC)	100 to 240VAC (+10%/-15%) (85 to 264VAC)	
Input frequency		—	50/60Hz ±5%		
Input voltage distortion factor		—	5% or less		
Max. input apparent power		45W	160VA		130VA
Inrush current		100A 1ms or less (at 24VDC input)	20A 8ms or less (Note-4)		
Rated output current	5VDC	6A	8.5A		6A
	24VDC	—	—		
Overcurrent protection (Note-1)	5VDC	6.6A or more	9.9A or more		6.6A or more
	24VDC	—			
Overvoltage protection (Note-2)	5VDC	5.5 to 6.5V			
	24VDC	—			
Efficiency		70% or more			
Allowable momentary power failure time (Note-3)		10ms or less (at 24VDC input)	20ms or less		
Dielectric withstand voltage		510VAC per minute across inputs/LG and outputs/FG (Altitude 0 to 2000m (0 to 6561.68ft.))	Across inputs/LG and outputs/FG 2300VAC per minute (Altitude 0 to 2000m (0 to 6561.68ft.))		
Insulation resistance		10MΩ or more by insulation resistance tester	Across inputs and outputs, across inputs and LG, across outputs and FG 10MΩ or more by insulation resistance tester (500VDC)		
Noise durability		By noise simulator of 500Vp-p noise voltage, 1μs noise width and 25 to 60Hz noise frequency	<ul style="list-style-type: none"> By noise simulator of 1,500Vp-p noise voltage, 1μs noise width and 25 to 60Hz noise frequency Noise voltage IEC61000-4-4, 2kV 		
Operation indication		LED indication (Normal: ON (Green), Error: OFF)	LED indication (Normal: ON (Green), Error: OFF) (Note-5)	LED indication (Normal: ON (Green), Error: OFF)	LED indication (POWER LED, LIFE LED) (Note-6)
Fuse		Built-in (Unchangeable by user)			
Contact output section	Application	ERR contact			ERR contact, LIFE OUT contact
	Rated switching voltage/current	24VDC, 0.5A			
	Minimum switching load	5VDC, 1mA			
	Response time	OFF to ON: 10ms or less. ON to OFF: 12ms or less			
	Life time	Mechanical: 20 million times or more Electrical: 100 thousand times or more at rated switching voltage/current			
	Surge suppressor	None			
	Fuse	None			
Terminal screw size		M3.5 screw			
Applicable wire size		0.75 to 2mm ²			

2 SYSTEM CONFIGURATION

Power supply modules specifications (Q63P, Q64P, Q64PN, Q61P-D) (continued)

Item	Q63P	Q64P	Q64PN	Q61P-D
Applicable solderless terminal	RAV1.25 to 3.5, RAV2 to 3.5, thickness 0.8mm or less. Two solderless terminals can be connected to one terminal.			
Applicable tightening torque	0.66 to 0.89 N•m			
Exterior dimensions[mm(inch)]	98(H) × 55.2(W) × 90(D) (3.86(H) × 2.17(W) × 3.54(D))	98(H) × 55.2(W) × 115(D) (3.86(H) × 2.17(W) × 4.53(D))		98(H) × 55.2(W) × 90(D) (3.86(H) × 2.17(W) × 4.53(D))
Mass [kg]	0.33	0.40	0.47	0.45

POINTS

(Note-1): Overcurrent protection

The overcurrent protection device shuts off the 5V, 24VDC circuit and stops the system if the current flowing in the circuit exceeds the specified value.

The LED of the power supply module is turned off or lights up in dim green when voltage is lowered. If this device is activated, switch the input power supply off and eliminate the cause such as insufficient current capacity or short. Then, a few minutes later, switch it on to restart the system.

The initial start for the system takes place when the current value becomes normal.

(Note-2): Overvoltage protection

The overvoltage protection device shuts off the 5VDC circuit and stops the system if a voltage of 5.5VDC or more is applied to the circuit.

When this device is activated, the power supply module LED is switched OFF.

If this happens, switch the input power OFF, then a few minutes later ON. This causes the initial start for the system to take place. The power supply module must be changed if the system is not booted and the LED remains OFF.

POINTS

(Note-3): Allowable momentary power failure time

(1) For AC input power supply

- If the momentary power failure time is within 20ms, the system detects an AC down and suspends the operation processing. However, the system continues operations after the power comes back.
- If the momentary power failure time exceeds 20ms, the system either continues or initially starts the operations depending on the power supply load. In case that the operation processing is continued, the system operates the same as when the momentary power failure time is within 20ms.
- When the AC supply of the AC input module is the same as that of the power supply module, the connected sensor is prevented from turning OFF due to the momentary power failure. However, if only the power supply module and an AC input module are connected on the AC line, detection of the AC down for the power supply module may be delayed by the internal capacitor of the AC input module. To prevent the detection of the AC down from being delayed, connect a load of approx. 30mA per AC input module on the AC line.

(2) For DC input power supply

- If the momentary power failure is within 10ms^(Note), the system detects a 24VDC down and suspends the operation processing. However, the system continues operations after the power comes back.
- If the momentary power failure time exceeds 20ms, the system either continues or initially starts the operations depending on the power supply load. In case that the operation processing is continued, the system operates the same as when the momentary power failure time is within 20ms.

(Note): This is for a 24VDC input. If the input is 24VDC or less, the time will be 10ms or less.

(Note-4): Inrush current

When power is switched on again immediately (within 5 seconds) after power-off, an inrush current of more than the specified value (2ms or less) may flow. Reapply power 5 seconds after power-off.

When selecting a fuse and breaker in the external circuit, take account of the blow out, detection characteristics and above matters.

(Note-5): During the operation, do not allow the input voltage to change from 200VAC level (170 to 264VAC) to 100VAC level (85 to 132VAC).

If changed, the POWER LED turns OFF and the system operation stops.

(Note-6): Refer to "QCPU User's Manual (Hardware Design, Maintenance and Inspection)" for details of the Q61P-D display status.

2 SYSTEM CONFIGURATION

(2) Names of Parts and Setting

This section describes the names of the parts of each power module.

- Q61P-A1 (100 to 120VAC input, 5VDC 6A output)
- Q61P-A2 (200 to 240VAC input, 5VDC 6A output)
- Q61P (100 to 240VAC input, 5VDC 6A output)
- Q62P (100 to 240VAC input, 5VDC 3A/24VDC 0.6A output)
- Q63P (24VDC input, 5VDC 6A output)
- Q64P (100 to 120VAC/200 to 240VAC input, 5VDC 8.5A output)
- Q64PN (100 to 240VAC input, 5VDC 8.5A output)

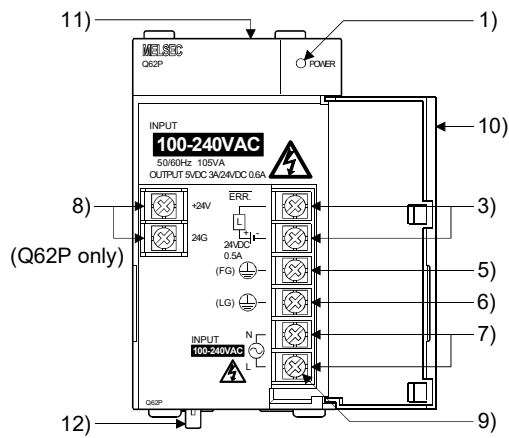

- Q61P-D (100 to 240VAC input, 5VDC 6A output)

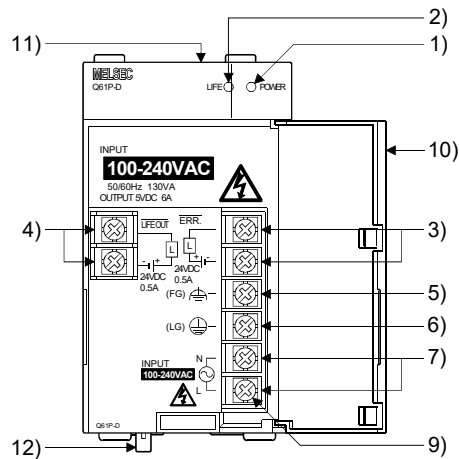

2 SYSTEM CONFIGURATION

No.	Name		Application
1)	POWER LED	AC input power supply	<p>ON (green) : Normal (5VDC output, momentary power failure within 20ms)</p> <p>OFF : • AC power supply is ON, however, the power supply module is out of order. (5VDC error, overload, internal circuit failure, blown fuse)</p> <ul style="list-style-type: none"> • AC power supply is not ON • Power failure (including an momentary power failure of more than 20ms)
		DC input power supply	<p>ON (green) : Normal (5VDC output, momentary power failure within 10ms)</p> <p>OFF : • DC power supply is ON, however, the power supply module is out of order. (5VDC error, overload, internal circuit failure, blown fuse)</p> <ul style="list-style-type: none"> • DC power supply is not ON • Power failure (including an momentary power failure of more than 10ms)
2)	LIFE LED		<p>ON (green) : When operation has started</p> <p>ON (orange) : Remaining life of the module approx. 50%</p> <p>FLASH (orange) : • ON for 5 seconds and OFF for 1 second: Remaining life of the module is approx. 1 year</p> <ul style="list-style-type: none"> • At intervals of 0.5 seconds: Remaining life of the module is approx. 6 months <p>OFF : • Module life expired</p> <ul style="list-style-type: none"> • Ambient temperature is out of range (The ambient temperature of the module is exceeding the specification and the life detection function has stopped.) <p>ON (red) : Ambient temperature is out of range (The ambient temperature of the module is exceeding the specification.)</p> <p>FLASH (red) : Function failure (at intervals of 1 second)</p>
3)	$\overline{\text{ERR}}$ terminal		<ul style="list-style-type: none"> • Turned ON when the whole system operates normally. • This terminal turns OFF (opens) when the power is not input, a stop error (including a reset) occurs in the CPU module, or the fuse is blown. • In a Multiple CPU system configuration, turned OFF (opens) when a stop error occurs in any of the CPU modules. <p>Normally OFF when loaded in an extension base unit.</p>
4)	$\overline{\text{LIFE OUT}}$ terminal		<ul style="list-style-type: none"> • The output signal of the terminal turns off (opens) when the end of the life is detected. (Applicable only when the remaining life is 1 year or less). • Flicker-OFF (opens) when the life diagnostics error (including detection error) is detected. (Note-2) • Flicker-OFF (opens) when the ambient temperature is detected to be out of range. • The output signal of the terminal turns OFF (opens) when the watchdog timer error is detected in the module. <p>The 4 operations listed above are also available when the terminal is mounted on an extension base unit.</p>
5)	FG terminal		Ground terminal connected to the shield pattern of the printed circuit board.
6)	LG terminal		Grounding for the power supply filter. The potential of Q61P-A1, Q61P-A2, Q61P, Q61P-D, Q62P, Q64P and Q64PN terminal is 1/2 of the input voltage.

2 SYSTEM CONFIGURATION

No.	Name	Application
7)	Power input terminals	<ul style="list-style-type: none"> • Power input terminals connected to a power supply of 100VAC. (Q61P-A1) • Power input terminals connected to a power supply of 200VAC. (Q61P-A2) • Power input terminals connected to a power supply of 100VAC to 200VAC. (Q61P, Q61P-D, Q62P, Q64PN) • Power input terminals connected to a power supply of 24VDC. (Q63P) • Power input terminals connected to a power supply of 100VAC/200VAC. (Q64P)
8)	+24V, 24G terminals (Q62P only)	Used to supply 24VDC power to inside the output module. (using external wiring)
9)	Terminal screw	M3.5×7 screw
10)	Terminal cover	Protective cover of the terminal block
11)	Module fixing screw hole	Used to fix the module to the base unit. M3×12 screw (user-prepared) (Tightening torque: 0.36 to 0.48 N•m)
12)	Module mounting lever	Used to load the module into the base unit.

(Note-1): When using the Q61P-D in a system configured with an extension base unit, the POWER LED of the Q61P-D on the extension base unit may turn a dull red color when the power is turned OFF. Note that this does not indicate an error.

(Note-2): Flicker-OFF indicates that the output signal of the terminal turns OFF and ON three times at intervals of one second before turning OFF (opens).

POINTS		
(1) The Q61P-A1 is dedicated for inputting a voltage of 100VAC. Do not input a voltage of 200VAC into it or trouble may occur on the Q61P-A1.		
Power module type	Supply power voltage	
	100VAC	200VAC
Q61P-A1	Operates normally.	Power supply module causes trouble.
Q61P-A2	Power supply module does not cause trouble. CPU module cannot be operated.	Operates normally.
(2) The Q63P is dedicated for inputting a voltage of 24VDC. Do not input a voltage of except 24VDC into it or trouble may occur on the Q63P.		
(3) Q64P automatically switches the input range 100/200VAC. Therefore, it is not compatible with the intermediate voltage (133 to 169VAC). The CPU module may not operate normally if the above intermediate voltage is applied.		
(4) Ensure that the earth terminals LG and FG are grounded. (Ground resistance : 100 Ω or less) Since the LG terminal has a half of the input voltage, touching this terminal may result in an electric shock.		
(5) When the Q61P-A1, Q61P-A2, Q61P, Q61P-D, Q62P, Q63P, Q64P or Q64PN is loaded on the extension base unit, a system error cannot be detected by the $\overline{\text{ERR}}$ terminal. (The $\overline{\text{ERR}}$ terminal is always OFF.)		
(6) Cables for the $\overline{\text{ERR}}$ contact and the $\overline{\text{LIFE OUT}}$ contact must be 30m or more and installed in the control panel.		

2 SYSTEM CONFIGURATION

(3) Selection of the power supply module

The power supply module is selected according to the total of current consumption of the modules, and peripheral devices supplied by its power module.

5VDC internal current consumption of shared equipment with PLC might be changed. Be sure to refer to the MELSEC-Q series PLC Manuals.

(a) Calculation example of power supply selection

<System configuration (Q173DSCPU use)>

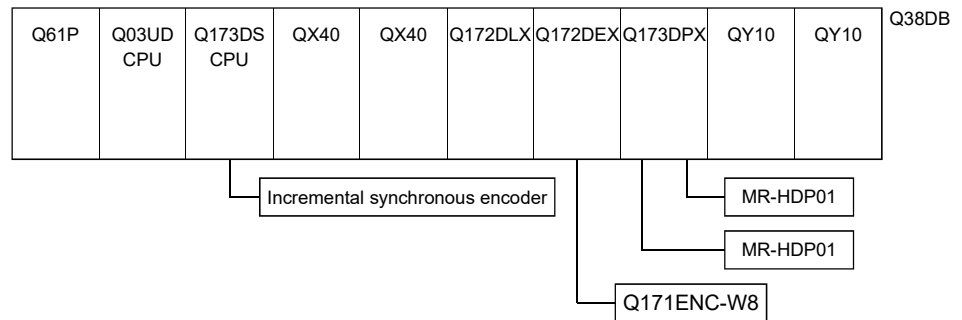

• 5VDC current consumption of each module

Q03UDCPU	: 0.33 [A]	Q171ENC-W8	: 0.25 [A]
Q173DSCPU	: 1.75 [A]	Q173DPX	: 0.38 [A]
Incremental synchronous encoder	: 0.20 [A]	MR-HDP01	: 0.06 [A]
QX40	: 0.05 [A]	QY10	: 0.43 [A]
Q172DLX	: 0.06 [A]	Q38DB	: 0.23 [A]
Q172DEX	: 0.19 [A]		

• Power consumption of overall modules

$$I_{5V} = 0.33 + 1.75 + 0.20 + 0.05 \times 2 + 0.06 + 0.19 + 0.25 + 0.38 + 0.06 \times 2 + 0.43 \times 2 + 0.23 = 4.47[A]$$

Select of the power supply module (Q61P (100/240VAC) 6A) according to this internal current consumption 4.47[A].

POINT

Configure the system in such a way that the total current consumption at 5VDC of all the modules is the allowable value or less.

(4) Life detection power supply module

The Life detection power supply module (Q61P-D) estimates its remaining life internally and displays the service life.

The remaining life of the module can be checked with the LIFE LED located on the front of the module and ON/OFF of the LIFE OUT terminals.

Refer to "QCPU User's Manual (Hardware Design, Maintenance and Repair)" for details of the life detection power supply module.

2 SYSTEM CONFIGURATION

2.5.3 Base unit and extension cable

This section describes the specifications of the extension cables for the base units (Main base unit or extension base unit), and the specification standards of the extension base unit.

5VDC internal current consumption of base unit might be changed. Be sure to refer to the MELSEC-Q series PLC Manuals.

(1) Base unit specifications

(a) Main base unit specifications

Item \ Type	Q35DB	Q38DB	Q312DB
Number of I/O modules	5	8	12
Possibility of extension	Extendable		
Applicable module	Q series modules		
5VDC internal current consumption [A]	0.23	0.23	0.24
Fixing hole size	M4 screw hole or $\phi 4.5$ hole (for M4 screw)		
Exterior dimensions [mm(inch)]	245(W) \times 98(H) \times 44.1(D) (9.65(W) \times 3.86(H) \times 1.74(D))	328(W) \times 98(H) \times 44.1(D) (12.91(W) \times 3.86(H) \times 1.74(D))	439(W) \times 98(H) \times 44.1(D) (17.28(W) \times 3.86(H) \times 1.74(D))
Mass [kg]	0.32	0.41	0.54
Attachment	Fixing screw M4 \times 14 4 pieces	Fixing screw M4 \times 14 5 pieces	

(Note): It is impossible to mount the main base unit by DIN rail when using the Motion CPU module.

Doing so could result in vibration that may cause erroneous operation.

(b) Extension base unit specifications

1) Type requiring power supply module

Item \ Type	Q63B	Q65B	Q68B	Q612B
Number of I/O modules	3	5	8	12
Possibility of extension	Extendable			
Applicable module	Q series modules			
5VDC internal current consumption [A]	0.11	0.11	0.12	0.13
Fixing hole size	M4 screw hole or $\phi 4.5$ hole (for M4 screw)			
Exterior dimensions [mm(inch)]	189(W) \times 98(H) \times 44.1(D) (7.44(W) \times 3.86(H) \times 1.74(D))	245(W) \times 98(H) \times 44.1(D) (9.65(W) \times 3.86(H) \times 1.74(D))	328(W) \times 98(H) \times 44.1(D) (12.91(W) \times 3.86(H) \times 1.74(D))	439(W) \times 98(H) \times 44.1(D) (17.28(W) \times 3.86(H) \times 1.74(D))
Mass [kg]	0.23	0.28	0.38	0.48
Attachment	Fixing screw M4 \times 14 4 pieces ^(Note)			

(Note): The 5 base mounting screws are included with the Q68B and Q612B that have 5 base mounting holes.

2 SYSTEM CONFIGURATION

2) Type not requiring power supply module

Item \ Type	Q52B	Q55B
Number of I/O modules	2	5
Possibility of extension	Extendable	
Applicable module	Q series modules	
5VDC internal current consumption [A]	0.08	0.10
Fixing hole size	M4 screw hole or ϕ 4.5 hole (for M4 screw)	
Exterior dimensions [mm(inch)]	106(W) \times 98(H) \times 44.1(D) (4.17(W) \times 3.86(H) \times 1.74(D))	189(W) \times 98(H) \times 44.1(D) (7.44(W) \times 3.86(H) \times 1.74(D))
Mass [kg]	0.14	0.23
Attachment	Fixing screw M4 \times 14 4 pieces	

(2) Extension cable specifications

The list below describes the specifications of the extension cables which can be used.

Item \ Type	QC05B	QC06B	QC12B	QC30B	QC50B	QC100B
Cable length[m(ft.)]	0.45(1.48)	0.6(1.97)	1.2(3.94)	3.0(9.84)	5.0(16.40)	10.0(32.81)
Application	Connection between the main base unit and extension base unit, or connection between the extension base units.					
Mass [kg]	0.15	0.16	0.22	0.40	0.60	1.11

POINT

When the extension cables are used in combination, limit the overall length of the combined cable to 13.2m (43.31ft.).

2 SYSTEM CONFIGURATION

(3) Names of parts of the base unit

Names of parts of the base unit are described below.

(a) Main base unit (Q35DB, Q38DB, Q312DB)

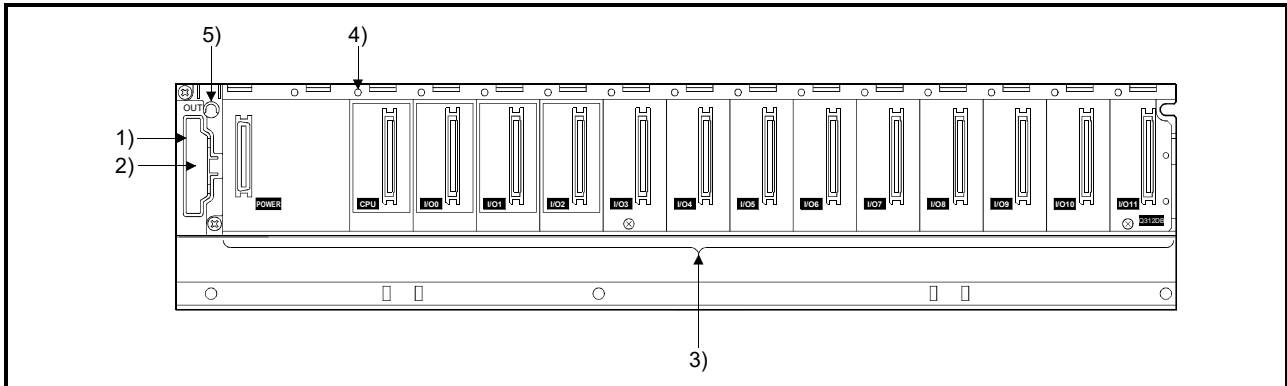

No.	Name	Application
1)	Extension cable connector	Connector for connecting an extension cable (for signal communications with the extension base unit)
2)	Base cover	Protective cover of extension cable connector. Before an extension cable is connected, the area of the base cover surrounded by the groove under the word "OUT" on the base cover must be removed with a tool such as nippers.
3)	Module connector	Connector for installing the Q series power supply module, CPU module, Motion module, I/O modules, and intelligent function module. To the connectors located in the spare space where these modules are not installed, attach the supplied connector cover or the blank cover module (QG60) to prevent entry of dirt.
4)	Module fixing screw hole	Screw hole for fixing the module to the base unit. Screw size: M3×12
5)	Base mounting hole	Hole for mounting this base unit onto the panel of the control panel (for M4 screw)

(Note): It is impossible to mount the main base unit by DIN rail when using the Motion CPU module. Doing so could result in vibration that may cause erroneous operation.

2 SYSTEM CONFIGURATION

(4) I/O allocations

It is possible to allocate unique I/O No.s for each Motion CPU independently of the PLC's I/O No.s. (I/O No.s are unique between the Q series PLC CPU within a given system, but the I/O No.s of the Motion CPU are unique for each Motion CPU.)

ON/OFF data input to the Motion CPU is handled via input devices PX□□, while ON/OFF data output from the Motion CPU is handled via output devices PY□□. It is not mandatory to match the I/O device PX/PY No.s used in the Motion program with the PLC I/O No.s; but it is recommended to make them match as much as possible.

The following figure shows an example of I/O allocation.

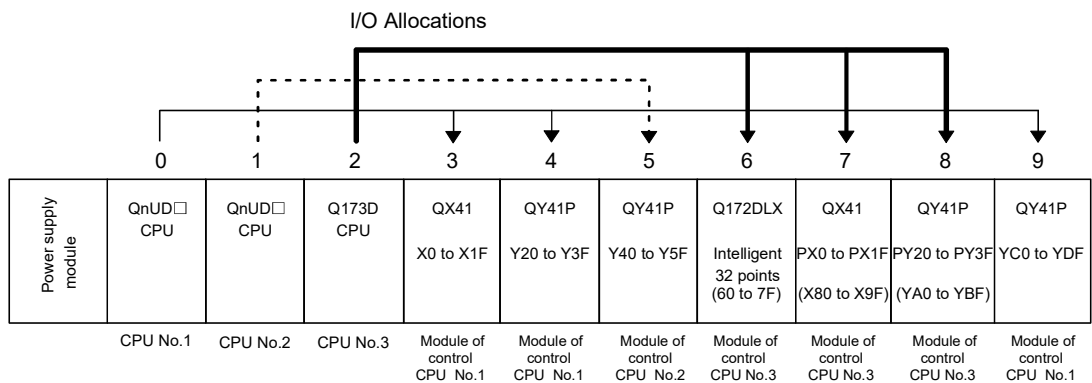

(Note-1): When the number of modules to be installed is 32 points.

(Note-2): When the PX/PY No. does not match the PLC I/O No.

Refer to the Q173D(S)CPU/Q172D(S)CPU Motion Controller Programming Manual (COMMON) about the I/O allocation setting method, and refer to the "QnUCPU User's Manual (Function Explanation, Program Fundamentals)" about the I/O allocation setting method of the PLC CPU.

POINT

I/O device of the Motion CPU can be set in the range PX/PY000 to PX/PYFFF. The real I/O points must be 256 points or less. (As for the I/O No., it is possible not to continue.)

2 SYSTEM CONFIGURATION

2.5.4 Q172DLX Servo external signals interface module

Q172DLX receives external signals (servo external signals) required for positioning control.

(1) Q172DLX name of parts

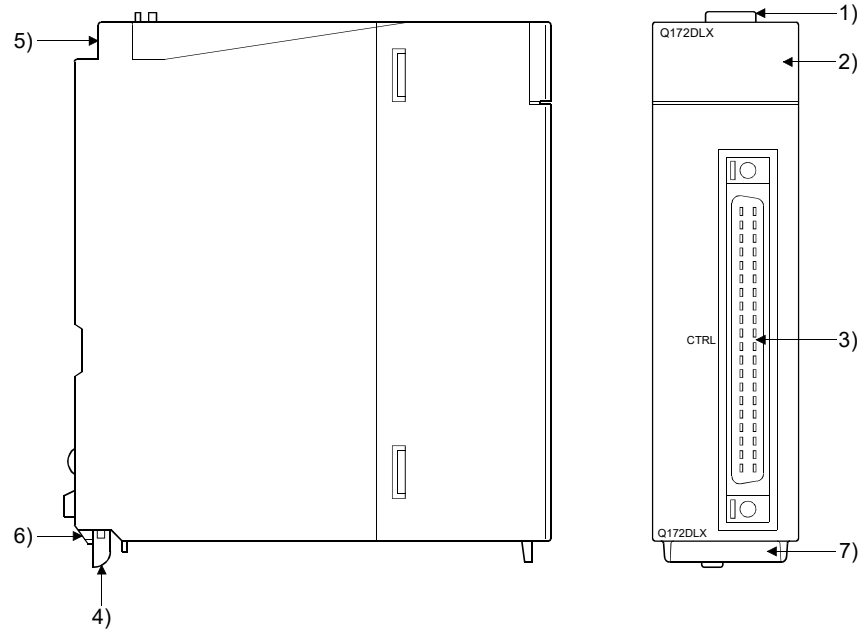

No.	Name	Application				
1)	Module fixing hook	Hook used to fix the module to the base unit. (Single-motion installation)				
2)	Input indicator LED	Display the servo external input status from the external equipment. <table border="1" style="width: 100%; border-collapse: collapse;"> <thead> <tr> <th>LED</th> <th>Details</th> </tr> </thead> <tbody> <tr> <td>0 to 1F</td> <td>Display for servo external signal input status of each axis.</td> </tr> </tbody> </table> <p>The proximity dog/speed-position switching signal (DOG/CHANGE) does not turn ON without setting Q172DLX in the system setting.</p>	LED	Details	0 to 1F	Display for servo external signal input status of each axis.
LED	Details					
0 to 1F	Display for servo external signal input status of each axis.					
3)	CTRL connector	The servo external signal input connector of each axis.				
4)	Module mounting lever	Used to install the module to the base unit.				
5)	Module fixing screw hole	Hole for the screw used to fix to the base unit. (M3×12 screw : Purchase from the other supplier)				
6)	Module fixing projection	Projection used to fix to the base unit.				
7)	Serial number display	Display the serial number described on the rating plate.				

POINT

Input indicator LED of the proximity dog/speed-position switching signal (DOG/CHANGE) turns ON at the following conditions.

- Q172DLX is set on the system setting of MT Developer2.
- The proximity dog/speed-position switching signal (DOG/CHANGE) is input.

2 SYSTEM CONFIGURATION

(2) Performance specifications

(a) Module specifications

Item	Specifications
Number of I/O occupying points	32 points(I/O allocation: Intelligent, 32 points)
Internal current consumption(5VDC) [A]	0.06
Exterior dimensions [mm(inch)]	98(H)× 27.4(W)× 90(D) (3.86(H)× 1.08(W)× 3.54(D))
Mass [kg]	0.15

(b) Input

Item	Specifications
Number of input points	Servo external signals : 32 points (Upper stroke limit, Lower stroke limit, Stop input, Proximity dog/Speed-position switching signal) (4 points × 8 axes)
Input method	Sink/Source type
Common terminal arrangement	32 points/common (common terminal: B1, B2)
Isolation method	Photocoupler
Rated input voltage	12/24VDC
Rated input current	12VDC 2mA/24VDC 4mA
Operating voltage range	10.2 to 26.4VDC (12/24VDC +10/ -15%, ripple ratio 5% or less)
ON voltage/current	10VDC or more/2.0mA or more
OFF voltage/current	1.8VDC or less/0.18mA or less
Input resistance	Approx. 5.6kΩ
Response time of the Upper/Lower stroke limit and STOP signal	OFF to ON ON to OFF 1ms
Response time of the proximity dog, Speed- position switching signal	OFF to ON ON to OFF 0.4ms/0.6ms/1ms (CPU parameter setting, Default 0.4ms)
Operation indicator	ON indication (LED)
External connector type	40 pin connector
Applicable wire size	0.3mm ²
Applicable connector for the external connection	A6CON1 (Attachment), A6CON2, A6CON3, A6CON4 (Optional)
Applicable connector/ Terminal block converter module	A6TBXY36, A6TBXY54, A6TBXY70 (Optional)

2 SYSTEM CONFIGURATION

(3) Connection of servo external signals interface module

(a) Servo external signals

There are the following servo external signals.

(Upper stroke limit is limit value of address increase direction/lower stroke limit is limit value of an address decrease direction.)

The Q172DLX is assigned a set of input No.s per axis. Make the system setting of MT Developer2 to determine the I/O No.s corresponding to the axis No.s.

Servo external signal	Application	Number of points on one Q172DLX
Upper stroke limit input (FLS)	For detection of upper and lower stroke limits.	32 points (4 points/8 axes)
Lower stroke limit input (RLS)		
Stop signal input (STOP)	For stopping under speed or positioning control.	
Proximity dog/ Speed-position switching input (DOG/CHANGE)	For detection of proximity dog at proximity dog or count method home position return or for switching from speed to position switching control.	

(b) The pin layout of the CTRL connector

Use the CTRL connector on the front of the Q172DLX module to connect to servo external signals.

The following is the pin layout of the Q172DLX CTRL connector as viewed from the front.

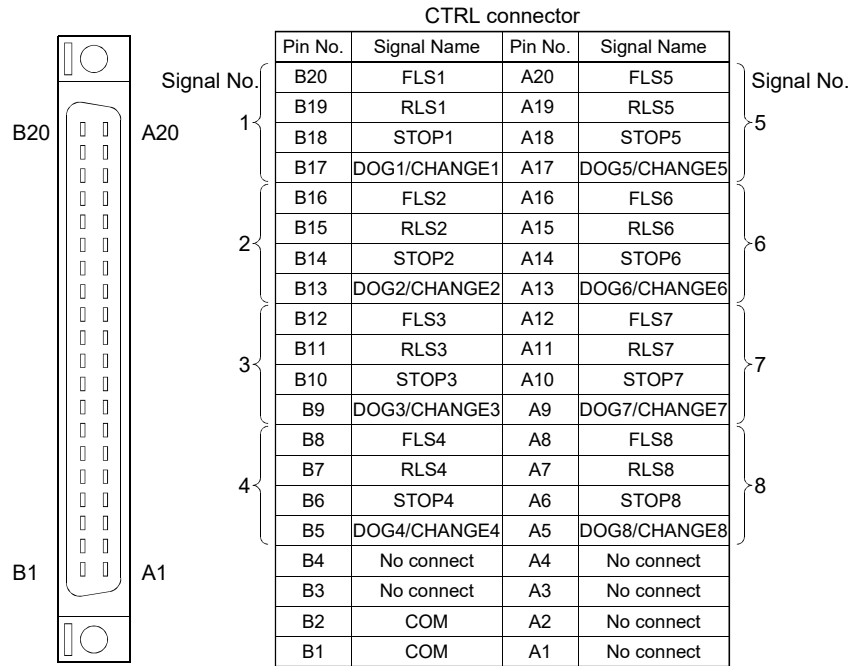

Applicable connector model name

- A6CON1 type soldering type connector
 - FCN-361J040-AU connector (FUJITSU COMPONENT LIMITED)
 - FCN-360C040-B connector cover
- } (Attachment)
- A6CON2 type Crimp-contact type connector
 - A6CON3 type Pressure-displacement type connector
 - A6CON4 type soldering type connector
- } (Optional)

DOG/CHANGE, STOP, RLS, FLS functions of each axis(1 to 8)	
•DOG/CHANGE	Proximity dog/Speed-position switching signal
•STOP	Stop signal
•RLS	Lower stroke limit
•FLS	Upper stroke limit

For information about signal details, refer to the programming manual.

(Note) : Connector/terminal block conversion modules and cables can be used at the wiring of CTRL connector.

A6TBXY36/A6TBXY54/A6TBX70 : Connector/terminal block converter module

AC□TB (□:Length [m]) : Connector/terminal block converter module cable

POINT

Signal No. 1 to 8 can be assigned to the specified axis. Make the assignment in the system settings of MT Developer2.

2 SYSTEM CONFIGURATION

(4) Interface between CTRL connector and servo external signal

Input or Output	Signal name	Pin No.	LED	Wiring example	Internal circuit	Specification	Description		
Input	FLS1	B20	0			• Supply voltage 12 to 24 VDC (10.2 to 26.4 VDC, stabilized power supply)	FLS		
	FLS2	B16	4				FLS		
	FLS3	B12	8				FLS		
	FLS4	B8	C				FLS		
	FLS5	A20	10				FLS		
	FLS6	A16	14				FLS		
	FLS7	A12	18			FLS			
	FLS8	A8	1C			FLS			
	RLS1	B19	1			Lower stroke limit input		• High level 10.0 VDC or more/ 2.0mA or more	RLS
	RLS2	B15	5						RLS
	RLS3	B11	9						RLS
	RLS4	B7	D						RLS
	RLS5	A19	11						RLS
	RLS6	A15	15						RLS
	RLS8	A11	19			RLS			
	RLS8	A7	1D			RLS			
	STOP1	B18	2			Stop signal input		• Low level 1.8 VDC or less/ 0.18mA or less	STOP
	STOP2	B14	6						STOP
	STOP3	B10	A						STOP
	STOP4	B6	E						STOP
	STOP5	A18	12						STOP
	STOP6	A14	16						STOP
	STOP7	A10	1A						STOP
	STOP8	A6	1E						STOP
DOG/CHANGE1	B17	3	Proximity dog/ Speed-position switching signal		• Low level 1.8 VDC or less/ 0.18mA or less	DOG/CHANGE			
DOG/CHANGE2	B13	7				DOG/CHANGE			
DOG/CHANGE3	B9	B				DOG/CHANGE			
DOG/CHANGE4	B5	F				DOG/CHANGE			
DOG/CHANGE5	A17	13				DOG/CHANGE			
DOG/CHANGE6	A13	17				DOG/CHANGE			
DOG/CHANGE7	A9	1B				DOG/CHANGE			
DOG/CHANGE8	A5	1F				DOG/CHANGE			
Power supply (Note)		B1 B2					Common terminals for servo external input signal.		

(Note): As for the connection to power line (B1, B2), both "+" and "-" are possible.

⚠ CAUTION

- Always use a shield cable for connection of the CTRL connector and external equipment, and avoid running it close to or bundling it with the power and main circuit cables to minimize the influence of electromagnetic interface. (Separate them more than 200mm (0.66ft.) away.)
- Connect the shield wire of the connection cable to the FG terminal of the external equipment.
- Make parameter setting correctly. Incorrect setting may disable the protective functions such as stroke limit protection.
- Always wire the cables when power is off. Not doing so may damage the circuit of modules.
- Wire the cable correctly. Wrong wiring may damage the internal circuit.

2 SYSTEM CONFIGURATION

2.5.5 Q172DEX Synchronous encoder interface module

Q172DEX receive external signals required for serial absolute synchronous encoder.
The installation position of Q172DEX is only main base.

(1) Q172DEX name of parts

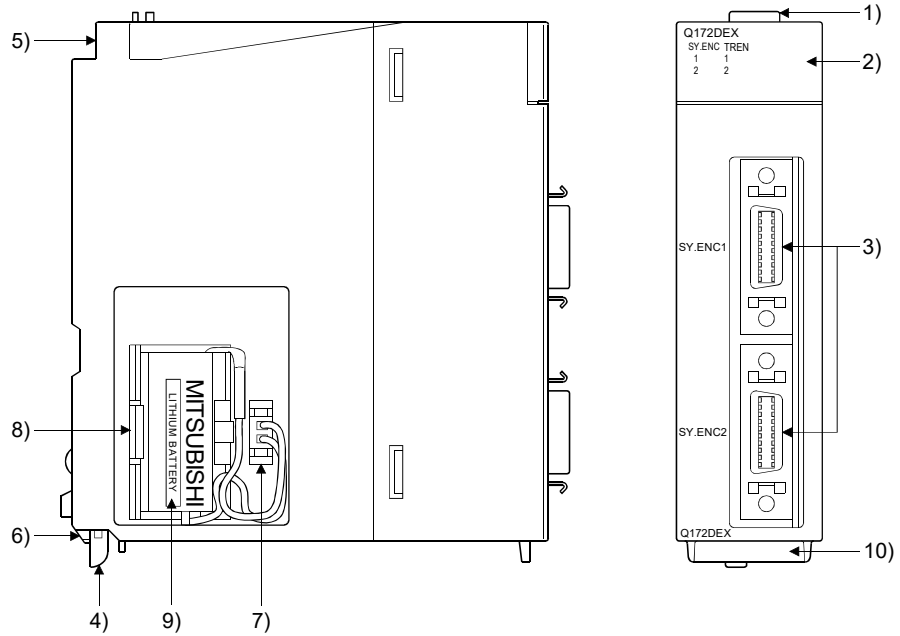

No.	Name	Application						
1)	Module fixing hook	Hook used to fix the module to the base unit. (Single-motion installation)						
2)	Input indicator LED	Display the input status from the external equipment. <table border="1" style="width: 100%; border-collapse: collapse;"> <thead> <tr> <th>LED</th> <th>Details</th> </tr> </thead> <tbody> <tr> <td>SY.ENC 1, 2</td> <td>Display for signal input status of each serial absolute synchronous encoder. (LED turns ON at the normal connection (first switching to virtual mode).)</td> </tr> <tr> <td>TREN 1, 2</td> <td>Display for signal status of tracking enable.</td> </tr> </tbody> </table> <p>The tracking enable signal does not turn ON without setting Q172DEX in the system setting.</p>	LED	Details	SY.ENC 1, 2	Display for signal input status of each serial absolute synchronous encoder. (LED turns ON at the normal connection (first switching to virtual mode).)	TREN 1, 2	Display for signal status of tracking enable.
LED	Details							
SY.ENC 1, 2	Display for signal input status of each serial absolute synchronous encoder. (LED turns ON at the normal connection (first switching to virtual mode).)							
TREN 1, 2	Display for signal status of tracking enable.							
3)	SY. ENC connector	Input connector of the serial absolute synchronous encoder.						
4)	Module mounting lever	Used to install the module to the base unit.						
5)	Module fixing screw hole	Hole for the screw used to fix to the base unit (M3×12 screw : Purchase from the other supplier)						
6)	Module fixing projection	Projection used to fix to the base unit.						
7)	Battery connector	For connection of battery lead wire.						
8)	Battery holder	Used to the set the Battery (A6BAT/MR-BAT) to the holder.						
9)	Battery (A6BAT/MR-BAT)	For Serial absolute synchronous encoder battery backup.						
10)	Serial number display	Display the serial number described on the rating plate.						

2 SYSTEM CONFIGURATION

POINT
(1) Input indicator LED of the serial absolute synchronous encoder signal turns ON at the normal connection (first switching to virtual mode).
(2) Input indicator LED of the tracking enable signal turns ON at the following conditions. <ul style="list-style-type: none"> • Q172DEX is set in the system setting of MT Developer2. • The tracking enable signal is input.

(2) Performance specifications

(a) Module specifications

Item	Specifications
Number of I/O occupying points	32 points(I/O allocation: Intelligent, 32 points)
Internal current consumption(5VDC)[A]	0.19
Exterior dimensions [mm(inch)]	98(H)×27.4(W)×90(D) (3.86(H)×1.08(W)×3.54(D))
Mass [kg]	0.15

(b) Tracking enable signal input

Item	Specifications
Number of input points	Tracking enable signal : 2 points
Input method	Sink/Source type
Common terminal arrangement	1 point/common (Common terminal: TREN.COM)
Isolation method	Photocoupler
Rated input voltage	12/24VDC
Rated input current	12VDC 2mA/24VDC 4mA
Operating voltage range	10.2 to 26.4VDC (12/24VDC +10/ -15%, ripple ratio 5% or less)
ON voltage/current	10VDC or more/2.0mA or more
OFF voltage/current	1.8VDC or less/0.18mA or less
Input resistance	Approx. 5.6kΩ
Response time	OFF to ON
	ON to OFF
Operation indicator	ON indication (LED)

2 SYSTEM CONFIGURATION

(c) Serial absolute synchronous encoder input

Item	Specifications	
Applicable types	Q171ENC-W8	Q170ENC
Applicable signal types	Differential-output type: (SN75C1168 or equivalent)	
Transmission method	Serial communications	
Synchronous method	Counter-clock-wise (viewed from end of shaft)	
Communication speed	2.5Mbps	
Position detection method	Absolute (ABS) method	
Resolution	4194304pulse/rev (22bit)	262144pulse/rev (18bit)
Number of modules	2/module	
External connector type	20 pin connector	
Applicable connector for the external connection	Q170ENC CNS (Optional)	
Applicable wire	MB14B0023 12Pair	
Connecting cable	Q170ENC CBL□M (□=cable length 2m(6.56ft.), 5m(16.40ft.), 10m(32.81ft.), 20m(65.62ft.), 30m(98.43ft.), 50m(164.04ft.)) ^(Note-1)	
Cable length	Up to 50m (164.04ft.)	
Back up the absolute position.	Depends on A6BAT/MR-BAT.	
Battery service life time (value in actual)	12000[h], (Example of encoders × 2)	
	24000[h], (Example of encoders × 1)	

(Note-1): You can use these cables when the tracking enable signal is not used.

When the tracking enable signal is used, fabricate the cable on the customer side.

2 SYSTEM CONFIGURATION

(3) Select to number of the synchronous encoder modules

Synchronous encoders are available in voltage-output type (incremental), differential-output type (incremental) and serial absolute output type.

Q172DEX can be connected to only serial absolute output type.

When using the incremental synchronous encoder of voltage-output type or differential-output type, must be used Q173DPX or built-in interface in Motion CPU of Q173DSCPU/Q172DSCPU. (The synchronous encoders are used in the SV22 virtual mode or SV22 advanced synchronous control.)

In addition, the usable numbers of synchronous encoders differ depending on the modules.

The following number of serial absolute synchronous encoders and incremental synchronous encoders combined can be used.

Motion CPU module	Applicable types	Connectable synchronous encoder
Q173DSCPU	Q171ENC-W8	Up to 12 modules (Q172DEX: Up to 6 modules)
Q172DSCPU		
Q173DCPU(-S1)	Q171ENC-W8,	Up to 8 modules (Q172DEX: Up to 4 modules)
Q172DCPU(-S1)	Q170ENC	

• Tracking enable signal

Tracking enable signal of Q172DEX is used in high-speed reading function or high-speed input request signal.

The external input signal of the synchronous encoder is indicated below.

External input signal of the synchronous encoder	Item	Number of points on one Q172DEX
Tracking enable signal input	High-speed reading function	2 points
	High-speed input request signal	

(4) Connection of synchronous encoder interface module.

(a) Connection with serial absolute synchronous encoder

Use the SY.ENC connector on the front of the Q172DEX module to connect to serial absolute synchronous encoder.

When tracking enable signal is not used, use the Q170ENCCBL□M encoder cable between the serial absolute synchronous encoder and SY.ENC connector.

The following is the pin layout of the Q172DEX SY.ENC connector as viewed from the front.

SY.ENC connector

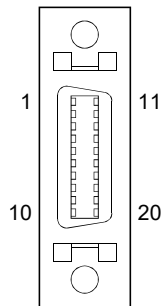

Pin No.	Signal name	Pin No.	Signal name
1	LG	11	LG
2	LG	12	LG
3	LG	13	No connect
4	TREN	14	TREN.COM
5	No connect	15	No connect
6	MD	16	MDR
7	MR	17	MRR
8	No connect	18	P5
9	BAT	19	P5
10	P5	20	P5

Applicable connector model names
 10120-3000PE connector
 10320-52F0-008 connector case
 (3M Japan Limited make)

(b) Interface with external equipment

The interface between the SY.ENC connector and external equipment is described below.

1) Wiring precautions

Ensure the connector lock after connecting the connector.

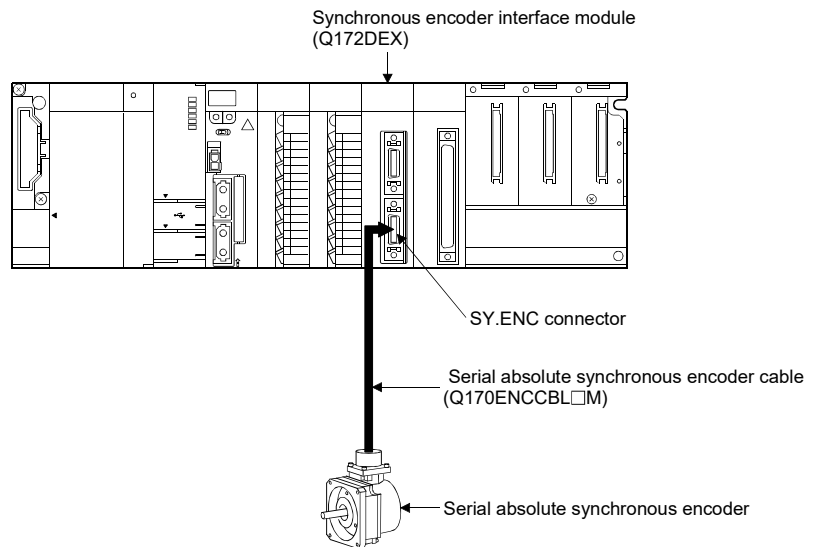

2 SYSTEM CONFIGURATION

(5) Interface between SY.ENC connector and external equipment

Input or Output	Signal name	Pin No.	Wiring example	Internal circuit	Specification	Description
Input	MD	6			<ul style="list-style-type: none"> • Transmission method: serial communications • Position detection method: absolute 	
	MDR	16				
	MR	7				
	MRR	17				
	P5	10 18 19 20				
	LG	1 2 3 11 12				
	BAT	9				
TREN (Note)	4					
TREN.COM (Note)	14					
SD	plate					

(Note): As for the connection to power line (TREN, TREN.COM), both "+" and "-" are possible.

⚠ CAUTION

- Always use a shield cable for connection of the SY.ENC connector and external equipment, and avoid running it close to or bundling it with the power and main circuit cables to minimize the influence of electromagnetic interface. (Separate them more than 200mm (0.66 ft.) away.)
- Connect the shield wire of the connection cable to the FG terminal of the external equipment.
- When increasing the cable length, use the cable 50m(164.04ft.) or less. Note that the cable should be run in the shortest possible distance to avoid induced noise.
- Always wire the cables when power is off. Not doing so may damage the circuit of modules.
- Wire the cable correctly. Wrong wiring may damage the internal circuit.

2 SYSTEM CONFIGURATION

(6) Details of encoder cable connections

(a) When not using tracking enable signal (Note-1)

SY.ENC side connector
10120-3000PE (connector)
10320-52F0-008(connector case)

Synchronous encoder side connector
D/MS3106B22-14S (plug)
D/MS3057-12A (cable clamp)

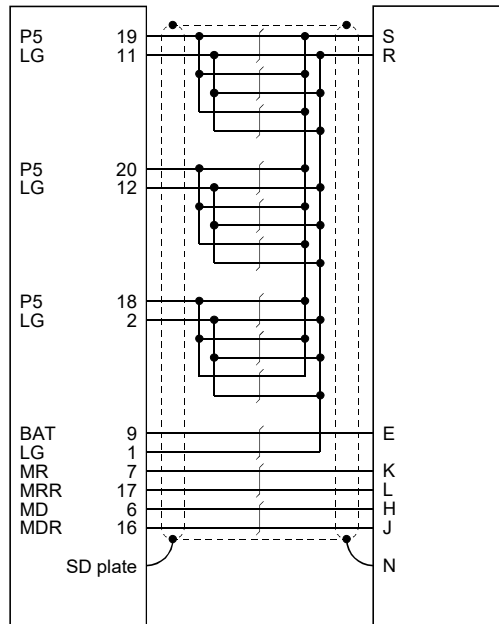

∩ : Twisted pair cable

Q170ENCCBL2M to Q170ENCCBL50M(50m (164.04ft.) or less)

(b) When using tracking enable signal (Note-1), (Note-2)

SY.ENC side connector
10120-3000PE (connector)
10320-52F0-008(connector case)

Synchronous encoder side connector
D/MS3106B22-14S (plug)
D/MS3057-12A (cable clamp)

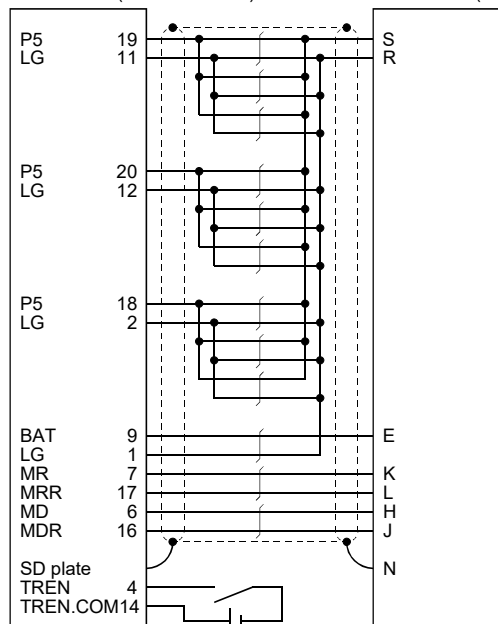

∩ : Twisted pair cable

Cable length 50m(164.04ft.) or less

(Note-1): Be sure to use a wire model name AWG24.

(Note-2): When using tracking enable signal, fabricate the encoder cable by customer side.

2 SYSTEM CONFIGURATION

(7) Connection of the battery

This section describes the battery specifications, handling precautions and installation of the Q172DEX.

(a) Specifications

The specifications of the battery for memory back-up are shown in the table below.

Battery Specifications

Item	Model name	A6BAT/MR-BAT
Classification		Thionyl chloride lithium primary battery
Normal voltage [V]		3.6
Nominal current [mAh]		1700
Storage life		5 years
Lithium content [g]		0.48
Applications		For backup absolute positioning data of the serial absolute synchronous encoder
Exterior dimensions [mm(inch)]		φ 16(0.63) × 30(1.18)

• Transport guidelines

Products are packed in compliance with the transportation regulations prior to shipment. When repacking any of the unpacked products for transportation, make sure to observe the IATA Dangerous Goods Regulations, IMDG (International Maritime Dangerous Goods) Code, and other local transportation regulations.

For details, please consult the shipping carrier used.

(b) Battery replacement

For Battery replacement procedure, refer to section 6.5.2.

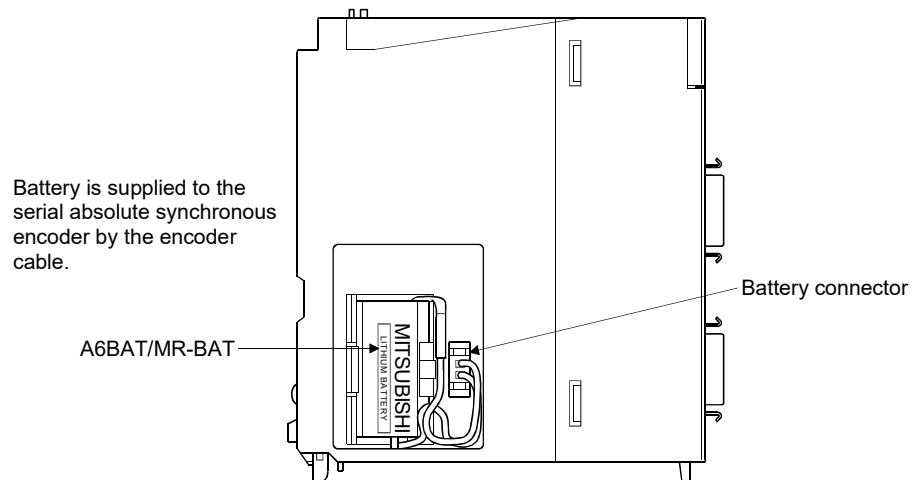

2 SYSTEM CONFIGURATION

(c) Battery life

Module type	Battery type		Battery life (Total power failure time) [h] (Note-1)				Backup time after alarm
			Power-on time ratio (Note-2)	Guaranteed value (Note-3) (MIN) (75°C (167°F))	Guaranteed value (Note-4) (TYP) (40°C (104°F))	Actual service value (Note-5) (Reference value) (TYP) (25°C (77°F))	
Q172DEX	Internal battery (A6BAT/ MR-BAT)	Q171ENC-W8/ Q170ENC×1	0%	3000	8000	24000	40 (After Error code 1152 occurrence)
			30%	4000	11000	34000	
			50%	6000	16000	43800	
			70%	10000	26000	43800	
			100%	43800	43800	43800	
		Q171ENC-W8/ Q170ENC×2	0%	1500	4000	12000	
			30%	2000	5500	17000	
			50%	3000	8000	21900	
			70%	5000	13000	21900	
			100%	43800	43800	43800	

(Note-1): The actual service value indicates the average value, and the guaranteed time indicates the minimum time.

(Note-2): The power-on time ratio indicates the ratio of Multiple CPU system power-on time to one day (24 hours).

(When the total power-on time is 17 hours and the total power-off time is 7 hours, the power-on time ratio is 70%.)

(Note-3): The guaranteed value (MIN) ; equivalent to the total power failure time that is calculated based on the characteristics value of the memory (SRAM) supplied by the manufacturer and under the storage ambient temperature range of -25°C to 75°C (-13 to 167°F) (operating ambient temperature of 0°C to 55°C (32 to 131°F)).

(Note-4): The guaranteed value (TYP); equivalent to the total power failure time that is calculated based on the normal air-conditioned environment (40°C (104°F)).

(Note-5): The actual service value (Reference value) ; equivalent to the total power failure time that is calculated based on the measured value and under the storage ambient temperature of 25°C (77°F). This value is intended for reference only, as it varies with characteristics of the memory.

POINTS

The self-discharge influences the life of battery without the connection to Q172DEX. The external battery should be exchanged approximately every 4 or 5 years. Exchange the battery with a new one in 4 to 5 years even if a total power failure time is guaranteed value or less.

CAUTION

- Do not short a battery.
- Do not charge a battery.
- Do not disassemble a battery.
- Do not burn a battery.
- Do not overheat a battery.
- Do not solder the battery terminals.
- Before touching the battery, always touch grounded metal, etc. to discharge static electricity from human body. Failure to do so may cause the module to fail or malfunction.
- Do not directly touch the module's conductive parts and electronic components. Touching them could cause an operation failure or damage the module.

2 SYSTEM CONFIGURATION

2.5.6 Q173DPX Manual pulse generator interface module

Q173DPX receives signals required for Manual pulse and Incremental synchronous encoder (Voltage-output/Open-collector type/Differential-output type) input.

(1) Q173DPX name of parts

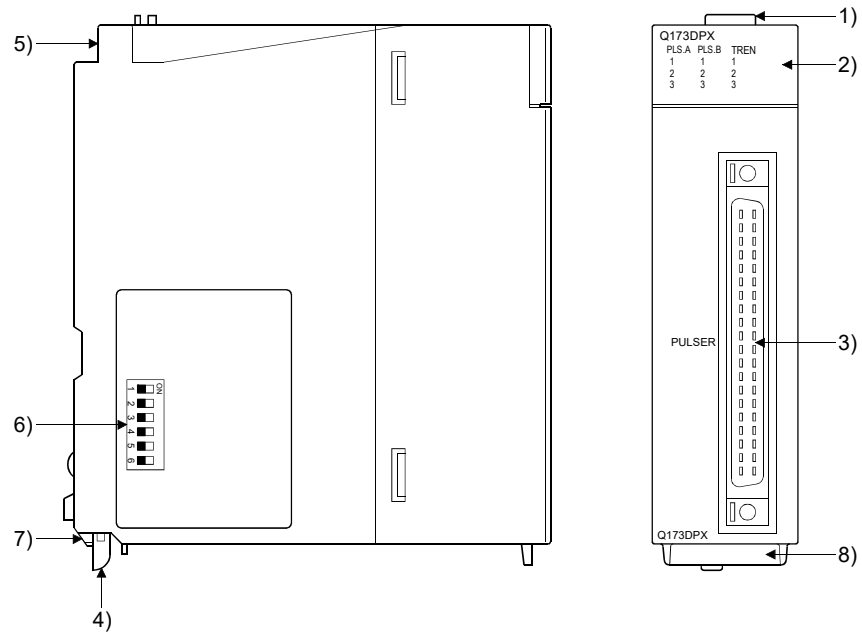

No.	Name	Application						
1)	Module fixing hook	Hook used to fix the module to the base unit. (Single-motion installation)						
2)	Input indicator LED	<p>Display the input status from the external equipment.</p> <table border="1"> <thead> <tr> <th>LED</th> <th>Details</th> </tr> </thead> <tbody> <tr> <td>PLS.A 1 to 3 PLS.B 1 to 3</td> <td>Display for input signal status of manual pulse generator/incremental synchronous encoder phases A, B</td> </tr> <tr> <td>TREN 1 to 3</td> <td>Display for signal status of tracking enable.</td> </tr> </tbody> </table> <p>The manual pulse generator/incremental synchronous encoder phases A, B and tracking enable signal does not turn ON without setting Q173DPX in the system setting.</p>	LED	Details	PLS.A 1 to 3 PLS.B 1 to 3	Display for input signal status of manual pulse generator/incremental synchronous encoder phases A, B	TREN 1 to 3	Display for signal status of tracking enable.
LED	Details							
PLS.A 1 to 3 PLS.B 1 to 3	Display for input signal status of manual pulse generator/incremental synchronous encoder phases A, B							
TREN 1 to 3	Display for signal status of tracking enable.							
3)	PULSER connector	Input connector of the Manual pulse generator/Incremental synchronous encoder.						
4)	Module mounting lever	Used to install the module to the base unit.						
5)	Module fixing screw hole	Hole for the screw used to fix to the base unit (M3×12 screw : Purchase from the other supplier)						

2 SYSTEM CONFIGURATION

No.	Name	Application
6)	Dip switches (Note-1)  (Factory default in OFF position)	Dip switch 1 SW1 SW2 OFF OFF ON ON ON OFF OFF ON
		Dip switch 2 SW3 SW4 OFF OFF ON ON ON OFF OFF ON
		Dip switch 3 SW5 SW6 OFF OFF ON ON ON OFF OFF ON
		Dip switch 4 SW7 SW8 OFF OFF ON ON ON OFF OFF ON
		Dip switch 5 SW9 SW10 OFF OFF ON ON ON OFF OFF ON
		Dip switch 6 SW11 SW12 OFF OFF ON ON ON OFF OFF ON
7)	Module fixing projection	Projection used to fix to the base unit.
8)	Serial number display	Display the serial number described on the rating plate.

(Note-1): The function is different depending on the operating system software installed.

⚠ CAUTION

- Before touching the DIP switches, always touch grounded metal, etc. to discharge static electricity from human body. Failure to do so may cause the module to fail or malfunction.
- Do not directly touch the module's conductive parts and electronic components. Touching them could cause an operation failure or damage the module.

POINTS

Input indicator LED of the manual pulse generator/incremental synchronous encoder phases A, B and tracking enable signal turns ON at the following conditions.

- (1) PLS.A 1 to 3, PLS.B 1 to 3
 - Q173DPX is set in the system setting of MT Developer2.
 - All axes servo ON command (M2042) turned on.
 - Manual pulse generator enable flag (M2051, M2052, M2053) turned on.
 - Manual pulse generator signal is input.
- (2) TREN 1 to 3
 - Q173DPX is set in the system setting of MT Developer2.
 - The tracking enable signal is input.

2 SYSTEM CONFIGURATION

(2) Performance specifications

(a) Module specifications

Item	Specifications
Number of I/O occupying points	32 points (I/O allocation: Intelligent, 32 points)
Internal current consumption(5VDC)[A]	0.38
Exterior dimensions [mm(inch)]	98(H)×27.4(W)×90(D) (3.86(H)×1.08(W)×3.54(D))
Mass [kg]	0.15

(b) Tracking enable signal input

Item	Specifications	
Number of input points	Tracking enable signal: 3 points	
Input method	Sink/Source type	
Common terminal arrangement	1 point/common (Common contact: TREN.COM)	
Isolation method	Photocoupler	
Rated input voltage	12/24VDC	
Rated input current	12VDC 2mA/24VDC 4mA	
Operating voltage range	10.2 to 26.4VDC (12/24VDC +10/-15%, ripple ratio 5% or less)	
ON voltage/current	10VDC or more/2.0mA or more	
OFF voltage/current	1.8VDC or less/0.18mA or less	
Input resistance	Approx. 5.6kΩ	
Response time	OFF to ON	0.4ms/0.6ms/1ms (CPU parameter setting, Default 0.4ms)
	ON to OFF	
Operation indicator	ON indication (LED)	

(Note): Functions are different depending on the operating system software installed.

(c) Manual pulse generator/Incremental synchronous encoder input

Item	Specifications	
Number of modules	3/module	
Voltage-output/ Open-collector type	High-voltage	3.0 to 5.25VDC
	Low-voltage	0 to 1.0VDC
Differential-output type (26LS31 or equivalent)	High-voltage	2.0 to 5.25VDC
	Low-voltage	0 to 0.8VDC
Input frequency	Up to 200kpps (After magnification by 4)	
Applicable types	<ul style="list-style-type: none"> • Voltage-output type/Open-collector type (5VDC), Recommended product: MR-HDP01 • Differential-output type (26LS31 or equivalent) 	
External connector type	40 pin connector	
Applicable wire size	0.3mm ²	
Applicable connector for the external connection	A6CON1 (Attachment) A6CON2, A6CON3, A6CON4 (Optional)	
Cable length	Voltage-output/ Open-collector type	30m (98.43ft.) (Open-collector type: 10m (32.81ft.))
	Differential-output type	

(3) Connection of manual pulse generator

Manual pulse generators of the voltage-output/open-collector type and differential-output type can be connected. Both connection methods are different. (Refer to this section (5).)

When the manual pulse generator is connected to the Q173DPX, it cannot be connected to the built-in interface in Motion CPU.

Motion CPU module	Connectable manual pulse generator
Q173DSCPU	Up to 3 modules (Q173DPX: Up to 1 module)
Q172DSCPU	
Q173DCPU(-S1)	
Q172DCPU(-S1)	

(4) Connection of incremental synchronous encoder

Incremental synchronous encoders of the voltage-output/Open-collector type and differential-output type can be connected. Both connection methods are different. (Refer to this section (5).)

Serial absolute synchronous encoder not connected to Q173DPX. Then connect to Q172DEX.

In addition, the usable numbers of synchronous encoders differ depending on the modules.

The following number of serial absolute synchronous encoders and incremental synchronous encoders combined can be used.

Motion CPU module	Connectable synchronous encoder
Q173DSCPU	Up to 12 modules (Q173DPX: Up to 4 modules)
Q172DSCPU	
Q173DCPU(-S1)	
Q172DCPU(-S1)	Up to 8 modules (Q173DPX: Up to 3 modules)

• Tracking enable signal

Tracking enable signal of Q173DPX is used to start the input from incremental synchronous encoders in the external input mode for the clutch.

The external input signal of the incremental synchronous encoder is indicated below.

This signal is used as the input start signal, high-speed reading function or high-speed input request signal from incremental synchronous encoder.

External input signal of the incremental synchronous encoder	Application	Number of points on one Q173DPX
Tracking enable signal input	Input start function from incremental synchronous encoder	Each 1 point (Total 3 points)

(5) Connection of manual pulse generator interface module
 (a) The pin layout of the PULSER connector

Use the PULSER connector on the front of the Q173DPX module to connect to manual pulse signals and incremental synchronous encoder signals.

The following is the pin layout of the Q173DPX PULSER connector as viewed from the front.

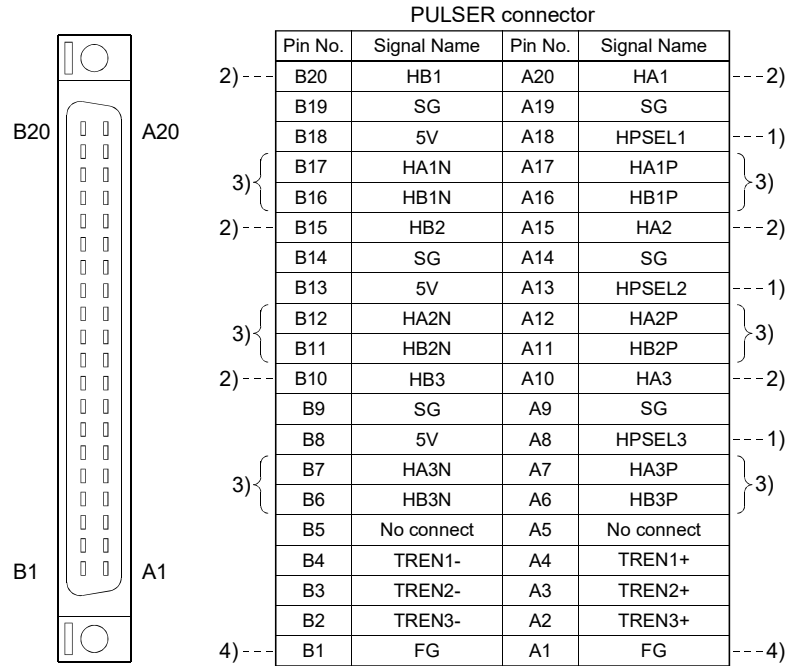

Applicable connector model name

- A6CON1 type soldering type connector
 - FCN-361J040-AU connector (FUJITSU COMPONENT LIMITED)
 - FCN-360C040-B connector cover
- } (Attachment)
- A6CON2 type Crimp-contact type connector
 - A6CON3 type Pressure-displacement type connector
 - A6CON4 type soldering type connector
- } (Optional)

- 1): Input type from manual pulse generator/incremental synchronous encoder switched by HPSEL□.
 Not connected : Voltage-output/open-collector type
 HPSEL□-SG connection : Differential-output type
 (Switching is possible for each input 1 to 3)
- 2): Voltage-output/open-collector type
 Connect the A-phase signal to HA1/HA2/HA3, and the B-phase signal to HB1/HB2/HB3.
- 3): Differential-output type
 Connect the A-phase signal to HA1P/HA2P/HA3P, and the A-phase inverse signal to HA1N/HA2N/HA3N.
 Connect the B-phase signal to HB1P/HB2P/HB3P, and the B-phase inverse signal to HB1N/HB2N/HB3N.
- 4): Connect the shield cable between manual pulse generator/incremental synchronous encoder and Q173DPX at the FG signal.
- 5): Connector/terminal block conversion modules cannot be used.

2 SYSTEM CONFIGURATION

(b) Interface between PULSER connector and manual pulse generator (Differential-output type)/Incremental synchronous encoder

Input or Output	Signal name		PIN No.			Wiring example	Internal circuit	Specification	Description
			1	2	3				
Input	Manual pulse generator, phase A	A+ HAOP	A17	A12	A7		<ul style="list-style-type: none"> Rated input voltage 5.5VDC or less HIGH level 2.0 to 5.25VDC/ 2mA or less LOW level 0.8VDC or less 26LS31 or equivalent 	<p>For connection manual pulse generator Phases A, B</p> <ul style="list-style-type: none"> Pulse width Leading edge, Trailing edge time Duty ratio: 50%±25% Phase difference <p>(1) Positioning address increases if Phase A leads Phase B. (2) Positioning address decreases if Phase B leads Phase A.</p>	
		Manual pulse generator, phase B	A+ HAOP	A16	A11				A6
		A- HAOP	B17	B12	B7				
	Select type signal HPSEL□		A18	A13	A8	(Note-2)			
Power supply	5V ^(Note-1)		B18	B13	B8				
	SG		A19 B19	A14 B14	A9 B9				

(Note-1): The 5V(P5)DC power supply from the Q173DPX must not be used if a separate power supply is applied to the Manual pulse generator/Incremental synchronous encoder.

If a separate power supply is used, be sure it is 5V voltage. Anything else may cause a failure.

(Note-2): Connect HPSEL□ to the SG terminal if the manual pulse generator (differential-output type) /incremental synchronous encoder is used.

2 SYSTEM CONFIGURATION

(c) Interface between PULSER connector and manual pulse generator (Voltage-output/Open-collector type)/ Incremental synchronous encoder.

Input or Output	Signal name	Pin No.			Wiring example	Internal circuit	Specification	Description
		1	2	3				
Input	Manual pulse generator, phase A HA□	A20	A15	A10		<ul style="list-style-type: none"> Rated input voltage 5.5VDC or less HIGH level 3 to 5.25VDC/ 2mA or less LOW level 1VDC or less/ 5mA or more 	For connection manual pulse generator Phases A, B <ul style="list-style-type: none"> Pulse width $20\mu\text{s}$ or more Phase A and B pulse widths are $5\mu\text{s}$ or more. (Duty ratio: $50\% \pm 25\%$) Leading edge, Trailing edge time $\dots 1\mu\text{s}$ or less Phase difference $2.5\mu\text{s}$ or more (1) Positioning address increases if Phase A leads Phase B. (2) Positioning address decreases if Phase B leads Phase A.	
	Manual pulse generator, phase B HB□	B20	B15	B10				
	Select type signal HPSEL□	A18	A13	A8				
Power supply	5V ^(Note-1)	B18	B13	B8				
	SG	A19 B19	A14 B14	A9 B9				

(Note-1) : The 5V(P5)DC power supply from the Q173DPX must not be used if a separate power supply is applied to the Manual pulse generator/Incremental synchronous encoder.
 If a separate power supply is used, be sure it is 5V voltage. Anything else may cause a failure.

(d) Interface between PULSER connector and tracking enable signal

Input or Output	Signal name	Pin No.			Wiring example	Internal circuit	Specification	Description
		1	2	3				
Input	Tracking enable	TREN□+	A4	A3	A2			Tracking enable signal input.
		TREN□-	B4	B3	B2			

(Note): As for the connection to tracking enable (TREN□+, TREN□-), both "+" and "-" are possible.

2 SYSTEM CONFIGURATION

(6) Connection examples of manual pulse generator

(a) Differential-output type

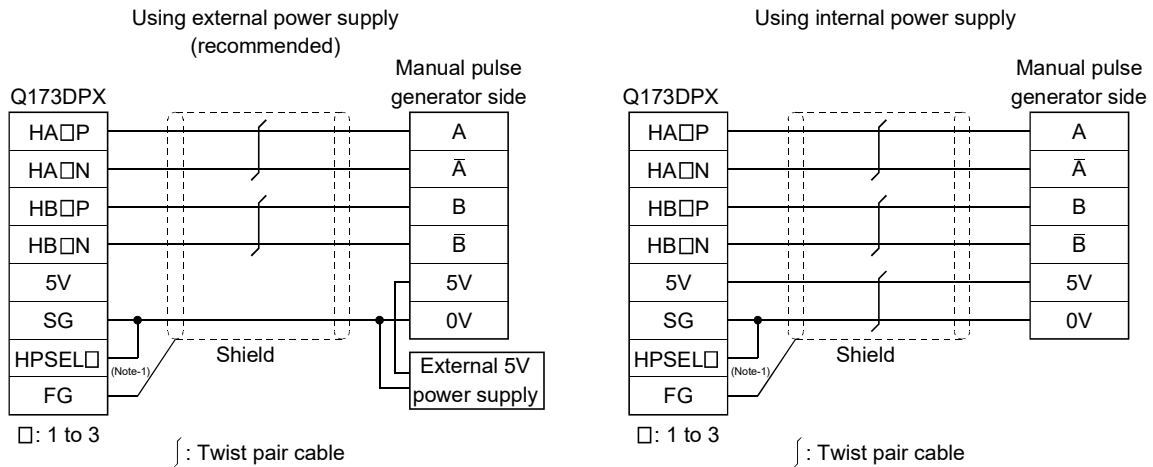

(Note-1): Connect HPSEL□ to the SG terminal if the manual pulse generator (differential-output type)/incremental synchronous encoder is used.

(b) Voltage-output type/open-collector type

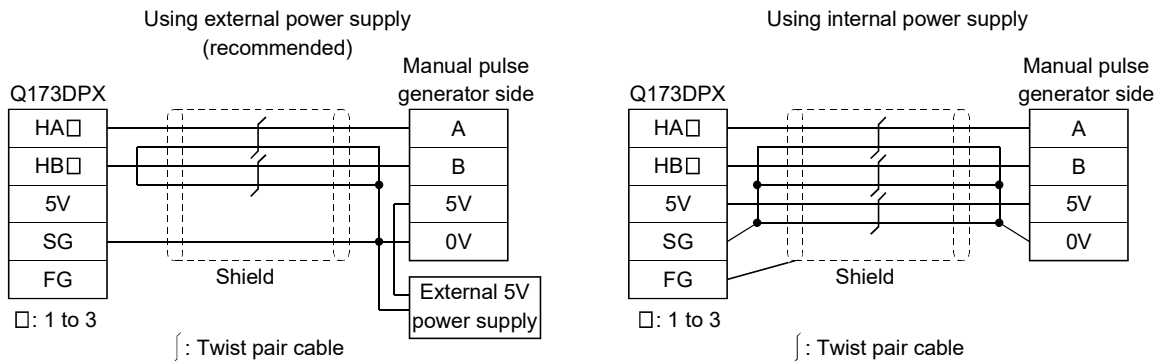

⚠ CAUTION

- If a separate power supply is applied to the manual pulse generator/incremental synchronous encoder, be sure it is 5V voltage. Anything else may cause a failure.
- Always wire the cables when power is off. Not doing so may damage the circuit of modules.
- Wire the cable correctly. Wrong wiring may damage the internal circuit.
- P5 terminal is the power supply for the manual pulse generator. Do not apply a voltage and do not use it for other purposes.

2 SYSTEM CONFIGURATION

2.5.7 Q173DSXY Safety signal module

Q173DSXY is used to input/output the safety signal.

(1) Q173DSXY name of parts

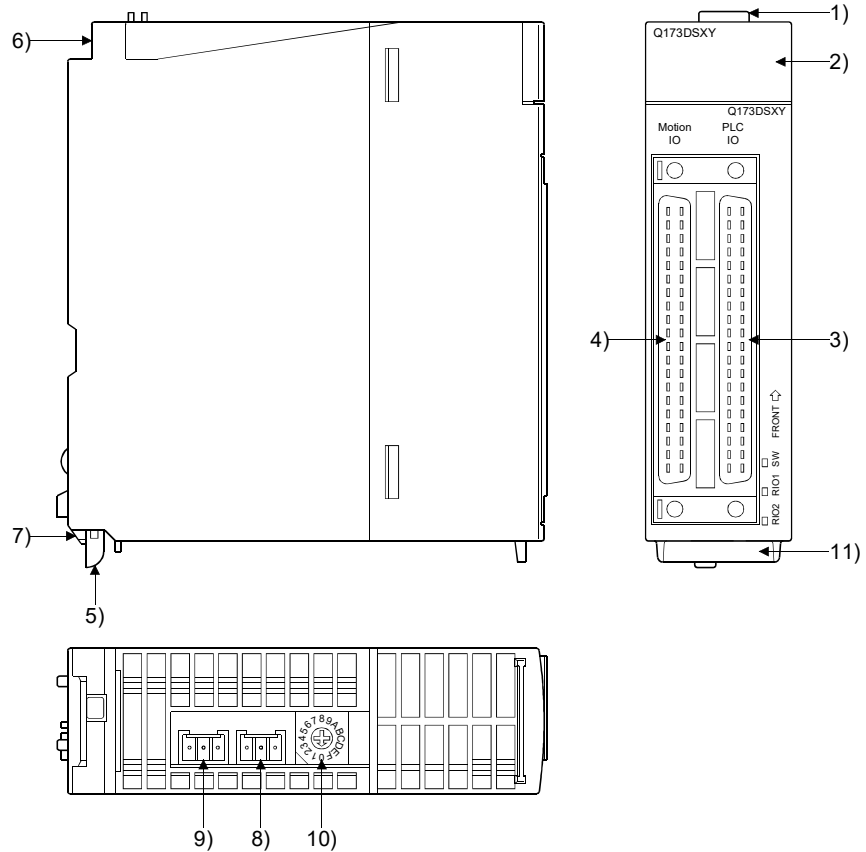

No.	Name	Application				
1)	Module fixing hook	Hook used to fix the module to the base unit. (Single-motion installation)				
2)	Input indicator LED	Display the input status from the external equipment. <table border="1" data-bbox="794 1541 1422 1664"> <thead> <tr> <th>LED</th> <th>Details</th> </tr> </thead> <tbody> <tr> <td>0 to 1F</td> <td>Display for I/O signal status of PLC CPU side.</td> </tr> </tbody> </table>	LED	Details	0 to 1F	Display for I/O signal status of PLC CPU side.
LED	Details					
0 to 1F	Display for I/O signal status of PLC CPU side.					
3)	PLC IO connector	Input/output connector of the PLC CPU.				
4)	Motion IO connector	Input/output connector of the Motion CPU.				
5)	Module mounting lever	Used to install the module to the base unit.				
6)	Module fixing screw hole	Hole for the screw used to fix to the base unit (M3×12 screw: Purchase from the other supplier)				
7)	Module fixing projection	Projection used to fix to the base unit.				
8)	RIO1 connector	RIO communication to Motion CPU (For connection to Motion CPU or Q173DSXY installed on the left)				

2 SYSTEM CONFIGURATION

No.	Name	Application								
9)	RIO2 connector	RIO communication for Motion CPU (For connection to Q173DSXY installed on the right)								
10)	Rotary switch for station number setting 	Set station number of safety signal module. <table border="1" data-bbox="796 423 1369 589"> <thead> <tr> <th>Setting ^(Note)</th> <th>Station number</th> </tr> </thead> <tbody> <tr> <td>0</td> <td>Station number 1 (Module 1)</td> </tr> <tr> <td>1</td> <td>Station number 2 (Module 2)</td> </tr> <tr> <td>2</td> <td>Station number 3 (Module 3)</td> </tr> </tbody> </table> <p>(Note): Do not set other than the above setting.</p>	Setting ^(Note)	Station number	0	Station number 1 (Module 1)	1	Station number 2 (Module 2)	2	Station number 3 (Module 3)
Setting ^(Note)	Station number									
0	Station number 1 (Module 1)									
1	Station number 2 (Module 2)									
2	Station number 3 (Module 3)									
11)	Serial number display	Display the serial number described on the rating plate.								

(2) Performance specifications (a) Module specifications

Item	Specifications
Number of I/O occupying points	32 points (I/O allocation: I/O mix, 32 points)
Internal current consumption(5VDC)[A]	0.2 (TYP. All points ON)
Exterior dimensions [mm(inch)]	98(H)×27.4(W)×90(D) (3.86(H)×1.08(W)×3.54(D))
Mass [kg]	0.15

2 SYSTEM CONFIGURATION

(b) Input/output

Item	Specifications
Number of input points	32 points × 2 lines (PLC CPU control 32 points + Motion CPU control 32 points, Safety input 20 points × 2 lines, Feedback input for output 12 points × 2 lines)
Input isolation method	Photocoupler
Rated input voltage	24VDC (±10%, ripple rate within 5%)
Rated input current	Approx. 4mA
Input resistance	Approx. 8.2kΩ
ON voltage/ON current	20V or more/3.0mA or more
OFF voltage/OFF current	5V or less/1.7mA or less
Input response time	PLC CPU control I/O : 10ms (initial value of digital filter) Motion CPU control I/O : 15ms (CR filter)
Input common method	32 points/common (PLC I/O and Motion I/O are separated.)
Input type	Type 1, Current sinking
Number of output points	12 points × 2 lines (PLC CPU control 12 points + Motion CPU control 12 points)
Output isolation method	Photocoupler
Rated load voltage	24VDC (±10%)
Maximum load current	(0.1A × 8 points, 0.2A × 4 points) × 2 lines Common current: 1.6A or less for each connector
Maximum inrush current	0.7A 10ms or less (0.2A output pin: 1.4A 10ms or less)
Output response time	1ms or less
Output common method	12 points/common (PLC I/O and Motion I/O are separated.)
Output type	Current sourcing
External power supply	24VDC (±10%, ripple rate within 5%)
Operation indicator (input/output)	ON indication (LED) (indicates PLC CPU's 32 points)
Communication with PLC CPU	Parallel bus communication (Via main base unit)
Communication with Motion CPU	Serial communication (RS-485), Q173DSXYCBL□M cable use
Applicable wire size	0.3mm ²
Applicable connector for the external connection	A6CON1 (Attachment), A6CON2, A6CON3, A6CON4 (Optional)
Connector/terminal block conversion module	A6TBXY36 (Optional), FA-LTB40P (Optional: Mitsubishi Electric Engineering Co., Ltd. make)
Cable for connector/terminal block conversion module	AC50TB (included with A6TBXY36), FA-CBL□FMV-M (included with FA-LTB40P)
Number of modules	Up to 3 modules

2 SYSTEM CONFIGURATION

(c) The pin layout of the Motion IO connector/PLC IO connector
Use the Motion IO connector and PLC IO connector on the front of the Q173DSXY module to connect to I/O signals.

The following is the pin layout of the Q173DSXY Motion IO connector and PLC IO connector as viewed from the front.

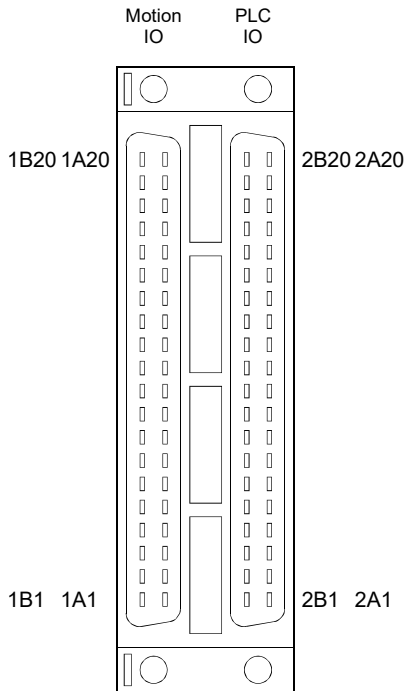

Motion IO connector				PLC IO connector			
Pin No.	Signal Name	Pin No.	Signal Name	Pin No.	Signal Name	Pin No.	Signal Name
1B20	MC-X00	1A20	MC-X10	2B20	PLC-X00	2A20	PLC-X10
1B19	MC-X01	1A19	MC-X11	2B19	PLC-X01	2A19	PLC-X11
1B18	MC-X02	1A18	MC-X12	2B18	PLC-X02	2A18	PLC-X12
1B17	MC-X03	1A17	MC-X13	2B17	PLC-X03	2A17	PLC-X13
1B16	MC-X04	1A16	MC-X14	2B16	PLC-X04	2A16	PLC-X14
1B15	MC-X05	1A15	MC-X15	2B15	PLC-X05	2A15	PLC-X15
1B14	MC-X06	1A14	MC-X16	2B14	PLC-X06	2A14	PLC-X16
1B13	MC-X07	1A13	MC-X17	2B13	PLC-X07	2A13	PLC-X17
1B12	MC-X08	1A12	MC-X18	2B12	PLC-X08	2A12	PLC-X18
1B11	MC-X09	1A11	MC-X19	2B11	PLC-X09	2A11	PLC-X19
1B10 (Note-1), (Note-2)	MC-Y0A/X0A	1A10 (Note-1)	MC-Y1A/X1A	2B10 (Note-1), (Note-2)	PLC-Y0A/X0A	2A10 (Note-1)	PLC-Y1A/X1A
1B9 (Note-1)	MC-Y0B/X0B	1A9 (Note-18)	MC-Y1B/X1B	2B9 (Note-1)	PLC-Y0B/X0B	2A9 (Note-1)	PLC-Y1B/X1B
1B8	MC-Y0C/X0C	1A8	MC-Y1C/X1C	2B8	PLC-Y0C/X0C	2A8	PLC-Y1C/X1C
1B7	MC-Y0D/X0D	1A7	MC-Y1D/X1D	2B7	PLC-Y0D/X0D	2A7	PLC-Y1D/X1D
1B6	MC-Y0E/X0E	1A6	MC-Y1E/X1E	2B6	PLC-Y0E/X0E	2A6	PLC-Y1E/X1E
1B5	MC-Y0F/X0F	1A5	MC-Y1F/X1F	2B5	PLC-Y0F/X0F	2A5	PLC-Y1F/X1F
1B4	Not connect	1A4	Not connect	2B4	Not connect	2A4	Not connect
1B3	Not connect	1A3	Not connect	2B3	Not connect	2A3	Not connect
1B2	24VDC(COM1)	1A2	0V(COM2)	2B2	24VDC(COM1)	2A2	0V(COM2)
1B1	24VDC(COM1)	1A1	0V(COM2)	2B1	24VDC(COM1)	2A1	0V(COM2)

(Note-1): 0.2[A] output is possible. (The others are 0.1[A] output.)

(Note-2): Controlled by system as shut-off signal. (Safety observation function normally is ON, abnormally is OFF.)

Applicable connector model name

A6CON1 type soldering type connector	}	(Attachment)
FCN-361J040-AU connector (FUJITSU COMPONENT LIMITED)		
FCN-360C040-B connector cover		
A6CON2 type Crimp-contact type connector	}	(Optional)
A6CON3 type Pressure-displacement type connector		
A6CON4 type soldering type connector		

(Note): Connector/terminal block conversion modules and cables can be used at the wiring of connector.

A6TBXY36 : Connector/terminal block converter module

AC□TB (□:Length [m]): Connector/terminal block converter module cable

2 SYSTEM CONFIGURATION

(3) Interface between Motion IO connector/PLC IO connector and servo external signal

Input or Output	Signal name		Pin No. (Note-1)	LED (Note-2)	Wiring example	Internal circuit	Specification
	Motion IO	PLC IO					
Input	MC-X00	PLC-X00	□B20	0		<ul style="list-style-type: none"> • Supply voltage 24VDC • High level 20.0VDC or more/ 3.0mA or more • Low level 5.0VDC or less/ 1.7mA or less 	
	MC-X01	PLC-X01	□B19	1			
	MC-X02	PLC-X02	□B18	2			
	MC-X03	PLC-X03	□B17	3			
	MC-X04	PLC-X04	□B16	4			
	MC-X05	PLC-X05	□B15	5			
	MC-X06	PLC-X06	□B14	6			
	MC-X07	PLC-X07	□B13	7			
	MC-X08	PLC-X08	□B12	8			
	MC-X09	PLC-X09	□B11	9			
	MC-X10	PLC-X10	□A20	0			
	MC-X11	PLC-X11	□A19	1			
	MC-X12	PLC-X12	□A18	2			
	MC-X13	PLC-X13	□A17	3			
	MC-X14	PLC-X14	□A16	4			
	MC-X15	PLC-X15	□A15	5			
	MC-X16	PLC-X16	□A14	6			
	MC-X17	PLC-X17	□A13	7			
	MC-X18	PLC-X18	□A12	8			
MC-X19	PLC-X19	□A11	9				
Output	MC-Y0A/X0A	PLC-Y0A/X0A	□B10	A		<ul style="list-style-type: none"> • Maximum load current 0.1A × 8 points (2 lines) • 0.2A × 4 points (2 lines) • Common current 1.6A or less 	
	MC-Y0B/X0B	PLC-Y0B/X0B	□B9	B			
	MC-Y0C/X0C	PLC-Y0C/X0C	□B8	C			
	MC-Y0D/X0D	PLC-Y0D/X0D	□B7	D			
	MC-Y0E/X0E	PLC-Y0E/X0E	□B6	E			
	MC-Y0F/X0F	PLC-Y0F/X0F	□B5	F			
	MC-Y1A/X1A	PLC-Y1A/X1A	□A10	A			
	MC-Y1B/X1B	PLC-Y1B/X1B	□A9	B			
	MC-Y1C/X1C	PLC-Y1C/X1C	□A8	C			
	MC-Y1D/X1D	PLC-Y1D/X1D	□A7	D			
MC-Y1E/X1E	PLC-Y1E/X1E	□A6	E				
MC-Y1F/X1F	PLC-Y1F/X1F	□A5	F				
Power supply	24VDC(COM1)	24VDC(COM1)	□B2				
	24VDC(COM1)	24VDC(COM1)	□B1				
	0VDC(COM2)	0VDC(COM2)	□A2				
	0VDC(COM2)	0VDC(COM2)	□A1				

(Note-1): □ = 1: Motion IO, 2: PLC IO
 (Note-2): PLC CPU side only

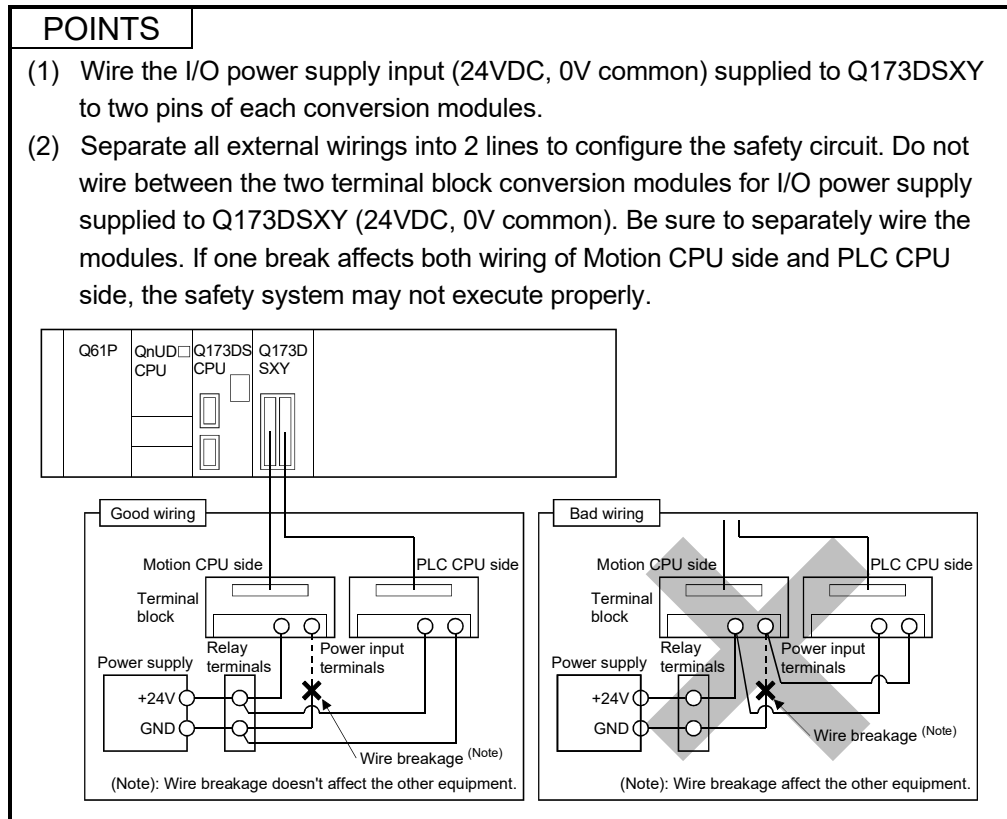

⚠ CAUTION

- Measure the input voltage to Q173DSXY with the input connector part. Be sure to select DC power supply within the range of 21.6VDC to 26.4VDC included ripple voltage and spike voltage and wire.
- When wiring in the Q173DSXY, be sure that it is done correctly by checking the product's rated voltage and the terminal layout. Connecting a power supply that is different from the rating or incorrectly wiring the product could result in fire or damage.
Wire the cable correctly. Wrong wiring may damage the internal circuit.
- Always use a shield cable for connection of the connector and external equipment, and avoid running it close to or bundling it with the power and main circuit cables to minimize the influence of electromagnetic interface. (Separate them more than 100mm(0.33ft.) away.)
- Connect the shield wire of the connection cable to the FG terminal of the external equipment.
- Make parameter setting correctly. Incorrect setting may disable the protective functions such as safety functions.
- Always wire the cables when power is off. Not doing so may damage the circuit of modules.
- Do not touch the case of Q173DSXY while the power is ON and for a short time after the power is turned OFF. In this timing, these parts become very hot and may lead to burns.

(4) Wiring example for the safety signal module

(a) Wiring example for door signal to safety signal module and AC contactor.

Wiring example to shut off contactor by the following methods are shown in the diagram below.

- Shut-off signal from the Motion CPU side of safety signal module
- Shut-off signal from the PLC CPU side of safety signal module
- Contactor shut-off output MC1 and MC2 of servo amplifier

Input the output signal of auxiliary normally closed contact into the safety signal module to detect the weld of contactor.

Door sensor used as a safety signal should have two outputs and is wired to both Motion CPU side and PLC CPU side. Sensor and switch used as safety signal should be the ones for weak signal use (e.g. twin contact) to prevent contact failure.

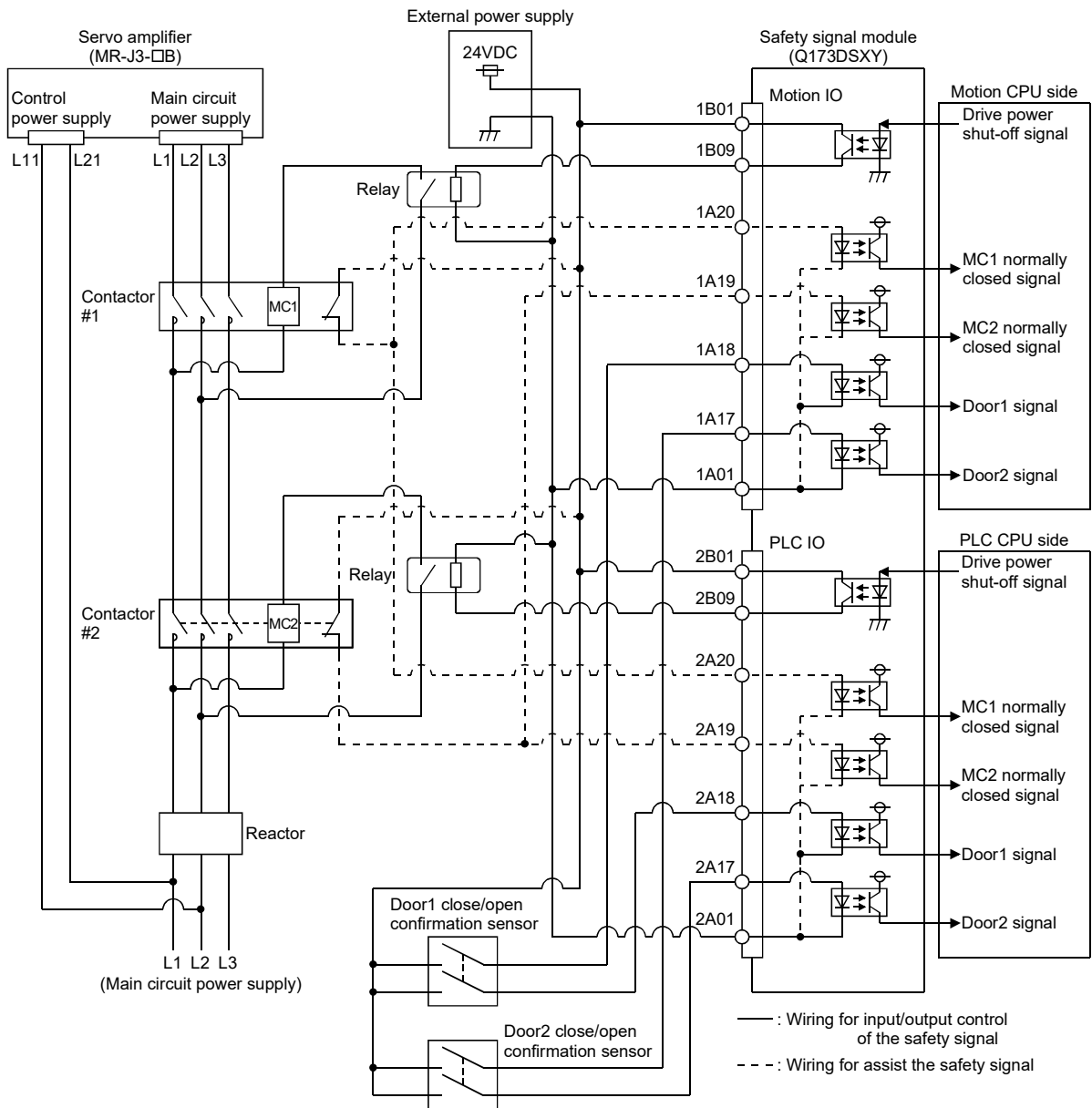

2 SYSTEM CONFIGURATION

(b) Wiring example for door signal to safety signal module and STO terminal. Wiring example to wire the following methods are shown in the diagram below.

- Shut-off signal from the Motion CPU side of safety signal module
- Shut-off signal from the PLC CPU side of safety signal module
- STO terminal of servo amplifier

Door sensor used as a safety signal should have two outputs and is wired to both Motion CPU side and PLC CPU side. Sensor and switch used as safety signal should be the ones for weak signal use (e.g. twin contact) to prevent contact failure.

POINTS

Servo amplifier (MR-J5(W)-□B) does not support safety communication.

1) MR-J4-□B use

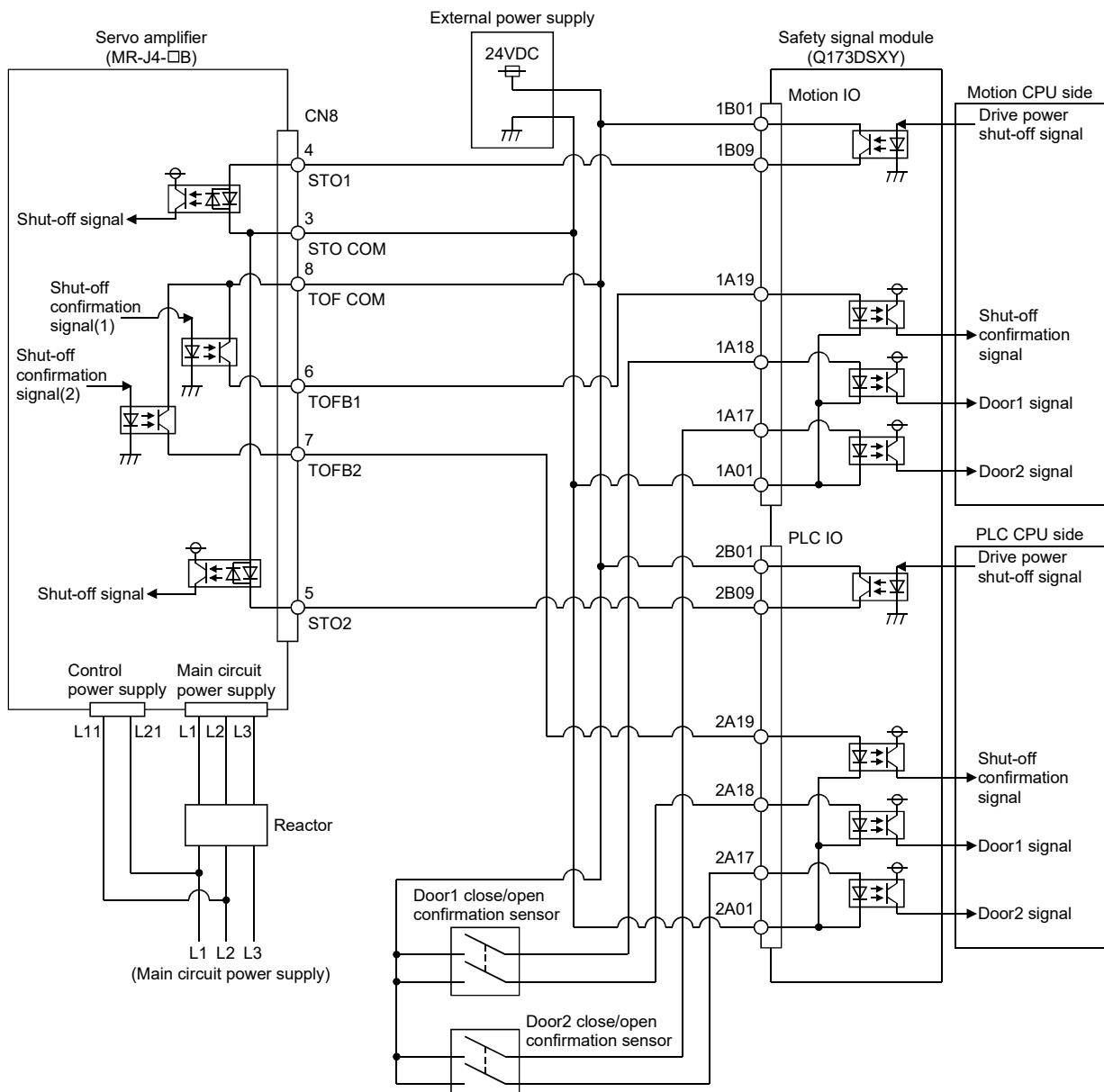

2 SYSTEM CONFIGURATION

2) MR-J3-□BS use

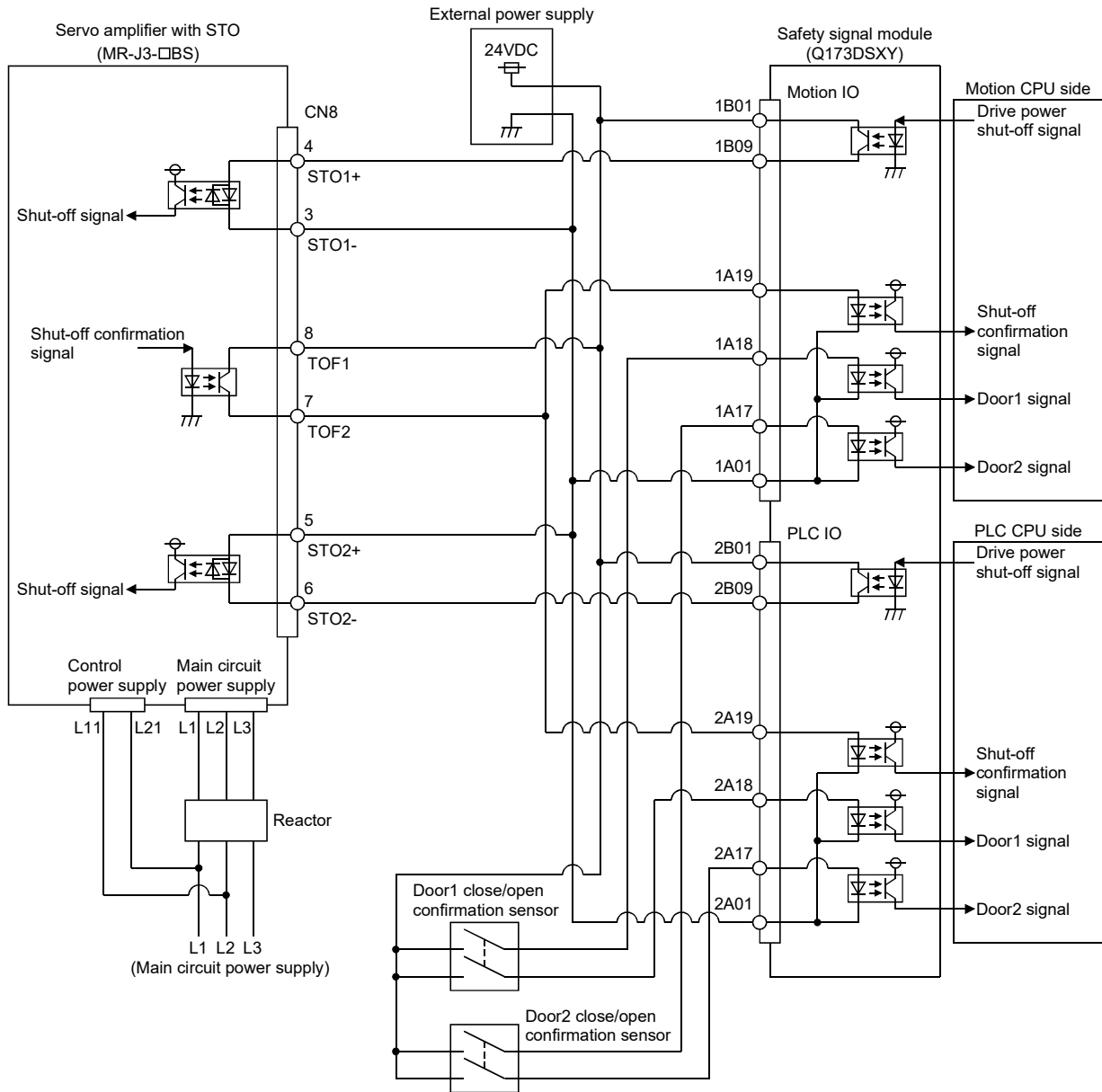

2 SYSTEM CONFIGURATION

(c) Wiring example for external pulse input to safety signal module.

The wiring diagram for external pulse input signal and safety signal module shows below.

Safety module performs the safety diagnostics of external pulse generator, therefore you need to wire them so that external pulse generator is supplied power by the safety signal module, and the generated pulse becomes input signal of safety signal module.

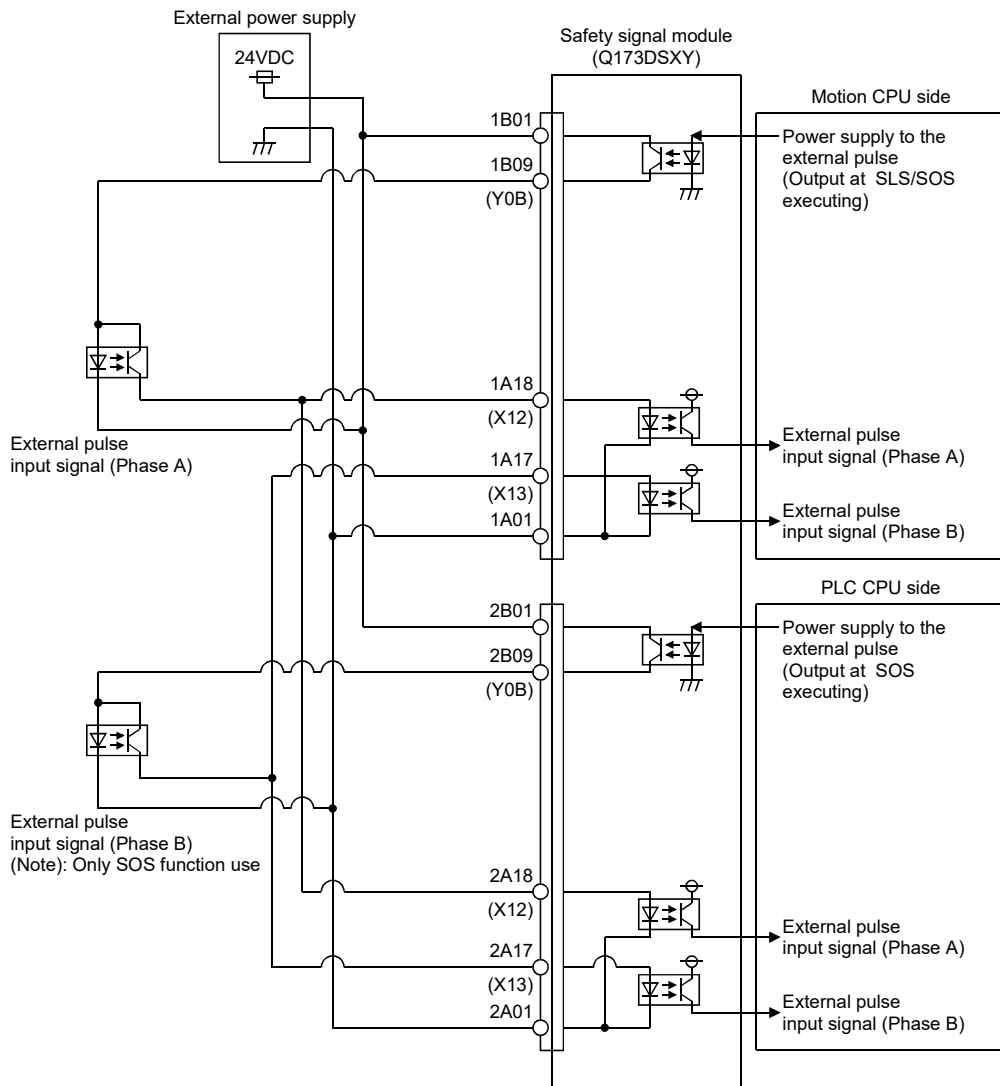

2 SYSTEM CONFIGURATION

2.5.8 Manual pulse generator/Serial absolute synchronous encoder

(1) Manual pulse generator specifications

Item	Specifications
Model name	MR-HDP01 ^(Note-1)
Ambient temperature	-10 to 60°C (14 to 140°F)
Pulse resolution	25pulse/rev(100 pulse/rev after magnification by 4)
Output method	Voltage-output/Output current: Up to 20mA
Power supply voltage	4.5 to 13.2VDC
Current consumption [mA]	60
Output level	"H" level: Power supply voltage ^(Note-2) -1V or more (with no load) "L" level: 0.5V or less (with maximum leading-in)
Life time	1,000,000 revolutions or more (at 200r/min)
Permitted axial loads	Radial load: Up to 19.6N, Thrust load: Up to 9.8N
Mass [kg]	0.4
Number of max. revolution	Instantaneous Up to 600r/min. normal 200r/min
Pulse signal status	2 signals: A phase, B: phase, 90° phase difference
Start friction torque	0.06N•m (20°C (68°F))

(Note-1): Use MR-HDP01 by connecting with Q173DPX or built-in interface in Motion CPU.

(Note-2): If a separate power supply is used, be sure it is 5VDC ± 0.25V voltage.

2 SYSTEM CONFIGURATION

(2) Serial absolute synchronous encoder specifications

Item	Specifications	
Model name	Q171ENC-W8 (Note-1), (Note-2)	Q170ENC (Note-1), (Note-2)
Ambient temperature	-5 to 55°C (23 to 131°F)	
Resolution	4194304pulse/rev	262144pulse/rev
Transmission method	Serial communications (Connected to Q172DEX)	
Direction of increasing addresses	CCW (viewed from end of shaft)	
Protective construction	Dustproof/Waterproof (IP67: Except for the shaft-through portion.)	Dustproof/Waterproof (IP65: Except for the shaft-through portion.)
Permitted speed at power ON	3600r/min	
Permitted speed at power OFF (Note-3)	500r/min	
Permitted axial loads	Radial load : Up to 19.6N, Thrust load : Up to 9.8N	
Runout at input shaft tip	0.02mm(0.00079 inch) or less (15mm(0.59 inch) from tip)	
Start friction torque	0.04N•m (20°C (68°F))	0.02N•m (20°C (68°F))
Recommended coupling	Bellows coupling	
Permitted angular acceleration	40000rad/s ²	
Vibration resistance	5G (50 to 200Hz)	
Shock resistance	50G (11ms or less)	
Internal current consumption [A]	0.25	
Mass [kg]	0.6	
Connecting cable [m(ft.)]	Q170ENCBL□M(-A) (□=Cable length : 2(6.56), 5 (16.40), 10 (32.81), 20 (65.62), 30 (98.43), 50 (164.04))	
Communications method	Differential driver/receiver	
Transmission distance	Up to 50m (164.04ft.)	

(Note-1): Use by connecting with Q172DEX.

(Note-2): When "o-ring" is required, please purchase separately by customers.

(Note-3): If it exceeds a permitted speed at power OFF, a position displacement is generated.

2 SYSTEM CONFIGURATION

2.5.9 SSCNETⅢ cables

Between the Motion CPU module and servo amplifiers, or servo amplifier and servo amplifier connected by SSCNETⅢ cable. When using the Q172D(S)CPU, SSCNETⅢ cable for connection to servo amplifier can be used for only 1 line. (Connect to CN1.) When using the Q173D(S)CPU, SSCNETⅢ cables for connection to servo amplifier can be used for up to 2 lines. (Connect to CN1 and CN2.)

Up to 16 servo amplifiers can be connected to SSCNETⅢ(/H) per 1 line.

(However, when using the Q172DCPU(-S1), up to 8 servo amplifiers can be connected.)

(1) SSCNETⅢ cable specifications

Model name		Cable length [m(ft.)]	Description
MR-J3BUS□M (Standard cord for inside panel)	MR-J3BUS015M	0.15 (0.49)	<ul style="list-style-type: none"> • Motion CPU ↔ Servo amplifier • Servo amplifier ↔ Servo amplifier
	MR-J3BUS03M	0.3 (0.98)	
	MR-J3BUS05M	0.5 (1.64)	
	MR-J3BUS1M	1 (3.28)	
	MR-J3BUS3M	3 (9.84)	
MR-J3BUS□M-A (Standard cable for outside panel)	MR-J3BUS5M-A	5 (16.40)	
	MR-J3BUS10M-A	10 (32.81)	
	MR-J3BUS20M-A	20 (65.62)	
MR-J3BUS□M-B (Long distance cable)	MR-J3BUS30M-B	30 (98.43)	
	MR-J3BUS40M-B	40 (131.23)	
	MR-J3BUS50M-B	50 (164.04)	

2 SYSTEM CONFIGURATION

(2) Connection between the Q173D(S)CPU and servo amplifiers

Connect the SSCNET III cables to the following connectors.

Refer to Section 4.2.1 for the connection and disconnection of SSCNET III cable.

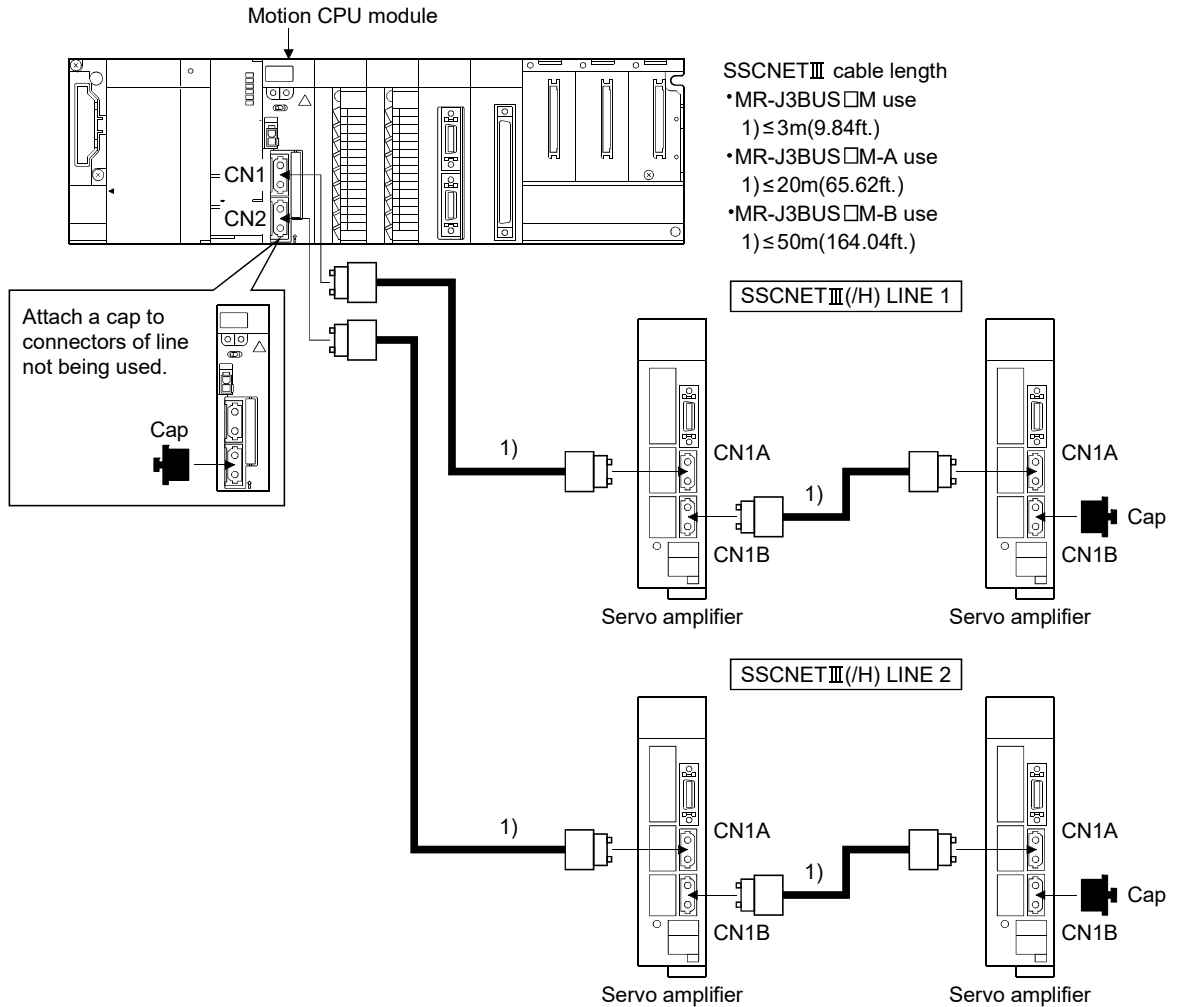

(Note): It cannot communicate if the connection of CN1A and CN1B is mistaken.

2 SYSTEM CONFIGURATION

(3) Connection between the Q172D(S)CPU and servo amplifiers

Connect the SSCNET III cables to the following connectors.

Refer to Section 4.2.1 for the connection and disconnection of SSCNET III cable.

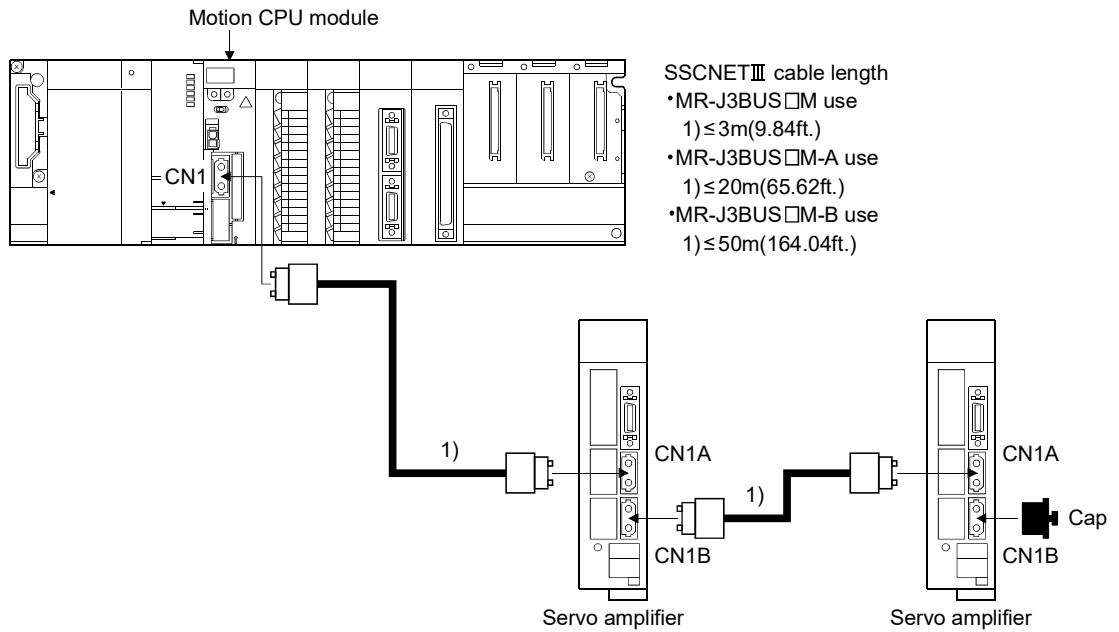

(Note): It cannot communicate if the connection of CN1A and CN1B is mistaken.

2 SYSTEM CONFIGURATION

(4) Setting of the axis No. and axis select rotary switch of servo amplifier

Axis No. is used to set the axis numbers of servo amplifiers connected to SSCNET III connector(CN□) in the program.

The following range can be set in the Motion CPU module.

Axis No. is set for each SSCNET III(/H) line in the system setting of MT Developer2. Axis No. is allocated and set for the setting axis number (d01 to d16) of servo amplifier.

	Axis No. setting range
Q173DSCPU	1 to 32
Q173DCPU(-S1)	
Q172DSCPU	1 to 16
Q172DCPU(-S1)	1 to 8

Since the axis number (d01 to d16) of a servo amplifier on the system setting screen corresponds to the rotary switches (SW1/SW2) (0 to F)/axis select rotary switch (0 to F) of a servo amplifier, set the rotary switches (SW1/SW2)/axis select rotary switch referring to Table 2.1 in (a) or Table 2.2 in (b) below.

- Setting display of axis No.

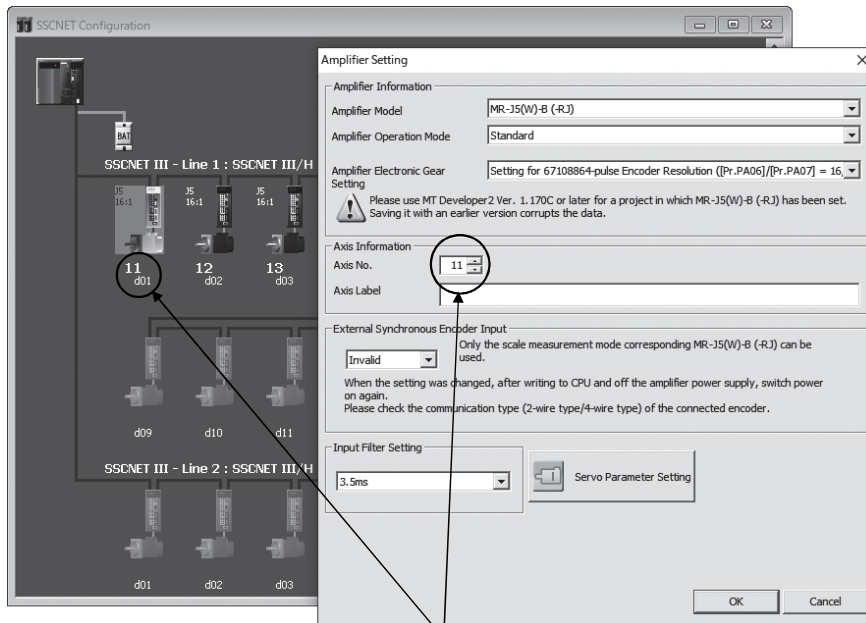

Set the axis No. relative to axis number (dno.).

- Rotary switch (SW1/SW2) / Axis select rotary switch (Servo amplifier)

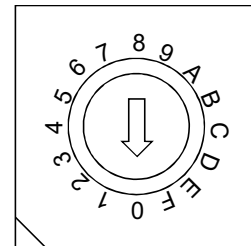

(Note): Correspondence between dno. and axis select rotary switch of servo amplifiers is shown in Table 2.1.

2 SYSTEM CONFIGURATION

(a) When using MR-J5(W)-□B

Correspondence between the dno. and the rotary switches (SW1/SW2) is shown in Table 2.1.

Table 2.1 Correspondence between dno.s and rotary switches (SW1/SW2) of servo amplifier

dno.(Note1)	SSCNETⅢ(/H) line	Rotary switch		dno. (Note1)	SSCNETⅢ(/H) line	Rotary switch	
		SW1	SW2			SW1	SW2
d01	1	"0"	"0"	d01	2	"0"	"0"
d02	1	"0"	"1"	d02	2	"0"	"1"
d03	1	"0"	"2"	d03	2	"0"	"2"
d04	1	"0"	"3"	d04	2	"0"	"3"
d05	1	"0"	"4"	d05	2	"0"	"4"
d06	1	"0"	"5"	d06	2	"0"	"5"
d07	1	"0"	"6"	d07	2	"0"	"6"
d08	1	"0"	"7"	d08	2	"0"	"7"
d09	1	"0"	"8"	d09	2	"0"	"8"
d10	1	"0"	"9"	d10	2	"0"	"9"
d11	1	"0"	"A"	d11	2	"0"	"A"
d12	1	"0"	"B"	d12	2	"0"	"B"
d13	1	"0"	"C"	d13	2	"0"	"C"
d14	1	"0"	"D"	d14	2	"0"	"D"
d15	1	"0"	"E"	d15	2	"0"	"E"
d16	1	"0"	"F"	d16	2	"0"	"F"

(Note1): The dno. is number of servo amplifier axis displayed with the system setting of MT Developer2.

Axis No. is set relative to dno. in the system settings.

(Note2): Set rotary switch (SW1) to "0". Rotary switch (SW1) cannot be set to any value other than "0" (1 to F).

(b) When using MR-J4(W)-□B/MR-J3(W)-□B

Correspondence between the dno. and the axis select rotary switch of the servo amplifier is shown in Table 2.2.

Table 2.2 Correspondence between dno.s and axis select rotary switches of servo amplifier

dno. (Note)	SSCNETⅢ(/H) line	Axis select rotary switch	dno. (Note)	SSCNETⅢ(/H) line	Axis select rotary switch
d01	1	"0"	d01	2	"0"
d02	1	"1"	d02	2	"1"
d03	1	"2"	d03	2	"2"
d04	1	"3"	d04	2	"3"
d05	1	"4"	d05	2	"4"
d06	1	"5"	d06	2	"5"
d07	1	"6"	d07	2	"6"
d08	1	"7"	d08	2	"7"
d09	1	"8"	d09	2	"8"
d10	1	"9"	d10	2	"9"
d11	1	"A"	d11	2	"A"
d12	1	"B"	d12	2	"B"
d13	1	"C"	d13	2	"C"
d14	1	"D"	d14	2	"D"
d15	1	"E"	d15	2	"E"
d16	1	"F"	d16	2	"F"

(Note1): The dno. is number of servo amplifier axis displayed with the system setting of MT Developer2.

Axis No. is set relative to dno. in the system settings.

2 SYSTEM CONFIGURATION

(c) Connector No. of Motion CPU module

Correspondence between SSCNET III(/H) line and connector No. of Motion CPU module is shown in Table 2.2.

Table 2.3 Correspondence between SSCNET III(/H) line No. and connector No. of Motion CPU module

SSCNET III(/H) line No.	Connector No. of Motion CPU module
1	CN1
2	CN2

(Note): Number of SSCNET III(/H) lines: Q173D(S)CPU: 2 lines/Q172D(S)CPU: 1 line

POINTS

The setting of axis select rotary switch is different depending on the servo amplifier. Refer to the "Servo amplifier Instruction Manual" for details.
--

2 SYSTEM CONFIGURATION

2.5.10 Battery

This section describes the battery specifications and handling precautions used in the Motion CPU.

(1) Battery specifications

Item	Model name	Q6BAT
Classification		Manganese dioxide lithium primary battery
Initial voltage [V]		3.0
Nominal current [mAh]		1800
Storage life		Actually 5 years (Room temperature)
Lithium content [g]		0.57
Applications		For memory data backup of SRAM built-in Motion CPU
Exterior dimensions [mm(inch)]		φ 16(0.63) x 32(1.26)

- Transport guidelines

Products are packed in compliance with the transportation regulations prior to shipment. When repacking any of the unpacked products for transportation, make sure to observe the IATA Dangerous Goods Regulations, IMDG (International Maritime Dangerous Goods) Code, and other local transportation regulations.

For details, please consult the shipping carrier used.

2 SYSTEM CONFIGURATION

(2) Data back-up of Motion CPU module by the battery

Be sure to use the battery.

- For Q173DSCPU/Q172DSCPU
Set the battery (Q6BAT) to battery holder.
- For Q173DCPU(-S1)/Q172DCPU(-S1)
Set the battery (Q6BAT) to battery holder unit (Q170DBATC).

The programs, parameters, motion devices(#), latch range devices and absolute position data of SRAM built-in Motion CPU module are not backed up without using the battery.

In the following status, the backup time after power OFF is 3 minutes.

- The battery connector/Q6BAT lead connector is disconnected.
- The battery cable/lead wire of Q6BAT is broken.

Module type	Battery type	Battery life (Total power failure time) [h] (Note-1)				Backup time after alarm
		Power-on time ratio (Note-2)	Guaranteed value (Note-3) (MIN) (75°C (167°F))	Guaranteed value (Note-4) (TYP) (40°C (104°F))	Actual service value (Note-5) (Reference value) (TYP) (25°C (77°F))	
Q173D(S)CPU/ Q172D(S)CPU	Battery (Q6BAT)	0%	20000	43800	43800	90 (After SM51/SM52 ON)
		30%	27000			
		50%	31000			
		70%	36000			
		100%	43800			

(Note-1): The actual service value indicates the average value, and the guaranteed value indicates the minimum value.

(Note-2): The power-on time ratio indicates the ratio of Multiple CPU system power-on time to one day (24 hours).

(When the total power-on time is 17 hours and the total power-off time is 7 hours, the power-on time ratio is 70%.)

(Note-3): The guaranteed value (MIN) ; equivalent to the total power failure time that is calculated based on the characteristics value of the memory (SRAM) supplied by the manufacturer and under the storage ambient temperature range of -25°C to 75°C (-13 to 167°F) (operating ambient temperature of 0°C to 55°C (32 to 131°F)).

(Note-4): The guaranteed value (TYP) ; equivalent to the total power failure time that is calculated based on the normal air-conditioned environment (40°C (104°F)).

(Note-5): The actual service value (Reference value) ; equivalent to the total power failure time that is calculated based on the measured value and under the storage ambient temperature of 25°C (77°F). This value is intended for reference only, as it varies with characteristics of the memory.

POINTS

The self-discharge influences the life of battery without the connection to Motion CPU module. The external battery should be exchanged approximately every 4 or 5 years.

Exchange the battery with a new one in 4 to 5 years even if a total power failure time is guaranteed value or less.

⚠ CAUTION

- Do not short a battery.
- Do not charge a battery.
- Do not disassemble a battery.
- Do not burn a battery.
- Do not overheat a battery.
- Do not solder the battery terminal.
- The programs, parameters, motion devices(#), latch range devices and absolute position data of SRAM built-in Motion CPU module are not backed up without using the battery.

(3) Connection procedure with Motion CPU module

(a) Q173DSCPU/Q172DSCPU

- 1) Open the battery cover.
- 2) Set Q6BAT to battery holder.
- 3) Connect the lead connector of Q6BAT to the battery connector.
- 4) Close the battery cover.

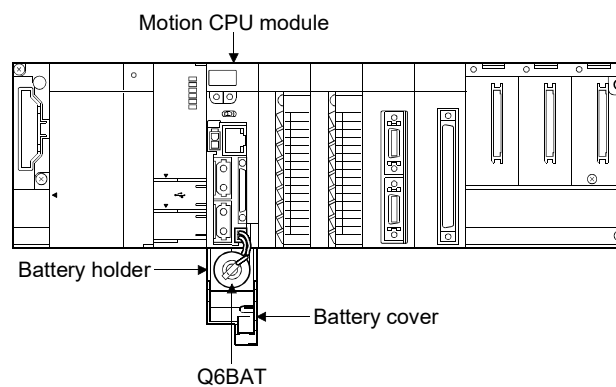

2 SYSTEM CONFIGURATION

- (b) Q173DCPU(-S1)/Q172DCPU(-S1)
- 1) Set Q6BAT to Battery holder unit(Q170DBATC).
 - 2) Connect the lead connector of Q6BAT to the connector (BATTERY) of Q170DBATC.
 - 3) Connect between the connector (BAT) of Motion CPU module and connector (CPU) of Q170DBATC.

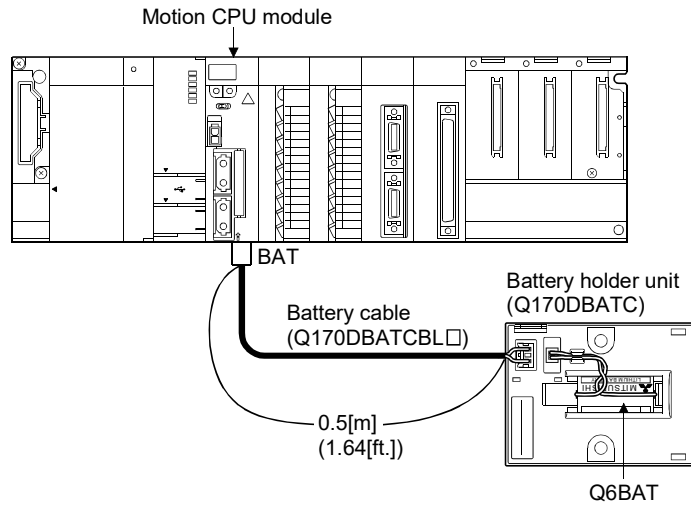

2 SYSTEM CONFIGURATION

2.5.11 Forced stop input terminal

(1) Table of the forced stop input terminal specifications

Item		Specifications
Number of input points		Forced stop signal : 1 point
Input method		Sink/Source type
Rated input current		2.4mA
Isolation method		Photocoupler
Operating voltage range		20.4 to 26.4VDC (+10/ -15%, ripple ratio 5% or less)
ON voltage/current		17.5VDC or more/2.0mA or more
OFF voltage/current		1.8VDC or less/0.18mA or less
Input resistance		Approx. 10k Ω
Response time	OFF to ON	1ms or less
	ON to OFF	
External connector type		2 pin connector
Recommended wire size		0.3mm ² (AWG22)

3. DESIGN

3.1 System Designing Procedure

System designing procedure is shown below.

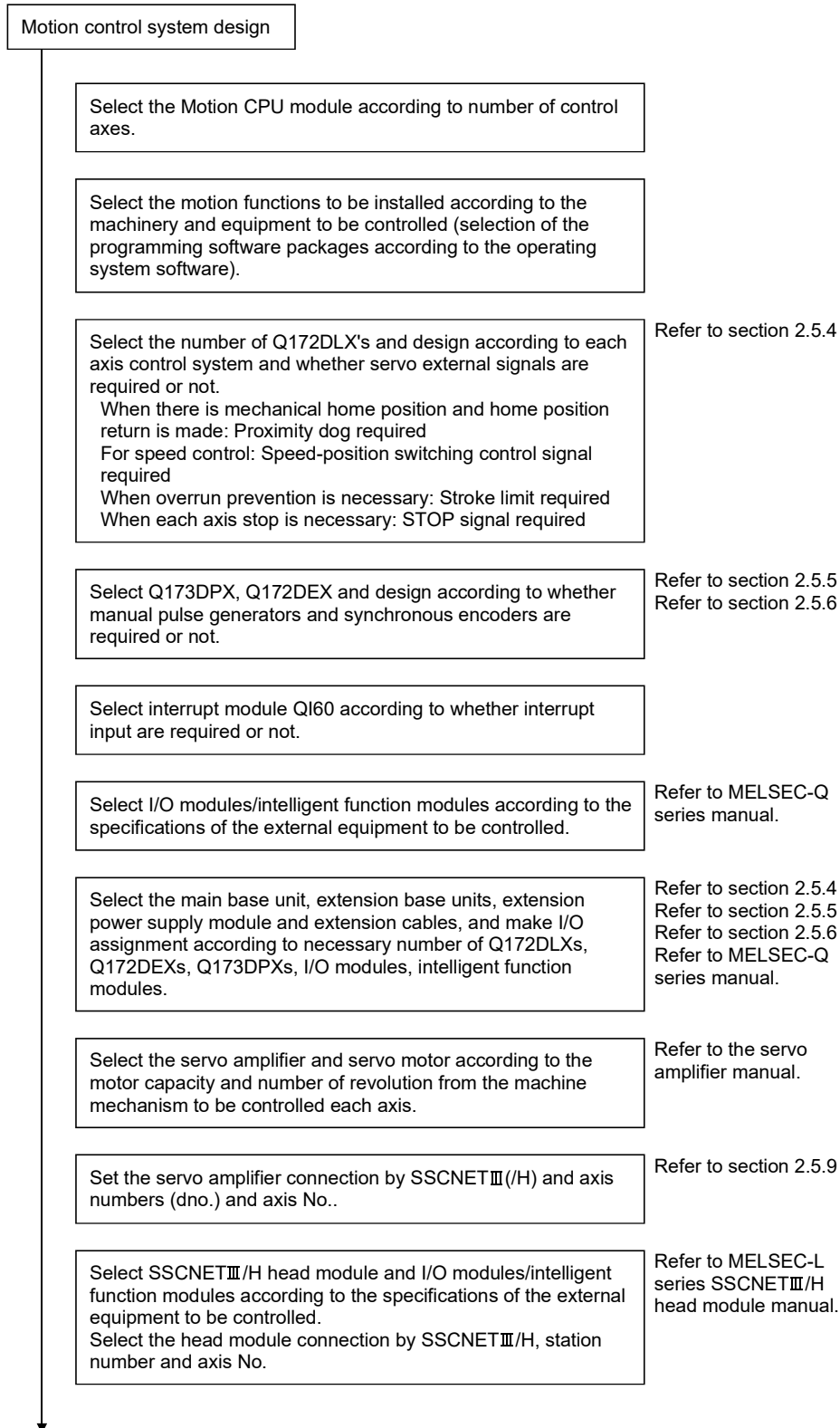

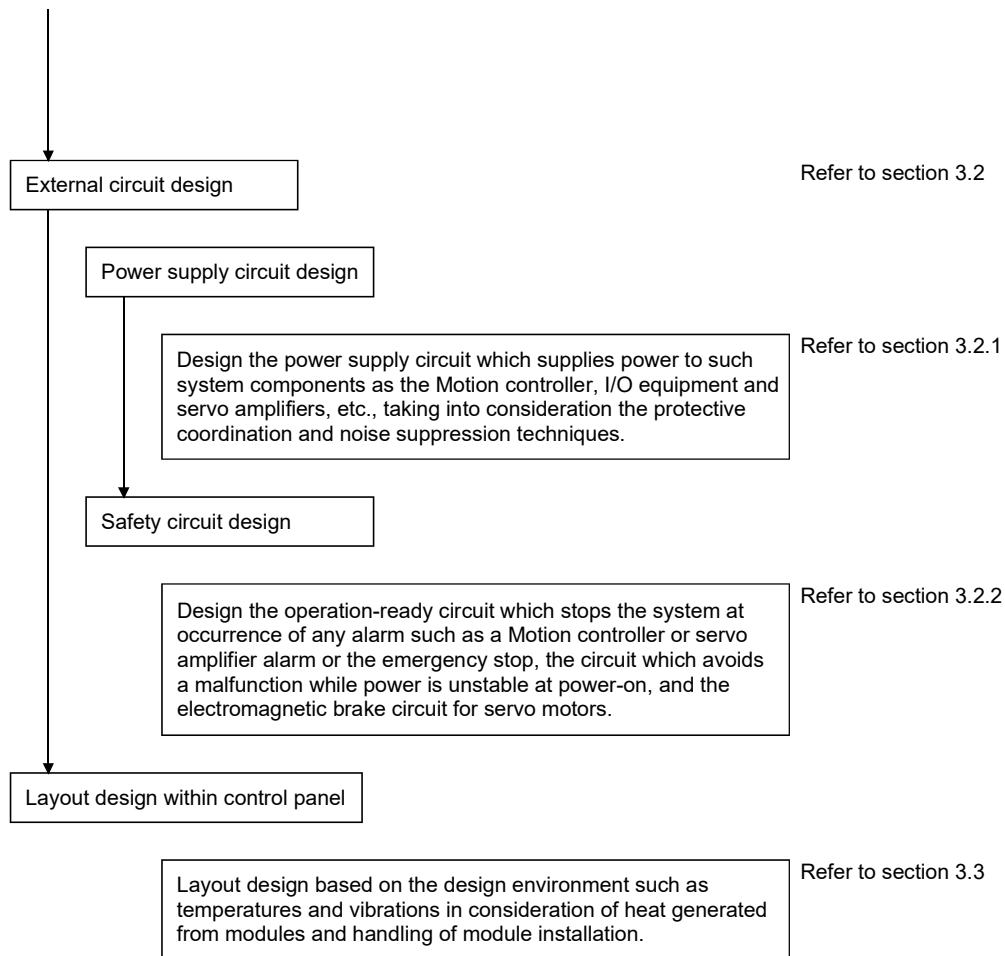

⚠ CAUTION

- Provide appropriate circuits external to the Motion controller to prevent cases where danger may result from abnormal operation of the overall system in the event of an external power supply fault or Motion controller failure.
- Mount the Motion controller, servo amplifier, servo motor and regenerative resistor on incombustible. Mounting them directly or close to combustibles will lead to fire.
- If a fault occurs in the Motion controller or servo amplifier, shut the power OFF at the servo amplifier's power source. If a large current continues to flow, fire may occur.
- When using a regenerative resistor, shut the power OFF with an error signal. The regenerative resistor may abnormally overheat due to a fault in the regenerative transistor, etc., and may lead to fire.
- Always take heat measures such as flame proofing for the inside of the control panel where the servo amplifier or regenerative resistor is mounted and for the wires used. Failing to do so may lead to fire.
- Do not apply a voltage other than that specified in the instruction manual on any terminal. Doing so may lead to destruction or damage.
- Do not mistake the polarity (+ / -), as this may lead to destruction or damage.

CAUTION

- Do not touch the heat radiating fins of controller or servo amplifier, regenerative resistor and servo motor, etc. while the power is ON and for a short time after the power is turned OFF. In this timing, these parts become very hot and may lead to burns.
- Always turn the power OFF before touching the servo motor shaft or coupled machines, as these parts may lead to injuries.
- Do not go near the machine during test operations or during operations such as teaching. Doing so may lead to injuries.
- Always mount a leakage breaker on the Motion controller and servo amplifier power source.
- If mounting of an electromagnetic contactor for power shut off during an error, etc., is specified in the instruction manual for the servo amplifier, etc., always mount the electromagnetic contactor.
- Mount an emergency stop circuit externally so that the operation can be stopped immediately and the power shut off.
- Use the Motion controller, servo amplifier, servo motor and regenerative resistor with the correct combinations listed in the instruction manual. Other combinations may lead to fire or faults.
- If safety standards (ex., robot safety rules, etc.,) apply to the system using the Motion controller, servo amplifier and servo motor, make sure that the safety standards are satisfied.
- Construct a safety circuit externally of the Motion controller or servo amplifier if the abnormal operation of the Motion controller or servo amplifier differ from the safety directive operation in the system.
- In systems where coasting of the servo motor will be a problem during the forced stop, the emergency stop, servo OFF or when the power is shut OFF, use dynamic brakes.
- Make sure that the system considers the coasting amount even when using dynamic brakes.
- In systems where perpendicular shaft dropping may be a problem during the forced stop, the emergency stop, servo OFF or when the power is shut OFF, use both dynamic brakes and electromagnetic brakes.
- The dynamic brakes must be used only during the forced stop, the emergency stop and errors where servo OFF occurs. These brakes must not be used for normal braking.
- The brakes (electromagnetic brakes) assembled into the servo motor are for holding applications, and must not be used for normal braking.
- The system must have a mechanical allowance so that the machine itself can stop even if the stroke limits switch is passed through at the max. speed.
- Use wires and cables that have a wire diameter, heat resistance and bending resistance compatible with the system.
- Use wires and cables within the length of the range described in the instruction manual.
- The ratings and characteristics of the parts (other than Motion controller, servo amplifier, servo motor) used in a system must be compatible with the Motion controller, servo amplifier and servo motor.
- Install a cover on the shaft so that the rotary parts of the servo motor are not touched during operation.
- There may be some cases where holding by the electromagnetic brakes is not possible due to the life or mechanical structure (when the ball screw and servo motor are connected with a timing belt, etc.). Mount a stopping device to ensure safety on the machine side.

3 DESIGN

3.2 External Circuit Design

As to the ways to design the external circuits of the Motion system, this section describes the method and instructions for designing the power supply circuits and safety circuits, etc. (Example: Q173DSCPU/Q172DSCPU and MR-J4-□B use)

(1) Sample system circuit design for motion control

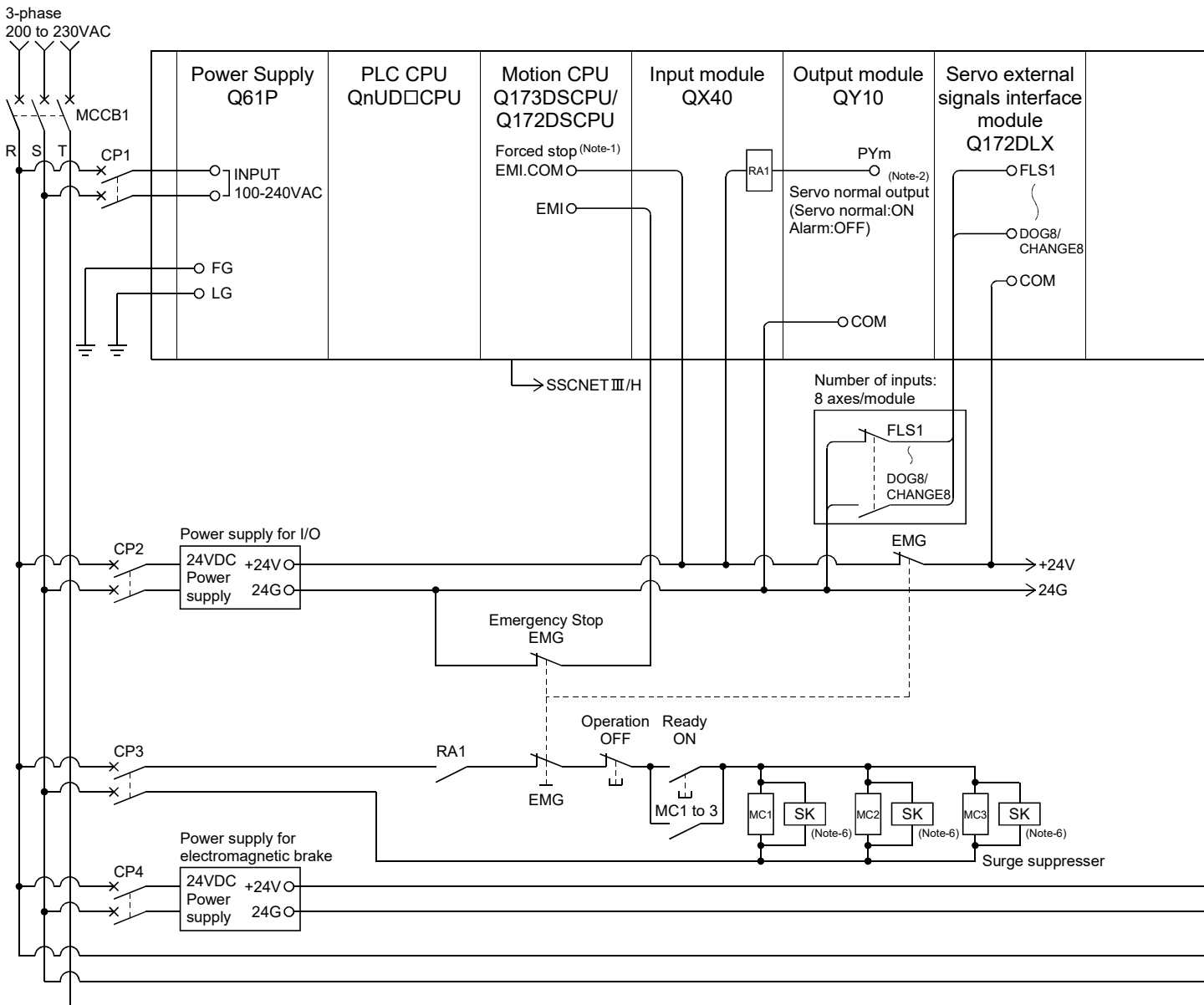

3 DESIGN

POINT	
(1) (Note-1): Make the forced stop input cable within 30m(98.43ft.). The forced stop by the forced stop terminal of input module is also possible.	<p><Example> For control axis 1, axis 2 and axis 3</p>
(2) (Note-2): Motion SFC program example is shown in the right record.	
(3) (Note-3): It is also possible to use a full wave rectified power supply as the power supply for the electromagnetic brake.	
(4) (Note-4): It is also possible to use forced stop signal of the servo amplifier.	
(5) (Note-5): Refer to the servo amplifier instruction manuals for selection of the circuit breaker and electromagnetic contactor.	
(6) (Note-6): The surge suppressor is recommended to be used for an AC relay or electromagnetic contactor (MC) near the servo amplifier. Refer to the servo amplifier instruction manual for selection of the surge suppressor.	

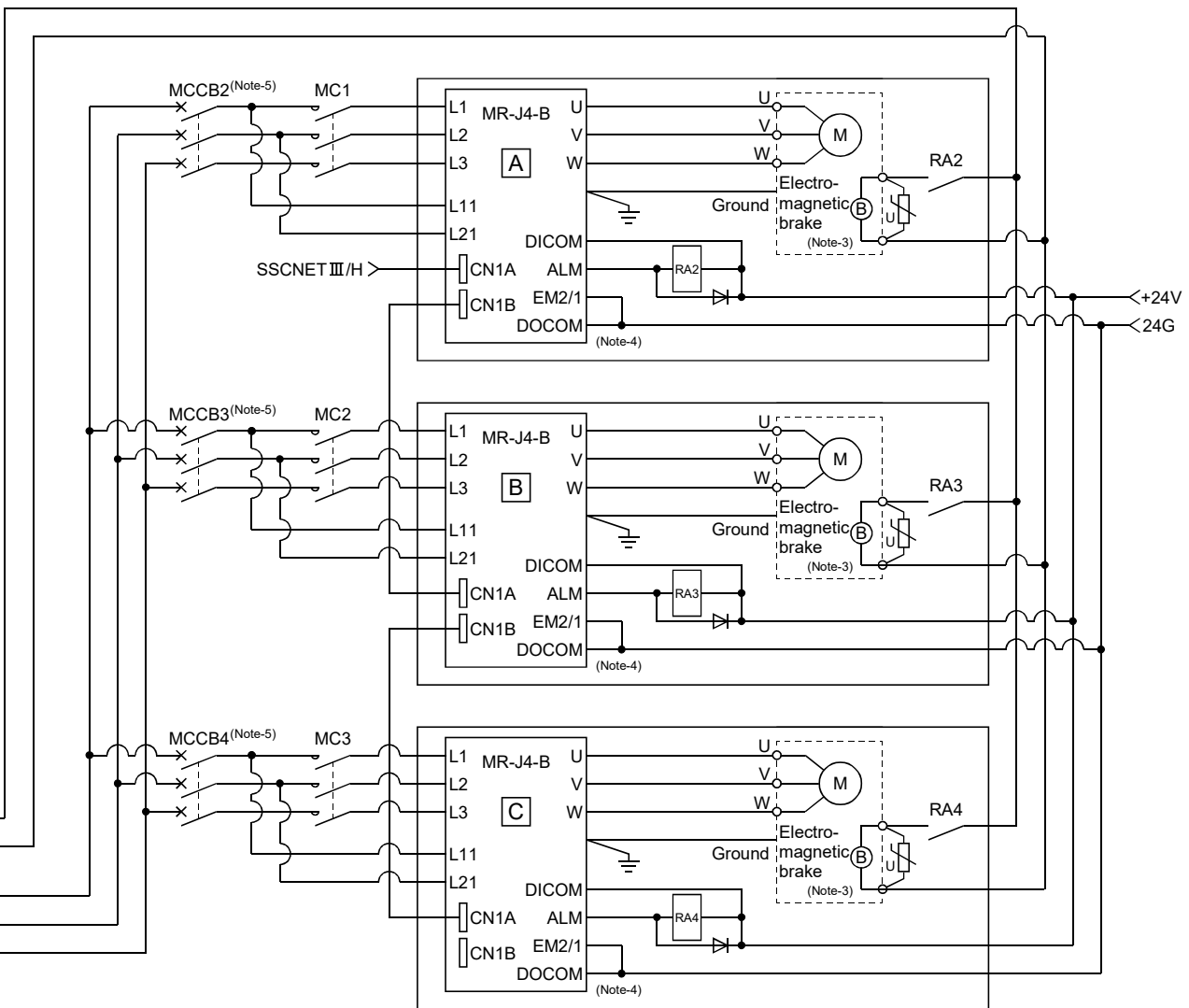

(Note-1): When the control power supply of servo amplifier is shut off, it is not possible to communicate with the servo amplifier after that. Example) When the control power supply L11/L21 of servo amplifier in figure [B] above is shut off, it is also not possible to communicate with the servo amplifier [C].

If only a specific servo amplifier main circuit power supply is shut off, be sure to shut off the main circuit power supply L1/L2/L3, and do not shut off the control power supply L11/L21.

(Note-2): Be sure to shut off the both of main circuit power supply L1/L2/L3 and control power supply L11/L21 after disconnection of SSCNET communication by the connect/disconnect function of SSCNET communication at the time of exchange of servo amplifier. At this time, it is not possible to communicate between the servo amplifier and Motion controller. Therefore, be sure to exchange the servo amplifier after stopping the operating of machine beforehand.

(2) System design circuit example of the PLC I/O

(a) System design circuit example (when not using ERR terminal of power supply module)

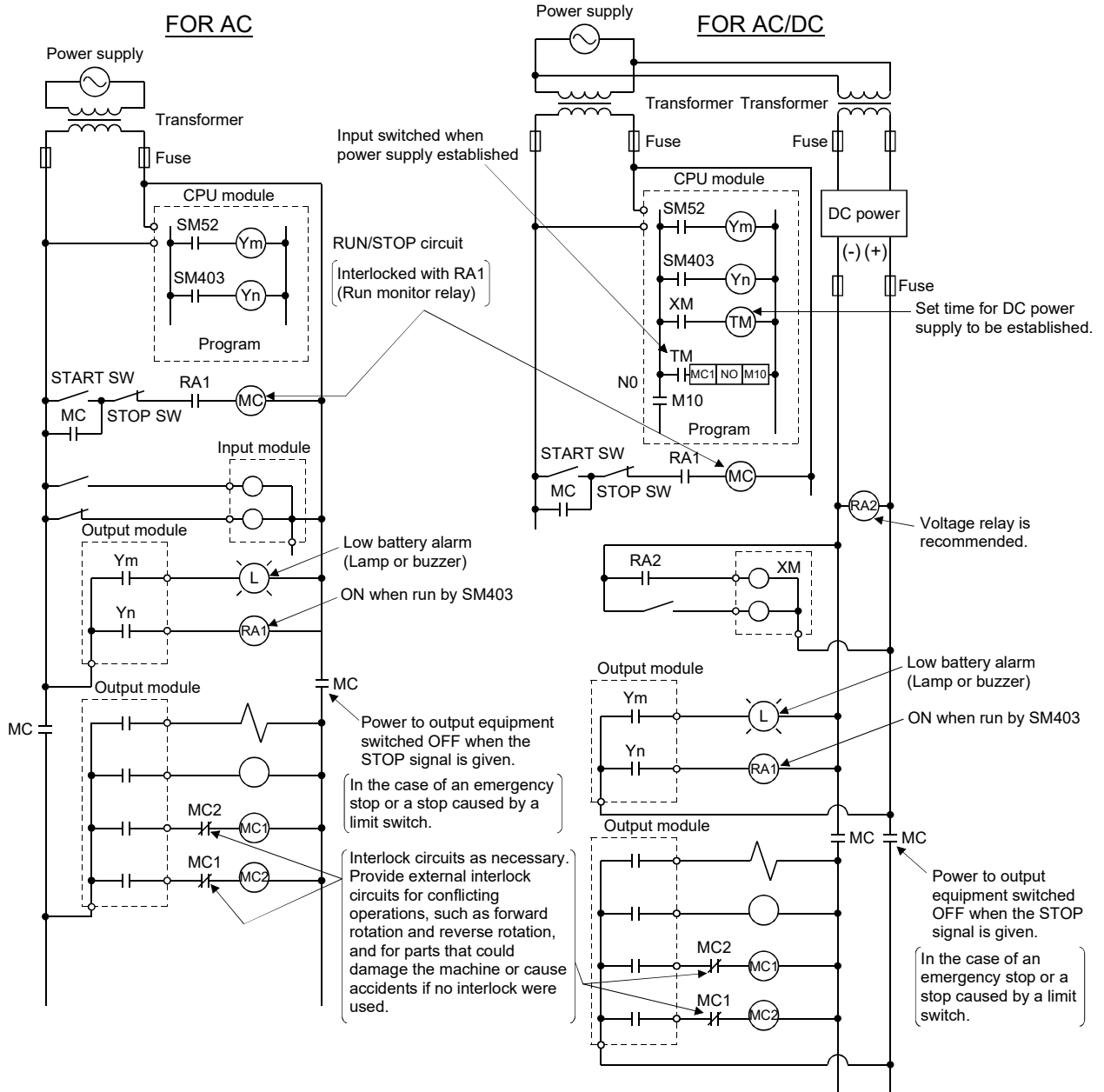

The power-ON procedure is as follows:

For AC

- 1) Switch power ON.
- 2) Set CPU to RUN.
- 3) Turn ON the start switch.
- 4) When the magnetic contactor (MC) comes on, the output equipment is powered and may be driven by the program.

For AC/DC

- 1) Switch power ON.
- 2) Set CPU to RUN.
- 3) When DC power is established, RA2 goes ON.
- 4) Timer (TM) times out after the DC power reaches 100[%]. (The TM set value should be the period of time from when RA2 goes ON to the establishment of 100[%] DC voltage. Set this value to approximately 0.5 seconds.)
- 5) Turn ON the start switch.
- 6) When the electromagnetic contactor (MC) comes on, the output equipment is powered and may be driven by the program. (If a voltage relay is used at RA2, no timer (TM) is required in the program.)

(b) System design circuit example (when using \overline{ERR} terminal of power supply module)

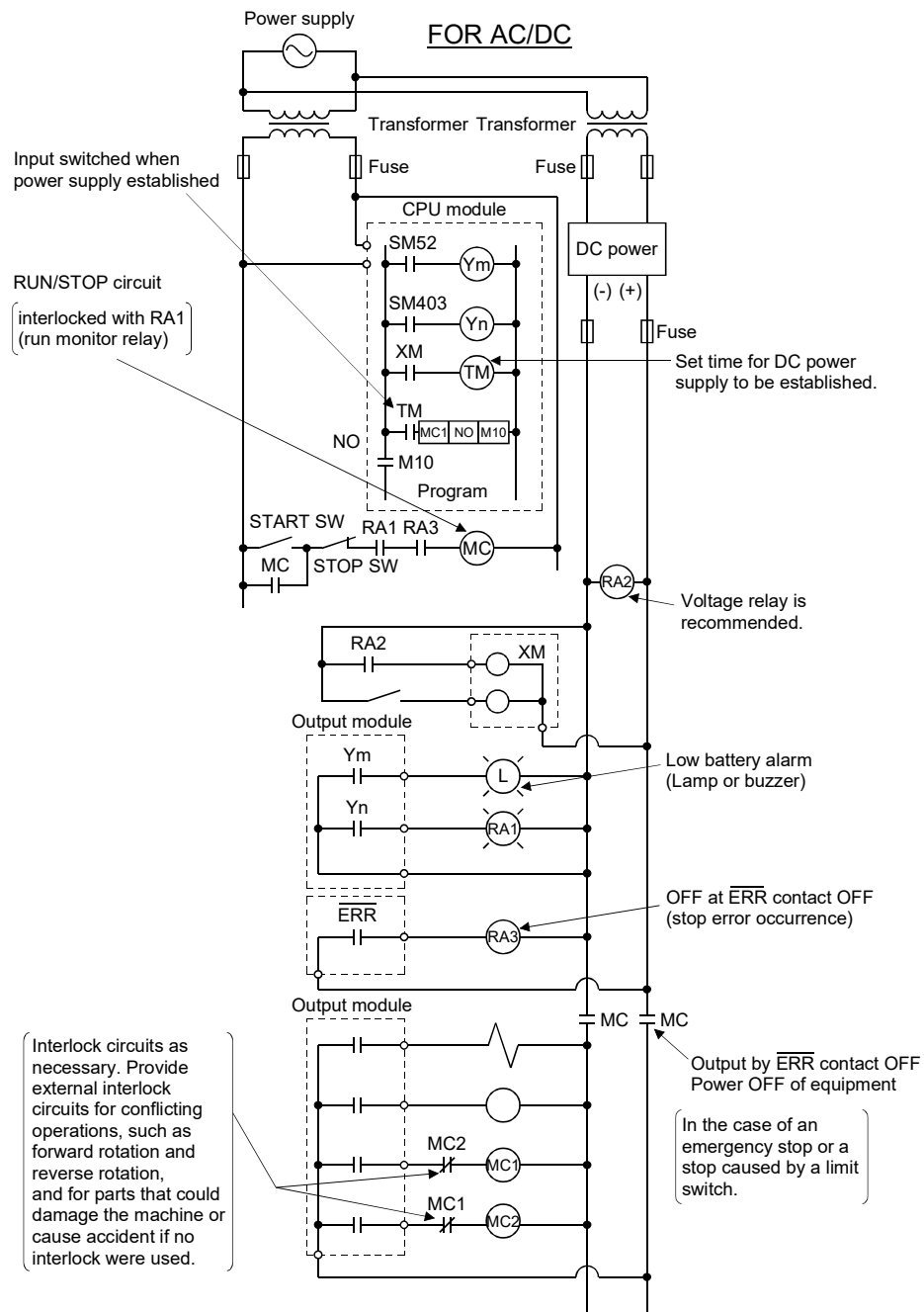

The power-ON procedure is as follows:

For AC/DC

- 1) Switch power ON.
- 2) Set CPU to RUN.
- 3) When DC power is established, RA2 goes ON.
- 4) Timer (TM) times out after the DC power reaches 100[%]. (The TM set value should be the period of time from when RA2 goes ON to the establishment of 100[%] DC voltage. Set this value to approximately 0.5 seconds.)
- 5) Turn ON the start switch.
- 6) When the magnetic contactor (MC) comes on, the output equipment is powered and may be driven by the program. (If a voltage relay is used at RA2, no timer (TM) is required in the program.)

3.2.1 Power supply circuit design

This section describes the protective coordination and noise suppression techniques of the power supply circuit.

(1) Separation and protective coordination (leakage current protection, over current protection) of power supply lines

Separate the lines for Multiple CPU system power supplies from the lines for I/O devices and servo amplifiers as shown below.

When there is much noise, connect an insulation transformer.

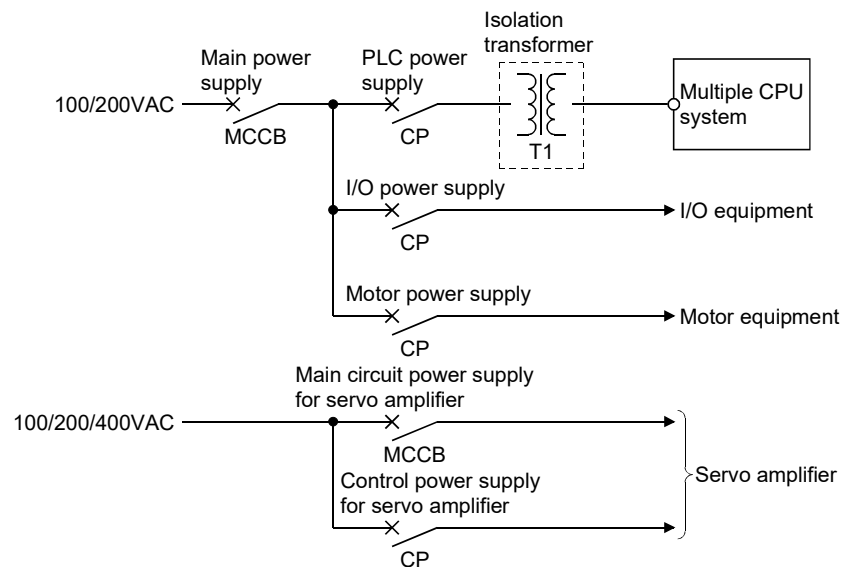

(2) Grounding

The Motion system may malfunction as it is affected by various noises such as electric path noises from the power supply lines, radiated and induced noises from other equipment, servo amplifiers and their cables, and electromagnetic noises from contactors. To avoid such troubles, connect the earthing ground of each equipment and the shield grounds of the shielded cables to the earth.

For grounding, use the exclusive ground terminal wire of each equipment or a single-point earth method to avoid grounding by common wiring, where possible, since noises may sneak from other equipment due to common impedances.

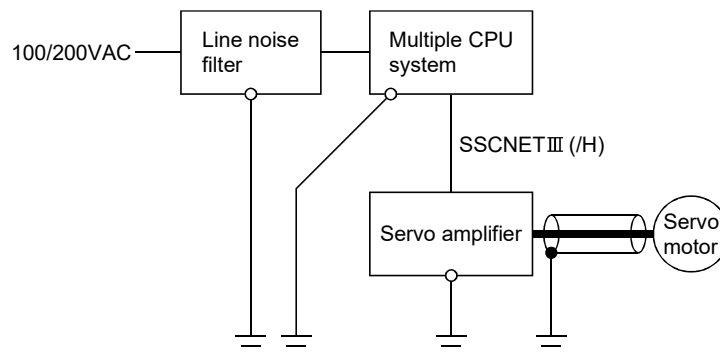

(Note): Be sure to ground the line noise filter, Multiple CPU system, servo amplifier and servo motor. (Ground resistance: 100 Ω or less)

3.2.2 Safety circuit design

(1) Concept of safety circuits

When the Multiple CPU system is powered on and off, normal control output may not be done momentarily due to a delay or a startup time difference between the Multiple CPU system power supply and the external power supply (DC in particular) for the control target.

Also, an abnormal operation may be performed if an external power supply fault or Motion controller failure takes place.

To prevent any of these abnormal operations from leading to the abnormal operation of the whole system and in a fail-safe viewpoint, areas which can result in machine breakdown and accidents due to abnormal operations (e.g. emergency stop, protective and interlock circuits) should be constructed outside the Multiple CPU system.

(2) Emergency stop circuit

The circuit should be constructed outside of the Multiple CPU system or servo amplifier. Shut off the power supply to the external servo amplifier by this circuit, make the electromagnetic brakes of the servo motor operated.

(3) Forced stop circuit

(a) The forced stop of all servo amplifiers is possible in a lump by using the forced stop input of Motion CPU modules. After forced stop, the forced stop factor is removed and the forced stop canceled.

(The servo error detection signal does not turn on with the forced stop.)

The forced stop input cannot be invalidated in the parameter setting of system setting.

Make the forced stop input cable within 30[m] (98.43[ft.]).

The wiring example for the forced stop input of Motion CPU module is shown below.

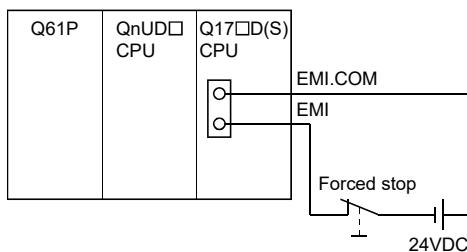

<Motion CPU module>

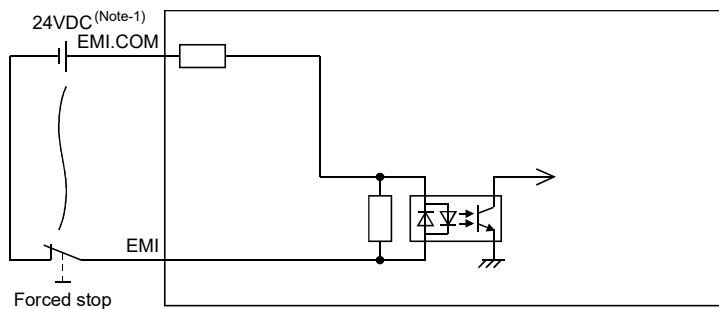

(Note): The forced stop input can not be invalidated in the system settings.

(Note-1): As for the connection, both "+" and "-" are possible.

- (b) The forced stop of all servo amplifiers is possible in a lump by using the forced stop input of input modules. After forced stop, the forced stop factor is removed and the forced stop canceled.

(The servo error detection signal does not turn on with the forced stop.)

The forced stop input can be set by allocation of the device number in the parameter setting of system setting. When the device is used, apply 24VDC voltage on EMI connector and invalidate the forced stop input of EMI connector.

The wiring example that uses the forced stop input of input module (QX10) is shown below.

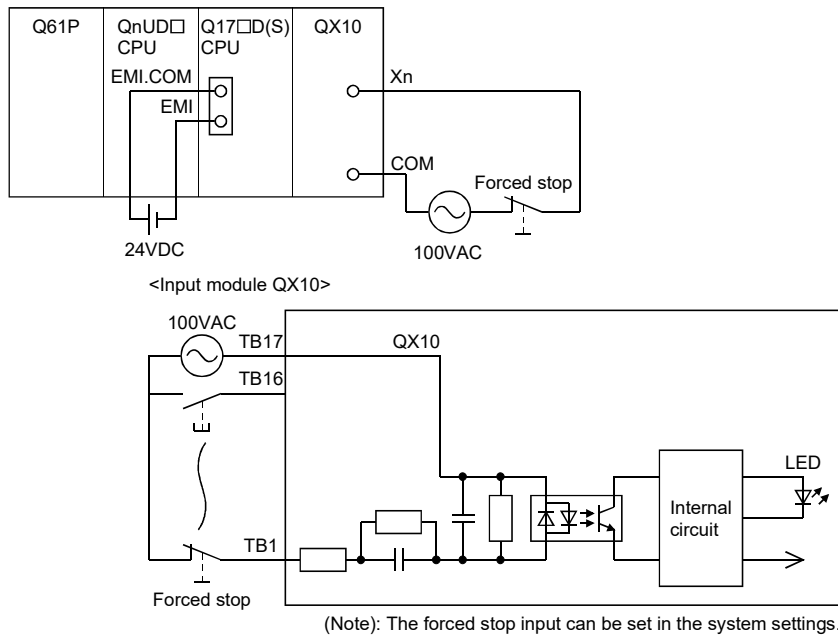

- (c) It is also possible to use the forced stop signal of the servo amplifier. Refer to manual of the servo amplifier about servo motor capacity.

Operation status of the emergency stop, servo amplifier forced stop, and the Motion controller forced stop are as follows.

Item	Operation of the signal ON	Remark
Emergency stop	Servo OFF	The power supply of the servo amplifier is shut off by external circuit, and the servo motor stops.
Servo amplifier forced stop		A stop command from the external circuit to the servo amplifier is output, and the servo amplifier stops the servo motor.
Motion controller forced stop		A stop command from the Motion controller to the servo amplifier is output, and the servo amplifier stops the servo motor.

3.3 Layout Design within the Control Panel

3.3.1 Mounting environment

Mount the Motion controller system in the following environment conditions.

- (1) Ambient temperature is within the range of 0 to 55[°C] (32 to 131[°F]) .
- (2) Ambient humidity is within the range of 5 to 95[%]RH.
- (3) No condensing from sudden temperature changes
- (4) No corrosive or inflammable gas
- (5) There must not be a lot of conductible dust, iron filings, oil mist, or salt, organic solvents.
- (6) No direct sunlight
- (7) No strong electrical or magnetic fields
- (8) No direct vibrations or shocks on the Motion controller

3.3.2 Calculating heat generation by Motion controller

The ambient temperature inside the panel storing the Motion controller must be suppressed to an ambient temperature of 55°C(131°F) or less, which is specified for the Motion controller.

For the design of a heat releasing panel, it is necessary to know the average power consumption (heating value) of the devices and instruments stored inside.

Here the method of obtaining the average power consumption of system is described. From the power consumption, calculate a rise in ambient temperature inside the control panel.

How to calculate average power consumption

The power consuming parts of the Motion controller are roughly classified into six blocks as shown below.

(1) Power consumption of power supply module

The power conversion efficiency of the power supply module is approx. 70[%], while 30 [%] of the output power is consumed as heat. As a result, 3/7 of the output power is the power consumption.

Therefore the calculation formula is as follows.

$$W_{PW} = \frac{3}{7} \times (I_{5V} \times 5) [W]$$

I_{5V} : Current consumption of 5VDC logic circuit of each module

(2) Total power consumption for 5VDC logic circuits of all modules (including CPU module)

The power consumption of the 5VDC output circuit section of the power supply module is the power consumption of each module (including the current consumption of the base unit).

$$W_{5V} = I_{5V} \times 5 [W]$$

(3) A total of 24VDC average power consumption of the output module

The average power of the external 24VDC power is the total power consumption of each module.

$$W_{24V} = I_{24V} \times 24 \times \text{Simultaneous ON rate} [W]$$

I_{24V} : Average current consumption of 24VDC power supply for internal consumption of the output module [A]

(Power consumption for simultaneous ON points)

(4) Average power consumption due to voltage drop in the output section of the output module (Power consumption for simultaneous ON points)

$$W_{OUT} = I_{OUT} \times V_{drop} \times \text{Number of outputs} \times \text{Simultaneous ON rate} [W]$$

I_{OUT} : Output current (Current in actual use) [A]

V_{drop} : Voltage drop in each output module [V]

- (5) Average power consumption of the input section of the input module (Power consumption for simultaneous ON points)

$$W_{IN} = I_{IN} \times E \times \text{Number of input points} \times \text{Simultaneous ON rate [W]}$$

I_{IN} : Input current (Effective value for AC) [A]

E : Input voltage (Voltage in actual use) [V]

- (6) Power consumption of the external power supply section of the intelligent function module

$$W_s = I_{5V} \times 5 + I_{24V} \times 24 + I_{100V} \times 100 [W]$$

The total of the power consumption values calculated for each block is the power consumption of the overall Motion system

$$W = W_{PW} + W_{5V} + W_{24V} + W_{OUT} + W_{IN} + W_s [W]$$

From this overall power consumption [W], calculate the heating value and a rise in ambient temperature inside the panel.

The outline of the calculation formula for a rise in ambient temperature inside the panel is shown below.

$$T = \frac{W}{UA} [^{\circ}\text{C}]$$

W : Power consumption of overall Motion system (value obtained above)

A : Surface area inside the panel [m^2]

U : When the ambient temperature inside the panel is uniformed by a fan..... 6
 When air inside the panel is not circulated..... 4

POINT
<p>If the temperature inside the panel has exceeded the specified range, it is recommended to mount a heat exchanger to the panel to lower the temperature. If a normal ventilating fan is used, dust will be sucked into the Motion controller together with the external air, and it may affect the performance of the Motion controller.</p>

(7) Example of average power consumption calculation
(Q173DCPU use)

(a) System configuration

Q61P	Q03UD CPU	Q173D CPU	QX40	QX40	Q172D LX	Q172D EX	Q173D PX	QY10	QY10	Q38DB
------	--------------	--------------	------	------	-------------	-------------	-------------	------	------	-------

(b) 5VDC current consumption of each module

Q03UDCPU (Note)	: 0.33 [A]
Q173DCPU	: 1.25 [A]
QX40 (Note)	: 0.05 [A]
Q172DLX	: 0.06 [A]
Q172DEX	: 0.19 [A]
Q173DPX	: 0.38 [A]
QY10 (Note)	: 0.43 [A]
Q38DB (Note)	: 0.23 [A]

(Note) : 5VDC internal current consumption of shared equipments with PLC might be changed. Be sure to refer to the MELSEC-Q series PLC Manuals.

(c) Power consumption of power module

$$W_{PW} = 3/7 \times (0.33 + 1.25 + 0.05 + 0.05 + 0.06 + 0.19 + 0.38 + 0.43 + 0.43 + 0.23) \times 5 = 7.29 \text{ [W]}$$

(d) Total power consumption for 5VDC logic circuits of all modules

$$W_{5V} = (0.33 + 1.25 + 0.05 + 0.05 + 0.06 + 0.19 + 0.38 + 0.43 + 0.43 + 0.23) \times 5 = 17 \text{ [W]}$$

(e) A total of 24VDC average power consumption of the output module

$$W_{24V} = 0 \text{ [W]}$$

(f) Average power consumption due to voltage drop in the output section of the output module

$$W_{OUT} = 0 \text{ [W]}$$

(g) Average power consumption of the input section of the input module

$$W_{IN} = 0.004 \times 24 \times 32 \times 1 = 3.07 \text{ [W]}$$

(h) Power consumption of the power supply section of the intelligent function module.

$$W_s = 0 \text{ [W]}$$

(i) Power consumption of overall system

$$W = 7.29 + 17 + 0 + 0 + 3.07 + 0 = 27.36 \text{ [W]}$$

3 DESIGN

3.4 Design Checklist

At the worksite, copy the following table for use as a check sheet.

Item	Sub Item	Design confirmation		Check
Module selection	Motion CPU module selection	Number of axes	axes	<input type="checkbox"/>
		Motion CPU module selection		<input type="checkbox"/>
		Manual pulse generator	pcs.	<input type="checkbox"/>
		Incremental synchronous encoder	pcs.	<input type="checkbox"/>
		Number of I/O points	points	<input type="checkbox"/>
	PLC CPU module selection	Number of I/O points	points	<input type="checkbox"/>
		PLC CPU module selection		<input type="checkbox"/>
	Motion module selection	Manual pulse generator	pcs.	<input type="checkbox"/>
		Synchronous encoder	pcs.	<input type="checkbox"/>
		Upper limit point	points	<input type="checkbox"/>
		Lower limit point	points	<input type="checkbox"/>
		STOP input point	points	<input type="checkbox"/>
		Proximity dog input point	points	<input type="checkbox"/>
		Speed switching input point	points	<input type="checkbox"/>
		Tracking enable signal point	points	<input type="checkbox"/>
		Q172DLX	modules	<input type="checkbox"/>
		Q172DEX	modules	<input type="checkbox"/>
	Q173DPX	modules	<input type="checkbox"/>	
	Main base unit selection	Motion CPU module	modules	<input type="checkbox"/>
		I/O module/intelligent function module installed to main base unit	modules	<input type="checkbox"/>
		Main base unit selection		<input type="checkbox"/>
	Extension base unit and extension cable selection	Number of I/O modules/intelligent function modules installed to extension base unit	modules	<input type="checkbox"/>
		Distance between Main base unit and extension base unit	mm (inch)	<input type="checkbox"/>
Extension base unit selection			<input type="checkbox"/>	
Extension cable selection			<input type="checkbox"/>	
External circuit design	Fail-safe circuit design	Avoidance of operation failure at power-on		<input type="checkbox"/>
		Avoidance of hazard at Motion controller failure		<input type="checkbox"/>
Layout design	Module layout design	Conformance with general specifications such as ambient temperature, humidity, dust, etc.		<input type="checkbox"/>
		Total power consumption of base unit (Calculate the heating value)	W	<input type="checkbox"/>
		Layout in consideration of clearances between enclosure's inside walls, other structures and modules and heats generated by modules within the control panel.		<input type="checkbox"/>

4. INSTALLATION AND WIRING

4.1 Module Installation

4.1.1 Instructions for handling

CAUTION

- Use the Motion controller in an environment that meets the general specifications contained in this manual. Using this Motion controller in an environment outside the range of the general specifications could result in electric shock, fire, operation failure, and damage to or deterioration of the product.
- While pressing the installation lever located at the bottom of module, insert the module fixing projection into the fixing hole in the base unit until it stops. Then, securely install the module with the fixing hole as a supporting point. Incorrect installation of the module can cause an operation failure, damage or drop.
When using the Motion controller in the environment of much vibration, tighten the module with a screw. Tighten the screw in the specified torque range. Under tightening may cause a drop, short circuit or operation failure. Over tightening may cause a drop, short circuit or operation failure due to damage to the screw or module.
- Be sure to connect the extension cable to connectors of the base unit correctly. After connecting, check them for looseness. Poor connections could cause an input or output failure.
- Completely turn off the externally supplied power used in the system before installation or removing the module. Not doing so could result in electric shock or damage to the product.
- Do not install/remove the module onto/from base unit or terminal block more than 50 times, after the first use of the product. Doing so may cause the module to malfunction due to poor contact of connector.
- Do not directly touch the module's conductive parts and electronic components. Doing so may cause an operation failure or damage the module.
- Lock the control panel and prevent access to those who are not certified to handle or install electric equipment.
- Do not touch the heat radiating fins of the Motion CPU module while the power is ON and for a short time after the power is turned OFF. In this timing, these parts become very hot and may lead to burns. Remove the modules while paying attention.

This section describes instructions for handling the CPU, Motion, I/O, intelligent function and power supply modules, base units and so on.

- (1) Module, terminal block connectors and pin connectors are made of resin; do not drop them or subject them to strong impact.
- (2) Do not remove modules' printed circuit boards from the enclosure in order to avoid changes in operation.

4 INSTALLATION AND WIRING

- (3) Tighten the module fixing screws and terminal block screws within the tightening torque range specified below.

Location of screw	Tightening torque range [N•m]
Motion CPU module fixing screw (M3 × 13 screw)	0.36 to 0.48
Module fixing screw (M3 × 12 screw)	0.36 to 0.48
I/O module terminal block screw (M3 screw)	0.42 to 0.58
I/O module terminal block fixing screw (M3.5 screw)	0.68 to 0.92
Power supply module terminal screw (M3.5 screw)	0.68 to 0.92

- (4) Be sure to install a power supply module on the main base unit and extension base unit. Even if the power supply module is not installed, when the I/O modules and intelligent function module installed on the base units are light load type, the modules may be operated. In this case, because a voltage becomes unstable, we cannot guarantee the operation.
- (5) When using an extension cable, keep it away from the main circuit cable (high voltage and large current).
Keep a distance of 100mm (3.94inch) or more from the main circuit.
- (6) Be sure to fix a main base unit to the panel using mounting screws. Not doing so could result in vibration that may cause erroneous operation.

Mount a main base unit in the following procedure.

- (a) Fit the two base unit top mounting screws into the enclosure.

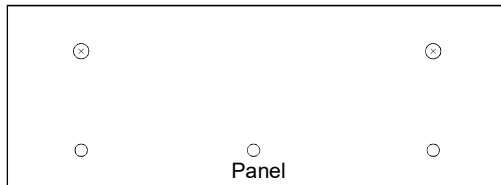

- (b) Place the right-hand side notch of the base unit onto the right-hand side screw.

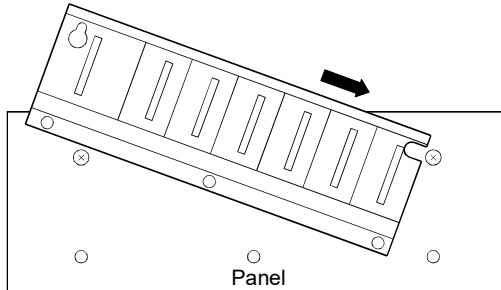

4 INSTALLATION AND WIRING

- (c) Place the left-hand side pear-shaped hole of the base unit onto the left-hand side screw.

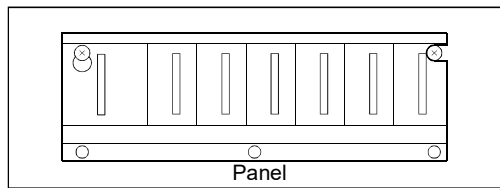

- (d) Fit the mounting screws into the holes at the bottom of the base unit, and then retighten the all mounting screws.

(Note): Mount a main base unit to a panel, with no module installed in the right-end slot.

Remove the base unit after removing the module from the right-end slot.

4 INSTALLATION AND WIRING

4.1.2 Instructions for mounting the base unit

When mounting the Motion controller to an enclosure or similar, fully consider its operability, maintainability and environmental resistance.

(1) Fitting dimensions

Fitting dimensions of each base unit are as follows:

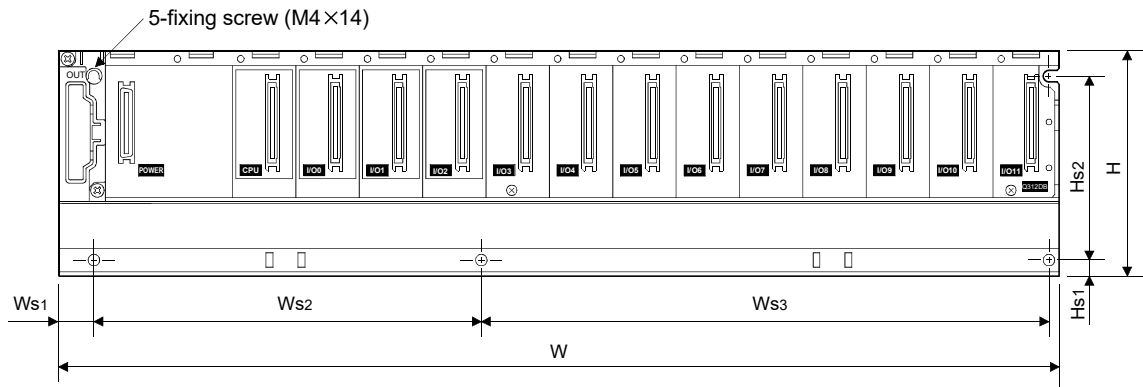

	Q35DB	Q38DB	Q312DB	Q63B	Q65B	Q68B	Q612B	Q52B	Q55B
W	245	328 (12.91)	439 (17.28)	189 (7.44)	245 (9.65)	328 (12.91)	439 (17.28)	106 (4.17)	189 (7.44)
Ws1	15.5 (0.61)								
Ws2	224.5 ± 0.3 (8.84 ± 0.01)	170 ± 0.3 (6.69 ± 0.01)	170 ± 0.3 (6.69 ± 0.01)	167 ± 0.3 (6.57 ± 0.01)	222.5 ± 0.3 (8.76 ± 0.01)	190 ± 0.3 (7.48 ± 0.01)	190 ± 0.3 (7.48 ± 0.01)	83.5 ± 0.3 (3.29 ± 0.01)	167 ± 0.3 (6.57 ± 0.01)
Ws3	(Ws2 + Ws3)	138 ± 0.3 (5.43 ± 0.01)	249 ± 0.3 (9.80 ± 0.01)	(Ws2 + Ws3)	(Ws2 + Ws3)	116 ± 0.3 (4.57 ± 0.01)	227 ± 0.3 (8.93 ± 0.01)	(Ws2 + Ws3)	(Ws2 + Ws3)
H	98 (3.86)								
Hs1	7 (0.28)								
Hs2	80 ± 0.3 (3.15 ± 0.01)								

[Unit: mm (inch)]

4 INSTALLATION AND WIRING

(2) Module mounting position

Keep the clearances shown below between the top/bottom faces of the module and other structures or parts to ensure good ventilation and facilitate module replacement.

(Note): It is impossible to mount the main base unit by DIN rail.

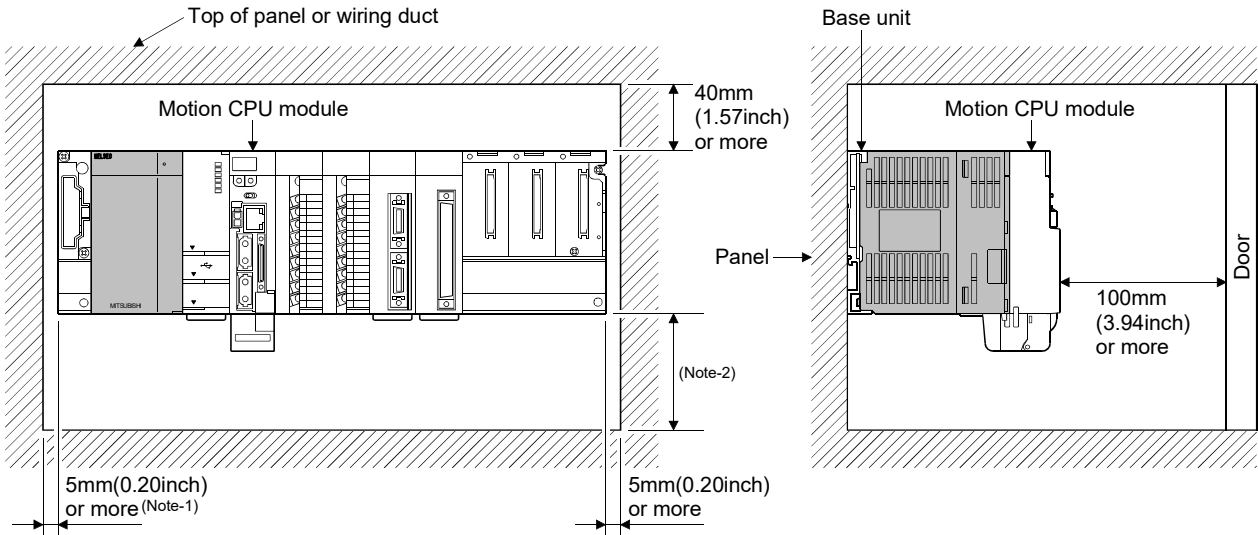

(Note-1): 20mm (0.79inch) or more when the adjacent module is not removed and the extension cable is connected.

(Note-2): Q173DSCPU/Q172DSCPU use-----70mm (2.76inch) or more

Q173DCPU(-S1)/Q172DCPU(-S1) use-----100mm (3.94inch) or more

(3) Module mounting orientation

(a) Mount the Motion controller in the orientation shown below to ensure good ventilation for heat release.

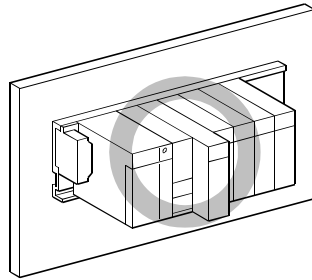

(b) Do not use it in either of the orientations shown below.

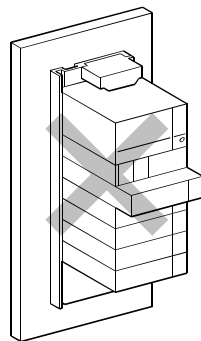

Vertical

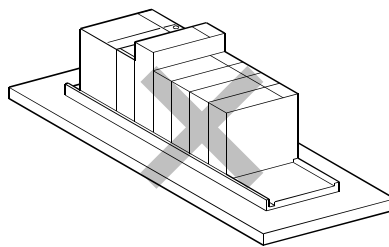

Flat

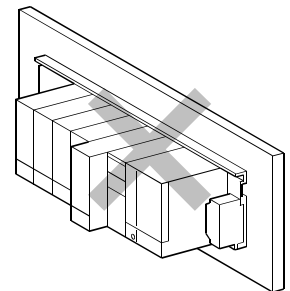

Upside down

4 INSTALLATION AND WIRING

(4) Mounting surface

Mount the base unit on a flat surface. If the mounting surface is not even, this may strain the printed circuit boards and cause malfunctions.

(5) Mounting of unit in an area where the other devices are mounted

Avoid mounting base unit in proximity to vibration sources such as large magnetic contractors and no-fuse circuit breakers; mount those on a separate panel or at a distance).

(6) Distances from the other devices

In order to avoid the effects of radiated noise and heat, provide the clearances indicated below between the Motion controller and devices that generate noise or heat (contactors and relays, etc.).

- In front of Motion controller : 100mm (3.94inch) or more
- On the right and left of Motion controller : 50mm (1.97inch) or more

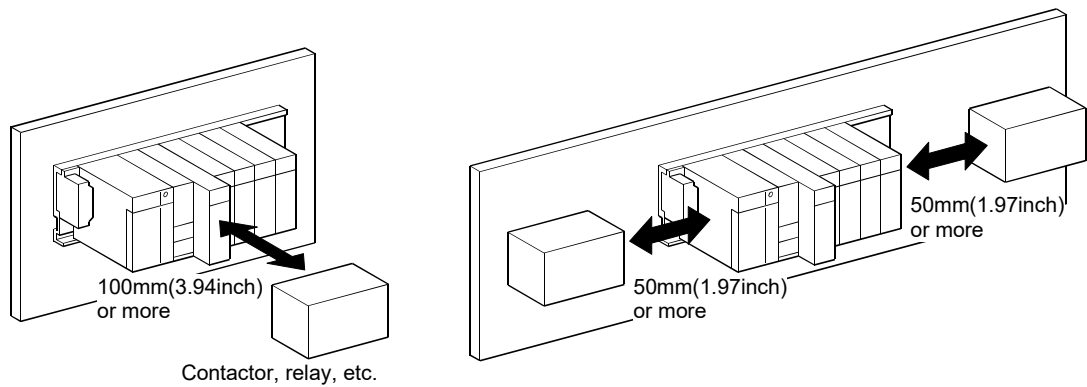

4 INSTALLATION AND WIRING

4.1.3 Installation and removal of module

This section describes how to install and remove a power supply module, PLC CPU module, Motion CPU module, Motion module, I/O module, intelligent function module or another module to and from the base unit.

(1) Installation and removal of the module from base unit

(a) Installation

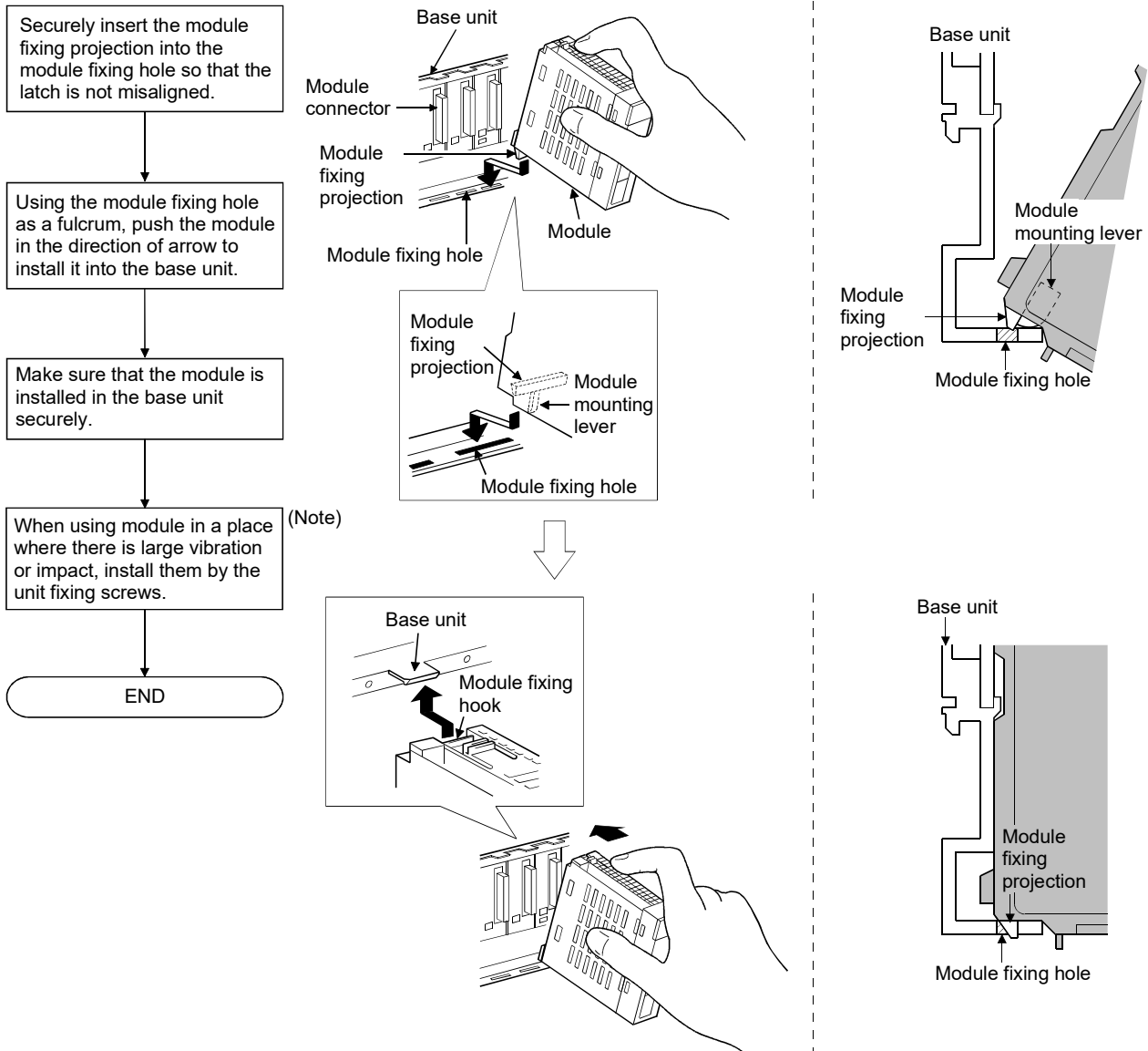

POINTS

- (1) When installing the module, always insert the module fixing projection into the module fixing hole of the base unit.
At that time, securely insert the module fixing projection so that it does not come off from the module fixing hole.
If the module is forcibly installed without the latch being inserted, the module connector and module will be damaged.
- (2) When using the modules in a place where there is large vibration or impact, screw the module to the base unit.
Module fixing screw: M3×12 (user-prepared)
Screw the Motion CPU module to the main base unit using supplied fixing screws (M3×13).
- (3) Do not install/remove the module onto/from base unit or terminal block more than 50 times, after the first use of the product. Doing so may cause the module to malfunction due to poor contact of connector.

CAUTION

- While pressing the installation lever located at the bottom of module, insert the module fixing projection into the fixing hole in the base unit until it stops. Then, securely install the module with the fixing hole as a supporting point. Incorrect installation of the module can cause an operation failure, damage or drop.
When using the Motion controller in the environment of much vibration, tighten the module with a screw.
Tighten the screw in the specified torque range. Under tightening may cause a drop, short circuit or operation failure. Over tightening may cause a drop, short circuit or operation failure due to damage to the screw or module.

(b) Removal

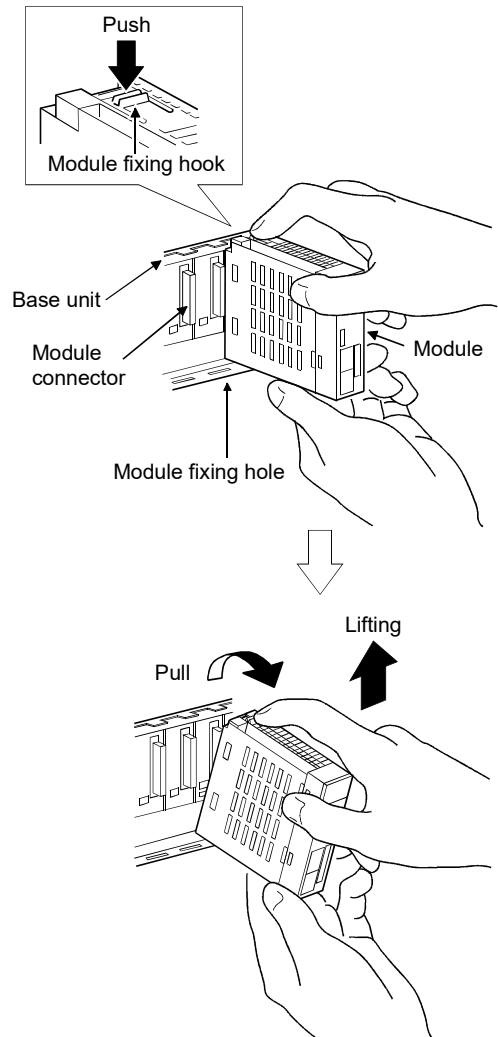
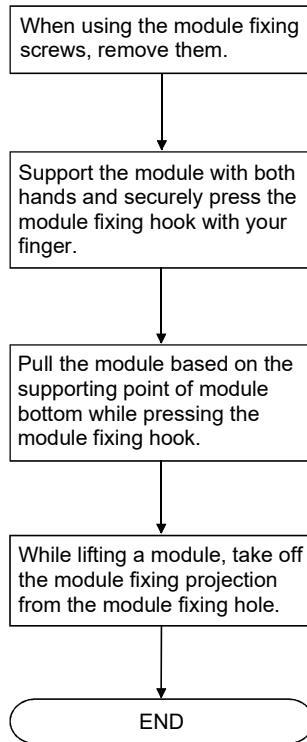

POINT

When the module fixing screw is used, always remove the module by removing the module fixing screw and then taking the module fixing projection off the module fixing hole of the base unit. Attempting to remove the module by force may damage the module fixing projection.

⚠ CAUTION

- Do not touch the heat radiating fins of the Motion CPU module while the power is ON and for a short time after the power is turned OFF. In this timing, these parts become very hot and may lead to burns. Remove the modules while paying attention.

4 INSTALLATION AND WIRING

4.1.4 Instructions for mounting of the battery holder unit **QD**

When mounting the battery holder unit (Q170DBATC) to an enclosure or similar, fully consider its mounting position and orientation.

(1) **Module mounting position**

Mount the battery holder unit within 50cm(1.64ft.) or less (Battery cable length: 50cm(1.64ft.)) from the Motion controller.

(2) **Mounting surface**

Mount the battery holder unit on a flat surface.

(3) **Module mounting orientation**

Do not mount the battery holder unit downward. Doing so may lead to battery liquid to leak at damage to the battery.

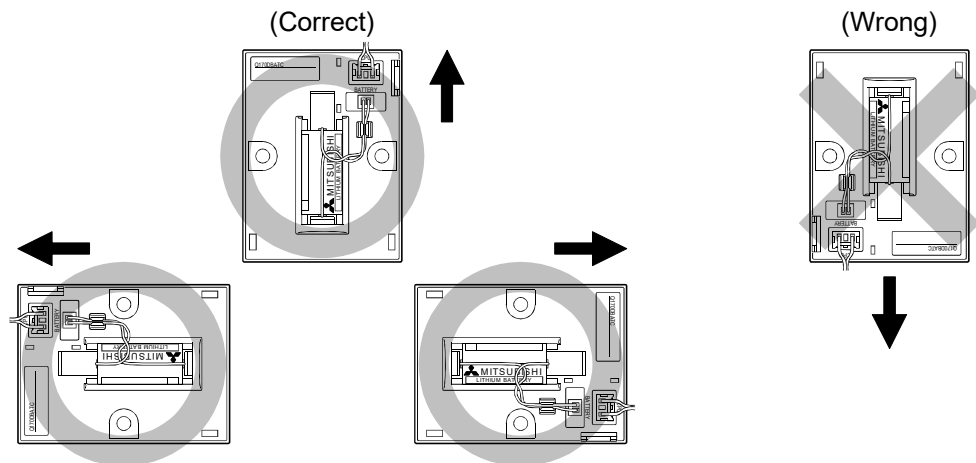

4.2 Connection and Disconnection of Cable

4.2.1 SSCNET III cable

(1) Precautions for handling the SSCNET III cable

- Do not stamp the SSCNET III cable.
- When laying the SSCNET III cable, be sure to secure the minimum cable bend radius or more. If the bend radius is less than the minimum cable bend radius, it may cause malfunctions due to characteristic deterioration, wire breakage, etc.
- For connection and disconnection of SSCNET III cable, hold surely a tab of cable connector.

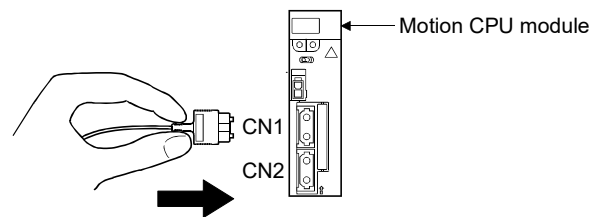

(2) Connection of SSCNET III cable

- For connection of SSCNET III cable to the Motion CPU module, connect it to the SSCNET III connector CN1 or CN2 of Motion CPU module while holding a tab of SSCNET III cable connector. Be sure to insert it until it clicks.
- If the cord tip for the SSCNET III cable is dirty, optical transmission is interrupted and it may cause malfunctions. If it becomes dirty, wipe with a bonded textile, etc. Do not use solvent such as alcohol.

(3) Disconnection of SSCNET III cable

- For disconnection of SSCNET III cable, pull out it while holding a tab of SSCNET III cable connector or the connector.
- After disconnection of SSCNET III cable, be sure to put a cap (attached to Motion CPU module or servo amplifier) to the Motion CPU module and servo amplifier.
- For SSCNET III cable, attach the tube for protection optical cord's end face on the end of connector.

(4) Precautions of SSCNETⅢ cable wiring

SSCNETⅢ cable is made from optical fiber. If optical fiber is added a power such as a major shock, lateral pressure, haul, sudden bending or twist, its inside distorts or breaks, and optical transmission will not be available. Especially, as optical fiber for MR-J3BUS□M and MR-J3BUS□M-A is made of synthetic resin, it melts down if being left near the fire or high temperature. Therefore, do not make it touched the part, which becomes high temperature, such as radiator or regenerative option of servo amplifier, or servo motor.

Be sure to use optical fiber within the range of operating temperature described in this manual.

Read described item of this section carefully and handle it with caution.

(a) Minimum bend radius

Make sure to lay the cable with greater radius than the minimum bend radius. Do not press the cable to edges of equipment or others. For SSCNETⅢ cable, the appropriate length should be selected with due consideration for the dimensions and arrangement of Motion controller and servo amplifier. When closing the door of control panel, pay careful attention for avoiding the case that SSCNETⅢ cable is hold down by the door and the cable bend becomes smaller than the minimum bend radius.

Model name of SSCNETⅢ cable	Minimum bend radius[mm(inch)]
MR-J3BUS□M	25(0.98)
MR-J3BUS□M-A	Enforced covering cord : 50 (1.97) Cord : 25 (0.98)
MR-J3BUS□M-B	Enforced covering cord : 50 (1.97) Cord : 30 (1.18)

(b) Tension

If tension is added on the SSCNETⅢ cable, the increase of transmission loss occurs because of external force which concentrates on the fixing part of SSCNETⅢ cable or the connecting part of SSCNETⅢ connector. At worst, the breakage of SSCNETⅢ cable or damage of SSCNETⅢ connector may occur. For cable laying, handle without putting forced tension.

Model name of SSCNETⅢ cable	Tension strength[N]	
MR-J3BUS□M	□=015	70
	□=03 to 3	140
MR-J3BUS□M-A	420 (Enforced covering cord)	
MR-J3BUS□M-B	980 (Enforced covering cord)	

(c) Lateral pressure

If lateral pressure is added on the SSCNET III cable, the cable itself distorts, internal optical fiber gets stressed, and then transmission loss will increase. At worst, the breakage of SSCNET III cable may occur. As the same condition also occurs at cable laying, do not tighten up SSCNET III cable with a thing such as nylon band (TY-RAP). Do not trample it down or tuck it down with the door of control panel or others.

(d) Twisting

If SSCNET III cable is twisted, it will become the same stress added condition as when local lateral pressure or bend is added. Consequently, transmission loss increases, and the breakage of SSCNET III cable may occur at worst.

(e) Disposal

When incinerating optical cable (cord) used for SSCNET III cable, hydrogen fluoride gas or hydrogen chloride gas which is corrosive and harmful may be generated. For disposal of SSCNET III cable, request for specialized industrial waste disposal services who has incineration facility for disposing hydrogen fluoride gas or hydrogen chloride gas.

(f) Wiring process of SSCNET III cable

Put the SSCNET III cable in the duct or fix the cable at the closest part to the Motion CPU module with bundle material in order to prevent SSCNET III cable from putting its own weight on SSCNET III connector. Leave the following space for wiring.

• Putting in the duct

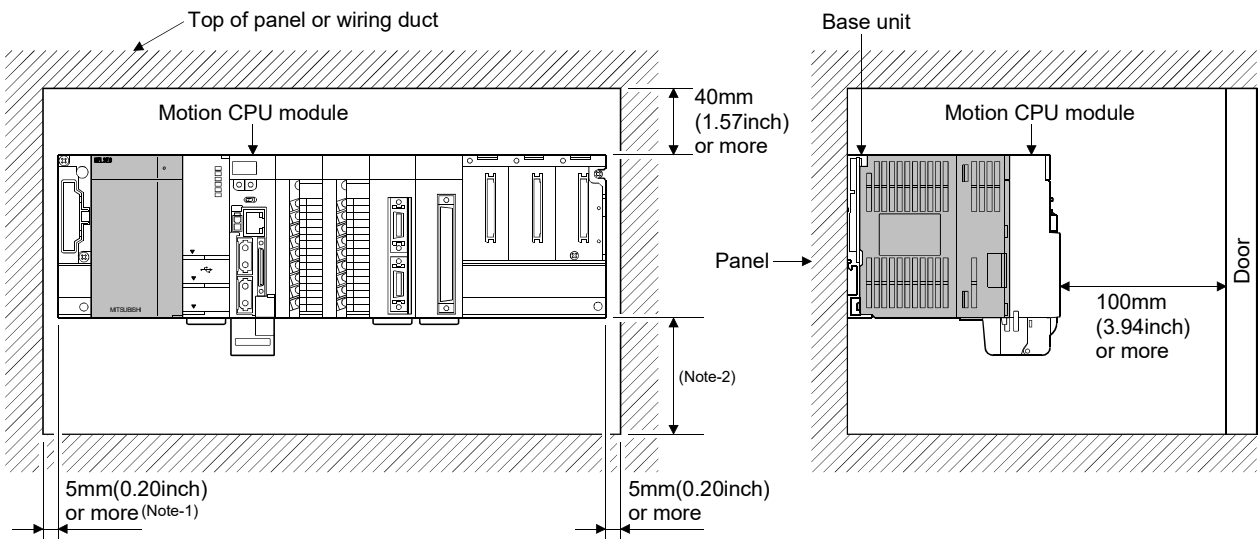

(Note-1): 20mm (0.79inch) or more when the adjacent module is not removed and the extension cable is connected.
 (Note-2): Q173DSCPU/Q172DSCPU use -----70mm (2.76inch) or more
 Q173DCPU(-S1)/Q172DCPU(-S1) use -----100mm (3.94inch) or more

4 INSTALLATION AND WIRING

- Bundle fixing

Optical cord should be given loose slack to avoid from becoming smaller than the minimum bend radius, and it should not be twisted. When bundling the cable, fix and hold it in position by using cushioning such as sponge or rubber which does not contain migratable plasticizing.

If using adhesive tape for bundling the cable, fire resistant acetate cloth adhesive tape 570F (Teraoka Seisakusho Co., Ltd) is recommended.

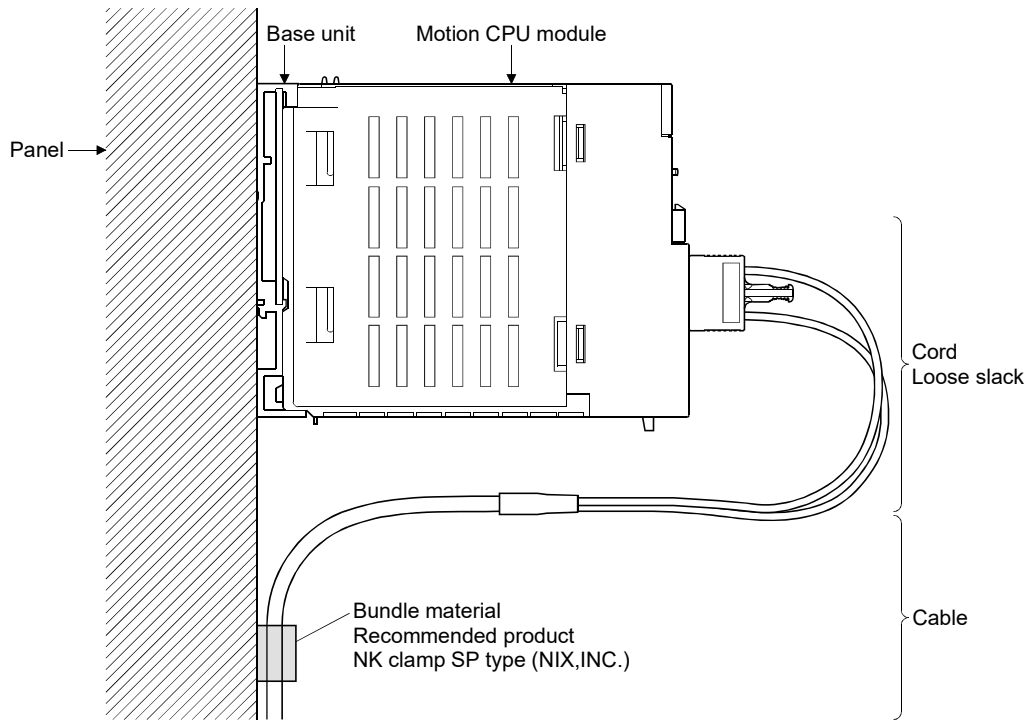

POINTS

- (1) Be sure to connect SSCNETIII cable with the above connector. If the connection is mistaken, between the Motion CPU module and servo amplifier cannot be communicated.
- (2) Forced removal of the SSCNETIII cable from the Motion CPU module will damage the Motion CPU modules and SSCNETIII cables.
- (3) After removal of the SSCNETIII cable, be sure to put a cap on the SSCNETIII connector. Otherwise, adhesion of dirt deteriorates in characteristic and it may cause malfunctions.
- (4) Do not remove the SSCNETIII cable while turning on the power supply of Multiple CPU system and servo amplifier.
Do not see directly the light generated from SSCNETIII connector of Motion CPU module or servo amplifier and the end of SSCNETIII cable. When the light gets into eye, may feel something is wrong for eye. (The light source of SSCNETIII cable complies with class1 defined in JISC6802 or IEC60825-1.)
- (5) If the SSCNETIII cable is added a power such as a major shock, lateral pressure, haul, sudden bending or twist, its inside distorts or brakes, and optical transmission will not be available.
Be sure to take care enough so that the short SSCNETIII cable is added a twist easily.
- (6) Be sure to use the SSCNETIII cable within the range of operating temperature described in this manual. Especially, as optical fiber for MR-J3BUS□M and MR-J3BUS□M-A are made of synthetic resin, it melts down if being left near the fire or high temperature. Therefore, do not make it touched the part which becomes high temperature, such as radiator or regenerative option of servo amplifier, or servo motor.
- (7) When laying the SSCNETIII cable, be sure to secure the minimum cable bend radius or more.
- (8) Put the SSCNETIII cable in the duct or fix the cable at the closest part to the Motion CPU module with bundle material in order to prevent SSCNETIII cable from putting its own weight on SSCNETIII connector.
When laying cable, the optical cord should be given loose slack to avoid from becoming smaller than the minimum bend radius, and it should not be twisted.
When bundling the cable, fix and hold it in position by using cushioning such as sponge or rubber which does not contain migratable plasticizing.
If using adhesive tape for bundling the cable, fire resistant acetate cloth adhesive tape 570F (Teraoka Seisakusho Co., Ltd) is recommended.

POINTS

- (9) Migrating plasticizer is used for vinyl tape. Keep the MR-J3BUS□M, and MR-J3BUS□M-A cables away from vinyl tape because the optical characteristic may be affected.

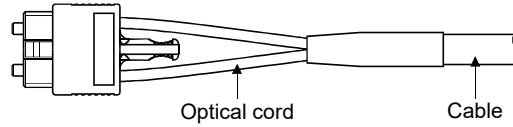

SSCNETⅢ cable	Cord	Cable
MR-J3BUS□M	△	—
MR-J3BUS□M-A	△	△
MR-J3BUS□M-B	○	○

○: Normally, cable is not affected by plasticizer.

△: Phthalate ester plasticizer such as DBP and DOP may affect optical characteristic of cable.

Generally, soft polyvinyl chloride (PVC), polyethylene resin (PE) and fluorine resin contain non-migrating plasticizer and they do not affect the optical characteristic of SSCNETⅢ cable. However, some wire sheaths and cable ties, which contain migrating plasticizer (phthalate ester), may affect MR-J3BUS□M and MR-J3BUS□M-A cables (made of plastic). In addition, MR-J3BUS□M-B cable (made of quartz glass) is not affected by plasticizer.

- (10) If the adhesion of solvent and oil to the cord part of SSCNETⅢ cable may lower the optical characteristic and machine characteristic. If it is used such an environment, be sure to do the protection measures to the cord part.
- (11) When keeping the Motion CPU or servo amplifier, be sure to put on a cap to connector part so that a dirt should not adhere to the end of SSCNETⅢ connector.
- (12) SSCNETⅢ connector to connect the SSCNETⅢ cable is put a cap to protect light device inside connector from dust. For this reason, do not remove a cap until just before connecting SSCNETⅢ cable. Then, when removing SSCNETⅢ cable, make sure to put a cap.
- (13) Keep the cap and the tube for protecting light cord end of SSCNETⅢ cable in a plastic bag with a zipper of SSCNETⅢ cable to prevent them from becoming dirty.
- (14) When exchanging the Motion controller or servo amplifier, make sure to put a cap on SSCNETⅢ connector. When asking repair of Motion controller or servo amplifier for some troubles, make also sure to put a cap on SSCNETⅢ connector. When the connector is not put a cap, the light device may be damaged at the transit. In this case, exchange and repair of light device is required.

4.2.2 Battery cable **QD**

(1) Handling the battery cable

(a) Precautions for handling the battery cable

- For connection or removal of the battery cable, do it surely while holding a connector.

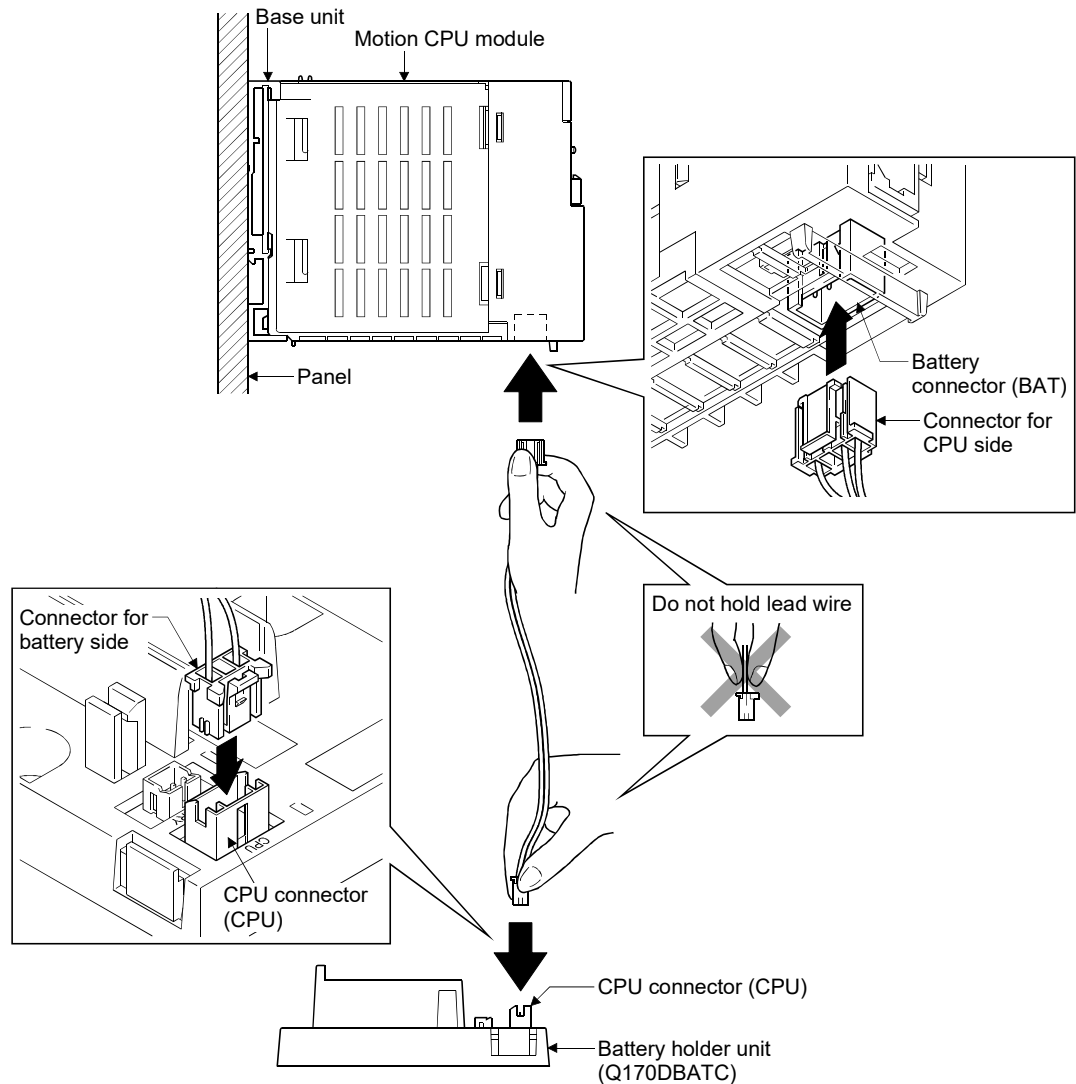

(b) Connection of the battery cable

- For connection of a connector to the Motion CPU module, connect it surely to the battery connector (BAT) of Motion CPU module while holding a connector. Be sure to insert it until it clicks.
- For connection of a connector to the battery holder unit, connect it surely to the CPU connector (CPU) of battery holder while holding a connector. Be sure to insert it until it clicks

(c) Removal of the battery cable

- For removal of the battery cable, pull out it while holding a connector.

4 INSTALLATION AND WIRING

POINT
(1) Forcibly removal the battery cable from the battery holder unit will damage the battery holder unit, battery cable.
(2) As for the battery cable, the shape of connector is different on Motion CPU side and battery holder side. Be sure to connect after confirming shape.
(3) The programs, parameters, motion devices (#), latch range devices and absolute position data of SRAM built-in Motion CPU module are not backed up if the battery connector is not connect correctly.

4.2.3 Forced stop input cable

(1) Precautions for handling the forced stop input cable

- For connection or removal of the forced stop input cable, do it surely while holding a forced stop input connector.

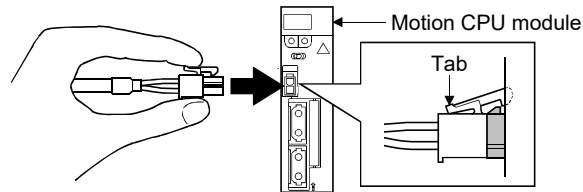

(2) Connection of the forced stop input cable

- For connection of a forced stop input cable to the Motion CPU module, connect it surely to a forced stop input connector of Motion CPU module while holding a connector. Be sure to insert it until it clicks.

(3) Removal of the forced stop input cable

- For removal of the forced stop input cable, push a tab and pull out the cable while holding a connector.

POINTS
<p>The following handling will damage the Motion CPU module or forced stop input cable.</p> <ul style="list-style-type: none">• Forced removal of the forced stop input cable from the CPU module.• The forced stop input cable is twined other cables.• Excessive power is applied at cable laying. <p>Wire the cable correctly.</p>

4 INSTALLATION AND WIRING

4.2.4 Internal I/F connector cable

(1) Precautions on use of Internal I/F connector cable

When using the modules in a place where there is large vibration or impact, fix the internal I/F connector cable to the control panel.

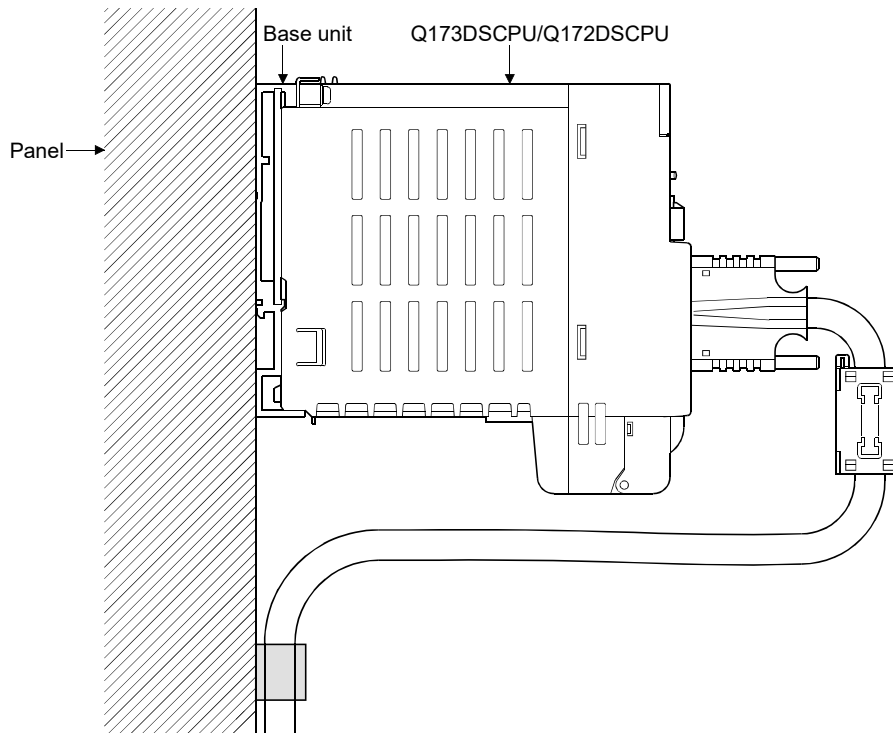

4 INSTALLATION AND WIRING

4.3 Mounting of Battery

(1) Handling the battery lead wire

(a) Q173DSCPU/Q172DSCPU

1) Precautions for mounting the battery

- Set the battery to the battery holder correctly after confirming "+" side and "-" side for the battery.

2) Precautions for handling the battery lead wire

- For connection or removal of the battery lead wire, do it surely while holding a battery lead connector.

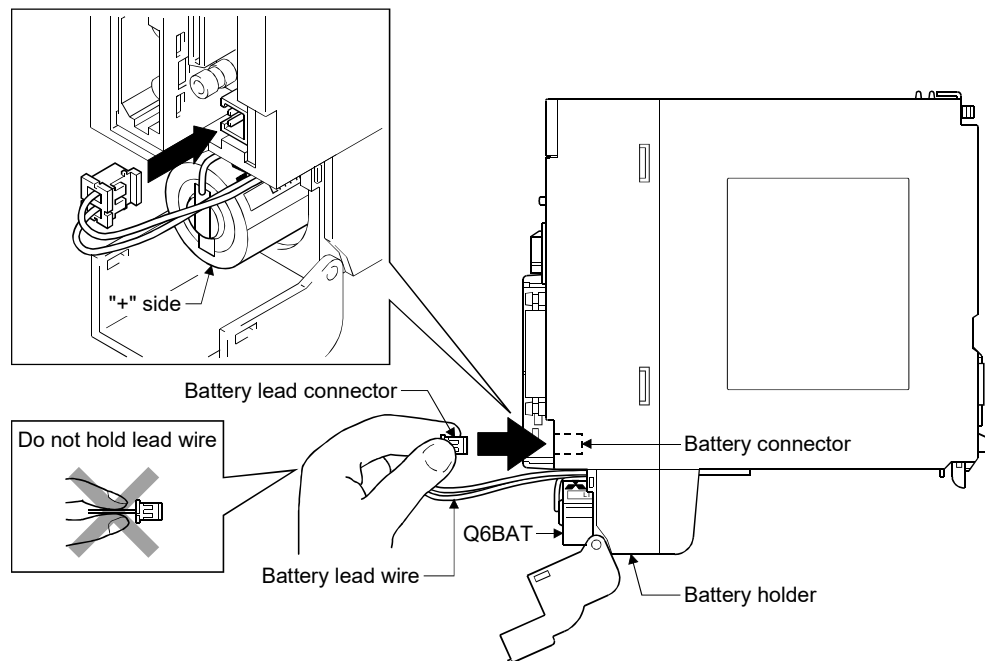

3) Connection of the battery lead wire

- For connection of a battery (Q6BAT), connect it surely to a battery connector while holding a battery lead connector. Be sure to insert it until it clicks.

4) Removal of the battery lead wire

- For removal of the battery lead wire, pull out it while holding a battery lead connector.

4 INSTALLATION AND WIRING

(b) Q173DCPU(-S1)/Q172DCPU(-S1)

1) Precautions for handling the battery lead wire

- For connection or removal of the battery lead wire, do it surely while holding a battery lead connector.

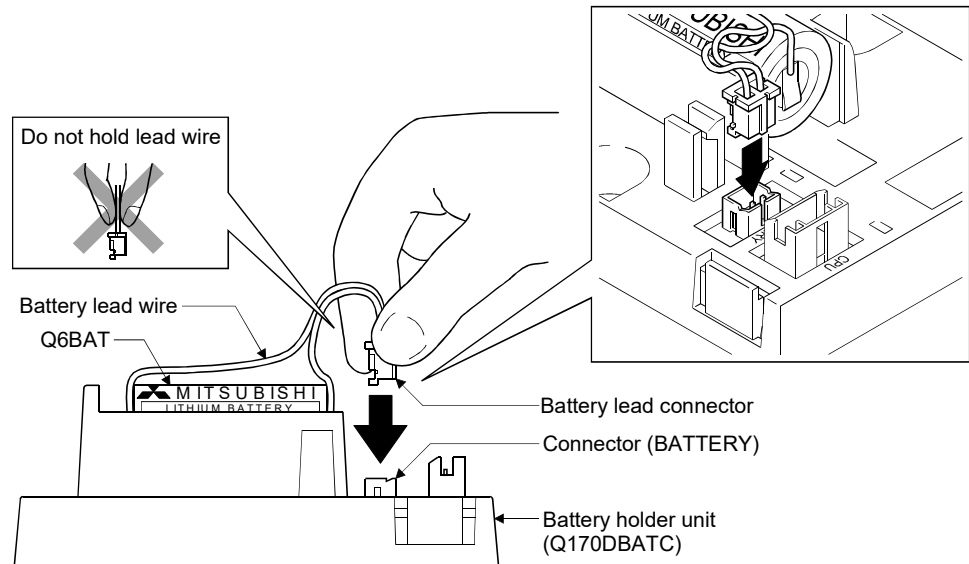

2) Connection of the battery lead wire

- For connection of a battery (Q6BAT) to the battery holder unit, connect it surely to a connector (BATTERY) of battery holder unit while holding a battery lead connector. Be sure to insert it until it clicks.

3) Removal of the battery lead wire

- For removal of the battery lead wire, pull out it while holding a battery lead connector.

POINT

- (1) Forced removal the battery lead wire will damage the battery connector, battery lead wire.
- (2) The programs, parameters, motion devices (#), latch range devices and absolute position data of SRAM built-in Motion CPU module are not backed up if the battery connector is not connect correctly.

4.4 Mounting of Serial Absolute Synchronous Encoder

This section describes precautions for handling the serial absolute synchronous encoder.

- (1) If the serial absolute synchronous encoder is linked to a chain, timing belt, or gears, the machine rotating shaft should be supported by a separate bearing and connected to serial absolute synchronous encoder through a coupling. Ensure that excessive force (greater than the permitted shaft load) is not applied to the shaft of serial absolute synchronous encoder.

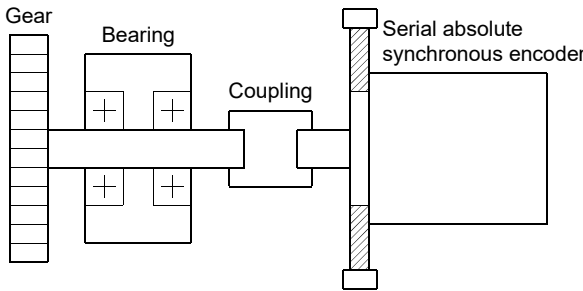

Table 4.1 Permitted Shaft Loads

	Radial direction	Thrust direction
Permitted shaft load	Up to 19.6MN	Up to 9.8N

- (2) Excessive load is applied to the shaft of serial absolute synchronous encoder by the large mounting errors in eccentricity and angle of deviation. As a result, it might damage the machine or shorten extremely the life. Minimize loads applied to the shaft such that they make within the permitted shaft load range.

⚠ CAUTION

- The serial absolute synchronous encoder contains a glass disk and precision mechanism. Take care when handling it. The encoder performance may deteriorate if it is dropped or subjected to shocks or vibration exceeding the prescribed limits.
- Do not connect the shaft of serial absolute synchronous encoder directly to machine side rotary shaft. Always after connecting the shaft of serial absolute synchronous encoder to another bearing once, connect the shaft through a flexible coupling.
- Never hit the end of the serial absolute synchronous encoder coupling shaft with a hammer when connecting the coupling to it. The large loads applied to serial absolute synchronous encoder will damage it.
- The serial absolute synchronous encoder uses optical parts. Mount it in an atmosphere where there are extremely few water drops and little oil and dust.
- When installing a serial absolute synchronous encoder in any place where it is exposed to water and/or oil, provide protection from oil and water, e.g. mount a cover. In addition, run the cable downward to prevent oil and/or water from running on the cable into the serial absolute synchronous encoder. When it is inevitable to mount the serial absolute synchronous encoder vertically or obliquely, trap for the cable.
- Use the serial absolute synchronous encoder within the specified temperature range (-5 to 55°C (23 to 131°F)).

4 INSTALLATION AND WIRING

4.5 Wiring

4.5.1 Instructions for wiring

DANGER

- Completely turn off the externally supplied power used in the system before installation or placing wiring. Not doing so could result in electric shock or damage to the product.
- When turning on the power supply or operating the module after wiring, be sure that the module's terminal covers are correctly attached. Not attaching the terminal cover could result in electric shock.

CAUTION

- Be sure to ground of the earth terminal FG and LG. Not doing so could result in electric shock or operation failure. (Ground resistance: 100Ω or less)
- When wiring in the Motion controller, be sure that it is done correctly by checking the product's rated voltage and the terminal layout. Connecting a power supply that is different from the rating or incorrectly wiring the product could result in fire or damage.
- External connections shall be crimped or pressure welded with the specified tools, or correctly soldered. Imperfect connections could result in short circuit, fire, or operation failure.
- Tighten the terminal screws within the specified torque range. If the terminal screws are loose, it could result in short circuit, fire, or operation failure. Tightening the terminal screws too far may cause damages to the screws and/or the module, resulting in drop, short circuit, or operation failure.
- Be sure there are no foreign matters such as sawdust or wiring debris inside the module. Such debris could cause fire, damage, or operation failure.
- The module has an ingress prevention label on its top to prevent foreign matter, such as wiring debris, from entering the module during wiring.
Do not remove this label during wiring.
Before starting system operation, be sure to remove this label because of heat dissipation.

This section describes instructions for the wiring of the power supply.

Refer to the "7 EMC directives" for grounding method and measure against noise.

(1) Power supply wiring

- (a) 100VAC, 200VAC and 24VDC wires should be twisted as dense as possible respectively. Connect the modules with the shortest distance.

Also, to reduce the voltage drop to the minimum, use the thickest wires (Up to 2.0mm²) possible.

Use the wires of the following core size for wiring.

Application	Recommended core size	AWG ^(Note-1)
100VAC, 200VAC, 24VDC wires	2.0mm ² or more	AWG14 or less
I/O equipment	0.3 to 0.75mm ² (Outside diameter 2.8mm (0.11inch) or less)	AWG18 to AWG22
Ground wire	2.0mm ² or more	AWG14 or less

(Note-1): AWG stands for "American Wire Gauge". AWG is a unit of the thickness of conducting wire.

4 INSTALLATION AND WIRING

- (b) Do not bundle the 100VAC and 24VDC wires with, or run them close to, the main circuit (high voltage, large current) and I/O signal lines (including common line).
Reserve a distance of at least 100mm (3.94inch) from adjacent wires.

- (c) Momentary power failure may be detected or the Multiple CPU system may be reset due to surge caused by lightning.

As measures against surge caused by lightning, connect a surge absorber for lightning as shown below.

Using the surge absorber for lightning can reduce the influence of lightning.

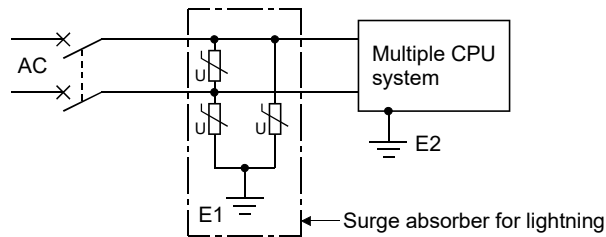

POINTS

- (1) Separate the ground of the surge absorber for lightning (E1) from that of the Multiple CPU system (E2).
- (2) Select a surge absorber for lightning whose power supply voltage does not exceed the maximum allowable circuit voltage even at the time of maximum power supply voltage elevation.

(2) Wiring of I/O equipment

- (a) Insulation-sleeved crimping terminals cannot be used with the terminal block. It is recommended to cover the wire connections of the crimping terminals with mark or insulation tubes.
- (b) The wires used for connection to the terminal block should be 0.3 to 0.75mm² in core and 2.8mm (0.11inch) or less in outside diameter.
- (c) Run the input and output lines away from each other.
- (d) When the wiring cannot be run away from the main circuit and power lines, use a batch-shielded cable and ground it on the Motion controller side. In some cases, ground it on the opposite side.

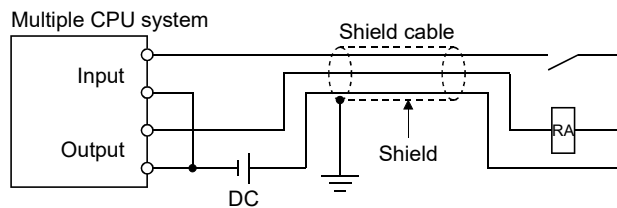

- (e) Where wiring runs through piping, ground the piping without fail.
- (f) Run the 24VDC input line away from the 100VAC and 200VAC lines.

- (g) Wiring of 200m (656.17ft.) or longer distance will give rise to leakage currents due to the line capacity, resulting in a fault.
Refer to the troubleshooting chapter of the I/O Module User's Manual.
- (h) As a countermeasure against the power surge due to lightning, separate the AC wiring and DC wiring and connect a surge absorber for lightning (Refer to Section 4.5.1(1)).
Failure to do so increases the risk of I/O device failure due to lightning.

(3) Grounding

For grounding, follow the steps (a) to (c) shown below.

- (a) Use a dedicated grounding wire as far as possible.
(Ground resistance: 100Ω or less)
- (b) When a dedicated grounding cannot be performed, use (2) Common Grounding shown below.

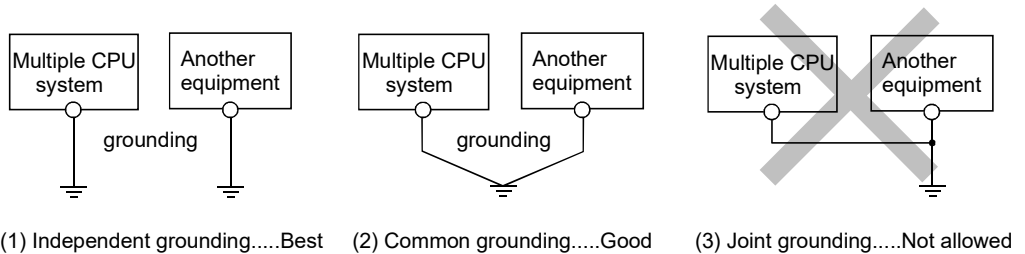

- (c) For grounding a cable, use the cable of 2mm² or more.
Position the ground-contact point as nearly to the Multiple CPU system as possible, and reduce the length of the grounding cable as much as possible.

4 INSTALLATION AND WIRING

4.5.2 Connecting to the power supply module

The following diagram shows the wiring example of power lines, grounding lines, etc. to the main and extension base units.

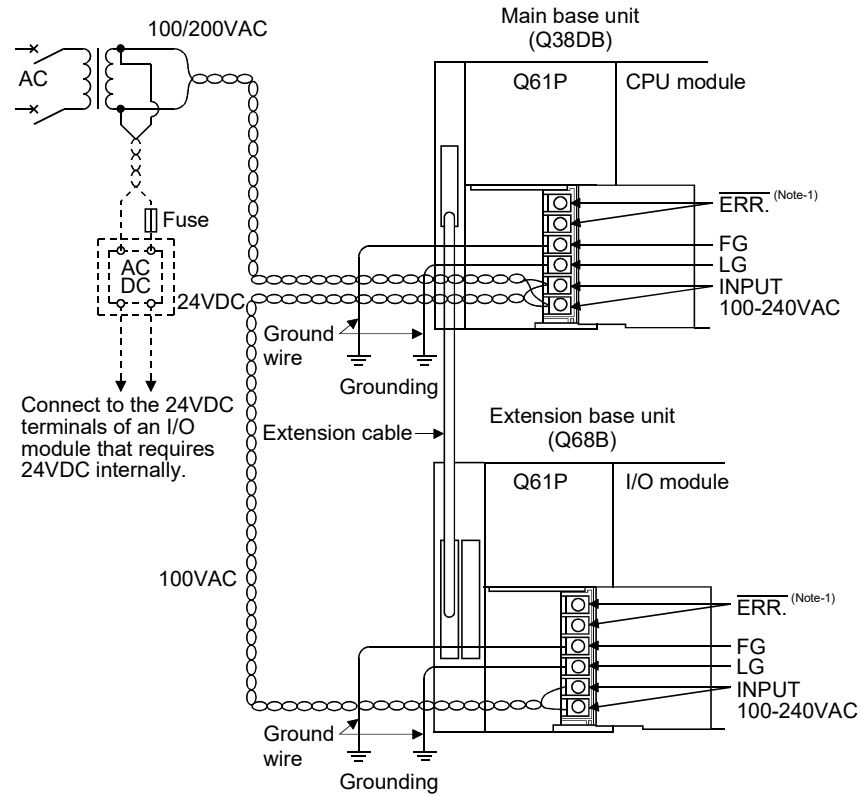

(Note-1): The operation of the $\overline{\text{ERR.}}$ terminal is as follows.

<When the power supply module is installed on the main base unit>

The terminal turns OFF (opens) when the AC power is not input, a CPU module stop error (including a reset) occurs, or the fuse of the power supply module is blown.

<When the power supply module is installed on the extension base unit>

The terminal is always OFF(open).

POINT

- (1) Use the thickest possible (up to 2mm^2) wires for the 100/200VAC and 24VDC power cables. Be sure to twist these wires starting at the connection terminals. For wiring a terminal block, be sure to use a solderless terminal. To prevent a short circuit should any screws loosen, use solderless terminals with insulation sleeves of 0.8mm (0.03inch) or less. Also, only two solderless terminals can be connected per terminal block.

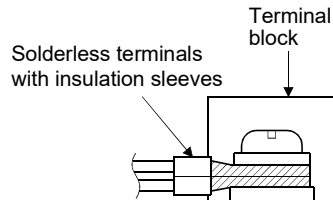





- (2) Ensure that the earth terminals LG and FG are grounded.
(Ground resistance : 100Ω or less)
If not, the programmable controller may become susceptible to noise.
Since the LG terminal has a half of the input voltage, touching this terminal may result in an electric shock.
- (3) No system error can be detected by the $\overline{\text{ERR}}$ terminal of an extension base unit. (The $\overline{\text{ERR}}$ terminal is always set off.)

5. START-UP PROCEDURES

5.1 Check Items Before Start-up

Table 5.1 Check items before start-up

Part name	Confirmation Items	Check	Reference
Main base unit/ Extension base unit	(1) Check that the main base unit is Q35DB, Q38DB or Q312DB.	<input type="checkbox"/>	2.5.3
	(2) Check that the model name of module is correct.	<input type="checkbox"/>	2.3
	(3) Check that the installation order is correct.	<input type="checkbox"/>	2.1.4
	(4) Check that the damage for installed modules.	<input type="checkbox"/>	
	(5) Check that the modules are installed correctly.	<input type="checkbox"/>	4.1.3
	(6) Check for looseness, rattling or distorted installation.	<input type="checkbox"/>	4.1.1
	(7) Check that the module fixing screw tightening torque is as specified.	<input type="checkbox"/>	
		(8) Check that the total I/O points of I/O modules and intelligent function modules do not exceed the I/O points of the CPU module.	<input type="checkbox"/>
Power supply module	(1) Check that the model name of power supply modules is correct.	<input type="checkbox"/>	2.5.2
	(2) Check that the wire sizes of cables are correct.	<input type="checkbox"/>	4.5.1
	(3) Check that the power line is wired correctly.	<input type="checkbox"/>	
	(4) Check that FG and LG are wired correctly.	<input type="checkbox"/>	4.5.2
	(5) Check that the terminal screws are tightened correctly.	<input type="checkbox"/>	
	(6) Check that the terminal screws are tightening torque is as specified.	<input type="checkbox"/>	4.1.1
	(7) Check that the 100VAC, 200VAC and 24VDC wires are twisted as closely as possible respectively and run in the shortest distance.	<input type="checkbox"/>	4.5.1
	(8) Check that cables are not binded with 100VAC, 200VAC and 24VDC wires or run close to the power wires.	<input type="checkbox"/>	
	(9) Check the grounding of the earth terminal FG and LG.	<input type="checkbox"/>	4.5.2
PLC CPU module	(1) Check that the model name of PLC CPU modules is correct.	<input type="checkbox"/>	2.1.4 2.3
	(2) Check that the modules are installed to CPU slot or I/O slot 0 to 2 of the main base unit.	<input type="checkbox"/>	2.1.4
Q173D(S)CPU/ Q172D(S)CPU Motion CPU module	(1) Check that the Q173HCPU(-T)/Q172HCPU(-T)/Q173CPUN(-T)/ Q173CPUN(-T)/Q173CPU/Q172CPU is not used.	<input type="checkbox"/>	2.1.4
	(2) Check that the modules are installed to I/O slot 0 to 2 of the main base unit.	<input type="checkbox"/>	
	(3) Check that the module fixing screws are tightened correctly.	<input type="checkbox"/>	4.1.1
	(4) Check that the forced stop input is wired correctly.	<input type="checkbox"/>	3.2
	(5) Check that the battery is installed.	<input type="checkbox"/>	
	(6) Check that the battery cables are connected correctly. 	<input type="checkbox"/>	4.2.2
	(7) Check that the battery lead connector is connected correctly. 	<input type="checkbox"/>	4.3
	(8) Check that the built-in interface in Motion CPU is wired correctly. 	<input type="checkbox"/>	2.5.1
	(9) Check that the manual pulse generator/incremental synchronous encoder is wired correctly. 	<input type="checkbox"/>	

5 START-UP PROCEDURES

Part name	Confirmation Items	Check	Reference
Q172DLX Servo external signals interface module/ Q172DEX synchronous encoder interface module/ Q173DPX Manual pulse generator interface module	(1) Check that the Q172DEX is installed to I/O slot 3 to 11 of the main base unit.	<input type="checkbox"/>	2.1.4
	(2) Check that the Q172DLX/Q173DPX is installed to I/O slot 3 to 11 when installation to the main base unit.	<input type="checkbox"/>	
	(3) Check that the installation position of modules correspond to the system setting.	<input type="checkbox"/>	Refer to the "Q173D(S)CPU/Q172D(S)CPU Motion controller Programming Manual (COMMON)".
	(4) Check that the connection with external equipments is correct.	<input type="checkbox"/>	2.5.4 2.5.5 2.5.6
	(5) Check that the battery is connected to connector of Q172DEX correctly.	<input type="checkbox"/>	6.5.2
I/O module	(1) Check that the wire size of cable is correct.	<input type="checkbox"/>	Refer to the I/O Module Type Building Block User's Manual
	(2) Check that the terminal block screws are tightened correctly.	<input type="checkbox"/>	
	(3) Check that the cables connected to each terminal of terminal block correspond to the signal names.	<input type="checkbox"/>	
	(4) Check that the external power supply are connected correctly. (24VDC, 5VDC)	<input type="checkbox"/>	
	(5) Check that the 100VAC, 200VAC and 24VDC wires are twisted as closely as possible respectively and run in the shortest distance.	<input type="checkbox"/>	4.5.1
	(6) Check that the 100VAC, 200VAC and 24VDC wires are not bind the cable together with and run close to the I/O wires.	<input type="checkbox"/>	
	(7) Check that the I/O wires are wired correctly.	<input type="checkbox"/>	
SSCNET III cable	(1) Check that the model name of SSCNET III cables is correct.	<input type="checkbox"/>	2.5.9
	(2) Check that the connecting position for connector of SSCNET III cables are correct.	<input type="checkbox"/>	4.2.1
	(3) Check that the SSCNET III cables are connected correctly.	<input type="checkbox"/>	
	(4) Check for looseness, rattling or distorted connection.	<input type="checkbox"/>	
	(5) Check that the minimum bend radius or more secured.	<input type="checkbox"/>	
	(6) Check that the MR-J3BUS□M or MR-J3BUS□M-A do not come in contact with wires/cables that use materials where the plasticizing material is contained.	<input type="checkbox"/>	
Battery holder unit (Q170DBATC) QD	(1) Check that the lead connector of Q6BAT is connected to the connector (BATTERY) correctly.	<input type="checkbox"/>	4.3
	(2) Check that the mounting orientation is correct. (Do not mount it downward.)	<input type="checkbox"/>	4.1.4
	(3) Check that the battery cable is connected correctly.	<input type="checkbox"/>	4.2.2
	(4) Check for looseness, rattling or distorted mounting.	<input type="checkbox"/>	4.1.1
	(5) Check that the module fixing screw tightening torque is as specified.	<input type="checkbox"/>	
Serial absolute synchronous encoder (Q171ENC-W8/Q170ENC)	(1) Check that the amplitude, eccentricity and axial displacement relative to the machine side rotary shaft are within the permissible values.	<input type="checkbox"/>	4.4
	(2) Check that a flexible coupling is used for coupling with the machine side rotary shaft.	<input type="checkbox"/>	
	(3) Check that the damage for units.	<input type="checkbox"/>	4.4
	(4) Check that the forcible impact is given on modules.	<input type="checkbox"/>	

5 START-UP PROCEDURES

5.2 Start-up Adjustment Procedure

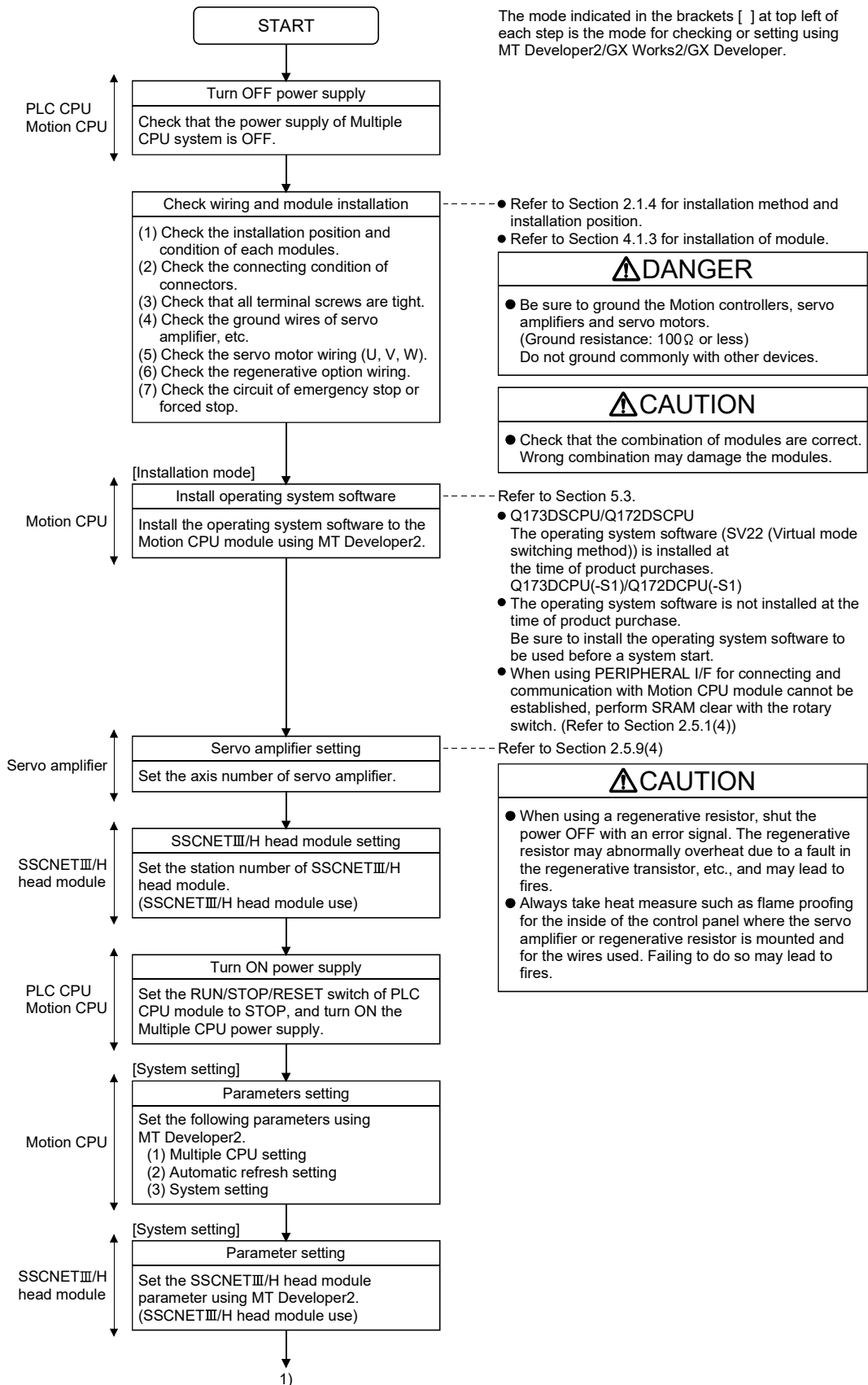

5 START-UP PROCEDURES

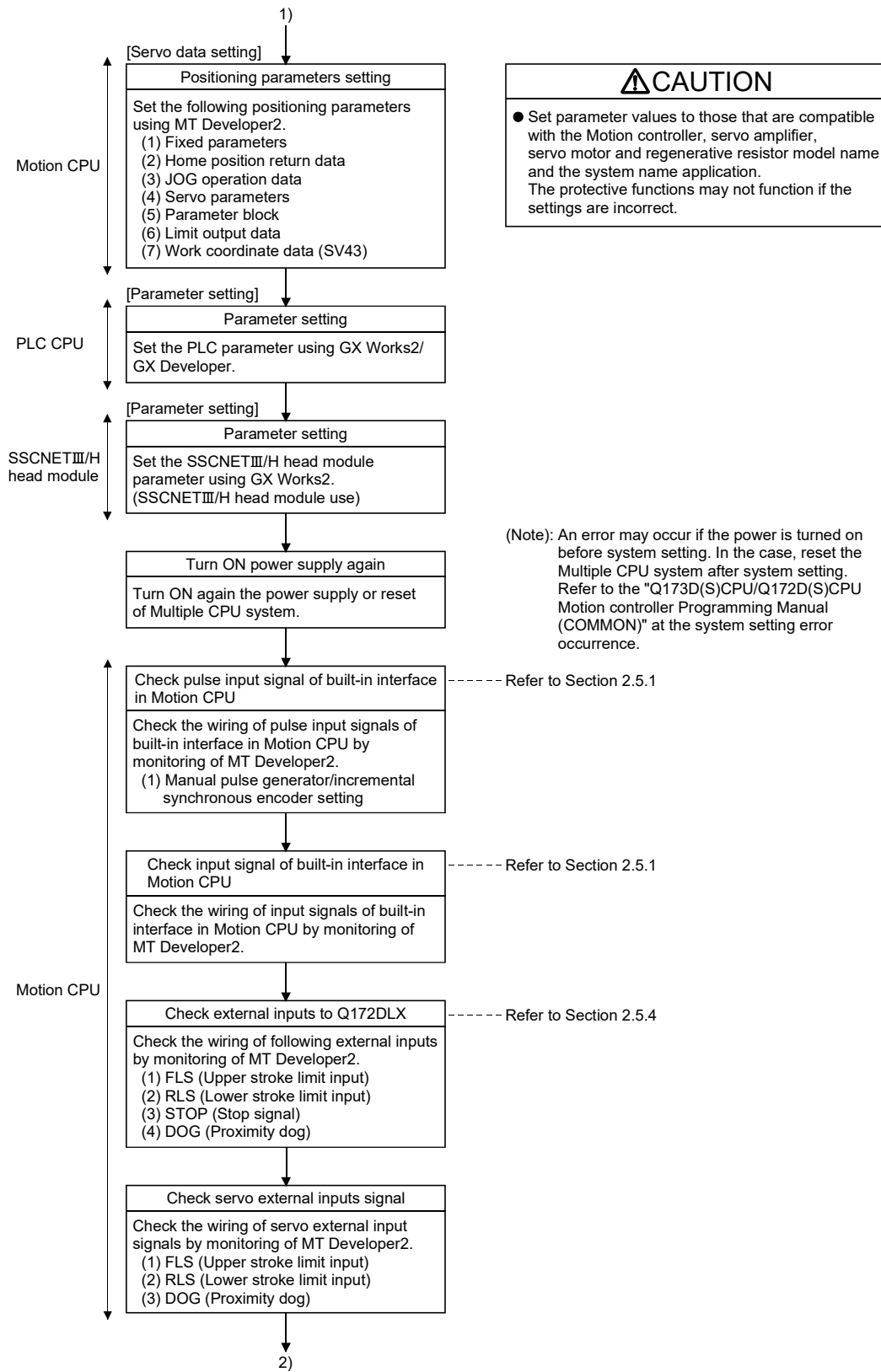

5 START-UP PROCEDURES

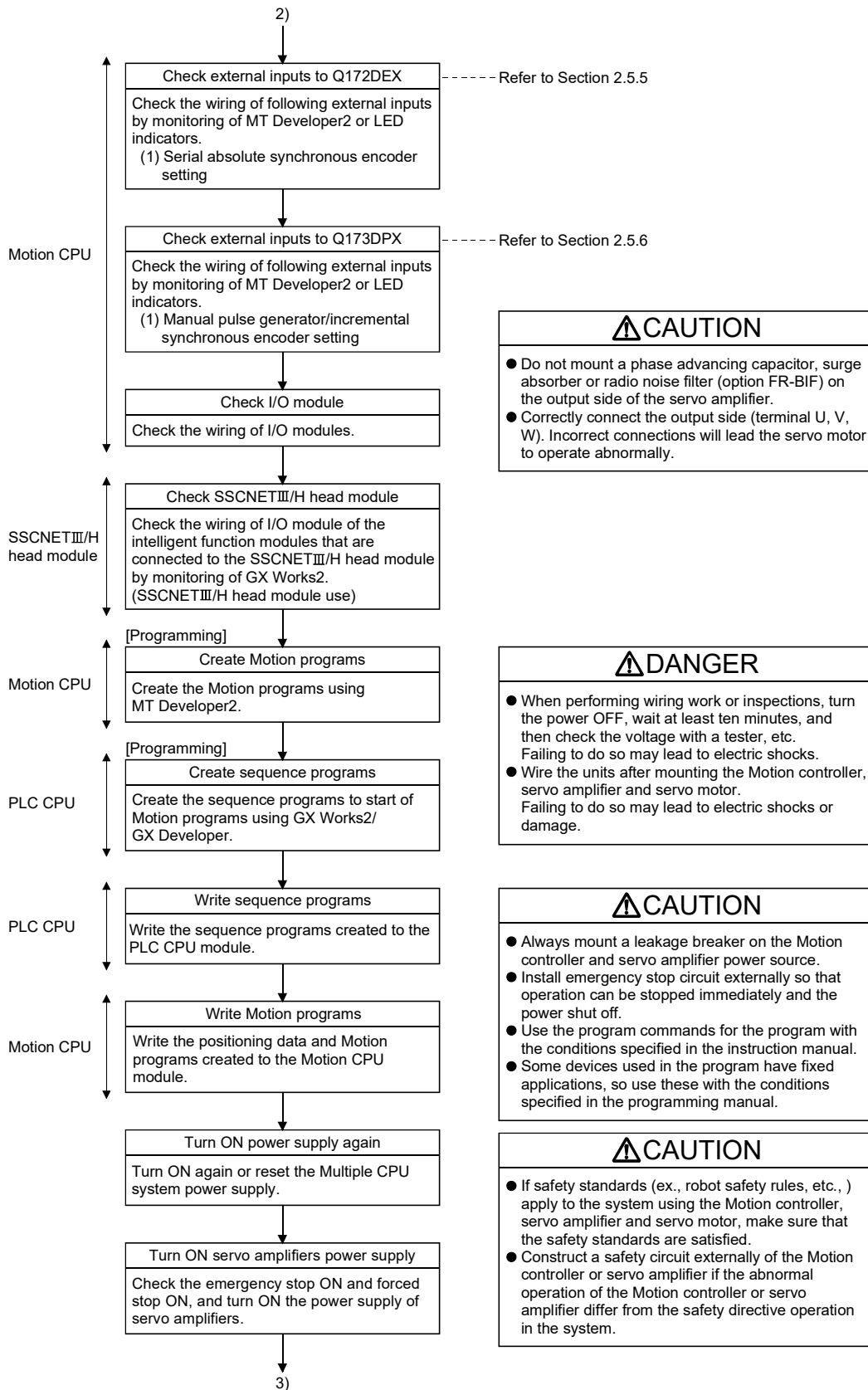

5 START-UP PROCEDURES

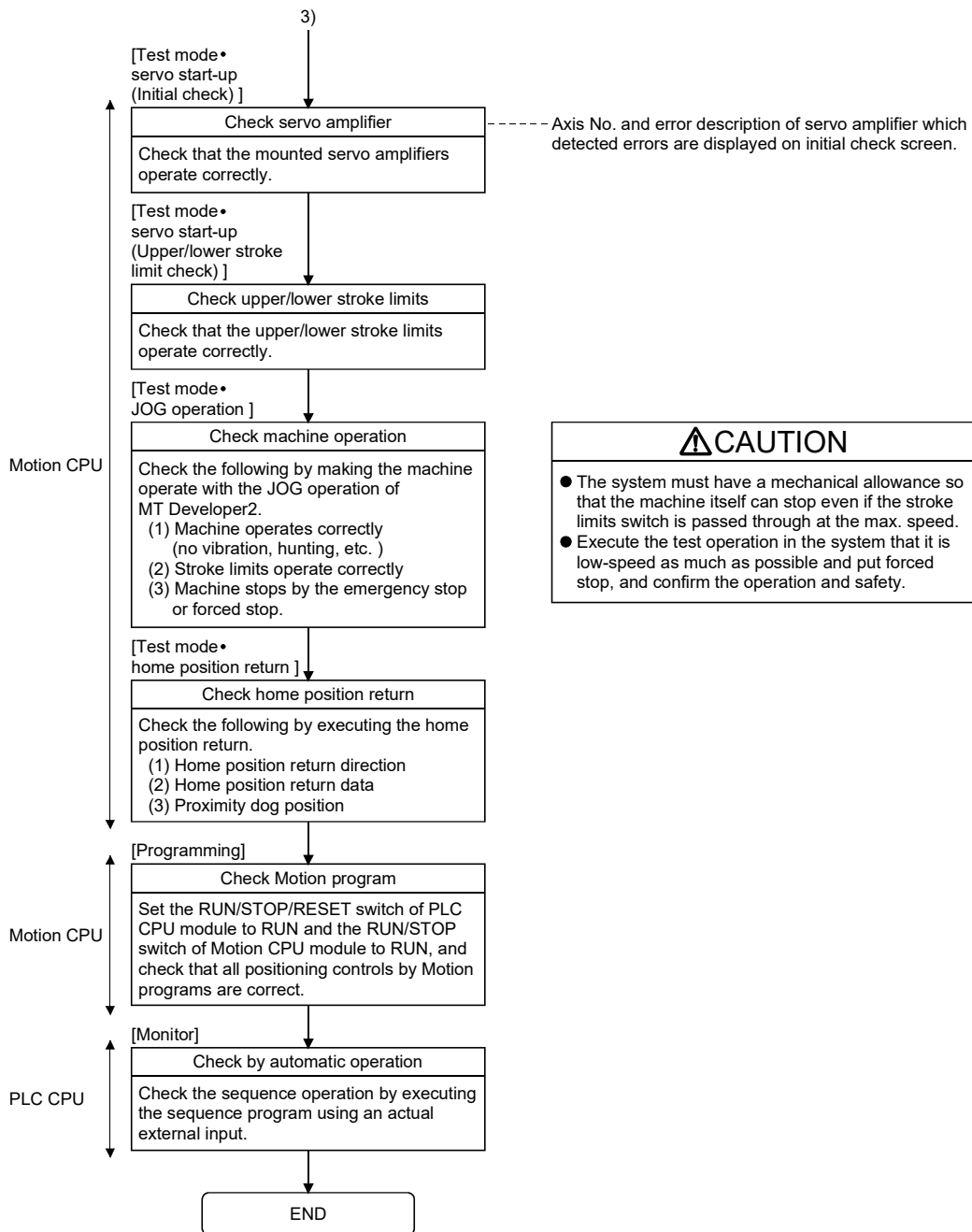

⚠ CAUTION
<ul style="list-style-type: none"> ● The system must have a mechanical allowance so that the machine itself can stop even if the stroke limits switch is passed through at the max. speed. ● Execute the test operation in the system that it is low-speed as much as possible and put forced stop, and confirm the operation and safety.

POINTS
<ol style="list-style-type: none"> (1) Make note of servo motor module names before the servo motor is mounted on a machine. The servo motor rating plate may not be visible after the servo motor is mounted. (2) When the servo amplifier, servo motor is first turned on, check the operation before the servo motor is mounted on a machine to avoid an unexpected accidents such as machine breakage.

5 START-UP PROCEDURES

5.3 Operating System Software Installation Procedure

The operating system software must be installed to the Motion CPU module by using the MT Developer2.

The installation procedure is shown below.

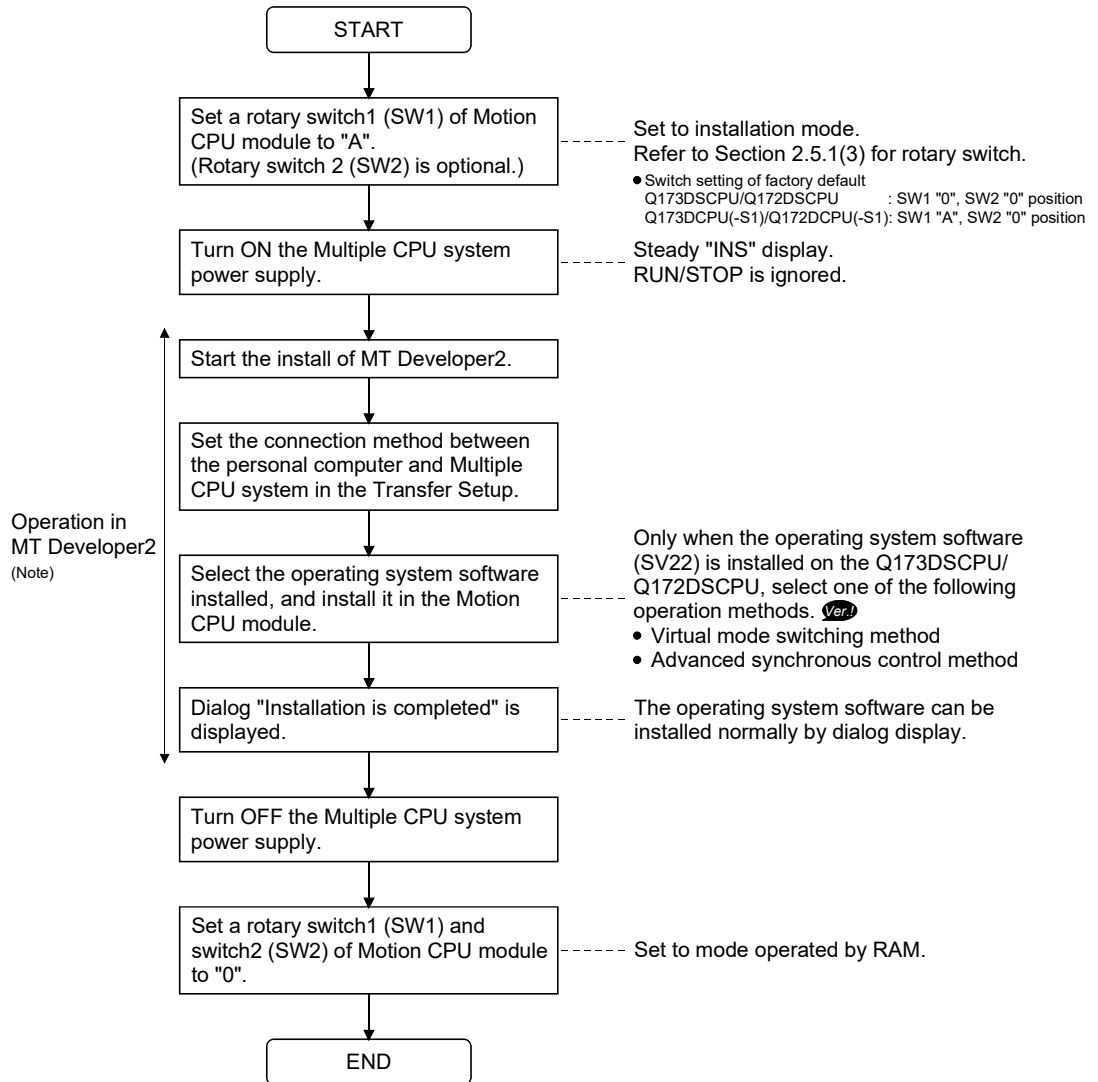

(Note): Install the operating system software by screen of MT Developer2. Refer to help of MT Developer2 for details.

Ver.!: Refer to Section 1.3 for the software version that supports this function.

POINTS
<p>(1) When the software security key function is used in Q173DSCPU/Q172DSCPU, if the software security key of the operating system software already installed in Motion CPU is different from that embedded to the operating system software to be installed, "Clear all" is executed at installation. It is recommended to backup the data in advance using MT Developer2.</p> <p>(2) State of the Motion CPU module at the time of product purchase is shown below.</p> <ul style="list-style-type: none"> • Q173DSCPU/Q172DSCPU The operating system software (SV22 (Virtual mode switching method)) is installed at the time of product purchase. • Q173DCPU(-S1)/Q172DCPU(-S1) The operating system software is not installed at the time of product purchase. Be sure to install the operating system software to be used before a system start. <p>(3) Be sure to turn power supply OFF before changing rotary switch setting.</p> <p>(4) Even if the operating system software is installed, the programs, parameters and absolute position data written in the Motion CPU module not rewritten.</p> <p>(5) Do not do any of the following while installing operation system software. Doing so could result damage the Motion CPU module.</p> <ul style="list-style-type: none"> • Turn OFF the power supply of Multiple CPU system. • Change the RUN/STOP/RESET switch of PLC CPU module to RESET. • Turn OFF the power supply of the personal computer. • Pull out the personal computer's communication cable. <p>(6) When installing the operating system software to several Motion CPU modules on the same base unit, be sure to set all Motion CPU modules that have not been installed to installation mode (set rotary switch1 (SW1) to "A" position.). (Note): If the power supply is turned ON without setting all Motion CPU modules that have not been installed to installation mode, it does not operate normally. Be sure to install the operating system software before system start.</p> <p>(7) Only when the operating system software (SV22) is installed on the Q173DSCPU/Q172DSCPU, select one of the following operation methods.</p> <p>Ver.!</p> <ul style="list-style-type: none"> • Virtual mode switching method • Advanced synchronous control method <p>To change the operation method after the operating system software is installed, install the operating system software (SV22) again, or change the operation method in "Change CPU operation method" of MT Developer2. Refer to help of MT Developer2 for details.</p>

Ver.! : Refer to Section 1.3 for the software version that supports this function.

5 START-UP PROCEDURES

5.4 Trial Operation and Adjustment Checklist

At the worksite, copy the following table for use as a check sheet.

Work Step	Item	Check Items	Check	
Before power supply ON	Installation of unit/module and basic wiring	Check that each module is installed correctly.	<input type="checkbox"/>	
		Check that each connector is connected correctly.	<input type="checkbox"/>	
		Check each terminal screw for looseness.	<input type="checkbox"/>	
		Check that the earth wires of power supply module or servo amplifiers, etc. are correct.	<input type="checkbox"/>	
		Check that the servo motor wiring is correct.	<input type="checkbox"/>	
		Check that the regenerative option wiring is correct.	<input type="checkbox"/>	
		Check that the circuit of emergency stop and forced stop are correct.	<input type="checkbox"/>	
		Check that the wiring of each power supply and I/O are correct.	<input type="checkbox"/>	
Power supply ON/ Motion CPU module in STOP status/ PLC CPU module in STOP status	Installation of OS	Check that the operating system software is compatible.	<input type="checkbox"/>	
	System setting	Check that the system setting is correct.	<input type="checkbox"/>	
	Q172DLX/Servo amplifier external signal	Check that the upper/lower stroke limit inputs are correct.	<input type="checkbox"/>	
		Check that the STOP signal input is correct. (Q172DLX only)	<input type="checkbox"/>	
	Program/positioning data	Check that the proximity dog and speed/position switching signal input are correct.	<input type="checkbox"/>	
		Check that the Motion program, sequence program and positioning data are stored in the PLC/Motion CPU module correctly.	<input type="checkbox"/>	
	Motion CPU module in RUN status/ PLC CPU module in STOP status	Basic axis operations (Check each axis)	Check the communications with servo amplifiers.	<input type="checkbox"/>
			Check that the rotation direction for JOG operation is correct.	<input type="checkbox"/>
			Check that the upper/lower limit switches operate correctly.	<input type="checkbox"/>
			Check that the rotation at maximum command speed is motor rating or less.	<input type="checkbox"/>
Check that the machine operates correctly by the JOG operation.			<input type="checkbox"/>	
Check that the machine stops by the upper/lower stroke limit.			<input type="checkbox"/>	
Motion CPU module in RUN status/ PLC CPU module in RUN status	Manual operation	Check each operation in manual operation mode of system during Motion program execution.	<input type="checkbox"/>	
		Check that the machine operation stops immediately by the emergency stop or forced stop.	<input type="checkbox"/>	
		Check the operation of each actuator and confirmation limit switch.	<input type="checkbox"/>	
		Check that the emergency stop, forced stop and equipment alarm signals are correct.	<input type="checkbox"/>	
	Automatic operation	Checks in compliance with control specifications specific to system and equipment.	<input type="checkbox"/>	
		Check each operation in automatic operation mode of system during Motion program execution.	<input type="checkbox"/>	
		Check that the automatic operation motions.	<input type="checkbox"/>	
		Check that the machine operation stops immediately by the emergency stop or forced stop.	<input type="checkbox"/>	
Torque check	Check that the module or equipment alarm causes an immediate stop or cycle stop.	<input type="checkbox"/>		
	Check that the restoring operation can be performed after an alarm stop.	<input type="checkbox"/>		
		Make other checks in compliance with control specifications specific to system and equipment.	<input type="checkbox"/>	
		Check that the acceleration/deceleration torque is maximum torque or less.	<input type="checkbox"/>	
		Check that the continuous effective load torque is rated torque or less.	<input type="checkbox"/>	

6. INSPECTION AND MAINTENANCE

DANGER

- Do not touch the terminals while power is on. Doing so could cause electric shock.
- Correctly connect the battery. Also, do not charge, disassemble, heat, place in fire, short circuit, or solder the battery.
Mishandling of a battery may cause overheating, cracks or ignition which could result in injury and fire.
- Switch off all phases of the externally supplied power used in the system when cleaning the module or retightening the terminal or module mounting screws.
Not doing so could result in electric shock.
Under tightening of terminal screws can cause a short circuit or malfunction.
Over tightening of screws can cause damages to the screws and/or the module, resulting in fallout, short circuits, or malfunction.
- The capacitor is mounted to the modules. Do not incinerate the modules so that the incineration of capacitor may cause burst.
For disposal of the modules, request for specialized industrial waste disposal services who has incineration facility.

CAUTION

- Read the manual carefully and pay careful attention to safety for the on-line operation (especially program change, forced stop or operation change) performed by connecting peripheral devices to the Motion controller during operation.
Erroneous operation may cause machine breakage or accident.
- Never try to disassemble or modify module. It may cause product failure, operation failure, injury or fire.
- Use any radio communication device such as a cellular phone or a PHS phone more than 25cm (9.84 inch) away in all directions of the Motion controller.
Failure to do so may cause a malfunction.
- Completely turn off the externally supplied power used in the system before installation or removing the module. Not doing so could result in electric shock, damage to the module or operation failure.
- Do not install/remove the module on to/from base unit or terminal block more than 50 times, after the first use of the product. Doing so may cause the module to malfunction due to poor contact of connector.
- Do not drop or impact the battery installed to the module. Doing so may damage the battery, causing battery liquid to leak in the battery.
Do not use the dropped or impacted battery, but dispose of it.
- Before touching the module, always touch grounded metal, etc. to discharge static electricity from human body. Failure to do so may cause the module to fail or malfunction.
- Do not directly touch the module's conductive parts and electronic components. Touching them could cause an operation failure or damage the module.

In order that you can use the Motion controller in normal and optimal condition at all times, this section describes those items that must be maintained or inspected daily or at regular intervals.

6 INSPECTION AND MAINTENANCE

6.1 Maintenance Works

6.1.1 Instruction of inspection works

In order that can use the Motion controller in safety and normal, those items that must be inspected list below.

DANGER

- Never open the front case or terminal covers while the power is ON or the unit is running, as this may lead to electric shocks.
- Never run the unit with the front case or terminal cover removed. The high voltage terminal and charged sections will be exposed and may lead to electric shocks.
- Never remove the front case or terminal cover at times other than wiring work or periodic inspections even if the power is OFF. The insides of the Motion controller and servo amplifier are charged and may lead to electric shocks.
- When performing wiring work or inspections, turn the power OFF, wait at least ten minutes, and then check the voltage with a tester, etc. Failing to do so may lead to electric shocks.
- Never operate the switches with wet hands, as this may lead to electric shocks.
- Do not damage, apply excessive stress, place heavy things on or sandwich the cables, as this may lead to electric shocks or fire.
- Do not touch the Motion controller, servo amplifier or servo motor terminal blocks while the power is ON, as this may lead to electric shocks or fire.
- Do not touch the built-in power supply, built-in grounding or signal wires of the Motion controller and servo amplifier, as this may lead to electric shocks.

CAUTION

- Be sure to ground the Motion controller, servo amplifier and servo motor. Do not ground commonly with other devices. (Ground resistance : 100 Ω or less)
- The wiring work and inspections must be done by a qualified technician.
- Wire the units after mounting the Motion controller, servo amplifier and servo motor. Failing to do so may lead to electric shocks or damage.
- Perform the daily and periodic inspections according to the instruction manual.
- Perform maintenance and inspection after backing up the program and parameters for the Motion controller and servo amplifier.
- Do not place fingers or hands in the clearance when opening or closing any opening.
- Periodically replace consumable parts such as batteries according to the instruction manual.
- Do not touch the lead sections such as ICs or the connector contacts.
- Do not place the Motion controller or servo amplifier on metal that may cause a power leakage or wood, plastic or vinyl that may cause static electricity buildup.
- Do not perform a megger test (insulation resistance measurement) during inspection.
- When replacing the Motion controller or servo amplifier, always set the new unit settings correctly.

⚠ CAUTION

- After maintenance and inspections are completed, confirm that the position detection of the absolute position detector function is correct.
- Do not short circuit, charge, overheat, incinerate or disassemble the batteries.
- The electrolytic capacitor will generate gas during a fault, so do not place your face near the Motion controller or servo amplifier.
- The electrolytic capacitor and fan will deteriorate. Periodically change these to prevent secondary damage from faults. Replacements can be made by our sales representative.
- If an error occurs in the self diagnosis of the Motion controller or servo amplifier, confirm the check details according to the instruction manual, and restore the operation.
- If a dangerous state is predicted in case of a power failure or product failure, in order to prevent that state, use a servo motor with electromagnetic brakes for maintenance or mount a brake mechanism externally.
- Use a double circuit construction so that the electromagnetic brake operation circuit can be operated by emergency stop signals set externally.

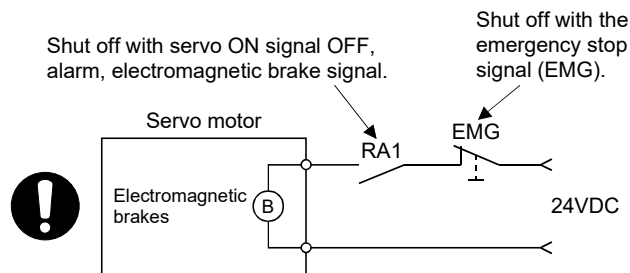







- If an error occurs, remove the cause, secure the safety and then resume operation after alarm release.
- The unit may suddenly restart after a power failure is restored, so do not go near the machine. (Design the machine so that personal safety can be ensured even if the machine restarts suddenly.)
- Confirm and adjust the program and each parameter before operation. Unpredictable movements may occur depending on the machine.
- Extreme adjustments and changes may lead to unstable operation, so never make them.
- Do not apply a voltage other than that specified in the instruction manual on any terminal. Doing so may lead to destruction or damage.
- Do not mistake the terminal connections, as this may lead to destruction or damage.
- Do not mistake the polarity (+ / -), as this may lead to destruction or damage.
- Do not touch the heat radiating fins of controller or servo amplifier, regenerative resistor and servo motor, etc., while the power is ON and for a short time after the power is turned OFF. In this timing, these parts become very hot and may lead to burns.
- Always turn the power OFF before touching the servo motor shaft or coupled machines, as these parts may lead to injuries.
- Do not go near the machine during test operations or during operations such as teaching. Doing so may lead to injuries.
- Do not bunch the control wires or communication cables with the main circuit or power wires, or lay them closely. They should be installed 100mm (3.94inch) or more from each other. Trying to bunch or install could result in noise that would cause operation failure.

6 INSPECTION AND MAINTENANCE

6.2 Daily Inspection

The items that must be inspected daily are shown below.

Table 6.1 Daily Inspection

Item	Inspection item	Inspection	Criterion	Action		
1	Mounting of base unit	Check that the fixing screws are not loose and the cover is not dislocated.	The screws and cover must be mounted securely.	Retighten the screws.		
2	Installation of Motion modules and I/O modules	Check that the module is not dislocated and the unit fixing hook is engaged securely.	The module fixing hook must be engaged and installed correctly.	Securely engaged the module fixing hook.		
3	Connecting conditions	Check for loose terminal screws.	Screws should not be loose.	Retighten the terminal screws.		
		Check the distance between solderless terminals.	The proper clearance should be provided between solderless terminals.	Correct.		
		Check the connector part of the cable.	Connections should not be loose.	Retighten the connector fixing screws.		
4	Power supply module	[POWER] LED	Check that the LED is ON.	The LED must be ON (green). (Abnormal if the LED is OFF or ON (red)).	Refer to "QnUCPU User's Manual (Function Explanation, Program Fundamentals)".	
		PLC CPU module	[MODE] LED	Check that the LED is ON.		The LED must be ON (green). (Abnormal if the LED is OFF or flickering.)
			[RUN] LED	Check that the LED is ON in RUN status.		The LED must be ON. (Abnormal if the LED is OFF.)
			[ERR.] LED	Check that the LED is OFF.		The LED must be OFF. (Abnormal if the LED is ON or flickering.)
			[BAT.] LED	Check that the LED is OFF.		The LED must be OFF. (Abnormal if the LED is ON.)
	Module indication LED	Normal		Steady "RUN" display. (Abnormal if "RUN" does not display or incorrect display.)	Refer to Section 2.5.1	
				Steady "STP" display. (Abnormal if "STP" does not display or incorrect display.)		
		Motion CPU module	Battery error warning (2.7V or less)		"BT1" does not display. (Abnormal if steady "BT1" display.)	Refer to Section 6.5
			Battery error warning (2.5V or less)		"BT2" does not display. (Abnormal if steady "BT2" display.)	
		Others	WDT error		"..." does not display. (Abnormal if steady "..." display.)	Refer to Section 2.5.1
					"AL" does not flash. (Abnormal if "..." flashes.)	
		I/O module	Input LED	Check that the LED is ON/OFF.	The LED must be ON when the input power is turned ON. The LED must be OFF when the input power is turned OFF. (Abnormal if the LED does not turn ON or turn OFF as indicated above.)	Refer to "I/O Module Type Building Block User's Manual".
	Output LED		Check that the LED is ON/OFF.	The LED must be ON when the output power is turned ON. The LED must be OFF when the output power is turned OFF. (Abnormal if the LED does not turn ON or turn OFF as indicated above.)		

6 INSPECTION AND MAINTENANCE

6.3 Periodic Inspection

The items that must be inspected one or two times every 6 months to 1 year are listed below. When the equipment is moved or modified, or layout of the wiring is changed, also implement this inspection.

Table 6.2 Periodic Inspection

Item	Inspection item	Inspection	Criterion	Action	
1	Ambient environment	Ambient temperature	0 to 55 °C (32 to 131 °F)	When the controller is used in the board, the ambient temperature in the board becomes the ambient temperature.	
		Ambient humidity	Measure with a thermometer and a hygrometer. 5 to 95 % RH		
		Atmosphere	Measure corrosive gas. No corrosive gases		
2	Power voltage	Measure a voltage across the terminals of 100/200VAC and 24VDC.	85 to 132VAC 170 to 264VAC 15.6 to 31.2VDC	Change the power supply.	
3	Installation	Looseness, rattling	Move the module to check for looseness and rattling.	The module must be installed solidly.	Retighten the screws. If the CPU modules, Motion modules, I/O modules, or power supply modules are loose, fix it with screws.
		Adhesion of dirt and foreign matter	Check visually.	Dirt and foreign matter must not be present.	Remove and clean.
4	Connection	Looseness of terminal screws	Try to further tighten screws with a screwdriver.	Screws must not be loose.	Retighten the terminal screws.
		Proximity of solderless terminals to each other	Check visually.	Solderless terminals must be positioned at proper intervals.	Correct.
		Looseness of connectors	Check visually.	Connectors must not be loose.	Retighten the connector fixing screws.
5	Battery	Check the 7-segment LED at the front side of CPU module.	Must be turned OFF "BT1" or "BT2" display.	Even if the lowering of a battery capacity is not shown, replace the battery with a new one if a service life time of the battery is exceeded.	
		Check the length of term after purchasing the battery	Must not be used more than 5 years.		
		Check that SM51 or SM58 is turned OFF using MT Developer2 in monitor.	Must be turned OFF.	Replace the battery with a new one when SM51 or SM58 is ON.	

6.4 Life

The following parts must be changed periodically as listed below. However, if any part is found faulty, it must be changed immediately even when it has not yet reached the end of its life, which depends on the operating method and environmental conditions. For parts replacement, please contact your sales representative.

Table 6.3 Life

Module name	Part name	Life guideline	Remark
Motion CPU module	Electrolytic capacitor	10 years	Life guideline is reference time. If faulty, it must be changed immediately even when it has not yet reached the life guideline.
Motion module			
Synchronous encoder	Capacitor	20,000 to 30,000 hours	
	Bearings		

(1) Capacitor

The life of the capacitor greatly depends on ambient temperature and operating conditions. The capacitor will reach the end of its in 10 years of continuous operation in normal air-conditioned environment.

(2) Bearing

Change the bearings in 20,000 to 30,000 hours as a guideline under rated speed. This differs on the operating conditions, The bearings must also be changed if unusual noise or vibration is found during inspection.

6.5 Battery

The battery installed in the Motion CPU module is used for data retention during the power failure of the program memory and latch device. Special relays (SM51, SM52, SM58 or SM59) turn on due to the decrease of battery voltage. Even if the special relays turn on, the program and retained data are not erased immediately. However, if these relays are overlooked, the contents may be erased. After relay SM51 or SM58 turns on, replace the battery quickly within the data retention time for power failure (3 minutes).

POINT	
(1)	SM51 or SM58 turns on when the battery voltage falls below the specified value, and remains ON even after the battery voltage is recovered to the normal value. SM51 or SM58 turns off by power supply on again or reset.
(2)	After SM51, SM52, SM58 or SM59 turns on, replace the battery quickly. <ul style="list-style-type: none">• SM51 or SM52 turns on at the battery voltage 2.5V or less.• SM58 or SM59 turns on at the battery voltage 2.7V or less.
(3)	If SM51 turns on, the details for the programs, parameters, motion device(#), latch range device and absolute position data of SRAM built-in Motion CPU module cannot be guaranteed. It is recommended to back-up the data periodically.
(4)	For Q173DSCPU/Q172DSCPU, whether or not to check the battery of Motion CPU can be set in the system basic setting of system setting. If "Perform battery check" is not set, a self-diagnosis error will not occur and the 7-segment LED "BT1" or "BT2" is not displayed. Refer to the "Q173D(S)CPU/Q172D(S)CPU Motion controller Programming Manual (COMMON)" for details.

6 INSPECTION AND MAINTENANCE

6.5.1 Battery life

The battery life is shown below.

Module type	Battery type		Battery life (Total power failure time) [h] (Note-1)				Backup time after alarm (Note-6)
			Power-on time ratio (Note-2)	Guaranteed value (Note-3) (MIN) (75°C (167°F))	Guaranteed value (Note-4) (TYP) (40°C (104°F))	Actual service value (Note-5) (Reference value) (TYP) (25°C (77°F))	
Q173D(S)CPU/ Q172D(S)CPU (Note-7)	Battery (Q6BAT)		0%	20000	43800	43800	90 (After SM51/SM52 ON)
			30%	27000			
			50%	31000			
			70%	36000			
			100%	43800			
Q172DEX	Internal battery (A6BAT/MR-BAT)	Q171ENC-W8/ Q170ENC×1	0%	3000	8000	24000	40 (After Error code 1152 occurrence)
			30%	4000	11000	34000	
			50%	6000	16000	43800	
			70%	10000	26000	43800	
			100%	43800	43800	43800	
		Q171ENC-W8/ Q170ENC×2	0%	1500	4000	12000	
			30%	2000	5500	17000	
			50%	3000	8000	21900	
			70%	5000	13000	21900	
			100%	43800	43800	43800	

(Note-1): The actual service value indicates the average value, and the guaranteed value indicates the minimum value.

(Note-2): The power-on time ratio indicates the ratio of Multiple CPU system power-on time to one day (24 hours).

(When the total power-on time is 17 hours and the total power-off time is 7 hours, the power-on time ratio is 70%.)

(Note-3): The guaranteed value (MIN) ; equivalent to the total power failure time that is calculated based on the characteristics value of the memory (SRAM) supplied by the manufacturer and under the storage ambient temperature range of -25°C to 75°C (-13 to 167°F) (operating ambient temperature of 0°C to 55°C (32 to 131°F)).

(Note-4): The guaranteed value (TYP) ; equivalent to the total power failure time that is calculated based on the normal air-conditioned environment (40°C (104°F)).

(Note-5): The actual service value (Reference value) ; equivalent to the total power failure time that is calculated based on the measured value and under the storage ambient temperature of 25°C (77°F). This value is intended for reference only, as it varies with characteristics of the memory.

(Note-6): In the following status, the backup time after power OFF is 3 minutes.

- The battery connector/Q6BAT lead connector is disconnected.
- The battery cable/lead wire of Q6BAT is broken.

(Note-7): Set the battery (Q6BAT) to battery holder unit (Q170DBATC) when using the Q173DCPU(-S1)/Q172DCPU(-S1).

POINT	
(1)	Do not use the battery exceeding its guaranteed life.
(2)	<p>When the battery hours (total power failure time) may exceed its guaranteed value, take the following measure.</p> <ul style="list-style-type: none"> • Perform ROM operation to protect a program even if the battery dies at the Multiple CPU system power-OFF. • If SM51 turns on, the contents for programs, parameters, motion device(#), latch range device and absolute position data cannot be guaranteed. It is recommended to back-up the data periodically.
(3)	When the total power failure time exceeds its guaranteed value, and SM51, SM52, SM58 and SM59 turns on, immediately change the battery. Even if the alarm has not yet occurred, it is recommended to replace the battery periodically according to the operating condition
(4)	<p>The self-discharge influences the life of battery without the connection to Q173D(S)CPU/Q172D(S)CPU/Q172DEX. The external battery should be exchanged approximately every 4 or 5 years.</p> <p>And, exchange the battery with a new one in 4 to 5 years even if a total power failure time is guaranteed value or less.</p>
(5)	<p>It is recommended to shift to the mode operated by ROM after the programs and parameters are fixed. The erasing of the programs and parameters can be avoided even if the battery decrease. (The ROM writing cannot be executed for the current position of the servo motor in the absolute position system, home position and latch device. Back up them beforehand using MT Developer2.)</p> <p>Refer to Section 4.4 of the "Q173D(S)CPU/Q172D(S)CPU Motion controller Programming Manual (COMMON)" for details of the ROM operation.</p>

6.5.2 Battery replacement procedure

(1) Battery replacement procedure of the Motion CPU module

When the battery has been exhausted, replace the battery with a new one in accordance with the procedure shown below.

POINTS
<p>When replacing the battery, pay attention to the following.</p> <p>(1) The Multiple CPU power supply must be on for 10 minutes or longer before dismounting the battery. QDS</p> <p>(2) Back up the data using MT Developer2 before starting replacement.</p> <p>(3) Firstly back up the data stored in the Motion CPU to the personal computer which is installed MT Developer2 then replace the battery with a new one.</p> <p>After setting the battery, verify the backing up the data to the personal computer which is installed MT Developer2 and the data in the Motion CPU module, confirm the data is not changing.</p> <p>In the following status, the backup time after power OFF is 3 minutes.</p> <ul style="list-style-type: none">• The battery connector/Q6BAT lead connector is disconnected.• The battery cable/lead wire of Q6BAT is broken.

(a) Q173DSCPU/Q172DSCPU battery replacement procedure

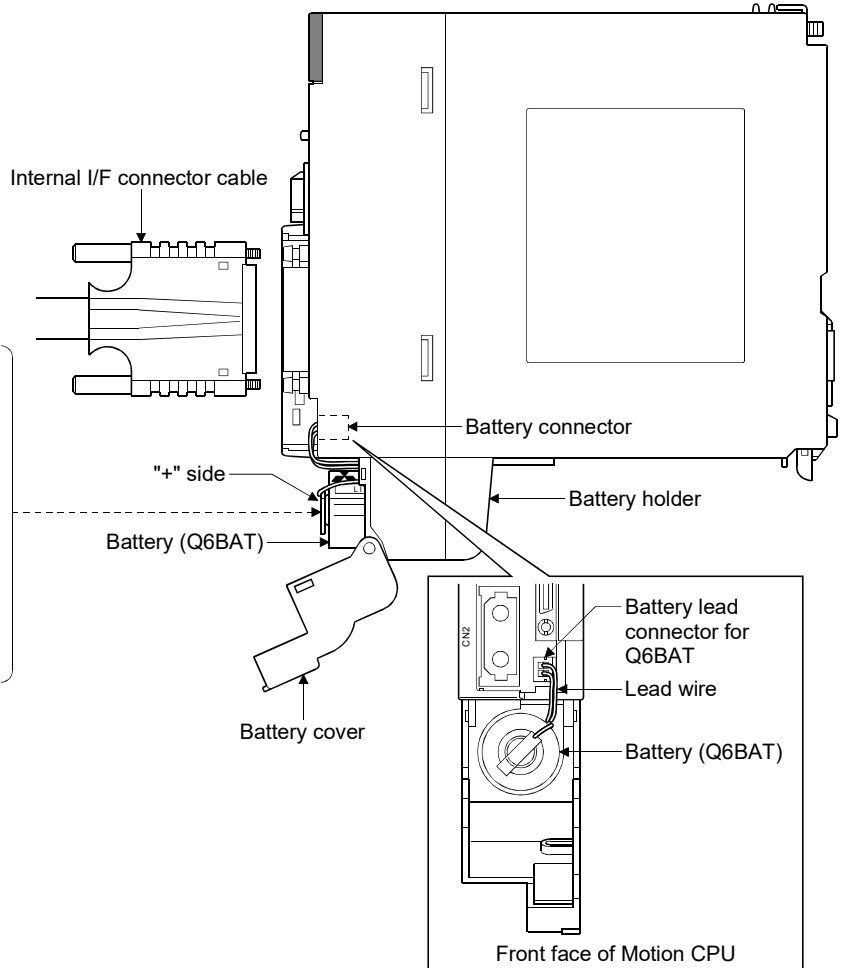
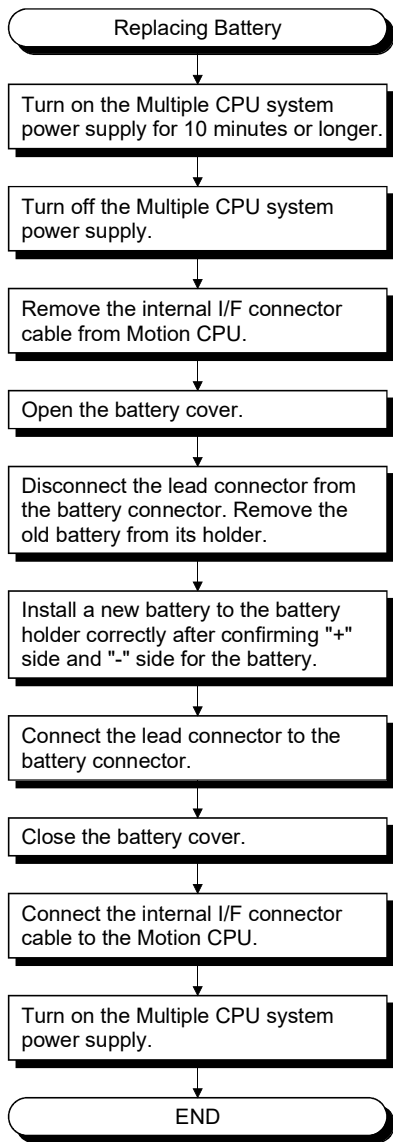

(b) Q173DCPU(-S1)/Q172DCPU(-S1) battery replacement procedure

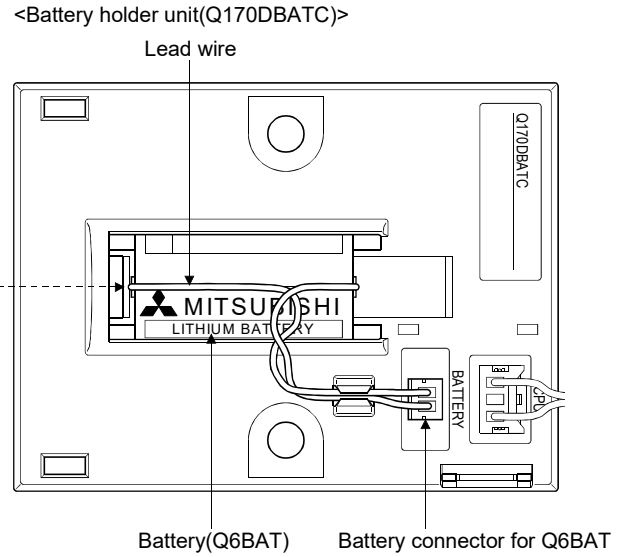
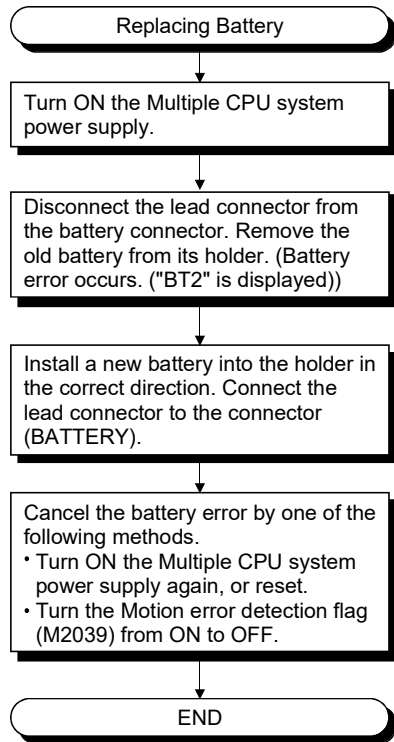

(2) Q172DEX module battery replacement procedure

When the battery has been exhausted, replace the battery with a new one in accordance with the procedure shown below.

POINT
<p>When replacing the battery, pay attention to the following.</p> <p>(1) The Multiple CPU power supply must be on for 10 minutes or longer before dismounting the battery.</p> <p>(2) Encoder data in the memory are backed up for a while by a capacitor even after the battery is removed. However, since data in the memory may be erased if the time for replacement exceeds the backup time shown the following guaranteed value, replace the battery quickly.</p> <ul style="list-style-type: none"> • Backup time by capacitor : 3 minutes

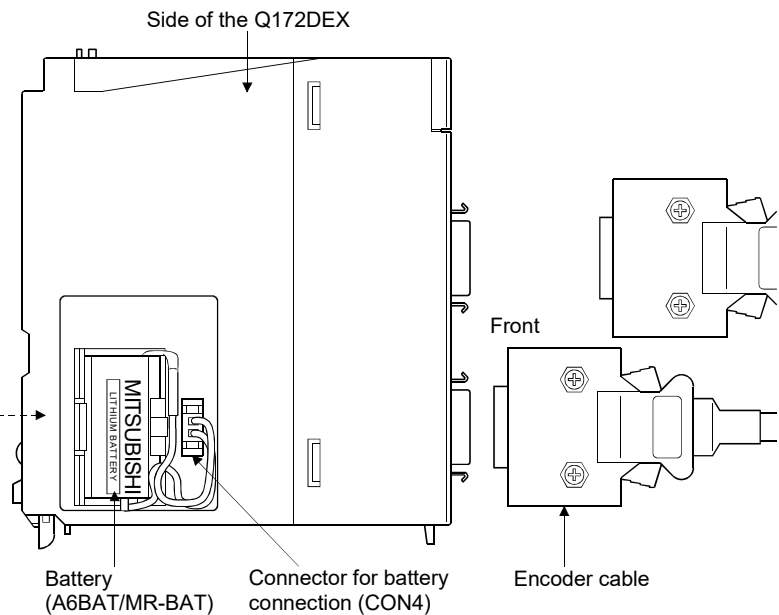
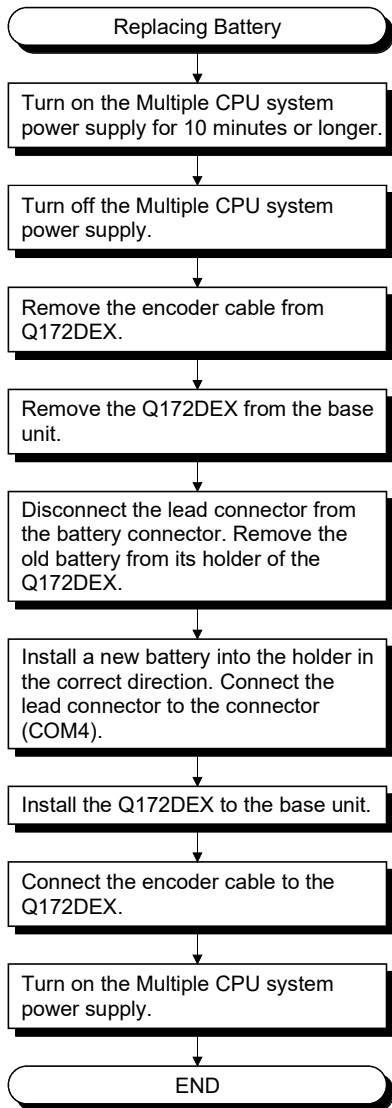

6.5.3 Resuming operation after storing the Motion controller

When the operation is to be resumed after being stored with the battery removed or the battery has gone flat during storage, the contents of programs, parameters, motion device(#), latch range device and absolute position data cannot be guaranteed. Before resuming operation, write the contents of programs, parameters, motion device(#), latch range device and absolute position data backed up prior to storage to SRAM built-in Motion CPU module.

POINT
(1) Before storing the Motion controller, always back up the contents of programs, parameters, motion device(#), latch range device and absolute position data to SRAM built-in Motion CPU module.
(2) When using PERIPHERAL I/F for connecting and communication with Motion controller cannot be established, perform SRAM clear with the rotary switch. (Refer to Section 2.5.1(4))

6.5.4 Symbol for the new EU battery directive

This section describes a symbol for the new EU Battery Directive (2006/66/EC) that is labeled batteries.



Note: This symbol mark is for EU countries only.

This symbol mark is according to the directive 2006/66/EC Article 20 Information for end-users and Annex II.

Your MITSUBISHI ELECTRIC product is designed and manufactured with high quality materials and components which can be recycled and/or reused.

This symbol means that batteries and accumulators, at their end-of-life, should be disposed of separately from your household waste.

If a chemical symbol is printed beneath the symbol shown above, this chemical symbol means that the battery or accumulator contains a heavy metal at a certain concentration. This will be indicated as follows:

Hg: mercury (0.0005%), Cd: cadmium (0.002%), Pb: lead (0.004%)

In the European Union there are separate collection systems for used batteries and accumulators.

Please, dispose of batteries and accumulators correctly at your local community waste collection/recycling centre.

Please, help us to conserve the environment we live in!

6.6 Troubleshooting

This section describes the various types of trouble that occur when the system is operated, and causes and corrective actions of these troubles.

6.6.1 Troubleshooting basics

The basic three points that must be followed in the troubleshooting are as follows.

(1) Visual inspection

Visually check the following.

- (a) Movement of machine (stopped condition, operating condition)
- (b) Power supply on/off
- (c) Status of input/output devices
- (d) Installation condition of the Power supply module, Motion CPU module, PLC CPU module, I/O module, Motion module, intelligent function module, SSCNET III cable, Synchronous encoder cable.
- (e) State of wiring (I/O cables, cables)
- (f) Display states of various types of indicators
PLC CPU module : MODE LED, RUN LED, ERR. LED, BAT LED, I/O LED, etc.
Motion CPU module : 7-segment LED (Installation mode, Operation mode, Battery error, STOP/RUN, etc.)
- (g) Status of setting of various types of switches (Setting of No. of stages of extension base, power interrupt hold-on status).

After checking (a) to (g), monitor the operating conditions of servo motors and error code using MT Developer2 and GX Works2/GX Developer.

(2) Check of trouble

Check to see how the operating condition varies while the Motion controller is operated as follows.

- (a) Set the RUN/STOP switch of Motion CPU module to STOP.
- (b) Reset the trouble with the RUN/STOP/RESET switch of PLC CPU module.
- (c) Turn ON and OFF the Multiple CPU system power supply.

(3) Narrowing down the range of trouble occurrence causes

Estimate the troubled part in accordance with items (1) and (2) above.

- (a) Multiple CPU system or external devices
- (b) Motion CPU or PLC CPU
- (c) I/O module or others
- (d) Servo program or Motion SFC program/Motion program
- (e) Sequence program

6.6.2 Troubleshooting of Motion CPU module

This section describes the contents of troubles for the error codes and corrective actions of the troubles.

As for troubleshooting of PLC CPU, refer to the QCPU User's Manual (Hardware Design, Maintenance and Inspection) of their respective modules.

As for troubleshooting of I/O modules, refer to the "I/O Module Type Building Block User's Manual" of their respective modules.

POINT
Check that the operating system software is installed before starting the Motion CPU module.

(1) Troubleshooting flowchart

The following show the contents of the troubles classified into a variety of groups according to the types of events.

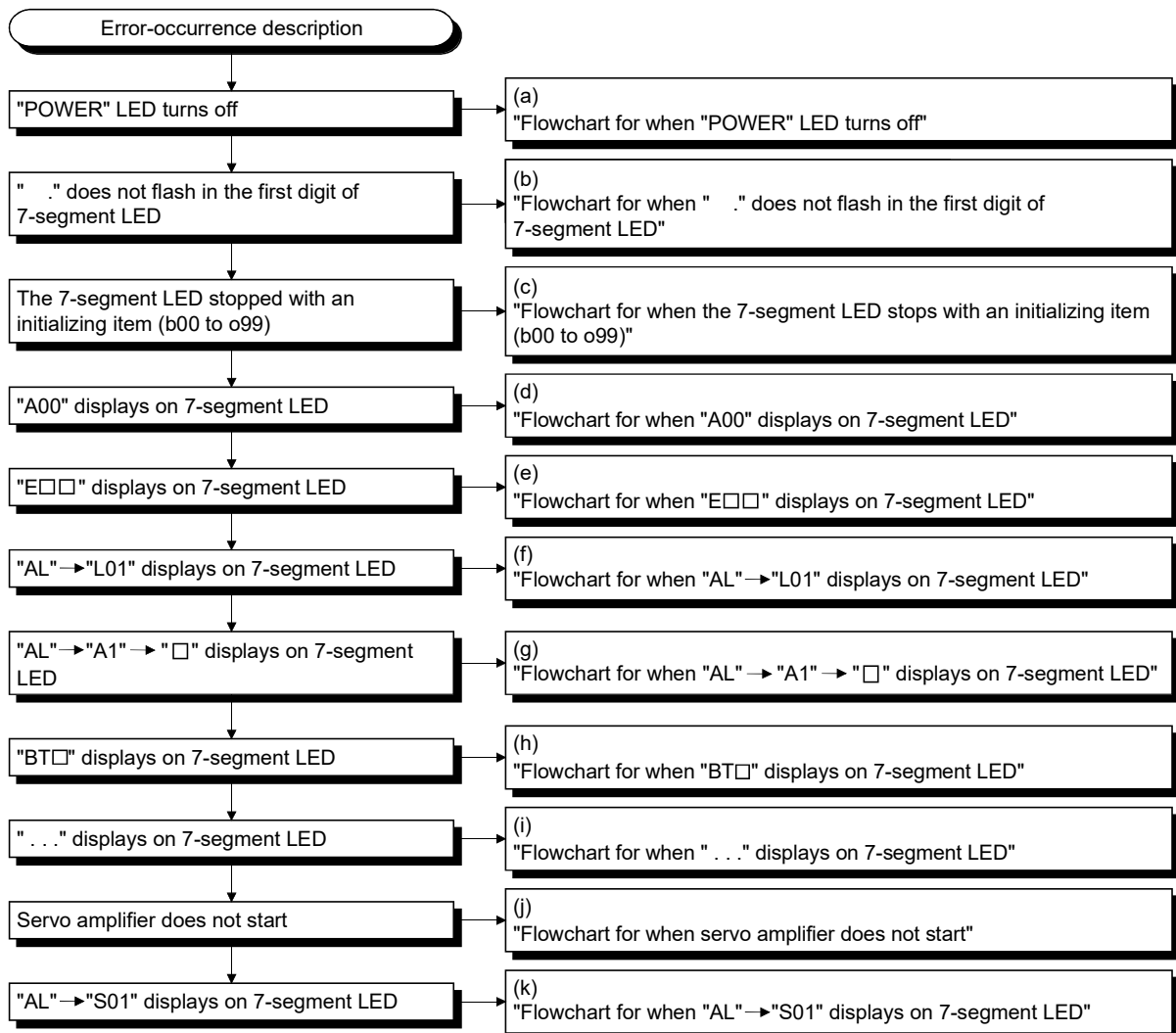

(a) Flowchart for when "POWER" LED turns off

The following shows the flowchart for when "POWER" LED of the power supply module turns off at the power supply ON or during operation.

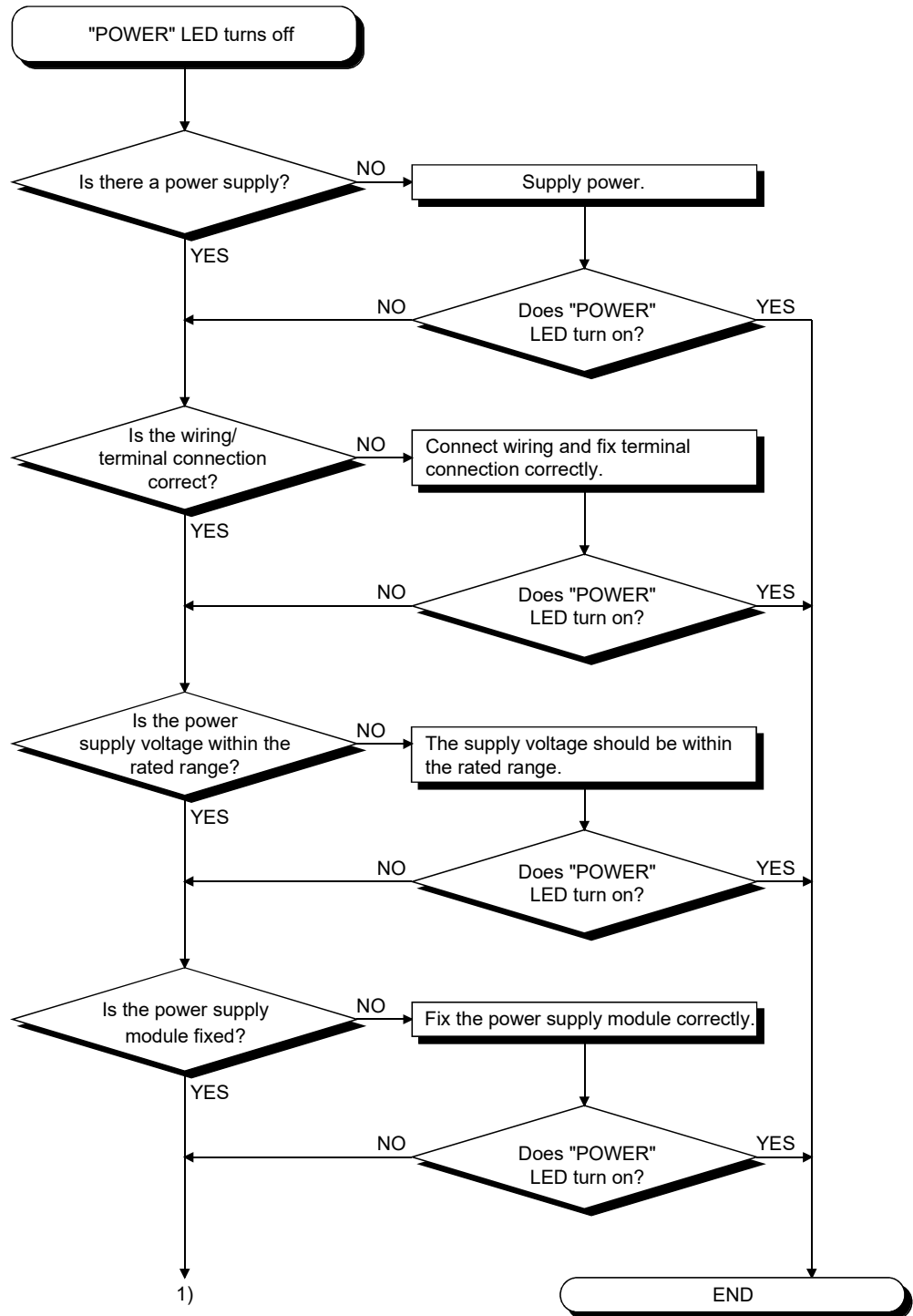

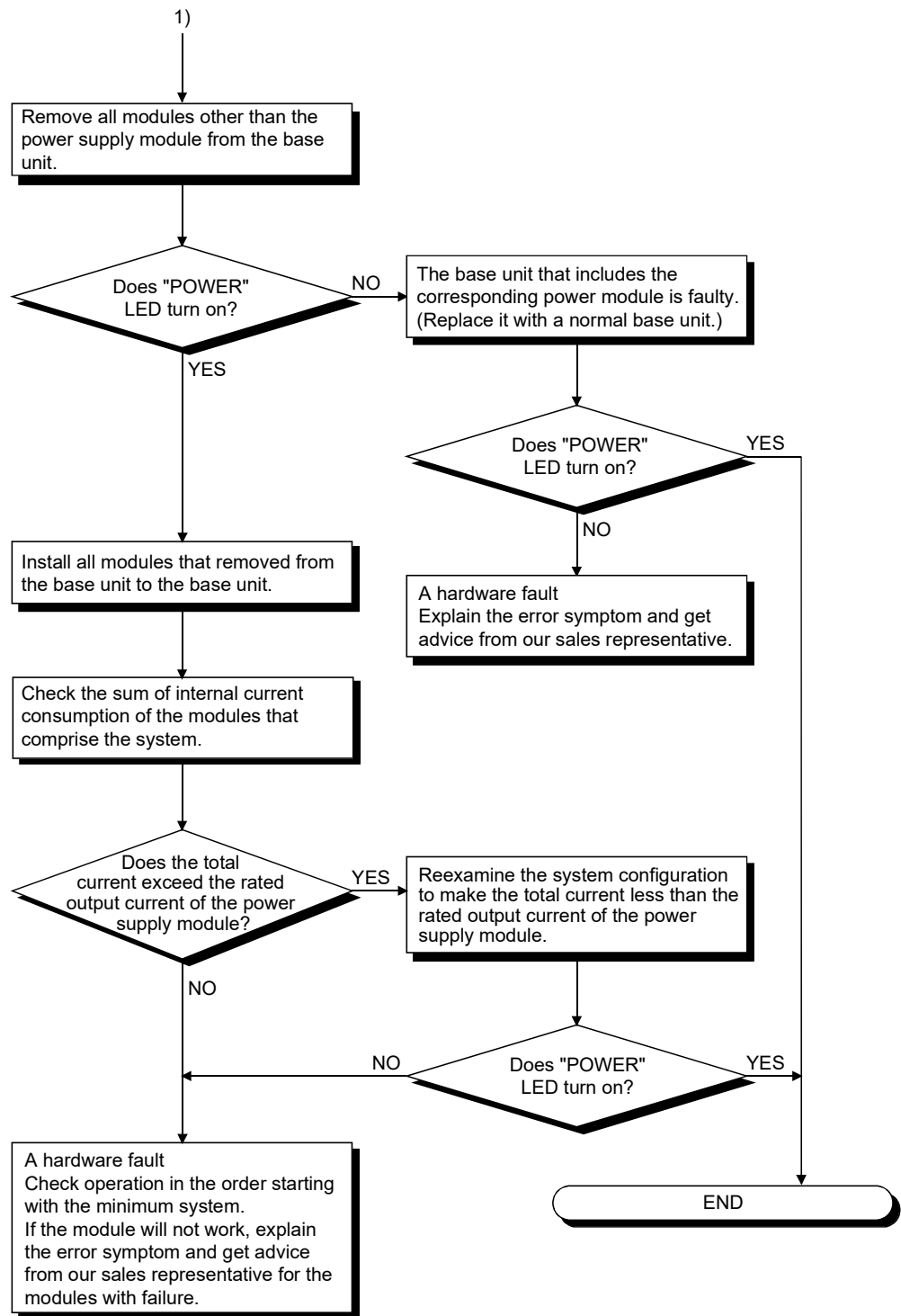

(b) Flowchart for when "." does not flash in the first digit of 7-segment LED

The following shows the flowchart for when "." does not flash in the first digit of 7-segment LED.

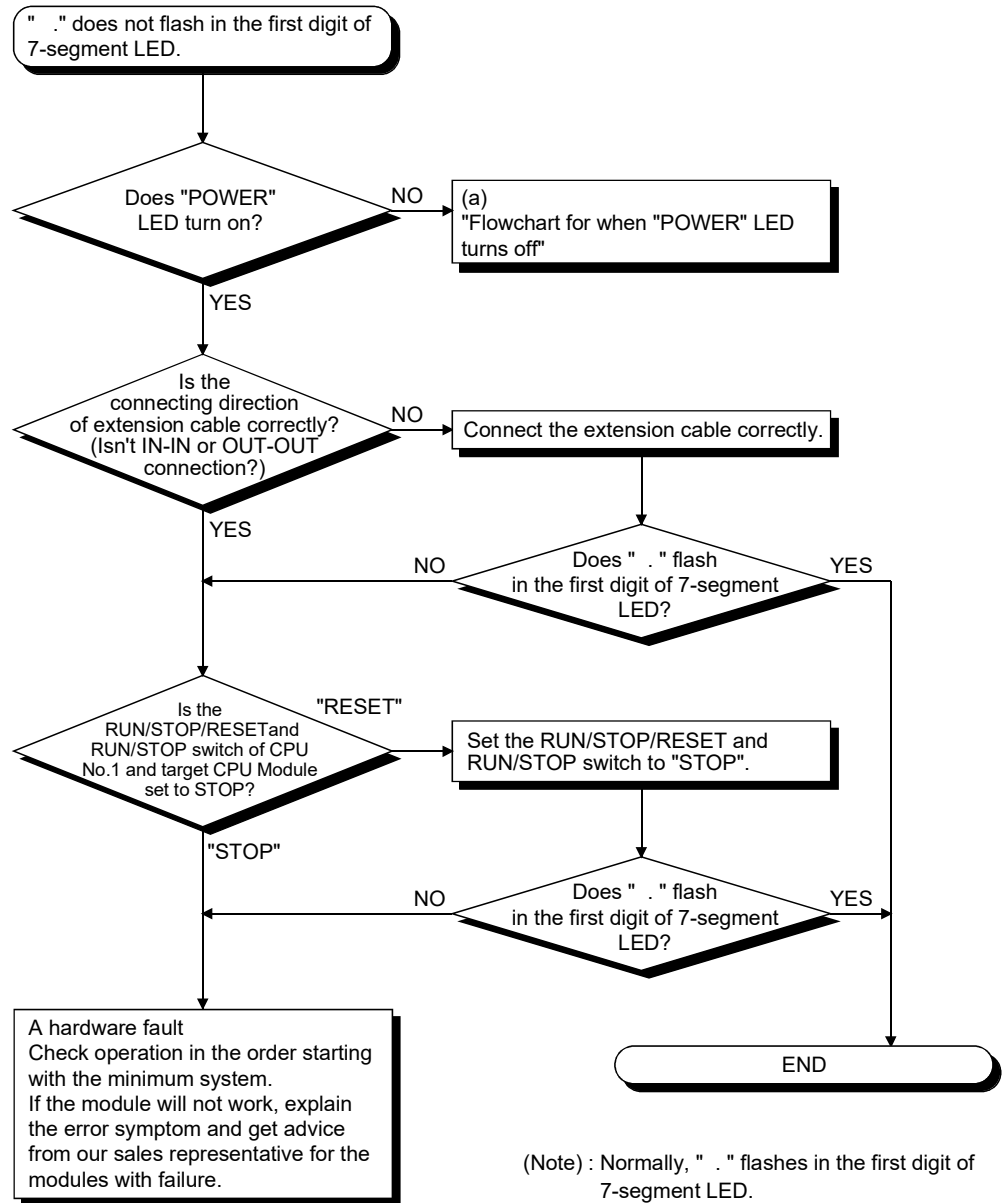

(c) Flowchart for when the 7-segment LED stops with an initializing item (b00 to o99)

The following shows the flowchart for when the 7-segment LED stops with an initializing item (b00 to o99).

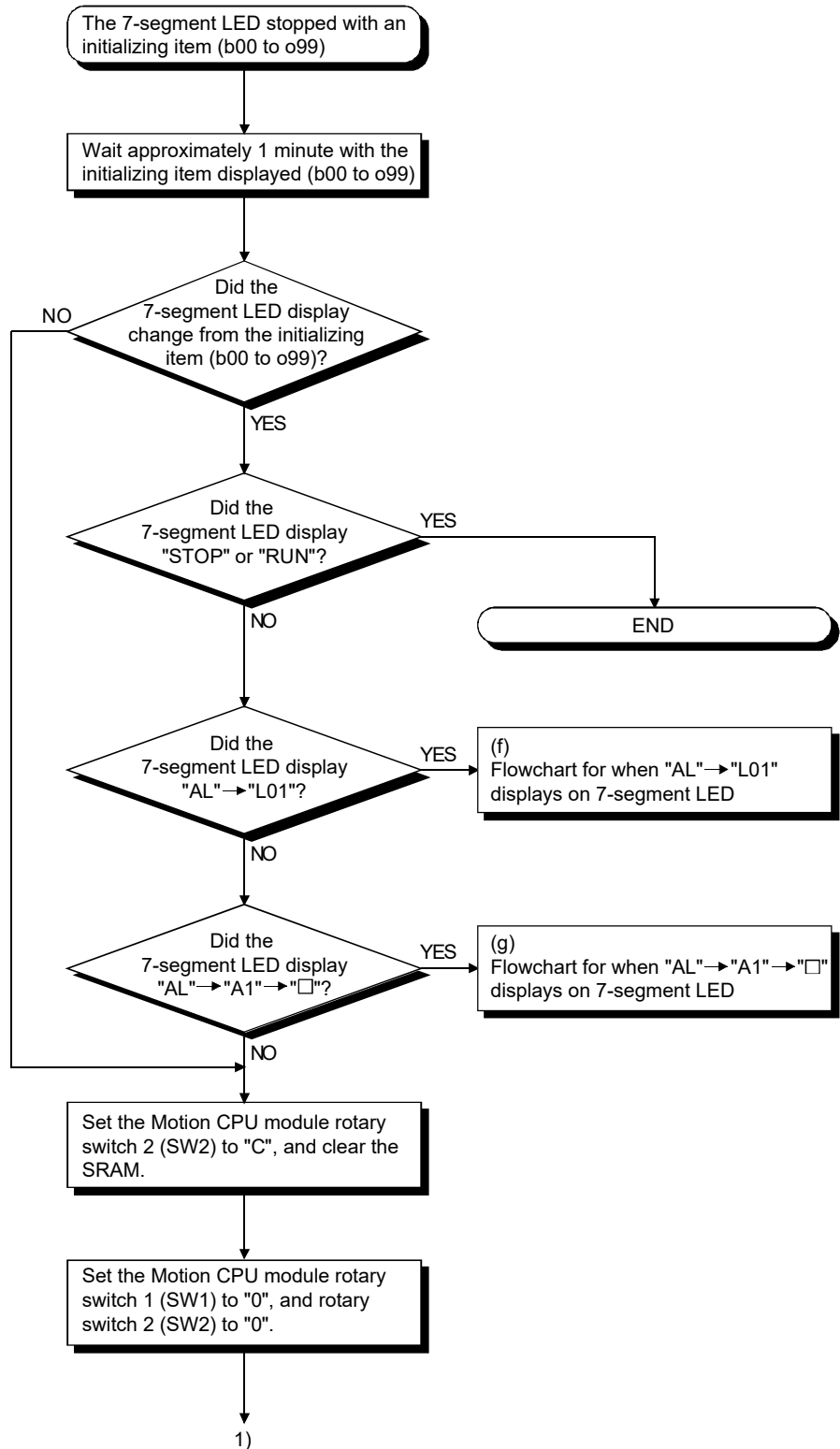

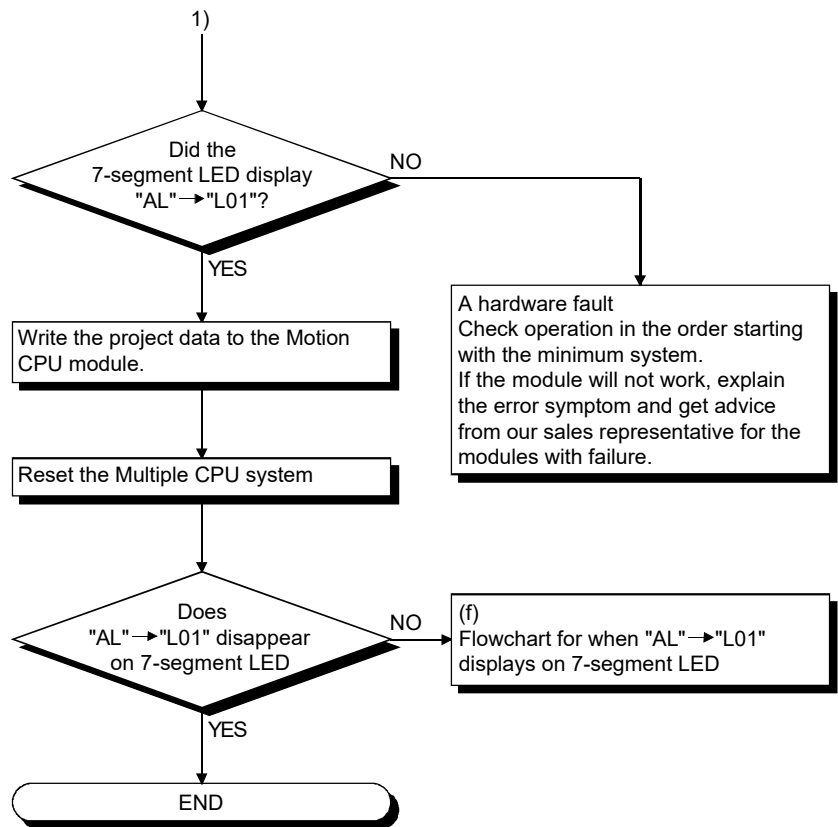

(d) Flowchart for when "A00" displays on 7-segment LED

"A00" displays when the operating system software is not installed.
The following shows the flowchart for when "A00" displays on 7-segment LED at the power supply ON or operation start.

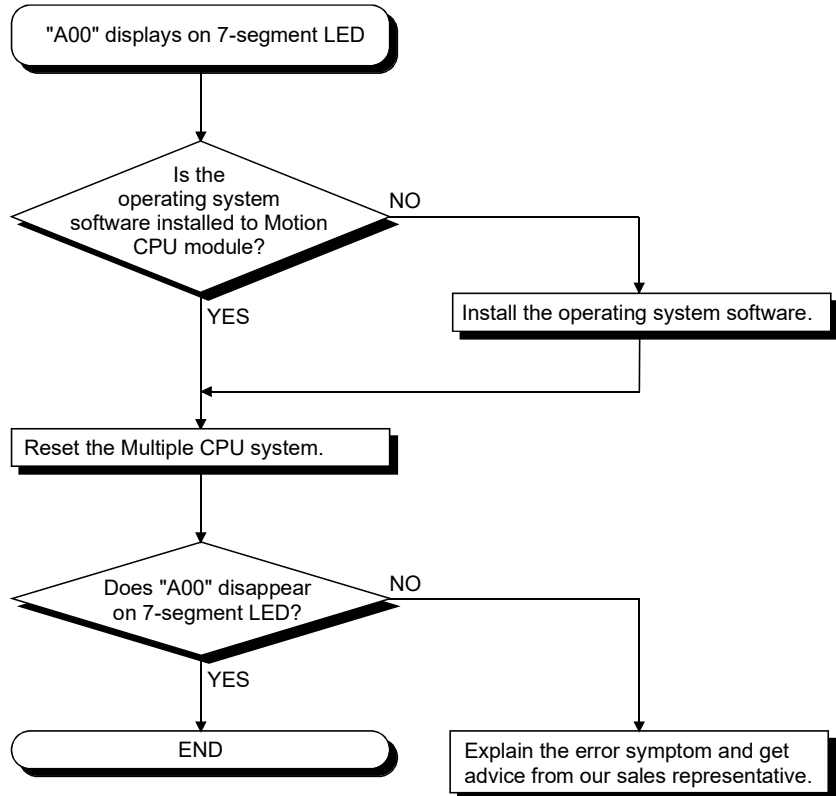

(e) Flowchart for when "E□□" displays on 7-segment LED

"E□□" displays when a hardware fault or software fault occurs.

The following shows the flowchart for when "E□□" displays on 7-segment LED at the power supply ON or operation start.

"□" indicates the error code.

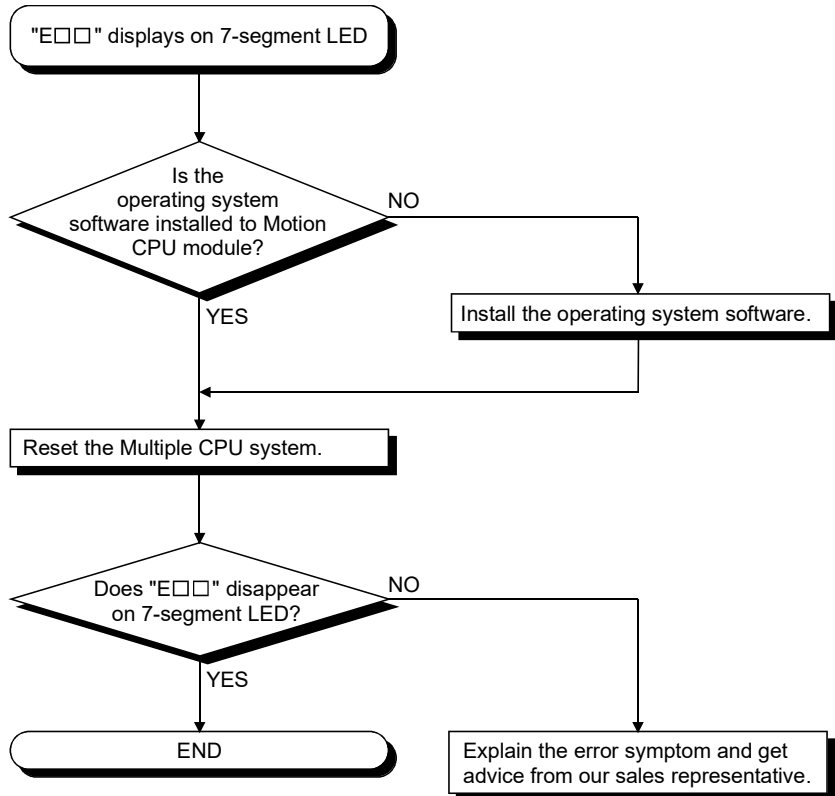

(f) Flowchart for when "AL" → "L01" displays on 7-segment LED

"AL" (flashes 3 times) → Steady "L01" display" displays at the system setting error occurrence.

The following shows the flowchart for when ""AL" (flashes 3 times) → Steady "L01" display" displays during operation.

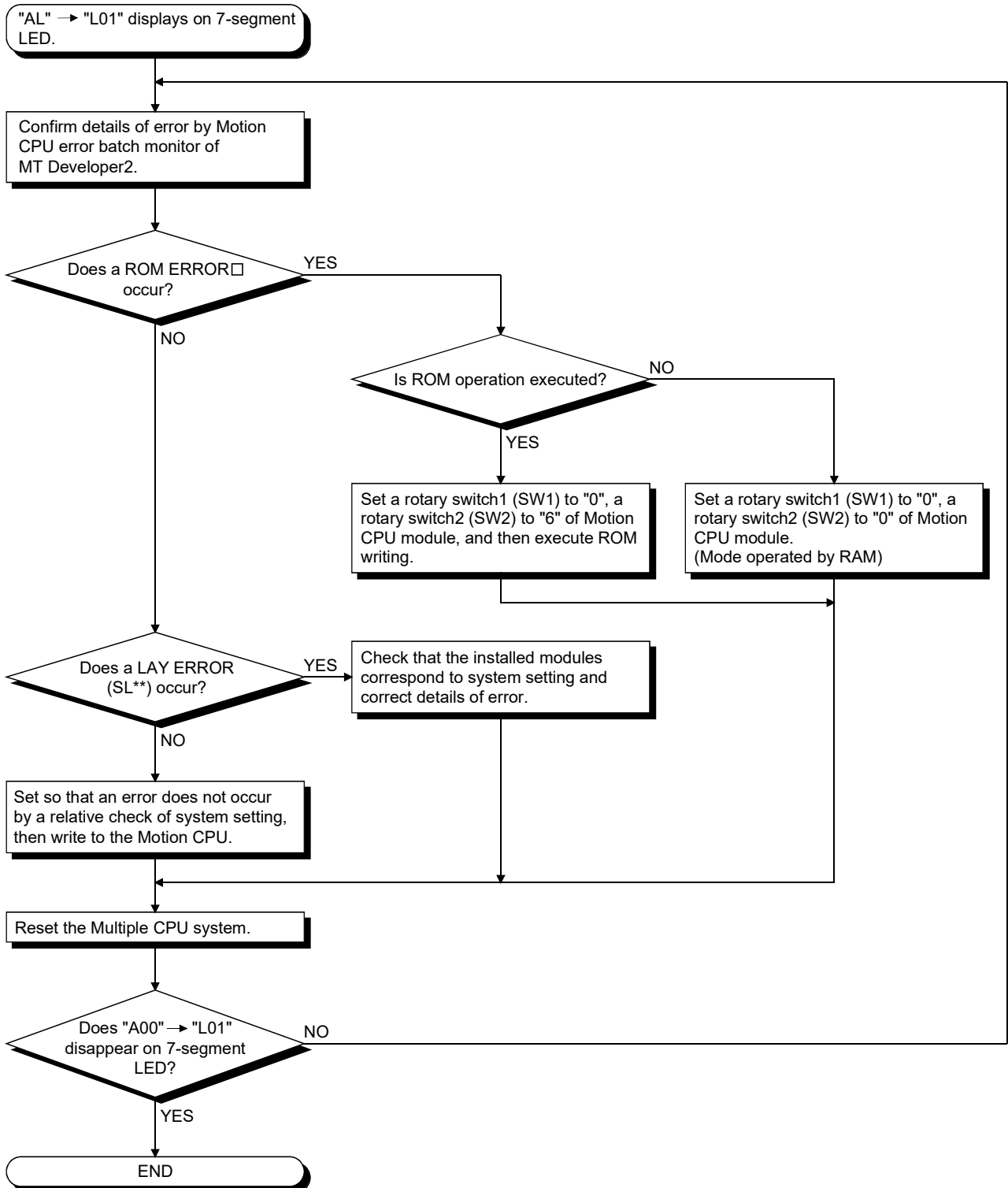

(g) Flowchart for when "AL" → "A1" → "□" displays on 7-segment LED.

"AL" (flashes 3 times) → Steady "A1" display → "□" displays at the self-diagnosis error occurrence.

The following shows the flowchart for when "AL" (flashes 3 times) → Steady "A1" display → "□" displays during operation.

□: 4-digits error code is displayed in two sequential flashes of 2-digits each.

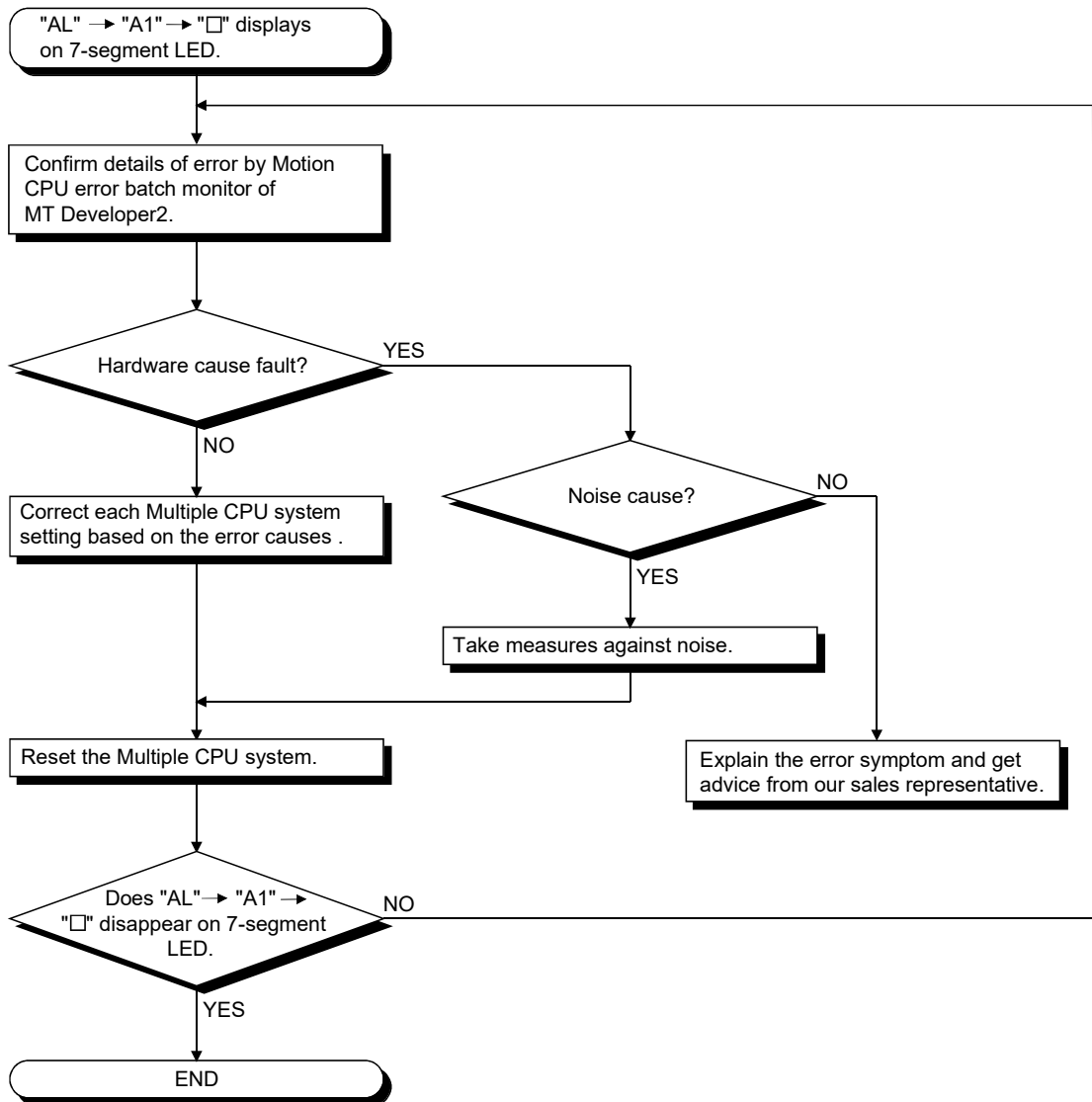

(h) Flowchart for when "BT□" displays on 7-segment LED

"BT1" or "BT2" displays when the battery voltage is lowered.

"BT1" or "BT2" displays at the following cases.

- BT1: Battery voltage 2.7V or less
- BT2: Battery voltage 2.5V or less

The following shows the flowchart for when "BT1" or "BT2" displays on 7-segment LED.

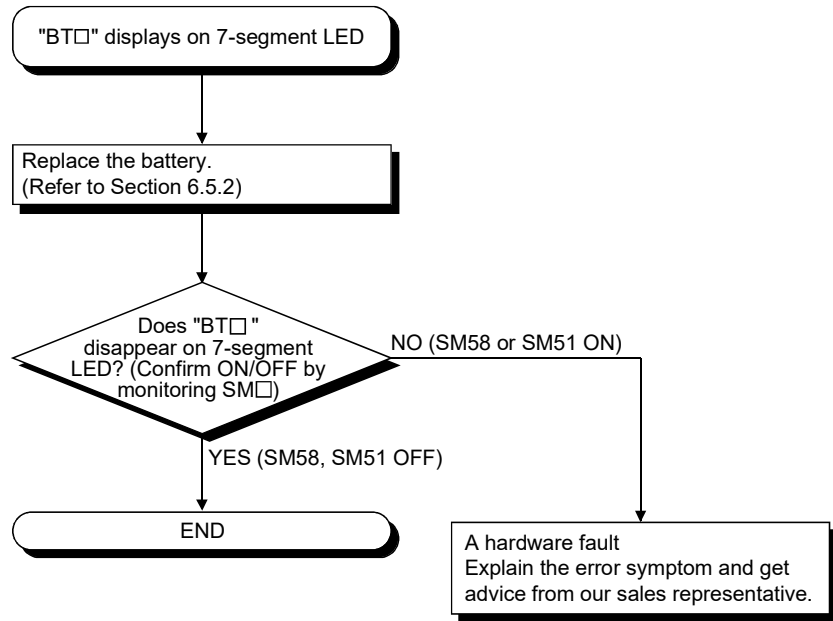

REMARK

If SM51, SM58 turns on, the contents of the programs, parameters, motion device(#), latch range device and absolute position data cannot be guaranteed. It is recommended to back-up the data periodically.

(i) Flowchart for when ". . ." displays on 7-segment LED

". . ." displays at the WDT error occurrence.

The following shows the flowchart for when ". . ." displays on 7-segment LED during operation.

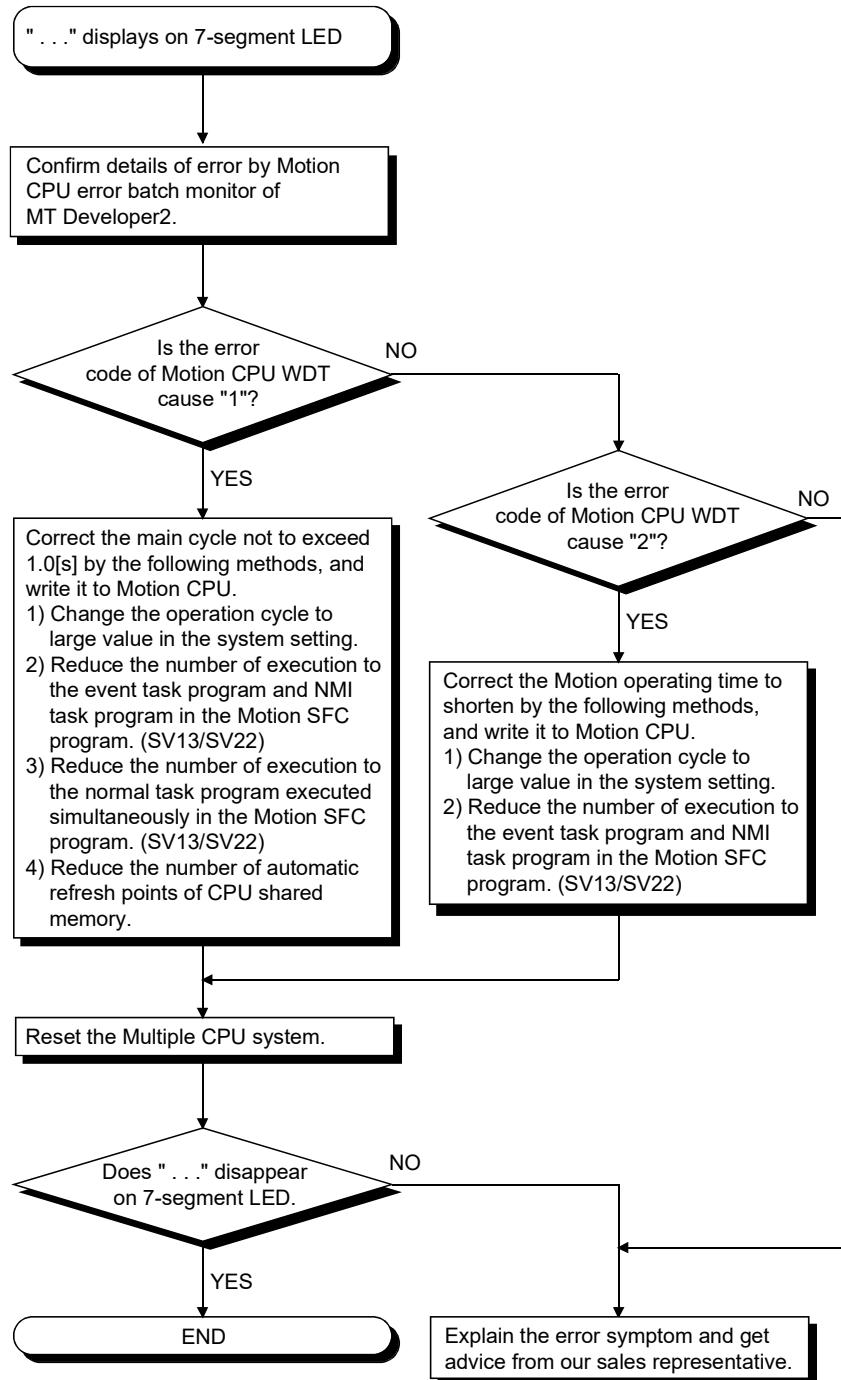

(j) Flowchart for when servo amplifier does not start

The following shows the flowchart for when servo amplifier does not start.

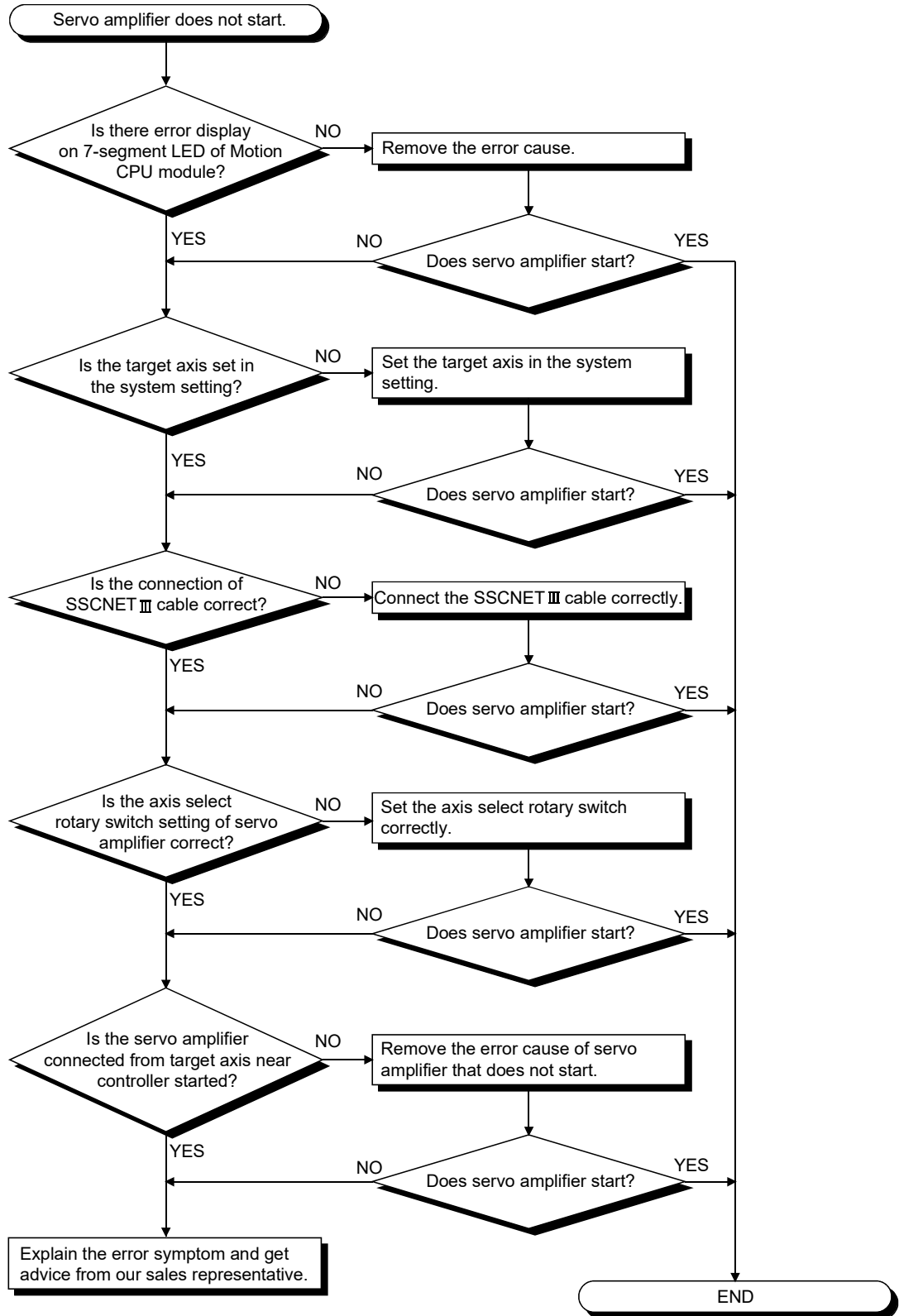

(k) Flowchart for when "AL" → "S01" displays on 7-segment LED

"AL" (flashes 3 times) → Steady "S01" display" displays at the servo error occurrence.

The following shows the flowchart for when ""AL" (flashes 3 times) → Steady "S01" display" displays on 7-segment LED during operation.

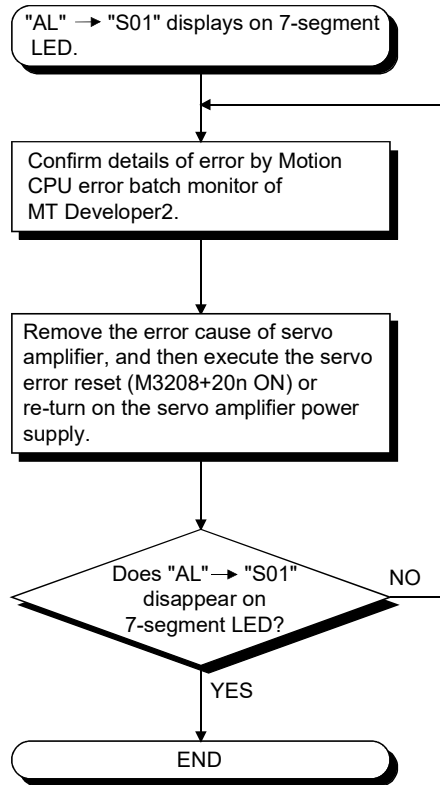

6.6.3 Confirming error code

The error codes and error contents can be read using MT Developer2. Refer to help of MT Developer2 for details of operating method.

6.6.4 Internal input circuit troubleshooting **QDS**

This section describes possible problems with internal input circuits and their corrective actions.

(1) Internal input circuit troubleshooting

The following describes possible problems with internal input circuits and their corrective actions.

Table 6.4 Internal Input Circuit Troubleshooting and Corrective Action

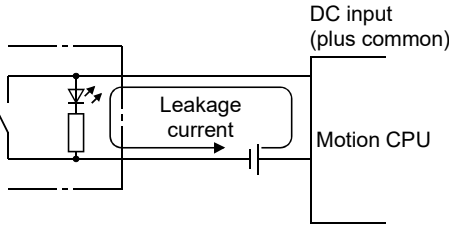
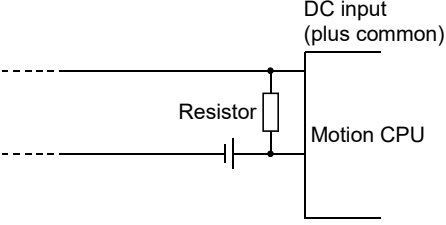
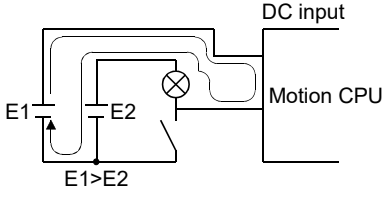
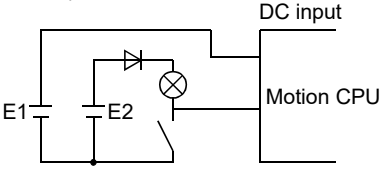
Condition	Cause	Corrective action
<p>Example 1</p> <p>Internal input signal is not turned OFF.</p>	<ul style="list-style-type: none"> Drive by switch with LED indicator. 	<ul style="list-style-type: none"> Connect an appropriate resistor so that the current across the Motion CPU becomes lower than the off current.  <p>(Note): A calculation example of the resistance to be connected is shown below.</p>
<p>Example 2</p> <p>Internal input signal is not turned OFF.</p>	<ul style="list-style-type: none"> Sneak path due to the use of two power supplies. 	<ul style="list-style-type: none"> Use only one power supply. Connect a sneak path prevention diode. <p>(Figure below)</p> 

<Calculation example of Example 1>

If a switch with LED display is connected to Motion CPU, and current of 4 [mA] is leaked.

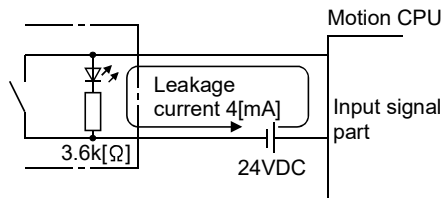

(a) Because the condition for OFF voltage (0.9[mA]) of Motion CPU is not satisfied. Connect a resistor as shown below.

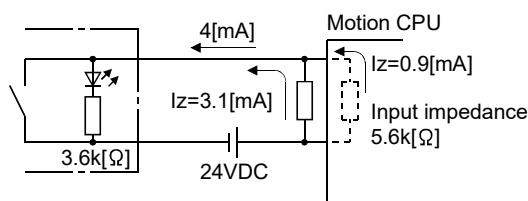

- (b) Calculate the connecting resistor value R as indicated below.
To satisfy the 0.9 [mA] OFF current of the Motion CPU, the resistor R to be connected may be the one where 3.1 [mA] or more will flow.

IR: $I_z = Z(\text{Input impedance}) \cdot R$

$$R \leq \frac{I_z}{I_R} \times Z(\text{Input impedance}) = \frac{0.9}{3.1} \times 5.6 \times 10^3 = 1625[\Omega]$$

$$R < 1625 [\Omega]$$

Assuming that resistor R is 1500 [Ω], the power capacity W of resistor R is:

$$W = (\text{Input voltage})^2 \div R = 26.4^2 \div 1500 = 0.464 [\text{W}]$$

- (c) The power capacity of the resistor selected is 3 to 5 times greater than the actual current consumption. 1.5k [Ω], 2 to 3 [W] resistor may therefore be connected to the terminal in question.

MEMO

7. EMC DIRECTIVES

Compliance to the EMC Directive, which is one of the EU Directives, has been a legal obligation for the products sold in European countries since 1996 as well as the Low Voltage Directive since 1997.

Manufacturers who recognize their products are compliant to the EMC and Low Voltage Directives are required to declare that and print a "CE mark" on their products.

(1) Authorized representative in Europe

Authorized representative in Europe is shown below.

Name : Mitsubishi Electric Europe B.V.

Address: Gothaer strase 8, 40880 Ratingen, Germany

7.1 Requirements for Compliance with the EMC Directive

The EMC Directive specifies that products placed on the market must be so constructed that they "do not cause excessive electromagnetic interference (emissions)" and "are not unduly affected by electromagnetic interference (immunity)". Section 7.1.1 through Section 7.1.4 summarize the precautions on compliance with the EMC Directive of the machinery constructed with the Motion controllers.

These precautions are based on the requirements and the standards of the regulation, however, it does not guarantee that the entire machinery constructed according to the descriptions will comply with above-mentioned directive. The method and judgement for complying with the EMC Directive must be determined by the person who constructs the entire machinery.

7 EMC DIRECTIVES

7.1.1 Standards relevant to the EMC directive

The standards relevant to the EMC Directive are listed in table below.

Certification	Test item	Test details	Standard value
EN61000-6-4:2007 EN61131-2:2007	EN55011:2007/A2:2007 Radiated emission ^(Note-1)	Radio waves from the product are measured.	30M-230MHz QP ^(Note-2) : 40dB μ V/m (10m (32.81ft.) in measurement range) 230M-1000MHz QP: 47dB μ V/m (10m (32.81ft.) in measurement range)
	EN55011:2007/A2:2007 ^(Note-3) (Power line) EN55022:2006/A1:2007 ^(Note-4) (Electrical communication port) Conducted emission	Noise from the product to the power line and electrical communication port is measured.	AC power line 0.15M-0.5MHz QP : 79dB μ V AV ^(Note-5) : 66dB μ V 0.5M-30MHz QP: 73dB μ V AV: 60dB μ V Electrical communication port 0.15M-0.5MHz QP, AV: Logarithmic decrease 0.5M-30MHz QP: 87dB μ V AV: 74dB μ V
EN61000-6-2:2005 EN61131-2:2007	EN61000-4-2:1995 +A1:1998+A2:2001 Electrostatic discharge immunity	Immunity test in which electrostatic discharge is applied to the product.	8kV: 10 times at 1 second interval, Air discharge 4kV: 10 times at 1 second interval, Contact discharge
	EN61000-4-3:2006 Radiated immunity ^(Note-1)	Immunity test in which electric fields are radiated to the product.	80-1000MHz 10V/m, 1400M-2000MHz 3V/m, 2000M-2700MHz 1V/m, 80%AM modulation @1kHz
	EN61000-4-4:2004 Electrical fast transient/ burst (EFT/B) immunity	Immunity test in which burst noise is applied to the power cable and signal line.	AC power line : ± 2 kV/5kHz DC power line : ± 2 kV/5kHz I/O, communication line : ± 1 kV/5kHz
	EN61000-4-5:2006 Surge immunity	Immunity test in which surge is applied to the power line and signal line.	AC power line Common mode: ± 2.5 kV Differential mode: ± 1.5 kV DC power line Common mode: ± 0.5 kV Differential mode: ± 0.5 kV I/O, communication line Common mode: ± 1 kV
	EN61000-4-6:2007 +A:2001 Conducted immunity	Immunity test in which high frequency noise is applied to the power line and signal line.	0.15-80MHz, 80%AM modulation @1kHz, 10Vrms
	EN61000-4-11:2004 ^(Note-3) Short interruptions immunity	Immunity test in which power supply has short interruptions.	0% of rated voltage, 250cycle
	EN61000-4-11:2004 ^(Note-3) Voltage dip	Test in which voltage dip is applied to the power supply.	40% of rated voltage, 10cycle 70% of rated voltage, 25cycle
EN61131-2:2007	EN61131-2:2007 ^(Note-3) Voltage dip immunity	Immunity test in which voltage dip is applied to the power supply.	0% of rated voltage, 0.5cycle 20 times

(Note-1): This product is an open type device (a device designed to be housed inside other equipment) and must be installed inside a conductive control panel.

The corresponding test has been done with the programmable controller installed inside a control panel.

(Note-2): QP : Quasi-peak value

(Note-3): For the AC power supply line.

(Note-4): For the electrical communication port.

(Note-5): AV: Average value

7.1.2 Installation instructions for EMC directive

(1) Installation

Motion controller is an open type device and must be installed inside a control panel for use.

This not only ensures safety but also ensures effective shielding of Motion controller-generated electromagnetic noise.

(a) Control panel

- 1) Use a conductive control panel.
- 2) When attaching the control panel's top plate or base plate, expose bare metal surface and weld so that good surface contact can be made between the panel and plate.
- 3) To ensure good electrical contact with the control panel, mask the paint on the installation bolts of the inner plate in the control panel so that contact between surfaces can be ensured over the widest possible area.
- 4) Ground the control panel with a thick wire so that a low impedance connection to ground can be ensured even at high frequencies.
- 5) Holes made in the control panel must be 10cm (3.94inch) diameter or less. If the holes are 10cm (3.94 inch) or larger, radio frequency noise may be emitted.

In addition, because radio waves leak through a clearance between the control panel door and the main unit, reduce the clearance as much as practicable.

The leakage of radio waves can be suppressed by the direct application of an EMI gasket on the paint surface.

(2) Connection of power line and ground wire

It is necessary to use the Motion controller grounding terminal only when it is in the grounded condition. Be sure to ground the grounding for the safety reasons and EMC Directives.

Ground wire and power supply cable for the Motion controller system must be connected as described below.

- (a) Provide a grounding point near the FG terminals. Ground the FG terminals (FG : Frame Ground) with the thickest and shortest wire possible. (The wire length must be 30cm (11.81inch) or shorter.) The FG terminals function is to pass the noise generated in the Motion controller system to the ground, so wire the ground wire as short as possible to ensure a low impedance. The wire itself carries a large noise content and thus short wiring means that the wire is prevented from acting (noise emission) as an antenna.

(3) Cables

The cables extracted from the control panel contain a high frequency noise component. On the outside of the control panel, therefore, they serve as antennas to emit noise. To prevent noise emission, use shielded cables for the cables which are connected to the I/O modules and intelligent function modules and may be extracted to the outside of the control panel.

The use of a shielded cable also increases noise resistance.

The signal lines (including common line) of the programmable controller, which are connected to I/O modules, intelligent function modules and/or extension cables, have noise durability in the condition of grounding their shields by using the shielded cables. If a shielded cable is not used or not grounded correctly, the noise resistance will not meet the specified requirements.

(a) Grounding of shield section of shield cable

- 1) Ground the exposed shield section of the shielded cable close to the module. When the grounded cables and the not yet grounded cables are bundled, the cables might be induced to electromagnetic.
- 2) Ground the exposed shield section to spacious area on the control panel. A clamp can be used as shown in Figure 7.2.

In this case, mask the inner wall surface when coating the control panel, and contact the exposed shield section with the clamp at the exposed bare metal surface.

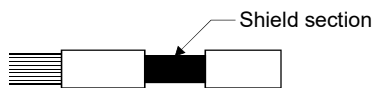

Figure 7.1 Part to be exposed

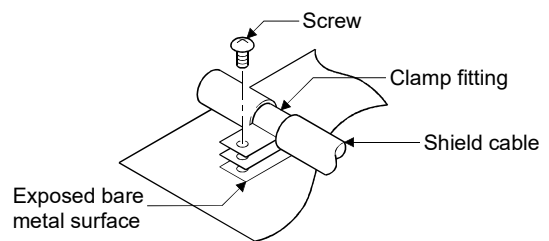

Figure 7.2 Shield grounding (Correct example)

Note) The method of grounding with a vinyl-coated wire soldered onto the shielded section of the shielded cable as in shown Figure 7.3 is not recommended. Doing so will raise the high-frequency impedance, resulting in loss of the shielding effect.

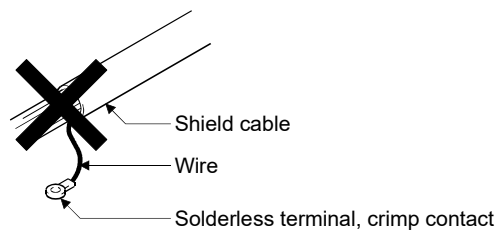

Figure 7.3 Shield grounding (Incorrect example)

(4) Precautions relevant to the electrostatic discharge

There is a weak part to electrostatic discharge in the surface of the module. Before touching the module, always touch grounded metal, etc. to discharge static electricity from human body. Failure to do so may cause the module to fail or malfunction.

Do not directly touch the module's conductive parts and electronic components. Touching them could cause an operation failure or damage the module.

7.1.3 Parts of measure against noise

(1) Ferrite core

A ferrite core has the effect of reducing noise in the 30MHz to 100MHz band. It is not required to fit ferrite cores to cables, but it is recommended to fit ferrite cores if shield cables pulled out of the enclosure do not provide sufficient shielding effects.

Note that the ferrite cores must be fitted to the cables in the position immediately before they are pulled out of the enclosure. If the fitting position is improper, the ferrite will not produce any effect.

- Ferrite core (Recommended product)

Manufacturer	Model name
TDK	ZCAT3035-1330

(2) Noise filter (power supply line filter)

A noise filter is a component which has an effect on conducted noise. The attachment of the noise filter to the power supply line of the servo amplifier and Multiple CPU system's power supply is effective for the reducing noise. (The noise filter has the effect of reducing conducted noise of 10 MHz or less.)

- Noise ferrite (Recommended product)

Manufacturer	Model name
Mitsubishi Electric	FR-BLF
Soshin Electric	HF3010A-UN

The precautions required when installing a noise filter are described below.

- (a) Do not bundle the wires on the input side and output side of the noise filter. When bundled, the output side noise will be induced into the input side wires from which the noise was filtered.

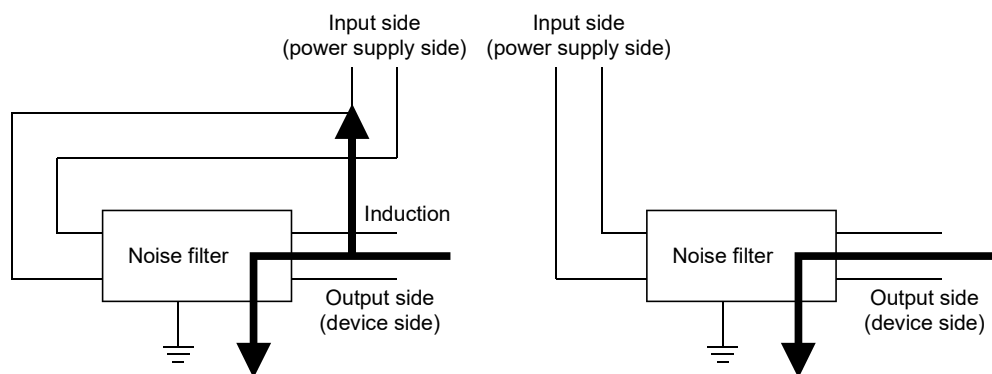

The noise will be included when the input and output wires are bundled.

Separate and lay the input and output wires.

Figure 7.4 Precautions on noise filter

- (b) Ground the noise filter grounding terminal to the control cabinet with the shortest wire possible (approx. 10cm (3.94 inch)).

(3) Cable clamp

It is also possible to ground the exposed shielded part of the cable to the panel with the cable clamp.

- Ground the shield at a position 20 to 30cm (7.87 to 11.81 inch) away from the module.
- When the cables pulled out from the control panel, ground the cables at a position 5 to 10cm (1.97 to 3.94inch) away from the input/output hole of the control panel with the cable clamp (AD75CK), etc.

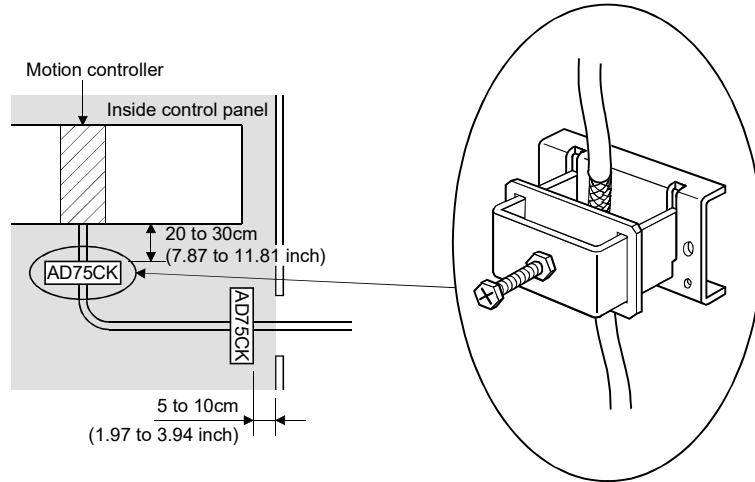

- Cable clamp (Recommended product)

Manufacturer	Model name
Mitsubishi Electric	AERSBAN-DSET
	AERSBAN-ESET
	AD75CK

⚠ CAUTION

- Do not ground the cable clamp to the top of control panel. Doing so may lead to damage by drop of screws, etc. during installation or removing the cable clamp.

7 EMC DIRECTIVES

7.1.4 Example of measure against noise

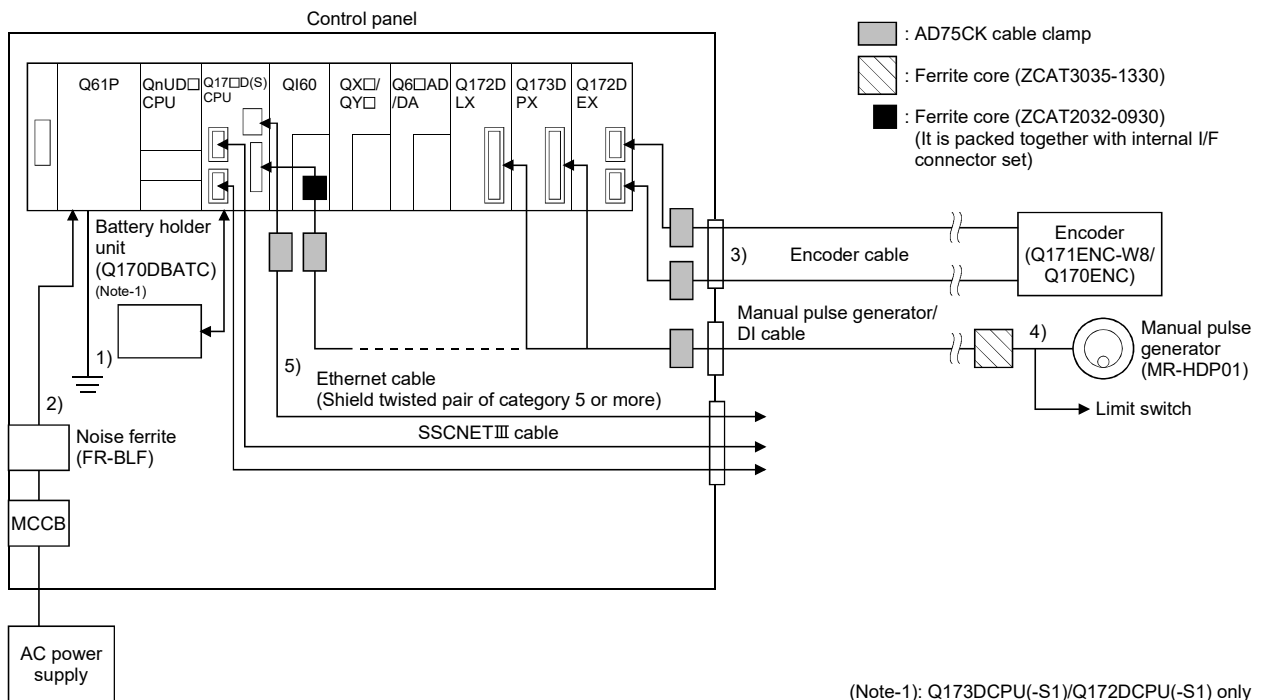

- 1) Ground the FG terminal of the Motion controller and 24VDC power supply module to the control panel.
- 2) Measure against noise of the power supply cable
 - Wire the power supply cable as short as possible using the twisted cable.
 - Set a line filter (FR-BLF) near the exit/entrance of control panel and in secondary side of MCCB. (Approx. 4 turn)
- 3) Measure against noise of the encoder cable
 - When the cables are extracted from the control panel, ground the cables at a position 5 to 10cm (1.97 to 3.94inch) away from the exit/entrance of the control panel with the cable clamp, etc.
 - Refer to the Section 2.5.5 and Appendix 1.2 for encoder cable.
 - Use shielded twisted pair cable.
- 4) Measure against noise of the manual pulse generator/external signal input cable
 - When the cables are extracted from the control panel, ground the cables at a position 5 to 10cm (1.97 to 3.94inch) away from the exit/entrance of the control panel with the cable clamp, etc.
 - Refer to the Section 2.5.6 for manual pulse generator.
 - Use shielded twisted pair cable.
 - Refer to the Section 2.5.4 for external signal input.
 - Use shielded twisted pair cable between the external signal and COM signal.
 - When the cables are connected to internal I/F connector of Q173DSCPU/Q172DSCPU and extracted from the control panel, ground the cables at a position 20 to 30cm (1.97 to 3.94inch) away from the module with the cable clamp, etc. Use a shielded cable.
 - Refer to the Section 2.5.1 and Appendix 1.5 for internal I/F connector cable.
- 5) Measure against noise of the internal I/F cable
 - When the cables are extracted from the control panel, ground the cables at a position 20 to 30cm (1.97 to 3.94inch) away from the module with the cable clamp, etc. Use a shielded cable.

(1) Refer to Section 2 for the following cables.

- Ethernet cable
- USB cable
- SSCNET III cable
- Battery cable
- Forced stop input cable

- (2) In wiring inside the panel, the power line connected to the power or servo amplifier and the communication cable such as bus connection cable or network cable must not be mixed. If the cables are installed closely with each other for wiring reasons, using a separator (made of metal) can make the cables less influenced by noise.
Mixing the power line and communication cable may cause malfunction due to noise.

APPENDICES

APPENDIX 1 Cables

In this cable connection diagram, maker names of connectors are omitted.
Refer to "APPENDIX 2.8 Connector" for maker names of connectors.

APPENDIX 1.1 SSCNET III cables

Generally use the SSCNET III cables available as our products.
Refer to APPENDIX 1.7 for long distance cable up to 100(328.08)[m(ft.)] and ultra-long bending life cable.

(1) Model explanation

Numeral in the column of cable length on the table is a symbol put in the "□" part of cable model. Cables of which symbol exists are available.

Cable model	Cable length [m(ft.)]										Bending life	Application/remark	
	0.15 (0.49)	0.3 (0.98)	0.5 (1.64)	1 (3.28)	3 (9.84)	5 (16.40)	10 (32.81)	20 (65.62)	30 (98.43)	40 (131.23)			50 (164.04)
MR-J3BUS□M	015	03	05	1	3	/	/	/	/	/	/	Standard	Standard cord for inside panel
MR-J3BUS□M-A	/	/	/	/	/	5	10	20	/	/	/	Standard	Standard cable for outside panel
MR-J3BUS□M-B (Note-1)	/	/	/	/	/	/	/	/	30	40	50	Long bending life	Long distance cable

(Note-1) : For the cable of less than 30[m(98.43ft.)], contact your nearest Mitsubishi Electric sales representative.

(2) Specifications

		Description				
SSCNET III cable model		MR-J3BUS□M		MR-J3BUS□M-A	MR-J3BUS□M-B	
SSCNET III cable length [m(ft.)]		0.15 (0.49)	0.3 to 3 (0.98 to 9.84)	5 to 20 (16.40 to 65.62)	30 to 50 (98.43 to 164.04)	
Optical cable (Cord)	Minimum bend radius [mm(inch)]	25(0.98)		Enforced covering cord: 50 (1.97) Cord: 25 (0.98)	Enforced covering cord: 50 (1.97) Cord: 30(1.18)	
	Tension strength [N]	70	140	420 (Enforced covering cord)		
	Temperature range for use [°C(°F)] (Note-1)	-40 to 80 (-40 to 176)			-20 to 70 (-4 to 158)	
	Ambient	Indoors (no direct sunlight), No solvent or oil				
	External appearance [mm(inch)]					

(Note-1): This temperature range for use is the value for optical cable (cord) only.

(Note-2): Dimension of connector fiber insert location. The distance of two cords is changed by how to bend it.

App.

POINTS
(1) If the end face of cord tip for the SSCNETⅢ cable is dirty, optical transmission is interrupted and it may cause malfunctions. If it becomes dirty, wipe with a bonded textile, etc. Do not use solvent such as alcohol.
(2) Do not add impossible power to the connector of the SSCNETⅢ cable.
(3) When incinerating the SSCNETⅢ cable (optical fiber), hydrogen fluoride gas or hydrogen chloride gas which is corrosive and harmful may be generated. For disposal of the SSCNETⅢ cable (optical fiber), request for specialized industrial waste disposal services who has incineration facility for disposing hydrogen fluoride gas or hydrogen chloride gas.

(a) MR-J3BUS□M

1) Model explanation

Type: MR-J3BUS□M-*

Symbol	Cable type
None	Standard cord for inside panel
A	Standard cable for outside panel
B	Long distance cable

Symbol	Cable length [m(ft.)]
015	0.15(0.49)
03	0.3(0.98)
05	0.5(1.64)
1	1(3.28)
3	3(9.84)
5	5(16.40)
10	10(32.81)
20	20(65.62)
30	30(98.43)
40	40(131.23)
50	50(164.04)

2) Exterior dimensions

• MR-J3BUS015M

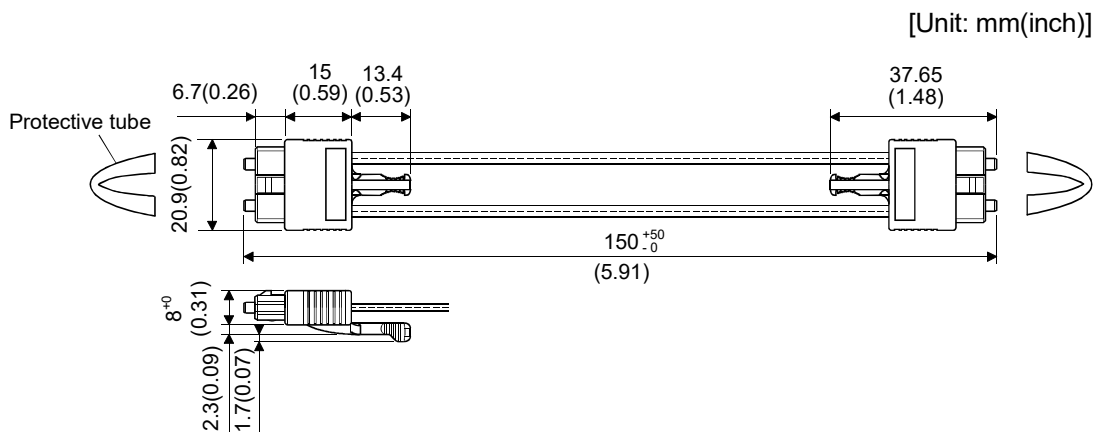

APPENDICES

- MR-J3BUS03M to MR-J3BUS3M

Refer to the table of this section (1) for cable length (L).

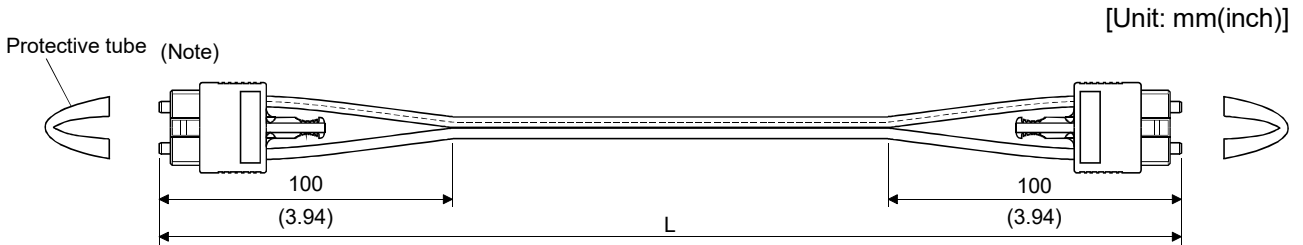

(Note): Dimension of connector part is the same as that of MR-J3BUS015M.

- MR-J3BUS5M-A to MR-J3BUS20M-A, MR-J3BUS30M-B to MR-J3BUS50M-B

Refer to the table of this section (1) for cable length (L).

SSCNET III cable	Variation [mm(inch)]	
	A	B
MR-J3BUS5M-A to MR-J3BUS20M-A	100(3.94)	30(1.18)
MR-J3BUS30M-B to MR-J3BUS50M-B	150(5.91)	50(1.97)

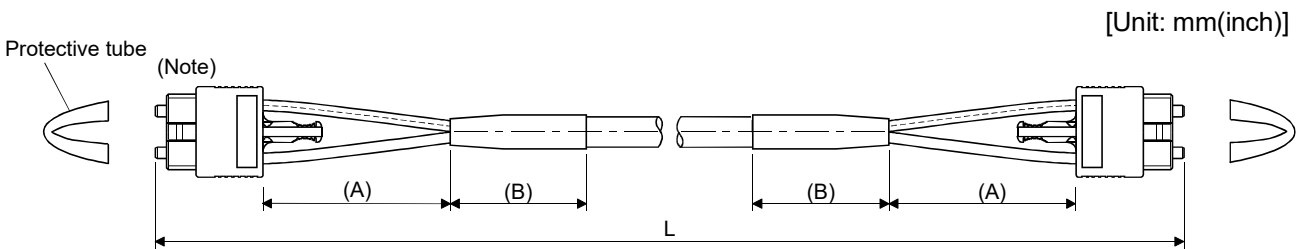

(Note): Dimension of connector part is the same as that of MR-J3BUS015M.

POINTS

Keep the cap and the tube for protecting light cord end of SSCNET III cable in a plastic bag with a zipper of SSCNET III cable to prevent them from becoming dirty.

APPENDIX 1.2 Serial absolute synchronous encoder cable

Generally use the serial absolute synchronous encoder cables available as our products. If the required length is not found in our products, fabricate the cable on the customer side.

(1) Selection

The following table indicates the serial absolute synchronous encoder cables used with the serial absolute synchronous encoder.

Connector sets are also available for your fabrication.

Table 1.1 Encoder cable models

Type	Length [m(ft.)]	Remark
Q170ENCCBL□M	2(6.56), 5(16.40), 10(32.81),	Q171ENC-W8/Q170ENC ↔ Q172DEX
Q170ENCCBL□M-A	20(65.62), 30(98.43), 50(164.04)	Q171ENC-W8 ↔ MR-J4-□B-RJ

Use the following or equivalent twisted pair cables as the serial absolute synchronous encoder cables.

Table 1.2 Connector sets

Connector sets type	Description	Remark
Q170ENCCNS	<ul style="list-style-type: none"> Connector shell kits Plug cable clamp 	Q171ENC-W8/Q170ENC ↔ Q172DEX
MR-J3CN2	<ul style="list-style-type: none"> Servo amplifier connector 	Q171ENC-W8 ↔ MR-J4-□B-RJ

Table 1.3 Wire specifications

Core size [mm ²]	Number of cores	Characteristics of one core			Finished OD [mm (inch)] (Note-2)	Remark
		Structure [Number of wires/mm]	Conductor resistance [Ω/km]	Insulating sheath OD d[mm (inch)] (Note-1)		
0.2	24 (12 pair)	40/0.08	105 or less	0.88 (0.035)	11.0 (0.43)	Q171ENC-W8/Q170ENC ↔ Q172DEX
					9.0 (0.35)	Q171ENC-W8 ↔ MR-J4-□B-RJ

(Note-1): "d" is as shown below.

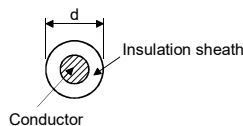

(Note-2): Standard OD (Outside Diameter). Maximum OD is about 10% larger.

⚠ CAUTION

- When fabricating the encoder cable, do not make incorrect connection. Wrong connection will cause runaway or explosion.

(3) Q170ENCCBL□M-A
 (a) Model explanation

Type: Q170ENCCBL□M-A

Symbol	Cable length [m(ft.)]
2	2(6.56)
5	5(16.40)
10	10(32.81)
20	20(65.62)
30	30(98.43)
50	50(164.04)

(b) Connection diagram

When fabricating a cable, use the recommended wire and connector set (MR-J3CN2) for encoder cable given on this section (1), and make the cable as shown in the following connection diagram. Maximum cable length is 50m(164.04ft.).

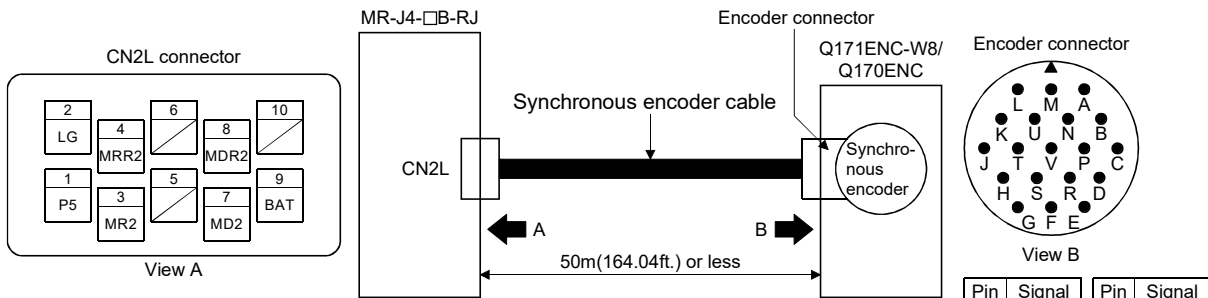

MR-J4-□B-RJ side
 36210-0100PL (plug)
 36310-3200-008(shell)

Encoder side
 D/MS3106B22-14S(plug)
 D/MS3057-12A(cable clamp)

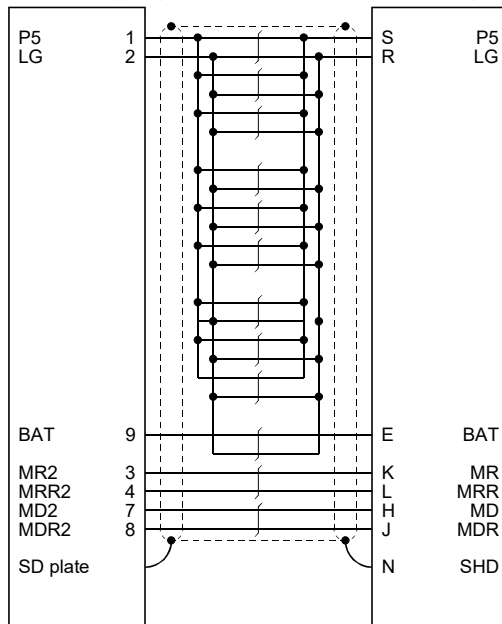

Twisted pair cable
 Cable length 50m(164.04ft.) or less

(Note): Wire the cable as shown in figure below so that twisted pair for signal do not touch.

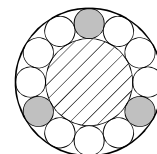

Twisted pair for signal (BAT/LG, MR/MRR, MD/MDR)
 Twisted pair (P5/LG)
 Core

APPENDIX 1.3 Battery cable

Generally use the battery cable available as our products. If the required length is not found in our products, fabricate the cable on the customer side. Make the battery cable within 0.5m(1.64ft.).

(1) Q170DBATCBL□M

(a) Model explanation

Type : Q170DBATCBL□M

Symbol	Cable length [m(ft.)]
05	0.5(1.64)

(b) Connection diagram

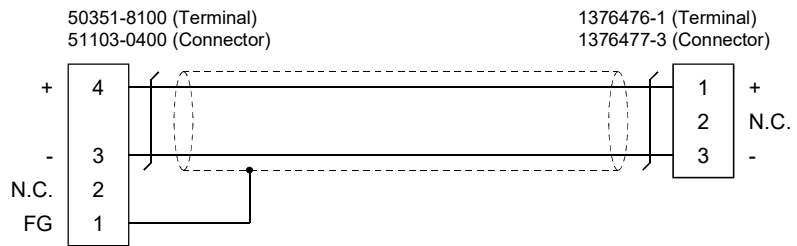
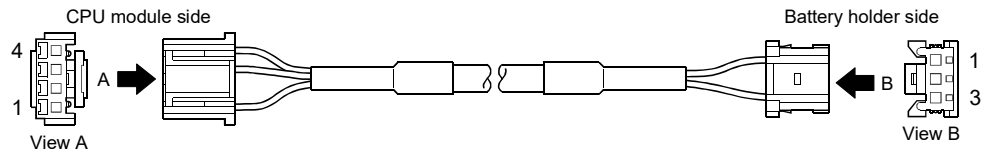

∫ : Twisted pair cable
 (Note) : Use a cable of wire size AWG24.

APPENDIX 1.4 Forced stop input cable

Generally use the forced stop input cable available as our products. If the required length is not found in our products, fabricate the cable on the customer side. Make the forced stop input cable within 30m(98.43ft.).

- (1) Q170DEMICBL□M
 - (a) Model explanation
 - Type : Q170DEMICBL□M

Symbol	Cable length [m(ft.)]
05	0.5(1.64)
1	1(3.28)
3	3(9.84)
5	5(16.40)
10	10(32.81)
15	15(49.21)
20	20(65.62)
25	25(82.02)
30	30(98.43)

(b) Connection diagram

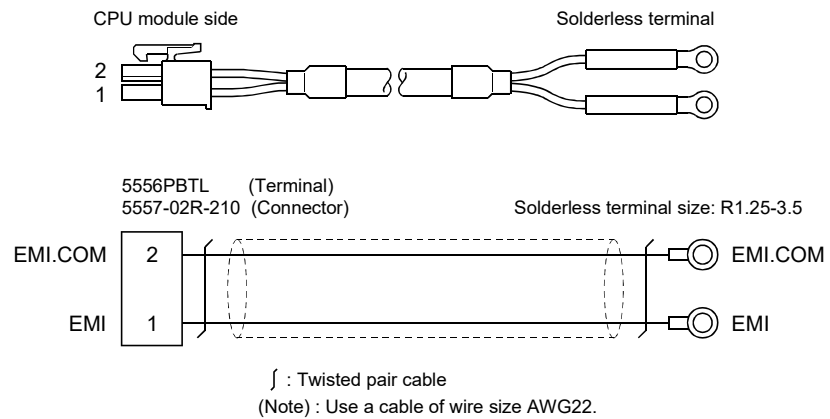

APPENDIX 1.5 Internal I/F connector cable

Fabricate the internal I/F connector cable on the customer side.

CAUTION

- When fabricating the internal I/F connector cable, do not make incorrect connection.
Doing so may cause an operation failure or damage the module.
- When fabricating the internal I/F connector cable, be sure to attach a ferrite core (ZCAT2030-0930).
Not doing so may cause an operation failure or damage the module with noise.

(1) Differential-output type

(a) Connection diagram

Make the cable within 30m(98.43ft.).

Attach a ferrite core included with the internal I/F connector set within 1 to 5(0.39 to 1.97)[cm(inch)] from the Motion CPU module.

1) When using an external power supply

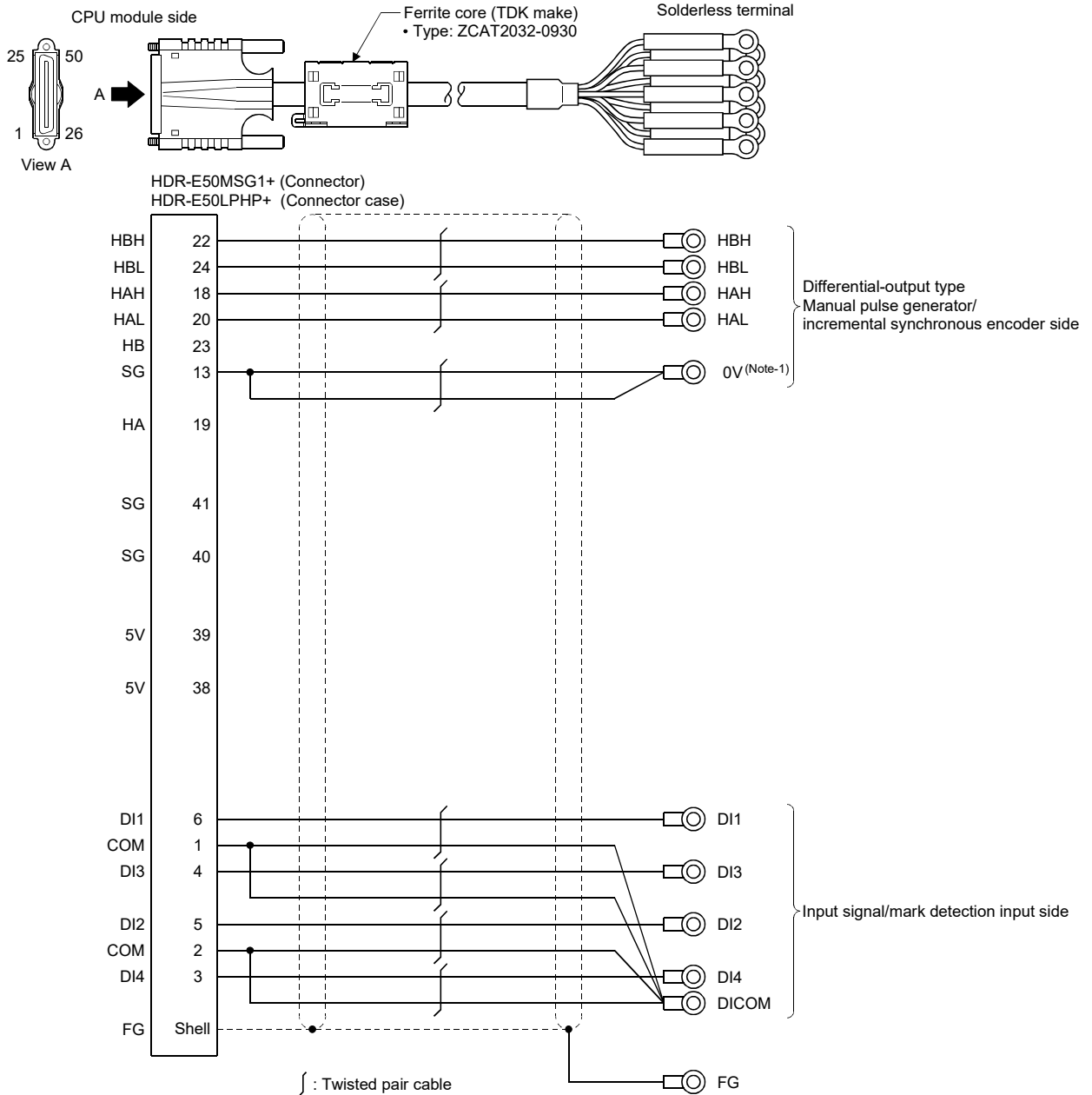

(Note-1): When using external power supply, connect SG to 0V of a separate power supply.

2) When using an internal power supply

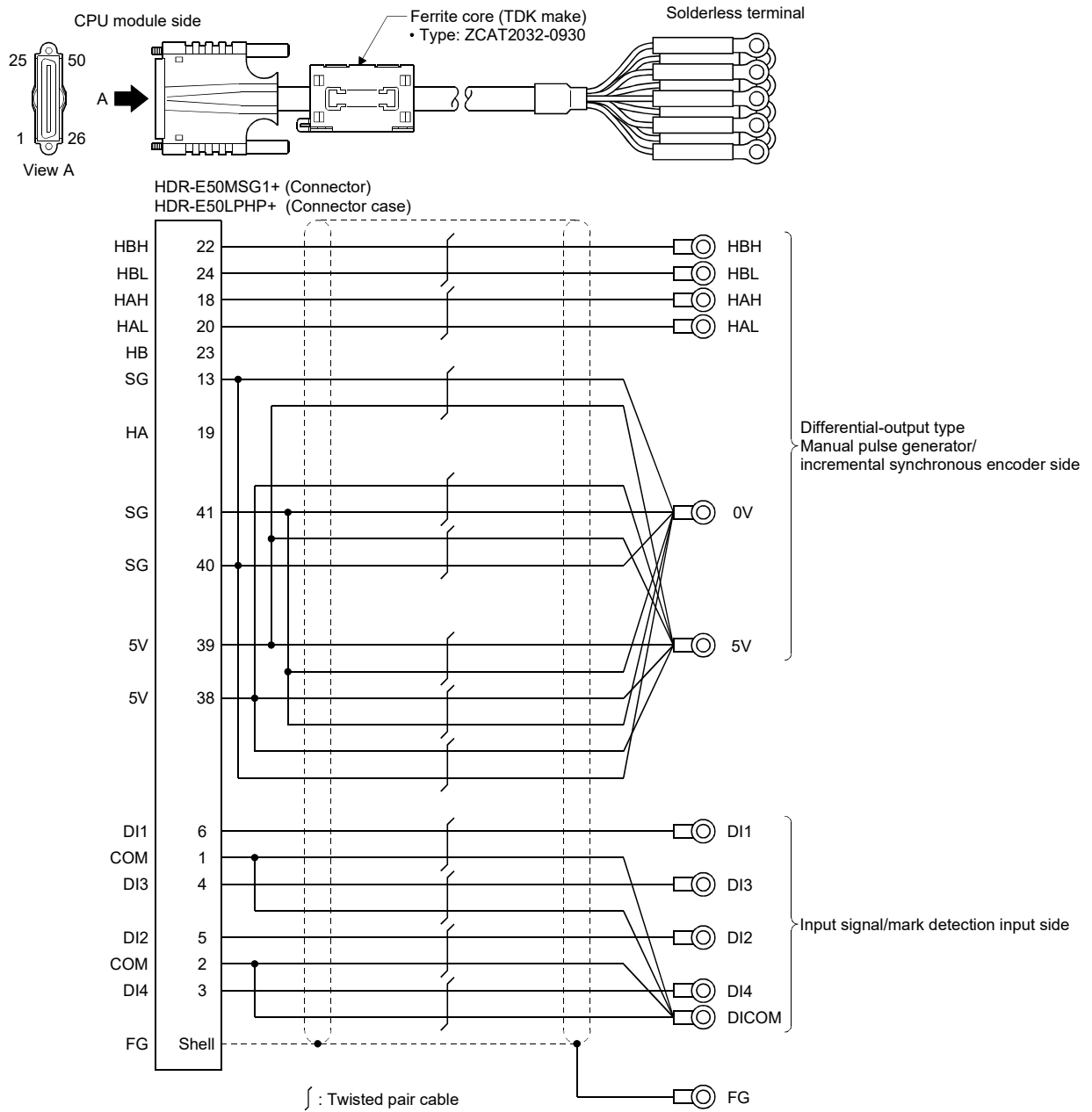

(2) Voltage-output/Open-collector type
 (a) Connection diagram

Make the cable within 10m(32.81ft.).

Attach a ferrite core included with the internal I/F connector set within 1 to 5(0.39 to 1.97)[cm(inch)] from the Motion CPU module.

1) When using an external power supply

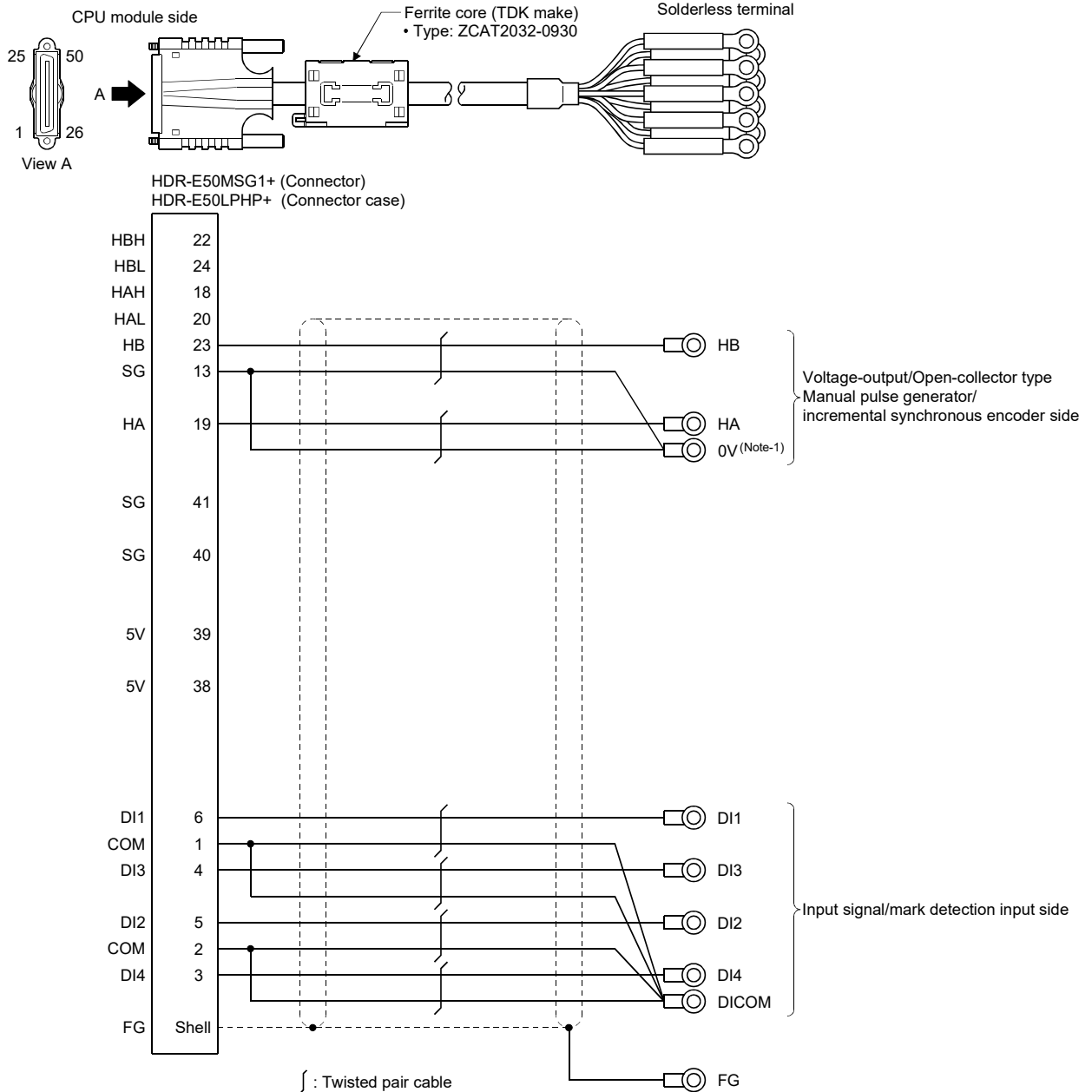

(Note-1): When using external power supply, connect SG to 0V of a separate power supply.

2) When using an internal power supply

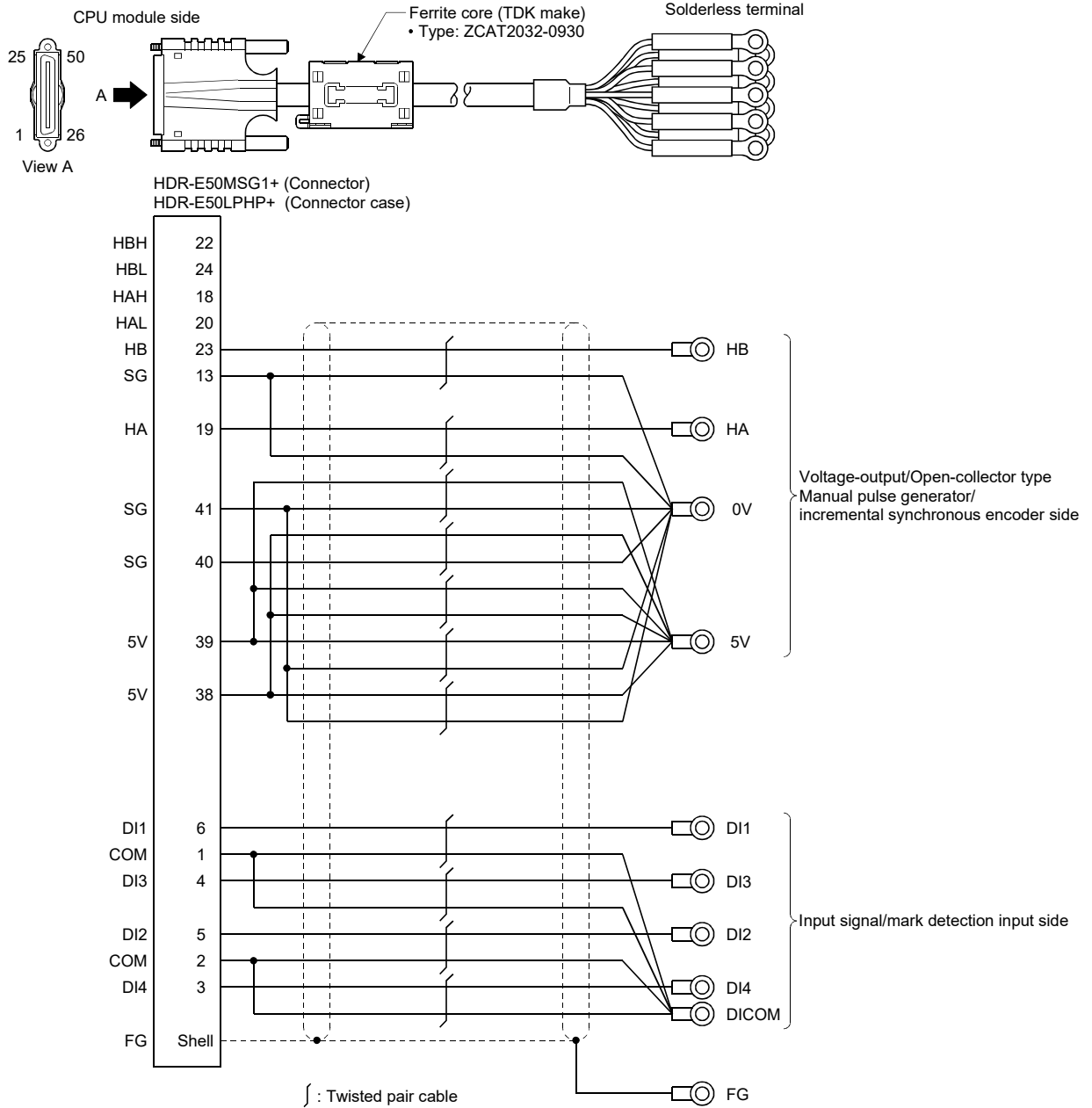

APPENDIX 1.6 RIO cable

Generally use the RIO cable available as our products. If the required length is not found in our products, fabricate the cable on the customer side. Make the RIO cable within 0.5m(1.64ft.).

- (1) Q173DSXYCBL□M
 - (a) Model explanation
 - Type: Q173DSXYCBL□M

Symbol	Cable length [m(ft.)]
01	0.1(0.33)
05	0.5(1.64)

(b) Connection diagram

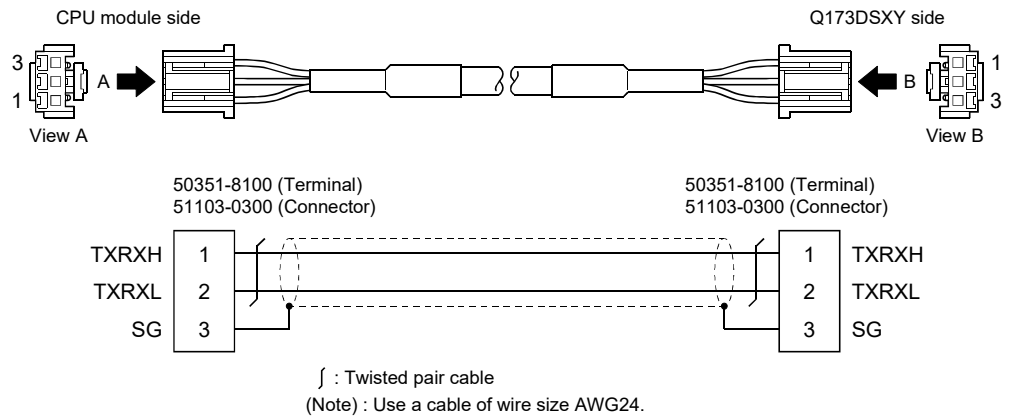

APPENDIX 1.7 SSCNET III cables (SC-J3BUS□M-C) manufactured by Mitsubishi Electric System & Service Co., Ltd.

POINTS
<ul style="list-style-type: none"> • For the details of the SSCNET III cables, contact your local sales office. • Do not look directly at the light generated from CN1A/CN1B connector of servo amplifier or the end of SSCNET III cable. The light can be a discomfort when it enters the eye.

The cable is available per 1[m] up to 100[m]. The number of the length (1 to 100) will be in the □ part in the cable model.

Cable model	Cable length [m(ft.)]	Bending life	Application/remark
	1 to 100 (3.28 to 328.08)		
SC-J3BUS□M-C	1 to 100	Ultra-long bending life	Long distance cable

APPENDICES

APPENDIX 2 Exterior Dimensions

APPENDIX 2.1 Motion CPU module

(1) Q172DSCPU

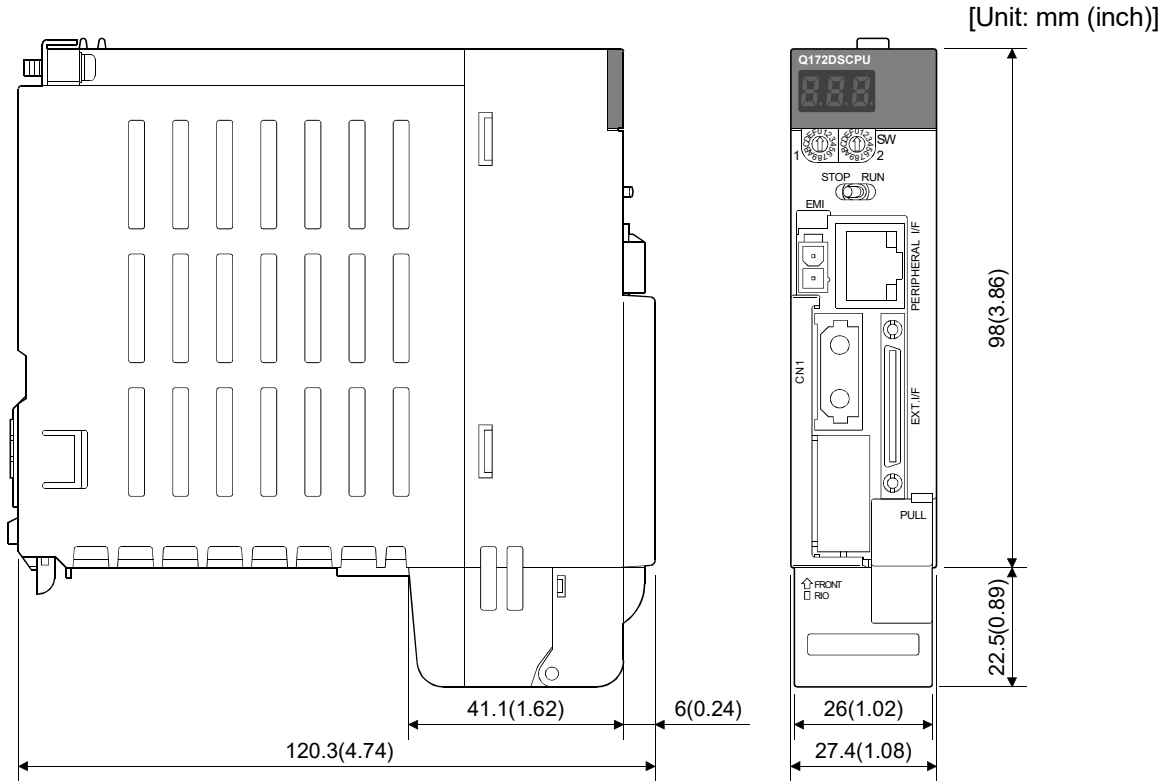

(2) Q173DSCPU

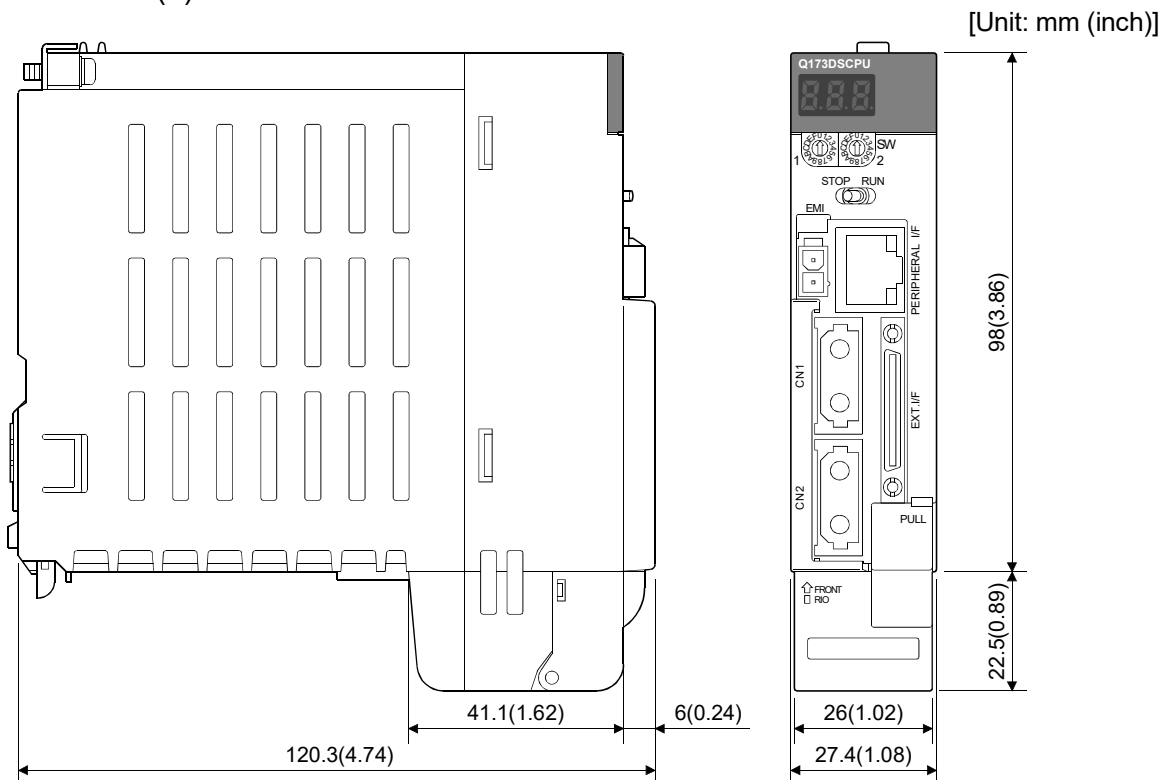

(3) Q172DCPU

[Unit: mm (inch)]

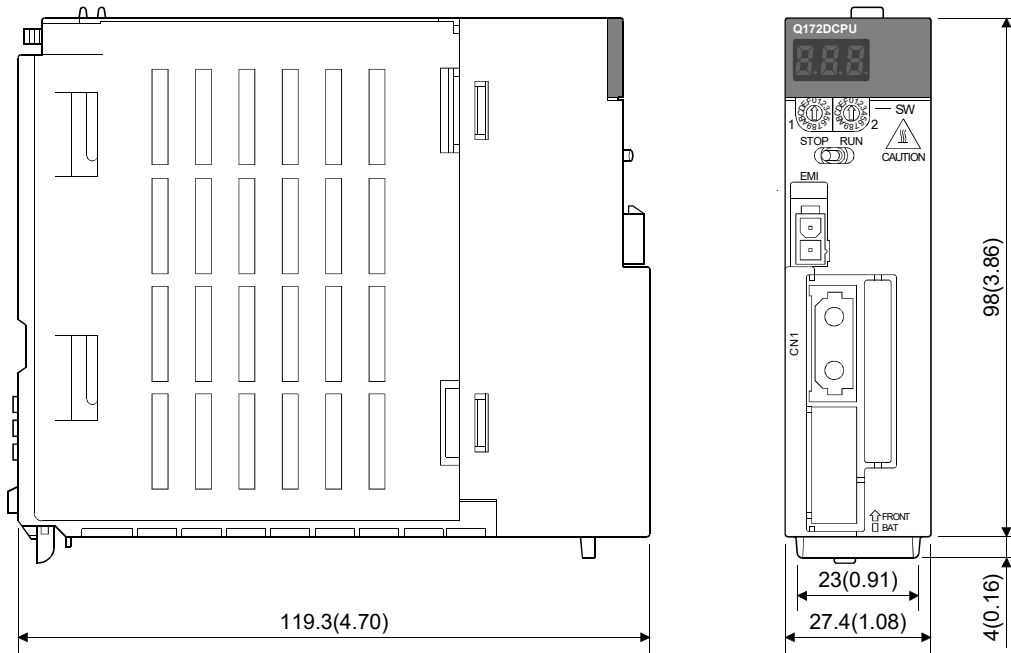

(4) Q173DCPU

[Unit: mm (inch)]

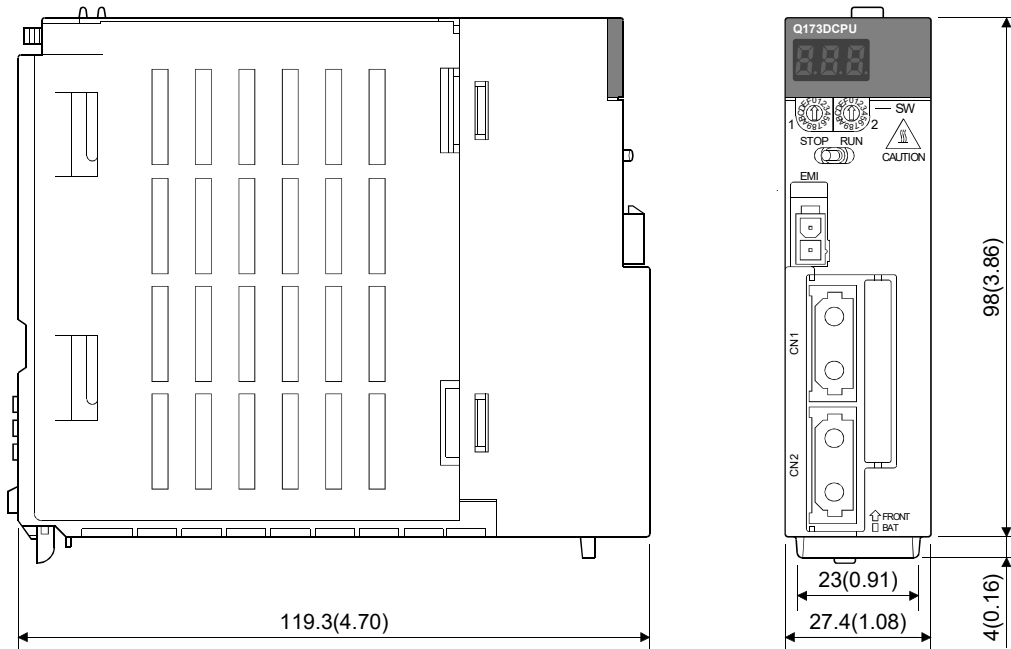

(5) Q172DCPU-S1

[Unit: mm (inch)]

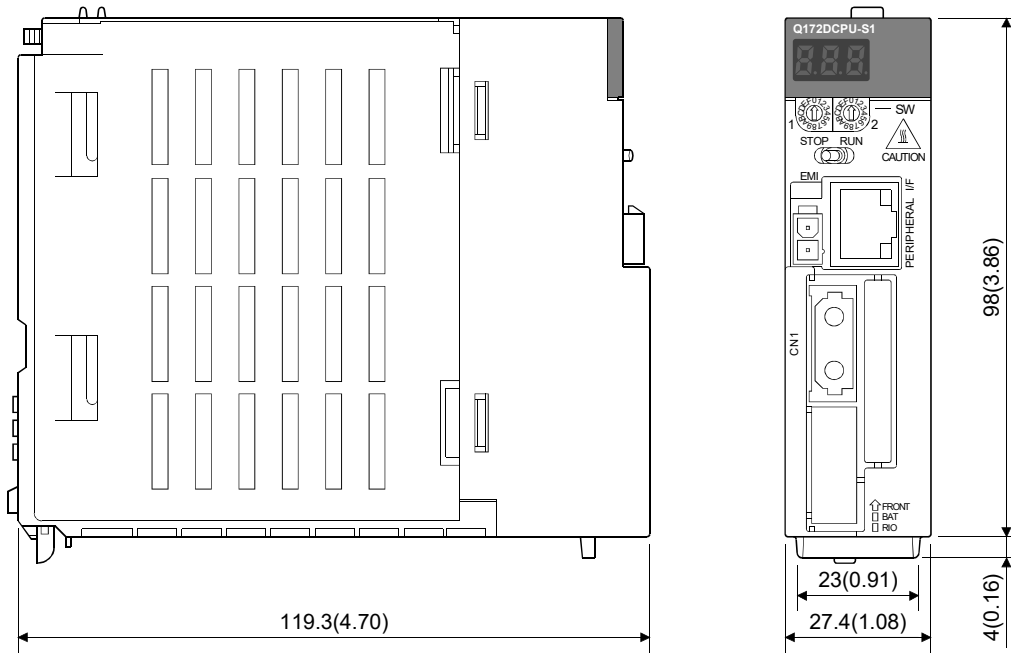

(6) Q173DCPU-S1

[Unit: mm (inch)]

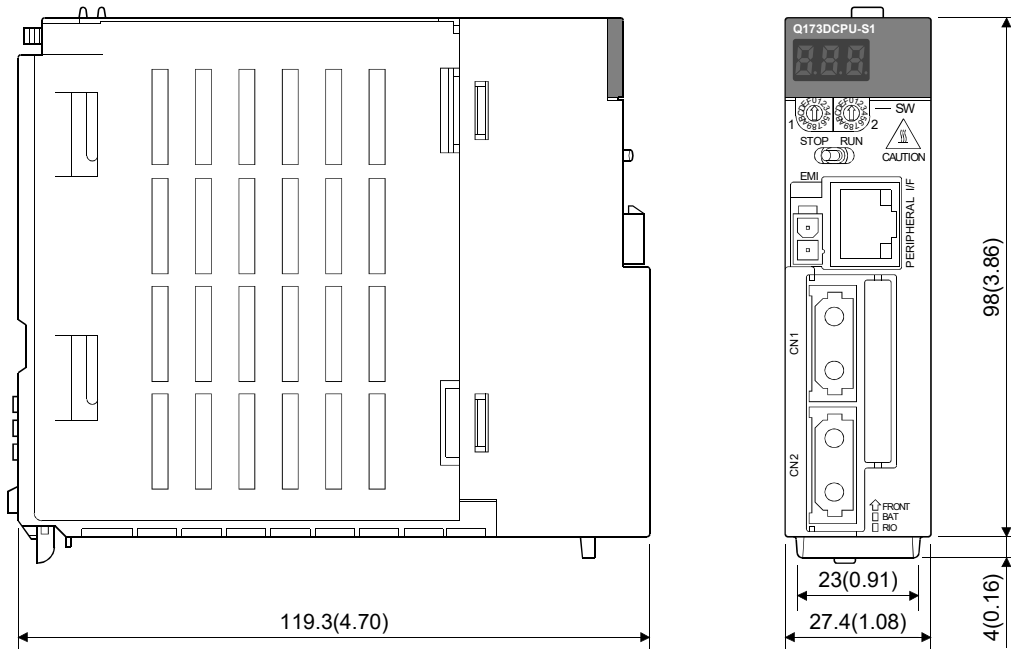

APPENDICES

APPENDIX 2.2 Servo external signals interface module (Q172DLX)

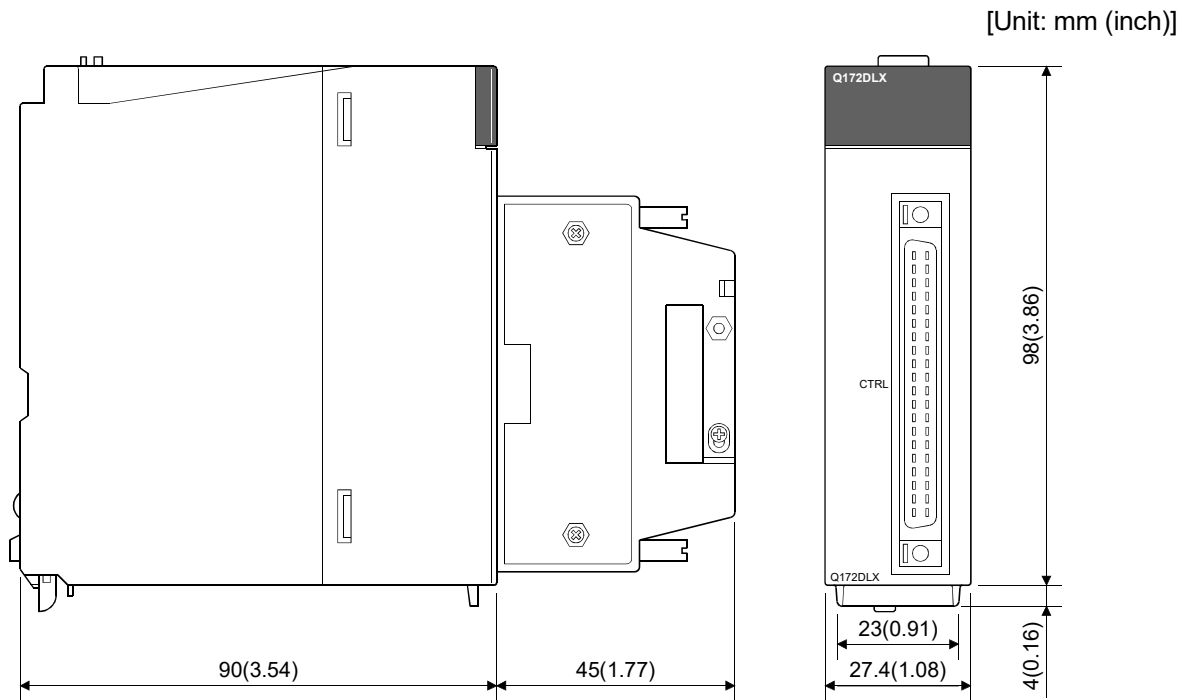

APPENDIX 2.3 Synchronous encoder interface module (Q172DEX)

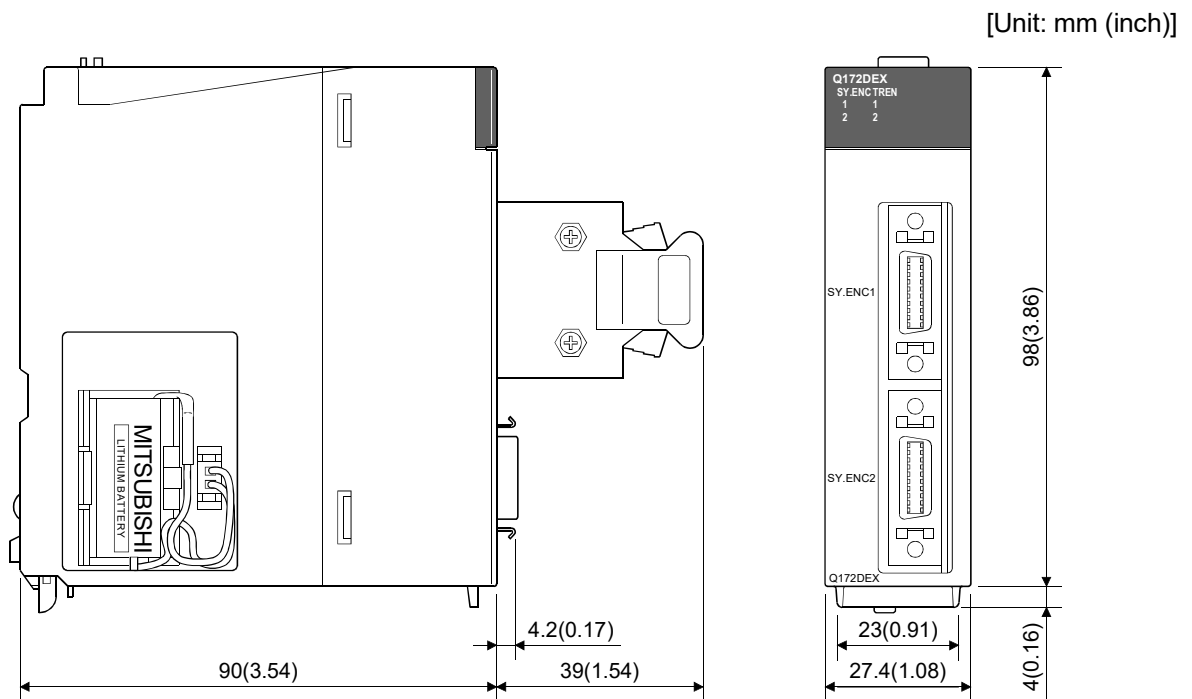

APPENDIX 2.4 Manual pulse generator interface module (Q173DPX)

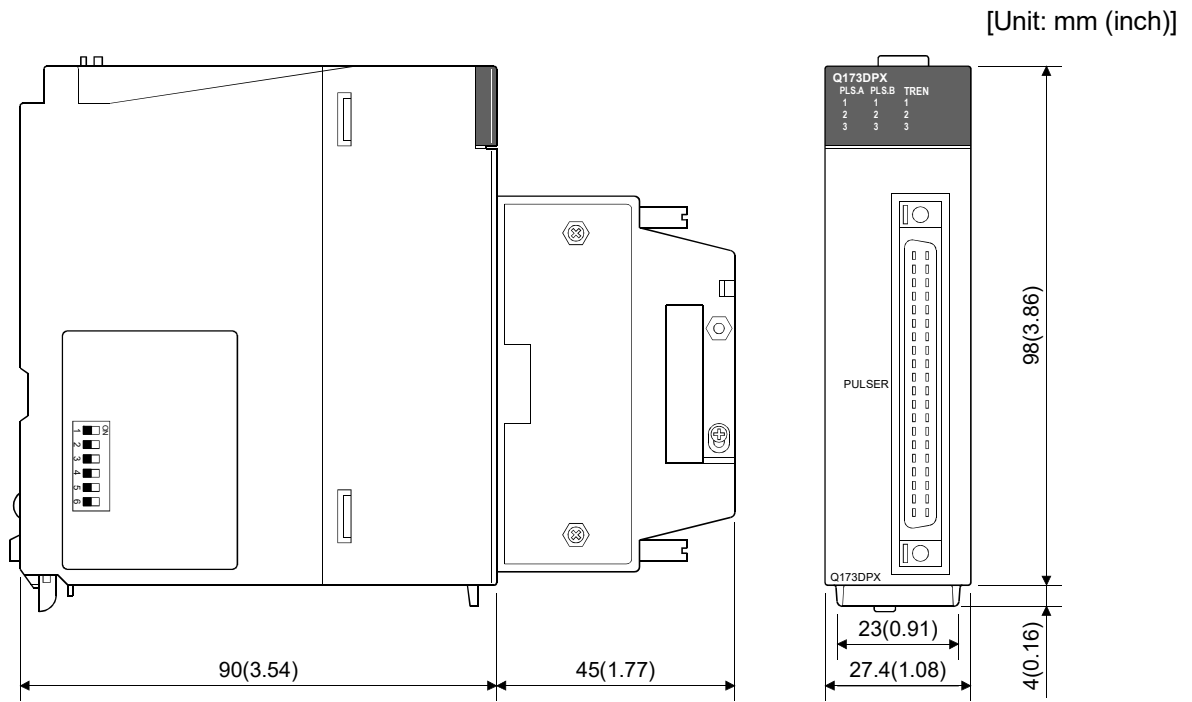

APPENDIX 2.5 Safety signal module (Q173DSXY)

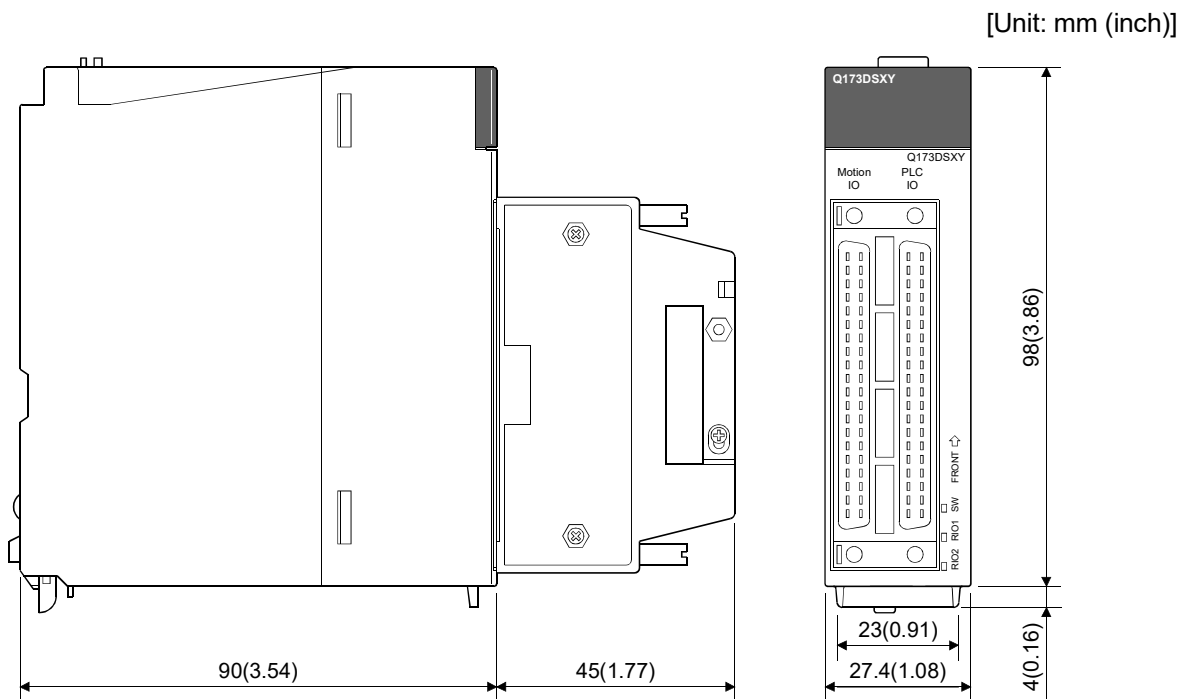

APPENDIX 2.6 Power supply module

[Unit: mm (inch)]

(1) Q61P-A1, Q61P-A2, Q61P, Q61P-D, Q62P, Q63P

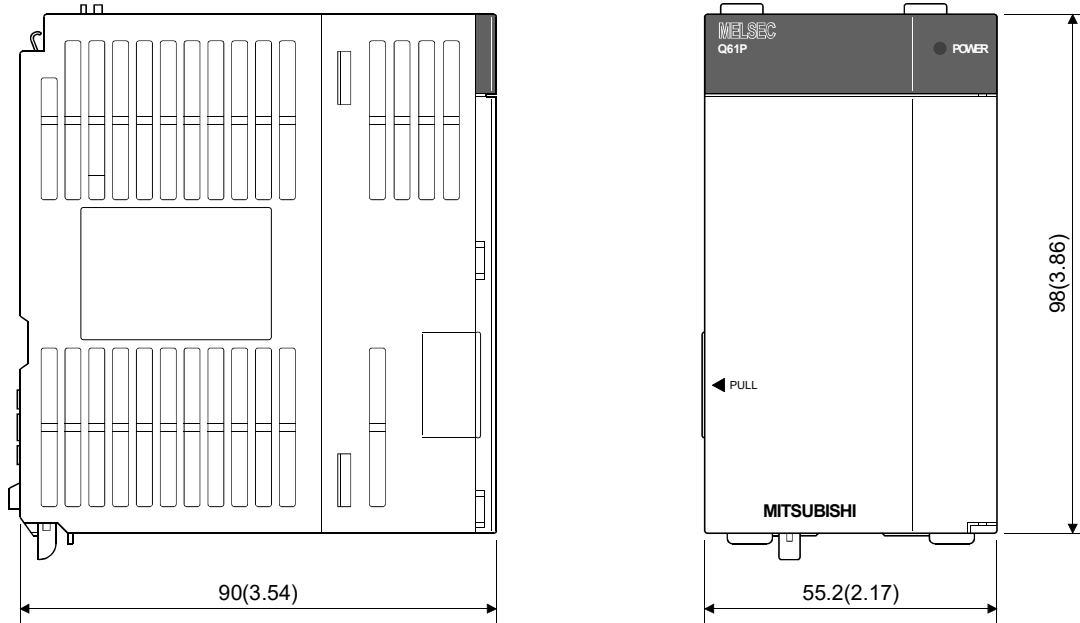

(2) Q64P

[Unit: mm (inch)]

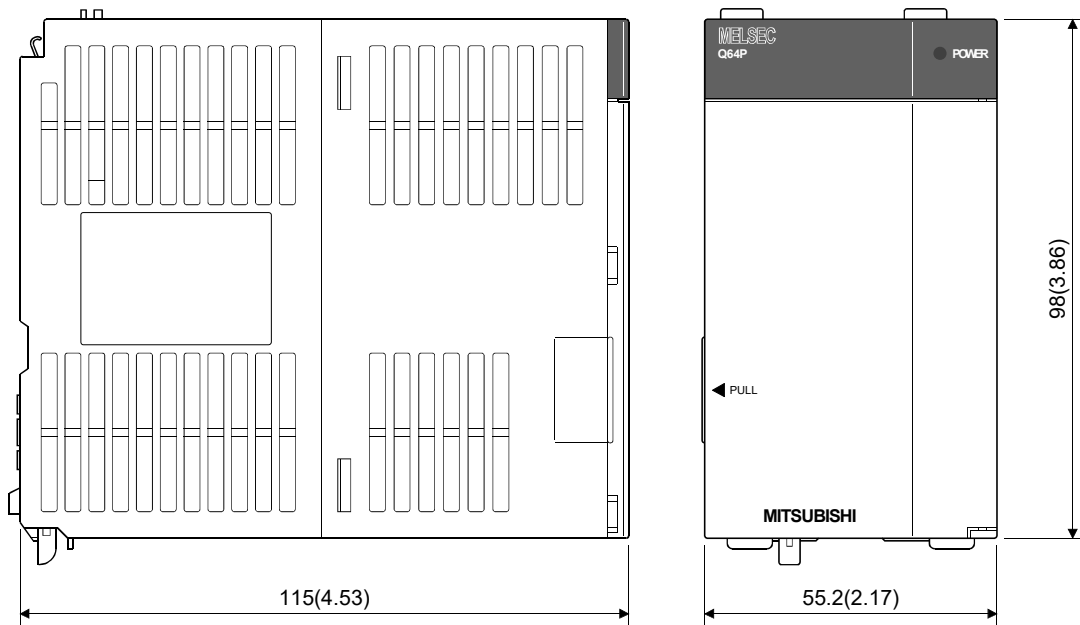

(3) Q64PN

[Unit: mm (inch)]

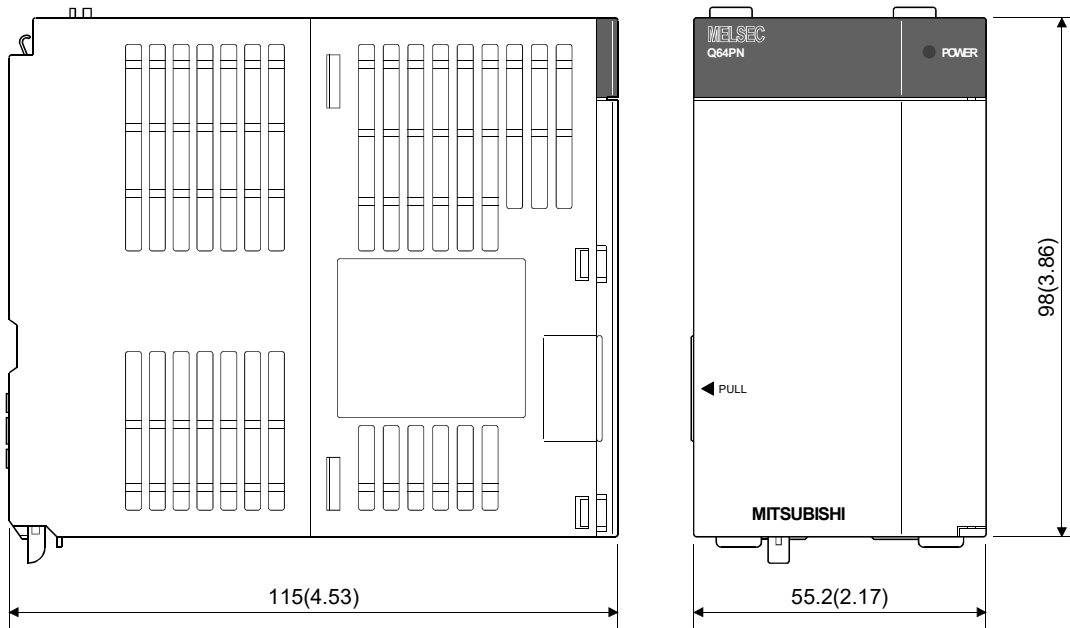

APPENDIX 2.7 Battery holder unit (Q170DBATC)

[Unit: mm (inch)]

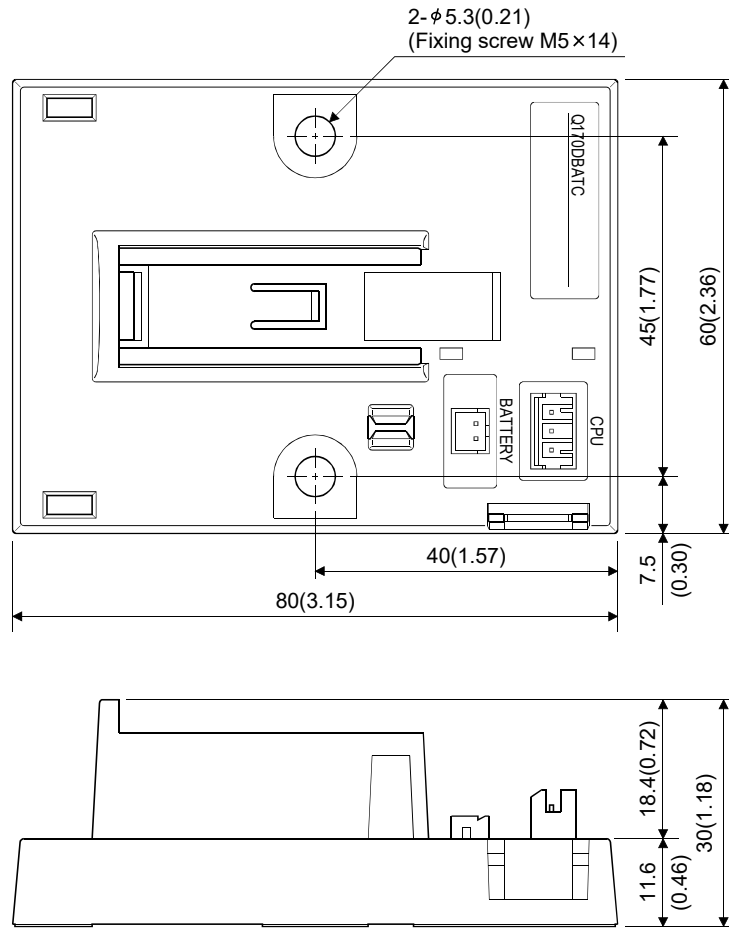

APPENDIX 2.8 Connector

(1) Cable connector for serial absolute synchronous encoder
(3M Japan Limited make (MDR type))

Number of pins	Type	Type	
		Connector	Connector case
20	Solder connection type (Quick release metal latch type)	10120-3000PE	10320-52F0-008
	Solder connection type (Threaded type)	10120-3000PE	10320-52A0-008
	Insulation displacement type (Quick release metal latch type)	10120-6000EL ^(Note)	10320-3210-000 ^(Note)

(Note): These connectors are not options. Please purchase them by customer.

(a) Solder connection type (Quick release metal latch type)

Type Connector : 10120-3000PE
Connector case : 10320-52F0-008

[Unit: mm (inch)]

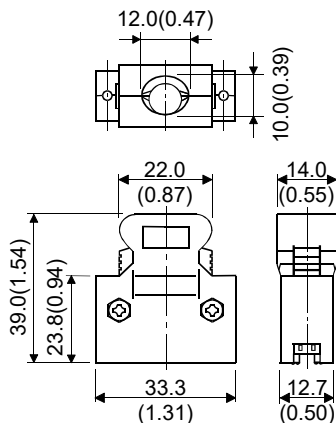

(b) Solder connection type (Threaded type)

Type Connector : 10120-3000PE
Connector case : 10320-52A0-008

[Unit: mm (inch)]

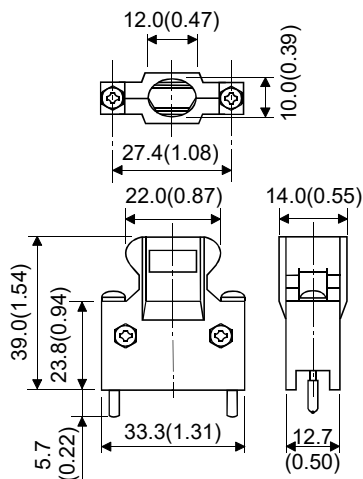

(c) Insulation displacement type (Quick release metal latch type)

Type Connector : 10120-6000EL
 Connector case : 10320-3210-000

[Unit: mm (inch)]

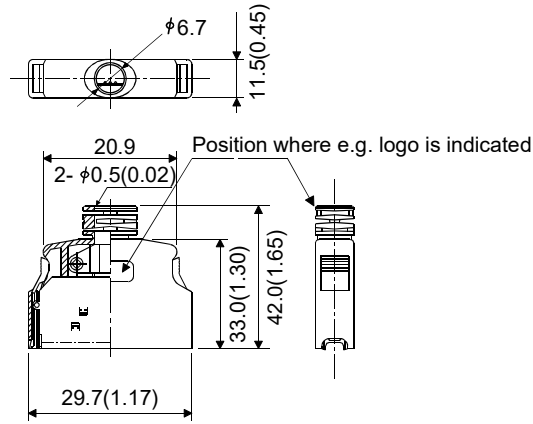

(2) Cable connector for serial absolute synchronous encoder
 (3M Japan Limited make (SCR type))

Type Plug: 36210-0100PL
 Shell: 36310-3200-008

[Unit: mm (inch)]

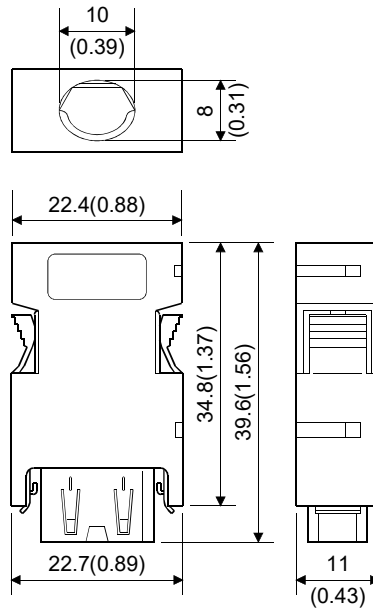

(3) SSCNETⅢ cable connector

[Unit: mm (inch)]

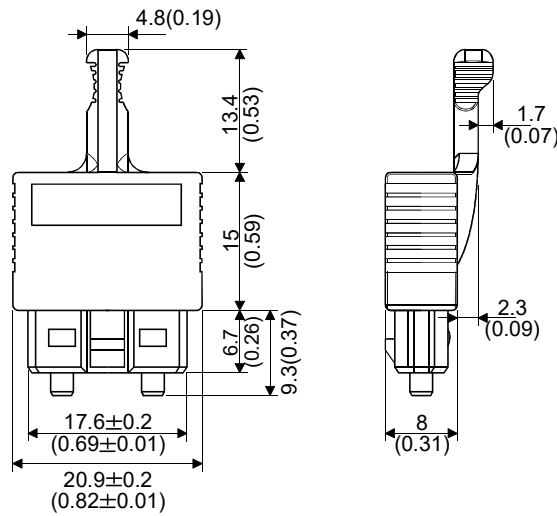

(4) Battery cable connector

(a) Battery holder side (Tyco Electronics Japan G.K. make)

Type Connector : 1376477-3

Terminal : 1376476-1

[Unit: mm (inch)]

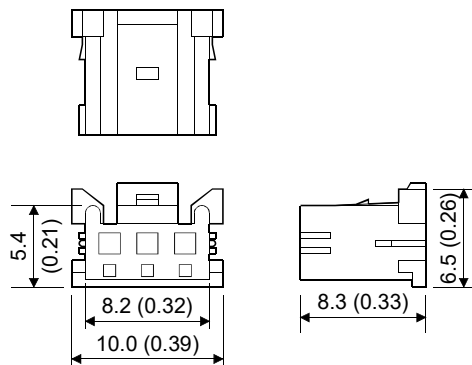

(b) CPU module side (Molex, LLC make)

Type Connector : 51103-0400

Terminal : 50351-8100

[Unit: mm (inch)]

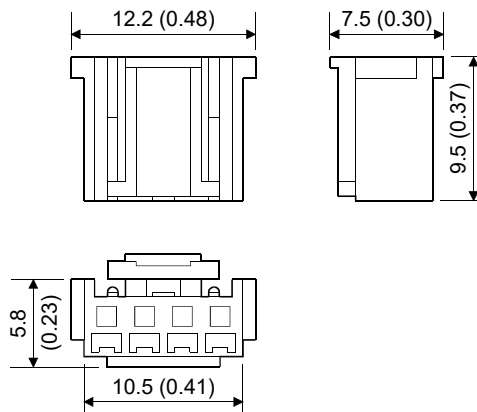

(5) Forced stop input connector (Molex, LLC make)

Type Connector : 5557-02R-210

Terminal : 5556PBTL

[Unit: mm (inch)]

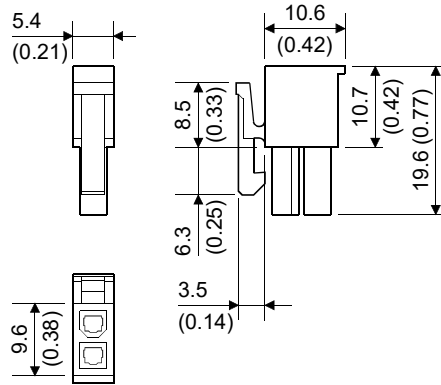

(6) Internal I/F connector (HONDA TSUSHIN KOGYO CO., LTD. make)

Type Connector : HDR-E50MSG1+ (Soldering type)
 HDR-E50MAG1+ (AWG30) (Pressure-displacement type)
 HDR-E50MG1+ (AWG28) (Pressure-displacement type)

Connector case: HDR-E50LPHP+

[Unit: mm (inch)]

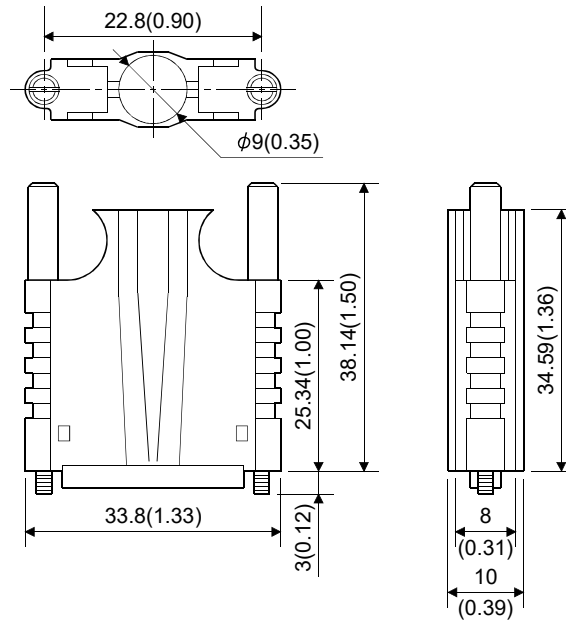

(7) RIO connector (Molex, LLC make)

Type Connector: 55103-300

Terminal: 50351-8100

[Unit: mm (inch)]

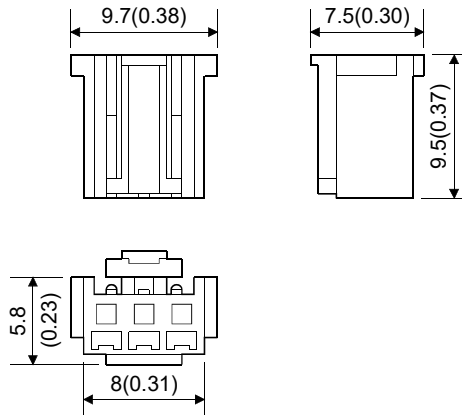

APPENDICES

APPENDIX 2.9 Manual pulse generator (MR-HDP01)

[Unit: mm (inch)]

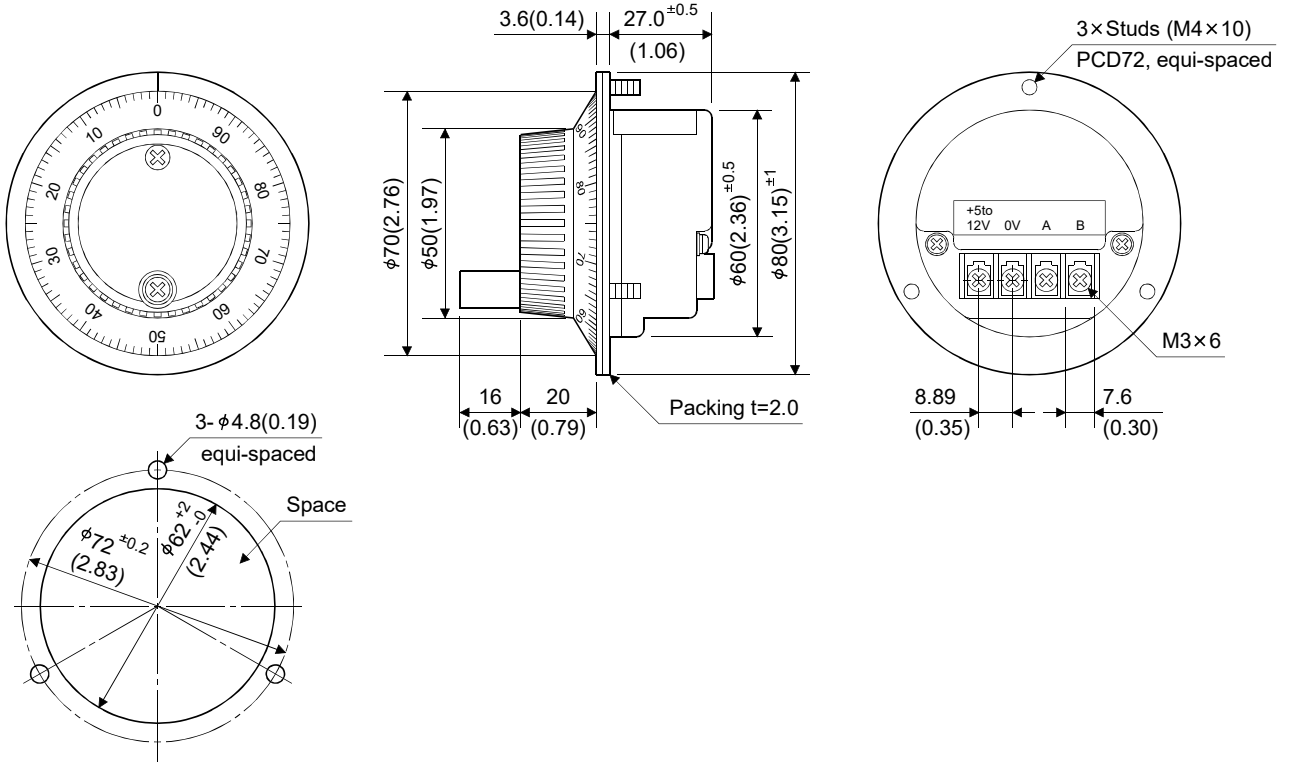

The figure of a processing disc

APPENDIX 2.10 Serial absolute synchronous encoder

(1) Q171ENC-W8

[Unit: mm (inch)]

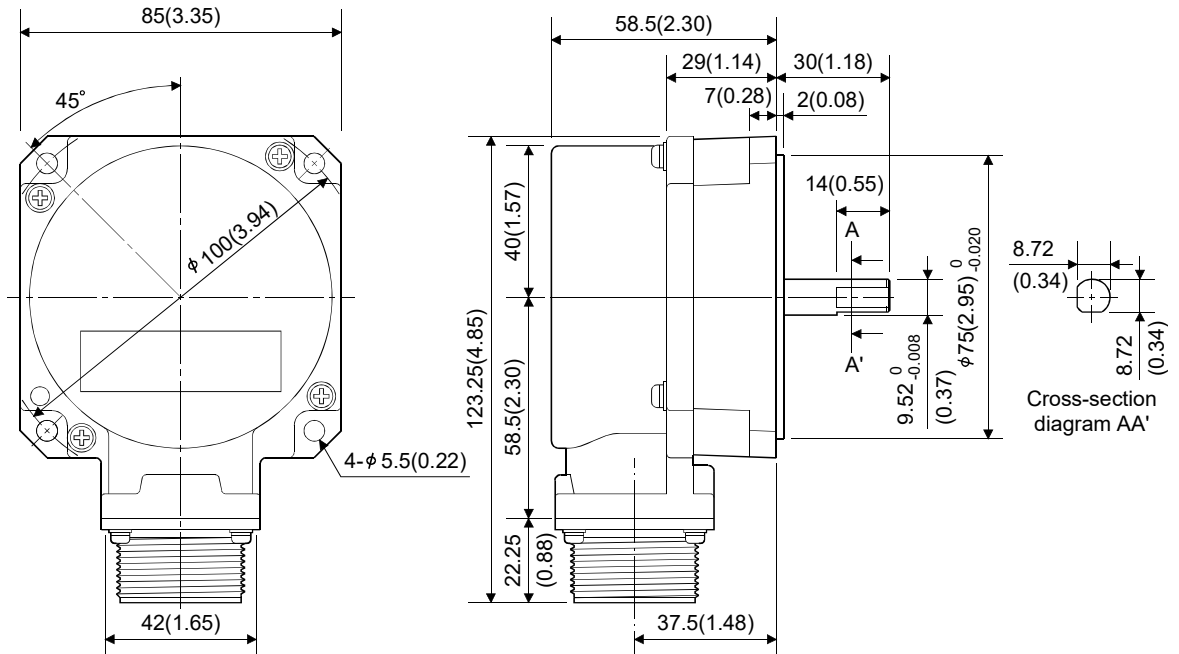

(2) Q170ENC

[Unit: mm (inch)]

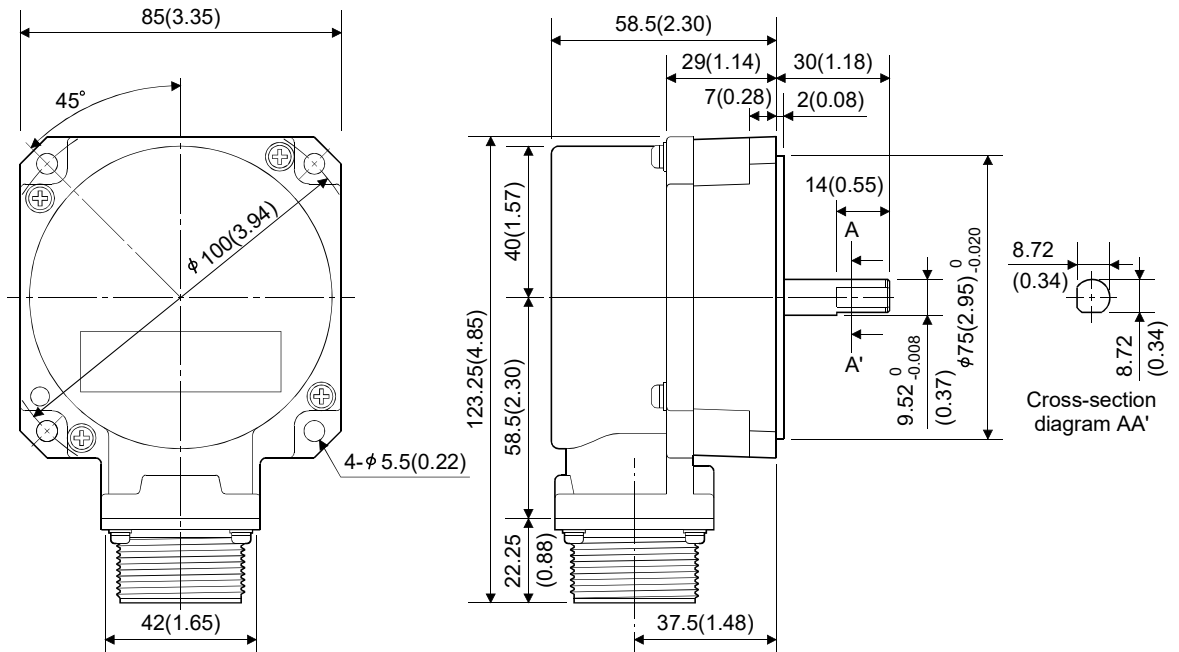

WARRANTY

Please confirm the following product warranty details before using this product.

1. Gratis Warranty Term and Gratis Warranty Range

We will repair any failure or defect hereinafter referred to as "failure" in our FA equipment hereinafter referred to as the "Product" arisen during warranty period at no charge due to causes for which we are responsible through the distributor from which you purchased the Product or our service provider. However, we will charge the actual cost of dispatching our engineer for an on-site repair work on request by customer in Japan or overseas countries. We are not responsible for any on-site readjustment and/or trial run that may be required after a defective unit is repaired or replaced.

[Gratis Warranty Term]

The term of warranty for Product is thirty six (36) months after your purchase or delivery of the Product to a place designated by you or forty two (42) months from the date of manufacture whichever comes first "Warranty Period". Warranty period for repaired Product cannot exceed beyond the original warranty period before any repair work.

[Gratis Warranty Range]

- (1) You are requested to conduct an initial failure diagnosis by yourself, as a general rule.
It can also be carried out by us or our service company upon your request and the actual cost will be charged. However, it will not be charged if we are responsible for the cause of the failure.
- (2) This limited warranty applies only when the condition, method, environment, etc. of use are in compliance with the terms and conditions and instructions that are set forth in the instruction manual and user manual for the Product and the caution label affixed to the Product.
- (3) Even during the term of warranty, the repair cost will be charged on you in the following cases;
 - 1) A failure caused by your improper storing or handling, carelessness or negligence, etc., and a failure caused by your hardware or software problem
 - 2) A failure caused by any alteration, etc. to the Product made on your side without our approval
 - 3) A failure which may be regarded as avoidable, if your equipment in which the Product is incorporated is equipped with a safety device required by applicable laws and has any function or structure considered to be indispensable according to a common sense in the industry
 - 4) A failure which may be regarded as avoidable if consumable parts designated in the instruction manual, etc. are duly maintained and replaced
 - 5) Any replacement of consumable parts (battery, fan, etc.)
 - 6) A failure caused by external factors such as inevitable accidents, including without limitation fire and abnormal fluctuation of voltage, and acts of God, including without limitation earthquake, lightning and natural disasters
 - 7) A failure generated by an unforeseeable cause with a scientific technology that was not available at the time of the shipment of the Product from our company
 - 8) Any other failures which we are not responsible for or which you acknowledge we are not responsible for

2. Onerous Repair Term after Discontinuation of Production

- (1) We may accept the repair at charge for another seven (7) years after the production of the product is discontinued.
The announcement of the stop of production for each model can be seen in our Sales and Service, etc.
- (2) Please note that the Product (including its spare parts) cannot be ordered after its stop of production.

3. Service in overseas countries

Our regional FA Center in overseas countries will accept the repair work of the Product; However, the terms and conditions of the repair work may differ depending on each FA Center. Please ask your local FA center for details.

4. Exclusion of Loss in Opportunity and Secondary Loss from Warranty Liability

Regardless of the gratis warranty term, Mitsubishi shall not be liable for compensation to:

- (1) Damages caused by any cause found not to be the responsibility of Mitsubishi.
- (2) Loss in opportunity, lost profits incurred to the user by Failures of Mitsubishi products.
- (3) Special damages and secondary damages whether foreseeable or not, compensation for accidents, and compensation for damages to products other than Mitsubishi products.
- (4) Replacement by the user, maintenance of on-site equipment, start-up test run and other tasks.

5. Change of Product specifications

Specifications listed in our catalogs, manuals or technical documents may be changed without notice.

6. Precautions for Choosing the Products

- (1) For the use of our Motion controller, its applications should be those that may not result in a serious damage even if any failure or malfunction occurs in Motion controller, and a backup or fail-safe function should operate on an external system to Motion controller when any failure or malfunction occurs.
- (2) Our Motion controller is designed and manufactured as a general purpose product for use at general industries. Therefore, applications substantially influential on the public interest for such as atomic power plants and other power plants of electric power companies, and also which require a special quality assurance system, including applications for railway companies and government or public offices are not recommended, and we assume no responsibility for any failure caused by these applications when used.
In addition, applications which may be substantially influential to human lives or properties for such as airlines, medical treatments, railway service, incineration and fuel systems, man-operated material handling equipment, entertainment machines, safety machines, etc. are not recommended, and we assume no responsibility for any failure caused by these applications when used.
We will review the acceptability of the abovementioned applications, if you agree not to require a specific quality for a specific application. Please contact us for consultation.
- (3) Mitsubishi shall have no responsibility or liability for any problems involving programmable controller trouble and system trouble caused by DoS attacks, unauthorized access, computer viruses, and other cyberattacks.

Microsoft, Windows, Windows NT, Windows Vista, and Windows XP are either registered trademarks or trademarks of Microsoft Corporation in the United States and/or other countries.

The company names, system names and product names mentioned in this manual are either registered trademarks or trademarks of their respective companies.

In some cases, trademark symbols such as '™' or '®' are not specified in this manual.

IB(NA)-0300133-N(2204)MEE

MODEL: Q173D-U-E

MODEL CODE: 1XB927

MITSUBISHI ELECTRIC CORPORATION

HEAD OFFICE : TOKYO BUILDING, 2-7-3 MARUNOUCHI, CHIYODA-KU, TOKYO 100-8310, JAPAN
NAGOYA WORKS : 1-14, YADA-MINAMI 5-CHOME, HIGASHI-KU, NAGOYA, JAPAN

When exported from Japan, this manual does not require application to the
Ministry of Economy, Trade and Industry for service transaction permission.

Specifications subject to change without notice.