



Motion Controller

MELSEC **Q** series

Q173D(S)CPU/Q172D(S)CPU  
Motion Controller  
Programming Manual (COMMON)

---

-Q172DCPU  
-Q173DCPU  
-Q172DCPU-S1  
-Q173DCPU-S1  
-Q172DSCPU  
-Q173DSCPU

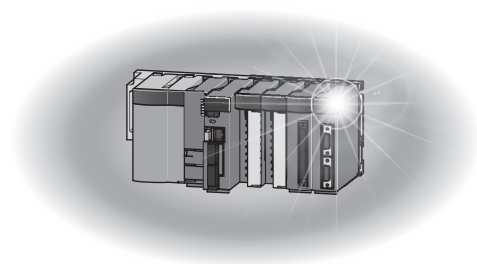

## ● SAFETY PRECAUTIONS ●

(Please read these instructions before using this equipment.)

Before using this product, please read this manual and the relevant manuals introduced in this manual carefully and pay full attention to safety to handle the product correctly.

These precautions apply only to this product. Refer to the Q173D(S)CPU/Q172D(S)CPU Users manual for a description of the Motion controller safety precautions.

In this manual, the safety instructions are ranked as "DANGER" and "CAUTION".

 **DANGER**

Indicates that incorrect handling may cause hazardous conditions, resulting in death or severe injury.

 **CAUTION**

Indicates that incorrect handling may cause hazardous conditions, resulting in medium or slight personal injury or physical damage.

Depending on circumstances, procedures indicated by  CAUTION may also be linked to serious results.

In any case, it is important to follow the directions for usage.

Please save this manual to make it accessible when required and always forward it to the end user.

## For Safe Operations

### 1. Prevention of electric shocks

#### DANGER

- Never open the front case or terminal covers while the power is ON or the unit is running, as this may lead to electric shocks.
- Never run the unit with the front case or terminal cover removed. The high voltage terminal and charged sections will be exposed and may lead to electric shocks.
- Never open the front case or terminal cover at times other than wiring work or periodic inspections even if the power is OFF. The insides of the Motion controller and servo amplifier are charged and may lead to electric shocks.
- Completely turn off the externally supplied power used in the system before mounting or removing the module, performing wiring work, or inspections. Failing to do so may lead to electric shocks.
- When performing wiring work or inspections, turn the power OFF, wait at least ten minutes, and then check the voltage with a tester, etc. Failing to do so may lead to electric shocks.
- Be sure to ground the Motion controller, servo amplifier and servo motor. (Ground resistance : 100  $\Omega$  or less) Do not ground commonly with other devices.
- The wiring work and inspections must be done by a qualified technician.
- Wire the units after installing the Motion controller, servo amplifier and servo motor. Failing to do so may lead to electric shocks or damage.
- Never operate the switches with wet hands, as this may lead to electric shocks.
- Do not damage, apply excessive stress, place heavy things on or sandwich the cables, as this may lead to electric shocks.
- Do not touch the Motion controller, servo amplifier or servo motor terminal blocks while the power is ON, as this may lead to electric shocks.
- Do not touch the built-in power supply, built-in grounding or signal wires of the Motion controller and servo amplifier, as this may lead to electric shocks.

### 2. For fire prevention

#### CAUTION

- Install the Motion controller, servo amplifier, servo motor and regenerative resistor on incombustible. Installing them directly or close to combustibles will lead to fire.
- If a fault occurs in the Motion controller or servo amplifier, shut the power OFF at the servo amplifier's power source. If a large current continues to flow, fire may occur.
- When using a regenerative resistor, shut the power OFF with an error signal. The regenerative resistor may abnormally overheat due to a fault in the regenerative transistor, etc., and may lead to fire.
- Always take heat measures such as flame proofing for the inside of the control panel where the servo amplifier or regenerative resistor is installed and for the wires used. Failing to do so may lead to fire.
- Do not damage, apply excessive stress, place heavy things on or sandwich the cables, as this may lead to fire.

### 3. For injury prevention

#### CAUTION

- Do not apply a voltage other than that specified in the instruction manual on any terminal. Doing so may lead to destruction or damage.
- Do not mistake the terminal connections, as this may lead to destruction or damage.
- Do not mistake the polarity ( + / - ), as this may lead to destruction or damage.
- Do not touch the heat radiating fins of controller or servo amplifier, regenerative resistor and servo motor, etc., while the power is ON and for a short time after the power is turned OFF. In this timing, these parts become very hot and may lead to burns.
- Always turn the power OFF before touching the servo motor shaft or coupled machines, as these parts may lead to injuries.
- Do not go near the machine during test operations or during operations such as teaching. Doing so may lead to injuries.

### 4. Various precautions

Strictly observe the following precautions.

Mistaken handling of the unit may lead to faults, injuries or electric shocks.

#### (1) System structure

#### CAUTION

- Always install a leakage breaker on the Motion controller and servo amplifier power source.
- If installation of an electromagnetic contactor for power shut off during an error, etc., is specified in the instruction manual for the servo amplifier, etc., always install the electromagnetic contactor.
- Install the emergency stop circuit externally so that the operation can be stopped immediately and the power shut off.
- Use the Motion controller, servo amplifier, servo motor and regenerative resistor with the correct combinations listed in the instruction manual. Other combinations may lead to fire or faults.
- Use the Motion controller, base unit and motion module with the correct combinations listed in the instruction manual. Other combinations may lead to faults.
- If safety standards (ex., robot safety rules, etc.,) apply to the system using the Motion controller, servo amplifier and servo motor, make sure that the safety standards are satisfied.
- Construct a safety circuit externally of the Motion controller or servo amplifier if the abnormal operation of the Motion controller or servo amplifier differ from the safety directive operation in the system.
- In systems where coasting of the servo motor will be a problem during the forced stop, emergency stop, servo OFF or power supply OFF, use dynamic brakes.
- Make sure that the system considers the coasting amount even when using dynamic brakes.
- In systems where perpendicular shaft dropping may be a problem during the forced stop, emergency stop, servo OFF or power supply OFF, use both dynamic brakes and electromagnetic brakes.

## CAUTION

- The dynamic brakes must be used only on errors that cause the forced stop, emergency stop, or servo OFF. These brakes must not be used for normal braking.
- The brakes (electromagnetic brakes) assembled into the servo motor are for holding applications, and must not be used for normal braking.
- The system must have a mechanical allowance so that the machine itself can stop even if the stroke limits switch is passed through at the max. speed.
- Use wires and cables that have a wire diameter, heat resistance and bending resistance compatible with the system.
- Use wires and cables within the length of the range described in the instruction manual.
- The ratings and characteristics of the parts (other than Motion controller, servo amplifier and servo motor) used in a system must be compatible with the Motion controller, servo amplifier and servo motor.
- Install a cover on the shaft so that the rotary parts of the servo motor are not touched during operation.
- There may be some cases where holding by the electromagnetic brakes is not possible due to the life or mechanical structure (when the ball screw and servo motor are connected with a timing belt, etc.). Install a stopping device to ensure safety on the machine side.

### (2) Security

## CAUTION

- To maintain the security (confidentiality, integrity, and availability) of the programmable controller and the system against unauthorized access, denial-of-service (DoS) attacks, computer viruses, and other cyberattacks from external devices via the network, take appropriate measures such as firewalls, virtual private networks (VPNs), and antivirus solutions.

### (3) Parameter settings and programming

## CAUTION

- Set the parameter values to those that are compatible with the Motion controller, servo amplifier, servo motor and regenerative resistor model and the system application. The protective functions may not function if the settings are incorrect.
- The regenerative resistor model and capacity parameters must be set to values that conform to the operation mode, servo amplifier and servo power supply module. The protective functions may not function if the settings are incorrect.
- Set the mechanical brake output and dynamic brake output validity parameters to values that are compatible with the system application. The protective functions may not function if the settings are incorrect.
- Set the stroke limit input validity parameter to a value that is compatible with the system application. The protective functions may not function if the setting is incorrect.

## CAUTION

- Set the servo motor encoder type (increment, absolute position type, etc.) parameter to a value that is compatible with the system application. The protective functions may not function if the setting is incorrect.
- Set the servo motor capacity and type (standard, low-inertia, flat, etc.) parameter to values that are compatible with the system application. The protective functions may not function if the settings are incorrect.
- Set the servo amplifier capacity and type parameters to values that are compatible with the system application. The protective functions may not function if the settings are incorrect.
- Use the program commands for the program with the conditions specified in the instruction manual.
- Set the sequence function program capacity setting, device capacity, latch validity range, I/O assignment setting, and validity of continuous operation during error detection to values that are compatible with the system application. The protective functions may not function if the settings are incorrect.
- Some devices used in the program have fixed applications, so use these with the conditions specified in the instruction manual.
- The input devices and data registers assigned to the link will hold the data previous to when communication is terminated by an error, etc. Thus, an error correspondence interlock program specified in the instruction manual must be used.
- Use the interlock program specified in the intelligent function module's instruction manual for the program corresponding to the intelligent function module.

### (4) Transportation and installation

## CAUTION

- Transport the product with the correct method according to the mass.
- Use the servo motor suspension bolts only for the transportation of the servo motor. Do not transport the servo motor with machine installed on it.
- Do not stack products past the limit.
- When transporting the Motion controller or servo amplifier, never hold the connected wires or cables.
- When transporting the servo motor, never hold the cables, shaft or detector.
- When transporting the Motion controller or servo amplifier, never hold the front case as it may fall off.
- When transporting, installing or removing the Motion controller or servo amplifier, never hold the edges.
- Install the unit according to the instruction manual in a place where the mass can be withstood.
- Do not get on or place heavy objects on the product.
- Always observe the installation direction.
- Keep the designated clearance between the Motion controller or servo amplifier and control panel inner surface or the Motion controller and servo amplifier, Motion controller or servo amplifier and other devices.

## ⚠ CAUTION

- Do not install or operate Motion controller, servo amplifiers or servo motors that are damaged or that have missing parts.
- Do not block the intake/outtake ports of the Motion controller, servo amplifier and servo motor with cooling fan.
- Do not allow conductive matter such as screw or cutting chips or combustible matter such as oil enter the Motion controller, servo amplifier or servo motor.
- The Motion controller, servo amplifier and servo motor are precision machines, so do not drop or apply strong impacts on them.
- Securely fix the Motion controller, servo amplifier and servo motor to the machine according to the instruction manual. If the fixing is insufficient, these may come off during operation.
- Always install the servo motor with reduction gears in the designated direction. Failing to do so may lead to oil leaks.
- Store and use the unit in the following environmental conditions.

Environment	Conditions	
	Motion controller/Servo amplifier	Servo motor
Ambient temperature	According to each instruction manual.	0°C to +40°C (With no freezing) (32°F to +104°F)
Ambient humidity	According to each instruction manual.	80% RH or less (With no dew condensation)
Storage temperature	According to each instruction manual.	-20°C to +65°C (-4°F to +149°F)
Atmosphere	Indoors (where not subject to direct sunlight). No corrosive gases, flammable gases, oil mist or dust must exist	
Altitude	According to each instruction manual	
Vibration	According to each instruction manual	

- When coupling with the synchronous encoder or servo motor shaft end, do not apply impact such as by hitting with a hammer. Doing so may lead to detector damage.
- Do not apply a load larger than the tolerable load onto the synchronous encoder and servo motor shaft. Doing so may lead to shaft breakage.
- When not using the module for a long time, disconnect the power line from the Motion controller or servo amplifier.
- Place the Motion controller and servo amplifier in static electricity preventing vinyl bags and store.
- When storing for a long time, please contact with our sales representative.  
Also, execute a trial operation.
- When fumigants that contain halogen materials such as fluorine, chlorine, bromine, and iodine are used for disinfecting and protecting wooden packaging from insects, they cause malfunction when entering our products.  
Please take necessary precautions to ensure that remaining materials from fumigant do not enter our products, or treat packaging with methods other than fumigation (heat method).  
Additionally, disinfect and protect wood from insects before packing products.

## (5) Wiring

### ⚠ CAUTION

- Correctly and securely wire the wires. Reconfirm the connections for mistakes and the terminal screws for tightness after wiring. Failing to do so may lead to run away of the servo motor.
- After wiring, install the protective covers such as the terminal covers to the original positions.
- Do not install a phase advancing capacitor, surge absorber or radio noise filter (option FR-BIF) on the output side of the servo amplifier.
- Correctly connect the output side (terminal U, V, W) and ground. Incorrect connections will lead the servo motor to operate abnormally.
- Do not connect a commercial power supply to the servo motor, as this may lead to trouble.
- Do not mistake the direction of the surge absorbing diode installed on the DC relay for the control signal output of brake signals, etc. Incorrect installation may lead to signals not being output when trouble occurs or the protective functions not functioning.

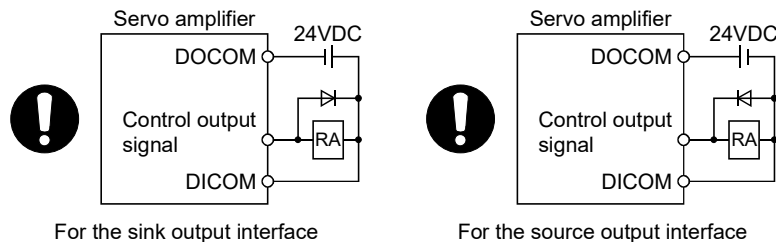

- Do not connect or disconnect the connection cables between each unit, the encoder cable or PLC expansion cable while the power is ON.
- Securely tighten the cable connector fixing screws and fixing mechanisms. Insufficient fixing may lead to the cables coming off during operation.
- Do not bundle the power line or cables.

## (6) Trial operation and adjustment

### ⚠ CAUTION

- Confirm and adjust the program and each parameter before operation. Unpredictable movements may occur depending on the machine.
- Extreme adjustments and changes may lead to unstable operation, so never make them.
- When using the absolute position system function, on starting up, and when the Motion controller or absolute position motor has been replaced, always perform a home position return.
- Before starting test operation, set the parameter speed limit value to the slowest value, and make sure that operation can be stopped immediately by the forced stop, etc. if a hazardous state occurs.



(7) Usage methods

**⚠ CAUTION**

- Immediately turn OFF the power if smoke, abnormal sounds or odors are emitted from the Motion controller, servo amplifier or servo motor.
- Always execute a test operation before starting actual operations after the program or parameters have been changed or after maintenance and inspection.
- Do not attempt to disassemble and repair the units excluding a qualified technician whom our company recognized.
- Do not make any modifications to the unit.
- Keep the effect or electromagnetic obstacles to a minimum by installing a noise filter or by using wire shields, etc. Electromagnetic obstacles may affect the electronic devices used near the Motion controller or servo amplifier.
- When using the CE Mark-compliant equipment, refer to the User's manual for the Motion controllers and refer to the corresponding EMC guideline information for the servo amplifiers, inverters and other equipment.
- Use the units with the following conditions.

Item	Conditions
Input power	According to each instruction manual.
Input frequency	According to each instruction manual.
Tolerable momentary power failure	According to each instruction manual.

(8) Corrective actions for errors

**⚠ CAUTION**

- If an error occurs in the self diagnosis of the Motion controller or servo amplifier, confirm the check details according to the instruction manual, and restore the operation.
- If a dangerous state is predicted in case of a power failure or product failure, use a servo motor with electromagnetic brakes or install a brake mechanism externally.
- Use a double circuit construction so that the electromagnetic brake operation circuit can be operated by emergency stop signals set externally.

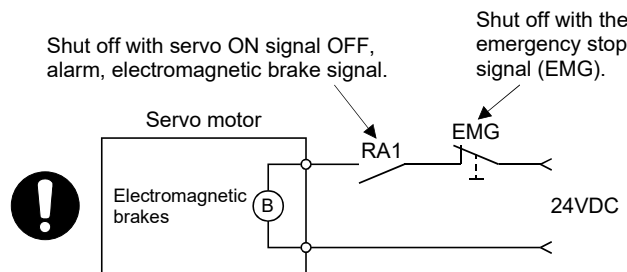

- If an error occurs, remove the cause, secure the safety and then resume operation after alarm release.
- The unit may suddenly resume operation after a power failure is restored, so do not go near the machine. (Design the machine so that personal safety can be ensured even if the machine restarts suddenly.)

## (9) Maintenance, inspection and part replacement

### CAUTION

- Perform the daily and periodic inspections according to the instruction manual.
- Perform maintenance and inspection after backing up the program and parameters for the Motion controller and servo amplifier.
- Do not place fingers or hands in the clearance when opening or closing any opening.
- Periodically replace consumable parts such as batteries according to the instruction manual.
- Do not touch the lead sections such as ICs or the connector contacts.
- Before touching the module, always touch grounded metal, etc. to discharge static electricity from human body. Failure to do so may cause the module to fail or malfunction.
- Do not directly touch the module's conductive parts and electronic components. Touching them could cause an operation failure or give damage to the module.
- Do not place the Motion controller or servo amplifier on metal that may cause a power leakage or wood, plastic or vinyl that may cause static electricity buildup.
- Do not perform a megger test (insulation resistance measurement) during inspection.
- When replacing the Motion controller or servo amplifier, always set the new module settings correctly.
- When the Motion controller or absolute value motor has been replaced, carry out a home position return operation using one of the following methods, otherwise position displacement could occur.
  - 1) After writing the servo data to the Motion controller using programming software, switch on the power again, then perform a home position return operation.
  - 2) Using the backup function of the programming software, load the data backed up before replacement.
- After maintenance and inspections are completed, confirm that the position detection of the absolute position detector function is correct.
- Do not drop or impact the battery installed to the module. Doing so may damage the battery, causing battery liquid to leak in the battery. Do not use the dropped or impacted battery, but dispose of it.
- Do not short circuit, charge, overheat, incinerate or disassemble the batteries.
- The electrolytic capacitor will generate gas during a fault, so do not place your face near the Motion controller or servo amplifier.
- The electrolytic capacitor and fan will deteriorate. Periodically replace these to prevent secondary damage from faults. Replacements can be made by our sales representative.
- Lock the control panel and prevent access to those who are not certified to handle or install electric equipment.
- Do not burn or break a module and servo amplifier. Doing so may cause a toxic gas.

#### (10) About processing of waste

When you discard Motion controller, servo amplifier, a battery (primary battery) and other option articles, please follow the law of each country (area).

### CAUTION

- This product is not designed or manufactured to be used in equipment or systems in situations that can affect or endanger human life.
- When considering this product for operation in special applications such as machinery or systems used in passenger transportation, medical, aerospace, atomic power, electric power, or submarine repeating applications, please contact your nearest Mitsubishi Electric sales representative.
- Although this product was manufactured under conditions of strict quality control, you are strongly advised to install safety devices to forestall serious accidents when it is used in facilities where a breakdown in the product is likely to cause a serious accident.

#### (11) General cautions

- All drawings provided in the instruction manual show the state with the covers and safety partitions removed to explain detailed sections. When operating the product, always return the covers and partitions to the designated positions, and operate according to the instruction manual.

REVISIONS

\* The manual number is given on the bottom left of the back cover.

Print Date	* Manual Number	Revision
Sep., 2007	IB(NA)-0300134-A	First edition
Sep., 2010	IB(NA)-0300134-B	[Additional model/function] Software for SV43, Amplifier-less operation function, Q10UD(E)HCPU, Q13UD(E)HCPU, Q20UD(E)HCPU, Q26UD(E)HCPU, QX40H, QX70H, QH80H, QX90H, MR-J3-□BS [Additional correction/partial correction] Safety precautions, About Manuals, Restrictions by the software's version, Checking serial number and operating system software version, Servo parameters, Warranty
Sep., 2011	IB(NA)-0300134-C	[Additional model] Q173DCPU-S1, Q172DCPU-S1, Q50UDEHCPU, Q100UDEHCPU, GX Works2, MR Configurator2 [Additional function] External input signal (DOG) of servo amplifier, Communication via PERIPHERAL I/F [Additional correction/partial correction] Safety precautions, About Manuals, Restrictions by the software's version
Mar., 2012	IB(NA)-0300134-D	[Additional model] Q173DSCPU, Q172DSCPU, MR-J4-□B, MR-J4W-□B, [Additional function] Servo external signal parameters, Software security key, Mark detection function [Additional correction/partial correction] About Manuals, Manual Page Organization, Restrictions by the software's version, Programming software version, Individual parameters, Servo parameter change function, Optional data monitor function, Special relays/Special registers list, System setting errors, Differences between Motion CPU
Sep., 2012	IB(NA)-0300134-E	[Additional function] Advanced synchronous control, High-speed input request signal setting [Additional correction/partial correction] About Manuals, Restrictions by the software's version, Programming software version, Individual parameters, Limit switch output function, Protection by password, Mark detection function, Special relays/Special registers list, Self-diagnosis error, Differences between Motion CPU
Apr., 2013	IB(NA)-0300134-F	[Additional model] LJ72MS15, Intelligent function module [Additional function] Driver communication function, Connection of SSCNETⅢ/H head module [Additional correction/partial correction] About Manuals, Restrictions by the software's version, System data setting list, Individual parameters, Special relays/Special registers list, System setting error, Self-diagnosis error, Differences between Motion CPU
Nov., 2013	IB(NA)-0300134-G	[Additional correction/partial correction] Safety precautions, Restrictions by the software's version, System data setting list, Optional data monitor function, Driver communication function (SSCNETⅢ/H), Special registers list, System setting error, Self-diagnosis error, Differences between Motion CPU

Print Date	* Manual Number	Revision
Dec., 2015	IB(NA)-0300134-H	[Additional correction/partial correction] Other restrictions, Restrictions by the software's version, System data setting list, Limit output setting data, Optional data monitor function, Connect/disconnect function of SSCNET communication, Communication function via PERIPHERAL I/F, Mark detection setting, Special registers, Self-diagnosis error, Differences between Q173DSCPU/Q172DSCPU/Q173DCPU(-S1)/Q172DCPU(-S1)/Q173HCPU/Q172HCPU, Warranty
Mar., 2017	IB(NA)-0300134-J	[Additional correction/partial correction] Safety precautions, Other restrictions, Restrictions by the software's version, System data setting list, Optional data monitor function, MC protocol communication, Mark detection function, Special registers, System setting errors, Differences between Motion CPU, Warranty
Dec., 2019	IB(NA)-0300134-K	[Additional correction/partial correction] Equipment configuration in system
Apr., 2022	IB(NA)-0300134-L	[Additional model] MR-J5-□B, MR-J5W-□B [Additional correction/partial correction] Safety precautions, About Manuals, Equipment configuration in system, System overall configuration, Other restrictions, Restrictions by the software's version, System data setting list, Individual parameters, Servo parameter read/change function, Optional data monitor function, Special registers list, System setting error, Motion CPU self error, Differences between Motion CPU, Warranty

Japanese Manual Number IB(NA)-0300126

This manual confers no industrial property rights or any rights of any other kind, nor does it confer any patent licenses. Mitsubishi Electric Corporation cannot be held responsible for any problems involving industrial property rights which may occur as a result of using the contents noted in this manual.

## INTRODUCTION

Thank you for choosing the Mitsubishi Electric Motion controller Q173D(S)CPU/Q172D(S)CPU.  
Before using the equipment, please read this manual carefully to develop full familiarity with the functions and performance of the Motion controller you have purchased, so as to ensure correct use.

## CONTENTS

Safety Precautions .....	A- 1
Revisions .....	A-11
Contents .....	A-13
About Manuals .....	A-16
Manual Page Organization .....	A-19

<b>1. OVERVIEW</b>	<b>1- 1 to 1-36</b>
--------------------	---------------------

1.1 Overview.....	1- 1
1.2 Features .....	1- 3
1.2.1 Features of Motion CPU .....	1- 3
1.2.2 Basic specifications of Q173D(S)CPU/Q172D(S)CPU.....	1- 5
1.3 Hardware Configuration .....	1-11
1.3.1 Motion system configuration .....	1-11
1.3.2 Q173DSCPU/Q172DSCPU System overall configuration .....	1-14
1.3.3 Q173DCPU(-S1)/Q172DCPU(-S1) System overall configuration.....	1-16
1.3.4 Software packages.....	1-18
1.3.5 Restrictions on motion systems .....	1-20
1.4 Checking Serial Number and Operating System Software Version.....	1-25
1.4.1 Checking serial number .....	1-25
1.4.2 Checking operating system software version.....	1-28
1.5 Restrictions by the Software's Version.....	1-30
1.6 Programming Software Version.....	1-36

<b>2. MULTIPLE CPU SYSTEM</b>	<b>2- 1 to 2-36</b>
-------------------------------	---------------------

2.1 Multiple CPU System .....	2- 1
2.1.1 Overview.....	2- 1
2.1.2 Installation position of CPU module.....	2- 2
2.1.3 Precautions for using I/O modules and intelligent function modules.....	2- 3
2.1.4 Modules subject to installation restrictions .....	2- 4
2.1.5 How to reset the Multiple CPU system.....	2- 6
2.1.6 Operation for CPU module stop error.....	2- 7
2.2 Starting Up the Multiple CPU System .....	2-10
2.2.1 Startup Flow of the Multiple CPU system.....	2-10
2.3 Communication Between the PLC CPU and the Motion CPU in the Multiple CPU System.....	2-12
2.3.1 CPU shared memory.....	2-12
2.3.2 Multiple CPU high speed transmission.....	2-15
2.3.3 Multiple CPU high speed refresh function .....	2-30
2.3.4 Clock synchronization between Multiple CPU .....	2-34
2.3.5 Multiple CPU synchronous startup .....	2-35
2.3.6 Control instruction from PLC CPU to Motion CPU.....	2-36

<b>3. COMMON PARAMETERS</b>	<b>3- 1 to 3-30</b>
-----------------------------	---------------------

3.1 System Settings .....	3- 1
3.1.1 System data settings .....	3- 2
3.1.2 Common system parameters .....	3- 5
3.1.3 Individual parameters .....	3-11
3.2 I/O Number Assignment .....	3-22
3.2.1 I/O number assignment of each module .....	3-22
3.2.2 I/O number of each CPU module .....	3-24
3.2.3 I/O number setting .....	3-25
3.3 Servo Parameters .....	3-26
3.4 Servo External Signal Parameters .....	3-27

<b>4. AUXILIARY AND APPLIED FUNCTIONS</b>	<b>4- 1 to 4-118</b>
---	----------------------

4.1 Limit Switch Output Function .....	4- 1
4.1.1 Operations .....	4- 1
4.1.2 Limit output setting data .....	4- 4
4.1.3 Operations (SV22 advanced synchronous control only) .....	4- 9
4.1.4 Limit output setting data (SV22 advanced synchronous control only) .....	4-11
4.2 Absolute Position System .....	4-18
4.2.1 Current value control .....	4-21
4.3 High-Speed Reading of Specified Data .....	4-22
4.4 ROM Operation Function .....	4-24
4.4.1 Specifications of 7-segment LED/switches .....	4-24
4.4.2 Outline of ROM operation .....	4-26
4.4.3 Operating procedure of the ROM operation function .....	4-31
4.5 Security Function .....	4-33
4.5.1 Protection by password .....	4-33
4.5.2 Protection by software security key .....	4-40
4.6 All Clear Function .....	4-45
4.7 Communication Via Network .....	4-46
4.7.1 Specifications of the communications via network .....	4-46
4.8 Monitor Function of the Main Cycle .....	4-47
4.9 Servo Parameter Read/Change Function .....	4-48
4.10 Optional Data Monitor Function .....	4-51
4.11 SSCNET Control Function .....	4-54
4.11.1 Connect/disconnect function of SSCNET communication .....	4-55
4.11.2 Amplifier-less operation function .....	4-59
4.12 Remote Operation .....	4-63
4.12.1 Remote RUN/STOP .....	4-63
4.12.2 Remote latch clear .....	4-65
4.13 Communication Function via PERIPHERAL I/F .....	4-66
4.13.1 Direct connection .....	4-66
4.13.2 Connection via HUB .....	4-69
4.13.3 MC protocol communication .....	4-75
4.14 Mark Detection Function .....	4-82
4.14.1 Operations .....	4-83
4.14.2 Mark detection setting .....	4-84

4.15 High-speed Input Request Signal Setting (SV22 advanced synchronous control only) .....	4-95
4.16 Driver Communication Function .....	4-98
4.16.1 Control details.....	4-99
4.16.2 Precautions during control .....	4-100
4.16.3 Servo parameter.....	4-104
4.17 Intelligent Function Modules Controlled by Motion CPU .....	4-105
4.18 Connection of SSCNET III/H Head Module .....	4-108
4.18.1 System configuration.....	4-108
4.18.2 SSCNET III/H head module parameters .....	4-109
4.18.3 Data operation of intelligent function module by Motion SFC program.....	4-117
4.18.4 Data of refresh device .....	4-117
4.18.5 Precautions when using SSCNET III/H head module.....	4-117

APPENDICES
------------

APP- 1 to APP-50
------------------

APPENDIX 1 Special Relays/Special Registers .....	APP- 1
APPENDIX 1.1 Special relays .....	APP- 1
APPENDIX 1.2 Special registers .....	APP- 5
APPENDIX 1.3 Replacement of special relays/special registers .....	APP-13
APPENDIX 2 System Setting Errors .....	APP-16
APPENDIX 3 Self-diagnosis Error .....	APP-19
APPENDIX 4 Differences Between Q173DSCPU/Q172DSCPU/Q173DCPU(-S1)/Q172DCPU(-S1)/ Q173HCPU/Q172HCPU .....	APP-32
APPENDIX 4.1 Differences between Q173DSCPU/Q172DSCPU/Q173DCPU(-S1)/Q172DCPU(-S1)/ Q173HCPU/Q172HCPU .....	APP-32
APPENDIX 4.2 Comparison of devices.....	APP-37
APPENDIX 4.3 Differences of the operating system software .....	APP-47



## About Manuals

The following manuals are also related to this product.

When necessary, order them by quoting the details in the tables below.

### Related Manuals

#### (1) Motion controller

Manual Name	Manual Number (Model Code)
<b>Q173D(S)CPU/Q172D(S)CPU Motion controller User's Manual</b> This manual explains specifications of the Motion CPU modules, Q172DLX Servo external signal interface module, Q172DEX Synchronous encoder interface module, Q173DPX Manual pulse generator interface module, Power supply modules, Servo amplifiers, SSCNETIII cables and Synchronous encoder, and the maintenance/inspection for the system, trouble shooting and others.	IB-0300133 (1XB927)
<b>Q173D(S)CPU/Q172D(S)CPU Motion controller Programming Manual (COMMON)</b> This manual explains the Multiple CPU system configuration, performance specifications, common parameters, auxiliary/applied functions, error lists and others.	IB-0300134 (1XB928)
<b>Q173D(S)CPU/Q172D(S)CPU Motion controller (SV13/SV22) Programming Manual (Motion SFC)</b> This manual explains the functions, programming, debugging, error lists for Motion SFC and others.	IB-0300135 (1XB929)
<b>Q173D(S)CPU/Q172D(S)CPU Motion controller (SV13/SV22) Programming Manual (REAL MODE)</b> This manual explains the servo parameters, positioning instructions, device lists, error lists and others.	IB-0300136 (1XB930)
<b>Q173D(S)CPU/Q172D(S)CPU Motion controller (SV22) Programming Manual (VIRTUAL MODE)</b> This manual explains the dedicated instructions to use the synchronous control by virtual main shaft, mechanical system program create mechanical module, servo parameters, positioning instructions, device lists, error lists and others.	IB-0300137 (1XB931)
<b>Q173DSCPU/Q172DSCPU Motion controller (SV22) Programming Manual (Advanced Synchronous Control)</b> This manual explains the dedicated instructions to use the synchronous control by synchronous control parameters, device lists, error lists and others.	IB-0300198 (1XB953)
<b>Q173D(S)CPU/Q172D(S)CPU Motion controller Programming Manual (Safety Observation)</b> This manual explains the details, safety parameters, safety sequence program instructions, device lists and error lists and others for safety observation function by Motion controller.	IB-0300183 (1XB945)
<b>Motion controller Setup Guidance (MT Developer2 Version1)</b> This manual explains the items related to the setup of the Motion controller programming software MT Developer2.	IB-0300142 ( — )

## (2) PLC

Manual Name	Manual Number (Model Code)
<p>QCPU User's Manual (Hardware Design, Maintenance and Inspection)</p> <p>This manual explains the specifications of the QCPU modules, power supply modules, base units, extension cables, memory card battery, and the maintenance/inspection for the system, trouble shooting, error codes and others.</p>	SH-080483ENG (13JR73)
<p>QnUCPU User's Manual (Function Explanation, Program Fundamentals)</p> <p>This manual explains the functions, programming methods and devices and others to create programs with the QCPU.</p>	SH-080807ENG (13JZ27)
<p>QCPU User's Manual (Multiple CPU System)</p> <p>This manual explains the Multiple CPU system overview, system configuration, I/O modules, communication between CPU modules and communication with the I/O modules or intelligent function modules.</p>	SH-080485ENG (13JR75)
<p>QnUCPU User's Manual (Communication via Built-in Ethernet Port)</p> <p>This manual explains functions for the communication via built-in Ethernet port of the CPU module.</p>	SH-080811ENG (13JZ29)
<p>MELSEC-Q/L Programming Manual (Common Instruction)</p> <p>This manual explains how to use the sequence instructions, basic instructions, application instructions and micro computer program.</p>	SH-080809ENG (13JW10)
<p>MELSEC-Q/L/QnA Programming Manual (PID Control Instructions)</p> <p>This manual explains the dedicated instructions used to exercise PID control.</p>	SH-080040 (13JF59)
<p>MELSEC-Q/L/QnA Programming Manual (SFC)</p> <p>This manual explains the system configuration, performance specifications, functions, programming, debugging, error codes and others of MELSAP3.</p>	SH-080041 (13JF60)
<p>I/O Module Type Building Block User's Manual</p> <p>This manual explains the specifications of the I/O modules, connector, connector/terminal block conversion modules and others.</p>	SH-080042 (13JL99)
<p>MELSEC-L SSCNETⅢ/H Head Module User's Manual</p> <p>This manual explains specifications of the head module, procedures before operation, system configuration, installation, wiring, settings, and troubleshooting.</p>	SH-081152ENG (13JZ78)



### (3) Servo amplifier

Manual Name	Manual Number (Model Code)
MR-J5-B/MR-J5W-B User's Manual (Introduction) This manual explains the specifications, functions, start-up procedure and others for AC Servo MR-J5-B/ MR-J5W-B Servo amplifier.	IB-0300578ENG ( — )
MR-J5 User's Manual (Hardware) This manual explains the installation, wiring, use option and others for AC Servo MR-J5-B/MR-J5W-B Servo amplifier.	SH-030298ENG ( — )
MR-J5 User's Manual (Function) This manual explains how to use each function required to operate the AC Servo MR-J5-B/MR-J5W-B Servo amplifier.	SH-030300ENG ( — )
MR-J5 User's Manual (Adjustment) This manual explains the operation status adjustment procedure, adjustment method and others for AC Servo MR-J5-B/MR-J5W-B Servo amplifier.	SH-030306ENG ( — )
MR-J5 User's Manual (Troubleshooting) This manual explains the causes of alarms, and warnings, etc. for AC Servo MR-J5-B/MR-J5W-B Servo amplifier.	SH-030312ENG ( — )
MR-J5-B/MR-J5W-B User's Manual (Parameters) This manual explains the parameters for AC Servo MR-J5-B/MR-J5W-B Servo amplifier.	IB-0300581ENG ( — )
SSCNETⅢ/H Interface AC Servo MR-J4- _B_(-RJ) Servo amplifier Instruction Manual This manual explains the I/O signals, parts names, parameters, start-up procedure and others for AC Servo MR-J4- _B_(-RJ) Servo amplifier.	SH-030106 (1CW805)
SSCNETⅢ/H Interface Multi-axis AC Servo MR-J4W2- _B_/MR-J4W3- _B_/MR-J4W2-0303B6 Servo amplifier Instruction Manual This manual explains the I/O signals, parts names, parameters, start-up procedure and others for Multi- axis AC Servo MR-J4W2- _B_/MR-J4W3- _B_/MR-J4W2-0303B6 Servo amplifier.	SH-030105 (1CW806)
SSCNETⅢ interface MR-J3-□B Servo amplifier Instruction Manual This manual explains the I/O signals, parts names, parameters, start-up procedure and others for MR-J3-□B Servo amplifier.	SH-030051 (1CW202)
SSCNETⅢ interface 2-axis AC Servo Amplifier MR-J3W-0303BN6/MR-J3W-□B Servo amplifier Instruction Manual This manual explains the I/O signals, parts names, parameters, start-up procedure and others for 2-axis AC Servo Amplifier MR-J3W-0303BN6/MR-J3W-□B Servo amplifier.	SH-030073 (1CW604)
SSCNETⅢ Compatible Linear Servo MR-J3-□B-RJ004U□ Instruction Manual This manual explains the I/O signals, parts names, parameters, start-up procedure and others for Linear Servo MR-J3-□B-RJ004U□ Servo amplifier.	SH-030054 (1CW943)
SSCNETⅢ Compatible Fully Closed Loop Control MR-J3-□B-RJ006 Servo amplifier Instruction Manual This manual explains the I/O signals, parts names, parameters, start-up procedure and others for Fully Closed Loop Control MR-J3-□B-RJ006 Servo amplifier.	SH-030056 (1CW304)
SSCNETⅢ Interface Direct Drive Servo MR-J3-□B-RJ080W Instruction Manual This manual explains the I/O signals, parts names, parameters, start-up procedure and others for Direct Drive Servo MR-J3-□B-RJ080W Servo amplifier.	SH-030079 (1CW601)

Manual Name	Manual Number (Model Code)
SSCNETⅢ interface Drive Safety integrated MR-J3-□B Safety Servo amplifier Instruction Manual This manual explains the I/O signals, parts names, parameters, start-up procedure and others for safety integrated MR-J3-□B Safety Servo amplifier.	SH-030084 (1CW205)

Manual Page Organization

The symbols used in this manual are shown below.

Symbol	Description
	Symbol that indicates correspondence to only Q173DSCPU/Q172DSCPU.
	Symbol that indicates correspondence to only Q173DCPU(-S1)/Q172DCPU(-S1).



## 1. OVERVIEW

## 1.1 Overview

This programming manual describes the common items of each operating system software, such as the Multiple CPU system of the operating system software packages "SW7DNC-SV□□□" and "SW8DNC-SV□□□" for Motion CPU module (Q173D(S)CPU/Q172D(S)CPU).

In this manual, the following abbreviations are used.

Generic term/Abbreviation	Description
Q173D(S)CPU/Q172D(S)CPU or Motion CPU (module)	Q173DSCPU/Q172DSCPU/Q173DCPU/Q172DCPU/Q173DCPU-S1/ Q172DCPU-S1 Motion CPU module
Q172DLX/Q172DEX/Q173DPX/ Q173DSXY or Motion module	Q172DLX Servo external signals interface module/ Q172DEX Synchronous encoder interface module <sup>(Note-1)</sup> / Q173DPX Manual pulse generator interface module/ Q173DSXY Safety signal module
MR-J5(W)-□B	Servo amplifier model MR-J5-□B/MR-J5W-□B
MR-J4(W)-□B	Servo amplifier model MR-J4-□B/MR-J4W-□B
MR-J3(W)-□B	Servo amplifier model MR-J3-□B/MR-J3W-□B
AMP or Servo amplifier	General name for "Servo amplifier model MR-J5-□B/MR-J5W-□B/MR-J4-□B/ MR-J4W-□B/MR-J3-□B/MR-J3W-□B"
QCPU, PLC CPU or PLC CPU module	QnUD(E)(H)CPU/QnUDVCPU
Multiple CPU system or Motion system	Abbreviation for "Multiple PLC system of the Q series"
CPUn	Abbreviation for "CPU No.n (n= 1 to 4) of the CPU module for the Multiple CPU system"
Operating system software	General name for "SW7DNC-SV□□□/SW8DNC-SV□□□"
SV13	Operating system software for conveyor assembly use (Motion SFC) : SW8DNC-SV13□□
SV22	Operating system software for automatic machinery use (Motion SFC) : SW8DNC-SV22□□
SV43	Operating system software for machine tool peripheral use : SW7DNC-SV43□□
Programming software package	General name for MT Developer2/GX Works2/GX Developer/MR Configurator□
MELSOFT MT Works2	Abbreviation for "Motion controller engineering environment MELSOFT MT Works2"
MT Developer2 <sup>(Note-2)</sup>	Abbreviation for "Motion controller programming software MT Developer2 (Version 1.00A or later)"
GX Works2	Abbreviation for "Programmable controller engineering software MELSOFT GX Works2 (Version 1.15R or later)"
GX Developer	Abbreviation for "MELSEC PLC programming software package GX Developer (Version 8.48A or later)"
MR Configurator□ <sup>(Note-2)</sup>	General name for "MR Configurator/MR Configurator2"
MR Configurator	Abbreviation for "Servo setup software package MR Configurator (Version C0 or later)"
MR Configurator2	Abbreviation for "Servo setup software package MR Configurator2 (Version 1.01B or later)"
Manual pulse generator or MR-HDP01	Abbreviation for "Manual pulse generator (MR-HDP01)"
Serial absolute synchronous encoder or Q171ENC-W8/Q170ENC	Abbreviation for "Serial absolute synchronous encoder (Q171ENC-W8/ Q170ENC)"

# 1 OVERVIEW

Generic term/Abbreviation	Description
SSCNET III/H <sup>(Note-3)</sup>	High speed synchronous network between Motion controller and servo amplifier
SSCNET III <sup>(Note-3)</sup>	
SSCNET III(/H) <sup>(Note-3)</sup>	General name for SSCNET III/H, SSCNET III
Absolute position system	General name for "system using the servo motor and servo amplifier for absolute position"
Battery holder unit	Battery holder unit (Q170DBATC)
Intelligent function module	General name for module that has a function other than input or output such as A/D converter module and D/A converter module.
SSCNET III/H head module	Abbreviation for "MELSEC-L series SSCNET III/H head module (LJ72MS15)"
Optical hub unit or MR-MV200	Abbreviation for "SSCNET III/H compatible optical hub unit (MR-MV200)"

(Note-1): Q172DEX can be used in SV22.

(Note-2): This software is included in Motion controller engineering environment "MELSOFT MT Works2".

(Note-3): SSCNET: Servo System Controller NETwork

## REMARK

For information about each module, design method for program and parameter, refer to the following manuals relevant to each module.

Item	Reference Manual	
Motion CPU module/Motion unit	Q173D(S)CPU/Q172D(S)CPU Motion controller User's Manual	
PLC CPU, peripheral devices for sequence program design, I/O modules and intelligent function module	Manual relevant to each module	
Operation method for MT Developer2	Help of each software	
SV13/SV22	<ul style="list-style-type: none"> <li>• Design method for Motion SFC program</li> <li>• Design method for Motion SFC parameter</li> <li>• Motion dedicated PLC instruction</li> </ul>	Q173D(S)CPU/Q172D(S)CPU Motion controller (SV13/SV22) Programming Manual (Motion SFC)
	<ul style="list-style-type: none"> <li>• Design method for positioning control program in the real mode</li> <li>• Design method for positioning control parameter</li> </ul>	Q173D(S)CPU/Q172D(S)CPU Motion controller (SV13/SV22) Programming Manual (REAL MODE)
	<ul style="list-style-type: none"> <li>• Design method for safety observation parameter</li> <li>• Design method for user made safety sequence program</li> </ul>	Q173D(S)CPU/Q172D(S)CPU Motion controller Programming Manual (Safety Observation)
SV22 (Virtual mode)	<ul style="list-style-type: none"> <li>• Design method for mechanical system program</li> </ul>	Q173D(S)CPU/Q172D(S)CPU Motion controller (SV22) Programming Manual (VIRTUAL MODE)
SV22 (Advanced synchronous control)	<ul style="list-style-type: none"> <li>• Design method for synchronous control parameter</li> </ul>	Q173DSCPU/Q172DSCPU Motion controller (SV22) Programming Manual (Advanced Synchronous Control)

## 1.2 Features

The Motion CPU and Multiple CPU system have the following features.

### 1.2.1 Features of Motion CPU

#### (1) Q series PLC Multiple CPU system

(a) Load distribution of processing can be performed by controlling the complicated servo control with Motion CPU and the machine control or information control with PLC CPU. Therefore, the flexible system configuration can be realized.

(b) The Motion CPU and PLC CPU are selected flexibly, and the Multiple CPU system up to 4 CPU modules can be realized.

The Motion CPU module for the number of axis to be used can be selected.

Q173DSCPU : Up to 32 axes

Q172DSCPU : Up to 16 axes

Q173DCPU(-S1) : Up to 32 axes

Q172DCPU(-S1) : Up to 8 axes

The PLC CPU module for the program capacity to be used can be selected.  
(One or more PLC CPU is necessary with the Multiple CPU system.)

(c) The device data access of the Motion CPU and the Motion SFC program (SV13/SV22)/Motion program (SV43) start can be executed from PLC CPU by the Motion dedicated PLC instruction.

#### (2) High speed operation processing

(a) The minimum operation cycle of the Motion CPU is made 0.22[ms] (Q173DSCPU/Q172DSCPU use), and it correspond with high frequency operation.

(b) High speed PLC control is possible by the universal model QCPU.

#### (3) Connection between the Motion controller and servo amplifier with high speed synchronous network by SSCNET III(/H)

(a) High speed synchronous network by SSCNET III(/H) connect between the Motion controller and servo amplifier, and batch control the charge of servo parameter, servo monitor and test operation, etc.  
It is also realised reduce the number of wires.

(b) The maximum distance between the Motion CPU and servo amplifier, servo amplifier and servo amplifier of the SSCNET III cable on the same bus was set to 100(328.08)[m(ft.)] for SSCNET III/H, 50(164.04)[m(ft.)] for SSCNET III, and the flexibility improved at the Motion system design.



- (4) The operating system software package for your application needs  
By installing the operating system software for applications in the internal flash memory of the Motion CPU, the Motion controller suitable for the machine can be realized. And, it also can correspond with the function improvement of the software package.
- (a) Conveyor assembly use (SV13)  
Offer linear interpolation, circular interpolation, helical interpolation, constant-speed control, speed control, fixed-pitch feed and etc. by the dedicated servo instruction. Ideal for use in conveyors and assembly machines.
- (b) Automatic machinery use (SV22)  
In addition to the functions (real mode) equivalent to the software package for conveyor assembly use (SV13), provides synchronous control and offers electronic cam control. Ideal for use in automatic machinery.
- 1) Q173DSCPU/Q172DSCPU  
Select the operation method from the following methods when installing the operating system software.  
The operation method can be switched by using MT Developer2.
- Virtual mode switching method:  
By using the common device (real mode/virtual mode switching request flag), switching between the positioning control in the real mode and the synchronous control, electronic cam control by mechanical support language (virtual mode) is enabled.
  - Advanced synchronous control method:  
In addition to the positioning control in the real mode, provides synchronous control by setting the synchronous control parameter (advanced synchronous control) by using the synchronous control start signal for each axis.
- 2) Q173DCPU(-S1)/Q172DCPU(-S1)  
By using the common device (real mode/virtual mode switching request flag), switching between the positioning control in the real mode and the synchronous control, electronic cam control by mechanical support language (virtual mode) is enabled.
- (c) Machine tool peripheral use (SV43)  
Offer linear interpolation, circular interpolation, helical interpolation, constant speed positioning and etc. by the EIA language (G-code). Ideal for use in machine tool peripheral.

# 1 OVERVIEW

## 1.2.2 Basic specifications of Q173D(S)CPU/Q172D(S)CPU

### (1) Module specifications

Item	Q173DSCPU	Q172DSCPU	Q173DCPU	Q173DCPU-S1	Q172DCPU	Q172DCPU-S1
Internal current consumption (5VDC) [A]	1.75 (Note-1)	1.44 (Note-1)	1.25	1.30	1.25	1.30
Mass [kg]	0.38		0.33			
Exterior dimensions [mm(inch)]	120.5 (4.74)(H) × 27.4 (1.08)(W) × 120.3 (4.74)(D)		98 (3.85)(H) × 27.4 (1.08)(W) × 119.3 (4.70)(D)			

(Note-1): The current consumption (0.2[A]) of manual pulse generator/incremental synchronous encoder connected to the internal I/F connector is not included.

### (2) SV13/SV22 Motion control specifications/performance specifications

#### (a) Motion control specifications

Item	Q173DSCPU	Q172DSCPU	Q173DCPU(-S1)	Q172DCPU(-S1)	
Number of control axes	Up to 32 axes	Up to 16 axes	Up to 32 axes	Up to 8 axes	
Operation cycle (default)	SV13	0.22ms/ 1 to 4 axes 0.44ms/ 5 to 10 axes 0.88ms/ 11 to 24 axes 1.77ms/25 to 32 axes	0.22ms/ 1 to 4 axes 0.44ms/ 5 to 10 axes 0.88ms/ 11 to 16 axes	0.44ms/ 1 to 6 axes 0.88ms/ 7 to 18 axes 1.77ms/19 to 32 axes	0.44ms/ 1 to 6 axes 0.88ms/ 7 to 8 axes
	SV22	0.44ms/ 1 to 6 axes 0.88ms/ 7 to 16 axes 1.77ms/17 to 32 axes	0.44ms/ 1 to 6 axes 0.88ms/ 7 to 16 axes	0.44ms/ 1 to 4 axes 0.88ms/ 5 to 12 axes 1.77ms/13 to 28 axes 3.55ms/29 to 32 axes	0.44ms/ 1 to 4 axes 0.88ms/ 5 to 8 axes
Interpolation functions	Linear interpolation (Up to 4 axes), Circular interpolation (2 axes), Helical interpolation (3 axes)				
Control modes	PTP(Point to Point) control, Speed control, Speed-position switching control, Fixed-pitch feed, Constant speed control, Position follow-up control, Speed control with fixed position stop, Speed switching control, High-speed oscillation control, Speed-torque control, Synchronous control (SV22 (Virtual mode switching method/Advanced synchronous control method))		PTP(Point to Point) control, Speed control, Speed-position switching control, Fixed-pitch feed, Constant speed control, Position follow-up control, Speed control with fixed position stop, Speed switching control, High-speed oscillation control, Synchronous control (SV22)		
Acceleration/ deceleration control	Trapezoidal acceleration/deceleration, S-curve acceleration/deceleration, Advanced S-curve acceleration/deceleration				
Compensation	Backlash compensation, Electronic gear, Phase compensation (SV22)				
Programming language	Motion SFC, Dedicated instruction, Mechanical support language (SV22) (Note-1)		Motion SFC, Dedicated instruction, Mechanical support language (SV22)		
Servo program capacity	16k steps				
Number of positioning points	3200 points (Positioning data can be designated indirectly)				
Peripheral I/F	USB/RS-232/Ethernet (Via PLC CPU) PERIPHERAL I/F (Motion CPU)		USB/RS-232/Ethernet (Via PLC CPU) PERIPHERAL I/F (Motion CPU) (Note-2)		

# 1 OVERVIEW

## Motion control specifications (continued)

Item		Q173DSCPU	Q172DSCPU	Q173DCPU(-S1)	Q172DCPU(-S1)
Home position return function		Proximity dog method (2 types), Count method (3 types), Data set method (2 types), Dog cradle method, Stopper method (2 types), Limit switch combined method, Scale home position signal detection method, Dogless home position signal reference method, Driver home position return method		Proximity dog method (2 types), Count method (3 types), Data set method (2 types), Dog cradle method, Stopper method (2 types), Limit switch combined method, Scale home position signal detection method	
		Home position return re-try function provided, home position shift function provided			
JOG operation function		Provided			
Manual pulse generator operation function		Possible to connect 3 modules (Q173DPX use) Possible to connect 1 module (Built-in interface in Motion CPU use) (Note-3)		Possible to connect 3 modules (Q173DPX use)	
Synchronous encoder operation function (Note-4)		Possible to connect 12 modules (SV22 use) (Q172DEX + Q173DPX + Built-in interface in Motion CPU + Via device (Note-5) + Via servo amplifier (Note-5), (Note-6) + Multiple CPU synchronous control (Note-5)		Possible to connect 12 modules (SV22 use) (Q172DEX + Q173DPX)	Possible to connect 8 modules (SV22 use) (Q172DEX + Q173DPX)
M-code function		M-code output function provided, M-code completion wait function provided			
Limit switch output function	SV13	Number of output points 32 points Watch data: Motion control data/Word device			
	SV22	Virtual mode switching method: Number of output points 32 points Advanced synchronous control method: Number of output points 64 points × 2 settings Output timing compensation Watch data: Motion control data/Word device		Number of output points 32 points Watch data: Motion control data/Word device	
ROM operation function		Provided			
Multiple CPU synchronous control (Note-5)		Provided		None	
External input signal		Q172DLX, External input signals (FLS/RLS/DOG) of servo amplifier, Built-in interface in Motion CPU (DI), Bit device		Q172DLX or External input signals (FLS/RLS/DOG) of servo amplifier	
High-speed reading function (Note-7)		Provided (Via built-in interface in Motion CPU, Via input module, Via tracking of Q172DEX/Q173DPX)		Provided (Via input module, Via tracking of Q172DEX/Q173DPX)	
Forced stop		Motion controller forced stop (EMI connector, System setting), Forced stop terminal of servo amplifier			
Number of I/O points		Total 256 points (Built-in interface in Motion CPU (Input 4 points) + I/O module + Intelligent function module)		Total 256 points (I/O module)	
Mark detection function	Mark detection mode setting	Continuous detection mode, Specified number of detection mode, Ring buffer mode		None	
	Mark detection signal	Built-in interface in Motion CPU (4 points), Bit device, DOG/CHANGE signal of Q172DLX			
	Mark detection setting	32 settings			
Clock function		Provided			
Security function		Provided (Protection by software security key or password)		Provided (Protection by password)	

# 1 OVERVIEW

## Motion control specifications (continued)

Item		Q173DSCPU	Q172DSCPU	Q173DCPU(-S1)	Q172DCPU(-S1)
All clear function		Provided			
Remote operation		Remote RUN/STOP, Remote latch clear			
Optional data monitor function	SSCNETⅢ/H	Up to 6 data/axis (Communication data: Up to 6 points/axis)		None	
	SSCNETⅢ	Up to 3 data/axis (Communication data: Up to 3 points/axis)			
Digital oscilloscope function		Motion buffering method (Real-time waveform can be displayed) Sampling data: Word 16CH, Bit 16CH		Motion buffering method (Real-time waveform can be displayed) Sampling data: Word 4CH, Bit 8CH	
Absolute position system		Made compatible by setting battery to servo amplifier. (No battery required when a servo motor with a batteryless absolute position encoder is used) (Possible to select the absolute data method or incremental method for each axis)			
SSCNET communication (Note-8)	Communication type	SSCNETⅢ/H, SSCNETⅢ		SSCNETⅢ	
	Number of lines	2 lines (Note-9)	1 line (Note-9)	2 lines	1 line
Driver communication function (Note-10)		Provided		None	
Number of Motion related modules	Q172DLX	4 modules usable	2 modules usable	4 modules usable	1 module usable
	Q172DEX	6 modules usable			4 modules usable
	Q173DPX	4 modules usable (Note-11)			3 modules usable (Note-11)
Number of SSCNETⅢ/H head module connection stations		Up to 8 stations usable (Up to 4 stations/line)	Up to 4 stations usable	Unusable	
Number of optical hub unit connections		Up to 32 units usable (Up to 16 units/line)	Up to 16 units usable	Unusable	

(Note-1): SV22 virtual mode only

(Note-2): Q173DCPU-S1/Q172DCPU-S1 only

(Note-3): When the manual pulse generator is used via the built-in interface in Motion CPU, the Q173DPX cannot be used.

(Note-4): Any incremental synchronous encoder connected to the built-in interface in Motion CPU will automatically be assigned an Axis No. one integer greater than the number of encoders connected to any Q172DEX modules and Q173DPX modules.

(Note-5): SV22 advanced synchronous control only

(Note-6): Servo amplifier (MR-J5(W)-□B/MR-J4(W)-□B) only.

Refer to "Q173DSCPU/Q172DSCPU Motion controller Programming Manual (Advanced Synchronous Control)" for details on devices that can be used as a synchronous encoder axis.

(Note-7): This cannot be used in SV22 advanced synchronous control.

(Note-8): The servo amplifiers for SSCNET cannot be used.

(Note-9): SSCNETⅢ and SSCNETⅢ/H cannot be combined in the same line.

For Q173DSCPU, SSCNETⅢ or SSCNETⅢ/H can be set every line.

(Note-10): Servo amplifier (MR-J5-□B/MR-J4-□B/MR-J3-□B) only.

(Note-11): When using the incremental synchronous encoder (SV22 use), you can use above number of modules.

When connecting the manual pulse generator, you can use only 1 module.

# 1 OVERVIEW

## (b) Motion SFC Performance Specifications

Item		Q173DSCPU/Q172DSCPU	Q173DCPU(-S1)/Q172DCPU(-S1)		
Motion SFC program capacity	Code total (Motion SFC chart + Operation control + Transition)	652k bytes	543k bytes		
	Text total (Operation control + Transition)	668k bytes	484k bytes		
Motion SFC program	Number of Motion SFC programs	256 (No.0 to 255)			
	Motion SFC chart size/program	Up to 64k bytes (Included Motion SFC chart comments)			
	Number of Motion SFC steps/program	Up to 4094 steps			
	Number of selective branches/branch	255			
	Number of parallel branches/branch	255			
	Parallel branch nesting	Up to 4 levels			
Operation control program (F/FS) / Transition program (G)	Number of operation control programs	4096 with F(Once execution type) and FS(Scan execution type) combined. (F/FS0 to F/FS4095)			
	Number of transition programs	4096(G0 to G4095)			
	Code size/program	Up to approx. 64k bytes (32766 steps)			
	Number of blocks(line)/program	Up to 8192 blocks (in the case of 4 steps(min)/blocks)			
	Number of characters/block	Up to 128 (comment included)			
	Number of operand/block	Up to 64 (operand: constants, word device, bit devices)			
	( ) nesting/block	Up to 32 levels			
Descriptive expression	Operation control program	Calculation expression, bit conditional expression, branch/repetition processing	Calculation expression, bit conditional expression		
	Transition program	Calculation expression/bit conditional expression/ comparison conditional expression			
Execute specification	Number of multi execute programs	Up to 256			
	Number of multi active steps	Up to 256 steps/all programs			
	Executed task	Normal task	Execute in main cycle of Motion CPU		
		Event task (Execution can be masked.)	Fixed cycle	Execute in fixed cycle (0.22ms, 0.44ms, 0.88ms, 1.77ms, 3.55ms, 7.11ms, 14.2ms)	Execute in fixed cycle (0.44ms, 0.88ms, 1.77ms, 3.55ms, 7.11ms, 14.2ms)
			External interrupt	Executes when the input set to the event task factor in the input module controlled by the Motion CPU (16 points) turns ON.	
PLC interrupt			Execute with interrupt instruction (D(P).GINT) from PLC CPU.		
NMI task	Executes when the input set to the NMI task factor in the input module controlled by the Motion CPU (16 points) turns ON.				
Number of I/O points (X/Y)		8192 points			
Number of real I/O points (PX/PY)		256 points (Built-in interface in Motion CPU (Input 4 points) + I/O module + Intelligent function module)	256 points (I/O module)		
Number of devices (Device In the Motion CPU only) (Included the positioning dedicated device)	Internal relays (M)	12288 points			
	Link relays (B)	8192 points			
	Annunciators (F)	2048 points			
	Special relays (SM)	2256 points			
	Data registers (D)	8192 points (Note-1)	8192 points		
	Link registers (W)	8192 points			
	Special registers (SD)	2256 points			
	Motion registers (#)	12288 points			
	Coasting timers (FT)	1 point (888µs)			
Multiple CPU area devices (U□\G)		Up to 14336 points usable (Note-2)			

(Note-1): 19824 points can be used for SV22 advanced synchronous control.

(Note-2): Usable number of points changes according to the system settings.

# 1 OVERVIEW

## (3) SV43 Motion control specifications/performance specifications (a) Motion control specifications

Item		Q173DCPU(-S1)	Q172DCPU(-S1)
Number of control axes		Up to 32 axes	
Operation cycle (default)		0.44ms/ 1 to 4 axes 0.88ms/ 5 to 12 axes 1.77ms/13 to 28 axes 3.55ms/29 to 32 axes	0.44ms/ 1 to 4 axes 0.88ms/ 5 to 8 axes
Interpolation functions		Linear interpolation (Up to 4 axes), Circular interpolation (2 axes), Helical interpolation (3 axes)	
Control modes		PTP (Point to Point) control, Constant speed positioning, High-speed oscillation control	
Acceleration/deceleration control		Trapezoidal acceleration/deceleration, S-curve acceleration/deceleration	
Compensation		Backlash compensation, Electronic gear	
Programming language		Dedicated instruction (EIA language)	
Motion program capacity		504k bytes	
Number of programs		1024	
Number of simultaneous start programs		Axis designation program : 32 Control program : 16	Axis designation program : 8 Control program : 16
Number of positioning points		Approx. 10600 points (Positioning data can be designated indirectly)	
Peripheral I/F		USB/RS-232/Ethernet (Via PLC CPU), PERIPHERAL I/F (Motion CPU) (Note-1)	
Home position return function		Proximity dog method (2 types), Count method (3 types), Data set method (2 types), Dog cradle method, Stopper method (2 types), Limit switch combined method, Scale home position signal detection method ----- Home position return re-try function provided, home position shift function provided	
JOG operation function		Provided	
Manual pulse generator operation function		Possible to connect 3 modules (Q173DPX use)	
M-code function		M-code output function provided, M-code completion wait function provided	
Limit switch output function		Number of output points 32 points Watch data: Motion control data/Word device	
Skip function		Provided	
Override ratio setting function		Override ratio setting : -100 to 100[%]	
ROM operation function		Provided	
External input signal		Q172DLX or External input signals (FLS/RLS/DOG) of servo amplifier	
High-speed reading function		Provided (Via input module, Via tracking of Q173DPX)	
Forced stop		Motion controller forced stop (EMI connector, System setting), Forced stop terminal of servo amplifier	
Number of I/O points		Total 256 points (I/O module)	
Clock function		Provided	
Security function		Provided (Protection by password)	
All clear function		Provided	
Remote operation		Remote RUN/STOP, Remote latch clear	
Digital oscilloscope function		Provided	
Absolute position system		Made compatible by setting battery to servo amplifier. (Possible to select the absolute data method or incremental method for each axis)	
SSCNET communication (Note-2)	Communication type	SSCNETⅢ	
	Number of lines	2 lines	1 line
Number of Motion related modules	Q172DLX	4 modules usable	1 module usable
	Q173DPX	1 module usable	

(Note-1): Q173DCPU-S1/Q172DCPU-S1 only

(Note-2): The servo amplifiers for SSCNET cannot be used.

# 1 OVERVIEW

## (b) Motion program performance specifications

Item		Q173DCPU(-S1)/Q172DCPU(-S1)
Program capacity	Total of program files	504k bytes
	Number of programs	Up to 1024 (No. 1 to 1024)
Operation controls	Arithmetic operation	Unary operation, Addition and subtraction operation, Multiplication and division operation, Remainder operation
	Comparison operation	Equal to, Not equal to
	Logical operation	Logical shift operation, Logical negation, Logical AND, Logical OR, Exclusive OR
G-codes	Positioning command	G00, G01, G02, G03, G04, G09, G12, G13, G23, G24, G25, G26, G28, G30, G32, G43, G44, G49, G53, G54, G55, G56, G57, G58, G59, G61, G64, G90, G91, G92, G98, G99, G100, G101
M-codes	Output command to data register	M****
Special M-codes	Program control command	M00, M01, M02, M30, M98, M99, M100
Variable	Device variable	X, Y, M, B, F, D, W, #, U□\G
Functions	Trigonometric function	SIN, COS, TAN, ASIN, ACOS, ATAN
	Numerical function	ABS, SQR, BIN, LN, EXP, BCD, RND, FIX, FUP, INT, FLT, DFLT, SFLT
Instructions	Start/end	CALL, CLEAR
	Home position return	CHGA
	Speed/torque setting	CHGV, CHGT, TL
	Motion control	WAITON, WAITOFF, EXEON, EXEOFF
	Jump/repetition processing	CALL, GOSUB, GOSUBE, IF...GOTO, IF...THEN...ELSE IF...ELSE...END, WHILE...DO...BREAK...CONTINUE...END
	Data operation	BMOV, BDMOV, FMOV, BSET, BRST, SET, RST, MULTW, MULTR, TO, FROM, ON, OFF, IF...THEN...SET/RST/OUT, PB
Number of controls	Program calls (GOSUB/GOSUBE)	Up to 8
	Program calls (M98)	Up to 8
Number of devices (Device In the Motion CPU only) (Included the positioning dedicated device)	Internal relays (M)	8192 points
	Link relays (B)	8192 points
	Annunciators (F)	2048 points
	Special relays (SM)	2256 points
	Data registers (D)	8192 points
	Link registers (W)	8192 points
	Special registers (SD)	2256 points
	Motion registers (#)	8736 points
	Coasting timers (FT)	1 point (888μs)
Multiple CPU area devices (U□\G)		Up to 14336 points usable (Note)

(Note): Usable number of points changes according to the system settings.

# 1 OVERVIEW

## 1.3 Hardware Configuration

This section describes the Motion controller system configuration, precautions on use of system, and configured equipments.

### 1.3.1 Motion system configuration

#### (1) Equipment configuration in system (a) Q173DSCPU/Q172DSCPU

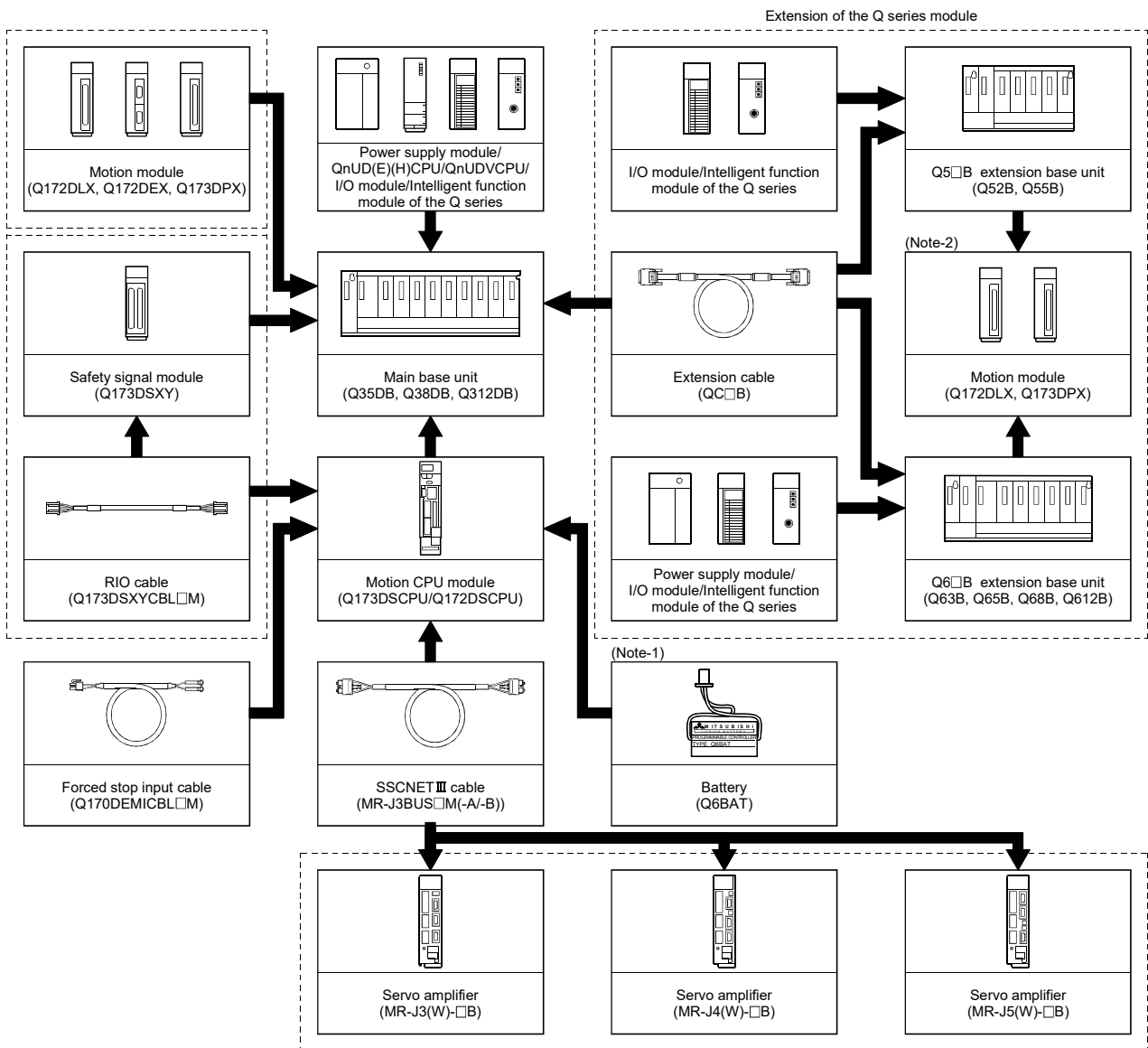

□ It is possible to select the best according to the system.

(Note-1): Be sure to install the Battery (Q6BAT). It is packed together with Q173DSCPU/Q172DSCPU.

(Note-2): Q172DEX cannot be used in the extension base unit. Install it to the main base unit.



(b) Q173DCPU(-S1)/Q172DCPU(-S1)

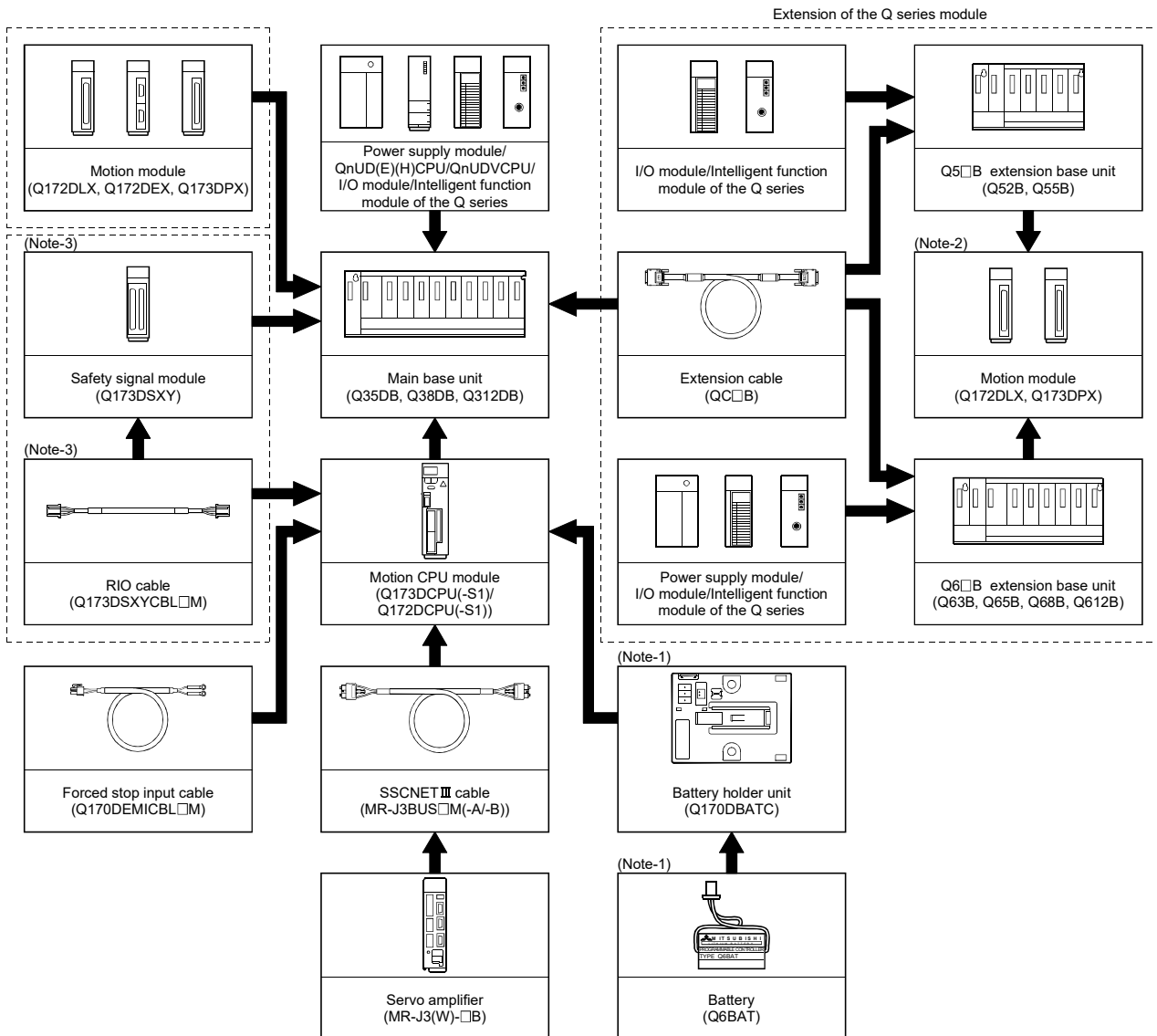

- It is possible to select the best according to the system.
- (Note-1): Be sure to install the Battery (Q6BAT) to the Battery holder unit (Q170DBATC). It is packed together with Q173DCPU(-S1)/Q172DCPU(-S1).
- (Note-2): Q172DEX cannot be used in the extension base unit. Install it to the main base unit.
- (Note-3): Q173DCPU-S1/Q172DCPU-S1 only.

(2) Peripheral device configuration for the Q173D(S)CPU/  
Q172D(S)CPU

The following (a)(b)(c) can be used.

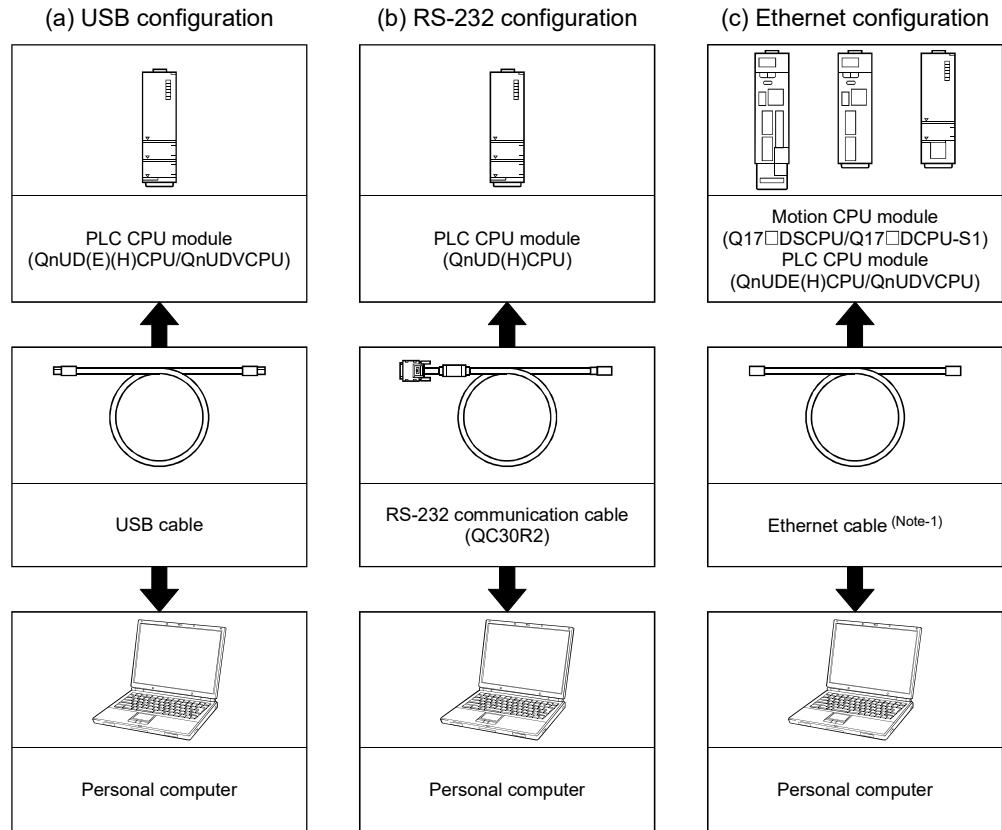

(Note-1): Corresponding Ethernet cables

1) Connecting to Motion CPU module

Part name	Connection type	Cable type	Ethernet standard	Specification
Ethernet cable	Connection with HUB	Straight cable	10BASE-T	Compliant with Ethernet standards, category 5 or higher. • Shielded twisted pair cable (STP cable)
			100BASE-TX	
	Direct connection	Crossover cable	10BASE-T	
			100BASE-TX	

[Selection criterion of cable]

- Category : 5 or higher
- Diameter of lead : AWG26 or higher
- Shield : Copper braid shield and drain wire  
Copper braid shield and aluminium layered type shield

2) Connecting to PLC CPU module

Refer to the "QnUCPU User's Manual (Communication via Built-in Ethernet Port)".

# 1 OVERVIEW

## 1.3.2 Q173DSCPU/Q172DSCPU System overall configuration

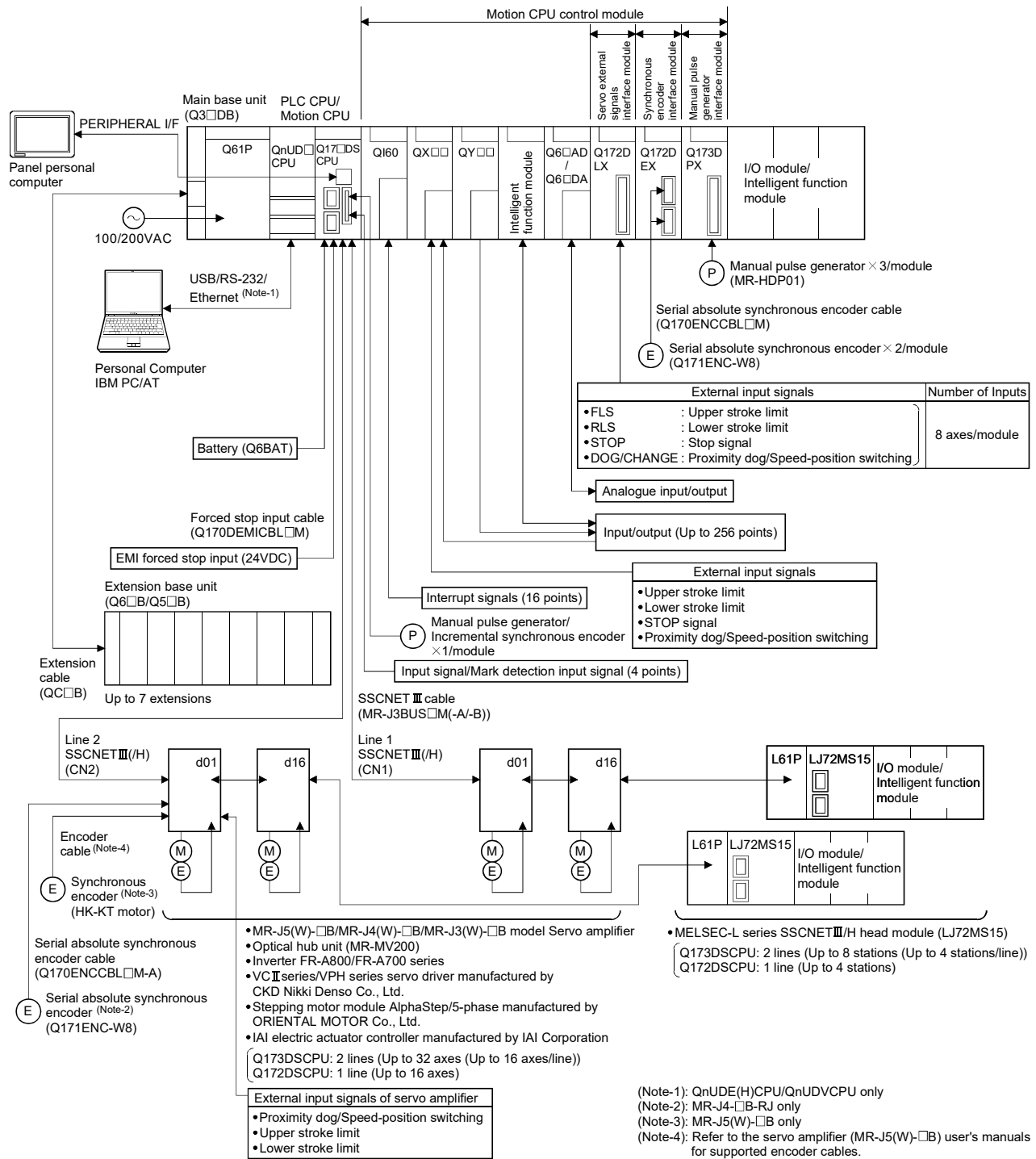

### CAUTION

- Construct a safety circuit externally of the Motion controller or servo amplifier if the abnormal operation of the Motion controller or servo amplifier differ from the safety directive operation in the system.
- The ratings and characteristics of the parts (other than Motion controller, servo amplifier and servo motor) used in a system must be compatible with the Motion controller, servo amplifier and servo motor.
- Set the parameter values to those that are compatible with the Motion controller, servo amplifier, servo motor and regenerative resistor model and the system application. The protective functions may not function if the settings are incorrect.

# 1 OVERVIEW

## 1.3.3 Q173DCPU(-S1)/Q172DCPU(-S1) System overall configuration

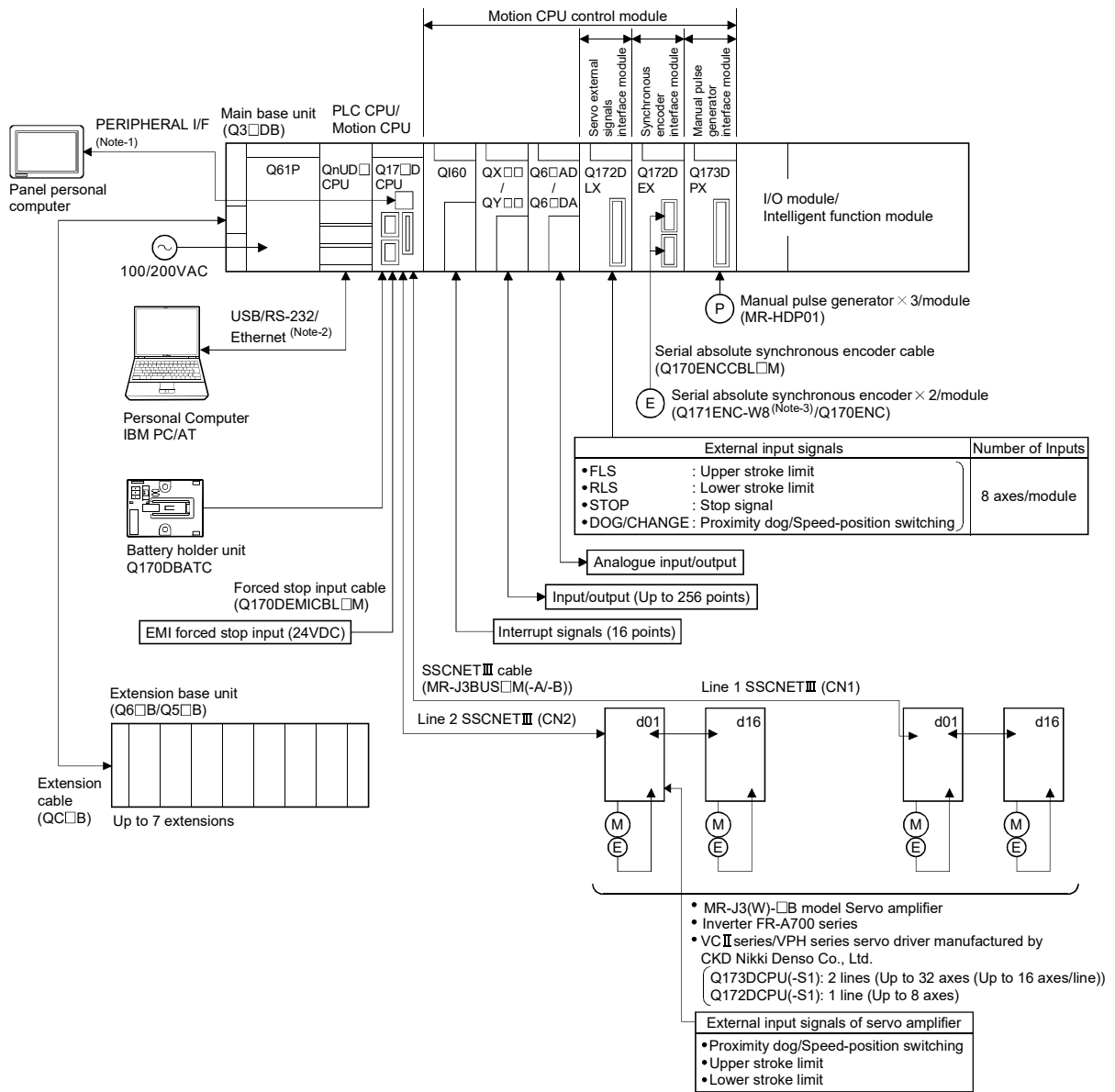

(Note-1): Q173DCPU-S1/Q172DCPU-S1 only

(Note-2): QnUDE(H)CPU/QnUDVCPU only

(Note-3): When using Q171ENC-W8, set "Q170ENC" in the system settings.  
The Q171ENC-W8 encoder resolution operates at 262144[pulse].

### CAUTION

- Construct a safety circuit externally of the Motion controller or servo amplifier if the abnormal operation of the Motion controller or servo amplifier differ from the safety directive operation in the system.
- The ratings and characteristics of the parts (other than Motion controller, servo amplifier and servo motor) used in a system must be compatible with the Motion controller, servo amplifier and servo motor.
- Set the parameter values to those that are compatible with the Motion controller, servo amplifier, servo motor and regenerative resistor model and the system application. The protective functions may not function if the settings are incorrect.

# 1 OVERVIEW

## 1.3.4 Software packages

### (1) Operating system software

Application	Software package			
	Q173DSCPU (Note-1)	Q172DSCPU (Note-1)	Q173DCPU(-S1)	Q172DCPU(-S1)
Conveyor assembly use <b>SV13</b>	SW8DNC-SV13QJ	SW8DNC-SV13QL	SW8DNC-SV13QB	SW8DNC-SV13QD
Automatic machinery use <b>SV22</b>	SW8DNC-SV22QJ	SW8DNC-SV22QL	SW8DNC-SV22QA	SW8DNC-SV22QC
Machine tool peripheral use <b>SV43</b>	—	—	SW7DNC-SV43QA	SW7DNC-SV43QC

(Note-1): The operating system software (SV22 (Virtual mode switching method)) is installed at the time of product purchases.

### (2) Operating system software type/version

#### (a) Confirmation method in the operating system (CD)

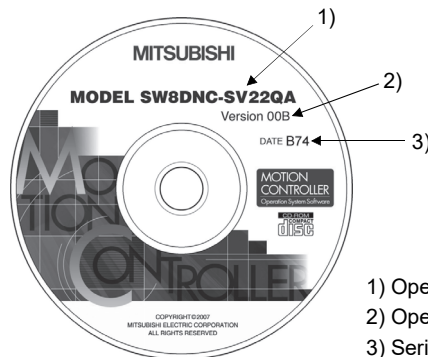

- 1) Operating system software type
- 2) Operating system software version
- 3) Serial number

Example) When using Q173DCPU, SV22 and version 00B.

- 1) SW8DNC-SV22QA
- 2) 00B

#### (b) Confirmation method in MT Developer2

The operating system software type and version of connected CPU can be confirmed on the following screens.

- 1) Installation screen
- 2) CPU information screen displayed by menu bar [Help] → [CPU Information]

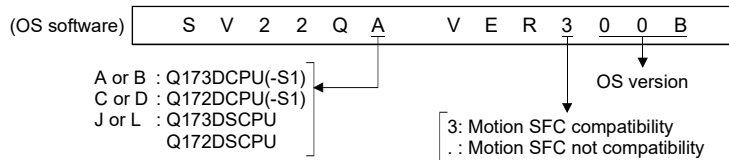

### (3) Programming software packages

#### (a) Motion controller engineering environment

Part name	Model name
MELSOFT MT Works2 (MT Developer2 (Note-1))	SW1DND-MTW2-E

(Note-1): This software is included in Motion controller engineering environment "MELSOFT MT Works2".

## (4) Related software packages

### (a) PLC software package

Model name	Software package
GX Works2	SW1DND-GXW2-E
GX Developer	SW8D5C-GPPW-E

### (b) Servo set up software package

Model name	Software package
MR Configurator2	SW1DNC-MRC2-E
MR Configurator <sup>(Note-1)</sup>	MRZJW3-SETUP221E

(Note-1): Q173DSCPU/Q172DSCPU is not supported.

### POINTS

When the operation of Windows<sup>®</sup> is unclear in the operation of this software, refer to the manual of Windows<sup>®</sup> or guide-book from the other supplier.



## 1.3.5 Restrictions on motion systems

### (1) Combination of Multiple CPU system

- (a) Motion CPU module cannot be used as standalone module.  
Be sure to install the universal model PLC CPU module to CPU No.1.  
For Universal model PLC CPU module, "Multiple CPU high speed transmission function" must be set in the Multiple CPU settings.
- (b) Only Multiple CPU high speed main base unit (Q35DB/Q38DB/Q312DB) can be used.
- (c) The combination of Q173DSCPU/Q172DSCPU/Q173DCPU(-S1)/Q172DCPU(-S1) and Q173HCPU(-T)/Q172HCPU(-T)/Q173CPUN(-T)/Q172CPUN(-T) cannot be used.  
The combination of Q173DSCPU/Q172DSCPU/Q173DCPU(-S1)/Q172DCPU(-S1) can be used.
- (d) Up to four modules of universal model PLC CPU modules/Motion CPU modules can be installed from the CPU slot (the slot on the right side of power supply module) to slot 2 of the main base unit. CPU modules called as CPU No.1 to CPU No.4 from the left sequentially.  
There is no restriction on the installation order of CPU No.2 to No.4.  
For CPU module except CPU No.1, an empty slot can be reserved for addition of CPU module. An empty slot can be set between CPU modules.  
However, the installation condition when combining with the High performance PLC CPU module/Process CPU module/PC CPU module/C controller module is different depending on the specification of CPU modules, refer to the Manuals of each CPU modules.
- (e) It takes about 10 seconds to startup (state that can be controlled) of Motion CPU. Make a Multiple CPU synchronous startup setting suitable for the system.
- (f) Execute the automatic refresh of the Motion CPU modules and universal model PLC CPU modules by using the automatic refresh of Multiple CPU high speed transmission area setting.  
When the High performance PLC CPU module/Process CPU module/PC CPU module/C controller module is installed in the combination of Multiple CPU system, the Motion CPU module cannot execute the automatic refresh with these modules.
- (g) Use the Motion dedicated PLC instructions that starts by "D(P)". The Motion dedicated PLC instructions that starts by "S(P)." cannot be used. When the High performance PLC CPU module/Process CPU module/PC CPU module/C controller module is installed in the combination of Multiple CPU system, the Motion dedicated PLC instruction from these modules cannot be executed.

### (2) Motion modules

- (a) Installation position of Q172DEX<sup>(Note-1)</sup> and Q173DSXY is only the main base unit.  
It cannot be used on the extension base unit.
- (b) Q172DLX/Q173DPX can be installed on any of the main base unit/  
extension base unit.
- (c) Q172DLX/Q172DEX<sup>(Note-1)</sup>/Q173DPX cannot be installed in CPU slot and I/O  
slot 0 to 2 of the main base unit. Wrong installation might damage the main  
base unit.
- (d) Q173DSXY cannot be used in Q173DCPU/Q172DCPU.
- (e) Q172EX(-S1/-S2/-S3)/Q172LX/Q173PX(-S1) for Q173HCPU(-T)/  
Q172HCPU(-T)/Q173CPUN(-T)/Q172CPUN(-T)/Q173CPU/Q172CPU  
cannot be used.
- (f) Be sure to use the Motion CPU as the control CPU of Motion modules  
(Q172DLX, Q172DEX<sup>(Note-1)</sup>, Q173DPX, etc.) for Motion CPU. They will not  
operate correctly if PLC CPU is set and installed as the control CPU by  
mistake. Motion CPU is treated as a 32-point intelligent module by PLC CPU  
of other CPU.
- (g) Q173DSXY is managed with PLC CPU.  
The Motion CPU to connect Q173DSXY is only CPU No.2 in the Multiple  
CPU system. Q173DSXY cannot be used for the CPU No. 3 or 4.

(Note-1): Q172DEX can be used in SV22. It cannot be used in SV13/SV43.

(3) Other restrictions

- (a) Motion CPU module cannot be set as the control CPU of intelligent function module (excluding some modules) or Graphic Operation Terminal(GOT).
- (b) Be sure to use the battery.
- (c) There are following methods to execute the forced stop input.
  - Use a EMI connector of Motion CPU module
  - Use a device set in the forced stop input setting of system setting
- (d) Forced stop input for EMI connector of Motion CPU module cannot be invalidated by the parameter.  
 When the device set in the forced stop input setting is used without use of EMI connector of Motion CPU module, apply 24VDC voltage on EMI connector and invalidate the forced stop input of EMI connector.
- (e) Be sure to use the cable for forced stop input (sold separately). The forced stop cannot be released without using it.
- (f) Set "SSCNET III/H" or "SSCNET III" for every line in the SSCNET setting of system setting to communicate with the servo amplifiers and SSCNET III(/H) compatible equipment.  
 The following shows the servo amplifiers and SSCNET III(/H) compatible equipment that can be used when "SSCNET III/H" and "SSCNET III" are set.

Servo amplifier/SSCNET III(/H) compatible equipment		SSCNET setting	
		SSCNET III/H	SSCNET III
Servo amplifier	MR-J5(W)-□B	○	×
	MR-J4(W)-□B	○	○ (Note-1)
	MR-J3(W)-□B	×	○
Inverter	FR-A800 series	○	○
	FR-A700 series	×	○
SSCNET III/H head module	LJ72MS15	○	×
Servo driver manufactured by CKD Nikki Denso Co., Ltd	VCII series	○	○
	VPH series	○	○
Stepping motor module AlphaStep/5-phase manufactured by ORIENTAL MOTOR Co., Ltd.		○	×
IAI electric actuator controller manufactured by IAI Corporation		○	×

○: Usable ×: Unusable



(Note-1): Operated in J3 compatibility mode

**POINTS**

It is possible to use different servo amplifiers on the same SSCNET III/H line, but when high accuracy synchronization on the load side is needed for multiple axes such as for interpolation control or synchronous control, build a system using servo amplifiers of the same servo series.

: Refer to Section 1.5 for the software version that supports this function.

(g) The following are restrictions for the communication type depending on the operation cycle.

Operation cycle	Communication type	
	SSCNET III/H 	SSCNET III
0.22ms 	<ul style="list-style-type: none"> <li>MR-J4W3-□B (software version A2 or earlier) cannot be used. <sup>(Note-1)</sup></li> <li>One SSCNET III/H head module per line can be set.</li> <li>AlphaStep/5-phase cannot be used. <sup>(Note-2)</sup></li> <li>Up to 2 axes per IAI electric actuator controller can be set. <sup>(Note-4)</sup></li> </ul>	<ul style="list-style-type: none"> <li>The maximum number of control axes per line is four axes.</li> <li>Set the axis select rotary switch of the servo amplifier to "0 to 3". If the axis select rotary switch of servo amplifier is set to "4 to F", the servo amplifiers are not recognized.</li> <li>MR-J4W3-□B (software version A2 or earlier) cannot be used. <sup>(Note-1)</sup></li> <li>MR-J3W-□B cannot be used.</li> <li>FR-A700 series, VCI series, and VPH series cannot be used. <sup>(Note-3)</sup></li> </ul>
0.44ms	<ul style="list-style-type: none"> <li>Two SSCNET III/H head modules per line can be set.</li> <li>Up to 4 axes per IAI electric actuator controller can be set. <sup>(Note-4)</sup></li> </ul>	<ul style="list-style-type: none"> <li>The maximum number of control axes per line is eight axes.</li> <li>Set the axis select rotary switch of the servo amplifier to "0 to 7". If the axis select rotary switch of servo amplifier is set to "8 to F", the servo amplifiers are not recognized.</li> </ul>
0.88ms or more	—	—

—: No restriction

(Note-1): MR-J4W3-□B (Software version A3 or later) supports operation cycle 0.22ms. However, when using operation cycle 0.22ms, some functions are restricted. Refer to the servo amplifier instruction manual for details.

(Note-2): When AlphaStep/5-phase is set in system settings, operation is carried out with operation cycle at 0.44ms.

(Note-3): When FR-A700 series, VCI series, or VPH series is set in system settings, operation is carried out with operation cycle at 0.44ms.

(Note-4): When the setting exceeds the number of control axes per controller, a major error (error code: 1350) occurs. Set the operation cycle as follows according to the number of control axes per controller.

Number of control axes per controller	Operation cycle
1 to 2 axes	0.22ms or more
3 to 4 axes	0.44ms or more
5 axes or more	0.88ms or more

(h) If there is an axis which is not set at least 1 axis by system setting in applicable servo amplifier at MR-J5W-□B or MR-J4W-□B use, all axes connected to applicable servo amplifier and subsequent servo amplifiers cannot be connected. Set "Not used" to the applicable axis with a dip switch for the axis which is not used by MR-J5W-□B or MR-J4W-□B. 

(i) It is impossible to mount the main base unit by DIN rail when using the Motion CPU module.

Doing so could result in vibration that may cause erroneous operation.

(j) The module name displayed by "System monitor" - "Product information list" of GX Works2/GX Developer is different depending on the function version of Motion modules (Q172DLX, Q172DEX, Q173DPX).

(Note): Even if the function version "C" is displayed, it does not correspond to the online module change.

Module name	Model display	
	Function version "B"	Function version "C"
Q172DLX	Q172LX	Q172DLX
Q172DEX	MOTION-UNIT	Q172DEX
Q173DPX	MOTION-UNIT	Q173DPX

(k) Use the Graphic Operation Terminal (GOT) that supports Motion CPU (Q173D(S)CPU/Q172D(S)CPU).

## 1.4 Checking Serial Number and Operating System Software Version

Checking for the serial number of Motion CPU module and Motion module, and the operating system software version is described below.

### 1.4.1 Checking serial number

#### (1) Motion CPU module (Q173DSCPU/Q172DSCPU)

##### (a) Rating plate

The rating plate is situated on the side face of the Motion CPU module.  
The SERIAL line displays the Motion CPU module serial No.

##### (b) Front of Motion CPU module

The serial number is displayed on the battery cover situated on the lower front side of the Motion CPU module.

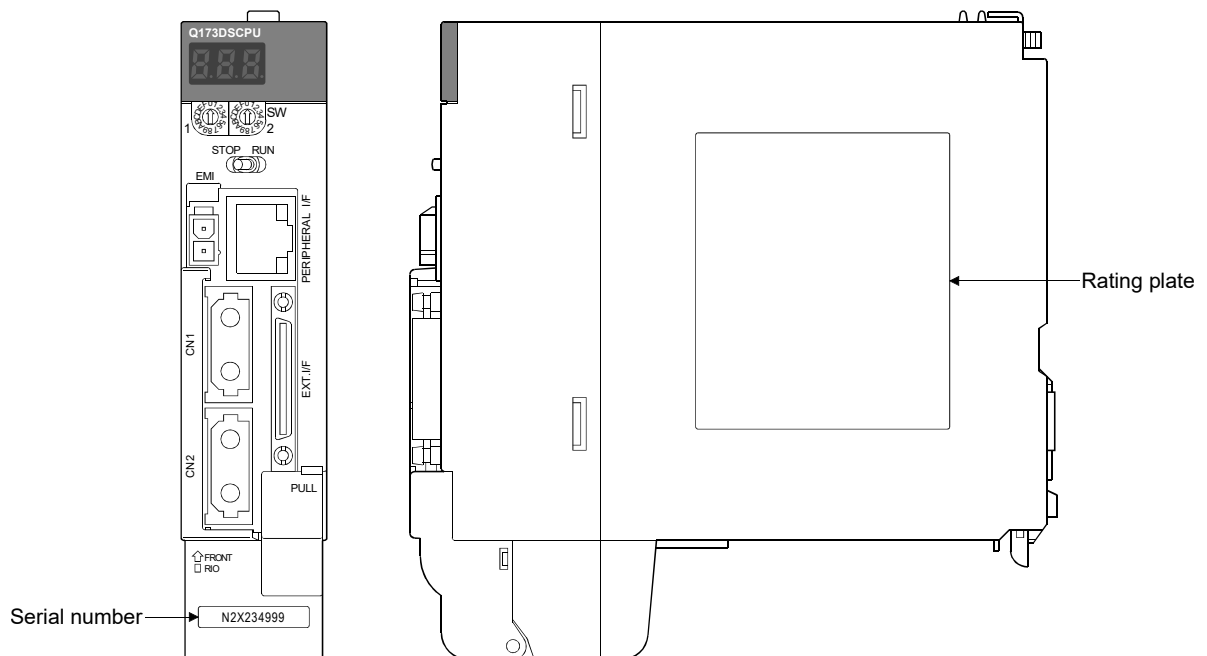

##### (c) System monitor (product information list)

The serial number can be checked on the system monitor screen in GX Works2/GX Developer. (Refer to Section 1.4.2.)

## (2) Motion CPU module (Q173DCPU(-S1)/Q172DCPU(-S1))

### (a) Rating plate

The rating plate is situated on the side face of the Motion CPU module.  
The SERIAL line displays the Motion CPU module serial No.

### (b) Front of Motion CPU module

The serial number is displayed on the protruding portion situated on the lower front side of the Motion CPU module.

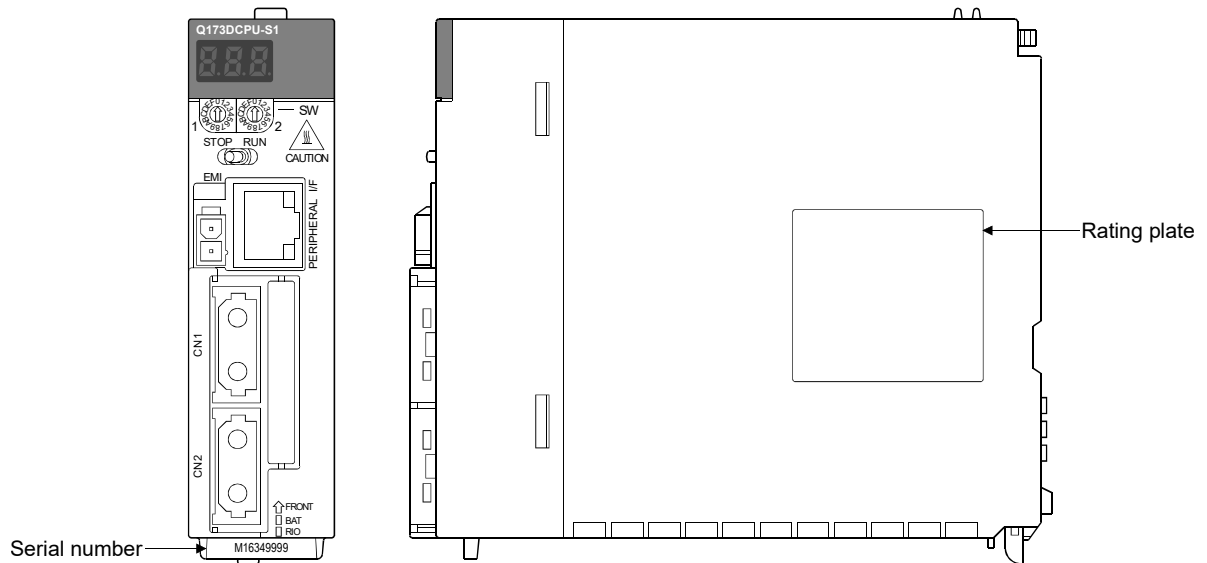

### (c) System monitor (product information list)

The serial number can be checked on the system monitor screen in GX Works2/GX Developer. (Refer to Section 1.4.2.)

## REMARK

The serial number display was corresponded from the Motion CPU modules manufactured in early October 2007.

## (3) Motion module (Q172DLX/Q172DEX/Q173DPX/Q173DSXY)

### (a) Rating plate

The rating plate is situated on the side face of the Motion module.  
The SERIAL line displays the Motion CPU module serial No.

### (b) Front of Motion module

The serial No. is displayed on the protruding portion situated on the lower front side of the Motion module.

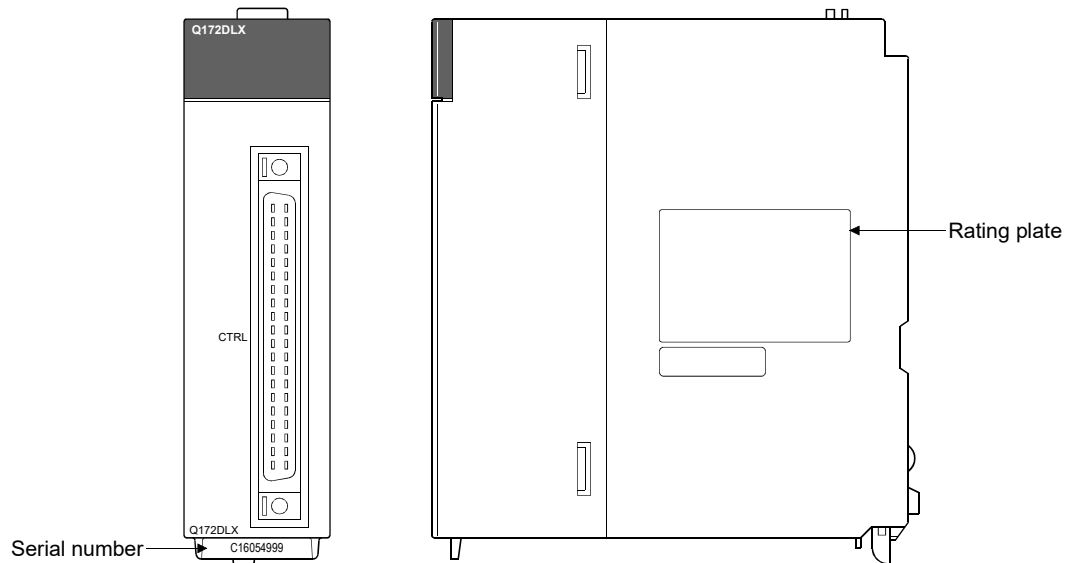

### REMARK

The serial number display was corresponded from the Motion modules manufactured in early April 2008.



# 1 OVERVIEW

## 1.4.2 Checking operating system software version **Ver.!**

The operating system software version can be checked on the system monitor screen in GX Works2/GX Developer.

Select [Product Information List] button on the system monitor screen displayed on [Diagnostics] – [System monitor] of GX Works2/GX Developer to check on the product information list.

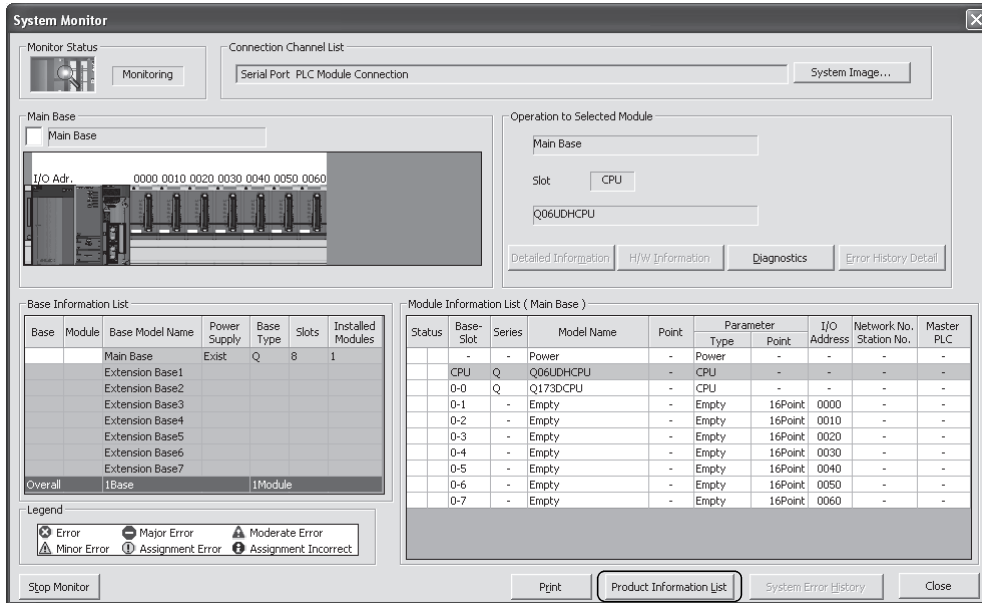

Serial number of Motion CPU module

Operating system software version

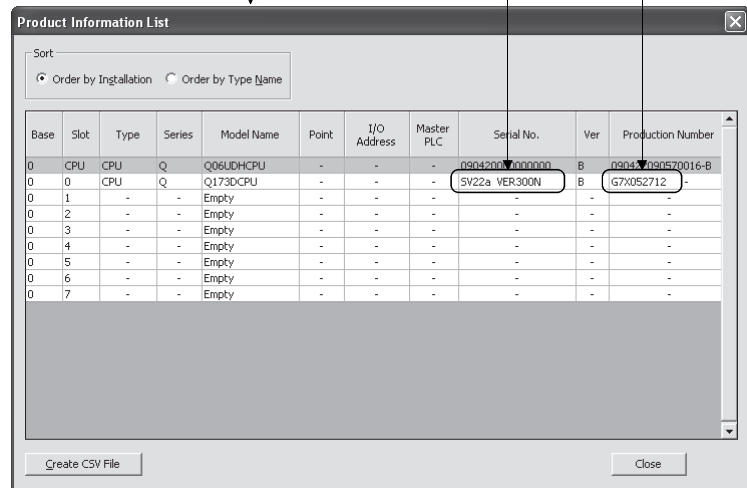

<Screen: GX Works2>

**Ver.!**: Refer to Section 1.5 for the software version that supports this function.

### REMARK

- (1) "Serial number of Motion CPU module" and "Operating system software version" on the system monitor (Product Information List) screen of GX Works2/GX Developer was corresponded from the Motion CPU modules manufactured in early October 2007.
- (2) The operating system software version can also be checked on the system monitor screen in CD-ROM of operating system software or MT Developer2. (Refer to Section 1.3.4.)

# 1 OVERVIEW

## 1.5 Restrictions by the Software's Version

There are restrictions in the function that can be used by the version of the operating system software and programming software.

The combination of each version and a function is shown in Table1.1.

Table 1.1 Restrictions by the Software's Version

Function	Operating system software version <sup>(Note-1), (Note-2)</sup>		
	Q173DSCPU/Q172DSCPU	Q173DCPU(-S1)/Q172DCPU(-S1)	
	SV13/SV22	SV13/SV22	SV43
Checking Motion controller's serial number and operating system software version in GX Developer	—	00D	—
Advanced S-curve acceleration/deceleration (Except constant-speed control (CPSTART) of servo program.)	—	00H	/
Direct drive servo MR-J3-□B-RJ080W	—	00H	00B
Servo amplifier display servo error code (#8008+20n)	—	00H	00B
0.44ms fixed-cycle event task	—	00H	/
444μs coasting timer (SD720, SD721)	—	00H	00B
Synchronous encoder current value monitor in real mode	—	00H	/
Display of the past ten times history in current value history monitor	—	00H	00C
Amplifier-less operation	—	00H	/
Servo instruction (Home position return (ZERO), high speed oscillation (OSC)) and manual pulse generator operation in mixed function of virtual mode/real mode	—	00H	/
Advanced S-curve acceleration/deceleration in constant-speed control (CPSTART) of servo program.	—	00K	/
External input signal (DOG) of servo amplifier in home position return of count method and speed-position switching control	—	00G	00B
Communication via PERIPHERAL I/F	—	00H	00C
Motion SFC operation control instruction Type conversion (DFLT, SFLT)	—	00L	—
Vision system dedicated function (MVOPEN, MVLOAD, MVTRG, MVPST, MVIN, MVFIN, MVCLOSE, MVCOM)	—	00L	/
Home position return of scale home position signal detection method	—	00L	00C
Real time display function in digital oscilloscope function	—	00N	Not support
Rapid stop deceleration time setting error invalid function	—	00S	/

# 1 OVERVIEW

	Programming software version					Section of reference
	MELSOFT MT Works2 (MT Developer2)			MR Configurator2	MR Configurator	
	Q173DSCPU/Q172DSCPU	Q173DCPU(-S1)/Q172DCPU(-S1)				
	SV13/SV22	SV13/SV22	SV43			
—	—	—	—	—	Section 1.4	
1.39R	1.06G	/	—	—	(Note-4)	
1.39R	1.06G	1.06G	1.01B	C2	/	
—	—	—	—	—	(Note-4), (Note-5)	
1.39R	1.06G	/	—	—	(Note-3)	
—	—	—	—	—	APPENDIX 1.2	
—	—	/	—	—	(Note-5)	
1.39R	1.06G	1.39R	—	—	Section 4.2	
—	—	/	—	—	Section 4.11	
1.39R	1.09K	/	—	—	(Note-5)	
1.39R	1.09K	/	—	—	(Note-4)	
1.39R	1.15R	Not support	—	—	/	
1.39R	1.15R	1.39R	—	—	Section 4.13	
1.39R	1.15R	—	—	—	(Note-3)	
1.39R	1.15R	/	—	—	(Note-3)	
1.39R	1.15R	1.39R	—	—	(Note-4)	
1.39R	1.17T	1.39R	—	—	/	
—	—	/	—	—	(Note-4)	

—: There is no restriction by the version.

(Note-1): SV13/SV22 is the completely same version.

(Note-2): The operating system software version can be confirmed in the operating system software (CD-ROM), MT Developer2 or GX Works2/GX Developer. (Refer to Section 1.3, 1.4.)

(Note-3): Q173D(S)CPU/Q172D(S)CPU Motion controller (SV13/SV22) Programming Manual (Motion SFC)

(Note-4): Q173D(S)CPU/Q172D(S)CPU Motion controller (SV13/SV22) Programming Manual (REAL MODE)

(Note-5): Q173D(S)CPU/Q172D(S)CPU Motion controller (SV22) Programming Manual (VIRTUAL MODE)

(Note-6): Q173D(S)CPU/Q172D(S)CPU Motion controller Programming Manual (Safety Observation)

(Note-7): Q173DSCPU/Q172DSCPU Motion controller (SV22) Programming Manual (Advanced Synchronous Control)

# 1 OVERVIEW

Table 1.1 Restrictions by the Software's Version (continued)

Function	Operating system software version <sup>(Note-1), (Note-2)</sup>		
	Q173DSCPU/Q172DSCPU	Q173DCPU(-S1)/Q172DCPU(-S1)	
	SV13/SV22	SV13/SV22	SV43
Vision system dedicated function (MVOOUT)	—	00S	
Motion SFC operation control instruction Program control (IF - ELSE - IEND, SELECT -CASE - SEND, FOR -NEXT, BREAK)	—	00R	
Display format depending on the error setting data information of motion error history device (#8640 to #8735)	—	00S	
Product information list device (#8736 to #8751)	—	00S	
Safety observation function	—	00S	
Feed current value update command (M3212+20n) valid in speed control (I)	00B	Not support	
External forced stop input ON latch (SM506)	00B	00S	
Operation method (SD560)	00B	Not support	
Advanced synchronous control	00B	Not support	
Limit switch output function expansion	00B	Not support	
Driver communication function (SSCNETⅢ)	00C	Not support	
Intelligent function module support	00C	Not support	
SSCNETⅢ/H head module connection	00C	Not support	
Cam auto-generation (CAMMK) easy stroke ratio cam	00C	Not support	
Acceleration/deceleration time change function	00C	Not support	
Home position return of dogless home position signal reference method	00C	Not support	
Setting range expansion of backlash compensation amount	00C	Not support	
Multiple CPU synchronous control	00C	Not support	
Cam axis length per cycle change during synchronous control	00C	Not support	
Servo driver VCⅡ series manufactured by CKD Nikki Denso Co., Ltd.	SSCNETⅢ	—	00L
	SSCNETⅢ/H	00D	Not support
Inverter FR-A700 series	—	—	
Synchronous encoder via servo amplifier	00D	Not support	
Driver communication function (SSCNETⅢ/H)	00D	Not support	
Optical hub unit connection	00F	Not support	
Home position return of driver home position return method	00H	Not support	
Stepping motor module AlphaStep/5-phase manufactured by ORIENTAL MOTOR Co., Ltd.	00H	Not support	
Servo driver VPH series manufactured by CKD Nikki Denso Co., Ltd.	00H	Not support	
IAI electric actuator controller manufactured by IAI Corporation	00H	Not support	
Inverter FR-A800 series	00J	Not support	

# 1 OVERVIEW

	Programming software version					Section of reference
	MELSOFT MT Works2 (MT Developer2)			MR Configurator2	MR Configurator	
	Q173DSCPU/Q172DSCPU	Q173DCPU(-S1)/Q172DCPU(-S1)				
	SV13/SV22	SV13/SV22	SV43			
1.39R	1.39R		—	—	(Note-3)	
1.39R	1.39R		—	—	(Note-3)	
—	—		—	—	(Note-3)	
—	—		—	—	(Note-4), (Note-5)	
1.39R	1.39R		—	—	(Note-6)	
—	Not support		—	—	(Note-4)	
—	—		—	—	APPENDIX 1.1	
—	Not support		—	—	APPENDIX 1.2	
1.47Z	Not support		—	—	(Note-7)	
1.47Z	Not support		—	—	Section 4.1.3 Section 4.1.4	
—	Not support		—	—	Section 4.16	
1.56J	Not support		—	—	Section 4.17	
1.56J	Not support		—	—	Section 4.18	
1.56J	Not support		—	—	(Note-3)	
1.56J	Not support		—	—	(Note-4)	
1.56J	Not support		—	—	(Note-4)	
1.56J	Not support		—	—	(Note-4)	
1.56J	Not support		—	—	(Note-7)	
1.56J	Not support		—	—	(Note-7)	
1.56J	Not support		—	—	(Note-7)	
1.34L	1.15R		—	—	(Note-4)	
1.56J	Not support		—	—	(Note-4)	
1.34L	1.15R		—	—	(Note-4)	
1.68W	Not support		1.23Z	Not support	(Note-7)	
1.68W	Not support		1.23Z	Not support	Section 4.16	
—	Not support		—	—	(Note-4)	
1.118Y	Not support		—	—	(Note-4)	
1.118Y	Not support		—	—	(Note-4)	
1.118Y	Not support		—	—	(Note-4)	
1.118Y	Not support		—	—	(Note-4)	
—	—		—	—	(Note-4)	

—: There is no restriction by the version.

(Note-1): SV13/SV22 is the completely same version.

(Note-2): The operating system software version can be confirmed in the operating system software (CD-ROM), MT Developer2 or GX Works2/GX Developer. (Refer to Section 1.3, 1.4.)

(Note-3): Q173D(S)CPU/Q172D(S)CPU Motion controller (SV13/SV22) Programming Manual (Motion SFC)

(Note-4): Q173D(S)CPU/Q172D(S)CPU Motion controller (SV13/SV22) Programming Manual (REAL MODE)

(Note-5): Q173D(S)CPU/Q172D(S)CPU Motion controller (SV22) Programming Manual (VIRTUAL MODE)

(Note-6): Q173D(S)CPU/Q172D(S)CPU Motion controller Programming Manual (Safety Observation)

(Note-7): Q173DSCPU/Q172DSCPU Motion controller (SV22) Programming Manual (Advanced Synchronous Control)

# 1 OVERVIEW

Table 1.1 Restrictions by the Software's Version (continued)

Function	Operating system software version <sup>(Note-1), (Note-2)</sup>		
	Q173DSCPU/Q172DSCPU	Q173DCPU(-S1)/Q172DCPU(-S1)	
	SV13/SV22	SV13/SV22	SV43
Improvement of absolute positioning operation for servo driver VCI/VPH series manufactured by CKD Nikki Denso Co., Ltd., and stepping motor module AlphaStep/5-phase manufactured by ORIENTAL MOTOR Co., Ltd.	00L	Not support	
Servo amplifier MR-J5(W)-□B support	00Y	Not support	
DOG/CHANGE signal input method support	00Y	Not support	

# 1 OVERVIEW

	Programming software version					Section of reference
	MELSOFT MT Works2 (MT Developer2)			MR Configurator2	MR Configurator	
	Q173DSCPU/Q172DSCPU	Q173DCPU(-S1)/Q172DCPU(-S1)				
	SV13/SV22	SV13/SV22	SV43			
	—	—	/	—	—	(Note-4)
	1.170C	Not support	/	1.130L	Not support	/
	1.170C	Not support	/	—	—	Section 3.1.3

—: There is no restriction by the version.

(Note-1): SV13/SV22 is the completely same version.

(Note-2): The operating system software version can be confirmed in the operating system software (CD-ROM), MT Developer2 or GX Works2/GX Developer. (Refer to Section 1.3, 1.4.)

(Note-3): Q173D(S)CPU/Q172D(S)CPU Motion controller (SV13/SV22) Programming Manual (Motion SFC)

(Note-4): Q173D(S)CPU/Q172D(S)CPU Motion controller (SV13/SV22) Programming Manual (REAL MODE)

(Note-5): Q173D(S)CPU/Q172D(S)CPU Motion controller (SV22) Programming Manual (VIRTUAL MODE)

(Note-6): Q173D(S)CPU/Q172D(S)CPU Motion controller Programming Manual (Safety Observation)

(Note-7): Q173DSCPU/Q172DSCPU Motion controller (SV22) Programming Manual (Advanced Synchronous Control)



# 1 OVERVIEW

---

## 1.6 Programming Software Version

The programming software versions that support Motion CPU are shown below.

Motion CPU	MELSOFT MT Works2 (MT Developer2)		MR Configurator2	MR Configurator
	SV13/SV22	SV43		
Q173DSCPU	1.39R (Note-1)		1.10L	Not support
Q172DSCPU	1.39R (Note-1)		1.10L	Not support
Q173DCPU-S1	1.00A (Note-2)	1.03D (Note-3)	1.00A	C0 (Note-4)
Q172DCPU-S1	1.00A (Note-2)	1.03D (Note-3)	1.00A	C0 (Note-4)
Q173DCPU	1.00A	1.03D	1.00A	C0 (Note-4)
Q172DCPU	1.00A	1.03D	1.00A	C0 (Note-4)

(Note-1): Use version 1.47Z or later to use advanced synchronous control method.

(Note-2): Use version 1.12N or later to communicate via PERIPHERAL I/F.

(Note-3): Use version 1.23Z or later to communicate via PERIPHERAL I/F.

(Note-4): Use version C1 or later to use MR Configurator combination with MT Developer2.

## 2. MULTIPLE CPU SYSTEM

### 2.1 Multiple CPU System

#### 2.1.1 Overview

(1) What is Multiple CPU system?

A Multiple CPU system is a system in which more than one PLC CPU module and Motion CPU module (up to 4 modules) are mounted on several main base unit in order to control the I/O modules and intelligent function modules. Each Motion CPU controls the servo amplifiers connected by SSCNETⅢ cable.

(2) System configuration based on load distribution

(a) By distributing such tasks as servo control, machine control and information control among multiple processors, the flexible system configuration can be realized.

(b) You can increase the number of control axes by using a multiple Motion CPU modules.

It is possible to control up to 96 axes by using the three CPU modules (Q173DSCPU/Q173DCPU(-S1)).

(c) By distributing the high-load processing performed on a single PLC CPU over several CPU modules, it is possible to reduce the overall system PLC scan time.

(3) Communication between CPUs in the Multiple CPU system

(a) Since device data of other CPUs can be automatically read by the automatic refresh function, the self CPU can also use them as those of self CPU.

(Note): When the High performance PLC CPU module/Process CPU module/PC CPU module/C controller module is mounted in the combination of Multiple CPU system, the Motion dedicated PLC instruction from these modules cannot be executed.

(b) Motion dedicated PLC instructions can be used to access device data from the PLC CPU to Motion CPU and start Motion SFC program (SV13/SV22)/ Motion program (SV43).

## 2 MULTIPLE CPU SYSTEM

### 2.1.2 Installation position of CPU module

Up to four PLC CPUs and Motion CPUs can be installed from the CPU slot (the right side slot of the power supply module) to slots 2 of the main base unit.

The Motion CPU module cannot be installed in the CPU slot.

The PLC CPU module must be installed in the CPU slot (CPU No.1) in the Multiple CPU system.

There is no restriction on the installation order for CPU modules (CPU No.2 to 4).

The combination of Q173DSCPU/Q172DSCPU and Q173DCPU(-S1)/Q172DCPU(-S1) can be used.

(Note): Refer to the manual for each CPU module when the High performance PLC CPU module, Process CPU module, PC CPU module and C controller module is mounted in the combination of Multiple CPU.

Table 2.1 Example for CPU module installation

Number of CPUs	Installation position of CPU module				
	Power supply	CPU	0	1	2
2	QnUD□ CPU	Q17□D(S) CPU			
	CPU No.1	CPU No.2	CPU No.3	CPU No.4	
3	QnUD□ CPU	Q17□D(S) CPU	QnUD□ CPU		
	CPU No.1	CPU No.2	CPU No.3	CPU No.4	
4	QnUD□ CPU	Q17□D(S) CPU	QnUD□ CPU	CPU empty	
	CPU No.1	CPU No.2	CPU No.3	CPU No.4	

CPU 0 1 2 : Slot number

An empty slot can be reserved for future addition of a CPU module.

Set the number of CPU modules including empty slots in the Multiple CPU setting, and set the type of the slots to be emptied to "PLC (Empty)" in the CPU setting.

(Example 1)

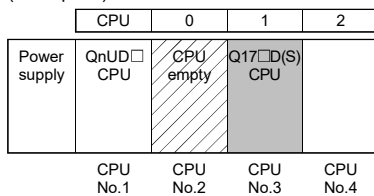

(Example 2)

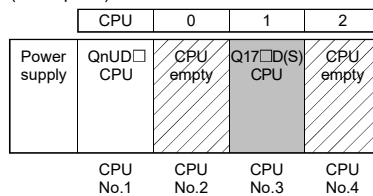

(Example 3)

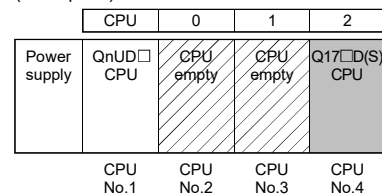

### 2.1.3 Precautions for using I/O modules and intelligent function modules

#### (1) Modules controllable by the Motion CPU

Modules controllable by the Motion CPU are shown below.

- Motion modules (Q172DLX, Q172DEX, Q173DPX)
- I/O modules (QX□, QX□-□, QY□, QY□-□, QH□, QX□Y□)
- Intelligent function module <sup>(Note-1)</sup>
- Interrupt module (QI60)

(Note-1): Refer to Section 4.17 for corresponding intelligent function module.

#### (2) Compatibility with the Multiple CPU system

The intelligent function modules of function version "B" or later support the Multiple CPU system. Be sure to use the PLC CPU as a control CPU for the intelligent function modules (network modules etc.) that cannot be controlled by the Motion CPU.

#### (3) Access range from non-controlled CPU

- (a) The Motion CPU can access only the modules controlled by the self CPU. It cannot access the modules controlled by other CPUs.
- (b) Access range from non-controlled PLC CPU for the modules controlled by the Motion CPU are shown below.

Table 2.2 Access range to non-controlled module

Access target		I/O setting outside of the group (Set by PLC CPU)	
		Disabled (Not checked)	Enabled (Checked)
Motion module (Q172DLX, Q172DEX, Q173DPX)		×	×
Input (X)		×	○
Output (Y)		×	×
Buffer memory	Read	×	×
	Write	×	×

○ : Accessible    × : Inaccessible

#### REMARK

- The function version of an intelligent function module can be checked on the rated plate of the intelligent function module or in the GX Works2/GX Developer system monitor product information list.
- Refer to the "Q173D(S)CPU/Q172D(S)CPU Motion controller User's Manual" for the model name which can be controlled by the Motion CPU.

## 2 MULTIPLE CPU SYSTEM

### 2.1.4 Modules subject to installation restrictions

(1) Modules subject to install restrictions for the Motion CPU are shown below. Use within the restrictions listed below.

(a) SV13/SV22

Description	Model name		Maximum installable modules per CPU			
			Q173DSCPU	Q172DSCPU	Q173DCPU(-S1)	Q172DCPU(-S1)
Servo external signals interface module	Q172DLX		4 modules	2 modules	4 modules	1 module
Serial absolute synchronous interface module	Q172DEX (Note-2)		6 modules			4 modules
Manual pulse generator interface module	Q173DPX (Note-1)	Incremental serial encoder use (Note-2)	4 modules			3 modules
		Manual pulse generator only use	1 module			
Input module	QX□ QX□-□		Total 256 points (Note-5)		Total 256 points	
Output module	QY□ QY□-□					
Input/output composite module	QH□ QX□Y□					
Intelligent function module (Note-3)	Analogue input module	Q6□AD□ Q6□AD-□				
	Analogue output module	Q6□DA□ Q6□DA-□				
	General	(Note-4)				
Interrupt module	QI60		1 module			

(Note-1): When the Manual pulse generator and the serial encoder are used at the same time with the SV22, the Q173DPX installed in the slot of the smallest number is used for manual pulse generator input.

(Note-2): SV22 only.

(Note-3): A maximum of 4 intelligent function modules can be used.

(Note-4): Refer to Section 4.17 for corresponding intelligent function module.

(Note-5): Number of I/O points is total of "Built-in interface in Motion CPU (Input 4 points) + I/O module + intelligent function module".

## 2 MULTIPLE CPU SYSTEM

### (b) SV43

Description	Model name		Maximum installable modules per CPU	
			Q173DCPU(-S1)	Q172DCPU(-S1)
Servo external signals interface module	Q172DLX		4 modules	1 module
Manual pulse generator interface module	Q173DPX	Manual pulse generator only use	1 module	1 module
Input module	QX□ QX□-□		Total 256 points	
Output module	QY□ QY□-□			
Input/output composite module	QH□ QX□Y□			
Intelligent function module (Note-1)	Analogue input module	Q6□AD□ Q6□AD-□		
	Analogue output module	Q6□DA□ Q6□DA-□		

(Note-1): A maximum of 4 intelligent function modules can be used.

- (2) A total of eight base units including one main base unit and seven extension base units can be used. However, the usable slots (number of modules) are limited to 64 per system including empty slots. If a module is installed in slot 65 or subsequent slot, an error (SP. UNIT LAY ERROR) will occur. Make sure all modules are installed in slots 1 to 64. (Even when the total number of slots provided by the main base unit and extension base units exceeds 65 (such as when six 12-slot base units are used), an error does not occur as long as the modules are installed within slots 1 to 64.)

POINT
(1) Q172DLX/Q172DEX/Q173DPX cannot be installed in CPU slot and I/O slot 0 to 2 of the main base unit. Wrong installation might damage the main base unit.
(2) Q172DEX can be installed in the main base unit only. It cannot be used in the extension base unit.

## 2 MULTIPLE CPU SYSTEM

---

### 2.1.5 How to reset the Multiple CPU system

The entire Multiple CPU system can be reset by resetting CPU No.1.

The CPU modules of No.2 to No.4, I/O modules and intelligent function modules will be reset when PLC CPU No.1 is reset.

If a stop error occurs in any of the CPUs on the Multiple CPU system, either reset CPU No.1 or restart the Multiple CPU system (power supply ON → OFF → ON) for recovery. (Recovery is not allowed by resetting the error-stopped CPU modules other than CPU No.1.)

POINT
(1) It is not possible to reset the CPU modules of No.2 to No.4 individually in the Multiple CPU system. If an attempt to reset any of those PLC CPU modules during operation of the Multiple CPU system, a "MULTI CPU DOWN (error code: 7000)" error will occur for the other CPUs, and the entire Multiple CPU system will be halted. However, depending on the timing in which any of PLC CPU modules other than No.1 has been reset, an error other than the "MULTI CPU DOWN" may halt the other PLC CPUs/Motion CPUs.
(2) A "MULTI CPU DOWN (error code: 7000)" error will occur regardless of the operation mode (All stop by stop error of CPU "n"/continue) set at the "Multiple CPU setting" screen when any of PLC CPU modules of No.2 to No.4 is reset. (Refer to Section 2.1.6.)

## 2 MULTIPLE CPU SYSTEM

### 2.1.6 Operation for CPU module stop error

The entire system will behave differently depending whether a stop error occurs in CPU No.1 or any of CPU No.2 to No.4 in the Multiple CPU system.

#### (1) When a stop error occurs at CPU No.1

- (a) A "MULTI CPU DOWN (error code: 7000)" error occurs at the other CPUs and the Multiple CPU system will be halted when a stop error occurs at the PLC CPU No.1. (Note-1)
- (b) The following procedure to restore the system is shown below.
  - 1) Confirm the error cause with the PLC diagnostics on GX Works2/ GX Developer.
  - 2) Remove the error cause.
  - 3) Either reset the PLC CPU No.1 or restart the power to the Multiple CPU system (power ON → OFF → ON).

All CPUs on the entire Multiple CPU system will be reset and the system will be restored when PLC CPU No. 1 is reset or the Multiple CPU system is reapplied.

#### (2) When a stop error occurs at CPU other than No.1

Whether the entire system is halted or not is determined by the Multiple CPU setting's "Operating Mode" setting when a stop error occurs in a PLC CPU module/Motion CPU module other than CPU No.1.

The default is set for all CPUs to be stopped with a stop error.

When you do not want to stop all CPUs at occurrence of a stop error in a PLC CPU module/Motion CPU module, remove the check mark that corresponds to the CPU No. so that its error will not stop all CPUs. (See arrow A.)

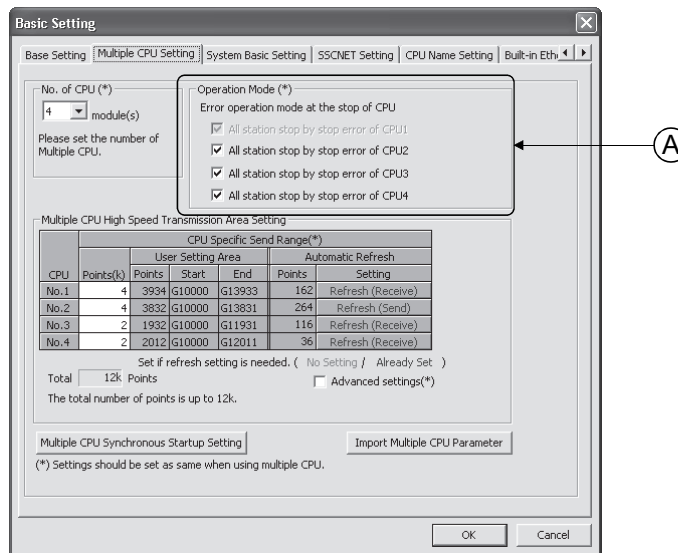

- (a) When a stop error occurs in the CPU module for which "All station stop by stop error of CPU 'n' " has been set, a "MULTI CPU DOWN (error code: 7000)" error occurs for the other PLC CPU module/Motion CPU modules and the Multiple CPU system will be halted. (Note-1)



- (b) When a stop error occurs in the CPU module for which "All station stop by stop error of CPU 'n'" has not been set, a "MULTI EXE. ERROR (error code: 7020)" error occurs in all other CPUs but operations will continue.

### POINT

(Note-1): When a stop error occurs, a "MULTI CPU DOWN (error code : 7000)" will occur at the CPU on which the error was detected.

Depending on the timing of error detection, a "MULTI CPU DOWN" error may be detected in a CPU of "MULTI CPU DOWN" status, not the first CPU on which a stop error occurs.

Because of this, CPU No. different from the one of initial error CPU may be stored in the error data's common information category.

To restore the system, remove the error cause on the CPU that is stopped by an error other than "MULTI CPU DOWN".

In the screen below, the cause of the CPU No.2 error that did not cause the "MULTI CPU DOWN" error is to be removed.

The stop error can be checked on the PLC diagnostics screen in GX Works2/GX Developer.

The screenshot shows the 'PLC Diagnostics' window. The 'Error Information' section is active, displaying a table of current errors:

PLC No.	Status	Current Error (Abbreviation)	Current Error (Detail)	Year/Month/Day	Time
1	▲	7000 MULTI CPU DOWN	MULTI CPU DOWN	2011-5-27	10:52:32
2	▲	10014 Not Found	Unregistration Error	2000-2-22	1:6:55
3					
4					

Below this, the 'Error History (PLC No.1)' section shows a list of past errors:

Status	No.	Error Message (Abbreviation)	Error Message (Detail)	Year/Month/Day	Time
▲	7000	MULTI CPU DOWN	MULTI CPU DOWN	2011-5-27	10:52:32
▲	1500	AC/DC DOWN	AC/DC DOWN	2011-4-28	11:53:7
▲	1500	AC/DC DOWN	AC/DC DOWN	2011-4-28	11:49:43
▲	3015	PARAMETER ERROR	PARAMETER ERROR	2011-4-28	11:40:56
▲	3015	PARAMETER ERROR	PARAMETER ERROR	2011-4-28	11:36:43
▲	7000	MULTI CPU DOWN	MULTI CPU DOWN	2011-4-28	11:24:30
▲	7000	MULTI CPU DOWN	MULTI CPU DOWN	2011-4-28	11:23:4
▲	7000	MULTI CPU DOWN	MULTI CPU DOWN	2011-4-28	11:22:10
▲	1500	AC/DC DOWN	AC/DC DOWN	2011-3-1	11:19:2
▲	1500	AC/DC DOWN	AC/DC DOWN	2011-2-28	18:39:1
▲	1500	AC/DC DOWN	AC/DC DOWN	2011-2-23	11:10:46
▲	1500	AC/DC DOWN	AC/DC DOWN	2011-2-23	11:5:22
▲	1500	AC/DC DOWN	AC/DC DOWN	2011-2-22	19:4:26

<Screen: GX Works2>

- (c) Observe the following procedures to restore the system.
- 1) Confirm the error-detected CPU No. and error cause with the PLC diagnostics on GX Works2/GX Developer.
  - 2) If the error code occurred in Motion CPU 10000 to 10999, confirm the error cause with monitor of MT Developer2.
  - 3) Remove the error cause.
  - 4) Either reset the PLC CPU No.1 or restart the power to the Multiple CPU system (power ON → OFF → ON).

All CPUs on the entire Multiple CPU system will be reset and the system will be restored when PLC CPU No.1 is reset or the power to the Multiple CPU system is reapplied.

## 2 MULTIPLE CPU SYSTEM

### (3) Operation at a Motion CPU error

Operations at a Motion CPU error are shown below.

Category	Type of error	Operation	Remark
Operation disable errors	System setting error	Does not operate from the beginning (does not run).	• All actual output PY points turn OFF. No effect on other CPUs.
	WDT error	Varies depending on the error.	• All actual output PY points turn OFF. Other CPUs may also stop depending on the parameter setting.
	Self-diagnosis error	Stops at a CPU DOWN error.	
	Other CPU DOWN error	Operation corresponding to STOP (M2000 OFF). Depends on the "Operation mode upon CPU stop error" setting.	• All actual output PY points turn OFF.
Operation continuous enable errors	Self-diagnosis error	Operation continues when the continuous error occurred.	• Only the applicable program stops (the program may continue depending on the type of error). • Actual output PY retains output. • No effect on other CPUs.
	Motion SFC error <sup>(Note-1)</sup>	Processing stops for each program or axis instead of the Motion CPU stopping all the processing.	
	Minor error		
	Major error		
	Servo error		
	Servo program setting error <sup>(Note-1)</sup>		
Motion program setting error <sup>(Note-2)</sup>			

(Note-1): SV13/SV22 use.

(Note-2): SV43 use.

## 2 MULTIPLE CPU SYSTEM

### 2.2 Starting Up the Multiple CPU System

This section describes a standard procedure to start up the Multiple CPU system.

#### 2.2.1 Startup Flow of the Multiple CPU system

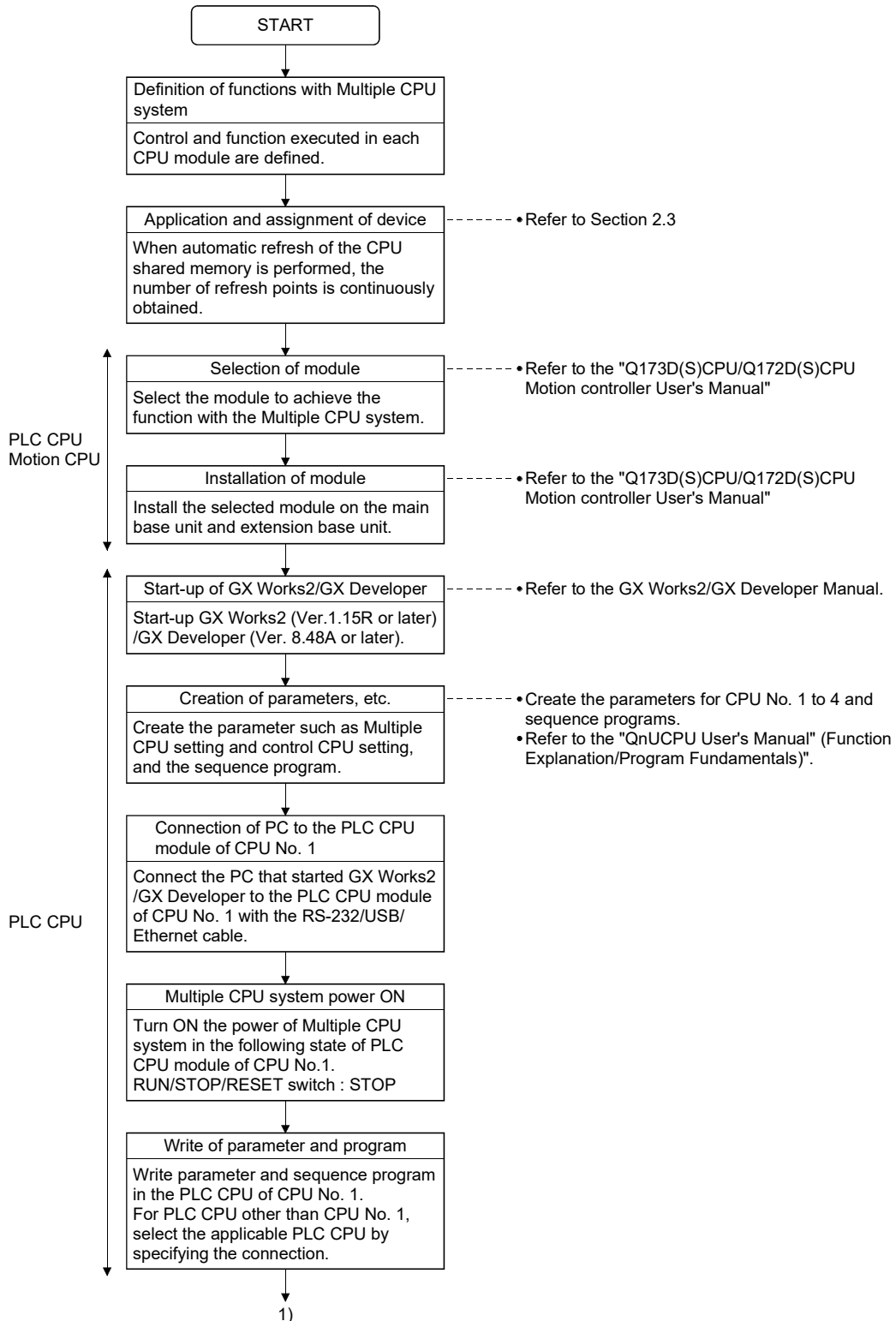

## 2 MULTIPLE CPU SYSTEM

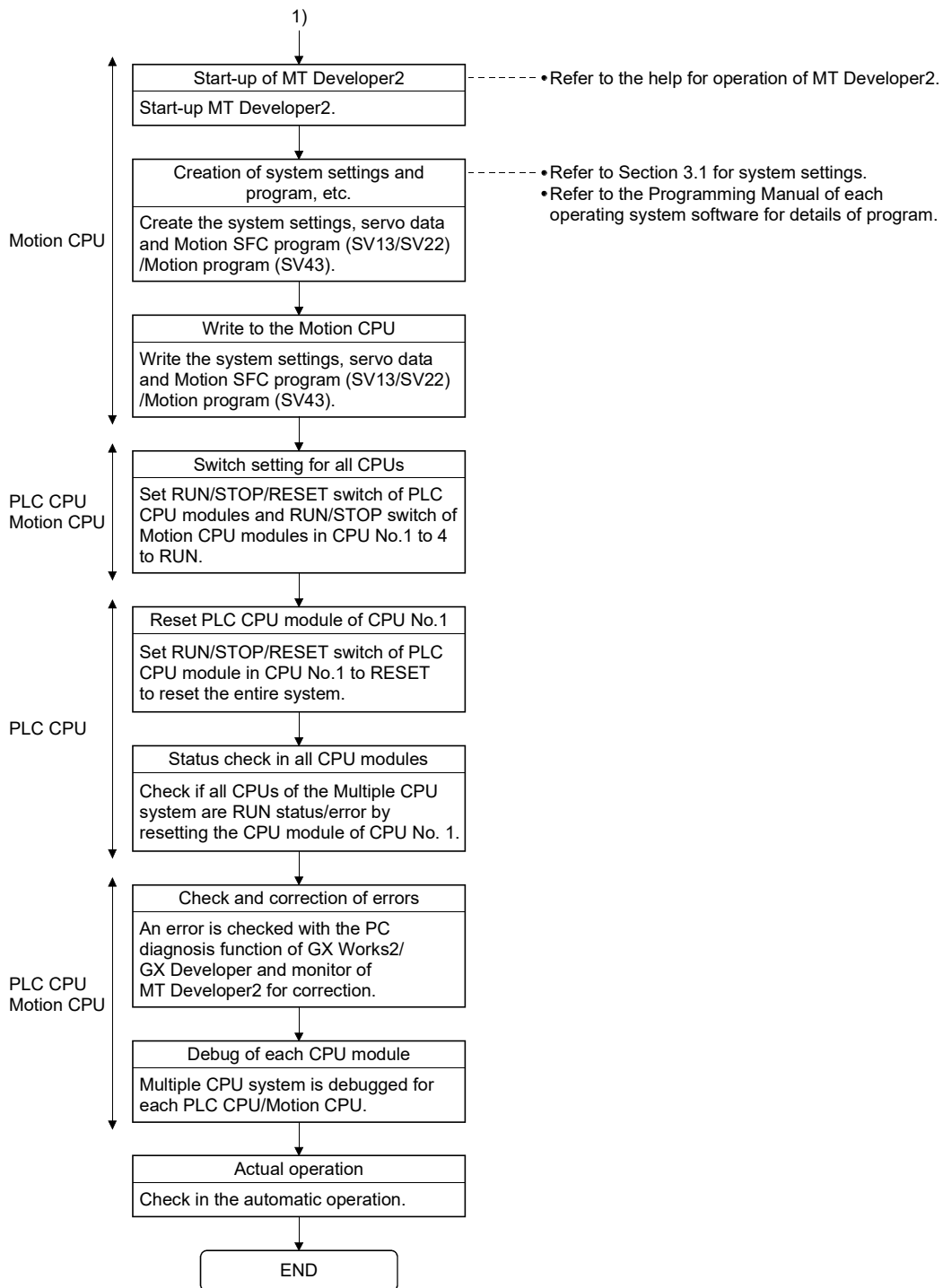

(Note): Installation of the operating system software is required to the Motion CPU module before start of the Multiple CPU system.

Refer to Chapter 5 of the "Q173D(S)CPU/Q172D(S)CPU Motion controller User's Manual" for installation of the Motion CPU operating system software.

## 2 MULTIPLE CPU SYSTEM

### 2.3 Communication Between the PLC CPU and the Motion CPU in the Multiple CPU System

#### 2.3.1 CPU shared memory

##### (1) Structure of CPU shared memory

The CPU shared memory is memory provided for each CPU module and by which data are written or read between CPU modules of the Multiple CPU system.

The CPU shared memory consists of four areas.

- Self CPU operation information area
- System area
- User setting area
- Multiple CPU high speed transmission area

The CPU shared memory configuration and the availability of the communication from the self CPU using the CPU shared memory by program are shown below.

CPU shared memory		Self CPU		Other CPU	
		Write	Read	Write	Read
(0H) 0 to (1FFH) 511 (200H) 512	Self CPU operation information area	×	○ <sup>(Note-2)</sup>	×	○ <sup>(Note-2)</sup>
to (7FFH) 2047 (800H) 2048	System area	×	×	×	○ <sup>(Note-2)</sup>
to (FFFH) 4095 (1000H) 4096	User setting area	○ <sup>(Note-1)</sup>	○ <sup>(Note-2)</sup>	×	○ <sup>(Note-2)</sup>
to (270FH) 9999 (2710H) 10000	Unusable	×	×	×	×
to up to (5F0FH) 24335	Multiple CPU high speed transmission area (Variable size in 0 to 14k[points]: 1k words in unit)	○ <sup>(Note-3)</sup>	○ <sup>(Note-3)</sup>	×	○ <sup>(Note-3)</sup>

○ : Communication allowed    × : Communication not allowed

#### REMARK

(Note-1): Use the MULTW instruction to write to the user setting area of the self CPU in the Motion CPU.

Use the S.TO instruction to write to the user setting area of the self CPU in the PLC CPU.

(Note-2): Use the MULTR instruction to read the shared memory of self CPU and other CPU in the Motion CPU.

Use the FROM instruction/Multiple CPU area device (U□\G□) to read the shared memory of the Motion CPU from the PLC CPU.

(Note-3): Refer to Section 2.3.2(1) for the access method of Multiple CPU high speed transmission area.

## 2 MULTIPLE CPU SYSTEM

### (a) Self CPU operation information area (0H to 1FFH)

- 1) The following information of self CPU is stored as the Multiple CPU system

Table 2.3 Table of self CPU operation information areas

CPU shared memory address	Name	Detail	Description (Note)	Corresponding special register
0H	Information availability	Information availability flag	The area to confirm if information is stored in the self CPU's operation information area (1H to 1FH) or not. • 0: Information not stored in the self CPU's operation information area. • 1: Information stored in the self CPU's operation information area.	—
1H	Diagnostic error	Diagnostic error number	An error No. identified during diagnosis is stored in BIN.	SD0
2H	Time the diagnostic error occurred	Time the diagnostic error occurred	The year and month that the error number was stored in the CPU shared memory's 1H address is stored with two digits of the BCD code.	SD1
3H			The date and time that the error number was stored in the CPU shared memory's 1H address is stored with two digits of the BCD code.	SD2
4H			The minutes and seconds that the error number was stored in the CPU shared memory's 1H address is stored with two digits of the BCD code.	SD3
5H	Error information identification code	Error information identification code	Stores an identification code to determine what error information has been stored in the common error information and individual error information.	SD4
6H to 10H	Common error information	Common error information	The common information corresponding to the error number identified during diagnosis is stored.	SD5 to SD15
11H to 1BH	Individual error information	Individual error information	The individual information corresponding to the error number identified during diagnostic is stored.	SD16 to SD26
1CH	Empty	—	Cannot be used	—
1DH	Switch status	CPU switch status	Stores the CPU module switch status.	SD200
1EH	Empty	—	Cannot be used	—
1FH	CPU operation status	CPU operation status	Stores the CPU module's operation status.	SD203

(Note): Refer to the corresponding special register for details.

- 2) The self CPU operation information area is refreshed every time the applicable register has been changed in the main cycle.
- 3) Other PLC CPU can use FROM instruction to read data from the self CPU operation information area.  
However, because there is a delay in data updating, use the read data for monitoring purposes only.

### (b) System area

The area used by the operating systems (OS) of the PLC CPU/Motion CPU.

### (c) User setting area

The area for communication between CPU modules in the Multiple CPU system by MULTR/MULTW instruction of Motion CPU.

(PLC CPU use FROM/S.TO instruction or Multiple CPU area devices to communicate between CPU modules.)

Refer to the Programming Manual of operating system software for MULTR/MULTW instruction.

## 2 MULTIPLE CPU SYSTEM

### (d) Multiple CPU high speed transmission area

The area corresponding to the Multiple CPU high speed main base unit (Q3□DB) and Multiple CPU high speed transmission that uses the drive system controllers including PLC CPU and Motion CPU.

The image chart of Multiple CPU high speed transmission area is shown below.

Refer to Section 2.3.2(1) for access to the Multiple CPU high speed transmission area of self CPU and other CPU.

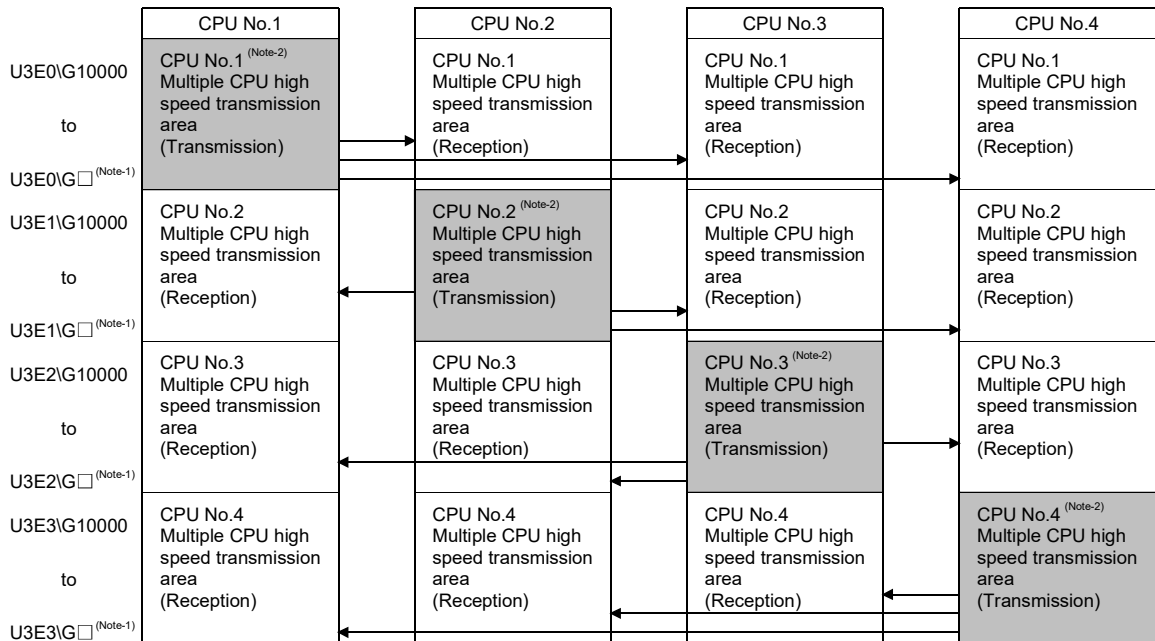

(Note-1) : The final device is "10000+(A×1024-B-1)".

A : Data transmission size of each CPU (1k words in unit)

B : Size used in the automatic refresh of each CPU.

Refer to Section "2.3.2 Multiple CPU high speed transmission" for the size setting of A and B.

(Note-2) : Transmission area to write/read in the self CPU.

Reception area from the other CPU can be read only.

It is updated every 0.88ms.

2.3.2 Multiple CPU high speed transmission

(1) Multiple CPU high speed transmission

Multiple CPU high speed transmission is a function for fixed cycle data transmission between Multiple CPUs (Multiple CPU high speed transmission cycle is 0.88[ms].).

Secure data transmission is possible without effecting the PLC CPU scan time or Motion CPU main cycle because the data transmission and execution of sequence program and Motion SFC program/Motion program can be executed with parallel processing.

High speed response between multiple CPUs is realized by synchronizing the Multiple CPU high speed transmission cycle with Motion CPU operation cycle.

The following methods of data transmission exist between Multiple CPUs for Multiple CPU high speed transmission.

- Use the Multiple CPU area device  
Set the Multiple CPU high speed transmission area by setting the Multiple CPU area device (U□\G□) in the program.
- Automatic refresh method  
Refresh the internal devices of each CPU by automatic refresh via "Multiple CPU high speed transmission area".

(a) Multiple CPU area device method

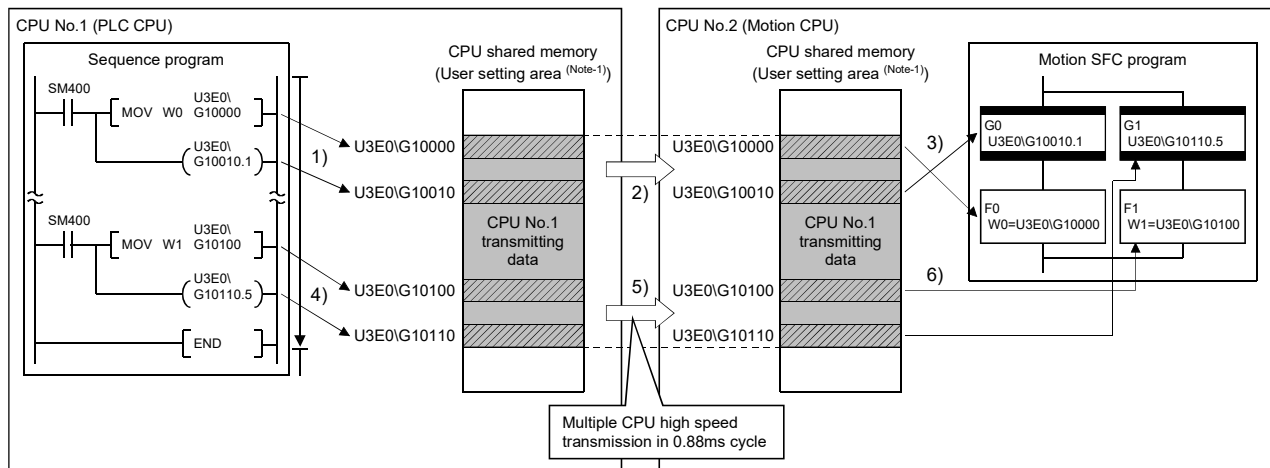

- 1), 4) : Write data in the user setting area (Note-1) by the instruction that uses the Multiple CPU area device.  
 3), 6) : Read data from the user setting area (Note-1) by the instruction that uses the Multiple CPU area device.  
 2), 5) : Transmit the contents of user setting area (Note-1) to the other CPU with by Multiple CPU high speed transmission in 0.88ms cycle.

Note-1: The area composed in the Multiple CPU high speed transmission area.  
 (Refer to Section "(3) Memory configuration of Multiple CPU high speed transmission area".)



## 2 MULTIPLE CPU SYSTEM

### 1) Access to Multiple CPU high speed transmission area

#### a) SV13/SV22

- Description of Multiple CPU area device

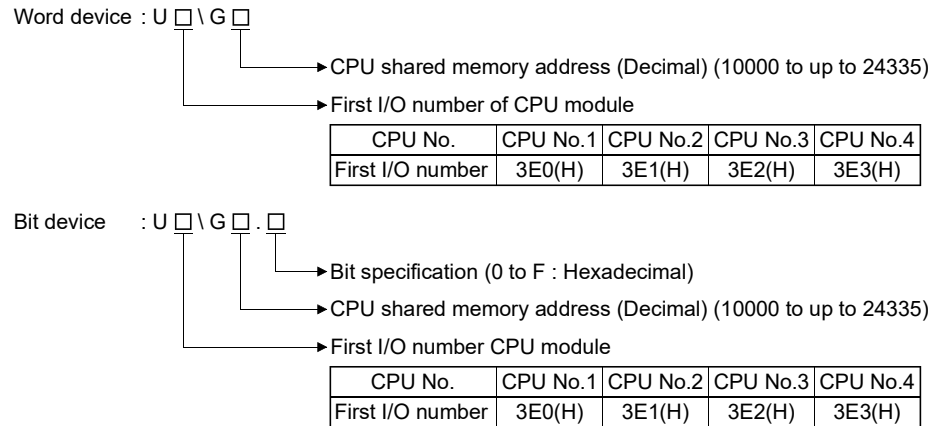

#### (Example)

- Multiple CPU high speed transmission memory address of CPU No.2: 10002

U3E1\G10002

- Bit 14 of CPU No.3 Multiple CPU high speed transmission memory address 10200

U3E2\G10200.E

- Example of access in the program

<Motion SFC program>

- Store K12345678 to the Multiple CPU high speed transmission memory 10200,10201 of self CPU (CPU No.2).

U3E1\G10200L = K12345678

- Turn on bit 12 of the Multiple CPU high speed transmission memory 10301 of self CPU (CPU No.3)

SET U3E2\G10301.C

<Servo program>

- Program which executes the positioning for Axis 1 to position set in the Multiple CPU high speed transmission memory 10400, 10401 of CPU No.1 at the speed set in the 10402, 10403 of CPU No.1, and uses bit 1 of CPU No.1 Multiple CPU high speed transmission memory 10404 of CPU No.1 as a cancel signal.

ABS-1		
Axis	1,	U3E0\G10400
Speed		U3E0\G10402
Cancel		U3E0\G10404.1

## 2 MULTIPLE CPU SYSTEM

### b) SV43

- Description of Multiple CPU area device

Word device : # Q  \

→ CPU shared memory address (Decimal) (0 to up to 14335)<sup>(Note)</sup>

→ CPU No.

CPU No.	CPU No.1	CPU No.2	CPU No.3	CPU No.4
Set value	0	1	2	3

Bit device : # Q  \  .

→ Bit specification (0 to F : Hexadecimal)

→ CPU shared memory address (Decimal) (0 to up to 14335)<sup>(Note)</sup>

→ CPU No.

CPU No.	CPU No.1	CPU No.2	CPU No.3	CPU No.4
Set value	0	1	2	3

(Note): Write the value that attracted 10000 from specified CPU shared memory address.  
(Accessible memory address : 10000 to 24335)

(Example)

- Multiple CPU high speed transmission memory address of CPU No.2: 10002

#Q1\2

- Bit 14 of CPU No.3 Multiple CPU high speed transmission memory address 10200

#Q2\200.E

- Example of access in the program

<Motion program>

- Store K12345678 to the Multiple CPU high speed transmission memory 10200,10201 of self CPU (CPU No.2).

#Q1\200:L = K12345678;

- Turn on bit 12 of the Multiple CPU high speed transmission memory 10301 of self CPU (CPU No.3)

SET #Q2\301.C;

- Program which executes the positioning for Axis X to position set in the Multiple CPU high speed transmission memory 10400, 10401 of CPU No.1 at the speed set in the 10402, 10403 of CPU No.1, and uses bit 1 of CPU No.1 Multiple CPU high speed transmission memory 10404 of CPU No.1 as a skip signal.

G32 X#Q0\400:L F#Q0\402:L SKIP #Q\404.1;

#### POINT

This method can be used to access only the Multiple CPU high speed transmission area of CPU shared memory. It cannot be used to access the CPU shared memory (0 to 4095).

## 2 MULTIPLE CPU SYSTEM

### (b) Example of using automatic refresh method

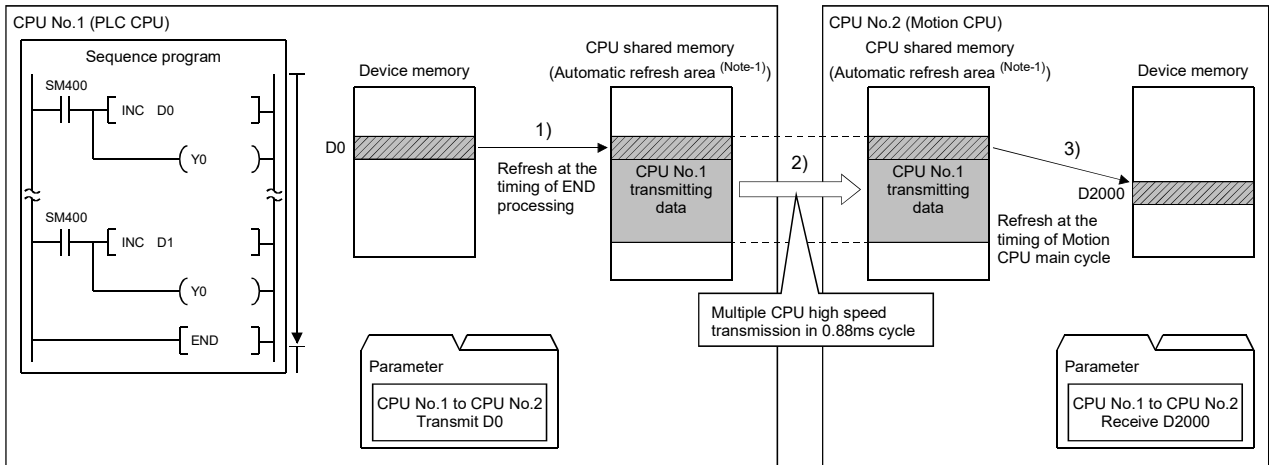

- 1) Transmit the content of D0 to the automatic refresh area <sup>(Note-1)</sup> at the time of END processing by parameter setting.
- 2) Transmit the content of automatic refresh area <sup>(Note-1)</sup> to the other CPU by Multiple CPU high speed transmission at 0.88ms cycle.
- 3) Read the content of automatic refresh area <sup>(Note-1)</sup> at the time of Motion CPU main cycle and transmit it to D2000 by parameter setting.

Note-1: The area composed in the Multiple CPU high speed transmission area.  
(Refer to Section "(3) Memory configuration of Multiple CPU high speed transmission area".)

### (2) System configuration

Multiple CPU high speed transmission can be used only between CPU modules for the Multiple CPU high speed transmission installed in the Multiple CPU high speed main base unit (Q3□DB).

The system configuration specification is shown in Table 2.4.

Table 2.4 System configuration to use Multiple CPU high speed transmission

Object	Restrictions
Base unit	Multiple CPU high speed main base unit (Q3□DB) is used.
CPU module	QnUD(E)(H)CPU/QnUDVCPU is used for CPU No.1.
	Q173D(S)CPU/Q172D(S)CPU and QnUD(E)(H)CPU/QnUDVCPU are used for CPU No.2 to CPU No.4

"MULTI EXE. ERROR (error code: 7011) will occur if the power supply of Multiple CPU system is turned on without matching the system configuration shown in Table 2.4.

## 2 MULTIPLE CPU SYSTEM

### (3) Memory configuration of Multiple CPU high speed transmission area

Memory configuration of Multiple CPU high speed transmission area is shown below.

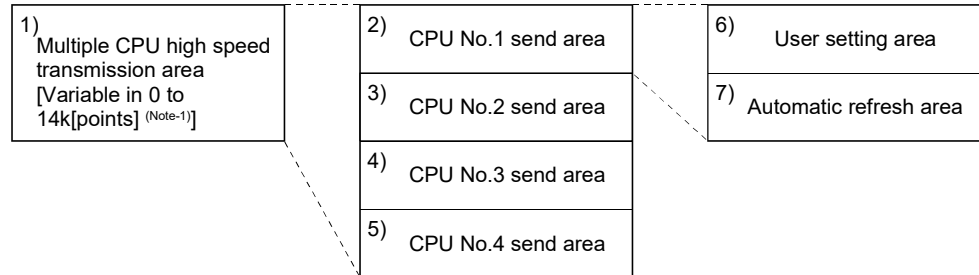

(Note-1): Multiple CPU high speed transmission area;  
 14k[points]: Maximum value when constituted with two CPUs  
 13k[points]: Maximum value when constituted with three CPUs  
 12k[points]: Maximum value when constituted with four CPUs

Table 2.5 Description of area

No.	Name	Description	Size	
			Setting range	Setting unit
1)	Multiple CPU high speed transmission area	<ul style="list-style-type: none"> <li>Area for data transmission between each CPU module in the Multiple CPU system.</li> <li>The area up to 14k [points] is divided between each CPU module that constitutes the Multiple CPU system.</li> </ul>	0 to 14k	1k
2)	CPU No. n send area (n=1 to 4)	<ul style="list-style-type: none"> <li>Area to store the send data of each CPU module.</li> <li>Sends the data stored in the send area of self CPU to the other CPUs.</li> <li>Other CPU send area stores the data received from the other CPUs.</li> </ul>	0 to 14k	1k
3)				
4)				
5)				
6)	User setting area	<ul style="list-style-type: none"> <li>Area for data communication with other CPUs using the Multiple CPU area device.</li> <li>Can be accessed by the user program using the Multiple CPU area device.</li> <li>Refer to Section 2.3.2 (1) for details of this area.</li> </ul>	0 to 14k	2
7)	Automatic refresh area	<ul style="list-style-type: none"> <li>Area for communicating device data with other CPUs by the communication using the automatic refresh.</li> <li>Access by user program is disabled.</li> <li>Refer to Section "(4)(b) Automatic refresh setting" for details of this area.</li> </ul>	0 to 14k	2

(4) Parameter setting

The parameter setting list for use with the Multiple CPU high speed transmission is shown in Table 2.6.

Table 2.6 Multiple CPU high speed transmission parameter list

Name	Description	Target CPU
Multiple CPU high speed transmission area setting	Set the size of the Multiple CPU high speed transmission area allocated in each CPU module which composes the Multiple CPU system.	All CPUs
Automatic refresh setting	Set the range to execute the data transmission by the automatic refresh function among the user area in the Multiple CPU high speed transmission area.	

(a) Multiple CPU high speed transmission area setting

Multiple CPU high speed transmission area setting screen and setting range are shown below.

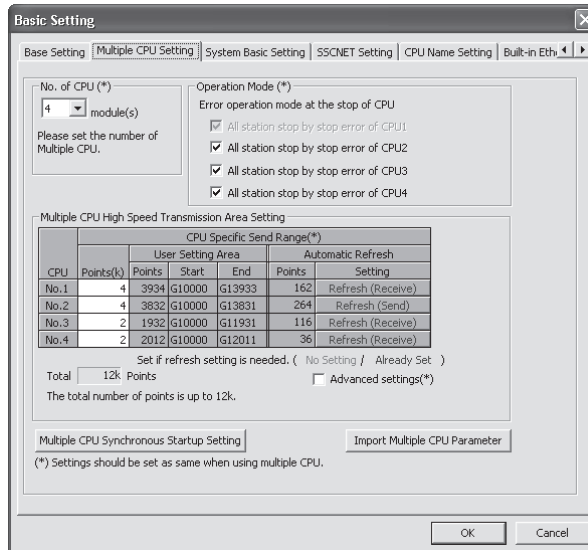

## 2 MULTIPLE CPU SYSTEM

Table 2.7 Parameter setting items of Multiple CPU high speed transmission area setting

Item	Setting description	Setting/display value	Restriction	Consistency check																								
CPU	CPU No. corresponding to displayed parameters.	CPU No.1 to No.4	—	—																								
CPU specific send range	<p>Set the number of points of data that each CPU module sends. Default value assigned to each CPU is shown below.</p> <table border="1"> <thead> <tr> <th rowspan="2">Number of CPUs</th> <th colspan="4">Default value of CPU specific send range [points]</th> </tr> <tr> <th>CPU No.1</th> <th>CPU No.2</th> <th>CPU No.3</th> <th>CPU No.4</th> </tr> </thead> <tbody> <tr> <td>2</td> <td>7k</td> <td>7k</td> <td>—</td> <td>—</td> </tr> <tr> <td>3</td> <td>7k</td> <td>3k</td> <td>3k</td> <td>—</td> </tr> <tr> <td>4</td> <td>3k</td> <td>3k</td> <td>3k</td> <td>3k</td> </tr> </tbody> </table>	Number of CPUs	Default value of CPU specific send range [points]				CPU No.1	CPU No.2	CPU No.3	CPU No.4	2	7k	7k	—	—	3	7k	3k	3k	—	4	3k	3k	3k	3k	<p>Range: 0 to 14k [points] Unit: 1k [point] (Points: Word in units)</p>	<ul style="list-style-type: none"> <li>Set the total of all CPUs to be the following points or lower. When constituted with two CPUs: 14k [points] When constituted with three CPUs: 13k [points] When constituted with four CPUs: 12k [points]</li> </ul>	Provided
Number of CPUs	Default value of CPU specific send range [points]																											
	CPU No.1	CPU No.2	CPU No.3	CPU No.4																								
2	7k	7k	—	—																								
3	7k	3k	3k	—																								
4	3k	3k	3k	3k																								
Automatic refresh	<p>Used when communicating with the other CPU using the automatic refresh. Number of points that is set by the "automatic refresh setting" is displayed.</p>	<p>Range: 0 to 14336 [points] Unit: 2 [points]</p>	Do not exceed the number of points of the CPU specific send range.	—																								
User setting area	<p>Used when communicating with the other CPU using the program. The value where the "number of points set in the automatic refresh" is subtracted from the "CPU specific send range setting" is displayed.</p>	<p>Range: 0 to 14336 [points] Unit: 2 [points]</p>	—	—																								

**POINT**

Selecting "Advanced setting" enables the ability to change the number of points from 1k to 2k in the system area used for Motion dedicated PLC instructions. Changing the number of points in the system area to 2k increases the number of Motion dedicated PLC instructions that can be executed concurrently in a scan. The screen where "Advanced setting" is selected is shown below. Refer to the "Q173D(S)CPU/Q172D(S)CPU Motion controller (SV13/SV22) Programming Manual (Motion SFC)" for the Motion dedicated PLC instruction.

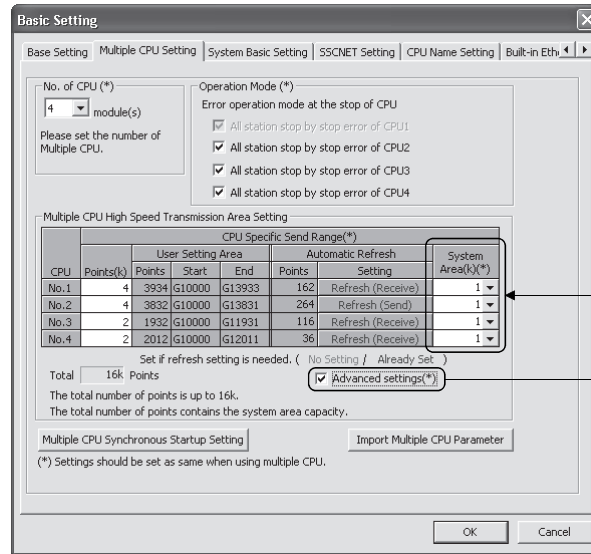

System area is displayed by selecting "Advanced settings".

Item	Setting description	Setting/display value (Points: Word in units)	Restriction	Data size consistency check
CPU specific send range	Set the number of points of data that each CPU module sends.	Range: 0 to 14k [points] Unit: 1k [points]	<ul style="list-style-type: none"> <li>Set the total of all CPUs to be the following points or lower.</li> <li>When constituted with two CPUs: 14k [points]</li> <li>When constituted with three CPUs: 13k [points]</li> <li>When constituted with four CPUs: 12k [points]</li> </ul>	Provided
System area	Set the number of points for a system area to be assigned for each CPU module. (Default value of system area size is 1k [point].)	Range: 1k/2k [points]	—	Provided
Total	Display the total number of points of the self CPU send area and the system area that are assigned to the each CPU module.	Range: 1 to 16k [points] Unit: 1k [points]	Set the total of all CPUs to 16.0k points or lower.	—

## 2 MULTIPLE CPU SYSTEM

### (b) Automatic refresh setting

Setting for use of the automatic refresh function in the Multiple CPU high speed transmission area.

Up to 32 setting ranges can be set for each CPU module.

Automatic refresh setting screen and setting range are shown below.

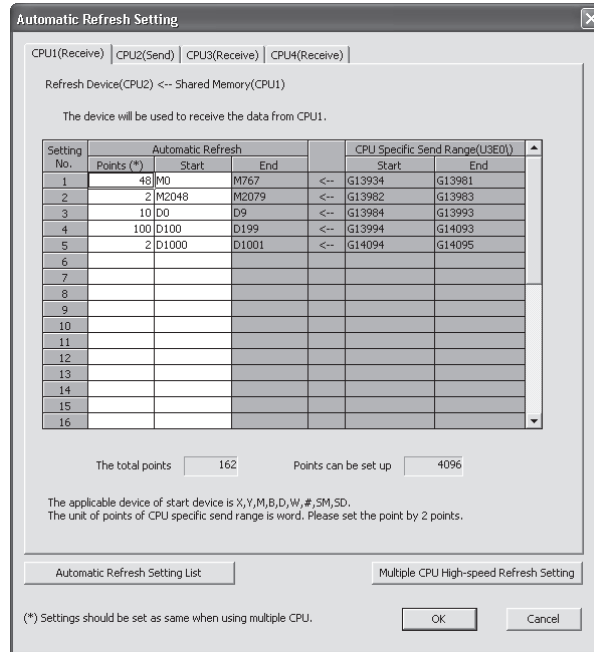

Table 2.8 Parameter setting items of automatic refresh setting

Item	Setting description	Setting range	Restriction	Data size consistency check
CPU selection	Select the CPU module for editing of the CPU specific send range setting.	CPU No.1 to No.4	• CPU No. which exceeds the number of CPU modules cannot be selected.	—
Setting No.	The setting No. for transmission of each CPU module is displayed. Automatic refresh is executed between devices set to the same setting No. for all CPUs that constitute the Multiple CPU system.	1 to 32	—	—
Points	Set the number of points for data communication.	Range: 2 to 14336 [points] Unit: 2 [points]	• Setting which exceeds the number of points of the self CPU send area allocated to each CPU module (CPU specific send range) cannot be set. • Bit device can be specified in units of 32 points (2 words) only.	Provided
Start	Specifies the device which performs the data communication (automatic refresh). Specifies the device sent by the self CPU when the "Send source CPU selection" is the self CPU, and specifies the device received by the self CPU when the CPU specific send range setting is the other CPU.	Usable device ( X, Y, M, B, D, W, #, SM, SD) Note) Set "blank" when automatic refresh is not executed.	• Bit device can be specified in units of 16 points (1 word) only. • Device number cannot be duplicated.	None



## 2 MULTIPLE CPU SYSTEM

### POINT

The processing performance of automatic refresh improves when devices are transmitted in 2 word sets. Therefore, it is recommended to set the start device as 2 word unit by inputting an even device number.

#### 1) Operation example of automatic refresh

##### a) 2 CPU modules (1 PLC CPU, 1 Motion CPU) use

- Parameter setting

The setting example of automatic refresh is shown below.

#### • CPU No.1 (PLC CPU) (GX Works2/GX Developer) <Screen: GX Works2>

Set the device transmitted to CPU No.2.

No.	Points(*)	Auto Refresh		CPU Specific Send Range (USER1)	
		Start	End	Start	End
1	40	M200	M3039	-->	G17128 G17167
2					
3					
4					
5					
6					
7					
8					
9					
10					
11					
12					
13					
14					
15					
16					

Total Points: 40    Settable Points: 7168

Available start devices are X,Y,M,L,B,D,W,R,DR,SM,SD,SB,SW.  
Word is used for points. Every 2 points are counted as a set.

(\*1) Setting should be set as same when using multiple CPU.

#### • CPU No.2 (Motion CPU) (MT Developer2)

Set the device received from CPU No.1.

Setting No.	Points(*)	Automatic Refresh		CPU Specific Send Range(USER1)	
		Start	End	Start	End
1	40	M200	M3039	<--	G17128 G17167
2					
3					
4					
5					
6					
7					
8					
9					
10					
11					
12					
13					
14					
15					
16					

The total points: 40    Points can be set up: 7168

The applicable device of start device is X,Y,M,B,D,W,#,SM,SD.  
The unit of points of CPU specific send range is word. Please set the point by 2 points.

(\*1) Settings should be set as same when using multiple CPU.

Set the device received from CPU No.2.

No.	Points(*)	Auto Refresh		CPU Specific Send Range (USER1)	
		Start	End	Start	End
1	640	D0	D639	<--	G16488 G17127
2	40	M2400	M3039	<--	G17128 G17167
3					
4					
5					
6					
7					
8					
9					
10					
11					
12					
13					
14					
15					
16					

Total Points: 680    Settable Points: 7168

Available start devices are X,Y,M,L,B,D,W,R,DR,SM,SD,SB,SW.  
Word is used for points. Every 2 points are counted as a set.

(\*1) Setting should be set as same when using multiple CPU.

Set the device transmitted to CPU No.1.

Setting No.	Points(*)	Automatic Refresh		CPU Specific Send Range(USER1)	
		Start	End	Start	End
1	640	D0	D639	-->	G16488 G17127
2	40	M2400	M3039	-->	G17128 G17167
3					
4					
5					
6					
7					
8					
9					
10					
11					
12					
13					
14					
15					
16					

The total points: 680    Points can be set up: 7168

The applicable device of start device is X,Y,M,B,D,W,#,SM,SD.  
The unit of points of CPU specific send range is word. Please set the point by 2 points.

(\*1) Settings should be set as same when using multiple CPU.

(Note) : The operation example of automatic refresh is shown on the next page.

## 2 MULTIPLE CPU SYSTEM

- Operation example

The example of operating automatic refresh is shown below.

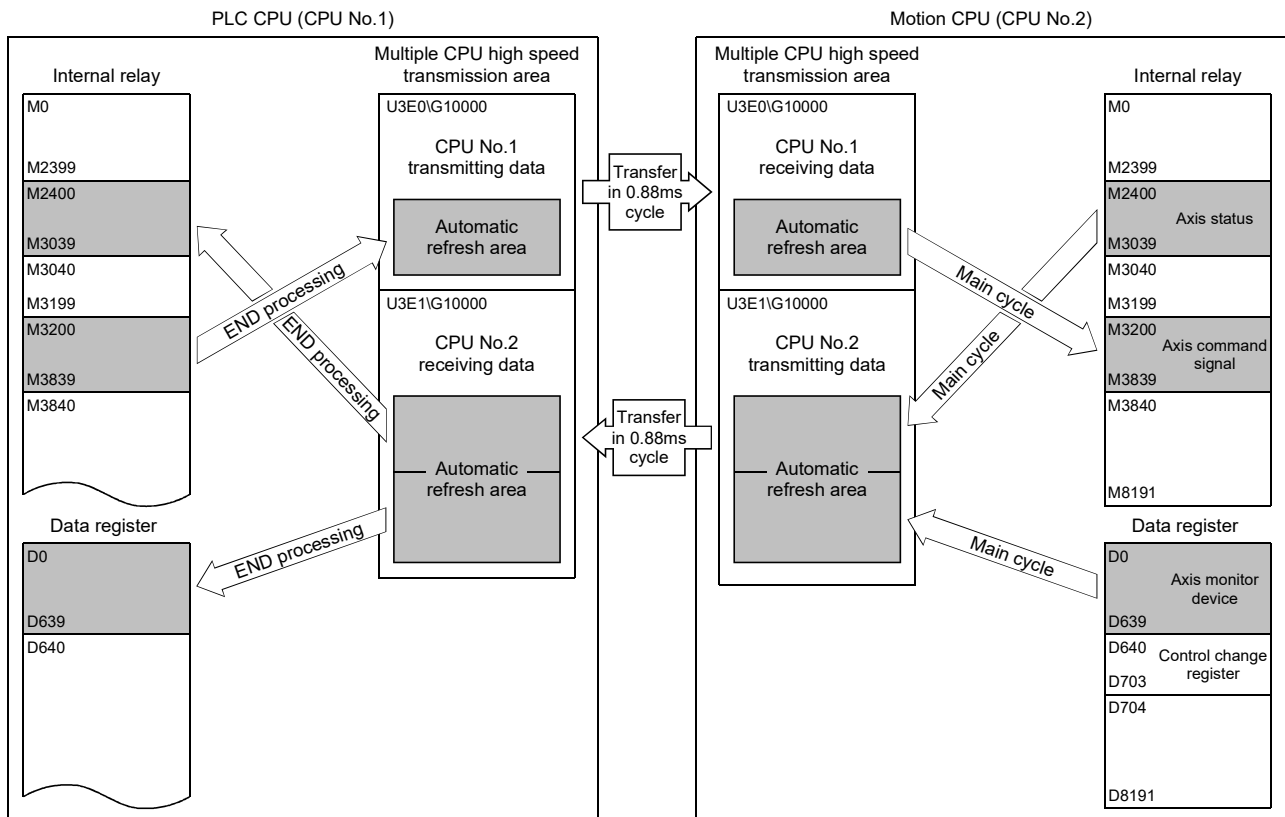

## 2 MULTIPLE CPU SYSTEM

b) 3 CPU modules (1 PLC CPU, 2 Motion CPUs) use

- Parameter setting

The setting example of automatic refresh is shown below.

• CPU No.1 (PLC CPU) (GX Works2/GX Developer) <Screen: GX Works2>

• CPU No.2 (Motion CPU) (MT Developer2)

Set the device transmitted to CPU No.2 and No.3.

Set the device received from CPU No.1.

No.	Points(*)	Start	End	Start	End
1	48	M3072	M3839	->	G16836 G16883
2	48	M7072	M7839	->	G16884 G16931
3	118	D640	D757	->	G16932 G17049
4	118	D1640	D1757	->	G17050 G17167
5					
6					
7					
8					
9					
10					
11					
12					
13					
14					
15					
16					

Total Points: 332    Settable Points: 7168

Setting No.	Points (*)	Start	End	Start	End
1	48	M3072	M3839	<-	G16836 G16883
2	48	M7072	M7839	<-	G16884 G16931
3	118	D640	D757	<-	G16932 G17049
4	118	D1640	D1757	<-	G17050 G17167
5					
6					
7					
8					
9					
10					
11					
12					
13					
14					
15					
16					

The total points: 332    Points can be set up: 7168

Set "blank" to refresh the device of CPU No.3.

Set the device received from CPU No.2.

Set the device transmitted to CPU No.1 and No.3.

No.	Points(*)	Start	End	Start	End
1	66	M2000	M3055	<-	G12366 G12431
2	640	D0	D639	<-	G12432 G13071
3					
4					
5					
6					
7					
8					
9					
10					
11					
12					
13					
14					
15					
16					

Total Points: 706    Settable Points: 3072

Setting No.	Points (*)	Start	End	Start	End
1	66	M2000	M3055	->	G12366 G12431
2	640	D0	D639	->	G12432 G13071
3					
4					
5					
6					
7					
8					
9					
10					
11					
12					
13					
14					
15					
16					

The total points: 706    Points can be set up: 3072

Set the device received from CPU No.3.

Set the device received from CPU No.3.

No.	Points(*)	Start	End	Start	End
1	66	M2000	M3055	<-	G12366 G12431
2	640	D1000	D1639	<-	G12432 G13071
3					
4					
5					
6					
7					
8					
9					
10					
11					
12					
13					
14					
15					
16					

Total Points: 706    Settable Points: 3072

Setting No.	Points (*)	Start	End	Start	End
1	66	M2000	M3055	X	G12366 G12431
2	640	D1000	D1639	X	G12432 G13071
3					
4					
5					
6					
7					
8					
9					
10					
11					
12					
13					
14					
15					
16					

The total points: 706    Points can be set up: 3072

Set "blank" to refresh the device of CPU No.3.

## 2 MULTIPLE CPU SYSTEM

### • CPU No.3 (Motion CPU) (MT Developer2)

Set the device received from CPU No.1.

Automatic Refresh Setting

CPU1(Receive) | CPU2(Receive) | CPU3(Send)

Refresh Device(CPU3) <- Shared Memory(CPU1)

The device will be used to receive the data from CPU1.

Setting No.	Points (*)	Automatic Refresh		CPU Specific Send Range(USE01)
		Start	End	
1	48			X G10836 G10899
2	49	M0072	D0879	<- G10894 G10931
3	118			X G10932 G10969
4	118	D040	D757	<- G17050 G17167
5				
6				
7				
8				
9				
10				
11				
12				
13				
14				
15				
16				

The total points: 332 Points can be set up: 7168

The applicable device of start device is X,Y,M,B,D,W,#,SM,SD.  
The unit of points of CPU specific send range is word. Please set the point by 2 points.

Automatic Refresh Setting List Multiple CPU High-speed Refresh Setting

(\*) Settings should be set as same when using multiple CPU. OK Cancel

Set "blank" not to refresh the device of CPU No.2.

Set the device received from CPU No.2.

Automatic Refresh Setting

CPU1(Receive) | CPU2(Receive) | CPU3(Send)

Refresh Device(CPU3) <- Shared Memory(CPU2)

The device will be used to receive the data from CPU2.

Setting No.	Points (*)	Automatic Refresh		CPU Specific Send Range(USE11)
		Start	End	
1	68			X G12366 G12431
2	69			X G12432 G13071
3				
4				
5				
6				
7				
8				
9				
10				
11				
12				
13				
14				
15				
16				

The total points: 706 Points can be set up: 3072

The applicable device of start device is X,Y,M,B,D,W,#,SM,SD.  
The unit of points of CPU specific send range is word. Please set the point by 2 points.

Automatic Refresh Setting List Multiple CPU High-speed Refresh Setting

(\*) Settings should be set as same when using multiple CPU. OK Cancel

Set "blank" not to refresh the device of CPU No.2.

Set the device transmitted to CPU No.1 and No.2.

Automatic Refresh Setting

CPU1(Receive) | CPU2(Receive) | CPU3(Send)

Refresh Device(CPU3) -> Shared Memory(CPU3)

The device will be used to send the data to other CPU.

Setting No.	Points (*)	Automatic Refresh		CPU Specific Send Range(USE21)
		Start	End	
1	M0000	M0055		<-> G12366 G12431
2	640	D039		<-> G12432 G13071
3				
4				
5				
6				
7				
8				
9				
10				
11				
12				
13				
14				
15				
16				

The total points: 706 Points can be set up: 3072

The applicable device of start device is X,Y,M,B,D,W,#,SM,SD.  
The unit of points of CPU specific send range is word. Please set the point by 2 points.

Automatic Refresh Setting List Multiple CPU High-speed Refresh Setting

(\*) Settings should be set as same when using multiple CPU. OK Cancel

(Note): The operation example of automatic refresh is shown on the next page.

## 2 MULTIPLE CPU SYSTEM

### • Operation example

The example of operating automatic refresh is shown below.

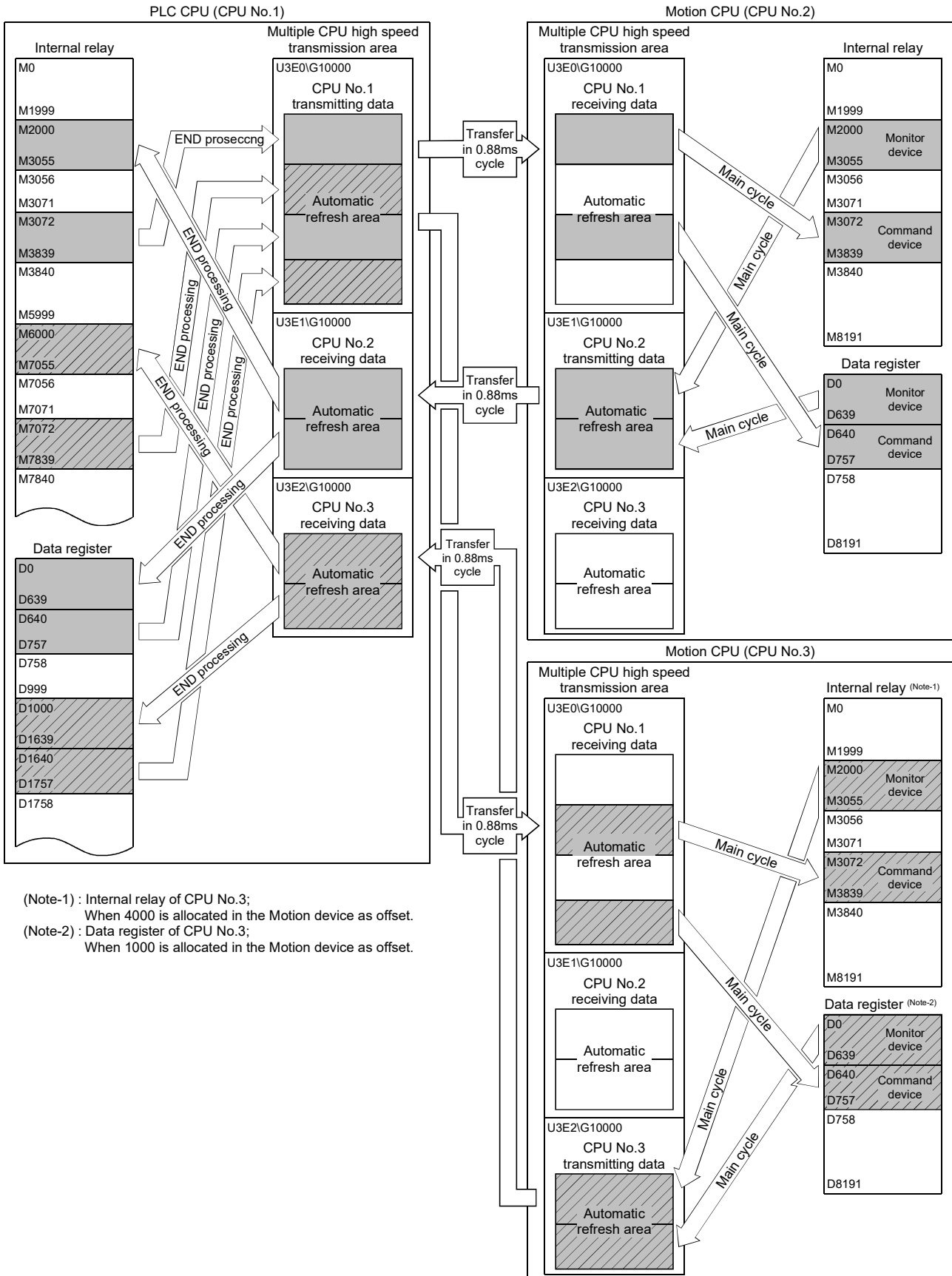

**POINT**

Set the following operation for automatic refresh setting using GX Works2/ GX Developer.

- 1) Select tab "Multiple CPU high speed transmission area setting".
- 2) Set "Use Multiple CPU high speed transmission".

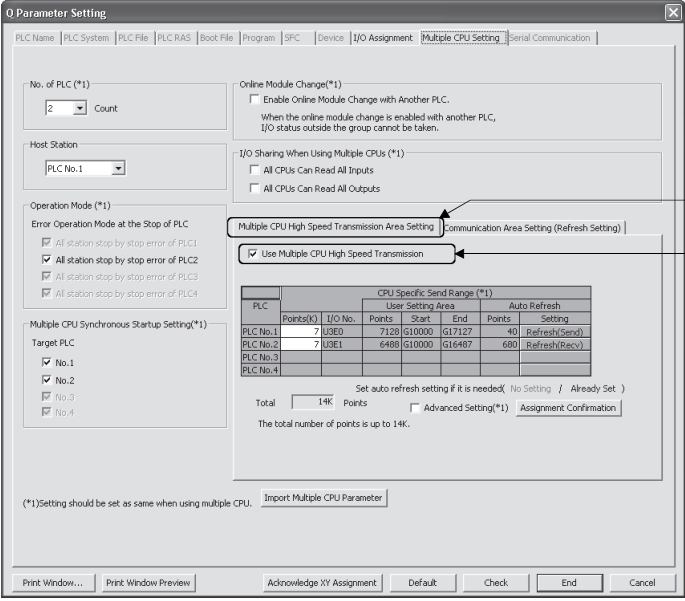

<Screen: GX Works2>

(c) Data size consistency check

Whether the Multiple CPU setting parameters are the same for all CPUs or not is automatically checked. A "PARAMETER ERROR (error code: 3012, 3015)" will occur if they do not match.

(5) Precautions

(a) Assurance of data sent between CPUs

Due to the timing of data sent from the self CPU and automatic refresh in any of the other CPUs, old data and new data may become mixed (data separation).

The following shows the methods for avoiding data separation at communications by automatic refresh.

1) Data consistency for 32 bit data

Transfer data with automatic refresh method is in units of 32 bits. Since automatic refresh is set in units of 32 bits, 32-bit data does not separate.

- For word data

2 words data can be prevented from separating by using an even number to set the first number of each device in automatic refresh setting.

2) Data consistency for data exceeding 32 bits

In automatic refresh method, data is read in descending order of the setting number in automatic refresh setting parameter.

Transfer data separation can be avoided by using a transfer number lower than the transfer data as an interlock device.

## 2 MULTIPLE CPU SYSTEM

### 2.3.3 Multiple CPU high speed refresh function

This function is used to update the data between internal devices of Motion CPU and the Multiple CPU high speed transmission area. This occurs every operation cycle as defined in the device setting of automatic refresh in the self CPU.

Classification	Item	Description	Setting/display value	Restriction
Display	Setting No.	Setting No. which executes high speed refresh is displayed.	1 to 128 (Up to 128)	
	CPU	CPU No. set in the automatic refresh setting is automatically displayed by setting devices. Self CPU : Refresh from the internal device of Motion CPU to Multiple CPU high speed transmission area. Other CPU : Refresh from the Multiple CPU high speed transmission area to internal device of Motion CPU.	CPU No. 1 to No.4	
User setting	Device setting	Set the device No. of Motion CPU to execute the high speed refreshes.	Usable device : D, W, #, SD, M, X, Y, B, SM	<ul style="list-style-type: none"> <li>The start device number must be a multiple of 16 for the bit device.</li> <li>Do not set a device not setting also set in the automatic refresh.</li> <li>No. of "start device + number of points" cannot exceed setting range of each setting No. in automatic refresh setting.</li> <li>Do not overlap the device No. between setting No..</li> </ul>
	Points	Set the number of points to refresh data of each data in word unit. (Note) Refresh is not executed when not set.	Range: 2 to 256 [points] Unit: 2 points (Note-1)	<ul style="list-style-type: none"> <li>Sets the total of all CPUs to 256 points or lower.</li> </ul>
	Refresh cycle	Operation cycle (fixed)	—	<ul style="list-style-type: none"> <li>When the operation cycle is smaller than 0.88ms, the operation cycle is 0.88ms.</li> </ul>

(Note-1) : Point in word unit.

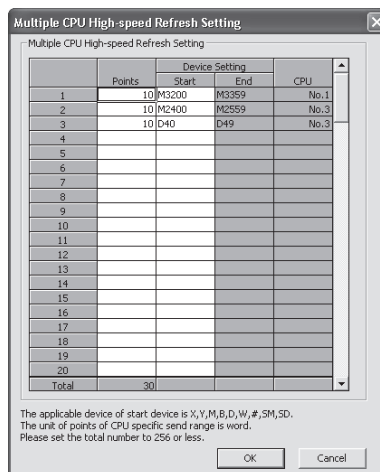

- (1) Application example of Multiple CPU high speed refresh function  
Multiple CPU high speed refresh function is used as in the following applications.
- 1) Read the data such as the real current value and synchronous encoder current value with PLC CPU at high speed.
  - 2) Exchange the FIN waiting signal at high speed.

## 2 MULTIPLE CPU SYSTEM

### (2) Operation example of Multiple CPU high speed refresh function

#### (a) Parameter setting

The automatic refresh setting of Multiple CPU high speed refresh is shown below.

• CPU No.1 (PLC CPU) (GX Works2/GX Developer) <Screen: GX Works2>  
Set the device transmitted to CPU No.2.

Set the device received from CPU No.2.

• CPU No.2 (Motion CPU) (MT Developer2)  
Set the device received from CPU No.1.

Set the device transmitted to CPU No.1.

Set the device to executed the Multiple CPU high speed refresh.

(Note) : The operating example of Multiple CPU high speed refresh function is shown in "(b) Operation example".



**POINT**

Set the following operation for automatic refresh setting using GX Works2/ GX Developer.

- 1) Select tab "Multiple CPU high speed transmission area setting".
- 2) Set "Use Multiple CPU high speed transmission".

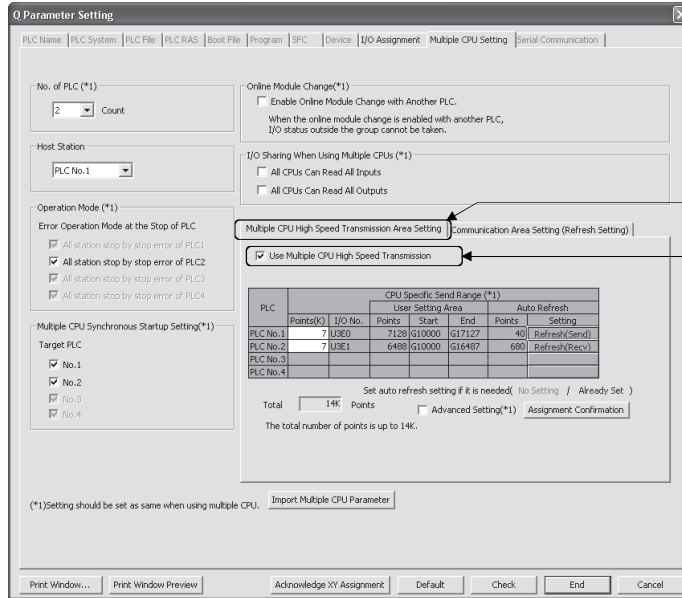

<Screen: GX Works2>

## 2 MULTIPLE CPU SYSTEM

### (b) Operation example

The example of operating Multiple CPU high speed refresh function is shown below.

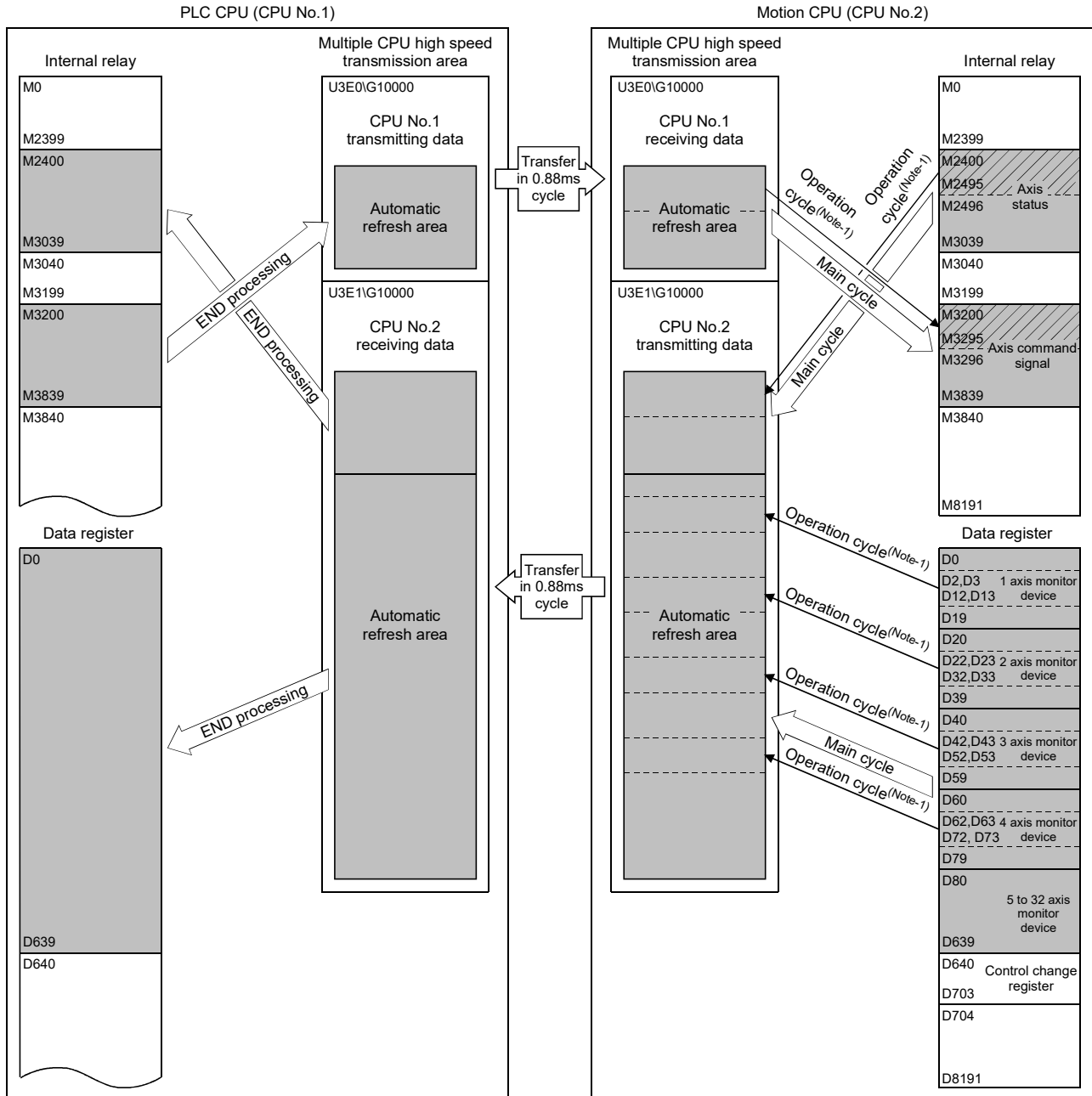

(Note-1): When the operation cycle is smaller than 0.88ms, the operation cycle is 0.88ms.

- The statuses of M2400 to M2495 for axis 1 to axis 4 in axis status M2400 to M3039 which is being automatically refreshed are updated to the Multiple CPU high speed transmission area every operation cycle.
- The command signals of M3200 to M3295 for axis 1 to axis 4 in axis command signal M3200 to M3839 which is being automatically refreshed are updated from the Multiple CPU high speed transmission area to Motion CPU positioning dedicated devices every operation cycle.

- The real current value for axis 1 to axis 4 and M-code in axis monitor device D0 to D639 which is being automatically refreshed are updated to the Multiple CPU high speed transmission area every operation cycle.

### 2.3.4 Clock synchronization between Multiple CPU

The clock of each CPU is synchronized with the clock of CPU No. 1.  
The clock data used for synchronization in a Multiple CPU system can be edited.

#### (1) Setting of clock data

Set the clock of CPU No.1. The Motion CPU module operates automatically by the clock of CPU No.1.

<b>POINT</b>
--------------

The clock data of CPU No.1 is automatically set even if the clocks of CPU No. 2 to 4 are set independently.
---

#### (2) Synchronization of clock data

All clocks are synchronized with CPU No.1 immediately after turning ON/resetting power and every 1-second interval thereafter.

#### (3) Information of clock

The clock data that CPU No. 1 transmits is year, month, day, day of week, hour, minute and second.

#### (4) Error

Since CPU No.1 sets the clock data at 1-second intervals, an error of up to 1 second may occur to the clock of CPU No.2 to 4.

### 2.3.5 Multiple CPU synchronous startup

Multiple CPU synchronous startup function synchronizes the startups of CPU No.1 to CPU No.4. (It takes about ten seconds to startup for Motion CPU.)

Since this function monitors the startup of each CPU module, when other CPU is accessed by a user program, an interlock program which checks the CPU module startup is unnecessary.

With the Multiple CPU synchronous startup function, the startup is synchronized with the slowest CPU module to startup; therefore, the system startup may be slow.

#### POINT

Multiple CPU synchronous startup function is for accessing each CPU module in a Multiple CPU system without needing an interlock.

This function is not for starting an operation simultaneously among CPU modules after startup.

#### (1) Multiple CPU synchronous startup setting

To use the Multiple CPU synchronous startup function, check No.1 to No.4 of target CPU in Multiple CPU settings in system setting of MT Developer2. (Set it in the Multiple CPU setting of PLC parameter setting of GX Works2/ GX Developer for PLC CPU.)

"Set Sync. startup setting of CPU□" is set for No.1 to 4 at default.

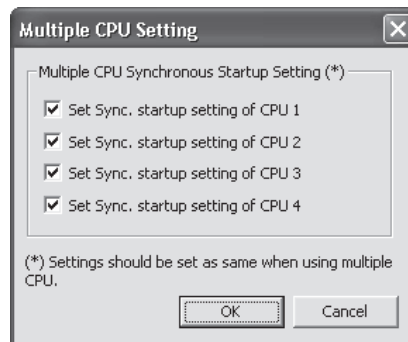

Set the same Multiple CPU synchronous startup for all CPUs that constitute the Multiple CPU system.

The self-diagnosis error "PARAMETER ERROR (error code: 3015)" will occur if all CPU modules that constitute the Multiple CPU system do not have the same setting.

When this function is not used (each CPU startup without synchronization), startup of each CPU module can be confirmed by using special relays SM220 to SM223 (CPU No.1 to 4 READY complete flag).

## 2 MULTIPLE CPU SYSTEM

### 2.3.6 Control instruction from PLC CPU to Motion CPU

Control can be instructed from the PLC CPU to the Motion CPU using the Motion dedicated PLC instructions listed in the table below.

Refer to the "Q173D(S)CPU/Q172D(S)CPU Motion controller (SV13/SV22)

Programming Manual (Motion SFC)" for the details of each instruction.

(Control may not be instructed from one Motion CPU to another Motion CPU.)

Instruction name	Description	
	SV13/SV22	SV43
D(P).SFCS	Start request of the Motion SFC program (Program No. may be specified.)	Start request of the Motion program (Control program)
D(P).SVST	Start request of the specified servo program	Start request of the specified Motion program (Axis designation program)
D(P).CHGA	Current value change request of the specified axis	Home position return request of the specified axis
D(P).CHGAS <b>QDS</b> <b>Ver.!</b>	Current value change request of the specified command generation axis	Unusable
D(P).CHGV	Speed change request of the specified axis	
D(P).CHGVS <b>QDS</b> <b>Ver.!</b>	Speed change request of the specified command generation axis	Unusable
D(P).CHGT	Torque control value change request of the specified axis	
D(P).CHGT2 <b>QDS</b>	Torque control value individual change request of the specified axis	Unusable
D(P).GINT	Execute request of an event task to the other CPU (Motion CPU)	Unusable
D(P).DDWR	Writes device data of the self CPU (PLC CPU) to the device of other CPU (Motion CPU)	
D(P).DDRDR	Reads device data of other CPU (Motion CPU) to the device of self CPU (PLC CPU)	

For example, by using the D(P).SFCS instruction of Motion dedicated PLC instruction, the Motion SFC of the Motion CPU can be started from the PLC CPU.

<Example>

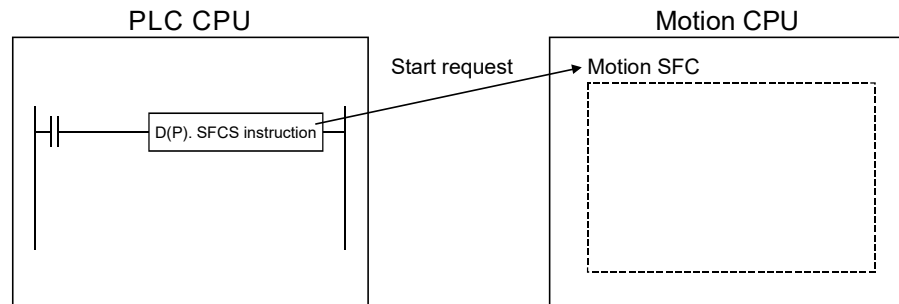



**Ver.!** : Refer to Section 1.5 for the software version that supports this function.

### 3. COMMON PARAMETERS

#### 3.1 System Settings

In the Multiple CPU system, the common system parameters and individual parameters are set for each CPU and written to each CPU.

- (1) The base settings, Multiple CPU settings and Motion slot settings are set in the common system parameter setting.
- (2) The following are set in the individual parameter setting.
  - System basic setting
  - SSCNET setting 
  - CPU name setting
  - Built-in Ethernet port setting
  - CPU setting
  - Manual pulse generator/synchronous encoder setting 
  - Servo amplifier setting
  - High-speed read setting
  - Optional data monitor setting
  - Mark detection setting 
- (3) The data setting and correction can be performed in dialog form using MT Developer2.

### 3 COMMON PARAMETERS

#### 3.1.1 System data settings

Table 3.1 lists the system data items to be set.

Table 3.1 System data setting list

	Item		Setting range	Initial value	Remark	
Common system parameters	Base setting	Main base	5/8/12 slots	Main base: 8 slots	Set the number of slots in the main base or extension base.	
		Extension base	Stage 1 to 7: Nothing/2/3/5/8/10/12 slots	Stage 1 to 7:Nothing		
	Multiple CPU setting	No. of CPU	2/3/4 modules	2 modules	Set the total number of Multiple CPUs including PLC CPU(s).	
		Error operation mode at the stop of CPU	Stop/do not stop all CPUs upon an error in CPU No. 1 to 4. (The setting range varies depending on the number of Multiple CPUs.)	Stop all CPUs upon error in CPU Nos. 1 to 4	Set whether or not to stop the entire system when a CPU stop error occurs in each CPU.	
		Multiple CPU high speed transmission area setting	CPU specific send range	0 to 14k points	Varies depending on the number of CPUs.	Refer to Section 2.3.2.
			System area	1 to 2k points	1	
	Automatic refresh setting	Point: 2 to 14336 points	None	None		
		Start: Set target device for automatic refresh.				
	Multiple CPU synchronous startup setting	Set/do not set CPU No. 1 to 4 as the synchronized startup. (The setting range varies depending on the number of Multiple CPUs.)	Set CPU No. 1 to 4 as the synchronized startup.	Refer to Section 2.3.5.		
	Motion slot setting	Module arrangement	Within the main base and extension base slots	None	Install the modules controlled by the self CPU in the main base and/or extension base(s).	
Individual module		Varies depending on the module.	Varies depending on the module.	Set detailed items for each module controlled by the self CPU.		
Individual parameters	System basic setting	Operation cycle	0.2ms <sup>ON</sup> /0.4ms/0.8ms/1.7ms/3.5ms/7.1ms/14.2ms <sup>OFF</sup> /Default setting	Default setting	Set the operation cycle of motion control.	
		Operation at STOP to RUN	M2000 is turned on by switching from STOP to RUN./M2000 is turned on by switching from STOP to RUN and setting 1 in the set register.	M2000 is turned on by switching from STOP to RUN.	Set the condition in which the PLC ready flag (M2000) turns on.	
		Error setting on servo warning	Output error/Not output error	Output error	Set whether or not to output error to motion error history or self-diagnosis error on servo warning.	
		Error check	Perform battery check/Not perform battery check	Perform battery check	Set whether or not to check the battery of Motion CPU.	
		Forced stop (Note-1)	Nothing/X (PX) (0 to 1FFF)/M (0 to 8191)	Nothing	Set the bit device to use forced stop in the program. However, the forced stop input by EMI terminal of Motion CPU module cannot be invalidated using parameter setting.	
		Latch range	M (0 to 8191)/B (0 to 1FFF)/F (0 to 2047)/D (0 to 8191)/W (0 to 1FFF)	None	Set the latch range of device memory.	
		DOG/CHANGE signal input method	Response time priority method/Fixed cycle input method/Operation cycle input method	Fixed cycle input method	Sets the input method when an input device (PX) is set to a DOG/CHANGE signal.	
	SSCNET setting	Communication type	SSCNETⅢ/H / SSCNETⅢ	SSCNETⅢ/H	Set the communication type for every line.	
	CPU name setting	Label	Up to 10 characters	None	Set the label (name application) and comment of Motion CPU.	
		Comment	Up to 64 characters	None		
Built-in Ethernet port setting	IP address setting	Input format	Decimal/Hexadecimal	Decimal	Refer to Section 4.13.	
		IP address	Decimal : 0.0.0.1 to 223.255.255.254 Hexadecimal : 00.00.00.01 to DF.FF.FF.FE	192.168.3.39		
			Subnet mask pattern	Decimal : 192.0.0.0 to 255.255.255.252 Hexadecimal : C0.00.00.01 to FF.FF.FF.FC		None
		Default router IP address	Decimal : 0.0.0.1 to 223.255.255.254 Hexadecimal : 00.00.00.01 to DF.FF.FF.FE	None		
	Communication data code	Binary code/ASCII code	Binary code			

### 3 COMMON PARAMETERS

Table 3.1 System data setting list (Continued)

		Item	Setting range	Initial value	Remark	
Individual parameters	Built-in Ethernet port setting	Enable online change (MC protocol)	Enable online change/Disable online change	Disable online change	Refer to Section 4.13.	
		Open setting	—	None		
	CPU setting	Self CPU installation position setting	Set self CPU/other CPU/CPU (empty) for slots 0/1/2. (The setting range varies depending on the number of Multiple CPUs installed.)	None	None	Set the installation position of the self CPU in the main base.
		Input setting 	Input setting	Used/Unused	Unused	Set the input signal of built-in interface in Motion CPU (DI)/mark detection input signal.
			First input No.	0000 to 0FF0 (in units 16 points)	0000	
			High-speed read setting (Note-2)	Used/Unused	Unused	
		Input signal detection direction 	Valid on leading edge (Normal open contact)/ Valid on trailing edge (Normal closed contact)	Valid on leading edge (Normal open)		
		Multiple CPU synchronous control setting (Note-3)  	Independent CPU/master CPU/slave CPU for self CPU.	Independent CPU		Set the Multiple CPU synchronous control setting in each CPU.
	Status device setting	Set device to "Synchronous controlling", "Status for each CPU", and "Error status for each CPU and axis". Bit device : X, Y, M, B, F Word device : D, W, #, U□\G	None			
	Manual pulse generator/incremental synchronous encoder setting 	CPU built-in Manual pulse generator/incremental synchronous encoder (INC)	Used/Not used	Not used	Set the manual pulse generator/synchronous encoder of built-in interface in Motion CPU.	
		Input type setting	Differential output type/ Voltage output/open collector type	Differential output type		
	Amplifier setting 	Amplifier information	Amplifier model	<Communication type "SSCNET III/H" use> MR-J5(W)-B(-RJ)/MR-J4(W)-B(-RJ)/ FR-A800-1/FR-A800-2/ VCII (CKD Nikki Denso)/ VPH (CKD Nikki Denso)/αSTEP/ 5-Phase (ORIENTAL MOTOR)/ IAI Driver for Electric Actuator (IAI) ----- <Communication type "SSCNET III" use> MR-J3(W)-B/MR-J3-B(S) Fully closed/ MR-J3(W)-B Linear/MR-J3(W)-B DD motor/ FR-A700/VCII (CKD Nikki Denso)/ VPH (CKD Nikki Denso)	MR-J5(W)-B(-RJ)	Set the model name, axis No. and other details for the servo amplifiers.
			Amplifier operation mode	<Communication type "SSCNET III/H" use> Standard/Fully closed/Linear/DD motor	Standard	
			Amplifier electronic gear setting 	<"MR-J5(W)-B(-RJ)" use> Setting for 67108864-pulse encoder resolution ([Pr.PA06]/[Pr.PA07] = 16/1)/ Setting for other encoders ([Pr.PA06]/[Pr.PA07] = 1/1)	Setting for 67108864-pulse encoder resolution ([Pr.PA06]/[Pr.PA07] = 16/1)	
			Axis information	Axis No.	Q173DSCPU: Up to 2 lines, 32 axes Q172DSCPU: Up to 1 line, 16 axes	
Axis label		Up to 32 characters	None			
External synchronous encoder input (Note-3) 		Invalid/ABS/INC	Invalid			
Input filter setting		<"MR-J5(W)-B(-RJ)" use> Nothing/0.5ms/1.0ms/1.5ms/2.0ms/2.5ms/ 3.0ms/3.5ms/4.0ms/4.5ms/5.0ms/5.5ms ----- <"MR-J4(W)-B(-RJ)" use> Nothing/0.8ms/1.7ms/2.6ms/3.5ms	3.5ms			

: Refer to Section 1.5 for the software version that supports this function.



### 3 COMMON PARAMETERS

Table 3.1 System data setting list (Continued)

	Item	Setting range	Initial value	Remark	
Individual parameters	Amplifier setting <b>QD</b>	Allowable travel during Power-Off	<Communication type "SSCNET III" use> 0 to 8191 revolution	10	Set the model name, axis No. and other details for the servo amplifiers.
		ABS/INC setting (Note-4) <b>Ver.</b>	INC/ABS	INC	
		Amplifier model	MR-J3(W)-B/MR-J3-B(S) Fully closed/ MR-J3(W)-B Linear/MR-J3(W)-B DD motor/ FR-A700/VCII (CKD Nikki Denso)	MR-J3(W)-B	
		Axis No.	Q173DCPU(-S1): Up to 2 lines, 32 axes Q172DCPU(-S1): Up to 1 line, 8 axes	None	
		Axis name (SV43)	Q173DCPU(-S1): X/Y/Z/U/V/W/A/B/CX/CY/ CZ/CU/CV/CW/CA/CB/DX/ DY/DZ/DU/DV/DW/DA/DB/ EX/EY/EZ/EU/EV/EW/EA/ EB Q172DCPU(-S1): X/Y/Z/U/V/W/A/B/C	None	
		External signal input setting	Amplifier input invalid/Amplifier input valid	Amplifier input invalid	
		Input filter setting	Nothing/0.8ms/1.7ms/2.6ms/3.5ms	3.5ms	
		Allowable travel during Power-Off	0 to 8191 revolution	10	
	ABS/INC setting (Note-4) <b>Ver.</b>	INC/ABS	INC		
	High-speed reading data (Note-2)	Pulse/synchronous encoder I/F module	Either of Q172DEX and Q173DPX. Q172DEX: Up to 2 points Q173DPX: Up to 3 points	None	Refer to Section 4.3.
		PLC input module	Either of one input module and built-in interface in Motion CPU <b>QDS</b> Input module: Up to 8 points Built-in interface in Motion CPU (DI): Up to 4 points		
	Optional data monitor setting <b>QDS</b>	Optional data monitor setting	<Communication type "SSCNET III/H" use> Set 1 to 6 for each axis. ..... <Communication type "SSCNET III" use> Set 1 to 3 for each axis. ..... Q173DSCPU: Up to 32 axes Q172DSCPU: Up to 16 axes	None	Refer to Section 4.10.
		Optional data monitor setting <b>QD</b>	Set 1 to 3 for each axis. Q173DCPU(-S1): Up to 32 axes Q172DCPU(-S1): Up to 8 axes		
	Mark detection setting <b>QDS</b>	Mark detection setting	Set 1 to 32.	None	Refer to Section 4.14.
High-speed input request signal (Note-3) <b>QDS</b> <b>Ver.</b>	High-speed input request signal	Set 1 to 32.	None	Refer to Section 4.15.	
Head module <b>QDS</b> <b>Ver.</b>	Head module	Set module 1 to 4 for each line. Q173DSCPU: 2 lines (Up to 8 modules) Q172DSCPU: 1 line (Up to 4 modules)	None	Refer to Section 4.18	

(Note-1): The forced stop can also be executed by the EMI forced stop terminal of Motion CPU module or forced stop terminal of servo amplifier besides the forced stop input setting.

(Note-2): This cannot be set in SV22 advanced synchronous control. **QDS**

(Note-3): This can be set only in SV22 advanced synchronous control. **QDS**

(Note-4): This can be set only when "VCII (CKD Nikki Denso)" is selected in amplifier model.

**Ver.!**: Refer to Section 1.5 for the software version that supports this function.

### 3 COMMON PARAMETERS

---

#### 3.1.2 Common system parameters

(1) Parameters for operating the Multiple CPU system

In the Multiple CPU system, the common system parameters and individual parameter for each CPU are set and written into each CPU. Regarding the Motion CPU, the items in System Settings related to the entire Multiple CPU system must be identical to the parameter settings in the PLC CPU.

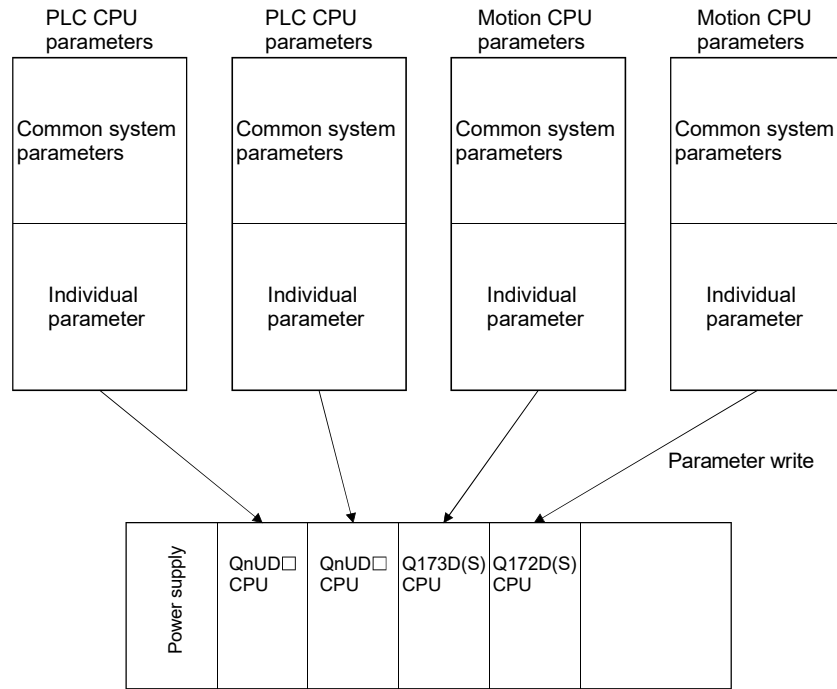

### 3 COMMON PARAMETERS

#### (2) Parameters common throughout the Multiple CPU system

In the Motion CPU, during initialization the parameters in the table below are verified against the parameters in the PLC CPU of CPU No. 1. Unmatched parameters generate a PARAMETER ERROR (error code: 3012, 3015), so the parameters show below must be set identically between Motion CPUs and the PLC CPU of CPU No.1. (If the system settings are changed in a Motion CPU, it is necessary to reset. Therefore, the parameters are checked only during initialization.)

The parameter No. of unmatched parameter is set in the error individual information (SD16) by this error occurrence.

The parameters of the other CPUs via "Multiple CPU parameter utilization" can be used in MT Developer2/GX Works2/GX Developer. The common parameters must be set for each Motion CPU.

Table of Parameters cross-Multiple CPU system

Type of parameter				Verification item	Parameter number	Remark	
Name in Motion CPU		Name in PLC CPU					
Multiple CPU setting	No. of CPU		No. of PLC		Number of CPUs	0E00H	
	Operating mode		Operating mode		Operation mode for CPU stop error	0E01H	
	Multiple CPU high speed transmission area setting	CPU specific send range	Multiple CPU settings	CPU specific send range	Points of CPU specific send range	E008H	Refer to Section 2.3.2.
		System area		System area	System area size	E008H	Refer to Section 2.3.2. This parameter can be set when "Advanced setting" is selected.
		Automatic refresh setting		Automatic refresh setting	Points of automatic refresh	E009H	Refer to Section 2.3.2. (Automatic refresh using Multiple CPU high speed transmission area)
Multiple CPU synchronous startup setting		Multiple CPU synchronous startup setting		Synchronize Multiple CPU startup or not	E00BH	Refer to Section 2.3.5.	
Motion slot setting		I/O assignment	Detailed settings	Control PLC	Control CPU No.	0406H	Verify module only set in the system settings in the Motion CPU side.
Base setting			Basic setting	Slots	Total number of bases	0401H	Not verified if base settings are omitted in the PLC CPU side.
				Base	Base No. Number of base slots		

### 3 COMMON PARAMETERS

#### (a) Multiple CPU settings

Set the following items identically in Multiple CPU Settings (Motion CPU) in MT Developer2 and in Multiple CPU Settings (PLC CPU) in GX Works2/ GX Developer.

- Number of CPU modules (Included CPU empty slots)
- Operation mode when a CPU stop error occurred
- Multiple CPU high speed transmission area setting (Must be set the same for all CPUs)
- Multiple CPU synchronous startup setting

#### Multiple CPU Settings (Motion CPU) in MT Developer2

The screenshot shows the 'Basic Setting' dialog box for Multiple CPU settings in MT Developer2. It includes a 'Multiple CPU Synchronous Startup Setting' sub-dialog box. Callouts point to specific settings:

- Number of CPU modules:** Points to the 'No. of CPU (\*)' dropdown set to 2.
- Error operation mode at the stop of CPU:** Points to the 'Operation Mode (\*)' section with checkboxes for error handling.
- Multiple CPU high speed transmission area setting:** Points to the 'Multiple CPU High Speed Transmission Area Setting' table.
- Multiple CPU synchronous startup setting:** Points to the 'Multiple CPU Synchronous Startup Setting (\*)' sub-dialog box.

CPU	Points(k)	User Setting Area			Automatic Refresh	
		Points	Start	End	Points	Setting
No.1	7	7006	G10000	G17005	162	Refresh (Receive)
No.2	7	6904	G10000	G16903	264	Refresh (Send)
No.3						
No.4						

#### Multiple PLC Setting (PLC CPU setting) in GX Works2/GX Developer

<Screen: GX Works2>

The screenshot shows the 'Q Parameter Setting' dialog box for Multiple PLC settings in GX Works2. It includes a 'Multiple CPU High Speed Transmission Area Setting' sub-dialog box. Callouts point to specific settings:

- Select tab "Multiple CPU high speed transmission area setting":** Points to the 'Multiple CPU High Speed Transmission Area Setting' sub-dialog box.
- Set "Use multiple CPU high speed transmission":** Points to the 'Use Multiple CPU High Speed Transmission' checkbox.

PLC	Points(k)	I/O No.	User Setting Area			Auto Refresh	
			Points	Start	End	Points	Setting
PLC No.1	7	USE0	7006	G10000	G17005	162	Refresh(Send)
PLC No.2	7	USE1	6904	G10000	G16903	264	Refresh(Recv)
PLC No.3							
PLC No.4							

### 3 COMMON PARAMETERS

(b) Motion slot settings

Set the modules controlled by the self CPU by the Motion Slot Settings (Motion CPU) in MT Developer2. In GX Works2/GX Developer, set the slot for Motion CPU control as the CPU number of Motion CPU in I/O Assignment Settings (PLC CPU).

Motion Slot Setting (Motion CPU) in MT Developer2

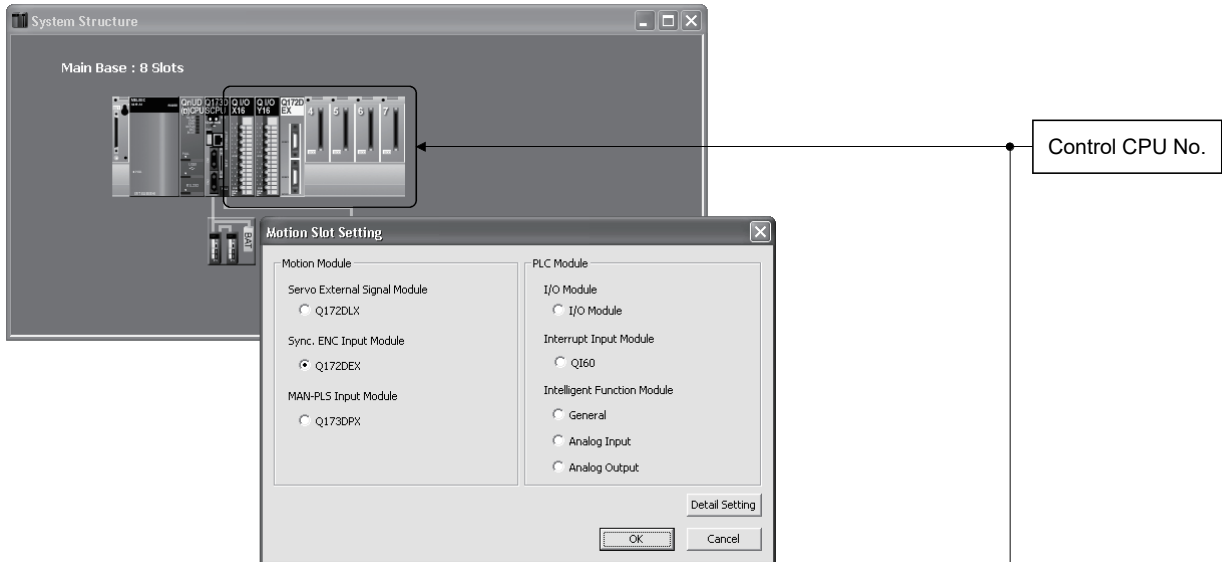

I/O Assignment Setting (PLC CPU setting) in GX Works2/GX Developer

<Screen: GX Works2>

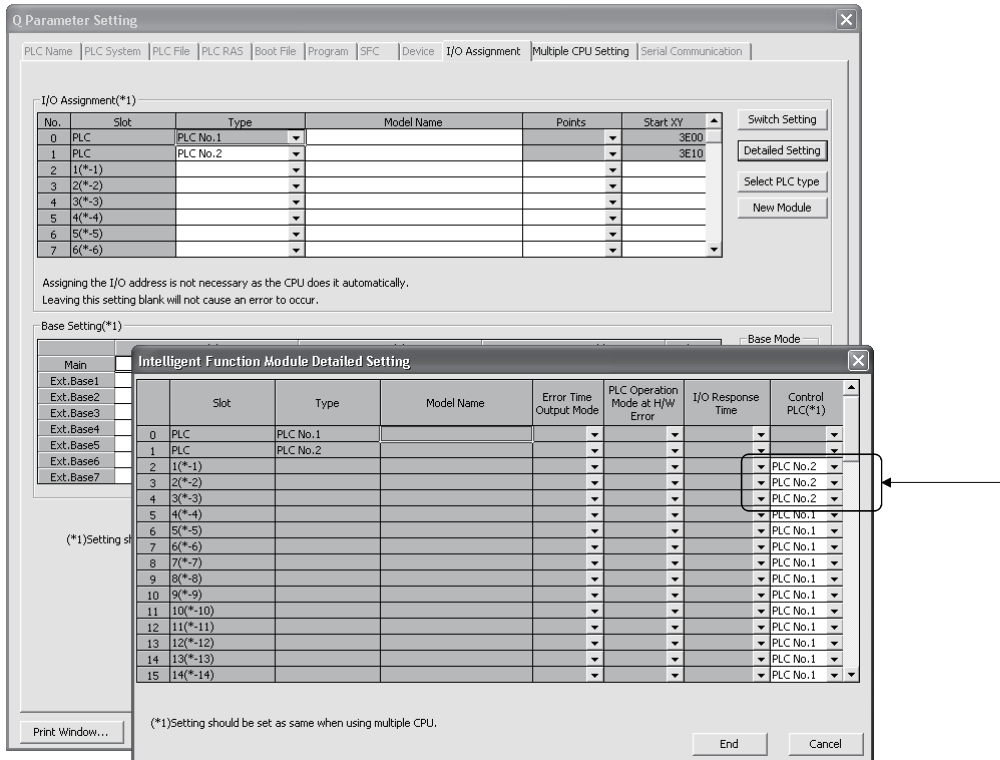

(Note): Motion slot setting items are different depending on the operating system software.

### 3 COMMON PARAMETERS

(c) Base settings

Set the total number of bases and number of slots in each base identically between Base Settings (Motion CPU) in MT Developer2 and I/O Assignment Settings (PLC CPU) in GX Works2/GX Developer. In GX Works2/GX Developer, the detailed settings may be omitted by setting the base mode "Auto".

Base Settings (Motion CPU) in MT Developer2

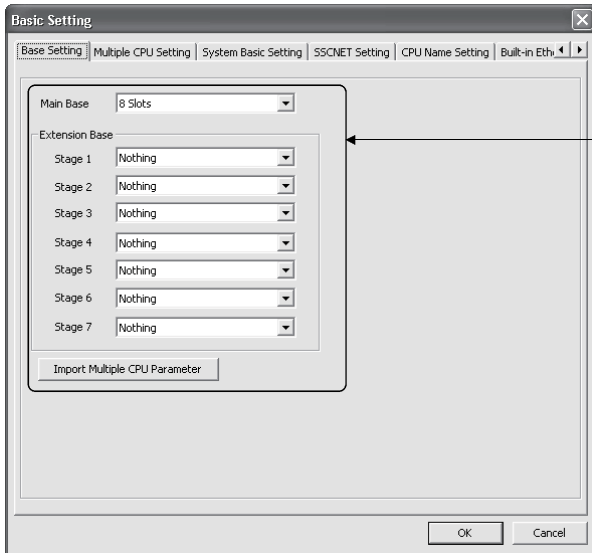

Total number of bases and number of slots in each base

I/O Assignment Settings (PLC CPU setting) in GX Works2/GX Developer

<Screen: GX Works2>

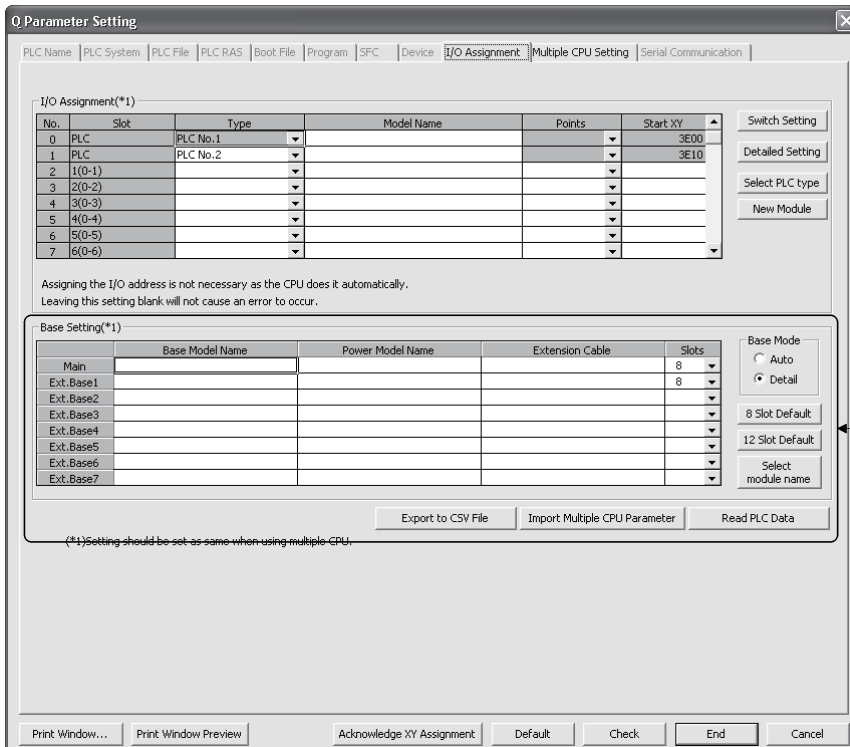

(Note) : Only the Motion CPU may be set without setting the PLC CPU.

**POINT**

GOT is recognized as an intelligent function modules "16 points×10 slots" on the base (number of extension bases and slot No. are set in the GOT parameter.) for bus connection with GOT.

Set the one extension base (16 points×10 slots) for connection with GOT, then set "10 slots" as number of extension bases for connection with GOT in the Basic Setting (base setting) of MT Developer2.

<Example>

When the "2nd stage" of extension base is set as connection with GOT.  
(Set "10 Slots/GOT(Bus connection)" as "2nd stage" of extension base in the base setting.)

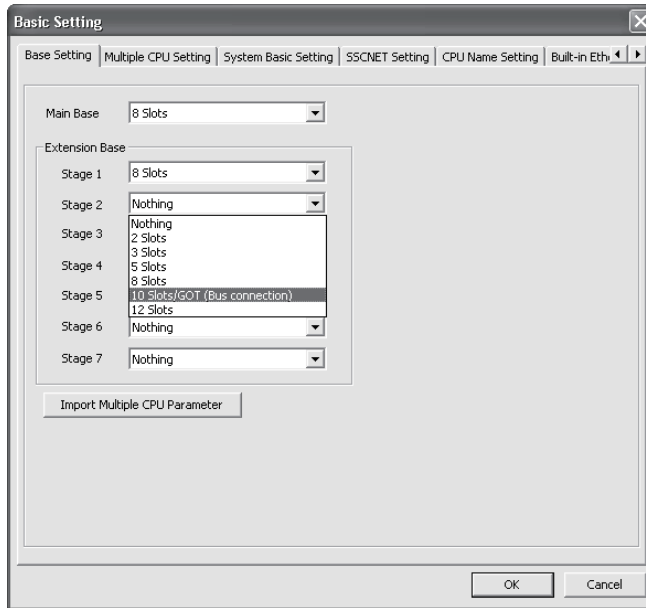

### 3 COMMON PARAMETERS

#### 3.1.3 Individual parameters

##### (1) System basic setting

The following explains each item to be set in system basic setting.

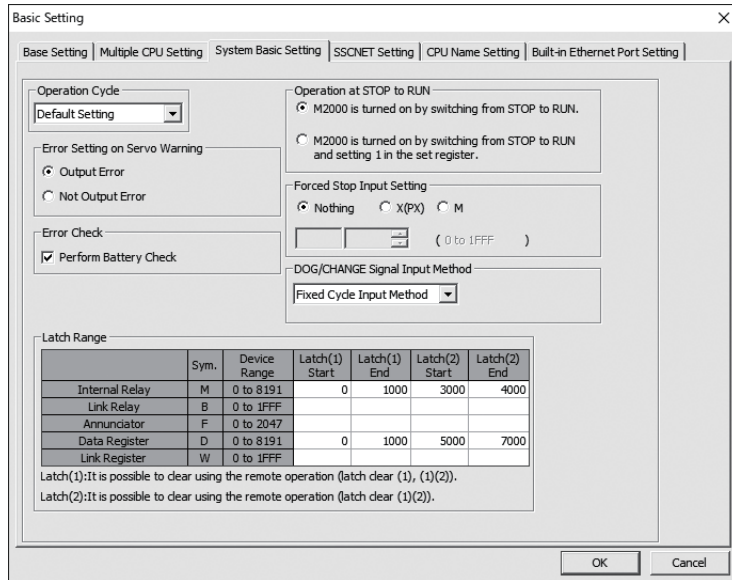

##### (a) Operation cycle

- 1) Set the of motion operation cycle (cycles at which a position command is computed and sent to the servo amplifier).

The setting range is 0.2ms ~~QDS~~/0.4ms/0.8ms/1.7ms/3.5ms/7.1ms/14.2ms ~~QD~~/Default setting.

- 2) The default value is "Default Setting". When "Default Setting" is selected, the operation cycle is set according to the table below based on the number of axes for servo amplifier set in the System Settings.

Operating system	Number of axes		Operation cycle setting	Actual operation cycle
	Q173DSCPU/ Q172DSCPU	Q173DCPU(-S1)/ Q172DCPU(-S1)		
SV13	1 to 4 axes	—	0.2 ms	0.222...ms
	5 to 10 axes	1 to 6 axes	0.4 ms	0.444...ms
	11 to 24 axes	7 to 18 axes	0.8 ms	0.888...ms
	25 to 32 axes	19 to 32 axes	1.7 ms	1.777...ms
SV22	1 to 6 axes	1 to 4 axes	0.4 ms	0.444...ms
	7 to 16 axes	5 to 12 axes	0.8 ms	0.888...ms
	17 to 32 axes	13 to 28 axes	1.7 ms	1.777...ms
	—	29 to 32 axes	3.5 ms	3.555...ms
SV43	—	1 to 4 axes	0.4 ms	0.444...ms
	—	5 to 12 axes	0.8 ms	0.888...ms
	—	13 to 28 axes	1.7 ms	1.777...ms
	—	29 to 32 axes	3.5 ms	3.555...ms



- 3) If the duration of motion operation has exceeded the operation cycle, the operation cycle over flag (M2054) turns ON. Even when "Automatic setting" is selected, the duration of motion operation may exceed the operation cycle depending on the control conditions. The actual duration of motion operation (unit:  $\mu\text{s}$ ) is stored in Motion operation cycle (SD522), and the current setting of operation cycle (unit:  $\mu\text{s}$ ) is stored in operation cycle of Motion CPU setting (SD523). Monitor these special registers and adjust the set value of operation cycle so that the actual duration of motion operation will not exceed the set operation cycle. (A WDT or other error may occur in the Motion CPU.)
- (b) Operation at STOP to RUN  
Set the condition in which the PLC ready flag (M2000) turns ON. Select the following either.
- 1) M2000 turns ON by switching from STOP to RUN. (Default)  
Condition in which the M2000 turns from OFF to ON.
- Move the RUN/STOP switch from STOP to RUN.
  - Turn ON the Multiple CPU system's power supply with the RUN/STOP switch set to RUN.
- Condition in which the M2000 turns from ON to OFF
- Move the RUN/STOP switch from RUN to STOP.
- 2) M2000 turns ON by switching from STOP to RUN and by setting "1" in the setting register.  
Condition in which the M2000 turns from OFF to ON
- Set "1" in the setting register (D704) of the PLC ready flag or turn ON the PLC ready flag (M3072) with the RUN/STOP switch set to RUN. (The Motion CPU detects the change from "0" to "1" in the lowest bit of D704.)
- Condition in which the M2000 turns from ON to OFF
- Set "0" in the setting register (D704) of the PLC ready flag or turn OFF the PLC ready flag (M3072) with the RUN/STOP switch set to RUN. (The Motion CPU detects the change from "1" to "0" in the lowest bit of D704.)
  - Move the RUN/STOP switch from RUN to STOP.
- (c) Forced stop  
Set the bit device used for executing a forced stop in which all servo-amplifier axes are stopped immediately in the program. Either X (PX) or M can be specified. No default value has been set. The set bit device is designated as contact B and performs the following control in response to ON/OFF of the device.
- Bit device is turned OFF ...Forced stop input is ON (forced stop)
  - Bit device is turned ON ....Forced stop input is OFF (forced stop is released.)
- The forced stop input by EMI terminal of Motion CPU module cannot be invalidated using parameter setting.

### 3 COMMON PARAMETERS

(d) Error setting on servo warning 

Set whether or not to output error on servo warning.

Device No.	Signal name	Error setting on servo warning		
		Output error	Not output error	
M2039	Motion error detection flag	○	×	
D8+20n (Note-1)	Servo error code	○	×	
#8008+20n (Note-1)	Servo amplifier display servo error code	○	○	
#8640+12n (Note-2)	Motion error history	Error Motion SFC program No.	×	
#8641+12n (Note-2)		Error type	×	
#8642+12n (Note-2)		Error program No.	×	
#8643+12n (Note-2)		Error block No./Motion SFC list/ Line No./Axis No.	×	
#8644+12n (Note-2)		Error code	×	
#8645+12n (Note-2)		Error occurrence time (Year/month)	×	
#8646+12n (Note-2)		Error occurrence time (Day/hour)	×	
#8647+12n (Note-2)		Error occurrence time (Minute/second)	×	
#8648+12n (Note-2)		Error setting data information	×	
#8650+12n (Note-2)		Error setting data	○	×
#8651+12n (Note-2)				
SM0		Diagnostic error	○	×
SM1	Self-diagnostic error	○	×	
SD0	Diagnostic errors	○	×	
SD1	Clock time for diagnostic error occurrence	○	×	
SD2		○	×	
SD3		○	×	
SD4	Error information categories	○	×	
SD5 to SD15	Error common information	○	×	
SD16 to SD26	Error individual information	○	×	

○ : Device is updated on servo warning.

× : Device is not updated on servo warning.

(Note-1): "n" in the device No. indicates the numerical value (axis No.1 to 32 : n= 0 to 31) which correspond to axis No.

(Note-2): "n" in the device No. indicates the numerical value (n=0 to 7) which correspond to motion error history.

(e) Error check 

Set whether or not to check the battery of Motion CPU. The default value is set to "Perform battery check". If "Perform battery check" is not set, a self-diagnosis error (error code: 1600) will not occur and the 7-segment LED "BT1" or "BT2" is not also displayed. And, a detection of motion error detection flag (M2039) and update of motion error history are restricted. However, the devices (SM51, SM52, SM58, SM59) for detection of battery level turn ON/OFF.

<b>POINT</b>
--------------

- |   |
|---|
| <p>(1) Use this setting to restrict the output of battery error in the incremental system configuration using ROM operation.</p> <p>(2) The battery is necessary to use the absolute position system or latch data. Be sure to set "Perform battery check".</p> |
|---|

(f) Latch range

Set the following latching ranges for M, B, F, D and W, respectively.

- Latch (1): It is possible clear using the remote operation (Latch clear(1), Latch clear (1)(2)).
- Latch (2): It is possible clear using the remote operation (Latch clear (1)(2)).

(g) DOG/CHANGE signal input method 

Set the method for inputting the DOG/CHANGE signals when "4: Bit device" is set to the DOG/CHANGE signals of the servo external signal parameters and the input device (PX) assigned to the input module is set.

- Response time priority method : Inputs the most recent signal status.
- Fixed cycle input method : Inputs the signal status every 0.44ms by fixed cycle processing. (When the operation cycle is 0.22ms, the signal status will be input every 0.22ms.)
- Operation cycle input method : Inputs the signal status every operation cycle.

<b>POINT</b>
--------------

- |   |
|---|
| <p>(1) When setting the DOG/CHANGE signal input method to "response time priority method", the accuracy of the count method home position return and speed-position switching control will improve, but the processing time will lengthen due to the increase in the number of communication attempts with the input module. When this happens, setting the input method to "fixed cycle input method" may lead to improved processing time with no significant drop in accuracy.</p> <p>(2) When there is a large amount of data communication between modules, such as when a large number of modules are connected to each other, this causes an increase in the DOG/CHANGE signal input processing time. When this happens, setting the signal to "operation cycle input method" may lead to improved processing time.</p> <p>(3) Changing the DOG/CHANGE signal input method setting will not affect operation in the following circumstances.</p> <ul style="list-style-type: none"><li>• When a setting other than "4: Bit device" is set to the DOG/CHANGE signals of the servo external signal parameters.</li><li>• When a device not assigned to an input module is set.</li></ul> |
|---|

---

 : Refer to Section 1.5 for the software version that supports this function.

---

#### (2) SSCNET setting

The following explains item to be set in SSCNET setting.

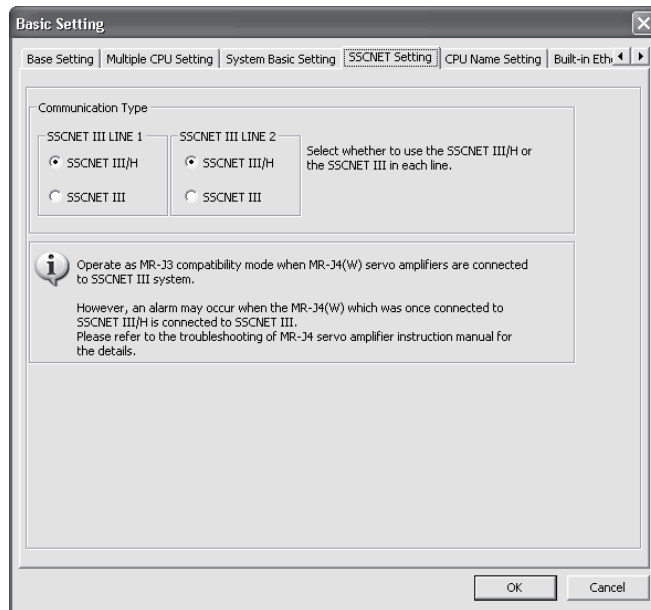

##### (a) Communication type

Set the communication type to communicate with the servo amplifier for every line.

- SSCNET III/H : MR-J5(W)-□B, MR-J4(W)-□B
- SSCNET III : MR-J3(W)-□B

(3) CPU setting

The following explains item to be set in CPU setting.

- SV22 advanced synchronous control use

- SV13/SV22 virtual mode use

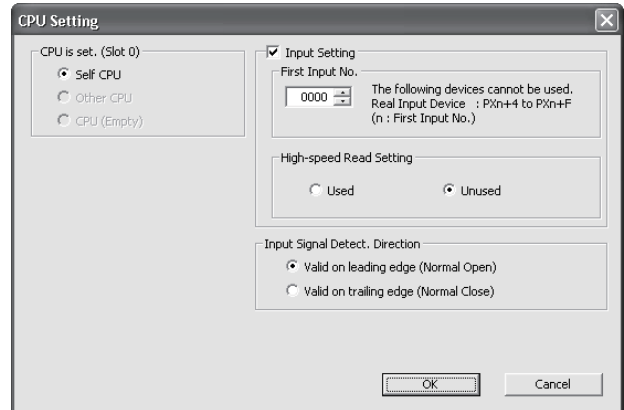
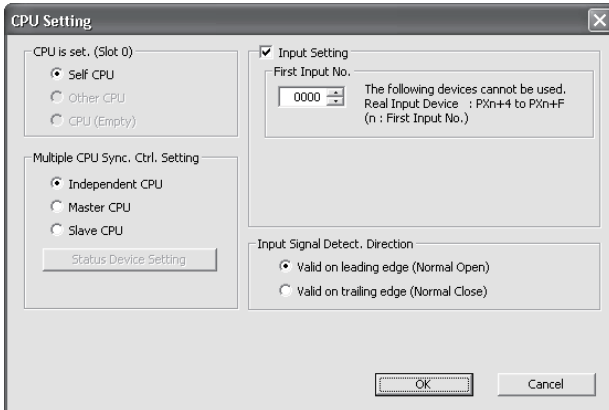

(a) Self CPU installation position setting

Set the installation position of the self CPU installed to the main base.

- Self CPU : Set the self CPU.
- Other CPU : Set the other CPU.
- CPU (Empty): Set as empty slot.

(b) Input setting **QDS**

Set to use the input signal.

There are two kinds of applications of the input and mark detection for the Built-in interface in Motion CPU (DI).

The same signal can be used simultaneously by the input and mark detection.

Input setting	Input signal	Mark detection
Used	Usable as the real input device (PX)	Usable as the real input device (PX) or mark detection signal (DI)
Unused	Unusable	Usable as the mark detection signal (DI)

1) First input No.

Set the first input No. of real input device (PX).

The case of "real input device (PX): units of 16 points" is as follows.

- Real input (PX): 4 points + Dummy (Unusable: Fixed at 0) 12 points (Example) When the first input No. is set to 0(H).

- PX0 to PX3 (Real input), PX4 to PXF (Unusable: Fixed at 0)

2) High-speed read setting

Set to use the built-in interface in Motion CPU as input signal in the high-speed reading function.

- Used : Use built-in interface in Motion CPU (DI).
- Unused : Not use built-in interface in Motion CPU (DI).

Refer to Section 4.3 for the High-speed reading function.

(Note): This cannot be set in SV22 advanced synchronous control.



(c) Input signal detection direction **QDS**

Set the detection direction of mark detection signal when the built-in interface in Motion CPU (DI) is used in the mark detection function.

- Valid on leading edge : Mark detection is executed by turning OFF to ON the mark detection signal.
- Valid on trailing edge : Mark detection is executed by turning ON to OFF the mark detection signal.

Refer to Section 4.14 for the mark detection function.

(d) Multiple CPU synchronous control setting **QDS** **Ver.1**

When setting self CPU, set the master CPU and slave CPU that constitute the multiple CPU synchronous control system.

(Note): This can be set only in SV22 advanced synchronous control.

- Independent CPU : Operate as independent CPU
- Master CPU : Operate as master CPU
- Slave CPU : Operate as slave CPU

1) Status device setting

When setting the master CPU and slave CPU, set the status devices to monitor the information of other CPUs. The following items are set with word device (D, W, #, U□\G), or bit device (X, Y, M, B, F).

Item	Multiple CPU synchronous control setting	
	Master CPU	Slave CPU
Synchronous controlling	○	○
Status for each CPU	○	○
Error status for each CPU and axis	○	○
Master CPU input axis	Transfer information	○
	Error information	○

○: Settable    ×: Unsettable

Refer to "Q173DSCPU/Q172DSCPU Motion controller (SV22) Programming Manual (Advanced Synchronous Control)" for Multiple CPU synchronous control.

---

**Ver.1** : Refer to Section 1.5 for the software version that supports this function.





---

### 3 COMMON PARAMETERS

#### (4) Individual module settings

The setting items for each module are shown below.

##### (a) Setting items for each Motion module

Module name	Item	Setting range	Initial value	Number of usable modules				
				Q173DSCPU	Q172DSCPU	Q173DCPU(-S1)	Q172DCPU(-S1)	
Q172DLX Servo external signals module (Note-1)	DOG signal contact 	Normal open/Normal close (Set the DOG signal for 8 points.)	Normal open	4	2	4	1	
	External signal setting 	Set the number of axes for which the 8 axes input is used.	Unused					
	DOG signal detection direction 	Valid on leading edge/ Valid on trailing edge	Valid on leading edge					
	I/O response time setting	0.4/0.6/1 ms (DOG/CHANGE response time)	0.4 ms					
Q172DEX Synchronous encoder input module	Synchronous encoder setting	Used/Unused	Unused	6 (SV22)			4 (SV22)	
	Synchronous encoder selection (Note-2) 	Q171ENC-W8 (4194304 [pulse])/Q171ENC-W8 (262144[pulse])/MR-HENC (16384[pulse])	Q171ENC-W8 (4194304 [pulse])					
	Synchronous encoder selection (Note-3) 	Q170ENC/MR-HENC	Q170ENC					
	TREN signal contact (Note-4) 	Normal open/Normal close (Set the TREN signal for 2 points.)	Normal open					
	I/O response time setting	0.4/0.6/1 ms (TREN response time)	0.4 ms					
	High-speed read setting (Note-5)	Used/Unused	Unused					
Q173DPX Manual pulse generator input module	Manual pulse generator setting (SV13/SV43)	Used only	Used	1 (SV13) 4 (SV22)			1 (SV13/SV43) 4 (SV22)	1 (SV13/SV43) 3 (SV22)
	Manual pulse generator/ Synchronous encoder setting (SV22)	Used/Unused	P <input type="checkbox"/> Used					
	I/O response time setting	0.4/0.6/1 ms (TREN response time)	0.4 ms					
	High-speed read setting (Note-4)	Used/Unused	Unused					

(Note-1): Set the external signals used in each axis in the servo external signal parameter of servo data setting when using Q173DSCPU/Q172DSCPU. (Refer to Section 3.4.) 

(Note-2): Select the encoder resolution of Q171ENC-W8 from 4194304[pulse] or 262144[pulse] depending on the synchronous encoder selection setting.

(Note-3): Use the "Q170ENC" setting when using Q171ENC-W8 with Q173DCPU(-S1)/Q172DCPU(-S1).  
The Q171ENC-W8 encoder resolution operates at 262144[pulse]. 

(Note-4): This can be set only in SV22 advanced synchronous control. 

(Note-5): This cannot be set in SV22 advanced synchronous control. 

### 3 COMMON PARAMETERS



(b) Setting items for each PLC module

Module name		Item	Setting range	Initial value	Number of usable modules	
					Q173DSCPU/ Q172DSCPU	Q173DCPU(-S1)/ Q172DCPU(-S1)
I/O module	Input module QX□/ QX□-□	First I/O No.	0000 to 0FF0 (in units of 16 points)	0000	Total 256 points or less (Note-3)	Total 256 points or less
		Point	16/32/48/64/128/256	16		
		High-speed read setting (Note-4)	Used/Unused	Unused		
		I/O response time setting (setting for high-speed input module in parentheses)	1/5/10/20/70 ms (0.1/0.2/0.4/0.6/1 ms)	10 ms (0.2 ms)		
	Output module QY□/ QY□-□	First I/O No.	0000 to 0FF0 (in units of 16 points)	0000		
		Point	16/32/48/64/128/256	16		
	Input/Output composite module QH□/ QX□Y□	First I/O No.	0000 to 0FF0 (in units of 16 points)	0000		
		Point	16/32/48/64/128/256	16		
		I/O response time setting	1/5/10/20/70 ms	10 ms		
		High-speed read setting (Note-4)	Used/Unused	Unused		
Intelligent function module (Note-1)	Analogue input module Q6□AD□/ Q6□AD-□	First I/O No.	0000 to 0FF0 (in units of 16 points)	0000		
		Input range	4 to 20mA/0 to 20mA/1 to 5V/0 to 5V/-10 to 10V/0 to 10V/ User range	4 to 20mA		
		Temperature drift compensation	Used/None	Used		
		Resolution mode	Normal/High	Normal		
		Operation mode	Normal (A/D conversion)/ Offset gain setting	Normal (A/D conversion)		
	Analogue output module Q6□DA□/ Q6□DA-□	First I/O No.	0000 to 0FF0 (in units of 16 points)	0000		
		Output range	4 to 20mA/0 to 20mA/1 to 5V/0 to 5V/-10 to 10V/User range	4 to 20mA		
		HOLD/CLEAR function	CLEAR only	CLEAR		
		Output mode	Normal (Asynchronous)/ Synchronous output	Normal (Asynchronous)		
		Resolution mode	Normal/High	Normal		
		Operation mode	Normal (D/A conversion)/ Offset gain setting	Normal (D/A conversion)		



### 3 COMMON PARAMETERS

Setting items for each PLC module (Continues)

Module name		Item	Setting range	Initial value	Number of usable modules		
					Q173DSCPU/ Q172DSCPU	Q173DCPU(-S1)/ Q172DCPU(-S1)	
Intelligent function module (Note-1)	General (Note-2)  	First I/O No.	0000 to 0FF0 (in units of 16 points)	0000	Total 256 points or less (Note-3)	—	
		Points	16 points/32 points/48 points/64 points/128 points/256 points	16 points			
		Switch setting	Input format	Binary/Decimal/Hexadecimal			Hexadecimal
			Switch 1 to 5	0000 to FFFF			0000
	Error time output mode	Clear/Maintain	Clear				
Interrupt module QI60		I/O response time setting	0.1/0.2/0.4/0.6/1 ms	0.2 ms	1 (SV13/SV22)		

(Note-1): A maximum of 4 intelligent function modules can be used.

(Note-2): Refer to Section 4.17 for corresponding intelligent function module.

(Note-3): Number of I/O points is total of "Built-in interface in Motion CPU (Input 4 points) + I/O module + intelligent function module". 

(Note-4): This cannot be set in SV22 advanced synchronous control. 

---

: Refer to Section 1.5 for the software version that supports this function.

---

#### (5) External signal input

Servo external signal (Upper stroke limit/Lower stroke limit/Stop signal/Proximity dog) can be selected for every axis from the following methods.

(a) Q172DLX Servo external signals interface module use

- Q173DSCPU/Q172DSCPU

Select "Q172DLX signal" for every axis with signal type in the servo external signal parameter of servo data setting, and set the module No. and signal No.

- Q173DCPU(-S1)/Q172DSCPU(-S1)

Set the servo external signals interface module (Q172DLX) in the Motion Slot Setting of the System Setting, and then set axis No. in the External signal setting of the Detailed Setting.

(b) Servo amplifier input device use (Servo amplifier use only)

- Q173DSCPU/Q172DSCPU

Set "Amplifier input" for every axis with signal type in the servo external signal parameter of servo data setting.

- Q173DCPU(-S1)/Q172DSCPU(-S1)

Set "Amplifier input valid" as the external signal input setting in the "Amplifier setting" of system setting.

1) There are following restrictions to use.

- Stop signal (STOP) cannot be used.
- When the Q173DCPU(-S1)/Q172DSCPU(-S1) is used, count method home position return or speed-position switching control cannot be used depending on the operating system software's version. (Refer to Section 1.5 for the software version that supports this function.)
- The variation for ON/OFF timing of the external input signal (DOG) of servo amplifier may occur according to the input filter setting value of external signal input setting.

Review the input filter setting value compatible with the applications.

Use the Q172DLX or built-in interface in Motion CPU (DI)  to execute the high-accuracy control.

2) The correspondence of external signal and input device is shown below.

External signals	Input device (CN3) <sup>(Note)</sup>
Upper stroke limit (FLS)	DI1
Lower stroke limit (RLS)	DI2
Proximity dog (DOG)	DI3

(Note): Refer to the "Servo Amplifier Instruction Manual" for pin configurations.

3) Set the external signal setting in the "Input Filter Setting".

(Note): The setting value set by "Input Filter Setting" of system setting is valid even if the input filter setting is set by servo parameter "Input filter setting (PD11)".

(c) Input device use 

Select "Bit device" for every axis with signal type in the servo external signal parameter of servo data setting, and set the device No.

### 3 COMMON PARAMETERS

---

#### 3.2 I/O Number Assignment

In the Multiple CPU system, I/O numbers are used for interactive transmission between the Motion CPU and I/O modules and intelligent function modules, or between PLC CPU and Motion CPU.

##### 3.2.1 I/O number assignment of each module

The Multiple CPU system is different from the Single CPU system in the position (slot) of I/O number "0H" for PLC CPU.

However, I/O number of control module can be assigned independently for each CPU for Motion CPU.

###### (1) Position of I/O number "0H"

- (a) The number of slots set with the Multiple CPU settings are occupied by the PLC CPU/Motion CPU on the Multiple CPU system.
- (b) I/O modules and intelligent function modules are installed from the right of the slots occupied by PLC CPU/Motion CPU.
- (c) I/O number of Motion CPU control module can be assigned independently for each CPU.

The I/O number of PLC CPU control module for an I/O module or intelligent function module mounted to the next slot to those occupied by CPU modules is set as "0H" and consecutive numbers are then allocated sequentially to the right.

###### (d) Notation of I/O number

- Receiving of ON/OFF data by Motion CPU is deemed input (PX), while outputting of ON/OFF data from Motion CPU is deemed output (PY).
- I/O number is expressed in hexadecimal.

#### REMARK

- 1) If the number of CPU modules installed on the main base unit is less than the number set at the "Multiple CPU setting", set the open slot(s) to "PLC (Empty)". Refer to Section 2.1.2 for the "PLC (Empty)" setting.
- 2) The I/O numbers for the Multiple CPU system can be confirmed with the system monitor of GX Works2/GX Developer.

### 3 COMMON PARAMETERS

#### (2) I/O number assignment of Motion CPU control module

Mitsubishi Electric recommends that I/O No. assignment be set as consecutive No. that are common throughout all CPUs.

However, the I/O number of input modules, output modules, input/output composite modules, and intelligent function modules controlled with the Motion CPU can also be set with no relation to the I/O number of PLC CPU.

(I/O number of the Motion CPU control modules is indicated as PX/PY.)

I/O number of the Motion CPU control modules cannot be assigned by I/O assignment settings of PLC CPU.

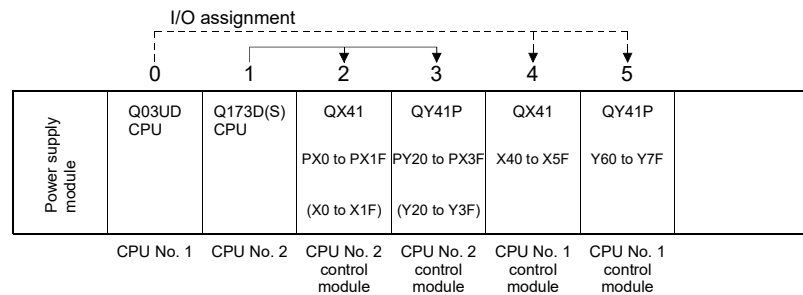

#### (3) Setting of the Motion CPU control modules by the PLC CPU

Follow the table below when Motion CPU control modules are set in I/O Assignment Settings of the PLC CPU. (The PLC CPU handles the Q172DLX, Q172DEX and Q173DPX as intelligent function modules having 32 occupied points.) Type and number of points may be left unset.

Module name		Type	Number of points	Remarks
Input module		Input	Selected according to the module.	<ul style="list-style-type: none"> <li>For the control CPU, set the CPU that corresponds to the Motion CPU (required).</li> <li>Type and number of points may be left unset.</li> </ul>
	QX□-S1	Hi, input		
	QX□H	Hi, input/Interrupt		
Output module		Output		
Input/Output composite module		I/O Mix		
Intelligent function module (Note-1)	Analogue input module	Intelligent		
	Analogue output module			
	General			
Interrupt module (QI60)		Interrupt	16 points	
Q172DLX		Intelligent	32 points	
Q172DEX				
Q173DPX				

(Note-1): Refer to Section 4.17 for corresponding intelligent function module.

POINT
(1) Set the I/O device of the Motion CPU within the range from PX/PY000 to PX/PYFFF. Set the number of real I/O points within 256 points. (I/O No. may not be consecutive.)
(2) As for the Motion CPU, the Q172DLX, Q172DEX, Q173DPX and QI60 are not included in the number of real I/O points.

### 3 COMMON PARAMETERS

---

#### 3.2.2 I/O number of each CPU module

In the Multiple CPU system, I/O numbers are assigned to each CPU module to specify installed CPU modules.

The I/O number for each CPU module is fixed to the corresponding slot and cannot be changed.

The I/O number allocated to each CPU module in the Multiple CPU system is shown below.

CPU module installation position	CPU slot	Slot 0	Slot 1	Slot 2
First I/O number	3E00H	3E10H	3E20H	3E30H

The I/O number of PLC CPU/Motion CPU are used in the following cases.

- When writing data to the CPU shared memory of self CPU using the S.TO instruction.
- When reading data from the CPU shared memory of other CPU using the FROM instruction.
- When reading data from the CPU shared memory of other CPU using an intelligent function module device (U□\G□)
- When reading device data directly from the Motion CPU from the PLC CPU using the "D(P).DDR" instruction.
- When writing device data directly to the Motion CPU from the PLC CPU using the "D(P).DDWR" instruction.

Refer to Section 2.3.6 or the "Q173D(S)CPU/Q172D(S)CPU Motion controller (SV13/SV22) Programming Manual (Motion SFC)" for the Motion dedicated PLC instruction.

### 3 COMMON PARAMETERS

#### 3.2.3 I/O number setting

Set the modules installed in each slot of the main base or extension base and assign the control CPU of applicable slot as the self CPU in the Motion Slot setting of the system setting for Motion CPU.

Set the I/O No. of modules controlled with the Motion CPU module.

The following modules must be set the I/O No.

- Input module
- Output module
- Input/Output composite module
- Intelligent function module (Note-1)

(Note-1): Refer to Section 4.17 for corresponding intelligent function module.

Select the applicable module in the Motion slot setting, and set I/O No. in "First I/O No." of the Detail setting.

Refer to the help of MT Developer2 for details.

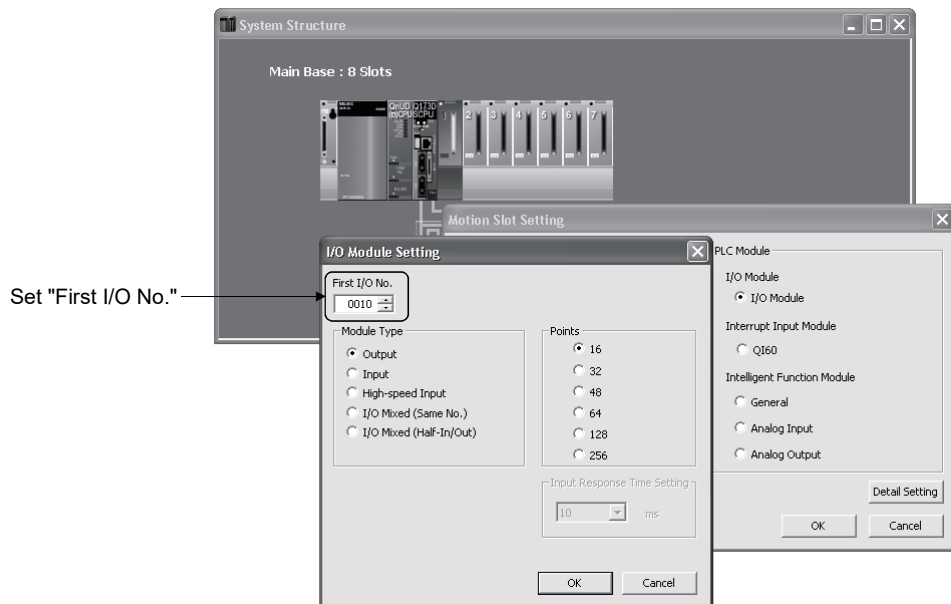

#### POINT

I/O No.s cannot be assigned automatically, unlike a PLC CPU for which I/O No. are assigned automatically if such setting is omitted in the Motion CPU. In the Motion CPU, be sure to set the first I/O No. in System Settings for each module used.

### 3 COMMON PARAMETERS

#### 3.3 Servo Parameters

The servo parameters control the data fixed by the specifications of the servo amplifier and servo motor controlled in the parameter set for each axis and the control of the servo motor.

The servo parameters are set by the Setup software (MR Configurator□).

Refer to the "Servo amplifier Instruction Manual" for details of the servo parameters. Refer to the help for handling of MR Configurator□.

Servo amplifier Instruction Manual list is shown below.

Servo amplifier type	Instruction manual name
MR-J5-□B	MR-J5-B/MR-J5W-B User's Manual (Parameters) (IB-0300581ENG)
MR-J5W-□B	
MR-J4-□B	SSCNETⅢ/H Interface AC Servo MR-J4-□B (-RJ) Servo amplifier Instruction Manual (SH-030106)
MR-J4W-□B	SSCNETⅢ/H interface Multi-axis AC Servo MR-J4W2-□B/MR-J4W3-□B/MR-J4W2-0303B6 Servo amplifier Instruction Manual (SH-030105)
MR-J3-□B	SSCNETⅢ interface MR-J3-□B Servo amplifier Instruction Manual (SH-030051)
MR-J3W-□B	SSCNETⅢ interface 2-axis AC Servo Amplifier MR-J3W-0303BN6/MR-J3W-□B Servo amplifier Instruction Manual (SH-030073)
MR-J3-□B-RJ004	SSCNETⅢ Compatible Linear Servo MR-J3-□B-RJ004U□ Instruction Manual (SH-030054)
MR-J3-□B-RJ006	SSCNETⅢ Compatible Fully Closed Loop Control MR-J3-□B-RJ006 Servo amplifier Instruction Manual (SH-030056)
MR-J3-□B-RJ080W	SSCNETⅢ interface Direct Drive Servo MR-J3-□B-RJ080W Instruction Manual (SH-030079)
MR-J3-□B Safety	SSCNETⅢ interface Drive Safety integrated MR-J3-□B Safety Servo amplifier Instruction Manual (SH-030084)

POINTS
<p>When the parameter that should turn on servo amplifier power supply again is changed, make the Multiple CPU system reset or power supply OFF to ON. And, once turn OFF the servo amplifier's power supply and then turn ON it again. After changing the amplifier model in amplifier setting of system setting and writing the servo parameters to the Motion CPU, be sure to turn ON the power supply of the Multiple CPU system again, or reset. If the servo amplifier is connected with the Multiple CPU system power supply turned ON, a parameter error may occur.</p>

### 3 COMMON PARAMETERS

#### 3.4 Servo External Signal Parameters

This parameter is used to the servo external signal (Upper stroke limit (FLS), Lower stroke limit (RLS), Stop signal (STOP), Proximity dog/Speed-position switching (DOG/CHANGE)) used for each axis.

The setting items for servo external signal are shown below.

Servo external signal parameter list

Item		Setting range					Default value
		Invalid	Q172DLX signal	Amplifier input	DI signal	Bit device	
FLS signal	Signal type	0: Invalid	1: Q172DLX signal	2: Amplifier input	—	4: Bit device	0: Invalid
	Q172DLX module No.	—	1 to 4	—		—	—
	Q172DLX signal No.	—	1 to 8	—		—	—
	Device	—	—	—		Bit device	—
	Contact	—	0: Normal open 1: Normal close	0: Normal open 1: Normal close		0: Normal open 1: Normal close	—
RLS signal	Signal type	0: Invalid	1: Q172DLX signal	2: Amplifier input	—	4: Bit device	0: Invalid
	Q172DLX module No.	—	1 to 4	—		—	—
	Q172DLX signal No.	—	1 to 8	—		—	—
	Device	—	—	—		Bit device	—
	Contact	—	0: Normal open 1: Normal close	0: Normal open 1: Normal close		0: Normal open 1: Normal close	—
STOP signal	Signal type	0: Invalid	1: Q172DLX signal	—	—	4: Bit device	0: Invalid
	Q172DLX module No.	—	1 to 4			—	—
	Q172DLX signal No.	—	1 to 8			—	—
	Device	—	—			Bit device	—
	Contact	—	0: Normal open 1: Normal close			0: Normal open 1: Normal close	—
DOG signal	Signal type	0: Invalid	1: Q172DLX signal	2: Amplifier input	3: DI signal	4: Bit device (Note-3)	0: Invalid
	Q172DLX module No./ DI signal name	—	1 to 4	—	1 to 4	—	—
	Q172DLX signal No.	—	1 to 8	—	—	—	—
	Device	—	—	—	—	Bit device (Note-3)	—
	Contact	—	— (Note-1)	0: Normal open 1: Normal close	— (Note-2)	0: Normal open 1: Normal close	—

(Note-1): Select "Q172DLX" in the motion slot setting of system setting, and set the contact in the detail setting.

(Note-2): Set the contact in the "CPU setting" of system setting.

(Note-3): When setting "4: Bit device" and "PX" to the device, set the "DOG/CHANGE signal input method" in system basic setting of system setting.

#### (1) Signal type

Set the signal type to use as the servo external signal.

##### (a) Invalid

The servo external signal is invalid.

##### (b) Q172DLX signal

The signal (FLS/RLS/STOP/DOG) of Q172DLX is used as the external signal.



### 3 COMMON PARAMETERS

(c) Amplifier input

The input signal of servo amplifier is used as the following servo external signals.

Input signal	Servo external signal
DI1	Upper stroke limit (FLS)
DI2	Lower stroke limit (RLS)
DI3	Proximity dog (DOG)

(d) DI signal

The built-in interface in Motion CPU (DI1 to DI4) is used as the proximity dog/speed-position switching (DOG/CHANGE).  
Set the DOG signal only.

(e) Bit device

The optional bit device is used as the servo external signal.

(2) Q172DLX module No.

Set the module No. of Q172DLX.

From the Q172DLX installed in the smallest number is set to No.1 to 4.

Set this item when only "Q172DLX signal" is selected with the signal type.

Module No. setting range
1 to 4

(3) Q172DLX signal No.

Set the signal No. of servo external signal.

Set this item when only "Q172DLX signal" is selected with the signal type.

Signal No. setting range
1 to 8

(4) Device

Usable devices are shown below.

Item	Device No. setting range
Input relay	X0 to X1FFF (Note-1)
Output relay	Y0 to Y1FFF
Internal relay	M0 to M8191
Link relay	B0 to B1FFF
Annunciator	F0 to F2047
Special relay	SM0 to SM1999
Multiple CPU area device	U□\G10000.0 to U□\G (10000+p-1).F (Note-2)

(Note-1): The range of "PXn+4 to PXn+F" cannot be used (fixed at 0) for the input device (PXn+0 to PXn+F) allocated to the built-in interface in Motion CPU (DI).  
(n: First input No.)

(Note-2): "p" indicates the user setting area points of the Multiple CPU high speed transmission area for each CPU.

Refer to Chapter 2 for the user setting area points of the Multiple CPU high speed transmission area.

#### (5) Contact

Set the signal contact used as the servo external signal.

For Q172DLX signal, select "Q172DLX" in the motion slot setting of system setting, and set this item in the details setting.

For DI signal, set this item in the "CPU setting" of system setting

##### (a) Normal open

- FLS signal ON : The upper stroke limit is detected, and "operation of direction that the feed current value increase" cannot be executed.
- RLS signal ON : The lower stroke limit is detected, and "operation of direction that the feed current value decrease" cannot be executed.
- STOP signal ON : The stop signal is detected, and an operation stops.
- DOG signal ON : The proximity dog/speed-position switching signal is detected, and the home position return operation and speed-position switching control is executed.

##### (b) Normal close

- FLS signal OFF : The upper stroke limit is detected, and "operation of direction that the feed current value increase" cannot be executed.
- RLS signal OFF : The lower stroke limit is detected, and "operation of direction that the feed current value decrease" cannot be executed.
- STOP signal OFF : The stop signal is detected, and an operation stops.
- DOG signal OFF : The proximity dog/speed-position switching signal is detected, and the home position return operation and speed-position switching control is executed.



## 4. AUXILIARY AND APPLIED FUNCTIONS

### 4.1 Limit Switch Output Function

This function is used to output the ON/OFF signal corresponding to the data range of the watch data set per output device.

Motion control data or optional word data can be used as watch data. (Refer to Section 4.1.2 for details.) A maximum output device for 32 points can be set regardless of the number of axes.

<b>POINT</b>
For SV22 advanced synchronous control, specifications are different from those of the conventional limit switch output function and a maximum output device of 64 points can be set. (Refer to Section 4.1.3 and Section 4.1.4 for details.) <b>QDS</b>

#### 4.1.1 Operations

- (1) ON output to an output device is made while the watch data value is in the ON output region set with (ON Value) and (OFF Value) in the limit switch output function.
  - (a) (ON Value), (OFF Value) and watch data value are handled as signed data. ON output region where an ON output is made to the output device is governed by the magnitude relationship between (ON Value) and (OFF Value) as indicated below.

Relationship between (ON Value) and (OFF Value)	ON output region
$(ON\ Value) < (OFF\ Value)$	$(ON\ Value) \leq (watch\ data\ value) < (OFF\ Value)$
$(ON\ Value) > (OFF\ Value)$	$(ON\ Value) \leq (watch\ data\ value)$ $(Watch\ data\ value) < (OFF\ Value)$
$(ON\ Value) = (OFF\ Value)$	Output OFF in whole region

#### 1) $(ON\ Value) < (OFF\ Value)$

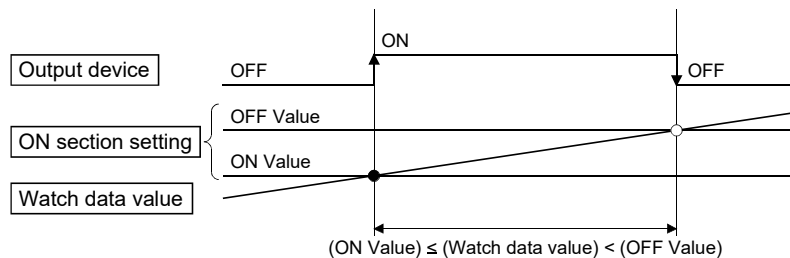

## 4 AUXILIARY AND APPLIED FUNCTIONS

### 2) (ON Value) > (OFF Value)

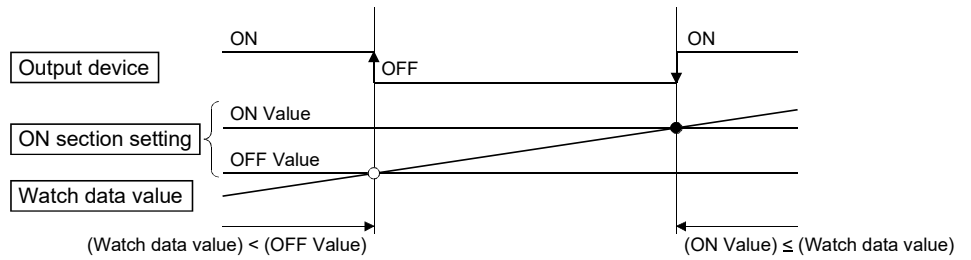

### 3) (ON Value) = (OFF Value)

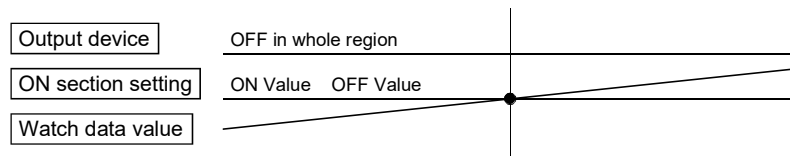

- (b) The limit switch outputs are controlled based on each watch data during the PCPU READY complete status (SM500: ON) by the PLC ready flag (M2000) from OFF to ON.

When the PCPU READY complete flag (SM500) turns OFF by turning the PLC ready flag (M2000) from ON to OFF, all points turn OFF. When (ON Value) and (OFF Value) are specified with word devices, the word device contents are input to the internal area when the PLC ready flag (M2000) turns from OFF to ON.

After that, the word device contents are input per motion operation cycle, and limit switch outputs are controlled.

- (c) Multiple outputs (Up to 32 points) can be also set to one watch data. In each setting, the output device may be the same.

If multiple ON section settings have been made to the same output device, the logical add of the output results in the regions is output.

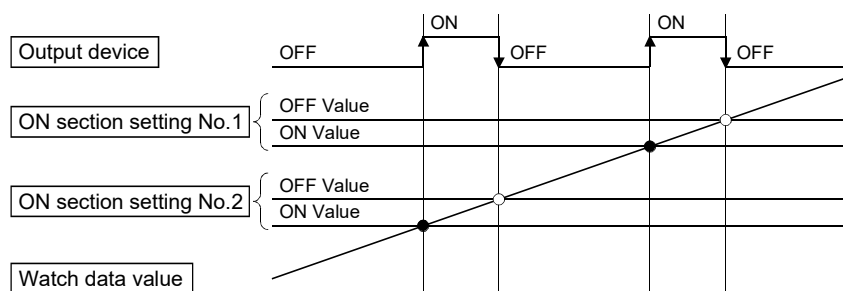

- (2) Output enable/disable bit can be set and executed enable/disable of the limit switch outputs point-by-point.

Limit switch output control is executed when the output enable/disable bit is ON, and the output is OFF when it is OFF.

If there is no setting, the outputs are always enabled.

## 4 AUXILIARY AND APPLIED FUNCTIONS

- (3) Forced output bit can be set and turned the forcibly output of the limit switch outputs point-by-point ON.

The output is ON when the forced output bit is ON. Priority is given to control of this setting over off (disable) of the "output enable/disable bit".

If there is no setting, no forced outputs are not always made.

- (4) When the multiple watch data, ON region, output enable/disable bit and forced output bit are set to the same output device, the logical add of output results of the settings is output.

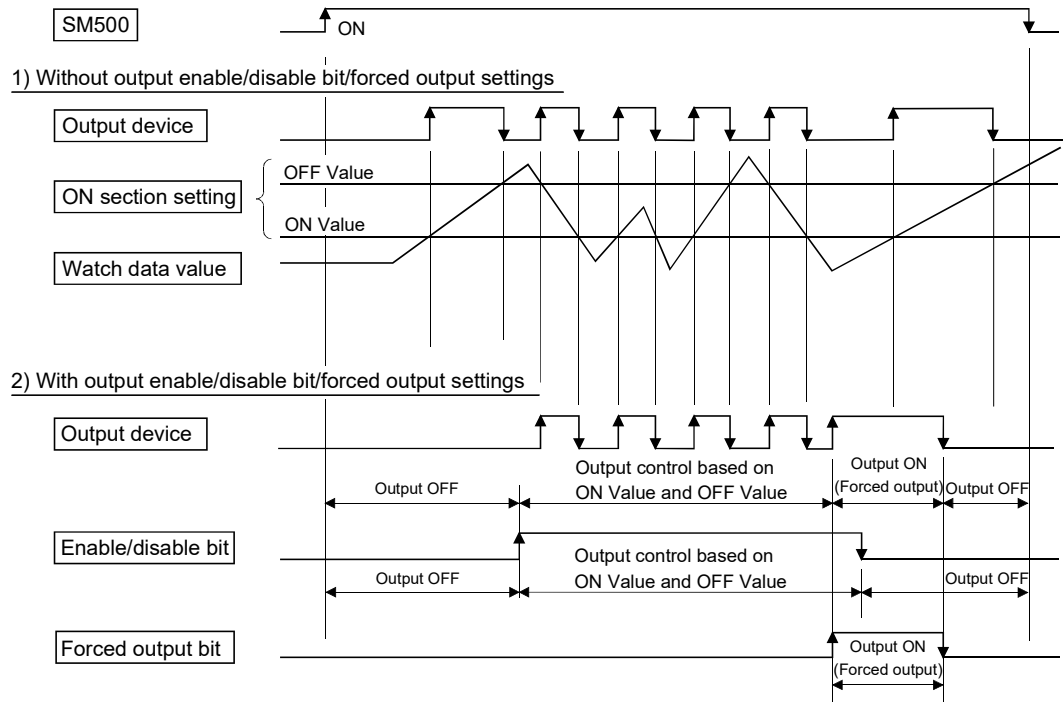

## 4 AUXILIARY AND APPLIED FUNCTIONS

### 4.1.2 Limit output setting data

Limit output data list are shown below.

Up to 32 points of output devices can be set.

(The following items of No.1 to No.5 are set together as one point.)

No.	Item		Setting range	Fetch cycle	Refresh cycle	Remarks
1	Output device		Bit device (X, Y, M, B, U□\G)	—	Operation cycle	—
2	Watch data	Watch data setting	Motion control data/word device data	Operation cycle	—	
		Axis <sup>(Note-1)</sup>	1 to 32			
		Name <sup>(Note-1)</sup>	Refer to (2) of this section			
		Device <sup>(Note-2)</sup>	Word device (D, W, #, U□\G)			
	Data type <sup>(Note-2)</sup>	16-bit integer type/32-bit integer type/64-bit floating-point type				
3	ON section setting	ON Value	Word device (D, W, #, U□\G)/constant (K, H)			
		OFF Value				
4	Output enable/disable bit setting	Output enable/disable bit	Invalid (default)/Valid	Operation cycle	—	ON : Enable OFF : Disable Invalid: Always enable
		Output enable/disable bit device	Bit device (X, Y, M, B, F, SM, U□\G)			
5	Forced output bit setting	Forced output bit	Invalid (default)/Valid			
		Forced output bit device	Bit device (X, Y, M, B, F, SM, U□\G)			Invalid: No forced outputs are always made (OFF status)

(Note-1): When Motion control data is selected

(Note-2): When word device data is selected

## 4 AUXILIARY AND APPLIED FUNCTIONS

### (1) Output device

- (a) Set the bit device which outputs the ON/OFF signal toward the preset watch data.
- (b) As the output device, the following bit devices are used.

Item	Device No. setting range
Input relay <sup>(Note-1)</sup>	X0 to X1FFF <sup>(Note-4)</sup>
Output relay <sup>(Note-2)</sup>	Y0 to Y1FFF
Internal relay <sup>(Note-3)</sup>	M0 to M8191
Link relay	B0 to B1FFF
Multiple CPU area device	U□\G10000.0 to U□\G (10000+p-1).F <sup>(Note-5), (Note-6)</sup>

(Note-1): PX is write-disabled and it cannot be used as the output device.

For X, only the free No. of the input card non-loading can be used.

(Note-2): The real output device range (PY) is also included.

(Note-3): M2001 to M2032 cannot be used to the output device.

Be careful because it affect a positioning operation, when the positioning dedicated devices are set.

(Note-4): The range of "PXn+4 to PXn+F" cannot be used (fixed at 0) for the input device (PXn+0 to PXn+F) allocated to the built-in interface in Motion CPU (DI). (n: First input No.) **QDS**

(Note-5): "p" indicates the user setting area points of the Multiple CPU high speed transmission area for each CPU.

(Note-6): Only device of the self CPU can be used.



## 4 AUXILIARY AND APPLIED FUNCTIONS

### (2) Watch data

This data is used to perform the limit switch output function. This data is comparison data to output the ON/OFF signal. The output device is ON/OFF-controlled according to the ON section setting.

As the watch data, motion control data or optional word device data can be used.

#### (a) Motion control data

Watch data that can be set is shown in the table below.

##### 1) SV13/SV22

Name	Unit	Data type	Axis No. setting range				Remarks
			Q173DSCPU	Q172DSCPU	Q173DCPU(-S1)	Q172DCPU(-S1)	
Feed current value	Position command	32-bit integer type	1 to 32	1 to 16	1 to 32	1 to 8	—
Actual current value							
Deviation counter value	pulse						
Motor current value	0.1%	16-bit integer type					
Motor speed <sup>(Note-1)</sup>	0.1r/min	32-bit integer type					
Cam axis current value within one-revolution	pulse						
Virtual servo motor feed current value							
Virtual current value after differential gear							
Encoder current value after differential gear							
Synchronous encoder current value		1 to 12					

(Note-1): The motor speed ( $\times 0.1$ [mm/s]) is stored at linear servo use.

##### 2) SV43

Name	Unit	Data type	Axis No. setting range		Remarks
			Q173DCPU(-S1)	Q172DCPU(-S1)	
Machine value	Position command	32-bit integer type	1 to 32	1 to 8	—
Real machine value					
Deviation counter value	pulse				
Motor current value	0.1%	16-bit integer type			
Motor speed <sup>(Note-1)</sup>	0.1r/min	32-bit integer type			
Current value	Position command				

(Note-1): The motor speed ( $\times 0.1$ [mm/s]) is stored at linear servo use.

## 4 AUXILIARY AND APPLIED FUNCTIONS

### (b) Word device data

#### 1) Device

Use word device as watch data.

Item	Device No. setting range
Data register	D0 to D8191
Link register	W0 to W1FFF
Motion register	#0 to #9215
Multiple CPU area device	U□\G10000 to U□\G (10000+p-1) <sup>(Note-1)</sup>

(Note-1): "p" indicates the user setting area points of the Multiple CPU high speed transmission area for each CPU.

#### 2) Data type

The following data type is set as the data type to be compared.

Data type	Remarks
16-bit integer type	—
32-bit integer type	Set the device No. as an even No.
64-bit floating-point type	

### (3) ON section setting

(a) The data range which makes the output device turn ON/OFF toward the watch data.

(b) The following word devices, and constant (Hn/Kn) can be used as the ON Value and OFF Value of the data range.

The data type of device/constant to be set is the same as the type of watch data.

Item	Device No. setting range
Data register	D0 to D8191
Link register	W0 to W1FFF
Motion register	#0 to #9215
Multiple CPU area device	U□\G10000 to U□\G (10000+p-1) <sup>(Note-1)</sup>
Constant	Hn/Kn

(Note-1) : "p" indicates the user setting area points of the Multiple CPU high speed transmission area for each CPU.

### (4) Output enable/disable bit setting

(a) Set the status of output enable/disable bit when the limit switch output is forbidden during operation.

The following control is exercised.

Output enable/disable bit	Control description	
Invalid (always enable)	Limit switch output is turned ON/OFF based on the	
Valid	ON (enable)	ON section setting (ON Value, OFF Value).
	OFF (disable)	Limit switch output is turned OFF.

## 4 AUXILIARY AND APPLIED FUNCTIONS

### (b) Usable devices

Item	Device No. setting range
Input relay <sup>(Note-1)</sup>	X0 to X1FFF <sup>(Note-2)</sup>
Output relay <sup>(Note-3)</sup>	Y0 to Y1FFF
Internal relay	M0 to M8191
Link relay	B0 to B1FFF
Annunciator	F0 to F2047
Special relay	SM0 to SM1999
Multiple CPU area device	U□\G10000.0 to U□\G (10000+p-1).F <sup>(Note-4)</sup>

(Note-1): The real input range(PX) is included.

(Note-2): The range of "PXn+4 to PXn+F" cannot be used (fixed at 0) for the input device (PXn+0 to PXn+F) allocated to the built-in interface in Motion CPU (DI). (n: First input No.) **QDS**

(Note-3): The real input range(PY) is included.

(Note-4): "p" indicates the user setting area points of the Multiple CPU high speed transmission area for each CPU.

### (5) Forced output bit

- (a) Set the "forced output bit" when you want to forcibly provide the limit switch outputs during operation.

The following control is exercised.

Output enable/disable bit		Control description
Invalid		Limit switch outputs are turned ON/OFF on the basis of the "output enable/disable bit" and ON section setting (ON Value, OFF Value).
Valid	OFF	
	ON	

### (b) Usable devices

Item	Device No. setting range
Input relay	X0 to X1FFF <sup>(Note-1)</sup>
Output relay	Y0 to Y1FFF
Internal relay	M0 to M8191
Link relay	B0 to B1FFF
Annunciator	F0 to F2047
Special relay	SM0 to SM1999
Multiple CPU area device	U□\G10000.0 to U□\G (10000+p-1).F <sup>(Note-2)</sup>

(Note-1): The range of "PXn+4 to PXn+F" cannot be used (fixed at 0) for the input device (PXn+0 to PXn+F) allocated to the built-in interface in Motion CPU (DI). (n: First input No.) **QDS**

(Note-2): "p" indicates the user setting area points of the Multiple CPU high speed transmission area for each CPU.

#### POINT

Refer to Chapter 2 for the user setting area points of the Multiple CPU high speed transmission area.

## 4 AUXILIARY AND APPLIED FUNCTIONS

### 4.1.3 Operations (SV22 advanced synchronous control only)

- (1) ON output to an output device is made while the watch data value is in the ON region set with lower limit value and upper limit value in the limit switch output function.

Up to two ON regions can be set for each limit output setting data.

- (a) Lower limit value, upper limit value and watch data value are handled as signed data.

ON output region where an ON output is made to the output device is governed by the magnitude relationship between lower limit value and upper limit value as indicated below.

Relationship between lower limit value and upper limit value	ON output region
Lower limit value < Upper limit value	Lower limit value $\leq$ (watch data value) < Upper limit value
Lower limit value > Upper limit value	Lower limit value $\leq$ (watch data value) (Watch data value) < Upper limit value
Lower limit value = Upper limit value	Output OFF in whole region

#### 1) Lower limit value < Upper limit value

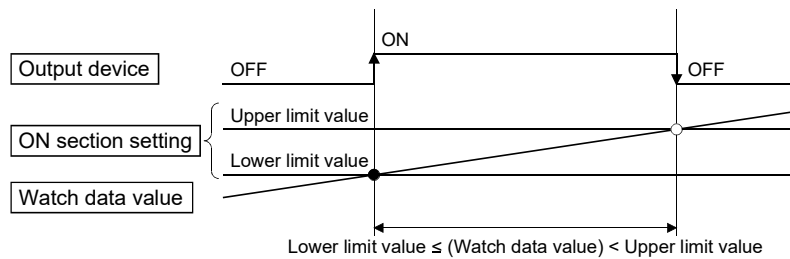

#### 2) Lower limit value > Upper limit value

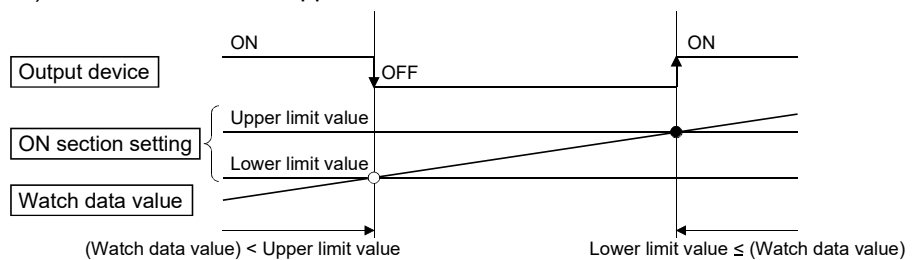

#### 3) Lower limit value = Upper limit value

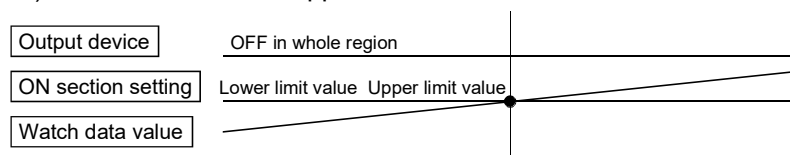

: Refer to Section 1.5 for the software version that supports this function.

## 4 AUXILIARY AND APPLIED FUNCTIONS

- (b) The limit switch outputs are controlled based on each watch data during the READY complete status (SM500: ON) by the PLC ready flag (M2000) from OFF to ON.

With the setting of "M2000 keep the output device when turns OFF" invalid, when the READY complete flag (SM500) turns OFF by turning the PLC ready flag (M2000) from ON to OFF, all points turn OFF.

With the setting of "M2000 keep the output device when turns OFF" valid for output devices other than Y devices, the output devices do not turn OFF even when the PLC ready flag (M2000) turns from ON to OFF. The setting is valid for all the output devices.

Y devices always turn OFF when the PLC ready flag (M2000) turns from ON to OFF.

When lower limit value and upper limit value are specified with word devices, the word device contents are input to the internal area when the PLC ready flag (M2000) turns from OFF to ON.

After that, the word device contents are input per motion operation cycle, and limit switch outputs are controlled.

- (c) Multiple outputs (Up to 64 points) can be also set to one watch data. In each setting, the output device may be the same.

If both of the two regions of the ON section setting are used or if the same output device is designated by multiple output settings (regardless of whether or not the watch data is the same), the logical add of the output results in the regions is output.

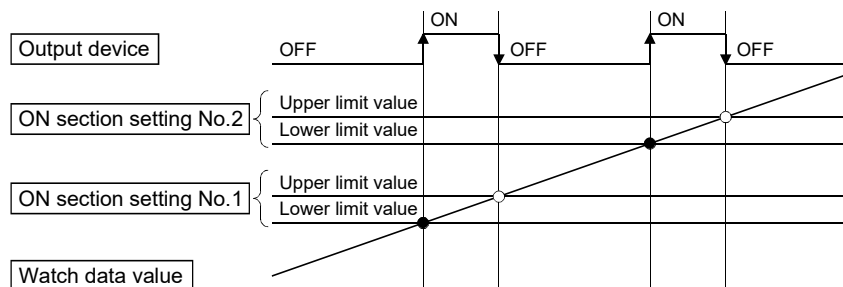

- (2) Forced OFF bit can be set to forcibly turn off the output of the output device point-by-point.  
When the forced OFF bit is ON, the output is OFF.
- (3) Forced ON bit can be set to forcibly turn on the output of the output device point-by-point.  
When the forced ON bit is ON, the output is ON.  
Priority is given to control of this setting over ON of the "forced OFF bit" (forced output OFF).

## 4 AUXILIARY AND APPLIED FUNCTIONS

### 4.1.4 Limit output setting data (SV22 advanced synchronous control only)

Limit output data list are shown below.

Up to 64 points of output devices can be set.

(The following items of No.2 to No.7 are set together as one point.)

No.	Item		Setting range	Fetch cycle	Refresh cycle	Remarks
1	M2000 keep the output device when turns OFF		Invalid (default)/Valid	—	—	
2	Output device	Output device	Bit device (X, Y, M, B, U□\G)		Operation cycle	
		16 point unit batch output setting	Invalid (default)/Valid			
3	Limit output compensation time		-5000000 to 5000000[μs] Word device (D, W, #, U□\G)	Operation cycle	—	—
4	Watch data	Watch data setting	Motion control data/word device data/word device data (ring counter)			
		Axis (Note-1)	1 to 32			
		Name (Note-1)	Refer to (4) of this section			
		Device (Note-2), (Note-3)	Word device (D, W, #, U□\G)			
		Data type (Note-2), (Note-3)	16-bit integer type/32-bit integer type			
		Ring counter value (Note-3)	16-bit integer type: K1 to K32767, H0001 to H7FFF 32-bit integer type: K1 to K2147483647, H00000001 to H7FFFFFFF	—		
5	ON section setting	ON section 1	Upper limit value	Word device (D, W, #, U□\G)/constant (K, H)	Operation cycle	
			Lower limit value			
		ON section 2	Upper limit value			
			Lower limit value			
6	Forced OFF bit	Forced OFF bit	Invalid (default)/Valid	Operation cycle		
		Forced OFF bit device	Bit device (X, Y, M, B, F, SM, U□\G)			
7	Forced ON bit	Forced ON bit	Invalid (default)/Valid			
		Forced ON bit device	Bit device (X, Y, M, B, F, SM, U□\G)			

(Note-1): When Motion control data is selected

(Note-2): When word device data is selected

(Note-3): When word device data (ring counter) is selected

 : Refer to Section 1.5 for the software version that supports this function.

## 4 AUXILIARY AND APPLIED FUNCTIONS

(1) M2000 keep the output device when turns OFF

With this setting valid for output devices other than Y devices, the output devices do not turn OFF even when the PLC ready flag (M2000) turns from ON to OFF. The setting is valid for all the output devices. Y devices always turn OFF when the PLC ready flag (M2000) turns from ON to OFF.

(2) Output device

(a) Set the bit device which outputs the ON/OFF signal toward the preset watch data.

(b) As the output device, the following bit devices are used.

Item	Device No. setting range
Input relay <sup>(Note-1)</sup>	X0 to X1FFF <sup>(Note-4)</sup>
Output relay <sup>(Note-2)</sup>	Y0 to Y1FFF
Internal relay <sup>(Note-3)</sup>	M0 to M8191
Link relay	B0 to B1FFF
Multiple CPU area device	U□\G10000.0 to U□\G (10000+p-1).F <sup>(Note-5), (Note-6)</sup>

(Note-1): PX is write-disabled and it cannot be used as the output device.

For X, only the free No. of the input card non-loading can be used.

(Note-2): The real output device range (PY) is also included.

(Note-3): Be careful because it affect a positioning operation, when the positioning dedicated devices are set.

(Note-4): The range of "PXn+4 to PXn+F" cannot be used (fixed at 0) for the input device (PXn+0 to PXn+F) allocated to the built-in interface in Motion CPU (DI). (n: First input No.) 

(Note-5): "p" indicates the user setting area points of the Multiple CPU high speed transmission area for each CPU.

(Note-6): Only device of the self CPU can be used.

- (c) When the 16 point unit batch output setting is valid, the batch output of the sequential 16 point unit devices has less effect on the operation cycle as compared with the output of each output device point-by-point. When the 16 point unit batch output setting is valid, it is recommended to set multiple output devices as sequential 16 point unit output devices. The sequential devices to be output in a 16 point unit batch is counted as one set and up to 4 sets can be set. When the 16 point unit batch output setting is valid, among the 16 point unit devices, the devices that are not used as the output devices are always OFF.

16 point unit batch output setting	Control description
Invalid	The output device is output point-by-point.
Valid	The sequential 16-point output devices are output in a batch.

## 4 AUXILIARY AND APPLIED FUNCTIONS

---

### (3) Limit output compensation time

Compensate the output timing of the output device.

Set it to compensate for output signal delays. (Set a positive value to compensate for a delay.)

The timing is compensated as "-5000000" when the compensation time is set to less than -5000000, and it is compensated as "5000000" when it is set to more than 5000000.

#### (a) Direct designation

Setting range
-5000000 to 5000000[μs]

#### (b) Indirect designation

Item	Device No. setting range <sup>(Note-1)</sup>
Data register	D0 to D8191
Link register	W0 to W1FFF
Motion register	#0 to #9215
Multiple CPU area device	U□\G10000 to U□\G (10000+p-1) <sup>(Note-2)</sup>

(Note-1): Set an even number as the first device.

(Note-2): "p" indicates the user setting area points of the Multiple CPU high speed transmission area for each CPU.



## 4 AUXILIARY AND APPLIED FUNCTIONS

### (4) Watch data

This data is used to perform the limit switch output function. This data is comparison data to output the ON/OFF signal. The output device is ON/OFF-controlled according to the ON section setting.

As the watch data, motion control data, word device data or word device data (ring counter) can be used.

#### (a) Motion control data

Settable watch data is shown in the following table.

Name	Unit	Data type	Axis No. setting range		Remarks	
			Q173DSCPU	Q172DSCPU		
Feed current value	Control unit	32-bit integer type	1 to 32	1 to 16	—	
Actual current value						
Motor actual current value						
Servo command value	pulse					
Position feedback <sup>(Note-1)</sup>						
Absolute encoder one-revolution position <sup>(Note-1)</sup>						
Absolute encoder multiple revolution position	—	16-bit integer type	1 to 32	1 to 16	—	
Deviation counter value	pulse	32-bit integer type				
Servo command speed	pulse/s					
Motor speed	0.01r/min					
Motor current value	0.1%	16-bit integer type	32-bit integer type	1 to 12	Valid in synchronous control	
Command generation axis feed current value	Control unit					
Command generation axis cumulative current value						
Command generation axis current value per cycle						
Synchronous encoder axis current value	Encoder axis unit					
Synchronous encoder axis current value per cycle						
Cam axis current value per cycle	Cam axis cycle unit	1 to 32				1 to 16
Cam axis current value per cycle (Actual)						

(Note-1): For MR-J5(W)-□B, the value displayed is the value (command unit) multiplied by the reciprocal of the electronic gear ratio of the servo amplifier.

By configuring the electronic gear settings to the servo amplifier's "Electronic gear numerator (PA06)" and "Electronic gear denominator (PA07)" servo parameters, the data becomes the same watch data as for MR-J4(W)-□B.

#### (b) Word device data/word device data (ring counter)

##### 1) Device

Use word device as watch data.

Item	Device No. setting range
Data register	D0 to D19823
Link register	W0 to W1FFF
Motion register	#0 to #9215
Multiple CPU area device	U□\G10000 to U□\G (10000+p-1) <sup>(Note-1)</sup>

(Note-1): "p" indicates the user setting area points of the Multiple CPU high speed transmission area for each CPU.

## 4 AUXILIARY AND APPLIED FUNCTIONS

### 2) Data type

The following data type is set as the data type to be compared.

Data type	Remarks
16-bit integer type	—
32-bit integer type	Set the device No. as an even No.

### 3) Ring counter value

When the watch data is the word device data (ring counter), the ring counter value is set.

Data type	Remarks
16-bit integer type	H0001 to H7FFF
32-bit integer type	K1 to K2147483647, H00000001 to H7FFFFFFF

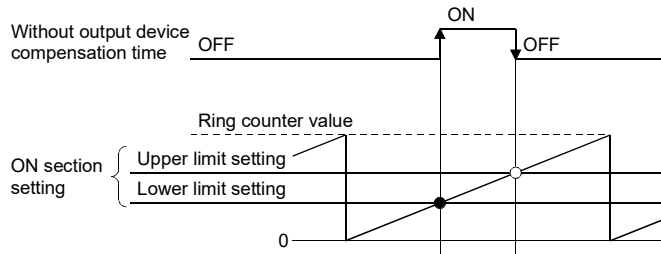

### POINT

For the word device data updated as ring counter, when the output timing is compensated without setting the correct ring counter value or when the output timing is compensated by setting the ring counter for the word device data that is not updated as ring counter, the output device may not be output at the correct timing.

### (5) ON section setting

- (a) The data range which makes the output device turn ON/OFF toward the watch data.

Up to two ON regions can be set for each limit output setting data.

- (b) The following word devices, and constant (Hn/Kn) can be used as the lower limit value and upper limit value of the data range.

The data type of device/constant to be set is the same as the type of watch data.

Item	Device No. setting range
Data register	D0 to D8191
Link register	W0 to W1FFF
Motion register	#0 to #9215
Multiple CPU area device	U□\G10000 to U□\G (10000+p-1) <sup>(Note-1)</sup>
Constant	Hn/Kn

(Note-1): "p" indicates the user setting area points of the Multiple CPU high speed transmission area for each CPU.

## 4 AUXILIARY AND APPLIED FUNCTIONS

### (6) Forced OFF bit

- (a) Set the "forced OFF bit" when forced OFF of the output device is desired during operation.

The following control is exercised.

Forced OFF bit		Control description
Invalid		Output device is turned ON/OFF based on the ON section setting.
Valid	OFF	
	ON	Output device is turned OFF.

- (b) Usable devices

Item	Device No. setting range
Input relay <sup>(Note-1)</sup>	X0 to X1FFF <sup>(Note-2)</sup>
Output relay <sup>(Note-3)</sup>	Y0 to Y1FFF
Internal relay	M0 to M12287
Link relay	B0 to B1FFF
Annunciator	F0 to F2047
Special relay	SM0 to SM1999
Multiple CPU area device	U□\G10000.0 to U□\G (10000+p-1).F <sup>(Note-4)</sup>

(Note-1): The real input range(PX) is included.

(Note-2): The range of "PXn+4 to PXn+F" cannot be used (fixed at 0) for the input device (PXn+0 to PXn+F) allocated to the built-in interface in Motion CPU (DI). (n: First input No.)

(Note-3): The real input range(PY) is included.

(Note-4): "p" indicates the user setting area points of the Multiple CPU high speed transmission area for each CPU.

## 4 AUXILIARY AND APPLIED FUNCTIONS

### (7) Forced ON bit

- (a) Set the "forced ON bit" when forced ON of the output device is desired during operation.

The following control is exercised.

Forced ON bit		Control description
Invalid		Output device is turned ON/OFF based on the ON section setting .
Valid	OFF	Output device is turned ON.
	ON	

- (b) Usable devices

Item	Device No. setting range
Input relay	X0 to X1FFF <sup>(Note-1)</sup>
Output relay	Y0 to Y1FFF
Internal relay	M0 to M8191
Link relay	B0 to B1FFF
Annunciator	F0 to F2047
Special relay	SM0 to SM1999
Multiple CPU area device	U□\G10000.0 to U□\G (10000+p-1).F <sup>(Note-2)</sup>

(Note-1): The range of "PXn+4 to PXn+F" cannot be used (fixed at 0) for the input device (PXn+0 to PXn+F) allocated to the built-in interface in Motion CPU (DI). (n: First input No.)

(Note-2): "p" indicates the user setting area points of the Multiple CPU high speed transmission area for each CPU.

#### POINT

Refer to Chapter 2 for the user setting area points of the Multiple CPU high speed transmission area.

### 4.2 Absolute Position System

The positioning control for absolute position system can be performed using the absolute-position-compatible servo motors and servo amplifiers.

If the machine position is set at the system starting, home position return is not necessary because the absolute position is detected at the power on.

The machine position is set with the home position return using the Motion SFC program (SV13/SV22)/Motion program (SV43) or MT Developer2.

(1) Conditions of the absolute position system start

Perform a home position return after machine adjustment at the absolute position system start.

(2) In the absolute positioning system, the absolute position may be lost in the following cases:

Set the absolute position with a home position return.

(a) The battery unit is removed or replaced. <sup>(Note-1)</sup>

(b) The battery error of the servo amplifier occurs. <sup>(Note-1)</sup> (It is detected at the servo amplifier power on).

(c) The machine is disrupted by a shock.

(d) The cable between servo amplifier and encoder is removed, or the servo amplifier or encoder is replaced.

(Note-1): Only when using MR-J4(W)-□B or MR-J3(W)-□B.

(3) The current value history can be monitored using of the "System setting allowable travel during power off" or "Monitor" using MT Developer2.

(Refer to the help of MT Developer2 for details.)

## 4 AUXILIARY AND APPLIED FUNCTIONS

- (4) If a major error (error code: 1202, 12020) occurs because of a communication error between the servo amplifier and encoder, home position return request (M2409+20n) turns ON, and absolute position data is erased.

However, the erasing of the absolute position data can be avoided with the following combinations.

Operating system software		Servo amplifier		Operation of home position return request (M2409+20n) when error occurs
Q173DSCPU/ Q172DSCPU	Q173DCPU(-S1)/ Q172DCPU(-S1)	Model name	Software version	
00Y or later	Not support	MR-J5-□B	—	Home position return request (M2409+20n: OFF) does not turn ON. (Note-1)
		MR-J5-□B-RJ		
		MR-J5W-□B		
00B or later	00S or later	MR-J4-□B	C3 or later	
		MR-J4-□B-RJ		
		MR-J4W-□B		
		MR-J3-□B		
		MR-J3-□B-RJ006	C5 or later	
		MR-J3-□B Safety		
		MR-J3-□B-RJ004	B1 or later	
		MR-J3-□B-RJ080W		
		MR-J3W-□B		
Others				Home position return request (M2409+20n: ON) turns ON. (absolute position data is lost)

—: There is no restriction by the version.

(Note-1): The history for the number of times a major error (error code: 1202, 12020) occurred is not displayed in the current value history for MT Developer2 that does not support the display of the current value history of the past 10 times. Use a version of MT Developer2 that supports the display of the current value history of the past 10 times. (Refer to Section 1.5.)

### CAUTION

- After removing or replacing the battery unit, correctly install the new unit and set the absolute position.
- After a servo amplifier battery error occurs, eliminate the cause of the error and ensure operation is safe before setting the absolute position.
- After the machine is disrupted by a shock, make the necessary checks and repairs, and ensure operation is safe before setting the absolute position.

## 4 AUXILIARY AND APPLIED FUNCTIONS

---

POINT
-------

- |  |
|--|
| <p>(1) The address setting range of absolute position system is -2147483648 to 2147483647. It is not possible to restore position commands that exceed this limit, or current values after a power interruption.<br/>For an infinite feed operation, configure the [degree] setting.</p> <p>(2) Even when the current value address is changed by a current value change instruction, the restored data for the current value after a power interruption is the value based on the status prior to execution of the current value change instruction.</p> <p>(3) When home position return has not been completed (home position return request is ON), restoration of the current value after a power interruption is not possible.</p> |
|--|

## 4 AUXILIARY AND APPLIED FUNCTIONS

---

### 4.2.1 Current value control

The current value when using the ABS encoder is controlled by the following functions.

- (1) The validity of encoder data during operation is checked.
  - (a) Checks that the amount of change of the encoder in a 3.5[ms] interval is within 180 degrees at the motor axis. (An error is displayed when abnormal.)
  - (b) Checks the consistency of the encoder data and feedback positions controlled with the servo amplifier. (An error is displayed when abnormal.)

- (2) The following values can be monitored by the current value history monitor of MT Developer2.

Monitor conditions	Monitor value
Multiple CPU system power ON/OFF	Encoder current value, Servo command value, Monitor current value
Home position return completion	

- (a) Current value history monitor  
Month/day/hour/minute  
The time at the completion of home position return and servo amplifier power supply ON/OFF is indicated.
  - (b) Encoder current value  
When using the servo amplifier, the multiple revolution data and within-one-revolution data read from the encoder is indicated.  
(Note): For MR-J5(W)-□B, the value displayed is the value (command unit) multiplied by the reciprocal of the electronic gear ratio of the servo amplifier.
  - (c) Servo command value  
The command value issued to the servo amplifier is indicated.
  - (d) Monitor current value  
The current value controlled in the Motion CPU is indicated.  
(Note): A value near the feed current value is indicated. However, because the monitor current value and feed current value are different data, it is not abnormal even if a different value is indicated.
  - (e) Alarms  
When an error for current value restoration occurs at the servo amplifier power on, an error code is indicated.
- (3) By setting of the "Allowable travel during power off", if the encoder data changes exceeding the setting range during power-off, it checks at servo amplifier power-on. (An error is displayed at the abnormal.)  
"Allowable travel during power off" cannot be set when using the linear servo motor and direct drive motor.
  - (4) The current value history of the past 10 times is indicated at the servo amplifier's power ON/OFF. 

---

: Refer to Section 1.5 for the software version that supports this function.

---



## 4 AUXILIARY AND APPLIED FUNCTIONS

### 4.3 High-Speed Reading of Specified Data

This function is used to store the specified positioning data in the specified device (D, W, U□\G). The signal from input module controlled in the Motion CPU is used as a trigger.

It can be set in the system setting of MT Developer2.

<b>POINT</b>
High-speed reading function cannot be used in the SV22 advanced synchronous control. 

#### (1) Positioning data that can be set

##### (a) SV13/SV22

Setting data	Word No.	Unit	Remarks
Feed current value	2	10 <sup>-1</sup> [μm], 10 <sup>-5</sup> [inch], 10 <sup>-5</sup> [degree], [pulse]	
Real current value	2	10 <sup>-1</sup> [μm], 10 <sup>-5</sup> [inch], 10 <sup>-5</sup> [degree], [pulse]	
Deviation counter value	2	[pulse]	
M-code	1	—	
Torque limit value	1	[%]	
Motor current value	1	[%]	
Motor speed (Note-1)	2	[r/min]	
Servo command value	2	[pulse]	
Feed current value (Virtual)	2	[pulse]	
Encoder current value (Note-2)	2	[pulse]	
M-code (Virtual)	1	—	Valid in SV22 virtual mode only
Current value after differential gear (Virtual)	2	[pulse]	
Encoder current value after differential gear	2	[pulse]	
Cam axis 1 revolution current value	2	[pulse]	
Execute cam No.	1	—	
Execute stroke amount	2	10 <sup>-1</sup> [μm], 10 <sup>-5</sup> [inch], [pulse]	
Optional address (Fixed to 4 bytes)	2	—	

(Note-1): The motor speed (unit [mm/s]) is stored at linear servo use.

(Note-2): It is also valid in real mode for the version (Refer to Section 1.5) that supports "synchronous encoder current value in real mode".

## 4 AUXILIARY AND APPLIED FUNCTIONS

### (b) SV43

Setting data	Word No.	Unit	Remarks
Machine value	2	10 <sup>-4</sup> [mm], 10 <sup>-5</sup> [inch], 10 <sup>-5</sup> [degree]	
Real machine value	2	10 <sup>-4</sup> [mm], 10 <sup>-5</sup> [inch], 10 <sup>-5</sup> [degree]	
Deviation counter value	2	[pulse]	
M-code	1	—	
Torque limit value	1	[%]	
Motor current value	1	[%]	
Motor speed (Note-1)	2	[r/min]	
Servo command value	2	[pulse]	
Optional address (Fixed to 4 bytes)	2	—	

(Note-1): The motor speed (unit [mm/s]) is stored at linear servo use.

#### POINT

If the wrong address is set in the absolute address, the WDT error will occur.  
Explain to our sales representative before setting the absolute address.

### (2) Modules and signals to be used

Input module	Signal	Read timing	Number of settable points
Q172DEX	TREN	0.8[ms]	2
Q173DPX			3
Built-in interface in Motion CPU QDS	PX device (Note-2)		4
PLC input module (Note-1)			8

(Note-1): Only one PLC input module can be used.

(Note-2): Either the input signal of the built-in interface in Motion CPU (DI) or the PLC input module can be used. QDS

### (3) Usable devices

Word devices	Usable devices
D	0 to 8191
W	0 to 1FFF
U□\G	10000 to (10000 + p-1) (Note-1), (Note-2)

(Note-1): "p" indicates the user setting area points of the Multiple CPU high speed transmission area for each CPU.

(Note-2): Only device of the self CPU can be used.

#### POINT

- (1) Set an even numbered device No. in the two word data.
- (2) Refer to Chapter 2 for the user setting area points of the Multiple CPU high speed transmission area.

## 4 AUXILIARY AND APPLIED FUNCTIONS

### 4.4 ROM Operation Function

This function is used to operate based on the data in the FLASH ROM built-in Motion CPU module that the user programs and parameters have been stored.

#### 4.4.1 Specifications of 7-segment LED/switches

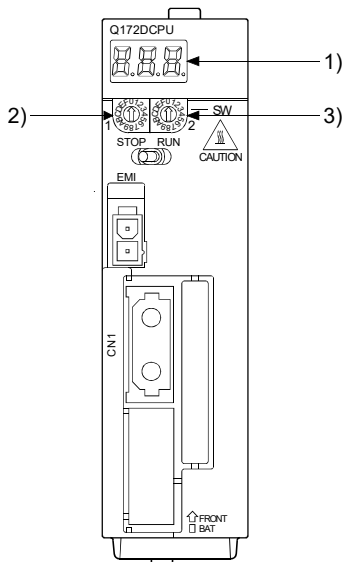

No.	Items	Functions
1)	7-segment LED	• Indicate the operation state and error information.
2)	Rotary switch 1 (SW1)	• Set the operation mode (Normal mode, Installation mode and mode operated by ROM, etc.)
3)	Rotary switch 2 (SW2)	• Each switch setting is 0 to F.

#### (1) Operation mode

"Operation mode" of the Motion CPU is set by the rotary switch setting of Motion CPU module at the power supply ON of the Multiple CPU system.

The rotary switch setting, operation mode and operation mode overview are shown below.

##### (a) Rotary switch setting and operation mode



Rotary switch setting <sup>(Note-1)</sup>		Operation mode
SW1	SW2	
A	Any setting (Except C)	Installation mode
0	0	Mode operated by RAM
0	6	Mode operated by ROM
0	8	Ethernet IP address display mode
Any setting	C	SRAM clear <sup>(Note-2)</sup>

(Note-1): Do not set other than the above setting.

(Note-2): The programs, parameters, motion devices (#), devices of latch data and absolute position data of SRAM built-in Motion CPU module are cleared.

## 4 AUXILIARY AND APPLIED FUNCTIONS

(b) Operation mode overview

Operation mode	7-segment LED	Operation overview
Mode operated by RAM		<ul style="list-style-type: none"> <li>• " . " remains flashing in the first digit of 7-segment LED.</li> <li>• It operates based on the user programs and parameters stored in the SRAM built-in Motion CPU module.</li> <li>• The user programs and parameters for the ROM operation can be written to the FLASH ROM built-in Motion CPU module.</li> </ul>
Mode operated by ROM		<ul style="list-style-type: none"> <li>• " . " remains flashing in the first digit and steady " . " display in the second digit of 7-segment LED.</li> <li>• Operation starts after the user programs and parameters stored in the FLASH ROM built-in Motion CPU module are read to the SRAM built-in Motion CPU module at power supply on or reset of the Multiple CPU system. If the ROM writing is not executed, even if the user programs and parameters are changed using the MT Developer2 during mode operated by ROM, operation starts with the contents of the FLASH ROM built-in Motion CPU module at next power supply on or reset.</li> <li>• Also, If the ROM writing is not executed, even if the auto tuning data are reflected on the servo parameter of Motion CPU by operation in the auto-tuning setting, operation starts with the contents of the FLASH ROM built-in Motion CPU module at next power supply on or reset.</li> </ul>

### POINT

- (1) Be sure to turn OFF the Multiple system's power supply before the rotary switch setting change.
- (2) It is recommended to shift to the mode operated by ROM after the programs and parameters are fixed. The erasing of the programs and parameters can be avoided even if the battery decrease. (The ROM writing cannot be executed for the current position of the servo motor in the absolute position system, home position and latch device. Back up them beforehand using MT Developer2.)

## 4 AUXILIARY AND APPLIED FUNCTIONS

### 4.4.2 Outline of ROM operation

When the ROM writing is requested to the Motion CPU module using the MT Developer2, the programs and parameters stored in the SRAM built-in Motion CPU module are batch-written to the FLASH ROM, after the data of FLASH ROM built-in Motion CPU are erased.

When the Motion CPU starts in the "Mode operated by ROM", a normal operation starts, after the data written in the FLASH ROM is read to the SRAM.

The programs and parameters created by the MT Developer2 must be written beforehand to the FLASH ROM built-in Motion CPU module at the ROM operation. The following methods for ROM writing are shown below.

- Write the programs and parameters written in the SRAM built-in Motion CPU module to the FLASH ROM built-in Motion CPU module.
- Write the programs and parameters of the MT Developer2 to the SRAM built-in Motion CPU module, and then write them to the FLASH ROM built-in Motion CPU module.

The data batch written to the FLASH ROM built-in Motion CPU module by ROM writing are shown below. Backup data except the following (current position of servo motor in absolute position system, home position and latch device.) cannot be written to the FLASH ROM.

SV13	SV22	SV43
System setting data		
Each parameter for servo control		
Servo program		—
Motion SFC parameter		Motion parameter
Motion SFC program		Motion program
—	Mechanical system program	—
—	Cam data	—

POINT
<p>(1) "Backup • load" operation of the MT Developer2 targets the SRAM built-in Motion CPU module. (The FLASH ROM built-in Motion CPU module is not targeted.) Set to "Mode operated by ROM" after ROM writing to execute the ROM operation after "Backup • load" operation at the Motion CPU module exchange.</p> <p>(2) The FLASH ROM built-in Motion CPU module serves as a life in 100000 times writing. Make the ROM writing within 100000 times. If it passes over a life, "writing error" will occur, replace the Motion CPU module.</p> <p>(3) The online change of Motion SFC program executes the Motion SFC program performed the online change from the next scanning at the mode operated by ROM. Operation starts with the contents of the Motion SFC program written in the FLASH ROM built-in Motion CPU module at next power supply on or reset.</p> <p>(4) It needs to meet the following conditions for the ROM writing. (a) PLC ready flag (M2000) OFF (b) Not installation mode</p>

## 4 AUXILIARY AND APPLIED FUNCTIONS

- (1) Write the programs and parameters written in the SRAM built-in Motion CPU module to the FLASH ROM built-in Motion CPU module for the ROM operation.

<ROM writing>

- Mode operated by RAM/Mode operated by ROM

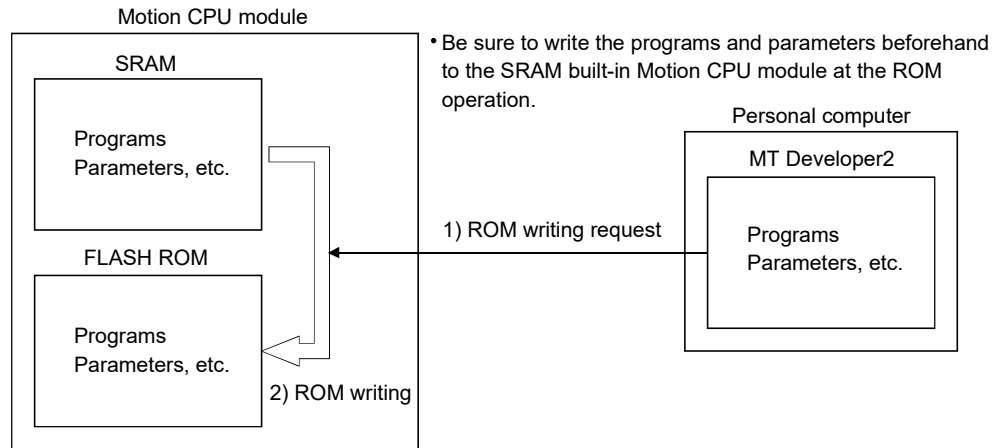

<ROM operation>

- Mode operated by ROM

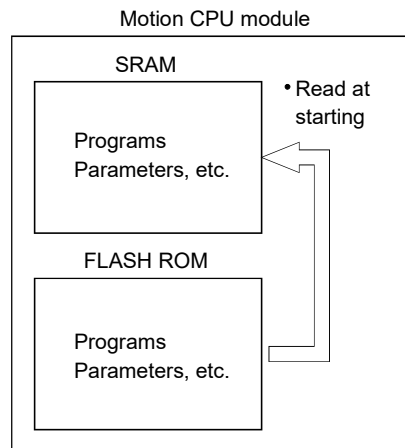

## 4 AUXILIARY AND APPLIED FUNCTIONS

- (a) Writing procedure for the data of SRAM built-in Motion CPU module to the ROM.

Execute the ROM writing to the FLASH ROM built-in Motion CPU module by selecting the [Execute] button on the Export to ROM Format screen displayed by the menu bar [Online] - [Export to ROM Format].

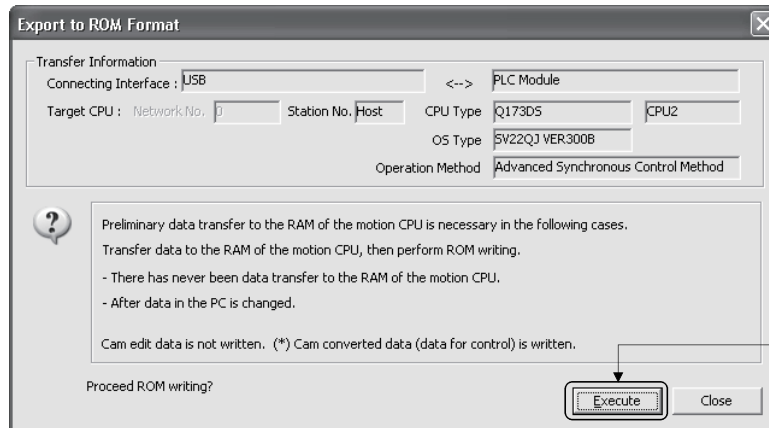

Refer to the help of MT Developer2 for details of the operation procedures.

### POINT

Be sure to write the all data beforehand to SRAM built-in Motion CPU module at the ROM writing.

## 4 AUXILIARY AND APPLIED FUNCTIONS

- (2) Write the programs and parameters of the MT Developer2 to the SRAM built-in Motion CPU module, and then write them to the FLASH ROM built-in Motion CPU module for the ROM operation.

<Data writing + ROM writing>

- Mode operated by RAM/Mode operated by ROM

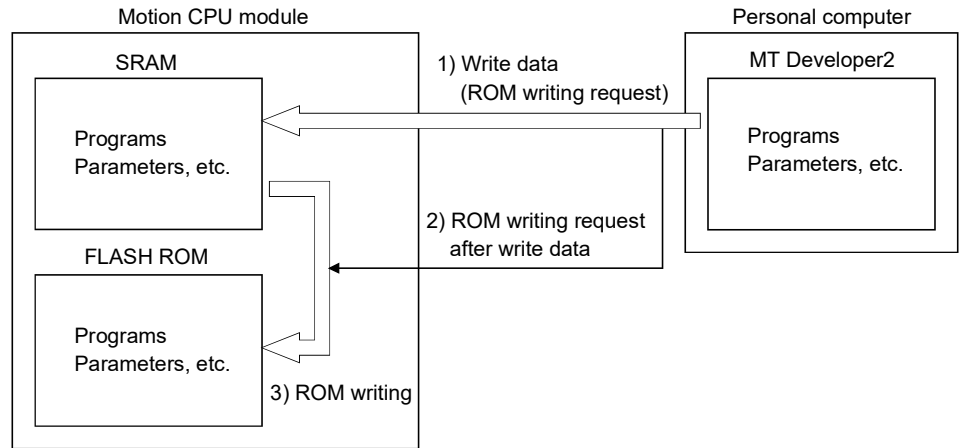

<ROM operation>

- Mode operated by ROM

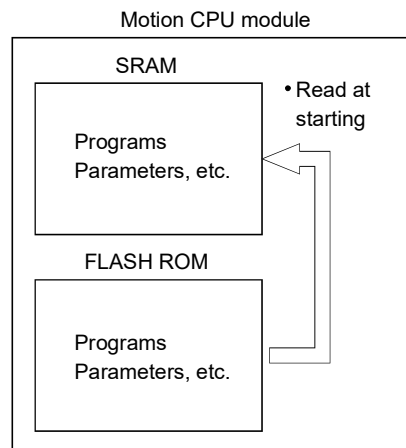



## 4 AUXILIARY AND APPLIED FUNCTIONS

- (a) Writing procedure for the data of MT Developer2 to the ROM.  
Check the data written in the Motion CPU by selecting the [Program memory + CPU ROM] of target memory on the Write to CPU screen displayed by the menu bar [Online] - [Write to CPU].

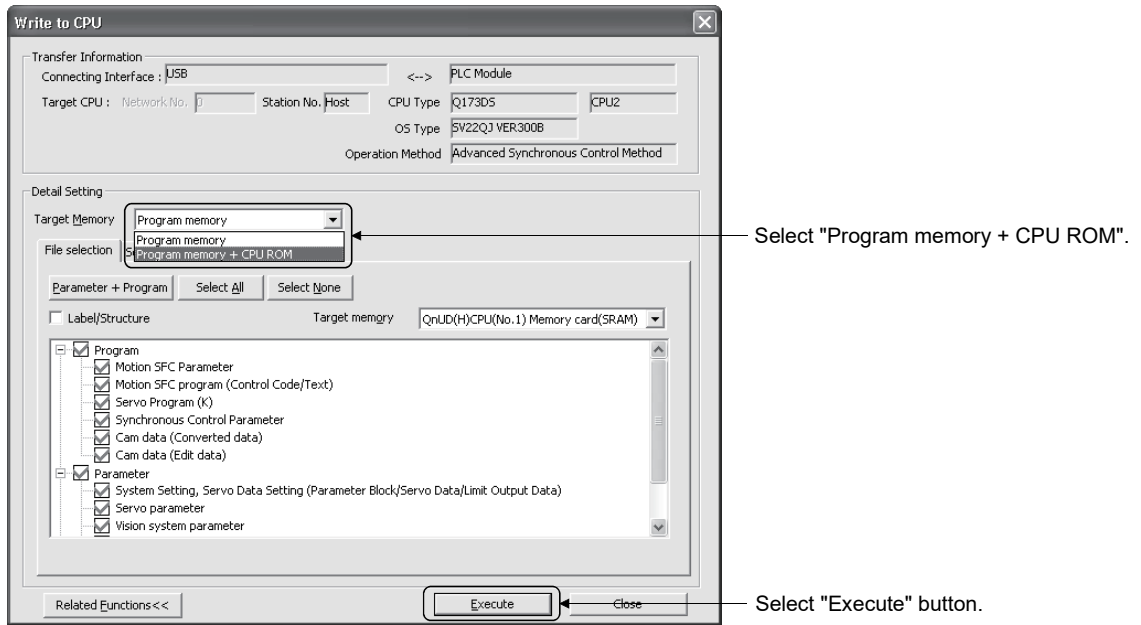

(Note): The display of selectable data are different depending on the operating software.

Refer to the help of MT Developer2 for details of the operation procedures.

### POINT

Be sure to write the all data beforehand to SRAM built-in Motion CPU module at the ROM writing.

4.4.3 Operating procedure of the ROM operation function

(1) ROM operation procedure

The ROM operation procedure is shown below.

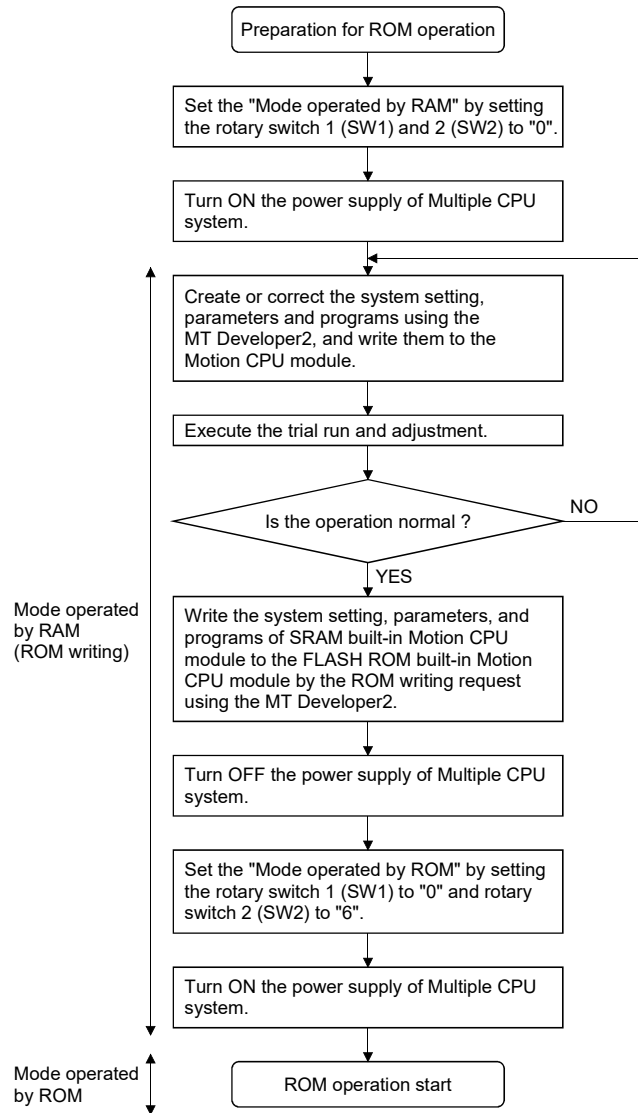

(2) Operation at the "Mode operated by ROM"

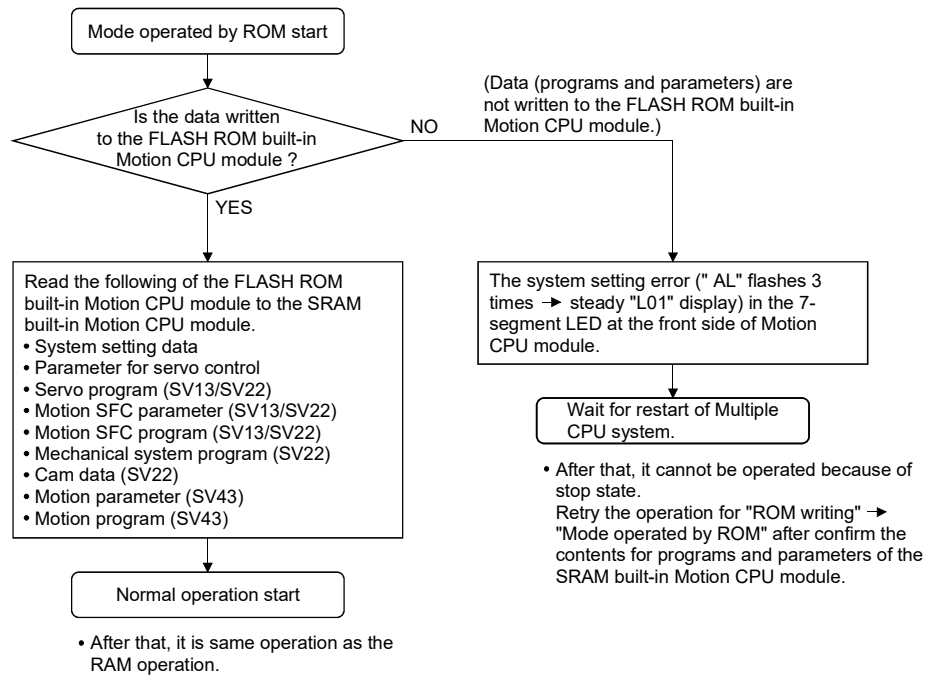

POINT
(1) Change the operation mode using the rotary switch of Motion CPU module.
(2) Confirm the operation mode by the 7-segment LED of Motion CPU module.

## 4 AUXILIARY AND APPLIED FUNCTIONS

### 4.5 Security Function

#### 4.5.1 Protection by password

This function is used to protect the user data of Motion CPU by registering a password. The illegal reading or writing of the user data are prevented by setting a password. Registered password can be changed and deleted.

##### (1) Operating procedure password

[Register/Change Password] or [Delete Password] screen is used to register/change/delete a password. Select from a menu bar or each screen of MT Developer2 to display these screen.

- Select from a menu bar

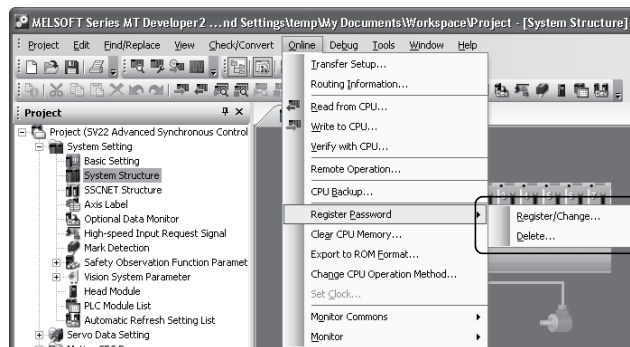

- Select from each screen of Write to CPU/Read from CPU/Verify with CPU

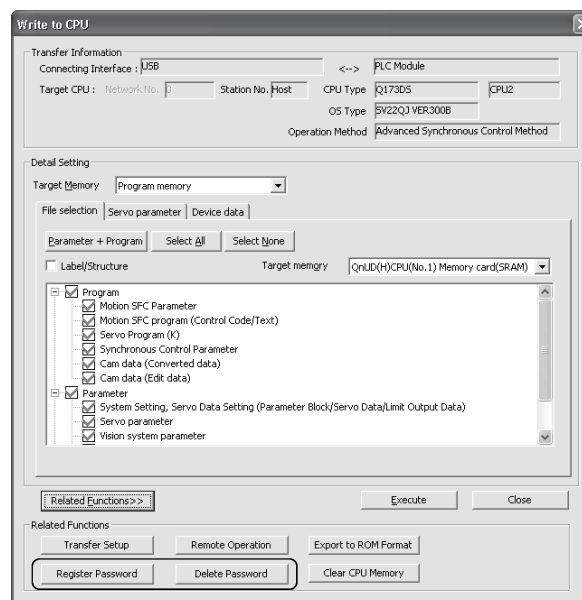



## 4 AUXILIARY AND APPLIED FUNCTIONS

---

### (2) User data protected by password

The user data protected in this function are shown below.

"Write Protection" or "Read/Write Protection" can be set every user data.

Operating system software	User data	Protected contents
SV13/SV22	Motion SFC program	Motion SFC programs (Control code, text) and motion SFC parameters
	Servo program	Servo programs and program allocation
	Safety observation function parameter <sup>(Note-1)</sup> 	Safety signal comparison parameter and speed monitoring parameter
SV22	Mechanical system program <sup>(Note-2)</sup>	Mechanical system programs
	Synchronous control parameter <sup>(Note-3)</sup>  	Input axis parameter and synchronous parameter
	Cam data	Cam data (Converted data, edit data <sup>(Note-4)</sup> )
SV43	Motion program	Motion programs and motion parameters

(Note-1): Q173DSCPU/Q172DSCPU/Q173DCPU-S1/Q172DCPU-S1 only.

(Note-2): Virtual mode only.

(Note-3): Advanced synchronous control only.

(Note-4): Cam edit data "Read from CPU/Write to CPU/Verity with CPU" is possible for the MT Developer2 version "1.09k or later".

---

: Refer to Section 1.5 for the software version that supports this function.

---

## 4 AUXILIARY AND APPLIED FUNCTIONS

### (3) Password registration/change

Execute the password registration/change on the "Register/Change password" screen of MT Developer2.

Refer to the help of MT Developer2 for details of the operation procedures.

<SV13/SV22 use>

	Type	Registration	Password	Registration Condition
1	Motion SFC Program	*	*****	Write Protection
2	Servo Program	*		Write Protection
3	Mechanical System Program		****	Read/Write Protection
4	Cam Data (Converted/Edit)			Write Protection
5	Safety Monitoring Function Parameter			Write Protection

Buttons: Batch Settings..., Refresh, Execute, Close

<SV43 use>

	Type	Registration	Password	Registration Condition
1	Motion Program	*	*****	Write Protection

Buttons: Refresh, Execute, Close

Items	Details
Type	Type of user data
Registration	"*" is displayed when a password is registered in the Motion CPU.
Password	Enter initial registration/change password. Alphanumeric character (ASCII) of 6 or less Match case (Not full-size character) (Note-1): Make the item an empty column when a password is not registered.
Registration condition	A registration condition set in the Motion CPU is displayed. • Write Protection • Read/Write Protection New registration condition can be selected by password input.

POINT
(1) Be sure to register/change password when the Motion CPU is in STOP state. Registering/changing password when in RUN state may cause the Motion SFC program to operate incorrectly.
(2) If a user has forgotten a registration password, clear a password of Motion CPU by the all clear function. However, the all password data and user data are cleared by the all clear function. Re-write the user data to the Motion CPU. (Refer to Section 4.6 for details.)
(3) ROM operation can be executed by user data registered a password. The password setting is also included in the ROM writing/reading data.
(4) The password data is not saved in a project without project save. Be sure to save project.
(5) If an operation stops by reset or power OFF of the Multiple CPU system while a password registration/change, the user data may not be registered. Register/change a password again to restore the user data.

## 4 AUXILIARY AND APPLIED FUNCTIONS

### (4) Password delete

Execute the password delete on the "Delete password" screen of MT Developer2.

Refer to the help of MT Developer2 for details of the operation procedures.

<SV13/SV22 use>

	Type	Registration	Password
1	Motion SFC Program	*	*****
2	Servo Program	*	
3	Mechanical System Program		
4	Cam Data (Converted/Edit)		
5	Safety Monitoring Function Parameter		

<SV43 use>

	Type	Registration	Password
1	Motion Program	*	*****

Items	Details
Type	Type of user data
Registration	"*" is displayed when a password is registered in the Motion CPU.
Password	Enter old password. (Note-1): Make the item an empty column when a password is not registered.

POINT
<p>(1) Be sure to delete password when the Motion CPU is in STOP state. Deleting password when in RUN state may cause the Motion SFC program to operate incorrectly.</p> <p>(2) The password data is not saved in a project without project save. Be sure to save project.</p> <p>(3) If an operation stops by reset or power OFF of the Multiple CPU system while delete of password, the data may not be deleted. Delete a password again to restore the user data.</p>



## 4 AUXILIARY AND APPLIED FUNCTIONS

### (5) Password check

When operating the user data that sets password, the check password screen is displayed automatically.

Protection by the password temporarily released by success of password check. A password is memorized until MT Developer2 ends. (Since protection by password is automatically released temporarily at the user data operation, a check password screen is not displayed.)

Refer to the help of MT Developer2 for details of the operation procedure.

<SV13/SV22 use>

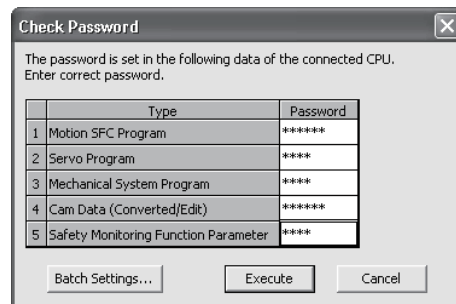

<SV43 use>



Items	Details
Type	Type of user data
Password	Enter old password.

## 4 AUXILIARY AND APPLIED FUNCTIONS

### (6) Password save

Registered/changed/deleted password or password read with user data from "Read from CPU" screen displayed by reading operation of the data can be saved in a project data.

A password saved in a project data can be registered with user data, when the user data are written in the Motion CPU that does not set password from "Write to CPU" screen displayed by menu [Online] → [Write to CPU].

Select menu [Project] → [Save] to save the updated password data in a project.

#### (a) Status of password data for each operation

Operation	Status of password data
Read	When a password is set in the call source Motion CPU, the password contents are called and the password data in a project are updated.
Write	When a password data is set in a project, if a password is not set in the write designation Motion CPU, the password contents are also written.
Verification	Password data in a project are not updated.
ROM writing	Password contents registered in the write designation Motion CPU are written in ROM.
Online change (SV13/SV22)	Password contents of write designation Motion CPU are not updated.
Backup	It is saved in backup data including also the password contents registered in the call source Motion CPU. The password data in a project is not updated.
Load	Password contents in backup data are written in the write designation Motion CPU.
Register/change password	New password contents are written in the write designation Motion CPU. Password data in a project is also updated to new password contents.
Delete password	A password is deleted from the write designation Motion CPU. A password is deleted also from the password data in a project.
Project diversion	The password data in diverting source project is not diverted.

#### POINT

- (1) The password data is not saved in a project without project save.
- (2) Save a project after delete of password to delete the password data in a project. Or, create a project without password data by creating new project and diverting user data from a project with password data.

4.5.2 Protection by software security key **QDS**

This function is used to protect the user data by setting the software security key to the project, operating system software, and MT Developer2 to limit the computer which operates the project and Motion CPU which runs the project.

The software security key is created in MT Developer2 and registered to the operating system software when the operating system software is installed to Motion CPU. It is also registered to the user program when the project is created.

The software security key verify is executed between MT Developer2 and Motion CPU during communication of the computer and Motion CPU. If the keys are not matched, the communication is not possible.

Only the enabled computer can communicate with Motion CPU. When the user data are leaked, copying and analyzing the data are prevented.

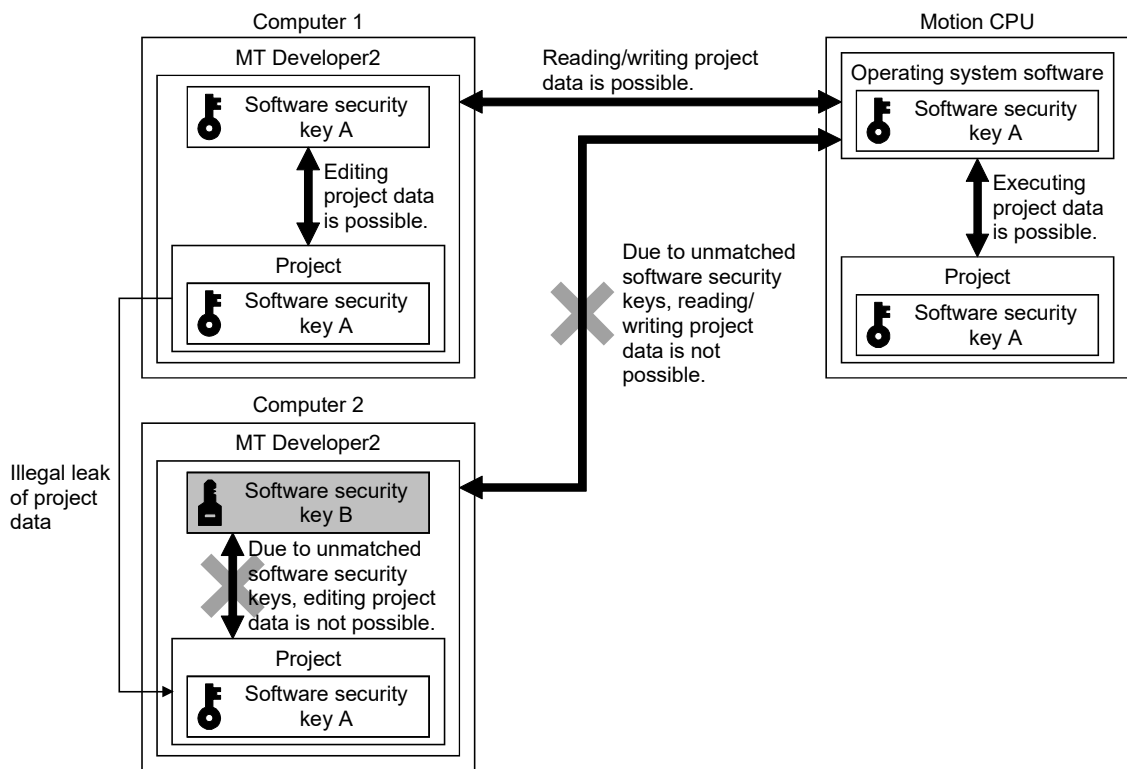

**POINT**  
 Even when the communication between MT Developer2 and Motion CPU is not possible due to the unmatched software security keys, monitoring and servo parameter reading/writing are possible in MR Configurator□.

**⚠ CAUTION**

- If the software security key set in the project data or operating system software cannot be imported to MT Developer2, the software security key cannot be released even in repair or maintenance, and the project data cannot be referred to permanently. Mitsubishi Electric Corporation cannot be held responsible for any damage which may occur as a result of not being able to refer to the project data for our customers or other individuals and organizations. Please be aware of this when using the software security key.

(1) Overview of software security key

The software security key is controlled with the software security key name. Eight software security key names can be registered to MT Developer2.

Key function level (Administrator/Developer/User) is set in the software security key, and some operations are restricted depending on the key function level.

The software security key can be exported/imported and used in computers other than the computer where it is created.

Key expiration date can be set when exporting the key. When the expiration date is expired, re-export/import the key since the communication with Motion CPU is not possible. (Even when the expiration date is expired, the operation of Motion CPU continues.)

The exported software security key cannot be imported and re-exported.

When replacing computers, delete the software security key from the project and Motion CPU and create the software security key again in the new computer.

The details of key function level are shown below.

Items	Details								
Software security key name	<ul style="list-style-type: none"> <li>• Set when creating the software security key.</li> <li>• Alphanumeric character of 16 or less (symbols such as "!" ' #\$\$%&amp;()+,- /;&lt;=&gt;?@[ ]^_`{ }~" and space can be also used.)</li> <li>• The characters are case-sensitive.</li> </ul>								
Key function level	<ul style="list-style-type: none"> <li>• Any of "Administrator", "Developer" or "User"</li> <li>• Set when exporting the software security key.</li> <li>• The level of newly created software security key is "Administrator".</li> </ul> <p data-bbox="679 1144 959 1167">&lt;Prohibited operation function&gt;</p> <table border="1" data-bbox="679 1167 1422 1563"> <thead> <tr> <th data-bbox="684 1173 863 1207">Key function level</th> <th data-bbox="863 1173 1417 1207">Prohibited operation function</th> </tr> </thead> <tbody> <tr> <td data-bbox="684 1207 863 1240">Administrator</td> <td data-bbox="863 1207 1417 1240">• None</td> </tr> <tr> <td data-bbox="684 1240 863 1274">Developer</td> <td data-bbox="863 1240 1417 1274">• Deleting the key from the project</td> </tr> <tr> <td data-bbox="684 1274 863 1556">User</td> <td data-bbox="863 1274 1417 1556"> <ul style="list-style-type: none"> <li>• Deleting the key from the project</li> <li>• External output of program data</li> <li>• Exporting the project verify</li> <li>• Copying data among projects of Motion SFC</li> <li>• Exporting cam data</li> <li>• Copying and exporting device comments</li> <li>• Exporting the servo program list</li> <li>• Printing project data</li> <li>• Saving sampling data of the digital oscilloscope (Note-1)</li> </ul> </td> </tr> </tbody> </table>	Key function level	Prohibited operation function	Administrator	• None	Developer	• Deleting the key from the project	User	<ul style="list-style-type: none"> <li>• Deleting the key from the project</li> <li>• External output of program data</li> <li>• Exporting the project verify</li> <li>• Copying data among projects of Motion SFC</li> <li>• Exporting cam data</li> <li>• Copying and exporting device comments</li> <li>• Exporting the servo program list</li> <li>• Printing project data</li> <li>• Saving sampling data of the digital oscilloscope (Note-1)</li> </ul>
Key function level	Prohibited operation function								
Administrator	• None								
Developer	• Deleting the key from the project								
User	<ul style="list-style-type: none"> <li>• Deleting the key from the project</li> <li>• External output of program data</li> <li>• Exporting the project verify</li> <li>• Copying data among projects of Motion SFC</li> <li>• Exporting cam data</li> <li>• Copying and exporting device comments</li> <li>• Exporting the servo program list</li> <li>• Printing project data</li> <li>• Saving sampling data of the digital oscilloscope (Note-1)</li> </ul>								
Key expiration date	<ul style="list-style-type: none"> <li>• "Not Specified" or the period from the date when the key is exported to the expiration date (1 to 365 days)</li> <li>• Set when exporting the software security key.</li> </ul>								

(Note-1): Enabled/disabled can be set for saving sampling data of the digital oscilloscope.

## 4 AUXILIARY AND APPLIED FUNCTIONS

### (2) Start-up procedure of software security key

The operation of software security key function is executed on the software security key management screen of MT Developer2.

Select the menu bar [Tools]-[Software Security Key Management].

Refer to the help of MT Developer2 for details of the operation procedures.

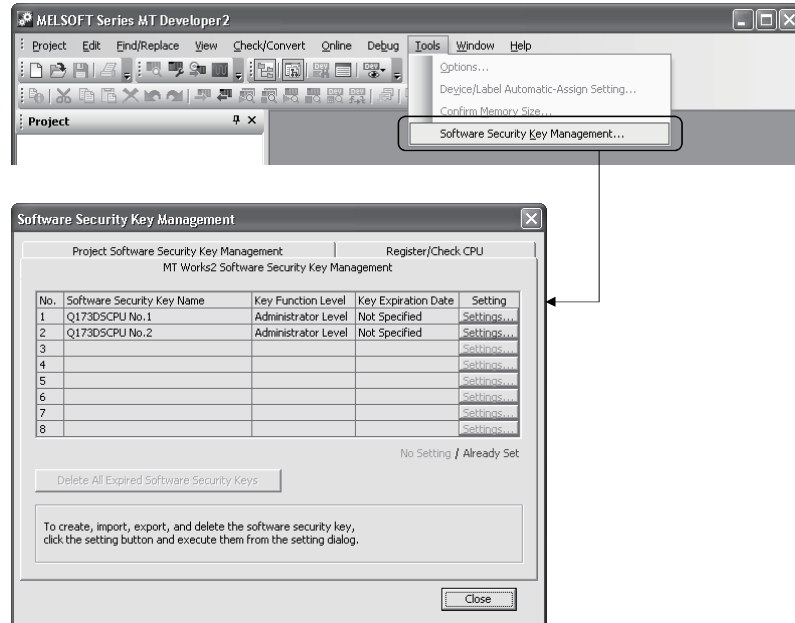

Operation details of software security key function are shown below

Items	Details
Software security key creation	Create the software security key in MT Developer2.
Software security key export	Write the software security key that can be used in MT Developer2 of other computers to the file.
Software security key import	Register the exported software security key to MT Developer2.
Software security key embedding (Installation of operating system software)	Embed the software security key to Motion CPU at installation of the operating system software.
Software security key embedding (Project)	Embed the software security key to the project.
Software security key delete (Delete from the project)	Delete the software security key from the project.
Software security key delete (Delete from MT Developer2)	Delete the software security key from MT Developer2.
Software security key information confirmation	Confirm the software security key information registered to the operating system software.

(3) Operating procedure of software security key function  
 (a) Using procedure of software security key

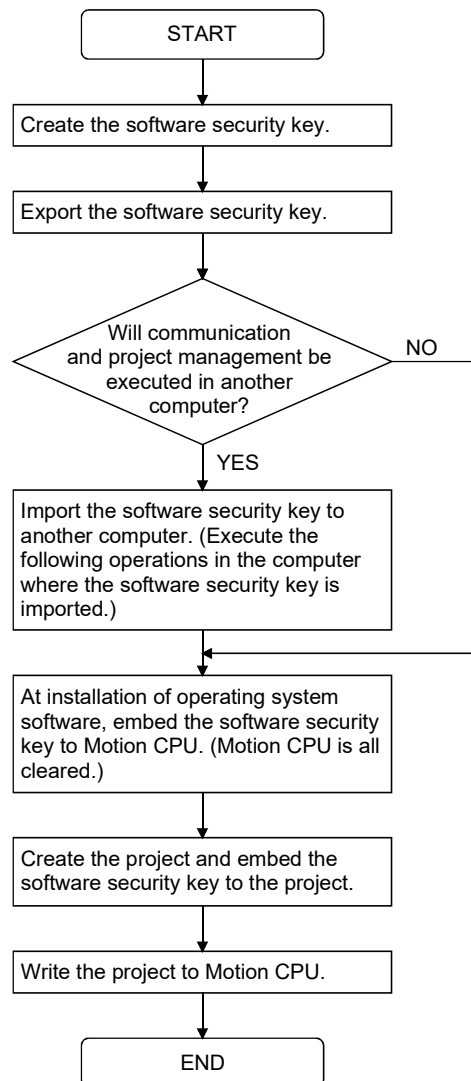

POINT
(1) Backup the exported data after exporting the software security key. Be sure to store the data in a safe place.
(2) If the software security key of the operating system software already installed in Motion CPU is different from that embedded to the operating system software to be installed, "Clear all" is executed at installation. It is recommended to backup the data in advance using MT Developer2. If the software security keys are matched, the programs, parameters and absolute position data that are written to Motion CPU are not re-written.

(b) Delete procedure of software security key

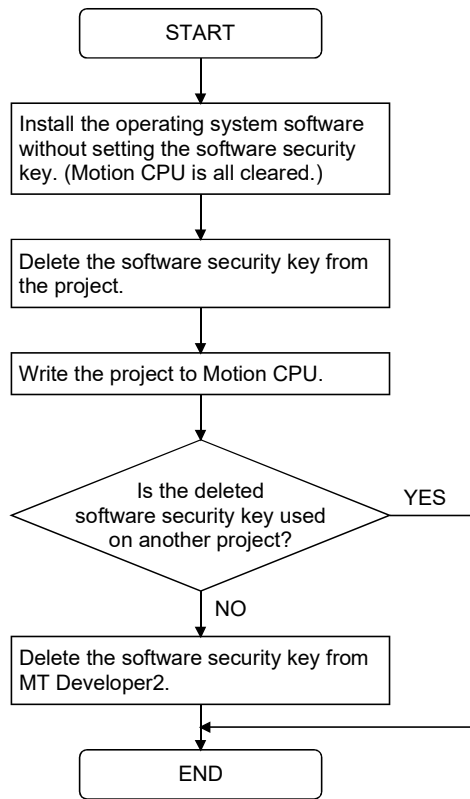

## 4 AUXILIARY AND APPLIED FUNCTIONS

### 4.6 All Clear Function

This function is used to clear the all user data, password setting, device memory, backup area and user data area of FLASH ROM in the Motion CPU module.

#### (1) Procedure for clear all

- (a) Set the Motion CPU module to installation mode (Set a rotary switch 1 (SW1) to "A".)
- (b) Execute the all clear.  
Select the menu bar [Online]-[Clear CPU Memory].

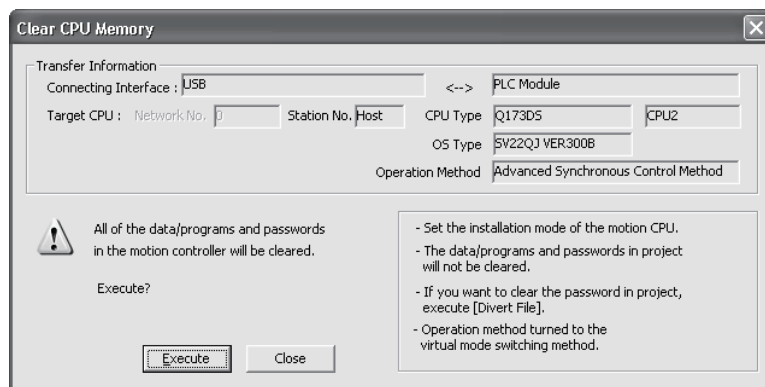

Refer to the help of MT Developer2 for details of the operation procedure.

#### POINT

- (1) Set the Motion CPU module to installation mode to clear all.  
Be sure to set a rotary switch after power supply OFF.
- (2) The user data area of FLASH ROM built-in Motion CPU module is also cleared.
- (3) All user data and password setting are cleared at the "Clear all".  
It is recommended to be backup them in advance using MT Developer2.
- (4) When all clear is executed for user data created by the operating system software type "SV22" of Q173DSCPU/Q172DSCPU, the operation method becomes "virtual mode switching method".



### 4.7 Communication Via Network

The communication between the personal computer and the Motion CPU is possible via Q series Network module (CC-LinkIE, CC-Link, MELSECNET/10(H), Ethernet and etc.) in the Motion CPU module.

Refer to the PLC manuals for the specifications of each network modules of CC-LinkIE, CC-Link, MELSECNET/10(H), Ethernet and Serial communication, the handling method.

#### 4.7.1 Specifications of the communications via network

- (1) Communications via network enables using MT Developer2 in the Motion CPU.
- (2) Access range of the communications via network of the Motion CPU is an access range equivalent to connection PLC CPU using GX Works2/GX Developer. Refer to the operating manual of GX Works2/GX Developer for details.
- (3) By setting the routing parameter to the control CPU of the network module and the CPU which connected the peripheral devices in the network by MELSECNET/10(H) and Ethernet, it is possible to relay to 8 network points and communicate.
- (4) Because the Motion CPU cannot become the control CPU of the network module, there is not setting item of the network module and network parameter. However, when connecting with the CPU on the other network from the peripheral device which connected the Motion CPU, it needs to the setting of the routing parameter.
- (5) It can operate by remote control the monitor or program editing of the Motion CPU via the intranet using the Ethernet module.

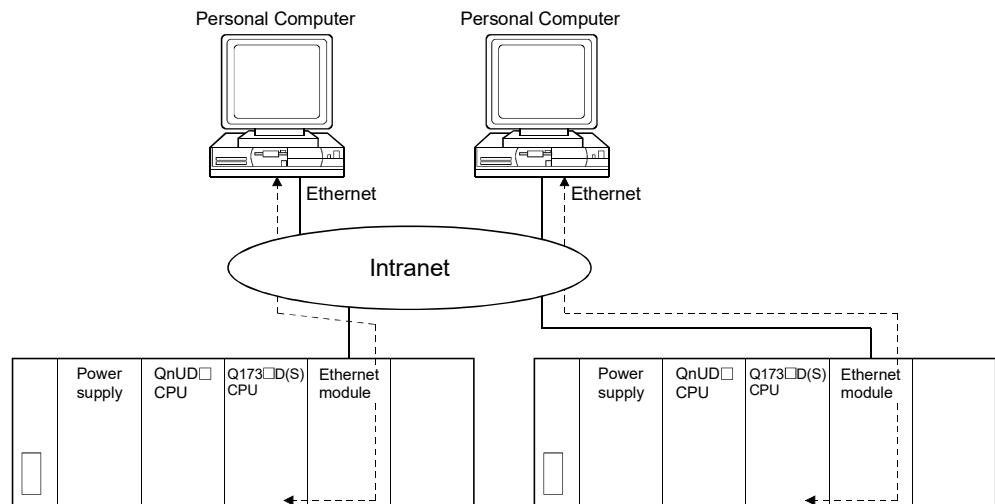

### 4.8 Monitor Function of the Main Cycle

- (1) Information for main cycle of the Motion CPU (process cycle executed at free time except for motion control) is stored to the special register.
- (2) Since the automatic refresh of CPU shared memory, normal task of Motion SFC program (SV13/SV22) and Motion program (SV43) are executed in the main cycle, make it reference for process time, etc. to program.
- (3) There are following methods to shorten a main cycle.
  - (a) Lengthen an operation cycle setting.
  - (b) Reduce the number of event task programs to execute in the Motion SFC program. (SV13/SV22)
  - (c) Reduce the number of normal task programs to execute simultaneously in the Motion SFC program. (SV13/SV22)
  - (d) Reduce the number of automatic refresh points of CPU shared memory.
  - (e) Reduce the number of Motion programs to execute simultaneously. (SV43)
- (4) When a main cycle is lengthened (more than 1.0[s]), a WDT error may occur in the Motion CPU.
- (5) Details of main cycle monitor register is shown below.

No.	Name	Meaning	Details
SD520	Scan time	Current scan time (1ms units)	<ul style="list-style-type: none"> <li>• Current scan time is stored in the unit 1[ms].</li> <li>• Range (0 to 65535[ms])</li> </ul>
SD521	Maximum scan time	Maximum scan time (1ms units)	<ul style="list-style-type: none"> <li>• Maximum main cycle is stored in the unit 1[ms].</li> <li>• Range (0 to 65535[ms])</li> </ul>

## 4 AUXILIARY AND APPLIED FUNCTIONS

### 4.9 Servo Parameter Read/Change Function

- (1) When the servo parameters are changed, the Motion CPU will be automatically read the servo parameters and reflected them to the servo parameter storage area in the Motion CPU. Therefore, an operation to read servo parameters is unnecessary in the following cases.
- (a) The parameters are changed by auto tuning.
  - (b) The parameters are changed by connecting directly MR Configurator□ to the servo amplifier.

#### POINT

If the power supply of Multiple CPU system is turned off/reset or the power supply of servo amplifier is turned off immediately after change, it may not be reflected.

- (2) After executing the servo parameter reading function, when it needs to reflect the servo parameters changed to the MT Developer2, read the servo parameters from the Motion CPU and save data.
- (3) The servo parameters of the axis specified from the Motion CPU can be changed or displayed individually. **QDS**
- Use the following special registers to change or display the servo parameter.
- (a) "Servo parameter write/read request" device

No.	Name	Meaning	Details	Set by
SD552	Servo parameter write/read request	Servo parameter read value	<ul style="list-style-type: none"> <li>• The read value of servo parameter which executed "2: 1 word read request" in SD804 is stored. (For MR-J5(W)-□B, the read value (low 1 word) of servo parameter is stored.)</li> <li>• The read value (low 1 word) of servo parameter which executed "4: 2 word read request" in SD804 is stored.</li> </ul>	System (At read request)
SD553			<ul style="list-style-type: none"> <li>• The read value (high 1 word) of servo parameter which executed "4: 2 word read request" in SD804 is stored.</li> </ul>	
SD804 (Note-1)		Servo parameter write/read request flag	<ul style="list-style-type: none"> <li>• The "write/read request" is executed after setting of the axis No. and servo parameter No. 1: 1 word write request 2: 1 word read request 3: 2 word write request (Note-2) 4: 2 word read request (Note-2)</li> <li>• "0" is automatically set by Motion CPU after completion of servo parameter write/read request. ("1" is stored by Motion CPU at write/read error.)</li> </ul>	
SD805		Axis No.	<ul style="list-style-type: none"> <li>• The axis No. to write/read servo parameter is stored. Q173DSCPU: 1 to 32 Q172DSCPU: 1 to 16</li> </ul>	User

## 4 AUXILIARY AND APPLIED FUNCTIONS

No.	Name	Meaning	Details	Set by
SD806	Servo parameter write/read request	Servo parameter No.	<ul style="list-style-type: none"> <li>The servo parameter No. to be written/read is stored in hexadecimal.</li> </ul> <div style="display: flex; align-items: center;"> <span style="margin-right: 5px;">H</span> <div style="display: flex; gap: 5px;"> <div style="border: 1px solid black; width: 20px; height: 20px; display: flex; align-items: center; justify-content: center;">□</div> <div style="border: 1px solid black; width: 20px; height: 20px; display: flex; align-items: center; justify-content: center;">□</div> <div style="border: 1px solid black; width: 20px; height: 20px; display: flex; align-items: center; justify-content: center;">□</div> <div style="border: 1px solid black; width: 20px; height: 20px; display: flex; align-items: center; justify-content: center;">□</div> </div> </div> <ul style="list-style-type: none"> <li>→ Parameter No.</li> <li>→ Parameter group No.               <ul style="list-style-type: none"> <li>• 0: PA      • 9: PO</li> <li>• 1: PB      • A: PS</li> <li>• 2: PC      • B: PL (MR-J5(W)-□B, MR-J4(W)-□B only)</li> <li>• 3: PD      • C: PT (MR-J4(W)-□B only)</li> <li>• 4: PE</li> <li>• 5: PF</li> </ul> </li> <li>→ Fixed at 0</li> </ul>	User
SD807		Servo parameter setting value	<ul style="list-style-type: none"> <li>The setting value of servo parameter to be written is stored when "1: 1 word write request" is set in SD804. (For MR-J5(W)-□B, the setting value (low 1 word) of servo parameter to be written is stored.)</li> </ul>	
SD808		Servo parameter setting value (2 word)	<ul style="list-style-type: none"> <li>The setting value of servo parameter to be written is stored when "3: 2 word write request" is set in SD804.</li> </ul>	
SD809				

(Note-1): Do not execute the automatic refresh.

(Note-2): This can be set only in MR-J5(W)-□B.

### (b) Procedure for servo parameter write

#### 1) 1 word write procedure

1. Set the axis No., servo parameter No. and servo parameter setting value in SD805 to SD807.

↓

2. Set "1: 1 word write request" in SD804.

↓

3. Check that "0" is set in SD804.

(Completion of write)

#### 2) 2 word write procedure

1. Set the axis No., servo parameter No. and servo parameter setting value in SD805, SD806, SD808, and SD809.

↓

2. Set "3: 2 word write request" in SD804.

↓

3. Check that "0" is set in SD804.

(Completion of write)

### (c) Procedure for servo parameter read

#### 1) 1 word read procedure

1. Set the axis No. and servo parameter No. in SD805 and SD806.

↓

2. Set "2: 1 word read request" in SD804.

↓

3. Check that "0" is set in SD804.

(Completion of read)

↓

4. Stores the read value in SD552

## 4 AUXILIARY AND APPLIED FUNCTIONS

---

- 2) 2 word read procedure
  1. Set the axis No. and servo parameter No. in SD805 and SD806.  
↓
  2. Set "4: 2 word read request" in SD804.  
↓
  3. Check that "0" is set in SD804.  
(Completion of read)  
↓
  4. Stores the read value in SD552 (low 1 word) and SD553 (high 1 word).

POINT
(1) New servo parameter is reflected to Motion CPU, therefore, the servo parameter of Motion CPU side does not need to change.
(2) When the axis No., servo parameter No. or servo parameter setting value is outside the setting range, "-1: write/read error" is stored in the servo parameter write/read request flag. The setting value of servo parameter is reflected to Motion CPU even when the write error occurred. Be sure to set within the setting range.

## 4 AUXILIARY AND APPLIED FUNCTIONS

### 4.10 Optional Data Monitor Function

The optional data monitor function stores the data in the servo amplifier in specified word devices and monitors the data.

#### (1) Optional data monitor setting

Set the data of MR-J5(W)-□B and MR-J4(W)-□B (setting 1 to 6 per axis), and MR-J3(W)-□B (setting 1 to 3 per axis).

It can be set by the system setting of MT Developer2.

No.	Item	Setting range
1	Setting 1 to 6	Data type
2		Storage device No.
		Refer to (a) of this section
		Word device (D, W, #, U□\G)

#### (a) Data type

##### 1) Q173DSCPU/Q172DSCPU use

Set the total of number of communication data points per 1 axis as shown below.

MR-J5(W)-□B and MR-J4(W)-□B: Up to 6 points

MR-J3(W)-□B: Up to 3 points

When setting an axis of servo amplifier (MR-J4-□B-RJ) selected as "101: Synchronous encoder via servo amplifier" by [Pr.320]

Synchronous encoder axis type, set the number of communication data points so that the total comes to 2 points or less per axis.

Data type	Unit	Number of words	Number of communication data points	Servo amplifier			Remark
				MR-J5(W)-□B	MR-J4(W)-□B	MR-J3(W)-□B	
Effective load ratio	[%]	1	1	○	○	○	
Regenerative load ratio	[%]	1	1	○	○	○	
Peak load ratio	[%]	1	1	○	○	○	
Position F/B	[pulse]	2	0	○ (Note-3)	○	○	
Encoder position within 1 revolution	[pulse]	2	0	○ (Note-3)	○	○	
Encoder multi-revolution counter	[rev]	1	0	○	○	○	
Load inertia moment ratio	[× 0.1]	1	1	○	○	○	Linear servo motor use
Load mass ratio							
Model loop gain	[rad/s]	1	1	○	○	○	
Bus voltage	[V]	1	1	○	○	○	
Cumulative current value	[Position command] (Note-1)	2	0	○	○	○	
Servo motor speed	[r/min]	1	1	○	○	○	Linear servo motor use
Servo motor speed	[mm/s]						
Selected droop pulse	[pulse]	2	2	○ (Note-3)	○	○	
Unit power consumption (Note-2)	[W]	1	1	○	○	×	

## 4 AUXILIARY AND APPLIED FUNCTIONS

Data type	Unit	Number of words	Number of communication data points	Servo amplifier			Remark
				MR-J5(W)-□B	MR-J4(W)-□B	MR-J3(W)-□B	
Unit total power consumption (Note-2)	[Wh]	2	2	○	○	×	
Instantaneous torque	[0.1%]	1	1	○	○	×	Linear servo motor use
Instantaneous thrust							
Load side encoder information1	[pulse]	2	2	○	○	○	Fully closed control or synchronous encoder via servo amplifier use
Load side encoder information2	—	2	2	○	○	○	
Z-phase counter	[pulse]	2	2	○	○	×	Linear servo motor use
Servo motor thermistor temperature	[°C]	1	1	○	○	○	
Torque equivalent to disturbance	[0.1%]	1	1	○	○	×	Linear servo motor use
Thrust equivalent to disturbance							
Overload alarm margin	[0.1%]	1	1	○	○	×	
Excessive error alarm margin	[16pulse]	1	1	○ (Note-3)	○	×	
Settling time	[ms]	1	1	○	○	×	
Overshoot amount	[pulse]	1	1	○ (Note-3)	○	×	
Servo motor/Load side position deviation	[pulse]	2	2	○ (Note-3)	○	×	Fully closed control use
Servo motor/Load side speed deviation	[0.01r/min]	2	2	○	○	×	
External encoder counter value	[pulse]	2	2	×	×	×	Stepping driver use
Internal temperature of encoder	[°C]	1	1	○	○	×	Software version C4 or later of MR-J4(W)-□B

○: Settable ×: Unsettable

(Note-1): The position command is command unit set in the servo data setting.

(Note-2): In the servo amplifier for multiple axes, the measured value of whole unit is monitored. When these values set to each axis of multi-axis servo amplifier, the same value can be monitored in each axis. Use the monitored value of not each axis but each module to calculate the module power consumption power consumption and unit integral power consumption of multiple modules.

(Note-3): For MR-J5(W)-□B, the value displayed is the value (command unit) multiplied by the reciprocal of the electronic gear ratio of the servo amplifier. By configuring the electronic gear settings to the servo amplifier's "Electronic gear numerator (PA06)" and "Electronic gear denominator (PA07)" servo parameters, the data becomes the same data as for MR-J4(W)-□B.

## 4 AUXILIARY AND APPLIED FUNCTIONS

### 2) Q173DCPU(-S1)/Q172DCPU(-S1) use

Data type	Unit	Number of words	Servo amplifier	Remark
			MR-J3(W)-□B	
Effective load ratio	[%]	1	<input type="radio"/>	
Regenerative load ratio	[%]	1	<input type="radio"/>	
Peak load ratio	[%]	1	<input type="radio"/>	
Position F/B	[pulse]	2	<input type="radio"/>	
Encoder position within 1 revolution	[pulse]	2	<input type="radio"/>	
Load inertia moment ratio	[× 0.1]	1	<input type="radio"/>	Linear servo motor use
Load mass ratio			<input type="radio"/>	
Model loop gain	[rad/s]	1	<input type="radio"/>	
Bus voltage	[V]	1	<input type="radio"/>	

○: Settable ×: Unsettable

#### (b) Storage device No.

Specify the word data to store monitor data.

Word device	Device that can be set
D	0 to 8191
W	0 to 1FFF
#	0 to 7999
U□\G	10000 to (10000+p-1) (Note-1), (Note-2)

(Note-1): "p" indicates the user setting area points of the Multiple CPU high speed transmission area for each CPU.

(Note-2): Only device of the self CPU can be used.

#### POINT

- (1) The updating cycle of data is every operation cycle.
- (2) Set an even numbered device No. in the two word data.
- (3) Refer to Chapter 2 for the user setting area points of the Multiple CPU high speed transmission area.



## 4 AUXILIARY AND APPLIED FUNCTIONS

### 4.11 SSCNET Control Function

The following controls are possible in the SSCNET control function.

Function	Application
Connect/disconnect of SSCNET communication	Temporarily connect/disconnect of SSCNET communication is executed during Multiple CPU system's power supply ON. This function is used to exchange the servo amplifiers or SSCNETⅢ cables.
Start/release of amplifier-less operation	Start/release of amplifier-less operation is requested. This function is used to confirm the operation without connection of the servo amplifier.

#### (1) Device list

Set the request in SSCNET control (command) (SD803), and the process status is stored in SSCNET control (status) (SD508).

##### (a) SSCNET control (status) devices

Device No.	Overview	Set by												
SD508	The execute status <sup>(Note)</sup> of the SSCNET control is stored.	System												
	<table border="1"> <thead> <tr> <th>Monitoring value</th> <th>Status</th> <th>Contents</th> </tr> </thead> <tbody> <tr> <td>0</td> <td>Command accept waiting</td> <td>Connect/disconnect command of SSCNET communication or start/release command of amplifier-less operation can be accepted.</td> </tr> <tr> <td>-1</td> <td>Execute waiting</td> <td>Waiting for connect/disconnect execute command after accepting the connect/disconnect command of SSCNET communication or start/release command of amplifier-less operation.</td> </tr> <tr> <td>-2</td> <td>Executing</td> <td>Connect/disconnect command of SSCNET communication or start/release command of amplifier-less operation is being executed.</td> </tr> </tbody> </table>		Monitoring value	Status	Contents	0	Command accept waiting	Connect/disconnect command of SSCNET communication or start/release command of amplifier-less operation can be accepted.	-1	Execute waiting	Waiting for connect/disconnect execute command after accepting the connect/disconnect command of SSCNET communication or start/release command of amplifier-less operation.	-2	Executing	Connect/disconnect command of SSCNET communication or start/release command of amplifier-less operation is being executed.
	Monitoring value		Status	Contents										
	0		Command accept waiting	Connect/disconnect command of SSCNET communication or start/release command of amplifier-less operation can be accepted.										
-1	Execute waiting	Waiting for connect/disconnect execute command after accepting the connect/disconnect command of SSCNET communication or start/release command of amplifier-less operation.												
-2	Executing	Connect/disconnect command of SSCNET communication or start/release command of amplifier-less operation is being executed.												

(Note): The status for amplifier-less operation status is set in the amplifier-less operation status flag (SM508). (Refer to Section 4.11.2.)

##### (b) SSCNET control (command) devices

Device No.	Overview	Set by																																								
SD803	Set the SSCNET control command.	User																																								
	<table border="1"> <thead> <tr> <th>Setting value</th> <th>Command</th> <th>Contents</th> <th>Connect/disconnect</th> <th>Amplifier-less operation</th> </tr> </thead> <tbody> <tr> <td>0</td> <td>No command</td> <td>Set "0" if there is no command.</td> <td>○</td> <td>○</td> </tr> <tr> <td>1 to 32</td> <td>Disconnect command of SSCNET communication</td> <td>Set axis No. "1 to 32" to be disconnected.</td> <td>○</td> <td></td> </tr> <tr> <td>-10</td> <td>Connect command of SSCNET communication</td> <td>Set "-10" to connect axis while disconnecting.</td> <td>○</td> <td></td> </tr> <tr> <td>-20</td> <td>Start command 1 of amplifier-less operation (EMI invalid)</td> <td>Set "-20" to change from the normal operation to amplifier-less operation. EMI signal is invalid during amplifier-less operation, and the wiring of EMI signal is not necessary.</td> <td></td> <td>○</td> </tr> <tr> <td>-21</td> <td>Start command 2 of amplifier-less operation (EMI valid)</td> <td>Set "-21" to change from the normal operation to amplifier-less operation. EMI signal is valid during amplifier-less operation, and the wiring of EMI signal is necessary.</td> <td></td> <td>○</td> </tr> <tr> <td>-25</td> <td>Release command of amplifier-less operation</td> <td>Set "-25" to change from the amplifier-less operation to normal operation.</td> <td></td> <td>○</td> </tr> <tr> <td>-2</td> <td>Execute command</td> <td>Set "-2" to execute the processing when the SSCNET control (status) (SD508) is execute waiting after setting the value of each command</td> <td>○</td> <td>○</td> </tr> </tbody> </table>		Setting value	Command	Contents	Connect/disconnect	Amplifier-less operation	0	No command	Set "0" if there is no command.	○	○	1 to 32	Disconnect command of SSCNET communication	Set axis No. "1 to 32" to be disconnected.	○		-10	Connect command of SSCNET communication	Set "-10" to connect axis while disconnecting.	○		-20	Start command 1 of amplifier-less operation (EMI invalid)	Set "-20" to change from the normal operation to amplifier-less operation. EMI signal is invalid during amplifier-less operation, and the wiring of EMI signal is not necessary.		○	-21	Start command 2 of amplifier-less operation (EMI valid)	Set "-21" to change from the normal operation to amplifier-less operation. EMI signal is valid during amplifier-less operation, and the wiring of EMI signal is necessary.		○	-25	Release command of amplifier-less operation	Set "-25" to change from the amplifier-less operation to normal operation.		○	-2	Execute command	Set "-2" to execute the processing when the SSCNET control (status) (SD508) is execute waiting after setting the value of each command	○	○
	Setting value		Command	Contents	Connect/disconnect	Amplifier-less operation																																				
	0		No command	Set "0" if there is no command.	○	○																																				
	1 to 32		Disconnect command of SSCNET communication	Set axis No. "1 to 32" to be disconnected.	○																																					
	-10		Connect command of SSCNET communication	Set "-10" to connect axis while disconnecting.	○																																					
	-20		Start command 1 of amplifier-less operation (EMI invalid)	Set "-20" to change from the normal operation to amplifier-less operation. EMI signal is invalid during amplifier-less operation, and the wiring of EMI signal is not necessary.		○																																				
	-21		Start command 2 of amplifier-less operation (EMI valid)	Set "-21" to change from the normal operation to amplifier-less operation. EMI signal is valid during amplifier-less operation, and the wiring of EMI signal is necessary.		○																																				
-25	Release command of amplifier-less operation	Set "-25" to change from the amplifier-less operation to normal operation.		○																																						
-2	Execute command	Set "-2" to execute the processing when the SSCNET control (status) (SD508) is execute waiting after setting the value of each command	○	○																																						

## 4 AUXILIARY AND APPLIED FUNCTIONS

---

### 4.11.1 Connect/disconnect function of SSCNET communication

Temporarily connect/disconnect of SSCNET communication is executed during Multiple CPU system's power supply ON.

This function is used to exchange the servo amplifiers or SSCNET III cables.

Set the request for the connect/disconnect of SSCNET communication in SSCNET control (command) (SD803), and the status for the command accept waiting or execute waiting is stored in SSCNET control (status) (SD508).

Use this device to connect the servo amplifiers disconnected by this function.

When the power supply module of head axis of each SSCNET line (servo amplifier connected directly to the Motion CPU module) turns OFF/ON, this function is not necessary.

POINT
(1) Servo amplifiers connected after the axis specified for SSCNET communication disconnect processing are also disconnected. Confirm the LED display of the servo amplifier for "AA" after completion of SSCNET communication disconnect processing. And then, turn OFF the servo amplifier's power supply.
(2) The SSCNET control (status) (SD508) only changes into the execute waiting status (-1) even if the disconnect command of SSCNET communication (1 to 32) or connect command of SSCNET communication (-10) is set in SSCNET control (command) (SD803). The actual processing is not executed. Set the execute command (-2) in SSCNET control (command) (SD803) to execute.
(3) When the disconnect command of SSCNET communication (1 to 32) is set to axis not disconnect, the SSCNET control (status) (SD508) returns the command accept waiting status (0) without entering the execute waiting status (-1).
(4) Operation failure may occur in some axes if the servo amplifier's power supply is turned OFF without using the disconnect function. Be sure to turn OFF the servo amplifier's power supply by the disconnect function.
(5) When the connect/disconnect command is executed to the axis allocated to B-axis and C-axis of MR-J5W-□B and MR-J4W-□B, or B-axis of MR-J3W-□B, it can be disconnected, however it cannot be reconnected. Execute the connect/disconnect command to the A-axis.
(6) Only the release command of amplifier-less operation can be accepted during amplifier-less operation. The connect/disconnect command cannot be accepted.
(7) If using the connect/disconnect function of SSCNET communication in a line used to perform driver communication, connection/disconnection is only possible at the first axis (the servo amplifier directly connected to Motion CPU). Refer to Section 4.16 for details.

## 4 AUXILIARY AND APPLIED FUNCTIONS

- (1) Procedure to connect/disconnect of SSCNET communication  
 Procedure to connect/disconnect at the exchange of servo amplifiers or SSCNETⅢ cables is shown below.

(a) Procedure to disconnect

- 1) Set the axis No. to disconnect in SD803. (Setting value: 1 to 32)
- ↓
- 2) Check that "-1: Execute waiting" is set in SD508.  
(Disconnect execute waiting)
- ↓
- 3) Set "-2: Execute command" in SD803.
- ↓
- 4) Check that "0: Command accept waiting" is set in SD508.  
(Completion of disconnection)
- ↓
- 5) Turn OFF the servo amplifier's power supply after checking the LED display "AA" of servo amplifier to be disconnected.

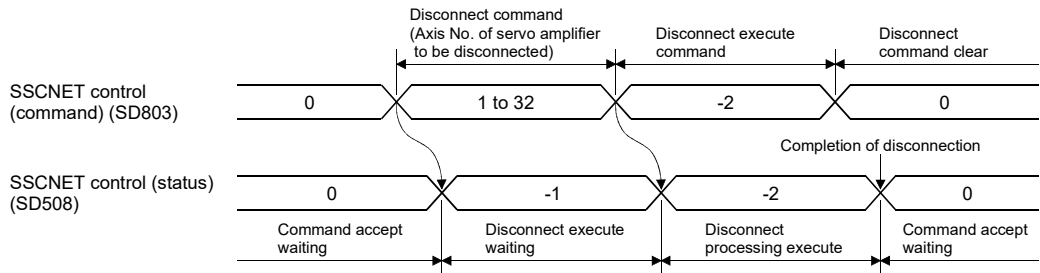

(b) Procedure to connect

- 1) Turn ON the servo amplifier's power supply.
- ↓
- 2) Set "-10: Connect command of SSCNET communication" in SD803.
- ↓
- 3) Check that "-1: Execute waiting" is set in SD508.  
(Connect execute waiting)
- ↓
- 4) Set "-2: Execute command" in SD803.
- ↓
- 5) Check that "0: Command accept waiting" is set in SD508.  
(Completion of connection)
- ↓
- 6) Resume operation of servo amplifier after checking the servo ready (M2415+20n) ON.

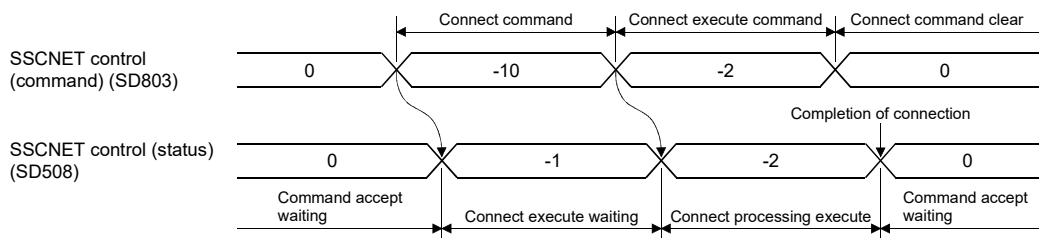

## 4 AUXILIARY AND APPLIED FUNCTIONS

### (2) Program

(a) Program to connect/disconnect the servo amplifiers after Axis 5 of self CPU

Disconnect procedure : Turn OFF the servo amplifier's control circuit power supply after checking the LED display "AA" of servo amplifier.

Connect procedure : Resume operation of servo amplifier after checking the servo ready (M2415+20n) ON.

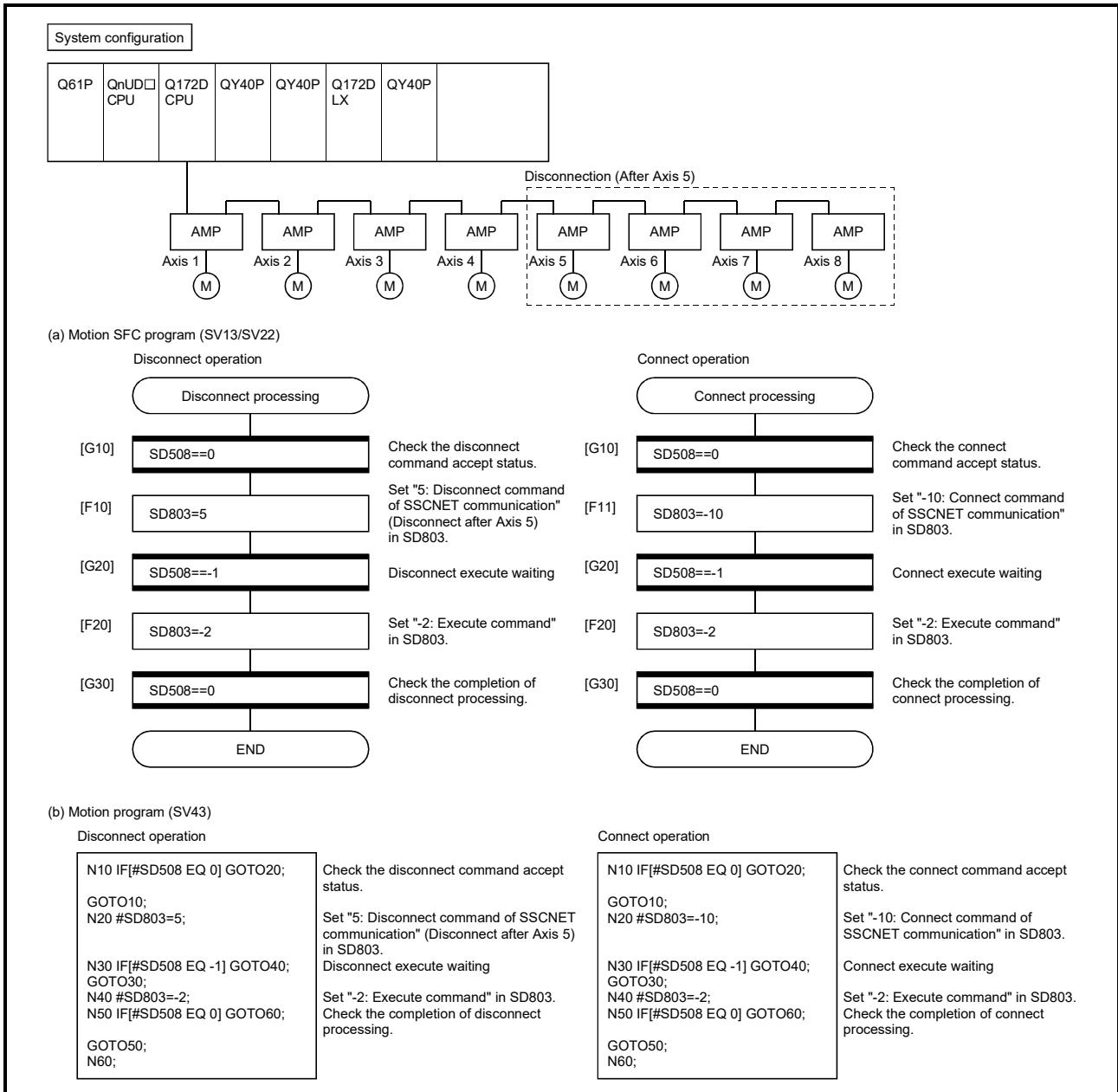

## 4 AUXILIARY AND APPLIED FUNCTIONS

- (b) Program to connect/disconnect the servo amplifiers after Axis 5 connected to the Motion CPU (CPU No.2) by the PLC CPU (CPU No.1).

Disconnect procedure : Turn OFF the servo amplifier's control circuit power supply after checking the LED display "AA" of servo amplifier by turning X0 from OFF to ON.

Connect procedure : Resume operation of servo amplifier after checking the servo ready (M2415+20n) of servo amplifier by turning X1 from OFF to ON.

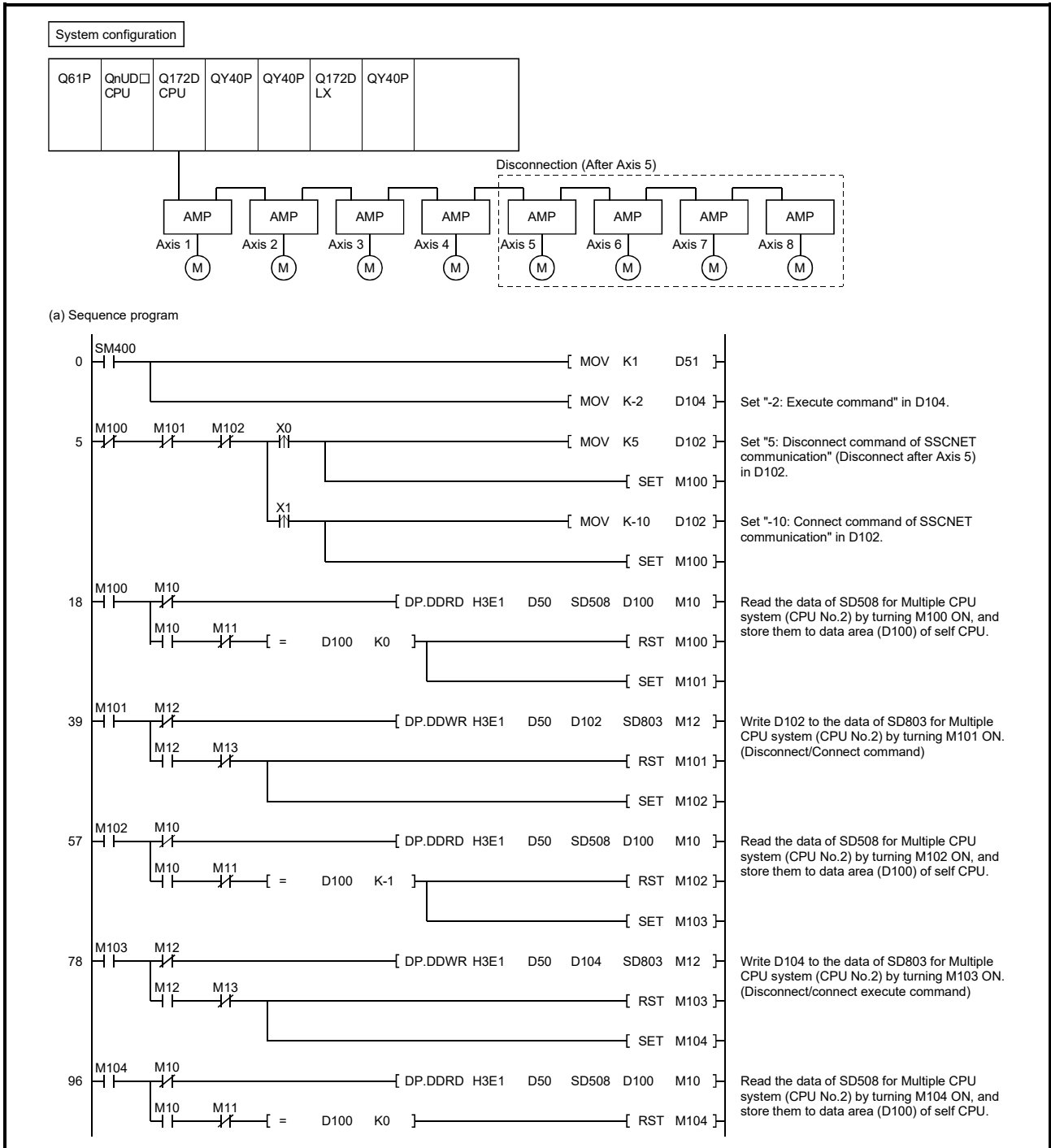

## 4 AUXILIARY AND APPLIED FUNCTIONS

### 4.11.2 Amplifier-less operation function **Ver.!**

This function is used to confirm for the operation without connecting the servo amplifiers at the starting or debugging.

The start/release request of amplifier-less operation is set in SSCNET control (command) (SD803), and status of the command accepting waiting or execute waiting is stored in SSCNET control (status) (SD508).

Confirm the amplifier-less operation status by the amplifier-less operation status (SM508).

POINT
(1) The SSCNET control (status) (SD508) only changes into the execute waiting status (-1) even if the start command of amplifier-less operation 1/2 (-20/-21) or release command of amplifier-less operation (-25) in SSCNET control (command) (SD803). The actual processing is not executed. Set the execute command (-2) in SSCNET control (command) (SD803) to executed.
(2) Only the release command of amplifier-less operation can be accepted during amplifier-less operation. The start command for the other amplifier-less operation cannot be accepted.
(3) The operation of servo motor or the timing of operation cycle, etc. at the amplifier-less operation is different from the case where the servo amplifiers are connected. Confirm the operation finally with a real machine.
(4) The amplifier-less operation becomes invalid immediately after the Multiple CPU system's power supply ON or reset.

#### (1) Amplifier-less operation status flag

Device No.	Signal name	Overview	Set by
SM508	Amplifier-less operation status flag	The amplifier-less operation status is stored. OFF : During normal operation ON : During amplifier-less operation	System

---

**Ver.!** : Refer to Section 1.5 for the software version that supports this function.

---

## 4 AUXILIARY AND APPLIED FUNCTIONS

### (2) Control details

Operation during amplifier-less operation is shown below.

Item	Operation
Servo amplifier type	<p>Depending on the details of the system settings, the following types can be connected.</p> <p>(1) Q173DSCPU/Q172DSCPU use</p> <p>(a) For communication type "SSCNETⅢ/H"</p> <p>1) When setting MR-J5-□B</p> <ul style="list-style-type: none"> <li>• Servo amplifier : MR-J5-10B</li> <li>• Servo motor : HK-KT053 (Note-1)</li> </ul> <p>2) When setting anything other than MR-J5-□B</p> <ul style="list-style-type: none"> <li>• Servo amplifier : MR-J4-10B</li> <li>• Servo motor : HG-KR053</li> </ul> <p>(b) For communication type "SSCNETⅢ"</p> <ul style="list-style-type: none"> <li>• Servo amplifier : MR-J3-10B</li> <li>• Servo motor : HF-KP053</li> </ul> <p>(2) Q173DCPU(-S1)/Q172DCPU(-S1) use</p> <ul style="list-style-type: none"> <li>• Servo amplifier : MR-J3-10B</li> <li>• Servo motor : HF-KP053</li> </ul>
Servo amplifier status	<ul style="list-style-type: none"> <li>• Deviation counter value : Always 0</li> <li>• Motor speed : Motor speed for the command</li> <li>• Motor current value : At the amplifier-less operation start: "0" (The motor current value can be simulated during amplifier-less operation by changing the motor current value (#8001+20n) using the user program.)</li> <li>• Servo ready signal : This signal changes depending on the status of all axes servo ON command (M2042) or servo OFF command (M3215+20n).</li> <li>• Torque limiting signal : This signal turns ON by the following condition.  Motor current value  ≥ Torque limit value (Note): When the positive direction and negative direction of torque limit value is set individually using CHGT2 instruction is as follows. <b>QDS</b>  Motor current value  ≥ Positive direction torque limit or Negative direction torque limit value</li> <li>• Zero pass signal : Always ON</li> </ul>
Servo amplifier external signal (At the setting valid)	<p>Each signals is shown below at the amplifier-less operation start.</p> <p>(1) Q173DSCPU/Q172DSCPU use</p> <ul style="list-style-type: none"> <li>• FLS signal (M2411+20n) : Normal open: OFF/Normal close: ON</li> <li>• RLS signal (M2412+20n) : Normal open: OFF/Normal close: ON</li> <li>• DOG/CHANGE signal (M2414+20n) : Normal open: OFF/Normal close: ON</li> </ul> <p>(2) Q173DCPU(-S1)/Q172DCPU(-S1) use</p> <ul style="list-style-type: none"> <li>• FLS signal (M2411+20n) : ON</li> <li>• RLS signal (M2412+20n) : ON</li> <li>• DOG/CHANGE signal (M2414+20n) : OFF</li> </ul> <p>The servo amplifier external signals can be operated during amplifier-less operation by turning ON/OFF the FLS signal (M2411+20n), RLS signal (M2412+20n) or DOG/CHANGE signal (M2414+20n) using the user program.</p>
Home position return	All home position return methods can be used.
Absolute position system	<p>The absolute position is controlled as the normal servo amplifier connection.</p> <p>(1) At the amplifier-less operation start The absolute position is restored by the saved absolute position data. The absolute position is restored as the travel value "0" during the servo amplifier's power supply OFF.</p> <p>(2) During amplifier-less operation Suppose the servo motor operated during amplifier-less operation, and the absolute position data is refreshed.</p> <p>(3) The servo amplifiers are connected after amplifier-less operation The absolute position is restored by the refreshed absolute position data during amplifier-less operation. When the distance between the motor position of saved absolute position data and actual motor position is the allowable travel during Power-Off or more away, the minor error (Error code: 901 (real mode)/9010 (virtual mode)) will occur. If the distance is "±2147483648[pulse]" or more away, the absolute position is restored normally.</p>
Operation using MR Configurator□	Online operation and monitor of the servo amplifiers cannot be executed.

## 4 AUXILIARY AND APPLIED FUNCTIONS

Item	Operation
Optional data monitor	Only "position F/B" and "encoder position within 1 revolution" are possible. The other monitor values are "0".
Driver communication	Cannot change to amplifier-less operation when connected and not connected servo amplifier axes are mixed. Change to amplifier-less operation when all axes are connected, or disconnect all axes of the servo amplifier.
SSCNETⅢ/H head module	The module is disconnected during amplifier-less operation.

(Note-1): The servo motor encoder resolution operates at 4194304[pulse/rev].

### (3) Procedure to start/release of amplifier-less operation

#### (a) Procedure to start

1) Set "-20: Start command 1 of amplifier-less operation (EMI invalid)" in SD803.

↓

2) Check that "-1: Execute waiting" is set in SD508.  
(Start processing execute waiting of amplifier-less operation)

↓

3) Set "-2: Execute command" in SD803.

↓

4) Check that "0: Command accept waiting" is set in SD508.  
(Start processing completion of amplifier-less operation)

↓

5) Check that "ON: During amplifier-less operation" is set in SM508.  
Resume operation of servo amplifier after checking the servo ready (M2415+20n) ON.

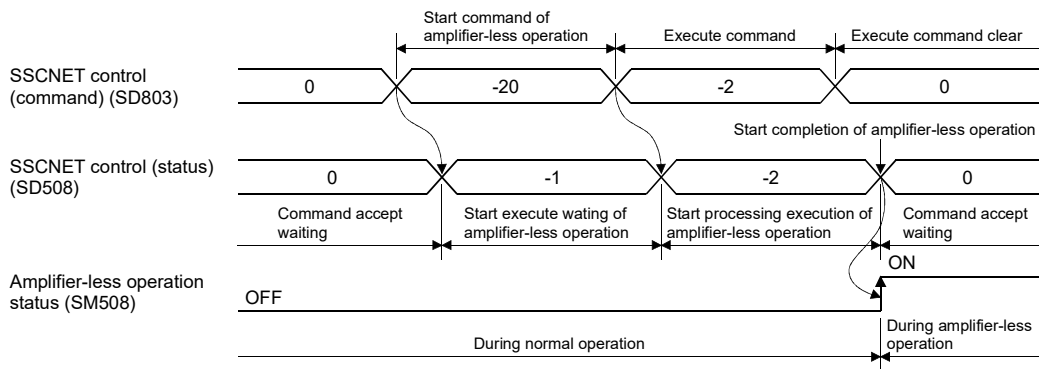



## 4 AUXILIARY AND APPLIED FUNCTIONS

### (b) Procedure to release

- 1) Set "-25: Release command of amplifier-less operation" in SD803.
- ↓
- 2) Check that "-1: Execute waiting" is set in SD508.  
(Release processing execute waiting of amplifier-less operation)
- ↓
- 3) Set "-2: Execute command" in SD803.
- ↓
- 4) Check that "0: Command accept waiting" is set in SD508.
- ↓
- 5) Check that "OFF: During normal operation" is set in SM508.  
(Release processing completion of amplifier-less operation. When the servo amplifiers are connected, they are automatically reconnected.)

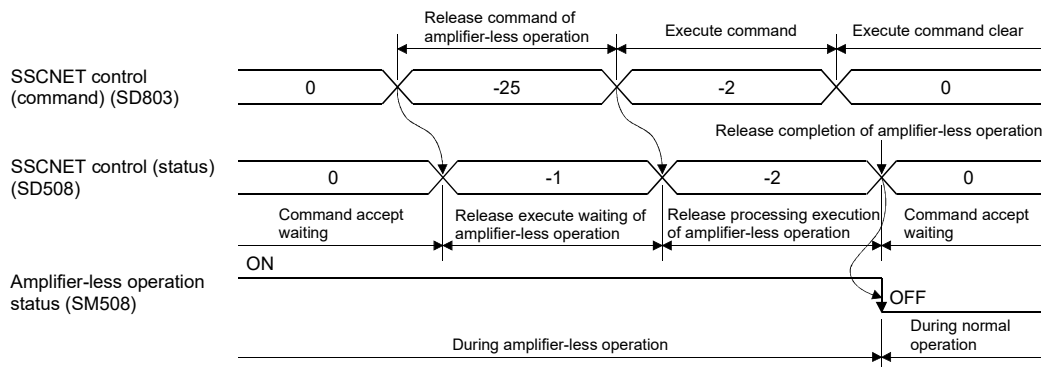

### (4) Program

Program to start/release of amplifier-less operation for the self CPU

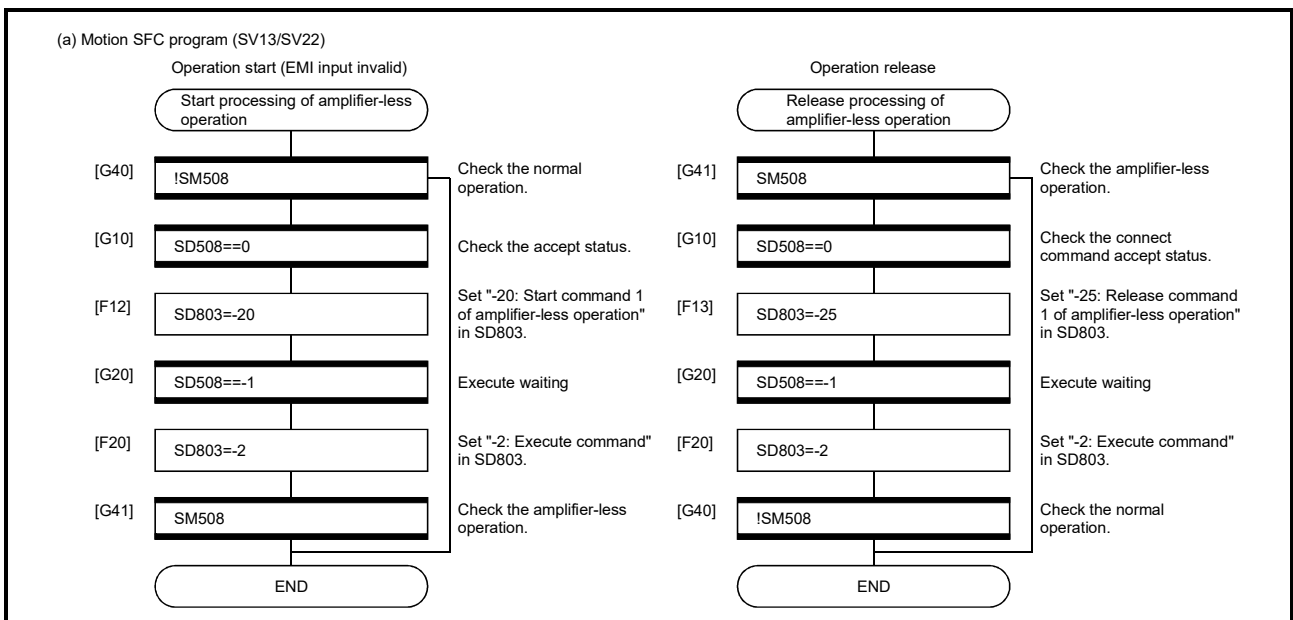

## 4 AUXILIARY AND APPLIED FUNCTIONS

### 4.12 Remote Operation

This function is used to control the following operation of Motion CPU using MT Developer2.

- Remote RUN/STOP
- Remote latch clear

#### POINT

Latch clear can be executed only using the remote control of MT Developer2.

#### 4.12.1 Remote RUN/STOP

The PLC ready flag (M2000) is turned ON/OFF using MT Developer2 with RUN/STOP switch of Motion CPU module set to RUN.

##### (1) Operation procedure

Select [RUN] or [STOP] on "CPU remote operation" screen displayed by menu [Online] – [Remote Operation], and click [Execute] button.

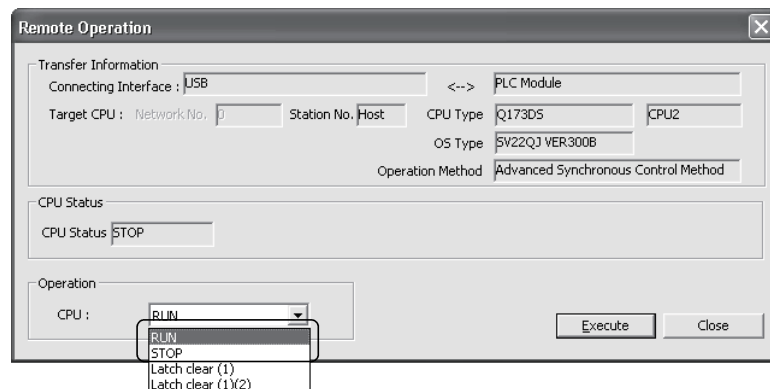

Refer to the help of MT Developer2 for details of the operation procedure.

**POINT**

(1) Remote RUN cannot be executed if RUN/STOP switch sets to STOP.  
 Operation after remote operation by RUN/STOP switch is shown below.

		Position of RUN/STOP switch	
		RUN	STOP
Remote operation	Execute remote RUN	RUN	STOP
	Execute remote STOP	STOP	STOP

(2) The following parameters are read by turning on the PLC ready flag (M2000).

- Fixed parameter
- Home position return data
- JOG operation data
- Parameter block
- Work coordinate data (SV43)
- Servo parameter
- Mechanical system program (SV22 virtual mode)
- Motion SFC parameter (SV13/SV22)
- Motion parameter (SV43)
- Limit switch output data
- Cam data (SV22 advanced synchronous control)

**REMARK**

The PLC ready flag (M2000) can also be turned ON/OFF (PCPU READY complete flag (SM500) ON/OFF) in the following methods.

- RUN/STOP switch change
- PLC ready flag (M2000) ON/OFF

## 4 AUXILIARY AND APPLIED FUNCTIONS

### 4.12.2 Remote latch clear

Device data of Motion CPU that latched are cleared by MT Developer2 at PLC ready flag (M2000) OFF (PCPU READY complete flag (SM500) OFF). Operation for remote latch clear is combined with remote RUN/STOP.

- (1) Operation procedure
  - (a) Turn OFF the PLC ready flag (M2000) (PCPU READY complete flag (SM500) OFF) by remote STOP.
  - (b) Select [Latch clear (1)] or [Latch clear (1)(2)] on "CPU remote operation" screen displayed by menu [Online] – [Remote Operation], and click [Execute] button.

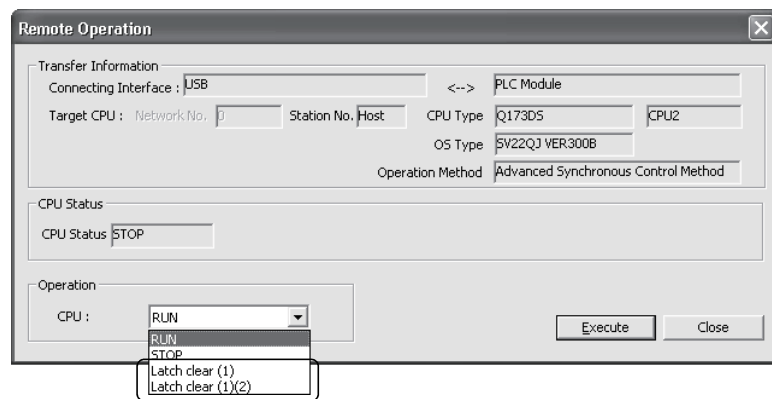

(Note): Execute remote RUN to turn ON the PLC ready flag (M2000) after remote latch clear.

Refer to the help of MT Developer2 for details of the operation procedure.

#### POINT

- (1) Remote latch clear cannot be operated while the PLC ready flag (M2000) is ON (PCPU READY complete flag (SM500) is ON) or test mode.
- (2) The following latch area are cleared in the remote latch clear operation.
  - Latch clear (1) : Clear the range set in latch area (1)
  - Latch clear (1)(2) : Clear the range set in latch area (1) and (2)
- (3) The user area (#0 to #7999) of motion device are also cleared by executing remote latch clear.
- (4) All of the user device not latched are cleared by the remote latch clear operation of latch area (1) and (2).
- (5) Set the range of latch area (1) and (2) in the system basic setting of system setting. (Refer to Section 3.1.3.)

## 4 AUXILIARY AND APPLIED FUNCTIONS

### 4.13 Communication Function via PERIPHERAL I/F **Ver.!**

The built-in Ethernet Motion CPU (Q173DSCPU /Q172DSCPU/Q173DCPU-S1/ Q172DCPU-S1) can communicate data by connecting built-in PERIPHERAL I/F of the Motion CPU with personal computers and/or display devices, etc. using an Ethernet cable.

There are following three ways to communicate between the Motion CPU and MT Developer2.

- "Direct connection" connected with the Ethernet cable
- "Connection via HUB" connected via HUB
- MC protocol communication

#### POINT

- (1) When using PERIPHERAL I/F for connecting and communication with the Motion CPU cannot be established, perform SRAM clear with the rotary switch. When SRAM clear is performed with the rotary switch, all user data is erased therefore backup data with MT Developer2 as necessary. Refer to "Q173D(S)CPU/Q172D(S)CPU Motion controller User's Manual" for details of SRAM clear.
- (2) The Motion CPU does not support SLMP. PERIPHERAL I/F cannot be used for SLMP communication.

#### 4.13.1 Direct connection

Between the Motion CPU and MT Developer2 can be connected using one Ethernet cable without HUB.

The direct connection enables communication with only specifying connection target. IP address setting is not required.

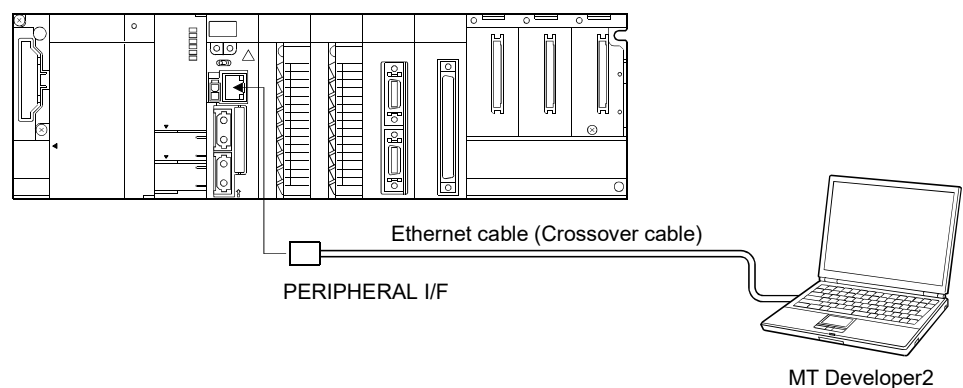

**Ver.!**: Refer to Section 1.5 for the software version that supports this function.

## 4 AUXILIARY AND APPLIED FUNCTIONS

### (1) Communication setting in MT Developer2 side

Set the items on the Transfer Setup screen in MT Developer2 as shown below.

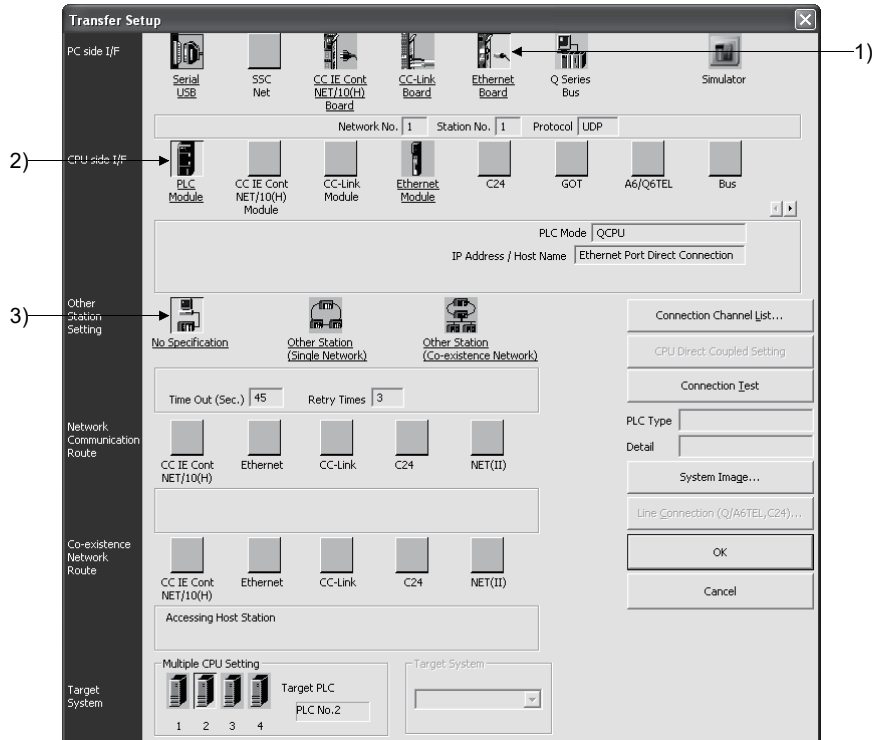

1) Select [Ethernet Board] for PC side I/F.

2) Select [PLC Module] for CPU side I/F.

Select the "Ethernet Port Direct Connection" on the CPU side I/F Detailed Setting of PLC Module screen.

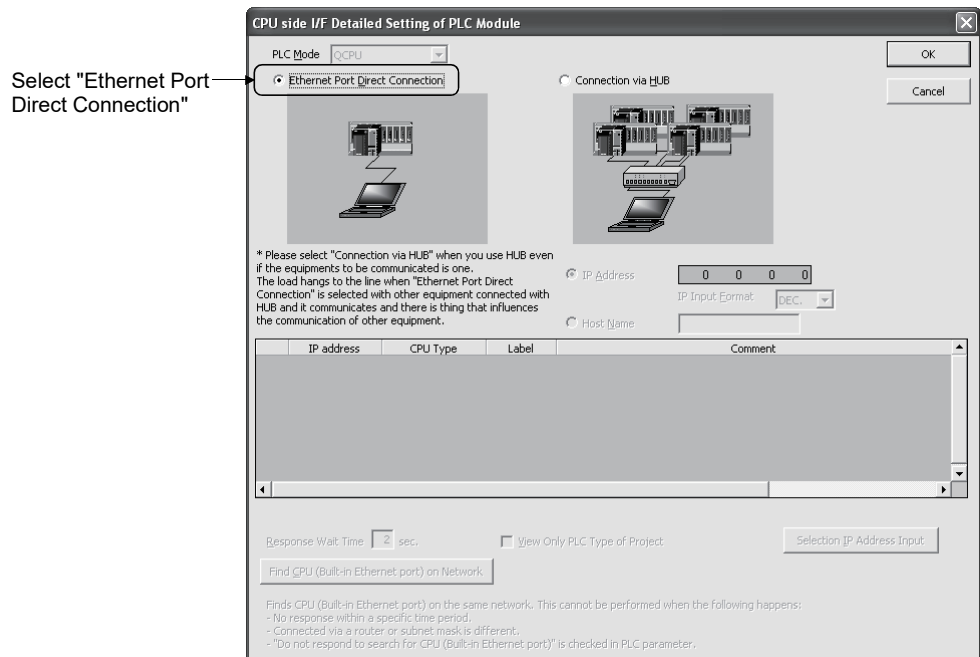

3) Make the setting for Other Station Setting.

Select it according to the operating environment.

### (2) Precautions

Precautions for direct connection are shown below.

#### (a) Connection to LAN line

When the Motion CPU is connected to LAN line, do not perform communication using direct connection. If performed, the communication may put a load to LAN line and adversely affect communications of other devices.

#### (b) Connection not connected directly

- The system configuration that connects a Motion CPU with an external device using a hub as shown below is not regarded as direct connection.

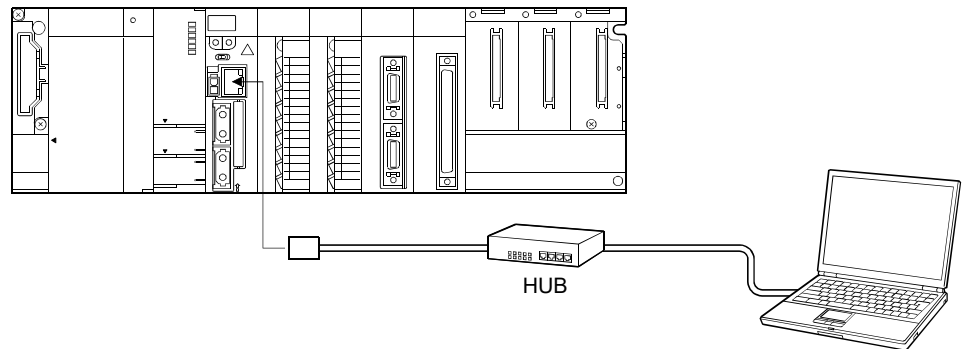

- When two or more Ethernet ports are enabled in the network connections setting on the personal computer, communication by direct connection is not possible. In the setting, leave only one Ethernet port enabled for direct connection and disable the other Ethernet ports.

#### (c) Condition in which direct connection communication may not be available

Under the following conditions, direct connection communication may not be available. In that case, check the setting of the Motion CPU and/or personal computer.

- In the Motion CPU IP address, bits corresponding to "0" in the personal computer subnet mask are all ON or all OFF.

(Example) Motion CPU IP address : 64. 64. 255. 255  
Personal computer IP address : 64. 64. 1. 1  
Personal computer subnet mask : 255.255. 0. 0

- In the Motion CPU IP address, bits corresponding to the host address for each class in the personal computer IP address are all ON or all OFF.

(Example) Motion CPU IP address : 64. 64. 255. 255  
Personal computer IP address : 192.168. 0. 1  
Personal computer subnet mask : 255. 0. 0. 0

## 4 AUXILIARY AND APPLIED FUNCTIONS

### 4.13.2 Connection via HUB

Between the Motion CPU and MT Developer2 can be connected via HUB.

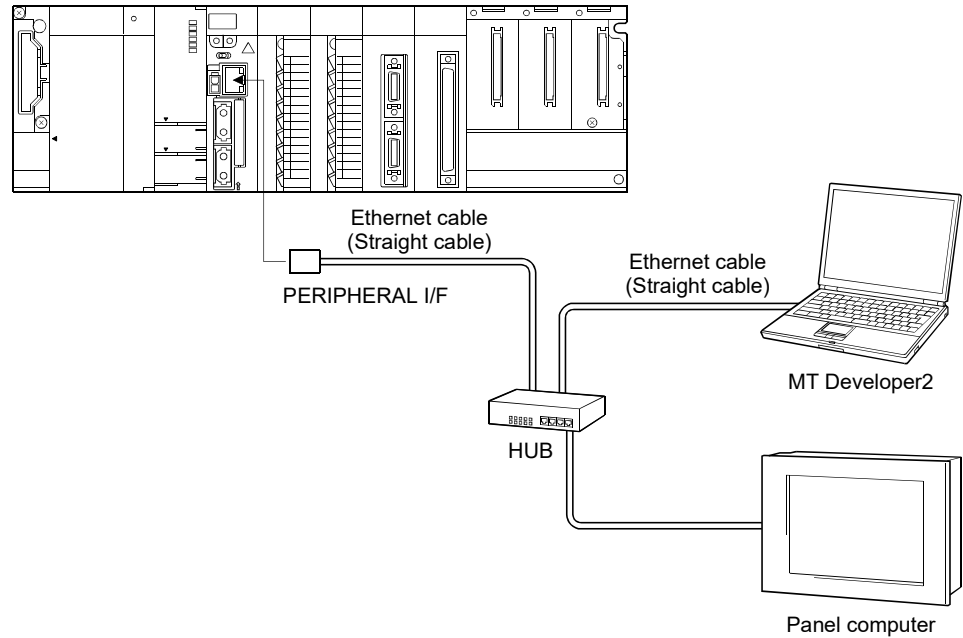

#### (1) Setting in Motion CPU side

Set the items on the Built-in Ethernet Port Setting in Basic Setting as shown below.

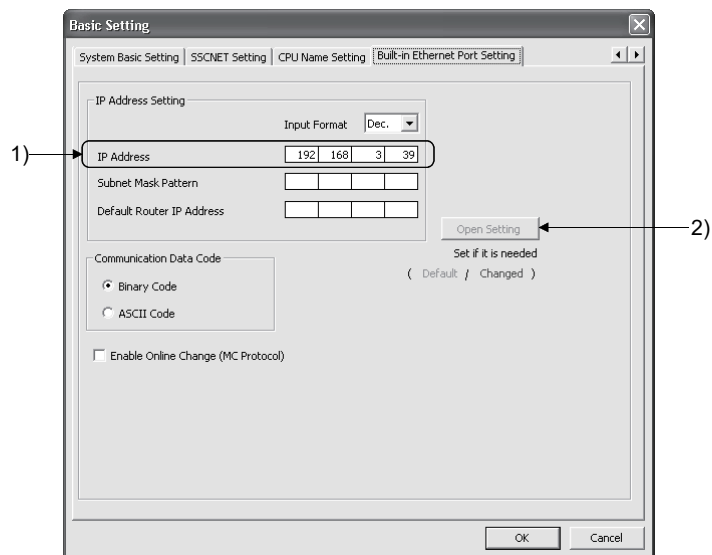

- 1) Set the Motion CPU IP address.  
(Default IP address: 192.168.3.39)  
Change the IP address if required.  
No need to set "Subnet Mask Pattern" and "Default Router IP Address".



## 4 AUXILIARY AND APPLIED FUNCTIONS

---

- 2) Select the protocol ("TCP" or "UDP") to be used, in accordance with the external device on the Built-in Ethernet Port Open Setting screen. Select "TCP" to emphasize communication reliability.

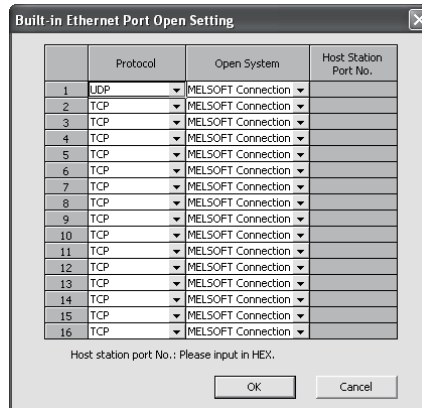

- Enabling the parameters of Motion CPU  
Using Ethernet direct connection or USB/RS-232 connection, write the settings in parameter to the Motion CPU by selecting [Online] - [Write to CPU] in MT Developer2. After writing the parameter settings, power the Multiple CPU system OFF to ON or reset using the RUN/STOP/RESET switch so that the parameters become valid.

Connect directly with an Ethernet cable (crossover cable) between the personal computer and Motion CPU to write the parameters using the Ethernet cable. Refer to Section 4.13.1 for details.

## 4 AUXILIARY AND APPLIED FUNCTIONS

### (2) Communication setting in MT Developer2 side

Set the items on the Transfer Setup screen in MT Developer2 as shown below.

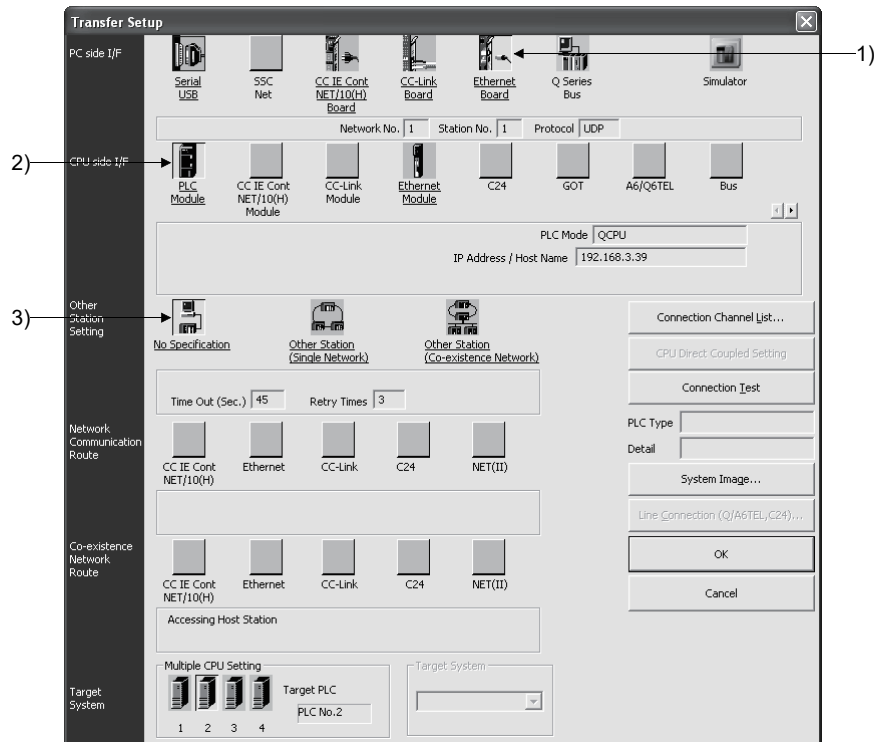

1) Select [Ethernet Board] for PC side I/F.

2) Select [PLC Module] for CPU side I/F.

Select the "Connection via HUB" on the CPU side I/F Detailed Setting of PLC Module screen, and set the Motion CPU IP address.

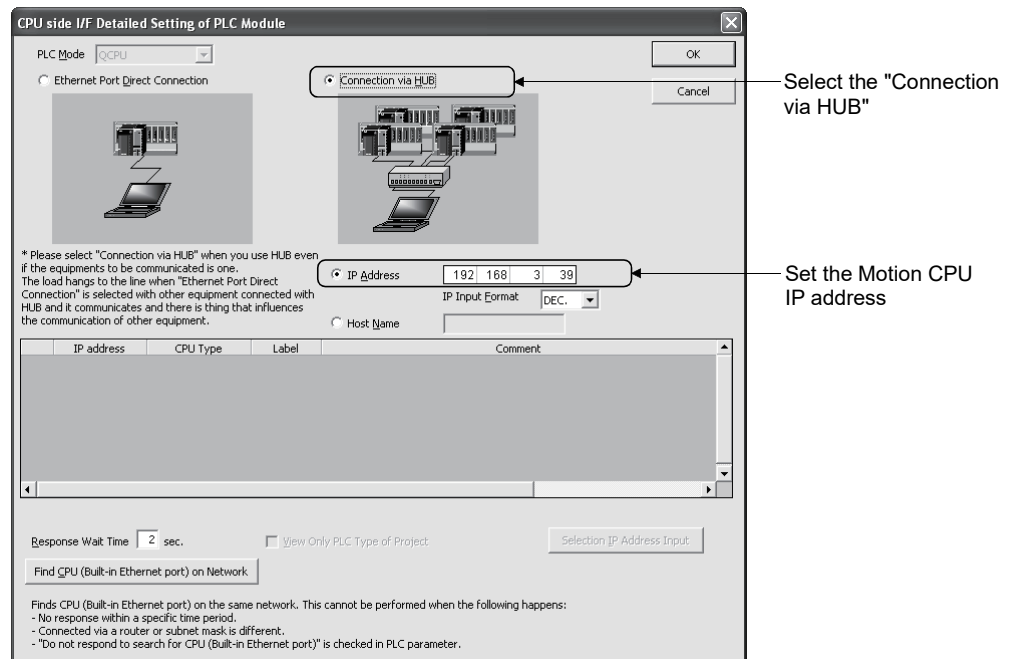

3) Make the setting for Other Station Setting.

Select it according to the operating environment.

**POINT**

The Find CPU function can be used for specifying the IP address for Motion CPU side in the connection via HUB.

This function can be activated in [Find CPU (Built-in Ethernet port) on Network] of CPU side I/F Detailed Setting of PLC Module screen, finds the Motion CPU connected to the same HUB as MT Developer2, and displays a list. Select the connecting Motion CPU and click [Select IP Address Input] button to set the IP address for Motion CPU side.

Found Motion CPU is displayed.

[Selection IP Address Input] button

[Find CPU (Built-in Ethernet port) on Network] button

	IP address	CPU Type	Label	Comment
1	192.168.3.39	Q173D5CPU	CPU-01	Q173D5CPU-S1 No1
1	192.168.3.40	Q173D5CPU	CPU-02	Q173D5CPU-S1 No2
1	192.168.3.41	Q172D5CPU	CPU-03	Q172D5CPU-S1 No3

- Set the label and comment of the Motion CPU in [CPU Name Setting] of Basic Setting. The label and comment set in [CPU Name Setting] are displayed on the CPU side I/F Detailed Setting of PLC Module screen.

Item	Description	Setting range
Label	Enter a label (name and/or purpose) of the Motion CPU.	Up to 10 characters
Comment	Enter comments regarding the Motion CPU.	Up to 64 characters

## 4 AUXILIARY AND APPLIED FUNCTIONS

### (3) Precautions

Precautions for connection via HUB are shown below.

- (a) When the personal computer that can connect to LAN line is used, set the same value for Motion CPU IP address as the following personal computer IP address.

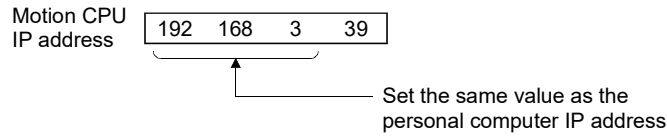

(Example) Personal computer IP address: "192.168.3.1"

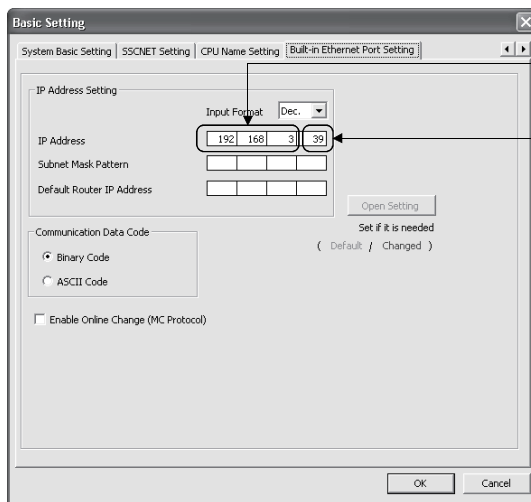
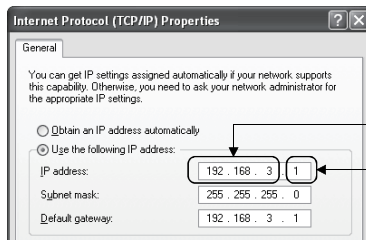

<Setting for Motion CPU side>

Set the same value as the personal computer IP address.  
(Example) 192.168.3.□

Set the IP address not used with devices connected to network.  
(Example) □.□.□.39

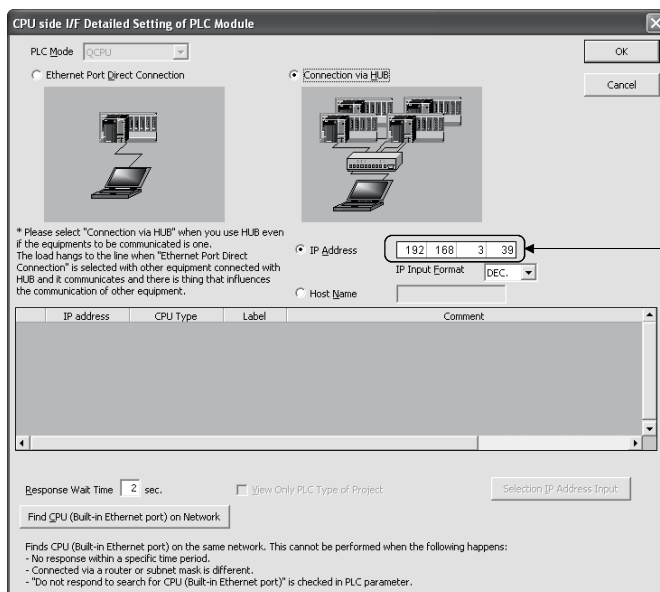

<Setting for MT Developer2 side>

Set the same value as the Motion CPU IP address.  
(Example) 192.168.3.39

## 4 AUXILIARY AND APPLIED FUNCTIONS

---

- (b) The maximum number of devices that can access to one Motion CPU simultaneously is 16.
- (c) Hubs with 10BASE-T or 100BASE-TX ports can be used.  
(The ports must comply with the IEEE802.3 100BASE-TX or IEEE802.3 10BASE-T standards.)
- (d) The Ethernet cables must to be installed away from power cabling/lines.
- (e) The module operation is not guaranteed if any of the following connection is used. Check the module operation on the user side.
  - Connections using the Internet (general public line)
  - Connections using devices in which a firewall is installed
  - Connections using broadband routers
  - Connections using wireless LAN
- (f) When multiple Motion CPUs are connected to MT Developer2, beware of the below cautions:
  - IP addresses must be different for each Motion CPU.
  - Different projects must be used for each Motion CPUs on MT Developer2.

## 4 AUXILIARY AND APPLIED FUNCTIONS

### 4.13.3 MC protocol communication

PERIPHERAL I/F of the Motion CPU enables communication using the MC protocol (Note-1).

External devices such as personal computers and display devices read/write device data from/to the Motion CPU using the MC protocol.

External devices monitor the operation of the Motion CPU, analyze data, and manage production by reading/writing device data.

#### REMARK

(Note-1): The MC protocol is an abbreviation for the MELSEC communication protocol.

The MELSEC communication protocol is a name of the communication method used to access CPU modules from external devices in accordance with the communication procedure of Q-series programmable controllers (such as serial communication modules, Ethernet modules).

For details on the MC protocol, refer to the "MELSEC-Q/L Communication Protocol Reference Manual".

#### POINT

Only the Motion CPU, and other CPUs in a Multiple CPU system can be communicated with from external devices such as personal computers and display devices by using the PERIPHERAL I/F for MC protocol communication. Accessing CPU modules on other stations with CC-Link via the Motion CPU is not possible.

#### (1) Setting for MC protocol communication

Setting for communication using the MC protocol is described below.

Set the items of following (a) to (c) in the Built-in Ethernet Port Setting of the Basic Setting of MT Developer2.

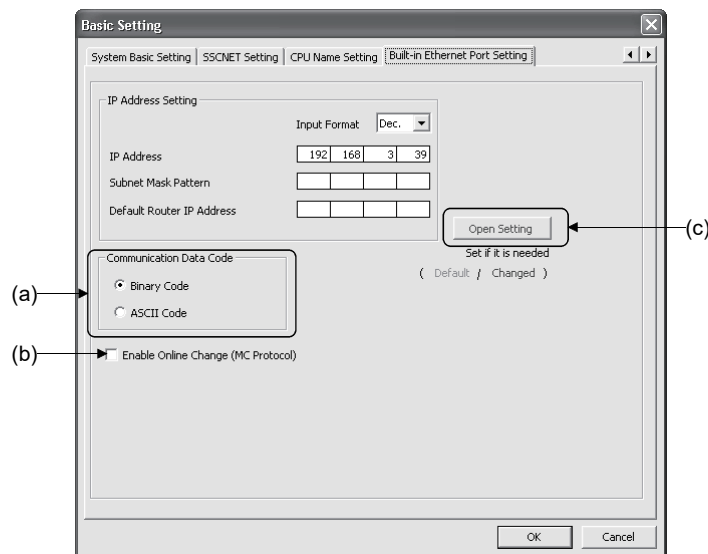

## 4 AUXILIARY AND APPLIED FUNCTIONS

- (a) Communication data code  
Select a communication data code used for the MC protocol, "Binary code" or "ASCII code".
- (b) Enable online change (MC protocol)  
Check the checkbox to enable online change when writing data to the Motion CPU from the external device that communicates using the MC protocol.  
For details on the available functions with this setting, refer to this section (2).
- (c) Open Setting  
Set the following items.
  - 1) Protocol  
Select a connection used as MC protocol. (Up to 16 CPU modules can be connected.)
  - 2) Open System  
Select "MC protocol".
  - 3) Host Station Port No. (Required)  
Set the host station port number (in hexadecimal).
    - Setting range : 0401H to 1387H, 1392H to FFEH

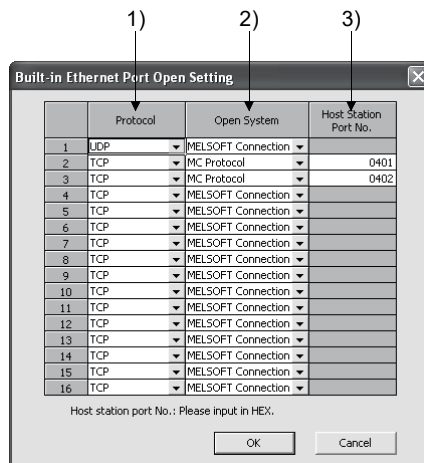

### POINT

When the "Enable online change (MC protocol)" box is unchecked, if a data write request is sent from an external device to the Motion CPU which is in the RUN status, data will not be written to the Motion CPU and the module returns the NAK message.

## 4 AUXILIARY AND APPLIED FUNCTIONS

### (2) Command list

When the PERIPHERAL I/F of the Motion CPU communicates using the MC protocol, commands listed in table below can be executed.

Function		Command (Subcommand) (Note-1)	Description	Number of processed points	Status of Motion CPU			
					STOP	Write enabled	Write disabled	
Device memory	Batch read	In units of bits	0401 (0001)	Reads bit devices in units of one point.	ASCII : 3584 points BIN : 7168 points	○	○	○
		In units of words	0401 (0000)	Reads bit devices in units of 16 points.	960 words (15360 points)			
				Reads word devices in units of one point.	960 points			
	Batch write	In units of bits	1401 (0001)	Writes bit devices in units of one point.	ASCII : 3584 points BIN : 7168 points	○	○	×
		In units of words	1401 (0000)	Writes bit devices in units of 16 points.	960 words (15360 points)			
				Writes word devices in units of one point.	960 points			
	Random read (Note-2)	In units of words	0403 (0000)	Reads bit devices in units of 16 or 32 points by randomly specifying a device or device number.	192 points	○	○	○
				Reads word devices in units of one or two points by randomly specifying a device or device number.				
	Test (Random write)	In units of bits	1402 (0001)	Sets/resets bit devices in units of one point by randomly specifying a device or device number.	188 points	○	○	×
		In units of words (Note-2)	1402 (0000)	Sets/resets bit devices in units of 16 or 32 points by randomly specifying a device or device number.	(Note-5)			
				Writes word devices in units of one or two points by randomly specifying a device or device number.				
	Monitor registration (Note-2), (Note-3), (Note-4), (Note-6)	In units of words	0801 (0000)	Registers bit devices to be monitored in units of 16 or 32 points.	192 points	○	○	○
Registers word devices to be monitored in units of one or two points.								
Monitor (Note-6)	In units of words	0802 (0000)	Monitors devices registered.	Number of registered points	○	○	○	

○: Available, ×: Not available

(Note-1): Subcommand is for the QnA-compatible 3E frame.

(Note-2): Devices such as TS, TC, SS, SC, CS, and CC cannot be specified in units of words.

For the monitor registration, an error (4032H) occurs during the monitor operation.

(Note-3): During monitor registration, monitor condition cannot be set.

(Note-4): Do not execute monitor registration from multiple external devices. If executed, the last monitor registration becomes valid.

(Note-5): Set the number of processed points so that the following condition is satisfied.

$(\text{Number of word access points}) \times 12 + (\text{Number of double-word access points}) \times 14 \leq 1920$

• Bit devices are regarded as 16 bits during word access and 32 bits during double-word access.

• Word devices are regarded as 1 word during word access and 2 words during double-word access.

(Note-6): Only Motion CPU module connected by Ethernet can be used.



## 4 AUXILIARY AND APPLIED FUNCTIONS

### (3) Available devices

The devices available in commands used in the MC protocol communication function is shown below.

#### (a) PLC CPU

Classification	Device	Device code		Device number range (Default)		Remarks	
		ASCII code (Note-1)	Binary code				
Internal system device	Special relay	SM	91h	000000 to 002047	Decimal	—	
	Special register	SD	A9h	000000 to 002047	Decimal		
Internal user device	Input	X *	9Ch	000000 to 001FFF	Hexadecimal	—  • When the device number range is changed, access is possible up to the largest device number after the change. • Local devices cannot be accessed.	
	Output	Y *	9Dh	000000 to 001FFF	Hexadecimal		
	Internal relay	M *	90h	000000 to 008191	Decimal		
	Latch relay	L *	92h	000000 to 008191	Decimal		
	Annunciator	F *	93h	000000 to 002047	Decimal		
	Edge relay	V *	94h	000000 to 002047	Decimal		
	Link relay	B *	A0h	000000 to 001FFF	Hexadecimal		
	Data register	D *	A8h	000000 to 012287	Decimal		
	Link register	W *	B4h	000000 to 001FFF	Hexadecimal		
	Timer	Contact	TS	C1h	000000 to 002047		Decimal
		Coil	TC	C0h			
		Current value	TN	C2h			
	Retentive timer	Contact	SS	C7h	000000 to 002047		Decimal
		Coil	SC	C6h			
		Current value	SN	C8h			
	Counter	Contact	CS	C4h	000000 to 001023		Decimal
		Coil	CC	C3h			
		Current value	CN	C5h			
		Link special relay	SB	A1h	000000 to 0007FF		Hexadecimal
		Link special register	SW	B5h	000000 to 0007FF		Hexadecimal
	Step relay	S *	98h	000000 to 008191	Decimal		
	Direct input	DX	A2h	000000 to 000FFF	Hexadecimal		
	Direct Output	DY	A3h	000000 to 000FFF	Hexadecimal		
Index register	Index register	Z *	CCh	000000 to 000019	Decimal	—	
File register	File register	R *	AFh	000000 to 032767	Decimal		
		ZR	B0h	000000 to 3FD7FF	Hexadecimal		
Extended data register	Extended data register	D *	A8h	• Binary: 000000 to 4184063 (4086k points maximum) • ASCII: 000000 to 999999 (976.6k points maximum)	Decimal	If the number of points is set on the PLC file tab of PLC parameter, access is possible up to the largest device number after the setting. However, in the ASCII code communication, the number of points described on the left is the access limit.	
Extended link register	Extended link register	W *	B4h	000000 to 3FD7FF (4086k points maximum)	Hexadecimal	If the number of points is set on the PLC file tab of PLC parameter, access is possible up to the largest device number after the setting.	

(Note-1): When data is communicated in ASCII code, the second character " \*" can be designated a blank space (code: 20H).

## 4 AUXILIARY AND APPLIED FUNCTIONS

### (b) Motion CPU

Classification	Device	Device code		Device number range (Default)		Remarks
		ASCII code (Note-1)	Binary code			
Internal system device	Special relay	SM	91h	000000 to 002255	Decimal	—
	Special register	SD	A9h	000000 to 002255	Decimal	
Internal user device	Input	X *	9Ch	000000 to 001FFF	Hexadecimal	Including actual input device PX.
	Output	Y *	9Dh	000000 to 001FFF	Hexadecimal	Including actual input device PY.
	Internal relay	M *	90h	000000 to 012287	Decimal	—
	Annunciator	F *	93h	000000 to 002047	Decimal	
	Link relay	B *	A0h	000000 to 001FFF	Hexadecimal	
	Data register	D *	A8h	000000 to 008191 (Note-2)	Decimal	
	Link register	W *	B4h	000000 to 001FFF	Hexadecimal	
Motion register	# *	E0h	000000 to 012287	Decimal		

(Note-1): When data is communicated in ASCII code, the second character "\*" can be designated a blank space (code: 20H).

(Note-2): The range of 000000 to 019823 is valid in the SV22 advanced synchronous control.

### (4) Precautions

#### (a) Number of connected modules

In the connection with external devices using the MC protocol, the number of Motion CPUs set as "MELSOFT Connection" in the Open Setting on Built-in Ethernet Port Setting of Basic Setting can be connected simultaneously.

#### (b) Data communication frame

Table below shows the frames available in the communication function using the MC protocol with PERIPHERAL I/F.

Communication frame	Communication function using the MC protocol with PERIPHERAL I/F
4E frame	×
QnA-compatible 3E frame	○
A-compatible 1E frame	×

○: Available, ×: Not available

#### (c) Access range

- 1) Only Motion CPU connected by Ethernet can be accessed.  
Accessing a Motion CPU not connected by Ethernet results in an error.
- 2) Accessing a Motion CPU on another station in CC-Link IE controller network, MELSECNET/H, Ethernet or CC-Link via a connected Motion CPU is not possible.

#### (d) Precautions when UDP protocol is selected

- 1) If a new request message is sent to the same UDP port while the port waits for a response message, the new request message is discarded.
- 2) Setting same host station port number to multiple UDP ports is regarded as one setting. When communicating with multiple external devices using the same host station port number, select TCP protocol.

(e) Response message receive processing

Figure below shows an example of the response message receive processing on the external device side.

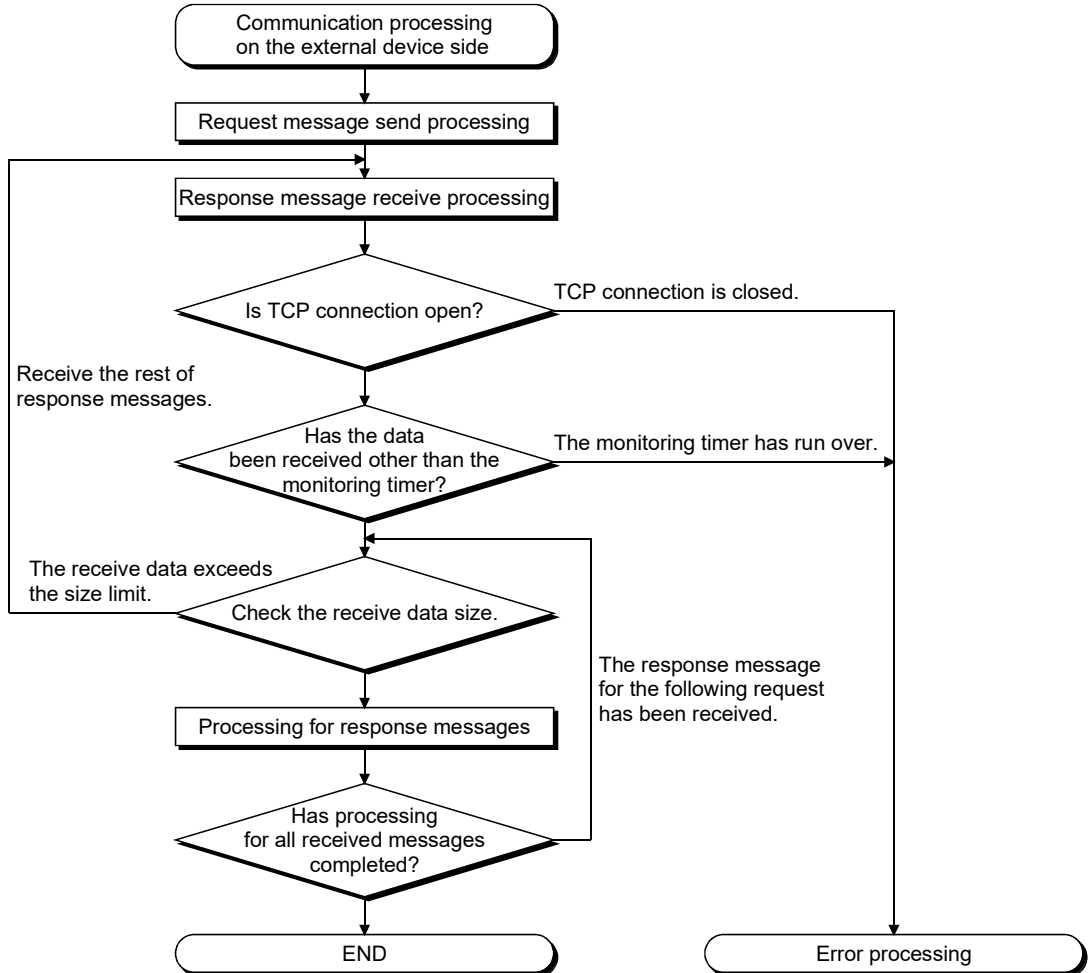

**REMARK**

Personal computers use the TCP socket functions internally for Ethernet communication.

These functions do not have boundary concept. Therefore, when data is sent by executing the "send" function once, the "recv" function needs to be executed once or more to receive the same data. (One execution of the "send" function does not correspond to one execution of the "recv" function.)

For this reason, receive processing described above is required on the external device side. If the "recv" function is used in blocking mode, data may be read by executing the function once.

## 4 AUXILIARY AND APPLIED FUNCTIONS

### (5) Error codes for communication using MC protocol

Table below shows the error codes, error descriptions, and corrective actions that will be sent from the Motion CPU to an external device when an error occurs during communication using the MC protocol.

No.	Error code (Hexadecimal)	Description	Corrective action
1	4000H to 4FFFH	Motion CPU detected error (Error that occurred in other than communication using the MC protocol)	Refer to the QCPU User's Manual (Hardware Design, Maintenance and Inspection) and take corrective action.
2	0055H	When the setting for online change is disabled on the Built-in Ethernet Port Setting of Basic Setting in MT Developer2, an external device requested online change to the Motion CPU.	<ul style="list-style-type: none"> <li>• When enabling online change, write data.</li> <li>• Change the status of the Motion CPU to STOP and write data.</li> </ul>
3	C050H	When the communication data code setting is set to ASCII code in the Built-in Ethernet Port Setting, ASCII code data that cannot be converted to binary code was received.	<ul style="list-style-type: none"> <li>• Set the communication data code to binary code and restart the Motion CPU for communication.</li> <li>• Correct the send data on the external device side and resend the data.</li> </ul>
4	C051H to C054H	The number of device points for reading/writing is outside the allowable range.	Correct the number of device points for reading/writing and resend the data to the Motion CPU.
5	C056H	The read/write request data exceeds the allowable address range.	Correct the start address or the number of device points for reading/writing, and resend the data to the Motion CPU. (Do not exceed the allowable address range.)
6	C058H	The request data length after the ASCII to binary conversion does not match the data size of the character area (a part of text data).	Correct the text data or the request data length of the header data, and resend the data to the Motion CPU.
7	C059H	<ul style="list-style-type: none"> <li>• The command and/or subcommand are specified incorrectly.</li> <li>• The command and/or subcommand not supported in the Motion CPU are specified.</li> </ul>	<ul style="list-style-type: none"> <li>• Check the request data.</li> <li>• Use commands and/or subcommands supported in the Motion CPU.</li> </ul>
8	C05BH	The Motion CPU cannot read/write data from/to the specified device.	Check the device for reading/writing data.
9	C05CH	The request data is incorrect. (ex. specifying data in units of bits for reading/writing of word devices)	Correct the request data (such as subcommand correction) and resend the data to the Motion CPU.
10	C05DH	Monitor registration is not performed.	Perform the monitor registration before monitor operation.
11	C05FH	The external device sent a request that cannot be executed in the Motion CPU.	<ul style="list-style-type: none"> <li>• Correct the network number, PC number, request destination module I/O number, and request destination module station number.</li> <li>• Correct the read/write request data.</li> </ul>
12	C060H	The request data is incorrect. (ex. incorrect specification of data for bit devices)	Correct the request data and resend the data to the Motion CPU. (ex. data correction)
13	C061H	The request data length does not match the data size of the character area (a part of text data)	Correct the text data or the request data length of the header data, and resend the data to the Motion CPU.
14	C070H	The device memory extension cannot be specified for the target station.	Read/Write data to the device memory without specifying the extension.
15	C0B5H	Data that cannot communicate in the Motion CPU is specified.	<ul style="list-style-type: none"> <li>• Check the request data.</li> <li>• Stop the current request.</li> </ul>

4.14 Mark Detection Function **QDS**

Any motion control data and all device data can be latched at the input timing of the mark detection signal. Also, data within a specific range can be latched by specifying the data detection range.

The following three modes are available for execution of mark detection.

(1) Continuous Detection mode

The latched data is always stored at mark detection.

Operation is the same as the high-speed reading function.

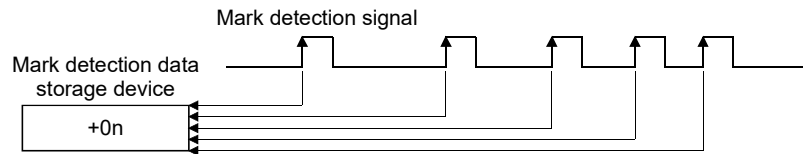

(2) Specified Number of Detection mode

The latched data from a specified number of detections is stored.

Example) Number of detections: 3

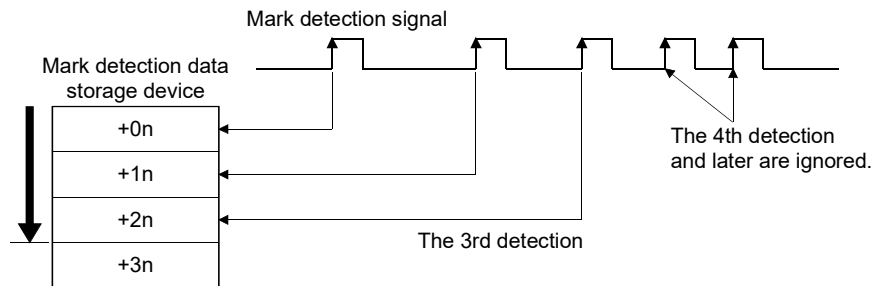

(3) Ring Buffer mode

The latched data is stored in a ring buffer for a specified number of detections.

The latched data is always stored at mark detection.

Example) Number of detections: 4

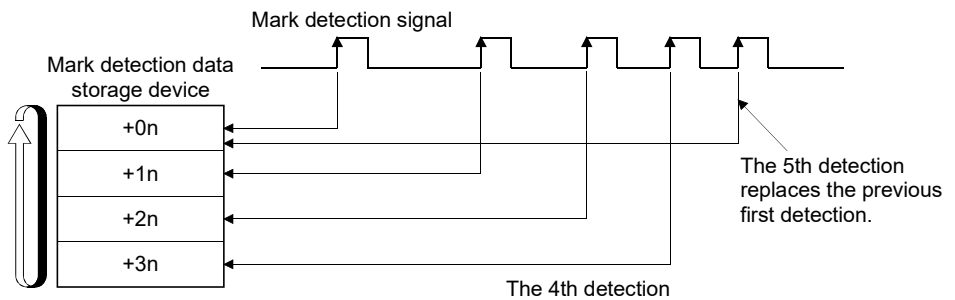

(Note): "n" in above figure is different depending on the data type storage device.

- 16-bit integer type : 1
- 32-bit integer type : 2
- 64-bit floating-point type: 4

4.14.1 Operations

Operations done at mark detection are shown below.

- Calculations for the mark detection data are estimated at leading edge/trailing edge of the mark detection signal.

However, when the Specified Number of Detection mode is set, the current mark detection is checked against the counter value for number of mark detections and then it is determined whether or not to latch the current detection data.

- When a mark detection data range is set, it is first confirmed whether the mark detection data is within the range or not. Data outside the range are not detected.
- The mark detection data is stored in the first device of the mark detection data storage area according to the mark detection mode, and then the number of mark detections counter is updated.

Operation examples for each mode are shown in the table below.

(1) Continuous Detection mode

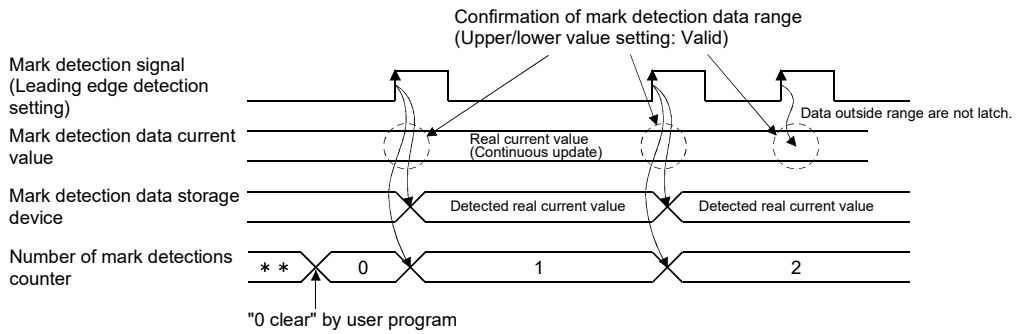

(2) Specified Number of Detection mode (Number of detections: 2)

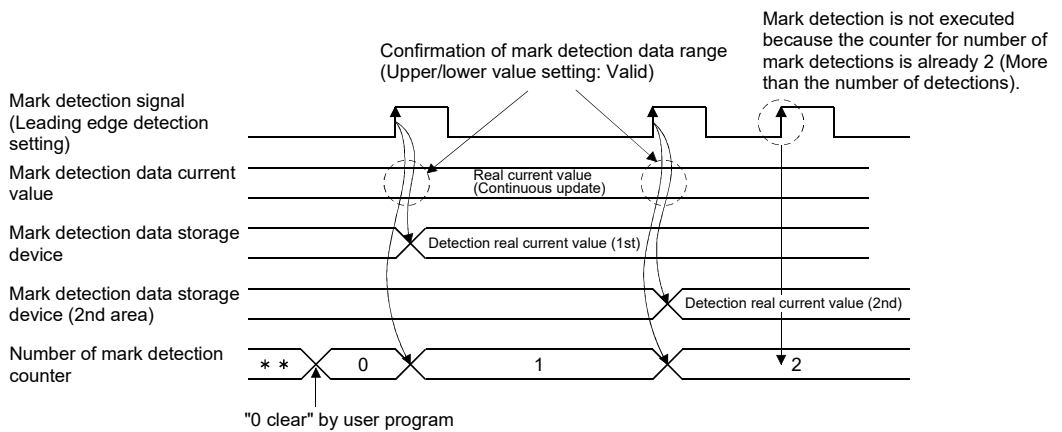

## 4 AUXILIARY AND APPLIED FUNCTIONS

### 4.14.2 Mark detection setting

This section describes the mark detection setting items.  
Up to 32 mark detection settings can be registered.

No.	Item		Setting range
1	Mark detection signal	Mark detection signal	Built-in interface in Motion CPU (DI1 to DI4)/Q172DLX (DOG)/Device
		Device (Note-1)	Bit device (X, Y, M, B, SM, U□\G)
		Mark signal detection direction (Note-2)	Valid on leading edge/Valid on trailing edge
		Q172DLX module No. (Note-3)	1 to 4
		Q172DLX signal No. (Note-3)	1 to 8
2	Mark detection signal compensation time (Note-4)		-5000000 to 5000000[μs]/Word device (D, W, #, U□\G)
3	Mark detection data	Mark detection data	Motion control data/Device
		Axis No. (Note-5)	1 to 32
		Set data (Note-5)	Refer to (3) of this section
		Device (Note-1)	Word device (D, W, #, SD, U□\G)
		Data type (Note-1)	16-bit integer type/32-bit integer type/64-bit floating-point type
		Estimate calculation (Note-1)	Valid (Normal data)/Valid (Ring counter)/Invalid
		Ring counter value (Note-1)	16-bit integer type : K1 to K32767, H001 to H7FFF 32-bit integer type : K1 to K2147483647, H00000001 to H7FFFFFFF 64-bit floating-point type : K2.23E-308 to K1.79E+308
4	Mark detection data storage device		Word device (D, W, #, U□\G)
5	Mark data range	Upper value	Direct designation (K, H)/Word device (D, W, #, U□\G) 16-bit integer type : K-32768 to K32767, H0000 to HFFFF 32-bit integer type : K-2147483648 to K2147483647, H00000000 to HFFFFFFF 64-bit floating-point type : K-1.79E+308 to K-2.23E-308, K0, K2.23E-308 to K1.79E+308
		Lower value	
6	Mark detection mode setting	Mark detection mode setting	Continuous detection mode/Specified No. of detection mode/Ring buffer mode/Device (Note-6)
		Number of detections	1 to 8192 (Specified number of detection mode/Ring buffer mode)
		Device (Note-1)	Word device (D, W, #, U□\G)
		Mark detection times counter	— (Note-7) (Continuous detection mode)/Word device (D, W, #, U□\G)
7	Mark detection current value monitor device		— (Note-7)/Word device (D, W, #, U□\G)
8	Mark detection signal status		— (Note-7)/Bit device (X, Y, M, B, U□\G)

(Note-1): When device is selected.

(Note-2): Set the input signal detection direction of built-in interface in Motion CPU (DI) in the "CPU Setting" of system setting.

For the input signal detection direction of Q172DLX (DOG/CHANGE), select "Q172DLX" of "Motion slot setting" and set the direction with detail setting.

(Note-3): When Q172DLX (DOG) is selected.

(Note-4): The mark detection signal compensation time cannot be set if "Invalid" is selected in the estimate calculation. (0[μs] is set.)

(Note-5): When Motion control data is selected.

(Note-6): When the setting value is outside the range of "-8192 to 8192", the mark detection is invalid.

(Note-7): This setting can be omitted.

## 4 AUXILIARY AND APPLIED FUNCTIONS

### (1) Mark detection signal

Set the input signal for mark detection.

#### (a) Module input signal

##### 1) Built-in interface in Motion CPU

Input module	Signal	Module No.		Signal No.	Detection accuracy [μs]	Signal detection direction (Leading edge/Trailing edge)
		Q173DSCPU	Q172DSCPU			
Built-in interface in Motion CPU	DI	—		1 to 4	30	Set direction in the "CPU Setting" of system settings.

##### 2) Q172DLX

- Install the Q172DLX to the main base to use Q172DLX (DOG/CHANGE). If the Q172DLX is installed to the extension base, the mark detection function cannot be used.
- The mark detection operation is executed at the DOG/CHANGE signal input with the count method home position return or speed-position switching control.  
Set the device in the "mark detection mode setting" and setting value outside "-8192 to 8192" to disable mark detection.
- The signal that does not set the axis No. in the system setting can be also used as the mark detection signal.

Input module	Signal	Module No.		Signal No.	Detection accuracy [μs]	Signal detection direction (Leading edge/Trailing edge)
		Q173DSCPU	Q172DSCPU			
Q172DLX	DOG/CHANGE	1 to 4	1 to 2	1 to 8	<ul style="list-style-type: none"> <li>• I/O response time 0.4[ms]: 69</li> <li>• I/O response time 0.6[ms]: 133</li> <li>• I/O response time 1.0[ms]: 261</li> </ul>	Select "Q172DLX" of "Motion slot setting" in the system setting and set the direction with detail setting.

#### (b) Bit device

Bit device	Setting range	Detection accuracy [μs]	Signal detection direction (Leading edge/Trailing edge)
X(PX)	0 to 1FFF (Note-1)	<ul style="list-style-type: none"> <li>• Operation cycle 222[μs] : 222</li> <li>• Operation cycle 444[μs] or more : 444</li> </ul>	Set direction in the mark detection signal detection direction.
Y(PY)	0 to 1FFF		
M	0 to 8191 (Note-2)		
B	0 to 1FFF		
SM	0 to 1999		
U□\G	10000.0 to (10000+p-1).F (Note-3)		

(Note-1): The range of "PXn+4 to PXn+F" cannot be used (fixed at 0) for the input device (PXn+0 to PXn+F) allocated to the built-in interface in Motion CPU (DI). (n: First input No.)

(Note-2): The range of M0 to M12287 is valid in the SV22 advanced synchronous control.

(Note-3): "p" indicates the user setting area points of the Multiple CPU high speed transmission area for each CPU.



## 4 AUXILIARY AND APPLIED FUNCTIONS

(c) Mark detection signal detection direction

Set whether to execute the mark detection to enable on leading edge (OFF to ON) or enable on trailing edge (ON to OFF) of input signal.

Set the input signal detection direction in the System Settings as shown below.

- For built-in interface in Motion CPU (DI)  
Set direction in the "CPU Setting" of system settings.
- For Q172DLX (DOG/CHANGE)  
Select "Q172DLX" of "Motion slot setting" in the system setting and set the direction with detail setting.

Input signal detection direction	Remarks
Valid on leading edge	The mark detection is executed when the mark detection signal transitions from OFF to ON.
Valid on trailing edge	The mark detection is executed when the mark detection signal transitions from ON to OFF.

(2) Mark detection signal compensation time

Compensate the output timing of the mark detection signal.

Set it to compensate for sensor input delays, etc. (Set a positive value to compensate for a delay.)

However, the mark detection signal compensation time cannot be set if "Invalid" is selected in the estimate calculation. (0[μs] is set.)

The timing is compensated as "-5000000" when the compensation time is set to less than -5000000, and it is compensated as "5000000" when it is set to more than 5000000.

(a) Direct designation

Setting range
-5000000 to 5000000 [μs]

(b) Indirect designation

Word device	Setting range <sup>(Note-1)</sup>	Remarks
D	0 to 8191 <sup>(Note-2)</sup>	The setting value is input for every operation cycle.
W	0 to 1FFF	
#	0 to 9215	
U□\G	10000 to (10000+p-1) <sup>(Note-3)</sup>	

(Note-1): Set an even number as the first device.

(Note-2): The range of D0 to D19823 is valid in the SV22 advanced synchronous control.

(Note-3): "p" indicates the user setting area points of the Multiple CPU high speed transmission area for each CPU.

## 4 AUXILIARY AND APPLIED FUNCTIONS

---

When using the "real current value" in mark detection data, set the mark detection signal compensation time referring to the following chart.

Operation cycle setting [ms]	Mark detection signal compensation time [ $\mu$ s]
0.22	$-222+\alpha$
0.44	$-444+\alpha$
0.88	$-888+\alpha$
1.77	$-1777+\alpha$
3.55	$-3555+\alpha$
7.11	$-7111+\alpha$

$\alpha$ : Sensor input delay time.

## 4 AUXILIARY AND APPLIED FUNCTIONS

### (3) Mark detection data

Set the data to latch at mark detection.

#### (a) Motion control data

Settable Motion control data is shown in the table below.

Item	Unit	Data type	Axis No. setting range		Remarks
			Q173DSCPU	Q172DSCPU	
Feed current value	10 <sup>-1</sup> [μm], 10 <sup>-5</sup> [inch], 10 <sup>-5</sup> [degree], [pulse]	32-bit integer type	1 to 32	1 to 16	—
Actual current value					
Motor actual current value					
Servo command value					
Position feedback (Note-1)					
Absolute encoder one-revolution position (Note-1)					
Absolute encoder multiple revolution position	—	16-bit integer type			
Deviation counter value	[pulse]	32-bit integer type	1 to 32	1 to 16	—
Servo command speed	[pulse/s]				
Motor speed	0.01[r/min]				
Motor current value	0.1[%]				
Synchronous encoder current value	[pulse]	32-bit integer type	1 to 12 (Note-2)		Valid in SV22 only
Feed current value (V)			1 to 32	1 to 16	Valid in SV22 virtual mode only
Cam axis current value within one-revolution (Actual) (Note-3)					
Command generation axis feed current value	Control unit	32-bit integer type	1 to 32	1 to 16	Valid in SV22 advanced synchronous control only
Command generation axis cumulative current value					
Command generation axis current value per cycle					
Synchronous encoder axis current value	Encoder axis unit	32-bit integer type	1 to 12 (Note-4)		Valid in SV22 advanced synchronous control only
Synchronous encoder axis current value per cycle					
Cam axis current value per cycle	Cam axis cycle unit	32-bit integer type	1 to 32	1 to 16	Ver. 1
Cam axis current value per cycle (Actual) (Note-5)					

(Note-1): For MR-J5(W)-□B, the value displayed is the value (command unit) multiplied by the reciprocal of the electronic gear ratio of the servo amplifier. By configuring the electronic gear settings to the servo amplifier's "Electronic gear numerator (PA06)" and "Electronic gear denominator (PA07)" servo parameters, the data becomes the same data as for MR-J4(W)-□B.

(Note-2): Set the synchronous encoder No. (P1 to 12) allocated in the system setting.

(Note-3): Current value within one cam shaft revolution takes into consideration the delay of the servo amplifier.

(Note-4): Set the axis No. (axis 1 to 12) of the synchronous encoder axis parameter set in the synchronous control parameter.

(Note-5): Current value per cycle takes into consideration the delay of the servo amplifier.

**Ver. 1**: Refer to Section 1.5 for the software version that supports this function.

## 4 AUXILIARY AND APPLIED FUNCTIONS

Since the delay time inherent to the system exists in the current value data of the synchronous encoder axis, there may be a difference between the actual current value and the current value of mark detection. When the "synchronous encoder current value", "synchronous encoder axis current value" or "synchronous encoder axis current value per cycle" is used in the mark detection data, the mark detection signal compensation time shown below can be set to compensate the delay. However, when the "phase compensation advance time" is set in the synchronous control parameter to compensate the delay of the synchronous encoder, setting of the mark detection signal compensation time is not necessary.

Synchronous encoder type	Mark detection signal compensation time [ $\mu$ s]
Built-in interface in Motion CPU	0
Incremental synchronous encoder	0
MR-HENC	-232
Q171ENC-W8	-276

### (b) Device

#### 1) Word device data

Set word device as mark detection data.

Word device	Setting range	Remarks
D	0 to 8191 <sup>(Note-1)</sup>	—
W	0 to 1FFF	
#	0 to 9215	
SD	0 to 1999	
U□\G	10000 to (10000+p-1) <sup>(Note-2)</sup>	

(Note-1): "p" indicates the user setting area points of the Multiple CPU high speed transmission area for each CPU.

(Note-2): The range of D0 to D19823 is valid in the SV22 advanced synchronous control.

#### 2) Data type

Set the data type in word device data setting.

Data type	Remarks
16-bit integer type	—
32-bit integer type	Set the device No. as an even No.
64-bit floating-point type	

## 4 AUXILIARY AND APPLIED FUNCTIONS

### 3) Estimate calculation

Set the estimate calculation to "Valid/Invalid" in the word device data setting.

Estimate calculation		Ring counter value	
Valid	Normal data	—	
	Ring counter	16-bit integer type	K1 to K32767, H0001 to H7FFF
		32-bit integer type	K1 to K2147483647, H00000001 to H7FFFFFFF
		64-bit floating-point type	K2.23E-308 to K1.79E+308
Invalid		—	

#### a) Estimate calculation : Valid

Calculation for word device data in the operation cycle is estimated. The latch data is the value estimated at the timing in which the mark detection signal is input. The value is calculated as shown in the figure below whether the word device data is normal data or a ring counter. Set the ring counter value for the ring counter.

##### • Valid (Normal data)

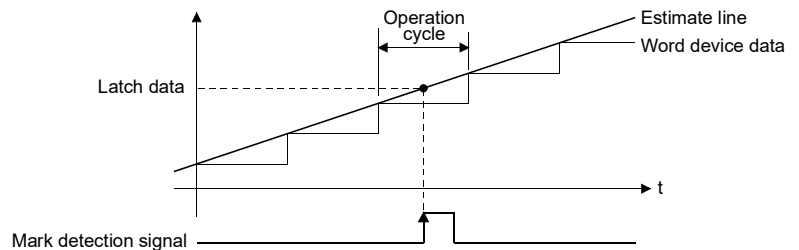

##### • Valid (Ring counter)

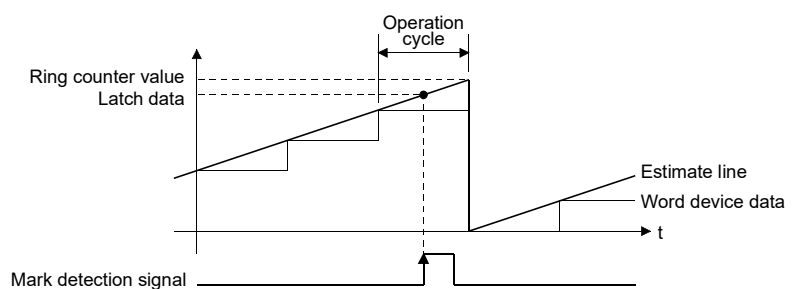

#### POINT

If "Valid (Normal data)" is selected for word device data updated as a ring counter, the latch data may not be estimated correctly.

b) Estimate calculation : Invalid

Calculation for word device data in operation cycle is not estimated. The latch data is the word device data at the timing in which the mark detection signal is input. The detection accuracy is the operation cycle regardless of the mark detection signal type.

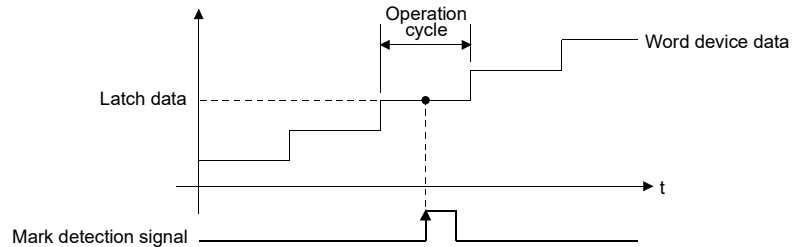

(4) Mark detection data storage device

Set the mark detection data storage device (first device to use in the "Specified Number of Detections mode" or "Ring Buffer mode").

When using the "Specified Number of Detections mode" or "Ring Buffer mode", reserve the device area to accommodate the number of detections.

Word device	Setting range <sup>(Note-1)</sup>	Remarks
D	0 to 8191 <sup>(Note-2)</sup>	—
W	0 to 1FFF	
#	0 to 9215 <sup>(Note-3)</sup>	
U□\G	10000 to (10000+p-1) <sup>(Note-4)</sup>	

(Note-1): Set an even numbered device in the 32-bit integer type/64-bit floating-point type.

(Note-2): The range of D0 to D19823 is valid in the SV22 advanced synchronous control.

(Note-3): The data can be stored in #9216 to #12287 in the "Specified Number of Detections mode" or "Ring Buffer mode".

(Note-4): "p" indicates the user setting area points of the Multiple CPU high speed transmission area for each CPU.

(5) Mark detection data range

When the data at mark detection is within the range, they are stored in the mark detection data storage device and the number of mark detections counter is incremented by 1. When outside of range, mark detection is not processed.

- Upper limit value > Lower limit value

The mark detection is executed when the mark detection data is "greater or equal to the lower limit value and less than or equal to the upper limit value".

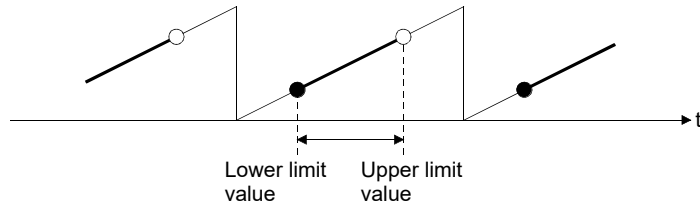

- Upper limit value < Lower limit value

The mark detection is executed when the mark detection data is "greater or equal to the lower limit value or less than or equal to the upper limit value".

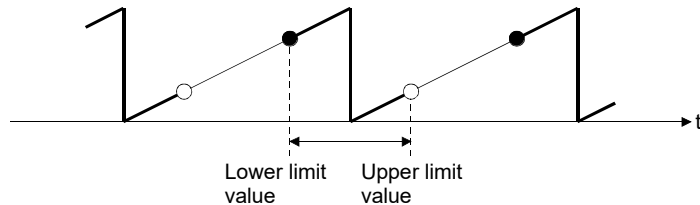

- Upper limit value = Lower limit value

The mark detection range is not checked. The mark detection is always executed.

(a) Direct designation

Data type	Setting range
16-bit integer type	K-32768 to K32767, H0000 to HFFFF
32-bit integer type	K-2147483648 to K2147483647, H00000000 to HFFFFFFF
64-bit floating-point type	K-1.79E+308 to K-2.23E-308, K0, K2.23E-308 to K1.79E+308

(b) Indirect designation

Word device	Setting range <sup>(Note-1)</sup>	Remarks
D	0 to 8191 <sup>(Note-2)</sup>	The setting value is input for every operation cycle.
W	0 to 1FFF	
#	0 to 9215	
U□\G	10000 to (10000+p-1) <sup>(Note-3)</sup>	

(Note-1): Set an even numbered device in the 32-bit integer type/64-bit floating-point type.

(Note-2): The range of D0 to D19823 is valid in the SV22 advanced synchronous control.

(Note-3): "p" indicates the user setting area points of the Multiple CPU high speed transmission area for each CPU.

## 4 AUXILIARY AND APPLIED FUNCTIONS

### (6) Mark detection mode setting

Set the data storage method of mark detection.

#### (a) Direct designation

Mode	Number of detections	Operation for mark detection	Mark detection data storage method
Continuous detection mode	—	Always	The data is updated in the mark detection data storage device.
Specified number of detection mode	1 to 8192	Number of detections (If the number of mark detections counter is the number of detections or more, the mark detection is not executed.)	The data is stored in the following device area. "Mark detection data storage device + Number of mark detections counter × Mark detection data size"
Ring buffer mode	1 to 8192	Always (The mark detection data storage device is used as a ring buffer for the number of detections.)	

#### (b) Indirect designation

Word device	Setting range	Remarks
D	0 to 8191 <sup>(Note-1)</sup>	<ul style="list-style-type: none"> <li>Used as 1 word device.</li> <li>Set the mark detection mode using the following setting values.                             <ul style="list-style-type: none"> <li>0 : Continuous detection mode</li> <li>1 to 8192 : Specified number of detection mode (Set the number of detections.)</li> <li>-8192 to -1 : Ring buffer mode (Set the value that make the number of buffers into negative value.)</li> <li>Others : Mark detection : Invalid</li> </ul> </li> <li>The setting value is input for every operation cycle.</li> </ul>
W	0 to 1FFF	
#	0 to 9215	
U□\G	10000 to (10000+p-1) <sup>(Note-2)</sup>	

(Note-1): The range of D0 to D19823 is valid in the SV22 advanced synchronous control.

(Note-2): "p" indicates the user setting area points of the Multiple CPU high speed transmission area for each CPU.

### (7) Number of mark detections counter

The counter value is incremented by 1 at mark detection. Preset the initial value (0, etc.) in the user program to execute the mark detection in "Specified Number of Detections mode" or "Ring Buffer mode".

This setting can be omitted when the continuous detection mode is selected.

Word device	Setting range	Remarks
D	0 to 8191 <sup>(Note-1)</sup>	<ul style="list-style-type: none"> <li>Used as 1 word device.</li> <li>The counter is updated as follows after the mark detection data storage.                             <ul style="list-style-type: none"> <li>Continuous detection mode: 0 to 65535 The counter value is incremented by 1. It returns to 0 when the counter value exceeds 65535.</li> <li>Specified number of detection mode: 0 to (number of detections) The counter value is incremented by 1.</li> <li>Ring buffer mode: 0 to (number of buffers -1) The counter value is incremented by 1. It returns to 0 when the counter value reaches the set number of buffers or more.</li> </ul> </li> </ul>
W	0 to 1FFF	
#	0 to 9215	
U□\G	10000 to (10000+p-1) <sup>(Note-2)</sup>	

(Note-1): The range of D0 to D19823 is valid in the SV22 advanced synchronous control.

(Note-2): "p" indicates the user setting area points of the Multiple CPU high speed transmission area for each CPU.



## 4 AUXILIARY AND APPLIED FUNCTIONS

### (8) Mark detection current value monitor device

The current value of mark detection data can be monitored.

This setting can be omitted.

Word device	Setting range <sup>(Note-1)</sup>	Remarks
D	0 to 8191 <sup>(Note-2)</sup>	The monitor value is updated for every operation cycle.
W	0 to 1FFF	
#	0 to 9215	
U□\G	10000 to (10000+p-1) <sup>(Note-3)</sup>	

(Note-1): Set an even number as device in the 32-bit integer type/64-bit floating-point type.

(Note-2): The range of D0 to D19823 is valid in the SV22 advanced synchronous control.

(Note-3): "p" indicates the user setting area points of the Multiple CPU high speed transmission area for each CPU.

### (9) Mark detection signal status

The ON/OFF status of mark detection signal can be monitored.

This setting can be omitted.

Bit device	Setting range	Remarks
X	0 to 1FFF <sup>(Note-1)</sup>	The ON/OFF status is reflected for every operation cycle.
Y	0 to 1FFF	
M	0 to 8191	
B	0 to 1FFF	
U□\G	10000.0 to (10000+p-1).F <sup>(Note-2)</sup>	

(Note-1): The range of "PXn+4 to PXn+F" cannot be used (fixed at 0) for the input device (PXn+0 to PXn+F) allocated to the built-in interface in Motion CPU (DI). (n: First input No.)

(Note-2): Set an even number as device in the 32-bit integer type/64-bit floating-point type.

## 4 AUXILIARY AND APPLIED FUNCTIONS

### 4.15 High-speed Input Request Signal Setting (SV22 advanced synchronous control only)



Set the high-speed input request signal assignment.

The high-speed input request signal is the signal to execute the high-accuracy control of the clutch ON/OFF operation of synchronous control or the counter enable/counter disable/current value change operation of the synchronous encoder axis.

The example of current value change of the synchronous encoder axis using Q173DPX (TREN1) as the high-speed input request signal is shown below.

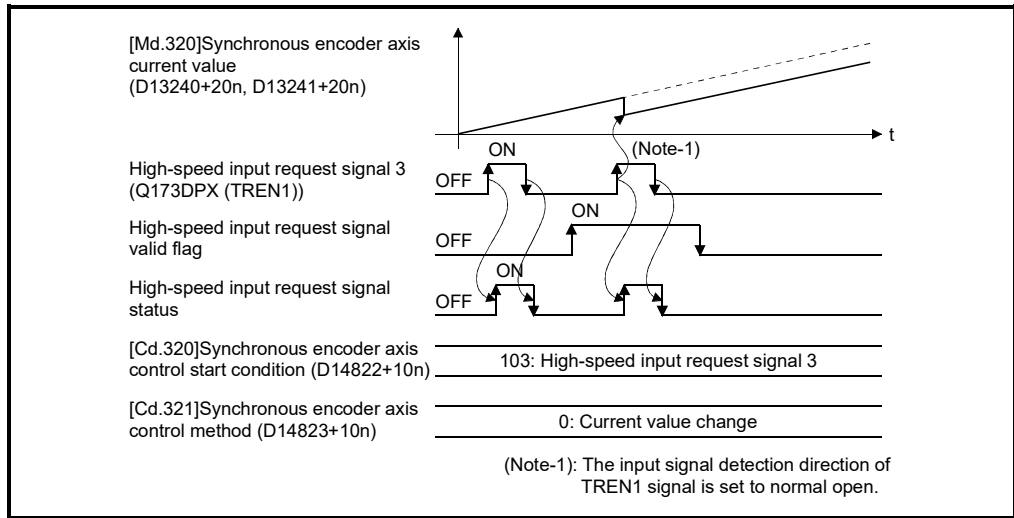

#### (1) High-speed input request signal setting

The High-speed input request signal setting data are shown below.

Up to 32 signals can be registered.

No.	Item	Setting range
1	High-speed input request signal (Note-1)	Built-in interface in Motion CPU (DI)/Q172DLX (DOG/CHANGE)/Q172DEX (TREN)/Q173DPX (TREN)
2	High-speed input request signal compensation time	-5000000 to 5000000[μs]/Word device (D, W, #, U□\G)
3	High-speed input request signal valid flag	— (Note-2)/Bit device (X, Y, M, B, U□\G)
4	High-speed input request signal status	— (Note-2)/Bit device (X, Y, M, B, U□\G)

(Note-1): Set the input signal detection direction of built-in interface in Motion CPU (DI) in the "CPU Setting" of system setting.

For the input signal detection direction of Q172DLX (DOG/CHANGE), select "Q172DLX" of "Motion slot setting" and set the direction with detail setting.

For the input signal detection direction of Q172DEX (TREN), select "Q172DEX" of "Motion slot setting" and set the direction with detail setting.

For the input signal detection direction of Q172DPX (TREN), set the direction with dip switch of Q173DPX.

(Note-2): This setting can be omitted.

**Ver.!** : Refer to Section 1.5 for the software version that supports this function.

## 4 AUXILIARY AND APPLIED FUNCTIONS

### (a) High-speed input request signal

Set the input signal for high-speed input request signal.

#### 1) Built-in interface in Motion CPU

Input module	Signal	Module No.		Signal No.	Detection accuracy [μs]	Signal detection direction (Leading edge/Trailing edge)
		Q173DSCPU	Q172DSCPU			
Built-in interface in Motion CPU	DI	—		1 to 4	30	Set direction in the "CPU Setting" of system settings.

#### 2) Q172DLX/Q172DEX/Q173DPX

Install the Q172DLX to the main base to use Q172DLX (DOG/CHANGE)/Q172DEX (TREN)/Q173DPX (TREN).

If the Q172DLX/Q172DEX/Q173DPX is installed to the extension base, the high-speed input request signal cannot be used.

Input module	Signal	Module No.		Signal No.	Detection accuracy [μs]	Signal detection direction (Leading edge/Trailing edge)
		Q173DSCPU	Q172DSCPU			
Q172DLX	DOG/CHANGE	1 to 4	1 to 2	1 to 8	<ul style="list-style-type: none"> <li>• I/O response time 0.4[ms]: 69</li> <li>• I/O response time 0.6[ms]: 133</li> <li>• I/O response time 1.0[ms]: 261</li> </ul>	Select "Q172DLX" of "Motion slot setting" in the system setting and set the direction with detail setting.
Q172DEX	TREN	1 to 6		1 to 2		Select "Q172DEX" of "Motion slot setting" in the system setting and set the direction with detail setting.
Q173DPX	TREN	1 to 4		1 to 3		Set the direction with dip switch of Q173DPX.

### (b) High-speed input request signal compensation time

Compensate the input timing of the high-speed input request signal.

Set it to compensate for sensor input delays, etc. Set a positive value to compensate for a delay, and set a negative value to compensate for an advance.

However, high-speed input request status outputs the status of the signal with no relation to the set value.

The timing is compensated as "-5000000" when the compensation time is set to less than -5000000, and it is compensated as "5000000" when it is set to more than 5000000.

#### 1) Direct designation

Setting range
-5000000 to 5000000 [μs]

#### 2) Indirect designation

Word device	Setting range <sup>(Note-1)</sup>	Remarks
D	0 to 8191	The setting value is input for every operation cycle.
W	0 to 1FFF	
#	0 to 9215	
U□\G	10000 to (10000+p-1) <sup>(Note-2)</sup>	

(Note-1): Set an even number as the first device.

(Note-2): "p" indicates the user setting area points of the Multiple CPU high speed transmission area for each CPU.

## 4 AUXILIARY AND APPLIED FUNCTIONS

### (c) High-speed input request signal valid flag

The high-speed input request signal is valid only when the flag is ON.

The high-speed input request signal is invalid when the flag is OFF.

This setting can be omitted.

When the setting is omitted, the high-speed input request signal is valid at all times.

Bit device	Setting range	Remarks
X	0 to 1FFF (Note-1)	ON/OFF command is input when the high-speed input request signal is detected.
Y	0 to 1FFF	
M	0 to 8191	
B	0 to 1FFF	
U□\G	10000.0 to (10000+p-1).F (Note-2)	

(Note-1): The range of "PXn+4 to PXn+F" cannot be used (fixed at 0) for the input device (PXn+0 to PXn+F) allocated to the built-in interface in Motion CPU (DI). (n: First input No.)

(Note-2): "p" indicates the user setting area points of the Multiple CPU high speed transmission area for each CPU.

### (d) High-speed input request signal status

The ON/OFF status of high-speed input request signal can be monitored.

ON/OFF status can be monitored regardless of the status of the high-speed input request signal valid flag.

This setting can be omitted.

Bit device	Setting range	Remarks
X	0 to 1FFF (Note-1)	The ON/OFF status is reflected for every operation cycle.
Y	0 to 1FFF	
M	0 to 8191	
B	0 to 1FFF	
U□\G	10000.0 to (10000+p-1).F (Note-2)	

(Note-1): The range of "PXn+4 to PXn+F" cannot be used (fixed at 0) for the input device (PXn+0 to PXn+F) allocated to the built-in interface in Motion CPU (DI). (n: First input No.)

(Note-2): "p" indicates the user setting area points of the Multiple CPU high speed transmission area for each CPU.

### POINT

When signal is inputted in a state where the detection of high-speed input request signal is unnecessary ([St.380] Synchronous control (M10880+n) is turned OFF, or [Rq.320] Synchronous encoder axis control request (M11601+4n) is turned OFF), the high-speed input request signal valid flag turns OFF. Turn ON when the detection of high-speed input request signal is necessary.

## 4 AUXILIARY AND APPLIED FUNCTIONS

### 4.16 Driver Communication Function

This function uses the "Master-slave operation function" of servo amplifier. The Motion CPU controls the master axis and the slave axis is controlled by data communication (driver communication) between servo amplifiers without going through the Motion CPU.

This function is used for the case such as to operate the ball screw controlled by multiple axes via the belt.

There are restrictions in the function that can be used by the version of the servo amplifier.

Refer to the "Servo amplifier Instruction Manual" for details.

The following shows the number of settable axes for the master axis and slave axis.

Model name	Number of SSCNETⅢ(/H) lines	Number of control axes	Combination of number of settable axes			Remark
			Master axis		Slave axis	
			SSCNETⅢ (Note-1)	SSCNETⅢ/H (Note-2)		
Q173DSCPU	2 lines	32 axes	1 axis to 8 axes	1 axis to 16 axes	—	The axes other than the master axis and slave axis can be used as normal axis.
Q172DSCPU	1 line	16 axes	1 axis to 4 axes	1 axis to 8 axes		

—: No restriction

(Note-1): Up to 4 axes per line are settable in the master axis.

(Note-2): Up to 8 axes per line are settable in the master axis.

#### POINT

Driver communication function is only valid in MR-J5-□B, MR-J4-□B, and MR-J3-□B. Multi-axis servo amplifiers (MR-J5W-□B, MR-J4W-□B, and MR-J3W-□B) cannot be used. Nor can MR-J4W-□B be used in MR-J3-□B compatibility mode.

In addition, when using MR-J5-□B, make sure that the master axes and the slave axes used are both MR-J5-□B. Using different servo amplifier series together will cause a major error (error code: 1366) to occur.

: Refer to Section 1.5 for the software version that supports this function.

## 4 AUXILIARY AND APPLIED FUNCTIONS

### 4.16.1 Control details

Set the master axis and slave axis in the servo parameter.

Execute each control of Motion CPU in the master axis. (However, be sure to execute the servo ON/OFF of slave axis, and error reset at servo error occurrence in the slave axis.) The servo amplifier set as master axis receives command (positioning command, speed command, torque command) from the Motion CPU, and sends the control data to the servo amplifier set as slave axis by driver communication between servo amplifiers.

The servo amplifier set as the slave axis is controlled by the control data transmitted from the master axis by driver communication between servo amplifiers.

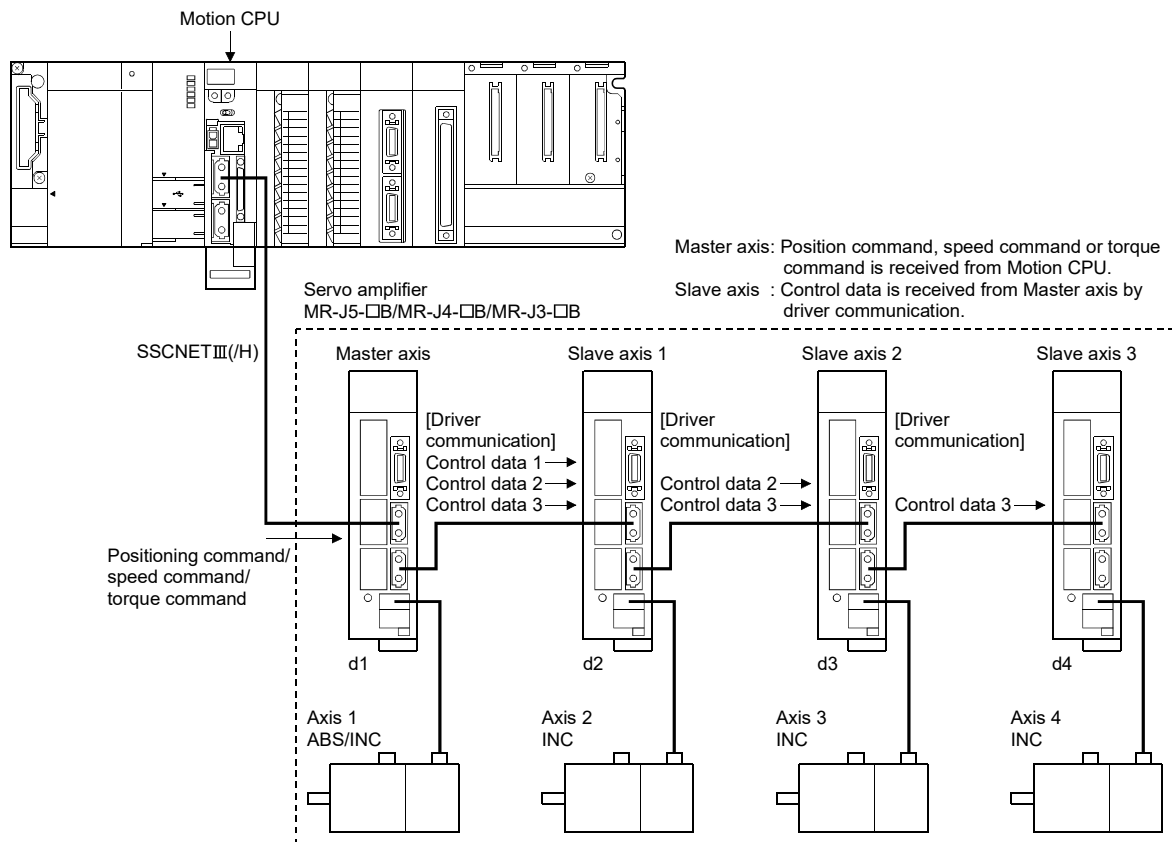

#### POINT

When a servo amplifier fails due to a SSCNET III(H) communication failure, communication with the axes after the failed axis cannot be executed. For this reason, be sure to connect the master axis to the position closest to the Motion CPU.

4.16.2 Precautions during control

<b>⚠ CAUTION</b>
<ul style="list-style-type: none"> <li>● During operation by driver communication function, the positioning control or JOG operation, etc. by servo program is not interrupted even if a servo error occurs in the slave axis. Be sure to stop the master axis by user program.</li> </ul>

(1) Servo amplifier

- (a) For the axes where driver communication is executed, be sure to use a servo amplifier that supports driver communication.
- (b) Driver communication function is only valid in MR-J5-□B, MR-J4-□B, and MR-J3-□B. Multi-axis servo amplifiers (MR-J5W-□B, MR-J4W-□B, and MR-J3W-□B) cannot be used. Nor can MR-J4W-□B be used in MR-J3-□B compatibility mode.  
In addition, when using MR-J5-□B, make sure that the master axes and the slave axes used are both MR-J5-□B. Using different servo amplifier series together will cause a major error (error code: 1366) to occur.
- (c) Be sure to connect the master CPU and slave CPU in the same SSCNET III(/H) line.
- (d) The master CPU and slave CPU combination is set in the servo parameters. After writing the servo parameters, turn ON again or reset the Multiple CPU system power supply so that the parameters become valid.
- (e) The differences between SSCNET III and SSCNET III/H communication type in driver communication function are shown below.

	Communication type	
	SSCNET III	SSCNET III/H
Communication with servo amplifiers after Multiple CPU system power supply ON.	Servo amplifiers cannot be operated until connection with all axes set by system setting is confirmed.	Servo amplifier cannot be operated until connection with all axes set to driver communication is confirmed. Normal axes (axes not set to driver communication) can also be connected after the network is established.
Connect/disconnect with servo amplifier	Only the first axis of the SSCNET line (servo amplifier connected directly to the Motion CPU) can connect/disconnect. Servo amplifiers other than the first axis can be disconnected but cannot be connected.	Only the first axis of the SSCNET line (servo amplifier connected directly to the Motion CPU) can connect/disconnect. Only normal axes (axes not set to driver communication) other than the first axis can be connected when they are disconnected. However, when axes set to driver communication are disconnected, they cannot communicate with servo amplifiers that were connected after disconnecting. (The servo amplifier's LED display remains "AA")

## 4 AUXILIARY AND APPLIED FUNCTIONS

- (f) If all axes set to driver communication are not detected at the start of communication with the servo amplifier, all axes connected to that line, including normal axes cannot be operated. (The servo amplifier's LED display remains "Ab").

Check with the following SSCNETⅢ searching flags (SM532, SM533) if a SSCNET line can be operated.

When all normal axes and axes set to driver communication are connected, the SSCNETⅢ searching flags (SM532, SM533) turn OFF.

Device No.	Name	Details	Set by
SM532	SSCNETⅢ searching flag (Line 1)	<ul style="list-style-type: none"> <li>• Turns ON when searching axes that have been set by system setting in line 1 or line 2.</li> <li>• Turns OFF when all axes that have been set by system setting in line 1 or line 2 have been searched.</li> </ul>	S (Change status)
SM533	SSCNETⅢ searching flag (Line 2)	OFF: Search complete ON : Searching	

### (2) Positioning dedicated device used for positioning control of slave axis

In the slave axis, only the following positioning dedicated devices are valid.

Do not use devices other than the following.

#### (a) Axis status

- Zero pass (M2406+20n) (Note-1)
- Servo error detection (M2408+20n)
- Servo ready (M2415+20n)

(Note-1): Because the slave axis cannot execute home position return, it does not use this in control.

#### (b) Axis command signal

- Servo error reset command (M3208+20n)
- Servo OFF command (M3215+20n)

#### (c) Axis monitor device

- Servo error code (D8+20n)
- Torque limit value (D14+20n)

#### (d) Control change register

JOG speed setting register (D640+2n, D641+2n) that apply to the slave axis become invalid.

JOG speed setting register (D640+2n, D641+2n) in virtual mode become valid for the virtual servo.



(e) Common device

The following common devices that apply to the slave axis cannot be used.  
Do not use an interlock.

- Start accept flag (M2001 to M2032)
- Speed change accepting flag (M2061 to M2092)
- Automatic decelerating flag (M2128 to M2159)
- Speed change "0" accepting flag (M2240 to M2271)
- Control loop monitor status (M2272 to M2303)

(3) Current position management

- (a) Set "0: Used in incremental system" in " Absolute position detection system (PA03)" of servo parameter for slave axis.
- (b) Because the slave axis is in torque control and operates by input from the master axis, current feed value and deviation counter are not updated. However, the real current value is updated with a value within motor shaft 32 bit operation range (pulse unit).  
(During servo ON, the current feed value is not a value that reflects the motor movement amount. If servo is turned OFF, the current feed value is a value that reflects the motor movement amount. The deviation counter is always 0.)
- (c) The home position return request (M2409+20n) of slave axis is always ON but has no influence on the control of slave axis.
- (d) During slave operation, the following slave axis external signals, and parameters are invalid.
- Upper stroke limit signal (FLS)
  - Lower stroke limit signal (RLS)
  - Stop signal (STOP)
  - Upper/lower stroke limit value of fixed parameter
- (e) Do not operate the slave axis by a method other than driver communication with the master axis. If operated by a method other than driver communication, commands to the servo amplifier become invalid and current feed value and other current position management cannot be guaranteed.

(4) Servo program

Do not set the slave axis to the start axis of the servo program.

When slave axis is started, the position commands to the servo amplifier become invalid.

### (5) Mechanical system program

- (a) Do not set the slave axis to the output modules of the mechanical system program or the real mode axis. When the slave axis is set to output modules of the mechanical system program or the real mode axis, the position commands to the servo amplifier become invalid.
- (b) If a servo error occurs in the slave axis during operation by driver communication function, the "Error time operation mode" which was set in the mechanical system program does not apply. Measures at an error occurrence should be executed in the user program.

### (6) Advanced synchronous control

- (a) The master axis can be set to the servo input axis, or the output axis.
- (b) When the slave axis is set to the servo input axis, set [Pr.300] Servo input axis type to "2: Real current value", or "4: Feedback value".  
When set to anything else, the slave axis does not operate as input axis.
- (c) Do not set the slave axis to output axis. When the slave axis is set to output axis, the position commands to the servo amplifier become invalid.

### (7) Motion dedicated PLC instruction

Do not execute the following Motion dedicated PLC instructions for slave axis. When executed they become invalid.

- D(P).SVST (Start request of the specified servo program)
- D(P).CHGV (Speed change request of the specified axis)

### (8) Motion SFC program

Do not execute the following instructions for slave axis. When executed they become invalid.

- CHGV (Speed change request)
- CHGP (Target position change request)

### (9) Control mode of master axis

The control mode of the master axis can switch between position control mode, speed control mode, and torque control mode. For the master axis, when a switch to continuous operation to torque control mode is executed, there is a minor error (error code: 155), and the control mode does not switch.

### (10) Control mode of slave axis

- (a) Because the slave axis is always controlled by torque mode, the control mode (b2, b3) of servo status1 (#8010+20n) is in torque control mode ([0, 1]).
- (b) Do not operate slave axis by speed-torque control. For the slave axis, when a control mode switch is executed, or is operated by speed-torque control, the speed-torque control commands become invalid.

## 4 AUXILIARY AND APPLIED FUNCTIONS

### 4.16.3 Servo parameter

Set the following parameters for the axes that execute the master-slave operation.  
(Refer to the "Servo amplifier Instruction Manual" for details.)

No.	Item	Setting details	Setting range		
			MR-J5-□B	MR-J4-□B	MR-J3-□B
PA04	Function selection A-1	Set the forced stop input and forced stop deceleration function. (Note): Set "0: Forced stop deceleration function disabled" for forced stop deceleration function selection.	00000000h to 00002100h	0000h to 2100h	0000h to 2100h
PD15	Driver communication setting	Set the master axis and slave axis.	00000000h to 00000011h	0000h to 0011h	0000h to 0011h
PD16	Driver communication setting Master transmit data selection 1	Set the transmitted data at master axis setting.	00000000h to 0000FFFFh	0000h to FFFFh	0000h to FFFFh
PD17	Driver communication setting Master transmit data selection 2		00000000h to 0000FFFFh	0000h to FFFFh	0000h to FFFFh
PD20	Driver communication setting Master axis No. selection 1 for slave	Set the axis No. (d1 to d16) of master axis at slave axis setting.	0 to 32	0 to 32	0 to 16
PD30	Master-slave operation - Torque command coefficient on slave	Set the coefficient to reflect the internal torque command with the torque command value from the master axis.	0 to 500	0 to 500	0000h to 01FFh
PD31	Master-slave operation - Speed limit coefficient on slave	Set the coefficient to reflect the internal speed limit command with the speed limit command value from the master axis.	0 to 500	0 to 500	0000h to 01FFh
PD32	Master-slave operation - Speed limit adjusted value on slave	Set the lowest value of the internal speed limit.	0 to 32767	0 to 32767	0000h to 7FFFh

#### POINT

After writing the servo parameters to the Motion CPU, turn ON again or reset the Multiple CPU system power supply so that the parameters become valid.

## 4 AUXILIARY AND APPLIED FUNCTIONS





### 4.17 Intelligent Function Modules Controlled by Motion CPU

The Motion CPU can be used as the control CPU of intelligent function modules (excluding some modules).

Up to 4 intelligent function modules in total can be used.

The intelligent function modules that can be controlled by the Motion CPU are shown in Table 4.1.

Table 4.1 Intelligent function modules controlled by Motion CPU list

Module name	Model name	Number of points	Number of usable modules		Remark			
			Q173DSCPU/ Q172DSCPU	Q173DCPU(-S1)/ Q172DCPU(-S1)				
Analogue input module	Q68ADV	16 points	Total 4 modules (256 points or less)	Total 4 modules (256 points or less)				
	Q62AD-DGH							
	Q66AD-DG							
	Q68ADI							
	Q64AD							
	Q64AD-GH							
	Q68AD-G							
Analogue output module	Q68DAVN							
	Q68DAIN							
	Q62DAN							
	Q62DA-FG							
	Q64DAN							
	Q66DA-G							
Analogue input/output module	Q64AD2DA							
High-speed counter module 	QD62D	32 points	Total 4 modules (256 points or less (Note-1))	—	Cannot use coincidence detection interrupt function.			
	QD65PD2				Cannot use coincidence detection interrupt function and periodic interrupt function.			
Positioning module 	QD75P1							
	QD75P2							
	QD75P4							
	QD75D1							
	QD75D2							
	QD75D4							
	QD75MH1							
	QD75MH2							
Simple Motion module 	QD77MS2							
	QD77MS4							
	QD77MS16							
Control unit of displacement sensor 	UQ1-01				Manufactured by Optex FA Co., LTD. Cannot use dedicated setting software.			
	UQ1-02							

(Note-1): Number of I/O points is total of "Built-in interface in Motion CPU (Input 4 points) + I/O module + intelligent function module".

: Refer to Section 1.5 for the software version that supports this function.

## 4 AUXILIARY AND APPLIED FUNCTIONS

### (1) Setting method

Select "General", "Analog input", or "Analog output" in the Motion slot setting of intelligent function module and set the detail setting.

Refer to the help of MT Developer2 for details of the operation procedures.

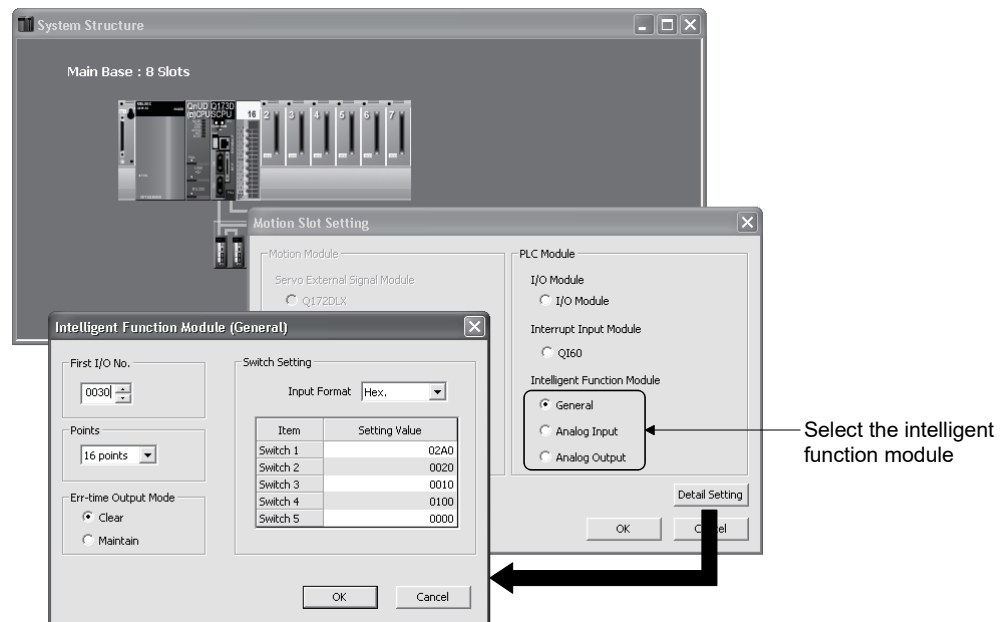

### POINT

- (1) Modules that can be used as a Motion CPU (Q172DLX, Q173DPX, Q172DEX, QI60 etc.) cannot be set as an intelligent function module. When these are set as intelligent function module, there is a system setting error.
- (2) The valid/invalid of "Error time output mode" settings differ for each intelligent function module. Refer to the manual of each intelligent function module for details.

### (2) Access to the intelligent function module

Use the TO and FROM instructions from Motion SFC programs to access the buffer memory of the intelligent function modules.

Also, you can access the I/O signal of the intelligent function module in the first I/O No. set in the system setting.

### POINT

When reading or writing 2 words of data or more using the FROM instruction or TO instruction, if the start address of the buffer memory is set to an even number, data will be read/written in units of 2 words.

## 4 AUXILIARY AND APPLIED FUNCTIONS

### (3) Usage example

An example using Q64AD2DA is shown below.

#### (a) Detail setting

Setting item		Setting details
First I/O No.		0030
Points		16 points
Switch setting	Input format	Hexadecimal
	Switch 1	02A0H (CH1 to CH4: Input range setting)
	Switch 2	0020H (CH5, CH6: Output range setting)
	Switch 3	0010H (CH5, CH6: Analog output HOLD/CLEAR function)
	Switch 4	0100H (High resolution mode setting)
Switch 5	0000H (Fixed at 0)	
Error time output mode		Clear

#### (b) Motion SFC program

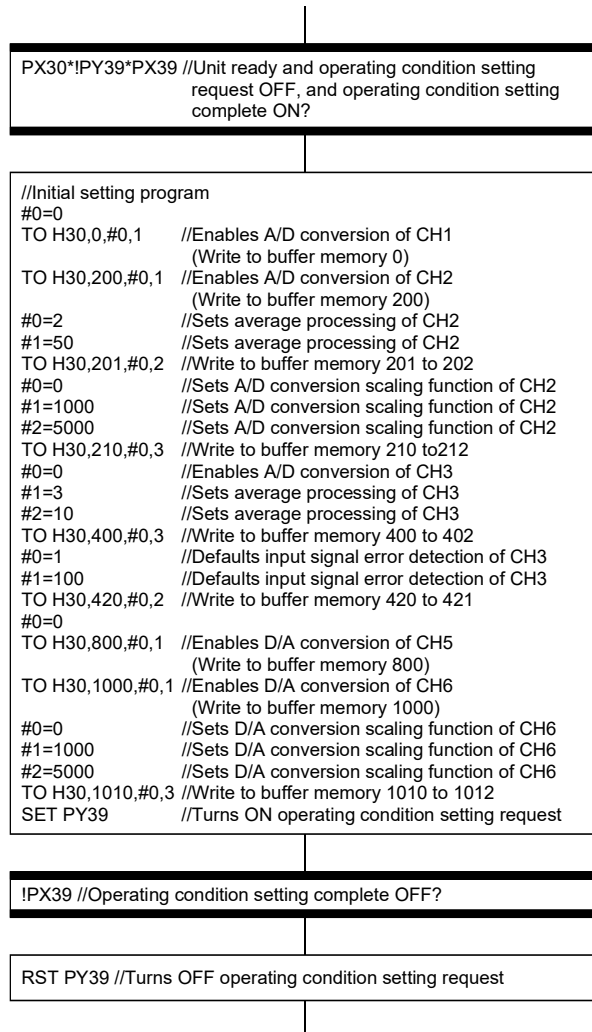

## 4 AUXILIARY AND APPLIED FUNCTIONS

### 4.18 Connection of SSCNETⅢ/H Head Module

The MELSEC-L series SSCNETⅢ/H head module (LJ72MS15) can be connected to Q173DSCPU/Q172DSCPU (SV13/SV22).

#### 4.18.1 System configuration

A system configuration that uses SSCNETⅢ/H head modules is shown below.

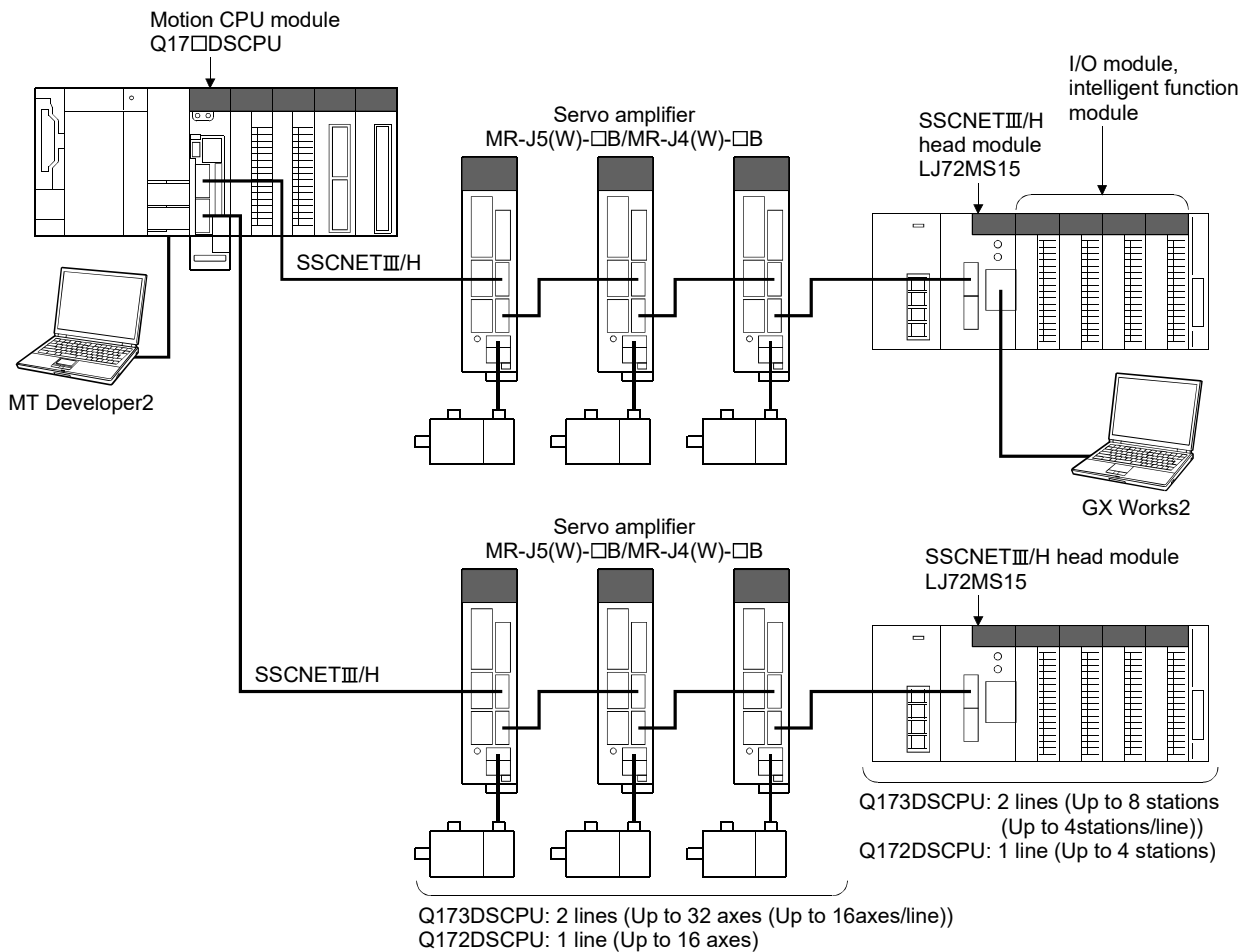

#### POINT

The parameters of the SSCNETⅢ/H head module and modules mounted to the SSCNETⅢ/H head module are set using GX Works2.  
 Refer to the "MELSEC-L SSCNETⅢ/H Head Module User's Manual" for details of the SSCNETⅢ/H head module.

 : Refer to Section 1.5 for the software version that supports this function.

## 4 AUXILIARY AND APPLIED FUNCTIONS

### 4.18.2 SSCNETⅢ/H head module parameters

#### (1) Parameter setting

Set the parameters to use the SSCNETⅢ/H head module.

The parameters are set using MT Developer2.

The setting items for parameters are shown in table 4.2.

Table 4.2 SSCNETⅢ/H head module parameter list

No.	Item	Setting range	Default value
1	Valid setting	0: Invalid/1: Valid	0: Invalid
2	Station number	1 to 64	—
3	Axis No.	0 to 8	—
4	Refresh device setting (CPU side) (Input: RX, RWr/ Output: RY, RWw)	Device name	Bit device : X, Y, M, B Word device : D, W, #, U□\G
		Points	Bit device : 16 to 512 Word device : 1 to 32
		Start	X0 to X1FFF/Y0 to Y1FFF/M0 to M8191/B0 to B1FFF/ D0 to D8191 (Note-1)/#0 to #9215/W0 to W1FFF/ U□\G10000 to (U□\G10000+p-1) (Note-2)
5	Status device	M0 to M8176/B0 to B1FFF/ D0 to D8191/#0 to #9215/W0 to W1FFF/ U□\G10000 to (U□\G10000+p-1) (Note-2)	—
6	Monitor device	D0 to D8191/#0 to #9215/W0 to W1FFF/ U□\G10000 to (U□\G10000+p-1) (Note-2)	—
7	Command device	M0 to M8176/B0 to B1FFF/ D0 to D8191/#0 to #9215/W0 to W1FFF/ U□\G10000 to (U□\G10000+p-1) (Note-2)	—

(Note-1): Range of D0 to D19823 is valid for SV22 advanced synchronous control.

(Note-2): "p" indicates the user setting area points of the Multiple CPU high speed transmission area for each CPU.

POINT	
(1) The number of SSCNETⅢ/H head module stations that can be connected to a SSCNETⅢ/H line according to operation cycle settings, are as follows.	
Operation cycle [ms]	Stations connected
0.88	Up to 4 stations
0.44	Up to 2 stations
0.22	Up to 1 station

#### (a) Valid setting

Set valid/invalid of SSCNETⅢ/H head module

- 0: Invalid ..... Not using SSCNETⅢ/H head module
- 1: Valid ..... Using SSCNETⅢ/H head module



## 4 AUXILIARY AND APPLIED FUNCTIONS

(b) Station number

Set the station number of SSCNET III/H head module.

The same station number can be used for line 1 and line 2.

Cannot use the same station number as the axis No. of the servo amplifier.

(Example) When using servo amplifier setting "d01", cannot set station number to "1".

Setting range
1 to 64

(c) Axis No.

Set the axis No. of SSCNET III/H head module.

(For Motion SFC programs, this number is used for specifying).

Cannot use the same axis No. for line 1 and line 2.

The same Motion axis No. and axis No. can be used.

Communication is not executed with a station that has axis No. set to "0".

(Use as a reserved axis.)

There can be duplicate axis No. 0.

Setting range
0 to 8

(d) Refresh device setting (CPU side)

Set the device (Input: RX, RWr/Output: RY, RWw) for storage of link data.

Motion CPU device is set using automatic refresh by cyclic transmission of the SSCNET III/H head module.

Link devices (RX, RWr, RY, RWw) of the Motion CPU are automatically assigned in MT Developer2.

**POINT**

Link devices (RX, RWr, RY, RWw) of the Motion CPU are used only for internal processing. These cannot be used in user data such as Motion SFC programs etc.

1) Device name

Set the device name that stores link data.

• Bit device : X, Y, M, B

• Word device : D, W, #, U□\G

2) Points

Set the points of the device that stores link data. Set the points of the device in units of words.

The total points for input (RX+RWr), and output (RY+RWw) must be 64 bytes or less.

Device	Setting range
Bit device (X, Y, M, B) <sup>(Note-1)</sup>	16 to 512
Word device (D, W, #, U□\G)	1 to 32

(Note-1): Set in units of 16 points (1 word).

## 4 AUXILIARY AND APPLIED FUNCTIONS

### 3) Start

Set the start device number that stores link data.

For bit devices, set a multiple of 16.

#### • Bit device

Bit device	Setting range
X	0 to 1FFF
Y	0 to 1FFF
M	0 to 8191
B	0 to 1FFF

#### • Word device

Word device	Setting range
D	0 to 8191 <sup>(Note-1)</sup>
W	0 to 1FFF
#	0 to 9215
U□\G	10000 to (10000+p-1) <sup>(Note-2), (Note-3)</sup>

(Note-1): The range of D0 to D19823 is valid in the SV22 advanced synchronous control.

(Note-2): "p" indicates the user setting area points of the Multiple CPU high speed transmission area for each CPU.

(Note-3): Only device of the self CPU can be used.

### (e) Status device

Set the device for storage of the status of the SSCNETⅢ/H head module.

#### 1) Usable devices are shown below.

#### • Bit device

Bit device	Setting range <sup>(Note-1)</sup>
M	0 to 8191
B	0 to 1FFF

(Note-1): Set the start device as a unit of 16 points.

#### • Word device

Word device	Setting range
D	0 to 8191
W	0 to 1FFF
#	0 to 9215
U□\G	10000 to (10000+p-1) <sup>(Note-1), (Note-2)</sup>

(Note-1): "p" indicates the user setting area points of the Multiple CPU high speed transmission area for each CPU.

(Note-2): Only device of the self CPU can be used.

## 4 AUXILIARY AND APPLIED FUNCTIONS

- 2) The device uses 16 points (1 point if a word device) from the specified device number.

The details stored in the status device are shown below.

Off set	Signal name	Refresh cycle
+0	Unusable	—
+1		
+2		
+3		
+4		
+5		
+6		
+7	During stop error	Operation cycle
+8	Unusable	—
+9		
+10		
+11		
+12		
+13		
+14		
+15	During continue error	Operation cycle

- a) During stop error

Can be used to judge whether there is an error or not by the signal turning ON when a stop error is detected in the SSCNETⅢ/H head module.

The applicable error code is stored in the error code signal of the monitor device set in (f) of this section.

If error is reset by turning ON the error reset command, or turning ON the SSCNETⅢ/H head module power supply again, the signal turns OFF.

- b) During continue error

Can be used to judge whether there is an error or not by the signal turning ON when a continue error is detected in the SSCNETⅢ/H head module.

The applicable error code is stored in the error code signal of the monitor device set in (f) of this section.

If error is reset by turning ON the error reset command, or turning ON the SSCNETⅢ/H head module power supply again, the signal turns OFF.

## 4 AUXILIARY AND APPLIED FUNCTIONS

(f) Monitor device

Set the devices for monitoring the status of SSCNET III/H head module.

1) Usable devices are shown below.

• Word device

Word device	Setting range
D	0 to 8191
W	0 to 1FFF
#	0 to 9215
U□\G	10000 to (10000+p-1) (Note-1), (Note-2)

(Note-1): "p" indicates the user setting area points of the Multiple CPU high speed transmission area for each CPU.

(Note-2): Only device of the self CPU can be used.

2) The device uses 10 points per word from the specified device number. The details stored in the status device are shown below.

Off set	Signal name	Refresh cycle
+0	Module operating status	Operation cycle
+1	Error code	
+2	Accumulative count for communication retry	At a communication retry
+3	Maximum continuous times for communication retry	
+4	Unusable	—
+5		
+6		
+7		
+8		
+9		

a) Module operating status

Stores the operating status of SSCNET III/H head module.

- 0: No communication
- 1: STOP status
- 2: RUN status
- 3: ERROR status

b) Error code

Stores the error code when an error is detected in the SSCNET III/H head module. (Continue error and stop error)

If error is reset by turning ON the error reset command, or the SSCNET III/H head module power supply is turned ON again, this device is also cleared.

c) Accumulative count for communication retry

Holds the accumulative count for communication retry with the SSCNET III/H head module.

d) Maximum continuous times for communication retry

Counts each time a communication retry with the SSCNET III/H head module occurs. When communication is successful, the count is "0".

## 4 AUXILIARY AND APPLIED FUNCTIONS

(g) Command device

Set the device for commands to SSCNETⅢ/H head module.

1) Usable devices are shown below.

• Bit device

Bit device	Setting range (Note-1)
M	0 to 8191
B	0 to 1FFF

(Note-1): Set the start device as a unit of 16 points.

• Word device

Word device	Setting range
D	0 to 8191
W	0 to 1FFF
#	0 to 9215
U□VG	10000 to (10000+p-1) (Note-1)

(Note-1): "p" indicates the user setting area points of the Multiple CPU high speed transmission area for each CPU.

2) The device uses 16 points (1 point if a word device) from the specified device number.

The details stored in the command device are shown below.

Off set	Signal name	Refresh cycle
+0	Unusable	—
+1		
+2		
+3		
+4		
+5		
+6		
+7	Error reset command	Main cycle
+8	Unusable	—
+9		
+10		
+11		
+12		
+13		
+14		
+15		

## 4 AUXILIARY AND APPLIED FUNCTIONS

### a) Error reset command

Clears the error code storage device and resets the error code detection signal of the SSCNETⅢ/H head module. At an error reset command, turn this signal OFF after confirming the error detection signal of the SSCNETⅢ/H head module is turned OFF.

However, depending on the error of the SSCNETⅢ/H head module, an error reset may not be executed, or conditions may apply to the error reset. In this case, the error code storage device is not cleared and the error code detection signal is not reset, even if an alarm reset is executed. Refer to the manual of the SSCNETⅢ/H head module for details.

### (2) Operation example of parameter

(a) When setting 2 SSCNETⅢ/H head modules (station 17, station 18) to SSCNET line 1.

#### 1) Parameter setting

The setting example of parameter is shown below.

Station number	Axis No.	Input/Output	Link device (Note-1)					Refresh device (CPU side)			Status device	Monitor device	Command device
			Device name	Points	Start	End		Points	Start	End			
17	1	Input	RX	128	0000	007F	→	128	M112	M239	M0	D2000	M16
			RWr	24	0000	0017	→	24	W0000	W0017			
		Output	RY	128	0000	007F	←	128	M240	M367			
			RWw	24	0000	0017	←	24	W0018	W002F			
18	2	Input	RX	0			→	0			M32	D2010	M48
			RWr	32	0018	0037	→	32	D2020	D2051			
		Output	RY	0			←	0					
			RWw	32	0018	0037	←	32	D2052	D2083			

(Note-1): Used only for internal processing of Motion CPU. The number of points set in the refresh device (CPU side) is automatically assigned in MT Developer2.

## 4 AUXILIARY AND APPLIED FUNCTIONS

### 2) Operation example

The example of operating parameter is shown below.

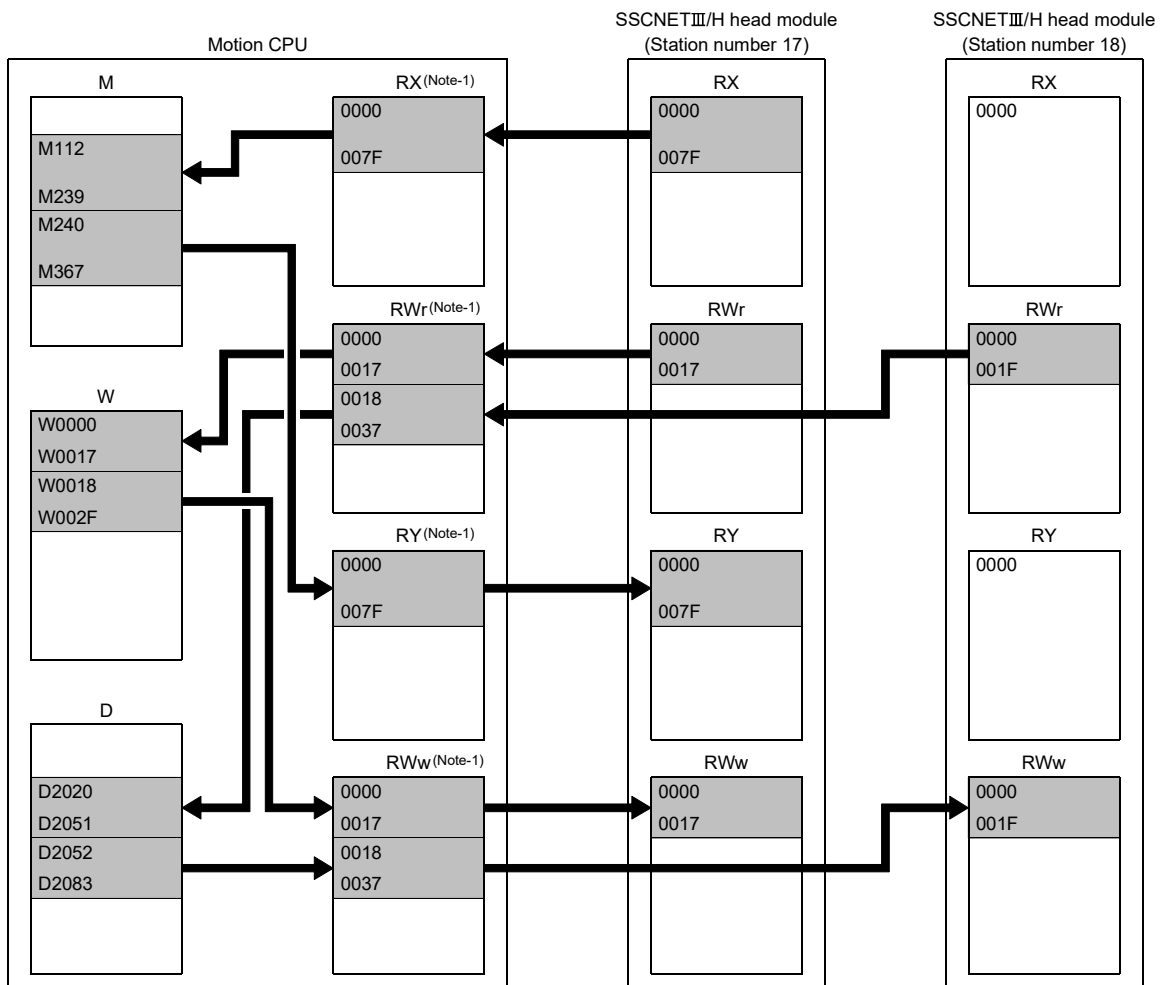

(Note-1): Used only for internal processing of Motion CPU. The number of points set in the refresh device (CPU side) is automatically assigned in MT Developer2.

## 4 AUXILIARY AND APPLIED FUNCTIONS

### 4.18.3 Data operation of intelligent function module by Motion SFC program

In addition to refresh of data by device, data read/write operations to the buffer memory of intelligent function modules on the SSCNET III/H head module can be executed by the RTO and RFROM instructions of Motion SFC programs. Refer to "Q173D(S)CPU/Q172D(S)CPU Motion controller (SV13/SV22) Programming Manual (Motion SFC)" for details.

Classification	Symbol	Instruction	Description
Others	RTO	Write buffer memory data to head module	Writes word device data to the buffer memory of the intelligent function module mounted to the SSCNET III/H head module.
	RFROM	Read buffer memory data from head module	Reads data from the buffer memory of the intelligent function module mounted to the SSCNET III/H head module, to the word device.

### 4.18.4 Data of refresh device

The refresh of data by device, for the status of Motion CPU, or when there is a communication failure with the head module are as follows.

	Refresh of data			
	Bit device		Word device	
	Input(RX)	Output(RY)	Input(RWr)	Output(RWw)
At communication failure occurrence	Clear		Maintain	
At STOP of Motion CPU	Maintain			
At Motion CPU operation stop error occurrence	Clear			

### 4.18.5 Precautions when using SSCNET III/H head module

- (1) Disconnect/reconnect function cannot be used for SSCNET III/H head module. If executed it is ignored.



# MEMO

---

---

---

---

---

---

---

---

---

---

---

---

---

---

---

---

---

---

---

---

---

---

---

---

---

---

## APPENDICES

### APPENDIX 1 Special Relays/Special Registers

#### APPENDIX 1.1 Special relays

Special relays are internal relays whose applications are fixed in the Motion CPU. For this reason, they cannot be used in the same way as the normal internal relays by the Motion SFC programs (SV13/SV22)/Motion programs (SV43). However, they can be turned ON/OFF as needed in order to control the Motion CPU.

The headings in the table that follows have the following meanings.

Item	Explanation
No.	• Indicates the device No. of the special relay.
Name	• Indicates the name of the special relay.
Meaning	• Indicates the nature of the special relay.
Details	• Indicates detailed information about the nature of the special relay.
Set by (When set)	<ul style="list-style-type: none"> <li>• Indicates whether the relay is set by the system or user, and, if it is set by system, when setting is performed.</li> <li>&lt;Set by&gt; <ul style="list-style-type: none"> <li>S: Set by system (Motion CPU)</li> <li>U: Set by user (Motion SFC program/Motion program or test operation using MT Developer2)</li> <li>S/U: Set by both system (Motion CPU) and user</li> </ul> </li> <li>&lt;When set&gt; Indicated only if setting is done by system (Motion CPU). <ul style="list-style-type: none"> <li>Main process: Set during each main processing (free time processing of the CPU)</li> <li>Initial process: Set only during initial processing (when power supply is turned ON, or when executed the reset)</li> </ul> </li> <li>Status change : Set only when there is a change in status</li> <li>Error : Set when error is occurred.</li> <li>Request : Set only when there is a user request (Special relay, etc.)</li> <li>Operation cycle : Set during each operation cycle of the Motion CPU.</li> </ul>

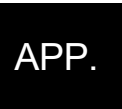



Table 1.1 Special relay list





No.	Name	Meaning	Details	Set by (When set)
SM0	Diagnostic error	OFF : No error ON : Error	<ul style="list-style-type: none"> <li>• Turn ON if an error occurs as a result of diagnosis.</li> <li>• Remains ON even if the condition is restored to normal thereafter.</li> <li>• Turn ON by ON to OFF of the Motion error detection flag (M2039) for except the stop error after confirming the error content.</li> </ul>	S (Occur an error)
SM1	Self-diagnostic error	OFF : No self-diagnostic error ON : Self-diagnostic error	<ul style="list-style-type: none"> <li>• Turn ON if an error occurs as a result of self-diagnosis.</li> <li>• Remains ON even if the condition is restored to normal thereafter.</li> <li>• Turn ON by ON to OFF of the Motion error detection flag (M2039) for except the stop error after confirming the error content.</li> </ul>	
SM51	Battery low latch	OFF : Normal ON : Battery low	<ul style="list-style-type: none"> <li>• Turn ON if the voltage of battery reduces to less than 2.5[V].</li> <li>• Remains ON even if the condition is restored to normal thereafter.</li> </ul>	
SM52	Battery low	OFF : Normal ON : Battery low	<ul style="list-style-type: none"> <li>• Turn on when the voltage of the battery reduces to less than 2.5[V].</li> <li>• Turn OFF when the voltage of external battery returns to normal.</li> </ul>	
SM53	AC/DC DOWN detection	OFF : AC/DC DOWN not detected	<ul style="list-style-type: none"> <li>• Turn ON if an instantaneous power failure of within 20[ms] occurs during use of the AC power supply module.</li> <li>Reset when the power supply is switched OFF, then ON.</li> </ul>	
		ON : AC/DC DOWN detected	<ul style="list-style-type: none"> <li>• Turn ON if an instantaneous power failure of within 10[ms] occurs during use of the AC power supply module.</li> <li>Reset when the power supply is switched OFF, then ON.</li> </ul>	
SM58	Battery low warning latch	OFF : Normal ON : Battery low	<ul style="list-style-type: none"> <li>• Turn ON if the voltage of battery reduces to less than 2.7[V].</li> <li>• Remains ON even if the condition is restored to normal thereafter.</li> </ul>	
SM59	Battery low warning	OFF : Normal ON : Battery low	<ul style="list-style-type: none"> <li>• Turn on when the voltage of the battery reduces to less than 2.7[V].</li> <li>• Turn OFF when the voltage of external battery returns to normal.</li> </ul>	
SM60	Fuse blown detection	OFF : Normal ON : Module with blown fuse	<ul style="list-style-type: none"> <li>• Turn ON if there is at least one output module whose fuse has blown.</li> <li>• Remains ON even if the condition is restored to normal thereafter.</li> </ul>	
SM211	Clock data error	OFF : No error ON : Error	<ul style="list-style-type: none"> <li>• Turn ON if an error occurs in clock data (SD210 to SD213) value, and turn OFF if no error is detected.</li> </ul>	
SM220 (Note-1)	CPU No.1 READY complete	OFF : CPU No.1 READY incompleton ON : CPU No.1 READY completion	<ul style="list-style-type: none"> <li>• Turn ON if CPU No. 1 which uses Multiple CPU high speed bus can be operated between Multiple CPU.</li> </ul>	S (Change status)
SM221 (Note-1)	CPU No.2 READY complete	OFF : CPU No.2 READY incompleton ON : CPU No.2 READY completion	<ul style="list-style-type: none"> <li>• Turn ON if CPU No. 2 which uses Multiple CPU high speed bus can be operated between Multiple CPU.</li> </ul>	
SM222 (Note-1)	CPU No.3 READY complete	OFF : CPU No.3 READY incompleton ON : CPU No.3 READY completion	<ul style="list-style-type: none"> <li>• Turn ON if CPU No. 3 which uses Multiple CPU high speed bus can be operated between Multiple CPU.</li> </ul>	
SM223 (Note-1)	CPU No.4 READY complete	OFF : CPU No.4 READY incompleton ON : CPU No.4 READY completion	<ul style="list-style-type: none"> <li>• Turn ON if CPU No. 4 which uses Multiple CPU high speed bus can be operated between Multiple CPU.</li> </ul>	
SM240	No.1 CPU resetting	OFF : CPU No.1 reset cancel	<ul style="list-style-type: none"> <li>• Goes OFF when reset of the No.1 CPU is cancelled.</li> </ul>	
		ON : CPU No.1 resetting	<ul style="list-style-type: none"> <li>• Comes ON when the No.1 CPU is resetting (including the case where the CPU module is removed from the base).</li> <li>• The other CPUs are also put in reset status.</li> </ul>	
			<ul style="list-style-type: none"> <li>• Goes OFF when reset of the No.2 CPU is cancelled.</li> </ul>	
SM241	No.2 CPU resetting	OFF : CPU No.2 reset cancel	<ul style="list-style-type: none"> <li>• Comes ON when the No.2 CPU is resetting (including the case where the CPU module is removed from the base).</li> <li>• The other CPUs result in "MULTI CPU DOWN" (error code: 7000).</li> </ul>	
		ON : CPU No.2 resetting		
SM242	No.3 CPU resetting	OFF : CPU No.3 reset cancel	<ul style="list-style-type: none"> <li>• Goes OFF when reset of the No.3 CPU is cancelled.</li> </ul>	
		ON : CPU No.3 resetting	<ul style="list-style-type: none"> <li>• Comes ON when the No.3 CPU is resetting (including the case where the CPU module is removed from the base).</li> <li>• The other CPUs result in "MULTI CPU DOWN" (error code: 7000).</li> </ul>	

Table 1.1 Special relay list (Continued)

No.	Name	Meaning	Details	Set by (When set)
SM243	No.4 CPU resetting	OFF : CPU No.4 reset cancel ON : CPU No.4 resetting	<ul style="list-style-type: none"> <li>Goes OFF when reset of the No.4 CPU is cancelled.</li> <li>Comes ON when the No.4 CPU is resetting (including the case where the CPU module is removed from the base).</li> <li>The other CPUs result in "MULTI CPU DOWN" (error code: 7000).</li> </ul>	S (Change status)
SM244	No.1 CPU error	OFF : CPU No.1 normal ON : CPU No.1 during stop error	<ul style="list-style-type: none"> <li>Goes OFF when the CPU No.1 is normal. (Including a continuation error)</li> <li>Comes ON when the CPU No.1 is during stop error. (Note-2)</li> </ul>	
SM245	No.2 CPU error	OFF : CPU No.2 normal ON : CPU No.2 during stop error	<ul style="list-style-type: none"> <li>Goes OFF when the CPU No.2 is normal. (Including a continuation error)</li> <li>Comes ON when the CPU No.2 is during stop error. (Note-2)</li> </ul>	
SM246	No.3 CPU error	OFF : CPU No.3 normal ON : CPU No.4 during stop error	<ul style="list-style-type: none"> <li>Goes OFF when the CPU No.3 is normal. (Including a continuation error)</li> <li>Comes ON when the CPU No.3 is during stop error. (Note-2)</li> </ul>	
SM247	No.4 CPU error	OFF : CPU No.4 normal ON : CPU No.4 during stop error	<ul style="list-style-type: none"> <li>Goes OFF when the CPU No.4 is normal. (Including a continuation error)</li> <li>Comes ON when the CPU No.4 is during stop error. (Note-2)</li> </ul>	
SM400	Always ON	ON _____ OFF	• Normally is ON.	S (Main processing)
SM401	Always OFF	ON _____ OFF _____	• Normally is OFF.	
SM500	PCPU READY complete	ON : PCPU READY completion OFF : PCPU READY incomplection	<ul style="list-style-type: none"> <li>When the PLC ready flag (M2000) turn OFF to ON, the fixed parameters, servo parameters and limit switch output data, etc., are checked, and if no error is detected, this flag turns ON.</li> <li>Turn OFF with PLC ready flag (M2000) OFF.</li> </ul>	S (Request)
SM501	Test mode ON	ON : TEST mode ON OFF : Except TEST mode	<ul style="list-style-type: none"> <li>Judge whether TEST mode ON or not using MT Developer2.</li> <li>If the TEST mode is not established by TEST mode request using MT Developer2, the TEST mode request error (SM510) turns ON.</li> </ul>	
SM502	External forced stop input	ON : Forced stop OFF OFF : Forced stop ON	• Confirm forced stop ON/OFF.	S (Operation cycle)
SM503	Digital oscilloscope executing	ON : Digital oscilloscope is stop OFF : Digital oscilloscope is executing	• Confirm the execution of digital oscilloscope using MT Developer2.	S (Change status)
SM505	Cam data writing flag 	OFF : Cam data not writing ON : Cam data writing	• Turn ON during cam data writing by executing the cam data write (CAMWR)/cam data write (cam open area: CAMWR2)/cam auto-generation (CAMMK).	
SM506	External forced stop input ON latch 	ON : External forced stop input is detected OFF : External forced stop input is not detected	<ul style="list-style-type: none"> <li>Turn ON when an external forced stop input is detected.</li> <li>Remains ON even if the condition is cancelled to thereafter.</li> </ul>	
SM508	Amplifier-less operation status	ON : During amplifier-less operation OFF : During normal operation	• Confirm the amplifier-less operation status.	S (Main processing)
SM510	TEST mode request error	ON : Abnormal OFF : Normal	<ul style="list-style-type: none"> <li>Turn ON if the TEST mode is not established by TEST mode request using MT Developer2.</li> <li>When this relay is ON, the error content is stored in the TEST mode request error register (SD510, SD511).</li> </ul>	S (Occur an error)
SM512	Motion CPU WDT error	ON : Abnormal OFF : Normal	<ul style="list-style-type: none"> <li>Turn ON when a "watchdog timer error" is detected by the Motion CPU self-diagnosis function.</li> <li>When the Motion CPU detects a WDT error, it executes an immediate stop without deceleration of the operating axes.</li> <li>The error cause is stored in the "Motion CPU WDT error cause (SD512)".</li> </ul>	

 : Refer to Section 1.5 for the software version that supports this function.

Table 1.1 Special relay list (Continued)

No.	Name	Meaning	Details	Set by (When set)
SM513	Manual pulse generator axis setting error	ON : At least one D714 to D719 setting is abnormal. OFF : All D714 to D719 settings are normal.	<ul style="list-style-type: none"> <li>Judge whether normal/abnormal of the register for manual pulse generator axis setting register (D714 to D719).</li> <li>When this relay is ON, the error content is stored in the manual pulse generator axis setting error register (SD513 to SD515).</li> </ul>	S (Occur an error)
SM516	Servo program setting error (SV13/SV22)/ Motion program setting error (SV43)	ON : Abnormal OFF : Normal	<ul style="list-style-type: none"> <li>Judge whether normal/abnormal of the positioning data of servo program(K) (SV13/SV22)/Motion program(SV43) specified with the Motion SFC program, and if error is detected this flag turns ON.</li> <li>The content of an error is stored at SD516, SD517.</li> </ul>	
SM526	Over heat warning latch	OFF : Normal ON : Abnormal	<ul style="list-style-type: none"> <li>Turn ON when the temperature of Motion CPU module becomes specified value 85[°C] (185[°F]) or more.</li> <li>Remains ON even if normal status is restored.</li> </ul>	
SM527	Over heat warning	OFF : Normal ON : Abnormal	<ul style="list-style-type: none"> <li>Turn ON when the temperature of Motion CPU module becomes specified value 85[°C] (185[°F]) or more.</li> <li>Turn OFF when the temperature of Motion CPU module returns to normal.</li> </ul>	
SM528	No.1 CPU MULTR complete	OFF to ON : CPU No.1 read completion	<ul style="list-style-type: none"> <li>Turn ON when the data read from CPU No.1 is normal by MULTR instruction.</li> </ul>	S (Read completion)
SM529	No.2 CPU MULTR complete	OFF to ON : CPU No.2 read completion	<ul style="list-style-type: none"> <li>Turn ON when the data read from CPU No.2 is normal by MULTR instruction.</li> </ul>	
SM530	No.3 CPU MULTR complete	OFF to ON : CPU No.3 read completion	<ul style="list-style-type: none"> <li>Turn ON when the data read from CPU No.3 is normal by MULTR instruction.</li> </ul>	
SM531	No.4 CPU MULTR complete	OFF to ON : CPU No.4 read completion	<ul style="list-style-type: none"> <li>Turn ON when the data read from CPU No.4 is normal by MULTR instruction.</li> </ul>	
SM532	SSCNET <sup>III</sup> searching flag (Line 1) 	OFF : Search complete ON : Searching	<ul style="list-style-type: none"> <li>Turns ON when searching axes that have been set to line 1 by system setting.</li> <li>Turns OFF when all axes that have been set to line 1 by system setting have been searched.</li> </ul>	S (Change status)
SM533	SSCNET <sup>III</sup> searching flag (Line 2) 	OFF : Search complete ON : Searching	<ul style="list-style-type: none"> <li>Turns ON when searching axes that have been set to line 2 by system setting.</li> <li>Turns OFF when all axes that have been set to line 2 by system setting have been searched.</li> </ul>	
SM561	Multiple CPU synchronous control initial complete flag 	OFF : Multiple CPU synchronous initial incomplete. ON : Multiple CPU synchronous initial complete.	<ul style="list-style-type: none"> <li>Turns ON when the initial processing of Multiple CPU synchronous control is completed.</li> </ul>	S (Initial processing)
SM801	Clock data read request	OFF : Ignored ON : Read request	<ul style="list-style-type: none"> <li>When this relay is ON, clock data is read to SD210 to SD213 as BCD values.</li> </ul>	U
SM805	Rapid stop deceleration time setting error invalid flag 	OFF : Setting error valid ON : Setting error invalid	<ul style="list-style-type: none"> <li>When this relay is ON, the large value than deceleration time can be set as rapid stop deceleration time. (The servo program setting error (error code: 51) will not occur.)</li> </ul>	

(Note-1): It is used for interlock condition of Multiple CPU high speed bus dedicated instruction when a synchronous system set in Multiple CPU synchronous startup setting of system setting.

(Note-2): The CPU No.1 is reset after the factor of the stop error is removed to cancel a stop error → Resetting is cancelled.

 : Refer to Section 1.5 for the software version that supports this function.

APPENDIX 1.2 Special registers

Special registers are internal registers whose applications are fixed in the Motion CPU. For this reason, it is not possible to use these registers in Motion SFC programs (SV13/SV22)/Motion programs (SV43) in the same way that normal registers are used.

However, data can be written as needed in order to control the Motion CPU. Data stored in the special registers are stored as BIN values if no special designation has been made to the contrary.

The headings in the table that follows have the following meanings.

Item	Explanation
Number	• Indicates the No. of the special register.
Name	• Indicates the name of the special register.
Meaning	• Indicates the nature of the special register.
Details	• Indicates detailed information about the nature of the special register.
Set by (When set)	<ul style="list-style-type: none"> <li>• Indicates whether the register is set by the system or user, and, if it is set by system, when setting is performed.</li> <li>&lt;Set by&gt;</li> <li>S: Set by system (Motion CPU)</li> <li>U: Set by user (Motion SFC program/Motion program or test operation using MT Developer2)</li> <li>S/U: Set by both system (Motion CPU) and user</li> <li>&lt;When set&gt; Indicated only if setting is done by system (Motion CPU).</li> <li>Main process: Set during each main processing (free time processing of the CPU)</li> <li>Initial process: Set only during initial processing (when power supply is turned ON, or when executed the reset)</li> <li>Status change : Set only when there is a change in status</li> <li>Error : Set when error is occurred.</li> <li>Request : Set only when there is a user request (Special relay, etc.)</li> <li>Operation cycle : Set during each operation cycle of the Motion CPU.</li> </ul>

Table 1.2 Special register list

No.	Name	Meaning	Details	Set by (When set)						
SD0	Diagnostic errors	Diagnostic error code	<ul style="list-style-type: none"> <li>Error codes for errors found by diagnosis are stored as BIN data.</li> <li>Refer to "APPENDIX 3" for details of the error code.</li> <li>After confirm the error content, except the stop error, it is possible to clear by ON to OFF of the Motion error detection flag (M2039).</li> <li>Clear SD0 to SD26 by ON to OFF of the Motion error detection flag (M2039) for except the stop error after confirming the error content.</li> </ul>	S (Occur an error)						
SD1	Clock time for diagnostic error occurrence	Clock time for diagnostic error occurrence	<ul style="list-style-type: none"> <li>The year (last two digits) and month that SD0 data was updated is stored as BCD 2-digit code.</li> </ul> <table border="1"> <tr> <td>B15 to B8</td> <td>B7 to B0</td> <td>Example : January 2006</td> </tr> <tr> <td>Year(0 to 99)</td> <td>Month(1 to 12)</td> <td>H0601</td> </tr> </table>		B15 to B8	B7 to B0	Example : January 2006	Year(0 to 99)	Month(1 to 12)	H0601
B15 to B8			B7 to B0		Example : January 2006					
Year(0 to 99)			Month(1 to 12)		H0601					
SD2	<ul style="list-style-type: none"> <li>The day and hour that SD0 data was updated is stored as BCD 2-digit code.</li> </ul> <table border="1"> <tr> <td>B15 to B8</td> <td>B7 to B0</td> <td>Example : 25th, 10 a.m</td> </tr> <tr> <td>Day(1 to 31)</td> <td>Hour(0 to 23)</td> <td>H2510</td> </tr> </table>	B15 to B8	B7 to B0		Example : 25th, 10 a.m	Day(1 to 31)	Hour(0 to 23)	H2510		
B15 to B8	B7 to B0	Example : 25th, 10 a.m								
Day(1 to 31)	Hour(0 to 23)	H2510								
SD3	<ul style="list-style-type: none"> <li>The minute and second that SD0 data was updated is stored as BCD 2-digit code.</li> </ul> <table border="1"> <tr> <td>B15 to B8</td> <td>B7 to B0</td> <td>Example : 35min., 48 sec.</td> </tr> <tr> <td>Minute(0 to 59)</td> <td>Second(0 to 59)</td> <td>H3548</td> </tr> </table>	B15 to B8	B7 to B0		Example : 35min., 48 sec.	Minute(0 to 59)	Second(0 to 59)	H3548		
B15 to B8	B7 to B0	Example : 35min., 48 sec.								
Minute(0 to 59)	Second(0 to 59)	H3548								
SD4	Error information categories	Error information category code	<ul style="list-style-type: none"> <li>Category codes which help indicate what type of information is being stored in the error common information areas (SD5 to SD15) and error individual information areas (SD16 to SD26) are stored. The category code for judging the error information type is stored.</li> </ul> <table border="1"> <tr> <td>B15 to B8</td> <td>B7 to B0</td> </tr> <tr> <td>Individual information category codes</td> <td>Common information category codes</td> </tr> </table> <ul style="list-style-type: none"> <li>The common information category codes store the following codes. 0: No error 1: Module No./CPU No./Base No.</li> <li>The individual information category codes store the following codes. 0: No error 5: Parameter No. 13:Parameter No./CPU No.</li> </ul>	B15 to B8	B7 to B0	Individual information category codes	Common information category codes			
B15 to B8	B7 to B0									
Individual information category codes	Common information category codes									
SD5	Error common information	Error common information	<ul style="list-style-type: none"> <li>Common information corresponding to the diagnostic error (SD0) is stored.</li> </ul>							
SD6			<ul style="list-style-type: none"> <li>The error common information type can be judged by SD4 (common information category code).</li> </ul>							
SD7			<ul style="list-style-type: none"> <li>1: Module No./CPU No./Base No.</li> </ul>							
SD8			<ul style="list-style-type: none"> <li>For the Multiple CPU system, Module No. or CPU No. is stored depending on the error that occurred.</li> </ul>							
SD9			<ul style="list-style-type: none"> <li>(Refer to corresponding error code for which No. has been stored.)</li> </ul>							
SD10			<ul style="list-style-type: none"> <li>CPU No.1: 1, CPU No.2: 2, CPU No.3: 3, CPU No.4: 4</li> </ul>							
SD11										
SD12										
SD13										
SD14										
SD15		<table border="1"> <thead> <tr> <th>No.</th> <th>Meaning</th> </tr> </thead> <tbody> <tr> <td>SD5</td> <td>Module No./CPU No./Base No.</td> </tr> <tr> <td>SD6</td> <td>I/O No.</td> </tr> <tr> <td>SD7 to SD15</td> <td>Empty</td> </tr> </tbody> </table>	No.	Meaning	SD5	Module No./CPU No./Base No.	SD6	I/O No.	SD7 to SD15	Empty
No.	Meaning									
SD5	Module No./CPU No./Base No.									
SD6	I/O No.									
SD7 to SD15	Empty									

Table 1.2 Special register list (Continued)

No.	Name	Meaning	Details	Set by (When set)														
SD16 SD17 SD18 SD19 SD20 SD21 SD22 SD23 SD24 SD25 SD26	Error individual information	Error individual information	<ul style="list-style-type: none"> <li>Individual information corresponding to the diagnostic error (SD0) is stored.</li> <li>The error individual information type can be judged by SD4 (individual information category code).</li> </ul> <p>5: Parameter No.</p> <table border="1"> <thead> <tr> <th>No.</th> <th>Meaning</th> </tr> </thead> <tbody> <tr> <td>SD16</td> <td>Parameter No.</td> </tr> <tr> <td>SD17 to SD26</td> <td>Empty</td> </tr> </tbody> </table> <p>0401H : Base setting                      0406H : Motion slot setting                      0E00H : Multiple CPU setting (Number of Multiple CPU's)                      0E01H : Multiple CPU setting (Operation mode/Multiple CPU synchronous startup)                      E008H : Multiple CPU high speed transmission area setting(CPU specific send range setting/ (System area))                      E009H/E00AH : Multiple CPU high speed transmission area setting (Automatic refresh setting)                      E00BH : Synchronous setting</p> <p>13: Parameter No./CPU No.</p> <table border="1"> <thead> <tr> <th>No.</th> <th>Meaning</th> </tr> </thead> <tbody> <tr> <td>SD16</td> <td>Parameter No.</td> </tr> <tr> <td>SD17</td> <td>CPU No.(1 to 4)</td> </tr> <tr> <td>SD18 to SD26</td> <td>Empty</td> </tr> </tbody> </table>	No.	Meaning	SD16	Parameter No.	SD17 to SD26	Empty	No.	Meaning	SD16	Parameter No.	SD17	CPU No.(1 to 4)	SD18 to SD26	Empty	S (Occur an error)
No.	Meaning																	
SD16	Parameter No.																	
SD17 to SD26	Empty																	
No.	Meaning																	
SD16	Parameter No.																	
SD17	CPU No.(1 to 4)																	
SD18 to SD26	Empty																	
SD53	AC/DC DOWN counter No.	Number of times for AC/DC DOWN	<ul style="list-style-type: none"> <li>Every time the input voltage fails to or below (85[%] AC power/65[%] DC power) the rating during calculation of the Motion CPU module, the value is incremented by 1 and stored in BIN code.</li> </ul>															
SD60	Fuse blown No.	Module No. with blown fuse	<ul style="list-style-type: none"> <li>The lowest station I/O No. of the module with the blown fuse is stored.</li> </ul>															
SD200	Status of switch	Status of CPU switch	<ul style="list-style-type: none"> <li>The CPU switch status is stored in the following format.</li> </ul> <p>1) CPU switch status      0: RUN                      1: STOP</p>															
SD203	Operating status of CPU	Operating status of CPU	<ul style="list-style-type: none"> <li>The CPU operating status is stored as indicated in the following figure.</li> </ul> <p>1) Operating status of CPU      0: RUN                      2: STOP                      2) STOP cause                  0: RUN/STOP switch                      4: Error</p>	S (Main processing)														



Table 1.2 Special register list (Continued)







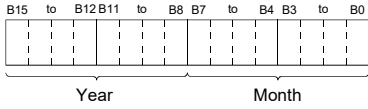
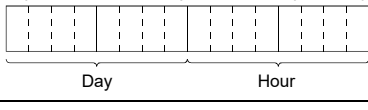
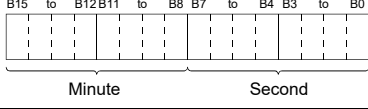
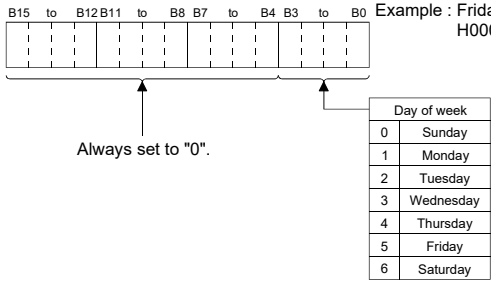

No.	Name	Meaning	Details	Set by (When set)														
SD210	Clock data	Clock data (Year, Month)	<ul style="list-style-type: none"> <li>The year (last two digits) and month are stored as BCD code.</li> </ul> 	S/U (Request)														
SD211		Clock data (Day, Hour)	<ul style="list-style-type: none"> <li>The day and hour are stored as BCD code.</li> </ul> 															
SD212		Clock data (Minute, Second)	<ul style="list-style-type: none"> <li>The minutes and seconds are stored as BCD code.</li> </ul> 															
SD213		Clock data (Day of week)	<ul style="list-style-type: none"> <li>The day of week is stored as BCD code.</li> </ul>  <p>Always set to "0".</p> <table border="1" data-bbox="962 965 1085 1149"> <thead> <tr> <th colspan="2">Day of week</th> </tr> </thead> <tbody> <tr><td>0</td><td>Sunday</td></tr> <tr><td>1</td><td>Monday</td></tr> <tr><td>2</td><td>Tuesday</td></tr> <tr><td>3</td><td>Wednesday</td></tr> <tr><td>4</td><td>Thursday</td></tr> <tr><td>5</td><td>Friday</td></tr> <tr><td>6</td><td>Saturday</td></tr> </tbody> </table>		Day of week		0	Sunday	1	Monday	2	Tuesday	3	Wednesday	4	Thursday	5	Friday
Day of week																		
0	Sunday																	
1	Monday																	
2	Tuesday																	
3	Wednesday																	
4	Thursday																	
5	Friday																	
6	Saturday																	
SD290	Device assignment	Number of points assigned for X	<ul style="list-style-type: none"> <li>Stores the number of points currently set for X devices.</li> </ul>	S (Initial processing)														
SD291		Number of points assigned for Y	<ul style="list-style-type: none"> <li>Stores the number of points currently set for Y devices.</li> </ul>															
SD292		Number of points assigned for M	<ul style="list-style-type: none"> <li>Stores the number of points currently set for M devices.</li> </ul>															
SD293		Number of points assigned for L	<ul style="list-style-type: none"> <li>Stores the number of points currently set for L devices.</li> </ul>															
SD294		Number of points assigned for B	<ul style="list-style-type: none"> <li>Stores the number of points currently set for B devices.</li> </ul>															
SD295		Number of points assigned for F	<ul style="list-style-type: none"> <li>Stores the number of points currently set for F devices.</li> </ul>															
SD296		Number of points assigned for SB	<ul style="list-style-type: none"> <li>Stores the number of points currently set for SB devices.</li> </ul>															
SD297		Number of points assigned for V	<ul style="list-style-type: none"> <li>Stores the number of points currently set for V devices.</li> </ul>															
SD298		Number of points assigned for S	<ul style="list-style-type: none"> <li>Stores the number of points currently set for S devices.</li> </ul>															
SD299		Number of points assigned for T	<ul style="list-style-type: none"> <li>Stores the number of points currently set for T devices.</li> </ul>															
SD300		Number of points assigned for ST	<ul style="list-style-type: none"> <li>Stores the number of points currently set for ST devices.</li> </ul>															
SD301		Number of points assigned for C	<ul style="list-style-type: none"> <li>Stores the number of points currently set for C devices.</li> </ul>															
SD302		Number of points assigned for D	<ul style="list-style-type: none"> <li>Stores the number of points currently set for D devices.</li> </ul>															
SD303		Number of points assigned for W	<ul style="list-style-type: none"> <li>Stores the number of points currently set for W devices.</li> </ul>															
SD304		Number of points assigned for SW	<ul style="list-style-type: none"> <li>Stores the number of points currently set for SW devices.</li> </ul>															
SD395	Multiple CPU No.	Multiple CPU No.	<ul style="list-style-type: none"> <li>CPU No. of the self CPU is stored.</li> </ul>															

Table 1.2 Special register list (Continued)











No.	Name	Meaning	Details	Set by (When set)						
SD500 SD501	Real mode axis information register	Real mode axis information register	<ul style="list-style-type: none"> <li>The information (Except real mode axis: 0/Real mode axis: 1) used as a real mode axis at the time of switching from real mode to virtual mode is stored. SD500 : b0 to b15 (Axis 1 to 16) SD501 : b0 to b15 (Axis 17 to 32)</li> <li>The real mode axis information does not change at the time of switching from virtual mode to real mode</li> </ul>	S (At virtual mode transition)						
SD502 SD503	Servo amplifier loading information	Servo amplifier loading information	<ul style="list-style-type: none"> <li>The loading status (loading: 1/non-loading: 0) of the servo amplifier checked, and stored as the bit data. SD502 : b0 to b15 (Axis 1 to 16) SD503 : b0 to b15 (Axis 17 to 32)</li> <li>The mounting status of changed axis after the power supply on is stored.</li> </ul>	S (Operation cycle)						
SD504 SD505 SD506	Real mode/virtual mode switching error information	Real mode /virtual mode switching error code	<ul style="list-style-type: none"> <li>When a mode switching error occurs in real-to-virtual or virtual-to-real mode switching, or a mode continuation error occurs in the virtual mode, its error information is stored.</li> </ul>	S (Occur an error)						
SD508	SSCNET control (Status)	<ul style="list-style-type: none"> <li>Connect/disconnect of SSCNET communication</li> <li>Start/release of amplifier-less operation</li> </ul>	<ul style="list-style-type: none"> <li>SD508 stores the executing state for connect/disconnect of SSCNET communication and start/release of amplifier-less operation.</li> </ul> <table border="1" style="margin-left: 20px;"> <tr> <td>0 : Command accept waiting</td> </tr> <tr> <td>-1 : Execute waiting</td> </tr> <tr> <td>-2 : Executing</td> </tr> </table>	0 : Command accept waiting	-1 : Execute waiting	-2 : Executing	S (Main processing)			
0 : Command accept waiting										
-1 : Execute waiting										
-2 : Executing										
SD510 SD511	Test mode request error information	It is operating in requirement error occurrence of the test mode, axis information	<ul style="list-style-type: none"> <li>Each axis is stopping: 0/Operating: 1, information is stored as a bit data. SD510 : b0 to b15 (Axis 1 to Axis 16) SD511 : b0 to b15 (Axis 17 to Axis 32)</li> </ul>							
SD512	Motion CPU WDT error cause	Error meaning of WDT error occurs	<ul style="list-style-type: none"> <li>The following error codes are stored in SD512.</li> </ul> <table border="1" style="margin-left: 20px;"> <tr> <td>1: S/W fault 1</td> </tr> <tr> <td>2: Operation cycle over</td> </tr> <tr> <td>4: WDT error</td> </tr> <tr> <td>300: S/W fault 3</td> </tr> <tr> <td>303: S/W fault 4</td> </tr> <tr> <td>304: RIO WDT error</td> </tr> </table>	1: S/W fault 1	2: Operation cycle over	4: WDT error	300: S/W fault 3	303: S/W fault 4	304: RIO WDT error	
1: S/W fault 1										
2: Operation cycle over										
4: WDT error										
300: S/W fault 3										
303: S/W fault 4										
304: RIO WDT error										
SD513 SD514 SD515	Manual pulse generator axis setting error	Manual pulse generator axis setting error information	<ul style="list-style-type: none"> <li>Contents of the manual pulse generator axis setting error is stored when the manual pulse generator axis setting error (SM513) turn on. (Normal: 0/Setting error: 1) SD513 : The manual pulse generator axis setting error is stored in b0 to b2 (P1 to P3). The smoothing magnification setting is stored in b3 to b5 (P1 to P3). SD514 : One pulse input magnification setting error is stored in b0 to b15 (axis 1 to axis 16). SD515 : One pulse input magnification setting error is stored in b0 to b15 (axis 17 to axis 32).</li> </ul>	S (Occur an error)						
SD516	Error program No.	Error program No. of servo program (SV13/SV22)/motion program (SV43)	<ul style="list-style-type: none"> <li>When the servo program setting error (SV13/SV22)/motion program setting error (SV43) (SM516) turns on, the erroneous servo program No. (SV13/SV22)/motion program No. (SV43) will be stored.</li> </ul>							
SD517	Error item information	Error code of servo program (SV13/SV22)/motion program (SV43)	<ul style="list-style-type: none"> <li>When the servo program setting error (SV13/SV22)/motion program setting error (SV43) (SM516) turns on, the error code corresponding to the erroneous setting item will be stored.</li> </ul>							
SD520	Scan time	Scan time (1ms units)	<ul style="list-style-type: none"> <li>Main cycle is stored in the unit 1ms. Setting range (0 to 65535[ms])</li> </ul>	S (Main processing)						
SD521	Maximum scan time	Maximum scan time (1ms units)	<ul style="list-style-type: none"> <li>The maximum value of the main cycle is stored in the unit 1ms. Setting range (0 to 65535[ms])</li> </ul>							
SD522	Motion operation cycle	Motion operation cycle	<ul style="list-style-type: none"> <li>The time required for motion operation cycle is stored in the [μs] unit.</li> </ul>	S (Operation cycle)						
SD523	Operation cycle of the Motion CPU setting	Operation cycle of the Motion CPU setting	<ul style="list-style-type: none"> <li>The setting operation cycle is stored in the [μs] unit.</li> </ul>	S (Initial processing)						

Table 1.2 Special register list (Continued)

No.	Name	Meaning	Details	Set by (When set)												
SD524	Maximum Motion operation cycle 	Maximum Motion operation cycle	• The maximum time for motion operation is stored every motion operation cycle in [ $\mu$ s] unit.	S (Operation cycle)												
SD550	System setting	Error code	• The error code indicating the details of system setting error is stored.	S (Occur an error)												
SD551	error information 	Error individual information	• The individual information of system setting error is stored.													
SD552	Servo parameter write/read request 	Servo parameter read value	• The read value of servo parameter which executed "2: 1 word read request" in SD804 is stored. (For MR-J5(W)-□B, the read value (low 1 word) of servo parameter is stored.)	S (Read request)												
SD553			• The read value (low 1 word) of servo parameter which executed "4: 2 word read request" in SD804 is stored.													
SD560	Operation method  	Operation method	• When the operating system software is SV22, the operation method information is stored. 0: Virtual mode switching method 1: Advanced synchronous control method	S (Initial processing)												
SD561	Multiple CPU synchronous control setting status  	Multiple CPU synchronous control setting status	• The CPU setting status of Multiple CPU synchronous control is stored. 0: Independent CPU 1: Master CPU 2: Slave CPU													
SD700	Device assignment	Number of points assigned for #	• Stores the number of points for device # used in the Motion CPU.													
SD701		Number of points assigned for CPU No.1 Multiple CPU area devices	• Stores the number of points currently set for CPU No.1 Multiple CPU area devices.													
SD702		Number of points assigned for CPU No.2 Multiple CPU area devices	• Stores the number of points currently set for CPU No.2 Multiple CPU area devices.													
SD703		Number of points assigned for CPU No.3 Multiple CPU area devices	• Stores the number of points currently set for CPU No.3 Multiple CPU area devices.													
SD704		Number of points assigned for CPU No.4 Multiple CPU area devices	• Stores the number of points currently set for CPU No.4 Multiple CPU area devices.													
SD720 SD721	444 $\mu$ s coasting timer	444 $\mu$ s coasting timer	<p>• Current value (SD720, SD721) is incremented by 1 per 444<math>\mu</math>s. Read SD720 device in 2 word unit.</p> <table border="1"> <thead> <tr> <th>Item</th> <th>Specification</th> </tr> </thead> <tbody> <tr> <td>Data size</td> <td>2 word (-2147483648 to 2147483647)</td> </tr> <tr> <td>Latch</td> <td>Cleared to zero at power-on or reset, a count rise is continued from now on.</td> </tr> <tr> <td>Usable tasks</td> <td>Normal, event, NMI</td> </tr> <tr> <td>Access</td> <td>Read only enabled</td> </tr> <tr> <td>Timer specifications</td> <td>444<math>\mu</math>s timer</td> </tr> </tbody> </table>	Item	Specification	Data size	2 word (-2147483648 to 2147483647)	Latch	Cleared to zero at power-on or reset, a count rise is continued from now on.	Usable tasks	Normal, event, NMI	Access	Read only enabled	Timer specifications	444 $\mu$ s timer	S (444 $\mu$ s)
Item	Specification															
Data size	2 word (-2147483648 to 2147483647)															
Latch	Cleared to zero at power-on or reset, a count rise is continued from now on.															
Usable tasks	Normal, event, NMI															
Access	Read only enabled															
Timer specifications	444 $\mu$ s timer															

: Refer to Section 1.5 for the software version that supports this function.

Table 1.2 Special register list (Continued)

No.	Name	Meaning	Details	Set by (When set)														
SD722 SD723	222µs coasting timer  	222µs coasting timer	<ul style="list-style-type: none"> <li>Current value (SD722, SD723) is incremented by 1 per 222µs. Read SD722 device in 2 word unit.</li> <li>This register is not updated when the operation cycle is set to other than 0.2ms.</li> </ul> <table border="1"> <thead> <tr> <th>Item</th> <th>Specification</th> </tr> </thead> <tbody> <tr> <td>Data size</td> <td>2 word (-2147483648 to 2147483647)</td> </tr> <tr> <td>Latch</td> <td>Cleared to zero at power-on or reset, a count rise is continued from now on.</td> </tr> <tr> <td>Usable tasks</td> <td>Normal, event, NMI</td> </tr> <tr> <td>Access</td> <td>Read only enabled</td> </tr> <tr> <td>Timer specifications</td> <td>222µs timer</td> </tr> </tbody> </table>	Item	Specification	Data size	2 word (-2147483648 to 2147483647)	Latch	Cleared to zero at power-on or reset, a count rise is continued from now on.	Usable tasks	Normal, event, NMI	Access	Read only enabled	Timer specifications	222µs timer	S (222µs)		
Item	Specification																	
Data size	2 word (-2147483648 to 2147483647)																	
Latch	Cleared to zero at power-on or reset, a count rise is continued from now on.																	
Usable tasks	Normal, event, NMI																	
Access	Read only enabled																	
Timer specifications	222µs timer																	
SD724	SSCNET III/H compatible optical hub unit loading information (Line 1)  	SSCNET III/H compatible optical hub unit loading information (Line 1)	<ul style="list-style-type: none"> <li>Checks the connection status (Installed: 1/Not installed: 0) of the optical hub unit and stores as bit data.</li> <li>SD724: b0 to b15 (Optical hub unit No. 1 to No. 16 on line 1)</li> <li>SD725: b0 to b15 (Optical hub unit No. 1 to No. 16 on line 2)</li> <li>(Note): No. 1 to No. 16 is the connection order from the Motion CPU</li> </ul>	S (Operation cycle)														
SD725	SSCNET III/H compatible optical hub unit loading information (Line 2)  	SSCNET III/H compatible optical hub unit loading information (Line 2)	<ul style="list-style-type: none"> <li>"1" is stored to the installation status of an optical hub unit with a servo amplifier connected.</li> <li>"0" is stored to the installation status when an optical hub unit is not connected after an optical hub unit that is not connected to a servo amplifier, or when the optical hub unit connected after an optical hub unit is not connected to a servo amplifier either.</li> <li>For optical hub units connected before an optical hub unit connected to a servo amplifier, "1" is stored to the installation status, regardless of whether there is a servo amplifier connection or not.</li> </ul>															
SD726	SSCNET III/H compatible optical hub unit communication error information (Line 1)  	SSCNET III/H compatible optical hub unit communication error information (Line 1)	<ul style="list-style-type: none"> <li>Checks the communication status (Communication error detected: 1/No communication error detected: 0) of the optical hub unit and stores as bit data.</li> <li>SD726: b0 to b15 (Optical hub unit No. 1 to No. 16 on line 1)</li> <li>SD727: b0 to b15 (Optical hub unit No. 1 to No. 16 on line 2)</li> <li>(Note): No. 1 to No. 16 is the connection order from the Motion CPU</li> </ul>	S (Occur an error)														
SD727	SSCNET III/H compatible optical hub unit communication error information (Line 2)  	SSCNET III/H compatible optical hub unit communication error information (Line 2)	<ul style="list-style-type: none"> <li>The device contents are not reset by turning power supply of optical hub unit OFF/reset, or by disconnecting/reconnecting communication with the Motion CPU. Reset the device contents manually.</li> </ul>															
SD803	SSCNET control (Command)	<ul style="list-style-type: none"> <li>Connect/disconnect of SSCNET communication</li> <li>Start/release of amplifier-less operation</li> </ul>	<ul style="list-style-type: none"> <li>SD803 is required for connect/disconnect of SSCNET communication and start/release of amplifier-less operation.</li> </ul> <table border="1"> <tbody> <tr> <td>0</td> <td>No command</td> </tr> <tr> <td>1 to 32</td> <td>Disconnect command of SSCNET communication</td> </tr> <tr> <td>-10</td> <td>Connect command of SSCNET communication</td> </tr> <tr> <td>-20</td> <td>Start command 1 of amplifier-less operation (EMI invalid)</td> </tr> <tr> <td>-21</td> <td>Start command 2 of amplifier-less operation (EMI valid)</td> </tr> <tr> <td>-25</td> <td>Release command of amplifier-less operation</td> </tr> <tr> <td>-2</td> <td>Execute command</td> </tr> </tbody> </table>	0	No command	1 to 32	Disconnect command of SSCNET communication	-10	Connect command of SSCNET communication	-20	Start command 1 of amplifier-less operation (EMI invalid)	-21	Start command 2 of amplifier-less operation (EMI valid)	-25	Release command of amplifier-less operation	-2	Execute command	U
0	No command																	
1 to 32	Disconnect command of SSCNET communication																	
-10	Connect command of SSCNET communication																	
-20	Start command 1 of amplifier-less operation (EMI invalid)																	
-21	Start command 2 of amplifier-less operation (EMI valid)																	
-25	Release command of amplifier-less operation																	
-2	Execute command																	

: Refer to Section 1.5 for the software version that supports this function.

Table 1.2 Special register list (Continued)

No.	Name	Meaning	Details	Set by (When set)
SD804 (Note-1)	Servo parameter write/read request	Servo parameter write/read request flag	<ul style="list-style-type: none"> <li>The "write/read request" is executed after setting of the axis No. and servo parameter No.</li> <li>1: 1 word write request</li> <li>2: 1 word read request</li> <li>3: 2 word write request (Note-2)</li> <li>4: 2 word read request (Note-2)</li> <li>"0" is automatically set by Motion CPU after completion of servo parameter write/read request. ("-1" is stored by Motion CPU at write/read error.)</li> </ul>	S/U
SD805		Axis No.	<ul style="list-style-type: none"> <li>The axis No. to write/read servo parameter is stored.</li> <li>Q173DSCPU: 1 to 32</li> <li>Q172DSCPU: 1 to 16</li> </ul>	U
SD806		Servo parameter No.	<ul style="list-style-type: none"> <li>The servo parameter No. to be written/read is stored in hexadecimal.</li> </ul> <div style="text-align: center;"> <p>H □ □ □ □</p> <p>→ Parameter No.</p> <p>→ Parameter group No.</p> <ul style="list-style-type: none"> <li>• 0: PA      • 9: PO</li> <li>• 1: PB      • A: PS</li> <li>• 2: PC      • B: PL (MR-J5(W)-□B, MR-J4(W)-□B only)</li> <li>• 3: PD      • C: PT (MR-J4(W)-□B only)</li> <li>• 4: PE</li> <li>• 5: PF</li> </ul> <p>→ Fixed at 0</p> </div> <ul style="list-style-type: none"> <li>VCII series/VPH series use</li> </ul> <div style="text-align: center;"> <p>H □ □ □ □</p> <p>→ Parameter No.</p> <p>→ Parameter group No.</p> <ul style="list-style-type: none"> <li>• 0: Group 0    • 5: Group 5</li> <li>• 1: Group 1    • 6: Group 6</li> <li>• 2: Group 2    • 7: Group 7</li> <li>• 3: Group 3    • 8: Group 8</li> <li>• 4: Group 4    • 9: Group 9</li> </ul> </div> <ul style="list-style-type: none"> <li>AlphaStep/5-phase use</li> </ul> <div style="text-align: center;"> <p>H □ □ □ □</p> <p>→ Parameter ID (Note)</p> <p>(Note): Refer to AlphaStep/5-phase instruction manual for details.</p> </div> <ul style="list-style-type: none"> <li>IAI electric actuator controller use</li> </ul> <div style="text-align: center;"> <p>H □ □ □ □</p> <p>→ Parameter No. ID (Note)</p> <p>(Note): Refer to IAI electric actuator controller instruction manual for details.</p> </div>	
			SD807	
SD808	Servo parameter setting value	<ul style="list-style-type: none"> <li>The setting value of servo parameter to be written is stored when "3: 2 word write request" is set in SD804.</li> </ul>		
SD809	Servo parameter setting value (2 word)			

(Note-1): Do not execute the automatic refresh.

(Note-2): This can be set only in MR-J5(W)-□B, VCII series/VPH series, and IAI electric actuator controller.

APPENDIX 1.3 Replacement of special relays/special registers

When a project of Q17□HCPU(-T)/Q17□CPUN(-T)/Q17□CPU is converted into a project of Q17□D(S)CPU by "File diversion" in MT Developer2, they are automatically allocated to "Automatically converted to special relays (SM2000 to SM2255), special registers (SD2000 to SD2255)". (Refer to table 1.3 and table 1.4.)

"Automatically converted to special relays (SM2000 to SM2255), special registers (SD2000 to SD2255)" output the same statuses and data as the "Special relay, special register of Q17□D(S)CPU".

When replacing "automatically converted to special relays (SM2000 to SM2255), special registers (SD2000 to SD2255)" into "Special relay, special register of Q17□D(S)CPU", confirm the device usage condition by "List of used device" of MT Developer2. (Refer to table 1.3 and table 1.4.)

Refer to the help of MT Developer2 for operation procedure of the list of used device.

<b>POINT</b>
When a project of Q17□HCPU(-T)/Q17□CPUN(-T)/Q17□CPU are copied from other project by program editor in MT Developer2, they are not replaced to "automatically converted to special relays (SM2000 to SM2255), special registers (SD2000 to SD2255)".

**REMARK**

Confirm the device usage condition by "List of used device" of MT Developer2" to change the device number used in a project of Q17□HCPU(-T)/Q17□CPUN(-T)/Q17□CPU except the special relays or special registers to the device number of Q17□D(S)CPU. (Refer to "APPENDIX 4.2 Comparison of devices".)

Table 1.3 Replacement of special relays

Device No.		Automatically converted to special relays	Q17□D(S)CPU Special relays	Name	Remark
Q17□HCPU(-T)/ Q17□CPUN(-T)/Q17□CPU	Special relay allocated device				
M9000	M2320	SM2000	SM60	Fuse blown detection	
M9005	M2321	SM2005	SM53	AC/DC DOWN detection	
M9006	M2322	SM2006	SM52	Battery low	
M9007	M2323	SM2007	SM51	Battery low latch	
M9008	M2324	SM2008	SM1	Self-diagnostic error	
M9010	M2325	SM2010	SM0	Diagnostic error	
M9025	M3136	—	—	Clock data set request	It operates by the clock data of CPU No.1
M9026	M2328	SM2026	SM211	Clock data error	
M9028	M3137	SM2028	SM801	Clock data read request	
M9036	M2326	SM2036	SM400	Always ON	
M9037	M2327	SM2037	SM401	Always OFF	
M9060	M3138	SM2060	—	Diagnostic error reset	Use M2039 for error reset operation.
M9073	M2329	SM2073	SM512	Motion CPU WDT error	
M9074	M2330	SM2074	SM500	PCPU READY complete	
M9075	M2331	SM2075	SM501	Test mode ON	
M9076	M2332	SM2076	SM502	External forced stop input	
M9077	M2333	SM2077	SM513	Manual pulse generator axis setting error	
M9078	M2334	SM2078	SM510	TEST mode request error	
M9079	M2335	SM2079	SM516	Servo program setting error (SV13/SV22)/ Motion program setting error (SV43)	
M9216	M2345	SM2216	SM528	No.1 CPU MULTR complete	
M9217	M2346	SM2217	SM529	No.2 CPU MULTR complete	
M9218	M2347	SM2218	SM530	No.3 CPU MULTR complete	
M9219	M2348	SM2219	SM531	No.4 CPU MULTR complete	
M9240	M2336	SM2240	SM240	No.1 CPU resetting	
M9241	M2337	SM2241	SM241	No.2 CPU resetting	
M9242	M2338	SM2242	SM242	No.3 CPU resetting	
M9243	M2339	SM2243	SM243	No.4 CPU resetting	
M9244	M2340	SM2244	SM244	No.1 CPU error	
M9245	M2341	SM2245	SM245	No.2 CPU error	
M9246	M2342	SM2246	SM246	No.3 CPU error	
M9247	M2343	SM2247	SM247	No.4 CPU error	

**POINT**

- (1) The special relay allocated devices (M2320 to M2399, M3136 to M3199) of Q17□HCPU(-T)/Q17□CPUN(-T)/Q17□CPU are not allocated to "Automatically converted to special relays". Confirm the device usage condition by "List of used device" of MT Developer2 to change them. (Refer to table 1.3.)
- (2) "Automatically converted to special relays SM2028 (Clock data set request)" is shown below.
  - Device OFF to ON : "Special relay of Q17□D(S)CPU" ON
  - Device ON to OFF : "Special relay of Q17□D(S)CPU" OFF

Table 1.4 Replacement of special registers

Device No.			Name	Remark
Q17□HCPU(-T)/ Q17□CPUN(-T)/Q17□CPU	Automatically converted to	Q17□D(S)CPU		
Special registers	special registers	Special registers		
D9000	SD2000	SD60	Fuse blown No.	
D9005	SD2005	SD53	AC/DC DOWN counter No.	
D9008	SD2008	SD0	Diagnostic errors	
D9010	SD2010	SD1	Clock time for diagnostic error occurrence (Year, month)	
D9011	SD2011	SD2	Clock time for diagnostic error occurrence (Day, hour)	
D9012	SD2012	SD3	Clock time for diagnostic error occurrence (Minute, second)	
D9013	SD2013	SD4	Error information categories	
D9014	SD2014	SD5	Error common information	
D9015	SD2015	SD203	Operating status of CPU	
D9017	SD2017	SD520	Scan time	
D9019	SD2019	SD521	Maximum scan time	
D9025	SD2025	SD210	Clock data (Year, month)	
D9026	SD2026	SD211	Clock data (Day, hour)	
D9027	SD2027	SD212	Clock data (Minute, second)	
D9028	SD2028	SD213	Clock data (Day of week)	
D9060	SD2060	—	Diagnostic error reset error No.	Use M2039 for error reset operation.
D9061	SD2061	SD395	Multiple CPU No.	
D9112	SD2112	SD508	SSCNET control (Status)	
		SD803	SSCNET control (Command)	
D9182	SD2182	SD510	Test mode request error	
D9183	SD2183	SD511		
D9184	SD2184	SD512	Motion CPU WDT error cause	
D9185	SD2185	SD513	Manual pulse generator axis setting error	
D9186	SD2186	SD514		
D9187	SD2187	SD515		
D9188	SD2188	SD522	Motion operation cycle	
D9189	SD2189	SD516	Error program No.	
D9190	SD2190	SD517	Error item information	
D9191	SD2191	SD502	Servo amplifier loading information	
D9192	SD2192	SD503		
D9193	SD2193	SD504		
D9194	SD2194	SD505	Real mode/virtual mode switching error information	
D9195	SD2195	SD506		
D9196	SD2196	—	PC link communication error codes	Q173D(S)CPU/ Q172D(S)CPU does not support PC link communication.
D9197	SD2197	SD523	Operation cycle of the Motion CPU setting	
D9200	SD2200	SD200	State of switch	
D9201	SD2201	—	State of LED	Use 7-segment LED in Q173D(S)CPU/ Q172D(S)CPU.

**POINT**

"Automatically converted to special registers SD2112 (SSCNET control)" are reflected to the Q17□D(S)CPU special registers by setting the data to devices.



APPENDIX 2 System Setting Errors

Motion CPUs generate a system configuration error under the following conditions.

Table 2.1 System Setting Errors



System setting error information 		Error name 	7-segment LED (Note-1)	Error code (Note-2)	Error cause	Check timing	Operation at error occurrence				
Error code (SD550)	Error individual information (SD551)										
2	Base No., Slot No.	LAY ERROR (SL * * ) (Note-4)	"AL" flashes 3- times ↓ "L01" display	10014 (Note-3)	<ul style="list-style-type: none"> <li>The slot set in system settings is vacant or a different module is installed.</li> <li>The axis No. setting overlaps in the system settings.</li> <li>The axis No. (function select switch) setting of servo amplifier overlaps in the same SSCNET III line.</li> <li>When MR-J5W-□B or MR-J4W-□B is used, the axis setting equal to the number of used axes set in the servo amplifier is not set in the system setting.</li> <li>The load of the fixed cycle system processing is high, and communication has become unstable. (This may be resolved by reviewing the "DOG/CHANGE signal input method" setting in the system basic setting of system setting.)</li> <li>The SSCNET III cable is disconnected, or there is a bad connection due to improper insertion in the SSCNET III cable connector.</li> <li>The servo amplifier is not set even by one axis in the system settings.</li> </ul>	Multiple CPU system's power supply ON/ Reset	Cannot be started. (Motion CPU system setting error)				
3	Axis No. of servo amplifier	AXIS NO. MULTIDEF									
4	None (0)	AMP NO SETTING									
6	Base No., Slot No.	SL * * UNIT ERROR (Note-4)						10016 (Note-5)	<ul style="list-style-type: none"> <li>The module installed in the slot of the motion CPU control is abnormal.</li> </ul>	Always	
8	Axis No.	—						<ul style="list-style-type: none"> <li>The setting which cannot use the driver communication is carried out with the motion controller and the servo amplifier corresponding to the driver communication.</li> </ul>	Multiple CPU system's power supply ON/ At start of communication with servo amplifier		
10	None (0)	I/O POINTS OVER						<ul style="list-style-type: none"> <li>The number of actual I/O points set in system settings exceeds 256.</li> </ul>	Multiple CPU system's power supply ON/ Reset		
11		AXIS NO. ERROR						<ul style="list-style-type: none"> <li>System setting data is not written.</li> </ul>			
13		SYS.SET DATA ERR						<ul style="list-style-type: none"> <li>System setting data is not written.</li> <li>System setting data is written without relative check. Or it is written at the state of error occurrence.</li> </ul>			
14	Axis No.	AMP TYPE ERROR * * ( * * : Axis No.1 to 32)						10014 (Note-3)	<ul style="list-style-type: none"> <li>The servo amplifier that cannot be used for the operating system software is set in the system settings.</li> <li>The servo amplifier series set in the system setting and installed servo amplifier series is different.</li> <li>An operation cycle that the servo amplifier does not support has been set.</li> </ul>	Servo amplifier's power supply ON	The servo amplifier for target axis does not operate, the axis does not start.
15	None (0)	ROM ERROR1						<ul style="list-style-type: none"> <li>Type of the operating system software of data written to ROM is different.</li> <li>Data is not written to ROM.</li> <li>Data size of ROM is abnormal.                             <ul style="list-style-type: none"> <li>Execute the ROM writing again.</li> <li>Check the adjustment for the version of Motion CPU, MT Developer2 and operating system software.</li> </ul> </li> </ul>	Multiple CPU system's power supply ON/ Reset	Cannot be started. (Motion CPU system setting error)	
16		ROM ERROR2									
17		ROM ERROR3 ( * * )									

Table 2.1 System Setting Errors (Continued)





System setting error information 		Error name 	7-segment LED (Note-1)	Error code (Note-2)	Error cause	Check timing	Operation at error occurrence	
Error code (SD550)	Error individual information (SD551)							
18	None (0)	ROM ERROR4 (* *)	"AL" flashes 3- times ↓ "L01" display	10014 (Note-3)	<ul style="list-style-type: none"> <li>Data of ROM is abnormal.</li> <li>Execute the ROM writing again.</li> <li>Check the adjustment for the version of Motion CPU, MT Developer2 and operating system software.</li> </ul>	Multiple CPU system's power supply ON/ Reset/ M2000 ON	Cannot be started. (Motion CPU system setting error)	
20	Base No., Slot No.	CAN'T USE SL (* *) (Note-4)			<ul style="list-style-type: none"> <li>The motion modules that cannot be used are installed.</li> <li>Use the Motion modules (Q172DLX, Q173DPX, Q172DEX).</li> </ul>			
21	Base No., Slot No.	UNIT SET ERR (* *) (Note-4)			<ul style="list-style-type: none"> <li>The system setting data that set the motion modules that cannot be used are written.</li> <li>Use the MT Developer2 of version corresponding to the Motion modules (Q172DLX, Q173DPX, Q172DEX).</li> </ul>			
22	None (0)	SAFERY SYS.ERR.			<ul style="list-style-type: none"> <li>The safety function parameters are set to the motion CPU that does not support the safety observation function.</li> <li>The safety signal monitor parameter is set to other than CPU No.2.</li> </ul>			
24		Fixed parameter unregistered error			<ul style="list-style-type: none"> <li>The fixed parameter is not written.</li> </ul>			
25		Parameter block unregistered error			<ul style="list-style-type: none"> <li>The parameter block is not written.</li> </ul>			
26	Axis No.	Servo parameter unregistered error			<ul style="list-style-type: none"> <li>The servo parameter of the system setting axis is not written.</li> <li>A servo amplifier model that the motion controller operating system software does not support is set in the system setting. (When using MR-J5(W)-□B)</li> </ul>			
27	None (0)	Software security key error			<ul style="list-style-type: none"> <li>The software security keys of the motion controller OS and the user project do not match.</li> <li>The software security key is embedded only in either of the motion controller OS or the user project.</li> </ul>			
28	None (0)	—			<ul style="list-style-type: none"> <li>The number of SSCNETIII/H head module stations exceeds the number of maximum stations which can be used at operation cycle.</li> </ul>			
29	Multiple CPU No. (2 to 4)	—			<ul style="list-style-type: none"> <li>The user setting area of Multiple CPU high speed transmission area is setting to less than 512 points in system of Multiple CPU synchronous control.</li> </ul>			At the initial process complete of Multiple CPU synchronous control after power ON of Multiple CPU system.
30		—			<ul style="list-style-type: none"> <li>The operating cycle is not same setting for master CPU and slave CPU or is setting to less than 0.88ms in system of Multiple CPU synchronous control.</li> </ul>			
31		—			<ul style="list-style-type: none"> <li>Setting multiple master CPU in system of Multiple CPU synchronous control.</li> </ul>			
32		None (0)			—			

Table 2.1 System Setting Errors (Continued)

System setting error information 		Error name 	7-segment LED (Note-1)	Error code (Note-2)	Error cause	Check timing	Operation at error occurrence
Error code (SD550)	Error individual information (SD551)						
33	None (0)	—	"AL" flashes 3- times ↓ "L01" display	10014 (Note-3)	<ul style="list-style-type: none"> <li>• Slave CPU is not setting in system of Multiple CPU synchronous control.</li> <li>• Slave CPU cannot be detected in system of Multiple CPU synchronous control, since each CPU startup timing is different.</li> </ul>	At the initial process complete of Multiple CPU synchronous control after power ON of Multiple CPU system.	Cannot be started. (Motion CPU system setting error)

(Note-1): ""AL" flashes 3-times → "L01" display" (Repetition) Error code is not displayed.

(Note-2): Error code stored in diagnostic error (SD0)

(Note-3): When the error code 10014 occurs, the system setting error flag (M2041) turns ON and the error name of table 2.1 is displayed on the error list monitor of MT Developer2.

(Note-4): " \* \* " part is indicated the following contents.

(Example) For LAY ERROR (SL \* \* )

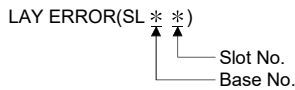

(Note-5): When the error code 10016 occurs, the motion slot fault detection flag (M2047) turns ON and the error name of table 2.1 is displayed on the error list monitor of MT Developer2.

APPENDIX 3 Self-diagnosis Error

Multiple CPU related errors are stored in the CPU shared memory "self CPU operation information area (1H to 1CH)" of each module and self diagnostic error information (SD0 to SD26) of the special register (SD) as the self diagnostic errors.

Error codes (1000 to 9999) of Multiple CPU related errors are common to each CPU module.

The error code (10000 to 10999) is stored as required at Motion CPU-specific error occurrence.

Confirm the error codes and contents by "Motion error history" on Motion CPU error batch monitor of MT Developer2 and remove the error cause if an error occurs.

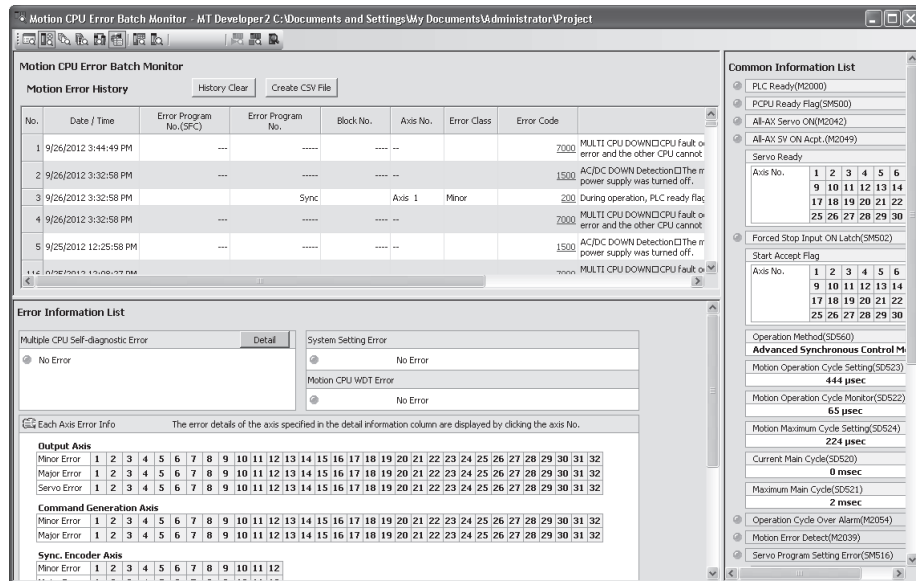

Confirm operation status and error occurrence of each CPU used in the Multiple CPU system by PLC diagnosis of GX Works2/GX Developer.

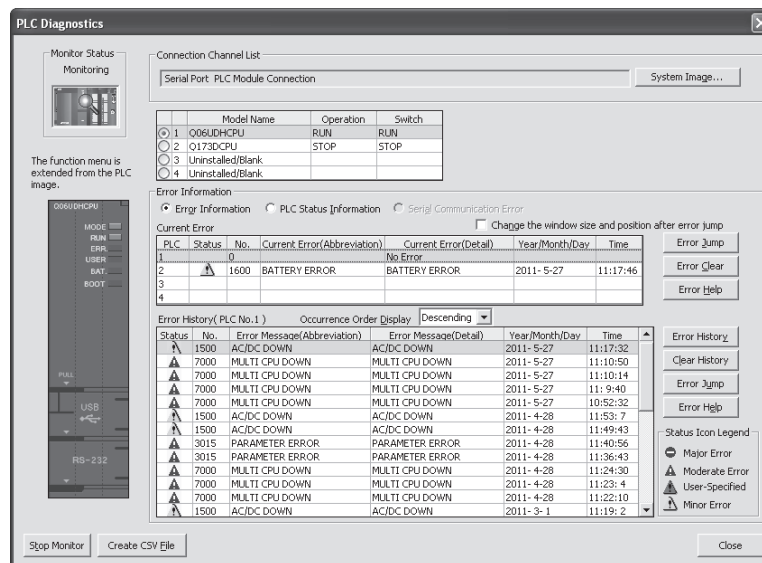

<Screen: GX Works2>

(1) Multiple CPU related errors which occurs in Motion CPU  
 Each digit of error code has been described as follows.

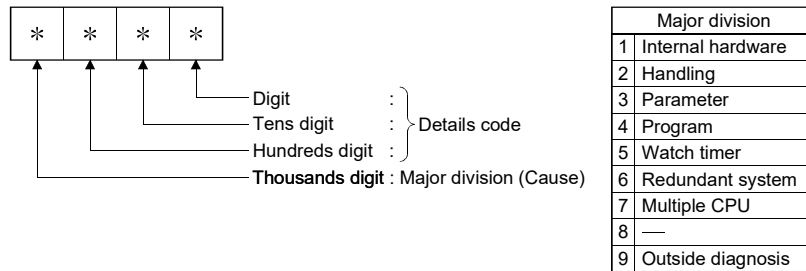

Table 3.1 Multiple CPU related errors which occurs in Motion CPU (1000 to 9999)

Item	Error code (SD0)	Error message	Common information (SD5 to SD15)	Individual Information (SD16 to SD26)	7-segment LED display	CPU operation status	Diagnostic timing
CPU hard error	1000	MAIN CPU DOWN	—	—	"AL" flashes 3 times ↓ Steady "A1" display ↓ 4 digits error code is displayed in two flashes of 2 digits each.	Stop	Always
	1001						
	1002						
	1003						
	1004						
CPU hard error	1005	RAM ERROR	—	—		Stop	At power ON/ At reset
	1006						
CPU hard error	1007	FUSE BREAK OFF	Module No.	—		Stop	Always
	1008						
	1009						
Module hard error	1105	SP. UNIT DOWN	Module No.	—	Stop	At power ON/ At reset	
	1150						
Module hard error	1401	SP. UNIT DOWN	Module No.	—	Stop	At power ON/ At reset	
	1403						
Base	1413	CONTROL-BUS. ERR.	—	—	Stop	Always	
	1414		Module No.				
	1415		Base No. (Note-2)				
	1416		CPU No. (Note-1)				

(Note-1): CPU No. is stored in slot No. of common information classification.

(Note-2): Base No. stored in "common information classification code" of "error information classification code" → "0 : Main base, 1 to 7 : Number of extension bases.

## APPENDICES

Error code (SD0)	Error contents and cause	Corrective action
1000	Runaway or failure of CPU module. (1) Malfunctioning due to noise or other reason (2) Hardware fault	(1) Take noise reduction measures. (2) Reset the CPU module and RUN it again. If the same error is displayed again, this suggests a CPU module hardware fault. Explain the error symptom and get advice from our sales representative.
1001		
1002		
1003		
1004		
1005		
1006		
1007		
1008		
1009		
1105	The CPU shared memory in the CPU module is faulty.	
1150	The memory of the CPU module in the Multiple CPU high speed transmission area is faulty.	
1300	There is an output module with a blown fuse.	Check FUSE. LED of the output modules and replace the module whose LED is lit.
1401	(1) There was no response from the Motion module/intelligent function module in the initial processing. (2) The size of the buffer memory of the Motion module/intelligent function module is invalid. (3) The unsupported module is mounted.	(1) Set the Motion module/intelligent function module used in the Motion CPU in the system setting. (2) When the unsupported module is mounted, remove it. When the corresponding module is supported, this suggests the Motion module, intelligent function module, CPU module and/or base unit is expecting a hardware fault. Explain the error symptom and get advice from our sales representative.
1403	(1) An error is detected at the intelligent function module. (2) The I/O module (including intelligent function module) is nearly removed or completely removed/mounted during running.	The CPU module, base unit and/or the intelligent function module that was accessed is experiencing a hardware fault. Explain the error symptom and get advice from our sales representative.
1413	An error is detected on the system bus.	Reset the CPU module and RUN it again. If the same error is displayed again, the intelligent function module, CPU module or base unit is faulty. Explain the error symptom and get advice from our sales representative.
1414		
1415		
1416		
1416	System bus fault was detected at power-on or reset.	

APPENDICES

Table 3.1 Multiple CPU related errors which occurs in Motion CPU (1000 to 9999)  
(Continued)

Item	Error code (SD0)	Error message	Common information (SD5 to SD15)	Individual Information (SD16 to SD26)	7-segment LED display	CPU operation status	Diagnostic timing					
Multiple CPU high speed bus	1430	MULTI-C.BUS ERR.	—	—	"AL" flashes 3 times ↓ Steady "A1" display ↓ 4 digits error code is displayed in two flashes of 2 digits each.	Stop	At power ON/ At reset					
	1431											
	1432											
	1433		CPU No.				—		—	—	—	—
	1434											
	1435											
Power supply	1500	AC/DC DOWN	—	—	None	Continue	Always					
Battery	1600	BATTERY ERROR	Drive name	—	Steady "BT1"	Continue	Always					
					Steady "BT2"							
Handling the intelligent function module/ Multiple CPU module	2100	SP. UNIT LAY ERR.	Module No.	—	"AL" flashes 3 times ↓ Steady "A1" display ↓ 4 digits error code is displayed in two flashes of 2 digits each.	Stop	At power ON/ At reset					
	2107											
	2124		—									
	2125	Module No.	—						—	—	—	—
	2140											
	2150											

## APPENDICES

Error code (SD0)	Error contents and cause	Corrective action
1430	The error of self CPU is detected in the Multiple CPU high speed bus.	Reset the CPU module and RUN it again. If the same error is displayed again, this suggests a CPU module hardware fault. Explain the error symptom and get advice from our sales representative.
1431	The communication error with other CPU is detected in the Multiple CPU high speed bus.	(1) Take noise reduction measures. (2) Check the main base unit mounting status of the CPU module. (3) Reset the CPU module and RUN it again. If the same error is displayed again, this suggests a CPU module or base unit hardware fault. Explain the error symptom and get advice from our sales representative.
1432	The communication time out with other CPU is detected in the Multiple CPU high speed bus.	Reset the CPU module and RUN it again. If the same error is displayed again, this suggests a CPU module hardware fault. Explain the error symptom and get advice from our sales representative.
1433	The communication error with other CPU is detected in the Multiple CPU high speed bus.	(1) Take noise reduction measures. (2) Check the main base unit mounting status of the CPU module.
1434		(3) Reset the CPU module and RUN it again. If the same error is displayed again, this suggests a CPU module or base unit hardware fault.
1435		Explain the error symptom and get advice from our sales representative.
1500	A momentary power supply interruption has occurred. The power supply went off.	Check the power supply.
1600	(1) The battery voltage in the CPU module has dropped below stipulated level. (2) The battery holder unit that install the battery is not mounted to the CPU module.	(1) Change the battery. (2) Mount the battery holder unit that installs the battery.
2100	In the I/O assignment setting of PLC CPU, the intelligent function module was allocated to an I/O module or vice versa.	Make the PLC parameter's I/O assignment setting again so it is consistent with the actual status of the intelligent function module and the CPU module.
2107	The first I/O No. set in the system settings is overlapped with the one for another module.	Make the I/O No. setting again so it is consistent with the actual status of the modules.
2124	(1) A module is mounted on the 65th or higher slot. (2) The extension base unit set to "None" is mounted.	(1) Remove the module mounted on the 65th or later slot. (2) Remove the extension base unit set to "None".
2125	(1) A module which the CPU cannot recognize has been mounted. (2) There was no response form the intelligent function module.	(1) Install an usable module. (2) The intelligent function module is experiencing a hardware fault. Explain the error symptom and get advice from our sales representative.
2140	The motion modules (Q172DLX, Q172DEX, Q173DPX, Q172LX, Q172EX (-S1/-S2/-S3), Q173PX (-S1)) are installed in CPU slot or I/O 0 to 2 slot.	Remove the Motion modules installed CPU slot or I/O 0 to 2 slot.
2150	In a Multiple CPU system, the control CPU of intelligent function module incompatible with the Multiple CPU system is set to other than CPU No.1.	(1) Change to the intelligent function module (function version B or later) compatible with the Multiple CPU system. (2) Change the control CPU of intelligent function module incompatible with the Multiple CPU system to CPU No.1.



APPENDICES

Table 3.1 Multiple CPU related errors which occurs in Motion CPU (1000 to 9999)  
(Continued)

Item	Error code (SD0)	Error message	Common information (SD5 to SD15)	Individual Information (SD16 to SD26)	7-segment LED display	CPU operation status	Diagnostic timing	
Parameter	3001	PARAMETER ERROR	—	Parameter No.	"AL" flashes 3 times ↓ Steady "A1" display ↓ 4 digits error code is displayed in two flashes of 2 digits each.	Stop	At power ON/ At reset/ STOP → RUN	
	3012						At power ON/ At reset	
	3013							
	3015			Parameter No./ CPU No.				
Multiple CPU	7000	MULTI CPU DOWN	CPU No. (Note-1) (Note-3)	—		"AL" flashes 3 times ↓ Steady "A1" display ↓ 4 digits error code is displayed in two flashes of 2 digits each.	Stop	Always
	7002		CPU No. (Note-1)					At power supply ON/ at reset
	7010	MULTI EXE. ERROR	CPU No. (Note-1)	—			Stop	At power supply ON/ at reset
	7011							
	7013		CPU No.					
	7020	MULTI CPU ERROR	CPU No. (Note-1)	—	Continue		Always	
	7030	CPU LAY. ERROR	CPU No.	—	Stop		At power supply ON/ at reset	
	7031							
7035	Module No.							

(Note-1): CPU No. is stored in slot No. of common information classification.

(Note-3): Because a stop error or CPU No. except CPU No. that it was reset becomes MULTI CPU DOWN simultaneously, a stop error or CPU No. except CPU No. that it was reset may store in the classification of common error information depending on timing.

# APPENDICES

Error code (SD0)	Error contents and cause	Corrective action
3001	The parameter settings are corrupted.	(1) Check the parameter item corresponding to the numerical value (parameter No.), and correct it. (2) Rewrite corrected parameters to the CPU module, reload or reset the Multiple CPU system power supply. (3) If the same error occurs, it is thought to be a hardware error. Explain the error symptom and get advice from our sales representative.
3012	Multiple CPU setting of Multiple CPU setting parameter or control CPU setting of system setting differs from that of the reference CPU settings.	Match the Multiple CPU setting of Multiple CPU setting parameter or control CPU setting of system setting with that of the reference CPU (CPU No.1) settings.
3013	Multiple CPU automatic refresh setting is any of the following. (1) When a bit device is specified as a refresh device, a number other than a multiple of 16 is specified for the refresh start device. (2) The device specified is other than the one that may be specified. (3) The number of send points is an odd number. (4) The total number of send points is greater than the maximum number of refresh points.	Check the following in the Multiple CPU automatic refresh setting and make correction. (1) When specifying the bit device, specify a multiple of 16 for the refresh start device. (2) Specify the device that may be specified for the refresh device. (3) Set the number of send points to an even number. (4) Set the total number of send points is within the range of the maximum number of refresh points.
3015	(1) "Use multiple CPU high speed transmission" is not set in the Multiple CPU setting of Universal model QCPU. (2) In a Multiple CPU system, the CPU verified is different from the one set in the parameter setting.	(1) Set "Use multiple CPU high speed transmission" in the Universal model QCPU. (2) Check the parameter item corresponding to the numerical value (parameter No./CPU No.) and parameter of target CPU, and correct them.
7000	In the operating mode of a Multiple CPU system, a CPU error occurred at the CPU where "All station stop by stop error of CPU" was selected. In a Multiple CPU system, CPU No.1 resulted in stop error at power-on and the other CPU cannot start. (This error occurred at CPU No.2 to 4)	Check the error of the CPU resulting in CPU module fault, and remove the errors.
7002	There is no response from the target CPU module in a Multiple CPU system during initial communication.	Reset the CPU module and RUN it again. If the same error is displayed again, this suggests the hardware fault of any of the CPU modules. Explain the error symptom and get advice from our sales representative.
7010	In a Multiple CPU system, a faulty CPU module was mounted.	Replace the faulty CPU module.
7011	Either of the following settings was made in a Multiple CPU system. (1) Multiple CPU automatic refresh setting was made for the inapplicable CPU module. (2) "I/O sharing when using multiple CPUs" setting was made for the inapplicable CPU module.	(1) Correct the Multiple CPU automatic refresh setting. (2) Correct the "I/O sharing when using multiple CPUs" setting.
7013	The system configuration for using the Multiple CPU high speed transmission function is not met. (1) The QnUD□CPU is not used for the CPU No.1. (2) The Multiple CPU high speed main base unit (Q3□DB) is not used.	Change to the system configuration to meet the conditions for using the Multiple CPU high speed transmission function.
7013	(1) CPU module which cannot be mounted in QnUD□CPU is mounted. (The module may break down.) (2) Q173HCPU, Q172HCPU, Q173CPUN, Q172CPUN is mounted.	Remove Q173HCPU, Q172HCPU, Q173CPUN, Q172CPUN.
7020	In the operating mode of a Multiple CPU system, an error occurred in the CPU where "system stop" was not selected. (The CPU module where no error occurred was used to detect an error.)	Check the error of the CPU resulting in CPU module fault, and remove the error.
7030	An assignment error occurred in the CPU-mountable slot (CPU slot, I/O slot 0 to 2) in excess of the number of CPU slot (with in the range of CPU number setting parameter).	(1) Set the same value to the number of CPU modules specified in the Multiple CPU setting of the PLC parameter and the number of mounted CPU modules (including CPU (empty)).
7031	An assignment error occurred in the CPU slot (within the range of the CPU number setting parameter).	(2) Make the same as the state of the installation of CPU module set in the system setting.
7035	The CPU module has been mounted on the inapplicable slot.	Mount the CPU module on the applicable slot.

(2) Motion CPU-specific errors

Each digit of error code has been described as follows.

Refer to programming manuals for error details.

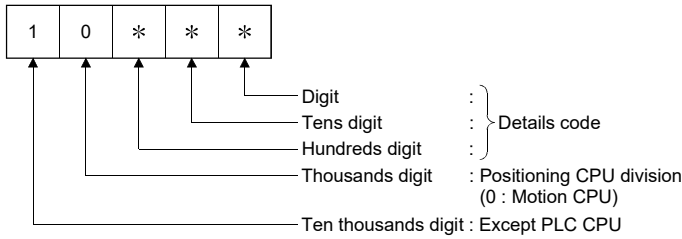

Details code	
002	Minor/major error (Command generation axis)(SV22)
003	Minor/major error
004	Minor/major error (Virtual servo motor axis)(SV22)
005	Minor/major error (Synchronous encoder axis)(SV22)
006	Servo error (MR-J3-□B, MR-J3-□B compatibility mode)
007	Servo program setting error (SV13/SV22)/ Motion program setting error (SV43)
008	Mode switching error (SV22)
009	Manual pulse generator axis setting error
010	TEST mode request error
011	WDT error
014	System setting error
015	Servo error (MR-J4-□B)
016	Motion slot fault
017	Servo error (MR-J5-□B)
020	Motion SFC control error (F/FS)
021	Motion SFC control error (G)
022	Motion SFC control error (K or others (Not F/FS, G))
023	Motion SFC control error (Motion SFC chart)
030	Motion CPU internal bus error
040	Inverter error
041	Servo driver error (CKD Nikki Denso)
042	SSCNETIII/H head module error
043	Stepping driver error
044	Stepping driver operation error
050	Safety observation error (Alarm)
051	Safety observation error (Warning)
060	Optical hub unit connection error
061	Optical hub unit communication error

Table 3.2 Motion CPU-specific errors (10000 to 10999)

Error code (SD0)	Error messages	Common information (SD5 to SD15)	Individual information (SD16 to SD26)	7-segment LED display	CPU operation status
10002	MC.UNIT ERROR	—	—	None	Continue
10003					
10004					
10005				"AL" flashes 3 times ↓ Steady "S01" display	
10006					
10007				None	
10008					
10009					
10010					
10011				Steady ". . ." display	

## APPENDICES

Error code (SD0)	Error contents and cause	Corrective action
10002	Minor/major errors had occurred in command generation axis. (SV22)	Check the Motion error history of MT Developer2 and the minor/major error codes of minor/major error code of minor/major error code storage device, and remove the error cause. Refer to the error codes for error details.
10003	Minor/major errors had occurred.	
10004	Minor/major errors had occurred in virtual servo motor axis. (SV22)	
10005	Minor/major errors had occurred in synchronous encoder axis. (SV22)	
10006	The servo errors had occurred in the servo amplifier (MR-J3-□B, MR-J3-□B compatibility mode) connected to the Motion CPU.	Check the Motion error history of MT Developer2 and the servo error codes of servo error code storage device, and remove the error cause of servo amplifier. Refer to the servo error code for details.
10007	Servo program setting (SV13/SV22)/Motion program setting error (SV43) error occurred.	Check the Motion error history of MT Developer2 and the servo program setting error (SV13/SV22)/Motion program setting error (SV43) storage device (error program No., error item information), and remove the error cause. Refer to the error codes for details.
10008	Real mode/virtual mode switching error occurred. (SV22)	Check the Motion error history of MT Developer2 and the real mode/virtual mode switching error storage device, and remove the error cause. Refer to the real mode/virtual mode switching error codes for details.
10009	Manual pulse generator axis setting error occurred.	Check the Motion error history of MT Developer2 and the manual pulse generator axis setting error storage device, and remove the error cause. Refer to the manual pulse generator axis setting error codes for details.
10010	Test mode request error occurred.	Check the Motion error history of MT Developer2 and the test mode request error storage device, and remove the error cause.
10011	WDT error occurred at Motion CPU.	Check the Motion error history of MT Developer2 and the Motion CPU WDT error factors, and remove the error cause.

Table 3.2 Motion CPU-specific errors (10000 to 10999) (Continued)

Error code (SD0)	Error messages	Common information (SD5 to SD15)	Individual information (SD16 to SD26)	7-segment LED display	CPU operation status
10014	MC.UNIT ERROR	—	—	"AL" flashes 3 times ↓ Steady "L01" display	Stop
10015				"AL" flashes 3 times ↓ Steady "S01" display	Continue
10016				"AL" flashes 3 times ↓ Steady "L01" display	Stop
10017				"AL" flashes 3 times ↓ Steady "S01" display	Continue
10020				None	Continue
10021					
10022					
10023					
10030				Stop	
10040				Continue	
10041					
10042					"AL" flashes 3 times ↓ Steady "S01" display
10043					
10044					
10050					None
10051					
10060					
10061					

# APPENDICES

Error code (SD0)	Error contents and cause	Corrective action
10014	System setting error occurred at Motion CPU.	Check the error message on error monitor screen of MT Developer2, and remove the error cause. And then, turn on the power supply again or reset the Multiple CPU system.
10015	The servo errors had occurred in the servo amplifier (MR-J4-□B) connected to the Motion CPU.	Check the Motion error history of MT Developer2 and the servo error codes of servo error code storage device, and remove the error cause of servo amplifier. Refer to the servo error code for details.
10016	Motion slot fault occurred at Motion CPU.	Check the error message on error monitor screen of MT Developer2, and remove the error cause. And then, turn on the power supply again or reset the Multiple CPU system.
10017	The servo errors had occurred in the servo amplifier (MR-J5-□B) connected to the Motion CPU.	Check the Motion error history of MT Developer2 and the servo error codes of servo error code storage device, and remove the error cause of servo amplifier. Refer to the servo error code for details.
10020	Motion SFC error occurred at Motion SFC program.	Check the Motion error history of MT Developer2, and remove the error cause. Refer to the Motion SFC error code for details.
10021		
10022		
10023		
10030	Motion CPU internal bus error occurred.	Motion CPU module hardware fault. Explain the error symptom and get advice from our sales representative.
10040	Inverter error occurred in the inverter connected with Motion CPU.	Check the Motion error history of MT Developer2 and the error code of the servo error code storage device. After that, remove the inverter error cause. For the detailed contents of the errors, check the servo error code.
10041	An error occurred in servo driver manufactured by CKD Nikki Denso with the Motion CPU connected.	Check the Motion error history of MT Developer2 and the error code of the servo error code storage device. After that, remove the error cause of servo driver manufactured by CKD Nikki Denso. For the detailed contents of the errors, check the servo error code.
10042	The errors had occurred in the SSCNETⅢ/H head module connected to the Motion CPU.	Check the Motion error history of MT Developer2 or the error codes of the SSCNETⅢ/H head module error storage device, then release the error cause of the SSCNETⅢ/H head module. For the details of the error definition, check the SSCNETⅢ/H head module error code.
10043	Error occurred in the stepping driver connected with Motion CPU.	Check the Motion error history of MT Developer2 and the error code of the servo error code storage device. After that, remove the stepping driver error cause.
10044	Operation error occurred in the stepping driver connected with Motion CPU.	For the detailed contents of the errors, check the servo error code.
10050	Safety observation error (alarm) occurred.	Check the Motion error history of MT Developer2 or the Safety observation error code storage device, then release the error cause.
10051	Safety observation error (warning) occurred.	For the details of the error definition, check the Safety observation error code.
10060	<ul style="list-style-type: none"> <li>• The number of the SSCNETⅢ/H compatible Optical Hub units exceeds the limit of connectable units.</li> <li>• The SSCNETⅢ/H compatible Optical Hub unit was connected via OUT2 or OUT3.</li> </ul>	<ul style="list-style-type: none"> <li>• Reduce the number of the SSCNETⅢ/H compatible Optical Hub units to less than the limit of connectable units.</li> <li>• Connect the SSCNETⅢ/H compatible Optical Hub unit via OUT1.</li> </ul>
10061	An error occurred in the SSCNETⅢ/H compatible Optical Hub unit.	Explain the error symptom and get advice from our sales representative.

(3) Self-diagnostic error information

No.	Name	Meaning	Details														
SD0	Diagnostic errors	Diagnostic error code	<ul style="list-style-type: none"> <li>Error codes for errors found by diagnosis are stored as BIN data.</li> </ul>														
SD1	Clock time for diagnostic error occurrence	Clock time for diagnostic error occurrence	<ul style="list-style-type: none"> <li>The year (last two digits) and month that SD0 data was updated is stored as BCD 2-digit code.  <table border="1" style="margin-left: 40px;"> <tr> <td>B15 to B8</td> <td>B7 to B0</td> <td>Example : January 2006</td> </tr> <tr> <td>Year(0 to 99)</td> <td>Month(1 to 12)</td> <td>H0601</td> </tr> </table> </li> </ul>	B15 to B8	B7 to B0	Example : January 2006	Year(0 to 99)	Month(1 to 12)	H0601								
B15 to B8			B7 to B0	Example : January 2006													
Year(0 to 99)			Month(1 to 12)	H0601													
SD2	<ul style="list-style-type: none"> <li>The day and hour that SD0 data was updated is stored as BCD 2-digit code.  <table border="1" style="margin-left: 40px;"> <tr> <td>B15 to B8</td> <td>B7 to B0</td> <td>Example : 25th, 10am</td> </tr> <tr> <td>Day(1 to 31)</td> <td>Hour(0 to 23)</td> <td>H2510</td> </tr> </table> </li> </ul>	B15 to B8	B7 to B0	Example : 25th, 10am	Day(1 to 31)	Hour(0 to 23)	H2510										
B15 to B8	B7 to B0	Example : 25th, 10am															
Day(1 to 31)	Hour(0 to 23)	H2510															
SD3	<ul style="list-style-type: none"> <li>The minute and second that SD0 data was updated is stored as BCD 2-digit code.  <table border="1" style="margin-left: 40px;"> <tr> <td>B15 to B8</td> <td>B7 to B0</td> <td>Example : 35min., 48 sec.</td> </tr> <tr> <td>Minute(0 to 59)</td> <td>Second(0 to 59)</td> <td>H3548</td> </tr> </table> </li> </ul>	B15 to B8	B7 to B0	Example : 35min., 48 sec.	Minute(0 to 59)	Second(0 to 59)	H3548										
B15 to B8	B7 to B0	Example : 35min., 48 sec.															
Minute(0 to 59)	Second(0 to 59)	H3548															
SD4	Error information categories	Error information category code	<ul style="list-style-type: none"> <li>Category codes which help indicate what type of information is being stored in the error common information areas (SD5 to SD15) and error individual information areas (SD16 to SD26) are stored. The category code for judging the error information type is stored.  <table border="1" style="margin-left: 40px;"> <tr> <td>B15 to B8</td> <td>B7 to B0</td> </tr> <tr> <td>Individual information category codes</td> <td>Common information category codes</td> </tr> </table> </li> <li>The common information category codes store the following codes.                      0: No error                      1: Module No./CPU No./Base No.                 </li> <li>The individual information category codes store the following codes.                      0: No error                      5: Parameter No.                      13:Parameter No./CPU No.                 </li> </ul>	B15 to B8	B7 to B0	Individual information category codes	Common information category codes										
B15 to B8	B7 to B0																
Individual information category codes	Common information category codes																
SD5 to SD15	Error common information	Error common information	<ul style="list-style-type: none"> <li>Common information corresponding to the diagnostic error (SD0) is stored.</li> <li>The error common information type can be judged by SD4(common information category code).                      1: Module No./CPU No./Base No.                 </li> </ul> <table border="1" style="margin-left: 40px;"> <thead> <tr> <th>No.</th> <th>Meaning</th> </tr> </thead> <tbody> <tr> <td>SD5</td> <td>Module No./CPU No./Base No.</td> </tr> <tr> <td>SD6</td> <td>I/O No.</td> </tr> <tr> <td>SD7 to SD15</td> <td>Empty</td> </tr> </tbody> </table>	No.	Meaning	SD5	Module No./CPU No./Base No.	SD6	I/O No.	SD7 to SD15	Empty						
No.	Meaning																
SD5	Module No./CPU No./Base No.																
SD6	I/O No.																
SD7 to SD15	Empty																
SD16 to SD26	Error individual information	Error individual information	<ul style="list-style-type: none"> <li>Individual information corresponding to the diagnostic error (SD0) is stored.</li> <li>The error individual information type can be judged by SD4(individual information category code).                      5: Parameter No.                 </li> </ul> <table border="1" style="margin-left: 40px;"> <thead> <tr> <th>No.</th> <th>Meaning</th> </tr> </thead> <tbody> <tr> <td>SD16</td> <td>Parameter No.</td> </tr> <tr> <td>SD17 to SD26</td> <td>Empty</td> </tr> </tbody> </table> <p>0401H : Base setting                      0406H : Motion slot setting                      0E00H : Multiple CPU setting (Number of Multiple CPU's)                      0E01H : Multiple CPU setting (Operation mode/ Multiple CPU synchronous startup)                      E008H : Multiple CPU high speed transmission area setting (CPU specific send range setting / (System area))                      E009H/E00AH : Multiple CPU high speed transmission area setting(Automatic refresh setting)                      E00BH : Synchronous setting</p> <p>13: Parameter No./CPU No.</p> <table border="1" style="margin-left: 40px;"> <thead> <tr> <th>No.</th> <th>Meaning</th> </tr> </thead> <tbody> <tr> <td>SD16</td> <td>Parameter No.</td> </tr> <tr> <td>SD17</td> <td>CPU No.(1 to 4)</td> </tr> <tr> <td>SD18 to SD26</td> <td>Empty</td> </tr> </tbody> </table>	No.	Meaning	SD16	Parameter No.	SD17 to SD26	Empty	No.	Meaning	SD16	Parameter No.	SD17	CPU No.(1 to 4)	SD18 to SD26	Empty
No.	Meaning																
SD16	Parameter No.																
SD17 to SD26	Empty																
No.	Meaning																
SD16	Parameter No.																
SD17	CPU No.(1 to 4)																
SD18 to SD26	Empty																

### (4) Release of Multiple CPU related error

The release operation of errors that continues operation for CPU can be executed.

Release the errors in the following procedure.

- 1) Remove the error cause.
- 2) Turn off the Motion error detection flag (M2039).

The special relays, special registers and 7-segment LED for the errors are returned to the status before error occurs after release of errors.

If the same error is displayed again after release of errors, an error is set again, and the Motion error detection flag (M2039) turns on.

### (5) Error setting on servo warning

Setting whether to output error on servo warning to the motion error history or self-diagnosis error of MT Developer2 is possible.

Set this parameter in the system basic setting of system setting.

(Refer to Section 3.1.3.)



## APPENDICES

### APPENDIX 4 Differences Between Q173DSCPU/Q172DSCPU/Q173DCPU(-S1)/ Q172DCPU(-S1)/Q173HCPU/Q172HCPU

#### APPENDIX 4.1 Differences between Q173DSCPU/Q172DSCPU/Q173DCPU(-S1)/ Q172DCPU(-S1)/Q173HCPU/Q172HCPU

Common differences to the operating system software are shown in Table 4.1. Refer to "APPENDIX 4.3 Differences of the operating system software " for characteristic differences to the operating system software. And, refer to "APPENDIX 4.2 Comparison of devices " for detailed differences of devices.

Table 4.1 Differences between Q173DSCPU/Q172DSCPU/Q173DCPU(-S1)/  
Q172DCPU(-S1)/Q173HCPU/Q172HCPU

Item	Q173DSCPU/Q172DSCPU	Q173DCPU(-S1)/Q172DCPU(-S1)	Q173HCPU/Q172HCPU
Peripheral I/F	USB/RS-232/Ethernet (Via PLC CPU) PERIPHERAL I/F (Motion CPU)	USB/RS-232/Ethernet (Via PLC CPU) PERIPHERAL I/F (Motion CPU) (Note-1)	USB/SSCNET
Battery	Demand		Add Q6BAT at continuous power failure for 1 month or more.
Forced stop input	<ul style="list-style-type: none"> <li>• Use EMI terminal of Motion CPU module.</li> <li>• Use device set by forced stop input setting in the system setting.</li> </ul>		Use device set by forced stop input setting in the system setting.
Multiple CPU high speed transmission memory for data transfer between CPU modules	Included		—
Number of real I/O points (PX/PY)	256 points (Built-in interface in Motion CPU (Input 4 points) + I/O module + Intelligent function module)	256 points (I/O module)	256 points (I/O module)
Device	Internal relays (M)	12288 points	
	Latch relays (L)	None (Latch for M is possible by latch setting)	
	Special relays (M)	—	
	Special relays (SM)	2256 points	
	Special registers (D)	—	
	Special registers (SD)	2256 points	
	Motion registers (#)	12288 points	
	Multiple CPU area devices (U□\G)	Up to 14336 points	
		Total 8192 points	
		256 points	
		—	
		256 points	
		—	
		8192 points	
		—	

(Note-1): Q173DCPU-S1/Q172DCPU-S1 only

Table 4.1 Differences between Q173DSCPU/Q172DSCPU/Q173DCPU(-S1)/  
Q172DCPU(-S1)/Q173HCPU/Q172HCPU (Continued)

Item		Q173DSCPU/Q172DSCPU	Q173DCPU(-S1)/Q172DCPU(-S1)	Q173HCPU/Q172HCPU
Motion dedicated PLC instructions	SV13/ SV22	D(P).DDRD, D(P).DDWR, D(P).SFCS, D(P).SVST, D(P).CHGT, D(P).CHGT2, D(P).CHGV, D(P).CHGVS (Note-2), D(P).CHGA, D(P).CHGAS (Note-2), D(P).GINT	D(P).DDRD, D(P).DDWR, D(P).SFCS, D(P).SVST, D(P).CHGT, D(P).CHGV, D(P).CHGA, D(P).GINT	S(P).DDRD, S(P).DDWR, S(P).SFCS, S(P).SVST, S(P).CHGT, S(P).CHGV, S(P).CHGA, S(P).GINT
	SV43	—	D(P).DDRD, D(P).DDWR, D(P).SFCS, D(P).SVST, D(P).CHGT, D(P).CHGV, D(P).CHGA	S(P).DDRD, S(P).DDWR, S(P).SFCS, S(P).SVST, S(P).CHGT, S(P).CHGV, S(P).CHGA
Interlock condition		Multiple instructions are executable continuously without interlock condition by the self CPU high speed interrupt accept flag from CPU□. □:CPU No.		Interlock condition by the to self CPU high speed interrupt accept flag from CPU□ is necessary.
Motion modules	SV13	Q172DLX, Q173DPX, Q173DSXY	Q172DLX, Q173DPX, Q173DSXY (Note-1)	Q172LX, Q173PX
	SV22	Q172DLX, Q172DEX, Q173DPX, Q173DSXY	Q172DLX, Q172DEX, Q173DPX, Q173DSXY (Note-1)	Q172LX, Q172EX, Q173PX
	SV43	—	Q172DLX, Q173DPX	Q172LX, Q173PX
System setting		<ul style="list-style-type: none"> <li>• QnUD(E)(H)CPU/QnUDVCP is set as CPU No.1.</li> <li>• Only Multiple CPU high speed main base unit (Q35DB/Q38DB/Q312DB) can be used as main base unit.</li> <li>• Q172DLX, Q172DEX and Q173DPX cannot be installed to I/O 0 to 2 slot.</li> </ul>		<ul style="list-style-type: none"> <li>• QnUD(H)CPU is set to CPU No.1.</li> <li>• Q3□B can be used as a main base unit.</li> <li>• Q172LX, Q172EX and Q173PX can be mounted to I/O 0 to 2 slot.</li> </ul>
Latch clear		Remote operation		L.CLR switch
RUN/STOP		Remote operation, RUN/STOP switch		RUN/STOP switch
ROM operation		<ul style="list-style-type: none"> <li>• ROM writing is executed with mode operated by RAM/ mode operated by ROM.</li> <li>• ROM writing can be executed for the data of MT Developer2.</li> </ul>		Rom writing is executed with installation mode/ mode written in ROM.
Model of operating system software	SV13/ SV22	SW8DNC-SV□Q□		SW6RN-SV□Q□
	SV43	—	SW7DNC-SV□Q□	SW5RN-SV□Q□
CPU module No.1		QnUD(E)(H)CPU/QnUDVCP		Qn(H)CPU
Installation orders CPU No.2 or later		No restriction		Install Motion CPU module on the right-hand side of PLC CPU module.
Combination of Motion CPU modules		Combination with Q173DCPU(-S1)/Q172D(-S1)CPU	Combination with Q173DSCPU/Q172DSCPU	Combination with Q173CPUN(-T)/Q172CPUN(-T).
CPU empty slot		Settable between CPU modules		Not settable between CPU modules
CPU shared memory	Multiple CPU high speed transmission area	Provided		None
	Access by Multiple CPU shared memory	Possible		Impossible

(Note-1): Q173DCPU-S1/Q172DCPU-S1 only

(Note-2): SV22 advanced synchronous control only

APPENDICES

Table 4.1 Differences between Q173DSCPU/Q172DSCPU/Q173DCPU(-S1)/  
Q172DCPU(-S1)/Q173HCPU/Q172HCPU (Continued)

Item		Q173DSCPU/Q172DSCPU	Q173DCPU(-S1)/Q172DCPU(-S1)	Q173HCPU/Q172HCPU
Automatic refresh	Memory	Multiple CPU high speed transmission area in CPU shared memory		Automatic refresh area in CPU shared memory
	Automatic refresh setting	32 range possible		4 range possible
	Multiple CPU high speed refresh function	Provided		None
LED display		7-segment LED display		Each LED of MODE, RUN, ERR, M.RUN, BAT and BOOT
Latch range setting	Latch (1)	It is possible to clear with latch clear(1) and latch clear (1)(2) of remote latch clear.		Range which can be cleared with the latch clear key.
	Latch (2)	It is possible to clear with lath clear(1)(2) of remote latch clear.		Range which cannot be cleared with the latch clear key.
All clear function		Execute with installation mode		Turn off the PLC ready flag (M2000) and test mode ON flag (M9075) to execute all clear.
Release of Multiple CPU related error		Turn off M2039.		Store the error code to be released in the special register D9060 and turn off to on the special relay M9060.
Self-diagnosis error		When the Motion CPU-specific errors occur, "10000 to 10999" is set in diagnostic errors (SD0) depending on the type of error. At this time, the self-diagnostic error flag (SM1) and diagnostic error flag (SM0) also turn ON.		When the Motion CPU-specific errors occur, 10000 is set in diagnostic errors (D9008). At this time, the self-diagnostic error flag (M9008) and diagnostic error flag (M9010) do not turn ON.
Motion error detection flag (M2039)		M2039 turns ON even if any errors occur in the Motion CPU module.		When the Motion CPU-specific errors occur, M2039 turn ON. M2039 does not turn ON at the Multiple CPU related errors (Error code of D9008: less then 10000) occurrence. (SV13/SV22) (Note): Unusable for SV43 use.
Software stroke limit		Invalid setting (All units) possible	Invalid setting (degree axis only) possible	
Battery error check of Motion CPU		Invalid setting possible	Anytime valid	
Error setting on servo warning		Selectable whether or not output error	Anytime output error	
Servo external signal		Q172DLX signal, Amplifier input, DI signal, Bit device	Q172DLX signal, Amplifier input	
Optional data monitor function		Up to 6 data (Up to 3 data in SSCNETⅢ)	Up to 3 data	
Axis label		32 characters	None	
Mark detection function		Up to 32	None	
Speed-torque control function		Provided	None	
Torque limit value		Individual change/monitoring of positive/negative direction torque limit value	Batch change/monitoring of positive/negative direction torque limit value	
Acceleration/deceleration time change function		Provided	None	

Table 4.1 Differences between Q173DSCPU/Q172DSCPU/Q173DCPU(-S1)/  
Q172DCPU(-S1)/Q173HCPU/Q172HCPU (Continued)

Item		Q173DSCPU/Q172DSCPU	Q173DCPU(-S1)/Q172DCPU(-S1)	Q173HCPU/Q172HCPU
Home position return function		Proximity dog method (2 types), Count method (3 types), Data set method (2 types), Dog cradle method, Stopper method (2 types), Limit switch combined method, Scale home position signal detection method, Dogless home position signal reference method, Driver home position return method	Proximity dog method (2 types), Count method (3 types), Data set method (2 types), Dog cradle method , Stopper method (2 types), Limit switch combined method, Scale home position signal detection method	Proximity dog method (2 types), Count method (3 types), Data set method (2 types), Dog cradle method, Stopper method (2 types), Limit switch combined method
PI-PID switching command		Provided	None	
Servo parameter read/change function		Provided	None	
Security function		Protection by software security key or password	Protection by password	
Digital oscilloscope function		Word 16CH, Bit 16CH Real-time display possible	Word 4CH, Bit 8CH Real-time display possible	
SSCNET III	Communication speed		50Mbps	
	Transmission distance	Standard cable	Up to 20m (65.62ft.) between stations Maximum overall distance 320m(1049.87ft.) (20m (65.62ft.) ×16 axes)	
		Long distance cable	Up to 50m (164.04ft.) between stations Maximum overall distance 800m (2624.67ft.) (50m (164.04ft.) ×16 axes)	
	Servo amplifier		MR-J3-□B, MR-J3W-□B, MR-J3-□B-RJ004, MR-J3-□B-RJ006, MR-J3-□B-RJ080W, MR-J3-□B Safety, FR-A700, VCII (CKD Nikki Denso), VPH (CKD Nikki Denso)	MR-J3-□B, MR-J3W-□B, MR-J3-□B-RJ004, MR-J3-□B-RJ006, MR-J3-□B-RJ080W, MR-J3-□B Safety, FR-A700, VCII (CKD Nikki Denso)

APPENDICES

Table 4.1 Differences between Q173DSCPU/Q172DSCPU/Q173DCPU(-S1)/  
Q172DCPU(-S1)/Q173HCPU/Q172HCPU (Continued)

Item		Q173DSCPU/Q172DSCPU	Q173DCPU(-S1)/Q172DCPU(-S1)	Q173HCPU/Q172HCPU
SSCNET III/H	Communication speed	150Mbps		Unusable
	Transmission distance	Standard cable	Up to 20m (65.62ft.) between stations Maximum overall distance 320m(1049.87ft.) (20m (65.62ft.) ×16 axes)	
		Long distance cable	Up to 100m (328.08ft.) between stations Maximum overall distance 1600m (5249.34ft.) (100m (328.08ft.) ×16 axes)	
	Servo amplifier	MR-J5-□B, MR-J5-□B-RJ, MR-J5W-□B, MR-J4-□B, MR-J4-□B-RJ, MR-J4W-□B, FR-A800, VCI (CKD Nikki Denso), VPH (CKD Nikki Denso), AlphaStep/5-Phase (ORIENTAL MOTOR), IAI electric actuator controller (IAI)		
Driver communication function		Provided	None	
SSCNET III/H head module connection		Can connect	Cannot connect	
SSCNET III/H compatible optical hub unit connection		Can connect	Cannot connect	
Multiple CPU synchronous control		Provided	None	

## APPENDICES

### APPENDIX 4.2 Comparison of devices

- (1) Motion registers  
 (a) Monitor devices

Table 4.2 Motion registers (Monitor devices) list

Device No.			Name	Remark
Q173DSCPU/ Q172DSCPU	Q173DCPU(-S1)/ Q172DCPU(-S1)	Q173HCPU/ Q172HCPU		
#8000 to #8019		#8064 to #8067	Axis 1 monitor device	
#8020 to #8039		#8068 to #8071	Axis 2 monitor device	
#8040 to #8059		#8072 to #8075	Axis 3 monitor device	
#8060 to #8079		#8076 to #8079	Axis 4 monitor device	
#8080 to #8099		#8080 to #8083	Axis 5 monitor device	
#8100 to #8119		#8084 to #8087	Axis 6 monitor device	
#8120 to #8139		#8088 to #8091	Axis 7 monitor device	
#8140 to #8159		#8092 to #8095	Axis 8 monitor device	
#8160 to #8179		#8096 to #8099	Axis 9 monitor device	
#8180 to #8199		#8100 to #8103	Axis 10 monitor device	
#8200 to #8219		#8104 to #8107	Axis 11 monitor device	
#8220 to #8239		#8108 to #8111	Axis 12 monitor device	
#8240 to #8259		#8112 to #8115	Axis 13 monitor device	
#8260 to #8279		#8116 to #8119	Axis 14 monitor device	
#8280 to #8299		#8120 to #8123	Axis 15 monitor device	
#8300 to #8319		#8124 to #8127	Axis 16 monitor device	
#8320 to #8339		#8128 to #8131	Axis 17 monitor device	
#8340 to #8359		#8132 to #8135	Axis 18 monitor device	
#8360 to #8379		#8136 to #8139	Axis 19 monitor device	
#8380 to #8399		#8140 to #8143	Axis 20 monitor device	
#8400 to #8419		#8144 to #8147	Axis 21 monitor device	
#8420 to #8439		#8148 to #8151	Axis 22 monitor device	
#8440 to #8459		#8152 to #8155	Axis 23 monitor device	
#8460 to #8479		#8156 to #8159	Axis 24 monitor device	
#8480 to #8499		#8160 to #8163	Axis 25 monitor device	
#8500 to #8519		#8164 to #8167	Axis 26 monitor device	
#8520 to #8539		#8168 to #8171	Axis 27 monitor device	
#8540 to #8559		#8172 to #8175	Axis 28 monitor device	
#8560 to #8579		#8176 to #8179	Axis 29 monitor device	
#8580 to #8599		#8180 to #8183	Axis 30 monitor device	
#8600 to #8619		#8184 to #8187	Axis 31 monitor device	
#8620 to #8639		#8188 to #8191	Axis 32 monitor device	

Table 4.3 Monitor devices list

Device No. (Note)			Name	Remark
Q173DSCPU/ Q172DSCPU	Q173DCPU(-S1)/ Q172DCPU(-S1)	Q173HCPU/ Q172HCPU		
#8000 + 20n		#8064 + 4n	Servo amplifier type	
#8001 + 20n		#8065 + 4n	Motor current value	
#8002 + 20n #8003 + 20n		#8066 + 4n #8067 + 4n	Motor speed	
#8004 + 20n #8005 + 20n		—	Command speed	New device in Q173DCPU/Q172DCPU
#8006 + 20n #8007 + 20n		—	Home position return re-travel value	
#8008 + 20n		—	Servo amplifier display servo error code	
#8009 + 20n	—	—	Parameter error No.	New device in Q173DSCPU/Q172DSCPU
#8010 + 20n	—	—	Servo status 1	
#8011 + 20n	—	—	Servo status 2	
#8012 + 20n	—	—	Servo status 3	
#8014 + 20n	—	—	Servo status 5	
#8018 + 20n	—	—	Servo status 7	

(Note): "n" in the device No. indicates the numerical value (axis No.1 to 32 : n= 0 to 31) which correspond to axis No.

(b) Motion error history

Table 4.4 Motion registers (Motion error history) list

Device No.			Name	Remark
Q173DSCPU/ Q172DSCPU	Q173DCPU(-S1)/ Q172DCPU(-S1)	Q173HCPU/ Q172HCPU (Note)		
#8640 to #8651		#8000 to #8007	Seventh error information in past (Oldest error information)	
#8652 to #8663		#8008 to #8015	Sixth error information in past	
#8664 to #8675		#8016 to #8023	Fifth error information in past	
#8676 to #8687		#8024 to #8031	Fourth error information in past	
#8688 to #8699		#8032 to #8039	Third error information in past	
#8700 to #8711		#8040 to #8047	Second error information in past	
#8712 to #8723		#8048 to #8055	First error information in past	
#8724 to #8735		#8056 to #8063	Latest error information	

(Note): Unusable for SV43 use.

Table 4.5 Motion error history list (SV13/SV22)

Device No. (Note)			Name	Remark
Q173DSCPU/ Q172DSCPU	Q173DCPU(-S1)/ Q172DCPU(-S1)	Q173HCPU/ Q172HCPU		
#8640 + 12n			#8000 + 8n	Error Motion SFC program No.
#8641 + 12n			#8001 + 8n	Error type
#8642 + 12n			#8002 + 8n	Error program No.
#8643 + 12n			#8003 + 8n	Error block No./Motion SFC list/Line No./Axis No.
#8644 + 12n			#8004 + 8n	Error code
#8645 + 12n			#8005 + 8n	Error occurrence time (Year/month)
#8646 + 12n			#8006 + 8n	Error occurrence time (Day/hour)
#8647 + 12n			#8007 + 8n	Error occurrence time (Minute/second)
#8648 + 12n			—	Error setting data information
#8649 + 12n			—	Unusable
#8650 + 12n			—	New device in Q173DCPU/Q172DCPU
#8651 + 12n			—	

(Note): "n" in the device No. indicates the numerical value (n=0 to 7) which correspond to motion error history.

Table 4.6 Motion error history list (SV43)

Device No. (Note)		Name	Remark
Q173DCPU(-S1)/ Q172DCPU(-S1)	Q173HCPU/Q172HCPU		
#8640 + 12n	—	Error type	New device in Q173DCPU/Q172DCPU
#8641 + 12n	—	Axis No.	
#8642 + 12n	—	Error code	
#8643 + 12n	—	Program No.	
#8644 + 12n	—	Sequence No.	
#8645 + 12n	—	Error block No.	
#8646 + 12n	—	Error occurrence time (Year/month)	
#8647 + 12n	—	Error occurrence time (Day/hour)	
#8648 + 12n	—	Error occurrence time (Minute/second)	
#8649 + 12n	—	Error setting data information	
#8650 + 12n	—	Error setting data	
#8651 + 12n	—		

(Note): "n" in the device No. indicates the numerical value (n=0 to 7) which correspond to motion error history.

(c) Product information list device

Table 4.7 Motion register (Product information list device) list

Device No. (Note)			Name	Remark
Q173DSCPU/ Q172DSCPU	Q173DCPU(-S1)/ Q172DCPU(-S1)	Q173HCPU/ Q172HCPU		
#8736 to #8743			Operating system software version	New device in Q173D(S)CPU/ Q172D(S)CPU
#8744 to #8751			Motion CPU module serial number	



(2) Special relays

Table 4.8 Special relay list

Device No.		Name	Remark	
Q173DSCPU/ Q172DSCPU	Q173DCPU(-S1)/ Q172DCPU(-S1)			Q173HCPU/ Q172HCPU
SM60		M9000/M2320	Fuse blown detection	
SM53		M9005/M2321	AC/DC DOWN detection	
SM52		M9006/M2322	Battery low	
SM51		M9007/M2323	Battery low latch	
SM1		M9008/M2324	Self-diagnostic error	
SM0		M9010/M2325	Diagnostic error	
—		M9025/M3136	Clock data set request	
SM211		M9026/M2338	Clock data error	
SM801		M9028/M3137	Clock data read request	
SM400		M9036/M2326	Always ON	
SM401		M9037/M2327	Always OFF	
—		M9060/M3138	Diagnostic error reset	Use M2039 for error reset operation.
SM512		M9073/M2329	Motion CPU WDT error	
SM500		M9074/M2330	PCPU READY complete	
SM501		M9075/M2331	Test mode ON	
SM502		M9076/M2332	External forced stop input	
SM513		M9077/M2333	Manual pulse generator axis setting error	
SM510		M9078/M2334	TEST mode request error	
SM516		M9079/M2335	Servo program setting error (SV13/SV22)/ Motion program setting error (SV43)	
SM528		M9216/M2345	No.1 CPU MULTR complete	
SM529		M9217/M2346	No.2 CPU MULTR complete	
SM530		M9218/M2347	No.3 CPU MULTR complete	
SM531		M9219/M2348	No.4 CPU MULTR complete	
SM240		M9240/M2336	No.1 CPU resetting	
SM241		M9241/M2337	No.2 CPU resetting	
SM242		M9242/M2338	No.3 CPU resetting	
SM243		M9243/M2339	No.4 CPU resetting	
SM244		M9244/M2340	No.1 CPU error	
SM245		M9245/M2341	No.2 CPU error	
SM246		M9246/M2342	No.3 CPU error	
SM247		M9247/M2343	No.4 CPU error	
SM58		—	Battery low warning latch	New device in Q173DCPU/Q172DCPU
SM59		—	Battery low warning	
SM220		—	CPU No.1 READY complete	
SM221		—	CPU No.2 READY complete	
SM222		—	CPU No.3 READY complete	
SM223		—	CPU No.4 READY complete	
SM503		—	Digital oscilloscope executing	
SM505		—	Cam data writing	New device in Q173DSCPU/Q172DSCPU
SM506		—	External forced stop input ON latch	New device in Q173D(S)CPU/ Q172D(S)CPU

Table 4.8 Special relay list (Continued)

Device No.			Name	Remark
Q173DSCPU/ Q172DSCPU	Q173DCPU(-S1)/ Q172DCPU(-S1)	Q173HCPU/ Q172HCPU		
SM508			Amplifier-less operation status flag	New device in Q173DCPU/Q172DCPU
SM526			Over heat warning latch	
SM527			Over heat warning	
SM532	—	—	SSCNETⅢ searching flag (Line 1)	New device in Q173DSCPU/Q172DSCPU
SM533	—	—	SSCNETⅢ searching flag (Line 2)	
SM561	—	—	Multiple CPU synchronous control initial complete flag	
SM805	—	—	Rapid stop deceleration time setting error invalid flag	

(3) Special registers

Table 4.9 Special registers list

Device No.			Name	Remark	
Q173DSCPU/ Q172DSCPU	Q173DCPU(-S1)/ Q172DCPU(-S1)	Q173HCPU/ Q172HCPU			
SD60		D9000	Fuse blown No.		
SD53		D9005	AC/DC DOWN counter No.		
SD0		D9008	Diagnostic errors		
SD1		D9010	Clock time for diagnostic error occurrence (Year, month)		
SD2		D9011	Clock time for diagnostic error occurrence (Day, hour)		
SD3		D9012	Clock time for diagnostic error occurrence (Minute, second)		
SD4		D9013	Error information categories		
SD5		D9014	Error common information	New device in Q173DCPU/Q172DCPU	
SD6		—			
SD7		—			
SD8		—			
SD9		—			
SD10		—			
SD11		—			
SD12		—			
SD13		—			
SD14		—			
SD15		—			
SD16		—			
SD17		—	Error individual information		
SD18		—			
SD19		—			
SD20		—			
SD21		—			
SD22		—			
SD23		—			
SD24		—			
SD25		—			
SD26		—			
SD203		D9015	Operating status of CPU		
SD520		D9017	Scan time		
SD521		D9019	Maximum scan time		
SD210		D9025	Clock data (Year, month)		
SD211		D9026	Clock data (Day, hour)		
SD212		D9027	Clock data (Minute, second)		
SD213		D9028	Clock data (Day of week)		
—		D9060	Diagnostic error reset error No.	Use M2039 for error reset operation.	
SD395		D9061	Multiple CPU No.		
SD508		D9112	SSCNET control (Status)		
SD803			SSCNET control (Command)		
SD510		D9182	Test mode request error		
SD511		D9183			

Table 4.9 Special registers list (Continued)

Device No.			Name	Remark
Q173DSCPU/ Q172DSCPU	Q173DCPU(-S1)/ Q172DCPU(-S1)	Q173HCPU/ Q172HCPU		
SD512		D9184	Motion CPU WDT error cause	
SD513		D9185	Manual pulse generator axis setting error	
SD514		D9186		
SD515		D9187		
SD522		D9188	Motion operation cycle	
SD516		D9189	Error program No.	
SD517		D9190	Error item information	
SD502		D9191	Servo amplifier loading information	
SD503		D9192		
SD504		D9193		
SD505		D9194	Real mode/virtual mode switching error information	
SD506		D9195		
—		D9196	PC link communication error codes	Q173D(S)CPU/ Q172D(S)CPU does not support PC link communication.
SD523		D9197	Operation cycle of the Motion CPU setting	
SD200		D9200	State of switch	
—		D9201	State of LED	Use 7-segment LED in Q173D(S)CPU/ Q172D(S)CPU.
SD524	—	—	Maximum Motion operation cycle	New device in Q173DSCPU/Q172DSCPU
SD550	—	—	System setting error information	
SD551	—	—		
SD552	—	—	Servo parameter write/read request	
SD553	—	—	Operation method	
SD560	—	—	Multiple CPU synchronous control setting status	New device in Q173DSCPU/Q172DSCPU
SD561	—	—		
SD700		—	Device assignment	New device in Q173DCPU/Q172DCPU
SD701		—		
SD702		—		
SD703		—		
SD704		—		
SD720		—	444μs coasting timer	
SD721		—		
SD722	—	—	222μs coasting timer	New device in Q173DSCPU/Q172DSCPU
SD723	—	—		
SD724	—	—	SSCNETⅢ/H compatible optical hub unit loading information (Line 1)	
SD725	—	—	SSCNETⅢ/H compatible optical hub unit loading information (Line 2)	
SD726	—	—	SSCNETⅢ/H compatible optical hub unit communication error information (Line 1)	
SD727	—	—	SSCNETⅢ/H compatible optical hub unit communication error information (Line 2)	

APPENDICES

---

Table 4.9 Special registers list (Continued)

Device No.			Name	Remark
Q173DSCPU/ Q172DSCPU	Q173DCPU(-S1)/ Q172DCPU(-S1)	Q173HCPU/ Q172HCPU		
SD804	—	—	Servo parameter write/read request	New device in Q173DSCPU/Q172DSCPU
SD805	—	—		
SD806	—	—		
SD807	—	—		
SD808	—	—	Servo parameter write/read request (2 word)	
SD809	—	—		

(4) Other devices

Table 4.10 Other devices list

Item	Q173DSCPU/Q172DSCPU	Q173DCPU(-S1)/Q172DCPU(-S1)	Q173HCPU/Q172HCPU	
Internal relays/ Data registers	M2320 to M2399	Unusable		Special relay allocated devices (Status)
	M2400 to M3039	Device area of 17 axes or more is usable as user devices in Q172DSCPU.	Device area of 9 axes or more is usable as user devices in Q172DCPU(-S1).	Device area of 9 axes or more is unusable as user devices in Q172HCPU.
	M3136 to M3199	Unusable		Special relay allocated devices (Command signal)
	M3200 to M3839	Device area of 17 axes or more is usable as user devices in Q172DSCPU.	Device area of 9 axes or more is usable as user devices in Q172DCPU(-S1).	Device area of 9 axes or more is unusable in Q172HCPU.
	D0 to D639 D640 to D703			
Personal computer link communication error flag	—		M2034	
Gain changing 2 command (Note-2)	M3206+20n (Note-1)	—	—	
PI-PID switching command	M3217 + 20n (Note-1)	—	—	
PCPU READY complete	SM500		D759	
Home position return re-travel value	D9 + 20n (Data shortened to 1 word) (Note-1) #8006 + 20n, #8007 + 20n (Referring at monitoring) (Note-1)		D9 + 20n (Note-1)	
Travel value change registers	Optional device (Set for D16 + 20n, D17 + 20n are also usable.) (Note-1)		D16 + 20n, D17 + 20n (Note-1)	
Indirect setting devices (Word devices)	D0 to D8191		D800 to D8191	
	W0 to W1FFF		W0 to W1FFF	
	#0 to #7999		#0 to #7999	
	U□\G10000 to U□\G(10000 + p - 1) (Note-3)		—	
Indirect setting devices (Bit devices)	X0 to X1FFF (Note-4)	X0 to X1FFF	X0 to X1FFFF	
	Y0 to Y1FFF	—	Y0 to Y1FFF	
	M0 to M8191	—	M/L0 to M/L8191	
	—	—	M9000 to M9255	
	B0 to B1FFF	—	B0 to B1FFF	
	F0 to F2047	—	F0 to F2047	
	U□\G10000.0 to U□\G(10000 + p - 1).F (Note-3)	—	—	
High-speed reading function settable devices	D0 to D8191		D800 to D3069, D3080 to D8191	
	W0 to W1FFF		W0 to W1FFF	
	U□\G10000 to U□\G(10000 + p - 1) (Note-3)		—	
Optional data monitor function settable devices	D0 to D8191		D0 to D8191	
	W0 to W1FFF		W0 to W1FFF	
	#0 to #7999		#0 to #7999	
	U□\G10000 to U□\G(10000 + p - 1) (Note-3)		—	

(Note-1): "n" in the above device No. indicates the numerical value (axis No.1 to 32 : n= 0 to 31) which correspond to axis No.

(Note-2): Servo amplifier MR-J5(W)-□B only.

(Note-3): "p" indicates the user setting area points of Multiple CPU high speed transmission area in each CPU.

(Note-4): The range of "PXn+4 to PXn+F" cannot be used (fixed at 0) for the input device (PXn+0 to PXn+F) allocated to the built-in interface in Motion CPU (DI). (n: First input No.)

Table 4.10 Other devices list (Continued)

Item	Q173DSCPU/Q172DSCPU	Q173DCPU(-S1)/Q172DCPU(-S1)	Q173HCPU/Q172HCPU	
Limit switch output data	Output device	X0 to X1FFF (Note-4)	X0 to X1FFF	X0 to X1FFF
		Y0 to Y1FFF	Y0 to Y1FFF	Y0 to Y1FFF
		M0 to M8191	M0 to M8191	M0 to M8191
		—	—	L0 to L8191
		B0 to B1FFF	B0 to B1FFF	B0 to B1FFF
		U□\G10000.0 to U□\G(10000 + p - 1).F (Note-3)	—	—
	Watch data	D0 to D8191	D0 to D8191	D0 to D8191
		W0 to W1FFF	W0 to W1FFF	W0 to W1FFF
		#0 to #9215	#0 to #8191	#0 to #8191
		U□\G10000 to U□\G(10000 + p - 1) (Note-3)	—	—
	ON section setting	D0 to D8191	D0 to D8191	D0 to D8191
		W0 to W1FFF	W0 to W1FFF	W0 to W1FFF
		#0 to #9215	#0 to #8191	#0 to #8191
		Constant (Hn/Kn) (Note-5)	Constant (Hn/Kn) (Note-5)	Constant (Hn/Kn) (Note-5)
	U□\G10000 to U□\G(10000 + p - 1) (Note-3)	—	—	
	Output enable/disable bit	X0 to X1FFF (Note-4)	X0 to X1FFF	X0 to X1FFF
Y0 to Y1FFF		Y0 to Y1FFF	Y0 to Y1FFF	
M0 to M8191		M0 to M8191	M0 to M8191	
—		—	L0 to L8191	
B0 to B1FFF		B0 to B1FFF	B0 to B1FFF	
F0 to F2047		F0 to F2047	F0 to F2047	
Forced output bit	SM0 to SM1999	M9000 to M9255	M9000 to M9255	
	U□\G10000.0 to U□\G(10000 + p - 1).F (Note-3)	—	—	

- (Note-1): "n" in the above device No. indicates the numerical value (axis No.1 to 32 : n= 0 to 31) which correspond to axis No.
- (Note-2): Servo amplifier MR-J5(W)-□B only.
- (Note-3): "p" indicates the user setting area points of Multiple CPU high speed transmission area in each CPU.
- (Note-4): The range of "PXn+4 to PXn+F" cannot be used (fixed at 0) for the input device (PXn+0 to PXn+F) allocated to the built-in interface in Motion CPU (DI). (n: First input No.)
- (Note-5): Setting range varies depending on the setting units.

**POINT**

Refer to Chapter 2 for number of user setting area points of Multiple CPU high speed transmission area.

APPENDIX 4.3 Differences of the operating system software

(1) Motion SFC (SV13/SV22)

Item		Q173DSCPU/Q172DSCPU	Q173DCPU(-S1)/Q172DCPU(-S1)	Q173HCPU/Q172HCPU
Motion SFC program capacity	Code total (Motion SFC chart + Operation control + Transition)	652k bytes	543k bytes	543k bytes
	Text total (Operation control + Transition)	668k bytes	484k bytes	484k bytes
Motion SFC program executing flag		X, Y, M, B, U□\G		—
Motion SFC program event task		Fixed cycle (0.22ms/0.44ms, 0.88ms, 1.77 ms, 3.55 ms, 7.11 ms, 14.2 ms)	Fixed cycle (0.44ms, 0.88ms, 1.77 ms, 3.55 ms, 7.11 ms, 14.2 ms)	Fixed cycle (0.88ms, 1.77 ms, 3.55 ms, 7.11 ms, 14.2 ms)
Task Parameter Limited count of repeat control		Normal task : 1 to 100000 Event task : 1 to 10000 NMI task : 1 to 10000		—
Operation control/transition control usable device (Word device)		D, W, U□\G, SD, #, FT		D, W, Special D, #, FT
Operation control/transition control usable device (Bit device)		X, PX, Y, PY, M, U□\G□.□, B, F, SM		X, PX, Y, PY, M, L, B, F, Special M
Instruction	Motion dedicated function	CHGV, CHGVS <sup>(Note-1)</sup> , CHGT, CHGT2, CHGP	CHGV, CHGT	CHGV, CHGT
	Others	EI, DI, NOP, BMOV, FMOV, MULTW, MULTR, TO, FROM, RTO, RFROM, TIME	EI, DI, NOP, BMOV, FMOV, MULTW, MULTR, TO, FROM, TIME	EI, DI, NOP, BMOV, FMOV, MULTW, MULTR, TO, FROM, TIME
	Vision system dedicated function <sup>(Note-2)</sup>	MVOPEN, MVLOAD, MVTRG, MVPST, MVIN, MVOUT, MVFIN, MVCLOSE, MVCOM		—
	Data control	SCL, DSCL		—
	Program control	IF - ELSE - IEND, SELECT - CASE - SEND, FOR - NEXT, BREAK		—
	Synchronous control dedicated function <sup>(Note-1)</sup>	CAMRD, CAMWR, CAMWR2, CAMMK, CAMPSCL	—	—

(Note-1): SV22 advanced synchronous control only.

(Note-2): Unusable in Q173DCPU/Q172DCPU.



(2) Virtual mode (SV22)

Item		Q173DSCPU/Q172DSCPU	Q173DCPU(-S1)/Q172DCPU(-S1)	Q173HCPU/Q172HCPU
Internal relay/ Data register	M4640 to M4687	Unusable as user devices	Device area of 9 axes or more is usable as user devices in the Q172DCPU.	Device area of 9 axes or more is unusable in the Q172HCPU.
	M5440 to M5487			
	D1120 to D1239			
Clutch status		Optional device (Set for M2160 to M2223 are also usable.)		M2160 to M2223
Cam axis command signals (Cam/ball screw switching command)		Optional device (Set for M5488 to M5519 are also usable.)		M5488 to M5519
Smoothing clutch complete signals		Optional device (Set for M5520 to M5583 are also usable.)		M5520 to M5583
Real mode axis information register		SD500, SD501		D790, D791
Indirect setting devices of mechanical system program (Word device)		D0 to D8191		D800 to D3069, D3080 to D8191
		W0 to W1FFF		W0 to W1FFF
		#0 to #7999		—
		U□\G10000 to U□\G(10000 + p - 1) (Note-1)		—
Indirect setting devices of mechanical system program (Bit device)		X0 to X1FFF (Note-2)	X0 to X1FFF	X0 to X1FFF
		Y0 to Y1FFF		Y0 to Y1FFF
		M0 to M8191		M/L0 to M/L8191
		—		M9000 to M9255
		B0 to B1FFF		B0 to B1FFF
		F0 to F2047		F0 to F2047
Virtual servo motor Command in-position range		1 to 2147483647	1 to 32767	1 to 32767
Cam	Number of pulses per cam shaft revolution	1 to 1073741824[pulse]/ Word device (D, W, #, U□\G)	1 to 1073741824[pulse]	1 to 1073741824[pulse]
	Output unit	mm, inch, pulse, degree	mm, inch, pulse	mm, inch, pulse
Speed change ratio of speed change gear		Upper limit value : 0 to 65535 Lower limit value : 0 to 65535		Upper limit value : 1 to 10000 Lower limit value : 1 to 10000
Permissible droop pulse value of output module		1 to 1073741824 [pulse]		1 to 65535[×100pulse]

(Note-1): "p" indicates user setting area points of Multiple CPU high speed transmission area in each CPU.

(Note-2): The range of "PXn+4 to PXn+F" cannot be used (fixed at 0) for the input device (PXn+0 to PXn+F) allocated to the built-in interface in Motion CPU (DI). (n: First input No.)

**POINT**

Refer to Chapter 2 for number of user setting area points of Multiple CPU high speed transmission area.

## APPENDICES

### (3) Motion program (SV43)

Item		Q173DCPU(-S1)/Q172DCPU(-S1)	Q173HCPU/Q172HCPU
DNC operation		None	Provided
Internal relay/ Data register	M4320 to M4335	Unusable	DNC status
Motion program capacity		504k bytes	248k bytes
Variable	Device variable	X, Y, M, B, F, D, W, #, U□\G	X, Y, M, B, F, D, W, #
Instructions	Jump/repetition processing	CALL, GOSUB, GOSUBE, IF...GOTO, IF...THEN...ELSE IF...ELSE...END, WHILE...DO...BREAK...CONTINUE...END	CALL, GOSUB, GOSUBE, IF...GOTO, IF...THEN...ELSE...END, WHILE...DO... END
Instructions symbol		AT (Acceleration): 1 to 65535[×0.001s]	—
		BT (Deceleration): 1 to 65535[×0.001s]	—
		AND (Conditional branch using word device)	—
Multiprogramming depth of IF statement/WHILE statement		Up to eight levels including IF statement and While statement	Up to three levels including IF statement and While statement
BSET, BRST		Bit set and reset for word devices is possible.	—
Setting range of M-code		0 to 32767 (32761 except special M-codes)	0 to 9999 (9993 except special M-codes)



# **WARRANTY**

Please confirm the following product warranty details before using this product.

## **1. Gratis Warranty Term and Gratis Warranty Range**

We will repair any failure or defect hereinafter referred to as "failure" in our FA equipment hereinafter referred to as the "Product" arisen during warranty period at no charge due to causes for which we are responsible through the distributor from which you purchased the Product or our service provider. However, we will charge the actual cost of dispatching our engineer for an on-site repair work on request by customer in Japan or overseas countries. We are not responsible for any on-site readjustment and/or trial run that may be required after a defective unit is repaired or replaced.

### **[Gratis Warranty Term]**

The term of warranty for Product is thirty six (36) months after your purchase or delivery of the Product to a place designated by you or forty two (42) months from the date of manufacture whichever comes first "Warranty Period". Warranty period for repaired Product cannot exceed beyond the original warranty period before any repair work.

### **[Gratis Warranty Range]**

- (1) You are requested to conduct an initial failure diagnosis by yourself, as a general rule.  
It can also be carried out by us or our service company upon your request and the actual cost will be charged. However, it will not be charged if we are responsible for the cause of the failure.
- (2) This limited warranty applies only when the condition, method, environment, etc. of use are in compliance with the terms and conditions and instructions that are set forth in the instruction manual and user manual for the Product and the caution label affixed to the Product.
- (3) Even during the term of warranty, the repair cost will be charged on you in the following cases;
  - 1) A failure caused by your improper storing or handling, carelessness or negligence, etc., and a failure caused by your hardware or software problem
  - 2) A failure caused by any alteration, etc. to the Product made on your side without our approval
  - 3) A failure which may be regarded as avoidable, if your equipment in which the Product is incorporated is equipped with a safety device required by applicable laws and has any function or structure considered to be indispensable according to a common sense in the industry
  - 4) A failure which may be regarded as avoidable if consumable parts designated in the instruction manual, etc. are duly maintained and replaced
  - 5) Any replacement of consumable parts (battery, fan, etc.)
  - 6) A failure caused by external factors such as inevitable accidents, including without limitation fire and abnormal fluctuation of voltage, and acts of God, including without limitation earthquake, lightning and natural disasters
  - 7) A failure generated by an unforeseeable cause with a scientific technology that was not available at the time of the shipment of the Product from our company
  - 8) Any other failures which we are not responsible for or which you acknowledge we are not responsible for

## **2. Onerous Repair Term after Discontinuation of Production**

- (1) We may accept the repair at charge for another seven (7) years after the production of the product is discontinued.  
The announcement of the stop of production for each model can be seen in our Sales and Service, etc.
- (2) Please note that the Product (including its spare parts) cannot be ordered after its stop of production.

## **3. Service in overseas countries**

Our regional FA Center in overseas countries will accept the repair work of the Product; However, the terms and conditions of the repair work may differ depending on each FA Center. Please ask your local FA center for details.

## **4. Exclusion of Loss in Opportunity and Secondary Loss from Warranty Liability**

Regardless of the gratis warranty term, Mitsubishi shall not be liable for compensation to:

- (1) Damages caused by any cause found not to be the responsibility of Mitsubishi.
- (2) Loss in opportunity, lost profits incurred to the user by Failures of Mitsubishi products.
- (3) Special damages and secondary damages whether foreseeable or not, compensation for accidents, and compensation for damages to products other than Mitsubishi products.
- (4) Replacement by the user, maintenance of on-site equipment, start-up test run and other tasks.

## **5. Change of Product specifications**

Specifications listed in our catalogs, manuals or technical documents may be changed without notice.

## 6. Precautions for Choosing the Products

- (1) For the use of our Motion controller, its applications should be those that may not result in a serious damage even if any failure or malfunction occurs in Motion controller, and a backup or fail-safe function should operate on an external system to Motion controller when any failure or malfunction occurs.
- (2) Our Motion controller is designed and manufactured as a general purpose product for use at general industries. Therefore, applications substantially influential on the public interest for such as atomic power plants and other power plants of electric power companies, and also which require a special quality assurance system, including applications for railway companies and government or public offices are not recommended, and we assume no responsibility for any failure caused by these applications when used.  
In addition, applications which may be substantially influential to human lives or properties for such as airlines, medical treatments, railway service, incineration and fuel systems, man-operated material handling equipment, entertainment machines, safety machines, etc. are not recommended, and we assume no responsibility for any failure caused by these applications when used.  
We will review the acceptability of the abovementioned applications, if you agree not to require a specific quality for a specific application. Please contact us for consultation.
- (3) Mitsubishi shall have no responsibility or liability for any problems involving programmable controller trouble and system trouble caused by DoS attacks, unauthorized access, computer viruses, and other cyberattacks.

Microsoft, Windows, Windows NT, Windows Vista, and Windows XP are either registered trademarks or trademarks of Microsoft Corporation in the United States and/or other countries.

The company names, system names and product names mentioned in this manual are either registered trademarks or trademarks of their respective companies.

In some cases, trademark symbols such as '™' or '®' are not specified in this manual.

IB(NA)-0300134-L(2204)MEE

MODEL: Q173D-P-COM-E

MODEL CODE: 1XB928

## **MITSUBISHI ELECTRIC CORPORATION**

HEAD OFFICE : TOKYO BUILDING, 2-7-3 MARUNOUCHI, CHIYODA-KU, TOKYO 100-8310, JAPAN  
NAGOYA WORKS : 1-14, YADA-MINAMI 5-CHOME, HIGASHI-KU, NAGOYA, JAPAN

When exported from Japan, this manual does not require application to the  
Ministry of Economy, Trade and Industry for service transaction permission.

Specifications subject to change without notice.