

MITSUBISHI

PROGRAMMABLE CONTROLLER

MELSEC-A

Mitsubishi General Use PC User's Manual

A1SJ71E71-B2-S3/A1SJ71E71-B5-S3 Ethernet Interface Module (Hardware)

Thank you for buying the Mitsubishi general-purpose programmable logic controller MELSEC-A Series

Prior to use, please read this manual thoroughly and familiarize yourself with the product



MODEL	A1SE71S3-U-H/W-E
MODEL CODE	13J855

IB (NA)-66688 E (0006) MEE

© 1996 MITSUBISHI ELECTRIC CORPORATION

SAFETY PRECAUTIONS

(Read these precautions before using)

When using Mitsubishi equipment, thoroughly read this manual and the associated manuals introduced in the manual. Also pay careful attention to safety and handle the module properly.

These precautions apply only to the installation of Mitsubishi equipment and the wiring with the external device. Refer to the user's manual of the CPU module to be used for a description of the PLC system safety precautions.

These ● SAFETY PRECAUTIONS ● classify the safety precautions into two categories: "DANGER" and "CAUTION".

◇ DANGER Procedures which may lead to a dangerous condition and cause death or serious injury if not carried out properly

△ CAUTION Procedures which may lead to a dangerous condition and cause superficial to medium injury, or physical damage only, if not carried out properly

Depending on circumstances, procedures indicated by CAUTION may also be linked to serious results.

In any case, it is important to follow the directions for usage.

Store this manual in a safe place so that you can take it out and read it whenever necessary. Always forward it to the end user.

DESIGN PRECAUTIONS

CAUTION

- When laying the control wire or communication cable, do not bundle with or place near main circuit or power line. Keep them at least 100 mm (3.94 in.) away from such cables. Noise may cause erroneous operation.

INSTALLATION PRECAUTIONS

CAUTION

- Use the PLC in the environment given in the general specifications section of the user's manual to be used. Using the PLC outside the range of the general specifications may result in electric shock, fire, or erroneous operation or may damage or degrade the product.

INSTALLATION PRECAUTIONS

CAUTION

- Insert the tabs at the bottom of the module into the holes in the base unit before installing the module, and then fasten module installation screws at the specified torque. Improper installation and fastening may cause erroneous operation, accidents, or the module to fall out.
- Tighten the screw within the range of specified torque. If the screws are loose, it may result in fallout, short circuits or malfunction. Tightening the screws to far may cause damage to the screw and/or the module, resulting in fallout, short circuits or malfunction.
- Make sure to switch all phases of the external power supply off before mounting or removing the module. If you do not switch off the external power supply, it will cause electric shock or damage to the product.
- Do not touch the electronic parts or the module conducting area directly. It may cause erroneous operation or failure.

WIRING PRECAUTIONS

CAUTION

- Perform correct pressure-displacement, crimp-contact or soldering for external wire connections using the tools specified by the manufacturers. Incorrect connection may cause short circuits, fire or malfunction.
- Attach connector to the module securely.
- Be sure to fix communication cables or power supply cables leading from the module by placing them in the duct or clamping them. Cables not placed in the duct or without clamping may hang or shift, allowing them to be accidentally pulled, which may cause a module malfunction and cable damage.
- Tighten the screw within the range of specified torque. If the screws are loose, it may result in short circuits or malfunction. Tightening the screws to far may cause damage to the screw and/or the module, resulting in fallout, short circuits or malfunction.
- Do not grab on the cable when removing the communication cable connected to the module. When removing the cable with a connector, hold the connector on the side that is connected to the module. When removing the cable connected to the terminal block, first loosen the screws on the part that is connected to the terminal block. Pulling the cable that is still connected to the module may cause a malfunction or damage to the module or cable.
- Solder coaxial cable connectors properly. Insufficient soldering may cause malfunction.
- Be sure that cuttings, wire chips, or other foreign matter do not enter the module. Foreign matter may start a fire or cause an accident or erroneous operation.

Related Manuals

The following product are available for this equipment. Refer to the table given below to choose suitable manuals.

Related Manual

Manual Name	Manual No (Model code)
Ethernet Interface Module User's Manual	SH 3598 (13J856)

Correspondence to EMC DIRECTIVE

To make the PLCs compliant with the EMC directive, refer to Chapter 3 "EMC AND LOW-VOLTAGE DIRECTIVE" in the user's manual (Hardware) of the CPU module to be used.

- When the CPU module user's manual (Hardware) does not include Chapter 3 "EMC AND LOW-VOLTAGE DIRECTIVE", refer to QnA Series CPU Compatible High-Speed Accessing Basic Base Unit -- Additional Explanation for Product Conforming to EMC Standards (IB-68837) (optional).

1. Overview

This manual describes how to install A1SJ71E71-B2/B5-S3 Ethernet Interface Module (hereafter abbreviated as E71) and how to wire them with external devices

After unpacking E71, please confirm that the following products are contained

Model name	Product name	No. of items
A1SJ71E71-B2-S3	A1SJ71E71-B2-S3 Ethernet Interface Module	1
	BCN T type adapter (UG 274/u)	1
A1SJ71E71-B5-S3	A1SJ71E71 B5-S3 Ethernet Interface Module	1

2. Performance Specifications

Performance Specifications of E71 are described below
For general specification, refer to User's Manual of CPU module to be used

Topic	Specifications	
	A1SJ71E71-B2-S3 10BASE2 (Cheapernet)	A1SJ71E71-B5-S3 10BASE5 (Ethernet)
Data transmission speed	10 Mbps	
Transmission method	Base band	
Maximum distance between nodes	925 m (3034.77 ft.)	2500 m (8202.10 ft.)
Maximum segment length	185 m (606.96 ft.)	500 m (1640.42 ft.)
Maximum number of nodes	30 nodes per segment	100 nodes per segment
Minimum distance between nodes	0.5 m (1.64 ft.)	2.5 m (8.20 ft.)
Sending/receiving communication data memory for storage	Fixed buffer	: 1 k word × 8
	Random access buffer	: 3 k word × 2
Number of external nodes that can be communicated with a single initial processing	Max 20 stations (1)	
Number of input output power points	32 points (*2)	
5 V DC internal consumption current [A]	0.52/0.57/0.49 (*3)	0.35

3. Settings and Names of Each Part

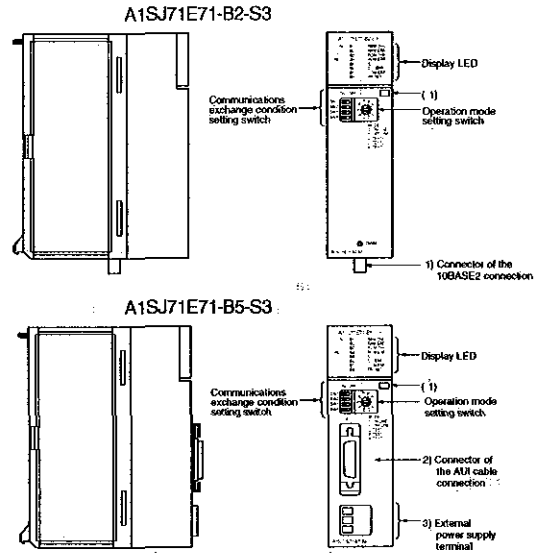

*1 The seal shows the hardware version and software version of a module
(Example)

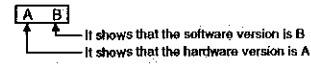

No	Designation	Contents
1)	Connector of the 10BASE2 connection	Connector for the connection of 10BASE2 use coaxial cable to E71
2)	Connector of the AUI cable connection	Connector for the connection of 10BASE5 use AUI cable (transceiver cable) to E71.
3)	External power source supply terminal	Power source terminals for power source supply to the transceiver in the connection of 10BASE5. (14.08 V to 15.75 V)

Topic	Specifications	
	A1SJ71E71-B2-S3 10BASE2 (Cheapernet)	A1SJ71E71-B5-S3 10BASE5 (Ethernet)
12 V DC external power supply capacity	(*4)	
External dimensions [mm (inch)]	130 (5.12) × 34.5 (1.36) × 93.6 (3.69)	
Mass [kg (lb)]	0.30 (0.66) (*5)	0.27 (0.594)

- *1 Number of nodes that can be communicated
- When using E71 of which software version is "K" or before
Maximum number of external nodes that can be communicated with a single initial processing of E71 is 20 stations
(The original station is included when a message is sent to several stations at once by UDP/IP)
More external nodes can be communicated by repeating the initial processing
 - When using E71 of which software version is "L" or later
There are no special restrictions

- *2 I/O assignment should be set by special 32 points when performed with GPP function
- *3 5 V DC internal consumption current of E71 depends on the hardware version
- E71 which hardware version is A : 0.52A
 - E71 which hardware version is B to D : 0.57A
 - E71 which hardware version is E or later : 0.49A

- *4 It is required to use that which satisfies the specifications of the transceiver and the AUI cable, considering the voltage drop in E71 (Maximum 0.8 V)

- *5 The value of T-shape adapter 20g including termination resistor value 10g

Notes

The following diagram indicates the longest between the nodes, and the segment length

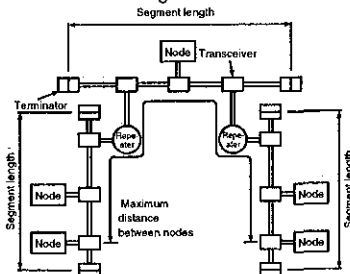

(1) Display LED display contents

```

RUN B1 RAM CHK
    B2 RAM ERR
    B3 ROMCHK
RDY B4 ROMERR
    B5 S C
    B6 S C ERR
BSY B7 COM ERR
    B8 FROM/TO
    
```

Display LED	Display contents	When lamp is lit	Lamp is not lit
RUN	Normal operation display	Normal	Abnormal
RDY	Standard display of communication exchange completion	Light flashing during on line operation	
BSY	Display during execution of communication exchange processing	Executing	Not executing
B1 to B8	Display of telecommunication line connection status of connection No n corresponding to Bn	Open completed	Closed status
RAM CHK	Display during execution of RAM test	During execution of test	Not testing
RAM ERR	Display of RAM abnormality detection	RAM abnormality	Normal
ROM CHK	Display during execution of ROM test	During execution of test	Not testing
ROM ERR	Display of ROM abnormality detection	ROM abnormality	Normal
S C	Display during self back to back test	During execution of test	Not testing
S C ERR	Display of self back to back abnormality detection	Back to back abnormality	Normal
COM ERR	Display of communication exchange abnormality detection	During detection of abnormality	Normal (no abnormalities)
FROM/TO	Display during data reading (FROM)/display during data writing (TO)	During the execution of reading/writing	Not reading/writing

- (2) Operation mode setting switch setting
Set the E71 operation mode (Usually set to on-line)

Operation mode setting switch	Setting number	Setting designation	Setting contents
	0	On line	Execute communication exchange with another node by regular operation mode.
	1	Off-line	Parallel off this module from network.
	2	Test 1	Execute self diagnosis from self back to back test.
	3	Test 2	Execute RAM test.
	4	Test 3	Execute ROM test.
	5 to 9		Use is impossible

(This is set at "0 (on-line)" at the time of shipping from factory)

- (3) Communications exchange condition setting switch setting
Set the conditions for data communication with other nodes

Communications exchange condition setting switch	Switch	Setting designation	Setting contents
	SW1	TCP time out error temporary circuit process selection	Selection of circuit processing when a TCP time out error occurrence (Usually set to OFF)
			OFF: Close the circuit.
	SW2	Data code selection	Select a classification of data codes of communication exchange data of another node.
			OFF: Communication exchange by binary code.
	SW3	CPU communications exchange timing setting	During the RUN of PLC CPU, select approval/prohibition of the data reading from another node
			OFF: Writing prohibited.
	SW4	Initial timing setting	Select the timing which starts initial processing (Usually set to OFF.)
			OFF: Quick start (start without delay)—Set when entirely constructed in a single network.
			ON: Normal start (start after a 20 second delay)—Set when entirely constructed in multiple networks.

(This is set at "OFF" at the time of shipping from factory)

4. Loading and Installation

The following is explanations of the handling precautions and installation environment which is common to modules when handling E71 from unpacking to installation

For the details of loading and installation of the module, refer to User's Manual of CPU module to be used

4.1 Handling precautions

The following is an explanation of handling precautions of the module

- Because the case of the module is made of resin, be careful not to drop it or expose it to strong impact
- Execute tightening of the module's installation screws within the range indicated below

Screw position	Tightening torque range
Electrical supply cord connection terminal screw (M2.5 screw)	40 N cm
Module fixing screw (M4 screw)	78 to 118 N cm

4.2 Installation environment

Do not install the Ans series PLC in the following environments

- Where the ambient temperature exceeds the 0 to 55°C range
- Where the ambient humidity exceeds the 10 to 90% RH range
- Where condensation is produced by sudden temperature changes
- Where corrosive or combustible gas is present
- Where dust, iron powder and other conductive powder, oil mist, salt, or organic solvents are prevalent
- In direct sunlight
- Where a strong electric or magnetic field is generated
- Where vibration and shock may be transmitted directly to the module

5. Connection to a Network

The following is an explanation of the connection method of the E71 to the 10BASE5 or the 10BASE2

Point

Installation procedures of the 10BASE5 and 10BASE2 require sufficient safety measures. For the execution of such operations as terminal processing of connection cable, trunk line cable etc., please consult with a trained professional

5.1 Connection to 10BASE2

The following is an explanation of the method of connecting the E71 to the 10BASE2 network

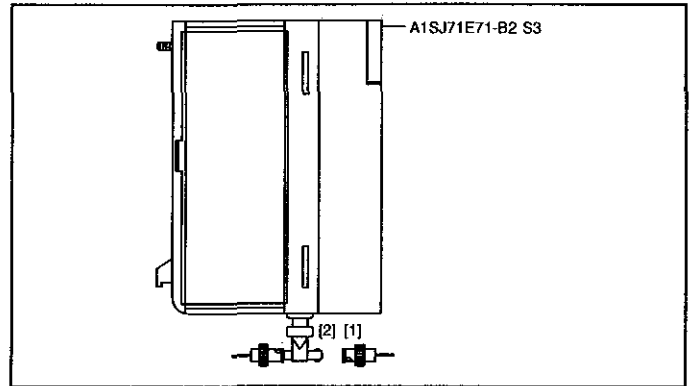

Diagram 5.1 Connection diagram of the coaxial cable for 10BASE2

Method of connecting the coaxial cable for 10BASE2

- Line up the ratchet [2] with the groove [1] in diagram 5.1 while pushing it in
- While pushing in the connector, turn it 1/4 turn to the right
- Turn the connector until it locks
- Verify that the connector has locked

5.2 Connection to 10BASE5

The following is an explanation of the method of connecting E71 to the 10BASE5 network

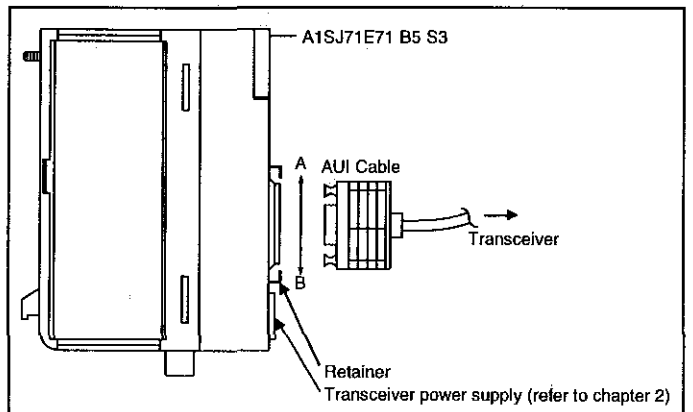

Diagram 5.2 AUI Cable connection diagram

Method of connecting the AUI cable (transceiver cable)*1

- Slide the retainer in the B direction of diagram 5.2
- Plug in the AUI cable side connector as far as it will go
- Slide the retainer in the A direction of diagram 5.2
- Verify that the AUI cable is locked
- Input the power supply to the transceiver *2

*1 Execute AUI cable connection when the power supply of the module installation station is turned off

*2 For the transceiver, generally use that which has the function called SQETEST or heartbeat (as a function of the transceiver, a signal for confirming that the transceiver is functioning normally after sending a communication)

Point

- (1) When the customer's products match the EMC instructions and the low voltage instructions for connecting E71, use the method in (3) below to install the ferrite core
 - (2) When there is a communication error caused by high frequency noise due to the installation environment, take the following steps
 - * The ferrite core can be installed using the steps in (3) below
 - * When communicating with TCP/IP, increase the count of communication retries
 - (3) Below are the steps for installing the ferrite core based on connection to the 10BASE2 and 10BASE5 network
Please install the ferrite core (*1) on the side of the E71 or external devices / the AUI cables transceiver
- *1 It is possible to use a TDK style ZCAT 2032-0930

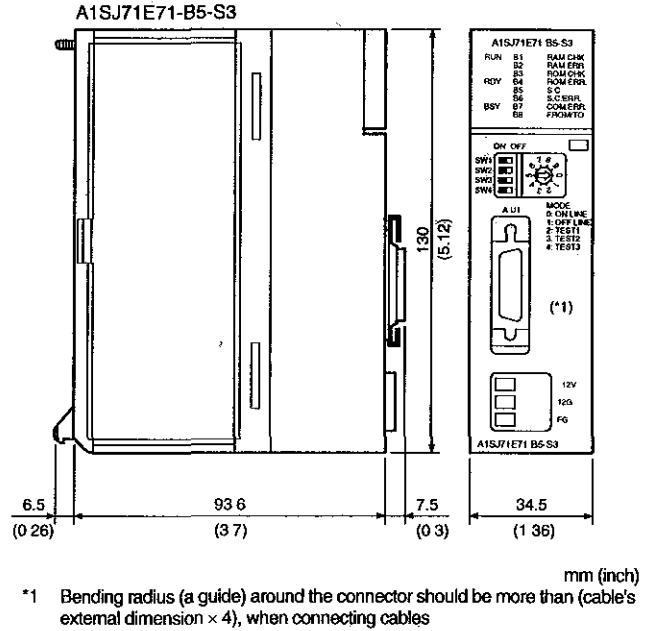
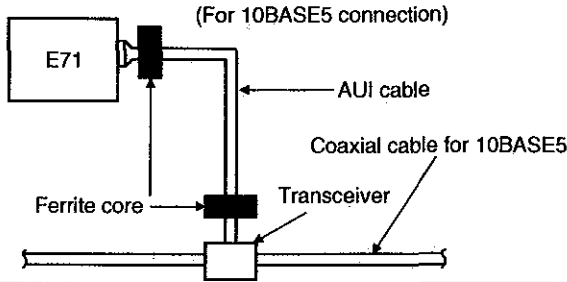

6. External Dimensions

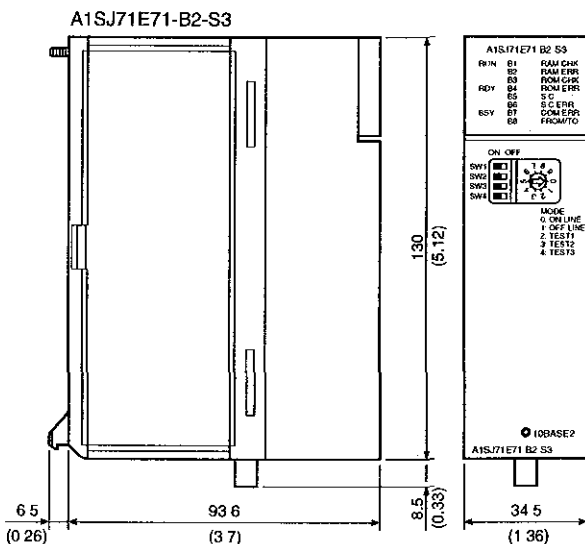

Warranty

Mitsubishi Electric shall not be liable for any loss caused by reasons for which Mitsubishi is not held accountable lost business opportunities or unrealized gain on the customer's side resulting from failure of the product, or any other damage secondary disaster, accident, damage to equipment other than the product or disruption of other business operations arising out of special circumstances which may or may not have been predicted at Mitsubishi

For safe use of the product

- This product is manufactured as a general-purpose product intended for general industrial use only. It is not designed nor manufactured for use in an equipment or system affecting human lives.
- If you are considering to use this product in equipment or systems for nuclear power generation, power generation, aerospace, medical or passenger transport applications, consult our sales representatives.
- This product is manufactured under our strict quality control system. However, if the product is used in the intended facility in such a way that a failure of the product may lead to serious accident or loss, incorporate backup or fail-safe functions into the system design.

USA	Mitsubishi Electric Automation Inc 500 Corporate Woods Parkway Vernon Hills IL 60061 Tel: 1-847-478-2100	Indonesia	P.T. Autoleknindo SUMBER MAKMUR Kompleks Agung Sedayu Peropindo (Harco Mangga Dua) Blok H No 4 Jl Mangga Dua Raya Jakarta Pusat 10730-Indonesia Tel: 62-21-336292
Brazil	MELCO TEC Rep. Com e Assessoria Tecnica Ltda Av Rio Branco 123-15 and 9/1507 Rio de Janeiro RJ CEP 20040-005 Brazil Tel: 55-21 221-8943	Thailand	F. A. Tech Co. Ltd. 1138/33-34 Rama 3 Road, Yannawa, Bangkok 10120 Thailand Tel: 66-2 295-2861
UK	Mitsubishi Electric Europe B.V. UK Branch Travelers Lane Hatfield Herts AL10 8XB UK Tel: 44-1707 276100	Hong Kong	Ryoden International Ltd 10th Floor Manulife Tower 169 Electric Road, North Point Hong Kong Tel: 852-2887 8870
Germany	Mitsubishi Electric Europe B.V. German Branch Gothaer Strasse 8 D-40880 Ratingen GERMANY Tel: 49-2102-468-0	China	Ryoden International Shanghai Ltd 3F Block 5 Building Automation Instrumentation Plaza 103 Cao Bao Rd. Shanghai 200233 China Tel: 86-21-6475-3228
South Africa	MSA Manufacturing (Pty) Ltd P O Box 39733 Bramley 201 8 Johannesburg South Africa Tel: 27 11-444-8060	Taiwan	Setsuyo Enterprise Co. Ltd 6F No 105 Wu-Kung 3rd RD, Wu-Ku Hsiang Taipei Hsine Taiwan R O C Tel: 886-2-2299-2499
India	Messung Systems Pvt Ltd Electronic Sadan NO-111 Unit No15 M I D C BHOSARI PUNE 411028 Tel: 91 212 793130	Australia	Mitsubishi Electric Australia Pty Ltd 348 Victoria Road Postal Bag No 2 Rydalmere N S W 2116 Australia Tel: 61-2 9684-7777
Singapore	Mitsubishi Electric Asia Pte Ltd 307 ALEXANDRA ROAD #05-01/02 MITSUBISHI ELECTRIC BUILDING SINGAPORE 159943 Tel: 65-470-2480		

MITSUBISHI ELECTRIC CORPORATION
HEAD OFFICE: 4-1-1 HONCHO, KOSUYAMA-KU, NAGOYA 465 JAPAN
TEL: 81-52-734-2111 FAX: 81-52-734-2112

When exported from Japan, this manual does not require application to the Ministry of International Trade and Industry for service transaction permission