

MITSUBISHI

Serial Communication Module

User's Manual
(Hardware)

A1SJ71QC24N1
A1SJ71QC24N1-R2

Thank you for buying the Mitsubishi general-purpose programmable logic controller MELSEC-QnA Series

Prior to use, please read both this manual and detailed manual thoroughly and familiarize yourself with the product.



MODEL	A1SJ71QC24N1-U-HW
MODEL CODE	13JP85
IB(NA)-0800330-B(1112)MEE	



● SAFETY PRECAUTIONS ●

(Read these precautions before using this product.)

Before using this product, please read this manual and the relevant manuals carefully and pay full attention to safety to handle the product correctly.

In this manual, the safety precautions are classified into two levels:

"⚠ WARNING" and "⚠ CAUTION".

 WARNING	Indicates that incorrect handling may cause hazardous conditions, resulting in death or severe injury.
 CAUTION	Indicates that incorrect handling may cause hazardous conditions, resulting in minor or moderate injury or property damage.

Under some circumstances, failure to observe the precautions given under "⚠ CAUTION" may lead to serious consequences.

Observe the precautions of both levels because they are important for personal and system safety.

Make sure that the end users read this manual and then keep the manual in a safe place for future reference.

[DESIGN PRECAUTIONS]

WARNING

- When using the notification function, the pager receiver may not be contacted due to the frequency transmission status from the system setup environment and error on the receiver side.
To ensure the safety of the PLC system, install a call circuit with a lamp display or buzzer sound.
- When performing the control of the PLC in operation (especially changing data, program, and operation status (remote run/stop)) by connecting a personal computer, etc. to the special function module, configure an interlock circuit in a sequence program so the safety of the overall system is always maintained.
Especially, when this control is performed to a remote PLC from an external device, troubles that have occurred on the PLC side may not be able to immediately be handled if there is a data communication error.
Define a troubleshooting agreement between external devices and the PLC CPU for data communication error occurrences, as well as construct an interlock circuit in the sequence program.

[DESIGN PRECAUTIONS]

CAUTION

- Do not bunch the control wires or communication cables with the main circuit or power wires, or install them close to each other.
They should be installed 100mm (3.9 inch) or more from each other.
Not doing so could result in noise that would cause malfunction.

[INSTALLATION PRECAUTIONS]

CAUTION

- Use the PLC in an environment that meets the general specifications contained in the user's manual of the CPU module.
Using this PLC in an environment outside the range of the general specifications could result in electric shock, fire, malfunction, and damage to or deterioration of the product.
- Be sure to shut off all phases of the external power supply used in the system before installation or cleaning.
Failure to do so may cause an electric shock or damage to the product.
- Insert the fixing projection on the module bottom into the fixing hole in the base unit and mount the module using the hole as a supporting point. (For the Q2AS series module, be sure to screw it to the base unit with the specified torque.)
Incorrect module mounting may cause a malfunction, failure or drop of the module.
- Tighten the screws within the range of specified torque.
If the screws are loose, it may result in fallout, short circuits, or malfunction.
Tightening the screw too far may cause damage to the screw and/or the module, resulting in fallout, short circuits, or malfunction.
- Do not directly touch the module's conductive parts or electronic components.
Doing so could cause malfunction or failure in the module.

[WIRING PRECAUTIONS]

CAUTION

- Be sure to fix communication cables leading from the module by placing them in the duct or clamping them.
Cables not placed in the duct or without clamping may hang or shift, allowing them to be accidentally pulled, which may result a module malfunction and cable damage.
- Perform correct pressure-displacement, crimp-contact or soldering for wire connections using the tools specified by the manufactures.
Attach connectors to the module securely.
- Before connecting the cables, check the type of interface to be connected. Connection, or erroneous wiring, to the wrong interface may failure the module and external devices.
- Tighten the terminal screws within the range of specified torque.
If the terminal screws are loose, it may result in short circuits or malfunction. Tightening the screw too far may cause damage to the screw and/or the module, resulting in fallout, short circuits, or malfunction.
- When detecting the communication cable from the module, do not pull the cable portion.
For cables with connectors, hold the connector at the junction to the module, then detach it.
For cables without connectors, first loosen the screw at the junction, then detach the cable.
Pulling the cable portion while it is connected to the module may cause malfunction or damage to the module and cable.
- Be sure there are no foreign substances such as sawdust or wiring debris inside the module.
Such debris could cause fires, failure, or malfunction.

[STARTING AND MAINTENANCE PRECAUTIONS]

WARNING

- Do not touch the connector while the power is on.
Doing so could cause malfunction.
- Be sure to shut off all phases of the external power supply used in the system before cleaning or screw retightening.
Failure to do so may result in failure or malfunction of the module.
If the screw is too loose, it may cause an accidental drop of the module, short circuit or malfunction.
Excessive screw tightening may cause damage to the screw and/or module, resulting in a drop of the module, short circuit or malfunction.

[STARTING AND MAINTENANCE PRECAUTIONS]

CAUTION

- Do not disassemble or modify the modules.
Doing so could cause failure, malfunction, injury, or fire.
- Be sure to shut off all phases of the external power supply used in the system before installing or removing the module.
Failure to do so may cause failure or malfunction of the module.
- Always make sure to touch the grounded metal to discharge the electricity charged in the body, etc., before touching the module.
Failure to do so may cause a failure or malfunctions of the module.

[OPERATING PRECAUTIONS]

WARNING

- Do not write data into the "system area" of the buffer memory of special function modules.
Also, do not output the "prohibited to use" signal as the output signal to a special function module from the PLC CPU.
Writing data into the "system area" or outputting a signal for "prohibited to use" may cause system malfunction in the PLC.

[OPERATING PRECAUTIONS]

CAUTION

- Before performing the control of the PLC in operation (especially changing data, program, and operation status (remote run/stop)) by connecting a personal computer, etc. to the special function module, read this manual carefully and confirm if the overall safety is maintained.

Failure to perform correct operations to change data, program, or the status may result in system malfunction, machine damage, or an accident.

- When using the module while values, such as buffer memory set values, are registered in the EEPROM, do not turn off the power supply for the module loading station not reset the PLC CPU.

If the power supply for the module loading station is turned off or the PLC CPU is reset while any values are registered, the data contents in the EEPROM become inconsistent and as a result the values must be set again in the buffer memory, etc. and reregistered to the EEPROM.

Also, this may cause failure and malfunction of the module.

[DISPOSAL PRECAUTIONS]

CAUTION

- When disposing of this product, treat it as industrial waste.

● CONDITIONS OF USE FOR THE PRODUCT ●

(1) Mitsubishi programmable controller ("the PRODUCT") shall be used in conditions;

- i) where any problem, fault or failure occurring in the PRODUCT, if any, shall not lead to any major or serious accident; and
- ii) where the backup and fail-safe function are systematically or automatically provided outside of the PRODUCT for the case of any problem, fault or failure occurring in the PRODUCT.

(2) The PRODUCT has been designed and manufactured for the purpose of being used in general industries.

MITSUBISHI SHALL HAVE NO RESPONSIBILITY OR LIABILITY (INCLUDING, BUT NOT LIMITED TO ANY AND ALL RESPONSIBILITY OR LIABILITY BASED ON CONTRACT, WARRANTY, TORT, PRODUCT LIABILITY) FOR ANY INJURY OR DEATH TO PERSONS OR LOSS OR DAMAGE TO PROPERTY CAUSED BY the PRODUCT THAT ARE OPERATED OR USED IN APPLICATION NOT INTENDED OR EXCLUDED BY INSTRUCTIONS, PRECAUTIONS, OR WARNING CONTAINED IN MITSUBISHI'S USER, INSTRUCTION AND/OR SAFETY MANUALS, TECHNICAL BULLETINS AND GUIDELINES FOR the PRODUCT.

("Prohibited Application")

Prohibited Applications include, but not limited to, the use of the PRODUCT in;

- Nuclear Power Plants and any other power plants operated by Power companies, and/or any other cases in which the public could be affected if any problem or fault occurs in the PRODUCT.
- Railway companies or Public service purposes, and/or any other cases in which establishment of a special quality assurance system is required by the Purchaser or End User.
- Aircraft or Aerospace, Medical applications, Train equipment, transport equipment such as Elevator and Escalator, Incineration and Fuel devices, Vehicles, Manned transportation, Equipment for Recreation and Amusement, and Safety devices, handling of Nuclear or Hazardous Materials or Chemicals, Mining and Drilling, and/or other applications where there is a significant risk of injury to the public or property.

Notwithstanding the above, restrictions Mitsubishi may in its sole discretion, authorize use of the PRODUCT in one or more of the Prohibited Applications, provided that the usage of the PRODUCT is limited only for the specific applications agreed to by Mitsubishi and provided further that no special quality assurance or fail-safe, redundant or other safety features which exceed the general specifications of the PRODUCTS are required. For details, please contact the Mitsubishi representative in your region.

REVISIONS

*The manual number is given on the bottom right of the cover.

Print Date	*Manual Number	Revision				
Dec., 2005	IB(NA)-0800330-A	First edition				
Dec., 2011	IB(NA)-0800330-B	<table border="1"><tr><td>Correction</td></tr><tr><td>COMPLIANCE WITH EMC AND LOW VOLTAGE DIRECTIVES, Chapter 3, Section 5.1, 5.2, Chapter 6</td></tr><tr><td>Addition</td></tr><tr><td>SAFETY PRECAUTIONS(Chinese), CONDITIONS OF USE FOR THE PRODUCT</td></tr></table>	Correction	COMPLIANCE WITH EMC AND LOW VOLTAGE DIRECTIVES, Chapter 3, Section 5.1, 5.2, Chapter 6	Addition	SAFETY PRECAUTIONS(Chinese), CONDITIONS OF USE FOR THE PRODUCT
Correction						
COMPLIANCE WITH EMC AND LOW VOLTAGE DIRECTIVES, Chapter 3, Section 5.1, 5.2, Chapter 6						
Addition						
SAFETY PRECAUTIONS(Chinese), CONDITIONS OF USE FOR THE PRODUCT						

This manual confers no industrial property rights or any rights of any other kind, nor does it confer any patent licenses. Mitsubishi electric Corporation cannot be held responsible for any problems involving industrial property rights which may occur as a result of using the contents noted in this manual.

CONTENTS

1. Overview	1
2. Transmission Specifications	2
2.1 When the Modem Function is not Used	2
2.2 When the Modem Function is Used	3
3. Part Names And Setting	4
4. Mounting and Installation	9
4.1 Handling Precautions	9
4.2 Installation Environment	9
5. External Wiring	10
5.1 Connecting RS-232C Line	10
5.2 Connecting RS-422/485 Line	13
6. External Dimensions	18

ABOUT THE MANUALS

The following product are available for this equipment.
Refer to the table given below to choose suitable manuals.

Related Manuals

Manual name	Manual No. (Model code)
Serial Communications Module Guidebook	IB-66622 (13JF11)
Serial Communications Module User's Manual (Modem Function Additional Version)	IB-66612 (13J825)
Computer Link Guidebook	SH-3510 (13JE76)
Computer Link Module (Com.link func./Print.func.) User's Manual	SH-3511 (13JE77)

COMPLIANCE WITH EMC AND LOW VOLTAGE DIRECTIVES

(1) Method of ensuring compliance

To ensure that Mitsubishi programmable controllers maintain EMC and Low Voltage Directives when incorporated into other machinery or equipment, certain measures may be necessary. Please refer to one of the following manuals.

- User's manual for the CPU module used
- User's manual (hardware) for the CPU module or base unit used

(2) Additional measures

To ensure that this product maintains EMC and Low Voltage Directives, please refer to one of the manuals listed under (1).

1. Overview

This manual describes how to install the following serial communications modules (hereinafter referred to as QC24N) and how to wire them with external devices.

When unpacking the module, check that the products listed in the table below are present.

Model	Product name	Quantity
A1SJ71QC24N1	A1SJ71QC24N1 serial communication module	1
	RS-422 communication terminal resistor 330Ω, 1/4W (orange/orange/brown/□) ^{*1}	2
	RS-485 communication terminal resistor 110Ω, 1/2W (brown/brown/brown/□) ^{*1}	2
A1SJ71QC24N1-R2	A1SJ71QC24N1-R2 serial communication module	1

*1 How to discriminate between the terminating resistors

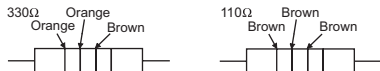

2. Transmission Specifications

The transmission specifications of the QC24N is shown below.
Refer to CPU module User's Manual for QC24N general specification.

2.1 When the Modem Function is not Used

The table below lists the transmission specification when the QC24N modem function is not used.

Item		Specifications		
		A1SJ71QC24N1	A1SJ71QC24N1-R2	
Interface	CH1	RS-232C	RS-232C	
	CH2	RS-422/485	RS-232C	
Communications system		Full-duplex/Half-duplex (Only RS-232C interface is selectable.)		
Synchronous system		Asynchronous system		
Transmission speed (Unit : bps)		300, 600, 1200, 2400, 4800, 9600, 14400, 19200, 28800, 38400, 57600, 115200 (The total of CH1 and CH2 must be within 230400 bps.)		
Data format	Start bit	1		
	Data bit	7 / 8		
	Parity bit	1 (yes) / 0 (no)		
	Stop bit	1 / 2		
Error detection	Parity check	Yes (odd/even) / No		
	Sum check code	Yes / No		
Transmission control	DTR/DSR	Yes (Only RS-232C interface is selectable.) / No		
	DC code	Yes (DC1/DC3, DC2/DC4) / No		
Writing to EEPROM		100,000 times for the same area (Max.)		
Line connection	Independent mode	Dedicated protocol	RS-232C 1: 1	
		Non procedure protocol	RS-422/485 1: 1, 1: n, m: n	
		Bidirectional protocol	* Only 1: 1 can be used for the bidirectional protocol. m: n can only be used for a dedicated protocol.	
	Linked mode	Dedicated protocol	1: n, m: n	(Link operation not available)
		Non procedure protocol	1: n	
		Bidirectional protocol	(Data communications not available)	
Transmission distance (Overall distance)		RS-232C 15m (49.2ft.) or less RS-422/485 1200m (3937.0ft.) or less		
5V DC Internal current consumption		0.38A	0.30A	
Number of occupied I/O points		32 points (*1)		
Weight		0.30kg (0.66lb)	0.26kg (0.57lb)	

*1 Set special 32 points when allocating I/O by GPP function. Set "AJ71QC24" as a model name registration when using dedicated command.

2.2 When the Modem Function is Used

The table below lists the transmission specification between QC24N and modem/terminal adapter of local station QC24N end (abbreviated as TA from here on) when the QC24N modem function is used.

The transmission specification items not shown in the table shall be the same as those listed in Section 2.1.

Item	Specifications	
	A1SJ71QC24N1	A1SJ71QC24N1-R2
Applicability of modem function	Usable	
Interface that can be used modem function	RS-232C	RS-232C (*1)
Linked mode between CH1 and CH2 for QC24N	Unusable	
Communications system	Full-duplex	
Synchronous system	Asynchronous system	
Transmission speed (unit: bps)	1200, 2400, 4800, 9600, 14400, 19200, 28800, 38400, 57600, 115200 (The total of CH1 and CH2 must be within 230400 bps.)	
Transmission control	RS-CS control yes / no (Selection)	
Applicability of data communication	Dedicated protocol	Communication enabled
	Non procedure protocol	Communication enabled
	Bidirectional protocol	Communication enabled
	Communication with link dedicated instruction	Communication disabled
Line connection (QC24N: Modem)	1: 1	

- *1 Communication by the modem function is possible using either of the two RS-232C interfaces.
However, it is possible to communicate with only CH1 side when communicating with the peripheral device for GPPQ.

3. Part Names And Setting

• A1SJ71QC24N1

• A1SJ71QC24N1-R2

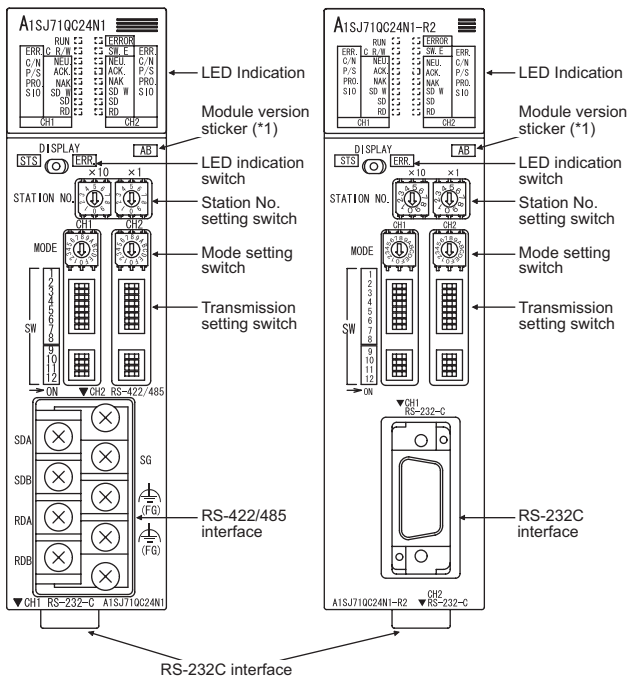

*1 Sticker showing the module hardware version and software version.

(Example)

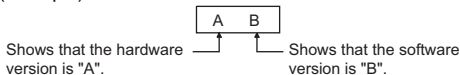

(1) LED Indication

The LEDs indicate the data communication status, operating status, error status of the QC24N.

	RUN	ERR.	
ERR.	C R/W	ERR.	SW.E
C/N	NEU.	ERR.	NEU.
P/S	ACK.	ERR.	ACK.
PRO.	NAK.	ERR.	NAK
SIO	SD W	ERR.	SD W
	SD	ERR.	SD
	RD	ERR.	RD
CH1		CH2	

LED Name	Meaning of LED Indication	LED ON (ON/BLINK)	LED OFF (OFF)	Initial Status of LED	Related Protocol			
					Dedicated	Non procedure	Bidirectional	
RUN	Normal Operation	Normal	Abnormal	ON				
ERROR	Error batch	Any of ERR. error, C/N error, P/S error, PRO. error, SIO error occur	Normal	OFF			○	
SD	CH□ send status	Blinks during data transmission	Not sent	OFF				
RD	CH□ receive status	Blinks during data reception	Not received	OFF				
Display select switch STS side	C R/W	Communicating with PC	Blinks during PC communications (when not communicating is OFF)		OFF			○
	SW. E	Switch setting error	Switch setting error	Normal	OFF			
	NEU.	CH□ neutral status	Transmission sequence initial status (Waiting to receive command messages)	Command message receive completed	*1			○
	ACK.	CH□ [Normal End] transmission	After [Normal End] transmitted	After [Abnormal End] transmitted	OFF			—

(Continued to next page)

LED Name		Meaning of LED Indication	LED ON (ON/BLINK)	LED OFF (OFF)	Initial Status of LED	Related Protocol		
						Dedicated	Non procedure	Bidirectional
Display select switch STS side	NAK	CH[] [Abnormal End] transmission	After [Abnormal End] transmitted	After [Normal end] transmitted	OFF	○	—	
	SD W	Send wait status	When data send wait state generated	After start of transmission	OFF	○		
Display select switch ERR. side.	ERR.	CH[] error occurrence	Switch setting error, mode switching error, send error, receive error, on-demand error	Normal	OFF	○		
	C/N	CH[] and PC CPU communications result	*2	Normal	OFF	○	—	
	P/S	CH[] parity/sum check error	Parity/sum check error	Normal	OFF	○		
	PRO.	CH[] protocol error	Communications protocol error	Normal	OFF	○	—	
	SIO	CH[] SIO error	Overrun, framing error	Normal	OFF	○		
When receive data purged because OS area is full.			Normal	OFF	—	○		

- *1 The indication is valid when the dedicated protocol is set as the target interface.
The LED is off when other than the dedicated protocol is set as the target interface.
- *2 The LED is turned on when an illegal communication request is received from an external device, or an error occurs while accessing the PLC CPU.

(2) Station number switch setting

Set the station number so that external devices can specify the PC as the target of access during data communication via the dedicated protocol.

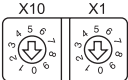
Station Switch Details	Description
<p>STATION NO.</p> 	<ol style="list-style-type: none">(1) Station number of the local QC24N is set from 0 to 31. (Do not set a station number over 32.)(2) X10 sets the station number 10 digit.(3) X1 sets the station number 1 digit.(4) Make sure that the station number setting does not overlap with another QC24N, etc., on the same network.(5) Not necessary to set the station numbers in connect order. Station numbers can also be skipped.

(The factory setting is [00].)

(3) Mode switch setting

Set data communication functions for each interface.

Mode Switch Details	Mode Switch No.	Setting Contents	
<p>MODE</p> 	0	When CH1 and CH2 operation is linked: Set CH1 to 0 Set CH2 to 1 to 6 When CH1 and CH2 operate independently: Setting impossible.	
	1	Dedicated protocol	Format 1
	2		Format 2
	3		Format 3
	4		Format 4
	5		Format 5
	6	Non procedure protocol	
	7	Bidirectional protocol	
	8 to D	Setting impossible	
	E	ROM/RAM/switch test	
F	Self loopback test		

(The factory setting is "1")

Point

Always set "1" to "7" for the mode setting switch on the interface side that is not connected to the external device.

(4) Transmission specifications switch setting

Set specifications for the communication with the data communication destination device, as well as other items.

Switch Details	Switch		Setting Item	Switch State		Notes
	CH1	CH2		OFF	ON	
	SW1		Operation setting	Independent operation	Linked operation	Be sure to set the CH1 to OFF. CH2 can be set to ON/OFF.
	SW2		Data bits setting	7 bits	8 bits	Parity bit not included.
	SW3		Parity bit enable/disable setting	Disable	Enable	When set to Enable, the setting of SW4 is effective.
	SW4		Even parity/odd parity setting	Odd	Even	Effective only when Parity Bit Enable is selected.
	SW5		Stop bit setting	1 bit	2 bits	—
	SW6		Sum check enable/disable setting	Disable	Enable	Dedicated protocol, bidirectional protocol
	SW7		Write during RUN enable/disable setting	Disable	Enable	Dedicated protocol
	SW8		Setting change enable/disable	Disable (prohibit)	Enable (allow)	Sets mode switching and EEPROM write allow/prohibit.
	SW9 to SW12		Transmission speed setting	(*1)		Can be set as long as the total of CH1 and CH2 is within 230400 bps.

(The factory settings are all OFF.)

*1 The data transmission speeds allowed to set are as follows:

		Transmission speed (unit: bps)											
		300	600	1200	2400	4800	9600	14400	19200	28800	38400	57600	115200
Switch	SW09	OFF	ON	OFF	ON	OFF	ON	OFF	ON	OFF	ON	OFF	ON
	SW10	OFF	OFF	ON	ON	OFF	OFF	ON	OFF	ON	ON	ON	ON
	SW11	OFF	OFF	OFF	OFF	ON	ON	OFF	ON	OFF	ON	OFF	OFF
	SW12	OFF	OFF	OFF	OFF	OFF	OFF	ON	OFF	ON	OFF	ON	ON

Settings other than above are not accepted.

4. Mounting and Installation

This section describes the handling precautions and installation environment common to all the modules when handling the QC24N from unpacking to installation.

Refer to the User's Manual of the PC CPU module used for a detailed description of mounting and installation of the module.

4.1 Handling Precautions

This section describes the module handling precautions.

- (1) The module case is made of plastic. Be sure not to drop it or subject it to strong vibration.
- (2) Tighten the module installation screws within the following tightening torque range.

Screw	Tightening Torque Range
RS-422/485 terminal block terminal screws (M3.5 screws)	59 to 88N•cm
Module installation screws (M4 screws)	78 to 118N•cm
RS-422/485 terminal block installation screws (M3 screws)	39 to 59N•cm
RS-232C connector installation screw (M2.6 screws)	19 to 24N•cm

4.2 Installation Environment

Do not install the Q2AS series PC in the following environments.

- (1) Where the ambient temperature exceeds the 0 to 55°C range.
- (2) Where the ambient humidity exceeds the 10 to 90% RH range.
- (3) Where condensation is produced by sudden temperature changes.
- (4) Where corrosive or combustible gas is present.
- (5) Where dust, iron powder and other conductive powder, oil mist, salt, or organic solvents are prevalent.
- (6) In direct sunlight.
- (7) Where a strong electric or magnetic field is generated.
- (8) Where vibration and shock may be transmitted directly to the module.

5. External Wiring

5.1 Connecting RS-232C Line

The standard connection procedure for RS-232C line is explained below.

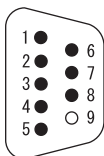

Pin No.	Signal Code	Signal Name	Signal Direction (QC24N (*1) ↔ External Device)
1	CD	Receive carrier detection	←
2	RD (RXD)	Received data	←
3	SD (TXD)	Send data	→
4	DTR (ER)	Data terminal ready	→
5	SG	Signal ground	—
6	DSR (DR)	Data set ready	←
7	RS (RTS)	Send request	→
8	CS (CTS)	Send enabled	←

*1 A1SJ71QC24N : CH1 side
 A1SJ71QC24N1-R2 : CH1 side/CH2 side

- (1) An example of connecting to an external device which is capable of turning ON/OFF the CD signal (pin 1)

(Full-duplex/Half-duplex communications)

QC24N Side		Connection and Signal Direction (Example)	External Device
Signal Name	Pin No.		Signal Name
CD	1		CD
RD (RXD)	2		RD (RXD)
SD (TXD)	3		SD (TXD)
DTR (ER)	4		DTR (ER)
SG	5		SG
DSR (DR)	6		DSR (DR)
RS (RTS)	7		RS (RTS)
CS (CTS)	8		CS (CTS)

- (2) An example of connecting to an external device which is not capable of turning ON/OFF the CD signal (pin 1)

- (a) An example for DC code control or DTR/DSR control

(Full-duplex communications)

QC24N side		Connection and Signal Direction (Example)	External Device
Signal Name	Pin No.		Signal Name
CD	1		CD
RD (RXD)	2		RD (RXD)
SD (TXD)	3		SD (TXD)
DTR (ER)	4		DTR (ER)
SG	5		SG
DSR (DR)	6		DSR (DR)
RS (RTS)	7		RS (RTS)
CS (CTS)	8		CS (CTS)

- (b) An example for DC code control

(Full-duplex communications)

QC24N Side		Connection and Signal Direction (Example)	External Device
Signal Name	Pin No.		Signal Name
CD	1		CD
RD (RXD)	2		RD (RXD)
SD (TXD)	3		SD (TXD)
DTR (ER)	4		DTR (ER)
SG	5		SG
DSR (DR)	6		DSR (DR)
RS (RTS)	7		RS (RTS)
CS (CTS)	8		CS (CTS)

- (3) Precaution when performing connections

- 1) Handle the FG signal and the shield of the connection cable in the following manner.

	Connection Method	Remark
FG signal	Connect to the connector cabinet area on the QC24N side.	<ul style="list-style-type: none"> Do not short circuit the FG signal and the SG signal of the connection cable. When the FG signal and the SG signal are internally connected on the external device side, do not connect the FG signal to the QC24N.
Shield	Connect to the FG terminal on the external device side or connector cabinet area on the QC24N side.	

- 2) When a normal data communication cannot be performed because of external noise even though the wiring has been made as 1), perform the wiring as follows:
- Connect between the FG terminal of the external device side and connector cabinet area of the QC24N side with the shield of the connection cable. On the external device side, however, follow the instruction manual of the external device.
 - Connect each signal other than SG of the connection cable by paring up with SG.

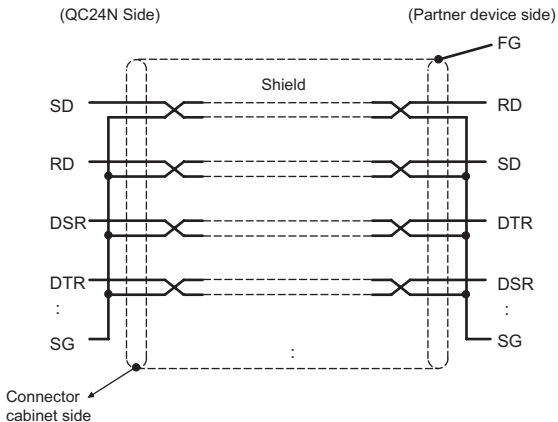

- 3) Do not connect a RS-422 device to the RS-232C interface. If a RS-422 device is connected, the RS-422 interface hardware on the connected device will be damaged, and communication will be disabled.

Point

When using QC24N's modem functions, use the RS-232C cable supplied with the modem/TA or a cable specified by the modem/TA for connection between the QC24N and the modem/TA.

5.2 Connecting RS-422/485 Line

The standard connection procedure for RS-422/485 line is explained below.

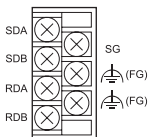

Signal Code	Signal Name	Signal Direction (QC24N (*1) ↔ External Device)
SDA	Send data (+)	→
SDB	Send data (-)	→
RDA	Received data (+)	←
RDB	Received data (-)	←
SG	Signal ground	↔
(FG)	Frame ground	↔
(FG)	Frame ground	↔

*1 A1SJ71QC24N1 : CH2 side
A1SJ71QC24N1-R2 : (None)

Point

If the QC24N is the first or last station on the RS-422/485 line, connect a terminal resistor of the following specifications to the RS-422/485 interface.

Data communication will be disturbed if a terminal resistor is not used.

- For RS-422 communication330 Ω, 1/4 W
- For RS-485 communication110 Ω, 1/2 W

- (1) When a QC24N is connected to each external device, connect a terminal resistor between RDA and RDB.
- (2) When the relationship between the numbers of connected external devices and QC24Ns is 1:n, connect terminal resistors between SDA and SDB and between RDA and RDB.
- (3) When the relationship between the numbers of connected external devices and QC24Ns is m: n, connect a terminal resistor between RDA and RDB.

The **R** in the wiring diagram below indicates the connection of a terminal resistor.

(1) Example of connecting external devices and QC24N by 1:1

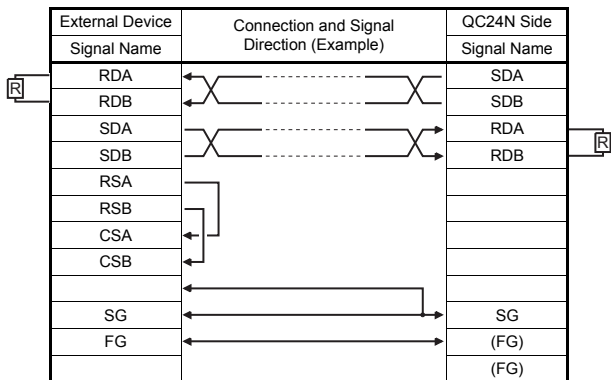

(2) Example of connecting external devices and QC24N by 1:n

1) Connecting external devices and QC24N using RS-232C

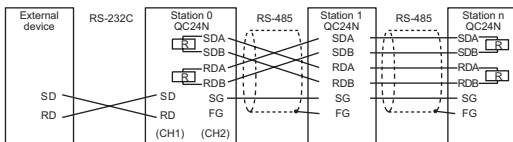

2) Connecting external devices and QC24N using RS-422

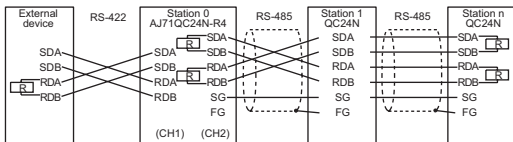

3) Connecting external devices and QC24N using RS-485

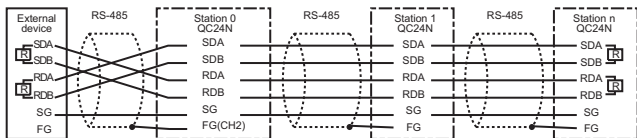

(3) Example of connecting external devices and QC24N by m: n

*Connecting external devices and QC24N using RS-485

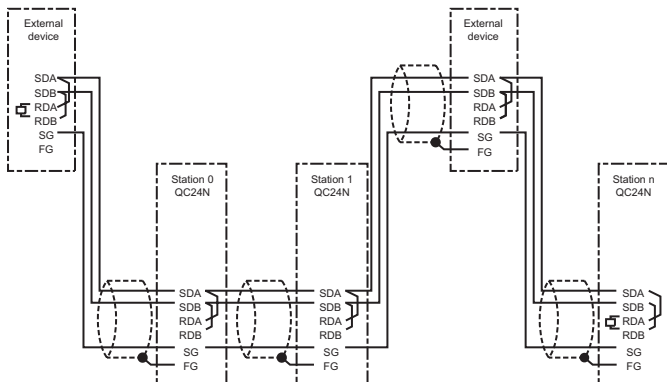

Point

In case of connecting external devices and QC24N by m: n, refer to Section 5.1 for an example of connecting external devices and QC24N using RS-232C.

- (4) Countermeasure for data receive errors at the external device with RS-422 and RS-422/485 connections
- During the data communication with external devices via QC24N RS-422/485 interface, if the external device receives an error data, install pull-up and pull-down resistors to the external device side (about $4.7\text{k}\Omega$, $1/4\text{ W}$ as a reference of resistor value). Installation of pull-up and pull-down resistors will prevent a data receive error.

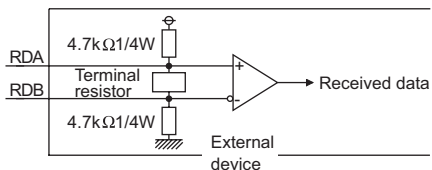

Point

When there is a pull-up or pull-down resistor at the external device, erroneous data is not received.

Remarks

The following describes the case when a pull-up or pull-down resistor is not installed to the external device.

- 1) When no station is sending, the send line becomes high impedance and noise, etc. may cause the send line to change and the external device to receive erroneous data.
In this case, there is probably a parity error or framing error.
Therefore, skip the erroneous data.
- 2) Since the first data during data reception is fixed in the following cases, also skip the receive data until the head data is received.
 - When using a dedicated protocol for data communication, the user selects the first data according to the mode and format used.
 - When performing data communication using user frames with Non procedure protocol, the user selects the first data according to the user frames registered in the QC24N.

(5) Connection precautions

- 1) When connecting the QC24N SG and FG signals to the external device, connect them according to the specifications of the external device.
- 2) Connect the shield of the connection cable to either of the FG signals of the connected device.
- 3) When a normal data communication cannot be performed because of external noise even though the wiring has been made as above, perform the wiring as follows:
 - Connect between the FG of both stations with the shield of the connection cable.
On the external device side, however, follow the instruction manual of the external device.
 - Connect the (FG) of the QC24N side to the FG terminal at the power supply module of the station which has a QC24N installed, or to the FG terminal of the control panel on which the QC24N PC is installed.
 - Connect nA and nB of each signal in the connection cable as a pair.

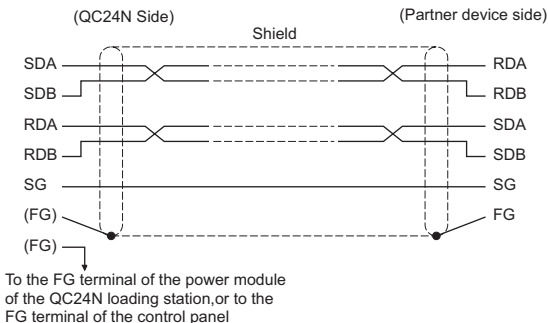

Point
(1) In the description of the setting and connection of the terminal resistor in this section, if the RS-232C – RS-422 converters, etc. are used on the stations on both ends of the network, the setting and connection of the terminal resistor is necessary on the converter side.
(2) The devices connected to the QC24N RS-422/485 interface must be unified with either RS-422 or RS-485 for 1:n and m: n connections.

6. External Dimensions

(1) A1SJ71QC24N1

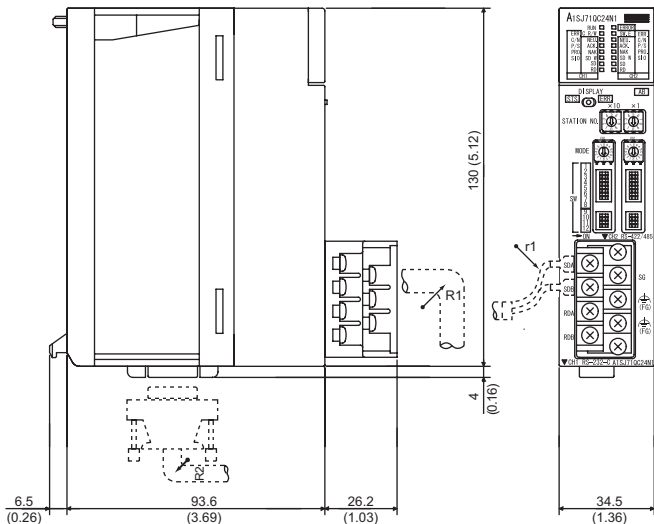

(Unit: mm (inch))

- R1(bend radius near terminal board) : Outside cable diameter \times 4
 R2(bend radius near connector) : Outside cable diameter \times 4
 r1(bend radius near crimp terminal) : Can be connected within the range over which bending is not excessive

(2) A1SJ71QC24N1-R2

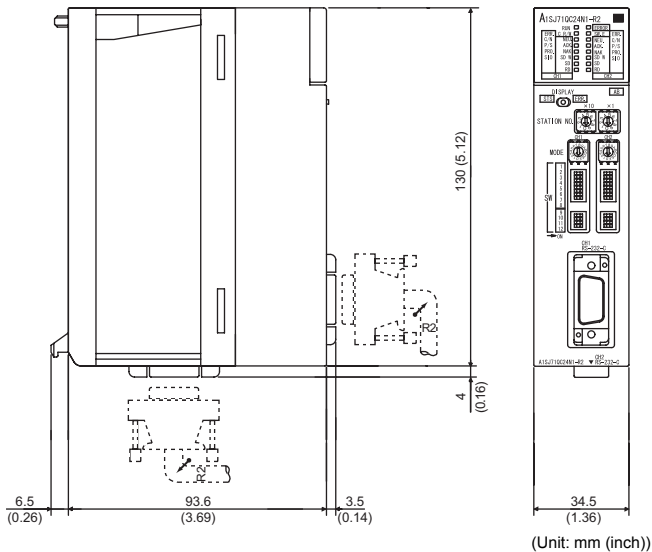

R2(bend radius near connector) : Outside cable diameter × 4

WARRANTY

Mitsubishi will not be held liable for damage caused by factors found not to be the cause of Mitsubishi; machine damage or lost profits caused by faults in the Mitsubishi products; damage, secondary damage, accident compensation caused by special factors unpredictable by Mitsubishi; damages to products other than Mitsubishi products; and to other duties.

Country/Region Sales office/Tel	Country/Region Sales office/Tel
U.S.A Mitsubishi Electric Automation Inc. 500 Corporate Woods Parkway Vernon Hills, IL 60061, U.S.A. Tel : +1-847-478-2100	China Mitsubishi Electric Automation (China) Ltd. 4/F Zhi Fu Plazz, No.80 Xin Chang Road, Shanghai 200003, China Tel : +86-21-6120-0808
Brazil MELCO-TEC Rep. Com.e Assessoria Tecnica Ltda. Rua Correia Dias, 184, Edifício Paraiso Trade Center-8 andar Paraiso, Sao Paulo, SP Brazil Tel : +55-11-5908-8331	Taiwan Setsuyo Enterprise Co., Ltd. 6F No.105 Wu-Kung 3rd.Rd, Wu-Ku Hsiang, Taipei Hsine, Taiwan Tel : +886-2-2299-2499
Germany Mitsubishi Electric Europe B.V. German Branch Gothaer Strasse 8 D-40880 Ratingen, GERMANY Tel : +49-2102-486-0	Korea Mitsubishi Electric Automation Korea Co., Ltd. 1480-6, Gayang-dong, Gangseo-ku Seoul 157-200, Korea Tel : +82-2-3660-9552
U.K Mitsubishi Electric Europe B.V. UK Branch Travellers Lane, Hatfield, Hertfordshire., AL10 8XB, U.K. Tel : +44-1707-276100	Singapore Mitsubishi Electric Asia Pte, Ltd. 307 Alexandra Road #05-01/02, Mitsubishi Electric Building, Singapore 159943 Tel : +65-6470-2480
Italy Mitsubishi Electric Europe B.V. Italian Branch Centro Dir. Colleoni, Pal. Perseo-Ingr.2 Via Paracelso 12, I-20041 Agrate Brianza., Milano, Italy Tel : +39-039-60531	Thailand Mitsubishi Electric Automation (Thailand) Co., Ltd. Bang-Chan Industrial Estate No.111 Moo 4, Serithai Rd, T.Kannayao, A.Kannayao, Bangkok 10230 Thailand Tel : +66-2-517-1326
Spain Mitsubishi Electric Europe B.V. Spanish Branch Carretera de Rubi 76-80, E-08190 Sant Cugat del Valles, Barcelona, Spain Tel : +34-93-565-3131	Indonesia P.T. Autoteknindo Sumber Makmur Muara Karang Selatan, Block A/Utara No.1 Kav. No.11 Kawasan Industri Pergudangan Jakarta - Utara 14440, P.O.Box 5045 Jakarta, 11050 Indonesia Tel : +62-21-6630833
France Mitsubishi Electric Europe B.V. French Branch 25, Boulevard des Bouvets, F-92741 Nanterre Cedex, France Tel : +33-1-5568-5568	India Messung Systems Pvt. Ltd. Electronic Sadan NO:III Unit No15, M.I.D.C Bhosari, Pune-411026, India Tel : +91-20-2712-3130
South Africa Circuit Breaker Industries Ltd. Private Bag 2016, ZA-1600 Isando, South Africa Tel : +27-11-928-2000	Australia Mitsubishi Electric Australia Pty. Ltd. 348 Victoria Road, Rydalmere, N.S.W 2116, Australia Tel : +61-2-9684-7777

MITSUBISHI ELECTRIC CORPORATION

HEAD OFFICE : TOKYO BUILDING, 2-7-3 MARUNOUCHI, CHIYODA-KU, TOKYO 100-8310, JAPAN
NAGOYA WORKS : 1-14, YADA-MINAMI 5-CHOME, HIGASHI-KU, NAGOYA, JAPAN

When exported from Japan, this manual does not require application to the Ministry of Economy, Trade and Industry for service transaction permission.

Specifications subject to change without notice.