

MITSUBISHI

Positioning Module

type A1SD71-S2

User's Manual

(Hardware)

Thank you for purchasing the Mitsubishi programmable logic controller MELSEC-A Series.

Prior to use, please read both this manual and detailed manual thoroughly to fully understand the product.



MODEL	A1SD71-S2(H/W)-U-E
MODEL CODE	13JE49
IB(NA)-66488-C(0509)MEE	

● SAFETY PRECAUTIONS ●

(Be sure to read these instructions before using the product.)

Before using this product, read this manual and the relevant manuals introduced in this manual carefully and handle the product correctly with full attention to safety.

Note that these precautions apply only to this product.

Refer to the user's manual of the CPU module for the PLC system safety precautions.



Indicates that incorrect handling may cause hazardous conditions, resulting in death or severe injury.



Indicates that incorrect handling may cause hazardous conditions, resulting in minor or moderate injury or property damage.

Note that failure to observe the  **CAUTION** level instructions may also lead to serious results according to the circumstances.

Be sure to observe the instructions of both levels to ensure personal safety.

Please save this manual to make it accessible when required and always forward it to the end user.

[DESIGN PRECAUTIONS]

DANGER

- Configure a safety circuit so that the safety of the overall system is maintained even when an external power error or PLC error occurs.
An accident may occur by a false output or a malfunction.
 - (1) Outside of the PLC, construct mechanical damage preventing interlock circuits such as emergency stop, positioning upper and lower limit switches.
 - (2) During zero return operation, the module is controlled by two data: zero return direction and zero return speed, and speed begins to decelerate when the near point dog turns on. If the zero return direction is set incorrectly, the module may continue to operate without decelerating. To prevent damage to the module in such cases, configure an interlock circuit outside the PLC.

CAUTION

- Do not bunch the control wires or communication cables with the main circuit or power wires, or install them close to each other.
They should be installed 100 mm (3.9 inch) or more from each other.
Not doing so could result in noise that would cause malfunction.

[INSTALLATION PRECAUTIONS]

CAUTION

- Use the PLC in an environment that meets the general specifications contained in this manual. Using this PLC in an environment outside the range of the general specifications could result in electric shock, fire, malfunction, and damage to or deterioration of the product.
- Insert the tabs at the bottom of the module into the mounting holes in the base module, and tighten the screws using the specified torque.
If the module is not properly installed, it may result in malfunctions, failure, or fallout.
- Securely connect a drive unit connector and peripheral connector to the corresponding connector of the module.
If not attached properly, a contact error may occur, resulting in incorrect input or output.
- Always attach a cover to connectors that are not used. If not covered, malfunctions may occur.
- Do not directly touch the module's conductive parts or electronic components.
Doing so could cause malfunction or failure in the module.

[WIRING PRECAUTIONS]

CAUTION

- Check the terminal layout and then wire the module correctly
- Be sure there are no foreign substances such as sawdust or wiring debris inside the module.
Such debris could cause fires, failure, or malfunction.

[STARTUP AND MAINTENANCE PRECAUTIONS]

DANGER

- Connect the battery correctly. Do not charge, disassemble, heat, short-circuit, solder the battery or throw it into the fire, as these may cause injury or fires due to heat generation, blowout or ignition.

CAUTION

- Be sure to shut off all phases of the external power supply used in the system before cleaning.
If you do not switch off the external power supply, it will cause malfunctions of the module.
- Do not disassemble or modify the modules. Doing so could cause failure, malfunction, injury, or fire.
- Be sure to shut off all phases of the external power supply used in the system before mounting or removing the module.
Failure to turn all phases OFF could lead to module trouble or malfunctioning.
- Always make sure to touch the grounded metal to discharge the electricity charged in the body, etc., before touching the module.
Failure to do so may cause a failure or malfunctions of the module.
- When performing test operation, set the parameter for the speed limit value to a slow setting and prepare for an immediate stop of the module should a dangerous condition occur during operation verification.

[USAGE PRECAUTIONS]

CAUTION

- Note that the all parameter settings are controlled based on the initial values if parameter setting is not made or a parameter error (set value is out of the range) occurs.

[DISPOSAL PRECAUTIONS]

CAUTION

- When disposing of this product, treat it as industrial waste.

Manual

The following table lists the manuals relevant to this product.
You can order them as necessary.

Relevant manual

Manual name	Manual No. (Model code)
Positioning module type AD71(S1/S2/S7),A1SD71-S2(S7) User's Manual	IB-66563 (13JE98)

Detailed Manual

Manual name	Manual No. (Model code)
Teaching unit for positioning module type AD71TU Operating Manual	IB-66067 (13J706)
Positioning module type AD71(SW0-AD71PE) Operating Manual	IB-66099 (13J707)
Positioning module type AD71(SW0IX-AD71PE) Operating Manual	IB-66508 (13JE75)

Conformation to the EMC and Low Voltage Directives

For details on making Mitsubishi PLC conform to the EMC and low voltage directives when installing it in your product, please refer to Chapter 3, "EMC Directive and Low Voltage Instruction" of the using PLC CPU module User's Manual (Hardware).

The CE logo is printed on the rating plate on the main body of the PLC that conforms to the EMC and low voltage directives.

1. Outline

This manual provides the specifications, part names and I/O interfaces for A1SD71-S2 positioning module (hereinafter referred to as A1SD71).

After unpacking A1SD71, confirm that all products shown below are included.

Product name	Quantity
A1SD71-S2 positioning module	1
External wiring connector (Model)	1
Connector FCN-361J040-AU	
Connector cover FCN-360C040-B	
FUJITSU COMPONENT LIMITED	

2. Performance Specifications

The performance specifications of the A1SD71 are shown below.

Item	Specifications	
Number of I/O points	48 points (number of occupied slots: 2)*	
Number of control axes	2 (simultaneous or independent)	
Interpolation	Linear interpolation (for simultaneous 2 axes)	
Positioning data	Capacity	400 points per axis
	Setting method	Input from A6GPP, A6PHP, A7PHP, A7HGP, A7LMS, AD71TU or sequence program
RAM memory backup	15 minutes without battery (25°C) Lithium battery guarantees power failure backup for a total of 300 days. Battery guaranteed for five years. Lithium content of a lithium battery: 0.48g	
Positioning	Modes	Positioning control mode Speed/positioning control switching mode Speed control mode Select using parameters (Same mode is applied to the X and Y axes)
	Method	Absolute and/or incremental method. Speed/positioning control switching mode. Incremental method (current address is switched to 0 when starting)

Item		Specifications
Positioning	Positioning units	Command method can be selected for each axis from the following four types. 1 to 16,252,928 (pulse) Max 162(m) (command unit: 0.1 to 10 μ m/pulse) Max 16200 (inch) (command unit: 1 \times 10 ⁻⁵ to 0.001 inch/pulse) Max 16200 (degree) (command unit: 1 \times 10 ⁻⁵ to 0.001 degree/pulse)
	Positioning speed	Command method can be selected for each axis from the following four types. 10 to 200000(pulse/sec) (command unit: 10 pulse/sec) 10 to 120000(mm/min) (command unit: 10 mm/min) 1 to 12000 (inch/min) (command unit: 1 inch/min) 1 to 12000 (degree/min) (command unit: 1 degree/min)
	Acceleration and deceleration	Automatic trapezoidal acceleration and deceleration
	Acceleration and deceleration times	64 to 50000 (ms)
	Backlash compensation	0 to 65535 \times position command unit (0 to 255 pulses if unit is pulse)
	Error compensation	The A1SD71 calibrates mechanical errors in the positioning control mode and velocity/positioning control switching mode.
Zero return		With zero address change function. Zero return direction and speed can be selected.
Jog operation function		Jog operation by jog start signal input.
M function		M code output
Internal current consumption		5 VDC 0.8A
External supply voltage, current		4.75 to 26.4 V max 50 mA
Size mm		130(H) \times 69.5(W) \times 93.6(D) (5.12 \times 2.74 \times 3.69) [mm (inch)]
Weight		0.38 kg

Remark

* I/O allocation for the 2 slots are as follows.

First-half slot : 16 vacant points

Second-half slot: 32 special-function module points

Refer to the user's manual of the PLC CPU for the general specifications.

3. Input/Output Interface

I/O	Internal circuit	Pin number		Signal	Description
		X axis	Y axis		
Input		5A	7A	Common	5 to 24 VDC (external supply)
		5B	7B	Drive unit ready (READY)	<ul style="list-style-type: none"> (1) LOW indicates the servo drive unit is ready and feed pulses are receivable. (2) The A1SD71 checks the drive unit ready signal prior to start. If not ready, the A1SD71 turns a zero return request ON. (3) Arrange for drive unit errors, e, g, a control power error, to set this signal HIGH. (4) Switching the signal to HIGH during positioning stops the operation. Resetting the signal will not restart the operation.
		6A	8A	Stop signal (STOP)	<ul style="list-style-type: none"> (1) Low to stop positioning. Signal duration 20 msec or more. (2) A1SD71 stops positioning by using this signal and switches the start signal OFF (HIGH). When switching from HIGH to LOW, positioning is not started.
		6B	8B	Zero-point signal (DOG)	<ul style="list-style-type: none"> (1) Used to detect near-point DOG during zero return. (2) In case of zero phase method of zero returning, a zero point will be a position where the first zero signal of resolver is given after the DOG is turned OFF.
		1A	3A	Enable signal	<ul style="list-style-type: none"> (1) Selects the control switching signal enable/disable. (2) LOW sets enable.
		1B	3B		
2A	4A	Control switching signal	<ul style="list-style-type: none"> (1) Used as the control switching command in the velocity/positioning control switching mode. (2) LOW switches control. 		
2B	4B				
9A	10A	Zerophase signal (PGO)	<ul style="list-style-type: none"> (1) Used as the zero signal at zero return. The zero-phase grid signal of the pulse encoder is normally used LOW at zero. (2) Used when the zero return method uses stopper stop and zero return complete is externally input. 		
9B	10B				

I/O	Internal circuit	Pin number		Signal	Description	
		X axis	Y axis			
Output		11A	13A	Start (<u>START</u>)	(1) LOW while positioning. (2) ON (LOW) during feed pulse output and dwell. Used as a brake release signal for servos with mechanical brakes. Feed pulse is output after this signal goes ON.	
		11B	13B			
		12A	14A	Error counter clear (<u>CLEAR</u>)	Given before and after zero return. Resets deviations in the servo error counter. 	
		12B	14B			
		17A	20A	(+) 24V power	5 to 24 VDC (external supply) 17B and 20B for 5 to 12 VDC. 17A and 20A for 24 VDC. <div style="border: 1px solid black; padding: 5px; display: inline-block;"> Point Power is supplied from either of them. Miswiring may cause module failures. </div>	
		17B	20B	(+) 5 to 15V power		
	15A	18A	A type	B type	Forward and reverse feed pulse. The operation direction follows the direction sign (SIGN) 	
	15B	18B	Forward feed pulse <u>PULSE F</u>	Feed pulse <u>PULSE</u>		B type
	16A	19A	Reverse feed pulse <u>PULSE R</u>	Direction sign <u>SIGN</u>	A type	
	16B	19B				

Select the A or B type by parameter setting.

4. Names of Each Part

The following shows the name of each part.

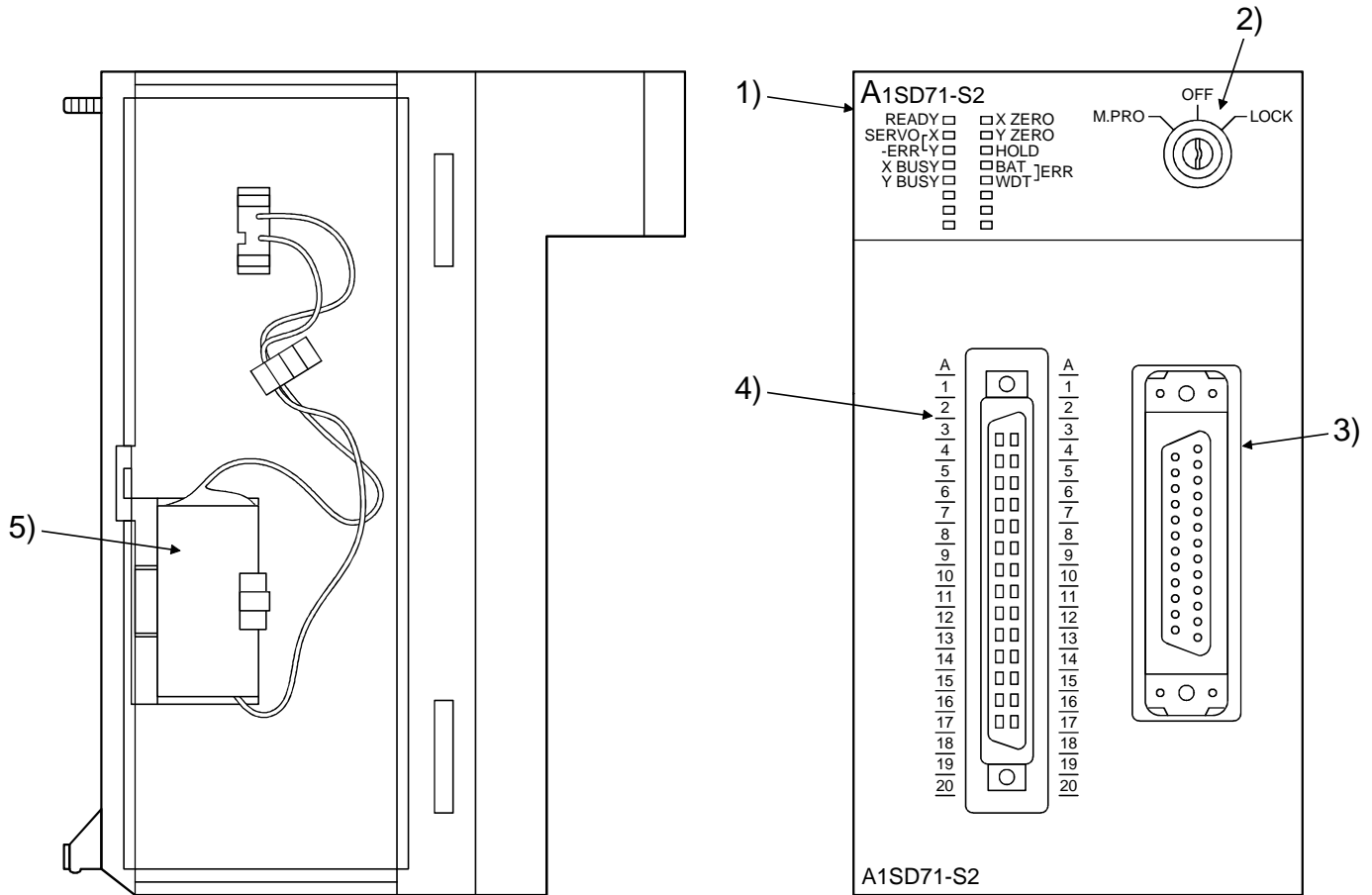

No.	Name	Description	
1)	LED indicator READY <input type="checkbox"/> <input type="checkbox"/> X ZERO SERVO-X <input type="checkbox"/> <input type="checkbox"/> Y ZERO -ERR-Y <input type="checkbox"/> <input type="checkbox"/> HOLD X BUSY <input type="checkbox"/> <input type="checkbox"/> BAT] ERR Y BUSY <input type="checkbox"/> <input type="checkbox"/> WDT] ERR <input type="checkbox"/> <input type="checkbox"/> <input type="checkbox"/> <input type="checkbox"/>	LED	Contents
		READY	Lights when the A1SD71 ready signal goes ON.
		SERVO-X -ERR-Y	Lights when the READY signal from the servo unit for the X or Y axis goes OFF.
		X BUSY	Lights when the X-axis BUSY signal goes ON.
		Y BUSY	Lights when the Y-axis BUSY signal goes ON.
		X ZERO	Lights when the X-axis zero return request signal goes ON.
		Y ZERO	Lights when the Y-axis zero return request signal goes ON.
		HOLD	Lights when there is an A1SD71 hardware fault.
		BAT] WDT] ERR	Lights when the battery error signal or WDT error signal goes ON.
2)	Keyswitches	M PRO	Sets memory protect for the setting data and positioning data areas.
		OFF	Cancels memory product for the setting data and positioning data areas.
		LOCK	Prohibits a pulse train output from the A1SD71.
3)	RS-422 connector	Used for connections with a peripheral device such as an A6GPP, A6PHP, A7PHP, A7HGP, A7LMS and AD71TU.	

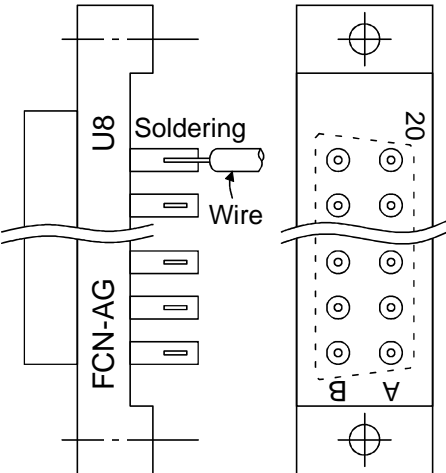
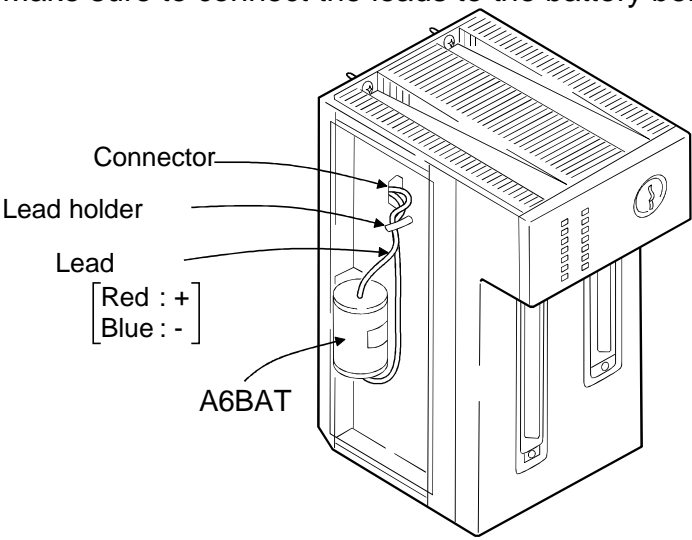
No.	Name	Description
4)	40 pin connector	<p>Used for connections with a drive units. The following shows the pin-outs of the attached external wiring connector. Install wiring by referring to the I/O interface.</p>  <p>The above is top view. The pins are numbered from A1 to A20 and from B1 to B20.</p>
5)	Battery	<p>Positioning data backup battery. Make sure to connect the leads to the battery before using A1SD71.</p> 

5. Handling Guideline

This chapter provides guidelines for handling A1SD71.

- (1) Since the case of the module is made of resin, do not drop or apply strong impact.
- (2) Make sure not to let conductive material such as wire chips or drill swarf get inside the module. If found inside, remove them.
- (3) Make sure to power off the PLC before mounting/removing the module to/from the base

- (4) Power off the PLC and drive unit before connecting/removing the drive unit connector.

Check the connector orientation, and then insert the drive unit connector straight into the corresponding connectors.

Tighten the connector using two fixing screws completely to ensure the connection.

If not intending to connect the drive unit, make sure to attach the connector cover to A1SD71 in advance.

- (5) Always make sure A1SD71 is not in BUSY status before connecting peripheral devices.

Check the connector orientation, and then insert the drive unit connector straight into the corresponding connectors.

Tighten the connector using two fixing screws completely to ensure the connection.

If not intending to connect the drive unit, make sure to attach the connector cover to A1SD71 in advance.

6. Start-up Procedure

This chapter provides an outline of start-up procedure for A1SD71.

For more information, refer to the user's manual for AD71(S1/S2/S7), A1SD71-S2(S7) positioning module.

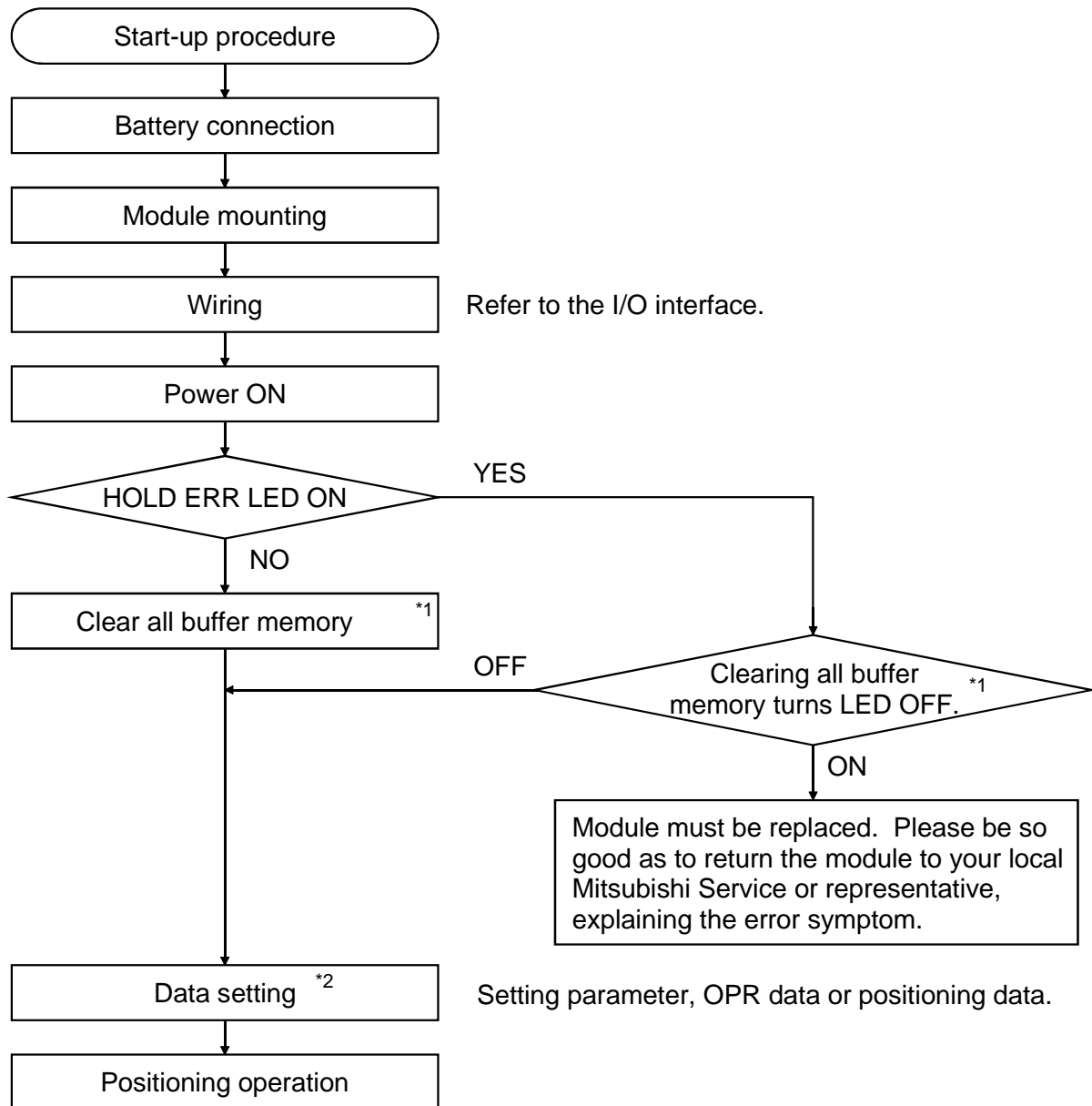

*1: Clear all buffer memory using the peripheral device or sequence program. However, all data cannot be cleared using peripheral device in the following cases. Write "0" using sequence program.

- Sudden stop deceleration time
- Positioning mode

*2: Even when intending to use only either X or Y axis, make sure to write both parameter and OPR data to the unused axis. Failure to do so may cause an error when OPR is made.

7. Wiring Precautions

- (1) Where excessive noise may apply to the pulse train signals, use shielded twisted paired cables to connect the A1SD71 and a drive unit.

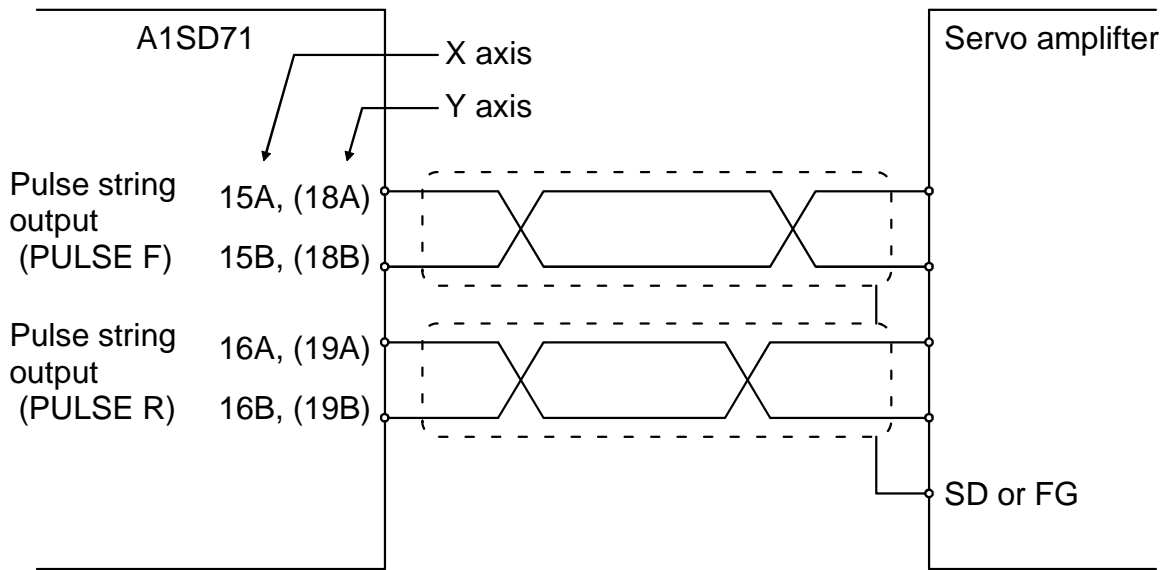

- (2) 24 VDC wiring notes

In case that a drive unit has a built-in power supply, do not use an external power supply with the built-in power supply for same circuitry. Otherwise a malfunction may occur by wraparound circuit current.

[Wraparound circuit]

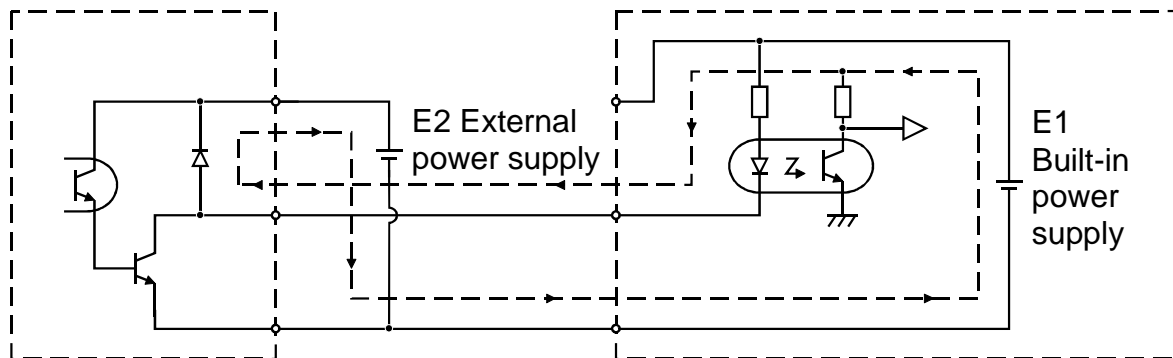

$E1 > E2$

Even if the pulse output of A1SD71 is OFF, the power supply flows in a servo unit pulse input line.

8. External Dimensions

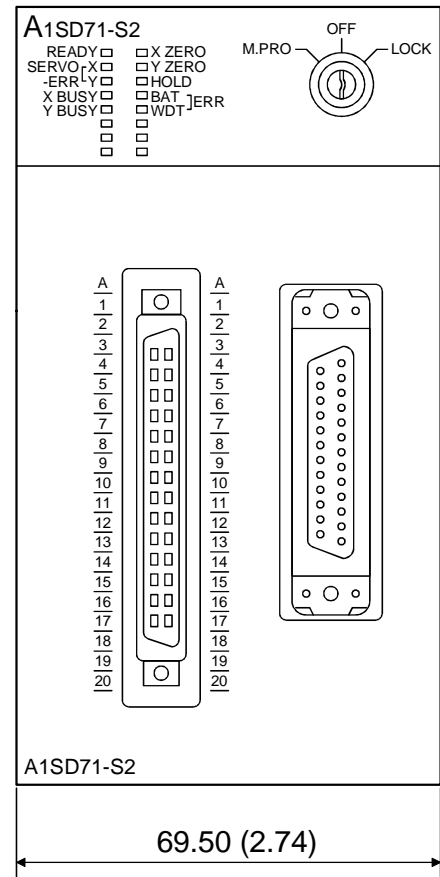
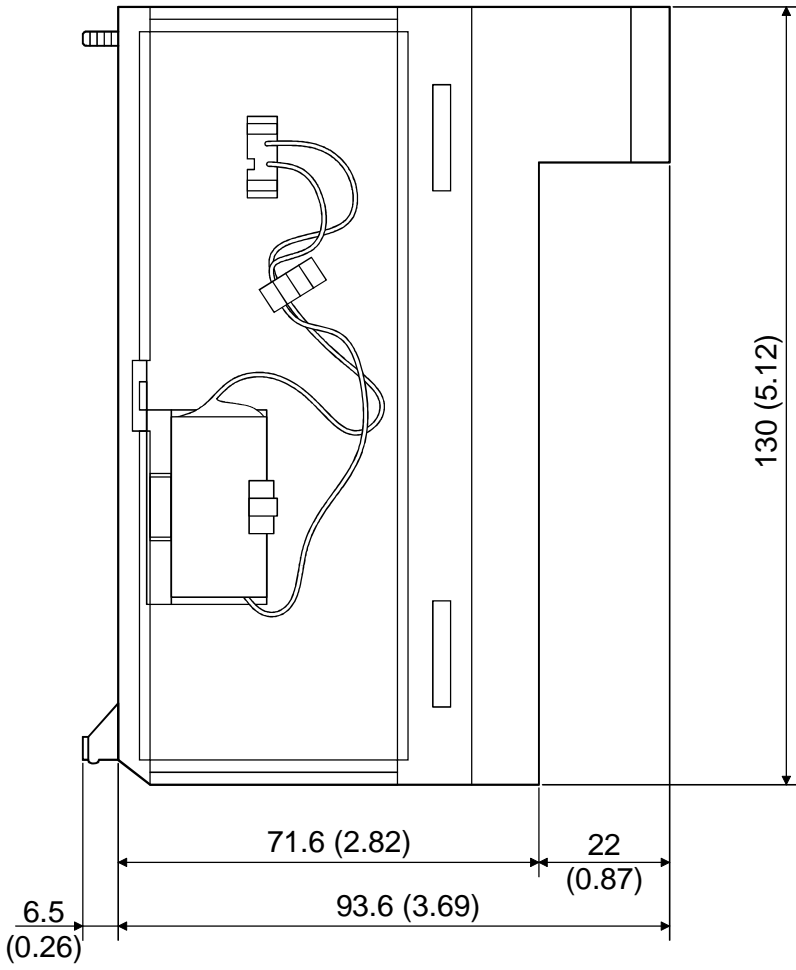

Unit: mm (inch)

Warranty

Mitsubishi will not be held liable for damage caused by factors found not to be the cause of Mitsubishi; machine damage or lost profits caused by faults in the Mitsubishi products; damage, secondary damage, accident compensation caused by special factors unpredictable by Mitsubishi; damages to products other than Mitsubishi products; and to other duties.

For safe use

- This product has been manufactured as a general-purpose part for general industries, and has not been designed or manufactured to be incorporated in a device or system used in purposes related to human life.
- Before using the product for special purposes such as nuclear power, electric power, aerospace, medicine or passenger movement vehicles, consult with Mitsubishi.
- This product has been manufactured under strict quality control. However, when installing the product where major accidents or losses could occur if the product fails, install appropriate backup or failsafe functions in the system.

Country/Region	Sales office/Tel	Country/Region	Sales office/Tel
U.S.A	Mitsubishi Electric Automation Inc. 500 Corporate Woods Parkway Vernon Hills, IL 60061 Tel : +1-847-478-2100	Hong Kong	Ryoden Automation Ltd. 10th Floor, Manulife Tower, 169 Electric Road, North Point, HongKong Tel : +852-2887-8870
Brazil	MELCO-TEC Rep. Com.e Assessoria Tecnica Ltda. Rua Correia Dias, 184, Edificio Paraiso Trade Center-8 andar Paraiso, Sao Paulo, SP Brazil Tel : +55-11-5908-8331	China	Ryoden Automation Shanghai Ltd. 3F Block5 Building Automation Instrumentation Plaza 103 Cao Bao Rd. Shanghai 200233 China Tel : +86-21-6120-0808
Germany	Mitsubishi Electric Europe B.V. German Branch Gothaer Strasse 8 D-40880 Ratingen, GERMANY Tel : +49-2102-486-0	Taiwan	Setsuyo Enterprise Co., Ltd. 6F., No.105 Wu-Kung 3rd.RD, Wu-Ku Hsiang, Taipei Hsine, Taiwan Tel : +886-2-2299-2499
U.K	Mitsubishi Electric Europe B.V. UK Branch Travellers Lane, Hatfield, Herts., AL10 8XB,UK Tel : +44-1707-276100	Korea	HAN NEUNG TECHNO CO.,LTD. 1F Dong Seo Game Channel Bldg., 660-11, Deungchon-dong Kangsec-ku, Seoul, Korea Tel : +82-2-3660-9552
Italy	Mitsubishi Electric Europe B.V. Italian Branch Centro Dir. Colleoni, Pal. Perseo-Ingr.2 Via Paracelso 12, 20041 Agrate B., Milano, Italy Tel : +39-039-6053344	Singapore	Mitsubishi Electric Asia Pte, Ltd. 307 Alexandra Road #05-01/02, Mitsubishi Electric Building Singapore 159943 Tel : +65-6473-2308
Spain	Mitsubishi Electric Europe B.V. Spanish Branch Carretera de Rubi 76-80 08190 Sant Cugat del Valles, Barcelona, Spain Tel : +34-93-565-3131	Thailand	F. A. Tech Co.,Ltd. 898/28,29,30 S.V.City Building,Office Tower 2,Floor 17-18 Rama 3 Road, Bangkokpang, Yannawa, Bangkok 10120 Tel : +66-2-682-6522
France	Mitsubishi Electric Europe B.V. French Branch 25 Boulevard des Bouvets, F-92741 Nanterre Cedex, France TEL: +33-1-5568-5568	Indonesia	P.T. Autoteknindo SUMBER MAKMUR Jl. Muara Karang Selatan Block a Utara No.1 Kav. No.11 Kawasan Industri/ Pergudangan Jakarta - Utara 14440 Tel : +62-21-663-0833
South Africa	Circuit Breaker Industries LTD. Tripswitch Drive, Elandsfontein Gauteng, South Africa Tel : +27-11-928-2000	India	Messung Systems Put,Ltd. Electronic Sadan NO:111 Unit No15, M.I.D.C BHOSARI,PUNE-411026, India Tel : +91-20-712-2807
		Australia	Mitsubishi Electric Australia Pty. Ltd. 348 Victoria Road, PostalBag, No 2, Rydalmere, N.S.W 2116, Australia Tel : +61-2-9684-7777

MITSUBISHI ELECTRIC CORPORATION

HEAD OFFICE : 1-8-12, OFFICE TOWER Z 14F HARUMI CHUO-KU 104-6212, JAPAN
NAGOYA WORKS : 1-14, YADA-MINAMI 5-CHOME, HIGASHI-KU, NAGOYA, JAPAN

When exported from Japan, this manual does not require application to the Ministry of Economy, Trade and Industry for service transaction permission.

Specifications subject to change without notice.
Printed in Japan on recycled paper.