

mitsubishi

Analog-Digital Converter Module

User's Manual
(Hardware)

A1S68AD

Thank you for purchasing the Mitsubishi programmable controller MELSEC-A Series.

Prior to use, please read both this manual and detailed manual thoroughly to fully understand the product.



Model	A1S68AD-U-HW
MODEL CODE	13JY17
IB(NA)-0800371-B(0805)MEE	

● SAFETY PRECAUTIONS ●

(Always read before starting use)

When using Mitsubishi equipment, thoroughly read this manual and the associated manuals introduced in the manual. Also pay careful attention to safety and handle the module properly.

The instructions given this manual are concerned with this product. Refer to the User's Manual of the CPU module in use for details on the safety instructions for the programmable controller system.

These ● SAFETY PRECAUTIONS ● classify the safety precautions into two categories: "DANGER" and "CAUTION".



DANGER

Procedures which may lead to a dangerous condition and cause death or serious injury if not carried out properly.



CAUTION

Procedures which may lead to a dangerous condition and cause superficial to medium injury, or physical damage only, if not carried out properly.

Depending on circumstances, procedures indicated by  **CAUTION** may also be linked to serious results.

In any case, it is important to follow the directions for usage.

Store this manual in a safe place so that you can take it out and read it whenever necessary. Always forward it to the end user.

[DESIGN PRECAUTIONS]

CAUTION

- Do not bundle the control wire and the communication cable with the main circuit or power line or keep them close to one another. Keep the control wire and the connection cable at least 100mm (3.94inch) away from the main circuit or power line: otherwise, noise or malfunctions will occur.

[INSTALLATION PRECAUTIONS]

CAUTION

- Use the programmable controller in the environment conditions given in the general specifications of the User's Manual for the A1S68AD.
Failure to do so may cause an electric shock, fire, malfunction, or damage to or deterioration of the product.
- Insert the tabs at the bottom of the module into the holes in the base module before installing module. Be sure to install the module in the base module with screws tightened to the specified torque.
Improper installation may cause erroneous operation, accident, or the module to fall out.

[WIRING PRECAUTIONS]

CAUTION

- Before connecting wires to the PLC, check the rated voltage and the terminal arrangement.
Connecting power of a different voltage or wiring incorrectly will result in fire or failure.
- Tighten the terminal screws within the specified torque range.
Undertightening can cause a short circuit or malfunction.
Overtightening can cause a short circuit or malfunction due to damage of the screws or module.
- Take all possible measures to prevent chips or wire scraps from entering the module.
Entry of foreign material will cause fire, failure of malfunctions.

[STARTING AND MAINTENANCE PRECAUTIONS]

DANGER

- Do not touch the terminals while they are live.
This will cause malfunctions.
- Make sure to switch all phases of the external power supply off before cleaning or re-tightening the terminal screws. Failure to do so will cause failure or malfunction of the module.
Not doing so can cause failure or malfunction of the module.

CAUTION

- Do not disassemble or tamper with the module.
This will cause failure, malfunctions, injuries or fire.
- Make sure to switch all phases of the external power supply off before mounting or removing the module.
Failure to do so will cause failure or malfunction of the module.
- If a voltage is input when a current input range is selected, failure may occur.
- Do not install/remove the terminal block more than 50 times after the first use of the product. (IEC 61131-2 compliant)
- Always make sure to touch the grounded metal to discharge the electricity charged in the body, etc., before touching the module.
Failure to do so may cause a failure or malfunction of the module.

[DISPOSAL PRECAUTIONS]

CAUTION

- When disposing of the product, treat it as industrial waste.

Revisions

* The manual number is noted at the lower right of the top cover.

Print Date	*Manual Number	Revision
Mar., 2008	IB(NA)-0800371-A	First printing
May,2008	IB(NA)-0800371-B	Partial correction Chapter 3

This manual confers no industrial property rights or any rights of any other kind, nor does it confer any patent licenses. Mitsubishi electric Corporation cannot be held responsible for any problems involving industrial property rights which may occur as a result of using the contents noted in this manual.

© 2008 MITSUBISHI ELECTRIC CORPORATION

CONTENTS

1. General Description	1
2. Performance Specifications	2
3. Nomenclature and Settings	3
4. Caution on Handling	6
5. Wiring	7
5.1 Cautions on Wiring	7
5.2 Module connection example	8
6. Outside Dimensions	10

About the Manuals

The following product are available for this equipment.
Refer to the table given below to choose suitable manuals.

Detailed Manual

Manual name	Manual No. (Model code)
Analog-Digital Converter Module type A1S68AD User's Manual	IB-66576 (13J757)

Conformance to the EMC and Low Voltage Directives

To configure a system meeting the requirements of the EMC and Low Voltage Directives when incorporating the Mitsubishi programmable controller (EMC and Low Voltage Directives compliant) into other machinery or equipment, refer to Chapter 3 "EMC AND LOW VOLTAGE DIRECTIVES" of the User's Manual (Hardware) for the CPU module used.

The CE mark, indicating compliance with the EMC and Low Voltage Directives, is printed on the rating plate of the programmable controller.

No additional measures are necessary for the compliance of this product with the EMC and Low Voltage Directives.

1. General Description

This manual provides the specifications and part names of the analog-digital converter module type A1S68AD (hereinafter referred to as "A1S68AD"), which is designed to use with the MELSEC-A series CPU module.

2. Performance Specifications

The following table shows the performance specifications of the A1S68AD.

Item	Specification	
Analog input	Voltage:-10 to 0 to +10 VDC (input resistance : 1MΩ or more) Current:0 to +20mA (input resistance : 250Ω)]*3	
Digital output	16-bit signed binary	
I/O characteristics *1	Analog input value	Digital output value
	0 to +10V	0 to +4000
	-10 to 10V	-2000 to +2000
	0 to 5V or 0 to 20mA 1 to 5V or 4 to 20mA	0 to +4000 0 to +4000
Maximum resolution	Analog input value	Digital output value
	0 to +10V	2.5mV
	-10 to 10V	5mV
	0 to 5V	1.25mV
	1 to 5V	1mV
	0 to 20mA 4 to 20mA	5μA 4μA
Overall accuracy (accuracy to full scale)	Within ±1% (Digital output value ±40)	
Maximum conversion time	0.5ms/1 channel (*2)	
Absolute maximum input	Voltage:±35V Current:±30mA	
Number of analog input points	8 channels/1 module	
Insulation method	Between input terminal and PLC power supply: Photocoupler insulation (Between channels: Not insulated)	
Number of occupied I/O points	Special, 32 points	
Connection terminal	20-terminal block	
External power supply	Unnecessary	
Applicable wire size	0.75 to 1.5mm ²	
Applicable solderless terminal	R1.25-3, 1.25-YS3, RAV1.25-3, V1.25-YS3A	
Internal current consumption (5VDC)	0.4A	
Weight	0.27 kg	

*1: The switch is set to an analog input value of 0 to +10V on delivery.

*2: The maximum conversion speed is 1ms/channel on all channels if averaging processing is set even for only one channel.

*3: For the selecting method of voltage input or current input, refer to Chapter 3.

POINT

The overall accuracy is applicable to the following analog input ranges:
Voltage: -10 to 0 to +10V
Current: 0 to +20mA

For the general specifications, refer to the detailed manual.

3. Nomenclature and Settings

The following gives the Names and settings of each section for each part of the A1S68AD

In this manual, modules whose hardware versions V or later are used for description.

For the names and settings for each part of modules whose hardware version U or earlier, refer to the Analog-Digital Converter Module type A1S68AD User's Manual (IB-66576).

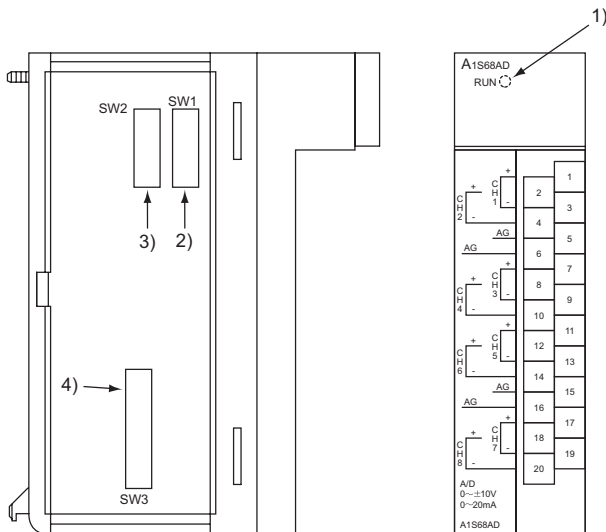

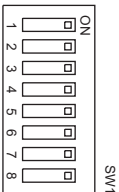
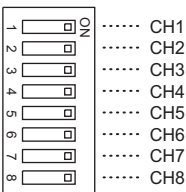
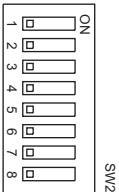
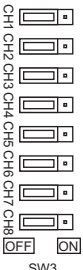
No.	Name and appearance	Description																								
1)	"RUN" LED	Displays the operating status of the A1S68AD. On :Normal operation. Flash :Write disabled error or average time/count setting error. Off :5 V power cut or watchdog timer error.																								
	RUN 																									
2)	Input range selector switch SW1	Used to set the input range of each channel. (Factory default: 0 to 10V) The DIP switch numbers 1-8 correspond to the channel numbers.																								
	 																									
3)	Input range selector switch SW2	Setting of CH1																								
	 <table border="1" data-bbox="388 604 953 902"> <thead> <tr> <th>Input Range</th> <th>SW1-1</th> <th>SW2-1</th> <th>SW3-1</th> </tr> </thead> <tbody> <tr> <td>-10 to 10V</td> <td>OFF</td> <td rowspan="2">OFF</td> <td rowspan="4">OFF</td> </tr> <tr> <td>0 to 10V</td> <td>ON</td> </tr> <tr> <td>0 to 5V</td> <td>OFF</td> <td rowspan="2">ON</td> </tr> <tr> <td>1 to 5V</td> <td>ON</td> </tr> <tr> <td>0 to 20mA</td> <td>OFF</td> <td rowspan="2">ON</td> <td rowspan="4">ON</td> </tr> <tr> <td>4 to 20mA</td> <td>ON</td> </tr> <tr> <td>Setting disabled</td> <td>OFF</td> <td rowspan="2">OFF</td> </tr> <tr> <td>Setting disabled</td> <td>ON</td> </tr> </tbody> </table>	Input Range	SW1-1	SW2-1	SW3-1	-10 to 10V	OFF	OFF	OFF	0 to 10V	ON	0 to 5V	OFF	ON	1 to 5V	ON	0 to 20mA	OFF	ON	ON	4 to 20mA	ON	Setting disabled	OFF	OFF	Setting disabled
Input Range	SW1-1	SW2-1	SW3-1																							
-10 to 10V	OFF	OFF	OFF																							
0 to 10V	ON																									
0 to 5V	OFF	ON																								
1 to 5V	ON																									
0 to 20mA	OFF	ON	ON																							
4 to 20mA	ON																									
Setting disabled	OFF	OFF																								
Setting disabled	ON																									
4)	Input range selector switch SW3	Set CH2-CH8 in the same manner.																								
																										

Caution

If voltage input appears when a current input range is selected, a failure may occur.

4. Caution on Handling

- (1) The module case and the terminal block are made of resin.
Do not drop the module or subject it to shock.
- (2) Do not remove the printed circuit board from the module case.
This could cause failure.
- (3) During wiring, take all possible measures to prevent wire scraps or foreign matter from entering the module.
If anything enters the module, remove it completely.
- (4) Tighten the module mounting screws and the terminal screws to the torques specified in the following table:

Screw	Tightening torque range (N•cm)
Module installation screw (M4 screw)	78 to 118
Terminal block terminal screw (M3.5 screw)	59 to 88
Terminal block mounting screw (M4 screw)	78 to 118

5. Wiring

This section gives the cautions on wiring and connection example for the module.

5.1 Cautions on Wiring

To establish a highly reliable system by making the best use of the A1S68AD functions, external wiring that is not susceptible to the effects of noise is required.

The cautions on external wiring are presented below:

- (1) Use separate cables for AC input current and external input signals to the A1S68AD. This can prevent the effects of surge or induction of the AC input current.
- (2) Keep the external wiring at least 10cm away from the main circuit, high-voltage wires or load-carrying wires other than those extending from the PLC: otherwise, the wiring will be affected by noise, surge or induction.
- (3) Generally, ground the shielded wire or shielded cable at one point on the PLC CPU. However, depending on the external noise level, it may be advisable to ground it at an external location.

5.2 Module connection example

The figure below shows an example of voltage input and current input connections.

(1) Voltage input connection

Signal source: 0 to $\pm 10V$

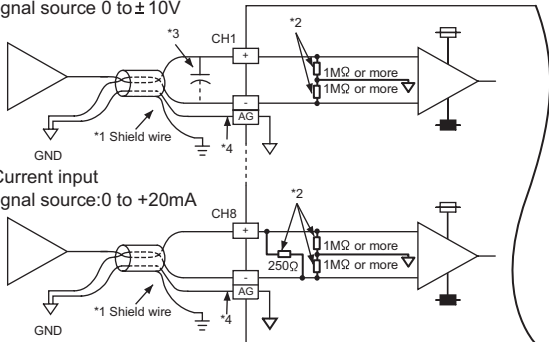

*1: Use a 2-pole twist shielded wire.

*2: Represents the input resistors of the A1S68AD. (For voltage input, turn off the 250 Ω resistor with the Input range selector switch.)

*3: If the external wiring causes noise or ripple, connect a capacitor of 0.1 to 0.47 μF (25V or more voltage resistance parts) between the V and COM terminals.

*4: AG is the GND terminal of the analog circuit. Connecting it to the GND terminal of an external device is not mandatory, but a higher level of accuracy may be obtained when it is connected. If there are three or more channels of the input range of -10 to 10V and the external devices connected to the channels shares a common line, the AG terminal must be connected the shared common line of the external device. (See the figure below.)

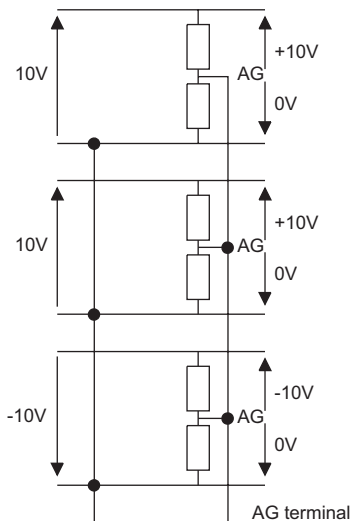

POINT

When the current input is selected, do not connect the sink type output device and the source output device together. If this happens, normal A/D conversion value cannot be stored.

6. Outside Dimensions

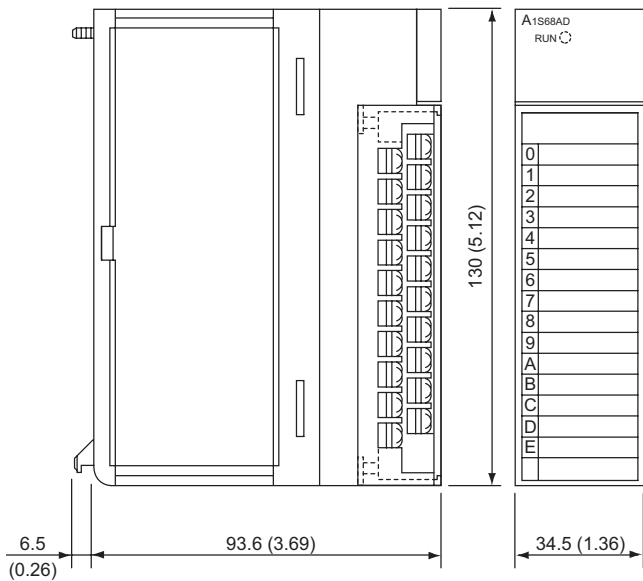

Unit:mm(inch)

Warranty

Mitsubishi will not be held liable for damage caused by factors found not to be the cause of Mitsubishi; machine damage or lost profits caused by faults in the Mitsubishi products; damage, secondary damage, accident compensation caused by special factors unpredicable by Mitsubishi; damages to products other than Mitsubishi products; and to other duties.

For safe use

- This product has been manufactured as a general-purpose part for general industries, and has not been designed or manufactured to be incorporated in a device or system used in purposes related to human life.
- Before using the product for special purposes such as nuclear power, electric power, aerospace, medicine or passenger movement vehicles, consult with Mitsubishi.
- This product has been manufactured under strict quality control. However, when installing the product where major accidents or losses could occur if the product fails, install appropriate backup or failsafe functions in the system.

Country/Region	Sales office/Tel	Country/Region	Sales office/Tel
U.S.A	Mitsubishi Electric Automation Inc. 500 Corporate Woods Parkway Vernon Hills, IL 60061, U.S.A. Tel : +1-847-478-2100	Hong Kong	Mitsubishi Electric Automation (Hong Kong) Ltd. 10th Floor, Manulife Tower, 169 Electric Road, North Point, Hong Kong Tel : +852-2887-8870
Brazil	MELCO-TEC Rep. Com.e Assessoria Tecnica Ltda. Rua Correia Dias, 184, Edificio Paraiso Trade Center-8 andar Paraiso, Sao Paulo, SP Brazil Tel : +55-11-5908-8331	China	Mitsubishi Electric Automation (Shanghai) Ltd. 4/F Zhi Fu Plaza, No.80 Xin Chang Road, Shanghai 200003, China Tel : +86-21-6120-0808
Germany	Mitsubishi Electric Europe B.V. German Branch Gothaer Strasse 8 D-40880 Ratingen, GERMANY Tel : +49-2102-486-0	Taiwan	Setsubo Enterprise Co., Ltd. 6F No.105 Wu-Kung 3rd.Rd, Wu-Ku Hsiang, Taipei Hsine, Taiwan Tel : +886-2-2299-2499
U.K	Mitsubishi Electric Europe B.V. UK Branch Travellers Lane, Hatfield, Hertfordshire., AL10 8XB, U.K. Tel : +44-1707-276100	Korea	Mitsubishi Electric Automation Korea Co., Ltd. 1480-6, Gayang-dong, Gangseo-ku Seoul 157-200, Korea Tel : +82-2-3660-9552
Italy	Mitsubishi Electric Europe B.V. Italian Branch Centro Dir. Colleoni, Pal. Perseo-Ingr.2 Via Paracelso 12, I-20041 Agrate Brianza., Milano, Italy Tel : +39-039-60531	Singapore	Mitsubishi Electric Asia Pte, Ltd. 307 Alexandra Road #05-01/02, Mitsubishi Electric Building, Singapore 159943 Tel : +65-6470-2460
Spain	Mitsubishi Electric Europe B.V. Spanish Branch Carretera de Rubi 76-80, E-08190 Sant Cugat del Valles, Barcelona, Spain Tel : +34-93-565-3131	Thailand	Mitsubishi Electric Automation (Thailand) Co., Ltd. Bang-Chan Industrial Estate No.111 Moo 4, Serithai Rd, T.Kannayao, A.Kannayao, Bangkok 10230 Thailand Tel : +66-2-517-1326
France	Mitsubishi Electric Europe B.V. French Branch 25, Boulevard des Bouvets, F-92741 Nanterre Cedex, France TEL: +33-1-5568-5568	Indonesia	P.T. Autoteknindo Sumber Makmur Muara Karang Selatan, Block A/Utara No.1 Kav. No.11 Kawasan Industri Pergudangan Jakarta - Utara 14440, P.O.Box 5045 Jakarta, 11050 Indonesia Tel : +62-21-6630833
South Africa	Circuit Breaker Industries Ltd. Private Bag 2016, ZA-1600 Isando, South Africa Tel : +27-11-928-2000	India	Messung Systems Pvt. Ltd. Electronic Sadan NO:III Unit No15, M.I.D.C Bhosari, Pune-411026, India Tel : +91-20-2712-3130
		Australia	Mitsubishi Electric Australia Pty. Ltd. 348 Victoria Road, Rydalmere, N.S.W 2116, Australia Tel : +61-2-9684-7777

MITSUBISHI ELECTRIC CORPORATION

HEAD OFFICE : TOKYO BUILDING, 2-7-3 MARUNOUCHI, CHYODA-KU, TOKYO 100-8310, JAPAN
NAGOYA WORKS : 1-14, YADA-MINAMI 5-CHOME, HIGASHI-KU, NAGOYA, JAPAN

When exported from Japan, this manual does not require application to the Ministry of Economy, Trade and Industry for service transaction permission.

Specifications subject to change without notice.
Printed in Japan on recycled paper.