

PROGRAMMABLE CONTROLLERS

**MELSEC iQ-F**  
series

MELSEC iQ-F FX5

Simple Motion Module Function Block Reference

---



# CONTENTS

<b>CHAPTER 1</b>	<b>List of FBs</b>	<b>2</b>
<b>CHAPTER 2</b>	<b>Simple Motion Module FB</b>	<b>4</b>
2.1	M+FX5SSC_SetPositioningData	4
2.2	M+FX5SSC_StartPositioning	8
2.3	M+FX5SSC_JOG	11
2.4	M+FX5SSC_MPG	14
2.5	M+FX5SSC_ChangeSpeed	17
2.6	M+FX5SSC_ChangeAccDecTime	20
2.7	M+FX5SSC_ChangePosition	24
2.8	M+FX5SSC_Restart	27
2.9	M+FX5SSC_OperateError	29
2.10	M+FX5SSC_InitializeParameter	33
2.11	M+FX5SSC_WriteFlash	35
2.12	M+FX5SSC_ChangeServoParameter	37
2.13	M+FX5SSC_ChangeTorqueControlMode	41
2.14	M+FX5SSC_ChangeSpeedControlMode	45
2.15	M+FX5SSC_ChangePositionControlMode	48
2.16	M+FX5SSC_ChangeContinuousTorqueMode	51
2.17	M+FX5SSC_Sync	56
2.18	M+FX5SSC_ChangeSyncEncoderPosition	59
2.19	M+FX5SSC_DisableSyncEncoder	62
2.20	M+FX5SSC_EnableSyncEncoder	65
2.21	M+FX5SSC_ResetSyncEncoderError	68
2.22	M+FX5SSC_ConnectSyncEncoder	72
2.23	M+FX5SSC_MoveCamReferencePosition	74
2.24	M+FX5SSC_ChangeCamPositionPerCycle	77
2.25	M+FX5SSC_ChangeMainShaftGearPositionPerCycle	80
2.26	M+FX5SSC_ChangeAuxiliaryShaftGearPositionPerCycle	83
2.27	M+FX5SSC_MoveCamPositionPerCycle	86
2.28	M+FX5SSC_MakeRotaryCutterCam	89
2.29	M+FX5SSC_CalcCamCommandPosition	92
2.30	M+FX5SSC_CalcCamPositionPerCycle	94
	<b>INSTRUCTION INDEX</b>	<b>96</b>
	REVISIONS	98

# 1 List of FBs

This FB list is for using the MELSEC iQ-F series Simple Motion module.

Name	Description
M+FX5SSC_SetPositioningData	Sets positioning data (Da.1 to Da.4, Da.6 to Da.10, Da.20 to Da.22).
M+FX5SSC_StartPositioning	Starts the positioning operation.
M+FX5SSC_JOG	Performs the JOG operation or inching operation.
M+FX5SSC_MPG	Performs the manual pulse generator operation.
M+FX5SSC_ChangeSpeed	Changes the speed.
M+FX5SSC_ChangeAccDecTime	Changes the acceleration/deceleration time at a speed change.
M+FX5SSC_ChangePosition	Changes the target position.
M+FX5SSC_Restart	Restarts the axis being stopped.
M+FX5SSC_OperateError	Monitors errors and warnings, and resets errors.
M+FX5SSC_InitializeParameter	Initializes the parameter.
M+FX5SSC_WriteFlash	Writes the parameter, positioning data, and block start data in the buffer memory to the flash ROM.
M+FX5SSC_ChangeServoParameter	Changes the servo parameter after the servo amplifier is activated.
M+FX5SSC_ChangeTorqueControlMode	Activates the torque control mode.
M+FX5SSC_ChangeSpeedControlMode	Activates the speed control mode.
M+FX5SSC_ChangePositionControlMode	Activates the position control mode.
M+FX5SSC_ChangeContinuousTorqueMode	Activates the continuous operation to torque control mode.
M+FX5SSC_Sync	Starts and ends the synchronous control.
M+FX5SSC_ChangeSyncEncoderPosition	Changes the synchronous encoder axis current value and synchronous encoder axis current value per cycle.
M+FX5SSC_DisableSyncEncoder	Disables inputs from the synchronous encoder axis.
M+FX5SSC_EnableSyncEncoder	Enables inputs from the synchronous encoder axis.
M+FX5SSC_ResetSyncEncoderError	Reads error information from the synchronous encoder axis, and resets the error.
M+FX5SSC_ConnectSyncEncoder	Connects a synchronous encoder via CPU.
M+FX5SSC_MoveCamReferencePosition	Adds the movement amount set in the synchronous control change value to the cam reference position to move the cam reference position.
M+FX5SSC_ChangeCamPositionPerCycle	Changes the cam axis current value per cycle to a synchronous control change value.
M+FX5SSC_ChangeMainShaftGearPositionPerCycle	Changes the current value per cycle after main shaft gear to a synchronous control change value.
M+FX5SSC_ChangeAuxiliaryShaftGearPositionPerCycle	Changes the current value per cycle after auxiliary shaft gear to a synchronous control change value.
M+FX5SSC_MoveCamPositionPerCycle	Adds the movement amount set in the synchronous control change value to a cam axis current value per cycle to move the cam axis current value per cycle.
M+FX5SSC_MakeRotaryCutterCam	Automatically generates the cam for a rotary cutter.
M+FX5SSC_CalcCamCommandPosition	Calculates a cam axis feed current value, and outputs the calculation result.
M+FX5SSC_CalcCamPositionPerCycle	Calculates a cam axis current value per cycle, and outputs the calculation result.



# 2 Simple Motion Module FB

## 2.1 M+FX5SSC\_SetPositioningData

### Name

M+FX5SSC\_SetPositioningData

### Overview

Item	Description
Function overview	Sets positioning data (Da.1 to Da.4, Da.6 to Da.10, Da.20 to Da.22).
Symbol	<pre> graph LR     subgraph M+FX5SSC_SetPositioningData         direction TB         I1["(1) B : i_bEN"]         I2["(2) DUT : i_stModule"]         I3["(3) UW : i_uAxis"]         I4["(4) UW : i_uDataNo"]         O5["(5) o_bENO : B"]         O6["(6) o_bOK : B"]         O7["(7) o_bErr : B"]         O8["(8) o_uErrld : UW"]     end         </pre>

### Labels

#### Input labels

No.	Variable name	Name	Data type	Setting range	Description
(1)	i_bEN	Execution command	Bit	ON, OFF	ON: The FB is activated. OFF: The FB is not activated.
(2)	i_stModule	Module label	Structure	The setting range differs depending on the module label.	Specify the module label of the MELSEC iQ-F Simple Motion module.
(3)	i_uAxis	Target axis	Word [unsigned]	1 to 8	Specify the axis No. The setting range differs depending on the module used.
(4)	i_uDataNo	Positioning data No.	Word [unsigned]	1 to 100	Specify the positioning data No.

#### Output labels

No.	Variable name	Name	Data type	Default value	Description
(5)	o_bENO	Execution status	Bit	OFF	ON: The execution command is ON. OFF: The execution command is OFF.
(6)	o_bOK	Completed without error	Bit	OFF	When ON, it indicates that setting the positioning data has been completed.
(7)	o_bErr	Error flag	Bit	OFF	When ON, it indicates that an error has occurred in the FB.
(8)	o_uErrld	Error code	Word [unsigned]	0	The error code generated in the FB is stored.

## ■Disclosed labels

Variable name	Name	Data type	Setting range	Description
pb_uOpePattern	Da.1: Operation pattern	Word [unsigned]	0: Positioning complete 1: Continuous positioning control 3: Continuous path control	Specify whether positioning of a certain data No. is to be ended with just that data, or whether the positioning for the next data No. is to be carried out in succession.
pb_uCtrlSys	Da.2: Control method	Word [unsigned]	01H: ABS Linear 1 02H: INC Linear 1 03H: Feed 1 04H: FWD V1 05H: RVS V1 06H: FWD V/P 07H: RVS V/P 08H: FWD P/V 09H: RVS P/V 0AH: ABS Linear 2 0BH: INC Linear 2 0CH: Feed 2 0DH: ABS ArcMP 0EH: INC ArcMP 0FH: ABS ArcRGT 10H: ABS ArcLFT 11H: INC ArcRGT 12H: INC ArcLFT 13H: FWD V2 14H: RVS V2 15H: ABS Linear 3 16H: INC Linear 3 17H: Feed 3 18H: FWD V3 19H: RVS V3 1AH: ABS Linear 4 1BH: INC Linear 4 1CH: Feed 4 1DH: FWD V4 1EH: RVS V4 80H: NOP 81H: Address CHG 82H: JUMP 83H: LOOP 84H: LEND	Sets the control system for positioning control.
pb_uAccTimeNo	Da.3: Acceleration time No.	Word [unsigned]	0: Acceleration time 0 1: Acceleration time 1 2: Acceleration time 2 3: Acceleration time 3	Set any of the acceleration time 0 to 3 as the acceleration time for positioning.
pb_uDecTimeNo	Da.4: Deceleration time No.	Word [unsigned]	0: Deceleration time 0 1: Deceleration time 1 2: Deceleration time 2 3: Deceleration time 3	Set any of the deceleration time 0 to 3 as the deceleration time for positioning.
pb_uInterpolatedAxNo1	Da.20: Axis to be interpolated No.1	Word [unsigned]	0H: Axis 1 selected 1H: Axis 2 selected 2H: Axis 3 selected 3H: Axis 4 selected 4H: Axis 5 selected 5H: Axis 6 selected 6H: Axis 7 selected 7H: Axis 8 selected	Set the axis to be interpolated (interpolation axis) to execute the 2- to 4-axis interpolation operation.
pb_uInterpolatedAxNo2	Da.21: Axis to be interpolated No.2	Word [unsigned]	0H: Axis 1 selected 1H: Axis 2 selected 2H: Axis 3 selected 3H: Axis 4 selected 4H: Axis 5 selected 5H: Axis 6 selected 6H: Axis 7 selected 7H: Axis 8 selected	Set the axis to be interpolated (interpolation axis) to execute the 3- and 4-axis interpolation operation.

Variable name	Name	Data type	Setting range	Description
pb_uInterpolatedAxNo3	Da.22: Axis to be interpolated No.3	Word [unsigned]	0H: Axis 1 selected 1H: Axis 2 selected 2H: Axis 3 selected 3H: Axis 4 selected 4H: Axis 5 selected 5H: Axis 6 selected 6H: Axis 7 selected 7H: Axis 8 selected	Set the axis to be interpolated (interpolation axis) to execute the 4-axis interpolation operation.
pb_uMcode	Da.10: M code	Word [unsigned]	Da.2: Control method = 82H: JUMP instruction • 0 to 10 Da.2: Control method = 83H: LOOP • 1 to 65535 Da.2: Control method = Other than the above • 0 to 65535	Set an "M code", a "condition data No.", or the "Number of LOOP to LEND repetitions" corresponding to the "Da.2: Control method".
pb_uDwellTime	Da.9: Dwell time	Word [unsigned]	Da.2: Control method = 82H: JUMP instruction • 1 to 600 Da.2: Control method = 82H: Other than JUMP instruction • 0 to 65535	Set the "dwell time" or "positioning data No." corresponding to the "Da.2: Control method".
pb_udCmdSpd	Da.8: Command speed	Double word [signed]	Pr.1: Unit setting = 0, 1, 2 • 1 to 2000000000 Pr.1: Unit setting = 3 • 1 to 1000000000 FFFFFFFFH: Current speed (Speed set for the previous positioning data No.)	Set the command speed for positioning.
pb_dPositAdr	Da.6: Positioning address	Double word [signed]	Pr.1: Unit setting = 0, 1, 3 • Da.2: Control method = 06H to 09H: 0 to 2147483647 • Da.2: Control method = Other than 06H to 09H:- 2147483648 to 2147483647 Pr.1: Unit setting = 2 • Da.2: Control method = 01H, 0AH, 15H, 1AH, 81H, 20H, 22H, 23H: 0 to 35999999 • Da.2: Control method = 02H, 0BH, 16H, 1BH, 03H, 0CH, 17H, 1CH, 20H, 22H, 23H: -2147483648 to 2147483647 • Da.2: Control method = 06H, 07H: 0 to 2147483647 (INC mode), 0 to 35999999 (ABS mode) • Da.2: Control method = 08H, 09H: 0 to 2147483647	Set the address to be used as the target value for positioning control.
pb_dArcAdr	Da.7: Arc address	Double word [signed]	-2147483648 to 2147483647	This data is required only when performing circular interpolation control.

## FB details

Item	Description	
Applicable hardware and software	Applicable module	FX5-40SSC-S, FX5-80SSC-S
	Applicable CPU	MELSEC iQ-F series
	Applicable engineering software	FX5-40SSC-S: GX Works3 (Version 1.010L or later) FX5-80SSC-S: GX Works3 (Version 1.030G or later)
Programming language	Ladder	
Number of steps (maximum)	311 steps	
Function description	<ul style="list-style-type: none"> <li>By turning ON i_bEN (Execution command), the set positioning data is written to the buffer memory.</li> <li>When the setting value of the target axis is out of the range, o_bErr (Error flag) turns ON, the FB processing is interrupted, and the error code 100 (Hexadecimal) is stored in o_uErrId (Error code).</li> <li>When the setting value of the positioning data No. is out of the range, o_bErr (Error flag) turns ON, the FB processing is interrupted, and the error code 101 (Hexadecimal) is stored in o_uErrId (Error code).</li> </ul>	
Compiling method	Macro type	
FB operation type	Pulsed execution (single scan execution type)	



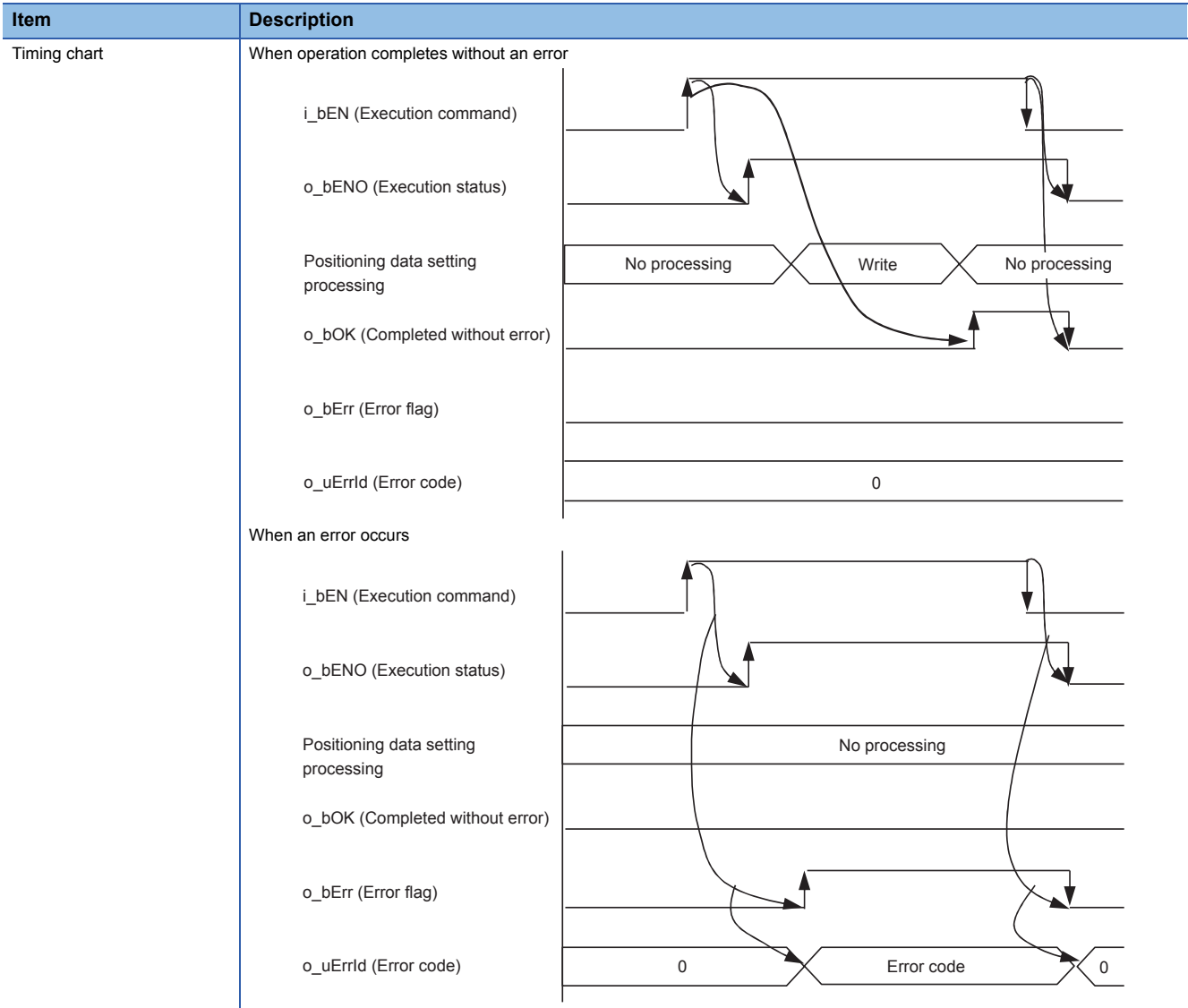

Restrictions and precautions

- The FB does not include error recovery processing. Program the error recovery processing separately in accordance with the required system operation.
- The FB cannot be used in an interrupt program.
- Ensure that i\_bEN (Execution command) is capable of being turned OFF by the program. Do not use this FB in programs that are only executed once such as a subroutine and FOR-NEXT loop because i\_bEN (Execution command) cannot be turned OFF.
- When this FB is used twice or more, precaution must be taken to avoid repetition of the target axis.
- Every input must be provided with a value for proper FB operation.

### Error codes

Error code	Description	Action
100 (Hexadecimal)	The setting value of i_uAxis (Target axis) is out of the range. The target axis is not within the range of 1 to 8.	Please try again after confirming the setting.
101 (Hexadecimal)	The setting value of i_uDataNo (Positioning data No.) is out of the range. The positioning data No. is not within the range of 1 to 100.	Please try again after confirming the setting.

### Version upgrade history

Version	Date	Description
00A	2015/04/23	First edition
01A	2016/07/15	Add the 8-axis module for the applicable module. Extend the target axis and the axis to be interpolated into 8 axes.

## 2.2 M+FX5SSC\_StartPositioning

### Name

M+FX5SSC\_StartPositioning

### Overview

Item	Description
Function overview	Starts the positioning operation.
Symbol	

### Labels

#### ■Input labels

No.	Variable name	Name	Data type	Setting range	Description
(1)	i_bEN	Execution command	Bit	ON, OFF	ON: The FB is activated. OFF: The FB is not activated.
(2)	i_stModule	Module label	Structure	The setting range differs depending on the module label.	Specify the module label of the MELSEC iQ-F Simple Motion module.
(3)	i_uAxis	Target axis	Word [unsigned]	1 to 8	Specify the axis No. The setting range differs depending on the module used.
(4)	i_uStartNo	Cd.3: Positioning start No.	Word [unsigned]	1 to 600: Positioning data No. 7000 to 7004: Block start designation 9001: Machine home position return 9002: Fast-home position return 9003: Current value changing 9004: Simultaneous starting of multiple axes	Set the positioning start No. corresponding to the control to be started in Cd.3: Positioning start No.

#### ■Output labels

No.	Variable name	Name	Data type	Default value	Description
(5)	o_bENO	Execution status	Bit	OFF	ON: The execution command is ON. OFF: The execution command is OFF.
(6)	o_bOK	Completed without error	Bit	OFF	When ON, it indicates that executing this FB has been completed. However, this label does not turn ON when a module error occurs at the start.
(7)	o_bErr	Error flag	Bit	OFF	When ON, it indicates that an error has occurred in the FB.
(8)	o_uErrId	Error code	Word [unsigned]	0	The error code generated in the FB is stored.

## FB details

Item	Description
Applicable hardware and software	Applicable module FX5-40SSC-S, FX5-80SSC-S
	Applicable CPU MELSEC iQ-F series
	Applicable engineering software FX5-40SSC-S: GX Works3 (Version 1.010L or later) FX5-80SSC-S: GX Works3 (Version 1.030G or later)
Programming language	Ladder
Number of steps (maximum)	497 steps
Function description	<ul style="list-style-type: none"> <li>By turning ON i_bEN (Execution command), the control corresponding to i_uStartNo (Cd.3: Positioning start No.) is started.</li> <li>This FB is activated by turning ON the positioning start signal.</li> <li>Only when the conditions are met, the positioning start signal is turned ON by turning ON i_bEN (Execution command). The conditions are the following: READY signal is ON, positioning start signal is OFF, start complete signal is OFF, and BUSY signal is OFF. If any of the conditions is not met, the error code 200 (hexadecimal) is stored in o_uErrId (Error code).</li> <li>When the start complete signal is turned ON or i_bEN (Execution command) is turned OFF, the positioning start signal is turned OFF.</li> <li>When the setting value of the target axis is out of the range, o_bErr (Error flag) turns ON, the FB processing is interrupted, and the error code 100 (Hexadecimal) is stored in o_uErrId (Error code).</li> <li>When the setting value of the positioning start No. is out of the range, o_bErr (Error flag) turns ON, the FB processing is interrupted, and the error code 102 (Hexadecimal) is stored in o_uErrId (Error code).</li> </ul>
Compiling method	Macro type
FB operation type	Pulsed execution (multiple scan execution type)
Timing chart	<p>When operation completes without an error</p> <p>When an error occurs</p>

Item	Description
Restrictions and precautions	<ul style="list-style-type: none"> <li>• The FB does not include error recovery processing. Program the error recovery processing separately in accordance with the required system operation.</li> <li>• The FB cannot be used in an interrupt program.</li> <li>• Ensure that i_bEN (Execution command) is capable of being turned OFF by the program. Do not use this FB in programs that are only executed once such as a subroutine and FOR-NEXT loop because i_bEN (Execution command) cannot be turned OFF.</li> <li>• This FB turns ON and OFF the positioning start signal. Thus, do not operate the positioning start signal by the other means while being executed.</li> <li>• When this FB is used twice or more, create an interlock to prevent the FBs from being activated at the same time.</li> <li>• When this FB is used twice or more, precaution must be taken to avoid repetition of the target axis.</li> <li>• This FB does not set the data when started. Data required for controlling the start No. must be set on the parameter or buffer memory.</li> <li>• Every input must be provided with a value for proper FB operation.</li> </ul>

## Error codes

Error code	Description	Action
100 (Hexadecimal)	The setting value of i_uAxis (Target axis) is out of the range. The target axis is not within the range of 1 to 8.	Please try again after confirming the setting.
102 (Hexadecimal)	The setting value of i_uStartNo (Cd.3: Positioning start No.) is out of the range. The positioning start No. is not within the range of 1 to 600, 7000 to 7004, and 9001 to 9004.	Please try again after confirming the setting.
200 (Hexadecimal)	The condition for positioning start is not met. Any of the following conditions is not met. <ul style="list-style-type: none"> <li>• READY signal: On</li> <li>• Positioning start signal: Off</li> <li>• Start complete signal: Off</li> <li>• BUSY signal: Off</li> </ul>	Execute the FB when all of the following conditions are met. <ul style="list-style-type: none"> <li>• READY signal: On</li> <li>• Positioning start signal: Off</li> <li>• Start complete signal: Off</li> <li>• BUSY signal: Off</li> </ul>

## Version upgrade history

Version	Date	Description
00A	2015/04/23	First edition
01A	2016/07/15	Add the 8-axis module for the applicable module. Extend the target axis into 8 axes.

## 2.3 M+FX5SSC\_JOG

### Name

M+FX5SSC\_JOG

### Overview

Item	Description
Function overview	Performs the JOG operation or inching operation.
Symbol	<p>The diagram shows a rectangular block labeled 'M+FX5SSC_JOG'. On the left side, there are seven input lines labeled (1) through (7): (1) B : i_bEN, (2) DUT : i_stModule, (3) UW : i_uAxis, (4) B : i_bFJog, (5) B : i_bRJog, (6) UD : i_udJogSpeed, and (7) UW : i_ulnching. On the right side, there are four output lines labeled (8) through (11): (8) o_bENO : B, (9) o_bOK : B, (10) o_bErr : B, and (11) o_uErrId : UW.</p>

### Labels

#### Input labels

No.	Variable name	Name	Data type	Setting range	Description
(1)	i_bEN	Execution command	Bit	ON, OFF	ON: The FB is activated. OFF: The FB is not activated.
(2)	i_stModule	Module label	Structure	The setting range differs depending on the module label.	Specify the module label of the MELSEC iQ-F Simple Motion module.
(3)	i_uAxis	Target axis	Word [unsigned]	1 to 8	Specify the axis No. The setting range differs depending on the module used.
(4)	i_bFJog	Forward run JOG command	Bit	ON, OFF	Turn ON this label when performing the forward run JOG operation or forward run inching operation.
(5)	i_bRJog	Reverse run JOG command	Bit	ON, OFF	Turn ON this label when performing the reverse run JOG operation or reverse run inching operation.
(6)	i_udJogSpeed	Cd.17: JOG speed	Double word [unsigned]	Pr.1: Unit setting = mm/ inch/degree*1 • 1 to 200000000*2 Pr.1: Unit setting = pulse • 1 to 1000000000	Specify the JOG speed. For inching operation, set 0.
(7)	i_ulnching	Cd.16: Inching movement amount	Word [unsigned]	0 to 65535 0: JOG operation (0 to 32767: Set by decimal number. 32768 to 65535: Convert the number to hexadecimal number and set.)	Specify the inching movement amount. For JOG operation, set 0.

\*1 When "Pr.1 Unit setting" is set to "degree" and "Pr.83 Speed control 10 × multiplier setting for degree axis" is valid, the value is set as 10 times of setting value.

\*2 The value is set corresponding to the setting of "Pr.1 Unit setting".

## Output labels

No.	Variable name	Name	Data type	Default value	Description
(8)	o_bENO	Execution status	Bit	OFF	ON: The execution command is ON. OFF: The execution command is OFF.
(9)	o_bOK	Completed without error	Bit	OFF	ON: The JOG command is ON. OFF: The JOG command is OFF.
(10)	o_bErr	Error flag	Bit	OFF	When ON, it indicates that an error has occurred in the FB.
(11)	o_uErrId	Error code	Word [unsigned]	0	The generated error code in the FB is stored.

## FB details

Item	Description	
Applicable hardware and software	Applicable module	FX5-40SSC-S, FX5-80SSC-S
	Applicable CPU	MELSEC iQ-F series
	Applicable engineering software	FX5-40SSC-S: GX Works3 (Version 1.010L or later) FX5-80SSC-S: GX Works3 (Version 1.030G or later)
Programming language	Ladder	
Number of steps (maximum)	447 steps	
Function description	<ul style="list-style-type: none"> <li>By turning ON i_bFJog (Forward run JOG command) or i_bRJog (Reverse run JOG command) after i_bEN (Execution command) is turned ON, the JOG operation or inching operation is performed.</li> <li>When i_bFJog (Forward run JOG command) and i_bRJog (Reverse run JOG command) are ON at the same time, the operation stops.</li> <li>When i_bEN (Execution command) is turned OFF from ON during operation that has been started by i_bFJog (Forward run JOG command) or i_bRJog (Reverse run JOG command), the operation stops.</li> <li>When i_bRJog (Reverse run JOG command) is turned ON during forward run JOG operation, the operation stops. However, when i_bRJog (Reverse run JOG command) is turned OFF from ON, the forward run JOG operation restarts. (This relation is also applied to the reverse run JOG operation and i_bFJog (Forward run JOG command).)</li> <li>When the setting value of the target axis is out of the range, o_bErr (Error flag) turns ON, the FB processing is interrupted, and the error code 100 (Hexadecimal) is stored in o_uErrId (Error code).</li> </ul>	
Compiling method	Macro type	
FB operation type	Real-time execution	
Timing chart	<p>When operation completes without an error</p> <p>When an error occurs</p>	

Item	Description
Restrictions and precautions	<ul style="list-style-type: none"> <li>The FB does not include error recovery processing. Program the error recovery processing separately in accordance with the required system operation.</li> <li>The FB cannot be used in an interrupt program.</li> <li>Ensure that i_bEN (Execution command) is capable of being turned OFF by the program. Do not use this FB in programs that are only executed once such as a subroutine and FOR-NEXT loop because i_bEN (Execution command) cannot be turned OFF.</li> <li>This FB turns ON and OFF the forward run JOG start signal (Cd.181) or reverse run JOG start signal (Cd.182). Thus, do not turn ON or OFF the forward run JOG start signal (Cd.181) or reverse run JOG start signal (Cd.182) by the other means while this FB is being executed.</li> <li>When this FB is used twice or more or other FB that operates the same as the signal this FB does, create an interlock to prevent the FBs from being activated at the same time.</li> <li>When this FB is used twice or more, precaution must be taken to avoid repetition of the target axis.</li> <li>Setting a large value for the JOG speed from the beginning is dangerous. For the safety, set a small value first, and increase the value gradually while checking the operation to determine the value optimal for the control.</li> <li>When values other than 0 are set in both i_ulnching (Cd.16: Inching movement amount) and i_udJogSpeed (Cd.17: JOG speed), inching operation is performed.</li> <li>Every input must be provided with a value for proper FB operation.</li> </ul>

## Error codes

Error code	Description	Action
100 (Hexadecimal)	The setting value of i_uAxis (Target axis) is out of the range. The target axis is not within the range of 1 to 8.	Please try again after confirming the setting. (Turn OFF the forward run JOG command or reverse run JOG command, turn ON i_bEN from OFF, and turn ON the forward run JOG command or reverse run JOG command again.)

## Version upgrade history

Version	Date	Description
00A	2015/04/23	First edition
01A	2016/07/15	Add the 8-axis module for the applicable module. Extend the target axis into 8 axes.

## 2.4 M+FX5SSC\_MPG

### Name

M+FX5SSC\_MPG

### Overview

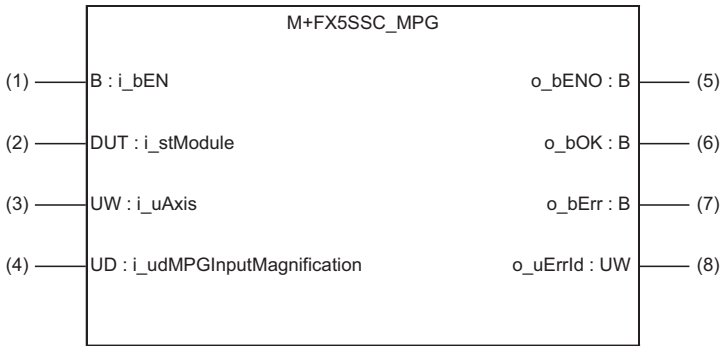
Item	Description
Function overview	Performs the manual pulse generator operation.
Symbol	 <p>The diagram shows a rectangular block labeled 'M+FX5SSC_MPG'. On the left side, there are four input terminals: (1) B : i_bEN, (2) DUT : i_stModule, (3) UW : i_uAxis, and (4) UD : i_udMPGInputMagnification. On the right side, there are four output terminals: (5) o_bENO : B, (6) o_bOK : B, (7) o_bErr : B, and (8) o_uErrId : UW.</p>

### Labels

#### ■Input labels

No.	Variable name	Name	Data type	Setting range	Description
(1)	i_bEN	Execution command	Bit	ON, OFF	ON: The FB is activated. OFF: The FB is not activated.
(2)	i_stModule	Module label	Structure	The setting range differs depending on the module label.	Specify the module label of the MELSEC iQ-F Simple Motion module.
(3)	i_uAxis	Target axis	Word [unsigned]	1 to 8	Specify the axis No. The setting range differs depending on the module used.
(4)	i_udMPGInputMagnification	Cd.20: Manual pulse generator 1 pulse input magnification	Double word [unsigned]	1 to 10000	Set the input magnification of the manual pulse generator 1 pulse. When the setting value is 0, the magnification is 1. When the setting value is 10,001 or higher, the magnification is 10,000.

#### ■Output labels

No.	Variable name	Name	Data type	Default value	Description
(5)	o_bENO	Execution status	Bit	OFF	ON: The execution command is ON. OFF: The execution command is OFF.
(6)	o_bOK	Completed without error	Bit	OFF	When ON, it indicates that the manual pulse generator operation has been enabled.
(7)	o_bErr	Error flag	Bit	OFF	When ON, it indicates that an error has occurred in the FB.
(8)	o_uErrId	Error code	Word [unsigned]	0	The error code generated in the FB is stored.

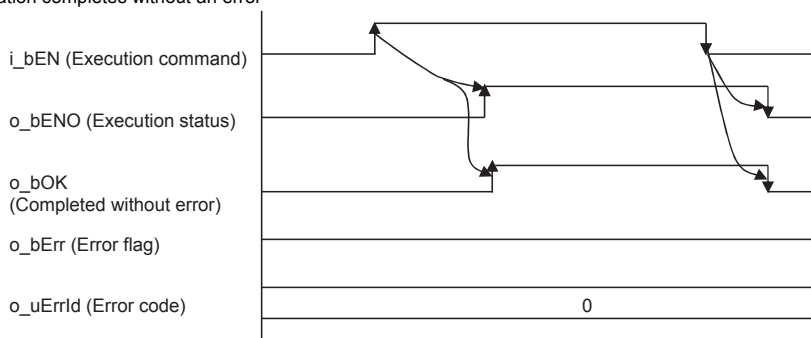
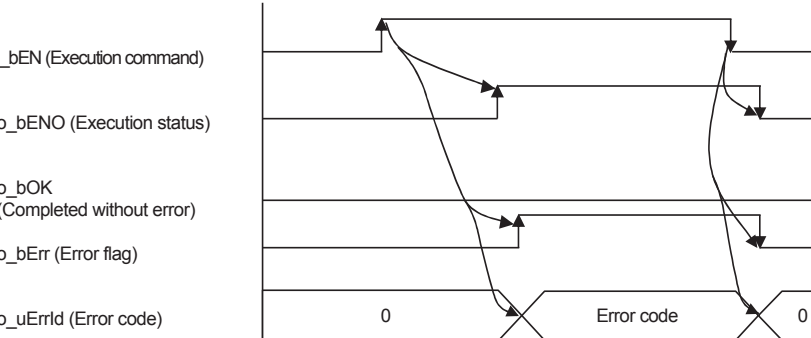

## FB details

Item	Description	
Applicable hardware and software	Applicable module	FX5-40SSC-S, FX5-80SSC-S
	Applicable CPU	MELSEC iQ-F series
	Applicable engineering software	FX5-40SSC-S: GX Works3 (Version 1.010L or later) FX5-80SSC-S: GX Works3 (Version 1.030G or later)
Programming language	Ladder	
Number of steps (maximum)	305 steps	
Function description	<ul style="list-style-type: none"> <li>By turning ON or OFF i_bEN (Execution command), manual pulse generator operation is enabled or disabled.</li> <li>This FB is constantly executed after i_bEN (Execution command) is turned ON.</li> <li>The workpiece moves according to the pulses input from the manual pulse generator while o_bOK (Completed without error) is ON.</li> <li>When the setting value of the target axis is out of the range, o_bErr (Error flag) turns ON, the FB processing is interrupted, and the error code 100 (Hexadecimal) is stored in o_uErrId (Error code).</li> </ul>	
Compiling method	Macro type	
FB operation type	Real-time execution	
Timing chart	<p>When operation completes without an error</p>  <p>When an error occurs</p> 	
Restrictions and precautions	<ul style="list-style-type: none"> <li>The FB does not include error recovery processing. Program the error recovery processing separately in accordance with the required system operation.</li> <li>The FB cannot be used in an interrupt program.</li> <li>Ensure that i_bEN (Execution command) is capable of being turned OFF by the program. Do not use this FB in programs that are only executed once such as a subroutine and FOR-NEXT loop because i_bEN (Execution command) cannot be turned OFF.</li> <li>Do not change i_uAxis (Target axis) while i_bEN (Execution command) is ON.</li> <li>When this FB is used twice or more, precaution must be taken to avoid repetition of the target axis.</li> <li>Every input must be provided with a value for proper FB operation.</li> </ul>	

## Error codes

Error code	Description	Action
100 (Hexadecimal)	The setting value of i_uAxis (Target axis) is out of the range. The target axis is not within the range of 1 to 8.	Please try again after confirming the setting.

## Version upgrade history

Version	Date	Description
00A	2015/04/23	First edition
01A	2016/07/15	Add the 8-axis module for the applicable module. Extend the target axis into 8 axes.

## 2.5 M+FX5SSC\_ChangeSpeed

### Name

M+FX5SSC\_ChangeSpeed

### Overview

Item	Description
Function overview	Changes the speed.
Symbol	<pre> graph LR     subgraph M+FX5SSC_ChangeSpeed         direction LR         i_bEN["(1) B : i_bEN"]         i_stModule["(2) DUT : i_stModule"]         i_uAxis["(3) UW : i_uAxis"]         i_udSpeedChangeValue["(4) UD : i_udSpeedChangeValue"]         o_bENO["(5) o_bENO : B"]         o_bOK["(6) o_bOK : B"]         o_bErr["(7) o_bErr : B"]         o_uErrId["(8) o_uErrId : UW"]     end         </pre>

### Labels

#### Input labels

No.	Variable name	Name	Data type	Setting range	Description
(1)	i_bEN	Execution command	Bit	ON, OFF	ON: The FB is activated. OFF: The FB is not activated.
(2)	i_stModule	Module label	Structure	The setting range differs depending on the module label.	Specify the module label of the MELSEC iQ-F Simple Motion module.
(3)	i_uAxis	Target axis	Word [unsigned]	1 to 8	Specify the axis No. The setting range differs depending on the module used.
(4)	i_udSpeedChangeValue	Cd.14: New speed value	Double word [unsigned]	Pr.1: Unit setting = mm/inch/degree <sup>*1</sup> • 0 to 2000000000 <sup>*2</sup> Pr.1: Unit setting = pulse • 0 to 1000000000	Set a new speed.

\*1 When "Pr.1 Unit setting" is set to "degree" and "Pr.83 Speed control 10 × multiplier setting for degree axis" is valid, the value is set as 10 times of setting value.

\*2 The value is set corresponding to the setting of "Pr.1 Unit setting".

#### Output labels

No.	Variable name	Name	Data type	Default value	Description
(5)	o_bENO	Execution status	Bit	OFF	ON: The execution command is ON. OFF: The execution command is OFF.
(6)	o_bOK	Completed without error	Bit	OFF	When ON, it indicates that changing the speed has been completed.
(7)	o_bErr	Error flag	Bit	OFF	When ON, it indicates that an error has occurred in the FB.
(8)	o_uErrId	Error code	Word [unsigned]	0	The generated error code in the FB is stored.

## FB details

Item	Description	
Applicable hardware and software	Applicable module	FX5-40SSC-S, FX5-80SSC-S
	Applicable CPU	MELSEC iQ-F series
	Applicable engineering software	FX5-40SSC-S: GX Works3 (Version 1.010L or later) FX5-80SSC-S: GX Works3 (Version 1.030G or later)
Programming language	Ladder	
Number of steps (maximum)	243 steps	
Function description	<ul style="list-style-type: none"> <li>By turning ON i_bEN (Execution command), the speed used for the control is changed to a new speed.</li> <li>When the setting value of the target axis is out of the range, o_bErr (Error flag) turns ON, the FB processing is interrupted, and the error code 100 (Hexadecimal) is stored in o_uErrId (Error code).</li> </ul>	
Compiling method	Macro type	
FB operation type	Pulsed execution (multiple scan execution type)	
Timing chart	<p>When operation completes without an error</p> <p>When an error occurs</p>	

Item	Description
Restrictions and precautions	<ul style="list-style-type: none"> <li>The FB does not include error recovery processing. Program the error recovery processing separately in accordance with the required system operation.</li> <li>The FB cannot be used in an interrupt program.</li> <li>Ensure that i_bEN (Execution command) is capable of being turned OFF by the program. Do not use this FB in programs that are only executed once such as a subroutine and FOR-NEXT loop because i_bEN (Execution command) cannot be turned OFF.</li> <li>When this FB is used twice or more, precaution must be taken to avoid repetition of the target axis.</li> <li>Every input must be provided with a value for proper FB operation.</li> <li>When i_bEN (Execution command) is turned ON while the BUSY signal is OFF, o_bErr (Error flag) turns ON, the FB processing is interrupted, and the error code 201 (Hexadecimal) is stored in o_uErrId (Error code).</li> </ul>

## Error codes

Error code	Description	Action
100 (Hexadecimal)	The setting value of i_uAxis (Target axis) is out of the range. The target axis is not within the range of 1 to 8.	Please try again after confirming the setting.
201 (Hexadecimal)	This FB is executed before positioning operation starts.	Please try again during positioning operation.

## Version upgrade history

Version	Date	Description
00A	2015/04/23	First edition
01A	2016/07/15	Add the 8-axis module for the applicable module. Extend the target axis into 8 axes.

## 2.6 M+FX5SSC\_ChangeAccDecTime

### Name

M+FX5SSC\_ChangeAccDecTime

### Overview

Item	Description
Function overview	Changes the acceleration/deceleration time at a speed change.
Symbol	<pre> graph LR     subgraph M+FX5SSC_ChangeAccDecTime         direction TB         I1["(1) B : i_bEN"]         I2["(2) DUT : i_stModule"]         I3["(3) UW : i_uAxis"]         I4["(4) B : i_bEnable"]         I5["(5) UD : i_udNewAccelerationTime"]         I6["(6) UD : i_udNewDecelerationTime"]         O7["(7) o_bENO : B"]         O8["(8) o_bOK : B"]         O9["(9) o_bErr : B"]         O10["(10) o_uErrId : UW"]     end     I1 --- O7     I2 --- O8     I3 --- O9     I4 --- O10     I5 --- O7     I6 --- O10                     </pre>

### Labels

#### ■Input labels

No.	Variable name	Name	Data type	Setting range	Description
(1)	i_bEN	Execution command	Bit	ON, OFF	ON: The FB is activated. OFF: The FB is not activated.
(2)	i_stModule	Module label	Structure	The setting range differs depending on the module label.	Specify the module label of the MELSEC iQ-F Simple Motion module.
(3)	i_uAxis	Target axis	Word [unsigned]	1 to 8	Specify the axis No. The setting range differs depending on the module used.
(4)	i_bEnable	Acceleration/ deceleration time change enabled flag	Bit	ON: Enabled OFF: Disabled	Set this label to enable or disable acceleration/deceleration time changes.
(5)	i_udNewAccelerationTime	Cd.10: New acceleration time value	Double word [unsigned]	0 to 8388608 (ms)	Set a new acceleration time. When 0 is set, the acceleration time is not changed after the speed is changed. In this case, the previously set acceleration time is applied to the control.
(6)	i_udNewDecelerationTime	Cd.11: New deceleration time value	Double word [unsigned]	0 to 8388608 (ms)	Set a new deceleration time. When 0 is set, the deceleration time is not changed after the speed is changed. In this case, the previously set deceleration time is applied to the control.

#### ■Output labels

No.	Variable name	Name	Data type	Default value	Description
(7)	o_bENO	Execution status	Bit	OFF	ON: The execution command is ON. OFF: The execution command is OFF.
(8)	o_bOK	Completed without error	Bit	OFF	When ON, it indicates that setting acceleration/deceleration time change has been completed.
(9)	o_bErr	Error flag	Bit	OFF	When ON, it indicates that an error has occurred in the FB.
(10)	o_uErrId	Error code	Word [unsigned]	0	The error code generated in the FB is stored.

## FB details

Item	Description	
Applicable hardware and software	Applicable module	FX5-40SSC-S, FX5-80SSC-S
	Applicable CPU	MELSEC iQ-F series
	Applicable engineering software	FX5-40SSC-S: GX Works3 (Version 1.010L or later) FX5-80SSC-S: GX Works3 (Version 1.030G or later)
Programming language	Ladder	
Number of steps (maximum)	269 steps	
Function description	<ul style="list-style-type: none"> <li>By turning ON <code>i_bEN</code> (Execution command), the setting of the acceleration/deceleration time is changed according to <code>i_bEnable</code> (Acceleration/deceleration time change enabled flag). When <code>i_bEnable</code> (Acceleration/deceleration time change enabled flag) is ON, <code>i_udNewAccelerationTime</code> (Cd.10: New acceleration time value) and <code>i_udNewDecelerationTime</code> (Cd.11: New deceleration time value) are set and Cd.12: Acceleration/deceleration time change value during speed change, enable/disable is changed to 1: Enables modifications to acceleration/deceleration time. When <code>i_bEnable</code> (Acceleration/deceleration time change enabled flag) is OFF, <code>i_udNewAccelerationTime</code> (Cd.10: New acceleration time value) and <code>i_udNewDecelerationTime</code> (Cd.11: New deceleration time value) are not set and Cd.12: Acceleration/deceleration time change value during speed change, enable/disable is changed to 0: Disables modifications to acceleration/deceleration time.</li> <li>When the setting value of the target axis is out of the range, <code>o_bErr</code> (Error flag) turns ON, the FB processing is interrupted, and the error code 100 (Hexadecimal) is stored in <code>o_uErrId</code> (Error code).</li> </ul>	
Compiling method	Macro type	
FB operation type	Pulsed execution (single scan execution type)	

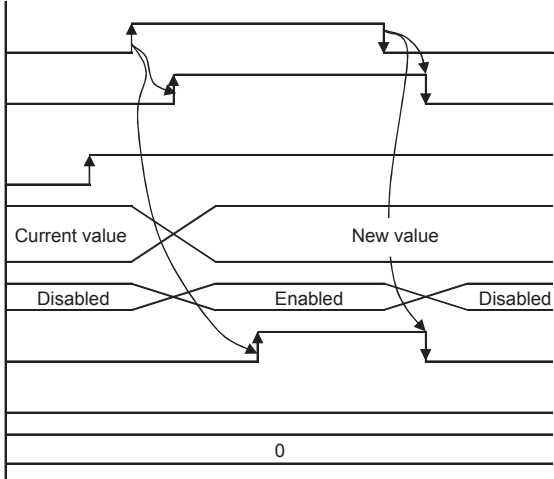
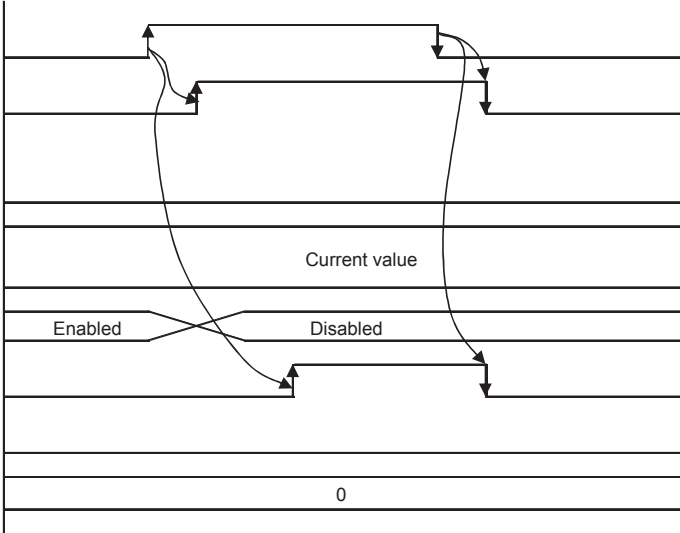
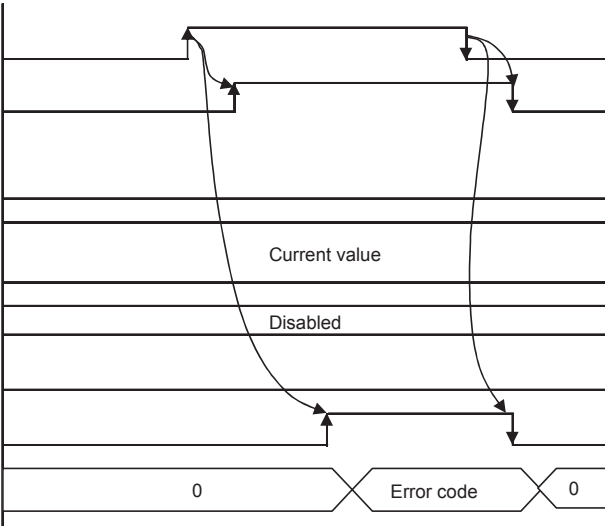
Item	Description
Timing chart	<p>When operation completes without an error</p> <ul style="list-style-type: none"> <li>(When Cd.12: Acceleration/deceleration time change value during speed change, enable/disable is enabled)</li> </ul>  <ul style="list-style-type: none"> <li>(When Cd.12: Acceleration/deceleration time change value during speed change, enable/disable is disabled)</li> </ul>  <p>When an error occurs</p> 



Item	Description
Restrictions and precautions	<ul style="list-style-type: none"> <li>• The FB does not include error recovery processing. Program the error recovery processing separately in accordance with the required system operation.</li> <li>• The FB cannot be used in an interrupt program.</li> <li>• Ensure that i_bEN (Execution command) is capable of being turned OFF by the program. Do not use this FB in programs that are only executed once such as a subroutine and FOR-NEXT loop because i_bEN (Execution command) cannot be turned OFF.</li> <li>• When this FB is used twice or more, precaution must be taken to avoid repetition of the target axis.</li> <li>• A duplicated coil warning may occur during compile operation. However, this is not a problem and the FB will operate without an error.</li> <li>• Every input must be provided with a value for proper FB operation.</li> </ul>

## Error codes

Error code	Description	Action
100 (Hexadecimal)	The setting value of i_uAxis (Target axis) is out of the range. The target axis is not within the range of 1 to 8.	Please try again after confirming the setting.

## Version upgrade history

Version	Date	Description
00A	2015/04/23	First edition
01A	2016/07/15	Add the 8-axis module for the applicable module. Extend the target axis into 8 axes.

# 2.7 M+FX5SSC\_ChangePosition

## Name

M+FX5SSC\_ChangePosition

## Overview

Item	Description
Function overview	Changes the target position.
Symbol	<p>The diagram shows a rectangular box labeled 'M+FX5SSC_ChangePosition'. On the left side, there are five input variables: (1) B : i_bEN, (2) DUT : i_stModule, (3) UW : i_uAxis, (4) D : i_dTargetNewPosition, and (5) UD : i_udTargetNewSpeed. On the right side, there are three output variables: o_bENO : B (6), o_bOK : B (7), and o_uErrId : UW (8). The output o_uErrId is also labeled with (9) next to it.</p>

## Labels

### Input labels

No.	Variable name	Name	Data type	Setting range	Description
(1)	i_bEN	Execution command	Bit	ON, OFF	ON: The FB is activated. OFF: The FB is not activated.
(2)	i_stModule	Module label	Structure	The setting range differs depending on the module label.	Specify the module label of the MELSEC iQ-F Simple Motion module.
(3)	i_uAxis	Target axis	Word [unsigned]	1 to 8	Specify the axis No. The setting range differs depending on the module used.
(4)	i_dTargetNewPosition	Cd.27: Target position change value (New address)	Double word [signed]	Pr.1: Unit setting = mm • ABS: -2147483648 to 2147483647 • INC: -2147483648 to 2147483647 Pr.1: Unit setting = inch • ABS: -2147483648 to 2147483647 • INC: -2147483648 to 2147483647 Pr.1: Unit setting = degree • ABS: 0 to 35999999 • INC: -2147483648 to 2147483647 Pr.1: Unit setting = pulse • ABS: -2147483648 to 2147483647 • INC: -2147483648 to 2147483647	Set the new positioning address when changing the target position during positioning operation.
(5)	i_udTargetNewSpeed	Cd.28: Target position change value (New speed)	Double word [unsigned]	Pr.1: Unit setting = mm/inch/degree <sup>*1</sup> • 0 to 2000000000 <sup>*2</sup> Pr.1: Unit setting = pulse • 0 to 1000000000	Set the new speed when changing the target position during positioning operation. When 0 is set, the speed is not changed.

\*1 When "Pr.1 Unit setting" is set to "degree" and "Pr.83 Speed control 10 × multiplier setting for degree axis" is valid, the value is set as 10 times of setting value.

\*2 The value is set corresponding to the setting of "Pr.1 Unit setting".

## Output labels

No.	Variable name	Name	Data type	Default value	Description
(6)	o_bENO	Execution status	Bit	OFF	ON: The execution command is ON. OFF: The execution command is OFF.
(7)	o_bOK	Completed without error	Bit	OFF	When ON, it indicates that the module has accepted the target position change values.
(8)	o_bErr	Error flag	Bit	OFF	When ON, it indicates that an error has occurred in the FB.
(9)	o_uErrId	Error code	Word [unsigned]	0	The generated error code in the FB is stored.

## FB details

Item	Description	
Applicable hardware and software	Applicable module	FX5-40SSC-S, FX5-80SSC-S
	Applicable CPU	MELSEC iQ-F series
	Applicable engineering software	FX5-40SSC-S: GX Works3 (Version 1.010L or later) FX5-80SSC-S: GX Works3 (Version 1.030G or later)
Programming language	Ladder	
Number of steps (maximum)	296 steps	
Function description	<ul style="list-style-type: none"> <li>By turning ON i_bEN (Execution command), the target position is changed according to the value set in i_dTargetNewPosition (Cd.27: Target position change value (New address)) and the speed is changed according to the value set in i_udTargetNewSpeed (Cd.28: Target position change value (New speed)) during position control.</li> <li>When the setting value of the target axis is out of the range, o_bErr (Error flag) turns ON, the FB processing is interrupted, and the error code 100 (Hexadecimal) is stored in o_uErrId (Error code).</li> </ul>	
Compiling method	Macro type	
FB operation type	Pulsed execution (multiple scan execution type)	
Timing chart	<p>When operation completes without an error</p> <p>When an error occurs</p>	

Item	Description
Restrictions and precautions	<ul style="list-style-type: none"> <li>The FB does not include error recovery processing. Program the error recovery processing separately in accordance with the required system operation.</li> <li>The FB cannot be used in an interrupt program.</li> <li>Ensure that i_bEN (Execution command) is capable of being turned OFF by the program. Do not use this FB in programs that are only executed once such as a subroutine and FOR-NEXT loop because i_bEN (Execution command) cannot be turned OFF.</li> <li>When this FB is used twice or more, precaution must be taken to avoid repetition of the target axis.</li> <li>Every input must be provided with a value for proper FB operation.</li> <li>When i_bEN (Execution command) is turned ON while the BUSY signal is OFF, o_bErr (Error flag) turns ON, the FB processing is interrupted, and the error code 201 (Hexadecimal) is stored in o_uErrId (Error code).</li> </ul>

## Error codes

Error code	Description	Action
100 (Hexadecimal)	The setting value of i_uAxis (Target axis) is out of the range. The target axis is not within the range of 1 to 8.	Please try again after confirming the setting.
201 (Hexadecimal)	This FB is executed before positioning operation starts.	Please try again during positioning operation.

## Version upgrade history

Version	Date	Description
00A	2015/04/23	First edition
01A	2016/07/15	Add the 8-axis module for the applicable module. Extend the target axis into 8 axes.

## 2.8 M+FX5SSC\_Restart

### Name

M+FX5SSC\_Restart

### Overview

Item	Description
Function overview	Restarts the axis being stopped.
Symbol	

### Labels

#### Input labels

No.	Variable name	Name	Data type	Setting range	Description
(1)	i_bEN	Execution command	Bit	ON, OFF	ON: The FB is activated. OFF: The FB is not activated.
(2)	i_stModule	Module label	Structure	The setting range differs depending on the module label.	Specify the module label of the MELSEC iQ-F Simple Motion module.
(3)	i_uAxis	Target axis	Word [unsigned]	1 to 8	Specify the axis No. The setting range differs depending on the module used.

#### Output labels

No.	Variable name	Name	Data type	Default value	Description
(4)	o_bENO	Execution status	Bit	OFF	ON: The execution command is ON. OFF: The execution command is OFF.
(5)	o_bOK	Completed without error	Bit	OFF	When ON, it indicates that the module has accepted the restart command request.
(6)	o_bErr	Error flag	Bit	OFF	When ON, it indicates that an error has occurred in the FB.
(7)	o_uErrId	Error code	Word [unsigned]	0	The generated error code in the FB is stored.

### FB details

Item	Description	
Applicable hardware and software	Applicable module	FX5-40SSC-S, FX5-80SSC-S
	Applicable CPU	MELSEC iQ-F series
	Applicable engineering software	FX5-40SSC-S: GX Works3 (Version 1.010L or later) FX5-80SSC-S: GX Works3 (Version 1.030G or later)
Programming language	Ladder	
Number of steps (maximum)	282 steps	
Function description	<ul style="list-style-type: none"> <li>Only when the conditions are met, the positioning operation that is stopped due to an error is restarted by turning ON i_bEN (Execution command). The conditions are the following: the positioning complete signal is OFF and the axis operation status is a stop. When any of the conditions is not met, o_bErr (Error flag) turns ON, the FB processing is interrupted, and the error code 202 (Hexadecimal) is stored in o_uErrId (Error code).</li> <li>When the setting value of the target axis is out of the range, o_bErr (Error flag) turns ON, the FB processing is interrupted, and the error code 100 (Hexadecimal) is stored in o_uErrId (Error code).</li> </ul>	

Item	Description
Compiling method	Macro type
FB operation type	Pulsed execution (multiple scan execution type)
Timing chart	<p>When operation completes without an error</p> <p>When an error occurs</p>
Restrictions and precautions	<ul style="list-style-type: none"> <li>The FB does not include error recovery processing. Program the error recovery processing separately in accordance with the required system operation.</li> <li>The FB cannot be used in an interrupt program.</li> <li>Ensure that i_bEN (Execution command) is capable of being turned OFF by the program. Do not use this FB in programs that are only executed once such as a subroutine and FOR-NEXT loop because i_bEN (Execution command) cannot be turned OFF.</li> <li>When this FB is used twice or more, precaution must be taken to avoid repetition of the target axis.</li> <li>Every input must be provided with a value for proper FB operation.</li> </ul>

## Error codes

Error code	Description	Action
100 (Hexadecimal)	The setting value of i_uAxis (Target axis) is out of the range. The target axis is not within the range of 1 to 8.	Please try again after confirming the setting.
202 (Hexadecimal)	The conditions for positioning restart are not met. Any of the following conditions is not met. <ul style="list-style-type: none"> <li>Positioning complete signal: Off</li> <li>Axis operation status: Stop</li> </ul>	Please try again when all the following conditions are satisfied. <ul style="list-style-type: none"> <li>Positioning complete signal: Off</li> <li>Axis operation status: Stop</li> </ul>

## Version upgrade history

Version	Date	Description
00A	2015/04/23	First edition
01A	2016/07/15	Add the 8-axis module for the applicable module. Extend the target axis into 8 axes.

## 2.9 M+FX5SSC\_OperateError

### Name

M+FX5SSC\_OperateError

### Overview

Item	Description
Function overview	Monitors errors and warnings, and resets errors.
Symbol	<p>The diagram shows a rectangular block labeled 'M+FX5SSC_OperateError'. On the left side, there are four input variables: (1) B : i_bEN, (2) DUT : i_stModule, (3) UW : i_uAxis, and (4) B : i_bErrReset. On the right side, there are eight output variables: o_bENO : B (5), o_bOK : B (6), o_bModuleErr : B (7), o_uModuleErrId : UW (8), o_bModuleWarn : B (9), o_uModuleWarnId : UW (10), o_bErr : B (11), and o_uErrId : UW (12).</p>

### Labels

#### Input labels

No.	Variable name	Name	Data type	Setting range	Description
(1)	i_bEN	Execution command	Bit	ON, OFF	ON: The FB is activated. OFF: The FB is not activated.
(2)	i_stModule	Module label	Structure	The setting range differs depending on the module label.	Specify the module label of the MELSEC iQ-F Simple Motion module.
(3)	i_uAxis	Target axis	Word [unsigned]	1 to 8	Specify the axis No. The setting range differs depending on the module used.
(4)	i_bErrReset	Error reset command	Bit	ON, OFF	ON: Errors are reset. OFF: Errors are not reset.

## ■Output labels

No.	Variable name	Name	Data type	Default value	Description
(5)	o_bENO	Execution status	Bit	OFF	ON: The execution command is ON. OFF: The execution command is OFF.
(6)	o_bOK	Completed without error	Bit	OFF	When ON, it indicates that resetting the error has been completed.
(7)	o_bModuleErr	Axis error detection	Bit	OFF	When ON, it indicates that an axis error has occurred.
(8)	o_uModuleErrId	Axis error code	Word [unsigned]	0	An error code of an error that has occurred in the module of the specified axis is stored.
(9)	o_bModuleWarn	Axis warning detection	Bit	OFF	When ON, it indicates that an axis warning has occurred.
(10)	o_uModuleWarnId	Axis warning code	Word [unsigned]	0	A warning code of a warning that has occurred in the module of the specified axis is stored.
(11)	o_bErr	Error flag	Bit	OFF	When ON, it indicates that an error has occurred in the FB.
(12)	o_uErrId	Error code	Word [unsigned]	0	The generated error code in the FB is stored.

## FB details

Item	Description	
Applicable hardware and software	Applicable module	FX5-40SSC-S, FX5-80SSC-S
	Applicable CPU	MELSEC iQ-F series
	Applicable engineering software	FX5-40SSC-S: GX Works3 (Version 1.010L or later) FX5-80SSC-S: GX Works3 (Version 1.030G or later)
Programming language	Ladder	
Number of steps (maximum)	396 steps	
Function description	<ul style="list-style-type: none"> <li>• By turning ON i_bEN (Execution command), errors of the target axis are monitored.</li> <li>• When a module error occurs, an error code is stored in o_uModuleErrId (Axis error code).</li> <li>• After i_bEN (Execution command) is turned ON, the generated error is reset by turning ON i_bErrReset (Error reset command).</li> <li>• When a warning occurs in the module, the warning can be reset by turning ON i_bErrReset (Error reset command).</li> <li>• When the setting value of the target axis is out of the range, o_bErr (Error flag) turns ON, the FB processing is interrupted, and the error code 100 (Hexadecimal) is stored in o_uErrId (Error code).</li> </ul>	
Compiling method	Macro type	
FB operation type	Real-time execution	



Item	Description
Timing chart	<p>When operation completes without an error</p> <p>When an error occurs</p>
Restrictions and precautions	<ul style="list-style-type: none"> <li>• The FB does not include error recovery processing. Program the error recovery processing separately in accordance with the required system operation.</li> <li>• The FB cannot be used in an interrupt program.</li> <li>• Ensure that i_bEN (Execution command) is capable of being turned OFF by the program. Do not use this FB in programs that are only executed once such as a subroutine and FOR-NEXT loop because i_bEN (Execution command) cannot be turned OFF.</li> <li>• When this FB is used twice or more, precaution must be taken to avoid repetition of the target axis.</li> <li>• Do not change i_uAxis (Target axis) while i_bEN (Execution command) is ON.</li> <li>• Every input must be provided with a value for proper FB operation.</li> </ul>

### Error codes

Error code	Description	Action
100 (Hexadecimal)	The setting value of i_uAxis (Target axis) is out of the range. The target axis is not within the range of 1 to 8.	Please try again after confirming the setting.

## Version upgrade history

Version	Date	Description
00A	2015/04/23	First edition
01A	2016/07/15	Add the 8-axis module for the applicable module. Extend the target axis into 8 axes.

# 2.10 M+FX5SSC\_InitializeParameter

## Name

M+FX5SSC\_InitializeParameter

## Overview

Item	Description
Function overview	Initializes the parameter.
Symbol	<pre> graph LR     subgraph M+FX5SSC_InitializeParameter         direction TB         i_bEN((1) B : i_bEN)         i_stModule((2) DUT : i_stModule)         o_bENO((3) o_bENO : B)         o_bOK((4) o_bOK : B)         o_bErr((5) o_bErr : B)         o_uErrId((6) o_uErrId : UW)     end             </pre>

## Labels

### Input labels

No.	Variable name	Name	Data type	Setting range	Description
(1)	i_bEN	Execution command	Bit	ON, OFF	ON: The FB is activated. OFF: The FB is not activated.
(2)	i_stModule	Module label	Structure	The setting range differs depending on the module label.	Specify the module label of the MELSEC iQ-F Simple Motion module.

### Output labels

No.	Variable name	Name	Data type	Default value	Description
(3)	o_bENO	Execution status	Bit	OFF	ON: The execution command is ON. OFF: The execution command is OFF.
(4)	o_bOK	Completed without error	Bit	OFF	When ON, it indicates that initializing the parameter has been completed.
(5)	o_bErr	Error flag	Bit	OFF	Always OFF
(6)	o_uErrId	Error code	Word [unsigned]	0	Always 0

## FB details

Item	Description	
Applicable hardware and software	Applicable module	FX5-40SSC-S, FX5-80SSC-S
	Applicable CPU	MELSEC iQ-F series
	Applicable engineering software	FX5-40SSC-S: GX Works3 (Version 1.010L or later) FX5-80SSC-S: GX Works3 (Version 1.030G or later)
Programming language	Ladder	
Number of steps (maximum)	66 steps	
Function description	By turning ON i_bEN (Execution command), the setting data stored in the buffer memory and the flash ROM of the FX5-40SSC-S/FX5-80SSC-S is reset to the factory setting.	
Compiling method	Macro type	
FB operation type	Pulsed execution (multiple scan execution type)	

Item	Description
Timing chart	<p>The timing chart illustrates the sequence of events for the M+FX5SSC_InitializeParameter function block. It features six digital signals over time:</p> <ul style="list-style-type: none"> <li><b>i_bEN (Execution command):</b> A pulse that starts high, goes low, and then returns high.</li> <li><b>o_bENO (Execution status):</b> Goes high when i_bEN is first high and returns to low when i_bEN returns to low.</li> <li><b>Cd.2: Parameter initialization request:</b> A pulse that starts high, goes low, and then returns high.</li> <li><b>o_bOK (Completed without error):</b> Goes high when Cd.2 is first high and returns to low when Cd.2 returns to low.</li> <li><b>o_bErr (Error flag):</b> Remains low throughout the entire process.</li> <li><b>o_uErrId (Error code):</b> Remains at 0 throughout the entire process.</li> </ul>
Restrictions and precautions	<ul style="list-style-type: none"> <li>• The FB does not include error recovery processing. Program the error recovery processing separately in accordance with the required system operation.</li> <li>• The FB cannot be used in an interrupt program.</li> <li>• Ensure that i_bEN (Execution command) is capable of being turned OFF by the program. Do not use this FB in programs that are only executed once such as a subroutine and FOR-NEXT loop because i_bEN (Execution command) cannot be turned OFF.</li> <li>• Every input must be provided with a value for proper FB operation.</li> <li>• Before using this FB, make sure that the PLC READY signal is OFF.</li> <li>• After the setting data is initialized, reset the CPU module or restart the power of the programmable controller.</li> </ul>

## Error codes

Error code	Description	Action
None	None	None

## Version upgrade history

Version	Date	Description
00A	2015/04/23	First edition

# 2.11 M+FX5SSC\_WriteFlash

## Name

M+FX5SSC\_WriteFlash

## Overview

Item	Description
Function overview	Writes the parameter, positioning data, and block start data in the buffer memory to the flash ROM.
Symbol	

## Labels

### Input labels

No.	Variable name	Name	Data type	Setting range	Description
(1)	i_bEN	Execution command	Bit	ON, OFF	ON: The FB is activated. OFF: The FB is not activated.
(2)	i_stModule	Module label	Structure	The setting range differs depending on the module label.	Specify the module label of the MELSEC iQ-F Simple Motion module.

### Output labels

No.	Variable name	Name	Data type	Default value	Description
(3)	o_bENO	Execution status	Bit	OFF	ON: The execution command is ON. OFF: The execution command is OFF.
(4)	o_bOK	Completed without error	Bit	OFF	When ON, it indicates that writing the setting data to the flash ROM has been completed.
(5)	o_bErr	Error flag	Bit	OFF	Always OFF
(6)	o_uErrId	Error code	Word [unsigned]	0	Always 0

## FB details

Item	Description	
Applicable hardware and software	Applicable module	FX5-40SSC-S, FX5-80SSC-S
	Applicable CPU	MELSEC iQ-F series
	Applicable engineering software	FX5-40SSC-S: GX Works3 (Version 1.010L or later) FX5-80SSC-S: GX Works3 (Version 1.030G or later)
Programming language	Ladder	
Number of steps (maximum)	66 steps	
Function description	By turning ON i_bEN (Execution command), the setting data in the buffer memory is written to the flash ROM.	
Compiling method	Macro type	
FB operation type	Pulsed execution (multiple scan execution type)	

Item	Description
Timing chart	<p>The timing chart illustrates the sequence of events for the Flash ROM writing request. The input signal <b>i_bEN (Execution command)</b> is a pulse that starts at a low level, transitions to high, and then returns to low. The output signal <b>o_bENO (Execution status)</b> is a pulse that starts at a high level, transitions to low, and then returns to high. The input signal <b>Cd.1: Flash ROM writing request</b> is a pulse that starts at a low level, transitions to high, and then returns to low. The output signal <b>o_bOK (Completed without error)</b> is a pulse that starts at a low level, transitions to high, and then returns to low. The output signal <b>o_bErr (Error flag)</b> is a pulse that starts at a low level, transitions to high, and then returns to low. The output signal <b>o_uErrId (Error code)</b> is a pulse that starts at a low level, transitions to high, and then returns to low.</p>
Restrictions and precautions	<ul style="list-style-type: none"> <li>• The FB does not include error recovery processing. Program the error recovery processing separately in accordance with the required system operation.</li> <li>• The FB cannot be used in an interrupt program.</li> <li>• Ensure that <b>i_bEN (Execution command)</b> is capable of being turned OFF by the program. Do not use this FB in programs that are only executed once such as a subroutine and FOR-NEXT loop because <b>i_bEN (Execution command)</b> cannot be turned OFF.</li> <li>• Every input must be provided with a value for proper FB operation.</li> <li>• Before using this FB, make sure that the PLC READY signal is OFF.</li> </ul>

## Error codes

Error code	Description	Action
None	None	None

## Version upgrade history

Version	Date	Description
00A	2015/04/23	First edition

# 2.12 M+FX5SSC\_ChangeServoParameter

## Name

M+FX5SSC\_ChangeServoParameter

## Overview

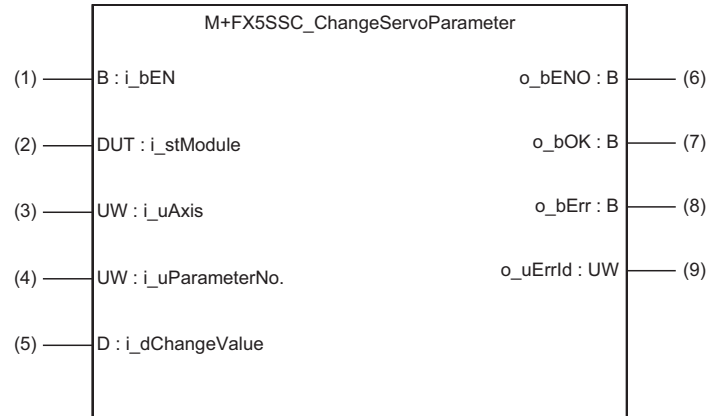
Item	Description
Function overview	Changes the servo parameter after the servo amplifier is activated.
Symbol	

## Labels

### Input labels

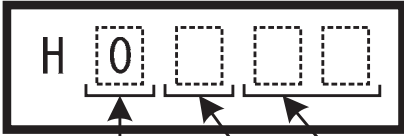
No.	Variable name	Name	Data type	Setting range	Description
(1)	i_bEN	Execution command	Bit	ON, OFF	ON: The FB is activated. OFF: The FB is not activated.
(2)	i_stModule	Module label	Structure	The setting range differs depending on the module label.	Specify the module label of the MELSEC iQ-F Simple Motion module.
(3)	i_uAxis	Target axis	Word [unsigned]	1 to 8	Specify the axis No. The setting range differs depending on the module used.
(4)	i_uParameterNo	Cd.131: Parameter No.	Word [unsigned]	H0001 to H0C40	<p>Set the servo parameter No. to be changed. Set the data in the same specifications as [Cd.131] of the system control data. Even when the data No. different from the data specifications of [Cd.131] is specified, the execution of this FB is completed normally. In this case, an error may occur in the Simple Motion module. The following figure shows the data specifications of [Cd.131].</p> <p>Setting value</p>  <p>Writing mode 0: Writing to the RAM</p> <p>Parameter No. setting 01h to 40h</p> <p>Parameter group 0: PA group 1: PB group 2: PC group 3: PD group 4: PE group 5: PF group 9: PO group A: PS group</p>
(5)	i_dChangeValue	Cd.132: Change data	Double word [signed]	Refer to the Servo Amplifier Instruction Manual.	Set the servo parameter value to be changed.

### Output labels

No.	Variable name	Name	Data type	Default value	Description
(6)	o_bENO	Execution status	Bit	OFF	ON: The execution command is ON. OFF: The execution command is OFF.
(7)	o_bOK	Completed without error	Bit	OFF	When ON, it indicates that changing the servo parameter has been completed.
(8)	o_bErr	Error flag	Bit	OFF	When ON, it indicates that an error has occurred in the FB.
(9)	o_uErrId	Error code	Word [unsigned]	0	The error code generated in the FB is stored.



## FB details

Item	Description	
Applicable hardware and software	Applicable module	FX5-40SSC-S, FX5-80SSC-S
	Applicable CPU	MELSEC iQ-F series
	Applicable engineering software	FX5-40SSC-S: GX Works3 (Version 1.010L or later) FX5-80SSC-S: GX Works3 (Version 1.030G or later)
Programming language	Ladder	
Number of steps (maximum)	274 steps	
Function description	<ul style="list-style-type: none"> <li>By turning ON i_bEN (Execution command), the servo parameter after the servo amplifier is started is changed.</li> <li>When the target axis of the input label is incorrectly set, o_bErr turns ON and the error code is stored in o_uErrId.</li> </ul>	
Compiling method	Macro type	
FB operation type	Pulsed execution (multiple scan execution type)	
Timing chart	<p>When operation completes without an error</p> <p>When an error occurs</p>	
Restrictions and precautions	<ul style="list-style-type: none"> <li>The FB does not include error recovery processing. Program the error recovery processing separately in accordance with the required system operation.</li> <li>The FB cannot be used in an interrupt program.</li> <li>Ensure that i_bEN (Execution command) is capable of being turned OFF by the program. Do not use this FB in programs that are only executed once such as a subroutine and FOR-NEXT loop because i_bEN (Execution command) cannot be turned OFF.</li> <li>When this FB is used twice or more, precaution must be taken to avoid repetition of the target axis.</li> <li>Every input must be provided with a value for proper FB operation.</li> <li>Before using this FB, make sure that communication with the servo amplifier is established.</li> <li>When this FB fails writing the parameter, o_bOK (Completed without error) does not turn ON.</li> <li>The setting items and range differ depending on the module used in the system.</li> <li>This FB does not support the servo parameter write with 2-word.</li> </ul>	

## Error codes

Error code	Description	Action
100 (Hexadecimal)	The setting value of i_uAxis (Target axis) is out of the range. The target axis is not within the range of 1 to 8.	Please try again after confirming the setting.

## Version upgrade history

Version	Date	Description
00A	2015/04/23	First edition
01A	2016/07/15	Add the 8-axis module for the applicable module. Extend the target axis into 8 axes.

# 2.13 M+FX5SSC\_ChangeTorqueControlMode

## Name

M+FX5SSC\_ChangeTorqueControlMode

## Overview

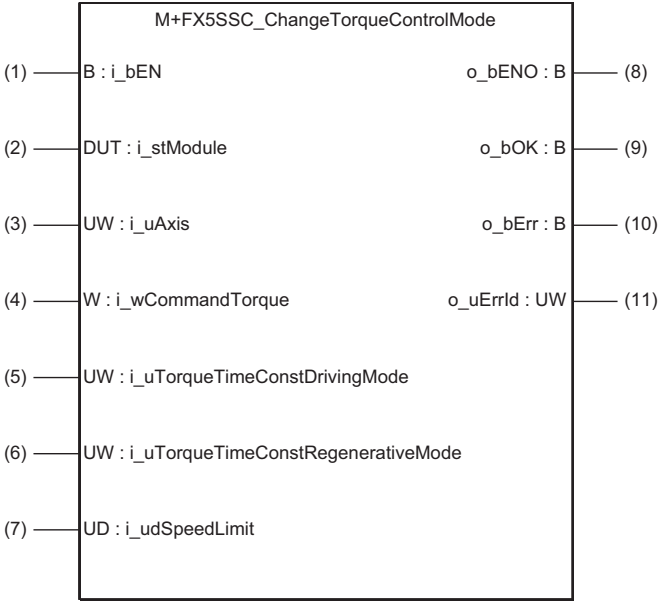
Item	Description
Function overview	Activates the torque control mode.
Symbol	

## Labels

### ■Input labels

No.	Variable name	Name	Data type	Setting range	Description
(1)	i_bEN	Execution command	Bit	ON, OFF	ON: The FB is activated. OFF: The FB is not activated.
(2)	i_stModule	Module label	Structure	The setting range differs depending on the module label.	Specify the module label of the MELSEC iQ-F Simple Motion module.
(3)	i_uAxis	Target axis	Word [unsigned]	1 to 8	Specify the axis No. The setting range differs depending on the module used.
(4)	i_wCommandTorque	Cd.143: Command torque at torque control mode	Word [signed]	-10000 to 10000	Set the command torque at torque control mode.
(5)	i_uTorqueTimeConstDrivingMode	Cd.144: Torque time constant at torque control mode (Forward direction)	Word [unsigned]	0 to 65535 (0 to 32767: Set by decimal number. 32768 to 65535: Convert the number to hexadecimal number and set.)	Set the time constant for the driving of torque control mode.
(6)	i_uTorqueTimeConstRegenerativeMode	Cd.145: Torque time constant at torque control mode (Negative direction)	Word [unsigned]	0 to 65535 (0 to 32767: Set by decimal number. 32768 to 65535: Convert the number to hexadecimal number and set.)	Set the time constant for the regeneration of torque control mode.
(7)	i_udSpeedLimit	Cd.146: Speed limit value at torque control mode	Double word [unsigned]	Pr.1: Unit setting = mm/inch/degree <sup>*1</sup> • 0 to 2000000000 <sup>*2</sup> Pr.1: Unit setting = pulse • 0 to 1000000000	Set the speed limit value at torque control mode.

\*1 When "Pr.1 Unit setting" is set to "degree" and "Pr.83 Speed control 10 × multiplier setting for degree axis" is valid, the value is set as 10 times of setting value.

\*2 The value is set corresponding to the setting of "Pr.1 Unit setting".

### ■Output labels

No.	Variable name	Name	Data type	Default value	Description
(8)	o_bENO	Execution status	Bit	OFF	ON: The execution command is ON. OFF: The execution command is OFF.
(9)	o_bOK	Completed without error	Bit	OFF	When ON, it indicates that changing to the torque control mode has been completed.
(10)	o_bErr	Error flag	Bit	OFF	When ON, it indicates that an error has occurred in the FB.
(11)	o_uErrId	Error code	Word [unsigned]	0	The error code generated in the FB is stored.

## FB details

Item	Description
Applicable hardware and software	Applicable module FX5-40SSC-S, FX5-80SSC-S
	Applicable CPU MELSEC iQ-F series
	Applicable engineering software FX5-40SSC-S: GX Works3 (Version 1.010L or later) FX5-80SSC-S: GX Works3 (Version 1.030G or later)
Programming language	Ladder
Number of steps (maximum)	424 steps
Function description	<ul style="list-style-type: none"> <li>By turning ON i_bEN (Execution command), the torque control mode is activated for the specified axis.</li> <li>When this FB is executed under torque control, the command torque and speed limit value are changed.</li> <li>When the setting value of the target axis is out of the range, o_bErr (Error flag) turns ON, the FB processing is interrupted, and the error code 100 (Hexadecimal) is stored in o_uErrId (Error code).</li> </ul>
Compiling method	Macro type
FB operation type	Pulsed execution (multiple scan execution type)
Timing chart	<p>When operation completes without an error</p> <p>When an error occurs</p>
Restrictions and precautions	<ul style="list-style-type: none"> <li>The FB does not include error recovery processing. Program the error recovery processing separately in accordance with the required system operation.</li> <li>The FB cannot be used in an interrupt program.</li> <li>Ensure that i_bEN (Execution command) is capable of being turned OFF by the program. Do not use this FB in programs that are only executed once such as a subroutine and FOR-NEXT loop because i_bEN (Execution command) cannot be turned OFF.</li> <li>When this FB is used twice or more, precaution must be taken to avoid repetition of the target axis.</li> <li>Every input must be provided with a value for proper FB operation.</li> <li>When this FB fails switching the mode, o_bOK (Completed without error) does not turn ON.</li> </ul>

## Error codes

Error code	Description	Action
100 (Hexadecimal)	The setting value of i_uAxis (Target axis) is out of the range. The target axis is not within the range of 1 to 8.	Please try again after confirming the setting.

## Version upgrade history

Version	Date	Description
00A	2015/04/23	First edition
01A	2016/07/15	Add the 8-axis module for the applicable module. Extend the target axis into 8 axes.

# 2.14 M+FX5SSC\_ChangeSpeedControlMode

## Name

M+FX5SSC\_ChangeSpeedControlMode

## Overview

Item	Description
Function overview	Activates the speed control mode.
Symbol	<pre> graph LR     subgraph M+FX5SSC_ChangeSpeedControlMode         direction TB         i_bEN["(1) B : i_bEN"]         i_stModule["(2) DUT : i_stModule"]         i_uAxis["(3) UW : i_uAxis"]         i_dCommandSpeed["(4) D : i_dCommandSpeed"]         i_uSpeedAccelerationTime["(5) UW : i_uSpeedAccelerationTime"]         i_uSpeedDecelerationTime["(6) UW : i_uSpeedDecelerationTime"]         o_bENO["(7) o_bENO : B"]         o_bOK["(8) o_bOK : B"]         o_bErr["(9) o_bErr : B"]         o_uErrId["(10) o_uErrId : UW"]     end         </pre>

## Labels

### Input labels

No.	Variable name	Name	Data type	Setting range	Description
(1)	i_bEN	Execution command	Bit	ON, OFF	ON: The FB is activated. OFF: The FB is not activated.
(2)	i_stModule	Module label	Structure	The setting range differs depending on the module label.	Specify the module label of the MELSEC iQ-F Simple Motion module.
(3)	i_uAxis	Target axis	Word [unsigned]	1 to 8	Specify the axis No. The setting range differs depending on the module used.
(4)	i_dCommandSpeed	Cd.140: Command speed at speed control mode	Double word [signed]	Pr.1: Unit setting = mm/inch/degree* <sup>1</sup> • -2000000000 to 2000000000* <sup>2</sup> Pr.1: Unit setting = pulse • -1000000000 to 1000000000	Set the command speed at speed control mode.
(5)	i_uSpeedAccelerationTime	Cd.141: Acceleration time at speed control mode	Word [unsigned]	0 to 65535 (0 to 32767: Set by decimal number. 32768 to 65535: Convert the number to hexadecimal number and set.)	Set the acceleration time at speed control mode.
(6)	i_uSpeedDecelerationTime	Cd.142: Deceleration time at speed control mode	Word [unsigned]	0 to 65535 (0 to 32767: Set by decimal number. 32768 to 65535: Convert the number to hexadecimal number and set.)	Set the deceleration time at speed control mode.

\*1 When "Pr.1 Unit setting" is set to "degree" and "Pr.83 Speed control 10 × multiplier setting for degree axis" is valid, the value is set as 10 times of setting value.

\*2 The value is set corresponding to the setting of "Pr.1 Unit setting".

## Output labels

No.	Variable name	Name	Data type	Default value	Description
(7)	o_bENO	Execution status	Bit	OFF	ON: The execution command is ON. OFF: The execution command is OFF.
(8)	o_bOK	Completed without error	Bit	OFF	When ON, it indicates that changing to the speed control mode has been completed.
(9)	o_bErr	Error flag	Bit	OFF	When ON, it indicates that an error has occurred in the FB.
(10)	o_uErrId	Error code	Word [unsigned]	0	The error code generated in the FB is stored.

## FB details

Item	Description	
Applicable hardware and software	Applicable module	FX5-40SSC-S, FX5-80SSC-S
	Applicable CPU	MELSEC iQ-F series
	Applicable engineering software	FX5-40SSC-S: GX Works3 (Version 1.010L or later) FX5-80SSC-S: GX Works3 (Version 1.030G or later)
Programming language	Ladder	
Number of steps (maximum)	372 steps	
Function description	<ul style="list-style-type: none"> <li>By turning ON i_bEN (Execution command), the speed control mode is activated for the specified axis.</li> <li>When this FB is executed under speed control, the command speed is changed.</li> <li>When the setting value of the target axis is out of the range, o_bErr (Error flag) turns ON, the FB processing is interrupted, and the error code 100 (Hexadecimal) is stored in o_uErrId (Error code).</li> </ul>	
Compiling method	Macro type	
FB operation type	Pulsed execution (multiple scan execution type)	
Timing chart	<p>When operation completes without an error</p> <p>When an error occurs</p>	



Item	Description
Restrictions and precautions	<ul style="list-style-type: none"> <li>• The FB does not include error recovery processing. Program the error recovery processing separately in accordance with the required system operation.</li> <li>• The FB cannot be used in an interrupt program.</li> <li>• Ensure that i_bEN (Execution command) is capable of being turned OFF by the program. Do not use this FB in programs that are only executed once such as a subroutine and FOR-NEXT loop because i_bEN (Execution command) cannot be turned OFF.</li> <li>• When this FB is used twice or more, precaution must be taken to avoid repetition of the target axis.</li> <li>• Every input must be provided with a value for proper FB operation.</li> <li>• When this FB fails switching the mode, o_bOK (Completed without error) does not turn ON.</li> </ul>

## Error codes

Error code	Description	Action
100 (Hexadecimal)	The setting value of i_uAxis (Target axis) is out of the range. The target axis is not within the range of 1 to 8.	Please try again after confirming the setting.

## Version upgrade history

Version	Date	Description
00A	2015/04/23	First edition
01A	2016/07/15	Add the 8-axis module for the applicable module. Extend the target axis into 8 axes.

# 2.15 M+FX5SSC\_ChangePositionControlMode

## Name

M+FX5SSC\_ChangePositionControlMode

## Overview

Item	Description
Function overview	Activates the position control mode.
Symbol	<div style="text-align: center;"><pre>graph LR; subgraph M+FX5SSC_ChangePositionControlMode; direction TB; i_bEN((1) B : i_bEN); i_stModule((2) DUT : i_stModule); i_uAxis((3) UW : i_uAxis); o_bENO((4) o_bENO : B); o_bOK((5) o_bOK : B); o_bErr((6) o_bErr : B); o_uErrId((7) o_uErrId : UW); end;</pre></div>

## Labels

### ■Input labels

No.	Variable name	Name	Data type	Setting range	Description
(1)	i_bEN	Execution command	Bit	ON, OFF	ON: The FB is activated. OFF: The FB is not activated.
(2)	i_stModule	Module label	Structure	The setting range differs depending on the module label.	Specify the module label of the MELSEC iQ-F Simple Motion module.
(3)	i_uAxis	Target axis	Word [unsigned]	1 to 8	Specify the axis No. The setting range differs depending on the module used.

### ■Output labels

No.	Variable name	Name	Data type	Default value	Description
(4)	o_bENO	Execution status	Bit	OFF	ON: The execution command is ON. OFF: The execution command is OFF.
(5)	o_bOK	Completed without error	Bit	OFF	When ON, it indicates that changing to the positioning control mode has been completed.
(6)	o_bErr	Error flag	Bit	OFF	When ON, it indicates that an error has occurred in the FB.
(7)	o_uErrId	Error code	Word [unsigned]	0	The error code generated in the FB is stored.

## FB details

Item	Description	
Applicable hardware and software	Applicable module	FX5-40SSC-S, FX5-80SSC-S
	Applicable CPU	MELSEC iQ-F series
	Applicable engineering software	FX5-40SSC-S: GX Works3 (Version 1.010L or later) FX5-80SSC-S: GX Works3 (Version 1.030G or later)
Programming language	Ladder	
Number of steps (maximum)	419 steps	
Function description	<ul style="list-style-type: none"> <li>By turning ON i_bEN (Execution command), the position control mode is activated for the specified axis.</li> <li>When this FB is executed during position control, the execution is completed without any processing.</li> <li>When the setting value of the target axis is out of the range, o_bErr (Error flag) turns ON, the FB processing is interrupted, and the error code 100 (Hexadecimal) is stored in o_uErrId (Error code).</li> </ul>	
Compiling method	Macro type	
FB operation type	Pulsed execution (multiple scan execution type)	
Timing chart	<p>When operation completes without an error</p> <p>When an error occurs</p>	
Restrictions and precautions	<ul style="list-style-type: none"> <li>The FB does not include error recovery processing. Program the error recovery processing separately in accordance with the required system operation.</li> <li>The FB cannot be used in an interrupt program.</li> <li>Ensure that i_bEN (Execution command) is capable of being turned OFF by the program. Do not use this FB in programs that are only executed once such as a subroutine and FOR-NEXT loop because i_bEN (Execution command) cannot be turned OFF.</li> <li>When this FB is used twice or more, precaution must be taken to avoid repetition of the target axis.</li> <li>Every input must be provided with a value for proper FB operation.</li> <li>When this FB fails switching the mode, o_bOK (Completed without error) does not turn ON.</li> </ul>	

## Error codes

Error code	Description	Action
100 (Hexadecimal)	The setting value of i_uAxis (Target axis) is out of the range. The target axis is not within the range of 1 to 8.	Please try again after confirming the setting.

## Version upgrade history

Version	Date	Description
00A	2015/04/23	First edition
01A	2016/07/15	Add the 8-axis module for the applicable module. Extend the target axis into 8 axes.

# 2.16 M+FX5SSC\_ChangeContinuousTorqueMode

## Name

M+FX5SSC\_ChangeContinuousTorqueMode

## Overview

Item	Description
Function overview	Activates the continuous operation to torque control mode.

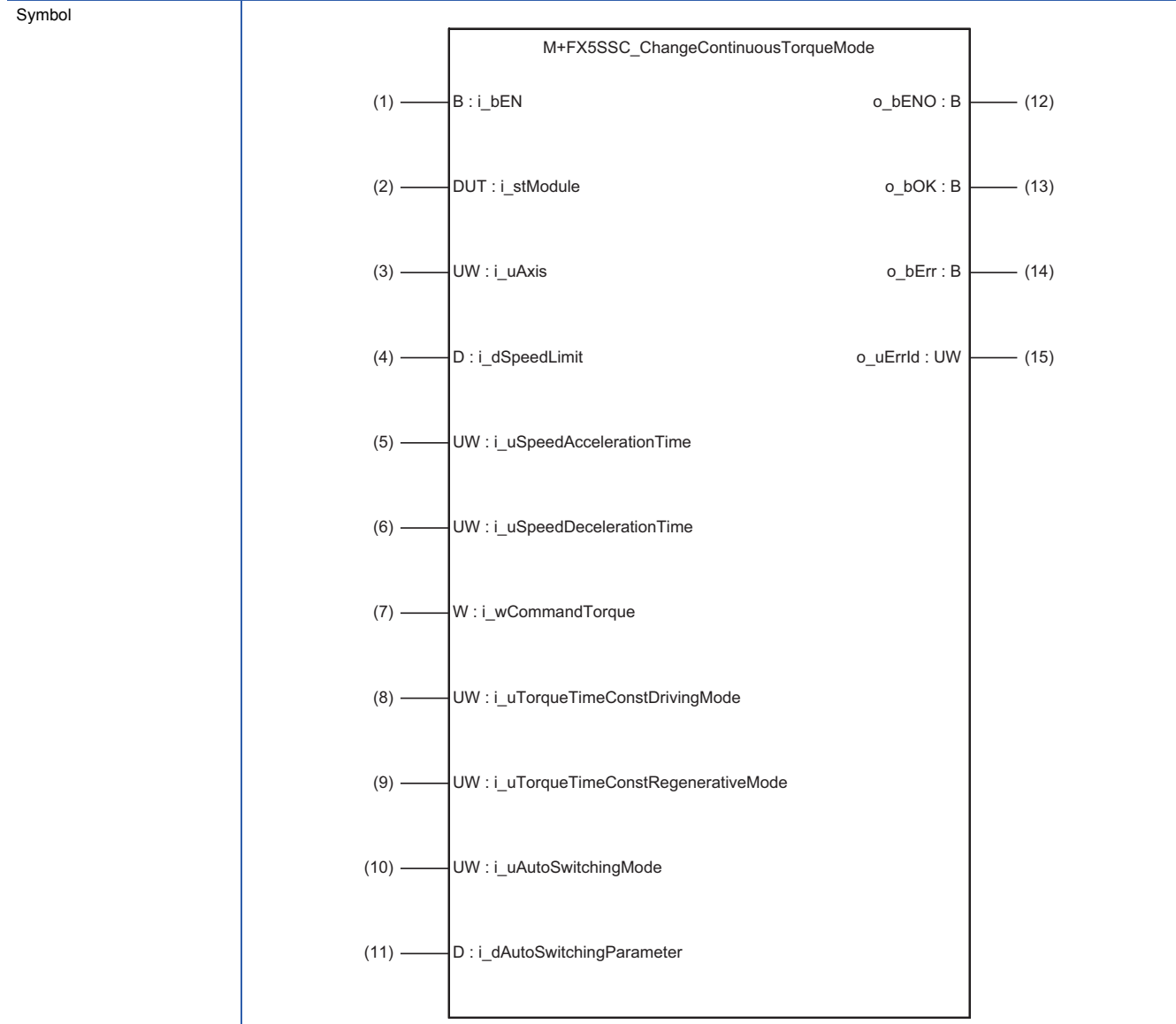

## Labels

### Input labels

No.	Variable name	Name	Data type	Setting range	Description
(1)	i_bEN	Execution command	Bit	ON, OFF	ON: The FB is activated. OFF: The FB is not activated.
(2)	i_stModule	Module label	Structure	The setting range differs depending on the module label.	Specify the module label of the MELSEC iQ-F Simple Motion module.
(3)	i_uAxis	Target axis	Word [unsigned]	1 to 8	Specify the axis No. The setting range differs depending on the module used.
(4)	i_dSpeedLimit	Cd.147: Speed limit value at continuous operation to torque control mode	Double word [signed]	Pr.1: Unit setting = mm/inch/degree* <sup>1</sup> • -2000000000 to 2000000000* <sup>2</sup> Pr.1: Unit setting = pulse • -1000000000 to 1000000000	Set the speed limit value at continuous operation to torque control mode.
(5)	i_uSpeedAccelerationTime	Cd.148: Acceleration time at continuous operation to torque control mode	Word [unsigned]	0 to 65535 (0 to 32767: Set by decimal number. 32768 to 65535: Convert the number to hexadecimal number and set.)	Set the acceleration time at continuous operation to torque control mode.
(6)	i_uSpeedDecelerationTime	Cd.149: Deceleration time at continuous operation to torque control mode	Word [unsigned]	0 to 65535 (0 to 32767: Set by decimal number. 32768 to 65535: Convert the number to hexadecimal number and set.)	Set the deceleration time at continuous operation to torque control mode.
(7)	i_wCommandTorque	Cd.150: Target torque at continuous operation to torque control mode	Word [signed]	-10000 to 10000	Set the target torque at continuous operation to torque control mode.
(8)	i_uTorqueTimeConstDriving Mode	Cd.151: Torque time constant at continuous operation to torque control mode (Forward direction)	Word [unsigned]	0 to 65535 (0 to 32767: Set by decimal number. 32768 to 65535: Convert the number to hexadecimal number and set.)	Set the time constant for the driving at continuous operation to torque control mode.
(9)	i_uTorqueTimeConstRegenerativeMode	Cd.152: Torque time constant at continuous operation to torque control mode (Negative direction)	Word [unsigned]	0 to 65535 (0 to 32767: Set by decimal number. 32768 to 65535: Convert the number to hexadecimal number and set.)	Set the time constant for the regeneration at continuous operation to torque control mode.
(10)	i_uAutoSwitchingMode	Cd.153: Control mode auto-shift selection	Word [unsigned]	0 to 2	Set the switching condition of the control mode to switch to continuous operation to torque control mode.
(11)	i_dAutoSwitchingParameter	Cd.154: Control mode auto-shift parameter	Double word [signed]	Pr.1: Unit setting = mm/inch • -2147483648 to 2147483647* <sup>2</sup> Pr.1: Unit setting = degree • 0 to 35999999* <sup>2</sup> Pr.1: Unit setting = pulse • -2147483648 to 2147483647	Set the condition value when the control mode auto-shift selection is set to 1 or 2.

\*1 When "Pr.1 Unit setting" is set to "degree" and "Pr.83 Speed control 10 × multiplier setting for degree axis" is valid, the value is set as 10 times of setting value.

\*2 The value is set corresponding to the setting of "Pr.1 Unit setting".

### Output labels

No.	Variable name	Name	Data type	Default value	Description
(12)	o_bENO	Execution status	Bit	OFF	ON: The execution command is ON. OFF: The execution command is OFF.
(13)	o_bOK	Completed without error	Bit	OFF	When ON, it indicates that changing to the continuous operation to torque control mode has been completed.
(14)	o_bErr	Error flag	Bit	OFF	When ON, it indicates that an error has occurred in the FB.
(15)	o_uErrId	Error code	Word [unsigned]	0	The error code generated in the FB is stored.

## FB details

Item	Description	
Applicable hardware and software	Applicable module	FX5-40SSC-S, FX5-80SSC-S
	Applicable CPU	MELSEC iQ-F series
	Applicable engineering software	FX5-40SSC-S: GX Works3 (Version 1.010L or later) FX5-80SSC-S: GX Works3 (Version 1.030G or later)
Programming language	Ladder	
Number of steps (maximum)	633 steps	
Function description	<ul style="list-style-type: none"> <li>• By turning ON i_bEN (Execution command), the continuous operation to torque control mode is activated for the specified axis.</li> <li>• When this FB is executed during continuous operation to torque control mode, the speed limit value and target torque are changed.</li> <li>• When the setting value of the target axis is out of the range, o_bErr (Error flag) turns ON, the FB processing is interrupted, and the error code 100 (Hexadecimal) is stored in o_uErrId (Error code).</li> </ul>	
Compiling method	Macro type	
FB operation type	Pulsed execution (multiple scan execution type)	

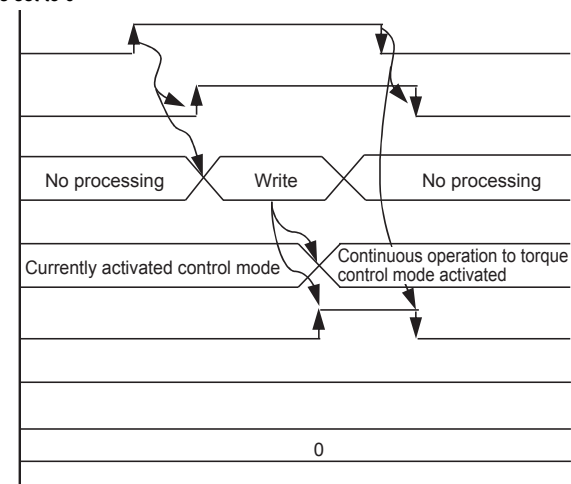
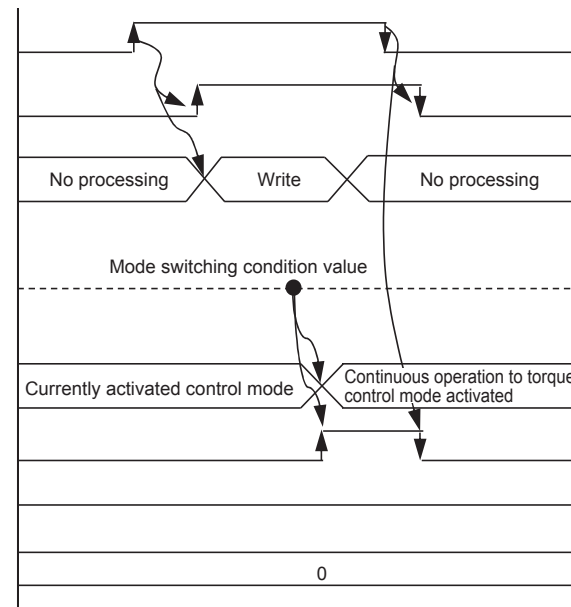
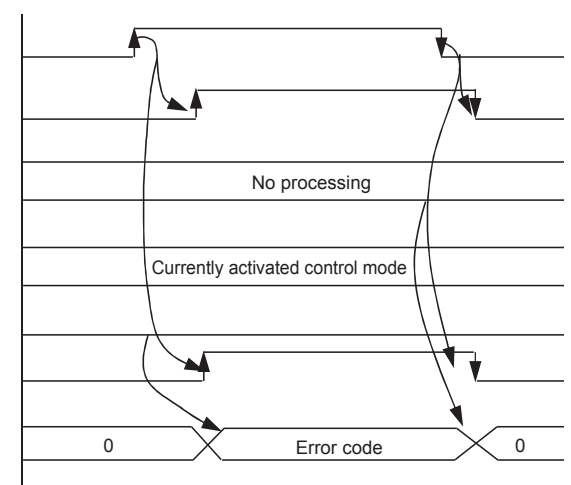
Item	Description
Timing chart	<p>When operation completes without an error</p> <ul style="list-style-type: none"> <li>When the control mode auto-shift selection is set to 0</li> </ul>  <ul style="list-style-type: none"> <li>When the control mode auto-shift selection is set to other than 0</li> </ul>  <p>When an error occurs</p> 



Item	Description
Restrictions and precautions	<ul style="list-style-type: none"> <li>The FB does not include error recovery processing. Program the error recovery processing separately in accordance with the required system operation.</li> <li>The FB cannot be used in an interrupt program.</li> <li>Ensure that i_bEN (Execution command) is capable of being turned OFF by the program. Do not use this FB in programs that are only executed once such as a subroutine and FOR-NEXT loop because i_bEN (Execution command) cannot be turned OFF.</li> <li>When this FB is used twice or more, precaution must be taken to avoid repetition of the target axis.</li> <li>Every input must be provided with a value for proper FB operation.</li> <li>When this FB fails switching the mode, o_bOK (Completed without error) does not turn ON.</li> </ul>

## Error codes

Error code	Description	Action
100 (Hexadecimal)	The setting value of i_uAxis (Target axis) is out of the range. The target axis is not within the range of 1 to 8.	Please try again after confirming the setting.

## Version upgrade history

Version	Date	Description
00A	2015/04/23	First edition
01A	2016/07/15	Add the 8-axis module for the applicable module. Extend the target axis into 8 axes.

# 2.17 M+FX5SSC\_Sync

## Name

M+FX5SSC\_Sync

## Overview

Item	Description
Function overview	Starts and ends the synchronous control.
Symbol	<pre> graph LR     subgraph M+FX5SSC_Sync         direction TB         i_bEN["(1) B : i_bEN"]         i_stModule["(2) DUT : i_stModule"]         i_uOutputAxis["(3) UW : i_uOutputAxis"]         o_bENO["(4) o_bENO : B"]         o_bOK["(5) o_bOK : B"]         o_bErr["(6) o_bErr : B"]         o_uErrId["(7) o_uErrId : UW"]     end </pre>

## Labels

### Input labels

No.	Variable name	Name	Data type	Setting range	Description
(1)	i_bEN	Execution command	Bit	ON, OFF	ON: The FB is activated. OFF: The FB is not activated.
(2)	i_stModule	Module label	Structure	The setting range differs depending on the module label.	Specify the module label of the MELSEC iQ-F Simple Motion module.
(3)	i_uOutputAxis	Output axis No.	Word [unsigned]	1 to 8	Specify the axis No. for which synchronous control is started. The setting range differs depending on the module used.

### Output labels

No.	Variable name	Name	Data type	Default value	Description
(4)	o_bENO	Execution status	Bit	OFF	ON: The execution command is ON. OFF: The execution command is OFF.
(5)	o_bOK	Completed without error	Bit	OFF	When ON, it indicates that synchronous control has been started.
(6)	o_bErr	Error flag	Bit	OFF	When ON, it indicates that an error has occurred in the FB.
(7)	o_uErrId	Error code	Word [unsigned]	0	The error code generated in the FB is stored.

## FB details

Item	Description	
Applicable hardware and software	Applicable module	FX5-40SSC-S, FX5-80SSC-S
	Applicable CPU	MELSEC iQ-F series
	Applicable engineering software	FX5-40SSC-S: GX Works3 (Version 1.010L or later) FX5-80SSC-S: GX Works3 (Version 1.030G or later)
Programming language	Ladder	
Number of steps (maximum)	195 steps	
Function description	<ul style="list-style-type: none"> <li>By turning ON i_bEN (Execution command), synchronous control of the output axis No. is started. Turning OFF i_bEN (Execution command) ends the synchronous control.</li> <li>When the setting value of the output axis No. is out of the range, o_bErr (Error flag) turns ON, the FB processing is interrupted, and the error code 100 (Hexadecimal) is stored in o_uErrId (Error code).</li> <li>The synchronous control does not start while the READY signal is OFF, the BUSY signal is ON, or the error detection signal is ON.</li> </ul>	
Compiling method	Macro type	
FB operation type	Pulsed execution (multiple scan execution type)	
Timing chart	<p>When operation completes without an error</p> <p>When an error occurs</p>	
Restrictions and precautions	<ul style="list-style-type: none"> <li>The FB does not include error recovery processing. Program the error recovery processing separately in accordance with the required system operation.</li> <li>The FB cannot be used in an interrupt program.</li> <li>When this FB is used twice or more, precaution must be taken to avoid repetition of the output axis No.</li> <li>Every input must be provided with a value for proper FB operation.</li> </ul>	

## Error codes

Error code	Description	Action
100 (Hexadecimal)	The output axis No. is not within the setting range.	Please try again after confirming the setting.

## Version upgrade history

Version	Date	Description
00A	2015/04/23	First edition
01A	2016/07/15	Add the 8-axis module for the applicable module. Extend the output axis No. into 8 axes.

# 2.18 M+FX5SSC\_ChangeSyncEncoderPosition

## Name

M+FX5SSC\_ChangeSyncEncoderPosition

## Overview

Item	Description
Function overview	Changes the synchronous encoder axis current value and synchronous encoder axis current value per cycle.
Symbol	<pre> graph LR     subgraph M+FX5SSC_ChangeSyncEncoderPosition         direction TB         B["(1) B : i_bEN"]         DUT["(2) DUT : i_stModule"]         UW1["(3) UW : i_uSyncEncAxis"]         UW2["(4) UW : i_uStartControl"]         D["(5) D : i_dNewPosition"]         B --- DUT --- UW1 --- UW2 --- D     end     B --- B_OUT["(6) o_bENO : B"]     DUT --- DUT_OUT["(7) o_bOK : B"]     UW1 --- UW_OUT["(8) o_bErr : B"]     UW2 --- UW_OUT --- D --- D_OUT["(9) o_uErrId : UW"]         </pre>

## Labels

### Input labels

No.	Variable name	Name	Data type	Setting range	Description
(1)	i_bEN	Execution command	Bit	ON, OFF	ON: The FB is activated. OFF: The FB is not activated.
(2)	i_stModule	Module label	Structure	The setting range differs depending on the module label.	Specify the module label of the MELSEC iQ-F Simple Motion module.
(3)	i_uSyncEncAxis	Synchronous encoder axis No.	Word [unsigned]	1 to 4: Synchronous encoder axis No.	Set the synchronous encoder axis No. whose current value is to be changed.
(4)	i_uStartControl	Cd.320: Synchronous encoder axis control start	Word [unsigned]	1: Start for synchronous encoder axis control 101 to 108: High-speed input start for synchronous encoder axis control (axis 1 to axis 8)	When 1 is set, synchronous encoder axis control is started. When 101 to 108 is set, the synchronous encoder axis control starts based on the high-speed input request (external command signal). The setting range differs depending on the module used.
(5)	i_dNewPosition	Cd.322: Synchronous encoder axis current value setting address	Double word [signed]	Pr.321: Synchronous encoder axis unit setting = mm/inch/degree/pulse • -2147483648 to 2147483647 <sup>*1</sup>	Set the new current value after a current value change.

\*1 The value is set corresponding to the setting of "Pr.321 Synchronous encoder axis unit setting".

### Output labels

No.	Variable name	Name	Data type	Default value	Description
(6)	o_bENO	Execution status	Bit	OFF	ON: The execution command is ON. OFF: The execution command is OFF.
(7)	o_bOK	Completed without error	Bit	OFF	When ON, it indicates that setting the synchronous encoder axis current value change has been completed.
(8)	o_bErr	Error flag	Bit	OFF	When ON, it indicates that an error has occurred in the FB.
(9)	o_uErrId	Error code	Word [unsigned]	0	The error code generated in the FB is stored.

## FB details

Item	Description	
Applicable hardware and software	Applicable module	FX5-40SSC-S, FX5-80SSC-S
	Applicable CPU	MELSEC iQ-F series
	Applicable engineering software	FX5-40SSC-S: GX Works3 (Version 1.010L or later) FX5-80SSC-S: GX Works3 (Version 1.030G or later)
Programming language	Ladder	
Number of steps (maximum)	269 steps	
Function description	<ul style="list-style-type: none"> <li>The operation method differs depending on the setting value of the synchronous encoder axis control start. When the setting value is 1, the synchronous encoder axis current value is changed by turning ON i_bEN (Execution command). When the setting value is 101 to 108, the synchronous encoder axis current value is changed by the high speed input request [DI] after i_bEN (Execution command) is turned ON.</li> <li>When the setting value of the synchronous encoder axis No. is out of the range, o_bErr (Error flag) turns ON, the FB processing is interrupted, and the error code 100 (Hexadecimal) is stored in o_uErrId (Error code).</li> <li>When this FB is executed for the synchronous encoder axis for which the synchronous encoder axis enabled flag is OFF, o_bErr (Error flag) turns ON, the FB processing is interrupted, and the error code 301 (Hexadecimal) is stored in o_uErrId (Error code).</li> </ul>	
Compiling method	Macro type	
FB operation type	Pulsed execution (single scan execution type)	
Timing chart	<p>When operation completes without an error</p> <p>When an error occurs</p>	
Restrictions and precautions	<ul style="list-style-type: none"> <li>The FB does not include error recovery processing. Program the error recovery processing separately in accordance with the required system operation.</li> <li>The FB cannot be used in an interrupt program.</li> <li>When this FB is used twice or more, precaution must be taken to avoid repetition of the synchronous encoder axis No.</li> <li>Every input must be provided with a value for proper FB operation.</li> </ul>	

## Error codes

Error code	Description	Action
100 (Hexadecimal)	The synchronous encoder axis No. is not within the setting range.	Please try again after confirming the setting.
301 (Hexadecimal)	The synchronous encoder axis enabled flag of the synchronous encoder axis No. is OFF.	Please try again after confirming the setting.

## Version upgrade history

Version	Date	Description
00A	2015/04/23	First edition

# 2.19 M+FX5SSC\_DisableSyncEncoder

## Name

M+FX5SSC\_DisableSyncEncoder

## Overview

Item	Description
Function overview	Disables inputs from the synchronous encoder axis.
Symbol	<pre> graph LR     subgraph M+FX5SSC_DisableSyncEncoder         direction LR         i_bEN((1) B : i_bEN)         i_stModule((2) DUT : i_stModule)         i_uSyncEncAxis((3) UW : i_uSyncEncAxis)         i_uStartControl((4) UW : i_uStartControl)         o_bENO((5) o_bENO : B)         o_bOK((6) o_bOK : B)         o_bErr((7) o_bErr : B)         o_uErrId((8) o_uErrId : UW)     end </pre>

## Labels

### Input labels

No.	Variable name	Name	Data type	Setting range	Description
(1)	i_bEN	Execution command	Bit	ON, OFF	ON: The FB is activated. OFF: The FB is not activated.
(2)	i_stModule	Module label	Structure	The setting range differs depending on the module label.	Specify the module label of the MELSEC iQ-F Simple Motion module.
(3)	i_uSyncEncAxis	Synchronous encoder axis No.	Word [unsigned]	1 to 4: Synchronous encoder axis No.	Set the synchronous encoder axis No. whose inputs are to be disabled.
(4)	i_uStartControl	Cd.320: Synchronous encoder axis control start	Word [unsigned]	1: Start for synchronous encoder axis control 101 to 108: High-speed input start for synchronous encoder axis control (axis 1 to axis 8)	When 1 is set, synchronous encoder axis control is started. When 101 to 108 is set, the synchronous encoder axis control starts based on the high-speed input request (external command signal). The setting range differs depending on the module used.

### Output labels

No.	Variable name	Name	Data type	Default value	Description
(5)	o_bENO	Execution status	Bit	OFF	ON: The execution command is ON. OFF: The execution command is OFF.
(6)	o_bOK	Completed without error	Bit	OFF	When ON, it indicates that disabling the synchronous encoder axis counter has been completed.
(7)	o_bErr	Error flag	Bit	OFF	When ON, it indicates that an error has occurred in the FB.
(8)	o_uErrId	Error code	Word [unsigned]	0	The error code generated in the FB is stored.



## FB details

Item	Description
Applicable hardware and software	Applicable module FX5-40SSC-S, FX5-80SSC-S
	Applicable CPU MELSEC iQ-F series
	Applicable engineering software FX5-40SSC-S: GX Works3 (Version 1.010L or later) FX5-80SSC-S: GX Works3 (Version 1.030G or later)
Programming language	Ladder
Number of steps (maximum)	216 steps
Function description	<ul style="list-style-type: none"> <li>The operation method differs depending on the setting value of the synchronous encoder axis control start. When the setting value is 1, the synchronous encoder axis counter is disabled by turning ON i_bEN (Execution command). When the setting value is 101 to 108, the synchronous encoder axis counter is disabled by the high speed input request [DI] after i_bEN (Execution command) is turned ON.</li> <li>When the setting value of the synchronous encoder axis No. is out of the range, o_bErr (Error flag) turns ON, the FB processing is interrupted, and the error code 100 (Hexadecimal) is stored in o_uErrId (Error code).</li> <li>When this FB is executed for the synchronous encoder axis for which the synchronous encoder axis enabled flag is OFF, o_bErr (Error flag) turns ON, the FB processing is interrupted, and the error code 301 (Hexadecimal) is stored in o_uErrId (Error code).</li> </ul>
Compiling method	Macro type
FB operation type	Pulsed execution (single scan execution type)
Timing chart	<p>When operation completes without an error</p> <p>When an error occurs</p>
Restrictions and precautions	<ul style="list-style-type: none"> <li>The FB does not include error recovery processing. Program the error recovery processing separately in accordance with the required system operation.</li> <li>The FB cannot be used in an interrupt program.</li> <li>When this FB is used twice or more, precaution must be taken to avoid repetition of the synchronous encoder axis No.</li> <li>Every input must be provided with a value for proper FB operation.</li> </ul>

## Error codes

Error code	Description	Action
100 (Hexadecimal)	The synchronous encoder axis No. is not within the setting range.	Please try again after confirming the setting.
301 (Hexadecimal)	The synchronous encoder axis enabled flag of the synchronous encoder axis No. is OFF.	Execute the FB again after turning ON the synchronous encoder axis setting enabled flag.

## Version upgrade history

Version	Date	Description
00A	2015/04/23	First edition

## 2.20 M+FX5SSC\_EnableSyncEncoder

### Name

M+FX5SSC\_EnableSyncEncoder

### Overview

Item	Description
Function overview	Enables inputs from the synchronous encoder axis.
Symbol	<pre> graph LR     subgraph M+FX5SSC_EnableSyncEncoder         direction LR         i_bEN((1) B : i_bEN)         i_stModule((2) DUT : i_stModule)         i_uSyncEncAxis((3) UW : i_uSyncEncAxis)         i_uStartControl((4) UW : i_uStartControl)         o_bENO((5) o_bENO : B)         o_bOK((6) o_bOK : B)         o_bErr((7) o_bErr : B)         o_uErrId((8) o_uErrId : UW)     end     i_bEN --- o_bENO     i_stModule --- o_bOK     i_uSyncEncAxis --- o_bErr     i_uStartControl --- o_uErrId                     </pre>

### Labels

#### Input labels

No.	Variable name	Name	Data type	Setting range	Description
(1)	i_bEN	Execution command	Bit	ON, OFF	ON: The FB is activated. OFF: The FB is not activated.
(2)	i_stModule	Module label	Structure	The setting range differs depending on the module label.	Specify the module label of the MELSEC iQ-F Simple Motion module.
(3)	i_uSyncEncAxis	Synchronous encoder axis No.	Word [unsigned]	1 to 4: Synchronous encoder axis No.	Set the synchronous encoder axis No. whose inputs are to be enabled.
(4)	i_uStartControl	Cd.320: Synchronous encoder axis control start	Word [unsigned]	1: Start for synchronous encoder axis control 101 to 108: High-speed input start for synchronous encoder axis control (axis 1 to axis 8)	When 1 is set, synchronous encoder axis control is started. When 101 to 108 is set, the synchronous encoder axis control starts based on the high-speed input request (external command signal). The setting range differs depending on the module used.

#### Output labels

No.	Variable name	Name	Data type	Default value	Description
(5)	o_bENO	Execution status	Bit	OFF	ON: The execution command is ON. OFF: The execution command is OFF.
(6)	o_bOK	Completed without error	Bit	OFF	When ON, it indicates that enabling the synchronous encoder axis counter has been completed.
(7)	o_bErr	Error flag	Bit	OFF	When ON, it indicates that an error has occurred in the FB.
(8)	o_uErrId	Error code	Word [unsigned]	0	The error code generated in the FB is stored.

## FB details

Item	Description	
Applicable hardware and software	Applicable module	FX5-40SSC-S, FX5-80SSC-S
	Applicable CPU	MELSEC iQ-F series
	Applicable engineering software	FX5-40SSC-S: GX Works3 (Version 1.010L or later) FX5-80SSC-S: GX Works3 (Version 1.030G or later)
Programming language	Ladder	
Number of steps (maximum)	216 steps	
Function description	<ul style="list-style-type: none"> <li>The operation method differs depending on the setting value of the synchronous encoder axis control start. When the setting value is 1, the synchronous encoder axis counter is enabled by turning ON i_bEN (Execution command). When the setting value is 101 to 108, the synchronous encoder axis counter is enabled by the high speed input request [DI] after i_bEN (Execution command) is turned ON.</li> <li>When the setting value of the synchronous encoder axis No. is out of the range, o_bErr (Error flag) turns ON, the FB processing is interrupted, and the error code 100 (Hexadecimal) is stored in o_uErrId (Error code).</li> <li>When this FB is executed for the synchronous encoder axis for which the synchronous encoder axis enabled flag is OFF, o_bErr (Error flag) turns ON, the FB processing is interrupted, and the error code 301 (Hexadecimal) is stored in o_uErrId (Error code).</li> </ul>	
Compiling method	Macro type	
FB operation type	Pulsed execution (single scan execution type)	
Timing chart	<p>When operation completes without an error</p> <p>When an error occurs</p>	
Restrictions and precautions	<ul style="list-style-type: none"> <li>The FB does not include error recovery processing. Program the error recovery processing separately in accordance with the required system operation.</li> <li>The FB cannot be used in an interrupt program.</li> <li>When this FB is used twice or more, precaution must be taken to avoid repetition of the synchronous encoder axis No.</li> <li>Every input must be provided with a value for proper FB operation.</li> </ul>	

## Error codes

Error code	Description	Action
100 (Hexadecimal)	The synchronous encoder axis No. is not within the setting range.	Please try again after confirming the setting.
301 (Hexadecimal)	The synchronous encoder axis enabled flag of the synchronous encoder axis No. is OFF.	Execute the FB again after turning ON the synchronous encoder axis setting enabled flag.

## Version upgrade history

Version	Date	Description
00A	2015/04/23	First edition

# 2.21 M+FX5SSC\_ResetSyncEncoderError

## Name

M+FX5SSC\_ResetSyncEncoderError

## Overview

Item	Description
Function overview	Reads error information from the synchronous encoder axis, and resets the error.
Symbol	<p>The diagram shows a rectangular block labeled 'M+FX5SSC_ResetSyncEncoderError'. On the left side, there are four input variables: (1) B : i_bEN, (2) DUT : i_stModule, (3) UW : i_uSyncEncAxis, and (4) B : i_bResetError. On the right side, there are eight output variables: (5) o_bENO : B, (6) o_bOK : B, (7) o_bModuleErr : B, (8) o_uErrorNo : UW, (9) o_bModuleWarn : B, (10) o_uWarningNo : UW, (11) o_bErr : B, and (12) o_uErrId : UW.</p>

## Labels

### Input labels

No.	Variable name	Name	Data type	Setting range	Description
(1)	i_bEN	Execution command	Bit	ON, OFF	ON: The FB is activated. OFF: The FB is not activated.
(2)	i_stModule	Module label	Structure	The setting range differs depending on the module label.	Specify the module label of the MELSEC iQ-F Simple Motion module.
(3)	i_uSyncEncAxis	Synchronous encoder axis No.	Word [unsigned]	1 to 4: Synchronous encoder axis No.	Set the synchronous encoder axis No. from which the error No. and warning No. are read.
(4)	i_bResetError	Error reset request	Bit	ON, OFF	Turn ON this label to reset errors. Turn OFF this label after the error reset is completed.

## ■ Output labels

No.	Variable name	Name	Data type	Default value	Description
(5)	o_bENO	Execution status	Bit	OFF	ON: The execution command is ON. OFF: The execution command is OFF.
(6)	o_bOK	Completed without error	Bit	OFF	When ON, it indicates that the error detection flag and warning detection flag of the synchronous encoder axis status have been turned OFF.
(7)	o_bModuleErr	Error detection	Bit	OFF	When ON, it indicates that the synchronous encoder axis error has occurred.
(8)	o_uErrorNo	Error No.	Word [unsigned]	0	When the synchronous encoder axis error is detected, the error code corresponding to the error is stored.
(9)	o_bModuleWarn	Warning detection	Bit	OFF	When ON, it indicates that the synchronous encoder axis warning has occurred.
(10)	o_uWarningNo	Warning No.	Word [unsigned]	0	When the synchronous encoder axis warning is detected, the warning code corresponding to the warning is stored.
(11)	o_bErr	Error flag	Bit	OFF	When ON, it indicates that an error has occurred in the FB.
(12)	o_uErrId	Error code	Word [unsigned]	0	The error code generated in the FB is stored.

## FB details

Item	Description	
Applicable hardware and software	Applicable module	FX5-40SSC-S, FX5-80SSC-S
	Applicable CPU	MELSEC iQ-F series
	Applicable engineering software	FX5-40SSC-S: GX Works3 (Version 1.010L or later) FX5-80SSC-S: GX Works3 (Version 1.030G or later)
Programming language	Ladder	
Number of steps (maximum)	447 steps	
Function description	<ul style="list-style-type: none"> <li>By turn ON i_bEN (Execution command), the synchronous encoder axis error and warning information of the synchronous encoder axis No. are read.</li> <li>When the error reset request is ON, the error and warning are reset.</li> <li>When the setting value of the synchronous encoder axis No. is out of the range, o_bErr (Error flag) turns ON, the FB processing is interrupted, and the error code 100 (Hexadecimal) is stored in o_uErrId (Error code).</li> </ul>	
Compiling method	Macro type	
FB operation type	Real-time execution	

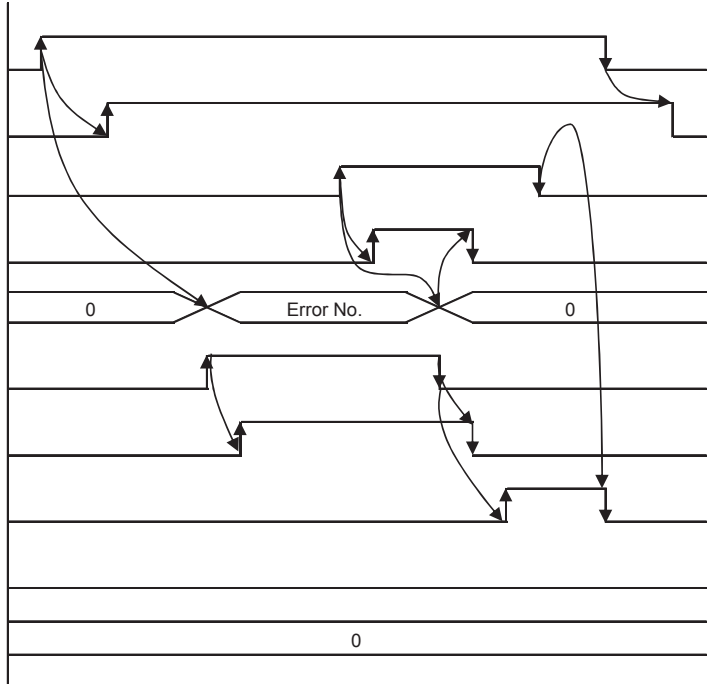
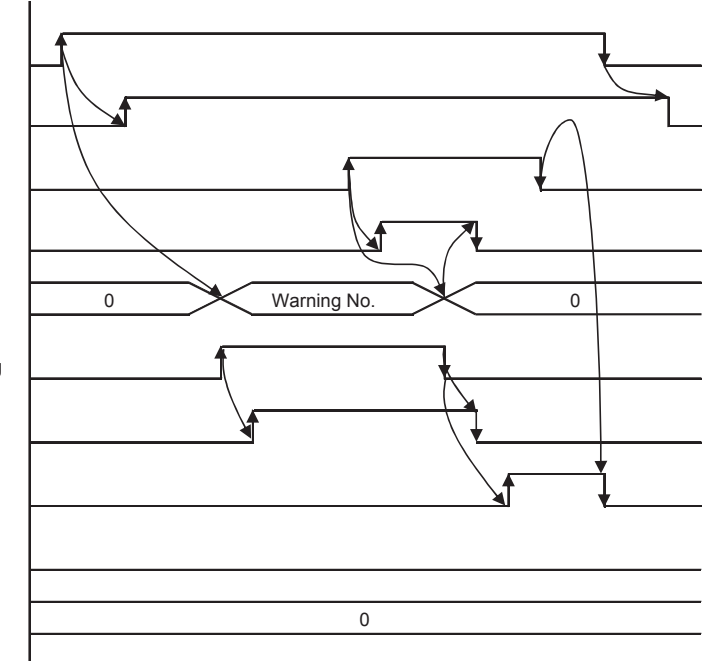
Item	Description
Timing chart	<p>When operation completes without an error (error reset)</p>  <p>When operation completes without an error (warning reset)</p> 



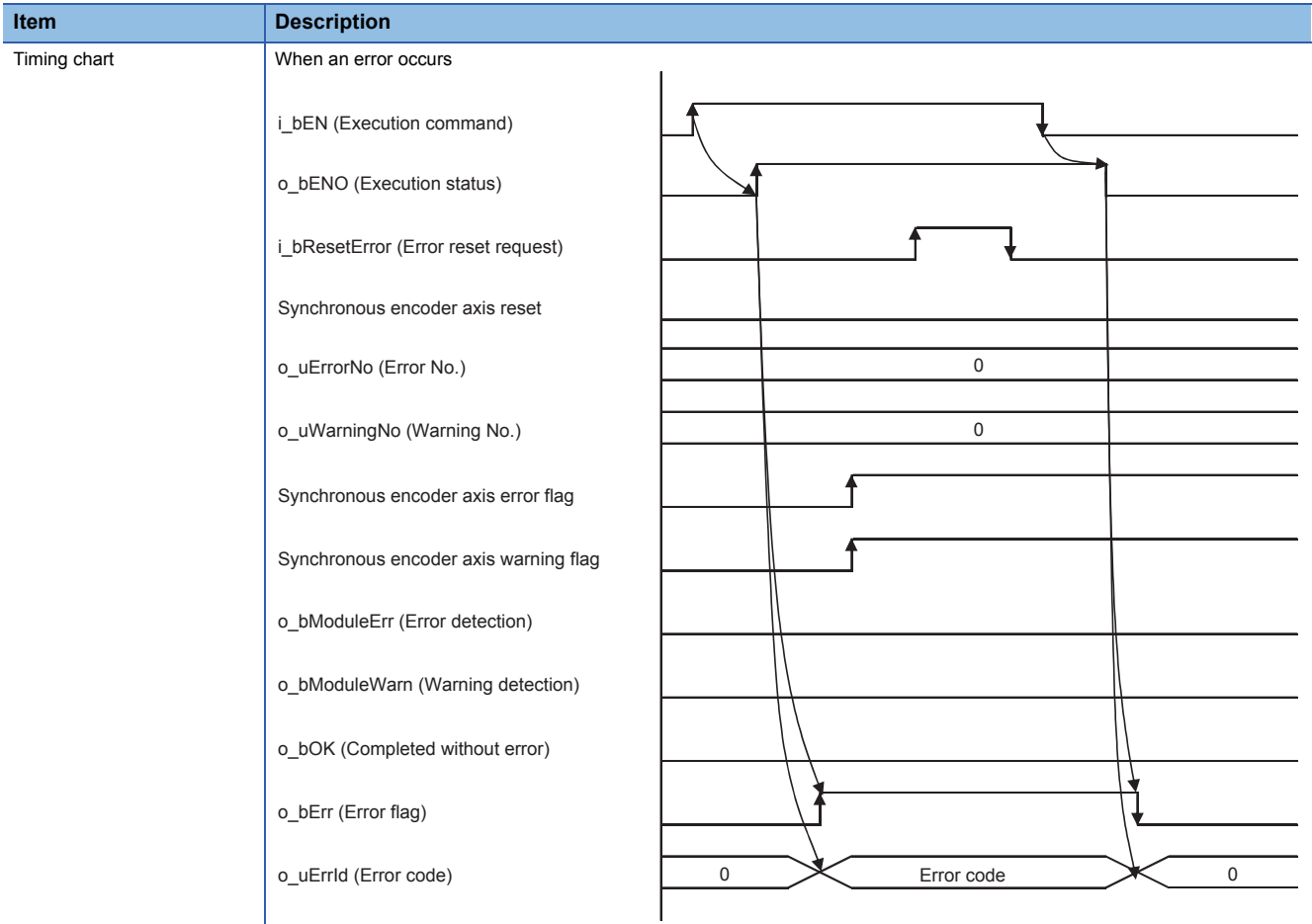

- Restrictions and precautions
- The FB does not include error recovery processing. Program the error recovery processing separately in accordance with the required system operation.
  - The FB cannot be used in an interrupt program.
  - When this FB is used twice or more, precaution must be taken to avoid repetition of the synchronous encoder axis No.
  - Every input must be provided with a value for proper FB operation.

### Error codes

Error code	Description	Action
100 (Hexadecimal)	The synchronous encoder axis No. is not within the setting range.	Please try again after confirming the setting.

### Version upgrade history

Version	Date	Description
00A	2015/04/23	First edition

## 2.22 M+FX5SSC\_ConnectSyncEncoder

### Name

M+FX5SSC\_ConnectSyncEncoder

### Overview

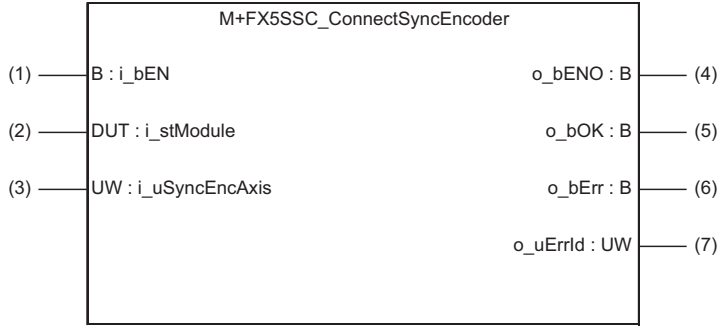
Item	Description
Function overview	Connects a synchronous encoder via CPU.
Symbol	

### Labels

#### Input labels

No.	Variable name	Name	Data type	Setting range	Description
(1)	i_bEN	Execution command	Bit	ON, OFF	ON: The FB is activated. OFF: The FB is not activated.
(2)	i_stModule	Module label	Structure	The setting range differs depending on the module label.	Specify the module label of the MELSEC iQ-F Simple Motion module.
(3)	i_uSyncEncAxis	Synchronous encoder axis No.	Word [unsigned]	1 to 4: Synchronous encoder axis No.	Set the synchronous encoder axis No. for which the connection command of the synchronous encoder via CPU is executed.

#### Output labels

No.	Variable name	Name	Data type	Default value	Description
(4)	o_bENO	Execution status	Bit	OFF	ON: The execution command is ON. OFF: The execution command is OFF.
(5)	o_bOK	Completed without error	Bit	OFF	When ON, it indicates that the connecting valid flag of the synchronous encoder axis status has been turned ON.
(6)	o_bErr	Error flag	Bit	OFF	When ON, it indicates that an error has occurred in the FB.
(7)	o_uErrId	Error code	Word [unsigned]	0	The error code generated in the FB is stored.

### FB details

Item	Description	
Applicable hardware and software	Applicable module	FX5-40SSC-S, FX5-80SSC-S
	Applicable CPU	MELSEC iQ-F series
	Applicable engineering software	FX5-40SSC-S: GX Works3 (Version 1.010L or later) FX5-80SSC-S: GX Works3 (Version 1.030G or later)
Programming language	Ladder	
Number of steps (maximum)	226 steps	

Item	Description
Function description	<ul style="list-style-type: none"> <li>By turning ON i_bEN (Execution command), the synchronous encoder of the synchronous encoder axis No. is connected via CPU.</li> <li>When the setting value of the synchronous encoder axis No. is out of the range, o_bErr (Error flag) turns ON, the FB processing is interrupted, and the error code 100 (Hexadecimal) is stored in o_uErrId (Error code).</li> <li>When this FB is executed for the synchronous encoder axis for which the synchronous encoder axis enabled flag is OFF, o_bErr (Error flag) turns ON, the FB processing is interrupted, and the error code 301 (Hexadecimal) is stored in o_uErrId (Error code).</li> </ul>
Compiling method	Macro type
FB operation type	Pulsed execution (multiple scan execution type)
Timing chart	<p>When operation completes without an error</p> <p>When an error occurs</p>
Restrictions and precautions	<ul style="list-style-type: none"> <li>The FB does not include error recovery processing. Program the error recovery processing separately in accordance with the required system operation.</li> <li>The FB cannot be used in an interrupt program.</li> <li>When this FB is used twice or more, precaution must be taken to avoid repetition of the synchronous encoder axis No.</li> <li>Every input must be provided with a value for proper FB operation.</li> </ul>

## Error codes

Error code	Description	Action
100 (Hexadecimal)	The synchronous encoder axis No. is not within the setting range.	Please try again after confirming the setting.
301 (Hexadecimal)	The synchronous encoder axis enabled flag of the synchronous encoder axis No. is OFF.	Execute the FB again after turning ON the synchronous encoder axis setting enabled flag.

## Version upgrade history

Version	Date	Description
00A	2015/04/23	First edition

## 2.23 M+FX5SSC\_MoveCamReferencePosition

### Name

M+FX5SSC\_MoveCamReferencePosition

### Overview

Item	Description															
Function overview	Adds the movement amount set in the synchronous control change value to the cam reference position to move the cam reference position.															
Symbol	<div style="border: 1px solid black; padding: 10px; width: fit-content; margin: 0 auto;"> <p style="text-align: center;">M+FX5SSC_MoveCamReferencePosition</p> <table style="width: 100%; border-collapse: collapse;"> <tr> <td style="width: 30%;">(1) — B : i_bEN</td> <td style="width: 40%;"></td> <td style="width: 30%;">o_bENO : B — (6)</td> </tr> <tr> <td>(2) — DUT : i_stModule</td> <td></td> <td>o_bOK : B — (7)</td> </tr> <tr> <td>(3) — UW : i_uOutputAxis</td> <td></td> <td>o_bErr : B — (8)</td> </tr> <tr> <td>(4) — D : i_dSyncCtrlChangeValue</td> <td></td> <td>o_uErrId : UW — (9)</td> </tr> <tr> <td>(5) — UW : i_uSyncCtrlReflectionTime</td> <td></td> <td></td> </tr> </table> </div>	(1) — B : i_bEN		o_bENO : B — (6)	(2) — DUT : i_stModule		o_bOK : B — (7)	(3) — UW : i_uOutputAxis		o_bErr : B — (8)	(4) — D : i_dSyncCtrlChangeValue		o_uErrId : UW — (9)	(5) — UW : i_uSyncCtrlReflectionTime		
(1) — B : i_bEN		o_bENO : B — (6)														
(2) — DUT : i_stModule		o_bOK : B — (7)														
(3) — UW : i_uOutputAxis		o_bErr : B — (8)														
(4) — D : i_dSyncCtrlChangeValue		o_uErrId : UW — (9)														
(5) — UW : i_uSyncCtrlReflectionTime																

### Labels

#### ■Input labels

No.	Variable name	Name	Data type	Setting range	Description
(1)	i_bEN	Execution command	Bit	ON, OFF	ON: The FB is activated. OFF: The FB is not activated.
(2)	i_stModule	Module label	Structure	The setting range differs depending on the module label.	Specify the module label of the MELSEC iQ-F Simple Motion module.
(3)	i_uOutputAxis	Output axis No.	Word [unsigned]	1 to 8	Set the axis No. whose cam reference position is to be moved. The setting range differs depending on the module used.
(4)	i_dSyncCtrlChangeValue	Cd.408: Synchronous control change value	Double word [signed]	-2147483648 to 2147483647 *1,2	Set the amount of the cam reference position movement.
(5)	i_uSyncCtrlReflectionTime	Cd.409: Synchronous control reflection time	Word [unsigned]	0 to 65535 (ms) (0 to 32767: Set by decimal number. 32768 to 65535: Convert the number to hexadecimal number and set.)	Set the reflection time for the synchronous control change.

\*1 The output axis position unit is set to the value corresponding to the setting of "Pr.1 Unit setting" and the cam axis cycle unit is set to the value corresponding to the setting of "Pr.438 Cam axis cycle unit setting".

\*2 The setting range is the same even if the unit differs.

#### ■Output labels

No.	Variable name	Name	Data type	Default value	Description
(6)	o_bENO	Execution status	Bit	OFF	ON: The execution command is ON. OFF: The execution command is OFF.
(7)	o_bOK	Completed without error	Bit	OFF	When ON, it indicates that moving the cam reference position has been completed.
(8)	o_bErr	Error flag	Bit	OFF	When ON, it indicates that an error has occurred in the FB.
(9)	o_uErrId	Error code	Word [unsigned]	0	The error code generated in the FB is stored.

## FB details

Item	Description
Applicable hardware and software	Applicable module FX5-40SSC-S, FX5-80SSC-S
	Applicable CPU MELSEC iQ-F series
	Applicable engineering software FX5-40SSC-S: GX Works3 (Version 1.010L or later) FX5-80SSC-S: GX Works3 (Version 1.030G or later)
Programming language	Ladder
Number of steps (maximum)	427 steps
Function description	<ul style="list-style-type: none"> <li>By turning ON i_bEN (Execution command), the cam reference position of the output axis No. is moved.</li> <li>If i_bEN (Execution command) is turned OFF during movement of the cam reference position, the operation stops during the movement and o_bOK (Completed without error) does not turn ON.</li> <li>When the setting value of the output axis No. is out of the range, o_bErr (Error flag) turns ON, the FB processing is interrupted, and the error code 100 (Hexadecimal) is stored in o_uErrId (Error code).</li> <li>When this FB is executed for the output axis No. with which synchronous control is not executed, o_bErr (Error flag) turns ON, the FB processing is interrupted, and the error code 300 (Hexadecimal) is stored in o_uErrId (Error code).</li> </ul>
Compiling method	Macro type
FB operation type	Pulsed execution (multiple scan execution type)
Timing chart	<p>When operation completes without an error</p> <p>When an error occurs</p>
Restrictions and precautions	<ul style="list-style-type: none"> <li>The FB does not include error recovery processing. Program the error recovery processing separately in accordance with the required system operation.</li> <li>The FB cannot be used in an interrupt program.</li> <li>When this FB is used twice or more, precaution must be taken to avoid repetition of the output axis No.</li> <li>If this FB is used together with other synchronous control change FBs that have the same output axis No., secure one operation cycle or more after o_bOK (Completed without error) of this FB turns ON and before the FBs are executed.</li> <li>Every input must be provided with a value for proper FB operation.</li> </ul>

## Error codes

Error code	Description	Action
100 (Hexadecimal)	The output axis No. is not within the setting range.	Please try again after confirming the setting.
300 (Hexadecimal)	The FB is executed for the output axis No. with which synchronous control is not executed.	Please try again after confirming the setting.

## Version upgrade history

Version	Date	Description
00A	2015/04/23	First edition
01A	2016/07/15	Add the 8-axis module for the applicable module. Extend the output axis No. into 8 axes.

## 2.24 M+FX5SSC\_ChangeCamPositionPerCycle

### Name

M+FX5SSC\_ChangeCamPositionPerCycle

### Overview

Item	Description
Function overview	Changes the cam axis current value per cycle to a synchronous control change value.
Symbol	<pre> graph LR     subgraph M+FX5SSC_ChangeCamPositionPerCycle         direction LR         B["(1) B : i_bEN"]         DUT["(2) DUT : i_stModule"]         UW["(3) UW : i_uOutputAxis"]         D["(4) D : i_dSyncCtrlChangeValue"]         o_bENO["o_bENO : B (5)"]         o_bOK["o_bOK : B (6)"]         o_bErr["o_bErr : B (7)"]         o_uErrId["o_uErrId : UW (8)"]     end     B --- o_bENO     DUT --- o_bOK     UW --- o_bErr     D --- o_uErrId         </pre>

### Labels

#### Input labels

No.	Variable name	Name	Data type	Setting range	Description
(1)	i_bEN	Execution command	Bit	ON, OFF	ON: The FB is activated. OFF: The FB is not activated.
(2)	i_stModule	Module label	Structure	The setting range differs depending on the module label.	Specify the module label of the MELSEC iQ-F Simple Motion module.
(3)	i_uOutputAxis	Output axis No.	Word [unsigned]	1 to 8	Set the axis No. whose cam axis current value per cycle is to be changed. The setting range differs depending on the module used.
(4)	i_dSyncCtrlChangeValue	Cd.408: Synchronous control change value	Double word [signed]	-2147483648 to 2147483647 <sup>*1,2</sup>	Set the cam axis current value per cycle to be changed. The setting value is converted within the range from 0 to (Cam axis length per cycle - 1).

\*1 The output axis position unit is set to the value corresponding to the setting of "Pr.1 Unit setting" and the cam axis cycle unit is set to the value corresponding to the setting of "Pr.438 Cam axis cycle unit setting".

\*2 The setting range is the same even if the unit differs.

#### Output labels

No.	Variable name	Name	Data type	Default value	Description
(5)	o_bENO	Execution status	Bit	OFF	ON: The execution command is ON. OFF: The execution command is OFF.
(6)	o_bOK	Completed without error	Bit	OFF	When ON, it indicates that changing the cam axis current value per cycle has been completed.
(7)	o_bErr	Error flag	Bit	OFF	When ON, it indicates that an error has occurred in the FB.
(8)	o_uErrId	Error code	Word [unsigned]	0	The error code generated in the FB is stored.

## FB details

Item	Description	
Applicable hardware and software	Applicable module	FX5-40SSC-S, FX5-80SSC-S
	Applicable CPU	MELSEC iQ-F series
	Applicable engineering software	FX5-40SSC-S: GX Works3 (Version 1.010L or later) FX5-80SSC-S: GX Works3 (Version 1.030G or later)
Programming language	Ladder	
Number of steps (maximum)	317 steps	
Function description	<ul style="list-style-type: none"> <li>By turning ON i_bEN (Execution command), the cam axis current value per cycle of the output axis No. is changed.</li> <li>When the setting value of the output axis No. is out of the range, o_bErr (Error flag) turns ON, the FB processing is interrupted, and the error code 100 (Hexadecimal) is stored in o_uErrId (Error code).</li> <li>When this FB is executed for the output axis No. with which synchronous control is not executed, o_bErr (Error flag) turns ON, the FB processing is interrupted, and the error code 300 (Hexadecimal) is stored in o_uErrId (Error code).</li> </ul>	
Compiling method	Macro type	
FB operation type	Pulsed execution (multiple scan execution type)	
Timing chart	<p>When operation completes without an error</p> <p>When an error occurs</p>	
Restrictions and precautions	<ul style="list-style-type: none"> <li>The FB does not include error recovery processing. Program the error recovery processing separately in accordance with the required system operation.</li> <li>The FB cannot be used in an interrupt program.</li> <li>When this FB is used twice or more, precaution must be taken to avoid repetition of the output axis No.</li> <li>If this FB is used together with other synchronous control change FBs that have the same output axis No., secure one operation cycle or more after o_bOK (Completed without error) of this FB turns ON and before the FBs are executed.</li> <li>Every input must be provided with a value for proper FB operation.</li> </ul>	



## Error codes

Error code	Description	Action
100 (Hexadecimal)	The output axis No. is not within the setting range.	Please try again after confirming the setting.
300 (Hexadecimal)	The FB is executed for the output axis No. with which synchronous control is not executed.	Please try again after confirming the setting.

## Version upgrade history

Version	Date	Description
00A	2015/04/23	First edition
01A	2016/07/15	Add the 8-axis module for the applicable module. Extend the output axis No. into 8 axes.

# 2.25 M+FX5SSC\_ChangeMainShaftGearPositionPerCycle

## Name

M+FX5SSC\_ChangeMainShaftGearPositionPerCycle

## Overview

Item	Description		
Function overview	Changes the current value per cycle after main shaft gear to a synchronous control change value.		
Symbol	<div style="border: 1px solid black; padding: 10px; width: fit-content; margin: 0 auto;"> <p style="text-align: center;">M+FX5SSC_ChangeMainShaftGearPositionPerCycle</p> <table style="width: 100%; border-collapse: collapse;"> <tr> <td style="width: 50%; vertical-align: top;"> <p>(1) — B : i_bEN</p> <p>(2) — DUT : i_stModule</p> <p>(3) — UW : i_uOutputAxis</p> <p>(4) — D : i_dSyncCtrlChangeValue</p> </td> <td style="width: 50%; vertical-align: top; text-align: right;"> <p>o_bENO : B — (5)</p> <p>o_bOK : B — (6)</p> <p>o_bErr : B — (7)</p> <p>o_uErrId : UW — (8)</p> </td> </tr> </table> </div>	<p>(1) — B : i_bEN</p> <p>(2) — DUT : i_stModule</p> <p>(3) — UW : i_uOutputAxis</p> <p>(4) — D : i_dSyncCtrlChangeValue</p>	<p>o_bENO : B — (5)</p> <p>o_bOK : B — (6)</p> <p>o_bErr : B — (7)</p> <p>o_uErrId : UW — (8)</p>
<p>(1) — B : i_bEN</p> <p>(2) — DUT : i_stModule</p> <p>(3) — UW : i_uOutputAxis</p> <p>(4) — D : i_dSyncCtrlChangeValue</p>	<p>o_bENO : B — (5)</p> <p>o_bOK : B — (6)</p> <p>o_bErr : B — (7)</p> <p>o_uErrId : UW — (8)</p>		

## Labels

### Input labels

No.	Variable name	Name	Data type	Setting range	Description
(1)	i_bEN	Execution command	Bit	ON, OFF	ON: The FB is activated. OFF: The FB is not activated.
(2)	i_stModule	Module label	Structure	The setting range differs depending on the module label.	Specify the module label of the MELSEC iQ-F Simple Motion module.
(3)	i_uOutputAxis	Output axis No.	Word [unsigned]	1 to 8	Set the axis No. whose current value per cycle after main shaft gear is to be changed. The setting range differs depending on the module used.
(4)	i_dSyncCtrlChangeValue	Cd.408: Synchronous control change value	Double word [signed]	-2147483648 to 2147483647 <sup>*1*2</sup>	Set the current value per cycle after main shaft gear to be changed. The setting value is converted within the range from 0 to (Cam axis length per cycle - 1).

\*1 The output axis position unit is set to the value corresponding to the setting of "Pr.1 Unit setting" and the cam axis cycle unit is set to the value corresponding to the setting of "Pr.438 Cam axis cycle unit setting".

\*2 The setting range is the same even if the unit differs.

### Output labels

No.	Variable name	Name	Data type	Default value	Description
(5)	o_bENO	Execution status	Bit	OFF	ON: The execution command is ON. OFF: The execution command is OFF.
(6)	o_bOK	Completed without error	Bit	OFF	When ON, it indicates that changing the current value per cycle after main shaft gear has been completed.
(7)	o_bErr	Error flag	Bit	OFF	When ON, it indicates that an error has occurred in the FB.
(8)	o_uErrId	Error code	Word [unsigned]	0	The error code generated in the FB is stored.

## FB details

Item	Description
Applicable hardware and software	Applicable module FX5-40SSC-S, FX5-80SSC-S
	Applicable CPU MELSEC iQ-F series
	Applicable engineering software FX5-40SSC-S: GX Works3 (Version 1.010L or later) FX5-80SSC-S: GX Works3 (Version 1.030G or later)
Programming language	Ladder
Number of steps (maximum)	317 steps
Function description	<ul style="list-style-type: none"> <li>By turning ON i_bEN (Execution command), the current value per cycle after main shaft gear of the output axis No. is changed.</li> <li>When the setting value of the output axis No. is out of the range, o_bErr (Error flag) turns ON, the FB processing is interrupted, and the error code 100 (Hexadecimal) is stored in o_uErrId (Error code).</li> <li>When this FB is executed for the output axis No. with which synchronous control is not executed, o_bErr (Error flag) turns ON, the FB processing is interrupted, and the error code 300 (Hexadecimal) is stored in o_uErrId (Error code).</li> </ul>
Compiling method	Macro type
FB operation type	Pulsed execution (multiple scan execution type)
Timing chart	<p>When operation completes without an error</p> <p>When an error occurs</p>
Restrictions and precautions	<ul style="list-style-type: none"> <li>The FB does not include error recovery processing. Program the error recovery processing separately in accordance with the required system operation.</li> <li>The FB cannot be used in an interrupt program.</li> <li>When this FB is used twice or more, precaution must be taken to avoid repetition of the output axis No.</li> <li>If this FB is used together with other synchronous control change FBs that have the same output axis No., secure one operation cycle or more after o_bOK (Completed without error) of this FB turns ON and before the FBs are executed.</li> <li>Every input must be provided with a value for proper FB operation.</li> </ul>

## Error codes

Error code	Description	Action
100 (Hexadecimal)	The output axis No. is not within the setting range.	Please try again after confirming the setting.
300 (Hexadecimal)	The FB is executed for the output axis No. with which synchronous control is not executed.	Please try again after confirming the setting.

## Version upgrade history

Version	Date	Description
00A	2015/04/23	First edition
01A	2016/07/15	Add the 8-axis module for the applicable module. Extend the output axis No. into 8 axes.

# 2.26 M+FX5SSC\_ChangeAuxiliaryShaftGearPositionPerCycle

## Name

M+FX5SSC\_ChangeAuxiliaryShaftGearPositionPerCycle

## Overview

Item	Description
Function overview	Changes the current value per cycle after auxiliary shaft gear to a synchronous control change value.
Symbol	

## Labels

### Input labels

No.	Variable name	Name	Data type	Setting range	Description
(1)	i_bEN	Execution command	Bit	ON, OFF	ON: The FB is activated. OFF: The FB is not activated.
(2)	i_stModule	Module label	Structure	The setting range differs depending on the module label.	Specify the module label of the MELSEC iQ-F Simple Motion module.
(3)	i_uOutputAxis	Output axis No.	Word [unsigned]	1 to 8	Set the axis No. whose current value per cycle after auxiliary shaft gear is to be changed. The setting range differs depending on the module used.
(4)	i_dSyncCtrlChangeValue	Cd.408: Synchronous control change value	Double word [signed]	-2147483648 to 2147483647 <sup>*1,2</sup>	Set the current value per cycle after auxiliary shaft gear to be changed. The setting value is converted within the range from 0 to (Cam axis length per cycle - 1).

\*1 The output axis position unit is set to the value corresponding to the setting of "Pr.1 Unit setting" and the cam axis cycle unit is set to the value corresponding to the setting of "Pr.438 Cam axis cycle unit setting".

\*2 The setting range is the same even if the unit differs.

### Output labels

No.	Variable name	Name	Data type	Default value	Description
(5)	o_bENO	Execution status	Bit	OFF	ON: The execution command is ON. OFF: The execution command is OFF.
(6)	o_bOK	Completed without error	Bit	OFF	When ON, it indicates that changing the current value per cycle after auxiliary shaft gear has been completed.
(7)	o_bErr	Error flag	Bit	OFF	When ON, it indicates that an error has occurred in the FB.
(8)	o_uErrId	Error code	Word [unsigned]	0	The error code generated in the FB is stored.

## FB details

Item	Description	
Applicable hardware and software	Applicable module	FX5-40SSC-S, FX5-80SSC-S
	Applicable CPU	MELSEC iQ-F series
	Applicable engineering software	FX5-40SSC-S: GX Works3 (Version 1.010L or later) FX5-80SSC-S: GX Works3 (Version 1.030G or later)
Programming language	Ladder	
Number of steps (maximum)	317 steps	
Function description	<ul style="list-style-type: none"> <li>By turning ON i_bEN (Execution command), the current value per cycle after auxiliary shaft gear of the output axis No. is changed.</li> <li>When the setting value of the output axis No. is out of the range, o_bErr (Error flag) turns ON, the FB processing is interrupted, and the error code 100 (Hexadecimal) is stored in o_uErrId (Error code).</li> <li>When this FB is executed for the output axis No. with which synchronous control is not executed, o_bErr (Error flag) turns ON, the FB processing is interrupted, and the error code 300 (Hexadecimal) is stored in o_uErrId (Error code).</li> </ul>	
Compiling method	Macro type	
FB operation type	Pulsed execution (multiple scan execution type)	
Timing chart	<p>When operation completes without an error</p> <p>When an error occurs</p>	
Restrictions and precautions	<ul style="list-style-type: none"> <li>The FB does not include error recovery processing. Program the error recovery processing separately in accordance with the required system operation.</li> <li>The FB cannot be used in an interrupt program.</li> <li>When this FB is used twice or more, precaution must be taken to avoid repetition of the output axis No.</li> <li>If this FB is used together with other synchronous control change FBs that have the same output axis No., secure one operation cycle or more after o_bOK (Completed without error) of this FB turns ON and before the FBs are executed.</li> <li>Every input must be provided with a value for proper FB operation.</li> </ul>	

## Error codes

Error code	Description	Action
100 (Hexadecimal)	The output axis No. is not within the setting range.	Please try again after confirming the setting.
300 (Hexadecimal)	The FB is executed for the output axis No. with which synchronous control is not executed.	Please try again after confirming the setting.

## Version upgrade history

Version	Date	Description
00A	2015/04/23	First edition
01A	2016/07/15	Add the 8-axis module for the applicable module. Extend the output axis No. into 8 axes.

## 2.27 M+FX5SSC\_MoveCamPositionPerCycle

### Name

M+FX5SSC\_MoveCamPositionPerCycle

### Overview

Item	Description
Function overview	Adds the movement amount set in the synchronous control change value to a cam axis current value per cycle to move the cam axis current value per cycle.
Symbol	<div style="text-align: center;"> </div>

### Labels

#### Input labels

No.	Variable name	Name	Data type	Setting range	Description
(1)	i_bEN	Execution command	Bit	ON, OFF	ON: The FB is activated. OFF: The FB is not activated.
(2)	i_stModule	Module label	Structure	The setting range differs depending on the module label.	Specify the module label of the MELSEC iQ-F Simple Motion module.
(3)	i_uOutputAxis	Output axis No.	Word [unsigned]	1 to 8	Set the axis No. whose cam axis current value per cycle is to be moved. The setting range differs depending on the module used.
(4)	i_dSyncCtrlChangeValue	Cd.408: Synchronous control change value	Double word [signed]	-2147483648 to 2147483647 <sup>*1,2</sup>	Set the amount of the cam axis current value per cycle movement.
(5)	i_uSyncCtrlReflectionTime	Cd.409: Synchronous control reflection time	Word [unsigned]	0 to 65535 (ms) (0 to 32767: Set by decimal number. 32768 to 65535: Convert the number to hexadecimal number and set.)	Set the reflection time for the synchronous control change.

\*1 The output axis position unit is set to the value corresponding to the setting of "Pr.1 Unit setting" and the cam axis cycle unit is set to the value corresponding to the setting of "Pr.438 Cam axis cycle unit setting".

\*2 The setting range is the same even if the unit differs.

#### Output labels

No.	Variable name	Name	Data type	Default value	Description
(6)	o_bENO	Execution status	Bit	OFF	ON: The execution command is ON. OFF: The execution command is OFF.
(7)	o_bOK	Completed without error	Bit	OFF	When ON, it indicates that moving the cam axis current value per cycle has been completed.
(8)	o_bErr	Error flag	Bit	OFF	When ON, it indicates that an error has occurred in the FB.
(9)	o_uErrId	Error code	Word [unsigned]	0	The error code generated in the FB is stored.



## FB details

Item	Description	
Applicable hardware and software	Applicable module	FX5-40SSC-S, FX5-80SSC-S
	Applicable CPU	MELSEC iQ-F series
	Applicable engineering software	FX5-40SSC-S: GX Works3 (Version 1.010L or later) FX5-80SSC-S: GX Works3 (Version 1.030G or later)
Programming language	Ladder	
Number of steps (maximum)	427 steps	
Function description	<ul style="list-style-type: none"> <li>By turning ON i_bEN (Execution command), the cam axis current value per cycle of the output axis No. is moved.</li> <li>If i_bEN (Execution command) is turned OFF during movement of the cam axis current value per cycle, the operation stops during the movement and o_bOK (Completed without error) does not turn ON.</li> <li>When the setting value of the output axis No. is out of the range, o_bErr (Error flag) turns ON, the FB processing is interrupted, and the error code 100 (Hexadecimal) is stored in o_uErrId (Error code).</li> <li>When this FB is executed for the output axis No. with which synchronous control is not executed, o_bErr (Error flag) turns ON, the FB processing is interrupted, and the error code 300 (Hexadecimal) is stored in o_uErrId (Error code).</li> </ul>	
Compiling method	Macro type	
FB operation type	Pulsed execution (multiple scan execution type)	
Timing chart	<p>When operation completes without an error</p> <p>When an error occurs</p>	
Restrictions and precautions	<ul style="list-style-type: none"> <li>The FB does not include error recovery processing. Program the error recovery processing separately in accordance with the required system operation.</li> <li>The FB cannot be used in an interrupt program.</li> <li>When this FB is used twice or more, precaution must be taken to avoid repetition of the output axis No.</li> <li>If this FB is used together with other synchronous control change FBs that have the same output axis No., secure one operation cycle or more after o_bOK (Completed without error) of this FB turns ON and before the FBs are executed.</li> <li>Every input must be provided with a value for proper FB operation.</li> </ul>	

## Error codes

Error code	Description	Action
100 (Hexadecimal)	The output axis No. is not within the setting range.	Please try again after confirming the setting.
300 (Hexadecimal)	The FB is executed for the output axis No. with which synchronous control is not executed.	Please try again after confirming the setting.

## Version upgrade history

Version	Date	Description
00A	2015/04/23	First edition
01A	2016/07/15	Add the 8-axis module for the applicable module. Extend the output axis No. into 8 axes.

## 2.28 M+FX5SSC\_MakeRotaryCutterCam

### Name

M+FX5SSC\_MakeRotaryCutterCam

### Overview

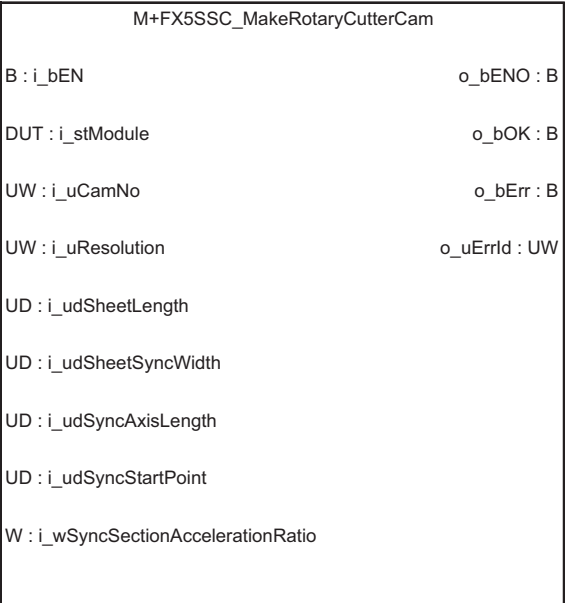
Item	Description
Function overview	Automatically generates the cam for a rotary cutter.
Symbol	 <p>The diagram shows a rectangular block titled 'M+FX5SSC_MakeRotaryCutterCam'. On the left side, there are 9 input ports labeled (1) through (9) with their respective data types: (1) B : i_bEN, (2) DUT : i_stModule, (3) UW : i_uCamNo, (4) UW : i_uResolution, (5) UD : i_udSheetLength, (6) UD : i_udSheetSyncWidth, (7) UD : i_udSyncAxisLength, (8) UD : i_udSyncStartPoint, and (9) W : i_wSyncSectionAccelerationRatio. On the right side, there are 4 output ports labeled (10) through (13) with their respective data types: (10) o_bENO : B, (11) o_bOK : B, (12) o_bErr : B, and (13) o_uErrId : UW.</p>

## Labels

### ■ Input labels

No.	Variable name	Name	Data type	Setting range	Description
(1)	i_bEN	Execution command	Bit	ON, OFF	ON: The FB is activated. OFF: The FB is not activated.
(2)	i_stModule	Module label	Structure	The setting range differs depending on the module label.	Specify the module label of the MELSEC iQ-F Simple Motion module.
(3)	i_uCamNo	Cd.609: Cam auto-generation cam No.	Word [unsigned]	1 to 128	Set the cam No. to be automatically generated.
(4)	i_uResolution	Cd.611: Cam auto-generation data: Cam resolution	Word [unsigned]	256/512/1024/2048/4096/8192/16384	Set the resolution of the cam to be generated.
(5)	i_udSheetLength	Cd.611: Cam auto-generation data: Sheet length	Double word [unsigned]	1 to 2147483647 [(Optional) same unit (such as 0.1 mm)]	Set the sheet length. Set this value in the cam axis length per cycle.
(6)	i_udSheetSyncWidth	Cd.611: Cam auto-generation data: Sheet synchronous width	Double word [unsigned]	1 to 2147483647 [(Optional) same unit (such as 0.1 mm)]	Set the sheet length of the synchronous section.
(7)	i_udSyncAxisLength	Cd.611: Cam auto-generation data: Synchronous axis length	Double word [unsigned]	1 to 2147483647 [(Optional) same unit (such as 0.1 mm)]	Set the cycle length of the rotary cutter shaft.
(8)	i_udSyncStartPoint	Cd.611: Cam auto-generation data: Synchronization starting point	Double word [unsigned]	1 to 2147483647 [(Optional) same unit (such as 0.1 mm)]	Set the length from the beginning of the sheet to the start of the synchronous section.
(9)	i_wSyncSectionAccelerationRatio	Cd.611: Cam auto-generation data: Synchronous section acceleration ratio	Word [signed]	-5000 to 5000 [0.01%]	Set this label when the synchronous speed in the synchronous section needs to be adjusted. The speed is "Synchronous speed × (100% + Acceleration ratio)" in the synchronous section.

### ■ Output labels

No.	Variable name	Name	Data type	Default value	Description
(10)	o_bENO	Execution status	Bit	OFF	ON: The execution command is ON. OFF: The execution command is OFF.
(11)	o_bOK	Completed without error	Bit	OFF	When ON, it indicates that the cam automatic generation has been completed.
(12)	o_bErr	Error flag	Bit	OFF	Always OFF
(13)	o_uErrId	Error code	Word [unsigned]	0	Always 0

## FB details

Item	Description	
Applicable hardware and software	Applicable module	FX5-40SSC-S, FX5-80SSC-S
	Applicable CPU	MELSEC iQ-F series
	Applicable engineering software	FX5-40SSC-S: GX Works3 (Version 1.010L or later) FX5-80SSC-S: GX Works3 (Version 1.030G or later)
Programming language	Ladder	
Number of steps (maximum)	157 steps	
Function description	By turning ON i_bEN (Execution command), the cam for a rotary cutter is automatically generated.	
Compiling method	Macro type	
FB operation type	Pulsed execution (multiple scan execution type)	
Timing chart	<p>The timing chart illustrates the sequence of events for the FB. It shows four signals over time: i_bEN (Execution command), o_bENO (Execution status), Cam auto-generation request, and o_bOK (Completed without error). i_bEN is a pulsed signal that starts high and then goes low. o_bENO is a signal that goes high when i_bEN starts and remains high until i_bEN goes low. Cam auto-generation request is a pulsed signal that starts high when i_bEN starts and goes low when i_bEN goes low. o_bOK is a signal that goes high when Cam auto-generation request starts and remains high until Cam auto-generation request goes low.</p>	
Restrictions and precautions	<ul style="list-style-type: none"> <li>• The FB does not include error recovery processing. Program the error recovery processing separately in accordance with the required system operation.</li> <li>• Even if a warning occurs in the execution of this FB, o_bOK (Completed without error) turns ON.</li> <li>• The FB cannot be used in an interrupt program.</li> <li>• Every input must be provided with a value for proper FB operation.</li> </ul>	

## Error codes

Error code	Description	Action
None	None	None

## Version upgrade history

Version	Date	Description
00A	2015/04/23	First edition

## 2.29 M+FX5SSC\_CalcCamCommandPosition

### Name

M+FX5SSC\_CalcCamCommandPosition

### Overview

Item	Description																												
Function overview	Calculates a cam axis feed current value, and outputs the calculation result.																												
Symbol	<div style="text-align: center;"> <p style="text-align: center;">M+FX5SSC_CalcCamCommandPosition</p> <table style="margin: auto; border-collapse: collapse;"> <tr> <td style="text-align: right;">(1) —</td> <td>B : i_bEN</td> <td style="text-align: left;">o_bENO : B</td> <td style="text-align: left;">(8)</td> </tr> <tr> <td style="text-align: right;">(2) —</td> <td>DUT : i_stModule</td> <td style="text-align: left;">o_bOK : B</td> <td style="text-align: left;">(9)</td> </tr> <tr> <td style="text-align: right;">(3) —</td> <td>UW : i_uCamNo</td> <td style="text-align: left;">o_dResult : D</td> <td style="text-align: left;">(10)</td> </tr> <tr> <td style="text-align: right;">(4) —</td> <td>D : i_dStroke</td> <td style="text-align: left;">o_bErr : B</td> <td style="text-align: left;">(11)</td> </tr> <tr> <td style="text-align: right;">(5) —</td> <td>UD : i_udLengthPerCycle</td> <td style="text-align: left;">o_uErrId : UW</td> <td style="text-align: left;">(12)</td> </tr> <tr> <td style="text-align: right;">(6) —</td> <td>D : i_dReferencePosition</td> <td></td> <td></td> </tr> <tr> <td style="text-align: right;">(7) —</td> <td>UD : i_udCommandPositionPerCycle</td> <td></td> <td></td> </tr> </table> </div>	(1) —	B : i_bEN	o_bENO : B	(8)	(2) —	DUT : i_stModule	o_bOK : B	(9)	(3) —	UW : i_uCamNo	o_dResult : D	(10)	(4) —	D : i_dStroke	o_bErr : B	(11)	(5) —	UD : i_udLengthPerCycle	o_uErrId : UW	(12)	(6) —	D : i_dReferencePosition			(7) —	UD : i_udCommandPositionPerCycle		
(1) —	B : i_bEN	o_bENO : B	(8)																										
(2) —	DUT : i_stModule	o_bOK : B	(9)																										
(3) —	UW : i_uCamNo	o_dResult : D	(10)																										
(4) —	D : i_dStroke	o_bErr : B	(11)																										
(5) —	UD : i_udLengthPerCycle	o_uErrId : UW	(12)																										
(6) —	D : i_dReferencePosition																												
(7) —	UD : i_udCommandPositionPerCycle																												

### Labels

#### Input labels

No.	Variable name	Name	Data type	Setting range	Description
(1)	i_bEN	Execution command	Bit	ON, OFF	ON: The FB is activated. OFF: The FB is not activated.
(2)	i_stModule	Module label	Structure	The setting range differs depending on the module label.	Specify the module label of the MELSEC iQ-F Simple Motion module.
(3)	i_uCamNo	Cd.613: Cam position calculation: Cam No.	Word [unsigned]	0 to 256	Set the cam No. used for the calculation cam.
(4)	i_dStroke	Cd.614: Cam position calculation: Stroke amount	Double word [signed]	-2147483648 to 2147483647 <sup>*1</sup>	Set the cam stroke amount used for the cam position calculation.
(5)	i_udLengthPerCycle	Cd.615: Cam position calculation: Cam axis length per cycle	Double word [unsigned]	1 to 2147483647 <sup>*2</sup>	Set the cam axis length per cycle used for the cam position calculation.
(6)	i_dReferencePosition	Cd.616: Cam position calculation: Cam reference position	Double word [signed]	-2147483648 to 2147483647 <sup>*1</sup>	Set the cam reference position used for the cam position calculation.
(7)	i_udCommandPositionPerCycle	Cd.617: Cam position calculation: Cam axis current value per cycle	Double word [unsigned]	0 to (Cam axis length per cycle) <sup>*2</sup>	Set the cam axis current value per cycle used for the cam position calculation.

\*1 The setting range is the same even if the output axis position unit differs.

\*2 The setting range is the same even if the cam axis cycle unit differs. The cam axis cycle unit is set to the value corresponding to the setting of "Pr.438 Cam axis cycle unit setting".

## Output labels

No.	Variable name	Name	Data type	Default value	Description
(8)	o_bENO	Execution status	Bit	OFF	ON: The execution command is ON. OFF: The execution command is OFF.
(9)	o_bOK	Completed without error	Bit	OFF	When ON, it indicates that calculating the cam axis feed current value has been completed.
(10)	o_dResult	Cam position calculation result	Double word [signed]	0	The result of the cam axis feed current value calculation is stored.
(11)	o_bErr	Error flag	Bit	OFF	Always OFF
(12)	o_uErrId	Error code	Word [unsigned]	0	Always 0

## FB details

Item	Description	
Applicable hardware and software	Applicable module	FX5-40SSC-S, FX5-80SSC-S
	Applicable CPU	MELSEC iQ-F series
	Applicable engineering software	FX5-40SSC-S: GX Works3 (Version 1.010L or later) FX5-80SSC-S: GX Works3 (Version 1.030G or later)
Programming language	Ladder	
Number of steps (maximum)	135 steps	
Function description	By turning ON i_bEN (Execution command), the cam axis feed current value is calculated.	
Compiling method	Macro type	
FB operation type	Pulsed execution (multiple scan execution type)	
Timing chart	<p>The timing chart illustrates the sequence of events for the FB. It shows five signals over time: i_bEN (Execution command), o_bENO (Execution status), Cam position calculation request, o_dResult (Cam position calculation result), and o_bOK (Completed without error). i_bEN is a pulsed signal. When i_bEN goes ON, o_bENO goes ON. The Cam position calculation request is also pulsed. o_dResult starts at 0, then transitions to a 'Calculation result' value. o_bOK goes ON after the calculation is complete.</p>	
Restrictions and precautions	<ul style="list-style-type: none"> <li>The FB does not include error recovery processing. Program the error recovery processing separately in accordance with the required system operation.</li> <li>Even if a warning occurs in the execution of this FB, o_bOK (Completed without error) turns ON.</li> <li>The FB cannot be used in an interrupt program.</li> <li>Every input must be provided with a value for proper FB operation.</li> </ul>	

## Error codes

Error code	Description	Action
None	None	None

## Version upgrade history

Version	Date	Description
00A	2015/04/23	First edition

## 2.30 M+FX5SSC\_CalcCamPositionPerCycle

### Name

M+FX5SSC\_CalcCamPositionPerCycle

### Overview

Item	Description
Function overview	Calculates a cam axis current value per cycle, and outputs the calculation result.
Symbol	

### Labels

#### Input labels

No.	Variable name	Name	Data type	Setting range	Description
(1)	i_bEN	Execution command	Bit	ON, OFF	ON: The FB is activated. OFF: The FB is not activated.
(2)	i_stModule	Module label	Structure	The setting range differs depending on the module label.	Specify the module label of the MELSEC iQ-F Simple Motion module.
(3)	i_uCamNo	Cd.613: Cam position calculation: Cam No.	Word [unsigned]	0 to 256	Set the cam No. used for the calculation cam.
(4)	i_dStroke	Cd.614: Cam position calculation: Stroke amount	Double word [signed]	-2147483648 to 2147483647 <sup>*1</sup>	Set the cam stroke amount used for the cam position calculation.
(5)	i_udLengthPerCycle	Cd.615: Cam position calculation: Cam axis length per cycle	Double word [unsigned]	1 to 2147483647 <sup>*2</sup>	Set the cam axis length per cycle used for the cam position calculation.
(6)	i_dReferencePosition	Cd.616: Cam position calculation: Cam reference position	Double word [signed]	-2147483648 to 2147483647 <sup>*1</sup>	Set the cam reference position used for the cam position calculation.
(7)	i_udCommandPositionPerCycle	Cd.617: Cam position calculation: Cam axis current value per cycle	Double word [unsigned]	0 to (Cam axis length per cycle) <sup>*2</sup>	Set the current value from which the cam search used for the cam position calculation is started.
(8)	i_dCommandPosition	Cd.618: Cam position calculation: Cam axis feed current value	Double word [signed]	-2147483648 to 2147483647 <sup>*1</sup>	Set the cam axis feed current value used for the cam position calculation.

\*1 The setting range is the same even if the output axis position unit differs.

\*2 The setting range is the same even if the cam axis cycle unit differs. The cam axis cycle unit is set to the value corresponding to the setting of "Pr.438 Cam axis cycle unit setting".



## Output labels

No.	Variable name	Name	Data type	Default value	Description
(9)	o_bENO	Execution status	Bit	OFF	ON: The execution command is ON. OFF: The execution command is OFF.
(10)	o_bOK	Completed without error	Bit	OFF	When ON, it indicates that calculating the cam axis current value per cycle has been completed.
(11)	o_dResult	Cam position calculation result	Double word [signed]	0	The result of the cam axis current value per cycle calculation is stored.
(12)	o_bErr	Error flag	Bit	OFF	Always OFF
(13)	o_uErrId	Error code	Word [unsigned]	0	Always 0

## FB details

Item	Description	
Applicable hardware and software	Applicable module	FX5-40SSC-S, FX5-80SSC-S
	Applicable CPU	MELSEC iQ-F series
	Applicable engineering software	FX5-40SSC-S: GX Works3 (Version 1.010L or later) FX5-80SSC-S: GX Works3 (Version 1.030G or later)
Programming language	Ladder	
Number of steps (maximum)	149 steps	
Function description	By turning ON i_bEN (Execution command), the cam axis current value per cycle is calculated.	
Compiling method	Macro type	
FB operation type	Pulsed execution (multiple scan execution type)	
Timing chart	<p>The timing chart illustrates the sequence of events for the FB. It shows five signals over time: i_bEN (Execution command), o_bENO (Execution status), Cam position calculation request, o_dResult (Cam position calculation result), and o_bOK (Completed without error). i_bEN is a pulsed signal. When i_bEN is ON, o_bENO turns ON. The Cam position calculation request is also pulsed. o_dResult starts at 0, then shows a 'Calculation result' pulse, and returns to 0. o_bOK turns ON after the calculation result is processed.</p>	
Restrictions and precautions	<ul style="list-style-type: none"> <li>The FB does not include error recovery processing. Program the error recovery processing separately in accordance with the required system operation.</li> <li>Even if a warning occurs in the execution of this FB, o_bOK (Completed without error) turns ON.</li> <li>The FB cannot be used in an interrupt program.</li> <li>Every input must be provided with a value for proper FB operation.</li> </ul>	

## Error codes

Error code	Description	Action
None	None	None

## Version upgrade history

Version	Date	Description
00A	2015/04/23	First edition

# INSTRUCTION INDEX

---

## M

M+FX5SSC_CalcCamCommandPosition . . . . .	92
M+FX5SSC_CalcCamPositionPerCycle . . . . .	94
M+FX5SSC_ChangeAccDecTime . . . . .	20
M+FX5SSC_ChangeAuxiliaryShaftGearPositionPerCycle . . . . .	83
M+FX5SSC_ChangeCamPositionPerCycle . . . . .	77
M+FX5SSC_ChangeContinuousTorqueMode . . . . .	51
M+FX5SSC_ChangeMainShaftGearPositionPerCycle . . . . .	80
M+FX5SSC_ChangePosition . . . . .	24
M+FX5SSC_ChangePositionControlMode . . . . .	48
M+FX5SSC_ChangeServoParameter . . . . .	37
M+FX5SSC_ChangeSpeed . . . . .	17
M+FX5SSC_ChangeSpeedControlMode . . . . .	45
M+FX5SSC_ChangeSyncEncoderPosition . . . . .	59
M+FX5SSC_ChangeTorqueControlMode . . . . .	41
M+FX5SSC_ConnectSyncEncoder . . . . .	72
M+FX5SSC_DisableSyncEncoder . . . . .	62
M+FX5SSC_EnableSyncEncoder . . . . .	65
M+FX5SSC_InitializeParameter . . . . .	33
M+FX5SSC_JOG . . . . .	11
M+FX5SSC_MakeRotaryCutterCam . . . . .	89
M+FX5SSC_MoveCamPositionPerCycle . . . . .	86
M+FX5SSC_MoveCamReferencePosition . . . . .	74
M+FX5SSC_MPG . . . . .	14
M+FX5SSC_OperateError . . . . .	29
M+FX5SSC_ResetSyncEncoderError . . . . .	68
M+FX5SSC_Restart . . . . .	27
M+FX5SSC_SetPositioningData . . . . .	4
M+FX5SSC_StartPositioning . . . . .	8
M+FX5SSC_Sync . . . . .	56
M+FX5SSC_WriteFlash . . . . .	35

# MEMO

---

# REVISIONS

---

\*The manual number is given on the bottom left of the back cover.

Revision date	*Manual number	Description
April 2015	BCN-B62005-719-A	First edition
October 2016	BCN-B62005-719-B	■ Added model FX5-80SSC-S ■ Added or modified parts Chapter 1, 2

Japanese manual number: BCN-B62005-717-B

This manual confers no industrial property rights of any other kind, nor does it confer any patent licenses. Mitsubishi Electric Corporation cannot be held responsible for any problems involving industrial property rights which may occur as a result of using the contents noted in this manual.

© 2015 MITSUBISHI ELECTRIC CORPORATION



Manual number: BCN-B62005-719-B(1610)MEE

When exported from Japan, this manual does not require application to the Ministry of Economy, Trade and Industry for service transaction permission.

## **mitsubishi electric corporation**

HEAD OFFICE: TOKYO BUILDING, 2-7-3 MARUNOUCHI, CHIYODA-KU, TOKYO 100-8310, JAPAN  
NAGOYA WORKS: 1-14, YADA-MINAMI 5-CHOME, HIGASHI-KU, NAGOYA, JAPAN

Specifications are subject to change without notice.