

Programmable Controller

MELSEC iQ-F
series

MELSEC iQ-F
FX5 User's Manual (CC-Link IE TSN)

WHEN USING AN INDUSTRIAL SWITCH WITH CC-Link IE TSN

To connect modules on CC-Link IE TSN, a dedicated industrial switch (for CC-Link IE TSN Class B) may be required depending on parameter settings or the network topology used.

Read the following carefully.

☞ Page 60 SYSTEM CONFIGURATION

☞ Page 125 Industrial switch

SAFETY PRECAUTIONS

(Read these precautions before use.)

Before using this product, please read this manual and the relevant manuals introduced in this manual carefully and pay full attention to safety in order to handle the product correctly.

This manual classifies the safety precautions into two categories: [⚠ WARNING] and [⚠ CAUTION].

 WARNING	Indicates that incorrect handling may cause hazardous conditions, resulting in death or severe injury.
 CAUTION	Indicates that incorrect handling may cause hazardous conditions, resulting in minor or moderate injury or property damage.

Depending on the circumstances, procedures indicated by [⚠ CAUTION] may also cause severe injury.

It is important to follow all precautions for personal safety.

Store this manual in a safe place so that it can be read whenever necessary. Always forward it to the end user.

[Design Precautions]

WARNING

- Make sure to set up the following safety circuits outside the programmable controller to ensure safe system operation even during external power supply problems or programmable controller failure. Otherwise, malfunctions may cause serious accidents.
 - Most importantly, set up the following: an emergency stop circuit, a protection circuit, an interlock circuit for opposite movements (such as normal vs. reverse rotation), and an interlock circuit (to prevent damage to the equipment at the upper and lower positioning limits).
 - Note that when the CPU module detects an error, such as a watchdog timer error, during self-diagnosis, all outputs are turned off. - Also, when an error that cannot be detected by the CPU module occurs in an input/output control block, output control may be disabled. External circuits and mechanisms should be designed to ensure safe machinery operation in such a case.
 - Note that when an error occurs in a relay or transistor of an output circuit, the output might stay on or off. For output signals that may lead to serious accidents, external circuits and mechanisms should be designed to ensure safe machinery operation in such a case.
 - In an output circuit, when a load current exceeding the rated current or an overcurrent caused by a load short-circuit flows for a long time, it may cause smoke and fire. To prevent this, configure an external safety circuit, such as a fuse.
 - For the operating status of each station after a communication failure, refer to manuals relevant to the network. Incorrect output or malfunction may result in an accident.
 - Construct an interlock circuit in the program so that the whole system always operates on the safe side before executing the control (for data change) of the programmable controller in operation. Read the manual thoroughly and ensure complete safety before executing other controls (for program change, parameter change, forcible output and operation status change) of the programmable controller in operation. Otherwise, the machine may be damaged and accidents may occur due to erroneous operations.
 - Especially, in the case of a control from an external device to a remote programmable controller, immediate action cannot be taken for a problem on the programmable controller due to a communication failure. Determine the handling method as a system when communication failure occurs along with configuration of interlock circuit on a program, by considering the external equipment and CPU module.
 - Do not write any data to the "system area" and "write-protect area" of the buffer memory in the module. Executing data writing to the "system area" or "write protect area" may cause malfunction of the programmable controller alarm. For the "system area" or "write-protect area", refer to  Page 226 Buffer Memory.
 - If a communication cable is disconnected, the network may be unstable, resulting in a communication failure of multiple stations. Construct an interlock circuit in the program so that the system always operates on the safe side even if communications fail. Incorrect output or malfunction may result in an accident.
-

[Design Precautions]

CAUTION

- Do not bundle the control line and communication cables together with or lay them close to the main circuit or power line. Keep a distance of 100mm or more between them. Failure to do so may result in malfunction due to noise.
 - Simultaneously turn on and off the power supplies of the CPU module and extension modules.
-

[Security Precautions]

WARNING

- To maintain the security (confidentiality, integrity, and availability) of the programmable controller and the system against unauthorized access, denial-of-service (DoS) attacks, computer viruses, and other cyberattacks from unreliable networks and devices via the network, take appropriate measures such as firewalls, virtual private networks (VPNs), and antivirus solutions.
-

[Installation Precautions]

WARNING

- Make sure to cut off all phases of the power supply externally before attempting installation or wiring work. Failure to do so may cause electric shock or damage to the product.
 - Use the product within the generic environment specifications described in the User's Manual (Hardware) of the CPU module used.
Never use the product in areas with excessive dust, oily smoke, conductive dusts, corrosive gas (salt air, Cl₂, H₂S, SO₂ or NO₂), flammable gas, vibration or impacts, or expose it to high temperature, condensation, or rain and wind.
If the product is used in such conditions, electric shock, fire, malfunctions, deterioration or damage may occur.
-

[Installation Precautions]

CAUTION

- Do not touch the conductive parts of the product directly. Doing so may cause device failures or malfunctions.
 - When drilling screw holes or wiring, make sure that cutting and wiring debris do not enter the ventilation slits of the programmable controller. Failure to do so may cause fire, equipment failures or malfunctions.
 - For the product supplied together with a dust proof sheet, the sheet should be affixed to the ventilation slits before the installation and wiring work to prevent foreign objects such as cutting and wiring debris.
However, when the installation work is completed, make sure to remove the sheet to provide adequate ventilation. Failure to do so may cause fire, equipment failures or malfunctions.
 - Install the product on a flat surface. If the mounting surface is rough, undue force will be applied to the PC board, thereby causing nonconformities.
 - Install the product securely using a DIN rail or mounting screws.
 - Work carefully when using a screwdriver such as installation of the product. Failure to do so may cause damage to the product or accidents.
 - Connect the extension cables, peripheral device cables, input/output cables and battery connecting cable securely to their designated connectors. Loose connections may cause malfunctions.
 - Turn off the power to the programmable controller before attaching or detaching the following devices. Failure to do so may cause device failures or malfunctions.
 - Peripheral devices, expansion board, expansion adapter, and connector conversion adapter
 - Extension modules, bus conversion module, and connector conversion module
 - Battery
-

[Wiring Precautions]

WARNING

- Make sure to cut off all phases of the power supply externally before attempting installation or wiring work. Failure to do so may cause electric shock or damage to the product.
 - Make sure to attach the terminal cover, provided as an accessory, before turning on the power or initiating operation after installation or wiring work. Failure to do so may cause electric shock.
 - The temperature rating of the cable should be 80°C or more.
 - Make sure to wire the screw terminal block in accordance with the following precautions. Failure to do so may cause electric shock, equipment failures, a short-circuit, wire breakage, malfunctions, or damage to the product.
 - The disposal size of the cable end should follow the dimensions described in the User's Manual (Hardware) of the CPU module used.
 - Tightening torque should follow the specifications in the User's Manual (Hardware) of the CPU module used.
 - Tighten the screws using a Phillips-head screwdriver No.2 (shaft diameter 6mm or less). Make sure that the screwdriver does not touch the partition part of the terminal block.
-

[Wiring Precautions]

CAUTION

- Perform class D grounding (grounding resistance: 100Ω or less) of the grounding terminal on the CPU module and extension modules with a wire 2mm² or thicker.
Do not use common grounding with heavy electrical systems (refer to the User's Manual (Hardware) for the CPU module used).
 - Connect the power supply wiring to the dedicated terminals described in this manual. If an AC power supply is connected to a DC input/output terminal or DC power supply terminal, the programmable controller will burn out.
 - Do not wire vacant terminals externally. Doing so may damage the product.
 - Install module so that excessive force will not be applied to terminal blocks, power connectors, I/O connectors, communication connectors, or communication cables. Failure to do so may result in wire damage/breakage or programmable controller failure.
 - Make sure to observe the following precautions in order to prevent any damage to the machinery or accidents due to malfunction of the programmable controller caused by abnormal data written to the programmable controller due to the effects of noise:
 - Do not bundle the power line, control line and communication cables together with or lay them close to the main circuit, high-voltage line, load line or power line. As a guideline, lay the power line, control line and connection cables at least 100mm away from the main circuit, high-voltage line, load line or power line.
 - Ground the shield of the shielded wire or shield cable at one point on the programmable controller. However, do not use common grounding with heavy electrical systems.
 - For Ethernet cables to be used in the system, select the ones that meet the specifications in this manual. If not, normal data transmission is not guaranteed.
-

[Startup and Maintenance Precautions]

WARNING

- Do not touch any terminal while the programmable controller's power is on. Doing so may cause electric shock or malfunctions.
 - Before cleaning or retightening terminals, cut off all phases of the power supply externally. Failure to do so in the power ON status may cause electric shock.
 - Before modifying the program in operation, forcible output, running or stopping the programmable controller, read through this manual carefully, and ensure complete safety. An operation error may damage the machinery or cause accidents.
 - Do not change the program in the programmable controller from two or more peripheral equipment devices at the same time. (i. e. from an engineering tool and a GOT) Doing so may cause destruction or malfunction of the programmable controller program.
-

[Startup and Maintenance Precautions]

CAUTION

- Do not disassemble or modify the programmable controller. Doing so may cause fire, equipment failures, or malfunctions.
For repair, consult your local Mitsubishi Electric representative.
 - Turn off the power to the programmable controller before connecting or disconnecting any extension cable. Failure to do so may cause device failures or malfunctions.
 - Turn off the power to the programmable controller before attaching or detaching the following devices. Failure to do so may cause device failures or malfunctions.
 - Peripheral devices, expansion board, expansion adapter, and connector conversion adapter
 - Extension modules, bus conversion module, and connector conversion module
 - Battery
-

[Operating Precautions]

CAUTION

- Construct an interlock circuit in the program so that the whole system always operates on the safe side before executing the control (for data change) of the programmable controller in operation. Read the manual thoroughly and ensure complete safety before executing other controls (for program change, parameter change, forcible output and operation status change) of the programmable controller in operation. Otherwise, the machine may be damaged and accidents may occur due to erroneous operations.
 - Note that when the CPU module or intelligent function module detects an error, such as a watchdog timer error, during self-diagnosis, the entire system may not be reset. In this case, power off and on the system.
-

[Disposal Precautions]

CAUTION

- Please contact a certified electronic waste disposal company for the environmentally safe recycling and disposal of your device.
-

[Transportation Precautions]

CAUTION

- The programmable controller is a precision instrument. During transportation, avoid impacts larger than those specified in the general specifications of the User's Manual (Hardware) of the CPU module used by using dedicated packaging boxes and shock-absorbing palettes. Failure to do so may cause failures in the programmable controller. After transportation, verify operation of the programmable controller and check for damage of the mounting part, etc.
-

INTRODUCTION

Thank you for purchasing the Mitsubishi Electric MELSEC iQ-F series programmable controllers.

This manual contains text, diagrams and explanations which will guide the reader in the correct installation, safe use and operation of the CC-Link IE TSN module of MELSEC iQ-F series and should be read and understood before attempting to install or use the module.

Always forward it to the end user.

Regarding use of this product

- This product has been manufactured as a general-purpose part for general industries, and has not been designed or manufactured to be incorporated in a device or system used in purposes related to human life.
- Before using the product for special purposes such as nuclear power, electric power, aerospace, medicine or passenger movement vehicles, consult Mitsubishi Electric.
- This product has been manufactured under strict quality control. However when installing the product where major accidents or losses could occur if the product fails, install appropriate backup or failsafe functions in the system.

Note

- If in doubt at any stage during the installation of the product, always consult a professional electrical engineer who is qualified and trained in the local and national standards. If in doubt about the operation or use, please consult the nearest Mitsubishi Electric representative.
- Since the examples indicated by this manual, technical bulletin, catalog, etc. are used as a reference, please use it after confirming the function and safety of the equipment and system. Mitsubishi Electric will accept no responsibility for actual use of the product based on these illustrative examples.
- This manual content, specification etc. may be changed, without a notice, for improvement.
- The information in this manual has been carefully checked and is believed to be accurate; however, if you notice a doubtful point, an error, etc., please consult your local Mitsubishi Electric representative. When doing so, please provide the manual number given at the end of this manual.

CONTENTS

WHEN USING AN INDUSTRIAL SWITCH WITH CC-Link IE TSN	1
SAFETY PRECAUTIONS	1
INTRODUCTION	7
RELEVANT MANUALS	12
TERMS	12
GENERIC TERMS AND ABBREVIATIONS	12
CHAPTER 1 OVERVIEW	13
CHAPTER 2 SPECIFICATIONS	15
2.1 General Specifications	15
2.2 Power Supply Specifications	15
2.3 Performance Specifications of CC-Link IE TSN	15
2.4 Performance Specifications of Ethernet	17
2.5 Part Names	18
LED indication	19
CHAPTER 3 PROCEDURES BEFORE OPERATION	20
CHAPTER 4 FUNCTIONS	22
4.1 Function List	22
4.2 Cyclic Transmission	25
Communications using RX, RY, RWr, and RWw	26
Link refresh	31
Cyclic data assurance	33
Communication cycle coexistence	38
I/O maintenance settings	39
4.3 Transient Transmission	44
Communications using a dedicated instruction	44
Communications using the SLMP	45
Communications using the engineering tool	45
4.4 Ethernet Connection	46
Connection with MELSOFT products	46
Connection with SLMP-compatible devices	49
4.5 Security	50
IP filter	50
Remote password	52
4.6 RAS	56
Device station disconnection	56
Automatic return	56
Master station duplication detection	56
IP address duplication detection	57
Time synchronization	58
4.7 Others	59
Device station parameter automatic setting	59

CHAPTER 5	SYSTEM CONFIGURATION	60
5.1	Structure of CC-Link IE TSN Class B Devices and Ethernet Devices	62
	Structure of unicast mode	63
	Structure of multicast mode	65
	Structure with modules on CC-Link IE TSN only	67
	Structure of modules on CC-Link IE TSN and Ethernet devices	71
5.2	Structure of CC-Link IE TSN Class B/A Devices (CC-Link IE TSN Protocol version 2.0 Only) and Ethernet Devices	72
	Structure of unicast mode	74
	Structure of multicast mode	76
	Structure with modules on CC-Link IE TSN only	78
	Structure of modules on CC-Link IE TSN and Ethernet devices	87
5.3	Structure of CC-Link IE TSN Class B/A Devices (Mixture of CC-Link IE TSN Protocol version 1.0 and 2.0) and Ethernet Devices	89
	Connection configuration of CC-Link IE TSN-compatible devices	93
5.4	Structure of CC-Link IE TSN Class B/A Devices (CC-Link IE TSN Protocol version 1.0 Only) and Ethernet Devices	94
	Structure of unicast mode	95
	Structure of multicast mode	97
	Structure with modules on CC-Link IE TSN only	100
	Structure of modules on CC-Link IE TSN and Ethernet devices	108
5.5	Connection Examples	110
	Structure of CC-Link IE TSN Class B devices only	110
	Structure of CC-Link IE TSN Class B devices and Ethernet devices	112
	Structure of CC-Link IE TSN Class B/A devices only	114
	Structure of CC-Link IE TSN Class B/A devices and Ethernet devices	119
5.6	Precautions for System Configuration	120
CHAPTER 6	WIRING	122
6.1	Power Supply Wiring	122
	Grounding	122
6.2	CC-Link IE TSN Wiring	123
CHAPTER 7	PARAMETER SETTINGS	126
7.1	Setting Parameters	126
7.2	Required Settings	126
	Station Type	126
	Network No.	127
	Parameter Setting Method	127
	Station No./IP Address Setting	128
7.3	Basic Settings	129
	Refresh settings	130
	Network Topology	132
	Communication Period Setting	132
	Connection Device Information	133
	Device Station Setting	133
7.4	Application Settings	134
	Communication Speed	134
	Supplementary Cyclic Settings	135
	Transient Transmission Group No.	135

Communication Mode	135
Parameter Name	135
Module Operation Mode	136
Security	136
7.5 "CC-Link IE TSN Configuration" Window	137
Parameter setting of a device station	137
Connected/Disconnected module detection	139
Parameter processing of a device station	141
Command execution to device stations	143
CHAPTER 8 DEDICATED INSTRUCTION	144
<hr/>	
8.1 Precautions for Dedicated Instructions	145
CHAPTER 9 PROGRAMMING	146
<hr/>	
9.1 Precautions for Programming	146
9.2 Communication Example Between the Master Station and Local Station.	147
System configuration	147
Link device assignment	147
Setting in the master station	150
Settings in the local stations	153
Checking the network status	155
Program example (At unicast mode)	156
Program example (At multicast mode)	160
9.3 Examples of Communication with CC-Link IE TSN Class A Remote Stations	163
System configuration	163
Setting in the master station	165
Remote station settings	168
Settings in the local stations	169
Checking the network status	171
Program examples	172
CHAPTER 10 TROUBLESHOOTING	174
<hr/>	
10.1 Checking with LED	174
10.2 Checking the Module Status	177
Module diagnostics	177
Module communication test	179
10.3 Checking the Network Status	180
CC-Link IE TSN/CC-Link IE Field diagnostics	180
Communication test	187
Remote operation	188
10.4 Troubleshooting by Symptom	189
10.5 List of Error Codes	200
10.6 List of Parameter Numbers	221
10.7 Event List	222
APPENDICES	223
<hr/>	
Appendix 1 External Dimensions	223
Appendix 2 Standard Compliant Model	224
UL, cUL standards compliant model	224
EU Directive (CE marking) compliance	224

Measures to comply with the EMC Directive	224
Precautions for compliance with EU Directive	225
Compliance with UKCA marking	225
Appendix 3 Buffer Memory	226
List of buffer memory addresses	226
Details of buffer memory addresses	232
Appendix 4 List of Link Special Relay (SB)	246
Appendix 5 List of Link Special Register (SW)	252
Appendix 6 Processing Time	258
Cyclic transmission delay time	259
Communication cycle intervals	262
Appendix 7 Port Number	275
Appendix 8 Added and Enhanced Functions	276
Appendix 9 Software Licenses and Copyrights	277
INDEX	278
<hr/>	
REVISIONS	280
WARRANTY	281
TRADEMARKS	282

RELEVANT MANUALS

Manual name (manual number)	Description
MELSEC iQ-F FX5S/FX5UJ/FX5U/FX5UC User's Manual (Hardware) [SH-082452ENG]	Details of hardware of the FX5 CPU module, including performance specifications, wiring, installation, and maintenance
MELSEC iQ-F FX5 User's Manual (Application) <JY997D55401>	Basic knowledge about programming, functions of the CPU module, devices/labels, and parameter settings
MELSEC iQ-F FX5 Programming Manual (Program Design) <JY997D55701>	Program specifications, such as ladder diagrams, ST, and FBD/LD programs, and labels
MELSEC iQ-F FX5 Programming Manual (Instructions, Standard Functions/Function Blocks) <JY997D55801>	Specifications of the instructions and functions that can be used in programs
MELSEC iQ-F FX5 User's Manual (CC-Link IE TSN) <SH-082215ENG> (This manual)	Description of the CC-Link IE TSN module
MELSEC iQ-F FX5 User's Manual (Communication) <SH-082625ENG>	Description of the communication function of the built-in CPU module and the Ethernet module
GX Works3 Operating Manual <SH-081215ENG>	Explanation of system configuration, parameter settings, and online operations of GX Works3

TERMS

Unless otherwise specified, this manual uses the following terms.

Term	Description
CC-Link IE TSN Class	A group of devices and industrial switches compatible with CC-Link IE TSN, ranked according to the functions and performance by the CC-Link Partner Association. For CC-Link IE TSN Class, refer to the CC-Link IE TSN Installation Manual (BAP-C3007ENG-001) published by the CC-Link Partner Association.
Engineering tool	The product name of the software package for the MELSEC programmable controllers
GX Works3	A generic term for the product model name SWnDND-GXW3 (n represents the version.)

GENERIC TERMS AND ABBREVIATIONS

Unless otherwise specified, this manual uses the following generic terms and abbreviations.

Generic term and abbreviation	Description
Ethernet-equipped module	A generic term for the following modules when the Ethernet communication function is used: <ul style="list-style-type: none"> • CPU module • FX5-ENET • FX5-ENET/IP
FX5 CPU module	A generic term for the FX5U CPU module and FX5UC CPU module
FX5U CPU module	A generic term for the FX5U-32MR/ES, FX5U-32MT/ES, FX5U-32MT/ESS, FX5U-64MR/ES, FX5U-64MT/ES, FX5U-64MT/ESS, FX5U-80MR/ES, FX5U-80MT/ES, FX5U-80MT/ESS, FX5U-32MR/DS, FX5U-32MT/DS, FX5U-32MT/DSS, FX5U-64MR/DS, FX5U-64MT/DS, FX5U-64MT/DSS, FX5U-80MR/DS, FX5U-80MT/DS, and FX5U-80MT/DSS
FX5UC CPU module	A generic term for the FX5UC-32MT/D, FX5UC-32MT/DSS, FX5UC-64MT/D, FX5UC-64MT/DSS, FX5UC-96MT/D, FX5UC-96MT/DSS, FX5UC-32MT/DS-TS, FX5UC-32MT/DSS-TS, and FX5UC-32MR/DS-TS
I/O module	A generic term for the input modules, output modules, I/O modules, powered I/O modules, and high-speed pulse I/O modules
SD memory card	A generic term for the memory cards: NZ1MEM-2GBSD, NZ1MEM-4GBSD, NZ1MEM-8GBSD, NZ1MEM-16GBSD, L1MEM-2GBSD, and L1MEM-4GBSD SD memory card means Secure Digital Memory Card. A storage medium consisting of flash memory
Intelligent module	An abbreviation for the intelligent function module

1 OVERVIEW

- CC-Link IE TSN is a high-speed (1Gbps) and large-capacity open field network that is based on Ethernet (1000BASE-T).
- The FX5-CCLGN-MS master/local module for CC-Link IE TSN (hereinafter referred to as FX5-CCLGN-MS) is an intelligent function module for connecting to CC-Link IE TSN as a master or local station.
- Wiring of CC-Link IE TSN supports a line topology, star topology, and coexistence of line and star topologies.
- Data can be communicated between the FX5 CPU module and FX5-CCLGN-MS using the FROM/TO instructions via the buffer memory. In addition, data can be used in a program by being replaced with data in internal devices, such as X, Y, B, W, SB, and SW, using the auto refresh function.

Data communication

■Cyclic transmission

Data is periodically communicated among stations on the network using link devices.

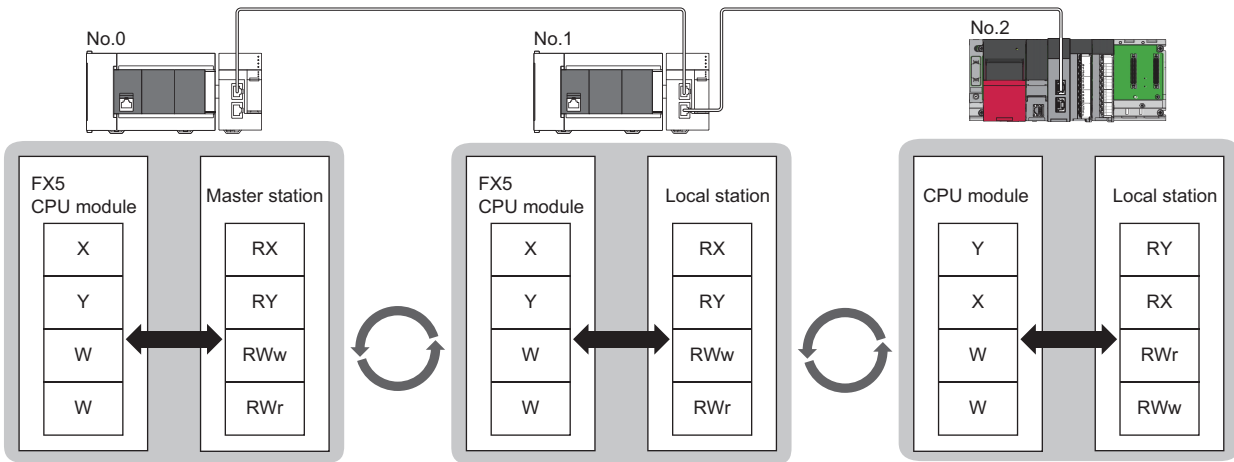

No.0: station number 0
 No.1: station number 1
 No.2: station number 2

■Transient transmission

Data is read/written from the master station or local station to devices in a CPU module of the local station or the buffer memory areas of a remote station using the dedicated instructions.

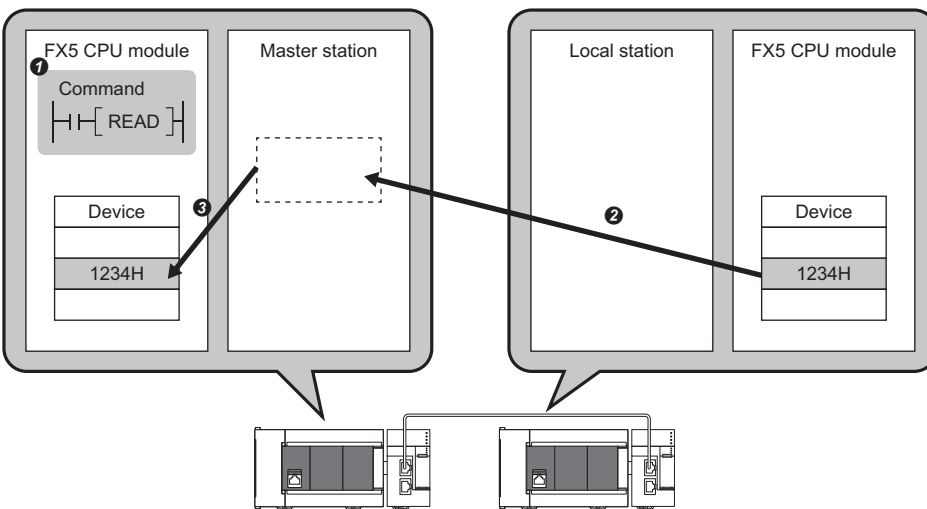

MEMO

2 SPECIFICATIONS

This chapter describes the specifications of the FX5-CCLGN-MS.

2.1 General Specifications

The general specifications of the FX5-CCLGN-MS other than the following are same as those of the FX5 CPU module to be connected.

For the general specifications, refer to the following.

📖 MELSEC iQ-F FX5S/FX5UJ/FX5U/FX5UC User's Manual (Hardware)

Item	Specifications	
Operating ambient temperature	-20 to 55°C*1	
Withstand voltage	500VAC for 1 minute	Between all terminals and ground terminal
Insulation resistance	10MΩ or higher by 500VDC insulation resistance tester	

*1 When using the FX5-CCLGN-MS manufactured in December 2020 or earlier, the operating ambient temperature is -20 to 50°C. The operating ambient temperature of the programmable controller system is the same.

2.2 Power Supply Specifications

The following table lists the power supply specifications.

Item	Specifications	
External power supply	Power supply voltage	24VDC +20%/-15%
	Allowable instantaneous power failure time	Operation continues for an instantaneous power failure of 1ms or less.
	Current consumption	220mA

2.3 Performance Specifications of CC-Link IE TSN

The following table lists the performance specifications of CC-Link IE TSN for the FX5-CCLGN-MS.

Item	Description		
Station type	Master or local station		
Station number	<ul style="list-style-type: none"> • Master station: 0 • Local station: 1 to 120 		
Number of connectable modules	One module can be connected to the CPU module for each station type. <ul style="list-style-type: none"> • Master station: 1 • Local station: 1 		
Maximum number of link points per network	RX	16K points (16384 points, 2K bytes)	
	RY	16K points (16384 points, 2K bytes)	
	RWr	8K points (8192 points, 16K bytes)	
	RWw	8K points (8192 points, 16K bytes)	
Maximum number of link points per station*1	Master station	RX	8K points (8192 points, 1K bytes)
		RY	8K points (8192 points, 1K bytes)
		RWr	4K points (4096 points, 8K bytes)
		RWw	4K points (4096 points, 8K bytes)
	Local station	RX	16K points (16384 points, 2K bytes)
		RY	16K points (16384 points, 2K bytes)
		RWr	8K points (8192 points, 16K bytes)
		RWw	8K points (8192 points, 16K bytes)
Communication speed	<ul style="list-style-type: none"> • 1Gbps • 100Mbps*4 		
Minimum synchronization cycle	250.00μs		
CC-Link IE TSN Class	B		

Item	Description	
CC-Link IE TSN Protocol version	<ul style="list-style-type: none"> • 2.0^{*4*5} • 1.0 	
Maximum number of connectable stations	When used as a master station	61 ^{*3}
	When used as a local station	121
Station-based data assurance	When used as a master station	61 ^{*3}
	When used as a local station	121
Communication cable	Ethernet cable which satisfies standard: (📖 Page 125 Ethernet cable)	
Overall cable distance	Line topology	12000m (when 121 stations are connected)
	Others	Depends on the system configuration.
Maximum station-to-station distance	100m	
Network number setting range	1 to 239	
Network topology	Line topology, star topology (Coexistence of line topology and star topology is also possible.)	
Communication method	Time sharing method	
Multicast filter	Supported	
Transient transmission capacity	1920 bytes	
Number of occupied I/O points	8 points	
Applicable CPU module	FX5UJ CPU module (Version 1.040 or later) FX5U CPU module (Version 1.210 or later) FX5UC CPU module ^{*2} (Version 1.210 or later)	
Applicable engineering tool	GX Works3 version 1.090U or later (for FX5UJ CPU module) GX Works3 version 1.065T or later (for FX5U CPU module) GX Works3 version 1.065T or later (for FX5UC CPU module)	

- *1 The maximum number of points for all link devices may not be used simultaneously depending on the number of device stations or the number of points and assignments of the link devices that are set in the "Network Configuration Settings" of the "Basic Settings".
- *2 To connect the FX5-CCLGN-MS to the FX5UC CPU module, the FX5-CNV-IFC and FX5-C1PS-5V are required.
- *3 The maximum number of connectable stations (61) includes the master station. When connecting multiple master stations, such as the FX5-CCLGN-MS and the FX5-40/80SSC-G, which use device station parameters for the CPU module, the total number of device stations must be less than or equal to the number of device station parameter files that can be saved in the CPU module. For details on the number of device station parameter files that can be saved in the FX5 CPU module, refer to the following.
📖 MELSEC iQ-F FX5 User's Manual (Application)
- *4 This setting can be used for the firmware version "1.010" or later.
- *5 Even for a firmware version "1.010" or later of the FX5-CCLGN-MS, when the CC-Link IE TSN Protocol version of the remote station is 1.0, the FX5-CCLGN-MS may operate with the CC-Link IE TSN Protocol version 1.0.

2.4 Performance Specifications of Ethernet

The following table lists the performance specifications of Ethernet for the FX5-CCLGN-MS.

Item	Description	
Data transmission speed	<ul style="list-style-type: none"> • 1Gbps • 100Mbps*4 	
Communication mode	1000BASE-T	Full-duplex
	100BASE-TX*4	Full-duplex
Interface	RJ45 connector (Auto MDI/MDI-X)	
Maximum frame size	1518 bytes	
Jumbo frame	Not available	
Maximum segment length	100m (distance between an industrial switch and a station)*1	
Number of cascade connections	*2	
IP version	Compatible with IPv4	
Number of simultaneous open connections (maximum number of connections)	Connection with MELSOFT products	8 connections*3
	Connection to SLMP-compatible devices	8 connections*3

*1 For maximum segment length (length between industrial switches), consult the manufacturers of the industrial switches used.

*2 Consult the manufacturers of the industrial switches used.

*3 In the case of one connection per device, up to eight devices can be connected.

*4 This setting can be used for the firmware version "1.010" or later.

Point

The operation of commercial devices used for the following applications is not guaranteed. Check the operation before using the module.

- Internet (general public line) (Internet-access service offered by an Internet service provider or a telecommunications carrier)
- Firewall device(s)
- Broadband router(s)
- Wireless LAN

2.5 Part Names

This section describes the part names of the FX5-CCLGN-MS.

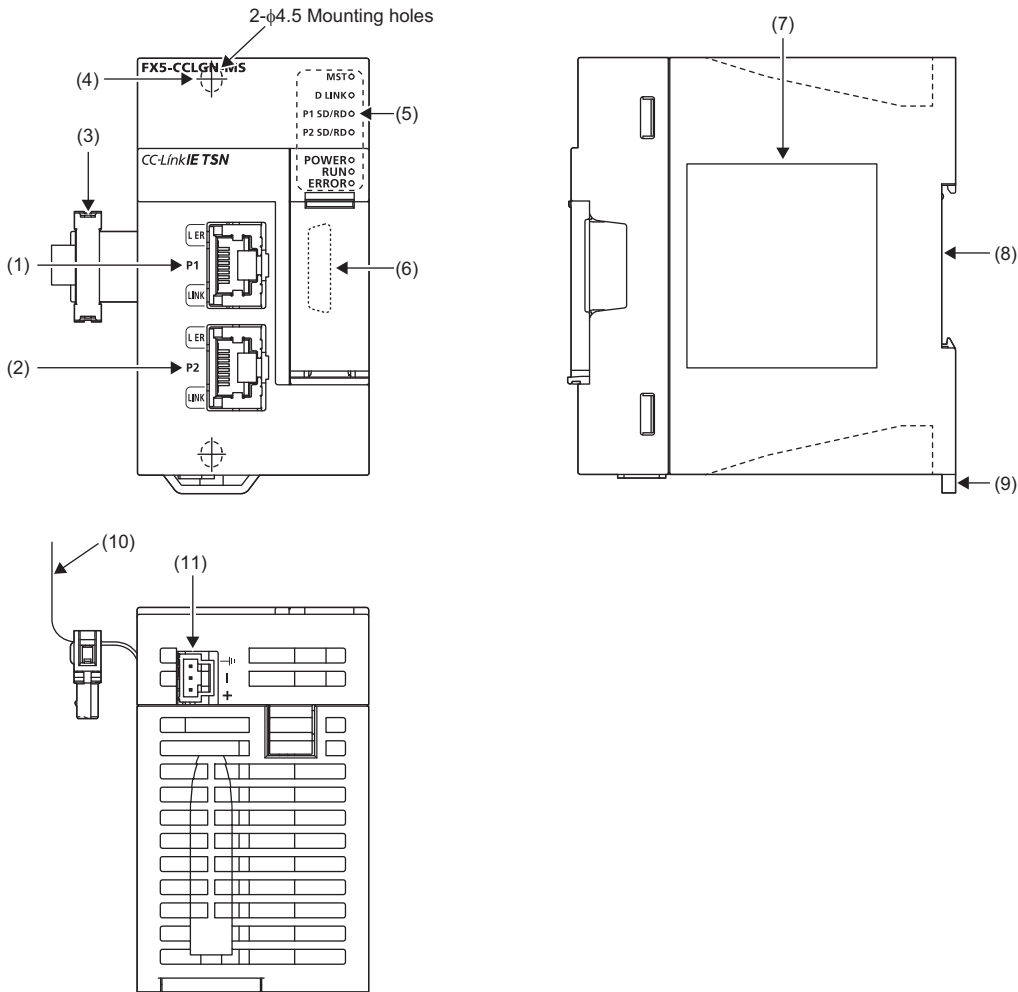

No.	Name	Description
(1)	Modular jack for P1 (RJ45) (with cap)	A port for CC-Link IE TSN connection. Connects an Ethernet cable. For wiring methods and wiring precautions, refer to the following. ☞ Page 122 WIRING
(2)	Modular jack for P2 (RJ45) (with cap)	Same as the modular jack for P1 (RJ45)
(3)	Extension cable	A cable for connecting a module when adding the FX5-CCLGN-MS
(4)	Hole for direct installation	A screw hole for direct installation (2-φ4.5, Installation screw: M4 screw)
(5)	Operation status display LEDs	Indicate the operating status of the module. For details, refer to the following. ☞ Page 19 LED indication
(6)	Extension connector	A connector for connecting an extension cable of an extension module
(7)	Nameplate	Displays product model, manufacturer serial number, power supply specifications, and MAC address.
(8)	DIN rail mounting groove	Used for mounting a module onto a DIN46277 (width: 35mm) DIN rail
(9)	DIN rail mounting hook	Used for mounting a module onto a DIN46277 (width: 35mm) DIN rail
(10)	Pullout tab	Used for drawing out an extension cable
(11)	Power connector	A connector for connecting a power cable

LED indication

The following table lists the LED indications.

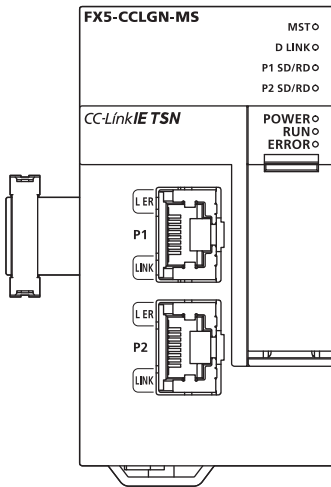

LED name	LED color	Description	
MST	Green	Indicates the operating status. On: Operating as a master station Off: Operating as a local station	
D LINK ^{*1}	Green	Indicates the cyclic transmission status. On: Cyclic transmission being performed Flashing: Cyclic transmission stopped Off: Disconnected	
P1 SD/RD	Green	Indicates the data sending/receiving status. On: Data ^{*2} being sent or received Off: Data ^{*2} neither sent nor received	
P2 SD/RD	Green	Indicates the data sending/receiving status. On: Data ^{*2} being sent or received Off: Data ^{*2} neither sent nor received	
POWER	Green	Indicates the power supply status. On: Power-on Off: Power-off	
RUN	Green	Indicates the operating status. On: Normal operation Flashing: Module communication test Off: Error	
ERROR ^{*1}	Red	Indicates the error status. On: Error, or error detection in progress on all stations Flashing (500ms interval): Detection of a data link faulty station in progress <ul style="list-style-type: none"> • Unicast mode: Flashing only at the master station • Multicast mode: Flashing at the master station and local station. However, the LED does not flash at the local station if a data link error occurs at the CC-Link IE TSN Class A remote station during data link. (The LED remains off.) Flashing (200ms interval): Error Off: Normal operation	
P1	L ER ^{*1}	Red	Indicates the port status of P1. On: Abnormal data received Off: Normal data received
	LINK	Green	Indicates the link status of P1. On: Link-up Off: Link-down
P2	L ER ^{*1}	Red	Indicates the port status of P2. On: Abnormal data received Off: Normal data received
	LINK	Green	Indicates the link status of P2. On: Link-up Off: Link-down

*1 The LED is always off in offline mode.

*2 Data of cyclic transmission and transient transmission on CC-Link IE TSN are included.

3 PROCEDURES BEFORE OPERATION

This chapter describes the procedures before operation.

1. Checking the specifications of the FX5-CCLGN-MS

Check the specifications of the FX5-CCLGN-MS. (☞ Page 15 SPECIFICATIONS)

2. Mounting the FX5-CCLGN-MS

Mount the FX5-CCLGN-MS to the FX5 CPU module. For details, refer to the following.

📖 MELSEC iQ-F FX5S/FX5UJ/FX5U/FX5UC User's Manual (Hardware)

3. Wiring

Connect an Ethernet cable to the FX5-CCLGN-MS.

Wiring (☞ Page 122 WIRING)

4. Network configuration

Configure the system and set the parameters which are required for start-up.

Parameter setting (☞ Page 126 PARAMETER SETTINGS)

5. Network diagnostics

Use the network diagnostics to check that cables are connected properly and that modules are communicating correctly with the set parameters.

For details, refer to the following.

☞ Page 180 Checking the Network Status

6. Programming

Create a program. For details, refer to the following.

☞ Page 146 PROGRAMMING

7. Debugging

Use the CC-Link IE TSN/CC-Link IE Field diagnostics for debugging.

4 FUNCTIONS

4.1 Function List

The following tables list the functions of CC-Link IE TSN.

The symbols in the availability column mean as follows:

○: Available, ×: Not available

Cyclic transmission

This function communicates data periodically among stations on the network using link devices.

Function		Description	Availability		Reference
			Master station	Local station	
Communications using RX, RY, RWr, and RWw		Communicates data in units of bits and words between the master station and device stations.	○	○	Page 26 Communications using RX, RY, RWr, and RWw
Link refresh		Automatically transfers data between the link devices of the FX5-CCLGN-MS and the devices of the FX5 CPU module.	○	○	Page 31 Link refresh
Cyclic data assurance		Assures the cyclic data integrity in units of 32 bits or station-based units.	○	×	Page 33 Cyclic data assurance
Communication cycle coexistence		When device stations with different communication cycles are included in the network, communicates data using multiple communication cycles according to each device station.	○	×	Page 38 Communication cycle coexistence
I/O maintenance settings	Output mode upon CPU error	When a stop error occurs in the FX5 CPU module, set whether to hold or clear output on the sending side.	○	○	Page 39 I/O maintenance settings
	Output hold/clear setting during CPU STOP	When the status of the FX5 CPU module changes from RUN to STOP, set whether to hold or clear output on the sending side.	○	○	
	Data link faulty station setting	Set whether to clear or hold input from a disconnected station. Set it on the receiving side.	○	○	

Transient transmission

This function is used for data communications at any timing and has the following three types.

Function		Description	Availability		Reference
			Master station	Local station	
Communications using a dedicated instruction		Reads/writes data from the master station or local station to devices in a CPU module of the local station using the dedicated instructions.	○	○	Page 44 Communications using a dedicated instruction
Communications using the SLMP		This type of the data communication is used to read/write data from the external device, such as a personal computer or HMI (Human Machine Interface), to devices in the CPU module of the master station and local station and the buffer memory areas of the remote station via an SLMP.	○	○	Page 45 Communications using the SLMP
Communications using the engineering tool		Sets parameters of each station or monitors each station using the engineering tool.	○	○	Page 45 Communications using the engineering tool

Ethernet connection

This function connects an Ethernet device to a module without interfering with CC-Link IE TSN.

Function	Description	Availability		Reference
		Master station	Local station	
Connection with MELSOFT products	Programming and monitoring of the programmable controller are performed via Ethernet using the engineering tool.	○	○	Page 46 Connection with MELSOFT products
Connection with SLMP-compatible devices	Connects SLMP-compatible devices (such as a personal computer or a vision sensor) to the FX5-CCLGN-MS.	○	○	Page 49 Connection with SLMP-compatible devices

Security

This function ensures security according to the network environment by restricting access for each communication path to the FX5 CPU module.

Function	Description	Availability		Reference
		Master station	Local station	
IP filter	Identifies the IP address of the access source, and prevents unauthorized access.	○	○	Page 50 IP filter
Remote password	Permits or prohibits access from the external device to the FX5 CPU module via the FX5-CCLGN-MS.	○	○	Page 52 Remote password

RAS

RAS stands for Reliability, Availability, and Serviceability. This function improves overall usability of automated equipment.

Function	Description	Availability		Reference
		Master station	Local station	
Device station disconnection	Stops data link of the station where an error occurred, and continues data link only for stations that are operating normally.	○	×	Page 56 Device station disconnection
Automatic return	Restarts the data link automatically when the device station that was disconnected due to an error becomes normal again.	○	○	Page 56 Automatic return
Master station duplication detection	When one network has multiple master stations, detects duplication.	○	×	Page 56 Master station duplication detection
IP address duplication detection	When one network has stations with the same IP address, detects duplication.	○	○	Page 57 IP address duplication detection
Time synchronization	Synchronizes the time of device stations with the time synchronization source (CPU module of the master station).	○	○	Page 58 Time synchronization

Troubleshooting

This function checks the status of modules and networks by executing diagnostics and operation tests using the engineering tool.

Function	Description	Availability		Reference
		Master station	Local station	
Module communication test	Checks the module hardware when the communications using the FX5-CCLGN-MS is unstable.	○	○	Page 179 Module communication test
CC-Link IE TSN/CC-Link IE Field diagnostics	Monitors the status of CC-Link IE TSN. The network maps, stations where data link is not operating, selected station communication status monitor, and others are displayed on the engineering tool.	○	○	Page 180 CC-Link IE TSN/CC-Link IE Field diagnostics
Communication test	Checks if transient transmission data can be properly routed from the own station to the communication target.	○	○	Page 187 Communication test

Others

Function	Description	Availability		Reference
		Master station	Local station	
"CC-Link IE TSN Configuration" window	Parameter setting of a device station	○	×	Page 137 Parameter setting of a device station
	Detection of connected/disconnected devices	○	×	Page 139 Connected/Disconnected module detection
	Parameter processing of a device station	○	×	Page 141 Parameter processing of a device station
	Command execution to device stations	○	○	Page 143 Command execution to device stations
Reserved station setting	Reserved stations are device stations to be included among the stations in the network for future extension and set in the parameters. These stations are not connected to actual networks, and are not regarded as faulty stations even if they are not connected. By setting a reserved station, link device assignment will not change even if the device station is connected (or the reservation is cleared). Therefore, modification of the program is not required.	○	×	Page 137 "CC-Link IE TSN Configuration" Window
Error invalid station setting	An error invalid station is a device station that is set to be not detected as a faulty station by the master station. It is also set when a device station is to be replaced during data link.	○	×	Page 137 "CC-Link IE TSN Configuration" Window
Device station parameter automatic setting	This function saves parameters of the device station in the master station, and automatically sets the parameters when the device station is connected or returned to the network.	○	×	Page 59 Device station parameter automatic setting
Station number/IP address setting using a program	Sets a station number and IP address to the own station which has no station number and IP address setting using a program. This function allows project data items of stations with the same program and network parameters (excluding the station numbers and IP addresses) to be the same, leading to reduced development work hours.	○	○	Page 144 Other dedicated instructions

4.2 Cyclic Transmission

This function communicates data periodically among stations on the network using link devices.

- The link devices can be assigned in "Network Configuration Settings" under "Basic Settings". (☞ Page 137 "CC-Link IE TSN Configuration" Window)
- The link refresh is assigned in "Refresh Settings" under "Basic Settings". (☞ Page 130 Refresh settings)

Cyclic transmission operates as follows with the communication mode set by the module parameter of the master station.

Communication mode	Description
Unicast mode	<ul style="list-style-type: none"> • Cyclic data is sent to one station. • When this communication mode is used, the local station cannot receive cyclic data from another station. Use this mode when there is no local station or when it is not required for the local station to receive cyclic data from another station. • The cyclic transmission time of this mode is shorter than the cyclic transmission time of multicast mode. (☞ Page 262 Communication cycle intervals)
Multicast mode	<ul style="list-style-type: none"> • Cyclic data is sent to multiple stations. • When this mode is used, the local station can receive cyclic data from another station. Use this mode when it is required for the local station to receive cyclic data from another station. • The cyclic transmission time of this mode is longer than the cyclic transmission time of unicast mode. (☞ Page 262 Communication cycle intervals)

Point

- When communicating in multicast mode, the local station cannot receive RX and RWr sent by the CC-Link IE TSN Class A remote station. (☞ Page 30 At multicast mode)
- To allow the local station to obtain RX and RWr sent by the CC-Link IE TSN Class A remote station, use the program to send RX and RWr from the master station to the local station. (☞ Page 163 Examples of Communication with CC-Link IE TSN Class A Remote Stations)
- When communicating in multicast mode, set "Communication Period Setting" for the local station under "Network Configuration Settings" to "Basic Period".
- If a data link error occurs in multicast mode, ERROR LED at the local station flashes. However, even if a data link error occurs at the CC-Link IE TSN Class A remote station during data link, ERROR LED at the local station does not flash. (The LED remains off.)
- When communicating in multicast mode, 'Data link error status of each station' (SB00B0) and 'Total number of device stations present value' (SW0059) at the local station can be checked by SB and SW. However, the information of the CC-Link IE TSN Class A remote station may not be checked by some SB and SW.

Communications using RX, RY, RWr, and RWw

This function allows data communications in units of bits and in units of words between the master station and device station.

Master station and local stations

■At unicast mode

1:1 communications between the master station and each local station. Local stations do not communicate with each other.

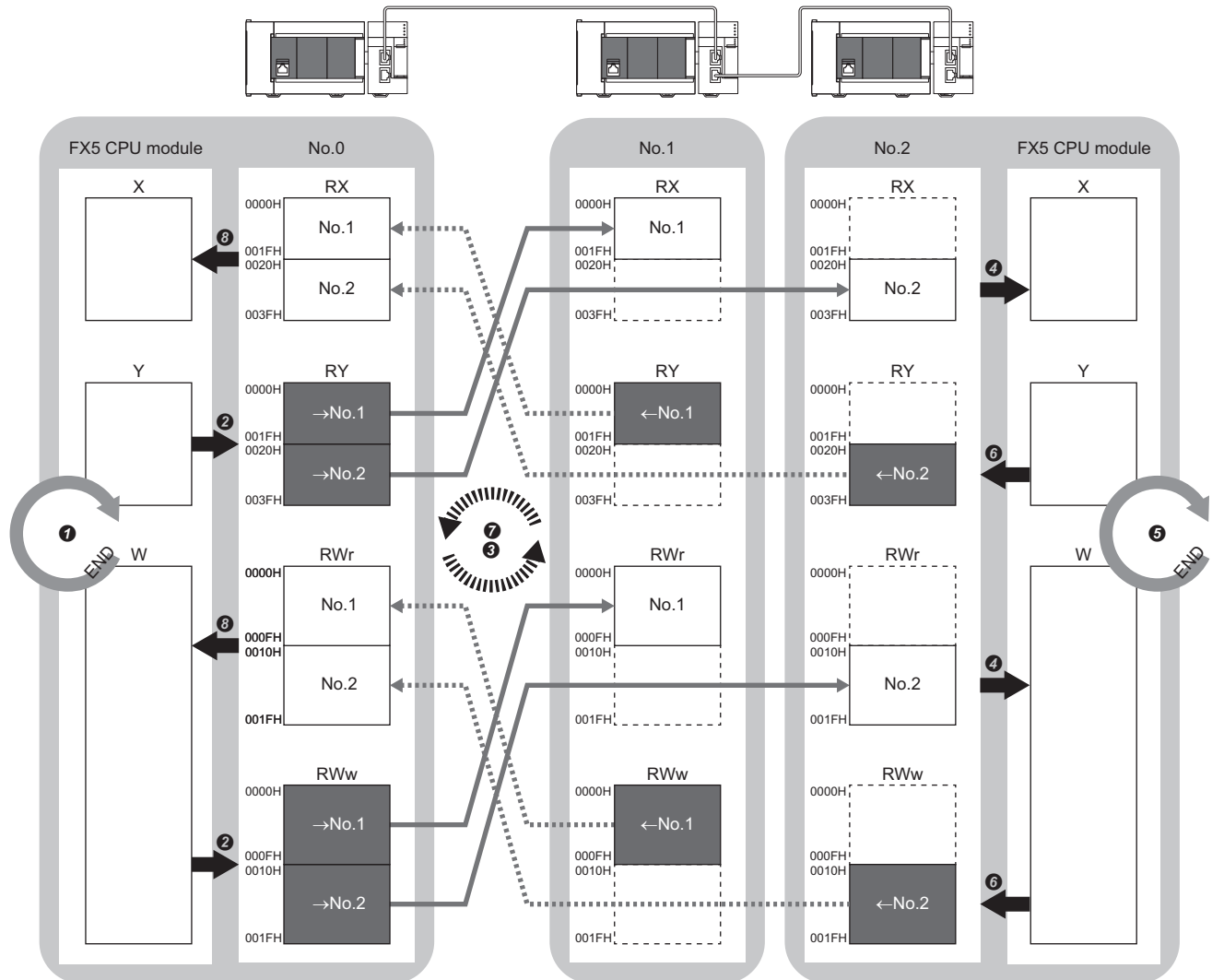

No.0, No.1, No.2: Station No.0 (master station), station No.1, station No.2
 →No.1, →No.2: Send range: to station No.1, send range: to station No.2
 ←No.1, ←No.2: Send range: from station No.1, send range: from station No.2

• Output from the master station

- The device is turned on by the sequence scan of the FX5 CPU module in the master station, and END processing is performed.
- The status data of the device of the FX5 CPU module is stored in the link devices (RY, RWw) of the FX5-CCLGN-MS by link refresh.
- The status data of the link devices (RY, RWw) of the master station is stored in the link devices (RX, RWr) of the local station by cyclic data transfer processing.
- The status data of the link devices (RX, RWr) of the local station is stored in the devices of the CPU module by link refresh.

• Input from the local station

- The device is turned on by the sequence scan of the FX5 CPU module in the local station, and END processing is performed.
- The status data of the device of the CPU module is stored in the link devices (RY, RWw) of the local station by link refresh.
- The status data of the link devices (RY, RWw) of the local station is stored in the link devices (RX, RWr) of the master station by cyclic data transfer processing.
- The status data of the link devices (RX, RWr) of the master station is stored in the devices of the CPU module by link refresh.

■At multicast mode

- The master station and local station send data on the line in multicast mode in each send range.
- The CC-Link IE TSN Class A local station communicates data in the same communication range as the CC-Link IE TSN Class B local station.

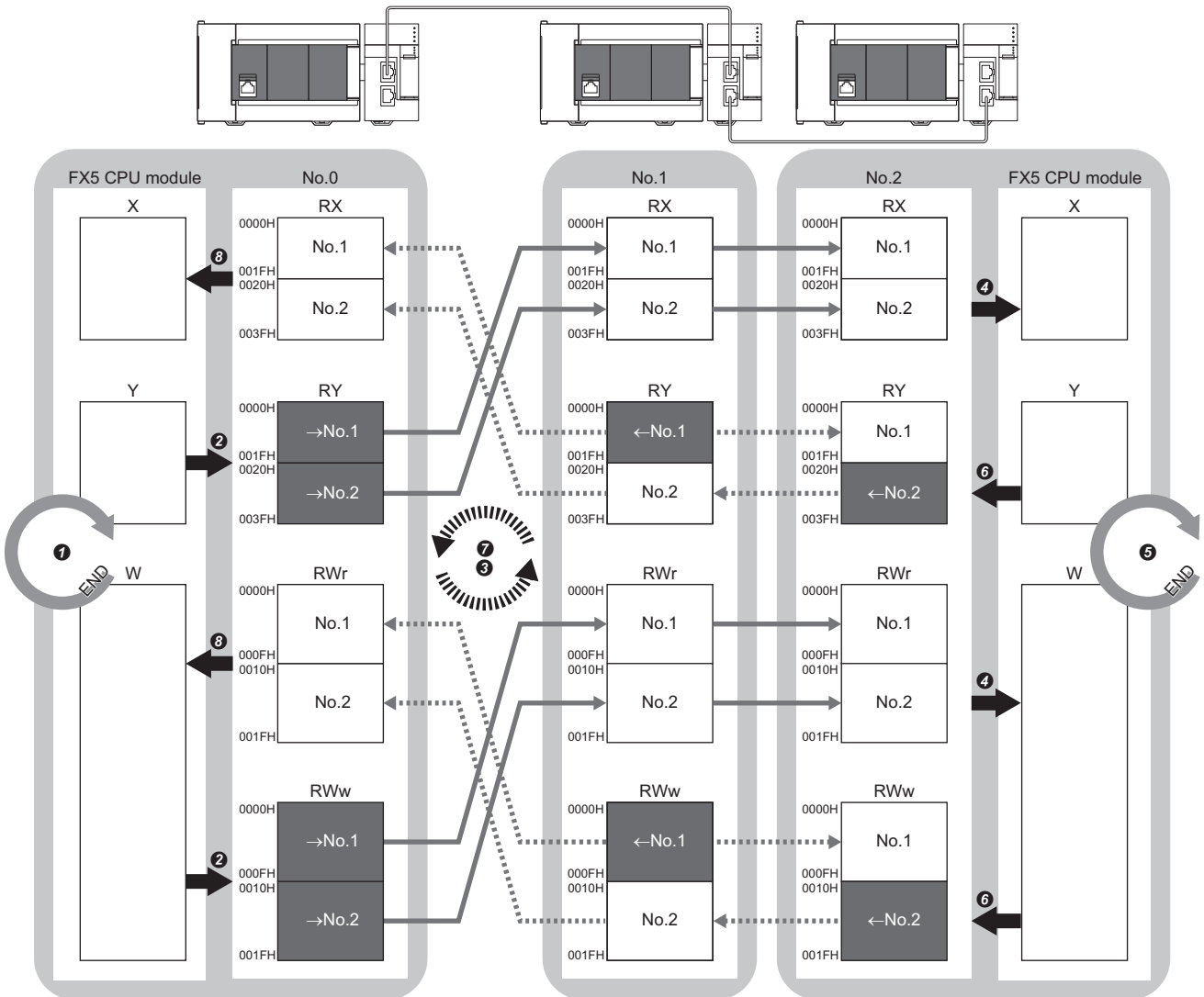

No.0, No.1, No.2: Station No.0 (master station), station No.1, station No.2
 →No.1, →No.2: Send range: to station No.1, send range: to station No.2
 ←No.1, ←No.2: Send range: from station No.1, send range: from station No.2

• Output from the master station

- ① The device is turned on by the sequence scan of the FX5 CPU module in the master station, and END processing is performed.
- ② The status data of the device of the CPU module is stored in the link devices (RY, RWw) of the master station by link refresh.
- ③ The status data of the link devices (RY, RWw) of the master station is stored in the link devices (RX, RWr) of the local station on the same network by cyclic data transfer processing.
- ④ The status data of the link devices (RX, RWr) of the local station is stored in the devices of the CPU module by link refresh.

• Input from the local station

- ⑤ The device is turned on by the sequence scan of the FX5 CPU module in the local station, and END processing is performed.
- ⑥ The status data of the device of the CPU module is stored in the link devices (RY, RWw) of the local station by link refresh.
- ⑦ The status data of the link devices (RY, RWw) of the local station (station No.2) is stored in the link devices (RX, RWr) of the master station on the same network and in the link devices (RY, RWw) of the local station (station No.1) by cyclic data transfer processing.
- ⑧ The status data of the link devices (RX, RWr) of the master station is stored in the devices of the CPU module by link refresh.

Master station and remote stations

■At unicast mode

1:1 communications between the master station and each remote station. Remote stations do not communicate with each other.

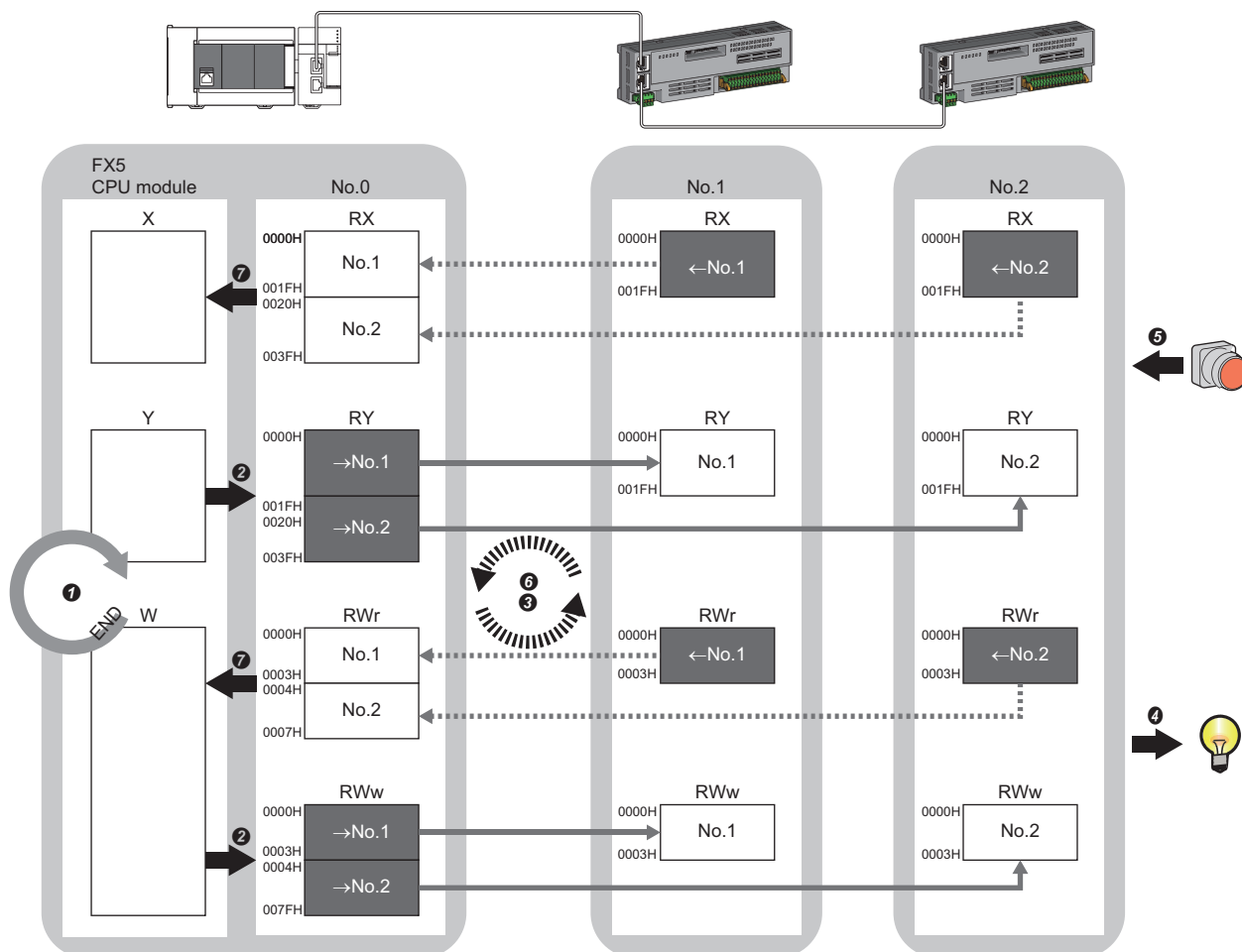

No.0, No.1, No.2: Station No.0 (master station), station No.1, station No.2
 →No.1, →No.2: Send range: to station No.1, send range: to station No.2
 ←No.1, ←No.2: Send range: from station No.1, send range: from station No.2
 Class A: CC-Link IE TSN Class A device
 Class B: CC-Link IE TSN Class B device

• Output from the master station

- 1 The device of the FX5 CPU module turns on.
- 2 The status data of the device of the CPU module is stored in the link devices (RY, RWw) of the master station by link refresh.
- 3 The status data of the link devices (RY, RWw) of the master station is stored in the link devices (RY, RWw) of each remote station by cyclic data transfer processing.
- 4 The status data of the link devices (RY, RWw) of the remote station is output to the external device.

• Input from the remote station

- 5 The status data of the external device is stored in the link devices (RX, RWr) of the remote station.
- 6 The status data of the link devices (RX, RWr) of the remote station is stored in the link devices (RX, RWr) of the master station by cyclic data transfer processing.
- 7 The status data of the link devices (RX, RWr) of the master station is stored in the devices of the CPU module by link refresh.

■At multicast mode

- The master station and remote station send data on the line in multicast mode in each send range.
- The master station receives all data, but the remote station discards the data of another remote station. Therefore, communications at each station are performed in the same manner as unicast mode. (☞ Page 28 At unicast mode)

Coexistence of remote stations and local stations

■At unicast mode

- 1:1 communications between the master station and each remote station, and between the master station and each local station.
- Communications are not performed between remote stations, between local stations, and between a remote station and a local station.

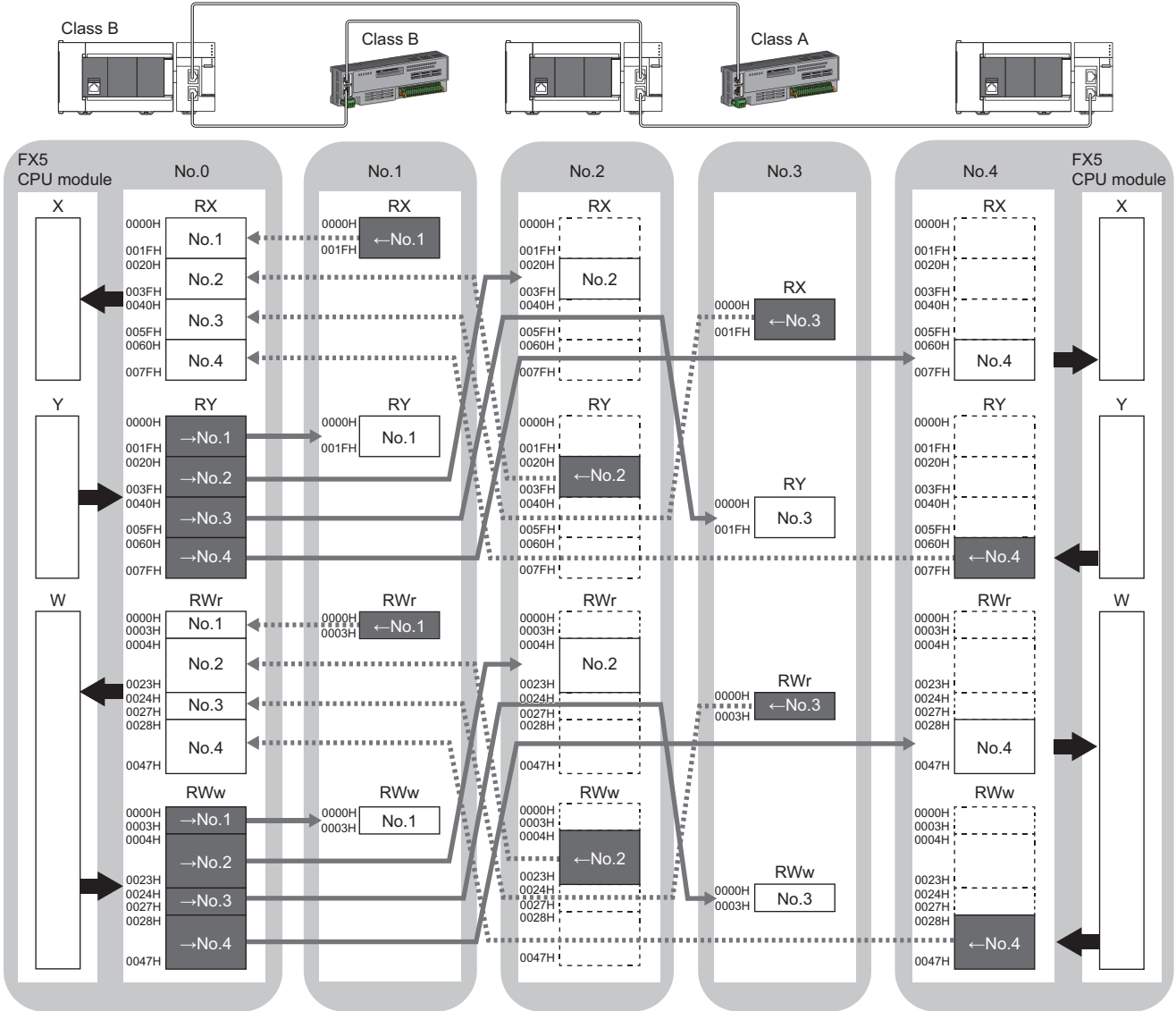

No.0, No.1, No.2, No.3, No.4: station No.0 (master station), station No.1, station No.2, station No.3, station No.4

→No.1, →No.2, →No.3, →No.4: Send range: to station No.1, send range: to station No.2, send range: to station No.3, send range: to station No.4

←No.1, ←No.2, ←No.3, ←No.4: Send range: from station No.1, send range: from station No.2, send range: from station No.3, send range: from station No.4

Class A: CC-Link IE TSN Class A device

Class B: CC-Link IE TSN Class B device

■At multicast mode

- The master station and each local station can obtain data of all device stations.
- The CC-Link IE TSN Class A local station communicates data in the same communication range as the CC-Link IE TSN Class B local station.

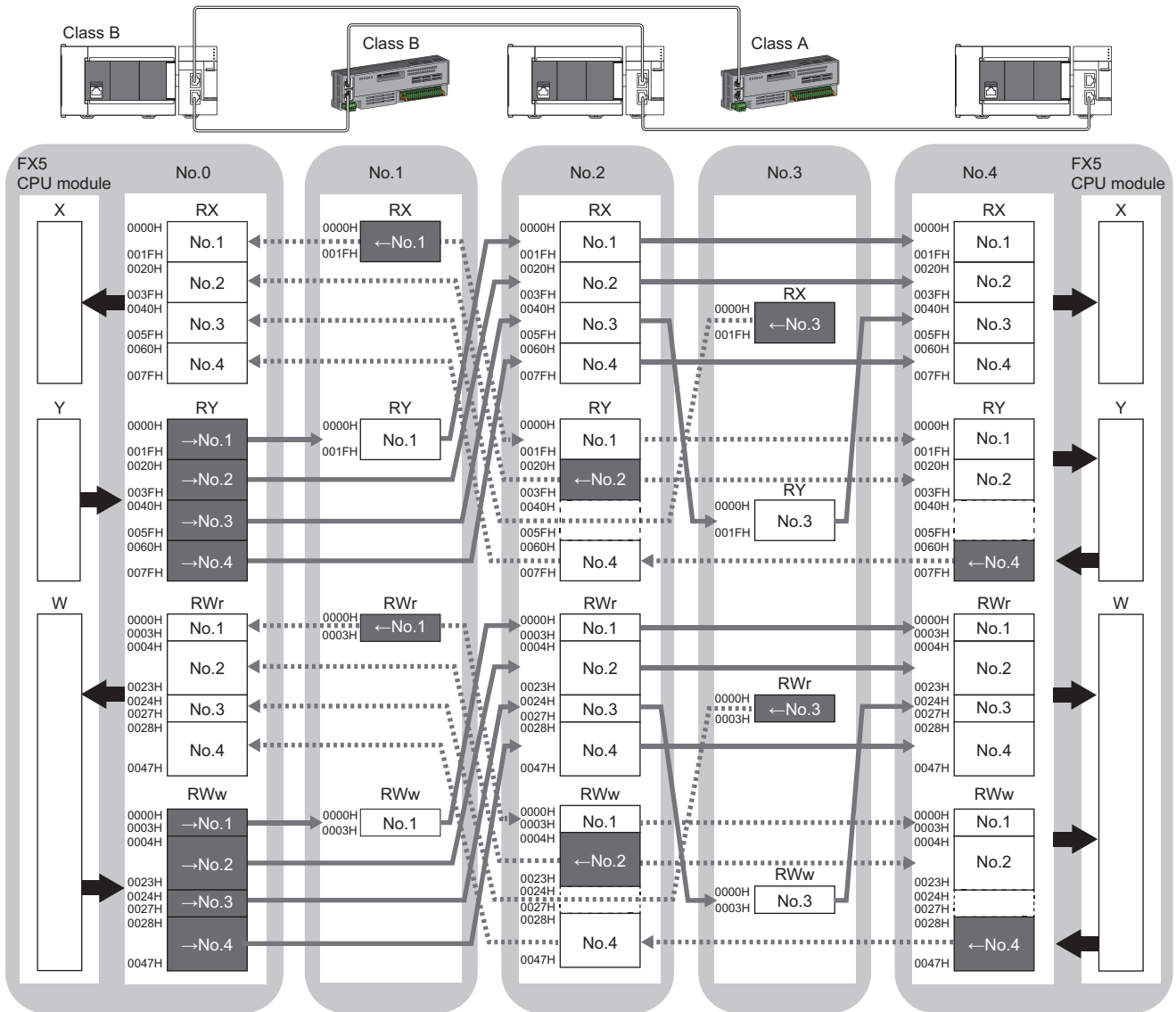

No.0, No.1, No.2, No.3, No.4: station No.0 (master station), station No.1, station No.2, station No.3, station No.4

→No.1, →No.2, →No.3, →No.4: Send range: to station No.1, send range: to station No.2, send range: to station No.3, send range: to station No.4

←No.1, ←No.2, ←No.3, ←No.4: Send range: from station No.1, send range: from station No.2, send range: from station No.3, send range: from station No.4

Class A: CC-Link IE TSN Class A device

Class B: CC-Link IE TSN Class B device

Link refresh

This function automatically transfers data between the devices of the FX5-CCLGN-MS and the devices of the FX5 CPU module.

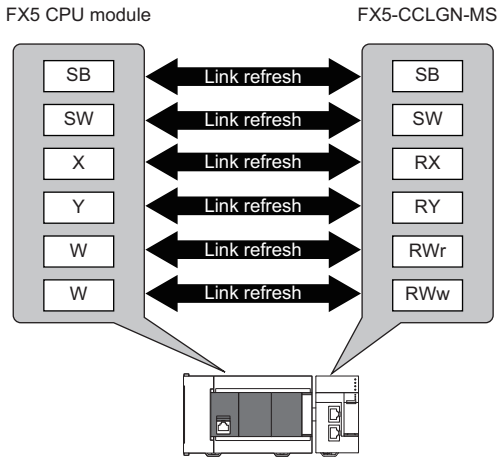

Concept of the link refresh range (number of points)

The link refresh is performed in the range set in "Refresh Settings" under "Basic Settings" and also specified in "Network Configuration Settings".

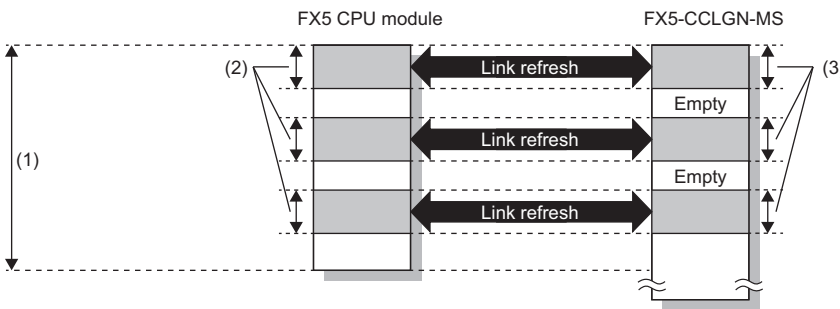

- (1) Range set in "Refresh Settings" under "Basic Settings"
- (2) Actual link refresh range
- (3) Range set in "Network Configuration Settings" under "Basic Settings"

Shortening the transmission delay time

The transmission delay time can be shortened by reducing the number of link refresh points and shortening a communication cycle interval. (☞ Page 262 Communication cycle intervals)

To reduce the number of link refresh points, in "Refresh Settings" under "Basic Settings", set only the link devices used in the FX5 CPU module as the link refresh range. (☞ Page 130 Refresh settings)

Point

Link refresh is performed in END processing of the sequence scan of the FX5 CPU module.

Setting method

The link refresh is assigned in "Refresh Settings" under "Basic Settings". (📖 Page 130 Refresh settings)

Precautions

■ Latched devices of the FX5 CPU module

If data in latched devices of the FX5 CPU module are cleared to zero on a program when the FX5 CPU module is powered off and on or reset, the data may be output without being cleared to zero, depending on the timing of the cyclic data transfer processing and link refresh. To prevent data in latched devices from being output, execute the following methods.

FX5 CPU module device	How to disable the device data
Latch relay (L), file register (R)	Use the device initial value of the FX5 CPU module to clear the device to zero.*1
FX5 CPU module device within the latch range	Delete all the latch range settings specified in "Latch Interval Operation Setting" under "Device Latch Interval Setting" in "Memory/Device Setting" of "CPU Parameter".

*1 For the initial device value setting of the FX5 CPU module, refer to the following.

📖 MELSEC iQ-F FX5 User's Manual (Application)

Cyclic data assurance

This function assures the cyclic data integrity in units of 32 bits or station-based units.

○: Assured, ×: Not assured

Method	Description	Link refresh	Access to buffer memory
32-bit data assurance	Assures data in 32-bit units. Data is automatically assured by satisfying assignment conditions of link devices.	○	○
Station-based block data assurance	Assures data in station-based units. Data is assured by enabling the station-based block data assurance in the parameter setting.	○	×
Interlock program	Assures data of more than 32 bits. Data is assured by configuring interlocks on programs.	○	○

Point

When a remote station is in the network, use station-based block data assurance. If it is disabled, the functions of the remote station cannot be assured.

32-bit data assurance

Assures RWr and RWw data in 32-bit units.

■Data assurance at the time of access to link devices

When link refresh target devices are accessed, the integrity of 32-bit data can be assured by satisfying the following conditions:

- The start device number of RWr and RWw is a multiple of 2
- The number of points assigned to RWr and RWw is a multiple of 2.

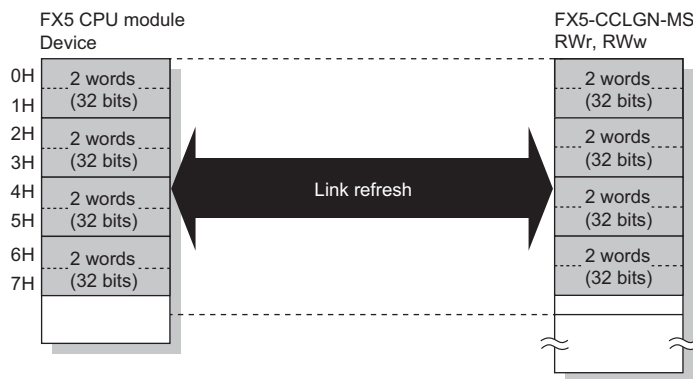

■Data assurance at the time of access to buffer memory

The integrity of 32-bit data can be assured by satisfying the following conditions:

- Access using the DMOV instruction
- The start address of the buffer memory is a multiple of 2.

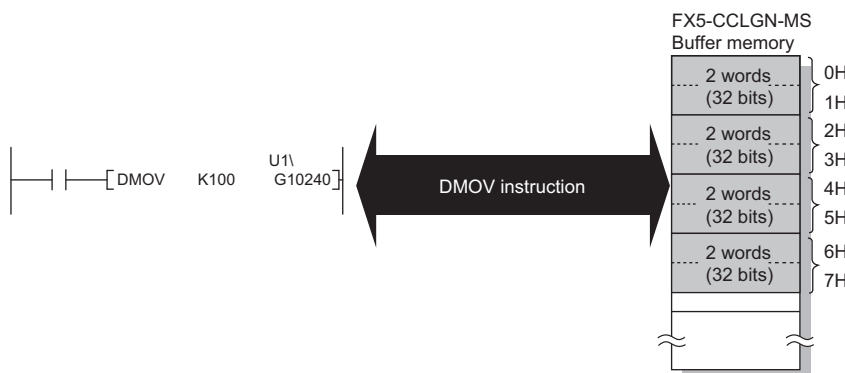

Station-based block data assurance

Integrity of the cyclic data is assured for each station by handshake between the FX5 CPU module and the FX5-CCLGN-MS for a link refresh.

Setting

Set station-based block data assurance under "Supplementary Cyclic Settings" in "Application Settings" of the master station. (Page 134 Application Settings)

Once this setting is enabled on the master station, integrity of the data for all stations is assured for each station.

Access to link devices

During a link refresh, data is assured for each station as shown below.

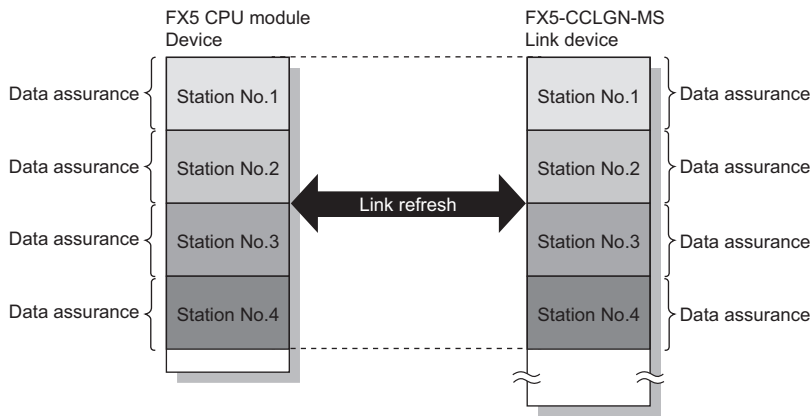

Interlock program

Data of more than 32 bits can be assured without using the station-based block data assurance setting. Use either of the following methods for interlocking:

- Data assurance by handshake of the remote I/O
- Data assurance by handshake of the remote register

Data assurance by handshake of the remote I/O

The following shows an example of sending data in W0 to W3 of the master station (station No.0) to W100 to W103 of the local station (station No.1). (X1000 and Y1000 are used for a handshake to the FX5 CPU module.)

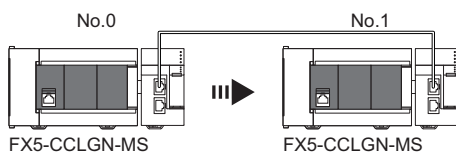

- Data flow

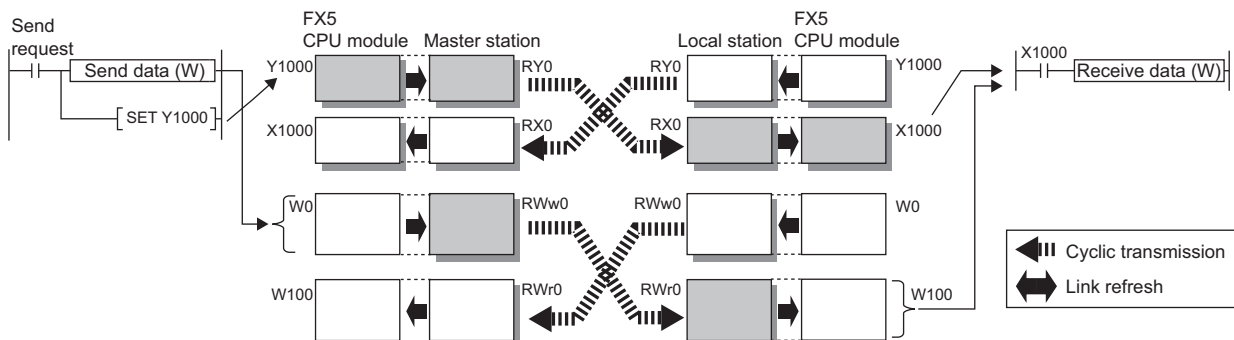

• Program

Sending station: Master station (station No.0)

Classification	Setting details															
Label to be defined	Define global labels as shown below:															
	<table border="1"> <thead> <tr> <th></th> <th>Label Name</th> <th>Data Type</th> <th>Class</th> <th>Assign (Device/Label)</th> </tr> </thead> <tbody> <tr> <td>1</td> <td>bStartDirection</td> <td>Bit</td> <td>VAR_GLOBAL</td> <td>M0</td> </tr> <tr> <td>2</td> <td>uTransferFrom</td> <td>Word [Signed]</td> <td>VAR_GLOBAL</td> <td>D0</td> </tr> </tbody> </table>		Label Name	Data Type	Class	Assign (Device/Label)	1	bStartDirection	Bit	VAR_GLOBAL	M0	2	uTransferFrom	Word [Signed]	VAR_GLOBAL	D0
	Label Name	Data Type	Class	Assign (Device/Label)												
1	bStartDirection	Bit	VAR_GLOBAL	M0												
2	uTransferFrom	Word [Signed]	VAR_GLOBAL	D0												



Receiving station: Local station (station No.1)

Classification	Setting details										
Label to be defined	Define global labels as shown below:										
	<table border="1"> <thead> <tr> <th></th> <th>Label Name</th> <th>Data Type</th> <th>Class</th> <th>Assign (Device/Label)</th> </tr> </thead> <tbody> <tr> <td>1</td> <td>uTransferTo</td> <td>Word [Signed]</td> <td>VAR_GLOBAL</td> <td>D0</td> </tr> </tbody> </table>		Label Name	Data Type	Class	Assign (Device/Label)	1	uTransferTo	Word [Signed]	VAR_GLOBAL	D0
	Label Name	Data Type	Class	Assign (Device/Label)							
1	uTransferTo	Word [Signed]	VAR_GLOBAL	D0							



• Program flow

- ❶ The master station checks that the send request bStartDirection (M0) is turned on, and transfers contents of uTransferFrom [0] to [3] (D0 to D3) to the send data W0 to W3.
- ❷ When the transfer is completed, the master station turns on Y1000.
- ❸ The local station checks that X1000 is turned on, and transfers contents of the receive data W100 to W103 to uTransferTo [0] to [3] (D0 to D3).
- ❹ When the transfer is completed, the local station turns on Y1000.
- ❺ The master station checks that X1000 is turned on, and turns off Y1000.
- ❻ The local station checks that X1000 is turned off, and turns off the reception complete signal Y1000.

Precautions

When performing handshake of the remote I/O (RX, RY), set a device to be used as a handshake flag after a remote register that prevents data inconsistency in the "Refresh Settings". Otherwise, the data inconsistency may occur even when the program above is used.

📖 Page 130 Refresh settings

■ Data assurance by handshake of the remote register

The following shows an example of sending data in W0 to W3 of the master station (station No.0) to W100 to W103 of the local station (station No.1). (B0 and B40 are used for a handshake to the FX5 CPU module.)

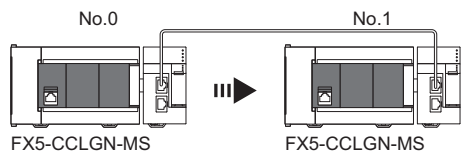

• Data flow

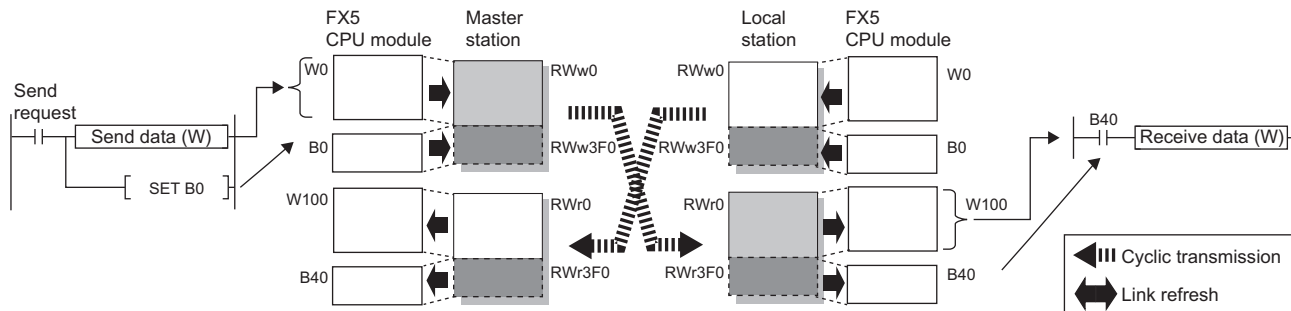

• Program

Sending station: Master station (station No.0)

Classification	Setting details															
Label to be defined	Define global labels as shown below:															
	<table border="1"> <thead> <tr> <th></th> <th>Label Name</th> <th>Data Type</th> <th>Class</th> <th>Assign (Device/Label)</th> </tr> </thead> <tbody> <tr> <td>1</td> <td>bStartDirection</td> <td>Bit</td> <td>VAR_GLOBAL</td> <td>M0</td> </tr> <tr> <td>2</td> <td>uTransferFrom</td> <td>Word [Signed]</td> <td>VAR_GLOBAL</td> <td>D0</td> </tr> </tbody> </table>		Label Name	Data Type	Class	Assign (Device/Label)	1	bStartDirection	Bit	VAR_GLOBAL	M0	2	uTransferFrom	Word [Signed]	VAR_GLOBAL	D0
	Label Name	Data Type	Class	Assign (Device/Label)												
1	bStartDirection	Bit	VAR_GLOBAL	M0												
2	uTransferFrom	Word [Signed]	VAR_GLOBAL	D0												



Receiving station: Local station (station No.1)

Classification	Setting details										
Label to be defined	Define global labels as shown below:										
	<table border="1"> <thead> <tr> <th></th> <th>Label Name</th> <th>Data Type</th> <th>Class</th> <th>Assign (Device/Label)</th> </tr> </thead> <tbody> <tr> <td>1</td> <td>uTransferTo</td> <td>Word [Signed]</td> <td>VAR_GLOBAL</td> <td>D0</td> </tr> </tbody> </table>		Label Name	Data Type	Class	Assign (Device/Label)	1	uTransferTo	Word [Signed]	VAR_GLOBAL	D0
	Label Name	Data Type	Class	Assign (Device/Label)							
1	uTransferTo	Word [Signed]	VAR_GLOBAL	D0							



• Program flow

- ❶ The master station checks that the send request bStartDirection (M0) is turned on, and transfers contents of uTransferFrom [0] to [3] to the send data W0 to W3.
- ❷ When the transfer is completed, the master station turns on B0.
- ❸ The local station checks that B40 is turned on, and transfers contents of the receive data W100 to W103 to uTransferTo [0] to [3] (D0 to D3).
- ❹ When the transfer is completed, the local station turns on B0.
- ❺ The master station checks that B40 is turned on, and turns off B0.
- ❻ The local station checks that B40 is turned off, and turns off B0.

Communication cycle coexistence

When device stations with different communication cycles are included in the network, communicates data using multiple communication cycles according to each device station.

The time for each communication cycle is the total time of cyclic transmission, transient transmission, and system reservation time.

Even if device stations with different communication cycles are connected to a network, a device station with a high-speed communication cycle is not affected by a device station with a low speed communication cycle.

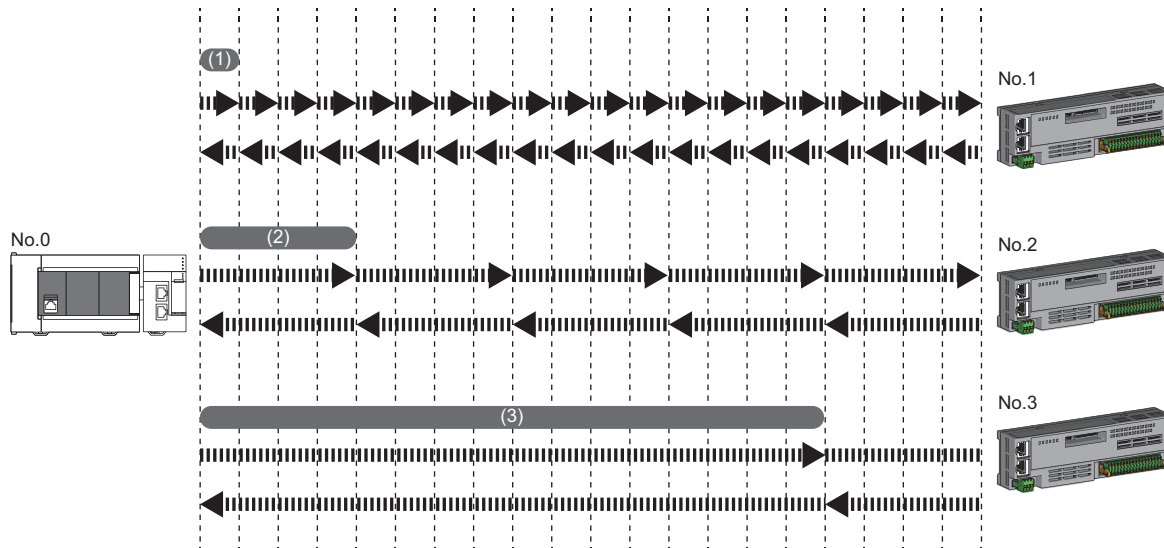

- (1) Basic cycle
- (2) Normal speed
- (3) Low speed

Setting method

The master station communicates with device stations by using three communication cycles that are the basic cycle under "Basic Period Setting", and "Normal-Speed" and "Low-Speed" under "Multiple Period Setting". ( Page 132 Communication Period Setting)

The communication cycle of each device station can be selected from "Basic Period", "Normal-Speed", or "Low-Speed" in "Network Configuration Settings" under "Basic Settings".

Precautions

When "Communication Mode" under "Application Settings" is set to "Multicast", set "Communication Period Setting" for the local station in "Network Configuration Settings" to "Basic Period".

I/O maintenance settings

When using cyclic transmission, set whether to hold or clear output on the sending side or input on the receiving side by using the following settings of (A), (B), and (C). (☞ Page 135 Supplementary Cyclic Settings)

- Setting on sending side (A): "Output Mode upon CPU Error" when a stop error occurred in the FX5 CPU module on the sending side
- Setting on sending side (B): "Output Hold/Clear Setting during CPU STOP" when the status of the FX5 CPU module on the sending side changed from RUN to STOP
- Setting on receiving side (C): "Data Link Faulty Station Setting" when the sending side is disconnected

☞ [Application Settings] ⇒ [Supplementary Cyclic Settings] ⇒ [I/O Maintenance Settings]

Input data hold/clear operation on the receiving side

4

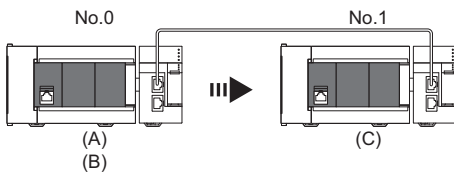

■ If an FX5 CPU module stop error occurred on the sending side

- If both settings (A) and (B) on the sending side are "Hold", input data on the receiving side is held.
- If setting (A) or (B) on the sending side is "Clear", input data on the receiving side is cleared. (The sending side sends the data cleared to 0.)

■ If the FX5 CPU module on the sending side changed from RUN to STOP

- If setting (B) on the sending side is "Hold", input data on the receiving side is held.
- If setting (B) on the sending side is "Clear", input data on the receiving side is cleared. (The sending side sends the data cleared to 0.)

■ If the sending side disconnected

- If setting (C) on the receiving side is "Hold", input data before disconnection is held on the receiving side.
- If setting (C) on the receiving side is "Clear", input data on the receiving side is cleared.

Precautions

■ When "Output Hold/Clear Setting during CPU STOP" is set to "Clear"

When the FX5 CPU module is in the STOP state, the forced output to device stations cannot be executed using the engineering tool.

Output data hold/clear operation during CPU STOP

The following figure shows the devices where the setting of "Output Hold/Clear Setting during CPU STOP" is enabled when the FX5 CPU module on the sending side changes from RUN to STOP.

■At unicast mode

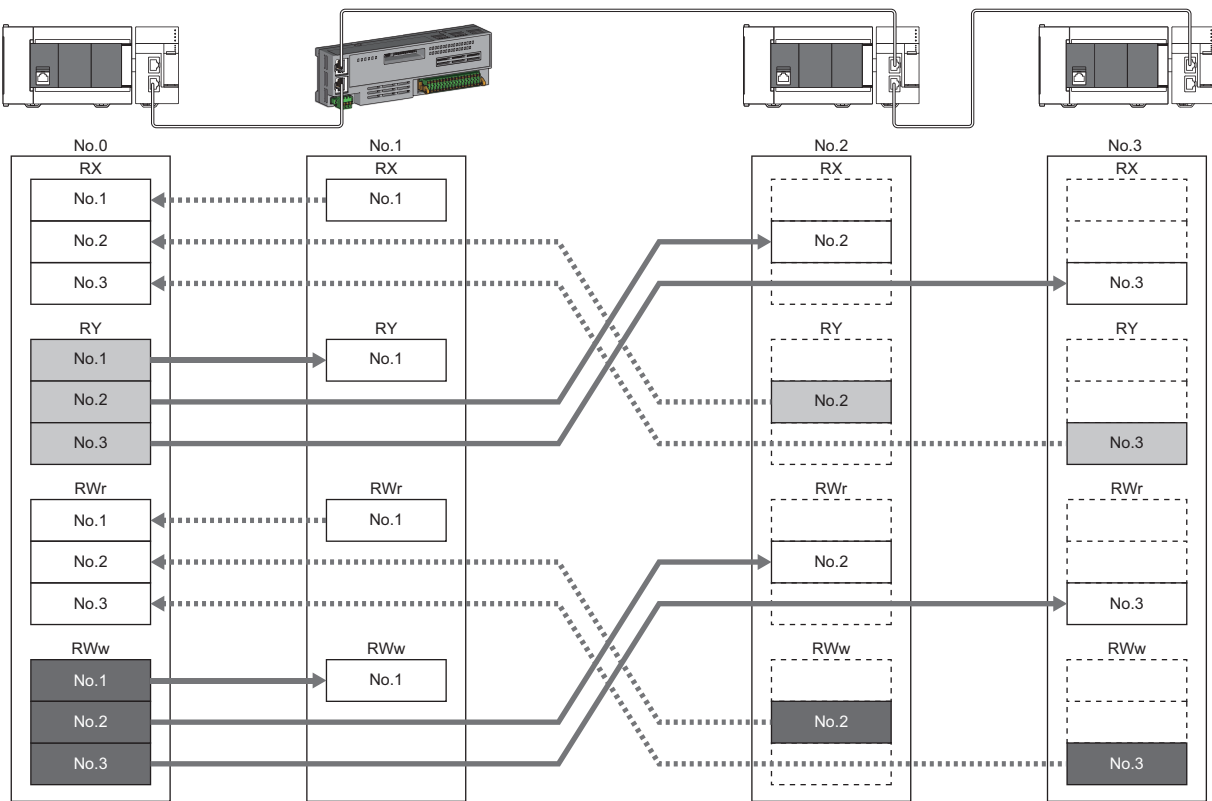

- : When the link refresh source is set to a source other than Y, data is held or cleared according to the parameter setting. When the link refresh source is set to Y, data is cleared regardless of the parameter setting.
- : Data is held regardless of the parameter setting.

■At multicast mode

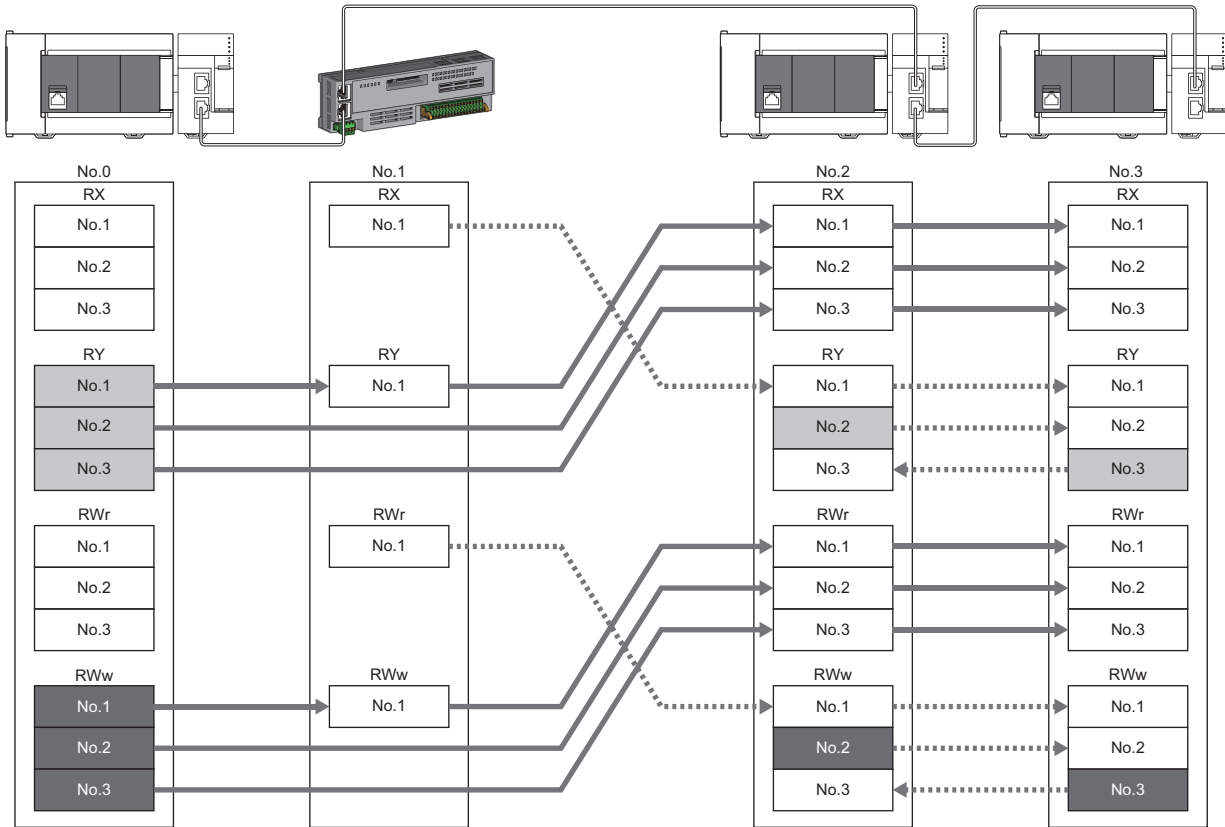

- : When the link refresh source is set to a source other than Y, data is held or cleared according to the parameter setting. When the link refresh source is set to Y, data is cleared regardless of the parameter setting.
- : Data is held regardless of the parameter setting.

Input data hold/clear operation from the data link faulty station

The following figure shows the devices where "Data Link Faulty Station Setting" is enabled when each station becomes faulty.

■At unicast mode

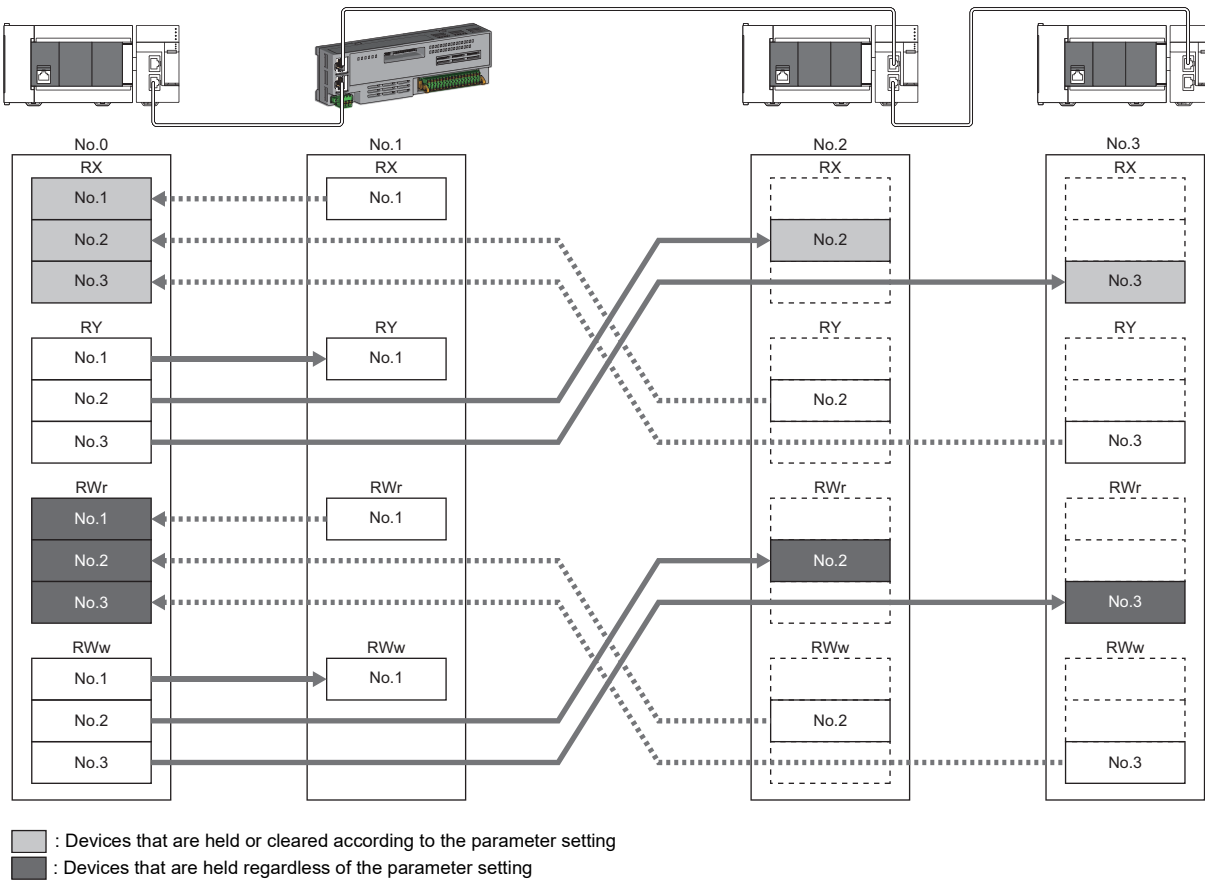

■At multicast mode

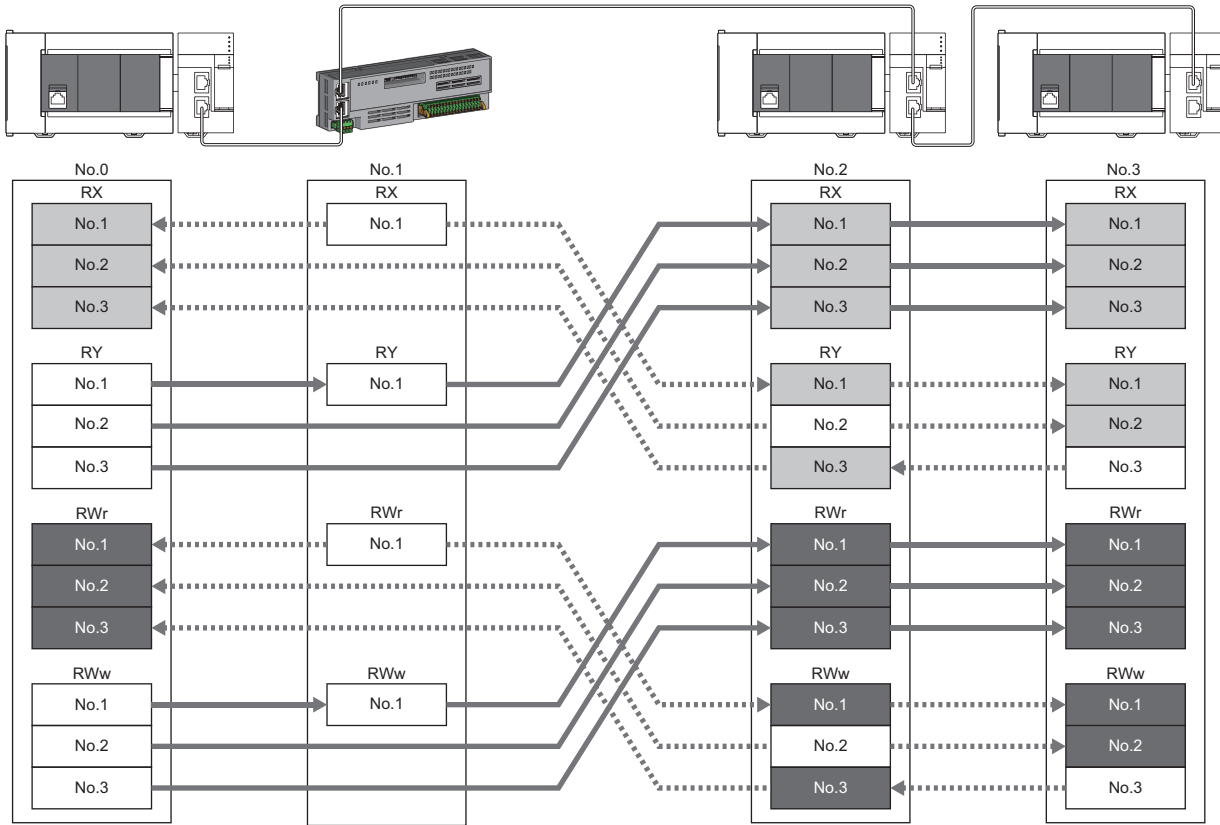

- : Devices that are held or cleared according to the parameter setting
- : Devices that are held regardless of the parameter setting

4.3 Transient Transmission

This function is used for data communications at any timing and has the following three types.

☞ Page 44 Communications using a dedicated instruction

☞ Page 45 Communications using the SLMP

☞ Page 45 Communications using the engineering tool

FX5-CCLGN-MS can communicate only in the same network.

Communications using a dedicated instruction

This type of the data communication is used to read/write data from the master station or local station to devices in a CPU module of the local station using the dedicated instructions.

For dedicated instructions that can be used and details on dedicated instructions, refer to the following.

☞ Page 144 DEDICATED INSTRUCTION

📖 MELSEC iQ-F FX5 Programming Manual (Instructions, Standard Functions/Function Blocks)

Ex.

Accessing a local station using the dedicated instruction (READ instruction)

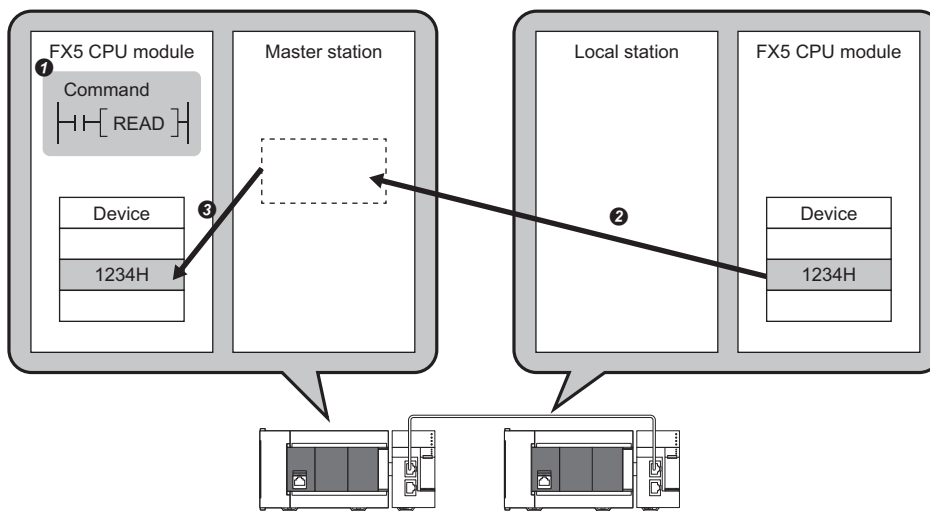

Communications using the SLMP

This type of the data communication is used to read/write data from the external device, such as a personal computer or HMI (Human Machine Interface), to devices in the CPU module of the master station and local station and the buffer memory areas of the remote station via an SLMP.

The FX5-CCLGN-MS operates as the SLMP server, and sends and receives SLMP messages. For details on SLMP, refer to the following.

📖 MELSEC iQ-F FX5 User's Manual (Communication)

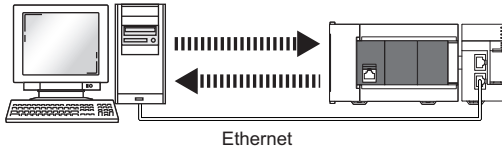

Precautions

For SLMP communications, set the same communication speed for the connected station and access destination. If the communication speed differs between the connected station and access destination, SLMP communications may not be performed.

Communications using the engineering tool

This type of the data communication is used to perform the settings of or monitor each station using the engineering tool.

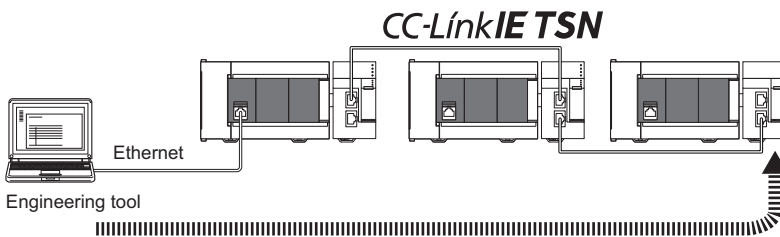

4.4 Ethernet Connection

This function connects an Ethernet device to a module without interfering with CC-Link IE TSN.

Connection with MELSOFT products

Programming and monitoring of the programmable controller are performed via Ethernet using the engineering tool. This function enables remote control using long-distance connectivity and high-speed communications via Ethernet.

The following table lists the methods of connecting the FX5-CCLGN-MS to MELSOFT products (such as engineering tool).

○: Connection available, ×: Connection not available

Connection method	Purpose	Availability	Reference
		MELSOFT product	
Connection via a HUB (Connection by specifying the IP address)	To connect multiple MELSOFT products	○	Page 46 Connection via a HUB
Connection via a HUB (Connection by specifying the network number and station number)	To connect multiple MELSOFT products	○	

Restriction

A station with a communication speed different from the communication speed of the station to which the engineering tool is connected cannot be connected by specifying another station. The online and debug function of the engineering tool may not be used.

Connection via a HUB

■ Settings on the FX5-CCLGN-MS side

- For connection by specifying the IP address, set the IP address using "Required Settings". ( Page 128 Station No./IP Address Setting)
- For connection by specifying the network number and station number, set the network number and station number in "Required Settings".

Neither of connections require "Network Configuration Settings" under "Basic Settings".

■ Settings on the engineering tool side

Set in the "Specify Connection Destination Connection" window.

 [Online] ⇒ [Current Connection Destination]

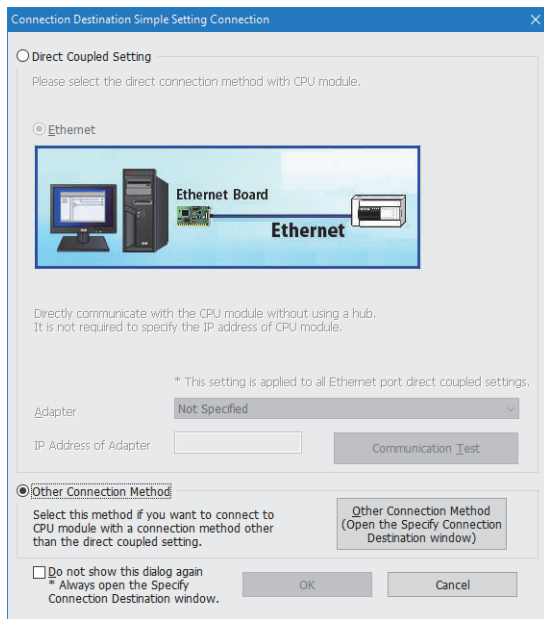

 [Other Connection Method] ⇒ [Other Connection Method (Open the Specify Connection Destination window)]

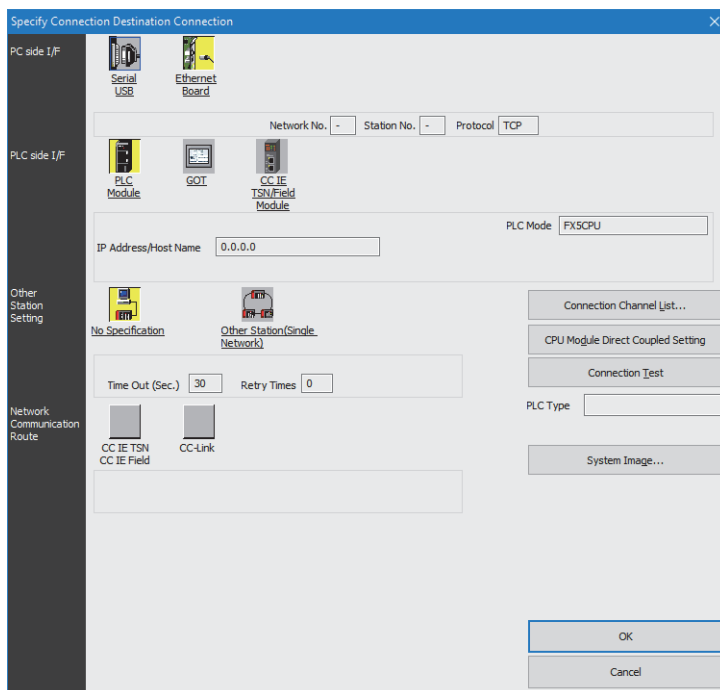

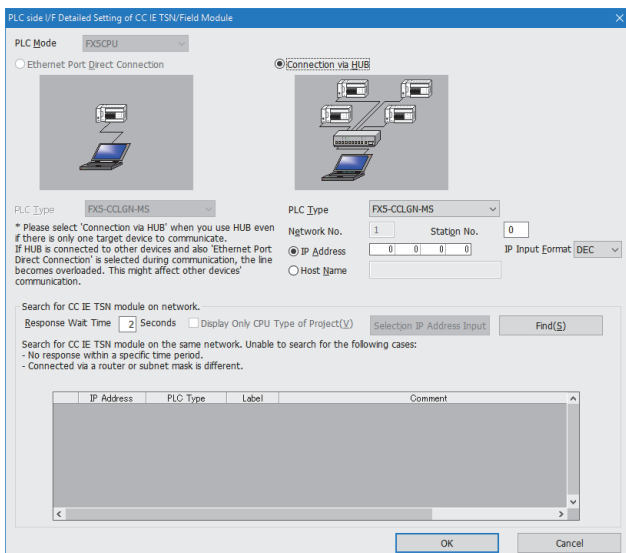
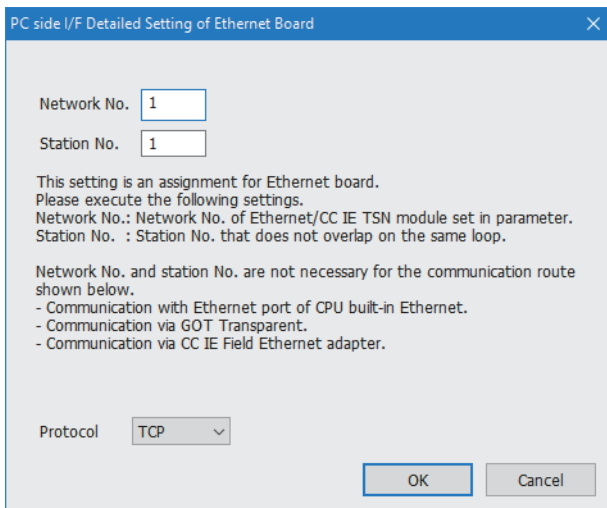

1. Set "PC side I/F" to "Ethernet Board".
2. Double-click "Ethernet Board", and open the "PC side I/F Detailed Setting of Ethernet Board" window.
3. Set the network number, station number, and protocol of the personal computer.

TCP: A connection is established during communication. Since data is exchanged while checking that the data has correctly reached the communication destination, the data reliability can be ensured. Note that the line load is larger than UDP/IP communications.

UDP: Since a connection is not established during communication and whether the communication destination has correctly received the data is not checked, the line load is lower. Note that the data reliability is lower than TCP/IP communications.

4. Set the "PLC side I/F" to the module to be connected.
5. Double-click the icon set in step 4, and open the detailed setting window.
6. Select "Connection via a HUB" for the connection method, and enter the station number and IP address or host name of the FX5-CCLGN-MS.
7. Specify "Other Station Setting" or "Network Communication Route" if necessary.

■ Searching modules on the network

For a connection using an industrial switch, a list of modules that can be searched for will appear by clicking the [Find] button on the detailed setting window.

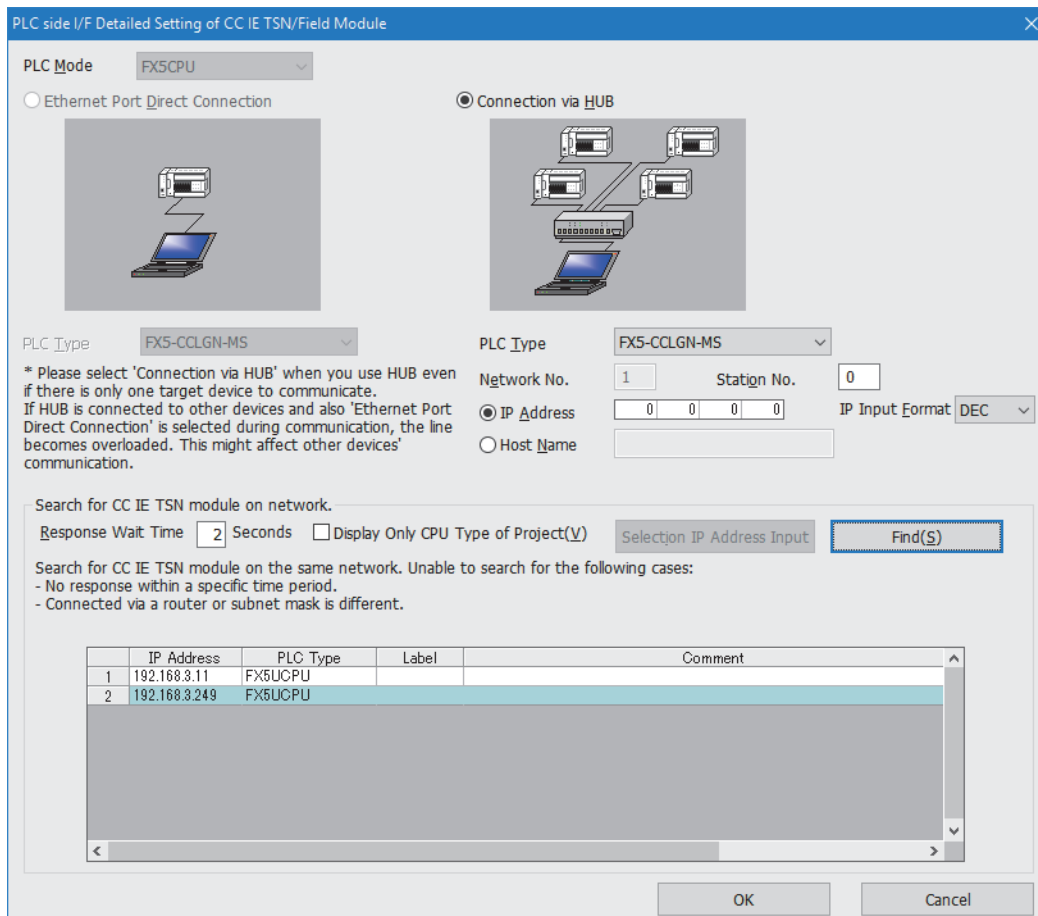

Search target modules are as follows.

- FX5 CPU module connected to the same industrial switch as the engineering tool
- FX5 CPU module connected to a cascade-connected industrial switch

If the connected FX5-CCLGN-MS does not appear in the list after searching for the modules on the network, check the following items.

- Search cannot be performed if it is disabled with the IP filter.
- Modules connected via a router cannot be searched for.
- If modules with the same IP address are listed, correct the setting of the IP address in "Network Configuration Settings" under "Basic Settings" of the master station.
- If the service processing load of the search-target FX5 CPU module is high, a search for the corresponding module may not be performed. If the search cannot be performed, increase the response waiting time in the search dialog, and execute the search again.

Connection with SLMP-compatible devices

SLMP-compatible devices (such as a personal computer or a vision sensor) are connected to the FX5-CCLGN-MS.

For details on SLMP, refer to the following.

SLMP Reference Manual

Restriction

- To execute communications using SLMP, set the same communication speed for the connected station and access destination. If the communication speed differs between the connected station and access destination, when communications using SLMP are executed, the communications may not be performed.
- When the system configuration is mixed with an Ethernet device, there are restrictions for the network topology and connection destination of the Ethernet device. (Page 60 SYSTEM CONFIGURATION)

4.5 Security

This function ensures security according to the network environment by restricting access for each communication path to the FX5 CPU module. The following two access restriction methods can be used.

☞ Page 50 IP filter

☞ Page 52 Remote password

IP filter

This function identifies the IP address of the access source, and prevents unauthorized access.

By setting the IP address of the access source using the engineering tool, IP packets are allowed or blocked. (The IP packets received from the access source are allowed or blocked. IP packets sent from the own station are ignored.)

Use of this function is recommended when using in an environment connected to a LAN line.

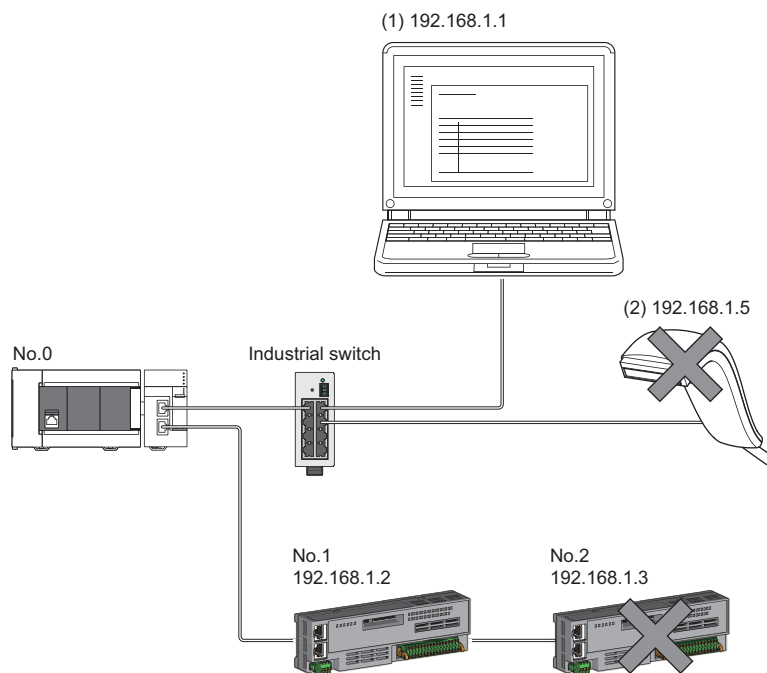

When the "Allow" IP addresses are set to 192.168.1.1 and 192.168.1.2 using the IP filter of the master station No.0:

Only the Ethernet device (1) and device station No.1 can access the master station, and the Ethernet device (2) and device station No.2 cannot access the master station.

Point

The IP filter is one method of preventing unauthorized access (such as a program or data destruction) from an external device. It does not completely prevent unauthorized access. Take appropriate measures other than this function if the safety of the programmable controller system must be maintained against unauthorized access from an external device. Mitsubishi shall not be held liable for any system problems that may occur from unauthorized access.

Examples of measures for unauthorized access are as follows.

- Install a firewall.
- Install a personal computer as a relay station, and control the relay of send/receive data with an application program.
- Install an external device for which the access rights can be controlled as a relay station. (Contact the network service provider or equipment dealer for details on the external devices for which access rights can be controlled.)

Setting method

1. Set the IP address to be allowed or blocked in the "IP Filter Settings" window of "Security" under "Application Settings".
( Page 136 Security)

A warning is displayed in the following cases.

- When blocking the IP address of the device station set in "Network Configuration Settings" under "Basic Settings" was attempted
- When a device station is not set in "Network Configuration Settings" under "Basic Settings", and the "Allow" target IP address is not set in the "IP Filter Settings" window (because the IP filter blocks every IP address)

2. Write the module parameters to the FX5 CPU module.
3. The IP filter is enabled when the FX5 CPU module is powered off and on or reset.

Point

Even if the connection was specified in "Network Configuration Settings" under "Basic Settings" or by a program, access from the external device is either allowed or blocked according to the setting in the "IP Filter Settings" window.

Setting target

Allow or block should be set to all IP addresses that connect to the same network. Also, set allow or block to the IP address of the device station that is registered in "Network Configuration Settings" under "Basic Settings".

Register the setting details to the master station, and allow or block the IP packets received from the device station with the registered IP address.

Operation

Even for the device station registered in "Network Configuration Settings" under "Basic Settings", a station with an IP address set as blocked becomes a disconnected station. As a result, cyclic transmission and transient transmission are not performed. Such a station is also displayed as a disconnected station on the "CC-Link IE TSN/CC-Link IE Field Diagnostics" window. However, Ethernet devices are not displayed on the "CC-Link IE TSN/CC-Link IE Field Diagnostics" window. ( Page 180 CC-Link IE TSN/CC-Link IE Field diagnostics)

Precautions

- Do not set the IP address of the master station or of a device station as blocked. When a device station is set as blocked while using line topology, cyclic and transient transmissions cannot be performed on the device stations that are connected after the device station set as blocked.

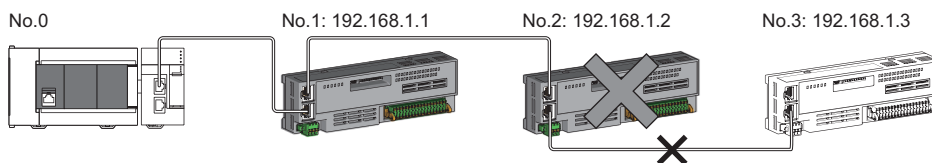

When the "Deny" IP address is set to 192.168.1.2 using the IP filter of the master station No.0:

Only the device station No.1 can access the master station, and the device station No.2 and device station No.3 cannot access the master station.

- If there is a proxy server in the LAN line, block the IP address of the proxy server. If the IP address is allowed, access from personal computers that access the proxy server will not be prevented.
- To block access from an external device to another station, block access to the connected station (station connected directly to an external device) by using the IP filter.

Remote password

This function permits or prohibits access from the external device to the FX5 CPU module via the FX5-CCLGN-MS. This prevents unauthorized access to the FX5 CPU module from a remote location.

Point

The remote password is one method of preventing unauthorized access (such as program or data destruction) from an external device. It does not completely prevent unauthorized access. Take appropriate measures other than this function if the safety of the programmable controller system must be maintained against unauthorized access from an external device. Mitsubishi shall not be held liable for any system problems that may occur from unauthorized access.

Examples of measures for unauthorized access are as follows.

- Install a firewall.
 - Install a personal computer as a relay station, and control the relay of send/receive data with an application program.
 - Install an external device for which the access rights can be controlled as a relay station. (Contact the network service provider or equipment dealer for details on the external devices for which access rights can be controlled.)
-

Number of settable modules

Only one password for "Register Password" can be registered.

Maximum settable remote passwords are three (master station, local station, and a CPU module).

Setting method

Set a remote password on the "Remote Password Setting" window.

[Navigation window] ⇒ [Parameter] ⇒ [Remote Password]

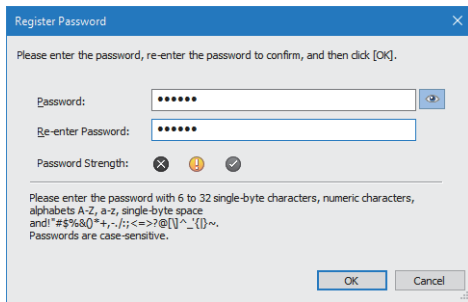

Register Password

Please enter the password, re-enter the password to confirm, and then click [OK].

Password:

Re-enter Password:

Password Strength:

Please enter the password with 6 to 32 single-byte characters, numeric characters, alphabets A-Z, a-z, single-byte space and! "#%&*+,-./:;<=>?@[^\`_{}~-. Passwords are case-sensitive.

1. Click the [Password] button, and register the remote password on the "Register Password" window.

 [Password] button

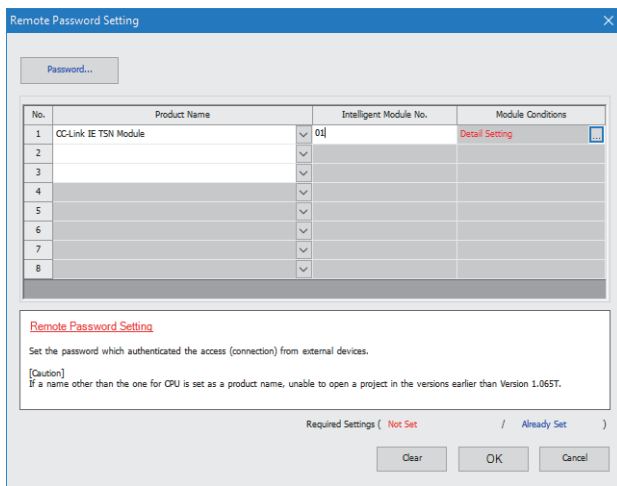

Remote Password Setting

No.	Product Name	Intelligent Module No.	Module Conditions
1	CC-Link IE TSN Module	01	Detail Setting <input type="button" value="ⓧ"/>
2			
3			
4			
5			
6			
7			
8			

Remote Password Setting

Set the password which authenticated the access (connection) from external devices.

[Caution]
If a name other than the one for CPU is set as a product name, unable to open a project in the versions earlier than Version 1.065T.

Required Settings (Not Set / Already Set)

2. Select the module for which the remote password is to be applied, and set the "Intelligent Module No."

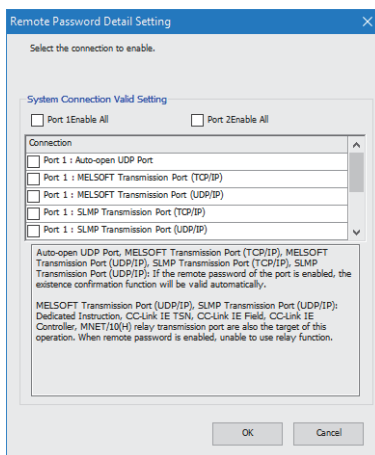

Remote Password Detail Setting

Select the connection to enable.

System Connection Valid Setting

Port 1 Enable All Port 2 Enable All

Connection

Port 1 : Auto-open UDP Port

Port 1 : MELSOFT Transmission Port (TCP/IP)

Port 1 : MELSOFT Transmission Port (UDP/IP)

Port 1 : SLMP Transmission Port (TCP/IP)

Port 1 : SLMP Transmission Port (UDP/IP)

Auto-open UDP Port, MELSOFT Transmission Port (TCP/IP), MELSOFT Transmission Port (UDP/IP), SLMP Transmission Port (TCP/IP), SLMP Transmission Port (UDP/IP): If the remote password of the port is enabled, the existence confirmation function will be valid automatically.

MELSOFT Transmission Port (UDP/IP), SLMP Transmission Port (UDP/IP): Dedicated Instruction, CC-Link IE TSN, CC-Link IE Field, CC-Link IE Controller, MNET/IQ(H) relay transmission port are also the target of this operation. When remote password is enabled, unable to use relay function.

3. Set the target connection on the "Remote Password Detail Setting" window.

 "Detail Setting" for the target module

4. Write the remote password to the FX5 CPU module.
5. The remote password is enabled when the FX5 CPU module is powered off and on or reset.

■PING

This function uses the PING command to perform an alive check of external devices whose access is permitted in UDP communications. When this function is used for UDP communications, check if the security setting of external devices (such as a firewall) is set to respond to PING.

Access permitted/prohibited processing operation

The following describes the processing for permitting or prohibiting access from the external device to the FX5 CPU module with a remote password.

■Access permit processing (Unlock processing)

The external device trying to communicate unlocks the remote password set for the connected FX5-CCLGN-MS.

If the password is not unlocked, the FX5-CCLGN-MS to which the external device is connected prohibits access, so an error occurs in the external device.

The unlocking methods are as follows.

- SLMP dedicated command (Remote Password Unlock)
- Password input from engineering tool

■Access processing

Access to the specified station is possible when the remote password is correctly unlocked. Execute any access.

■Access prohibit processing (Lock processing)

When access to the specified station ends, lock the remote password from the external device to disable subsequent access.

The locking methods are as follows.

- SLMP dedicated command (Remote Password Lock)
- Lock with engineering tool (executed automatically)

Remote password check operation

■Communications that are checked

The FX5-CCLGN-MS checks the remote password for a communication request made to the own station or another station received from the external device.

When checking a remote password for modules with multiple connections, the connection for which the remote password is set is the target.

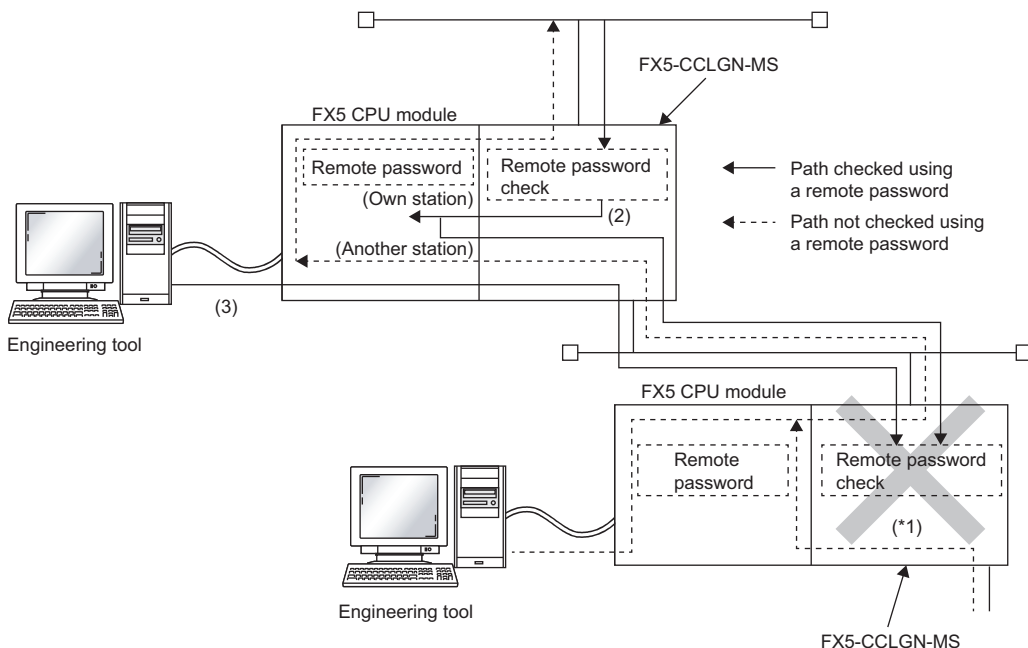

*1 Since the remote password check is set, the communication request from the external device is not accepted. If the remote password check is not set, the communication request can be accepted and data communications from the external device can be performed.

■ Accessible station

The station accessible from the external device when a remote password is set for the FX5 CPU module and the station that can unlock/lock the remote password are limited to those with the same network number.

The following figure shows an example when the remote password is set for multiple stations in the system.

Ex.

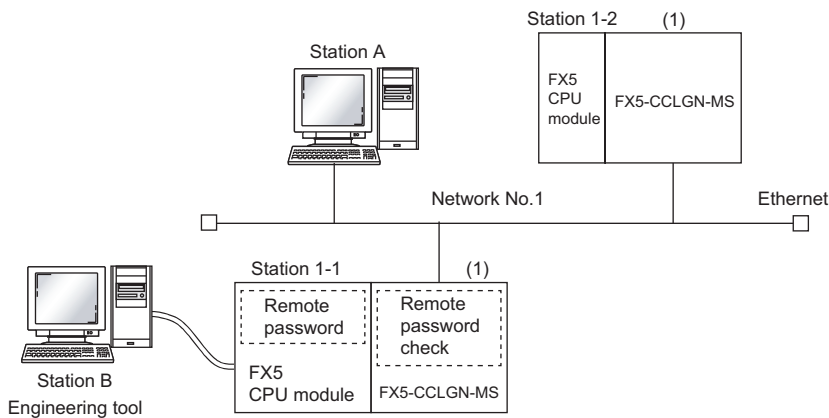

The password can be unlocked and locked by the following external devices.

- 1-1 station (1): A station only

The A station can access the ○ station after the remote password for 1-1 station (1) is unlocked. The △ station can be accessed if the communication line is open.

The B station can access the △ station if the communication line is open.

○: Station accessible from external device after remote password is unlocked

△: Station accessible from external device even if remote password is not unlocked

External device (Request source)	Target programmable controller (request destination)	
	1-1 station CPU	1-2 station CPU
A station	○	△
B station	△	△

Precautions

The following describes the precautions when remote password is used.

■ Setting of remote password for connection

Set the remote password for the connection used for data communications with an external device that can execute the unlock/lock processing.

■ When remote password is set for UDP/IP connection

- Determine the external device to communicate with and perform data communications. (With UDP/IP, after the remote password is unlocked, data can be exchanged with devices other than the unlocked external device too. Determine the communication destination before starting to use.)
- Always lock the remote password after data communication is finished. (If the remote password is not locked, the unlocked state is held until timeout occurs.)

■ TCP/IP close processing

If the TCP/IP is closed before the TCP/IP is locked, the FX5 CPU module will automatically start the lock processing.

■ Remote password valid range

The remote password is valid only for access from the FX5-CCLGN-MS for which the parameters are set. In a system configuration in which multiple modules are used, set a remote password for each module which requires a remote password.

■ Accessing the programmable controller of another station

When the external device is accessing the programmable controller of another station via the FX5-CCLGN-MS, accessing the programmable controller may not be possible if a remote password is set for the FX5 CPU module at the relay station or station to be accessed.

4.6 RAS

RAS stands for Reliability, Availability, and Serviceability. This function improves overall usability of automated equipment.

Device station disconnection

Data link of the station where an error occurred is stopped, and the data link continues only for stations that are operating normally.

Automatic return

The data link is automatically restarted when the device station that was disconnected due to an error becomes normal again.

Precautions

- When removing a device station while the system is operating, check that the device station is either performing cyclic transmission or is disconnected.
- When removing the FX5-CCLGN-MS, check that the D LINK LED is either on or off.

Master station duplication detection

When one network has multiple master stations, duplication is detected.

- When multiple master stations are simultaneously powered on, or when multiple master stations are simultaneously connected, Master station duplication (error code: 300FH) is detected in all master stations and cyclic transmission cannot be performed in any stations.

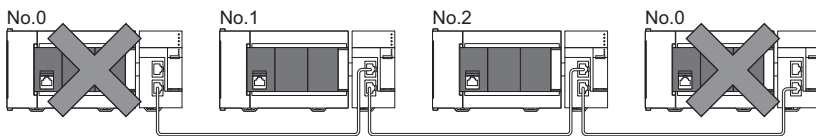

- When another master station is added to the network during data link, Master station duplication (error code: 300FH) is detected in the added master station and cyclic transmission cannot be performed. Other stations continue data link.

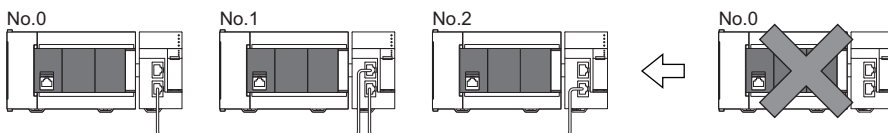

- When two networks are connected during data link, Master station duplication (error code: 300FH) is detected in master stations on both networks and cyclic transmission cannot be performed in any stations.

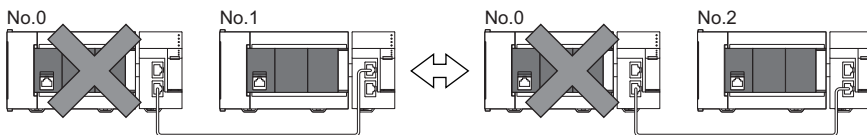

IP address duplication detection

When one network has stations with the same IP address, duplication is detected.

Precautions

When IP address duplication is detected in the master station (error codes: 1802H, 3021H), change the IP address of the corresponding station, and power off and on the master station, or reset it.

Detection in each station

When adding a device station, if a station with the same IP address already exists, IP address duplication (error code : 2160H) is detected in a station to be added, and data link cannot be performed. (Other stations continue data link.)

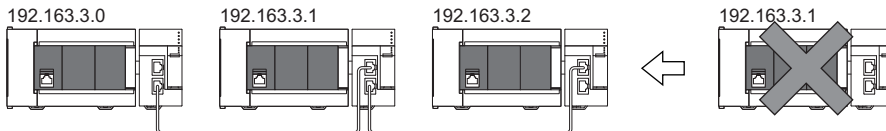

4

Precautions

When a device station that is already connected (linked up) with an industrial switch (for CC-Link IE TSN Class B) is added to the network together with the industrial switch (for CC-Link IE TSN Class B), an overlapping IP address is not detected in the station to be added. If IP address duplication (error code: 1802H) is detected in the master station, disconnect the relevant device station from the network. Otherwise, multiple stations with the same IP address will exist on the same network, possibly leading to transient transmission being sent to an unintended station.

Detection in the master station

■At cyclic transmission startup

If the startup processing of cyclic transmission is executed by powering off and on the master station, when a station with the same IP address is in the network, IP address duplication (error code: 3021H) is detected in the master station, and data link cannot be performed.

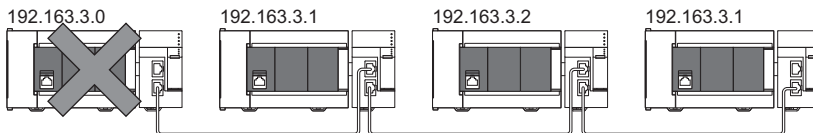

■Cyclic transmission in progress

During cyclic transmission, IP address duplication is regularly checked in the master station. When there are overlapping IP addresses, IP address duplication (error code: 1802H) is detected in the master station, and cyclic transmission cannot be performed with the relevant device station. (Other stations continue data link.)

Precautions

In any of the following combinations, IP address duplication is not detected when cyclic transmission starts up in the master station.

- Ethernet device and CC-Link IE TSN device
- Ethernet device and Ethernet device

Time synchronization

The time of device stations is synchronized with the time synchronization source (CPU module of the master station).

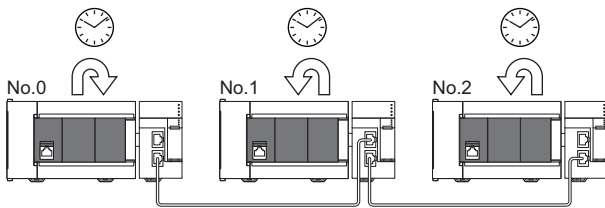

Setting method

The time synchronization is set to the buffer memory. (☞ Page 240 Time synchronization)

Set the same time zone to the CPU modules of the master and local stations.

Point

When the FX5-CCLGN-MS is used as the master station, do not connect time synchronization devices whose time synchronization priority is 0 to 15. For the priority verification method and setting method, refer to the manual of the time synchronization device.

Precautions

- When this function is used, the time setting function (SNTP client) of the Ethernet-equipped module cannot be used. (☞ MELSEC iQ-F FX5 User's Manual (Ethernet Communication))
- When time synchronization is also to be performed for the CPU module of the local station, time synchronization on the local station side needs to be set as well.
- When multiple FX5-CCLGN-MSs are mounted to an FX5 CPU module, set time synchronization for only one FX5-CCLGN-MS. When time synchronization is set for multiple, they are overwritten by the time that is synchronized later.

4.7 Others

Device station parameter automatic setting

This function saves parameters of the device station in the master station, and automatically sets the parameters when the device station is connected or returned to the network.

Device station parameter automatic setting from the master station

1. Parameters of the device station set using the engineering tool are saved in the memory of the FX5 CPU module in the master station or the SD memory card by writing.
2. When the device station is connected or returned to the network by power-on, saved parameters are automatically set from the master station.

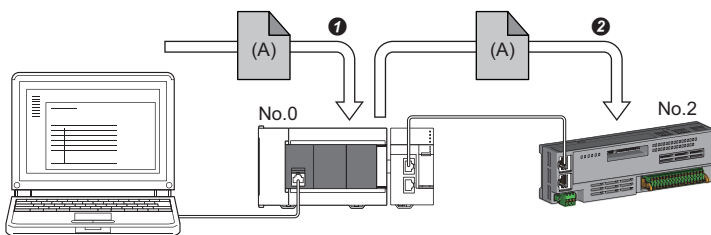

- ① Save parameter (A) of the device station to the FX5 CPU module in the master station.
- ② When the device station is returned/connected, saved parameter (A) is automatically set from the master station to the device station.

Point

- The master station starts data link with the device station after parameters of the device station are automatically set.
- The device station parameter automatic setting is also executed for device stations set as reserved stations.

Setting method

Set in the "Parameter of Device Station" window. (☞ Page 141 Parameter processing of a device station)

Precautions

- A device station whose device station parameter automatic setting abnormally ended does not start data link, and 'Execution result of device station parameter automatic setting' (SW0160 to SW0167) turns on. Check 'Detailed execution result of device station parameter automatic setting' (SW0194) and the event history and perform corrective actions according to Action of the error codes list.
- Check if the checkbox of "Parameter Automatic Setting" of the device station is selected in "Network Configuration Settings" under "Basic Settings".
- Check if the IP address of the device station in the "Network Configuration settings" under "Basic Settings" matches the actual IP address of the device station.
- When the communication speed differs between the master station and the station for which the device station parameter automatic setting is performed, the device station parameter automatic setting may end abnormally. When the setting ends abnormally, check that their communication speeds match.
- When the parameters of a device station are stored in the SD memory card, "Memory Card Parameter" ⇔ "Setting of File/Data Use or Not in Memory Card" ⇔ "Parameter of Device Station" for the FX5 CPU module is set to "Use" to write the memory card parameters and device station settings to the SD memory card.
- There is a limit to the number of device station parameter files that can be saved in the FX5 CPU module. For details, refer to the following.

📖 MELSEC iQ-F FX5 User's Manual (Application)

5 SYSTEM CONFIGURATION

CC-Link IE TSN is configured using Ethernet cables. (☞ Page 125 Ethernet cable)

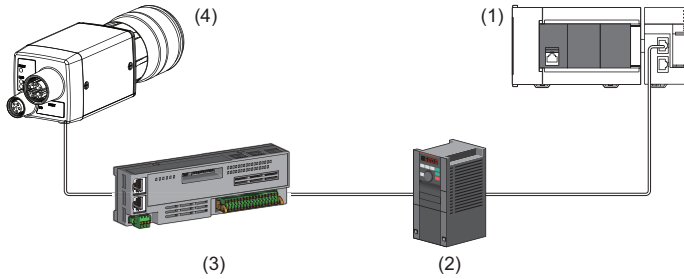

- (1) FX5-CCLGN-MS
- (2) Inverter device
- (3) Remote I/O module
- (4) Ethernet device (such as a vision sensor)

System configuration list

The following table shows the system configuration list.

Configuration	Firmware version of the master station	CC-Link IE TSN Protocol version of CC-Link IE TSN-compatible device	Reference
Structure of CC-Link IE TSN Class B devices and Ethernet devices	—	—	Page 62 Structure of CC-Link IE TSN Class B Devices and Ethernet Devices
Structure of CC-Link IE TSN Class B/A devices and Ethernet devices	"1.010" or later	2.0 only	Page 72 Structure of CC-Link IE TSN Class B/A Devices (CC-Link IE TSN Protocol version 2.0 Only) and Ethernet Devices
		Mixture of 1.0 and 2.0	Page 89 Structure of CC-Link IE TSN Class B/A Devices (Mixture of CC-Link IE TSN Protocol version 1.0 and 2.0) and Ethernet Devices
	"1.002" or earlier	1.0 only	Page 94 Structure of CC-Link IE TSN Class B/A Devices (CC-Link IE TSN Protocol version 1.0 Only) and Ethernet Devices

Point

The firmware version can be found in the of the following locations.

- The module diagnostics (CPU diagnostics) window of the engineering tool
- 'MIB information firmware version' (Un\G41) (☞ Page 232 MIB information firmware version (Un\G41))

For details on MIB information, refer to the following.

☞ Page 226 Buffer Memory

Precautions

To connect modules on CC-Link IE TSN, a dedicated industrial switch (for CC-Link IE TSN Class B) may be required depending on parameter settings or the network topology used.

Unicast mode and multicast mode

Cyclic transmission differs depending on the communication mode set by the module parameter of the master station. The communication modes are as follows:

- Unicast mode
- Multicast mode

For details, refer to the following.

☞ Page 25 Cyclic Transmission

CC-Link IE TSN Class Setting

From "Connection Device Information" under "Basic Settings" of the engineering tool, select either of the following items according to devices to be connected.

Connected device information	System configuration	Industrial switch	Standard
CC-Link IE TSN Class B Only	Select this if the system is to be configured without connecting the CC-Link IE TSN Class A device. <ul style="list-style-type: none"> ☞ Page 67 Connection with modules on CC-Link IE TSN only ☞ Page 71 Connection with modules on CC-Link IE TSN and Ethernet devices 	Industrial switch (for CC-Link IE TSN Class B)	IEEE802.1AS
Mixture of CC-Link IE TSN Class B/A or CC-Link IE TSN Class A Only	Select this if a CC-Link IE TSN Class A device is connected to a CC-Link IE TSN Class B device or if you want to configure a system with a CC-Link IE TSN Class A connected in the future. (Connection is also possible when the system is configured with CC-Link IE TSN Class B devices only.) <ul style="list-style-type: none"> ☞ Page 72 Structure of CC-Link IE TSN Class B/A Devices (CC-Link IE TSN Protocol version 2.0 Only) and Ethernet Devices ☞ Page 89 Structure of CC-Link IE TSN Class B/A Devices (Mixture of CC-Link IE TSN Protocol version 1.0 and 2.0) and Ethernet Devices ☞ Page 94 Structure of CC-Link IE TSN Class B/A Devices (CC-Link IE TSN Protocol version 1.0 Only) and Ethernet Devices 	Industrial switch (for CC-Link IE TSN Class A)	IEEE 802.1AS or IEEE 1588 ^{*1}

*1 IEEE 1588 if the firmware version of the master station is "1.002" or earlier.

IEEE 802.1AS or IEEE 1588 depending on the CC-Link IE TSN Protocol version of the CC-Link IE TSN-compatible device when the firmware version of the master station is "1.010" or later.

For details, refer to the following.

☞ Page 93 Connection configuration of CC-Link IE TSN-compatible devices

Ethernet connection

For connection with MELSOFT products and connection with SLMP-compatible devices, refer to the following.

☞ Page 23 Ethernet connection

5.1 Structure of CC-Link IE TSN Class B Devices and Ethernet Devices

This section describes the system configuration when "Connection Device Information" under "Basic Settings" of the engineering tool is set to "CC-Link IE TSN Class B Only".

For the maximum number of connectable stations when "Connection Device Information" under "Basic Settings" of the master station is set to "CC-Link IE TSN Class B Only", check the following.

☞ Page 15 Performance Specifications of CC-Link IE TSN

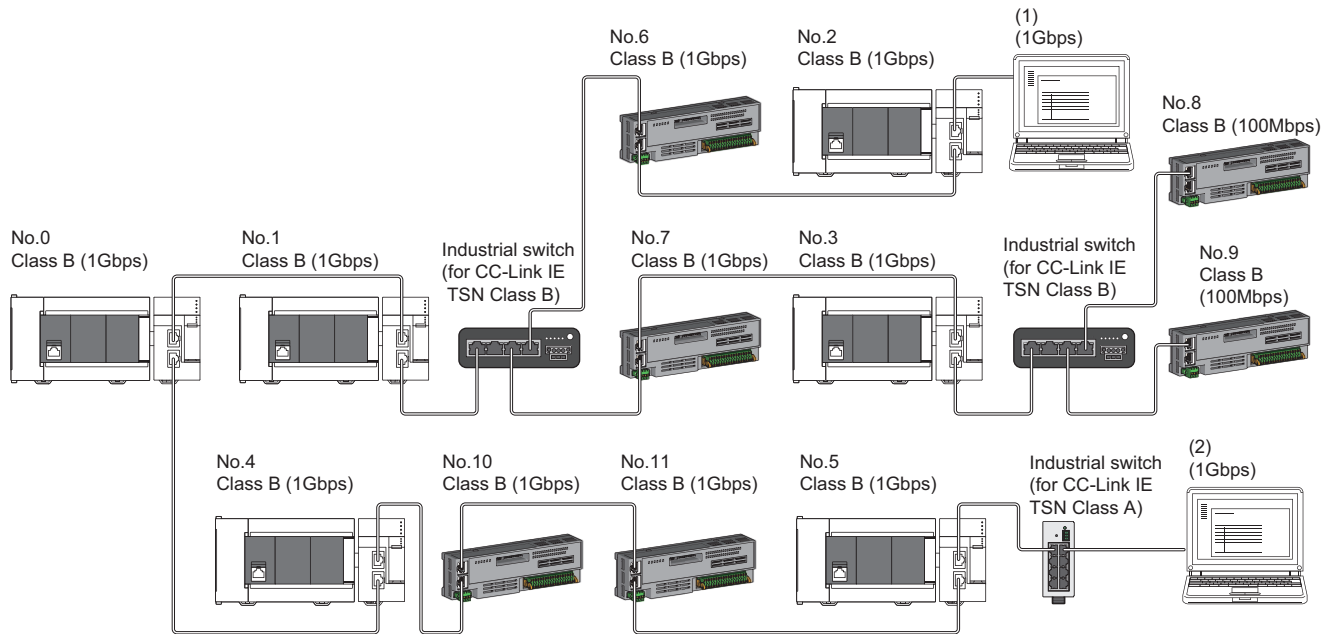

- No.0: Master station
- No.1, No.2, No.3, No.4, and No.5: Local station
- No.6, No.7, No.8, No.9, No.10, and No.11: Remote station
- (1), (2): Ethernet device
- Class B: CC-Link IE TSN Class B device

The availability of connection of network configuration devices varies depending on the communication mode and communication speed.

- Unicast mode

☞ Page 63 When the communication speed for the master station is set to 1Gbps

☞ Page 64 When the communication speed for the master station is set to 100Mbps

- Multicast mode

☞ Page 65 When the communication speed for the master station is set to 1Gbps

☞ Page 66 When the communication speed for the master station is set to 100Mbps

The following terms are used to describe the terms in the tables referenced.

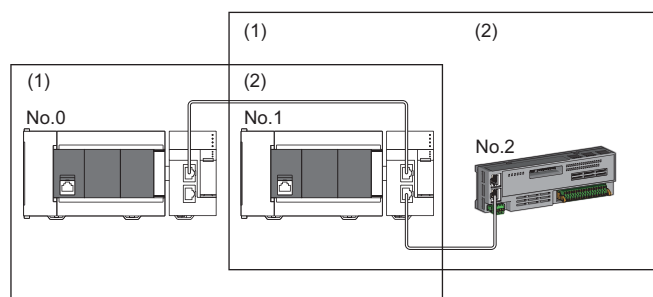

- No.0: Master station
- No.1: Local station
- No.2: Remote station
- (1) Device on the master station side (The master station or a device near the master station)
- (2) Device on the end side (A device far from the master station)

Structure of unicast mode

This mode indicates the availability of connection with a network configuration device when "Communication Mode" under "Application Settings" is set to "Unicast".

When the communication speed for the master station is set to 1Gbps

The following table lists the availability of connection with a network configuration device when the communication speed for the master station is set to 1Gbps.

○: Connection available, △: Connection available via an industrial switch, ×: Connection not available

S: Industrial switches (for CC-Link IE TSN Class B) can be used.

H: Industrial switches (for CC-Link IE TSN Class A) can be used.

Device on the master station side (A device near the master station)		Device on the end side (A device far from the master station)					
		Local station (CC-Link IE TSN Class B device)		Remote station (CC-Link IE TSN Class B device)		Ethernet device	
		1Gbps	100Mbps	1Gbps	100Mbps	1Gbps	100Mbps
Master station (CC-Link IE TSN Class B device)	1Gbps	○S	×	○S	△S ^{*1*3}	○SH	△SH ^{*3}
	100Mbps	×	×	×	×	×	×
Local station (CC-Link IE TSN Class B device)	1Gbps	○S	×	○S	△S ^{*1*2*3}	○SH	△SH ^{*3}
	100Mbps	×	×	×	×	×	×
Remote station (CC-Link IE TSN Class B device)	1Gbps	○S	×	○S	△S ^{*1*2*3}	○SH	△SH ^{*3}
	100Mbps	×	×	×	○S ^{*1*2*3}	×	○SH ^{*3}

*1 For a device station with a communication speed of 100Mbps, set "Communication Period Setting" to "Low-Speed".

*2 A connection cannot be established if the total cyclic data size of all device stations on the 100Mbps device side exceeds 2K bytes. This includes the devices with a communication speed of 100Mbps that form a boundary between the communication speed of 1Gbps and 100Mbps. (☞ Page 121 Calculation of the total cyclic data size)

*3 When the firmware version of the master station is "1.002" or earlier, only one of P1 or P2 can be used. When using both P1 and P2, configure the system with the devices that support the multicast mode. (☞ Page 65 Structure of multicast mode)

Precautions

When an industrial switch (for CC-Link IE TSN Class B) is used, check the industrial switch (for CC-Link IE TSN Class B) specifications on the CC-Link Partner Association website (www.cc-link.org).

When the communication speed for the master station is set to 100Mbps

This mode indicates the availability of connection with a network configuration device when "Communication Speed" of the master station set to "100Mbps".

○: Connection available, △: Connection available via an industrial switch, ×: Connection not available

S: Industrial switches (for CC-Link IE TSN Class B) can be used.

H: Industrial switches (for CC-Link IE TSN Class A) can be used.

Device on the master station side (A device near the master station)		Device on the end side (A device far from the master station)					
		Local station (CC-Link IE TSN Class B device)		Remote station (CC-Link IE TSN Class B device)		Ethernet device	
		1Gbps	100Mbps	1Gbps	100Mbps	1Gbps	100Mbps
Master station (CC-Link IE TSN Class B device)	100Mbps	×	○S ^{*1}	×	○S ^{*1}	×	○SH
	1Gbps	×	×	×	×	×	×
Local station (CC-Link IE TSN Class B device)	100Mbps	×	○S ^{*1}	×	○S ^{*1}	×	○SH
	1Gbps	×	×	×	×	×	×
Remote station (CC-Link IE TSN Class B device)	100Mbps	×	○S ^{*1}	×	○S ^{*1}	×	○SH
	1Gbps	×	×	×	×	×	×

*1 For a device station with a communication speed of 100Mbps, set "Communication Period Setting" to "Basic Period" or "Normal-Speed".

Precautions

When an industrial switch (for CC-Link IE TSN Class B) is used, check the industrial switch (for CC-Link IE TSN Class B) specifications on the CC-Link Partner Association website (www.cc-link.org).

Structure of multicast mode

This mode indicates the availability of connection with a network configuration device when "Communication Mode" under "Application Settings" is set to "Multicast".

When the communication speed for the master station is set to 1Gbps

The following table lists the availability of connection with a network configuration device when the communication speed for the master station is set to 1Gbps.

○: Connection available, △: Connection available via an industrial switch, ×: Connection not available

S: Industrial switches (for CC-Link IE TSN Class B) can be used.

H: Industrial switches (for CC-Link IE TSN Class A) can be used.

Device on the master station side (A device near the master station)		Device on the end side (A device far from the master station)					
		Local station (CC-Link IE TSN Class B device)		Remote station (CC-Link IE TSN Class B device)		Ethernet device	
		1Gbps	100Mbps	1Gbps	100Mbps	1Gbps	100Mbps
Master station (CC-Link IE TSN Class B device)	1Gbps	○S ^{*2}	×	○S ^{*2}	△S ^{*1*2*5}	○SH ^{*2*3}	△SH ^{*2*3*5}
	100Mbps	×	×	×	×	×	×
Local station (CC-Link IE TSN Class B device)	1Gbps	○S ^{*2}	×	○S ^{*2}	△S ^{*1*2*4*6}	○SH ^{*2*6}	△SH ^{*2*6}
	100Mbps	×	×	×	×	×	×
Remote station (CC-Link IE TSN Class B device)	1Gbps	○S ^{*2}	×	○S ^{*2}	△S ^{*1*2*4*6}	○SH ^{*2*6}	△SH ^{*2*6}
	100Mbps	×	×	×	○S ^{*1*2*4}	×	○SH ^{*2*6}

- *1 For a device station with a communication speed of 100Mbps, set "Communication Period Setting" to "Low-Speed".
- *2 When the device is connected on the end side via the industrial switch as shown below, communication may not be possible depending on the type of the device.
The communication will be enabled by configuring settings with the industrial switch so that the multicast frame (with multicast MAC address 09:00:70:00:10:02 and 09:00:70:00:10:05) will not be transferred to the ports specified below.

Connection structure that cannot be communicated	Port that prohibits multicast frame transfer
Device stations with communication speeds of 1Gbps and 100Mbps coexist.	Connection port of the device station with 100Mbps
A local station and Ethernet device coexist.	Connection port of the Ethernet device
The remote station and Ethernet device coexist.	

- *3 Since cyclic data is sent to the Ethernet device when the Ethernet device is connected to the master station with firmware version "1.002" or earlier, communication may not be possible depending on the type of the Ethernet device.
- *4 A connection cannot be established if the total cyclic data size of all device stations on the 100Mbps device side exceeds 2K bytes. This includes the devices with a communication speed of 100Mbps that form a boundary between the communication speed of 1Gbps and 100Mbps. (☞ Page 121 Calculation of the total cyclic data size)
- *5 When the firmware version of the master station is "1.002" or earlier, only one of P1 or P2 can be used.
- *6 Use the devices that support multicast filtering for the local stations or remote stations on the master station side. To check whether multicast filtering is supported or not, refer to the user's manuals for the devices used.

Precautions

When an industrial switch (for CC-Link IE TSN Class B) is used, check the industrial switch (for CC-Link IE TSN Class B) specifications on the CC-Link Partner Association website (www.cc-link.org).

When the communication speed for the master station is set to 100Mbps

This mode indicates the availability of connection with a network configuration device when "Communication Speed" of the master station set to "100Mbps".

○: Connection available, △: Connection available via an industrial switch, ×: Connection not available

S: Industrial switches (for CC-Link IE TSN Class B) can be used.

H: Industrial switches (for CC-Link IE TSN Class A) can be used.

Device on the master station side (A device near the master station)		Device on the end side (A device far from the master station)					
		Local station (CC-Link IE TSN Class B device)		Remote station (CC-Link IE TSN Class B device)		Ethernet device	
		1Gbps	100Mbps	1Gbps	100Mbps	1Gbps	100Mbps
Master station (CC-Link IE TSN Class B device)	100Mbps	×	○S ^{*1*3}	×	○S ^{*1*3}	×	○SH ^{*2*3}
Local station (CC-Link IE TSN Class B device)	1Gbps	×	×	×	×	×	×
	100Mbps	×	○S ^{*1*3}	×	○S ^{*1*3}	×	○SH ^{*3*4}
Remote station (CC-Link IE TSN Class B device)	1Gbps	×	×	×	×	×	×
	100Mbps	×	○S ^{*1*3}	×	○S ^{*1*3}	×	○SH ^{*3*4}

*1 For a device station with a communication speed of 100Mbps, set "Communication Period Setting" to "Basic Period" or "Normal-Speed".

*2 Since cyclic data is sent to the Ethernet device when the Ethernet device is connected to the master station with firmware version "1.002" or earlier, communication may not be possible depending on the type of the Ethernet device.

*3 When the device is connected on the end side via the industrial switch as shown below, communication may not be possible depending on the type of the device.

The communication will be enabled by configuring settings with the industrial switch so that the multicast frame (with multicast MAC address 09:00:70:00:10:02 and 09:00:70:00:10:05) will not be transferred to the ports specified below.

Connection structure that cannot be communicated	Port that prohibits multicast frame transfer
A local station and Ethernet device coexist.	Connection port of the Ethernet device
The remote station and Ethernet device coexist.	

*4 Use the devices that support multicast filtering for the local stations or remote stations on the master station side. To check whether multicast filtering is supported or not, refer to the user's manuals for the devices used.

Precautions

When an industrial switch (for CC-Link IE TSN Class B) is used, check the industrial switch (for CC-Link IE TSN Class B) specifications on the CC-Link Partner Association website (www.cc-link.org).

Structure with modules on CC-Link IE TSN only

Connection with modules on CC-Link IE TSN only

Line topology

The network is configured in a line topology. An industrial switch (for CC-Link IE TSN Class B) is not required. When an error occurs in a device station, the stations connected after the faulty station will be disconnected.

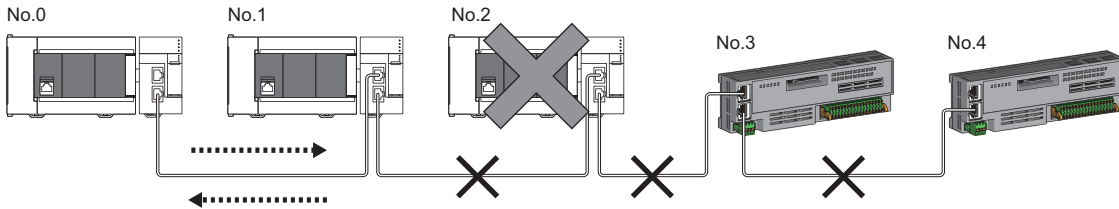

No.0: Master station
No.1, No.2: Local station
No.3, No.4: Remote station

Star topology

The network is configured in a star topology via an industrial switch (for CC-Link IE TSN Class B). This allows devices to be added easily.

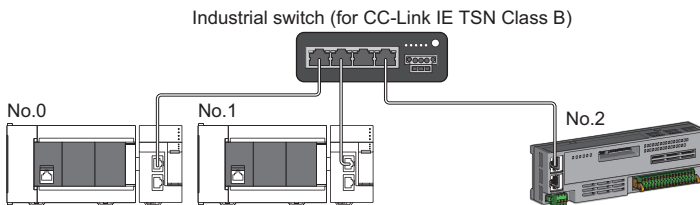

No.0: Master station
No.1: Local station
No.2: Remote station

Even when an error occurs in a device station, a data link can be continued with the stations that are operating normally.

Coexistence of line and star topologies

Line and star topologies can be mixed in the same network configuration.

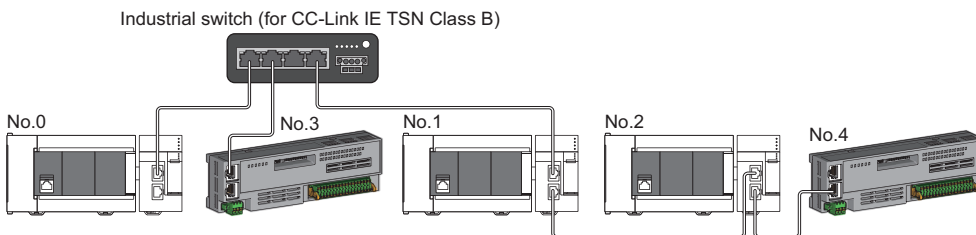

No.0: Master station
No.1, No.2: Local station
No.3, No.4: Remote station

Connection with modules on CC-Link IE TSN with a communication speed of 100Mbps

The following shows the network topologies when a CC-Link IE TSN module with a communication speed of 100Mbps is connected.

Line topology

The communication speed of the module must be adjusted for connection. (When connecting modules with different communication speeds, an industrial switch (for CC-Link IE TSN Class B) is required.)

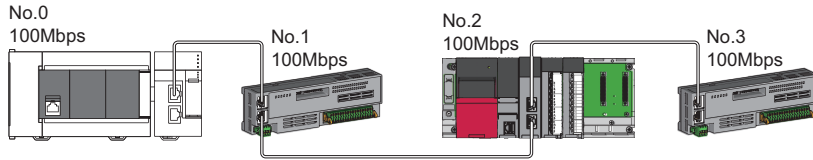

No.0: Master station
No.1, No.3: Remote station
No.2: Local station

Star topology

The network is configured in a star topology via an industrial switch.

- When the master station with a communication speed of 1Gbps and a remote station with a communication speed of 100Mbps exist in the structure, set "Communication Period Setting" to "Low-Speed" for the remote station with a communication speed of 100Mbps.

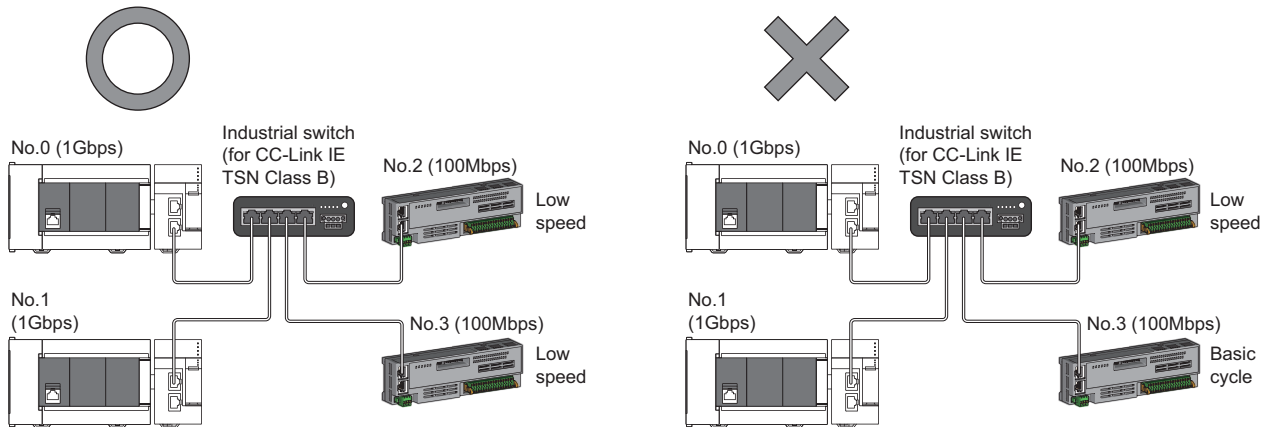

No.0: Master station
No.1: Local station
No.2, No.3: Remote station

- The same communication speed must be set for the master station and local station.

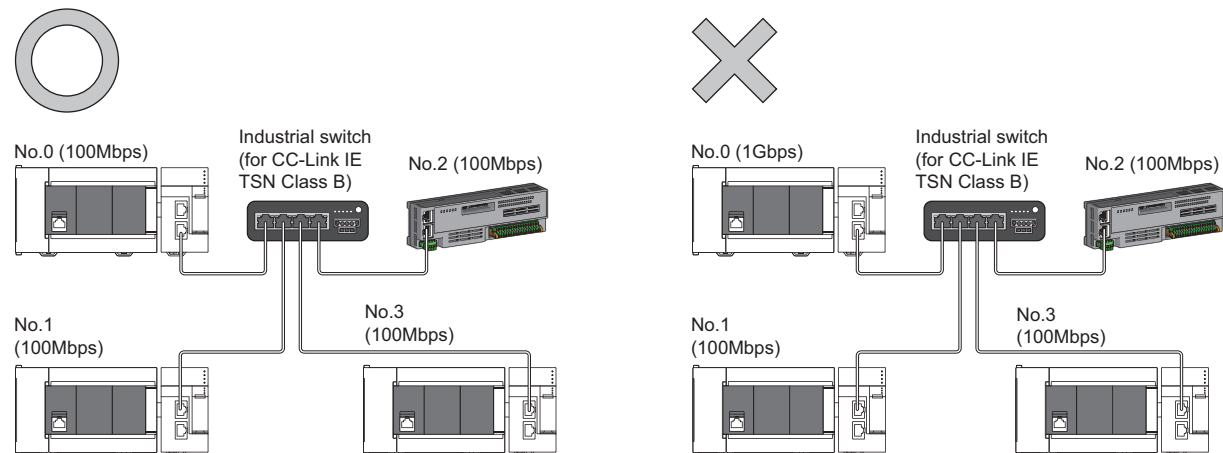

No.0: Master station
No.1, No.3: Local station
No.2: Remote station

- When "Communication Mode" is set to "Multicast" and "Communication Speed" of the master station is set to "1Gbps", communication may not be possible depending on the type of the device if device stations with different communication speeds of 1Gbps and 100Mbps coexist on the end side via the industrial switch. The communication will be enabled by configuring settings with the industrial switch (for CC-Link IE TSN Class B) so that the multicast frame (with multicast MAC address 09:00:70:00:10:02 and 09:00:70:00:10:05) will not be transferred to the device station with 100Mbps.

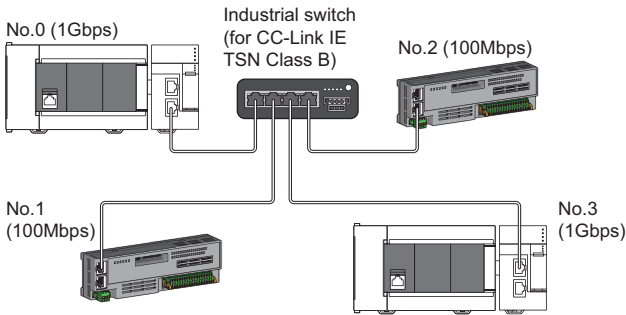

No.0: Master station
 No.1, No.2: Remote station
 No.3: Local station

Coexistence of line and star topologies

Line and star topologies can be mixed in the same network configuration.

- When the master station with a communication speed of 1Gbps and a remote station with a communication speed of 100Mbps exist in the structure, set "Communication Period Setting" to "Low-Speed" for the remote station with a communication speed of 100Mbps.

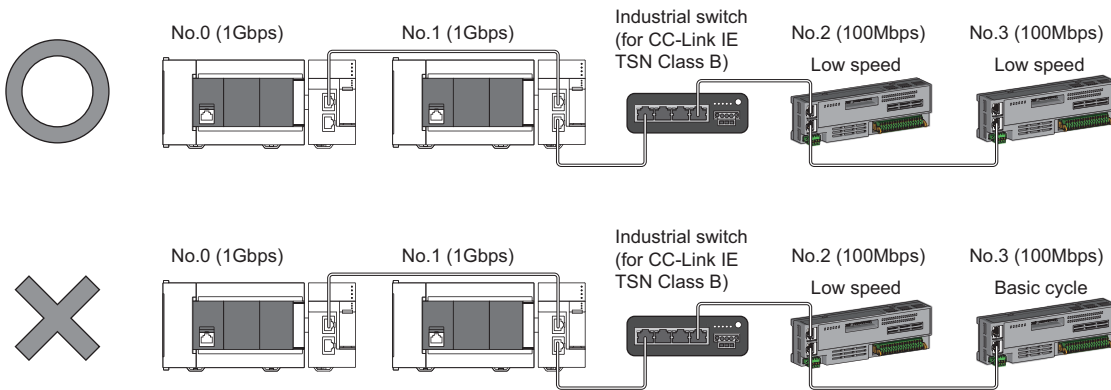

No.0: Master station
 No.1: Local station
 No.2, No.3: Remote station

- When the communication speed of the master station is 1Gbps, a connection cannot be established if the total cyclic data size of all device stations on the 100Mbps device side exceeds 2K bytes. This includes the devices with a communication speed of 100Mbps that form a boundary between the communication speed of 1Gbps and 100Mbps.

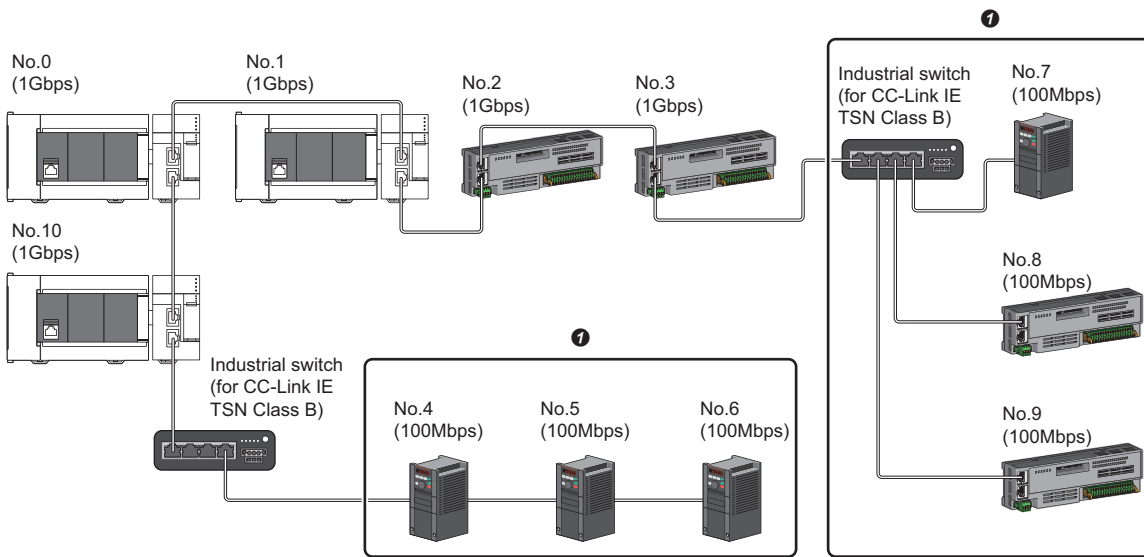

- No.0: Master station
 No.1, No.10: Local station
 No.2, No.3, No.4, No.5, No.6, No.7, No.8, No.9: Remote station
 ① Set the total cyclic data size within 2K bytes.

Structure of modules on CC-Link IE TSN and Ethernet devices

Connection with modules on CC-Link IE TSN and Ethernet devices

Line topology

The network with modules and devices is configured in a line topology. An industrial switch (for CC-Link IE TSN Class B) is not required.

Connect Ethernet devices to the end of the network.

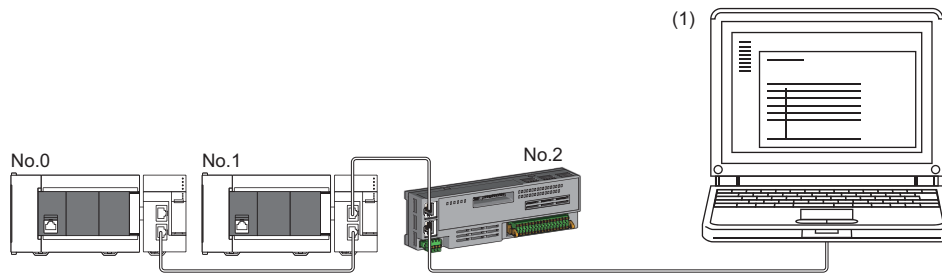

No.0: Master station
 No.1: Local station
 No.2: Remote station
 (1) Ethernet device (such as a personal computer)

When an error occurs in a device station, the stations connected after the faulty station will be disconnected.

Star topology

The network is configured in a star topology via an industrial switch.

Device stations cannot be connected with an industrial switch (for CC-Link IE TSN Class A). Line and star topologies should be mixed in the same network configuration.

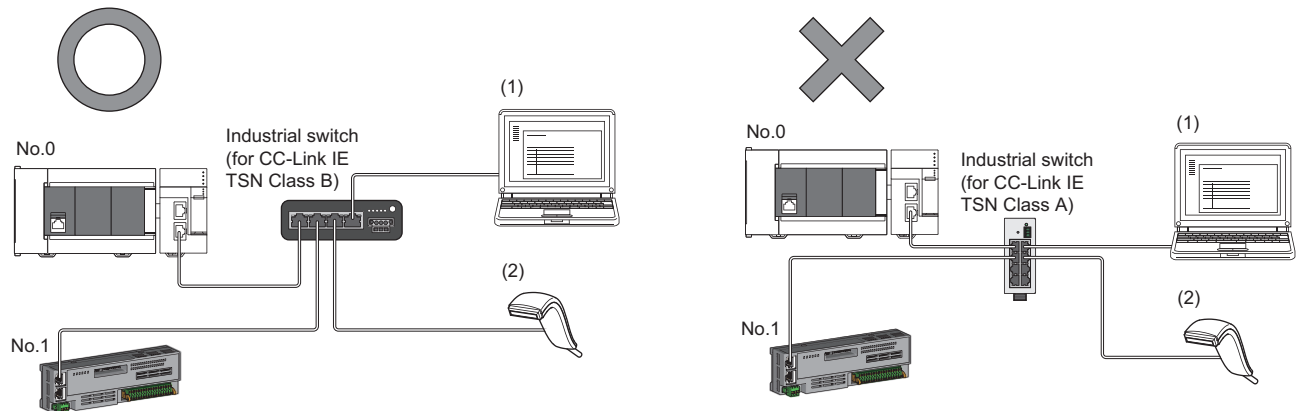

No.0: Master station
 No.1: Remote station
 (1), (2): Ethernet device

Coexistence of line and star topologies

Line and star topologies can be mixed in the same network configuration.

- Connect Ethernet devices to the end of the network.

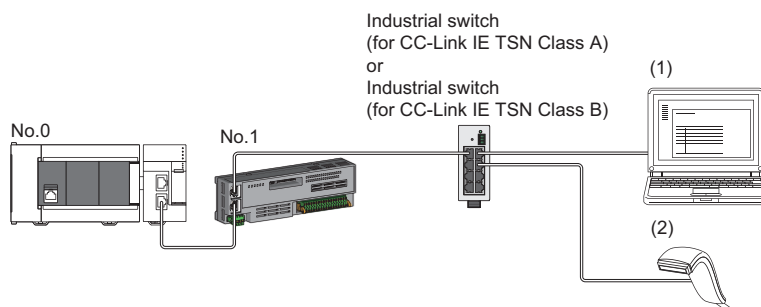

No.0: Master station
 No.1: Remote station
 (1), (2): Ethernet device

5.2 Structure of CC-Link IE TSN Class B/A Devices (CC-Link IE TSN Protocol version 2.0 Only) and Ethernet Devices

The following diagram shows the system configuration under the conditions below:

- "Mixture of CC-Link IE TSN Class B/A or CC-Link IE TSN Class A Only" set for "Connection Device Information" under "Basic Settings" in the engineering tool
- Master station firmware version "1.010" or later
- CC-Link IE TSN-compatible devices with the CC-Link IE TSN Protocol version 2.0 only

For the maximum number of connectable stations when "Connection Device Information" under "Basic Settings" of the master station is set to "Mixture of CC-Link IE TSN Class B/A or CC-Link IE TSN Class A Only", check the following.

☞ Page 15 Performance Specifications of CC-Link IE TSN

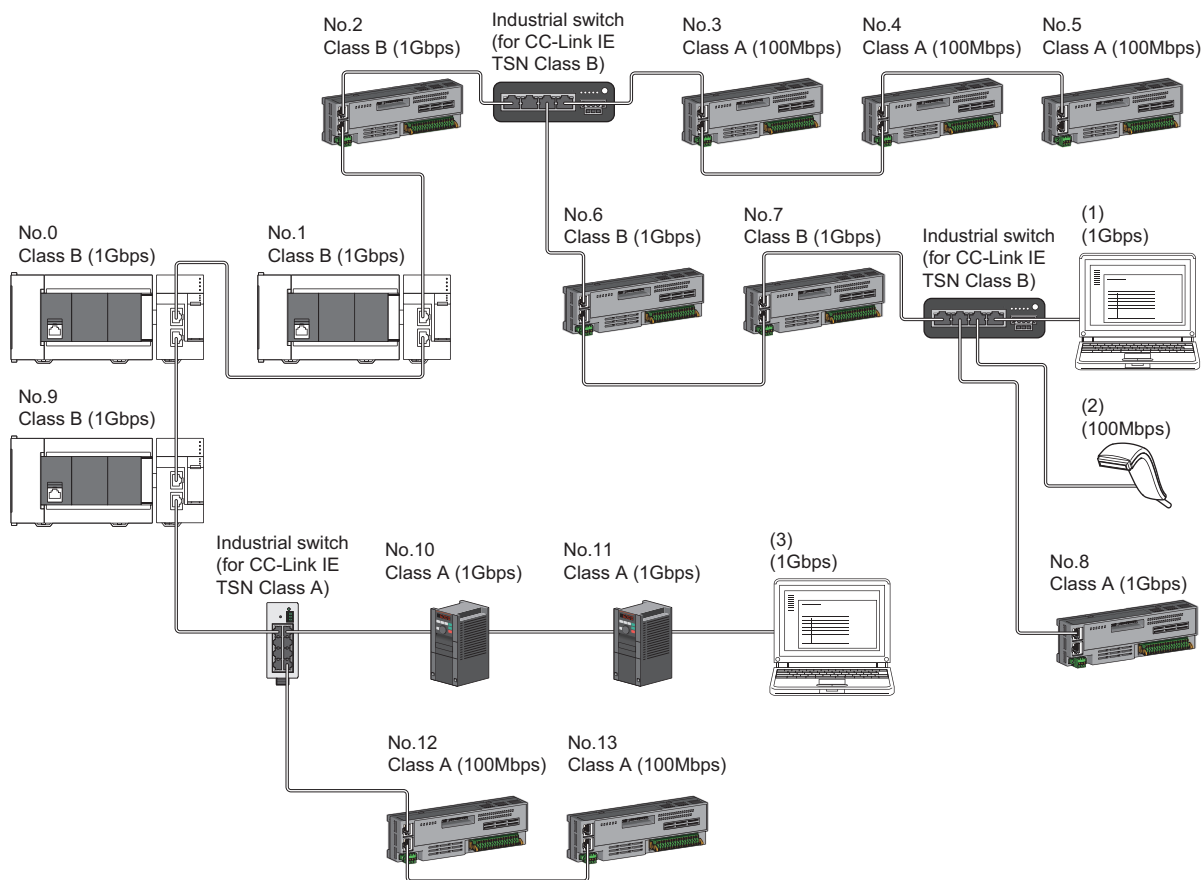

- No.0: Master station
- No.1, No.9: Local station
- No.2 to No.8, No.10 to No.13: Remote station
- (1), (2), (3): Ethernet device
- Class A: CC-Link IE TSN Class A device
- Class B: CC-Link IE TSN Class B device

The availability of connection of network configuration devices varies depending on the communication mode and communication speed.

- Unicast mode

☞ Page 74 When the communication speed for the master station is set to 1Gbps

☞ Page 75 When the communication speed for the master station is set to 100Mbps

- Multicast mode

☞ Page 76 When the communication speed for the master station is set to 1Gbps

☞ Page 77 When the communication speed for the master station is set to 100Mbps

The following terms are used to describe the terms in the tables referenced.

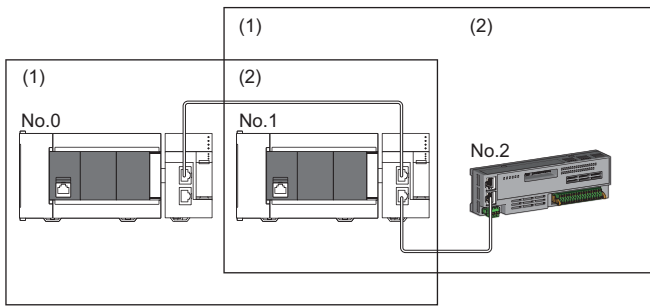

- No.0: Master station
- No.1: Local station
- No.2: Remote station
- (1) Device on the master station side (The master station or a device near the master station)
- (2) Device on the end side (A device far from the master station)

Structure of unicast mode

This mode indicates the availability of connection with a network configuration device when "Communication Mode" under "Application Settings" is set to "Unicast".

When the communication speed for the master station is set to 1Gbps

The following table lists the availability of connection with a network configuration device when the communication speed for the master station is set to 1Gbps.

○: Connection available, △: Connection available via an industrial switch, ×: Connection not available

S: Industrial switches (for CC-Link IE TSN Class B) can be used.

H: Industrial switches (for CC-Link IE TSN Class A) can be used.

Device on the master station side (A device near the master station)		Device on the end side (A device far from the master station)							
		Local station (CC-Link IE TSN Class B device)		Remote station (CC-Link IE TSN Class B device)		Remote station (CC-Link IE TSN Class A device)		Ethernet device	
		1Gbps	100Mbps	1Gbps	100Mbps	1Gbps	100Mbps	1Gbps	100Mbps
Master station (CC-Link IE TSN Class B device)	1Gbps	○S	×	○S	△S ^{*1}	○SH ^{*2}	△SH ^{*1*2}	○SH	△SH
Local station (CC-Link IE TSN Class B device)	1Gbps	○S	×	○S	△S ^{*1*3}	○SH ^{*2}	△SH ^{*1*2}	○SH	△SH
	100Mbps	×	×	×	×	×	×	×	×
Remote station (CC-Link IE TSN Class B device)	1Gbps	○S	×	○S	△S ^{*1*3}	○SH ^{*2}	△SH ^{*1*2}	○SH	△SH
	100Mbps	×	×	×	○S ^{*1*3}	×	○SH ^{*1*2*3}	×	○SH
Remote station (CC-Link IE TSN Class A) device	1Gbps	×	×	×	×	○SH	△SH ^{*1}	○SH	△SH
	100Mbps	×	×	×	×	×	○SH ^{*1}	×	○SH

*1 For a device station with a communication speed of 100Mbps, set "Communication Period Setting" to "Low-Speed".

*2 Use of an industrial switch (for CC-Link IE TSN Class B) is recommended if CC-Link IE TSN Class A devices are connected via an industrial switch.

*3 A connection cannot be established if the total cyclic data size of all device stations on the 100Mbps device side exceeds 2K bytes. This includes the devices with a communication speed of 100Mbps that form a boundary between the communication speed of 1Gbps and 100Mbps. ( Page 121 Calculation of the total cyclic data size)

Precautions

When an industrial switch (for CC-Link IE TSN Class B) is used, check the industrial switch (for CC-Link IE TSN Class B) specifications on the CC-Link Partner Association website (www.cc-link.org).

When the communication speed for the master station is set to 100Mbps

This mode indicates the availability of connection with a network configuration device when "Communication Speed" of the master station set to "100Mbps".

○: Connection available, △: Connection available via an industrial switch, ×: Connection not available

S: Industrial switches (for CC-Link IE TSN Class B) can be used.

H: Industrial switches (for CC-Link IE TSN Class A) can be used.

Device on the master station side (A device near the master station)		Device on the end side (A device far from the master station)							
		Local station (CC-Link IE TSN Class B device)		Remote station (CC-Link IE TSN Class B device)		Remote station (CC-Link IE TSN Class A device)		Ethernet device	
		1Gbps	100Mbps	1Gbps	100Mbps	1Gbps	100Mbps	1Gbps	100Mbps
Master station (CC-Link IE TSN Class B device)	100Mbps	×	○S ^{*1}	×	○S ^{*1}	×	○SH ^{*2}	×	○SH
Local station (CC-Link IE TSN Class B device)	1Gbps	×	×	×	×	×	×	×	×
	100Mbps	×	○S ^{*1}	×	○S ^{*1}	×	○SH ^{*2}	×	○SH
Remote station (CC-Link IE TSN Class B device)	1Gbps	×	×	×	×	×	×	×	×
	100Mbps	×	○S ^{*1}	×	○S ^{*1}	×	○SH ^{*2}	×	○SH
Remote station (CC-Link IE TSN Class A device)	1Gbps	×	×	×	×	×	×	×	×
	100Mbps	×	×	×	×	×	○SH	×	○SH

*1 For a device station with a communication speed of 100Mbps, set "Communication Period Setting" to "Basic Period" or "Normal-Speed".

*2 Use of an industrial switch (for CC-Link IE TSN Class B) is recommended if CC-Link IE TSN Class A devices are connected via an industrial switch.

Precautions

When an industrial switch (for CC-Link IE TSN Class B) is used, check the industrial switch (for CC-Link IE TSN Class B) specifications on the CC-Link Partner Association website (www.cc-link.org).

Structure of multicast mode

This mode indicates the availability of connection with a network configuration device when "Communication Mode" under "Application Settings" is set to "Multicast".

When the communication speed for the master station is set to 1Gbps

The following table lists the availability of connection with a network configuration device when the communication speed for the master station is set to 1Gbps.

○: Connection available, △: Connection available via an industrial switch, ×: Connection not available

Industrial switches (for CC-Link IE TSN Class B) can be used.

Industrial switches (for CC-Link IE TSN Class A) can be used.

Device on the master station side (A device near the master station)		Device on the end side (A device far from the master station)							
		Local station (CC-Link IE TSN Class B device)		Remote station (CC-Link IE TSN Class B device)		Remote station (CC-Link IE TSN Class A device)		Ethernet device	
		1Gbps	100Mbps	1Gbps	100Mbps	1Gbps	100Mbps	1Gbps	100Mbps
Master station (CC-Link IE TSN Class B device)	1Gbps	○S ^{*2}	×	○S ^{*2}	△S ^{*1*2}	○SH ^{*2*4}	△SH ^{*1*2*4}	○SH ^{*2}	△SH ^{*2}
Local station (CC-Link IE TSN Class B device)	1Gbps	○S ^{*2}	×	○S ^{*2}	△S ^{*1*2*3*5}	○SH ^{*2*3*4}	△SH ^{*1*2*3*4}	○SH ^{*2*3}	△SH ^{*2*3}
	100Mbps	×	×	×	×	×	×	×	×
Remote station (CC-Link IE TSN Class B device)	1Gbps	○S ^{*2}	×	○S ^{*2}	△S ^{*1*2*3*5}	○SH ^{*2*3*4}	△SH ^{*1*2*3*4}	○SH ^{*2*3}	△SH ^{*2*3}
	100Mbps	×	×	×	○S ^{*1*2*5}	×	○SH ^{*1*2*3*4*5}	×	○SH ^{*2*3}
Remote station (CC-Link IE TSN Class A device)	1Gbps	×	×	×	×	○SH ^{*2}	△SH ^{*1*2}	○SH	△SH
	100Mbps	×	×	×	×	×	○SH ^{*1*2}	×	○SH

*1 For a device station with a communication speed of 100Mbps, set "Communication Period Setting" to "Low-Speed".

*2 When the device is connected on the end side via the industrial switch as shown below, communication may not be possible depending on the type of the device.

The communication will be enabled by configuring settings with the industrial switch so that the multicast frame (with multicast MAC address 09:00:70:00:10:02 and 09:00:70:00:10:05) will not be transferred to the ports specified below.

Connection structure that cannot be communicated	Port that prohibits multicast frame transfer
Device stations with communication speeds of 1Gbps and 100Mbps coexist.	Connection port of the device station with 100Mbps
A local station and Ethernet device coexist.	Connection port of the Ethernet device
A local station and CC-Link IE TSN Class A remote station coexist.	Connection port of the CC-Link IE TSN Class A remote station

*3 Use the devices that support multicast filtering for the local stations or remote stations on the master station side. To check whether multicast filtering is supported or not, refer to the user's manuals for the devices used.

*4 Use of an industrial switch (for CC-Link IE TSN Class B) is recommended if CC-Link IE TSN Class A devices are connected via an industrial switch.

*5 A connection cannot be established if the total cyclic data size of all device stations on the 100Mbps device side exceeds 2K bytes. This includes the devices with a communication speed of 100Mbps that form a boundary between the communication speed of 1Gbps and 100Mbps. (Page 121 Calculation of the total cyclic data size)

Precautions

When an industrial switch (for CC-Link IE TSN Class B) is used, check the industrial switch (for CC-Link IE TSN Class B) specifications on the CC-Link Partner Association website (www.cc-link.org).

When the communication speed for the master station is set to 100Mbps

This mode indicates the availability of connection with a network configuration device when "Communication Speed" of the master station set to "100Mbps".

○: Connection available, △: Connection available via an industrial switch, ×: Connection not available

S: Industrial switches (for CC-Link IE TSN Class B) can be used.

H: Industrial switches (for CC-Link IE TSN Class A) can be used.

Device on the master station side (A device near the master station)		Device on the end side (A device far from the master station)							
		Local station (CC-Link IE TSN Class B device)		Remote station (CC-Link IE TSN Class B device)		Remote station (CC-Link IE TSN Class A device)		Ethernet device	
		1Gbps	100Mbps	1Gbps	100Mbps	1Gbps	100Mbps	1Gbps	100Mbps
Master station (CC-Link IE TSN Class B device)	100Mbps	×	○S ^{*1*2}	×	○S ^{*1*2}	×	○SH ^{*2*4}	×	○SH ^{*2}
Local station (CC-Link IE TSN Class B device)	1Gbps	×	×	×	×	×	×	×	×
	100Mbps	×	○S ^{*1*2}	×	○S ^{*1*2}	×	○SH ^{*2*3*4}	×	○SH ^{*2*3}
Remote station (CC-Link IE TSN Class B device)	1Gbps	×	×	×	×	×	×	×	×
	100Mbps	×	○S ^{*1*2}	×	○S ^{*1*2}	×	○SH ^{*2*3*4}	×	○SH ^{*2*3}
Remote station (CC-Link IE TSN Class A device)	1Gbps	×	×	×	×	×	×	×	×
	100Mbps	×	×	×	×	×	○SH ^{*2}	×	○SH

*1 For a device station with a communication speed of 100Mbps, set "Communication Period Setting" to "Basic Period" or "Normal-Speed".

*2 When the device is connected on the end side via the industrial switch as shown below, communication may not be possible depending on the type of the device.

The communication will be enabled by configuring settings with the industrial switch so that the multicast frame (with multicast MAC address 09:00:70:00:10:02 and 09:00:70:00:10:05) will not be transferred to the ports specified below.

Connection structure that cannot be communicated	Port that prohibits multicast frame transfer
A local station and Ethernet device coexist.	Connection port of the Ethernet device
A local station and CC-Link IE TSN Class A remote station coexist.	Connection port of the CC-Link IE TSN Class A remote station

*3 Use the devices that support multicast filtering for the local stations or remote stations on the master station side. To check whether multicast filtering is supported or not, refer to the user's manuals for the devices used.

*4 Use of an industrial switch (for CC-Link IE TSN Class B) is recommended if CC-Link IE TSN Class A devices are connected via an industrial switch.

Precautions

When an industrial switch (for CC-Link IE TSN Class B) is used, check the industrial switch (for CC-Link IE TSN Class B) specifications on the CC-Link Partner Association website (www.cc-link.org).

Structure with modules on CC-Link IE TSN only

Connection with modules on CC-Link IE TSN only

Line topology

Connect a CC-Link IE TSN Class A device to the end of an CC-Link IE TSN Class B device.

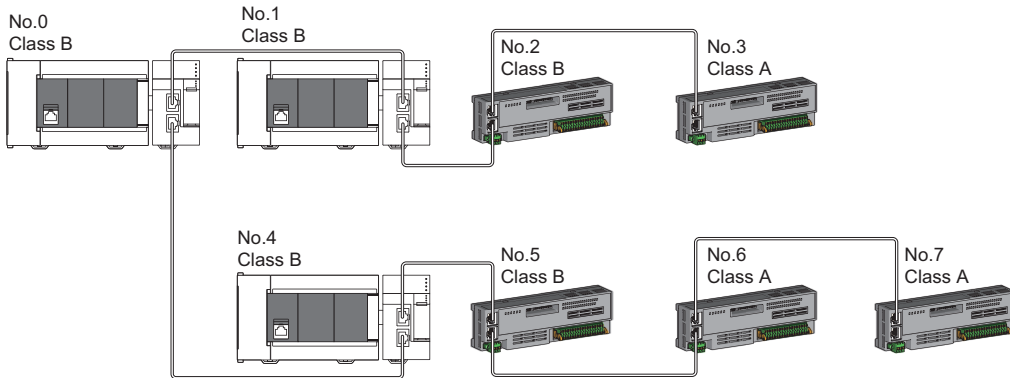

No.0: Master station
No.1, No.4: Local station
No.2, No.3, No.4, No.5, No.6, and No.7: Remote station
Class A: CC-Link IE TSN Class A device
Class B: CC-Link IE TSN Class B device

Star topology

The network is configured in a star topology via an industrial switch.

- When connecting a CC-Link IE TSN Class B device in a star topology, connect with an industrial switch (for CC-Link IE TSN Class B).

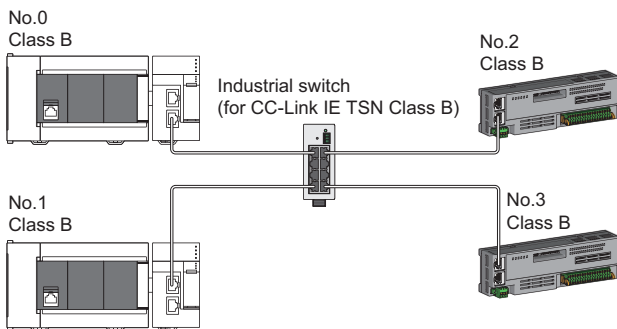

No.0: Master station
No.1: Local station
No.2, No.3: Remote station
Class A: CC-Link IE TSN Class A device
Class B: CC-Link IE TSN Class B device

- When connecting a CC-Link IE TSN Class A device in a star topology, connect via an industrial switch (for CC-Link IE TSN Class B) or an industrial switch (for CC-Link IE TSN Class A).

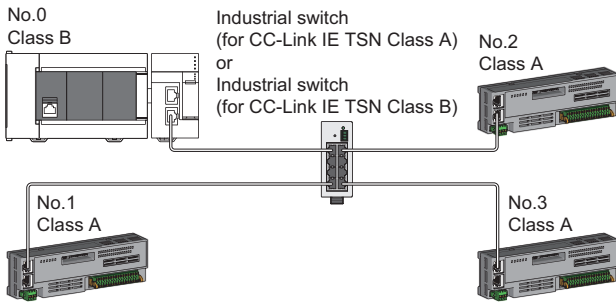

No.0: Master station
 No.1, No.2, and No.3: Remote station
 Class A: CC-Link IE TSN Class A device
 Class B: CC-Link IE TSN Class B device

- When the communication mode setting is multicast, communication may not be possible depending on the device if both a local station and a CC-Link IE TSN Class A remote station are connected on the end side via an industrial switch. The communication will be enabled by configuring settings with the hub so that the multicast frame (with multicast MAC address 09:00:70:00:10:02 and 09:00:70:00:10:05) will not be transferred to the an authentication Class A remote station port.

Multicast mode

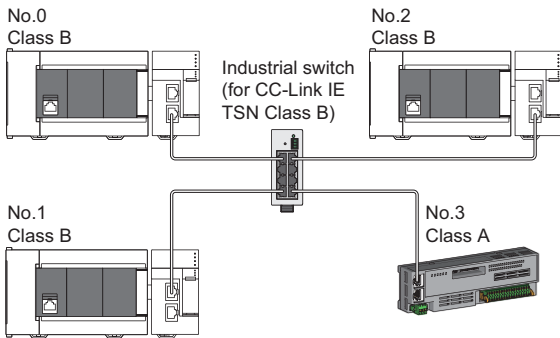

No.0: Master station
 No.1, No.2: Local station
 No.3: Remote station
 Class A: CC-Link IE TSN Class A device
 Class B: CC-Link IE TSN Class B device

■ Coexistence of line and star topologies

Line and star topologies can be mixed according to the availability of connection as described below.

- When connecting a CC-Link IE TSN Class A device in a star topology, connect with an industrial switch (for CC-Link IE TSN Class B) or an industrial switch (for CC-Link IE TSN Class A).

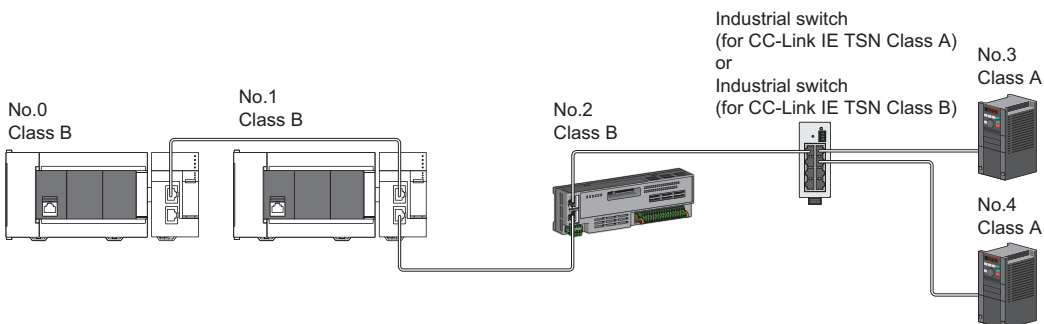

No.0: Master station
 No.1: Device station
 No.2, No.3, and No.4: Remote station
 Class A: CC-Link IE TSN Class A device
 Class B: CC-Link IE TSN Class B device

- When connecting a CC-Link IE TSN Class B device in a star topology, connect with an industrial switch (for CC-Link IE TSN Class B).

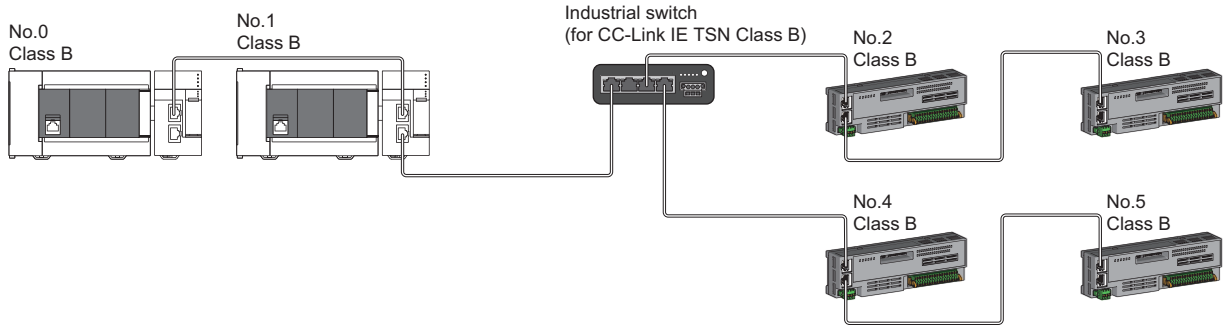

No.0: Master station
 No.1: Local station
 No.2, No.3, No.4, and No.5: Remote station
 Class B: CC-Link IE TSN Class B device

- When connecting CC-Link IE TSN Class A devices in a configuration where CC-Link IE TSN Class B devices are connected to an industrial switch (for CC-Link IE TSN Class B), connect the CC-Link IE TSN Class A devices via an industrial switch (for CC-Link IE TSN Class B).

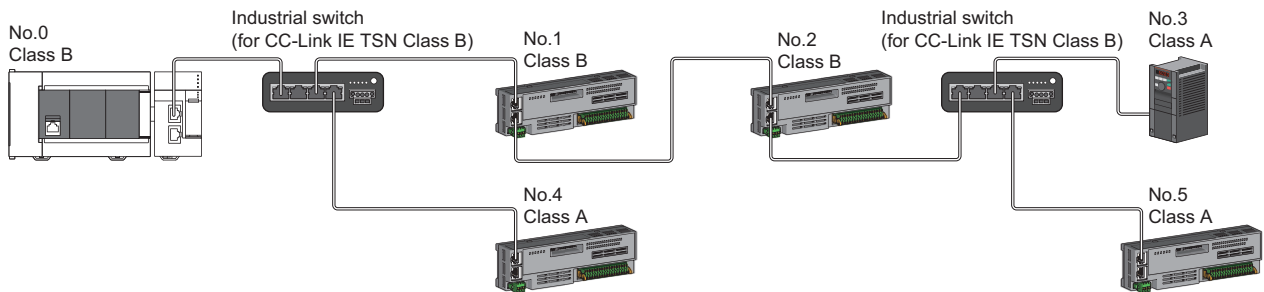

No.0: Master station
 No.1, No.2, No.3, No.4, and No.5: Remote station
 Class A: CC-Link IE TSN Class A device
 Class B: CC-Link IE TSN Class B device

- Also, if "TSN HUB Setting" is set to "Use TSN HUB" and CC-Link IE TSN Class B devices are connected with an industrial switch (for CC-Link IE TSN Class B) in a star topology, a CC-Link IE TSN Class A device station can be connected using an industrial switch (for CC-Link IE TSN Class A) by using separate ports of the master station according to the CC-Link IE TSN Class.

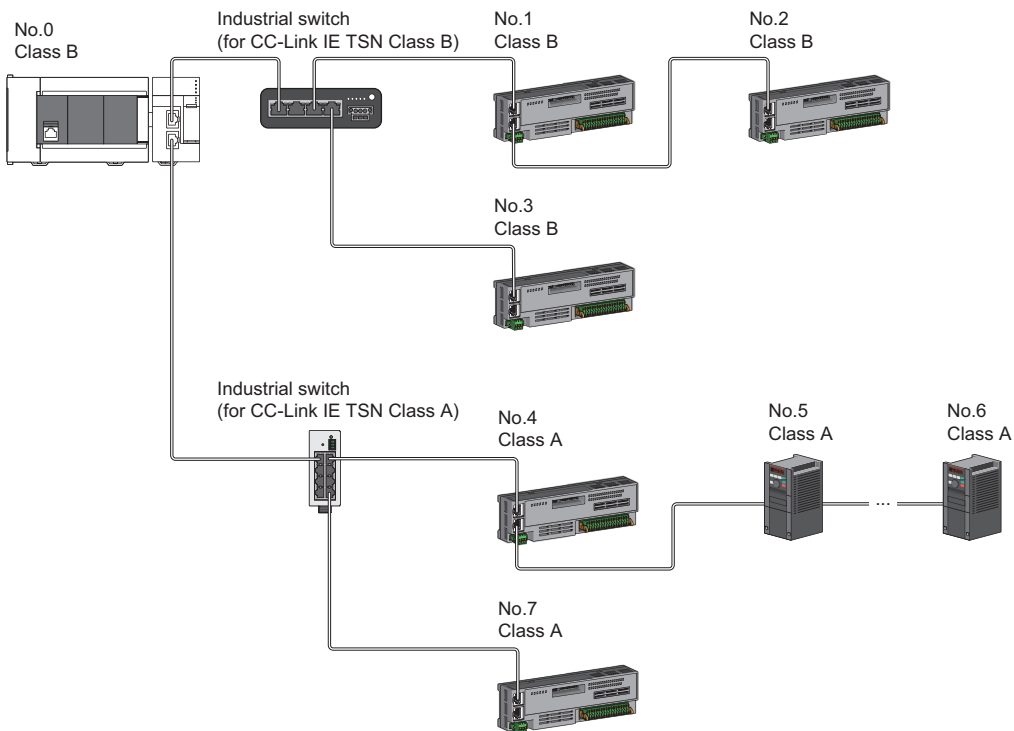

No.0: Master station
 No.1 to No.7: Remote station
 Class A: CC-Link IE TSN Class A device
 Class B: CC-Link IE TSN Class B device

Precautions

In the following configuration, an industrial switch (for CC-Link IE TSN Class B) cannot be connected.

- If "TSN HUB Setting" is set to "Not to Use TSN HUB", industrial switches (for CC-Link IE TSN Class B) cannot be connected. When an industrial switch (for CC-Link IE TSN Class B) is connected, device stations may not perform a data link. When connecting an industrial switch (for CC-Link IE TSN Class B), set "TSN HUB Setting" to "Use TSN HUB".

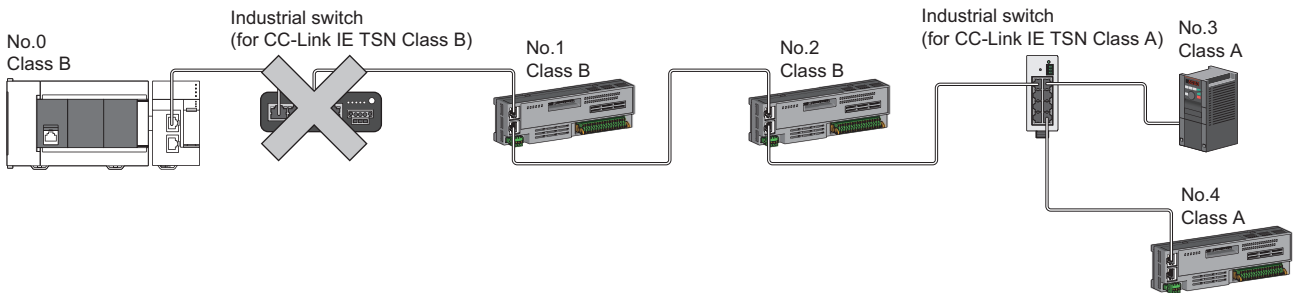

No.0: Master station

No.1, No.2, No.3, and No.4: Remote station

Class A: CC-Link IE TSN Class A device

Class B: CC-Link IE TSN Class B device

- If "TSN HUB Setting" is set to "Not to Use TSN HUB", connection in a star topology with an industrial switch (for CC-Link IE TSN Class B) is not possible. When a device station is connected to an industrial switch (for CC-Link IE TSN Class B), the device station may not perform a data link. In this case, a connection configuration error (error code: 1806H) occurs in the master station. When connecting an industrial switch (for CC-Link IE TSN Class B), set "TSN HUB Setting" to "Use TSN HUB".

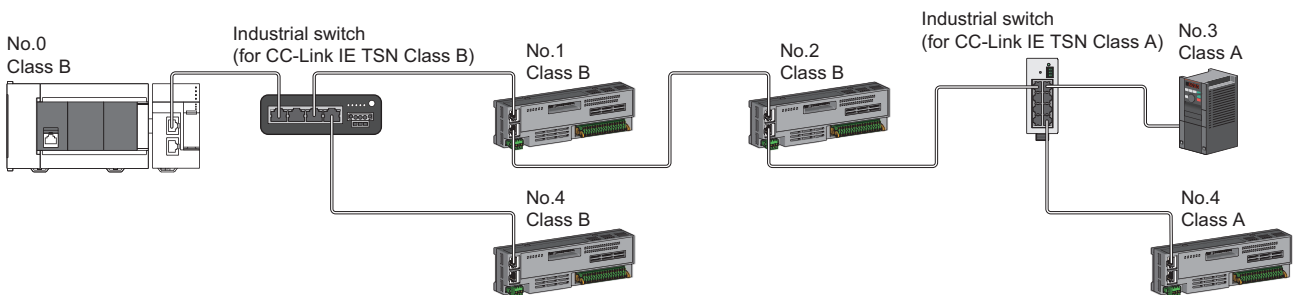

No.0: Master station

No.1, No.2, No.3, No.4, and No.5: Remote station

Class A: CC-Link IE TSN Class A device

Class B: CC-Link IE TSN Class B device

Connection with modules on CC-Link IE TSN with a communication speed of 100Mbps

This section describes the network topology when "Communication Speed" under "Application Settings" is set to "100Mbps".

Line topology

Adjust the communication speed of the module to 100Mbps to establish connections. (When connecting modules with different communication speeds, an industrial switch is required.)

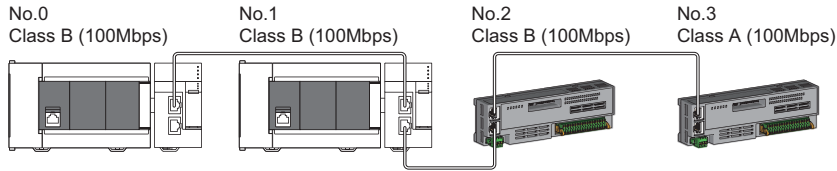

No.0: Master station
 No.1: Local station
 No.2, No.3: Remote station

Star topology

The network is configured in a star topology via an industrial switch.

- When the master station with a communication speed of 1Gbps and a local or remote station with a communication speed of 100Mbps exist in the structure, set "Communication Period Setting" to "Low-Speed" for the local or remote station with a communication speed of 100Mbps.

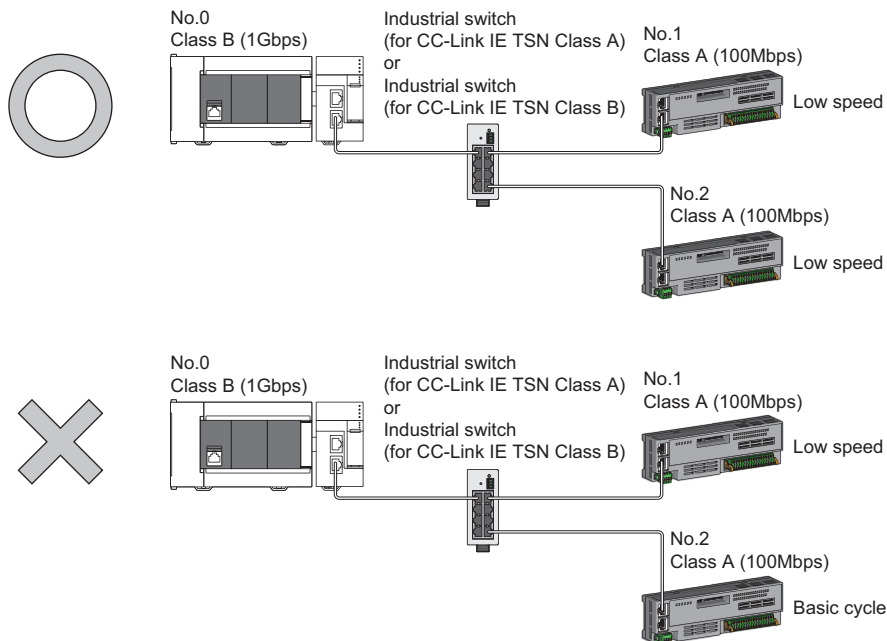

No.0: Master station
 No.1, No.2: Remote station
 Class A: CC-Link IE TSN Class A device
 Class B: CC-Link IE TSN Class B device

- Set the same communication speed (100Mbps) for the master station and local stations.

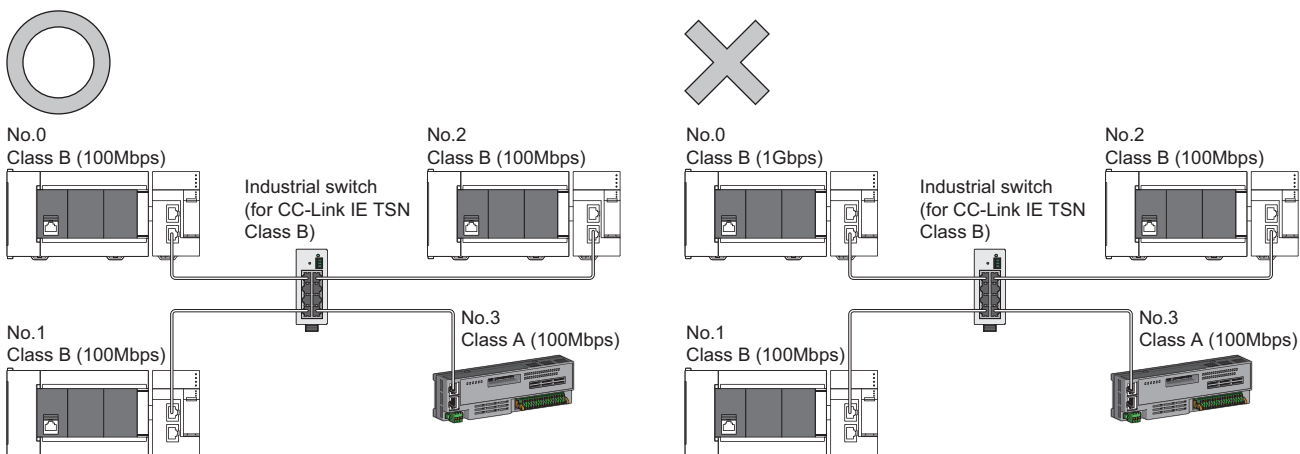

No.0: Master station
 No.1, No.2: Local station
 No.3: Remote station
 Class A: CC-Link IE TSN Class A device
 Class B: CC-Link IE TSN Class B device

- When "Communication Mode" is set to "Multicast" and the communication speed of the master station is 1Gbps, communication may not be possible depending on the type of the device if device stations with different communication speeds of 1Gbps and 100Mbps coexist on the end side via the industrial switch. The communication will be enabled by configuring settings with the industrial switch so that the multicast frame (with multicast MAC address 09:00:70:00:10:02 and 09:00:70:00:10:05) will not be transferred to the port of the device station with 100Mbps.

Multicast mode

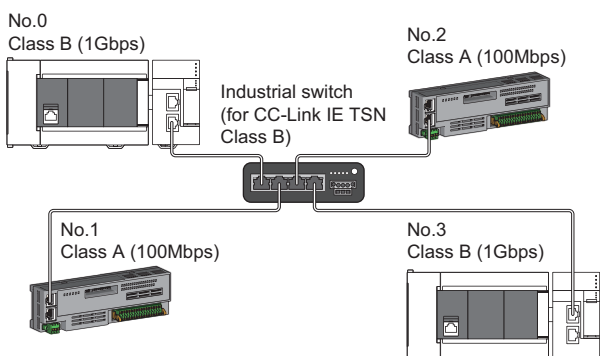

No.0: Master station
 No.1, No.2: Remote station
 No.3: Local station
 Class A: CC-Link IE TSN Class A device
 Class B: CC-Link IE TSN Class B device

■ Coexistence of line and star topologies

Line and star topologies can be mixed in the same network configuration.

- When the master station with a communication speed of 1Gbps and a local or remote station with a communication speed of 100Mbps exist in the structure, set "Communication Period Setting" to "Low-Speed" for the local or remote station with a communication speed of 100Mbps.

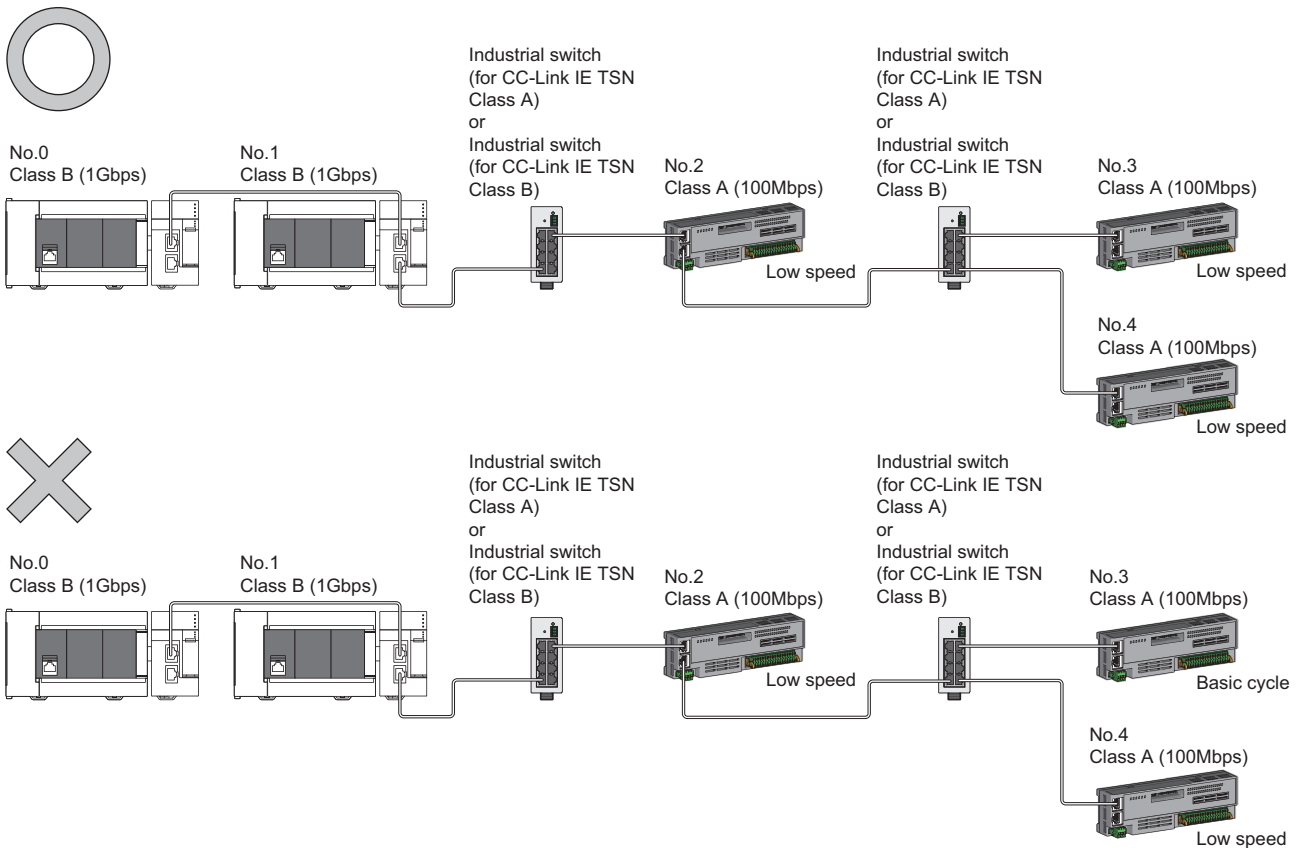

No.0: Master station
 No.1: Local station
 No.2, No.3, and No.4: Remote station
 Class A: CC-Link IE TSN Class A device
 Class B: CC-Link IE TSN Class B device

- If the communication speed of the master station is 1Gbps, the total cyclic data size of all device stations on the 100Mbps device side at the boundary between communication speeds of 1Gbps and 100Mbps must not exceed 2K bytes.

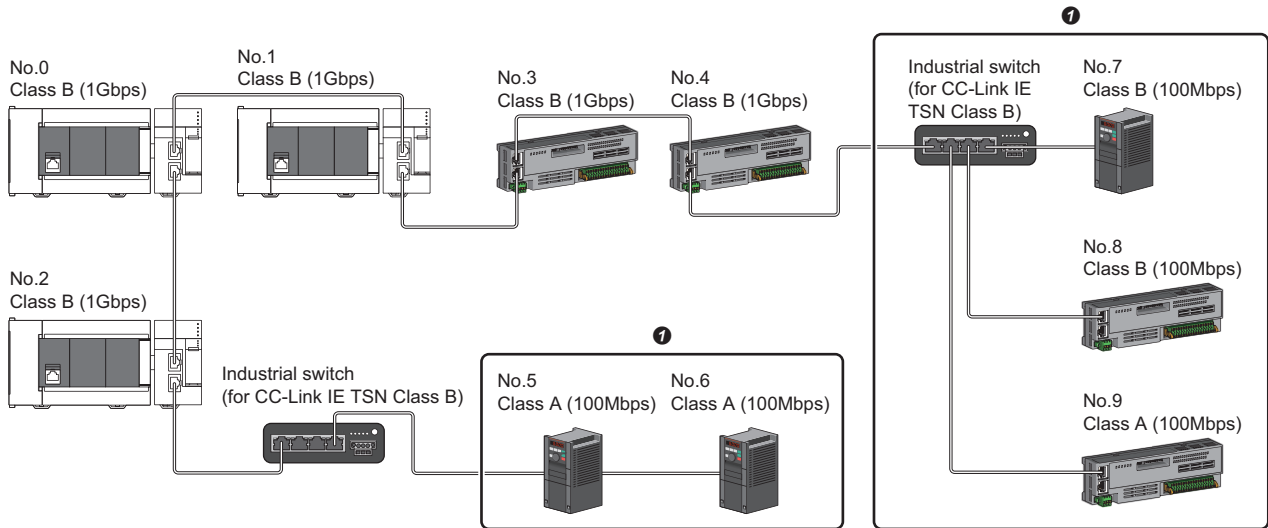

No.0: Master station
 No.1, No.2: Local station
 No.3, No.4, No.5, No.6, No.7, No.8, and No.9: Remote station
 Class A: CC-Link IE TSN Class A device
 Class B: CC-Link IE TSN Class B device
 ❶ Set the total cyclic data size within 2K bytes.

Structure of modules on CC-Link IE TSN and Ethernet devices

Connection with modules on CC-Link IE TSN and Ethernet devices

Line topology

The network with modules and devices is configured in a line topology. An industrial switch (for CC-Link IE TSN Class A) is not required.

Up to eight modules on CC-Link IE TSN can be connected to P1 or P2 of the master station at the position indicated with (1). Connect Ethernet devices to the end of the network.

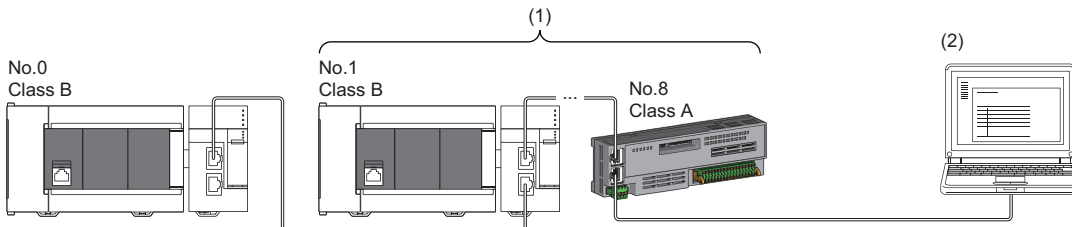

No.0: Master station
No.1: Local station (1st device)
No.8: Remote station (8th device)
(2) Ethernet device
Class A: CC-Link IE TSN Class A device
Class B: CC-Link IE TSN Class B device

When an error occurs in a device station, the stations connected after the faulty station will be disconnected.

Star topology

Modules or devices are connected in a star topology via an industrial switch.

- Since cyclic data is sent to an Ethernet device when "Communication Mode" is set to "Multicast" and a local station is used with an Ethernet device on the end side via an industrial switch, communication may not be possible depending on the type of Ethernet device. The communication will be enabled by configuring settings with the industrial switch so that the multicast frame (with multicast MAC address 09:00:70:00:10:02 and 09:00:70:00:10:05) will not be transferred to the port of the Ethernet device.

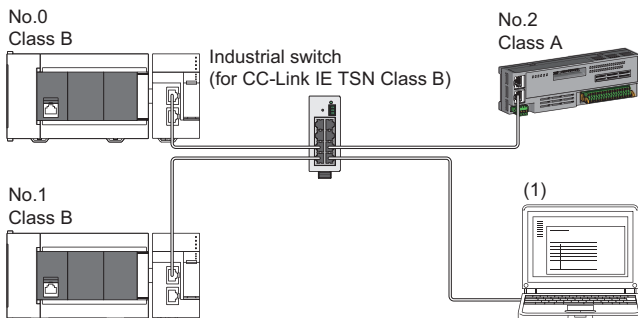

No.0: Master station
No.1: Local station
No.2: Remote station
(1) Ethernet device
Class A: CC-Link IE TSN Class A device
Class B: CC-Link IE TSN Class B device

■ Coexistence of line and star topologies

Line and star topologies can be mixed according to the availability of each connection.

- Connect Ethernet devices at the end of line topology.
- When connecting an Ethernet device in a star topology, connect it with an industrial switch (for CC-Link IE TSN Class B) or an industrial switch (for CC-Link IE TSN Class A).

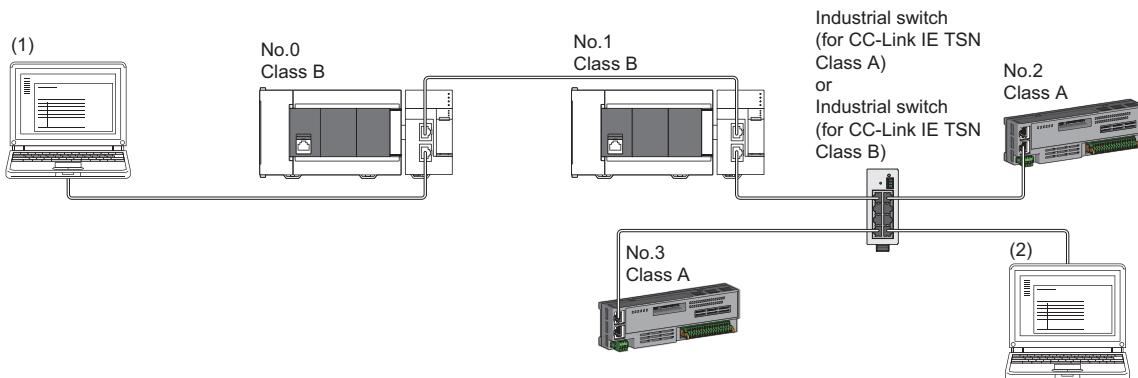

No.0: Master station

No.1: Local station

No.2, No.3: Remote station

(1), (2): Ethernet device

Class A: CC-Link IE TSN Class A device

Class B: CC-Link IE TSN Class B device

5.3 Structure of CC-Link IE TSN Class B/A Devices (Mixture of CC-Link IE TSN Protocol version 1.0 and 2.0) and Ethernet Devices

The following diagram shows the system configuration under the conditions below:

- "Mixture of CC-Link IE TSN Class B/A or CC-Link IE TSN Class A Only" set for "Connection Device Information" under "Basic Settings" in the engineering tool
- Master station firmware version "1.010" or later
- CC-Link IE TSN-compatible devices with the protocol versions 1.0 and 2.0

For the maximum number of connectable stations when "Connection Device Information" under "Basic Settings" of the master station is set to "Mixture of CC-Link IE TSN Class B/A or CC-Link IE TSN Class A Only", check the following.

☞ Page 15 Performance Specifications of CC-Link IE TSN

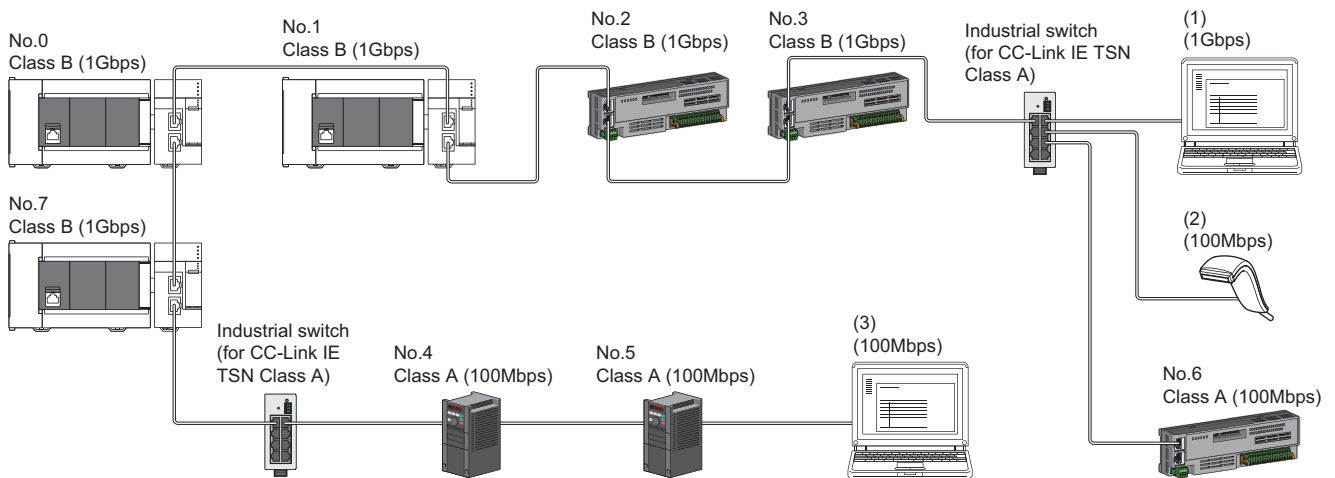

- No.0: Master station
- No.1, No.7: Local station
- No.2, No.3, No.4, No.5, No.6: Remote station
- (1), (2), (3): Ethernet device
- Class A: CC-Link IE TSN Class A device
- Class B: CC-Link IE TSN Class B device

The following terms are used to describe the terms in the tables.

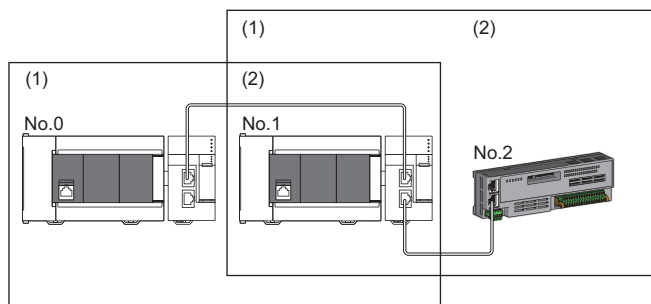

- No.0: Master station
- No.1: Local station
- No.2: Remote station
- (1) Device on the master station side (The master station or a device near the master station)
- (2) Device on the end side (A device far from the master station)

Setting method

■ Operating protocol setting

The protocol for operation when a device supporting the CC-Link IE TSN Protocol version 2.0 and a device supporting the CC-Link IE TSN Protocol version 1.0 coexist in the network can be set with 'Protocol information' (Un\G44320 to Un\G44335) in the buffer memory. The setting value is enabled after the system is reset or the power is turned off and on, and is held by the FX5-CCLGN-MS.

For details on the buffer memory, refer to the following.

 Page 237 Protocol information (Un\G44320 to Un\G44335)

1. Check the protocol currently held by the FX5-CCLGN-MS with 'Protocol setting status' (Un\G44325).
2. To change the protocol, store the set value in 'Protocol setting' (Un\G44322) and set 'Write request' (Un\G44321) to 1.
3. Check that 'Write execution status' (Un\G44323) is 1 and that 'Setting result' (Un\G44324) is 0. If 'Setting result' (Un\G44324) is not set to 0, check the error code, and set again.
4. Reset the CPU modules or power off and on the system.

Point

- The operating protocol setting can be performed with the firmware version "1.010" or later of the FX5-CCLGN-MS.
- The protocol for operation during the initialization sequence is determined and stored in 'Protocol operating status' (Un\G44320). Alternatively, to change the protocol before resetting the CPU module or turning the power off and on in step 4, change the write request to 0 before changing the value for the protocol setting. After changing the value, change 'Write request' (Un\G44321) to 1 again.

Precautions

Set the operating protocol before operating the system, when cables are not connected.

If the setting is changed during system operation, problems such as failure to update a link special relay (SB) or link special register (SW) may occur temporarily.

Precautions

- For details on troubleshooting by symptom, refer to the following.

 Page 189 Troubleshooting by Symptom

- The protocol in operation can be found in 'Protocol operating status' (Un\G44320).
- If the device station used is "CC-Link IE TSN Class A" and "Communication Period Setting" is set to "Low-Speed", sending/receiving cyclic data within the "Low-Speed" period to/from the device station with "Communication Period Setting" set to "Low-Speed" cannot be guaranteed depending on the setting values for the maximum response time for the time managed polling method, communication cycle interval, and low-speed setting. In this case, a communication cycle setting error (error code: 31ABH) occurs and the FX5-CCLGN-MS stops.
- If "CC-Link IE TSN Class Setting" is "CC-Link IE TSN Class A" and a device station where "Communication Period Setting" is set to "Low-Speed" exists, parameter values that can guarantee the sending/receiving of cyclic data to/from the device station are stored in "Multiple cycle setting (low speed)" (Un\G44594) and "Communication cycle intervals (Calculation value)" (Un\G44595), and in the device station set to "Low-Speed" in "Communication Period Setting" and the "Low-Speed" period. Set the "Multiple Period Setting" to "Low-Speed" and "Communication Period Interval Setting" to a value equal to or greater than the value stored in "Multiple cycle setting (low speed)" (Un\G44594) and "Communication cycle intervals (Calculation value)" (Un\G44595).
- When "CC-Link IE TSN Class Setting" of the general CC-Link IE TSN module added to "Network Configuration Settings" is set to "CC-Link IE TSN Class A", if "Multiple Period Setting" is set to "Low-Speed" and "Communication Period Interval Setting" are set to 'Multiple period setting (low speed)' (Un\G44594) and 'Communication cycle interval (calculation value)' (Un\G44595), the cyclic data may not be sent/received. In this case, add the actual device to be used to "Network Configuration Settings", or refer to the manual for the device used to check the maximum response time for the time managed polling method and calculate and set the communication cycle interval setting value.

Operation when versions of connected devices are combined

The following tables show whether restrictions apply to possible combinations of connected devices that support the CC-Link IE TSN Protocol version 2.0 and those that do not.

- Restrictions: Up to eight CC-Link IE TSN Class B devices can be connected to each port of the master station

CC-Link IE TSN Protocol version 2.0 support		Restrictions
CC-Link IE TSN Class A device	CC-Link IE TSN Class B device	
Non-supporting products included	Non-supporting products included	Yes
	Supporting products only	Yes
Supporting products only	Non-supporting products included	Not available
	Supporting products only	Not available

- Restrictions: Connection cannot be made if the total cyclic data size of all device stations on the CC-Link IE TSN Class A device side that form a boundary between CC-Link IE TSN Class B and CC-Link IE TSN Class A devices exceeds 2K bytes.

CC-Link IE TSN Protocol version 2.0 support		Restrictions
CC-Link IE TSN Class A device	CC-Link IE TSN Class B device	
Non-supporting products included	Non-supporting products included	Yes
	Supporting products only	Yes
Supporting products only	Non-supporting products included	Yes
	Supporting products only	Not available

Operation when combined with versions of other products

The following tables show how parameters used for the FX5-CCLGN-MS operate in combination with other products that support or do not support the CC-Link IE TSN Protocol version 2.0.

- "CC-Link IE TSN Class Setting" for each device station in the "CC-Link IE TSN Configuration" window of the "Network Configuration Settings"

CC-Link IE TSN Protocol version 2.0 support		Operation
Engineering tool	Module	
Not supported	Not supported	CC-Link IE TSN Protocol version 1.0
	Supported	CC-Link IE TSN Protocol version 1.0
Supported	Not supported	CC-Link IE TSN Protocol version 1.0
	Supported	CC-Link IE TSN Protocol version 1.0/2.0

- Multiplier setting for "Low-Speed" in "Multiple Period Setting" under "Basic Settings"

CC-Link IE TSN Protocol version 2.0 support		Operation
Engineering tool	Module	
Not supported	Not supported	Only "×16" settable
	Supported	Only "×16" settable
Supported	Not supported	A value other than "×16" results in a network parameter error (error code: 2221H)
	Supported	"×16", "×32", "×64", or "×128" selectable

- "TSN HUB Setting" in "Connection Device Information" under "Basic Settings"

CC-Link IE TSN Protocol version 2.0 support		Operation
Engineering tool	Module	
Not supported	Not supported	Setting not allowed
	Supported	Setting not allowed
Supported	Not supported	CC-Link IE TSN Protocol version 1.0 regardless of the setting value
	Supported	Operate according to the setting value

Precautions

If parameters are written with an engineering tool of software version "1.085P" or later for a project created with an engineering tool of software version earlier than "1.085P" without opening "Network Configuration Settings" once, the module operates with the CC-Link IE TSN Protocol version 1.0.

Connection configuration of CC-Link IE TSN-compatible devices

The following table shows time synchronization methods based on the CC-Link IE TSN Protocol version 2.0 support status of each CC-Link IE TSN-compatible device in the network.

With CC-Link IE TSN Protocol version 1.0: Devices that do not support the CC-Link IE TSN Protocol version 2.0 are included.

CC-Link IE TSN Protocol version 2.0 only: There are only devices that support the CC-Link IE TSN Protocol version 2.0.

Mixture of device station CC-Link IE TSN Protocol version 1.0/2.0		Time synchronization method for devices				Connection specifications
CC-Link IE TSN Class A device	CC-Link IE TSN Class B device	CC-Link IE TSN Class A device		CC-Link IE TSN Class B device		
		CC-Link IE TSN Protocol version 1.0	CC-Link IE TSN Protocol version 2.0	CC-Link IE TSN Protocol version 1.0	CC-Link IE TSN Protocol version 2.0	
With CC-Link IE TSN Protocol version 1.0	With CC-Link IE TSN Protocol version 1.0	IEEE 1588	Not available	IEEE 1588	IEEE 1588	Refer to the following. ☞ Page 94 Structure of CC-Link IE TSN Class B/A Devices (CC-Link IE TSN Protocol version 1.0 Only) and Ethernet Devices
	CC-Link IE TSN Protocol version 2.0 only	IEEE 1588	Not available	—	IEEE 1588	
CC-Link IE TSN Protocol version 2.0 only	With CC-Link IE TSN Protocol version 1.0	—	Not available	IEEE 802.1AS	IEEE 802.1AS	Refer to the following. ☞ Page 72 Structure of CC-Link IE TSN Class B/A Devices (CC-Link IE TSN Protocol version 2.0 Only) and Ethernet Devices
	CC-Link IE TSN Protocol version 2.0 only	—	Not available	—	IEEE 802.1AS	

Precautions

- The protocol in operation can be found in 'Protocol operating status' (Un\G44320) in the buffer memory.
- While a device is operating with the CC-Link IE TSN Protocol version 2.0, device stations that do not support the CC-Link IE TSN Protocol version 2.0 may not perform a data link. If a device station that does not support the CC-Link IE TSN Protocol version 2.0 is detected, that station does not perform a data link, the event code 00C80 is registered on the master station, and the information about the station that does not support it is stored in 'CC-Link IE TSN Protocol version 2.0 support status for each station' (SW01A0 to SW01A7).
- In a configuration where devices with the CC-Link IE TSN Protocol versions 2.0 and 1.0 coexist, if data link starts late on CC-Link IE TSN Class A devices due to variation in power-on sequences and start times of device stations at system start-up, devices with the CC-Link IE TSN Protocol version 1.0 may not perform a data link. (The event code 00C80 is registered on the master station.)
- If a device station that does not support the CC-Link IE TSN Protocol version 2.0 does not perform a data link, set the operating protocol by using buffer memory to perform a data link in the device station with CC-Link IE TSN Protocol version 1.0 fixed. (☞ Page 90 Operating protocol setting) However, when protocol setting (Un\G44322) is set to 1: CC-Link IE TSN Protocol version 1.0 fixed, the values of the communication cycle interval and cyclic transmission time when the device is operating with CC-Link IE TSN Protocol version 1.0 are stored in 'Communication cycle interval (calculation value)' (SW0072) and 'Cyclic transmission time (calculation value)' (SW0073). For this reason, if a device station that supports the CC-Link IE TSN Protocol version 2.0 also needs to perform a data link, refer to "Communication cycle intervals (Calculation value)" (Un\G44596), "Cyclic transmission time (Calculation value)" (Un\G44597)", and "Transient transmission time (Calculation value)" (Un\G44598) and set values in "Communication Period Interval Setting", "Cyclic Transmission Time" and "Transient transmission Time" in "Communication Period Setting" under "Basic Settings".

5.4 Structure of CC-Link IE TSN Class B/A Devices (CC-Link IE TSN Protocol version 1.0 Only) and Ethernet Devices

The following diagram shows the system configuration under the conditions below:

- "Mixture of CC-Link IE TSN Class B/A or CC-Link IE TSN Class A Only" set for "Connection Device Information" under "Basic Settings" in the engineering tool
- When the firmware version of the master station is "1.002" or earlier or there are only CC-Link IE TSN-compatible devices with the CC-Link IE TSN Protocol version 1.0

For the maximum number of connectable stations when "Connection Device Information" under "Basic Settings" of the master station is set to "Mixture of CC-Link IE TSN Class B/A or CC-Link IE TSN Class A Only", check the following.

☞ Page 15 Performance Specifications of CC-Link IE TSN

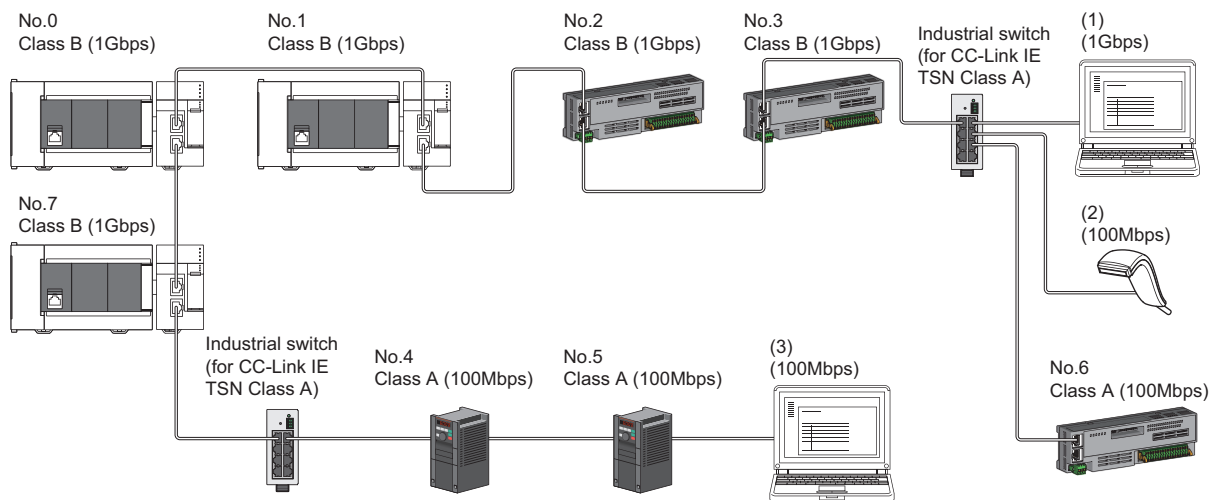

- No.0: Master station
- No.1, No.7: Local station
- No.2, No.3, No.4, No.5, and No.6: Remote station
- (1), (2), (3): Ethernet device
- Class A: CC-Link IE TSN Class A device
- Class B: CC-Link IE TSN Class B device

The availability of connection of network configuration devices varies depending on the communication mode and communication speed.

- Unicast mode

☞ Page 95 When the communication speed for the master station is set to 1Gbps

☞ Page 96 When the communication speed for the master station is set to 100Mbps

- Multicast mode

☞ Page 97 When the communication speed for the master station is set to 1Gbps

☞ Page 99 When the communication speed for the master station is set to 100Mbps

The following terms are used to describe the terms in the tables referenced.

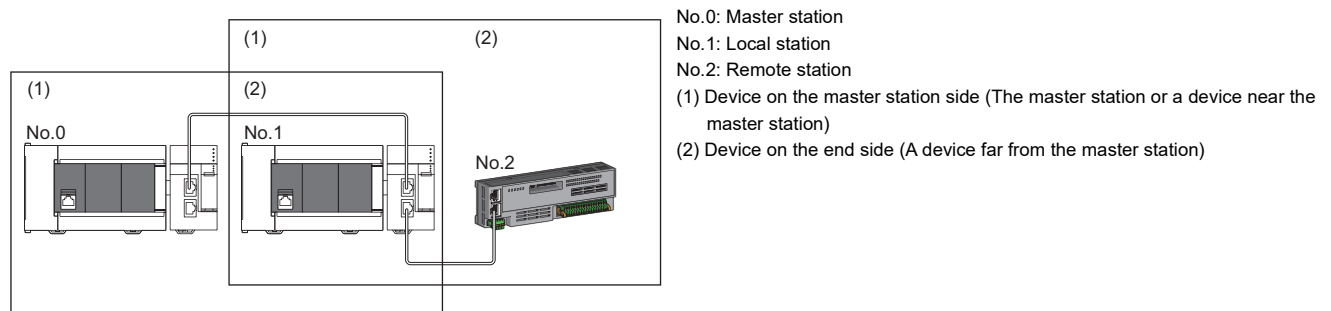

- No.0: Master station
- No.1: Local station
- No.2: Remote station
- (1) Device on the master station side (The master station or a device near the master station)
- (2) Device on the end side (A device far from the master station)

Structure of unicast mode

This mode indicates the availability of connection with a network configuration device when "Communication Mode" under "Application Settings" is set to "Unicast".

When the communication speed for the master station is set to 1Gbps

The following table lists the availability of connection with a network configuration device when the communication speed for the master station is set to 1Gbps.

○: Connection available, △: Connection available via an industrial switch, ×: Connection not available

S: Industrial switches (for CC-Link IE TSN Class B) can be used.

H: Industrial switches (for CC-Link IE TSN Class A) can be used.

Device on the master station side (A device near the master station)		Device on the end side (A device far from the master station)							
		Local station (CC-Link IE TSN Class B device)		Remote station (CC-Link IE TSN Class B device)		Remote station (CC-Link IE TSN Class A device)		Ethernet device	
		1Gbps	100Mbps	1Gbps	100Mbps	1Gbps	100Mbps	1Gbps	100Mbps
Master station (CC-Link IE TSN Class B device)	1Gbps	○S	×	○S	△S ^{*1*3}	○SH	△SH ^{*1*3}	○SH	△SH ^{*3}
Local station (CC-Link IE TSN Class B device)	1Gbps	○S	×	○S	△S ^{*1*3*4}	○SH ^{*2}	△SH ^{*1*2*3}	○SH	△SH ^{*3}
	100Mbps	×	×	×	×	×	×	×	×
Remote station (CC-Link IE TSN Class B device)	1Gbps	○S	×	○S	△S ^{*1*3*4}	○SH ^{*2}	△SH ^{*1*2*3}	○SH	△SH ^{*3}
	100Mbps	×	×	×	○S ^{*1*3*4}	×	○SH ^{*1*2*3*4}	×	○SH ^{*3}
Remote station (CC-Link IE TSN Class A) device	1Gbps	×	×	×	×	○SH ^{*2}	△SH ^{*1*2*3}	○SH	△SH ^{*3}
	100Mbps	×	×	×	×	×	○SH ^{*1*2*3}	×	○SH ^{*3}

- *1 For a device station with a communication speed of 100Mbps, set "Communication Period Setting" to "Low-Speed".
- *2 Connection cannot be made if the total cyclic data size of all device stations on the CC-Link IE TSN Class A device side that form a boundary between CC-Link IE TSN Class B and CC-Link IE TSN Class A devices exceeds 2K bytes. (☞ Page 121 Calculation of the total cyclic data size)
- *3 If the firmware version of the master station is "1.002" or earlier, only one of P1 or P2 can be used. When using both P1 and P2, configure the system with the devices that support the multicast mode. (☞ Page 97 Structure of multicast mode)
- *4 A connection cannot be established if the total cyclic data size of all device stations on the 100Mbps device side exceeds 2K bytes. This includes the devices with a communication speed of 100Mbps that form a boundary between the communication speed of 1Gbps and 100Mbps. (☞ Page 121 Calculation of the total cyclic data size)

Precautions

When an industrial switch (for CC-Link IE TSN Class B) is used, check the industrial switch (for CC-Link IE TSN Class B) specifications on the CC-Link Partner Association website (www.cc-link.org).

When the communication speed for the master station is set to 100Mbps

This mode indicates the availability of connection with a network configuration device when "Communication Speed" of the master station set to "100Mbps".

○: Connection available, △: Connection available via an industrial switch, ×: Connection not available

S: Industrial switches (for CC-Link IE TSN Class B) can be used.

H: Industrial switches (for CC-Link IE TSN Class A) can be used.

Device on the master station side (A device near the master station)		Device on the end side (A device far from the master station)							
		Local station (CC-Link IE TSN Class B device)		Remote station (CC-Link IE TSN Class B device)		Remote station (CC-Link IE TSN Class A device)		Ethernet device	
		1Gbps	100Mbps	1Gbps	100Mbps	1Gbps	100Mbps	1Gbps	100Mbps
Master station (CC-Link IE TSN Class B device)	100Mbps	×	○S ^{*2}	×	○S ^{*2}	×	○SH	×	○SH
Local station (CC-Link IE TSN Class B device)	1Gbps	×	×	×	×	×	×	×	×
	100Mbps	×	○S ^{*2}	×	○S ^{*2}	×	○SH ^{*1}	×	○SH
Remote station (CC-Link IE TSN Class B device)	1Gbps	×	×	×	×	×	×	×	×
	100Mbps	×	○S ^{*2}	×	○S ^{*2}	×	○SH ^{*1}	×	○SH
Remote station (CC-Link IE TSN Class A device)	1Gbps	×	×	×	×	×	×	×	×
	100Mbps	×	×	×	×	×	○SH ^{*1}	×	○SH

*1 Connection cannot be made if the total cyclic data size of all device stations on the CC-Link IE TSN Class A device side that form a boundary between CC-Link IE TSN Class B and CC-Link IE TSN Class A devices exceeds 2K bytes. (Page 121 Calculation of the total cyclic data size)

*2 For a device station with a communication speed of 100Mbps, set "Communication Period Setting" to "Basic Period" or "Normal-Speed".

Precautions

When an industrial switch (for CC-Link IE TSN Class B) is used, check the industrial switch (for CC-Link IE TSN Class B) specifications on the CC-Link Partner Association website (www.cc-link.org).

Structure of multicast mode

This mode indicates the availability of connection with a network configuration device when "Communication Mode" under "Application Settings" is set to "Multicast".

When the communication speed for the master station is set to 1Gbps

The following table lists the availability of connection with a network configuration device when the communication speed for the master station is set to 1Gbps.

○: Connection available, △: Connection available via an industrial switch, ×: Connection not available

S: Industrial switches (for CC-Link IE TSN Class B) can be used.

H: Industrial switches (for CC-Link IE TSN Class A) can be used.

Device on the master station side (A device near the master station)		Device on the end side (A device far from the master station)							
		Local station (CC-Link IE TSN Class B device)		Remote station (CC-Link IE TSN Class B device)		Remote station (CC-Link IE TSN Class A device)		Ethernet device	
		1Gbps	100Mbps	1Gbps	100Mbps	1Gbps	100Mbps	1Gbps	100Mbps
Master station (CC-Link IE TSN Class B device)	1Gbps	○S ^{*7*8}	×	○S ^{*7}	△S ^{*1*5*7}	○SH ^{*4*7*8}	△SH ^{*1*4*5*7*8}	○SH ^{*3*7}	△SH ^{*3*5*7}
Local station (CC-Link IE TSN Class B device)	1Gbps	○S ^{*7*8}	×	○S ^{*7}	△S ^{*1*6*7*9}	○SH ^{*2*6*7*8}	△SH ^{*1*2*6*7*8}	○SH ^{*6*7}	△SH ^{*6*7}
	100Mbps	×	×	×	×	×	×	×	×
Remote station (CC-Link IE TSN Class B device)	1Gbps	○S ^{*7*8}	×	○S ^{*7}	△S ^{*1*6*7*9}	○SH ^{*2*6*7*8}	△SH ^{*1*2*6*7*8}	○SH ^{*6*7}	△SH ^{*6*7}
	100Mbps	×	×	×	○S ^{*1*7*9}	×	○SH ^{*1*2*6*7*8*9}	×	○SH ^{*6*7}
Remote station (CC-Link IE TSN Class A device)	1Gbps	×	×	×	×	○SH ^{*2*7*8}	△SH ^{*1*2*7*8}	○SH ^{*7}	△SH ^{*7}
	100Mbps	×	×	×	×	×	○SH ^{*1*2*7*8}	×	○SH ^{*7}

- *1 For a device station with a communication speed of 100Mbps, set "Communication Period Setting" to "Low-Speed".
- *2 Connection cannot be made if the total cyclic data size of all device stations on the CC-Link IE TSN Class A device side that form a boundary between CC-Link IE TSN Class B and CC-Link IE TSN Class A devices exceeds 2K bytes. (Page 121 Calculation of the total cyclic data size)
- *3 Since cyclic data is sent to the Ethernet device when the Ethernet device is connected to the master station with the firmware version "1.002" or earlier, communication may not be possible depending on the type of the Ethernet device.
- *4 Since cyclic data is sent to a CC-Link IE TSN Class A remote station when the CC-Link IE TSN Class A remote station is connected to the master station with the firmware version "1.002" or earlier, communication may not be possible depending on the type of the CC-Link IE TSN Class A remote station.
- *5 If the firmware version of the master station is "1.002" or earlier, only one of P1 or P2 of the master station can be used. When using both P1 and P2 of the master station, connect a local station or remote station that supports multicast filtering as a device on the master station side.
- *6 Use the devices that support multicast filtering for the local stations or remote stations on the master station side. To check whether multicast filtering is supported or not, refer to the user's manuals for the devices used.
- *7 When the device is connected on the end side via the industrial switch as shown below, communication may not be possible depending on the type of the device.
The communication will be enabled by configuring settings with the industrial switch so that the multicast frame (with multicast MAC address 09:00:70:00:10:02 and 09:00:70:00:10:05) will not be transferred to the ports specified below.

Connection structure that cannot be communicated	Port that prohibits multicast frame transfer
Device stations with communication speeds of 1Gbps and 100Mbps coexist.	Connection port of the device station with 100Mbps
A local station and Ethernet device coexist.	Connection port of the Ethernet device
When the firmware version of the master station is "1.010" or later, a local station and CC-Link IE TSN Class A remote station coexist.	Connection port of the CC-Link IE TSN Class A remote station
The remote station and Ethernet device coexist.	Connection port of the Ethernet device

- *8 When the firmware version of the master station is "1.002" or earlier, a local station and CC-Link IE TSN Class A remote station cannot be connected together on the end side via the industrial switch.
- *9 A connection cannot be established if the total cyclic data size of all device stations on the 100Mbps device side exceeds 2K bytes. This includes the devices with a communication speed of 100Mbps that form a boundary between the communication speed of 1Gbps and 100Mbps. ( Page 121 Calculation of the total cyclic data size)

Precautions

When an industrial switch (for CC-Link IE TSN Class B) is used, check the industrial switch (for CC-Link IE TSN Class B) specifications on the CC-Link Partner Association website (www.cc-link.org).

When the communication speed for the master station is set to 100Mbps

This mode indicates the availability of connection with a network configuration device when "Communication Speed" of the master station set to "100Mbps".

○: Connection available, △: Connection available via an industrial switch, ×: Connection not available

S: Industrial switches (for CC-Link IE TSN Class B) can be used.

H: Industrial switches (for CC-Link IE TSN Class A) can be used.

Device on the master station side (A device near the master station)		Device on the end side (A device far from the master station)							
		Local station (CC-Link IE TSN Class B device)		Remote station (CC-Link IE TSN Class B device)		Remote station (CC-Link IE TSN Class A device)		Ethernet device	
		1Gbps	100Mbps	1Gbps	100Mbps	1Gbps	100Mbps	1Gbps	100Mbps
Master station (CC-Link IE TSN Class B device)	100Mbps	×	○S ^{*2'6'7}	×	○S ^{*2}	×	○SH ^{*4'6'7}	×	○SH ^{*3'6}
Local station (CC-Link IE TSN Class B device)	1Gbps	×	×	×	×	×	×	×	×
	100Mbps	×	○S ^{*2'6'7}	×	○S ^{*2}	×	○SH ^{*1'5'6'7}	×	○SH ^{*5'6}
Remote station (CC-Link IE TSN Class B device)	1Gbps	×	×	×	×	×	×	×	×
	100Mbps	×	○S ^{*2'6'7}	×	○S ^{*2}	×	○SH ^{*1'5'6'7}	×	○SH ^{*5'6}
Remote station (CC-Link IE TSN Class A device)	1Gbps	×	×	×	×	×	×	×	×
	100Mbps	×	×	×	×	×	○SH ^{*1'6'7}	×	○SH ^{*6}

*1 Connection cannot be made if the total cyclic data size of all device stations on the CC-Link IE TSN Class A device side that form a boundary between CC-Link IE TSN Class B and CC-Link IE TSN Class A devices exceeds 2K bytes. (☞ Page 121 Calculation of the total cyclic data size)

*2 For a device station with a communication speed of 100Mbps, set "Communication Period Setting" to "Basic Period" or "Normal-Speed".

*3 Since cyclic data is sent to the Ethernet device when the Ethernet device is connected to the master station with the firmware version "1.002" or earlier, communication may not be possible depending on the type of the Ethernet device.

*4 Since cyclic data is sent to a CC-Link IE TSN Class A remote station when the CC-Link IE TSN Class A remote station is connected to the master station with the firmware version "1.002" or earlier, communication may not be possible depending on the type of the CC-Link IE TSN Class A remote station.

*5 Use the devices that support multicast filtering for the local stations or remote stations on the master station side. To check whether multicast filtering is supported or not, refer to the user's manuals for the devices used.

*6 When the device is connected on the end side via the industrial switch as shown below, communication may not be possible depending on the type of the device.

The communication will be enabled by configuring settings with the industrial switch so that the multicast frame (with multicast MAC address 09:00:70:00:10:02 and 09:00:70:00:10:05) will not be transferred to the ports specified below.

Connection structure that cannot be communicated	Port that prohibits multicast frame transfer
A local station and Ethernet device coexist.	Connection port of the Ethernet device
When the firmware version is "1.010" or later, a local station and CC-Link IE TSN Class A remote station coexist.	Connection port of the CC-Link IE TSN Class A remote station

*7 When the firmware version of the master station is "1.002" or earlier, a local station and CC-Link IE TSN Class A remote station cannot be connected together on the end side via the industrial switch.

Precautions

When an industrial switch (for CC-Link IE TSN Class B) is used, check the industrial switch (for CC-Link IE TSN Class B) specifications on the CC-Link Partner Association website (www.cc-link.org).

Structure with modules on CC-Link IE TSN only

Connection with modules on CC-Link IE TSN only

Line topology

The network is configured in a line topology.

- Up to eight CC-Link IE TSN Class B devices can be connected to P1 or P2 of the master station.

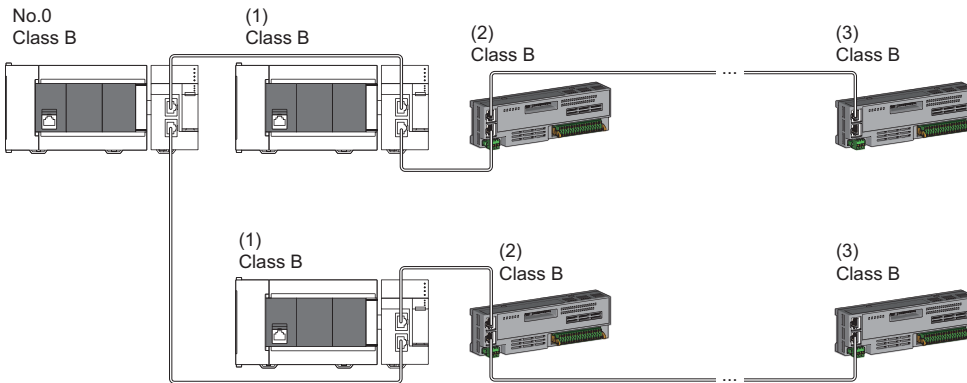

No.0: Master station
 (1) Local station (1st device)
 (2) Remote station (2nd device)
 (3) Remote station (8th device)
 Class B: CC-Link IE TSN Class B device

- A CC-Link IE TSN Class B device cannot be connected to a CC-Link IE TSN Class A device.

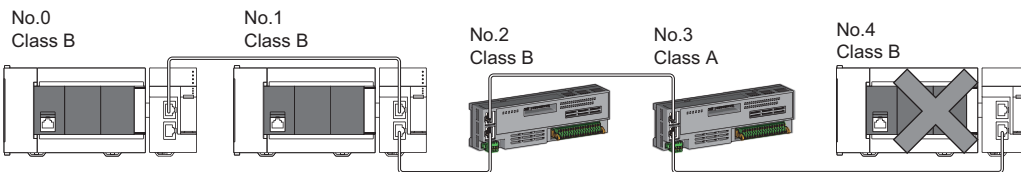

No.0: Master station
 No.1, No.4: Local station
 No.2, No.3: Remote station
 Class A: CC-Link IE TSN Class A device
 Class B: CC-Link IE TSN Class B device

- Connection cannot be made if the total cyclic data size of all device stations on the CC-Link IE TSN Class A device side that form a boundary between CC-Link IE TSN Class B and CC-Link IE TSN Class A devices exceeds 2K bytes.

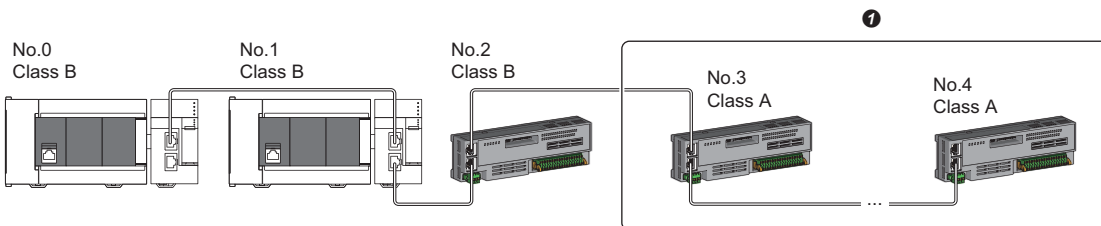

No.0: Master station
 No.1: Local station
 No.2, No.3, and No.4: Remote station
 Class A: CC-Link IE TSN Class A device
 Class B: CC-Link IE TSN Class B device
 ❶ Set the total cyclic data size within 2K bytes.

- When the device stations are CC-Link IE TSN Class A devices only, up to 60 device stations can be connected.

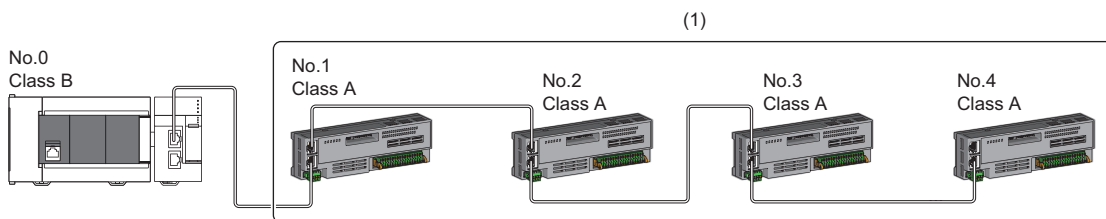

No.0: Master station
 No.1, No.2, No.3, and No.4: Remote station
 Class A: CC-Link IE TSN Class A device
 Class B: CC-Link IE TSN Class B device
 (1): Total number of device stations: Up to 60

■Star topology

The network is configured in a star topology via an industrial switch.

- When connecting a CC-Link IE TSN Class B device in a star topology, an industrial switch (for CC-Link IE TSN Class B) must be used.

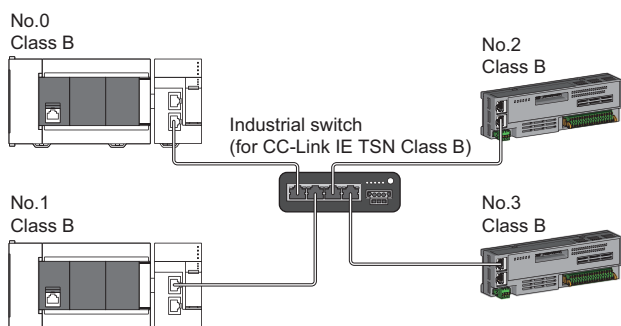

No.0: Master station
 No.1: Local station
 No.2, No.3: Remote station
 Class B: CC-Link IE TSN Class B device

- To connect a CC-Link IE TSN Class A device to a CC-Link IE TSN Class B device in a star topology or to connect a CC-Link IE TSN Class A device to a CC-Link IE TSN Class A device in a star topology, connect them via an industrial switch (for CC-Link IE TSN Class B) or an industrial switch (for CC-Link IE TSN Class A).

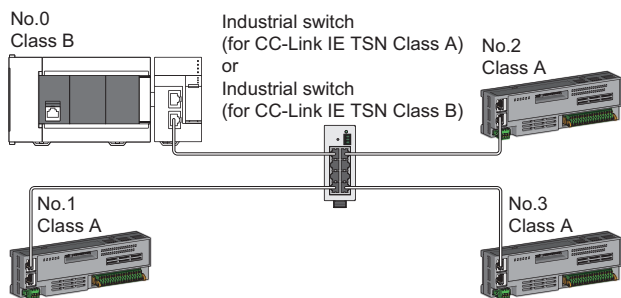

No.0: Master station
 No.1, No.2, and No.3: Remote station
 Class A: CC-Link IE TSN Class A device
 Class B: CC-Link IE TSN Class B device

- When "Communication Mode" is set to "Multicast", communication may not be possible depending on the device if both a local station and a CC-Link IE TSN Class A remote station are connected on the end side via an industrial switch. The communication will be enabled by configuring settings with the hub so that the multicast frame (with multicast MAC address 09:00:70:00:10:02 and 09:00:70:00:10:05) will not be transferred to the an authentication Class A remote station port.

Multicast mode

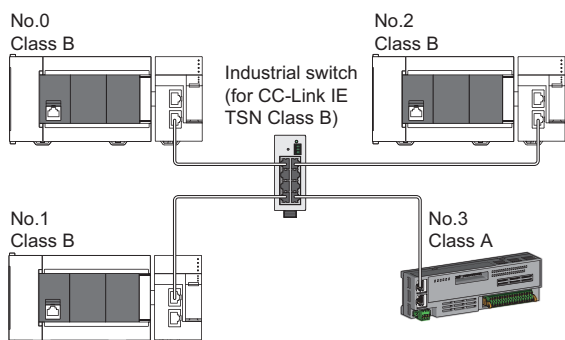

No.0: Master station
 No.1, No.2: Local station
 No.3: Remote station
 Class A: CC-Link IE TSN Class A device
 Class B: CC-Link IE TSN Class B device

■ Coexistence of line and star topologies

Line and star topologies can be mixed according to the availability of connection as described below.

- Configure the system with the number of CC-Link IE TSN Class B device stations and industrial switches (for CC-Link IE TSN Class B) as eight or less in total for each port of the master station on the transmission path from the master station to the CC-Link IE TSN Class B device of the end.
- When connecting CC-Link IE TSN Class A devices, they must be connected to the end side of a CC-Link IE TSN Class B device or to an industrial switch (for CC-Link IE TSN Class B). In this case, the network can be configured in a star topology with an industrial switch (for CC-Link IE TSN Class B) or an industrial switch (for CC-Link IE TSN Class A).

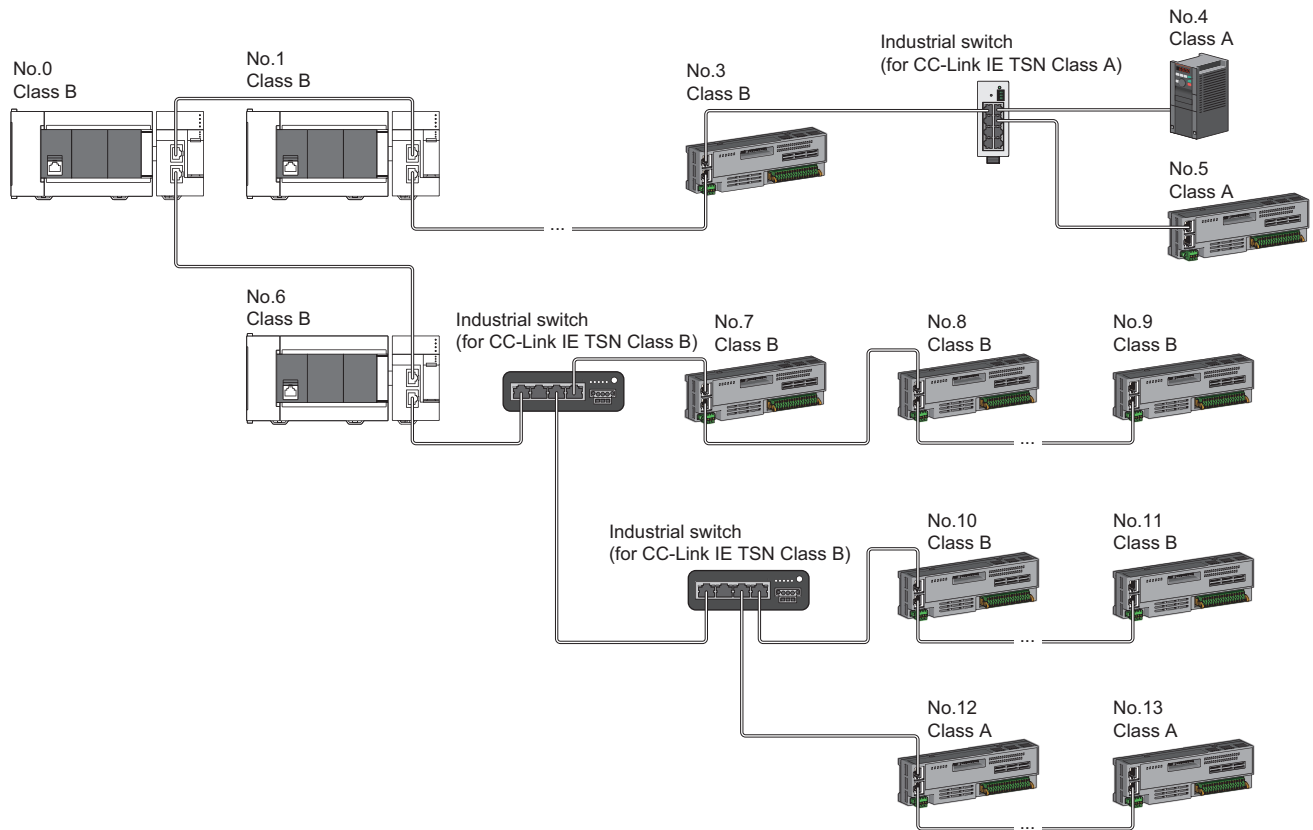

- No. 0: Master station
- No. 1, No. 6: Device station (1st device)
- No. 3, No. 9, and No. 11: Device station (8th station)
- No. 4, No. 5, No. 7, No. 8, and No. 10: Device station
- Class A: CC-Link IE TSN Class A device
- Class B: CC-Link IE TSN Class B device

- Connection cannot be made if the total cyclic data size of all device stations on the CC-Link IE TSN Class A device side that form a boundary between CC-Link IE TSN Class B and CC-Link IE TSN Class A devices exceeds 2K bytes.

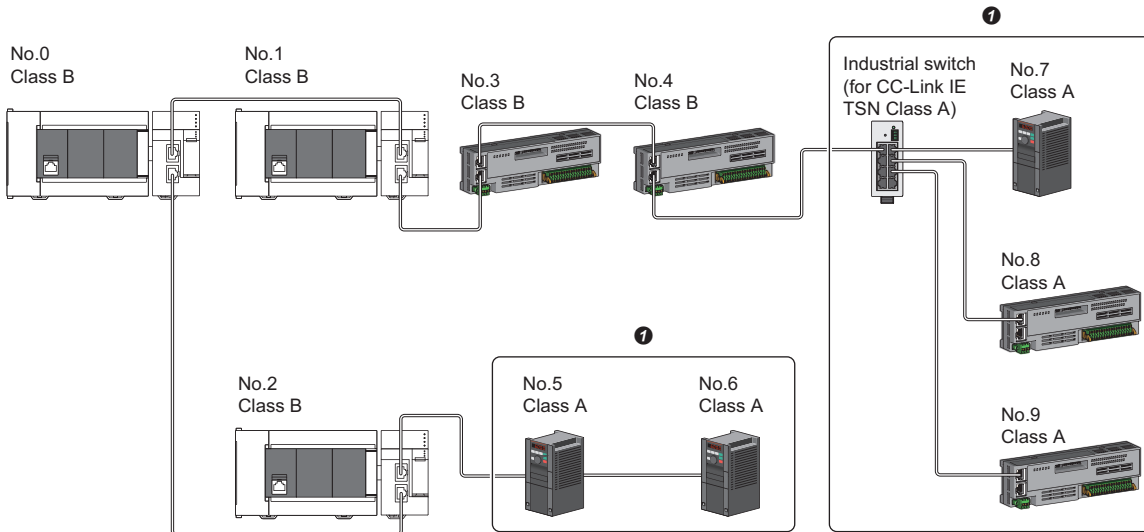

- No.0: Master station
 No.1, No.2: Local station
 No.3, No.4, No.5, No.6, No.7, No.8, and No.9: Remote station
 Class A: CC-Link IE TSN Class A device
 Class B: CC-Link IE TSN Class B device
 ❶ Set the total cyclic data size within 2K bytes.

Connection with modules on CC-Link IE TSN with a communication speed of 100Mbps

This section describes the network topology when "Communication Speed" under "Application Settings" is set to "100Mbps".

Line topology

In a configuration where modules with a communication speed of 100Mbps exist, the communication speed must be the same for all connected modules. When connecting modules with different communication speeds, an industrial switch (for CC-Link IE TSN Class A) is required. Therefore, the line topology is not available for the FX5-CCLGN-MS.

Star topology

The network is configured in a star topology via an industrial switch.

- When the master station with a communication speed of 1Gbps and a local or remote station with a communication speed of 100Mbps exist in the structure, set "Communication Period Setting" to "Low-Speed" for the local or remote station with a communication speed of 100Mbps.

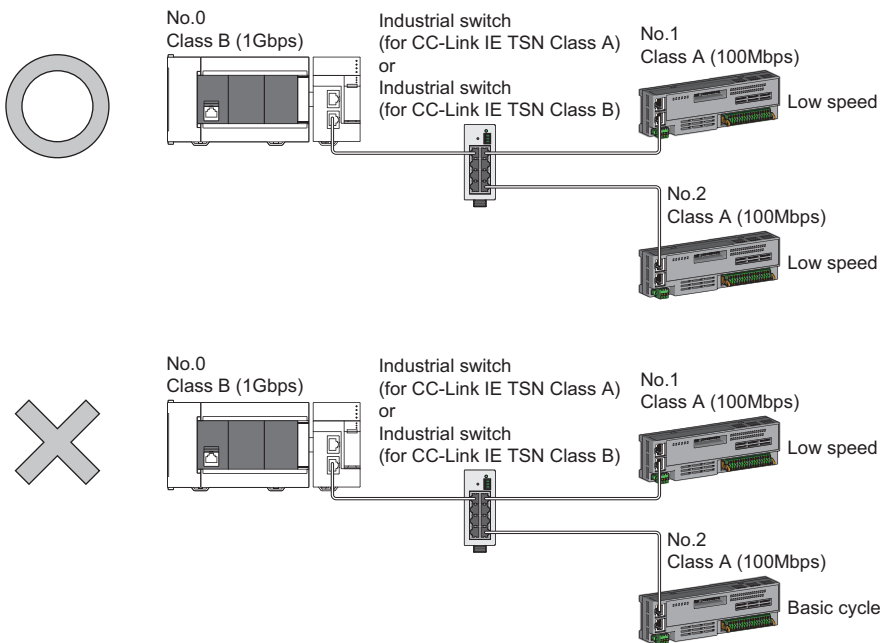

No.0: Master station
 No.1, No.2: Remote station
 Class A: CC-Link IE TSN Class A device
 Class B: CC-Link IE TSN Class B device

- Set the same communication speed for the master station and local stations.

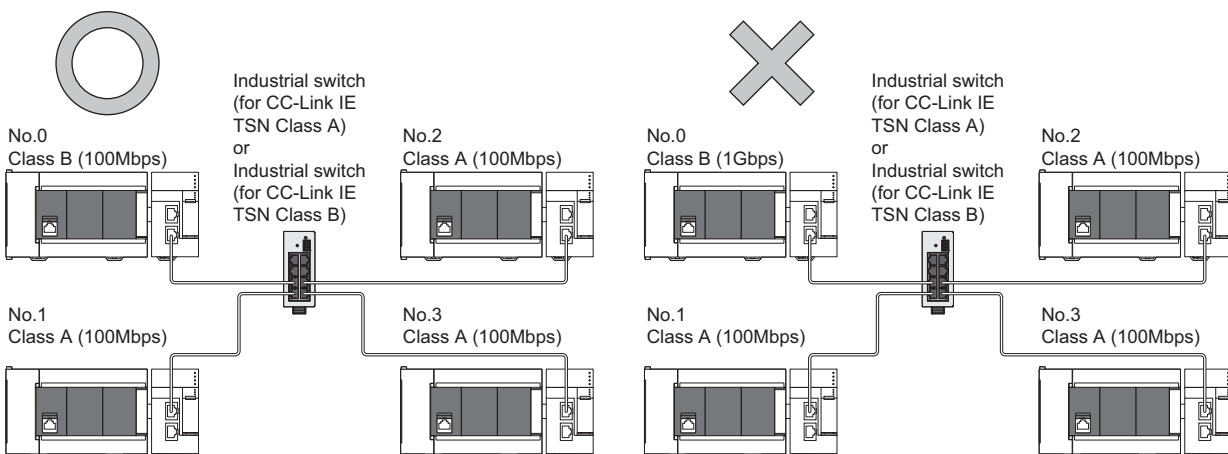

No.0: Master station
 No.1, No.2, and No.3: Local station
 Class A: CC-Link IE TSN Class A device
 Class B: CC-Link IE TSN Class B device

- When "Communication Mode" is set to "Multicast" and the communication speed of the master station is 1Gbps, communication may not be possible depending on the type of the device if device stations with different communication speeds of 1Gbps and 100Mbps coexist on the end side via the industrial switch. The communication will be enabled by configuring settings with the industrial switch so that the multicast frame (with multicast MAC address 09:00:70:00:10:02 and 09:00:70:00:10:05) will not be transferred to the port of the device station with 100Mbps.

Multicast mode

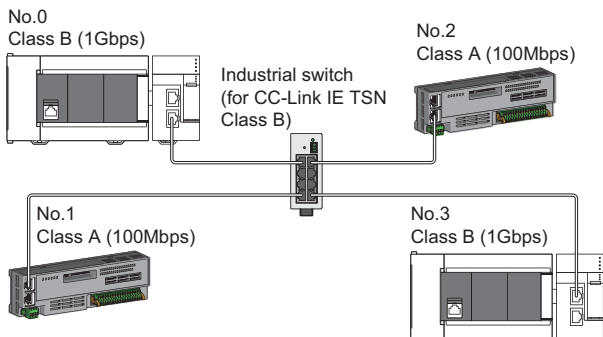

No.0: Master station
 No.1, No.2: Remote station
 No.3: Local station
 Class A: CC-Link IE TSN Class A device
 Class B: CC-Link IE TSN Class B device

■ Coexistence of line and star topologies

Line and star topologies can be mixed in the same network configuration.

- Configure the system with the number of CC-Link IE TSN Class B device stations and industrial switches (for CC-Link IE TSN Class B) as eight or less in total for each port of the master station on the transmission path from the master station to the CC-Link IE TSN Class B device of the end.
- When the master station with a communication speed of 1Gbps and a remote station with a communication speed of 100Mbps exist in the structure, set "Communication Period Setting" to "Low-Speed" for the remote station with a communication speed of 100Mbps.

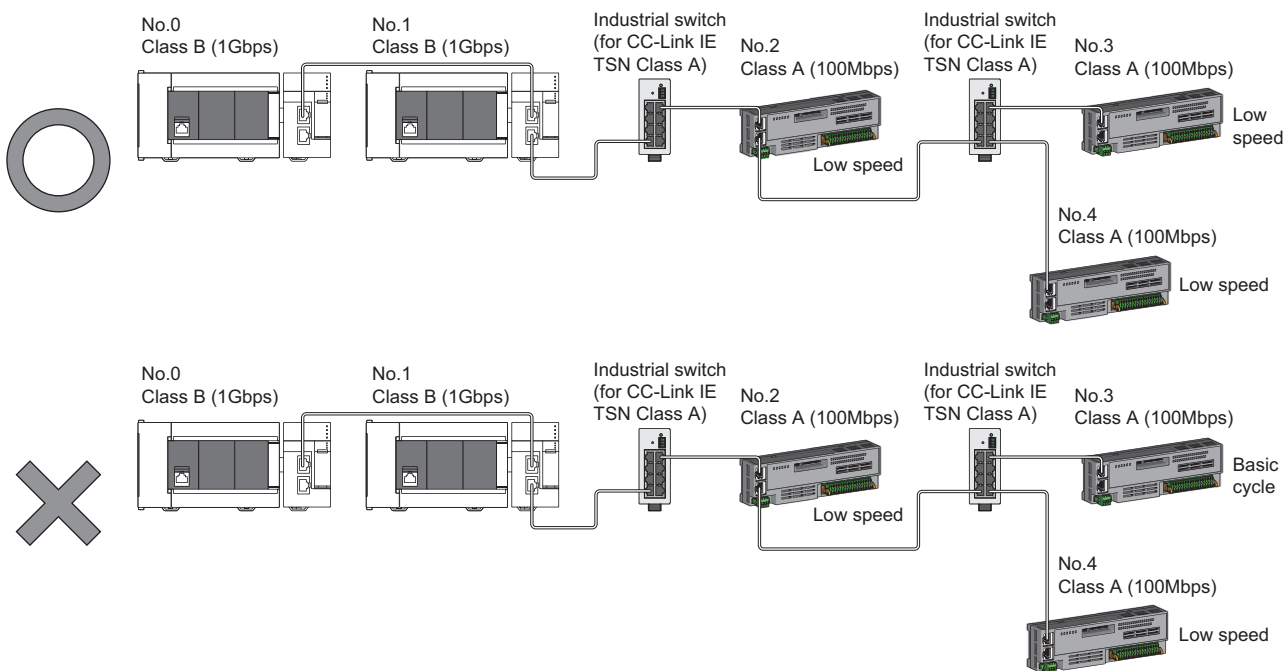

No.0: Master station
 No.1: Local station
 No.2, No.3, and No.4: Remote station
 Class A: CC-Link IE TSN Class A device
 Class B: CC-Link IE TSN Class B device

- When the communication speed of the master station is 1Gbps, a connection cannot be established if the total cyclic data size of all device stations on the 100Mbps device side exceeds 2K bytes. This includes the devices with a communication speed of 100Mbps that form a boundary between the communication speed of 1Gbps and 100Mbps.

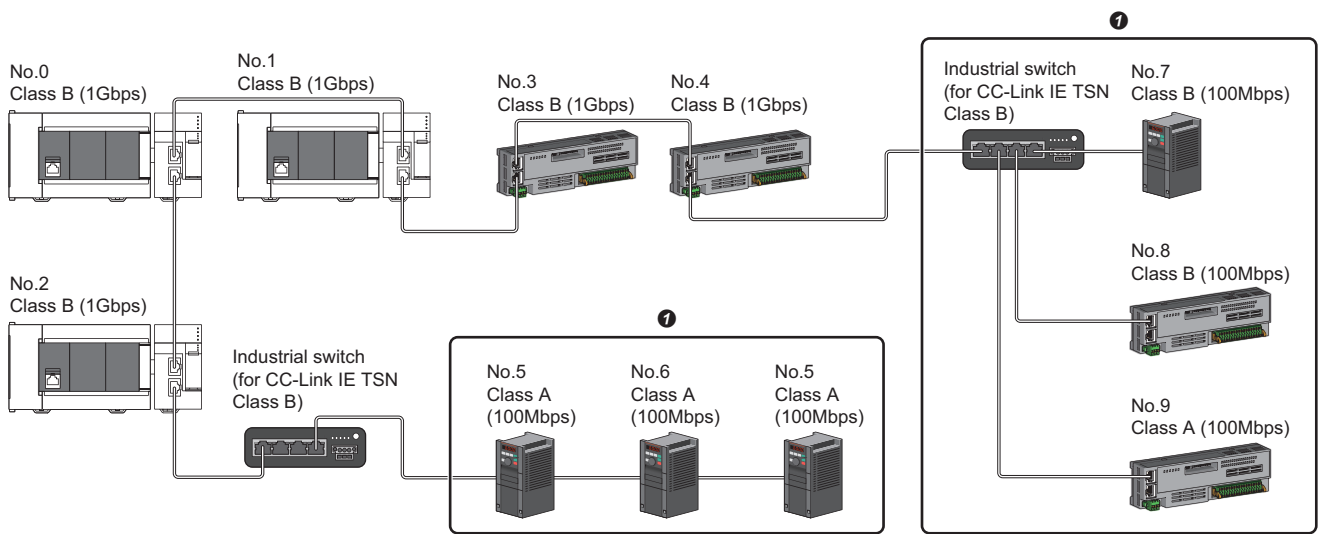

- No.0: Master station
 No.1, No.10: Local station
 No.2, No.3, No.4, No.5, No.6, No.7, No.8, No.9: Remote station
 ❶ Set the total cyclic data size within 2K bytes.

Structure of modules on CC-Link IE TSN and Ethernet devices

Connection with modules on CC-Link IE TSN and Ethernet devices

Line topology

The network with modules and devices is configured in a line topology. An industrial switch (for CC-Link IE TSN Class A) is not required.

Up to eight modules on CC-Link IE TSN can be connected to P1 or P2 of the master station at the position indicated with (1). Connect Ethernet devices to the end of the network.

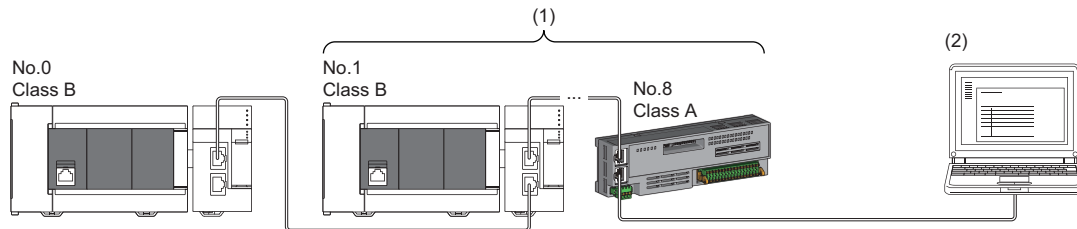

- No.0: Master station
- No.1: Local station (1st module)
- No.8: Remote station (8th module)
- (2) Ethernet device
- Class A: CC-Link IE TSN Class A device
- Class B: CC-Link IE TSN Class B device

When an error occurs in a device station, the stations connected after the faulty station will be disconnected.

Star topology

Modules or devices are connected in a star topology via an industrial switch.

- Since cyclic data is sent to an Ethernet device when "Communication Mode" is set to "Multicast" and both a local station and Ethernet device are used on the end side via an industrial switch, communication may not be possible depending on the type of Ethernet device. The communication will be enabled by configuring settings with the industrial switch so that the multicast frame (with multicast MAC address 09:00:70:00:10:02 and 09:00:70:00:10:05) will not be transferred to the port of the Ethernet device.

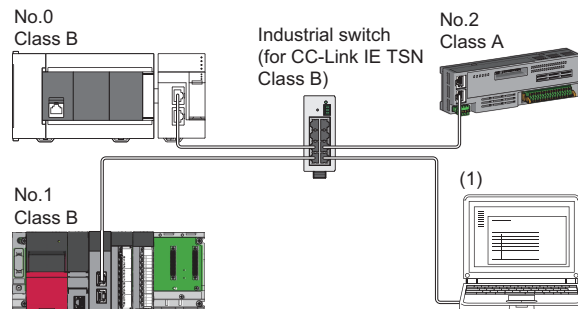

- No.0: Master station
- No.1: Local station
- No.2: Remote station
- (1) Ethernet device
- Class A: CC-Link IE TSN Class A device
- Class B: CC-Link IE TSN Class B device

■ Coexistence of line and star topologies

Line and star topologies can be mixed according to the availability of each connection.

- Configure the system with the number of CC-Link IE TSN Class B device stations and industrial switches (for CC-Link IE TSN Class B) as eight or less in total for each port of the master station on the transmission path from the master station to the CC-Link IE TSN Class B device of the end.
- Connect Ethernet devices at the end of line topology.
- When connecting an Ethernet device in a star topology, connect it with an industrial switch (for CC-Link IE TSN Class A) or an industrial switch (for CC-Link IE TSN Class B).

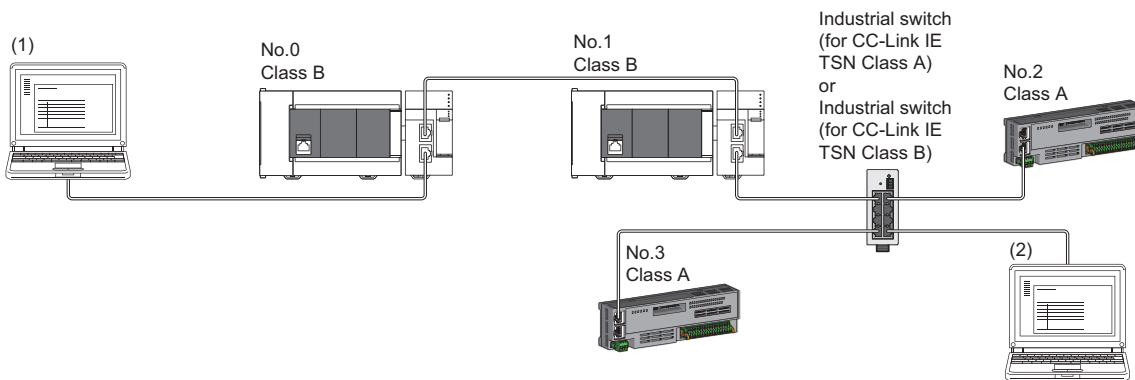

No.0: Master station
No.1: Local station
No.2, No.3: Remote station
(1), (2): Ethernet device
Class A: CC-Link IE TSN Class A device
Class B: CC-Link IE TSN Class B device

5.5 Connection Examples

Category	Connection	Description	Reference
Structure of CC-Link IE TSN Class B devices only	Connection of remote I/O modules and inverters (for line topology)	<ul style="list-style-type: none"> The master station and all of the device stations are CC-Link IE TSN Class B. Line topology 	Page 110 Connection of remote I/O modules and inverters (for line topology)
	Connection of remote I/O modules and inverters (for star topology)	<ul style="list-style-type: none"> The master station and all of the device stations are CC-Link IE TSN Class B. Star topology 	Page 111 Connection of remote I/O modules and inverters (for star topology)
	Connection of local stations	<ul style="list-style-type: none"> Structure of only the master station and local stations (CC-Link IE TSN Class B) Line topology 	Page 111 Connection of local stations
Structure of CC-Link IE TSN Class B devices and Ethernet devices	Direct connection of Ethernet devices	<ul style="list-style-type: none"> Connection of Ethernet devices to the structure of CC-Link IE TSN Class B devices only Direct connection of Ethernet devices to CC-Link IE TSN-compatible devices 	Page 112 Direct connection of Ethernet devices
	Connection of Ethernet devices to an industrial switch	<ul style="list-style-type: none"> Connection of Ethernet devices to the structure of CC-Link IE TSN Class B devices only Connection of Ethernet devices via an industrial switch 	Page 113 Connection of Ethernet devices to an industrial switch
Structure of CC-Link IE TSN Class B/A devices only	Connection of inverters (Only the master station is CC-Link IE TSN Class B.)	Structure of all of the device stations being CC-Link IE TSN Class A	Page 114 Connection of inverters (Only the master station is CC-Link IE TSN Class B.)
	Connection of remote I/O modules and inverters	Structure of CC-Link IE TSN Class B/A devices coexisting as device stations	Page 117 Connection of remote I/O modules and inverters
	Connection of remote I/O modules (CC-Link IE TSN Class B) and inverters	Connection of CC-Link IE TSN Class B devices and CC-Link IE TSN Class A devices separately for each connection port of the master station	Page 118 Connection of remote I/O modules (CC-Link IE TSN Class B) and inverters
Structure of CC-Link IE TSN Class B/A devices and Ethernet devices	Direct connection of Ethernet devices	Connection of Ethernet devices to the structure of CC-Link IE TSN Class B/A devices coexisting	Page 119 Connection of Ethernet devices

Structure of CC-Link IE TSN Class B devices only

Connection of remote I/O modules and inverters (for line topology)

The following figure shows connection of master/local module + remote I/O modules + inverters (for line topology).

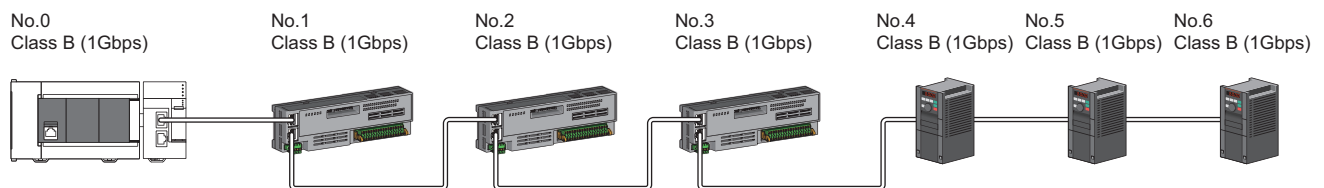

No.0: FX5-CCLGN-MS (master station)
 No.1, No.2, and No.3: Remote I/O module (remote station)
 No.4, No.5, and No.6: Inverter (remote station)

Point

- Device stations can be connected up to the maximum number of connectable stations specified in the CC-Link IE TSN performance specifications.
- There is no fixed orientation, such as IN and OUT, of a connection port of each station. Any ports, such as P1 and P1, P2 and P2, and P1 and P2, can be connected each other.
- Since the master station has two connection ports (P1 and P2), both the ports can be used to connect devices. To use only one of them, specific settings are not required.

Connection of remote I/O modules and inverters (for star topology)

The following figure shows connection of master/local module + remote I/O modules + inverters (for star topology).

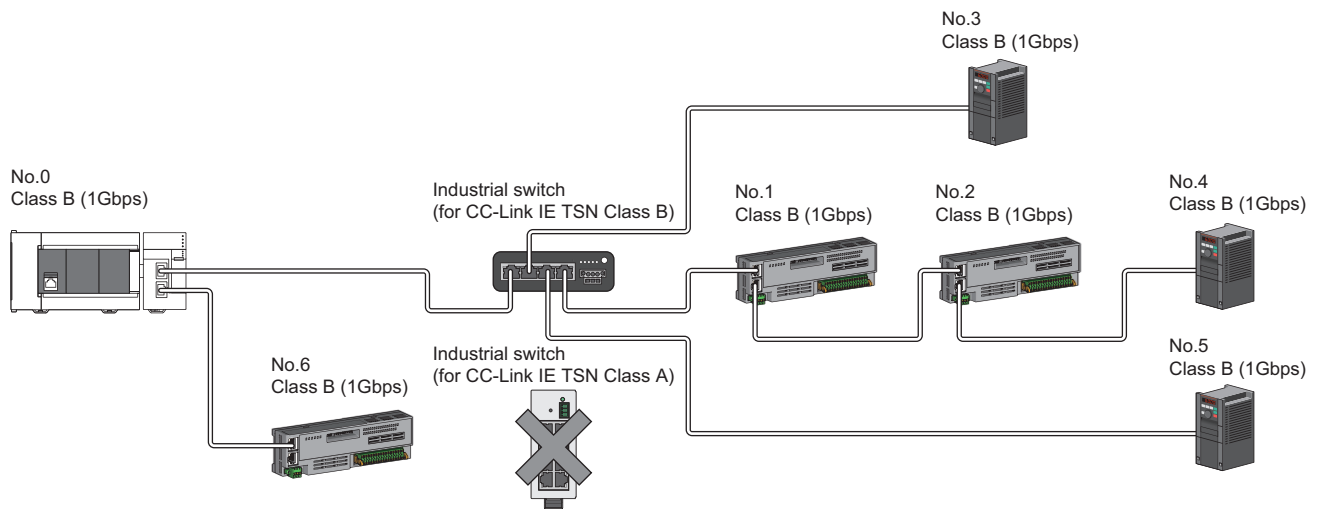

No.0: FX5-CCLGN-MS (master station)
 No.1, No.2, and No.6: Remote I/O module (remote station)
 No.3, No.4, and No.5: Inverter (remote station)

5

Point

- Device stations can be connected up to the maximum number of connectable stations specified in the CC-Link IE TSN performance specifications.
- Since the master station has two connection ports (P1 and P2), both the ports can be used to connect devices. To use only one of them, specific settings are not required.
- A system in which line topology and star topology coexist using an industrial switch (for CC-Link IE TSN Class B) can be configured. (For the available industrial switches (for CC-Link IE TSN Class B), refer to the CC-Link Partner Association website (www.cc-link.org.)
- To use an industrial switch (for CC-Link IE TSN Class B), settings such as the IP address and communication cycle for communicating on CC-Link IE TSN are required.
- Industrial switches (for CC-Link IE TSN Class A) cannot be used. (By using a general-purpose switching hub, an error related to device station disconnection or time synchronization may occur.)

Connection of local stations

The following figure shows connection of master/local module + local stations.

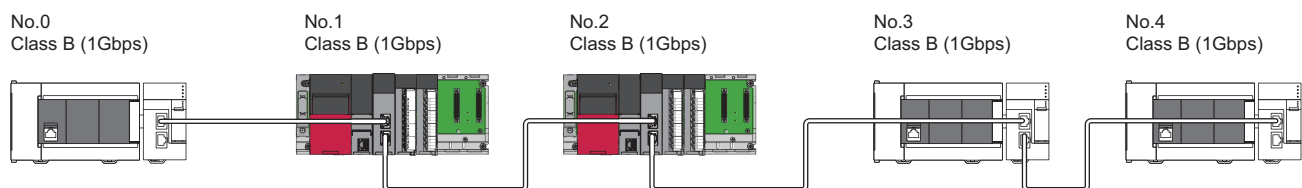

No.0: FX5-CCLGN-MS (master station)
 No.1, No.2: RJ71GN11-T2 (local station)
 No.3, No.4: FX5-CCLGN-MS (local station)

Point

- Local stations can be connected up to the maximum number of connectable stations specified in the CC-Link IE TSN performance specifications.
- Depending on the communication mode (unicast mode/multicast mode) of the master station, cyclic memory map of the local stations changes to the one-to-one range between the master station and a local station or the range including the communication range of other stations. When a local station shares data with other stations, use multicast mode.

Structure of CC-Link IE TSN Class B devices and Ethernet devices

Direct connection of Ethernet devices

The following figure shows direct connection of Ethernet devices to CC-Link IE TSN-compatible devices.

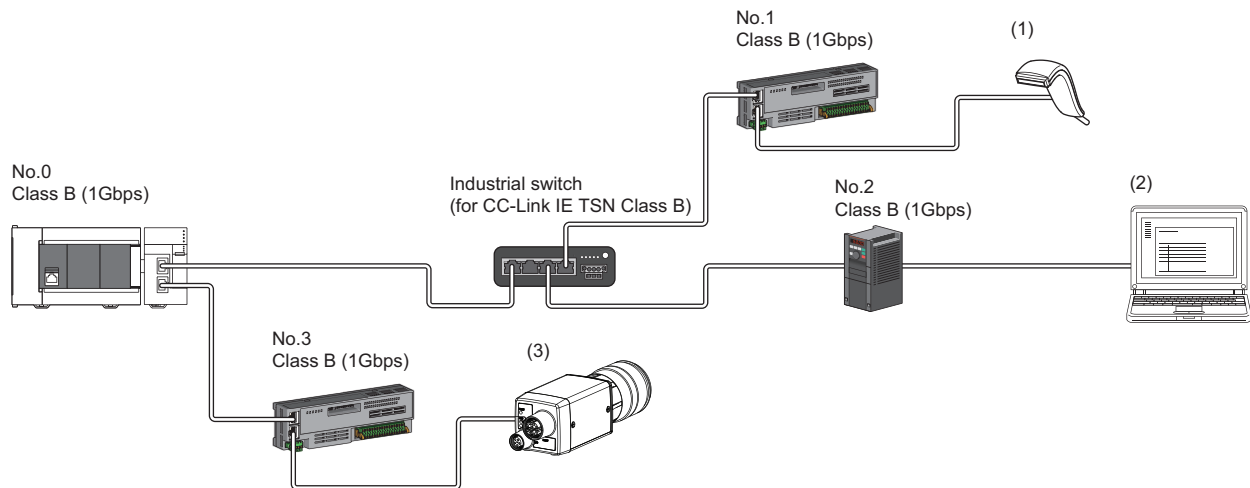

No.0: FX5-CCLGN-MS (Master station)
No.1, No.3: Remote I/O module (Remote station)
No.2: Inverter (Remote station)
(1), (2), (3): Ethernet device

Point

- The Ethernet devices (1Gbps) can be directly connected to unused ports of the CC-Link IE TSN-compatible devices without the industrial switch.
- The Ethernet devices can perform MELSOFT connection and SLMP communications with the master station. They also can communicate with each other using a protocol that supports each other. For the maximum number of MELSOFT connection and SLMP communications, refer to the following.

☞ Page 17 Performance Specifications of Ethernet

- Since the CC-Link IE TSN-compatible devices have a smaller memory capacity for packet reception compared to the industrial switches, packets may not reach external devices if the Ethernet devices are directly connected and high-frequent communications are performed. This can be solved by using an industrial switch (for CC-Link IE TSN Class B) and expanding the memory capacity for packet reception.

Connection of Ethernet devices to an industrial switch

The configuration for connecting Ethernet devices to industrial switches (for CC-Link IE TSN Class B) and industrial switches (for CC-Link IE TSN Class A) in the configuration is shown below.

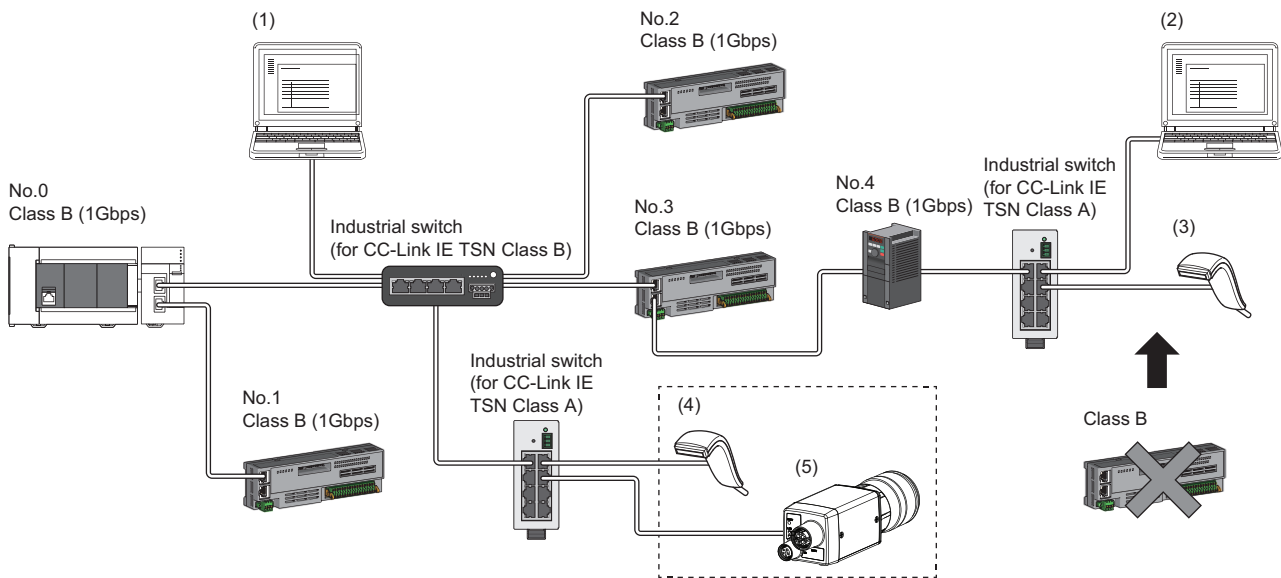

No.0: FX5-CCLGN-MS (master station)
 No.1, No.2, and No.3: Remote I/O module (remote station)
 No.4: Inverter (remote station)
 (1), (2), (3), (4), (5): Ethernet device

Point

- The Ethernet devices can be connected to the industrial switch (for CC-Link IE TSN Class A) connected to the end of the line topology. The Ethernet devices can also be connected to an industrial switch (for CC-Link IE TSN Class B) in the network or an industrial switch (for CC-Link IE TSN Class A) connected to the industrial switch (for CC-Link IE TSN Class B).
- The Ethernet devices can perform MELSOFT connection and SLMP communications with the master station. They also can communicate with each other using a protocol that supports each other. For the maximum number of MELSOFT connection and SLMP communications, refer to the following.
 ➔ Page 17 Performance Specifications of Ethernet
- When connecting the Ethernet device (100Mbps), use an industrial switch that supports the communication speed of 1Gbps/100Mbps.
- The CC-Link IE TSN Class B devices cannot be used by connecting them to the industrial switches (for CC-Link IE TSN Class A) installed for Ethernet device connection. CC-Link IE TSN Class A devices can be used by connecting to them.
- Since Ethernet communications use the transient transmission band on CC-Link IE TSN, the throughput of the Ethernet communications may decrease when the basic communication cycle is extremely short or when a large number of packets are communicated. This can be solved by correcting the communication frequency and the number of connected Ethernet devices.

Structure of CC-Link IE TSN Class B/A devices only

Connection of inverters (Only the master station is CC-Link IE TSN Class B.)

■ If an industrial switch is used to configure a system (master station: 1Gbps)

The following figure shows connection of master/local module (1Gbps) + inverters. (Only the master station is CC-Link IE TSN Class B.)

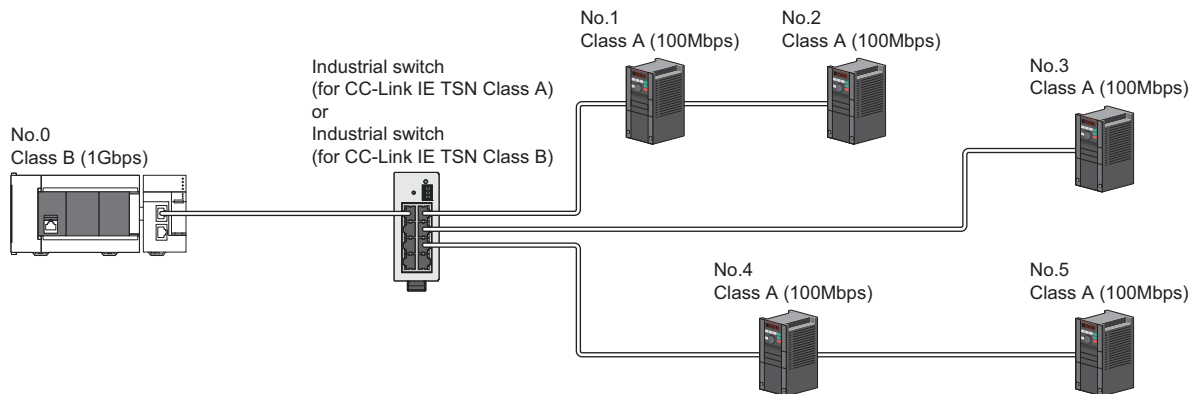

No.0: FX5-CCLGN-MS (Master station)

No.1, No.2, No.3, No.4, and No.5: Inverter (Remote station)

Point

- When all the device stations are CC-Link IE TSN Class A, they can be connected up to the maximum number of connectable stations specified in the CC-Link IE TSN performance specifications.
- If the firmware version is "1.002" or earlier, use an industrial switch (for CC-Link IE TSN Class A) that supports the communication speed of 1Gbps/100Mbps to convert the communication speed.
- If the firmware version is "1.010" or later, use an industrial switch (for CC-Link IE TSN Class B) or industrial switch (for CC-Link IE TSN Class A) that supports the communication speed of 1Gbps/100Mbps to convert the communication speed to 100Mbps. When using an industrial switch (for CC-Link IE TSN Class B), set "TSN HUB Setting" to "Use TSN HUB".
- Connection after the industrial switch (for CC-Link IE TSN Class B) or industrial switch (for CC-Link IE TSN Class A) can be a line topology, star topology, or coexistence of line and star topologies.
- Set "Connection Device Information" of the master station parameters to "Mixture of CC-Link IE TSN Class B/A or CC-Link IE TSN Class A Only". In "Network Configuration Settings" under "Basic Settings", set "Communication Period Setting" of the inverters to "Low-Speed".

■ If an industrial switch is not used to configure a system (master station: 100Mbps)

The following figure shows connection of master/local module (100Mbps) + inverters. (Only the master station is CC-Link IE TSN Class B.)

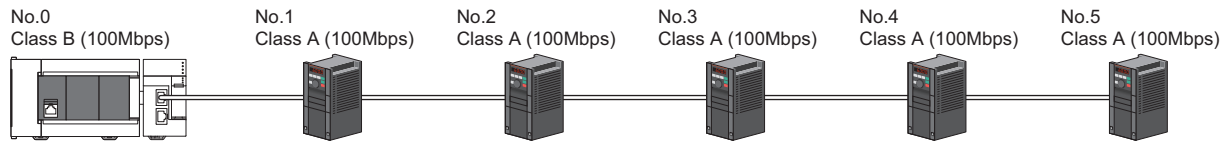

No.0: FX5-CCLGN-MS (Master station)

No.1, No.2, No.3, No.4, and No.5: Inverter (Remote station)

Point

- When all the device stations are CC-Link IE TSN Class A, they can be connected up to the maximum number of connectable stations specified in the CC-Link IE TSN performance specifications.
- To branch the network with a firmware version of "1.002" or earlier, an industrial switch (for CC-Link IE TSN Class A) can be used.
- To branch the network with a firmware version of "1.010" or later, an industrial switch (for CC-Link IE TSN Class B) or an industrial switch (for CC-Link IE TSN Class A) can be used. When using an industrial switch (for CC-Link IE TSN Class B), set "TSN HUB Setting" to "Use TSN HUB".
- Set "Connection Device Information" of the master station parameters to "Mixture of CC-Link IE TSN Class B/A or CC-Link IE TSN Class A Only". In addition, because the FX5-CCLGN-MS with a firmware version of "1.002" or earlier does not support 100Mbps communication, refer to the following.

☞ Page 114 If an industrial switch is used to configure a system (master station: 1Gbps)

■ If an industrial switch is used to configure a system (master station: 100Mbps)

The following figure shows connection of master/local module (100Mbps) + inverters. (Only the master station is CC-Link IE TSN Class B.)

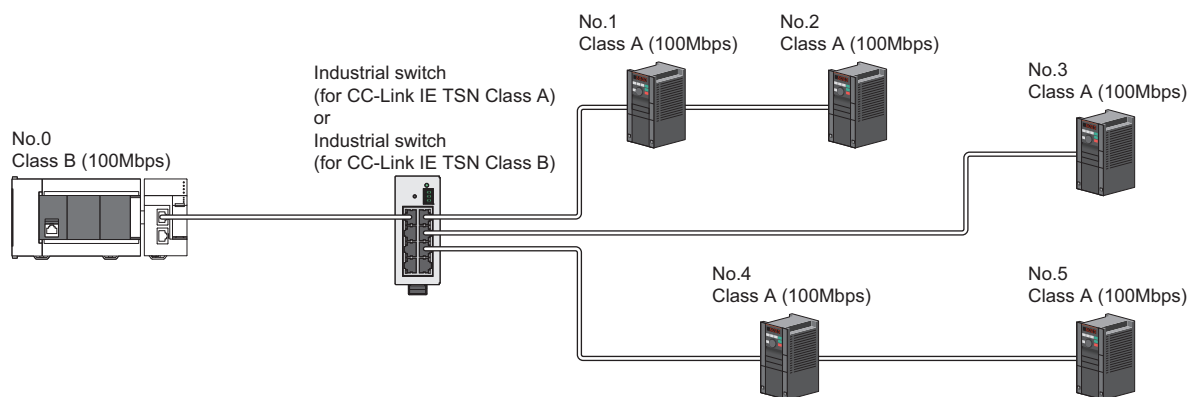

No.0: FX5-CCLGN-MS (Master station)

No.1, No.2, No.3, No.4, and No.5: Inverter (Remote station)

Point

- When all the device stations are CC-Link IE TSN Class A, they can be connected up to the maximum number of connectable stations specified in the CC-Link IE TSN performance specifications.
- To branch the network with a firmware version of "1.002" or earlier, an industrial switch (for CC-Link IE TSN Class A) can be used.
- To branch the network with a firmware version of "1.010" or later, an industrial switch (for CC-Link IE TSN Class B) or an industrial switch (for CC-Link IE TSN Class A) can be used. When using an industrial switch (for CC-Link IE TSN Class B), set "TSN HUB Setting" to "Use TSN HUB".
- Connection after the industrial switch (for CC-Link IE TSN Class B) or industrial switch (for CC-Link IE TSN Class A) can be a line topology, star topology, or coexistence of line and star topologies.
- Set "Connection Device Information" of the master station parameters to "Mixture of CC-Link IE TSN Class B/A or CC-Link IE TSN Class A Only". In addition, because the FX5-CCLGN-MS with a firmware version of "1.002" or earlier does not support 100Mbps communication, refer to the following.

☞ Page 114 If an industrial switch is used to configure a system (master station: 1Gbps)

Connection of remote I/O modules and inverters

The following figure shows connection of master/local module + remote I/O modules + inverters.

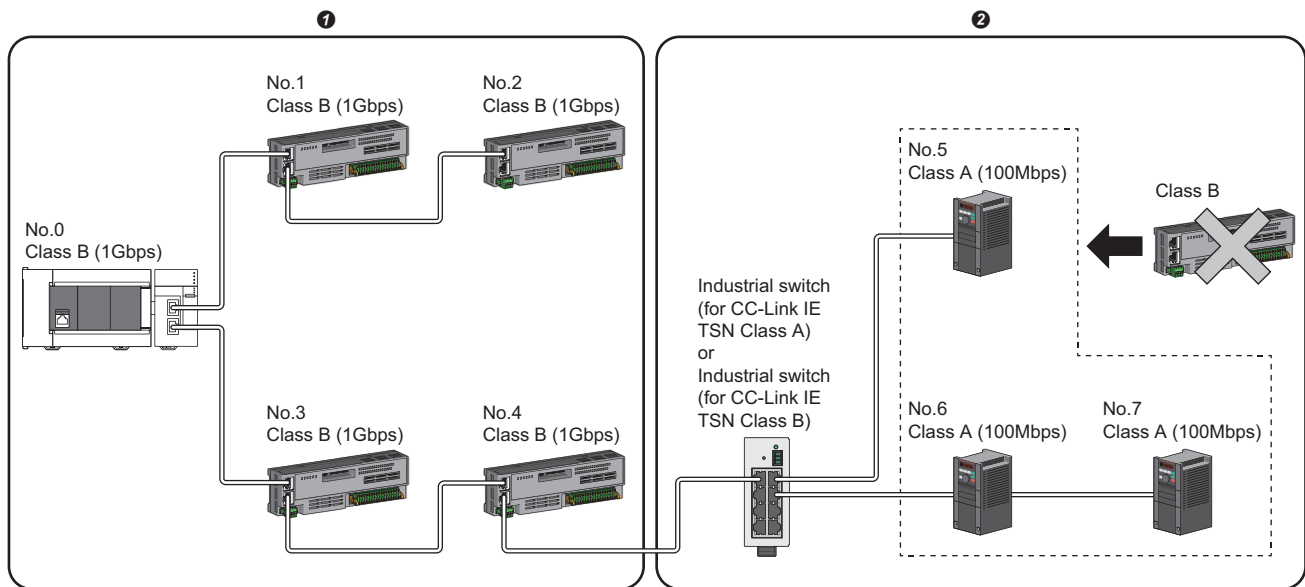

- No.0: FX5-CCLGN-MS (master station)
 No.1, No.2, No.3, and No.4: Remote I/O module (remote station)
 No.5, No.6, and No.7: Inverter (remote station)
 ① CC-Link IE TSN Class B device area
 ② CC-Link IE TSN Class A device area

5

Point

- If the firmware version is "1.002" or earlier, connect in the order of the master station → the CC-Link IE TSN Class B device area → the CC-Link IE TSN Class A device area. Use an industrial switch (for CC-Link IE TSN Class A) on the boundary between the CC-Link IE TSN Class B and CC-Link IE TSN Class A device areas.
- If the firmware version is "1.010" or later, connect in the order of the master station → the CC-Link IE TSN Class B device area → the CC-Link IE TSN Class A device area. Use an industrial switch (for CC-Link IE TSN Class B) or an industrial switch (for CC-Link IE TSN Class A) on the boundary between the CC-Link IE TSN Class B and CC-Link IE TSN Class A device areas. When using an industrial switch (for CC-Link IE TSN Class B), set "TSN HUB Setting" to "Use TSN HUB".
- If the firmware version is "1.002" or earlier, industrial switches (for CC-Link IE TSN Class B) or industrial switches (for CC-Link IE TSN Class A) cannot be used on the CC-Link IE TSN Class B side.
- If the firmware version is "1.010" or later, industrial switches (for CC-Link IE TSN Class A) cannot be used on the CC-Link IE TSN Class B side.
- If the firmware version is "1.002" or earlier, up to eight CC-Link IE TSN Class B devices can be connected per port (up to 16 devices for two ports).
- If the firmware version is "1.010" or later and any CC-Link IE TSN Class A device that does not support the CC-Link IE TSN Protocol version 2.0 is included, up to eight CC-Link IE TSN Class B devices can be connected per port (up to 16 devices for two ports). If all CC-Link IE TSN Class A devices support the CC-Link IE TSN Protocol version 2.0, nine and more CC-Link IE TSN Class B devices can be connected.
- A CC-Link IE TSN Class B device cannot be connected after a CC-Link IE TSN Class A device.
- Set "Connection Device Information" of the master station parameters to "Mixture of CC-Link IE TSN Class B/A or CC-Link IE TSN Class A Only". In "Network Configuration Settings" under "Basic Settings", set "Communication Period Setting" of the inverters to "Low-Speed". Set "Communication Mode" under "Application Settings" to "Multicast".

Precautions

If the firmware version is "1.002" or earlier, connection cannot be made if the total cyclic data size of the CC-Link IE TSN Class A devices exceeds 2K bytes. (The total cyclic data size of the CC-Link IE TSN Class A devices in the entire system configuration, regardless of the connection path) For example, when the cyclic data size of one device is 0.2K bytes, the upper limit is 10 devices.

If the firmware version is "1.010" or later and there is any CC-Link IE TSN Class B or A device that does not support the CC-Link IE TSN Protocol version 2.0, connection cannot be made if the total cyclic data size of the CC-Link IE TSN Class A devices (the total cyclic data size of the CC-Link IE TSN Class A devices in the entire system configuration, regardless of the connection path) exceeds 2K bytes.

For cyclic data size of each device, refer to the manual for the device used.

Connection of remote I/O modules (CC-Link IE TSN Class B) and inverters

The following figure shows connection of master/local module + remote I/O modules (CC-Link IE TSN Class B) + inverters.

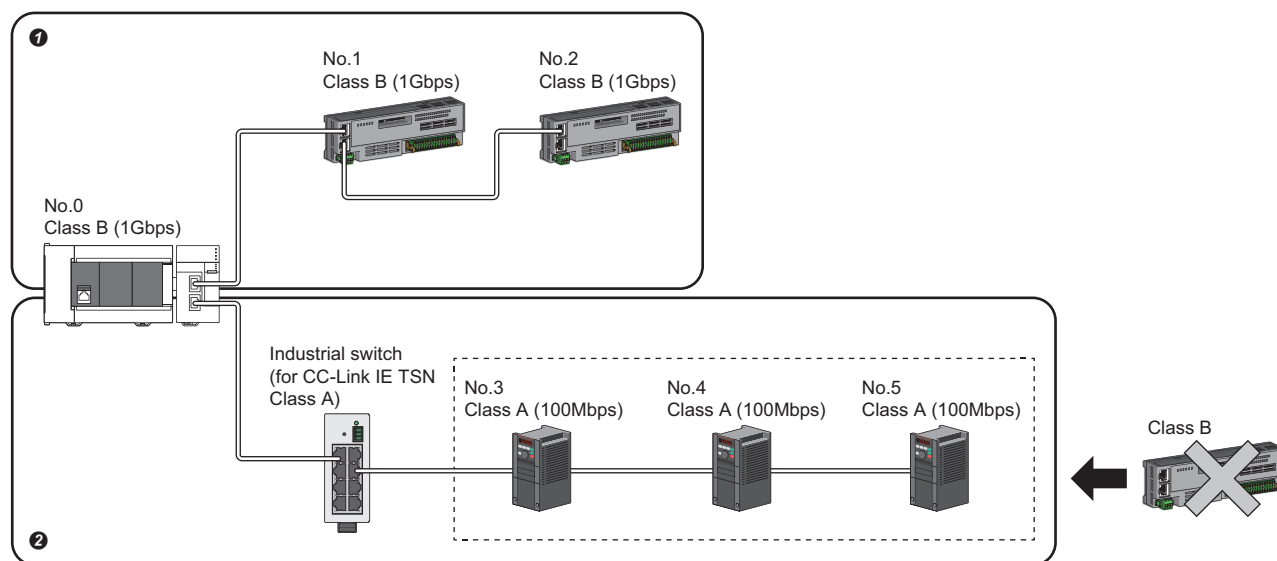

- No.0: FX5-CCLGN-MS (master station)
 No.1, No.2: Remote I/O module (remote station)
 No.3, No.4, and No.5: Inverter (remote station)
 ① CC-Link IE TSN Class B device area
 ② CC-Link IE TSN Class A device area

Point

- To build this configuration, use the FX5-CCLGN-MS with a firmware version of "1.010" or later for the master station.
 - If the firmware version is "1.010" or later, industrial switches (for CC-Link IE TSN Class A) cannot be used on the CC-Link IE TSN Class B side. (Only the line topology is supported.) Also, set "TSN HUB Setting" to "Use TSN HUB".
 - If the firmware version is "1.010" or later and any CC-Link IE TSN Class A device that does not support the CC-Link IE TSN Protocol version 2.0 is included, up to eight CC-Link IE TSN Class B devices can be connected per port (up to 16 devices for two ports). If all CC-Link IE TSN Class A devices support the CC-Link IE TSN Protocol version 2.0, nine and more CC-Link IE TSN Class B devices can be connected.
 - For the maximum number of inverters and CC-Link IE TSN Class B devices that can be connected in total, refer to the following.
- ☞ Page 15 Performance Specifications of CC-Link IE TSN
- Set "Connection Device Information" of the master station parameters to "Mixture of CC-Link IE TSN Class B/A or CC-Link IE TSN Class A Only". In "Network Configuration Settings" under "Basic Settings", set "Communication Period Setting" of the inverters to "Low-Speed". Set "Communication Mode" under "Application Settings" to "Unicast".
 - A CC-Link IE TSN Class B device cannot be connected after a CC-Link IE TSN Class A device.

Structure of CC-Link IE TSN Class B/A devices and Ethernet devices

Connection of Ethernet devices

The configuration for connecting Ethernet devices to CC-Link IE TSN-compatible devices or industrial switches (for CC-Link IE TSN Class A) in the configuration is shown below.

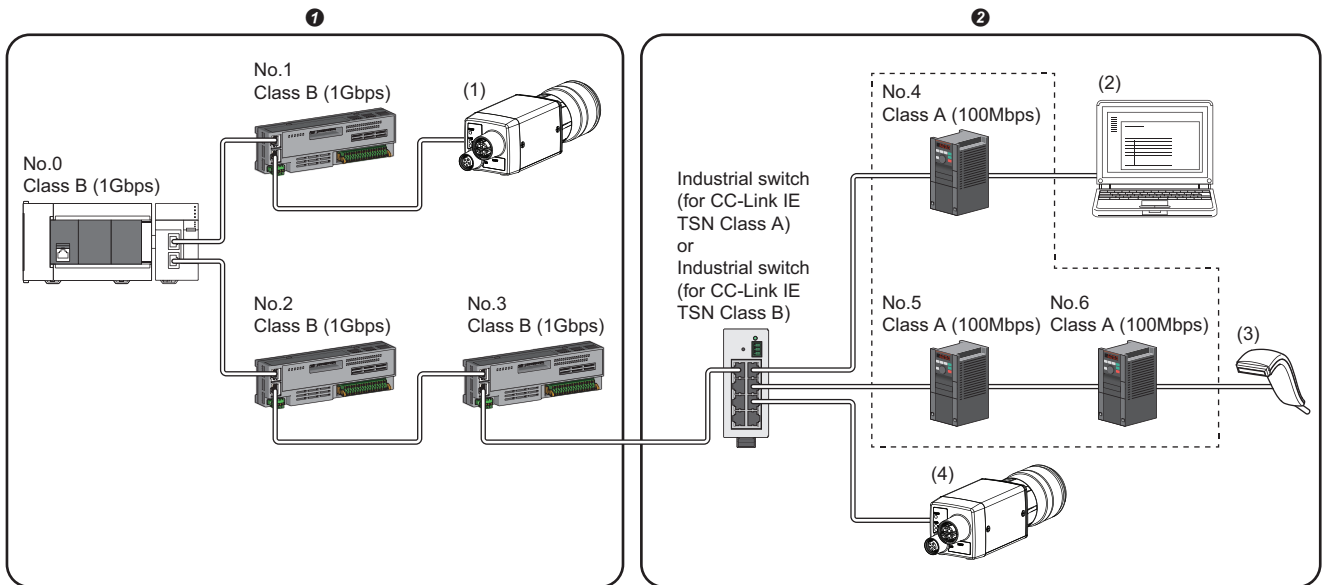

- No.0: FX5-CCLGN-MS (master station)
- No.1, No.2, and No.3: Remote I/O module (remote station)
- No.4, No.5, and No.6: Inverter (remote station)
- (1), (2), (3), (4): Ethernet device
- ① CC-Link IE TSN Class B device area
- ② CC-Link IE TSN Class A device area

Point

- The Ethernet devices (1Gbps) can be directly connected to unused ports of the CC-Link IE TSN-compatible devices without the industrial switch.
- The Ethernet devices (100Mbps) can be connected to industrial switches (for CC-Link IE TSN Class A) installed on the boundary between the CC-Link IE TSN Class B and CC-Link IE TSN Class A device areas.
- The Ethernet devices can perform MELSOFT connection and SLMP communications with the master station. They also can communicate with each other using a protocol that supports each other. For the maximum number of MELSOFT connection and SLMP communications, refer to the following.

☞ Page 17 Performance Specifications of Ethernet

- Since the CC-Link IE TSN-compatible devices have a smaller memory capacity for packet reception compared to the industrial switches, packets may not reach external devices if the Ethernet devices are directly connected and high-frequent communications are performed.
- Since Ethernet communications use the transient transmission band on CC-Link IE TSN, the throughput of the Ethernet communications may decrease when the basic communication cycle is extremely short or when a large number of packets are communicated. This can be solved by correcting the communication frequency and the number of connected Ethernet devices.

5.6 Precautions for System Configuration

Restriction of firmware version

■Combination of the engineering tool and FX5-CCLGN-MS

The following table shows operations according to the combination of the engineering tool and the firmware version of the FX5-CCLGN-MS.

Engineering tool	FX5-CCLGN-MS	
	Firmware version "1.002" or earlier	Firmware version "1.010" or later
Earlier than software version "1.085P"	Operates normally.	<ul style="list-style-type: none"> • The restrictions of the connection configuration are the same as those of the firmware version "1.002" or earlier. • If a parameter is written, the communication speed cannot be set, resulting in a speed of 1Gbps. • The system reserved time cannot be set, resulting in operation at 20μs. • "TSN HUB Setting" cannot be set, resulting in operation with "Not to Use TSN HUB". • "CC-Link IE TSN Class Setting" cannot be set for device stations so that the FX5-CCLGN-MS operates without CC-Link IE TSN Class. • "Multiple Period Setting" cannot be set to "Low-Speed", resulting in $\times 16$ operation.
Software version "1.085P" or later	<ul style="list-style-type: none"> ■If "Communication Speed" is set to 100Mbps <ul style="list-style-type: none"> • For the master station, the error code 2440H occurs on the CPU side. • For local stations, no errors occur on the CPU side, but no data link is performed because the station number is not set internally. ■If "Low-Speed" in "Multiple Period Setting" is set to a value other than "$\times 16$" <ul style="list-style-type: none"> • The error code 2221H occurs. <p>The newly added parameters below are not recognized on the module side and no error judgment or notification process is implemented, resulting in the same operation as with the firmware version "1.002" or earlier.</p> <ul style="list-style-type: none"> • System Reservation Time • TSN HUB Setting • CC-Link IE TSN Class Setting 	Operates normally.

■Combination of the master station and local stations

For the FX5-CCLGN-MS, when using the CC-Link IE TSN Protocol version 2.0 (mixture of CC-Link IE TSN Class B/A), perform the firmware update on modules with "1.002" or earlier to update to "1.010" or later before use.

However, if the CC-Link IE TSN Protocol version 2.0 (mixture of CC-Link IE TSN Class B/A) is used and any CC-Link IE TSN Class A device station that does not support the CC-Link IE TSN Protocol version 2.0 is included in the network, operation reverts to the CC-Link IE TSN Protocol version 1.0, and the restrictions of the connection configuration apply accordingly. In addition, if a station that does not support the CC-Link IE TSN Protocol version 2.0 is connected after performing a data link with the CC-Link IE TSN Protocol version 2.0 (mixture of CC-Link IE TSN Class B/A), that station does not perform a data link.

Devices connected to the same network

Do not connect the devices as described below. Doing so may cause the disconnection of all stations.

- A module on CC-Link IE TSN and a device having network types other than an Ethernet device (such as CC-Link IE Controller Network and CC-Link IE Field Network) are connected to the same network.
- A module on CC-Link IE TSN and an Ethernet device (such as a personal computer), both of which are on different networks, are connected to one industrial switch.

Adding a device station with no IP address setting

In a line topology, do not connect a device station with no IP address setting at a place other than the end of the network. A data link may not be performed in the device stations after the device station with no IP address setting.

CC-Link IE TSN/CC-Link IE Field diagnostics

If operations such as the following are performed, the actual network configuration and the network map of the CC-Link IE TSN/CC-Link IE Field diagnostics may be a mismatch.

Network configuration	Operation
Star topology	<ul style="list-style-type: none">• Powering off and on a device station or industrial switch• Connecting/disconnecting an Ethernet cable connected to the industrial switch• Disconnecting an Ethernet cable from a device station and connecting it to another device station or an industrial switch• Disconnecting more than nine stations, or half the number of device stations or more in the system• Changing the network topology when adding a device station
Line topology	<ul style="list-style-type: none">• Simultaneously powering off/on multiple stations• Simultaneously connecting/disconnecting Ethernet cables to/from multiple stations (When a data link faulty station returns, a data link error will occur in all the stations.)• Disconnecting more than nine stations, or half the number of device stations or more in the system• Changing the network topology when adding a device station

Point

The actual network configuration and network map can be matched by executing the network map update of the CC-Link IE TSN/CC-Link IE Field diagnostics. ( Page 180 CC-Link IE TSN/CC-Link IE Field diagnostics)

Calculation of the total cyclic data size

The following shows the calculation formula of the total cyclic data size. The part of the variable surrounded by double quotes (" ") is the setting value of "Network Configuration Settings" under "Basic Settings".

Total cyclic data size = $204 + (146 \times \text{Number of local stations}) + (106 \times \text{Number of remote stations}) + (\text{Number of "RX setting" points} \div 8) + (\text{Number of "RWr setting" points} \times 2)$ [byte]

6 WIRING

This chapter describes the wiring methods, wiring products, and wiring precautions when using the FX5-CCLGN-MS.

6.1 Power Supply Wiring

Power connector layout

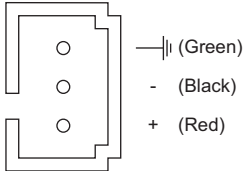

Power supply wiring

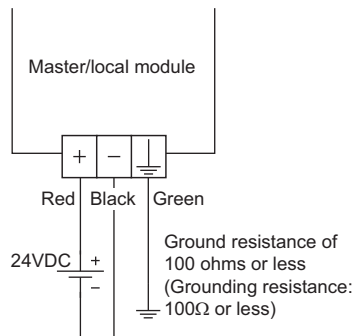

Grounding

Observe the following:

- Provide grounding with a ground resistance of 100Ω or less.
- Provide independent grounding when possible.
- If independent grounding cannot be provided, provide "shared grounding" as shown below.

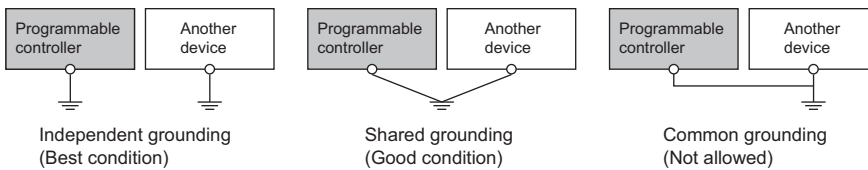

- Keep the distance between the grounding point and the programmable controller as close as possible to shorten the length of ground cable.

6.2 CC-Link IE TSN Wiring

This section describes the wiring when using CC-Link IE TSN.

Wiring methods

The following describes connection and disconnection of the Ethernet cable.

■Connecting the cable

1. Power off the FX5-CCLGN-MS and the external device.
2. Push the Ethernet cable connector into the FX5-CCLGN-MS until it clicks. Pay attention to the connector's direction.
3. Lightly pull it to check that it is securely connected.
4. Power on the FX5-CCLGN-MS and the external device.
5. Check whether the LINK LED of the port connected with an Ethernet cable is on. ^{*1}

^{*1} The time between the Ethernet cable connection and the LINK LED turning on may vary. The LINK LED usually turns on in a few seconds. Note, however, that the time may be extended further if the link-up processing is repeated depending on the status of the device on the line. If the LINK LED does not turn on, refer to the following and take corrective actions.

🔑 Page 174 TROUBLESHOOTING



Both P1 connector and P2 connectors can be used.

- When only one of P1 and P2 connectors is used in a star topology, either P1 or P2 connector is applicable.
- When both ports are used in a line topology, P1-P1, P2-P2, and P1-P2 connections are acceptable.

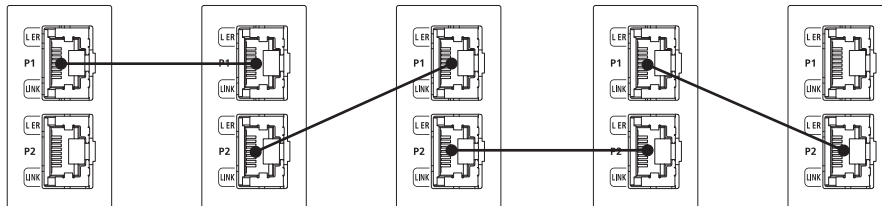

■Disconnecting the cable

1. Power off the FX5-CCLGN-MS.
2. Press the latch down and unplug the Ethernet cable.

■Precautions

- The bending radius of the Ethernet cable is limited. For details, check the specifications of the Ethernet cable to be used.
- Place the Ethernet cable in a duct or clamp them. If not, dangling cable may swing or inadvertently be pulled, resulting in damage to the module or cables or malfunction due to poor contact.
- When installing a cable, do not touch the core of the cable-side or module-side connector, and protect it from dirt or dust. If oil from your hand, dirt or dust is attached to the core, it can increase transmission loss, arising a problem in a data link.
- Hold the connector part when connecting and disconnecting the Ethernet cable. Pulling the cable connected to the module may result in malfunction or damage to the module or cable.
- Check that the Ethernet cable is not disconnected or not shorted and there is no problem with the connector connection.
- Do not use Ethernet cables with broken latches. Doing so may cause the cable to unplug or malfunction.
- For connectors without Ethernet cables, attached caps should be mounted to prevent foreign matter such as dirt or dust.
- The maximum station-to-station distance of the Ethernet cable is 100m. However, the length may be shorter depending on the operating environment of the cable. For details, contact the manufacturer of the cable used.
- In a line topology, do not connect a device station with no IP address setting or a device station that is not in the master station's network configuration between the master station and device stations, or between device stations. A data link may not be performed between the master station and device stations with no IP address setting or device stations that are connected after the connection of a device station that is not in the master station's network configuration.

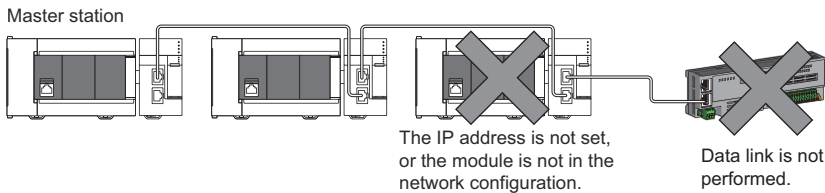

- Communication with the Ethernet device may not be performed depending on the specifications of the connected Ethernet device or industrial switch. If communications are not possible, reduce the communication data volume of the Ethernet device.

Wiring products

The following describes the devices used for CC-Link IE TSN.

■Ethernet cable

Use Ethernet cable that meets the following standards.

Communication speed	Ethernet cable	Connector	Type
1Gbps	Category 5e or higher, straight cable (double shielded, STP)	RJ45 connector	The following conditioning cables: • IEEE 802.3 (1000BASE-T) • ANSI/TIA/EIA-568-B (Category 5e)
100Mbps	Category 5 or higher, straight cable (double shielded, STP)	RJ45 connector	The following conditioning cables: • IEEE 802.3 (100BASE-TX) • ANSI/TIA/EIA-568-B (Category 5)

Cables for CC-Link IE TSN are available from Mitsubishi Electric System & Service Co., Ltd. (Catalogs for cable are also available.)

In addition, the connector processing of cable length is available for your preference. Please consult your local Mitsubishi representative.

Communication speed	Type	Model (Manufacturer)
1Gbps	Category 5e or higher, straight cable (double shielded, STP)	SC-E5EW series (Mitsubishi Electric System & Service Co., Ltd.)

6

Point

A communication error may occur due to high-frequency noise from devices other than a programmable controller in a given connection environment. The following describes countermeasures to be taken on the FX5-CCLGN-MS side to avoid high-frequency noise influence.

Wiring

- Use a duplex shield type cable.
- Do not bundle the cable with the main circuit or power cable or do not place it near those lines.
- Place the cable in a duct.

■Industrial switch

Use the following industrial switches.

Term	Description	CC-Link IE TSN Class
Industrial switch (for CC-Link IE TSN Class B)	For the models and usage methods of the industrial switches, refer to the CC-Link Partner Association website (www.cc-link.org).	CC-Link IE TSN Class B device
NZ2MHG-TSNT□	A CC-Link IE TSN industrial managed switch that falls under the industrial switch (for CC-Link IE TSN Class B) category  CC-Link IE TSN Industrial Managed Switch User's Manual	
Industrial switch (for CC-Link IE TSN Class A)	For the models and usage methods of the industrial switches, refer to the CC-Link Partner Association website (www.cc-link.org).	CC-Link IE TSN Class A device

An industrial switch can be used for cascade connection.

When the industrial switch is used for cascade connection, check the specifications of the industrial switch used.

Precautions

- Since there are different restrictions for system configuration using an industrial switch (for CC-Link IE TSN Class B) and system configuration using an industrial switch (for CC-Link IE TSN Class A), setting with an engineering tool is required. ( Page 60 SYSTEM CONFIGURATION)
- Do not configure a ring topology when modules are connected to an industrial switch. Doing so, all stations will fail and data links cannot be performed.

7 PARAMETER SETTINGS

This chapter describes the parameter settings required for communications between the FX5-CCLGN-MS and other stations.

7.1 Setting Parameters

1. Add the FX5-CCLGN-MS in the engineering tool.
 - ☞ [Navigation window] ⇒ [Parameter] ⇒ [Module Information] ⇒ Right-click ⇒ [Add New Module]
2. The required settings, basic settings, and application settings are included in the parameter settings. Select one of the settings from the tree on the following window.
 - ☞ [Navigation window] ⇒ [Parameter] ⇒ [Module Information] ⇒ Target Module
3. After setting parameters, click the [Apply] button.
4. Write parameters to the FX5 CPU module using the engineering tool.
 - ☞ [Online] ⇒ [Write to PLC]
5. The parameters are reflected by resetting the FX5 CPU module or powering off and on the system.

7.2 Required Settings

Set such items as the station type and network number of the FX5-CCLGN-MS.

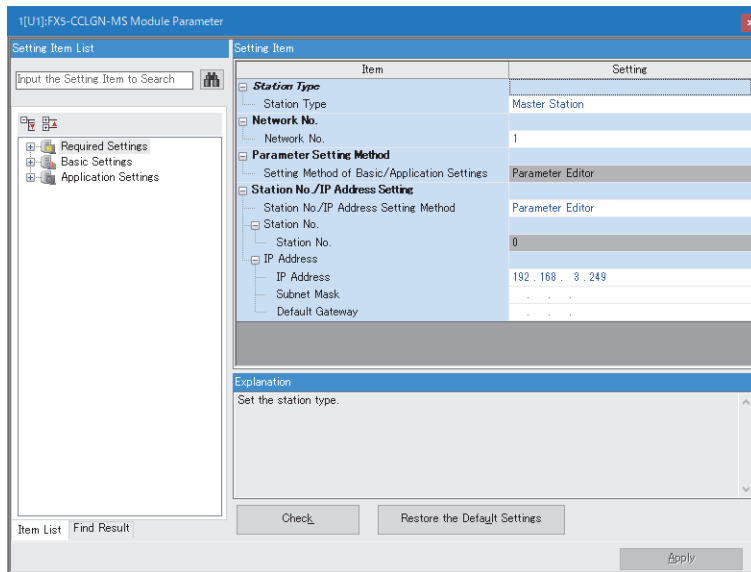

Item	Description	Reference
Station Type	Set the station type of the FX5-CCLGN-MS.	Page 126 Station Type
Network No.	Set the network number of the FX5-CCLGN-MS.	Page 127 Network No.
Parameter Setting Method	Set "Basic Settings" and "Application Settings" items using the engineering tool or in program.	Page 127 Parameter Setting Method
Station No./IP Address Setting	Set the station number or IP address of the FX5-CCLGN-MS.	Page 128 Station No./IP Address Setting

Station Type

Set the station type of the FX5-CCLGN-MS.

Item	Description	Setting range
Station Type	Select whether to use the FX5-CCLGN-MS as the master station or local station. Only one master station can be set in a network.	<ul style="list-style-type: none"> • Master Station • Local Station (Default: Station type set in the "Add New Module" window.)

Network No.

Set the network number of the FX5-CCLGN-MS.

Item	Description	Setting range
Network No.	Set the network number of the FX5-CCLGN-MS.	1 to 239 (Default: 1)

Precautions

Set a network number that does not duplicate any other network numbers.

When a network number is duplicated in the same system, an error will occur in the CPU module.

In particular, when using an Ethernet-equipped module (CPU module) at default, the IP address is 192.168.3.250 and the network number is the third octet of the IP address, thus 3. Because setting the network number of the FX5-CCLGN-MS to 3 causes duplication, set another network number.

Parameter Setting Method

Set "Basic Settings" and "Application Settings" items using the engineering tool or in program.

Item	Description	Setting range
Setting Method of Basic/ Application Settings	Select this item to set the parameter using the engineering tool. The following are advantages. <ul style="list-style-type: none">• All parameters can be easily set in the window without creating a program for setting.• Data can be automatically transferred from the link special relay (SB), link special register (SW), and link devices of the FX5-CCLGN-MS to the devices of the FX5 CPU module.	Parameter Editor (fixed)

7

Station number/IP address setting of a local station

The station number/IP address of a local station can be also set using the G(P).UINI instruction. This allows project data items other than the station number/IP address to be shared. (📖 MELSEC iQ-F FX5 Programming Manual (Instructions, Standard Functions/Function Blocks))

The procedure for setting the station number of a local station is as follows.

1. Set "Station No./IP Address Setting Method" under "Station No./IP Address Setting" in "Required Settings" to "Program".
2. Set "Setting Method of Basic/Application Settings" under "Parameter Setting Method" in "Required Settings" to "Parameter Editor".
3. Set the station number using the G(P).UINI instruction.

Station No./IP Address Setting

Set the station number and IP address of the own station of the FX5-CCLGN-MS.

Item	Description	Setting range
Station No./IP Address Setting Method	Select whether to set the station number using the engineering tool or set the station number/IP address using a program (G(P).UINI instruction). This item can be set only for a local station. When selecting "Program", use the G(P).UINI instruction to set the station number/IP address. (MELSEC iQ-F FX5 Programming Manual (Instructions, Standard Functions/Function Blocks))	<ul style="list-style-type: none"> Parameter Editor Program (Default: Parameter Editor)
Station No.	Set the station number of the FX5-CCLGN-MS. This item can be set only for a local station. To set the station number in this setting, set "Station No./IP Address Setting Method" to "Parameter Editor". Set a station number different from those used in the same network.	<ul style="list-style-type: none"> Master station: Fixed to "0" Local station: 1 to 120 (Default: 1)
IP Address	Set the IP address of the own station. Set an IP address different from those used in other stations. (Page 57 IP address duplication detection) Do not set the following values. <ul style="list-style-type: none"> The third and fourth octets are all 0 or all 1. The host address bits are all 0 or all 1. Reserved address 	0.0.0.1 to 223.255.255.254 (00.00.00.01 to DF.FF.FF.FE) (Default: Master station 192.168.3.249, local station 192.168.3.11)
Subnet Mask	Set the subnet mask. Set the same value for the master station and device station. If the subnet mask is empty, the address class (class A, class B, class C) is determined from the setting of "IP Address", and operation is done with the subnet mask according to the address class. The subnet mask for each class is as follows. <ul style="list-style-type: none"> Class A: 255.0.0.0 Class B: 255.255.0.0 Class C: 255.255.255.0 The IP address for each class is as follows. <ul style="list-style-type: none"> Class A: 0.x.x.x to 127.x.x.x Class B: 128.x.x.x to 191.x.x.x Class C: 192.x.x.x to 223.x.x.x The host address for each class is the 0 section shown below. <ul style="list-style-type: none"> Class A: 255.0.0.0 Class B: 255.255.0.0 Class C: 255.255.255.0 	<ul style="list-style-type: none"> Empty 0.0.0.1 to 255.255.255.255 (00.00.00.01 to FF.FF.FF.FF) (Default: empty)
Default Gateway	Set the default gateway.	<ul style="list-style-type: none"> Empty 0.0.0.1 to 223.255.255.254 (00.00.00.01 to DF.FF.FF.FE) (Default: empty)

7.3 Basic Settings

Set the network configurations, refresh settings, or other parameters for the FX5-CCLGN-MS.

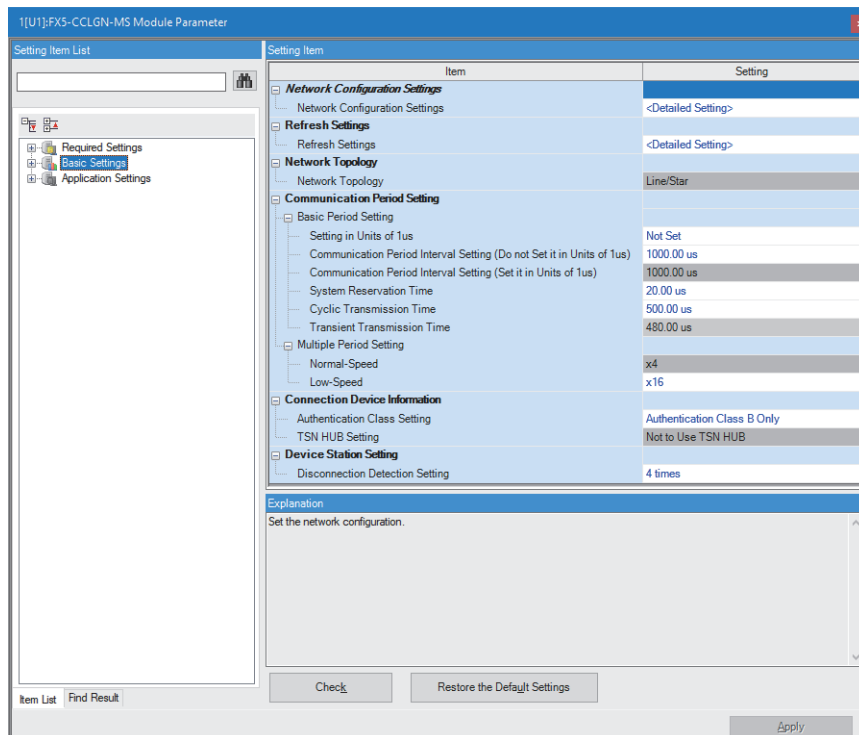

In this manual, "Authentication Class" is described as "CC-Link IE TSN Class".

○: Can be set, ×: Cannot be set

Item	Description	Availability		Reference
		Master station	Local station	
Network Configuration Settings	Set the parameters of device stations (the number of points and assignment of link devices) in the master station.	○	×	Page 137 "CC-Link IE TSN Configuration" Window
Refresh Settings	Assign link refresh ranges between the following devices. • SB, SW, link devices (RX, RY, RWr, RWw) of the FX5-CCLGN-MS ↔ Devices of the FX5 CPU module	○	○	Page 130 Refresh settings
Network Topology	Select the network topology type according to the actual network configuration.	○	×	Page 132 Network Topology
Communication Period Setting	Perform basic cycle setting and multiple cycle setting.	○	×	Page 132 Communication Period Setting
Connection Device Information	Set the CC-Link IE TSN Class of connected devices.	○	×	Page 133 Connection Device Information
Device Station Setting	Set the number of consecutive communication failures until a device station is considered disconnected.	○	×	Page 133 Device Station Setting

Refresh settings

Assign link refresh ranges between the following devices.

- SB, SW, link devices (RX, RY, RWr, RWw) of the FX5-CCLGN-MS ↔ Devices of the FX5 CPU module

Setting method

The procedure for the refresh settings is as follows.

1. Set the required items.
2. Click the [Apply] button to finish "Refresh Settings".

Setting items

The setting items for the refresh settings are as follows.

No.	Link Side					CPU Side				
	Device Name	Points	Start	End		Target	Device Name	Points	Start	End
-	SB				↔					
-	SW				↔					
1					↔					
2					↔					

Item	Description	Setting range																																																												
		For master stations	For local stations																																																											
Device Assignment Method	Right-click in the setting window and select a link device assignment method from the "Device Assignment Method" menu. <ul style="list-style-type: none"> • Start/End: Enter the start and end numbers of link devices. • Points/Start: Enter the numbers of points and start numbers of link devices. 	<ul style="list-style-type: none"> • Start/End • Points/Start (Default: Start/End) 																																																												
—	Link Side Set the link refresh ranges of SB and SW. One link refresh range can be set for each of SB and SW. (☞ Page 31 Link refresh) <div style="border: 1px dashed gray; padding: 5px; margin: 10px 0;"> Ex. <table border="1" style="width: 100%; border-collapse: collapse;"> <thead> <tr> <th rowspan="2">No.</th> <th colspan="4">Link Side</th> <th rowspan="2"></th> <th colspan="4">CPU Side</th> </tr> <tr> <th>Device Name</th> <th>Points</th> <th>Start</th> <th>End</th> <th>Target</th> <th>Device Name</th> <th>Points</th> <th>Start</th> <th>End</th> </tr> </thead> <tbody> <tr> <td>-</td> <td>SB</td> <td>512</td> <td>00000</td> <td>001FF</td> <td>↔</td> <td>Specify Device</td> <td>SB</td> <td>512</td> <td>00000</td> <td>001FF</td> </tr> <tr> <td>-</td> <td>SW</td> <td>512</td> <td>00000</td> <td>001FF</td> <td>↔</td> <td>Specify Device</td> <td>SW</td> <td>512</td> <td>00000</td> <td>001FF</td> </tr> </tbody> </table> </div> <div style="display: flex; justify-content: space-around; align-items: center;"> <div style="border: 1px dashed gray; padding: 5px; text-align: center;"> <table style="width: 100%; border-collapse: collapse;"> <tr><td style="width: 20px;">00000H</td><td style="width: 100px;">Device name (SB)</td><td style="width: 20px;">00000H</td></tr> <tr><td style="text-align: center;">⋮</td><td></td><td style="text-align: center;">⋮</td></tr> <tr><td style="text-align: center;">001FFH</td><td></td><td style="text-align: center;">001FFH</td></tr> </table> </div> <div style="font-size: 2em;">↔</div> <div style="border: 1px dashed gray; padding: 5px; text-align: center;"> <table style="width: 100%; border-collapse: collapse;"> <tr><td style="width: 20px;">00000H</td><td style="width: 100px;">Device name (SB)</td><td style="width: 20px;">00000H</td></tr> <tr><td style="text-align: center;">⋮</td><td></td><td style="text-align: center;">⋮</td></tr> <tr><td style="text-align: center;">001FFH</td><td></td><td style="text-align: center;">001FFH</td></tr> </table> </div> </div> <div style="display: flex; justify-content: space-around; align-items: center; margin-top: 10px;"> <div style="text-align: center;"> <p>FX5-CCLGN-MS</p> </div> <div style="text-align: center;"> <p>FX5 CPU module</p> </div> </div>	No.	Link Side					CPU Side				Device Name	Points	Start	End	Target	Device Name	Points	Start	End	-	SB	512	00000	001FF	↔	Specify Device	SB	512	00000	001FF	-	SW	512	00000	001FF	↔	Specify Device	SW	512	00000	001FF	00000H	Device name (SB)	00000H	⋮		⋮	001FFH		001FFH	00000H	Device name (SB)	00000H	⋮		⋮	001FFH		001FFH	<ul style="list-style-type: none"> ■ Device Name <ul style="list-style-type: none"> • SB (fixed) • SW (fixed) ■ Points <ul style="list-style-type: none"> • SB: 16 to 4096 (set in increments of 16 points) • SW: 1 to 4096 (Default: empty) ■ Start <ul style="list-style-type: none"> • SB: 0H to FF0H (set in increments of 16 points) • SW: 0H to FFFH (set in increments of 1 point) (Default: empty) ■ End <ul style="list-style-type: none"> • SB: FH to FFFH (set in increments of 16 points) • SW: 0H to FFFH (set in increments of 1 point) (Default: empty) ■ Target <ul style="list-style-type: none"> • Specify Device (Default: empty) ■ Device name <ul style="list-style-type: none"> • Specify Device (link side is SB): SB, M, L, B, D, R • Specify Device (link side is SW): SW, M, L, B, D, R (Default: empty) ■ Points, End <p>Displayed according to setting of "Start". (Default: empty)</p> ■ Start <p>Device range of FX5 CPU modules (Set bit devices in increments of 16 points and word devices in increments of 4 points.) (Default: empty)</p> 	
No.	Link Side					CPU Side																																																								
	Device Name	Points	Start	End		Target	Device Name	Points	Start	End																																																				
-	SB	512	00000	001FF	↔	Specify Device	SB	512	00000	001FF																																																				
-	SW	512	00000	001FF	↔	Specify Device	SW	512	00000	001FF																																																				
00000H	Device name (SB)	00000H																																																												
⋮		⋮																																																												
001FFH		001FFH																																																												
00000H	Device name (SB)	00000H																																																												
⋮		⋮																																																												
001FFH		001FFH																																																												

Item	Description	Setting range																																																										
		For master stations	For local stations																																																									
1 to 256	Link Side Set the link refresh ranges of RX, RY, RWr, and RWw. A maximum of 256 points can be set for the link refresh range of each. (☞ Page 31 Link refresh) <div style="border: 1px dashed gray; padding: 5px; margin-bottom: 10px;"> Ex. <table border="1" style="font-size: small; border-collapse: collapse;"> <thead> <tr> <th colspan="4">Link Side</th> <th colspan="4">CPU Side</th> </tr> <tr> <th>No.</th> <th>Device Name</th> <th>Points</th> <th>Start</th> <th>End</th> <th>Target</th> <th>Device Name</th> <th>Points</th> <th>Start</th> <th>End</th> </tr> </thead> <tbody> <tr> <td>1</td> <td>RX</td> <td>256</td> <td>00000</td> <td>000FF</td> <td>Specify Device</td> <td>X</td> <td>256</td> <td>1000</td> <td>1377</td> </tr> <tr> <td>2</td> <td>RY</td> <td>256</td> <td>00000</td> <td>000FF</td> <td>Specify Device</td> <td>Y</td> <td>256</td> <td>1000</td> <td>1377</td> </tr> <tr> <td>3</td> <td>RWr</td> <td>256</td> <td>00000</td> <td>000FF</td> <td>Specify Device</td> <td>W</td> <td>256</td> <td>00000</td> <td>000FF</td> </tr> <tr> <td>4</td> <td>RWw</td> <td>256</td> <td>00000</td> <td>000FF</td> <td>Specify Device</td> <td>W</td> <td>256</td> <td>00100</td> <td>001FF</td> </tr> </tbody> </table> </div>	Link Side				CPU Side				No.	Device Name	Points	Start	End	Target	Device Name	Points	Start	End	1	RX	256	00000	000FF	Specify Device	X	256	1000	1377	2	RY	256	00000	000FF	Specify Device	Y	256	1000	1377	3	RWr	256	00000	000FF	Specify Device	W	256	00000	000FF	4	RWw	256	00000	000FF	Specify Device	W	256	00100	001FF	<ul style="list-style-type: none"> ■ Device name <ul style="list-style-type: none"> • RX, RY, RWr, RWw (Default: empty) ■ Points <ul style="list-style-type: none"> • RX, RY: 16 to 8192 (set in increments of 16 points) • RWr, RWw: 4 to 4096 (set in increments of 4 points) (Default: empty) ■ Start <ul style="list-style-type: none"> • RX, RY: 0H to 1FF0H (set in increments of 16 points) • RWr, RWw: 0 to FFCH (set in increments of 4 points) (Default: empty) ■ End <ul style="list-style-type: none"> • RX, RY: FH to 1FFFH (set in increments of 16 points) • RWr, RWw: 3H to FFFH (set in increments of 4 points) (Default: empty) ■ Target <ul style="list-style-type: none"> • Specify Device (Default: empty) ■ Device name <ul style="list-style-type: none"> • Specify Device (link side is RX): X, M, L, B, D, W, R • Specify Device (link side is RY): Y, M, L, B, D, W, R • Specify Device (link side is RWr, RWw): M, L, B, D, W, R (Default: empty) ■ Points, End Displayed according to setting of "Start". (Default: empty) ■ Start Device range of FX5 CPU modules (Set bit devices in increments of 16 points and word devices in increments of 4 points.) (Default: empty)
	Link Side				CPU Side																																																							
No.	Device Name	Points	Start	End	Target	Device Name	Points	Start	End																																																			
1	RX	256	00000	000FF	Specify Device	X	256	1000	1377																																																			
2	RY	256	00000	000FF	Specify Device	Y	256	1000	1377																																																			
3	RWr	256	00000	000FF	Specify Device	W	256	00000	000FF																																																			
4	RWw	256	00000	000FF	Specify Device	W	256	00100	001FF																																																			
CPU Side	 FX5-CCLGN-MS FX5 CPU module																																																											

Precautions

■ Device set to "CPU Side"

Set a device range not to overlap the one used for the following:

- "Refresh settings" of intelligent function modules

■ Link refresh range

Set only link devices used in the FX5 CPU module for link refresh range. Doing so will reduce the number of excess points, resulting in a shorter link refresh time.



Network Topology

Select the network topology type according to the actual network configuration.

Setting is not required and can be left as "Line/Star" (default).

Communication Period Setting

Perform basic cycle setting and multiple cycle setting.

- Basic cycle setting requires calculation of the communication cycle interval and cyclic transmission time. ( Page 262 Communication cycle intervals)
- Multiple cycle setting is used when communication cycles coexist. ( Page 38 Communication cycle coexistence)

Item	Description	Setting range
Basic Period Setting	Setting in Units of 1 μ s	Select whether to set the basic cycle in increments of 1 μ s. <ul style="list-style-type: none"> • Set • Do Not set (Default: Do Not set)
	Communication Period Interval Setting (Do Not Set it in Units of 1 μ s)	Input a communication cycle interval. <ul style="list-style-type: none"> • 250.00μs • 500.00μs • 1000.00μs • 2000.00μs • 4000.00μs • 8000.00μs (Default: 1000.00 μ s)
	Communication Period Interval Setting (Set it in Units of 1 μ s)	Input a communication cycle interval. 250.00 μ s to 10000.00 μ s (in increments of 1 μ s) (Default: 1000.00 μ s)
	System Reservation Time	Necessary time for the system to guarantee the communication cycle interval. <ul style="list-style-type: none"> • 20.00μs • 200.00μs (Default: 20.00 μ s)
	Cyclic Transmission Time	Of communication cycle intervals, set the time to be allocated to cyclic transmission. 5.00 μ s to 9966.00 μ s (in increments 1 μ s) (Default: 500.00 μ s)
	Transient Transmission Time	The value of "Communication Period Interval Setting" minus "Cyclic Transmission Time" and "System Reservation Time" is displayed. 14.00 μ s to 9975.00 μ s (in increments of 1 μ s) (Default: 480.00 μ s)
Multiple Cycle Setting	Normal-Speed	Select the "Normal-Speed" cycle for a basic cycle. Setting is not required and can be left as "x4". (Default: x4)
	Low-Speed	Select the "Low-Speed" cycle for a basic cycle. <ul style="list-style-type: none"> • x16 • x32 • x64 • x128 (Default: x16)

Point

When the industrial switch (for CC-Link IE TSN Class B) is used, set the timeslot information from the setting values in "Basic Period Setting".

The timeslot information can be checked with the buffer memory. ( Page 234 Timeslot information)

Connection Device Information

Set the information of the connected device.

Item	Description	Setting range
CC-Link IE TSN Class Setting	Sets the CC-Link IE TSN Class of connected devices.	<ul style="list-style-type: none">• CC-Link IE TSN Class B Only• Mixture of CC-Link IE TSN Class B/A or CC-Link IE TSN Class A Only (Default: CC-Link IE TSN Class B Only)
TSN HUB Setting	Sets whether to use an industrial switch (for CC-Link IE TSN Class B).	<ul style="list-style-type: none">• Not to Use TSN HUB• Use TSN HUB (Default: Not to Use TSN HUB)

Precautions

- To connect an industrial switch (for CC-Link IE TSN Class B) to the structure of a mixture of CC-Link IE TSN Class B and CC-Link IE TSN Class A devices, set "TSN HUB Setting" to "Use TSN HUB".
- If an industrial switch (for CC-Link IE TSN Class B) is connected with "TSN HUB Setting" set to "Not to Use TSN HUB", device stations may not perform data link.
- If an industrial switch (for CC-Link IE TSN Class B) is used for connection in a star topology with "TSN HUB Setting" set to "Not to Use TSN HUB", device stations connected to the industrial switch (for CC-Link IE TSN Class B) do not perform data link. Also, a connection configuration error (error code: 1806H) occurs in the master station.

Device Station Setting

Set items related to the device station.

Item	Description	Setting range
Disconnection Detection Setting	Set the number of consecutive communication failures until a device station is considered disconnected.	<ul style="list-style-type: none">• 2 times• 4 times• 8 times (Default: 4 times)

Precautions

The disconnection detection setting does not necessarily guarantee that the disconnection is performed according to the number of times set. When disconnection is detected, a bit of the disconnected station in 'Data link status of each station' (SW00B0 to SW00B7) turns on. However, the time required this may be at least four times the time required for the number of consecutive communication failures set in the disconnection detection setting.

7.4 Application Settings

Set the supplementary cyclic settings, transient transmission group number, and other settings for the FX5-CCLGN-MS.

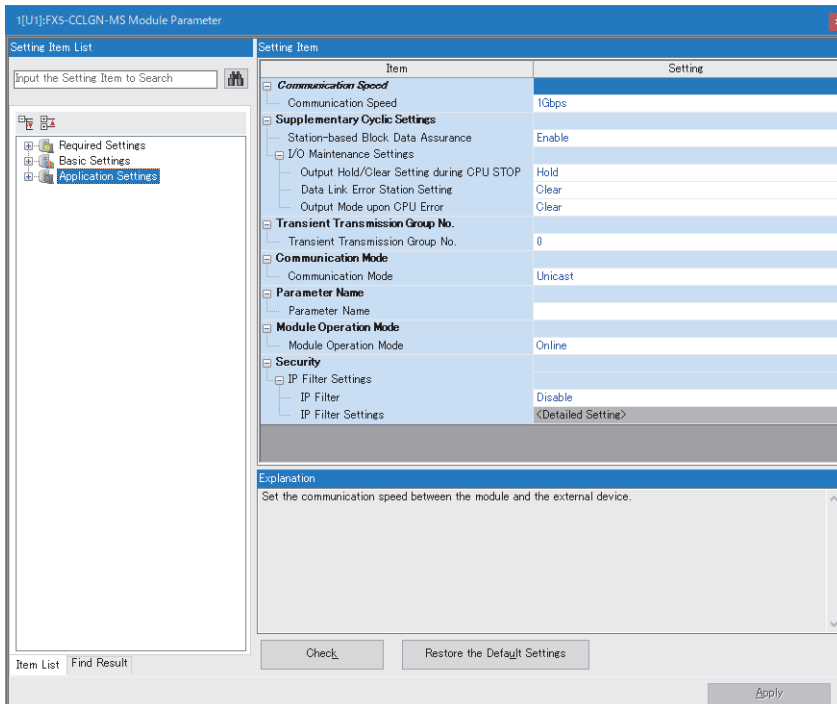

Item	Description	Reference
Communication Speed	Set the communication speed.	Page 134 Communication Speed
Supplementary Cyclic Settings	Set the station-based block data assurance and I/O maintenance settings.	Page 135 Supplementary Cyclic Settings
Transient Transmission Group No.	Set the transient function.	Page 135 Transient Transmission Group No.
Communication Mode	Set the communication mode.	Page 135 Communication Mode
Parameter Name	Set a name for the module parameter if desired.	Page 135 Parameter Name
Module Operation Mode	Set the mode for the FX5-CCLGN-MS.	Page 136 Module Operation Mode
Security	Set the security measures for access to the Ethernet device.	Page 136 Security

Communication Speed

Set the communication speed.

Item	Description	Setting range
Communication Speed	Select the communication speed.	<ul style="list-style-type: none"> 1Gbps 100Mbps (Default: 1Gbps)

For details on the connection of modules or devices based on the communication speed setting, refer to the following.

☞ Page 60 SYSTEM CONFIGURATION

Supplementary Cyclic Settings

Set the station-based block data assurance and I/O maintenance settings.

Item	Description	Setting range
Station-based Block Data Assurance	Select whether to ensure data integrity of the data blocks being refreshed between the FX5 CPU module and the FX5-CCLGN-MS. (Page 33 Cyclic data assurance)	<ul style="list-style-type: none"> • Enable • Disable (Default: Enable)
I/O Maintenance Settings	Output Hold/Clear Setting during CPU STOP	Select whether cyclic data output is held or cleared when the FX5 CPU module mounted with the FX5-CCLGN-MS is set to the STOP state. (Page 39 I/O maintenance settings)
	Data Link Error Station Setting	Select whether input data from the master station is held or cleared when a data link error occurs. (Page 39 I/O maintenance settings)
	Output Mode upon CPU Error	Select whether cyclic transmission output data is held or cleared when a stop error occurs in the FX5 CPU module mounted with the FX5-CCLGN-MS. (Page 39 I/O maintenance settings)

Transient Transmission Group No.

Set the transient transmission group number.

Item	Description	Setting range
Transient Transmission Group No.	Set the group number to perform transient transmission using group specification.	0 to 32 (0: No group specification) (Default: 0)

Communication Mode

Set the communication mode.

Item	Description	Setting range
Communication Mode	Set the communication mode.	<ul style="list-style-type: none"> • Unicast • Multicast (Default: Unicast)

Parameter Name

Set a name for the module parameter if desired.

Item	Description	Setting range
Parameter Name	Set a name for the module parameter if desired.	Up to 8 one-byte or two-byte characters (Default: empty)

Module Operation Mode

Set the mode for the FX5-CCLGN-MS.

For details on the module communication test mode, refer to the following.

 Page 179 Module communication test

Item	Description	Setting range
Module Operation Mode	<p>Online</p> <ul style="list-style-type: none"> Select this mode to connect the FX5-CCLGN-MS to the network for performing data link with other stations. <p>Offline</p> <ul style="list-style-type: none"> Select this mode to disconnect the FX5-CCLGN-MS from the network and not perform data link with other stations. <p>Module Communication Test</p> <ul style="list-style-type: none"> Select this mode to check the hardware of the FX5-CCLGN-MS. Select this mode to check the module hardware when communications are unstable. 	<ul style="list-style-type: none"> Online Offline Module Communication Test (Default: Online)

Restriction

The following functions are disabled when "Module Operation Mode" is set to "Offline" or "Module Communication Test". ( Page 22 FUNCTIONS)

- Cyclic transmission
- Transient transmission
- RAS
- Interrupt request to CPU module

In line topology, data link is not performed for stations connected after a station in offline mode.

Security

Set the security measures for access to the Ethernet device.

Item	Description	Setting range
IP Filter Settings	IP Filter	Set whether to use the IP filter. <ul style="list-style-type: none"> • Do Not Use • Use (Default: Do Not Use)
	IP Filter Settings	Set the IP addresses to be allowed or denied. —

IP Filter Settings

Up to 32 IP addresses can be set as an IP address to be allowed or denied by the IP filter.

Range specification as a single setting and specification of the IP addresses to be excluded from the set range are also possible.

Item	Description	Setting range
Access from IP address below	Select whether to allow or deny the access from the specified IP addresses.	<ul style="list-style-type: none"> • Allow • Deny (Default: Allow)
Range Setting	Select this item when specifying the IP addresses by range.	(Default: Clear)
IP Address	Set the IP addresses to be allowed or denied. When selecting "Range Setting", enter the start IP address (left field) and end IP address (right field) of the range.	0.0.0.1 to 223.255.255.254 (Default: empty)
IP Address Excluded from Range	When selecting "Range Setting", set the IP address to be excluded from the set range. Up to 32 IP addresses can be set.	0.0.0.1 to 223.255.255.254 (Default: empty)

7.5 "CC-Link IE TSN Configuration" Window

Perform the parameter setting of device stations, the detection of connected/disconnected devices, or others.

- [Navigation window] ⇒ [Parameter] ⇒ [Module Information] ⇒ Target module ⇒ [Module Parameter] ⇒ [Basic Settings] ⇒ [Network Configuration Settings]

Parameter setting of a device station

Set parameters of device stations (the number of points and assignment of link devices) in the master station.

1. Select the module in "Module List" and drag it to the list of stations or the network map.

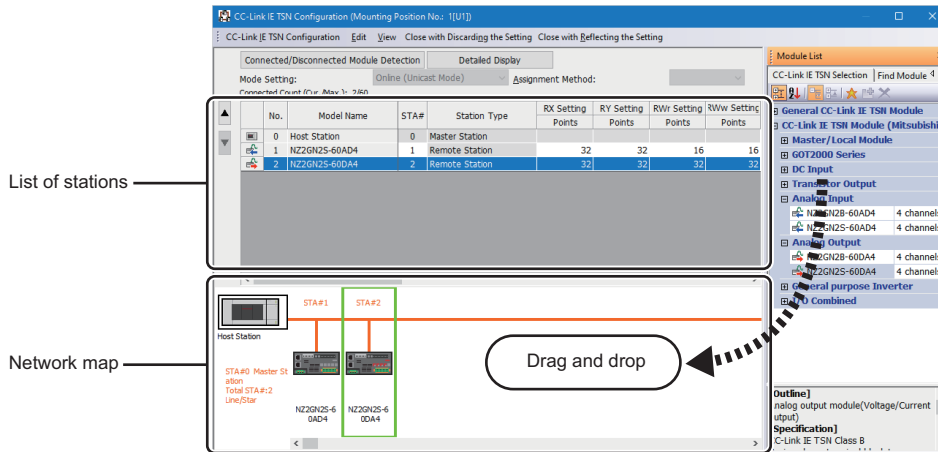

2. Set the required items.
3. Select [Close with Reflecting the Setting] and close the "CC-Link IE TSN Configuration" window.

Setting items

- Simple Display: Click the [Simple Display] button to display a narrow portion of items. Use for operation with default settings or the minimum required settings. (Default)
- Detailed Display: Click the [Detailed display] button to display all items.

Simple display	Detailed display	Description	Setting range
—	Assignment Method	Select a link device assignment method. • Points/Start: Enter the numbers of points and start numbers of link devices. • Start/End: Enter the start and end numbers of link devices.	• Points/Start • Start/End (Default: Points/Start)
No.		The total number of device stations set in the "CC-Link IE TSN Configuration" window is displayed.	—
Model Name		The module model name is displayed. To set a module where the profile is not registered, select it from the "General CC-Link IE TSN Module" list or register the profile before setting the model name. For how to register a profile, refer to the following. GX Works3 Operating Manual	—
STA#		Enter the station number of each device station connected to the network. Station numbers do not need to be set consecutively, but must be unique.	• Master station: Fixed to "0" • Device station: 1 to 120 (Default: Serial number of added stations)
Station Type		Set the station types. Select the station types same as those of the modules connected to the network.	• Master Station • Local Station • Remote Station (Default: Varies depending on the set module)
RX Setting		Assign RX/Ry points in increments of 16. (Page 26 Communications)	• Number of points: 16 to 8192
RY Setting		Modules with settings provided by profile are automatically set from selected models. (Excluding modules with a number of points that is not fixed)	• Start: 0H to 1FFFH • End: FH to 1FFFFH (Default: Varies depending on the set module)

Simple display	Detailed display	Description	Setting range
RWw Setting		Assign RWw/RWr points in increments of 4. (☞ Page 26 Communications using RX, RY, RWr, and RWw)	<ul style="list-style-type: none"> Number of points: 4 to 4096 Start: 0H to FFCH End: 3H to FFFH (Default: Varies depending on the set module)
RWr Setting		Modules with settings provided by profile are automatically set from selected models. (Excluding modules with a number of points that is not fixed)	
Parameter Automatic Setting		Set whether to set the parameters of each device station automatically. This cannot be set for extension modules. However, the parameter automatic setting of extension modules is interlocked with the settings of the connected main module.	<ul style="list-style-type: none"> Check: Distribute parameters Do Not check: Do not distribute parameters (Default: Do Not check)
IP Address		Set the IP address of a station that performs cyclic transmission.	0.0.0.1 to 223.255.255.254 (Default: The first to third octets have the same values as the master station, the fourth octet has a serial number from 1 to 254)
Subnet Mask		Set a subnet mask to identify a network address. Set the same value for the master station and device station. Even if a device station has a different subnet mask from the master station, it does not result in an input error. If 255.255.255.255 is set, leave it empty.	<ul style="list-style-type: none"> 0.0.0.1 to 255.255.255.255 Empty (Default: The same value if there is a master station)
Default Gateway		Set the default gateway address to connect to the external network.	<ul style="list-style-type: none"> 0.0.0.1 to 223.255.255.254 Empty (Default: empty)
Reserved/Error Invalid Station		Set the device station as a reserved station or error invalid station. <ul style="list-style-type: none"> No Setting: The device station is connected to the network. Reserved Station: The device station is reserved in the parameters for future expansion. By using a reserved station, link device assignment will not change even if the device station is added (reservation is canceled). Therefore, modification of the program is not required. Physical connection of the device station on the network is not required. Error Invalid Station: Even if a device station is disconnected during data link, the master station will not detect the device station as a faulty station. 	<ul style="list-style-type: none"> No Setting Reserved Station Error Invalid Station (Default: No setting, master station is fixed as empty)
Communication Period Setting		When multiple communication cycles are set, set the cycle of each device station. (☞ Page 38 Communication cycle coexistence)	<ul style="list-style-type: none"> Basic Period Normal-Speed Low-Speed (Default: Basic cycle, master station is fixed as empty)
CC-Link IE TSN Class Setting		Set the CC-Link IE TSN Class of the device for each device station.	<ul style="list-style-type: none"> CC-Link IE TSN Class B CC-Link IE TSN Class A (Default: Varies depending on the device)
Station Information	■Alias Enter the name of a device if required. The name entered is displayed in "Network Status" of the "CC-Link IE TSN/CC-Link IE Field Diagnostics" window. For the extension module of the remote station, the name is not displayed in the "CC-Link IE TSN/CC-Link IE Field Diagnostics" window, even if entered.	Up to 32 one-byte characters (one-byte or two-byte) (Default: empty)	
	■Comment Information entered in "Comment1" on the "Properties" window displayed by right-clicking the module in the list of stations or the network map is displayed.	Up to 32 one-byte characters (one-byte or two-byte) (Default: empty)	
	■Station-specific mode setting Set the station-specific mode of the device station. (Only when the device station supports the station-specific mode)	The setting varies depending on the set module.	

Point 

Because a portion of the setting items are not displayed in simple display, when there are deficiencies in setting items that are not displayed, the "Output" window may display a warning or error by selecting [Close with Reflecting the Setting].

If a warning is displayed, switch to detailed display and correct the items.

Connected/Disconnected module detection

This function detects connected device stations, and displays the stations on the "CC-Link IE TSN Configuration" window.

1. Click the [Connected/Disconnected Module Detection] button.
2. When the [Execute] button is clicked according to the instruction on the window, connected device stations are detected and displayed on the "CC-Link IE TSN Configuration" window.

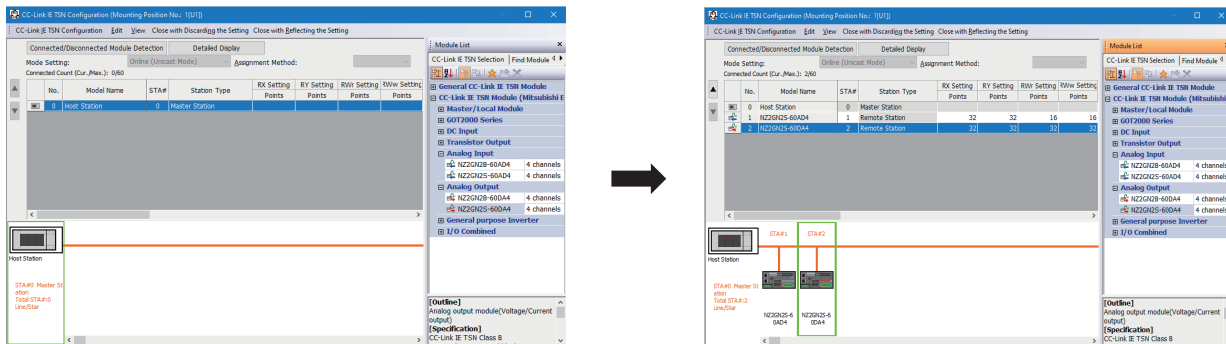

3. Check items in the list of stations and change them as necessary. (☞ Page 137 Setting items)
4. Select [Close with Reflecting the Setting] and close the "CC-Link IE TSN Configuration" window.

Point

Detection of connected/disconnected devices cannot be executed in the following cases.

- The FX5-CCLGN-MS is not in online mode. (☞ Page 136 Module Operation Mode)
- The actual system configuration is incorrect. (Such as IP address duplication)
- The master station does not perform data link.

Connection/Disconnection/Replacement

When the [Connected/Disconnected Module Detection] button is clicked while the saved CC-Link IE TSN structure is displayed, IP addresses of detected device stations are compared with the saved IP addresses of device stations and displayed as follows by connection/disconnection/replacement.

IP address verification result	Operation	Display	When station numbers of detected device stations are not set
Detected device stations are in the saved CC-Link IE TSN structure.	Replace	When parameters between a detected device station and a saved CC-Link IE TSN structure mismatch, the parameters are replaced with the parameters of the detected device station. When the model name, model version, and station type are mismatched, the following settings are inherited. <ul style="list-style-type: none"> • "RX Setting", "RY Setting", "RWr Setting", "RWw Setting" • "IP Address" of the master station • "Subnet Mask" • "Default Gateway" • "Reserved/Error Invalid Station" (however, if "Reserved Station" is set, the setting will change to the default.) • "Network Synchronous Communication" • "Communication Period Setting" If only the station number is mismatched, only the station number is reflected, and all the settings are inherited. (However, if the station number of the detected device has not been set, the station number of the device before replacement is inherited.)	The station number takes over the station number of the saved CC-Link IE TSN structure.
Device stations in the saved CC-Link IE TSN structure are not detected.	Disconnect	<ul style="list-style-type: none"> • Modules other than extension modules: Setting of "Reserved/Error Invalid Station" is changed to "Reserved Station". • Extension modules: Are deleted. 	—

IP address verification result	Operation	Display	When station numbers of detected device stations are not set
Detected device stations are not in the saved CC-Link IE TSN structure.	Connect	Detected device stations are added. (Settings other than "IP Address", "STA#", and "Station Type" are default) When adding a device, the defaults other than IP address, station number, and station type are set. (However, if the station number of the detected device has not been set, the station number is also set to the default.) Added device stations are displayed in the list of stations in the following order. <ul style="list-style-type: none"> • Modules other than extension modules: In the order of IP addresses, following disconnected device stations. • Extension modules: In the order of sub-IDs, following connected main modules and extension modules. 	A station number is automatically numbered as the lowest unused station number in the range from 1 to 120. The order of automatic numbering is the same as the displayed order in the list of stations (see left).

Precautions

In the CC-Link IE TSN structure, when a station number is set to a device station and parameters are written to the FX5 CPU module, the station number of the device station is held in the master station. When parameters are not to be written in FX5 CPU modules, they are saved in the CC-Link IE TSN structure as device stations with the station number not set.

Point

Register the profile of the target device to detect in advance.

If the profile is not registered, the following may be displayed.

- "Model Name" is "General Remote Station", "General Local Station", or "General Extension Module".
- "Station Type" is "Remote Station", "Local Station", or "Extension Module".

For how to register a profile, refer to the following.

 GX Works3 Operating Manual

Restriction

- Even when the profile is registered, if modules that are not available for detection of connected/disconnected devices are used, "Model Name" and "Station Type" are not displayed correctly.
- This function is not available for local stations.
- Reserved stations or data link faulty stations cannot be detected by this function.
- If this function is executed when the device station has been disconnected after the master station was powered on, the setting of "Reserved Station/Error Invalid Station" does not change to "Reserved Station", but it becomes "No Setting".
- A module that cannot be used with FX5-CCLGN-MS, for example, a module with a safety communication function or a module that requires a CANopen profile, may be detected.
- Some of the devices cannot be detected at extension device stations.
- If automatic detection is executed while the CPU module is running, the programmable controller scan time may increase depending on the system configuration.

Parameter processing of a device station

This function reads and saves the parameters from the device station, and writes the saved parameters to the device station. Also, it automatically sets parameters of the device station from the master station. (☞ Page 59 Device station parameter automatic setting)

☞ [Navigation window] ⇒ [Parameter] ⇒ [Module Information] ⇒ Target module ⇒ [Basic Settings] ⇒ [Network Configuration Settings]

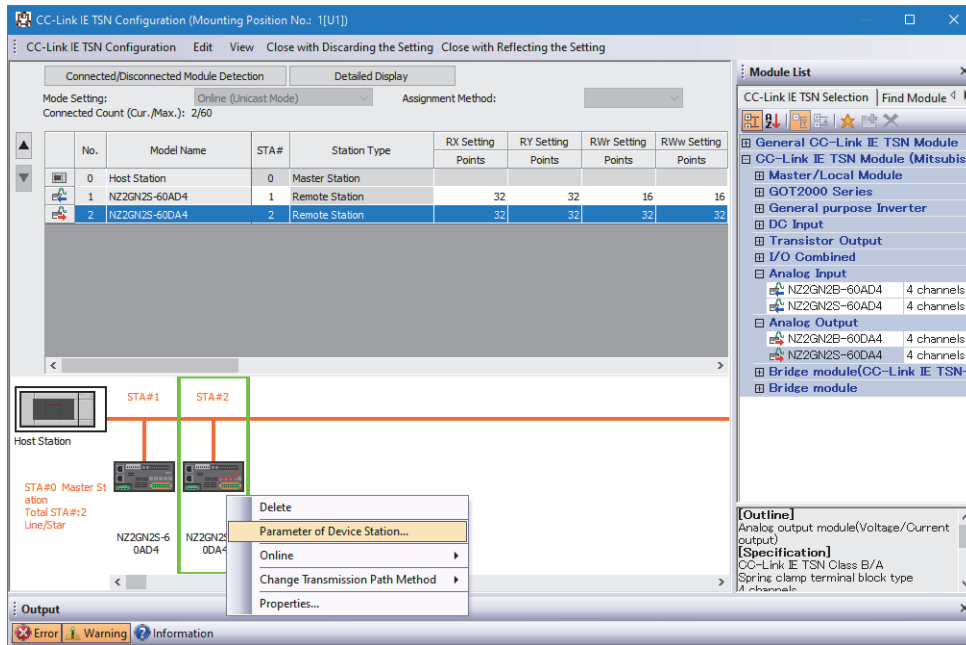

Select and right-click the device station, and select "Parameter of Device Station" to display the "Parameter of Device Station" window.

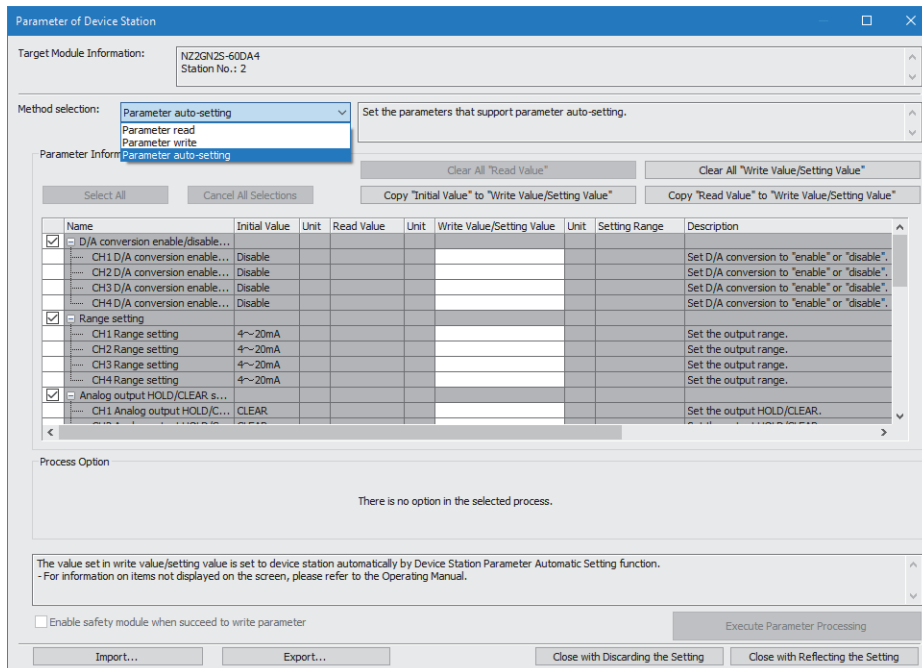

Item	Description
Target Module Information	Information for the selected device stations is displayed.
Method selection	<p>Select processing to be executed for selected device stations.</p> <ul style="list-style-type: none"> Parameter auto-setting: Automatically set contents of "Write Value/Setting Value" to the device station. (☞ Page 59 Device station parameter automatic setting) Parameter read: Read parameters from the selected device station. Parameter write: Write parameters to the selected device station.

Item		Description
Parameter Information	[Clear All "Read Value"] button	Click to clear all setting details that were read using "Parameter read".
	[Clear All "Write Value/Setting Value"] button	Click to clear all setting details that are written using "Parameter write".
Processing option		When there are options for processing selected by "Method Selection", setting items are displayed.
[Import] button		Read contents of parameter processing created in a CSV file.
[Export] button		Output contents of parameter processing set in this window to a CSV file.

Procedure for clearing a saved parameter

When returning the saved parameters of a not-required device station to the not-set status, perform the following procedure.

1. If the saved parameters are to be saved, output them in a CSV file using the [Export] button.
2. Delete not-required device stations from the list of stations.
3. Select the same module as the deleted device station in "Module List", and drag it to the list of stations or the network map.

Conditions for clearing a saved parameter

Saved parameters of a device station can be cleared under the following conditions.

When saved parameters are cleared, execute "Parameter auto-setting" or "Parameter read" in the "Parameter of Device Station" window and read the parameters of the device station.

Item	Operation	Description
"CC-Link IE TSN Configuration" window	Open the "CC-Link IE TSN Configuration" window.	When there is not a device station with the station number that matches saved parameters in the "CC-Link IE TSN Configuration" window, saved parameters of the relevant device station are skipped. Skipped parameters of the device station are cleared.
	Reflect setting and close the window.	Saved parameters of a device station that is not in the actual system configuration are cleared.
	Execute detection of connected/disconnected devices.	All saved parameters are cleared.
	Change the function version in the "Properties" window.	When the "Properties" window is closed, saved parameters are cleared.
"Parameter of Device Station" window	Open the "Parameter of Device Station" window.	Saved parameters that mismatch the relevant device station are skipped. Clicking the [Close with Reflecting the Setting] button in the above state clears the skipped saved parameters.
Module Parameter	Manually delete "Network Configuration Settings" to apply.	Parameters of "Network Configuration Settings" return to default.
	Change the "Setting Method of Basic/Application Settings" under "Parameter Setting Method" in "Required Settings" from "Parameter Editor" to "Program".	
	Change "Station Type" or set parameters that do not exist.	
System Parameter	Divert system parameters from another project.	Parameters of the device station are not diverted.
Module Configuration	Delete a module and check.	Parameters are deleted together with the module.
Navigation window	Delete a module.	
Read from PLC	Read module parameters that have a different network configuration and the same Intelligent module No.	Parameters are overwritten.
Navigation window	Import the data of a simple motion module to take network settings.	
MELSOFT Navigator	Reflect the parameter.	Saved parameters are cleared.

Command execution to device stations

This function executes commands (Error clear request, Error history clear request) to a device station.

[Navigation window] ⇒ [Parameter] ⇒ [Module Information] ⇒ Target module ⇒ [Basic Settings] ⇒ [Network Configuration Settings]

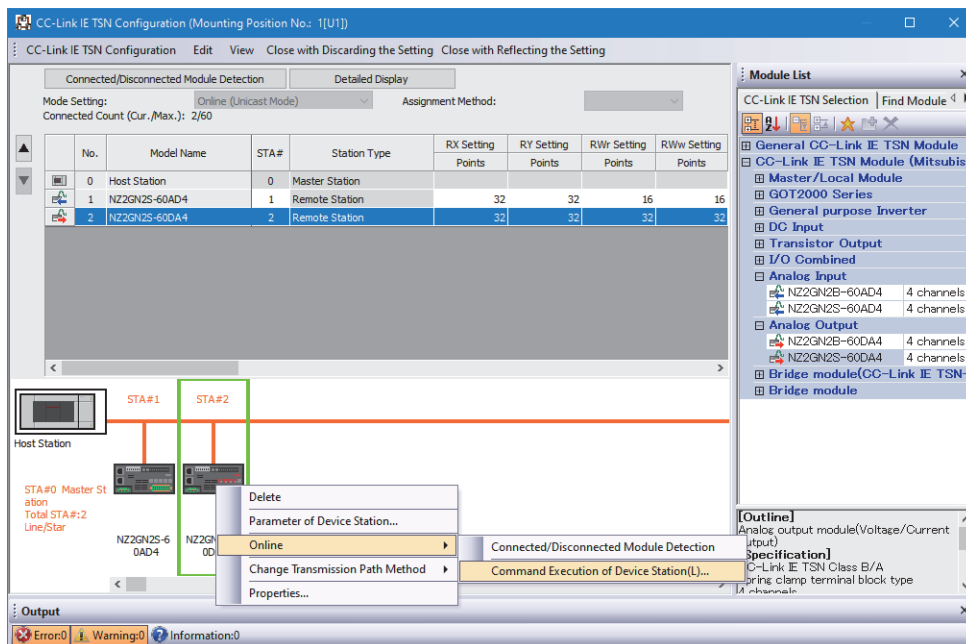

Select and right-click the device station, select "Command Execution of Device Station" from "Online" to display the "Command Execution of Device Station" window.

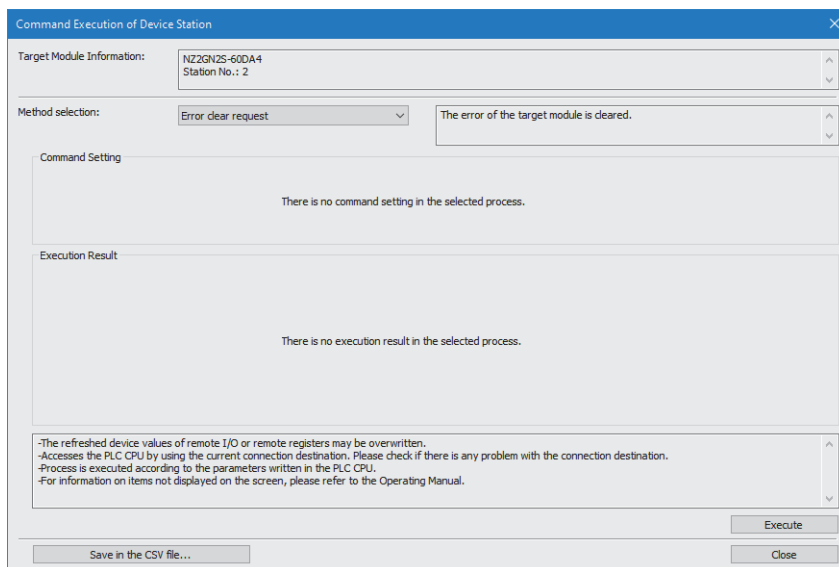

Item	Description
Target Module Information	Information for the selected device stations is displayed.
Method selection	Select processing to be executed for selected device stations. <ul style="list-style-type: none"> • Error clear request • Error history clear request
Command setting	When there are command settings for processing selected by "Method selection", setting items are displayed.
Execution Result	Execution results of the processing selected in "Method selection" are displayed.
[Save in the CSV file] button	Outputs the contents of this window to a CSV file.

8 DEDICATED INSTRUCTION

This chapter describes the transmission ranges and dedicated instructions that can be used in the FX5-CCLGN-MS.



For details on dedicated instructions, refer to the following.

MELSEC iQ-F FX5 Programming Manual (Instructions, Standard Functions/Function Blocks)

Link dedicated instructions

The following table lists the instructions used for transient transmission to or from programmable controllers on other stations.

■Instruction list

Instruction	Description
GP.READ	Reads the data from devices in the programmable controller of another station.
GP.SREAD	Reads the data from devices in the programmable controller of another station. For the GP.SREAD instruction, when the reading of the data is completed, another station's devices are turned on. Other stations can recognize that the data was read by GP.SREAD.
GP.WRITE	Writes the data to devices in the programmable controller of another station.
GP.SWRITE	Writes the data to devices in the programmable controller of another station. For the GP.SWRITE instruction, when the writing of the data is completed, another station's devices are turned on. Other stations can recognize that the data was written by GP.SWRITE.
GP.SEND	Sends data to the programmable controller of another station.
GP.RECV	Reads the data received from the programmable controller of another station.

■Transient transmission ranges

In a single network system, communication with all stations on the network is possible.

Other dedicated instructions

Set the parameter in the FX5-CCLGN-MS.

■Instruction list

Instruction	Description
G(P).UINI	Sets the station number and IP address in the FX5-CCLGN-MS.

8.1 Precautions for Dedicated Instructions

This section describes precautions when using dedicated instructions.

Precautions for dedicated instructions (common)

■When changing data specified by dedicated instructions

Do not change any data (such as control data) until execution of the dedicated instruction is completed.

■When the dedicated instruction is not completed

Check whether the mode of the FX5-CCLGN-MS is set to online.

A dedicated instruction cannot be executed when the mode is offline or module communication test.

Precautions for link dedicated instructions

The following describes precautions when executing multiple link dedicated instructions simultaneously.

■Channel of the link dedicated instructions

When executing multiple link dedicated instructions simultaneously, check that the channels for the instructions are not duplicated. Link dedicated instructions with the same channel number cannot be executed simultaneously. To use the same channel for multiple link dedicated instructions, configure an interlock so that an instruction is executed after completion of another.

■When link dedicated instructions are executed simultaneously

When link dedicated instructions are executed simultaneously, the subsequently requested instruction is skipped. When the instruction is skipped, the dedicated instruction skip flag (SM699) turns on.

9 PROGRAMMING

This chapter describes programming and startup examples of CC-Link IE TSN.

9.1 Precautions for Programming

This section describes precautions to create CC-Link IE TSN programs.

Cyclic transmission program

For a cyclic transmission program, configure an interlock with the following module labels (link special relay (SB), link special register (SW)).

- 'Data link error status of own station' (SB0049)
- 'Data link status of each station' (SW00B0 to SW00B7)

9.2 Communication Example Between the Master Station and Local Station

The following system configuration is used to explain communication between the master station and local station.

System configuration

- CPU module: FX5 CPU module
- Master/local module: FX5-CCLGN-MS (Intelligent module No.: 0000H to 001FH)

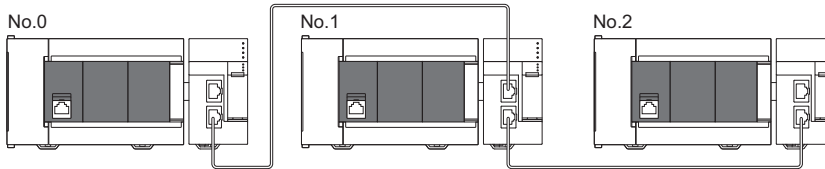

No.0: Master station (station No.0)
 No.1: Local station (station No.1)
 No.2: Local station (station No.2)

Link device assignment

For RX, RY, RWr, and RWw, 256 points are assigned to each station.

Unicast mode

■RX/RY assignment

Each of the following No.0 to No.2 represents a station number.

No.0 is master station, and No.1 and No.2 are local stations.

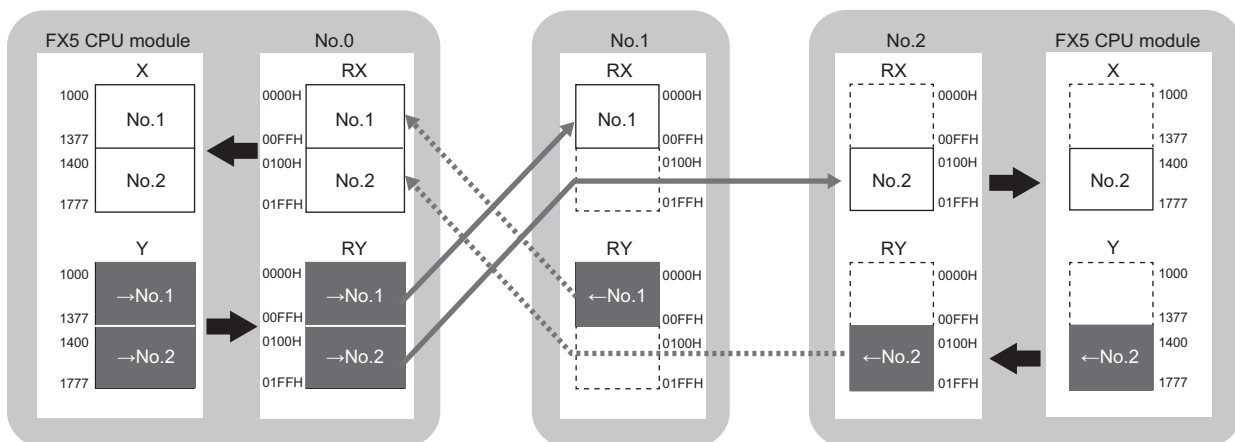

→No.1, →No.2: Send range: to station No.1, send range: to station No.2
 ←No.1, ←No.2: Send range: from station No.1, send range: from station No.2

■RWr/RWw assignment

Each of the following No.0 to No.2 represents a station number.

No.0 is master station, and No.1 and No.2 are local stations.

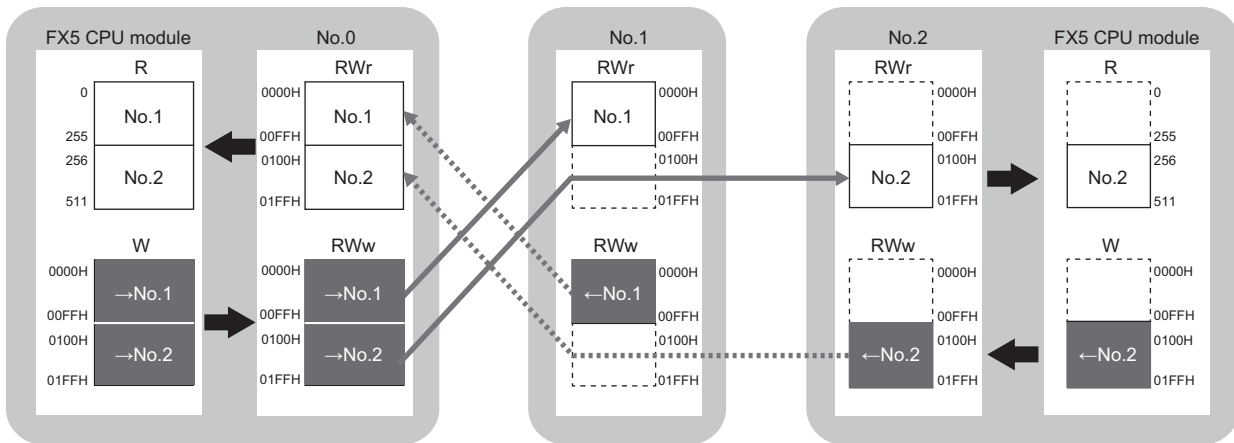

→No.1, →No.2: Send range: to station No.1, send range: to station No.2

←No.1, ←No.2: Send range: from station No.1, send range: from station No.2

Multicast mode

■RX/RX assignment

Each of the following No.0 to No.2 represents a station number.
No.0 is master station, and No.1 and No.2 are local stations.

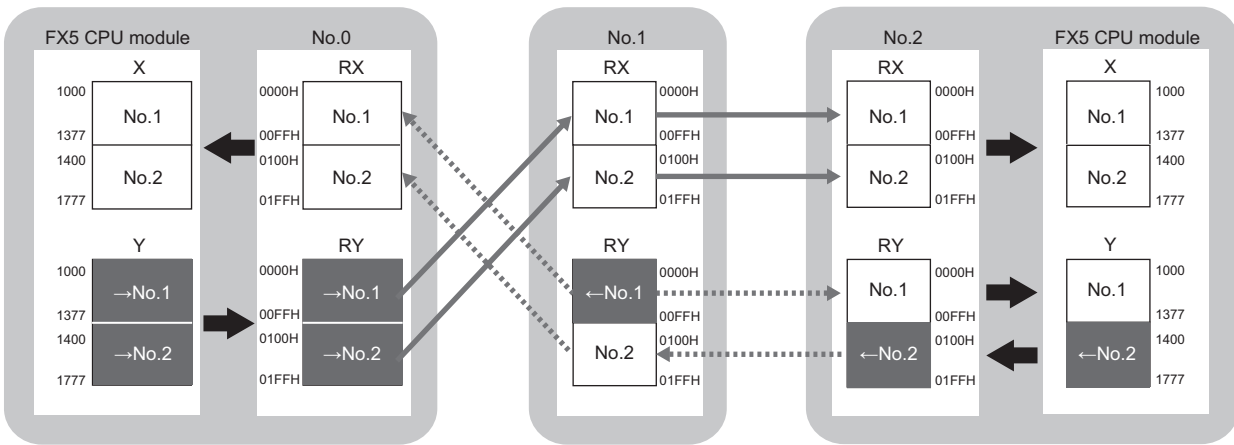

→No.1, →No.2: Send range: to station No.1, send range: to station No.2
←No.1, ←No.2: Send range: from station No.1, send range: from station No.2

■RWw/RWw assignment

Each of the following No.0 to No.2 represents a station number.
No.0 is master station, and No.1 and No.2 are local stations.

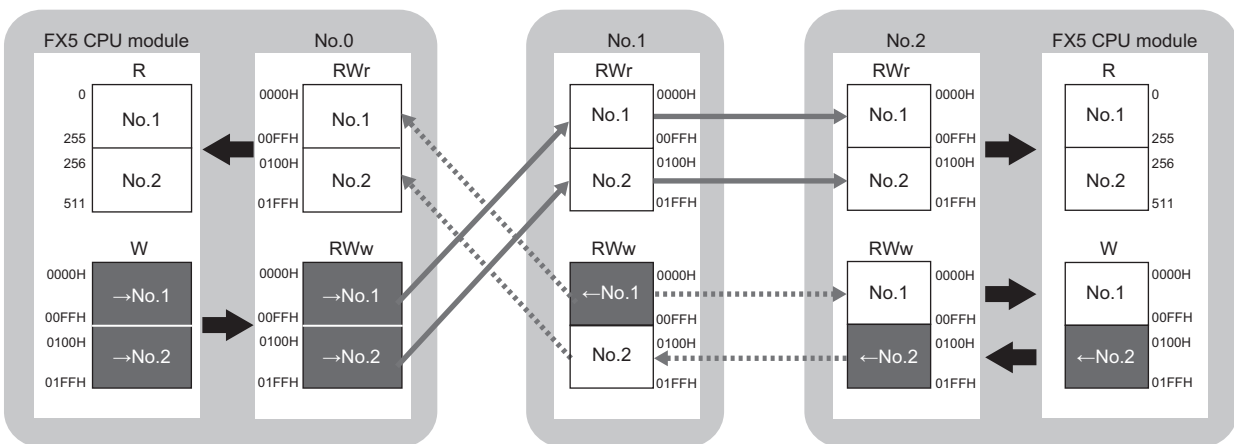

→No.1, →No.2: Send range: to station No.1, send range: to station No.2
←No.1, ←No.2: Send range: from station No.1, send range: from station No.2

Setting in the master station

Connect the engineering tool to the FX5 CPU module on the master station and set the parameters.

1. Set the FX5 CPU module as follows.

 [Project] ⇒ [New]

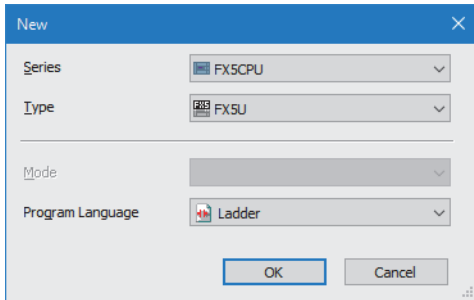

2. Click the [Setting Change] button to use the module label.

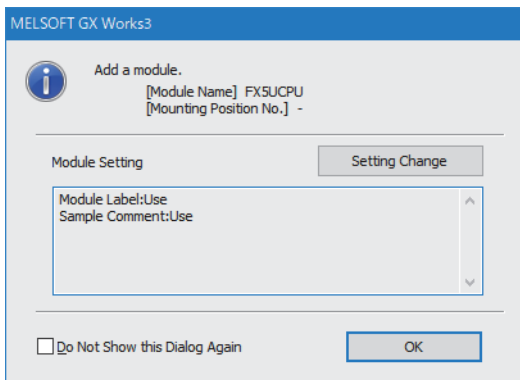

3. Set the FX5-CCLGN-MS as follows.

[Navigation window] ⇒ [Parameter] ⇒ [Module Information] ⇒ Right-click ⇒ [Add New Module]

4. Click the [OK] button to add a module label of the FX5-CCLGN-MS.

5. Set the items in "Required Settings" as follows.

[Navigation window] ⇒ [Parameter] ⇒ [Module Information] ⇒ [FX5-CCLGN-MS] ⇒ [Required Settings]

Item	Setting
Station Type	
Station Type	Master Station
Network No.	
Network No.	1
Parameter Setting Method	
Setting Method of Basic/Application Settings	Parameter Editor
Station No./IP Address Setting	
Station No./IP Address Setting Method	Parameter Editor
Station No.	
Station No.	0
IP Address	
IP Address	192.168.3.249
Subnet Mask	.
Default Gateway	.

6. Set the network configuration as follows. (Set the IP address for each station.)

[Navigation window] ⇒ [Parameter] ⇒ [Module Information] ⇒ [FX5-CCLGN-MS] ⇒ [Basic Settings] ⇒ [Network Configuration Settings]

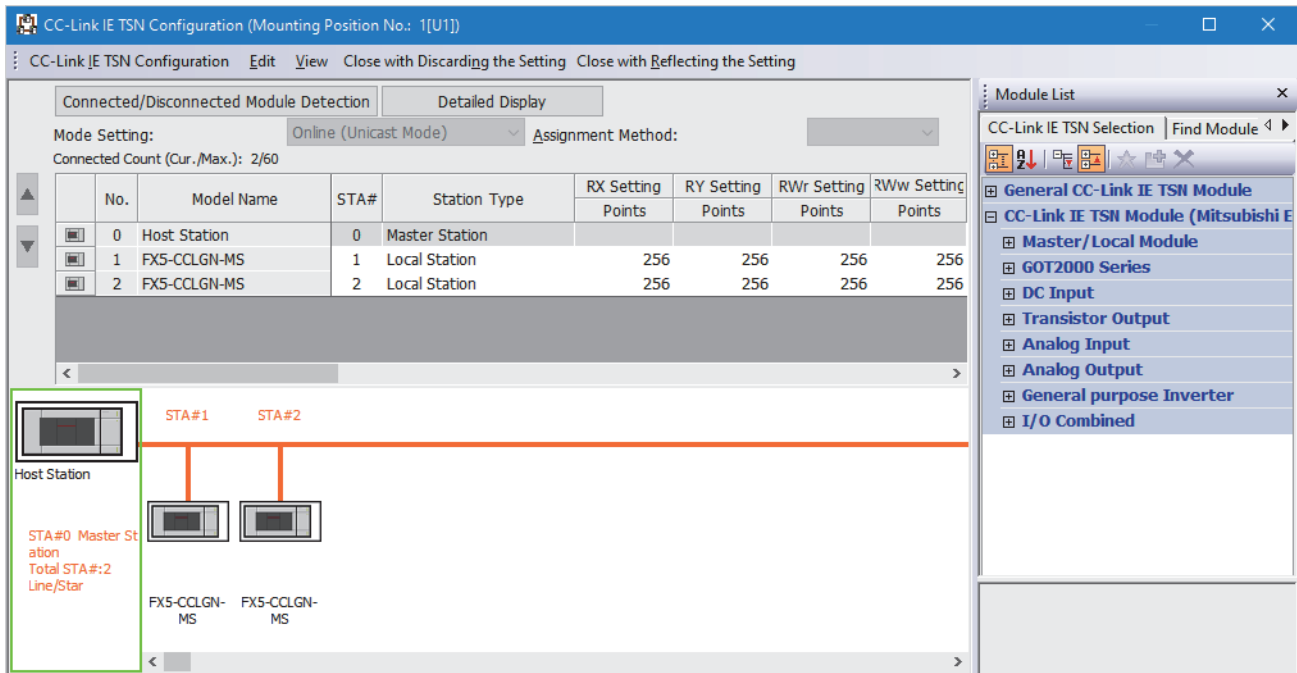

7. Click the [Close with Reflecting the Setting] button to close the "CC-Link IE TSN Configuration" window.

8. Set the refresh settings as follows.

[Navigation window] ⇒ [Parameter] ⇒ [Module Information] ⇒ [FX5-CCLGN-MS] ⇒ [Basic Settings] ⇒ [Refresh Settings]

No.	Link Side					CPU Side				
	Device Name	Points	Start	End		Target	Device Name	Points	Start	End
-	SB				↔					
-	SW				↔					
1	RX	512	00000	001FF	↔	Specify Device	X	512	1000	1777
2	RY	512	00000	001FF	↔	Specify Device	Y	512	1000	1777
3	RWw	512	00000	001FF	↔	Specify Device	W	512	00000	001FF
4	RWr	512	00000	001FF	↔	Specify Device	R	512	0	511

9. In "Communication Mode" under "Application Settings", set "Unicast" or "Multicast".

[Navigation window] ⇒ [Parameter] ⇒ [Module Information] ⇒ [FX5-CCLGN-MS] ⇒ [Application Settings] ⇒ [Communication Mode]

10. Click the [Apply] button.

11. Write the set parameters to the FX5 CPU module on the master station. Then, reset the FX5 CPU module or power off and on the system.

[Online] ⇒ [Write to PLC]

Point

In this example, default values are used for parameters that are not shown above. For the parameters, refer to the following.

☞ Page 126 PARAMETER SETTINGS

Settings in the local stations

Connect the engineering tool to the FX5 CPU module on the local station and set parameters. Set the same setting for station No.1 and station No.2.

1. Set the FX5 CPU module and add the module labels of the FX5 CPU module. The setting method of the FX5 CPU module and addition method of the module label are the same as those of the master station. (☞ Page 165 Setting in the master station)
2. Set the FX5-CCLGN-MS as follows.

☞ [Navigation window] ⇒ [Parameter] ⇒ [Module Information] ⇒ Right-click ⇒ [Add New Module]

Module Selection	
Module Type	Network Module
Model Name	FX5-CCLGN-MS
Station Type	Local Station
Advanced Settings	
Mounting Position	
Mounting Position No.	1
Intelligent Module No.	01 H
Serial Communication ch	-
Number of Input Points	-
Number of Output Points	-
Number of Output Points	
Select the number of output points.	

3. Add the module labels of the FX5-CCLGN-MS. The addition method of the module label is the same as that of the master station. (☞ Page 165 Setting in the master station)

4. Set the items in "Required Settings" as follows.

[Navigation window] ⇒ [Parameter] ⇒ [Module Information] ⇒ [FX5-CCLGN-MS] ⇒ [Required Settings]

- For station No.1

Item	Setting
Station Type	
Station Type	Local Station
Network No.	
Network No.	1
Parameter Setting Method	
Setting Method of Basic/Application Settings	Parameter Editor
Station No./IP Address Setting	
Station No./IP Address Setting Method	Parameter Editor
Station No.	
Station No.	1
IP Address	
IP Address	192.168.3.1
Subnet Mask	. . .
Default Gateway	. . .

- For station No.2

Item	Setting
Station Type	
Station Type	Local Station
Network No.	
Network No.	1
Parameter Setting Method	
Setting Method of Basic/Application Settings	Parameter Editor
Station No./IP Address Setting	
Station No./IP Address Setting Method	Parameter Editor
Station No.	
Station No.	2
IP Address	
IP Address	192.168.3.2
Subnet Mask	. . .
Default Gateway	. . .

5. Set the refresh settings as follows. Set the local stations with station No.1 and station No.2 to the same refresh settings.

[Navigation window] ⇒ [Parameter] ⇒ [Module Information] ⇒ [FX5-CCLGN-MS] ⇒ [Basic Settings] ⇒ [Refresh Settings]

No.	Link Side					CPU Side				
	Device Name	Points	Start	End		Target	Device Name	Points	Start	End
-	SB				↔					
-	SW				↔					
1	RX	512	00000	001FF	↔	Specify Device	X	512	1000	1777
2	RY	512	00000	001FF	↔	Specify Device	Y	512	1000	1777
3	RWw	512	00000	001FF	↔	Specify Device	W	512	00000	001FF
4	RWr	512	00000	001FF	↔	Specify Device	R	512	0	511

6. Click the [Apply] button.

7. Write the set parameters to the FX5 CPU module on the local station. Then, reset the FX5 CPU module or power off and on the system.

[Online] ⇒ [Write to PLC]

Point

In this example, default values are used for parameters that are not shown above. For the parameters, refer to the following.

☞ Page 126 PARAMETER SETTINGS

Checking the network status

Once parameters are set for the master station and local station, check whether data links between the master station and local station is normally operating. For the check, use the CC-Link IE TSN/CC-Link IE Field diagnostics of the engineering tool.

1. Connect the engineering tool to the FX5 CPU module on the master station.
2. Start the CC-Link IE TSN/CC-Link IE Field diagnostics.

 [Diagnostics] ⇒ [CC-Link IE TSN/CC-Link IE Field Diagnostics]

If the following display appears, a data link is normal.

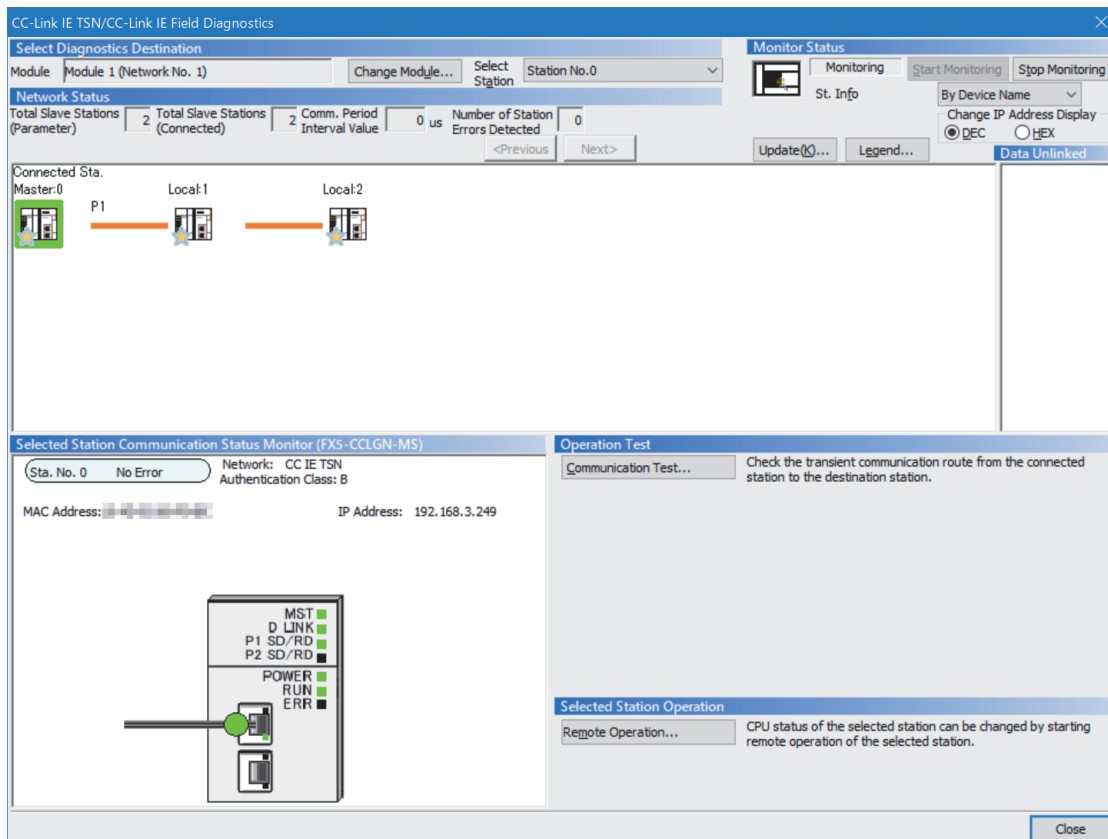

In this manual, "Authentication Class" is described as "CC-Link IE TSN Class".

If an error icon appears in "Network Status" area, use the CC-Link IE TSN/CC-Link IE Field diagnostics to identify the cause of the error and take corrective actions. ( Page 180 Checking the Network Status)

Program example (At unicast mode)

This section describes a program example when "Communication Mode" under "Application Settings" is set to "Unicast".

Master station (station No.0)

Classification	Label name	Description	Device																																				
Module label	FX5CCLGN_1.bSts_DataLinkError_D	Data link error status of own station	SB0049																																				
	FX5CCLGN_1.bnSts_DataLinkError_Station_D[1]	Data link status of each station (station No.1)	SW00B0.0																																				
	FX5CCLGN_1.bnSts_DataLinkError_Station_D[2]	Data link status of each station (station No.2)	SW00B0.1																																				
Label to be defined	Define global labels as shown below:																																						
	<table border="1"> <thead> <tr> <th></th> <th>Label Name</th> <th>Data Type</th> <th>Class</th> <th>Assign (Device/Label)</th> </tr> </thead> <tbody> <tr> <td>1</td> <td>bStartDirection_1</td> <td>Bit</td> <td>VAR_GLOBAL</td> <td>M0</td> </tr> <tr> <td>2</td> <td>bStartDirection_2</td> <td>Bit</td> <td>VAR_GLOBAL</td> <td>M1</td> </tr> <tr> <td>3</td> <td>wnSendDataStationNo1</td> <td>Word [Signed]</td> <td>VAR_GLOBAL</td> <td>R1 000</td> </tr> <tr> <td>4</td> <td>wnRecvDataStationNo1</td> <td>Word [Signed]</td> <td>VAR_GLOBAL</td> <td>R2 000</td> </tr> <tr> <td>5</td> <td>wnSendDataStationNo2</td> <td>Word [Signed]</td> <td>VAR_GLOBAL</td> <td>R1 300</td> </tr> <tr> <td>6</td> <td>wnRecvDataStationNo2</td> <td>Word [Signed]</td> <td>VAR_GLOBAL</td> <td>R2 300</td> </tr> </tbody> </table>					Label Name	Data Type	Class	Assign (Device/Label)	1	bStartDirection_1	Bit	VAR_GLOBAL	M0	2	bStartDirection_2	Bit	VAR_GLOBAL	M1	3	wnSendDataStationNo1	Word [Signed]	VAR_GLOBAL	R1 000	4	wnRecvDataStationNo1	Word [Signed]	VAR_GLOBAL	R2 000	5	wnSendDataStationNo2	Word [Signed]	VAR_GLOBAL	R1 300	6	wnRecvDataStationNo2	Word [Signed]	VAR_GLOBAL	R2 300
	Label Name	Data Type	Class	Assign (Device/Label)																																			
1	bStartDirection_1	Bit	VAR_GLOBAL	M0																																			
2	bStartDirection_2	Bit	VAR_GLOBAL	M1																																			
3	wnSendDataStationNo1	Word [Signed]	VAR_GLOBAL	R1 000																																			
4	wnRecvDataStationNo1	Word [Signed]	VAR_GLOBAL	R2 000																																			
5	wnSendDataStationNo2	Word [Signed]	VAR_GLOBAL	R1 300																																			
6	wnRecvDataStationNo2	Word [Signed]	VAR_GLOBAL	R2 300																																			

Master station (station No.0)

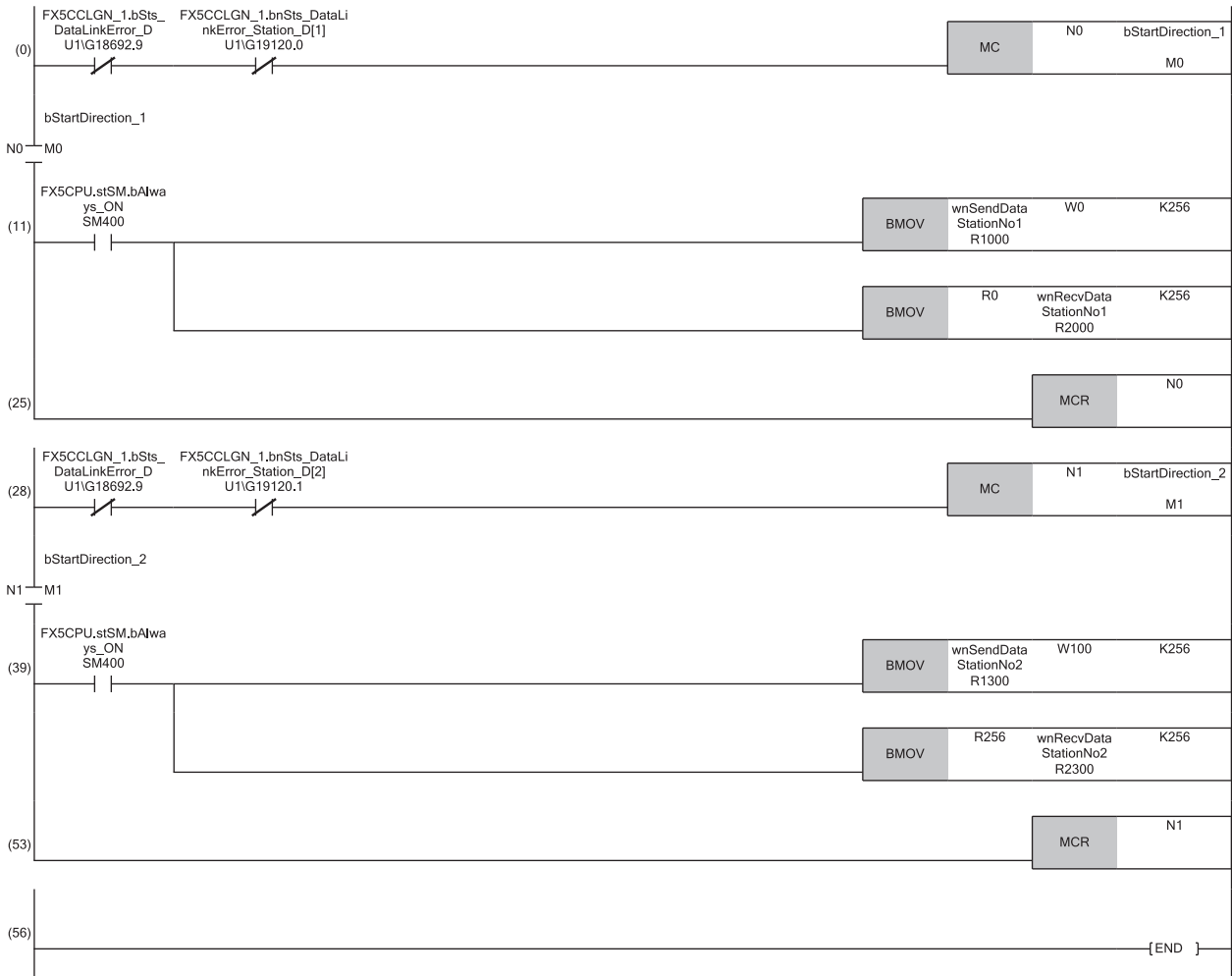

- (11) Communication program with the local station (station No.1)
- (39) Communication program with the local station (station No.2)



If no response is received for several cycles, 'Data link status of each station' (SW00B0 to SW00B7) is determined to be a cyclic transmission faulty station.

Local station (station No.1, station No.2)

Classification	Label name	Description	Device																				
Module label	FX5CCLGN_1.bSts_DataLinkError_D	Data link error status of own station	SB0049																				
Label to be defined	Define global labels as shown below:																						
	• Local station (station No.1)																						
	<table border="1"> <thead> <tr> <th></th> <th>Label Name</th> <th>Data Type</th> <th>Class</th> <th>Assign (Device/Label)</th> </tr> </thead> <tbody> <tr> <td>1</td> <td>bStartDirection</td> <td>Bit</td> <td>VAR_GLOBAL</td> <td>M0</td> </tr> <tr> <td>2</td> <td>wnSendDataMaster</td> <td>Word [Signed]</td> <td>VAR_GLOBAL</td> <td>R2000</td> </tr> <tr> <td>3</td> <td>wnRecvDataMaster</td> <td>Word [Signed]</td> <td>VAR_GLOBAL</td> <td>R1000</td> </tr> </tbody> </table>				Label Name	Data Type	Class	Assign (Device/Label)	1	bStartDirection	Bit	VAR_GLOBAL	M0	2	wnSendDataMaster	Word [Signed]	VAR_GLOBAL	R2000	3	wnRecvDataMaster	Word [Signed]	VAR_GLOBAL	R1000
	Label Name	Data Type	Class	Assign (Device/Label)																			
1	bStartDirection	Bit	VAR_GLOBAL	M0																			
2	wnSendDataMaster	Word [Signed]	VAR_GLOBAL	R2000																			
3	wnRecvDataMaster	Word [Signed]	VAR_GLOBAL	R1000																			
	• Local station (station No.2)																						
	<table border="1"> <thead> <tr> <th></th> <th>Label Name</th> <th>Data Type</th> <th>Class</th> <th>Assign (Device/Label)</th> </tr> </thead> <tbody> <tr> <td>1</td> <td>bStartDirection</td> <td>Bit</td> <td>VAR_GLOBAL</td> <td>M0</td> </tr> <tr> <td>2</td> <td>wnSendDataMaster</td> <td>Word [Signed]</td> <td>VAR_GLOBAL</td> <td>R2300</td> </tr> <tr> <td>3</td> <td>wnRecvDataMaster</td> <td>Word [Signed]</td> <td>VAR_GLOBAL</td> <td>R1300</td> </tr> </tbody> </table>				Label Name	Data Type	Class	Assign (Device/Label)	1	bStartDirection	Bit	VAR_GLOBAL	M0	2	wnSendDataMaster	Word [Signed]	VAR_GLOBAL	R2300	3	wnRecvDataMaster	Word [Signed]	VAR_GLOBAL	R1300
	Label Name	Data Type	Class	Assign (Device/Label)																			
1	bStartDirection	Bit	VAR_GLOBAL	M0																			
2	wnSendDataMaster	Word [Signed]	VAR_GLOBAL	R2300																			
3	wnRecvDataMaster	Word [Signed]	VAR_GLOBAL	R1300																			

Local station (station No.1)

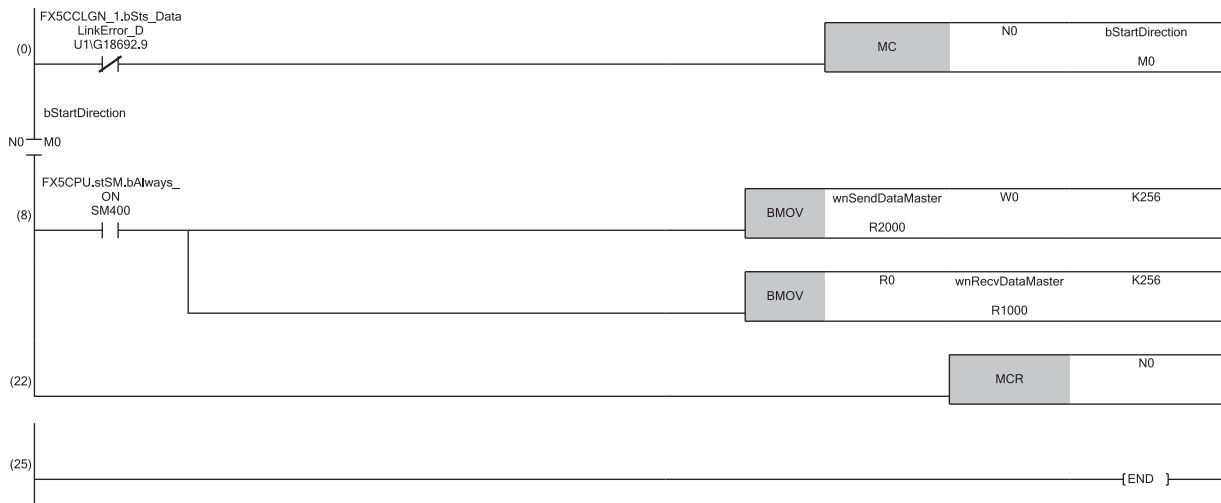

(8) Communication program with the master station (station No.0)

Local station (station No.2)

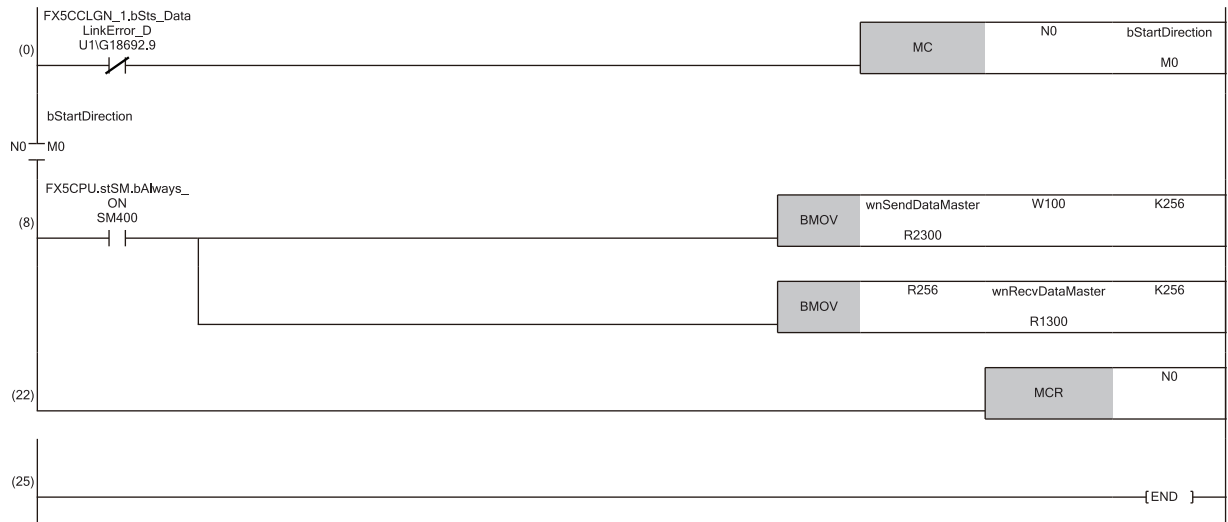

(8) Communication program with the master station (station No.0)



When "Communication Mode" is set to "Unicast", 'Data link status of each station' (SW00B0 to SW00B7) cannot be used as an interlock in the local station. Execute communications with other stations, taking account of the operating status in stations to be communicated.

Program example (At multicast mode)

This section describes a program example when "Communication Mode" under "Application Settings" is set to "Multicast".

Master station (station No.0)

Classification	Label name	Description	Device	
Module label	FX5CCLGN_1.bnSts_DataLinkError_D	Data link error status of own station	SB0049	
	FX5CCLGN_1.bnSts_DataLinkError_Station_D[1]	Data link status of each station (station No.1)	SW00B0.0	
	FX5CCLGN_1.bnSts_DataLinkError_Station_D[2]	Data link status of each station (station No.2)	SW00B0.1	
Label to be defined	Define global labels as shown below:			
	Label Name	Data Type	Class	Assign (Device/Label)
1	bStartDirection_1	Bit	VAR_GLOBAL	M0
2	bStartDirection_2	Bit	VAR_GLOBAL	M1
3	wnSendDataStationNo1	Word [Signed]	VAR_GLOBAL	R1 000
4	wnRecvDataStationNo1	Word [Signed]	VAR_GLOBAL	R2 000
5	wnSendDataStationNo2	Word [Signed]	VAR_GLOBAL	R1 300
6	wnRecvDataStationNo2	Word [Signed]	VAR_GLOBAL	R2 300

Master station (station No.0)

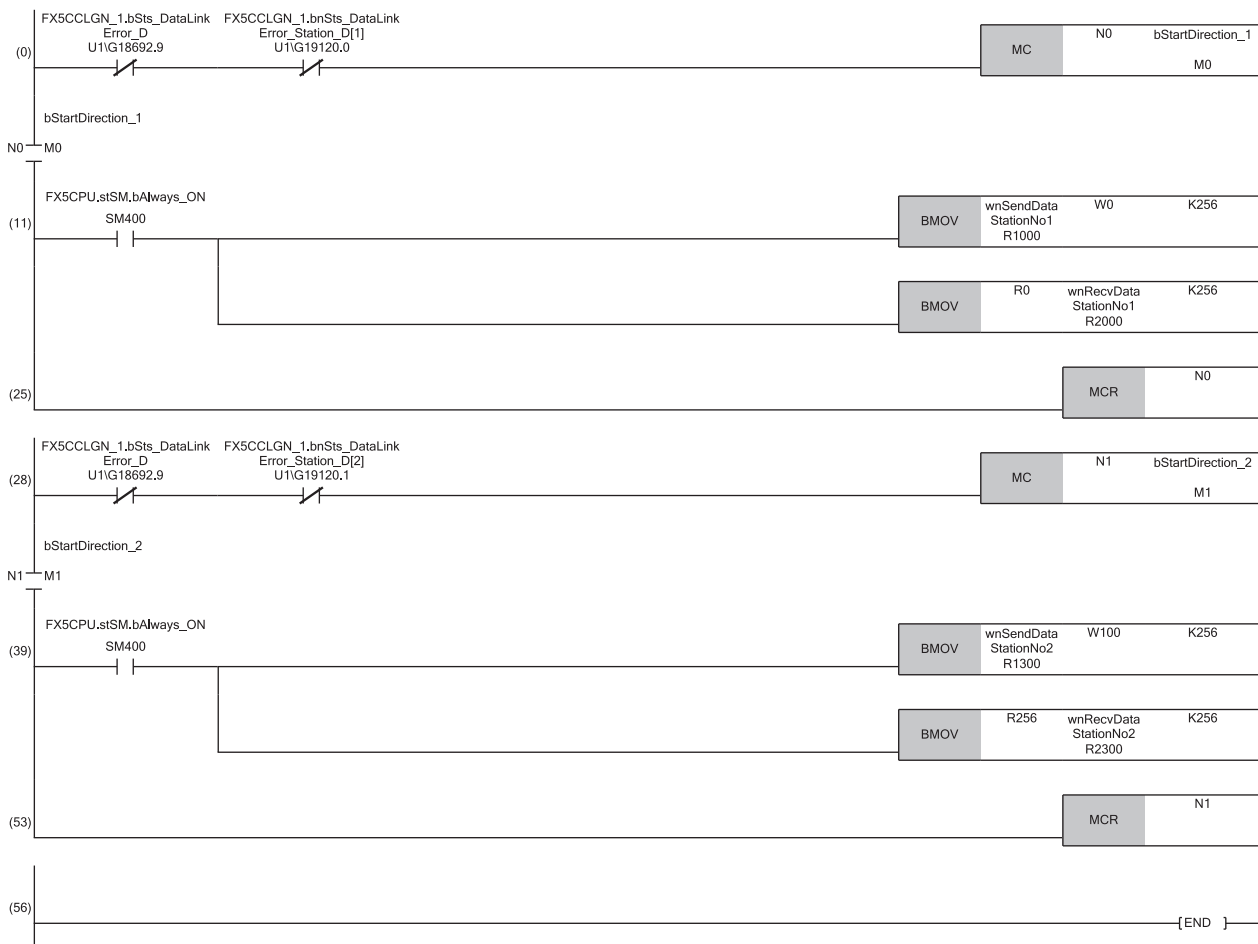

(11) Communication program with the local station (station No.1)

(39) Communication program with the local station (station No.2)

Local station (station No.1, station No.2)

Classification	Label name	Description	Device	
Module label	FX5CCLGN_1.bSts_DataLinkError_D	Data link error status of own station	SB0049	
	FX5CCLGN_1.bnSts_DataLinkError_Station_D[1]	Data link status of each station (station No.1)	SW00B0.0	
	FX5CCLGN_1.bnSts_DataLinkError_Station_D[2]	Data link status of each station (station No.2)	SW00B0.1	
Label to be defined	Define global labels as shown below:			
	• Local station (station No.1)			
	Label Name	Data Type	Class	Assign (Device/Label)
	1 bStartDirection	Bit	VAR_GLOBAL	M0
	2 wnSendDataMaster	Word [Signed]	VAR_GLOBAL	R2000
	3 wnRecvDataMaster	Word [Signed]	VAR_GLOBAL	R1000
	4 wnRecvDataLocal2	Word [Signed]	VAR_GLOBAL	R3000
	5 bStartDirection_2	Bit	VAR_GLOBAL	M2
	• Local station (station No.2)			
	Label Name	Data Type	Class	Assign (Device/Label)
	1 bStartDirection	Bit	VAR_GLOBAL	M0
	2 wnSendDataMaster	Word [Signed]	VAR_GLOBAL	R2300
	3 wnRecvDataMaster	Word [Signed]	VAR_GLOBAL	R1300
	4 wnRecvDataLocal1	Word [Signed]	VAR_GLOBAL	R3300
	5 bStartDirection_1	Bit	VAR_GLOBAL	M1

Local station (station No.1)

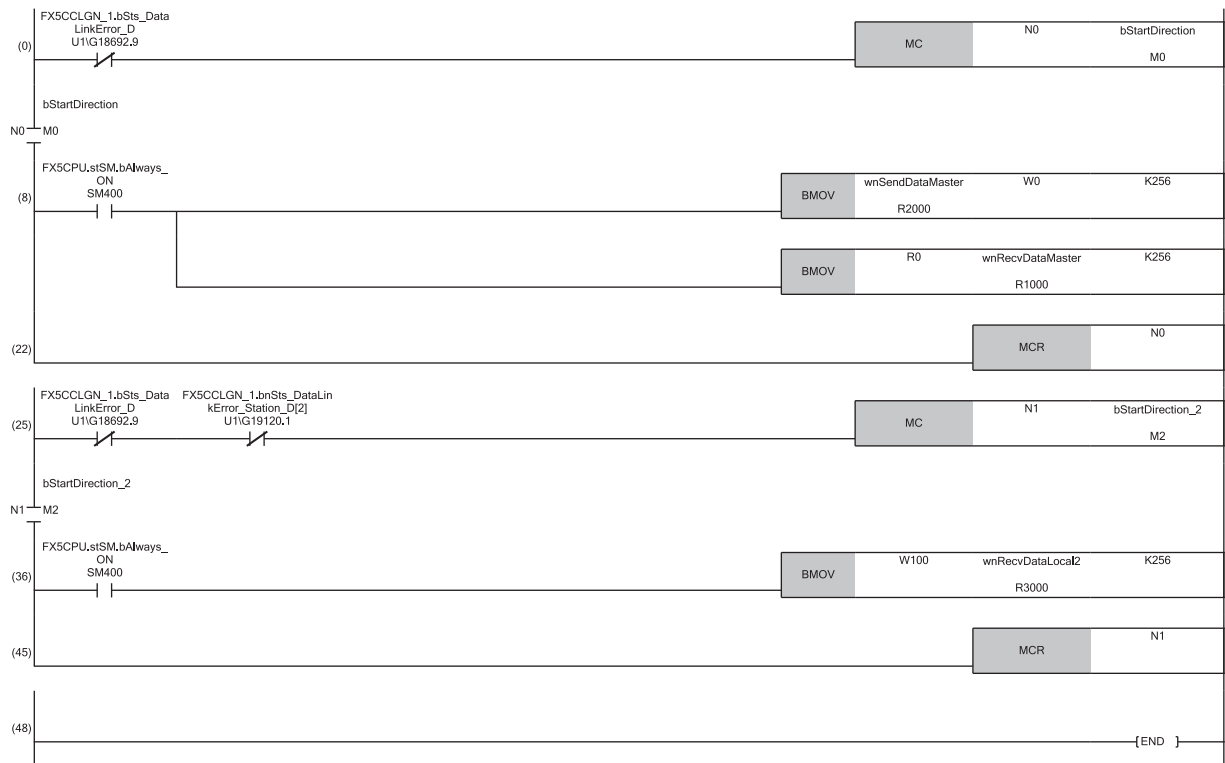

(8) Communication program with the master station (station No.0)

(36) Communication program with the local station (station No.2)

Local station (station No.2)

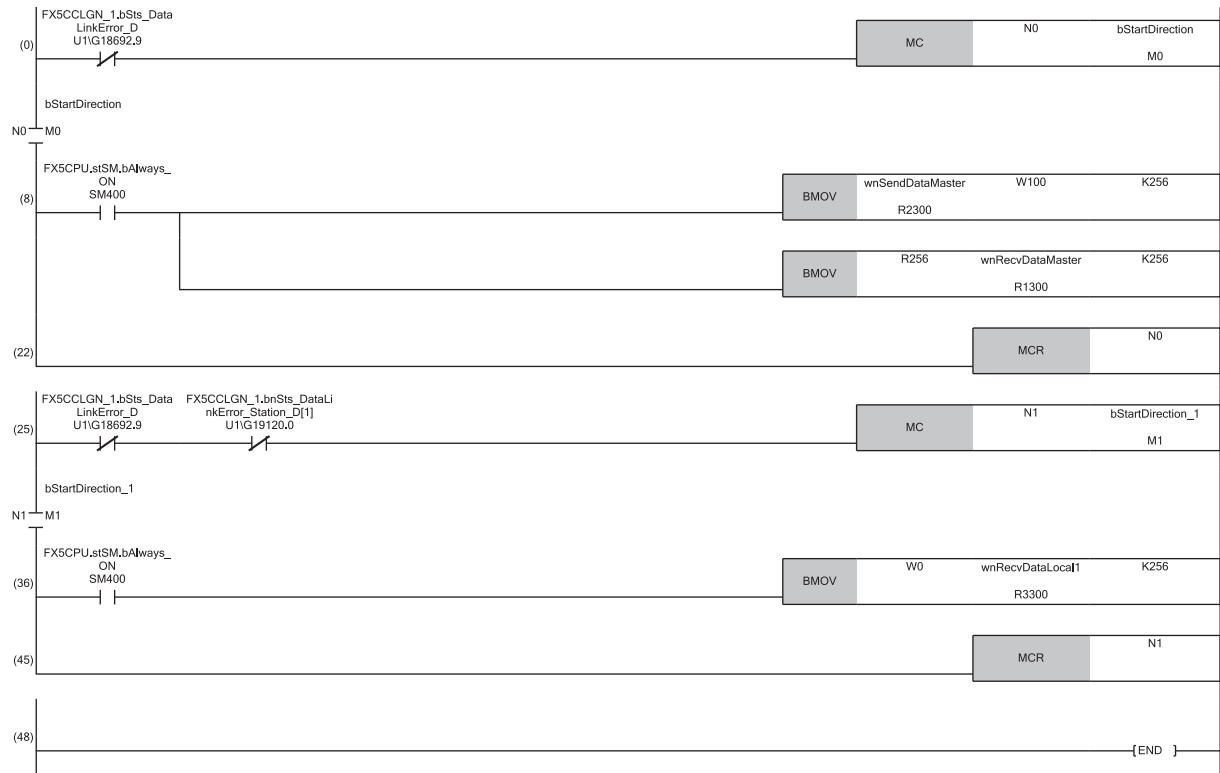

(8) Communication program with the master station (station No.0)

(36) Communication program with the local station (station No.1)

9.3 Examples of Communication with CC-Link IE TSN Class A Remote Stations

When "Communication Mode" is set to "Multicast", the local station cannot obtain data output by the CC-Link IE TSN Class A remote station. Use the following communication examples so that the local station can obtain data output by the CC-Link IE TSN Class A remote station.

System configuration

The following is an example of communications between the CC-Link IE TSN Class B master station (station No.0), CC-Link IE TSN Class A remote station (station No.1), and local station (station No.2).

System configuration

- CPU module: FX5 CPU module
- Master/local module: FX5-CCLGN-MS
- Remote module: CC-Link IE TSN Class A remote station

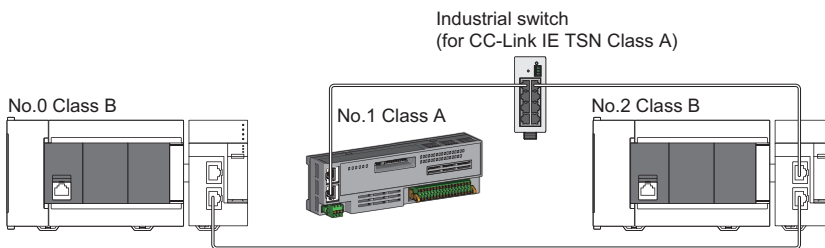

- No.0: CC-Link IE TSN Class B master station (station No.0)
 No.1: CC-Link IE TSN Class A remote station (station No.1)
 No.2: CC-Link IE TSN Class B local station (station No.2)

Link device assignment

For RX and RWr, 128 points are assigned to each station.

For RY and RWw, 128 points are assigned to a remote station and 256 points to a local station.

■RX/RX assignment

Each of the following No.0 to No.2 represents a station number.

- No.0: Master station (station No.0)
- No.1: Remote station (station No.1)
- No.2: Local station (station No.2)

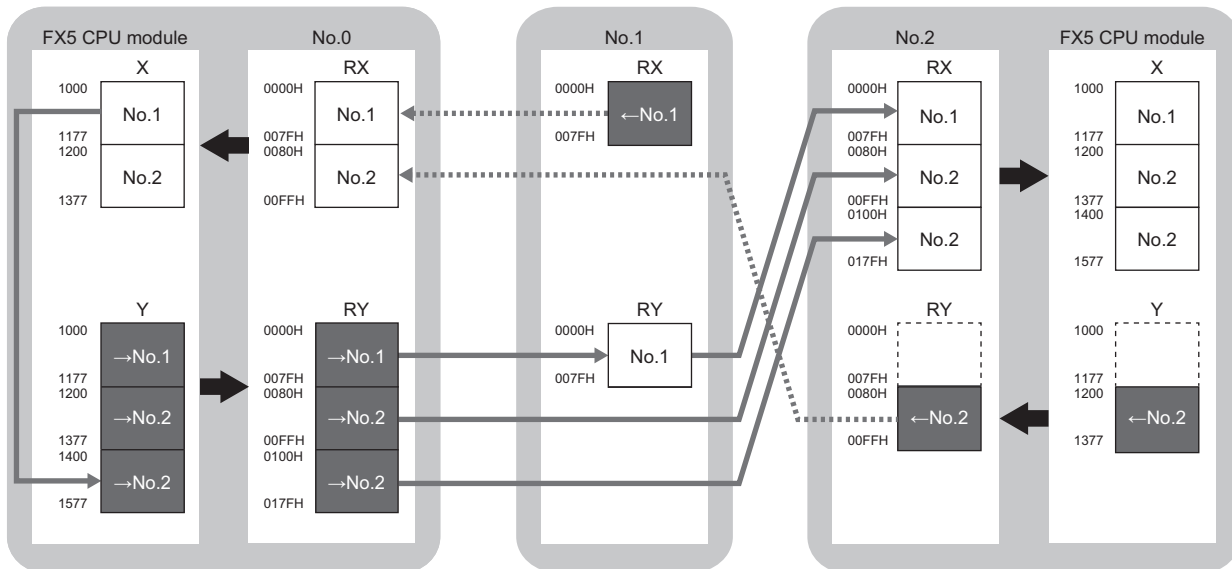

→No.1, →No.2: Send range: to station No.1, send range: to station No.2

←No.1, ←No.2: Send range: from station No.1, send range: from station No.2

■RWr/RWw assignment

Each of the following No.0 to No.2 represents a station number.

- No.0: Master station (station No.0)
- No.1: Remote station (station No.1)
- No.2: Local station (station No.2)

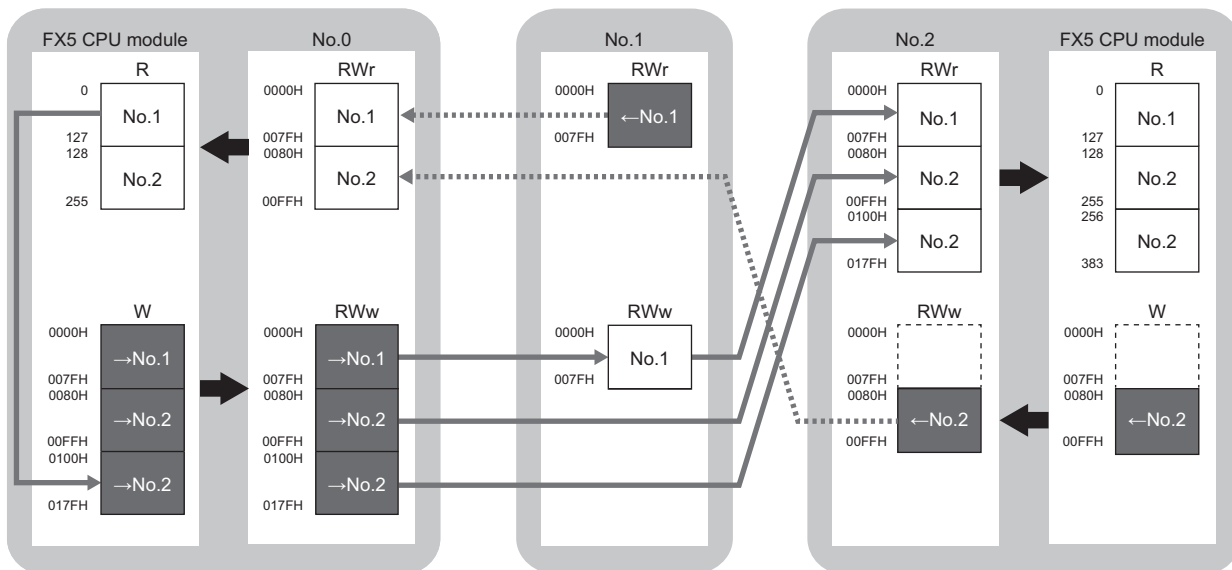

→No.1, →No.2: Send range: to station No.1, send range: to station No.2

←No.1, ←No.2: Send range: from station No.1, send range: from station No.2

Setting in the master station

Connect the engineering tool to the FX5 CPU module on the master station and set the parameters.

1. Set the FX5 CPU module as follows.

 [Project] ⇒ [New]

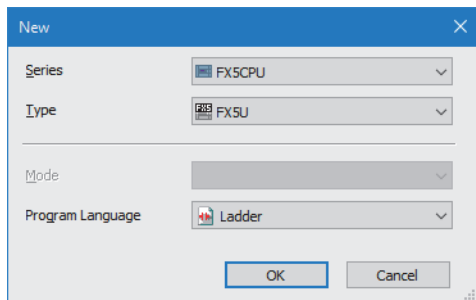

2. Click the [Setting Change] button to use the module label.

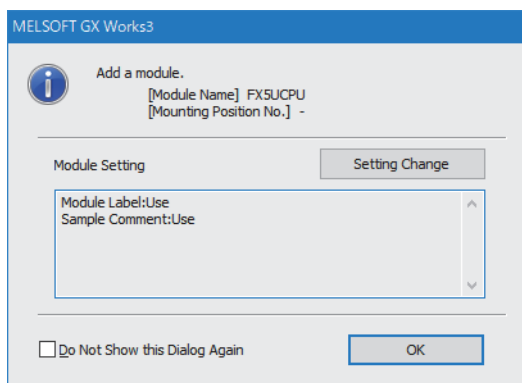

3. Set the FX5-CCLGN-MS as follows.

 [Navigation window] ⇒ [Parameter] ⇒ [Module Information] ⇒ Right-click ⇒ [Add New Module]

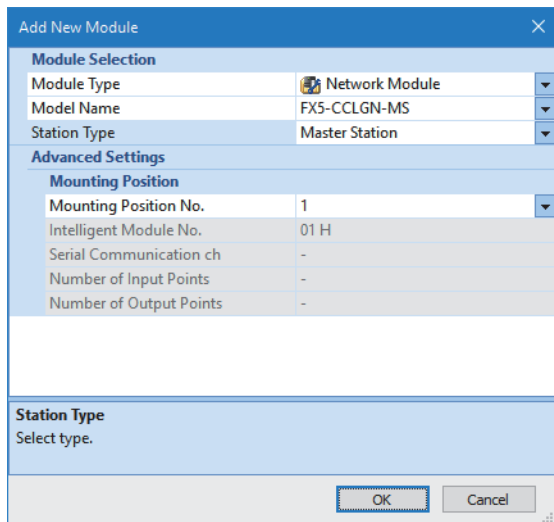

4. Click the [OK] button to add a module label of the FX5-CCLGN-MS.

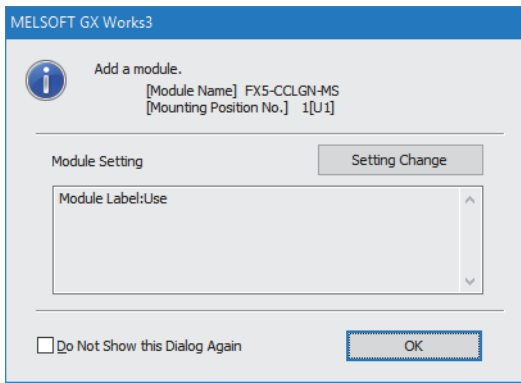

5. Set the items in "Required Settings" as follows.

[Navigation window] ⇒ [Parameter] ⇒ [Module Information] ⇒ [FX5-CCLGN-MS] ⇒ [Required Settings]

Item	Setting
Station Type	
Station Type	Master Station
Network No.	
Network No.	1
Parameter Setting Method	
Setting Method of Basic/Application Settings	Parameter Editor
Station No./IP Address Setting	
Station No./IP Address Setting Method	Parameter Editor
Station No.	0
IP Address	
IP Address	192 . 168 . 3 . 249
Subnet Mask	. . .
Default Gateway	. . .

6. Set the items in "Basic Settings" as follows.

[Navigation window] ⇒ [Parameter] ⇒ [Module Information] ⇒ [FX5-CCLGN-MS] ⇒ [Basic Settings]

Item	Setting
Network Configuration Settings	
Network Configuration Settings	<Detailed Setting>
Refresh Settings	
Refresh Settings	<Detailed Setting>
Network Topology	
Network Topology	Line/Star
Communication Period Setting	
Basic Period Setting	
Setting in Units of 1us	Not Set
Communication Period Interval Setting (Do not Set it in Units of 1us)	1000.00 us
Communication Period Interval Setting (Set it in Units of 1us)	1000.00 us
System Reservation Time	20.00 us
Cyclic Transmission Time	500.00 us
Transient Transmission Time	480.00 us
Multiple Period Setting	
Normal-Speed	x4
Low-Speed	x16
Connection Device Information	
Authentication Class Setting	Mixture of Authentication Class B/A or Authentication Class A Only
TSN HUB Setting	
TSN HUB Setting	Not to Use TSN HUB
Device Station Setting	
Disconnection Detection Setting	4 times

In this manual, "Authentication Class" is described as "CC-Link IE TSN Class".

7. Set the network configuration as follows. (Set the IP address for each station.)

[Navigation window] ⇒ [Parameter] ⇒ [Module Information] ⇒ [FX5-CCLGN-MS] ⇒ [Basic Settings] ⇒ [Network Configuration Settings]

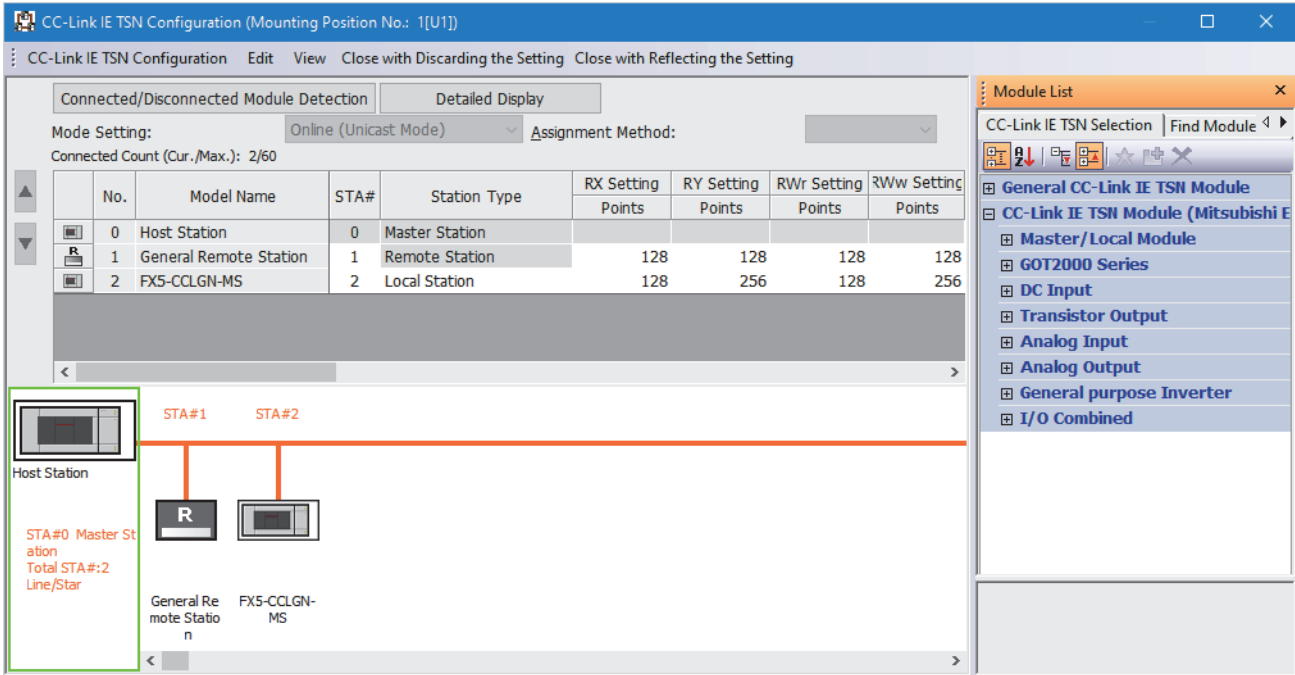

8. Click the [Close with Reflecting the Setting] button to close the "CC-Link IE TSN Configuration" window.

9. Set the refresh settings as follows.

[Navigation window] ⇒ [Parameter] ⇒ [Module Information] ⇒ [FX5-CCLGN-MS] ⇒ [Basic Settings] ⇒ [Refresh Settings]

No.	Link Side					CPU Side				
	Device Name	Points	Start	End		Target	Device Name	Points	Start	End
-	SB				↔					
-	SW				↔					
1	RX	256	00000	000FF	↔	Specify Device	X	256	1000	1377
2	RY	384	00000	0017F	↔	Specify Device	Y	384	1000	1577
3	RWw	384	00000	0017F	↔	Specify Device	W	384	00000	0017F
4	RWr	256	00000	000FF	↔	Specify Device	R	256	0	255

10. Set the items in "Application Settings" as follows.

[Navigation window] ⇒ [Parameter] ⇒ [Module Information] ⇒ [FX5-CCLGN-MS] ⇒ [Application Settings]

Item	Setting
Communication Speed	
Communication Speed	1Gbps
Supplementary Cyclic Settings	
Station-based Block Data Assurance	Enable
I/O Maintenance Settings	
Output Hold/Clear Setting during CPU STOP	Hold
Data Link Error Station Setting	Clear
Output Mode upon CPU Error	Clear
Transient Transmission Group No.	
Transient Transmission Group No.	0
Communication Mode	
Communication Mode	Multicast
Parameter Name	
Parameter Name	
Module Operation Mode	
Module Operation Mode	Online
Security	
IP Filter Settings	
IP Filter	Disable
IP Filter Settings	<Detailed Setting>

11. Click the [Apply] button.

12. Write the set parameters to the FX5 CPU module on the master station. Then, reset the FX5 CPU module or power off and on the system.

[Online] ⇒ [Write to PLC]

Point

In this example, default values are used for parameters that are not shown above. For the parameters, refer to the following.

☞ Page 126 PARAMETER SETTINGS

Remote station settings

Set the setting of the IP address set in "Network Configuration Settings" of the master station.

Settings in the local stations

Connect the engineering tool to the FX5 CPU module on the local station and set parameters.

1. Set the FX5 CPU module and add the module labels of the FX5 CPU module. The setting method of the FX5 CPU module and addition method of the module label are the same as those of the master station. (☞ Page 165 Setting in the master station)
2. Set the FX5-CCLGN-MS as follows.

☞ [Navigation window] ⇒ [Parameter] ⇒ [Module Information] ⇒ Right-click ⇒ [Add New Module]

3. Set to use the FX5-CCLGN-MS module label. The addition method of the module label is the same as that of the master station. (☞ Page 165 Setting in the master station)
4. Set the items in "Required Settings" as follows.

☞ [Navigation window] ⇒ [Parameter] ⇒ [Module Information] ⇒ [FX5-CCLGN-MS] ⇒ [Required Settings]

Item	Setting
Station Type	
Station Type	Local Station
Network No.	
Network No.	1
Parameter Setting Method	
Setting Method of Basic/Application Settings	Parameter Editor
Station No./IP Address Setting	
Station No./IP Address Setting Method	Parameter Editor
Station No.	
Station No.	2
IP Address	
IP Address	192 . 168 . 3 . 11
Subnet Mask	. . .
Default Gateway	. . .

5. Set the refresh settings as follows.

 [Navigation window] ⇒ [Parameter] ⇒ [Module Information] ⇒ [FX5-CCLGN-MS] ⇒ [Basic Settings] ⇒ [Refresh Settings]

No.	Link Side					CPU Side				
	Device Name	Points	Start	End		Target	Device Name	Points	Start	End
-	SB				↔					
-	SW				↔					
1	RX	384	00000	0017F	↔	Specify Device	X	384	1000	1577
2	RY	256	00000	000FF	↔	Specify Device	Y	256	1000	1377
3	RWw	256	00000	000FF	↔	Specify Device	W	256	00000	000FF
4	RWr	384	00000	0017F	↔	Specify Device	R	384	0	383

6. Set the items in "Application Settings" as follows.

 [Navigation window] ⇒ [Parameter] ⇒ [Module Information] ⇒ [FX5-CCLGN-MS] ⇒ [Application Settings]

Item	Setting
Communication Speed	
Communication Speed	1Gbps
Supplementary Cyclic Settings	
I/O Maintenance Settings	
Output Hold/Clear Setting during CPU STOP	Hold
Data Link Error Station Setting	Clear
Output Mode upon CPU Error	Clear
Transient Transmission Group No.	
Transient Transmission Group No.	0
Parameter Name	
Parameter Name	
Module Operation Mode	
Module Operation Mode	Online
Security	
IP Filter Settings	
IP Filter	Disable
IP Filter Settings	<Detailed Setting>

7. Click the [Apply] button.

8. Write the set parameters to the FX5 CPU module on the local station. Then, reset the FX5 CPU module or power off and on the system.

 [Online] ⇒ [Write to PLC]

Point 

In this example, default values are used for parameters that are not shown above. For the parameters, refer to the following.

 Page 126 PARAMETER SETTINGS

Checking the network status

After starting up the system, check whether data link can be normally performed. For the check, use the CC-Link IE TSN/CC-Link IE Field diagnostics of the engineering tool.

1. Connect the engineering tool to the FX5 CPU module on the master station.
2. Start the CC-Link IE TSN/CC-Link IE Field diagnostics.

 [Diagnostics] ⇒ [CC-Link IE TSN/CC-Link IE Field Diagnostics]

If the following display appears, a data link is normal.

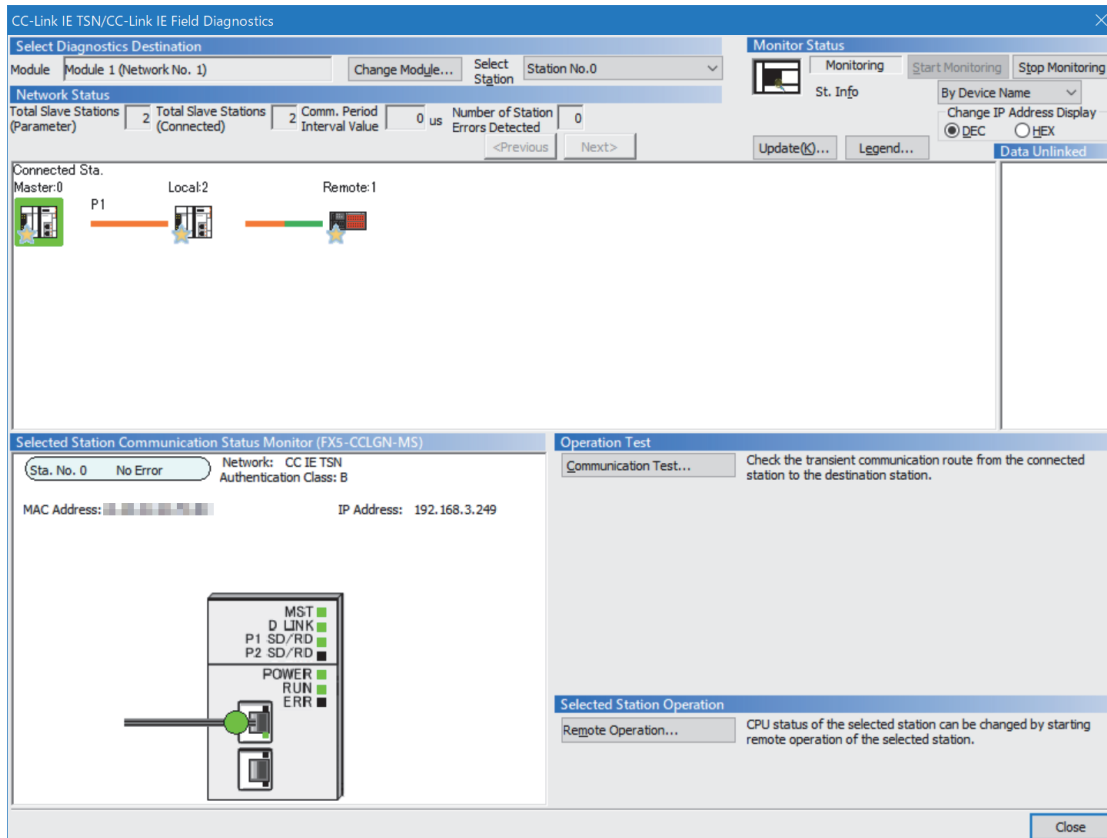

In this manual, "Authentication Class" is described as "CC-Link IE TSN Class".

If an error icon appears in "Network Status" area, use the CC-Link IE TSN/CC-Link IE Field diagnostics to identify the cause of the error and take corrective actions. ( Page 180 Checking the Network Status)

Program examples

The following is a program example of communications between the CC-Link IE TSN Class B master station (station No.0), CC-Link IE TSN Class A remote station (station No.1), and local station (station No.2).

Master station (station No.0)

Classification	Label name	Description	Device	
Module label	FX5CCLGN_1.bSts_DataLinkError_D	Data link error status of own station	SB0049	
	FX5CCLGN_1.bnSts_DataLinkError_Station_D[1]	Data link status of each station (station No.1)	SW00B0.0	
	FX5CCLGN_1.bnSts_DataLinkError_Station_D[2]	Data link status of each station (station No.2)	SW00B0.1	
Label to be defined	Define global labels as shown below:			
	Label Name	Data Type	Class	Assign (Device/Label)
	1 bStartDirection_1	Bit	VAR_GLOBAL	M0
	2 bStartDirection_2	Bit	VAR_GLOBAL	M1
	3 wnSendDataStationNo1	Word [Signed]	VAR_GLOBAL	R1 000
	4 wnRecvDataStationNo1	Word [Signed]	VAR_GLOBAL	R2 000
	5 wnSendDataStationNo2	Word [Signed]	VAR_GLOBAL	R1 300
	6 wnRecvDataStationNo2	Word [Signed]	VAR_GLOBAL	R2 300

Master station (station No.0)

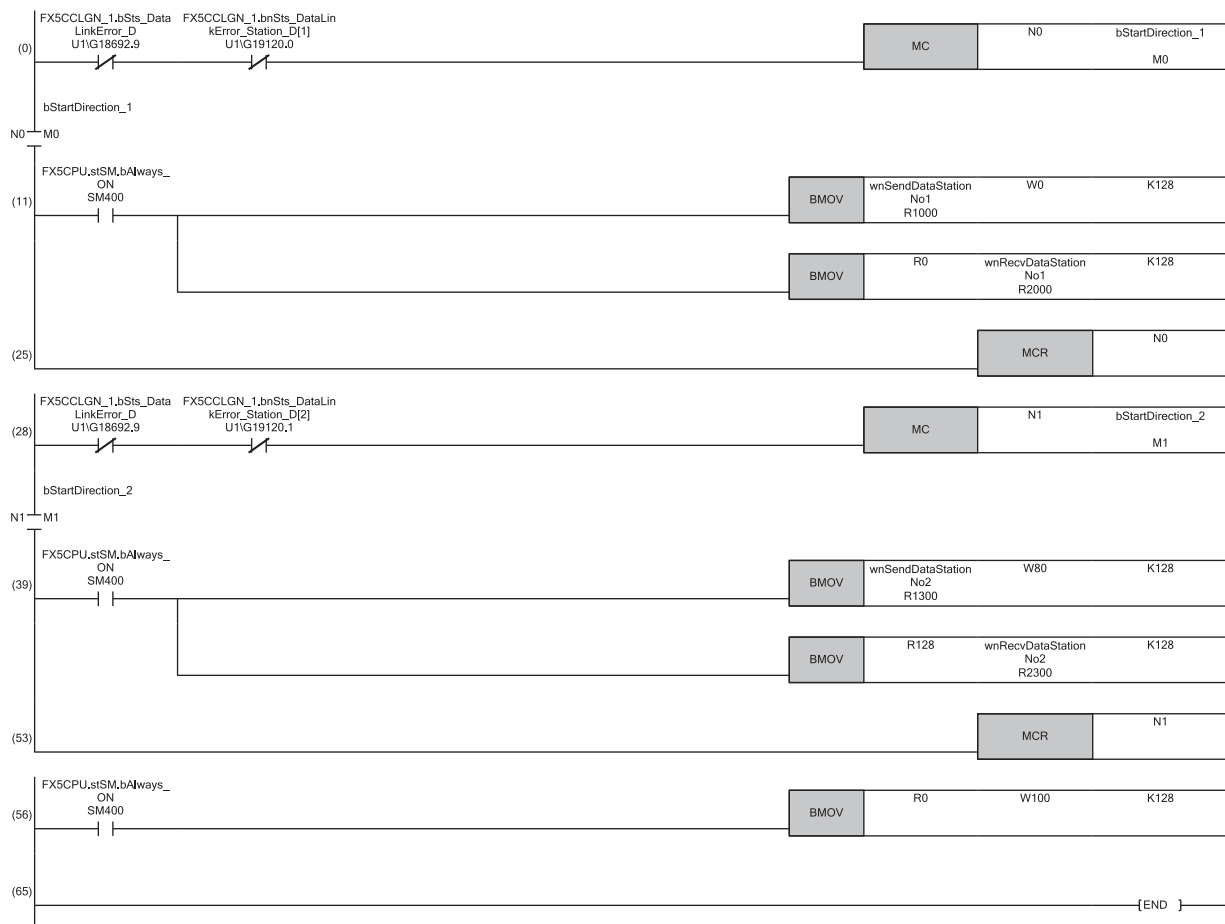

(11) Communication program with the remote station (station No.1)

(39) Communication program with the local station (station No.2)

(56) Program for sending data received from the remote station (station No.1) to the local station (station No.2)

Local station (station No.2)

Classification	Label name	Description	Device	
Module label	FX5CCLGN_1.bSts_DataLinkError_D	Data link error status of own station	SB0049	
Label to be defined	Define global labels as shown below: • Local station (station No.2)			
	Label Name	Data Type	Class	Assign (Device/Label)
1	bStartDirection	Bit	VAR_GLOBAL	M0
2	wnSendDataMaster	Word [Signed]	VAR_GLOBAL	R2300
3	wnRecvDataMaster	Word [Signed]	VAR_GLOBAL	R1300
4	wnRecvDataStationNo1	Word [Signed]	VAR_GLOBAL	R1600

Local station (station No.2)

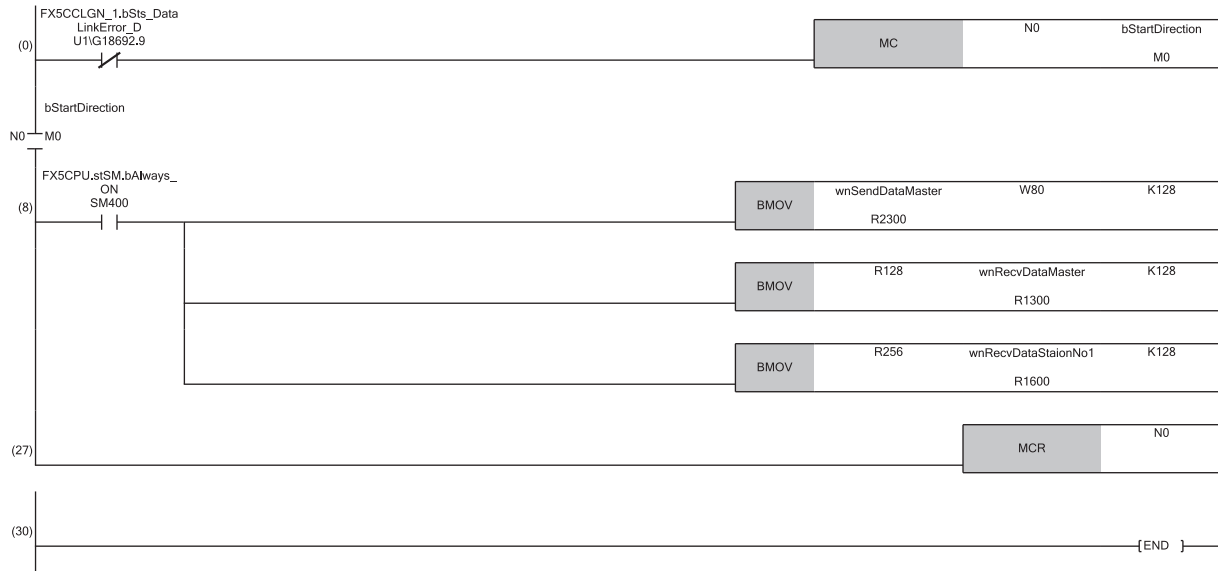

(8) Communication program with the master station (station No.0) and the remote station (station No.1)

10 TROUBLESHOOTING

This chapter describes troubleshooting of CC-Link IE TSN.

10.1 Checking with LED

This section describes troubleshooting with LEDs.

When the RUN LED turns off

When the RUN LED turns off after powering on the FX5-CCLGN-MS, check the following.

Check item	Action
Is the FX5-CCLGN-MS mounted correctly?	Securely mount the FX5-CCLGN-MS on the FX5 CPU module.

If the above action does not solve the problem, perform the module communication test to check for hardware failure. ( Page 179 Module communication test)

When the ERROR LED turns on or is flashing

When the ERROR LED turns on or is flashing, check the following.

Check item	Action
Does any error occur in the module diagnostics?	Take the actions displayed on the window.
Is a disconnected station displayed by the CC-Link IE TSN/CC-Link IE Field diagnostics?	<ul style="list-style-type: none"> • Perform the network configuration setting and communication cycle setting in accordance with the station actually connected. • Execute the following for the disconnected station. <ul style="list-style-type: none">  Page 175 When the D LINK LED turns off or is flashing ■ For firmware version "1.010" or later <ul style="list-style-type: none"> • When the communication speed of the data link faulty station is set to 100Mbps and the communication speed of the master station is set to 1Gbps the multicast mode, perform the following wiring. <ol style="list-style-type: none"> (1) Connect the data link faulty station to the device supporting the multicast filter. ■ For firmware version "1.002" or earlier <ul style="list-style-type: none"> • When the communication speed of the data link faulty station is set to 100Mbps and the communication speed of the master station is set to 1Gbps, perform the following wiring and setting. <ol style="list-style-type: none"> (1) Use one of P1 or P2 of the master station. (2) Connect the device that supports multicast filtering to the data link faulty station and set to the multicast mode.
Are RX, RY, RWr, and RWw assigned for the CC-Link IE TSN configuration of the master station?	Check that all the assignment of RX, RY, RWr, and RWw of a station where an error occurs is not blank.
Is the event code 00C81 registered in the event history?	Take the following action for the device station with the IP address displayed in the detailed information of the event history. <ul style="list-style-type: none"> • Match "CC-Link IE TSN Class Setting" in "Network Configuration Setting" under "Basic Settings" of the master station to the CC-Link IE TSN Class of the device station.
Is the event code 00C72 registered in the event history?	<ul style="list-style-type: none"> • Update the engineering tool to the latest version. Take the following action for the device station with the IP address displayed in the detailed information of the event history. <ul style="list-style-type: none"> • Update the firmware of the device stations to the latest version.

If the above actions do not solve the problem, perform the module communication test to check for hardware failure. ( Page 179 Module communication test)

When the D LINK LED turns off or is flashing



When the D LINK LED turns off or is flashing, check the following.

Check item	Action
Is the master station operating normally?	<ul style="list-style-type: none"> • If an error occurs in the FX5 CPU module on the master station, eliminate the cause of the FX5 CPU module error. • If an error occurs in the FX5-CCLGN-MS on the master station, take action according to the module diagnosis procedure.
Is the master station connected to the network?	Connect the master station to the network.
Does the IP address of each station match the "Network Configuration Settings" of the master station?	Correct the setting of the IP address in "Network Configuration Settings" of the master station.
In the "Network Configuration Settings" of the master station, are the third and fourth octets of the IP address duplicated with those of any other stations?	<ul style="list-style-type: none"> • Set IP addresses in a way that does not duplicate the third to fourth octets of the IP address in all stations. • Set the IP address and subnet mask to match the network addresses of all stations. • Set the third and fourth octets of the IP address to values other than all 0 or all 1. • Set the host section to a value other than all 0 or all 1. • Set an address other than some reserved addresses fixed for special purposes as the IP address.
In the "Network Configuration Settings" of the master station, does the network address (the subnet mask part of the IP address) match the master station?	
Are the third and fourth octets of the IP address set to values other than all 0 or all 1?	
Is the host section set to a value other than all 0 or all 1?	
Is there a reserved address fixed for a special purpose set as the IP address?	
Do the used Ethernet cables conform to the Ethernet standard?	Replace the cables with Ethernet cables which conform to the standard. (☞ Page 15 Performance Specifications of CC-Link IE TSN)
Is the industrial switch used operating normally?	<ul style="list-style-type: none"> • Use an industrial switch that conforms to the standard. (☞ Page 15 Performance Specifications of CC-Link IE TSN) • Power off and on the industrial switch.
Does the station-to-station distance meet the specifications?	Set the station-to-station distance within range. (☞ Page 15 Performance Specifications of CC-Link IE TSN)
Does the cabling condition (bending radius) meet the specifications?	Refer to the manual for the Ethernet cable, and correct the bending radius.
Is any Ethernet cable disconnected?	Replace the Ethernet cable.
Is the network configured in the ring topology?	Configure the network to avoid the ring topology.
Has the time synchronization source station been reset?	<ul style="list-style-type: none"> • Since a station is temporarily disconnected after switching the time synchronization source, wait for it to return. • Avoid unnecessary disconnections or returns in a station that is the time synchronization source.
Is the time synchronization source station turned off?	
Is the time synchronization source station operating normally?	Take action by referring to the manual for the time synchronization device.
Has any other station been reset?	<ul style="list-style-type: none"> • Avoid unnecessary reset since a station is disconnected while resetting. • Start other stations.
Are other stations turned off?	Power on other stations.
Are other stations connected to the FX5-CCLGN-MS operating normally?	Execute the CC-Link IE TSN/CC-Link IE Field diagnostics from the master station to identify the faulty module of another station. After identification, take action by referring to the manual for the relevant module.
Is the IP address of another station set?	Set an IP address to a device station with no IP address setting.
Are other stations set in the network configuration of the master station?	Set connected device stations in the network configuration of the master station.
Is a type of wiring described in the restrictions in the wiring specifications mistakenly performed?	Correct the wiring. (☞ Page 122 WIRING)
Are station numbers unique?	Change the duplicated station number.
Is the IP address duplicated with another station?	Change the IP address of the duplicated station.
Does the number of device stations connected exceed the maximum number of connectable stations? (When used as a master station)	Ensure that when the master station operates, the number of device stations connected is within the maximum number of connectable stations specified in the CC-Link IE TSN performance specifications.
Are 121 or more device stations connected? (When used as a local station)	☞ Page 15 Performance Specifications of CC-Link IE TSN When the local stations operate, configure the system in which the number of connecting device stations is not more than 120.
Do CC-Link IE TSN devices and Ethernet devices coexist?	Correct the wiring. (☞ Page 122 WIRING)
Does the IP filter setting mistakenly block communications from the IP address of another station?	Change the IP filter setting parameter to allow communication for the IP address of another station.

Check item	Action
Are time synchronization devices with time synchronization priority of 0 to 15 connected?	Remove time synchronization devices with time synchronization priority of 0 to 15, or change the priority to between 16 and 255.  Manual for the time synchronization devices used
Is the connected industrial switch (for CC-Link IE TSN Class B) operating normally?	Power off and on the industrial switch (for CC-Link IE TSN Class B). Check the industrial switch (for CC-Link IE TSN Class B) parameters and correct their settings. For the setting method, refer to the manual for the industrial switch (for CC-Link IE TSN Class B). The main check items are as follows: <ul style="list-style-type: none"> • Enable each port of the industrial switch (for CC-Link IE TSN Class B). • Set the communication speed and port type to Auto. • Match the settings for the time synchronization and communication cycle of the industrial switch (for CC-Link IE TSN Class B) to those of the master station. • Match the VLAN setting of the master station to that of the device stations.



When the L ER LED turns on

When the L ER LED turns on, check the following.

Check item	Action
Are the Ethernet cables used normally?	<ul style="list-style-type: none"> • Use an Ethernet cable that conforms to the standard. ( Page 15 Performance Specifications of CC-Link IE TSN) • Set the station-to-station distance within range. ( Page 15 Performance Specifications of CC-Link IE TSN) • If the Ethernet cable is disconnected, reconnect it.
Is the industrial switch used operating normally?	<ul style="list-style-type: none"> • Use an industrial switch that conforms to the standard. ( Page 15 Performance Specifications of CC-Link IE TSN) • Power off and on the industrial switch.
Is "Module Operation Mode" under "Application Settings" of the master station set to "Online"?	Set "Module Operation Mode" under "Application Settings" of the master station to "Online".
Is there any source of noise near the module or cables?	Change the location of the module or cables.

When the LINK LED turns off

When the LINK LED turns off, check the following.

Check item	Action
Do the used Ethernet cables conform to the Ethernet standard?	Replace the cables with Ethernet cables which conform to the standard. ( Page 125 Ethernet cable)
Does the station-to-station distance meet the specifications?	Set the station-to-station distance within range. ( Page 15 Performance Specifications of CC-Link IE TSN)
Does the cabling condition (bending radius) meet the specifications?	Refer to the manual for the Ethernet cable, and correct the bending radius.
Is any Ethernet cable disconnected?	Replace the Ethernet cable.
Is the industrial switch used operating normally?	<ul style="list-style-type: none"> • Use an industrial switch that conforms to the standard. ( Page 125 Industrial switch) • Power off and on the industrial switch.
Are other stations connected to the FX5-CCLGN-MS operating normally?	Take action by referring to the manual for the modules of other stations.
Does the communication speed of the connected device match the communication speed set in "Communication Speed"?	Connect the device with the communication speed set in "Communication Speed".
Is the communication speed of connected devices 1Gbps?	Connect devices that support a communication speed of 1Gbps.
If the communication speed is set to 100Mbps for the master station and local stations to connect a device with a communication speed of 100Mbps, is the auto-negotiation of the connected device valid?	Enable the auto-negotiation of the connected device. Or, connect a device with auto-negotiation enabled.

If the above actions do not solve the problem, perform the module communication test to check for hardware failure. ( Page 179 Module communication test)

10.2 Checking the Module Status

Module diagnostics

The following items can be checked in the "Module Diagnostics" window for the FX5-CCLGN-MS.

Item	Description
[Error Information] tab	Displays the details of the errors currently occurring and the corrective actions for these errors. "-" may be displayed in "Occurrence Data" of an error that occurred immediately after the power was turned on. To check the occurrence date, click the [Event History] button and refer to the event history.
[Module Information List] tab	Displays the LED information and individual information of the FX5-CCLGN-MS.
Supplementary Function	CCIET/CCIEF diagnostics
	Enables checking the cause to resolve the problem when an error occurs in the CC-Link IE TSN. (Page 180 Checking the Network Status)

Error Information

The details of the errors currently occurring and the corrective actions for these errors are displayed in the [Error Information] tab.

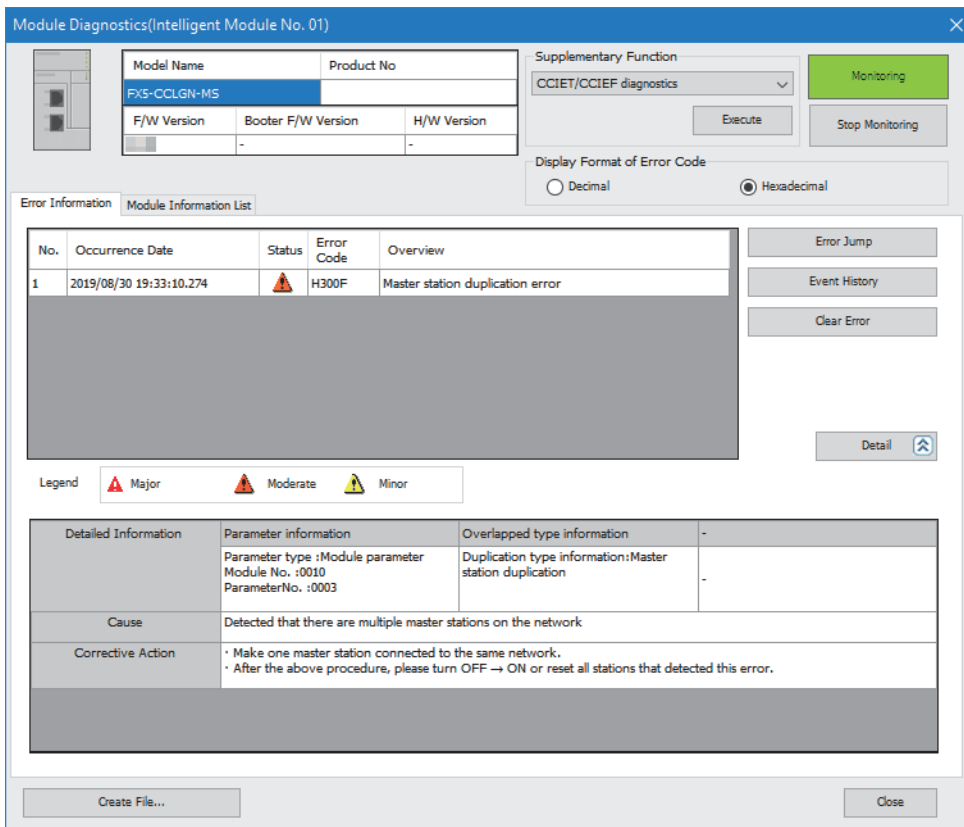

Item	Description
Status	Major: An error such as hardware failure or memory failure. The module stops operating. Moderate: An error, such as parameter error, which affects module operation. The module stops operating. Minor: An error such as communication failure. The module continues operating.
Error code	Page 200 List of Error Codes
[Event History] button	Click this button to check the history of errors that have occurred on the network, errors detected for each module, and operations that have been executed. (Page 222 Event List)
Detailed Information	Displays up to three information items for each error, such as parameter information, operation source information, and system configuration information. (Page 221 List of Parameter Numbers)
Cause	Displays the detailed error causes.
Action	Displays the actions to eliminate the error causes.

Module Information List

The LED information and individual information of the FX5-CCLGN-MS are displayed in the [Module Information List] tab.

Module Diagnostics(Intelligent Module No. 01)

Model Name: FX5-CCLGN-MS
Product No: [Blank]
F/W Version: [Blank] | Booter F/W Version: - | H/W Version: -

Supplementary Function: CCIET/CCIEF diagnostics
Buttons: Monitoring, Execute, Stop Monitoring

Display Format of Error Code: Decimal Hexadecimal

Item	Content
LED information	
RUN	On: Normal operation
ERROR	Flashing: Error, data link faulty, station being detected
MST	On: Operating as a master station
D LINK	Off: Disconnecting
P1 SD/RD	Off: Data not sent nor received
P2 SD/RD	Off: Data not sent nor received
Individual information	
Station Type	Master Station
NetworkNo.	1
Station Number	0
Transient transmission groupNo.	No group specification
IP address (1st octet)	192
IP address (2nd octet)	168
IP address (3rd octet)	3
IP address (4th octet)	249
MAC address (1st octet)	10
MAC address (2nd octet)	4D
MAC address (3rd octet)	0
MAC address (4th octet)	60
MAC address (5th octet)	F9
MAC address (6th octet)	BA
P1 Communication Speed	1Gbps
P2 Communication Speed	Disconnected

Buttons: Create File..., Close

Item	Description	
LED information	Displays the LED status of the FX5-CCLGN-MS.	
Individual information	Station Type	Displays the station type set for the selected module.
	Network No.	Displays the network number set for the selected module.
	Station Number	Displays the station number set for the selected module.
	Transient transmission group No.	Displays the transient transmission group number set for the selected module.
	IP address	Displays the IP address set for the selected module.
	MAC address	Displays the MAC address of the selected module.
	P1 Communication Speed	Displays the communication speed set using the auto-negotiation function.
P2 Communication Speed		

Module communication test

The module communication test checks the hardware of the FX5-CCLGN-MS. The module hardware is checked when the communication using the FX5-CCLGN-MS is unstable.

The following table lists the tests performed.

Test item	Description
Internal self-loopback test	Checks whether the communication function of the module can be performed normally.
External self-loopback test	Checks whether the communication can be performed normally with the Ethernet cable connected between two connectors of the module.

Procedure

1. Set the following setting to "Module Communication Test".

 [Navigation window] ⇒ [Parameter] ⇒ [Module Information] ⇒ Target module ⇒ [Module Parameter] ⇒ [Application Settings] ⇒ [Module Operation Mode]

2. Connect the P1 and P2 of the FX5-CCLGN-MS with an Ethernet cable.

3. Write the module parameters to the FX5 CPU module.

4. Reset or power off and on the FX5 CPU module to start the module communication test.

Point

- Do not execute access to buffer memory during the module communication test. Otherwise, the test may be completed with an error.
- Do not perform a module communication test while connected to another station. The operation of the other station may fail. Be sure to use an Ethernet cable to connect together the P1 and P2 of the FX5-CCLGN-MS on which a module communication test is performed.

Checking on the status and result of the module communication test

The test status and result can be checked with the LED indications of the module.

Test status	RUN LED	ERROR LED
Test in progress	Flashing	Off
Normal completion	On	Off
Completed with an error	On	On

10.3 Checking the Network Status

The network status is checked and troubleshooting is performed by using the CC-Link IE TSN/CC-Link IE Field diagnostics to check the network status and error definition and by performing an operation test to check communications.

CC-Link IE TSN/CC-Link IE Field diagnostics

For CC-Link IE TSN, perform status monitoring, operation tests, or others.

Precautions

In the following cases, the CC-Link IE TSN/CC-Link IE Field diagnostics cannot start.

- The FX5-CCLGN-MS is not connected to FX5 CPU modules specified on the "Specify Connection Destination Connection" window.
- "Module Operation Mode" under "Application Settings" of the FX5-CCLGN-MS is not set to online mode.
- The module error (error code: 20E0H) occurs.
- The engineering tool is not connected to a station with the same communication speed as the master station.
- The network topology of the diagnostics destination does not support the version of the engineering tool or module.

Function list

The following table lists the functions of the CC-Link IE TSN/CC-Link IE Field diagnostics.

○: Diagnosed △: Diagnosed with restrictions ×: Not diagnosed

Function type	Function	Description	Connection destination of engineering tool		Reference
			Master station	Local station	
Network status monitor function	Network map	<ul style="list-style-type: none"> • Displays the network configuration of CC-Link IE TSN. This function displays the current status of the same network as a network map, and displays the Ethernet cable connection status, IP address duplication, and station disconnection status. A network map to be displayed is automatically generated from the current configuration on the network. • Whether an error occurred in any of the devices and Ethernet cables that configure the network can be checked. In addition, the operating status of a station set in the network parameters can be checked. 	○	○	Page 183 "CC-Link IE TSN/CC-Link IE Field Diagnostics" window
	Selected Station Communication Status Monitor	<ul style="list-style-type: none"> • Displays the module status and communication status of the selected station. If an error occurred in the module, this function displays diagnostic information such as the cause of the error and corrective action. • Detailed error definition of the selected station and corrective action for the error can be checked. 	○	○	
	Data Unlinked	<ul style="list-style-type: none"> • Displays a station with its setting existing in the network parameters but not displayed in the network map (a station that has never joined the network). • This function can check the non-existence of a station set in the network parameter. 	○	○	

Function type	Function	Description	Connection destination of engineering tool		Reference
			Master station	Local station	
Operation test/ execution function	Communication Test	<ul style="list-style-type: none"> This test specifies the network number and station number or the IP address to check whether transient transmission can be performed from the connected station (own station) to the communication destination. Transient transmission to the specified communication destination (on the same network only) can be checked. 	○	○	Page 187 Communication test
Remote Operation		This function can remotely operate (RUN, STOP, and RESET) the FX5 CPU module and device station.	△*1	△*1	Page 188 Remote operation

*1 If the setting on the "Specify Connection Destination Connection" window of the engineering tool is as follows, remote operation cannot be executed with "All Stations Specified".
 Connection via Ethernet with the selections "Ethernet Board" for the personal computer-side I/F and "CC IE TSN/Field Module" for the programmable controller-side I/F

Restriction

When starting the CC-Link IE TSN/CC-Link IE Field diagnostics by specifying "Other Station (Single Network)" or "Other Station (Co-existence Network)" in "Other Station Setting" on the "Specify Connection Destination Connection" window, the following restrictions apply.

- A communication test cannot be used.
- If MELSECNET/H, multidrop connection of serial communication modules, an interface board for a personal computer, or network modules of the MELSEC-Q/L series are included in the communication path, diagnostics cannot start.

Usage methods

The following describes how to use the CC-Link IE TSN/CC-Link IE Field diagnostics.

1. Connect the engineering tool to the FX5 CPU module.
 If a device station cannot be monitored due to an error such as Ethernet cable disconnection, directly connect the engineering tool to the device station.
2. Start the CC-Link IE TSN/CC-Link IE Field diagnostics.
 [Diagnostics] ⇒ [CC-Link IE TSN/CC-Link IE Field Diagnostics]
3. When the following window opens, select the FX5-CCLGN-MS to be diagnosed and click the [OK] button to start the CC-Link IE TSN/CC-Link IE Field diagnostics.

Modules are listed in the order configured in module information.

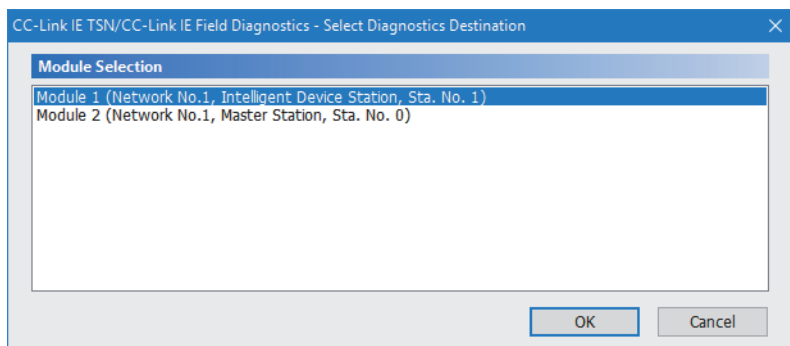

Point

When two FX5-CCLGN-MSs with the same network number are mounted on the FX5 CPU module, the FX5-CCLGN-MS which is closer to the FX5 CPU module is always diagnosed, regardless of setting.

4. Select the station to be diagnosed from "Select Station" or in the network map.

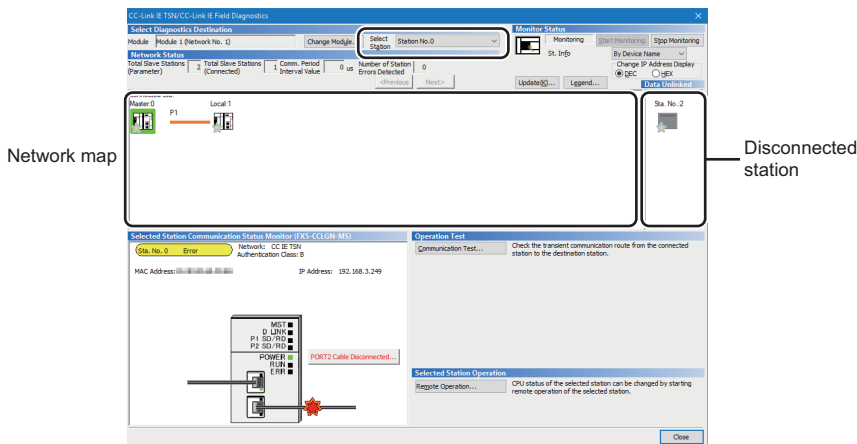

In this manual, "Authentication Class" is described as "CC-Link IE TSN Class".

- An icon indicating an error is displayed on the module icon of the station where an error occurs.
- A disconnected station that has performed data link is indicated with the disconnected station icon in the network map. However, a disconnected station in the following cases are displayed on the right end of the area.

Stations displayed on the right end of the area.

- A station that was reconnected to a network after disconnecting/inserting the Ethernet cable or powering off and on the system, and remains disconnected
 - A disconnected station with the station icon deleted in the network map by clicking the [Update] button
- The "Error" icon is displayed on the icon of a cable where a communication error occurs. To check the details of the communication error, click the neighboring stations of the "Error" icon.

Point

When the station to be diagnosed cannot be selected, the status of network number mismatch or duplication of master stations cannot be checked using the CC-Link TSN/CC-Link IE Field diagnostics. Connect the engineering tool directly to the station where the error has occurred, and check the error details on the "System Monitor" window.

5. The status of a station selected in "Network Status" is displayed in "Selected Station Communication Status Monitor". (Page 183 "CC-Link IE TSN/CC-Link IE Field Diagnostics" window)

The station status is displayed on the top of "Selected Station Communication Status Monitor".

If an error occurs, a button indicating the error such as [PORT2 Communication Error] is displayed in "Selected Station Communication Status Monitor". Click the button to check the error details and actions.

6. Various tests and operations can be performed by clicking the "Operation Test" or "Selected Station Operation" on the bottom left of the window. (Page 187 Communication test, Page 188 Remote operation)

"CC-Link IE TSN/CC-Link IE Field Diagnostics" window

Network map

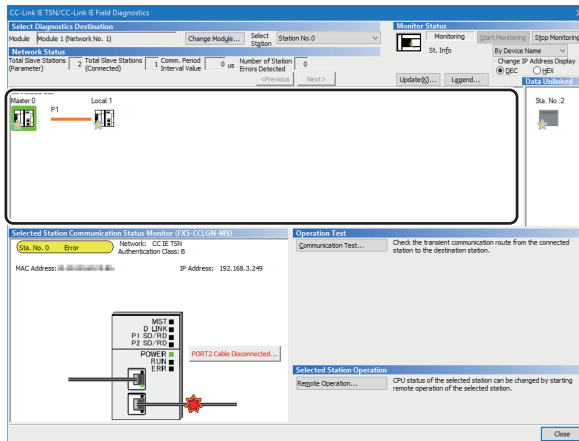

In this manual, "Authentication Class" is described as "CC-Link IE TSN Class".

Item		Description
Select Diagnostics Destination	Module	The FX5-CCLGN-MS under diagnostics is displayed.
	[Change Module] button	Allows to change the target FX5-CCLGN-MS when multiple FX5-CCLGN-MSs are mounted. When two FX5-CCLGN-MSs with the same network number are mounted on the FX5 CPU module, the FX5-CCLGN-MS which is closer to the FX5 CPU module is always diagnosed, regardless of setting.
	Select Station	Selects the station number of the station to be diagnosed. A station to be diagnosed can also be selected by clicking the module icon displayed in the network map.
Monitor Status	[Start Monitoring] button	Starts monitoring the CC-Link IE TSN/CC-Link IE Field diagnostics.
	[Stop Monitoring] button	Stops monitoring the CC-Link IE TSN/CC-Link IE Field diagnostics.
[Update] button		If the actual network configuration and network map of the "CC-Link IE TSN/CC-Link IE Field Diagnostics" window are inconsistent, the network map update is executed so they are matched. A data link error may momentarily occur in all the stations, and outputs of the connected device stations may turn off since all stations on the network will be reconnected when executing the network map update. Set output data if needed.
[Legend] button		Displays the meaning of icons displayed in the "CC-Link IE TSN/CC-Link IE Field Diagnostics" window.
St. Info		The display name of the device station can be selected from "By Device Name", "By Station Type", "By Model Name", or "By IP Address". (Default: "By Device Name") "By Device Name" displays the information entered in "Alias" of "Network Configuration Settings" under "Basic Settings". The station type is displayed when the "Alias" is not entered.
Network Status	Total Device Stations (Parameter)	Displays the total number of device stations set in "Network Configuration Settings" under "Basic Settings".
	Total Device Stations (Connected)	Displays the total number of device stations (number of device stations) that are actually connected by data link in the CC-Link IE TSN.
	Communication Cycle Interval Setting value	The communication cycle interval set in "Communication Period Setting" under "Basic Settings" of the master station is displayed. (μ s unit)
	Number of Station Errors Detected	Indicates the number of error stations in the displayed network.
	Change IP Address Display	Allows to select from "DEC" or "HEX" for IP address display on the selected communication status monitor and network map. (Default: Decimal)
	Network map	Indicates the CC-Link IE TSN structure and the status of each station. (Page 184 Network map)
	Data Unlinked	Displays a disconnected station that has been set in "Network Configuration Settings" under "Basic Settings" but has not yet performed data link. Reserved stations or error invalid stations are also included.
Selected Station Communication Status Monitor		Displays status of the station selected in "Network Status". (Page 186 Selected Station Communication Status Monitor)
Operation Test	[Communication Test] button	Performs a communication test. (Page 187 Communication test)
Selected Station Operation	[Remote Operation] button	Performs remote operations (such as RUN, STOP, and RESET operations) on the FX5 CPU module. (Page 179 Module communication test)

Network map

Icon

The module type and station number are displayed with an icon.

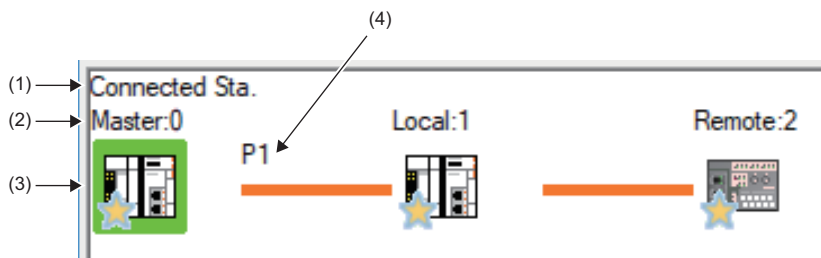

- Click: Selection
- Right-click: Executes tests or debugging.
- keys on the keyboard: Move the focus to the module to be diagnosed, and determine it with the key.



No.	Description
(1)	Displays the station (own station) where the engineering tool is connected.
(2)	Displays the station type and station number. "?" is displayed when a station number has not been set. When the background of the text is colored, the relevant station may have been set as a reserved station or an error invalid station. Click the [Legend] button to check the meaning of the background colors.
(3)	Module status is displayed. Click the [Legend] button to check the meaning of the icon. When the "Error (Illegal ring connection detected)" icon is displayed, take actions displayed in "Troubleshooting" of "Error details". (Page 186 When a station where an error has occurred is selected)
(4)	P1 or P2 to which an Ethernet cable is connected is displayed.

Network map

A network map is displayed according to the connection status.

Connection status	Display of the network map
<p>Line topology</p>	
<p>Star topology</p>	
<p>Coexistence of line and star topologies</p>	

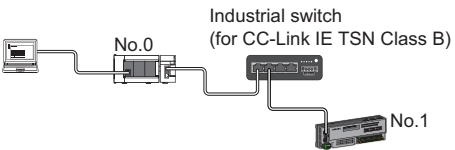
In the following cases, the network map is displayed differently from the actual connection status.

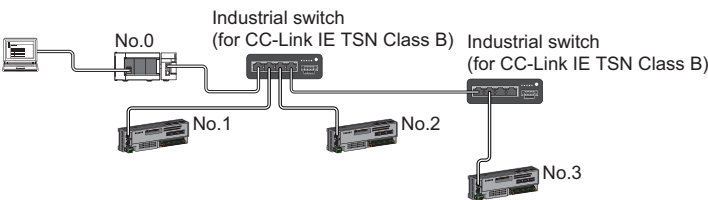
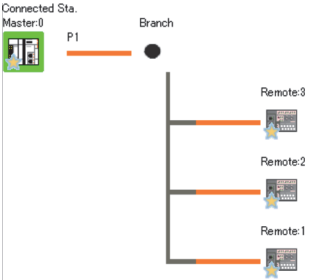
Connection status	Display of the network map
<p>Two stations are connected through an industrial switch.</p> 	<p>Branches are not displayed in the network map.</p> 
<p>Industrial switches are in cascade connection.</p> 	<p>Only one branch is displayed.</p> 

Precautions

Stations in offline mode are not displayed in the network map. In line topology, stations connected after a station in offline mode are not displayed because they are disconnected.

Selected Station Communication Status Monitor

Status of the station selected in "Network Status" is displayed.

■When a station where an error has occurred is selected

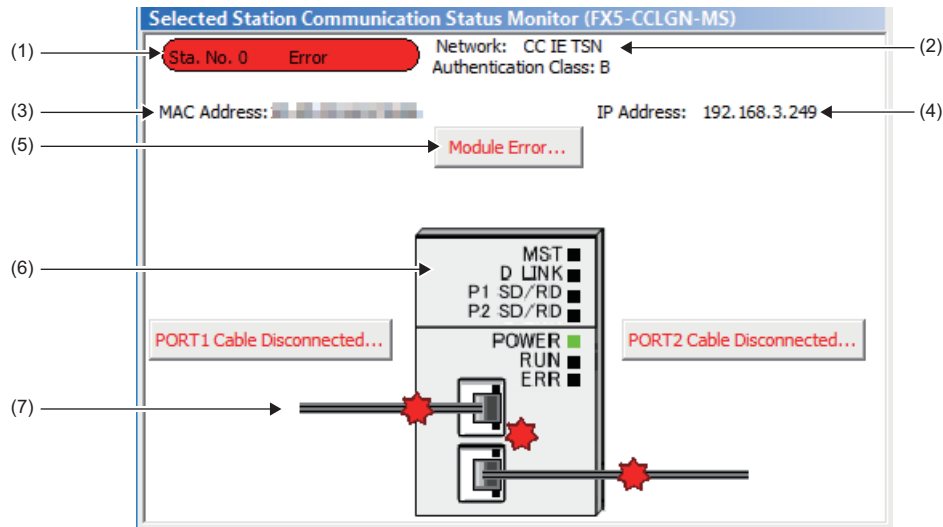

In this manual, "Authentication Class" is described as "CC-Link IE TSN Class".

No.	Description
(1)	Indicates the station number and operating status. <ul style="list-style-type: none"> • Station number No error (light blue): Normal operation • Station number Error (yellow): Error (Data link is continued) • Station number Error (red): Error (Data link is stopped)
(2)	Displays the network type.
(3)	Displays a MAC address.*1
(4)	Displays an IP address.
(5)	Click this button to check error details. Take actions according to the description displayed in "Error Factor" and "Troubleshooting".
(6)	The LED status of a module and communication status of P1 and P2 is displayed. (Page 19 LED indication)
(7)	Status of the Ethernet cables connected to P1 and P2 is displayed.

*1 When 00-00-00-00-00-00 is displayed as a MAC address, the status of the selected station cannot be checked with the selected station communication status monitor. Connect the engineering tool directly to the station where the error has occurred, and check the error details on the "System Monitor" window.

■When a selected station is not available for communication status monitor

The information of devices are not displayed. The "Error details" window (detailed information, error factor, troubleshooting) is displayed.

Communication test

This function checks if transient transmission data can be properly routed from the own station to the communication target. Depending on selection for "Communication Method" ("Network No./Station No." or "IP Address"), the range that can be checked may vary.

Selection of "Communication Method"	Communication target of transient transmission	
	Stations on the same network	Stations on the other network
Network No./Station No.	<input type="radio"/> Available for check	<input checked="" type="radio"/> Not available for check
IP Address	<input type="radio"/> Available for check	<input checked="" type="radio"/> Not available for check

The following explains the procedure for a communication test.

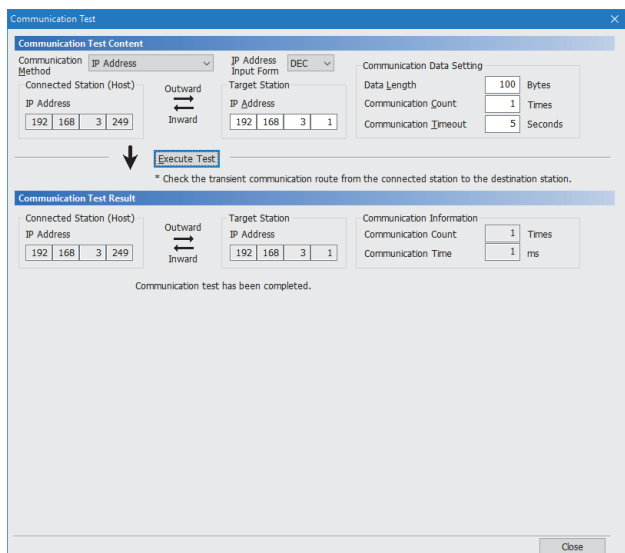

1. Display the "Communication Test" window and select "Network No./Station No." or "IP Address" from "Communication Method".
 [Diagnostics] ⇒ [CC-Link IE TSN/CC-Link IE Field Diagnostics] ⇒ [Communication Test] button
2. Enter values for "Target Station" and "Communication Data Setting".
3. Click the [Execute Test] button to execute the communication test. If an error occurs, take corrective actions according to the error message.

Precautions

- When a relay sending station is set to "Target Station", the communication test ends with an error. Set a relay receiving station to "Target Station".

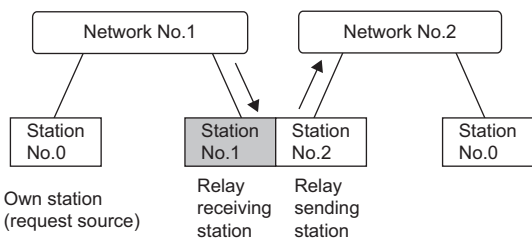

- When "Network No./Station No." is selected for "Communication Method" and a station mounted on the same system (module connected with a connector or cable) is set for "Target Station", the communication test ends with an error.
- This test cannot check whether transient transmission can be performed from the connected station (own station) to a station on another network by specifying an IP address.
- Since this function uses PING, a communication test target station communication error (error code D919H) occurs if the communication target does not respond to PING. When executing this function, check if the security setting (such as firewall) of the communication target is set to respond to PING. Moreover, if the target is set not to respond to PING in the security settings (such as a firewall), it may take some time until a timeout error occurs on the engineering tool. For details on when communication of the engineering tool is not allowed in the firewall settings of Windows, refer to the following.

GX Works3 Operating Manual

Remote operation

This function executes remote operations (such as RUN, STOP, and RESET operations) to the station selected on the "CC-Link IE TSN/CC-Link IE Field Diagnostics" window, from the engineering tool. (Remote operation for device stations is available only for RESET.)

The displayed window varies depending on the station selected. For the operations with a module other than the FX5-CCLGN-MS selected, refer to the manual for the module used.

Procedure

To perform remote operations, follow the steps below.

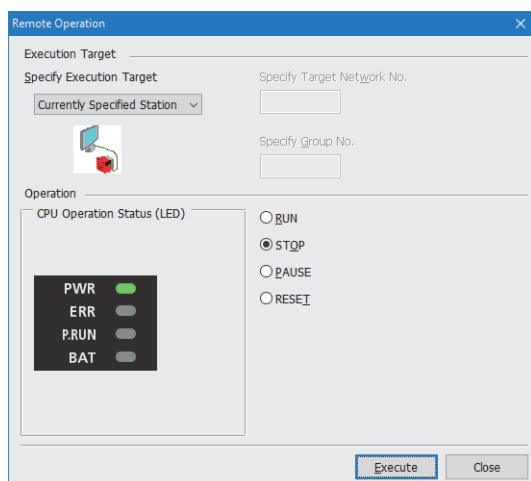

1. Select the module where the remote operations are performed in the "CC-Link IE TSN/CC-Link IE Field Diagnostics" window.
2. Click the [Remote Operation] button in the "CC-Link IE TSN/CC-Link IE Field Diagnostics" window, or right-click a module icon in the "Network Status" and click [Remote Operation].

The "Remote Operation" window is displayed.

3. Specify "Current Specified Station" in "Specify Execution Target".

The remote operations are performed only to the CPU module on the station selected in the CC-Link IE TSN/CC-Link IE Field diagnostics.

4. Select a remote operation (RUN, STOP, PAUSE, or RESET) to be performed in "Operation" to the CPU module. *1
5. Click the [Execute] button to perform the remote operation.

*1 To perform remote RESET, set "Remote Reset Setting" under "Operation Related Setting" of "CPU Parameter" to "Enable" in advance.



For details on the remote operations, refer to the user's manual for the CPU module used.

10.4 Troubleshooting by Symptom

This section describes troubleshooting by symptom. Perform the troubleshooting by symptom when a data link cannot be performed with the target station even though no error occurs in the FX5-CCLGN-MS. If an error has occurred in the FX5-CCLGN-MS, identify the error cause using the engineering tool. (🔧 Page 180 Checking the Network Status)

When cyclic transmission cannot be performed

The following table lists the actions to be taken if cyclic transmission cannot be performed to the master station.

Check item	Action	
Is the D LINK LED of the FX5-CCLGN-MS turned on?	Perform troubleshooting for when the D LINK LED turns off or is flashing. (🔧 Page 175 When the D LINK LED turns off or is flashing)	
Do the station types set in "Network Configuration Settings" of the master station match those set for the connected device stations?	<ul style="list-style-type: none"> • Check 'Station type match status of each station' (SB00E8) and 'Station type match status' (SW00E8 to SW00EF) to correct the station type of stations in which the station type does not match. • Correct that "Network Configuration Settings" of the master station and the actual system configuration match. 	
When "Connection Device Information" is set to "CC-Link IE TSN Class B Only", is an industrial switch (for CC-Link IE TSN Class B) used?	<p>Correct the industrial switch and its settings. For the setting method, refer to the manual for the industrial switch used.</p> <ul style="list-style-type: none"> • For details on precautions and restrictions on the system configuration when using an industrial switch (for CC-Link IE TSN Class B), refer to the CC-Link Partner Association website. (www.cc-link.org) • Correct the industrial switch delay time according to the industrial switch used. (🔧 Page 262 Communication cycle intervals) For the industrial switch delay time of the industrial switch used, consult the manufacturer. 	
When "Communication Speed" of the master station is set to "100Mbps", is "Basic Settings" ⇒ "Communication Period Setting" ⇒ "Basic Period Setting" ⇒ "System Reservation Time" of the master station set to 20μs?	Set "System Reservation Time" to 200μs.	
Does the IP filter setting mistakenly block communications from the IP address of another station?	Change the IP filter setting parameter to allow communication for the IP address of another station.	
The connection device information of the master station is set to "CC-Link IE TSN Class B Only".	Are CC-Link IE TSN Class A devices connected?	Disconnect the CC-Link IE TSN Class A devices.
	Is an industrial switch (for CC-Link IE TSN Class A) connected between the CC-Link IE TSN Class B devices?	Check the connected devices and remove the industrial switch (for CC-Link IE TSN Class A) or connect the industrial switch (for CC-Link IE TSN Class B).
The connection device information of the master station is set to "Mixture of CC-Link IE TSN Class B/A or CC-Link IE TSN Class A Only".	<p>■For firmware version "1.002" or earlier</p> Are nine or more CC-Link IE TSN Class B devices and industrial switches connected in total to each port of the master station in the transmission path from the master station to the CC-Link IE TSN Class B device of the end?	Check the connected devices and reduce the number of CC-Link IE TSN Class B devices and industrial switches to eight or less in total for each port of the master station in the transmission path from the master station to the CC-Link IE TSN Class B device of the end.
	Is any CC-Link IE TSN Class B device other than the master station connected in a star topology via an industrial switch (for CC-Link IE TSN Class A)?	Other than the master station, do not connect CC-Link IE TSN Class B devices to an industrial switch (for CC-Link IE TSN Class A) in star topology. Alternatively, connect CC-Link IE TSN Class B devices to an industrial switch (for CC-Link IE TSN Class B).
	Is an industrial switch (for CC-Link IE TSN Class A) connected between the master station and CC-Link IE TSN Class B devices?	<p>Check the connected device and connect the master station to CC-Link IE TSN Class B devices in line topology instead of using an industrial switch (for CC-Link IE TSN Class A).</p> <p>Check the connected device and connect the master station with CC-Link IE TSN Class B devices via an industrial switch (for CC-Link IE TSN Class B).</p>
	<p>■For firmware version "1.002" or earlier</p> In multicast mode, is the CC-Link IE TSN Class A remote station connected to the master station?	<ul style="list-style-type: none"> • Connect the CC-Link IE TSN Class A remote station to a local station or remote station supporting the multicast filter. • Set unicast mode.
	In multicast mode, is the CC-Link IE TSN Class A remote station connected to a local station or remote station that does not support the multicast filter?	<ul style="list-style-type: none"> • Connect the CC-Link IE TSN Class A remote station to a local station or remote station supporting the multicast filter. • Set unicast mode.

Check item	Action	
<p>The connection device information of the master station is set to "Mixture of CC-Link IE TSN Class B/A or CC-Link IE TSN Class A Only".</p>	<ul style="list-style-type: none"> • Configure settings with the industrial switch so that the multicast frame (with multicast MAC address 09:00:70:00:10:02 and 09:00:70:00:10:05) will not be transferred to the port of the CC-Link IE TSN Class A remote station. • Check the connected device and do not enable a local station and a CC-Link IE TSN Class A remote station to connect on the end side via the industrial switch. • Set unicast mode. 	
<p>Is an Ethernet device connected to a place other than the end of the network?</p>	<p>Check the connected device and connect the Ethernet device at the end of the network.</p>	
<p>Is an industrial switch (for CC-Link IE TSN Class A) other than an industrial switch (for CC-Link IE TSN Class A) (NZ2EHG-T8(N) or DT135TX) used?</p>	<p>Use the NZ2EHG-T8(N) or DT135TX.</p>	
<p>■For firmware version "1.010" or later Is the event code 00C81 registered in the event history?</p>	<p>Change "CC-Link IE TSN Class Setting" under "Network Configuration Setting" or "CC-Link IE TSN Class Setting" on the device station side so that the "CC-Link IE TSN Class Setting" for each station match.</p>	
<p>When the device stations to be used operate with the CC-Link IE TSN Protocol version 2.0, is a master station that does not support the CC-Link IE TSN Protocol version 2.0 used?</p>	<ul style="list-style-type: none"> • Update the firmware of the master station to a version supporting the CC-Link IE TSN Protocol version 2.0. • Replace the master station with a master station supporting the CC-Link IE TSN Protocol version 2.0. 	
<p>■For firmware version "1.010" or later Is the event code 00C80 registered in the event history?</p>	<ul style="list-style-type: none"> • Check 'CC-Link IE TSN Protocol version 2.0 support status for each station' (SW01A0 to SW01A7), and update the firmware of the device station that does not support the CC-Link IE TSN Protocol version 2.0 to a version supporting the CC-Link IE TSN Protocol version 2.0. • Replace the device station with a device station supporting the CC-Link IE TSN Protocol version 2.0. 	
<p>■For firmware version "1.010" or later Is 'Protocol operating status' (UnG44320) set to "2" (A device is operating with the CC-Link IE TSN Protocol version 2.0)?</p>	<p>Is 'CC-Link IE TSN Protocol version 2.0 support status for each station' (SW01A0 to SW01A7) set to "0: Not supported"?</p>	<p>■When a device station that does not support the CC-Link IE TSN Protocol version 2.0 can be updated to/replaced with a device station supporting the CC-Link IE TSN Protocol version 2.0</p> <ul style="list-style-type: none"> • Update the firmware of the device station that does not support the CC-Link IE TSN Protocol version 2.0 to a version supporting the CC-Link IE TSN Protocol version 2.0. • Replace the device station with a device station supporting the CC-Link IE TSN Protocol version 2.0. <p>■When a device station that does not support the CC-Link IE TSN Protocol version 2.0 cannot be updated to/replaced with a device station supporting the CC-Link IE TSN Protocol version 2.0</p> <ul style="list-style-type: none"> • Set the operating protocol to the CC-Link IE TSN Protocol version 1.0 fixed. <p> Page 237 Protocol information</p> <ul style="list-style-type: none"> • Power on the device stations and devices in the communication path, and then power on the master station.
<p>■For firmware version "1.010" or later Is 'Protocol operating status' (UnG44320) set to "1" (A device is operating with the CC-Link IE TSN Protocol version 1.0)?</p>	<p>Is 'CC-Link IE TSN Protocol version 2.0 support status for each station' (SW01A0 to SW01A7) set to "0: Not supported"?</p>	<ul style="list-style-type: none"> • Update the firmware of the device station that does not support the CC-Link IE TSN Protocol version 2.0 to a version supporting the CC-Link IE TSN Protocol version 2.0. • Replace the device station with a device station supporting the CC-Link IE TSN Protocol version 2.0.
	<p>Are nine or more CC-Link IE TSN Class B devices and industrial switches connected in total to each port of the master station in the transmission path from the master station to the CC-Link IE TSN Class B device of the end?</p>	<p>Check the connected devices and reduce the number of CC-Link IE TSN Class B devices and industrial switches to eight or less in total for each port of the master station in the transmission path from the master station to the CC-Link IE TSN Class B device of the end.</p>
	<p>Does the cyclic data size exceed 2K bytes in total for CC-Link IE TSN Class A devices connected to a CC-Link IE TSN Class B device other than the master station? (Including when an industrial switch is used to connect to a CC-Link IE TSN Class B device)</p>	<ul style="list-style-type: none"> • Use an industrial switch (for CC-Link IE TSN Class B) to connect to CC-Link IE TSN Class B devices. (When an industrial switch is used to establish a connection, change the industrial switch (for CC-Link IE TSN Class A) to an industrial switch (for CC-Link IE TSN Class B).) • Restrict the number of connected stations so that the cyclic data size of the CC-Link IE TSN Class A devices does not exceed 2K bytes in total. • Connect the CC-Link IE TSN Class A devices to the master station.

Check item		Action
<p>The connection device information of the master station is set to "Mixture of CC-Link IE TSN Class B/A or CC-Link IE TSN Class A Only".</p>	<p>■For firmware version "1.010" or later Do the system configuration of mixture of CC-Link IE TSN Class B/A and "TSN HUB Setting" in "Connection Device Information" under "Basic Settings" differ?</p>	<p>For details, refer to the following. ☞ Page 199 A CC-Link IE TSN Class A device does not perform data link.</p>
	<p>Is the event code 00C72 registered in the event history?</p>	<ul style="list-style-type: none"> • Update the engineering tool to the latest version. • Take the following action for the device station with the IP address displayed in the detailed information of the event history. • Update the firmware of the device stations to the latest version.
<p>When the station is connected in line topology, is the communication speed setting matched among stations?</p>		<p>Correct "Communication Speed" under "Application Settings" so that the communication speed is matched for each station.</p>
<p>Is there any reason on the device station side why cyclic communication is not performed?</p>		<ul style="list-style-type: none"> • Check if an error has occurred on the device station. • Check if the device station settings and parameters are correct. • Refer to the manual of the device station for troubleshooting.
<p>Is the event code 00C44 registered in the event history?</p>		<p>Set the same communication speed for the master station and the device station parameter automatic setting target station.</p>
<p>Is a device number outside the setting range set for a link side device in "Refresh Setting"?</p>		<p>Check that the device numbers of RX and RWr set in "Refresh Setting" are within the applicable range.</p>
<p>When "Communication Speed" of the master station is 1Gbps, does the cyclic data size exceed 2K bytes in total for all device stations on the 100Mbps device side at the boundary between a 1Gbps CC-Link IE TSN Class B device except for the master station and 100Mbps CC-Link IE TSN Class B device?</p>		<ul style="list-style-type: none"> • Restrict the number of connected stations so that the cyclic data size of 100Mbps devices does not exceed 2K bytes in total. • Connect 100Mbps device to the master station.
<p>■For firmware version "1.002" or earlier When the communication speed of the master station and CC-Link IE TSN Class A device station each are 1Gbps, is "Communication Period Setting" of the CC-Link IE TSN Class A device station set to "Basic Period" or "Normal Speed"?</p>		<ul style="list-style-type: none"> • Update the firmware version of the master station to "1.010" or later. • For the values set for "Communication Period Interval Setting" and "Cyclic Transmission Time" each in "Communication Period Setting" under "Basic Settings", set a value not smaller than the minimum value for the communication cycle interval (cyclic data transfer processing time). <p>☞ Page 262 Communication cycle intervals</p>

If the above actions do not solve the problem, perform the module communication test to check for hardware failure. (☞ Page 179 Module communication test)

When transient transmission cannot be performed



The following lists the actions to be taken if transient transmission cannot be performed with the target station, and the engineering tool cannot perform monitoring.

Check item	Action	
Is the D LINK LED of the FX5-CCLGN-MS flashing or turned on?	Perform troubleshooting to be performed when the D LINK LED turns off. (☞ Page 175 When the D LINK LED turns off or is flashing)	
Is the data link status of the target station normal?	In the CC-Link IE TSN/CC-Link IE Field diagnostics, identify the cause of the error and take action. (☞ Page 180 Checking the Network Status)	
Are the following data set correctly when a module FB or dedicated instruction is executed? <ul style="list-style-type: none"> • Target station CPU type • Target network number • Target station number 	Correct the section where the module FB or dedicated instruction is executed in the program.	
Is the network number duplicated on the network?	Correct the parameter so that duplication does not occur among network numbers.	
Are multiple link dedicated instructions with the same channel setting executed simultaneously?	<ul style="list-style-type: none"> • Set a different channel to each instruction. • Shift the execution timing of the link dedicated instructions. 	
Does the IP filter setting mistakenly block communications from the IP address of another station?	Change the IP filter setting parameter to allow communication for the IP address of another station.	
The connection device information of the master station is set to "CC-Link IE TSN Class B Only".	Are CC-Link IE TSN Class A devices connected?	Disconnect the CC-Link IE TSN Class A devices.
	Is an industrial switch (for CC-Link IE TSN Class A) connected?	Remove the industrial switch (for CC-Link IE TSN Class A) or connect the industrial switch (for CC-Link IE TSN Class B).
The connection device information of the master station is set to "Mixture of CC-Link IE TSN Class B/A or CC-Link IE TSN Class A Only".	<ul style="list-style-type: none"> ■ For firmware version "1.002" or earlier Are nine or more CC-Link IE TSN Class B devices and industrial switches connected in total to each port of the master station in the transmission path from the master station to the CC-Link IE TSN Class B device of the end?	Check the connected devices and reduce the number of CC-Link IE TSN Class B devices and industrial switches to eight or less in total for each port of the master station in the transmission path from the master station to the CC-Link IE TSN Class B device of the end.
	Is any CC-Link IE TSN Class B device other than the master station connected in a star topology via an industrial switch (for CC-Link IE TSN Class A)?	Other than the master station, do not connect CC-Link IE TSN Class B devices to an industrial switch (for CC-Link IE TSN Class A) in star topology. Alternatively, connect CC-Link IE TSN Class B devices to an industrial switch (for CC-Link IE TSN Class B).
	Is an industrial switch (for CC-Link IE TSN Class A) connected between the master station and CC-Link IE TSN Class B devices?	Check the connected device and connect the master station to CC-Link IE TSN Class B devices in line topology instead of using an industrial switch (for CC-Link IE TSN Class A). Check the connected device and connect the master station with CC-Link IE TSN Class B devices via an industrial switch (for CC-Link IE TSN Class B).
	<ul style="list-style-type: none"> ■ For firmware version "1.002" or earlier In multicast mode, is the CC-Link IE TSN Class A remote station connected to the master station?	<ul style="list-style-type: none"> • Connect the CC-Link IE TSN Class A remote station to a local station or remote station supporting the multicast filter. • Set unicast mode.
	In multicast mode, is the CC-Link IE TSN Class A remote station connected to a local station or remote station that does not support the multicast filter?	<ul style="list-style-type: none"> • Connect the CC-Link IE TSN Class A remote station to a local station or remote station supporting the multicast filter. • Set unicast mode.
	In multicast mode, are a local station and a CC-Link IE TSN Class A remote station connected on the end side using an industrial switch?	<ul style="list-style-type: none"> • Configure settings with the industrial switch so that the multicast frame (with multicast MAC address 09:00:70:00:10:02 and 09:00:70:00:10:05) will not be transferred to the port of the CC-Link IE TSN Class A remote station. • Check the connected device and do not enable a local station and a CC-Link IE TSN Class A remote station to connect on the end side via the industrial switch. • Set unicast mode.
	Is an Ethernet device connected to a place other than the end of the network?	Check the connected device and connect the Ethernet device at the end of the network.
	Is an industrial switch (for CC-Link IE TSN Class A) other than an industrial switch (for CC-Link IE TSN Class A) (NZ2EHG-T8(N) or DT135TX) used?	Use the NZ2EHG-T8(N) or DT135TX.
	<ul style="list-style-type: none"> ■ For firmware version "1.010" or later Is the event code 00C81 registered in the event history?	Change "CC-Link IE TSN Class Setting" under "Network Configuration Setting" or "CC-Link IE TSN Class Setting" on the device station side so that the "CC-Link IE TSN Class Setting" for each station match.

Check item	Action
<p>The connection device information of the master station is set to "Mixture of CC-Link IE TSN Class B/A or CC-Link IE TSN Class A Only".</p>	<ul style="list-style-type: none"> Update the firmware of the master station to a version supporting the CC-Link IE TSN Protocol version 2.0. Replace the master station with a master station supporting the CC-Link IE TSN Protocol version 2.0.
<p>When the device stations to be used operate with the CC-Link IE TSN Protocol version 2.0, is a master station that does not support the CC-Link IE TSN Protocol version 2.0 used?</p> <p>■ For firmware version "1.010" or later Is the event code 00C80 registered in the event history?</p>	<ul style="list-style-type: none"> Check 'CC-Link IE TSN Protocol version 2.0 support status for each station' (SW01A0 to SW01A7), and update the firmware of the device station that does not support the CC-Link IE TSN Protocol version 2.0 to a version supporting the CC-Link IE TSN Protocol version 2.0. Replace the device station with a device station supporting the CC-Link IE TSN Protocol version 2.0.
<p>■ For firmware version "1.010" or later Is 'Protocol operating status' (Un\G44320) set to "2" (A device is operating with the CC-Link IE TSN Protocol version 2.0)?</p>	<p>Is 'CC-Link IE TSN Protocol version 2.0 support status for each station' (SW01A0 to SW01A7) set to "0: Not supported"?</p>
<p>■ When a device station that does not support the CC-Link IE TSN Protocol version 2.0 can be updated to/replaced with a device station supporting the CC-Link IE TSN Protocol version 2.0</p> <ul style="list-style-type: none"> Update the firmware of the device station that does not support the CC-Link IE TSN Protocol version 2.0 to a version supporting the CC-Link IE TSN Protocol version 2.0. Replace the device station with a device station supporting the CC-Link IE TSN Protocol version 2.0. <p>■ When a device station that does not support the CC-Link IE TSN Protocol version 2.0 cannot be updated to/replaced with a device station supporting the CC-Link IE TSN Protocol version 2.0</p> <ul style="list-style-type: none"> Set the operating protocol to the CC-Link IE TSN Protocol version 1.0 fixed. <p>📖 Page 237 Protocol information</p> <ul style="list-style-type: none"> Power on the device stations and devices in the communication path, and then power on the master station. 	
<p>■ For firmware version "1.010" or later Is 'Protocol operating status' (Un\G44320) set to "1" (A device is operating with the CC-Link IE TSN Protocol version 1.0)?</p>	<p>Is 'CC-Link IE TSN Protocol version 2.0 support status for each station' (SW01A0 to SW01A7) set to "0: Not supported"?</p>
<ul style="list-style-type: none"> Update the firmware of the device station that does not support the CC-Link IE TSN Protocol version 2.0 to a version supporting the CC-Link IE TSN Protocol version 2.0. Replace the device station with a device station supporting the CC-Link IE TSN Protocol version 2.0. 	
<p>Are nine or more CC-Link IE TSN Class B devices and industrial switches connected in total to each port of the master station in the transmission path from the master station to the CC-Link IE TSN Class B device of the end?</p>	<p>Check the connected devices and reduce the number of CC-Link IE TSN Class B devices and industrial switches to eight or less in total for each port of the master station in the transmission path from the master station to the CC-Link IE TSN Class B device of the end.</p>
<p>Does the cyclic data size exceed 2K bytes in total for CC-Link IE TSN Class A devices connected to a CC-Link IE TSN Class B device other than the master station? (Including when an industrial switch is used to connect to a CC-Link IE TSN Class B device)</p>	<ul style="list-style-type: none"> Use an industrial switch (for CC-Link IE TSN Class B) to connect to CC-Link IE TSN Class B devices. (When an industrial switch is used to establish a connection, change the industrial switch (for CC-Link IE TSN Class A) to an industrial switch (for CC-Link IE TSN Class B).) Restrict the number of connected stations so that the cyclic data size of the CC-Link IE TSN Class A devices does not exceed 2K bytes in total. Connect the CC-Link IE TSN Class A devices to the master station.
<p>■ For firmware version "1.010" or later Do the system configuration of mixture of CC-Link IE TSN Class B/A and "TSN HUB Setting" in "Connection Device Information" under "Basic Settings" differ?</p>	<p>For details, refer to the following.</p> <p>📖 Page 199 A CC-Link IE TSN Class A device does not perform data link.</p>
<p>Is the event code 00C72 registered in the event history?</p>	<ul style="list-style-type: none"> Update the engineering tool to the latest version. Take the following action for the device station with the IP address displayed in the detailed information of the event history. Update the firmware of the device stations to the latest version.
<p>When the station is connected in line topology, is the communication speed setting matched among stations?</p>	<p>Correct "Communication Speed" under "Application Settings" so that the communication speed is matched for each station.</p>

Check item	Action
Is there any reason on the device station side why cyclic communication is not performed?	<ul style="list-style-type: none"> • Check if an error has occurred on the device station. • Check if the device station settings and parameters are correct. • Refer to the manual of the device station for troubleshooting.
Is the event code 00C44 registered in the event history?	Set the same communication speed for the master station and the device station parameter automatic setting target station.
Is a device number outside the setting range set for a link side device in "Refresh Setting"?	Check that the device numbers of RX and RWr set in "Refresh Setting" are within the applicable range.
When "Communication Speed" of the master station is 1Gbps, does the cyclic data size exceed 2K bytes in total for all device stations on the 100Mbps device side at the boundary between a 1Gbps CC-Link IE TSN Class B device except for the master station and 100Mbps CC-Link IE TSN Class B device?	<ul style="list-style-type: none"> • Restrict the number of connected stations so that the cyclic data size of 100Mbps devices does not exceed 2K bytes in total. • Connect 100Mbps device to the master station.
<p>■For firmware version "1.002" or earlier</p> <p>When the communication speed of the master station and CC-Link IE TSN Class A device station each are 1Gbps, is "Communication Period Setting" of the CC-Link IE TSN Class A device station set to "Basic Period" or "Normal Speed"?</p>	<ul style="list-style-type: none"> • Update the firmware version of the master station to "1.010" or later. • For the values set for "Communication Period Interval Setting" and "Cyclic Transmission Time" each in "Communication Period Setting" under "Basic Settings", set a value not smaller than the minimum value for the communication cycle interval (cyclic data transfer processing time). <p> Page 262 Communication cycle intervals</p>

If the above actions do not solve the problem, perform the following tests to check for an error.

- Communication test ( Page 187 Communication test)
- Module communication test ( Page 179 Module communication test)

When a station is disconnected from the network

The following is the action to be taken when a station in data link is disconnected.

Check item	Action
Is the ambient temperature for the module outside the specified range?	Keep the ambient temperature within the specified range by taking action such as removing heat source.

If the above action does not solve the problem, perform the module communication test to check for hardware failure. (☞
Page 179 Module communication test)

When a station is repeatedly disconnected and reconnected

The following lists the actions to be taken when a station in data link is repeatedly disconnected and reconnected.

Check item	Action
Do the used Ethernet cables conform to the Ethernet standard?	If not, replace them with Ethernet cables that satisfy the Ethernet standard. (☞ Page 125 Ethernet cable)
Is the station-to-station distance 100m or less?	Change the station-to-station distance to 100m or less.
Does the cabling condition (bending radius) meet the specifications?	Refer to the manual for the Ethernet cable, and if the bending radius exceeds the specified range, correct the bending radius.
Is any Ethernet cable disconnected?	If an Ethernet cable is disconnected, replace the Ethernet cable.
Is the industrial switch used in the system operating normally?	<ul style="list-style-type: none"> Check that an industrial switch that conforms to the standard is used. (☞ Page 125 Industrial switch) Power off and on the industrial switch.
Is the time synchronization source station operating normally?	Take action by referring to the manual for the module of the time synchronization source station.
Are resets of other stations repeated?	Avoid unnecessary reset since a station is disconnected while resetting.
Are other stations repeatedly powering on/off?	Avoid unnecessary power-off, since a station is disconnected while turned off.
When "Communication Speed" of the master station is set to "100Mbps", is "Basic Settings" ⇒ "Communication Period Setting" ⇒ "Basic Period Setting" ⇒ "System Reservation Time" of the master station set to 200μs?	Set "System Reservation Time" to 200μs.
When the communication speed of the master station is set to 1Gbps and a CC-Link IE TSN Class B/A device with a communication speed of 100Mbps is used, is "Communication Period Setting" set to "Basic Period" or "Normal-Speed"?	For a CC-Link IE TSN Class B/A device with a communication speed of 100Mbps, set "Communication Period Setting" to "Low-Speed".
<p>■For firmware version "1.010" or later</p> <p>When the communication speed of the master station is set to 1Gbps and a CC-Link IE TSN Class B/A device with a communication speed of 100Mbps is used in multicast mode, is the station disconnected and returned repeatedly even if "Communication Period Setting" is set to "Low-Speed"?</p> <p>■For firmware version "1.002" or earlier</p> <p>When the communication speed of the master station is set to 1Gbps and a CC-Link IE TSN Class B/A device with a communication speed of 100Mbps is used, is the station disconnected and returned repeatedly even if "Communication Period Setting" is set to "Low-Speed"?</p>	<p>■For firmware version "1.010" or later</p> <p>Perform the following wiring and setting.</p> <ul style="list-style-type: none"> Connect the data link faulty station to the device supporting the multicast filter. <p>■For firmware version "1.002" or earlier</p> <p>Perform the following wiring and setting.</p> <ul style="list-style-type: none"> Use one of P1 or P2 of the master station. Connect the device that supports multicast filtering to the data link faulty station and set to the multicast mode.
In multicast mode, are a local station and a CC-Link IE TSN Class A remote station connected on the end side using an industrial switch?	<ul style="list-style-type: none"> Configure settings with the industrial switch so that the multicast frame (with multicast MAC address 09:00:70:00:10:02 and 09:00:70:00:10:05) will not be transferred to the port of the CC-Link IE TSN Class A remote station. Check the connected device and do not enable a local station and a CC-Link IE TSN Class A remote station to connect on the end side via the industrial switch. Set unicast mode.
Is 'Protocol operating status' (UnIG44320) set to "1" (A device is operating with the CC-Link IE TSN Protocol version 1.0)?	<p>Does the cyclic data size exceed 2K bytes in total for CC-Link IE TSN Class A devices connected to a CC-Link IE TSN Class B device other than the master station? (Including when an industrial switch (for CC-Link IE TSN Class A) is used to connect to a CC-Link IE TSN Class B device)</p> <ul style="list-style-type: none"> Use an industrial switch (for CC-Link IE TSN Class B) to connect to CC-Link IE TSN Class B devices. (When an industrial switch (for CC-Link IE TSN Class A) is used to establish a connection, change the industrial switch (for CC-Link IE TSN Class A) to an industrial switch (for CC-Link IE TSN Class B).) Does the cyclic data size exceed 2K bytes in total for CC-Link IE TSN Class A devices connected to a CC-Link IE TSN Class B device other than the master station? (Including when an industrial switch (for CC-Link IE TSN Class A) is used to connect to a CC-Link IE TSN Class B device)
<p>■For firmware version "1.010" or later</p> <p>Do the system configuration of mixture of CC-Link IE TSN Class B/A and "TSN HUB Setting" in "Connection Device Information" under "Basic Settings" differ?</p>	<p>For details, refer to the following.</p> <p>☞ Page 199 A CC-Link IE TSN Class A device does not perform data link.</p>

Check item	Action
Does any of the stations breaks any restriction for the industrial switch (for CC-Link IE TSN Class B)?	Follow the restrictions for the industrial switch (for CC-Link IE TSN Class B). For the restrictions, refer to the manual for the industrial switch (for CC-Link IE TSN Class B) used.
When "Communication Speed" of the master station is 1Gbps, does the cyclic data size exceed 2K bytes in total for all device stations on the 100Mbps device side at the boundary between a 1Gbps CC-Link IE TSN Class B device except for the master station and the 100Mbps CC-Link IE TSN Class B device?	<ul style="list-style-type: none"> Restrict the number of connected stations so that the cyclic data size of 100Mbps devices does not exceed 2K bytes in total. Connect 100Mbps device to the master station.
■For firmware version "1.002" or earlier In multicast mode, is the CC-Link IE TSN Class A remote station connected to the master station?	<ul style="list-style-type: none"> Connect the CC-Link IE TSN Class A remote station to a local station or remote station supporting the multicast filter. Set unicast mode.
In multicast mode, is the CC-Link IE TSN Class A remote station connected to a local station or remote station that does not support the multicast filter?	<ul style="list-style-type: none"> Connect the CC-Link IE TSN Class A remote station to a local station or remote station supporting the multicast filter. Set unicast mode.

If the above actions do not solve the problem, perform the module communication test to check for hardware failure. ( Page 179 Module communication test)

When communication is unstable

When cyclic transmission delay time is long or when a transient transmission timeout occurs, check the following items.

Check item	Action
Is the L ER LED of the FX5-CCLGN-MS turned on?	Perform troubleshooting to be performed when the L ER LED turns on. ( Page 176 When the L ER LED turns on)
Is the ambient temperature for the module outside the specified range?	Keep the ambient temperature within the specified range by taking action such as removing heat source.
Is any error shown in "Selected Station Communications Status Monitor" of CC-Link IE TSN/CC-Link IE Field diagnostics?	If an error occurs, perform a module communication test.
Is there any noise affecting the system?	Change the installation of the modules and wiring so that the system is not affected by noise.

If the above actions do not solve the problem, perform the module communication test to check for hardware failure. ( Page 179 Module communication test)

When communication with an SLMP-compatible device cannot be performed

When communication with an SLMP-compatible device cannot be performed, check the following items.

Check item	Action
Has the connection with the external device been opened normally?	<ul style="list-style-type: none"> • If the connection with the external device is not opened, perform the open processing.*1 • If an error occurs, check and eliminate the error cause.
Is the correct command format used for the command type, device specification, address specification, and others?	Correct the command to be sent.
Did the external device send a command?	If the external device did not send a command, send a command to this module.
Was a response returned to the device that had sent the command?	<ul style="list-style-type: none"> • If no response was returned, check if the correct IP address was specified in the command. If not, correct the IP address and send the command again. • If a response was returned, check the end and error codes to correct the faulty area.
Is the same communication speed set for the connected device and access destination?	Change the connection destination so that the connected station and the access destination have the same communication speed, and execute communication.
■For firmware version "1.002" or earlier When communicating in multicast mode, is an Ethernet device connected to the master station?	<ul style="list-style-type: none"> • Connect the Ethernet device to the local station or remote station supporting the multicast filter. • Set unicast mode. • Take actions so that the Ethernet device does not receive multicast cyclic data.
In multicast mode, is an Ethernet device connected to a local station or remote station that does not support the multicast filter?	<ul style="list-style-type: none"> • Connect the Ethernet device to the local station or remote station supporting the multicast filter. • Set unicast mode. • Take actions so that the Ethernet device does not receive multicast cyclic data.
In multicast mode, are a local station and an Ethernet device connected on the end side using an industrial switch?	<ul style="list-style-type: none"> • Configure settings with the industrial switch so that the multicast frame (with multicast MAC address 09:00:70:00:10:02 and 09:00:70:00:10:05) will not be transferred to the port of the Ethernet device. • Check the connected device and do not connect a local station and an Ethernet device on the end side via the industrial switch. • Set unicast mode. • Take actions so that the Ethernet device does not receive multicast cyclic data.

*1 If the connection of only the external device is closed due to cable disconnection, personal computer restart, or other reasons, reopen the connection using the same port used before the error occurred. A connection is not closed if another Active open request is received from the external device with a different IP address or a port number.

If the above actions do not solve the problem, perform the module communication test to check for hardware failure. ( Page 179 Module communication test)

When the time synchronization does not operate for the control CPU of a local station

When the time synchronization does not operate for the control CPU of a local station, check the following items.

Check item	Action
Has the clock data been changed by the clock function of the CPU module?	Check the clock function of the CPU module to see if the clock data has been changed.

When communications with Ethernet devices cannot be performed

When communications (CC-Link IE TSN/CC-Link IE Field diagnostics, transient transmission, remote password, or communication test) with Ethernet devices cannot be performed, check the following items.

Check item	Action
Is the firewall or proxy server setting enabled on the Ethernet device?	Check and correct the firewall and proxy server settings on the Ethernet device such as checking if a response to the PING command (ICMP echo request) is disabled.
Is the antivirus software on the Ethernet device blocking the communication?	Check and correct the antivirus software settings on the Ethernet device. <ul style="list-style-type: none"> • Is the security setting level of the antivirus software low? • Is a response to the PING command (ICMP echo request) disabled in the firewall settings?
When communicating in multicast mode, is an Ethernet device connected to the master station?	<ul style="list-style-type: none"> • Connect the Ethernet device to the local station or remote station supporting the multicast filter. • Set unicast mode. • Take actions so that the Ethernet device does not receive multicast cyclic data.
In multicast mode, is an Ethernet device connected to a local station or remote station that does not support the multicast filter?	Connect the Ethernet device to the local station or remote station supporting the multicast filter.
In multicast mode, are a local station and an Ethernet device connected on the end side using an industrial switch?	<ul style="list-style-type: none"> • Configure settings with the industrial switch so that the multicast frame (with multicast MAC address 09:00:70:00:10:02 and 09:00:70:00:10:05) will not be transferred to the port of the Ethernet device. • Check the connected device and do not connect a local station and an Ethernet device on the end side via the industrial switch. • Set unicast mode. • Take actions so that the Ethernet device does not receive multicast cyclic data.

Point

For details when communications of GX Works3 are not allowed in the firewall settings of Windows, refer to the following.

 GX Works3 Operating Manual

If the above actions do not solve the problem, perform the module communication test to check for hardware failure. ( Page 179 Module communication test)

When the link device cannot communicate although the data link is normal

When the link device cannot communicate although the data link is normal (D LINK LED is on), check the following items.

Check item	Action
Is "Reserved/Error Invalid Station" of the device station set to "Reserved Station" in "Network Configuration Settings" of the master station?	Set "Reserved/Error Invalid Station" of the device station to "No Setting".
Is the input/output bit setting or input/output word setting of the device station set in "Network Configuration Settings" of the master station? (Simple display)	Set a link device used in the device station correctly.
Are "RX Setting", "RY Setting", "RWw Setting", "RWr Setting", "LB Setting", and "LW Setting" of the device station set in "Network Configuration Settings" of the master station? (Detailed display)	Set a link device used in the device station correctly.
Does the device station support the link devices set in "Network Configuration Settings" of the master station?	Correct the link devices to be assigned to the device station in "Network Configuration Settings" of the master station.
Is the link refresh setting range correct?	Correct the setting in "Refresh Settings" of "Basic Settings".
Is the refresh range of "CPU Side" in "Refresh Settings" duplicated with that of "CPU Side" of another network module?	Correct the setting in "Refresh Settings" of "Basic Settings".
Is the transfer range set in "Interlink Transmission Settings" correct?	Correct the transfer range set in "Interlink Transmission Settings".
Are the settings in "Transfer Source Module" and "Transfer Destination Module" of "Interlink Transmission Settings" correct?	Correct the settings in "Transfer Source Module" and "Transfer Destination Module" of "Interlink Transmission Settings".
When the local station cannot receive cyclic data from another station, is "Communication Mode" of the master station set to "Multicast"?	Set "Communication Mode" of the master station to "Multicast".

A CC-Link IE TSN Class A device does not perform data link.

■When "Not to Use TSN HUB" is set

When "TSN HUB Setting" in "Connection Device Information" under "Basic Settings" is set to "Not to Use TSN HUB", check the following.

Check item	Action
Is a CC-Link IE TSN Class B device connected to a CC-Link IE TSN Class A device via an industrial switch (for CC-Link IE TSN Class B)?	<ul style="list-style-type: none"> Set "TSN HUB Setting" in "Connection Device Information" under "Basic Settings" to "Use TSN HUB". Connect the CC-Link IE TSN Class B device and CC-Link IE TSN Class A device directly. Alternatively, connect them via an industrial switch (for CC-Link IE TSN Class A).
Is an industrial switch (for CC-Link IE TSN Class B) used for connection between CC-Link IE TSN Class B devices?	<ul style="list-style-type: none"> Set "TSN HUB Setting" in "Connection Device Information" under "Basic Settings" to "Use TSN HUB". Do not use an industrial switch (for CC-Link IE TSN Class B) for connection between CC-Link IE TSN Class B devices.

■When "Use TSN HUB" is set

When "TSN HUB Setting" in "Connection Device Information" under "Basic Settings" is set to "Use TSN HUB", check the following.

Check item	Action
Are a CC-Link IE TSN Class B device and CC-Link IE TSN Class A device connected directly or via an industrial switch (for CC-Link IE TSN Class A)?	<ul style="list-style-type: none"> Set "TSN HUB Setting" in "Connection Device Information" under "Basic Settings" to "Not to Use TSN HUB". Connect the CC-Link IE TSN Class B device and CC-Link IE TSN Class A device via an industrial switch (for CC-Link IE TSN Class B). Connect the master station and CC-Link IE TSN Class A device directly or via an industrial switch (for CC-Link IE TSN Class A). Ensure that the total cyclic data size of all device stations on the CC-Link IE TSN Class A device side that form a boundary between CC-Link IE TSN Class B and CC-Link IE TSN Class A devices does not exceed 2K bytes.

10.5 List of Error Codes

The following table lists the error codes, error definitions and causes, and actions for the errors that occur in the processing for data communication between the FX5-CCLGN-MS and external devices or occur by processing requests from the FX5 CPU module on the own station.

Error codes are displayed in the [Error Information] tab in the "Module Diagnostics" window of the FX5-CCLGN-MS. (Page 177 Error Information)

Error code	Error definition and causes	Action	Detailed information 1
			Detailed information 2
1124H	<ul style="list-style-type: none"> The default gateway is not set correctly. The gateway IP address is not set correctly. The default gateway/gateway IP address (network address after the subnet mask) is different from that of the IP address of the own node. 	<ul style="list-style-type: none"> Correct the default gateway IP address. Set the same network address as that of the IP address. 	<ul style="list-style-type: none"> Parameter information Parameter type Intelligent module No. Parameter No. Network No. Station No. —
1128H	The port number is incorrect.	Correct the port number.	—
1129H	System error	Please consult your local Mitsubishi representative.	—
112DH to 112EH	System error	Please consult your local Mitsubishi representative.	—
1134H	System error	Please consult your local Mitsubishi representative.	—
1152H	The IP address is not set correctly.	Correct the IP addresses.	<ul style="list-style-type: none"> Parameter information Parameter type Intelligent module No. Parameter No. Network No. Station No. —
1155H	<ul style="list-style-type: none"> The specified connection was already closed in TCP/IP communications. Open processing is not performed. 	<ul style="list-style-type: none"> Perform the open processing for the specified connection. Check if the open processing has been performed in the external device. 	—
1157H	<ul style="list-style-type: none"> The specified connection was already closed in UDP/IP communications. Open processing is not performed. 	<ul style="list-style-type: none"> Perform the open processing for the specified connection. Check if the open processing has been performed in the external device. 	—
1158H	System error	Please consult your local Mitsubishi representative.	—
1166H	System error	Please consult your local Mitsubishi representative.	—
1167H	Unsent data found, but could not be sent.	<ul style="list-style-type: none"> Check the settings for connection with the external device. Check the operation of the external device or industrial switch. Since there may be congestion of packets on the line, send data after a certain period of time. Check if the Ethernet cable is disconnected. Check that there is no connection failure with the industrial switch. Execute the communication test, and if the test was completed with an error, take corrective action. 	—

Error code	Error definition and causes	Action	Detailed information 1
			Detailed information 2
1802H	During data link, overlapping IP addresses have been detected.	Change the IP address of devices with a duplicated IP address.	<ul style="list-style-type: none"> ■Operation source information <ul style="list-style-type: none"> • IP address ■IP address duplication information <ul style="list-style-type: none"> • Duplication station 1 MAC address (1st octet, 2nd octet) • Duplication station 1 MAC address (3rd octet, 4th octet) • Duplication station 1 MAC address (5th octet, 6th octet) • Duplication station 2 MAC address (1st octet, 2nd octet) • Duplication station 2 MAC address (3rd octet, 4th octet) • Duplication station 2 MAC address (5th octet, 6th octet)
1803H	Over the number of stations that can be connected.	Reduce the number of CC-Link IE TSN Class B devices and industrial switches (for CC-Link IE TSN Class B) to eight or less in total for each port of the master station in the transmission path from the master station to the CC-Link IE TSN Class B device of the end.	—
1804H	<p>During data link, invalid connection structure has been detected.</p> <ul style="list-style-type: none"> • A CC-Link IE TSN Class B station is connected further on the end side than a CC-Link IE TSN Class A station. • With the master station with a communication speed of 1Gbps, further on the end side than a station with a communication speed of 100Mbps, a station with a communication speed of 1Gbps is connected. • With the master station with a communication speed of 100Mbps, a station with a communication speed of 1Gbps is connected. • For a master station with a communication speed of 100Mbps, "Communication Period Setting" of the CC-Link IE TSN Class B station with a communication speed of 100Mbps is set to "Low-Speed". • With the master station with a communication speed of 1Gbps, "Communication Period Setting" of the station with a communication speed of 100Mbps is set to "Basic Period" or "Normal-Speed" (×4). • The communication speed of the master station and local station are not matched. <p>■Multicast mode</p> <ul style="list-style-type: none"> • A CC-Link IE TSN Class A local station is connected further on the end side than a CC-Link IE TSN Class A remote station. • When the master station has a communication speed of 1Gbps, stations with a communication speed of 1Gbps and 100Mbps are connected on the end side of the industrial switch. 	<p>Check the connection and setting on the end side of the station shown in detailed information 2 and take the following actions.</p> <ul style="list-style-type: none"> • Connect the CC-Link IE TSN Class A station further on the end than the CC-Link IE TSN Class B station. • If the master station has a communication speed of 1Gbps, connect the station with a communication speed of 1Gbps on the master station side rather than on the side where a station with a communication speed of 100Mbps is connected. • If the master station has a communication speed of 100Mbps, set the communication speed of the device station to 100Mbps. • If the master station has a communication speed of 100Mbps, set "Communication Period Setting" of the CC-Link IE TSN Class B station with a communication speed of 100Mbps to "Basic Period" or "Normal-Speed" (×4). • If the master station has a communication speed of 1Gbps, set "Communication Period Setting" to "Low-Speed" for the station with a communication speed of 100Mbps. • Set the same communication speed for the master station and local station. <p>■Multicast mode</p> <ul style="list-style-type: none"> • Connect the CC-Link IE TSN Class A remote station further on the end than the CC-Link IE TSN Class A local station. • If the master station has a communication speed of 1Gbps, do not connect both a station with a communication speed of 1Gbps and a station with the speed of 100Mbps on the end side of the industrial switch. 	<ul style="list-style-type: none"> ■Own station information <ul style="list-style-type: none"> • Intelligent module No. • Network No. • Station No. • IP address ■Target station information <ul style="list-style-type: none"> • Network No. • Station No. • IP address

Error code	Error definition and causes	Action	Detailed information 1
			Detailed information 2
1805H	<ul style="list-style-type: none"> The total cyclic data size of all device stations on the CC-Link IE TSN Class A device side that form a boundary between CC-Link IE TSN Class B and CC-Link IE TSN Class A devices exceeds 2K bytes. The total cyclic data size of all device stations on the side of the station with a communication speed of 100Mbps at the boundary between the station with a communication speed of 1Gbps and the station with a communication speed of 100Mbps exceeds 2K bytes. 	<p>Check the connection and setting on the end side of the station shown in detailed information 2 based on the error definition and cause and take the following actions.</p> <ul style="list-style-type: none"> Ensure that the total cyclic data size of all device stations on the CC-Link IE TSN Class A device side that form a boundary between CC-Link IE TSN Class B and CC-Link IE TSN Class A devices does not exceed 2K bytes. Do not set the total cyclic data size of all device stations on the side of the station with a communication speed of 100Mbps at the boundary between the station with a communication speed of 1Gbps and the station with a communication speed of 100Mbps to exceed 2K bytes. 	<ul style="list-style-type: none"> ■Own station information <ul style="list-style-type: none"> Intelligent module No. Network No. Station No. IP address ■Target station information <ul style="list-style-type: none"> Network No. Station No. IP address
1806H	<ul style="list-style-type: none"> When "TSN HUB Setting" is set to "Not to Use TSN HUB", connection of the CC-Link IE TSN Class B devices in a star topology has been detected. A CC-Link IE TSN Class B device is connected further on the end side than a CC-Link IE TSN Class A device. 	<ul style="list-style-type: none"> Disconnect the industrial switch connected with the CC-Link IE TSN Class B device. Set "TSN HUB Setting" to "Use TSN HUB". Connect the CC-Link IE TSN Class A device further on the end than the CC-Link IE TSN Class B device. 	<ul style="list-style-type: none"> ■Own station information <ul style="list-style-type: none"> Intelligent module No. Network No. Station No. IP address ■—
1811H	A stop error has been detected in the CPU module.	Check the error of the CPU module in "Module Diagnostics" of the engineering tool and take action.	—
1830H	Number of reception requests of transient transmission (link dedicated instruction) exceeded the upper limit of simultaneously processable requests.	Lower the transient transmission usage frequency, and retry the operation.	—
1845H	Too much processing of transient transmission (link dedicated instruction) and cannot perform transient transmission.	Correct the transient transmission (link dedicated instruction) execution count.	—
1D01H	System error	Please consult your local Mitsubishi representative.	—
1D10H to 1D11H	System error	Please consult your local Mitsubishi representative.	—
1D20H	System error	Please consult your local Mitsubishi representative.	—
20E0H	The module cannot communicate with the CPU module.	The hardware failure of the CPU module may have been occurred. Please consult your local Mitsubishi representative.	—
2160H	IP address duplication was detected.	Check the IP addresses.	—
2220H	The parameter setting is corrupted.	Check the detailed information of the error in "Module Diagnostics" of the engineering tool, and write the displayed parameter. If the same error occurs again, the possible cause is a hardware failure of the module. Please consult your local Mitsubishi representative.	<ul style="list-style-type: none"> ■Parameter information <ul style="list-style-type: none"> Parameter type ■—
2221H	<ul style="list-style-type: none"> The set value is out of the range. Or the setting values of the master station and local stations are not consistent. Parameters that are not supported by the firmware version of the network module have been set. 	<ul style="list-style-type: none"> Check the detailed information of the error in "Module Diagnostics" of the engineering tool, and correct the parameter setting corresponding to the parameter number. Check the firmware version of the network module. If parameters that are not supported are set, update the firmware version or correct the parameters. 	<ul style="list-style-type: none"> ■Parameter information <ul style="list-style-type: none"> Parameter type Intelligent module No. Parameter No. Network No. Station No. ■—
24C0H to 24C3H	System error	Please consult your local Mitsubishi representative.	—
24C6H	System error	Please consult your local Mitsubishi representative.	—
2600H	System error	Please consult your local Mitsubishi representative.	—
2610H	System error	Please consult your local Mitsubishi representative.	—
3000H	System error	Please consult your local Mitsubishi representative.	—

Error code	Error definition and causes	Action	Detailed information 1
			Detailed information 2
3009H	The result when the value set in "Communication Period Interval Setting" in "Communication Period Setting" under "Basic Settings" of the master station is multiplied by "Communication Period Setting" of the device station set in "Network Configuration Settings" under "Basic Settings" is out of the range.	<p>Check the detailed information in "Module Diagnostics" of the engineering tool. Correct the parameter settings described below so that the result when the value set in "Communication Period Interval Setting" in "Communication Period Setting" under "Basic Settings" of the master station is multiplied by "Communication Period Setting" of the device station set in "Network Configuration Settings" under "Basic Settings" becomes within 16ms.</p> <ul style="list-style-type: none"> • "Communication Period Interval Setting" in "Basic Settings" • "Communication Period Setting" of the relevant device station in "Network Configuration Settings" <p>Set a value to "Communication Period Setting" of device stations by selecting a multiple value on "Multiple Period Setting" of "Communication Period Setting" under "Basic Settings".</p>	<ul style="list-style-type: none"> ■— ■Target station information <ul style="list-style-type: none"> • Station Number • IP address
300AH	<ul style="list-style-type: none"> • The combination of the local station firmware version and the master station firmware version is incorrect. • The set value is out of the range. Or the setting values of the master station and local stations are not consistent. 	<ul style="list-style-type: none"> • Check the firmware versions of the master station and local station. If the combination is incorrect, update the firmware version of the older local station or that of the master station. • Check the detailed information of the error in "Module Diagnostics" of the engineering tool, and correct the parameter setting of the master station corresponding to the parameter number. • If the same error occurs again, the possible cause is a hardware failure of the module. Please consult your local Mitsubishi representative. 	<ul style="list-style-type: none"> ■Parameter information <ul style="list-style-type: none"> • Parameter type • Intelligent module No. • Parameter No. • Network No. • Station No. ■—
300BH	The Announce frame send cycle parameter error was detected.	<ul style="list-style-type: none"> • Check the Announce frame send cycle parameter setting value of the device operating as the grandmaster. When the FX5-CCLGN-MS is operating as the grandmaster, reset the CPU module, and run it again. • If the same error occurs again even after taking the above measure, the possible cause is a hardware failure of the module. Please consult your local Mitsubishi representative. 	—
300CH	A propagation delay send cycle parameter error was detected.	<ul style="list-style-type: none"> • Check the propagation delay send cycle parameter setting value of the device operating as the grandmaster. When the FX5-CCLGN-MS is operating as the grandmaster, reset the CPU module, and run it again. • If the same error occurs again even after taking the above measure, the possible cause is a hardware failure of the module. Please consult your local Mitsubishi representative. 	—
300DH	The Sync frame send cycle parameter error was detected.	<ul style="list-style-type: none"> • Check the Sync frame send cycle parameter setting value of the device operating as the grandmaster. When the FX5-CCLGN-MS is operating as the grandmaster, reset the CPU module, and run it again. • If the same error occurs again even after taking the above measure, the possible cause is a hardware failure of the module. Please consult your local Mitsubishi representative. 	—
300EH	The set values of the master station and local station do not match.	Set the same parameter setting values for "Network No." and "Station No." of the local station to the setting values of the master station.	<ul style="list-style-type: none"> ■Parameter information <ul style="list-style-type: none"> • Parameter type • Intelligent module No. • Parameter No. • Network No. • Station No. ■—
300FH	Multiple master stations were detected in the network.	<ul style="list-style-type: none"> • Connect only one master station on the same network. • After taking the above action, power off and on or reset all stations where the error was detected. 	<ul style="list-style-type: none"> ■Parameter information <ul style="list-style-type: none"> • Parameter type • Intelligent module No. • Parameter No. ■Overlapped type information <ul style="list-style-type: none"> • 5: Master station duplication

Error code	Error definition and causes	Action	Detailed information 1
			Detailed information 2
3010H	The value set in "Communication Period Interval Setting" in "Communication Period Setting" under "Basic Settings" of the master station is smaller than the communication cycle interval calculated by the number of stations and points of device stations that was set in "Network Configuration Settings" under "Basic Settings".	Set the value of "Communication Period Interval Setting" as a value equal to or larger than the value in the detailed information displayed in "Module Diagnostics" using "Communication Period Setting" under "Basic Settings" of the master station.	<ul style="list-style-type: none"> ■— ■Communication Period Interval Information • Communication Period Interval (Calculation value: μs)
3011H	The value set in "Cyclic transmission time" in "Communication Period Setting" under "Basic Settings" of the master station is smaller than the cyclic transmission time calculated by the number of stations and points of device stations set in "Network Configuration Settings" under "Basic Settings".	Set the value of "Cyclic Transmission Time" as a value equal to or larger than the value in the detailed information displayed in "Module Diagnostics" using "Communication Period Setting" under "Basic Settings" of the master station.	<ul style="list-style-type: none"> ■— ■Communication Period Interval Information • Cyclic Transmission Time (Calculation value: μs)
3012H	System error	Please consult your local Mitsubishi representative.	—
3013H	The value set in "Transient Transmission Time" in "Communication Period Setting" under "Basic Settings" of the master station is smaller than the transient transmission time calculated using the number of device stations and the points of device stations set in "Network Configuration Settings" under "Basic Settings".	Set "Communication Period Interval Setting" and "Cyclic Transmission Time" so that the value of "Transient Transmission Time" in "Communication Period Setting" under "Basic Settings" of the master station is equal to or larger than the value shown in the detailed information displayed in "Module Diagnostics".	<ul style="list-style-type: none"> ■— ■Communication Period Interval Information • Transient Transmission Time (Calculation value: μs)
3014H	When "Communication Mode" under "Application Settings" of the master station is set to "Multicast", in the "Network Configuration Settings" of the "Basic Settings", "Communication Period Setting" of the local station is set to "Normal-Speed" or "Low-Speed".	<ul style="list-style-type: none"> • Set "Communication Mode" in "Application Settings" of the master station to "Unicast". • In "Network Configuration Settings" under "Basic Settings" of the master station, set "Communication Period Setting" of the local station to "Basic Period". 	<ul style="list-style-type: none"> ■Parameter information • Parameter type • Intelligent module No. • Parameter No. ■Target station information • Station Number • IP address
3015H	The value set in "Communication Period Interval Setting" in "Communication Period Setting" under "Basic Settings" of the master station is smaller than the communication cycle interval calculated by the number of stations and points of device stations that was set in "Network Configuration Settings" under "Basic Settings".	Set the value of "Communication Period Interval Setting" as a value equal to or larger than the value of "Communication Period Interval (Calculation value)" (SW0072) of a local station using "Communication Period Setting" under "Basic Settings" of the master station. (☞ Page 262 Communication cycle intervals)	—
3016H	System error	Please consult your local Mitsubishi representative.	—
3017H	The value set in "Cyclic transmission time" in "Communication Period Setting" under "Basic Settings" of the master station is smaller than the cyclic transmission time calculated by the number of stations and points of device stations set in "Network Configuration Settings" under "Basic Settings".	Set the value of "Cyclic Transmission Time" as a value equal to or larger than the value of "Cyclic Transmission Time (Calculation value)" (SW0073) of a local station using "Communication Period Setting" under "Basic Settings" of the master station. (☞ Page 262 Communication cycle intervals)	—
3018H	The value set in "Transient Transmission Time" in "Communication Period Setting" under "Basic Settings" of the master station is smaller than the transient transmission time calculated using the number of device stations and the points of device stations set in "Network Configuration Settings" under "Basic Settings".	Set "Communication Period Interval Setting" and "Cyclic Transmission Time" so that the value of "Transient Transmission Time" in "Communication Period Setting" under "Basic Settings" of the master station is equal to or larger than the value of "Transient Transmission Time (Calculation value)" (SW0078) of a local station. (☞ Page 262 Communication cycle intervals)	—

Error code	Error definition and causes	Action	Detailed information 1
			Detailed information 2
3021H	At startup of data link, IP address duplication among device stations has been detected.	Correct the IP addresses of the device stations.	<ul style="list-style-type: none"> ■ Operation source information • IP address ■ IP address duplication information • Duplication station 1 MAC address (1st octet, 2nd octet) • Duplication station 1 MAC address (3rd octet, 4th octet) • Duplication station 1 MAC address (5th octet, 6th octet) • Duplication station 2 MAC address (1st octet, 2nd octet) • Duplication station 2 MAC address (3rd octet, 4th octet) • Duplication station 2 MAC address (5th octet, 6th octet)
3040H to 3042H	System error	Please consult your local Mitsubishi representative.	—
3060H	The send/receive data size exceeds the allowable range.	<ul style="list-style-type: none"> • Check and change the send data size of the Ethernet-equipped module or the external device. • If the same error occurs again even after taking the above, the possible cause is a hardware failure of the error module or CPU module. Please consult your local Mitsubishi representative. 	—
3110H to 3111H	System error	Please consult your local Mitsubishi representative.	—
3120H	System error	Please consult your local Mitsubishi representative.	—
3121H	The cyclic transmission setting information received from the master station exceeds the setting range.	Write the module parameter to the CPU module again. If the same error occurs again even after taking the above, please consult your local Mitsubishi representative.	—
3130H	Devices with time synchronization priority of 0 to 15 have been connected.	Remove devices with time synchronization priority of 0 to 15, or change the priority to between 16 and 255.	—
3135H	Over the number of stations that can be connected.	Reduce the number of CC-Link IE TSN Class B devices to eight or less for each port of the master station.	—
3136H	An illegal ring topology was detected.	Set a line topology or star topology, and turn off and on or reset all stations.	—
31ABH	Sending/receiving cyclic data within the "Low-Speed" period to/from a device station with "Communication Period Setting" set to "Low-Speed" cannot be guaranteed.	<ul style="list-style-type: none"> • Set "Low-Speed" in "Multiple Period Setting" to a value that is equal to or higher than the one displayed for 'Multiple period setting (low speed)' (Un\G44594). • Set "Communication Period Interval Setting" in "Basic Period Setting" to a value that is equal to or higher than the one displayed for 'Communication cycle interval (calculation value)' (Un\G44595). 	<ul style="list-style-type: none"> ■ Parameter information • Parameter type ■ —
31ACH	The settings do not match between "CC-Link IE TSN Class Setting" of the device stations set in "Network Configuration Setting" and "CC-Link IE TSN Class Setting" under "Connection Device Information" of "Basic Settings".	Set "CC-Link IE TSN Class Setting" in "Network Configuration Setting" of the device stations to "CC-Link IE TSN Class B". Alternatively, set "CC-Link IE TSN Class Setting" under "Connection Device Information" of "Basic Settings" to "Mixture of CC-Link IE TSN Class B/A or CC-Link IE TSN Class A Only".	<ul style="list-style-type: none"> ■ Parameter information • Parameter type ■ —
3600H	Response data of the dedicated instruction cannot be created.	<ul style="list-style-type: none"> • Increase the request interval. • Decrease the number of request nodes. • Wait for a response to the previous request before sending the next request. • Correct the timeout value. 	—
3601H to 3603H	System error	Please consult your local Mitsubishi representative.	—

Error code	Error definition and causes	Action	Detailed information 1
			Detailed information 2
3607H to 360DH	System error	Please consult your local Mitsubishi representative.	—
3C00H	A hardware failure has been detected.	<ul style="list-style-type: none"> Take measures to reduce noise. Reset the CPU module, and run it again. If the same error occurs again even after taking the above, the possible cause is a hardware failure of the module or extension cable. Please consult your local Mitsubishi representative. 	—
3C01H	A hardware failure has been detected.	<ul style="list-style-type: none"> Take measures to reduce noise. Reset the CPU module, and run it again. If the same error occurs again even after taking the above, the possible cause is a hardware failure of the module or extension cable. Please consult your local Mitsubishi representative. 	—
3C02H	A hardware failure has been detected.	<ul style="list-style-type: none"> Take measures to reduce noise. Reset the CPU module, and run it again. If the same error occurs again even after taking the above, the possible cause is a hardware failure of the module or extension cable. Please consult your local Mitsubishi representative. 	—
3C0FH	A hardware failure has been detected.	<ul style="list-style-type: none"> Take measures to reduce noise. Reset the CPU module, and run it again. If the same error occurs again even after taking the above, the possible cause is a hardware failure of the module or extension cable. Please consult your local Mitsubishi representative. 	—
3C10H	A hardware failure has been detected.	<ul style="list-style-type: none"> Take measures to reduce noise. Reset the CPU module, and run it again. If the same error occurs again even after taking the above, the possible cause is a hardware failure of the module or extension cable. Please consult your local Mitsubishi representative. 	—
3C13H	A hardware failure has been detected.	Reset the CPU module, and run it again. If the same error occurs again even after doing so, the possible cause is a hardware failure of the error module or CPU module. Please consult your local Mitsubishi representative.	—
3C14H	A hardware failure has been detected.	Reset the CPU module, and run it again. If the same error occurs again even after doing so, the possible cause is a hardware failure of the error module or CPU module. Please consult your local Mitsubishi representative.	—
3C2FH	An error was detected in the memory.	Reset the CPU module, and run it again. If the same error occurs again even after taking the above, the possible cause is a hardware failure of the error module. Please consult your local Mitsubishi representative.	—
3E01H	Network type of the own station is unexpected setting.	Rewrite the module parameter using the engineering tool. If the same error occurs again even after taking the above, the possible cause is a hardware failure of the error module. Please consult your local Mitsubishi representative.	—
3E02H	A time synchronization error was detected.	Reset the CPU module, and run it again. If the same error occurs again even after doing so, the possible cause is a hardware failure of the error module or CPU module. Please consult your local Mitsubishi representative.	—
3E03H	An error was detected in the memory.	Reset the CPU module, and run it again. If the same error occurs again even after doing so, the possible cause is a hardware failure of the error module or CPU module. Please consult your local Mitsubishi representative.	—
3E04H	A hardware failure has been detected.	Reset the CPU module, and run it again. If the same error occurs again even after doing so, the possible cause is a hardware failure of the error module or CPU module. Please consult your local Mitsubishi representative.	—
4000H to 4FFFH	Errors detected by the CPU module (📖 User's Manual for the CPU module used)		
C011H	The port number of the external device is not set correctly.	Correct the port number of the external device.	—

Error code	Error definition and causes	Action	Detailed information 1
			Detailed information 2
C012H	The port number used in a connection already opened is set. (For TCP/IP)	Correct the port numbers of the Ethernet-equipped module and the external device.	—
C013H	The port number used in a connection already opened is set. (For UDP/IP)	Correct the port numbers of the Ethernet-equipped module and the external device.	—
C015H	The data was sent to the connected device while the IP address setting of the device set in the network configuration setting was incorrect.	<ul style="list-style-type: none"> • Correct the IP address of the connected device in the network configuration setting. • Check that the IP address class of the connected device is set to A, B, or C in the network configuration setting. 	—
C017H	A connection could not be established in the open processing.	<ul style="list-style-type: none"> • Check the operation of the external device. • Check if the open processing has been performed in the external device. • When a firewall is set in the external device, check if access is permitted. • Check if the Ethernet cable is disconnected. 	—
C018H	The specified IP address of the external device is incorrect.	Correct the specified IP address of the external device.	—
C032H	The external device does not send an ACK response in the TCP/IP communications.	<ul style="list-style-type: none"> • Since there may be congestion of packets on the line, send data after a certain period of time. • Check if the Ethernet cable is disconnected. 	—
C035H	The alive status of an external device could not be checked.	<ul style="list-style-type: none"> • Check the operation of the external device. • Check if the Ethernet cable is disconnected. 	—
C037H	<ul style="list-style-type: none"> • The receive buffer or send buffer is not sufficient. • The window size of the external device is not sufficient. 	<ul style="list-style-type: none"> • Check the operation of the external device or industrial switch. • When the value of the 'Receive Buffer Status Storage Area' (Un\G68126) is 0001H, reduce the reception frequency of data from the external device. 	—
C038H	Data was not sent correctly with UDP/IP.	<ul style="list-style-type: none"> • Check the settings for connection with the external device (including an industrial switch) and the operation of the external device (error or during resetting). Check that there is no connection failure (if the Ethernet cable is disconnected). • Since there may be congestion of packets on the line, send data after a certain period of time. • Execute the PING test and communication status test, and if the test was completed with an error, take the corrective action. • Correct the network number and station number/IP address of the target station of the dedicated instruction. 	—
C039H	Data was not sent correctly with TCP/IP.	<ul style="list-style-type: none"> • Check the settings for connection with the external device (including an industrial switch) and the operation of the external device (error or during resetting). Check that there is no connection failure (if the Ethernet cable is disconnected). • Since there may be congestion of packets on the line, send data after a certain period of time. • Execute the PING test and communication status test, and if the test was completed with an error, take the corrective action. 	—
C040H	<ul style="list-style-type: none"> • Sufficient data for the data length could not be received. • The remaining part of the message divided at the TCP/IP level could not be received. 	<ul style="list-style-type: none"> • Correct the data length of the communication data. • Since there may be congestion of packets on the line, send the data again from the external device after a random amount of time has passed. 	—
C050H	ASCII code data that cannot be converted to binary code was received.	Check if the ASCII code data that cannot be converted into binary code data was sent from the external device.	—
C051H	<ul style="list-style-type: none"> • The number of read/write points from/to the device of SLMP message is out of the allowable range in the CPU module (in units of words). • The number of write points for the long counter of SLMP message is not in two-word units. 	Correct the number of read/write points and send the SLMP message to the Ethernet-equipped module again.	—
C052H	The number of read/write points from/to the device of SLMP message is out of the allowable range in the CPU module (in units of bits).	Correct the number of read/write points and send the SLMP message to the Ethernet-equipped module again.	—
C053H	The number of read/write points from/to the random device of SLMP message is out of the allowable range in the CPU module (in units of bits).	Correct the number of read/write points and send the SLMP message to the Ethernet-equipped module again.	—

Error code	Error definition and causes	Action	Detailed information 1
			Detailed information 2
C054H	The number of read/write points from/to the random device of SLMP message is out of the allowable range in the CPU module (in units of words, double words).	Correct the number of read/write points and send the SLMP message to the Ethernet-equipped module again.	—
C055H	The read/write size from/to the file data of SLMP message is out of the allowable range.	Correct the read/write size and send the SLMP message to the Ethernet-equipped module again.	—
C056H	The read/write request exceeds the largest address.	<ul style="list-style-type: none"> • Correct the start address or the number of read/write points so that the request does not exceed the largest address and send the data to the Ethernet-equipped module again. • If the access target and connection stations are modules of the MELSEC iQ-R series, send the SLMP message again to the Ethernet-equipped module using 00□3 and 00□2 of subcommands. 	—
C057H	The request data length of the SLMP message does not match the number of data in the character (a part of text).	Check and correct the text or request data length, and send the SLMP message to the Ethernet-equipped module again.	—
C058H	The request data length of the SLMP message after the ASCII/binary conversion does not match with the number of data in the character (a part of text).	Check and correct the text or request data length, and send the SLMP message to the Ethernet-equipped module again.	—
C059H	<ul style="list-style-type: none"> • The specified command and subcommand of the SLMP message are incorrect • A function that is not supported by the target device was executed. 	<ul style="list-style-type: none"> • Check that there are no errors in the specification of the command and subcommand of the SLMP message. • Check whether the function executed is supported by the target device. • Check the version of the target device. 	—
C05AH	The Ethernet-equipped module cannot read/write data from/to the device specified by the SLMP message.	Correct the specification of the device to be read/written and send the SLMP message to the Ethernet-equipped module again.	—
C05BH	The Ethernet-equipped module cannot read/write data from/to the device specified by the SLMP message.	Correct the specification of the device to be read/written and send the SLMP message to the Ethernet-equipped module again.	—
C05CH	<ul style="list-style-type: none"> • The received request data of the SLMP message is incorrect. • The setting value of the communication setting when the iQSS function is executed is out of range. • When the iQSS function is executed, the items of communication setting which cannot be set on the target device are set. • When the iQSS function is executed, the required setting items have not been set to the target device. 	<ul style="list-style-type: none"> • Correct the request data and send the SLMP message to the Ethernet-equipped module again. • Correct the setting details of when the iQSS function is executed, and retry the operation. 	—
C05DH	The "Monitor Request" command is received before the monitor registration is performed by the "Monitor Registration/Clear" command of the SLMP message.	Register the monitoring data using "Monitor Registration/Clear" command and perform monitoring.	—
C05EH	<ul style="list-style-type: none"> • The time between reception of the SLMP request message by the Ethernet-equipped module and the returned response from the access destination exceeded the monitoring timer value set in the SLMP command. • An unresponsive command was sent to another network station as the access destination. (If this error does not cause any problems, it can be ignored.) 	<ul style="list-style-type: none"> • Increase the monitoring timer value. • Check if the access destination is operating normally. • Correct the network number or request destination station number. • If the access destination is a module with a different network number, check if the network number is not in use. 	—
C05FH	This request cannot be executed to the access destination specified by the SLMP message.	Correct the access destination.	—
C060H	The request details for bit devices of the SLMP message is incorrect.	Correct the request details and send the SLMP message to the Ethernet-equipped module again.	—

Error code	Error definition and causes	Action	Detailed information 1
			Detailed information 2
C061H	<ul style="list-style-type: none"> The request data length of the SLMP message does not match the number of data in the character (a part of text). The write data length specified by the label write command is not even byte. When the iQSS function is executed, incorrect frame is received. 	<ul style="list-style-type: none"> Check and correct the text or request data length, and send the SLMP message to the Ethernet-equipped module again. Add one byte of dummy data, and specify the length as an even number of bytes. Check the operating status and connection status of the target device at the time the iQSS function is executed. Check the connection of the Ethernet cable and industrial switch at the time the iQSS function is executed. Check the line status of Ethernet at the time the iQSS function is executed. Reset the CPU module and device to be targets of the iQSS function, and retry the operation. <p>For errors that occur when the iQSS function is executed, contact the manufacturer of the target device if the above actions do not solve the problem.</p>	—
C06FH	The network number of request destination specified by the SLMP request message is not available for communications with the station number 121 or larger.	<ul style="list-style-type: none"> If the 3E or 4E frame is used at SLMP, check that there is no error for the network number of the request destination and station number. If the station number extension frame is used at SLMP, check that there is no error for the network number of the request destination and station number. 	—
C070H	The device memory cannot be extended for the access destination specified by the SLMP message.	<ul style="list-style-type: none"> Correct the SLMP message to read/write data without the device memory set for extension. Specify the extension of the device memory only for an Ethernet-equipped module mounted station and a MELSEC iQ-R/Q/QnACPU via CC-Link IE Controller Network, MELSECNET/H, or MELSECNET/10. 	—
C071H	The number of device points for data read/write set for modules other than a MELSEC iQ-R/Q/QnACPU with the SLMP message is out of the range.	Correct the number of read/write points and send the SLMP message to the Ethernet-equipped module again.	—
C072H	The request details of the SLMP message are incorrect. (For example, a request for data read/write in bit units has been issued to a word device.)	<ul style="list-style-type: none"> Check if the data can be requested to the access destination. Correct the request details and send the SLMP message to the Ethernet-equipped module again. 	—
C073H	The access destination of the SLMP message cannot issue this request. (For example, the number of double word access points cannot be specified for modules other than a MELSEC iQ-R/Q/QnACPU.)	Correct the request details of the SLMP message.	—
C075H	The request data length for the label access is out of range.	<ul style="list-style-type: none"> Correct the number of read/write points and send the SLMP message to the Ethernet-equipped module again. Correct the label to shorten the label name and send the SLMP message to the Ethernet-equipped module again. 	—
C081H	The termination processing for the Ethernet-equipped module that is involved with the reinitialization processing is being performed, and arrival of link dedicated instructions cannot be checked.	Finish all the communications to perform the reinitialization processing of the Ethernet-equipped module.	—
C087H	IP address of the destination external device could not be acquired.	<ul style="list-style-type: none"> Correct the IP address in the network station number ↔ IP information setting. Check if the network or station number of the external device is correctly specified by using control data of the dedicated instruction. Check if the Ethernet cable is disconnected. 	—
C0B2H	There is insufficient space in the receive buffer or the send buffer of the relay station or external station for the MELSOFT connection, link dedicated instructions, or SLMP. (Send - receive buffer full error)	<p>Increase the request interval (execution interval) and execute the operation.</p> <ul style="list-style-type: none"> Do not access through one station using the MELSOFT connection, link dedicated instruction, or SLMP. Wait for a response to the previous request before sending the next request. Correct the timer setting value for data communication of the Ethernet-equipped module. 	—

Error code	Error definition and causes	Action	Detailed information 1
			Detailed information 2
C0B3H	A request that cannot be processed was issued from the CPU module.	<ul style="list-style-type: none"> • Correct the request details. • Correct the network number or request destination station number. 	—
C0D4H	The number of relay stations to communicate with other networks exceeds the allowable range.	<ul style="list-style-type: none"> • Check if the specification (network number/station number) for the communication destination is correct. • Check that the number of relay stations accessing the communication destination is 7 or less. • Correct the settings in the network station number ↔ IP information setting for the stations from the own station to the communication destination. 	—
C0D8H	The number of specified blocks exceeded the range.	Correct the number of blocks.	—
C0D9H	The specified subcommand of the SLMP message is incorrect.	Correct the subcommand.	—
C1A4H	<ul style="list-style-type: none"> • There is an error with the command, subcommand, or request destination module I/O number specified by the SLMP message. • A function that is not supported by the target device was executed. 	<ul style="list-style-type: none"> • Correct the command, subcommand, or request destination module I/O number specified by SLMP message. • Check the version of the target device. 	—
C1A7H	The specified network number is incorrect.	Correct the specified network number.	—
C1A9H	The specified device number is incorrect.	Correct the specified device number.	—
C1ADH	The specified data length is incorrect.	Correct the specified data length.	—
C1CCH	System error	Please consult your local Mitsubishi representative.	—
C200H	The remote password is incorrect.	Correct the remote password, and unlock/lock the remote password again.	—
C201H	The remote password status of the port used for communications is in the lock status.	After unlocking the remote password, perform communications.	—
C202H	When another station was accessed, the remote password could not be unlocked.	When accessing another station, do not set the remote password on the relay station or access station, or do not execute the remote password check on them.	—
C203H	An error has occurred when checking the remote password.	Correct the remote password, and unlock/lock the remote password again.	—
C204H	The device is different from the one requesting the remote password unlock processing.	Request the lock processing of the remote password from the external device that requested the unlock processing of the remote password.	—
C207H	The file name has too many characters.	Name the file with 255 characters or less.	—
C208H	The password length is out of range.	Set the password within 6 to 32 characters.	—
C612H	The module processing was completed with an error.	<ul style="list-style-type: none"> • Execute the communication status test, and if the test was completed with an error, take the corrective action. • Execute the module communication test, and check that there is no failure in the module. 	—
C613H	The module processing was completed with an error.	<ul style="list-style-type: none"> • Execute the communication status test, and if the test was completed with an error, take the corrective action. • Execute the module communication test, and check that there is no failure in the module. 	—
C615H	The module processing was completed with an error.	<ul style="list-style-type: none"> • Execute the communication status test, and if the test was completed with an error, take the corrective action. • Execute the module communication test, and check that there is no failure in the module. 	—
C810H	Remote password authentication has failed when required.	Set a correct password and perform password authentication again.	—
C811H	Remote password authentication has failed when required.	Set a correct password and perform password authentication again one minute later.	—
C812H	Remote password authentication has failed when required.	Set a correct password and perform password authentication again 5 minutes later.	—
C813H	Remote password authentication has failed when required.	Set a correct password and perform password authentication again 15 minutes later.	—
C814H	Remote password authentication has failed when required.	Set a correct password and perform password authentication again 60 minutes later.	—

Error code	Error definition and causes	Action	Detailed information 1
			Detailed information 2
C815H	Remote password authentication has failed when required.	Set a correct password and perform password authentication again 60 minutes later.	—
C816H	The security function was activated and remote password authentication cannot be performed.	Set a correct password and perform password authentication again after a certain period of time.	—
C842H	Cannot reach to the destination network number.	Execute the link dedicated instruction again after correcting the target network number/station number.	—
C844H	Incorrect frame was received. • Unsupported command	<ul style="list-style-type: none"> • Replace the network module with a module of the version supporting the function that has been executed. • If the error occurs again even after taking the above, please consult your local Mitsubishi representative. 	—
C900H	Communication failed.	Do not execute communication from multiple engineering tools to the same master station simultaneously.	—
C901H	The size of the request data to the external device or response data from the external device exceeds the range supported for communications.	Correct the size of the request data or response data to within 1500 bytes.	—
C902H	Communication was interrupted because no response was returned from the external device.	Execute the communication test, and if the test was completed with an error, take corrective action.	—
C903H	Failed to send request to the external device.	<ul style="list-style-type: none"> • Correct the IP address of the external device. • Check if the subnet mask of the external device matches the master station. • Check if the external device matches the communication speed. • Check if the Ethernet cable is connected properly and there is no failure. 	—
CA00H to CA0AH	System error	Please consult your local Mitsubishi representative.	—
CCC7H to CCCCH	System error	Please consult your local Mitsubishi representative.	—
CCD3H to CCD6H	System error	Please consult your local Mitsubishi representative.	—
CCDAH	System error	Please consult your local Mitsubishi representative.	—
CCFFH	System error	Please consult your local Mitsubishi representative.	—
CF40H	Incorrect frame was received.	<ul style="list-style-type: none"> • Check the operating status and connection status of the target device. • Check the connection of the Ethernet cable and industrial switch. • Check the line status of Ethernet. • Reset the CPU module and target device, and retry the operation. If the above actions do not solve the problem, contact the manufacturer of the target device.	—
CF41H	Incorrect frame was received.	<ul style="list-style-type: none"> • Check the operating status and connection status of the target device. • Check the connection of the Ethernet cable and industrial switch. • Check the line status of Ethernet. • Reset the CPU module and target device, and retry the operation. If the above actions do not solve the problem, contact the manufacturer of the target device.	—
CF42H	Incorrect frame was received.	<ul style="list-style-type: none"> • Check the operating status and connection status of the target device. • Check the connection of the Ethernet cable and industrial switch. • Check the line status of Ethernet. • Reset the CPU module and target device, and retry the operation. If the above actions do not solve the problem, contact the manufacturer of the target device.	—
CF43H	An error has occurred.	<ul style="list-style-type: none"> • Check the operating status of the external device. • Check if there is any error in the line status. If the above actions do not solve the problem, contact the manufacturer of the target device.	—

Error code	Error definition and causes	Action	Detailed information 1
			Detailed information 2
CF44H	Incorrect frame was received.	<ul style="list-style-type: none"> • Check the operating status and connection status of the target device. • Check the connection of the Ethernet cable and industrial switch. • Check the line status of Ethernet. • Reset the CPU module and target device, and retry the operation. If the above actions do not solve the problem, contact the manufacturer of the target device.	—
D03BH to D03CH	System error	Please consult your local Mitsubishi representative.	—
D0A3H	Send processing of the transient transmission has failed.	<ul style="list-style-type: none"> • Check the network status using the CC-Link IE TSN/CC-Link IE Field diagnostics of the engineering tool, and take action. • When the own station, target station, or relay station detected an error, identify the cause of the error and take action. • Correct the target station number of transient data, and retry the operation. 	—
D203H	The read data or write address of the transient transmission is incorrect.	Correct the read data or write address at the transient request source, and retry the operation.	—
D205H	The target station number of transient transmission is incorrect.	Correct the target station number at the transient request source, and retry the operation.	—
D20AH	The target network number of transient transmission is incorrect.	Correct the target network number at the transient request source, and retry the operation.	—
D20BH	There was no master station when the specified master station was specified for transient transmission.	Correct the target station number at the transient request source, and retry the operation.	—
D20CH	There was no master station when the current master station was specified for transient transmission.	Correct the target station number at the transient request source, and retry the operation.	—
D20DH	Transmission completion wait timeout has occurred in transient data transmission.	<ul style="list-style-type: none"> • Check the network status using the CC-Link IE TSN/CC-Link IE Field diagnostics of the engineering tool, and take action. • When the own station, target station, or relay station detected an error, identify the cause of the error and take action. • Lower the transient transmission usage frequency, and retry the operation. • Check if the industrial switch and the Ethernet cables at the request source are connected properly. 	—
D20EH	The header information of transient transmission is incorrect.	Correct the header information at the transient request source, and retry the operation.	—
D20FH	In transient transmission, the command which cannot be requested to all or a group of stations was executed with all stations specification or group specification.	Check that the command can be requested to all or a group of stations at the transient request source, and retry the operation.	—
D211H	Transient transmission was performed when the station number/IP address of the own station had not been set yet.	Set the station number/IP address using the UINI instruction, and perform transient transmission again.	—
D213H	<ul style="list-style-type: none"> • The command of transient transmission is incorrect. • The CC-Link IE TSN/CC-Link IE Field diagnostics was used for the network to which the relay receiving station belongs. • This function is not available for the module of the connection destination. 	<ul style="list-style-type: none"> • Correct the request command at the transient request source, and retry the operation. • Review the connection destination so that the CC-Link IE TSN/CC-Link IE Field diagnostics is used for the network to which the relay sending station belongs. • Refer to the manual for the module of the connection destination, and check whether the module supports this function. If the module does not support the function, update firmware version so that the module supports the function. 	—
D214H	The data length of transient transmission is incorrect.	Correct the data length at the transient request source, and retry the operation.	—
D239H	SLMP transmission failed.	<ul style="list-style-type: none"> • Retry the operation after a while. • If the error occurs again even after taking the above, please consult your local Mitsubishi representative. 	—
D240H	The network number specification of the dedicated instruction is incorrect.	Correct the network number at the request source of the dedicated instruction, and retry the operation.	—

Error code	Error definition and causes	Action	Detailed information 1
			Detailed information 2
D241H	The target station number of the dedicated instruction is incorrect.	Correct the target station number at the request source of the dedicated instruction, and retry the operation.	—
D242H	The command code of the dedicated instruction is incorrect.	Correct the command code at the request source of the dedicated instruction, and retry the operation.	—
D243H	The channel specified in the dedicated instruction is incorrect.	Correct the used channel within the allowable range at the request source of the dedicated instruction, and retry the operation.	—
D244H	The transient data is incorrect.	<ul style="list-style-type: none"> • Correct the transient data at the transient request source, and retry the operation. • If the error occurs again even after taking the above, please consult your local Mitsubishi representative. 	—
D245H	The target station number of the dedicated instruction is incorrect.	Correct the target station number at the request source of the dedicated instruction, and retry the operation.	—
D247H	When the dedicated instruction was executed, response from the target station was received twice.	<ul style="list-style-type: none"> • Check the network status using the CC-Link IE TSN/CC-Link IE Field diagnostics of the engineering tool, and take action. • Check if the industrial switch and the Ethernet cables at the request source are connected properly. 	—
D249H	The target station CPU type of the dedicated instruction is incorrect.	Correct the CPU type of the target station at the request source of the dedicated instruction, and retry the operation.	—
D24AH	The arrival monitoring time specification of the dedicated instruction is incorrect.	<ul style="list-style-type: none"> • Correct the arrival monitoring time at the request source of the dedicated instruction, and retry the operation. • When the own station, target station, or relay station detected an error, identify the cause of the error and take action. • Lower the transient transmission usage frequency, and retry the operation. • Check if the industrial switch and the Ethernet cables at the request source are connected properly. 	—
D24BH	The number of resends specified in the dedicated instruction is incorrect.	<ul style="list-style-type: none"> • Correct the number of resends at the request source of the dedicated instruction, and retry the operation. • When the own station, target station, or relay station detected an error, identify the cause of the error and take action. • Lower the transient transmission usage frequency, and retry the operation. • Check if the industrial switch and the Ethernet cables at the request source are connected properly. 	—
D24CH	The network number specification of the dedicated instruction is incorrect.	Correct the network number at the request source of the dedicated instruction, and retry the operation.	—
D24DH	The channel specified in the dedicated instruction is incorrect.	<ul style="list-style-type: none"> • Set 1 to 2 for the target channel number in the control data when executing the SEND instruction. • Correct the number of the channel used by own station in the control data, and retry the operation. 	—
D24EH	The target station setting in the dedicated instruction is incorrect.	<ul style="list-style-type: none"> • The value set for the control block of the dedicated instruction is out of range. Correct the value and retry the operation. • If the error occurs again even after taking the above, please consult your local Mitsubishi representative. 	—
D24FH	The dedicated instruction was executed when the station number/IP address of the own station had not been set yet.	<ul style="list-style-type: none"> • Specify the station number/IP address using the UINI instruction, and execute the instruction again. • If the error occurs again even after taking the above, please consult your local Mitsubishi representative. 	—
D251H	At execution of a dedicated instruction, or group specification or all stations specification of the target station, the execution type is set with arrival check.	<ul style="list-style-type: none"> • Execute again after changing the execution type in the control data to no arrival check. • If the error occurs again even after taking the above, please consult your local Mitsubishi representative. 	—

Error code	Error definition and causes	Action	Detailed information 1
			Detailed information 2
D253H	A response timeout has occurred when the dedicated instruction was executed.	<ul style="list-style-type: none"> • Check the network status using the CC-Link IE TSN/CC-Link IE Field diagnostics of the engineering tool, and take action. • For IP address specification, it is not possible to target stations beyond a relay station. Execute the dedicated instruction by specifying the network number/station number. • Increase the number of resends at the request source of the dedicated instruction, and retry the operation. • Lower the transient transmission usage frequency, and retry the operation. • Execute the dedicated instruction for a target station that supports the executed dedicated instruction. • For the RECV instruction, correct the channels used by own station in the control data, and retry the operation. • For the RECV instruction, check that 'RECV execution request flag CH1' (SB0030) to 'RECV execution request flag CH8' (SB0037) are on. • Correct the network number and station number/IP address of the target station of the dedicated instruction. • Check if the Ethernet cable is disconnected. • If the error occurs again even after taking the above, please consult your local Mitsubishi representative. 	—
D254H	A dedicated instruction which the target station does not support was executed.	<ul style="list-style-type: none"> • Change the target station at the station that executed the SEND instruction. • If the error occurs again even after taking the above, please consult your local Mitsubishi representative. 	—
D255H	The target station number of the dedicated instruction is incorrect.	<ul style="list-style-type: none"> • Correct the target station number in the control data, and retry the operation. • If the error occurs again even after taking the above, please consult your local Mitsubishi representative. 	—
D256H	The execution or error completion type of the dedicated instruction is incorrect.	<ul style="list-style-type: none"> • Correct the execution or error completion type in the control data, and retry the operation. • If the error occurs again even after taking the above, please consult your local Mitsubishi representative. 	—
D257H	The request type of the REQ instruction is incorrect.	<ul style="list-style-type: none"> • Correct the request type in the request data, and retry the operation. • If the error occurs again even after taking the above, please consult your local Mitsubishi representative. 	—
D258H	The control station does not exist when the dedicated instruction was executed to the specified control station or current control station.	<ul style="list-style-type: none"> • Correct the target station number in the control data, and retry the operation. • If the error occurs again even after taking the above, please consult your local Mitsubishi representative. 	—
D25AH	The dedicated instruction was executed specifying the channel in use.	<ul style="list-style-type: none"> • Retry the operation after a while. • Change the channels used by own station or the target station's channel in the control data. • Execute the RECV instruction at the external device, and then execute the SEND instruction. 	—
D25BH	The dedicated instruction was executed specifying the channel in use.	Change the channels used by own station or the target station's channel in the control data.	—
D25DH	The transient data is incorrect.	<ul style="list-style-type: none"> • Correct the transient data at the transient request source, and retry the operation. • If the error occurs again even after taking the above, please consult your local Mitsubishi representative. 	—
D25FH	System error	Please consult your local Mitsubishi representative.	—
D260H	System error	Please consult your local Mitsubishi representative.	—
D262H to D26CH	System error	Please consult your local Mitsubishi representative.	—
D26FH to D272H	System error	Please consult your local Mitsubishi representative.	—

Error code	Error definition and causes	Action	Detailed information 1
			Detailed information 2
D273H	The request data size of transient transmission is incorrect.	<ul style="list-style-type: none"> Correct the request command at the transient request source, and retry the operation. If the error occurs again even after taking the above, please consult your local Mitsubishi representative. 	—
D275H	Other dedicated instructions are in execution, and the executed instruction cannot be processed.	<ul style="list-style-type: none"> Other dedicated instructions are in execution. Execute again after a while. If the error occurs again even after taking the above, please consult your local Mitsubishi representative. 	—
D27AH	The own station number set in the UINI instruction is incorrect.	<ul style="list-style-type: none"> Set the station number of the own station in the control data to a value from 1 to 120, and retry the operation. If the error occurs again even after taking the above, please consult your local Mitsubishi representative. 	—
D27BH	The IP address set in the UINI instruction is incorrect.	<ul style="list-style-type: none"> Execute again after correcting the IP address in the control data. If the error occurs again even after taking the above, please consult your local Mitsubishi representative. 	—
D27CH	System error	Please consult your local Mitsubishi representative.	—
D27FH	System error	Please consult your local Mitsubishi representative.	—
D2C0H to D2D1H	System error	Please consult your local Mitsubishi representative.	—
D2D2H	The IP address/port number of the target station is incorrect.	<ul style="list-style-type: none"> Execute again after correcting the port number of the target station in the setting data. If the error occurs again even after taking the above, please consult your local Mitsubishi representative. 	—
D2D3H	Send processing of the transient transmission has failed.	<ul style="list-style-type: none"> Check the network status using the CC-Link IE TSN/CC-Link IE Field diagnostics of the engineering tool, and take action. When the own station, target station, or relay station detected an error, identify the cause of the error and take action. Correct the target IP address of transient data, and retry the operation. 	—
D602H	Parameter error	<ul style="list-style-type: none"> Write the network parameter to the CPU module again. If the error occurs again even after taking the above, please consult your local Mitsubishi representative. 	—
D605H	Parameter error	<ul style="list-style-type: none"> Write the network parameter to the CPU module again. If the error occurs again even after taking the above, please consult your local Mitsubishi representative. 	—
D60BH to D610H	System error	Please consult your local Mitsubishi representative.	—
D611H	Parameter error (each station device range assignment error (RWw))	<ul style="list-style-type: none"> Write the network parameter to the CPU module again. Execute again after correcting the size of the device station link device in the setting data. If the error occurs again even after taking the above, please consult your local Mitsubishi representative. 	—
D612H	Parameter error (each station device range assignment error (RWw))	<ul style="list-style-type: none"> Write the network parameter to the CPU module again. Execute again after correcting the offset of the device station link device in the setting data. If the error occurs again even after taking the above, please consult your local Mitsubishi representative. 	—
D613H	Parameter error (each station device range assignment error (RWr))	<ul style="list-style-type: none"> Write the network parameter to the CPU module again. Execute again after correcting the size of the device station link device in the setting data. If the error occurs again even after taking the above, please consult your local Mitsubishi representative. 	—
D614H	Parameter error (each station device range assignment error (RWr))	<ul style="list-style-type: none"> Write the network parameter to the CPU module again. Execute again after correcting the offset of the device station link device in the setting data. If the error occurs again even after taking the above, please consult your local Mitsubishi representative. 	—

Error code	Error definition and causes	Action	Detailed information 1
			Detailed information 2
D615H	Parameter error (each station device range assignment error (RY))	<ul style="list-style-type: none"> Write the network parameter to the CPU module again. Execute again after correcting the size of the device station link device in the setting data. If the error occurs again even after taking the above, please consult your local Mitsubishi representative. 	—
D616H	Parameter error (each station device range assignment error (RY))	<ul style="list-style-type: none"> Write the network parameter to the CPU module again. Execute again after correcting the offset of the device station link device in the setting data. If the error occurs again even after taking the above, please consult your local Mitsubishi representative. 	—
D617H	Parameter error (each station device range assignment error (RX))	<ul style="list-style-type: none"> Write the network parameter to the CPU module again. Execute again after correcting the size of the device station link device in the setting data. If the error occurs again even after taking the above, please consult your local Mitsubishi representative. 	—
D618H	Parameter error (each station device range assignment error (RX))	<ul style="list-style-type: none"> Write the network parameter to the CPU module again. Execute again after correcting the offset of the device station link device in the setting data. If the error occurs again even after taking the above, please consult your local Mitsubishi representative. 	—
D619H	Parameter error	<ul style="list-style-type: none"> Write the network parameter to the CPU module again. If the error occurs again even after taking the above, please consult your local Mitsubishi representative. 	—
D61AH	Parameter error	<ul style="list-style-type: none"> Write the network parameter to the CPU module again. If the error occurs again even after taking the above, please consult your local Mitsubishi representative. 	—
D61BH	Parameter error (device overlap error (RWw))	<ul style="list-style-type: none"> Write the network parameter to the CPU module again. Execute again after correcting the offset or size of the device station link device in the setting data. If the error occurs again even after taking the above, please consult your local Mitsubishi representative. 	—
D61CH	Parameter error (device overlap error (RWr))	<ul style="list-style-type: none"> Write the network parameter to the CPU module again. Execute again after correcting the offset or size of the device station link device in the setting data. If the error occurs again even after taking the above, please consult your local Mitsubishi representative. 	—
D61DH	Parameter error (device overlap error (RY))	<ul style="list-style-type: none"> Write the network parameter to the CPU module again. Execute again after correcting the offset or size of the device station link device in the setting data. If the error occurs again even after taking the above, please consult your local Mitsubishi representative. 	—
D61EH	Parameter error (device overlap error (RX))	<ul style="list-style-type: none"> Write the network parameter to the CPU module again. Execute again after correcting the offset or size of the device station link device in the setting data. If the error occurs again even after taking the above, please consult your local Mitsubishi representative. 	—
D61FH	System error	Please consult your local Mitsubishi representative.	—
D621H	Parameter error	<ul style="list-style-type: none"> Write the network parameter to the CPU module again. If the error occurs again even after taking the above, please consult your local Mitsubishi representative. 	—
D622H	Parameter error (error in the total number of device stations)	<ul style="list-style-type: none"> Write the network parameter to the CPU module again. Execute again after correcting the total number of device stations. If the error occurs again even after taking the above, please consult your local Mitsubishi representative. 	—
D625H	Parameter error (station-based block data assurance setting error)	<ul style="list-style-type: none"> Write the network parameter to the CPU module again. Execute again after correcting the station-based block data assurance setting. If the error occurs again even after taking the above, please consult your local Mitsubishi representative. 	—
D628H	Parameter error (station type error)	<ul style="list-style-type: none"> Write the network parameter to the CPU module again. Execute again after correcting the station type in the setting data. If the error occurs again even after taking the above, please consult your local Mitsubishi representative. 	—

Error code	Error definition and causes	Action	Detailed information 1
			Detailed information 2
D629H	Parameter error (station number range error)	<ul style="list-style-type: none"> • Write the network parameter to the CPU module again. • Execute again after correcting the station number in the setting data so it is within 1 to 120. • If the error occurs again even after taking the above, please consult your local Mitsubishi representative. 	—
D62AH	Parameter error (data link faulty station setting error)	<ul style="list-style-type: none"> • Write the network parameter to the CPU module again. • Execute again after correcting the data link faulty station setting. • If the error occurs again even after taking the above, please consult your local Mitsubishi representative. 	—
D62BH	Parameter error (output setting error during CPU STOP)	<ul style="list-style-type: none"> • Write the network parameter to the CPU module again. • Execute again after correcting the output settings during CPU STOP. • If the error occurs again even after taking the above, please consult your local Mitsubishi representative. 	—
D630H	System error	Please consult your local Mitsubishi representative.	—
D637H	The UINI instruction was executed at a station where the station number/IP address has been already set by parameter.	Execute again after setting "Station No./IP Address Setting Method" under "Station No./IP Address Setting" in "Required Settings" to "Program".	—
D639H	After setting a station number/IP address with the UINI instruction, the instruction was executed again.	Station number/IP address setting with the UINI instruction is limited to one time only. Reset the CPU module, and retry the operation.	—
D641H	Parameter error (IP address error)	<ul style="list-style-type: none"> • Write the network parameter to the CPU module again. • Execute again after correcting the IP address in the setting data. • If the error occurs again even after taking the above, please consult your local Mitsubishi representative. 	—
D642H	Parameter error (gateway address setting)	<ul style="list-style-type: none"> • Write the network parameter to the CPU module again. • Execute again after correcting the gateway address setting in the setting data. • If the error occurs again even after taking the above, please consult your local Mitsubishi representative. 	—
D643H	Parameter error (communication cycle setting)	<ul style="list-style-type: none"> • Write the network parameter to the CPU module again. • Execute again after correcting the communication cycle setting in the setting data. • If the error occurs again even after taking the above, please consult your local Mitsubishi representative. 	—
D644H	Parameter error (cyclic transmission time setting)	<ul style="list-style-type: none"> • Write the network parameter to the CPU module again. • Execute again after correcting the cyclic transmission time in the setting data. • If the error occurs again even after taking the above, please consult your local Mitsubishi representative. 	—
D645H	Parameter error (transient transmission time setting)	<ul style="list-style-type: none"> • Write the network parameter to the CPU module again. • Execute again after correcting the communication cycle setting or cyclic transmission time in the setting data. • If the error occurs again even after taking the above, please consult your local Mitsubishi representative. 	—
D646H	Parameter error (transmission path setting)	<ul style="list-style-type: none"> • Write the network parameter to the CPU module again. • Execute again after correcting the transmission path setting in the setting data. • If the error occurs again even after taking the above, please consult your local Mitsubishi representative. 	—
D647H	Parameter error (time synchronization setting)	<ul style="list-style-type: none"> • Write the network parameter to the CPU module again. • Execute again after correcting the time synchronization setting in the setting data. • If the error occurs again even after taking the above, please consult your local Mitsubishi representative. 	—
D648H	System error	Please consult your local Mitsubishi representative.	—
D649H	Parameter error (send timeslot setting)	<ul style="list-style-type: none"> • Write the network parameter to the CPU module again. • Execute again after correcting the send timeslot setting in the setting data. • If the error occurs again even after taking the above, please consult your local Mitsubishi representative. 	—

Error code	Error definition and causes	Action	Detailed information 1
			Detailed information 2
D64AH	Parameter error (number of data link error detection)	<ul style="list-style-type: none"> Write the network parameter to the CPU module again. Execute again after correcting the number of data link error detection in the setting data. If the error occurs again even after taking the above, please consult your local Mitsubishi representative. 	—
D64BH	Parameter error (number of occupied stations)	<ul style="list-style-type: none"> Write the network parameter to the CPU module again. Execute again after correcting the number of occupied stations in the setting data. If the error occurs again even after taking the above, please consult your local Mitsubishi representative. 	—
D64CH	System error	Please consult your local Mitsubishi representative.	—
D64DH	Parameter error (parameter automatic setting)	<ul style="list-style-type: none"> Write the network parameter to the CPU module again. Execute again after correcting the parameter automatic setting in the setting data. If the error occurs again even after taking the above, please consult your local Mitsubishi representative. 	—
D64EH	System error	Please consult your local Mitsubishi representative.	—
D64FH	Parameter error (cyclic frame cycle setting)	<ul style="list-style-type: none"> Write the network parameter to the CPU module again. Execute again after correcting the cyclic frame cycle setting in the setting data. If the error occurs again even after taking the above, please consult your local Mitsubishi representative. 	—
D650H	System error	Please consult your local Mitsubishi representative.	—
D651H	Parameter error (number of modules)	<ul style="list-style-type: none"> Write the network parameter to the CPU module again. Execute again after correcting the number of modules in the setting data. If the error occurs again even after taking the above, please consult your local Mitsubishi representative. 	—
D652H	Parameter error (communication mode setting)	<ul style="list-style-type: none"> Write the network parameter to the CPU module again. Execute again after correcting the communication mode setting in the setting data. If the error occurs again even after taking the above, please consult your local Mitsubishi representative. 	—
D653H	Parameter error (transient transmission group setting)	<ul style="list-style-type: none"> Write the network parameter to the CPU module again. Execute again after correcting the transient transmission group setting in the setting data. If the error occurs again even after taking the above, please consult your local Mitsubishi representative. 	—
D654H	System error	Please consult your local Mitsubishi representative.	—
D655H	Network addresses of the master station and device stations are incorrect.	Correct the IP address setting of the master station or device stations.	—
D656H	System error	Please consult your local Mitsubishi representative.	—
D657H	Parameter error	<ul style="list-style-type: none"> Write the network parameter to the CPU module again. If the error occurs again even after taking the above, please consult your local Mitsubishi representative. 	—
D658H	Parameter error	<ul style="list-style-type: none"> Write the network parameter to the CPU module again. If the error occurs again even after taking the above, please consult your local Mitsubishi representative. 	—
D65BH	Parameter error (CC-Link IE TSN Class setting)	<ul style="list-style-type: none"> Write the network parameter to the CPU module again. Execute the instruction again after correcting "CC-Link IE TSN Class Setting" in the setting data. If the error occurs again even after taking the above, please consult your local Mitsubishi representative. 	—
D65CH	Parameter error (TSN hub setting)	<ul style="list-style-type: none"> Write the network parameter to the CPU module again. Execute the instruction again after correcting "TSN HUB Setting" in the setting data. If the error occurs again even after taking the above, please consult your local Mitsubishi representative. 	—

Error code	Error definition and causes	Action	Detailed information 1
			Detailed information 2
D65DH	Parameter error (multiple period setting)	<ul style="list-style-type: none"> Write the network parameter to the CPU module again. Execute the instruction again after correcting "Multiple Period Setting" in the setting data. If the error occurs again even after taking the above, please consult your local Mitsubishi representative. 	—
D720H to D725H	System error	Please consult your local Mitsubishi representative.	—
D727H to D729H	System error	Please consult your local Mitsubishi representative.	—
D731H	System error	Please consult your local Mitsubishi representative.	—
D742H	System error	Please consult your local Mitsubishi representative.	—
D840H	Number of transient requests exceeded the upper limit of simultaneously processable requests.	<ul style="list-style-type: none"> Pause the transient transmission temporarily, and retry the operation. Lower the transient transmission usage frequency, and retry the operation. 	—
D841H	The request data size of memory read/write command is out of range.	Correct the read or write size specification at the transient request source, and retry the operation.	—
D842H	System error	Please consult your local Mitsubishi representative.	—
D843H	The module operation mode is set to a mode in which transient transmission cannot be executed.	After completion of the module communication test, retry the transient transmission.	—
D844H	Incorrect frame was received. <ul style="list-style-type: none"> Unsupported pre-conversion protocol Unsupported frame type Application header variable part Application header HDS Application header RTP Read command not requiring response 	Correct the request data at the transient request source, and retry the operation.	—
D902H	The online test data is incorrect.	<ul style="list-style-type: none"> Correct the data at the station that started the online test, and retry the operation. If the error occurs again even after taking the above, please consult your local Mitsubishi representative. 	—
D903H	During execution of the communication test, the test was retried.	After completion of the communication test, retry the operation.	—
D905H	A communication monitoring timeout has occurred in communication test.	<ul style="list-style-type: none"> Check the network status using the CC-Link IE TSN/CC-Link IE Field diagnostics of the engineering tool, and take action. Then, retry the operation. 	—
D906H	Transmission completion wait timeout has occurred in communication test.	<ul style="list-style-type: none"> Check the network status using the CC-Link IE TSN/CC-Link IE Field diagnostics of the engineering tool, and take action. Then, retry the operation. Lower the transient transmission usage frequency, and retry the operation. 	—
D909H	The header information of transient transmission is incorrect.	Correct the header information at the transient request source, and retry the operation.	—
D90AH	During execution of the communication test, the test was retried.	Check the network status using the CC-Link IE TSN/CC-Link IE Field diagnostics of the engineering tool, and take action. Then, retry the operation.	—
D90BH	The number of stations that communicate in the network is out of the specification range.	<ul style="list-style-type: none"> Check the network status using the CC-Link IE TSN/CC-Link IE Field diagnostics of the engineering tool, and take action. If the number of device stations per network is more than 120, reduce it to 120 or less. 	—
D90CH	The communication destination specified for the communication test is incorrect.	<ul style="list-style-type: none"> Correct "Target Station" of communication test, and retry the operation. Do not execute the communication test for own station and relay sending station. Set "Target Station" to other than own station and relay transmission station. The target station is mounted on the same CPU module as the connected station (own station). Do not execute the communication test for a station on the same CPU module as the connected station (own station). 	—

Error code	Error definition and causes	Action	Detailed information 1
			Detailed information 2
D90DH	An error was detected in the network module.	Please consult your local Mitsubishi representative.	—
D912H	Transient transmission sending failed.	<ul style="list-style-type: none"> Lower the transient transmission usage frequency, and retry the operation. Check if the industrial switch and the Ethernet cables are connected properly. 	—
D913H to D917H	An error was detected in the network module.	Please consult your local Mitsubishi representative.	—
D919H	No response from the target station of the communication test.	<ul style="list-style-type: none"> Correct the network number, station number, or IP address for the target station of the communication test. Check if the network configuration setting is correctly set in the master station within the same network as the target station of the communication test. When "IP Address" is selected for "Communication Method", "Communication Test" cannot be executed for stations on networks different from that of the connected station (own station). Change "Communication Method" to "Network No./Station No.". 	—
DA00H	An error was detected in the network module.	Please consult your local Mitsubishi representative.	—
DA10H to DA17H	An error was detected in the network module.	Please consult your local Mitsubishi representative.	—
DA19H	An error was detected in the network module.	Please consult your local Mitsubishi representative.	—
DA1AH	System error	Please consult your local Mitsubishi representative.	—
DA1BH	A dedicated instruction which the target station does not support was executed.	<ul style="list-style-type: none"> Change the target station at the station that executed the READ/SREAD/WRITE/SWRITE/SEND/ instruction. Correct the network number and station number/IP address of the target station of the dedicated instruction. 	—
DA1CH	The target station of the READ/SREAD/WRITE/SWRITE/SEND instruction does not exist.	If the target station of the READ/SREAD/WRITE/SWRITE/SEND instruction is disconnected, execute the dedicated instruction again after return of the target station.	—
DB00H	The station numbers of 121 stations or more are specified.	Check station numbers.	—
DC00H	The setting value is incorrect.	Write again after correcting the setting value.	—
DC01H	The setting value was not written correctly.	<ul style="list-style-type: none"> Write again. If the error occurs again even after taking the above, please consult your local Mitsubishi representative. 	—

10.6 List of Parameter Numbers

The following table lists the parameter numbers displayed in "Module Diagnostics".

If there is an error in the parameter settings and the parameter number is displayed, the corresponding parameter can be identified.

It is displayed in "Detailed information" in the [Error Information] tab in the "Module Diagnostics" window of the FX5-CCLGN-MS. (👉 Page 177 Error Information)

Item		Parameter No.			
Required Settings	Station Type	7100H			
	Network No.	7100H			
	Parameter Setting Method	7100H			
	Station No./IP Address Setting	Setting Method of Station No./IP Address Setting Method	7100H		
		Station No.	7100H		
		IP Address	IP Address	A012H	
			Subnet Mask	A012H	
	Default Gateway	A013H			
Basic Settings	Refresh Settings	7401H			
	Network Topology	A100H			
	Communication Period Setting	Basic Period Setting	Setting in Units of 1μs	A100H	
			Communication Period Interval Setting (Do Not Set it in Units of 1μs)	A100H	
			Communication Period Interval Setting (Set it in Units of 1μs)	A100H	
			Cyclic Transmission Time	A100H	
			Transient Transmission Time	A100H	
		Multiple Period Setting	Normal-Speed	A108H	
		Low-Speed	A108H		
	Connection Device Information	CC-Link IE TSN Class Setting	A100H		
		TSN HUB Setting	A100H		
Device Station Setting	Disconnection Detection Setting	A100H			
Application Settings	Supplementary Cyclic Settings	Station-based Block Data Assurance	A100H		
		I/O Maintenance Settings	Output Hold/Clear Setting during CPU STOP	A110H	
			Data Link Error Station Setting	A110H	
	Output Mode upon CPU Error		7101H		
	Transient Transmission Group No.	A010H			
	Parameter Name	7310H			
	Module Operation Mode	7100H			
	Security	IP Filter Settings	IP Filter	A03AH	
			IP Filter Settings	Deny/Allow	A03AH
				IP Address	A03AH
Range Setting				A03AH	
IP Address Excluded from Range	A03AH				

10.7 Event List

This section lists the events which occur in CC-Link IE TSN.

The event history is displayed when the [Event History] button in the [Error Information] tab in the "Module Diagnostics" window of the FX5-CCLGN-MS is clicked. ( Page 177 Error Information)

System		
Event code	Description	Cause
00800	Link-down	The system was linked down by removing a device (such as an external device).
00907	Divided messages receive timeout error	<ul style="list-style-type: none"> • Sufficient data for the data length could not be received. • The remaining part of the divided message could not be received.
00C40	Device station parameter automatic setting: Interruption	An abnormal response was received from the device station, and device station parameter automatic setting processing was interrupted. (For details on device station response codes, refer to the manual for the device station.)
00C41	Device station parameter automatic setting: Parameter update interruption	An abnormal response was received from the device station, and parameter update processing for the device station parameter automatic setting was interrupted. (For details on device station response codes, refer to the manual for the device station.)
00C42	Device station parameter automatic setting: System error	An error occurred while the device station parameter automatic setting was executing.
00C43	Device station parameter automatic setting: Transmission timeout	Transmission timed out while communicating with the device station parameter automatic setting.
00C44	Device station parameter automatic setting: Receive timeout	The specified period of time expired without receiving while communicating with the device station parameter automatic setting.
00C46	Device station parameter automatic setting: SLMP transmission error	An error occurred while transmitting with SLMP for the device station parameter automatic setting.
00C47	Device station parameter automatic setting: CPU module access failure	Access to the CPU module failed during device station parameter automatic setting.
00C48	Device station parameter automatic setting: No target station parameter	The station parameter file targeted during device station parameter automatic setting was not stored in the CPU module.
00C72	Maximum response time mismatch for the time managed polling method	<p>A maximum response time mismatch was detected for the time managed polling method.</p> <p>Update the engineering tool and the device stations to the latest version.</p>
00C80	Detection of device station that does not support the CC-Link IE TSN Protocol version 2.0	A device station that does not support the CC-Link IE TSN Protocol version 2.0 was detected.
00C81	CC-Link IE TSN Class setting mismatch	A mismatch was detected between the parameter of the master station and "CC-Link IE TSN Class Setting" of the device stations.

APPENDICES

Appendix 1 External Dimensions

The following shows the external dimensions of the FX5-CCLGN-MS.

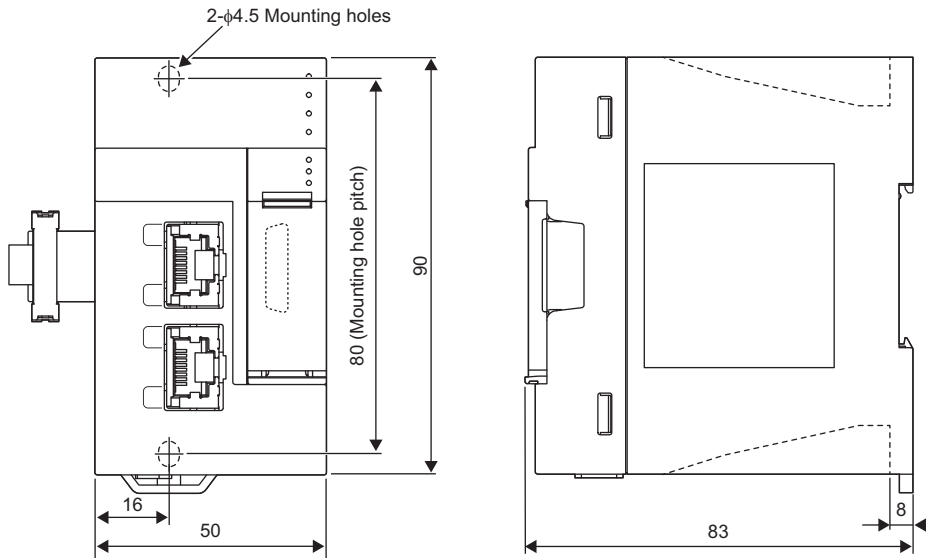

(Unit: mm)

• Weight: Approx. 0.3kg

Appendix 2 Standard Compliant Model

UL, cUL standards compliant model

The FX5-CCLGN-MS is compliant with UL standards (UL, cUL Standards).

UL, cUL File Number: E95239

For UL Standards compliant models, please consult your local Mitsubishi representative.

EU Directive (CE marking) compliance

Conformity of the entire machinery manufactured by using this product to the following directives is not guaranteed.

The manufacturer of the machinery must determine whether to declare conformity to the EMC Directive and the Low Voltage Directive (LVD). For details, consult Mitsubishi Electric separately.

Measures to comply with the EMC Directive

The following product, when used in accordance with instructions given by the relevant document, shows conformity to the EU directive (2014/30/EU) for electromagnetic compatibility through direct testing (using the following specified standards) and design analysis (by creating a technical structure file).

CAUTION

Use this product in a general industrial environment.

Product conformity item

Type: Programmable controller (open-type device)

Target product: FX5 manufactured in the following period

Manufactured on and after April 1, 2020	FX5-CCLGN-MS
---	--------------

Electromagnetic Compatibility (EMC) Directive	Remarks
EN 61131-2:2007 Programmable Controllers - Equipment requirements and tests	The product has been tested for all related items from the following. EMI • Radiated emission • Conducted emission EMS • Radiated electromagnetic field • Fast transient burst • Electrostatic discharge • High-energy surge • Voltage drops and interruptions • Conducted RF • Power frequency magnetic field

Precautions for compliance with EU Directive

Precautions when using the FX5-CCLGN-MS

When using the FX5-CCLGN-MS, attach ferrite cores with the power supplies of the CPU module and the FX5-CCLGN-MS. Attach the ferrite core with each cable wrapped around it three times at a location within approximately 200mm from the terminal block of the power cable and connector. (Ferrite core used for testing by Mitsubishi Electric: E04SR401938 manufactured by SEIWA ELECTRIC MFG. CO., LTD.)

Precautions when using an Ethernet port

Use a double shielded twisted pair cable as the 1000BASE-T cable. Strip a part of the jacket of the shielded twisted pair cable as shown below and ground both ends of the cable with the exposed shield to the largest area.

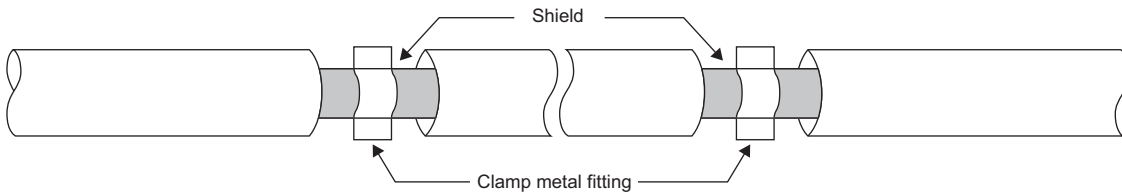

Power source of 24VDC power supply voltage

Supply power to the 24VDC power supply voltage of the FX5-CCLGN-MS from the AC/DC power supply installed in the same control panel. (AC/DC power supply used for testing by Mitsubishi Electric: PS5R-VE24 manufactured by IDEC CORPORATION.)

Compliance with UKCA marking

The requirements for compliance with UKCA marking are the same as that with EU directive (CE marking).

A

Appendix 3 Buffer Memory

The buffer memory is used to exchange data between the FX5-CCLGN-MS and the FX5 CPU module. Buffer memory values are reset to default when the FX5 CPU module is reset or the system is powered off.

List of buffer memory addresses

←: Same as the address of P1

P1		P2		Name	Read, write		
Address (decimal)	Address (hexadecimal)	Address (decimal)	Address (hexadecimal)				
0 to 28	0000H to 001CH	←		Module information area	System area		
29	001DH	←			Latest error code	Read	
30	001EH	←			Unique code	Read	
31	001FH	←			Firmware version	Read	
32 to 33	0020H to 0021H	←			System area		
34 to 35	0022H to 0023H	←			Input signals	Read	
36 to 39	0024H to 0027H	←			System area		
40	0028H	←			MIB information device version	Read	
41	0029H	←			MIB information firmware version	Read	
42	002AH	←			MIB information hardware version	Read	
43 to 255	002BH to 00FFH	←			System area		
256 to 1279	0100H to 04FFH	←			Device area	RX area	Read
1280 to 2303	0500H to 08FFH	←				RY area	Read, write
2304 to 10495	0900H to 28FFH	←		RWw area		Read, write	
10496 to 18687	2900H to 48FFH	←		RWr area		Read	
18688 to 18943	4900H to 49FFH	←		SB area		Read, write	
18944 to 23039	4A00H to 59FFH	←		SW area		Read, write	
23040 to 23551	5A00H to 5BFFH	←		System area			
23552 to 23553	5C00H to 5C01H	←		Timeslot 0 information	Timeslot 0 cycle start offset (ns unit)	Read	
23554	5C02H	←			Timeslot 0 cycle start offset (s unit)	Read	
23555	5C03H	←			System area		
23556 to 23557	5C04H to 5C05H	←			Timeslot 0 cycle end offset (ns unit)	Read	
23558	5C06H	←			Timeslot 0 cycle end offset (s unit)	Read	
23559 to 23563	5C07H to 5C0BH	←			System area		
23564	5C0CH	←			VID (VLAN Identifier)	Read	
23565	5C0DH	←			PCP (Priority Code Point)	Read	
23566	5C0EH	←			Ether Type	Read	
23567	5C0FH	←			System area		
23568 to 23679	5C10H to 5C7FH	←		Timeslot 1 to 7 information	Same as Timeslot 0 information	Read	
23680 to 23807	5C80H to 5CFFH	←		System area			
23808 to 23809	5D00H to 5D01H	←		RX offset/size information	Station No.0 RX offset	Read	
23810 to 23811	5D02H to 5D03H	←			Station No.0 RX size	Read	
⋮		←			⋮		
24288 to 24289	5EE0H to 5EE1H	←			Station No.120 RX offset	Read	
24290 to 24291	5EE2H to 5EE3H	←			Station No.120 RX size	Read	
24292 to 24831	5EE4H to 60FFH	←			System area		

P1		P2		Name	Read, write	
Address (decimal)	Address (hexadecimal)	Address (decimal)	Address (hexadecimal)			
24832 to 24833	6100H to 6101H	←		RY offset/size information	Station No.0 RY offset	Read
24834 to 24835	6102H to 6103H	←			Station No.0 RY size	Read
⋮		←			⋮	
25312 to 25313	62E0H to 62E1H	←			Station No.120 RY offset	Read
25314 to 25315	62E2H to 62E3H	←			Station No.120 RY size	Read
25316 to 25855	62E4H to 64FFH	←		System area		
25856 to 25857	6500H to 6501H	←		RWw offset/size information	Station No.0 RWw offset	Read
25858 to 25859	6502H to 6503H	←			Station No.0 RWw size	Read
⋮		←			⋮	
26336 to 26337	66E0H to 66E1H	←			Station No.120 RWw offset	Read
26338 to 26339	66E2H to 66E3H	←			Station No.120 RWw size	Read
26340 to 26879	66E4H to 68FFH	←		System area		
26880 to 26881	6900H to 6901H	←		RWr offset/size information	Station No.0 RWr offset	Read
26882 to 26883	6902H to 6903H	←			Station No.0 RWr size	Read
⋮		←			⋮	
27360 to 27361	6AE0H to 6AE1H	←			Station No.120 RWr offset	Read
27362 to 27363	6AE2H to 6AE3H	←			Station No.120 RWr size	Read
27364 to 27903	6AE4H to 6CFFH	←		System area		
27904 to 28159	6D00H to 6DFFH	←		System area		
28160	6E00H	←		Own station (network card) information	Manufacturer code	Read
28161	6E01H	←			Model type	Read
28162	6E02H	←			Model code (lower 2 bytes)	Read
28163	6E03H	←			Model code (upper 2 bytes)	
28164	6E04H	←			Version	Read
28165 to 28167	6E05H to 6E07H	←			MAC address	Read
28168	6E08H	←		Own station (controller) information	Controller information valid/invalid flag	Read
28169	6E09H	←			Manufacturer code	Read
28170	6E0AH	←			Model type	Read
28171	6E0BH	←			Model code (lower 2 bytes)	Read
28172	6E0CH	←			Model code (upper 2 bytes)	
28173	6E0DH	←			Version	Read
28174 to 28183	6E0EH to 6E17H	←			Model name string	Read
28184 to 28185	6E18H to 6E19H	←			Vendor-specific device information	Read
28186 to 28191	6E1AH to 6E1FH	←			System area	
28192 to 36607	6E20H to 8EFFH	←			System area	
36608	8F00H	←		Communication path determination status	Communication path determination status (network No.1 to 16)	Read
36609 to 36623	8F01H to 8F0FH	←			Communication path determination status (network No.17 to 239)	Read
36624 to 44319	8F10H to AD1FH	←		System area		
44320	AD20H	←		Protocol information	Protocol operating status	Read
44321	AD21H	←			Write request	Read, write
44322	AD22H	←			Protocol setting	Read, write
44323	AD23H	←			Write execution status	Read
44324	AD24H	←			Setting result	Read
44325	AD25H	←			Protocol setting status	Read
44326 to 44335	AD26H to AD2FH	←			System area	



P1		P2		Name		Read, write
Address (decimal)	Address (hexadecimal)	Address (decimal)	Address (hexadecimal)			
44336	AD30H	←		Timeslot information for device station cyclic transmission	Timeslot for cyclic transmission (Station No.1)	Read
⋮	⋮	←			⋮	
44395	AD6BH	←			Timeslot for cyclic transmission (Station No.60)	Read
44396 to 44591	AD6CH to AE2FH	←			System area	
44592 to 44593	AE30H to AE31H	←		System area		
44594	AE32H	←		Information for ensuring cyclic data are sent/received	Multiple period setting (low speed)	Read
44595	AE33H	←			Communication cycle interval (calculation value)	Read
44596	AE34H	←		Communication cycle setting value (CC-Link IE TSN Protocol version 2.0)	Communication cycle interval (calculation value)	Read
44597	AE35H	←			Cyclic transmission time (calculation value)	Read
44598	AE36H	←			Transient transmission time (calculation value)	Read
44599 to 44607	AE37H to AE3FH	←		System area		
44608	AE40H	←		Information for device station cyclic transmission	Multiplier for transmission delay information of CC-Link IE TSN Class A (low-speed)	Read
44609 to 44623	AE41H to AE4F	←			System area	
44624 to 51199	AE50H to C7FFH	←		System area		
51200	C800H	←		Time synchronization	Time distribution interval setting of the CPU module	Read, write
51201	C801H	←			Time reflection setting to the CPU module	Read, write
51202 to 51967	C802H to CAFFH	←		System area		
51968	CB00H	←		Grandmaster information	Grandmaster	Read
51969 to 51970	CB01H to CB02H	←			System area	
51971 to 51973	CB03H to CB05H	←			Grandmaster MAC address	Read
51974 to 51996	CB06H to CB1CH	←		System area		
51997	CB1DH	←		Time synchronization setting	PTP frame send source check enable/disable	Read, write
51998	CB1EH	←			PTP frame send source check result (P1)	Read
51999	CB1FH	←			PTP frame send source check result (P2)	Read
52000 to 52227	CB20H to CC03H	←		System area		

P1		P2		Name	Read, write	
Address (decimal)	Address (hexadecimal)	Address (decimal)	Address (hexadecimal)			
52228 to 52229	CC04H to CC05H	60164 to 60165	EB04H to EB05H	P1: Own node setting status storage area P2: System area	Own node IP address	Read
52230 to 52237	CC06H to CC0DH	60166 to 60173	EB06H to EB0DH		System area	
52238 to 52239	CC0EH to CC0FH	60174 to 60175	EB0EH to EB0FH		Subnet mask	Read
52240 to 52241	CC10H to CC11H	60176 to 60177	EB10H to EB11H		System area	
52242 to 52243	CC12H to CC13H	60178 to 60179	EB12H to EB13H		Default gateway IP address	Read
52244 to 52251	CC14H to CC1BH	60180 to 60187	EB14H to EB1BH		System area	
52252 to 52254	CC1CH to CC1EH	60188 to 60190	EB1CH to EB1EH		Own node MAC address	Read
52255	CC1FH	60191	EB1FH		Own node network number	Read
52256	CC20H	60192	EB20H		Station No.	Read
52257	CC21H	60193	EB21H		Transient transmission group No.	Read
52258 to 52260	CC22H to CC24H	60194 to 60196	EB22H to EB24H		System area	
52261	CC25H	60197	EB25H		Auto-open UDP port port number	Read
52262	CC26H	60198	EB26H		MELSOFT transmission port (TCP/IP) port number	Read
52263	CC27H	60199	EB27H		MELSOFT transmission port (UDP/IP) port number	Read
52264	CC28H	60200	EB28H		System area	
52265	CC29H	60201	EB29H		SLMP transmission port (TCP/IP) port number	Read
52266	CC2AH	60202	EB2AH		SLMP transmission port (UDP/IP) port number	Read
52267 to 52323	CC2BH to CC63H	60203 to 60259	EB2BH to EB63H		System area	
52324 to 52451	CC64H to CCE3H	60260 to 60387	EB64H to EBE3H		P1: Connection status storage area P2: System area	System area
52452 to 52458	CCE4H to CCEAH	60388 to 60394	EBE4H to EBEAH	Latest error code after the 2nd connection of MELSOFT transmission port (TCP/IP)		Read
52459 to 52579	CCEBH to CD63H	60395 to 60515	EBEBH to EC63H	System area		
52580 to 52586	CD64H to CD6AH	60516 to 60522	EC64H to EC6AH	Latest error code after the 2nd connection of SLMP transmission port (TCP/IP)		Read
52587 to 52735	CD6BH to CDFFH	60523 to 60671	EC6BH to ECFH	System area		
52736 to 52737	CE00H to CE01H	60672 to 60673	ED00H to ED01H	P1: System port latest error code storage area P2: System area	System area	
52738	CE02H	60674	ED02H		Auto-open UDP port latest error code	Read
52739	CE03H	60675	ED03H		MELSOFT transmission port (UDP/IP) latest error code	Read
52740	CE04H	60676	ED04H		MELSOFT transmission port (TCP/IP) latest error code	Read
52741	CE05H	60677	ED05H		SLMP transmission port (UDP/IP) latest error code	Read
52742	CE06H	60678	ED06H		SLMP transmission port (TCP/IP) latest error code	Read
52743	CE07H	60679	ED07H		SLMPSND instruction latest error code	Read
52744 to 52991	CE08H to CEFFH	60680 to 60927	ED08H to EDFFH		System area	



P1		P2		Name	Read, write	
Address (decimal)	Address (hexadecimal)	Address (decimal)	Address (hexadecimal)			
52992 to 52993	CF00H to CF01H	60928 to 60929	EE00H to EE01H	Status for each protocol (IP packet)	Received packet total count	Read
52994 to 52995	CF02H to CF03H	60930 to 60931	EE02H to EE03H		Received packet checksum error discard count	Read
52996 to 52997	CF04H to CF05H	60932 to 60933	EE04H to EE05H		Sent packet total count	Read
52998 to 53013	CF06H to CF15H	60934 to 60949	EE06H to EE15H		System area	
53014 to 53015	CF16H to CF17H	60950 to 60951	EE16H to EE17H		Simultaneous transmission error detection count (receive buffer full count)	Read
53016 to 53020	CF18H to CF1CH	60952 to 60956	EE18H to EE1CH		System area	
53021	CF1DH	60957	EE1DH		Receive abort count	Read
53022 to 53023	CF1EH to CF1FH	60958 to 60959	EE1EH to EE1FH		System area	
53024 to 53031	CF20H to CF27H	60960 to 60967	EE20H to EE27H	System area		
53032 to 53033	CF28H to CF29H	60968 to 60969	EE28H to EE29H	Status for each protocol (ICMP packet)	Received packet total count	Read
53034 to 53035	CF2AH to CF2BH	60970 to 60971	EE2AH to EE2BH		Received packet checksum error discard count	Read
53036 to 53037	CF2CH to CF2DH	60972 to 60973	EE2CH to EE2DH		Sent packet total count	Read
53038 to 53039	CF2EH to CF2FH	60974 to 60975	EE2EH to EE2FH		Received echo request total count	Read
53040 to 53041	CF30H to CF31H	60976 to 60977	EE30H to EE31H		Sent echo reply total count	Read
53042 to 53043	CF32H to CF33H	60978 to 60979	EE32H to EE33H		Sent echo request total count	Read
53044 to 53045	CF34H to CF35H	60980 to 60981	EE34H to EE35H		Received echo reply total count	Read
53046 to 53071	CF36H to CF4FH	60982 to 61007	EE36H to EE4FH		System area	
53072 to 53073	CF50H to CF51H	61008 to 61009	EE50H to EE51H	Status for each protocol (TCP packet)	Received packet total count	Read
53074 to 53075	CF52H to CF53H	61010 to 61011	EE52H to EE53H		Received packet checksum error discard count	Read
53076 to 53077	CF54H to CF55H	61012 to 61013	EE54H to EE55H		Sent packet total count	Read
53078 to 53079	CF56H to CF57H	61014 to 61015	EE56H to EE57H		System area	
53080 to 53111	CF58H to CF77H	61016 to 61047	EE58H to EE77H	System area		
53112 to 53113	CF78H to CF79H	61048 to 61049	EE78H to EE79H	Status for each protocol (UDP packet)	Received packet total count	Read
53114 to 53115	CF7AH to CF7BH	61050 to 61051	EE7AH to EE7BH		Received packet checksum error discard count	Read
53116 to 53117	CF7CH to CF7DH	61052 to 61053	EE7CH to EE7DH		Sent packet total count	Read
53118 to 53121	CF7EH to CF81H	61054 to 61057	EE7EH to EE81H		System area	
53122 to 53180	CF82H to CFBCH	61058 to 61116	EE82H to EEBCH	System area		
53181	CFBDH	61117	EEBDH	P1: Own node operating status storage area P2: System area	LED on/off status	Read
53182	CFBEH	61118	EEBEH	System area		
53183	CFBFH	61119	EEBFH	Own node operation status storage area (switching hub connection information area)	Communication mode	Read
53184	CFC0H	61120	EEC0H		Connection status	Read
53185	CFC1H	61121	EEC1H		Communication speed	Read
53186	CFC2H	61122	EEC2H		Disconnection count	Read
53187 to 53191	CFC3H to CFC7H	61123 to 61127	EEC3H to EEC7H	System area		
53192	CFC8H	61128	EEC8H	P1: Own node operation status storage area (IP address duplication status storage area) P2: System area	IP address duplication flag	Read
53193 to 53195	CFC9H to CFCBH	61129 to 61131	EEC9H to EECBH		MAC address of the station already connected to the network	Read
53196 to 53198	CFCCH to CFCEH	61132 to 61134	EECCH to EECEH		MAC address of the station with the IP address already used	Read
53199 to 53291	CFCFH to D02BH	61135 to 61227	EECFH to EF2BH	System area		

P1		P2		Name	Read, write	
Address (decimal)	Address (hexadecimal)	Address (decimal)	Address (hexadecimal)			
53292	D02CH	61228	EF2CH	P1: Area for sending/receiving instructions P2: System area	System area	
53293	D02DH	61229	EF2DH		RECV instruction execution request	Read
53294 to 53319	D02EH to D047H	61230 to 61255	EF2EH to EF47H		System area	
53320 to 53617	D048H to D171H	61256 to 61553	EF48H to F071H		System area	
53618 to 53621	D172H to D175H	61554 to 61557	F072H to F075H	Remote password lock status storage area	System area	
53622	D176H	61558	F076H		Remote password lock status system port	Read
53623 to 59575	D177H to E8B7H	61559 to 67511	F077H to 107B7H		System area	
59576 to 59639	E8B8H to E8F7H	67512 to 67575	107B8H to 107F7H	Remote password function monitoring area	System area	
59640	E8F8H	67576	107F8H		Auto-open UDP port continuous unlock failure count	Read
59641	E8F9H	67577	107F9H		MELSOFT transmission port (UDP/IP) continuous unlock failure count	Read
59642	E8FAH	67578	107FAH		MELSOFT transmission port (TCP/IP) continuous unlock failure count	Read
59643 to 59644	E8FBH to E8FCH	67579 to 67580	107FBH to 107FCH			System area
59645	E8FDH	67581	107FDH		SLMP transmission port (UDP/IP) continuous unlock failure count	Read
59646	E8FEH	67582	107FEH		SLMP transmission port (TCP/IP) continuous unlock failure count	Read
59647 to 59661	E8FFH to E90DH	67583 to 67597	107FFH to 1080DH			System area
59662 to 59934	E90EH to EA1EH	67598 to 67870	1080EH to 1091EH			System area
59935	EA1FH	67871	1091FH		P1: Network type information area (Network type information) P2: System area	Read
59936 to 60163	EA20H to EB03H	67872 to 68096	10920H to 10A00H		System area	
68097 to 68119	10A01H to 10A17H	←			System area	
68120	10A18H	←		Ethernet P1/2 common information	Initial status	Read
68121	10A19H	←			Initial error code	Read
68122 to 68125	10A1AH to 10A1DH	←			System area	
68126	10A1EH	←		Receive buffer status storage area (Receive buffer status)	Read	
68127 to 100351	10A1FH to 187FFH	←			System area	



Point

- Do not write data to "system areas". Doing so may cause malfunction of the programmable controller system.
- If the value in an area of one word becomes equal to or higher than 65536, the count stops at 65535 (FFFFH).

Details of buffer memory addresses

Module information area

■Latest error code (Un\G29)

The error code for the latest error that occurred in the FX5-CCLGN-MS is stored. (0 is stored in normal condition.)

For details on error codes, refer to the following.

 Page 200 List of Error Codes

■Unique code (Un\G30)

The unique code (6988H) of the FX5-CCLGN-MS is stored.

■Firmware version (Un\G31)

The firmware version of the FX5-CCLGN-MS is stored.

Ex.

When the firmware version of the FX5-CCLGN-MS is Ver.1.000: K1000

■Input signal (Un\G34 to Un\G35)

This signal is used to check the status of the FX5-CCLGN-MS.

Address	Bit	Signal name	Description
Un\G34	b0	Module failure	<ul style="list-style-type: none">• Off: Module normal• On: Module failure
	b1	Own station data link status	<ul style="list-style-type: none">• Off: Data link stop• On: Data link in progress Shows the data link status of the own station in the same way as 'Data link error status of own station' (SB0049). However, the ON/OFF status is reversed between this bit and 'Data link error status of own station' (SB0049).
	b3	Data link status of another station	<ul style="list-style-type: none">• Off: All stations normal• On: Faulty station exists The specifications are the same as the specifications for 'Data link error status of each station' (SB00B0).
	b15	Module READY	<ul style="list-style-type: none">• Off: Module not in operation• On: Available for module operation When b0 of Un\G34 turns on, this bit turns off.

■MIB information device version (Un\G40)

The MIB information device version of the FX5-CCLGN-MS is stored.

- 0: Ver.1.002 or earlier
- 2: Ver.1.010

■MIB information firmware version (Un\G41)

The MIB information firmware version of the FX5-CCLGN-MS is stored.

- 0: Ver.1.002 or earlier
- 2: Ver.1.010

■MIB information hardware version (Un\G42)

The MIB information hardware version of the FX5-CCLGN-MS is stored.

- 0: Ver.1.002 or earlier
- 1: Ver.1.010

Device area

The RX, RY, RWw, RWr, SB, and SW values are stored.

Remote input (RX) (Un\G256 to Un\G1279)

The RX value is stored. The RX start number and number of points for each station number can be checked by the RX offset/size information (Un\G23808 to Un\G24831). (Page 234 RX offset/size information)

Address	b15	b14	b13	b12	b11	b10	b9	b8	b7	b6	b5	b4	b3	b2	b1	b0
Un\G256	RX F	RX E	RX D	RX C	RX B	RX A	RX 9	RX 8	RX 7	RX 6	RX 5	RX 4	RX 3	RX 2	RX 1	RX 0
⋮																
Un\G1279	RX 3FFF	RX 3FFE	RX 3FFD	RX 3FFC	RX 3FFB	RX 3FFA	RX 3FF9	RX 3FF8	RX 3FF7	RX 3FF6	RX 3FF5	RX 3FF4	RX 3FF3	RX 3FF2	RX 3FF1	RX 3FF0

Each bit corresponds to 1 bit of RX.

Remote output (RY) (Un\G1280 to Un\G2303)

The RY value is stored. The RY start number and number of points for each station number can be checked by the RY offset/size information (Un\G24832 to Un\G25855). (Page 235 RY offset/size information)

Address	b15	b14	b13	b12	b11	b10	b9	b8	b7	b6	b5	b4	b3	b2	b1	b0
Un\G1280	RY F	RY E	RY D	RY C	RY B	RY A	RY 9	RY 8	RY 7	RY 6	RY 5	RY 4	RY 3	RY 2	RY 1	RY 0
⋮																
Un\G2303	RY 3FFF	RY 3FFE	RY 3FFD	RY 3FFC	RY 3FFB	RY 3FFA	RY 3FF9	RY 3FF8	RY 3FF7	RY 3FF6	RY 3FF5	RY 3FF4	RY 3FF3	RY 3FF2	RY 3FF1	RY 3FF0

Each bit corresponds to 1 bit of RY.

Remote register (RWw) (Un\G2304 to Un\G10495)

The RWw value is stored. The RWw start number and number of points for each station number can be checked by the RWw offset/size information (Un\G25856 to Un\G26879). (Page 235 RWw offset/size information)

Address	b15	b14	b13	b12	b11	b10	b9	b8	b7	b6	b5	b4	b3	b2	b1	b0
Un\G2304	RWw0															
Un\G2305	RWw1															
⋮																
Un\G10495	RWw1FFF															

Remote register (RWr) (Un\G10496 to Un\G18687)

The RWr value is stored. The RWr start number and number of points for each station number can be checked by the RWr offset/size information (Un\G26880 to Un\G27903). (Page 235 RWr offset/size information)

Address	b15	b14	b13	b12	b11	b10	b9	b8	b7	b6	b5	b4	b3	b2	b1	b0
Un\G10496	RWr0															
Un\G10497	RWr1															
⋮																
Un\G18687	RWr1FFF															

Link special relay (SB) (Un\G18688 to Un\G18943)

The SB value is stored.

Address	b15	b14	b13	b12	b11	b10	b9	b8	b7	b6	b5	b4	b3	b2	b1	b0
Un\G18688	SBF F	SBE E	SBD D	SBC C	SBB B	SBA A	SB9 9	SB8 8	SB7 7	SB6 6	SB5 5	SB4 4	SB3 3	SB2 2	SB1 1	SB0 0
⋮																
Un\G18943	SBFF F	SBFF E	SBFF D	SBFF C	SBFF B	SBFF A	SBFF 9	SBFF 8	SBFF 7	SBFF 6	SBFF 5	SBFF 4	SBFF 3	SBFF 2	SBFF 1	SBFF 0

Each bit corresponds to 1 bit of SB.

■Link special register (SW) (Un\G18944 to Un\G23039)

The SW value is stored.

Address	b15	b14	b13	b12	b11	b10	b9	b8	b7	b6	b5	b4	b3	b2	b1	b0
Un\G18944	SW0															
Un\G18945	SW1															
⋮																
Un\G23039	SWFFF															

Timeslot information

■Timeslot 0 information (Un\G23552 to Un\G23567)

Cycle start offset (ns, s unit) and cycle end offset (ns, s unit) of timeslot 0 are stored.

Address	Name	Description
Un\G23552 to Un\G23553	Cycle start offset (ns unit)	The ns digits of cycle start offset are stored. Stored range: 0 to 999999999ns
Un\G23554	Cycle start offset (s unit)	The s digits of cycle start offset are stored. Stored range: 0 to 65535s
Un\G23555	System area	
Un\G23556 to Un\G23557	Cycle end offset (ns unit)	The ns digits of cycle end offset are stored. Stored range: 0 to 999999999ns
Un\G23558	Cycle end offset (s unit)	The s digits of cycle end offset are stored. Stored range: 0 to 65535s
Un\G23559 to Un\G23563	System area	
Un\G23564	VID (VLAN Identifier)	The VID is stored. Stored range: 1 to 4094, 65535 (the VID is not used or the relayed frame is not determined based on the VID)
Un\G23565	PCP (Priority Code Point)	The PCP is stored. Stored range: 0 to 7, 65535 (the PCP is not used or the relayed frame is not determined based on the PCP)
Un\G23566	Ether Type	The Ether Type of the relayed frame is stored. Stored range: the Ether Type value of the relayed frame, 65535 (the relayed frame is not determined based on the Ether Type) If the timeslot is 0, 65535 is stored.
Un\G23567	System area	

■Timeslot 1 to 7 information (Un\G23568 to Un\G23679)

Timeslot 1 to 7 information is stored in the same order as Timeslot 0 information.

RX offset/size information

■RX offset/size information (Un\G23808 to Un\G24831)

The start number and the number of points of RX for each station are stored.

Address	Description
Un\G23808 to Un\G23809	Station No.0 offset
Un\G23810 to Un\G23811	Station No.0 size (in units of words)
Un\G23812 to Un\G23813	Station No.1 offset
Un\G23814 to Un\G23815	Station No.1 size (in units of words)
⋮	
Un\G24288 to Un\G24289	Station No.120 offset
Un\G24290 to Un\G24291	Station No.120 size (in units of words)
Un\G24292 to Un\G24831	System area

The buffer memory address for the offset and size of each station number can be calculated using the following formulas:

- Offset buffer memory address = 23808 + (station No.) × 4
- Size buffer memory address = 23810 + (station No.) × 4

RY offset/size information

■RY offset/size information (Un\G24832 to Un\G25855)

The start number and the number of points of RY for each station are stored.

Address	Description
Un\G24832 to Un\G24833	Station No.0 offset
Un\G24834 to Un\G24835	Station No.0 size (in units of words)
Un\G24836 to Un\G24837	Station No.1 offset
Un\G24838 to Un\G24839	Station No.1 size (in units of words)
⋮	
Un\G25312 to Un\G25313	Station No.120 offset
Un\G25314 to Un\G25315	Station No.120 size (in units of words)
Un\G25316 to Un\G25855	System area

The buffer memory address for the offset and size of each station number can be calculated using the following formulas:

- Offset buffer memory address = $24832 + (\text{station No.}) \times 4$
- Size buffer memory address = $24834 + (\text{station No.}) \times 4$

RWw offset/size information

■RWw offset/size information (Un\G25856 to Un\G26879)

The start number and the number of points of RWw for each station are stored.

Address	Description
Un\G25856 to Un\G25857	Station No.0 offset
Un\G25858 to Un\G25859	Station No.0 size (in units of words)
Un\G25860 to Un\G25861	Station No.1 offset
Un\G25862 to Un\G25863	Station No.1 size (in units of words)
⋮	
Un\G26336 to Un\G26337	Station No.120 offset
Un\G26338 to Un\G26339	Station No.120 size (in units of words)
Un\G26340 to Un\G26879	System area

The buffer memory address for the offset and size of each station number can be calculated using the following formulas:

- Offset buffer memory address = $25856 + (\text{station No.}) \times 4$
- Size buffer memory address = $25858 + (\text{station No.}) \times 4$

RWr offset/size information

■RWr offset/size information (Un\G26880 to Un\G27903)

The start number and the number of points of RWr for each station are stored.

Address	Description
Un\G26880 to Un\G26881	Station No.0 offset
Un\G26882 to Un\G26883	Station No.0 size (in units of words)
Un\G26884 to Un\G26885	Station No.1 offset
Un\G26886 to Un\G26887	Station No.1 size (in units of words)
⋮	
Un\G27360 to Un\G27361	Station No.120 offset
Un\G27362 to Un\G27363	Station No.120 size (in units of words)
Un\G27364 to Un\G27903	System area

The buffer memory address for the offset and size of each station number can be calculated using the following formulas:

- Offset buffer memory address = $26880 + (\text{station No.}) \times 4$
- Size buffer memory address = $26882 + (\text{station No.}) \times 4$

Own station information

The information of the own station on the network is stored.

■Own station (network card) information (Un\G28160 to Un\G28167)

Address	Name	Description
Un\G28160	Manufacturer code	The FX5-CCLGN-MS information of the own station is stored. (Also used in the CLPA conformance test.) (Updated even if set as an error invalid station.) (Updated even if set as a reserved station.)
Un\G28161	Model type	
Un\G28162	Model code (lower 2 bytes)	
Un\G28163	Model code (upper 2 bytes)	
Un\G28164	Version	
Un\G28165 to Un\G28167	MAC address	The own station MAC address is stored. Un\G28165: 5th byte, 6th byte of the MAC address Un\G28166: 3rd byte, 4th byte of the MAC address Un\G28167: 1st byte, 2nd byte of the MAC address

■Own station (controller) information (Un\G28168 to Un\G28191)

Address	Name	Description
Un\G28168	Controller information valid/invalid flag	Whether the value stored in the own station (controller) information is valid or invalid is stored. • 0: Invalid • 1: Valid
Un\G28169	Manufacturer code	The FX5-CCLGN-MS information of the own station is stored.
Un\G28170	Model type	
Un\G28171	Model code (lower 2 bytes)	
Un\G28172	Model code (upper 2 bytes)	
Un\G28173	Version	
Un\G28174 to Un\G28183	Model name string	
Un\G28184 to Un\G28185	Vendor-specific device information	
Un\G28186 to Un\G28191	System area	

Communication path determination status

■Communication path determination status (Un\G36608 to Un\G36623)

The determination information on the communication path for each network number of the destination station is stored.

- 0: Path undetermined
- 1: Path determined

Address	b15	b14	b13	b12	b11	b10	b9	b8	b7	b6	b5	b4	b3	b2	b1	b0
Un\G36608	16	15	14	13	12	11	10	9	8	7	6	5	4	3	2	1
:																
Un\G36622	Empty	239	238	237	236	235	234	233	232	231	230	229	228	227	226	225
Un\G36623	Empty															

The numbers in the table indicate network numbers.

Protocol information

■ Protocol information (Un\G44320 to Un\G44335)

Address	Name	Description
Un\G44320	Protocol operating status	The operating status of the protocol is stored. 0: The operating protocol is not determined, or "CC-Link IE TSN Class Setting" is set to "CC-Link IE TSN Class B Only" 1: A device is operating with CC-Link IE TSN Protocol version 1.0 2: A device is operating with CC-Link IE TSN Protocol version 2.0
Un\G44321	Write request	Write the protocol setting to the FX5-CCLGN-MS. 0: Do not write 1: Write
Un\G44322	Protocol setting	Set the operating protocol. 0: Automatic setting 1: CC-Link IE TSN Protocol version 1.0 fixed 2: CC-Link IE TSN Protocol version 2.0 Fixed
Un\G44323	Write execution status	The write execution status is stored to the FX5-CCLGN-MS. 0: Write not executed, or write execution in progress 1: Write execution complete
Un\G44324	Setting result	The setting result is stored. 0: Completed successfully Other than 0: Completed with an error (error code)
Un\G44325	Protocol setting status	The protocol setting held by the FX5-CCLGN-MS is stored. 0: Automatic setting 1: CC-Link IE TSN Protocol version 1.0 fixed 2: CC-Link IE TSN Protocol version 2.0 Fixed
Un\G44326 to Un\G44335	System area	—

The following describes the details of Protocol setting (Un\G44322).

- 0: Automatic setting

The CC-Link IE TSN Protocol version is automatically set according to the system configuration.

CC-Link IE TSN Class A device connection		CC-Link IE TSN Protocol version to be used
CC-Link IE TSN Protocol version 1.0	CC-Link IE TSN Protocol version 2.0	
Yes	—	1.0
No	—	2.0* ¹

*1 While a device is operating with the CC-Link IE TSN Protocol version 2.0, if the device that does not support the CC-Link IE TSN Protocol version 2.0 attempts to start a data link with the module, that device does not establish a data link.

- 1: CC-Link IE TSN Protocol version 1.0 fixed

The device operates with CC-Link IE TSN Protocol version 1.0 regardless of the system configuration.

- 2: CC-Link IE TSN Protocol version 2.0 Fixed

The device operates with CC-Link IE TSN Protocol version 2.0 regardless of the system configuration. A data link is not performed for stations that support the CC-Link IE TSN Protocol version 1.0.

Timeslot information for device station cyclic transmission

■Timeslot information for device station cyclic transmission (Un\G44336 to Un\G44395)

The timeslot for cyclic transmission is stored for each station number.

Address	Description
Un\G44336	The timeslot for cyclic transmission (Station No.1) is stored. <ul style="list-style-type: none"> • 0: Undetermined • 1: Timeslot 1 • 3: Timeslot 3 • 4: Timeslot 4 • 5: Timeslot 5 • 6: Timeslot 6
⋮	
Un\G44395	The timeslot for cyclic transmission (Station No.60) is stored. <ul style="list-style-type: none"> • 0: Undetermined • 1: Timeslot 1 • 3: Timeslot 3 • 4: Timeslot 4 • 5: Timeslot 5 • 6: Timeslot 6

Information for ensuring cyclic data are sent/received

■Multiple period setting (low speed) (Un\G44594)

The setting value of the multiple period setting (low speed) for ensuring that cyclic data are sent/received is stored.

- 0: Not calculated
- 16, 32, 64, 128: The "low speed" period for the basic period

(Conditions where a value is stored)

A value is stored in the buffer memory if the following conditions are met.

"CC-Link IE TSN Class Setting" of "Network Configuration Settings" is set to "CC-Link IE TSN Class A" and "Communication Period Setting" is set to "Low-Speed" for any of the device stations.

However, no value is stored in the buffer memory if the following condition is met.

In "Network Configuration Settings", "General CC-Link IE TSN Module" is set for all

■Communication cycle interval (calculation value) (Un\G44595)

The setting value of the communication period interval for ensuring that cyclic data are sent/received is stored.

- 0: Not calculated
- 125 to 4294967295: Communication cycle interval (unit: μ s)

(Conditions where a value is stored)

A value is stored in the buffer memory if the following conditions are met.

"CC-Link IE TSN Class Setting" of "Network Configuration Settings" is set to "CC-Link IE TSN Class A" and "Communication Period Setting" is set to "Low-Speed" for any of the device stations.

However, no value is stored in the buffer memory if the following condition is met.

In "Network Configuration Settings", "General CC-Link IE TSN Module" is set for all.

Communication cycle setting value (CC-Link IE TSN Protocol version 2.0)

■Communication cycle interval (calculation value) (Un\G44596)

The communication cycle interval calculated by the number of device stations and the number of points that are set in "Network Configuration Settings" under "Basic Settings" are stored. (Unit: μs)

The communication cycle interval (CC-Link IE TSN Protocol version 2.0) are stored regardless of the setting value of 'Protocol setting' (Un\G44322). If the device that supports CC-Link IE TSN Protocol version 2.0 and a device that supports the CC-Link IE TSN Protocol version 1.0 coexist, and if 'Protocol setting' (Un\G44322) is set to "1": CC-Link IE TSN Protocol version 1.0 fixed, refer to the value of this buffer memory and set the value to "Communication Period Interval Setting" in "Communication Period Setting" under "Basic Settings".

■Cyclic transmission time (calculation value) (Un\G44597)

The cyclic transmission time calculated by the number of device stations and the number of points that are set in "Network Configuration Settings" under "Basic Settings" is stored. (Unit: μs)

The cyclic transmission time (CC-Link IE TSN Protocol version 2.0) is stored regardless of the setting value of 'Protocol setting' (Un\G44322). If the device that supports CC-Link IE TSN Protocol version 2.0 and a device that supports the CC-Link IE TSN Protocol version 1.0 are coexistence, and if 'Protocol setting' (Un\G44322) is set to "1": CC-Link IE TSN Protocol version 1.0 fixed, refer to the value of this buffer memory and the value is set to "Cyclic Transmission Time" in "Communication Period Setting" under "Basic Settings".

■Transient transmission time (Calculation value) (Un\G44598)

The transient transmission time calculated by the number of device stations and the number of points that are set in "Network Configuration Settings" under "Basic Settings" is stored. (Unit: μs)

The transient transmission time (CC-Link IE TSN Protocol version 2.0) are stored regardless of the setting value of 'Protocol setting' (Un\G44322). If the device that supports CC-Link IE TSN Protocol version 2.0 and a device that supports the CC-Link IE TSN Protocol version 1.0 are coexistence, and if 'Protocol setting' (Un\G44322) is set to "1": CC-Link IE TSN Protocol version 1.0 fixed, refer to the value of this buffer memory and the value is set to "Transient Transmission Time" in "Communication Period Setting" under "Basic Settings".

Information for device station cyclic transmission

■Multiplier for transmission delay information of CC-Link IE TSN Class A (low-speed) (Un\G44608)

The multiplier n is stored for calculating the transmission delay time for device stations for which "CC-Link IE TSN Class A" is set and "Communication Period Setting" is set to "Low-Speed".

- 0: There are no device stations for which "CC-Link IE TSN Class A" is set and "Communication Period Setting" is set to "Low-Speed" in the network configuration.
- 1 or higher: Value of n

If Protocol operating status (Un\G44320) is "1" (A device is operating with the CC-Link IE TSN Protocol version 1.0), this is fixed to 1.

Time synchronization

■Time distribution interval setting of the CPU module (Un\G51200)

This setting specifies the interval for distributing the clock time of the CPU module on the same system as the master module from the master station to device stations.

When the setting is changed, the new setting value is enabled after the interval of the distribution operating with the old setting value has elapsed. The setting value is distributed once after the distribution interval elapses. If the new setting value needs to be enabled immediately, stop the distribution and set the value.

- 0000H: 10s
- 0001H to FFFE H: Send using the set time interval (second).
- FFFFH: Distribution stop

■Time reflection setting to the CPU module (Un\G51201)

- 0000H: Do not reflect the time in the CPU module.^{*1*2}
- 0001H: Reflect the time to the CPU module.

*1 The time that was set to the CPU module on the local station is used for operation.

*2 This setting reflects the time in the CPU module of the local station. Even if 0001H is set for this buffer memory area by the master station side, the time is not reflected in the CPU module of the local station.

Grandmaster information

The grandmaster status of the own station and MAC address are stored.

■Grandmaster (Un\G51968)

When the own station is the grandmaster, "1" is stored.

- 0: Another station is the grandmaster.
- 1: Own station is the grandmaster.

■Grandmaster MAC address (Un\G51971 to Un\G51973)

The grandmaster MAC address is stored.

- Un\G51971: 5th byte, 6th byte of the MAC address
- Un\G51972: 3rd byte, 4th byte of the MAC address
- Un\G51973: 1st byte, 2nd byte of the MAC address

Time synchronization setting

■PTP frame send source check enable/disable (Un\G51997)

- 0: Do not check
- 1: Check

■PTP frame send source check result (P1) (Un\G51998)

- 0: One send source
- 1: Two or more send sources

■PTP frame send source check result (P2) (Un\G51999)

- 0: One send source
- 1: Two or more send sources

Own node setting status storage area

■Own node IP address (Un\G52228 to Un\G52229)

The setting values of the IP address are stored.

Range: 1H to DFFFFFFEH

■Subnet mask (Un\G52238 to Un\G52239)

The setting values of the subnet mask are stored.

Range: 1H to FFFFFFFFH

0: No setting

■Default gateway IP address (Un\G52242 to Un\G52243)

The setting values of the default gateway are stored.

Range: 1H to DFFFFFFEH

0: No setting

■Own node MAC address (Un\G52252 to Un\G52254)

The own node MAC addresses are stored.

- Un\G52252: 5th byte, 6th byte of the MAC address
- Un\G52253: 3rd byte, 4th byte of the MAC address
- Un\G52254: 1st byte, 2nd byte of the MAC address

■Own node network number (Un\G52255)

The setting value of the network number is stored.

Range: 1 to 239

0: Network number not set

■Station number (Un\G52256)

The setting value of the station number is stored.

Range: 1 to 120

0: Station number not set

125: Master station

■Transient transmission group No. (Un\G52257)

The setting value of the transient transmission group number is stored.

Range: 1 to 32

0: No group specification

■Auto-open UDP port port number (Un\G52261)

The port number used for the auto-open UDP port is stored.

■MELSOFT transmission port (TCP/IP) port number (Un\G52262)

The port number used for the MELSOFT transmission port (TCP/IP) is stored.

■MELSOFT transmission port (UDP/IP) port number (Un\G52263)

The port number for the MELSOFT transmission port (UDP/IP) is stored.

■SLMP transmission port (TCP/IP) port number (Un\G52265)

The port number used for the SLMP transmission port (TCP/IP) is stored.

■SLMP transmission port (UDP/IP) port number (Un\G52266)

The port number used for the SLMP transmission port (UDP/IP) is stored.

Connection status storage area

■Latest error code after the 2nd connection of MELSOFT transmission port (TCP/IP) (Un\G52452 to Un\G52458)

The latest error code of the 2nd to 8th connection of the MELSOFT transmission port (TCP/IP) is stored.

■Latest error code after the 2nd connection of SLMP transmission port (TCP/IP) (Un\G52580 to Un\G52586)

The latest error code of the 2nd to 8th connection of the SLMP transmission port (TCP/IP) is stored.

System port latest error code storage area

■Auto-open UDP port latest error code (Un\G52738)

The latest error code of the auto-open UDP port is stored.

■MELSOFT transmission port (UDP/IP) latest error code (Un\G52739)

The latest error code of the MELSOFT transmission port (UDP/IP) is stored.

■MELSOFT transmission port (TCP/IP) latest error code (Un\G52740)

The latest error code of the MELSOFT transmission port (TCP/IP) is stored.

■SLMP transmission port (UDP/IP) latest error code (Un\G52741)

The latest error code of the SLMP transmission port (UDP/IP) is stored.

■SLMP transmission port (TCP/IP) latest error code (Un\G52742)

The latest error code of the SLMP transmission port (TCP/IP) is stored.

■SLMPSND instruction latest error code (Un\G52743)

The latest error code of the SLMPSND instruction is stored.

Status for each protocol (IP packet)

■Received packet total count (Un\G52992 to Un\G52993, Un\G60928 to Un\G60929)

The status is counted from 0 to 4294967295 (FFFFFFFFH).

■Received packet checksum error discard count (Un\G52994 to Un\G52995, Un\G60930 to Un\G60931)

The status is counted from 0 to 4294967295 (FFFFFFFFH).

■Sent packet total count (Un\G52996 to Un\G52997, Un\G60932 to Un\G60933)

The status is counted from 0 to 4294967295 (FFFFFFFFH).

■Simultaneous transmission error detection count (receive buffer full count) (Un\G53014 to Un\G53015, Un\G60950 to Un\G60951)

The status is counted from 0 to 4294967295 (FFFFFFFFH).

■Receive abort count (Un\G53021, Un\G60957)

The status is counted from 0 to 65535 (FFFFH).

Status for each protocol (ICMP packet)

■Received packet total count (Un\G53032 to Un\G53033, Un\G60968 to Un\G60969)

The status is counted from 0 to 4294967295 (FFFFFFFFH).

■Received packet checksum error discard count (Un\G53034 to Un\G53035, Un\G60970 to Un\G60971)

The status is counted from 0 to 4294967295 (FFFFFFFFH).

■Sent packet total count (Un\G53036 to Un\G53037, Un\G60972 to Un\G60973)

The status is counted from 0 to 4294967295 (FFFFFFFFH).

■Received echo request total count (Un\G53038 to Un\G53039, Un\G60974 to Un\G60975)

The status is counted from 0 to 4294967295 (FFFFFFFFH).

■Sent echo reply total count (Un\G53040 to Un\G53041, Un\G60976 to Un\G60977)

The status is counted from 0 to 4294967295 (FFFFFFFFH).

■Sent echo request total count (Un\G53042 to Un\G53043, Un\G60978 to Un\G60979)

The status is counted from 0 to 4294967295 (FFFFFFFFH).

■Received echo reply total count (Un\G53044 to Un\G53045, Un\G60980 to Un\G60981)

The status is counted from 0 to 4294967295 (FFFFFFFFH).

Status for each protocol (TCP packet)

■Received packet total count (Un\G53072 to Un\G53073, Un\G61008 to Un\G61009)

The status is counted from 0 to 4294967295 (FFFFFFFFH).

■Received packet checksum error discard count (Un\G53074 to Un\G53075, Un\G61010 to Un\G61011)

The status is counted from 0 to 4294967295 (FFFFFFFFH).

■Sent packet total count (Un\G53076 to Un\G53077, Un\G61012 to Un\G61013)

The status is counted from 0 to 4294967295 (FFFFFFFFH).

Status for each protocol (UDP packet)

■Received packet total count (Un\G53112 to Un\G53113, Un\G61048 to Un\G61049)

The status is counted from 0 to 4294967295 (FFFFFFFFH).

■Received packet checksum error discard count (Un\G53114 to Un\G53115, Un\G61050 to Un\G61051)

The status is counted from 0 to 4294967295 (FFFFFFFFH).

■Sent packet total count (Un\G53116 to Un\G53117, Un\G61052 to Un\G61053)

The status is counted from 0 to 4294967295 (FFFFFFFFH).

Own node operation status storage area (LED on/off status)

■Own node operation status storage area (LED on/off status) (Un\G53181)

ERROR LED (b0)

- 0: Off
- 1: On/flashing

Own node operation status storage area (switching hub connection information area)

■Communication mode (Un\G53183, Un\G61119)

- 0: Half-duplex
- 1: Full-duplex

■Connection status (Un\G53184, Un\G61120)

- 0: Switching hub not connected/disconnected
- 1: Switching hub connected

■Communication speed (Un\G53185, Un\G61121)

- 1: Operating at 100BASE-TX
- 2: Operating at 1000BASE-T

■Disconnection count (Un\G53186, Un\G61122)

The number of times the cable was disconnected is stored.

Own node operation status storage area (IP address duplication status storage area)

■IP address duplication flag (Un\G53192)

- 0: IP address not duplicated
- 1: IP address duplicated

■MAC address of the station already connected to the network (Un\G53193 to Un\G53195)

It is stored in the station with duplicated IP address.

■MAC address of the station with the IP address already used (Un\G53196 to Un\G53198)

It is stored in the station that has been already connected to the network.

Area for sending/receiving instructions

■RECV instruction execution request (Un\G53293)

RECV instruction execution request

- 0: No request
- 1: Requesting

Channels 1 to 8 are displayed in units of bits.

Remote password lock status storage area

■Remote password lock status system port (Un\G53622, Un\G61558)

[b0]: Auto-open UDP port

[b1]: MELSOFT transmission port (UDP/IP)

[b2]: MELSOFT transmission port (TCP/IP)

[b5]: SLMP transmission port (UDP/IP)

[b6]: SLMP transmission port (TCP/IP)

- 0: Unlocked/remote password not set
- 1: Lock status

Remote password function monitoring area

■Auto-open UDP port continuous unlock failure count (Un\G59640, Un\G67576)

The mismatch count of remote password at unlock of the auto-open UDP port is stored. The count is cleared when the password matches.

Range: 0 to 65535 (Values of 65535 or more are not changed)

■MELSOFT transmission port (UDP/IP) continuous unlock failure count (Un\G59641, Un\G67577)

The mismatch count of remote password at unlock of the MELSOFT transmission port (UDP/IP) is stored. The count is cleared when the password matches.

Range: 0 to 65535 (Values of 65535 or more are not changed)

■MELSOFT transmission port (TCP/IP) continuous unlock failure count (Un\G59642, Un\G67578)

The mismatch count of remote password at unlock of the MELSOFT transmission port (TCP/IP) is stored. The count is cleared when the password matches.

Range: 0 to 65535 (Values of 65535 or more are not changed)

■SLMP transmission port (UDP/IP) continuous unlock failure count (Un\G59645, Un\G67581)

The mismatch count of remote password at unlock of the SLMP transmission port (UDP/IP) is stored. The count is cleared when the password matches.

Range: 0 to 65535 (Values of 65535 or more are not changed)

■SLMP transmission port (TCP/IP) continuous unlock failure count (Un\G59646, Un\G67582)

The mismatch count of remote password at unlock of the SLMP transmission port (TCP/IP) is stored. The count is cleared when the password matches.

Range: 0 to 65535 (Values of 65535 or more are not changed)

Network type information area

■Network type information (Un\G59935)

- 5: CC-Link IE TSN

Ethernet P1/2 common information

■Initial status (Un\G68120)

The initial processing status of the FX5-CCLGN-MS Ethernet connection is stored.

[b0]: Initial normal completion status

- 0: —
- 1: Initialization normal completion

[b1]: Initial abnormal completion status

- 0: —
- 1: Initialization abnormal completion

[b2 to b15]: Not used (Use prohibited)

■Initial error code (Un\G68121)

The information when the initial processing is completed with an error is stored.

- 0: In initial processing or initial normal completion
- 1 or more: Initialization abnormal code

Receive buffer status storage area

■Receive buffer status (Un\G68126)

The receive buffer status is stored.

- 0: Receive buffer not full
- 1: Receive buffer full

Appendix 4 List of Link Special Relay (SB)

The link special relay (SB) is turned on/off depending on various factors during data link. Any error status of the data link can be checked by using or monitoring it in the program.

Application of link special relay (SB)

By using link special relay (SB), the status of CC-Link IE TSN can be checked from HMI (Human Machine Interfaces) as well as the engineering tool.

Refresh of link special relay (SB)

To use link special relay (SB), set them in "Refresh Settings" under "Basic Settings" so that they are refreshed to the devices of the FX5 CPU module. (📖 Page 130 Refresh settings)

Ranges turned on/off by users and by the system

The following ranges correspond to when the link special relay areas (SB) are assigned from SB0000 to SB0FFF.

- Turned on/off by users: SB0000 to SB001F
- Turned on/off by the system: SB0020 to SB0FFF

List of link special relay (SB)

The following table lists the link special relay areas (SB) when they are assigned from SB0000 to SB0FFF.



Do not turn on or off areas whose numbers are not in the following list. Doing so may cause malfunction of the programmable controller system.

No.	Name	Description	Availability		
			Master station	Local station	
				Unicast mode	Multicast mode
SB0006	Clear communication error count	Clears the link special register areas related to communication errors (SW0074 to SW0077, SW007C to SW007F) to 0. Off: Clear not requested On: Clear requested (valid while on)	○	○	○
SB0014	Cyclic data receive status clear	Clears 'Cyclic data receive status' (SB0064). While 'Cyclic data receive status clear' (SB0014) is on, the cyclic data receive status does not turn on. Off: Clear not requested On: Clear requested (enabled while on)	○	×	×
SB0030	RECV execution request flag CH1	Stores the data reception status of own station channel 1. Off: No data received On: Data received	○	○	○
SB0031	RECV execution request flag CH2	Stores the data reception status of own station channel 2. Off: No data received On: Data received	○	○	○
SB0032	RECV execution request flag CH3	Stores the data reception status of own station channel 3. Off: No data received On: Data received	○	○	○
SB0033	RECV execution request flag CH4	Stores the data reception status of own station channel 4. Off: No data received On: Data received	○	○	○
SB0034	RECV execution request flag CH5	Stores the data reception status of own station channel 5. Off: No data received On: Data received	○	○	○
SB0035	RECV execution request flag CH6	Stores the data reception status of own station channel 6. Off: No data received On: Data received	○	○	○
SB0036	RECV execution request flag CH7	Stores the data reception status of own station channel 7. Off: No data received On: Data received	○	○	○
SB0037	RECV execution request flag CH8	Stores the data reception status of own station channel 8. Off: No data received On: Data received	○	○	○
SB0040	Network type of own station	Stores the network type of the own station. On: CC-Link IE TSN	○	○	○
SB0043	Module operation mode of own station	Stores the module operation mode of the own station. Off: Online mode On: Other than online mode	○	○	○
SB0044	Station setting 1 of own station	Stores the station type of the own station. Off: Device station (other than the master station) On: Master station	○	○	○
SB0045	Station setting 2 of own station	Stores the communication mode of the own station. Off: Unicast mode On: Multicast mode	○	○	○
SB0046	Station number setting status of own station	Stores the station number setting status. Off: Station number set On: Station number not set (local station only) If parameters are set using the engineering tool, this relay is always off.	○	○	○

A

No.	Name	Description	Availability		
			Master station	Local station	
				Unicast mode	Multicast mode
SB0049	Data link error status of own station	Stores the data link error status of the own station. Off: Normal On: Error When this relay is turned on, the cause of the error can be checked with 'Cause of data link stop' (SW0049). Depending on the link refresh timing, the update of 'Cause of data link stop' (SW0049) may be offset by one sequence scan. (Also used in the CLPA conformance test.) (Updated even if set as an error invalid station.)	○	○	○
SB004A	CPU minor error status of own station	Stores the minor error status of the FX5 CPU module on the own station. Off: No minor error On: Minor error	○	○	○
SB004B	CPU moderate/major error status of own station	Stores the moderate/major error status of the FX5 CPU module on the own station. Off: No moderate/major error On: Moderate/major error	○	○	○
SB004C	CPU operating status of own station	Stores the operating status of the FX5 CPU module on the own station. Off: RUN On: STOP, PAUSE, or moderate/major error	○	○	○
SB004D	Received parameter error	Stores the status of received parameter. (For the master station, this relay stores the parameter status of the own station) Off: Normal On: Error	○	○	○
SB004F	Station number status of the operating station	Stores the station number setting method as follows when the station type of the own station is local station. Off: Set by parameters On: Set by program	×	○	○
SB0064	Cyclic data receive status	Shows the receive status in the communication cycle in which the cyclic data from the device station is set using "Disconnection Detection Setting" in the master station. Off: Cyclic data received On: Cyclic data not received consecutively (Conditions) • This relay turns on when an error is detected for one or more stations by an alive check. • Reserved stations and stations that surpass the maximum station number are ignored. (Also used in the CLPA conformance test.) (Updated even if set as an error invalid station.) (Updated even if set as a reserved station.)	○	×	×
SB006A	PORT1 link-down status of own station	Stores the link-down status of the own station P1 side. Off: Link-up On: Link-down The time until link-up starts after power-on or Ethernet cable connection may vary. Normally link-up takes several seconds. Depending on device status on the line, link-up processing is repeated and may increase the time. (Also used in the CLPA conformance test.) (Updated even if set as an error invalid station.) (Updated even if set as a reserved station.)	○	○	○
SB006B	PORT2 link-down status of own station	Stores the link-down status of the own station P2 side. Off: Link-up On: Link-down The time until link-up starts after power-on or Ethernet cable connection may vary. Normally link-up takes several seconds. Depending on device status on the line, link-up processing is repeated and may increase the time. (Also used in the CLPA conformance test.) (Updated even if set as an error invalid station.) (Updated even if set as a reserved station.)	○	○	○

No.	Name	Description	Availability		
			Master station	Local station	
				Unicast mode	Multicast mode
SB0074	Reserved station specification status	Stores the status of reserved station specification by parameter. The station number of the station set as a reserved station can be checked with 'Reserved station setting status' (SW00C0 to SW00C7). Off: Not specified On: Specified	○	×	○ ^{*1}
SB0075	Error invalid station setting status	Stores the status of error invalid station setting by parameter. The station number of the station set as an error invalid station can be checked with 'Error invalid station setting status' (SW00D0 to SW00D7). Off: Not specified On: Specified	○	×	○ ^{*1}
SB0077	Parameter reception status	Stores the status of parameter reception from the master station. Off: Reception complete On: Reception not completed	○	○	○
SB007B	Input data status of data link faulty station	Stores the setting status of "Data link faulty station setting" of the own station. Off: Clear On: Hold	○	○	○
SB007D	Hold/clear status setting for CPU STOP	Stores the setting status of "Output Hold/Clear Setting during CPU STOP" of the own station. Off: Hold On: Clear	○	○	○
SB007E	Type of IP Address	Stores the type of IP address. Off: IPv4 On: IPv6	○	○	○
SB007F	IP address setting status	Stores the status of the IP address setting by parameter. Off: No setting On: Set For local stations, this relay stores the acceptance status of the IP address from the master station.	○	○	○
SB00B0	Data link error status of each station	Stores the data link status of each station. Off: All stations normal On: Faulty station exists When this relay is turned on, the status of each station can be checked with 'Data link status of each station' (SW00B0 to SW00B7). Depending on the link refresh timing, the update of 'Data link status of each station' (SW00B0 to SW00B7) may be offset by one sequence scan. Since a local station cannot obtain the station information of the CC-Link IE TSN Class A remote station when communicating in multicast mode, "0: Data link normally operating station" is reflected to the CC-Link IE TSN Class A remote station. (Conditions) Reserved stations and stations that surpass the maximum station number are ignored.	○	×	○ ^{*1}
SB00B1	Data link error status of master station	Stores the data link status of the master station. Off: Normal On: Error	○	×	○ ^{*1}
SB00C0	Reserved station setting status	Stores whether a reserved station is set. Off: No setting On: Set When this relay is turned on, the status of each station can be checked with 'Reserved station setting status' (SW00C0 to SW00C7). Depending on the refresh timing, the update of 'Reserved station setting status' (SW00C0 to SW00C7) may be offset by one sequence scan.	○	×	○ ^{*1}



No.	Name	Description	Availability		
			Master station	Local station	
				Unicast mode	Multicast mode
SB00D0	Error invalid station setting current status	Set whether an error invalid station is set. Off: No setting On: Set When this relay is turned on, the status of each station can be checked with 'Error invalid station setting status' (SW00D0 to SW00D7). Depending on the refresh timing, the update of 'Error invalid station setting status' (SW00D0 to SW00D7) may be offset by one sequence scan.	○	×	○ ^{*1}
SB00E8	Station type match status of each station	Shows the station type match status of each station. 0: Station types of all stations match 1: Station type mismatch exists. This relay is turned to "0: Station types of all stations match" when all areas of 'Station type match status' (SW00E8 to SW00EF) are "0: Station type match". Depending on the refresh timing, the update of 'Station type match status' (SW00E8 to SW00EF) may be offset by one sequence scan.	○	×	○ ^{*1}
SB00F0	CPU operating status of each station	Stores the operating status of the CPU module on each station. Off: All stations at RUN or PAUSE state On: Station at STOP state, or station with a moderate/major error exists. When this relay is turned on, the status of each station can be checked with 'CPU operating status of each station' (SW00F0 to SW00F7). Depending on the refresh timing, the update of 'CPU operating status of each station' (SW00F0 to SW00F7) may be offset by one sequence scan. Since a local station cannot obtain the station information of the CC-Link IE TSN Class A remote station when communicating in multicast mode, "0: RUN, PAUSE" is reflected to the CC-Link IE TSN Class A remote station.	○	×	○ ^{*1}
SB00F1	CPU operating status of master station	Stores the operating status of the CPU module on the master station (master operating station). Off: RUN or PAUSE state On: STOP state, or moderate/major error	○	×	○ ^{*1}
SB0100	CPU moderate/major error status of each station	For local stations, stores the moderate/major error occurrence status of the CPU module on each station. For remote stations, stores the moderate/major error occurrence status of each station. Off: No station with a moderate/major error On: Station with a moderate/major error exists When this relay is turned on, the status of each station can be checked with 'CPU moderate/major error status of each station' (SW0100 to SW0107). Depending on the refresh timing, the update of 'CPU moderate/major error status of each station' (SW0100 to SW0107) may be offset by one sequence scan. Since a local station cannot obtain the station information of the CC-Link IE TSN Class A remote station when communicating in multicast mode, "0: No moderate/major error" is reflected to the CC-Link IE TSN Class A remote station.	○	×	○ ^{*1}
SB0101	CPU moderate/major error status of master station	Stores the moderate/major error occurrence status of the CPU module on the master station (master operating station). Off: No moderate/major error On: Moderate/major error	○	×	○ ^{*1}

No.	Name	Description	Availability		
			Master station	Local station	
				Unicast mode	Multicast mode
SB0110	CPU minor error status of each station	For local stations, stores the minor error occurrence status of the CPU module on each station. For remote stations, stores the minor error occurrence status of each station. Off: All stations normal or station with a moderate/major error exists. On: Station with a minor error exists. When this relay is turned on, the status of each station can be checked with 'CPU minor error status of each station' (SW0110 to SW0117). Depending on the refresh timing, the update of 'CPU minor error status of each station' (SW0110 to SW0117) may be offset by one sequence scan. Since a local station cannot obtain the station information of the CC-Link IE TSN Class A remote station when communicating in multicast mode, "0: Normal, or a moderate or serious error occurring" is reflected to the CC-Link IE TSN Class A remote station.	○	×	○ ^{*1}
SB0111	CPU minor error status of master station	Stores the minor error occurrence status of the CPU module on the master station (master operating station). Off: No minor error or a moderate/major error On: Minor error	○	×	○ ^{*1}

*1 This register is enabled when 'Data link status of own station' (SB0049) is off.



Appendix 5 List of Link Special Register (SW)

The link special register (SW) stores the information during data link as a numerical value. Faulty areas and causes can be checked by using or monitoring the link special register (SW) in programs.

Application of link special register (SW)

By using link special register (SW), the status of CC-Link IE TSN can be checked from HMI (Human Machine Interfaces) as well as the engineering tool.

Refresh of link special register (SW)

To use link special register (SW), set them in "Refresh Settings" under "Basic Settings" so that they are refreshed to the devices of the FX5 CPU module. (📖 Page 130 Refresh settings)

Range where data is stored by users and range where data is stored by the system

The following ranges correspond to when the link special register areas (SW) are assigned from SW0000 to SW0FFF.

- Stored by users: SW0000 to SW001F
- Stored by the system: SW0020 to SW0FFF

List of link special register (SW)

The following table lists the link special register areas (SW) when they are assigned from SW0000 to SW0FFF.



Do not write any data to an area whose number is not on the following list. Doing so may cause malfunction of the programmable controller system.

No.	Name	Description	Availability												
			Master station	Local station											
				Unicast mode	Multicast mode										
SW0030	Link dedicated instructions processing result CH1	Stores the processing results of the link dedicated instruction that used channel 1 of the own station. 0: Completed successfully 1 or greater: Completed with an error (Error code is stored.)	<input type="radio"/>	<input type="radio"/>	<input type="radio"/>										
SW0031	Link dedicated instructions processing result CH2	Stores the processing results of the link dedicated instruction that used channel 2 of the own station. 0: Completed successfully 1 or greater: Completed with an error (Error code is stored.)	<input type="radio"/>	<input type="radio"/>	<input type="radio"/>										
SW0040	Network number	Stores the network number of the own station. Range: 1 to 239	<input type="radio"/>	<input type="radio"/>	<input type="radio"/>										
SW0042	Station number	Stores the station number of the own station. Master station range: 125 Local station range: 1 to 120, 255 (station number not set)	<input type="radio"/>	<input type="radio"/>	<input type="radio"/>										
SW0043	Mode status of own station	Stores the module operation mode setting or communication mode setting of the own station. 0: Online mode/Unicast mode 1: Online mode/Multicast mode 2: Offline mode B: Module communication test mode	<input type="radio"/>	<input type="radio"/>	<input type="radio"/> *1										
SW0045	Module type	Stores the hardware status of the own station. <div style="text-align: center;"> <table border="1" style="margin-left: auto; margin-right: auto;"> <tr> <td style="text-align: center;">b15</td> <td style="text-align: center;">...</td> <td style="text-align: center;">b2</td> <td style="text-align: center;">b1</td> <td style="text-align: center;">b0</td> </tr> <tr> <td style="text-align: center;">0</td> <td style="text-align: center;">...</td> <td style="text-align: center;">0</td> <td style="text-align: center;">0</td> <td style="text-align: center;">0</td> </tr> </table> </div> Model type (b1, b0) 00: Module 01: Board 10: HMI (Human Machine Interface)	b15	...	b2	b1	b0	0	...	0	0	0	<input type="radio"/>	<input type="radio"/>	<input type="radio"/>
b15	...	b2	b1	b0											
0	...	0	0	0											
SW0046 to SW0047	IPv4 address	Shows the IP address (IPv4) set in the own station. <table border="1" style="margin-left: auto; margin-right: auto;"> <tr> <td style="width: 50px;">SW0046</td> <td style="width: 100px; text-align: center;">(1)</td> <td style="width: 100px; text-align: center;">(2)</td> </tr> <tr> <td>SW0047</td> <td style="text-align: center;">(3)</td> <td style="text-align: center;">(4)</td> </tr> </table>	SW0046	(1)	(2)	SW0047	(3)	(4)	<input type="radio"/>	<input type="radio"/>	<input type="radio"/>				
SW0046	(1)	(2)													
SW0047	(3)	(4)													
SW0049	Cause of data link stop	Stores the cause that stopped the data link of the own station. 00H: At normal communication or power-on 02H: Monitoring time timeout 05H: No device station (master station only) 10H: Parameter not received (local station only) 11H: Outside the range of own station numbers 12H: Reserved station setting of own station (local station only) 14H: Master station duplication (master station only) 16H: Station number not set (local station only) 18H: Parameter error 19H: Parameter communication in progress 20H: CPU module moderate error, major error 60H: Illegal ring topology (master station only) (Also used in the CLPA conformance test.) (Updated even if set as an error invalid station.) (Updated even if set as a reserved station.)	<input type="radio"/>	<input type="radio"/>	<input type="radio"/>										



No.	Name	Description	Availability		
			Master station	Local station	
				Unicast mode	Multicast mode
SW004B	CPU status of own station	Stores the status of the FX5 CPU module on the own station. 00H: No CPU module mounted 01H: STOP (normal) 02H: STOP (moderate/major error) 03H: STOP (minor error) 04H: RUN (normal) 05H: RUN (minor error) 07H: PAUSE 0EH: Reset in progress 0FH: Initial processing in progress	○	○	○
SW004C	Parameter setting status	Stores the status of parameter settings. 0: Normal 1 or greater: Error definition (Error code is stored.) (Conditions) • This register is enabled when 'Received parameter error' (SB004D) is on.	○	○	○
SW0058	Total number of device stations setting value	Stores the total number of device stations that are set by the parameters. Range: 1 to 120	○	○	○
SW0059	Total number of device stations present value	Stores the total number of device stations that are actually connected by data link. Range: 1 to 120 (0 when own station is disconnected) Since a local station cannot obtain the station information of the CC-Link IE TSN Class A remote station when communicating in multicast mode, the CC-Link IE TSN Class A remote station is reflected as a station that is performing data link normally.	○	×	○ ^{*1}
SW005B	Maximum data link station number	Stores the maximum station number of the station where the data link is normally performed. Range: 1 to 120 (0 when own station is disconnected) Since a local station cannot obtain the station information of the CC-Link IE TSN Class A remote station when communicating in multicast mode, the CC-Link IE TSN Class A remote station is reflected as a station that is performing data link normally. (Conditions) • This register is enabled when 'Data link error status of own station' (SB0049) is off.	○	×	○ ^{*1}
SW0060	Communication cycle intervals	Stores the setting value of "Communication Period Interval Setting" set with the module parameter of the master station. (Unit: μs)	○	○	○
SW0061	System reserved time	Stores the setting value of "System Reservation Time" set with the module parameter of the master station. (Unit: μs)	○	○	○
SW0062	Cyclic transmission time	Stores the setting value of "Cyclic Transmission Time" set with the module parameter of the master station. (Unit: μs)	○	○	○
SW0063	Transient transmission time	Stores the setting value of "Transient Transmission Time" set with the module parameter of the master station. (Unit: μs)	○	○	○
SW0064	Multiple cycle setting (medium speed)	Stores the setting value of "Multiple Period Setting (Normal-Speed)" set with the module parameter of the master station.	○	○	○
SW0065	Multiple cycle setting (low speed)	Stores the setting value of "Multiple Period Setting (Low-Speed)" set with the module parameter of the master station.	○	○	○
SW0066	Connection status of own station	Stores the connection status of the own station. 00H: Normal (communication in progress on P1 and P2) 01H: Normal (communication in progress on P1, cable disconnected on P2) 10H: Normal (cable disconnected on P1, communication in progress on P2) 11H: Disconnected (cable disconnected on P1 and P2) 12H: Disconnected (cable disconnected on P1, establishing line on P2) 21H: Disconnected (establishing line on P1, cable disconnected on P2) 22H: Disconnected (establishing line on P1 and P2)	○	○	○
SW0072	Communication cycle intervals (calculation value)	Stores the communication cycle intervals calculated by the number of device stations and the number of points that are set in "Network Configuration Settings" under "Basic Settings". (Unit: μs)	○	○	○

No.	Name	Description	Availability		
			Master station	Local station	
				Unicast mode	Multicast mode
SW0073	Cyclic transmission time (calculation value)	Stores the cyclic transmission time calculated by the number of device stations and the number of points that are set in "Network Configuration Settings" under "Basic Settings". (Unit: μ s)	<input type="radio"/>	<input type="radio"/>	<input type="radio"/>
SW0074	PORT1 cable disconnection detection count	Stores the cumulative count that was detected for cable disconnections at the P1 side. When 'Clear communication error count' (SB0006) is turned on, the stored count is cleared. When FFFFH (maximum value 65535) is counted, the value returns to 0 and the module continues to count.	<input type="radio"/>	<input type="radio"/>	<input type="radio"/>
SW0075	PORT1 receive error detection count	Stores the cumulative count that error data was received at the P1 side. The count stores only error data that is not transmitted to all stations. When 'Clear communication error count' (SB0006) is turned on, the stored count is cleared. When FFFFH (maximum value 65535) is counted, counting stops.	<input type="radio"/>	<input type="radio"/>	<input type="radio"/>
SW0076	PORT1 total number of received data (lower 1 word)	Stores the cumulative count that data was received at the P1 side. When 'Clear communication error count' (SB0006) is turned on, the stored count is cleared. When FFFFFFFFH (maximum value 4294967295) is counted, counting stops.	<input type="radio"/>	<input type="radio"/>	<input type="radio"/>
SW0077	PORT1 total number of received data (upper 1 word)				
SW0078	Transient transmission time (calculation value)	Stores the transient transmission time calculated by the number of device stations and the number of points that are set in "Network Configuration Settings" under "Basic Settings". (Unit: μ s)	<input type="radio"/>	<input type="radio"/>	<input type="radio"/>
SW007C	PORT2 cable disconnection detection count	Stores the cumulative count that was detected for cable disconnections at the P2 side. When 'Clear communication error count' (SB0006) is turned on, the stored count is cleared. When FFFFH (maximum value 65535) is counted, the value returns to 0 and the module continues to count.	<input type="radio"/>	<input type="radio"/>	<input type="radio"/>
SW007D	PORT2 receive error detection count	Stores the cumulative count that error data was received at the P2 side. The count stores only error data that is not transmitted to all stations. When 'Clear communication error count' (SB0006) is turned on, the stored count is cleared. When FFFFH (maximum value 65535) is counted, counting stops.	<input type="radio"/>	<input type="radio"/>	<input type="radio"/>
SW007E	PORT2 total number of received data (lower 1 word)	Stores the cumulative count that data was received at the P2 side. When 'Clear communication error count' (SB0006) is turned on, the stored count is cleared. When FFFFFFFFH (maximum value 4294967295) is counted, counting stops.	<input type="radio"/>	<input type="radio"/>	<input type="radio"/>
SW007F	PORT2 total number of received data (upper 1 word)				
SW00B0 to SW00B7	Data link status of each station	Stores the data link status of each station. 0: Data link normally operating station 1: Data link faulty station • If multiple stations change from faulty to normal, because they are reconnected to the network one by one per cycle, the time until the status changes to "0: Data link normally operating station" may vary by several seconds. • If no response is received for several cycles, the station is determined to be a data link faulty station. Since a local station cannot obtain the station information of the CC-Link IE TSN Class A remote station when communicating in multicast mode, "0: Data link normally operating station" is reflected to the CC-Link IE TSN Class A remote station. (Conditions) • Stations that surpass the maximum station number are ignored. (Also used in the CLPA conformance test.)	<input type="radio"/>	<input checked="" type="radio"/>	<input type="radio"/> *1
SW00C0 to SW00C7	Reserved station setting status	Stores the reserved station setting status of each station. 0: Station other than a reserved station 1: Reserved station (Conditions) • Stations that surpass the maximum station number are ignored. (Also used in the CLPA conformance test.)	<input type="radio"/>	<input checked="" type="radio"/>	<input type="radio"/> *1



No.	Name	Description	Availability		
			Master station	Local station	
				Unicast mode	Multicast mode
SW00C8 to SW00CF	Parameter setting status	Stores the status of parameter settings. 0: No parameter setting 1: Parameter set (Conditions) • Stations that surpass the maximum station number are ignored.	○	×	○ ^{*1}
SW00D0 to SW00D7	Error invalid station setting status	Stores the error invalid station setting status of each station. 0: Station other than an error invalid station 1: Error invalid station (Conditions) • Stations that surpass the maximum station number are ignored.	○	×	○ ^{*1}
SW00E8 to SW00EF	Station type match status	Shows the match status of the parameters with the station types. (This is available only for the number of connected modules.) 0: Station type matched 1: Station type mismatch	○	×	○ ^{*1}
SW00F0 to SW00F7	CPU operating status of each station	Stores the CPU operating status of each station. 0: RUN or PAUSE state 1: STOP state or moderate/major error (Conditions) • Reserved stations and stations that surpass the maximum station number are ignored. • Since a local station cannot obtain the station information of the CC-Link IE TSN Class A remote station when communicating in multicast mode, the CC-Link IE TSN Class A remote station becomes the RUN or PAUSE state.	○	×	○ ^{*1}
SW0100 to SW0107	CPU moderate/major error status of each station	Stores the moderate/major error occurrence status of each station. 0: No moderate/major error 1: Moderate/major error occurring (Conditions) • If an error occurs, data prior to error is held. • Reserved stations and stations that surpass the maximum station number are ignored. • Since a local station cannot obtain the station information of the CC-Link IE TSN Class A remote station when communicating in multicast mode, "0: No moderate/major error" is reflected to the CC-Link IE TSN Class A remote station.	○	×	○ ^{*1}
SW0110 to SW0117	CPU minor error status of each station	Stores the minor error occurrence status of each station. 0: Normal, or a moderate or serious error occurring 1: Minor error occurring (Conditions) • Reserved stations and stations that surpass the maximum station number are ignored. • Since a local station cannot obtain the station information of the CC-Link IE TSN Class A remote station when communicating in multicast mode, "0: Normal, or a moderate or serious error occurring" is reflected to the CC-Link IE TSN Class A remote station.	○	×	○ ^{*1}
SW0160 to SW0167	Execution result of device station parameter automatic setting function	When the device station parameter automatic setting is completed with an error, the bit of the target station is turned on. On: Completed with an error Off: Completed successfully When the setting is completed with an error, the error code is stored in 'Detailed execution result of device station parameter automatic setting' (SW0194). When completed with an error caused by the master station, the bit is not turned on.	○	×	×
SW0194	Detailed execution result of device station parameter automatic setting	When the device station parameter automatic setting is completed with an error, the error code is stored. When completed with an error caused by the device station, the bit of the target station of 'Execution result of device station parameter automatic setting function' (SW0160 to SW0167) is turned on.	○	×	×
SW0198	Link dedicated instructions processing result CH3	Stores the processing results of the link dedicated instruction that used channel 3 of the own station. 0: Completed successfully 1 or greater: Completed with an error (Error code is stored.)	○	○	○

No.	Name	Description	Availability		
			Master station	Local station	
				Unicast mode	Multicast mode
SW0199	Link dedicated instructions processing result CH4	Stores the processing results of the link dedicated instruction that used channel 4 of the own station. 0: Completed successfully 1 or greater: Completed with an error (Error code is stored.)	○	○	○
SW019A	Link dedicated instructions processing result CH5	Stores the processing results of the link dedicated instruction that used channel 5 of the own station. 0: Completed successfully 1 or greater: Completed with an error (Error code is stored.)	○	○	○
SW019B	Link dedicated instructions processing result CH6	Stores the processing results of the link dedicated instruction that used channel 6 of the own station. 0: Completed successfully 1 or greater: Completed with an error (Error code is stored.)	○	○	○
SW019C	Link dedicated instructions processing result CH7	Stores the processing results of the link dedicated instruction that used channel 7 of the own station. 0: Completed successfully 1 or greater: Completed with an error (Error code is stored.)	○	○	○
SW019D	Link dedicated instructions processing result CH8	Stores the processing results of the link dedicated instruction that used channel 8 of the own station. 0: Completed successfully 1 or greater: Completed with an error (Error code is stored.)	○	○	○
SW01A0 to SW01A7	CC-Link IE TSN Protocol version 2.0 support status for each station	The CC-Link IE TSN Protocol version 2.0 support status for each station is stored. (Station No.1 to 120) 0: Not supported 1: Supported (Condition) Stations that surpass the maximum station number are ignored.	○	×	×
SW04A0	Time synchronization method	Stores the time synchronization method. 0: IEEE1588 1: IEEE802.1AS	○	×	×
SW04B0 to SW04B7	Station time synchronization status	Stores the time synchronization status for each station. (Station No.1 to 60) 0: Time asynchronous station 1: Time synchronized station For time synchronized stations, the time synchronization method can be found in 'Time synchronization method' (SW04A0). (Condition) Stations that surpass the maximum station number are ignored.	○	×	×

*1 This register is enabled when 'Data link status of own station' (SB0049) is off.



Appendix 6 Processing Time

The transmission delay time of CC-Link IE TSN consists of the time components below. (☞ Page 259 Cyclic transmission delay time)

(1) Master station sequence scan time + (2) Communication cycle interval (cyclic data transfer processing time) + (3) Device station processing time

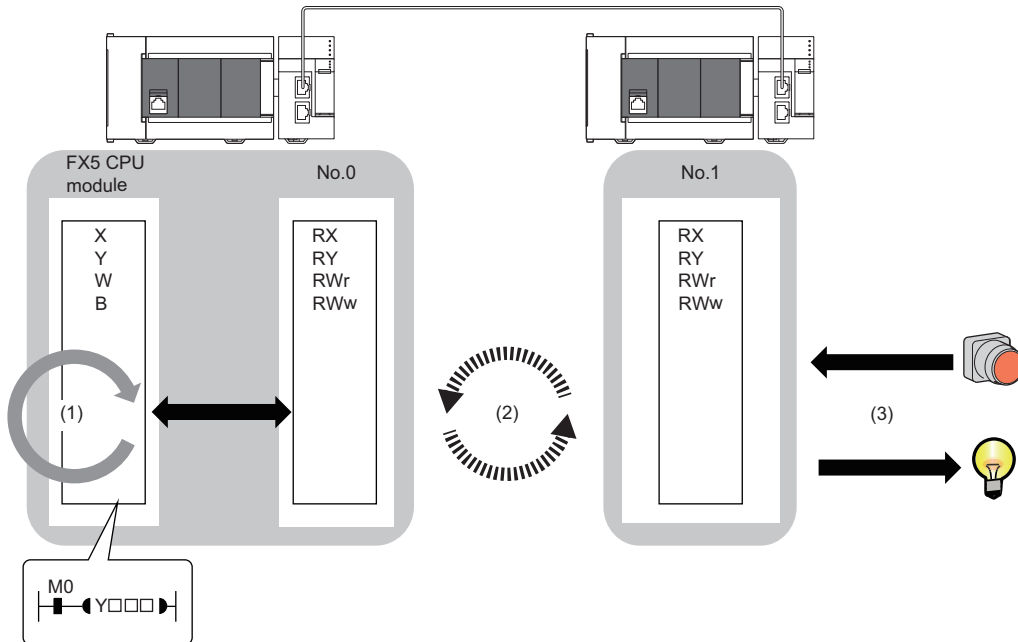

- Sequence scan time: ☞ MELSEC iQ-F FX5 User's Manual (Application)
- Communication cycle interval (cyclic data transfer processing time): ☞ Page 262 Communication cycle intervals
- Device station processing time: ☞ Manual for the device station used

Cyclic transmission delay time

This section shows how to calculate the following cyclic transmission delay time.

- The time between the transmission source CPU module device turning on or off and the transmission destination CPU module device turning on or off
- The time between data setting in the transmission source CPU module device and the data being stored in the transmission destination CPU module device

In "Basic Settings" of the master station, when "Communication Period Setting" of the communication destination in "Network Configuration Settings" is set to an option other than "Basic Period", multiply the LS (communication period interval) by the multiplier corresponding to the set option, which is specified in "Multiple Period Setting" under "Communication Period Setting". In this case, the multiplier is determined according to "CC-Link IE TSN Class Setting" in "Network Configuration Settings" as follows:

- For "CC-Link IE TSN Class B": The multiplier specified for "Multiple Period Setting" in "Basic Settings"
- For "CC-Link IE TSN Class A" and "Normal-Speed": The multiplier specified for "Multiple Period Setting" in "Basic Settings"
- For "CC-Link IE TSN Class A" and "Low-Speed": (The multiplier specified for "Multiple Period Setting" in "Basic Settings") × n

The number n can be found in 'Information for device station cyclic transmission' (Un\G44608).

Stations with "CC-Link IE TSN Class A" and "Low-Speed" set are grouped by the data size of the Ms and Ss frames. The number n is determined by the number of these groups.

The following table shows the algorithm for determining the number n.

No.	Processing	Detail	Loop 1	Loop 2	Branch	
					Yes	No
1	Start	Check stations in "Network Configuration Settings" for the master station in the order of the No. column to assign stations with "CC-Link IE TSN Class A" and "Low-Speed" set to groups.	—	—	—	—
2	Loop as many times as the number of stations (i=1; i≤the number of stations to set; i++)	Check device stations with values 1 to 60 set in the No. column of "Network Configuration Settings" for the master station one by one.	No.2 to No.11	—	—	—
3	Are both "CC-Link IE TSN Class A" and "Low-Speed" set?	Check "CC-Link IE TSN Class" and "Communication Period Setting" for the No. i station in "Network Configuration Settings" for the master station. If both "CC-Link IE TSN Class A" and "Low-Speed" are set, perform processes.		—	→No.4	→No.11
4	Determine the data sizes (DMsi and DSsi) of the Ms and Ss frames.	The following formulas are used to determine the data sizes (DMsi and DSsi) of the Ms and Ss frames. DMsi = (HBL × n1i) + (16 × n2i) + ndmi DSsi = (HBL × n3i) + (20 × n4i) + ndsi		—	—	—
5	Loop to the maximum number of groups (j=1; j≤60; j++)	Up to 2K bytes can be allocated to a group. Determine which group number (1 to 60) the ith station can be allocated to by checking from the group number 1 to 60.		No.5 to No.10	—	—
6	Is GMsj + Dmsi ≤ 2048 true?	Define GMsj as the total value of the data sizes of the Ms frames assigned to the jth group and determine whether the following condition is met. GMsj+DMsi≤2048			→No.7	→No.10
7	Is GSsj + DSsi ≤ 2048 true?	Define GSsj as the total value of the data sizes of the Ss frames assigned to the jth group and determine whether the following condition is met. GSsj+DSsi≤2048			→No.8	→No.10
8	Update the data sizes (GMsj and GSsj) of assigned groups.	If the conditions No.6 and No.7 are both met, update the values of GMsj and GSsj.			—	—
9	Assign the group number j to the ith station.	If the conditions No.6 and No.7 are both met, assign the group number j to the ith station.			—	—
10	End of the No.5 loop	—		—	—	—
11	End of the No.2 loop	—		—	—	—
12	Determine the maximum value J of the group numbers.	After assigning group numbers to all stations with "CC-Link IE TSN Class A" and "Low-Speed" set, determine the maximum value J of the group numbers.	—	—	—	—
13	Value of n = J ÷ 4 rounded up to the nearest integer	The following formula is used to determine the number n. Value of n = J ÷ 4 rounded up to the nearest integer	—	—	—	—
14	End	—	—	—	—	—



The following table shows the variables used in the algorithm.

Name of variable	Description
HBL	42
n1i	Value of $(ndmi + (16 \times n2i)) \div 1488$ rounded up to the nearest integer
n2i	$(RYbi+RWwbi)$ RYbi: Value of (Points of "RY setting" for the ith station with "CC-Link IE TSN Class A" and "Low-Speed" set) $\div 11776$ rounded up to the nearest integer RWwbi: Value of (Points of "RWw setting" for the ith station with "CC-Link IE TSN Class A" and "Low-Speed" set) $\div 736$ rounded up to the nearest integer
ndmi	$(\text{Points of "RY setting" for the } i\text{th station with "CC-Link IE TSN Class A" and "Low-Speed" set}) \div 8 + (\text{Points of "RWw setting" for the } i\text{th station with "CC-Link IE TSN Class A" and "Low-Speed" set}) \times 2$
n3i	Value of $(ndsi + (20 \times n4i)) \div 1488$ rounded up to the nearest integer
n4i	$(RXbi+RWrb i)+1$ RXbi: Value of (Points of "RX setting" for the ith station with "CC-Link IE TSN Class A" and "Low-Speed" set) $\div 11744$ rounded up to the nearest integer RWrb i: Value of (Points of "RWr setting" for the ith station with "CC-Link IE TSN Class A" and "Low-Speed" set) $\div 734$ rounded up to the nearest integer
ndsi	$(\text{Points of "RX setting" for the } i\text{th station with "CC-Link IE TSN Class A" and "Low-Speed" set}) \div 8 + (\text{Points of "RWr setting" for the } i\text{th station with "CC-Link IE TSN Class A" and "Low-Speed" set}) \times 2 + 8$

Ex.

For the inverter FR-E800 (RX: 32 points and RWr: 32 points)

If $1 \leq SnA \leq 44$, $n=1$

If $45 \leq SnA \leq 88$, $n=2$

If $89 \leq SnA \leq 120$, $n=3$

Master station ← remote station

When data is transmitted from a remote station (input) to the master station (RX/RW_r).

Calculation value	Station-based block data assurance	No station-based block data assurance
Normal value	$(SM \times 1) + (LS \times n1) + Rio$	$(SM \times 1) + (LS \times 1) + Rio$
Maximum value	$(SM \times 1) + (LS \times (n1 + 1)) + Rio$	$(SM \times 1) + (LS \times 2) + Rio$

Variable

Name of variable	Description	Unit
SM	Master station sequence scan time	μs
LS	Communication cycle interval	μs
Rio	Processing time of the remote station	μs
n1	Round up the calculated value to the nearest integer of $(SM \div LS)$	—

Master station → remote station

When data is transmitted from the master station (RY/RW_w) to a remote station (output).

Calculation value	Station-based block data assurance	No station-based block data assurance
Normal value	$(SM \times n2) + (LS \times 1) + Rio$	$(SM \times 1) + (LS \times 1) + Rio$
Maximum value	$(SM \times n2) + (LS \times 2) + Rio$	$(SM \times 2) + (LS \times 2) + Rio$

Variable

Name of variable	Description	Unit
SM	Master station sequence scan time	μs
LS	Communication cycle interval	μs
Rio	Processing time of the remote station	μs
n2	Round up the calculated value to the nearest integer of $(LS \div SM)$	—

Master station ← local station

When data is transmitted from a local station to the master station as follows:

- Master station (RX) ← local station (RY)
- Master station (RW_r) ← local station (RW_w)

Calculation value	Station-based block data assurance	No station-based block data assurance
Normal value	If $LS < SL$: $(SM \times 1) + (LS \times (n1 + 1)) + (SL \times 1)$	$(SM \times 1) + (LS \times 2) + (SL \times 1)$
	If $LS \geq SL$: $(SM \times 1) + (LS \times (n1 + 2))$	
Maximum value	$(SM \times 2) + (LS \times (n1 + 2)) + (SL \times 1)$	$(SM \times 2) + (LS \times 3) + (SL \times 1)$

■Variable

Name of variable	Description	Unit
SM	Master station sequence scan time	μs
LS	Communication cycle interval	μs
SL	Local station sequence scan time	μs
n1	Round up the calculated value to the nearest integer of $(SM \div LS)$	—

Master station → local station

When data is transmitted from the master station to a local station as follows:

- Master station (RY) → local station (RX)
- Master station (RW_w) → local station (RW_r)

Calculation value	Station-based block data assurance	No station-based block data assurance
Normal value	If $LS < SM$: $(SM \times 1) + (LS \times (n3 + 1)) + (SL \times 1)$	$(SM \times 1) + (LS \times 2) + (SL \times 1)$
	If $LS \geq SM$: $(LS \times (n3 + 2)) + (SL \times 1)$	
Maximum value	$(SM \times 1) + (LS \times (n3 + 2)) + (SL \times 2)$	$(SM \times 1) + (LS \times 3) + (SL \times 2)$

■Variable

Name of variable	Description	Unit
SM	Master station sequence scan time	μs
LS	Communication cycle interval	μs
SL	Local station sequence scan time	μs
n3	Round up the calculated value to the nearest integer of $(SL \div LS)$	—

Communication cycle intervals

The minimum value of the communication cycle interval (cyclic data transfer processing time) is calculated by the following calculation formula. The parts enclosed in double quotation marks (" ") in the table of Variable are the values set for "Network Configuration Settings" under "Basic Settings".

Communication mode	Master station communication speed	Reference to calculation formula
Unicast mode	1Gbps	Page 263 Unicast mode (1Gbps)
	100Mbps	Page 266 Unicast mode (100Mbps)
Multicast mode	1Gbps	Page 269 Multicast mode (1Gbps)
	100Mbps	Page 272 Multicast mode (100Mbps)

Precautions

■When cyclic transmission is not performed with a calculation value

The minimum values for communication cycle interval and cyclic transmission time calculated by the formulas serve as a guide. If cyclic transmission is not performed with a calculation value as a setting value, add the largest value below to the minimum value of the cyclic transmission time and set the value again.

- 10% of minimum value of the calculated cyclic transmission time
- Communication speed of the master station is 1Gbps: Number of device stations \times 2 μ s
- Communication speed of the master station is 100Mbps: Number of device stations \times 20 μ s

Each calculation value obtained from the calculation formulas mentioned above are stored in the following SW.

- SW0072: Communication cycle interval (calculation value) [μ s]
- SW0073: Cyclic transmission time (calculation value) [μ s]
- SW0078: Transient transmission time (calculation value) [μ s]

■When the calculation value is larger than the set value

If each calculation result is larger than the set value of "Basic Period Setting" under "Basic Settings" as follows, an error occurs.

When an error occurs, each calculation value is displayed in "Detailed information" in the [Error Information] tab of module diagnostics. Correct each set value of "Basic Period Setting" referring to the calculation value displayed so that the set value is equal to or larger than the calculation value.

- 3010H: When the communication cycle interval (calculation value) [μ s] is larger than the set value of "Communication Period Interval Setting"
- 3011H: When the cyclic transmission time (calculation value) [μ s] is larger than the set value of "Cyclic Transmission Time"
- 3013H: When the transient transmission time (calculation value) [μ s] is larger than the displayed value of "Transient Transmission Time"

■When a general CC-Link IE TSN module is CC-Link IE TSN Class A

When "CC-Link IE TSN Class Setting" of the general CC-Link IE TSN module added to the list of stations in "Network Configuration Settings" is set to CC-Link IE TSN Class A and 'Communication cycle interval (calculation value)' (SW0072) and 'Cyclic transmission time (calculation value)' (SW0073) are set to "Communication Period Interval Setting" and "Cyclic Transmission Time", the cyclic transmission may not be performed. In such a case, perform either of the following operation.

- Select the device to be actually used from "Module List" and add the device to the list of station.
- Check the maximum response time for the time-managed polling by referring to the manual of device to be used, and calculate and set the values of the communication cycle interval and cyclic transmission time.

Unicast mode (1Gbps)

■ Calculation formula

Communication cycle interval [ns] = $\alpha_c + \alpha_p$ or 250000, whichever is larger. Round up values of α_c and α_p that are less than 1 μ s.

Cyclic transmission time [ns] = α_c

- α_c : This value varies depending on whether a CC-Link IE TSN Class A device station with the basic period or normal speed period exists or not.

Item	Calculation formula
When a CC-Link IE TSN Class A device station with the basic period or normal speed period does not exist	(The largest value in items No.1 to No.5) + No.6
When a CC-Link IE TSN Class A device station with the basic period or normal speed period exists	((The value in No.1 or No.2, whichever is larger) + (the value in No.3 or No.4, whichever is larger), or the value in No.5, whichever is larger) + No.6 + No.7
No.	Calculation formula
1	$\{(50 \times n1) + (16 \times n2) + ndm\} \times 8 + (Sn - 1) \times 830 + 14000 + nh$
2	$\{(30 \times n1) + (16 \times n2) + ndm\} \times 4 + (1661 \times n1) + (Sn - 1) \times 830 + 14300 + nh$
3	$\{(50 \times n3) + (20 \times n4) + nds\} \times 8 + 14000 + nh$
4	$\{(50 \times n5) + (20 \times n6) + ndl\} \times 8 + (Sn - 1) \times 830 + 14000 + nh$
5	50000
6	$E \times n7$
7	Largest value of the maximum response times for the time managed polling method for CC-Link IE TSN Class A device stations with "Basic Period" and "Normal-Speed" set

Point

For details on the maximum response time for the time managed polling method of a device station, refer to the user's manual for the device station used.

- α_p : Cyclic processing time [ns] is calculated by $p1 + p4$. Round up values that are less than 1 μ s.

■ Variable

Name of variable	Description
n1	Value of $(ndm + (16 \times n2)) / 1488$ rounded up to the nearest integer or Sn, whichever is larger
n2	$Sn \times (RYb + RWwb)$ RYb: Value of (Total number of points of "RY setting") / $(11776 \times Sn)$ rounded up to the nearest integer RWwb: Value of (Total number of points of "RWw setting") / $(736 \times Sn)$ rounded up to the nearest integer
ndm	$((\text{Total number of points of "RY setting"}) / 8) + ((\text{Total number of points of "RWw setting"}) \times 2)$
Sn	Number of device stations
Ln	Number of local stations
nh	Industrial switch delay time \times Number of industrial switches connected to the network Industrial switch delay time: 50000 ¹
n3	$Sn \times nhs$ nhs: Value of $(nds + (20 \times n4)) / (1488 \times Sn)$ rounded up to the nearest integer
n4	$Sn \times (RXb + RWrb) + Sn$ RXb: Value of (Total number of points of "RX setting") / $(11744 \times Sn)$ rounded up to the nearest integer RWrb: Value of (Total number of points of "RWr setting") / $(734 \times Sn)$ rounded up to the nearest integer
nds	$((\text{Total number of points of "RX setting"}) / 8) + ((\text{Total number of points of "RWr setting"}) \times 2) + 8 \times Sn$
n5	Value of $(ndl + 20 \times n6) / 1488$ rounded up to the nearest integer
n6	$(ndl - 8) / 1468 + 1$
ndl	$(RXl / 8) + (RWrl \times 2) + 8$ RXl: Number of points of "RX setting" of the device station ² to be used as the maximum number of link points RWrl: Number of points of "RWr setting" of the device station ² to be used as the maximum number of link points
E	$E: (Sn - 1) \times 830 + 39102$ Round up values of E that are less than 1 μ s.
n7	When "CC-Link IE TSN Class Setting" is set to "Mixture of CC-Link IE TSN Class B/A or CC-Link IE TSN Class A Only", and "TSN HUB Setting" is set to "Not to Use TSN HUB": 4 Other than the above: 0

Name of variable	Description
p1: RX/RY/RWr/RWw processing time	$\{((\text{Total number of points of "RX setting"}) + (\text{Total number of points of "RY setting"})) / 8 + ((\text{Total number of points of "RWr setting"}) + (\text{Total number of points of "RWw setting"})) \times 2\} \times 5 + (\text{Sn} \times 3300)$ However, if Total number of points of "RY setting" = Total number of points of "RX setting" = Total number of points of "RWr setting" = Total number of points of "RWw setting" = 0, then p1 = 0.
p4: RX/RY/RWr/RWw data transfer time ^{*3*5}	$((\text{dw} \times \text{kX}) + \text{kY}) \times \text{Mg} + \text{kM}$ However, if dW is 0, p4 = 0.
dw: Total number of words	$((\text{sRX} + \text{sRY}) / 16) + \text{sRWr} + \text{sRWw}$ [Word]
sRX	Total number of points of "RX setting" ^{*4}
sRY	Total number of points of "RY setting" ^{*4}
sRWr	Total number of points of "RWr setting" ^{*4}
sRWw	Total number of points of "RWw setting" ^{*4}
kX	dW is less than 1000 [words]: 580 dW is 1000 [words] or more: 254
kY	dW is less than 1000 [words]: 160000 dW is 1000 [words] or more: 477200
Mg	Station-based block data assurance setting Assured: 1 Not assured: 1.55
kM	When used as a master station: $\text{Sn} \times 10000$ When used as a local station: 0

- *1 The industrial switch delay time changes depending on the industrial switch model and settings.
- *2 This is the device station with the largest calculation value when, for each device station, ("RX setting"/8) + ("RWr setting" × 2) is calculated.
- *3 When the FX5-CCLGN-MS is used as a local station, add a value of p4 to the "Communication Period Setting" under "Basic Settings" of the master station.
- *4 When used as a master station: Total number of points to be set for device stations
When used as a local station (multicast): Total number of points of device stations set at the master station
When used as a local station (unicast): Total number of points set for the own station (FX5-CCLGN-MS) at the master station
- *5 The relation of dw (Total number of words) and p4 (RX/RY/RWr/RWw data transfer time) is as follows. (Station-based block data assurance: When "not assured")
When used as a master station

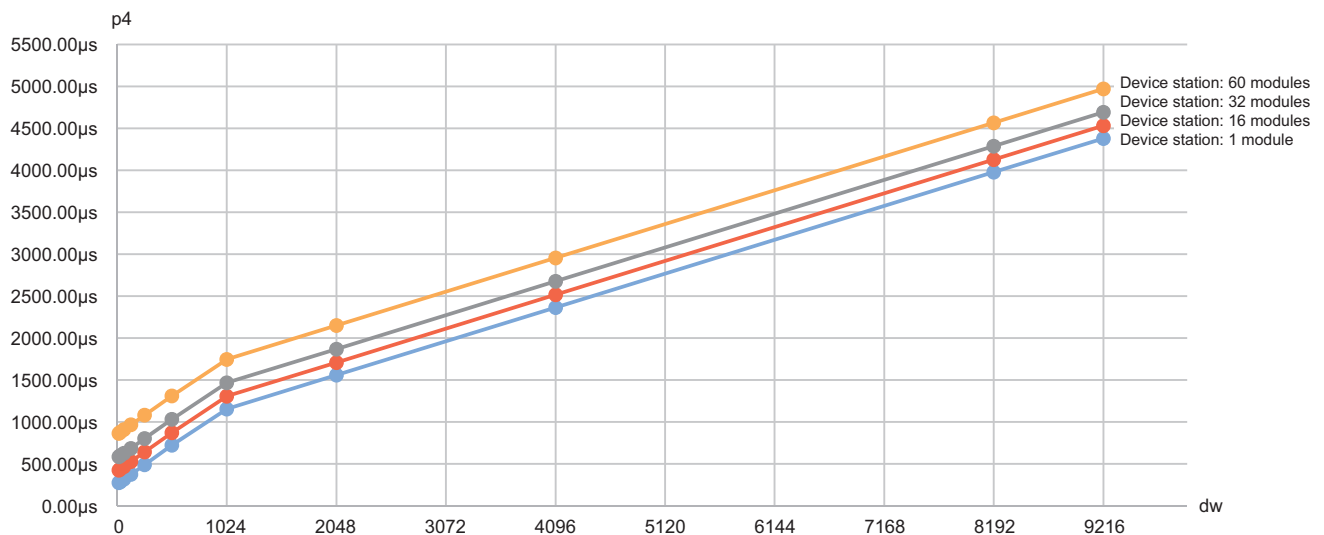

When used as a local station

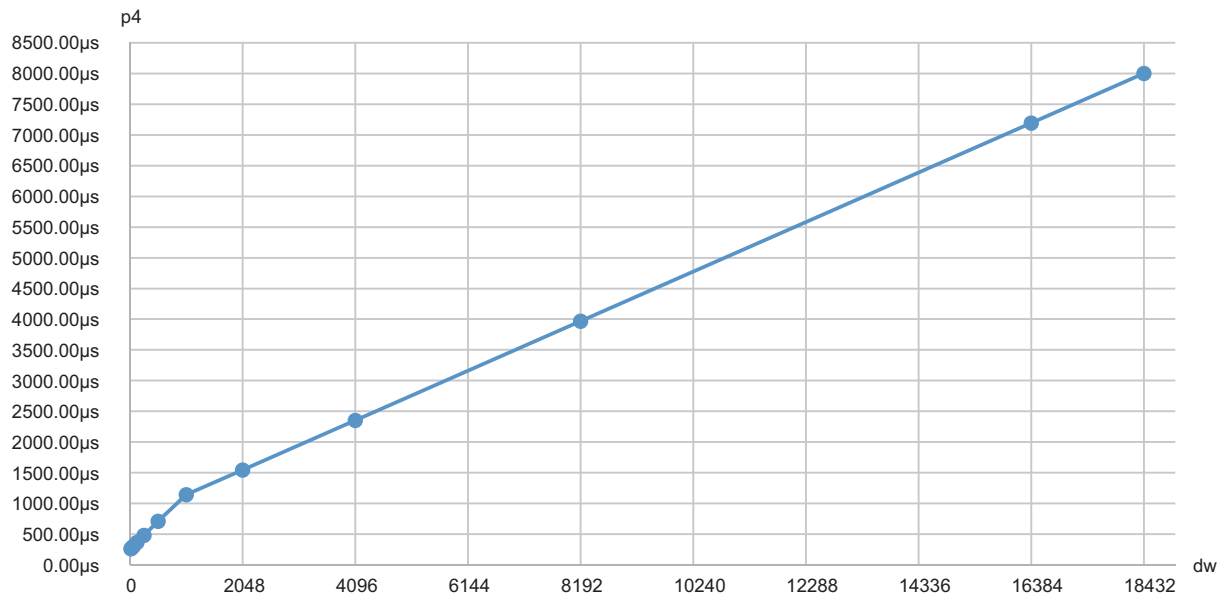

Unicast mode (100Mbps)

■ Calculation formula

Communication cycle interval [ns] = $\alpha_c + \alpha_p$. Round up values of α_c and α_p that are less than 1 μ s.

Cyclic transmission time [ns] = α_c

- α_c : This value varies depending on whether a CC-Link IE TSN Class A device station with the basic period or normal speed period exists or not.

Item	Calculation formula
When a CC-Link IE TSN Class A device station with the basic period or normal speed period does not exist	(The largest value in items No.1 to No.4) + No.5
When a CC-Link IE TSN Class A device station with the basic period or normal speed period exists	(No.1 + (the value in No.2 or No.3, whichever is larger), or the value in No.4, whichever is larger) + No.5 + No.6

No.	Calculation formula
1	$\{(42 \times n1) + (16 \times n2) + ndm\} \times 80 + (Sn - 1) \times 5150 + 14000 + nh$
2	$\{(42 \times n3) + (20 \times n4) + nds\} \times 80 + 14000 + nh$
3	$\{(42 \times n5) + (20 \times n6) + ndl\} \times 80 + (Sn - 1) \times 5150 + 14000 + nh$
4	50000
5	$D \times n7$
6	Largest value of the maximum response times for the time managed polling method for CC-Link IE TSN Class A device stations with "Basic Period" and "Normal-Speed" set



For details on the maximum response time for the time managed polling method of a device station, refer to the user's manual for the device station used.

Cyclic processing time [ns] = α_p or 340000, whichever is larger. Round up values that are less than 1 μ s.

- α_p : Cyclic processing time [ns] is calculated by $p1 + p4$. Round up values that are less than 1 μ s.

■ Variable

Name of variable	Description
n1	Value of $(ndm + (16 \times n2))/1488$ rounded up to the nearest integer or Sn, whichever is larger
n2	$Sn \times (RYb + RWwb)$ RYb: Value of (Total number of points of "RY setting")/(11776 \times Sn) rounded up to the nearest integer RWwb: Value of (Total number of points of "RWw setting")/(736 \times Sn) rounded up to the nearest integer
ndm	$((\text{Total number of points of "RY setting"})/8) + ((\text{Total number of points of "RWw setting"}) \times 2)$
Sn	Number of device stations
Ln	Number of local stations
nh	Industrial switch delay time \times Number of industrial switches connected to the network Industrial switch delay time: 160000 ¹
n3	$Sn \times nhs$ nhs: Value of $(nds + (20 \times n4))/(1488 \times Sn)$ rounded up to the nearest integer
n4	$Sn \times (RXb + RWrb) + Sn$ RXb: Value of (Total number of points of "RX setting")/(11744 \times Sn) rounded up to the nearest integer RWrb: Value of (Total number of points of "RWr setting")/(734 \times Sn) rounded up to the nearest integer
nds	$((\text{Total number of points of "RX setting"})/8) + ((\text{Total number of points of "RWr setting"}) \times 2) + 8 \times Sn$
n5	Value of $(ndl + 20 \times n6)/1488$ rounded up to the nearest integer
n6	$(ndl-8)/1468+1$
ndl	$(RXl/8) + (RWrl \times 2) + 8$ RXl: Number of points of "RX setting" of the device station ² to be used as the maximum number of link points RWrl: Number of points of "RWr setting" of the device station ² to be used as the maximum number of link points
D	$D: (Sn-1) \times 5150 + 187440$ Round up values of D that are less than 1 μ s.
n7	When "CC-Link IE TSN Class Setting" is set to "Mixture of CC-Link IE TSN Class B/A or CC-Link IE TSN Class A Only", and "TSN HUB Setting" is set to "Not to Use TSN HUB": 4 Other than the above: 0

Name of variable	Description
p1: RX/RY/RWr/RWw processing time	$\{((\text{Total number of points of "RX setting"}) + (\text{Total number of points of "RY setting"})) / 8 + ((\text{Total number of points of "RWr setting"}) + (\text{Total number of points of "RWw setting"})) \times 2\} \times 5 + (\text{Sn} \times 3300)$ However, if Total number of points of "RY setting" = Total number of points of "RX setting" = Total number of points of "RWr setting" = Total number of points of "RWw setting" = 0, then p1 = 0.
p4: RX/RY/RWr/RWw data transfer time ^{*3*5}	$((\text{dw} \times \text{kX}) + \text{kY}) \times \text{Mg} + \text{kM}$ However, if dW is 0, p4 = 0.
dw: Total number of words	$((\text{sRX} + \text{sRY}) / 16) + \text{sRWr} + \text{sRWw}$ [Word]
sRX	Total number of points of "RX setting" ^{*4}
sRY	Total number of points of "RY setting" ^{*4}
sRWr	Total number of points of "RWr setting" ^{*4}
sRWw	Total number of points of "RWw setting" ^{*4}
kX	dW is less than 1000 [words]: 580 dW is 1000 [words] or more: 254
kY	dW is less than 1000 [words]: 160000 dW is 1000 [words] or more: 477200
Mg	Station-based block data assurance setting Assured: 1 Not assured: 1.55
kM	When used as a master station: $\text{Sn} \times 10000$ When used as a local station: 0

- *1 The industrial switch delay time changes depending on the industrial switch model and settings.
- *2 This is the device station with the largest calculation value when, for each device station, ("RX setting"/8) + ("RWr setting" × 2) is calculated.
- *3 When the FX5-CCLGN-MS is used as a local station, add a value of p4 to the "Communication Period Setting" under "Basic Settings" of the master station.
- *4 When used as a master station: Total number of points to be set for device stations
When used as a local station (multicast): Total number of points of device stations set at the master station
When used as a local station (unicast): Total number of points set for the own station (FX5-CCLGN-MS) at the master station
- *5 The relation of dw (Total number of words) and p4 (RX/RY/RWr/RWw data transfer time) is as follows. (Station-based block data assurance: When "not assured")
When used as a master station

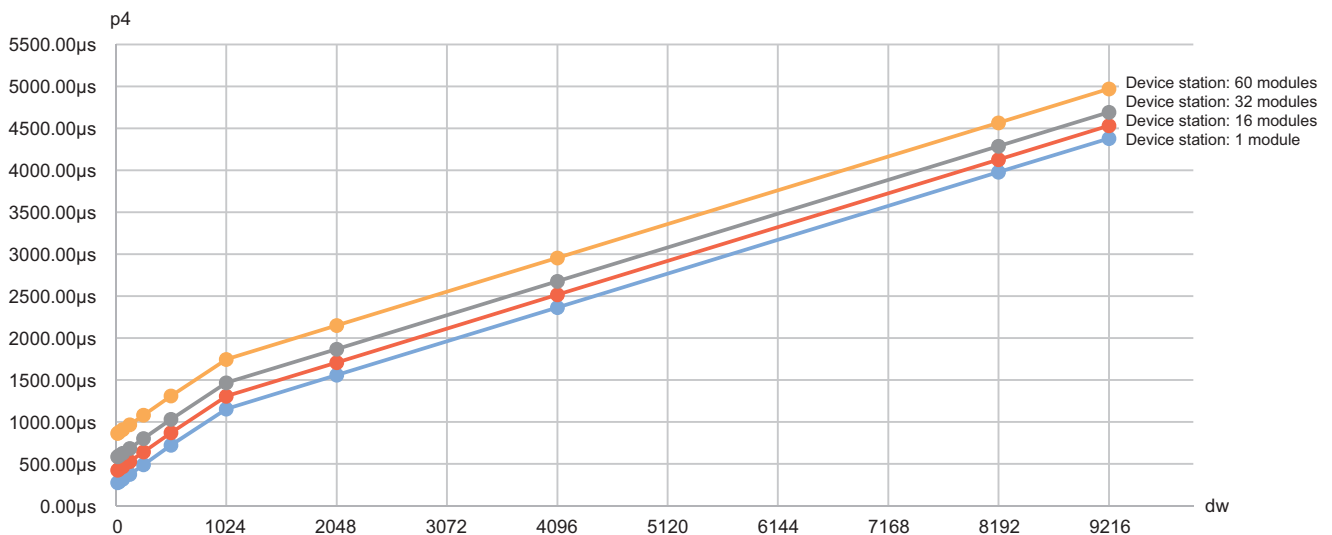

When used as a local station

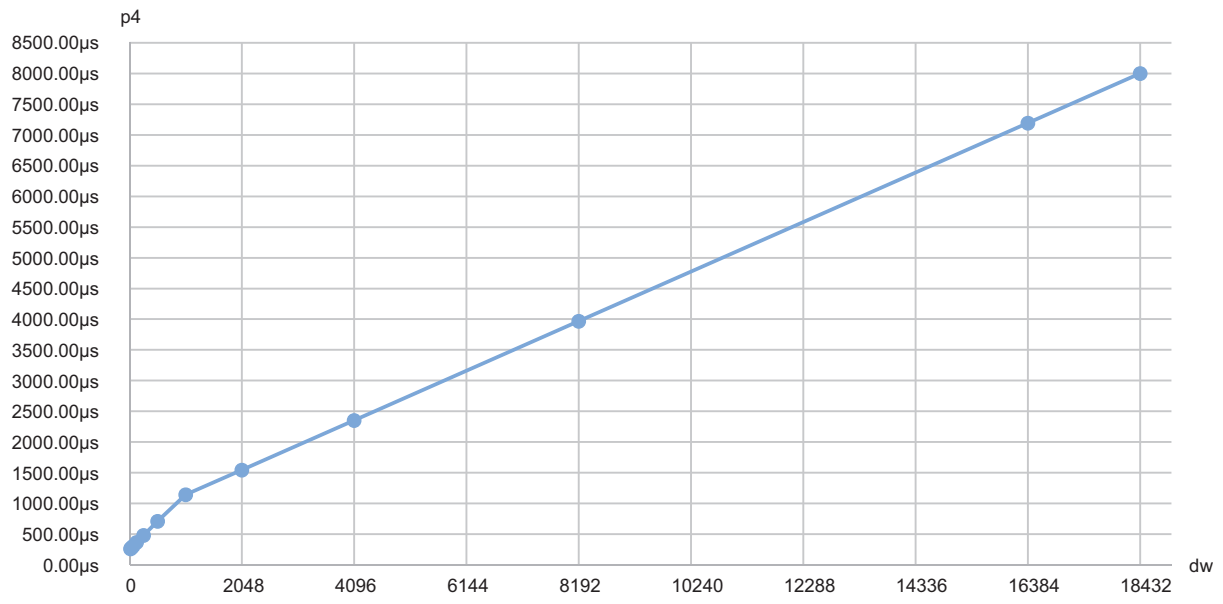

Multicast mode (1Gbps)

■ Calculation formula

Communication cycle interval [ns] = $\alpha_c + \alpha_p$ or 250000, whichever is larger. Round up values of α_c and α_p that are less than 1 μ s.

Cyclic transmission time [ns] = α_c

- α_c : This value varies depending on whether a CC-Link IE TSN Class A device station with the basic period or normal speed period exists or not.

Item	Calculation formula
When a CC-Link IE TSN Class A device station with the basic period or normal speed period does not exist	(Largest value of the calculation formulae No.1, No.2, and No.5) + No.6.
When a CC-Link IE TSN Class A device station with the basic period or normal speed period exists	(Largest value the calculation formulae No.1, No.2, and No.5) + No.6 + No.7

No.	Calculation formula
1	$\{(50 \times (n1r + n1l)) + (16 \times (n2r + n2l)) + (ndmr + ndml)\} \times 8 + (Sn - 1) \times 830 + 14000 + nh + (\text{No.3 or No.4, whichever is larger})$
2	$\{(30 \times (n1r + n1l)) + (16 \times (n2r + n2l)) + (ndmr + ndml)\} \times 4 + (1661 \times (n1r + n1l)) + (Sn - 1) \times 830 + 14300 + nh + (\text{No.3 or No.4, whichever is larger})$
3	$\{(50 \times n3) + (20 \times n4) + nds\} \times 8 + 14000 + nh$
4	$\{(50 \times n5) + (20 \times n6) + ndl\} \times 8 + (Sn - 1) \times 830 + 14000 + nh$
5	50000
6	$E \times n7$
7	Largest value of the maximum response times for the time managed polling method for CC-Link IE TSN Class A device stations with "Basic Period" and "Normal-Speed" set

Point

For details on the maximum response time for the time managed polling method of a device station, refer to the user's manual for the device station used.

- α_p : Cyclic processing time [ns] is calculated by $p1 + p4$. Round up values that are less than 1 μ s.

■ Variable

Name of variable	Description
n1r	Value of $(ndmr + (16 \times n2r)) / 1488$ rounded up to the nearest integer or Rn , whichever is larger
n1l	Round up the calculated value to the nearest integer of $(ndml + (16 \times n2l)) / 1488$
n2r	$Rn \times (RYrb + RWwrb)$ RYrb: Value of (Total number of points of "RY setting" set in the remote station) / $(11776 \times Rn)$ rounded up to the nearest integer RWwrb: Value of (Total number of points of "RWw setting" set in the remote station) / $(736 \times Rn)$ rounded up to the nearest integer
n2l	$RYlb + RWwlb + 1$ RYlb: Value of $(\text{Total number of points of "RY setting"}^2) / 11776$ rounded up to the nearest integer RWwlb: Value of $(\text{Total number of points of "RWw setting"}^2) / 736$ rounded up to the nearest integer
ndmr	$((\text{Total number of points of "RY setting" set in the remote station}) / 8) + ((\text{Total number of points of "RWw setting" set in the remote station}) \times 2)$
ndml	$((\text{Total number of points of "RY setting"}^2) / 8) + ((\text{Total number of points of "RWw setting"}^2) \times 2) + 24$
Sn	Number of device stations
Rn	Number of remote stations
Ln	Number of local stations
nh	Industrial switch delay time \times Number of industrial switches connected to the network Industrial switch delay time: 50000 ¹
n3	$Sn \times nhs$ nhs: Value of $(nds + (20 \times n4)) / (1488 \times Sn)$ rounded up to the nearest integer
n4	$Sn \times (RXb + RWrb) + Sn$ RXb: Value of (Total number of points of "RX setting") / $(11744 \times Sn)$ rounded up to the nearest integer RWrb: Value of (Total number of points of "RWr setting") / $(734 \times Sn)$ rounded up to the nearest integer
nds	$((\text{Total number of points of "RX setting"}) / 8) + ((\text{Total number of points of "RWr setting"}) \times 2) + 8 \times Sn$
n5	Value of $(ndl + 20 \times n6) / 1488$ rounded up to the nearest integer
n6	$(ndl - 8) / 1468 + 1$
ndl	$(RXl / 8) + (RWrl \times 2) + 8$ RXl: Number of points of "RX setting" of the device station ³ to be used as the maximum number of link points RWrl: Number of points of "RWr setting" of the device station ³ to be used as the maximum number of link points

Name of variable	Description
E	E: (Sn-1)×830+39102 Round up values of E that are less than 1 μs.
n7	When "CC-Link IE TSN Class Setting" is set to "Mixture of CC-Link IE TSN Class B/A or CC-Link IE TSN Class A Only", and "TSN HUB Setting" is set to "Not to Use TSN HUB": 4 Other than the above: 0
p1: RX/RX/RWr/RWw processing time	{((Total number of points of "RX setting") + (Total number of points of "RY setting"))/8 + ((Total number of points of "RWr setting") + (Total number of points of "RWw setting")) × 2} × 5 + (Sn × 3300) However, if Total number of points of "RY setting" = Total number of points of "RX setting" = Total number of points of "RWr setting" = Total number of points of "RWw setting" = 0, then p1 = 0.
p4: RX/RX/RWr/RWw data transfer time ^{*4*6}	((dw×kX)+kY)×Mg+kM However, if dW is 0, p4 = 0.
dw: Total number of words	((sRX+sRY)/16) + sRWr+sRWw [Word]
sRX	Total number of points of "RX setting" ^{*5}
sRY	Total number of points of "RY setting" ^{*5}
sRWr	Total number of points of "RWr setting" ^{*5}
sRWw	Total number of points of "RWw setting" ^{*5}
kX	dW is less than 1000 [words]: 580 dW is 1000 [words] or more: 254
kY	dW is less than 1000 [words]: 160000 dW is 1000 [words] or more: 477200
Mg	Station-based block data assurance setting Assured: 1 Not assured: 1.55
kM	When used as a master station: Sn × 10000 When used as a local station: 0

- *1 The industrial switch delay time changes depending on the industrial switch model and settings.
- *2 A sum of values starting from the smallest value set in "Start" to the largest value set in "End" of "Network Configuration Settings".
- *3 This is the device station with the largest calculation value when, for each device station, ("RX setting"/8) + ("RWr setting" × 2) is calculated.
- *4 When the FX5-CCLGN-MS is used as a local station, add a value of p4 to the "Communication Period Setting" under "Basic Settings" of the master station.
- *5 When used as a master station: Total number of points to be set for device stations
When used as a local station (multicast): Total number of points of device stations set at the master station
When used as a local station (unicast): Total number of points set for the own station (FX5-CCLGN-MS) at the master station
- *6 The relation of dw (Total number of words) and p4 (RX/RX/RWr/RWw data transfer time) is as follows. (Station-based block data assurance: When "not assured")
When used as a master station

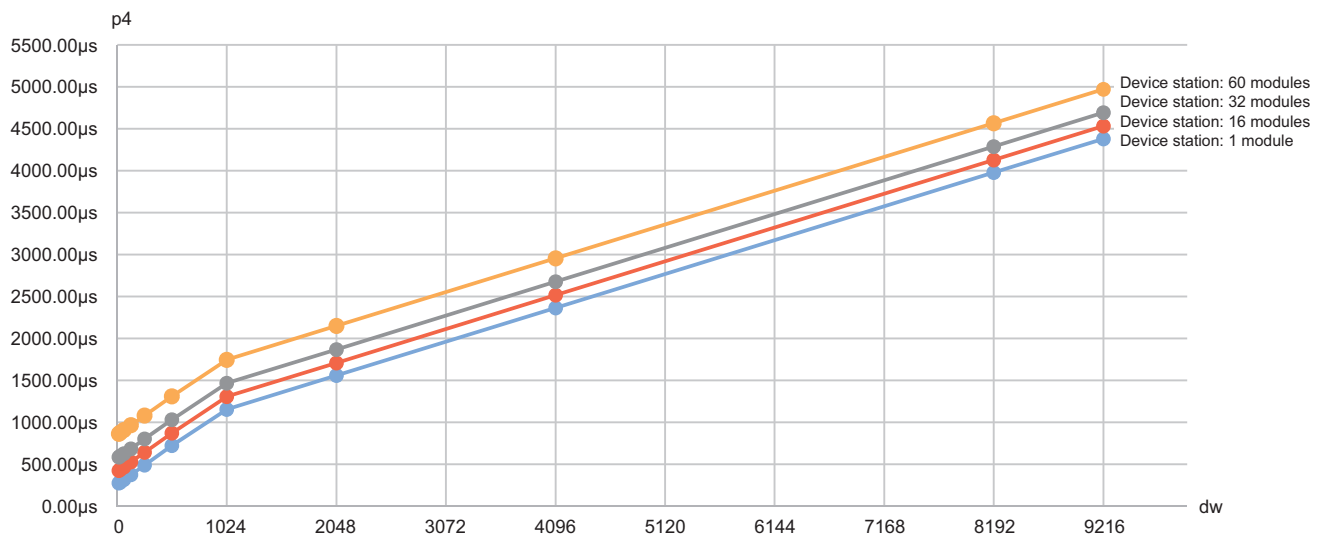

When used as a local station

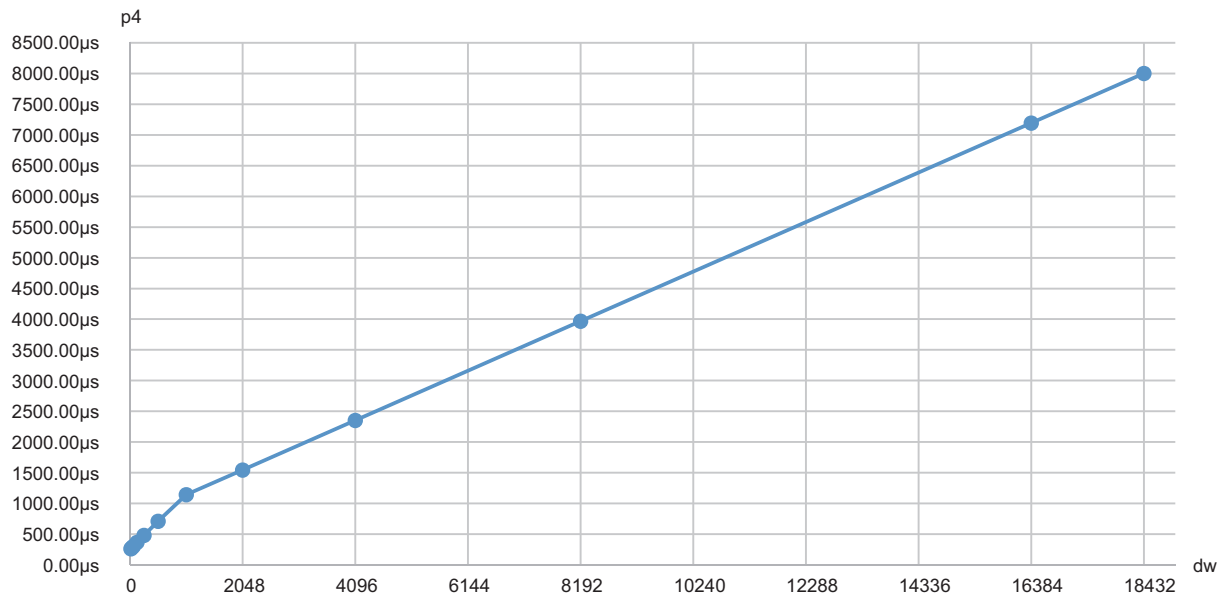

Multicast mode (100Mbps)

■ Calculation formula

Communication cycle interval [ns] = $\alpha_c + \alpha_p$. Round up values of α_c and α_p that are less than 1 μ s.

Cyclic transmission time [ns] = α_c

- α_c : This value varies depending on whether a CC-Link IE TSN Class A device station with the basic period or normal speed period exists or not.

Item	Calculation formula
When a CC-Link IE TSN Class A device station with the basic period or normal speed period does not exist	(The value in No.1 or No.4, whichever is larger) + No.5
When a CC-Link IE TSN Class A device station with the basic period or normal speed period exists	(The value in No.1 or No.4, whichever is larger) + No.5 + No.6

No.	Calculation formula
1	$\{(42 \times (n1r + n1l)) + (16 \times (n2r + n2l)) + (ndmr + ndml)\} \times 80 + (Sn - 1) \times 5150 + 14000 + nh + (\text{No.2 or No.3, whichever is larger})$
2	$\{(42 \times n3) + (20 \times n4) + nds\} \times 80 + 14000 + nh$
3	$\{(42 \times n5) + (20 \times n6) + ndl\} \times 80 + (Sn - 1) \times 5150 + 14000 + nh$
4	50000
5	$D \times n7$
6	Largest value of the maximum response times for the time managed polling method for CC-Link IE TSN Class A device stations with "Basic Period" and "Normal-Speed" set



For details on the maximum response time for the time managed polling method of a device station, refer to the user's manual for the device station used.

Cyclic processing time [ns] = α_p or 340000, whichever is larger. Round up values that are less than 1 μ s.

- α_p : Cyclic processing time [ns] is calculated by $p1 + p4$. Round up values that are less than 1 μ s.

■ Variable

Name of variable	Description
n1r	Value of $(ndmr + (16 \times n2r)) / 1488$ rounded up to the nearest integer or Rn, whichever is larger
n1l	Round up the calculated value to the nearest integer of $(ndml + (16 \times n2l)) / 1488$
n2r	$Rn \times (RYrb + RWwrb)$ RYrb: Value of (Total number of points of "RY setting" set in the remote station) / $(11776 \times Rn)$ rounded up to the nearest integer RWwrb: Value of (Total number of points of "RWw setting" set in the remote station) / $(736 \times Rn)$ rounded up to the nearest integer
n2l	$RYlb + RWwlb + 1$ RYlb: Value of $(\text{Total number of points of "RY setting"}^2) / 11776$ rounded up to the nearest integer RWwlb: Value of $(\text{Total number of points of "RWw setting"}^2) / 736$ rounded up to the nearest integer
ndmr	$((\text{Total number of points of "RY setting" set in the remote station}) / 8) + ((\text{Total number of points of "RWw setting" set in the remote station}) \times 2)$
ndml	$((\text{Total number of points of "RY setting"}^2) / 8) + ((\text{Total number of points of "RWw setting"}^2) \times 2) + 24$
Sn	Number of device stations
Rn	Number of remote stations
Ln	Number of local stations
nh	Industrial switch delay time \times Number of industrial switches connected to the network Industrial switch delay time: 160000 ^{*1}
n3	$Sn \times nhs$ nhs: Value of $(nds + (20 \times n4)) / (1488 \times Sn)$ rounded up to the nearest integer
n4	$Sn \times (RXb + RWrb) + Sn$ RXb: Value of (Total number of points of "RX setting") / $(11744 \times Sn)$ rounded up to the nearest integer RWrb: Value of (Total number of points of "RWr setting") / $(734 \times Sn)$ rounded up to the nearest integer
nds	$((\text{Total number of points of "RX setting"}) / 8) + ((\text{Total number of points of "RWr setting"}) \times 2) + 8 \times Sn$
n5	Value of $(ndl + 20 \times n6) / 1488$ rounded up to the nearest integer
n6	$(ndl - 8) / 1468 + 1$
ndl	$(RXl / 8) + (RWrl \times 2) + 8$ RXl: Number of points of "RX setting" of the device station ^{*3} to be used as the maximum number of link points RWrl: Number of points of "RWr setting" of the device station ^{*3} to be used as the maximum number of link points

Name of variable	Description
D	D: $(S_n - 1) \times 5150 + 187440$ Round up values of D that are less than 1 μ s.
n7	When "CC-Link IE TSN Class Setting" is set to "Mixture of CC-Link IE TSN Class B/A or CC-Link IE TSN Class A Only", and "TSN HUB Setting" is set to "Not to Use TSN HUB": 4 Other than the above: 0
p1: RX/RY/RWr/RWw processing time	$\{((\text{Total number of points of "RX setting"}) + (\text{Total number of points of "RY setting"})) / 8 + ((\text{Total number of points of "RWr setting"}) + (\text{Total number of points of "RWw setting"})) \times 2\} \times 5 + (S_n \times 3300)$ However, if Total number of points of "RY setting" = Total number of points of "RX setting" = Total number of points of "RWr setting" = Total number of points of "RWw setting" = 0, then p1 = 0.
p4: RX/RY/RWr/RWw data transfer time ^{*4*6}	$((dw \times kX) + kY) \times Mg + kM$ However, if dW is 0, p4 = 0.
dw: Total number of words	$((sRX + sRY) / 16) + sRWr + sRWw$ [Word]
sRX	Total number of points of "RX setting" ^{*5}
sRY	Total number of points of "RY setting" ^{*5}
sRWr	Total number of points of "RWr setting" ^{*5}
sRWw	Total number of points of "RWw setting" ^{*5}
kX	dW is less than 1000 [words]: 580 dW is 1000 [words] or more: 254
kY	dW is less than 1000 [words]: 160000 dW is 1000 [words] or more: 477200
Mg	Station-based block data assurance setting Assured: 1 Not assured: 1.55
kM	When used as a master station: $S_n \times 10000$ When used as a local station: 0

- *1 The industrial switch delay time changes depending on the industrial switch model and settings.
- *2 A sum of values starting from the smallest value set in "Start" to the largest value set in "End" of "Network Configuration Settings".
- *3 This is the device station with the largest calculation value when, for each device station, ("RX setting"/8) + ("RWr setting" \times 2) is calculated.
- *4 When the FX5-CCLGN-MS is used as a local station, add a value of p4 to the "Communication Period Setting" under "Basic Settings" of the master station.
- *5 When used as a master station: Total number of points to be set for device stations
When used as a local station (multicast): Total number of points of device stations set at the master station
When used as a local station (unicast): Total number of points set for the own station (FX5-CCLGN-MS) at the master station
- *6 The relation of dw (Total number of words) and p4 (RX/RY/RWr/RWw data transfer time) is as follows. (Station-based block data assurance: When "not assured")
When used as a master station

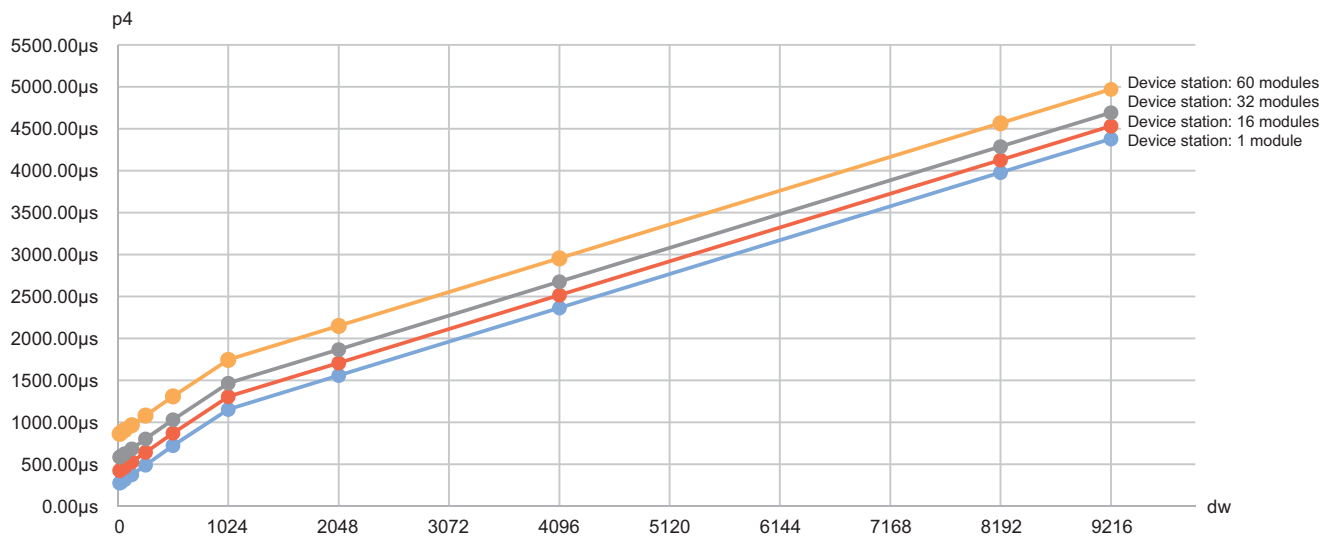

When used as a local station

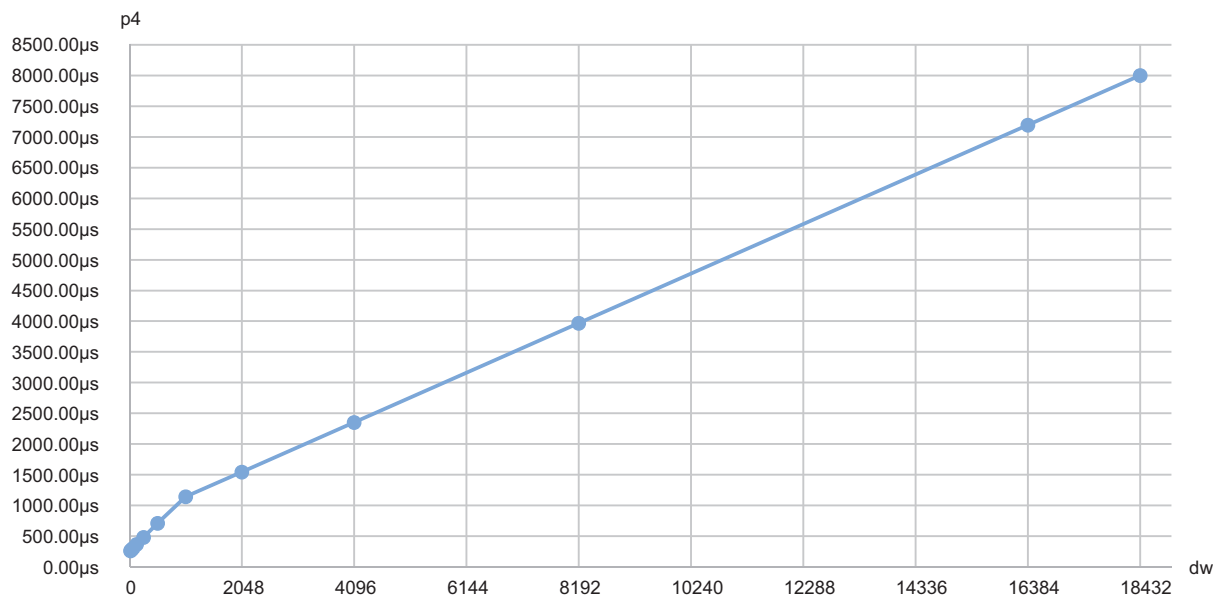

Point

The calculated result (μs) is stored in 'Communication cycle interval (calculation value)' (SW0072), 'Cyclic transmission time (calculation value)' (SW0073), and 'Transient transmission time (calculation value)' (SW0078).

The calculated result (μs) is compared with "Communication Period Interval Setting", "Cyclic Transmission Time", and "Transient Transmission Time" set in "Communication Period Setting" under "Basic Settings". If any of them are lower than the calculated result (μs), an error occurs. In this case, change the setting values that have caused the error to a value that is higher than the value shown in the detailed information of module diagnostics. The following error codes may occur.

- 3010H: The calculated communication cycle interval is higher than the communication cycle interval set in the engineering tool.
- 3011H: The calculated cyclic transmission time is higher than the cyclic transmission time set in the engineering tool.
- 3013H: The calculated transient transmission time is higher than the transient transmission time set in the engineering tool.

When "CC-Link IE TSN Class Setting" of the general CC-Link IE TSN module added to the list of stations in "Network Configuration Settings" is set to CC-Link IE TSN Class A and 'Communication cycle interval (calculation value)' (SW0072) and 'Cyclic transmission time (calculation value)' (SW0073) are set to "Communication Period Interval Setting" and "Cyclic Transmission Time", the cyclic transmission may not be able to be performed. In such a case, select the actual device to be used from "Module List" to add to the list of stations, or refer to the manual for the device used to check the maximum response time for the time managed polling method and calculate and set the communication cycle interval and cyclic transmission time.

Appendix 7 Port Number

A port number for the system cannot be specified.

Port number		Applications
Decimal	Hexadecimal	
20 to 21	14H to 15H	For system
161 to 162	A1H to A2H	For system
5000	1388H	For system
5001	1389H	MELSOFT transmission port (UDP/IP)
5002 to 5009	138AH to 1391H	For system
5010	1392H	SLMP transmission port (UDP/IP)
5011	1393H	SLMP transmission port (TCP/IP)
5552 to 5553	15B0H to 15B1H	For system
5554	15B2H	MELSOFT transmission port (TCP/IP)
5555	15B3H	Auto-open UDP port
5560 to 5562	15B8H to 15BAH	For system
5565	15BDH	For system
45237 to 45239	B0B5H to B0B7H	For system
61440 to 61442	F000H to F002H	For system
61448	F008H	For system
61450 to 61451	F00AH to F00BH	For system
61460 to 61464	F014H to F018H	For system
61500 to 61501	F03CH to F03DH	For system
62000 to 65534	F230H to FFFE H	For system

Appendix 8 Added and Enhanced Functions

The following table lists the added and enhanced functions in the FX5-CCLGN-MS.

Added and enhanced functions	Firmware version
Updated the firmware using the engineering tool* ¹	"1.002" or later
Communication speed of 100Mbps supported	"1.010" or later
Time managed polling method (CC-Link IE TSN Protocol version 2.0) support	"1.010" or later

*1 For details on firmware update, refer to the following.

 MELSEC iQ-F FX5 User's Manual (Application)

Appendix 9 Software Licenses and Copyrights

This section describes the licenses and copyrights of software used in this product.

MD5 Message-Digest Algorithm

This product includes code that was developed by RSA Data Security, Inc.

Copyright (C) 1991-2, RSA Data Security, Inc.

License to copy and use this software is granted provided that it is identified as the "RSA Data Security, Inc. MD5 Message-Digest Algorithm" in all material mentioning or referencing this software or this function.

License is also granted to make and use derivative works provided that such works are identified as "derived from the RSA Data Security, Inc. MD5 Message-Digest Algorithm" in all material mentioning or referencing the derived work.

RSA Data Security, Inc. makes no representations concerning either the merchantability of this software or the suitability of this software for any particular purpose. It is provided "as is" without express or implied warranty of any kind.

These notices must be retained in any copies of any part of this documentation and/or software.

INDEX

0 to 9

32-bit data assurance 33

A

Automatic return 23

C

CC-Link IE TSN/CC-Link IE Field diagnostics. . . . 24
Coexistence of line and star topologies
. 67,69,71,79,85,88,103,106,109
Communication cycle coexistence 22
Communication Mode 134
Communication mode 17
Communication Speed 134
Communication test 187
Communications using a dedicated instruction . . . 22
Communications using the engineering tool 22
Communications using the SLMP 22
Cyclic data assurance 22

D

Data Link Error Station Setting 135
Data transmission speed 17
Device Assignment Method 130
Device station parameter automatic setting 24

E

Error information 177
Error invalid station setting 24

I

I/O Maintenance Settings. 135
I/O maintenance settings 22
IP filter 50
IP filter settings 136

L

Line topology 67,68,71,78,83,87,100,105,108
Link dedicated instructions. 144
Link refresh 22
Lock processing 54

M

Maximum frame size 17
Maximum segment length 17
Module communication test 179
Module information list. 177
Module Operation Mode 134,136

N

Network No. 126
Network status 183

O

Other dedicated instructions 144
Output Hold/Clear Setting during CPU STOP. . . . 135
Output Mode upon CPU Error 135

P

Parameter Name 134,135
Parameter setting method 126

R

Remote operation 188
Remote password check operation 54
Reserved station setting 24

S

Security 134
Select diagnostics destination 183
Selected station communication status monitor . . 183
Star topology 67,68,71,78,83,87,101,105,108
Station No./IP address setting 126
Station number setting using a program 24
Station type 126
Station-based Block Data Assurance 135
Station-based block data assurance 34
Supplementary Cyclic Settings 134
Supplementary function. 177

T

Transient Transmission Group No. 134

U

Unlock processing 54

W

Wiring products 125

MEMO

REVISIONS

Date	Revision	Description
May 2020	A	First edition
September 2020	B	■Added or modified parts SAFETY PRECAUTIONS, WARRANTY
January 2021	C	■Added or modified parts Section 2.1, 2.3, 5.1, 5.2, 10.1, 10.4
April 2021	D	■Added or modified part Introduction, RELEVANT MANUAL, Section 2.3, 4.7, 5.1, 5.2, 5.3, 7.5, 10.1, Appendix 2
December 2021	E	■Added or modified parts SAFETY PRECAUTIONS, Appendix 8
April 2022	F	■Added or modified parts WHEN USING A SWITCHING HUB WITH CC-Link IE TSN, RELEVANT MANUALS, Section 2.1, 2.3, 2.4, Chapter 3, Section 4.1, 4.7, Chapter 5, Section 6.2, 7.3, 7.4, 7.5, 10.1, 10.2, 10.4, 10.5, 10.6, 10.7, Appendix 2, 3, 5, 6, 8, 9
October 2022	G	■Added or modified parts Section 2.3, 4.1, Appendix 6, TRADEMARKS
June 2023	H	■Added or modified parts INTRODUCTION, RELEVANT MANUALS, Section 2.4, Chapter 4, 5, Section 6.2, Chapter 7, Section 9.3, Chapter 10, Appendix 2, 6

Japanese manual number: SH-082214-H

This manual confers no industrial property rights or any rights of any other kind, nor does it confer any patent licenses. Mitsubishi Electric Corporation cannot be held responsible for any problems involving industrial property rights which may occur as a result of using the contents noted in this manual.

© 2020 MITSUBISHI ELECTRIC CORPORATION

WARRANTY

Please confirm the following product warranty details before using this product.

1. Gratis Warranty Term and Gratis Warranty Range

If any faults or defects (hereinafter "Failure") found to be the responsibility of Mitsubishi occurs during use of the product within the gratis warranty term, the product shall be repaired at no cost via the sales representative or Mitsubishi Service Company. However, if repairs are required onsite at domestic or overseas location, expenses to send an engineer will be solely at the customer's discretion. Mitsubishi shall not be held responsible for any re-commissioning, maintenance, or testing on-site that involves replacement of the failed module.

[Gratis Warranty Term]

The gratis warranty term of the product shall be for one year after the date of purchase or delivery to a designated place. Note that after manufacture and shipment from Mitsubishi, the maximum distribution period shall be six (6) months, and the longest gratis warranty term after manufacturing shall be eighteen (18) months. The gratis warranty term of repair parts shall not exceed the gratis warranty term before repairs.

[Gratis Warranty Range]

- (1) The range shall be limited to normal use within the usage state, usage methods and usage environment, etc., which follow the conditions and precautions, etc., given in the instruction manual, user's manual and caution labels on the product.
- (2) Even within the gratis warranty term, repairs shall be charged for in the following cases.
 1. Failure occurring from inappropriate storage or handling, carelessness or negligence by the user. Failure caused by the user's hardware or software design.
 2. Failure caused by unapproved modifications, etc., to the product by the user.
 3. When the Mitsubishi product is assembled into a user's device, Failure that could have been avoided if functions or structures, judged as necessary in the legal safety measures the user's device is subject to or as necessary by industry standards, had been provided.
 4. Failure that could have been avoided if consumable parts (battery, backlight, fuse, etc.) designated in the instruction manual had been correctly serviced or replaced.
 5. Relay failure or output contact failure caused by usage beyond the specified life of contact (cycles).
 6. Failure caused by external irresistible forces such as fires or abnormal voltages, and failure caused by force majeure such as earthquakes, lightning, wind and water damage.
 7. Failure caused by reasons unpredictable by scientific technology standards at time of shipment from Mitsubishi.
 8. Any other failure found not to be the responsibility of Mitsubishi or that admitted not to be so by the user.

2. Onerous repair term after discontinuation of production

- (1) Mitsubishi shall accept onerous product repairs for seven (7) years after production of the product is discontinued.
Discontinuation of production shall be notified with Mitsubishi Technical Bulletins, etc.
- (2) Product supply (including repair parts) is not available after production is discontinued.

3. Overseas service

Overseas, repairs shall be accepted by Mitsubishi's local overseas FA Center. Note that the repair conditions at each FA Center may differ.

4. Exclusion of loss in opportunity and secondary loss from warranty liability

Regardless of the gratis warranty term, Mitsubishi shall not be liable for compensation to:

- (1) Damages caused by any cause found not to be the responsibility of Mitsubishi.
- (2) Loss in opportunity, lost profits incurred to the user by Failures of Mitsubishi products.
- (3) Special damages and secondary damages whether foreseeable or not, compensation for accidents, and compensation for damages to products other than Mitsubishi products.
- (4) Replacement by the user, maintenance of on-site equipment, start-up test run and other tasks.

5. Changes in product specifications

The specifications given in the catalogs, manuals or technical documents are subject to change without prior notice.

6. Product application

- (1) In using the Mitsubishi MELSEC programmable controller, the usage conditions shall be that the application will not lead to a major accident even if any problem or fault should occur in the programmable controller device, and that backup and fail-safe functions are systematically provided outside of the device for any problem or fault.
- (2) The Mitsubishi programmable controller has been designed and manufactured for applications in general industries, etc. Thus, applications in which the public could be affected such as in nuclear power plants and other power plants operated by respective power companies, and applications in which a special quality assurance system is required, such as for railway companies or public service purposes shall be excluded from the programmable controller applications.
In addition, applications in which human life or property that could be greatly affected, such as in aircraft, medical applications, incineration and fuel devices, manned transportation, equipment for recreation and amusement, and safety devices, shall also be excluded from the programmable controller range of applications. However, in certain cases, some applications may be possible, providing the user consults their local Mitsubishi representative outlining the special requirements of the project, and providing that all parties concerned agree to the special circumstances, solely at the user's discretion.
- (3) Mitsubishi shall have no responsibility or liability for any problems involving programmable controller trouble and system trouble caused by DoS attacks, unauthorized access, computer viruses, and other cyberattacks.

TRADEMARKS

Microsoft and Windows are trademarks of the Microsoft group of companies.

The company names, system names and product names mentioned in this manual are either registered trademarks or trademarks of their respective companies.

In some cases, trademark symbols such as [™] or [®] are not specified in this manual.

Manual number: SH(NA)-082215ENG-H(2306)MEE

MODEL: FX5-U-CCIETSN-E

MODEL CODE: 09R739

MITSUBISHI ELECTRIC CORPORATION

HEAD OFFICE: TOKYO BLDG., 2-7-3, MARUNOUCHI, CHIYODA-KU, TOKYO 100-8310, JAPAN
NAGOYA WORKS: 1-14, YADA-MINAMI 5-CHOME, HIGASHI-KU, NAGOYA 461-8670, JAPAN

When exported from Japan, this manual does not require application to the
Ministry of Economy, Trade and Industry for service transaction permission.

Specifications subject to change without notice.