



Programmable Controller

MELSEC iQ-F
series



MELSEC iQ-F
FX5UC User's Manual (Hardware)

SAFETY PRECAUTIONS

(Read these precautions before use.)

Before using this product, please read this manual and the relevant manuals introduced in this manual carefully and pay full attention to safety in order to handle the product correctly.

If the equipment is used in a manner not specified by the manufacturer, the protection provided by the equipment may be impaired.

This manual classifies the safety precautions into two categories: [ WARNING] and [ CAUTION].

WARNING

Indicates that incorrect handling may cause hazardous conditions, resulting in death or severe injury.

CAUTION

Indicates that incorrect handling may cause hazardous conditions, resulting in minor or moderate injury or property damage.

Depending on the circumstances, procedures indicated by [ CAUTION] may also cause severe injury.

It is important to follow all precautions for personal safety.

Store this manual in a safe place so that it can be read whenever necessary. Always forward it to the end user.

[DESIGN PRECAUTIONS]

WARNING

- Make sure to set up the following safety circuits outside the PLC to ensure safe system operation even during external power supply problems or PLC failure. Otherwise, malfunctions may cause serious accidents.
 - Most importantly, set up the following: an emergency stop circuit, a protection circuit, an interlock circuit for opposite movements (such as normal vs. reverse rotation), and an interlock circuit (to prevent damage to the equipment at the upper and lower positioning limits.)
 - Note that when the CPU module detects an error, such as a watchdog timer error, during self-diagnosis, all outputs are turned off. Also, when an error that cannot be detected by the CPU module occurs in an input/output control block, output control may be disabled. External circuits and mechanisms should be designed to ensure safe machinery operation in such a case.
 - Note that when an error occurs in a relay, transistor or triac of an output circuit, the output might stay on or off. For output signals that may lead to serious accidents, external circuits and mechanisms should be designed to ensure safe machinery operation in such a case.
 - Construct an interlock circuit in the program so that the whole system always operates on the safe side before executing the control (for data change) of the PLC in operation.
Read the manual thoroughly and ensure complete safety before executing other controls (for program change, parameter change, forcible output and operation status change) of the PLC in operation.
Otherwise, the machine may be damaged and accidents may occur due to erroneous operations.
 - In an output circuit, when a load current exceeding the current rating or an overcurrent caused by a load short-circuit flows for a long time, it may cause smoke and fire. To prevent this, configure an external safety circuit, such as a fuse.
 - For the operating status of each station after a communication failure of the network, refer to relevant manuals for the network. Incorrect output or malfunction may result in an accident.
-

WARNING

[Precautions for using products in a UL/cUL Class I, Division 2 environment]

- Products*¹ with the CI.I, DIV.2 mark on the rating plate are suitable for use in Class I, Division 2, Groups A, B, C and D hazardous locations, or nonhazardous locations only.

This mark indicates that the product is certified for use in the Class I, Division 2 environment where flammable gases, vapors, or liquids exist under abnormal conditions. When using the products in the Class I, Division 2 environment, observe the following to reduce the risk of explosion.

- This device is open-type and is to be installed in an enclosure suitable for the environment and require a tool or key to open.
- Warning - Explosion Hazard - Substitution of any component may impair suitability for Class I, Division 2.
- Warning - Explosion Hazard - Do not disconnect equipment while the circuit is live or unless the area is known to be free of ignitable concentrations.
- Do not open the cover of the CPU module and remove the battery unless the area is known to be nonhazardous.

*1 Products conforming to the UL explosion-proof standard are as follows:

Manufactured in October 2017 onwards

· FX5 CPU module

FX5UC-32MT/D, FX5UC-32MT/DSS, FX5UC-64MT/D, FX5UC-64MT/DSS, FX5UC-96MT/D, FX5UC-96MT/DSS

· FX5 extension module

FX5-C16EX/D, FX5-C16EX/DS, FX5-C16EYT/D, FX5-C16EYT/DSS, FX5-C32EX/D, FX5-C32EX/DS, FX5-C32EYT/D, FX5-C32EYT/DSS, FX5-C32ET/D, FX5-C32ET/DSS, FX5-232ADP, FX5-485ADP, FX5-C1PS-5V, FX5-CNV-BUSC, FX5-4AD-ADP, FX5-4DA-ADP

[DESIGN PRECAUTIONS]

CAUTION

- When an inductive load such as a lamp, heater, or solenoid valve is controlled, a large current (approximately ten times greater than normal) may flow when the output is turned from off to on. Take proper measures so that the flowing current does not exceed the value corresponding to the maximum load specification of the resistance load.
- After the CPU module is powered on or is reset, the time taken to enter the RUN status varies depending on the system configuration, parameter settings, and/or program size.
Design circuits so that the entire system will always operate safely, regardless of this variation in time.
- Simultaneously turn on and off the power supplies of the CPU module and extension modules.
- If a long-time power failure or an abnormal voltage drop occurs, the PLC stops, and output is turned off. When the power supply is restored, it will automatically restart (when the RUN/STOP/RESET switch is on RUN side).

[SECURITY PRECAUTIONS]

WARNING

- To maintain the security (confidentiality, integrity, and availability) of the programmable controller and the system against unauthorized access, denial-of-service (DoS) attacks, computer viruses, and other cyberattacks from unreliable networks and devices via network, take appropriate measures such as firewalls, virtual private networks (VPNs), and antivirus solutions.
-

[INSTALLATION PRECAUTIONS]

WARNING

- Make sure to cut off all phases of the power supply externally before attempting installation or wiring work. Failure to do so may cause electric shock or damage to the product.
- Use the product within the generic environment specifications described in  Page 29 Generic Specifications of this manual.

Never use the product in areas with excessive dust, oily smoke, conductive dusts, corrosive gas (salt air, Cl₂, H₂S, SO₂ or NO₂), flammable gas, vibration or impacts, or expose it to high temperature, condensation, or rain and wind.

If the product is used in such conditions, electric shock, fire, malfunctions, deterioration or damage may occur.

[INSTALLATION PRECAUTIONS]

CAUTION

- Do not touch the conductive parts of the product directly. Doing so may cause device failures or malfunctions.
 - When drilling screw holes or wiring, make sure that cutting and wiring debris do not enter the ventilation slits of the PLC. Failure to do so may cause fire, equipment failures or malfunctions.
 - For product supplied together with a dust proof sheet, the sheet should be affixed to the ventilation slits before the installation and wiring work to prevent foreign objects such as cutting and wiring debris.
However, when the installation work is completed, make sure to remove the sheet to provide adequate ventilation. Failure to do so may cause fire, equipment failures or malfunctions.
 - Install the product on a flat surface. If the mounting surface is rough, undue force will be applied to the PC board, thereby causing nonconformities.
 - Install the product securely using a DIN rail.
 - Connect the expansion adapter securely to their designated connectors. Loose connections may cause malfunctions.
 - Work carefully when using a screwdriver such as installation of the product. Failure to do so may cause damage to the product or accidents.
 - Connect the extension cables, peripheral device cables, input/output cables and battery connecting cable securely to their designated connectors. Loose connections may cause malfunctions.
 - When using an SD memory card, insert it into the SD memory card slot. Check that it is inserted completely. Poor contact may cause malfunction.
 - Turn off the power to the PLC before attaching or detaching the following devices. Failure to do so may cause equipment failures or malfunctions.
 - Peripheral devices, expansion adapter, and connector conversion adapter
 - Extension modules, bus conversion module and connector conversion module
 - Battery
 - Hold the connector part of the Ethernet cable and perform installation or removal in a straight direction. If the cable is pulled out while connected to the module, it may cause damage to the module or the cable, or may cause a malfunction due to poor cable contact.
-

[WIRING PRECAUTIONS]

WARNING

- Make sure to cut off all phases of the power supply externally before attempting installation or wiring work. Failure to do so may cause electric shock or damage to the product.
 - Make sure to attach the terminal cover, provided as an accessory, before turning on the power or initiating operation after installation or wiring work. Failure to do so may cause electric shock.
 - The temperature rating of the cable should be 80°C or more.
It may differ depending on the extension devices. For details, refer to the user's manual of the extension devices.
 - Make sure to wire the screw terminal block in accordance with the following precautions. Failure to do so may cause electric shock, equipment failures, a short-circuit, wire breakage, malfunctions, or damage to the product.
 - The disposal size of the cable end should follow the dimensions described in the manual.
 - Tightening torque should follow the specifications in the manual.
 - Tighten the screws using a Phillips-head screwdriver No. 2 (shaft diameter 6 mm or less). Make sure that the screwdriver does not touch the partition part of the terminal block.
 - Make sure to properly wire to the terminal block (European type) in accordance with the following precautions. Failure to do so may cause electric shock, equipment failures, a short-circuit, wire breakage, malfunctions, or damage to the product.
 - The disposal size of the cable end should follow the dimensions described in the manual.
 - Tightening torque should follow the specifications in the manual.
 - Twist the ends of stranded wires and make sure that there are no loose wires.
 - Do not solder-plate the electric wire ends.
 - Do not connect more than the specified number of wires or electric wires of unspecified size.
 - Affix the electric wires so that neither the terminal block nor the connected parts are directly stressed.
 - Make sure to properly wire to the spring clamp terminal block in accordance with the following precautions. Failure to do so may cause electric shock, equipment failures, a shortcircuit, wire breakage, malfunctions, or damage to the product.
 - The disposal size of the cable end should follow the dimensions described in the manual.
 - Twist the ends of stranded wires and make sure that there are no loose wires.
 - Do not solder-plate the electric wire ends.
 - Do not connect more than the specified number of wires or electric wires of unspecified size.
 - Affix the electric wires so that neither the terminal block nor the connected parts are directly stressed.
-

[WIRING PRECAUTIONS]

CAUTION

- Perform class D grounding (grounding resistance: 100 Ω or less) of the grounding terminal on the CPU module and extension modules with a wire 2 mm² or thicker.
Do not use common grounding with heavy electrical systems (refer to  Page 103 Grounding).
 - Connect the power supply wiring to the dedicated terminals described in this manual. If an AC power supply is connected to a DC input/output terminal or DC power supply terminal, the PLC will burn out.
 - Do not wire vacant terminals externally. Doing so may damage the product.
 - Install module so that excessive force will not be applied to terminal blocks, power connectors, I/O connectors, communication connectors, or communication cables. Failure to do so may result in wire damage/breakage or PLC failure.
 - Make sure to observe the following precautions in order to prevent any damage to the machinery or accidents due to malfunction of the PLC caused by abnormal data written to the PLC due to the effects of noise.
 - Do not bundle the power line, control line and communication cables together with or lay them close to the main circuit, high-voltage line, load line or power line. As a guideline, lay the power line, control line and communication cables at least 100 mm away from the main circuit, high-voltage line, load line or power line.
 - Ground the shield of the shielded wire or shielded cable at one point on the PLC. However, do not use common grounding with heavy electrical systems.
 - Ground the shield of the analog input/output cable in accordance with the manuals of each model. However, do not use common grounding with heavy electrical systems.
-

[STARTUP AND MAINTENANCE PRECAUTIONS]

WARNING

- Do not touch any terminal while the PLC's power is on. Doing so may cause electric shock or malfunctions.
 - Before cleaning or retightening terminals, cut off all phases of the power supply externally. Failure to do so in the power ON status may cause electric shock.
 - Before modifying the program in operation, forcible output, running or stopping the PLC, read through this manual carefully, and ensure complete safety. An operation error may damage the machinery or cause accidents.
 - Do not change the program in the PLC from two or more peripheral equipment devices at the same time. (i.e. from an engineering tool and a GOT) Doing so may cause destruction or malfunction of the PLC program.
 - Use the battery for memory backup in conformance to this manual.
 - Use the battery for the specified purpose only.
 - Connect the battery correctly.
 - Do not charge, disassemble, heat, put in fire, short-circuit, connect reversely, weld, swallow or burn the battery, or apply excessive forces (vibration, impact, drop, etc.) to the battery.
 - Do not store or use the battery at high temperatures or expose to direct sunlight.
 - Do not expose to water, bring near fire or touch liquid leakage or other contents directly.
 - When replacing the battery, make sure to use our specified product (FX3U-32BL).
 - When a battery error occurs ("BAT" LED is lit in red), follow the description in this manual.Incorrect handling of the battery may cause heat excessive generation, bursting, ignition, liquid leakage or deformation, and lead to injury, fire or failures and malfunction of facilities and other equipment.
-

[STARTUP AND MAINTENANCE PRECAUTIONS]

CAUTION

- Do not disassemble or modify the PLC. Doing so may cause fire, equipment failures, or malfunctions. For repair, contact your local Mitsubishi Electric representative.
 - After the first use of the SD memory card, do not insert/remove the memory card more than 500 times. 500 times or more may cause malfunction.
 - Turn off the power to the PLC before connecting or disconnecting any extension cable. Failure to do so may cause equipment failures or malfunctions.
 - Turn off the power to the PLC before attaching or detaching the following devices. Failure to do so may cause equipment failures or malfunctions.
 - Peripheral devices, expansion adapter and connector conversion adapter
 - Extension modules, bus conversion module, and connector conversion module
 - Battery
 - Do not use the chemicals for cleaning.
 - If there is the possibility of touching the PLC inside a control panel in maintenance, make sure to discharge to avoid the influence of static electricity.
 - Since there are risks such as burn injuries, please do not touch the surface of the equipment with bare hands when it is operating in an environment which exceeds ambient temperature of 50°C.
-

[OPERATION PRECAUTIONS]

CAUTION

- Construct an interlock circuit in the program so that the whole system always operates on the safe side before executing control (for data change) of the PLC in operation. Read the manual thoroughly and ensure complete safety before executing other controls (for program change, parameter change, forcible output and operation status change) of the PLC in operation. Otherwise, the machine may be damaged and accidents may occur by erroneous operations.
-



[DISPOSAL PRECAUTIONS]

CAUTION

- Please contact a certified electronic waste disposal company for the environmentally safe recycling and disposal of your device.
 - When disposing of batteries, separate them from other waste according to local regulations. (For details on the Battery Directive in EU countries, refer to  Page 202 Handling of Batteries and Devices with Built-in Batteries in EU Member States.)
-

[TRANSPORTATION PRECAUTIONS]

CAUTION



- When transporting the PLC with the optional battery, turn on the PLC before shipment, confirm that the battery mode is set using a parameter and the BAT LED is OFF, and check the battery life. If the PLC is transported with the BAT LED ON or the battery exhausted, the battery-backed data may be unstable during transportation.
 - The PLC is a precision instrument. During transportation, avoid impacts larger than those specified in the general specifications ( Page 29 Generic Specifications) by using dedicated packaging boxes and shock-absorbing palettes. Failure to do so may cause failures in the PLC. After transportation, verify operation of the PLC and check for damage of the mounting part, etc.
 - When transporting lithium batteries, follow required transportation regulations. (For details on the regulated products, refer to  Page 202 Handling of Batteries and Devices with Built-in Batteries in EU Member States.)
 - When fumigants that contain halogen materials such as fluorine, chlorine, bromine, and iodine are used for disinfecting and protecting wooden packaging from insects, they cause malfunction when entering our products. Please take necessary precautions to ensure that remaining materials from fumigant do not enter our product, or treat packaging with methods other than fumigation (heat method). Additionally, disinfect and protect wood from insects before packing products.
-



PRÉCAUTIONS DE SÉCURITÉ

(Lire ces précautions avant toute utilisation du produit.)

Avant d'utiliser ce produit, lire attentivement ce manuel ainsi que les manuels auxquels il renvoie, et toujours considérer la sécurité comme de la plus haute importance en manipulant le produit correctement.

Si vous utilisez mal l'équipement, la protection peut ne pas fonctionner.

Dans ce manuel les précautions de sécurité sont regroupées en deux catégories : [ AVERTISSEMENT] et [ ATTENTION].

 AVERTISSEMENT	Attire l'attention sur le fait qu'une négligence peut créer une situation de danger avec risque de mort ou de blessures graves.
 ATTENTION	Attire l'attention sur le fait qu'une négligence peut créer une situation de danger avec risque de blessures légères ou de gravité moyennes ou risque de dégâts matériels.

Dans certaines circonstances, le non-respect d'une précaution de sécurité introduite sous le titre [ ATTENTION] peut avoir des conséquences graves.

Les précautions de ces deux niveaux doivent être observées dans leur intégralité car elles ont trait à la sécurité des personnes et aussi du système.

Veiller à ce que les utilisateurs finaux lisent ce manuel qui doit être conservé soigneusement à portée de main pour s'y référer autant que de besoin.

[PRÉCAUTIONS DE CONCEPTION]

AVERTISSEMENT

- Assurez-vous de configurer les circuits de sécurité suivants en dehors du contrôleur programmable pour assurer un fonctionnement sûr du système, même pendant les problèmes d'alimentation externe ou la panne du contrôleur programmable. Faute de quoi, des dysfonctionnements peuvent causer des accidents graves.
 - Configurez surtout ce qui suit : un circuit d'arrêt d'urgence, un circuit de protection, un circuit de verrouillage pour les mouvements opposés (tels que la rotation normale ou inversée) et un circuit de verrouillage (pour éviter d'endommager l'équipement aux niveaux supérieur et inférieur de limites de positionnement).
 - Notez que lorsque le module CPU détecte une erreur, telle qu'une erreur de minuteur de surveillance, pendant l'auto-diagnostic, toutes les sorties sont désactivées. En outre, lorsqu'une erreur qui ne peut pas être détectée par le module CPU se produit dans un bloc de contrôle E/S, la commande de sortie peut être désactivée. Les circuits et mécanismes externes devraient être conçus pour assurer un fonctionnement sûr des machines dans un tel cas.
 - Notez que lorsqu'une erreur se produit dans un relais, un transistor ou un triac d'un circuit de sortie, la sortie peut rester activée ou désactivée. Pour les signaux de sortie susceptibles d'entraîner des accidents graves, des circuits et mécanismes externes devraient être conçus pour assurer le fonctionnement sûr des machines dans un tel cas.
 - Construire un circuit de verrouillage dans le programme afin que l'ensemble du système fonctionne toujours sur le côté sûr avant d'exécuter le contrôle (pour le changement de données) du contrôleur programmable en fonctionnement. Lisez attentivement le manuel et assurez-vous une sécurité complète avant d'exécuter d'autres commandes (pour le changement de programme, le changement de paramètre, la sortie forcée et le changement d'état d'opération) du contrôleur programmable en cours de fonctionnement. Faute de quoi, la machine peut être endommagée et des accidents peuvent se produire en raison d'opérations erronées.
-

AVERTISSEMENT

- Dans un circuit de sortie, si le courant de charge excède la valeur nominale ou si une surintensité causée par un court-circuit à la charge persiste longtemps, il peut en résulter un dégagement de fumée avec départ de feu. Pour éviter cela, il faut configurer un circuit de sécurité externe tel qu'un fusible.
- Quant à l'état d'opération de chacune des stations en cas de problème de communication, voir les manuels correspondants pour le réseau. Une sortie erronée ou un dysfonctionnement peut être à l'origine d'un accident.

[Précautions d'utilisation des produits en environnement de UL/cUL Class I, Division 2]

- Les produits ^{*1} marques Cl.I, DIV.2 sur la plaque signalétique peuvent être utilisés en Class I, Division 2, local dangereux de groupe A, B, C et D, ou uniquement en local non dangereux. Ce logo indique que le produit est homologué pour utilisation en environnement de Class I, Division 2 ou, dans des circonstances anormales, il peut y avoir présence de gaz, vapeurs ou liquides inflammables. Si le produit est utilisé en environnement de Class I, Division 2, observer les précautions suivantes pour réduire le risque d'explosion.
 - Cet appareil est de type ouvert et il doit être installé dans une enceinte appropriée à l'environnement et ne pouvant être ouverte qu'au moyen d'une clé ou d'un outil.
 - Avertissement - Danger d'explosion - Toute substitution de composant peut compromettre l'aptitude à l'utilisation en Class I, Division 2.
 - Avertissement - Danger d'explosion - Ne pas déconnecter l'équipement quand le circuit est sous tension, ni avant de s'être assuré de l'absence d'atmosphère inflammable.
 - Ne pas ouvrir le couvercle du module CPU et ne pas retirer la batterie avant d'avoir vérifié que l'atmosphère est sans danger.

*1 Les produits sont conformés à la norme pour anti-explosion UL comme suit :

Fabriqué à partir d'octobre 2017

· Module FX5 CPU

FX5UC-32MT/D, FX5UC-32MT/DSS, FX5UC-64MT/D, FX5UC-64MT/DSS, FX5UC-96MT/D, FX5UC-96MT/DSS

· Module d'extension FX5

FX5-C16EX/D, FX5-C16EX/DS, FX5-C16EYT/D, FX5-C16EYT/DSS, FX5-C32EX/D, FX5-C32EX/DS, FX5-C32EYT/D, FX5-C32EYT/DSS, FX5-C32ET/D, FX5-C32ET/DSS, FX5-232ADP, FX5-485ADP, FX5-C1PS-5V, FX5-CNV-BUSC, FX5-4AD-ADP, FX5-4DA-ADP

[PRÉCAUTIONS DE CONCEPTION]

ATTENTION

- À la commande d'une charge inductive comme une lampe, un réchauffeur ou une électrovanne, un fort courant (environ 10 fois supérieur à l'intensité normale) peut traverser la sortie quand celle-ci passe de OFF à ON. Prenez les mesures appropriées pour que l'intensité de courant ne dépasse pas la valeur correspondant à la spécification de charge maximale de la charge de résistance.
 - À la mise sous tension ou à la réinitialisation du module CPU, le temps nécessaire à l'entrée en état RUN dépend de la configuration du système, du paramétrage et/ou de la taille du programme. Concevoir les circuits de manière que tout le système fonctionne en sécurité à tout moment, indépendamment de cette variation de temps.
 - Lancez et éteignez simultanément les blocs d'alimentation du module CPU et des modules d'extension.
 - Si une panne de courant de longue durée ou une chute de tension anormale se produit, le contrôleur programmable s'arrête et la sortie est désactivée. Lorsque l'alimentation est rétablie, elle redémarre automatiquement (lorsque le commutateur RUN/STOP/RESET est sur le côté RUN).
-

[PRÉCAUTIONS DE SÉCURITÉ]

AVERTISSEMENT

- Pour maintenir la sécurité (confidentialité, intégrité et disponibilité) de produit et du système contre les accès non autorisés, les attaques par déni de service (DoS), les virus informatiques et autres cyberattaques depuis des réseaux ou des appareils peu fiables via le réseau, prendre les mesures appropriées telles que la configuration d'un pare-feu ou d'un réseau privé virtuel (VPN), ou l'installation d'un logiciel antivirus sur l'ordinateur.
-

[PRÉCAUTIONS D'INSTALLATION]

AVERTISSEMENT

- Assurez-vous de couper toutes les phases de l'alimentation externe avant d'essayer l'installation ou le câblage. Faute de quoi, il y a risque d'électrocution ou d'endommagement du produit.
 - Utilisez le produit dans les spécifications d'environnement générique décrites dans la  Page 29 Generic Specifications de ce manuel.
Ne jamais utiliser le produit dans les zones à poussières excessives, à fumées grasses, à poussières conductrices, à gaz corrosifs (air salé, Cl₂, H₂S, SO₂ ou NO₂), à gaz inflammables, à vibrations ou à impacts, ou l'exposer à haute température, à condensation ou à pluie et vent.
Si le produit est utilisé dans de telles conditions, l'électrocution, le feu, des dysfonctionnements, des détériorations ou des dommages peuvent se produire.
-

[PRÉCAUTIONS D'INSTALLATION]

ATTENTION

- Ne pas toucher directement les parties conductrices du produit. Cela pourrait être à l'origine d'une panne ou d'un dysfonctionnement.
 - Lors du perçage des trous de vis ou du câblage, assurez-vous que les débris de coupe et de câblage ne pénètrent pas dans les fentes de ventilation du contrôleur programmable. Faute de quoi, il y a risque de départ de feu, de panne ou de dysfonctionnement de l'équipement.
 - Pour le produit fourni avec une feuille anti-poussière, la feuille doit être fixée aux fentes de ventilation avant l'installation et le câblage pour éviter les objets étrangers tels que les débris de coupe et de câblage.
Cependant, lorsque les travaux d'installation sont terminés, assurez-vous d'enlever la feuille pour assurer une ventilation adéquate. Faute de quoi, il y a risque de départ de feu, de panne ou de dysfonctionnement de l'équipement.
 - Installez le produit sur une surface plane. Si la surface de montage est rugueuse, une force excessive sera appliquée à la carte PC, ce qui entraînera des non-conformités.
 - Installez le produit solidement à l'aide d'un rail DIN.
 - Connectez l'adaptateur d'extension de manière sécurisée à leurs connecteurs désignés. Les connexions lâches peuvent provoquer des dysfonctionnements.
 - Travailler soigneusement lorsque vous utilisez un tournevis comme pour l'installation du produit. Faute de quoi, il y a risque d'endommagement du produit ou des accidents.
 - Connectez les câbles d'extension, les câbles de périphériques, les câbles d'entrée/sortie et le câble de connexion de la batterie solidement à leurs connecteurs désignés. Les connexions lâches peuvent provoquer des dysfonctionnements.
 - Lorsque vous utilisez une carte mémoire SD, insérez-la dans la fente de la carte mémoire SD. Vérifier que la carte a été poussée bien à fond dans le logement. Tout mauvais contact peut provoquer des dysfonctionnements.
 - Coupez l'alimentation du contrôleur programmable avant d'attacher ou de détacher les appareils suivants. Faute de quoi, il y a risque de panne ou de dysfonctionnement des équipements.
 - Périphériques, adaptateur d'extension et adaptateur de conversion de connecteur
 - Modules d'extension, module de conversion de bus et module de conversion de connecteur
 - Batterie
 - Tenir la partie connecteur du câble Ethernet et l'installer ou le retirer tout droit.
En outre, si le câble est retiré alors qu'il est connecté au module, il peut endommager le module ou le câble, ou provoquer un dysfonctionnement dû au mauvais contact du câble.
-

[PRÉCAUTIONS DE CABLAGE]

AVERTISSEMENT

- Assurez-vous de couper toutes les phases de l'alimentation externe avant d'essayer l'installation ou le câblage. Faute de quoi, il y a risque d'électrocution ou d'endommagement du produit.
 - Assurez-vous d'attacher le couvercle de borne, fourni en tant qu'accessoire, avant d'alimentation ou d'opération de lancement après installation ou câblage. Faute de quoi, il y a risque d'électrocution.
 - La température nominale du câble doit être de 80°C ou plus.
Il peut varier en fonction des équipements d'extension. Pour les détails, voir le Manuel de l'Utilisateur des équipements d'extension.
 - Assurez-vous de brancher le bornier à vis conformément aux précautions suivantes. Faute de quoi, il y a risque d'électrocution ou de panne d'équipement, de court-circuit, de rupture de fil, de dysfonctionnements ou de dommages au produit.
 - La taille de l'extrémité du câble lors de la mise au rebut doit suivre les dimensions décrites dans le manuel.
 - Le couple de serrage doit suivre les spécifications du manuel.
 - Serrer les vis à l'aide d'un tournevis Phillips n° 2 (diamètre de l'arbre de 6 mm ou moins). Assurez-vous que le tournevis ne touche pas la partie de séparation du bornier.
 - Assurez-vous de bien câbler le bornier (type européen) conformément aux précautions suivantes. Faute de quoi, il y a risque d'électrocution, de panne d'équipement, de court-circuit, de rupture de fil, de dysfonctionnements ou de dommages au produit.
 - La taille de l'extrémité du câble lors de la mise au rebut doit suivre les dimensions décrites dans le manuel.
 - Le couple de serrage doit suivre les spécifications du manuel.
 - Tordre les extrémités des fils échoués et s'assurer qu'il n'y a pas de fils lâches.
 - Ne pas souder et plaquer les extrémités des fils électriques.
 - Ne pas connecter plus que le nombre spécifié de fils ou fils électriques de taille non spécifiée.
 - Fixez les fils électriques afin que ni le bornier ni les pièces connectées ne soient directement soumis à une contrainte.
 - Assurez-vous de bien câbler la plaque à bornes avec bride à ressort conformément aux précautions suivantes. Faute de quoi, il y a le risque d'électrocutions, de pannes d'équipement, de court-circuit, de rupture du fil, de dysfonctionnements ou de dommages au produit.
 - La taille des extrémités du câble lors de la mise au rebut doit suivre les dimensions décrites dans le manuel.
 - Tordre les extrémités des fils échoués et s'assurer qu'il n'y a pas de fils lâches.
 - Ne pas souder et plaquer les extrémités des fils électriques.
 - Ne pas connecter plus que le nombre spécifié de fils ou fils électriques de taille non spécifiée.
 - Fixez les fils électriques de sorte que ni le bornier ni les pièces connectées ne soient directement soumis à une contrainte.
-

[PRÉCAUTIONS DE CABLAGE]

ATTENTION

- Effectuer la mise à la terre classe D (résistance à la mise à la terre : 100 Ω ou moins) de la borne de mise à la terre sur le module CPU et les modules d'extension avec un fil de 2 mm² ou plus épais. Ne pas utiliser de mise à la terre commune pour les systèmes électriques lourds (voir  Page 103 Grounding).
 - Connectez le câblage d'alimentation aux bornes dédiées décrites dans ce manuel. Quand l'alimentation AC est connectée à une borne d'E/S ou à une borne d'alimentation DC, le contrôleur programmable s'éteindra.
 - Ne pas câbler les bornes vides à l'extérieur. Cela pourrait endommager le produit.
 - Installer le module afin que la force excessive ne soit pas appliquée aux borniers, aux connecteurs d'alimentation, aux connecteurs E/S, aux connecteurs de communication ou aux câbles de communication. Faute de quoi, il y a risque d'endommagement ou de rupture ou de panne du contrôleur programmable.
 - Assurez-vous d'observer les précautions suivantes afin d'éviter tout endommagement aux machines ou les accidents dues au dysfonctionnement du contrôleur programmable causé par des données anormales écrites sur le contrôleur programmable en raison d'effets du bruit.
 - Ne pas regrouper la ligne d'alimentation, la ligne de commande et les câbles de communication, ou ni les placer près du circuit principal, la ligne à haute tension, la ligne de charge ou la ligne d'alimentation. À titre indicatif, posez la ligne d'alimentation, la ligne de commande et les câbles de communication au moins à 100 mm du circuit principal, de la ligne à haute tension, de la ligne de charge ou de la ligne d'alimentation.
 - Effectuer la mise à la terre du blindage du fil blindé ou du câble blindé en un point sur le contrôleur programmable. Toutefois, ne pas utiliser de mise à la terre commune avec des systèmes électriques lourds.
 - Effectuer la mise à la terre du blindage du câble E/S analogique conformément aux manuels de chaque modèle. Toutefois, ne pas utiliser de mise à la terre commune avec des systèmes électriques lourds.
-

[PRÉCAUTIONS DE MISE EN SERVICE ET DE MAINTENANCE]

AVERTISSEMENT

- Ne toucher aucune borne quand le contrôleur programmable est sous tension. Cela pourrait être à l'origine d'électrocutions ou de dysfonctionnements.
 - Avant de nettoyer ou de resserrer les bornes, couper toutes les phases de l'alimentation externe. Faute de quoi, il y a risque d'électrocution avec les bornes sous tension.
 - Avant d'effectuer une modification au programme en cours, une sortie forcée, ou une exécution ou un arrêt du contrôleur programmable, lisez attentivement ce manuel et assurez-vous une sécurité complète. Une opération erronée peut endommager la machine ou provoquer des accidents.
 - Ne pas modifier le programme dans le contrôleur programmable à partir de deux ou plusieurs périphériques en même temps (c'est-à-dire à partir d'un outil d'ingénierie et d'un GOT). Cela pourrait être à l'origine des destructions ou des dysfonctionnement du programme du contrôleur programmable.
-

AVERTISSEMENT

- Utiliser la batterie pour la sauvegarde de la mémoire conformément à ce manuel.
 - Utiliser la batterie uniquement dans le but spécifié.
 - Raccorder la batterie correctement.
 - Ne pas charger, ni démonter, ni chauffer, ni mettre en feu, ni court-circuiter, ni relier inversement, ni souder, ni avaler ou ni brûler la batterie, ou ni appliquer aucune force excessive (vibration, impact, chute, etc.) à la batterie.
 - Ne pas stocker ni utiliser la batterie à haute température ou ni l'exposer aux rayons directs du soleil.
 - Ne pas exposer à l'eau, ni rapprocher du feu ou ni toucher des fuites de liquide ou d'autres contenus directement.
 - Toujours utiliser le produit (FX3U-32BL) désigné par notre société pour le remplacement.
 - En cas d'erreur de batterie (la DEL [BAT] s'allume en rouge), procéder conformément au manuel.
- Une manipulation incorrecte de la batterie peut causer une génération excessive de chaleur, un éclatement, un allumage, une fuite de liquide ou une déformation, et entraîner des blessures, des feux ou des pannes et des dysfonctionnements des installations et d'autres équipements.
-

[PRÉCAUTIONS DE MISE EN SERVICE ET DE MAINTENANCE]

ATTENTION

- Ne pas démonter ni modifier le contrôleur programmable. Cela pourrait causer un départ de feu, une panne ou un dysfonctionnement des équipements.
Pour réparation, contactez votre représentant local de Mitsubishi Electric.
 - Après la mise en service de la carte-mémoire SD, ne pas insérer/retirer la carte-mémoire plus de 500 fois. Cette opération de plus de 500 fois peut causer un dysfonctionnement.
 - Coupez l'alimentation du contrôleur programmable avant de connecter ou déconnecter les câbles d'extension. Faute de quoi, il y a risque de panne ou de dysfonctionnement des équipements.
 - Coupez l'alimentation du contrôleur programmable avant d'attacher ou de détacher les appareils suivants. Faute de quoi, il y a risque de panne ou de dysfonctionnement des équipements.
 - Périphériques, adaptateur d'extension et adaptateur de conversion de connecteur
 - Modules d'extension, module de conversion de bus et module de conversion de connecteur
 - Batterie
 - Ne pas utiliser de produit chimique pour le nettoyage.
 - Si le contact avec le contrôleur logique programmable dans le boîtier de commutation est possible lors de l'entretien, etc., toujours éliminer l'électricité statique pour éviter son influence.
 - En raison de risques de brûlures, veuillez ne pas toucher la surface de l'appareil à mains nues, lorsqu'il fonctionne dans un environnement dont la température ambiante dépasse 50°C.
-

[PRECAUTIONS D'OPÉRATION]

ATTENTION

- Construire un circuit de verrouillage dans le programme afin que l'ensemble du système fonctionne toujours sur le côté sûr avant d'exécuter la commande (pour le changement de données) du contrôleur programmable en fonctionnement. Lisez attentivement le manuel et assurez-vous une sécurité complète avant d'exécuter d'autres commandes (pour le changement de programme, le changement de paramètre, la sortie forcée et le changement d'état d'opération) du contrôleur programmable en cours de fonctionnement. Sinon, la machine peut être endommagée et des accidents peuvent se produire à cause des opérations erronées.
-



[PRÉCAUTIONS DE MISE AU REBUT]

ATTENTION

- Veuillez contacter une société certifiée de mise au rebut des déchets électroniques pour le recyclage et la mise au rebut écologique de votre équipement.
 - Les piles ou batteries doivent être mises au rebut séparément des autres déchets et conformément à la réglementation locale. (Pour les détails de la directive sur les piles et batteries dans les pays de l'UE, reportez-vous à la  Page 202 Handling of Batteries and Devices with Built-in Batteries in EU Member States.)
-

[PRÉCAUTIONS DE TRANSPORT]

ATTENTION

- Lors du transport du contrôleur programmable équipé de la batterie en option, allumez le contrôleur programmable avant l'expédition, confirmez que le mode batterie est réglé à l'aide d'un paramètre et que la LED BAT est éteinte (OFF) et vérifiez la durée de vie de la batterie. Si le contrôleur programmable est transporté avec la LED BAT sous tension (ON) ou la batterie épuisée, les données sauvegardées par batterie peuvent être instables pendant le transport.
 - Le contrôleur programmable est un instrument de précision. Pendant le transport, évitez de donner des chocs supérieurs à ceux spécifiés dans les spécifications générales ( Page 29 Generic Specifications) en utilisant des boîtes d'emballage dédiées et des palettes amortisseuse. Faute de quoi, il y a risque de panne du contrôleur programmable. Après le transport, vérifiez le bon fonctionnement du contrôleur programmable et contrôlez l'absence de dégâts des pièces de montage, etc.
 - Pour le transport des piles au lithium, respecter la réglementation afférente à ce transport. (Pour les détails des produits, reportez-vous à la  Page 202 Handling of Batteries and Devices with Built-in Batteries in EU Member States.)
 - Lorsque les fumigants contenant des matières halogènes comme le fluor, le chlore, le brome et l'iode sont utilisés pour désinfecter et protéger les emballages en bois des insectes, ils provoquent des dysfonctionnements lors de leur entrée dans nos produits. Prenez les précautions nécessaires pour vous assurer que les matériaux restants du fumigant ne pénètrent pas dans nos produits ou que l'emballage est traité avec des méthodes autres que la fumigation (méthode de la chaleur). En outre, désinfectez et protégez le bois des insectes avant d'emballer les produits.
-

INTRODUCTION

This manual contains text, diagrams and explanations which will guide the reader in the correct installation, safe use and operation of the FX5UC Programmable Controllers and should be read and understood before attempting to install or use the module.

Always forward it to the end user.

Regarding use of this product

- This product has been manufactured as a general-purpose part for general industries, and has not been designed or manufactured to be incorporated in a device or system used in purposes related to human life.
- Before using the product for special purposes such as nuclear power, electric power, aerospace, medicine or passenger movement vehicles, consult Mitsubishi Electric.
- This product has been manufactured under strict quality control. However when installing the product where major accidents or losses could occur if the product fails, install appropriate backup or failsafe functions in the system.

Note

- If in doubt at any stage during the installation of the product, always consult a professional electrical engineer who is qualified and trained in the local and national standards. If in doubt about the operation or use, please consult the nearest Mitsubishi Electric representative.
- Since the examples indicated by this manual, technical bulletin, catalog, etc. are used as a reference, please use it after confirming the function and safety of the equipment and system. Mitsubishi Electric will accept no responsibility for actual use of the product based on these illustrative examples.
- This manual content, specification etc. may be changed, without a notice, for improvement.
- The information in this manual has been carefully checked and is believed to be accurate; however, if you notice a doubtful point, an error, etc., please contact the nearest Mitsubishi Electric representative. When doing so, please provide the manual number given at the end of this manual.

MEMO

CONTENTS

SAFETY PRECAUTIONS	1
PRÉCAUTIONS DE SÉCURITÉ	8
INTRODUCTION	16
RELEVANT MANUALS	24
TERMS	24
CHAPTER 1 OUTLINE	26
1.1 Part Names	26
Front panel	26
Side	27
CHAPTER 2 SPECIFICATIONS	29
2.1 Generic Specifications	29
2.2 Power Supply Specifications	30
DC power supply	30
2.3 Input Specifications	31
24 V DC input (sink/source)	31
2.4 Output Specifications	33
Transistor output	33
Relay output	34
2.5 Input/Output Derating Curve	34
2.6 Performance Specifications	35
2.7 Communication Specifications	37
Built-in Ethernet communication	37
Built-in RS-485 communication	38
2.8 External Dimensions	38
CPU module	38
2.9 Terminal Layout	39
CHAPTER 3 PRODUCT LIST	42
3.1 Overall Configuration	42
3.2 CPU Module	43
3.3 Extension Module	44
I/O module	44
Intelligent function module	47
FX5 safety extension modules	49
Extension power supply module	50
Connector conversion module	50
Bus conversion module	50
3.4 Expansion Adapter	51
3.5 Extended Extension Cable and Connector Conversion Adapter	51
Extended extension cable	51
Connector conversion adapter	51
3.6 Terminal Module	52
3.7 SD Memory Card	52
3.8 Battery	52
3.9 Communication Cable	52
3.10 Engineering Tool	52

CHAPTER 4	SYSTEM CONFIGURATION	53
4.1	Rules of System Configuration	54
4.2	Limitations on the Number of Connected Extension Devices	58
	Number of connected expansion adapters	58
	Number of connected extension modules (including extended extension cable)	58
4.3	Limitation on the Number of Input/Output Points	62
	Total number of I/O points and remote I/O points	63
	Calculation of the number of input/output points	64
	Calculation of the number of remote I/O points	65
4.4	Limitation on Current Consumption	69
	Power supply check from the CPU module (current consumption calculation)	69
	Power supply check from the powered input/output module (current consumption calculation)	71
	Power supply check from extension power supply module (current consumption calculation)	72
4.5	Rules of System Configuration and Examples of Reconfiguration	74
	System configuration example	74
	System reconfiguration example	77
4.6	Numbers and Assignment in System	82
	Module input/output number	82
	Module number of extension modules	82
CHAPTER 5	INSTALLATION	83
5.1	Installation Location	83
	Installation location in enclosure	83
	Spaces in enclosure	83
	Layout in enclosure	84
5.2	Examination for Installing Method in Enclosure	85
5.3	Procedures for Installing on and Detaching from DIN Rail	86
	Preparation for installation	86
	Installation of CPU module	86
	Installation of extension modules (extension cable type)	87
	Installation of terminal modules	87
	Removal of CPU module	87
5.4	Procedures for Installing Directly (with M4 Screws)	88
	Hole pitches for direct mounting	88
	Hole pitches when extension module connected	89
	Installation of extension module (extension cable type)	89
5.5	Connecting Methods for CPU Module and Extension Devices	90
	Connection of extension devices	90
	Connecting method A - connection of an expansion adapter	90
	Connecting method B - connection of an extension module (extension connector type)	91
	Connecting method C - connection of a connector conversion module (extension connector type) or the extension power supply module and an extension module (extension cable type)	92
	Connecting method D - connection between extension modules (extension cable type)	92
	Connecting method E - connection of extended extension cable and connector conversion adapter	93
	Connecting method F - connection of a bus conversion module and an FX3 intelligent function module	93
	Connection of power cables	94
	Removal of power cables	95
	Connection of I/O cables	95

CHAPTER 6 WIRING **97**

6.1	Wiring Preparations	97
	Wiring procedure	97
6.2	Cable Connecting Procedure	98
	European-type terminal block	98
	Spring Clamp Terminal Block	99
	Screw terminal block	101
6.3	Grounding	103
6.4	Power Supply Wiring	104
	Examples of DC power supply wiring	104
6.5	Input Wiring	106
	24 V DC input	106
	Input wiring example	111
	Input wiring examples of terminal modules	114
6.6	Output Wiring	116
	Transistor output	116
	Relay output	119
	Triac output	122
	Output wiring example	124
	Output wiring examples of terminal modules	127
6.7	Examples of Wiring for Various Uses	131
	Positioning function	131
	Communication function	131
	High-speed counter	131
	Interruption	134
	Digital switch	135
	Input matrix	137
	Seven segment with latch	138

CHAPTER 7 OPERATION ADJUSTMENT **140**

7.1	Preparation for Operation	140
	Preliminary inspection	140
	Procedure until operation	140
	Connection with a personal computer	141
7.2	Operation and Test	142
	Self-diagnostic function	142
	Monitoring and debugging	142
7.3	Running, Stopping, and Resetting	143
	Methods of running, stopping, and resetting	143

CHAPTER 8 MAINTENANCE AND INSPECTION **144**

8.1	Daily Inspection	144
8.2	Periodic Inspection	144
8.3	Battery	145
	Part names	145
	Specifications	145
	Battery attachment	145
	Battery replacement	146
	Special relay for low battery voltage	148

CHAPTER 9 TROUBLESHOOTING	149
9.1 Troubleshooting Procedure	149
9.2 Checking with LEDs	149
Checking the PWR LED	149
Checking the BAT LED	149
Checking the ERR LED	150
Checking the P.RUN LED	150
9.3 Troubleshooting using the engineering tool	151
System monitor	151
Module diagnostics	152
Event history	153
9.4 Error Status and Operations on Occurrence of an Error	154
9.5 Backing Up the Data	155
9.6 Canceling Errors	155
9.7 Troubleshooting for Each Symptom	156
I/O operation (CPU module, I/O module)	156
PLC write, PLC read	157
Boot operation	157
APPENDIX	158
Appendix 1 How to Check the Date of Manufacture	158
Appendix 2 Standards	159
Certification of UL, cUL standards	159
Compliance with EC directive (CE Marking)	159
Compliance with UKCA marking	162
Appendix 3 Precautions for Operating Ambient Temperature	163
Appendix 4 I/O Module	164
Product configuration	164
Product list	164
Specifications	167
External dimensions and component names	175
Terminal layout	181
Appendix 5 Connector Conversion Module	184
External dimensions and component names	184
Specifications	184
Appendix 6 SD Memory Card	185
Part names	185
Specifications	185
Insertion and removal of the SD memory card	186
Appendix 7 Terminal Module	187
Product configuration	187
Product list	187
Specifications	188
External dimensions and component names	193
Terminal layout	194
Internal circuit	195
Appendix 8 Precautions for Battery Transportation	201
Control-subject product	201
Precautions for transportation	201

Appendix 9 Handling of Batteries and Devices with Built-in Batteries in EU Member States	202
Disposal precautions	202
Exportation precautions	202
Appendix 10 Added and Changed Functions	203

INDEX **205**

REVISIONS	207
WARRANTY	209
TRADEMARKS	210

RELEVANT MANUALS

Manual name <manual number>	Description
MELSEC iQ-F FX5UC User's Manual (Hardware) <JY997D61401> (This manual)	Describes the details of hardware of the FX5UC CPU module, including input/output specifications, wiring, installation, and maintenance.
MELSEC iQ-F FX5 User's Manual (Startup) <JY997D58201>	Describes the performance specifications, procedures before operation, and troubleshooting of the FX5 CPU module.
MELSEC iQ-F FX5 User's Manual (Application) <JY997D55401>	Describes the basic knowledge required for program design, functions of the CPU module, devices/labels, and parameters.
MELSEC iQ-F FX5 User's Manual (Serial Communication) <JY997D55901>	Describes the N:N network, Parallel link, MELSEC Communication protocol, inverter communication, non-protocol communication, and predefined protocol support.
MELSEC iQ-F FX5 User's Manual (MELSEC Communication Protocol) <JY997D60801>	Explains methods for the device that is communicating with the CPU module by MC protocol to read and write the data of the CPU module.
MELSEC iQ-F FX5 User's Manual (MODBUS Communication) <JY997D56101>	Describes the MODBUS serial communication and MODBUS/TCP communication.
MELSEC iQ-F FX5 User's Manual (Ethernet Communication) <JY997D56201>	Describes the Ethernet communication function of the CPU module built-in and the Ethernet module.
MELSEC iQ-F FX5 User's Manual (SLMP) <JY997D56001>	Explains methods for the device that is communicating with the CPU module by SLMP to read and write the data of the CPU module.
MELSEC iQ-F FX5 User's Manual (Positioning Control - CPU module built-in, High-speed pulse input/output module) <JY997D56301>	Describes the positioning function of the CPU module built-in and the high-speed pulse input/output module.
MELSEC iQ-F FX5 User's Manual (Analog Control - CPU module built-in, Expansion adapter) <JY997D60501>	Describes the analog function of the CPU module built-in and the analog adapter.
MELSEC iQ-F FX5 Programming Manual (Program Design) <JY997D55701>	Describes the specifications of ladder, ST, FBD/LD, and SFC programs, and labels.
GX Works3 Operating Manual <SH-081215ENG>	Describes the system configuration, parameter settings, and online operations of GX Works3.

TERMS

Unless otherwise specified, this manual uses the following terms.

- indicates a variable part to collectively call multiple models or versions.

(Example) FX5-C32EX/D, FX5-C32ET/D, FX5-C32EYT/D ⇒ FX5-C32E□/D

- For details on the FX3 devices that can be connected with the FX5UC CPU module, refer to  Page 42 PRODUCT LIST.

Terms	Description
Analog adapter	Generic term for FX5-4A-ADP, FX5-4AD-ADP, FX5-4DA-ADP, FX5-4AD-PT-ADP, and FX5-4AD-TC-ADP
Battery	Different name for FX3U-32BL
Bus conversion module	Generic term for Bus conversion module (extension cable type) and Bus conversion module (extension connector type)
Bus conversion module (extension cable type)	Different name for FX5-CNV-BUS
Bus conversion module (extension connector type)	Different name for FX5-CNV-BUSC
Communication adapter	Generic term for FX5-232ADP and FX5-485ADP
Connector conversion adapter	Different name for FX5-CNV-BC
Connector conversion module (extension connector type)	Different name for FX5-CNV-IFC
Engineering tool	The product name of the software package for the MELSEC programmable controllers
Expansion adapter	Generic term for adapter for FX5 CPU module
Extended extension cable	Generic term for FX5-30EC and FX5-65EC
Extension module	Generic term for FX5 extension modules, FX3 function modules, Extension modules (extension cable type) and Extension module (extension connector type)
Extension module (extension cable type)	Generic term for Input modules (extension cable type), Output modules (extension cable type), Input/output modules (extension cable type), Powered input/output module, High-speed pulse input/output module, Intelligent function modules, Safety extension modules, and Bus conversion module (extension cable type)
Extension module (extension connector type)	Generic term for Input modules (extension connector type), Output modules (extension connector type), Input/output modules (extension connector type), Extension power supply module, Connector conversion module (extension connector type), and Bus conversion module (extension connector type)

Terms	Description
Extension power supply module	Different name for FX5-C1PS-5V
FX3	Generic term for FX3S, FX3G, FX3GC, FX3U, and FX3UC PLCs
FX3 extension module	Different name for FX3 intelligent function module
FX3 intelligent function module	Generic term for FX3U-4AD, FX3U-4DA, FX3U-4LC, FX3U-1PG, FX3U-2HC, FX3U-16CCL-M, FX3U-64CCL, FX3U-128ASL-M, and FX3U-32DP
FX5	Generic term for FX5UJ, FX5U and FX5UC PLCs
FX5 CPU module	Generic term for FX5UJ CPU module, FX5U CPU module and FX5UC CPU module
FX5 extension module	Generic term for I/O modules, FX5 extension power supply modules, FX5 intelligent function modules, and FX5 safety extension modules
FX5 intelligent function module	Generic term for FX5-4AD, FX5-4DA, FX5-8AD, FX5-4LC, FX5-20PG-P, FX5-20PG-D, FX5-40SSC-G, FX5-80SSC-G, FX5-40SSC-S, FX5-80SSC-S, FX5-ENET, FX5-ENET/IP, FX5-CCLGN-MS, FX5-CCLIEF, FX5-CCL-MS, FX5-ASL-M, and FX5-DP-M
FX5 safety extension module	Generic term for safety main modules and safety expansion modules
FX5UC CPU module	Generic term for FX5UC-32MT/D, FX5UC-32MT/DSS, FX5UC-64MT/D, FX5UC-64MT/DSS, FX5UC-96MT/D, FX5UC-96MT/DSS, FX5UC-32MT/DS-TS, FX5UC-32MT/DSS-TS, and FX5UC-32MR/DS-TS
GOT	Generic term for Mitsubishi Electric Graphic Operation Terminal GOT1000 and GOT2000 series
GX Works3	The product name of the software package, SWnDND-GXW3, for the MELSEC programmable controllers (The 'n' represents a version.)
High-speed pulse input/output module	Generic term for FX5-16ET/ES-H and FX5-16ET/ESS-H
I/O module	Generic term for Input modules, Output modules, Input/output modules, Powered input/output modules, and High-speed pulse input/output modules
Input module	Generic term for Input modules (extension cable type) and Input modules (extension connector type)
Input module (extension cable type)	Generic term for FX5-8EX/ES and FX5-16EX/ES
Input module (extension connector type)	Generic term for FX5-C16EX/D, FX5-C16EX/DS, FX5-C32EX/D, FX5-C32EX/DS, and FX5-C32EX/DS-TS
Input/output module	Generic term for Input/output modules (extension cable type) and Input/output modules (extension connector type)
Input/output module (extension cable type)	Generic term for FX5-16ER/ES, FX5-16ET/ES, and FX5-16ET/ESS
Input/output module (extension connector type)	Generic term for FX5-C32ET/D, FX5-C32ET/DSS, FX5-C32ET/DS-TS, and FX5-C32ET/DSS-TS
Intelligent function module	Generic term for FX5 intelligent function modules and FX3 intelligent function modules
Intelligent module	The abbreviation for intelligent function modules
Output module	Generic term for Output modules (extension cable type) and Output modules (extension connector type)
Output module (extension cable type)	Generic term for FX5-8EYR/ES, FX5-8EYT/ES, FX5-8EYT/ESS, FX5-16EYR/ES, FX5-16EYT/ES, and FX5-16EYT/ESS
Output module (extension connector type)	Generic term for FX5-C16EYT/D, FX5-C16EYT/DSS, FX5-C16EYR/D-TS, FX5-C32EYT/D, FX5-C32EYT/DSS, FX5-C32EYT/D-TS, and FX5-C32EYT/DSS-TS
Peripheral device	Generic term for engineering tools and GOTs
Powered input/output module	Generic term for FX5-32ER/DS, FX5-32ET/DS, and FX5-32ET/DSS
Safety expansion module	Generic term for expansion modules installed to a safety main module
Safety input expansion module	Different name for FX5-SF-8DI4
Safety main module	Different name for FX5-SF-MU4T5
SD memory card	Generic term for NZ1MEM-2GBSD, NZ1MEM-4GBSD, NZ1MEM-8GBSD, NZ1MEM-16GBSD, L1MEM-2GBSD and L1MEM-4GBSD SD memory cards Abbreviation of Secure Digital Memory Card. Device that stores data using flash memory.



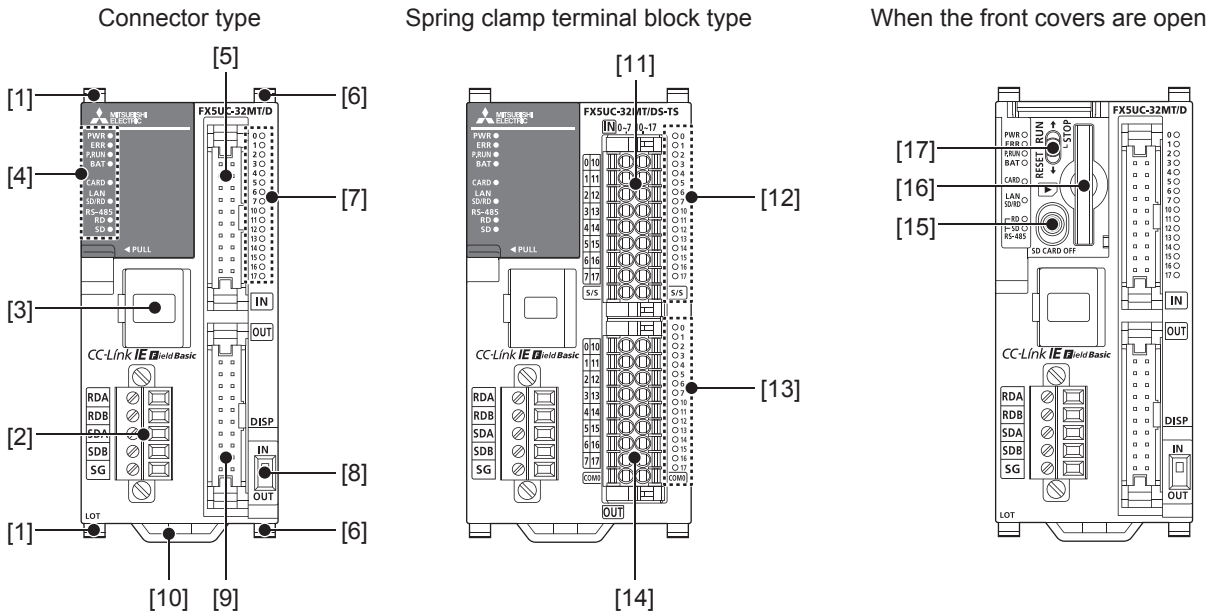

1 OUTLINE

1.1 Part Names

Front panel





No.	Name	Description
[1]	Expansion adapter connecting hooks	When connecting an expansion adapter, secure it with these hooks.
[2]	Built-in RS-485 communication terminal block	Terminal block for connection with RS-485-compatible devices
[3]	Built-in Ethernet communication connector	Connector for connection with Ethernet-compatible devices (with cap) For a connector which is not connected with the Ethernet cable, install a cap provided as an accessory in order to block dust or dirt. For details, refer to MELSEC iQ-F FX5 User's Manual (Ethernet Communication).
[4]	Operation status display LED	
	PWR LED	Indicates whether the CPU module is powered or not. Lit: Powered Off: Not powered or hardware error (Page 149 Checking with LEDs)
	ERR LED	Indicates the error status of the CPU module. (Page 149 Checking with LEDs) Lit: Error or hardware error Flashing: Factory default setting, error, hardware error, or resetting Off: Operating normally
	P.RUN LED	Indicates the program running status. Lit: Operating normally Flashing: Paused, Stopped (program mismatched), or online program change (PAUSE or RUN was set at the time of online program change.) (Page 149 Checking with LEDs) Off: Stopped or stop error
	BAT LED	Indicates the battery status. Flashing: Battery error Off: Operating normally (Page 149 Checking with LEDs)
	CARD LED	Indicates whether an SD memory card can be used or not. Lit: Can be used or cannot be removed. Flashing: In preparation Off: Not inserted or can be removed.
	SD/RD LED	Lit when the CPU module is sending or receiving data through built-in Ethernet communication.
	RD LED	Lit when the CPU module is receiving data through built-in RS-485 communication.
	SD LED	Lit when the CPU module is sending data through built-in RS-485 communication.

No.	Name	Description
[5]	Input connector	Connector for connecting input signal cables. For details on the terminal layout, refer to  Page 39 Terminal Layout.
[6]	Extension module connecting hook	When connecting an expansion module, secure it with these hooks.
[7]	I/O display LED	Lit when the input or output is on.
[8]	DISP switch	Switches input/output of the I/O display LED.
[9]	Output connector	Connector for connecting output signal cables. For details on the terminal layout, refer to  Page 39 Terminal Layout.
[10]	DIN rail mounting hook	Hook for mounting a CPU module on a DIN rail of DIN46277 (35 mm wide).
[11]	Input terminal	Terminals for input. For details on the terminal layout, refer to  Page 39 Terminal Layout.
[12]	Input display LED	Lit when input is on.
[13]	Output display LED	Lit when output is on.
[14]	Output terminal	Terminals for output. For details on the terminal layout, refer to  Page 39 Terminal Layout.
[15]	SD memory card disable switch	Switch for disabling access to the SD memory card when the card is to be removed.
[16]	SD memory card slot	Slot for inserting an SD memory card.
[17]	RUN/STOP/RESET switch	Switch for operating the CPU module. ( Page 143 Methods of running, stopping, and resetting) RUN: Runs the program STOP: Stops the program RESET: Resets the CPU module (hold the switch on the RESET side for approximately 1 second.)

Side

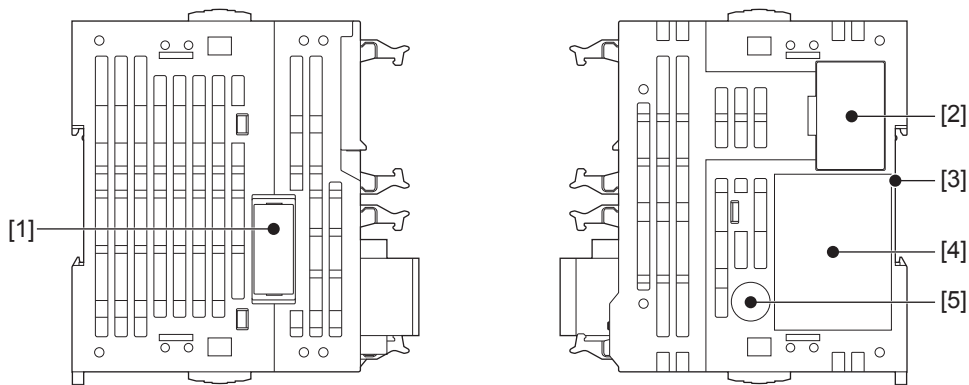
Left side/right side





No.	Name	Description
[1]	Expansion adapter connector cover	Cover for protecting the expansion adapter connector.
[2]	Subsequent extension connector cover	Cover for protecting the subsequent extension connector.
[3]	DIN rail mounting groove	The module can be installed on a DIN46277 rail (35 mm wide).
[4]	Nameplate printing	The product model name, manufacturer's serial number, power supply specifications, and MAC address are shown.  is a mark that instructs to use the cable with an appropriate temperature rating (80°C or more) for wiring.
[5]	Genuine product certification label	Genuine product certification label to prevent counterfeiting

Point

Products that do not have the genuine product certification label or nameplate are not covered by the warranty.

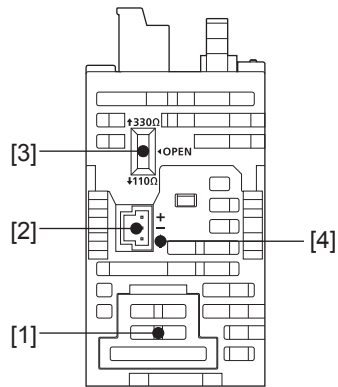
Bottom side



No.	Name	Description
[1]	Battery cover	Cover for protecting the battery connecting connector.
[2]	Power connector for CPU module	Connector for connecting power cables.
[3]	RS-485 terminal resistor selector switch	Switch for switching terminal resistance for built-in RS-485 communication.
[4]	Terminal names	 shows a function grounding terminal.

Point



Use a tool such as a screwdriver to operate the RS-485 terminal resistance selector switch. Make sure that the tip of a tool does not damage the switch or case.

2 SPECIFICATIONS

The CPU module specifications are explained below.

2.1 Generic Specifications

Item	Specifications				
Operating ambient temperature ^{*1}	-20 to 55°C, non-freezing ^{*2,3}				
Storage ambient temperature	-25 to 75°C, non-freezing				
Operating ambient humidity	5 to 95%RH, non-condensation ^{*4}				
Storage ambient humidity	5 to 95%RH, non-condensation				
Vibration resistance ^{*5,6}	—	Frequency	Acceleration	Half amplitude	Sweep count
	Installed on DIN rail	5 to 8.4 Hz	—	1.75 mm	10 times each in X, Y, Z directions (80 min in each direction)
8.4 to 150 Hz		4.9 m/s ²	—		
Shock resistance ^{*5}	147 m/s ² , Action time: 11 ms, 3 times by half-sine pulse in each direction X, Y, and Z				
Noise durability ^{*7}	By noise simulator at noise voltage of 1000 Vp-p, noise width of 1 μs and period of 30 to 100 Hz				
Grounding	Class D grounding (grounding resistance: 100 Ω or less) <Common grounding with a heavy electrical system is not allowed.> ^{*8}				
Working atmosphere	Free from corrosive or flammable gas and excessive conductive dust				
Operating altitude ^{*9}	0 to 2000 m				
Installation location	Inside a control panel ^{*10}				
Overvoltage category ^{*11}	II or less				
Pollution degree ^{*12}	2 or less				

- *1 The simultaneous ON ratio of available PLC inputs or outputs changes with respect to the ambient temperature, refer to  Page 34 Input/Output Derating Curve.
- *2 The operating ambient temperature is 0 to 55°C for products manufactured before June 2016. For details on Intelligent function modules and FX5 safety extension modules, refer to manuals of each product.
- *3 In the case where operating ambient temperature is lower than 0°C, the specifications are different from the above description. For details, refer to  Page 163 Precautions for Operating Ambient Temperature.
- *4 When used in a low-temperature environment, use in an environment with no sudden temperature changes. If there are sudden temperature changes because of opening/closing of the control panel or other reasons, condensation may occur, which may cause a fire, fault, or malfunction. Furthermore, use an air conditioner in dehumidifier mode to prevent condensation.
- *5 The criterion is shown in IEC61131-2.
- *6 When the system has equipment which specification values are lower than above mentioned vibration resistance specification values, the vibration resistance specification of the whole system is corresponding to the lower specification.
- *7 When using the FX5 safety extension modules under the severe noise environment, implement external noise countermeasures with a surge absorber and ferrite core.
- *8 For grounding, refer to  Page 103 Grounding.
- *9 The PLC cannot be used at a pressure higher than the atmospheric pressure to avoid damage.
- *10 The programmable controller is assumed to be installed in an environment equivalent to indoor.
- *11 This indicates the section of the power supply to which the equipment is assumed to be connected between the public electrical power distribution network and the machinery within premises. Category II applies to equipment for which electrical power is supplied from fixed facilities. The withstand surge voltage for the equipment with the rated voltage up to 300 V is 2500 V.
- *12 This index indicates the degree to which conductive material is generated in the environment in which the equipment is used. Pollution level 2 is when only non-conductive pollution occurs. Temporary conductivity caused by condensation must be expected occasionally.

Dielectric withstand voltage test and insulation resistance test

Perform dielectric withstand voltage test and insulation resistance test at the following voltages between each terminal and the CPU module ground terminal.

■ CPU module, I/O module

Between terminals	Dielectric withstand voltage	Insulation resistance	Remarks
Between power supply terminal (24 V DC) and ground terminal	500 V AC for one minute	10 MΩ or higher by 500 V DC insulation resistance tester	—
Between input terminal (24 V DC) and ground terminal			—
Between output terminal (transistor) and ground terminal			—
Between output terminal (relay) and ground terminal	1.5 kV AC for one minute		—

■Expansion adapter

For information concerning the dielectric withstand voltage and insulation resistance of each expansion adapter, refer to manuals of each expansion adapter.

■Intelligent function module, FX5 safety extension module

For information concerning dielectric withstand voltage and insulation resistance of the following modules, refer to the user's manuals of each module.

- Intelligent function module
- FX5 safety extension module

2.2 Power Supply Specifications

The CPU module power supply specifications are explained below.

For the consumption current of each extension module, refer to  Page 42 PRODUCT LIST or manuals of each extension module.

DC power supply

Item		Specifications
Power supply voltage		24 V DC
Voltage fluctuation range		+20%, -15%
Allowable instantaneous power failure time ^{*2}		Operation can be continued upon occurrence of instantaneous power failure for 5 ms or less.
Power fuse		125 V, 3.15 A Time-lag fuse
Rush current	FX5UC-32M□/□	35 A max. 0.5 ms or less/24 V DC
	FX5UC-64MT/□	40 A max. 0.5 ms or less/24 V DC
	FX5UC-96MT/□	
Power consumption ^{*1}	FX5UC-32M□/□	5 W/24 V DC [30 W/24 V DC +20%, -15%]
	FX5UC-64MT/□	8 W/24 V DC [33 W/24 V DC +20%, -15%]
	FX5UC-96MT/□	11 W/24 V DC [36 W/24 V DC +20%, -15%]
24 V DC power supply capacity		500 mA
5 V DC power supply capacity		720 mA

*1 This item shows value when only the CPU module is used.

The value in [] is the value in the maximum configuration connectable to the CPU module. (The value does not include the external 24 V DC power supply of extension devices)

*2 The FX5 safety extension module is not subject to the allowable momentary power failure time.

Point

The following shows the power failure detection time of the FX5UC CPU module.

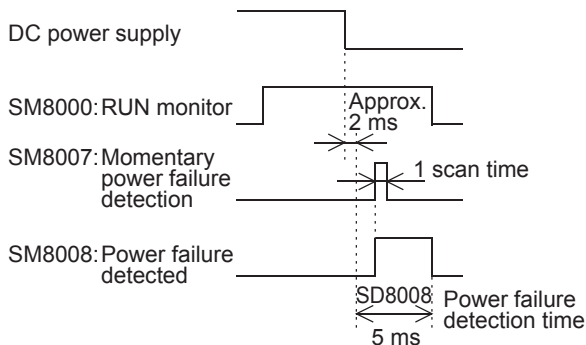



2.3 Input Specifications

The CPU module input specifications are explained below.

24 V DC input (sink/source)

Input numbers in the table indicate the CPU module numbers.

Item		Specifications	
No. of input points	FX5UC-32M□/□	16 points	
	FX5UC-64MT/□	32 points	
	FX5UC-96MT/□	48 points	
Connection type	FX5UC-□MT/D(SS)	Connector	
	FX5UC-32M□/□-TS	Spring clamp terminal block	
Input type	FX5UC-□MT/D	Sink	
	FX5UC-□M□/DS□	Sink/source	
Input signal voltage		24 V DC +20%, -15%	
Input signal current	X0 to X17	5.3 mA/24 V DC	
	X20 and subsequent	4.0 mA/24 V DC	
Input impedance	X0 to X17	4.3 kΩ	
	X20 and subsequent	5.6 kΩ	
ON input sensitivity current	X0 to X17	3.5 mA or more	
	X20 and subsequent	3.0 mA or more	
OFF input sensitivity current		1.5 mA or less	
Input response frequency	FX5UC-32M□/□	X0 to X5	200 kHz
	FX5UC-64MT/□, FX5UC-96MT/□	X0 to X7	When capturing pulses of a response frequency of 50 to 200 kHz, refer to  Page 110 When a high-speed pulse is captured.
	FX5UC-32M□/□	X6 to X17	10 kHz
	FX5UC-64MT/□, FX5UC-96MT/□	X10 to X17	
	FX5UC-64MT/□, FX5UC-96MT/□	X20 and subsequent	0.1±0.05 kHz
Pulse waveform	Waveform		
			T1 (pulse width)
			T2 (rise/fall time)
	FX5UC-32M□/□	X0 to X5	2.5 μs or more
	FX5UC-64MT/□, FX5UC-96MT/□	X0 to X7	
	FX5UC-32M□/□	X6 to X17	50 μs or more
FX5UC-64MT/□, FX5UC-96MT/□	X10 to X17		
Input response time (H/W filter delay)	FX5UC-32M□/□	X0 to X5	ON: 2.5 μs or less OFF: 2.5 μs or less
	FX5UC-64MT/□, FX5UC-96MT/□	X0 to X7	
	FX5UC-32M□/□	X6 to X17	ON: 30 μs or less OFF: 50 μs or less
	FX5UC-64MT/□, FX5UC-96MT/□	X10 to X17	
	FX5UC-64MT/□, FX5UC-96MT/□	X20 and subsequent	ON: 50 μs or less OFF: 150 μs or less
Input response time (Digital filter setting value)		None, 10 μs, 50 μs, 0.1 ms, 0.2 ms, 0.4 ms, 0.6 ms, 1 ms, 5 ms, 10 ms (initial value), 20 ms, 70 ms When using this product in an environment with much noise, set the digital filter.	

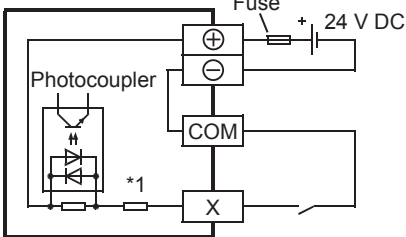
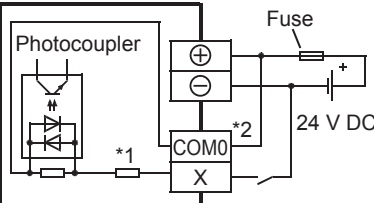
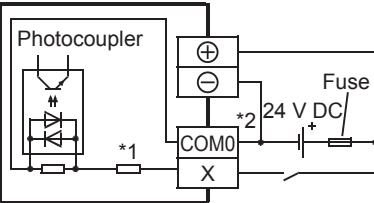
Item	Specifications		
Input signal format (Input sensor form)	FX5UC-□MT/D	No-voltage contact input NPN open collector transistor	
	FX5UC-□M□/DS□	No-voltage contact input Sink: NPN open collector transistor Source: PNP open collector transistor	
Input circuit insulation	Photo-coupler insulation		
Indication of input operation	FX5UC-□MT/D(SS)	LED is lit when input is on (DISP switch: IN)	
	FX5UC-32M□/□-TS	LED is lit when input is on	
Input circuit configuration	FX5UC-□MT/D	 <p style="text-align: center;">*1: Input impedance</p>	
	FX5UC-□M□/DS□	<p>• Sink input wiring</p>  <p>*1 Input impedance *2 For spring clamp terminal block type, the [COM0] terminal is the [S/S] terminal.</p>	<p>• Source input wiring</p>  <p>*1 Input impedance *2 For spring clamp terminal block type, the [COM0] terminal is the [S/S] terminal.</p>

2.4 Output Specifications

The CPU module output specifications are explained below.

Transistor output

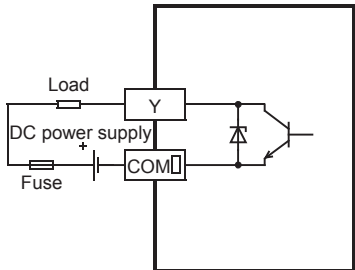
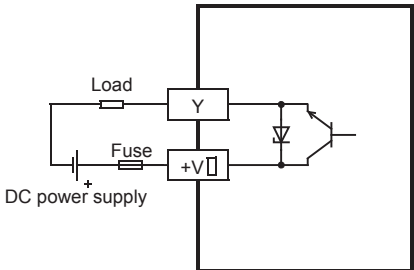
Item		Output specifications	
No. of output points	FX5UC-32MT/□	16 points	
	FX5UC-64MT/□	32 points	
	FX5UC-96MT/□	48 points	
Connection type	FX5UC-□MT/D(SS)	Connector	
	FX5UC-32MT/DS(S)-TS	Spring clamp terminal block	
Output type	FX5UC-□MT/D(S-TS)	Transistor/sink output	
	FX5UC-□MT/DSS(-TS)	Transistor/source output	
External power supply		5-30 V DC	
Max. load	Y0 to Y3	0.3 A/point	The total load current per common terminal should be the following value. • 8 output points/common terminal: 0.8 A or less*1 For details of the common, refer to Page 39 Terminal Layout.
	Y4 and subsequent	0.1 A/point	
Open circuit leakage current		0.1 mA or less/30 V DC	
Voltage drop when ON	Y0 to Y3	1.0 V or less	
	Y4 and subsequent	1.5 V or less	
Response time	Y0 to Y3	2.5 μs or less/10 mA or more (5-24 V DC)	
	Y4 and subsequent	0.2 ms or less/100 mA (24 V DC)	
Output circuit insulation		Photo-coupler insulation	
Indication of output operation	FX5UC-□MT/D(SS)	LED is lit when output is on (DISP switch: OUT)	
	FX5UC-32MT/DS(S)-TS	LED is lit when output is on	
Output circuit configuration		Sink output wiring  A common number is input in the □ of [COM].	Source output wiring  A common number is input in the □ of [+V].

*1 When two common terminals are connected outside the CPU module, resistance load is 1.6 A or less.

Relay output

Item		Output Specifications
No. of output points	FX5UC-32MR/DS-TS	16 points
Connection type		Spring clamp terminal block
Output type		Relay
External power supply		30 V DC or less 240 V AC or less ("250 V AC or less" if not a CE, UL, cUL compliant item)
Max. load		2 A/point The total load current per common terminal should be the following value. • 8 output points/common terminal: 4 A or less* ¹ For details on the common, refer to Page 39 Terminal Layout.
Min. load		5 V DC, 2 mA (reference values)
Open circuit leakage current		—
Response time	OFF→ON	Approx. 10 ms
	ON→OFF	Approx. 10 ms
Output circuit insulation		Mechanical insulation
Indication of output operation		LED is lit when output is on

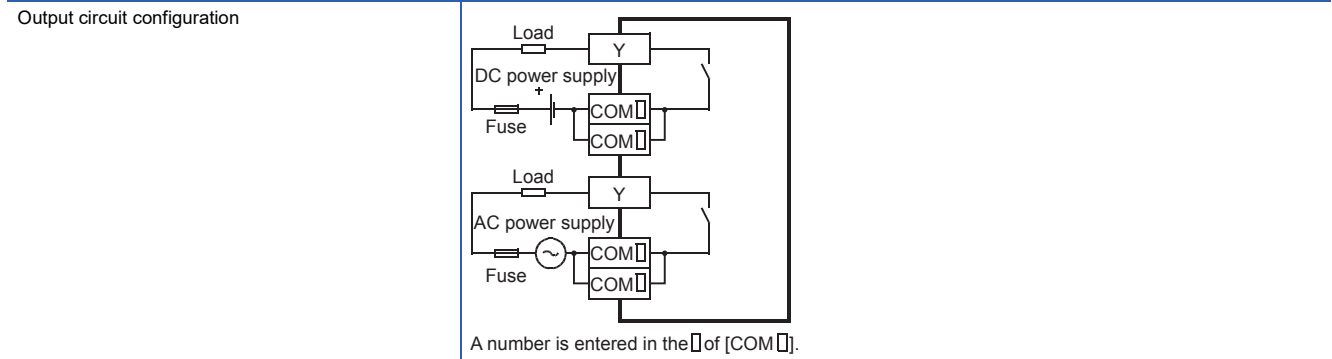

*1 When two common terminals are connected outside the CPU module, resistance load is 8 A or less.

2.5 Input/Output Derating Curve

The derating curve below shows the simultaneous ON ratio of available PLC inputs or outputs with respect to the ambient temperature. Use the PLC within the simultaneous input or output ON ratio range shown in the figure.

Derating curve

Simultaneous ON ratio

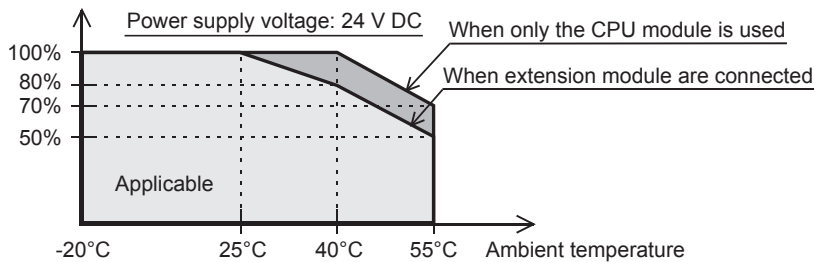

2.6 Performance Specifications

Item		Specifications
Control system		Stored-program repetitive operation
Input/output control system		Refresh system (Direct access input/output allowed by specification of direct access input/output [DX, DY])
Programming specifications	Programming language	Ladder diagram (LD), structured text (ST), function block diagram/ladder diagram (FBD/LD), sequential function chart (SFC) ^{*1}
	Programming extension function	Function block (FB), function (FUN), label programming (local/global)
	Constant scan	0.2 to 2000 ms (can be set in 0.1 ms increments)
	Fixed cycle interrupt	1 to 60000 ms (can be set in 1 ms increments)
	Timer performance specifications	100 ms, 10 ms, 1 ms
	No. of program executions	32
	No. of FB files	16 (Up to 15 for user)
Operation specifications	Execution type	Standby type, initial execution type, scan execution type, fixed-cycle execution type, event execution type
	Interrupt type	Internal timer interrupt, input interrupt, high-speed comparison match interrupt, interrupt by modules ^{*2}
Command processing time	LD X0	34 ns ^{*3}
	MOV D0 D1	34 ns ^{*3}
Memory capacity	Program capacity	64 k steps/128 k steps ^{*1} (128 kbytes/256 kbytes, flash memory)
	SD memory card	Memory card capacity (SD/SDHC memory card: Max. 16 Gbytes)
	Device/label memory	150 kbytes ^{*1}
	Data memory/standard ROM	5 Mbytes
Flash memory (Flash ROM) write count		Maximum 20000 times
File storage capacity	Device/label memory	1
	Data memory P: No. of program files FB: No. of FB files	P: 32, FB: 16
	SD Memory Card	NZ1MEM-2GBSD: 511 ^{*4} NZ1MEM-4GBSD, NZ1MEM-8GBSD, NZ1MEM-16GBSD: 65534 ^{*4}
Clock function	Display data	Year, month, day, hour, minute, second, day of week (leap year automatic detection)
	Precision	Differences per month ± 45 sec./25°C (TYP)
Power failure retention (clock data ^{*5})	Retention method	Large-capacity capacitor
	Retention time	10 days (Ambient temperature: 25°C)
No. of input/output points	(1) No. of input/output points	256 points or less/384 points or less ^{*1}
	(2) No. of remote I/O points	384 points or less/512 points or less ^{*1}
	Total No. of points of (1) and (2)	512 points or less
Power failure retention (device)	Power failure retention capacity	Maximum 12 k word ^{*6}

*1 For supported versions, refer to  Page 203 Added and Changed Functions.

*2 Interrupt from the intelligent function module and high-speed pulse input/output module.

*3 When the program capacity is 64 k steps.

*4 The value listed above indicates the number of files stored in the root folder.

*5 Clock data is retained using the power accumulated in a large-capacity capacitor incorporated into the PLC. When voltage of the large-capacity capacitor drops, clock data is no longer accurately retained. The retention period of a fully charged capacitor (electricity is conducted across the PLC for at least 30 minutes) is 10 days (ambient temperature: 25°C). How long the capacitor can hold the data depends on the operating ambient temperature. When the operating ambient temperature is high, the holding period is short.

*6 It is possible to back up all devices in device (high-speed) area. When a battery is used, it is also possible to back up devices in device (standard) area.

Number of device points

Item		Base	Max. number of points		
No. of user device points	Input relay (X)	8	1024 points	The total number of X and Y assigned to input/output points is up to 256 points/384 points ^{*1} .	
	Output relay (Y)	8	1024 points		
	Internal relay (M)	10	32768 points (can be changed with parameter) ^{*2}		
	Latch relay (L)	10	32768 points (can be changed with parameter) ^{*2}		
	Link relay (B)	16	32768 points (can be changed with parameter) ^{*2}		
	Annunciator (F)	10	32768 points (can be changed with parameter) ^{*2}		
	Link special relay (SB)	16	32768 points (can be changed with parameter) ^{*2}		
	Step relay (S)	10	4096 points (fixed)		
	Timer system	Timer (T)	10	1024 points (can be changed with parameter) ^{*2}	
	Accumulation timer system	Accumulation timer (ST)	10	1024 points (can be changed with parameter) ^{*2}	
	Counter system	Counter (C)	10	1024 points (can be changed with parameter) ^{*2}	
		Long counter (LC)	10	1024 points (can be changed with parameter) ^{*2}	
	Data register (D)		10	8000 points (can be changed with parameter) ^{*2}	
	Link register (W)		16	32768 points (can be changed with parameter) ^{*2}	
	Link special register (SW)		16	32768 points (can be changed with parameter) ^{*2}	
No. of system device points	Special relay (SM)	10	10000 points (fixed)		
	Special register (SD)	10	12000 points (fixed)		
Module access device	Intelligent function module device	10	65536 points (designated by U□\G□)		
No. of index register points	Index register (Z) ^{*3}	10	24 points		
	Long index register (LZ) ^{*3}	10	12 points		
No. of file register points	File register (R)	10	32768 points (can be changed with parameter) ^{*2}		
	Extended file register (ER)	10	32768 points (are stored in SD memory card)		
No. of nesting points	Nesting (N)	10	15 points (fixed)		
No. of pointer points	Pointer (P)	10	4096 points		
	Interrupt pointer (I)	10	178 points (fixed)		
No. of SFC points	SFC block device (BL)	10	32 points		
	SFC transition device (TR)	10	0 points (Used only as device comments.)		
Others	Decimal constant (K)	Signed	— 16 bits: -32768 to +32767, 32 bits: -2147483648 to +2147483647		
		Unsigned	— 16 bits: 0 to 65535, 32 bits: 0 to 4294967295		
	Hexadecimal constant (H)	— 16 bits: 0 to FFFF, 32 bits: 0 to FFFFFFFF			
	Real constant (E)	Single precision	— E-3.40282347+38 to E-1.17549435-38, 0, E1.17549435-38 to E3.40282347+38		
	Character string		— Shift-JIS code: Max. 255 single-byte characters (256 including NULL) Unicode max. 255 characters (256 including NULL) ^{*1}		

*1 For supported versions, refer to  Page 203 Added and Changed Functions.

*2 Can be changed with parameters within the capacity range of the CPU built-in memory.

*3 The sum of index register (Z) and long index register (LZ) is 24 words.

2.7 Communication Specifications

The built-in Ethernet and built-in RS-485 communication specifications are as explained below.

Built-in Ethernet communication

For details of built-in Ethernet communication, refer to the following.

📖 MELSEC iQ-F FX5 User's Manual (MODBUS Communication)

📖 MELSEC iQ-F FX5 User's Manual (Ethernet Communication)

📖 MELSEC iQ-F FX5 User's Manual (SLMP)

📖 CC-Link IE Field Network Basic Reference Manual

Item		Specifications
Data transmission speed		100/10 Mbps
Communication mode		Full-duplex (FDX)/ Half-duplex (HDX) ^{*1}
Interface		RJ45 connector
Transmission method		Base band
Maximum segment length (The distance between hub and node)		100 m
Cascade connection	100BASE-TX	Max. 2 stages ^{*2}
	10BASE-T	Max. 4 stages ^{*2}
Protocol type		CC-Link IE field network Basic, MELSOFT connection, SLMP (3E/1E frame), Socket communication, Predefined protocol support, FTP server, FTP client, MODBUS/TCP communication, SNMP client, Web server (HTTP), Simple CPU communication function
Number of simultaneously open connections allowed		Total of 8 connections ^{*3*4} (Up to 8 external devices can access one CPU module at the same time.)
Hub ^{*1}		Hubs with 100BASE-TX or 10BASE-T ports can be used.
Insulation method		Pulse transformer insulation
IP address ^{*5}		Initial value: 192.168.3.250
Cable used ^{*6}	For 100BASE-TX connection	Ethernet standard-compatible cable, category 5 or higher (STP cable)
	For 10BASE-T connection	Ethernet standard-compatible cable, category 3 or higher (STP cable)

*1 IEEE802.3x flow control is not supported.

*2 Number of stages that can be connected when a repeater hub is used. When a switching hub is used, check the specifications of the switching hub used.

*3 The first device for MELSOFT connection is not included in the number of connections. (The second and the following devices are included.)

*4 The CC-Link IE field network Basic, FTP server, FTP client, SNMP client, Web server and simple CPU communication function are not included in the number of connections.

*5 If the first octet is 0 or 127, a parameter error (2222H) will occur. (Example: 0.0.0.0, 127.0.0.0, etc.)

*6 A straight cable can be used. If a personal computer or GOT and CPU module are directly connected a cross cable can be used.

Built-in RS-485 communication

For details of built-in RS-485 communication, refer to the following.

- 📖 MELSEC iQ-F FX5 User's Manual (Serial Communication)
- 📖 MELSEC iQ-F FX5 User's Manual (MELSEC Communication Protocol)
- 📖 MELSEC iQ-F FX5 User's Manual (MODBUS Communication)

Item	Specifications
Transmission standards	Conforms to RS-485/RS-422 specifications
Data transmission speed	Max. 115.2 kbps
Communication method	Full-duplex (FDX) / Half-duplex (HDX)
Maximum total extension distance	50 m
Protocol type	MELSOFT connection, Non-protocol communication, MELSEC communication protocol (1C/3C/4C frames), MODBUS RTU, Predefined protocol support, Inverter communication, N:N network, Parallel link
Insulation method	Not insulated
Terminal resistors	Built-in (OPEN/110 Ω/330 Ω)
Terminal block used	European-type terminal block

2.8 External Dimensions

CPU module

Connector type

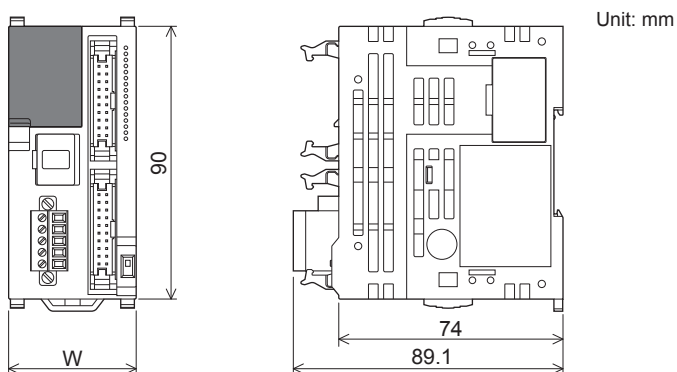

Model	W	Mass (weight)
FX5UC-32MT/D FX5UC-32MT/DSS	42.1 mm	Approx. 0.2 kg
FX5UC-64MT/D FX5UC-64MT/DSS	62.2 mm	Approx. 0.3 kg
FX5UC-96MT/D FX5UC-96MT/DSS	82.3 mm	Approx. 0.35 kg

- Exterior color...Main body: Munsell 0.6B7.6/0.2
- Accessories...Manual supplied with product, FX2NC-100MPCB power cable: 1 m, FX2NC-100BPCB power cable: 1 m(FX5UC-□MT/D only)

Spring clamp terminal block type

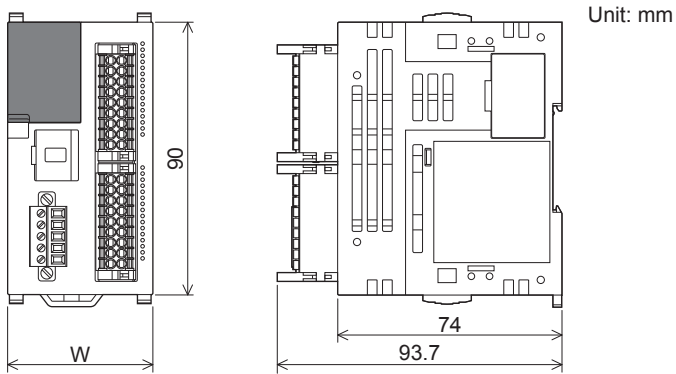

Model	W	Mass (weight)
FX5UC-32MT/DS-TS FX5UC-32MT/DSS-TS	48.1 mm	Approx. 0.25 kg
FX5UC-32MR/DS-TS	68.2 mm	Approx. 0.35 kg

- Exterior color...Main body: Munsell 0.6B7.6/0.2
- Accessories...Manual supplied with product, FX2NC-100MPCB power cable: 1 m

2.9 Terminal Layout

Built-in RS-485 terminal

European-type terminal block

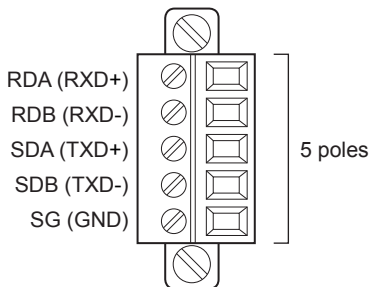

Built-in Ethernet connector

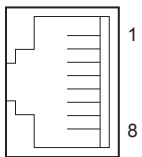

Pin	Signal name
1	TXD+
2	TXD-
3	RXD+
4	Not used
5	Not used
6	RXD-
7	Not used
8	Not used

Input/output connectors

FX5UC-32MT/D

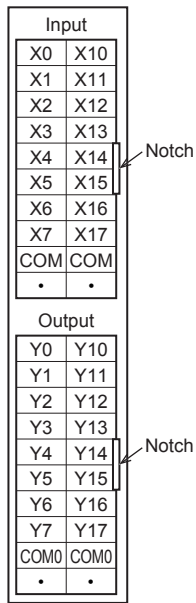

FX5UC-32MT/DSS

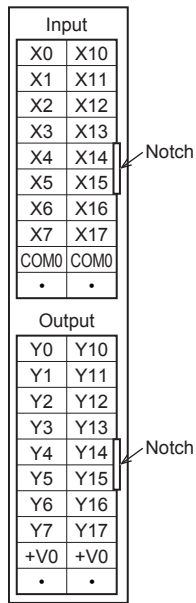

FX5UC-64MT/D

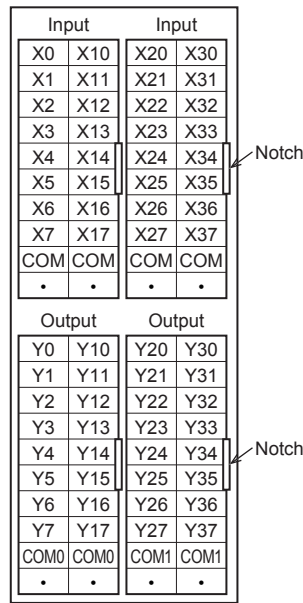

FX5UC-64MT/DSS

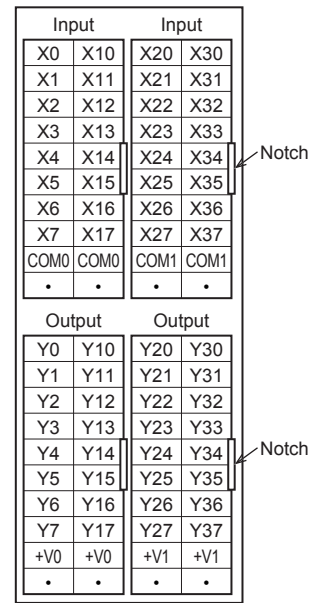

FX5UC-96MT/D

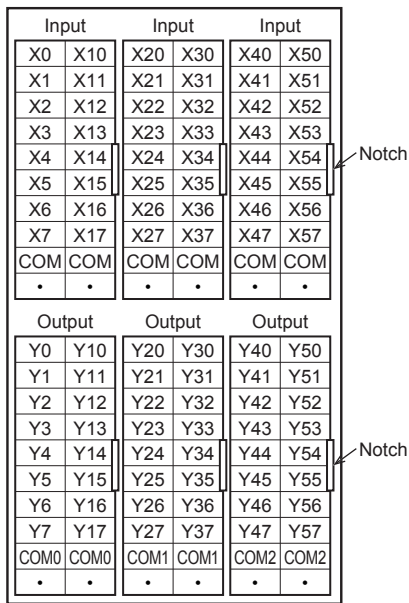

FX5UC-96MT/DSS

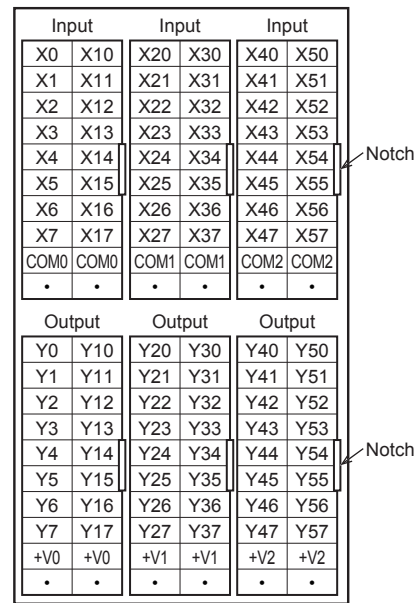

Input/output terminal

FX5UC-32MT/DS-TS

Input	
X0	X10
X1	X11
X2	X12
X3	X13
X4	X14
X5	X15
X6	X16
X7	X17
S/S	S/S
Output	
Y0	Y10
Y1	Y11
Y2	Y12
Y3	Y13
Y4	Y14
Y5	Y15
Y6	Y16
Y7	Y17
COM0	COM0

FX5UC-32MT/DSS-TS

Input	
X0	X10
X1	X11
X2	X12
X3	X13
X4	X14
X5	X15
X6	X16
X7	X17
S/S	S/S
Output	
Y0	Y10
Y1	Y11
Y2	Y12
Y3	Y13
Y4	Y14
Y5	Y15
Y6	Y16
Y7	Y17
+V0	+V0

FX5UC-32MR/DS-TS

Input*1		Input*1	
X0	X0	X10	X10
X1	X1	X11	X11
X2	X2	X12	X12
X3	X3	X13	X13
X4	X4	X14	X14
X5	X5	X15	X15
X6	X6	X16	X16
X7	X7	X17	X17
S/S0	S/S0	S/S1	S/S1
Output*1		Output*1	
Y0	Y0	Y10	Y10
Y1	Y1	Y11	Y11
Y2	Y2	Y12	Y12
Y3	Y3	Y13	Y13
Y4	Y4	Y14	Y14
Y5	Y5	Y15	Y15
Y6	Y6	Y16	Y16
Y7	Y7	Y17	Y17
COM0	COM0	COM1	COM1

*1 Terminals with the same name (X0 and X0, Y0 and Y0, etc.) are internally connected.

Power connector

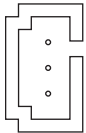

- 1 ⊕ (Red)
- 2 ⊖ (Black)
- 3 Ground (Green)

3 PRODUCT LIST

The following shows the system configuration equipment of the FX5UC.

3.1 Overall Configuration

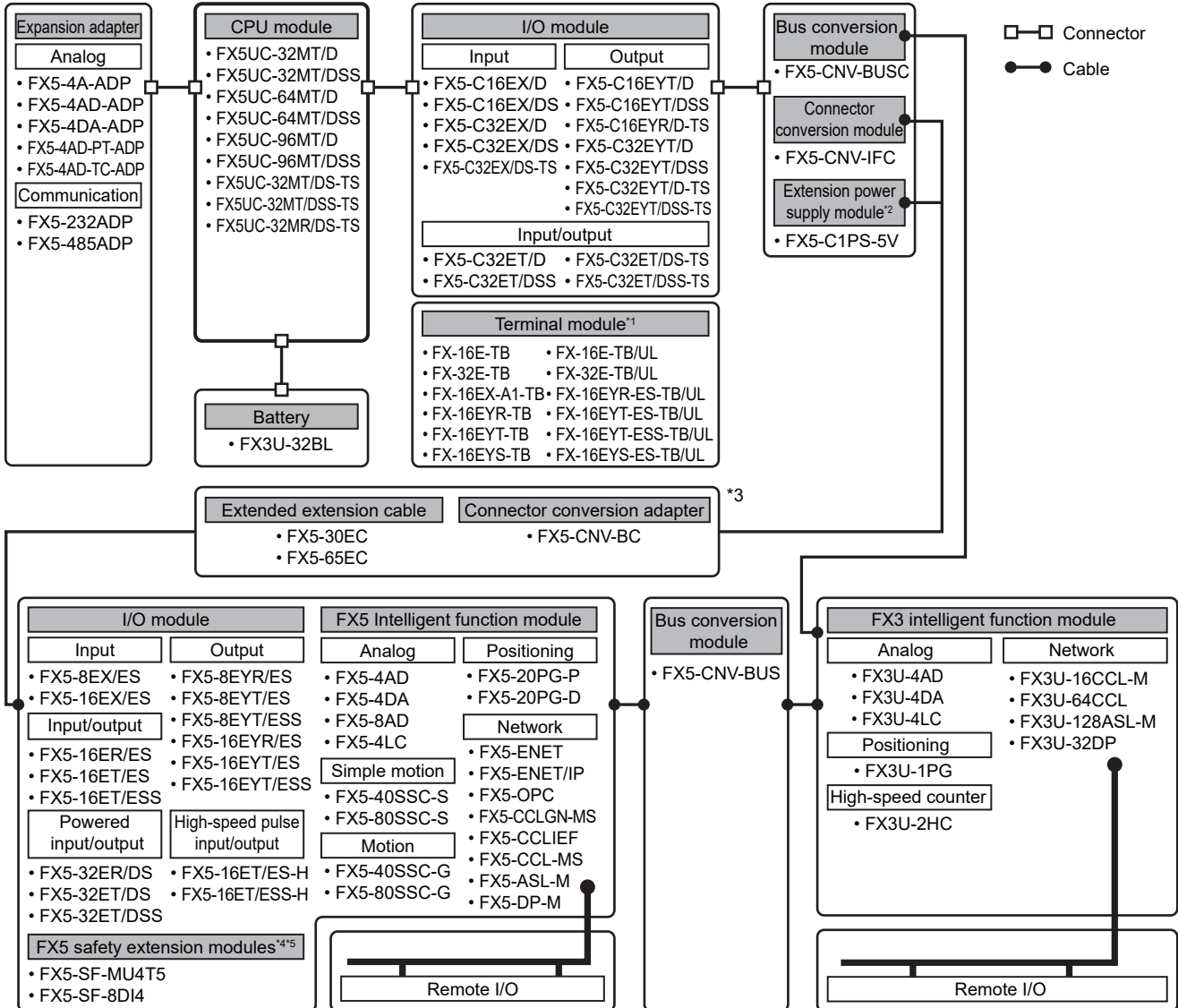

- *1 Terminal module is used when the input/output connection type of a CPU module or an I/O module is a connector.
- *2 The extension connector of the extension power supply module can use either connector connection or cable connection. When using connector connection, an extension connector type module can be connected.
- *3 Use this to connect a module (extension cable type) located distantly or on a second stage. The connector conversion adapter (FX5-CNV-BC) is required when the connection destination is a module of extension cable type (except for extension power supply module). When also using a bus conversion module in the same system, connect the powered input/output module directly after the extended extension cable.
- *4 When the FX5 safety extension module is connected, the extension module cannot be connected to the subsequent (right side). Also, the FX5 safety extension module cannot be used together with a motion module (FX5-40SSC-G, FX5-80SSC-G) with firmware version "1.000". For the restrictions when using additional equipment, refer to Page 55 Limitations when using extension devices.
- *5 When using the FX5 safety extension module together with an extension module that requires external power supply, there are restrictions on the order in which the power is supplied. For details, refer to Page 104 Power Supply Wiring.

3.2 CPU Module

The CPU module incorporates a CPU, memory, input/output terminals, and power supply.

FX5UC – ○ ○ M □ / □

Total number of input/output points

CPU module

Power supply, input/output type: The module having "TS" in the model name is the spring clamp terminal block type.

- T/D: DC power supply/24 V DC (sink) input/Transistor (sink) output
- T/DSS(-TS): DC power supply/24 V DC (sink/source) input/Transistor (source) output
- T/DS-TS: DC power supply/24 V DC (sink/source) input/Transistor (sink) output
- R/DS-TS: DC power supply/24 V DC (sink/source) input/Relay output

3

24 V DC sink and source input type

Model	No. of input/output points			Input type	Output type	Input/output connection type	Power supply capacity			
	Total No. of points	No. of input points	No. of output points				5 V DC power supply	24 V DC power supply		
FX5UC-32MT/D	32 points	16 points	16 points	24 V DC (sink)	Transistor (sink)	Connector	720 mA	500 mA		
FX5UC-32MT/DSS				24 V DC (sink/source)	Transistor (source)					
FX5UC-32MT/DS-TS				Transistor (sink)	Spring clamp terminal block					
FX5UC-32MT/DSS-TS				Transistor (source)						
FX5UC-32MR/DS-TS				Relay						
FX5UC-64MT/D	64 points	32 points	32 points	24 V DC (sink)	Transistor (sink)	Connector	720 mA	500 mA		
FX5UC-64MT/DSS				24 V DC (sink/source)	Transistor (source)					
FX5UC-96MT/D	96 points	48 points	48 points	24 V DC (sink)	Transistor (sink)	Connector			720 mA	500 mA
FX5UC-96MT/DSS				24 V DC (sink/source)	Transistor (source)					

Point

The model name of the CPU module can be checked on the nameplate on the right side. After extension devices are connected, the nameplate cannot be seen. Check the model name in the following places.

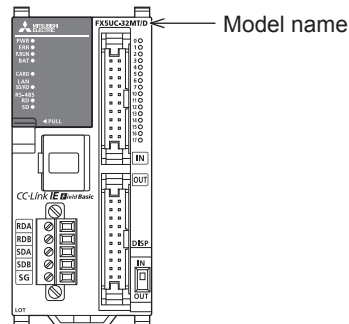

3.3 Extension Module

Extension modules are used to expand inputs/outputs, functions, and others.

The two connection types, extension connector type and extension cable type, are provided for extension modules.

- Extension connector type
- Extension cable type

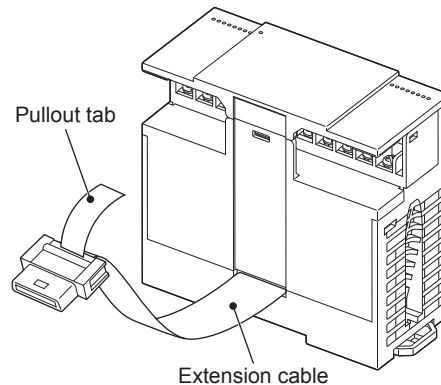
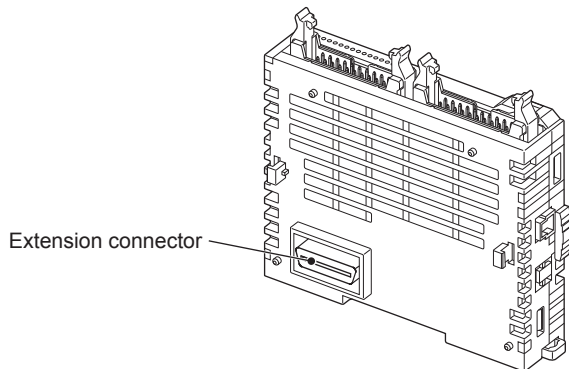

FX5-CNV-IFC or FX5-C1PS-5V is required to use modules of extension cable type.

I/O module

I/O modules are used to expand inputs/outputs.

For details, refer to [Page 164 I/O Module](#).

FX5 — △ ○ ○ E □ / □

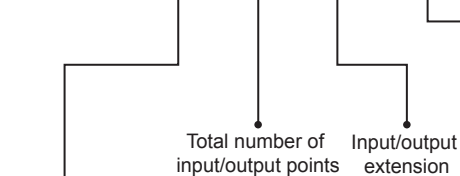

Connection type of extension module

- No symbol: Extension cable
- C: Extension connector

Input/output type: The module having "TS" in the model name is the spring clamp terminal block type.

Input module

- X/D: 24 V DC (sink) input
- X/DS(-TS): 24 V DC (sink/source) input
- X/ES: 24 V DC (sink/source) input

Output module

- YT/D(-TS): Transistor (sink) output
- YT/DSS(-TS): Transistor (source) output
- YR/D-TS: Relay output
- YR/ES: Relay output
- YT/ES: Transistor (sink) output
- YT/ESS: Transistor (source) output

Input/output module

- T/D: 24 V DC (sink) input/Transistor (sink) output
- T/DSS(-TS): 24 V DC (sink/source) input/Transistor (source) output
- T/DS-TS: 24 V DC (sink/source) input/Transistor (sink) output
- R/ES: 24 V DC (sink/source) input/relay output
- T/ES: 24 V DC (sink/source) input/transistor (sink) output
- T/ESS: 24 V DC (sink/source) input/transistor (source) output

Powered input/output module

- R/DS: DC power supply/24 V DC (sink/source) input/relay output
- T/DS: DC power supply/24 V DC (sink/source) input/transistor (sink) output
- T/DSS: DC power supply/24 V DC (sink/source) input/transistor (source) output

High-speed pulse input/output module

- T/ES-H: 24 V DC (sink/source) input/Transistor (sink) output
- T/ESS-H: 24 V DC (sink/source) input/Transistor (source) output

Input module

Input modules are used to expand inputs.

■ Extension connector type

Model	Number of input/output points			Input type	Output type	Input/output connection type	Current consumption		
	Total No. of points	No. of input points	No. of output points				5 V DC power supply	24 V DC power supply	External 24 V DC power supply (24 V DC power supply for input circuits)
FX5-C16EX/D	16 points	16 points	—	24 V DC (sink)	—	Connector	100 mA	—	65 mA
FX5-C16EX/DS				24 V DC (sink/source)					
FX5-C32EX/D	32 points	32 points	—	24 V DC (sink)	—	Connector	120 mA	—	130 mA
FX5-C32EX/DS				24 V DC (sink/source)					
FX5-C32EX/DS-TS				Spring clamp terminal block					

■ Extension cable type

Model	Number of input/output points			Input type	Output type	Input/output connection type	Current consumption		
	Total No. of points	No. of input points	No. of output points				5 V DC power supply	24 V DC power supply	External 24 V DC power supply (24 V DC power supply for input circuits)
FX5-8EX/ES	8 points	8 points	—	24 V DC (sink/source)	—	Screw terminal block	75 mA	—	50 mA
FX5-16EX/ES	16 points	16 points					100 mA		85 mA

Output module

Output modules are used to expand outputs.

■ Extension connector type

Model	Number of input/output points			Input type	Output type	Input/output connection type	Current consumption		
	Total No. of points	No. of input points	No. of output points				5 V DC power supply	24 V DC power supply	
FX5-C16EYT/D	16 points	—	16 points	—	Transistor (sink)	Connector	100 mA	100 mA	
FX5-C16EYT/DSS					Transistor (source)				
FX5-C16EYR/D-TS					Relay				Spring clamp terminal block
FX5-C32EYT/D	32 points	—	32 points	—	Transistor (sink)	Connector	120 mA	200 mA	
FX5-C32EYT/DSS					Transistor (source)				
FX5-C32EYT/D-TS					Transistor (sink)				Spring clamp terminal block
FX5-C32EYT/DSS-TS					Transistor (source)				

■ Extension cable type

Model	Number of input/output points			Input type	Output type	Input/output connection type	Current consumption	
	Total No. of points	No. of input points	No. of output points				5 V DC power supply	24 V DC power supply
FX5-8EYR/ES	8 points	—	8 points	—	Relay	Screw terminal block	75 mA	75 mA
FX5-8EYT/ES					Transistor (sink)			
FX5-8EYT/ESS					Transistor (source)			
FX5-16EYR/ES	16 points	—	16 points	—	Relay	Screw terminal block	100 mA	125 mA
FX5-16EYT/ES					Transistor (sink)			
FX5-16EYT/ESS					Transistor (source)			

Input/output module

Input/output modules are used to expand inputs/outputs.

■ Extension connector type

Model	Number of input/output points			Input type	Output type	Input/output connection type	Current consumption		
	Total No. of points	No. of input points	No. of output points				5 V DC power supply	24 V DC power supply	External 24 V DC power supply (24 V DC power supply for input circuits)
FX5-C32ET/D	32 points	16 points	16 points	24 V DC (sink)	Transistor (sink)	Connector	120 mA	100 mA	65 mA
FX5-C32ET/DSS				24 V DC (sink/source)	Transistor (source)				
FX5-C32ET/DS-TS				Transistor (sink)	Spring clamp terminal block				
FX5-C32ET/DSS-TS				Transistor (source)					

■ Extension cable type

Model	No. of input/output points			Input type	Output type	Input/output connection type	Current consumption		
	Total No. of points	No. of input points	No. of output points				5 V DC power supply	24 V DC power supply	External 24 V DC power supply (24 V DC power supply for input circuits)
FX5-16ER/ES	16 points	8 points	8 points	24 V DC (sink/source)	Relay	Screw terminal block	100 mA	85 mA	40 mA
FX5-16ET/ES					Transistor (sink)				
FX5-16ET/ESS					Transistor (source)				

Powered input/output module

The powered input/output module includes a power supply and is used to expand input/output

Model	No. of input/output points			Input type	Output type	Input/output connection type	Power supply capacity	
	Total No. of points	No. of input points	No. of output points				5 V DC power supply	24 V DC power supply
FX5-32ER/DS	32 points	16 points	16 points	24 V DC (sink/source)	Relay	Screw terminal block	965 mA	310 mA
FX5-32ET/DS					Transistor (sink)			
FX5-32ET/DSS					Transistor (source)			

High-speed pulse input/output module

The high-speed pulse input/output module is a product for extending the high-speed input/output.

Model	No. of input/output points			Input type	Output type	Input/output connection type	Current consumption		
	Total No. of points	No. of input points	No. of output points				5 V DC power supply	24 V DC power supply	External 24 V DC power supply (24 V DC power supply for input circuits)
FX5-16ET/ES-H ^{*1}	16 points	8 points	8 points	24 V DC (sink/source)	Transistor (sink)	Screw terminal block	100 mA	85 mA	40 mA
FX5-16ET/ESS-H ^{*1}					Transistor (source)				

*1 For supported versions, refer to  Page 203 Added and Changed Functions.

Intelligent function module

Intelligent function modules, such as simple motion modules, have functions other than input/output.

For details, refer to manuals of each module.

FX5 intelligent function module

The following FX5 intelligent function module can be used in FX5UC systems using connector conversion modules.

For the connector conversion modules to be connected, refer to  Page 50 Connector conversion module.

■Analog

Model	Function	No. of occupied input/output points	Current consumption		
			5 V DC power supply	24 V DC power supply	External 24 V DC power supply
FX5-4AD ^{*1}	4-ch voltage input/current input	8 points	100 mA	40 mA	—
FX5-4DA ^{*1}	4-ch voltage output/current output	8 points	100 mA	—	150 mA
FX5-8AD ^{*1}	8-ch voltage input/current input/thermocouple input/resistance thermometer input	8 points	—	40 mA	100 mA
FX5-4LC ^{*1}	4-ch temperature control (thermocouple/resistance thermometer/micro voltage) 4-point current sensor input 4-point transistor output	8 points	140 mA	—	25 mA

■Positioning

Model	Function	No. of occupied input/output points	Current consumption		
			5 V DC power supply	24 V DC power supply	External 24 V DC power supply
FX5-20PG-P ^{*1}	Pulse output for 2-axis control (transistor)	8 points	—	—	120 mA
FX5-20PG-D ^{*1}	Pulse output for 2-axis control (differential driver)	8 points	—	—	165 mA

■Simple motion

Model	Function	No. of occupied input/output points	Current consumption		
			5 V DC power supply	24 V DC power supply	External 24 V DC power supply
FX5-40SSC-S	4-axis control (compatible with SSCNET III/H)	8 points	—	—	250 mA
FX5-80SSC-S ^{*1}	8-axis control (compatible with SSCNET III/H)	8 points	—	—	250 mA

■Motion

Model	Function	No. of occupied input/output points	Current consumption		
			5 V DC power supply	24 V DC power supply	External 24 V DC power supply
FX5-40SSC-G ^{*1}	4-axis control (compatible with CC-Link IE TSN)	8 points	—	—	240 mA
FX5-80SSC-G ^{*1}	8-axis control (compatible with CC-Link IE TSN)	8 points	—	—	240 mA

■Network

Model	Function	No. of occupied input/output points	Current consumption		
			5 V DC power supply	24 V DC power supply	External 24 V DC power supply
FX5-ENET ^{*1}	Ethernet communication	8 points	—	110 mA	—
FX5-ENET/IP ^{*1}	Ethernet communication (compatible with EtherNet/IP)	8 points	—	110 mA	—
FX5-OPC ^{*1}	OPC UA communication	8 points	—	110 mA	—
FX5-CCLGN-MS ^{*1}	CC-Link IE TSN master station/local station	8 points	—	—	220 mA
FX5-CCLIEF ^{*1}	Intelligent device station for CC-Link IE Field network	8 points	10 mA	—	230 mA
FX5-CCL-MS ^{*1}	Master station/intelligent device station for CC-Link (Ver. 2.00 and Ver.1.10 compatible)	8 points ^{*2}	—	—	100 mA
FX5-ASL-M ^{*1*3}	Master for AnyWireASLINK	8 points	200 mA	—	100 mA ^{*4}
FX5-DP-M ^{*1}	Master for PROFIBUS-DP	8 points	—	150 mA	—

*1 For supported versions, refer to  Page 203 Added and Changed Functions.

*2 When using with the master station, the number of remote I/O points is added. For details, refer to  Page 65 Calculation of the number of remote I/O points.

*3 Note that the warranty for this model differs from the ones for other PLCs. For details, refer to  MELSEC iQ-F FX5 User's Manual (AnyWireASLINK).

*4 This value does not include supply current to slave modules. For details, refer to  MELSEC iQ-F FX5 User's Manual (AnyWireASLINK).

FX3 intelligent function module

The following FX3 intelligent functions modules can be used in FX5UC systems by using bus conversion modules.

For the bus conversion modules to be connected, refer to  Page 50 Bus conversion module.

To use the modules, refer to  Page 55 Bus conversion module.

■Analog

Model	Function	No. of occupied input/output points	Current consumption		
			5 V DC power supply	24 V DC power supply	External 24 V DC power supply
FX3U-4AD	4-ch voltage/current input	8 points	110 mA	—	90 mA
FX3U-4DA	4-ch voltage/current output		120 mA	—	160 mA
FX3U-4LC	4-ch temperature control (thermocouple/resistance thermometer/micro voltage) 4-point current sensor input 4-point transistor output		160 mA	—	50 mA

■Positioning

Model	Function	No. of occupied input/output points	Current consumption		
			5 V DC power supply	24 V DC power supply	External 24 V DC power supply
FX3U-1PG	Pulse output for independent 1-axis control	8 points	150 mA	—	40 mA

■High-speed counter

Model	Function	No. of occupied input/output points	Current consumption	
			5 V DC power supply	24 V DC power supply
FX3U-2HC	2-ch high-speed counter	8 points	245 mA	—

■Network

Model	Function	No. of occupied input/output points	Current consumption		
			5 V DC power supply	24 V DC power supply	External 24 V DC power supply
FX3U-16CCL-M	Master station for CC-Link (compatible with Ver. 2.00 and Ver. 1.10)	8 points ^{*1}	—	—	240 mA
FX3U-64CCL	Intelligent device station for CC-Link	8 points	—	—	220 mA
FX3U-128ASL-M ^{*2}	Master for AnyWireASLINK	8 points ^{*3}	130 mA	—	100 mA ^{*4}
FX3U-32DP	Slave stations for PROFIBUS-DP	8 points	—	145 mA	—

*1 Number of remote I/O points is added. For details, refer to  Page 65 Calculation of the number of remote I/O points.

*2 Note that the warranty for this model differs from the ones for other PLCs. For details, refer to FX3U-128ASL-M User's Manual.

*3 The number of input/output points set by the rotary switch is added. For details, refer to FX3U-128ASL-M User's Manual.

*4 This value does not include supply current to slave modules. For details, refer to FX3U-128ASL-M User's Manual.

Precautions

- Some FX3 intelligent function modules are not supported. For details, refer to the user's manual for each product.
- When using the network module of the FX3 intelligent function module, set the parameter in the program.
- The bus speed for accessing the FX3 intelligent function module is the FX3 speed.

FX5 safety extension modules

FX5 safety extension module is a product for configuring a safety control system.

For details of the specifications of FX5 safety extension modules, refer to the hardware manual of product.

Model	Function	No. of occupied input/output points	Current consumption		
			5 V DC power supply	24 V DC power supply	External 24 V DC power supply
FX5-SF-MU4T5 ^{*1*2}	4-points safety input/4-points safety output	8 points	200 mA	5 mA	125 mA
FX5-SF-8DI4 ^{*1*2}	8-points safety input	0 point	—	—	125 mA ^{*3}

*1 For supported versions, refer to  Page 203 Added and Changed Functions.

*2 Note that the warranty for this model differs from the ones for other PLCs. For details, refer to  MELSEC iQ-F FX5 User's Manual (Safety Control).

*3 Supplied from external 24 V DC power supply of the FX5-SF-MU4T5.

Extension power supply module

The extension power supply module is an added power supply if the built-in power supply of the CPU module is insufficient. For details on the specifications of the extension power supply module, refer to MELSEC iQ-F FX5-C1PS-5V Hardware Manual.

Model	Function	No. of occupied input/output points	Power supply capacity	
			5 V DC power supply	24 V DC power supply
FX5-C1PS-5V	Extension power supply	—	1200 mA ^{*1}	625 mA ^{*1}

*1 If the ambient temperature exceeds 40°C, use the extension power supply module at the following current values within the derating range.

Derating curve

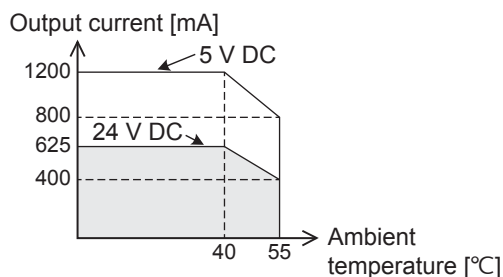

Connector conversion module

Connector conversion modules are used to connect FX5 extension module (extension cable type) in FX5UC systems.

Model	Function	No. of occupied input/output points	Current consumption	
			5 V DC power supply	24 V DC power supply
FX5-CNV-IFC	Connector conversion from CPU module or extension modules (extension connector type)	—	—	—

Bus conversion module

Bus conversion modules are used to connect FX3 intelligent functions modules in FX5UC systems. For details of the specifications of each bus conversion module, refer to the hardware manual of each product.

Model	Function	No. of occupied input/output points	Current consumption	
			5 V DC power supply	24 V DC power supply
FX5-CNV-BUSC	Bus conversion from CPU module or extension modules (extension connector type)	8 points	150 mA	—
FX5-CNV-BUS	Bus conversion from extension modules (extension cable type) or FX5 intelligent function modules	8 points	150 mA	—

3.4 Expansion Adapter

Expansion adapters are used to expand functions and are connected on the left side of the CPU module. For details of the specifications of each expansion adapter, refer to the hardware manual of each product.

Model	Function	No. of occupied input/output points	Current consumption		
			5 V DC power supply	24 V DC power supply	External 24 V DC power supply
FX5-4A-ADP	2-ch voltage input/current input, 2-ch voltage output/current output	—	10 mA	—	100 mA
FX5-4AD-ADP	4-CH voltage/current input	—	10 mA	20 mA	—
FX5-4DA-ADP	4-CH voltage/current output	—	10 mA	—	160 mA
FX5-4AD-PT-ADP ^{*1}	4-ch resistance thermometer sensor input	—	10 mA	20 mA	—
FX5-4AD-TC-ADP ^{*1}	4-ch thermocouple input	—	10 mA	20 mA	—
FX5-232ADP	For RS-232C communication	—	30 mA	30 mA	—
FX5-485ADP	For RS-485 communication	—	20 mA	30 mA	—

*1 For supported versions, refer to  Page 203 Added and Changed Functions.

3.5 Extended Extension Cable and Connector Conversion Adapter

Extended extension cable

Use this to install the FX5 extension module (extension cable type) at a remote location. When the connection destination is a module of extension cable type (except for extension power supply module), always use the connector conversion adapter (FX5-CNV-BC).

Model	Function
FX5-30EC	Distance between modules (0.30 m)
FX5-65EC	Distance between modules (0.65 m)

Connector conversion adapter

Adapter for connecting extended extension cable and module of extension cable type (except for extension power supply module).

Model	Function
FX5-CNV-BC	Connector conversion adapter for connecting extended extension cable and module of extension cable type (except for extension power supply module).

3.6 Terminal Module

For details of the terminal modules, refer to  Page 187 Terminal Module.

Model	Function	No. of occupied input/output points	Current consumption		
			5 V DC power supply	24 V DC power supply	External 24 V DC power supply
FX-16E-TB	Directly connected to the I/O connector of a PLC.	—	—	—	112 mA
FX-32E-TB		—	—	—	112 mA/16 points
FX-16EX-A1-TB	100 V AC input type	—	—	—	48 mA
FX-16EYR-TB	Relay output type	—	—	—	80 mA
FX-16EYT-TB	Transistor output type (sink output)	—	—	—	112 mA
FX-16EYS-TB	Triac output type	—	—	—	112 mA
FX-16E-TB/UL	Directly connected to the I/O connector of a PLC.	—	—	—	112 mA
FX-32E-TB/UL		—	—	—	112 mA/16 points
FX-16EYR-ES-TB/UL	Relay output type	—	—	—	80 mA
FX-16EYT-ES-TB/UL	Transistor output type (sink output)	—	—	—	112 mA
FX-16EYT-ESS-TB/UL	Transistor output type (source output)	—	—	—	112 mA
FX-16EYS-ES-TB/UL	Triac output type	—	—	—	112 mA

3.7 SD Memory Card

For details of the SD memory card, refer to  Page 185 SD Memory Card.

Model	Function
NZ1MEM-2GBSD	SD memory card (Mitsubishi product)
NZ1MEM-4GBSD	
NZ1MEM-8GBSD	
NZ1MEM-16GBSD	
L1MEM-2GBSD	
L1MEM-4GBSD	

3.8 Battery

For details of the battery, refer to  Page 145 Battery.

Model	Function
FX3U-32BL	Battery

3.9 Communication Cable

Use a communication cable to connect a PLC with a personal computer by RS-232C communication.

Model	Function
FX-232CAB-1	FX5-232ADP↔Personal computer

3.10 Engineering Tool

For design and programming of FX5UC systems, use GX Works3.

GX Works3 is an engineering tool used for settings, programming, debugging, and maintenance of the programmable controller.

For the operation method, refer to the  GX Works3 Operating Manual.

4 SYSTEM CONFIGURATION

Configuration of a whole system

The configuration of an entire system is shown below as an example.

For assignment of the module numbers for extension module, refer to Page 82 Module number of extension modules.

Ex.

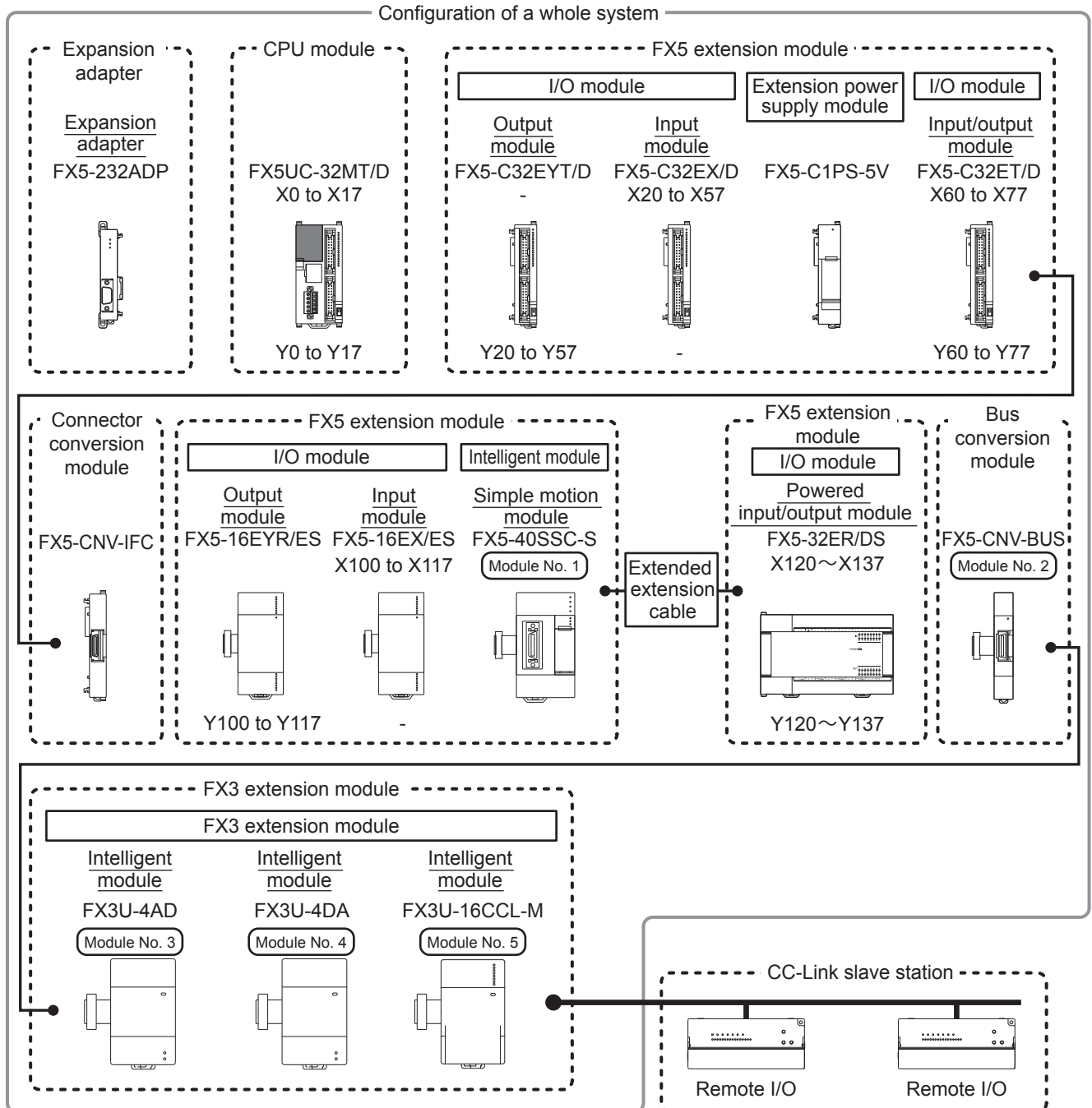

4.1 Rules of System Configuration

The system configuration must meet the following four requirements.

Number of connected extension devices

The number of extension devices that can be connected to a single system of FX5UC CPU modules is limited. For details, refer to [Page 58 Limitations on the Number of Connected Extension Devices](#).

Ex. System configuration example using input/output modules and intelligent modules.

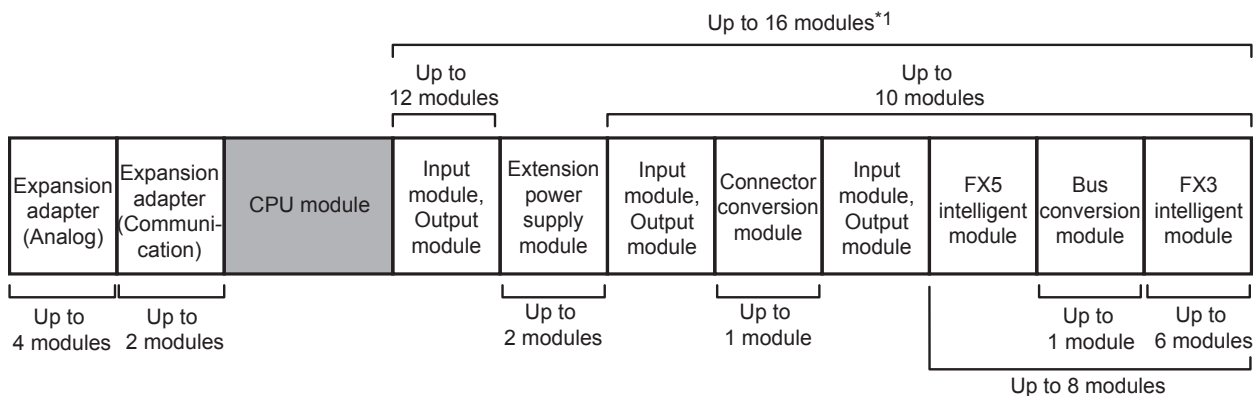

Ex. System configuration example using intelligent modules.

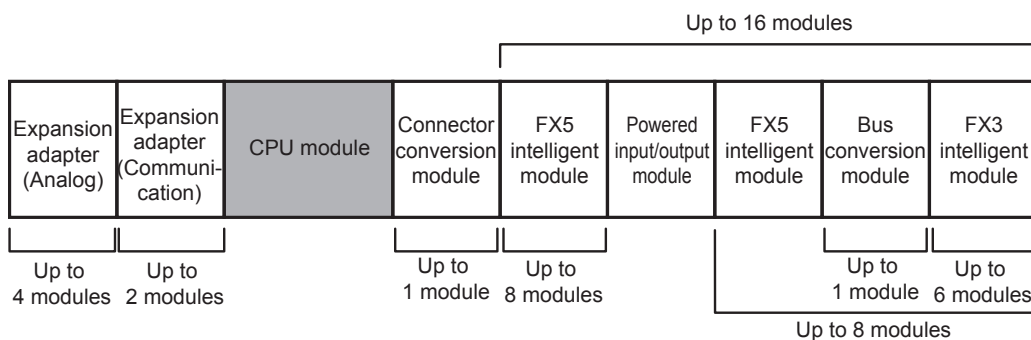

Ex. System configuration example using FX5 safety extension modules.

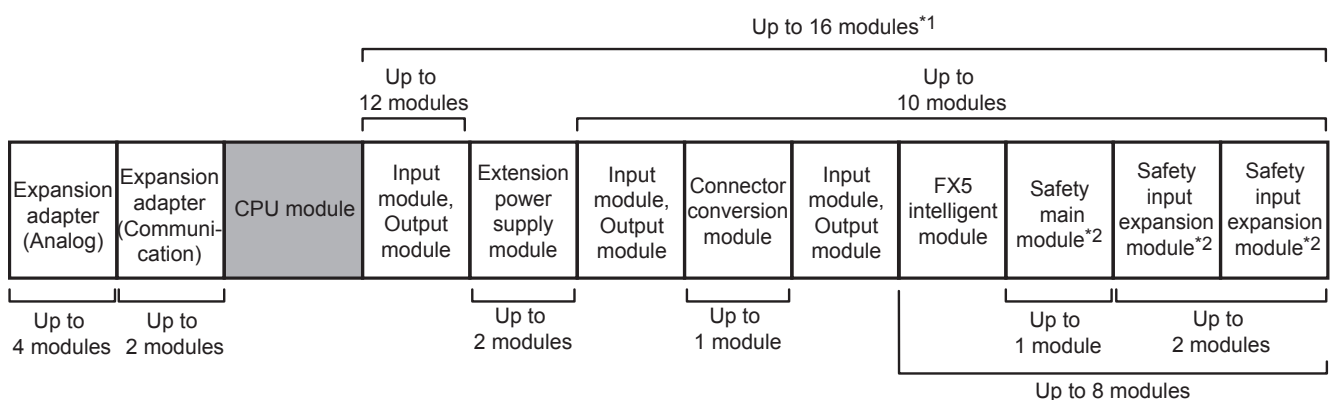

*1 Extension power supply module and connector conversion module are not included in the number of connected extension devices.

*2 Extension modules cannot be connected on the subsequent stage (the right side) of the FX5 safety extension module.

The FX5 safety extension module cannot be used together with motion modules.

Number of input/output points

With the FX5UC CPU modules, a total of up to 512 points or less including the number of input/output points of extension devices (max. 384 points) and number of remote I/O points can be controlled. However, the controllable number of points differs depending on the CPU module firmware version.

For details on the number of input/output points, refer to [Page 62 Limitation on the Number of Input/Output Points](#).

Current consumption

The power to the extension devices is supplied from a CPU module, powered input/output module or extension power supply module.

The number of extension devices that can be connected must be determined from the power supply capacity of the CPU module or extension power supply module.

For details on the current consumption, refer to [Page 69 Limitation on Current Consumption](#).

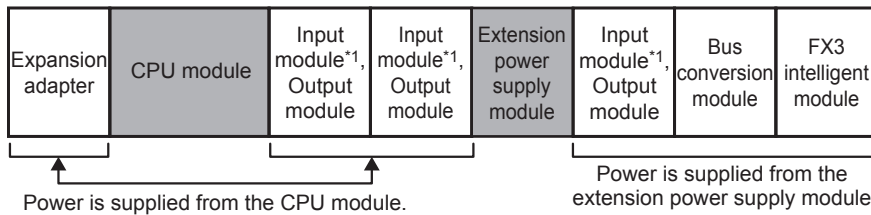

*1 The power to the input circuit of the input module is supplied from the external power supply.

Limitations when using extension devices

■Modules of extension cable type

FX5-CNV-IFC or FX5-C1PS-5V is required to use modules of extension connector type.

■Limitations on high-speed pulse input/output module

Up to four high-speed pulse input/output modules can be connected in a system.

■Bus conversion module

- A bus conversion module is required to use FX3 extension module. FX3 extension modules can be connected to the right side of the bus conversion module only.
- For limitations on the number of connected extension devices, refer to [Page 61 Connection to the bus conversion module \(connection with FX3 extension devices\)](#).

■ Limitations on intelligent function modules

Note that some intelligent function modules have limitations on the number of modules, order and combination in which they are added for each individual module.

Model	Limitation
FX5-40SSC-G	Up to four modules connectable per system. Up to four modules of FX5-40SSC-G, FX5-80SSC-G and FX5-CCLGN-MS (master station) in total connectable per system. Cannot be used together with FX5-SF-MU4T5 or FX5-SF-8DI4 when FX5-40SSC-G with firmware version "1.000" is used.
FX5-80SSC-G	Up to four modules connectable per system. Up to four modules of FX5-40SSC-G, FX5-80SSC-G and FX5-CCLGN-MS (master station) in total connectable per system. Cannot be used together with FX5-SF-MU4T5 or FX5-SF-8DI4 when FX5-40SSC-G with firmware version "1.000" is used.
FX5-ENET	Only one module may be connected per system.
FX5-ENET/IP	Only one module may be connected per system.
FX5-OPC	Only one module may be connected per system.
FX5-CCLGN-MS	One module can be connected to the system for each station type. <ul style="list-style-type: none"> • Master station: 1 • Local station: 1 When four modules of FX5-40SSC-G and FX5-80SSC-G are connected to a system in total, FX5-CCLGN-MS (master station) cannot be connected.
FX5-CCLIEF	Only one module may be connected per system.
FX5-CCL-MS	One module can be connected to the system for each station type. <ul style="list-style-type: none"> • Master station: 1 • Intelligent device station: 1 When using the FX5-CCL-MS as the master station, it cannot be used together with the FX3U-16CCL-M. When using the FX5-CCL-MS as the intelligent device station, it cannot be used together with the FX3U-64CCL.
FX5-ASL-M	Only one module may be connected per system. Use together with the FX3U-128ASL-M is not possible.
FX5-DP-M	Only one module may be connected per system.
FX3U-2HC	Up to two modules connectable per system. Connect a module of this type immediately after the bus conversion module.
FX3U-16CCL-M	Only one module may be connected per system. When using the FX5-CCL-MS as the master station, it cannot be used together with the FX5-CCL-MS.
FX3U-64CCL	Only one module may be connected per system. When using the FX5-CCL-MS as the intelligent device station, it cannot be used together with the FX5-CCL-MS.
FX3U-128ASL-M	Only one module may be connected per system. Use together with the FX5-ASL-M is not possible.

■ Limitations on FX5 safety extension modules

Note that some FX5 safety extension modules have limitations on the number of modules, order and combination in which they are added for each individual module.

Model	Limitation
FX5-SF-MU4T5	Only one module may be connected per system. Cannot be used together with a bus conversion module or FX3 extension module. To use a motion module (FX5-40SSC-G, FX5-80SSC-G) together, connect the motion module with firmware version "1.001" and above. To use an intelligent function module together besides an FX5 safety extension module and a motion module, use the module with the following firmware version. <ul style="list-style-type: none"> • FX5-20PG-P: "1.011" and above, FX5-20PG-D: "1.011" and above, FX5-CCLGN-MS: "1.002" and above, FX5-DP-M: "1.001" and above Place this module on the rightmost side of the system configuration, except when FX5-SF-8DI4 is connected.
FX5-SF-8DI4	Up to two modules connectable per system. Cannot be used together with a bus conversion module or FX3 extension module. To use a motion module (FX5-40SSC-G, FX5-80SSC-G) together, connect the motion module with firmware version "1.001" and above. To use an intelligent function module together besides an FX5 safety extension module and a motion module, use the module with the following firmware version. <ul style="list-style-type: none"> • FX5-20PG-P: "1.011" and above, FX5-20PG-D: "1.011" and above, FX5-CCLGN-MS: "1.002" and above, FX5-DP-M: "1.001" and above Connect immediately after FX5-SF-MU4T5 and place this module on the rightmost side of the system configuration.

■Using the extended extension cable

- The connector conversion adapter is required when the extended extension cable connection destination is a module of extension cable type (except for extension power supply module).
- When connecting a bus conversion module in the same system, connect the powered input/output module directly after the extended extension cable.
- This cannot be used with the FX3 extension module.

4.2 Limitations on the Number of Connected Extension Devices

Number of connected expansion adapters

There is a limitation on the number of expansion adapters connected to the FX5UC CPU module as follows.

Type	Limitation
Communication adapter	Up to 2 adapters can be connected
Analog adapter	Up to 2 adapters or 4 adapters can be connected

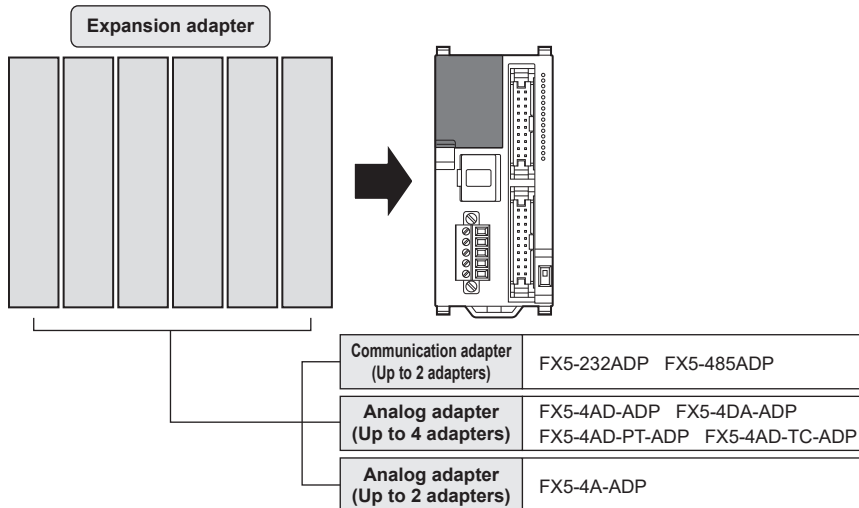

Precautions

- When using two or more FX5-4DA-ADP and connecting them next to FX5-4A-ADP, do not connect them to both sides of FX5-4A-ADP.
- When using two or more FX5-4DA-ADP or FX5-4A-ADP and connecting them next to FX5-4AD-TC-ADP, connect them to only one side of FX5-4AD-TC-ADP to satisfy the specification accuracy. Do not connect them to both sides. Also, when using FX5-4DA-ADP and FX5-4A-ADP and connecting them next to FX5-4AD-TC-ADP, connect them to only one side of FX5-4AD-TC-ADP. Do not connect them to both sides.

Number of connected extension modules (including extended extension cable)

Overall system limitation

There is a limitation on the number of connected extension modules in a whole system as follows.

Type	Limitation
Extension module	Up to 16 modules can be connected to a system. (excluding extension power supply module and connector conversion module)
Extension power supply module	Up to 2 modules can be connected to a system.
Safety main module	Only 1 module can be connected to a system. Place this module on the rightmost side of the system configuration, except when safety input expansion module is connected.
Safety input expansion module	Up to 2 modules can be connected to a system. Connect immediately after safety main module and place this module on the rightmost side of the system configuration.
Connector conversion module	Only 1 module can be connected to a system. When a module of extension cable type is connected on the subsequent stage of the FX5-C1PS-5V, a connector conversion module cannot be used.
Extended extension cable	Only 1 cable can be connected to a system.
Bus conversion module	Only 1 module can be connected to a system.

■When the FX5 safety extension modules are not connected

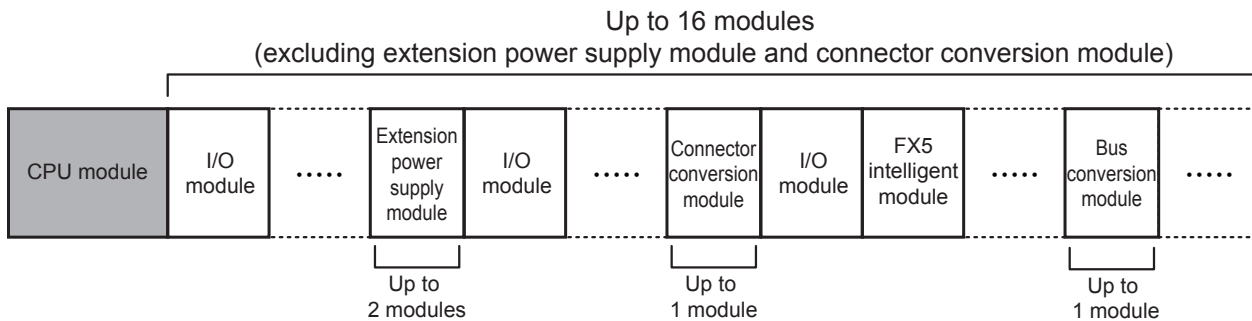

■When the FX5 safety extension modules are connected

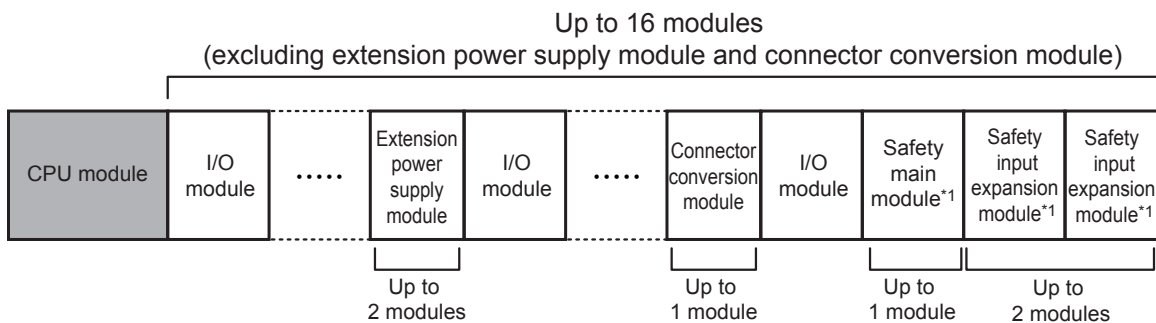

*1 Extension modules cannot be connected on the subsequent stage (the right side) of the FX5 safety extension module.

Connection to the CPU module

There is a limitation on the number of extension modules connected to the FX5UC CPU module as follows. The number of modules connected on the right side of the CPU module must be as follows.

Type	Limitation
Total No. of I/O modules, intelligent function modules, FX5 safety extension module, and bus conversion modules	Up to 12 modules can be connected.
Total No. of FX5 intelligent function modules, FX5 safety extension module, bus conversion module, FX3 intelligent function modules	Up to 8 modules can be connected.
Total No. of FX3 intelligent function modules	Up to 6 modules can be connected.

When the FX5 safety extension modules are connected, extension modules cannot be connected on the subsequent stage (the right side) of the FX5 safety extension module.

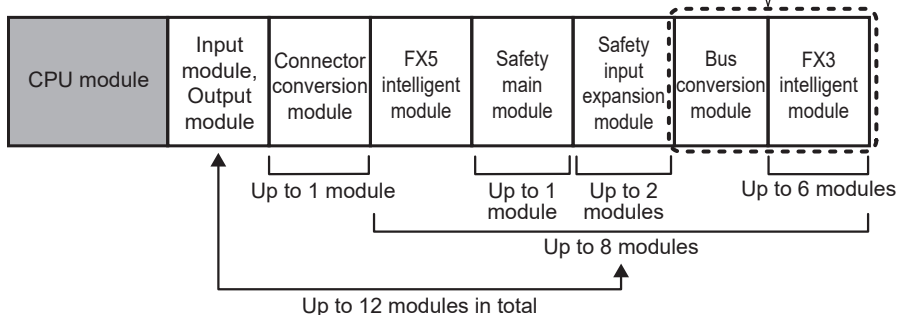

Connection to the powered input/output module

There is a limitation on the number of extension modules connected to the powered input/output module as follows.

The number of connected modules from the right side of the powered input/output module the next extension power supply module added later must be as follows.

Type	Limitations
Total No. of input modules, output modules intelligent function modules, FX5 safety extension module, and bus conversion modules	<u>Up to 10 modules</u> can be connected.
Total No. of intelligent function module, FX5 safety extension module, and bus conversion modules	<u>Up to 8 modules</u> can be connected.

When the FX5 safety extension modules are connected, extension modules cannot be connected on the subsequent stage (the right side) of the FX5 safety extension module.

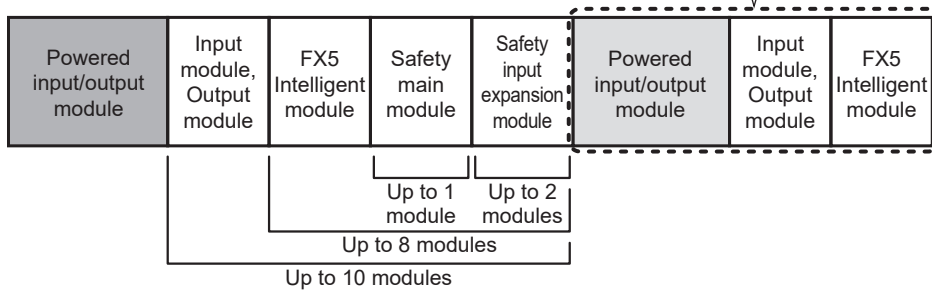

When the FX5 safety extension modules are connected, extension modules cannot be connected on the subsequent stage (the right side) of the FX5 safety extension module.

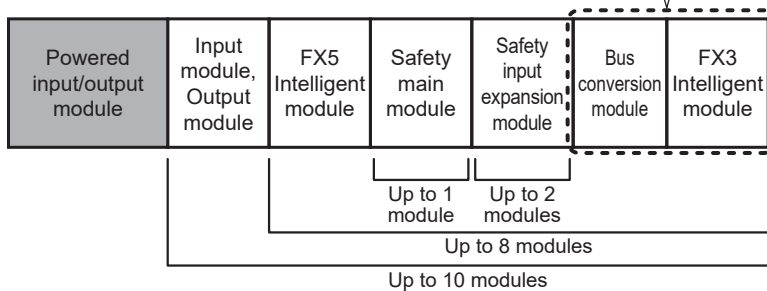

Connection to the extension power supply module

There is a limitation on the number of extension modules connected to the extension power supply module as follows. The number of connected modules from the right side of the extension power supply module to the next extension power supply module added later must be as follows.

Type	Limitation
Total No. of I/O modules, intelligent function modules, FX5 safety extension module, and bus conversion modules	<u>Up to 10 modules</u> can be connected.
Total No. of FX5 intelligent function modules, FX5 safety extension module, bus conversion modules, and FX3 intelligent function modules	<u>Up to 8 modules</u> can be connected.
Total No. of FX3 intelligent function modules	<u>Up to 6 modules</u> can be connected.

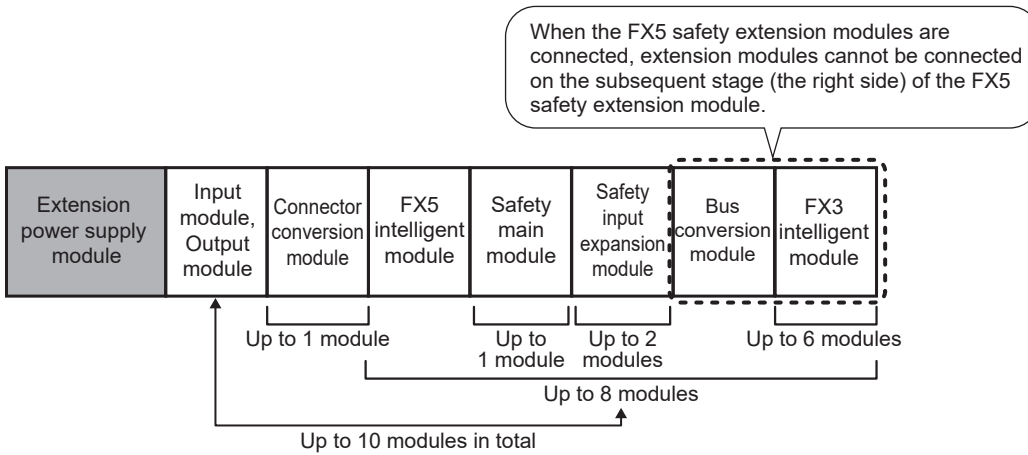

Point

The same restrictions apply when connecting modules to a second extension power supply module.

Connection to the bus conversion module (connection with FX3 extension devices)

There is a limitation on the number of extension modules connected to the bus conversion module as follows. The number of modules connected on the right side of the bus conversion module must be as follows.

Type	Limitation
Total No. of intelligent function modules	<u>Up to 6 modules</u> can be connected.

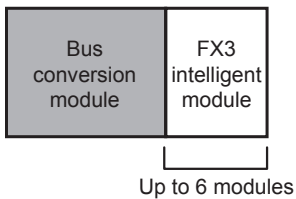

Precautions

- FX5 extension modules cannot be connected on the right side of the bus conversion module.
- FX5 safety extension modules cannot be used together with the bus conversion module.

4.3 Limitation on the Number of Input/Output Points

With the FX5UC CPU module, the number of input/output points of extension devices and number of remote I/O points can be controlled up to the following numbers of points.

In addition, the number of input/output points differs depending on the CPU module firmware version.

When the version of the CPU module is 1.110 or above

A total of 512 points including the number of input/output points of extension devices (max. 384 points) and the number of remote I/O points can be controlled.

GX Works3 version 1.050C or above is required. For details, refer to  Page 203 Added and Changed Functions.

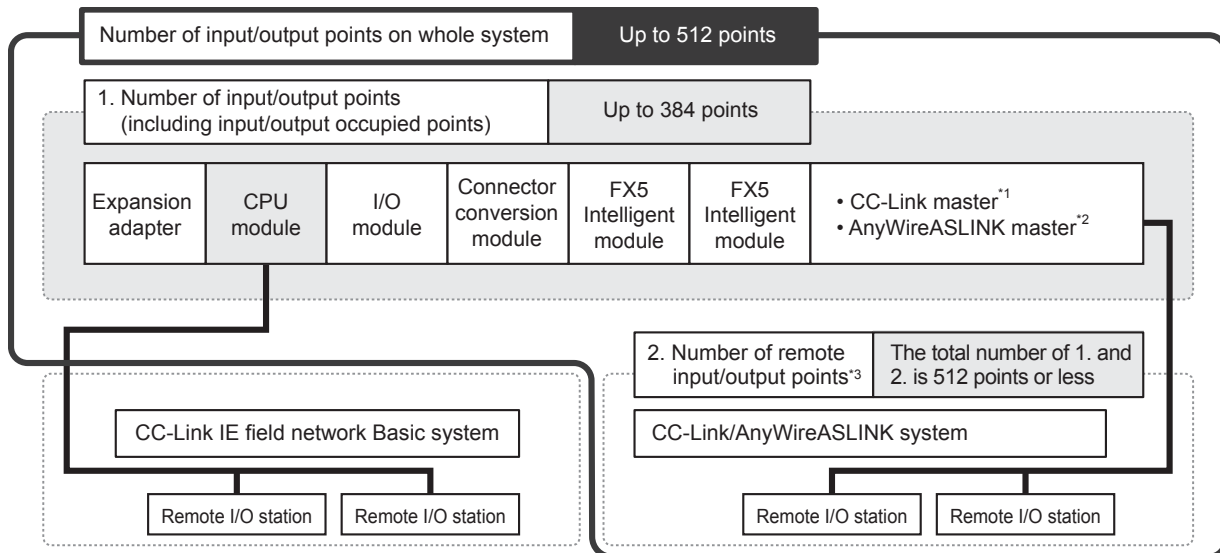

*1 A bus conversion module is required when using the FX3U-16CCL-M.

*2 A bus conversion module is required when using the FX3U-128ASL-M.

*3 The remote I/O station of CC-Link IE field network Basic is not calculated as the number of remote I/O points.

When the version of the CPU module is 1.100 or above and below 1.110

A total of 512 points including the number of input/output points of extension devices (max. 384 points) and the number of remote I/O points can be controlled.

GX Works3 version 1.047Z or above is required. For details, refer to  Page 203 Added and Changed Functions.

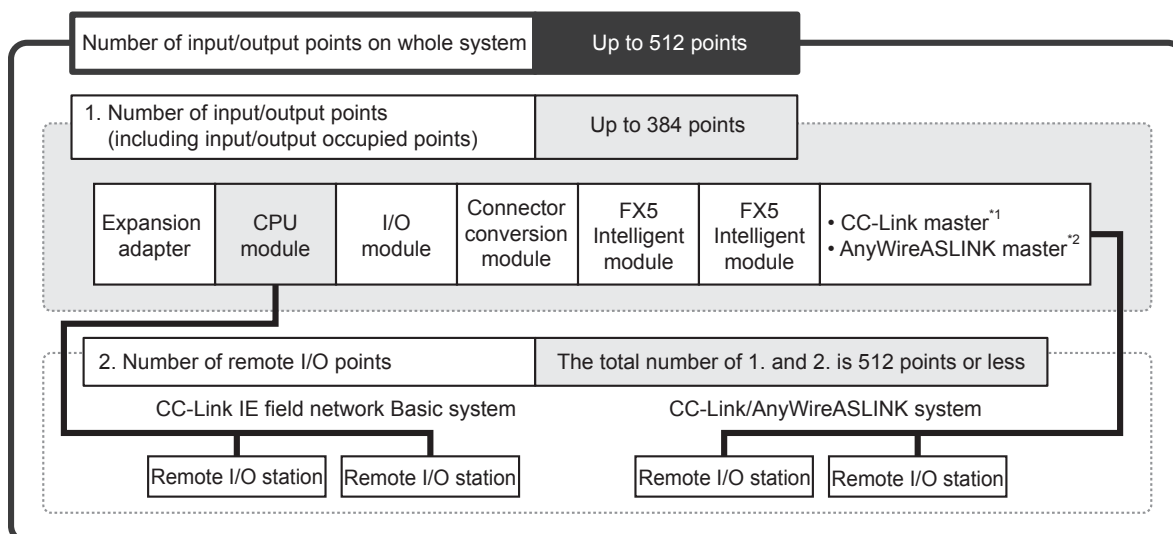

*1 A bus conversion module is required when using the FX3U-16CCL-M.

*2 A bus conversion module is required when using the FX3U-128ASL-M.

When the version of the CPU module is below 1.100

A total of 512 points including the number of input/output points of extension devices (max. 256 points) and the number of remote I/O points (max. 384 points) can be controlled.

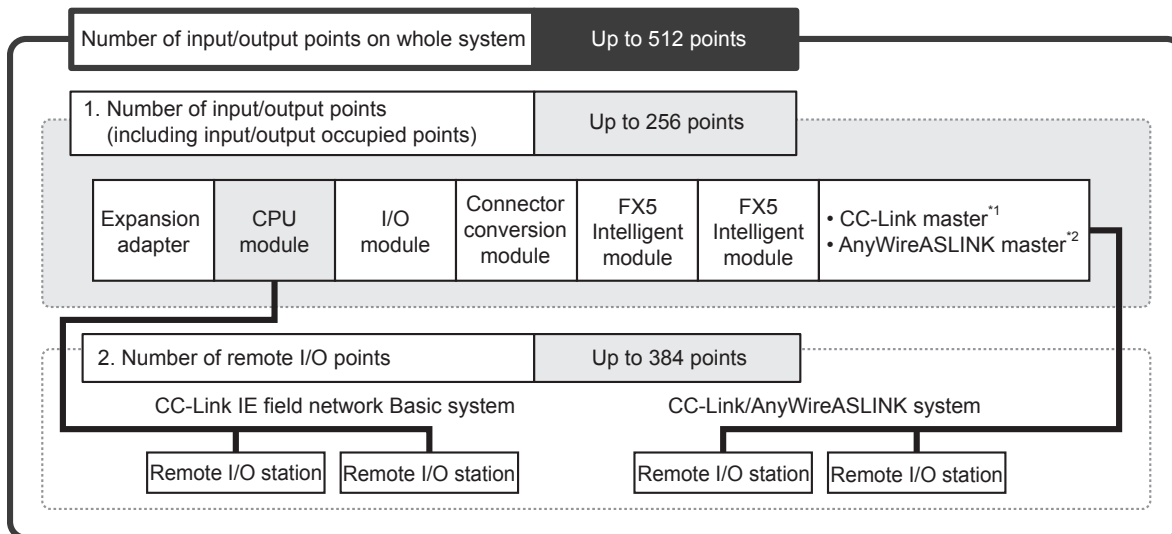

*1 A bus conversion module is required when using the FX3U-16CCL-M.

*2 A bus conversion module is required when using the FX3U-128ASL-M.

Total number of I/O points and remote I/O points

With the FX5UC CPU module, a total of 512 points or less including the number of input/output points of extension devices and number of remote I/O points can be controlled.

The total number of I/O points and remote I/O points must not exceed 512 points.

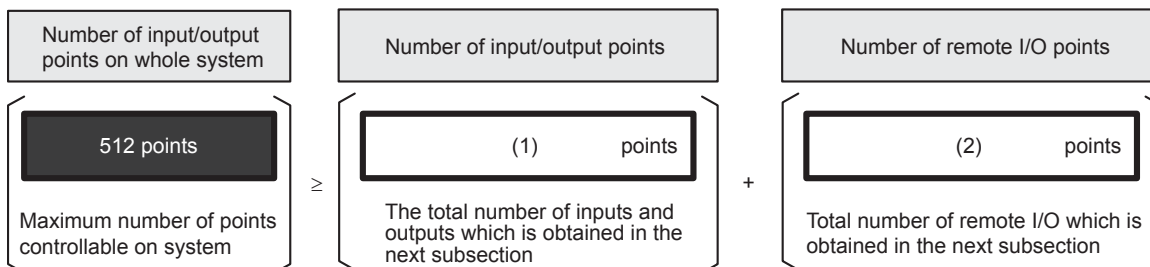

Calculation of the number of input/output points

The number of input/output points is the sum of the following numbers of the points. The number of input/output points differs depending on the CPU module firmware version.

- Number of input/output points on CPU module and I/O module
- Number of occupied input/output points of intelligent function modules, safety main modules, and bus conversion modules

Input/output points

■When the version of the CPU module is 1.100 or above

The total number of input/output points must not exceed 384 points.

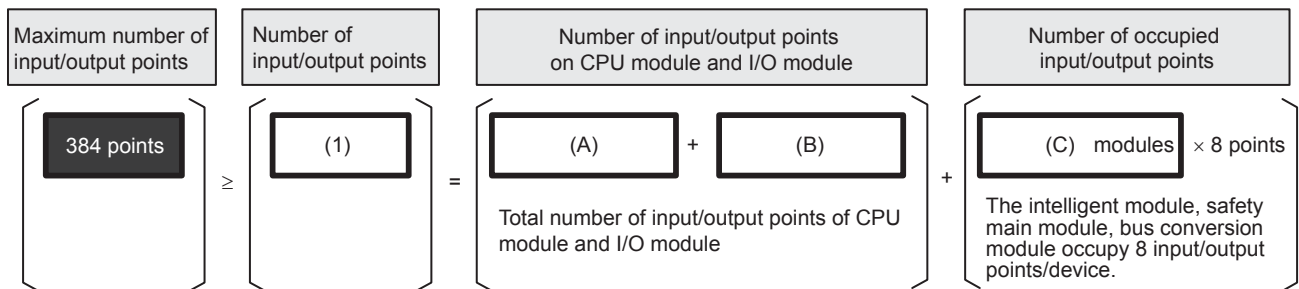

(A): Number of input/output points of CPU module

(B): Number of input/output points of I/O module

(C): Number of intelligent function modules, safety main module and bus conversion modules

■When the version of the CPU module is below 1.100

The total number of input/output points must not exceed 256 points.

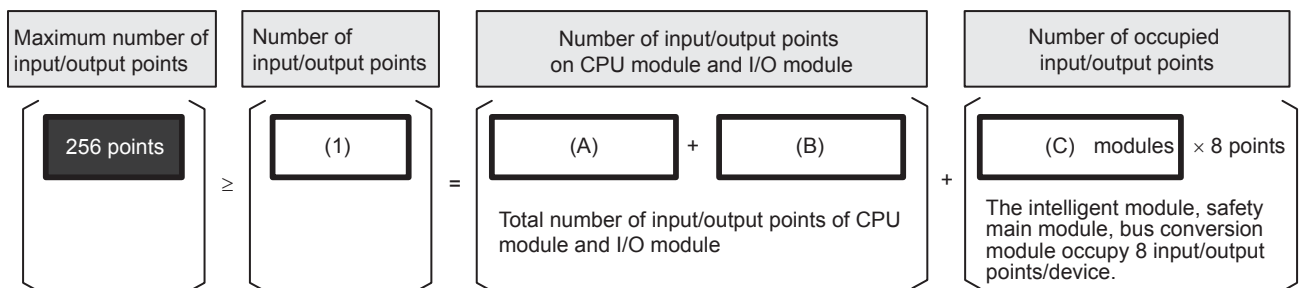

(A): Number of input/output points of CPU module

(B): Number of input/output points of I/O module

(C): Number of intelligent function modules, safety main module and bus conversion modules

Total number of input/output points of the CPU module and I/O modules

Count the total number of input/output points of the CPU module and I/O modules.

To obtain the total number of input/output points, count the input points (X0 and more) and output points (Y0 and more) of the CPU module and I/O modules.

For details of the number of input/output points by models, refer to the following.

☞ Page 43 CPU Module

☞ Page 44 I/O module

Number of occupied input/output points of intelligent function modules, safety main modules, and bus conversion modules

Count the number of occupied input/output points of intelligent function modules, safety main modules, and bus conversion modules.

The number of occupied input/output points per module is 8.

For details on the number of occupied input/output points by models, refer to the following.

☞ Page 47 Intelligent function module

☞ Page 49 FX5 safety extension modules

☞ Page 50 Bus conversion module

Calculation of the number of remote I/O points

If the master module of the network is used, calculate the number of remote I/O points connected on the network. The total number of remote I/O points differs depending on the CPU module firmware version.

Remote I/O points

■When the version of the CPU module is 1.110 or above

The total number of remote I/O points must not exceed "512 points - Number of input/output points".

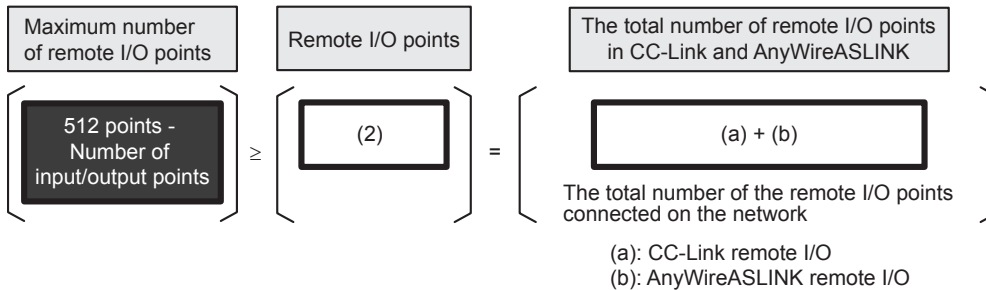

■When the version of the CPU module is 1.100 or above and below 1.110

The total number of remote I/O points must not exceed "512 points - Number of input/output points".

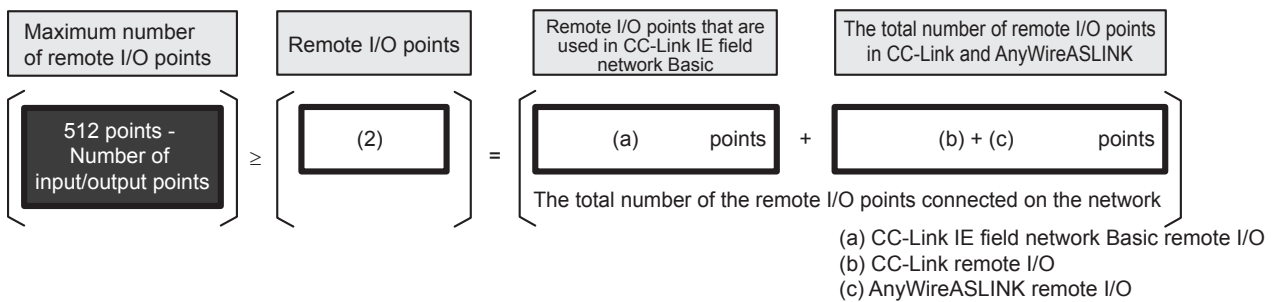

■When the version of the CPU module is below 1.100

The total number of remote I/O points must not exceed 384 points.

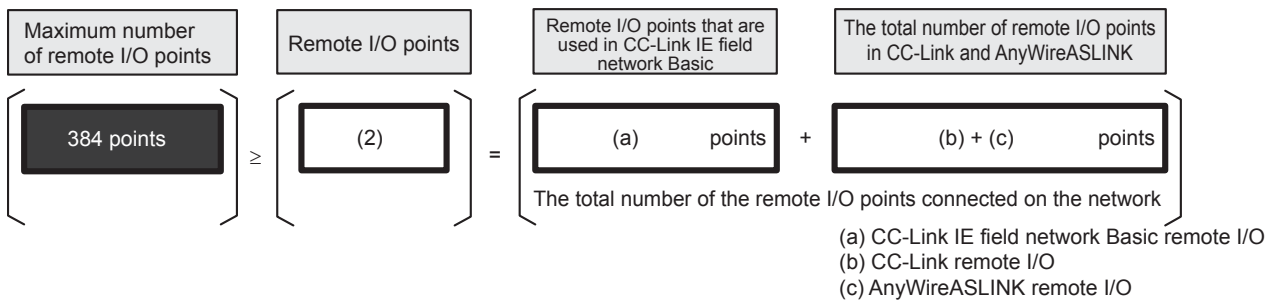

The maximum number of remote I/O points differs according to type of the network.

Precautions

- When CC-Link IE field network Basic is used, remote I/O points that are used in CC-Link IE field network Basic are occupied, and then remote I/O points of the intelligent function module are occupied. For information on CC-Link IE field network Basic, refer to [CC-Link IE Field Network Basic Reference Manual](#).
- When using CC-Link master (FX3U-16CCL-M) and AnyWireASLINK master (FX3U-128ASL-M) together, connect FX3U-128ASL-M on the left side. In the FX5UC CPU module, FX3U-16CCL-M parameters are set up by PLC program and will occupy up to 256 remote I/O points. Therefore, the remote I/O points of FX3U-128ASL-M that is connected to the right side may be less than 128 points when FX3U-16CCL-M is connected to the left side.

Ex.

When input/output points are 160 points, FX3U-16CCL-M is connected to the left side of FX3U-128ASL-M, and 256 points of remote I/O points to be used with FX3U-16CCL-M are occupied: 512 points - 160 points - 256 points = 96 points
Remote I/O points that can be used with FX3U-128ASL-M are 96 points or less.

Ex.

When input/output points are 160 points, FX3U-16CCL-M is connected to the right side of FX3U-128ASL-M, and the total number of remote I/O points to be used with FX3U-128ASL-M is 128 points: 512 points - 160 points - 128 points = 224 points
Remote I/O points that can be used with FX3U-16CCL-M are 224 points or less.

CC-Link IE field network Basic remote I/O

■When the version of the CPU module is 1.110 or above

CC-Link IE field network Basic is not calculated as the number of remote I/O points.

For details, refer to the following manual.

 CC-Link IE Field Network Basic Reference Manual

■When the version of the CPU module is below 1.110

Remote I/O points that are used in CC-Link IE field network Basic are calculated as "number of occupied stations × 64 points".

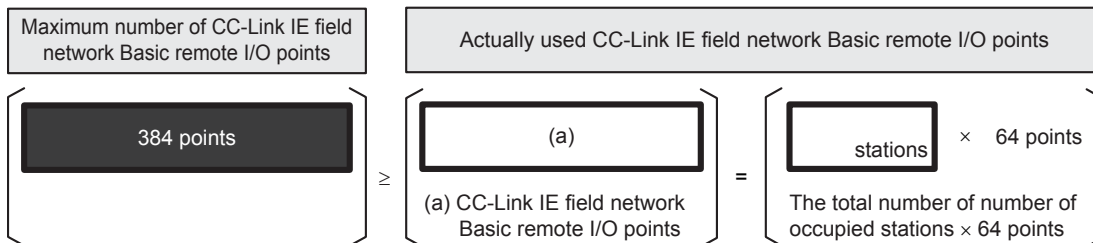

CC-Link remote I/O

The number of remote I/O points to be used in CC-Link are calculated as "number of remote I/O stations × 32 points".

Even if using less than 32 remote I/O points, calculate as "number of remote I/O stations × 32 points."

The number of remote I/O points differs depending on the CPU module firmware version.

■When the version of the CPU module is 1.100 or above

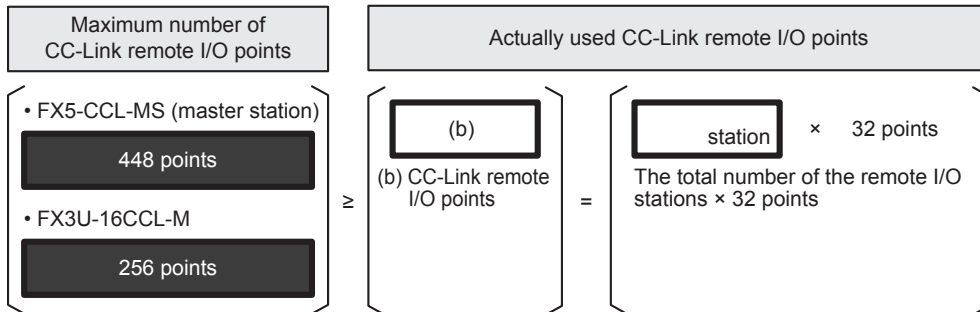

Point

Maximum number of the connected stations of the remote device station and the intelligent device station is 14 regardless of the number of remote I/O points. For details, refer to the following manual.

MELSEC iQ-F FX5 User's Manual (CC-Link)

■When the version of the CPU module is below 1.100

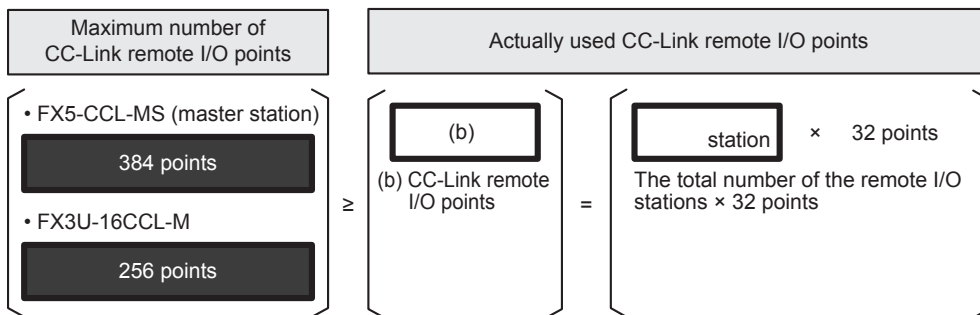

Point

Maximum number of the connected stations of the remote device station and the intelligent device station is 12 regardless of the number of remote I/O points. For details, refer to the following manual.

MELSEC iQ-F FX5 User's Manual (CC-Link)

AnyWireASLINK remote I/O

The number of I/O points set below is assigned to the remote I/O to be used with AnyWireASLINK.

- FX5-ASL-M: Set with the engineering tool parameters.
- FX3U-128ASL-M: Set with the rotary switch on the FX3U-128ASL-M main body.

For details, refer to the following manuals.

📖 MELSEC iQ-F FX5 User's Manual (AnyWireASLINK)

FX3U-128ASL-M User's Manual

The number of remote I/O points differs depending on the CPU module firmware version.

■ When the version of the CPU module is 1.100 or above

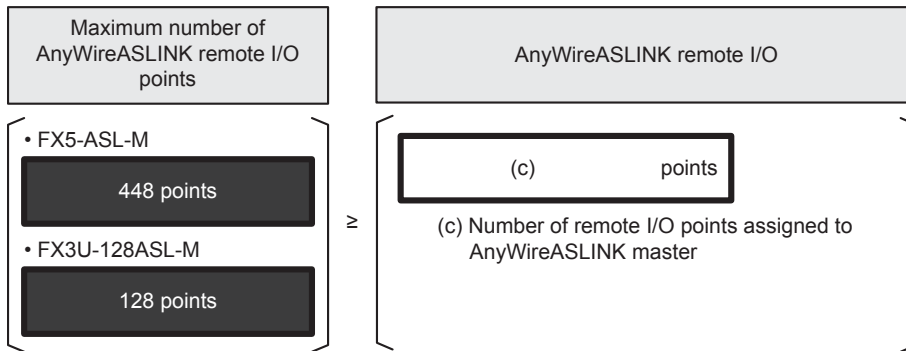

■ When the version of the CPU module is below 1.100

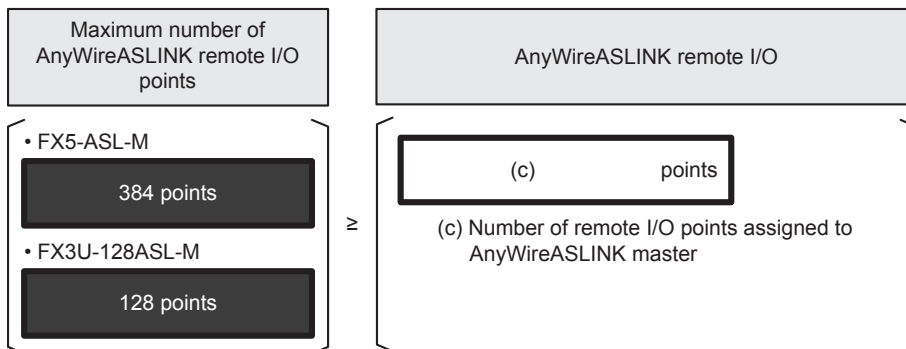

4.4 Limitation on Current Consumption

Power required for expansion adapters and extension modules is supplied from the CPU module, powered input/output module or extension power supply module. The number of extension devices that can be connected must be determined from the capacity of the power supply.

Power supply check from the CPU module (current consumption calculation)

Check if power can be supplied to extension devices with the power supply capacity of the CPU module.

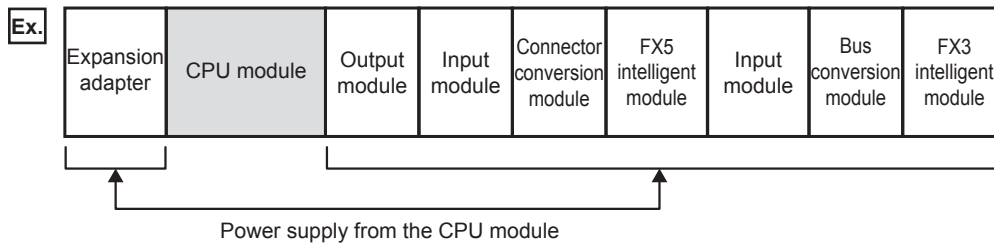

Calculate following the procedure below.

1. Check the power supply capacity of the CPU module used.

([Page 43 CPU Module](#))

Ex.

Type	Model	Power supply capacity	
		5 V DC power supply	24 V DC power supply
CPU module	FX5UC-32MT/D	720 mA	500 mA

2. Check the current consumption of extension devices.

([Page 44 Extension Module](#))

Ex.

Type	Model	Current consumption	
		5 V DC power supply	24 V DC power supply
Expansion adapter	FX5-232ADP	30 mA	30 mA
Output module	FX5-C32EYT/D	120 mA	200 mA
Input module	FX5-C32EX/D	120 mA	—
Connector conversion module	FX5-CNV-IFC	—	—
Simple motion module	FX5-40SSC-S	—	—
Input module	FX5-16EX/ES	100 mA	—
Bus conversion module	FX5-CNV-BUS	150 mA	—
Analog input	FX3U-4AD	110 mA	—

3. Calculate the total current consumption of each power supply.

Ex.

Power supply type	Total current consumption
5 V DC power supply	630 mA
24 V DC power supply	230 mA

4. Check if expansion to the CPU module is permitted.

- 5 V DC power supply

5 V DC power supply capacity	Current consumption	Calculation result
CPU module	Total number of extension devices	
<input type="text" value="720"/> mA	<input type="text" value="630"/> mA	<input type="text" value="90"/> mA
$720 \text{ mA} - 630 \text{ mA} = 90 \text{ mA} \geq 0 \text{ mA}$		
Ex.		

- 24 V DC power supply

24 V DC power supply capacity	Current consumption	Calculation result
CPU module	Total number of extension devices	
<input type="text" value="500"/> mA	<input type="text" value="230"/> mA	<input type="text" value="270"/> mA
$500 \text{ mA} - 230 \text{ mA} = 270 \text{ mA} \geq 0 \text{ mA}$		
Ex.		

If the calculation result is a negative value, the current consumption exceeds the power supply capacity of the CPU module. Reconfigure the system, adding extension power supply modules.

Power supply check from the powered input/output module (current consumption calculation)

If 5 V DC and 24 V DC power supplies of the CPU module are insufficient and system cannot be extended, add a powered input/output module.

Check if power can be supplied to extension modules with the power supply capacity of the powered input/output module.

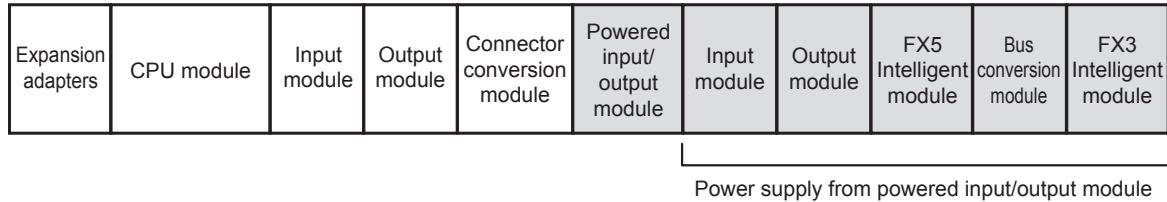

Calculate following the procedure below.

1. Check the power supply capacity of the powered input/output module.

(Page 47 Powered input/output module)

Ex.

Type	Model	Power supply capacity	
		5 V DC power supply	24 V DC power supply
Powered input/output module	FX5-32ER/DS	965 mA	310 mA

2. Check the current consumption of the extension module.

(Page 44 I/O module)

(Page 47 Intelligent function module)

Ex.

Type	Model	Current consumption	
		5 V DC power supply	24 V DC power supply
Input module	FX5-16EX/ES	100 mA	85 mA
Output module	FX5-16EYR/ES	100 mA	125 mA
Simple motion module	FX5-40SSC-S	—	—
Bus conversion module	FX5-CNV-BUS	150 mA	—
Analog input	FX3U-4AD	110 mA	—

3. Calculate the total current consumption of each power supply.

Ex.

Power supply type	Total current consumption
5 V DC power supply	460 mA
24 V DC power supply	210 mA

4. Check if expansion to the extension power supply module is permitted.

- 5 V DC power supply

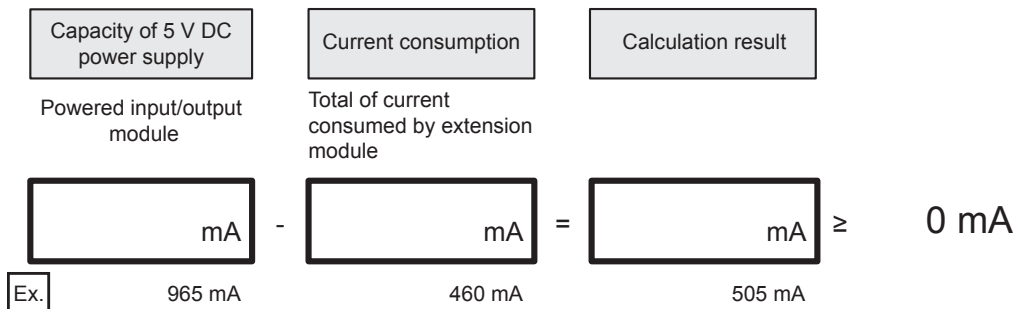

- 24 V DC power supply

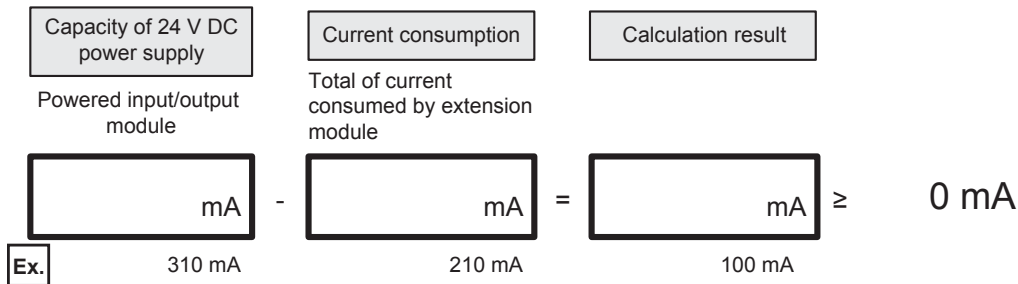

If the calculation result is a negative value, the current consumption exceeds the power supply capacity of the CPU module. Reconfigure the system, adding powered input/output module.

Power supply check from extension power supply module (current consumption calculation)

If 5 V DC and 24 V DC power supply of the CPU module is insufficient and cannot be extended, add an extension power supply module.

Check if power can be supplied to extension modules with the power supply capacity of the extension power supply module.

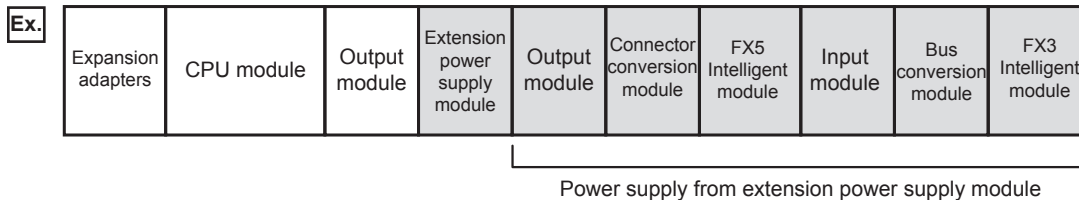

Calculate following the procedure below.

1. Check the power supply capacity of the extension power supply module used. (Page 50 Extension power supply module)

Ex.	Type	Model	Power supply capacity	
			5 V DC power supply	24 V DC power supply
	Extension power supply module	FX5-C1PS-5V	1200 mA	625 mA

If the ambient temperature exceeds 40°C, use the extension power supply module at the following current values within the derating range.

Derating curve

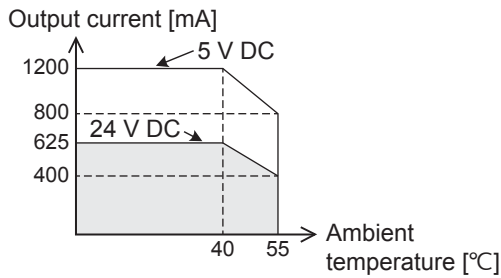

2. Check the current consumption of extension devices.

(☞ Page 44 Extension Module)

Ex.

Type	Model	Current consumption	
		5 V DC power supply	24 V DC power supply
Output module	FX5-C32EYT/D	120 mA	200 mA
Connector conversion module	FX5-CNV-IFC	—	—
Simple motion module	FX5-40SSC-S	—	—
Input module	FX5-16EX/ES	100 mA	—
Bus conversion module	FX5-CNV-BUS	150 mA	—
Analog input	FX3U-4AD	110 mA	—

3. Calculate the total current consumption of each power supply.

Ex.

Power supply type	Total current consumption
5 V DC power supply	480 mA
24 V DC power supply	200 mA

4. Check if expansion to the extension power supply module is permitted.

• 5 V DC power supply

5 V DC power supply capacity	Current consumption	Calculation result	
Extension power supply module	Total number of extension devices		
<div style="border: 1px solid black; width: 100px; height: 30px; margin: 0 auto;"></div> mA	<div style="border: 1px solid black; width: 100px; height: 30px; margin: 0 auto;"></div> mA	<div style="border: 1px solid black; width: 100px; height: 30px; margin: 0 auto;"></div> mA	$\geq 0 \text{ mA}$
Ex. 1200 mA	480 mA	720 mA	

• 24 V DC power supply

24 V DC power supply capacity	Current consumption	Calculation result	
Extension power supply module	Total number of extension devices		
<div style="border: 1px solid black; width: 100px; height: 30px; margin: 0 auto;"></div> mA	<div style="border: 1px solid black; width: 100px; height: 30px; margin: 0 auto;"></div> mA	<div style="border: 1px solid black; width: 100px; height: 30px; margin: 0 auto;"></div> mA	$\geq 0 \text{ mA}$
Ex. 625 mA	200 mA	425 mA	

If the calculation result is a negative value, the current consumption exceeds the power supply capacity of the extension power supply module.

Reconfigure the system, adding extension power supply modules.

4.5 Rules of System Configuration and Examples of Reconfiguration

The rules of system configuration are explained below referring to a sample system configuration using expansion adapter, I/O module, and intelligent function module.

In addition, the number of input/output points differs depending on the CPU module firmware version. For details on the number of input/output points, refer to [Page 62 Limitation on the Number of Input/Output Points](#).

For this system configuration example, the CPU module firmware version 1.100 is used.

System configuration example

The following system configuration is under consideration.

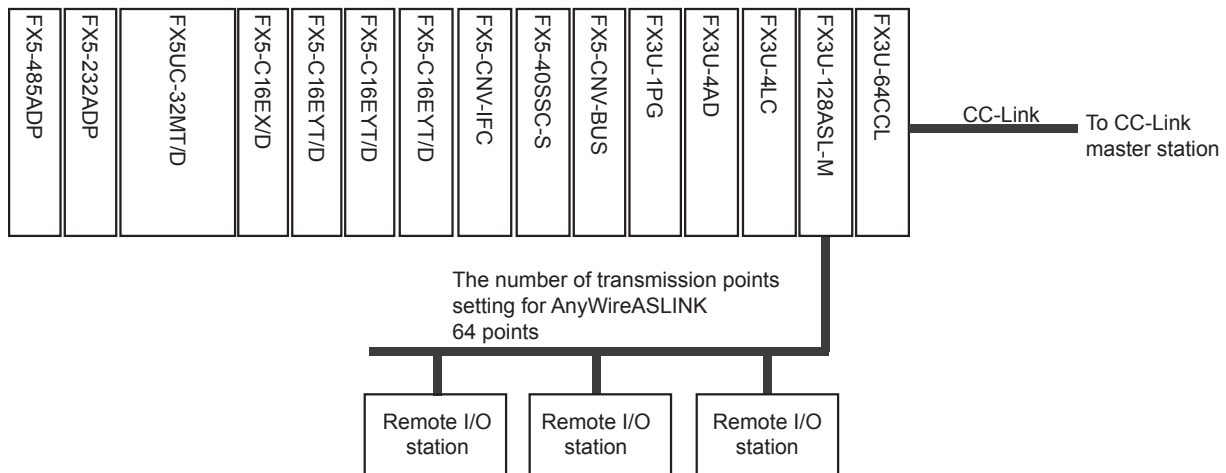

Check of limitation on the number of modules

Check if the sample system configuration is within the connectable-module range.

■Number of connected expansion adapters

([Page 58 Number of connected expansion adapters](#))

Type	No. of modules used	Limitations	Judgment
Expansion adapter (Communication)	2	Up to 2	OK

■Number of connected extension modules

• Number of modules connected on whole system

([Page 58 Overall system limitation](#))

Type	No. of modules used	Limitations	Judgment
Extension module	11 (Connector conversion module is excluded.)	Up to 16 (Extension power supply modules, connector conversion module are excluded.)	OK
Connector conversion module	1	Only 1	OK
Bus conversion module	1	Only 1	OK

• Number of modules connected to the CPU module

([Page 59 Connection to the CPU module](#))

Type	No. of modules used	Limitations	Judgment
Total No. of I/O modules, intelligent function modules, and bus conversion modules	11	Up to 12	OK
Total No. of intelligent function module and bus conversion modules	7	Up to 8	OK

• Number of modules connected to the bus conversion module

([Page 61 Connection to the bus conversion module \(connection with FX3 extension devices\)](#))

Type	No. of modules used	Limitations	Judgment
Total No. of intelligent function modules	5	Up to 6	OK

Check on limitations when using extension devices

Check the use of the extension devices.

■Use of the module of extension cable type

(☞ Page 55 Modules of extension cable type)

Limitations	Judgement
When using the extension cable type module, FX5-CNV-IFC or FX5-C1PS-5V should be connected.	OK

■Use of the bus conversion module

(☞ Page 55 Bus conversion module)

Limitations	Judgment
FX3 extension modules are connected on the right side of the bus conversion module.	OK
FX5 extension modules are connected on the left side of the bus conversion module.	OK

■Connection of intelligent function modules

(☞ Page 56 Limitations on intelligent function modules)

Model	Limitations	Judgment
FX3U-128ASL-M	Only one module may be connected to the system. Use together with the FX5-ASL-M is not possible.	OK
FX3U-64CCL	Only one module may be connected to the system. When using the FX5-CCL-MS as the intelligent device station, it cannot be used together with the FX5-CCL-MS.	OK

Check of limitation on the number of input/output points

Check if the number of input/output points of the sample system configuration is within the limit range.

■Number of input/output points

(☞ Page 64 Calculation of the number of input/output points)

Type	Model	No. of input/output points	No. of occupied input/output points
CPU module	FX5UC-32MT/D	32 points	—
Expansion adapter	FX5-232ADP	—	—
Expansion adapter	FX5-485ADP	—	—
Input module	FX5-C16EX/D	16 points	—
Output module	FX5-C16EYT/D	16 points	—
Output module	FX5-C16EYT/D	16 points	—
Output module	FX5-C16EYT/D	16 points	—
Connector conversion module	FX5-CNV-IFC	—	—
Simple motion module	FX5-40SSC-S	—	8 points
Bus conversion module	FX5-CNV-BUS	—	8 points
Pulse output module	FX3U-1PG	—	8 points
Analog input module	FX3U-4AD	—	8 points
Temperature controller module	FX3U-4LC	—	8 points
AnyWireASLINK master module	FX3U-128ASL-M	—	8 points
CC-Link intelligent device module	FX3U-64CCL	—	8 points

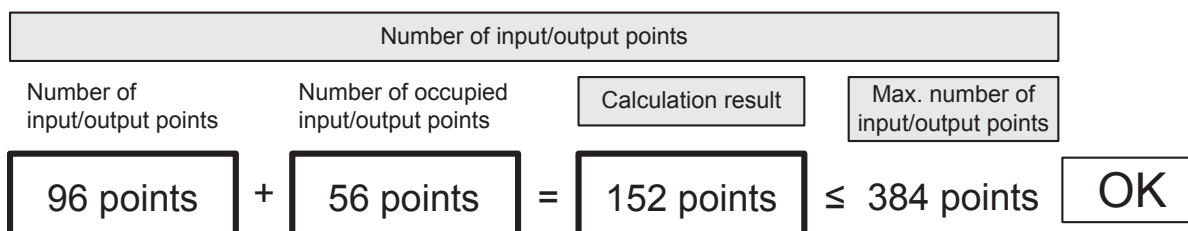

■ Number of remote I/O points

(☞ Page 65 Calculation of the number of remote I/O points)

Network	No. of remote I/O points
AnyWireASLINK	64 points

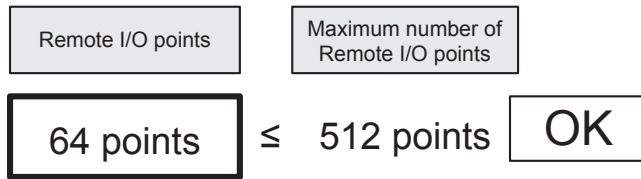

■ Total number of I/O points and remote I/O points

(☞ Page 62 Limitation on the Number of Input/Output Points)

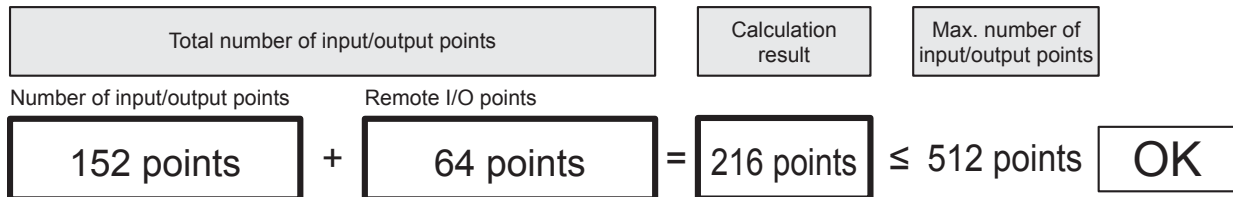

Check of limitation on current consumption

Check if power required for extension devices can be supplied from the CPU module and extension power supply module.

■ Check of power supply from the CPU module

(☞ Page 69 Power supply check from the CPU module (current consumption calculation))

- Power supply capacity of the CPU module

Type	Model	Power supply capacity	
		5 V DC power supply	24 V DC power supply
CPU module	FX5UC-32MT/D	720 mA	500 mA

- Current consumption of extension devices

Type	Model	Current consumption	
		5 V DC power supply	24 V DC power supply
Expansion adapter	FX5-232ADP	30 mA	30 mA
Expansion adapter	FX5-485ADP	20 mA	30 mA
Input module	FX5-C16EX/D	100 mA	—
Output module	FX5-C16EYT/D	100 mA	100 mA
Output module	FX5-C16EYT/D	100 mA	100 mA
Output module	FX5-C16EYT/D	100 mA	100 mA
Connector conversion module	FX5-CNV-IFC	—	—
Simple motion module	FX5-40SSC-S	—	—
Bus conversion module	FX5-CNV-BUS	150 mA	—
Pulse output module	FX3U-1PG	150 mA	—
Analog input module	FX3U-4AD	110 mA	—
Temperature controller module	FX3U-4LC	160 mA	—
AnyWireASLINK master module	FX3U-128ASL-M	130 mA	—
CC-Link intelligent device module	FX3U-64CCL	—	—

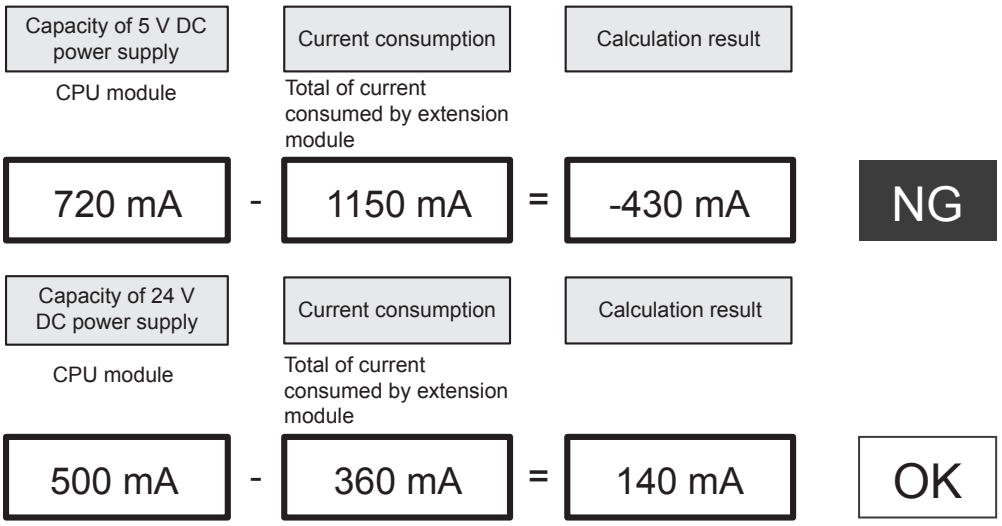

Result check

Because calculation results for 5 V DC or 24 V DC current consumption are negative, reconfiguration is necessary. The judgment procedure after reconfiguration is explained on the following pages.

System reconfiguration example

If current consumption of the 5 V DC or 24 V DC power supply is insufficient with the CPU module only, use an extension power supply module.

Reconfigure the example system configuration using an extension power supply module.

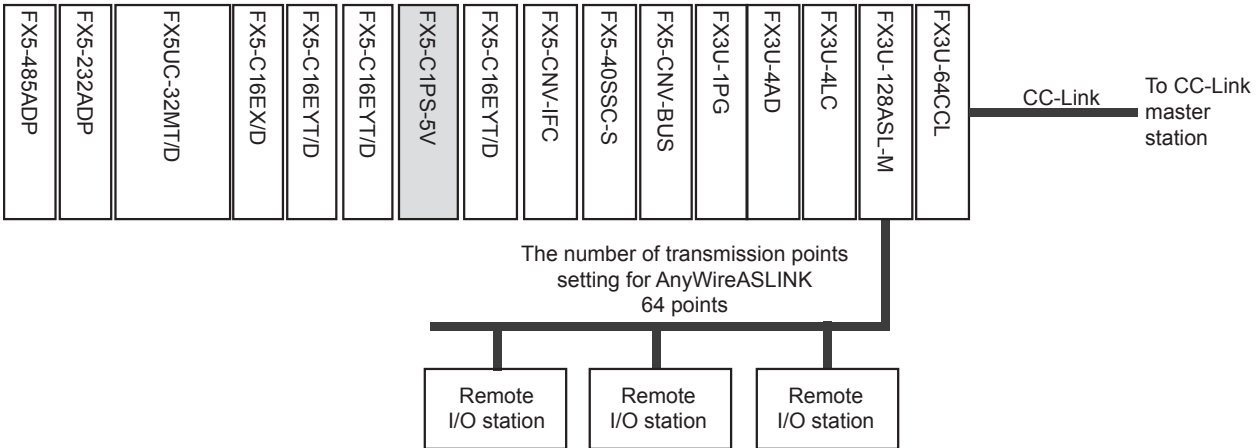

Check of limitation on the number of modules

Check if the example system configuration is within the connectable-module range.

■ Number of connected expansion adapters

(☞ Page 58 Number of connected expansion adapters)

Type	No. of modules used	Limitations	Judgment
Expansion adapter (Communication)	2	Up to 2	OK

■ Number of connected extension modules

• Number of modules connected on whole system

(☞ Page 58 Overall system limitation)

Type	No. of modules used	Limitations	Judgment
Extension module	11 (Extension power supply modules, connector conversion module are excluded.)	Up to 16 (Extension power supply modules, connector conversion module are excluded.)	OK
Extension power supply module	1	Up to 2	OK
Connector conversion module	1	Only 1	OK
Bus conversion module	1	Only 1	OK

• Number of modules connected to the CPU module

(☞ Page 59 Connection to the CPU module)

Type	No. of modules used	Limitations	Judgment
Total No. of I/O modules, intelligent function modules, and bus conversion modules	3	Up to 12	OK
Total No. of intelligent function module and bus conversion modules	0	Up to 8	OK

• Number of modules connected to extension power supply module

(☞ Page 61 Connection to the extension power supply module)

Type	No. of modules used	Limitations	Judgment
Total No. of I/O modules, intelligent function modules, and bus conversion modules	8	Up to 10	OK
Total No. of intelligent function module and bus conversion modules	7	Up to 8	OK

• Number of modules connected to the bus conversion module

(☞ Page 61 Connection to the bus conversion module (connection with FX3 extension devices))

Type	No. of modules used	Limitations	Judgment
Total No. of intelligent function modules	5	Up to 6	OK

Check on limitations when using extension devices

Check on limitations when using the extension devices.

■Use of the module of extension cable type

(☞ Page 55 Modules of extension cable type)

Limitations	Judgement
When using the extension cable type module, FX5-CNV-IFC or FX5-C1PS-5V should be connected.	OK

■Use of the bus conversion module

(☞ Page 55 Bus conversion module)

Limitations	Judgment
FX3 extension modules are connected on the right side of the bus conversion module.	OK
FX5 extension modules are connected on the left side of the bus conversion module.	OK

■Connection of intelligent function modules

(☞ Page 56 Limitations on intelligent function modules)

Model	Limitations	Judgment
FX3U-128ASL-M	Only one module may be connected to the system. Use together with the FX5-ASL-M is not possible.	OK
FX3U-64CCL	Only one module may be connected to the system. When using the FX5-CCL-MS as the intelligent device station, it cannot be used together with the FX5-CCL-MS.	OK

Check of limitation on the number of input/output points

Check if the number of input/output points of the sample system configuration is within the limit range.

■Number of input/output points

(☞ Page 64 Calculation of the number of input/output points)

Type	Model	No. of input/output points	No. of occupied input/output points
CPU module	FX5UC-32MT/D	32 points	—
Input module	FX5-C16EX/D	16 points	—
Output module	FX5-C16EYT/D	16 points	—
Output module	FX5-C16EYT/D	16 points	—
Extension power supply module	FX5-C1PS-5V	—	—
Output module	FX5-C16EYT/D	16 points	—
Connector conversion module	FX5-CNV-IFC	—	—
Simple motion module	FX5-40SSC-S	—	8 points
Bus conversion module	FX5-CNV-BUS	—	8 points
Pulse output module	FX3U-1PG	—	8 points
Analog input module	FX3U-4AD	—	8 points
Temperature controller module	FX3U-4LC	—	8 points
AnyWireASLINK master module	FX3U-128ASL-M	—	8 points
CC-Link intelligent device module	FX3U-64CCL	—	8 points

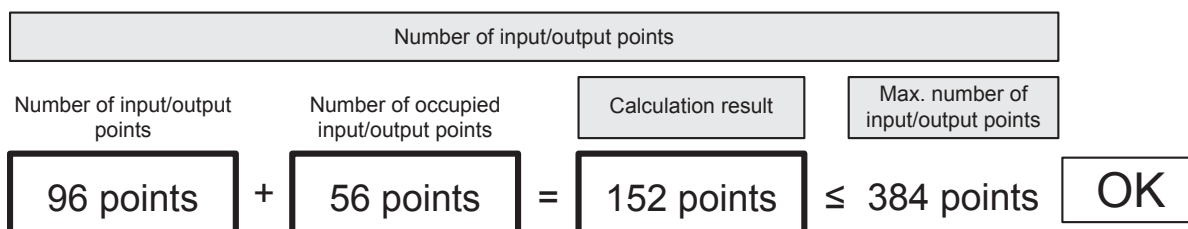

Number of remote I/O points

(☞ Page 65 Calculation of the number of remote I/O points)

Network	No. of remote I/O points
AnyWireASLINK	64 points

Remote I/O points	Maximum number of Remote I/O points
-------------------	-------------------------------------

$$64 \text{ points} \leq 512 \text{ points} \quad \text{OK}$$

Total number of I/O points and remote I/O points

(☞ Page 62 Limitation on the Number of Input/Output Points)

Total number of input/output points	Calculation result	Max. number of input/output points
-------------------------------------	--------------------	------------------------------------

$$152 \text{ points} + 64 \text{ points} = 216 \text{ points} \leq 512 \text{ points} \quad \text{OK}$$

Check of limitation on current consumption

Check if power required for extension devices can be supplied from the CPU module and extension power supply module.

Check of power supply from the CPU module

(☞ Page 69 Power supply check from the CPU module (current consumption calculation))

Power supply capacity of the CPU module

Type	Model	Power supply capacity	
		5 V DC power supply	24 V DC power supply
CPU module	FX5UC-32MT/D	720 mA	500 mA

Current consumption of extension devices

Type	Model	Current consumption	
		5 V DC power supply	24 V DC power supply
Expansion adapter	FX5-232ADP	30 mA	30 mA
Expansion adapter	FX5-485ADP	20 mA	30 mA
Input module	FX5-C16EX/D	100 mA	—
Output module	FX5-C16EYT/D	100 mA	100 mA
Output module	FX5-C16EYT/D	100 mA	100 mA

Capacity of 5 V DC power supply	Current consumption	Calculation result
---------------------------------	---------------------	--------------------

CPU module

Total of current consumed by extension module

$$720 \text{ mA} - 350 \text{ mA} = 370 \text{ mA} \quad \text{OK}$$

Capacity of 24 V DC power supply	Current consumption	Calculation result
----------------------------------	---------------------	--------------------

CPU module

Total of current consumed by extension module

$$500 \text{ mA} - 260 \text{ mA} = 240 \text{ mA} \quad \text{OK}$$

■ Check of power supply from the extension power supply module

(☞ Page 72 Power supply check from extension power supply module (current consumption calculation))

Power supply capacity of the extension power supply module

Type	Model	Power supply capacity	
		5 V DC power supply	24 V DC power supply
Extension power supply module	FX5-C1PS-5V	1200 mA	625 mA

Current consumption of extension devices

Type	Model	Current consumption	
		5 V DC power supply	24 V DC power supply
Output module	FX5-C16EYT/D	100 mA	100 mA
Connector conversion module	FX5-CNV-IFC	—	—
Simple motion module	FX5-40SSC-S	—	—
Bus conversion module	FX5-CNV-BUS	150 mA	—
Pulse output module	FX3U-1PG	150 mA	—
Analog input module	FX3U-4AD	110 mA	—
Temperature controller module	FX3U-4LC	160 mA	—
AnyWireASLINK master module	FX3U-128ASL-M	130 mA	—
CC-Link intelligent device module	FX3U-64CCL	—	—

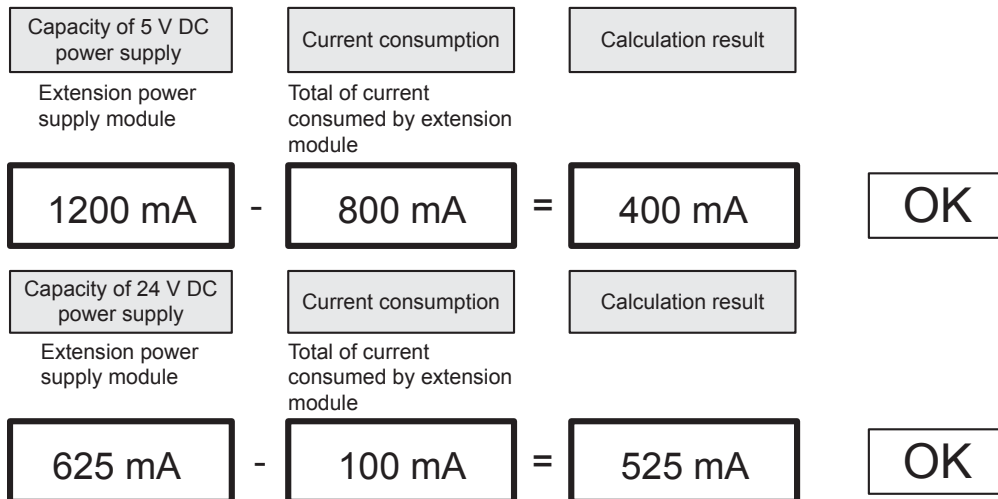

Result check

The reconfigured system is acceptable because the number of extension devices, consumption capacity of 5 V DC and 24 V DC power supply, and number of input/output points are all within the limit range.

4.6 Numbers and Assignment in System

Input/output numbers and module numbers in an FX5UC system are explained.

Module input/output number

The input/output numbers are octal numbers. Input is assigned to "X" and output to "Y."

Input/output numbers are used for communication of ON/OFF data between I/O modules and the CPU module.

- Input/output numbers (X/Y) are octal.

Input/output numbers (X/Y) are automatically assigned as shown below.

X0 to X7, X10 to X17, X20 to X27, ... X70 to X77, X100 to X107, ...

Y0 to Y7, Y10 to Y17, Y20 to Y27, ... Y70 to Y77, Y100 to Y107, ...

- Numbers for added I/O module

To an added I/O module, input numbers and output numbers following the input numbers and output numbers given to the preceding device are assigned. The last digit of the assigned numbers must begin with 0.

Module number of extension modules

The CPU module automatically assigns numbers (1 to 16) to intelligent function modules, safety main module or bus conversion module as module numbers in order of distance from the CPU module.

- Intelligent function modules, safety main module or bus conversion module connected to the CPU module

Module numbers are assigned to intelligent function modules in order of distance from the CPU module: No. 1 to No. 16.

- Products to which module numbers are not assigned

Module numbers are not assigned to the following extension devices.

I/O module	FX5-C32EX/D, FX5-C32EYT/D, etc.
Expansion adapter	FX5-232ADP, FX5-485ADP, etc.
Connector conversion module	FX5-CNV-IFC
Connector conversion adapter	FX5-CNV-BC
Extension power supply module	FX5-C1PS-5V
Safety input expansion module	FX5-SF-8DI4

Ex.

When the FX5 safety extension modules are not connected

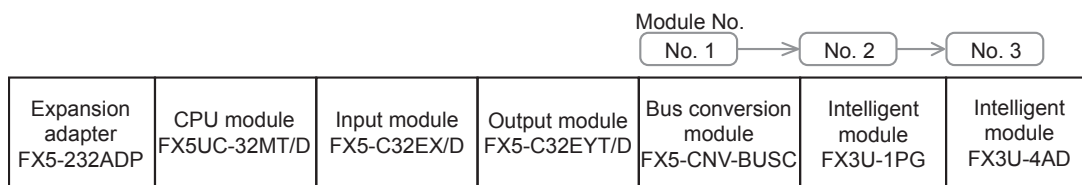

Ex.

When the FX5 safety extension modules are not connected

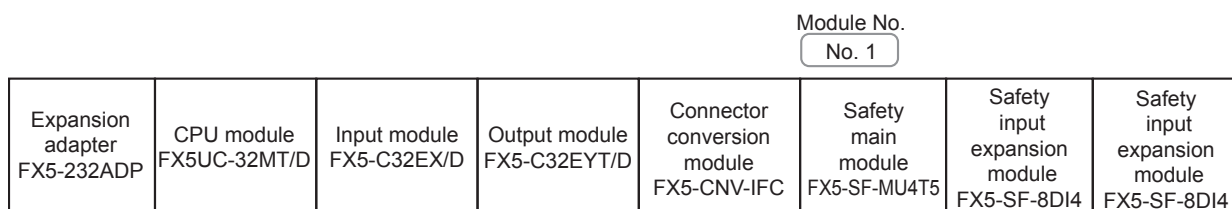

5 INSTALLATION

5.1 Installation Location

Use the PLC under the environmental conditions complying with the generic specifications (Page 29 Generic Specifications).

Installation location in enclosure

To prevent temperature rise, do not mount the PLC on the floor or ceiling, or in the vertical direction. Always mount the PLC horizontally on the wall as shown in the following figure.

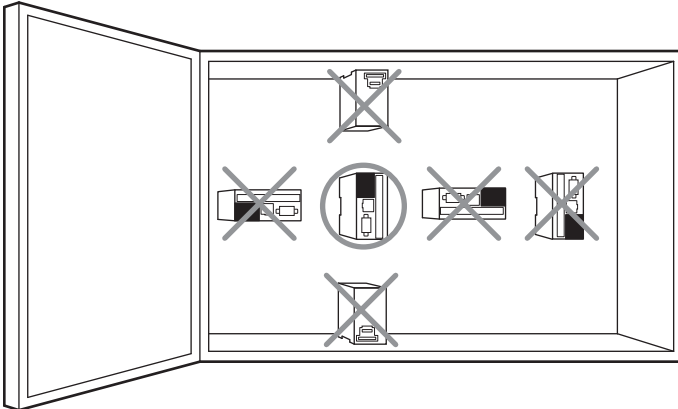

5

Spaces in enclosure

Extension devices can be connected on the left and right sides of the CPU module of the PLC. Keep a space of at least 50 mm between the module main body and other devices and structure.

Also, separate the PLC from high-voltage lines, high-voltage devices, and power devices when possible. Failure to do so may cause fire, equipment failures or malfunctions.

If you intend to add extension devices, keep necessary spaces on the left and right sides.

Configuration without extended extension cable

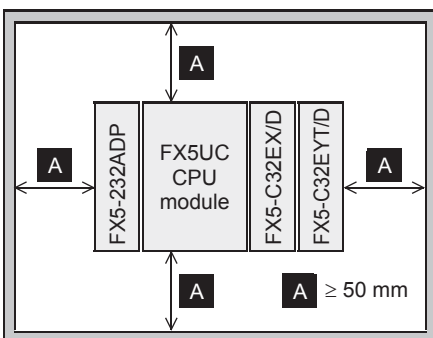

Configuration in 2 stages with extended extension cable

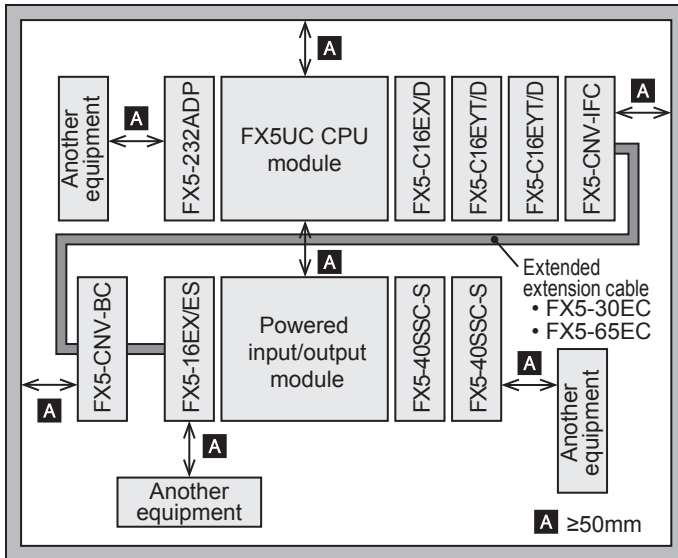

Layout in enclosure

The PLC components can be laid out in one stage or in two stages, upper and lower. The connecting procedures in each case are explained below.

Keep a space of at least 50 mm between the module main body or other devices and structure.

Also, separate the PLC from high-voltage lines, high-voltage devices, and power devices when possible. Failure to do so may cause fire, equipment failures or malfunctions.

Configuration in 1-stage layout

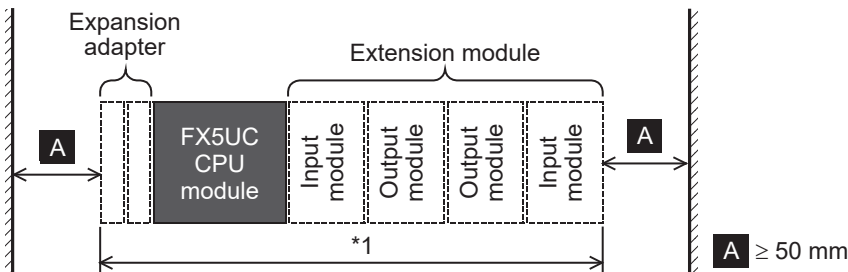

*1 For product dimensions or manual for various products, refer to [Page 164 I/O Module](#).

Configuration in 2-stage layout

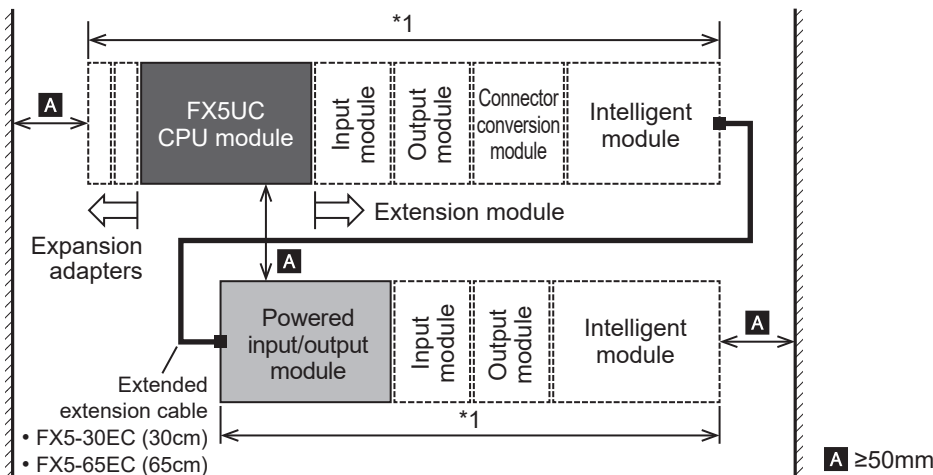

*1 For product dimensions or manual for various products, refer to [Page 164 I/O Module](#).

5.2 Examination for Installing Method in Enclosure

Examine the installation location of PLC considering the environmental conditions (☞ Page 29 Generic Specifications).

Point

When extension cables are used for the connection, install the products keeping a space of about 2 mm between them.

Installing on DIN rail

- The PLC can be installed on a DIN46277 rail (35 mm wide).
- The PLC can be easily moved and removed.
- The PLC installation height is the same as the DIN rail.

For details on the procedures for installing on and detaching from DIN rail, refer to ☞ Page 86 Procedures for Installing on and Detaching from DIN Rail.

Example of installation

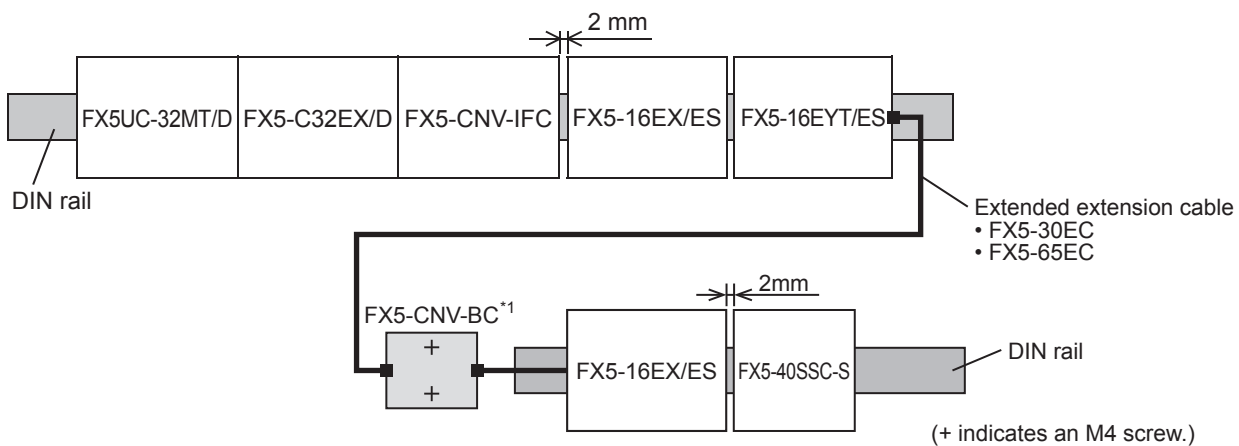

*1 FX5-CNV-BC can only be installed directly.

Example of combination of installation on DIN rail and direct installation

- The CPU module side can be installed on the DIN rail, and the extension modules extended by the extended extension cable can be directly installed.
- The PLC can be installed on a 35 mm wide DIN46277 rail.
- The PLC can be easily moved and removed.
- The PLC installation height is the same as the DIN rail.
- The PLC can be installed directly in the enclosure with M4 screws.

For details on the procedures for installing on and detaching from DIN rail, refer to ☞ Page 86 Procedures for Installing on and Detaching from DIN Rail. For mounting hole pitch, refer to ☞ Page 88 Removal of CPU module.

Example of installation

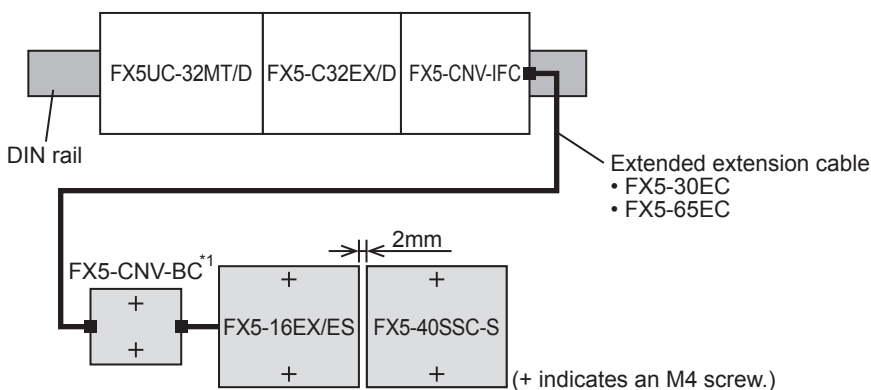

*1 FX5-CNV-BC can only be installed directly.

5.3 Procedures for Installing on and Detaching from DIN Rail

The CPU module can be installed on a DIN46277 rail (35 mm wide).

Preparation for installation

Connecting extension devices

Some extension devices must be mounted on the CPU module before the module is installed in the enclosure.

- Connect expansion adapters or extension modules (extension connector type) on the CPU module before mounting the PLC in the enclosure.
- Mount extension modules (extension cable type) or terminal modules in the enclosure after mounting the CPU module in the enclosure.
- Mount (replace) a battery before mounting the CPU module.

Affixing the dust proof sheet

The dust proof sheet should be affixed to the ventilation slits before beginning the installation and wiring work.

For the affixing procedure, refer to the instructions on the dust proof sheet.

Always remove the dust proof sheet when the installation and wiring work is completed.

Installation of CPU module

Connect expansion adapters or extension modules (extension connector type) on the CPU module before mounting the PLC in the enclosure.

For the connection method of the expansion adapters, refer to [Page 90 Connecting method A - connection of an expansion adapter](#).

For the connection method of the extension modules (extension connector type), refer to [Page 91 Connecting method B - connection of an extension module \(extension connector type\)](#).

1. Push out all DIN rail mounting hooks (A in the following figure).

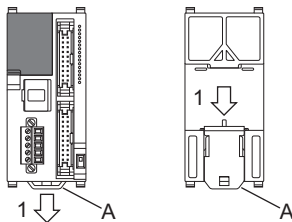

2. Fit the upper edge of the DIN rail mounting groove (B in the following figure) onto the DIN rail.

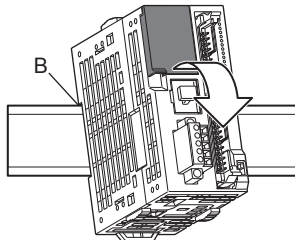

3. Lock the DIN rail mounting hooks (C in the following figure) while pressing the PLC against the DIN rail.

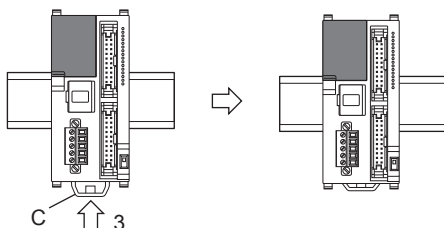

Installation of extension modules (extension cable type)

1. Push out the DIN rail mounting hook (A in the right figure) of the extension module (extension cable type).

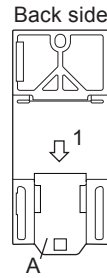

2. Fit the upper edge of the DIN rail mounting groove (B in the right figure) onto the DIN rail.
3. Push the product against the DIN rail.
4. Lock the DIN rail mounting hooks while pressing the product against the DIN rail.

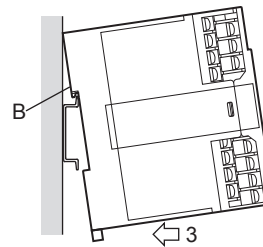

5. Connect the extension cable. For the connecting procedure of the extension cables, refer to [Page 90](#) Connecting Methods for CPU Module and Extension Devices.

Installation of terminal modules

1. Turn off all the power supplies connected to the CPU module, extension modules, or terminal modules.
2. Fit the upper edge of the DIN rail mounting groove (A in the right figure) onto the DIN rail.
3. Push the product against the DIN rail.

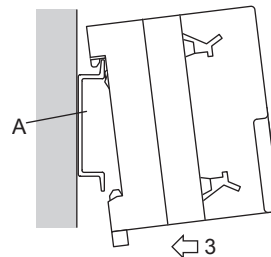

Removal of CPU module

1. Remove the connection cables including power cables and I/O cables.
2. Insert the tip of a flathead screwdriver into the hole of the DIN rail mounting hook (B in the right figure). This step also applies for the DIN rail mounting hooks of the expansion adapters or extension modules (connector type).
3. Move the flathead screwdriver as shown in the right figure to draw out the DIN rail mounting hooks of all devices.
4. Remove the product from the DIN rail (C in the right figure).
5. Push in the DIN rail mounting hooks (D in the right figure).

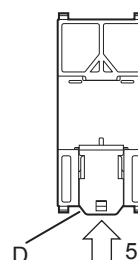
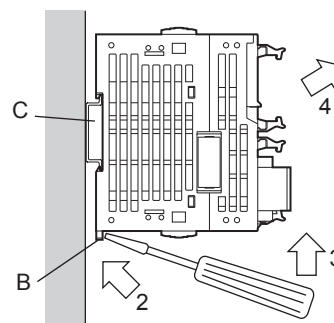

5.4 Procedures for Installing Directly (with M4 Screws)

The product can be installed directly in the enclosure (with screws).



Position the holes so that there is a gap of about 2 mm between the products.

Hole pitches for direct mounting

The product mounting hole pitches are shown below.
For pitch that varies depending on the product, refer to the table.

I/O module

Dimensions	Model name	Mounting hole pitch W Unit: mm
	FX5-8EX/ES FX5-8EYR/ES FX5-8EYT/ES FX5-8EYT/ESS FX5-16EX/ES FX5-16EYR/ES FX5-16EYT/ES FX5-16EYT/ESS FX5-16ER/ES FX5-16ET/ES FX5-16ET/ESS FX5-16ET/ES-H FX5-16ET/ESS-H	Refer to the figure shown to the left.
	FX5-32ER/DS FX5-32ET/DS FX5-32ET/DSS	140

Bus conversion module

Dimensions	Model name	Mounting hole pitch W Unit: mm
	FX5-CNV-BUS	Refer to the figure shown to the left.

Intelligent function module, FX5 safety extension module

For the mounting hole dimensions of intelligent function modules and FX5 safety extension modules, refer to the user's manuals of each product.

Hole pitches when extension module connected

Ex.

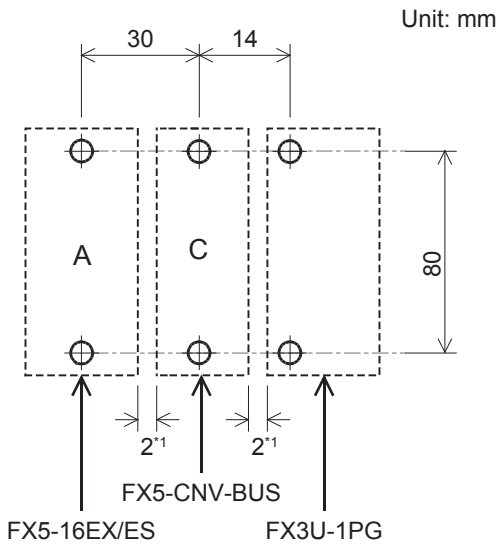

*1 The gap between products is 2 mm.

Installation of extension module (extension cable type)

1. Make mounting holes on the mounting surface according to the external dimensions diagram.
2. Push in the DIN rail mounting hook (A in the right figure) of the extension module (extension cable type). If the DIN rail mounting hook is not pushed in, the screw hole is covered, and the extension module cannot be mounted. (This procedure may not be required, depending on the model.)
3. Fit the extension module (extension cable type) (B in the right figure) to the holes, and secure it with M4 screws (C in the right figure).

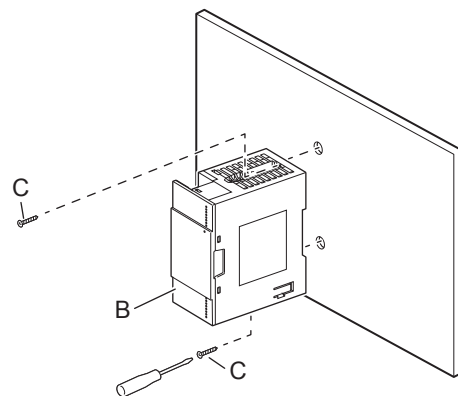
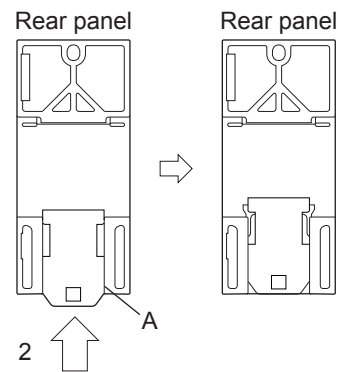

5.5 Connecting Methods for CPU Module and Extension Devices

This section explains the connection methods for extension devices.

Connection of extension devices

The connection method varies depending on the combination of products, i.e., the CPU module, expansion adapters, and extension modules.

The connecting methods are explained with the following configuration example.

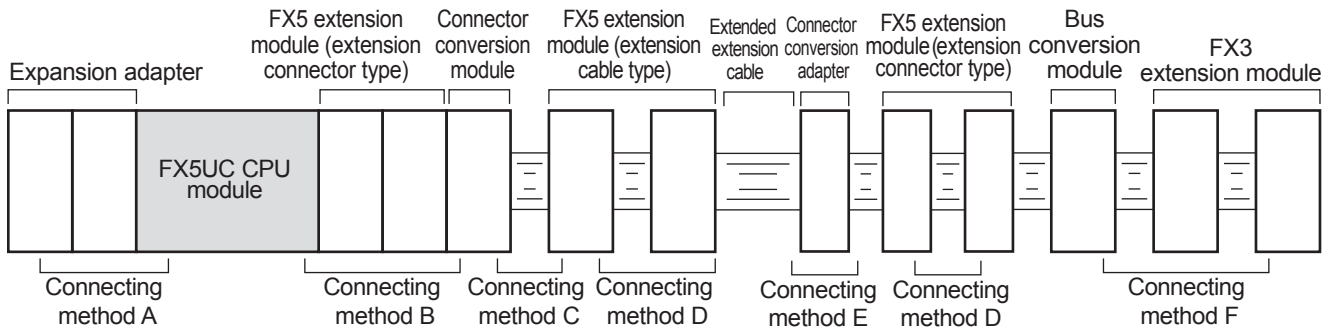

Connecting method A - connection of an expansion adapter

This subsection explains how to connect the expansion adapter to the CPU module.

1. Remove expansion adapter connector cover (A in the right figure).
2. Slide the hook for coupling the expansion adapter of the CPU module (B in the right figure).
3. Connect the expansion adapter to the CPU module as shown in the right figure.
4. Slide the hook for coupling the expansion adapter of the CPU module (B in the right figure) to fix the expansion adapter (C in the right figure).

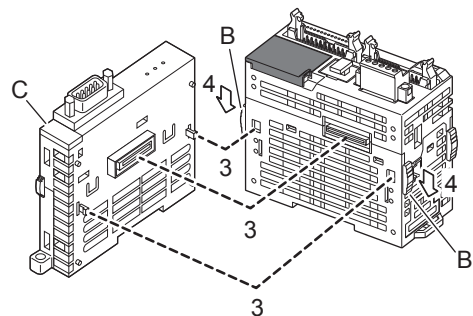
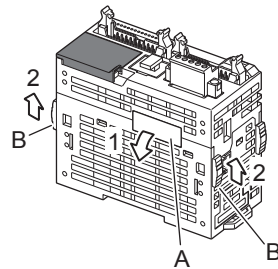

Connecting method B - connection of an extension module (extension connector type)

This subsection explains how to connect the extension module (extension connector type).

1. Slide the hook for coupling the extension module (A in the right figure) of the existing module (left side).
2. Remove the subsequent extension connector cover (B in the right figure).
3. Connect an extension module as shown in the right figure.
4. Slide the hook for coupling the extension module (A in the right figure) of the existing module to fix the extension module (C in the right figure).

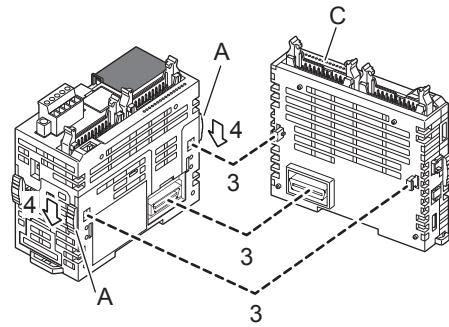
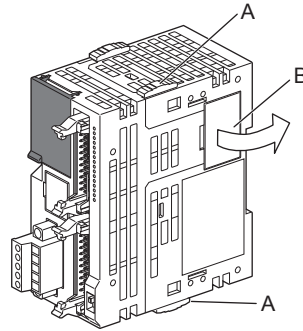

Extension connector of extension power supply module can use either extension cable type or the extension connector type.

Connecting method C - connection of a connector conversion module (extension connector type) or the extension power supply module and an extension module (extension cable type)

This subsection explains how to connect the extension module (extension cable type) to the connector conversion module (extension connector type) or the extension power supply module.

1. Remove the top cover (B in the right figure) of the existing module (left side) (A in the right figure). (Only extension power supply module.)
2. Connect the extension cable (C in the right figure) of the module to be connected (right side) to the existing module (left side) (A in the right figure).
3. Fit the top cover (B in the right figure). (Only extension power supply module.)
4. Draw out the pullout tab (D in the right figure) of the extension cable on the right side of the top cover. (Only extension power supply module.)

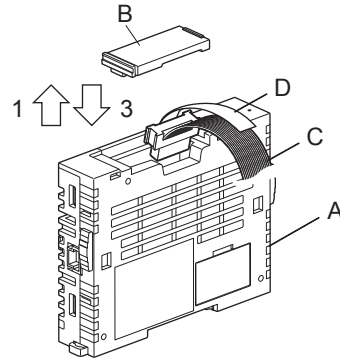

Restriction

Extension connector of extension power supply module can use either extension cable type or the extension connector type.

Precautions

Cautions on mounting and removing extension cables

- Make sure that the pullout tab of extension cables do not touch the conductive parts of the module.
- When removing the extension cable, pull the pullout tab of the extension cable straight up.

Connecting method D - connection between extension modules (extension cable type)

This subsection explains how to connect extension modules (extension cable type).

1. Remove the top cover (B in the right figure) of the existing module (left side) (A in the right figure).
2. Connect the extension cable (C in the right figure) of the module to be connected (right side) to the existing module (left side) (A in the right figure).
3. Fit the top cover (B in the right figure).
4. Draw out the pullout tab (D in the right figure) of the extension cable on the right side of the top cover.

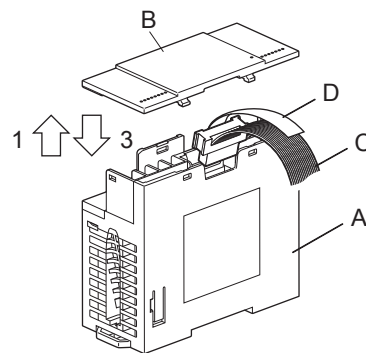

Point

Cautions on mounting and removing extension cables

- Make sure that the pullout tab of extension cables do not touch the conductive parts of the module.
- When removing the extension cable, pull the pullout tab of the extension cable straight up.

Connecting method E - connection of extended extension cable and connector conversion adapter

This subsection explains the procedures for connecting an extended extension cable and FX5-CNV-BC to the extension cable of the FX5 extension module.

1. Separate the case of FX5-CNV-BC into two pairs as shown right figure. To separate the case, use a precision flathead screwdriver. Slightly insert the tip of the screwdriver into part A shown in the right figure, and the hook (B in the right figure) will come off (4 places).

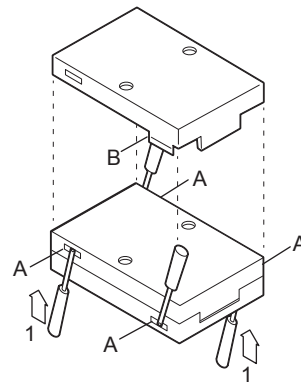

2. Connect the extended extension cable on the upstream side (C in the right figure).
3. Connect the extension cable on the downstream side (D in the right figure).
4. Pull the tab (E in the right figure) outside, fit the upper cover (F in the right figure) and the lower cover (G in the right figure), and press down the upper cover until it is hooked.

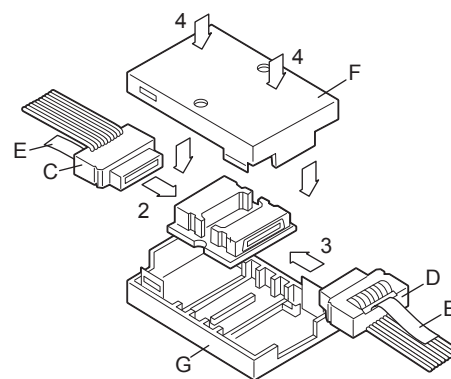

Connecting method F - connection of a bus conversion module and an FX3 intelligent function module

This subsection explains how to connect the FX3 extension module to the bus conversion module.

1. Connect the extension cable (A in the right figure) from the FX3 extension module to the subsequent extension connector of the bus conversion module.

This illustration is FX5-CNV-BUSC. When FX5-CNV-BUS is used, connect the extension cable to the bus conversion module in the same way.

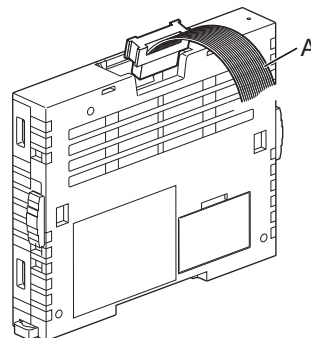

Connection of power cables

Power cable connection of the CPU module, extension power supply module and I/O modules

The power must be supplied to the FX5UC CPU module, FX5-C1PS-5V, FX5-C□EX/D, and FX5-C32ET/D.

Use the power cable for CPU modules to supply the power to the FX5UC CPU module and FX5-C1PS-5V.

To supply the power to FX5-C□EX/D and FX5-C32ET/D, use two power connectors (upper and lower) on each module for crossover wiring.

FX5-C□EX/DS(-TS) and FX5-C32ET/DS□ do not have power connectors. Supply the power to them using input connectors or input terminal blocks.

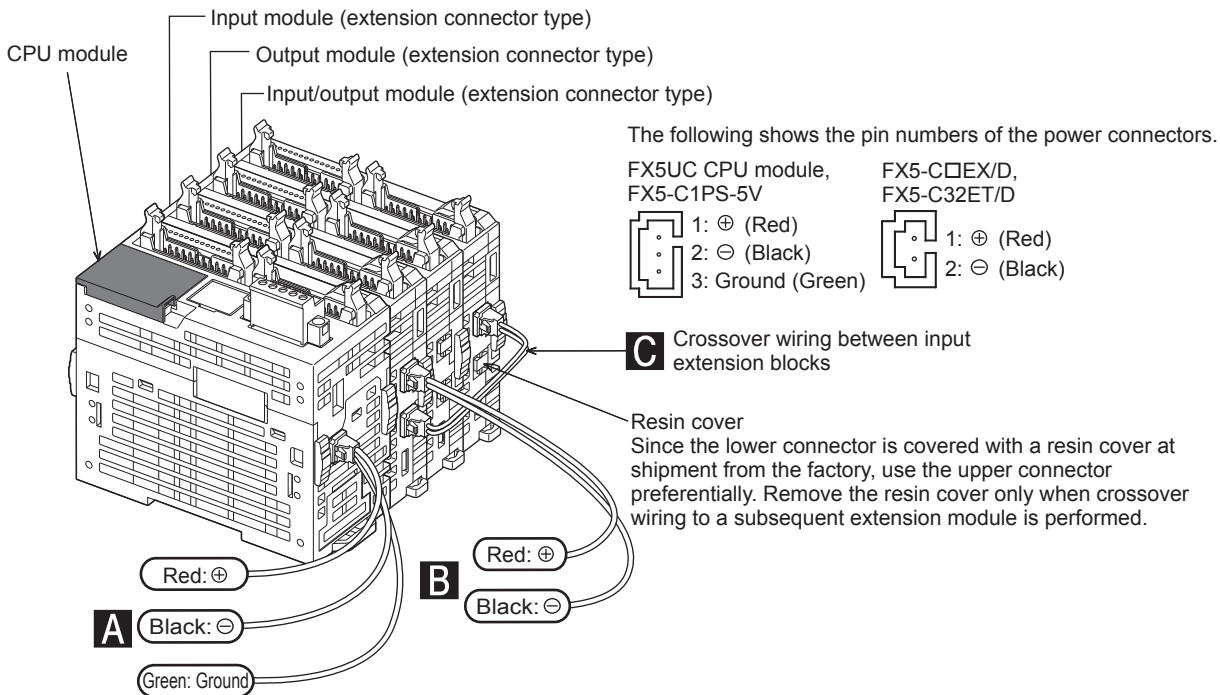

The following products are provided with power cables.

Classification	Application	Model	Length	Provided with
A	Power cable for CPU modules, extension power supply module	FX2NC-100MPCB	1 m	FX5UC-□MT/D, FX5UC-□MT/DSS, FX5UC-32M□/DS□-TS, FX5-C1PS-5V
B	Power cable for FX5-C□EX/D and FX5-C32ET/D	FX2NC-100BPCB ^{*1}	1 m	FX5UC-□MT/D
C	Power crossover cable for FX5-C□EX/D and FX5-C32ET/D	FX2NC-10BPCB1	0.1 m	FX5-C□EX/D, FX5-C32ET/D

*1 FX2NC-100BPCB is not provided with FX5UC-□MT/DSS and FX5UC-32M□/DS□-TS.

FX2NC-100BPCB is required to add FX5-C□EX/D and FX5-C32ET/D to FX5UC-□MT/DSS and FX5UC-32M□/DS□-TS unless crossover wiring is performed. Prepare the necessary modules as needed.

- Wiring FX5-C□EX/D or FX5-C32ET/D to a subsequent stage

Since the two power connectors on each module of FX5-C□EX/D and FX5-C32ET/D are connected in parallel inside the module, they have no difference and can be either an inlet port or outlet port for supplying the power. Thus, cables can be connected to either of the connectors.

However, since the lower connector is covered with a resin cover at shipment from the factory, use the upper connector preferentially. Remove the resin cover only when crossover wiring to a subsequent module is performed.

(FX5-C□EX/DS(-TS) and FX5-C32ET/DS□ do not have power connectors and the power is supplied from using input connectors or input terminal blocks. Thus, removing the resin cover is not required.)

Precautions

To perform crossover wiring, supply the power from the preceding module to the subsequent module. The power cannot be supplied from the subsequent module to the preceding module.

Removal of power cables

Hold part "a" on the connector of the power cable with your fingers, and remove the cable in the direction of the arrow.

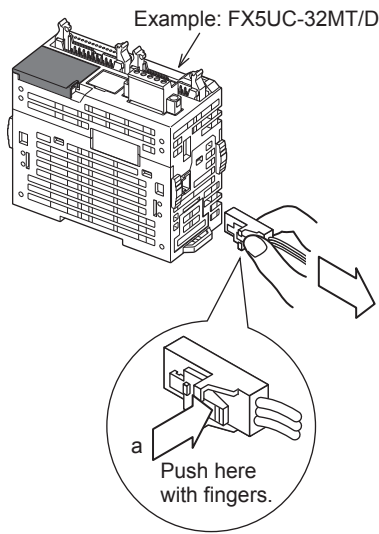

Precautions

If the power cable is removed by force, the cable may break.

Connection of I/O cables

I/O connectors

■ Cable connection to I/O connectors

I/O connectors conform to MIL-C-83503.

For I/O cables, refer to Page 96 Preparation of I/O connectors and prepare them.

- CPU module, I/O modules (extension connector type)

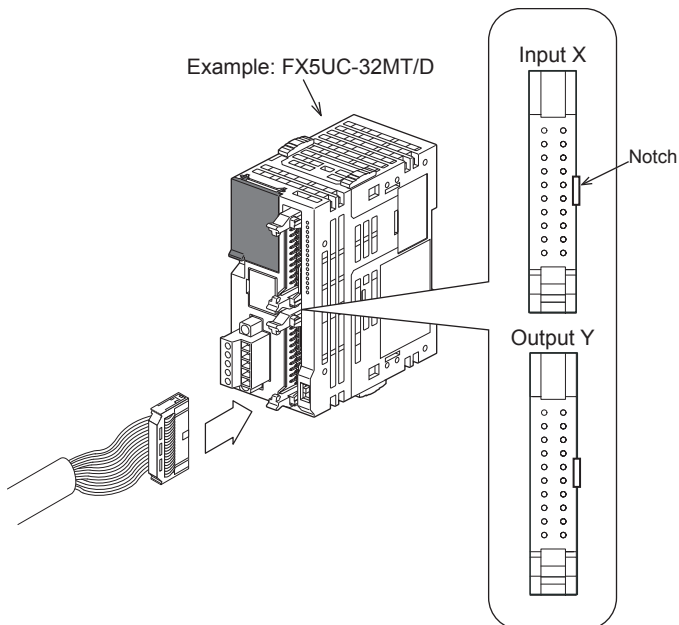

- Terminal module

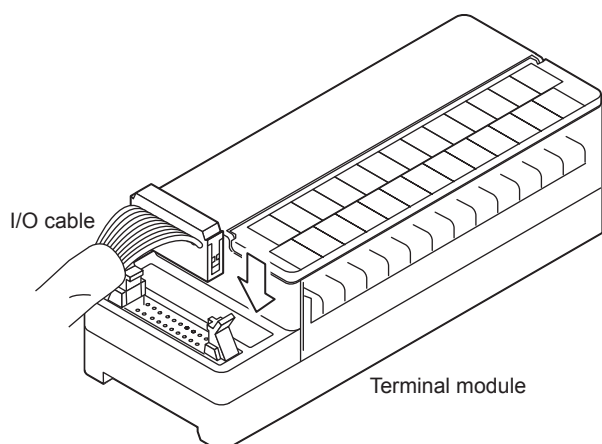

■Preparation of I/O connectors

- Suitable connector (commercial item)

Use 20-pin (1-key) sockets conforming to MIL-C-83503.

Check that the sockets do not interfere with peripheral parts including connector covers in advance.

- I/O cables (Mitsubishi option)

I/O cables on which connectors are attached are prepared.

Model	Length	Description	Type
FX-16E-500CAB-S	5 m	General-purpose I/O cable	<ul style="list-style-type: none"> • Single wire (Wire color: Red) • CPU module side: 20-pin connector is attached.
FX-16E-150CAB	1.5 m	Cables for connection of the terminal module and I/O connectors For the connection with the terminal module, refer to  Page 97 WIRING.	<ul style="list-style-type: none"> • Flat cables (with tube) • On both ends, 20-pin connectors are attached.
FX-16E-300CAB	3 m		
FX-16E-500CAB	5 m		
FX-16E-150CAB-R	1.5 m		<ul style="list-style-type: none"> • Round multicore cables • On both ends, 20-pin connectors are attached.
FX-16E-300CAB-R	3 m		
FX-16E-500CAB-R	5 m		

- Connectors for self-making I/O cables (Mitsubishi option)

Prepare wires and crimp tools by users.

Model and configuration of I/O connectors			Suitable wiring (UL-1061-compliant products are recommended) and tool	
Mitsubishi model		Part description (Manufactured by DDK Ltd.)	Wire size	Crimp tool (Manufactured by DDK Ltd.)
FX2C-I/O-CON for flat cables	10 sets	Crimp connector FRC2-A020-30S	AWG 28 (0.1 mm ²) 1.27-pitch 20 cores	357J-4674D main body 357J-4664N attachment
FX2C-I/O-CON-S for single wires	5 sets	Housing HU-200S2-001 Crimp contact HU-411S	AWG 22 (0.3 mm ²)	357J-5538
FX2C-I/O-CON-SA for single wires	5 sets	Housing HU-200S2-001 Crimp contact HU-411SA	AWG 20 (0.5 mm ²)	357J-13963

Contact for crimp tools: Fujikura Ltd.

- Certified connectors (commercially available connectors)

Connectors made by DDK Ltd. shown above

6 WIRING

6.1 Wiring Preparations

Wiring procedure

Before wiring, make sure that the source power supply is off.

1. Prepare the parts for wiring.

Prepare cables and crimp terminals required for wiring. ( Page 98 Cable Connecting Procedure)

2. Connect the power cable.

Connect the cable to the power connector.

Provide the protection circuit described in this chapter for the power supply circuit. ( Page 104 Power Supply Wiring)

3. Perform class D grounding (grounding resistance: 100 Ω or less) for the ground [] terminal.

Connect the grounded wire to the terminal. ( Page 103 Grounding)

4. Wire input [X] terminal.

Connect sensors and switches to the terminals. ( Page 106 Input Wiring)

5. Wire output [Y] terminal.

Connect the load to terminals.

( Page 116 Output Wiring)

6. Wire the built-in RS-485 communication terminal blocks and Ethernet communication connectors.

 MELSEC iQ-F FX5 User's Manual (Serial Communication)

 MELSEC iQ-F FX5 User's Manual (MODBUS Communication)

 MELSEC iQ-F FX5 User's Manual (Ethernet Communication)

7. Wire intelligent function modules, FX5 safety extension modules, and expansion adapters.

 MELSEC iQ-F FX5 User's Manual (Serial Communication)

 MELSEC iQ-F FX5 User's Manual (MODBUS Communication)

 MELSEC iQ-F FX5 User's Manual (Analog Control - CPU module built-in, Expansion adapter)

User's manual for each intelligent function module and FX5 safety extension module

6.2 Cable Connecting Procedure

The cable connecting procedure is explained below.

European-type terminal block

Wire the European-type terminal block in accordance with the following specifications.

Suitable wiring

	No. of wire per terminal	Wire size		Tightening torque
		Single wire, Strand wire	Ferrule with insulation sleeve	
Terminal block for built-in RS-485 communication, Communication adapter	One wire	0.3 to 0.5 mm ² (AWG22 to 20)	0.3 to 0.5 mm ² (AWG22 to 20)	0.22 to 0.25 N·m
	Two wires	0.3 mm ² (AWG22)	—	
Analog adapter	One wire	0.3 to 0.5 mm ² (AWG22 to 20)	0.3 to 0.5 mm ² (AWG22 to 20)	0.20 N·m
	Two wires	0.3 mm ² (AWG22)	—	

Precautions

Do not tighten terminal screws with torque beyond the specified range. Otherwise it may cause equipment failure or malfunction.

Wire end treatment

Treat stranded and solid wires as they are or use wire ferrules with insulation sleeves for wiring terminals.

■When stranded and solid wires are treated as they are

- Twist the end of stranded wires and make sure that there are no loose wires.
- Do not solder-plate the electric wire ends.

Stripping dimensions of electric wire ends

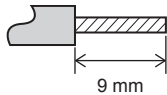

■When wire ferrules with insulation sleeves are used

Depending on the thickness of a wiring sheath used, it may be difficult to insert the sheath into an insulating sleeve. Refer to the external dimensions as a reference to select wires.

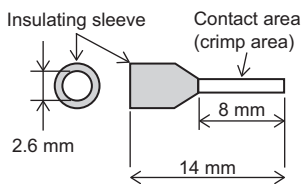

<Reference>

	Manufacturer	Model	Crimp tool
Terminal block for built-in RS-485 communication, Expansion adapter	Phoenix Contact GmbH & Co. KG	AI 0.5-8 WH	CRIMPFOX 6 CRIMPFOX 6T-F

■ Tool

For tightening terminals, use a small, commercially-available screwdriver with a straight tip. The recommended shape is shown in the figure on the right.

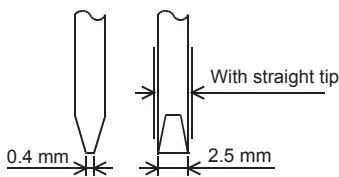

Precautions

When a precision screwdriver with a small grip is used, the specified tightening torque cannot be obtained. Use the following screwdriver or equivalent product (grip diameter: 25 mm) to obtain the tightening torque specified above.

<Reference>

Manufacturer	Model
Phoenix Contact GmbH & Co. KG	SZS 0.4 × 2.5

Spring Clamp Terminal Block

Wire the spring clamp terminal block in accordance with the following specifications.

For information regarding spring clamp terminal blocks for intelligent function modules and FX5 safety extension modules, refer to the user's manuals for each module.

Suitable wiring

The wires to connect the spring clamp terminal block are described below.

No. of wire per terminal	Wire size		
	Single wire, Strand wire	Ferrule with insulation sleeve	Ferrules without insulation sleeve
One wire	AWG24 to 16 (0.2 to 1.5 mm ²)	AWG23 to 19 (0.25 to 0.75 mm ²)	AWG23 to 16 (0.25 to 1.5 mm ²)

Wire end treatment

When not using a ferrule, strip the cable about 10 mm from the tip and connect it as a strand wire so that the wires do not separate. When using a ferrule, strip the cable about 10 mm from the tip to connect a wire ferrule at the striped area. Failure to do so may result in electric shock or short circuit between adjacent terminals because of the conductive part. If the wire strip length is too short, it may result in the unstable connection to the spring clamp terminal part.

Depending on the thickness of the sheath, it may be difficult to insert into the insulation sleeve, so select the wires by referring to the specifications in the diagram.

Strand wire/single wire	Ferrule with insulation sleeve

The following table shows wire ferrules and tools you can remove this part compatible with the terminal block. Use of items that are not listed in the following table may result in wire ferrule getting stuck to the terminals. Before use, carefully confirm that the wire ferrule can be removed.

<Reference product>

Manufacturer	Model	Wire size	Crimp tool
PHOENIX CONTACT GmbH & Co. KG	Al 0.5-10 WH	0.5 mm ²	CRIMPFOX 6
	Al 0.75-10 GY	0.75 mm ²	
	A 1.0-10	1.0 mm ²	
	A 1.5-10	1.5 mm ²	

Removing and installing the terminal block

Follow the below procedures to remove and install the terminal block.

■Lever position to lock and release

A 3-step stopper is attached to prevent the lever from rotating, facilitating installation and removal of the terminal block.

When removing or installing the terminal block, move the lever to the corresponding position.

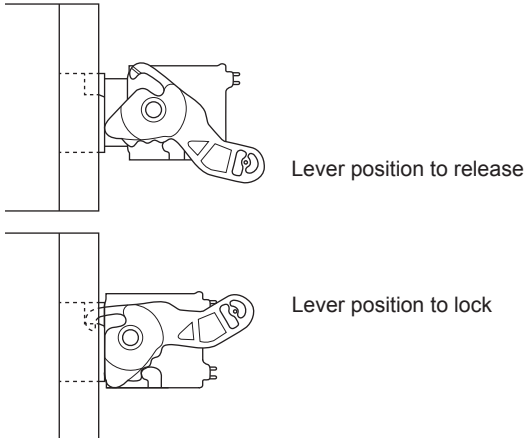

■Lever position to release

The figure left shows the lever position when the terminal block has been completely removed from the module.

Rotate the lever from the lock position to the release position, and lift the terminal block from the module.

■Lever position to lock

The figure left shows the lever position when the terminal block is completely engaged with the module.

Check that the lever is at the lock position, and pull the terminal block slightly to check that the module and terminal block are completely engaged.

■Removal procedure

Rotate the lever to the release position, and remove the terminal block from the module.

■Installation procedure

Move the lever to the release position, and insert the terminal block. When the terminal block is inserted sufficiently, the lever latch engages with the module and the terminal block is engaged with the module.

Point

- Insert the flathead screwdriver having a tip width of 2.0 to 2.5 mm to the groove of the lever, push up the flathead screwdriver, rotate the lever to the release position, and the terminal block can be removed from the module easily.

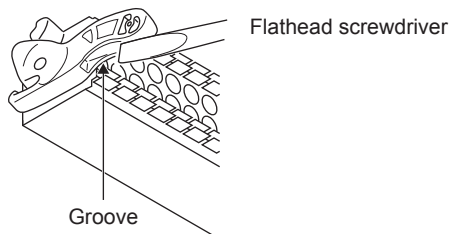

- After inserting the terminal block, check that the lever is at the lock position.

Precautions

When installing the terminal block, check that the lever is in the release position. If installation is performed while the lever is in the lock position, it may cause damage to the lever.

Connection and disconnection of the cable

Spring clamp terminal block is the push-in type, therefore, wiring without a tool is possible by simply inserting the connecting terminal to the terminal block. However, the push-in type does not support stranded wire, and a tool is required for connecting cables.

■ Connection of the cable

Fully insert a cable or bar solderless terminal whose end has been properly processed, into the wire insertion opening. If the cable or bar solderless terminal cannot be inserted with this procedure, fully insert the cable or bar solderless terminal while pushing the open/close button with a flathead screwdriver having a tip width of 2.0 to 2.5 mm. After fully inserting the cable or bar solderless terminal, remove the screwdriver.

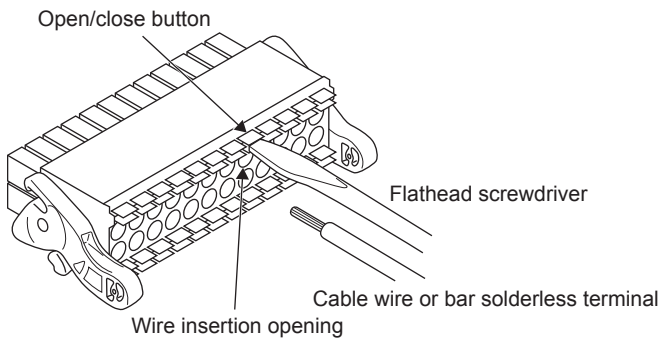

<Reference>

Manufacturer	Model
PHOENIX-CONTACT GmbH & Co. KG	SZS 0.4 × 2.5 VDE

Precautions

- Pull the cable or bar solderless terminal slightly to check that the cable is securely clamped.
- When wiring with the thick electric wire, make sure to prevent the conductive parts from protruding to the front of the terminal block.

■ Disconnection of the cable

While pushing the open/close button with a flathead screwdriver having a tip width of 2.0 to 2.5 mm, disconnect the cable or bar solderless terminal.

Screw terminal block

Wire the screw terminal block in accordance with the following specifications.

For information concerning screw terminal blocks for intelligent function modules, refer to User's manual for each intelligent function module.

Terminal block screw size and tightening torque

Model	Terminal screw size	Tightening torque
I/O module (extension cable type)	M3	0.5 to 0.8 N·m
Terminal module	M3.5	
Intelligent function module	Refer to User's manual for each product.	

Precautions

Do not tighten terminal screws exceeding the specified torque range. Otherwise it may cause equipment failure or malfunction.

Wire end treatment

Crimp terminal size differs depending on terminal screw size and wiring methods used.

- Use crimp terminals of the following sizes.

■M3 terminal screw

- When a single wire is connected to a single terminal

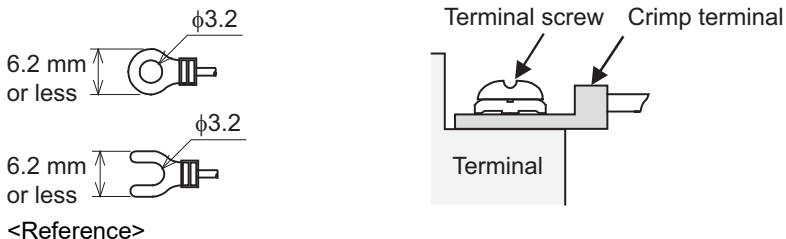

<Reference>

Terminal manufacturer	Type No.	Applicable cable	Certification	Pressure bonding tool
JST Mfg. Co., Ltd.	FV1.25-B3A	AWG22 to 16	UL Listed	YA-1 (JST Mfg. Co., Ltd.)
	FV2-MS3	AWG16 to 14		

- When two wires are connected to a single terminal^{*1}

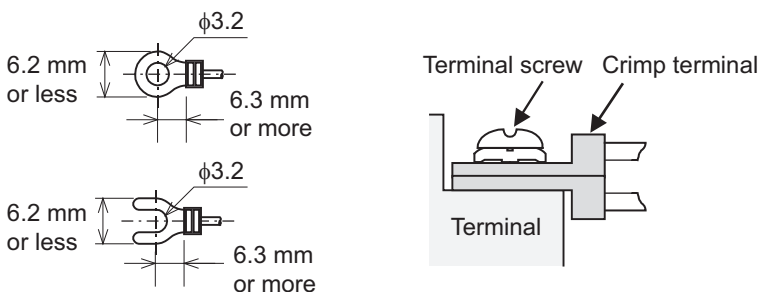

<Reference>

Terminal manufacturer	Type No.	Applicable cable	Certification	Pressure bonding tool
JST Mfg. Co., Ltd.	FV1.25-B3A	AWG22 to 16	UL Listed	YA-1 (JST Mfg. Co., Ltd.)

*1 To adapt the LVD directive (EN61010-2-201:2013) of the EC directive, avoid the wiring with two wires to the built-in terminal, and take an appropriate action such as adding an external terminal.

For the time of compliance with the LVD directive (EN61010-2-201:2013), refer to Page 160 Requirement for Compliance with LVD directive.

■M3.5 terminal screw

- When a single wire is connected to a single terminal

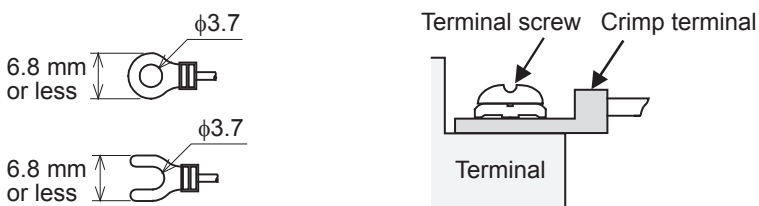

- When two wires are connected to a single terminal

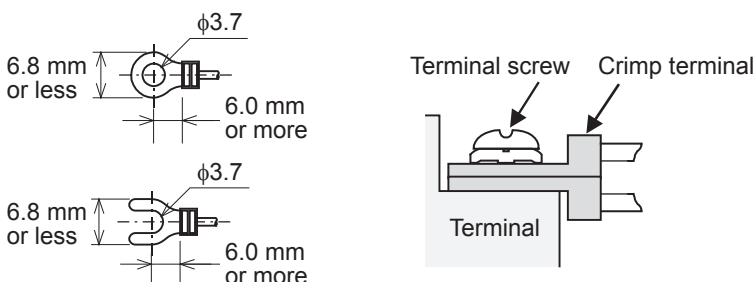

6.3 Grounding

Perform the following.

- Perform class D grounding (Grounding resistance: 100 Ω or less).
- Ground the PLC independently when possible.
- If the PLC cannot be grounded independently, perform the "Shared grounding" shown below.

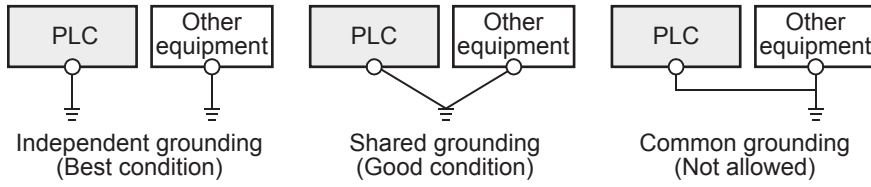

PLC extension devices (excluding communication adapters)

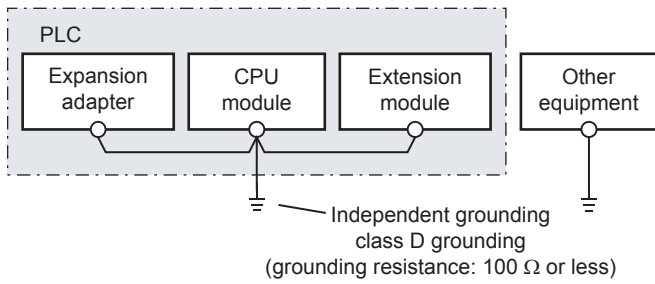

- Bring the grounding point close to the PLC as much as possible so that the ground cable can be shortened.

6.4 Power Supply Wiring

Examples of DC power supply wiring

Provide a 24 V DC power supply to FX5UC CPU module and other modules. Use dedicated connectors to provide the power supply. (Refer to Page 94 Connection of power cables.)

Power supply wiring example of FX5UC-32MT/D

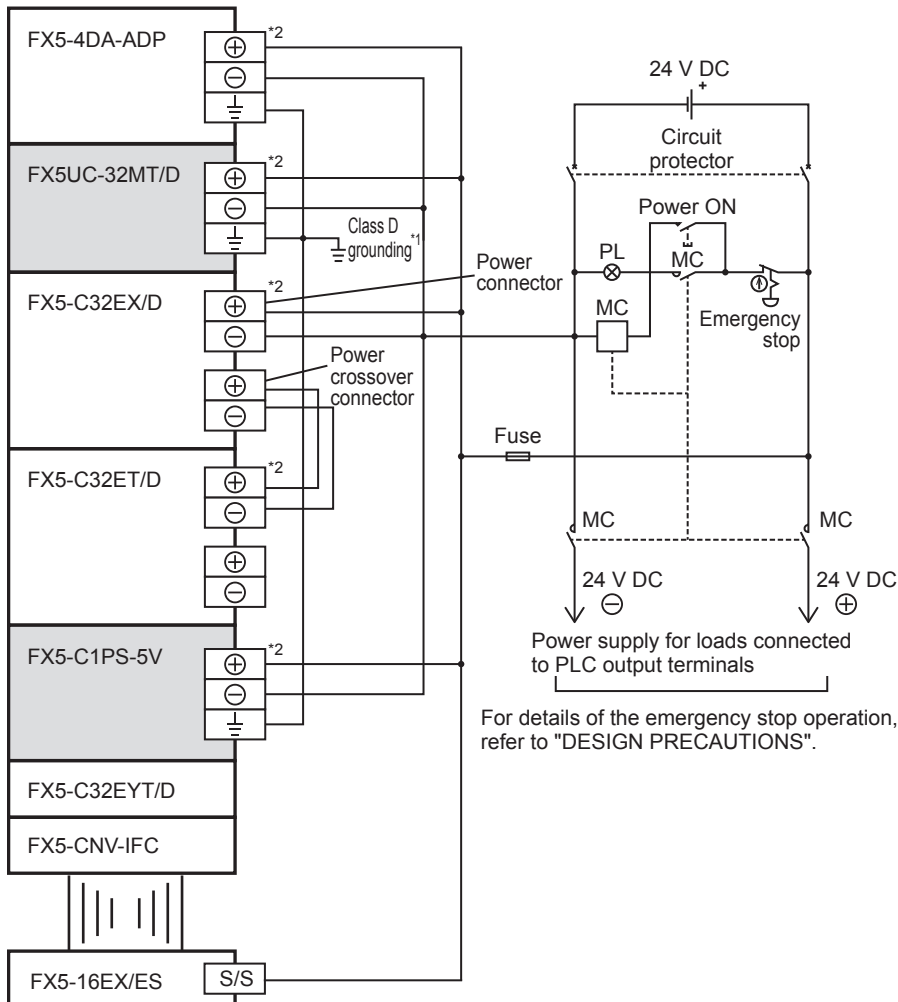

For details of the emergency stop operation, refer to "DESIGN PRECAUTIONS".

*1 The grounding resistance should be 100 Ω or less.

*2 Using the same power supply to each module and extension adapters is recommended. When a different power supply is used to them, turn on the power supply at the same time with the CPU module or earlier than the CPU module. When tuning off the power, confirm the safety of the system and turn off the CPU module at the same time. Some extension modules may not have power supply terminals.

Point

Power on all modules at the same time to use an safety extension module.

When there is a time lag at power-on, power on the modules in the following order: modules other than the safety extension module/CPU module*1, CPU module, safety extension module. If the above conditions are not satisfied, an error (error code: 3052H) may occur in the safety extension module. For details on wiring, refer to the following.

MELSEC iQ-F FX5 User's Manual (Safety Control)

*1 The modules other than the safety extension module/CPU module refers to the following.
Powered input/output module, extension power supply module, expansion adapter, intelligent function module

Power supply wiring example of FX5UC-32MT/DSS

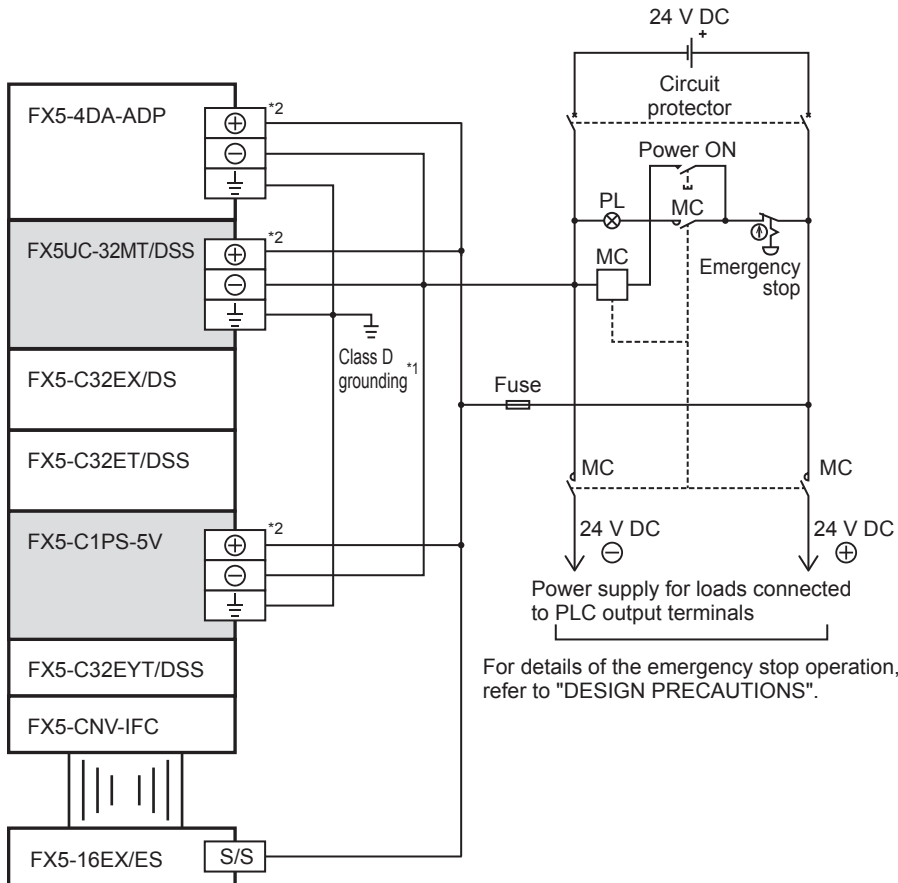

*1 The grounding resistance should be 100 Ω or less.

*2 Using the same power supply to each module and extension adapters is recommended. When a different power supply is used to them, turn on the power supply at the same time with the CPU module or earlier than the CPU module. When tuning off the power, confirm the safety of the system and turn off the CPU module at the same time. Some extension modules may not have power supply terminals.

Point

Power on all modules at the same time to use an safety extension module.

When there is a time lag at power-on, power on the modules in the following order: modules other than the safety extension module/CPU module^{*1}, CPU module, safety extension module. If the above conditions are not satisfied, an error (error code: 3052H) may occur in the safety extension module. For details on wiring, refer to the following.

📖 MELSEC iQ-F FX5 User's Manual (Safety Control)

*1 The modules other than the safety extension module/CPU module refers to the following.

Powered input/output module, extension power supply module, expansion adapter, intelligent function module

6.5 Input Wiring

The input wiring of the CPU modules, I/O modules, and terminal modules is explained below.

24 V DC input

For input specifications of the CPU modules, refer to [Page 31 Input Specifications](#).

For input specifications of the I/O modules, refer to [Page 169 Input specifications](#).

For input specifications of the terminal modules, refer to [Page 188 Input specifications](#).

Sink and source input

■ Differences between the sink input circuit and the source input circuit

- Sink input [-common]

Sink input means a DC input signal with a current flowing from the input (X) terminal. When a device such as a transistor output type sensor is connected, NPN open collector transistor output can be used.

Circuit example for FX5UC-32MT/D

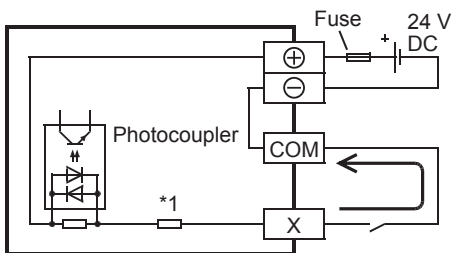

*1: Input impedance

Circuit example for FX5UC-32MT/DSS

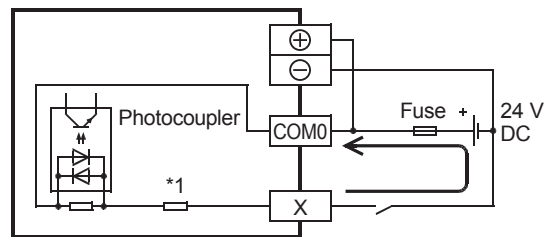

*1: Input impedance

- Source input [+common]

Source input means a DC input signal with a current flowing into the input (X) terminal. When a device such as a transistor output type sensor is connected, the PNP open collector transistor output can be used.

Circuit example for FX5UC-32MT/DSS

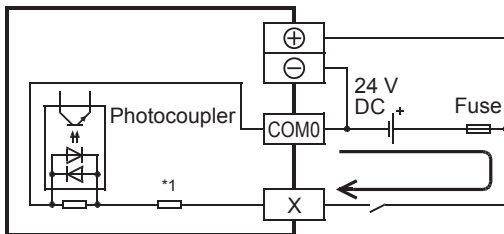

*1: Input impedance

■ Switching between sink/source inputs

Sink and source inputs for FX5UC-□M□/DS□ are switched by changing connection methods; the connection in which the current flows from the input (X) terminal or the connection in which the current flows into the input (X) terminal.

- Sink input: The connection in which the current flows from the input (X) terminal ([Page 112 Sink input wiring](#))
- Source input: The connection in which the current flows into the input (X) terminal ([Page 113 Source input wiring](#))

Point

Inputs (X) of FX5UC-□M□/DS□ can be set to either sink input or source input. However, sink and source input modes cannot be mixed.

Handling of 24 V DC input

Input terminal

Sink-input-dedicated type

When a no-voltage contact or NPN open collector transistor output is connected between an input (X) terminal and the [COM] terminal and the circuit is closed, the input (X) turns on.

At this time, the LED corresponding to the DISP switch lights up. (FX5-C16EX/D does not have the DISP switch.)

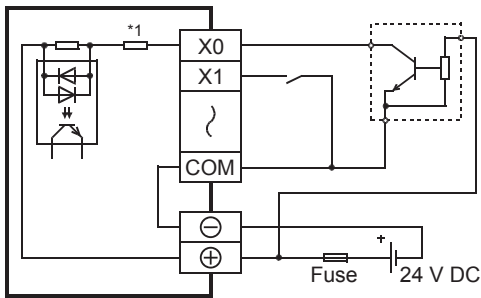

*1 Input impedance

Sink/source-input-common type

In the sink input, the input (X) is turned on by connecting 24 V DC [+] with the [COM] terminal or [S/S] terminal, and connecting a no-voltage contact or NPN open collector transistor output between the input terminal and 24 V DC to close the circuit.

At this time, the input display LED turns on. For the module having DISP switch, LED complying with DISP switch turns on.

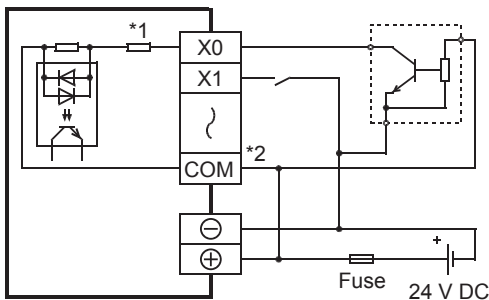

*1 Input impedance

*2 Depending on the module, the [COM] terminal is [S/S] terminal.

In the source input, the input (X) is turned on by connecting 24 V DC [-] with the [COM] terminal or [S/S] terminal, and connecting a no-voltage contact or PNP open collector transistor output between the input terminal and 24 V DC to close the circuit.

At this time, the input display LED turns on. For the module having DISP switch, LED complying with DISP switch turns on.

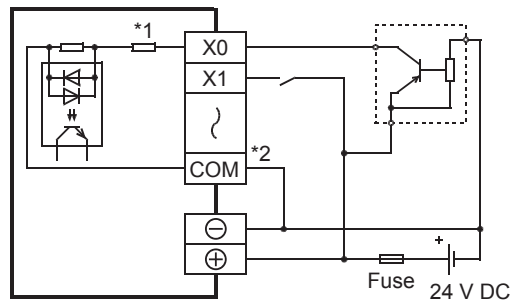

*1 Input impedance

*2 Depending on the module, the [COM] terminal is [S/S] terminal.

RUN terminal setting

X0 to X17 of a CPU module can be used as RUN contact terminals by setting parameters.

📖 MELSEC iQ-F FX5 User's Manual (Application)

Input circuit

- Function of an input circuit

The primary and secondary circuits for input are insulated with photocoupler, and the second circuit is provided with a C-R filter.

The C-R filter is designed to prevent malfunctions caused by chattering of the input contact and noise from input line.

Input has a response delay switching from ON to OFF and OFF to ON, shown in the following table.

Item			Specifications
Input response time (H/W filter delay)	FX5UC-32M□/□	X0 to X5	ON: 2.5 μs or less OFF: 2.5 μs or less
	FX5UC-64MT/□, FX5UC-96MT/□	X0 to X7	
	High-speed pulse input/output module	X0 to X5	
	FX5UC-32M□/□	X6 to X17	ON: 30 μs or less OFF: 50 μs or less
	FX5UC-64MT/□, FX5UC-96MT/□	X10 to X17	
	High-speed pulse input/output module	X6, X7	
	FX5UC-64MT/□, FX5UC-96MT/□	X20 and subsequent	
Input module, Input/output module, Powered input/output module			ON: 50 μs or less OFF: 150 μs or less

- Change of filter time

All input circuits have digital filters, and the input response time shown in the following table can be added by setting parameters. When using this product in an environment with much noise, set the digital filter.

Item	Specifications
Input response time (Digital filter setting value)	None, 10 μs, 50 μs, 0.1 ms, 0.2 ms, 0.4 ms, 0.6 ms, 1 ms, 5 ms, 10 ms (initial values), 20 ms, 70 ms

Input sensitivity

For the input signal current and input sensitivity current of the CPU modules, refer to [Page 31 Input Specifications](#).

For the input signal current and input sensitivity current of the I/O modules, refer to [Page 169 Input specifications](#).

Display of operation

The LED turns ON when the photocoupler is driven.

With FX5UC-□MT/D(SS), FX5-C32EX/D(S) or FX5-C32ET/D(SS), the LED target is switched with the DISP switch.

- FX5UC-□MT/D(SS), FX5-C32ET/D(SS): Input (IN)/Output (OUT)
- FX5-C32EX/D(S): Smaller number (F)/Larger number (L)

Precautions for connecting input devices

In the case of no-voltage contact

Use input devices appropriate for low electric current.

If no-voltage contacts for high current (switches) are used, contact failure may occur.

In the case of input device with built-in series diode

The voltage drop of the series diode should be the following value or less.

Also make sure that the input current is over the input-sensing level while the switches are on.

Item			Specifications
Voltage drop	FX5UC-32M□/□	X0 to X5	3.9 V
	FX5UC-64MT/□, FX5UC-96MT/□	X0 to X7	
	High-speed pulse input/output module	X0 to X5	
	FX5UC-32M□/□	X6 to X17	4.1 V
	FX5UC-64MT/□, FX5UC-96MT/□	X10 to X17	
	High-speed pulse input/output module	X6, X7	
	FX5UC-64MT/□, FX5UC-96MT/□	X20 and subsequent	
	Input module, Input/output module, Powered input/output module		

■ In the case of input device with built-in parallel resistance

Use a device with a parallel resistance R_p ($k\Omega$) of the following value or more.

Item		Specifications
Parallel resistance R_p ($k\Omega$)	FX5UC-32M□/□	X0 to X5
	FX5UC-64MT/□, FX5UC-96MT/□	X0 to X7
	High-speed pulse input/output module	X0 to X5
	FX5UC-32M□/□	X6 to X17
	FX5UC-64MT/□, FX5UC-96MT/□	X10 to X17
	High-speed pulse input/output module	X6, X7
	FX5UC-64MT/□, FX5UC-96MT/□	X20 and subsequent
	Input module, Input/output module, Powered input/output module	

If the resistance is less than the above parallel resistance R_p ($k\Omega$), connect a bleeder resistance R_b ($k\Omega$) obtained by the following formula as shown in the following figure.

Item		Specifications
Bleeder resistance R_b ($k\Omega$)	FX5UC-32M□/□	X0 to X5
	FX5UC-64MT/□, FX5UC-96MT/□	X0 to X7
	High-speed pulse input/output module	X0 to X5
	FX5UC-32M□/□	X6 to X17
	FX5UC-64MT/□, FX5UC-96MT/□	X10 to X17
	High-speed pulse input/output module	X6, X7
	FX5UC-64MT/□, FX5UC-96MT/□	X20 and subsequent
	Input module, Input/output module, Powered input/output module	

- Wiring example of sink-input-dedicated type (FX5UC-32MT/D)

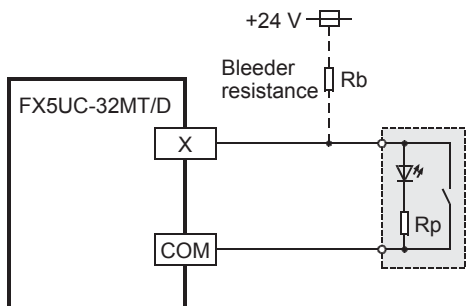

- Wiring example of sink/source-input-common type (FX5UC-32MT/DSS)

- Sink input wiring

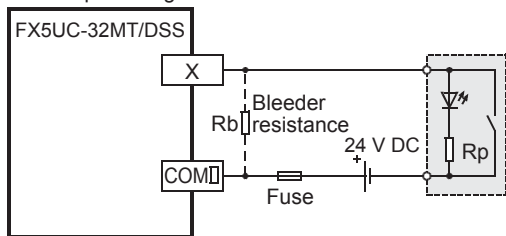

- Source input wiring

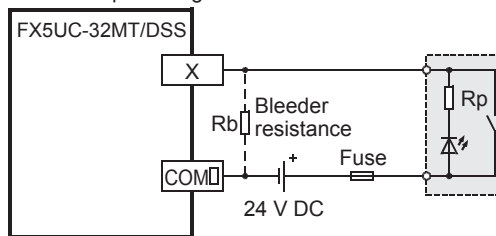

■ In the case of 2-wire proximity switch

Use a two-wire proximity switch whose leakage current, I_l is 1.5 mA or less when the switch is off.

If the resistance is larger than leakage current, I_l of 1.5 mA, connect a bleeder resistance R_b ($k\Omega$), obtained by the following formula as shown in the following figure.

Item		Specifications
Bleeder resistance R_b ($k\Omega$)	FX5UC-32M□/□	X0 to X5
	FX5UC-64MT/□, FX5UC-96MT/□	X0 to X7
	High-speed pulse input/output module	X0 to X5
	FX5UC-32M□/□	X6 to X17
	FX5UC-64MT/□, FX5UC-96MT/□	X10 to X17
	High-speed pulse input/output module	X6, X7
	FX5UC-64MT/□, FX5UC-96MT/□	X20 and subsequent
	Input module, Input/output module, Powered input/output module	

- Wiring example of sink-input-dedicated type (FX5UC-32MT/D)

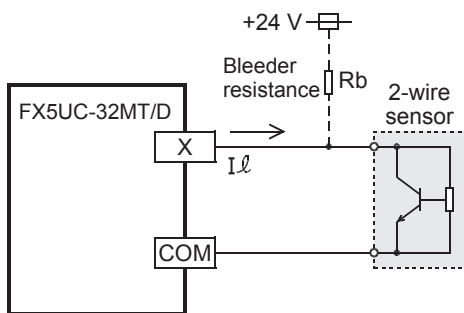

- Wiring example of sink/source-input-common type (FX5UC-32MT/DSS)

• Sink input wiring

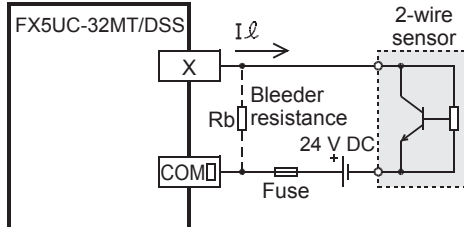

• Source input wiring

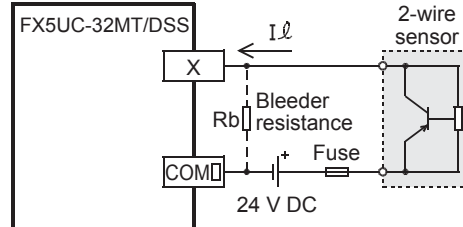

When a high-speed pulse is captured

When capturing pulses of a response frequency of 50 to 200 kHz on input X0 to X7 (FX5UC-32M□ and High-speed pulse input/output module is X0 to X5) wire the terminals as stated below.

- The wire length should be 5 m or less.
- Use shielded twisted-pair cables for connecting cables. Ground the shield of each shielded cable only on the CPU module side.
- Connect a 1.5 $k\Omega$ (1 W or more) bleeder resistance to the input terminal, so that the sum of the load current of the open collector transistor output on the mating device and the input current of the CPU module is 20 mA or more.

The above-mentioned restrictions are due to specifications of connecting device (encoder etc.). Please adjust the cable length and load, for connecting device.

Input wiring example

When a sink-input-dedicated CPU module is used

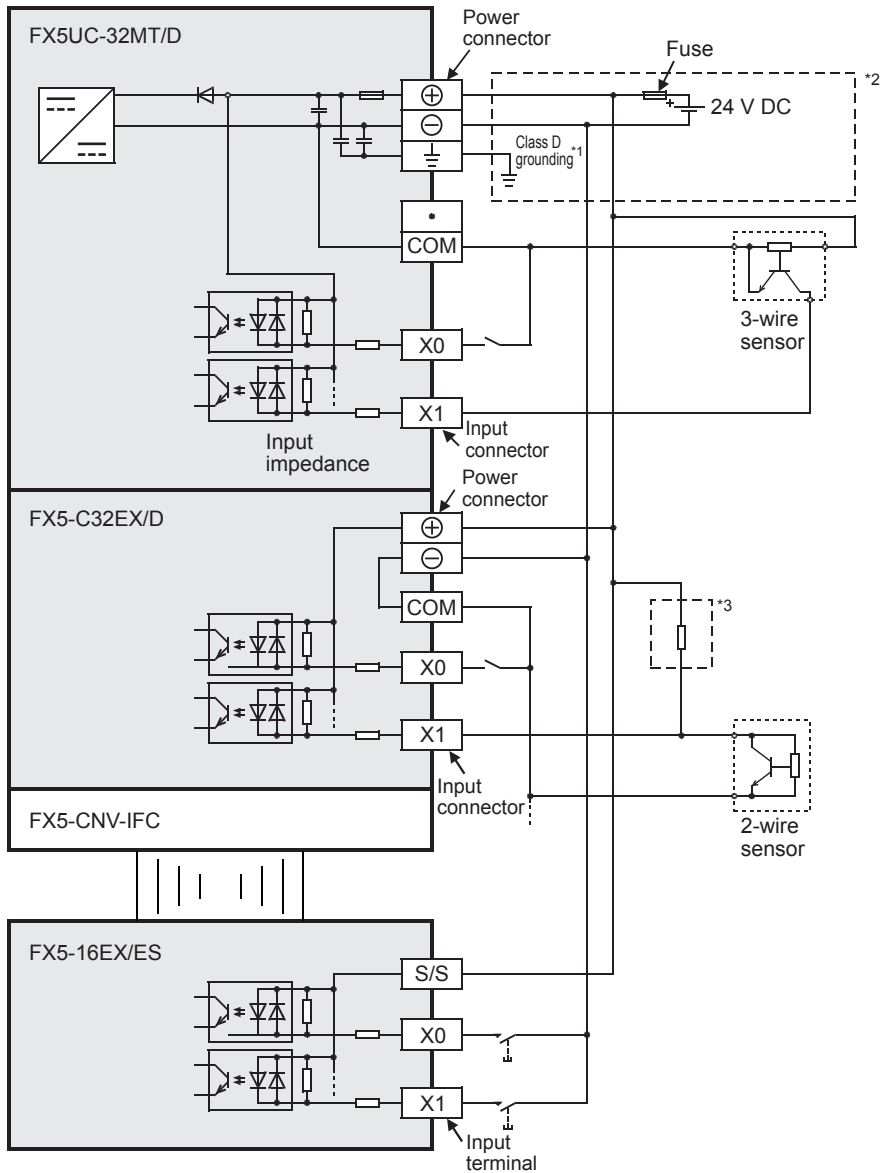

*1 The grounding resistance should be 100 Ω or less.

*2 Handle the power supply circuit properly in accordance with "Power Supply Wiring".

*3 For an input device having a parallel resistance or a two-wire proximity switch, a bleeder resistance may be required.

When a CPU module common to sink and source inputs is used

■ Sink input wiring

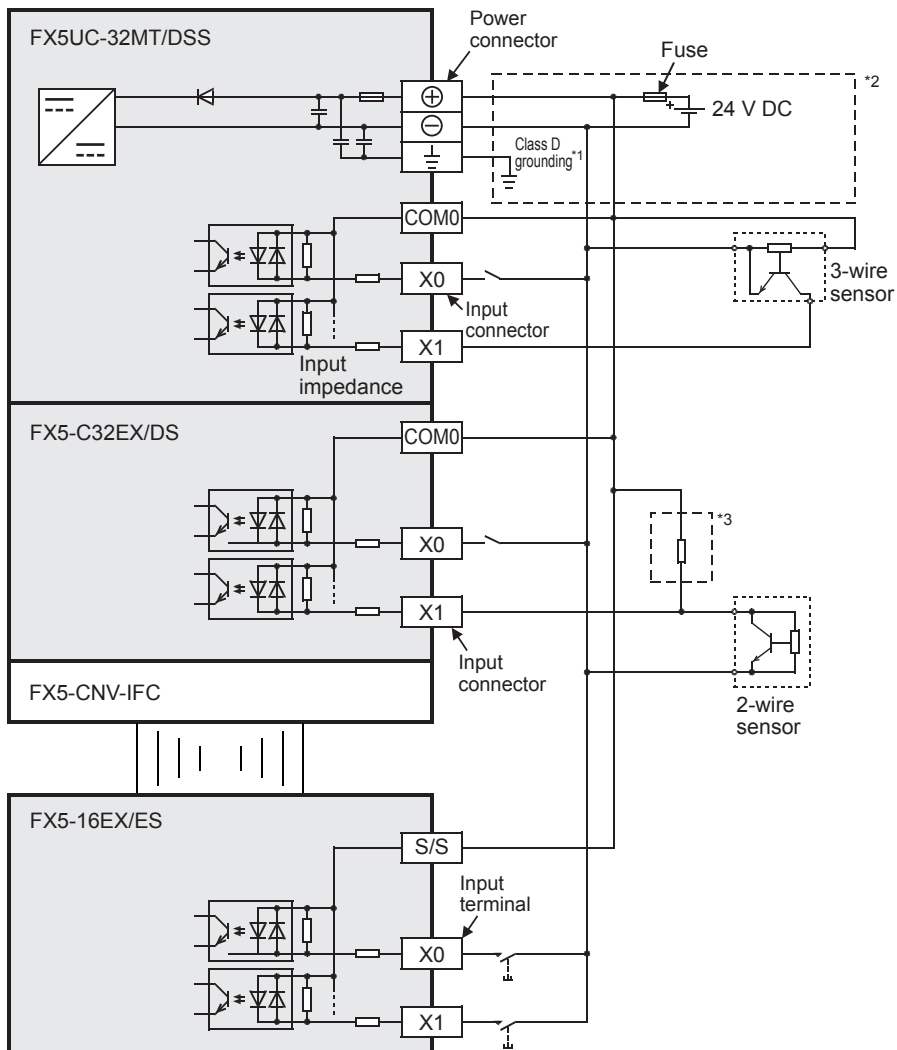

*1 The grounding resistance should be 100 Ω or less.

*2 Handle the power supply circuit properly in accordance with "Power Supply Wiring".

*3 For an input device having a parallel resistance or a two-wire proximity switch, a bleeder resistance may be required.

■ Source input wiring

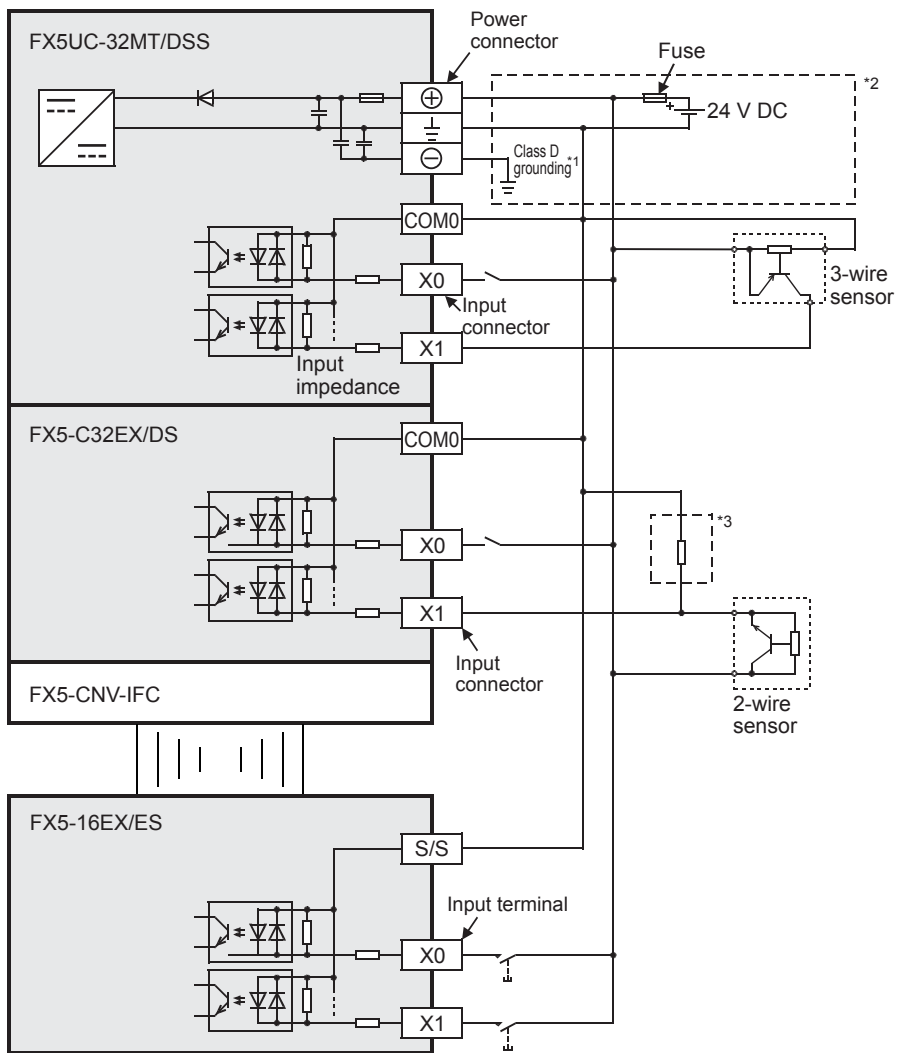

*1 The grounding resistance should be 100 Ω or less.

*2 Handle the power supply circuit properly in accordance with "Power Supply Wiring".

*3 For an input device having a parallel resistance or a two-wire proximity switch, a bleeder resistance may be required.

Input wiring examples of terminal modules

FX-16E-TB, FX-32E-TB

Connectable models: FX5UC-□MT/D, FX5-C□EX/D, FX5-C32ET/D

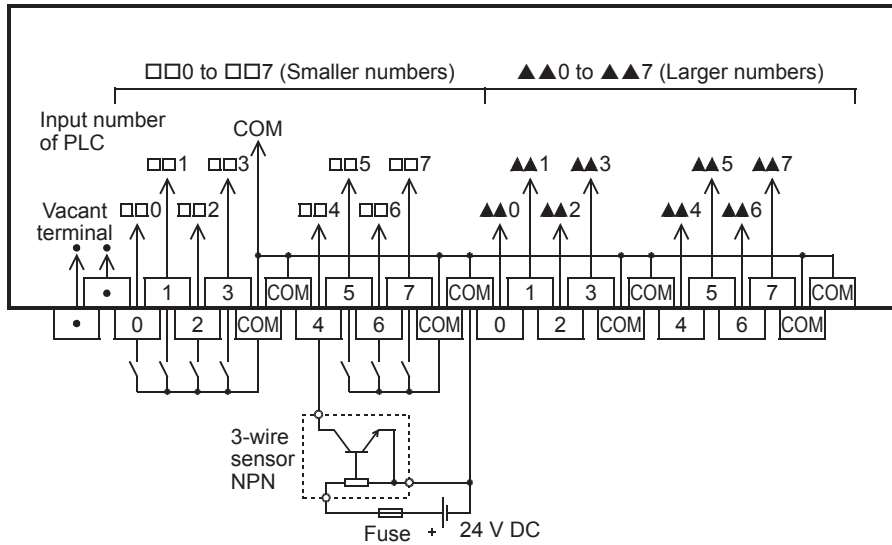

FX-16E-TB/UL, FX-32E-TB/UL

Connectable models: FX5UC-□MT/DSS, FX5-C□EX/DS, FX5-C32ET/DSS

- In the case of sink wiring

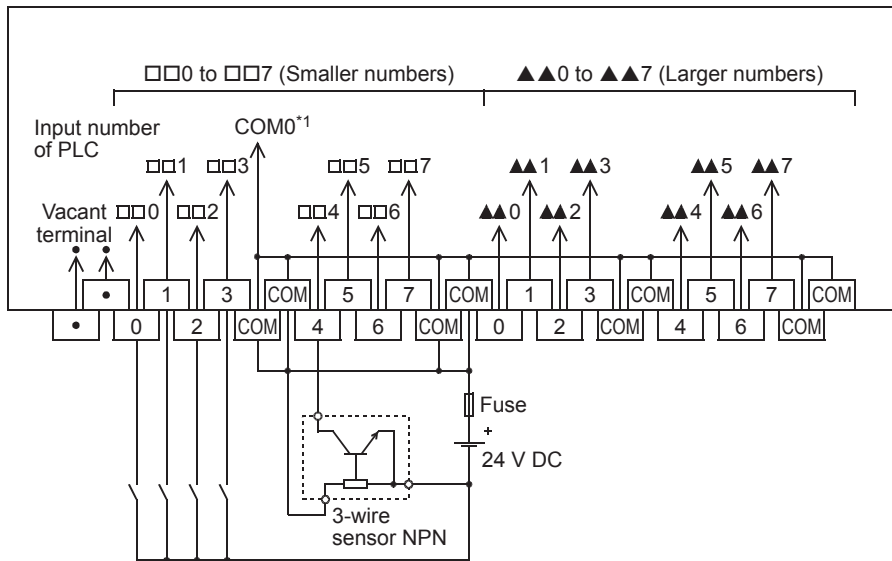

*1 Replace this number with the one of the connected connector.

- In the case of source wiring

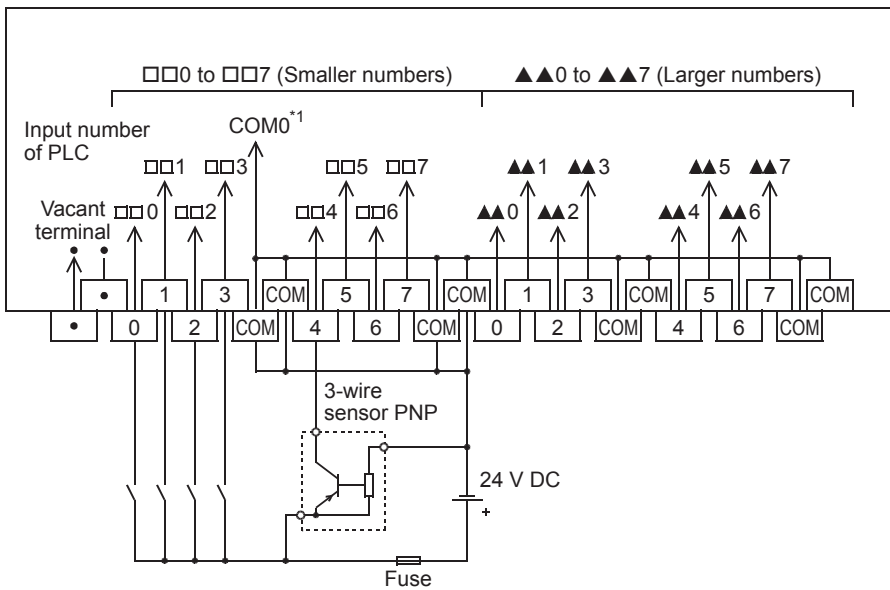

*1 Replace this number with the one of the connected connector.

FX-16EX-A1-TB

Connectable models: FX5UC-□MT/D, FX5-C□EX/D, FX5-C32ET/D

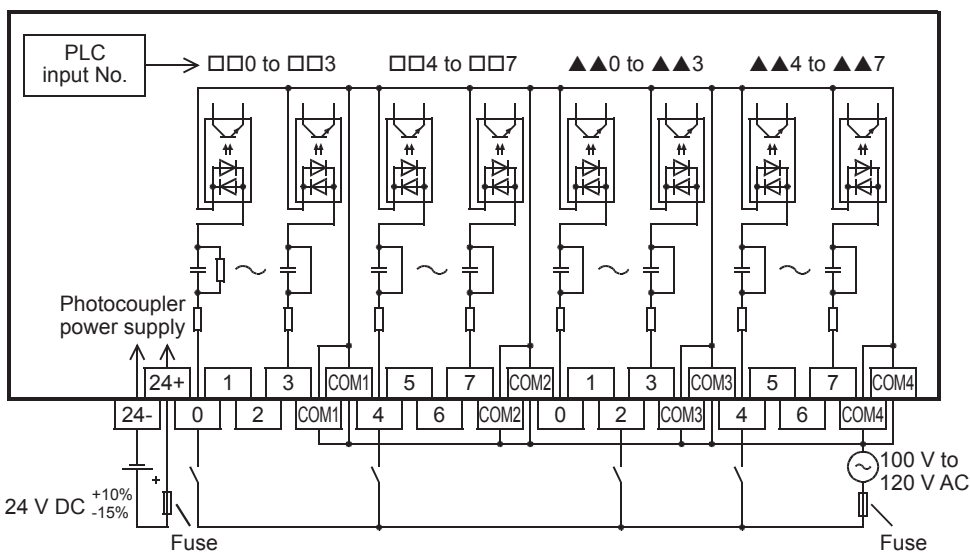

6.6 Output Wiring

The output wiring of the CPU modules, I/O modules, and terminal modules is explained below.

Transistor output

For output specifications of the CPU modules, refer to [Page 33 Output Specifications](#).

For output specifications of the I/O modules, refer to [Page 171 Output specifications](#).

For output specifications of the terminal modules, refer to [Page 189 Output specifications](#).

Sink and source output

Sink output and source output products are available for transistor outputs of the CPU module, I/O modules, and terminal modules.

■ Differences in circuit

- Sink output [-common]

Output to make load current flow into the output (Y) terminal is called sink output.

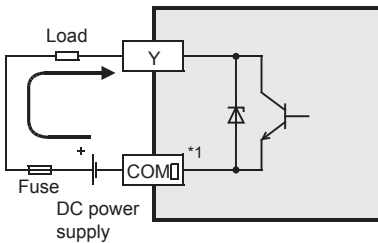

*1 The number "0" or "1" is applied in □.

- Source output [+common]

Output to make load current flow out of the output (Y) terminal is called source output.

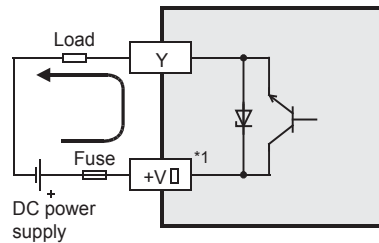

Handling of transistor output

■ Output terminal

For the CPU module, output module (extension connector type), and input/output module (extension connector type), the transistor output type is a 8-point common output type.

- Sink output

The COM□ (number) terminals that are connected each other inside the PLC are prepared. For external wiring, connect the COM□ (number) terminals outside the PLC to reduce the load per one COM□ terminal.

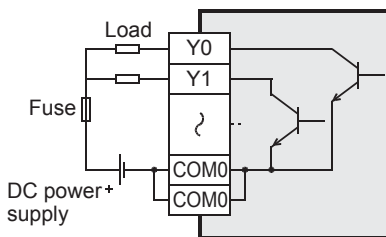

- Source output

The +V□ (number) terminals that are connected each other inside the PLC are prepared. For external wiring, connect the +V□ (number) terminals outside the PLC to reduce the load per one +V□ terminal.

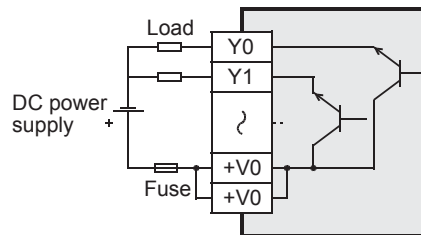

For the output module (extension cable type), input/output module (extension cable type), powered input/output module and high-speed pulse input/output module, the transistor output type is a 4-point or 8-point common output type.

• Sink output

Connect each COM□ (number) terminal to the minus side of the load power supply.
The COM□ terminals are not connected internally.

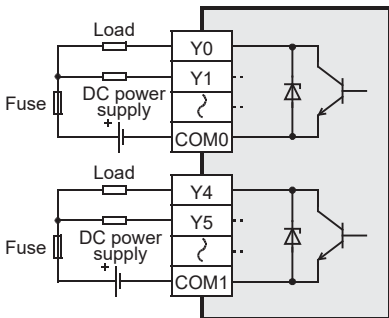

• Source output

Connect +V□ (number) terminal to the plus side of the load power supply.
The +V□ terminals are not connected internally.

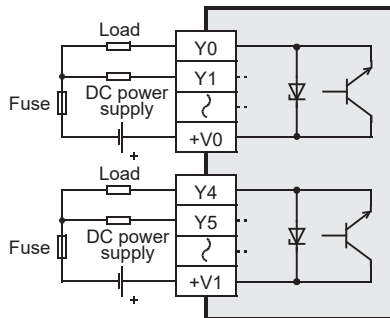

■External power supply

For driving the load, use a smoothing power supply of 5-30 V DC that can output a current two or more times the current rating of the fuse connected to the load circuit.

■Insulation of circuit

The internal circuit of the PLC and the output transistor are insulated with a photocoupler.
The common blocks are separated from one another.

■Display of operation

The LED turns on and the output transistor turns on when photocouplers are actuated.

With FX5UC-□MT/D(SS), FX5-C32EYT/D(SS) or FX5-C32ET/D(SS), the LED target is switched with the DISP switch.

- FX5UC-□MT/D(SS), FX5-C32ET/D(SS): Input (IN)/Output (OUT)
- FX5-C32EYT/D(SS): Smaller number (F)/Larger number (L)

■Response time

Time taken from when the photocoupler of the module is driven (or shut off) to when the transistor is turned on (or off) differs depending on the output terminal used. For specifications of each module, refer to the following.

For output specifications of the CPU modules, refer to [Page 33 Output Specifications](#).

For output specifications of the I/O modules, refer to [Page 171 Output specifications](#).

For output specifications of the terminal modules, refer to [Page 189 Output specifications](#).

Point

The transistor OFF time is longer under lighter loads. For example, under a load of 24 V DC 40 mA, the response time is approx. 0.3 ms.

When response performance is required under light loads, provide a dummy resistor as shown below to increase the load current.

• Sink output type

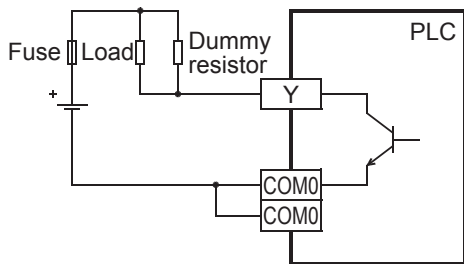

• Source output type

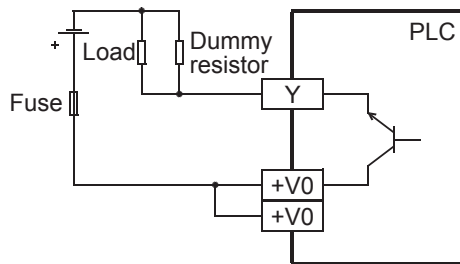

■Output current

Maximum load differs for each module. For specifications of each module, refer to the following.

For output specifications of the CPU modules, refer to [Page 33 Output Specifications](#).

For output specifications of the I/O modules, refer to [Page 171 Output specifications](#).

For output specifications of the terminal modules, refer to [Page 189 Output specifications](#).

When driving a semiconductor element, carefully check the input voltage characteristics of the applied element.

■Open circuit leakage current

0.1 mA or less.

Wiring precautions

■Protection circuit for load short-circuiting

A short-circuit at a load connected to an output terminal could cause burnout at the output device or the PCB.

To prevent this, a protection fuse should be inserted at the output. Use a load power supply capacity that is at least 2 times larger than the load current.

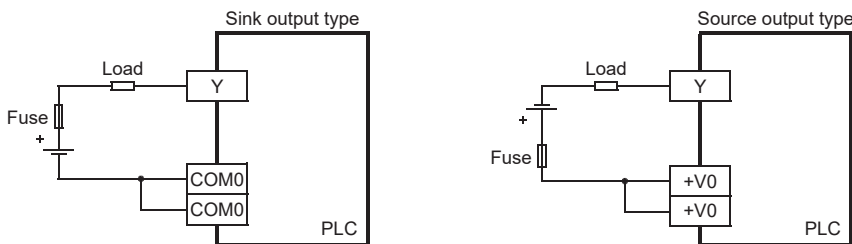

■Contact protection circuit for inductive loads

When an inductive load is connected, connect a diode (for commutation) in parallel with the load as necessary.

The diode (for commutation) must comply with the following specifications.

Standard	
Reverse voltage	5 to 10 times the load voltage
Forward current	Load current or more

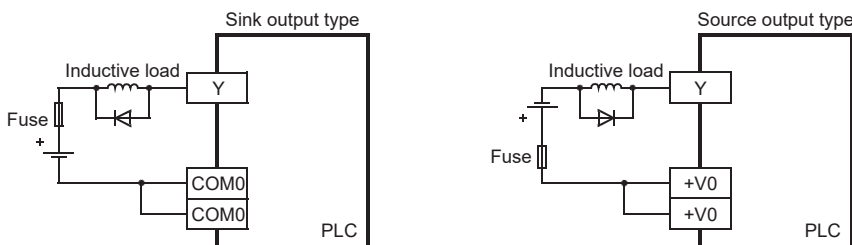

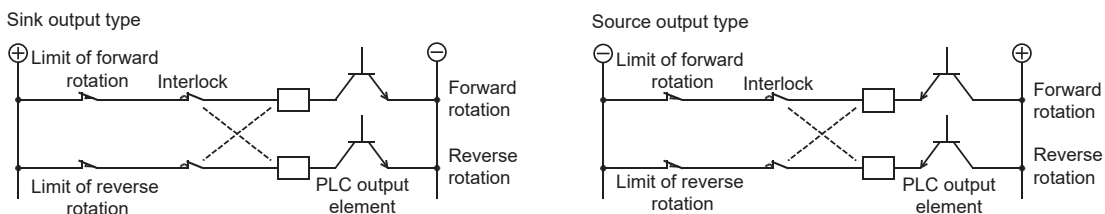

■Interlock

For loads such as forward/reverse contactors, etc., where a hazardous condition could result if switched ON simultaneously, an external interlock should be provided for interlocking along with an interlock in the PLC program as shown below.



Relay output

For output specifications of the CPU modules, refer to  Page 33 Output Specifications.

For output specifications of the I/O modules, refer to  Page 171 Output specifications.

For output specifications of the terminal modules, refer to  Page 189 Output specifications.

Product life of relay output contacts

The product life of relay contacts varies considerably depending on the load type used.

Note that loads generating reverse electromotive force or rush current may cause poor contact or welding of contacts which may lead to considerable reduction of the contact product life.

■Inductive load

Inductive loads generate large reverse electromotive force between contacts at shutdown, which may cause arc discharge. At a fixed current consumption, as the power factor (phase between current and voltage) gets smaller, the arc energy gets larger. The following table shows the standard life of contacts used for inductive loads, such as contactors and solenoid valves.

Model	Inductive load	Standard life
CPU module, FX5-C16EYR/D-TS, FX5-□EYR/ES, FX5-32ER/□, FX5-16ER/ES	20 VA	500,000 times
Terminal module	35 VA	

The following table shows the approximate life of a relay based on the results of our operation life test.

- Test condition: 1 sec. ON/1 sec. OFF

Load capacity		Contact life
■CPU module, FX5-C16EYR/D-TS, FX5-□EYR/ES, FX5-32ER/□, FX5-16ER/ES		
20 VA	0.2 A/100 V AC	3,000,000 times
	0.1 A/200 V AC	
35 VA	0.35 A/100 V AC	1,000,000 times
	0.17 A/200 V AC	
80 VA	0.8 A/100 V AC	200,000 times
	0.4 A/200 V AC	
■Terminal module		
35 VA	0.35 A/100 V AC	3,000,000 times
	0.17 A/200 V AC	
80 VA	0.8 A/100 V AC	1,000,000 times
	0.4 A/200 V AC	
120 VA	1.2 A/100 V AC	200,000 times
	0.6 A/200 V AC	

The product life of relay contacts becomes considerably shorter than the above conditions when the rush overcurrent is shut down.

Please refer to the following measures regarding the inductive load.

 Page 121 Contact protection circuit for inductive loads

Some types of inductive loads generate rush current 5 to 15 times the stationary current at activation. Make sure that the rush current does not exceed the current corresponding to the maximum specified resistance load.

■Lamp load

Lamp loads generally generate rush current 10 to 15 times the stationary current. Make sure that the rush current does not exceed the current corresponding to the maximum specified resistance load.

■Capacitive load

Capacitive loads can generate rush current 20 to 40 times the stationary current. Make sure that the rush current does not exceed the current corresponding to the maximum specified resistance load.

Capacitive loads such as capacitors may be present in electronic circuit loads including inverters.

■Resistance load

For maximum load specifications of resistance load, refer to the following.

For output specifications of the CPU modules, refer to [Page 33 Output Specifications](#).

For output specifications of the I/O modules, refer to [Page 171 Output specifications](#).

For output specifications of the terminal modules, refer to [Page 189 Output specifications](#).

Handling of relay output

■Output terminal

One common terminal is used for 4 or 8 relay output points.

The common terminal blocks can drive loads of different circuit voltage systems (for example: 100 V AC and 24 V DC).

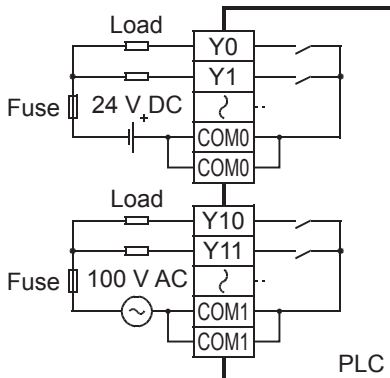

■External power supply

Use an external power supply of 30 V DC or less or 240 V AC or less (250 V AC or less when the module does not comply with CE, UL, or cUL standards) for loads.

■Insulation of circuit

The PLC internal circuit and external load circuits are electrically insulated between the output relay coil and contact.

The common terminal blocks are separated from one another.

■Display of operation

When power is applied to the output relay coil, the LED is lit, and the output contact is turned on.

■Response time

The response time of the output relay from when the power is applied to the coil until the output contact is turned on, and from when the coil is shut off until the output contact is turned off is approx. 10 ms.

■Output current

At a circuit voltage of 240 V AC or less (250 V AC or less when the module does not comply with CE, UL, or cUL standards), a resistance load of 2 A per point or an inductive load of 80 VA or less (100 V AC or 200 V AC) can be driven.

For the life of the contact for switching an inductive load, refer to [Page 119 Inductive load](#).

When an inductive load is switched, connect a diode (for commutation) or a surge absorber in parallel with this load.

DC circuit	AC circuit
Diode (for commutation)	Surge absorber

■Open circuit leakage current

There is no leakage current when the output are OFF.

Wiring precautions

■ Protection circuit for load short-circuiting

A short-circuit at a load connected to an output terminal could cause burnout at the output element or the PCB. To prevent this, a protection fuse should be inserted at the output.

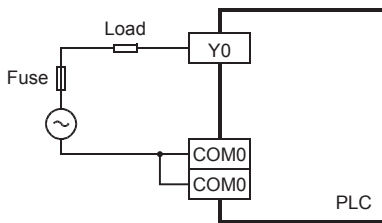

■ Contact protection circuit for inductive loads

An internal protection circuit for the relays is not provided for the relay output circuit in this product. It is recommended to use inductive loads with built-in protection circuits. When using loads without built-in protection circuits, insert an external contact protection circuit, etc. to reduce noise and extend the product life.

- DC circuit

Connect a diode in parallel with the load.

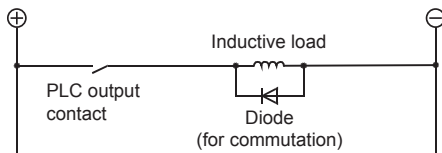

The diode (for commutation) must comply with the following specifications.

- Reverse voltage: 5 to 10 times as high as the load voltage
- Forward current: Load current or more

- AC circuit

Connect a surge absorber (CR composite parts such as surge killers, spark killers, etc.) parallel to the load.

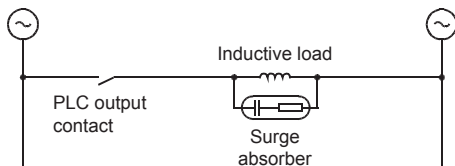

Select a surge absorber with voltage rating that is suitable for the output used. For other specifications, refer to the following.

- Electrostatic capacity: Approx. 0.1 μF
- Resistance: Approx. 100 to 200 Ω

■ Interlock

For loads such as forward/reverse contactors, etc., where a hazardous condition could result if switched ON simultaneously, an external interlock should be provided for interlocking along with an interlock in the PLC program, as shown below.

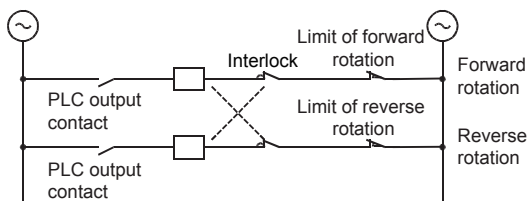

■In-phase

PLC output contacts (*) should be used in an "in-phase" manner.

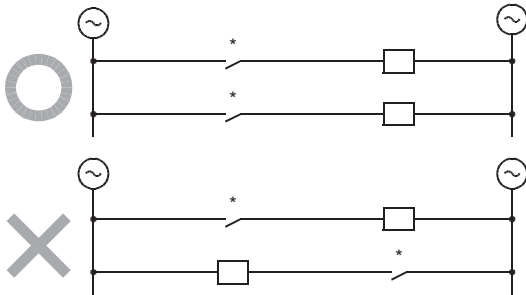

Triac output

For output specifications of the terminal modules, refer to Page 189 Output specifications.

Handling of triac output

■Output terminal

Four triac output points are covered by one common terminal. The common terminal blocks can drive loads of different circuit voltage systems (Example: 100 V AC and 24 V DC).

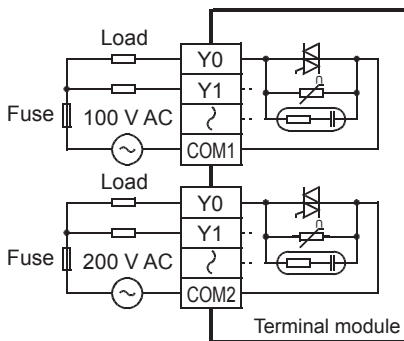

■Insulation of circuit

The internal circuit and the output element (triac) are insulated with photothyristors. The common blocks are separated from one another.

■Display of operation

The LED turns on and the output triac is turned on when photothyristors are actuated.

■Response time

The response time until the output triac is turned on after the photothyristors are actuated (or shut off) is 1 ms or less, and the response time until the output triac is turned off is 10 ms or less.

■Output current

Current of 0.3 A can flow per one output point. However, current of four output points should be 0.8 A (average of 0.2 A per one point) to suppress temperature rise. When a load with a high rush current is frequently turned on or off, the mean-square current should be 0.2 A or less.

<Example>

$$\sqrt{\frac{4^2 \times 0.02 + 0.4^2 \times 0.7}{0.02 + 0.7 + 10}} = 0.2 \text{ A}$$

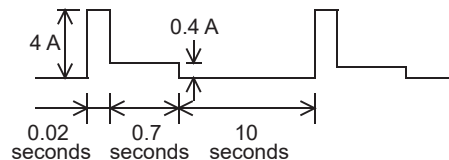

■Open circuit leakage current

C-R absorbers are connected in parallel at the triac output terminal for turning off the triac. Thus, open circuit leakage currents of 1 mA/100 V AC or 2 mA/200 V AC occurs. Since the triac output type has open circuit leakage currents, even after the triac output is turned off, a small relay and a minute current load with low rated operation currents may continuously operate.

Therefore, the load should be equal to or more than 0.4 VA/100 V AC or 1.6 VA/200 V AC. For loads lower than these values, connect the surge absorbers described later in parallel.

Wiring precautions

■Protection circuit for load short-circuiting

A short-circuit at a load connected to an output terminal could cause burnout at the output element or the PCB. To prevent this, a protection fuse should be inserted at the output.

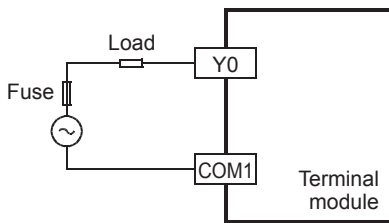

■Minute current load

C-R absorbers are connected in parallel at the triac output circuit for turning off the triac. When a minute current load of 0.4 VA or less/100 V AC or 1.6 VA or less/200 V AC is connected, a surge absorber must be connected in parallel with the load. Select a surge absorber with the rated voltage that is suitable for the output used. For other specifications, refer to the following.

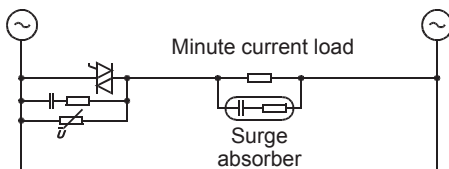

Standard

Electrostatic capacity: Approx. 0.1 μ F

Resistance: Approx. 100 to 200 Ω

■Interlock

For loads such as forward/reverse contactors, etc., where a hazardous condition could result if switched ON simultaneously, an external interlock should be provided for interlocking along with an interlock in the PLC program as shown below.

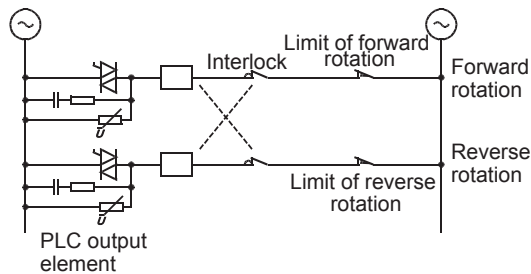

■In-phase

PLC output contacts (*1) should be used in an "in-phase" manner.

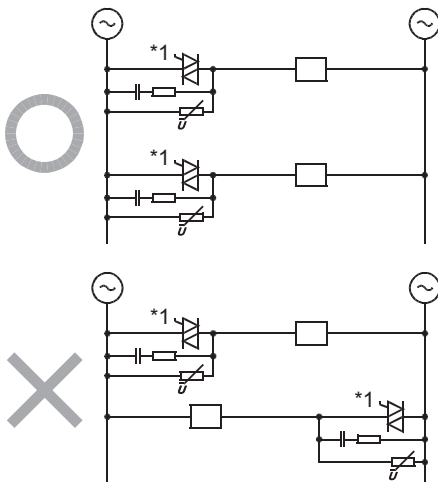

Output wiring example

Transistor output

■ Sink output type

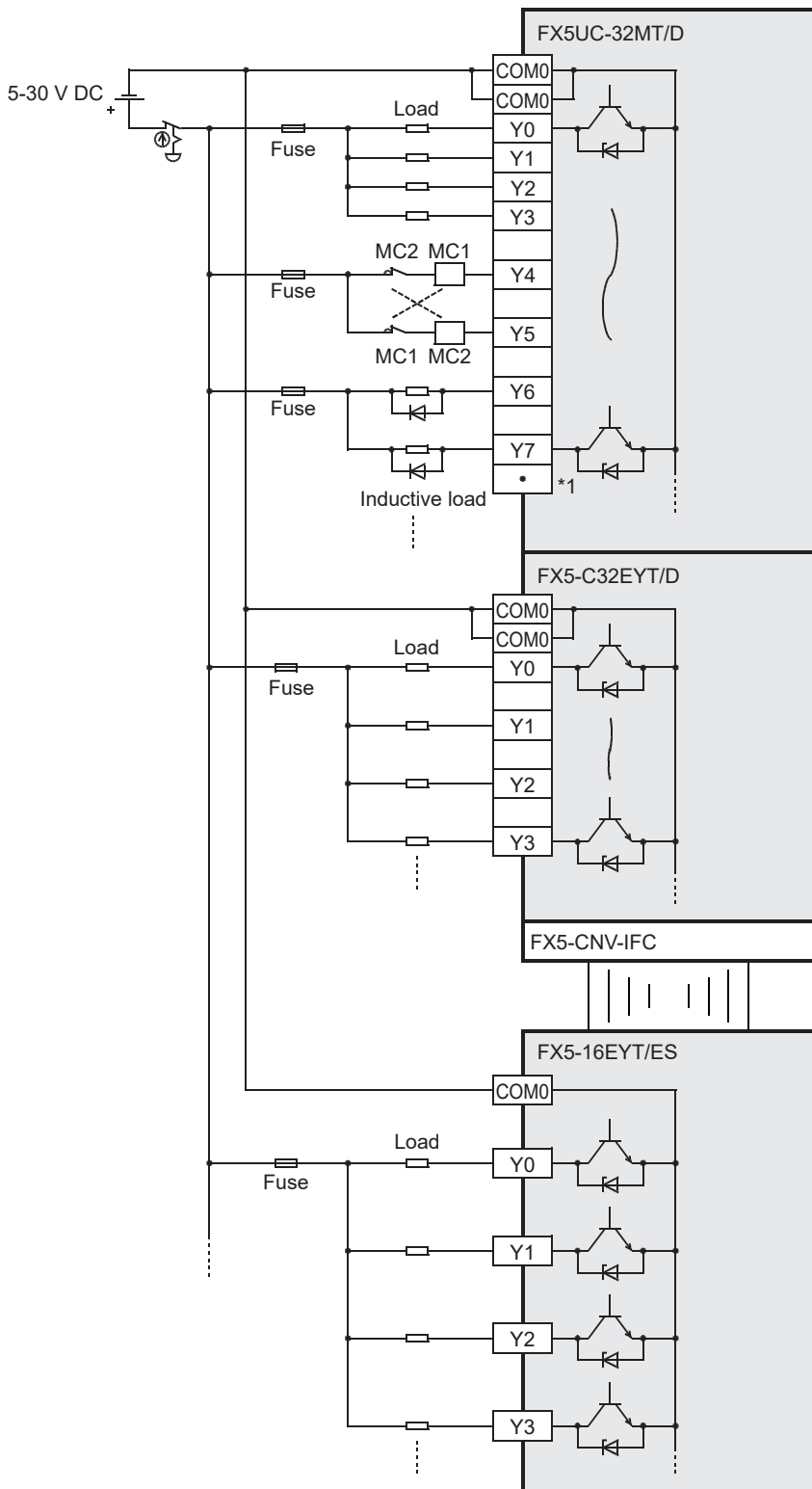

1 "" represents a vacant terminal.

■ Source output type

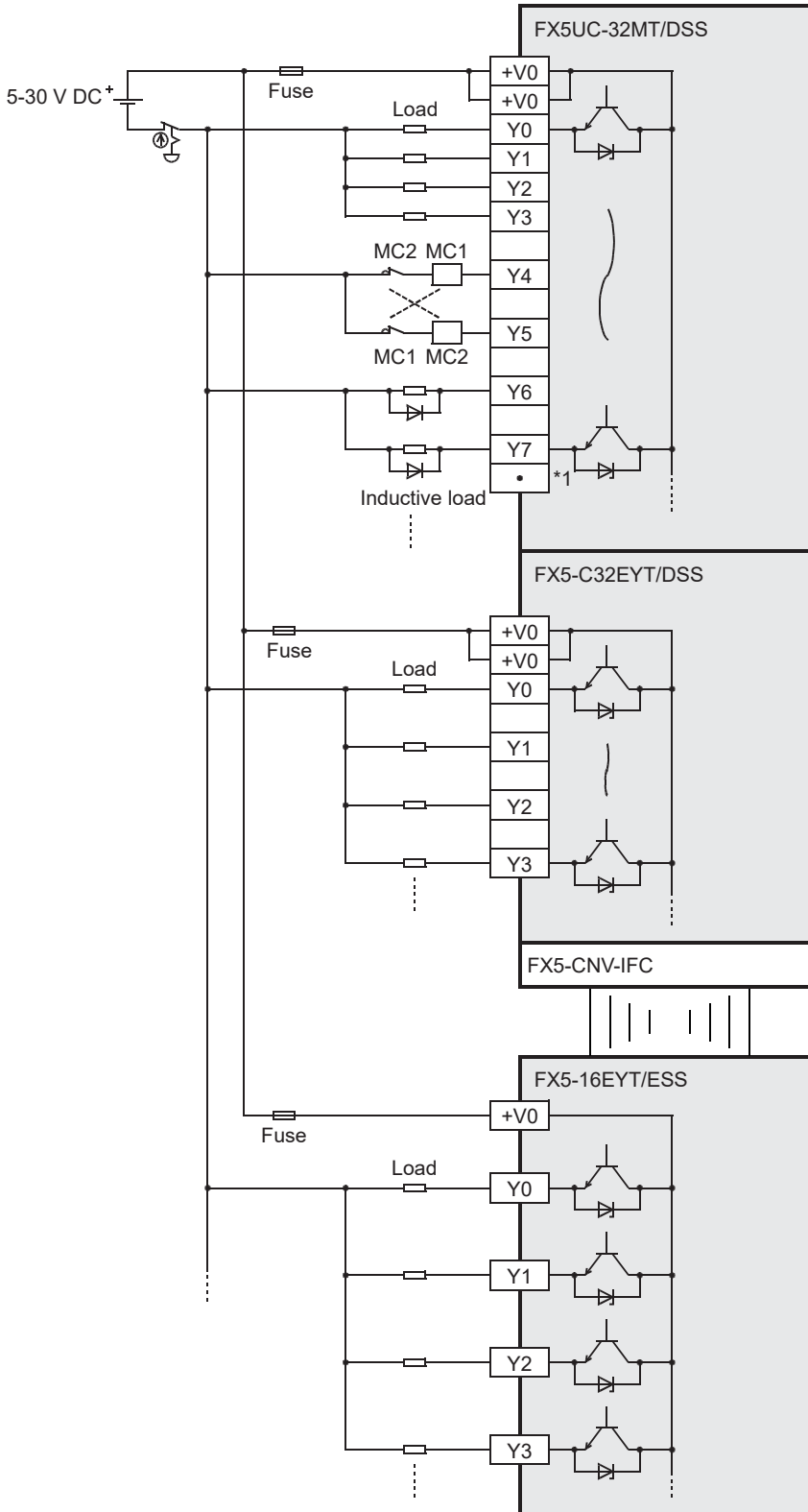

*1 "." represents a vacant terminal.

Relay output

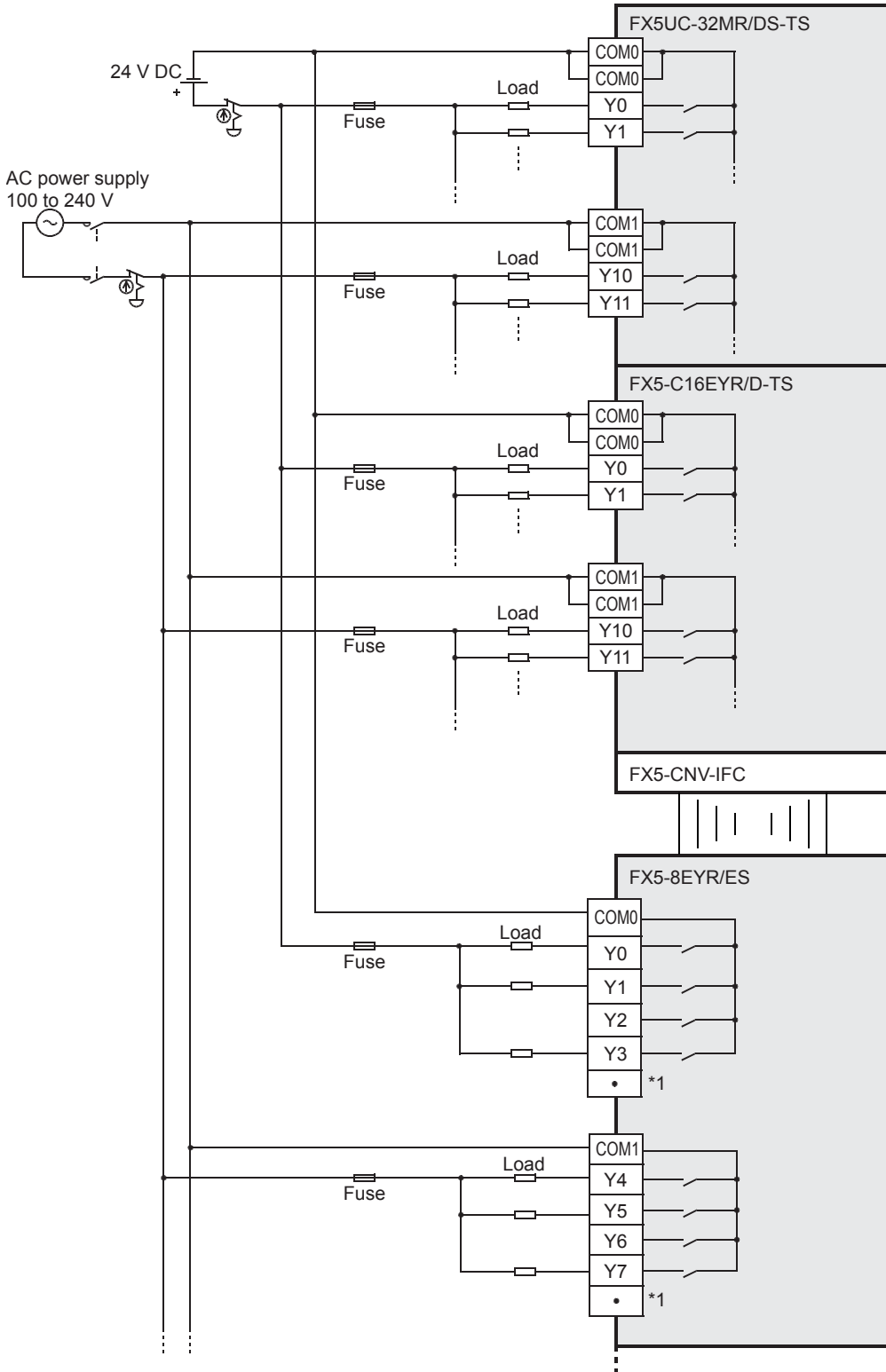

*1 "•" represents a vacant terminal.

Output wiring examples of terminal modules

FX-16E-TB, FX-32E-TB

Connectable models: FX5UC-□MT/D, FX5-C□EYT/D, FX5-C32ET/D

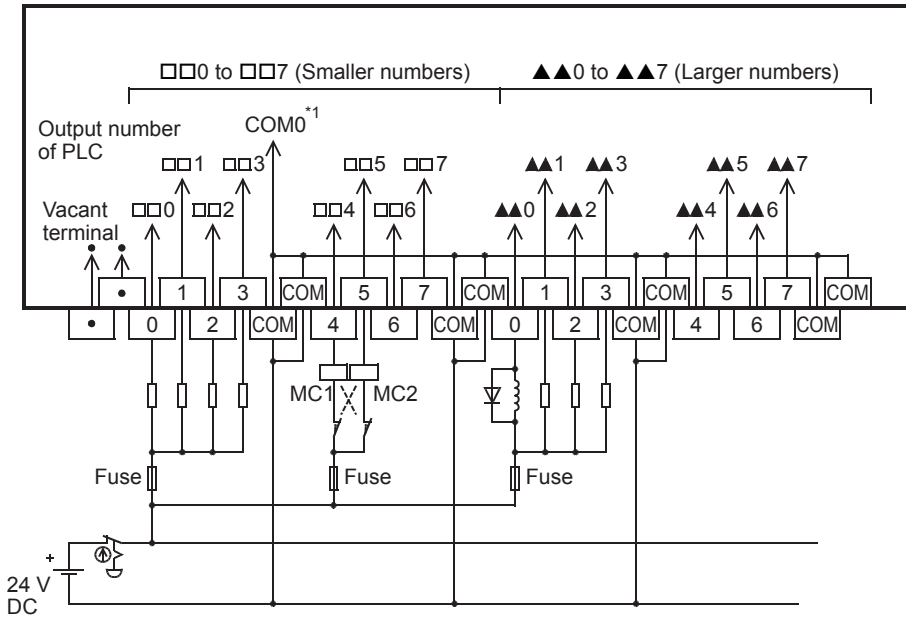

*1 Replace this number with the one of the connected connector.

FX-16E-TB/UL, FX-32E-TB/UL

Connectable models: FX5UC-□MT/DSS, FX5-C□EYT/DSS, FX5-C32ET/DSS

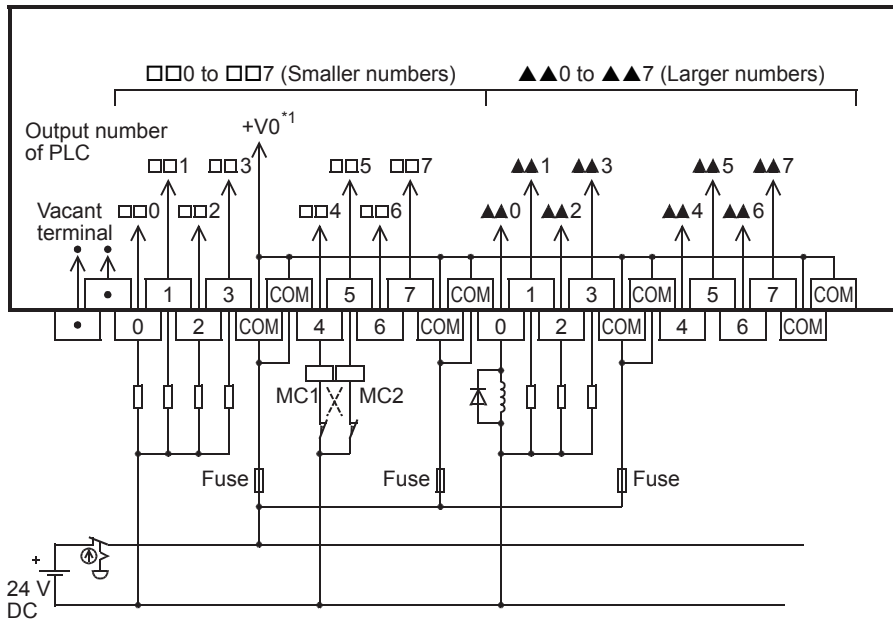

*1 Replace this number with the one of the connected connector.

FX-16EYR-TB, FX-16EYR-ES-TB/UL

Connectable models

FX-16EYR-TB: FX5UC-□MT/D, FX5-C□EYT/D, FX5-C32ET/D

FX-16EYR-ES-TB/UL: FX5UC-□MT/DSS, FX5-C□EYT/DSS, FX5-C32ET/DSS

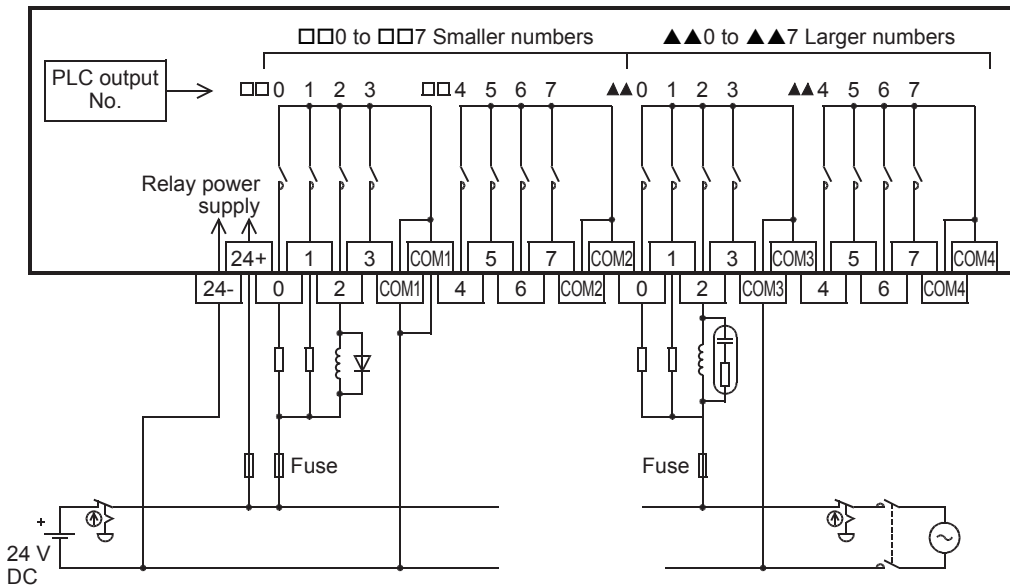

For external wiring precautions, refer to [Page 121 Wiring precautions](#).

For the life of a relay output contact, refer to [Page 119 Product life of relay output contacts](#).

FX-16EYT-TB

Connectable models: FX5UC-□MT/D, FX5-C□EYT/D, FX5-C32ET/D

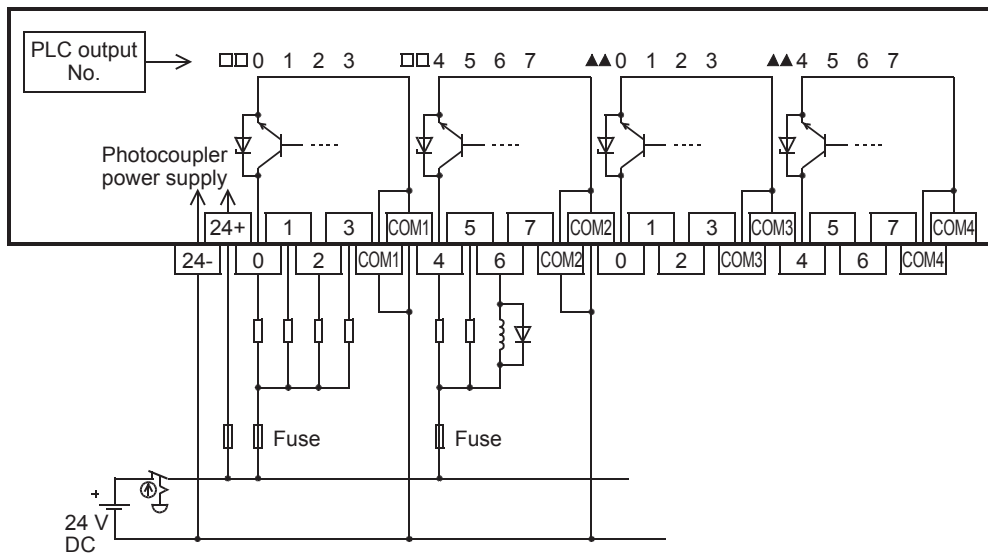

For external wiring precautions, refer to [Page 118 Wiring precautions](#).

FX-16EYT-ES-TB/UL

Connectable models: FX5UC-□MT/DSS, FX5-C□EYT/DSS, FX5-C32ET/DSS

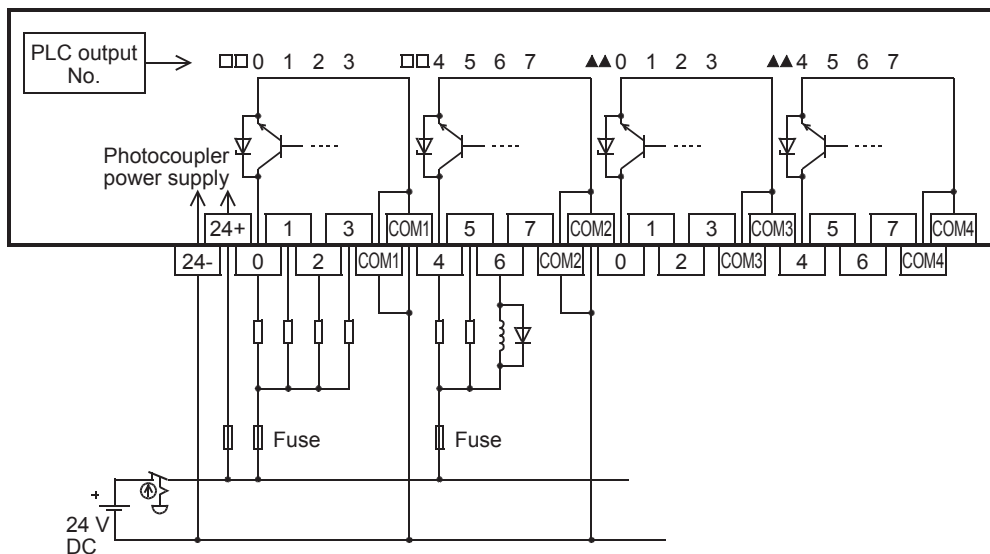

For external wiring precautions, refer to [Page 118 Wiring precautions](#).

FX-16EYT-ESS-TB/UL

Connectable models: FX5UC-□MT/DSS, FX5-C□EYT/DSS, FX5-C32ET/DSS

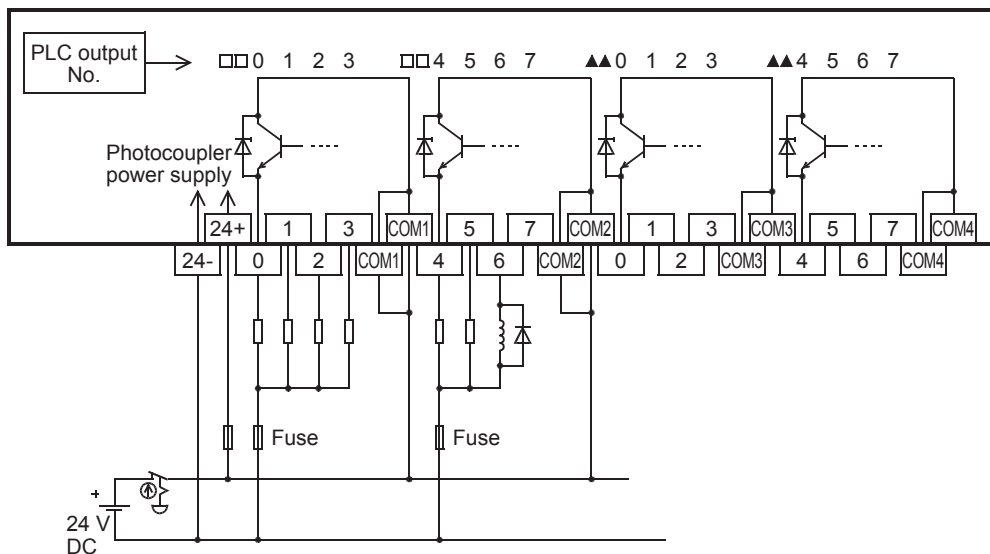

For external wiring precautions, refer to [Page 118 Wiring precautions](#).

FX-16EYS-TB

Connectable models: FX5UC-□MT/D, FX5-C□EYT/D, FX5-C32ET/D

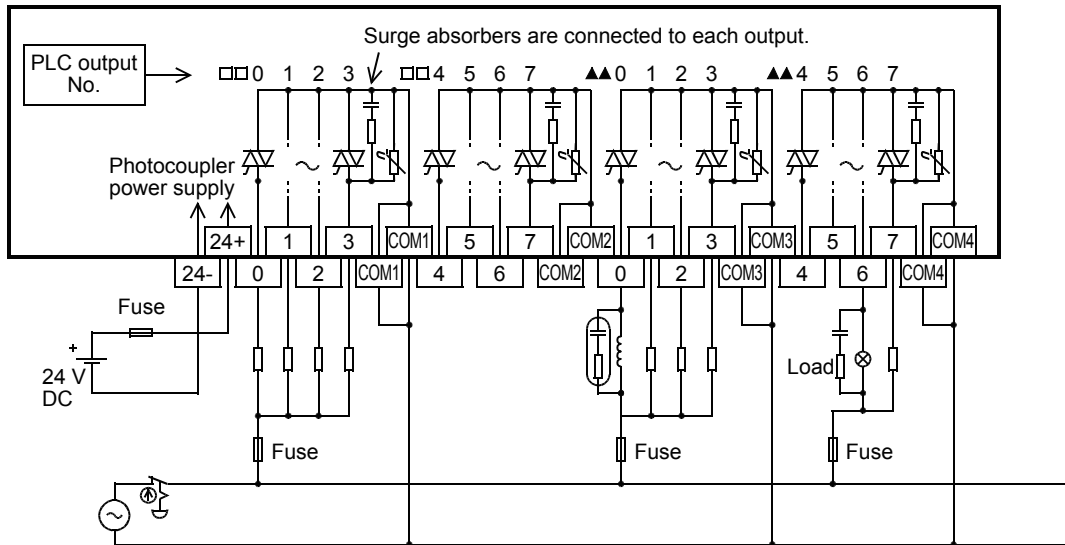

For external wiring precautions, refer to [Page 123 Wiring precautions](#).

FX-16EYS-ES-TB/UL

Connectable models: FX5UC-□MT/DSS, FX5-C□EYT/DSS, FX5-C32ET/DSS

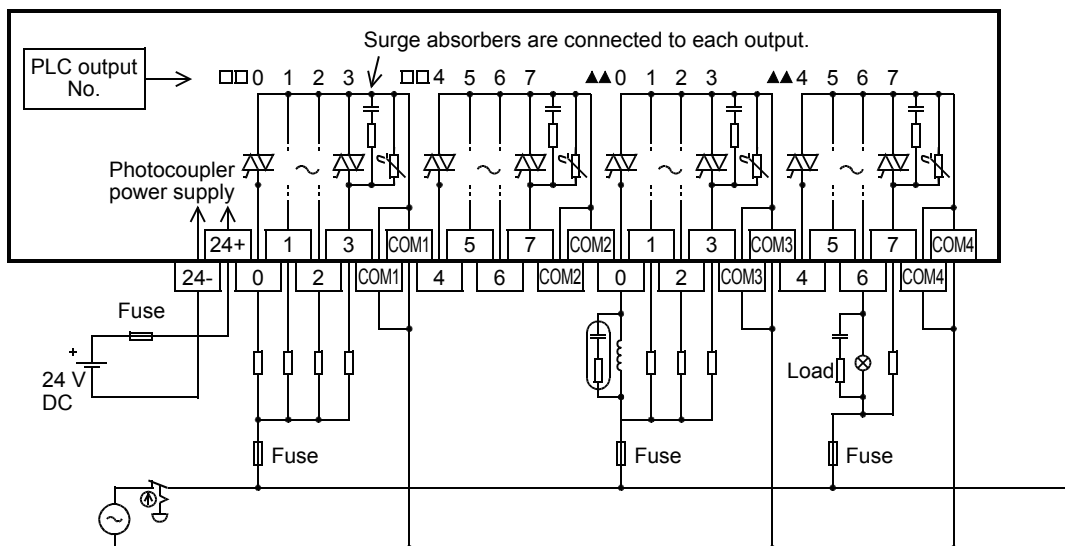

For external wiring precautions, refer to [Page 123 Wiring precautions](#).

6.7 Examples of Wiring for Various Uses

Notes about examples of wiring

The examples of wiring are given under the following conditions.

■Input/output number

The input/output numbers are the actual numbers on the program (They may differ from the numbers shown on the product terminals).

■Input/output specifications of products

Check the input/output specifications of products and examples of wiring.

- There are products for sink output and for source output.

■Examples of program

The examples of programming (instructions) are given based on the allocation of the input/output numbers for wiring.

For the instructions, refer to  MELSEC iQ-F FX5 Programming Manual (Instructions, Standard Functions/Function Blocks).

Positioning function

For wiring examples for the positioning function, refer to  MELSEC iQ-F FX5 User's Manual (Positioning Control - CPU module built-in, High-speed pulse input/output module).

Communication function

For wiring of the built-in RS-485 communication terminal blocks and communication adapters, refer to the following.

 MELSEC iQ-F FX5 User's Manual (Serial Communication)

 MELSEC iQ-F FX5 User's Manual (MODBUS Communication)

For wiring of the built-in Ethernet, refer to the following.

 MELSEC iQ-F FX5 User's Manual (Ethernet Communication)

High-speed counter

Examples of wiring for high-speed counters are shown below.

When capturing pulses of a response frequency of 50 to 200 kHz, refer to  Page 110 When a high-speed pulse is captured.

For details of the high-speed counters, refer to  MELSEC iQ-F FX5 User's Manual (Application).

For the programs, refer to  MELSEC iQ-F FX5 Programming Manual (Instructions, Standard Functions/Function Blocks).

1-phase 1-input (S/W)

The wiring examples in this section use the following settings. When settings other than those in the table are used, use the examples shown in the following figures as references for wiring.

CH to be used	Pulse input mode	External preset input	External enable input	Operation mode
CH1 (CPU module) or CH9 (high-speed pulse input/output module)	1-phase 1-input (S/W)	Invalid	Invalid	Normal mode

The settings of the high-speed counters are set by using the parameter settings of the engineering tool.

For details, refer to MELSEC iQ-F FX5 User's Manual (Application).

■ Example of wiring (NPN open collector transistor output rotary encoder)

• FX5UC-32MT/D

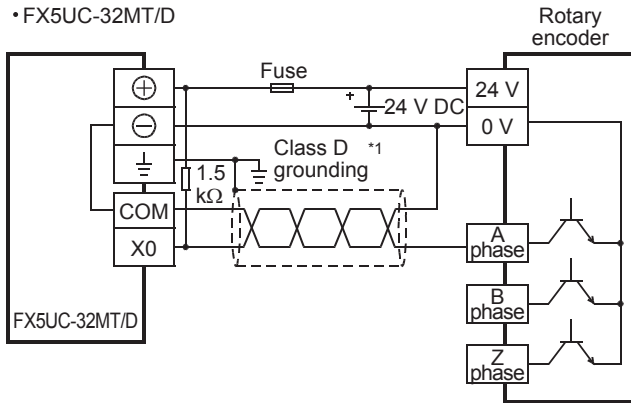

• FX5-16ET/ES-H

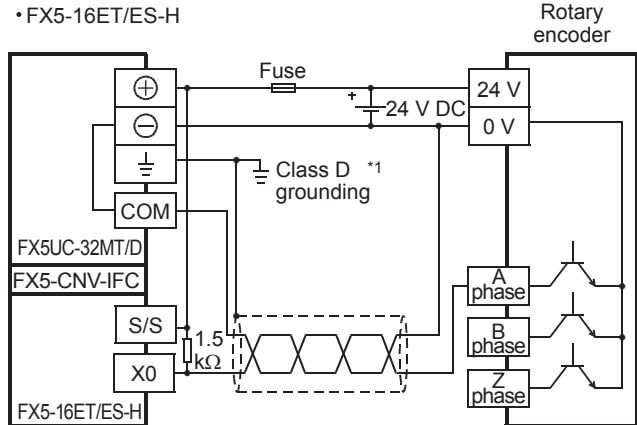

*1 The grounding resistance should be 100 Ω or less.

• FX5UC-32MT/DSS [Sink input wiring]

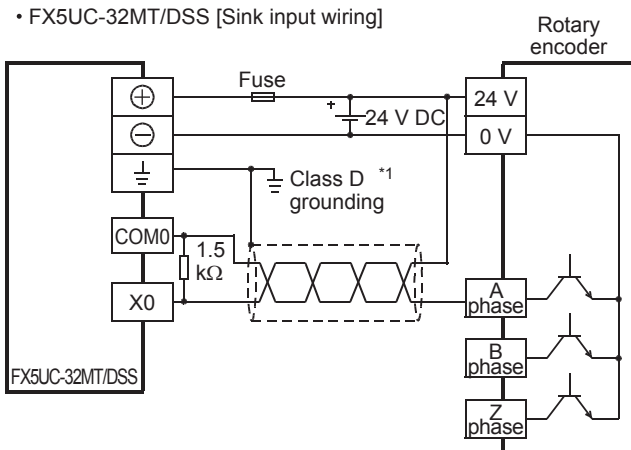

• FX5-16ET/ESS-H

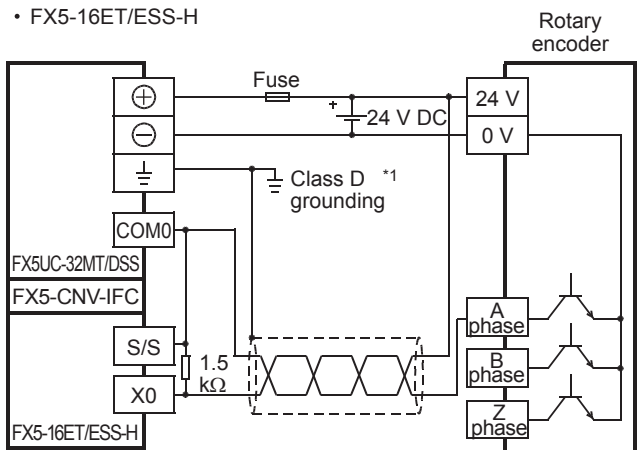

*1 The grounding resistance should be 100 Ω or less.

■ Example of wiring (PNP open collector transistor output rotary encoder)

• FX5UC-32MT/DSS [Source input wiring]

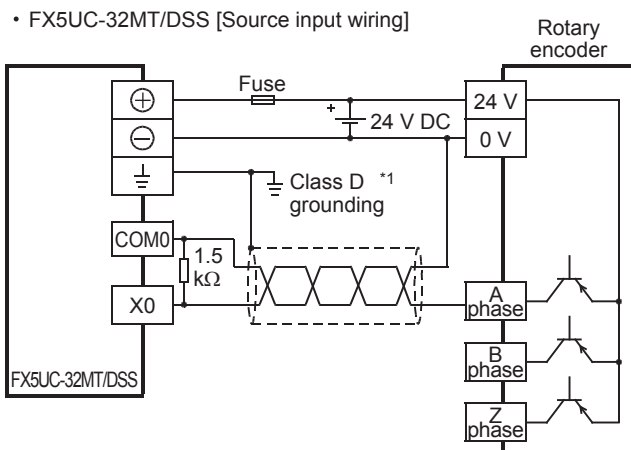

• FX5-16ET/ESS-H

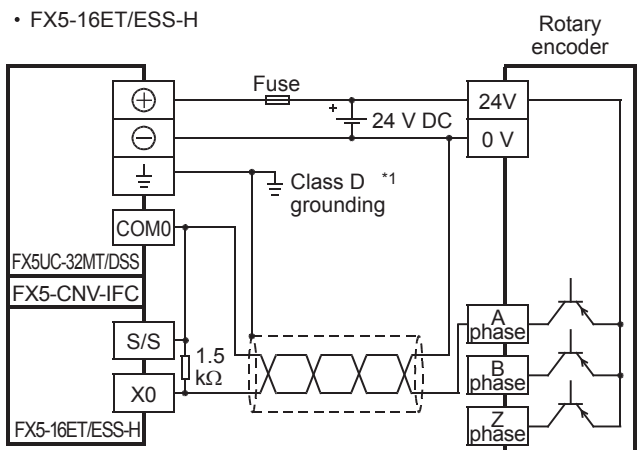

*1 The grounding resistance should be 100 Ω or less.

2-phase 2-input

The wiring examples in this section use the following settings. When settings other than those in the table are used, use the examples shown in the following figures as references for wiring.

CH to be used	Pulse input mode	External preset input	External enable input	Operation mode
CH2 (CPU module) or CH10 (high-speed pulse input/output module)	2-phase 2-input	Invalid	Invalid	Normal mode

The settings of the high-speed counters are set by using the parameter settings of the engineering tool.

For details, refer to MELSEC iQ-F FX5 User's Manual (Application).

■ Example of wiring (NPN open collector transistor output rotary encoder)

• FX5UC-32MT/D

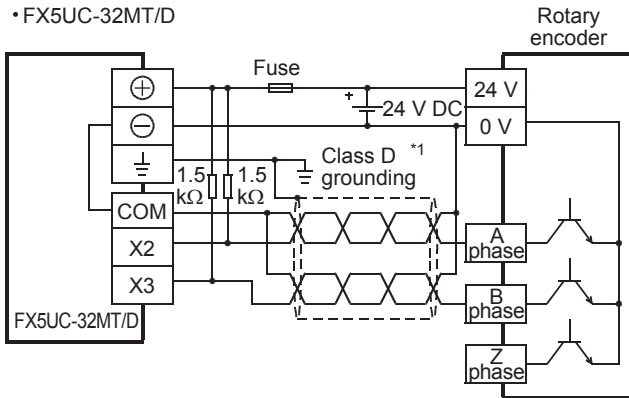

• FX5-16ET/ES-H

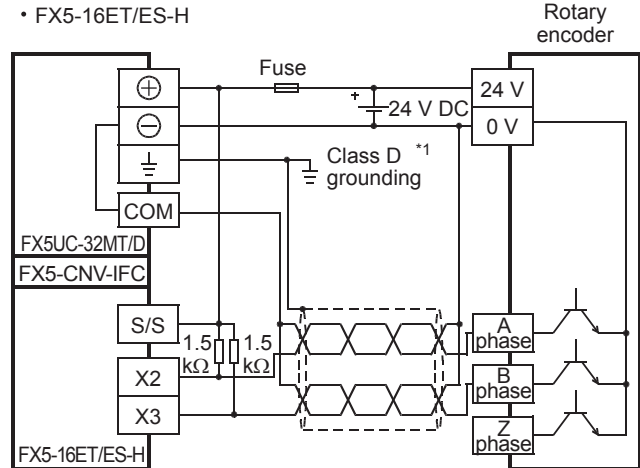

*1 The grounding resistance should be 100 Ω or less.

• FX5UC-32MT/DSS [Sink input wiring]

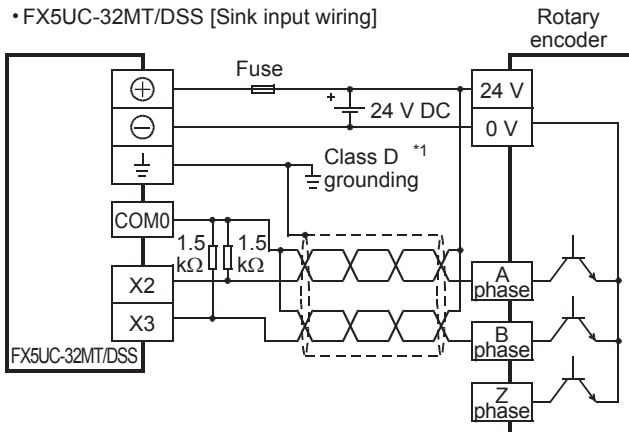

• FX5-16ET/ESS-H

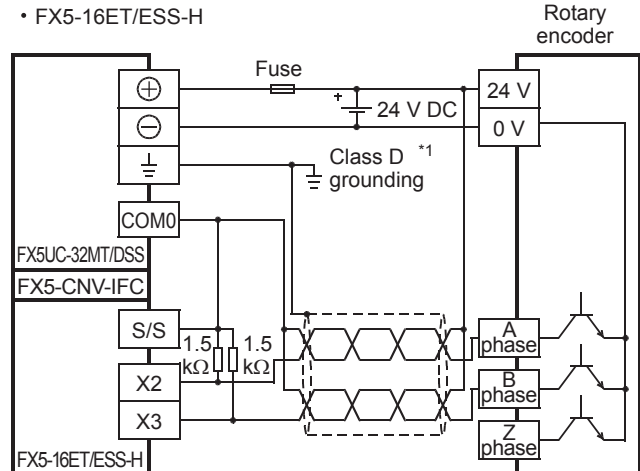

*1 The grounding resistance should be 100 Ω or less.

■ Example of wiring (PNP open collector transistor output rotary encoder)

• FX5UC-32MT/DSS [Source input wiring]

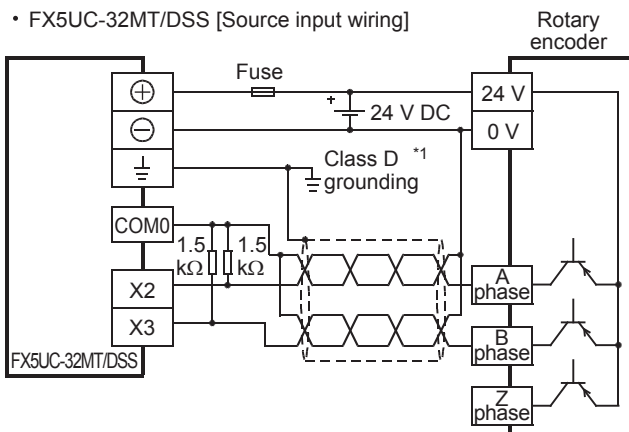

• FX5-16ET/ESS-H

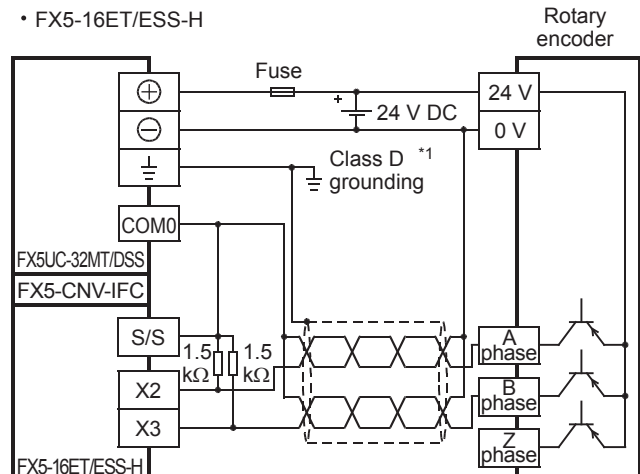

*1 The grounding resistance should be 100 Ω or less.

Interruption

Examples of wiring for when the input interruption function is used are shown below.

The same wiring is used for the pulse catch and pulse width measurement functions.

When capturing pulses of a response frequency of 50 to 200 kHz, refer to Page 110 When a high-speed pulse is captured.

For details of the input interruption function, pulse catch function, and pulse width measurement function, refer to MELSEC iQ-F FX5 User's Manual (Application).

Example of wiring

■3-wire sensor of NPN open collector transistor output

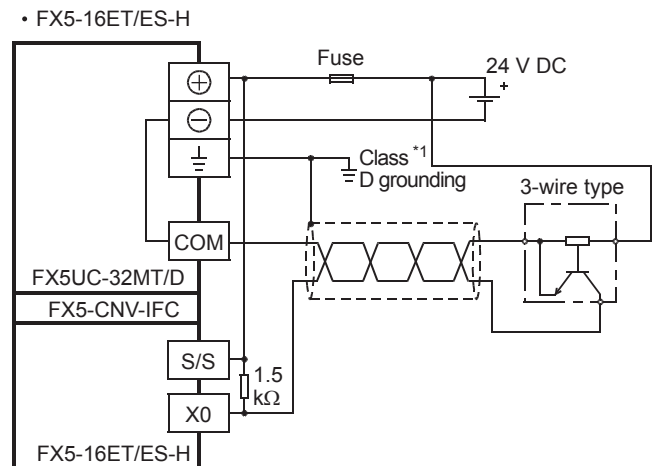
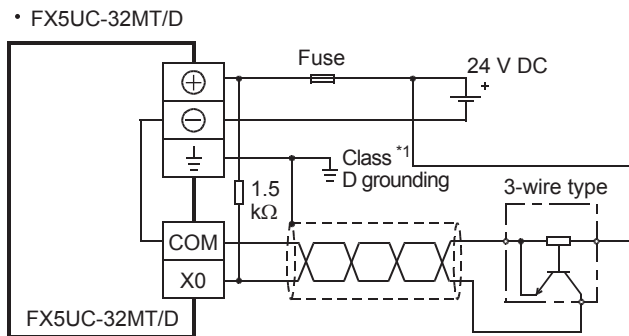

*1 The grounding resistance should be 100 Ω or less.

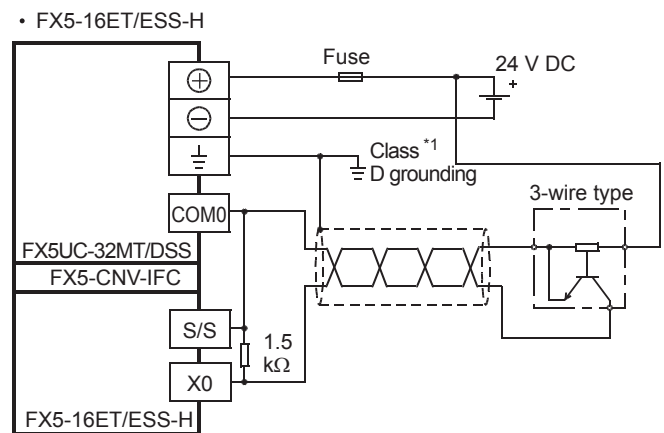
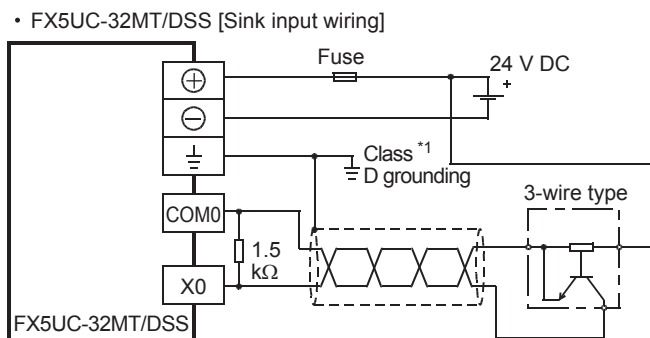

*1 The grounding resistance should be 100 Ω or less.

■3-wire sensor of PNP open collector transistor output

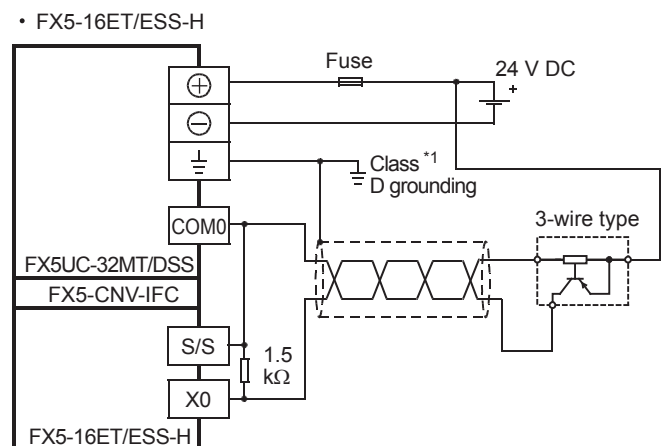
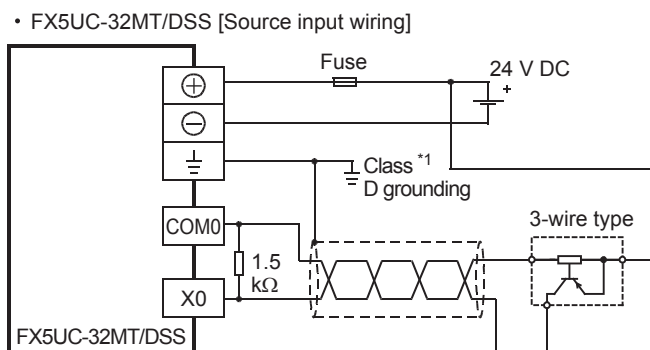

*1 The grounding resistance should be 100 Ω or less.

Digital switch

When DSW instructions are used

Examples of wiring for capturing values from a 4-digit digital switch to the data register D100 are given below.

For the instructions, refer to [MELSEC iQ-F FX5 Programming Manual \(Instructions, Standard Functions/Function Blocks\)](#).

Example of program

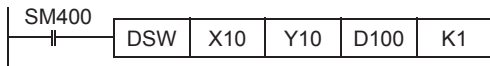

Example of wiring

- Sink wiring

The example is the wiring for the input/output of the FX5UC-32MT/D.

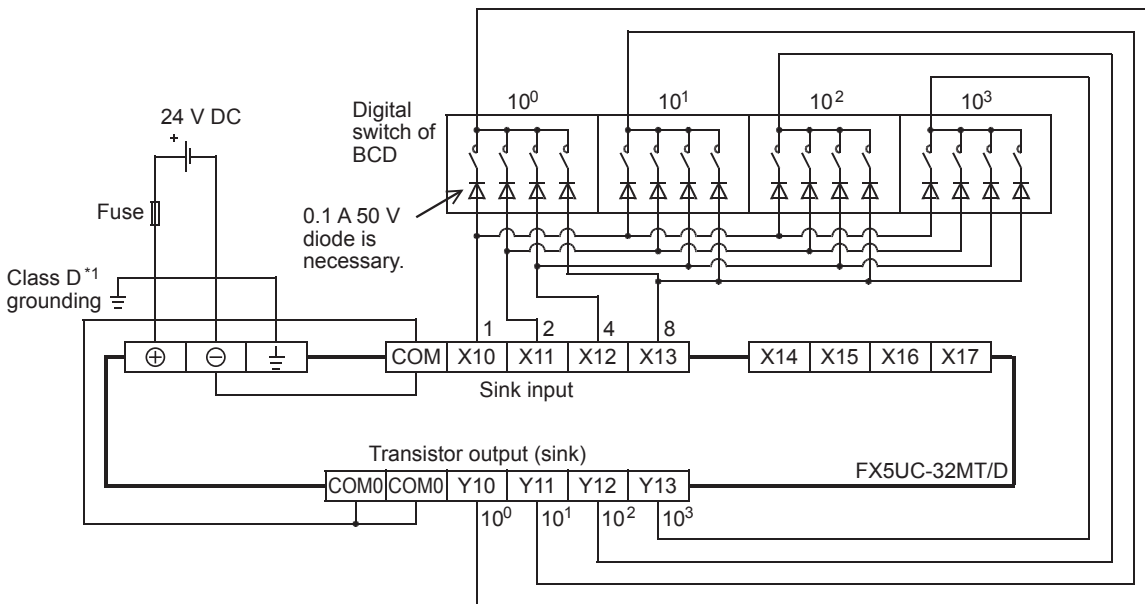

- Source wiring

The example is the wiring for the input/output of the FX5UC-32MT/DSS.

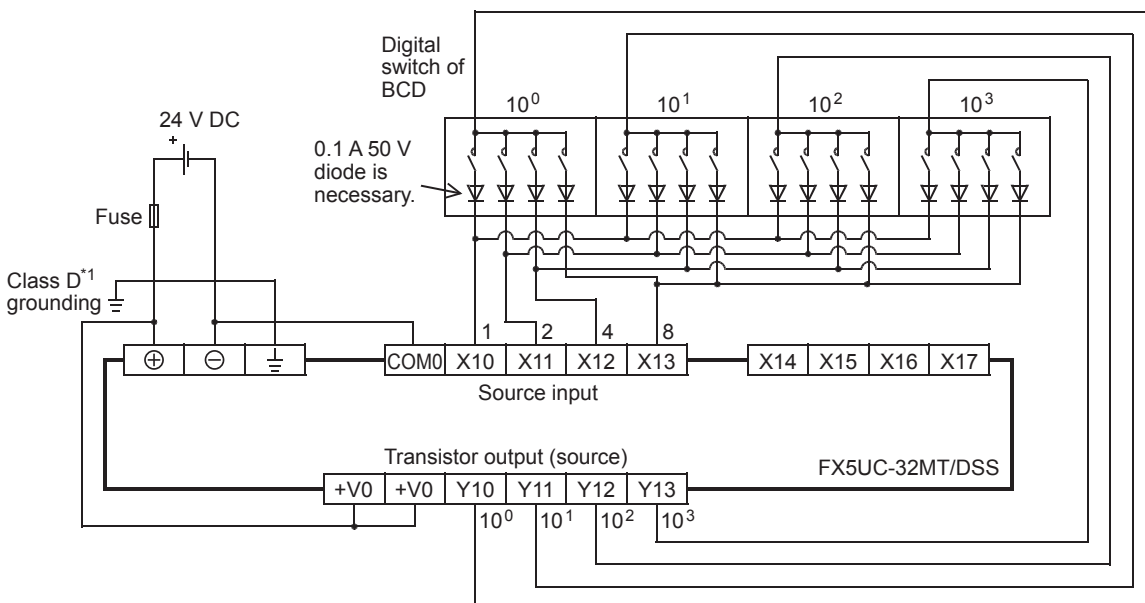

*1 The grounding resistance should be 100 Ω or less.

When BIN instructions are used

Examples of wiring for capturing values from a 2-digit digital switch to the data register D102 are given below.

For the instructions, refer to MELSEC iQ-F FX5 Programming Manual (Instructions, Standard Functions/Function Blocks).

Example of program

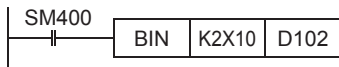

Example of wiring

- Sink wiring

The example is the wiring for the input/output of the FX5UC-32MT/D.

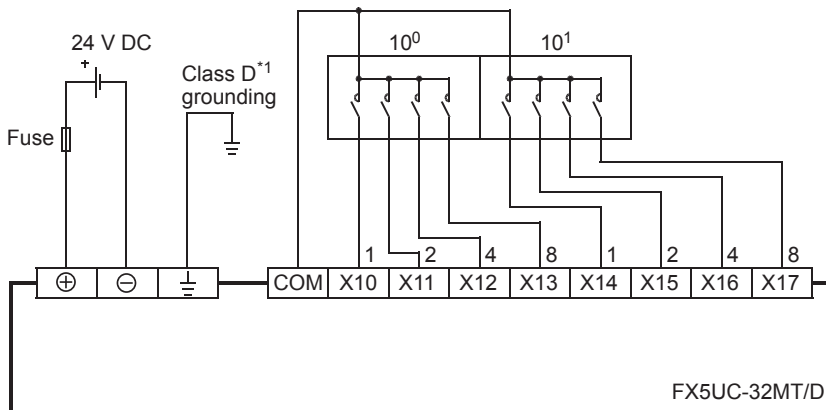

- Source wiring

The example is the wiring for the input/output of the FX5UC-32MT/DSS.

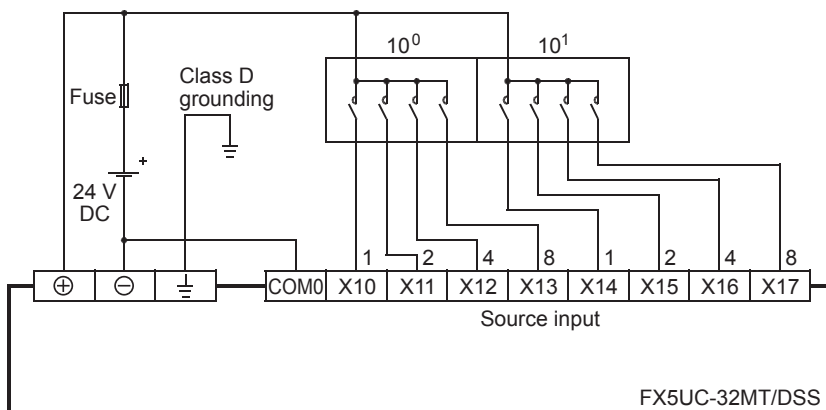

*1 The grounding resistance should be 100 Ω or less.

Input matrix

Examples of wiring to take ON/OFF status of 24 switches by using MTR instructions are given below.

For the instructions, refer to MELSEC iQ-F FX5 Programming Manual (Instructions, Standard Functions/Function Blocks).

Programming examples

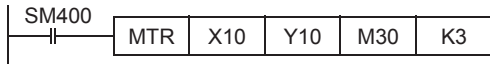

Wiring examples

- Sink wiring

The example is the wiring for the input/output of the FX5UC-32MT/D.

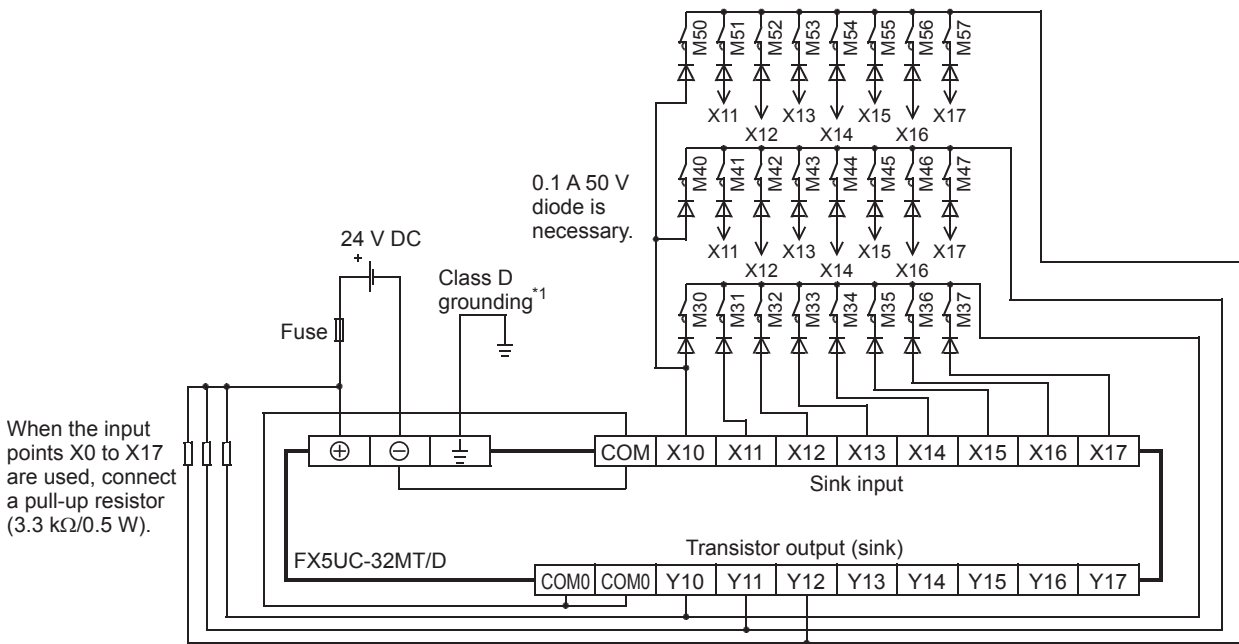

- Source wiring

The example is the wiring for the input/output of the FX5UC-32MT/DSS.

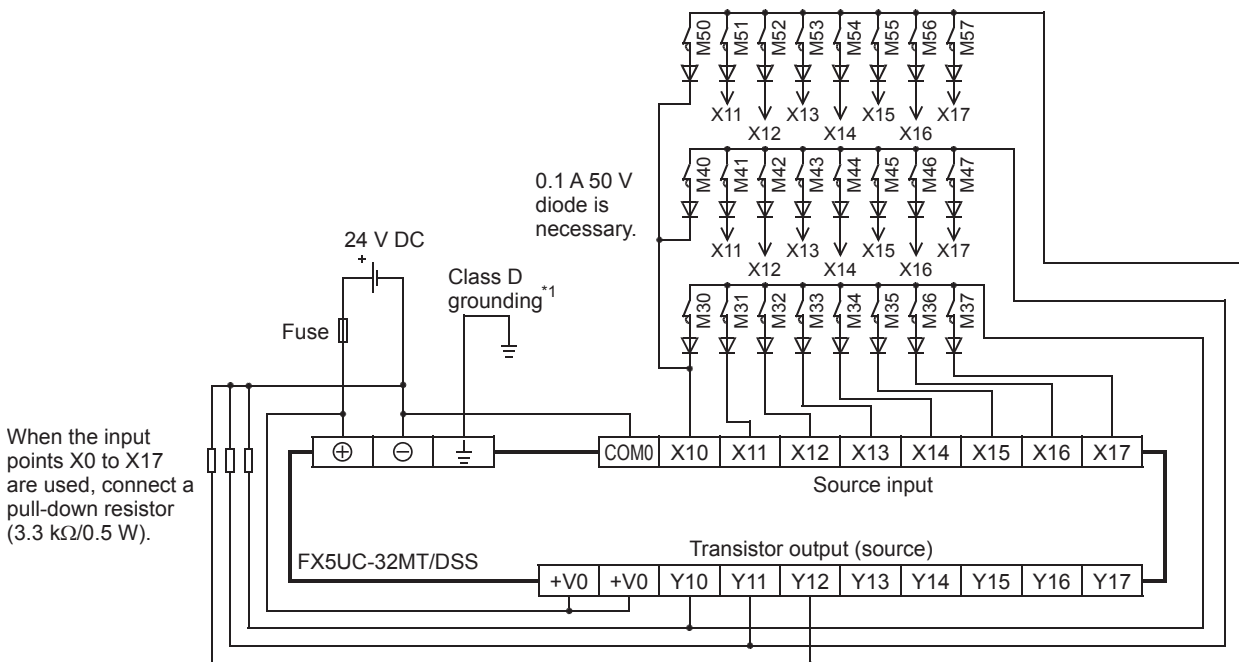

*1 The grounding resistance should be 100 Ω or less.

Seven segment with latch

When SEGL instructions are used

Examples of wiring for displaying the current value of D100 on the 4-digit 7-segment display are given below.

For the instructions, refer to MELSEC iQ-F FX5 Programming Manual (Instructions, Standard Functions/Function Blocks).

Example of program

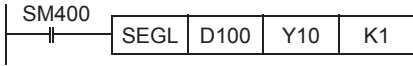

Example of program wiring

- Sink wiring

The example is the wiring for the input/output of the FX5UC-32MT/D.

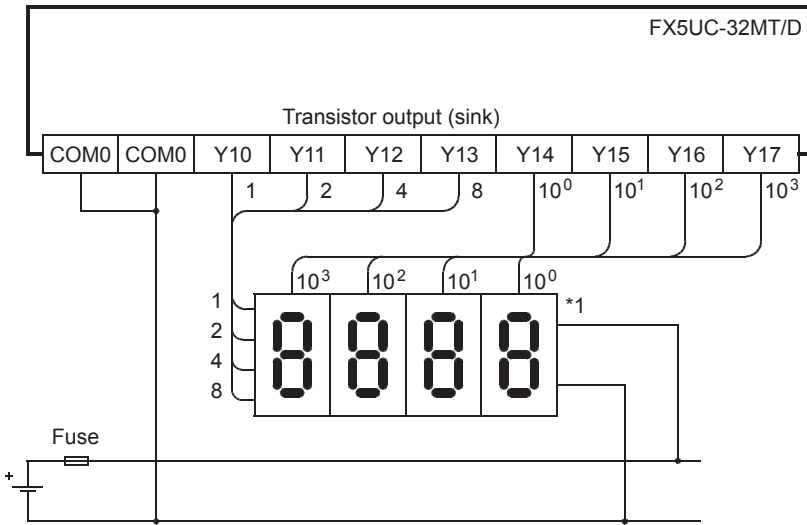

7-segment display used for sink wiring (for transistor output)

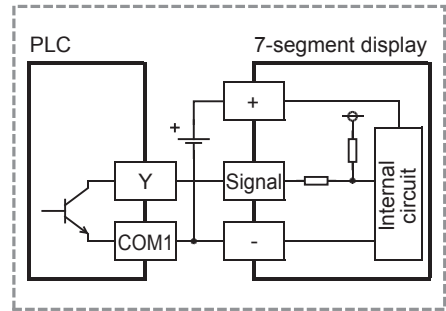

- Source wiring

The example is the wiring for the input/output of the FX5UC-32MT/DSS.

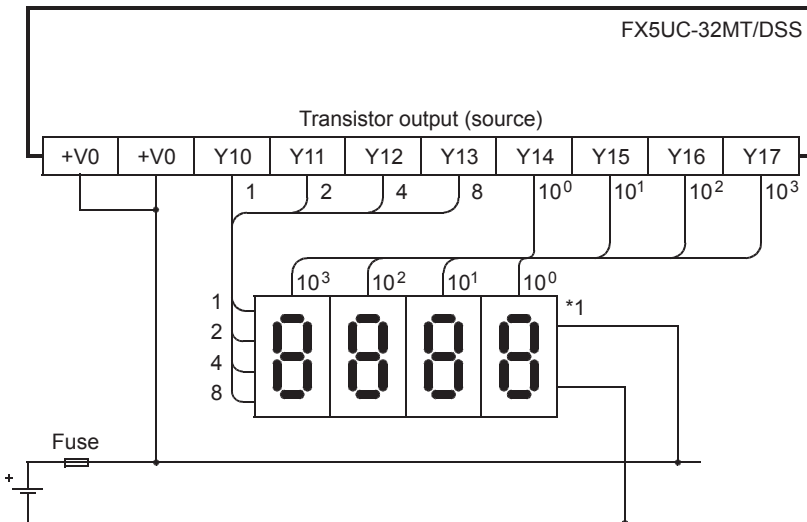

7-segment display used for source wiring (for transistor output)

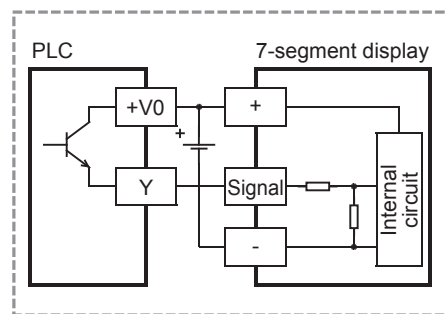

*1 Use a 7-segment display with a latch and a built-in BCD decoder.

When BCD instructions are used

Examples of wiring for displaying the current value of D100 on the 2-digit 7-segment display are given below.

For the instructions, refer to MELSEC iQ-F FX5 Programming Manual (Instructions, Standard Functions/Function Blocks).

Example of program



Examples of wiring

- Sink wiring

The example is the wiring for the input/output of the FX5UC-32MT/D.

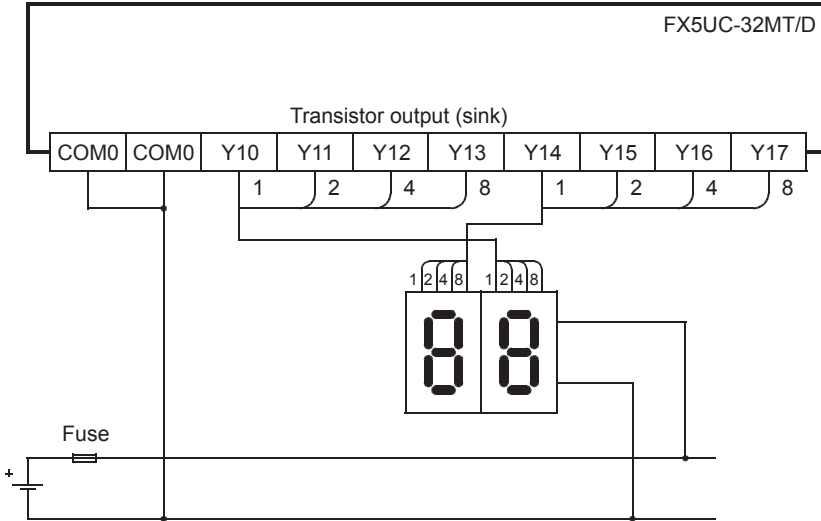

7-segment display used for sink wiring (for transistor output)

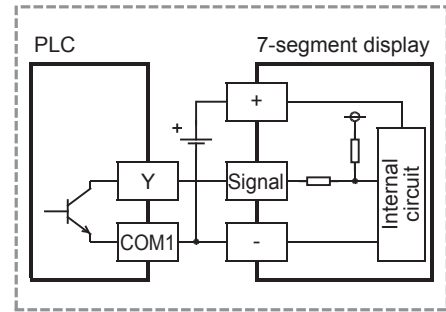

- Source wiring

The example is the wiring for the input/output of the FX5UC-32MT/DSS.

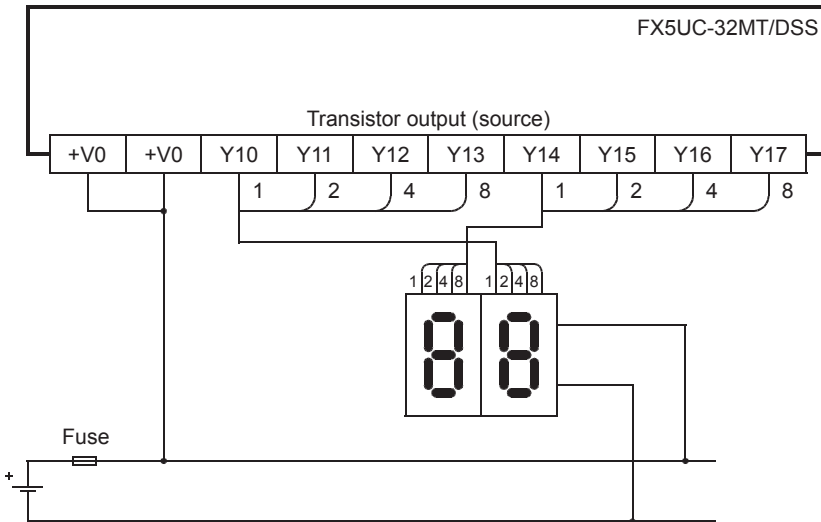

7-segment display used for source wiring (for transistor output)

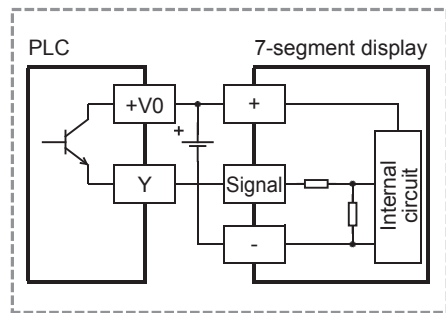

7 OPERATION ADJUSTMENT

7.1 Preparation for Operation

Preliminary inspection

Incorrect connection of the power supply terminal, contact of the DC input wire and power supply wire, or short-circuiting of output wires may result in serious damage.

Before applying power, check that the power supply and ground terminals are connected correctly and input/output devices are wired properly.

Dielectric withstand voltage test and insulation resistance test

The dielectric withstand voltage and insulation resistance test of the PLC should be measured in accordance with the following procedure.

1. Remove all input/output wires and power supply wires from the PLC.
2. Connect a crossing wire to each of the PLC terminals (power supply terminal, input terminals and output terminals) except the ground terminal. For the dielectric withstand voltage test of each terminal, refer to the general specifications for the product (refer to  Page 29 Generic Specifications).
3. Measure the dielectric withstand voltage and insulation resistance between each terminal and the ground terminal.
 - Dielectric withstand voltage: 1.5 kV AC or 500 V AC for 1 min (The terminals vary in dielectric withstand voltage.)
 - Insulation resistance: 10 MΩ or higher by 500 V DC insulation resistance tester

Procedure until operation

The procedure until operation is explained below.

1. Turn on the power of the system.

Check the following items before turning on the power of the system. When the CPU module with the factory default setting is powered on, the ERR LED flashes because the module has no programs.

- The power connector is connected correctly.
- The power supply voltage is within the specified range.
- The CPU module is in the stopped status.

2. Connection with a personal computer

Connect the CPU module with a personal computer on which an engineering tool has been installed. ( Page 141 Connection with a personal computer)

3. Format the CPU built-in memory.

Format the CPU built-in memory using the engineering tool. ( GX Works3 Operating Manual)

4. Parameter setting

Set the parameters needed for startup. ( GX Works3 Operating Manual)

- System parameters
- CPU parameters
- Module parameters

5. Programming

Create a program using the engineering tool. ( MELSEC iQ-F FX5 User's Manual (Application))

6. Write the parameters and the program.

Write the parameters and the program set with the engineering tool into the CPU module. ( GX Works3 Operating Manual)

7. Reboot the system.

Reboot the system by any of the following methods.

- Turning off and on the power
- Resetting the CPU module ( Page 143 Resetting method)

8. Check errors.

Check the ERR LED of the CPU module. If an error has occurred, check the contents of the error with Module Diagnostics (CPU Diagnostics) of the engineering tool and eliminate its cause.

9. Run the program.

Set the CPU module to the RUN status and make sure that the P.RUN LED of the CPU module lights up.

Precautions

Do not write a program with more than 64 k steps to the CPU module firmware version earlier than 1.100. The program does not operate normally.

Connection with a personal computer

Connect the CPU module with a personal computer on which an engineering tool has been installed.

The system configuration examples and GX Works3 settings are described below.

For details, refer to  GX Works3 Operating Manual.

Direct connection

Setting examples for accessing the CPU module that is directly connected with a personal computer are shown below.

■ Ethernet connection

- Ethernet port direct connection

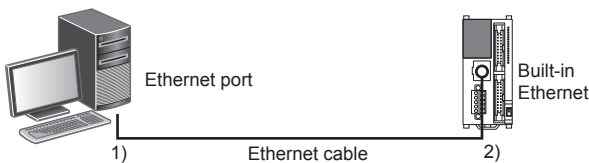

GX Works3 settings

No.	Item	Selection item	Internal setting	Input value
1)	PC side I/F	Ethernet Board	—	—
2)	PLC side I/F	PLC Module		Ethernet Port Direct Connection
	Other Station Setting	No Specification	Check at Communication Time	30 seconds
			Retry Times	0 times

Point

For the FX5 CPU module, the Ethernet adapter on the personal computer side used for the Ethernet port direct connection can be specified. Click the [CPU Module Direct Coupled Setting] button on the "Specify Connection Destination Connection" window to display the "CPU Module Direct Coupled Setting" window. Select the adapter on the window.

- Connection via HUB

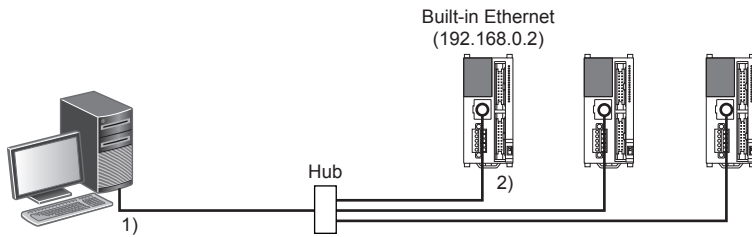

GX Works3 settings

No.	Item	Selection item	Internal setting	Input value
1)	PC side I/F	Ethernet Board	—	—
2)	PLC side I/F	PLC Module	Connection via HUB	IP Address 192.168.0.2
				Response Waiting Time 2 seconds
	Other Station Setting	No Specification	Check at Communication Time	30 seconds
			Retry Times	0 times

Serial connection

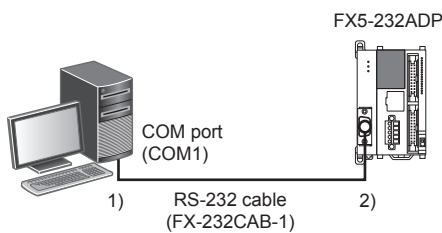

GX Works3 settings

No.	Item	Selection item	Internal setting	Input value
1)	PC side I/F	Serial/USB	RS-232C	—
			COM Port	COM1
			Transmission Speed	115.2Kbps
2)	PLC side I/F	PLC Module	PLC Mode	FX5CPU
			Other Station Setting	No Specification
			Retry Times	0 times

7.2 Operation and Test

Self-diagnostic function

When the power of the CPU module is turned on, the self-diagnostic function to check for errors starts in the module. The CPU module boots when there is no error with the hardware, parameters, and program.

When there are no errors, the module enters the RUN status (the P.RUN LED turns on) in response to the RUN instruction (☞ Page 143 Running, Stopping, and Resetting). If any error is detected, the "ERR" LED flashes or lights up.

Monitoring and debugging

The ON/OFF status of PLC's devices, current values or set values can be monitored or changed by using engineering tools. For details, refer to ☞ GX Works3 Operating Manual.

7.3 Running, Stopping, and Resetting

Methods of running, stopping, and resetting

The following two methods of running, stopping, and resetting the FX5UC CPU modules are provided.

Using the RUN/STOP/RESET switch

The operation status of the CPU module can be changed with the RUN/STOP/RESET switch.

Setting the RUN/STOP/RESET switch to the RUN position runs the program. Setting the switch to the STOP position stops the program.

Resetting method

Resetting can be performed with the RUN/STOP/RESET switch. Resetting is not performed immediately after the RUN/STOP/RESET switch is set to the RESET position.

Perform the following procedure to reset with the RUN/STOP/RESET switch.

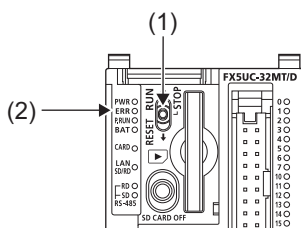

1. Set the RUN/STOP/RESET switch (1) to the RESET position for at least one second.
2. Make sure that the ERR LED (2) flashes several times.
3. Return the RUN/STOP/RESET switch to the STOP position.

Remote operation

The operation status of the CPU module can be changed externally with the RUN/STOP/RESET switch set to the RUN position. The operation status of the CPU module can be set to the PAUSE status.

Remote operation can be performed by either of the following methods.

- Using contacts (MELSEC iQ-F FX5 User's Manual (Application))
- Using engineering tools (GX Works3 Operating Manual)
- Using external devices using SLMP (MELSEC iQ-F FX5 User's Manual (SLMP))

Use of several running/stopping methods

When the RUN/STOP/RESET switch and RUN contact are used

- The RUN/STOP status of the PLC is determined by the conditions shown in the following table.

RUN/STOP/RESET switch status	Condition of the input specified as the RUN terminal by parameters	CPU module status
RUN	RUN	RUN
	STOP	STOP
STOP	RUN	STOP
	STOP	STOP

8 MAINTENANCE AND INSPECTION

8.1 Daily Inspection



Perform the following inspections on a daily basis.

Item	Inspection item	Description	
1	Installation status of the module	Looseness of mounting screws	Retighten the mounting screws.
		Mounting status of the module	The module should be securely mounted.
		Looseness of cover	The cover should not be off.
2	Connection status	Looseness of terminal screws	Retighten the terminal screws.
		Proximity of crimp terminals	Check the proximity between crimp terminals and correct the clearance.
		Looseness of connectors	Connect cable connectors securely.
3	LED status	Check that the LED status is normal.  Page 149 Checking with LEDs User's manuals for each module	

8.2 Periodic Inspection

Perform the following inspections once or twice every 6 months to a year.

Also perform the inspections when facilities have been relocated or modified or when wiring has been changed.

Item	Inspection item	Description	
1	Ambient environment	Operating ambient temperature	The temperature in the panel should be -20 to 55°C*1.
		Operating ambient humidity	The humidity in the panel should be 5 to 95%RH.
		Working atmosphere	Free from corrosive or flammable gas and excessive conductive dust
2	Power supply voltage	Voltage within the specified range should be supplied.	
3	Installation status	Dirt, foreign matter	Wipe away any dirt or foreign matter. Clean the module.
4	Connection status	Looseness of terminal screws	Retighten the terminal screws.
		Proximity of crimp terminals	Check the proximity between crimp terminals and correct the clearance.
		Looseness of connectors	Connect cable connectors securely.
5	Battery	BAT LED	The BAT LED should be turned off. If flashing, replace the battery with new one.
		Period following the battery purchase	Replace the battery with new one if 5 years or more have passed since the battery was purchased.
		OFF status of SM51 (SM8005) and SM52 (SM8006)	SM51 (SM8005) and SM52 (SM8006) should be off. If SM51 (SM8005) and SM52 (SM8006) are on, replace the battery with new one.
6	Module Diagnostics	The normal status of the system should be checked with the Module Diagnostics.  Page 152 Module diagnostics	
7	Relay contacts	Check the product life of relay outputs.  Page 119 Product life of relay output contacts	

*1 The operating ambient temperature is 0 to 55°C for products manufactured before June 2016.

Point

The product life of relay contacts varies considerably depending on the load type used. Note that loads generating reverse electromotive force or rush current may cause poor contact or deposition of contacts which may lead to considerable reduction of the contact product life.

 Page 119 Product life of relay output contacts

8.3 Battery

Part names

The Latch device memory and clock data upon power interruption. The battery is not incorporated in the CPU module during shipment from the factory. Order it if necessary. Parameter setting is required to back up the device memory and clock data. (☞ Page 146 Setting an optional battery using the engineering tool)

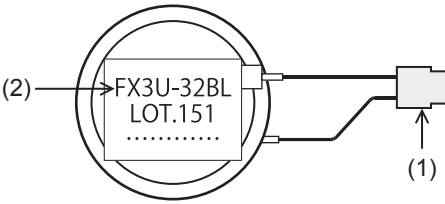
External appearance	No.	Name	Description
	(1)	Connector	Connected to the battery connector of the CPU module.
	(2)	Nameplate	Displays the model name and lot number.

Specifications

The following shows functional specifications of the battery.

Item	FX3U-32BL
Battery type	Lithium manganese dioxide battery
Nominal voltage	3.0 V
Life	Standard life: 5 years (at ambient temperature of 25°C) ^{*1}

*1 The life of the battery changes with respect to ambient temperature. (☞ Page 146 Battery life and replacement guidelines)

Battery attachment

The battery is not incorporated in the CPU module during shipment from the factory. To use the battery, attach it following the procedure below. Parameter setting is required to back up the device memory and clock data using the battery. (☞ Page 146 Setting an optional battery using the engineering tool)

Attachment procedure

1. Turn the power supply off.
2. Remove the battery cover (A in the figure below).

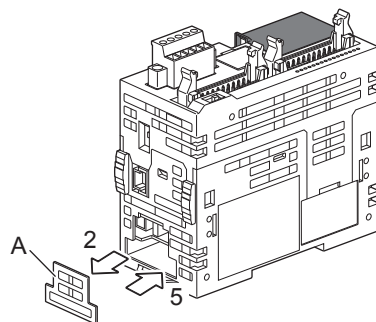

3. Push the battery into the battery holder (B in the figure below).
4. Insert the battery connector (C in the figure below) of the battery.

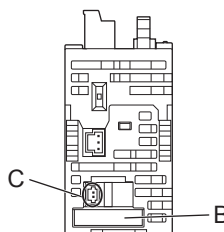

5. Attach the battery cover.

Setting an optional battery using the engineering tool

The following setting is required when the capacity of the latch device/latch label is increased using the optional battery. Note that the battery does not back up the data if the following setting is not provided.

Select the Navigation window ⇒ [Parameter] ⇒ [FX5UCPU] ⇒ [CPU Parameter] ⇒ [Memory/Device Setting] ⇒ [Device/Label Memory Area Setting] ⇒ [Detailed Setting] ⇒ [Device/Label Memory Area Setting] screen

	Label	Device
High Speed Area	Label: [] K Latch: [] K	12 K [Detailed Setting]
Standard Area	Label: 12 K Latch: 1 K	35 K [Detailed Setting]

Used Area

High Speed Area	[]	12 / 12K
Standard Area	[]	48 / 63K

Explanation

Set to use the option battery and to increase latch label volume.
(*'Mounted' is available in FX5U only)

OK Cancel

Set the option battery setting to "Mounted" in Device/Label Memory Area Setting screen.

Battery replacement

Battery life and replacement guidelines

When the battery voltage is low, the BAT LED on the panel flashes red while the power is on, and SM51 (SM8005) and SM52 (SM8006) turn ON. The memory can be retained for about one month after the LED turned on. However, the drop in battery voltage may not be detected immediately. Prepare a new battery and replace the battery with new one promptly.

Point

Standard life of FX3U-32BL: 5 years (at ambient temperature of 25°C)

The life of the battery changes with respect to ambient temperature.

When planning for battery replacement, please estimate the battery life according to the graph below and order replacement batteries in advance.

Battery life vs. temperature

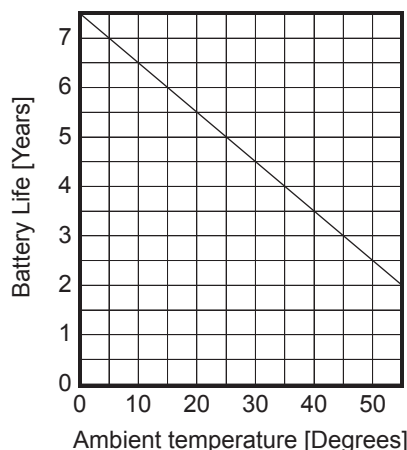

Replacement procedure

If the battery voltage is reduced, replace it following the procedure below.

Note the followings before replacement work.

- Turn on the power supply of the PLC for more than 10 sec.
- Back up the data of the CPU module with the engineering tool.

Even with the battery removed, the built-in capacitor holds the data of the memory for the power interruption time (20 sec.). Battery replacement steps 5 and 6 must be completed within the power interruption time (20 sec.). If the time taken for battery replacement is longer than the power interruption time, the data of the memory may be lost.

1. Turn the power supply on.
2. Back up the data of the CPU module with the engineering tool.
3. Turn the power supply off.
4. Remove the battery cover (A in the figure below).

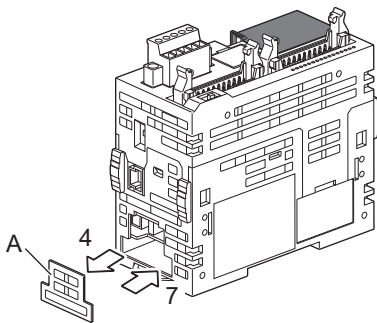

5. Disconnect the battery connector (B in the figure below) from the old battery, and remove the battery from the battery holder (C in the figure below). When extracting the old battery, hold the root part of the cable and pull the old battery straight out.

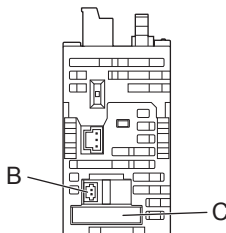

6. Install the new battery. (☞ Page 145 Battery attachment)
7. Attach the battery cover.

Point

- After replacing the battery, check whether the devices set by the latch and clock data are backed up correctly, confirm safety, and then run the PLC.
- If the devices set by the latch are not backed up correctly, clear them, and set their initial values and clock data again if necessary.
- If a long time has passed since the battery voltage is reduced, the data may not be retained by the battery. Make sure to back up the data of the CPU module with the engineering tool before battery replacement.

Reading the date of manufacture

How to read the battery lot number

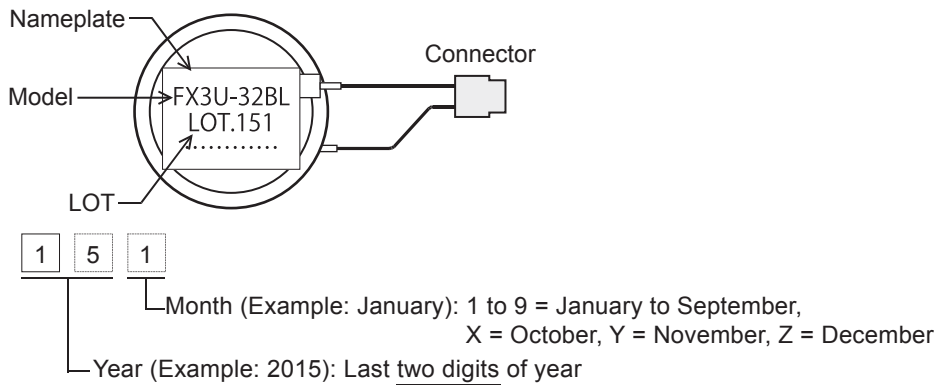

Special relay for low battery voltage

Prepare a system which allows constant external monitoring of the battery status, using a GOT, etc.

- SM52 (SM8005)

The special relay turns ON when the battery voltage is less than the specified value.

The special relay turns OFF when the battery voltage returns is normal.

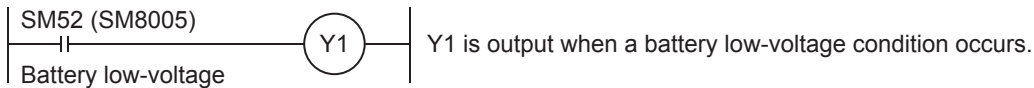

- SM51 (SM8006)

The special relay turns ON when the battery voltage is less than the specified value.

The special relay status ON even when the battery voltage is normal.

- SD8005

Battery voltage can be monitored.

9 TROUBLESHOOTING





Details on errors occurring in the system, their causes, and corrective actions are explained below. For details on troubleshooting for each module, refer to the manuals for the module.

Point

Saving the programs and devices used at the occurrence of an error helps identifying the cause of the error. ( Page 155 Backing Up the Data)

9.1 Troubleshooting Procedure

If an error occurs, perform troubleshooting in the following order.

1. Check that each module is properly mounted and wired.
2. Check the LEDs of the CPU module. ( Page 149 Checking with LEDs)
3. Check the LEDs of each intelligent function module and FX5 safety extension module. (Manuals for each module)
4. Connect the engineering tool, and execute the system monitor. The error module can be identified. ( Page 151 System monitor)
5. Select the error module, and execute the module diagnostics. The error cause and the action to be taken can be displayed. ( Page 152 Module diagnostics)
6. If the cause could not be specified by Module diagnostics, check the error history from the event history of the engineering tool to identify the cause. ( Page 153 Event history)
7. Check the cause of the error and take corrective actions.

9.2 Checking with LEDs

Check the module status with LEDs as a means to perform the primary diagnosis.

Checking the PWR LED

If the PWR LED is turned off, check the following items.

Item to check	Cause and action
Measure the voltage supplying to the CPU module.	If the power source is not supplying the proper voltage, provide a power source that does.
Remove extension modules and all wiring other than the one for the power supply, and turn on the power supply.	If the PWR LED turns on in this condition, or overloaded. Reconnect the modules and wire one by one to identify the cause.

If the PWR LED still does not turn on even after the items shown above are checked, there may be a hardware issue. Consult your local Mitsubishi Electric representative.

Checking the BAT LED

If the BAT LED is flashing, check the following items.

The LED is valid when the optional battery is installed and the LED is set to "display" for battery errors by using the parameter.

Item to check	Cause and action
Check the installation of the battery.	Install the battery properly.
Check the battery voltage.	If the battery voltage is reduced, replace the battery with a new one. Battery voltage can be monitored with PLC data register SD8005. ( Page 145 Battery)

Checking the ERR LED

If the ERR LED flashing

If the ERR LED flashing, check the following items.

Item to check	Cause and action
Write system parameters, CPU parameters, and program files, and turn on the power supply again.	Programs or parameters may not be written or damaged. Since a CPU module with the factory default setting has no programs, the ERR LED flashes.
Set the CPU module to the STOP status and turn on the power supply again.	When the ERR LED turns off, a watchdog timer error has probably occurred. Take any of the following measures. <ul style="list-style-type: none"> Review the program and avoid the maximum value (SD524, SD525) of the scan time exceeding the setting value of the scan time monitoring time which was set with parameters. Check that the input used for input interruption or pulse catch is not being abnormally turned on and off in one scan. Check that the frequency of the pulse input to the high-speed counter is within the specified range. Add some WDT instructions to the program and reset the watchdog timer several times in one scan.

If the ERR LED turns on

If the ERR LED turns on, check the following items.

Item to check	Cause and action
Provide a different power supply to the CPU module.	If the ERR LED turns on, noise may have affected the module. Consider taking the following measures. <ul style="list-style-type: none"> Check the ground wiring, and reexamine the wiring route and installation location. Fit a noise filter onto the power supply line.

If the ERR LED still does not turn off even after the items shown above are checked, there may be a hardware issue. Consult your local Mitsubishi Electric representative.

Checking the P.RUN LED

If the P.RUN LED is turned off, check the status of the ERR LED and take corrective actions. (☞ Page 150 Checking the ERR LED)

If the P.RUN LED is turned on, check the following items.

Cause	CPU module status	Action
After writing to PLC, the CPU module was set to RUN without resetting.	Stopped	Reset the CPU module or turn off and on the power supply, and then set the CPU module to RUN.
The operating status of the CPU module was changed to RUN or PAUSE at the time of online program change.	Operating status before the change	Wait until P.RUN LED stops flashing. (When the online program change is completed, P.RUN LED automatically stops flashing. After that, the operation status is switched.)

9.3 Troubleshooting using the engineering tool

Check the error or history using the engineering tool, and identify the error cause. More detailed information on the error as well as the error cause and action to be taken can be checked by using the engineering tool.

The engineering tool has the following functions for troubleshooting.

Function	Description
System monitor	Displays the module configuration, and detailed information and error status of each module. (Page 151 System monitor)
Module Diagnostics	This function diagnoses the module. (The current error and its details can be checked.) (Page 152 Module diagnostics)
Event history	This function displays event information including errors that occurred in the CPU module, expansion adapter, intelligent function module*1 and errors on the network. (Page 153 Event history)

*1 For supported versions of the intelligent function module, refer to Page 203 Added and Changed Functions.

For details on each function, refer to the following.

 GX Works3 Operating Manual

System monitor

This function displays the module configuration, and detailed information and error status of each module.

For the error module identified, the module diagnostics can be executed from this window.

 [Diagnostics] ⇒ [System Monitor]

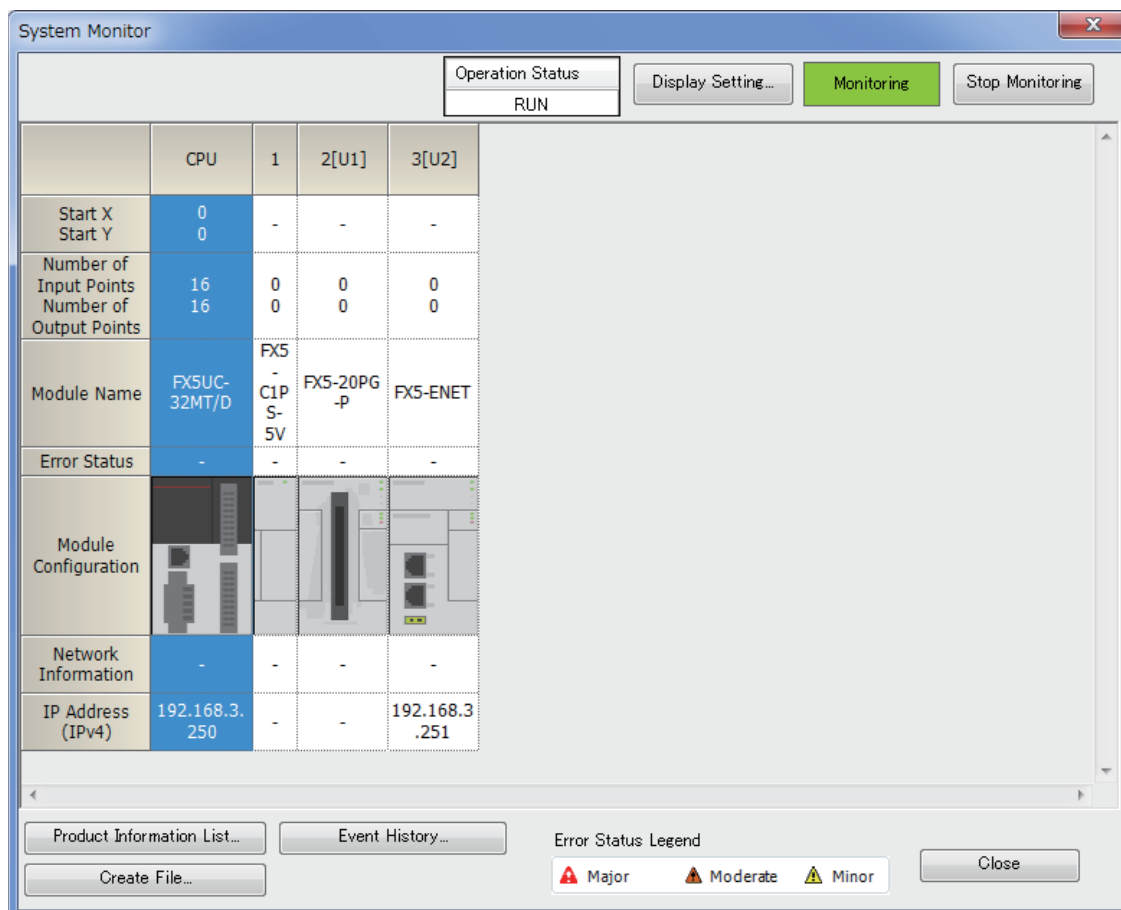

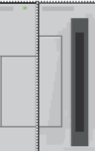
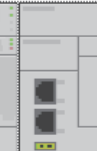
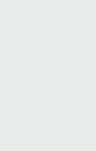
	CPU	1	2[U1]	3[U2]
Start X	0	-	-	-
Start Y	0	-	-	-
Number of Input Points	16	0	0	0
Number of Output Points	16	0	0	0
Module Name	FX5UC-32MT/D	FX5-C1P S-5V	FX5-20PG-P	FX5-ENET
Error Status	-	-	-	-
Module Configuration				
Network Information	-	-	-	-
IP Address (IPv4)	192.168.3.250	-	-	192.168.3.251

Module diagnostics

This function diagnoses the CPU module, expansion adapter, intelligent function module^{*1}, and FX5 safety extension module^{*1*2}. (The current error and its details can be checked.)

Information required for troubleshooting, such as the current error, details and cause of the error, and action to be taken, are displayed. The incorrect parameter setting and program error location can also be identified by selecting the error and clicking the [Error Jump] button. On the [Module Information List] tab, the LED status and the switch status of the target module can be checked.

*1 For supported versions of the intelligent function module and FX5 safety extension module, refer to Page 203 Added and Changed Functions.

*2 The information of an FX5-SF-8DI4 is integrated and displayed in the module diagnostics screen of an FX5-SF-MU4T5. When checking the status of an FX5-SF-8DI4, check the module diagnostic screen of the FX5-SF-MU4T5.

[Diagnostics] ⇒ [System Monitor] ⇒ Double-click the error module

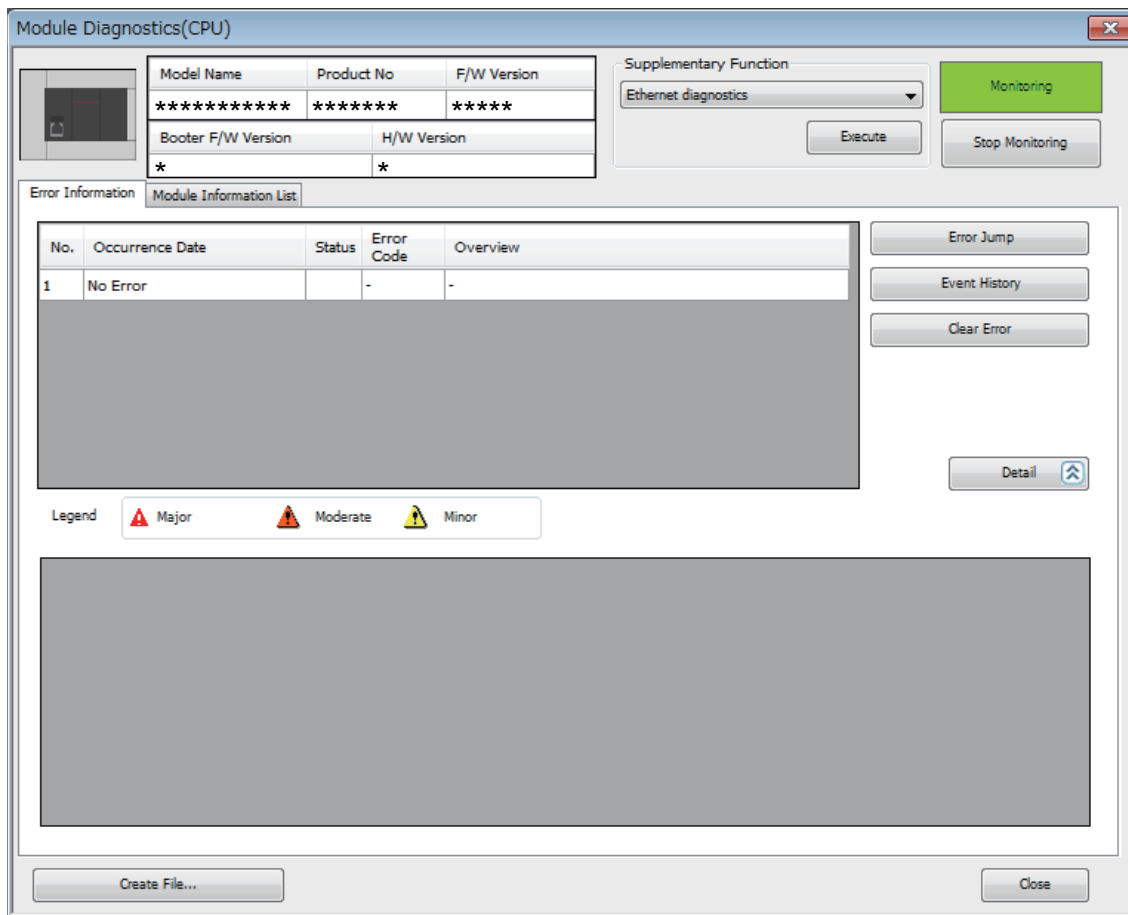

Event history

This function displays the event information, such as errors that occurred in the CPU module, expansion adapter, intelligent function module*¹ and network errors.

Since information collected before the CPU module is powered off or reset can also be displayed, the error cause can be identified based on the errors.

The displayed information can also be saved in CSV file format.

*¹ For supported versions of the intelligent function module, refer to  Page 203 Added and Changed Functions.

 [Diagnostics] ⇒ [System Monitor] ⇒ [Event History] button

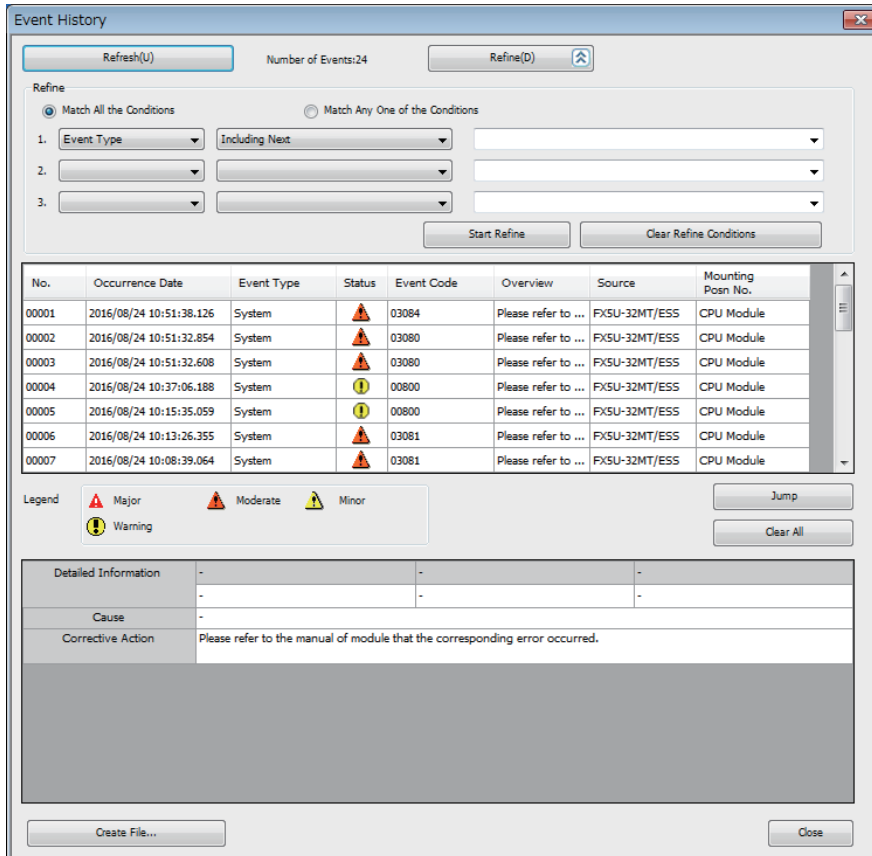

No.	Occurrence Date	Event Type	Status	Event Code	Overview	Source	Mounting Posn No.
00001	2016/08/24 10:51:38.126	System	Major	03084	Please refer to ...	FXSU-32MT/ESS	CPU Module
00002	2016/08/24 10:51:32.854	System	Major	03080	Please refer to ...	FXSU-32MT/ESS	CPU Module
00003	2016/08/24 10:51:32.608	System	Major	03080	Please refer to ...	FXSU-32MT/ESS	CPU Module
00004	2016/08/24 10:37:06.188	System	Warning	00800	Please refer to ...	FXSU-32MT/ESS	CPU Module
00005	2016/08/24 10:15:35.059	System	Warning	00800	Please refer to ...	FXSU-32MT/ESS	CPU Module
00006	2016/08/24 10:13:26.355	System	Major	03081	Please refer to ...	FXSU-32MT/ESS	CPU Module
00007	2016/08/24 10:08:39.064	System	Major	03081	Please refer to ...	FXSU-32MT/ESS	CPU Module

Legend: Major (Red Triangle), Moderate (Yellow Triangle), Minor (Green Triangle), Warning (Yellow Exclamation Mark)

Detailed Information: -

Cause: -

Corrective Action: Please refer to the manual of module that the corresponding error occurred.



Use the event history function to identify the cause of failure that occurred in facilities or devices.

For details on this function and collected information, refer to the following.

 MELSEC iQ-F FX5 User's Manual (Application)

For supported versions of the event history, refer to  Page 203 Added and Changed Functions.

9.4 Error Status and Operations on Occurrence of an Error

When an error occurs, the CPU module performs preconfigured actions depending on the status of the error.

Error status

Errors are classified into the following three types according to the urgency of the errors.

Error status	Program execution status	Description	Required action
Major error	Stop	The module is unable to continue its operation due to a hardware issue.	Perform troubleshooting. If the error still persists, consult your local Mitsubishi Electric representative.
Moderate error	Stop	The module is unable to carry out programs or continue the data communication with stations on the network due to improper program or parameter settings and temporary noise.	To resume the execution of the program or the data communication with the stations on the network, use the engineering tool to identify the cause of the error and take corrective actions.
Minor error	Continue	The module has detected a minor error or alarm. However, the execution of the program and the data communication with the stations on the network are continues.	Check the details of the error with the engineering tool. If necessary, take corrective actions for the error.

Operation at the occurrence of an error

Errors are classified into stop errors and continuable errors.

■Stop error

When a stop error occurs, the CPU module stops operation and enters the STOP status.

For details of parameters, refer to  MELSEC iQ-F FX5 User's Manual (Application).

■Continuable error

When a continuable error occurs, the CPU module will keep the operation status and carry out operations.

Only continuable errors can be canceled. When a continuable error is canceled and the CPU module is restored, the CPU module returns to the status before the occurrence of the error. Continuable errors can be canceled by either of the following methods.

- Using engineering tools
- Using special relays (SM) ( Page 155 Canceling Errors)

9.5 Backing Up the Data

Saving the following information immediately after the occurrence of an error helps analyzing the cause of the error.

- Parameters, programs, and device memory
- Error histories

Backing up parameters, programs, and device memory

The procedure for backing up parameters, programs, and device memory by using an engineering tool is explained below.

 [Online] ⇒ [Read from PLC]

1. Check the parameters, programs, and device memory to back up.
2. Click the [Execute] button to read the data.

Backing up devices and buffer memory

The procedure for backing up devices and buffer memory using the engineering tool is explained below.

 [Online] ⇒ [Read from PLC]

1. Click the "Device Memory" check box.
2. Click [Detail].
3. Input character strings in "Device Data Name" and select the devices to back up.
4. Select the "Buffer Memory Intelligent Module No." and input module number.
5. Click [OK], and then click [Execute] to read the data from the PLC.

9.6 Canceling Errors

Only continuable errors can be canceled.

If an error is canceled and the CPU module is recovered, the status of SM, SD, or LEDs returns to the status before the occurrence of the error. After an error is canceled and when the same error occurs again, this error is recorded again in the error history.

Continuable errors can be canceled by the following method.

Using special relays (SM)

Turning on and off SM50, all errors will be canceled.

9.7 Troubleshooting for Each Symptom

When the CPU module does not operate properly, check an appropriate item from the following and perform troubleshooting.

I/O operation (CPU module, I/O module)



Output does not turn on

Item to check	Action
Check for errors with external wiring.	Connect the external wiring properly.
Stop the PLC, and forcibly turn on or off the inoperable output with a peripheral device or an engineering tool.	<p>■When the output operates The output may be turned off unintentionally in the program. Review user program (Duplicate coils or RST instructions).</p> <p>■When the output does not operate Check the configuration of the connected devices and the connection of the extension cables. If the configuration of the external wiring and connected devices and the connection of the extension cables are acceptable, there may be a hardware issue. Consult your local Mitsubishi Electric representative.</p>

Output does not turn off

Item to check	Action
Check for errors with external wiring.	Connect the external wiring properly.
Stop the PLC and check that the output turns off.	<p>■When the output turns off The output may be turned on unintentionally in the program. Review user program (Duplicate coils or RST instructions).</p> <p>■When the output does not turn off There may be a hardware issue. Consult your local Mitsubishi Electric representative.</p>

Input does not turn on

Item to check	Action
<p>■FX5UC-□MT/D</p> <p>Remove the external wiring, and short-circuit the COM terminal and the input terminal. Check that the input turns on with LEDs and peripheral devices.</p>	<p>■When the input turns on Check that the input device does not have a built-in diode or parallel resistance. If so, refer to  Page 108 Precautions for connecting input devices.</p> <p>■When the input does not turn on Remove the external wiring, and measure the voltage between the COM terminal and the input terminal with a tester to check that the voltage is 24 V DC. When the input voltage is lower than 20.4 V DC, check that the PLC power supply voltage is "24 V DC +20%, -15%". Check the configuration of the external wiring and connected devices and the connection of the extension cables.</p>
<p>■FX5UC-□M□/DS□</p> <p>Remove the external wiring, and apply 24 V DC voltage "between the COM□ terminal and the input terminal" or "between the [S/S] terminal and the input terminal". Check that the input turns on with LEDs and peripheral devices.</p>	<p>■When the input turns on Check that the input device does not have a built-in diode or parallel resistance. If so, refer to  Page 108 Precautions for connecting input devices.</p> <p>■When the input does not turn on With a tester, check that the voltage "between the COM□ terminal and the input terminal" or "between the [S/S] terminal and the input terminal" is approx. 24 V DC. When the input voltage is lower than 20.4 V DC, check that the external power supply voltage is "24 V DC +20%, -15%". Check the configuration of the external wiring and connected devices and the connection of the extension cables.</p>

Input does not turn off

Item to check	Action
Check that there is no leakage current from input devices.	If the leakage current is 1.5 mA or more, connect a bleeder resistance. ( Page 108 Precautions for connecting input devices)

PLC write, PLC read

PLC write cannot be performed

If data cannot be written to the CPU module from the engineering tool, check the following items.

Item to check	Action
Check if a password is not registered.	Authenticate a password using the engineering tool.
When an SD memory card is the write destination, check that the write protection is not applied to the card.	Remove the write protection from the SD memory card.  Page 185 SD Memory Card
When an SD memory card is the write destination, check that the card is formatted.	Format the SD memory card.
Check that the size of the write data does not exceed the memory capacity.	<ul style="list-style-type: none"> • Ensure sufficient empty capacity. • After initializing the memory, write in the set of project data backed up by the customer.

If writing still cannot be performed even after the items shown above are checked, there may be a hardware issue. Consult your local Mitsubishi Electric representative.

Reading from the PLC cannot be performed

If data cannot be read from the CPU module to the engineering tool, check the specification of the target memory to be read. Check the memory and reset the CPU module. Then try PLC read again.

If reading still cannot be performed, there may be a hardware issue. Consult your local Mitsubishi Electric representative.

The program is unintentionally overwritten

The boot operation may be being performed. Read the parameters and review the boot file settings with the engineering tool. If the boot operation is not being performed, there may be a hardware issue. Consult your local Mitsubishi Electric representative.

For details on the boot operation, refer to  MELSEC iQ-F FX5 User's Manual (Application).

Boot operation

Boot operation cannot be performed from the SD memory card

Item to check	Action
Check for errors in the CPU module.	Remove the cause of the error.
Check that the file is set in the boot file settings of the parameters.	Set the file in the parameters.
Check that the file is set in the program file settings of the parameters.	
Check that the file to run is stored in the SD memory card.	Store the file to run.

If the boot operation cannot be performed even after the items shown above are checked, there may be a hardware issue. Consult your local Mitsubishi Electric representative.

APPENDIX

Appendix 1 How to Check the Date of Manufacture

Check the date of manufacture of the product as follows.

- Nameplate
- Module front surface (CPU module only)

Checking the nameplate

The date of manufacture of the product can be checked from the manufacturer's serial number "S/N" indicated on the nameplate of the product.. (For details of the battery, refer to  Page 148 Reading the date of manufacture.)

Ex.

CPU module

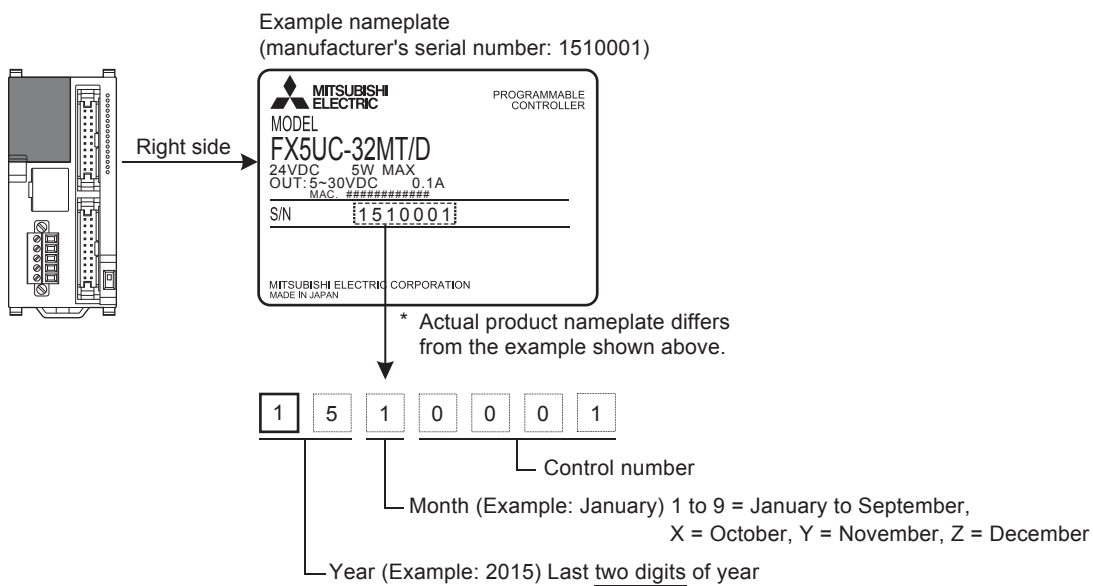

Check on the module front surface

The year and month of production of the product can be checked from the manufacturer's serial number LOT on the front (at the bottom) of the CPU module.

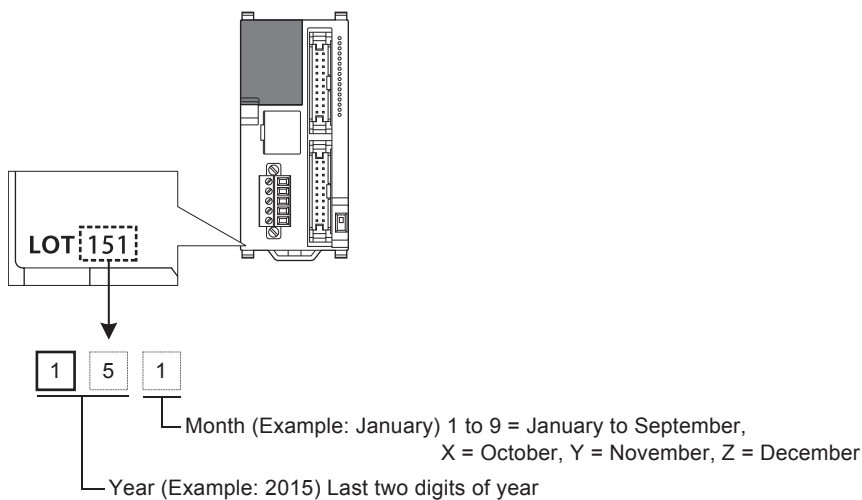

Appendix 2 Standards

Certification of UL, cUL standards

FX5UC CPU modules supports UL (UL, cUL) standards.

For models that support UL standards, refer to the following.

UL, cUL file number: E95239

Compliance with EC directive (CE Marking)

This product complies with EC directive, however, this document does not guarantee that a mechanical system including this product will comply with EC directive.

Compliance to EMC directive and LVD directive of the entire mechanical module should be checked by the user/ manufacturer. For more details please contact to the local Mitsubishi Electric sales site.

Requirement for compliance with EMC directive

The following products have shown compliance through direct testing (of the identified standards below) and design analysis (through the creation of a technical construction file) to the European Directive for Electromagnetic Compatibility (2014/30/ EU) when used as directed by the appropriate documentation.

■Product compatibility

Type: Programmable controller (open type equipment)

Models: FX5 manufactured

from October 1st, 2014	FX5-8EX/ES, FX5-8EYR/ES, FX5-8EYT/ES, FX5-8EYT/ESS, FX5-16EX/ES, FX5-16EYR/ES, FX5-16EYT/ES, FX5-16EYT/ESS, FX5-232ADP, FX5-485ADP, FX5-CNV-BUS
from January 1st, 2015	FX5UC-32MT/D, FX5UC-32MT/DSS, FX5-C32EX/D, FX5-C32EYT/D, FX5-C32ET/D, FX5-C32EX/DS, FX5-C32EYT/DSS, FX5-C32ET/DSS, FX5-4AD-ADP, FX5-4DA-ADP, FX5-CNV-BUSC, FX5-CNV-IFC
from October 1st, 2015	FX5UC-64MT/D, FX5UC-64MT/DSS, FX5UC-96MT/D, FX5UC-96MT/DSS, FX5-C16EX/D, FX5-C16EX/DS, FX5-C16EYT/D, FX5-C16EYT/DSS, FX5-C1PS-5V
from May 1st, 2016	FX5-32ER/DS, FX5-32ET/DS, FX5-32ET/DSS, FX5-16ET/ES-H, FX5-16ET/ESS-H, FX5-30EC, FX5-65EC, FX5-CNV-BC
from October 1st, 2016	FX5-16ER/ES, FX5-16ET/ES, FX5-16ET/ESS, FX5-4AD-PT-ADP, FX5-4AD-TC-ADP
from August 1st, 2017	FX5UC-32MT/DS-TS, FX5UC-32MT/DSS-TS, FX5-C32EX/DS-TS, FX5-C32EYT/D-TS, FX5-C32EYT/DSS-TS, FX5-C32ET/DS-TS, FX5-C32ET/DSS-TS
from January 1st, 2019	FX5UC-32MR/DS-TS, FX5-C16EYR/D-TS
from April 1st, 2021	FX5-4A-ADP

Electromagnetic compatibility (EMC) directive	Remarks
EN61131-2:2007 Programmable controllers - Equipment requirements and tests	Compliance with all relevant aspects of the standard. EMI <ul style="list-style-type: none"> • Radiated emission • Conducted emission EMS <ul style="list-style-type: none"> • Radiated electromagnetic field • Fast transient burst • Electrostatic discharge • High-energy surge • Voltage drops and interruptions • Conducted RF • Power frequency magnetic field

A

Requirement for Compliance with LVD directive

The following products have shown compliance through direct testing (of the identified standards below) and design analysis (through the creation of a technical construction file) to the European Directive for Low Voltage (2014/35/EU) when used as directed by the appropriate documentation.

■Product compatibility

Type: Programmable controller (open type equipment)

Models: FX5 manufactured

from October 1st, 2014	FX5-8EYR/ES, FX5-16EYR/ES
from May 1st, 2016	FX5-32ER/DS
from October 1st, 2016	FX5-16ER/ES
from January 1st, 2019	FX5UC-32MR/DS-TS, FX5-C16EYR/D-TS

For the products above, PLCs manufactured

before March 31st, 2018 are compliant with EN61131-2: 2007,

PLCs manufactured after April 1st, 2018 are compliant with EN61131-2: 2007 and EN61010-2-201: 2013.*¹

*¹ For some models, PLCs manufactured in March, 2018 are compliant with LVD directive successively.

Compliance with LVD directive	Remarks
EN61131-2:2007 Programmable controllers - Equipment requirements and tests	The equipment has been assessed as a component for fitting in a suitable control box which meets the requirements of EN61131-2:2007.
EN61010-2-201:2013 Safety of electrical equipment for measurement, control, and test	The equipment has been assessed as a component for fitting in a suitable control box which meets the requirements of EN61010-2-201:2013.

Caution for compliance with EC Directive

- Please use the FX5UC CPU modules while installed in conductive shielded control panels under a general industrial environment.
- Programmable controllers are open-type devices that must be installed and used within conductive control panels. Please secure the control box lid to the control box (for conduction). Installation within a control box greatly affects the safety of the system and aids in shielding noise from the programmable controller.
- For the control panel, use the product having sufficient strength, fire protectiveness and shielding property to an installation environment.
- 24 V DC of the power supply must be supplied from the circuit double/reinforced insulated from the main power supply (MAINS).
- If there is a possibility that the built-in Ethernet communication connector may be touched in operation, be sure to eliminate the static electricity or attach an Ethernet cap^{*1} to prevent the influence of static electricity.

*1 Reference product: MJ-JP68K manufactured by JST Mfg. Co., Ltd.

[Caution for compliance with the LVD directive (EN61010-2-201:2013)]^{*1}

- To an external connection port other than AC power supply terminal and AC input/output terminal, connect the circuit separated from a dangerous voltage by a double/reinforced insulation.
- Between the commons having the adjacent relay output terminals, if an external power supply is higher than 120 V AC, the insulation is basic. Therefore, when using 120 V AC or higher external power supply and 30 V DC/AC or lower external power supply between the adjacent commons, do not handle 30 V DC/AC or lower external power supply as a touchable part. (When handling 30 V DC/AC or lower external power supply as a touchable part, add a basic insulation.)
- Do not wire two or more crimp terminals to one terminal. (If the wiring with two or more wires is needed, take an appropriate action such as adding an external terminal.)
- For crimp terminals to be used for the wiring applied with 30 V AC or higher, use the products with insulating sleeves.
- Cutoff device such as a breaker or a circuit protector should be installed in accordance with the following precautions.
 - Use EN60947-1 or EN60947-3 standards.
 - Place the cutoff device so that it can be operated easily.
 - Specify that the cutoff device is for this equipment.

*1 For the time of compliance with the LVD directive (EN61010-2-201:2013), refer to  Page 160 Requirement for Compliance with LVD directive.

■Caution for when analog products are used

It is recommended to perform the following when precision of measuring and control is required.

As analog devices are sensitive by nature, their use should be considered carefully. For users of proprietary cables (dedicated for sensors or actuators), these users should follow those manufacturers' installation requirements.

Mitsubishi Electric recommends that shielded cables be used. If no other EMC protection is provided, users may experience temporary loss of accuracy between +10%/-10% in very heavy industrial areas.

However, Mitsubishi Electric suggests that if adequate EMC precautions are followed with general good EMC practice for the user's complete control system, users should expect normal errors as specified in this manual.

- Sensitive analog cables should not be laid in the same trunking or cable conduit as high voltage cabling. Where possible, users should run analog cables separately.
- Ground the shield of the analog input/output cable in accordance with the manuals of each model. However, do not use common grounding with heavy electrical systems.
- When reading analog values, EMC induced errors can be smoothed out by averaging the readings. This can be achieved either through functions on the analog special adapters/blocks or through a user's program in the FX5UC CPU module.

Perform the following when using the analog expansion adapter:

• Installation in Enclosure

Programmable controllers are open-type devices that must be installed and used within conductive control cabinets.

Please use the programmable controller while installed within a conductive shielded control cabinet. Installation within a control cabinet greatly affects the safety of the system and aids in shielding noise from the programmable controller.

- Control cabinet
 - The control cabinet must be conductive.
 - Ground the control cabinet with the thickest possible grounding cable.
 - To ensure that there is electric contact between the control cabinet and its door, connect the cabinet and its doors with thick wires.
 - In order to suppress the leakage of radio waves, the control cabinet structure must have minimal openings. Also, wrap the cable holes with a shielding cover or other shielding devices.
 - The gap between the control cabinet and its door must be as small as possible by attaching EMI gaskets between them.

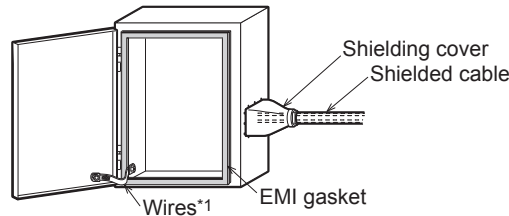

*1 These wires are used to improve the conductivity between the door and control cabinet.

- Cables
 - Make sure to use shielded cables as cables pulled out of the control cabinet.
 - Connect the shield such as shielded cables and shielding covers to the grounded control cabinet.
- It is possible that the accuracy temporarily fluctuates within $\pm 10\%$.

Perform the following when using the FX5-4AD-ADP:

- Set the number of times of winding to "2 turns" within approximately 200 mm from terminal block of the analog cable on the FX5-4AD-ADP side, and attach a ferrite core. (Ferrite core used in our test: E04SR401938 manufactured by SEIWA ELECTRIC MFG. CO., LTD.)

Perform the following when using the FX5-4DA-ADP:

- Set the number of times of winding to "2 turns" within approximately 200 mm from the connectors of the power cable on the FX5-4DA-ADP side, and attach a ferrite core. (Ferrite core used in our test: E04SR401938 manufactured by SEIWA ELECTRIC MFG. CO., LTD.)
- The FX5-4DA-ADP requires that the cable used for power supply is 30 m or less.

Perform the following when using the FX5-4A-ADP:

- Attach a ferrite core to the CPU module and the power supply of the FX5-4A-ADP. Set the number of times of winding to "2 turns" and attach the ferrite core within approximately 200 mm from the terminal block and the connector of the power cable. (Ferrite core used in our test: E04SR401938 manufactured by SEIWA ELECTRIC MFG. CO., LTD.)
- The FX5-4A-ADP requires that the cable used for power supply is 30 m or less.
- For 24 V DC power supply of FX5-4A-ADP, supply power from the AC/DC power supply in the same control cabinet. (AC/DC power supply used in our test: PS5R-VE24 manufactured by IDEC Corporation)

■Caution for when the built-in Ethernet port is used

- Use a shielded twisted pair cable for the 10BASE-T or 100BASE-TX cable. Strip a part of the jacket of a shielded twisted pair cable as shown below, and ground as much of the exposed shield as possible to both sides of the cables.
- Connect a ferrite core to both ends of the cable. (Ferrite core used in tests by Mitsubishi: ZCAT2035-0930A manufactured by TDK Co.)

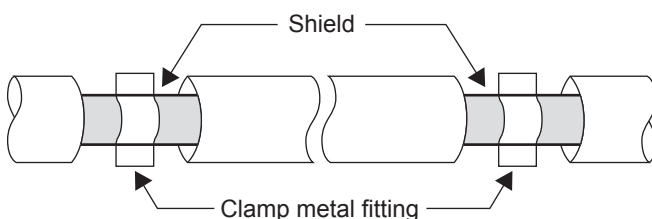

Compliance with UKCA marking

The requirements for compliance with UKCA marking are the same as that with EC directive (CE marking).

Appendix 3 Precautions for Operating Ambient Temperature

This section describes precautions when the device is used at an operating ambient temperature below 0°C.

Precaution when used at an operating ambient temperature below 0°C

- With some exceptions, the operating ambient temperature is -20 to 55°C for the FX5 PLCs manufactured in June 2016 onwards.
- The operating ambient temperature is 0 to 55°C for the FX5 PLCs manufactured before June 2016.
- When the device is used in a low-temperature environment, use care not to let the product freeze or condensation to occur.
- When used in a low-temperature environment, use in an environment with no sudden temperature changes. If there are sudden temperature changes because of opening/closing of the control panel or other reasons, condensation may occur, which may cause a fire, fault, or malfunction. Furthermore, use an air conditioner in dehumidifier mode to prevent condensation.

Related devices which cannot be used at an operating ambient temperature below 0°C

The following devices cannot be used at an operating ambient temperature below 0°C.

Device name
FX5-40SSC-S
FX5-80SSC-S
FX5-40SSC-G
FX5-80SSC-G
FX5-CNV-BUS
FX5-CNV-BUSC
Battery (FX3U-32BL)
SD memory card (NZ1MEM-2GBSD, NZ1MEM-4GBSD, NZ1MEM-8GBSD, NZ1MEM-16GBSD, L1MEM-2GBSD, L1MEM-4GBSD)
FX3 expansion module
Terminal module
Input/output cable (FX-16E-500CAB-S, FX-16E-□CAB, FX-16E-□CAB-R)

Specifications when used at an operating ambient temperature below 0°C

For using the device at an operating ambient temperature below 0°C, specifications are different from when used at an operating ambient temperature of 0 to 55°C.

Item		When used at 0 to 55°C	When used at below 0°C
Analog accuracy of FX5-4AD-ADP	Analog input	Within ±0.2% (±32 digit)	Within ±0.3% (±48 digit)
Analog accuracy of FX5-4A-ADP	Analog input	Within ±0.2% (±32 digit)	Within ±0.3% (±48 digit)
	Analog output	Within ±0.2% (Voltage ±40 mV, Current ±40 μA)	Within ±0.3% (Voltage ±60 mV, Current ±60 μA)



Appendix 4 I/O Module

Product configuration

There are various types of I/O modules. They differ in supply voltage, number of input/output points, input form, output form, and input/output connection type.

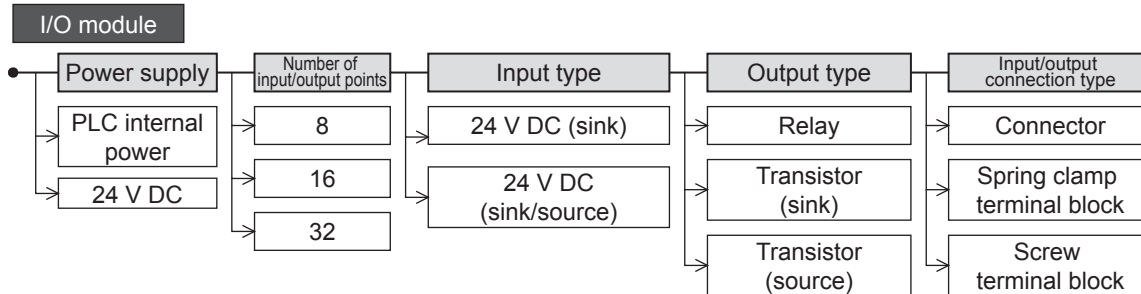

Product list

Input module

Sink : Sink, Source : Source

■ Extension connector type

Model	Input			Output			Input/output connection type
	Type	No. of points	Common wiring system	Type	No. of points	Common wiring system	
■ Input extension/sink input type							
FX5-C16EX/D	24 V DC	16	<input type="checkbox"/> Sink	—	—	—	Connector
FX5-C32EX/D	24 V DC	32	<input type="checkbox"/> Sink	—	—	—	Connector
■ Input extension/sink and source input type							
FX5-C16EX/DS	24 V DC	16	<input type="checkbox"/> Sink <input checked="" type="checkbox"/> Source	—	—	—	Connector
FX5-C32EX/DS	24 V DC	32	<input type="checkbox"/> Sink <input checked="" type="checkbox"/> Source	—	—	—	Connector
FX5-C32EX/DS-TS	24 V DC	32	<input type="checkbox"/> Sink <input checked="" type="checkbox"/> Source	—	—	—	Spring clamp terminal block

■ Extension cable type

Model	Input			Output			Input/output connection type
	Type	No. of points	Common wiring system	Type	No. of points	Common wiring system	
■ Input extension/sink and source input type							
FX5-8EX/ES	24 V DC	8	<input type="checkbox"/> Sink <input checked="" type="checkbox"/> Source	—	—	—	Screw terminal block
FX5-16EX/ES	24 V DC	16	<input type="checkbox"/> Sink <input checked="" type="checkbox"/> Source	—	—	—	Screw terminal block

Output module

Sink : Sink, Source : Source

■ Extension connector type

Model	Input			Output			Input/output connection type
	Type	No. of points	Common wiring system	Type	No. of points	Common wiring system	
■ Output extension/sink output type							
FX5-C16EYT/D	—	—	—	Transistor	16	<input type="checkbox"/> Sink	Connector
FX5-C32EYT/D	—	—	—	Transistor	32	<input type="checkbox"/> Sink	Connector
FX5-C32EYT/D-TS	—	—	—	Transistor	32	<input type="checkbox"/> Sink	Spring clamp terminal block
■ Output extension/source output type							
FX5-C16EYT/DSS	—	—	—	Transistor	16	<input checked="" type="checkbox"/> Source	Connector
FX5-C32EYT/DSS	—	—	—	Transistor	32	<input checked="" type="checkbox"/> Source	Connector
FX5-C32EYT/DSS-TS	—	—	—	Transistor	32	<input checked="" type="checkbox"/> Source	Spring clamp terminal block
■ Output extension/relay output type							
FX5-C16EYR/D-TS	—	—	—	Relay	16	—	Spring clamp terminal block

■ Extension cable type

Model	Input			Output			Input/output connection type
	Type	No. of points	Common wiring system	Type	No. of points	Common wiring system	
■ Output extension/relay output type							
FX5-8EYR/ES	—	—	—	Relay	8	—	Screw terminal block
FX5-16EYR/ES	—	—	—	Relay	16	—	Screw terminal block
■ Output extension/sink output type							
FX5-8EYT/ES	—	—	—	Transistor	8	<input type="checkbox"/> Sink	Screw terminal block
FX5-16EYT/ES	—	—	—	Transistor	16	<input type="checkbox"/> Sink	Screw terminal block
■ Output extension/source output type							
FX5-8EYT/ESS	—	—	—	Transistor	8	<input checked="" type="checkbox"/> Source	Screw terminal block
FX5-16EYT/ESS	—	—	—	Transistor	16	<input checked="" type="checkbox"/> Source	Screw terminal block

A

Input/output module

Sink, Source : Source

■ Extension connector type

Model	Input			Output			Input/output connection type
	Type	No. of points	Common wiring system	Type	No. of points	Common wiring system	
■ Input/output extension/sink input/output type							
FX5-C32ET/D	24 V DC	16	<input type="checkbox"/> Sink	Transistor	16	<input type="checkbox"/> Sink	Connector
■ Input/output extension/sink and source input/sink output type							
FX5-C32ET/DS-TS	24 V DC	16	<input type="checkbox"/> Sink <input checked="" type="checkbox"/> Source	Transistor	16	<input type="checkbox"/> Sink	Spring clamp terminal block
■ Input/output extension/sink and source input/source output type							
FX5-C32ET/DSS	24 V DC	16	<input type="checkbox"/> Sink <input checked="" type="checkbox"/> Source	Transistor	16	<input checked="" type="checkbox"/> Source	Connector
FX5-C32ET/DSS-TS	24 V DC	16	<input type="checkbox"/> Sink <input checked="" type="checkbox"/> Source	Transistor	16	<input checked="" type="checkbox"/> Source	Spring clamp terminal block

■ Extension cable type

Model	Input			Output			Input/output connection type
	Type	No. of points	Common wiring system	Type	No. of points	Common wiring system	
■ Input/output extension/sink and source input/relay output type							
FX5-16ER/ES	24 V DC	8	<input type="checkbox"/> Sink <input checked="" type="checkbox"/> Source	Relay	8	—	Screw terminal block
■ Input/output extension/sink and source input/sink output type							
FX5-16ET/ES	24 V DC	8	<input type="checkbox"/> Sink <input checked="" type="checkbox"/> Source	Transistor	8	<input type="checkbox"/> Sink	Screw terminal block
■ Input/output extension/sink and source input/source output type							
FX5-16ET/ESS	24 V DC	8	<input type="checkbox"/> Sink <input checked="" type="checkbox"/> Source	Transistor	8	<input checked="" type="checkbox"/> Source	Screw terminal block

Powered input/output module

Sink, Source : Source

Model	Input			Output			Input/output connection type
	Type	No. of points	Common wiring system	Type	No. of points	Common wiring system	
■ Input/output extension/sink and source input/relay output type (DC power supply/DC input type)							
FX5-32ER/DS	24 V DC	16	<input type="checkbox"/> Sink <input checked="" type="checkbox"/> Source	Relay	16	—	Screw terminal block
■ Input/output extension/sink and source input/sink output type (DC power supply/DC input type)							
FX5-32ET/DS	24 V DC	16	<input type="checkbox"/> Sink <input checked="" type="checkbox"/> Source	Transistor	16	<input type="checkbox"/> Sink	Screw terminal block
■ Input/output extension/sink and source input/source output type (DC power supply/DC input type)							
FX5-32ET/DSS	24 V DC	16	<input type="checkbox"/> Sink <input checked="" type="checkbox"/> Source	Transistor	16	<input checked="" type="checkbox"/> Source	Screw terminal block

High-speed pulse input/output module

Sink, Source : Source

Model	Input			Output			Input/output connection type
	Type	No. of points	Common wiring system	Type	No. of points	Common wiring system	
■ Input/output extension/sink and source input/sink output type							
FX5-16ET/ES-H	24 V DC	8	<input type="checkbox"/> Sink <input checked="" type="checkbox"/> Source	Transistor	8	<input type="checkbox"/> Sink	Screw terminal block
■ Input/output extension/sink and source input/source output type							
FX5-16ET/ESS-H	24 V DC	8	<input type="checkbox"/> Sink <input checked="" type="checkbox"/> Source	Transistor	8	<input checked="" type="checkbox"/> Source	Screw terminal block

Specifications

The general specifications are the same as those for the CPU module. ( Page 29 Generic Specifications)

Power Supply Specifications

■ Input module

Item	Specifications	
Voltage rating	24 V DC (supplied from external power supply) 5 V DC (supplied from PLC)	
Current consumption (5 V DC)	FX5-C16EX/□	100 mA
	FX5-C32EX/□	120 mA
	FX5-8EX/ES	75 mA
	FX5-16EX/ES	100 mA
Current consumption (24 V DC)	FX5-C16EX/□	(65 mA) ^{*1}
	FX5-C32EX/□	(130 mA) ^{*1}
	FX5-8EX/ES	(50 mA) ^{*1}
	FX5-16EX/ES	(85 mA) ^{*1}

*1 Since external power supply is used for input circuit in FX5UC CPU module systems, power supply from CPU module is not included.

■ Output module

Item	Specifications	
Voltage rating	24 V DC (supplied from PLC) 5 V DC (supplied from PLC)	
Current consumption (5 V DC)	FX5-C16EY□	100 mA
	FX5-C32EYT/□	120 mA
	FX5-8EY□	75 mA
	FX5-16EY□	100 mA
Current consumption (24 V DC)	FX5-C16EY□	100 mA
	FX5-C32EYT/□	200 mA
	FX5-8EY□	75 mA
	FX5-16EY□	125 mA

A

Input/output module

Item		Specifications
Voltage rating	Input	24 V DC (supplied from external power supply) 5 V DC (supplied from PLC)
	Output	24 V DC (supplied from PLC) 5 V DC (supplied from PLC)
Current consumption (5 V DC)	FX5-C32ET/□	120 mA
	FX5-16E□/E□	100 mA
Current consumption (24 V DC)	FX5-C32ET/□	Input (65 mA) ^{*1}
		Output 100 mA
	FX5-16E□/E□	125 mA (The current of the input circuit is included.) ^{*2}

*1 Since external power supply is used for input circuit in FX5UC CPU module systems, power supply from CPU module is not included.

*2 External power supply is used for input circuit in FX5UC CPU module systems, the current of 85 mA flows.

Powered input/output module

Item	Specifications
Voltage rating	24 V DC
Voltage fluctuation range	+20%, -30%
Allowable instantaneous power failure time ^{*2}	Operation can be continued upon occurrence of instantaneous power failure for 5 ms or less.
Power fuse	250 V, 3.15 A time-lag fuse
Rush current	50 A max. 0.5 ms or less/24 V DC
Power consumption ^{*1}	25 W
24 V DC built-in power supply	310 mA
5 V DC built-in power supply	965 mA

*1 This item shows value when all 24 V DC built-in power supplies are used in the maximum configuration connectable to the powered input/output module. (The current of the input circuit is included.)

*2 The FX5 safety extension module is not subject to the allowable momentary power failure time.

High-speed pulse input/output module

Item	Specifications
Voltage rating	24 V DC (supplied from external power supply) 5 V DC (supplied from PLC)
Current consumption (5 V DC)	100 mA
Current consumption (24 V DC)	125 mA (The current of the input circuit is included.) ^{*1}

*1 External power supply is used for input circuit in FX5UC CPU module systems, the current of 85 mA flows.

Exterior color, weight, accessories

Input module, Output module

Item	Specifications	
Exterior color	Munsell 0.6B7.6/0.2	
Mass (weight)	FX5-C16EX/□ FX5-C16EYT/□	Approx. 0.1 kg
	FX5-C16EYR/D-TS	Approx. 0.2 kg
	FX5-C32EX/□ FX5-C32EYT/□	Approx. 0.15 kg
	FX5-8E□	Approx. 0.2 kg
	FX5-16E□	Approx. 0.25 kg
Accessories	FX5-C□EX/D	FX2NC-10BPCB1
	FX5-8E□	Dust proof protection sheet
	FX5-16E□	

Input/output module

Item		Specifications
Exterior color		Munsell 0.6B7.6/0.2
Mass (weight)	FX5-C32ET/□	Approx. 0.15 kg
	FX5-16E□/E□	Approx. 0.25 kg
Accessories	FX5-C32ET/D	FX2NC-10BPCB1

Powered input/output module

Item		Specifications
External color		Munsell 0.6B7.6/0.2
Mass (weight)		Approx. 0.65 kg
Accessories		Extension cable, dust proof protection sheet

High-speed pulse input/output module

Item		Specifications
Exterior color		Munsell 0.6B7.6/0.2
Mass (weight)		Approx. 0.25 kg
Accessories		Manual supplied with product, dust proof protection sheet

Input specifications

There is the simultaneous ON ratio of available PLC inputs or outputs with respect to the ambient temperature. For details, refer to  Page 34 Input/Output Derating Curve.*1

*1 For an input/output module (extension cable type), refer to derating curves of the CPU module used. For an input/output module (extension connector type), refer to derating curves of the FX5UC CPU module regardless of the CPU module used.

Item		Specifications
No. of input points	FX5-C16EX/□	16 points
	FX5-C32EX/□	32 points
	FX5-C32ET/□	16 points
	FX5-8EX/ES	8 points
	FX5-16EX/ES	16 points
	FX5-32E□/D□	16 points
	FX5-16ER/ES	8 points
	FX5-16ET/E□	8 points
Connection type	FX5-C□EX/D(S), FX5-C32ET/D(SS)	Connector
	FX5-C32EX/DS-TS, FX5-C32ET/DS(S)-TS	Spring clamp terminal block
	FX5-□EX/ES, FX5-32E□/D□, FX5-16ER/ES, FX5-16ET/E□	Screw terminal block (M3 screws)
Input type	FX5-C□EX/D, FX5-C32ET/D	Sink
	FX5-C□EX/DS(-TS), FX5-C32ET/DS□, FX5-□EX/ES, FX5-32E□/D□, FX5-16ER/ES, FX5-16ET/E□	Sink/source
Input signal voltage		24 V DC +20%, -15%
Input signal current	Other than FX5-16ET/ E□-H	4.0 mA/24 V DC
	FX5-16ET/E□-H	5.3 mA/24 V DC
Input impedance	Other than FX5-16ET/ E□-H	5.6 kΩ
	FX5-16ET/E□-H	4.3 kΩ

Item		Specifications	
Input sensitivity current	ON	Other than FX5-16ET/E□-H	3.0 mA or more
		FX5-16ET/E□-H	3.5 mA or more
	OFF		1.5 mA or less
Input response frequency		FX5-16ET/E□-H	X0 to 5: 200 kHz X6, X7: 10 kHz
Input response time		Other than FX5-16ET/E□-H	ON: 50 μs or less OFF: 150 μs or less
		FX5-16ET/E□-H	X0 to X5: ON: 2.5 μs or less, OFF: 2.5 μs or less X6, X7: ON: 30 μs or less, OFF: 50 μs or less
Input signal format (Input sensor form)		FX5-C□EX/DS(-TS), FX5-C32ET/DS□, FX5-□EX/ES, FX5-32E□/D□, FX5-16ER/ES, FX5-16ET/E□	No-voltage contact input Sink: NPN open collector transistor Source: PNP open collector transistor
		FX5-C□EX/D, FX5-C32ET/D	No-voltage contact input Sink: NPN open collector transistor
Input circuit insulation			Photo-coupler insulation
Indication of input operation			LED is lit when input is on • With FX5-C32EX/D(S), the lower number/higher number order is switched with the DISP switch F/L. • With FX5-C32ET/D(SS), the input/output is switched with the DISP switch IN/OUT.
Input circuit configuration		FX5-C□EX/D, FX5-C32ET/D	
		FX5-C□EX/DS, FX5-C32ET/DSS	<div style="display: flex; justify-content: space-around;"> <div style="text-align: center;"> <p>Sink input wiring</p> </div> <div style="text-align: center;"> <p>Source input wiring</p> </div> </div>
		FX5-C32EX/DS-TS, FX5-C32ET/DS(S)-TS, FX5-□EX/ES, FX5-16ER/ES, FX5-16ET/E□	<div style="display: flex; justify-content: space-around;"> <div style="text-align: center;"> <p>Sink input wiring</p> </div> <div style="text-align: center;"> <p>Source input wiring</p> </div> </div>
		FX5-32E□/D□	<div style="display: flex; justify-content: space-around;"> <div style="text-align: center;"> <p>Sink input wiring</p> </div> <div style="text-align: center;"> <p>Source input wiring</p> </div> </div>

Output specifications

There is the simultaneous ON ratio of available PLC inputs or outputs with respect to the ambient temperature. For details, refer to  Page 34 Input/Output Derating Curve.

■ Transistor output (sink output)

Item		Specifications	
No. of output points	FX5-C16EYT/D	16 points	
	FX5-C32EYT/D(-TS)	32 points	
	FX5-C32ET/D(S-TS)	16 points	
	FX5-8EYT/ES	8 points	
	FX5-16EYT/ES	16 points	
	FX5-16ET/ES	8 points	
	FX5-32ET/DS	16 points	
	FX5-16ET/ES-H	8 points	
Connection type	FX5-C□EYT/D, FX5-C32ET/D	Connector	
	FX5-C32EYT/D-TS, FX5-C32ET/DS-TS	Spring clamp terminal block	
	FX5-□EYT/ES, FX5-16ET/ES, FX5-32ET/DS, FX5-16ET/ES-H	Screw terminal block (M3 screws)	
Output type		Transistor/sink output	
External power supply		5-30 V DC	
Output circuit insulation		Photo-coupler insulation	
Indication of output operation		LED is lit when output is on <ul style="list-style-type: none"> With FX5-C32EYT/D, the lower number/higher number order is switched with the DISP switch F/L. With FX5-C32ET/D, the input/output is switched with the DISP switch IN/OUT. 	
Max. load	FX5-C□EYT/D(-TS), FX5-C32ET/D(S-TS)	0.1 A/point The total load current of resistance loads per common terminal should be the following value. <ul style="list-style-type: none"> 8 output points/common terminal: 0.8 A or less 	
	FX5-□EYT/ES, FX5-16ET/ES, FX5-32ET/DS, FX5-16ET/ES-H	0.5 A/point The total load current of resistance loads per common terminal should be the following value. <ul style="list-style-type: none"> 4 output points/common terminal: 0.8 A or less 8 output points/common terminal: 1.6 A or less 	
Open circuit leakage current		0.1 mA/30 V DC	
Min. load		—	
Response time	OFF→ON	FX5-C□EYT/D(-TS), FX5-C32ET/D(S-TS)	0.2 ms or less/100 mA (at 24 V DC)
		FX5-□EYT/ES, FX5-16ET/ES, FX5-32ET/DS	0.2 ms or less/200 mA (at 24 V DC)
		FX5-16ET/ES-H	Y0, Y1, Y4, Y5: 2.5 μs or less/10 mA (at 5-24 V DC) Y2, Y3, Y6, Y7: 0.2 ms or less/200 mA (at 24 V DC)
	ON→OFF	FX5-C□EYT/D(-TS), FX5-C32ET/D(S-TS)	0.2 ms or less/100 mA (at 24 V DC)
		FX5-□EYT/ES, FX5-16ET/ES, FX5-32ET/DS	0.2 ms or less/200 mA (at 24 V DC)
		FX5-16ET/ES-H	Y0, Y1, Y4, Y5: 2.5 μs or less/10 mA (at 5-24 V DC) Y2, Y3, Y6, Y7: 0.2 ms or less/200 mA (at 24 V DC)
Maximum frequency		FX5-16ET/ES-H Y0, Y1, Y4, Y5: 200 kpps	
Voltage drop when ON		1.5 V or less (Y0, Y1, Y4, and Y5 of FX5-16ET/ES-H is 1.0 V or less)	

Item		Specifications
Output circuit configuration	FX5-C□EYT/D(-TS), FX5-C32ET/D(S-TS)	
	FX5-□EYT/ES, FX5-16ET/ES, FX5-32ET/DS, FX5-16ET/ES-H	

■ Transistor output (source output)

Item		Specifications
No. of output points	FX5-C16EYT/DSS	16 points
	FX5-C32EYT/DSS(-TS)	32 points
	FX5-C32ET/DSS(-TS)	16 points
	FX5-8EYT/ESS	8 points
	FX5-16EYT/ESS	16 points
	FX5-16ET/ESS	8 points
	FX5-32ET/DSS	16 points
	FX5-16ET/ESS-H	8 points
Connection type	FX5-C□EYT/DSS, FX5-C32ET/DSS	Connector
	FX5-C32EYT/DSS-TS, FX5-C32ET/DSS-TS	Spring clamp terminal block
	FX5-□EYT/ESS, FX5-16ET/ESS, FX5-32ET/DSS, FX5-16ET/ESS-H	Screw terminal block (M3 screws)
Output type	Transistor/source output	
External power supply	5-30 V DC	
Output circuit insulation	Photo-coupler insulation	
Indication of output operation	LED is lit when output is on <ul style="list-style-type: none"> • With FX5-C32EYT/DSS, the lower number/higher number order is switched with the DISP switch F/L. • With FX5-C32ET/DSS, the input/output is switched with the DISP switch IN/OUT. 	
Max. load	FX5-C□EYT/DSS(-TS), FX5-C32ET/DSS(-TS)	0.1 A/point The total load current of resistance loads per common terminal should be the following value. <ul style="list-style-type: none"> • 8 output points/common terminal: 0.8 A or less
	FX5-□EYT/ESS, FX5-16ET/ESS, FX5-32ET/DSS, FX5-16ET/ESS-H	0.5 A/point The total load current of resistance loads per common terminal should be the following value. <ul style="list-style-type: none"> • 4 output points/common terminal: 0.8 A or less • 8 output points/common terminal: 1.6 A or less
Open circuit leakage current	0.1 mA/30 V DC	
Min. load	—	

Item		Specifications	
Response time	OFF→ON	FX5-C□EYT/DSS(-TS), FX5-C32ET/DSS(-TS)	0.2 ms or less/100 mA (at 24 V DC)
		FX5-□EYT/ESS, FX5-16ET/ESS, FX5-32ET/DSS	0.2 ms or less/200 mA (at 24 V DC)
		FX5-16ET/ESS-H	Y0, Y1, Y4, Y5: 2.5 μs or less/10 mA (at 5-24 V DC) Y2, Y3, Y6, Y7: 0.2 ms or less/200 mA (at 24 V DC)
	ON→OFF	FX5-C□EYT/DSS(-TS), FX5-C32ET/DSS(-TS)	0.2 ms or less/100 mA (at 24 V DC)
		FX5-□EYT/ESS, FX5-16ET/ESS, FX5-32ET/DSS	0.2 ms or less/200 mA (at 24 V DC)
		FX5-16ET/ESS-H	Y0, Y1, Y4, Y5: 2.5 μs or less/10 mA (at 5-24 V DC) Y2, Y3, Y6, Y7: 0.2 ms or less/200 mA (at 24 V DC)
Maximum frequency	FX5-16ET/ESS-H	Y0, Y1, Y4, Y5: 200 kpps	
Voltage drop when ON		1.5 V or less (Y0, Y1, Y4, and Y5 of FX5-16ET/ESS-H is 1.0 V or less)	
Output circuit configuration	FX5-C□EYT/DSS(-TS), FX5-C32ET/DSS(-TS)		
	FX5-□EYT/ESS, FX5-16ET/ESS, FX5-32ET/DSS, FX5-16ET/ESS-H		

A

■Relay output

Item		Specifications
No. of output points	FX5-C16EYR/D-TS	16 points
	FX5-8EYR/ES	8 points
	FX5-16EYR/ES	16 points
	FX5-16ER/ES	8 points
	FX5-32ER/DS	16 points
Connection type	FX5-C16EYR/D-TS	Spring clamp terminal block
	FX5-8EYR/ES FX5-16EYR/ES FX5-16ER/ES FX5-32ER/DS	Screw terminal block (M3 screws)
	Output type	Relay
	External power supply	30 V DC or less 240 V AC or less (250 V AC or less when the module does not comply with CE, UL, or cUL standards)
Output circuit insulation	Mechanical insulation	
Indication of output operation	LED is lit when output is on	
Max. load	FX5-C16EYR/D-TS	2 A/point The total load current of resistance loads per common terminal should be the following value. • 8 output points/common terminal: 4 A or less*1
	FX5-8EYR/ES FX5-16EYR/ES FX5-16ER/ES FX5-32ER/DS	2 A/point The total load current of resistance loads per common terminal should be the following value. • 4 output points/common terminal: 8 A or less • 8 output points/common terminal: 8 A or less
	Open circuit leakage current	—
	Min. load	5 V DC, 2 mA (reference values)
Response time	OFF→ON	Approx. 10 ms
	ON→OFF	Approx. 10 ms
Output circuit configuration	FX5-C16EYR/D-TS	
	FX5-8EYR/ES FX5-16EYR/ES FX5-16ER/ES FX5-32ER/DS	

*1 When two common terminals are connected outside the I/O module, resistance load is 8 A or less.

External dimensions and component names

Input module, Output module

■ Extension connector type

- Connector type

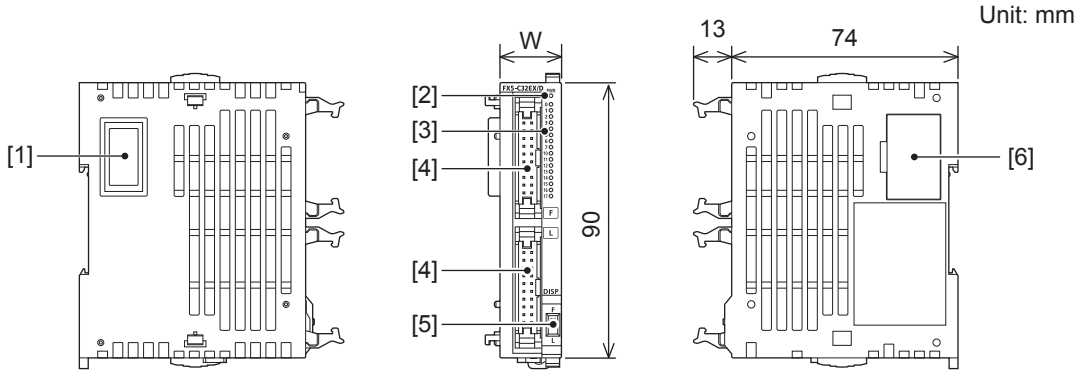

External dimensions

Model	W: mm
FX5-C16EX/D, FX5-C16EX/DS	14.6
FX5-C16EYT/D, FX5-C16EYT/DSS	
FX5-C32EX/D, FX5-C32EX/DS	20.1
FX5-C32EYT/D, FX5-C32EYT/DSS	

Part names

No.	Name	Description
[1]	Extension connector	Connector connected to extend modules
[2]	PWR LED	Indicates whether the input modules/output modules is powered or not. Lit: Powered Off: Not powered or hardware error
[3]	I/O display LED	Lit when input or output is on.
[4]	I/O connectors	Connector for connecting input signal cables or output signal cables For details on the terminal layout, refer to Page 181 Terminal layout .
[5]	DISP switch	Switches the display of smaller and larger numbers of the input display LED or output display LED. Smaller number: F Larger number: L
[6]	Extension connector	Connector for connecting the extension connector of an extension module

- Spring clamp terminal block type

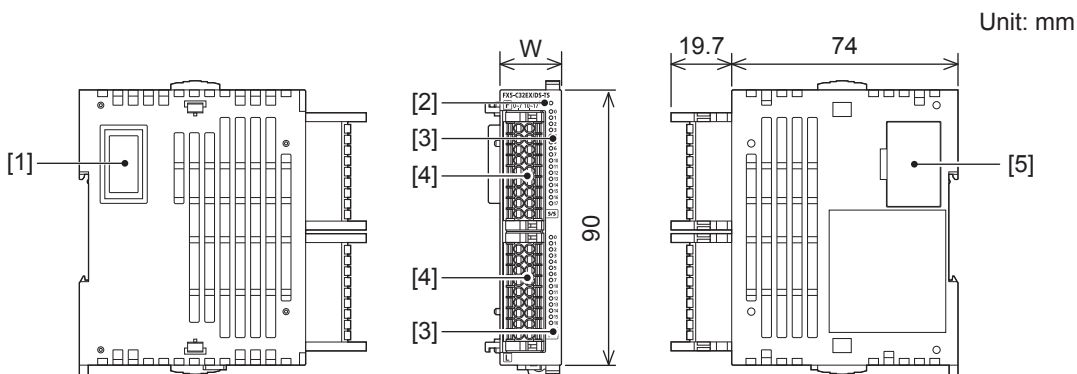

External dimensions

Model	W: mm
FX5-C32EX/DS-TS	20.1
FX5-C32EYT/D-TS, FX5-C32EYT/DSS-TS	
FX5-C16EYR/D-TS	30.7

Part names

No.	Name	Description
[1]	Extension connector	Connector connected to extend modules
[2]	PWR/POWER LED	Indicates whether the input modules/output modules is powered or not. Lit: Powered Off: Not powered or hardware error
[3]	I/O display LED	Lit when input or output is on.
[4]	I/O terminal	Terminals for input, or output. For details on the terminal layout, refer to  Page 181 Terminal layout.
[5]	Extension connector	Connector for connecting the extension connector of an extension module

■Extension cable type

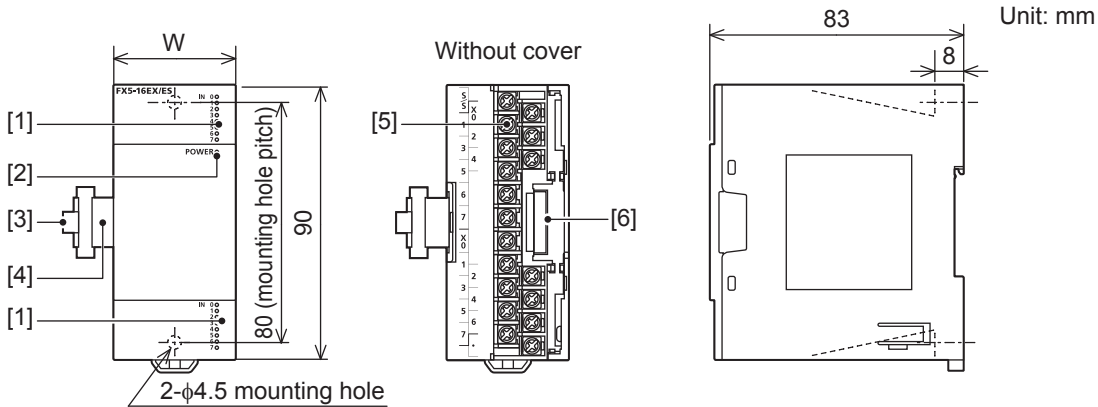

External dimensions

Model	W: mm
FX5-8EX/ES	40
FX5-8EYR/ES, FX5-8EYT/ES, FX5-8EYT/ESS	
FX5-16EX/ES	
FX5-16EYR/ES, FX5-16EYT/ES, FX5-16EYT/ESS	

Part names

No.	Name	Description
[1]	Input display LED, output display LED	Lit when input or output is on.
[2]	POWER LED	Indicates whether the input modules/output modules are powered or not. Lit: Powered Off: Not powered or hardware error
[3]	Pullout tab	Tab for pulling out an extension cable.
[4]	Extension cable	Cable used to connect the extension module.
[5]	I/O terminal	Terminals for input, or output. For details on the terminal layout, refer to  Page 181 Terminal layout.
[6]	Extension connector	Connector for connecting the extension cable of an extension module

Input/output module

■ Extension connector type

- Connector type

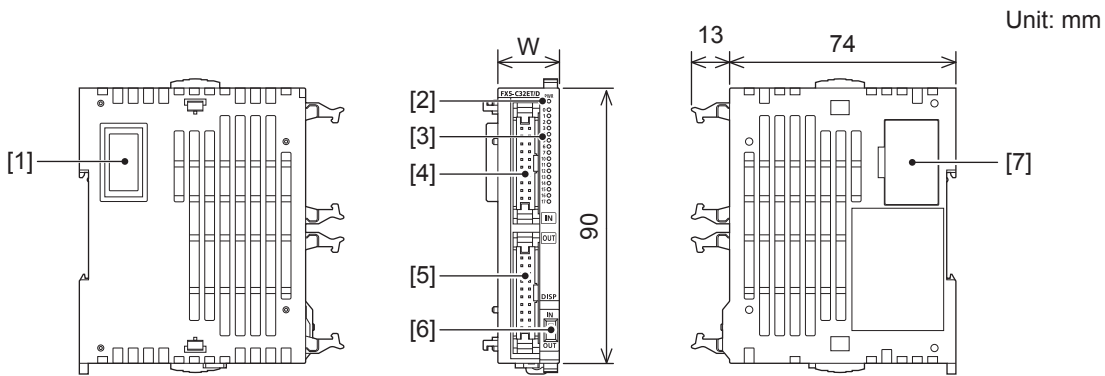

External dimensions

Model	W: mm
FX5-C32ET/D, FX5-C32ET/DSS	20.1

Part names

No.	Name	Description
[1]	Extension connector	Connector connected to extend modules
[2]	PWR LED	Indicates whether the input/output modules are powered or not. Lit: Powered Off: Not powered or hardware error
[3]	I/O display LED	Lit when input or output is on.
[4]	Input connector	Connector for connecting input signal cables. For details on the terminal layout, refer to Page 181 Terminal layout .
[5]	Output connector	Connector for connecting output signal cables. For details on the terminal layout, refer to Page 181 Terminal layout .
[6]	DISP switch	Switches input/output of the I/O display LED. Input: IN Output: OUT
[7]	Extension connector	Connector for connecting the extension connector of an extension module

- Spring clamp terminal block type

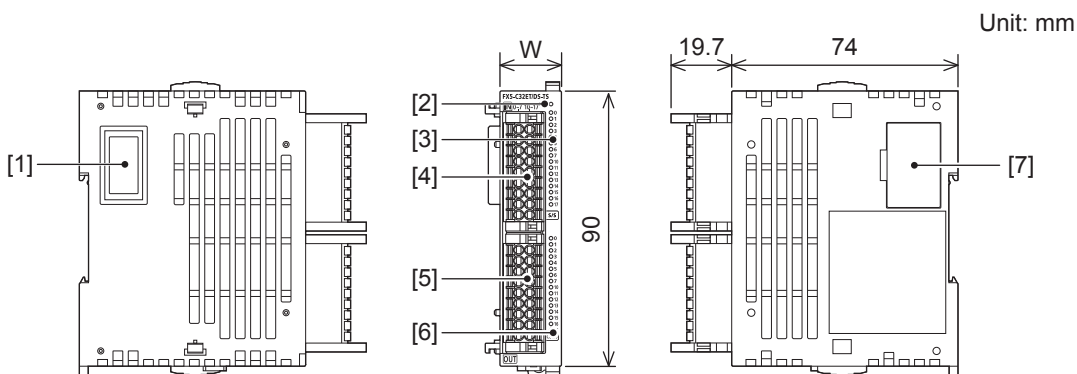



External dimensions

Model	W: mm
FX5-C32ET/DS-TS, FX5-C32ET/DSS-TS	20.1

A

Part names

No.	Name	Description
[1]	Extension connector	Connector connected to extend modules
[2]	PWR LED	Indicates whether the input modules/output modules is powered or not. Lit: Powered Off: Not powered or hardware error
[3]	Input display LED	Lit when input is on.
[4]	Input terminal	Terminals for input. For details on the terminal layout, refer to  Page 181 Terminal layout.
[5]	Output terminal	Terminals for output. For details on the terminal layout, refer to  Page 181 Terminal layout.
[6]	Output display LED	Lit when output is on.
[7]	Extension connector	Connector for connecting the extension connector of an extension module

■Extension cable type

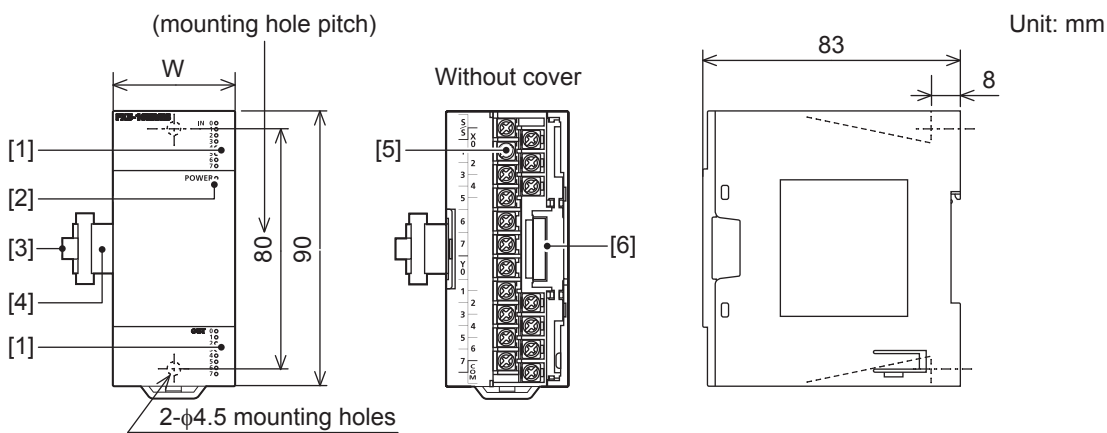

External dimensions

Model	W: mm
FX5-16ER/ES, FX5-16ET/ES, FX5-16ET/ESS	40

Part names

No.	Name	Description
[1]	Input display LED, output display LED	Lit when input or output is on.
[2]	POWER LED	Indicates whether the input modules/output modules is powered or not. Lit: Powered Off: Not powered or hardware error
[3]	Pullout tab	They are used when drawing out an extension cable.
[4]	Extension cable	Cable used to connect the extension module
[5]	Terminal	Terminals for input, and output. For details on the terminal layout, refer to  Page 181 Terminal layout.
[6]	Extension connector	Connector for connecting the extension cable of an extension module.

Powered input/output module

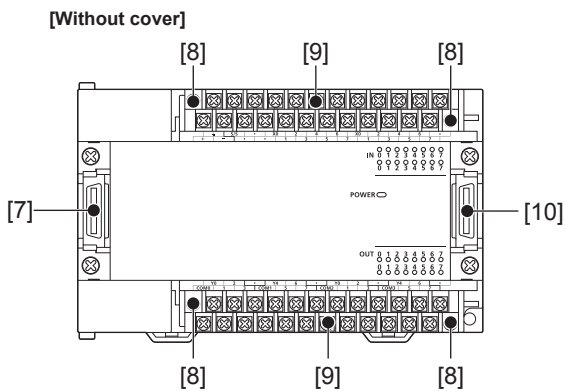
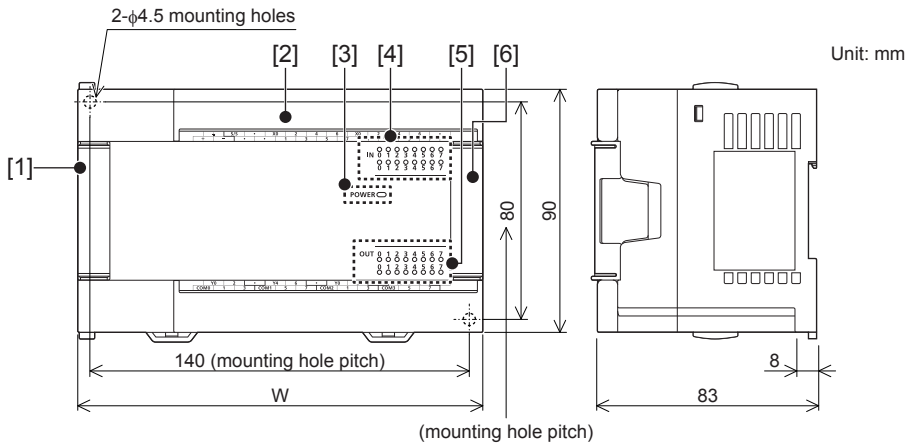

External dimensions

Model	W: mm
FX5-32ER/DS, FX5-32ET/DS, FX5-32ET/DSS	150

Part names

No.	Name	Description
[1]	Extension connector cover (for preceding module)	Cover for protecting the extension connector cover (for preceding module).
[2]	Terminal block cover	Cover for protecting the terminal block. The cover can be opened for wiring. Keep the covers closed while equipment is running (power is on).
[3]	POWER LED	Indicates whether the powered input/output module is powered or not. Lit: Powered Off: Not powered or hardware error
[4]	Input display LED	Lit when input is on.
[5]	Output display LED	Lit when output is on.
[6]	Extension connector cover (for next module)	Cover for protecting the extension connector cover (for next module).
[7]	Extension connector (for preceding module)	Connector for connecting the supplied extension cable that connects to the preceding module (the CPU module side).
[8]	Terminal block mounting screws	Gradually loosen the left and right screws (alternatingly) to remove the upper part of the terminal block.
[9]	Terminal	Terminals for power, input, and output.  shows a function grounding terminal. For details on the terminal layout, refer to Page 181 Terminal layout .
[10]	Extension connector (for next module)	Connector for connecting the extension cable of an extension module.

High-speed pulse input/output module

Unit: mm

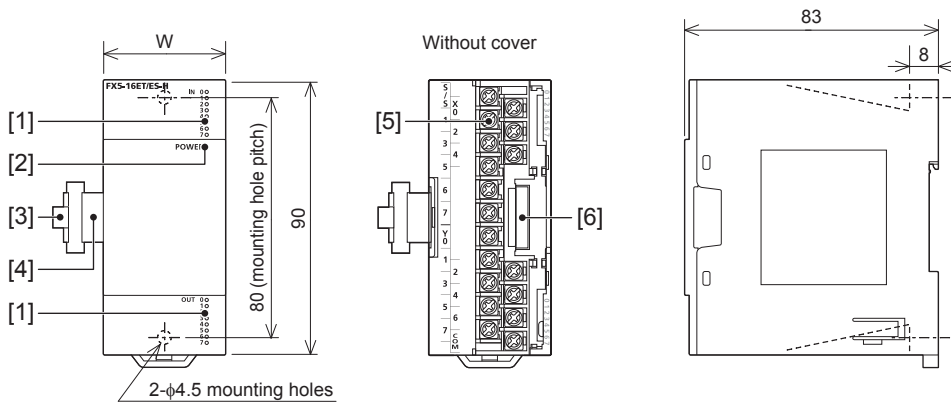

External dimensions

Model	W: mm
FX5-16ET/ES-H, FX5-16ET/ESS-H	40

Part names

No.	Name	Description
[1]	Input display LED, Output display LED	Lit when input or output is on.
[2]	POWER LED	Indicates whether the input modules/output modules is powered or not. Lit: Powered Off: Not powered or hardware error
[3]	Pullout tab	They are used when drawing out an extension cable.
[4]	Extension cable	Cable connected to extend modules
[5]	Terminal	Terminals for input, and output. For details on the terminal layout, refer to Page 181 Terminal layout .
[6]	Extension connector	Connector for connecting the extension cable of an extension module.

Terminal layout

Extension connector type

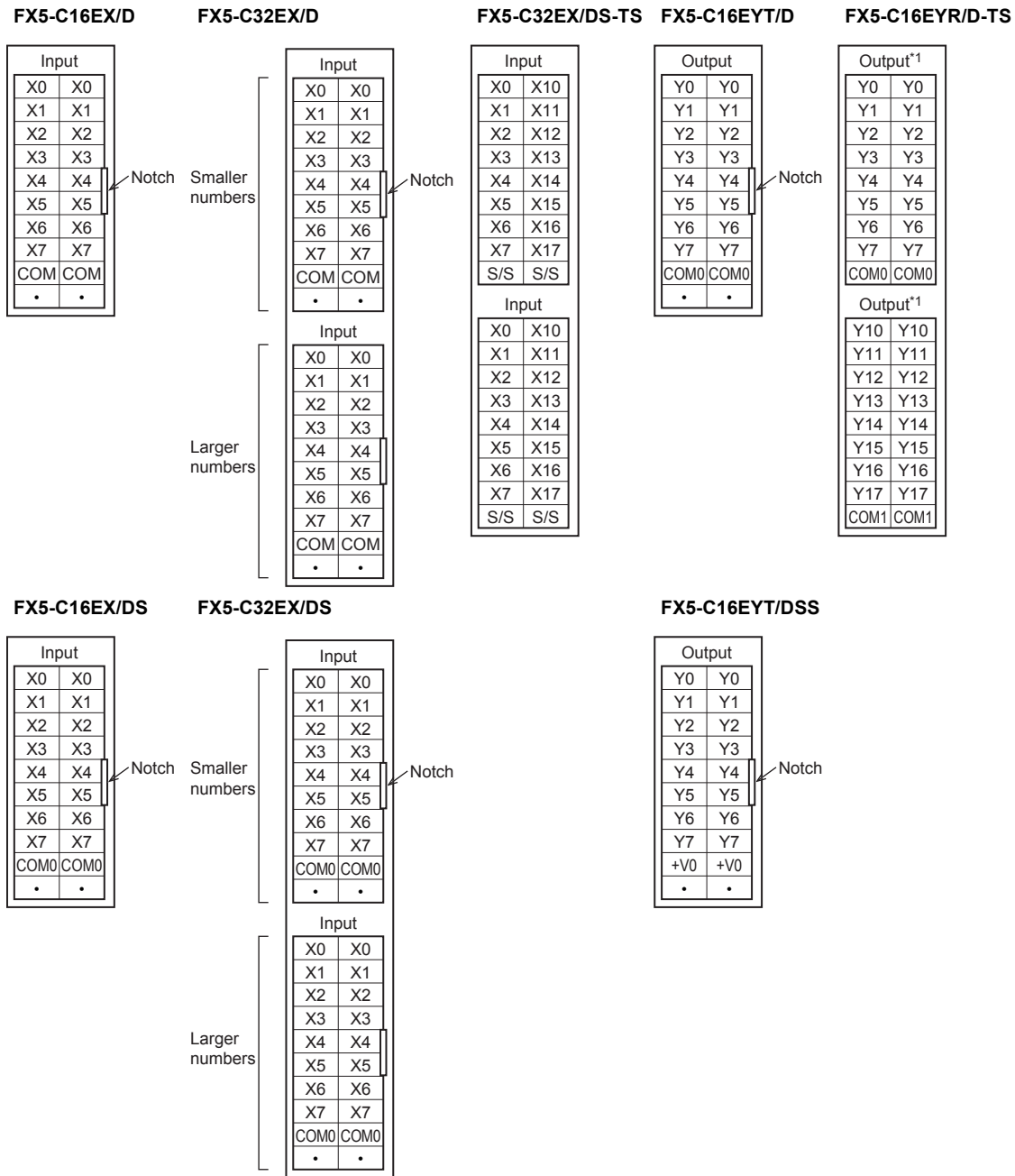

*1 Terminals with the same name (Y0 and Y0, Y10 and Y10, etc.) are internally connected.



FX5-C32EYT/D

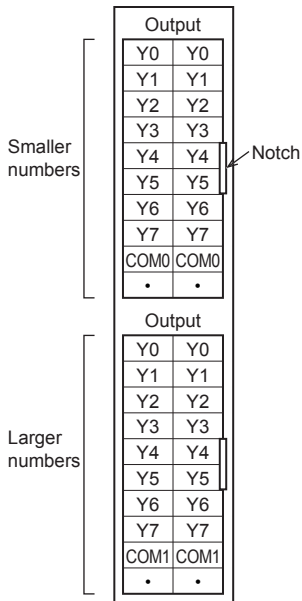

FX5-C32EYT/D-TS

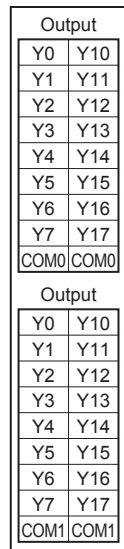

FX5-C32ET/D

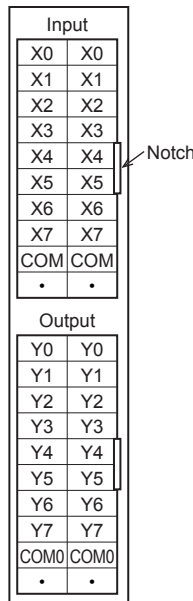

FX5-C32ET/DS-TS

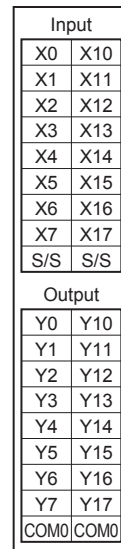

FX5-C32EYT/DSS

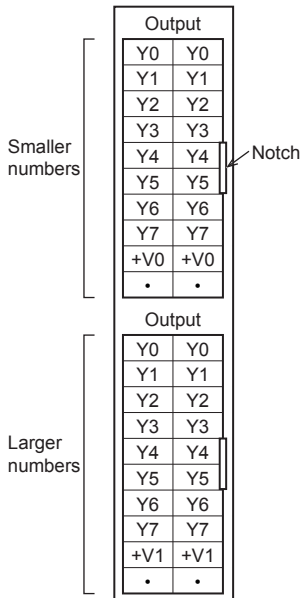

FX5-C32EYT/DSS-TS

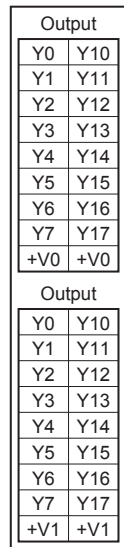

FX5-C32ET/DSS

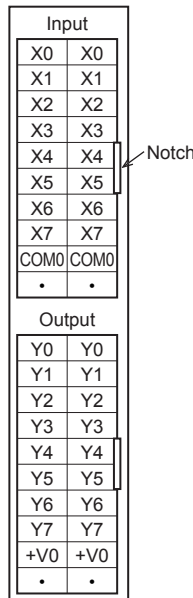

FX5-C32ET/DSS-TS

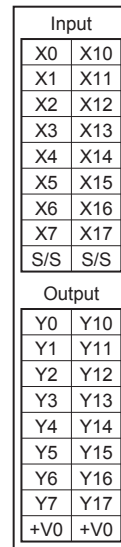

Extension cable type

FX5-8EX/ES



**FX5-8EYR/ES
FX5-8EYT/ES**

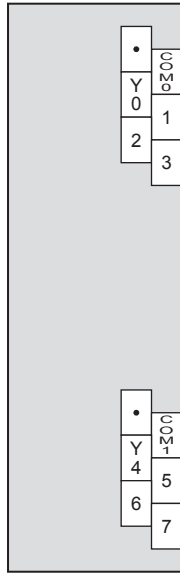

FX5-8EYT/ESS

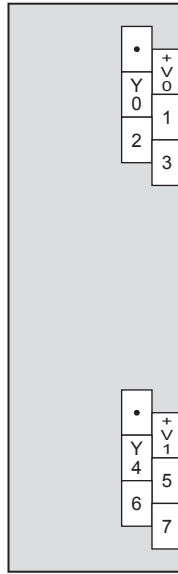

**FX5-16ER/ES
FX5-16ET/ES
FX5-16ET/ES-H**

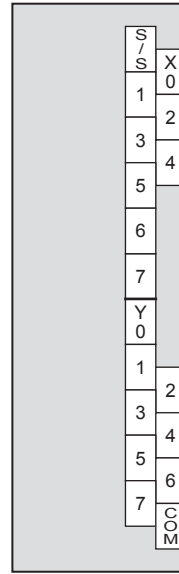

FX5-16EX/ES

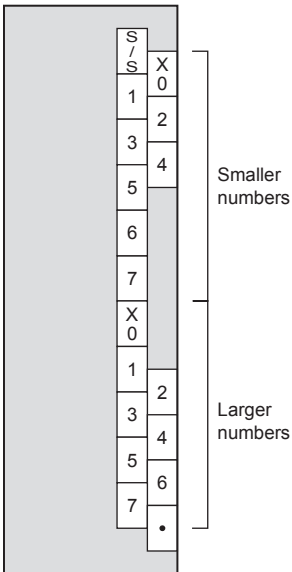

**FX5-16EYR/ES
FX5-16EYT/ES**

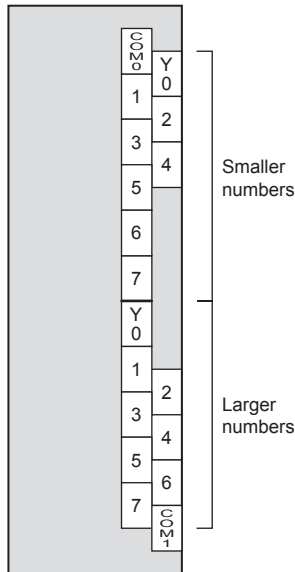

FX5-16EYT/ESS

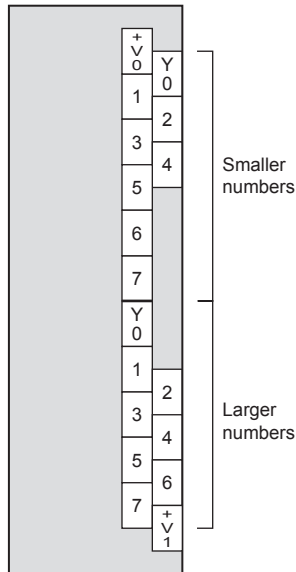

**FX5-16ET/ESS
FX5-16ET/ESS-H**

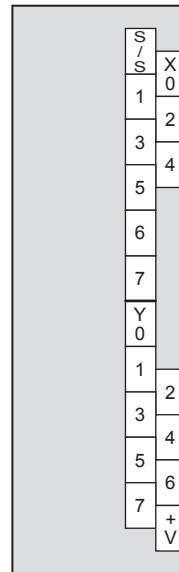

FX5-32E□/D□

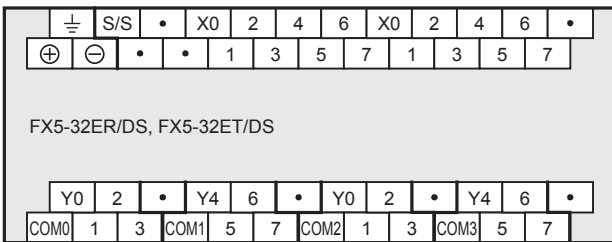

FX5-32ET/DSS

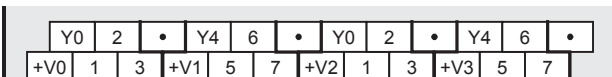

Appendix 5 Connector Conversion Module

Connector conversion modules are used to connect FX5 extension modules (extension cable type) in FX5UC systems.

External dimensions and component names

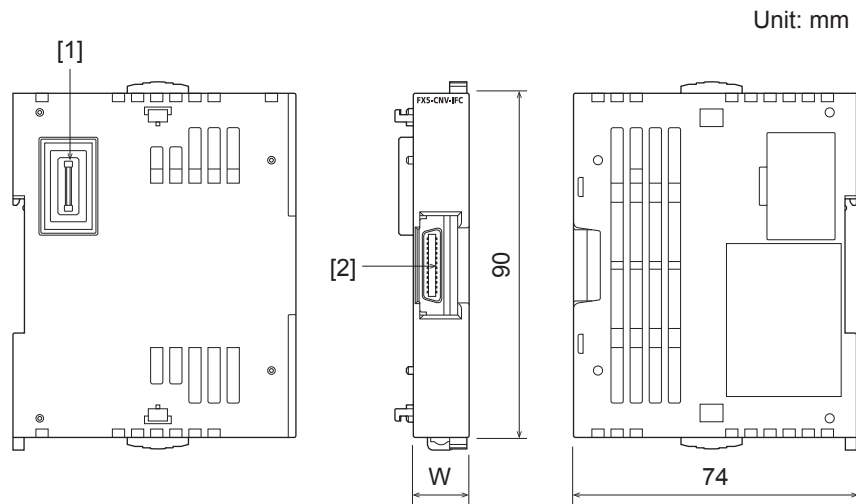

External dimensions

Model	W: mm
FX5-CNV-IFC	14.6

Part names

No.	Name	Description
[1]	Extension connector (for preceding module)	The extension connector that connects to the preceding module (the CPU module side).
[2]	Extension connector (for next module)	Connector for connecting the extension connector of an extension module (extension connector type).

Specifications

The generic specifications are the same as those for the CPU module. (☞ Page 29 Generic Specifications)

External color, weight, accessories

Item	Specifications
External color	Munsell 0.6B7.6/0.2
Mass (weight)	Approx. 60 g

Appendix 6 SD Memory Card

An SD memory card can be used by installing to the CPU module. For details of the function, refer to the following manual.
 MELSEC iQ-F FX5 User's Manual (Application)

Part names

This section describes the part names of the SD memory card.

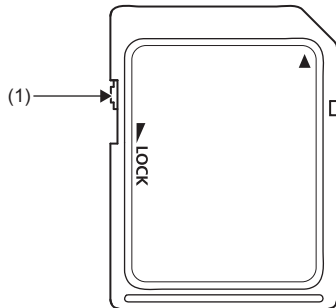

No.	Name	Description
(1)	Write protect switch	Setting the switch in the lock position prevents the data in the SD memory card from being deleted and overwritten.

Specifications

The following shows functional specifications of the SD memory card.

Item	NZ1MEM-2GBSD	NZ1MEM-4GBSD	NZ1MEM-8GBSD	NZ1MEM-16GBSD
Type	SD memory card	SDHC memory card		
Capacity	2 Gbytes	4 Gbytes	8 Gbytes	16 Gbytes
Number of writes	60,000 times	100,000 times		
External dimensions	Height	32 mm		
	Width	24 mm		
	Depth	2.1 mm		
Mass (weight)	2 g			

A

Point

For L1MEM-2GBSD and L1MEM-4GBSD, refer to the following.
 QCPU User's Manual(Hardware Design, Maintenance and Inspection)

Handling of the SD memory card

- Operational compatibility of the SD memory cards manufactured by Mitsubishi (NZ1MEM-□GBSD) with MELSEC iQ-F series CPU modules has been checked. Use of SD memory card other than a Mitsubishi SD memory card may result in loss of the data stored in the SD memory card, or problems such as system stop.
- When mounted in the CPU module, SD memory cards manufactured by Mitsubishi are compliant with IEC61131-2.
- The SDHC memory card can be used only with devices with an SDHC logo or whose user's manual lists an SDHC logo. Note that SDHC cards cannot be used with devices that support only "SD" specifications.
- Turning off or resetting the CPU module or removing the SD memory card while the card is being accessed may corrupt the data in the SD memory card. Always turn off or reset the CPU module or remove the SD memory card after disabling access to the SD memory card. With SM606 (SD memory card forced disable instruction) and SM607 (SD memory card forced disable status flag), the SD memory card can be disabled and its usage status can be checked.
- It is recommended that important data be periodically backed up to CD, DVD, or other media.

Formatting

To use any SD memory card in the CPU module, the card must be formatted. In the initial state after purchase, the SD memory card is not formatted. Insert the SD memory card to a CPU module and format the SD memory card using the engineering tool before use. Do not format the SD memory card using the personal computer. (GX Works3 Operating Manual)

Insertion and removal of the SD memory card

The following explains insertion and removal of the SD memory card.

Insertion procedure

Mount the SD memory card. Pay attention to the direction of the card and follow the procedure below.

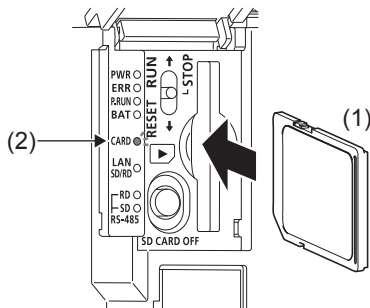

1. Insert the SD memory card (1) straight into the SD memory card slot. Make sure that the notch of the card is directed downward. After mounting, check that the card is mounted completely. If the card is mounted incompletely, malfunctions may occur because of poor contact.
2. The CARD LED (2) blinks until the SD memory card becomes available.
3. The CARD LED turns on when the SD memory card is available.
4. If the CARD LED does not turn on even though the SD memory card is mounted, make sure that SM606 (forcibly stop using SD memory card instruction) and SM607 (forcibly stop using SD memory card flag) are OFF by using engineering tools.

Removal procedure

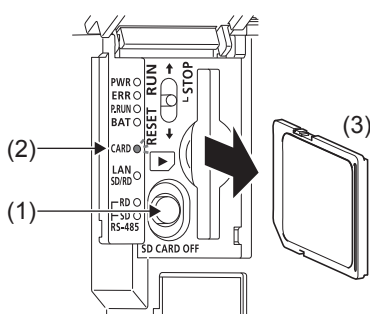

1. Press the SD memory card stop switch (1) for one second or more to stop access to the card. The CARD READY LED (2) blinks during the access stop operation, and then the LED is turned OFF when the operation is completed.
2. Insert the SD memory card (3) once, and then pull it straight.

Precautions

- When mounting or removing the SD memory card while the power is ON, follow the above-mentioned procedure. Otherwise, the data in the card may be broken.
- When removing the SD memory card which is being accessed by any function, the CARD LED is turned OFF after the access is completed. When the CARD LED is turned OFF depends on the accessing function.
- When SM605 (mount and remove memory card disabling flag) is ON, the CARD LED is not turned OFF even if the SD memory card stop switch is pressed. If the CARD LED is not turned OFF, turn ON SM606 (instruction of forcibly stop using SD memory card) so that the SD memory card cannot be used.

Appendix 7 Terminal Module

Product configuration

Terminal modules are used to convert connector-type I/O terminals into terminal blocks. By using terminal blocks (built-in element type) dedicated to input or output, capturing of AC input signals and format conversion into the relay/transistor/triac output can be performed.

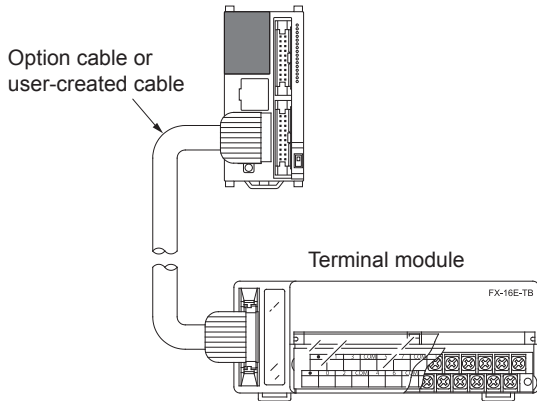

Product list

Sink input/sink output (transistor output)

Model	No. of input points	No. of output points	Function	Connection destination	Driving current
■Sink input/sink output (transistor output)					
FX-16E-TB	16 input points or 16 output points		Directly connected to I/O terminals of a PLC.	FX5UC-□MT/D, FX5-C□EX/D, FX5-C□EYT/D, FX5-C32ET/D	Refer to the following table.
FX-32E-TB	32 input points, 32 output points, or 16 input points and 16 output points				
FX-16EX-A1-TB	16	—	100 V AC input type	FX5UC-□MT/D, FX5-C□EX/D, FX5-C32ET/D	24 V DC 48 mA
FX-16EYR-TB	—	16	Relay output type	FX5UC-□MT/D, FX5-C□EYT/D, FX5-C32ET/D	24 V DC 80 mA
FX-16EYT-TB	—	16	Transistor output type (sink)		24 V DC 112 mA
FX-16EYS-TB	—	16	Triac output type		
■Sink and source common input/source output (transistor output)					
FX-16E-TB/UL	16 input points or 16 output points		Directly connected to I/O terminals of a PLC.	FX5UC-□MT/DSS, FX5-C□EX/DS, FX5-C□EYT/DSS, FX5-C32ET/DSS	Refer to the following table.
FX-32E-TB/UL	32 input points, 32 output points, or 16 input points and 16 output points				
FX-16EYR-ES-TB/UL	—	16	Relay output type	FX5UC-□MT/DSS, FX5-C□EYT/DSS, FX5-C32ET/DSS	24 V DC 80 mA
FX-16EYT-ES-TB/UL	—	16	Transistor output type (sink)		24 V DC 112 mA
FX-16EYT-ESS-TB/UL	—	16	Transistor output type (source)		
FX-16EYS-ES-TB/UL	—	16	Triac output type		

- The following table shows driving current of FX-16E-TB(/UL) and FX-32E-TB(/UL) that depends on the connection destination.

Connection destination	Power supply voltage	Current consumption
■Input connector		
FX5UC-□MT/D, FX5-C□EX/D, FX5-C32ET/D	Not required	
FX5UC-□MT/DSS, FX5-C□EX/DS, FX5-C32ET/DSS	24 V DC	112 mA/16 points
■Output connector		
FX5UC-□MT/D, FX5UC-□MT/DSS, FX5-C□EYT/D, FX5-C□EYT/DSS, FX5-C32ET/D, FX5-C32ET/DSS	The power supply appropriate to the connected load is required.	

A

Specifications

Exterior color, accessories

Item	Specifications
Exterior color	Munsell 0.08GY/7.64/0.81
Accessories	Input/output number label, terminal block layout card

Input specifications

■FX-16EX-A1-TB

Item	Specifications	
Input type	AC input	
Input signal voltage	100 to 120 V AC +10% -15% 50/60 Hz	
Input signal current	4.7 mA/100 V AC 50 Hz 6.2 mA/110 V AC 60 Hz	
Input impedance	Approx. 21 k Ω /50 Hz Approx. 18 k Ω /60 Hz	
Input sensitivity	ON	3.8 mA/80 V AC or more
	OFF	1.7 mA/30 V AC or less
Input response time *1	30 ms or less	
Input signal format (Input sensor form)	Voltage contact	
Input circuit insulation	Photo-coupler insulation	
Indication of input operation	No input LED (However, the 24 V power LED display exists.)	
Power consumption	1.2 W (48 mA 24 V DC)	
Input/output configuration circuit		
Unsupported applications	High-speed counter, input interruption, pulse catch, Speed Detection ((D)SPD) instruction, Input Matrix (MTR) instruction, Digital Switch (DSW) instruction, ABS Current Value Read (DBS) instruction, high-speed I/O function start/stop ((D)HIOEN) instruction	

*1 The response delay time of the CPU module is not included.

Output specifications

■ Relay output (FX-16EYR-TB, FX-16EYR-ES-TB/UL)

Item		Specifications	
Output type		Relay	
External voltage		250 V AC or less, 30 V DC or less	
Max. load	Resistance load	2 A/point	The total load current per common terminals (four points) should be 8 A or less.
	Inductive load	80 VA	
Min. load		5 V DC, 2 mA (reference values)	
Open circuit leakage current		—	
Response time		Approx. 10 ms	
ON voltage of output element		1.5 V	
Output circuit insulation		Mechanical insulation	
Indication of output operation		LED is lit when the power is supplied to relay coils.	
Power consumption		1.92 W (80 mA 24 V DC)	
Input/output configuration circuit	FX-16EYR-TB		
	FX-16EYR-ES-TB/UL		
Unsupported applications		Positioning, Pulse Y Output ((D)PLSY) instruction, Pulse Width Modulation ((D)PWM) instruction, ABS Current Value Read (DABS) instruction, Start/stop of high-speed I/O function ((D)HIOEN) instruction, Input Matrix (MTR) instruction, Digital Switch (DSW) instruction, Seven Segment With Latch (SEGL) instruction	

A

■ Transistor/sink output (FX-16EYT-TB, FX-16EYT-ES-TB/UL)

Item		Specifications	
Output type		Transistor/sink output	
External voltage		5-30 V DC	
Max. load	Resistance load	0.5 A/point	The total load current per common terminals (four points) should be 0.8 A or less.
	Inductive load	12 W/24 V DC	
Min. load		—	
Open circuit leakage current		0.1 mA/30 V DC	
Response time		OFF→ON	0.2 ms or less/24 V DC
		ON→OFF	1.5 ms or less/24 V DC
ON voltage of output element		1.5 V	
Output circuit insulation		Photo-coupler insulation	
Indication of output operation		LED is lit when the power is supplied to photo-couplers.	
Power consumption		2.7 W (112 mA 24 V DC)	
Input/output configuration circuit	FX-16EYT-TB		
	FX-16EYT-ES-TB/UL		
Unsupported applications		Positioning, Pulse Y Output ((D)PLSY) instruction, Pulse Width Modulation ((D)PWM) instruction, ABS Current Value Read (DABS) instruction, Start/stop of high-speed I/O function ((D)HIOEN) instruction, Input Matrix (MTR) instruction, Digital Switch (DSW) instruction, Seven Segment With Latch (SEGL) instruction	

■ Transistor/source output (FX-16EYT-ESS-TB/UL)

Item		Specifications	
Output type		Transistor/source output	
External voltage		5-30 V DC	
Max. load	Resistance load	0.5 A/point	The total load current per common terminals (four points) should be 0.8 A or less.
	Inductive load	12 W/24 V DC	
Min. load		—	
Open circuit leakage current		0.1 mA/30 V DC	
Response time		OFF→ON	0.2 ms or less/24 V DC
		ON→OFF	1.5 ms or less/24 V DC
ON voltage of output element		1.5 V	
Output circuit insulation		Photo-coupler insulation	
Indication of output operation		LED is lit when the power is supplied to photo-couplers.	
Power consumption		2.7 W (112 mA 24 V DC)	
Input/output configuration circuit			
Unsupported applications		Positioning, Pulse Y Output ((D)PLSY) instruction, Pulse Width Modulation ((D)PWM) instruction, ABS Current Value Read (DABS) instruction, Start/stop of high-speed I/O function ((D)HIOEN) instruction, Input Matrix (MTR) instruction, Digital Switch (DSW) instruction, Seven Segment With Latch (SEGL) instruction	

■ Triac output (FX-16EYS-TB, FX-16EYS-ES-TB/UL)

Item		Specifications	
Output type		Triac (SSR)	
External voltage		85 to 242 V AC	
Max. load	Resistance load	0.3 A/point	The total load current per common terminals (four points) should be 0.8 A or less.
	Inductive load	15 VA/100 V AC 36 VA/200 V AC	
Min. load		0.4 VA/100 V AC 1.6 VA/200 V AC	
Open circuit leakage current		1 mA/100 V AC 2 mA/200 V AC	
Response time		2 ms or less	
ON voltage of output element		—	
Output circuit insulation		Photo-coupler insulation	
Indication of output operation		LED is lit when the power is supplied to photo-thyristors.	
Power consumption		2.7 W (112 mA 24 V DC)	
Input/output configuration circuit	FX-16EYS-TB		
	FX-16EYS-ES-TB/UL		
Unsupported applications		Positioning, Pulse Y Output ((D)PLSY) instruction, Pulse Width Modulation ((D)PWM) instruction, ABS Current Value Read (DABS) instruction, Start/stop of high-speed I/O function ((D)HIOEN) instruction, Input Matrix (MTR) instruction, Digital Switch (DSW) instruction, Seven Segment With Latch (SEGL) instruction	

External dimensions and component names

• FX-16E-TB, FX-16E-TB/UL

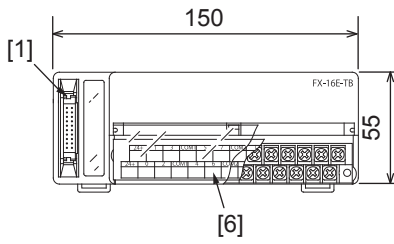

• FX-32E-TB, FX-32E-TB/UL

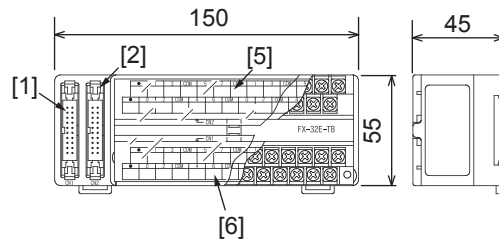

• FX-16EX-A1-TB

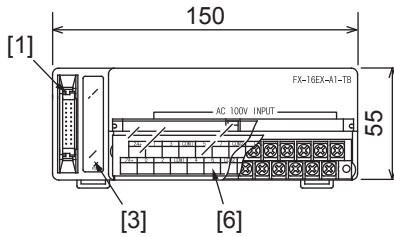

• FX-16EYR-TB, FX-16EYR-ES-TB/UL, FX-16EYT-TB, FX-16EYT-ES-TB/UL, FX-16EYT-ESS-TB/UL, FX-16EYS-TB, FX-16EYS-ES-TB/UL

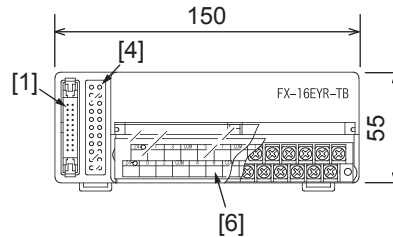

Unit: mm (inches)

No.	Name	Description
[1]	CN1 connector	Connector for connecting input signal cables or output signal cables for CN1
[2]	CN2 connector	Connector for connecting input signal cables or output signal cables for CN2 (FX-32E-TB and FX-32E-TB/UL only)
[3]	POWER LED	Indicates the conduction status. (FX-16EX-A1-TB only) Lit: Powered Off: Not powered or hardware error
[4]	Operation display LED	Turns on when the output is on. (FX-16EYR-TB, FX-16EYR-ES-TB/UL, FX-16EYT-TB, FX-16EYT-ES-TB/UL, FX-16EYT-ESS-TB/UL, FX-16EYS-TB, and FX-16EYS-ES-TB/UL only)
[5]	Terminal block for CN2 (M3.5 screws)	Input/output terminals for CN2 (FX-32E-TB and FX-32E-TB/UL only)
[6]	Terminal block for CN1 (M3.5 screws)	Input/output terminals for CN1



Terminal layout

- FX-16E-TB, FX-16E-TB/UL

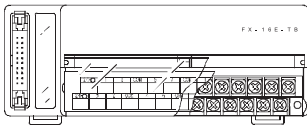

Smaller numbers										Larger numbers					
•	1	3	COM	5	7	COM	1	3	COM	5	7	COM			
•	0	2	COM	4	6	COM	0	2	COM	4	6	COM			

- FX-32E-TB, FX-32E-TB/UL

Smaller numbers										Larger numbers					
CN2	•	1	3	COM	5	7	COM	1	3	COM	5	7	COM		
	•	0	2	COM	4	6	COM	0	2	COM	4	6	COM		

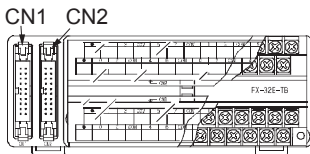

Smaller numbers										Larger numbers					
CN1	•	1	3	COM	5	7	COM	1	3	COM	5	7	COM		
	•	0	2	COM	4	6	COM	0	2	COM	4	6	COM		

- FX-16EX-A1-TB

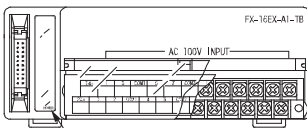

Smaller numbers										Larger numbers					
24+	1	3	COM1	5	7	COM2	1	3	COM3	5	7	COM4			
24-	0	2	COM1	4	6	COM2	0	2	COM3	4	6	COM4			

- FX-16EYR-TB, FX-16EYR-ES-TB/UL, FX-16EYT-TB, FX-16EYT-ES-TB/UL, FX-16EYT-ESS-TB/UL, FX-16EYS-TB, FX-16EYS-ES-TB/UL

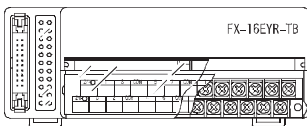

Smaller numbers										Larger numbers					
24+	1	3	COM1	5	7	COM2	1	3	COM3	5	7	COM4			
24-	0	2	COM1	4	6	COM2	0	2	COM3	4	6	COM4			

Internal circuit

FX-16E-TB, FX-32E-TB

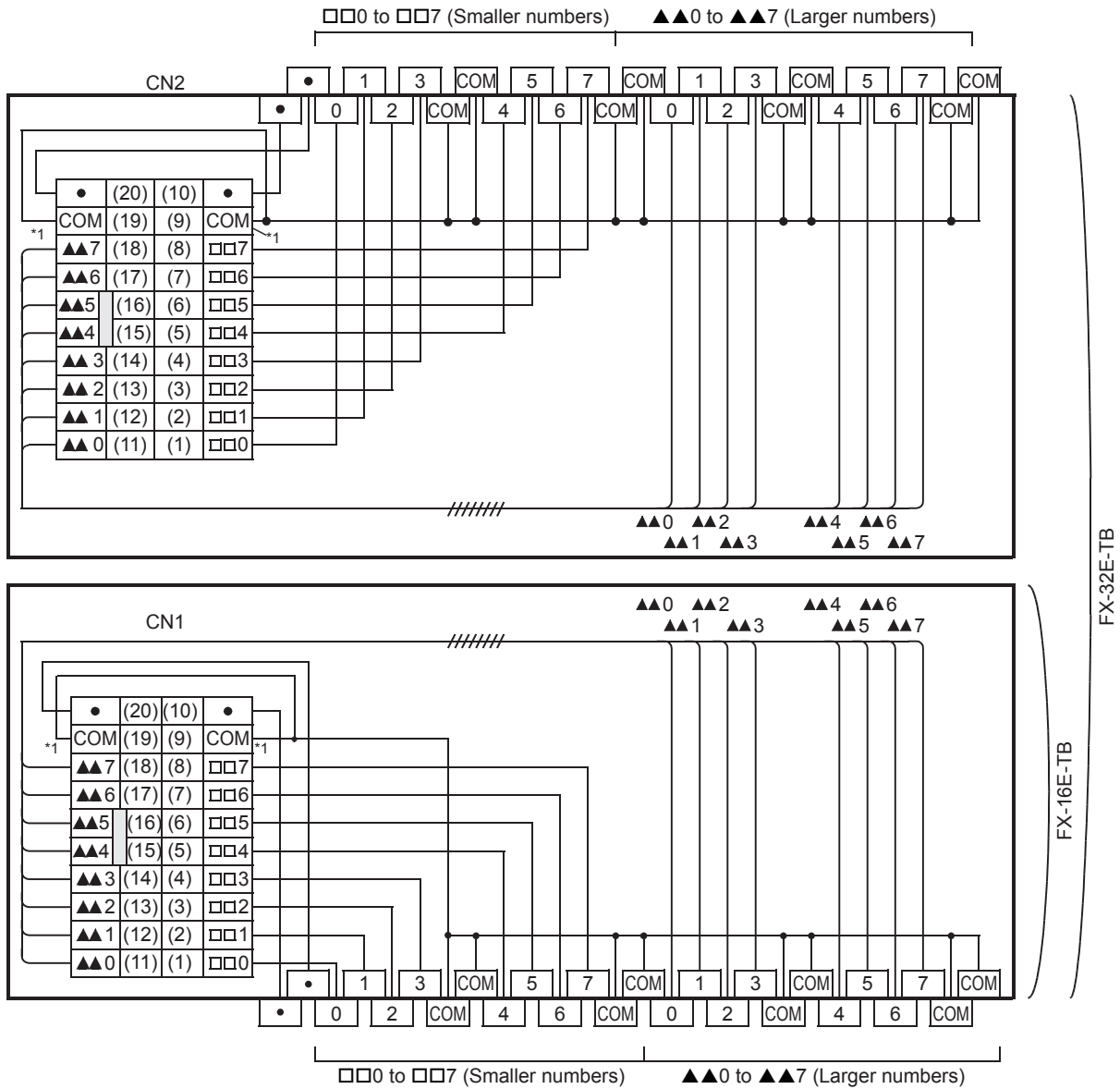

*1 Replace this number with the one of the connected connector.

A

FX-16E-TB/UL, FX-32E-TB/UL

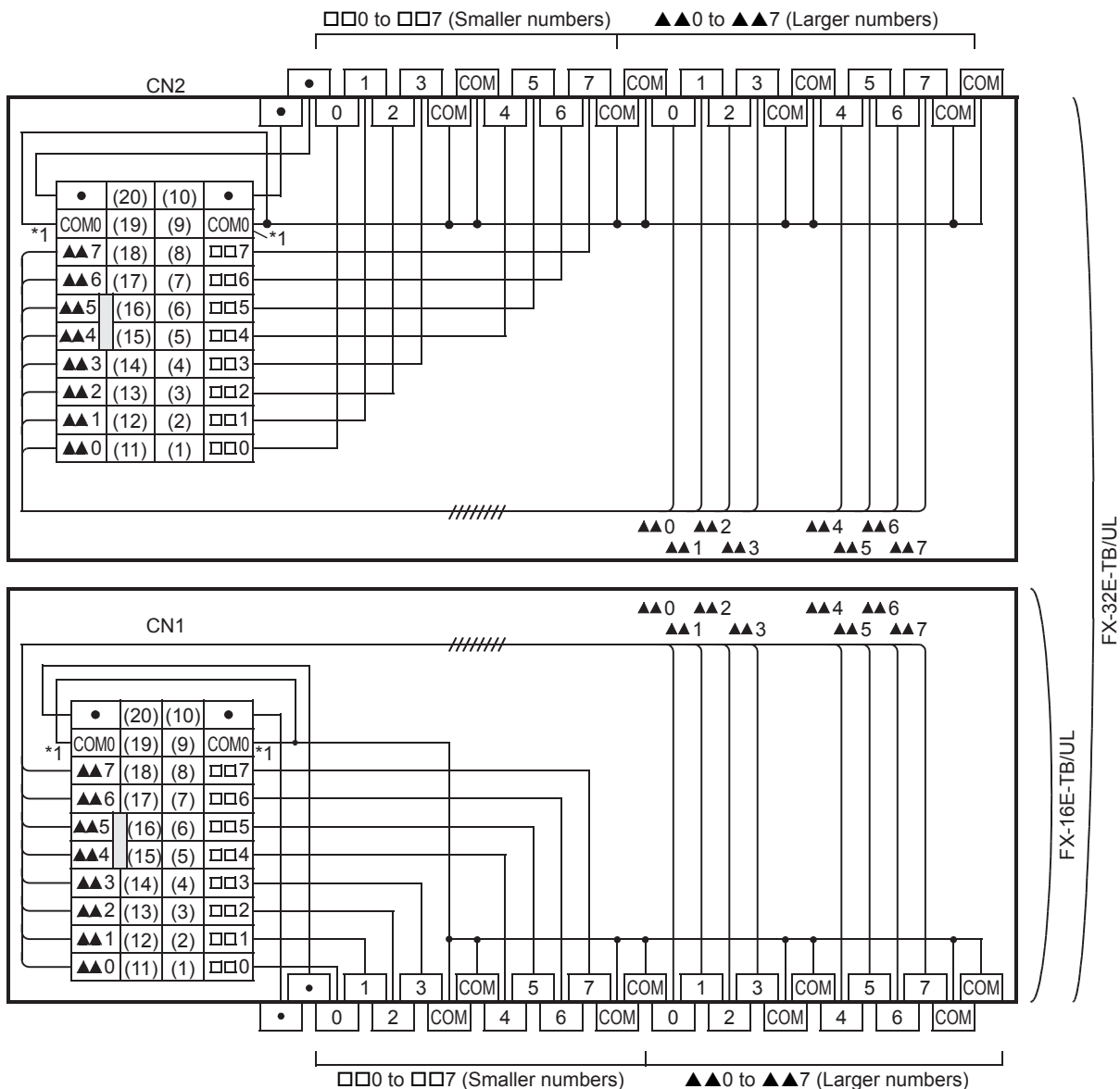

*1 Replace this number with the one of the connected connector.

FX-16EX-A1-TB

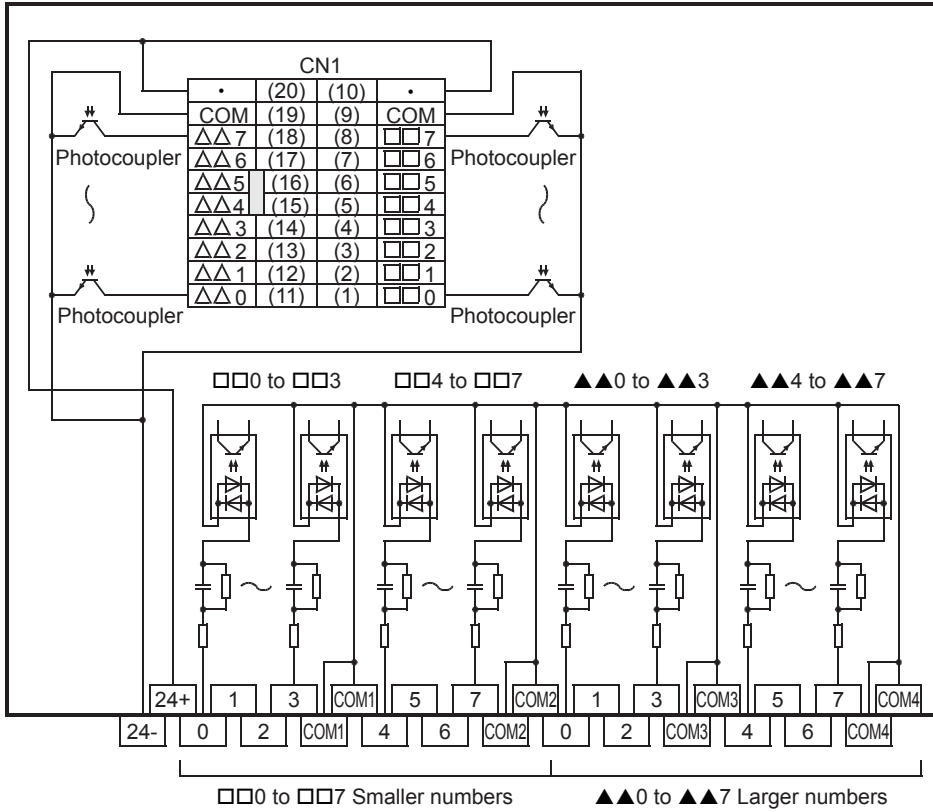

FX-16EYR-TB

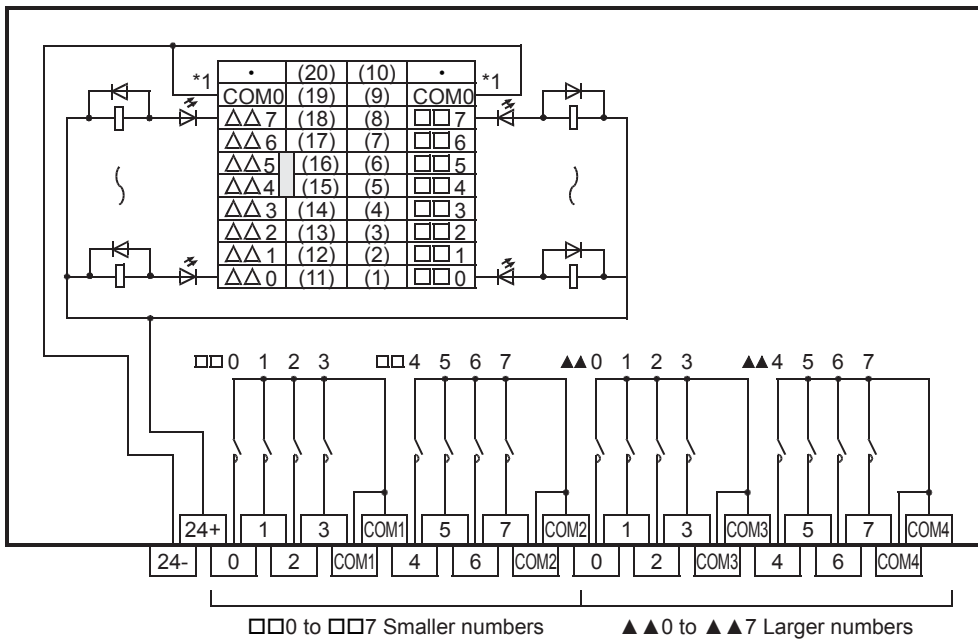

*1 Replace this number with the one of the connected connector.

A

FX-16EYR-ES-TB/UL

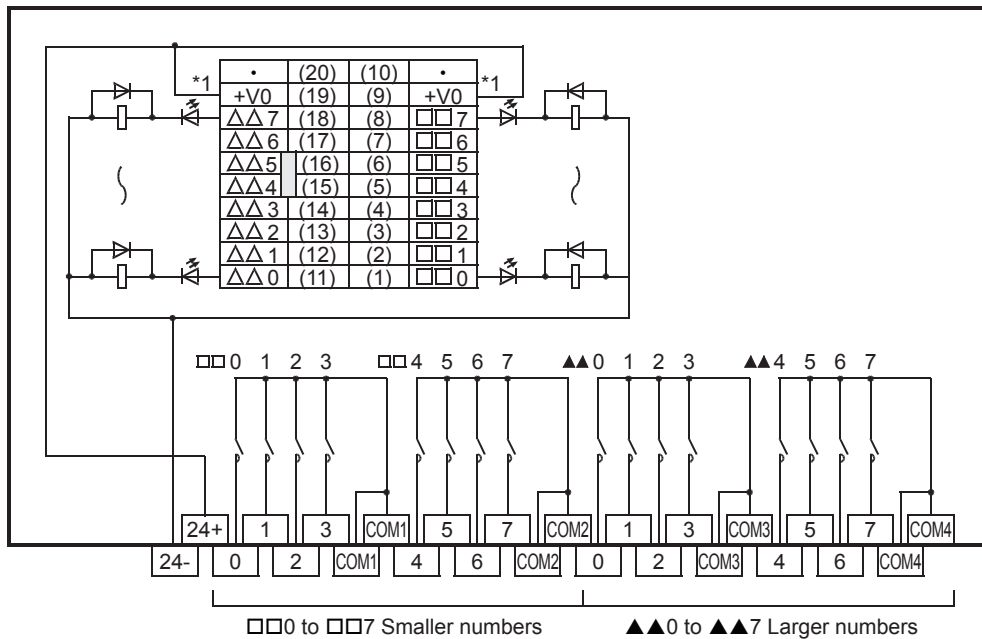

*1 Replace this number with the one of the connected connector.

FX-16EYT-TB

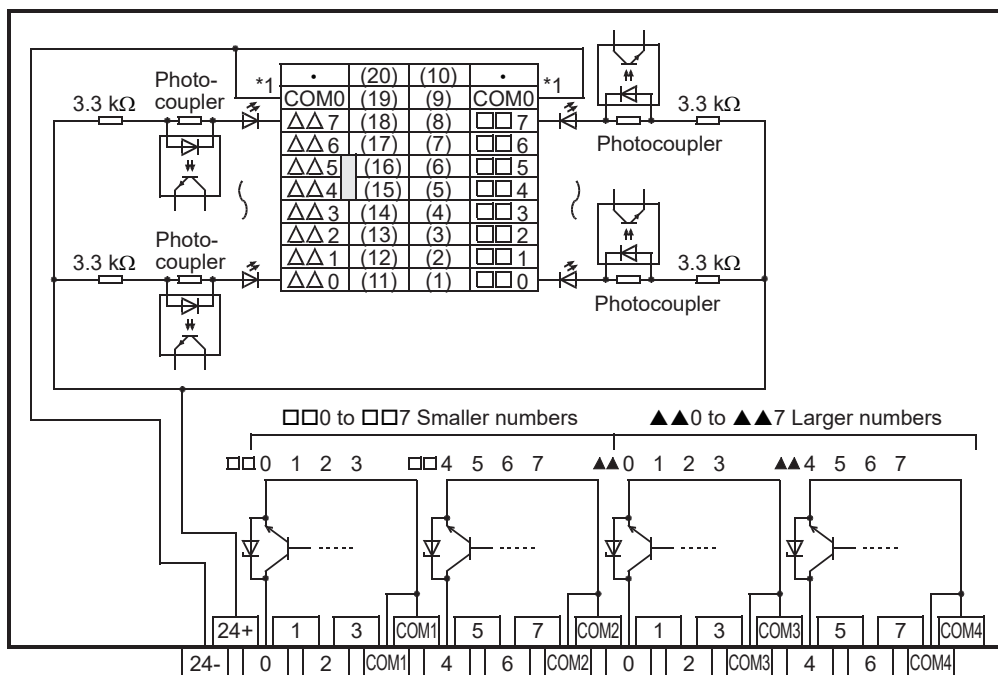

*1 Replace this number with the one of the connected connector.

FX-16EYT-ES-TB/UL

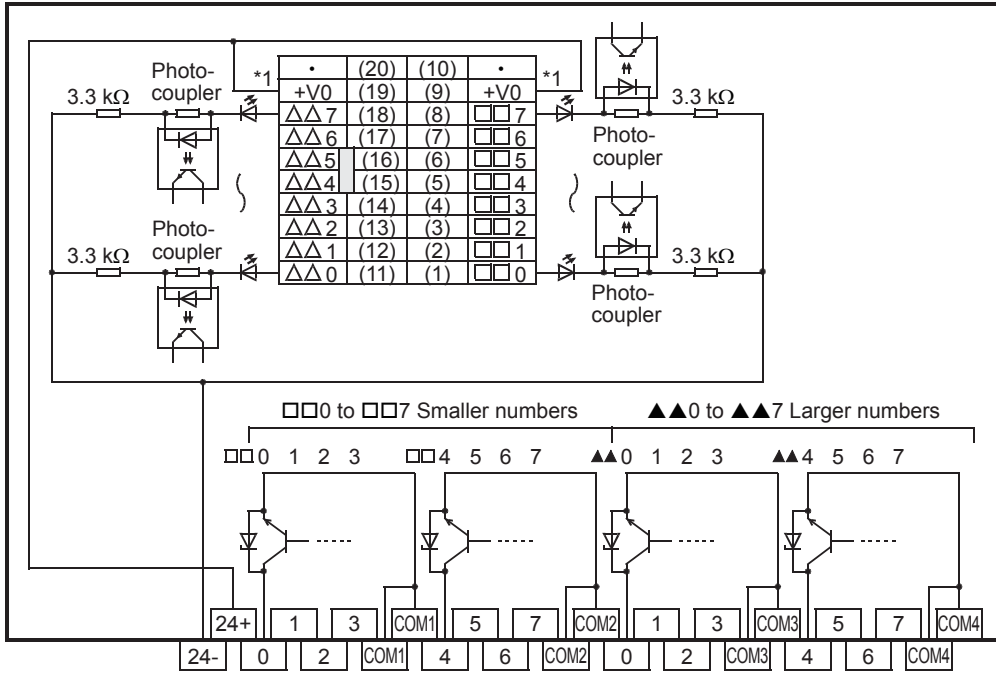

*1 Replace this number with the one of the connected connector.

FX-16EYT-ESS-TB/UL

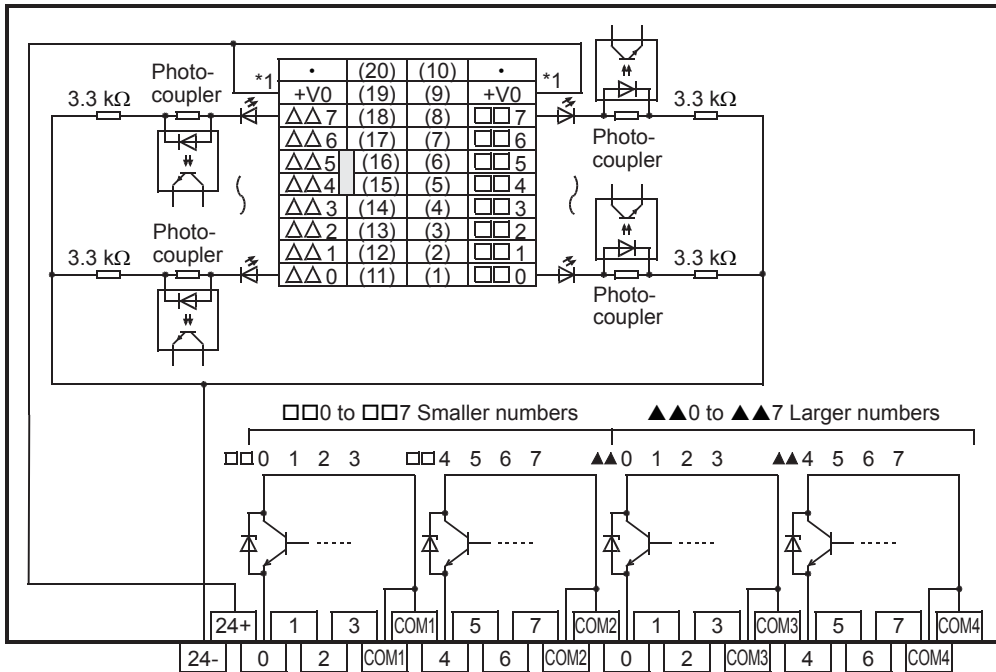

*1 Replace this number with the one of the connected connector.

A

FX-16EYS-TB

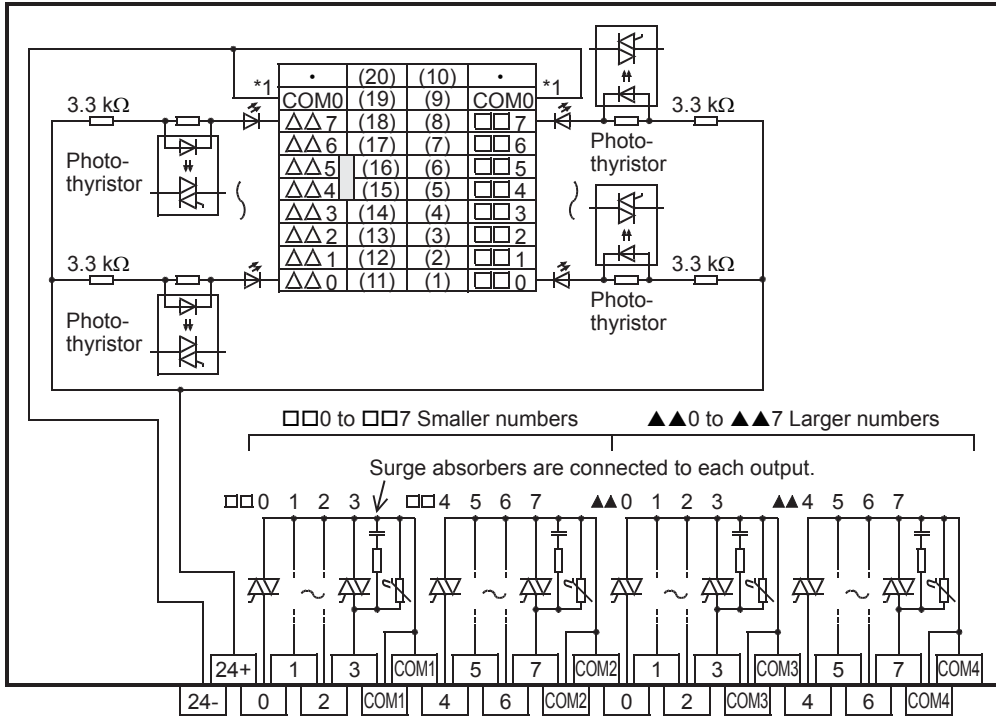

*1 Replace this number with the one of the connected connector.

FX-16EYS-ES-TB/UL

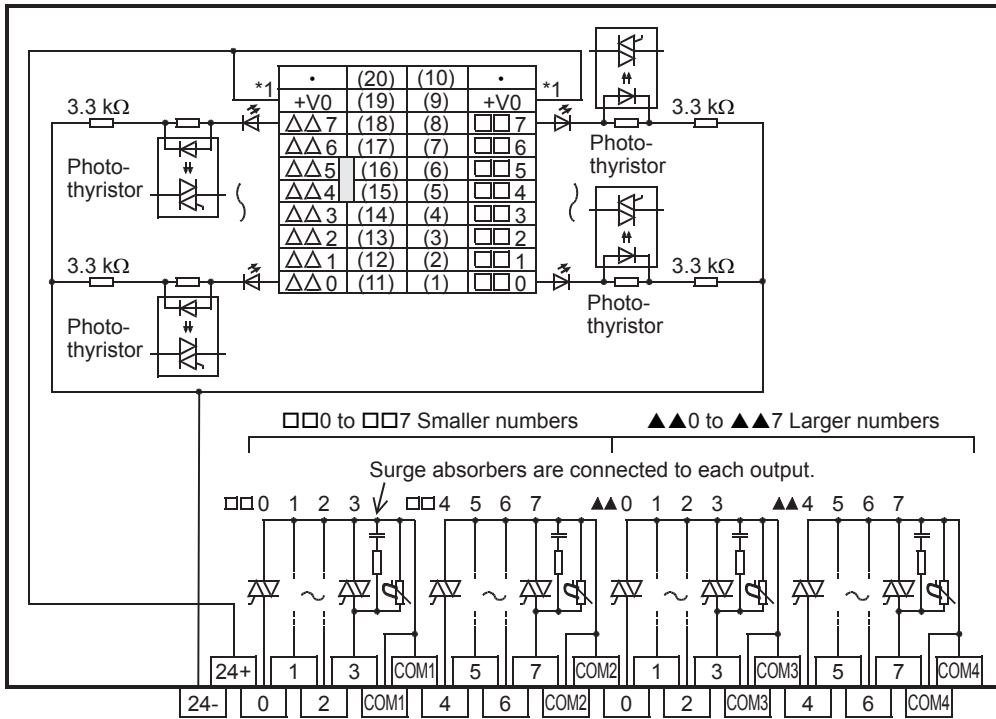

*1 Replace this number with the one of the connected connector.

Appendix 8 Precautions for Battery Transportation

When transporting lithium batteries, follow required transportation regulations.

Batteries used in the FX5UC CPU modules are classified as follows.

Control-subject product

Built-in

None (FX5UC CPU modules do not include batteries when shipped from the factory.)

Battery only (spare parts and optional parts)

Model	Battery type	Product form	Lithium contained (g/battery)	Weight ^{*1} (g/battery)
FX3U-32BL	Lithium-metal battery	Cell	0.15	30

*1 Weight in packaging.

Precautions for transportation

When transporting the product above, follow IATA Dangerous Goods Regulations, IMDG Code (International Maritime Dangerous Goods Code), and domestic transportation regulations in each country. For details, contact the transportation company to be used.

Appendix 9 Handling of Batteries and Devices with Built-in Batteries in EU Member States

This section describes the precautions for disposing of waste batteries in EU member states and exporting batteries and/or devices with built-in batteries to EU member states.

Disposal precautions

In EU member states, there is a separate collection system for waste batteries.

Dispose of batteries properly at the local community waste collection/recycling center.

The symbol shown in the following figure is printed on the batteries and packaging of batteries and devices with built-in batteries. This symbol indicates that batteries need to be disposed of separately from other wastes.

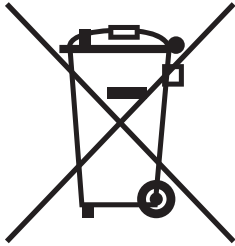

Restriction

This symbol is for EU member states only.

The symbol is specified in the new EU Battery Directive (2006/66/EC) Article 20 "Information for end-users" and Annex II.

Exportation precautions

The new EU Battery Directive (2006/66/EC) requires the following when marketing or exporting batteries and/or devices with built-in batteries to EU member states.

- To print the symbol on batteries, devices, or their packaging
- To explain the symbol in the manuals of the products

Labeling

To market or export batteries and/or devices with built-in batteries, which have no symbol, to EU member states, print the symbol shown in the figure above on the batteries, devices, or their packaging.

Explaining the symbol in the manuals



To export devices incorporating Mitsubishi programmable controllers to EU member states, provide the latest manuals that include the explanation of the symbol. If no Mitsubishi manuals are provided, separately attach an explanatory note regarding the symbol to each manual of the devices.

Point

The requirements apply to batteries and/or devices with built-in batteries manufactured before the enforcement date of the new EU Battery Directive (2006/66/EC).

Appendix 10 Added and Changed Functions

The functions added or changed with the CPU module and engineering tool, and the supported CPU modules' firmware version and engineering tool software version are given below.

- The firmware version can be confirmed with module diagnostics (CPU diagnostics). Refer to  Page 152 Module diagnostics for details on the module diagnostics (CPU diagnostics).
- Refer to the  GX Works3 Operating Manual for details on the software version.

Add/Change Function	Supported CPU module firmware version	Supported engineering tool software version	Reference
The following modules are supported. • FX5-16ET/ES-H • FX5-16ET/ESS-H	"1.030" and above	"1.025B" and above	Page 47
The following module is supported. • FX5-CCLIEF	"1.030" and above	"1.025B" and above	Page 48
Event history is supported.	"1.040" and above ^{*1}	"1.030G" and above	Page 153
The following module is supported. • FX5-80SSC-S	—	"1.030G" and above	Page 48
The following modules are supported. • FX5-4AD-TC-ADP • FX5-4AD-PT-ADP	"1.040" and above	"1.030G" and above	Page 51
The following modules are supported. • FX5-8AD • FX5-4LC • FX5-20PG-P • FX5-CCL-MS • FX5-ASL-M	"1.050" and above	"1.030M" and above	Page 47
The following modules are supported. • FX5-4AD • FX5-4DA	"1.050" and above	"1.040S" and above	Page 47
Expanding the number of input/output points to 384 points.	"1.100" and above	"1.047Z" and above	Page 35
Removing the limitation on the number of remote I/O points. (384 points) (However, the total number of remote I/O points and input/output points is 512 points or less.)	"1.100" and above	"1.047Z" and above	Page 35
Expanding the program capacity up to 128 k steps.	"1.100" and above	"1.047Z" and above	Page 35
The following module is supported. • FX5-20PG-D	"1.050" and above	"1.050C" and above	Page 47
The following modules are supported. • FX5-ENET • FX5-ENET/IP • FX5-DP-M	"1.110" and above	"1.050C" and above	Page 48
Expanding the number of remote I/O station of CC-Link IE field network Basic from 6 to 16 stations.	"1.110" and above	"1.050C" and above	Page 62
1C frame of MC protocol is supported.	"1.110" and above	"1.050C" and above	Page 37
The following modules are supported by module diagnostics and event history function. • FX5-20PG-P ^{*2} • FX5-20PG-D ^{*2} • FX5-ENET • FX5-ENET/IP	"1.110" and above	"1.050C" and above	Page 151
The following modules are supported. • FX5-SF-MU4T5 • FX5-SF-8DI4	"1.200" and above	"1.060N" and above	Page 49
The following module is supported. • FX5-CCLGN-MS	"1.210" and above	"1.065T" and above	Page 48
Expanding the device/label memory from 120 kbytes to 150 kbytes.	"1.210" and above	"1.065T" and above	Page 35
SFC programs are supported.	"1.220" and above	"1.070Y" and above	Page 35
The following modules are supported. • FX5-40SSC-G • FX5-80SSC-G	"1.230" and above	"1.072A" and above	Page 48
The following module is supported. • FX5-4A-ADP	"1.240" and above	"1.075D" and above	Page 51



Add/Change Function	Supported CPU module firmware version	Supported engineering tool software version	Reference
Unicode character strings are supported.	"1.240" and above	"1.075D" and above	Page 35
The following module is supported. • FX5-OPC	"1.245" and above	"1.077F" and above	Page 48

*1 Saving the event history file to the SD memory card is supported from CPU module serial No. 16Y**** and later.

*2 Supported from the firmware version 1.010 and later of FX5-20PG-P and FX5-20PG-D.

INDEX

B

BAT LED	26
Battery cover	28
Built-in Ethernet communication connector	26
Built-in RS-485 communication terminal block	26

C

CARD LED	26
--------------------	----

D

DIN rail mounting groove	27
DIN rail mounting hook	27
DISP switch	27

E

ERR LED	26
Expansion adapter connecting hooks	26
Expansion adapter connector cover	27
Extension module connecting hook	27

G

Genuine product certification label	27
---	----

I

I/O display LED	27
Input connector	27
Input display LED	27
Input terminal	27
Installation Location	83
Installing directly	88

M

Memory capacity	35
---------------------------	----

N

Nameplate printing	27
Number of input/output points	55

O

Operation status display LED	26
Output connector	27
Output display LED	27
Output terminal	27

P

P.RUN LED	26
Power connector for CPU module	28
PWR LED	26

R

RD LED	26
Remote I/O points	65
RS-485 terminal resistor selector switch	28
RUN/STOP/RESET switch	27

S

SD LED	26
SD memory card disable switch	27
SD memory card slot	27
SD/RD LED	26
Sink input	106
Source input	106
Subsequent extension connector cover	27

T

Terminal names	28
--------------------------	----

MEMO

REVISIONS

Revision date	Revision	Description
January 2015	A	First Edition
April 2015	B	A part of the cover design is changed.
October 2015	C	<p>■Added models FX5UC-64MT/D, FX5UC-64MT/DSS, FX5UC-96MT/D, FX5UC-96MT/DSS, FX5-C16EX/D, FX5-C16EX/DS, FX5-C16EYT/D, FX5-C16EYT/DSS, FX5-C1PS-5V</p> <p>■Added or modified parts RELEVANT MANUALS, TERMS, Section 2.2, 2.3, 2.4, 2.7, 2.8, 2.9, 3.1, 3.2, 3.3, 3.5, Chapter 4, Section 5.4, 6.2, 6.3, 6.4, 6.5, 6.6, 6.7, 9.7, Appendix1, 2, 3, 5, WARRANTY</p>
May 2016	D	<p>■Added models FX5-32ER/DS, FX5-32ET/DS, FX5-32ET/DSS, FX5-16ET/ES-H, FX5-16ET/ESS-H, FX5-CCLIEF, FX5-30EC, FX5-65EC, FX5-CNV-BC</p> <p>■Added or modified parts RELEVANT MANUALS, TERMS, Section 2.1, 2.6, 3.1, 3.3, 3.9, Chapter 4, 5, Section 6.5, 6.6, 6.7, 8.2, Appendix2, 3, 4</p>
October 2016	E	<p>■Added models FX5-16ER/ES, FX5-16ET/ES, FX5-16ET/ESS, FX5-80SSC-S, FX5-4AD-PT-ADP, FX5-4AD-TC-ADP</p> <p>■Added or modified parts RELEVANT MANUALS, TERMS, Section 2.6, 3.1, 3.3, 4.1, 4.2, 6.5, 6.6, 9.1, 9.3, Appendix 2, 4, 6, 10</p>
April 2017	F	<p>■Added models FX5-8AD, FX5-4LC, FX5-20PG-P, FX5-CCL-MS, FX5-ASL-M</p> <p>■Added or modified parts SAFETY PRECAUTIONS, RELEVANT MANUALS, TERMS, Section 3.1, 3.3, 4.1, 4.3, 4.5, Appendix 10</p>
August 2017	G	<p>■Added models FX5UC-32MT/DS-TS, FX5UC-32MT/DSS-TS, FX5-C32EX/DS-TS, FX5-C32EYT/D-TS, FX5-C32EYT/DSS-TS, FX5-C32ET/DS-TS, FX5-C32ET/DSS-TS</p> <p>■Added or modified parts SAFETY PRECAUTIONS, TERMS, Section 1.1, 2.3, 2.4, 2.8, 2.9, 3.1, 3.2, 3.3, 5.5, 6.2, 6.5, 6.6, 8.3, 9.7, Appendix 2, 4</p>
October 2017	H	<p>■Added models FX5-4AD, FX5-4DA</p> <p>■Added or modified parts RELEVANT MANUALS, TERMS, Section 2.6, 2.7, 3.1, 3.3, 9.2, 9.7, Appendix 10</p>
February 2018	J	<p>■Added or modified parts SAFETY PRECAUTIONS, Section 2.1, 2.3, 2.4, 5.1, 6.2, 6.6, Appendix 2, 4, 7</p>
July 2018	K	<p>■Added or modified parts TERMS, Section 2.6, 3.3, 4.1, 4.3, 4.5, 7.1, Appendix 4, 10</p>
October 2018	L	<p>■Added models FX5-20PG-D, FX5-DP-M, FX5-ENET</p> <p>■Added or modified parts RELEVANT MANUALS, TERMS, Section 1.1, 2.8, 3.1, 3.3, 4.1, 4.3, 9.1, 9.2, 9.3, Appendix 10</p>
January 2019	M	<p>■Added models FX5UC-32MR/DS-TS, FX5-C16EYR/D-TS</p> <p>■Added or modified parts SAFETY PRECAUTIONS, TERMS, Section 1.1, 2.1, 2.2, 2.3, 2.4, 2.8, 2.9, 3.1, 3.2, 3.3, 4.3, 5.5, 6.2, 6.5, 6.6, 8.1, 9.7, Appendix 2, 4, 6</p>
October 2019	N	<p>■Added models FX5-ENET/IP, FX5-SF-MU4T5, FX5-SF-8DI4</p> <p>■Added or modified parts RELEVANT MANUALS, TERMS, Section 2.1, 2.3, 2.4, 2.9, 3.1, 3.3, 4.1, 4.2, 4.3, 4.6, 5.1, 5.2, 5.5, 6.4, 9.4, Appendix 4, 7, 10</p>
May 2020	P	<p>■Added model FX5-CCLGN-MS</p> <p>■Added or modified parts RELEVANT MANUALS, TERMS, Section 2.1, 2.7, 3.1, 3.3, 3.10, 4.1, 4.2, 4.3, 5.4, 6.1, 6.2, 6.6, 6.7, 8.3, 9.1, 9.3, Appendix 7, 10</p>
August 2020	Q	<p>■Added or modified parts SAFETY PRECAUTIONS, WARRANTY</p>
October 2020	R	<p>■Added or modified parts SAFETY PRECAUTIONS, RELEVANT MANUALS, Section 2.6, 6.6, 8.3, 9.7, Appendix 2, 10</p>

Revision date	Revision	Description
January 2021	S	■Added or modified parts RELEVANT MANUALS, TERMS, Section 2.2, 3.1, 3.3, 4.1, 6.4, Appendix 3, 4, 10
April 2021	T	■Added or modified parts SAFETY PRECAUTIONS, RELEVANT MANUALS, TERMS, Section 2.6, 3.1, 3.3, 3.4, 4.2, Appendix 2, 3, 10
October 2021	U	■Added or modified parts RELEVANT MANUALS, TERMS, Section 3.1, 3.3, 4.1, 6.4, Appendix 2, 4, 10

This manual confers no industrial property rights or any rights of any other kind, nor does it confer any patent licenses. Mitsubishi Electric Corporation cannot be held responsible for any problems involving industrial property rights which may occur as a result of using the contents noted in this manual.

© 2015 MITSUBISHI ELECTRIC CORPORATION

WARRANTY

Please confirm the following product warranty details before using this product.

1. Gratis Warranty Term and Gratis Warranty Range

If any faults or defects (hereinafter "Failure") found to be the responsibility of Mitsubishi occurs during use of the product within the gratis warranty term, the product shall be repaired at no cost via the sales representative or Mitsubishi Service Company. However, if repairs are required onsite at domestic or overseas location, expenses to send an engineer will be solely at the customer's discretion. Mitsubishi shall not be held responsible for any re-commissioning, maintenance, or testing on-site that involves replacement of the failed module.

[Gratis Warranty Term]

The gratis warranty term of the product shall be for one year after the date of purchase or delivery to a designated place. Note that after manufacture and shipment from Mitsubishi, the maximum distribution period shall be six (6) months, and the longest gratis warranty term after manufacturing shall be eighteen (18) months. The gratis warranty term of repair parts shall not exceed the gratis warranty term before repairs.

[Gratis Warranty Range]

- (1) The range shall be limited to normal use within the usage state, usage methods and usage environment, etc., which follow the conditions and precautions, etc., given in the instruction manual, user's manual and caution labels on the product.
- (2) Even within the gratis warranty term, repairs shall be charged for in the following cases.
 1. Failure occurring from inappropriate storage or handling, carelessness or negligence by the user. Failure caused by the user's hardware or software design.
 2. Failure caused by unapproved modifications, etc., to the product by the user.
 3. When the Mitsubishi product is assembled into a user's device, Failure that could have been avoided if functions or structures, judged as necessary in the legal safety measures the user's device is subject to or as necessary by industry standards, had been provided.
 4. Failure that could have been avoided if consumable parts (battery, backlight, fuse, etc.) designated in the instruction manual had been correctly serviced or replaced.
 5. Relay failure or output contact failure caused by usage beyond the specified life of contact (cycles).
 6. Failure caused by external irresistible forces such as fires or abnormal voltages, and failure caused by force majeure such as earthquakes, lightning, wind and water damage.
 7. Failure caused by reasons unpredictable by scientific technology standards at time of shipment from Mitsubishi.
 8. Any other failure found not to be the responsibility of Mitsubishi or that admitted not to be so by the user.

2. Onerous repair term after discontinuation of production

- (1) Mitsubishi shall accept onerous product repairs for seven (7) years after production of the product is discontinued.
Discontinuation of production shall be notified with Mitsubishi Technical Bulletins, etc.
- (2) Product supply (including repair parts) is not available after production is discontinued.

3. Overseas service

Overseas, repairs shall be accepted by Mitsubishi's local overseas FA Center. Note that the repair conditions at each FA Center may differ.

4. Exclusion of loss in opportunity and secondary loss from warranty liability

Regardless of the gratis warranty term, Mitsubishi shall not be liable for compensation to:

- (1) Damages caused by any cause found not to be the responsibility of Mitsubishi.
- (2) Loss in opportunity, lost profits incurred to the user by Failures of Mitsubishi products.
- (3) Special damages and secondary damages whether foreseeable or not, compensation for accidents, and compensation for damages to products other than Mitsubishi products.
- (4) Replacement by the user, maintenance of on-site equipment, start-up test run and other tasks.

5. Changes in product specifications

The specifications given in the catalogs, manuals or technical documents are subject to change without prior notice.

6. Product application

- (1) In using the Mitsubishi MELSEC programmable controller, the usage conditions shall be that the application will not lead to a major accident even if any problem or fault should occur in the programmable controller device, and that backup and fail-safe functions are systematically provided outside of the device for any problem or fault.
- (2) The Mitsubishi programmable controller has been designed and manufactured for applications in general industries, etc. Thus, applications in which the public could be affected such as in nuclear power plants and other power plants operated by respective power companies, and applications in which a special quality assurance system is required, such as for railway companies or public service purposes shall be excluded from the programmable controller applications.
In addition, applications in which human life or property that could be greatly affected, such as in aircraft, medical applications, incineration and fuel devices, manned transportation, equipment for recreation and amusement, and safety devices, shall also be excluded from the programmable controller range of applications. However, in certain cases, some applications may be possible, providing the user consults their local Mitsubishi representative outlining the special requirements of the project, and providing that all parties concerned agree to the special circumstances, solely at the user's discretion.
- (3) Mitsubishi shall have no responsibility or liability for any problems involving programmable controller trouble and system trouble caused by DoS attacks, unauthorized access, computer viruses, and other cyberattacks.

TRADEMARKS

Anywire and AnyWireASLINK are either registered trademarks or trademarks of Anywire Corporation.

Phillips is a registered trademark of Phillips Screw Company.

The company names, system names and product names mentioned in this manual are either registered trademarks or trademarks of their respective companies.

In some cases, trademark symbols such as [™] or [®] are not specified in this manual.

Manual number: JY997D61401U

Model: FX5UC-U-HW-E

Model code: 09R558

mitsubishi electric corporation

HEAD OFFICE : TOKYO BUILDING, 2-7-3 MARUNOUCHI, CHIYODA-KU, TOKYO 100-8310, JAPAN
NAGOYA WORKS : 1-14, YADA-MINAMI 5-CHOME, HIGASHI-KU, NAGOYA, JAPAN

When exported from Japan, this manual does not require application to the
Ministry of Economy, Trade and Industry for service transaction permission.

Specifications subject to change without notice.