



Programmable Controller  
**MELSEC-F**

**FX-30P**

**OPERATION MANUAL**



**FX**





# Safety Precautions

(Read these precautions before use.)

Before installation, operation, maintenance or inspection of this product, thoroughly read through and understand this manual and all of the associated manuals. Also, take care to handle the module properly and safely.

This manual classifies the safety precautions into two categories:  **WARNING** and  **CAUTION**.

 <b>WARNING</b>	Indicates that incorrect handling may cause hazardous conditions, resulting in death or severe injury.
 <b>CAUTION</b>	Indicates that incorrect handling may cause hazardous conditions, resulting in medium or slight personal injury or physical damage.

Depending on the circumstances, procedures indicated by  **CAUTION** may also cause severe injury.

It is important to follow all precautions for personal safety.

Store this manual in a safe place so that it can be taken out and read whenever necessary. Always forward it to the end user.

## 1. OPERATION PRECAUTIONS

 <b>CAUTION</b>	Reference
<ul style="list-style-type: none"> <li>Thoroughly read the manual and sufficiently assure safety before executing the operation to forcibly set devices to ON/OFF or the operation to change present values and set values of word devices in the test mode. Otherwise, the machine may be damaged and accidents may occur by erroneous operations.</li> </ul>	57

## 2. DESIGN PRECAUTIONS

 <b>WARNING</b>	Reference
<ul style="list-style-type: none"> <li>When executing control (data changes) to an operating PLC, construct an interlock circuit in the sequence program so that the entire system operates conservatively. Additionally, when executing control such as program changes and operation status changes (status control) to an operating PLC, thoroughly read the manual and sufficiently confirm safety in advance.</li> <li>Make sure to have the following safety circuits outside the PLC to ensure safe system operation even during external power supply problems or PLC failure. Otherwise, malfunctions may cause serious accidents.                         <ol style="list-style-type: none"> <li>Most importantly, have the following: an emergency stop circuit, a protection circuit, an interlock circuit for opposite movements (such as normal vs. reverse rotation), and an interlock circuit (to prevent damage to the equipment at the upper and lower positioning limits).</li> <li>Note that when the PLC CPU detects an error, such as a watchdog timer error, during self-diagnosis, all outputs are turned off. Also, when an error that cannot be detected by the PLC CPU occurs in an input/output control block, output control may be disabled. External circuits and mechanisms should be designed to ensure safe machinery operation in such case.</li> </ol> </li> </ul>	28

 <b>CAUTION</b>	Reference
<ul style="list-style-type: none"> <li>Observe the following items. Failure to do so may cause incorrect data-writing through noise to the PLC and result in PLC failure, machine damage or other accidents.                         <ol style="list-style-type: none"> <li>Do not bundle the control line together with or lay it close to the main circuit or power line. As a guideline, lay the control line at least 100mm (3.94") or more away from the main circuit or power line. Noise may cause malfunctions.</li> <li>Ground the shield wire or shield of a shielded cable. Do not use common grounding with heavy electrical systems.</li> </ol> </li> <li>Install module so that excessive force will not be applied to the power connector. Failure to do so may result in wire damage/breakage or PLC failure.</li> </ul>	28

# Safety Precautions

(Read these precautions before use.)

## 3. INSTALLATION PRECAUTIONS

 CAUTION	Reference
<ul style="list-style-type: none"> <li>• Use the product within the generic environment specifications described in Section 2.1 of this manual. Never use the product in areas with excessive dust, oily smoke, conductive dusts, corrosive gas (salt air, Cl<sub>2</sub>, H<sub>2</sub>S, SO<sub>2</sub>, or NO<sub>2</sub>), flammable gas, vibration or impacts, or expose it to high temperature, condensation, or rain and wind. If the product is used in such conditions, electric shock, fire, malfunctions, deterioration or damage may occur.</li> <li>• Do not touch the conductive parts of the product directly. Doing so may cause device failures or malfunctions.</li> <li>• Connect cables securely to their designated connectors. Loose connections may cause malfunctions.</li> <li>• Do not connect a PLC and a personal computer at the same time to the FX-30P. Failure to do so may cause equipment failures or malfunctions.</li> </ul>	23

## 4. STARTUP AND MAINTENANCE PRECAUTIONS

 WARNING	Reference
<ul style="list-style-type: none"> <li>• Turn off the power to the PLC before attaching or detaching the battery. Doing so may cause equipment failures, or malfunctions.</li> <li>• Use the battery for memory backup correctly in conformance to this manual.               <ul style="list-style-type: none"> <li>- Use the battery only for the specified purpose.</li> <li>- Connect the battery correctly.</li> <li>- Do not charge, disassemble, heat, put in fire, short-circuit, connect reversely, weld, swallow or burn the battery, or apply excessive forces (vibration, impact, drop, etc.) to the battery.</li> <li>- Do not store or use the battery at high temperatures or expose to direct sunlight.</li> <li>- Do not expose to water, bring near fire or touch liquid leakage or other contents directly.</li> <li>- Incorrect handling of the battery may cause heat excessive generation, bursting, ignition, liquid leakage or deformation, and lead to injury, fire or failures and malfunctions of facilities and other equipment.</li> </ul> </li> <li>• Before modifying or disrupting the program in operation or running the PLC, carefully read through this manual and the associated manuals and ensure the safety of the operation. An operation error may damage the machinery or cause accidents.</li> <li>• Do not change the program in the PLC from two or more peripheral equipment devices at the same time. (i.e. from a programming tool and a GOT) Doing so may cause destruction or malfunction of the PLC program.</li> </ul>	23 140

 CAUTION	Reference
<ul style="list-style-type: none"> <li>• Do not disassemble or modify the PLC. Doing so may cause fire, equipment failures, or malfunctions. For repair, contact your local Mitsubishi Electric representative.</li> <li>• Turn off the power to the PLC before connecting or disconnecting cable. Failure to do so may cause equipment failures or malfunctions.</li> </ul>	23

## 5. DISPOSAL PRECAUTIONS

 CAUTION	Reference
<ul style="list-style-type: none"> <li>• Please contact a certified electronic waste disposal company for the environmentally safe recycling and disposal of your device. When disposing of batteries, separate them from other waste according to local regulations. (For details of the Battery Directive in EU countries, refer to Appendix G)</li> </ul>	20

## 6. TRANSPORTATION AND STORAGE PRECAUTIONS

 CAUTION	Reference
<ul style="list-style-type: none"> <li>• The FX-30P is a precision instrument. During transportation, avoid impacts larger than those specified in the general specifications (refer to Section 2.1) of this manual. Failure to do so may cause failures in the FX-30P. After transportation, verify the operations of the FX-30P.</li> <li>• Before transporting the FX-30P, make sure to turn on the power of the FX-30P, and confirm that an HPP low battery voltage error does not occur (or confirm that the HPP battery voltage is 2.7 V or more). If the FX-30P is transported when the battery voltage is low and the battery life is expired, the battery-backed data may not be held correctly during transportation.</li> <li>• When transporting lithium batteries, follow required transportation regulations. (For details of the regulated products, refer to Appendix F)</li> </ul>	20 140



# FX-30P

## Operation Manual

Manual number	JY997D34401
Manual revision	J
Date	6/2024

### Foreword

---

This manual contains text, diagrams and explanations which will guide the reader in the correct installation and operation of the FX-30P. It should be read and understood before attempting to install or use the unit. Store this manual in a safe place so that you can take it out and read it whenever necessary. Always forward it to the end user.

This manual confers no industrial property rights or any rights of any other kind, nor does it confer any patent licenses. Mitsubishi Electric Corporation cannot be held responsible for any problems involving industrial property rights which may occur as a result of using the contents noted in this manual.

## Outline Precautions

---

- This manual provides information for the use of the FX-30P HANDY PROGRAMMING PANEL. The manual has been written to be used by trained and competent personnel. The definition of such a person or persons is as follows;
    - 1) Any engineer who is responsible for the planning, design and construction of automatic equipment using the product associated with this manual should be of a competent nature, trained and qualified to the local and national standards required to fulfill that role. These engineers should be fully aware of all aspects of safety with aspects regarding to automated equipment.
    - 2) Any commissioning or maintenance engineer must be of a competent nature, trained and qualified to the local and national standards required to fulfill the job. These engineers should also be trained in the use and maintenance of the completed product. This includes being familiar with all associated manuals and documentation for the product. All maintenance should be carried out in accordance with established safety practices.
    - 3) All operators of the completed equipment should be trained to use that product in a safe and coordinated manner in compliance with established safety practices. The operators should also be familiar with documentation that is connected with the actual operation of the completed equipment.
- Note:** The term 'completed equipment' refers to a third party constructed device that contains or uses the product associated with this manual.
- This product has been manufactured as a general-purpose part for general industries, and has not been designed or manufactured to be incorporated in a device or system used in purposes related to human life.
  - Before using the product for special purposes such as nuclear power, electric power, aerospace, medicine or passenger movement vehicles, consult with Mitsubishi Electric.
  - This product has been manufactured under strict quality control. However when installing the product where major accidents or losses could occur if the product fails, install appropriate backup or failsafe functions into the system.
  - When combining this product with other products, please confirm the standards and codes of regulation to which the user should follow. Moreover, please confirm the compatibility of this product with the system, machines, and apparatuses to be used.
  - If there is doubt at any stage during installation of the product, always consult a professional electrical engineer who is qualified and trained in the local and national standards. If there is doubt about the operation or use, please consult the nearest Mitsubishi Electric representative.
  - Since the examples within this manual, technical bulletin, catalog, etc. are used as reference; please use it after confirming the function and safety of the equipment and system. Mitsubishi Electric will not accept responsibility for actual use of the product based on these illustrative examples.
  - The content, specification etc. of this manual may be changed for improvement without notice.
  - The information in this manual has been carefully checked and is believed to be accurate; however, if you notice any doubtful point, error, etc., please contact the nearest Mitsubishi Electric representative.

## Registration

---

Ethernet is a registered trademark of Fuji Xerox Co., Ltd. in Japan.

The company names, system names and product names mentioned in this manual are either registered trademarks or trademarks of their respective companies.

In some cases, trademark symbols such as <sup>TM</sup> or <sup>®</sup> are not specified in this manual.

# Table of Contents

<b>SAFETY PRECAUTIONS .....</b>	<b>(1)</b>
<b>Standards.....</b>	<b>7</b>
Certification of UL, cUL standards .....	7
Compliance with EC directive (CE Marking) .....	7
<b>Associated Manuals.....</b>	<b>9</b>
<b>Generic Names/Abbreviations/Explanation of key operations Used in the Manual .....</b>	<b>12</b>
<b>Reading the Manual .....</b>	<b>15</b>

---

## **1. Introduction** **16**

---

1.1 Outline.....	16
1.2 Major Features of the FX-30P .....	16
1.3 External Dimensions and Part Names .....	16
1.4 Key Layout .....	17
1.5 Function List.....	18

---

## **2. Specifications, Product configuration** **20**

---

2.1 General specifications.....	20
2.2 Power supply specification .....	20
2.3 Performance specification.....	21
2.4 Communication specification .....	21
2.4.1 Communication specification.....	21
2.4.2 Communication speed.....	21
2.5 Configuration.....	22
2.5.1 Product configuration.....	22
2.5.2 System configuration.....	22
2.5.3 Applicable PLC.....	22

---

## **3. Connection Method/Startup Procedure** **23**

---

3.1 Connection to the PLC .....	24
3.2 Connection to a personal computer .....	25
3.3 Startup procedure .....	25

---

## **4. Outline of Programming** **28**

---

4.1 Menu Structure.....	29
4.2 Common programming items.....	30
4.2.1 Programming screen .....	30
4.2.2 Key input.....	31
4.2.3 HELP screen .....	35
4.3 Functions used in programming.....	36
4.4 Types of program memories .....	36

<b>5. Online Mode</b>	<b>37</b>
5.1 Overview of online mode.....	37
5.2 Read.....	37
5.2.1 Overview of the read operation .....	37
5.2.2 Read by step No.....	37
5.2.3 Read by instruction.....	38
5.2.4 Read by pointer .....	38
5.2.5 Read by device.....	39
5.3 Write.....	39
5.3.1 Overview of the write operation.....	39
5.3.2 Input of basic instructions.....	40
5.3.3 Writing of application instructions.....	41
5.3.4 Input of labels (P, I).....	43
5.3.5 Input of numbers.....	44
5.3.6 Batch write of NOP to specified range (Program clear to specified range).....	45
5.3.7 Batch write of NOP to specify the entire range (Program all clear).....	45
5.3.8 Modification method (before/after confirmation).....	46
5.3.9 Modification of a device.....	48
5.4 Insert.....	49
5.4.1 Overview of the insert operation.....	49
5.4.2 Insert operation.....	50
5.5 Delete.....	51
5.5.1 Overview of the delete operation.....	51
5.5.2 Deletion of instructions and pointers .....	52
5.5.3 Batch deletion of a program by specifying the range to be deleted.....	53
5.5.4 Batch deletion of NOP instructions.....	53
5.6 Monitor .....	54
5.6.1 Overview of the monitor operation.....	54
5.6.2 List program monitor.....	55
5.6.3 Device monitor.....	55
5.6.4 Operation state monitor.....	56
5.7 Test.....	57
5.7.1 Overview of the test function .....	57
5.7.2 Forcible setting of devices to ON/OFF .....	58
5.7.3 Change the present value of word devices (T, C, D, V, Z, R).....	59
5.7.4 Change the set value of timers (T) and counters (C).....	60
5.8 Others Function.....	62
5.8.1 Overview of the others function.....	62
5.8.2 Change to offline .....	63
5.8.3 Diagnostics PLC.....	64
5.8.4 Memory cassette transfer.....	66
5.8.5 Parameter.....	71
5.8.6 Keyword.....	83
5.8.7 Device conversion .....	97
5.8.8 Latch clear .....	98
5.8.9 Device batch monitoring.....	100
5.8.10 BFM batch monitor .....	104
5.8.11 Baud rate .....	105
5.8.12 Clear PLC memory.....	106
5.8.13 Remote RUN/STOP .....	108
5.8.14 Set PLC clock.....	109

<b>6. Offline mode</b>	<b>110</b>
6.1 Outline of offline mode .....	110
6.2 Others Functions.....	111
6.2.1 Outline of others function.....	111
6.2.2 Change to online .....	112
6.2.3 Program check .....	113
6.2.4 HPP-FX Transfer .....	115
6.2.5 HPP-PC Transfer.....	122
6.2.6 PLC Type.....	124
6.2.7 HPP Memory clear .....	128
6.2.8 Program manager.....	129
<b>7. HPP setting</b>	<b>135</b>
7.1 Menu display language selection .....	135
7.2 Buzzer sound volume setting .....	135
7.3 LCD contrast adjustment.....	136
7.4 Backlight brightness adjustment .....	136
7.5 Screen save .....	136
7.6 HPP protection .....	137
7.7 HPP initialization .....	138
7.8 HPP F/W update .....	139
<b>8. Battery</b>	<b>140</b>
8.1 Battery Handling.....	140
8.2 Battery specifications, Battery life .....	140
8.2.1 Differences between FX-30P's internal battery and the optional battery.....	140
8.2.2 Battery life and replacement guidelines.....	141
8.3 Reading the date of manufacture.....	142
8.4 Battery Replacement.....	143
<b>Appendix A: ASCII Code</b>	<b>145</b>
Appendix A-1 ASCII Code Table .....	145
Appendix A-2 Examples of ASCII codes .....	145
<b>Appendix B: Message List</b>	<b>146</b>
Appendix B-1 Error messages list .....	146
Appendix B-2 Error messages displayed during PLC diagnostic/program check.....	148
Appendix B-2-1 For FX3S/FX3G/FX3GC/FX3U/FX3UC PLCs .....	148
Appendix B-2-2 For FX1S/FX1N/FX1NC/FX2N/FX2NC PLCs.....	156
Appendix B-2-3 For FX2(FX)/FX2C/FX0/FX0S/FX0N PLCs.....	161
<b>Appendix C: Major Key Operation List</b>	<b>164</b>



---

<b>Appendix D: Manufacturer's serial number/Version Information</b>	<b>166</b>
Appendix D-1 Version check method .....	166
Appendix D-2 Version Information .....	167
Appendix D-2-1 Checking the firmware version .....	167
Appendix D-2-2 Version upgrade history .....	167
<b>Appendix E: Discontinued models</b>	<b>169</b>
<b>Appendix F: Precautions for Battery Transportation</b>	<b>171</b>
Appendix F-1 Regulated FX-30P .....	171
Appendix F-2 Transport guidelines .....	171
<b>Appendix G: Handling of Batteries and Devices with Built-in Batteries in EU Member States</b>	<b>173</b>
Appendix G-1 Disposal precautions .....	173
Appendix G-2 Exportation precautions .....	173
Appendix G-3 Regulated FX-30P .....	174
<b>Warranty</b> .....	<b>175</b>
<b>Revised History</b> .....	<b>176</b>

---

## Standards

### Certification of UL, cUL standards

FX-30P units comply with the UL standards (UL, cUL).

UL, cUL File number :E95239

Regarding the standards that comply with the main unit, please refer to either the FX series product catalog or consult with your nearest Mitsubishi product provider.

### Compliance with EC directive (CE Marking)

This note does not guarantee that an entire mechanical module produced in accordance with the contents of this note will comply with the following standards.

Compliance to EMC directive and LVD directive for the entire mechanical module should be checked by the user / manufacturer. For more information please consult with your nearest Mitsubishi product provider.

Regarding the standards that comply with the main unit, please refer to either the FX series product catalog or consult with your nearest Mitsubishi product provider.

#### Requirement for Compliance with EMC directive

The following products have shown compliance through direct testing (of the identified standards below) and design analysis (through the creation of a technical construction file) to the European Directive for Electromagnetic Compatibility (2004/108/EC) when used as directed by the appropriate documentation.

#### Attention

This product is designed for use in industrial applications.

Type: Programmable Controller (Open Type Equipment)

Models: MELSEC FX series manufactured

from December 1st, 2008      FX-30P

Standard	Remark
EN61131-2:2007 Programmable controllers - Equipment requirements and tests	Compliance with all relevant aspects of the standard. EMI <ul style="list-style-type: none"> <li>• Radiated Emission</li> <li>• Conducted Emission</li> </ul> EMS <ul style="list-style-type: none"> <li>• Radiated electromagnetic field</li> <li>• Fast transient burst</li> <li>• Electrostatic discharge</li> <li>• High-energy surge</li> <li>• Voltage drops and interruptions</li> <li>• Conducted RF</li> <li>• Power frequency magnetic field</li> </ul>

**Caution for EC Directive**

Attach the ferrite core to the communication cables (PLC side).  
Attach the ferrite core in approximately 100mm(3.93") or less from connector on the PLC side.  
For the ferrite core use the following product or one with equivalent specifications.  
Model name: ZCAT2035-0930 (Manufactured by TDK co., Ltd.)

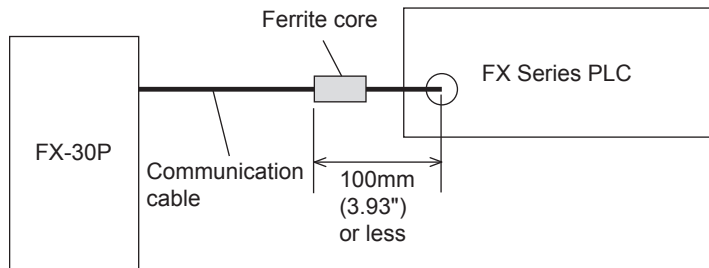

## Associated Manuals

Only the installation manual is packed together with the FX-30P.

For a detailed explanation of the FX-30P, refer to this manual.

For the hardware information and instructions of PLC main units, refer to the respective manuals.

For acquiring manuals, contact the representative you purchased the product from.

⊙ Essential manual

○ Manual required depending on application

△ Manual with additional manual for detailed explanation

		Manual name	Manual number	Contents	Model name code
<b>Manuals for PLC main unit</b>					
<b>■ FX3U PLC main unit</b>					
△	Supplied with product	FX3U Series Hardware Manual	JY997D50301	I/O specifications, wiring and installation of the PLC main unit FX3U extracted from the FX3U Series User's Manual - Hardware Edition. For detailed explanation, refer to the FX3U Series User's Manual - Hardware Edition.	-
⊙	Additional manual	FX3U Series User's Manual - Hardware Edition	JY997D16501	Details about the hardware including I/O specifications, wiring, installation and maintenance of the FX3U PLC main unit.	09R516
<b>■ FX3UC PLC main unit</b>					
△	Supplied with product	FX3UC(D, DS, DSS)Series Hardware Manual	JY997D50501	I/O specifications, wiring and installation of the PLC main unit FX3UC(D, DS, DSS) extracted from the FX3UC Series User's Manual - Hardware Edition. For detailed explanation, refer to the FX3UC Series User's Manual - Hardware Edition.	-
△	Supplied with product	FX3UC-32MT-LT-2 Hardware Manual	JY997D31601	I/O specifications, wiring and installation of the PLC main unit FX3UC-32MT-LT-2 extracted from the FX3UC Series User's Manual - Hardware Edition. For detailed explanation, refer to the FX3UC Series User's Manual - Hardware Edition.	-
△	Supplied with product	FX3UC-32MT-LT Hardware Manual (Only Japanese document)	JY997D12701	I/O specifications, wiring and installation of the PLC main unit FX3UC-32MT-LT extracted from the FX3UC Series User's Manual - Hardware Edition. For detailed explanation, refer to the FX3UC Series User's Manual - Hardware Edition.	-
⊙	Additional manual	FX3UC Series User's Manual - Hardware Edition	JY997D28701	Details about the hardware including I/O specifications, wiring, installation and maintenance of the FX3UC PLC main unit.	09R519
<b>■ FX3G PLC main unit</b>					
△	Supplied with product	FX3G Series Hardware Manual	JY997D46001	I/O specifications, wiring and installation of the PLC main unit FX3G extracted from the FX3G Series User's Manual - Hardware Edition. For detailed explanation, refer to the FX3G Series User's Manual - Hardware Edition.	-
⊙	Additional manual	FX3G Series User's Manual - Hardware Edition	JY997D31301	Details about the hardware including I/O specifications, wiring, installation and maintenance of the FX3G PLC main unit.	09R521
<b>■ FX3GC PLC main unit</b>					
△	Supplied with product	FX3GC Series Hardware Manual	JY997D45201	I/O specifications, wiring and installation of the PLC main unit FX3GC extracted from the FX3GC Series User's Manual - Hardware Edition. For detailed explanation, refer to the FX3GC Series User's Manual - Hardware Edition.	-
⊙	Additional manual	FX3GC Series User's Manual - Hardware Edition	JY997D45401	Details about the hardware including I/O specifications, wiring, installation and maintenance of the FX3GC PLC main unit.	09R533

		Manual name	Manual number	Contents	Model name code
<b>■ FX3S PLC main unit</b>					
△	Supplied with product	FX3S Series Hardware Manual	JY997D48401	I/O specifications, wiring and installation of the PLC main unit FX3S extracted from the FX3S Series User's Manual - Hardware Edition. For detailed explanation, refer to the FX3S Series User's Manual - Hardware Edition.	-
⊙	Additional manual	FX3S Series User's Manual - Hardware Edition	JY997D48601	Details about the hardware including I/O specifications, wiring, installation and maintenance of the FX3S PLC main unit.	09R535
<b>■ FX2N PLC main unit</b>					
⊙	Supplied with product	FX2N HARDWARE MANUAL	JY992D66301	Describes the contents of the FX2N PLC hardware including the specifications, wiring and installation procedure.	-
<b>■ FX2NC PLC main unit</b>					
⊙	Supplied with product	FX2NC (D/UL) HARDWARE MANUAL	JY992D87201	Describes the contents of the FX2NC PLC hardware including the specifications, wiring and installation procedure.	-
⊙	Supplied with product	FX2NC (DSS/DS) HARDWARE MANUAL	JY992D76401	Describes the contents of the FX2NC PLC hardware including the specifications, wiring and installation procedure.	-
<b>■ FX1N PLC main unit</b>					
⊙	Supplied with product	FX1N HARDWARE MANUAL	JY992D89301	Describes the contents of the FX1N PLC hardware including the specifications, wiring and installation procedure.	-
<b>■ FX1NC PLC main unit</b>					
⊙	Supplied with product	FX1NC HANDY MANUAL (Only Japanese document)	JY992D92101	Describes the contents of the FX1NC PLC hardware including the specifications, wiring and installation procedure.	-
<b>■ FX1S PLC main unit</b>					
⊙	Supplied with product	FX1S HARDWARE MANUAL	JY992D83901	Describes the contents of the FX1S PLC hardware including the specifications, wiring and installation procedure.	-
<b>■ FX0/FX0N PLC main unit</b>					
⊙	Supplied with product	FX0/FX0N HARDWARE MANUAL	JY992D47501	Describes the contents of the FX0/FX0N PLC hardware including the specifications, wiring and installation procedure.	-
<b>■ FX0S PLC main unit</b>					
⊙	Supplied with product	FX0S HARDWARE MANUAL	JY992D55301	Describes the contents of the FX0S PLC hardware including the specifications, wiring and installation procedure.	-
<b>■ FX PLC main unit</b>					
⊙	Supplied with product	FX-SERIES HARDWARE MANUAL	JY992D47401	Describes the contents of the FX PLC hardware including the specifications, wiring and installation procedure.	-
<b>■ FX2c PLC main unit</b>					
⊙	Supplied with product	FX2C HANDY MANUAL (Only Japanese document)	JY992D59001	Describes the contents of the FX2C PLC hardware including the specifications, wiring and installation procedure.	-
<b>■ FX1 PLC main unit</b>					
⊙	Supplied with product	FX1 HARDWARE MANUAL (Only Japanese document)	JY992D58801	Describes the contents of the FX1 PLC hardware including the specifications, wiring and installation procedure.	-



	Manual name	Manual number	Contents	Model name code
<b>■ Programming</b>				
⊙	Additional manual	FX0/FX0S/FX0N/FX/FX2C/FX2N PROGRAMMING MANUAL JY992D48301	Items related to programming in PLCs including explanation of basic instructions, applied instructions and various devices in FX0/FX0S/FX0N/FX/FX2C/FX2N PLCs.	-
⊙	Additional manual	FX1S/FX1N/FX2N/FX2NC PROGRAMMING MANUAL II JY992D88101	Items related to programming in PLCs including explanation of basic instructions, applied instructions and various devices in FX1S/FX1N/FX2N/FX2NC PLCs.	09R512
⊙	Additional manual	FX3S/FX3G/FX3GC/FX3U/FX3UC Series Programming Manual - Basic & Applied Instruction Edition JY997D16601	Items related to programming in PLCs including explanation of basic instructions, applied instructions and various devices in FX3S/FX3G/FX3GC/FX3U/FX3UC PLCs.	09R517
○	Additional manual	MELSEC-Q/L/F Structured Programming Manual (Fundamentals) SH-080782	Programming methods, specifications, functions, etc. required to create structured programs.	13JW06
○	Additional manual	FXCPU Structured Programming Manual [Device & Common] JY997D26001	Devices, parameters, etc. provided in structured projects of GX Works2.	09R925
○	Additional manual	FXCPU Structured Programming Manual [Basic & Applied Instruction] JY997D34701	Sequence instructions provided in structured projects of GX Works2.	09R926
○	Additional manual	FXCPU Structured Programming Manual [Application Functions] JY997D34801	Application functions provided in structured projects of GX Works2.	09R927
<b>Manuals for FX-30P</b>				
△	Supplied with product	FX-30P INSTALLATION MANUAL JY997D34201	Specifications, and installation of the FX-30P extracted from the FX-30P Operation Manual. For detailed explanation, refer to the FX-30P Operation Manual.	-
⊙	Additional manual	FX-30P Operation Manual (this manual) JY997D34401	Describes FX-30P type Handy programming panel details.	09R924
○	Additional manual	FX-30P F/W UPDATE TOOL Operation Manual JY997D36201	Describes FX-30P firmware update tool details.	-



## Generic Names/Abbreviations/Explanation of key operations Used in the Manual

Abbreviation/ generic name	Name
<b>Programmable controllers</b>	
FX3U Series	Generic name of FX3U Series PLCs
FX3U PLC or main unit	Generic name of FX3U Series PLC main units
FX3UC Series	Generic name of FX3UC Series PLCs
FX3UC PLC or main unit	Generic name of FX3UC Series PLC main units
FX3G Series	Generic name of FX3G Series PLCs
FX3G PLC or main unit	Generic name of FX3G Series PLC main units
FX3GC Series	Generic name of FX3GC Series PLCs
FX3GC PLC or main unit	Generic name of FX3GC Series PLC main units
FX3S Series	Generic name of FX3S Series PLCs
FX3S PLC or main unit	Generic name of FX3S Series PLC main units
FX2N Series	Generic name of FX2N Series PLCs
FX2N PLC or main unit	Generic name of FX2N Series PLC main units
FX2NC Series	Generic name of FX2NC Series PLCs
FX2NC PLC or main unit	Generic name of FX2NC Series PLC main units
FX1N Series	Generic name of FX1N Series PLCs
FX1N PLC or main unit	Generic name of FX1N Series PLC main units
FX1NC Series	Generic name of FX1NC Series PLCs
FX1NC PLC or main unit	Generic name of FX1NC Series PLC main units
FX1S Series	Generic name of FX1S Series PLCs
FX1S PLC or main unit	Generic name of FX1S Series PLC main units
FX0N Series	Generic name of FX0N Series PLCs
FX0N PLC or main unit	Generic name of FX0N Series PLC main units
FX0S Series	Generic name of FX0S Series PLCs
FX0S PLC or main unit	Generic name of FX0S Series PLC main units
FX0 Series	Generic name of FX0 Series PLCs
FX0 PLC or main unit	Generic name of FX0 Series PLC main units
FX2(FX) Series	Generic name of FX2(FX) Series PLCs
FX2(FX) PLC or main unit	Generic name of FX2(FX) Series PLC main units
FX2C Series	Generic name of FX2C Series PLCs
FX2C PLC or main unit	Generic name of FX2C Series PLC main units
FX1 Series	Generic name of FX1 Series PLCs
FX1 PLC or main unit	Generic name of FX1 Series PLC main units
<b>Expansion boards</b>	
Expansion board	Generic name of expansion boards. Connectable equipment may vary depending on the main unit. For connectable equipment, refer to the manual of the main unit.
<b>Special adapters</b>	
Special adapter	Generic name of special high speed I/O adapters, special communication adapters, and special analog adapters. Connectable equipment may vary depending on the main unit. For connectable equipment, refer to the manual of the main unit.





Abbreviation/ generic name	Name
<b>Extension equipment</b>	
I/O extension units/blocks	Generic name of I/O extension units, and I/O extension blocks. Connectable equipment may vary depending on the main unit. For connectable equipment, refer to the manual of the main unit.
Special function unit/block or special extension equipment	Generic name of special function units, and special function blocks. Connectable equipment may vary depending on the main unit. For connectable equipment, refer to the manual of the main unit.
Special function unit	Generic name of special extension units. Connectable equipment may vary depending on the main unit. For connectable equipment, refer to the manual of the main unit.
Special function block	Generic name of special function blocks. Connectable equipment may vary depending on the main unit. For connectable equipment, refer to the manual of the main unit.
<b>Options</b>	
Memory cassette	Generic name of memory cassettes (The models shown below): FX-RAM-8, FX-EEPROM-4, FX-EEPROM-8, FX-EEPROM-16, FX-EPROM-8, FX1N-EEPROM-8L, FX2N-ROM-E1, FX2NC-EEPROM-4C, FX2NC-EEPROM-16, FX2NC-EEPROM-16C, FX3G-EEPROM-32L, FX3U-FLROM-16, FX3U-FLROM-64, FX3U-FLROM-64L, and FX3U-FLROM-1M
Battery	Generic name of memory cassettes (The models shown below): F2-40BL, FX2NC-32BL, and FX3U-32BL
FX Series terminal block	FX-16E-TB, FX-32E-TB, FX-16EX-A1-TB, FX-16EYR-TB, FX-16EYT-TB, FX-16EYT-H-TB, FX-16EYS-TB, FX-16E-TB/UL, FX-32E-TB/UL, FX-16EYR-ES-TB/UL, FX-16EYT-ES-TB/UL, FX-16EYT-ESS-TB/UL, FX-16EYS-ES-TB/UL
<b>Peripheral equipment</b>	
Peripheral equipment	Generic name of programming software, handy programming panels, and display units
<b>Programming tools</b>	
Programming tool	Generic name of programming software and handy programming panels
Programming software	Generic name of programming software
GX Works2	Generic name of programming software packages SW □ DNC-GXW2-J and SW □ DNC-GXW2-E
GX Developer	Generic name of programming software packages SW □ D5C-GPPW-J and SW □ D5C-GPPW-E
Handy programming panel (HPP)	Generic name of programming panels FX-30P, FX-20P(-E) and FX-10P(-E)
30P	Abbreviation of FX-30P
<b>Manuals</b>	
FX3U Hardware Edition	FX3U Series User's Manual - Hardware Edition
FX3UC Hardware Edition	FX3UC Series User's Manual - Hardware Edition
FX3G Hardware Edition	FX3G Series User's Manual - Hardware Edition
FX3GC Hardware Edition	FX3GC Series User's Manual - Hardware Edition
FX3S Hardware Edition	FX3S Series User's Manual - Hardware Edition
Programming Manual	Generic name of FX0/FX0S/FX0N/FX/FX2C/FX2N PROGRAMMING MANUAL, FX1S/FX1N/FX2N/FX2NC PROGRAMMING MANUAL II, and FX3S/FX3G/FX3GC/FX3U/FX3UC Series Programming Manual - Basic & Applied Instruction Edition
FX3S/FX3G/FX3GC/FX3U/FX3UC Programming Manual	FX3S/FX3G/FX3GC/FX3U/FX3UC Series Programming Manual - Basic and Applied Instructions Edition
Communication Control Edition	FX Series User's Manual - Data Communication Edition
Analog Control Edition	FX3S/FX3G/FX3GC/FX3U/FX3UC Series User's Manual - Analog Control Edition
Positioning Control Edition	FX3S/FX3G/FX3GC/FX3U/FX3UC Series User's Manual - Positioning Edition
<b>Program, others</b>	
Program	Generic name of program, file register, comment, parameter
F/W	Abbreviation of firmware (Software used by the FX-30P to operate)





- Explanation of key operations

The following procedures are used for key operations.

 ,  ..... Press the  or  key.

  ..... Press the  key, then the  key in this order (Numeric input, etc.).

 →  ..... Press the  key, then the  key in this order.

  
↓  
 ..... Press the  key, then the  key in this order.

 ..... Input an arbitrary numeric value in 1 to several digits.

 ..... Press the  key several times repeatedly.

# Reading the Manual

In this manual, the following formats are used for describing common items.

- Shows the manual title.**  
This area shows the manual title for the current page.
- Shows the title of the chapter and the title of the section.**  
This area shows the title of the chapter and the title of the section for the current page.
- Indexes the chapter number.**  
The right side of each page indexes the chapter number for the page currently opened.

FX-30P Operation Manual

5 Online Mode  
5.1 Overview of online mode

## 5. Online Mode

---

### 5.1 Overview of online mode

In the online mode, the 30P directly accesses the program memory in the PLC. Refer to Chapter 7 for the HPP setting.

1) In the PLC, data is written to the built-in RAM when a memory cassette is not attached to the PLC, or to a memory cassette when it is attached to the PLC. Data cannot be written to a memory cassette if it is EPROM or if it is EEPROM or FLROM and the write protect switch is ON. Data cannot be written either while the PLC is in the RUN status.

2) By operation from the 30P, programs can be transferred between the built in PLC memory and a memory cassette attached to the PLC.

### 5.2 Read

Press the **RD/WR** key once to select the read mode, and press it again to select the write mode. (The mode is selected alternately.)

#### 5.2.1 Overview of the read operation

When the online mode is selected, programs written to the memory of the PLC (or the memory cassette if attached) are displayed in the 30P. When the offline mode is selected, programs written in the built in HPP RAM itself are displayed in the 30P.

- Read operation condition

PLC status		PLC memory			
RUN	STOP	Built in memory	RAM cassette	EEPROM cassette FLROM cassette	EPROM cassette
✓	✓	✓	✓	✓	✓

#### 5.2.2 Read by step No.

- Eight lines of the program are read and displayed from an instruction at the specified step No.
- If the specified step No. corresponds to an operand such as a set value of a timer or counter, eight lines are read and displayed from the instruction of the operand.
- Press the **GO** key again to scroll the screen display to the next line of the displayed instruction.
- Use the cursor control keys to scroll lines one by one.

**Basic operation**

```

STEP → Step No. → GO
            
```

**1**

**2**

**3**

**4**

**5**

**6**

**7**

**8**

**A**

**B**

33

The above is different from the actual page, as it is provided for explanation purposes only.



# 1. Introduction

## 1.1 Outline

The handy programming panel FX-30P is a compact, portable program monitor. Connect the FX-30P to a MELSEC-FX Series PLC, and use it for writing programs (sequence programs and parameters), as well as monitoring and testing devices.

## 1.2 Major Features of the FX-30P

- The FX-30P is a compact, portable program monitor.
- The liquid crystal display unit with 21 characters × 8 lines displays the program, PLC operation status (monitoring), operation guidance and error messages.
- The FX-30P offers both online mode and offline mode.  
The FX-30P directly accesses the memory of the connected PLC in the online mode, and accesses the built-in RAM in the offline mode.
- The FX-30P has a built-in battery to store programs written in the offline mode (which are stored in the RAM in the FX-30P) for approximately 5 years (Ambient temperature 25°C(77°F)).
- The FX-30P has a built-in flash memory to save up to 15 programs. The program management function can read out programs saved in the flash memory to the built-in RAM, write programs from the built-in RAM to the flash memory, and delete programs.
- The FX-30P reads/writes programs and provides a monitor display in list format.

## 1.3 External Dimensions and Part Names

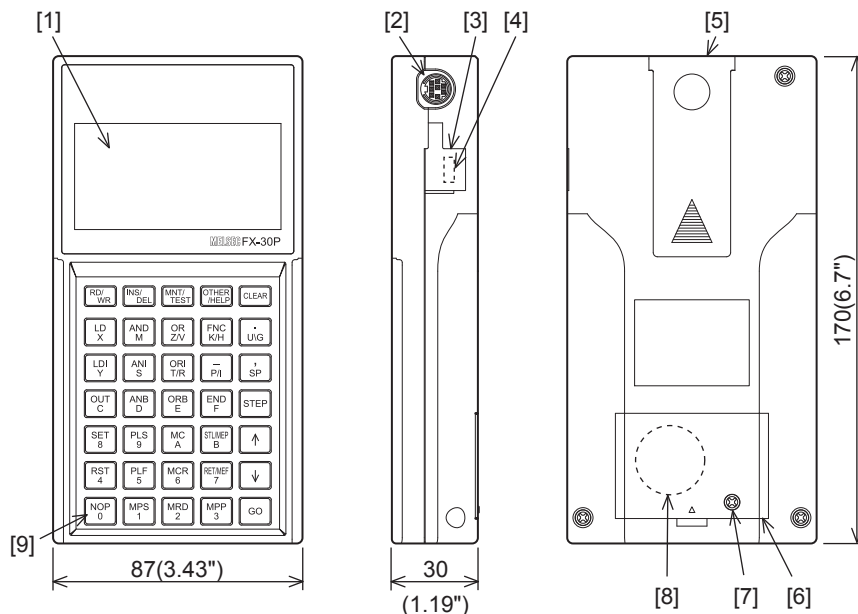

Unit: mm (inches)  
 MASS (Weight): 0.3kg (0.66lbs)

- [1] LCD display (With backlight)
- [2] PLC communication port
- [3] USB cover
- [4] USB communication port
- [5] Slide hook

- [6] Battery cover
- [7] Screw for battery cover anchoring
- [8] FX3U-32BL type battery (standard accessory)
- [9] Key

## 1.4 Key Layout

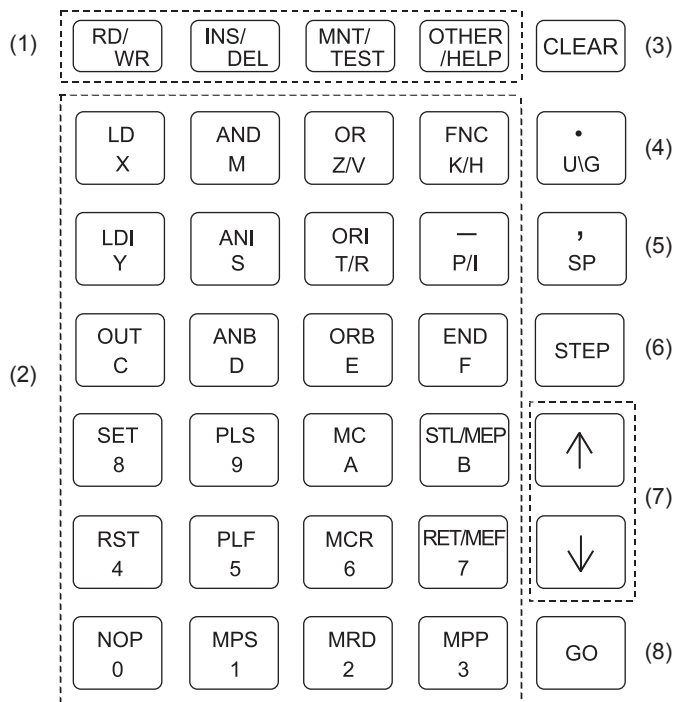

Each key provided on the FX-30P panel surface functions as follows:

(1)	Function keys (read/write, insert/delete, monitor/test and others/help)	Each key operates alternately. (When a key is pressed once, the function indicated in the upper part of the key is selected. When the key is pressed again, the function indicated in the lower part is selected.)
(2)	Instruction keys, device symbol keys and numeric keys	Instructions are provided in the upper part of each key, and numbers/device numbers are provided in the lower part of each key. The function is automatically changed over between the one indicated in the upper part and the other indicated in the lower part in accordance with operator's actions. Among symbols indicated in the lower part, each symbol is selected alternately for "Z/V", "K/H", "T/R" and "P/I". (Every time a key is pressed, either symbol is selected alternately.)
(3)	Clear key	Use this key to cancel the key input before pressing the [GO] key(before confirmation), clear an error message, or return to the previous screen.
(4)	Device symbol key	This key is provided to aid device symbol input. Use this key to directly specify a buffer memory or specify a device bit.
(5)	Space key	Use this key to enter a space in the entry column, specify a device or specify a constant.
(6)	Step key	Use this key to specify the step number.
(7)	Cursor control keys	Use these keys to move the line cursor and prompt, specify a device before or after the currently specified device, or scroll lines.
(8)	GO key	Use this key to confirm a command, execute a command, or scroll pages.

## 1.5 Function List

### 1) Online mode

Functions	Description	Reference	
Programming	Read	Reads (displays) sequence programs in the PLC.	Section 5.2
	Write	Writes sequence programs. (Key inputs in the 30P → Program memory in the PLC)	Section 5.3
	Insert	Inserts instructions into sequence programs. (Key inputs in the 30P → Program memory in the PLC)	Section 5.4
	Delete	Deletes instructions from sequence programs. (Key inputs in the 30P → Program memory in the PLC)	Section 5.5
Monitor	Reads (displays) the operation status in the PLC.	Section 5.6	
Test	Writes devices forcibly. (Key inputs in the 30P → Memory in the PLC)	Section 5.7	
Other	CHANGE TO OFFLINE	Switches the mode to offline.	Subsection 5.8.2
	DIAGNOSTICS PLC	Executes PLC diagnosis.	Subsection 5.8.3
	DATA TRANSFER	Transfers data from the memory cassette.	Subsection 5.8.4
	PARAMETER	Sets parameters.	Subsection 5.8.5
	KEYWORD	Sets the keyword.	Subsection 5.8.6
	DEVICE CONVERSION	Converts devices.	Subsection 5.8.7
	LATCH CLEAR	Clears the latch status.	Subsection 5.8.8
	DEV. BATCH MONITOR	Executes batch monitoring of devices.	Subsection 5.8.9
	BFM BATCH MONITOR	Executes batch monitoring of buffer memories.	Subsection 5.8.10
	BAUDRATE	Changes the baud rate.	Subsection 5.8.11
	CLEAR PLC MEMORY	Clears the memory inside the PLC.	Subsection 5.8.12
	REMOTE RUN/STOP	Switches the PLC mode between RUN and STOP.	Subsection 5.8.13
	SET PLC CLOCK	Sets the clock in the PLC.	Subsection 5.8.14
	HPP SETTING	Changes the setup of the HPP.	Chapter 7

## 2) Offline mode

Functions		Description	Reference
Programming	Read	Reads (displays) sequence programs in 30P.	Section 5.2
	Write	Writes sequence programs. (Key inputs in the 30P → Built in 30P RAM)	Section 5.3
	Insert	Inserts instructions into sequence programs. (Key inputs in the 30P → Built in 30P RAM)	Section 5.4
	Delete	Deletes instructions from sequence programs. (Key inputs in the 30P → Built in 30P RAM)	Section 5.5
Other	CHANGE TO ONLINE	Switches the mode to online.	Subsection 6.2.2
	PROGRAM CHECK	Executes program check.	Subsection 6.2.3
	HPP-FX TRANSFER	Transfers data between the RAM in the FX-30P and the FX PLC.	Subsection 6.2.4
	HPP-PC TRANSFER* <sup>1</sup>	Transfers data between the RAM in the FX-30P and the personal computer.	Subsection 6.2.5
	PARAMETER	Sets parameters.	Subsection 5.8.5
	DEVICE CONVERSION	Converts devices.	Subsection 5.8.7
	CHANGE PLC TYPE	Changes the PLC type.	Subsection 6.2.6
	HPP MEMORY CLEAR	Clears the memory inside the 30P.	Subsection 6.2.7
	PROGRAM MANAGER	Manages programs stored in the RAM and flash memory (15 blocks) in the FX-30P.	Subsection 6.2.8
HPP SETTING	Changes the setup of the HPP.	Chapter 7	

\*1. For firmware versions that support the HPP-PC TRANSFER function, refer to Subsection 6.2.5. Only available for FX3S/FX3G/FX3GC/FX3U/FX3UC PLC.

## 3) HPP setting

Functions	Description	Reference
LANGUAGE	Selects the display language among English, Japanese, and Chinese.	Section 7.1
BUZZER LEVEL	Adjusts the buzzer sound volume.	Section 7.2
DISPLAY CONTRAST	Adjusts the LCD display contrast.	Section 7.3
DISPLAY BRIGHTNESS	Adjusts the brightness of the LCD display backlight.	Section 7.4
SCREEN SAVE	Sets the screen saver.	Section 7.5
HPP PROTECT	Sets protection for programs stored in the FX-30P.	Section 7.6
HPP INITIALIZE	Returns the FX-30P to the factory default status.	Section 7.7
HPP F/W UPDATE	Updates the firmware of the FX-30P.	Section 7.8

1

Introduction

2

Specifications,  
product  
configuration

3

Connections,  
startup  
procedure

4

Outline of  
programming

5

Online mode

6

Offline mode

7

HPP setting

8

Battery

A

ASCII Code

B

Message List

## 2. Specifications, Product configuration

### DISPOSAL PRECAUTIONS



- Please contact a certified electronic waste disposal company for the environmentally safe recycling and disposal of your device. When disposing of batteries, separate them from other waste according to local regulations. (For details of the Battery Directive in EU countries, refer to Appendix G)

### TRANSPORT AND STORAGE PRECAUTIONS



- The FX-30P is a precision instrument. During transportation, avoid impacts larger than those specified in the general specifications (refer to Section 2.1) of this manual. Failure to do so may cause failures in the FX-30P. After transportation, verify the operations of the FX-30P.
- Before transporting the FX-30P, make sure to turn on the power of the FX-30P, and confirm that an HPP low battery voltage error does not occur (or confirm that the HPP battery voltage is 2.7 V or more). If the FX-30P is transported when the battery voltage is low and the battery life is expired, the battery-backed data may not be held correctly during transportation.
- When transporting lithium batteries, follow required transportation regulations. (For details of the regulated products, refer to Appendix F)

## 2.1 General specifications

Item	Specification			
Ambient temperature	0 to 40°C (32 to 104°F)			
Ambient humidity	5 to 95%RH (no condensation)			
Storage ambient temperature	-25 to 75°C (-13 to 167°F)			
Storage ambient humidity	5 to 95%RH (no condensation)			
Vibration resistance*1	Frequency (Hz)	Acceleration (m/s <sup>2</sup> )	Half amplitude (mm)	Sweep Count for X, Y, Z: 10 times (80 min. in each direction)
	5 to 9	-	3.5	
	9 to 150	9.8	-	
Shock resistance*1	147m/s <sup>2</sup> Acceleration, Action time: 11ms, 3 times by half-sine pulse in each direction X, Y, and Z			
Noise resistance	By noise simulator at noise voltage of 1,000Vp-p, noise width of 1μs, rise time of 1ns and period of 30 to 100Hz			
Working atmosphere	Free from corrosive or flammable gas and excessive conductive dust			
Working altitude	< 2000m*2			

\*1. The criterion is shown in IEC61131-2.

\*2. The PLC cannot be used at a pressure higher than the atmospheric pressure to avoid damage.

## 2.2 Power supply specification

Item		Specification
External power supply	Power supply voltage	5V DC ±5% (Power supply is supplied from PLC or personal computer.*1)
	Current consumption	Supplied from PLC 155mA (When the intensity of LCD backlight is set at the maximum value 8) 115mA (When the intensity of LCD backlight is set at the initial value 4)
		Supplied from personal computer 165mA (When the intensity of LCD backlight is set at the maximum value 8) 125mA (When the intensity of LCD backlight is set at the initial value 4)

\*1. Power supply by bus power



## 2.3 Performance specification

Item		Specification
Display unit	Type	STN monochrome (white/black) liquid crystal
	Resolution	128x64 dots
	Display size	W66.54(2.62) x H33.26(1.31)[mm](inch)
	Foreground color	Monochrome (white/black)
Backlight		White
Buzzer		Adjustable among 9 levels (including the buzzer OFF level)
Contrast adjustment		8-level adjustment
Intensity of LCD		Adjustable among 9 levels (including the backlight OFF level)
Key figure		35 pieces
Memory	Program capacity	Built-in RAM: 64K step RAM retention (for about five years, ambient temperature 25°C(77°F)) by battery. Built-in flash memory ROM: Up to 15 programs can be stored in the built-in flash memory ROM. Allowable number of writes: 100,000 times
	HPP held data	Display language setting (Japanese, English or Chinese), contrast, buzzer sound volume, brightness adjustment, screen saver and HPP protect key (saved in the built-in flash memory)

## 2.4 Communication specification

### 2.4.1 Communication specification

Item		Specification
For PLC communication	Communications standard	Serial RS-422 standard practice compliant 1ch
	Transmission speed	115.2/57.6/38.4/19.2/9.6kbps
	Connector shape configuration	RS-422 mini DIN 8 pin female
For personal computer communication	Communications standard	USB 2.0/1.1 standard practice compliant 1ch
	Transmission speed	After serial conversion is 115.2kbps
	Connector shape configuration	USB mini B plug female

### 2.4.2 Communication speed

- 1) Communication speed between the FX-30P and the PLC  
The table below shows the communication speed between the FX-30P and the PLC.

Transmission speed	FX1	FX2 FX2C	FX0 FX0S	FX0N	FX1S	FX1N FX1NC	FX2N FX2NC	FX3S	FX3G FX3GC	FX3U FX3UC
9.6Kbps	✓	✓	✓	✓	✓	✓	✓	✓	✓	✓
19.2Kbps	-	-	-	-	-	✓	✓	✓	✓	✓
38.4Kbps	-	-	-	-	-	-	-	✓	✓	✓
57.6Kbps	-	-	-	-	-	-	-	✓	✓	✓
115.2Kbps	-	-	-	-	-	-	-	✓	✓	✓

- 2) Communication speed between the FX-30P and the personal computer  
In conformance to USB 2.0 (full speed)

## 2.5 Configuration

### 2.5.1 Product configuration

1) Incorporated items list

Name	Quantity	Description
FX-30P	1 unit	HPP (Can also be used for the FX/FX2C Series PLC when the cable is changed.)
FX-20P-CAB0	1 cable	Program cable (HPP↔PLC), 1.5 m
Manual (Japanese version, English version)	1 manual each	Manual

2) Associated product list

Name	Description
FX-20P-CAB	Program cable (1.5 m) to connect FX1/FX2/FX2C PLC (sold separately)
MR-J3USBCBL3M	USB communication cable (3 m) (sold separately)
SW1DN-FX30P-UPDATE	Personal computer software to update the firmware of the FX-30P (Free)
FX3U-32BL	Battery to back up the built-in RAM (spare part, sold separately)
FX-30P-O-E	Separate manual (this manual, sold separately)

### 2.5.2 System configuration

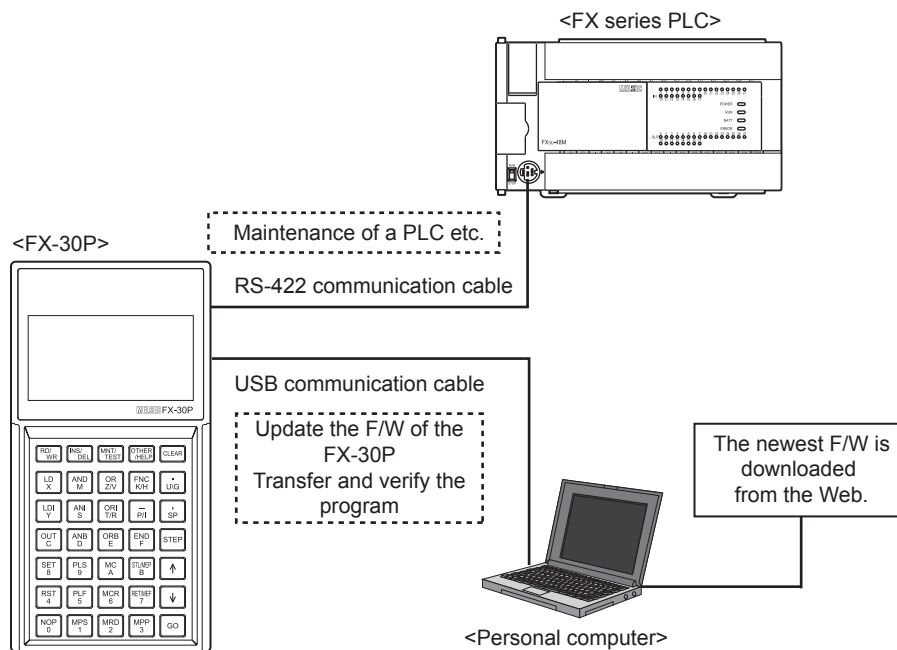

#### Caution

Do not connect a PLC and a personal computer at the same time to the FX-30P.

### 2.5.3 Applicable PLC

Model names
FX1/FX2(FX)/FX2C/FX0/FX0S/FX0N/FX1S/FX1N/FX1NC/FX2N/FX2NC/FX3S/FX3G/FX3GC/FX3U/FX3UC Series PLC*1

\*1. An FX-20P-CAB is necessary to connect the FX-30P with the FX1/FX2(FX)/FX2c PLC.

### 3. Connection Method/Startup Procedure

#### INSTALLATION PRECAUTIONS



- Use the product within the generic environment specifications described in Section 2.1 of this manual. Never use the product in areas with excessive dust, oily smoke, conductive dusts, corrosive gas (salt air, Cl<sub>2</sub>, H<sub>2</sub>S, SO<sub>2</sub>, or NO<sub>2</sub>), flammable gas, vibration or impacts, or expose it to high temperature, condensation, or rain and wind. If the product is used in such conditions, electric shock, fire, malfunctions, deterioration or damage may occur.
- Do not touch the conductive parts of the product directly. Doing so may cause device failures or malfunctions.
- Connect cables securely to their designated connectors. Loose connections may cause malfunctions.
- Do not connect a PLC and a personal computer at the same time to the FX-30P. Failure to do so may cause equipment failures or malfunctions.

#### STARTUP AND MAINTENANCE PRECAUTIONS



- Turn off the power to the PLC before attaching or detaching the battery. Doing so may cause equipment failures, or malfunctions.
- Use the battery for memory backup correctly in conformance to this manual.
  - Use the battery only for the specified purpose.
  - Connect the battery correctly.
  - Do not charge, disassemble, heat, put in fire, short-circuit, connect reversely, weld, swallow or burn the battery, or apply excessive forces (vibration, impact, drop, etc.) to the battery.
  - Do not store or use the battery at high temperatures or expose to direct sunlight.
  - Do not expose to water, bring near fire or touch liquid leakage or other contents directly.
  - Incorrect handling of the battery may cause heat excessive generation, bursting, ignition, liquid leakage or deformation, and lead to injury, fire or failures and malfunctions of facilities and other equipment.
- Before modifying or disrupting the program in operation or running the PLC, carefully read through this manual and the associated manuals and ensure the safety of the operation. An operation error may damage the machinery or cause accidents.
- Do not change the program in the PLC from two or more peripheral equipment devices at the same time. (i.e. from a programming tool and a GOT) Doing so may cause destruction or malfunction of the PLC program.

#### STARTUP AND MAINTENANCE PRECAUTIONS



- Do not disassemble or modify the PLC. Doing so may cause fire, equipment failures, or malfunctions. For repair, contact your local Mitsubishi Electric representative.
- Turn off the power to the PLC before connecting or disconnecting cable. Failure to do so may cause equipment failures or malfunctions.

1

Introduction

2

Specifications,  
product  
configuration

3

Connections,  
startup  
procedure

4

Outline of  
programming

5

Online mode

6

Offline mode

7

HPP setting

8

Battery

A

ASCII Code

B

Message List

### 3.1 Connection to the PLC

- 1) Connection to the FX0/FX0S/FX0N/FX1S/FX1N/FX1NC/FX2N/FX2NC/FX3S/FX3G/FX3GC/FX3U/FX3UC Series PLC.

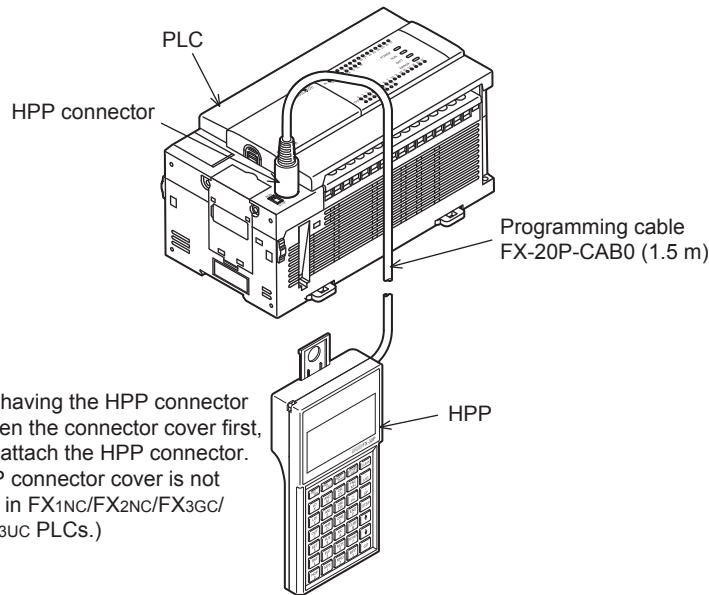

- 2) Connection to the FX1/FX2(FX)/FX2c Series PLC.

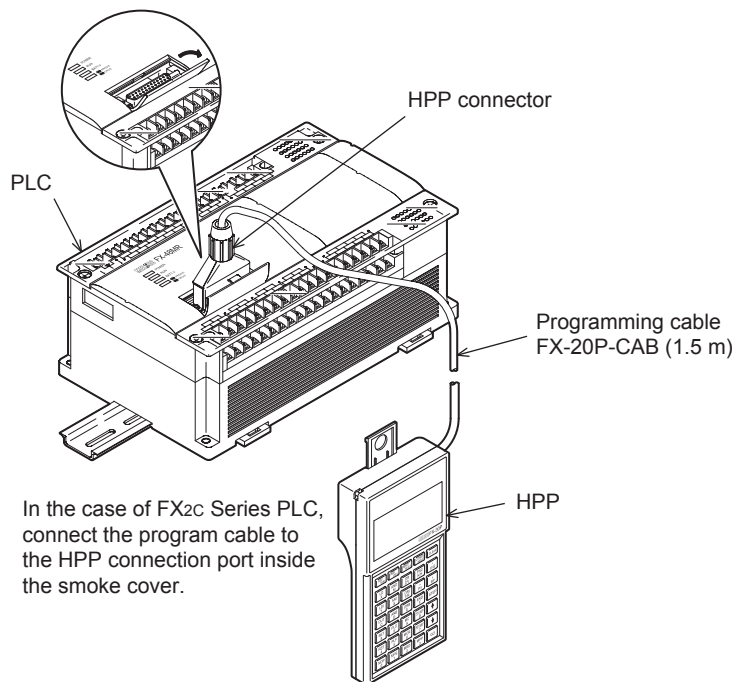

#### Caution

Never touch the PLC connection area of the HPP main unit. Static electricity may damage internal electrical circuits. Turn OFF the power of the PLC before connecting the HPP to the PLC.

## 3.2 Connection to a personal computer

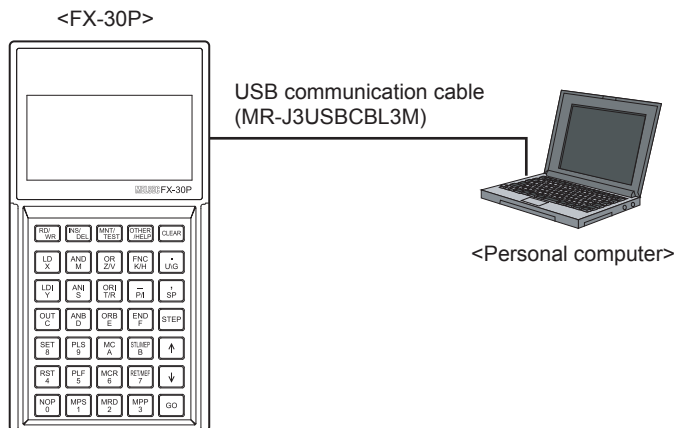

Connect the FX-30P to the USB communication port of a personal computer using a USB communication cable.

## 3.3 Startup procedure

- While the power of the PLC is OFF, connect the HPP to the PLC.
- The top screen is displayed for 2 seconds after the power is turned ON.
- The current firmware version is displayed at the bottom of the top screen.
- Turning the power of the FX-30P ON while pressing and holding the **GO** and **CLEAR** keys at the same time sets the FX-30P to the HPP F/W update standby status (if the manufacturer's serial number is 950000 or later).  
For details, refer to Section 7.8.

Connect the HPP to the PLC, power PLC ON.

```
#  COPYRIGHT (C) 2008  #
#                               #
#  MITSUBISHI           #
#  ELECTRIC             #
#  CORPORATION          #
#                               #
#  MELSEC  FX-30P      #
#  version 1.00        #
```

Firmware version



Displayed for 2 seconds after the power is turned ON

```
*SELECT LANGUAGE
ENGLISH
日本語
中文(简体)
中文(繁體)
```

- If the language is not selected for the following reasons, the language selection screen appears after the top screen.
    - If the power of the FX-30P is turned ON for the first time after delivery
    - If the HPP is initialized
- Select either language using the **↑** and **↓** keys, and then press the **GO** key to confirm the selection.

↓ To next page

- Select the online mode, offline mode, or HPP setting mode.

Select either mode using the  and  keys, and then press the  key to confirm the selection.



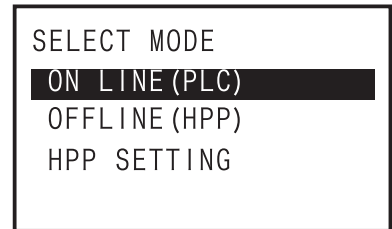

↓ From previous page



- When the online mode is selected and the keyword is set in the PLC



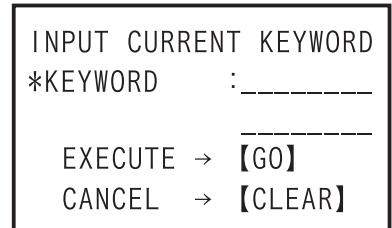

For details on the keyword, refer to Subsection 5.8.6.

- a) In the case of "FX3U/FX3UC Ver.2.20 or later, FX3S/FX3G/FX3GC."

-  → Keyword input
-  → Delete one character
-  → Confirm input
-  → Returns to the mode selection screen.



- b) When other than "FX3U/FX3UC Ver.2.20 or later, FX3S/FX3G/FX3GC."

-  → Keyword input
-  → Delete one character
-  → Confirm input
-  → Returns to the mode selection screen.

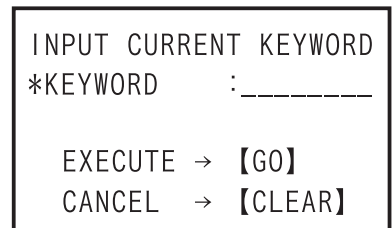



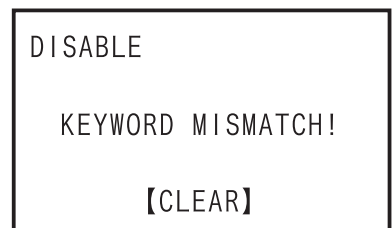

- c) When the input keyword is wrong

-  → Returns to the mode selection screen.



- Display after execution of an online change

- , , , 
- Switch to each mode

- a) TYPE: Displays the selected PLC basic unit name.
- b) VER.: Displays the version number of the PLC.

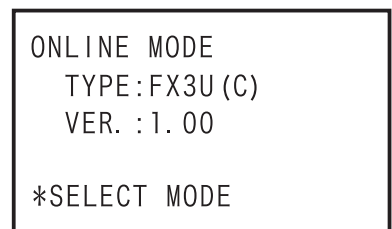

- When the offline mode is selected for the first time after the HPP is shipped from the factory or after the HPP is initialized

- **↑** , **↓** → Select the PLC type.
- **GO** → Confirm input
- **Num. Key** → Select and confirm
- **CLEAR** → Returns to the mode selection screen.

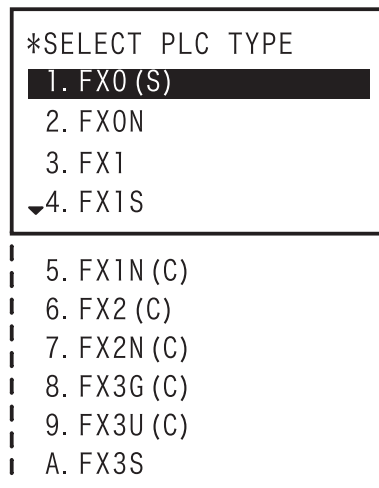

- When the offline mode is selected and the protect key is set in a program stored in the FX-30P

- **Num. Key** → Protect key input
- **↓** → Delete one character
- **GO** → Confirm input
- **CLEAR** → Returns to the mode selection screen.

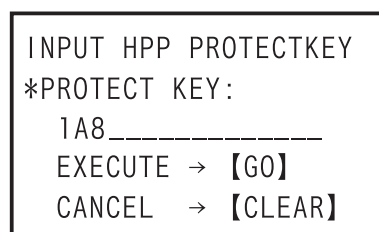

- a) When the input protect key is correct

- **CLEAR** → Displays the next mode selection screen.

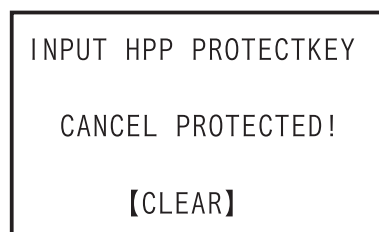

- b) When the input protect key is wrong

- **CLEAR** → Returns to the mode selection screen.

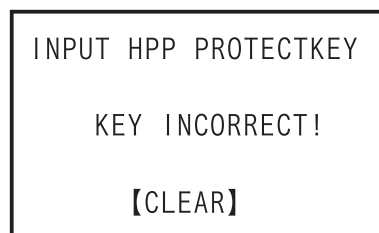

- Display after execution of an online change

- **RD/WR** , **INS/DEL** , **MNT/TEST** , **OTHER/HELP**  
→ Switch to each mode

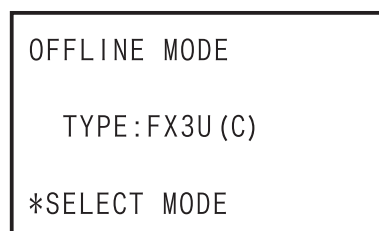

- a) TYPE: Displays the selected PLC basic unit name.

- HPP reset

Press the **RST** and **GO** keys at the same time to reset the HPP. When the HPP is reset, the top screen (which appears after the power is turned ON) appears.

- 1** Introduction
- 2** Specifications, product configuration
- 3** Connections, startup procedure
- 4** Outline of programming
- 5** Online mode
- 6** Offline mode
- 7** HPP setting
- 8** Battery
- A** ASCII Code
- B** Message List

## 4. Outline of Programming

### DESIGN PRECAUTIONS



- When executing control (data changes) to an operating PLC, construct an interlock circuit in the sequence program so that the entire system operates conservatively. Additionally, when executing control such as program changes and operation status changes (status control) to an operating PLC, thoroughly read the manual and sufficiently confirm safety in advance.
- Make sure to have the following safety circuits outside the PLC to ensure safe system operation even during external power supply problems or PLC failure.
 

Otherwise, malfunctions may cause serious accidents.

  - 1) Most importantly, have the following: an emergency stop circuit, a protection circuit, an interlock circuit for opposite movements (such as normal vs. reverse rotation), and an interlock circuit (to prevent damage to the equipment at the upper and lower positioning limits).
  - 2) Note that when the PLC CPU detects an error, such as a watchdog timer error, during self-diagnosis, all outputs are turned off. Also, when an error that cannot be detected by the PLC CPU occurs in an input/output control block, output control may be disabled. External circuits and mechanisms should be designed to ensure safe machinery operation in such case.

### DESIGN PRECAUTIONS



- Observe the following items. Failure to do so may cause incorrect data-writing through noise to the PLC and result in PLC failure, machine damage or other accidents.
  - 1) Do not bundle the control line together with or lay it close to the main circuit or power line. As a guideline, lay the control line at least 100mm (3.94") or more away from the main circuit or power line. Noise may cause malfunctions.
  - 2) Ground the shield wire or shield of a shielded cable. Do not use common grounding with heavy electrical systems.
- Install module so that excessive force will not be applied to the power connector. Failure to do so may result in wire damage/breakage or PLC failure.

In the FX-30P, use input keys and instruction list to create programs.

The destination to write a created program is different between the online mode and the offline mode.

In the online mode, a program is directly written to the program memory in the PLC. In the offline mode, a program is written to the built in HPP RAM. When operating the PLC with a program created in the offline mode, the program should be transferred from the HPP to the PLC.



## 4.1 Menu Structure

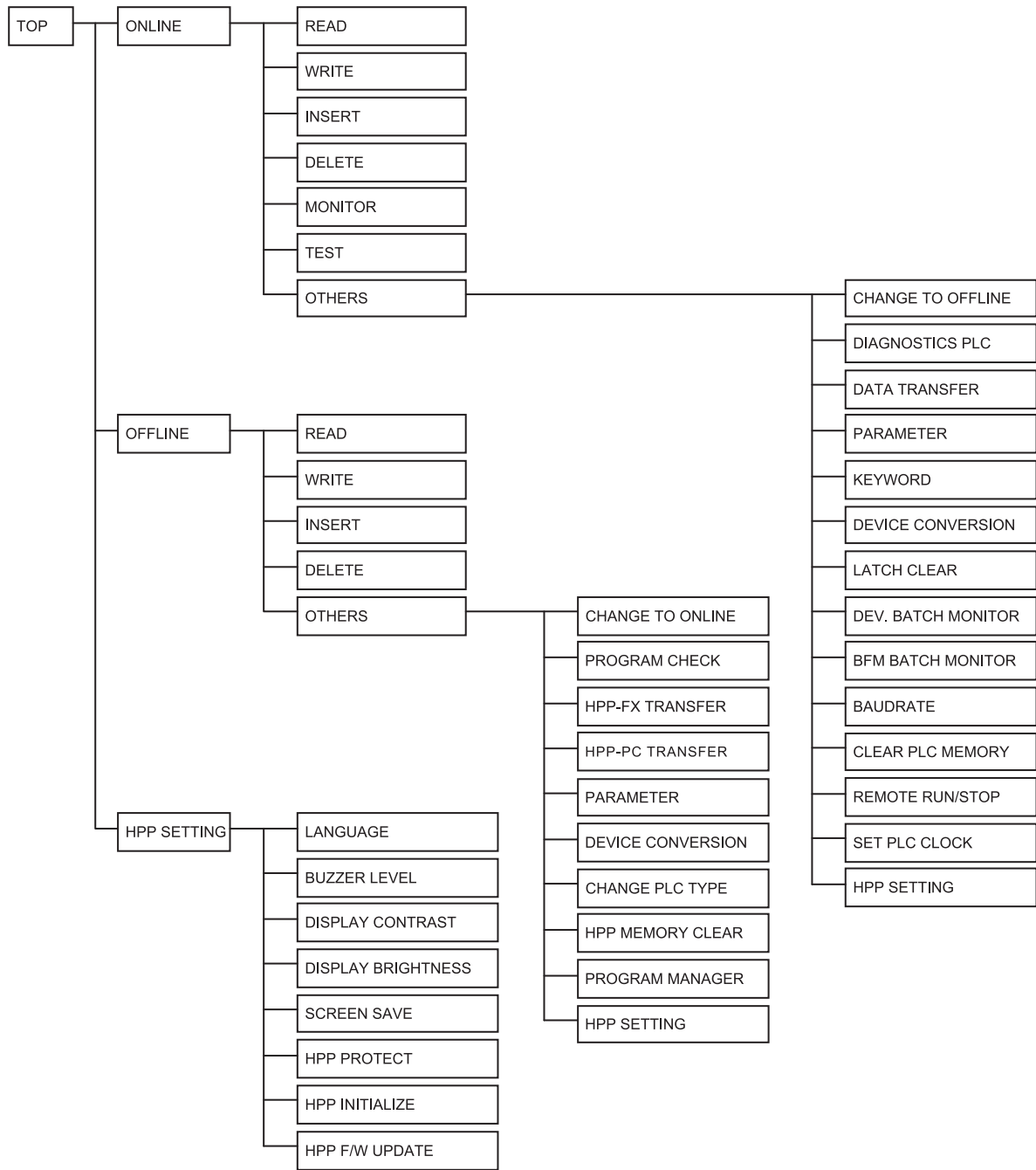

- 1** Introduction
- 2** Specifications, product configuration
- 3** Connections, startup procedure
- 4** Outline of programming
- 5** Online mode
- 6** Offline mode
- 7** HPP setting
- 8** Battery
- A** ASCII Code
- B** Message List

## 4.2 Common programming items

### 4.2.1 Programming screen

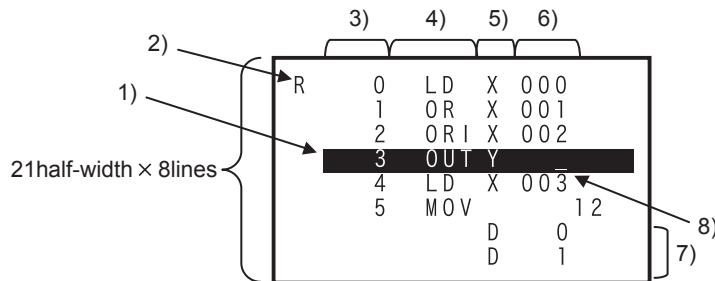

- 1) Line cursor  
Highlights the target line.
- 2) Function mode display  
Displays an alphabet which abbreviates each function.

Alphabet	Functions
R	Read
W	Write
I	Insert
D	Delete
M	Monitor
T	Test

- 3) Step number  
Indicated only at the head of an instruction.
  - 4) Instruction  
Indicates a basic instruction, step ladder instruction, or applied instruction.
  - 5) Device symbol  
Indicates a device or pointer.
  - 6) Device number  
Indicates the FNC number when an applied instruction is input.
  - 7) Application instruction operand  
Indicates one operand in each line after the instruction symbol.
  - 8) Prompt  
Indicates the position for key input, moves in accordance with the progress of the input operation, and disappears when the input operation is completed.
- Program creation method  
Create a program using the instruction list.  
Instructions are classified into basic instructions, step ladder instructions and applied instructions.  
On the programming screen, press and hold the  or  key for continuous input.

#### Caution

The displayed screen may be different depending on the PLC type.

### 4.2.2 Key input

1) Input of device

Device	Key operation		
X	X	→	Num. Key
Y	Y	→	Num. Key
M	M	→	Num. Key
S	S	→	Num. Key
T	T/R	→	Num. Key
C	C	→	Num. Key
D	D	→	Num. Key
V	Z/V	→ Z/V	→ Num. Key
Z	Z/V	→	Num. Key
R	T/R	→ T/R	→ Num. Key
P	P/I	→	Num. Key
I	P/I	→ P/I	→ Num. Key
N	Auto input		
K	K/H	→	Num. Key
H	K/H	→ K/H	→ Num. Key
E	E	→	Num. Key
U□\G□	U\G	→ Num. Key	→ Num. Key
D.□	D	→ Num. Key	→ . → Num. Key

- The **T/R**, **Z/V**, **P/I** and **K/H** keys operate alternately. When either key is pressed once, the device on the left side is selected. When it is pressed twice, the device on the right side is selected.
- When the **U\G** key is pressed, "U\\_G\_" is displayed on the screen. Input the unit number (0 to 7) first, and then input the BFM number.
- In the 30P, reading of ASC instruction can be displayed in ASCII characters, but character string cannot be entered directly. To write in the ASCII character, you just use the programming software.

- Example1. Input of [U0\G1200]

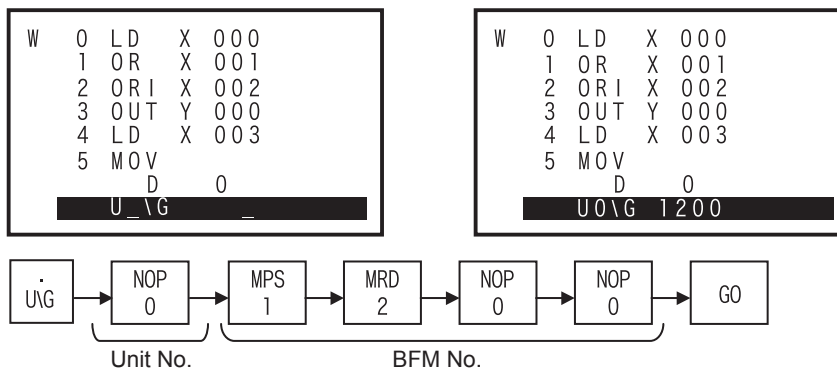

1	Introduction
2	Specifications, product configuration
3	Connections, startup procedure
4	Outline of programming
5	Online mode
6	Offline mode
7	HPP setting
8	Battery
A	ASCII Code
B	Message List

- Example2. Input of [LD D8000.1]

```

W 0 LD X 000
  1 OR X 001
  2 ORI X 002
  3 OUT Y 000
  4 LD D8000
  5 NOP
  6 NOP
  7 NOP
    
```

```

W 0 LD X 000
  1 OR X 001
  2 ORI X 002
  3 OUT Y 000
  4 LD D8000.1
  5 NOP
  6 NOP
  7 NOP
    
```

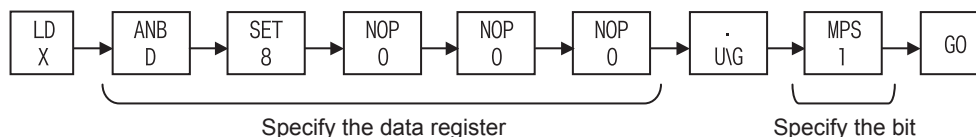

2) Input of basic instruction/step ladder instructions

Instruction	Key operation
LD	LD
LDI	LDI
LDP	LD → P/I
LDF	LD → F
AND	AND
ANI	ANI
ANDP	AND → P/I
ANDF	AND → F
OR	OR
ORI	ORI
ORP	OR → P/I
ORF	OR → F
ANB	ANB
ORB	ORB
MPS	MPS
MRD	MRD
MPP	MPP
INV	NOP → P/I
MEP	STL/MEP → STL/MEP
MEF	RET/MEF → RET/MEF
OUT	OUT
SET	SET
RST	RST
PLS	PLS
PLF	PLF
MC	MC
MCR	MCR
NOP	NOP
END	END
STL	STL/MEP
RET	RET/MEF

3) Input of application instructions

Device	Key operation
FNC number direct input	[FNC] → [Num. Key]
FNC number input after "HELP" display	[FNC] → [HELP] → [Num. Key]
Selective input from FNC history list	[FNC] → [HELP] → [HELP] → [Num. Key]
Selective input from FNC list (alphabetical order)	[FNC] → [HELP] → [HELP] → [HELP] → [↑] [↓] → [Num. Key]

- After pressing the [FNC] key, specify "double" or "pulse" before of after inputting an instruction.

- Example 1: Selective input of "DMOVP" from the FNC list (FNC number order)

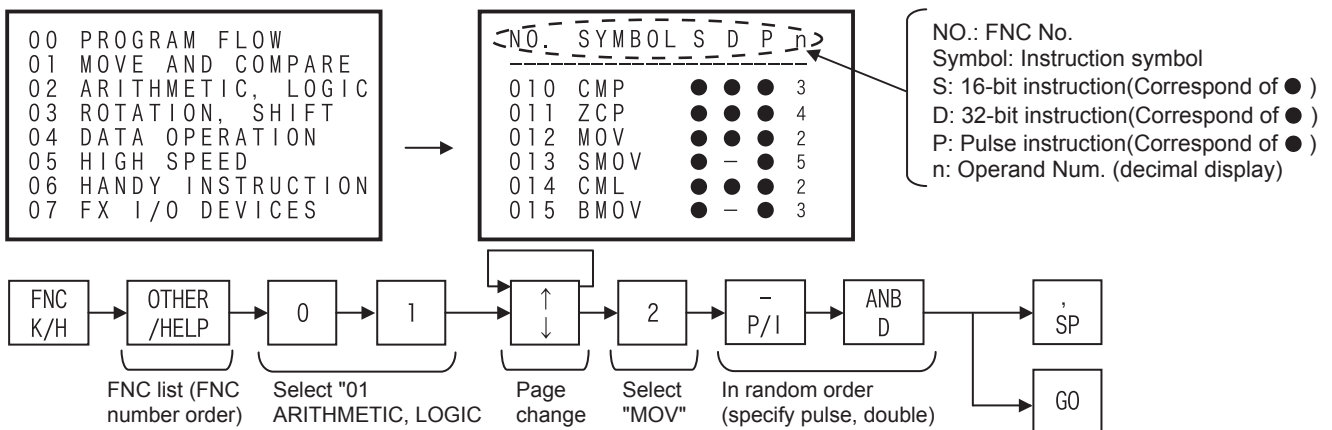

- Example 2: Selective input of "DMOVP" from the FNC history list

[Example of FNC history list display screen]

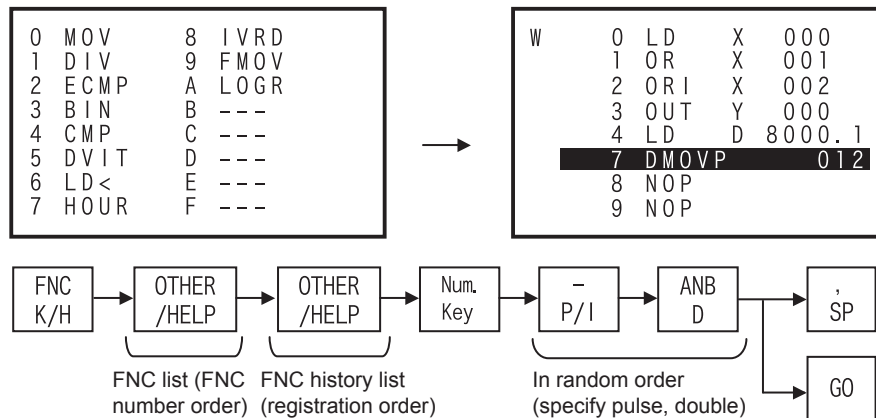

- Up to 16 instructions can be stored in the history (which is backed up by the battery).
- The latest item is displayed at the top (No. 0).
- When the history stores less than 16 items, unused lines are blank.

1	Introduction
2	Specifications, product configuration
3	Connections, startup procedure
4	Outline of programming
5	Online mode
6	Offline mode
7	HPP setting
8	Battery
A	ASCII Code
B	Message List

- Example 3: Selective input of "DMOVP" from the FNC list (alphabetical order)

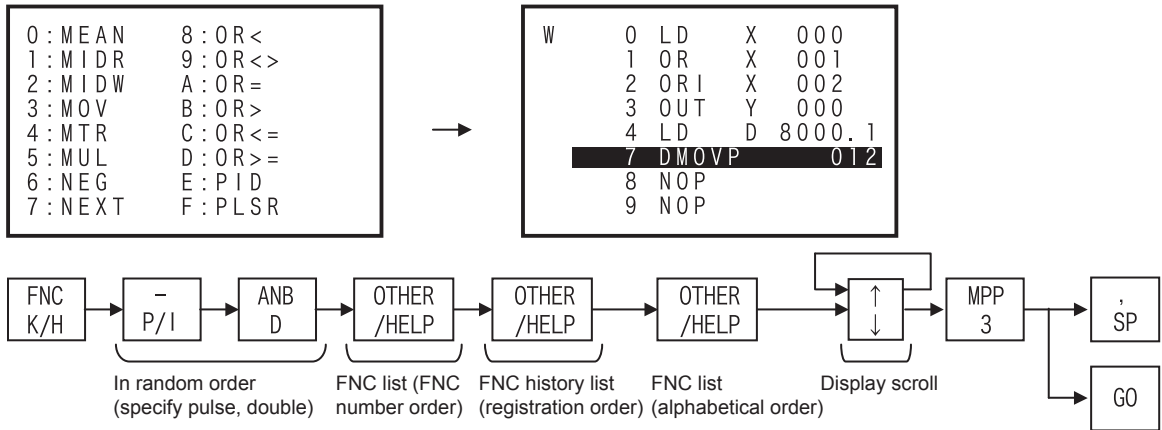

- Press and hold the ↓ key to scroll the display in the sequence "Symbols → A → B → C ... → Z → Symbols → A → ...". Release the ↓ key to stop scroll.
- Press and hold the ↑ key to scroll the display in the sequence "Symbols → Z → Y → X ... → A → Symbols → Z → ...". Release the ↑ key to stop scroll.

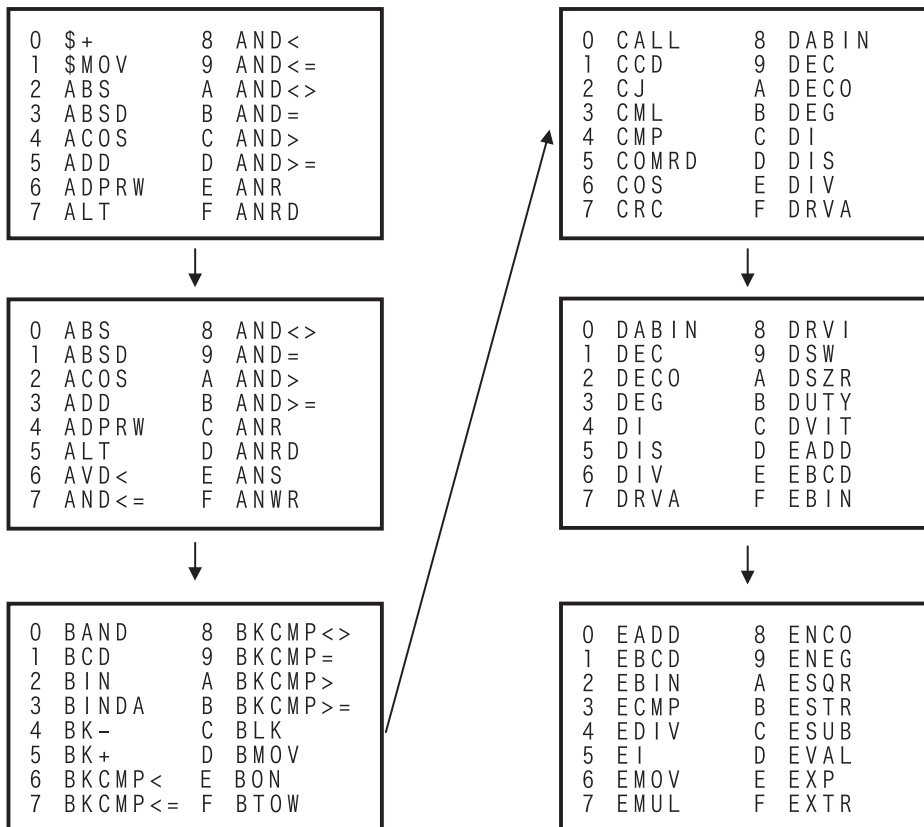

### 4.2.3 HELP screen

Press the **OTHER/HELP** key on the "Others" menu screen to display the information of the PLC and FX-30P. The displayed contents are different between the online mode and the offline mode. The HPP information is displayed on the HPP setting menu screen.

1) In online mode

ONLINE MODE (1/3) PLC TYPE: FX3U (C) PLC VERSION: 2.20 MEMORY: 64K STEP ▼	← Page count (Current page/Total number of pages) ← PLC model name ← PLC firmware version ← Memory capacity set in a parameter
ONLINE MODE (2/3) ▲CASSETTE: FLROM PROTECT SWITCH: OFF PLC BATTERY: 3.2V ▼	← Page count (Current page/Total number of pages) ← Memory cassette type ("---" is displayed when a memory cassette is not attached.) ← Write protect switch ON/OFF status (valid only for EEPROM or FLROM cassette) ← PLC battery voltage ("---" is displayed for a model not requiring a battery.)
ONLINE MODE (3/3) ▲RESTRICTION: YES WRITE PROTECT	← Page count (Current page/Total number of pages) ← Access restriction ("YES" or "NO") ← Access restriction details ("ALL PROTECT", "READ/WRITE PROTECT" or "WRITE PROTECT") (Blank when access restriction is not set)

2) In offline mode

OFFLINE MODE (1/2) PLC TYPE: FX3U (C) MEMORY: 64K STEP ▼	← Page count (Current page/Total number of pages) ← PLC model name set in a program inside the HPP ← Memory capacity set in a parameter
OFFLINE MODE (2/2) ▲HPP BATTERY: 3.0V HPP PROTECT: NO HPP VERSION: 1.00	← Page count (Current page/Total number of pages) ← HPP battery voltage ← HPP protection status ("YES" or "NO") ← HPP firmware version

- Press the **OTHER/HELP** key once on the programming screen to display the "Others" menu screen. Press the **OTHER/HELP** key again to display the "Help" screen in each mode.

3) In HPP setting

HPP INFORMATION ▲HPP BATTERY: 3.0V HPP PROTECT: NO HPP VERSION: 1.00	← HPP battery voltage ← HPP protection status ("YES" or "NO") ← HPP firmware version
---	--

- Press the **OTHER/HELP** key on the HPP setting screen to display the HPP information. Press the **OTHER/HELP** key again to return to the HPP setting screen.

<b>1</b>	Introduction
<b>2</b>	Specifications, product configuration
<b>3</b>	Connections, startup procedure
<b>4</b>	Outline of programming
<b>5</b>	Online mode
<b>6</b>	Offline mode
<b>7</b>	HPP setting
<b>8</b>	Battery
<b>A</b>	ASCII Code
<b>B</b>	Message List

## 4.3 Functions used in programming

Functions	Description	Reference
Read	Reads a created program from the program memory, and displays it. By specifying the step No., instruction, device, or pointer; an arbitrary position of the program can be displayed.	Section 5.2
Write	Writes a new program or overwrites an existing program for modification or addition.	Section 5.3
Insert	Inserts an instruction into an existing program and carries down later step No's.	Section 5.4
Delete	Deletes a specified instruction from an existing program and carries up later step No's. An instruction or pointer can be deleted. Batch deletion and deletion of specified ranges via the NOP instruction is also available.	Section 5.5

## 4.4 Types of program memories

- **RAM (Random Access Memory)**  
Data can be read from and written to this memory as needed. The data stored in this memory should be backed up by the battery because they disappear when the power is interrupted. This memory is used also as the internal memory of the HPP and PLC. If a memory cassette is of this type, programs stored in the memory cassette disappear when the memory cassette is removed from the PLC.
- **EEPROM (Electrically Erasable Programmable Read Only Memory)**  
This memory is a kind of read only memory, but data can be written as needed by applying a specified voltage. The data stored in this memory does not disappear even if the power is interrupted. The allowable number of data writes is restricted (10,000 times for memory cassettes and memory boards, and 20,000 times for the EEPROM in PLCs). The write protect switch is provided in memory cassettes and memory boards to prevent erroneous writing.
- **Flash Memory**  
This memory is a kind of EEPROM. Different from conventional EEPROM, data cannot be overwritten in units of bytes. It is necessary to delete unnecessary existing data in advance in units of blocks, and then write new data.
- **EPROM (Erasable Programmable Read Only Memory)**  
This is a kind of read only memory. Irradiate ultraviolet rays to delete the contents stored in this memory. For writing data, clear the whole contents stored in this memory, and then write data at one time using the ROM writer. The data stored in this memory does not disappear even if the power is interrupted.
- Even if the EEPROM, EPROM, or flash memory is provided for the PLC, a dedicated battery or large-capacity capacitor is required to hold the image memory.



## 5. Online Mode

### 5.1 Overview of online mode

In the online mode, the 30P directly accesses the program memory in the PLC.  
Refer to Chapter 7 for the HPP setting.

- 1) In the PLC, data is written to the built-in RAM when a memory cassette is not attached to the PLC, or to a memory cassette when it is attached to the PLC. Data cannot be written to a memory cassette if it is EPROM or if it is EEPROM or FLROM and the write protect switch is ON. Data cannot be written either while the PLC is in the RUN status.
- 2) By operation from the 30P, programs can be transferred between the built in PLC memory and a memory cassette attached to the PLC.

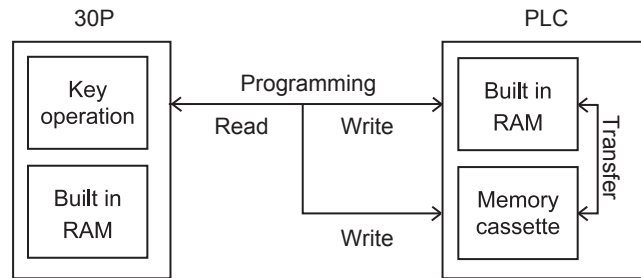

### 5.2 Read

Press the **RD/WR** key once to select the read mode, and press it again to select the write mode. (The mode is selected alternately.)

#### 5.2.1 Overview of the read operation

When the online mode is selected, programs written to the memory of the PLC (or the memory cassette if attached) are displayed in the 30P. When the offline mode is selected, programs written in the built in HPP RAM itself are displayed in the 30P.

- Read operation condition

PLC status		PLC memory			
RUN	STOP	Built in memory	RAM cassette	EEPROM cassette FLROM cassette	EPROM cassette
✓	✓	✓	✓	✓	✓

#### 5.2.2 Read by step No.

- Eight lines of the program are read and displayed from an instruction at the specified step No.
- If the specified step No. corresponds to an operand such as a set value of a timer or counter, eight lines are read and displayed from the instruction of the operand.
- Press the **GO** key again to scroll the screen display to the next line of the displayed instruction.
- Use the cursor control keys to scroll lines one by one.

##### Basic operation



- 1** Introduction
- 2** Specifications, product configuration
- 3** Connections, startup procedure
- 4** Outline of programming
- 5** Online mode
- 6** Offline mode
- 7** HPP setting
- 8** Battery
- A** ASCII Code
- B** Message List

### 5.2.3 Read by instruction

- For an applied instruction, press the **[FNC]** key and input the FNC No. in the format "**[FNC]** **[D]** **[1]** **[2]** **[GO]**", "**[FNC]** **[1]** **[2]** **[GO]**", etc. Both instructions are searched for regardless of the presence of the pulse symbol "P".
- The specified instruction word is searched from step No. 0, and eight lines are displayed on the screen from the first found instruction.
- Press the **[GO]** key again to search for the instruction with the same conditions from the next step of the currently found step.
- If all instances of the specified instruction words have been displayed or if a specified instruction word is not found at all, the message "NOT FOUND" is displayed. Program lines after the END instruction are not displayed.
- Use the cursor control keys to read the program step by step. The cursor keys function in the same way even while the program is being read by in pointer or device mode.

#### Basic operation

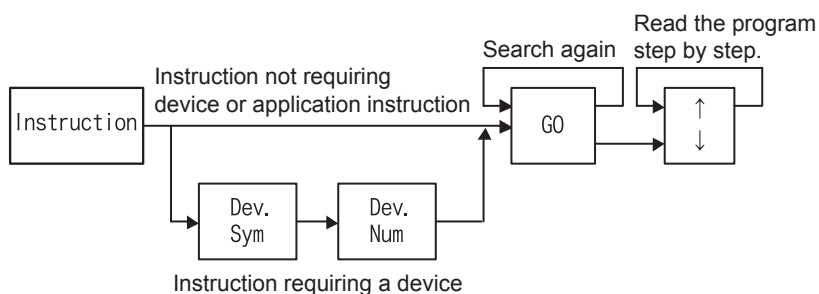

### 5.2.4 Read by pointer

- Eight lines are read and displayed from the specified label.
- If the specified label is not found, the message "NOT FOUND" is displayed. Program lines after the END instruction are not read.
- Read by pointer reads interrupt pointers and labels. Pointers specified as operands in applied instructions are not searched.

#### Basic operation

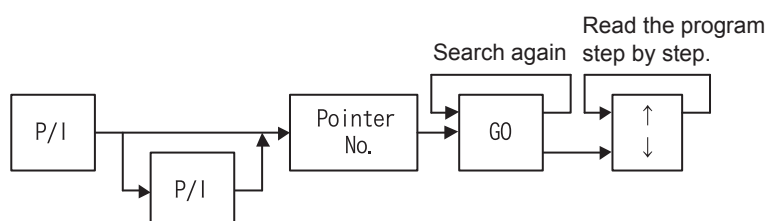

- Pointer (P)  
Number in the CJ or CALL instruction which specifies a jump destination label No.
- Label (P)  
Number of a quick reference title indicating the head of a jump destination specified by the pointer No.
- Interrupt pointer (I)  
Added at the top of an interrupt program. At the end of an interrupt program, "IRET (interrupt return instruction)" is added.

### 5.2.5 Read by device

- Only X, Y, M, S, T, C, D, R, V, and Z devices of Basic Instructions are searched. V and Z devices used as index registers are not included in the search.
- The specified device is searched for the step No. 0, and eight lines of the program are displayed from the first found instruction.
- Press the **GO** key again to search for a device of the same parameters from the next step of the currently found step.
- If the specified devices have not been found, the message "NOT FOUND" is displayed. Program lines after the END instruction are not read.

#### Basic operation

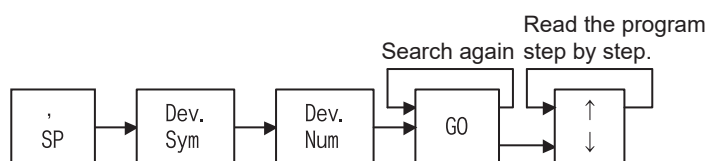

## 5.3 Write

Press the **RD/WR** key once to select the read mode, and press it again to select the write mode. (The mode is selected alternately.)

### 5.3.1 Overview of the write operation

Programs are written to the memory in the PLC in the online mode if a memory cassette is not attached to the PLC.

Programs are written to a memory cassette (except EPROM) in the online mode if it is attached to the PLC. (Set the write protect switch of the memory cassette to OFF if it is an EEPROM or FLROM.)

Programs are written to the RAM in the FX-30P in the offline mode.

Programs can only be written while the PLC is in STOP mode.

New programs can be written, and existing programs can be overwritten for modification.

When writing a new program, input instructions from step No. 0.

When overwriting an existing program for modification, put the cursor on a position to be modified, then input an instruction.

- Write operation condition

PLC status		PLC memory			
RUN	STOP	Built in memory	RAM cassette	EEPROM cassette FLROM cassette	EPROM cassette
-	✓	✓	✓	△*1	-

- \*1. Data can be written only while the write protect switch is OFF when an EEPROM or FLROM cassette is attached to the PLC.

### 5.3.2 Input of basic instructions

- Basic instructions are classified as those which are input individually such as "ORB" and "MPS", those which are input together with a device such as "LD X000" and "AND M0", and those which are input together with a device (first device) and set value (second device).
- The prompt is displayed while the FX-30P is waiting for input of a device symbol or device number.
- The device number range varies depending on the PLC model, and is checked when a program is input.
- The nesting level symbol "N" is automatically displayed when the MCR instruction is input.

#### Basic operation

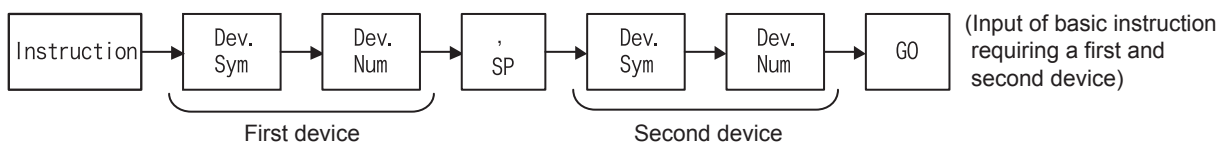
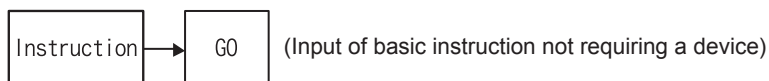

	Instruction words
Instruction words are entered individually	ANB, ORB, MPS, MRD, MPP, MEP, MEF, RET, END, NOP
Instruction words which are entered together with a device	LD, LDI, AND, ANI, OR, ORI, SET, RST, PLS, PLF, MCR, STL, OUT (excluding T and C)
Instruction words which are entered together with a first and second device	MC, OUT(T, C)

#### Contact instructions other than LD, LDI, AND, ANI, OR and ORI

Instruction	Key operation
LDP	LD P/I → Dev. Sym Dev. Num → GO
LDF	LD F → Dev. Sym Dev. Num → GO
ANDP	AND P/I → Dev. Sym Dev. Num → GO
ANDF	AND F → Dev. Sym Dev. Num → GO
ORP	OR P/I → Dev. Sym Dev. Num → GO
ORF	OR F → Dev. Sym Dev. Num → GO
INV	NOP P/I → GO
Comparison contact instruction	Comparison contact instructions can be entered in the same way as applied instructions. Refer to Subsection 5.3.3.

### 5.3.3 Writing of application instructions

- When entering an applied instruction, press the **[FNC]** key first, then input the instruction No. When entering the instruction No., directly input a desired No. or display the instruction symbol list by using the help function, search and find a desired instruction, then input it. If the instruction No. is not clear, use the help function.

- What is an operand

Operands are devices used for operations of instructions.

- For example, in the case of the MOV instruction,

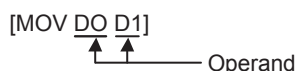

When entering an operand, make sure to input it in the order "[SP] + [operand]".

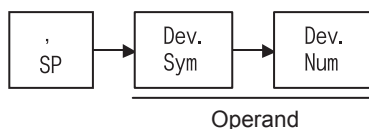

- Timing to specify the D (double)/P (pulse) instruction  
Specification of the D/P instruction is valid if it is executed in the same order as the display (operation example 1) or if it is executed after input of the instruction No. Either D and P can be specified first or the operator can press the **[HELP]** key to display the instruction word list, check whether D and P can be specified for the instruction, and then specify D and/or P.
- Restriction in programming when the FX2(FX)/FX2C Series PLC is used  
When a RAM file register is used as an operand, only the BMOV instruction is available.
- Using the ASC instruction, ASCII characters can only be read and not written. For writing ASCII characters, use the programming software.

1) Input by FNC No.

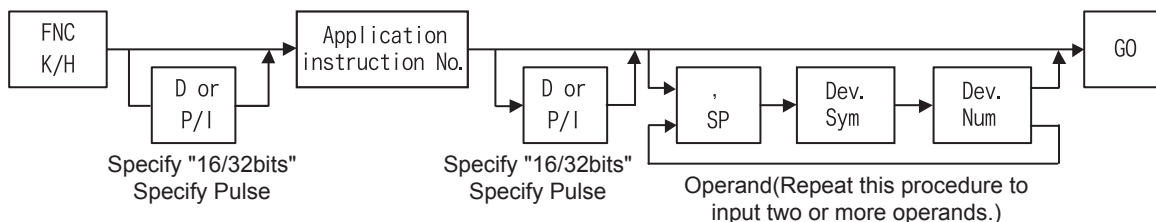

- An error will occur if an applied instruction is not supported in the PLC.
- Press the **[FNC]** and **[HELP]** keys in this order to display details of application instructions on screen. These detail items 0 to 29 are set on four screens, and the screens can be scrolled with the cursor control keys.
- Among the detail items, select a desired item by using the number keys. Input a number starting with the 100's digit, then the 10's digit, and finally the 1's digit. When the 10's digit is entered, instructions whose 10's digit is the same as input number are displayed on the screen. Only application instructions valid in the PLC being use are displayed in the list. Scroll the screens by using the cursor control keys, then entered a number for the 1's digit. The operation above specifies the applied instruction No.. Then, input an operand.

2) Searching for a FNC number using the help function, and inputting the detected FNC number

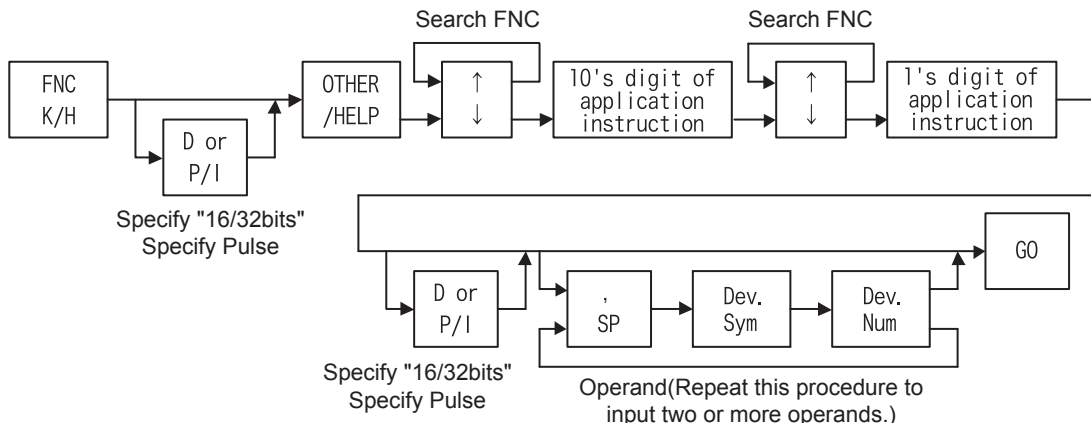

Display example

Step 2)

00	PROGRAM FLOW
01	MOVE AND COMPARE
02	ARITHMETIC, LOGIC
03	ROTATION, SHIFT
04	DATA OPERATION
05	HIGH SPEED
06	HANDY INSTRUCTION
07	FX I/O DEVICES

\*1

Step 3)

NO.	SYMBOL	S	D	P	n
010	CMP	●	●	●	3
011	ZCP	●	●	●	4
012	MOV	●	●	●	2
013	SMOV	●	—	●	5
014	CML	●	●	●	2
015	BMOV	●	—	●	3

\*2

Step 11)

W	1	DMOV	P	12
		D		0
		D		2
	10	NOP		
	11	NOP		
	12	NOP		
	13	NOP		
	14	NOP		

Key operation

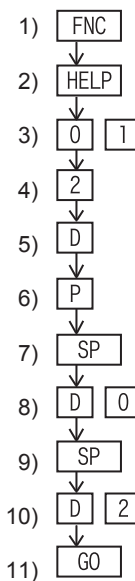

\*1 Detail categories of applied instructions

(The number on the left indicates the detail category number.)

- |                      |                       |
|----------------------|-----------------------|
| 00 PROGRAM FLOW      | 16 TIME CONTROL       |
| 01 MOVE AND COMPARE  | 17 EXTERNAL DEVICE    |
| 02 ARITHMETIC, LOGIC | 18 ADDITIONAL FUNC    |
| 03 ROTATION, SHIFT   | 19 BLOCK DATA OPS.    |
| 04 DATA OPERATION    | 20 CHARACTER STRING   |
| 05 HIGH SPEED        | 21 DATA OPERATION 3   |
| 06 HANDY INSTRUCTION | 22 DATA COMPARISON 1  |
| 07 FX I/O DEVICES    | 23 DATA COMPARISON 2  |
| 08 FX SER DEVICES    | 24 DATA COMPARISON 3  |
| 09 F2 DEVICES        | 25 DATA TABLE OPS. 1  |
| 10 DATA TRANSFER 2   | 26 DATA TABLE OPS. 2  |
| 11 FLOATING POINT 1  | 27 INV.,DATA TRANS. 3 |
| 12 FLOATING POINT 2  | 28 HIGH SPEED 2       |
| 13 FLOATING POINT 3  | 29 FILE REGISTER      |
| 14 DATA OPERATION 2  | 30 FX3U-CF-ADP INSTR. |
| 15 POSITIONING       |                       |

\*2 Contents shown in the applied instruction symbol list

①	②	③	④	⑤	⑥
NO.	SYMBOL	S	D	P	n
010	CMP	●	●	●	3
011	ZCP	●	●	●	4
012	MOV	●	●	●	2
013	SMOV	●	—	●	5
014	CML	●	●	●	2
015	BMOV	●	—	●	3

- ① NO.: FNC No.(The 2 digits indicates the detail category number.)
- ② Symbol: Instruction symbol
- ③ S: 16-bit instruction(Correspond of ● )
- ④ D: 32-bit instruction(Correspond of ● )
- ⑤ P: Pulse instruction(Correspond of ● )
- ⑥ n: Operand Num.(decimal display)

3) Selecting a FNC from the FNC history list using the help function, and inputting the selected FNC

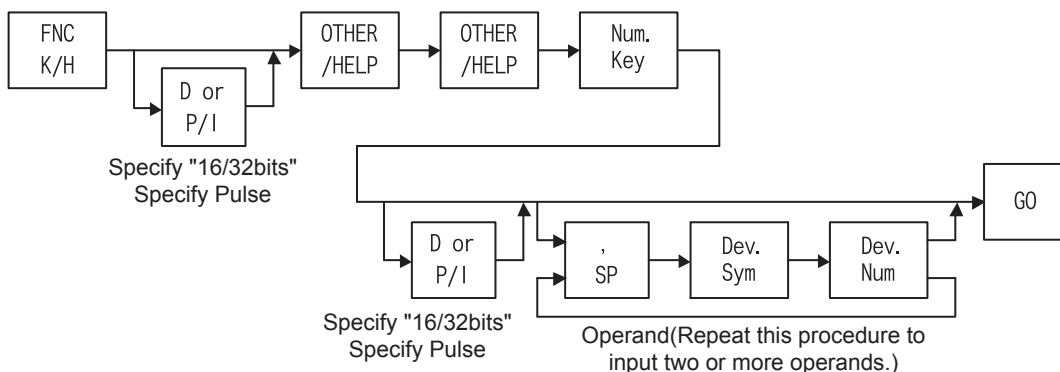

4) Selecting a FNC from the FNC list using the help function, and inputting the selected FNC

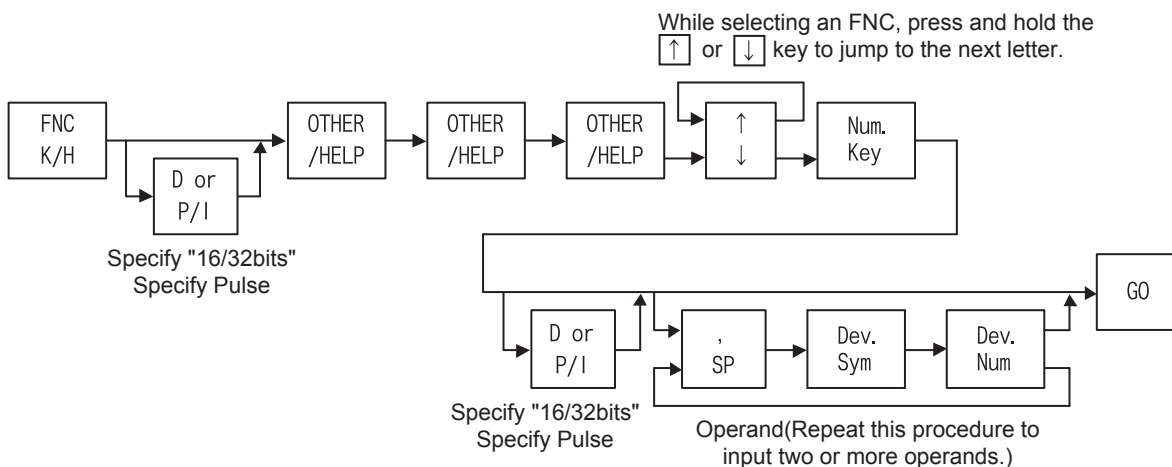

5.3.4 Input of labels (P, I)

- When using a P (pointer) or I (interrupt pointer) in a sequence program as a label, enter in the same way as instructions.

Basic operation

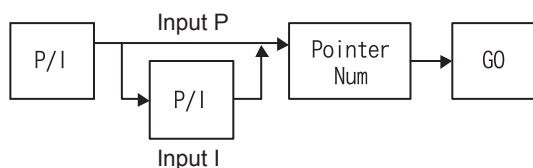

- 1 Introduction
- 2 Specifications, product configuration
- 3 Connections, startup procedure
- 4 Outline of programming
- 5 Online mode
- 6 Offline mode
- 7 HPP setting
- 8 Battery
- A ASCII Code
- B Message List

### 5.3.5 Input of numbers

- When numbers are entered, each number is shifted to the next digit in the display. Accordingly, if numbers are input beyond the displayable digits, numbers already input are deleted from the display screen from the oldest entry. When the device symbol is X or Y, if an input numeric value is less than 3 digits, "0" is displayed in the higher digits.
- Only numbers displayed on the screen are registered. Check the displayed numbers carefully when inputting a numeric value.

Example 1: When pressing the , , ,  and  keys for input to the four-digit display area

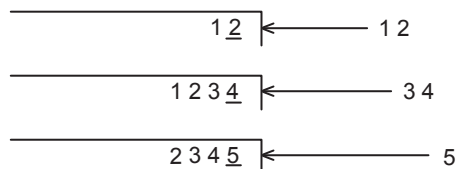

- Constant K (decimal number)  
The decimal constant specification range is as follows:
  - When word data (16 bits) is used ... K-32768 to K32767
  - When double data (32 bits) is used ... K-2,147,483,648 to K2,147,483,647

Example: K -50



- Constant H (hexadecimal number)  
The hexadecimal constant setting range is as follows:
  - When word data (16 bits) is used ... H0 to HFFFF
  - When double data (32 bits) is used ... H0 to HFFFFFFFF

Example: H1234



- Constant E (real number)  
The real number setting range is from  $-1.0 \times 2^{128}$  to  $-1.0 \times 2^{-126}$ , 0 and  $1.0 \times 2^{-126}$  to  $1.0 \times 2^{128}$ . In a sequence program, a real number can be specified in two methods, "normal expression" and "exponent expression".

- Normal expression: . . . Specify a numeric value as it is.  
For example, specify "10.2345" in the form "E10.2345"

Example: E10.2345



- Exponent expression: . . . Specify a numeric value in the format "(numeric value)  $\times 10^n$ ".  
For example, specify "1234" in the form "E1.234 + 3".  
"+3" in "E1.234 + 3" indicates "10<sup>3</sup>".

Example: E1.234 + 3

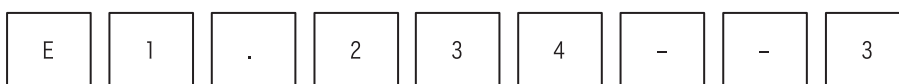



### 5.3.6 Batch write of NOP to specified range (Program clear to specified range)

- Write the NOP (no processing) instruction to a specified program range. If programs already exist in the specified range, they are overwritten by the NOP instruction. In the PLC, programs in the specified range are deleted.
- Press the **[RD/WR]** key, and move the cursor to the first step for writing the NOP instruction. At this point, the cursor cannot move to a line without the step No.
- If a specified end step No. is a jump No., the end of the instruction is registered as the end step.

#### Basic operation

Specified start step

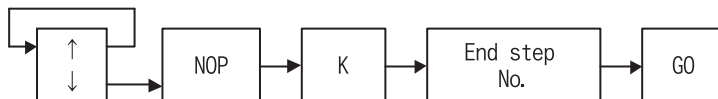

### 5.3.7 Batch write of NOP to specify the entire range (Program all clear)

- Write the NOP (no processing) instruction to the whole program range. If programs already exist in the program range, they are overwritten by the NOP instruction.
- This operation deletes all programs and parameters (including the keyword if the correct keyword has been input).
- Press the **[RD/WR]** key, and then press the **[NOP]** and **[A]** keys in this order. The cursor position does not affect the NOP instruction writing range.
- Press the **[GO]** key. When the message for confirming the program all clear operation appears, press the **[GO]** key to write the NOP instruction to the whole program range (program all clear). After the whole program range is cleared, the cursor moves to step No. 0.

#### Basic operation

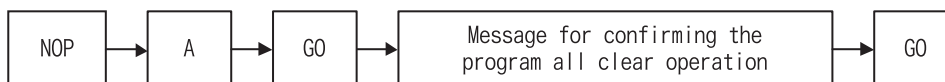

#### IMPORTANT

When the NOP instruction is written to the whole program range, every parameter is reset to the initial value, and the latched contents are cleared. As a result, the comment area becomes "0" block, and the file register area also becomes "0" block. The memory capacity is reset to the initial value of each PLC model.

If a memory cassette is attached and the online mode is selected, however, the memory capacity depends on the memory cassette capacity. The keyword is cleared.

- The following devices can be backed up against power failure in the FX Series PLC.
  - 1) M (Auxiliary relays)
  - 2) S (States)
  - 3) T (Timers)
  - 4) C (16-bit counters)
  - 5) C (32-bit counters)
  - 6) D (Data registers)
  - 7) D (File registers)
  - 8) R (Extension register)
  - 9) ER (Extension file register)

### 5.3.8 Modification method (before/after confirmation)

- A input program can be modified before confirmation (before the **GO** key is pressed) or after confirmation (after the **GO** key is pressed.)

Before confirmation, press the **CLEAR** key, then enter the correct contents again from an instruction. After confirmation, move the cursor to a line to be modified, then enter the correct contents.

- Press the **CLEAR** key once to cancel the second device before confirmation. Press the **CLEAR** key twice to cancel the selected instruction.

Reading a program, then overwriting a specified step in the unit of instruction

Example: Overwriting the OUT instruction in the step No. 100 with "T50" and "K123"

Display example

Step 4)

```
R 100 OUT M 100
  101 LDI X 010
  102 AND M 20
  103 AND M 30
  104 SET M 50
  105 OUT Y 012
  106 RST C 1
  108 LD M 70
```

Step 7)

```
W 100 OUT T 50
  101 LDI X 010
  102 AND M 20
  103 AND M 30
  104 SET M 50
  105 OUT Y 012
  106 RST C 1
  108 LD M 70
```

Step 9)

```
W 100 OUT T 50
      K 123
  101 LDI X 010
  102 AND M 20
  103 AND M 30
  104 SET M 50
  105 OUT Y 012
  106 RST C 1
```

Step 10)

```
W 100 OUT T 50
      K 123
  103 LDI X 010
  104 AND M 20
  105 AND M 30
  106 SET M 50
  107 OUT Y 012
  108 RST C 1
```

Key operation

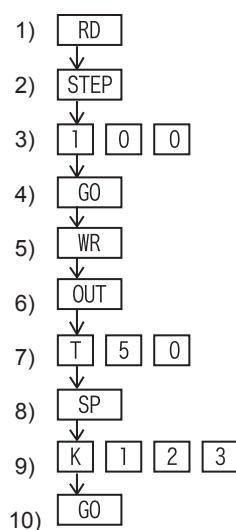

- Set values of timers and counters that can be changed by using the monitor function.(Refer to Section 5.6.)
- When consecutively overwriting an instruction or pointer near the currently read portion of the program, directly move the line cursor to the position to be overwritten.

- Handling of the step No. during overwriting  
 If the number of instruction or pointer steps is different before overwriting and during overwriting, perform the following processing and overwrite the step No. as well.  
 In the case of NOP, overwrite only NOP.

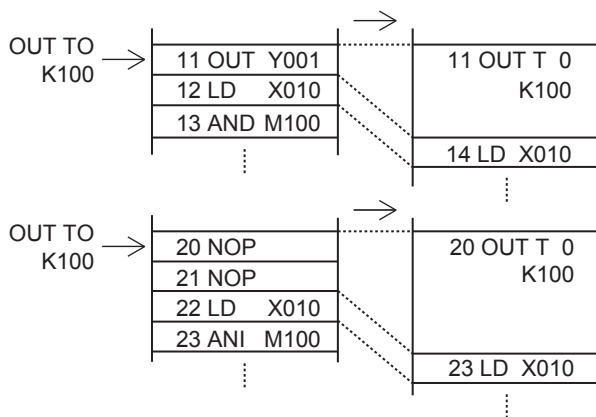

**Modification example of instruction accompanied by an operand**

- What is an operand?  
 Operands are devices used for operations of instructions.

- For example, in the case of MOV instruction,

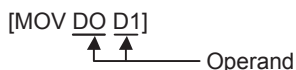

When inputting an operand, make sure to input it in the order "[SP] + [operand]".

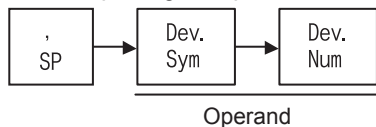

**Basic operation**

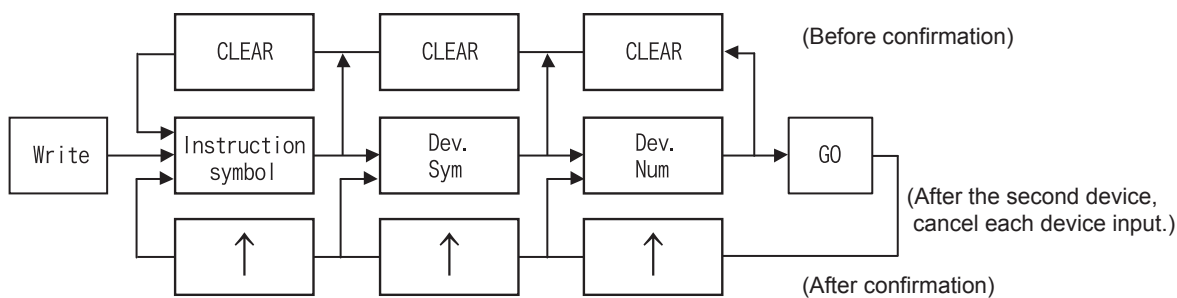

1 Introduction  
 2 Specifications, product configuration  
 3 Connections, startup procedure  
 4 Outline of programming  
 5 Online mode  
 6 Offline mode  
 7 HPP setting  
 8 Battery  
 A ASCII Code  
 B Message List

### 5.3.9 Modification of a device

#### Basic operation

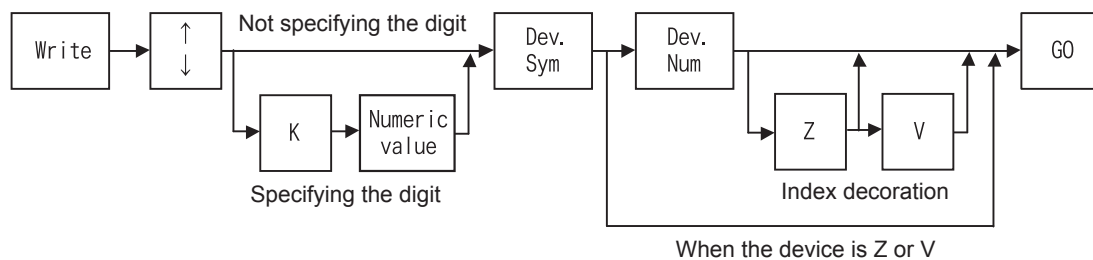

- One to eight digits can be specified.  
One digit uses 4 bits, and 8 digits uses 32 bits.
- "Z" and "V" indicate index registers.  
An index register is added to a device to modify the device No.

#### Overwriting only a specified instruction device

Example: Modifying the device K2 (digit specification) in the MOV P instruction in the step No. 100 from "X100" to "K1X0"

#### Display example

Step 4)

R	100	MOV P	12
		K2X	100
		D	1
105	LD	M	010
106	SET	M	50
107	OUT	Y	012
108	RST	C	1
110	LD	M	70

Step 8)

W	100	MOV P	12
		K1X	0
		D	1
105	LD	X	010
106	SET	M	50
107	OUT	Y	012
108	RST	C	1
110	LD	M	70

#### Key operation

- 1)
- 2)
- 3)
- 4)
- 5)
- 6)  (Put the cursor on a numeric value to be modified.)
- 7)
- 8)
- 9)

- Only lines without a step No. can be modified.  
(If a line with a step No. is to be modified, change it by editing the instruction.)
- When specifying the digit, press the  key first, then input a numeric value

## 5.4 Insert

Press the **INS/DEL** key once to select the insert mode. Press the **INS/DEL** key again to select the delete mode. (The mode is selected alternately.)

### 5.4.1 Overview of the insert operation

In the online mode, a program is inserted into the memory in the PLC if a memory cassette is not attached to the PLC.

In the online mode, a program is inserted into a memory cassette (except EPROM cassettes) if it is attached to the PLC. (When an EEPROM or FLROM cassette is attached, set the write protect switch to OFF.)

In the offline mode, a program is inserted into the RAM in the FX-30P.

Insertion is enabled when the PLC is in the STOP status.

Read a program, and insert an instruction or pointer in a specified position.

An instruction or pointer is inserted in a position above the step specified by the cursor. (Lines not displaying the step No. cannot be specified.)

After the inserted position, each step No. is automatically adjusted. (The display is shifted down.)

When inserting an instruction or pointer near the currently read portion of the program, directly move the line cursor to the desired position.

#### Basic operation

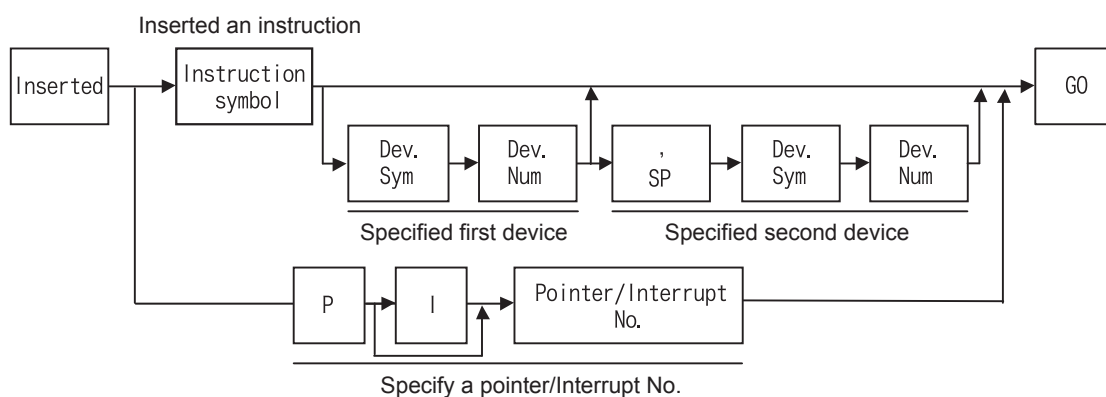

- Insert operation condition

PLC status		PLC memory			
RUN	STOP	Built in memory	RAM cassette	EEPROM cassette FLROM cassette	EPROM cassette
-	✓	✓	✓	△ *1	-

\*1. When an EEPROM or FLROM cassette is attached to the PLC, insertion is enabled only while the write protect switch is OFF.

<Online mode>

- Instructions and pointers are inserted into a program stored in the memory of the PLC.
- Instructions and pointers are inserted into a program stored in a memory cassette (except EPROM cassette) if it is attached to the PLC.
- Insertion is enabled when the PLC is in STOP status.

<Offline mode>

- Instructions and pointers are inserted into a program stored in the RAM in the FX-30P.
- Insertion is enabled into a program stored in the flash memory in the FX-30P after the program is transferred from the flash memory to the RAM in the FX-30P.

## 5.4.2 Insert operation

The insertion method is same as the writing method described in Section 5.3.

The existing instruction is overwritten by writing. On the other hand, the instructions existing in the step subject to insertion and later steps are shifted down by insertion.

### Cautions on inserting an instruction

If an instruction is inserted while the program memory is full and has no free space, a message is displayed and the insertion is not executed.

Example: Inserting the AND instruction M5 before the step No. 200

Display example

Step 4)

R	200	AND	T	100
	201	OR	C	20
	202	OUT	Y	020
	203	LD	M	010
	204	SET	M	50
	205	OUT	Y	012
	206	RST	C	1
	208	LD	M	70

Step 7)

I	200	AND	M	5
	200	AND	T	100
	201	OR	C	20
	202	OUT	Y	020
	203	LD	X	010
	204	SET	M	50
	205	OUT	Y	012
	206	RST	C	1

Step 8)

I	200	AND	M	5
	201	AND	T	100
	202	OR	C	20
	203	OUT	Y	020
	204	LD	X	010
	205	SET	M	50
	206	OUT	Y	012
	207	RST	C	1

Key operation

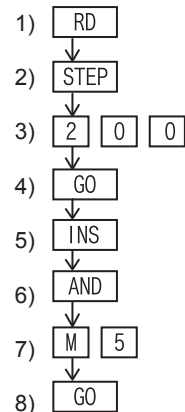

## 5.5 Delete

Press the **INS/DEL** key once to select the insert mode. Press the **INS/DEL** key twice to select the delete mode. (The mode is selected alternately.)

### 5.5.1 Overview of the delete operation

Read a program, and delete an instruction, pointer or NOP.

- Delete operation condition

PLC status		PLC memory			
RUN	STOP	Built in memory	RAM cassette	EEPROM cassette FLROM cassette	EPROM cassette
-	✓	✓	✓	Δ *1	-

\*1. When an EEPROM or FLROM cassette is attached to the PLC, deletion is enabled only while the write protect switch is OFF.

<Online mode>

- Instructions and pointers are deleted from a program stored in the memory of the PLC.
- Instructions and pointers are deleted from a program stored in a memory cassette (except EPROM cassette) if it is attached to the PLC.
- Deletion is enabled while the PLC is in the STOP status.

<Offline mode>

- Instructions and pointers are deleted from a program stored in the RAM in the FX-30P.
- Deletion is enabled from a program stored in the flash memory in the FX-30P after the program is transferred from the flash memory to the RAM in the FX-30P.

<b>1</b>	Introduction
<b>2</b>	Specifications, product configuration
<b>3</b>	Connections, startup procedure
<b>4</b>	Outline of programming
<b>5</b>	Online mode
<b>6</b>	Offline mode
<b>7</b>	HPP setting
<b>8</b>	Battery
<b>A</b>	ASCII Code
<b>B</b>	Message List

## 5.5.2 Deletion of instructions and pointers

### Basic operation

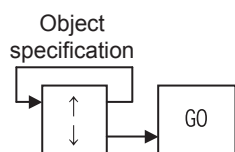

- Using operation above, the instruction in the cursor position is deleted.  
For instructions which use two or more lines such as set values of timers and counters and operands of applied instructions, when the instruction part, set value, or operand is deleted, all lines are deleted at the same time.
- After the deleted position, each step No. is automatically adjusted. (The display is shifted up.)

Example: Deleting "AND M10" in the step No. 10

Display example

Step 6)

D	100	AND	M	10
	101	SET	M	12
	102	LDI	X	010
	103	AND	M	30
	104	SET	M	50
	105	OUT	Y	012
	106	RST	C	1
	108	LD	M	70

Step 7)

D	100	SET	M	12
	101	LDI	X	010
	102	AND	M	30
	103	SET	M	50
	104	OUT	Y	012
	105	RST	C	1
	107	LD	M	70
	108	OUT	Y	020

Key operation

- 1)
- 2)
- 3)
- 4)
- 5)  } Select the delete function
- 6)
- 7)



### 5.5.3 Batch deletion of a program by specifying the range to be deleted

- The range of the program specified by step No.'s. is deleted.
- If an instruction in the specified start step No. uses two or more lines, the head of the instruction is regarded as the start step. If an instruction in the specified end step No. uses two or more lines, the end of the instruction is regarded as the end step.
- On the screen after the specified range is deleted, deleted steps are eliminated, and the program is displayed from the deleted start step No..

#### Basic operation

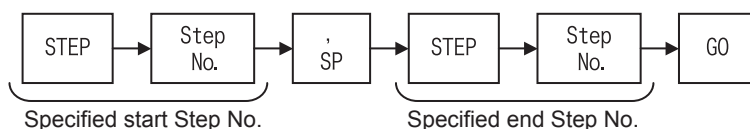

Example: Deleting the range from step No. 100 to step No. 140

#### Display example

Step 5)

```
D  100 AND  M  10
   101 SET  M  12
   102 LDI  X  010
   103 AND  M  30
   104 SET  M  50
   105 OUT  Y  012
   106 RST  C   1
RANGE 100 -
```

Step 7)

```
D  100 AND  M  10
   101 SET  M  12
   102 LDI  X  010
   103 AND  M  30
   104 SET  M  50
   105 OUT  Y  012
   106 RST  C   1
RANGE 100 - 140
```

Step 8)

```
D  100 SET  M  12
   101 LD   X  022
   102 AND  T  10
   103 SET  M  17
   104 OUT  Y  012
   105 RST  C   5
   107 LDI  M  24
   108 OUT  Y  020
```

#### Key operation

- 1)
- 2)
- 3)
- 4)
- 5)
- 6)
- 7)
- 8)

### 5.5.4 Batch deletion of NOP instructions

#### Basic operation

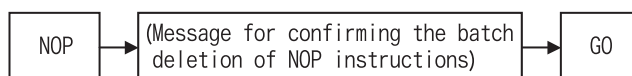

- All NOP instructions existing from step No. 0 to the final instruction (except the NOP instruction) are deleted at the same time. After batch deletion of NOP instructions, each step No. is automatically adjusted. (The display is shifted up.)

1

Introduction

2

Specifications,  
product  
configuration

3

Connections,  
startup  
procedure

4

Outline of  
programming

5

Online mode

6

Offline mode

7

HPP setting

8

Battery

A

ASCII Code

B

Message List

## 5.6 Monitor

Press the **[MNT/TEST]** key once to select the monitor function. Press the **[MNT/TEST]** key again to select the test function. (The function is selected alternately.)

### 5.6.1 Overview of the monitor operation

Display the PLC operation status on the 30P. (The monitor operation is available even when the PLC is in the STOP status.)

The monitor operation is valid only when the online mode is selected.

(If the offline mode is selected when the 30P started up, it can be changed to the online mode by using the others function.)

- Monitor operation condition

PLC status		PLC memory			
RUN	STOP	Built in memory	RAM cassette	EEPROM cassette FLROM cassette	EPROM cassette
✓	✓	✓	✓	✓	✓

- The PLC operation status is displayed in the FX-30P.
- The monitor function is valid only in the online mode.

#### The screen display

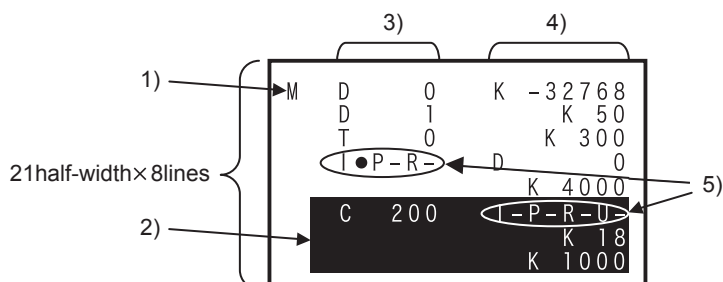

- 1) Mode  
Indicates the monitor mode (M).
- 2) Line cursor  
Moves among lines, and specifies a line to be tested.
- 3) Device  
Indicates the device symbol and device number.
- 4) Present value or T/C set value  
Displays the present value of devices and the set value of timers and counters.
- 5) T/C coil/contact ON/OFF status  
Displays the ON/OFF status of coils and contacts of timers and counters.  
I: Coil ON/OFF status P: Contact ON/OFF status R: Reset image  
U: Up/down-counter status  
(-: OFF, ● : ON)

### 5.6.2 List program monitor

- In the list program monitor, the list program is displayed and the status of contacts and coil driving are indicated.
- In conductive contacts and operating coils, "●" is added after the instruction.
- The SET and RST command are displayed in ON or OFF state of the device to be set or reset.

#### Basic operation

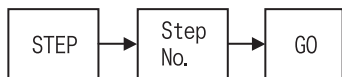

Example: Monitoring step No. 100

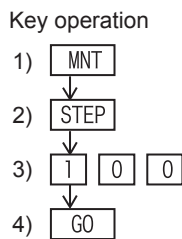
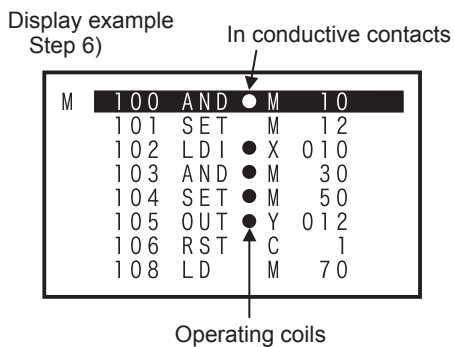

### 5.6.3 Device monitor

- Specify and display a device to be monitored.
- For bit devices (X, Y, M and S), the ON/OFF status is displayed. For timers (T) and counters (C), the present value and the set value are displayed. For data registers (D), index registers (V and Z), and extension registers (R), the present value is displayed.
- When displaying word devices (T, C, D, V, Z and R), press the  $\boxed{\text{U/G}}$  key to change the format between decimal and hexadecimal.
- When displaying a word device (D, V, Z and R) in 32bits, press the  $\boxed{\text{D}}$  key, and then press a key corresponding to the device type.

#### Basic operation

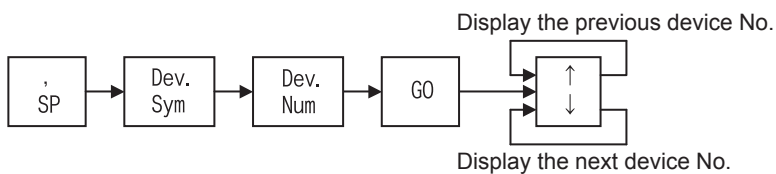

Example: Monitoring device X000

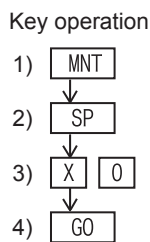
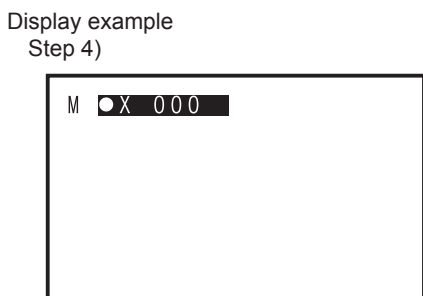

1	Introduction
2	Specifications, product configuration
3	Connections, startup procedure
4	Outline of programming
5	Online mode
6	Offline mode
7	HPP setting
8	Battery
A	ASCII Code
B	Message List

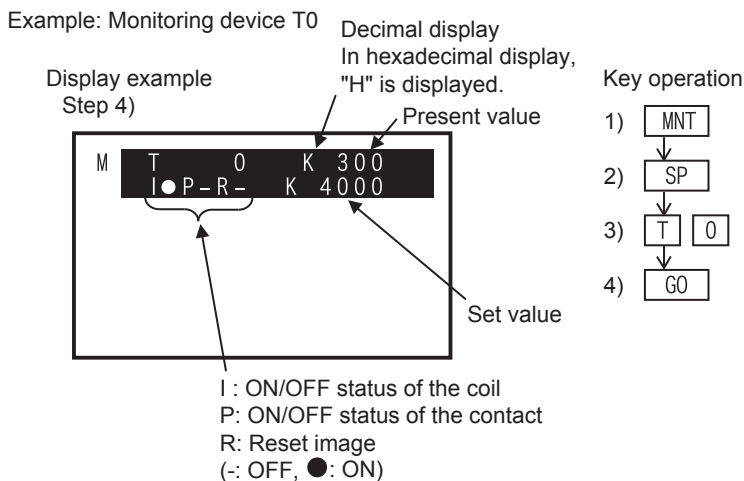

- When the set value is indirectly specified through a data register (D), the data register No and the present value of the data register are displayed as the set value.

Display example

When the set value is specified indirectly

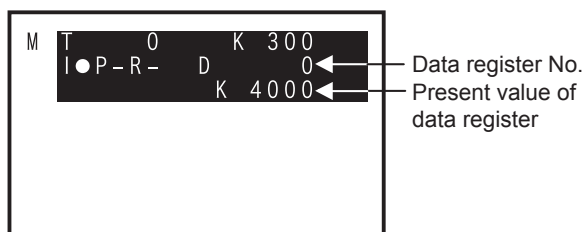

### 5.6.4 Operation state monitor

- When a step ladder type program is running in the PLC, up to eight operating states can be displayed.
- As the state changes, displayed No's. automatically indicate the operation process of the machine.
- Only the states in the range from S0 to S899, S1000 to S4095 can be monitored. S900 to S999 (for annunciators) are ignored.
- Before executing the operation state monitor, set M8047 (STL monitor valid) to ON in the PLC.

#### Basic operation



Display example

Operation state monitor

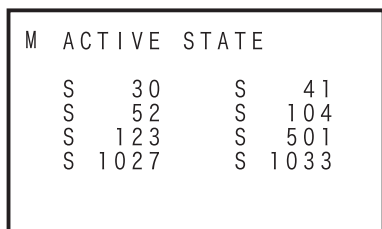

When M8047 (STL monitor) is set to OFF

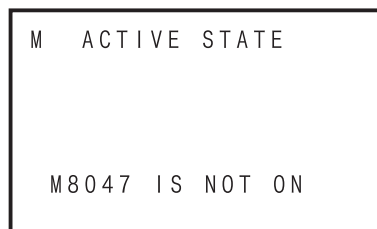

#### Monitoring annunciators

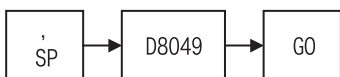

If M8049 is set to ON, the smallest No. of operating states among S900 to S999 can be monitored through the operation above.

## 5.7 Test

### OPERATION PRECAUTIONS



### CAUTION

- Thoroughly read the manual and sufficiently assure safety before executing the operation to forcibly set devices to ON/OFF or the operation to change present values and set values of word devices in the test mode. Otherwise, the machine may be damaged and accidents may occur by erroneous operations.

Press the **[MNT/TEST]** key once to select the monitor function. Press the **[MNT/TEST]** key again to select the test function. (The function is selected alternately.)

### 5.7.1 Overview of the test function

In the test mode, devices in the PLC can be forcibly set to ON/OFF, present values of word devices (T, C, D, V, Z and R) in the PLC can be changed, and set values of timers (T) and counters (C) in the PLC can be changed from the HPP. Perform the device monitor operation to display devices in the PLC to be changed.

- Test operation condition

PLC status		PLC memory			
RUN	STOP	Built in memory	RAM cassette	EEPROM cassette FLROM cassette	EPRM cassette
✓	✓	✓	✓	△ *1	△ *2

- \*1. The set value of timers and counters cannot be changed while an EEPROM cassette or FLROM cassette is attached to the PLC and the PLC is in the RUN status. When the protect switch is ON, set values cannot be changed.
- \*2. The set value of timers and counters cannot be changed while an EPRM cassette is attached to the PLC.
  - Turn ON or OFF devices forcibly, change the set value of word devices, and change the set value of timers and counters.
  - The test function is valid only in the online mode.

#### The screen display

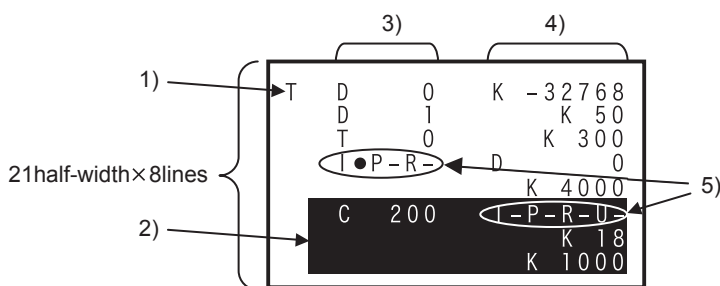

- 1) Mode  
Indicates the test mode (T).
- 2) Line cursor  
Moves among lines, and specifies a line to be tested.
- 3) Device  
Indicates the device symbol and device number.
- 4) Present value or T/C set value  
Displays the present value of devices and the set value of timers and counters.
- 5) T/C coil/contact ON/OFF status  
Displays the ON/OFF status of coils and contacts of timers and counters.  
I: Coil ON/OFF status P: Contact ON/OFF status R: Reset image  
U: Up/down-counter status  
(-: OFF, ●: ON)

## 5.7.2 Forcible setting of devices to ON/OFF

- From the 30P, forcibly set devices in the PLC to ON or OFF.
- The forcible ON/OFF operation is valid for input relays (X), output relays (Y), auxiliary relays (M), states (S), timers (T), and counters (C).
- The forcible ON/OFF operation sets ON or OFF for devices only in one operation cycle. While the PLC is in the RUN status, the forcible ON/OFF operation is actually valid to the present value clearing circuit for timers (T), counters (C), data registers (D), index registers (V and Z), and extension registers (R), set/reset circuits and self-holding circuits. (Forcible setting of timers to ON is valid only when a timer is driven by a program.)
- When the PLC is in the STOP status or if the target device is not used in the program, the result of the forcible ON/OFF operation is maintained. However, because a input refresh is executed to input relays (X) even if the PLC is in the STOP status, the result of the forcible ON/OFF operation is not maintained for input relays (X). (The result is updated to the input terminal status.)
- Present values of file registers can be cleared only while the program memory in the PLC is RAM or EEPROM, FLROM (with the write-protect switch set to OFF).

### Basic operation



Example: Forcibly setting the Y000 to ON/OFF

Display example

Step 1)

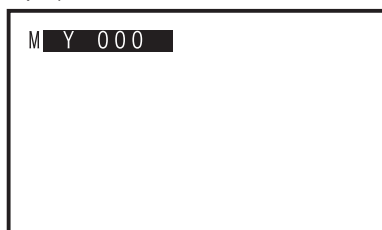

Step 3)

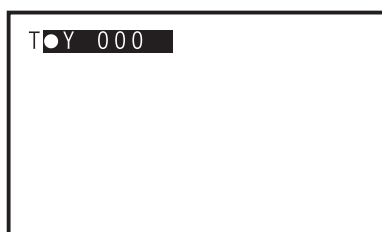

Step 4)

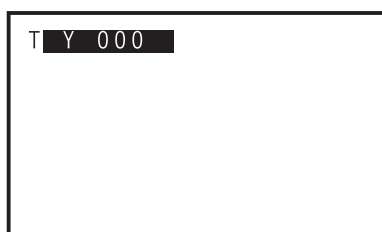



Key operation

- 1) Device monitor of the Y000
- 2) TEST
- 3) SET Forcible ON
- 4) RST Forcible OFF

- Set the PLC to the STOP status, then forcibly set output relays (Y) to ON/OFF to check the output wiring.

### 5.7.3 Change the present value of word devices (T, C, D, V, Z, R)

- From the 30P, change present values of word devices (T, C, D, V, Z and R) in the PLC.
- Input a decimal or hexadecimal number as the present value. (Use the  key to switch between decimal mode and hexadecimal mode.)
- For the display of word devices (T, C, D, V, Z and R), use the  key to switch between decimal mode and hexadecimal mode.
- Use this function to write data to file registers in the PLC. When the PLC is in the RUN status, this function is valid for the RAM in the PLC. While the PLC is in the STOP status, this function is valid for the RAM or the EEPROM, FLROM (with the write-protect switch set to OFF) in the PLC. In devices other than file registers, data registers (D), timers (T), counters (C), index registers (V and Z), and extension registers (R), present values can be changed without regard to the PLC status (RUN or STOP) and the program memory type.

#### Basic operation

Change the decimal and hexadecimal.

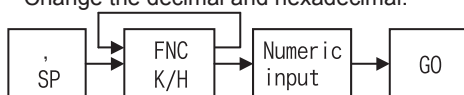

Example: Changing the present value of the D0  
Changing the present value of the D0 from "K0" to "K10"

Display example

Step 1)



Step 3)



Step 4)

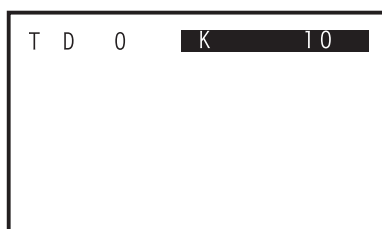

Key operation

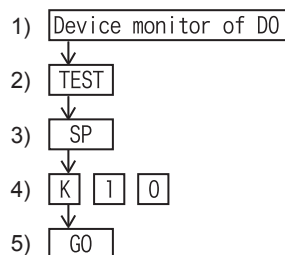

- When changing the present value of 32-bit data, execute the device monitor operation for 32-bit data (Refer to Subsection 5.6.3) in step 1). The operation after that is the same as that for 16-bit data.

1

Introduction

2

Specifications,  
product  
configuration

3

Connections,  
startup  
procedure

4

Outline of  
programming

5

Online mode

6

Offline mode

7

HPP setting

8

Battery

A

ASCII Code

B

Message List

### 5.7.4 Change the set value of timers (T) and counters (C)

- From the 30P, change set values of timers (T) and counters (C) existing in programs in the PLC.
- While the PLC is in RUN status, set values can be changed if the program memory is in the RAM. While the PLC is in STOP status, set values can be changed if the program memory is in the RAM or the EEPROM, FLROM (with the write-protect switch set to OFF).
- Set values can be changed in two ways: by changing the device monitor to test mode and by changing the list program monitor to test mode. If a set value is changed by using the device monitor in test mode, the timer (T) or the counter (C) nearest to step No. 0 in the program is automatically regarded as the target. When changing the set value of a timer (T) or counter (C) having same No., select a desired timer (T) or counter (C) in the list program monitor, then change its set value.

#### Basic operation

- Operation to change the device monitor to test mode.

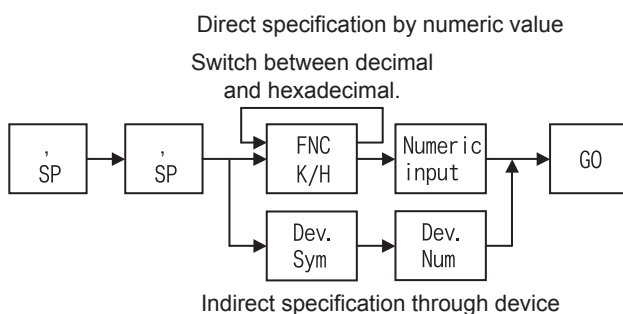

- Operation to change the list program monitor to test mode.

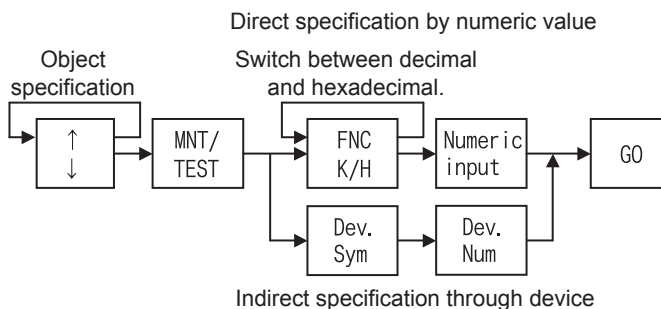



Example: Changing the set value from the device monitor  
Changing the set value of the T5 from "K100" to "K400"

Display example

Step 1)

```

M   T   5   K 0
  -P-R-   K 100
  
```

Step 4)

```

T   T   5   K 0
  -P-R-   K 100
  
```

Step 5)

```

T   T   5   K 0
  -P-R-   K 400
  
```

Key operation

- 1) Device monitor of the T5
- 2) TEST
- 3) SP Displays the prompt in the present value
- 4) SP Displays the prompt in the setting value
- 5) K 4 0 0
- 6) GO

- If the set value of a timer (T) is indirectly specified through a data register, the data register (D) No. can be changed by the operation above. When changing the present value of a data register (D) which indicates the actual set time, execute the present value change operation. (Refer to Subsection 5.7.3.)

Example: Changing the set value from the list program monitor

Changing the set value of "OUT C" in the step No. 15 from "K10" to "D20"

Display example

Step 1)

```

M   15 OUT C   0
      K 10
18 LDI X   010
19 AND M   20
20 AND M   30
21 SET M   50
22 OUT Y   012
23 RST C    1
  
```

Step 2)

```

M   15 OUT C   0
      K 10
18 LDI X   010
19 AND M   20
20 AND M   30
21 SET M   50
22 OUT Y   012
23 RST C    1
  
```

Step 4)

```

T   15 OUT C   0
      D 20
18 LDI X   010
19 AND M   20
20 AND M   30
21 SET M   50
22 OUT Y   012
23 RST C    1
  
```

Key operation

- 1) Display step No.15 in the list program monitor.
- 2) ↓
- 3) TEST
- 4) D 2 0
- 5) GO

## 5.8 Others Function

Press **[OTHER/HELP]** key once to display list of "others" function, press again to display HELP, and press once more to return to initial screen. (To transfer to alternate display.)  
For HPP setting, refer to Chapter 7.

### 5.8.1 Overview of the others function

- Even when a program operation is being executed, pressing the **[OTHER/HELP]** key displays the others menu screen.
- You can set the following modes in others function of online mode.
  - CHANGE TO OFFLINE (ONLINE → OFFLINE)
  - DIAGNOSTICS PLC
  - DATA TRANSFER
  - PARAMETER
  - KEYWORD
  - DEVICE CONVERSION
  - LATCH CLEAR
  - DEV. BATCH MONITOR
  - BFM BATCH MONITOR
  - BAUDRATE
  - CLEAR PLC MEMORY
  - REMOTE RUN/STOP
  - SET PLC CLOCK
  - HPP SETTING

#### "Others" menu screen when online mode is selected

```

ONLINE MODE
1. CHANGE TO OFFLINE
2. DIAGNOSTICS PLC
3. DATA TRANSFER
▼4. PARAMETER
5. KEYWORD
6. DEVICE CONVERSION
7. LATCH CLEAR
8. DEV. BATCH MONITOR
9. BFM BATCH MONITOR
A. BAUDRATE
B. CLEAR PLC MEMORY
C. REMOTE RUN/STOP
D. SET PLC CLOCK
E. HPP SETTING
  
```

- **[↑]**, **[↓]** → Menu select
- **[GO]** → Confirm selection
- **[Num. Key]** → Select, and confirm
- **[RD/WR]**, **[INS/DEL]**, **[MNT/TEST]** → Change over to each mode

- 1 to E can be selected and determined by the "**[1]**" to "**[E]**" keys.

## 5.8.2 Change to offline

To change to offline mode.

- Offline change-over condition

PLC status		PLC memory			
RUN	STOP	Built in memory	RAM cassette	EEPROM cassette FLROM cassette	EPRAM cassette
✓	✓	✓	✓	✓	✓

### The screen display

```
CHANGE TO OFFLINE
*EXECUTE?

EXECUTE → 【GO】
CANCEL → 【CLEAR】
```

- **GO** → Offline change execution
- **CLEAR** → Return to other menu

- When offline mode is selected first time after shipping or after HPP initialization.

```
*SELECT PLC TYPE
1. FX0 (S)
2. FX0N
3. FX1
4. FX1S
5. FX1N (C)
6. FX2 (C)
7. FX2N (C)
8. FX3G (C)
9. FX3U (C)
A. FX3S
```

- **↑**, **↓** → Select PLC type
- **GO** → Confirm selection
- **Num. Key** → Select and confirm
- **CLEAR** → Return to other menu

- When HPP protection is activated.

```
INPUT HPP PROTECTKEY
*PROTECT KEY:
  1A8_____
EXECUTE → 【GO】
CANCEL → 【CLEAR】
```

- **Num. Key** → protection key input
- **↓** → Delete one character
- **GO** → Confirm input
- **CLEAR** → Return to other menu

- When HPP protect keys are mismatched.

```
INPUT HPP PROTECTKEY

KEY INCORRECT!

【CLEAR】
```

- **CLEAR** → Return to protection key input screen

- Display after execution of change to offline mode

```

OFFLINE MODE

TYPE:FX3U (C)

*SELECT MODE
    
```

- **RD/WR**, **INS/DEL**, **MNT/TEST**, **OTHER/HELP**  
→ Return to other mode

- TYPE : To display the selected PLC basic unit name.

### 5.8.3 Diagnostics PLC

You can check the programs in the PLC for "I/O ERROR", "PC H/W ERROR", "LINK ERROR", "PARA ERROR", "GRAMMAR ERROR", "LADDER ERROR", "RUN TIME ERROR", etc. If an error is found after PLC diagnosis, the error number, error classification, error code, and error occurrence step number are all displayed. If multiple errors are found, other errors can be displayed by **↑** and **↓** key. (Max.99 errors)

- Condition of diagnostics PLC

PLC status		PLC memory			
RUN	STOP	Built in memory	RAM cassette	EEPROM cassette FLROM cassette	EPROM cassette
✓	✓	✓	✓	✓	✓

- PLC diagnosis of memory of PLC (judged at the PLC side).
- PLC diagnosis of memory cassette when memory cassette is attached.

#### The screen display

- 1) Diagnostics PLC top screen

```

DIAGNOSTICS PLC
*EXECUTE?

EXECUTE → GO
CANCEL → CLEAR
    
```

- **GO** → Diagnostics PLC execution
- **CLEAR** → Return to other menu

- 2) In the absence of an error

```

DIAGNOSTICS PLC

NO ERROR

CLEAR
    
```

- **CLEAR** → Return to other menu

3) In the presence of an error

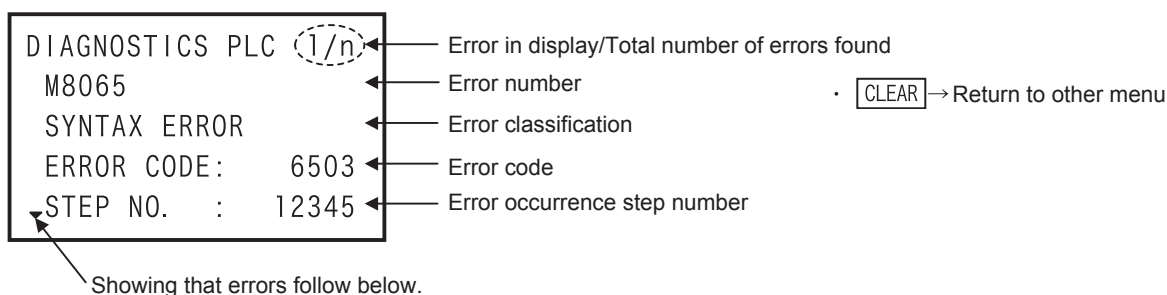

Showing that errors follow below.

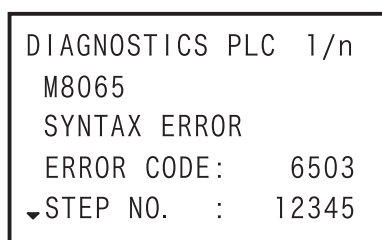

· [↑], [↓] → Change between multiple error detail displays.

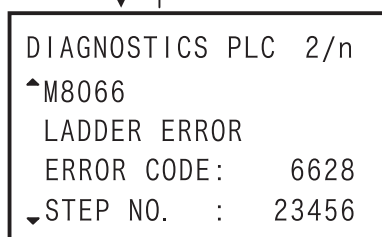

• Error list

✓: Applicable - : Not applicable

Special auxiliary relays	Error item	FX1	FX2, FX2C	FX0, FX0S	FX0N	FX1S, FX1N, FX1NC	FX2N, FX2NC	FX3S	FX3G, FX3GC	FX3U	FX3UC
M8060	I/O configuration error	✓	✓	-	-	-	✓	-	✓	✓	✓
M8061	PLC hardware error	✓	✓	✓	✓	✓	✓	✓	✓	✓	✓
M8062	PLC/PP communication error	✓	✓	-	-	✓	✓	✓*1	✓*2	✓*1	✓*1
M8063	Serial communication error 1	-	✓	-	Ver1.20 or later	✓	✓	✓	✓	✓	✓
M8438	Serial communication error 2	-	-	-	-	-	-	-	✓	✓	✓
M8064	Parameter error	✓	✓	✓	✓	✓	✓	✓	✓	✓	✓
M8065	Syntax error	✓	✓	✓	✓	✓	✓	✓	✓	✓	✓
M8066	Ladder error	✓	✓	✓	✓	✓	✓	✓	✓	✓	✓
M8067	Operation error	✓	✓	✓	✓	✓	✓	✓	✓	✓	✓
M8068	Operation error latch	✓	✓	✓	✓	✓	✓	✓	✓	✓	✓
M8109	I/O refresh error	-	-	-	-	-	✓	✓	✓	✓	✓
M8316	Unconnected I/O designation error	-	-	-	-	-	-	-	-	✓	✓
M8318	BFM initialization failure	-	-	-	-	-	-	-	-	✓	✓
M8449	Special block error	-	-	-	-	-	-	-	✓	✓	Ver.2.20 or later
M8487	USB communication error	-	-	-	-	-	-	✓	-	-	-
M8489	Special parameter error	-	-	-	-	-	-	✓	Ver.2.00 or later	Ver.3.10 or later	

\*1. When failure memory access in PP communication, M8062 is ON.

\*2. When a Serial communication error occurs, M8062 is ON.

- 1 Introduction
- 2 Specifications, product configuration
- 3 Connections, startup procedure
- 4 Outline of programming
- 5 Online mode
- 6 Offline mode
- 7 HPP setting
- 8 Battery
- A ASCII Code
- B Message List

### 5.8.4 Memory cassette transfer

- You can transfer or collate the program or parameter between PLC memory and memory cassette.
- The HPP automatically identifies the memory cassette type, then displays it.
- After creating or changing a program in the RAM, where it takes less time to write to, the program can be executed to operate the PLC from the EEPROM and FLROM, which have better storage capability.
- Transfer is disabled from a memory with a larger capacity to a memory that has a smaller capacity. (Such a transfer causes a parameter error.) In such a case change the parameters for the memory cassette first, then execute the transfer function again.
- After transfer of program, the 30P collates automatically, and confirms that the contents of the both are the same. As a result of collating, if the program is not identical, "VERIFY ERROR!" is displayed, and the step number of mismatches are also displayed at the same time.

• Condition of memory cassette transfer

PLC status		PLC memory			
RUN	STOP	Built in memory	RAM cassette	EEPROM cassette FLROM cassette	EPROM cassette
-	✓	✓	✓	△ *1	△ *2

- \*1. When an EEPROM or FLROM cassette is attached, only when the protect switch is OFF, you can transfer from built in PLC memory to the memory cassette.
- \*2. When an EPROM cassette is attached, you cannot transfer from built in PLC memory to the memory cassette.

#### The screen display and operation method

1) Memory cassette transfer top screen

The type of PLC memory is automatically determined by 30P, and the display differs in each case.

- For RAM : FX-RAM
- For EEPROM : FX-EEPROM

The type of memory cassette is automatically determined by 30P, and the display differs in each case.

- For an EEPROM cassette : CS-EEPROM
- For an EPROM cassette : CS-EPROM
- For a FLROM cassette : CS-FLROM
- For a RAM cassette : CS-RAM

- When the PLC memory is RAM, and EEPROM cassette is attached.

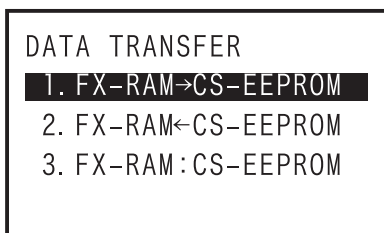

- , → Select transfer direction
- → Confirm selection
- → Select and confirm
- → Return to other menu

- When the PLC memory is RAM, and EPROM cassette is attached.

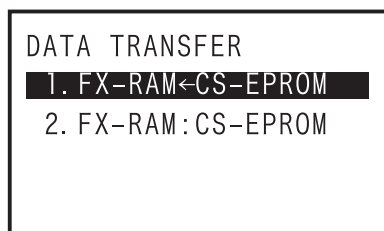

- , → Select transfer direction
- → Confirm selection
- → Select and confirm
- → Return to other menu

- When a memory cassette is not attached

```

DATA TRANSFER

NO MEMORY CASSETTE!

【CLEAR】
    
```

- **CLEAR** → Return to other menu

- 2) Transfer from PLC memory to memory cassette

```

FX-RAM→CS-FLROM
*EXECUTE?

EXECUTE → 【GO】
CANCEL  → 【CLEAR】
    
```

- **GO** → Memory cassette transfer execution
- **CLEAR** → Return to memory cassette transfer top screen

```

FX-RAM→CS-FLROM

EXECUTING. . .
    
```

- All key inputs disabled

```

FX-RAM→CS-FLROM

COMPLETE!

【CLEAR】
    
```

- **CLEAR** → Return to memory cassette transfer top screen

- Collate error; when parameters are mismatched

```

FX-RAM→CS-FLROM
VERIFY ERROR!
PARAMETER MISMATCH

【CLEAR】
    
```

- **CLEAR** → Return to memory cassette transfer top screen

- Collate error; when programs are mismatched

```

FX-RAM→CS-FLROM
VERIFY ERROR!
PROGRAM MISMATCH
STEP NO. :23456

【CLEAR】
    
```

- **CLEAR** → Return to memory cassette transfer top screen

<b>1</b>	Introduction
<b>2</b>	Specifications, product configuration
<b>3</b>	Connections, startup procedure
<b>4</b>	Outline of programming
<b>5</b>	Online mode
<b>6</b>	Offline mode
<b>7</b>	HPP setting
<b>8</b>	Battery
<b>A</b>	ASCII Code
<b>B</b>	Message List

- While PLC is in RUN

FX-RAM→CS-FLROM

PLC RUNNING!

【CLEAR】

- → Return to memory cassette transfer top screen

- When the protection switch of the memory cassette is ON

FX-RAM→CS-FLROM

PROTECT SWITCH ON!

【CLEAR】

- → Return to memory cassette transfer top screen

- In the event of a communication error

FX-RAM→CS-FLROM

COMMUNICATION ERROR!

【CLEAR】

- → Return to memory cassette transfer top screen

- It is not possible to transfer data when "Keyword", "Keyword + second keyword", "Keyword + Customer keyword", or "Cancel disable protect" are set in the PLC memory.
- It is not possible to transfer data when "Keyword + second keyword", "Keyword + Customer keyword", or "Cancel disable protect" are set in the memory cassette.

### 3) Transfer from memory cassette to PLC memory

FX-RAM←CS-FLROM

\*EXECUTE?

EXECUTE → 【GO】

CANCEL → 【CLEAR】

- → Memory cassette transfer execution
- → Return to memory cassette transfer top screen

FX-RAM←CS-FLROM

EXECUTING. . .

- All key inputs disabled

FX-RAM←CS-FLROM

COMPLETE!

【CLEAR】

- → Return to memory cassette transfer top screen



- Collate error; when parameters are mismatched

```
FX-RAM<CS-FLROM
VERIFY ERROR!
PARAMETER MISMATCH

【CLEAR】
```

- **CLEAR** → Return to memory cassette transfer top screen

- Collate error; when programs are mismatched

```
FX-RAM<CS-FLROM
VERIFY ERROR!
PROGRAM MISMATCH
STEP NO. :23456

【CLEAR】
```

- **CLEAR** → Return to memory cassette transfer top screen

- While PLC is in RUN

```
FX-RAM<CS-FLROM

PLC RUNNING!

【CLEAR】
```

- **CLEAR** → Return to memory cassette transfer top screen

- In the event of a communication error

```
FX-RAM<CS-FLROM

COMMUNICATION ERROR!

【CLEAR】
```

- **CLEAR** → Return to memory cassette transfer top screen

- It is not possible to transfer data when "Keyword + second keyword", "Keyword + Customer keyword", or "Cancel disable protect" are set in the PLC memory or the memory cassette.

**1**

Introduction

**2**Specifications,  
product  
configuration**3**Connections,  
startup  
procedure**4**Outline of  
programming**5**

Online mode

**6**

Offline mode

**7**

HPP setting

**8**

Battery

**A**

ASCII Code

**B**

Message List

4) Collation between PLC memory and memory cassette

FX-RAM:CS-FLROM  
\*EXECUTE?  
  
EXECUTE → **【GO】**  
CANCEL → **【CLEAR】**

- **【GO】** → PLC memory and memory cassette collation execution
- **【CLEAR】** → Return to memory cassette transfer top screen

FX-RAM:CS-FLROM  
  
EXECUTING. . .

- All key inputs disabled

FX-RAM:CS-FLROM  
  
COMPLETE!  
  
**【CLEAR】**

- **【CLEAR】** → Return to memory cassette transfer top screen

- In the event of a collation error or a parameter mismatch

FX-RAM:CS-FLROM  
VERIFY ERROR!  
PARAMETER MISMATCH  
  
**【CLEAR】**

- **【CLEAR】** → Return to memory cassette transfer top screen

- In the event of a collation error or a program mismatch

FX-RAM:CS-FLROM  
VERIFY ERROR!  
PROGRAM MISMATCH  
STEP NO. :23456  
  
**【CLEAR】**

- **【CLEAR】** → Return to memory cassette transfer top screen

- In the event of a communication error

FX-RAM:CS-FLROM  
  
COMMUNICATION ERROR!  
  
**【CLEAR】**

- **【CLEAR】** → Return to memory cassette transfer top screen

- It is not possible to verify data when "Keyword + second keyword", "Keyword + Customer keyword", or "Cancel disable protect" are set in the PLC memory or the memory cassette.

### 5.8.5 Parameter

You can set various parameters.

1) Overview of parameter settings

- In the online mode, set parameters in the memory of the PLC (memory cassette if it is attached). In the offline mode, set parameters of the HPP RAM.
- The parameter setting content is shown in the tree below.

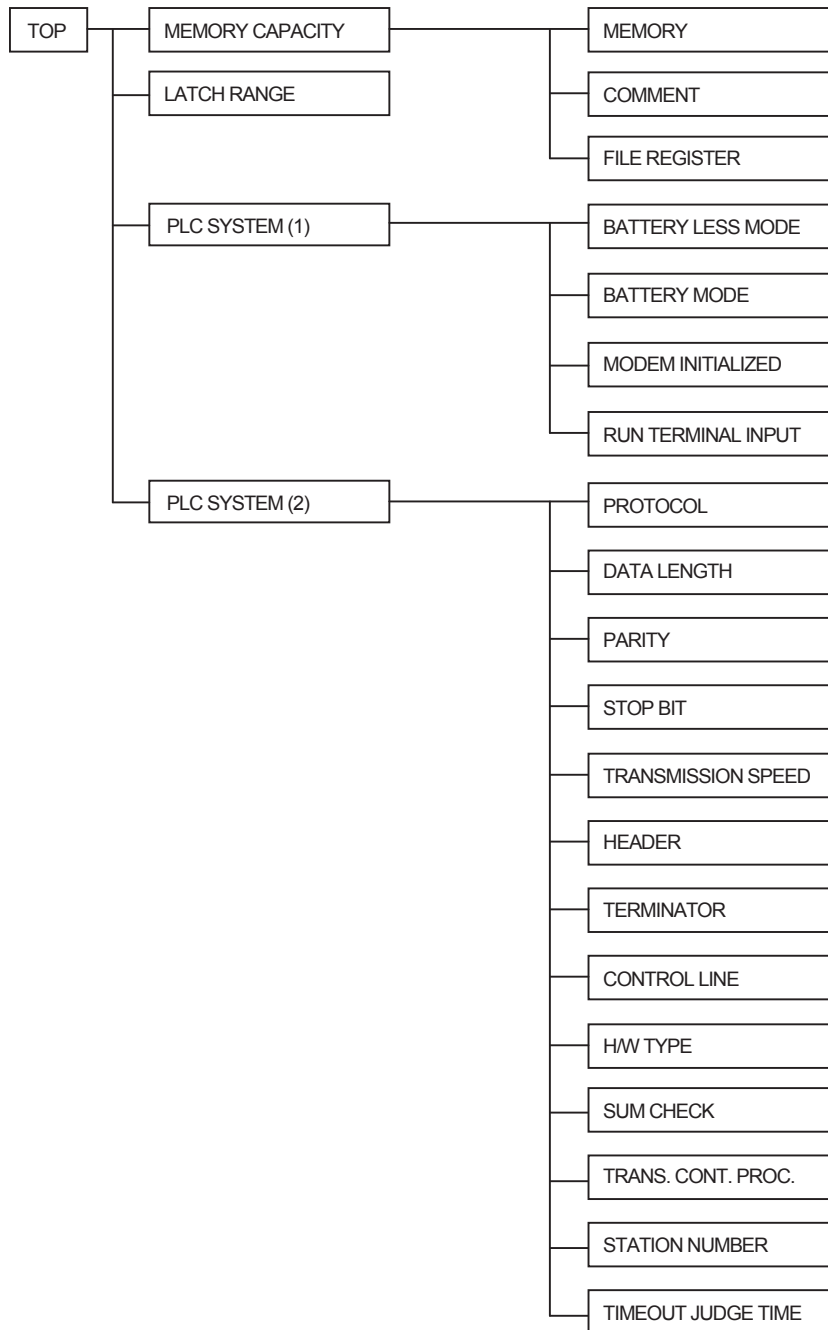

• Parameter setting condition

PLC status		PLC memory			
RUN	STOP	Built in memory	RAM cassette	EEPROM cassette FLROM cassette	EPROM cassette
-	✓	✓	✓	△ *1	-

\*1. When an EEPROM or FLROM cassette is attached, the parameter can be set only when protect switch is OFF.

1 Introduction

2 Specifications, product configuration

3 Connections, startup procedure

4 Outline of programming

5 Online mode

6 Offline mode

7 HPP setting

8 Battery

A ASCII Code

B Message List

2) Contents of Program Memory

a) The sequence program contains the setting value constant K of the timer and counter.

b) When writing or reading to or from of the file register, you must specify the block number of the parameter.

- Block 0 :No file register
- Block 1 :D1000 to D1499 500points/500steps
- Block 2 :D1000 to D1999 1000points/1000steps
- Block 3 :D1000 to D2499 1500points/1500steps
- Block 4 :D1000 to D2999 2000points/2000steps

Block 14 :D1000 to D7999 7000points/7000steps

c) The comment is registered comments the personal computer. You cannot write or read by using the HPP.

However, when a program in which a comment is already registered is transferred, it is written to the RAM in the 30P.

d) The parameter is a region for setting the capacity of program memory, device number range of latched memory, number of blocks of the file register, number of blocks of the comment region, keyword, and title (except PLC model name).

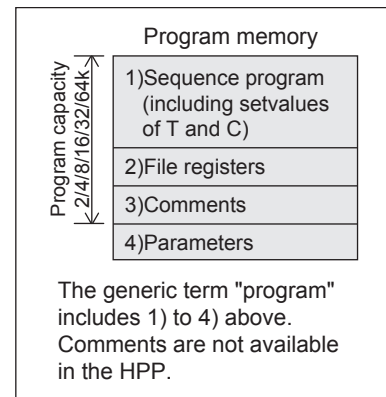

3) The screen display and operation method

a) Parameter top screen

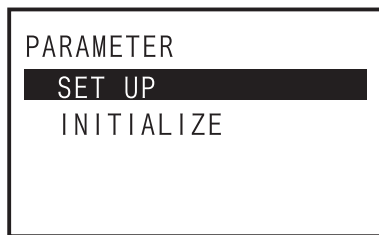

- , → Select
- → Confirm selection
- → Return to other menu

b) When parameter initialization is selected

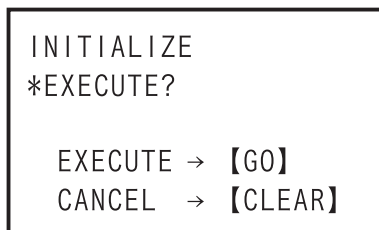

- → Initialize parameter execution
- → Return to parameter top screen

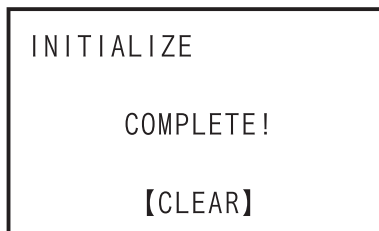

- → Return to parameter top screen

-In online mode, the parameter of PLC is initialized.  
-In offline mode, the parameter of the 30P RAM is initialized.

- When PLC is in RUN

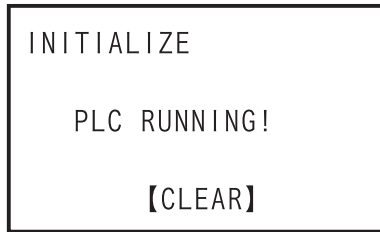

- [CLEAR] → Return to parameter top screen

- When the protection switch of the memory cassette is ON

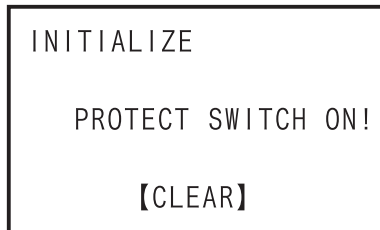

- [CLEAR] → Return to parameter top screen

- When EPROM cassette is attached

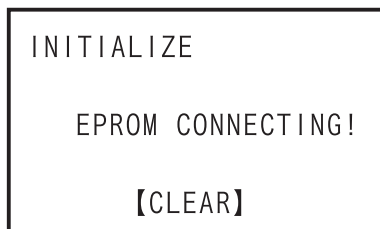

- [CLEAR] → Return to parameter top screen

- In the event of a communication error

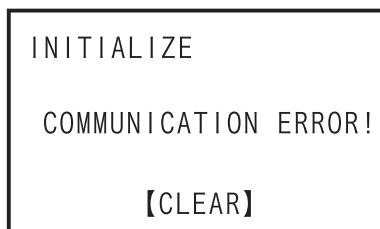

- [CLEAR] → Return to parameter top screen

- c) When the parameter setting is selected (parameter setting screen)

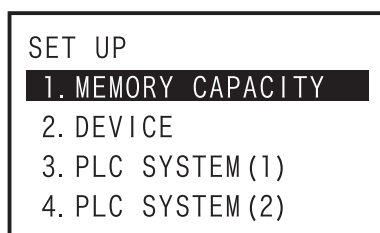

- [↑], [↓] → Select
- [GO] → Confirm selection
- [Num. Key] → Select and confirm
- [CLEAR] → If the parameter content is changed :  
Move to setting confirmation screen  
If the parameter content is not changed :  
Return to parameter setting top screen

-In online mode, parameters of the PLC are read out and listed.

-In offline mode, parameters of the HPP are listed.

-When the parameter content is changed, press [CLEAR] key on parameter setting screen, and move to the parameter setting confirmation screen. When the parameter content is not changed, return to the parameter top screen.

d) Parameter setting confirmation screen

```

SET UP
*UPDATE DATA
OK?
EXECUTE → 【GO】
CANCEL → 【CLEAR】
    
```

- **GO** → Writing to PLC execution
- **CLEAR** → Return to edited data discard confirmation screen.

```

SET UP

        COMPLETE!

        【CLEAR】
    
```

- **CLEAR** → Return to parameter top screen

- In online mode, the parameter is written to the PLC.
- In offline mode, the parameter is written to the 30P RAM.

- While PLC is in RUN

```

SET UP

        PLC RUNNING!

        【CLEAR】
    
```

- **CLEAR** → Return to parameter setting confirm screen

- When the protection switch of memory cassette is ON

```

SET UP

        PROTECT SWITCH ON!

        【CLEAR】
    
```

- **CLEAR** → Return to parameter write confirm screen

- When EPROM cassette is attached

```

SET UP

        EPROM CONNECTING!

        【CLEAR】
    
```

- **CLEAR** → Return to parameter write confirm screen

- In the event of a communication error

```

SET UP

        COMMUNICATION ERROR!

        【CLEAR】
    
```

- **CLEAR** → Return to parameter write confirm screen

e) Parameter setting edited data discard confirmation screen.

```

SET UP
*DISCARD EDITED DATA
OK?
EXECUTE → 【GO】
CANCEL → 【CLEAR】
    
```

- **GO** → Discard edited data, and return to the parameter top screen.
- **CLEAR** → Return to parameter setting screen without deleting edited data.

f) Memory capacity setting top screen

```

MEMORY CAPACITY
1. MEMORY
2. COMMENT
3. FILE REGISTER
PROGRAM 2000 STEP *1
    
```

- **↑**, **↓** → Select
- **GO** → Confirm selection
- **Num. Key** → Select and confirm
- **CLEAR** → When setting is correct :  
Return to parameter setting screen.  
When setting of comment capacity is not correct:  
Switches to incorrect comment capacity screen.  
When setting of file register capacity is not correct:  
Switches to incorrect file register capacity screen.

\*1. When setting the memory capacity, the program capacity is displayed in the lowest line (fifth line).  
When the setting of memory capacity is changed, the program capacity is also changed.

(Example) In the case of a FX3U PLC

Memory capacity, 64K steps  
Comment capacity, 1 block (= 500 steps)  
File register capacity, 1 block (=500 steps)

→ Program capacity, 63000 steps

- When the setting of the comment capacity is incorrect

```

MEMORY CAPACITY
CAPACITY
SETTING ERROR!
【CLEAR】
PROGRAM -2000 STEP
    
```

- **CLEAR** → Return to the memory capacity setting top screen

- When the setting of the file register capacity is incorrect

```

MEMORY CAPACITY
CAPA.
SETTING ERROR!
【CLEAR】
PROGRAM -2000 STEP
    
```

- **CLEAR** → Return to the memory capacity setting top screen

<b>1</b>	Introduction
<b>2</b>	Specifications, product configuration
<b>3</b>	Connections, startup procedure
<b>4</b>	Outline of programming
<b>5</b>	Online mode
<b>6</b>	Offline mode
<b>7</b>	HP setting
<b>8</b>	Battery
<b>A</b>	ASCII Code
<b>B</b>	Message List

- Memory capacity setting screen\*1

MEMORY	
800 STEP	
<b>2K STEP</b>	
▼ 4K STEP	
PROGRAM	2000 STEP
-----	
8K STEP	
16K STEP	
32K STEP	
64K STEP	

- ,  → Select
- → Confirm selection. Return to memory capacity setting top screen
- → Return to memory capacity setting top screen

\*1. When the memory capacity of the FX3s PLC is set to 16K steps, it is not possible to change the memory capacity here.

To change the memory capacity from 16K steps, the operation below is necessary.

- Parameter settings, if setting is not yet executed : Discard edited data
- Parameter settings, if setting has been executed : Initialize the parameter settings

- Comment capacity setting screen\*2

COMMENT	
<b>0</b> BLOCK	
(ONE BLOCK = 50)	
0~127BLOCK	
PROGRAM	64000 STEP

- → Setting
- → Confirm selection. Return to memory capacity setting top screen
- → Return to memory capacity setting top screen

- File register capacity setting screen\*2

FILE REGISTER	
<b>0</b> BLOCK	
(ONE BLOCK = 500)	
0~ 14BLOCK	
PROGRAM	64000 STEP

- → Setting
- → Confirm selection. Return to memory capacity setting top screen
- → Return to memory capacity setting top screen

\*2. When the memory capacity of the FX3s PLC is 16K steps, the program capacity is set to 4K steps, and the file register capacity can be set to the remaining 24 blocks (12K steps).

The remaining memory not set to file register memory is then allocated as comment capacity, which can be referred to but cannot be set.

g) Latch range setting screen

LATCH RANGE	
M	500-1023
S	<b>500</b> - 999
C (16bit)	100- 199
▼ C (32bit)	220- 255
-----	
D	200- 511

- ,  → Select
- → Device number input
- → When latch range setting is correct:  
Confirm, return to parameter setting screen.  
When latch range setting is not correct:  
Move to incorrect latch range setting screen.
- → Return to parameter setting screen



- When latch range setting is incorrect



- [CLEAR] → Return to latch range setting screen

h) PLC SYSTEM (1) top screen

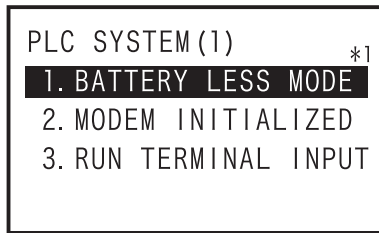

- [↑], [↓] → Select
- [GO] → Confirm selection
- [Num. Key] → Select and confirm
- [CLEAR] → Return to parameter setting screen

\*1. When a FX3G/FX3GC PLC is connected (in the case of offline, when the PLC type is a FX3G(C) PLC), a setting of "1. Battery mode" is provided.

- BATTERY LESS MODE setting screen

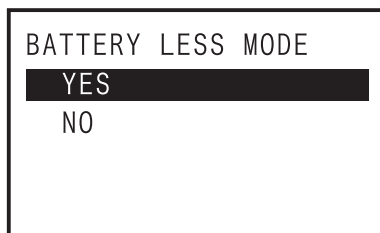

- [↑], [↓] → Select
- [GO] → Confirm selection. Return to PLC SYSTEM (1) top screen
- [CLEAR] → Return to PLC SYSTEM (1) top screen

- BATTERY MODE setting screen

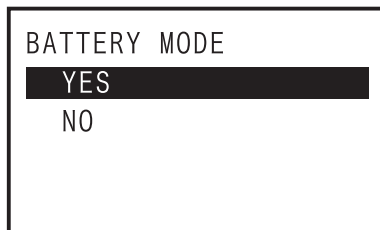

- [↑], [↓] → Select
- [GO] → Confirm selection. Return to PLC SYSTEM (1) top screen
- [CLEAR] → Return to PLC SYSTEM (1) top screen

- MODEM INITIALIZED setting screen

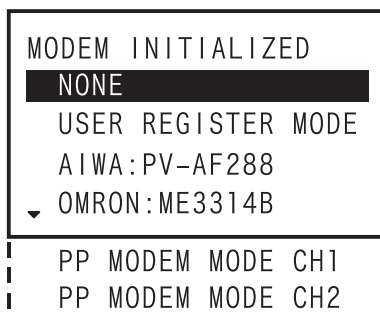

- [↑], [↓] → Select
- [GO] → Confirm selection. Return to PLC SYSTEM (1) top screen
- [CLEAR] → Return to PLC SYSTEM (1) top screen

1	Introduction
2	Specifications, product configuration
3	Connections, startup procedure
4	Outline of programming
5	Online mode
6	Offline mode
7	HP setting
8	Battery
A	ASCII Code
B	Message List

i) RUN terminal input setting screen

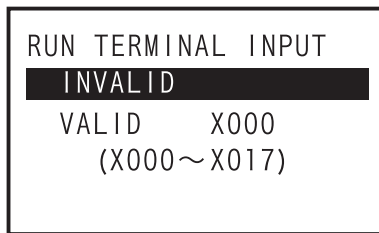

- , → Select
- → Setting of input relay number
- → When Absent:  
Confirm, return to PLC SYSTEM (1) top screen.  
When Present, and input number is correct:  
Confirm, return to PLC SYSTEM (1) top screen.  
When Present, and input number is not correct:  
Switches to incorrect input number setting screen.
- → Return to parameter list

- When the RUN terminal input is absent, select Absent by using key, and Confirm by pressing key.
- When the RUN terminal input is present, select Present by key, set the input relay number by keys, and decide by key.
- When the input number of RUN terminal is wrong

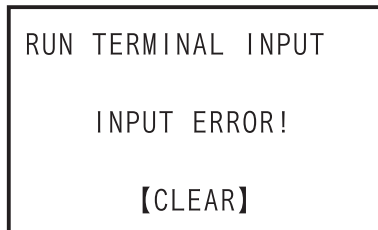

- → Return to RUN terminal input setting screen

j) PLC SYSTEM (2) top screen

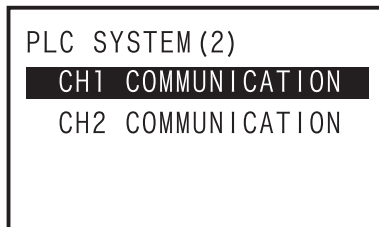

- , → Select
- → Confirm selection
- → Return to parameter setting screen

- Communication setting yes/no selection screen



- , → Select
- → Confirm selection, Move to next screen
- → Return to PLC SYSTEM (2) top screen

- Communication setting top screen

CHI COMMUNICATION
<b>PROTOCOL</b>
DATA LENGTH
PARITY
▼ STOP BIT
TRANSMISSION SPEED
HEADER
TERMINATOR
CONTROL LINE
H/W TYPE
SUM CHECK
TRANS. CONT. PROC.
STATION NUMBER
TIMEOUT JUDGE TIME

- ,  → Select
- → Confirm selection, Move to next screen
- → Return to communication setting yes/no select screen

- PROTOCOL setting screen

PROTOCOL
<b>FREE</b>
DEDICATED PROTOCOL

- ,  → Select
- → Confirm selection, Return to communication setting top screen
- → Return to communication setting top screen

- DATA LENGTH setting screen

DATA LENGTH
<b>7BIT</b>
8BIT

- ,  → Select
- → Confirm selection, Return to communication setting top screen
- → Return to communication setting top screen

- PARITY setting screen

PARITY
<b>NONE</b>
ODD
EVEN

- ,  → Select
- → Confirm selection, Return to communication setting top screen
- → Return to communication setting top screen

- STOP BIT setting screen

STOP BIT
<b>1BIT</b>
2BIT

- ,  → Select
- → Confirm selection, Return to communication setting top screen
- → Return to communication setting top screen

<b>1</b>	Introduction
<b>2</b>	Specifications, product configuration
<b>3</b>	Connections, startup procedure
<b>4</b>	Outline of programming
<b>5</b>	Online mode
<b>6</b>	Offline mode
<b>7</b>	HPP setting
<b>8</b>	Battery
<b>A</b>	ASCII Code
<b>B</b>	Message List

- TRANSMISSION SPEED setting screen

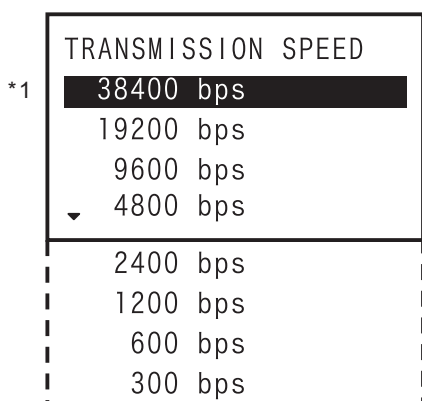

- ,  → Select
- → Confirm selection, Return to communication setting top screen
- → Return to communication setting top screen

\*1. For Ver. 1.20 and later versions of the FX-30P F/W, it is possible to set 38400 bps with the FX3U/FX3UC series.

- HEADER setting screen (Displayed only when no-procedure communication is selected in the protocol.)

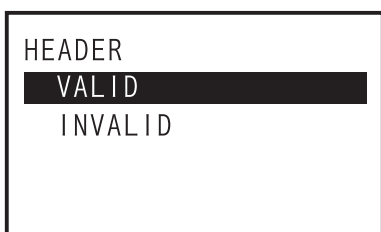

- ,  → Select
- → Confirm selection, Return to communication setting top screen
- → Return to communication setting top screen

- TERMINATOR setting screen (Displayed only when no-procedure communication is selected in the protocol.)

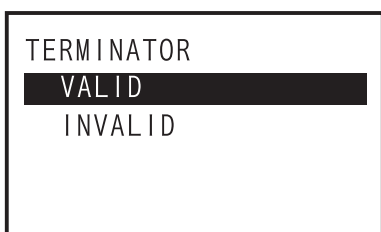

- ,  → Select
- → Confirm selection, Return to communication setting top screen
- → Return to communication setting top screen

- CONTROL LINE setting screen (Displayed only when no-procedure communication is selected in the protocol.)

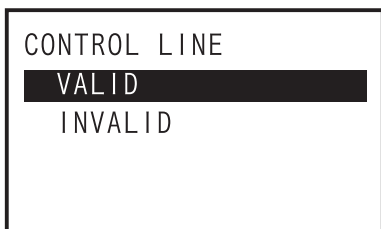

- ,  → Select
- → Confirm selection, Return to communication setting top screen
- → Return to communication setting top screen

- H/W TYPE setting screen

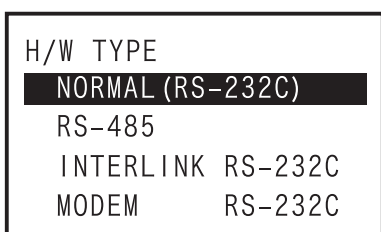

- ,  → Select
- → Confirm selection, Return to communication setting top screen
- → Return to communication setting top screen

- SUM CHECK setting screen

- ,  → Select
- → Confirm selection, Return to communication setting top screen
- → Return to communication setting top screen

- TRANS. CONT. PROC. setting screen

- ,  → Select
- → Confirm selection, Return to communication setting top screen
- → Return to communication setting top screen

- STATION NUMBER setting screen

- → Station number input (0 to F)
- → Confirm selection, Return to communication setting top screen
- → Return to communication setting top screen

- TIMEOUT JUDGE TIME setting screen

- → Time-out judging time input (10ms unit)
- → When input value is correct:  
Confirm, return to communication setting top screen.  
  
When input value is not correct:  
Switches to wrong time-out judging time setting screen.

- → Return to communication setting top screen

- When time-out judging time setting is incorrect

- → Return to TIMEOUT JUDGE TIME setting screen

1	Introduction
2	Specifications, product configuration
3	Connections, startup procedure
4	Outline of programming
5	Online mode
6	Offline mode
7	HPP setting
8	Battery
A	ASCII Code
B	Message List

4) Parameter list

✓ : Change settings enabled    - : Not applicable    △: Change settings disabled

Parameter		FX1	FX2, FX2C	FX0, FX0S	FX0N	FX1S	FX1N, FX1NC	FX2N, FX2NC	FX3S	FX3G, FX3GC	FX3U, FX3UC
MEMORY CAPACITY	MEMORY CAPA.	✓	✓	△ (Fixed)	△ (Fixed)	△ (Fixed)	✓	✓	✓	✓	✓
	FILE REGISTER CAPA.	△ (Fixed)	✓	△ (Fixed)	✓	✓	✓	✓	✓	✓	✓
	COMMENT CAPA.	✓	✓	△ (Fixed)	✓	✓	✓	✓	✓	✓	✓
DEVICE SETTING	LATCH RANGE	✓	✓	-	-	-	-	✓	-	-	✓
PLC SYSTEM (1)	BATTERY LESS MODE	-	-	-	-	-	-	✓	-	-	✓
	BATTERY MODE	-	-	-	-	-	-	-	-	✓	-
	MODEM INITIALIZED	-	-	-	-	✓	✓	✓	✓	✓	✓
	RUN TERMINAL INPUT	-	-	-	-	✓	✓	✓	✓	✓	✓
PLC SYSTEM (2)	PROTOCOL	-	-	-	-	✓	✓	✓	✓	✓	✓
	DATA LENGTH	-	-	-	-	✓	✓	✓	✓	✓	✓
	PARITY	-	-	-	-	✓	✓	✓	✓	✓	✓
	STOP BIT	-	-	-	-	✓	✓	✓	✓	✓	✓
	TRANSMISSION SPEED	-	-	-	-	✓	✓	✓	✓	✓	✓
	HEADER	-	-	-	-	✓	✓	✓	✓	✓	✓
	TERMINATOR	-	-	-	-	✓	✓	✓	✓	✓	✓
	CONTROL LINE	-	-	-	-	✓	✓	✓	✓	✓	✓
	H/W TYPE	-	-	-	-	✓	✓	✓	✓	✓	✓
	SUM CHECK	-	-	-	-	✓	✓	✓	✓	✓	✓
	TRANS. CONT. PROC.	-	-	-	-	✓	✓	✓	✓	✓	✓
	STATION NUMBER	-	-	-	-	✓	✓	✓	✓	✓	✓
	TIMEOUT JUDGE TIME	-	-	-	-	✓	✓	✓	✓	✓	✓
CH1/CH2	-	-	-	-	CH1	CH1	CH1	CH1	CH1/2	CH1/2	

### 5.8.6 Keyword

1) Overview of keyword setting

You can register, delete, cancel, or protect the keyword.

When the memory cassette is attached, you can register, delete, or cancel the keyword in the memory cassette.

The keyword setting is a function valid only in online mode.

When newly registering or changing the keyword, select "REGIST", and press **GO** key.

When deleting a registered keyword, select "DELETE", and press **GO** key.

In the case of FX3G/FX3U/FX3UC PLCs, in other modes than the setting of keyword (hexadecimal 8 digits), when desired to cancel the protected state by a registered keyword, select "DISABLE", and press **GO** key.

When the protection state by keyword is canceled, to set the protection state again, select "PROTECT", and press **GO** key.

• Condition of keyword setting

PLC status		PLC memory			
RUN	STOP	Built in memory	RAM cassette	EEPROM cassette FLROM cassette	EPROM cassette
△ *1	✓	✓	✓	△ *2	△ *3

\*1. While the PLC is in RUN, the keyword cannot be registered or deleted. You can only cancel the keyword. Keyword deletion and protect only are enabled.

\*2. When EEPROM cassette or FLROM cassette is attached, the keyword can be registered or deleted only when the protect switch is OFF.

\*3. When EPROM cassette is attached, the keyword cannot be registered or deleted.

• Handling of the keyword

By registering a keyword, changes in programs and data can be prohibited, and programs can be protected.

When the 30P is started up in the online mode for a program in the PLC in which a keyword has been registered, the program requests the operator to input the keyword first. If the keyword input by the operator corresponds with the previously registered keyword, all operations are enabled in the 30P. If the keyword is unknown, it is impossible to delete only the keyword.

If all programs (including parameters and keyword) may be erased, the operation can be started by entering a special keyword (8-digit **SP** key). Input of the special keyword is enabled only when "online" is selected after the power of the FX-30P is started or when "offline" is changed over to "online". As for the detail of the keyword, refer to the programming manual of each PLC.

• Type of keyword, reaction of PLC, and type of registration level

Keyword type	Registered level type	Registered characters (Number of characters)	Applicable PLC		
			FX3S, FX3G, FX3GC	FX3U, FX3UC	FX1, FX(FX2), FX2C, FX0, FX0S, FX0N, FX1S, FX1N, FX1NC, FX2N, FX2NC
Permanent PLC lock	Write prohibited Read and write prohibited All online operations prohibited	-	Applicable	Applicable (Ver.2.61 or later) <sup>*4</sup>	Not applicable
Keyword (8 digit)	All operations prohibited (A) Read/Incorrect write protection (B) Erroneous write prohibited (C)	0 to 9, A to F (8 characters)	Applicable	Applicable	Applicable
Keyword + Second keyword (16 digit)	Write prohibited Read and write prohibited All online operations prohibited	0 to 9, A to F (16 characters)	Applicable	Applicable (Ver.2.20 or later)	Not applicable
Customer keyword (16 digit)	Write prohibited Read and write prohibited All online operations prohibited	0 to 9, A to F (16 characters)	Applicable	Applicable (Ver.2.61 or later) <sup>*4</sup>	Not applicable

\*4. Supported by firmware versions 1.20 and later of the 30P.

1 Introduction

2 Specifications, product configuration

3 Connections, startup procedure

4 Outline of programming

5 Online mode

6 Offline mode

7 HPP setting

8 Battery

A ASCII Code

B Message List

- Screen display by keyword registered level type  
The screen displayed before the keyword input screen is different according to keyword registered level type.

- Registered level type: In the case of write prohibited, erroneous write prohibited\*<sup>1</sup>

```
ACCESS RESTRICTION
WR PROTECTION
*CANCEL RESTRICTION?
  YES → 【GO】
  NO  → 【CLEAR】
```

- **GO** → Move to keyword input screen
- **CLEAR** → Return to online mode top screen

\*1. First character of keyword (8-digit) is "C"

- Registered level type : In the case of read and write prohibited, read/incorrect write protection\*<sup>2</sup>

```
ACCESS RESTRICTION
RD/WR PROTECTION
*CANCEL RESTRICTION?
  YES → 【GO】
  NO  → 【CLEAR】
```

- **GO** → Move to keyword input screen
- **CLEAR** → Return to online mode top screen

\*2. First character of keyword (8-digit) is "B"

- Registered level type : In the case of all online operations prohibited, All operations prohibited\*<sup>3</sup>  
The keyword input screen is directly displayed.

\*3. First character of keyword (8-digit) is other than "B", "C"



2) The screen display and the operation method

a) Keyword top screen

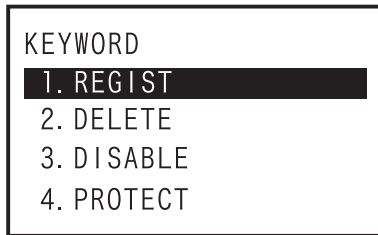

- , → Select
- → Confirm selection
- → Return to online other menu

b) Keyword registration (When other than "FX3U/FX3UC Ver.2.20 or later, FX3S/FX3G/FX3GC.")

- Keyword input screen

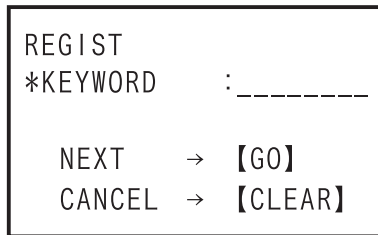

- → Keyword input
- → Delete one character
- → Confirm input and continue (registration confirmation screen)
- → Return to keyword top screen

Condition of keyword setting

- First characters : Except "B", "C" All operations prohibited (A)
- "B" Read/Incorrect write protection (B)
- "C" Erroneous write prohibited (C)

- Registration confirmation screen

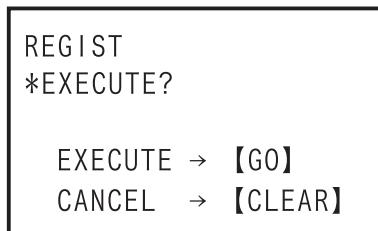

- → Execute
- → Return to keyword top screen

- When keyword is already registered (current keyword input screen)

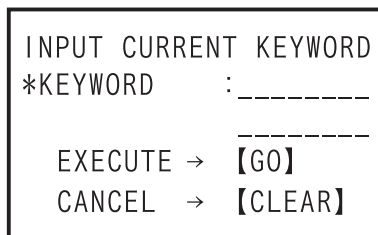

- → Keyword input
- → Delete one character
- → Execute
- → Return to keyword input screen

- When entered keyword and "current keyword" are different.

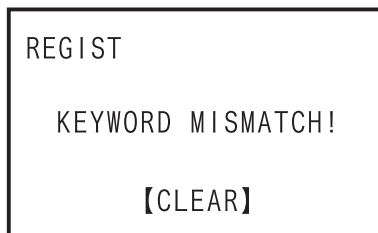

- → Return to present keyword input screen

1	Introduction
2	Specifications, product configuration
3	Connections, startup procedure
4	Outline of programming
5	Online mode
6	Offline mode
7	HPP setting
8	Battery
A	ASCII Code
B	Message List

- Registration end screen

REGIST  
COMPLETE!  
【CLEAR】

- → Return to keyword top screen

- When invalid keyword is entered

REGIST  
INPUT ERROR!  
【CLEAR】

- → Return to keyword input screen

- While PLC is in RUN

REGIST  
PLC RUNNING!  
【CLEAR】

- → Return to keyword input screen

- When the protect switch of memory cassette is ON

REGIST  
PROTECT SWITCH ON!  
【CLEAR】

- → Return to keyword input screen

- When an EPROM cassette is attached

REGIST  
EPROM CONNECTING!  
【CLEAR】

- → Return to keyword input screen

- In the event of a communication error

REGIST  
COMMUNICATION ERROR!  
【CLEAR】

- → Return to keyword input screen

c) Keyword registration (FX3U/FX3UC Ver.2.20 up to Ver.2.61)

- Keyword input screen

```

KEYWORD
*KEYWORD   : _____
*2nd KEYWORD: _____
EXECUTE →  【GO】
CANCEL  →  【CLEAR】
    
```

- **Num. Key** → Keyword input
- **↓** → Delete one character
- **GO** → Confirm input
- **CLEAR** → Return to keyword top screen

"Keyword + second keyword" is set in hexadecimal 16 digits from 0 to F.

- Protect level selection screen (this screen is not displayed by input of "keyword" only).

```

REGIST (SELECT LEVEL)
WRITE PROTECT
READ/WRITE PROTECT
ALL PROTECT
    
```

- **↑**, **↓** → Protect level select
- **GO** → Confirm selection
- **CLEAR** → Return to keyword top screen

- Registration confirmation screen

```

REGIST
*EXECUTE?

EXECUTE →  【GO】
CANCEL  →  【CLEAR】
    
```

- **GO** → Execute
- **CLEAR** → Return to keyword top screen

- When a keyword is already registered (current keyword input screen)

```

INPUT CURRENT KEYWORD
*KEYWORD   : _____
          : _____
EXECUTE →  【GO】
CANCEL  →  【CLEAR】
    
```

- **Num. Key** → Keyword input
- **↓** → Delete one character
- **GO** → Confirm input
- **CLEAR** → Return to keyword input screen

- When entered keyword and "current keyword" are different.

```

REGIST

KEYWORD MISMATCH!

【CLEAR】
    
```

- **CLEAR** → Return to present keyword input screen

<b>1</b>	Introduction
<b>2</b>	Specifications, product configuration
<b>3</b>	Connections, startup procedure
<b>4</b>	Outline of programming
<b>5</b>	Online mode
<b>6</b>	Offline mode
<b>7</b>	HPP setting
<b>8</b>	Battery
<b>A</b>	ASCII Code
<b>B</b>	Message List

- Registration end screen



- → Return to keyword top screen

- When an invalid keyword is entered
- When the PLC is in RUN
- When the protect switch of the memory cassette is ON
- In the event of a communication error
  - In the four cases above, the display and operation is the same for other PLCs as "FX3U/FX3UC Ver.2.20 or later, FX3S/FX3G/FX3GC PLCs."

d) Keyword registration (FX3U/ FX3UC Ver.2.61 and later\*1, FX3S/FX3G/FX3GC)

\*1. Supported by firmware versions 1.20 and later of the 30P.

- Keyword type selection screen

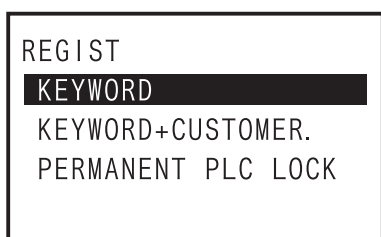

- ,  → Menu select
- → Confirm selection
- → Return to keyword top screen

- When "Keyword" is selected  
Same as FX3U/ FX3UC Ver.2.20 up to Ver.2.61 in c).
- When "Keyword" + "Customer keyword" is selected

- Keyword input screen

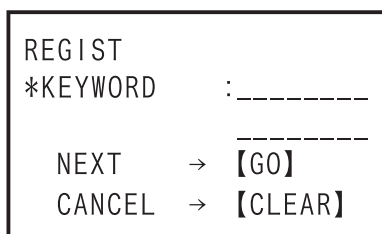

- → Keyword input
- → Delete one character
- → Next (Customer keyword input screen)
- → Return to keyword top screen

Keyword is set in hexadecimal 16 digits, from 0 to F.

- Customer keyword input screen

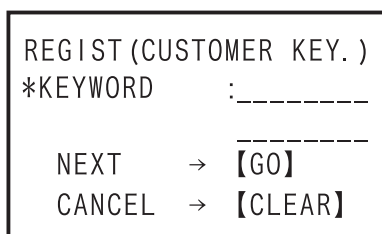

- → Customer keyword input
- → Delete one character
- → Next
- → Return to keyword input screen

"Customer keyword" is set in hexadecimal 16 digits from 0 to F.

- Protect level selection screen

```

REGIST (SELECT LEVEL)
WRITE PROTECT
READ/WRITE PROTECT
ALL PROTECT
    
```

- ,  → Protect level select
- → Confirm selection
- → Return to keyword top screen

- Registration confirmation screen

```

REGIST
*EXECUTE?

EXECUTE → 【GO】
CANCEL  → 【CLEAR】
    
```

- → Execute
- → Return to keyword top screen

- When a keyword is already registered (current keyword input screen)

```

INPUT CURRENT KEYWORD
*KEYWORD      : _____
               _____
EXECUTE → 【GO】
CANCEL  → 【CLEAR】
    
```

- → Keyword input
- → Delete one character
- → Confirm input
- → Return to keyword top screen

- When entered keyword and "current keyword" are different.

```

REGIST

KEYWORD MISMATCH!

【CLEAR】
    
```

- → Return to present keyword input screen

- Registration end screen

```

REGIST

COMPLETE!

【CLEAR】
    
```

- → Return to keyword top screen

- When an invalid keyword is entered
- When the PLC is in RUN
- When the protect switch of the memory cassette is ON
- In the event of a communication error
  - In the four cases above, the display and operation is the same for other PLCs as "FX3U/FX3UC Ver.2.20 or later, FX3S/FX3G/FX3GC PLCs."

- When "Cancel disable protect" is selected (protect level selection screen)

```

REGIST (SELECT LEVEL)
WRITE PROTECT
READ/WRITE PROTECT
ALL PROTECT
    
```

- ,  → Select protection level
- → Confirm selection
- → Return to keyword top screen

- Registration confirmation screen

```

REGIST
*EXECUTE?

EXECUTE → 【GO】
CANCEL → 【CLEAR】
    
```

- → Execute
- → Return to keyword top screen

- When a keyword is already registered (current keyword input screen)

```

INPUT CURRENT KEYWORD
*KEYWORD : _____
          : _____
EXECUTE → 【GO】
CANCEL → 【CLEAR】
    
```

- → Keyword input
- → Delete one character
- → Execute
- → Return to keyword top screen

- When entered "current keyword" is different

```

REGIST

KEYWORD MISMATCH!

【CLEAR】
    
```

- → Return to present keyword input screen

- Registration end screen

```

REGIST

COMPLETE!

【CLEAR】
    
```

- → Return to keyword top screen

- When an invalid keyword is entered
- When the PLC is in RUN
- When the protect switch of the memory cassette is ON
- In the event of a communication error
  - In the four cases above, the display and operation is the same for other PLCs as "FX3U/FX3UC Ver.2.20 or later, FX3S/FX3G/FX3GC PLCs."

e) Keyword deletion screen

- When a keyword is not registered

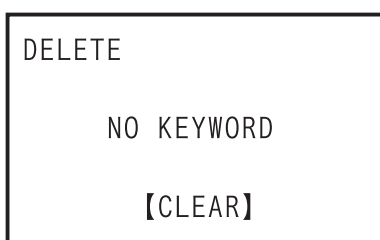

- **CLEAR** → Return to keyword top screen

- Keyword input screen

- When other than "FX3U/FX3UC Ver.2.20 or later, FX3S/FX3G/FX3GC."

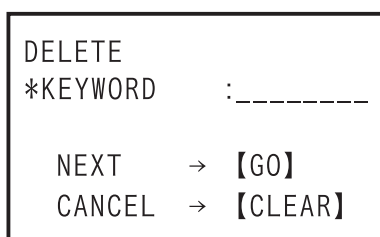

- **Num. Key** → Keyword input
- **↓** → Delete one character
- **GO** → Next
- **CLEAR** → Return to keyword top screen

When the "Keyword" is registered, it is entered in hexadecimal 8 digits from 0 to F.

- In the case of "FX3U/FX3UC Ver.2.20 or later, FX3S/FX3G/FX3GC."

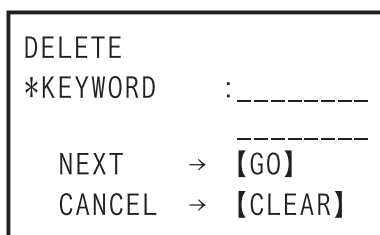

- **Num. Key** → Keyword input
- **↓** → Delete one character
- **GO** → Next
- **CLEAR** → Return to keyword top screen

When the "Keyword" is registered, it is entered in hexadecimal from 0 to F.

- Delete confirmation screen

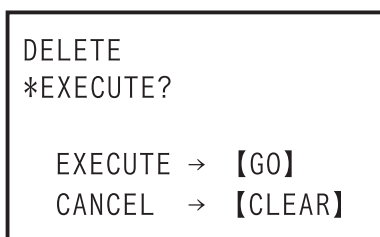

- **GO** → Execute
- **CLEAR** → Return to keyword top screen

- When the entered keyword and "current keyword" are different.

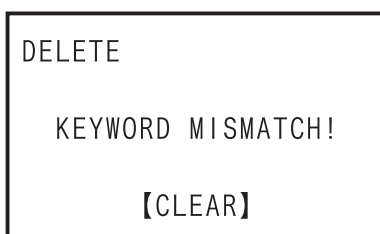

- **CLEAR** → Return to keyword input screen

<b>1</b>	Introduction
<b>2</b>	Specifications, product configuration
<b>3</b>	Connections, startup procedure
<b>4</b>	Outline of programming
<b>5</b>	Online mode
<b>6</b>	Offline mode
<b>7</b>	HPP setting
<b>8</b>	Battery
<b>A</b>	ASCII Code
<b>B</b>	Message List

- Delete end screen

DELETE  
COMPLETE!  
【CLEAR】

- → Return to keyword top screen

- When an invalid keyword is entered

DELETE  
INPUT ERROR!  
【CLEAR】

- → Return to keyword input screen

- When the PLC is in RUN

DELETE  
PLC RUNNING!  
【CLEAR】

- → Return to keyword input screen

- When the protect switch of the memory cassette is ON

DELETE  
PROTECT SWITCH ON!  
【CLEAR】

- → Return to keyword input screen

- When an EPROM cassette is attached

DELETE  
EPROM CONNECTING!  
【CLEAR】

- → Return to keyword input screen

- In the event of a communication error

DELETE  
COMMUNICATION ERROR!  
【CLEAR】

- → Return to keyword input screen



f) Keyword disable

- When a keyword is not registered

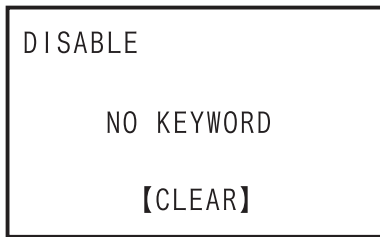

- **CLEAR** → Return to keyword top screen

- Keyword input screen

- When other than "FX3U/FX3UC Ver.2.20 or later, FX3S/FX3G/FX3GC."

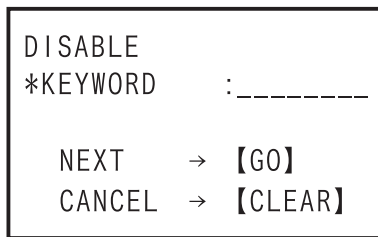

- **Num. Key** → Keyword input
- **↓** → Delete one character
- **GO** → Next
- **CLEAR** → Return to keyword top screen

When the "Keyword" is registered, it is entered in hexadecimal 8 digits from 0 to F.

- In the case of "FX3U/FX3UC Ver.2.20 or later, FX3S/FX3G/FX3GC."

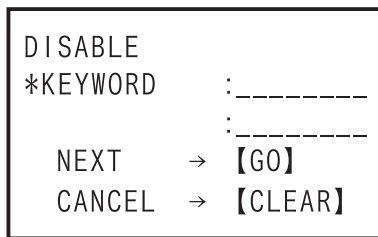

- **Num. Key** → Keyword input
- **↓** → Delete one character
- **GO** → Next
- **CLEAR** → Return to keyword top screen

When the "Keyword" is registered, it is entered in hexadecimal from 0 to F.

- Disable confirmation screen

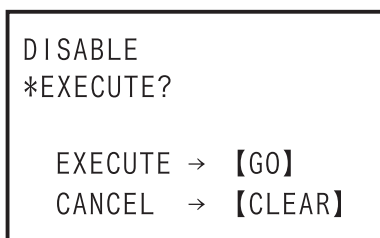

- **GO** → Execute
- **CLEAR** → Return to keyword top screen

- When the entered keyword and "current keyword" are different.

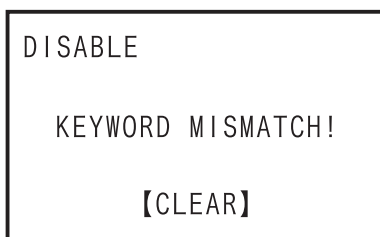

- **CLEAR** → Return to keyword input screen

1	Introduction
2	Specifications, product configuration
3	Connections, startup procedure
4	Outline of programming
5	Online mode
6	Offline mode
7	HPF setting
8	Battery
A	ASCII Code
B	Message List

- Disable end screen

DISABLE  
COMPLETE!  
【CLEAR】

- **CLEAR** → Return to keyword top screen

- When an invalid keyword is entered

DISABLE  
INPUT ERROR!  
【CLEAR】

- **CLEAR** → Return to keyword input screen

- In the event of a communication error

DISABLE  
COMMUNICATION ERROR!  
【CLEAR】

- **CLEAR** → Return to keyword input screen

g) Keyword protect

- When a keyword is not registered

PROTECT  
NO KEYWORD  
【CLEAR】

- **CLEAR** → Return to keyword top screen

- Protect confirmation screen

PROTECT  
\*EXECUTE?  
EXECUTE → 【GO】  
CANCEL → 【CLEAR】

- **GO** → Execute
- **CLEAR** → Return to keyword top screen

- Protect end screen

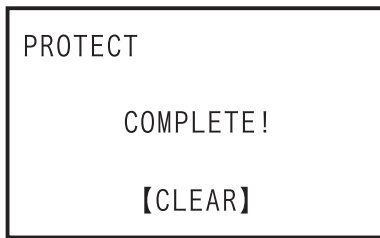

- **CLEAR** → Return to keyword top screen

- In the event of a communication error

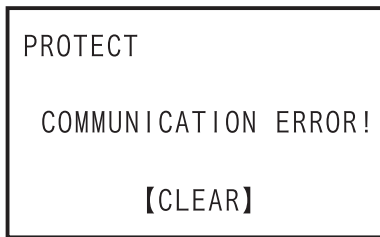

- **CLEAR** → Return to keyword top screen

3) Keyword level and HPP operation range

Operation		All online operations prohibited	Read/Incorrect write protection	Erroneous write prohibited
		■ □ □ □ □ □ □ □ *1	B □ □ □ □ □ □ □ □ *1	C □ □ □ □ □ □ □ □ *1
Programming	Read	-	-	✓
	Write	-	-	-
	Insert	-	-	-
	Delete	-	-	-
Monitor	Device monitor	-	✓	✓
	Conductivity check	-	-	✓
	Operation state monitor	-	✓	✓
Test	Forced ON/OFF	-	✓	✓
	Current value change	-	✓	✓
	Setting change	-	-	-
Others	Diagnostics PLC	-	-	✓ *2
	Data transfer	-	-	✓
	Parameter	-	-	-
	Keyword	✓	✓	✓
	Device convert	-	-	-
	Latch clear	-	✓	✓
	Device monitor	-	✓	✓
	BFM batch monitor	-	✓	✓
	PLC memory clear	✓ *3	✓	✓
	Remote RUN/STOP	-	✓	✓
PLC time setting	-	✓	✓	

\*1. The ■ indicates a hexadecimal numeral other than B or C; the □ indicates a hexadecimal numeral.  
 \*2. Only data transfer from the memory cassette to the PLC built-in memory is possible.  
 \*3. Operation is enabled only when clearing the PLC memory.

- 1** Introduction
- 2** Specifications, product configuration
- 3** Connections, startup procedure
- 4** Outline of programming
- 5** Online mode
- 6** Offline mode
- 7** HPP setting
- 8** Battery
- A** ASCII Code
- B** Message List

- 4) "Keyword + second keyword", "Master keyword", "Keyword + Customer keyword", "Cancel disable protect" level, and HPP operation range

Operation		WRITE PROTECT	READ/WRITE PROTECT	ALL PROTECT
Programming	Read	✓	-	-
	Write	-	-	-
	Insert	-	-	-
	Delete	-	-	-
Monitor	Device monitor	✓	✓	-
	Conductivity check	✓	-	-
	Operation state monitor	✓	✓	-
Test	Forced ON/OFF	✓	✓	-
	Current value change	✓	✓	-
	Setting change	-	-	-
Others	Diagnostics PLC	✓	-	-
	Data transfer	-	-	-
	Parameter	-	-	-
	Keyword	✓	✓	✓
	Device convert	-	-	-
	Latch clear	✓	-	-
	Device monitor	✓	✓	-
	BFM batch monitor	✓	✓	-
	PLC memory clear	✓	✓	✓ <sup>*1</sup>
	Remote RUN/STOP	✓	✓	-
PLC time setting	✓	✓	-	

\*1. Operation is enabled only when clearing the PLC memory.

### 5.8.7 Device conversion

A device is assigned the same value as another device of the same type. All corresponding devices in the program (including those after END command) are replaced.

- Device conversion condition

PLC status		PLC memory			
RUN	STOP	Built in memory	RAM cassette	EEPROM cassette FLROM cassette	EPROM cassette
-	✓	✓	✓	△ *1	-

\*1. When an EEPROM or FLROM cassette is attached, the device can be converted only when the protect switch is OFF.

<Online mode>

- The device is converted in the program in the memory of the PLC.
- When the memory cassette (excluding EPROM cassette) is attached, the device is converted in the program in the memory cassettes.
- The device can be changed only when the PLC is in STOP.

<Offline mode>

- The device is converted in the program in the 30P RAM.
- For a program in the 30P flash memory, the device can be converted after transferring to the RAM.

#### Basic operation



- The device can be converted only between devices of the same type.

#### The screen display and operation method

```

DEVICE CONVERSION
X  0  →  X  3

EXECUTE → 【GO】
CANCEL  → 【CLEAR】
    
```

- **Dev. Key** → Designate device type
- **Num. Key** → Designate device number
- **GO** → Confirm input
- **CLEAR** → Return to other menu

```

DEVICE CONVERSION
X  0  →  X  3
*EXECUTE?
EXECUTE → 【GO】
CANCEL  → 【CLEAR】
    
```

- **GO** → Execute
- **CLEAR** → Return to device number input one step before.

```

DEVICE CONVERSION
X  0  →  X  3

COMPLETE!
【CLEAR】
    
```

- **CLEAR** → Return to device conversion screen

- When the setting is not correct

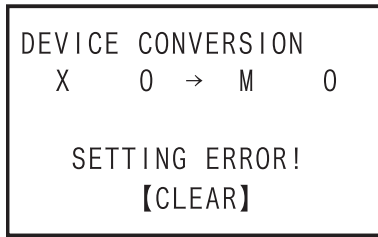

- [CLEAR] → Return to other menu

### 5.8.8 Latch clear

- Clear latched devices.
- The latch clear function is valid only in the online mode.
- The latch clear operation can be executed for auxiliary relays (M), states (S), counters (C), data registers (D), file registers (D) and extension registers (R) set in the latch range parameters.
- In the devices other than the file register, the latch clear operation is valid regardless of the type of program memory, whether RAM, EEPROM, FLROM or EPROM. When the program memory is EPROM, the file register cannot be cleared. In the case of EEPROM or FLROM, the content of the file register cannot be cleared unless the protect switch is turned OFF.
- Set the PLC to the STOP status before executing the latch clear operation.
- Latch clear condition

PLC status		PLC memory			
RUN	STOP	Built in memory	RAM cassette	EEPROM cassette FLROM cassette	EPROM cassette
-	✓	✓	✓	△ *1	△ *2

- \*1. When an EEPROM or FLROM cassette is attached, the content of file register can be cleared only when the protect switch is OFF.
- \*2. When an EPROM cassette is attached, the file register cannot be cleared.
- Applicable to FX1, FX2, FX2C, FX2N, FX2NC, FX3U and FX3UC PLCs only.

#### The screen display and the operation method

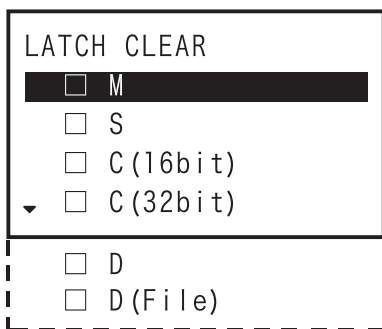

- [↑], [↓] → Move cursor
- [SET] → Select
- [RST] → Cancel
- [GO] → Move to latch clear execute confirmation screen
- [CLEAR] → Return to other menu

- Move the cursor to the type of the device to be cleared by using the [↑] or [↓] key, and select using [SET] key. The selected device can be deselected using [RST] key.
- Latch clear is executed only on selected devices.

• Check screen

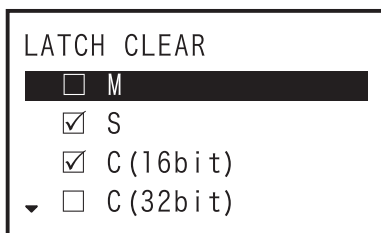

- ,  → Select
- → Confirm selection
- → Return to other menu

• Latch clear execution confirmation screen

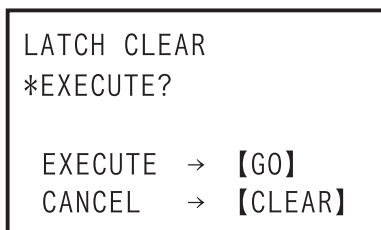

- → Latch clear execute
- → Return to latch clear selection screen

• Latch clear end screen

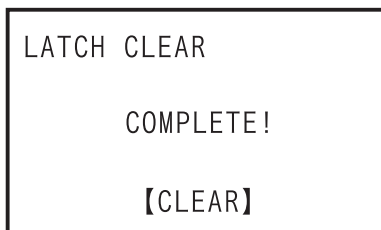

- → Return to other menu

• In the event of a communication error

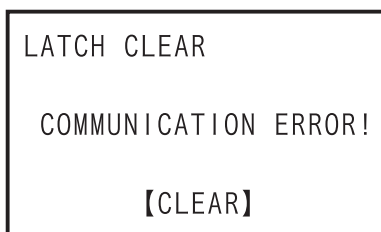

- → Return to other menu

<b>1</b>	Introduction
<b>2</b>	Specifications, product configuration
<b>3</b>	Connections, startup procedure
<b>4</b>	Outline of programming
<b>5</b>	Online mode
<b>6</b>	Offline mode
<b>7</b>	HPP setting
<b>8</b>	Battery
<b>A</b>	ASCII Code
<b>B</b>	Message List

### 5.8.9 Device batch monitoring

One type of device is selected, and listed.

- Condition of device batch monitor

PLC status		PLC memory			
RUN	STOP	Built in memory	RAM cassette	EEPROM cassette FLROM cassette	EPROM cassette
✓	✓	✓	✓	✓	✓

- One type of device is batch monitored out of the X, Y, M, S, T, C, D, R devices of the PLC.
- Device test is also enabled on the device batch monitor screen.
- The device batch monitor function is valid only in online mode.

#### The screen display and operation method

##### 1) Word device (D, R)

- 16 bits, decimal notation is selected.

M	R 30000	K	-32767
	R 30001	K	1
	R 30002	K	0
	R 30003	K	32767
	R 30004	K	-1
	R 30005	K	0
	R 30006	K	0
	R 30007	K	0

- 16 bits, hexadecimal notation is selected.

M	R 30000	H	8000
	R 30001	H	0001
	R 30002	H	0000
	R 30003	H	7FFF
	R 30004	H	FFFF
	R 30005	H	0000
	R 30006	H	0000
	R 30007	H	0000

- 32 bits, decimal notation is selected.

M	R 20001	R 20000	
	K		-1
	R 20003	R 20002	
	K		-2147483648
	R 20005	R 20004	
	K		0
	R 20007	R 20006	
	K		2147483647

- 32 bits, hexadecimal notation is selected.

M	R 20001	R 20000	
	H		FFFFFFFF
	R 20003	R 20002	
	H		80000000
	R 20005	R 20004	
	H		00000000
	R 20007	R 20006	
	H		7FFFFFFFF

- Real number is selected.

M	R 20001	R 20000	
	E		2.000000+003
	R 20003	R 20002	
	E		3.276700+004
	R 20005	R 20004	
	E		3.210000+001
	R 20007	R 20006	
	E		1.100001+001

- ASCII is selected.

M	R 30000	1	2
	R 30001	.	.
	R 30002	A	B
	R 30003	C	D
	R 30004	E	F
	R 30005	G	H
	R 30006	0	.
	R 30007	.	.



a) List display

Select "Device batch monitor", press **[SP]** key, enter the device symbol (D, R) and device number, press **[GO]** key to confirm, and display list. If not in "Monitor mode," press **[MNT/TEST]** key and select the monitor mode.

**Basic operation**

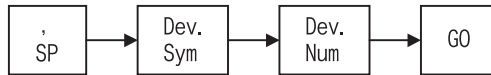

- To change between decimal and hexadecimal notation, press **[K/H]** key.
- To change between 16 bits and 32 bits, press **[D]** key.
- To change to ASCII display, press **[A]** key.
- To change to real number display, press **[E]** key.

b) Current value change

If not in "Test mode," press **[MNT/TEST]** key and select the test mode. Move the cursor to the line to be changed, press **[SP]** key, select decimal or hexadecimal notation using **[K/H]** key, and enter the value using **[Num. Key]** keys.

**Basic operation**

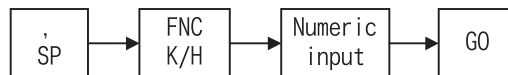

2) Timer, Counter (T, C)

• T or 16 bits C, decimal notation is selected.

M	T	0	K	100
	I-P-R-		K	32767
	T	1	K	500
	I•P•R-		K	500
	T	2	K	0
	I•P•R-		K	100
	T	3	K	214
	I-P-R•		K	3000

• T or 16 bits C, hexadecimal notation is selected.

M	T	0	H	0064
	I-P-R-		H	7FFF
	T	1	H	01F4
	I•P•R-		H	01F4
	T	2	H	0000
	I•P•R-		H	0064
	T	3	H	00D6
	I-P-R•		H	0BB8

• 32 bits C, decimal notation is selected.

M	C	200	I-P-R-U-	
			K	30000
			K	2360000
	C	201	I•P•R-U-	
			K	0
			D	0
			K	111111111

• 32 bits C, hexadecimal notation is selected.

M	C	200	I-P-R-U-	
			H	00007530
			H	002402C0
	C	201	I•P•R-U-	
			H	00000000
			D	0
			H	423A35C7

a) List display

Select "Device batch monitor", press **[SP]** key, enter the device symbol (T, C) and device number, press **[GO]** key to confirm, and display list. If not in "Monitor mode," press **[MNT/TEST]** key and select the monitor mode.

**Basic operation**



- To change between decimal and hexadecimal notation, press **[K/H]** key.
- To change between 16 bits and 32 bits, press **[D]** key.

1	Introduction
2	Specifications, product configuration
3	Connections, startup procedure
4	Outline of programming
5	Online mode
6	Offline mode
7	HPP setting
8	Battery
A	ASCII Code
B	Message List

b) Current value change

If not in "Test mode," press **[MNT/TEST]** key and select the test mode. Move the cursor to the device to be changed, press **[SP]** key, select decimal or hexadecimal notation using **[K/H]** key, and enter the value using **[Num. Key]** keys.

**Basic operation**

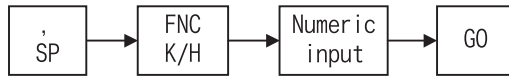

c) Setting value change

If not in "Test mode," press **[MNT/TEST]** key and select the test mode. Move the cursor to the device to be changed, press **[SP]** key twice, designate decimal or hexadecimal selection using **[K/H]** key, enter the value using **[Num. Key]** keys, and enter the device symbol and device number.

**Basic operation**

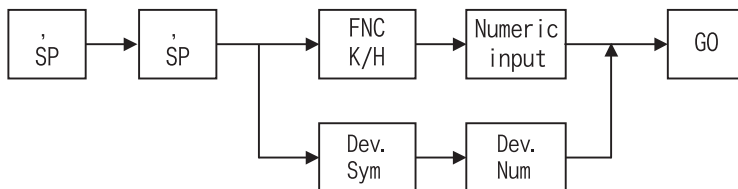

d) Forcible ON/OFF

If not in "Test mode," press **[MNT/TEST]** key and select the test mode. Move the cursor to the line to be tested, and press **[SET]**, **[RST]** key to turn ON, OFF by force.

**Basic operation**



3) Bit device multi-point display (X, Y, M, S)

M		+7	6	5	4	3	2	1	0
X000		-	•	•	•	•	•	•	•
X010		-	•	•	•	•	•	•	•
X020		-	•	•	•	•	•	•	•
X030		-	•	•	•	•	•	•	•
X040		•	•	•	•	•	•	•	•
X050		-	•	•	•	•	•	•	•
X060		•	•	•	•	•	•	•	•

M		+9	8	7	6	5	4	3	2	1	0
M8000		-	•	•	•	•	•	•	•	•	•
M8010		-	•	•	•	•	•	•	•	•	•
M8020		-	•	•	•	•	•	•	•	•	•
M8030		-	•	•	•	•	•	•	•	•	•
M8040		•	•	•	•	•	•	•	•	•	•
M8050		-	•	•	•	•	•	•	•	•	•
M8060		•	•	•	•	•	•	•	•	•	•

a) List display

Select "Device batch monitor", press **[SP]** key, enter the device symbol (X, Y, M, S) and device number, press **[GO]** key to confirm, and display list. If not in "Monitor mode," press **[MNT/TEST]** key and select the monitor mode.

**Basic operation**



b) Forcible ON/OFF

If not in "Test mode," press **[MNT/TEST]** key and select the test mode. Select the line to be tested by using **[↑]** or **[↓]** key, confirm the line by **[GO]** key, designate the device number using **[↑]**, **[↓]** keys, and turn ON, OFF by force by pressing **[SET]**, **[RST]** key.

**Basic operation**

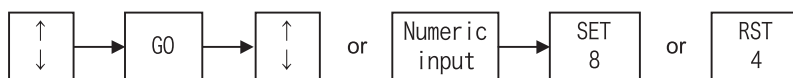

**Operation example**

When changing M2 from OFF to ON,

Display example

Step 6)

T		+9876543210
M	0	- . . . . . ■ . . . .
M	10	- . . . . . . . . . .
M	20	- . . . . . . . . . .
M	30	- . . . . . . . . . .
M	40	- . . . . . . . . . .
M	50	- . . . . . . . . . .
M	60	- . . . . . . . . . .

Step 7)

T		+9876543210
M	0	- . . . . . ■ . . . .
M	10	- . . . . . . . . . .
M	20	- . . . . . . . . . .
M	30	- . . . . . . . . . .
M	40	- . . . . . . . . . .
M	50	- . . . . . . . . . .
M	60	- . . . . . . . . . .

Key operation

- 1)
- 2)
- 3)
- 4)
- 5)
- 6)   Move the cursor to the position of M2.
- 7)

<b>1</b>	Introduction
<b>2</b>	Specifications, product configuration
<b>3</b>	Connections, startup procedure
<b>4</b>	Outline of programming
<b>5</b>	Online mode
<b>6</b>	Offline mode
<b>7</b>	HPP setting
<b>8</b>	Battery
<b>A</b>	ASCII Code
<b>B</b>	Message List

### 5.8.10 BFM batch monitor

The special function block is designated, and the buffer memory (BFM) is listed and monitored.

- Condition of buffer memory (BFM) batch monitoring

PLC status		PLC memory			
RUN	STOP	Built in memory	RAM cassette	EEPROM cassette FLROM cassette	EPROM cassette
✓	✓	✓	✓	✓	✓

- The special function block is designated, and the buffer memory (BFM) is listed.
- You can switch between decimal/hexadecimal notation, 16 bits/32 bits, real number, and ASCII display.
- The buffer memory (BFM) batch monitoring function is valid in online mode only.

#### The screen display and operation method

Unit No. (U0~U7)	BFM No. (#0~#32767)	Set value
U0	# 2400	K -32768
	# 2401	K 0
	# 2402	K 4000
	# 2403	K 1
	# 2404	K 7654
	# 2405	K 500
	# 2406	K -200
	# 2407	K 0

- ,  → Select
- → Return to other menu

The method for changing the display is same as in Subsection 5.8.9, Device batch monitor word device (D, R).

#### 1) List display

##### Basic operation

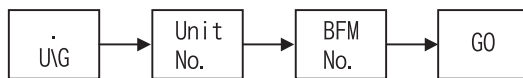

#### 2) Set value change

##### Basic operation



- FX1N, FX1NC, FX2N, FX2NC, FX3G, FX3GC, FX3U, FX3UC only can be monitored.
- FX0N-3A, FX2N-2AD, FX2N-2DA cannot be monitored.

### 5.8.11 Baud rate

You can set the communication baud rate with the PLC.

- Condition of the baud rate change

PLC status		PLC memory			
RUN	STOP	Built in memory	RAM cassette	EEPROM cassette FLROM cassette	EPROM cassette
✓	✓	✓	✓	✓	✓

- You can set the communication baud rate of the PLC and 30P.
- The communication baud rates which can be set up by the PLC differ. (Refer to Subsection 2.4.2.)
- The baud rate changing function is valid only in online mode.

#### The screen display and the operation method

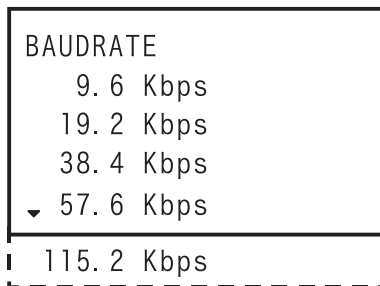

- ,  → Select
- → Confirm selection
- → Return to other menu

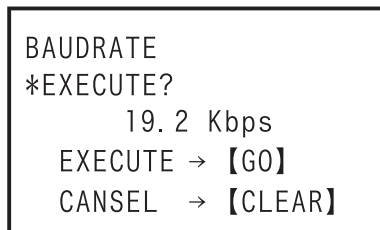

- → Execute
- → Return to baud rate setting screen

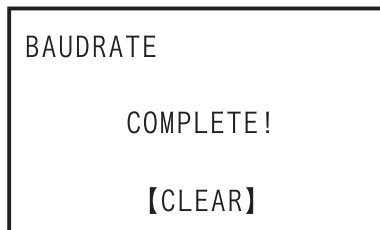

- → Return to other menu

1	Introduction
2	Specifications, product configuration
3	Connections, startup procedure
4	Outline of programming
5	Online mode
6	Offline mode
7	HP setting
8	Battery
A	ASCII Code
B	Message List

### 5.8.12 Clear PLC memory

To clear the memory inside the PLC.

- Condition of PLC memory clear

PLC status		PLC memory			
RUN	STOP	Built in memory	RAM cassette	EEPROM cassette FLROM cassette	EPROM cassette
-	✓	✓	✓	△ *1	-

\*1. When an EEPROM or FLROM cassette is attached, the PLC memory can be cleared only when the protect switch is OFF.

- To clear the memory inside the PLC (PLC memory, data devices, bit devices).
- To clear all PLC memory types (programs, parameters, file registers, device memory, extension file registers).
- To set all data devices to 0 (data registers (including file registers), extension registers, extension file registers).
- To turn OFF all bit devices (X, Y, M, S, T, C).
- When the memory cassette (excluding EPROM cassette) is attached, the memory in the memory cassette is cleared.
- The clear operation is enabled only while the PLC is in STOP. Clear operation is enabled only while the PLC is in STOP. However, if forced the STOP command (M8037) is ON while PLC is in RUN, the bit device cannot be cleared.
- The PLC memory clearing function is valid only in online mode.

#### The screen display and operation method

```

CLEAR PLC MEMORY
 PLC MEMORY
 DATA DEVICE
 BIT DEVICE
    
```

- ,  → Move cursor
- → Select
- → Cancel
- → Confirm selection
- → Return to other menu

```

CLEAR PLC MEMORY
 PLC MEMORY
 DATA DEVICE
 BIT DEVICE
    
```

- Move the cursor to the type of the memory to be cleared by using the  or  key, and select by  key, and it can be canceled by  key.
- Only the memory selected is cleared.
- PLC memory clear execution confirmation screen

```

CLEAR PLC MEMORY
*EXECUTE?

EXECUTE → 
CANCEL  → 
    
```

- → Execute PLC memory clear
- → Return to PLC memory clear selection screen

- PLC memory clear end screen

CLEAR PLC MEMORY  
COMPLETE!  
【CLEAR】

- **CLEAR** → Return to other menu

- When PLC is in RUN

CLEAR PLC MEMORY  
PLC RUNNING!  
【CLEAR】

- **CLEAR** → Return to PLC memory clear selection screen

- When the protect switch of the memory cassette is ON

CLEAR PLC MEMORY  
PROTECT SWITCH ON!  
【CLEAR】

- **CLEAR** → Return to PLC memory clear selection screen

- When an EPROM cassette is attached

CLEAR PLC MEMORY  
EPROM CONNECTING!  
【CLEAR】

- **CLEAR** → Return to PLC memory clear selection screen

- When forced STOP command (M8037) is ON while the PLC is in RUN

CLEAR PLC MEMORY  
FORCED STOP ON!  
【CLEAR】

- **CLEAR** → Return to PLC memory clear selection screen

- In the event of a communication error

CLEAR PLC MEMORY  
COMMUNICATION ERROR!  
【CLEAR】

- **CLEAR** → Return to PLC memory clear selection screen

**1**

Introduction

**2**Specifications,  
product  
configuration**3**Connections,  
startup  
procedure**4**Outline of  
programming**5**

Online mode

**6**

Offline mode

**7**

HPP setting

**8**

Battery

**A**

ASCII Code

**B**

Message List

### 5.8.13 Remote RUN/STOP

To switch the RUN/STOP state of the PLC using the HPP.

- Condition of the remote RUN/STOP

PLC status		PLC memory			
RUN	STOP	Built in memory	RAM cassette	EEPROM cassette FLROM cassette	EPROM cassette
✓	✓	✓	✓	✓	✓

- To switch the RUN/STOP state of the PLC.
- The display screen is switched automatically depending on the state of the PLC. (RUN -> STOP or STOP -> RUN)
- The remote RUN/STOP function is valid in online mode only.
- Applicable to FX1S, FX1N, FX1NC, FX2N, FX2NC, FX3S, FX3G, FX3GC, FX3U and FX3UC PLCs only.

#### The screen display and operation method

- When PLC is in STOP

```

REMOTE RUN/STOP
*EXECUTE?
  STOP → RUN
EXECUTE → 【GO】
CANCEL  → 【CLEAR】
    
```

- **GO** → Execute
- **CLEAR** → Return to other menu

```

REMOTE RUN/STOP

      COMPLETE!

      【CLEAR】
    
```

- **CLEAR** → Return to other menu

- When PLC is in RUN

```

REMOTE RUN/STOP
*EXECUTE?
  RUN  → STOP
EXECUTE → 【GO】
CANCEL → 【CLEAR】
    
```

- **GO** → Execute
- **CLEAR** → Return to other menu

```

REMOTE RUN/STOP

      COMPLETE!

      【CLEAR】
    
```

- **CLEAR** → Return to other menu



- In the event of a communication error

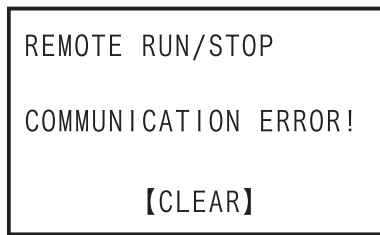

- **[CLEAR]** → Return to other menu

### 5.8.14 Set PLC clock

The PLC clock is set using the HPP.

- Condition of PLC clock setting

PLC status		PLC memory			
RUN	STOP	Built in memory	RAM cassette	EEPROM cassette FLROM cassette	EPROM cassette
✓	✓	✓	✓	✓	✓

- FX1S, FX1N, FX1NC, FX2N, FX3S, FX3G, FX3GC, FX3U, FX3UC are capable of setting the internal PLC clock.
- FX2, FX2C, FX2NC are capable of setting the clock only when the RTC cassette is attached.
- Other models are not able to set the clock.
- The PLC clock setting function is valid in online mode only.

#### The screen display and operation method

- 1) Two-digit display of the calendar year (D8018 ≠ K2000)

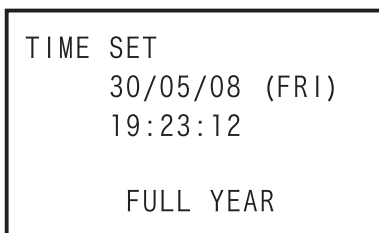

- **[SP]** → Move prompt
- **[Num. Key]** → Enter date, time
- **[GO]** → Confirm setting
- **[CLEAR]** → When the prompt is displayed (when the clock is being modified):  
The modified value are discarded, the prompt is hidden, and the current time is displayed.  
When the prompt is hidden (when the current time is displayed): Return to other menu

- 2) Four-digit display of the calendar year (D8018 = K2000)

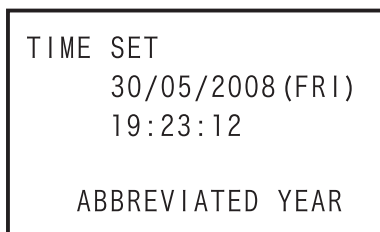

- **[SP]** → Move prompt
- **[Num. Key]** → Enter date, time
- **[GO]** → Confirm setting
- **[CLEAR]** → When the prompt is displayed (when the clock is being modified):  
The modified value are discarded, the prompt is hidden, and the current time is displayed.  
When the prompt is hidden (when the current time is displayed): Return to other menu

- The day of week is calculated and displayed based on the day, month, year. The user cannot set the day.
- The calendar year display can be changed between two digits and four digits. (When the appropriate value is written to D8018.)

## 6. Offline mode

### 6.1 Outline of offline mode

In the offline mode, the HPP accesses the built in 30P RAM.

Programs written to the built in 30P RAM can be batch-transferred to the built in PLC RAM or a memory cassette attached to the PLC. Firmware version 1.10 or later supports the HPP-PC TRANSFER function.

As for the functions similar to those in the online mode (read, write, insert, delete, parameter, device conversion), refer to Chapter 5. As for setting of the HPP, refer to Chapter 7.

- Programming in the offline mode is executed to the built in 30P RAM regardless of the program memory type in and the RUN/STOP status of the PLC.
- The batch transfer operation to the PLC can be performed in the following conditions.

	RUN/STOP status of PLC	Program memory in PLC
Write from HPP to PLC	STOP	RAM EEPROM* <sup>1</sup> FLROM* <sup>1</sup>
Read from PLC to HPP	RUN/STOP	RAM EEPROM FLROM EPROM
Collation between HPP and PLC		

\*1. When protect switch is OFF

#### Role of built in 30P RAM

In the offline mode, programming is executed to the built in 30P RAM.

Even if programming is executed to another PLC in the online mode by using the 30P programmed in the offline mode, programs saved in the 30P remain saved as they are. However, when the program is transferred and read out from the PLC in offline mode, the original program in the 30P is erased.

#### Role of built in 30P battery

The built in 30P RAM is protected from power failure by the built in 30P battery. Therefore, from the 30P in which the program is entered in offline mode, you can transfer and write to another PLC.

## 6.2 Others Functions

When **[OTHER/HELP]** key is pressed once, the OTHER function list is displayed, and when pressed again, the HELP is displayed, and when pressed once more, the display returns to the "OTHER" function list display. (Transfer to alternate)

### 6.2.1 Outline of others function

- Even while a program operation is being performed, pressing the **[OTHER/HELP]** key displays the others menu screen.
- In the others function in offline mode, the following settings are available.
  - CHANGE TO ONLINE (OFFLINE → ONLINE)
  - PROGRAM CHECK
  - HPP-FX TRANSFER
  - HPP-PC TRANSFER
  - PARAMETER
  - DEVICE CONVERSION
  - CHANGE PLC TYPE
  - HPP MEMORY CLEAR
  - PROGRAM MANAGER
  - HPP SETTING
- As for parameters, refer to Subsection 5.8.5, and as for the device conversion, refer to Subsection 5.8.7. As for HPP setting, refer to Chapter 7.
- For firmware versions that support the HPP-PC TRANSFER function, refer to Subsection 6.2.5.

#### "Others" menu screen when offline mode is selected (Firmware versions 1.10 or later)

<pre> OFFLINE MODE 1. CHANGE TO ONLINE 2. PROGRAM CHECK 3. HPP-FX TRANSFER ▼4. HPP-PC TRANSFER*1 5. PARAMETER 6. DEVICE CONVERSION 7. CHANGE PLC TYPE 8. HPP MEMORY CLEAR 9. PROGRAM MANAGER A. HPP SETTING           </pre>	<ul style="list-style-type: none"> <li>• <b>[↑]</b>, <b>[↓]</b> → Move cursor</li> <li>• <b>[GO]</b> → Confirm selection</li> <li>• <b>[Num. Key]</b> → Select</li> <li>• <b>[CLEAR]</b> → Return to other menu</li> </ul>
--	--

- Items 1 to A can be selected and set by numeric keys **[1]** to **[A]**.

- \*1. If "HPP-PC TRANSFER" is selected in the offline mode when the PLC type is other than FX3S, FX3G(C) or FX3U(C), screen does not change.

### 6.2.2 Change to online

To change over to the online mode.

- Condition of are online change

PLC status		PLC memory			
RUN	STOP	Built in memory	RAM cassette	EEPROM cassette FLROM cassette	EPRM cassette
✓	✓	✓	✓	✓	✓

#### The screen display

```

ONLINE MODE
*EXECUTE?

EXECUTE → 【GO】
CANCEL → 【CLEAR】
    
```

- 【GO】 → Online change execution
- 【CLEAR】 → Return to other menu

- When a keyword is set in the PLC  
For details on the keyword, refer to Subsection 5.8.6.

a) In the case of "FX3U/FX3UC V2.20 or later, FX3S/FX3G/FX3GC."

```

INPUT CURRENT KEYWORD
*KEYWORD      : _____
               : _____
EXECUTE → 【GO】
CANCEL  → 【CLEAR】
    
```

- Num. Key → Keyword input
- ↓ → Delete one character
- 【GO】 → Confirm input
- 【CLEAR】 → Return to other menu

b) When other than "FX3U/FX3UC V2.20 or later, FX3S/FX3G/FX3GC."

```

INPUT CURRENT KEYWORD
*KEYWORD      : _____
               : _____
EXECUTE → 【GO】
CANCEL  → 【CLEAR】
    
```

- Num. Key → Keyword input
- ↓ → Delete one character
- 【GO】 → Confirm input
- 【CLEAR】 → Return to other menu

c) When entered "keyword" is not matched

```

DISABLE

KEYWORD MISMATCH!

【CLEAR】
    
```

- 【CLEAR】 → Return to other menu

- Display after execution of online change

```

ONLINE MODE
TYPE : FX3U (C)
VER. : 1.00

*SELECT MODE
    
```

- 【RD/WR】 , 【INS/DEL】 , 【MNT/TEST】 , 【OTHER/HELP】  
→ Switch each mode
- TYPE : Displays the selected PLC basic unit name.
- VER. : Displays the version of the PLC.

### 6.2.3 Program check

The program check in offline mode includes checking of "PARAMETER ERROR", "SYNTAX ERROR", and "LADDER ERROR" only.

If an error is found after program check, the error number, error classification, error code, and error occurrence step number are displayed.

If multiple errors occur, other errors can be displayed by using  or  key. As for the error list, refer to Subsection 5.8.3.

- Program check condition

PLC status		PLC memory			
RUN	STOP	Built in memory	RAM cassette	EEPROM cassette FLROM cassette	EPRAM cassette
✓	✓	✓	✓	✓	✓

- The program is checked in the built in 30P RAM (judged at the 30P side).
- The program of built in 30P flash memory can be checked after being read out into the built in RAM.

#### The screen display

- 1) Program check top screen

```

PROGRAM CHECK
*EXECUTE?

EXECUTE → 【GO】
CANCEL  → 【CLEAR】
    
```

- → Program check execution
- → Return to other menu

- 2) In the absence of error

```

PROGRAM CHECK

NO ERROR

【CLEAR】
    
```

- → Return to other menu

3) In the presence of error(s)

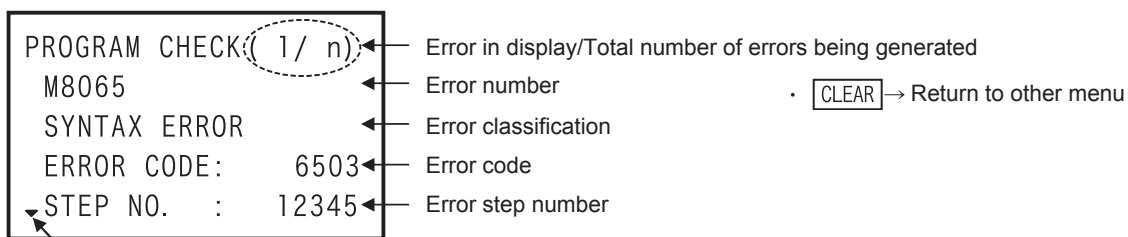

Showing that errors follow below

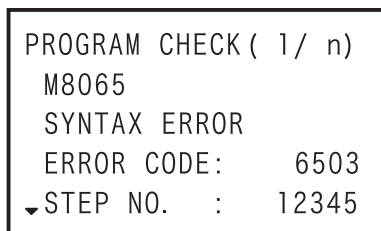

· ↑, ↓ → Changing between multiple error detail displays

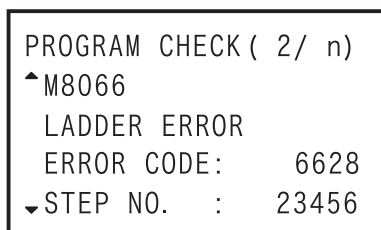

### 6.2.4 HPP-FX Transfer

- Programs and parameters are transferred and collated between the built in 30P memory.
- The 30P automatically identifies the memory cassette type, then displays the information.
- After creating or changing a program in the RAM, whose write time is shorter, the program can be mode to operate the PLC from the EEPROM, and FLROM that has better storage capability.
- Transfer is disabled from a memory having larger capacity to a memory that has a smaller capacity. (Such a transfer causes a parameter error.)  
In such a case change the parameters for the memory cassette first, then execute the transfer function again.

- After executing transfer, collate both programs, and confirm that the contents are equivalent. As a result of collating, if mismatched site is found in the program, a collation error is displayed, and the mismatched step number is displayed at the same time.
- Condition for transfer between the HPP and the FX Series PLC

PLC status		PLC memory			
RUN	STOP	Built in memory	RAM cassette	EEPROM cassette FLROM cassette	EPROM cassette
△ *1	✓	✓	✓	△ *2	△ *3

- \*1. While the PLC is in RUN, you can transfer or collate only from the PLC to the HPP.
- \*2. When the EEPROM cassette or the FLROM cassette is attached, transfer from the HPP to the memory cassette of PLC is enabled only when protect switch is OFF.
- \*3. When the EPROM cassette is attached, you cannot transfer from the HPP to the memory cassette.

#### The screen display and the operation method

##### 1) Transfer between the HPP and the FX top screen

- The type of built in PLC memory is automatically assessed by the 30P, and is displayed differently.
  - For built in RAM: FX-RAM
  - For built in EEPROM: FX-EEPROM

- The type of memory cassette is automatically assessed by the 30P, and is displayed differently.
  - For an attached EEPROM cassette: FX-CS-EEPROM
  - For an attached EPROM cassette: FX-CS-EPROM
  - For an attached FLROM cassette: FX-CS-FLROM
  - For an attached RAM cassette: FX-CS-RAM

- When the PLC is using the built in RAM (memory cassette not attached)

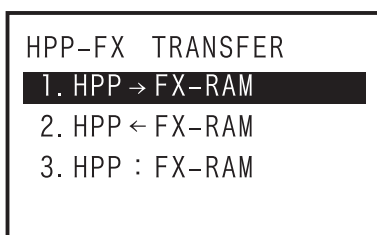

- , → Select transfer direction
- → Confirm selection
- → Select transfer direction and confirm
- → Return to other menu

- When the RAM cassette is attached for the PLC

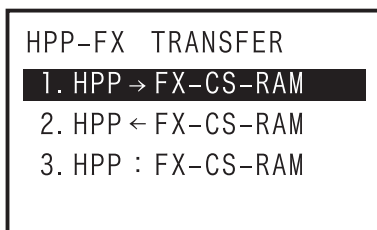

- , → Select transfer direction
- → Confirm selection
- → Select transfer direction and confirm
- → Return to other menu

1	Introduction
2	Specifications, product configuration
3	Connections, startup procedure
4	Outline of programming
5	Offline mode
6	Offline mode
7	HPP setting
8	Battery
A	ASCII Code
B	Message List

- When an EEPROM cassette is attached to the PLC

```
HPP-FX TRANSFER
1. HPP → FX-CS-EEPROM
2. HPP ← FX-CS-EEPROM
3. HPP : FX-CS-EEPROM
```

- ,  → Select transfer direction
- → Confirm selection
- → Select transfer direction and confirm
- → Return to other menu

- When an FLROM cassette is attached to the PLC

```
HPP-FX TRANSFER
1. HPP → FX-CS-FLROM
2. HPP ← FX-CS-FLROM
3. HPP : FX-CS-FLROM
```

- ,  → Select transfer direction
- → Confirm selection
- → Select transfer direction and confirm
- → Return to other menu

- When an EPROM cassette is attached to the PLC

```
HPP-FX TRANSFER
1. HPP ← FX-CS-EPROM
2. HPP : FX-CS-EPROM
```

- ,  → Select transfer direction
- → Confirm selection
- → Select transfer direction and confirm
- → Return to other menu

2) Transfer from HPP to PLC

- When a keyword is set in the PLC

- a) In the case of "FX3U/FX3UC V2.20 or later, FX3S/FX3G/FX3GC."

```
INPUT CURRENT KEYWORD
*KEYWORD      : _____
EXECUTE → 
CANCEL  → 
```

- → Keyword input
- → Delete one character
- → Confirm input
- → Return to HPP-FX transfer top screen

- b) When other than "FX3U/FX3UC V2.20 or later, FX3S/FX3G/FX3GC."

```
INPUT CURRENT KEYWORD
*KEYWORD      : _____
EXECUTE → 
CANCEL  → 
```

- → Keyword input
- → Delete one character
- → Confirm input
- → Return to HPP-FX transfer top screen

- c) When entered "keyword" is not matched

```
DISABLE
KEYWORD MISMATCH!

```

- → Return to keyword input screen



- Display after "1.HPP → FX-RAM" is selected

```
HPP→FX-RAM
*EXECUTE?

EXECUTE → 【GO】
CANCEL  → 【CLEAR】
```

- **GO** → Transfer to PLC
- **CLEAR** → Return to HPP-FX transfer top screen

```
HPP→FX-RAM
EXECUTING. . .
■ □ □ □ □ □ □ □ □ □
10 %
```

- All key inputs disabled

```
HPP→FX-RAM
COMPLETE!
■ ■ ■ ■ ■ ■ ■ ■ ■ ■
100 %
【CLEAR】
```

- **CLEAR** → Return to HPP-FX transfer top screen

- When PLC types are different between HPP and PLC.

```
HPP→FX-RAM
PLC MISMATCH!
*EXECUTE?
EXECUTE → 【GO】
CANCEL  → 【CLEAR】
```

- **GO** → Transfer to PLC
- **CLEAR** → Return to HPP-FX transfer top screen

- While PLC is in RUN

```
HPP→FX-CS-EEPROM

PLC RUNNING!

【CLEAR】
```

- **CLEAR** → Return to HPP-FX transfer top screen

- When protect switch of memory cassette is ON

```
HPP→FX-CS-EEPROM

PROTECT SWITCH ON!

【CLEAR】
```

- **CLEAR** → Return to HPP-FX transfer top screen

<b>1</b>	Introduction
<b>2</b>	Specifications, product configuration
<b>3</b>	Connections, startup procedure
<b>4</b>	Outline of programming
<b>5</b>	Offline mode
<b>6</b>	Offline mode
<b>7</b>	HPP setting
<b>8</b>	Battery
<b>A</b>	ASCII Code
<b>B</b>	Message List

- In the event of a communication error

```
HPP→FX-CS-EEPROM
COMMUNICATION ERROR!
【CLEAR】
```

- **CLEAR** → Return to HPP-FX transfer top screen

- When data in the HPP is abnormal

```
HPP→FX-CS-EEPROM
HPP DATA ERROR!
【CLEAR】
```

- **CLEAR** → Return to HPP-FX transfer top screen

- When an unjust parameter is set

```
HPP→FX-CS-EEPROM
PARAMETER ERROR!
【CLEAR】
```

- **CLEAR** → Return to HPP-FX transfer top screen

### 3) Transfer from PLC to HPP

- When a keyword is set in the PLC

- a) In the case of "FX3U/FX3UC V2.20 or later, FX3S/FX3G/FX3GC."

```
INPUT CURRENT KEYWORD
*KEYWORD      : _____
EXECUTE → 【GO】
CANCEL  → 【CLEAR】
```

- **Num. Key** → Keyword input
- **↓** → Delete one character
- **GO** → Confirm input
- **CLEAR** → Return to HPP-FX transfer top screen

- b) When other than "FX3U/FX3UC V2.20 or later, FX3S/FX3G/FX3GC."

```
INPUT CURRENT KEYWORD
*KEYWORD      : _____
EXECUTE → 【GO】
CANCEL  → 【CLEAR】
```

- **Num. Key** → Keyword input
- **↓** → Delete one character
- **GO** → Confirm input
- **CLEAR** → Return to HPP-FX transfer top screen

- c) When entered "keyword" is not matched

```
DISABLE
KEYWORD MISMATCH!
【CLEAR】
```

- **CLEAR** → Return to HPP-FX transfer top screen

- Display after "2.HPP ← FX-RAM" is selected

```
HPP←FX-RAM
*EXECUTE?

EXECUTE → 【GO】
CANCEL  → 【CLEAR】
```

- **GO** → Transfer to HPP
- **CLEAR** → Return to HPP-FX transfer top screen

```
HPP←FX-RAM
EXECUTING. . .
■ □ □ □ □ □ □ □ □ □
10 %
```

- All key inputs disabled

```
HPP←FX-RAM
COMPLETE!
■ ■ ■ ■ ■ ■ ■ ■ ■ ■
100 %
【CLEAR】
```

- **CLEAR** → Return to HPP-FX transfer top screen

- When PLC types are different between HPP and PLC.

```
HPP←FX-RAM
PLC MISMATCH!
*EXECUTE?
EXECUTE → 【GO】
CANCEL  → 【CLEAR】
```

- **CLEAR** → Return to HPP-FX transfer top screen
- **GO** → Transfer to HPP execution

- When an unjust parameter is set

```
HPP←FX-RAM

PARAMETER ERROR!

【CLEAR】
```

- **CLEAR** → Return to HPP-FX transfer top screen

- In the event of a communication error

```
HPP←FX-RAM

COMMUNICATION ERROR!

【CLEAR】
```

- **CLEAR** → Return to HPP-FX transfer top screen

<b>1</b>	Introduction
<b>2</b>	Specifications, product configuration
<b>3</b>	Connections, startup procedure
<b>4</b>	Outline of programming
<b>5</b>	Online mode
<b>6</b>	Offline mode
<b>7</b>	HPP setting
<b>8</b>	Battery
<b>A</b>	ASCII Code
<b>B</b>	Message List

4) Collation between HPP and PLC

- When a keyword is set in the PLC

a) In the case of "FX3U/FX3UC V2.20 or later, FX3S/FX3G/FX3GC."

```

INPUT CURRENT KEYWORD
*KEYWORD      : _____
EXECUTE →    【GO】
CANCEL  →    【CLEAR】
    
```

- → Keyword input
- → Delete one character
- → Confirm input
- → Return to HPP-FX transfer top screen

b) When other than "FX3U/FX3UC V2.20 or later, FX3S/FX3G/FX3GC."

```

INPUT CURRENT KEYWORD
*KEYWORD      : _____
EXECUTE →    【GO】
CANCEL  →    【CLEAR】
    
```

- → Keyword input
- → Delete one character
- → Confirm input
- → Return to HPP-FX transfer top screen

c) When entered "keyword" is not matched

```

DISABLE
KEYWORD MISMATCH!
【CLEAR】
    
```

- → Return to keyword input screen

- Display after "3.HPP:FX-RAM" is selected

```

HPP:FX-RAM
*EXECUTE?
EXECUTE →    【GO】
CANCEL  →    【CLEAR】
    
```

- → HPP-FX PLC collation execution
- → Return to HPP-FX transfer top screen

```

HPP:FX-RAM
EXECUTING. . .
■ □ □ □ □ □ □ □ □ □
10 %
    
```

- All key inputs disabled

```

HPP:FX-RAM
COMPLETE!
■ ■ ■ ■ ■ ■ ■ ■ ■ ■
100 %
【CLEAR】
    
```

- → Return to HPP-FX transfer top screen

- In the event of a collation error or parameter mismatch

```
HPP:FX-RAM
VERIFY ERROR!
PARAMETER MISMATCH

【CLEAR】
```

- **CLEAR** → Return to HPP-FX transfer top screen

- In the event of a collation error or program mismatch

```
HPP:FX-RAM
VERIFY ERROR!
PROGRAM MISMATCH
STEP NO. :26544
【CLEAR】
```

- **CLEAR** → Return to HPP-FX transfer top screen

- In the event of a communication error

```
HPP:FX-RAM

COMMUNICATION ERROR!

【CLEAR】
```

- **CLEAR** → Return to HPP-FX transfer top screen

### 6.2.5 HPP-PC Transfer

- This function transfers and verifies data between the RAM in the FX-30P and a personal computer (GX Works2, GX Developer).
- Programs stored in the flash memory in the FX-30P can be transferred to the RAM in the FX-30P first, and then transferred to a personal computer (GX Works2, GX Developer).
- Connect the FX-30P and a personal computer with a USB cable for data transfer and verification.
- It is necessary that the RAM in the FX-30P matches with the PLC type selected in the project in the personal computer (GX Works2, GX Developer).
- The HPP-PC Transfer is valid in offline mode only.
- Condition for transfer between the HPP and the personal computers (not related to the PLC status and memory)

PLC status		PLC memory			
RUN	STOP	Built in memory	RAM cassette	EEPROM cassette FLROM cassette	EPRAM cassette
-	-	-	-	-	-

- List of PLCs supporting the HPP-PC TRANSFER function

FX1	FX2 FX2C	FX0 FX0S	FX0N	FX1S	FX1N FX1NC	FX2N FX2NC	FX3S	FX3G FX3GC	FX3U FX3UC
-	-	-	-	-	-	-	✓*1	✓	✓

\*1. This function is supported only by GX Works2.

- Programming software and 30P F/W version supporting the HPP-PC TRANSFER function

Programming software	Programming software version	30P F/W version
GX Works2	Ver. 1.91V or later	Ver. 1.50 or later*2
GX Developer	Ver. 8.72A or later	Ver. 1.10 or later

\*2. Transfer of the following is not supported.

- Symbolic information (data indicating the program configuration such as labels and structure)
- "Ethernet Port" of the "PLC Parameter"
- "Network Parameter"

#### The screen display and the operation method

- 1) Transfer between the HPP and the personal computer top screen

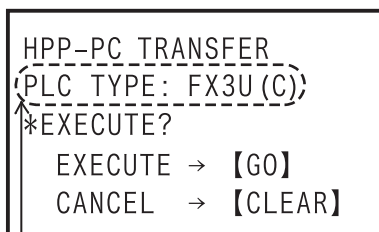

- **[GO]** → Confirm input
- **[CLEAR]** → Return to other menu

PLC type with built in 30P RAM

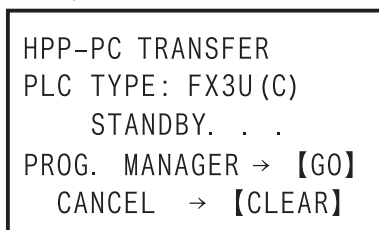

- **[GO]** → Display the program management menu  
→ **For details of the program management menu, refer to Subsection 6.2.8.**
- **[CLEAR]** → Return to other menu

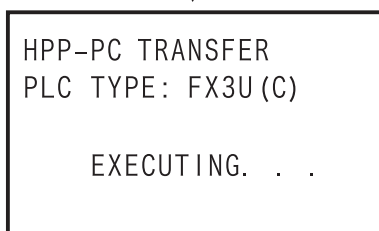

- All key inputs disabled (while transfer is executed between the FX-30P and a personal computer)  
→ Returns to the standby screen when the transfer is completed.

#### Caution

Check the transfer (or verification) progress on the personal computer screen.

**The operation using the personal computer (GX Works2, GX Developer)**

- 1) Set the FX-30P to communication standby status (by displaying the "STANDBY..." screen) first.
- 2) If a project is open in GX Works2 and GX Developer, confirm that the PLC type selected in the project matches the PLC type displayed on the FX-30P screen. (If transfer is executed while the PLC type does not match, an error occurs in the personal computer.)
- 3) In the case of GX Works2, in the lower left corner of the screen, select [Connection Destination]-[Current Connection]-[PC side I/F]-[RC-232C].  
In the case of GX Developer, from the menu bar, select [Online]-[Transfer setup]-[PC side I/F]-[RC-232C].  
(Communication is disabled if any item other than [RC-232C] is selected.)
- 4) Select [Online]-[Read from PLC] ([Write to PLC], or [Verify with PLC]).
- 5) Check the box of data to be transferred (or verified), and press the [GO] button.
- 6) Transfer (or verification) is executed.

## • Data transfer propriety list

Transfer data content	Read from PLC	Write to PLC	Verify with PLC
Parameter	✓	✓	✓
Program	✓	✓	✓
File register	✓	✓	✓
Device comment	✓	✓	✓
Device memory*1	-	-	-

- \*1. Device memories cannot be transferred or verified.  
 If "Device memory" is selected in "Read from PLC" and reading is executed, "0" is read except in some special data registers.  
 If "Device memory" is selected in "Write to PLC" and writing is executed, all transferred data is discarded.  
 If "Device memory" is selected in "Verify with PLC" and verification is executed, "0" is read except in some special data registers.

**Caution**

If parameters are verified from a personal computer (GX Works2, GX Developer), "CC-Link/LT setting is mismatch" may be displayed.

- **When a FX3uc-32MT-LT-2 is being verified**  
Please confirm CC-Link/LT set data on the parameter-setting screen of the personal computer (GX Works2, GX Developer).
- **When a FX3U/FX3uc Series other than a FX3uc-32MT-LT-2 is being verified**  
Since there is no CC-Link/LT active parameter in any types other than the FX3uc-32MT-LT-2, confirmation by the user is unnecessary.

### 6.2.6 PLC Type

PLC type in offline mode is changed.

When the PLC type is changed, some of the parameters return to initial values.

Refer to the table on the next page for restrictions in changing PLC type.

- Condition of PLC type

PLC status		PLC memory			
RUN	STOP	Built in memory	RAM cassette	EEPROM cassette FLROM cassette	EPROM cassette
✓	✓	✓	✓	✓	✓

#### The screen display and the operation method

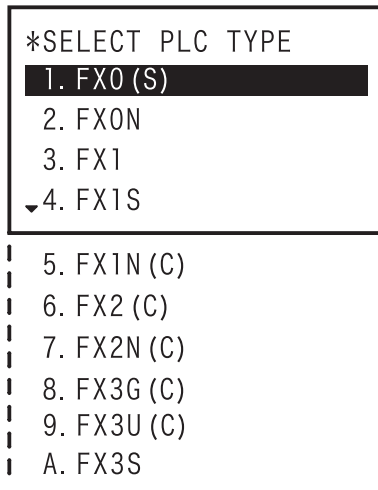

- ,  → Select the PLC type
- → Go to parameter change confirmation screen
- → Select and go to parameter change confirmation screen
- → Return to other menu

- Parameter change confirmation screen

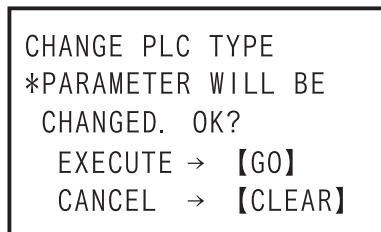

- → Execute
- → Return to other menu

- PLC type change completion screen

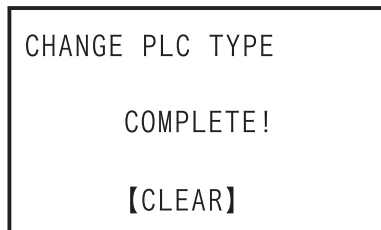

- → Return to other menu



• Changes Made between PLC Types

Change Type	Memory Capacity*1	Comment Capacity*1	File Register Capacity*1	Latch Range	PLC System Setting
FX0(S) → FX0N	● (2000 steps)	● (Block 0)	● (Block 0)	-	-
FX0(S) → FX1	● (2000 steps)	●	-	●	-
FX0(S) → FX1N(C)	● (8000 steps)	● (Block 0)	● (Block 0)	-	●
FX0(S) → FX1S	● (2000 steps)	● (Block 0)	● (Block 0)	-	●
FX0(S) → FX2(C)	● (2000 steps)	● (Block 0)	● (Block 0)	●	-
FX0(S) → FX2N(C)	● (8000 steps)	● (Block 0)	● (Block 0)	●	●
FX0(S) → FX3S	● (4000 steps)	● (Block 0)	● (Block 0)	-	●
FX0(S) → FX3G(C)	● (8000 steps)	● (Block 0)	● (Block 0)	-	●
FX0(S) → FX3U(C)	● (8000 steps)	● (Block 0)	● (Block 0)	●	●
FX0N → FX0(S)	● (800 steps)	-	-	-	-
FX0N → FX1	◎	◎	-	●	-
FX0N → FX1S	◎	◎	◎	-	●
FX0N → FX1N(C)	◎	◎	◎	-	●
FX0N → FX2(C)	◎	◎	◎	●	-
FX0N → FX2N(C)	◎	◎	◎	●	●
FX0N → FX3S	◎	◎	◎	-	●
FX0N → FX3G(C)	◎	◎	◎	-	●
FX0N → FX3U(C)	◎	◎	◎	●	●
FX1 → FX0(S)	● (800 steps)	-	-	-	-
FX1 → FX0N	★ (2000 steps)	★ (Block 0)	● (Block 0)	-	-
FX1 → FX1S	★ (2000 steps)	★ (Block 0)	★ (Block 0)	-	●
FX1 → FX1N(C)	◎	★ (Block 0)	● (Block 0)	-	●
FX1 → FX2(C)	◎	★ (Block 0)	● (Block 0)	●	-
FX1 → FX2N(C)	◎	★ (Block 0)	● (Block 0)	●	●
FX1 → FX3S	◎	★ (Block 0)	● (Block 0)	-	●
FX1 → FX3G(C)	◎	★ (Block 0)	● (Block 0)	-	●
FX1 → FX3U(C)	◎	★ (Block 0)	● (Block 0)	●	●
FX1S → FX0(S)	● (800 steps)	-	-	-	-
FX1S → FX0N	◎	◎	◎	-	-
FX1S → FX1	◎	◎	-	●	-
FX1S → FX1N(C)	◎	◎	◎	-	★
FX1S → FX2(C)	◎	◎	◎	●	-
FX1S → FX2N(C)	◎	◎	◎	●	★
FX1S → FX3S	◎	◎	◎	-	★
FX1S → FX3G(C)	◎	◎	◎	-	★
FX1S → FX3U(C)	◎	◎	◎	●	★

◎ : Settings before change are retained.

★ : The status before change is retained when the setting range is allowed in the change destination PLC type. The initial setting of the change destination PLC type is set when the selected setting range is not allowed.

● : Defaults of the CPU type after change are set.

- : Not applicable.

\*1. The value in ( ) is the initial setting for each PLC type.

1	Introduction
2	Specifications, product configuration
3	Connections, startup procedure
4	Outline of programming
5	Offline mode
6	Offline mode
7	HP setting
8	Battery
A	ASCII Code
B	Message List

Change Type	Memory Capacity*1	Comment Capacity*1	File Register Capacity*1	Latch Range	PLC System Setting
FX1N(C) → FX0(S)	● (800 steps)	-	-	-	-
FX1N(C) → FX0N	● (2000 steps)	★ (Block 0)	★ (Block 0)	-	-
FX1N(C) → FX1	★ (2000 steps)	★ (Block 0) <sup>*2</sup>	-	●	-
FX1N(C) → FX1S	● (2000 steps)	★ (Block 0)	★ (Block 0)	-	★
FX1N(C) → FX2(C)	◎	★ (Block 0)	★ (Block 0)	●	-
FX1N(C) → FX2N(C)	◎	◎	◎	●	★
FX1N(C) → FX3S	★ (4000 steps)	★ (Block 0)	★ (Block 0)	-	★
FX1N(C) → FX3G(C)	◎	◎	◎	-	★
FX1N(C) → FX3U(C)	◎	◎	◎	●	★
FX2(C) → FX0(S)	● (800 steps)	-	-	-	-
FX2(C) → FX0N	★ (2000 steps)	★ (Block 0)	★ (Block 0)	-	-
FX2(C) → FX1	★ (2000 steps)	★ (Block 0) <sup>*2</sup>	-	●	-
FX2(C) → FX1S	★ (2000 steps)	★ (Block 0)	★ (Block 0)	-	●
FX2(C) → FX1N(C)	◎	★ (Block 0)	★ (Block 0)	-	●
FX2(C) → FX2N(C)	◎	★ (Block 0)	★ (Block 0)	●	●
FX2(C) → FX3S	★ (4000 steps)	★ (Block 0)	★ (Block 0)	-	●
FX2(C) → FX3G(C)	◎	★ (Block 0)	★ (Block 0)	-	●
FX2(C) → FX3U(C)	◎	★ (Block 0)	★ (Block 0)	●	●
FX2N(C) → FX0(S)	● (800 steps)	-	-	-	-
FX2N(C) → FX0N	★ (2000 steps)	★ (Block 0)	★ (Block 0)	-	-
FX2N(C) → FX1	★ (2000 steps)	★ (Block 0) <sup>*2</sup>	-	●	-
FX2N(C) → FX1S	★ (2000 steps)	★ (Block 0)	★ (Block 0)	-	★
FX2N(C) → FX1N(C)	★ (8000 steps)	★ (Block 0)	★ (Block 0)	-	★
FX2N(C) → FX2(C)	★ (2000 steps)	★ (Block 0)	★ (Block 0)	●	-
FX2N(C) → FX3S	★ (4000 steps)	★ (Block 0) <sup>*3</sup>	★ (Block 0)	-	★
FX2N(C) → FX3G(C)	◎	◎	◎	-	★
FX2N(C) → FX3U(C)	◎	◎	◎	●	★

◎ : Settings before change are retained.

★ : The status before change is retained when the setting range is allowed in the change destination PLC type. The initial setting of the change destination PLC type is set when the selected setting range is not allowed.

● : Defaults of the CPU type after change are set.

- : Not applicable.

\*1. The value in () is the initial setting for each PLC type.

\*2. When PLC type is changed to FX1 and the memory capacity is 4K step, the initial value of the comment capacity becomes 4 blocks (2K step).

\*3. When PLC type is changed to FX3S and the memory capacity is 16K step, the initial value of the comment capacity is the value of 24 blocks (12K step) minus the file register capacity.

Change Type	Memory Capacity <sup>*1</sup>	Comment Capacity <sup>*1</sup>	File Register Capacity <sup>*1</sup>	Latch Range	PLC System Setting
FX3S → FX0(S)	● (800 steps)	-	-	-	-
FX3S → FX0N	★ (2000 steps)	★ (Block 0)	★ (Block 0)	-	-
FX3S → FX1	★ (2000 steps)	★ (Block 0) <sup>*2</sup>	-	●	-
FX3S → FX1S	★ (2000 steps)	★ (Block 0)	★ (Block 0)	-	★
FX3S → FX1N(C)	★ (8000 steps)	★ (Block 0)	★ (Block 0)	-	★
FX3S → FX2(C)	★ (2000 steps)	★ (Block 0)	★ (Block 0)	●	-
FX3S → FX2N(C)	◎	◎	◎	●	★
FX3S → FX3G(C)	◎	◎	◎	-	★
FX3S → FX3U(C)	◎	◎	◎	●	★
FX3G(C) → FX0(S) <sup>*3</sup>	● (800 steps)	-	-	-	-
FX3G(C) → FX0N <sup>*3</sup>	★ (2000 steps)	★ (Block 0)	★ (Block 0)	-	-
FX3G(C) → FX1 <sup>*3</sup>	★ (2000 steps)	★ (Block 0) <sup>*2</sup>	-	●	-
FX3G(C) → FX1S <sup>*3</sup>	★ (2000 steps)	★ (Block 0)	★ (Block 0)	-	★
FX3G(C) → FX1N(C) <sup>*3</sup>	★ (8000 steps)	★ (Block 0)	★ (Block 0)	-	★
FX3G(C) → FX2(C) <sup>*3</sup>	★ (2000 steps)	★ (Block 0)	★ (Block 0)	●	-
FX3G(C) → FX2N(C) <sup>*3</sup>	★ (8000 steps)	★ (Block 0)	★ (Block 0)	●	★
FX3G(C) → FX3S <sup>*3</sup>	★ (4000 steps)	★ (Block 0) <sup>*4</sup>	★ (Block 0)	-	★
FX3G(C) → FX3U(C) <sup>*3</sup>	◎	◎	◎	●	★
FX3U(C) → FX0(S) <sup>*3</sup>	● (800 steps)	-	-	-	-
FX3U(C) → FX0N <sup>*3</sup>	★ (2000 steps)	★ (Block 0)	★ (Block 0)	-	-
FX3U(C) → FX1 <sup>*3</sup>	★ (2000 steps)	★ (Block 0) <sup>*2</sup>	-	●	-
FX3U(C) → FX1S <sup>*3</sup>	★ (2000 steps)	★ (Block 0)	★ (Block 0)	-	★
FX3U(C) → FX1N(C) <sup>*3</sup>	★ (8000 steps)	★ (Block 0)	★ (Block 0)	-	★
FX3U(C) → FX2(C) <sup>*3</sup>	★ (2000 steps)	★ (Block 0)	★ (Block 0)	●	-
FX3U(C) → FX2N(C) <sup>*3</sup>	★ (8000 steps)	★ (Block 0)	★ (Block 0)	●	★
FX3U(C) → FX3S <sup>*3</sup>	★ (4000 steps)	★ (Block 0) <sup>*4</sup>	★ (Block 0)	-	★
FX3U(C) → FX3G(C) <sup>*3</sup>	★ (8000 steps)	★ (Block 0)	★ (Block 0)	-	★

◎ : Settings before change are retained.

★ : The status before change is retained when the setting range is allowed in the change destination PLC type. The initial setting of the change destination PLC type is set when the selected setting range is not allowed.

● : Defaults of the CPU type after change are set.

- : Not applicable.

\*1. The value in () is the initial setting for in each PLC type.

\*2. When PLC type is changed to FX1 and the memory capacity is 4K step, the initial value of the comment capacity becomes 4 blocks (2K step).

\*3. The special function memory capacity resets to the initial value (Block 0).

\*4. When PLC type is changed to FX3s and the memory capacity is 16K step, the initial value of the comment capacity is the value of 24 blocks (12K step) minus the file register capacity.

## 6.2.7 HPP Memory clear

The memory inside the 30P is cleared.

- HPP memory clearing condition

PLC status		PLC memory			
RUN	STOP	Built in memory	RAM cassette	EEPROM cassette FLROM cassette	EPROM cassette
✓	✓	✓	✓	✓	✓

- To clear all programs and parameters existing in the built in RAM of the 30P.
- All programs are NOP.
- Parameters are set to initial values of the PLC type selected in the offline mode.
- The HPP memory clearing function is valid in offline mode only.

### The screen display and the operation method

HPP MEMORY CLEAR *EXECUTE?  EXECUTE → 【GO】 CANCEL → 【CLEAR】	<ul style="list-style-type: none"> <li>• <b>GO</b> → Memory clearing execution</li> <li>• <b>CLEAR</b> → Return to other menu</li> </ul>
HPP MEMORY CLEAR  COMPLETE!  【CLEAR】	<ul style="list-style-type: none"> <li>• <b>CLEAR</b> → Return to other menu</li> </ul>

### 6.2.8 Program manager

This is to manage the programs saved in the flash memory inside the 30P.

- Condition of program management

PLC status		PLC memory			
RUN	STOP	Built in memory	RAM cassette	EEPROM cassette FLROM cassette	EPRAM cassette
✓	✓	✓	✓	✓	✓

- You can access the menus for new program save, program overwrite save, program read-out, program delete, program management information, etc.
- The program management function is valid in offline mode only.

- Program save capacity

Total capacity	Number of blocks being used in the program memory capacity
15 blocks	Program memory capacity is 800, 2K, 4K, 16K, 32K steps: 1 block used Program memory capacity is 64K steps: 2 blocks used

Up to 15 programs can be saved.

- Program composition (data which can be saved)

Item	Capacity
Parameter	-
Program	800, 2K, 4K, 8K, 16K, 32K, 64K steps

- 30P built in flash memory performance

Item	Description
Allowable number of writes	Each block 100,000 times

- Program management menu

Item	Function
Program list	To display a list of programs stored in the 30P program management area (built in 30P flash memory).
READ	To read out the program selected from the program list, to the built in 30P RAM.*1
RESAVE	The program in the built in 30P RAM is overwritten and saved in the program selected from the program list.
DELETE	To delete the program selected from the program list.*2
NEW SAVE	The program in the built in 30P RAM is newly saved in the 30P program management area (built in 30P flash memory).*3
ALL DELETE	To delete all programs in the 30P program management area (built in 30P flash memory).
PROG. MANAGER INF.	To display the number of programs saved in the 30P program management area (built in 30P flash memory) together with the number of blocks being used.

- \*1. When editing the program in the 30P program management area, you must read out into the built in 30P RAM. When being read out, the program originally existing in the built in 30P RAM is lost (due to being overwritten).
- \*2. Only the program in the 30P program management area is deleted. The program in the built in 30P RAM is not deleted.
- \*3. When saving a program for the first time, you must designate "program management name" to be managed in the 30P. Refer to the paragraph on program management name setting.

<b>1</b>	Introduction
<b>2</b>	Specifications, product configuration
<b>3</b>	Connections, startup procedure
<b>4</b>	Outline of programming
<b>5</b>	Offline mode
<b>6</b>	Offline mode
<b>7</b>	HPP setting
<b>8</b>	Battery
<b>A</b>	ASCII Code
<b>B</b>	Message List

- Management name setting  
You cannot set the same management name as a management name already registered.

Item	Description
Used characters	ASCII characters, 1-byte alphanumerics total 95 characters, 1-byte katakana total 64 characters*1
Number of characters	1 to 18 characters

\*1. 1-byte kana characters can be entered only when Japanese is selected in the language selection.

**The screen display and the operation method**

1) Program management top screen

PROGRAM MANAGER

**1. PROGRAM LIST**

2. NEW SAVE

3. ALL DELETE

4. PROG. MANAGER INF.

- ,  → Move cursor
- → Confirm selection
- → Select and confirm
- → Return to other menu

2) Program list

- Program list screen

PROGRAM LIST

**1. Temperature**  
FX3U(C) 32K step

2. (FX1N Position)  
(FX1N 8K step)

- ,  → Move cursor
- → Confirm selection
- → Program select and confirm
- → Return to program management top screen

← Program management name  
 ← PLC type, memory capacity

- When there is no saved program data.

PROGRAM LIST

NO DATA!

**[CLEAR]**

- → Return to program management top screen

- When program save data is broken

PROGRAM LIST

**1. Temperature**  
FX3U(C) 2K step

2. UNKNOWN PROGRAM  
UNKNOWN ??? step

- ,  → Move cursor
- → Confirm selection
- → Program select and confirm
- → Return to program management top screen

← Save data is broken

- Program operation screen

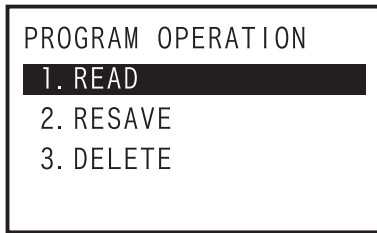

- ,  → Move cursor
- → Confirm selection
- → Select and confirm
- → Return to program management menu

3) Program read

- Program read confirmation screen

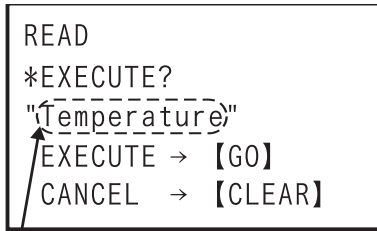

Program management name

- → Execute
- → Return to program list screen

- Program read completion screen

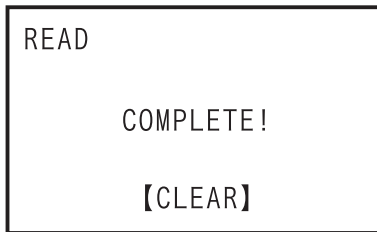

- → Return to program list screen

4) Program overwrite save

- Overwrite save confirmation screen

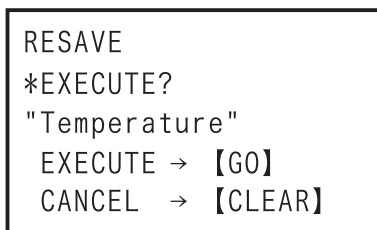

- → Execute
- → Return to program list screen

- Program overwrite save completion screen

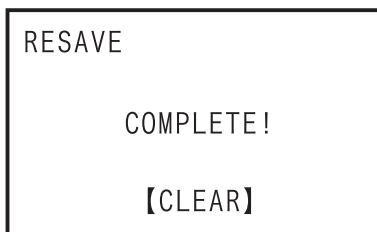

- → Return to program list screen

- When the built in 30P RAM data is abnormal

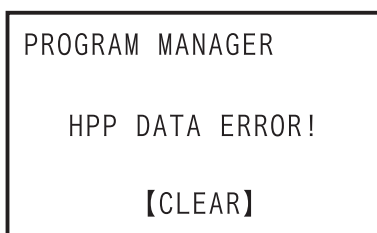

- → Return to program management menu

**1** Introduction

**2** Specifications, product configuration

**3** Connections, startup procedure

**4** Outline of programming

**5** Offline mode

**6** Offline mode

**7** HPP setting

**8** Battery

**A** ASCII Code

**B** Message List

- When exceeding storage capacity

```

RESAVE

OVER SIZE LIMIT!

【CLEAR】
    
```

- **CLEAR** → Return to program list screen

5) Program delete

- Program delete confirmation screen

```

DELETE
*EXECUTE?
"Temperature"
EXECUTE → 【GO】
CANCEL → 【CLEAR】
    
```

- **GO** → Execute
- **CLEAR** → Return to program list screen

- Program deletion completion screen

```

DELETE

COMPLETE!

【CLEAR】
    
```

- **CLEAR** → Return to program list screen

6) New save

- When exceeding storage capacity

```

NEW SAVE

OVER SIZE LIMIT!

【CLEAR】
    
```

- **CLEAR** → Return to program management menu

- When the built in 30P RAM data is abnormal

```

PROGRAM MANAGER

HPP DATA ERROR!

【CLEAR】
    
```

- **CLEAR** → Return to program management menu



- New save top screen

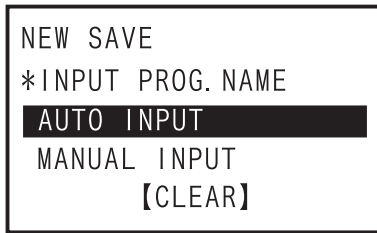

- ,  → Move cursor
- → Confirm selection
- → Return to program management menu

- When "AUTO INPUT" is selected, the 30P automatically specifies program management name ("PLC type\_"serial 3 digits"). (Example: FX3U(C)\_000)
  - When "MANUAL INPUT" is selected, the user must enter the management name.
- Program management name input screen

• When "AUTO INPUT" is selected

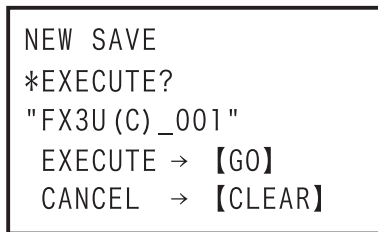

- → Execute
- → Return to program management screen

• When "MANUAL INPUT" is selected

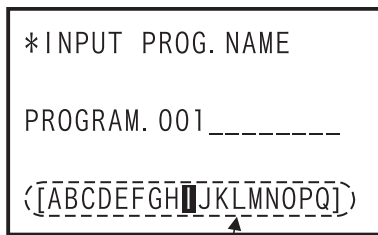

Character list display

- ,  → Move character cursor (character list in lowest line)
- → Select one character (highlighted character in character list in lowest line)
- → Delete one character
- → Number input
- → Confirm program management name
- → Return to program management menu

- Up to 18 characters can be entered in ASCII characters (1-byte alphanumerics, 1-byte katakana).
- 1-byte katakana can be entered only when "Japanese" is selected in language selection mode.

• When custom input is selected program management name confirmation screen

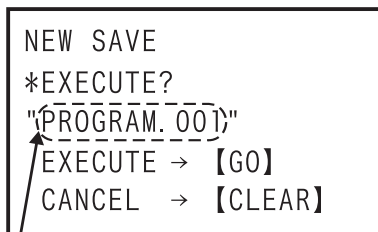

Program management name

- → Execute
- → Return to program management menu

1 Introduction

2 Specifications, product configuration

3 Connections, startup procedure

4 Outline of programming

5 Online mode

6 Offline mode

7 HPP setting

8 Battery

A ASCII Code

B Message List

- Programs new save completion screen

```

NEW SAVE

      COMPLETE!

      【CLEAR】
    
```

- **CLEAR** → Return to program management menu

7) All programs deletion

- All programs deletion confirmation screen

```

ALL DELETE
*EXECUTE?

EXECUTE → 【GO】
CANCEL  → 【CLEAR】
    
```

- **GO** → Execute
- **CLEAR** → Return to program management menu

- All programs deletion completion screen

```

ALL DELETE

      COMPLETE!

      【CLEAR】
    
```

- **CLEAR** → Return to program management menu

8) Program management information

- Program management information screen

```

PROG. MANAGER INF.
NUM. OF SAVED PROG.
      3 PROGRAM
NUM. OF USED BLOCK
      7/15 BLOCK
    
```

- **CLEAR** → Return to program management menu

## 7. HPP setting

Setting of the 30P main unit is performed. The setting content is stored in the flash memory.

### Menu screen display, operation method

HPPSETTING	•  ,  → Move cursor
<b>1. LANGUAGE</b>	•  → Confirm selection
2. BUZZER LEVEL	•  → Select and confirm
3. DISPLAY CONTRAST	•  → Return to other menu* <sup>1</sup>
▼4. DISPLAY BRIGHTNESS	
5. SCREEN SAVE	
6. HPP PROTECT	
7. HPP INITIALIZE	
8. HPP F/W UPDATE	

\*1. When performed on the direct HPP setting screen after the power is switched ON, it returns to the mode select screen.

### 7.1 Menu display language selection

To select the language of menu display and error display of 30P

#### The screen display and the operation method

LANGUAGE	•  ,  → Move cursor
<b>ENGLISH</b>	•  → Confirm selection. Go to completion screen.
日本語	•  → Cancel. Return to HPP setting menu screen.
中文(简体)	
中文(繁體)	

### 7.2 Buzzer sound volume setting

To adjust the buzzer sound.

Initial value : 4

#### The screen display and the operation method

BUZZER LEVEL	•  ,  ,  * <sup>2</sup> → Sound volume adjustment
0 1 2 3 <b>4</b> 5 6 7 8	•  → Confirm level. Go to the completion screen.
EXECUTE → <b>【GO】</b>	•  → Cancel. Return to HPP setting menu screen.
CANCEL → <b>【CLEAR】</b>	

When the buzzer volume is set to 0, the buzzer is OFF.

\*2. Setting using the supported from firmware versions 1.20 or later of the 30P.

1

Introduction

2

Specifications,  
product  
configuration

3

Connections,  
startup  
procedure

4

Outline of  
programming

5

Online mode

6

Offline mode

7

HPP setting

8

Battery

A

ASCII Code

B

Message List

## 7.3 LCD contrast adjustment

Initial value : 4

To adjust the LCD contrast.

### The screen display and the operation method

```

DISPLAY CONTRAST
  1 2 3 4 5 6 7 8

EXECUTE → 【GO】
CANCEL  → 【CLEAR】

```

- ,  ,  \*1 → Contrast adjustment
- → Confirm. Go to the completion screen.
- → Cancel. Return to HPP setting menu screen.

\*1. Setting using the  supported from firmware versions 1.20 or later of the 30P.

## 7.4 Backlight brightness adjustment

Initial value : 4

To adjust the backlight brightness of LCD.

### The screen display and the operation method

```

DISPLAY BRIGHTNESS
  0 1 2 3 4 5 6 7 8

EXECUTE → 【GO】
CANCEL  → 【CLEAR】

```

- ,  ,  \*2 → Brightness adjustment
- → Confirm. Go to the completion screen.
- → Cancel. Return to HPP setting menu screen.

When the brightness is set to 0, the backlight goes out completely.

\*2. Setting using the  supported from firmware versions 1.20 or later of the 30P.

## 7.5 Screen save

Initial value : 0

Set the time until the screen saver is started from stopping of key input operation to the 30P. When the screen saver starts, the backlight goes out, and the screen saver is displayed.

### The screen display and the operation method

```

SCREEN SAVE
*TIME          10 min
                (0, 1-60 min)

EXECUTE → 【GO】
CANCEL  → 【CLEAR】

```

- → Time input
- → Confirm input
- → Cancel. Return to completion screen.

- Setting range: 0 (screen saver not used) and 1 to 60 minutes
- Screen save completion screen

```

SCREEN SAVE

COMPLETE!

【CLEAR】

```

- → Cancel. Return to HPP setting menu screen.

- Screen save screen  
When the screen saver setting is from 1 to 60, the screen saver starts when the key is not manipulated for more than the specified time.

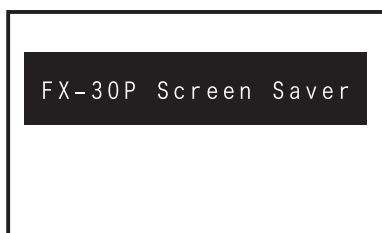

- If any key is manipulated, the screen returns to the screen before start of the screen save.

## 7.6 HPP protection

Programs saved in the built in 30P SRAM and the built in 30P flash memory are protected so as not to be accessed (read, written, or erased). When protected, you must enter the protection key when changing over to the offline mode.

- Input enabled characters: 0 to 9, A to F.  
Number of input enabled characters: 1 to 16 characters.

### The screen display and the operation method

- 1) HPP protect key setting screen (when HPP protect key is set)

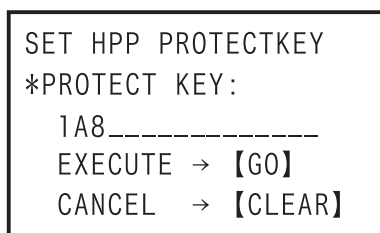

- → Enter protection key
- → Delete one character
- → Confirm entered key
- → Return to HPP setting menu screen.



- → Return to HPP setting menu screen.

- 2) HPP protect key deletion screen (when HPP protect key is not set)

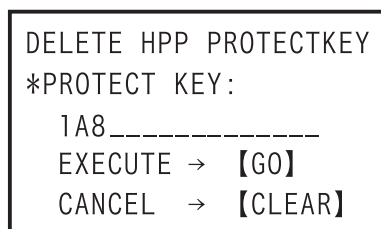

- → Enter protection key
- → Delete one character
- → Confirm entered key
- → Return to HPP setting menu screen.

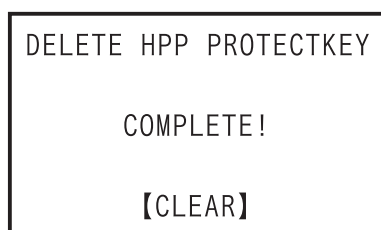

- → Return to HPP setting menu screen.

1	Introduction
2	Specifications, product configuration
3	Connections, startup procedure
4	Outline of programming
5	Online mode
6	Offline mode
7	HPP setting
8	Battery
A	ASCII Code
B	Message List

3) Protection key validation screen

```

INPUT HPP PROTECTKEY
*PROTECT KEY:
 1A8-----
EXECUTE → 【GO】
CANCEL  → 【CLEAR】
    
```

- **Num. Key** → Enter protection key
- **↓** → Delete one character
- **GO** → Confirm entered key
- **CLEAR** → Return to previous screen

```

INPUT HPP PROTECTKEY

CANCEL PROTECTED!

【CLEAR】
    
```

- **CLEAR** → Go to the next screen

- When protect keys are mismatched

```

INPUT HPP PROTECTKEY

KEY INCORRECT!

【CLEAR】
    
```

- **CLEAR** → Return to previous screen

## 7.7 HPP initialization

The 30P is returned to the initial shipping state (except for F/W). As a result, all of setting values of 30P, and contents in built in 30P RAM and built in 30P flash memory will be cleared.

### The screen display and the operation method

```

HPP INITIALIZE
*EXECUTE?

EXECUTE → 【GO】
CANCEL  → 【CLEAR】
    
```

- **GO** → Execute, switches to top screen when turning on power after completion.
- **CLEAR** → Cancel. Return to HPP setting menu screen.

```

HPP INITIALIZE

EXECUTING. . .
    
```

- All key inputs disabled

- After completion of HPP initialization, the display automatically switches to the top screen when turning on the power.
- If you forget the HPP protection key, the protection key can be canceled by initializing the HPP. However, all of setting values of HPP, and programs in built in 30P RAM and built in 30P flash memory will be erased.

## 7.8 HPP F/W update

This is to update the F/W by connecting the 30P with a personal computer.

→ For details of the F/W update tool using the personal computer, refer to the FX-30P F/W UPDATE TOOL operation manual.

### The screen display and the operation method

```
HPP F/W UPDATE
*EXECUTE?

EXECUTE → 【GO】
CANCEL  → 【CLEAR】
```

- **GO** → Execute update
- **CLEAR** → Return to HPP setting menu screen.

```
HPP F/W UPDATE

STANDBY. . .

CANCEL → 【CLEAR】
```

- **CLEAR** → Return to HPP setting menu screen.

```
HPP F/W UPDATE

EXECUTING. . .
```

- All key inputs disabled

- During communication, all key inputs are disabled.
- When F/W updating is completed, the 30P is reset, and the display is switched to the top screen when turning the power on.
- For setting the 30P to the HPP F/W update standby status, the following method is available (in 30Ps whose manufacturer's serial number is 950000 or later) in addition to the method above of displaying the HPP F/W UPDATE screen.

### HPP F/W update standby status setting method

- 1) Turn the power of the 30P OFF.
- 2) Turn the power of the 30P ON while pressing and holding the **GO** and **CLEAR** keys at the same time.
- 3) The 30P starts up, the following screen appears, and the 30P enters the F/W update standby status.

```
HPP F/W UPDATE

STANDBY. . .
```

- For resetting the F/W update standby status, turn the power of the 30P OFF once, and then turn it ON again.

## 8. Battery

### MAINTENANCE PRECAUTIONS



### WARNING

- Turn off the power to the PLC before attaching or detaching the battery. Doing so may cause equipment failures, or malfunctions.
- Use the battery for memory backup correctly in conformance to this manual.
  - Use the battery only for the specified purpose.
  - Connect the battery correctly.
  - Do not charge, disassemble, heat, put in fire, short-circuit, connect reversely, weld, swallow or burn the battery, or apply excessive forces (vibration, impact, drop, etc.) to the battery.
  - Do not store or use the battery at high temperatures or expose to direct sunlight.
  - Do not expose to water, bring near fire or touch liquid leakage or other contents directly.
  - Incorrect handling of the battery may cause heat excessive generation, bursting, ignition, liquid leakage or deformation, and lead to injury, fire or failures and malfunctions of facilities and other equipment.

### TRANSPORT AND STORAGE PRECAUTIONS



### CAUTION

- Before transporting the FX-30P, make sure to turn on the power of the FX-30P, and confirm that an HPP low battery voltage error does not occur (or confirm that the HPP battery voltage is 2.7 V or more).  
If the FX-30P is transported when the battery voltage is low and the battery life is expired, the battery-backed data may not be held correctly during transportation.
- When transporting lithium batteries, follow required transportation regulations.  
(For details of the regulated products, refer to Appendix F)

The 30P incorporates a battery (equivalent to FX3U-32BL).

When the battery voltage declines, the 30P battery voltage drop error appears (the message "Battery voltage drop!" is displayed when the power source is turned ON). In this case, replace the battery FX3U-32BL.

### 8.1 Battery Handling

- Precautions for battery transportation  
Refer to Appendix F.
- Battery handling for EU countries  
Refer to Appendix G.
- For battery handling in California, U.S.A.

Regarding California U.S.A. law,  
Perchlorate Material - special handling may apply,  
See <http://www.dtsc.ca.gov/hazardouswaste/perchlorate/>

### 8.2 Battery specifications, Battery life

Item	Specifications	Remark
Nominal voltage	3V	The battery voltage can be inspected from the HELP screen in the offline mode.

#### 8.2.1 Differences between FX-30P's internal battery and the optional battery

Although the optional battery (FX3U-32BL) serves as the same as the 30P's internal battery, they differ in the ways described below.

They may also have different external colors due to dates of manufacture.

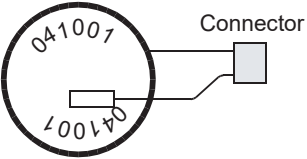
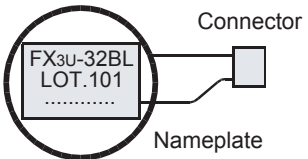

Item	30P Internal Battery	Optional Battery (Spare)
External appearance		<p data-bbox="943 259 1463 309">A nameplate label indicating the product model and lot No. is affixed.</p> 

### 8.2.2 Battery life and replacement guidelines

**FX3U-32BL battery life: Approx. 5 years (ambient temperature: 25°C(77°F))**

The life of the battery changes with respect to the ambient temperature.  
When planning for battery replacement, please estimate the battery life according to the graph to the right and order replacement batteries in advance.

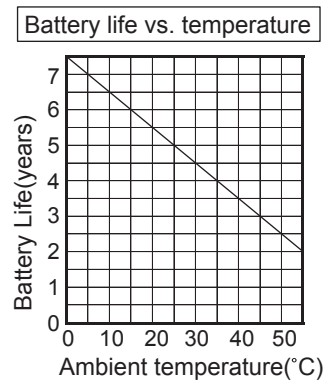

- 1** Introduction
- 2** Specifications, product configuration
- 3** Connections, startup procedure
- 4** Outline of programming
- 5** Online mode
- 6** Offline mode
- 7** HPP setting
- 8** Battery
- A** ASCII Code
- B** Message List

## 8.3 Reading the date of manufacture

### 1. Reading the optional battery's lot No.

Batteries with affixed nameplate labels are optional batteries.

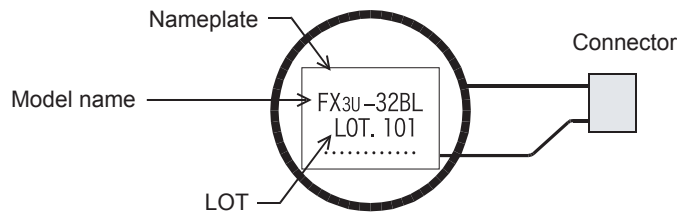

<Product during December, 2009 or earlier>

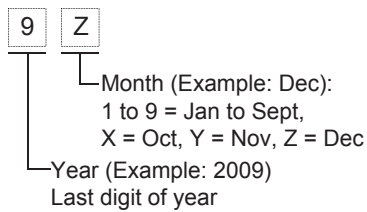

<Product from January, 2010>

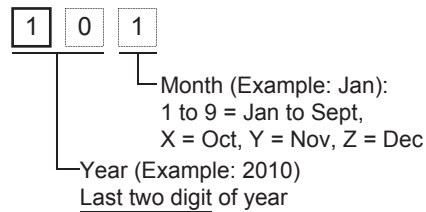

### 2. Reading the battery's year/month of manufacture [30P's internal battery]

Batteries without affixed nameplate labels (refer to item 1. above) are 30P internal batteries.

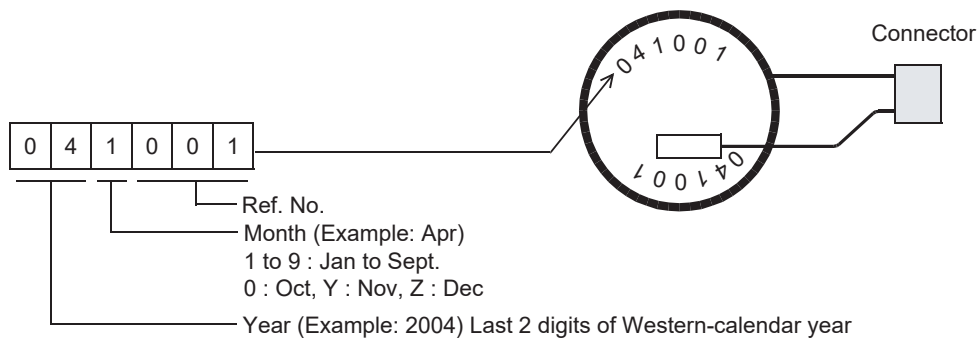

## 8.4 Battery Replacement

### 1 Turn OFF the power source. (Disconnect the connection cable between the PLC and personal computer.)

#### Caution

When data is saved in the built in 30P RAM, transfer to flash memory before battery exchange.  
(For the transfer method, refer to Subsection 6.2.8 program management)

### 2 Remove the battery cover screw.

Remove the battery cover screw "A" by using a screwdriver.

### 3 Detach the battery cover.

Detach the battery cover by inserting slotted screwdriver into the lower side of the battery cover "B", and then pushing down.

### 4 Remove the old battery.

Extract the old battery from the battery holder ("C"), and disconnect the battery connector ("D").

### 5 Install the new battery.

Connect the battery connector ("D") to the new battery, and insert the battery into the battery holder ("C").

### 6 Put on battery cover.

Fit in the upper side of battery cover "B" first, then push in the lower side to attach the cover.

### 7 Secure the battery cover with the battery cover screw.

Secure the battery cover screw "A" by using a screwdriver.

#### Caution

After exchanging the batteries, make sure the battery voltage is 3V or more by monitoring the HELP screen in offline mode.

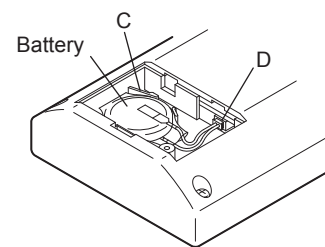
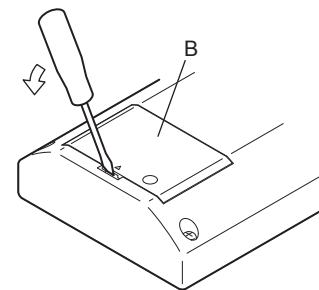
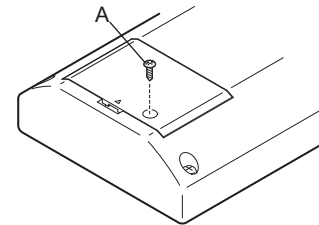

## MEMO

# Appendix A: ASCII Code

- \ (ASCII code: 5C) is displayed as "¥" when display language is selected in Japanese (LANGUAGE: 日本語).

## Appendix A-1 ASCII Code Table

Example. "A" becomes 41H (hexadecimal number) by ASCII code.

Hexadecimal	0	1	2	3	4	5	6	7	8	9	A	B	C	D	E	F	
0			SP	0	@	P	`	p			In this range, kana is displayed when the display language selected is Japanese (LANGUAGE: Japanese).						
1			!	1	A	Q	a	q									
2			"	2	B	R	b	r									
3			#	3	C	S	c	s									
4			\$	4	D	T	d	t									
5			%	5	E	U	e	u									
6			&	6	F	V	f	v									
7			'	7	G	W	g	w									
8			(	8	H	X	h	x									
9			)	9	I	Y	i	y									
A			*	:	J	Z	j	z									
B			+	;	K	[	k	{									
C			,	<	L	\	l										
D			-	=	M	]	m	}									
E			.	>	N	^	n	~									
F			/	?	O	_	o										

## Appendix A-2 Examples of ASCII codes

Decimal	ASCII (hexadecimal)
0	30
1	31
2	32
3	33
4	34
5	35
6	36
7	37
8	38
9	39

Alphabet	ASCII (hexadecimal)	Alphabet	ASCII (hexadecimal)
A	41	N	4E
B	42	O	4F
C	43	P	50
D	44	Q	51
E	45	R	52
F	46	S	53
G	47	T	54
H	48	U	55
I	49	V	56
J	4A	W	57
K	4B	K	58
L	4C	Y	59
M	4D	Z	5A

Symbol	ASCII (hexadecimal)
#	23
&	26
=	3D
\	5C

- 1** Introduction
- 2** Specifications, product configuration
- 3** Connections, startup procedure
- 4** Outline of programming
- 5** Online mode
- 6** Offline mode
- 7** HPP setting
- 8** Battery
- A** ASCII Code
- B** Message List

## Appendix B: Message List

### Appendix B-1 Error messages list

If an error message is displayed while the HPP is being operated, take proper action in accordance with the list below, then proceed to the next operation.

- Error message during menu operation

Message	Cause	Action
COMMUNICATION ERROR!	Communication failure with PLC or personal computer.	Check cable for abnormalities.
PARAMETER ERROR!	PLC or 30P parameter error.	Set the parameters correctly.
VERIFY ERROR!	Mismatched step data was found.	Correct the mismatch.
SETTING ERROR!	Setting contents are invalid.	Set proper contents.
PLC MISMATCH!	Different PLC is connected from the PLC type specified by the 30P.	Change PLC type of 30P according to the attached PLC.
PLC RUNNING!	Attempted to write data or other operations are not executable while PLC is in RUN mode.	Stop the PLC.
NO MEMORY CASSETTE!	Data writing to a memory cassette was executed to a PLC in which a memory cassette is not attached.	Attach memory cassette.
DEVICE ERROR!	An unavailable device was input.	Input a device in the allowable range.
PROTECT SWITCH ON!	Writing or another disabled operation was executed while the protect switch was ON in the memory cassette.	Execute by turning OFF the protect switch.
LOW BATTERY!	The voltage in the battery in the 30P has become 2.7 V or less.	Replace battery.
KEY INCORRECT!	An incorrect HPP protect key was input to reset or delete HPP protection.	Input the correct HPP protect key.
POWER SUPPLY ERROR!	Both a PLC and a personal computer were connected to the 30P at the same time.	Disconnect either the PLC or personal computer.
HPP DATA ERROR!	Something is wrong in a program stored in the 30P.	Clear the HPP memory, and initialize programs stored in the 30P.
KEYWORD MISMATCH!	An incorrect keyword was input to reset or delete the keyword in the PLC.	Enter correct keyword.
EPROM CONNECTING!	Writing or another disabled operation was executed to a PLC in which an EPROM cassette was attached.	Change to memory other than EPROM.
NO KEYWORD!	The keyword deletion, reset or protect operation was executed to a PLC in which the keyword was not set.	Set the keyword in the PLC, and then execute the keyword deletion, reset or protect operation.
ACCESS FORBIDDEN!	Writing or another disabled operation was executed to a PLC in which access restriction was set.	Reset or delete the access restriction.
NO DATA!	The program list display operation was executed in program management with no program saved.	Save programs, and then execute the program list display operation.
OVER SIZE LIMIT!	The program save operation was executed in program management while the program capacity exceeded the allowable value.	Delete some programs, and then execute the program save operation.
FAILURE!	Saving of a program failed.	Execute the program save operation again.
FORCED STOP ON!	The bit device clear operation was executed to a PLC in the forcible STOP status.	Reset the forcible STOP status, and then set the PLC to the STOP mode.
EXIST SAME NAME!	The program saving operation was executed using an existing program name.	Use a new program name.
NOT USABLE!	The selected function cannot be used under the current conditions.	Check the access restriction in the memory cassette and PLC.
COMMENT CAPACITY SETTING ERROR!	Setting is incorrect in comment capacity parameter.	Set correct comment capacity.
FILE REGISTER CAPA. SETTING ERROR!	Setting is incorrect in file register capacity parameter.	Set correct file register capacity.
LESS THAN 0 PROGRAM CAPACITY STEPPES!	The program capacity is set to "0 step" or less by the parameter setting.	Set the parameters correctly.

Message	Cause	Action
LATCH RANGE SETTING ERROR!	Setting is incorrect in latch range parameter.	Set correct latch range.
INPUT ERROR!	Invalid keyword is entered in keyword registration.	Enter correct keyword.

- Error messages displayed during program operation

Message	Cause	Action
COMMUNICATION ERROR	Communication failure with PLC.	Check cable for abnormality.
PLC RUNNING	Attempted to write data or other operations are not executable while PLC is in RUN mode.	Stop the PLC.
SETTING ERROR	Mismatched step data was found.	Set proper contents.
NOT USABLE	The selected function cannot be used under the current conditions.	Check the access restriction in the memory cassette and PLC.
WRITE FORBIDDEN	Writing or another disabled operation was executed to a PLC in which an EPROM cassette or a cassette with the protect switch ON was attached or the access restriction was set.	Check the access restriction in the memory cassette and PLC.
NO PROGRAM SPACE	There is no more available program storage area.	Change the parameter setting so that the program storage area becomes "1 step" or more.
STEP OVERFLOW	The specified step number is larger than the program size.	Specify a step number within the program size.
DEVICE ERROR	An unavailable device was input.	Input an available device.
INSTR. ERROR	An unavailable instruction was input.	Input an available instruction.
VERIFY ERROR	Mismatched step data was found.	Correct the mismatch.

1

Introduction

2

Specifications,  
product  
configuration

3

Connections,  
startup  
procedure

4

Outline of  
programming

5

Online mode

6

Offline mode

7

HPP setting

8

Battery

A

ASCII Code

B

Message List

## Appendix B-2 Error messages displayed during PLC diagnostic/program check

When a program error occurs in the PLC, the error code is stored in special data registers D8060 - D8067, D8438, D8449, D8487 and D8489. The following actions should be followed for diagnostic errors.

### Appendix B-2-1 For FX3s/FX3G/FX3GC/FX3U/FX3UC PLCs

Error code	PLC operation at error occurrence	Contents of error	Action				
<b>I/O configuration error [M8060(D8060)]</b>							
Ex-ample: 1020	Continues operation	<p>The head number of unconnected I/O device</p> <p>Example: When X020 is unconnected</p> <table border="1" style="margin-left: 40px;"> <tr> <td style="padding: 2px 5px;">1</td> <td style="padding: 2px 5px;">0</td> <td style="padding: 2px 5px;">2</td> <td style="padding: 2px 5px;">0</td> </tr> </table> <p style="margin-left: 40px;">BCD conversion value</p> <p style="margin-left: 40px;">↑                    ↑ Device number</p> <p style="margin-left: 40px;">1: Input (X), 0: Output (Y)</p> <ul style="list-style-type: none"> <li>• 1st to 3rd digits: Device number FX3G/FX3GC:10 to 177 FX3U/FX3UC:10 to 337</li> <li>• 4th digit: I/O type (1 = input (X), 0 = output (Y))</li> </ul> <p>Example: When 1020 is stored in D8060 Inputs X020 and later are unconnected.</p>	1	0	2	0	<p>Unconnected I/O relay numbers are programmed. The PLC continues its operation. Modify the program, check wiring connection, or add the appropriate unit/block.</p>
1	0	2	0				
<b>Serial communication error 2 [M8438 (D8438)]</b>							
0000	-	No error					
3801	Continues operation	Parity, overrun or framing error	<ul style="list-style-type: none"> <li>• Ethernet communication, inverter communication, computer link and programming: Ensure the parameters are correctly set according to their applications.</li> <li>• N:N network, parallel link, MODBUS communication, etc.: Check programs according to applications.</li> <li>• Remote maintenance: Ensure modem power is ON and check the settings of the AT commands.</li> <li>• Wiring: Check the communication cables for correct wiring.</li> </ul>				
3802		Communication character error					
3803		Communication data sum check error					
3804		Communication data format error					
3805		Command error					
3806		Communication time-out detected					
3807		Modem initialization error					
3808		N:N network parameter error					
3809		N:N Network setting error					
3812		Parallel link character error					
3813		Parallel link sum error					
3814		Parallel link format error					
3820		Inverter communication error					
3821	MODBUS communication error						
3830		Memory access error	<p>When the memory cassette is used, check whether it is mounted correctly.</p> <p>If the problem persists or if the memory cassette is not used, something may be malfunctioning inside the PLC. Consult your local Mitsubishi Electric representative.</p>				
3840		Special adapter connection error	Check connection of the special adapter.				
<b>PLC hardware error [M8061(D8061)]</b>							
0000	-	No error					
6101	Stops operation	Memory access error	<p>When the memory cassette is used, check whether it is mounted correctly.</p> <p>If the problem persists or if the memory cassette is not used, something may be malfunctioning inside the PLC. Consult your local Mitsubishi Electric representative.</p>				
6102		Operation circuit error	<p>Isolate the PLC and supply power to it using a different power supply.</p> <p>If the ERROR(ERR) LED turns OFF, noise may be affecting the PLC. Take the following measures.</p> <ul style="list-style-type: none"> <li>- Check the ground wiring, and reexamine the wiring route and installation location.</li> <li>- Fit a noise filter onto the power supply line.</li> </ul> <p>If the ERROR(ERR) LED does not turn OFF even after the above actions are taken, consult your local Mitsubishi Electric representative.</p>				



Error code	PLC operation at error occurrence	Contents of error	Action
<b>PLC hardware error [M8061(D8061)]</b>			
6103	Stops operation	I/O bus error (M8069 = ON)	Verify that extension cables are correctly connected.
6104		Powered extension unit 24 V failure (M8069 = ON)	
6105		Watchdog timer error	Confirm user program. The scan time exceeds the value stored in D8000.
6106		I/O table creation error (CPU error)	<ul style="list-style-type: none"> <li>When turning the power ON to the main unit, a 24V power failure occurs in a powered extension unit. (The error occurs if the 24V power is not supplied for 10 seconds or more after main power turns ON.)</li> <li>When turning main power ON, I/O assignment to CC-Link/LT (built into the FX3UC-32MT-LT(-2) PLC) is disabled.</li> </ul>
6107		System configuration error	Check the number of connected special function units/blocks. Some special function units/blocks have a connection number limit.
6112		Changed settings for the built-in CC-Link/LT special function block cannot be written to the attached flash memory cassette.	Verify that the memory cassette is installed correctly.
6113		Changed settings for the built-in CC-Link/LT special function block cannot be written to the attached write-protected flash memory cassette.	Set the protect switch to OFF.
6114		CC-Link/LT settings cannot be written to the built-in CC-Link/LT special function block.	Set the configuration again.
6115	A built-in CC-Link/LT special function block EEPROM writing time-out error occurred, or the built-in CC-Link/LT special function block configuration could not be completed normally in self CONFIG mode.	If the problem persists, something may be malfunctioning inside the PLC. Consult your local Mitsubishi Electric representative.	
<b>PLC/PP communication error (D8062), Serial communication error 0 [M8062 (D8062)]</b>			
0000	-	No error	
6201	Continues operation	Parity, overrun or framing error	Confirm the cable connection between the programming panel (PP)/programming device and the PLC. This error may occur when a cable is disconnected and reconnected during PLC monitoring.
6202		Communication character error	
6203		Communication data sum check error	
6204		Data format error	
6205		Command error	
6230		Memory access error	When the memory cassette is used, check whether it is mounted correctly. If the problem persists or if the memory cassette is not used, something may be malfunctioning inside the PLC. Consult your local Mitsubishi Electric representative.

1

Introduction

2

Specifications,  
product  
configuration

3

Connections,  
startup  
procedure

4

Outline of  
programming

5

Online mode

6

Offline mode

7

HPP setting

8

Battery

A

ASCII Code

B

Message List

Error code	PLC operation at error occurrence	Contents of error	Action
<b>Serial communication error 1 [M8063 (D8063)]</b>			
0000	-	No error	
6301	Continues operation	Parity, overrun or framing error	<ul style="list-style-type: none"> <li>Ethernet communication, inverter communication, computer link and programming: Ensure the parameters are correctly set according to their applications.</li> <li>N:N network, parallel link, MODBUS communication, etc.: Check programs according to applications.</li> <li>Remote maintenance: Ensure modem power is ON and check the settings of the AT commands.</li> <li>Wiring: Check the communication cables for correct wiring.</li> </ul>
6302		Communication character error	
6303		Communication data sum check error	
6304		Communication data format error	
6305		Command error	
6306		Communication time-out detected	
6307		Modem initialization error	
6308		N:N network parameter error	
6309		N:N Network setting error	
6312		Parallel link character error	
6313		Parallel link sum error	
6314		Parallel link format error	
6320		Inverter communication error	
6321		MODBUS communication error	
6330		Memory access error	When the memory cassette is used, check whether it is mounted correctly. If the problem persists or if the memory cassette is not used, something may be malfunctioning inside the PLC. Consult your local Mitsubishi Electric representative.
6340		Special adapter connection error	Check connection of the special adapter.
<b>Parameter error [M8064(D8064)]</b>			
0000	-	No error	
6401	Stops operation	Program sum check error	<ul style="list-style-type: none"> <li>STOP the PLC, and correctly set the parameters.</li> <li>Check that the following functions are not used with an unsupported PLC version when a memory cassette is attached: <ul style="list-style-type: none"> <li>Permanent PLC lock (supported in the FX3U/FX3UC PLCs of Ver. 2.61 or later)</li> <li>Read-protect the execution program for block passwords (supported in the FX3U/FX3UC PLCs of Ver. 3.00 or later)</li> <li>FX3U-FLROM-1M (supported in the FX3U/FX3UC PLCs of Ver. 3.00 or later)</li> </ul> </li> </ul>
6402		Memory capacity setting error	
6403		Latched device area setting error	
6404		Comment area setting error	
6405		File register area setting error	
6406		Special unit (BFM) initial value setting, positioning instruction setting sum check error	
6407		Special unit (BFM) initial value setting, positioning instruction setting error	
6409		Other setting error	
6411		Built-in CC-Link/LT special function block invalid parameter settings (LT-2 dedicated area).	
6412		Built-in CC-Link/LT special function block parameter settings sum check error (special function settings area).	
6413		Built-in CC-Link/LT special function block parameter settings sum check error (LT-2 dedicated area).	
6420		Special parameter sum check error	
6421		Special parameters setting error	

Error code	PLC operation at error occurrence	Contents of error	Action
<b>Syntax error [M8065(D8065)]</b>			
0000	-	No error	
6501	Stops operation	Incorrect combination of instruction, device symbol and device number	During programming, each instruction is checked. If a syntax error is detected, modify the instruction correctly.
6502		No OUT T or OUT C before setting value	
6503		<ul style="list-style-type: none"> <li>No setting value after OUT T or OUT C</li> <li>Insufficient number of operands for an applied instruction</li> </ul>	
6504		<ul style="list-style-type: none"> <li>Same label number is used more than once.</li> <li>Same interrupt input or high speed counter input is used more than once.</li> </ul>	
6505		Device number is out of allowable range.	
6506		Invalid instruction	
6507		Invalid label number [P]	
6508		Invalid interrupt input [I]	
6509		Other error	
6510		MC nesting number error	
<b>Circuit error [M8066(D8066)]</b>			
0000	-	No error	
6610	Stops operation	LD, LDI is continuously used 9 times or more.	This error occurs when a combination of instructions is incorrect in the entire circuit block or when the relationship between a pair of instructions is incorrect. Modify the instructions in the program mode so that their mutual relationship becomes correct.
6611		More ANB/ORB instructions than LD/LDI instructions	
6612		Less ANB/ORB instructions than LD/LDI instructions	
6613		MPS is continuously used 12 times or more.	
6614		No MPS instruction	
6615		No MPP instruction	
6616		No coil between MPS, MRD and MPP, or incorrect combination	
6617		Instruction below is not connected to bus line: STL, RET, MCR, P, I, DI, EI, FOR, NEXT, SRET, IRET, FEND or END	
6618		STL, MC or MCR can be used only in main program, but it is used elsewhere (e.g. in interrupt routine or subroutine).	
6619		Invalid instruction is used in FOR-NEXT loop: STL, RET, MC, MCR, I (interrupt pointer) or IRET.	
6620		FOR-NEXT instruction nesting level exceeded	
6621		Numbers of FOR and NEXT instructions do not match.	
6622		No NEXT instruction	
6623		No MC instruction	
6624		No MCR instruction	
6625		STL instruction is continuously used 9 times or more.	
6626		Invalid instruction is programmed within STL-RET loop: MC, MCR, I (interrupt pointer), SRET or IRET.	
6627		No STL instruction	
6628		Invalid instruction is used in main program: I (interrupt pointer), SRET or IRET	
6629		No P or I (interrupt pointer)	
6630	No SRET or IRET instruction STL-RET / MC-MCR instructions programmed in the subroutine.		
6631	SRET programmed in invalid location		
6632	FEND programmed in invalid location		

1

Introduction

2

Specifications,  
product  
configuration

3

Connections,  
startup  
procedure

4

Outline of  
programming

5

Online mode

6

Offline mode

7

HPP setting

8

Battery

A

ASCII Code

B

Message List

Error code	PLC operation at error occurrence	Contents of error	Action	
Operation error [M8067(D8067)]				
0000	-	No error		
6701	Continues operation	<ul style="list-style-type: none"> <li>No jump destination (pointer) for CJ or CALL instruction</li> <li>Label is undefined or out of P0 to P4095 due to indexing</li> <li>Label P63 is executed in CALL instruction; cannot be used in CALL instruction as P63 is for jumping to END instruction.</li> </ul>	<p>This error occurs in the execution of operation. Review the program, or check the contents of the operands used in the applied instructions.</p> <p>Even if the syntax or circuit design is correct, an operation error may still occur.</p> <p>For example: "T500Z" itself is not an error. But if Z had a value of 100, the timer T600 would be attempted to be accessed. This would cause an operation error since there is no T600 device available.</p>	
6702		CALL instruction nesting level is 6 or more		
6703		Interrupt nesting level is 3 or more		
6704		FOR-NEXT instruction nesting level is 6 or more.		
6705		Operand of applied instruction is inapplicable device.		
6706		Device number range or data value for operand of applied instruction exceeds limit.		
6707		File register is accessed without parameter setting of file register.		
6708		FROM/TO instruction error		<p>This error occurs in the execution of operation.</p> <ul style="list-style-type: none"> <li>Review the program and check the contents of the operands used in applied instructions.</li> <li>Verify that the specified buffer memories exist in the counterpart equipment.</li> <li>Verify that the extension cables are correctly connected.</li> </ul>
6709		Other (e.g. improper branching)		<p>This error occurs in the execution of operation. Review the program and check the contents of the operands used in applied instructions.</p> <p>Even if the syntax or circuit design is correct, an operation error may still occur.</p> <p>For example: "T500Z" itself is not an error. But if Z had a value of 100, the timer T600 would be attempted to be accessed. This would cause an operation error since there is no T600 device available.</p>
6710		Mismatch among parameters		This error occurs when the same device is used within the source and destination in a shift instruction, etc.
6730		Incorrect sampling time (TS) ( $TS \leq 0$ )		<p>&lt;PID instruction is stopped.&gt;</p> <p>This error occurs in the parameter setting value or operation data executing PID instruction. Check the contents of the parameters.</p>
6732		Incompatible input filter constant ( $\alpha$ ) ( $\alpha < 0$ or $100 \leq \alpha$ )		
6733		Incompatible proportional gain (KP) ( $KP < 0$ )		
6734		Incompatible integral time (TI) ( $TI < 0$ )		
6735	Incompatible derivative gain (KD) ( $KD < 0$ or $201 \leq KD$ )			
6736	Incompatible derivative time (TD) ( $TD < 0$ )			
6740	Sampling time (TS) $\leq$ Scan time	<Auto tuning is continued.> The operation is continued in the condition "sampling time (TS) = cyclic time (scan time)".		
6742	Variation of measured value exceeds limit. ( $\Delta PV < -32768$ or $+32767 < \Delta PV$ )	<p>&lt;PID operation is continued.&gt;</p> <p>The operation is continued with each parameter set to the maximum and minimum value.</p>		
6743	Deviation exceeds limit. ( $EV < -32768$ or $+32767 < EV$ )			
6744	Integral result exceeds limit. (Outside range from -32768 to +32767)			
6745	Derivative value exceeds limit due to derivative gain (KD).			
6746	Derivative result exceeds limit. (Outside range from -32768 to +32767)			
6747	PID operation result exceeds limit. (Outside range from -32768 to +32767)			

Error code	PLC operation at error occurrence	Contents of error	Action
Operation error [M8067(D8067)]			
6748	Continues operation	PID output upper limit set value < PID output lower limit set value.	<Transpose of output upper limit value and output lower limit value. → PID operation is continued.> Verify that the target setting contents are correct.
6749		Abnormal PID input variation alarm set value or output variation alarm set value (Set value < 0)	<Alarm output is not given. → PID operation is continued.> Verify that the target setting contents are correct.
6750		<Step response method> Improper auto tuning result	<Auto tuning is finished. → PID operation is started.> • The deviation at start of auto tuning is 150 or less. • The deviation at end of auto tuning is 1/3 or more of the deviation at start of auto tuning. Check the measured value and target value, and then execute auto tuning again.
6751		<Step response method> Auto tuning operation direction mismatch	<Auto tuning is forcibly finished. → PID operation is not started.> The operation direction estimated from the measured value at the start of auto tuning was different from the actual operation direction of the output during auto tuning. Correct the relationship among the target value, output value for auto tuning, and the measured value, and then execute auto tuning again.
6752		<Step response method> Improper auto tuning operation	<Auto tuning is finished. → PID operation is not started.> Because the set value was fluctuated during auto tuning, auto tuning was not executed correctly. Set the sampling time to a value larger than the output change cycle, or set a larger value for the input filter constant. After changing the setting, execute auto tuning again.
6753		<Limit cycle method> Abnormal output set value for auto tuning [ULV (upper limit) ≤ LLV (lower limit)]	<Auto tuning is forcibly finished. → PID operation is not started.>
6754		<Limit cycle method> Abnormal PV threshold (hysteresis) set value for auto tuning (SHPV < 0)	Check whether the target setting contents are correct.
6755		<Limit cycle method> Abnormal auto tuning transfer status (Data of device controlling transfer status is abnormally overwritten.)	<Auto tuning is forcibly finished. → PID operation is not started.> Ensure that devices occupied by PID instruction are not overwritten in the program.
6756		<Limit cycle method> Abnormal result due to excessive auto tuning measurement time ( $\tau_{on} > \tau$ , $\tau_{on} < 0$ , $\tau < 0$ )	<Auto tuning is forcibly finished. → PID operation is not started.> The auto tuning time is longer than necessary. Increase the difference (ULV - LLV) between the upper limit and lower limit of the output value for auto tuning, set a smaller value to the input filter constant ( $\alpha$ ), or set a smaller value to the PV threshold (SHPV) for auto tuning, and then check the result for improvement.
6757		<Limit cycle method> Auto tuning result exceeds proportional gain. (KP= outside range from 0 to 32767)	<Auto tuning is finished (KP = 32767). → PID operation is started.> The variation of the measured value (PV) is small compared with the output value. Multiply the measured value (PV) by "10" so that the variation of the measured value will increase during auto tuning.
6758		<Limit cycle method> Auto tuning result exceeds integral time. (TI = outside range from 0 to 32767)	<Auto tuning is finished (KP = 32767). → PID operation is started.> The auto tuning time is longer than necessary.
6759		<Limit cycle method> Auto tuning result exceeds derivative time. (TD = outside range from 0 to 32767)	Increase the difference (ULV - LLV) between the upper limit and lower limit of the output value for auto tuning, set a smaller value to the input filter constant ( $\alpha$ ), or set a smaller value to the PV threshold (SHPV) for auto tuning, and then check the result for improvement.
6760		ABS data read from servo sum check error	Check servo wiring and parameter setting. Also check the ABS instruction.
6762	Port specified by inverter communication instruction is already used in another communication.	Check to make sure the port is not specified by another instruction.	

1

Introduction

2

Specifications,  
product  
configuration

3

Connections,  
startup  
procedure

4

Outline of  
programming

5

Online mode

6

Offline mode

7

HPP setting

8

Battery

A

ASCII Code

B

Message List

Error code	PLC operation at error occurrence	Contents of error	Action
<b>Operation error [M8067(D8067)]</b>			
6763	Continues operation	1) Input (X) specified by DSZR, DVIT or ZRN instruction is already used in another instruction. 2) The interrupt signal device for DVIT instruction is outside the allowable setting range.	1) Check to make sure the input (X), as specified by a DSZR, DVIT or ZRN instruction, is not being used for the following purposes: - Input interrupt (including the delay function) - High speed counter C235 to C255 - Pulse catch M8170 to M8177 - SPD instruction 2) Check the contents of D8336 for the correct interrupt signal specification for DVIT instruction.
6764		Pulse output number is already used in a positioning instruction or pulse output instruction (PLSY, PWM, etc.).	Check to make sure the pulse output destination is not being driven by another positioning instruction.
6765		Number of applied instruction exceeds limit.	Verify that the number of times that applied instructions are used in the program does not exceed the specified limit.
6770		Memory access error	When the memory cassette is used, check whether it is mounted correctly. If the problem persists or if the memory cassette is not used, something may be malfunctioning inside the PLC. Consult your local Mitsubishi Electric representative.
6771		Memory cassette is not connected.	Check for the correct attachment of the memory cassette.
6772		Memory cassette is protected against writing.	The write-protect switch of the memory cassette was set to ON when data was transferred to the flash memory. Set the protect switch to OFF.
6773		Access error to memory cassette during writing in RUN mode	While data was written in the RUN mode, data was transferred to (read from or written to) the memory cassette.
<b>USB communication error [M8487 (D8487)]</b>			
8702	Continues operation	Communication character error	Confirm the cable connection between programming device and the PLC. This error may occur when a cable is disconnected and reconnected during PLC monitoring.
8703		Communication data sum check error	
8704		Data format error	
8705		Command error	
8706		Memory access error	When the memory cassette is used, check whether it is mounted correctly. If the problem persists or if the memory cassette is not used, something may be malfunctioning inside the PLC. Consult your local Mitsubishi Electric representative.

Error code	PLC operation at error occurrence	Contents of error	Action
<b>Special block error [M8449 (D8449)]</b>			
□020 <sup>*1</sup>	Continues operation	General data sum error	Verify that extension cables are correctly connected.
□021 <sup>*1</sup>		General data message error	
□022 <sup>*1</sup>		System access error	
□025 <sup>*1</sup>		Access sum error in other station via CC-Link	
□026 <sup>*1</sup>		Message error in other station via CC-Link	
□030 <sup>*1</sup>		Memory access error	When the memory cassette is used, check whether it is mounted correctly. If the problem persists or if the memory cassette is not used, something may be malfunctioning inside the PLC. Consult your local Mitsubishi Electric representative.
□080 <sup>*1</sup>		FROM/TO error	This error occurs in the execution of operation. <ul style="list-style-type: none"> <li>Review the program and check the contents of the operands used in the applied instructions.</li> <li>Verify that specified buffer memories exist in the counterpart equipment.</li> <li>Verify that extension cables are correctly connected.</li> </ul>
□090 <sup>*1</sup>	Peripheral equipment access error	<ul style="list-style-type: none"> <li>Check the cable connection between the programming panel (PP) / programming device and the PLC.</li> <li>Verify that extension cables are correctly connected.</li> </ul>	
<b>Special parameter error [M8489 (D8489)]</b>			
□□01 <sup>*2</sup>	Continues operation	Special parameter setting time-out error	Turn OFF the power, and check the power supply and connection of special adapters/special blocks.
□□02 <sup>*2</sup>		Special parameter setting error	Special parameters are set improperly. <ul style="list-style-type: none"> <li>Confirm troubleshooting for special adapters/special blocks, and set special parameters correctly.</li> <li>Set special parameters correctly, turn OFF the power, and then turn ON the power.</li> </ul>
□□03 <sup>*2</sup>		Special parameter transfer target unconnected error	Special parameters are set, but special adapters/special blocks are not connected. Check whether special adapters/special blocks are connected.
□□04 <sup>*2</sup>		Special parameter unsupported function	Check that special parameters with unsupported settings are not set for connected special adapters/special blocks.

\*1. The unit number 0 to 7 of the special function unit/block error is put in □.

\*2. "□□" indicates the following values for each special adapter/special block where an error has occurred.

If an error has occurred in 2 or more special adapters/special blocks, "□□" indicates the lowest unit number among the special adapters/special blocks in which an error has occurred.

Value of □□ (decimal)	Special adapter/special block where an error has occurred
00	Unit number 0 (Special block)
10	Unit number 1 (Special block)
20	Unit number 2 (Special block)
30	Unit number 3 (Special block)
40	Unit number 4 (Special block)
50	Unit number 5 (Special block)
60	Unit number 6 (Special block)
70	Unit number 7 (Special block)
81	Communication channel 1 (Special adapter)
82	Communication channel 2 (Special adapter)

1

Introduction

2

Specifications,  
product  
configuration

3

Connections,  
startup  
procedure

4

Outline of  
programming

5

Online mode

6

Offline mode

7

HPP setting

8

Battery

A

ASCII Code

B

Message List

## Appendix B-2-2 For FX1S/FX1N/FX1NC/FX2N/FX2NC PLCs

Error code	PLC operation at error occurrence	Contents of error	Action				
<b>I/O configuration error [M8060(D8060)]</b>							
Ex-ample: 1020	Continues operation	<p>The head number of unconnected I/O device Example: When X020 is unconnected</p> <table border="1" style="margin-left: 20px;"> <tr> <td style="padding: 2px 5px;">1</td> <td style="padding: 2px 5px;">0</td> <td style="padding: 2px 5px;">2</td> <td style="padding: 2px 5px;">0</td> </tr> </table> <p style="margin-left: 20px;">BCD conversion value</p> <p style="margin-left: 20px;">↑ Device number ↑ 1: Input (X), 0: Output (Y)</p> <ul style="list-style-type: none"> <li>• 1st to 3rd digits: Device number</li> <li>• 4th digit: I/O type (1 = input (X), 0 = output (Y))</li> </ul> <p>Example: When 1020 is stored in D8060 Inputs X020 and later are unconnected. The head number of unconnected I/O device</p>	1	0	2	0	Unconnected I/O relay numbers are programmed. The PLC continues its operation. Modify the program, check wiring connection, or add the appropriate unit/block.
1	0	2	0				
<b>PLC hardware error [M8061(D8061)]</b>							
0000	-	No error					
6101	Stops operation	RAM error	Confirm for the correct connection of extension cables.				
6102		Operation circuit error					
6103		I/O bus error (M8069 = ON)					
6104		Powered extension unit 24 V failure (M8069 = ON)					
6105		Watchdog timer error		Confirm user program. The scan time exceeds the value stored in D8000.			
6110		Function extension memory cassette error (sum error)	Verify that the function extension memory cassette is installed correctly.				
<b>PLC/PP communication error [M8062 (D8062)]</b>							
0000	-	No error					
6201 <sup>*1</sup>	Continues operation	Parity, overrun or framing error	Confirm the cable connection between the programming panel (PP)/programming device and the PLC. This error may occur when a cable is disconnected and reconnected during PLC monitoring.				
6202		Communication character error					
6203		Communication data sum check error					
6204		Communication data format error					
6205		Command error					
<b>Parallel link communication error 1 [M8063 (D8063)]</b>							
0000	-	No error					
6301 <sup>*1</sup>	Continues operation	Parity, overrun or framing error	<ul style="list-style-type: none"> <li>• Inverter communication, computer link and programming: Ensure the communication parameters are correctly set according to their applications.</li> <li>• N:N network, parallel link, etc.: Check programs according to applications.</li> <li>• Wiring: Check the communication cables for correct wiring.</li> </ul>				
6302		Communication character error					
6303		Communication data sum check error					
6304		Communication data format error					
6305		Command error					
6306		Communication time-out detected					
6307 to 6311		No error					
6312		Parallel link character error					
6313		Parallel link sum error					
6314		Parallel link format error					

\*1. A communication error may occur during automatic alignment of the transmission speed when programming communication is executed while the transmission speed of the peripheral equipment is set to 19.2 kbps because the transmission speed at power ON is set to 9.6 kbps in the main unit. Accordingly, when a communication error occurs at start of communication and problems are expected if the error flag (special auxiliary relay) remains ON, clear the error flag for the corresponding channel. When problems are expected if the error flag turns ON, execute programming communication after setting the transmission speed of the peripheral equipment to 9.6 kbps at power ON of the PLC.



Error code	PLC operation at error occurrence	Contents of error	Action
<b>Parameter error [M8064(D8064)]</b>			
0000	-	No error	
6401	Stops operation	Program sum check error	STOP the PLC, and correctly set the parameters.
6402		Memory capacity setting error	
6403		Latched device area setting error	
6404		Comment area setting error	
6405		File register area setting error	
6409		Other setting error	
<b>Syntax error [M8065(D8065)]</b>			
0000	-	No error	
6501	Stops operation	Incorrect combination of instruction, device symbol and device number	During programming, each instruction is checked. If a syntax error is detected, modify the instruction correctly.
6502		No OUT T or OUT C before setting value	
6503		<ul style="list-style-type: none"> <li>No setting value after OUT T or OUT C</li> <li>Insufficient number of operands for an applied instruction</li> </ul>	
6504		<ul style="list-style-type: none"> <li>Same label number is used more than once.</li> <li>Same interrupt input or high speed counter input is used more than once.</li> </ul>	
6505		Device number is out of allowable range.	
6506		Invalid instruction	
6507		Invalid label number [P]	
6508		Invalid interrupt input [I]	
6509		Other error	
6510		MC nesting number error	
6511		Same interrupt input or high speed counter input is used more than once.	
6512		EXTR is described while the extension memory cassette is not mounted.	
<b>Circuit error [M8066(D8066)]</b>			
0000	-	No error	
6601	Stops operation	LD, LDI is continuously used 9 times or more.	This error occurs when a combination of instructions is incorrect in the entire circuit block or when the relationship between a pair of instructions is incorrect. Modify the instructions in the program mode so that their mutual relationship becomes correct.
6602		<ul style="list-style-type: none"> <li>No LD/LDI instruction. The use of LD/LDI or ANB/ORB instruction is incorrect.</li> <li>The following instructions are not connected to the active bus line: STL, RET, MCR, (P)ointer, (I)nterrupt, EI,DI, SRET, IRET, FOR, NEXT, FEND and END.</li> <li>When MPP is missing</li> </ul>	
6603		MPS is used continuously more than 12 times	
6604		The use of MPS, MRD, MPP instruction is incorrect.	
6605		<ul style="list-style-type: none"> <li>The STL instruction is continuously used 9 times or more.</li> <li>MC, MCR instruction, (I)nterrupt pointer or SRET instruction is used within an STL program area.</li> <li>RET has not been used in the program or is not connected to an STL instruction.</li> </ul>	

1

Introduction

2

Specifications,  
product  
configuration

3

Connections,  
startup  
procedure

4

Outline of  
programming

5

Online mode

6

Offline mode

7

HPP setting

8

Battery

A

ASCII Code

B

Message List

Error code	PLC operation at error occurrence	Contents of error	Action
Circuit error [M8066(D8066)]			
6606	Stops operation	<ul style="list-style-type: none"> <li>No (P)ointer, (I)nterrupt pointer.</li> <li>No SRET/ IRET.</li> <li>An (I)nterrupt pointer, SRET or IRET has been used within the main program.</li> <li>STL, RET, MC or MCR have been used within either a subroutine or an interrupt routine.</li> </ul>	This error occurs when a combination of instructions is incorrect in the entire circuit block or when the relationship between a pair of instructions is incorrect. Modify the instructions in the program mode so that their mutual relationship becomes correct.
6607		<ul style="list-style-type: none"> <li>The use of FOR and NEXT is incorrect.</li> <li>The following instructions have been used within a FOR - NEXT loop : STL, RET, MC, MCR, IRET, SRET, FEND or END.</li> </ul>	
6608		<ul style="list-style-type: none"> <li>The use of MC/MCR is incorrect.</li> <li>Missing MCR NO.</li> <li>SRET, IRET instruction or an (I)nterrupt pointer has been used within an MC/MCR instruction area.</li> </ul>	
6609		Other error	
6610		LD, LDI is continuously used 9 times or more.	
6611		More ANB/ORB instructions than LD/LDI instructions	
6612		Less ANB/ORB instructions than LD/LDI instructions	
6613		MPS is continuously used 12 times or more.	
6614		No MPS instruction	
6615		No MPP instruction	
6616		No coil between MPS, MRD and MPP, or incorrect combination	
6617		Instruction below is not connected to bus line: STL, RET, MCR, P, I, DI, EI, FOR, NEXT, SRET, IRET, FEND or END	
6618		STL, MC or MCR can be used only in main program, but it is used elsewhere (e.g. in interrupt routine or subroutine).	
6619		Invalid instruction is used in FOR-NEXT loop: STL, RET, MC, MCR, I (interrupt pointer) or IRET.	
6620		FOR-NEXT instruction nesting level exceeded	
6621		Numbers of FOR and NEXT instructions do not match.	
6622		No NEXT instruction	
6623		No MC instruction	
6624		No MCR instruction	
6625		STL instruction is continuously used 9 times or more.	
6626		Invalid instruction is programmed within STL-RET loop: MC, MCR, I (interrupt pointer), SRET or IRET.	
6627		RET instruction not found	
6628		Invalid instruction is used in main program: I (interrupt pointer), SRET or IRET	
6629		No P or I (interrupt pointer)	
6630		No SRET or IRET instruction STL-RET / MC-MCR instructions programmed in the subroutine.	
6631		SRET programmed in invalid location	
6632		FEND programmed in invalid location	

Error code	PLC operation at error occurrence	Contents of error	Action
Operation error [M8067(D8067)]			
0000	-	No error	
6701	Continues operation	<ul style="list-style-type: none"> <li>No jump destination (pointer) for CJ or CALL instruction</li> <li>(P)ointer is designated in a block that comes after the END instruction</li> <li>An independent label is designated in a FOR-NEXT loop or a subroutine</li> </ul>	<p>This error occurs in the execution of operation. Review the program, or check the contents of the operands used in the applied instructions.</p> <p>Even if the syntax or circuit design is correct, an operation error may still occur.</p> <p>For example: "T200Z" itself is not an error. But if Z had a value of 100, the timer T300 would be attempted to be accessed. This would cause an operation error since there is no T600 device available.</p>
6702		CALL instruction nesting level is 6 or more	
6703		Interrupt nesting level is 3 or more	
6704		FOR-NEXT instruction nesting level is 6 or more.	
6705		Operand of applied instruction is inapplicable device.	
6706		Device number range or data value for operand of applied instruction exceeds limit.	
6707		File register is accessed without parameter setting of file register.	
6708		FROM/TO instruction error (It becomes applicable "RD3A and the WR3A instruction".)	<p>This error occurs in the execution of operation.</p> <ul style="list-style-type: none"> <li>Review the program, or check the contents of the operands used in the applied instructions.</li> <li>Verify that the specified buffer memories exist in the equipment.</li> <li>Verify that the extension cables are correctly connected.</li> </ul>
6709		Other error, i.e. missing IRE/ SRET, unauthorized FOR - NEXT relationship	<p>This error occurs in the execution of operation. Review the program, or check the contents of the operands used in the applied instructions.</p> <p>Even if the syntax or circuit design is correct, an operation error may still occur.</p> <p>For example: "T200Z" itself is not an error. But if Z had a value of 100, the timer T300 would be attempted to be accessed. This would cause an operation error since there is no T600 device available.</p>
6730		Incorrect sampling time (TS) ( $TS \leq 0$ )	
6732		Incompatible input filter constant ( $\alpha$ ) ( $\alpha < 0$ or $100 \leq \alpha$ )	<PID instruction is stopped.>
6733		Incompatible proportional gain (KP) ( $KP < 0$ )	This error occurs in the parameter setting value or operation data executing PID instruction.
6734		Incompatible integral time (TI) ( $TI < 0$ )	Check the contents of the parameters.
6735		Incompatible derivative gain (KD) ( $KD < 0$ or $201 \leq KD$ )	
6736	Incompatible derivative time (TD) ( $TD < 0$ )		
6740	Sampling time (TS) $\leq$ Scan time		
6742	Variation of measured value exceeds limit. ( $\Delta PV < -32768$ or $+32767 < \Delta PV$ )		
6743	Deviation exceeds limit. ( $EV < -32768$ or $+32767 < EV$ )	<Operation data is made into a maximum value and it is continuation of operation>	
6744	Integral result exceeds limit. (Outside range from -32768 to +32767)	This error occurs in the parameter setting value or operation data executing PID instruction.	
6745	Derivative value exceeds limit due to derivative gain (KD).	Check the contents of the parameters.	
6746	Derivative result exceeds limit. (Outside range from -32768 to +32767)		
6747	PID operation result exceeds limit. (Outside range from -32768 to +32767)		

1

Introduction

2

Specifications,  
product  
configuration

3

Connections,  
startup  
procedure

4

Outline of  
programming

5

Online mode

6

Offline mode

7

HPP setting

8

Battery

A

ASCII Code

B

Message List

Error code	PLC operation at error occurrence	Contents of error	Action
Operation error [M8067(D8067)]			
6750	Continues operation	<Step response method> Improper auto tuning result	<Auto tuning is finished. → PID operation is started.> <ul style="list-style-type: none"> <li>The deviation at start of auto tuning is 150 or less.</li> <li>The deviation at end of auto tuning is 1/3 or more of the deviation at start of auto tuning.</li> </ul> Check the measured value and target value, and then execute auto tuning again.
6751	-	<Step response method> Auto tuning operation direction mismatch	<Auto tuning is forcibly finished. → PID operation is not started.> The operation direction estimated from the measured value at the start of auto tuning was different from the actual operation direction of the output during auto tuning. Correct the relationship among the target value, output value for auto tuning, and the measured value, and then execute auto tuning again.
6752	-	<Step response method> Improper auto tuning operation	<Auto tuning is finished. → PID operation is not started.> Because the set value was fluctuated during auto tuning, auto tuning was not executed correctly. Set the sampling time to a value larger than the output change cycle, or set a larger value for the input filter constant. After changing the setting, execute auto tuning again.
6760	-	ABS data read from servo sum check error	Check servo wiring and parameter setting. Also check the ABS instruction.

## Appendix B-2-3 For FX2(FX)/FX2c/FX0/FX0s/FX0N PLCs

Error code	PLC operation at error occurrence	Contents of error	Action				
<b>I/O configuration error [M8060(D8060)]</b>							
Ex-ample: 1020	Continues operation	<p>The head number of unconnected I/O device Example: When X020 is unconnected</p> <table border="1"> <tr> <td>1</td> <td>0</td> <td>2</td> <td>0</td> </tr> </table> <p>BCD conversion value</p> <p>Device number</p> <p>1: Input (X), 0: Output (Y)</p> <ul style="list-style-type: none"> <li>1st to 3rd digits: Device number</li> <li>4th digit: I/O type (1 = input (X), 0 = output (Y))</li> </ul> <p>Example: When 1020 is stored in D8060 Inputs X020 and later are unconnected.</p>	1	0	2	0	Unconnected I/O relay numbers are programmed. The PLC continues its operation. Modify the program, check wiring connection, or add the appropriate unit/block.
1	0	2	0				
<b>PLC hardware error [M8061(D8061)]</b>							
0000	-	No error					
6101	Stops operation	RAM error	Confirm for the correct connection of extension cables.				
6102		Operation circuit error					
6103		I/O bus error (M8069 = ON)					
<b>PLC/PP communication error [M8062 (D8062)]</b>							
0000	-	No error					
6201	Continues operation	Parity, overrun or framing error	Confirm the cable connection between the programming panel (PP)/programming device and the PLC.				
6202		Communication character error					
6203		Communication data sum check error					
6204		Data format error					
6205		Command error					
<b>Parallel link communication adapter error 1 [M8063 (D8063)]</b>							
0000	-	No error					
6301	Continues operation	Parity, overrun or framing error	<ul style="list-style-type: none"> <li>Check both power and communications connections</li> <li>Special note regarding the 485 network.</li> <li>Because these errors are not transmitted through the network, they must be monitored by the unit acting as Master to the network.</li> </ul>				
6302		Communication character error					
6303		Communication data sum check error					
6304		Communication data format error					
6305		Command error					
6306		Communication time-out detected					
<b>Parameter error [M8064(D8064)]</b>							
0000	-	No error					
6401	Stops operation	Program sum check error	STOP the PLC, and correctly set the parameters.				
6402		Memory capacity setting error					
6403		Latched device area setting error					
6404		Comment area setting error					
6405		File register area setting error					
6409		Other setting error					

Error code	PLC operation at error occurrence	Contents of error	Action
<b>Syntax error [M8065(D8065)]</b>			
0000	-	No error	
6501	Stops operation	Incorrect combination of instruction, device symbol and device number	During programming, each instruction is checked. If a syntax error is detected, modify the instruction correctly.
6502		No OUT T or OUT C before setting value	
6503		<ul style="list-style-type: none"> <li>No setting value after OUT T or OUT C</li> <li>Insufficient number of operands for an applied instruction</li> </ul>	
6504		<ul style="list-style-type: none"> <li>Same label number is used more than once.</li> <li>Same interrupt input or high speed counter input is used more than once.</li> </ul>	
6505		Device number is out of allowable range.	
6509		Other error	
<b>Circuit error [M8066(D8066)]</b>			
0000	-	No error	
6601	Stops operation	LD, LDI is continuously used 9 times or more.	This error occurs when a combination of instructions is incorrect in the entire circuit block or when the relationship between a pair of instructions is incorrect. Modify the instructions in the program mode so that their mutual relationship becomes correct.
6602		<ul style="list-style-type: none"> <li>No LD/LDI instruction. The use of LD/LDI or ANB/ORB instruction is incorrect.</li> <li>The following instructions are not connected to the active bus line: STL, RET, MCR, (P)ointer, (I)nterrupt, EI,DI, SRET, IRET, FOR, NEXT, FEND and END.</li> <li>When MPP is missing</li> </ul>	
6603		MPS is used continuously more than 12 times	
6604		The use of MPS, MRD, MPP instruction is incorrect.	
6605		<ul style="list-style-type: none"> <li>The STL instruction is continuously used 9 times or more.</li> <li>MC, MCR instruction, (I)nterrupt pointer or SRET instruction is used within an STL program area.</li> <li>RET has not been used in the program or is not connected to an STL instruction.</li> </ul>	
6606		<ul style="list-style-type: none"> <li>No (P)ointer, (I)nterrupt pointer.</li> <li>No SRET/ IRET.</li> <li>An (I)nterrupt pointer, SRET or IRET has been used within the main program.</li> <li>STL, RET, MC or MCR have been used within either a subroutine or an interrupt routine.</li> </ul>	
6607		<ul style="list-style-type: none"> <li>The use of FOR and NEXT is incorrect.</li> <li>The following instructions have been used within a FOR - NEXT loop : STL, RET, MC, MCR, IRET, SRET, FEND or END.</li> </ul>	
6608		<ul style="list-style-type: none"> <li>The use of MC/MCR is incorrect.</li> <li>Missing MCR NO.</li> <li>SRET, IRET instruction or an (I)nterrupt pointer has been used within an MC/MCR instruction area.</li> </ul>	
6609		Other error	

Error code	PLC operation at error occurrence	Contents of error	Action	
Operation error [M8067(D8067)]				
0000	-	No error		
6701	Continues operation	<ul style="list-style-type: none"> <li>No jump destination (pointer) for CJ or CALL instruction</li> <li>(P)ointer is designated in a block that comes after the END instruction</li> <li>An independent label is designated in a FOR-NEXT loop or a subroutine</li> </ul>	<p>This error occurs in the execution of operation. Review the program, or check the contents of the operands used in the applied instructions.</p> <p>Even if the syntax or circuit design is correct, an operation error may still occur.</p> <p>For example: "T200Z" itself is not an error. But if Z had a value of 100, the timer T300 would be attempted to be accessed. This would cause an operation error since there is no T600 device available.</p>	
6702		CALL instruction nesting level is 6 or more		
6703		Interrupt nesting level is 3 or more		
6704		FOR-NEXT instruction nesting level is 6 or more.		
6705		Operand of applied instruction is inapplicable device.		
6706		Device number range or data value for operand of applied instruction exceeds limit.		
6707		File register is accessed without parameter setting of file register.		
6708		FROM/TO instruction error		<p>This error occurs in the execution of operation.</p> <ul style="list-style-type: none"> <li>Review the program, or check the contents of the operands used in the applied instructions.</li> <li>Verify that the specified buffer memories exist in the equipment.</li> <li>Verify that the extension cables are correctly connected.</li> </ul>
6709		Other error, i.e. missing IRE/ SRET, unauthorized FOR - NEXT relationship		<p>This error occurs in the execution of operation. Review the program, or check the contents of the operands used in the applied instructions.</p> <p>Even if the syntax or circuit design is correct, an operation error may still occur.</p> <p>For example: "T200Z" itself is not an error. But if Z had a value of 100, the timer T300 would be attempted to be accessed. This would cause an operation error since there is no T600 device available.</p>
6730		Incorrect sampling time (TS) ( $TS \leq 0$ )		<p>&lt;PID instruction is stopped.&gt;</p> <p>This error occurs in the parameter setting value or operation data executing PID instruction.</p> <p>Check the contents of the parameters.</p>
6732		Incompatible input filter constant ( $\alpha$ ) ( $\alpha < 0$ or $100 \leq \alpha$ )		
6733		Incompatible proportional gain (KP) ( $KP < 0$ )		
6734		Incompatible integral time (TI) ( $TI < 0$ )		
6735	Incompatible derivative gain (KD) ( $KD < 0$ or $201 \leq KD$ )			
6736	Incompatible derivative time (TD) ( $TD < 0$ )			
6740	Sampling time (TS) $\leq$ Scan time			
6742	Variation of measured value exceeds limit. ( $\Delta PV < -32768$ or $+32767 < \Delta PV$ )			
6743	Deviation exceeds limit. ( $EV < -32768$ or $+32767 < EV$ )	<p>&lt;Operation data is made into a maximum value and it is continuation of operation&gt;</p> <p>This error occurs in the parameter setting value or operation data executing PID instruction.</p> <p>Check the contents of the parameters.</p>		
6744	Integral result exceeds limit. (Outside range from -32768 to +32767)			
6745	Derivative value exceeds limit due to derivative gain (KD).			
6746	Derivative result exceeds limit. (Outside range from -32768 to +32767)			
6747	PID operation result exceeds limit. (Outside range from -32768 to +32767)			

1

Introduction

2

Specifications,  
product  
configuration

3

Connections,  
startup  
procedure

4

Outline of  
programming

5

Online mode

6

Offline mode

7

HPP setting

8

Battery

A

ASCII Code

B

Message List

## Appendix C: Major Key Operation List

Key operation example		Description		
HPP reset	• [RST]+[GO] (Key is pressed at the same time)	Resets the HPP (and displays the screen which is usually displayed during startup).		
Read	• [↑]/[↓]	Moves the cursor by 1 line at a time from the currently displayed position.		
	• [GO]	Scrolls the display by one screen.		
	• [STEP] [1] [0] [GO]	Searches and displays the program by step No. Press the [GO] key again to scroll the program by one screen.		
	• [LD] [X] [1] [0] [GO]	Searches and displays the program by instruction and device.	Press the [GO] key again to search the remaining portion of the program.	
	• [SP] [X] [1] [1] [GO]	Searches and displays the program by device.		
	• [FNC] [1] [2]	Searches and displays an (16-bit type) application instruction.		
	• [FNC] [D] [1] [2]	Searches and displays an (32-bit type) application instruction.		
	• [P] [0] [GO]	Searches and displays the program by label and pointer.		
Write	Contact instructions	• [LD] [X] [1] [0] [GO] • [LDI] [X] [1] [1] [GO]	For the LD, LDI, AND, ANI and ORI instructions, consecutively input a device after a contact instruction.	
		• [LD] [P/I] [X] [1] [2] [GO] • [LD] [F] [X] [1] [3] [GO]	For the LDP, LDF, ANP, ANF, ORP and ORF instructions, press the [P/I] or [F] key after a contact instruction, then consecutively input a device.	
		• [NOP] [P/I] [X] [1] [4] [GO]	For the INV instruction, press the [NOP] and [P/I] keys instead, then consecutively input a device after that.	
		Data comparison instructions	Input it as an application instruction.	
	Block instructions/instructions for storage during operation	• [ANB] [GO] • [ORB] [GO] • [MPS] [GO] • [MRD] [GO] • [MPP] [GO]	For block instructions (ANB and ORB) and instructions which store the intermediate result of the operation (MPS, MRD and MPP), input only an instruction.	
	Drive instructions	• [OUT] [Y] [2] [GO] • [OUT] [T] [0] [SP] [K] [1] [0] [0] [GO]	For the OUT instruction for an output (Y), auxiliary relay (M) or state (S), input a device after the instruction. For the OUT instruction for a timer (T) or counter (C), input a device and set value after the instruction.	
		• [SET] [M] [1] [0] [0] • [RST] [C] [1] [0]	For the SET and RST instructions, input a device after an instruction.	
	MC instructions	• [MC] [0] [SP] [M] [1] [0] [0] [GO] • [MCR] [0] [GO]	For the MC instruction, input the nesting level and device after it. For the MCR instruction, input the nesting level after it.	
	Application instructions (16-bit type)	• [FNC] [1] [2] [SP] [K] [1] [0] [SP] [D] [0] [GO] • [FNC] [HELP] [1] [2] [SP] [K] [1] [0] [SP] [D] [0] [GO]	For an application instruction, enter via the FNC No., then enter an operand after it. If the FNC No. is unknown, press the [FNC] key first, then press the [HELP] key to select an instruction. When entering an operand, press the [SP] key to delimit the instruction, the source and the destination. When entering a constant, press the [K] key once for decimal, or twice for hexadecimal ("H" is displayed.).	
	Application instructions (32-bit type)	• [FNC] [1] [2] [D] [SP] [K] [1] [0] [SP] [D] [0] [GO] • [FNC] [HELP] [1] [2] [D] [SP] [K] [1] [0] [SP] [D] [0] [GO]	When inputting a 32-bit instruction, press the [D] key after entering the FNC No. If the FNC No. is unknown, press the [FNC] key first, press the [HELP] key to select an instruction, then press the [D] key. In either case, input an operand after pressing the [D] key. When inputting an operand, press the [SP] key to delimit the instruction, the source and the destination. When inputting a constant, press the [K] key once for decimal, or twice for hexadecimal ("H" is displayed.).	



Key operation example		Description
Write	Application instructions (pulse execution)	<ul style="list-style-type: none"> <li>[FNC] [1] [2] [P] [SP] [K] [1] [0] [SP] [D] [0] [GO]</li> <li>[FNC] [HELP] [1] [2] [P] [SP] [K] [1] [0] [SP] [D] [0] [GO]</li> </ul> <p>When inputting an application instruction as a pulse execution instruction, press the [P] key after inputting the FNC No. If the FNC No. is unknown, press the [FNC] key first, press the [HELP] key to select an instruction, then press the [P] key. In either case, input an operand after pressing the [P] key.</p> <p>When inputting an operand, press the [SP] key to delimit the instruction, the source and the destination. When inputting a constant, press the [K] key once for decimal, or twice for hexadecimal ("H" is displayed.).</p>
	Application instructions (pulses execution instruction) (32-bit type)	<ul style="list-style-type: none"> <li>[FNC] [1] [2] [D] [P] [SP] [K] [1] [0] [SP] [D] [0] [GO]</li> <li>[FNC] [HELP] [1] [2] [D] [P] [SP] [K] [1] [0] [SP] [D] [0] [GO]</li> </ul> <p>When entering a 32-bit application instruction as a pulse execution instruction, press the [D] and [P] keys in this order after entering the FNC No. If the FNC No. is unknown, press the [FNC] key first, press the [HELP] key to select an instruction, then press the [D] and [P] keys in this order. In either case, input an operand after pressing the [D] and [P] keys.</p> <p>When entering an operand, press the [SP] key to delimit the instruction, the source and the destination. When entering a constant, press the [K] key once for decimal, or twice for hexadecimal ("H" is displayed.).</p>
	Application instructions (instruction only)	<ul style="list-style-type: none"> <li>[FNC] [4] [GO]</li> <li>[FNC] [HELP] [0] [4] [GO]</li> </ul> <p>For instructions not requiring operand, enter only an instruction by using the FNC No. If the FNC No. is unknown, press the [FNC] key, then press the [HELP] key to select an instruction.</p>
	Label	<ul style="list-style-type: none"> <li>[P] [0] [GO]</li> </ul> <p>Press the [P] key, then input the label No.</p>
	Pointer	<ul style="list-style-type: none"> <li>[I] [I] [1] [0] [1] [GO]</li> </ul> <p>Press the [I] key twice, then input the pointer No. (When the [I] key is pressed once, "P" is displayed in the display unit. When the [I] key is pressed twice, "I" is displayed.)</p>
	Step ladder	<ul style="list-style-type: none"> <li>[STL] [S] [0] [GO]</li> <li>[RET] [GO]</li> </ul> <p>As to the STL instruction, press the [STL] key, then input the state No. For the RET instruction, input only the instruction.</p>
	No processing instruction	<ul style="list-style-type: none"> <li>[NOP] [GO]</li> </ul> <p>Input only the NOP instruction.</p>
	END	<ul style="list-style-type: none"> <li>[END] [GO]</li> </ul> <p>Input only the END instruction.</p>
Special operation	<ul style="list-style-type: none"> <li>[NOP] [A] [GO] [GO]</li> </ul> <p>Program all clear In the online mode, this operation overwrites all programs saved in the memory in the PLC with the NOP (no processing) instruction. In the offline mode, this operation overwrites all programs saved to the 30P RAM using the NOP instruction.</p>	

# Appendix D: Manufacturer's serial number/Version Information

## Appendix D-1 Version check method

The manufacturing date of the product is identified by the number indicated by "S/N" written on the back label.

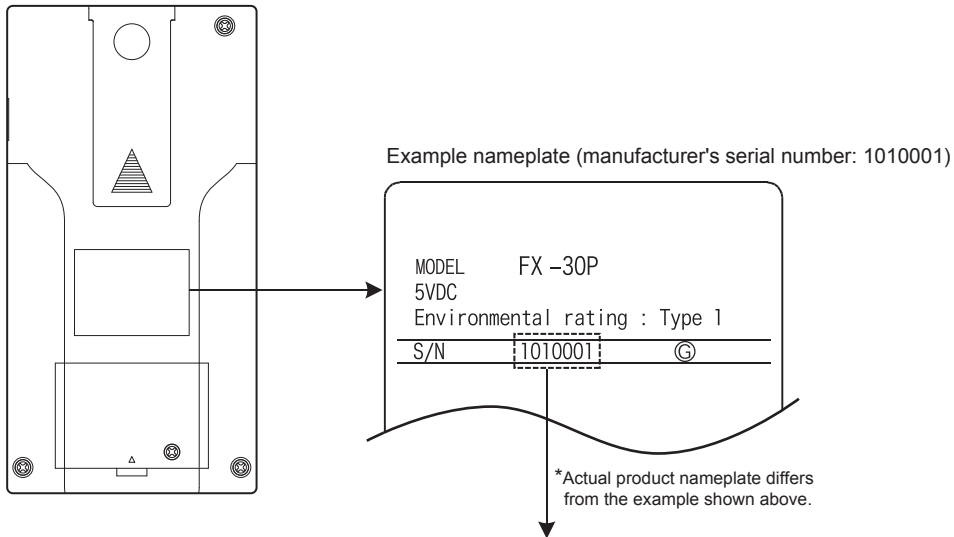

<Product during December, 2009 or earlier>

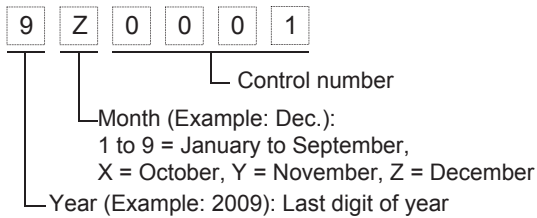

<Product from January, 2010>

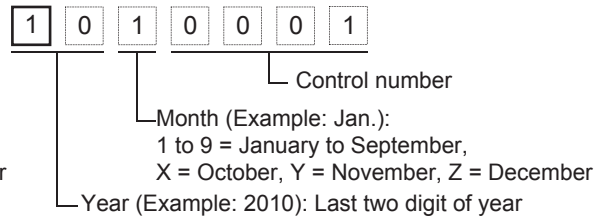

## Appendix D-2 Version Information

### Appendix D-2-1 Checking the firmware version

The firmware version of the 30P is the number to the right of "version" on the starting screen and the HELP screen.

- Starting screen

```
#  COPYRIGHT (C) 2008  #
#                      #
#  MITSUBISHI         #
#  ELECTRIC           #
#  CORPORATION        #
#                      #
#  MELSEC FX-30P     #
#  version 1.00      #
```

Firmware version

Displayed for 2 seconds after turning on the power.

- HELP screen

```
OFFLINE MODE (1/2)
PLC TYPE : FX3U(C)
MEMORY : 64K STEP
▼
OFFLINE MODE (2/2)
^HPP BATTERY : 3.0 V
HPP PROTECT : NO
HPP VERSION : 1.00
```

Firmware version

### Appendix D-2-2 Version upgrade history

The table below shows the version upgrade history for the FX-30P.

Version	Contents of version upgrade
Ver.1.00	First product
Ver.1.10	HPP-PC Transfer additions
Ver.1.20	Traditional Chinese characters are supported. FX3U/FX3UC PLC Ver. 2.70 is supported. <ul style="list-style-type: none"> <li>- Permanent PLC lock / Customer keyword is supported.</li> <li>- The baud rate "38400 bps" is supported in RS and RS2 instructions, inverter communication and computer link.</li> <li>- Supports FLCRT, FLDEL, FLWR, FLRD, FLCMD, FLSTRD, VRRD, VRSC, and IVMC instructions.</li> </ul>
Ver.1.30	FX3GC Series PLC is supported.
Ver.1.50	<ul style="list-style-type: none"> <li>- FX3S Series PLC is supported.</li> <li>- GX Works2 support is added to the HPP-PC TRANSFER function.</li> <li>- Supports IVMC instructions with the FX3G/FX3GC Series.</li> <li>- Special parameter error (M8489, D8489) is supported.</li> </ul>

For upgrading the firmware of the 30P, please refer to Section 7.8.

## **MEMO**

## Appendix E: Discontinued models

The table below shows discontinued models of MELSEC-F Series PLCs and programming tools described in this manual.

Discontinued model	Production stop date	Repair acceptance period
FX1, FX2(FX), FX2C, FX0 Series PLC	June 30, 2002	Until June 30, 2009
FX0S, FX0N Series PLC	January 31, 2006	Until January 31, 2013
FX2N, FX2NC Series PLC	September 30, 2012	Until September 30, 2019
FX1S, FX1N, FX1NC Series PLC	December 31, 2015	Until December 31, 2022

**C**  
Major key  
operation list

**D**  
Manufacturer's  
serial number

**E**  
Discontinued  
models

**F**  
Precautions for  
battery  
transportation

**G**  
Handling of  
batteries in EU  
member states

## MEMO

## Appendix F: Precautions for Battery Transportation

When transporting lithium batteries, follow the transportation regulations.  
The batteries for the FX-30P are classified as shown in following table.

### Appendix F-1 Regulated FX-30P

- 1) Included modules and batteries

Series name/product name	Used battery name	Battery type	Product supply status	Lithium Content (gram/unit)
FX-30P	FX3U-32BL	lithium metal battery	Cell	0.15

- 2) Batteries to be built in modules (spare parts and optional parts)

Product name	Battery type	Product supply status	Lithium Content (gram/unit)	Mass *1 (gram/unit)
FX3U-32BL	lithium metal battery	Cell	0.15	30

\*1. The value indicates the mass with packaging.

### Appendix F-2 Transport guidelines

Comply with IATA Dangerous Goods Regulations, IMDG code and the local transport regulations when transporting products listed above.  
Also, consult with the shipping carrier.

## MEMO



## Appendix G: Handling of Batteries and Devices with Built-in Batteries in EU Member States

This section describes the precautions for disposing of waste batteries in EU member states and exporting batteries and/or devices with built-in batteries to EU member states.

### Appendix G-1 Disposal precautions

In EU member states, there is a separate collection system for waste batteries. Dispose of batteries properly at the local community waste collection/recycling center.

The symbol shown in following figure is printed on the batteries and packaging of batteries and devices with built-in batteries used for Mitsubishi programmable controllers.

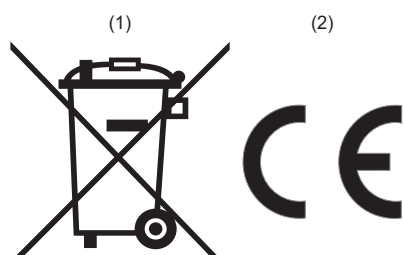

This symbol to the left is specified as below:

(1): EU Battery Directive (2006/66/EC)

(to be repealed on 18 August 2025)

(1)(2): EU Battery Regulation (EU 2023/1542)

- The symbol (1) indicates that batteries need to be disposed of separately from other wastes.
- If the chemical symbol is printed beneath the symbol (1) shown overleaf, this chemical symbol means that the battery or accumulator contains a heavy metal at a certain concentration. This will be indicated as follows:
  - Hg: mercury (0.0005%)
  - Cd: cadmium (0.002%)
  - Pb: lead (0.004%)

### Appendix G-2 Exportation precautions

EU Battery Directive (2006/66/EC) and EU Battery Regulation (EU 2023/1542) requires the following when marketing or exporting batteries and/or devices with built-in batteries to EU member states.

- To print the symbol on batteries, where that is not possible, on their manuals and their packaging.
- To explain the symbol in the manuals of the products.

#### 1) Labelling

To market or export batteries and/or devices with built-in batteries, which have no symbol (1)(2), to EU member states on August 18, 2024 or later, print the symbol (1)(2) shown in the figure above on the batteries, or their manuals and their packaging.

To market or export batteries and/or devices with built-in batteries, which have no symbol (1)(2), to EU member states on August 17, 2024 or before, print the symbol (1) shown in the figure above on the batteries, or their packaging.

#### 2) Explaining the symbol in the manuals

To export devices incorporating Mitsubishi programmable controller to EU member states on August 18, 2024 or later, provide the latest manuals that include the explanation of the symbol (1)(2).

If no Mitsubishi manuals or any old manuals without the explanation of the symbol (1)(2) are provided, separately attach an explanatory note regarding the symbol (1)(2) to each manual of the devices.

#### POINT

The requirements apply to batteries and/or devices with built-in batteries manufactured before the enforcement date of EU Battery Directive (2006/66/EC), or EU Battery Regulation (EU 2023/1542).

## Appendix G-3 Regulated FX-30P

---

- 1) Included modules and batteries

Series name/product name	Used battery name	Battery type
FX-30P	FX3U-32BL	Lithium Manganese Dioxide Battery

- 2) Batteries to be built in modules (spare parts and optional parts)

Product name	Battery type
FX3U-32BL	Lithium Manganese Dioxide Battery

## Warranty

Please confirm the following product warranty details before using this product.

### 1. Gratis Warranty Term and Gratis Warranty Range

If any faults or defects (hereinafter "Failure") found to be the responsibility of Mitsubishi occurs during use of the product within the gratis warranty term, the product shall be repaired at no cost via the sales representative or Mitsubishi Service Company. However, if repairs are required onsite at domestic or overseas location, expenses to send an engineer will be solely at the customer's discretion. Mitsubishi shall not be held responsible for any re-commissioning, maintenance, or testing on-site that involves replacement of the failed module.

#### [Gratis Warranty Term]

The gratis warranty term of the product shall be for one year after the date of purchase or delivery to a designated place. Note that after manufacture and shipment from Mitsubishi, the maximum distribution period shall be six (6) months, and the longest gratis warranty term after manufacturing shall be eighteen (18) months. The gratis warranty term of repair parts shall not exceed the gratis warranty term before repairs.

#### [Gratis Warranty Range]

- (1) The range shall be limited to normal use within the usage state, usage methods and usage environment, etc., which follow the conditions and precautions, etc., given in the instruction manual, user's manual and caution labels on the product.
- (2) Even within the gratis warranty term, repairs shall be charged for in the following cases.
  1. Failure occurring from inappropriate storage or handling, carelessness or negligence by the user. Failure caused by the user's hardware or software design.
  2. Failure caused by unapproved modifications, etc., to the product by the user.
  3. When the Mitsubishi product is assembled into a user's device, Failure that could have been avoided if functions or structures, judged as necessary in the legal safety measures the user's device is subject to or as necessary by industry standards, had been provided.
  4. Failure that could have been avoided if consumable parts (battery, backlight, fuse, etc.) designated in the instruction manual had been correctly serviced or replaced.
  5. Relay failure or output contact failure caused by usage beyond the specified Life of contact (cycles).
  6. Failure caused by external irresistible forces such as fires or abnormal voltages, and failure caused by force majeure such as earthquakes, lightning, wind and water damage.
  7. Failure caused by reasons unpredictable by scientific technology standards at time of shipment from Mitsubishi.
  8. Any other failure found not to be the responsibility of Mitsubishi or that admitted not to be so by the user.

### 2. Onerous repair term after discontinuation of production

- (1) Mitsubishi shall accept onerous product repairs for seven (7) years after production of the product is discontinued.  
Discontinuation of production shall be notified with Mitsubishi Technical Bulletins, etc.
- (2) Product supply (including repair parts) is not available after production is discontinued.

### 3. Overseas service

Overseas, repairs shall be accepted by Mitsubishi's local overseas FA Center. Note that the repair conditions at each FA Center may differ.

### 4. Exclusion of loss in opportunity and secondary loss from warranty liability

Regardless of the gratis warranty term, Mitsubishi shall not be liable for compensation to:

- (1) Damages caused by any cause found not to be the responsibility of Mitsubishi.
- (2) Loss in opportunity, lost profits incurred to the user by Failures of Mitsubishi products.
- (3) Special damages and secondary damages whether foreseeable or not, compensation for accidents, and compensation for damages to products other than Mitsubishi products.
- (4) Replacement by the user, maintenance of on-site equipment, start-up test run and other tasks.

### 5. Changes in product specifications

The specifications given in the catalogs, manuals or technical documents are subject to change without prior notice.

### 6. Product application

- (1) In using the Mitsubishi MELSEC programmable logic controller, the usage conditions shall be that the application will not lead to a major accident even if any problem or fault should occur in the programmable logic controller device, and that backup and fail-safe functions are systematically provided outside of the device for any problem or fault.
- (2) The Mitsubishi programmable logic controller has been designed and manufactured for applications in general industries, etc. Thus, applications in which the public could be affected such as in nuclear power plants and other power plants operated by respective power companies, and applications in which a special quality assurance system is required, such as for Railway companies or Public service purposes shall be excluded from the programmable logic controller applications.

In addition, applications in which human life or property that could be greatly affected, such as in aircraft, medical applications, incineration and fuel devices, manned transportation, equipment for recreation and amusement, and safety devices, shall also be excluded from the programmable logic controller range of applications.

However, in certain cases, some applications may be possible, providing the user consults their local Mitsubishi representative outlining the special requirements of the project, and providing that all parties concerned agree to the special circumstances, solely at the users discretion.

## Revised History

Date	Revision	Description
12/2008	A	First Edition
4/2009	B	<ul style="list-style-type: none"> <li>• Firmware Ver.1.10 is supported.</li> <li>- HPP-PC Transfer additions (Subsection 6.2.5 etc.).</li> <li>• The F/W update standby status setting method not using the HPP menu is added (Section 7.8).</li> <li>• Errors are corrected.</li> </ul>
8/2010	C	<ul style="list-style-type: none"> <li>• Firmware Ver.1.20 is supported.</li> <li>- Traditional Chinese characters are supported.</li> <li>- Permanent PLC lock / Customer keyword is supported by the FX3U/FX3UC Series.</li> <li>- The baud rate "38400 bps" is supported in RS and RS2 instructions, inverter communication and computer link by the FX3U/FX3UC Series.</li> <li>- Supports FLCRT, FLDEL, FLWR, FLRD, FLCMD, FLSTRD, VRRD, VRSC, and IVMC instructions with the FX3U/FX3UC Series.</li> <li>• The notation change of "Compliance with EC directive"</li> <li>• Precautions for Battery Transportation are added (Appendix F)</li> <li>• Handling of Batteries and Devices with Built-in Batteries in EU Member States are added (Appendix G)</li> <li>• Explanation corrections for manufacturer's serial number.</li> <li>• Errors are corrected.</li> </ul>
2/2012	D	<ul style="list-style-type: none"> <li>• Firmware Ver.1.30 is supported.</li> <li>- FX3GC Series PLC was added.</li> <li>• Errors are corrected.</li> </ul>
1/2013	E	<ul style="list-style-type: none"> <li>• Explanation corrections for error codes (Appendix B-2)</li> <li>• Errors are corrected.</li> </ul>
5/2013	F	<ul style="list-style-type: none"> <li>• Firmware Ver.1.50 is supported.</li> <li>- FX3s Series PLC was added.</li> <li>- GX Works2 support is added to the HPP-PC TRANSFER function.</li> <li>- Supports IVMC instructions with the FX3G/FX3GC Series.</li> <li>- Special parameter error (M8489, D8489) is supported.</li> <li>• Errors are corrected.</li> </ul>
4/2015	G	<ul style="list-style-type: none"> <li>• A part of the cover design is changed.</li> </ul>
3/2019	H	<ul style="list-style-type: none"> <li>• Discontinued models are added.</li> <li>• Errors are corrected.</li> </ul>
6/2024	J	<ul style="list-style-type: none"> <li>• The contents of EU Battery Regulation are added. (Appendix G)</li> </ul>



**FX-30P**

**OPERATION MANUAL**

**MITSUBISHI ELECTRIC CORPORATION**

HEAD OFFICE: TOKYO BUILDING, 2-7-3 MARUNOUCHI, CHIYODA-KU, TOKYO 100-8310, JAPAN

MODEL	FX-30P-O-E
MODEL CODE	09R924