



Programmable Controller
MELSEC-F

FX_{3UC} SERIES PROGRAMMABLE CONTROLLERS

USER'S MANUAL

Hardware Edition

Main Unit

FX_{3UC}-□MT/D
FX_{3UC}-□MT/DSS
FX_{3UC}-16MR/D-T
FX_{3UC}-16MR/DS-T
FX_{3UC}-32MT-LT-2
FX_{3UC}-32MT-LT

Input/Output Extension Block

FX_{2NC}-16E□-□
FX_{2NC}-32E□-□
FX_{2N}-8E□-□
FX_{2N}-16E□-□

Memory Cassette

FX_{3U}-FLROM-□

FX_{3UC}



Safety Precaution

(Read these precautions before use.)

Before installation, operation, maintenance or inspection of this product, thoroughly read through and understand this manual and all of the associated manuals. Also, take care to handle the module properly and safety.

If the equipment is used in a manner not specified by the manufacturer, the protection provided by the equipment may be impaired.

This manual classifies the safety precautions into two categories: **WARNING** and **CAUTION**.

 WARNING	Indicates that incorrect handling may cause hazardous conditions, resulting in death or severe injury.
 CAUTION	Indicates that incorrect handling may cause hazardous conditions, resulting in medium or slight personal injury or physical damage.

Depending on the circumstances, procedures indicated by **CAUTION** may also cause severe injury. It is important to follow all precautions for personal safety.

Store this manual in a safe place so that it can be taken out and read whenever necessary. Always forward it to the end user.

1. DESIGN PRECAUTIONS

 WARNING	Reference
<ul style="list-style-type: none">• Make sure to have the following safety circuits outside of the PLC to ensure safe system operation even during external power supply problems or PLC failure. Otherwise, malfunctions may cause serious accidents.<ol style="list-style-type: none">1) Most importantly, have the following: an emergency stop circuit, a protection circuit, an interlock circuit for opposite movements (such as normal vs. reverse rotation), and an interlock circuit (to prevent damage to the equipment at the upper and lower positioning limits).2) Note that when the PLC CPU detects an error, such as a watchdog timer error, during self-diagnosis, all outputs are turned off. Also, when an error that cannot be detected by the PLC CPU occurs in an input/output control block, output control may be disabled. External circuits and mechanisms should be designed to ensure safe machinery operation in such a case.3) Note that when an error occurs in a relay, triac or transistor output device, the output could be held either on or off. For output signals that may lead to serious accidents, external circuits and mechanisms should be designed to ensure safe machinery operation in such a case.• Note that when an error occurs in a remote I/O unit, the output could be held either on or off. For output signals that may lead to serious accidents, external circuits for monitoring should be provided.	124 151 157 190 211 236 273

 CAUTION	Reference
<ul style="list-style-type: none">• Do not bundle the control line and CC-Link/LT connection cables together with or lay them close to the main circuit or power line. As a guideline, lay the control line and CC-Link/LT connection cables at least 100 mm (3.94") or more away from the main circuit or power line. Noise may cause malfunctions.• Install the product so that excessive force will not be applied to peripheral device connectors, power connectors, input/output connectors, CC-Link/LT interface connectors or CC-Link/LT connection cables. Failure to do so may result in wire damage/breakage or PLC failure.	124 151 157 190 211 236 273

Safety Precaution

(Read these precautions before use.)

2. SECURITY PRECAUTIONS

WARNING	Reference
<ul style="list-style-type: none"> • To maintain the security (confidentiality, integrity, and availability) of the programmable controller and the system against unauthorized access, denial-of-service (DoS) attacks, computer viruses, and other cyberattacks from unreliable networks and devices via network, take appropriate measures such as firewalls, virtual private networks (VPNs), and antivirus solutions. 	124 151 157 190 211 236 273

3. INSTALLATION PRECAUTIONS

WARNING	Reference
<ul style="list-style-type: none"> • Make sure to cut off all phases of the power supply externally before attempting installation or wiring work. Failure to do so may cause electric shock or damage to the product. 	124 236

CAUTION	Reference				
<ul style="list-style-type: none"> • Use the product within the generic environment specifications described in Section 3.1 of this manual. Never use the product in areas with excessive dust, oily smoke, conductive dusts, corrosive gas (salt air, Cl₂, H₂S, SO₂ or NO₂), flammable gas, vibration or impacts, or expose it to high temperature, condensation, or rain and wind. If the product is used in such conditions, electric shock, fire, malfunctions, deterioration or damage may occur. • Do not touch the conductive parts of the product directly. Doing so may cause device failures or malfunctions. • Install the product securely using a DIN rail or mounting screws. <table border="1" style="width: 100%; margin-top: 5px;"> <tbody> <tr> <td style="padding: 2px;">Main unit, FX2NC Series I/O extension blocks, FX2NC/FX3UC Series special function blocks, special adapter, extension power supply unit, FX2NC-CNV-IF, FX2N-10GM, FX2N-20GM, FX Series terminal blocks</td> <td style="padding: 2px; text-align: center;">DIN rail only</td> </tr> <tr> <td style="padding: 2px;">FX0N/FX2N Series I/O extension blocks, FX0N/FX2N/FX3U Series special function blocks, FX2N-1RM(-E)</td> <td style="padding: 2px; text-align: center;">DIN rail or direct mounting</td> </tr> </tbody> </table> • Install the product on a flat surface. If the mounting surface is rough, undue force will be applied to the PC board, thereby causing nonconformities. • Make sure to affix the expansion board with tapping screws. Tightening torque should follow the specifications in the manual. Loose connections may cause malfunctions. • When drilling screw holes or wiring, make sure that cutting and wiring debris do not enter the ventilation slits. Failure to do so may cause fire, equipment failures or malfunctions. • Be sure to remove the dust proof sheet from the PLC's ventilation port when installation work is completed. Failure to do so may cause fire, equipment failures or malfunctions. • Connect the extension cables, peripheral device cables, input/output cables and battery connecting cable securely to their designated connectors. Loose connections may cause malfunctions. • Connect the display module, memory cassette, FX2NC Series I/O extension blocks, FX2NC-CNV-IF, extension power supply unit and expansion board securely to their designated connectors. Loose connections may cause malfunctions. • Turn off the power to the PLC before attaching or detaching the following devices. Failure to do so may cause equipment failures or malfunctions. <ul style="list-style-type: none"> - Peripheral devices, display modules, expansion boards and special adapters - Extension blocks, FX Series terminal blocks, connector conversion adapter and extension power supply unit - Battery and memory cassette 	Main unit, FX2NC Series I/O extension blocks, FX2NC/FX3UC Series special function blocks, special adapter, extension power supply unit, FX2NC-CNV-IF, FX2N-10GM, FX2N-20GM, FX Series terminal blocks	DIN rail only	FX0N/FX2N Series I/O extension blocks, FX0N/FX2N/FX3U Series special function blocks, FX2N-1RM(-E)	DIN rail or direct mounting	125 138 237
Main unit, FX2NC Series I/O extension blocks, FX2NC/FX3UC Series special function blocks, special adapter, extension power supply unit, FX2NC-CNV-IF, FX2N-10GM, FX2N-20GM, FX Series terminal blocks	DIN rail only				
FX0N/FX2N Series I/O extension blocks, FX0N/FX2N/FX3U Series special function blocks, FX2N-1RM(-E)	DIN rail or direct mounting				

Safety Precaution

(Read these precautions before use.)

4. WIRING PRECAUTIONS

 WARNING	Reference
<ul style="list-style-type: none">• Make sure to cut off all phases of the power supply externally before attempting installation or wiring work. Failure to do so may cause electric shock or damage to the product.• Make sure to attach the terminal cover, offered as an accessory, before turning on the power or initiating operation after installation or wiring work. Failure to do so may cause electric shock.• The temperature rating of the cable should be 80°C or more.	125 146 148 151 157 190 211 237 273

Safety Precaution

(Read these precautions before use.)

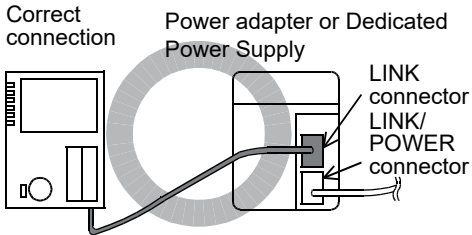
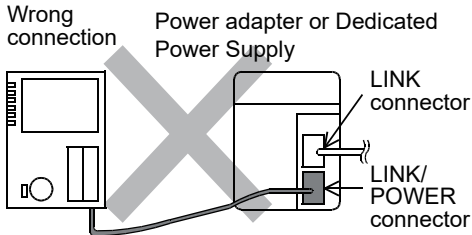
CAUTION	Reference
<ul style="list-style-type: none"> • Connect the DC power supply wiring to the dedicated terminals described in this manual. If an AC power supply is connected to a DC input/output terminal or DC power supply terminal, the PLC will burn out. • Do not wire vacant terminals externally. Doing so may damage the product. • Perform class D grounding (grounding resistance: 100Ω or less) to the grounding terminal on the main unit. Do not use common grounding with heavy electrical systems. • When drilling screw holes or wiring, make sure that cutting and wiring debris do not enter the ventilation slits. Failure to do so may cause fire, equipment failures or malfunctions. • Make sure to properly wire the FX0N/FX2N/FX3U Series extension equipment in accordance with the following precautions. Failure to do so may cause electric shock, equipment failures, a short-circuit, wire breakage, malfunctions, or damage to the product. <ul style="list-style-type: none"> - The disposal size of the cable end should follow the dimensions described in the manual. 126 - Tightening torque should follow the specifications in the manual. 146 - Tighten the screws using a Phillips-head screwdriver No.2 (shaft diameter 6mm (0.24") or less). 148 <li style="padding-left: 20px;">Make sure that the screwdriver does not touch the partition part of the terminal block. 152 • Make sure to properly wire to the terminal block (European type) in accordance with the following precautions. 158 <li style="padding-left: 20px;">Failure to do so may cause electric shock, equipment failures, a short-circuit, wire breakage, malfunctions, or damage to the product. 168 <li style="padding-left: 20px;"> <ul style="list-style-type: none"> - The disposal size of the cable end should follow the dimensions described in the manual. 169 - Tightening torque should follow the specifications in the manual. 170 - Twist the end of strand wire and make sure that there are no loose wires. 172 - Do not solder-plate the electric wire ends. 174 - Do not connect more than the specified number of wires or electric wires of unspecified size. 191 - Affix the electric wires so that neither the terminal block nor the connected parts are directly stressed. 200 • Make sure to properly wire to the FX Series terminal blocks in accordance with the following precautions. 201 <li style="padding-left: 20px;">Failure to do so may cause electric shock, equipment failures, a short-circuit, wire breakage, malfunctions, or damage to the product. 207 <li style="padding-left: 20px;"> <ul style="list-style-type: none"> - The disposal size of the cable end should follow the dimensions described in the manual. 210 - Tightening torque should follow the specifications in the manual. 212 - Tighten the screws using a Phillips-head screwdriver No.2 (shaft diameter 6mm (0.24") or less). 238 <li style="padding-left: 20px;">Make sure that the screwdriver does not touch the partition part of the terminal block. 247 • The FX3UC-32MT-LT(-2) has a built-in power supply. When connecting a power supply adapter or dedicated CC-Link/LT power supply, connect the built-in master to the LINK connector in the power supply adapter or dedicated power supply. 248 <li style="padding-left: 20px;">Connection to the LINK/POWER connector may cause failures. 250 <div style="display: flex; justify-content: space-around; align-items: flex-start;"> <div style="text-align: center;"> <p>Correct connection</p>  </div> <div style="text-align: center;"> <p>Wrong connection</p>  </div> </div>	

Safety Precaution

(Read these precautions before use.)

5. STARTUP AND MAINTENANCE PRECAUTIONS

 WARNING	Reference
<ul style="list-style-type: none"> • Do not touch any terminal while the PLC's power is on. Doing so may cause electric shock or malfunctions. • Before cleaning or retightening terminals, cut off all phases of the power supply externally. Failure to do so may cause electric shock. • Use the battery for memory backup correctly in conformance to this manual. <ul style="list-style-type: none"> - Use the battery only for the specified purpose. - Connect the battery correctly. - Do not charge, disassemble, heat, put in fire, short-circuit, connect reversely, weld, swallow or burn the battery, or apply excessive forces (vibration, impact, drop, etc.) to the battery. - Do not store or use the battery at high temperatures or expose to direct sunlight. - Do not expose to water, bring near fire or touch liquid leakage or other contents directly. - Incorrect handling of the battery may cause heat excessive generation, bursting, ignition, liquid leakage or deformation, and lead to injury, fire or failures and malfunctions of facilities and other equipment. - When replacing the battery, make sure to use our specified product (FX3U-32BL). - When a battery error occurs ("BAT" LED is lit in red), follow the description in this manual. • Before modifying or disrupting the program in operation or running the PLC, carefully read through this manual and the associated manuals and ensure the safety of the operation. An operation error may damage the machinery or cause accidents. 	274 359 434

 CAUTION	Reference
<ul style="list-style-type: none"> • Turn off the power to the PLC before attaching or detaching the memory cassette. If the memory cassette is attached or detached while the PLC's power is on, the data in the memory may be destroyed, or the memory cassette may be damaged. • Do not disassemble or modify the PLC. Doing so may cause fire, equipment failures, or malfunctions. For repair, contact your local Mitsubishi Electric representative. • Turn off the power to the PLC before connecting or disconnecting any extension cable. Failure to do so may cause equipment failures or malfunctions. • Turn off the power to the PLC before attaching or detaching the following devices. Failure to do so may cause equipment failures or malfunctions. <ul style="list-style-type: none"> - Peripheral devices, display module, expansion boards and special adapters - Extension blocks, FX Series terminal blocks, connector conversion adapter and extension power supply unit - Battery and memory cassette • Do not use the chemicals for cleaning. • If there is the possibility of touching the PLC inside a control panel in maintenance, make sure to discharge to avoid the influence of static electricity. 	274 359 434

6. DISPOSAL PRECAUTIONS

 CAUTION	Reference
<ul style="list-style-type: none"> • Please contact a certified electronic waste disposal company for the environmentally safe recycling and disposal of your device. When disposing of batteries, separate them from other waste according to local regulations. (For details of the Battery Directive in EU countries, refer to Appendix H) 	434

Safety Precaution

(Read these precautions before use.)

7. TRANSPORTATION AND STORAGE PRECAUTIONS

 CAUTION	Reference
<ul style="list-style-type: none">• Before transporting the PLC, turn on the power to the PLC to check that the BAT LED is off, and check the battery life. If the PLC is transported with the BAT LED on or the battery exhausted, the battery-backed data may be unstable during transportation.• The PLC is a precision instrument. During transportation, avoid impacts larger than those specified in Section 3.1. Failure to do so may cause failures in the PLC. After transportation, verify the operations of the PLC.• When transporting lithium batteries, follow required transportation regulations. (For details of the regulated products, refer to Appendix G)	434

FX3UC Series Programmable Controllers

User's Manual - Hardware Edition

Manual number	JY997D28701
Manual revision	U
Date	8/2022

Foreword

This manual contains text, diagrams and explanations which will guide the reader in the correct installation, safe use and operation of the FX3UC Series Programmable Controllers and should be read and understood before attempting to install or use the unit.

And, store this manual in a safe place so that you can take it out and read it whenever necessary. Always forward it to the end user.

This manual confers no industrial property rights or any rights of any other kind, nor does it confer any patent licenses. Mitsubishi Electric Corporation cannot be held responsible for any problems involving industrial property rights which may occur as a result of using the contents noted in this manual.

© 2007 MITSUBISHI ELECTRIC CORPORATION

Outline Precaution

- This manual provides information for the use of the FX3UC Series Programmable Controllers. The manual has been written to be used by trained and competent personnel. The definition of such a person or persons is as follows;
 - a) Any engineer who is responsible for the planning, design and construction of automatic equipment using the product associated with this manual should be of a competent nature, trained and qualified to the local and national standards required to fulfill that role. These engineers should be fully aware of all aspects of safety with regards to automated equipment.
 - b) Any commissioning or service engineer must be of a competent nature, trained and qualified to the local and national standards required to fulfill that job. These engineers should also be trained in the use and maintenance of the completed product. This includes being completely familiar with all associated documentation for the said product. All maintenance should be carried out in accordance with established safety practices.
 - c) All operators of the completed equipment should be trained to use that product in a safe and coordinated manner in compliance to established safety practices. The operators should also be familiar with documentation which is connected with the actual operation of the completed equipment.
- Note:** The term 'completed equipment' refers to a third party constructed device which contains or uses the product associated with this manual
- This product has been manufactured as a general-purpose part for general industries, and has not been designed or manufactured to be incorporated in a device or system used in purposes related to human life.
- Before using the product for special purposes such as nuclear power, electric power, aerospace, medicine or passenger movement vehicles, consult with Mitsubishi Electric.
- This product has been manufactured under strict quality control. However when installing the product where major accidents or losses could occur if the product fails, install appropriate backup or failsafe functions in the system.
- When combining this product with other products, please confirm the standard and the code, or regulations with which the user should follow. Moreover, please confirm the compatibility of this product to the system, machine, and apparatus with which a user is using.
- If in doubt at any stage during the installation of the product, always consult a professional electrical engineer who is qualified and trained to the local and national standards. If in doubt about the operation or use, please consult your local Mitsubishi Electric representative.
- Since the examples indicated by this manual, technical bulletin, catalog, etc. are used as a reference, please use it after confirming the function and safety of the equipment and system. Mitsubishi Electric will accept no responsibility for actual use of the product based on these illustrative examples.
- This manual content, specification etc. may be changed without a notice for improvement.
- The information in this manual has been carefully checked and is believed to be accurate; however, if you have noticed a doubtful point, a doubtful error, etc., please contact your local Mitsubishi Electric representative.

Registration

Anywire and AnyWireASLINK are either registered trademarks or trademarks of Anywire Corporation. The company names, system names and product names mentioned in this manual are either registered trademarks or trademarks of their respective companies.

In some cases, trademark symbols such as TM or [®] are not specified in this manual.

Table of Contents

SAFETY PRECAUTIONS	(1)
Standards	14
Certification of UL, cUL standards	14
Compliance with EC directive (CE Marking)	14
Requirement for Compliance with EMC directive	14
Requirement for Compliance with LVD directive	17
Caution for compliance with EC Directive	18
Compliance with UKCA marking	20
Associated Manuals	21
Generic Names and Abbreviations Used in Manuals	29

1. Outline	32
-------------------------	-----------

1.1 Major Features	32
1.2 Part names	35
1.2.1 FX3UC-□□MT/D(SS)	35
1.2.2 FX3UC-16MR/D(S)-T	37
1.2.3 FX3UC-32MT-LT-2	38
1.2.4 FX3UC-32MT-LT	40
1.3 Interpretation of Model Names (Main Units, I/O Extension Blocks)	42
1.4 List of Products	43
1.4.1 Main units	45
1.4.2 I/O Extension Blocks	45
1.4.3 Special function units/blocks	47
1.4.4 Expansion boards	50
1.4.5 Special adapters	50
1.4.6 Extension power supply unit	51
1.4.7 Connector conversion adapter	51
1.4.8 Memory cassettes/Battery/Extension cables	51
1.4.9 FX Series terminal blocks	52
1.4.10 Input/output cable • Input/output connector • Power cable	53
1.4.11 Power supply unit	53
1.4.12 Programming tool	53
1.5 Connection to programming tool	54
1.6 System overall configuration	55
1.7 Rules of System Configuration	56
1.8 Number of Input/Output Points and Maximum Number of Input/Output Points	58
1.8.1 Calculation of number of input/output points	58
1.8.2 Maximum number of input/output points when CC-Link master is used	60
1.8.3 Maximum number of input/output points when AnyWireASLINK master is used	61
1.8.4 Maximum number of input/output points when AS-i master is used	62
1.9 Calculation of 5V DC power supply capacity (current consumption)	63
1.10 Restriction in number of units in each group	64
1.10.1 In the case of the FX3UC-□□MT/D(SS), FX3UC-16MR/D(S)-T	64
1.10.2 In the case of the FX3UC-32MT-LT(-2)	67
1.11 Number of occupied I/O points and 5V DC current consumption	69
1.12 Selection Calculation Example 1 for System Configuration	73
1.12.1 Re-examination of suitability for configuration	75
1.13 Selection Calculation Example 2 for System Configuration	77
1.13.1 Re-examination of suitability for configuration	79
1.14 Selection Calculation Example 3 for System Configuration	81
1.14.1 Judgment of availability after reexamination of configuration	84
1.15 Assignment of Input/Output Numbers (X/Y)	86
1.15.1 Rules for input/output number (X/Y) assignment	86
1.15.2 Caution	86
1.15.3 Example of (X/Y) assignment	87

1.16 Unit Numbers of Special Function Units/Blocks	88
1.16.1 Rules of unit number assignment	88
1.16.2 Example of assigning	88
1.16.3 Application of unit number labels.....	89
1.16.4 Application of the trimmer layout label.....	90

2. External Dimensions and Terminal Arrangement 91

2.1 External Dimensions (MASS/Installation/Accessories)	91
2.1.1 Main Units.....	91
2.1.2 FX2NC Series Input/output Extension Block.....	94
2.1.3 FX2N Series Input/output Extension Block.....	95
2.1.4 FX0N Series Input/output Extension Block.....	96
2.1.5 FX0N/FX2N/FX2NC/FX3U/FX3UC Series special function block	96
2.1.6 Expansion boards.....	105
2.1.7 Special adapters.....	107
2.1.8 Power supply unit	108
2.1.9 Connector conversion adapter	109
2.1.10 Option	110
2.2 Terminal layout.....	111
2.2.1 Main units	111
2.2.2 FX2NC series input/output extension block	113
2.2.3 FX2N series input/output extension block	116
2.2.4 FX0N series input/output extension block	119
2.2.5 Expansion boards.....	120
2.2.6 Special adapters.....	121
2.2.7 Power supply unit	123

3. Generic Specifications/Installation Work 124

3.1 Generic Specifications	127
3.2 Installation location.....	128
3.3 Procedures for Installing on and Detaching from DIN Rail.....	129
3.3.1 Procedures for installing to and removing from DIN rail	129
3.3.2 Procedures for removal from DIN rail.....	130
3.3.3 Direct mounting (FX0N/FX2N/FX3U extension units/blocks)	130
3.4 Connection between main unit and extension equipment.....	131
3.4.1 Extension equipment connection configuration	131
3.4.2 Connecting method A (Main units and Extension units/blocks connecting)	132
3.4.3 Connecting method B (Connection of FX0N/FX2N/FX3U extension units/blocks).....	132
3.4.4 Connecting method C (Extension cable • FX2N-CNV-BC connecting)	133
3.4.5 Connecting method D (Connection of FX3UC-1PS-5V/FX2NC-CNV-IF to right side)	134
3.5 Expansion Board Connection [FX3UC-32MT-LT(-2) Only]	135
3.6 Special Adapter Connection.....	136
3.7 How to remove or install a memory cassette	137
3.8 Display module Installation / Removal (FX3UC-32MT-LT(-2) Only).....	139
3.8.1 Removal	139
3.8.2 Installing	139
3.9 Connection to peripheral device connecting connector	140
3.10 Connection of power supply cable	141
3.10.1 Power Cable types	141
3.10.2 Connection of power cable to main unit and extension block.....	141
3.10.3 Removal of the power cable	143
3.11 Connection to Input/Output Connector.....	144
3.11.1 Input/output connector [FX3UC Main unit, FX2NC Extension block].....	144
3.11.2 Terminal block for Europe [FX3UC-16MR/D(S)-T, FX2NC/FX3UC extension block]	146
3.11.3 Input/Output Terminal Blocks [FX0N/FX2N/FX3U Extension blocks].....	148
3.12 Grounding terminal of the FX3U-ENET-ADP	150

4. Power Supply Specifications and External wiring	151
4.1 Selection of the external DC power supply to prepare	153
4.1.1 Power supply specifications	153
4.1.2 The input range of power supply voltage	154
4.1.3 Power consumption of the extension equipment	154
4.2 Example External Wiring	155
5. Input Specifications and External wiring	157
5.1 Sink and source input (24V DC input type)	159
5.2 24V DC Input Type	160
5.2.1 24V DC Input Specifications	160
5.2.2 Input Derating Curve	163
5.2.3 Handling of 24V DC input	164
5.2.4 Instructions for connecting input devices	166
5.2.5 Examples of external wiring	168
5.3 5V DC Input [FX ₂ N-16EXL-C]	171
5.3.1 5V DC input specifications	171
5.3.2 Handling of 5V DC Input	171
5.3.3 Example of external wiring	172
5.4 AC input [FX ₂ N-8EX-UA1/UL, FX ₀ N-8EX-UA1/UL]	173
5.4.1 AC input specifications	173
5.4.2 Handling of 100V AC Input	173
5.4.3 Example of external wiring	174
5.5 High-speed Counters (C235 to C255)	175
5.5.1 High-speed counter type and device number	175
5.5.2 Input allocation of the High-Speed Counter	178
5.5.3 Current Value Update Timing and Comparison of Current Value	179
5.5.4 Related Devices (High-speed counter)	180
5.5.5 [Function switching] switching of logic of external reset input signal	181
5.5.6 [Function switching] switching of allocation and functions of input terminals	182
5.5.7 [Function switching] procedures for using 2-phase 2-count input counters C251 to C255 in 4 edge count mode	183
5.5.8 Conditions for Hardware Counter to be Handled as Software Counter	184
5.5.9 Calculation of Response Frequency and Overall Frequency	185
5.5.10 Cautions on Use	187
5.6 Input Interruption (I00□ to I50□) - With Delay Function	188
5.7 Pulse Catch (M8170 to M8177)	189
6. Output Specification and External Wiring	190
6.1 Sink and Source Output (Transistor)	192
6.2 Transistor Output	193
6.2.1 Transistor Output Specifications (Sink output type)	193
6.2.2 Transistor Output Specifications (Source output type)	195
6.2.3 Output Derating Curve	196
6.2.4 Handling of transistor output	196
6.2.5 External wiring precautions	199
6.2.6 Example of external wiring	200
6.3 Relay Output	202
6.3.1 Relay output specifications	202
6.3.2 Output Derating Curve	203
6.3.3 Product life of relay contacts	204
6.3.4 Handling of relay output	205
6.3.5 External wiring precautions	206
6.3.6 Example of external wiring	207

6.4 Triac (SSR) Output [FX ₂ N-16EYS]	208
6.4.1 Specifications	208
6.4.2 Handling of triac output	208
6.4.3 External wiring precautions	209
6.4.4 Example of external wiring	210

7. Examples of Wiring for Various Uses **211**

7.1 Notes about Examples of Wiring	212
7.2 Rotary Encoder [High-speed Counters C235 to C255]	213
7.2.1 1-phase 1-input [C235 to C245]	213
7.2.2 2-phase 2-input [C251 to C255]	214
7.3 Input Interruption - With Delay Function, Pulse Catch	216
7.4 Digital Switch [DSW (FNC 72)/BIN (FNC 19)]	217
7.4.1 When DSW instructions are used	217
7.4.2 When BIN instructions are used	221
7.5 Ten Key Input [TKY (FNC 70)]	224
7.6 Hexadecimal Input [HKY (FNC 71)]	226
7.7 Input Matrix [MTR (FNC 52)]	229
7.8 Seven Segment with Latch [SEGL (FNC 74)/BCD (FNC 18)]	232
7.8.1 When SEGL instructions are used	232
7.8.2 When BCD instructions are used	234

8. Terminal Block Specifications and External Wiring **236**

8.1 Overview	239
8.1.1 Product configuration	239
8.2 External Dimensions & Component Names	241
8.3 Terminal Arrangement	242
8.4 Installation Work	244
8.4.1 Mounting/Removal	244
8.4.2 Input/output cable connection	244
8.4.3 Connection to terminal block	245
8.5 FX-16E-TB/FX-32E-TB	246
8.5.1 Internal circuit	246
8.5.2 Example of input external wiring [sink wiring]	247
8.5.3 Example of output external wiring [sink wiring]	248
8.6 FX-16E-TB/UL, FX-32E-TB/UL	249
8.6.1 Internal circuit	249
8.6.2 Example of input external wiring [Sink/Source wiring]	250
8.6.3 Example of output external wiring [Source wiring]	251
8.7 FX-16EX-A1-TB	252
8.7.1 Specifications	252
8.7.2 Internal circuit	253
8.7.3 Example of input external wiring	253
8.8 FX-16EYR-TB	254
8.8.1 Specifications	254
8.8.2 Internal circuit	255
8.8.3 Example of output external wiring	255
8.8.4 External wiring precautions	256
8.8.5 Product life of relay contacts	257
8.9 FX-16EYR-ES-TB/UL	258
8.9.1 Specifications	258
8.9.2 Internal circuit	259
8.9.3 Example of output external wiring	259
8.9.4 External wiring precautions	259
8.9.5 Product life of relay contacts	259

8.10	FX-16EYT(-H)-TB	260
8.10.1	Specifications	260
8.10.2	Internal circuit	261
8.10.3	Example of output external wiring	261
8.10.4	External wiring precautions	262
8.11	FX-16EYT-ES-TB/UL	263
8.11.1	Specifications	263
8.11.2	Internal circuit	264
8.11.3	Example of output external wiring	264
8.11.4	External wiring precautions	264
8.12	FX-16EYT-ESS-TB/UL	265
8.12.1	Specifications	265
8.12.2	Internal circuit	266
8.12.3	Example of output external wiring	266
8.12.4	External wiring precautions	267
8.13	FX-16EYS-TB	268
8.13.1	Specifications	268
8.13.2	Internal circuit	269
8.13.3	Example of output external wiring	269
8.13.4	External wiring precautions	270
8.14	FX-16EYS-ES-TB/UL	271
8.14.1	Specifications	271
8.14.2	Internal circuit	272
8.14.3	Example of output external wiring	272
8.14.4	External wiring precautions	272

9. CC-Link/LT Built-in master [FX3UC-32MT-LT(-2) Only]

273

9.1	Outline	275
9.1.1	Differences between FX3UC-32MT-LT and FX3UC-32MT-LT-2	275
9.1.2	Outline of System	275
9.1.3	Procedures up until Operation (FX3UC-32MT-LT)	276
9.1.4	Procedures up until Operation (FX3UC-32MT-LT-2 parameter CONFIG mode)	277
9.1.5	Procedures up until Operation (FX3UC-32MT-LT-2 self CONFIG mode)	278
9.2	CC-Link/LT specifications	279
9.2.1	Performance specifications	279
9.2.2	Network wiring specifications	280
9.2.3	Cable specifications	280
9.2.4	The built-in power supply specifications for CC-Link/LT networks	281
9.3	System configuration [CC-Link/LT Built-in master functionality]	282
9.3.1	CC-Link/LT total configuration	282
9.3.2	Number of connectable additional CC-Link/LT masters	283
9.3.3	Cautions on use	284
9.4	Selection of connection cables, connectors and terminal resistors	284
9.4.1	Selection of cables	284
9.4.2	Selection of connectors	284
9.4.3	Selection of terminal resistors	285
9.5	Combination and mixed use of cables	285
9.5.1	Combination of trunk line cable and drop line cables	285
9.5.2	When using different cables together	285
9.5.3	System configuration examples	286
9.6	Selection of the power supply for CC-Link/LT	288
9.6.1	System power calculation procedure	288
9.6.2	Installation concept of power adapter or dedicated power supply	289
9.6.3	System power supply calculation [FX3UC-32MT-LT(-2) built-in power supply]	291
9.6.4	System configuration example 1	294
9.6.5	System configuration example 2 (When current consumption and voltage drop are large)	295
9.7	Design Precautions	297
9.7.1	Prevention of erroneous inputs and outputs to/from remote I/O modules	297
9.7.2	When using high flexible cable	298

9.8	Connection of Cables, Connectors and Terminating Resistors	299
9.8.1	Procedure	299
9.8.2	Connection outline for connection cables (Example: CC-Link/LT dedicated flat cables)	300
9.8.3	How to attach connectors for the dedicated flat cable (terminal/T-branch processing).....	300
9.8.4	How to attach connectors for the VCTF cable/high flexible cable (terminal/T-branch processing)	302
9.8.5	Inserting a connector [to power supply adapter/dedicated power supply].....	305
9.8.6	Connecting a connection cable to the CC-Link/LT interface connector.....	306
9.8.7	How to attach a terminating resistor.....	306
9.9	Setting of CC-Link/LT built-in master and remote I/O units (FX3UC-32MT-LT)	307
9.9.1	Setting DIP switches in built-in master (operation mode/Communication speed/Point mode)....	308
9.9.2	Station number setting of the remote I/O units	310
9.9.3	The start of the operation	311
9.10	Setting of CC-Link/LT built-in master and remote I/O units (FX3UC-32MT-LT-2).....	312
9.10.1	Setting by GX Developer (Transmission rate/Point mode/Station information).....	314
9.10.2	Station number setting of the remote I/O units	317
9.10.3	Starting operation (parameter CONFIG mode)	318
9.10.4	Starting operation (self CONFIG mode)	318
9.11	Details on the operation mode (FX3UC-32MT-LT).....	319
9.11.1	Setting of an Operation mode and on DIP switch.....	319
9.11.2	ONLINE mode	319
9.11.3	CONFIG mode.....	320
9.11.4	TEST mode (self-loop-back test).....	321
9.11.5	Test (TEST mode) execution procedure	322
9.12	Details on the operation mode [FX3UC-32MT-LT(-2)]	324
9.12.1	Parameter CONFIG mode.....	324
9.12.2	Self CONFIG mode	324
9.12.3	Changeover between Parameter CONFIG Mode and Self CONFIG Mode	325
9.12.4	Precautions on Use of CC-Link/LT Settings	325
9.13	Assignment of I/O numbers.....	326
9.13.1	I/O number assignment types.....	326
9.13.2	Setting the point mode (relationship between I/O numbers, station numbers and point mode)	326
9.13.3	Automatic assignment of I/O numbers (FX3UC-32MT-LT and FX3UC-32MT-LT-2 Self CONFIG Mode)	328
9.13.4	Automatic assignment of I/O numbers (FX3UC-32MT-LT-2 Parameter CONFIG Mode).....	329
9.13.5	Extension equipment types and I/O number assignment order.....	329
9.13.6	Example in which the point mode setting causes an invalid configuration	331
9.13.7	Number of occupied stations and Link scan time	332
9.13.8	Cautions on I/O number assignment.....	332
9.14	Specification of reserved station	333
9.15	Editing the detailed remote station information	333
9.15.1	How to edit detailed remote station information (FX3UC-32MT-LT).....	333
9.15.2	Buffer memory [BFM #32 to #95]	337
9.15.3	Cautions on use.....	337
9.16	Test run (communication test) and confirmation method	338
9.16.1	System configuration examples.....	338
9.16.2	Test run execution procedure (FX3UC-32MT-LT)	338
9.16.3	Test run execution procedure (FX3UC-32MT-LT-2)	342
9.17	Practical Program Examples	343
9.17.1	Practical Example 1 (Pattern 0).....	343
9.18	Data Link Processing Time	345
9.18.1	Link scan time.....	345
9.18.2	Transmission delay time.....	346
9.19	Buffer Memory.....	347
9.19.1	Used instruction.....	347
9.19.2	Buffer memory list.....	348

9.20	Details of buffer memory	350
9.20.1	Remote station connection information [BFM #0 (0h) to #3 (3h)].....	350
9.20.2	Link error station information [BFM #4 (4h) to #7 (7h)].....	350
9.20.3	Remote I/O error information [BFM #8 (8h) to #11 (Bh)].....	351
9.20.4	Reserved station information [BFM #16 (10h) to #19 (13h)]	351
9.20.5	Number of required input blocks [BFM #20 (14h)].....	352
9.20.6	Number of required output blocks [BFM #21 (15h)]	352
9.20.7	Data link final station information [BFM #22 (16h)].....	352
9.20.8	External switch information [BFM #26 (1Ah)] (FX3UC-32MT-LT only)	352
9.20.9	Command [BFM #27 (1Bh)].....	353
9.20.10	Status information [BFM #28 (1Ch)].....	354
9.20.11	Detailed error information [BFM #29 (1Dh)]	354
9.20.12	Model code [BFM #30 (1Eh)].....	355
9.20.13	Detailed remote station information [BFM #32 (20h) to #95 (5Fh)]	356
9.20.14	Remote device station input (output) data area [BFM #144 (90h) to #159 (9Fh) and #208 (D0h) to #223 (DFh)]	357
9.21	Details on the additional special devices (FX3UC-32MT-LT-2 only)	358
9.21.1	Details on the additional special auxiliary relays	358
9.21.2	Details on the additional special data register	358

10. Display Module [FX3UC-32MT-LT(-2) only] 359

10.1	Specifications	359
10.1.1	Display specifications	359
10.1.2	Operation button list	359
10.2	Summary of Functions	360
10.3	Procedure for Accessing the Menu Screen from the Title Screen	361
10.3.1	Title screen	361
10.3.2	Top screen (Main unit I/O operation display).....	361
10.3.3	Menu screen.....	362
10.4	Menu Structure.....	363
10.5	Monitor/Test Mode [Excluding User-Registered Devices].....	366
10.5.1	Relevant devices	366
10.5.2	Monitor mode operation.....	367
10.5.3	Monitor screen & status display.....	368
10.5.4	Test mode operation.....	370
10.5.5	Test mode operation notes.....	373
10.6	Monitor/Test Mode [User-Registered Devices]	374
10.6.1	Monitor mode operation.....	374
10.6.2	Test mode operation.....	375
10.7	Error Check	375
10.8	LANGUAGE (Menu Display Language Setting).....	376
10.8.1	Changing to Japanese menus	376
10.8.2	Changing to English menus.....	377
10.8.3	D8302 changes by program & related devices.....	377
10.9	Contrast.....	378
10.10	Clock Menu (Current Time Setting).....	379
10.10.1	Current time setting procedure	379
10.10.2	Displaying the current time	380
10.10.3	Changing the current time's "Year" from 2-digit format to 4-digit format	380
10.11	Keyword (Entry code).....	381
10.11.1	Keyword (Entry code) types & levels.....	381
10.11.2	Level-specific restrictions screen list	382
10.11.3	Keyword (Entry code) storage	383
10.11.4	Screens requiring keywords (entry codes) for access.....	383
10.11.5	Canceling a keyword (entry code).....	384
10.11.6	Enabling an entry code.....	385
10.12	Device All-Clear	385
10.12.1	Device all-clear operation.....	385

10.13	PLC Status	386
10.13.1	Display operation	386
10.13.2	PLC status display items	387
10.14	Scan Time (Scan Time Display).....	389
10.14.1	Scan time display operation	389
10.15	Cassette (Memory Cassette Transfers)	389
10.15.1	Transfer from internal RAM to memory cassette (Cassette <- RAM).....	389
10.15.2	Transfer from memory cassette to internal RAM (Cassette -> RAM).....	391
10.15.3	Memory cassette & internal RAM consistency check (Cassette : RAM)	392
10.16	CC-Link/LT settings (FX3UC-32MT-LT-2 only)	393
10.16.1	Precautions on Use of CC-Link/LT Settings.....	393
10.16.2	Reserved station change (parameter CONFIG mode).....	394
10.16.3	Transmission rate setting (parameter CONFIG mode).....	395
10.16.4	Self check (parameter CONFIG mode)	396
10.16.5	Transmission rate setting (self CONFIG mode)	397
10.16.6	Point mode setting (self CONFIG mode).....	397
10.16.7	CONFIG start (self CONFIG mode).....	398
10.16.8	Self check (self CONFIG mode).....	399
10.17	System Information (Restrictions From PLC).....	400
10.17.1	System information list	400
10.17.2	System information setting program example	401
10.18	Display Screen Protect Function.....	402
10.18.1	Keyword (Entry code) & display screen protect function levels and corresponding restrictions.....	402
10.18.2	Relationship between keyword (entry code) & display screen protect function.....	403
10.18.3	Keyword (Entry code) levels.....	403
10.18.4	System information - display screen protect function	404
10.18.5	Program example (screen protect function setting).....	404
10.18.6	Pointers for using the display screen protect function	404
10.19	Specifying a Hexadecimal Current Value Display Format	405
10.19.1	System information - specifying a hexadecimal current value display format	405
10.19.2	Program example 1 (specifying a hexadecimal data display format)	405
10.19.3	Program example 2 (specifying a decadal data display format).....	405
10.20	Operation Button ON/OFF Information	406
10.20.1	Various applications	406
10.20.2	System information - operation button ON/OFF information	406
10.21	User (User-Registered Device Setting).....	407
10.21.1	System information - user-registered device setting	407
10.21.2	Precaution when setting 3 or fewer devices	407
10.21.3	Program example 1 (when 4 devices are displayed as user-registered devices)	408
10.21.4	Program example 2 (when 3 or fewer devices are displayed as user-registered devices)	409
10.21.5	Program example 3 (when 5 or more devices are displayed as user-registered devices)	410
10.22	User Message Display Function	412
10.22.1	System information - user message display function	412
10.22.2	Shift JIS code arrangement precautions	412
10.22.3	Displaying a word device current value as a message.....	413
10.22.4	Program example 1 (user messages display switching)	413
10.22.5	Program example 2 ([+]/[-] buttons of user messages switching)	414
10.22.6	Program example 3 (user messages plus data display).....	415
10.22.7	Character data input procedure.....	418
10.23	Operation Error Messages & Corrective Actions	421
10.23.1	When a "Fatal error occurred" message appears	423
10.24	Menu Display Characters - Japanese & English Display Character Correspondence Table..	424

11. Memory Cassette/Battery	426
11.1 Memory Cassette (FX3U-FLROM-16/64/64L/1M)	426
11.1.1 Specifications	426
11.1.2 Component names & external dimensions	426
11.1.3 Saved Data Content	427
11.1.4 PROTECT switch setting	428
11.1.5 PROTECT switch operation	428
11.2 Memory Cassette <-> PLC (RAM Memory) Transfers by Loader Function	429
11.2.1 Tool for pressing the [WR] and [RD] keys	429
11.2.2 Writing (WR: 64L -> PLC)	429
11.2.3 Reading (RD: 64L <- PLC)	430
11.3 Transfers By Display Module Operation	430
11.4 Operation Precautions	431
11.5 FX3U-32BL (Battery)	431
11.5.1 Specifications	431
11.5.2 Battery Purpose	431
11.5.3 Special "battery low-voltage" device & notification program example	432
11.5.4 Battery life & replacement guidelines	432
11.5.5 Battery-Free Operation	432
11.5.6 Differences between main unit's internal battery and the optional battery	432
11.5.7 Reading the date of manufacture	433
11.5.8 Battery Related Precautions	433

12. Test Operation, Adjustment, Maintenance and Troubleshooting	434
12.1 Preparation for Test Operation	435
12.1.1 Preliminary inspection [power OFF]	435
12.1.2 Connection to built-in programming connector [power ON, PLC STOP]	435
12.2 Running and Stopping Procedures [Power ON]	436
12.2.1 Methods of running and stopping	436
12.2.2 Use of several running/stopping methods	437
12.3 Operation and Test [Power ON and PLC Running]	438
12.3.1 Self-diagnostic function	438
12.3.2 Test functions	438
12.3.3 Program modification function	439
12.4 Maintenance	440
12.4.1 Periodic inspection	440
12.4.2 Product life of relay contacts	440
12.4.3 Procedures for replacing battery	442
12.5 Troubleshooting with LEDs	443
12.5.1 POW LED [on/flashing/off]	443
12.5.2 BAT LED [on/off]	443
12.5.3 ERR LED [on/flashing/off]	444
12.5.4 L RUN LED [FX3UC-32MT-LT(-2) only]	444
12.5.5 L ERR. LED [FX3UC-32MT-LT(-2) only]	445
12.6 Judgment by Error Codes and Representation of Error Codes	446
12.6.1 Operation and check on display module	446
12.6.2 Operation and check by GX Developer	447
12.6.3 Representation of errors	448
12.6.4 Error Code List and Action	449
12.7 FX3UC-32MT-LT(-2) Built-in CC-Link/LT Troubleshooting	458
12.7.1 Status of each station during abnormal operation	458
12.7.2 Operation at blowout of built-in power fuse for CC-Link/LT	458
12.7.3 Detailed error information [BFM #29 (1Dh)]	459
12.7.4 Self check (FX3UC-32MT-LT-2)	460
12.7.5 Self check (FX3UC-32MT-LT)	462
12.7.6 Prevention of erroneous inputs and outputs to/from remote I/O modules	464

12.8 Troubleshooting	466
12.8.1 Output does not operate (main unit and input/output extension blocks)	466
12.8.2 24V DC input does not operate (main unit and input/output extension blocks).....	467
12.8.3 Cautions in registering keyword	467
12.8.4 Cautions on using block password	468

Appendix A: Version Information and Peripheral Equipment Connect ability 469

Appendix A-1 Version Upgrade History	469
Appendix A-1-1 How to look at manufacturer's serial number	469
Appendix A-1-2 Version check method	470
Appendix A-1-3 Version upgrade history	471
Appendix A-2 Programming Tool Applicability.....	473
Appendix A-2-1 Applicable versions of programming tool.....	473
Appendix A-2-2 In the case of programming tool (version) not applicable	474
Appendix A-2-3 Program transfer speed and programming tools	475
Appendix A-2-4 Cautions on connecting peripheral equipment by way of expansion board or special adapter.....	475
Appendix A-2-5 Cautions on write during RUN	476
Appendix A-2-6 Cautions on using transparent function by way of USB in GOT1000 Series.....	480
Appendix A-2-7 Cautions on using transparent port (2-port) function of GOT-F900 Series.....	481
Appendix A-3 Other Peripheral Equipment Applicability.....	482
Appendix A-3-1 Other Peripheral Equipment Applicability	482

Appendix B: Performance Specifications 483

Appendix C: Operation of Special Devices (M8000 -, D8000 -) 487

Appendix C-1 Special Auxiliary Relay (M8000 to M8511)	487
Appendix C-2 Special Data Register (D8000 to D8511).....	496
Appendix C-3 Analog special adapters special devices	506
Appendix C-3-1 Special auxiliary relays (M8260 to M8299).....	506
Appendix C-3-2 Special data registers (D8260 to D8299)	508

Appendix D: Instruction List 510

Appendix D-1 Basic Instructions	510
Appendix D-2 Step Ladder Instructions	510
Appendix D-3 Applied Instructions ... in Ascending Order of FNC Number.....	511

Appendix E: Character-code 515

Appendix E-1 ASCII Code Table	515
-------------------------------------	-----

Appendix F: Discontinued models 517

Appendix G: Precautions for Battery Transportation 519

Appendix G-1 Regulated FX3UC Series products	519
Appendix G-2 Transport guidelines	519

Appendix H: Handling of Batteries and Devices with Built-in Batteries in EU Member States	521
Appendix H-1 Disposal precautions.....	521
Appendix H-2 Exportation precautions	521
Appendix H-3 Regulated FX3uc Series products.....	521
Warranty.....	523
Revised History	524

Standards

Certification of UL, cUL standards

FX3UC series main units, FX3U series special adapters, extension power supply unit and FX2N/FX2NC series input/output extension blocks supporting UL, cUL standards are as follows:

UL, cUL file number : E95239

Models :

MELSEC FX3U(C) series manufactured

FX3UC-★ ★MT/D FX3UC-★ ★MT/DSS

Where ★ ★ indicates:16,32,64,96

FX3UC-16MR/D-T FX3UC-16MR/DS-T

FX3UC-32MT-LT-2

FX3U-232ADP(-MB) FX3U-485ADP(-MB) FX3U-ENET-ADP

FX3U-CF-ADP

FX3U-4AD-ADP FX3U-4DA-ADP FX3U-3A-ADP FX3U-4AD-PT-ADP

FX3U-4AD-PTW-ADP FX3U-4AD-PNK-ADP FX3U-4AD-TC-ADP

FX3UC-1PS-5V

Models :

MELSEC FX2Nc series manufactured

FX2NC-16EX(-DS) FX2NC-32EX(-DS) FX2NC-16EYT(-DSS) FX2NC-32EYT(-DSS)

FX2NC-16EX-T(-DS) FX2NC-16EYR-T(-DS)

Models :

MELSEC FX2N series manufactured

FX2N-8ER-ES/UL FX2N-8EX-ES/UL FX2N-8EYR-ES/UL FX2N-8EYR-S-ES/UL

FX2N-8EYT-ESS/UL FX2N-8EX-UA1/UL

FX2N-16EX-ES/UL FX2N-16EYR-ES/UL FX2N-16EYT-ESS/UL FX2N-16EYS

Compliance with EC directive (CE Marking)

This product complies with EC directive, however, this document does not guarantee that a mechanical system including this product will comply with EC directive.

Compliance to EMC directive and LVD directive of the entire mechanical module should be checked by the user / manufacturer. For more details please contact to the local Mitsubishi Electric sales site.

Requirement for Compliance with EMC directive

The following products have shown compliance through direct testing (of the identified standards below) and design analysis (through the creation of a technical construction file) to the European Directive for Electromagnetic Compatibility (2014/30/EU) when used as directed by the appropriate documentation.

Type : Programmable Controller (Open Type Equipment)

Models : MELSEC FX3U(C)/FX2NC series manufactured

from May 1st, 2005	FX3U-FLROM-16	FX3U-FLROM-64L		
from June 1st, 2005	FX3U-232ADP	FX3U-485ADP		
	FX3U-4AD-ADP	FX3U-4DA-ADP	FX3U-4AD-PT-ADP	FX3U-4AD-TC-ADP
	FX3U-232-BD	FX3U-422-BD	FX3U-485-BD	FX3U-CNV-BD
	FX3U-USB-BD			
	FX3U-FLROM-64			
from April 1st, 2007	FX3U-232ADP-MB	FX3U-485ADP-MB		
from September 1st, 2007	FX3UC-★ ★MT/D	FX3UC-★ ★MT/DSS		
	Where ★ ★ indicates:16,32,64,96			
from October 1st, 2007	FX3UC-1PS-5V			
	FX2NC-★ ★EX	FX2NC-★ ★EYT	FX2NC-★ ★EX-DS	FX2NC-★ ★EYT-DSS
	Where ★ ★ indicates:16,32			
	FX2NC-16EX-T	FX2NC-16EX-T-DS		
from December 1st, 2007	FX3U-4AD-PTW-ADP	FX3U-4AD-PNK-ADP		
from April 1st, 2008	FX3UC-32MT-LT-2	(from April 1st, 2008 to July 31st, 2010 are compliant with EN61131: 2003)		
from June 1st, 2009	FX3U-3A-ADP	FX3U-CF-ADP		
from August 1st, 2010	FX3U-8AV-BD			
from September 1st, 2010	FX3UC-16MR/D-T	FX3UC-16MR/DS-T		
from May 1st, 2011	FX3U-FLROM-1M			
from February 1st, 2012	FX3U-ENET-ADP			

Standard	Remark
EN61131-2:2007 Programmable controllers - Equipment requirements and tests	Compliance with all relevant aspects of the standard. EMI <ul style="list-style-type: none"> • Radiated Emission • Conducted Emission EMS <ul style="list-style-type: none"> • Radiated electromagnetic field • Fast transient burst • Electrostatic discharge • High-energy surge • Voltage drops and interruptions • Conducted RF • Power frequency magnetic field

Models : MELSEC FX2NC series manufactured

from March 1st, 1999	FX2NC-★ ★EX-DS	FX2NC-★ ★EYT-DSS
	Where ★ ★ indicates:16,32	
from August 1st, 1999	FX2NC-16EX-T-DS	FX2N-16EYR-T-DS
from October 1st, 2007	FX2NC-★ ★EX	FX2NC-★ ★EYT
	Where ★ ★ indicates:16,32	
	FX2NC-16EX-T	FX2NC-16EYR-T

Standard	Remark
EN61000-6-4:2007 - Generic emission standard Industrial environment	Compliance with all relevant aspects of the standard. <ul style="list-style-type: none"> • Emission-Enclosure port • Emission-Low voltage AC mains port • Emission-Telecommunications/network port
EN50081-2:1993 Electromagnetic compatibility	
EN61000-6-2:2005 - Generic immunity standard Industrial environment	Compliance with all relevant aspects of the standard. <ul style="list-style-type: none"> • RF Immunity • Fast Transients • ESD • Conducted • Surge • Power magnetic fields • Voltage drops and Voltage interruptions

Models : MELSEC FX2N series manufactured

from July 1st, 1997	FX2N-16EX-ES/UL	FX2N-16EYR-ES/UL	FX2N-16EYT-ESS/UL
from August 1st, 2005	FX2N-8ER-ES/UL	FX2N-8EX-ES/UL	FX2N-8EYR-ES/UL
	FX2N-8EYT-ESS/UL		
from September 1st, 2010	FX2N-8EYR-S-ES/UL		

For the products above, PLCs manufactured before March 31st, 2002 are compliant with EN50081-2 (EN61000-6-4) and EN50082-2 from April 1st, 2002 to April 30th, 2006 are compliant with EN50081-2 (EN61000-6-4) and EN61131-2:1994 +A11:1996+A12:2000 after May 1st, 2006 are compliant with EN61131-2:2007

Standard		Remark
EN61000-6-4:2007 - Generic emission standard Industrial environment	Electromagnetic compatibility	Compliance with all relevant aspects of the standard. <ul style="list-style-type: none"> • Emission-Enclosure port • Emission-Low voltage AC mains port • Emission-Telecommunications/network port
EN50082-2:1995	Electromagnetic compatibility - Generic immunity standard Industrial environment	Compliance with all relevant aspects of the standard. <ul style="list-style-type: none"> • RF immunity • Fast Transients • ESD • Conducted • Power magnetic fields
EN61131-2:1994 /A11:1996 /A12:2000	Programmable controllers - Equipment requirements and tests	Compliance with all relevant aspects of the standard. <ul style="list-style-type: none"> • Radiated electromagnetic field • Fast transient burst • Electrostatic discharge • Damped oscillatory wave
EN61131-2:2007	Programmable controllers - Equipment requirements and tests	Compliance with all relevant aspects of the standard. EMI <ul style="list-style-type: none"> • Radiated Emission • Conducted Emission EMS <ul style="list-style-type: none"> • Radiated electromagnetic field • Fast transient burst • Electrostatic discharge • High-energy surge • Voltage drops and interruptions • Conducted RF • Power frequency magnetic field

Requirement for Compliance with LVD directive

The following products have shown compliance through direct testing (of the identified standards below) and design analysis (through the creation of a technical construction file) to the European Directive for Low Voltage (2014/35/EU) when used as directed by the appropriate documentation.

Type : Programmable Controller (Open Type Equipment)

Models : MELSEC FX3UC series manufactured

from September 1st, 2010 FX3UC-16MR/D-T FX3UC-16MR/DS-T

For the products above, PLCs manufactured before April 30th, 2018 are compliant with EN61131-2: 2007,

PLCs manufactured after May 1st, 2018 are compliant with EN61131-2: 2007 and EN61010-2-201: 2013.*1

*1. For some models, PLCs manufactured in March, 2018 are compliant with LVD directive successively.

Standard	Remark
EN61131-2:2007 Programmable controllers - Equipment requirements and tests	The equipment has been assessed as a component for fitting in a suitable control box which meets the requirements of EN61131-2:2007
EN61010-2-201: 2013 Safety of electrical equipment for measurement, control, and test	The equipment has been assessed as a component for fitting in a suitable control box which meets the requirements of EN61010-2-201: 2013

Models : MELSEC FX2NC series manufactured

from August 1st, 1999 FX2NC-16EYR-T-DS

from October 1st, 2007 FX2NC-16EYR-T

For the products above, PLCs manufactured before April 30th, 2018 are compliant with EN61131-2: 2007,

PLCs manufactured after May 1st, 2018 are compliant with EN61131-2: 2007 and EN61010-2-201: 2013.*1

*1. For some models, PLCs manufactured in March, 2018 are compliant with LVD directive successively.

Standard	Remark
IEC1010-1:1990 /A1:1992 Safety requirements for electrical equipment for measurement, control, and laboratory use - General requirements BSEN61010-1 :1993 *2	The equipment has been assessed as a component for fitting in a suitable control box which meets the requirements of IEC 1010-1:1990+A1:1992
EN61010-2-201: 2013 Safety of electrical equipment for measurement, control, and test	The equipment has been assessed as a component for fitting in a suitable control box which meets the requirements of EN61010-2-201: 2013

*2. Compliance to BSEN61010-1 is claimed through virtue of direct compliance to IEC1010-1 and Amendment 1.

Models : MELSEC FX2N series manufactured

from July 1st, 1997 FX2N-16EYR-ES/UL
from August 1st, 2005 FX2N-8ER-ES/UL FX2N-8EYR-ES/UL
from September 1st, 2010 FX2N-8EYR-S-ES/UL

For the products above, PLCs manufactured before March 31st, 2002 are compliant with IEC1010-1
from April 1st, 2002 to April 30th, 2006 are compliant with EN61131-2:1994+A11:1996+A12:2000
from May 1st, 2006 to April 30th, 2018 are compliant with EN61131-2:2007
after May 1st, 2018 are compliant with EN61131-2: 2007 and EN61010-2-201: 2013.*1

*1. For some models, PLCs manufactured in March, 2018 are compliant with LVD directive successively.

Standard	Remark
IEC1010-1:1990 Safety requirements for electrical equipment for measurement, control, and laboratory use /A1:1992 - General requirements	The equipment has been assessed as a component for fitting in a suitable control box which meets the requirements of IEC 1010-1:1990+A1:1992
EN61131-2:1994 Programmable controllers /A11:1996 - Equipment requirements and tests /A12:2000	The equipment has been assessed as a component for fitting in a suitable control box which meets the requirements of EN61131-2:1994+A11:1996+A12:2000
EN61131-2:2007 Programmable controllers - Equipment requirements and tests	The equipment has been assessed as a component for fitting in a suitable control box which meets the requirements of EN61131-2:2007
EN61010-2-201: 2013 Safety of electrical equipment for measurement, control, and test	The equipment has been assessed as a component for fitting in a suitable control box which meets the requirements of EN61010-2-201: 2013

Caution for compliance with EC Directive

- Please use the FX3UC Series programmable controllers while installed in conductive shielded control panels under a general industrial environment.
- Programmable controllers are open-type devices that must be installed and used within conductive control panels. Please secure the control box lid to the control box (for conduction). Installation within a control box greatly affects the safety of the system and aids in shielding noise from the programmable controller.
- For the control panel, use the product having sufficient strength, fire protectiveness and shielding property to an installation environment.
- 24 V DC of the power supply must be supplied from the circuit double/reinforced insulated from the main power supply (MAINS).

Caution for compliance the LVD directive (EN61010-2-201:2013)*1

- To an external connection port other than AC power supply terminal and AC input/output terminal, connect the circuit separated from a dangerous voltage by a double/reinforced insulation.
- Between the commons having the adjacent relay output terminals, if an external power supply is higher than 120 V AC, the insulation is basic.
Therefore, when using 120 V AC or higher external power supply and 30 V DC/AC or lower external power supply between the adjacent commons, do not handle 30 V DC/ AC or lower external power supply as a touchable part, (When handling 30 V DC/AC or lower external power supply as a touchable part, add a basic insulation.)
- Do not wire two or more crimp terminals to one terminal. (If the wiring with two or more wires is needed, take an appropriate action such as adding an external terminal.)
- For crimp terminals to be used for the wiring applied with 30 V AC or higher, use the products with insulating sleeves.
- Cutoff device such as a breaker or a circuit protector should be installed in accordance with the following precautions.
 - Use EN60947-1 or EN60947-3 standards.
 - Place the cutoff device so that it can be operated easily.
 - Specify that the cutoff device is for this equipment.

*1. For the time of compliance with the LVD directive (EN61010-2-201:2013), refer to Requirement for Compliance with LVD directive.

Caution for Analog Products in use

The analog special adapters have been found to be compliant to the European standards in the aforesaid manual and directive. However, for the very best performance from what are in fact delicate measuring and controlled output devices, Mitsubishi Electric would like to make the following points;

As analog devices are sensitive by nature, their use should be considered carefully. For users of proprietary cables (integral with sensors or actuators), these users should follow those manufacturers' installation requirements.

Mitsubishi Electric recommends that shielded cables be used. If NO other EMC protection is provided, users may experience temporary loss or accuracy between +10% / -10% in very heavy industrial areas.

However, Mitsubishi Electric suggests that if adequate EMC precautions are followed for the users complete control system.

- Sensitive analog cables should not be laid in the same trunking or cable conduit as high voltage cabling. Where possible, users should run analog cables separately.
- Good cable shielding should be used. When terminating the shield at Earth - ensure that no earth loops are accidentally created.
- When reading analog values, EMC accuracy can be improved by averaging the readings. This can be achieved either through functions on the analog special adapters/blocks or through a user's program in the FX3UC Series PLC main unit.

Caution for CC-Link/LT Products in use

- Use the CC-Link/LT module in Zone A*¹ as defined in EN61131-2.

The terminal and the wiring for the following table can be used in zone B*¹.

Classification	Model	Terminal that can be used in zone B	Rated load voltage
Relay output* ²	CL1Y4-R1B1 CL1Y4-R1B2	Terminal to connect output signals and load power supply.	240V AC or less* ³ 30V DC or less
DC input/ Relay output* ²	CL1XY4-DR1B2 CL1XY8-DR1B2	Terminal to connect output signals and load power supply.	240V AC or less* ³ 30V DC or less
CC-Link/LT Dedicated Power Supply	CL1PSU-2A	Terminal block to connect power supply.	100/120/200/230/ 240V AC

*1. Zone defined in EN61131-2

Separation defined in EN61131-2 for EMC LVD regulation decided depending on condition in industrial setting.

Zone C = Factory mains which is isolated from public mains by dedicated transformers.

Zone B = Dedicated power distribution which is protected by secondary surge protection.

(300V or less in the rated voltage is assumed.)

Zone A = Local power distribution which is isolated from dedicated power distribution by AC/DC converters, isolation transformers, etc. (120V or less in the rated voltage is assumed.)

*2. Terminal block connection type.

*3. 250V AC or less when the unit does not comply with UL or cUL standards.

- When the following models use the CC-Link/LT power adapter model (CL1PAD1), a power line connecting to the external power supply terminal of the CL1PAD1 must be 30m (98'5") or less.

Classification	Model
Analog-Digital Converter* ⁴	CL2AD4-B
Digital-Analog Converter* ⁴	CL2DA2-B

*4. Terminal block connection type.

- For the control box, use the product having sufficient strength, fire protectiveness and shielding property to an installation environment.
- To an external connection port other than AC power supply terminal and AC output terminal, connect the circuit separated from a dangerous voltage by a double/reinforced insulation.
- For crimp terminals to be used for the wiring applied with 30 V AC or higher, use the products with insulating sleeves.
- Cutoff device such as a breaker or a circuit protector should be installed in accordance with the following precautions.
 - Use EN60947-1 or EN60947-3 standards.
 - Place the cutoff device so that it can be operated easily.
 - Specify that the cutoff device is for this equipment.

Compliance with UKCA marking

The requirements for compliance with the UKCA marking are the same as those with the EC Directive (CE marking).

Associated Manuals

FX3UC Series PLC main units supplied only with the hardware manual.

For the details of the hardware of FX3UC Series, refer to this manual.

For instructions for programming and hardware information on special function devices, refer to the relevant manuals.

⊙: Indispensable manuals ✓: Manuals necessary for some purposes △: Manuals with separate volumes for details

	Manual Name	Manual Number	Contents	Model Code	
Manuals for PLC main unit					
■FX3uc PLC main unit					
△	Supplied with product	FX3UC(D, DS, DSS) Series HARDWARE MANUAL	JY997D50501	Excerpts from the FX3UC Series User's Manual - Hardware Edition describing input/output specifications, wiring and installation of FX3UC(D, DS, DSS) Series PLC main units. For a detailed explanation, refer to this manual.	-
△	Supplied with product	FX3UC-32MT-LT-2 HARDWARE MANUAL	JY997D31601	Excerpts from the FX3UC Series User's Manual - Hardware Edition describing input/output specifications, wiring and installation of FX3UC-32MT-LT-2 PLC main units. For a detailed explanation, refer to this manual.	-
△	Supplied with product	FX3UC-32MT-LT HARDWARE MANUAL	JY997D12701	Excerpts from the FX3UC Series User's Manual - Hardware Edition describing input/output specifications, wiring and installation of FX3UC-32MT-LT PLC main units. For a detailed explanation, refer to this manual. (This Manual is available in Japanese only)	-
⊙	Separate volume	FX3UC Series User's Manual - Hardware Edition (this manual)	JY997D28701	Detailed explanations of the FX3UC Series PLC hardware, including input/output specifications, wiring, installation and maintenance.	09R519
■Programming					
⊙	Separate volume	FX3S/FX3G/FX3GC/ FX3U/FX3UC Series Programming Manual - Basic & Applied Instruction Edition	JY997D16601	Details on sequence programming for the FX3UC Series, including explanations of basic instructions, applied instructions, and PLC devices.	09R517
✓	Additional Manual	MELSEC-Q/L/F Structured Programming Manual (Fundamentals)	SH-080782	Programming methods, specifications, functions, etc. required to create structured programs.	13JW06
✓	Additional Manual	FXCPU Structured Programming Manual [Device & Common]	JY997D26001	Devices, parameters, etc. provided in structured projects of GX Works2.	09R925
✓	Additional Manual	FXCPU Structured Programming Manual [Basic & Applied instruction]	JY997D34701	Sequence instructions provided in structured projects of GX Works2.	09R926
✓	Additional Manual	FXCPU Structured Programming Manual [Application Functions]	JY997D34801	Application functions provided in structured projects of GX Works2.	09R927

	Manual Name	Manual Number	Contents	Model Code	
■ FX Series terminal block					
✓	Supplied with product	FX INPUT AND OUTPUT TERMINAL BLOCKS USER'S GUIDE	JY992D50401	Details on handling FX Series terminal blocks.	-
Manuals for communication control					
■ Common					
✓	Separate volume	FX Series User's Manual - Data Communication Edition	JY997D16901	Details on N:N Network, Parallel Link, Computer Link, and Non-Protocol communication (RS and RS2 instructions, and FX2N-232IF).	09R715
✓	Separate volume	FX3S/FX3G/FX3GC/FX3U/FX3UC Series User's Manual - MODBUS Serial Communication Edition	JY997D26201	Details on MODBUS serial communication in FX3S/FX3G/FX3GC/FX3U/FX3UC PLCs.	-
■ RS-232C/RS-422/RS-485/USB communication					
When using each product, refer also to the User's Manual - Hardware Edition for the PLC main unit to be installed and FX Series User's Manual - Data Communication Edition. For the MODBUS communication, refer to the FX3S/FX3G/FX3GC/FX3U/FX3UC Series User's Manual - MODBUS Serial Communication Edition.					
△	Supplied with product	FX3U-USB-BD User's Manual	JY997D13501	Details on the USB communication expansion board system configuration and procedures for installing the communication driver.	-
△	Supplied with product	FX3U-232-BD Installation Manual	JY997D12901	Details on handling the RS-232C communication expansion board.	-
△	Supplied with product	FX3U-232ADP-MB Installation Manual	JY997D26401	Details on handling the RS-232C communication special adapter.	-
△	Supplied with product	FX3U-232ADP Installation Manual	JY997D13701	Details on handling the RS-232C communication special adapter.	-
△	Supplied with product	FX2N-232IF Hardware Manual	JY992D73501	Details on handling the RS-232C communication special function block.	-
△	Supplied with product	FX3U-422-BD Installation Manual	JY997D13101	Details on handling the RS-422 communication expansion board.	-
△	Supplied with product	FX3U-485-BD Installation Manual	JY997D13001	Details on handling the RS-485 communication expansion board.	-
△	Supplied with product	FX3U-485ADP-MB Installation Manual	JY997D26301	Details on handling the RS-485 communication special adapter.	-
△	Supplied with product	FX3U-485ADP Installation Manual	JY997D13801	Details on handling the RS-485 communication special adapter.	-
■ Ethernet, CC-Link, CC-Link/LT, AnyWireASLINK, PROFIBUS-DP, MELSEC I/O LINK, and AS-i					
When using each product, refer also to the User's Manual - Hardware Edition for the PLC main unit to be installed.					
△	Supplied with product	FX3U-ENET-ADP Installation Manual	JY997D47401	Details on handling the FX3U-ENET-ADP Ethernet communication special adapter. When using, refer also to the FX3U-ENET-ADP User's Manual.	-
✓	Separate volume	FX3U-ENET-ADP User's Manual	JY997D45801	Details on the FX3U-ENET-ADP Ethernet communication special adapter.	09R725

		Manual Name	Manual Number	Contents	Model Code
✓	Supplied with product	FX-485PC-IF Hardware Manual	JY992D81801	Details on handling the RS-232C/RS-485 conversion interface. When using, refer also to the FX Series User's Manual - Data Communication Edition.	-
△	Supplied with product	FX3U-16CCL-M Installation Manual	JY997D43401	Details on handling the CC-Link master special function block. When using, refer also to the FX3U-16CCL-M User's Manual.	-
✓	Separate volume	FX3U-16CCL-M User's Manual	JY997D43601	Details on the CC-Link master special function block.	09R724
△	Supplied with product	FX2N-16CCL-M Hardware Manual	JY992D93201	Details on handling the CC-Link master special function block. When using, refer also to the FX2N-16CCLM User's Manual.	-
✓	Separate volume	FX2N-16CCL-M User's Manual	JY992D93101	Details on the CC-Link master special function block.	09R710
✓	Supplied with product	FX3U-64CCL Installation Manual	JY997D29801	Details on handling the CC-Link interface special function block. When using, refer also to the FX3U-64CCL User's Manual.	-
✓	Separate volume	FX3U-64CCL User's Manual	JY997D30401	Details on the CC-Link interface special function block.	09R718
△	Supplied with product	FX2N-32CCL Installation Manual	JY997D52401	Details on handling the CC-Link remote device station special function block. When using, refer also to the FX2N-32CCL User's Manual.	-
✓	Separate volume	FX2N-32CCL User's Manual	JY992D71801	Details on the CC-Link remote device station special function block.	09R711
✓	Supplied with product	Remote I/O station, remote device station and intelligent device station for CC-Link	As for the remote I/O station, remote device station and intelligent device station for CC-Link, refer to the relevant manuals and related documents.		-
△	Supplied with product	FX2N-64CL-M User's Manual - Hardware Volume	JY997D05401	Details on handling the CC-Link/LT master special function block. When using, refer also to the FX2N-64CL-M User's Manual - Detailed Volume.	-
✓	Separate volume	FX2N-64CL-M User's Manual - Detailed Volume	JY997D08501	Details on the CC-Link/LT master special function block.	-
✓	Supplied with product	Remote I/O station, remote device station, power supply adapter and dedicated power supply for CC-Link/LT	As for the remote I/O station, remote device station, power supply adapter and dedicated power supply for CC-Link/LT, refer to the relevant manuals and related documents.		-
△	Supplied with product	FX3U-128ASL-M Installation Manual	JY997D51901	Details on handling the FX3U-128ASL-M AnyWireASLINK master block. When using, refer also to the FX3U-128ASL-M User's Manual.	-
✓	Separate volume	FX3U-128ASL-M User's Manual	JY997D52101	Details on the FX3U-128ASL-M AnyWireASLINK master block.	09R731
△	Supplied with product	FX3U-64DP-M Installation Manual	JY997D19901	Details on handling the FX3U-64DP-M PROFIBUS-DP master block. When using, also refer to FX3U-64DP-M User's Manual.	-
✓	Separate volume	FX3U-64DP-M User's Manual	JY997D19201	Details on FX3U-64DP-M PROFIBUS-DP master block.	09R632

		Manual Name	Manual Number	Contents	Model Code
△	Supplied with product	FX3U-32DP Installation Manual	JY997D24901	Details on handling the FX3U-32DP PROFIBUS-DP Interface block. When using, also refer to FX3U-32DP User's Manual.	-
✓	Separate volume	FX3U-32DP User's Manual	JY997D25201	Details on FX3U-32DP PROFIBUS-DP Interface block.	09R633
✓	Supplied with product	FX2N-32ASI-M User's Manual	JY992D76901	Details on the AS-i system master special function block.	-
✓	Supplied with product	FX2N-16LNK-M User's Manual	JY992D73701	Details on the MELSEC I/O LINK master special function block.	09R709
Manuals for analog/temperature control					
■ Common					
✓	Separate volume	FX3S/FX3G/FX3GC/ FX3U/FX3UC Series User's Manual - Analog Control Edition	JY997D16701	Details on analog special function blocks (FX3U-4AD, FX3U-4DA, FX3UC-4AD) and analog special adapters (FX3U-***-***-ADP).	09R619
■ Analog input, temperature input and temperature control					
When using each product, refer also to the User's Manual - Hardware Edition for the PLC main unit to be installed.					
✓	Supplied with product	FX2N-2AD User's Guide	JY992D74701	Details on handling the 2-ch analog input special function block.	-
△	Supplied with product	FX3U-4AD Installation Manual	JY997D20701	Details on handling the 4-ch analog input special function block. When using, refer also to the FX3S/FX3G/FX3GC/FX3U/FX3UC Series User's Manual - Analog Control Edition.	-
△	Supplied with product	FX3U-4AD-ADP User's Manual	JY997D13901	Details on handling the 4-ch analog input special adapter. When using, refer also to the FX3S/FX3G/FX3GC/FX3U/FX3UC Series User's Manual - Analog Control Edition.	-
△	Supplied with product	FX3UC-4AD Installation Manual	JY997D14901	Details on handling the 4-ch analog input special function block. When using, refer also to the FX3S/FX3G/FX3GC/FX3U/FX3UC Series User's Manual - Analog Control Edition.	-
✓	Supplied with product	FX2N-4AD User's Guide	JY992D65201	Details on handling the 4-ch analog input special function block.	-
✓	Supplied with product	FX2NC-4AD User's Manual	JY997D07801	Details on handling the 4-ch analog input special function block.	-
✓	Supplied with product	FX2N-8AD User's Manual	JY992D86001	Details on handling the 8-ch analog input special function block (also used for thermocouple input).	09R608
△	Supplied with product	FX3U-4AD-PT-ADP User's Manual	JY997D14701	Details on handling the 4-ch Pt100 temperature sensor input special adapter. When using, refer also to the FX3S/FX3G/FX3GC/FX3U/FX3UC Series User's Manual - Analog Control Edition.	-
△	Supplied with product	FX3U-4AD-PTW-ADP User's Manual	JY997D29101	Details on handling the 4-ch Pt100 temperature sensor input special adapter. When using, refer also to the FX3S/FX3G/FX3GC/FX3U/FX3UC Series User's Manual - Analog Control Edition.	-

		Manual Name	Manual Number	Contents	Model Code
△	Supplied with product	FX3U-4AD-PNK-ADP User's Manual	JY997D29201	Details on handling the 4-ch Pt1000/Ni1000 temperature sensor input special adapter. When using, refer also to the FX3S/FX3G/FX3GC/FX3U/FX3UC Series User's Manual - Analog Control Edition.	-
✓	Supplied with product	FX2N-4AD-PT User's Guide	JY992D65601	Details on handling the 4-ch Pt100 temperature sensor input special function block.	-
△	Supplied with product	FX3U-4AD-TC-ADP User's Manual	JY997D14801	Details on handling the 4-ch thermocouple input special adapter. When using, refer also to the FX3S/FX3G/FX3GC/FX3U/FX3UC Series User's Manual - Analog Control Edition.	-
✓	Supplied with product	FX2N-4AD-TC User's Guide	JY992D65501	Details on handling the 4-ch thermocouple input special function block.	-
△	Supplied with product	FX3U-4LC Installation Manual	JY997D38901	Details on handling the 4-ch temperature control special function block. When using, refer also to the FX3U-4LC User's Manual.	-
✓	Additional Manual	FX3U-4LC User's Manual	JY997D39101	Detail on the 4-ch temperature control special function block.	09R625
△	Supplied with product	FX2N-2LC User's Guide	JY992D85601	Details on handling the 2-ch temperature control special function block. When using, refer also to the FX2N-2LC User's Manual.	-
✓	Separate volume	FX2N-2LC User's Manual	JY992D85801	Details on the 2-ch temperature control special function block.	09R607

■Analog output

When using each product, refer also to the User's Manual - Hardware Edition for the PLC main unit to be installed.

✓	Supplied with product	FX2N-2DA User's Guide	JY992D74901	Details on handling the 2-ch analog output special function block.	-
△	Supplied with product	FX3U-4DA Installation Manual	JY997D20801	Details on handling the 4-ch analog output special function block. When using, refer also to the FX3S/FX3G/FX3GC/FX3U/FX3UC Series User's Manual - Analog Control Edition.	-
△	Supplied with product	FX3U-4DA-ADP User's Manual	JY997D14001	Details on handling the 4-ch analog output special adapter. When using, refer also to the FX3S/FX3G/FX3GC/FX3U/FX3UC Series User's Manual - Analog Control Edition.	-
✓	Supplied with product	FX2N-4DA User's Guide	JY992D65901	Details on handling the 4-ch analog output special function block.	-
✓	Supplied with product	FX2NC-4DA User's Manual	JY997D07601	Details on handling the 4-ch analog output special function block.	-

■Analog input/output (mixed)

When using each product, refer also to the User's Manual - Hardware Edition for the PLC main unit to be installed.

✓	Supplied with product	FX0N-3A User's Guide	JY992D49001	Details on handling the 2-ch analog input and 1-ch analog output special function block.	-
✓	Supplied with product	FX2N-5A User's Manual	JY997D11401	Details on handling the 4-ch analog input and 1-ch analog output special function block.	09R616

		Manual Name	Manual Number	Contents	Model Code
△	Supplied with product	FX3U-3A-ADP User's Manual	JY997D35601	Details on handling the 2-ch analog input and 1-ch analog output special adapter. When using, refer also to FX3S/FX3G/FX3GC/FX3U/FX3UC Series User's Manual - Analog Control Edition.	-
Manuals for high-speed counter					
■ High-speed counter					
When using each product, refer also to the User's Manual - Hardware Edition for the PLC main unit to be installed.					
✓	Supplied with product	FX3U-2HC User's Manual	JY997D36701	Details on handling the 2-ch high-speed counter special function block.	-
✓	Supplied with product	FX2N-1HC User's Guide	JY992D65401	Details on handling the 1-ch high-speed counter special function block.	-
✓	Supplied with product	FX2NC-1HC User's Manual	JY997D30701	Details on handling the 1-ch high-speed counter special function block.	-
Manuals for positioning control					
■ Common					
✓	Separate volume	FX3S/FX3G/FX3GC/FX3U/FX3UC Series User's Manual - Positioning Control Edition	JY997D16801	Details on the positioning functions of FX3S/FX3G/FX3GC/FX3U/FX3UC Series.	09R620
■ Pulse output and positioning					
When using each product, refer also to the User's Manual - Hardware Edition for the PLC main unit to be installed.					
△	Supplied with product	FX3U-1PG Installation Manual	JY997D47101	Details on handling the 1-axis pulse output block. When using, refer also to the FX3U-1PG User's Manual.	-
✓	Separate volume	FX3U-1PG User's Manual	JY997D47301	Details on handling the 1-axis pulse output block.	09R629
△	Supplied with product	FX2N-1PG Installation Manual	JY997D50601	Details on handling the 1-axis pulse output block. When using, refer also to the FX2N/FX-1PG User's Manual.	-
✓	Separate volume	FX2N/FX-1PG User's Manual	JY992D65301	Details on handling the 1-axis pulse output block.	09R610
△	Supplied with product	FX2N-10PG Installation Manual	JY992D91901	Details on handling the 1-axis pulse output block. When using, refer also to the FX2N-10PG User's Manual.	-
✓	Separate volume	FX2N-10PG User's Manual	JY992D93401	Details on handling the 1-axis pulse output block.	09R611
△	Supplied with product	FX2N-10GM User's Guide	JY992D77701	Details on handling the 1-axis positioning special function unit. When using, refer also to the FX2N-10GM/FX2N-20GM Handy Manual.	-
△	Supplied with product	FX2N-20GM User's Guide	JY992D77601	Details on handling the 2-axis positioning special function unit. When using, refer also to the FX2N-10GM/FX2N-20GM Handy Manual.	-
✓	Separate volume	FX2N-10GM/FX2N-20GM Hardware/Programming Manual	JY992D77801	Details on handling the 1-axis/2-axis positioning special function units.	09R612

	Manual Name	Manual Number	Contents	Model Code	
■ Programmable cam switch					
When using each product, refer also to the User's Manual - Hardware Edition for the PLC main unit to be installed.					
✓	Supplied with product	FX2N-1RM-E-SET User's Manual	JY992D71101	Details on handling the programmable cam switch special function unit.	09R614
Manuals for FX3U-20SSC-H Positioning Block					
△	Supplied with product	FX3U-20SSC-H Installation Manual	JY997D21101	Details on handling the 2-axis positioning special function block. When using, refer also to the FX3U-20SSCH User's Manual.	-
✓	Separate volume	FX3U-20SSC-H User's Manual	JY997D21301	Details on the FX3U-20SSC-H positioning block.	09R622
✓	Supplied with product	FX Configurator-FP Operation Manual	JY997D21801	Operation details of the FX Configurator-FP configuration software.	09R916
Manuals for FX3U-CF-ADP					
△	Supplied with product	FX3U-CF-ADP Installation Manual	JY997D35201	Details on handling the CF card special adapter. When using, refer also to the FX3U-CF-ADP User's Manual.	-
✓	Separate volume	FX3U-CF-ADP User's Manual	JY997D35401	Details on the FX3U-CF-ADP special adapter.	09R720
Manuals for FX-30P					
△	Supplied with product	FX-30P Installation Manual	JY997D34201	Details on handling the FX-30P Handy Programming Panel. When using, refer also to the FX-30P Operation manual.	-
✓	Separate volume	FX-30P Operation Manual	JY997D34401	Details on the FX-30P Handy Programming Panel.	09R924
Other manuals					
When using each product, refer also to the User's Manual - Hardware Edition for the PLC main unit to be installed.					
■ Extension power supply unit					
△	Supplied with product	FX3UC-1PS-5V Installation Manual	JY997D12201	Details on handling the FX3UC-1PS-5V extension power supply unit. When using, refer also to the FX3UC Series User's Manual - Hardware Edition.	-
■ Connector conversion					
△	Supplied with product	FX3U-CNV-BD Installation Manual	JY997D13601	Details on handling the interface expansion board for connecting communication and analog special adapters.	-
■ Battery (maintenance option)					
△	Supplied with product	FX3U-32BL Battery	JY997D14101	Details on battery life and handling procedures. When using, refer also to the FX3UC Series User's Manual - Hardware Edition.	-
■ Display module					
△	Supplied with product	FX3U-7DM User's Manual	JY997D17101	Details on mounting and handling the display module.	-
■ Display module holder					
△	Supplied with product	FX3U-7DM-HLD User's Manual	JY997D15401	Details on mounting and handling the display module holder.	-
■ Memory cassette					
△	Supplied with product	FX3U-FLROM-16/64/64L/1M Hardware Manual	JY997D12801	Details on the memory cassette specifications and operating procedures.	-

		Manual Name	Manual Number	Contents	Model Code
■Variable analog potentiometers					
△	Supplied with product	FX3U-8AV-BD User's Manual	JY997D40901	Handling procedures of the 8-ch variable analog potentiometers expansion board. When using, refer to the FX3S/FX3G/FX3GC/FX3U/FX3UC Series Programming Manual - Basic and Applied Instruction Edition.	-

Generic Names and Abbreviations Used in Manuals

Generic Name and Abbreviation	Description
PLCs	
FX3U Series	Generic name for FX3U Series PLCs
FX3UC Series	Generic name for FX3UC Series PLCs
FX2N Series	Generic name for FX2N Series PLCs
FX2NC Series	Generic name for FX2NC Series PLCs
Main unit	Abbreviation of FX3UC Series PLCs
Expansion boards	Generic name for the following models FX3U-USB-BD, FX3U-232-BD, FX3U-422-BD, FX3U-485-BD, FX3U-8AV-BD, FX3U-CNV-BD
Input/Output extension block	Generic name for FX0N Input/Output extension block, FX2N Input/Output extension block, FX2NC Input/Output extension block
FX0N Series input/output extension blocks	Generic name for the following models FX0N-8ER, FX0N-8EX, FX0N-8EX-UA1/UL, FX0N-8EYR, FX0N-8EYT, FX0N-8EYT-H, FX0N-16EX, FX0N-16EYR, FX0N-16EYT
FX2N Series input/output extension blocks	Generic name for the following models FX2N-8ER, FX2N-8EX, FX2N-8EX-UA1/UL, FX2N-8EYR, FX2N-8EYT, FX2N-8EYT-H, FX2N-16EX, FX2N-16EX-C, FX2N-16EXL-C, FX2N-16EYR, FX2N-16EYT, FX2N-16EYS, FX2N-16EYT-C, FX2N-8ER-ES/UL, FX2N-8EX-ES/UL, FX2N-8EYR-ES/UL, FX2N-8EYR-S-ES/UL, FX2N-8EYT-ESS/UL, FX2N-16EX-ES/UL, FX2N-16EYR-ES/UL, FX2N-16EYT-ESS/UL
FX2NC Series input/output extension blocks	Generic name for the following models FX2NC-16EX-T, FX2NC-16EX, FX2NC-32EX, FX2NC-16EYR, FX2NC-16EYR-T, FX2NC-16EYT, FX2NC-32EYT, FX2NC-16EX-T-DS, FX2NC-16EX-DS, FX2NC-32EX-DS, FX2NC-16EYR-T-DS, FX2NC-16EYT-DSS, FX2NC-32EYT-DSS,
Special adapters	Generic name for the following models FX3U-232ADP(-MB), FX3U-485ADP(-MB), FX3U-ENET-ADP, FX3U-CF-ADP, FX3U-4AD-ADP, FX3U-4DA-ADP, FX3U-3A-ADP, FX3U-4AD-PT-ADP, FX3U-4AD-PTW-ADP, FX3U-4AD-PNK-ADP, FX3U-4AD-TC-ADP
Special function units/blocks	Generic name for FX2N Special function unit, FX0N Special function block, FX2N Special function block, FX2NC Special function block, FX3UC Special function block, FX3U Special function block
FX0N Series special function blocks	Generic name for the following models FX0N-3A
FX2N Series special function blocks	Generic name for the following models FX2N-232IF, FX2N-16CCL-M, FX2N-32CCL, FX2N-64CL-M, FX2N-16LNK-M, FX2N-32ASI-M, FX2N-2AD, FX2N-4AD, FX2N-8AD, FX2N-4AD-PT, FX2N-4AD-TC, FX2N-2LC, FX2N-2DA, FX2N-4DA, FX2N-5A, FX2N-1HC, FX2N-1PG(-E), FX2N-10PG
FX3U Series special function blocks	Generic name for the following models FX3U-16CCL-M, FX3U-64CCL, FX3U-128ASL-M, FX3U-64DP-M, FX3U-32DP, FX3U-4AD, FX3U-4LC, FX3U-4DA, FX3U-2HC, FX3U-1PG, FX3U-20SSC-H
FX2NC Series special function blocks	Generic name for the following models FX2NC-4AD, FX2NC-4DA, FX2NC-1HC
FX3UC Series special function blocks	Generic name for the following models FX3UC-4AD
FX2N Series special function units	Generic name for the following models FX2N-10GM, FX2N-20GM, FX2N-1RM(-E)-SET
Extension power supply unit	Abbreviation of model FX3UC-1PS-5V Extension power supply unit
Display module	Generic name for the following models FX3U-7DM
Memory cassettes	Generic name for the following models FX3U-FLROM-16, FX3U-FLROM-64, FX3U-FLROM-64L, FX3U-FLROM-1M

Generic Name and Abbreviation	Description
Battery	Abbreviation of model FX3U-32BL battery
FX Series terminal blocks	Generic name for the following models FX-16E-TB, FX-32E-TB, FX-16EX-A1-TB, FX-16EYR-TB, FX-16EYT-TB, FX-16EYT-H-TB, FX-16EYS-TB, FX-16E-TB/UL, FX-32E-TB/UL, FX-16EYR-ES-TB/UL, FX-16EYT-ES-TB/UL, FX-16EYT-ESS-TB/UL, FX-16EYS-ES-TB/UL
Extension cables	Generic name for the following models FX0N-30EC, FX0N-65EC
Input/output cables	Generic name for the following models FX-16E-500CAB-S, FX-16E-□□□CAB, FX-16E-□□□CAB-R, FX-A32E-□□□CAB 150, 300 or 500 is entered in □□□.
Connectors for input/output	Generic name for the following models FX2C-I/O-CON, FX2C-I/O-CON-S, FX2C-I/O-CON-SA
Power cable	Generic name for the following models FX2NC-100MPCB, FX2NC-100BPCB, FX2NC-10BPCB1
Built-in type CC-Link/LT master	Abbreviation of FX3UC-32MT-LT(-2) built-in master
(Additional) CC-Link/LT master	Abbreviation of FX2N-64CL-M master block
CC-Link master	Generic name for the following models FX3U-16CCL-M, FX2N-16CCL-M
Intelligent device stations	Abbreviation of FX3U-64CCL interface block
Remote I/O stations	Remote stations that handle information in bit units only
Remote device stations	Abbreviation of FX2N-32CCL interface block
Remote stations	Generic name for remote I/O stations and remote device stations
RD station	Generic name for remote device stations
Power supply adapter	Unit to be connected to supply power to the CC-Link/LT system
Dedicated power supply	Power supply to be connected to supply power to the CC-Link/LT system
AnyWireASLINK master	Abbreviation of model FX3U-128ASL-M AnyWireASLINK master block
AS-i master	Abbreviation of model FX2N-32ASI-M AS-i system master block
Peripheral devices	Generic name for programming software, handy programming panel (HPP) and indicator
Programming software	Generic name for the following models GX Works2, GX Developer, FX-PCS/WIN(-E)
GX Works2	Abbreviation of programming software packages SW□DNC-GXW2-J and SW□DNC-GXW2-E
GX Developer	Abbreviation of programming software packages SW□D5C-GPPW-J and SW□D5C-GPPW-E
FX-PCS/WIN(-E)	Abbreviation of programming software packages FX-PCS/WIN and FX-PCS/WIN-E
Handy programming panels	Generic name for the following models FX-30P, FX-20P(-E)-SET0, FX-20P(-E), FX-10P-SET0, FX-10P(-E)
Indicators	
GOT1000 Series	Generic name for GT16, GT15, GT14, GT11 and GT10
GOT-F900 Series	Generic name for F940WGOT, F940GOT, F930GOT, F920GOT, F940 Handy GOT, F920 Handy GOT, ET-940
F940WGOT	Abbreviation of F940WGOT-TWD
F940GOT	Generic name for F940GOT-SWD, F940GOT-LWD, F943GOT-SWD, F943GOT-LWD
F930GOT	Generic name for F930GOT-BWD, F933GOT-BWD, F930GOT-BBD-K
F920GOT	Generic name for F920GOT-BBD-K, F920GOT-BBD5-K
F940 Handy GOT	Generic name for F940GOT-SBD-H, F940GOT-LBD-H, F943GOT-SBD-H, F943GOT-LBD-H, F940GOT-SBD-RH, F940GOT-LBD-RH, F943GOT-SBD-RH, F943GOT-LBD-RH
F920 Handy GOT	Abbreviation of F920GOT-BBD-RH
ET-940	Generic name for ET-940BH, ET-940BH-L, ET-940PH, ET-940PH-L

Generic Name and Abbreviation	Description
Manuals	
Programming manual	Abbreviation of FX3S/FX3G/FX3GC/FX3U/FX3UC Series Programming Manual - Basic & Applied Instruction Edition
Data Communication Edition	Abbreviation of FX Series User's Manual - Data Communication Edition
MODBUS Serial Communication Edition	Abbreviation of FX3S/FX3G/FX3GC/FX3U/FX3UC Series User's Manual - MODBUS Serial Communication Edition
Analog Control Edition	Abbreviation of FX3S/FX3G/FX3GC/FX3U/FX3UC Series User's Manual - Analog Control Edition
Positioning Control Edition	Abbreviation of FX3S/FX3G/FX3GC/FX3U/FX3UC Series User's Manual - Positioning Control Edition

1. Outline

1.1 Major Features

1. Basic functions

[Up to 384 input/output points]

384 points in total include input/output points in the PLC (adjacent direct wiring) and remote input/output points in the network. Applicable networks are the CC-Link, AnyWireASLINK and AS-i systems.

(Up to 256 points in the FX3UC-32MT-LT earlier than Ver. 2.20)

→ Refer to Section 1.7.

[Powered extension units/blocks that can be connected]

FX2N/FX2NC Series input/output extension blocks can be connected.

Up to 8 FX0N/FX2N/FX3U/FX2NC/FX3UC Series special function units/blocks can be connected.

[Program memory]

The PLC has a 64K-step RAM memory.

Use of the memory cassette enables the program memory to be used as flash memory.

[Operation instructions]

Various instructions, such as floating-point and character string processing instructions and scaling instructions, are provided.

[Built-in RUN/STOP switch]

The PLC can be started and stopped with the built-in switch.

RUN and STOP commands can be given to the PLC through a general-purpose input terminal or peripheral device.

[Writing during RUN]

The programming software for personal computer enables you to modify the program while the PLC is running.

[Built-in clock function]

The PLC has a clock function to control the time.

[Programming tool]

Use a version of a programming tool supporting the FX3UC.

*For peripheral devices not applicable to the FX3U/FX3UC Series, specify FX2N Series or FX2(FX) Series for the model selection, and you can program the sequence. In this case, use instructions and devices within the ranges common to FX3UC Series and the selected model of PLC (FX2N or FX2(FX) Series).

[Remote debugging of program]

Programming software (GX Works2, GX Developer) enables you to remotely transfer programs and monitor PLC operation through a modem connected to the RS-232C expansion board or RS-232C communication special adapter.

2. Display module

(Only FX3UC-32MT-LT(-2))

[Monitor/test function]

Devices can be monitored and tested by operating the buttons on the display module.

The button operations can be disabled by the user program.

[Message display function]

User messages can be displayed on the display module by the user program.

[Other functions]

On the display module, you can set the time, adjust the contrast and display the PLC version and error codes.

3. Input/output high-speed processing functions of main unit

[High-speed counter function]

→ Refer to "Chapter 5 Input Specifications and External Wiring", "Chapter 7 Examples of Wiring for Various Uses" in this manual and the Programming Manual.

- 1-phase 100 kHz x 6 points + 10 kHz x 2 points
- 2-phase 50 kHz x 2 points

[Pulse catch function]

Signals with short ON width or OFF width can be captured without a complicated program.

→ Refer to "Chapter 5 Input Specifications and External Wiring", "Chapter 7 Examples of Wiring for Various Uses" in this manual and the Programming Manual.

Input terminal	Signal ON/OFF width
X000 to X005	5μs
X006, X007	50μs

[Input interruption function (with delay function)]

Interruption routines can be processed preferentially by external signals with a minimum ON or OFF width of 5 μs (X000 to X005). (Timer interruption and high-speed counter interruption functions are also provided.)

→ Refer to "Chapter 5 Input Specifications and External Wiring", "Chapter 7 Examples of Wiring for Various Uses" in this manual and the Programming Manual.

[Pulse output function]

When output terminals in the transistor output type main unit are used, pulses of up to 100 kHz can be output simultaneously to three axes (Y000, Y001, and Y002).

Programs can be easily created using various instructions.

→ Refer to Chapter 6 "Output Specifications and External Wiring" in this manual and the Positioning Control Edition.

[Various positioning instructions]

→ Refer to the Positioning Control Edition or the Programming Manual.

Instruction	Description
DSZR	Mechanical zero return instruction with DOG search function
ABS	Instruction to read the current value from a servo amplifier with absolute position (ABS) detecting function
DRVI	Positioning (relative positioning) to specify the movement from the current position
DRVA	Positioning (absolute positioning) to specify the target position based on an absolute value 0
PLSV	Instruction to change the pulse train output frequency
DVIT	Positioning for fixed-feed interruption drive
TBL	Instruction for positioning based on batch setting of positioning operation, moving distance and speed

4. Communication and network functions

An expansion board, special adapter or special function block for each communication function can be connected.

[Kinds of communication functions]

- Programming communication (RS-232C/RS-422/USB)
- N:N Network
- Parallel link
- Computer link

- Inverter communication
- Non-protocol communication (RS-232C/RS-485)
→ Refer to the Data Communication Edition.
- MODBUS communication (Supported in Ver. 2.40 or later)
→ Refer to MODBUS Serial Communication Edition.
- Ethernet (Supported in Ver. 3.10 or later)
→ Refer to FX3U-ENET-ADP User's Manual.
- CC-Link
 - Master station (Compatible with CC-Link Ver. 2.00 and Ver. 1.10): FX3U-16CCCL-M
 - Master station (Compatible with CC-Link Ver. 1.10): FX2N-16CCCL-M
 - Intelligent device station: FX3U-64CCCL
 - Remote device station: FX2N-32CCCL
→ Refer to the manual for each product.
- CC-Link/LT
 - CC-Link/LT Built-in Master (Only FX3UC-32MT-LT(-2))
→ Refer to Chapter 9 in this manual.
 - CC-Link/LT Additional Master (FX2N-64CL-M)
→ Refer to the manual for each product.
- AnyWireASLINK
 - Master station: FX3U-128ASL-M*1
 - Slave station
→ Refer to the manual for each product.

*1. Note that the warranty, etc. on this product differs from that on other programmable controller products. For details, refer to FX3U-128ASL-M User's Manual.
- PROFIBUS-DP
 - Master station: FX3U-64DP-M*2
 - Slave station: FX3U-32DP*2
→ Refer to the manual for each product.

*2. Cannot be connected to the FX3UC-32MT-LT(-2).
- AS-i system
 - Master station: FX2N-32ASI-M
 - Slave station
→ Refer to the manual for each product.

1	Outline
2	External Dimensions
3	Generic Specifications
4	Power Supply Specifications
5	Input Specifications
6	Output Specifications
7	Examples of Wiring for Various Uses
8	Terminal Block
9	CC-Link/LT Master FX3UC-LT(-2) only
10	Display module FX3UC-LT(-2) only

5. Analog functions

The special adapter and special function block for each analog function are connected.

→ **For information not provided in the Analog Control Edition, refer to the manual of each product.**

[Types of analog functions]

- Voltage/current input
- Voltage/current output
- Temperature sensor input (thermocouple and platinum resistance thermometer sensor)
- Temperature control

1.2 Part names

1.2.1 FX3UC-□□MT/D(SS)

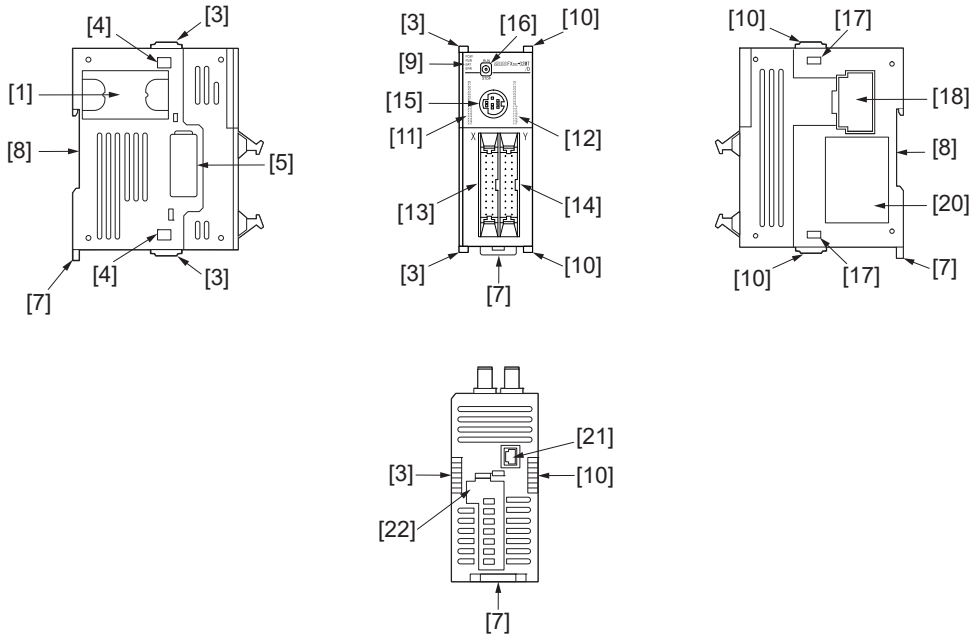

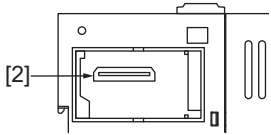
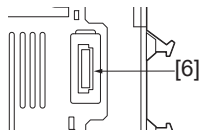
No.	Description
[1]	Memory cassette dummy cover When Memory cassette or Memory cassette dummy cover is removed 
[2]	Memory cassette connector
[3]	Special adapter connecting hooks
[4]	Special adapter connecting holes
[5]	Special adapter connector cover When special adapter connector cover is removed 
[6]	Special adapter connector
[7]	DIN rail mounting hooks
[8]	DIN rail mounting groove [DIN rail: DIN46277(35mm(1.38")wide)]

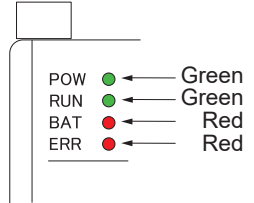
No.	Description
[9]	Display LEDs 
	POW LED On while the PLC power is ON.
	RUN LED On while the PLC is RUN.
	BAT LED Turns ON when the battery voltage drops.
	ERR LED Flashing when a program error occurs. Turns ON when a CPU error occurs.
[10]	FX3UC/FX2NC Extension block connecting hooks
[11]	Input LED
[12]	Output LED
[13]	Input connector
[14]	Output connector
[15]	Peripheral device connector (RS-422)
[16]	RUN/STOP switch
[17]	FX3UC/FX2NC Extension block connecting holes

1

Outline

2

External
Dimensions

3

Generic
Specifications

4

Power Supply
Specifications

5

Input
Specifications

6

Output
Specifications

7

Examples of
Wiring for
Various Uses

8

Terminal Block

9

CC-Link/LT
Master FX3UC-
LT(-2) only

10

Display module
FX3UC-LT(-2)
only

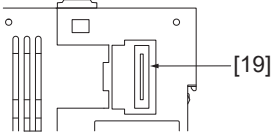
No.	Description	No.	Description
[18]	FX3UC/FX2NC Extension block connecting connector cover	[19]	FX3UC/FX2NC Extension block connector
	Extension block connector cover	[20]	Nameplate ^{*1}
		[21]	Power connector for main unit
		[22]	Battery cover

*1. ⚠ is a mark that instructs to use the cable with an appropriate temperature rating (80°C or more) for wiring.

1.2.2 FX3UC-16MR/D(S)-T

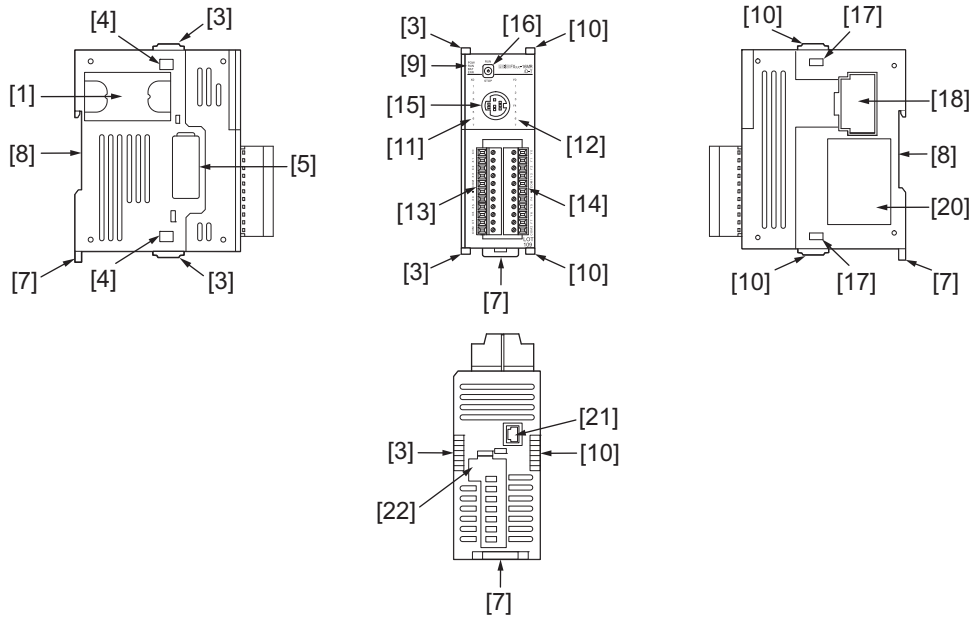

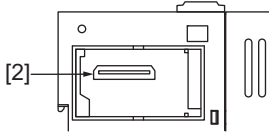
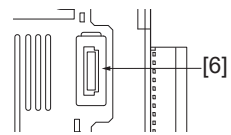
No.	Description
[1]	Memory cassette dummy cover When Memory cassette or Memory cassette dummy cover is removed 
[2]	Memory cassette connector
[3]	Special adapter connecting hooks
[4]	Special adapter connecting holes
[5]	Special adapter connector cover When special adapter connector cover is removed 
[6]	Special adapter connector
[7]	DIN rail mounting hooks
[8]	DIN rail mounting groove [DIN rail: DIN46277(35mm(1.38")wide)]

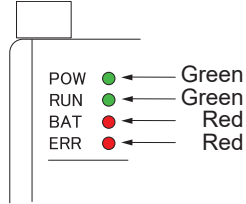
No.	Description
[9]	Display LEDs 
	POW LED On while the PLC power is ON.
	RUN LED On while the PLC is RUN.
	BAT LED Turns ON when the battery voltage drops.
	ERR LED Flashing when a program error occurs. Turns ON when a CPU error occurs.
[10]	FX3UC/FX2NC Extension block connecting hooks
[11]	Input LED
[12]	Output LED
[13]	Input terminal block
[14]	Output terminal block
[15]	Peripheral device connector (RS-422)
[16]	RUN/STOP switch
[17]	FX3UC/FX2NC Extension block connecting holes

1	Outline
2	External Dimensions
3	Generic Specifications
4	Power Supply Specifications
5	Input Specifications
6	Output Specifications
7	Examples of Wiring for Various Uses
8	Terminal Block
9	CC-Link/LT Master FX3UC-LT(-2) only
10	Display module FX3UC-LT(-2) only

No.	Description	No.	Description
[18]	FX3UC/FX2NC Extension block connecting connector cover	[19]	FX3UC/FX2NC Extension block connector
	Extension block connector cover	[20]	Nameplate*1
		[21]	Power connector for main unit
		[22]	Battery cover

*1. ⚠ is a mark that instructs to use the cable with an appropriate temperature rating (80°C or more) for wiring.

1.2.3 FX3UC-32MT-LT-2

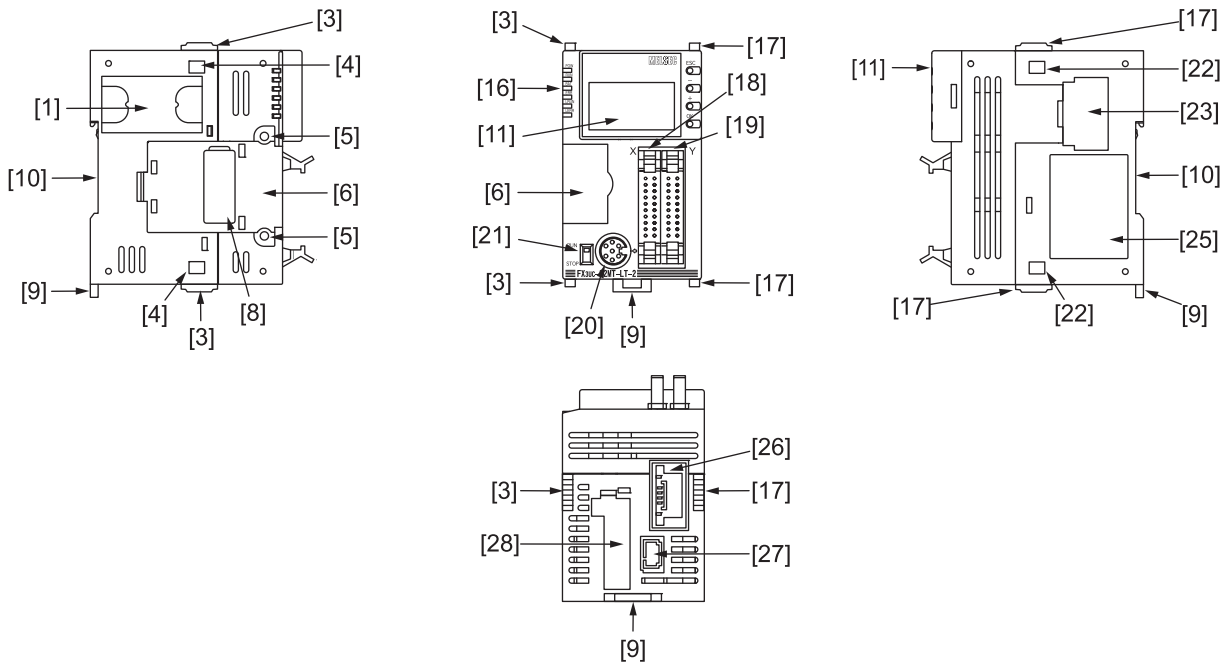

No.	Description
[1]	Memory cassette dummy cover When Memory cassette or Memory cassette dummy cover is removed
[2]	Memory cassette connector
[3]	Special adapter connecting hooks
[4]	Special adapter connecting holes
[5]	Expansion board fixing holes
[6]	Expansion board dummy cover When expansion board or expansion board dummy cover is removed
[7]	Expansion board connector
[8]	Special adapter connector cover Connectors are not provided when expansion board is not used.
[9]	DIN rail mounting hooks
[10]	DIN rail mounting groove [DIN rail: DIN46277(35mm(1.38")wide)]
[11]	Display Module When display module is removed

No.	Description												
[12]	"ESC" button												
[13]	"-" button												
[14]	"+" button												
[15]	"OK" button												
[16]	Display LEDs <table border="1"> <tr> <td>POW LED</td> <td>On while the PLC power is ON.</td> </tr> <tr> <td>RUN LED</td> <td>On while the PLC is RUN.</td> </tr> <tr> <td>BAT LED</td> <td>Turns ON when the battery voltage drops.</td> </tr> <tr> <td>ERR LED</td> <td>Flashing when a program error occurs. Turns ON when a CPU error occurs.</td> </tr> <tr> <td>L RUN LED</td> <td>On while data link is being executed (Built-in CC-Link/LT master)</td> </tr> <tr> <td>L ERR LED</td> <td>On during data link error (Built-in CC-Link/LT master)</td> </tr> </table>	POW LED	On while the PLC power is ON.	RUN LED	On while the PLC is RUN.	BAT LED	Turns ON when the battery voltage drops.	ERR LED	Flashing when a program error occurs. Turns ON when a CPU error occurs.	L RUN LED	On while data link is being executed (Built-in CC-Link/LT master)	L ERR LED	On during data link error (Built-in CC-Link/LT master)
POW LED	On while the PLC power is ON.												
RUN LED	On while the PLC is RUN.												
BAT LED	Turns ON when the battery voltage drops.												
ERR LED	Flashing when a program error occurs. Turns ON when a CPU error occurs.												
L RUN LED	On while data link is being executed (Built-in CC-Link/LT master)												
L ERR LED	On during data link error (Built-in CC-Link/LT master)												
[17]	FX3UC/FX2NC Extension block connecting hooks												
[18]	Input connector												
[19]	Output connector												
[20]	Peripheral device connector (RS-422)												
[21]	RUN/STOP switch												
[22]	FX3UC/FX2NC Extension block connecting holes												
[23]	FX3UC/FX2NC Extension block connector cover When Extension block connector cover is removed 												
[24]	FX3UC/FX2NC Extension block connector												
[25]	Nameplate*1												
[26]	CC-Link/LT interface connector												
[27]	Power connector for main unit												
[28]	Battery cover, FX3U-32BL battery (Supplied)												

*1. is a mark that instructs to use the cable with an appropriate temperature rating (80°C or more) for wiring.

1	Outline
2	External Dimensions
3	Generic Specifications
4	Power Supply Specifications
5	Input Specifications
6	Output Specifications
7	Examples of Wiring for Various Uses
8	Terminal Block
9	CC-Link/LT Master FX3UC-LT(-Z) only
10	Display module FX3UC-LT(-Z) only

1.2.4 FX3UC-32MT-LT

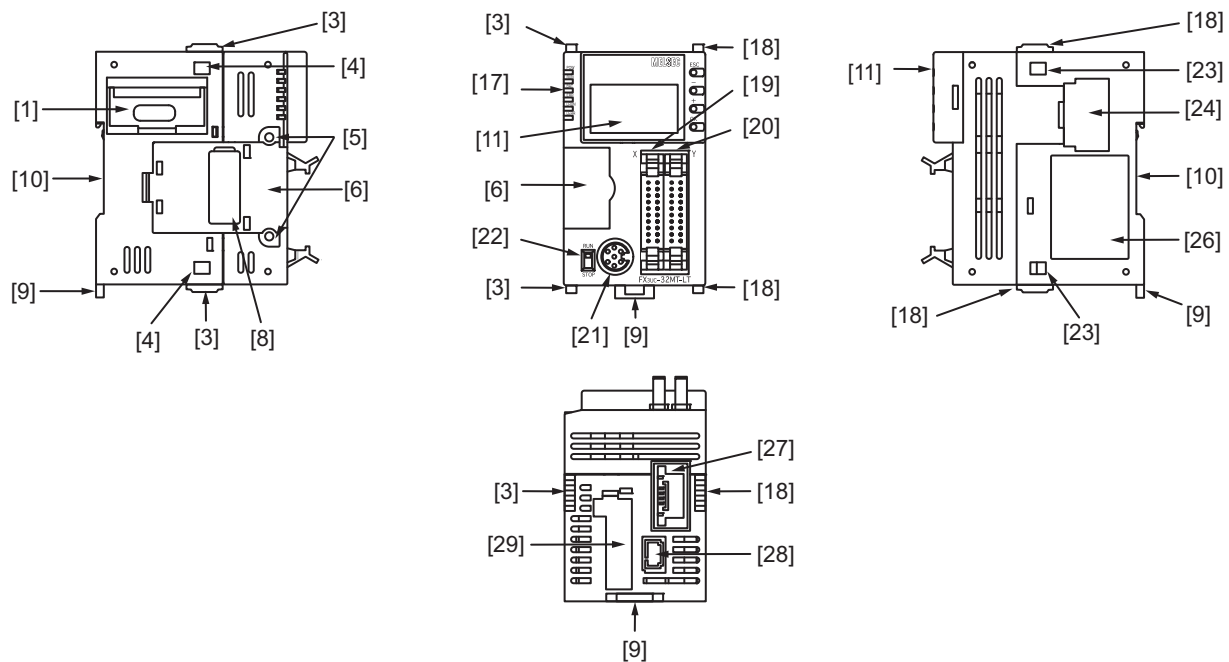

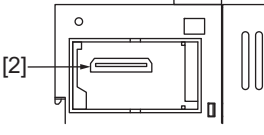
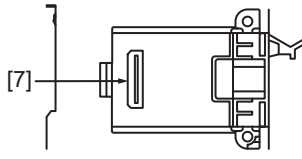
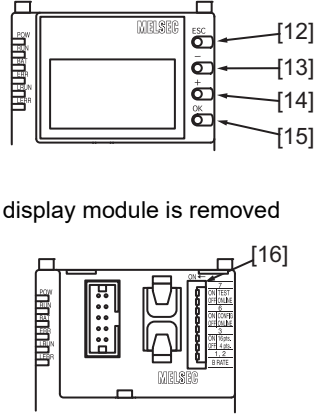
No.	Description
[1]	Memory cassette dummy cover When Memory cassette or Memory cassette dummy cover is removed 
[2]	Memory cassette connector
[3]	Special adapter connecting hooks
[4]	Special adapter connecting holes
[5]	Expansion board fixing holes
[6]	Expansion board dummy cover When expansion board or expansion board dummy cover is removed 
[7]	Expansion board connector
[8]	Special adapter connector cover Connectors are not provided when expansion board is not used.
[9]	DIN rail mounting hooks
[10]	DIN rail mounting groove [DIN rail: DIN46277(35mm(1.38"wide))]
[11]	Display Module When display module is removed 

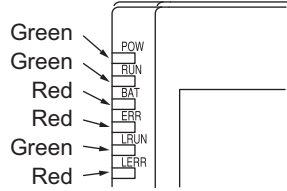
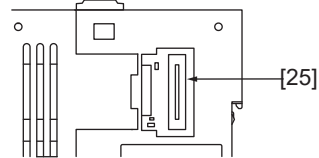
No.	Description												
[12]	"ESC" button												
[13]	"-" button												
[14]	"+" button												
[15]	"OK" button												
[16]	DIP switches for setting CC-Link/LT master function Display LEDs 												
[17]	<table border="1"> <tr> <td>POW LED</td> <td>On while to the PLC power is ON.</td> </tr> <tr> <td>RUN LED</td> <td>On while the PLC is RUN.</td> </tr> <tr> <td>BAT LED</td> <td>Turns ON when the battery voltage drops.</td> </tr> <tr> <td>ERR LED</td> <td>Flashing when a program error occurs. Turns ON when a CPU error occurs.</td> </tr> <tr> <td>L RUN LED</td> <td>On while data link is being executed (Built-in CC-Link/LT master)</td> </tr> <tr> <td>L ERR LED</td> <td>On during data link error (Built-in CC-Link/LT master)</td> </tr> </table>	POW LED	On while to the PLC power is ON.	RUN LED	On while the PLC is RUN.	BAT LED	Turns ON when the battery voltage drops.	ERR LED	Flashing when a program error occurs. Turns ON when a CPU error occurs.	L RUN LED	On while data link is being executed (Built-in CC-Link/LT master)	L ERR LED	On during data link error (Built-in CC-Link/LT master)
POW LED	On while to the PLC power is ON.												
RUN LED	On while the PLC is RUN.												
BAT LED	Turns ON when the battery voltage drops.												
ERR LED	Flashing when a program error occurs. Turns ON when a CPU error occurs.												
L RUN LED	On while data link is being executed (Built-in CC-Link/LT master)												
L ERR LED	On during data link error (Built-in CC-Link/LT master)												
[18]	FX3UC/FX2NC Extension block connecting hooks												
[19]	Input connector												
[20]	Output connector												
[21]	Peripheral device connector (RS-422)												
[22]	RUN/STOP switch												
[23]	FX3UC/FX2NC Extension block connecting holes												
[24]	FX3UC/FX2NC Extension block connector cover When Extension block connector cover is removed 												
[25]	FX3UC/FX2NC Extension block connector												
[26]	Nameplate *1												
[27]	CC-Link/LT interface connector												
[28]	Power connector for main unit												
[29]	Battery cover												

*1. ⚠ is a mark that instructs to use the cable with an appropriate temperature rating (80°C or more) for wiring.

1	Outline
2	External Dimensions
3	Generic Specifications
4	Power Supply Specifications
5	Input Specifications
6	Output Specifications
7	Examples of Wiring for Various Uses
8	Terminal Block
9	CC-Link/LT Master FX3UC-LT(-2) only
10	Display module FX3UC-LT(-2) only

1.3 Interpretation of Model Names (Main Units, I/O Extension Blocks)

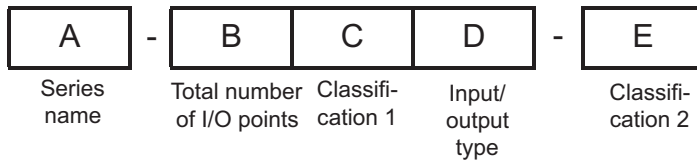

	Classification	Symbol	Description
A	Series name	FX3UC	FX3UC Series
		FX2NC	FX2NC Series
		FX2N	FX2N Series
		FX0N	FX0N Series
		FX	FX Series
B	Total number of I/O points	8	8 Points
		16	16 Points
		32	32 Points
		64	64 Points
		96	96 Points
C	Classification 1	M	Main units
		E	Input/Output extension blocks
D	Input/output type	R R/D	Input/output mixed Input : 24V DC (Sink) Output : Relay
		R/DS	Input/output mixed Input : 24V DC (Sink / Source) Output : Relay
		T T/D	Input/output mixed Input : 24V DC (Sink) Output : Transistor (Sink)
		T/DSS	Input/output mixed Input : 24V DC (Sink / Source) Output : Transistor (Source)
		X	Input dedicated Classification 2 "None" : 24V DC Input Classification 2 "UA1/UL" : 100V AC Input
		XL	Dedicated 5V DC Input
		YR	Dedicated relay output
		YR-S	Dedicated relay output (Separate reference terminals (Commons) type.)
		YT	Dedicated transistor output
YS	Dedicated triac output		
E	Classification 2	Non symbol	I/O connecting type <ul style="list-style-type: none"> • FX3UC Series : Connector • FX2NC Series : Connector • FX2N Series : Terminal block • FX0N Series : Terminal block
		LT LT-2	CC-Link/LT built-in master
		UA1/UL	Dedicated 100V AC input
		C	I/O connecting type : Connector
		T	I/O connecting type : Terminal block

1.4 List of Products

1. FX3uc-□□MT/D, FX3uc-16MR/D-T

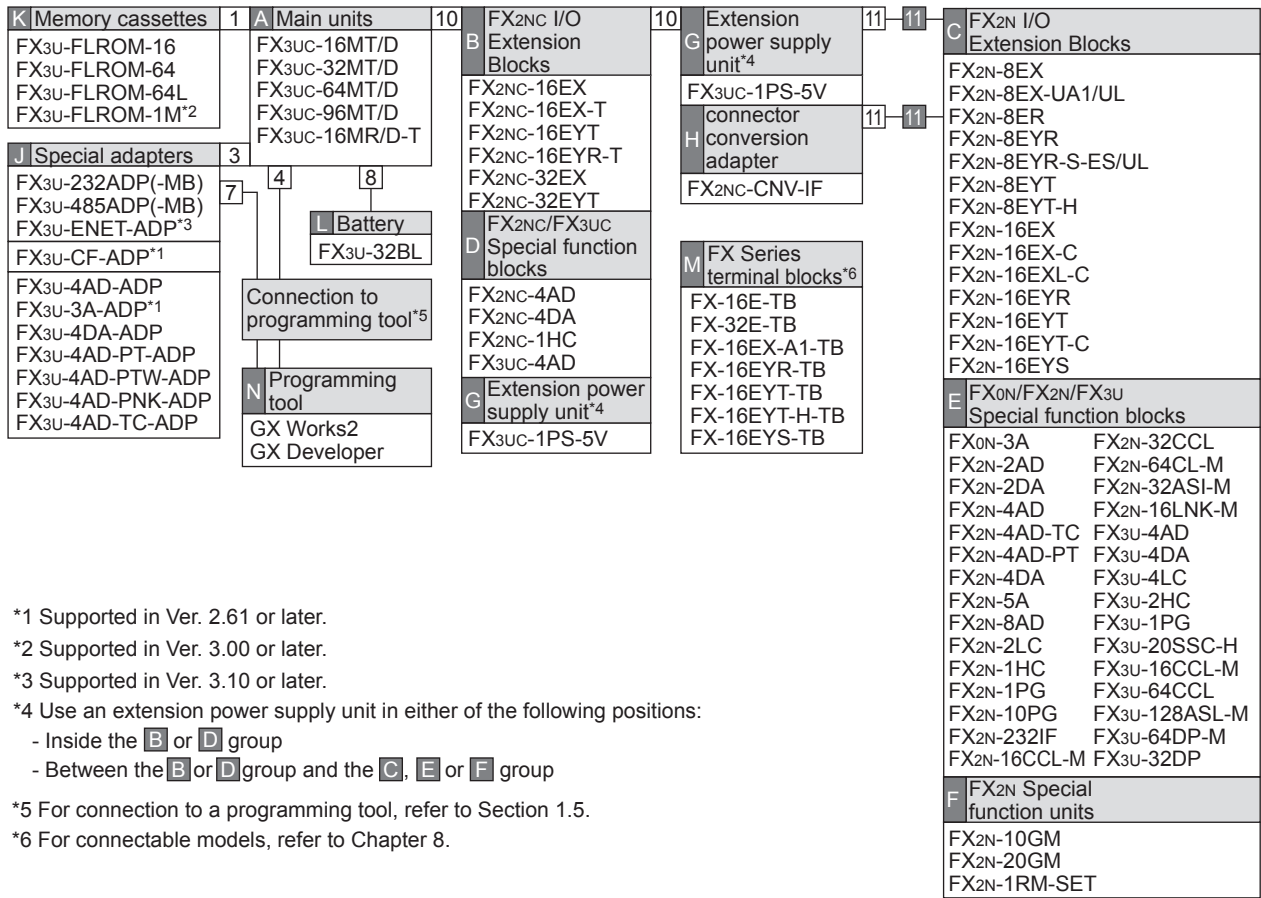

- *1 Supported in Ver. 2.61 or later.
- *2 Supported in Ver. 3.00 or later.
- *3 Supported in Ver. 3.10 or later.
- *4 Use an extension power supply unit in either of the following positions:
 - Inside the **B** or **D** group
 - Between the **B** or **D** group and the **C**, **E** or **F** group
- *5 For connection to a programming tool, refer to Section 1.5.
- *6 For connectable models, refer to Chapter 8.

2. FX3uc-□□MT/DSS, FX3uc-16MR/DS-T

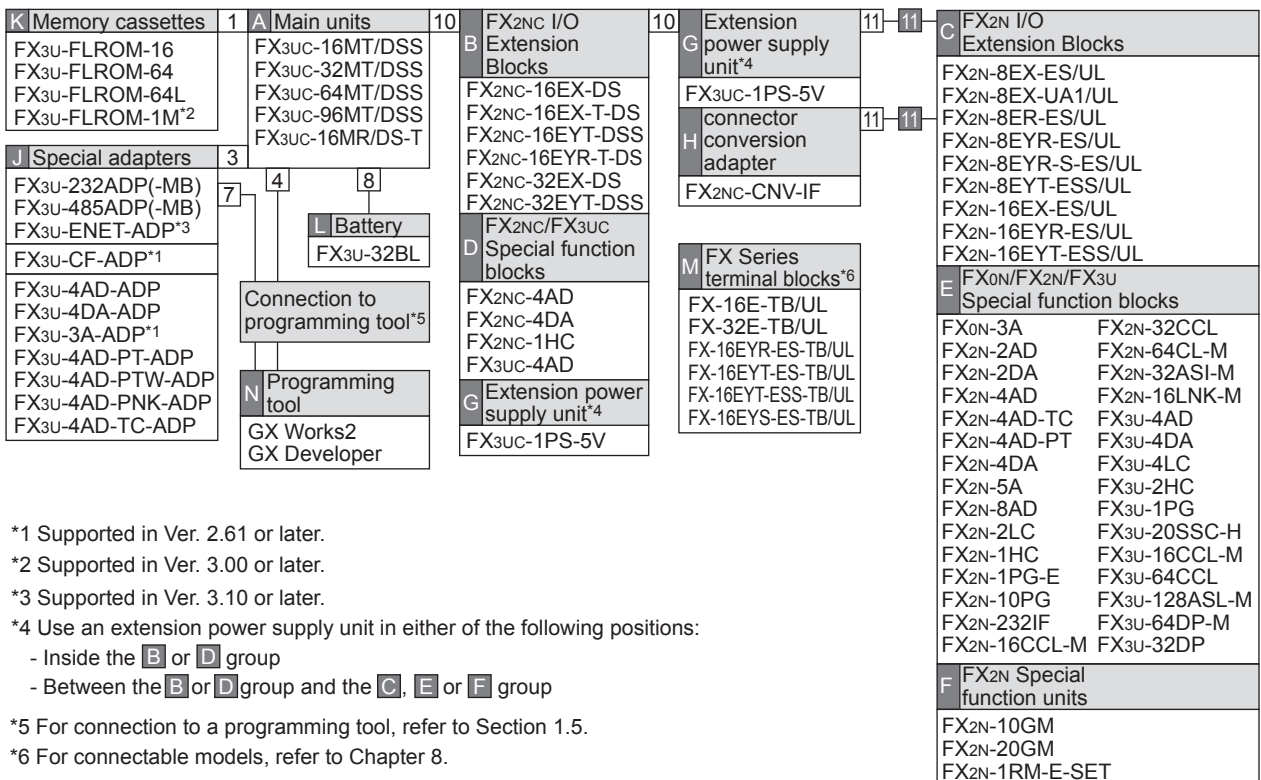

- *1 Supported in Ver. 2.61 or later.
- *2 Supported in Ver. 3.00 or later.
- *3 Supported in Ver. 3.10 or later.
- *4 Use an extension power supply unit in either of the following positions:
 - Inside the **B** or **D** group
 - Between the **B** or **D** group and the **C**, **E** or **F** group
- *5 For connection to a programming tool, refer to Section 1.5.
- *6 For connectable models, refer to Chapter 8.

1	Outline
2	External Dimensions
3	Generic Specifications
4	Power Supply Specifications
5	Input Specifications
6	Output Specifications
7	Examples of Wiring for Various Uses
8	Terminal Block
9	CC-Link/LT Master FX3uc-LT(-Z) only
10	Display module FX3uc-LT(-Z) only

3. FX3uc-32MT-LT-2, FX3uc-32MT-LT

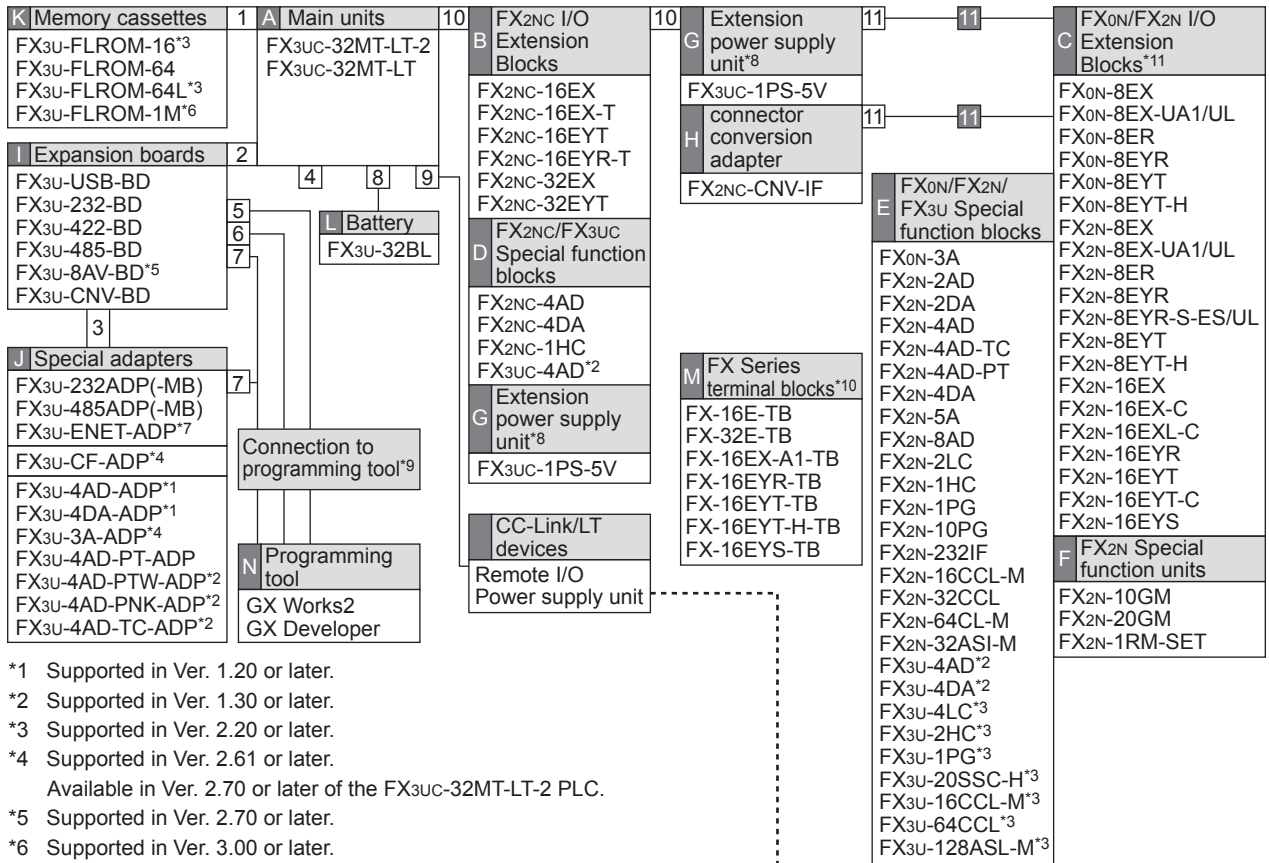

- *1 Supported in Ver. 1.20 or later.
- *2 Supported in Ver. 1.30 or later.
- *3 Supported in Ver. 2.20 or later.
- *4 Supported in Ver. 2.61 or later.
Available in Ver. 2.70 or later of the FX3uc-32MT-LT-2 PLC.
- *5 Supported in Ver. 2.70 or later.
- *6 Supported in Ver. 3.00 or later.
- *7 Supported in Ver. 3.10 or later.
- *8 Use an extension power supply unit in either of the following positions:
 - Inside the **B** or **D** group
 - Between the **B** or **D** group and the **C**, **E** or **F** group
- *9 For connection to a programming tool, refer to Section 1.5.
- *10 For connectable models, refer to Chapter 8.
- *11 FX0N I/O extension blocks can only be connected to the FX3uc-32MT-LT.

-- For CC-Link/LT product information, refer to catalogues.

No.	Cable or connection connector
1	Memory cassette connector
2	Expansion board connector
3	Special adapter connector
4	Peripheral device connector [RS-422] MINI DIN 8Pin
5	FX3U-422-BD MINI DIN 8Pin [RS-422]
6	FX3U-USB-BD USB Mini-B connector [USB2.0]

No.	Cable or connection connector
7	FX3U-232-BD D-SUB 9Pin [RS-232C] FX3U-232ADP(-MB) D-SUB 9Pin [RS-232C]
8	Battery connector
9	CC-Link/LT interface connector
10	Extension connector (FX2NC/FX3UC)
11	Extension connector (FX0N/FX2N/FX3U)
11	Extension cable *12

*12. When using an extension cable (FX0N-30EC or FX0N-65EC), use only one extension cable per system. Make sure to use the FX2N-CNV-BC when the extension cable is used to connect an extension block. This extension cable is not available when the FX3U-4LC or FX2N-8AD is located at the head position or when the connection destination is the FX2N-20GM, FX2N-10GM, FX2N-1RM-SET, or FX2N-1RM-E-SET.

→ Refer to Section 3.4.

1.4.1 Main units

A

Model name	Input		Output		Connecting type	Number of input/output points	Drive power supply	Current Capacity 5V DC (mA)
	Points	Type	Points	Type				
FX3UC-16MT/D	8	24V DC (Sink)	8	Transistor (sink)	Connector	16	24V DC	600
FX3UC-16MT/DSS	8	24V DC (Sink/Source)	8	Transistor (source)	Connector	16	24V DC	600
FX3UC-16MR/D-T	8	24V DC (Sink)	8	Relay	Terminal block	16	24V DC	600
FX3UC-16MR/DS-T	8	24V DC (Sink/Source)	8	Relay	Terminal block	16	24V DC	600
FX3UC-32MT/D	16	24V DC (Sink)	16	Transistor (sink)	Connector	32	24V DC	560
FX3UC-32MT/DSS	16	24V DC (Sink/Source)	16	Transistor (source)	Connector	32	24V DC	560
FX3UC-64MT/D	32	24V DC (Sink)	32	Transistor (sink)	Connector	64	24V DC	480
FX3UC-64MT/DSS	32	24V DC (Sink/Source)	32	Transistor (source)	Connector	64	24V DC	480
FX3UC-96MT/D	48	24V DC (Sink)	48	Transistor (sink)	Connector	96	24V DC	400
FX3UC-96MT/DSS	48	24V DC (Sink/Source)	48	Transistor (source)	Connector	96	24V DC	400
FX3UC-32MT-LT-2	16	24V DC (Sink)	16	Transistor (sink)	Connector	32	24V DC	350
FX3UC-32MT-LT	16	24V DC (Sink)	16	Transistor (sink)	Connector	32	24V DC	350

1.4.2 I/O Extension Blocks

1. FX2nc Series I/O Extension Blocks

B

Model name	Input		Output		Connecting type	Number of input/output points	5V DC current consumption (mA)
	Points	Type	Points	Type			
FX2NC-16EX-T	16	24V DC (Sink)	-	-	Terminal block	16	30
FX2NC-16EX-T-DS	16	24V DC (Sink/Source)	-	-	Terminal block	16	30
FX2NC-16EX	16	24V DC (Sink)	-	-	Connector	16	30
FX2NC-16EX-DS	16	24V DC (Sink/Source)	-	-	Connector	16	30
FX2NC-32EX	32	24V DC (Sink)	-	-	Connector	32	60
FX2NC-32EX-DS	32	24V DC (Sink/Source)	-	-	Connector	32	60
FX2NC-16EYR-T	-	-	16	Relay	Terminal block	16	50
FX2NC-16EYR-T-DS	-	-	16	Relay	Terminal block	16	50
FX2NC-16EYT	-	-	16	Transistor (sink)	Connector	16	50
FX2NC-16EYT-DSS	-	-	16	Transistor (source)	Connector	16	50
FX2NC-32EYT	-	-	32	Transistor (sink)	Connector	32	100
FX2NC-32EYT-DSS	-	-	32	Transistor (source)	Connector	32	100

2. FX2N/FX0N Series I/O Extension Blocks

When connected to one of the FX2N/FX0N I/O extension blocks listed in the following table, the FX2NC-CNV-IF or FX3UC-1PS-5V is required.

C

Model name	Input		Output		Connecting type	Number of input/output points	5V DC current consumption (mA)
	Points	Type	Points	Type			
FX2N-8ER	4	24V DC (Sink)	4	Relay	Terminal block	16*1	25
FX2N-8ER-ES/UL	4	24V DC (Sink/Source)	4		Terminal block	16*1	25
FX0N-8ER	4	24V DC (Sink)	4		Terminal block	16*1	25
FX2N-8EX-UA1/UL	8	100V AC	-	-	Terminal block	8	25
FX0N-8EX-UA1/UL	8	100V AC	-	-	Terminal block	8	25
FX2N-8EX	8	24V DC (Sink)	-	-	Terminal block	8	25
FX2N-8EX-ES/UL	8	24V DC (Sink/Source)	-	-	Terminal block	8	25
FX0N-8EX	8	24V DC (Sink)	-	-	Terminal block	8	25
FX2N-16EX	16		-	-	Terminal block	16	45
FX2N-16EX-ES/UL	16	24V DC (Sink/Source)	-	-	Terminal block	16	45
FX0N-16EX	16	24V DC (Sink)	-	-	Terminal block	16	40
FX2N-16EX-C	16		-	-	Connector	16	40
FX2N-16EXL-C	16	5V DC	-	-	Connector	16	35
FX2N-8EYR	-	-	8	Relay	Terminal block	8	30
FX2N-8EYR-ES/UL	-	-	8		Terminal block	8	30
FX2N-8EYR-S-ES/UL	-	-	8		Terminal block	8	30
FX0N-8EYR	-	-	8		Terminal block	8	30
FX2N-8EYT	-	-	8	Transistor (sink)	Terminal block	8	30
FX2N-8EYT-ESS/UL	-	-	8	Transistor (source)	Terminal block	8	30
FX0N-8EYT	-	-	8	Transistor (sink)	Terminal block	8	30
FX2N-8EYT-H	-	-	8		Terminal block	8	30
FX0N-8EYT-H	-	-	8		Terminal block	8	30
FX2N-16EYR	-	-	16	Relay	Terminal block	16	40
FX2N-16EYR-ES/UL	-	-	16		Terminal block	16	40

*1. Four inputs and four outputs are occupied as unused numbers.

C

Model name	Input		Output		Connecting type	Number of input/output points	5V DC current consumption (mA)
	Points	Type	Points	Type			
FX0N-16EYR	-	-	16	Relay	Terminal block	16	40
FX2N-16EYT	-	-	16	Transistor (sink)	Terminal block	16	180
FX2N-16EYT-ESS/UL	-	-	16	Transistor (source)	Terminal block	16	180
FX0N-16EYT	-	-	16	Transistor (sink)	Terminal block	16	40
FX2N-16EYT-C	-	-	16		Connector	16	180
FX2N-16EYS	-	-	16	Triac	Terminal block	16	160

1.4.3 Special function units/blocks

For details on each product, refer to the appropriate product manual.

1. Analog control

a) FX2NC/FX3UC Series

D

Model name	Description	Number of input/output points	5V DC current consumption (mA)
FX2NC-4AD	4-ch Voltage/current input	8	50
FX2NC-4DA	4-ch Voltage/current output	8	30
FX3UC-4AD	4-ch Voltage/current input	8	100

b) FX0N/FX2N/FX3U Series

When connected to the special function blocks of the following table, the FX2NC-CNV-IF or FX3UC-1PS-5V is required.

E

Model name	Description	Number of input/output points	5V DC current consumption (mA)
FX2N-2AD	2-ch Voltage/current input	8	20
FX2N-4AD	4-ch Voltage/current input	8	30
FX2N-8AD	8-ch Voltage/current/temperature (thermocouple) input	8	50
FX2N-4AD-PT	4-ch Temperature (resistance thermometer sensor) input	8	30
FX2N-4AD-TC	4-ch Temperature (thermocouple) input	8	30
FX2N-2DA	2-ch Voltage/current output	8	30
FX2N-4DA	4-ch Voltage/current output	8	30
FX0N-3A	2-ch Voltage/current input 1-ch Voltage/current output	8	30
FX2N-5A	4-ch Voltage/current input 1-ch Voltage/current output	8	70
FX2N-2LC	2 loop Temperature control (resistance thermometer sensor/thermocouple)	8	70
FX3U-4AD	4-ch Voltage/current input	8	110
FX3U-4DA	4-ch Voltage/current output	8	120
FX3U-4LC	4 loop Temperature control (resistance thermometer sensor/thermocouple/micro voltage input)	8	160

1	Outline
2	External Dimensions
3	Generic Specifications
4	Power Supply Specifications
5	Input Specifications
6	Output Specifications
7	Examples of Wiring for Various Uses
8	Terminal Block
9	CC-Link/LT Master FX3UC-LT(-Z) only
10	Display module FX3UC-LT(-Z) only

2. High-speed counter

a) FX2NC Series

E

Model name	Description	Number of input/ output points	5V DC current consumption (mA)
FX2NC-1HC	1-ch high-speed counter	8	90

b) FX2N/FX3U Series

When connected to the special function blocks in the following table, the FX2NC-CNV-IF or FX3UC-1PS-5V is required.

Model name	Description	Number of input/ output points	5V DC current consumption(mA)
FX2N-1HC	1-ch high-speed counter	8	90
FX3U-2HC	2-ch high-speed counter	8	245

3. Pulse output and positioning

When connected to the special function units/blocks in the following table, the FX2NC-CNV-IF or FX3UC-1PS-5V is required.

E

F

Model name	Description	Number of input/ output points	5V DC current consumption (mA)
FX3U-1PG	Pulse output for independent 1-axis control [200 kHz transistor output]	8	150
FX2N-1PG	Pulse output for independent 1-axis control [100 kHz transistor output]	8	55
FX2N-1PG-E	Pulse output for independent 1-axis control [100 kHz transistor output]	8	55
FX2N-10PG	Pulse output for independent 1-axis control [1 MHz differential line driver output]	8	120
FX3U-20SSC-H	Simultaneous 2-axis (independent 2-axis) control [Applicable to SSCNET III]	8	100
FX2N-10GM	Pulse output for independent 1-axis control [200 kHz transistor output]	8	-
FX2N-20GM	Pulse output for simultaneous 2-axis (independent 2-axis) control [200 kHz transistor output]	8	-
FX2N-1RM(-E)-SET	1-axis programmable cam switch	8 ^{*1}	-

*1. When two or more (up to 3) FX2N-1RM units are connected, 8 input/output points are occupied without regard to the number of connected units.

4. Data link and communication functions

When connected to the special function blocks in the following table, the FX2NC-CNV-IF or FX3UC-1PS-5V is required.

E

Model name	Description	Number of input/output points	5V DC current consumption (mA)
FX2N-232IF	1-ch RS-232C no-protocol communication	8	40
FX3U-16CCL-M	Master for CC-Link (Compatible with Ver. 2.00 and Ver. 1.10) Connectable stations: Remote I/O station, Remote device station, Intelligent device station	*1	-
FX2N-16CCL-M	Master for CC-Link (Compatible with Ver. 1.10) Connectable stations: Remote I/O station, Remote device station	*1	-
FX3U-64CCL	Intelligent device station for CC-Link [1 to 4 stations occupied]	8	-
FX2N-32CCL	Remote device station for CC-Link [1 to 4 stations occupied]	8	130
FX2N-64CL-M	Master for CC-Link/LT	*2	190
FX3U-128ASL-M	Master for AnyWireASLINK system	*3	130
FX3U-64DP-M	Master for PROFIBUS-DP	8	-
FX3U-32DP	Slave station for PROFIBUS-DP	8	-
FX2N-16LNK-M	Master for MELSEC I/O Link	*4	200
FX2N-32ASI-M	Master for AS-i system	*5	150

- *1. The number of input/output occupied points in the FX3U-16CCL-M and the FX2N-16CCL-M is obtained using the following formula:
Number of input/output occupied points = Number of remote I/O stations × 32 points + 8 points
- *2. The number of input/output occupied points in the FX2N-64CL-M is obtained using the following formula:
Number of input/output occupied points = Total number of input/output points in remote I/O stations + 8 points
- *3. The number of input/output occupied points in the FX3U-128ASL-M is obtained using the following formula:
Number of input/output occupied points = Set value of rotary switch + 8 points
- *4. The number of points varies according to the products connected to the network.
For details, refer to the FX2N-16LNK-M Manual.
- *5. The number of input/output occupied points in the FX2N-32ASI-M is obtained using the following formula:
Number of input/output points =
Main unit (Ver. 2.20 or later) Number of active slaves × 8 points + 8 points
Main unit (Earlier than Ver. 2.20) Number of active slaves × 4 points + 8 points

1	Outline
2	External Dimensions
3	Generic Specifications
4	Power Supply Specifications
5	Input Specifications
6	Output Specifications
7	Examples of Wiring for Various Uses
8	Terminal Block
9	CC-Link/LT Master FX3UC-LT(-2) only
10	Display module FX3UC-LT(-2) only

1.4.4 Expansion boards

1. Communication functions

I

Model name	Description	Number of input/output points	5V DC current consumption (mA)
FX3U-CNV-BD	Conversion of connector for fitting special adapter	0	-
FX3U-232-BD	For RS-232C communication	0	20
FX3U-422-BD	For RS-422 communication (having the same function as that of the peripheral device connector incorporated in the main unit)	0	20*1
FX3U-485-BD	For RS-485 communication	0	40
FX3U-USB-BD	For USB communication (for programming from a personal computer)	0	15
FX3U-8AV-BD	For 8-ch analog volume	0	20

*1. Add the current consumption shown below only when the following equipment is connected to the FX3U-422-BD.

Connection model name	5V DC current consumption (mA)	Application
FX-30P	115*2	Handy programming panel *2. When the intensity of the LCD backlight is set at the initial value 4. If the LCD backlight is set at the maximum value 8, it is handled as "155mA". *3. When the FX-20P-RWM is used, the current is 180mA.
FX-20P(-E)(-SET0)	150*3	
FX-10P-SET0 FX-10P(-E)	120	
FX-232AW/FX-232AWC	220	RS-232C/RS-422 converter
FX-232AWC-H	120	
FX-USB-AW	15	USB/RS-422 converter (USB side : 30mA)
FX-10DM(-E)(-SET0)	220	Display module
F920GOT-BBD5-K(-E)	220	Graphic operation terminal

1.4.5 Special adapters

1. Analog functions

J

Model name	Description	Number of input/output points	5V DC current consumption (mA)
FX3U-4AD-ADP	4-ch Voltage/current input	0	15
FX3U-4DA-ADP	4-ch Voltage/current output	0	15
FX3U-3A-ADP	2-ch Voltage/current input 1-ch Voltage/current output	0	20
FX3U-4AD-PT-ADP	4-ch Temperature (platinum resistance thermometer sensor) input (-50 to 250°C)	0	15
FX3U-4AD-PTW-ADP	4-ch Temperature (platinum resistance thermometer sensor) input (-100 to 600°C)	0	15
FX3U-4AD-PNK-ADP	4-ch Temperature (Pt1000/Ni1000 resistance thermometer sensor) input	0	15
FX3U-4AD-TC-ADP	4-ch Temperature (thermocouple) input	0	15

2. Communication functions

J

Model name	Description	Number of input/output points	5V DC current consumption (mA)
FX3U-232ADP(-MB)	RS-232C communication	0	30
FX3U-485ADP(-MB)	RS-485 communication	0	20
FX3U-ENET-ADP	Ethernet communication	0	30

3. CF card functions

J

Model name	Description	Number of input/output points	5V DC current consumption (mA)
FX3U-CF-ADP	CF card special adapter	0	50

1.4.6 Extension power supply unit

G

Model name	Description	Drive power supply	Current Capacity DC
FX3UC-1PS-5V	5V DC extension power supply	24V DC	5V DC 1A

1.4.7 Connector conversion adapter

Model name	Description	5V DC current consumption (mA)
FX2NC-CNV-IF H	Connector conversion adapter to connect an "I/O extension block for FX0N/FX2N" or "special function unit/block"	-
FX2N-CNV-BC	Connector conversion adapter to connect an "I/O extension block for FX0N/FX2N" or "special function block" and the extension cable FX0N-30/65EC	-

1.4.8 Memory cassettes/Battery/Extension cables

K

L

11

Classification	Model name	Description	
Memory cassettes K	FX3U-FLROM-16	16k-step flash memory	
	FX3U-FLROM-64	64k-step flash memory	
	FX3U-FLROM-64L	64k-step flash memory [with loader function]	
	FX3U-FLROM-1M	64k-step flash memory [There is an area (1300 kB) dedicated to the storage of symbolic information.]	
Battery L	FX3U-32BL	This battery backs up the following data. <ul style="list-style-type: none"> • Program memory in built-in RAM • Keep devices (battery backup devices) • Results of sampling trace • Time on clock 	
Extension cables 11	FX0N-65EC	0.65m (2'1")	These cables are used to mount input/output extension blocks for FX0N/FX2N and special function blocks ^{*1} for FX0N/FX2N/FX3U away from the main unit.
	FX0N-30EC	0.3m (0'11")	

*1. Not available when the FX3U-4LC or FX2N-8AD is located at the head position.

1.4.9 FX Series terminal blocks



Model name	Input points	Output points	Function	Drive power supply
FX-16E-TB	16 input points or 16 output points		To be directly connected to the PLC input/output connector	*1
FX-32E-TB	32 input points, 32 output points or 16 input/output points			
FX-16EX-A1-TB*2	16	-	100V AC input type	*4
FX-16EYR-TB*3	-	16	Relay output type	24V DC 80mA
FX-16EYT-TB*3	-	16	Transistor output type (Sink output)	24V DC 112mA
FX-16EYT-H-TB*3	-	16	Transistor output type (Sink output)	24V DC 112mA
FX-16EYS-TB*3	-	16	Triac output type	24V DC 112mA
FX-16E-TB/UL	16 input points or 16 output points		To be directly connected to the PLC input/output connector	*1
FX-32E-TB/UL	32 input points, 32 output points or 16 input/output points			
FX-16EYR-ES-TB/UL*3	-	16	Relay output type	24V DC 80mA
FX-16EYT-ES-TB/UL*3	-	16	Transistor output type (Sink output)	24V DC 112mA
FX-16EYT-ESS-TB/UL*3	-	16	Transistor output type (Source output)	24V DC 112mA
FX-16EYS-ES-TB/UL*3	-	16	Triac output type	24V DC 112mA

*1. The table below shows the drive power supply for each connection destination.

Connection destination	Power Supply Voltage	Current Consumption
Input connector		
FX3UC-□□MT/D, FX3UC-32MT-LT(-2), FX2NC-□□EX	Not required	
FX3UC-□□MT/DSS, FX2NC-□□EX-DS, FX2N-16EX-C	24V DC	112mA / 16 points
Output connector		
FX3UC-□□MT/D, FX3UC-□□MT/DSS, FX3UC-32MT-LT(-2), FX2NC-□□EYT, FX2NC-□□EYT-DSS, FX2N-16EYT-C	Power supply suitable to connected load is required.	

*2. The applications shown below are not supported.

Unsupported Applications	
High-speed processing	High-speed counter, input interruption, pulse catch, speed detection (SPD) instruction
Time division input	Input matrix (MTR) instruction, hexadecimal input (HKY) instruction, digital switch (DSW) instruction, arrow switch (ARWS) instruction
Other	Refresh and filter adjust (REFF) instruction, ten key input (TKY) instruction, absolute current value read (ABS) instruction

*3. The applications shown below are not supported.

Unsupported Applications	
Pulse output	Pulse Y output (PLSY) instruction, acceleration/deceleration setup (PLSR) instruction, pulse width modulation (PWM) instruction, DOG search zero return (DSZR) instruction, interruption positioning (DVIT) instruction, batch data positioning mode (TBL) instruction, absolute current value read (ABS) instruction, zero return (ZRN) instruction, variable speed pulse output (PLSV) instruction, drive to increment (DRVI) instruction, drive to absolute (DRVA) instruction
Time division input	Input matrix (MTR) instruction, hexadecimal input (HKY) instruction, digital switch (DSW) instruction, arrow switch (ARWS) instruction
Time division output	Seven segment with latch (SEGL) instruction, print (ASCII Code) (PR) instruction

*4. The table below shows the drive power supply for each connection destination.

Connection destination	Power Supply Voltage	Current Consumption
FX3UC-□□MT/D, FX3UC-32MT-LT(-2), FX2NC-□□EX	24V DC	48mA
FX2N-16EX-C	24V DC	160mA

1.4.10 Input/output cable • Input/output connector • Power cable

Classification	Model name	Description		
Input/output cables	FX-16E-500CAB-S	5m(16'4")	<ul style="list-style-type: none"> Single wire (Wire color: red) PLC side: A 20-pin connector 	
	FX-16E-150CAB	1.5m(4'11")	<ul style="list-style-type: none"> Flat cables (with tube) A 20-pin connector at both ends 	
	FX-16E-300CAB	3m(9'10")		
	FX-16E-500CAB	5m(16'4")		
	Input/output cables	FX-16E-150CAB-R	1.5m(4'11")	<ul style="list-style-type: none"> Round multicore cables A 20-pin connector at both ends
		FX-16E-300CAB-R	3m(9'10")	
		FX-16E-500CAB-R	5m(16'4")	
		FX-A32E-150CAB	1.5m(4'11")	
		FX-A32E-300CAB	3m(9'10")	
Input/output connector	FX-A32E-500CAB	5m(16'4")	<ul style="list-style-type: none"> One common terminal covers 32 input/output terminals. 	
	FX2C-I/O-CON	10-piece set	Input/output connector for flat cable	
	FX2C-I/O-CON-S	5-piece set	Input/output connector for bulk wire for 0.3 mm ² [AWG22]	
	FX2C-I/O-CON-SA	5-piece set	Input/output connector for bulk wire for 0.5 mm ² [AWG20]	
	FX-I/O-CON2-S	2 set	Input/output connector for bulk wire for 0.3 mm ² [AWG22] (For 40 pins)	
Power cable	FX-I/O-CON2-SA	2 set	Input/output connector for bulk wire for 0.5 mm ² [AWG20] (For 40 pins)	
	FX2NC-100MPCB	1m (3'3")	Power cable for main unit	
	FX2NC-100BPCB	1m (3'3")	Input power cable for FX2NC series input extension blocks	
	FX2NC-10BPCB1	0.1m(0'3")	Input power crossover cable for FX2NC series input extension blocks	

1.4.11 Power supply unit

Model name	Description	Drive power supply	Current Capacity DC
FX2N-20PSU	24V DC power supply	100V AC to 240V AC	24V DC 2A

1.4.12 Programming tool

The following programming tool supports FX3UC Series PLCs.
For inapplicable programming tools and versions, refer to Appendix A-2-2.

N

Model name	Description
GX Works2	Version 1.07H or later of SW□DNC-GXW2-J supports the FX3UC. Version 1.08J or later of SW□DNC-GXW2-E supports the FX3UC.
GX Developer	Version 8.13P or later of SW□D5C-GPPW-J supports the FX3UC. Version 8.18U or later of SW□D5C-GPPW-E supports the FX3UC. Although versions earlier than 8.13P(-J) or 8.18U(-E) can be used for programming by selecting the model "FX2N(C)", restrictions apply. For details, refer to Appendix A-2-2.
FX-30P	FX-30P supports from the first version.

1.5 Connection to programming tool

Peripheral device connector

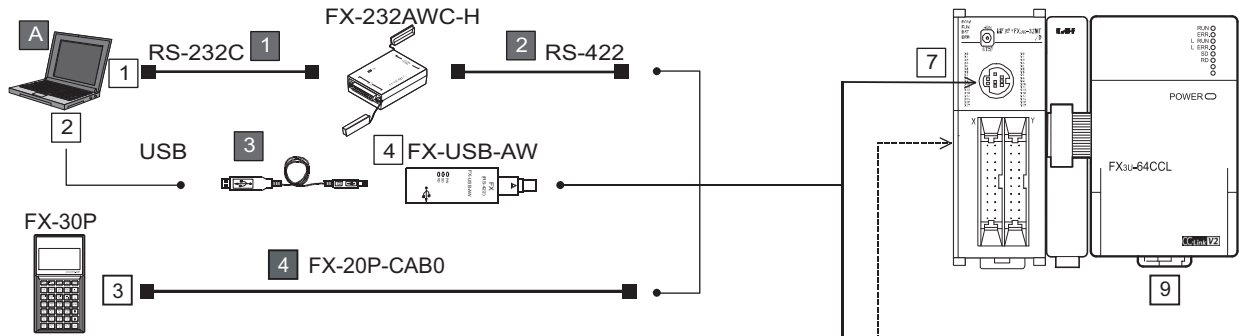

Special adapter

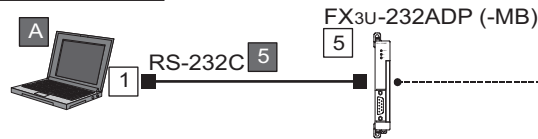

Expansion board

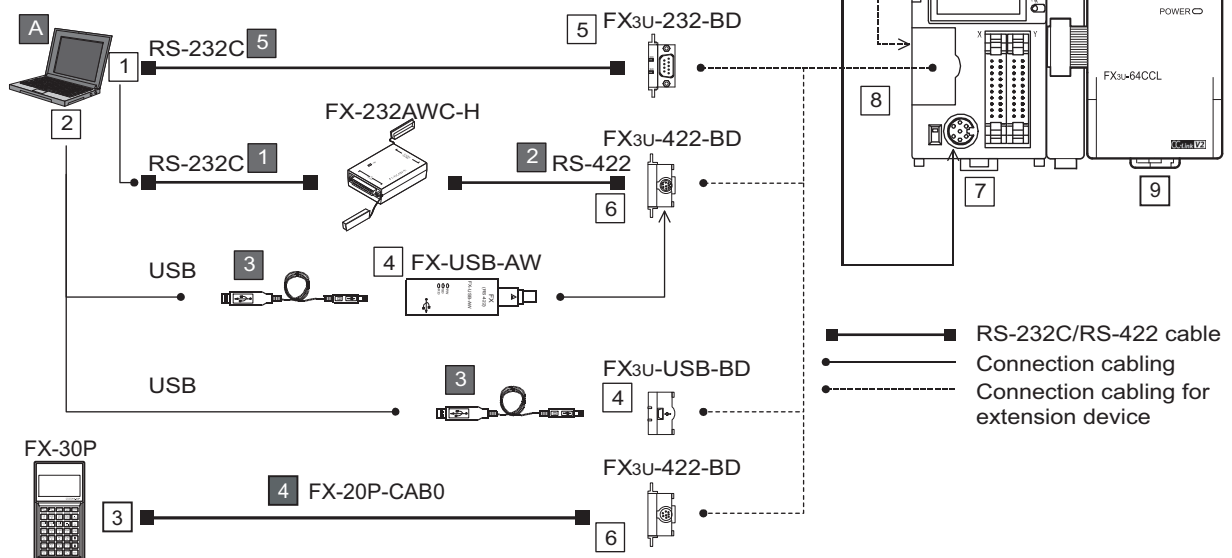

- RS-232C/RS-422 cable
- Connection cabling
- - - Connection cabling for extension device

* An expansion board is required to use a special adapter with the FX3UC-32MT-LT(-2).

No.	Shape of connector or combination with cable	No.	Shape of connector or combination with cable
1	D-SUB 9Pin	2	"FX-422CAB0" + 1 "F2-232CAB-1" + "FX-232AW/FX-232AWC/FX-232AWC-H"
	Half pitch 14Pin	3	FX-30P MINI DIN 8Pin [RS-422]
		4	FX-20P-CAB0
	D-SUB 25Pin	5	FX3U-USB-BD USB Mini-B connector [USB2.0] FX-USB-AW USB Mini-B connector [USB2.0]
6		FX3U-232BD D-SUB 9Pin [RS-232C] FX3U-232ADP(-MB) D-SUB 9Pin [RS-232C]	
2	USB A connector	7	FX3U-422BD MINI DIN 8Pin [RS-422]
		8	Peripheral device connector [RS-422] MINI DIN 8Pin
		9	Expansion board (special adapter) connector
			FX3U-64CCL CC-Link connection terminal block For details, refer to the FX3U-64CCL user's manual.

When FX-232AW or FX-232AWC is used, the communication baud rate is 19,200 bps or less.

1.6 System overall configuration

Products connectable to the FX3UC PLC are classified into the groups **A** to **G** as shown below.

For model names of products classified into the **C** and **D** groups, refer to "1.11 Number of input/output occupied points and 5V DC current consumption of each model".

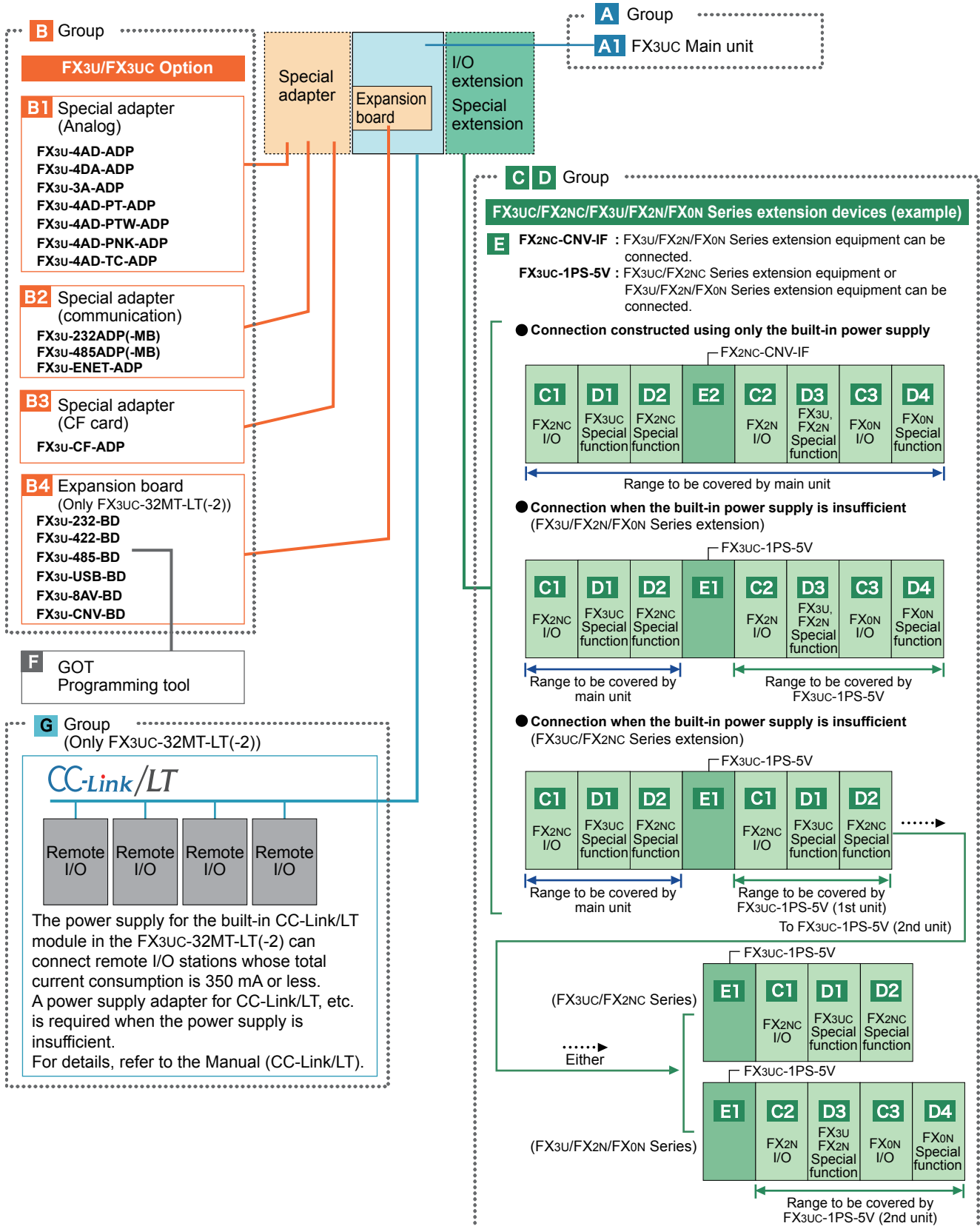

1	Outline
2	External Dimensions
3	Generic Specifications
4	Power Supply Specifications
5	Input Specifications
6	Output Specifications
7	Examples of Wiring for Various Uses
8	Terminal Block
9	CC-Link/LT Master FX3UC-LT(-2) only
10	Display module FX3UC-LT(-2) only

1.7 Rules of System Configuration

The system configuration must meet the following four requirements.

1. Number of input/output points

In the FX3UC-32MT-LT Ver. 2.20 or later, FX3UC-32MT-LT-2, FX3UC-□□MT/D(SS) and FX3UC-16MR/D(S)-T, up to 384 points are available in total including input/output points of the PLC and remote input/output points in the CC-Link, AnyWireASLINK and AS-i system.

For FX3UC-32MT-LT PLC versions earlier than Ver. 2.20, up to 256 points are available in total for the whole system.

→ For details, "Section 1.8 Number of Input/Output Points and Maximum Number of Input/Output Points".

FX3UC-32MT-LT Ver. 2.20 or later (Maximum Number of Input/Output Points 384 points)

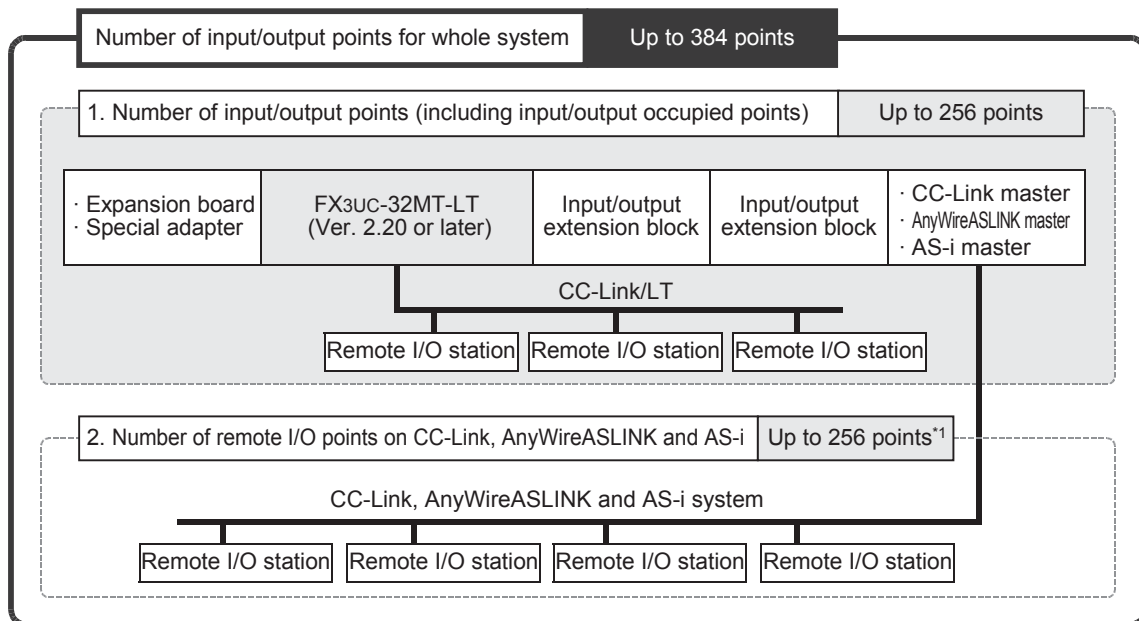

*1. The maximum number of remote input/output points varies depending on the network type. For details, refer to the following.

- When a CC-Link master is used, refer to Subsection 1.8.2.
- When AnyWireASLINK master is used, refer to Subsection 1.8.3.
- When an AS-i master is used, refer to Subsection 1.8.4.

FX3UC-32MT-LT Ver. 2.20 or less (Maximum Number of Input/Output Points 256 points)

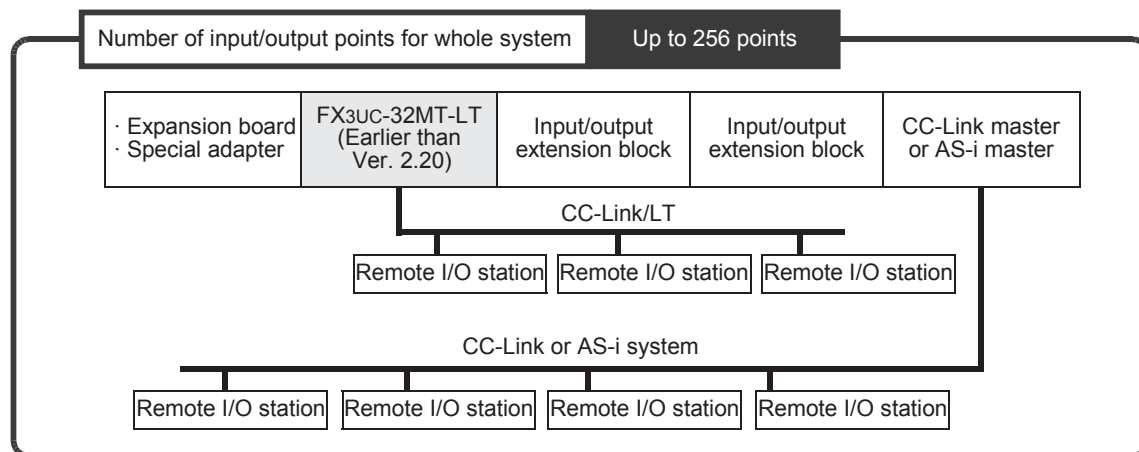

2. 5V DC power supply capacity (current consumption)

The main unit built-in power supply and the extension power supply unit supply power to extension equipment respectively.

The current consumption varies depending on the type of extension equipment.

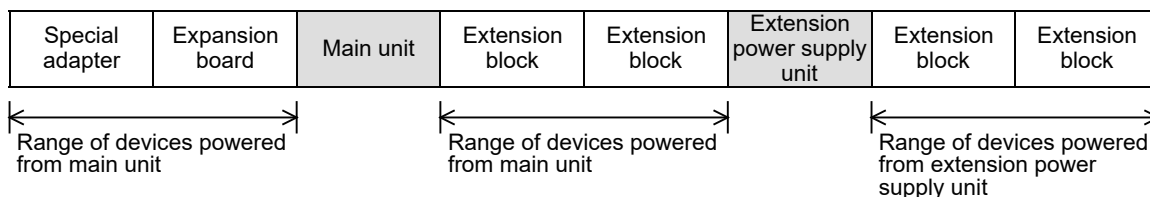

→ For details, refer to "1.9 Calculation of 5V DC power supply capacity (current consumption)".

3. Restriction in number of units for each group

The following numbers of expansion boards, special adapters and special function units/blocks can be connected.

→ For details of input/output extension blocks, refer to "1.10 Restriction in number of units in each group".

- 1) In the case of the FX3UC-□□MT/D(SS), FX3UC-16MR/D(S)-T

Special adapter (analog)	Special adapter (communication)	Special adapter (CF card)	Main unit	Input/output extension block	Special function unit	Special function block
--------------------------	---------------------------------	---------------------------	-----------	------------------------------	-----------------------	------------------------

Up to 4 units Up to 2 units*1 Only 1 unit*2 Up to 8 units

*1. When a CF card special adapter is used, only 1 adapter can be connected.

*2. When the total number of communication special adapters used is 2, the CF card special adapter cannot be connected.

- 2) In the case of the FX3UC-32MT-LT(-2)
- With a FX3U-CNV-BD expansion board

Special adapter (analog)	Special adapter (communication)	Special adapter (CF card)	FX3U-CNV-BD	Main unit	Input/output extension block	Special function unit	Special function block
--------------------------	---------------------------------	---------------------------	-------------	-----------	------------------------------	-----------------------	------------------------

Up to 4 units Up to 2 units*3 Only 1 unit*4 Up to 7 units

*3. When a CF card special adapter is used, only 1 adapter can be connected.

*4. When the total number of communication special adapters used is 2, the CF card special adapter cannot be connected.

- With an expansion board other than the FX3U-CNV-BD

Special adapter (analog)	Special adapter (communication)	Special adapter (CF card)	Expansion board (other than FX3U-CNV-BD)	Main unit	Input/output extension block	Special function unit	Special function block
--------------------------	---------------------------------	---------------------------	--	-----------	------------------------------	-----------------------	------------------------

Up to 4 units Only 1 unit*5 Only 1 unit*5 Up to 7 units

*5. Only one communication special adapter or one CF card special adapter can be connected.

4. Capacity of the CC-Link/LT power supply built in the FX3UC-32MT-LT(-2)

The power supply built in the main unit can connect remote I/O units whose total current consumption is up to 350mA.

When the power is insufficient, a dedicated power supply or power supply adapter for CC-Link/LT is required.

→ For details, refer to "9. CC-Link/LT Built-in Master Ability".

1	Outline
2	External Dimensions
3	Generic Specifications
4	Power Supply Specifications
5	Input Specifications
6	Output Specifications
7	Examples of Wiring for Various Uses
8	Terminal Block
9	CC-Link/LT Master FX3UC-LT(-2) only
10	Display module FX3UC-LT(-2) only

1.8 Number of Input/Output Points and Maximum Number of Input/Output Points

The number of input/output points and maximum number of input/output points varies depending on the PLC version and network type.

	Number of Input/Output Points*1	Maximum number of input/output points*1	Reference
FX3UC-32MT-LT Earlier than Ver. 2.20	256	256	Subsection 1.8.1.
FX3UC-32MT-LT Ver. 2.20 or later, FX3UC-32MT-LT-2, FX3UC-□□MT/D(SS) or FX3UC-16MR/D(S)-T when CC-Link, AnyWireASLINK and AS-i is not used	256	256	Subsection 1.8.1.
FX3UC-32MT-LT Ver. 2.20 or later, FX3UC-32MT-LT-2, FX3UC-□□MT/D(SS) or FX3UC-16MR/D(S)-T when CC-Link is used	256	384	Subsection 1.8.1. Subsection 1.8.2.
FX3UC-32MT-LT Ver. 2.20 or later, FX3UC-32MT-LT-2, FX3UC-□□MT/D(SS) or FX3UC-16MR/D(S)-T when AnyWireASLINK is used	256	384	Subsection 1.8.1. Subsection 1.8.3.
FX3UC-32MT-LT Ver. 2.20 or later, FX3UC-32MT-LT-2, FX3UC-□□MT/D(SS) or FX3UC-16MR/D(S)-T when AS-i is used	256	384	Subsection 1.8.1. Subsection 1.8.4.

*1. For the number of input/output points and maximum number of input/output points, refer to Section 1.7.

1.8.1 Calculation of number of input/output points

To obtain the total number of input/output points, count the input/output points of input/output extension blocks, the remote I/O points of the FX3UC-32MT-LT(-2) built-in master and the input/output occupied points of special function units/blocks.

1. Total the number of input/output points on the main unit and the number of those on the input/output extension blocks.

To obtain the total number of input/output points, count the input points (X000 and higher) and output points (Y000 and higher) of the main unit and input/output extension blocks.

2. Count the input/output points of the remote I/O stations connected to the FX3UC-32MT-LT(-2) built-in master, FX2N-64CL-M or FX2N-16LNK-M network.

Add the number of remote I/O points to the number of input/output points from the main unit and input/output powered extension units/blocks calculated in the above step.

- For the method of calculating the number of remote I/O points (CC-Link/LT built-in master), refer to Chapter 9.
- For the method of calculating the number of remote I/O points (FX2N-64CL-M), refer to the FX2N-64CL-M manual.
- For the method of calculating the number of remote I/O points (FX2N-16LNK-M), refer to the FX2N-16LNK-M manual.

3. Count the number of input/output occupied points of special function units/blocks.

The number of occupied input/output points per unit is 8.

The number of occupied input/output points of each type of device can be obtained by the following formula or from the list shown below.

→ For a list of occupied input/output points, refer to Section 1.11.

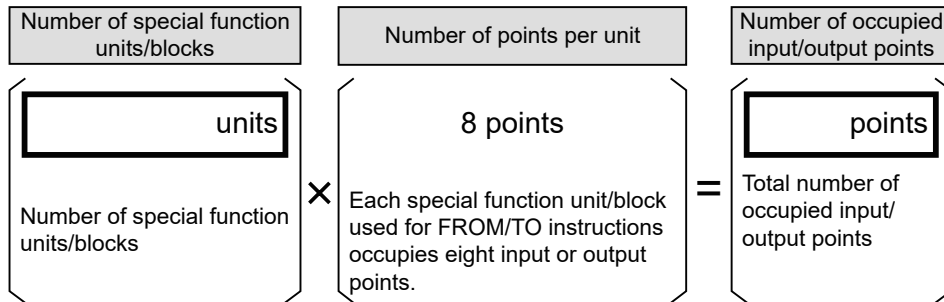

When connecting the special function units/blocks, take into consideration the combination, number of units/blocks and connecting order.

→ For details, refer to Section 1.10.

4. Calculate the total number of input/output points.

Total the number of points counted in Steps 1, 2 and 3, and check that it does not exceed 256 points (maximum number of input/output points).

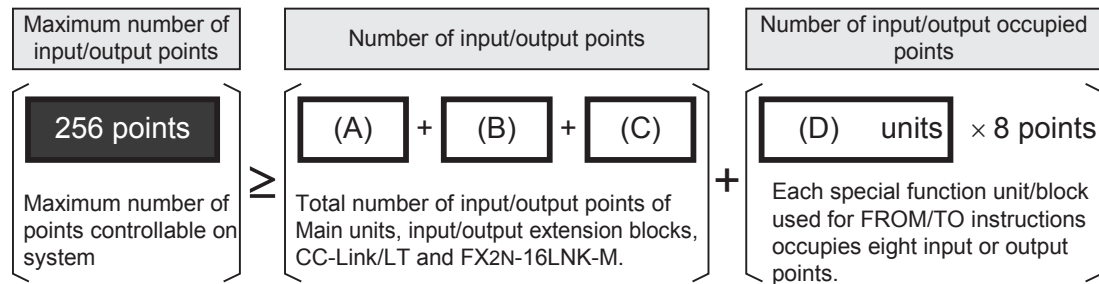

(A):Number of input/output points of main unit

(B):Number of input/output points of input/output extension blocks

(C):Number of remote I/O points of Built-in CC-Link/LT master, FX2N-64CL-M or FX2N-16LNK-M

(D):Number of special function units/blocks

5. When CC-Link, AnyWireASLINK and AS-i master is used, count the remote I/O points.

In the case of the FX3uc-32MT-LT Ver. 2.20 or later, FX3uc-32MT-LT-2, FX3uc-□□MT/D(SS) or FX3uc-16MR/D(S)-T

When a CC-Link, AnyWireASLINK and AS-i master is used, the total number of input/output points of the remote I/O stations connected on the network and the number of input/output points calculated in the previous step must be 384 or less.

For details, refer to the following subsection.

- 1) FX3U-16CCL-M, FX2N-16CCL-M (CC-Link master)

Calculate the number of remote I/O points connected on the network in the following step.

→ When a CC-Link master is used, refer to Subsection 1.8.2.

- 2) FX3U-128ASL-M (AnyWireASLINK master)

Calculate the number of remote I/O points connected on the network in the following step.

→ When AnyWireASLINK master is used, refer to Subsection 1.8.3.

- 3) FX2N-32ASI-M (AS-i master)

Calculate the number of remote I/O points connected on the network in the following step.

→ When an AS-i master is used, refer to Subsection 1.8.4.

In the case of the FX3uc-32MT-LT Ver. 2.20 or earlier

Up to 256 input/output points in total are available including the input/output points in remote I/O units connected in the network and the input/output points calculated in the previous step when the CC-Link master or AS-i master is used.

For details, refer to the following manuals respectively.

→ When a CC-Link master is used, refer to FX2N-16CCL-M manual.

→ When an AS-i master is used, refer to FX2N-32ASI-M manual.

1.8.2 Maximum number of input/output points when CC-Link master is used

1. Calculation of maximum number of input/output points

The maximum number of available input/output points is as follows when the FX3UC-32MT-LT Ver. 2.20 or later, FX3UC-32MT-LT-2, FX3UC-□□MT/D(SS) or FX3UC-16MR/D(S)-T and CC-Link master block are used.

→ For the method of calculating the number of I/O points, refer to Subsection 1.8.1.

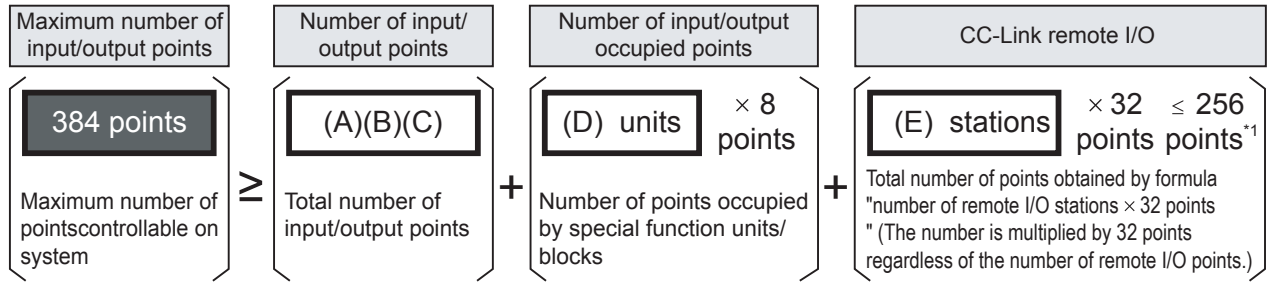

For details, refer to Subsection 1.8.1.

- (A): Number of input/output points of main unit
- (B): Number of input/output points of input/output extension blocks
- (C): Number of remote I/O points of CC-Link/LT built-in master(FX3UC-32MT-LT(-2)), FX2N-64CL-M, FX2N-16LNK-M.
- (D): Number of input/output points occupied by special function units/blocks
- (E): Number of remote I/O stations (units) connected to CC-Link master

*1. 224 points when the FX2N-16CCL-M is used.

The number of CC-Link points is calculated by the formula "32 points × number of stations" even when remote I/O stations with less than 32 points are used.

For details, refer to the manual of the CC-Link master block used.

When using together with the AnyWireASLINK master, make sure that the total number of remote I/O points in CC-Link and AnyWireASLINK master is 256 or less (and that the number of remote I/O points in the AnyWireASLINK master is up to 128). When CC-Link parameters are set by sequence program, all unused remote I/O points are occupied and become unavailable. When connecting the AnyWireASLINK master behind the CC-Link master, set CC-Link parameters using network parameters. For details, refer to FX3U-128ASL-M User's Manual.

2. Procedures for calculating number of input/output points based on example of system configuration

For the main unit, input/output extension blocks and CC-Link remote I/O stations, the number of input/output points and the total number of points are restricted.

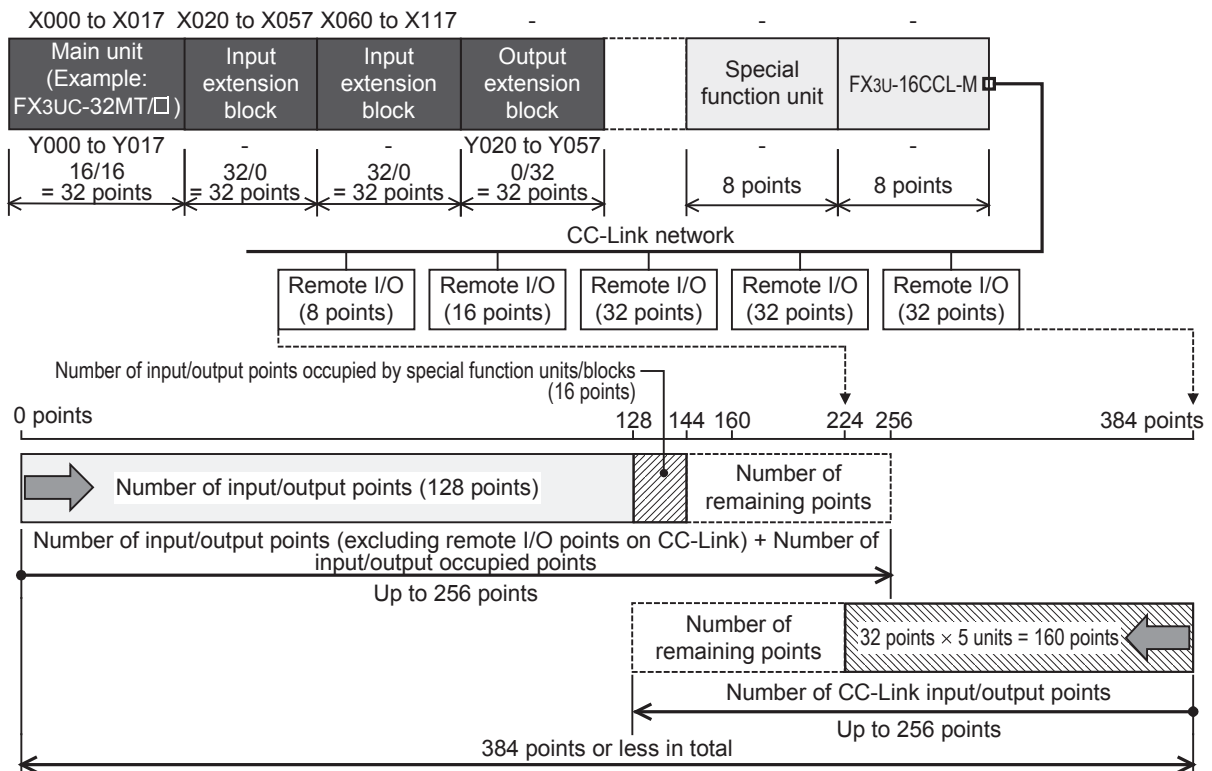

1.8.3 Maximum number of input/output points when AnyWireASLINK master is used

1. Calculation of maximum number of input/output points

The maximum number of input/output points available is as follows when the FX3UC-32MT-LT Ver. 2.20 or later, FX3UC-32MT-LT-2, FX3UC-□□MT/D(SS) or FX3UC-16MR/D(S)-T and an AnyWireASLINK master block are used.

→ For the method of calculating the number of I/O points, refer to Subsection 1.8.1.

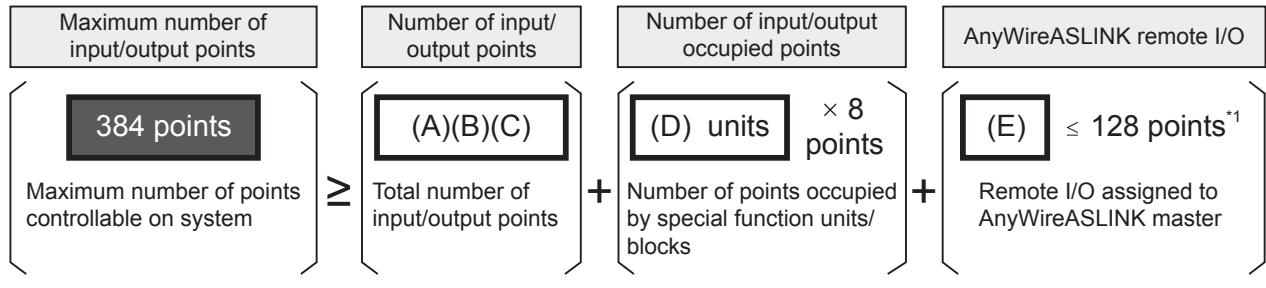

For details, refer to Subsection 1.8.1.

- (A): Number of input/output points of main unit
- (B): Number of input/output points of input/output extension blocks
- (C): Number of remote I/O points of CC-Link/LT built-in Master (FX3UC-32MT-LT(-2)), FX2N-64CL-M, FX2N-16LNK-M.
- (D): Number of input/output points occupied by special function units/blocks
- (E): Number of remote I/O points assigned to AnyWireASLINK master

*1. With regard to remote I/O of the AnyWireASLINK, input/output points set by the rotary switch of the AnyWireASLINK master are assigned. When using together with CC-Link master, make sure that the total number of remote I/O points in CC-Link and AnyWireASLINK master is 256 or less (and that the number of remote I/O points in the AnyWireASLINK master is up to 128). For details, refer to FX3U-128ASL-M User's Manual.

2. Procedures for calculating number of input/output points based on example of system configuration

For the main unit, input/output blocks and AnyWireASLINK, the number of input/output points and the total number of points are restricted.

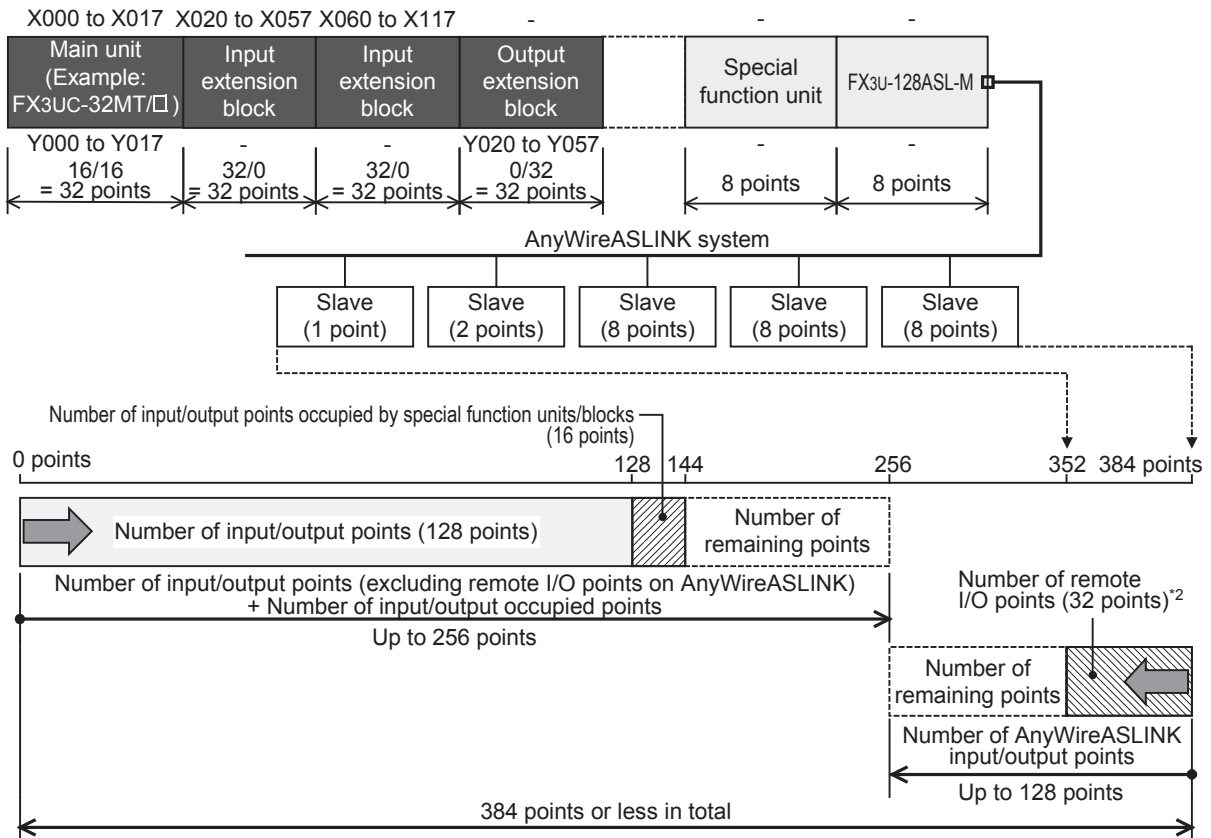

*2. When using 27 remote I/O points (8 points x 3 + 2 points + 1 point) shown above, assign 32 or more input/output points using the rotary switch of the AnyWireASLINK master.

- 1 Outline
- 2 External Dimensions
- 3 Generic Specifications
- 4 Power Supply Specifications
- 5 Input Specifications
- 6 Output Specifications
- 7 Examples of Wiring for Various Uses
- 8 Terminal Block
- 9 CC-Link/LT Master FX3UC-LT(-2) only
- 10 Display module FX3UC-LT(-2) only

1.8.4 Maximum number of input/output points when AS-i master is used

1. Calculation of maximum number of input/output points

The maximum number of input/output points available is as follows when the FX3UC-32MT-LT Ver. 2.20 or later, FX3UC-32MT-LT-2, FX3UC-□□MT/D(SS) or FX3UC-16MR/D(S)-T and an AS-i master block are used.

→ For the method of calculating the number of I/O points, refer to Subsection 1.8.1.

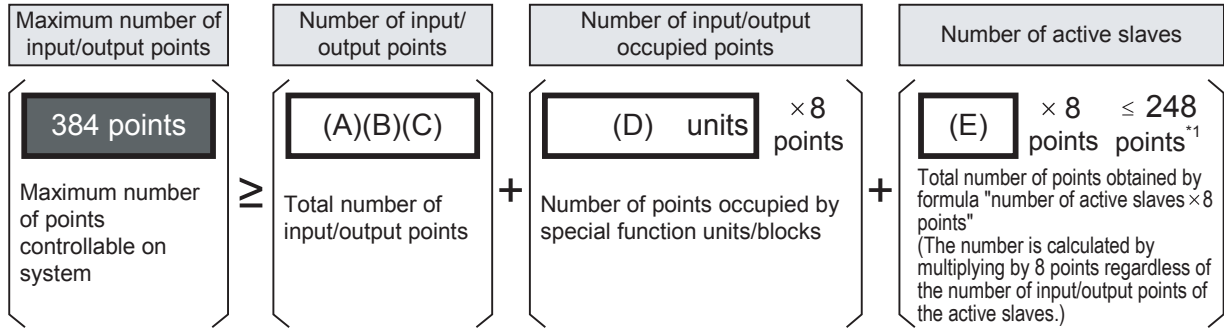

For the details, refer to Subsection 1.8.1.

- (A): Number of input/output points of main unit
- (B): Number of input/output points of input/output extension blocks
- (C): Number of remote I/O points of CC-Link/LT built-in master(FX3UC-32MT-LT(-2)), FX2N-64CL-M, FX2N-16LNK-M.
- (D): Number of input/output points occupied by special function units/blocks
- (E): Number of active slaves connected to AS-i system master block

*1. Up to 31 slaves can be connected to the AS-i system master block.

The maximum number is calculated by the formula "8 points × number of slaves" regardless of the number of I/O points used on one slave.

For details, refer to the AS-i System User's Manual.

2. Procedures for calculating number of input/output points based on example of system configuration

For the main unit, input/output blocks and AS-i system, the number of input/output points and the total number of points are restricted.

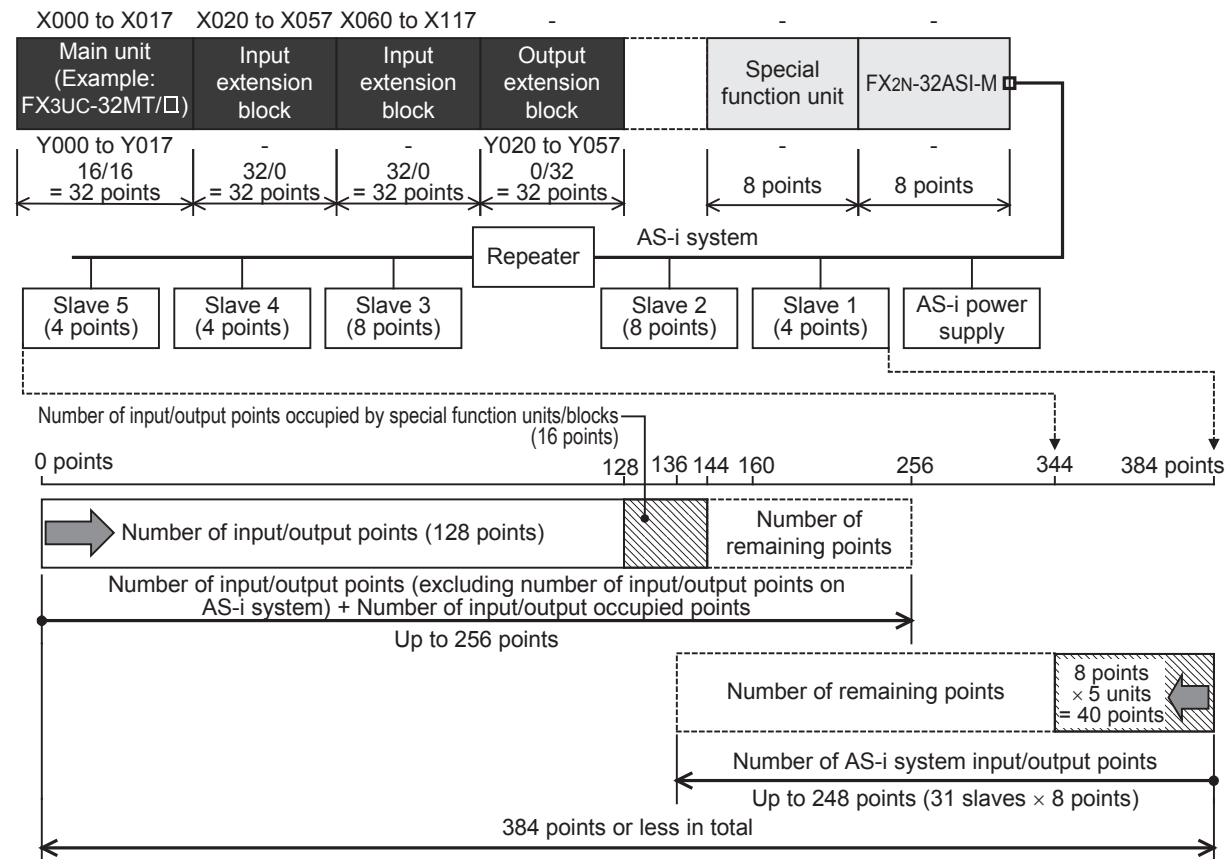

1.9 Calculation of 5V DC power supply capacity (current consumption)

Confirm the current consumption using the following procedures.

When the main unit built-in power supply is insufficient, add an extension power supply unit (FX3UC-1PS-5V) in accordance with the necessity.

- 1) Calculating the current in extension equipment that can receive power from the main unit built-in power supply.
Check whether the current consumption of extension equipment to be connected is not more than the capacity of the main unit built-in power supply.

A FX3UC Main unit

FX3UC-16MT/□: 600mA
FX3UC-16MR/D(S)-T: 600mA
FX3UC-32MT/□: 560mA
FX3UC-64MT/□: 480mA
FX3UC-96MT/□: 400mA
FX3UC-32MT-LT(-2): 350mA

B Special adapter Expansion board

C I/O extension devices

D Special function devices

F GOT Programming tool

Proceed to "2) FX3UC-1PS-5V" below.

When the capacity of the main unit built-in power supply is insufficient, connect an extension power supply unit (FX3UC-1PS-5V) **E1**. Select **D1**, **C1** or **D2** as **C** and **D** and proceed to 2).

Calculate the current consumption of the GOT/programming tool connected to the FX3U-422-BD.

A1 FX3UC Main unit	D1 FX3UC special function C1 FX2NC I/O D2 FX2NC special function	E1 FX3UC-1PS-5V
------------------------------	---	---------------------------

- 2) Calculating the current in extension equipment that can receive power from the extension power supply unit (FX3UC-1PS-5V)

- a) When only FX3UC/FX2NC Series units are connected for extension:

Proceed to 1) above. ... **E1** FX3UC-1PS-5V

C I/O extension devices

D Special function devices

C1 FX2NC I/O

D1 FX3UC special function
D2 FX2NC special function

1A(1000mA) ≥ [] mA + [] mA

When the capacity is still insufficient:
Connect one more extension power supply unit (FX3UC-1PS-5V) **E1**, and examine the configuration of the remaining extension equipment.

- b) When FX3UC, FX2NC, FX3U, FX2N and FX0N Series equipment are connected for extension
For connection including the FX3U, FX2N or FX0N Series extension equipment, the FX2NC-CNV-IF or FX3UC-1PS-5V is required:

Proceed to 1) above. ... **E1** FX3UC-1PS-5V

C I/O extension devices

D Special function devices

D1 FX3UC special function
C1 FX2NC I/O
D2 FX2NC special function

E2 FX2NC-CNV-IF

C2 FX2N I/O
C3 FX0N I/O

D3 FX3U/FX2N special function
D4 FX0N special function

When there are FX3UC or FX2NC Series extension equipment **D1**, **C1** or **D2**, connect them first, and then connect the FX2NC-CNV-IF.

[] mA + [] mA

When the capacity is still insufficient:
Adopt the connection configuration shown in a) above (but the FX2NC-CNV-IF **E2** is not allowed), connect the extension power supply unit (FX3UC-1PS-5V) **E1**, and then examine the entire configuration.

1	Outline
2	External Dimensions
3	Generic Specifications
4	Power Supply Specifications
5	Input Specifications
6	Output Specifications
7	Examples of Wiring for Various Uses
8	Terminal Block
9	CC-Link/LT Master FX3UC-LT(-2) only
10	Display module FX3UC-LT(-2) only

1.10 Restriction in number of units in each group

1.10.1 In the case of the FX3UC-□□MT/D(SS), FX3UC-16MR/D(S)-T

Confirm the number of units using the following procedures.

Division		Contents of restrictions																		
A Expansion boards		Not available when the main unit is the FX3UC-□□MT/D(SS) or FX3UC-16MR/D(S)-T.																		
B Special adapter	B1 Analog	Up to four units can be connected.																		
	B2 Communication	Up to two units can be connected. When a CF card special adapter is used, only 1 unit can be connected. Note that the number of connectable units is restricted for the following communication special adapter. <table border="1" style="width: 100%; border-collapse: collapse;"> <thead> <tr> <th style="width: 50%;">Model name</th> <th style="width: 50%;">Restriction</th> </tr> </thead> <tbody> <tr> <td>FX3U-ENET-ADP</td> <td>Only one FX3U-ENET-ADP unit can be connected to a single PLC main unit.</td> </tr> </tbody> </table>	Model name	Restriction	FX3U-ENET-ADP	Only one FX3U-ENET-ADP unit can be connected to a single PLC main unit.														
	Model name	Restriction																		
FX3U-ENET-ADP	Only one FX3U-ENET-ADP unit can be connected to a single PLC main unit.																			
B3 CF card	Only 1 unit can be connected. When two communication special adapters are used, the CF card special adapter cannot be connected.																			
C I/O extension devices D Special function devices - Special function units - Special function blocks	<ul style="list-style-type: none"> When the FX3UC-1PS-5V is used Up to 8 special function units/blocks in total can be connected in each system when the main unit is the FX3UC-□□MT/D(SS) or FX3UC-16MR/D(S)-T. Note that the number of connectable units is restricted in some models (as shown on the next page). When the FX3UC-1PS-5V is not used Up to 4 special function units/blocks in total can be connected to the FX3UC-□□MT/D(SS) or FX3UC-16MR/D(S)-T. After the FX2NC-CNV-IF, up to 4 I/O extension blocks and special function units/blocks in total can be connected. (When further connection is required, use the FX3UC-1PS-5V.) Example <table border="1" style="width: 100%; border-collapse: collapse; text-align: center;"> <tr> <td style="width: 12.5%;">FX3UC-32MT/D Main unit</td> <td style="width: 12.5%;">FX2NC-32EX</td> <td style="width: 12.5%;">FX2NC-16EYR-T</td> <td style="width: 12.5%;">FX3UC-4AD</td> <td style="width: 12.5%;">FX2NC-CNV-IF</td> <td style="width: 12.5%;">FX2N-8EYR</td> <td style="width: 12.5%;">FX3U-20SSC-H</td> <td style="width: 12.5%;">FX3U-4DA</td> <td style="width: 12.5%;">FX2N-1PG</td> </tr> <tr> <td colspan="5" style="border: none;">← Up to 4 special function units/blocks in total</td> <td colspan="4" style="border: none;">← Up to 4 I/O extension blocks and special function units/blocks in total →</td> </tr> </table>		FX3UC-32MT/D Main unit	FX2NC-32EX	FX2NC-16EYR-T	FX3UC-4AD	FX2NC-CNV-IF	FX2N-8EYR	FX3U-20SSC-H	FX3U-4DA	FX2N-1PG	← Up to 4 special function units/blocks in total					← Up to 4 I/O extension blocks and special function units/blocks in total →			
FX3UC-32MT/D Main unit	FX2NC-32EX	FX2NC-16EYR-T	FX3UC-4AD	FX2NC-CNV-IF	FX2N-8EYR	FX3U-20SSC-H	FX3U-4DA	FX2N-1PG												
← Up to 4 special function units/blocks in total					← Up to 4 I/O extension blocks and special function units/blocks in total →															
Continues to the next page.																				

Division	Contents of restrictions												
	In addition to the restrictions shown on the previous page, the number of units connectable to the main unit or extension power supply unit is restricted in the following models.												
	Connection target and number of connectable units												
	A FX3UC-□□MT/D FX3UC-16MR/D-T	E FX3UC-1PS-5V											
	<table border="1"> <tr><td>FX2NC-16EYR-T</td></tr> <tr><td>FX2N-8ER</td></tr> <tr><td>FX2N-8EYR</td></tr> <tr><td>FX2N-8EYR-S-ES/UL</td></tr> <tr><td>FX2N-8EYT</td></tr> <tr><td>FX2N-8EYT-H</td></tr> <tr><td>FX2N-16EYR</td></tr> <tr><td>FX0N-3A^{*2}</td></tr> <tr><td>FX2N-2AD^{*2}</td></tr> <tr><td>FX2N-2DA^{*2}</td></tr> <tr><td>FX3U-32DP^{*2}</td></tr> </table>	FX2NC-16EYR-T	FX2N-8ER	FX2N-8EYR	FX2N-8EYR-S-ES/UL	FX2N-8EYT	FX2N-8EYT-H	FX2N-16EYR	FX0N-3A ^{*2}	FX2N-2AD ^{*2}	FX2N-2DA ^{*2}	FX3U-32DP ^{*2}	<p>When the FX2NC-16EYR-T is not used, up to 4 units in total can be connected. When the FX2NC-16EYR-T is used, refer to the note^{*1} below.</p> <p>Up to 5 units in total can be connected.</p>
FX2NC-16EYR-T													
FX2N-8ER													
FX2N-8EYR													
FX2N-8EYR-S-ES/UL													
FX2N-8EYT													
FX2N-8EYT-H													
FX2N-16EYR													
FX0N-3A ^{*2}													
FX2N-2AD ^{*2}													
FX2N-2DA ^{*2}													
FX3U-32DP ^{*2}													
	Connection target and number of connectable units												
	A FX3UC-□□MT/DSS FX3UC-16MR/DS-T	E FX3UC-1PS-5V											
	<table border="1"> <tr><td>FX2NC-16EYR-T-DS</td></tr> <tr><td>FX2N-8ER-ES/UL</td></tr> <tr><td>FX2N-8EYR-ES/UL</td></tr> <tr><td>FX2N-8EYR-S-ES/UL</td></tr> <tr><td>FX2N-8EYT-ESS/UL</td></tr> <tr><td>FX2N-16EYR-ES/UL</td></tr> <tr><td>FX0N-3A^{*2}</td></tr> <tr><td>FX2N-2AD^{*2}</td></tr> <tr><td>FX2N-2DA^{*2}</td></tr> <tr><td>FX3U-32DP^{*2}</td></tr> </table>	FX2NC-16EYR-T-DS	FX2N-8ER-ES/UL	FX2N-8EYR-ES/UL	FX2N-8EYR-S-ES/UL	FX2N-8EYT-ESS/UL	FX2N-16EYR-ES/UL	FX0N-3A ^{*2}	FX2N-2AD ^{*2}	FX2N-2DA ^{*2}	FX3U-32DP ^{*2}	<p>When the FX2NC-16EYR-T-DS is not used, up to 4 units in total can be connected. When the FX2NC-16EYR-T-DS is used, refer to the note^{*1} below.</p> <p>Up to 5 units in total can be connected.</p>	
FX2NC-16EYR-T-DS													
FX2N-8ER-ES/UL													
FX2N-8EYR-ES/UL													
FX2N-8EYR-S-ES/UL													
FX2N-8EYT-ESS/UL													
FX2N-16EYR-ES/UL													
FX0N-3A ^{*2}													
FX2N-2AD ^{*2}													
FX2N-2DA ^{*2}													
FX3U-32DP ^{*2}													
	<p>^{*1} When the FX0N-3A, FX2N-2AD, FX2N-2DA or FX3U-32DP is used, up to 4 units in total can be connected. When the FX0N-3A, FX2N-2AD, FX2N-2DA or FX3U-32DP is not used, up to 5 units in total can be connected.</p> <p>^{*2} Consider the restriction for the number of special function equipment</p>												

- C** I/O extension devices
- D** Special function devices
- Special function units
 - Special function blocks

1	Outline
2	External Dimensions
3	Generic Specifications
4	Power Supply Specifications
5	Input Specifications
6	Output Specifications
7	Examples of Wiring for Various Uses
8	Terminal Block
9	CC-Link/LT Master FX3UC-LT(-2) only
10	Display module FX3UC-LT(-2) only

Division	Contents of restrictions																
<p>C I/O extension devices</p> <p>D Special function devices</p> <ul style="list-style-type: none"> - Special function units - Special function blocks 	<p>Note that the number of connectable units is restricted for the following special function units/blocks.</p> <table border="1" style="width: 100%; border-collapse: collapse;"> <thead> <tr> <th style="text-align: center;">Model name</th> <th style="text-align: center;">Restrictions</th> </tr> </thead> <tbody> <tr> <td style="text-align: center;">FX₃U-16CCL-M</td> <td> <ul style="list-style-type: none"> • Only one FX₃U-16CCL-M unit can be connected to a single PLC main unit. • This master cannot be used together with FX₂N-16CCL-M and the FX₂N-32ASI-M. </td> </tr> <tr> <td style="text-align: center;">FX₂N-16CCL-M</td> <td> <ul style="list-style-type: none"> • When multiple units are used, a remote I/O station cannot be connected to the second master station or later. • This master cannot be used together with FX₃U-16CCL-M, FX₃U-128ASL-M and the FX₂N-32ASI-M. </td> </tr> <tr> <td style="text-align: center;">FX₃U-128ASL-M</td> <td> <ul style="list-style-type: none"> • Only one FX₃U-128ASL-M unit can be connected to a single PLC main unit. • This master cannot be used together with FX₂N-16CCL-M and the FX₂N-32ASI-M. </td> </tr> <tr> <td style="text-align: center;">FX₂N-32ASI-M</td> <td> <ul style="list-style-type: none"> • Only one FX₂N-32ASI-M can be connected to a single PLC main unit. • This master cannot be used together with FX₃U-16CCL-M, FX₃U-128ASL-M and the FX₂N-16CCL-M. </td> </tr> <tr> <td style="text-align: center;">FX₃U-64CCL</td> <td>Only one FX₃U-64CCL unit can be connected to a single PLC main unit.</td> </tr> <tr> <td style="text-align: center;">FX₃U-64DP-M</td> <td>Only one FX₃U-64DP-M unit can be connected to a single PLC main unit.</td> </tr> <tr> <td style="text-align: center;">FX₂N-1RM-SET FX₂N-1RM-E-SET</td> <td>Up to 3 units can be sequentially connected to the end of a system. However, when three units are connected, they are counted as one unit, and the number of occupied input/output points is 8.</td> </tr> </tbody> </table>	Model name	Restrictions	FX ₃ U-16CCL-M	<ul style="list-style-type: none"> • Only one FX₃U-16CCL-M unit can be connected to a single PLC main unit. • This master cannot be used together with FX₂N-16CCL-M and the FX₂N-32ASI-M. 	FX ₂ N-16CCL-M	<ul style="list-style-type: none"> • When multiple units are used, a remote I/O station cannot be connected to the second master station or later. • This master cannot be used together with FX₃U-16CCL-M, FX₃U-128ASL-M and the FX₂N-32ASI-M. 	FX ₃ U-128ASL-M	<ul style="list-style-type: none"> • Only one FX₃U-128ASL-M unit can be connected to a single PLC main unit. • This master cannot be used together with FX₂N-16CCL-M and the FX₂N-32ASI-M. 	FX ₂ N-32ASI-M	<ul style="list-style-type: none"> • Only one FX₂N-32ASI-M can be connected to a single PLC main unit. • This master cannot be used together with FX₃U-16CCL-M, FX₃U-128ASL-M and the FX₂N-16CCL-M. 	FX ₃ U-64CCL	Only one FX ₃ U-64CCL unit can be connected to a single PLC main unit.	FX ₃ U-64DP-M	Only one FX ₃ U-64DP-M unit can be connected to a single PLC main unit.	FX ₂ N-1RM-SET FX ₂ N-1RM-E-SET	Up to 3 units can be sequentially connected to the end of a system. However, when three units are connected, they are counted as one unit, and the number of occupied input/output points is 8.
	Model name	Restrictions															
	FX ₃ U-16CCL-M	<ul style="list-style-type: none"> • Only one FX₃U-16CCL-M unit can be connected to a single PLC main unit. • This master cannot be used together with FX₂N-16CCL-M and the FX₂N-32ASI-M. 															
	FX ₂ N-16CCL-M	<ul style="list-style-type: none"> • When multiple units are used, a remote I/O station cannot be connected to the second master station or later. • This master cannot be used together with FX₃U-16CCL-M, FX₃U-128ASL-M and the FX₂N-32ASI-M. 															
	FX ₃ U-128ASL-M	<ul style="list-style-type: none"> • Only one FX₃U-128ASL-M unit can be connected to a single PLC main unit. • This master cannot be used together with FX₂N-16CCL-M and the FX₂N-32ASI-M. 															
	FX ₂ N-32ASI-M	<ul style="list-style-type: none"> • Only one FX₂N-32ASI-M can be connected to a single PLC main unit. • This master cannot be used together with FX₃U-16CCL-M, FX₃U-128ASL-M and the FX₂N-16CCL-M. 															
	FX ₃ U-64CCL	Only one FX ₃ U-64CCL unit can be connected to a single PLC main unit.															
	FX ₃ U-64DP-M	Only one FX ₃ U-64DP-M unit can be connected to a single PLC main unit.															
FX ₂ N-1RM-SET FX ₂ N-1RM-E-SET	Up to 3 units can be sequentially connected to the end of a system. However, when three units are connected, they are counted as one unit, and the number of occupied input/output points is 8.																

1.10.2 In the case of the FX3UC-32MT-LT(-2)

Confirm the number of units using the following procedures.

Division		Contents of restrictions																							
A Expansion boards		Only 1 unit can be connected.																							
	B1 Analog	Up to four units can be connected.																							
	B2 Communication	<ul style="list-style-type: none"> With a FX3U-CNV-BD expansion board. Up to two units total can be connected. When a CF card special adapter is used, only 1 adapter can be connected. With an expansion board other than the FX3U-CNV-BD. Only one communication special adapter or one CF card special adapter can be connected. 																							
		<p>Note that the number of connectable units is restricted for the following communication special adapter.</p> <table border="1"> <thead> <tr> <th>Model name</th> <th>Restriction</th> </tr> </thead> <tbody> <tr> <td>FX3U-ENET-ADP</td> <td>Only one FX3U-ENET-ADP unit can be connected to a single PLC main unit.</td> </tr> </tbody> </table>		Model name	Restriction	FX3U-ENET-ADP	Only one FX3U-ENET-ADP unit can be connected to a single PLC main unit.																		
Model name	Restriction																								
FX3U-ENET-ADP	Only one FX3U-ENET-ADP unit can be connected to a single PLC main unit.																								
B Special adapter	B3 CF card	<p>Only 1 unit can be connected.</p> <ul style="list-style-type: none"> With a FX3U-CNV-BD expansion board. When the total number of communication special adapters used is 2, the CF card special adapter cannot be connected. With an expansion board other than the FX3U-CNV-BD. Only one communication special adapter or one CF card special adapter can be connected. 																							
	<ul style="list-style-type: none"> When the FX3UC-1PS-5V is used Up to 7 special function units/blocks in total can be connected in each system when the main unit is the FX3UC-32MT-LT(-2). Note that the number of connectable units is restricted in some models (as shown below). When the FX3UC-1PS-5V is not used Note that the number of connectable units is restricted in some models (as shown below). (When further connection is required, use the FX3UC-1PS-5V.) The number of units connectable to the main unit or extension power supply unit is restricted in the following models. <table border="1"> <thead> <tr> <th rowspan="2">Model name</th> <th colspan="2">Connection target and number of connectable units</th> </tr> <tr> <th>A FX3UC-32MT-LT(-2)</th> <th>E FX3UC-1PS-5V</th> </tr> </thead> <tbody> <tr><td>FX2NC-16EYR-T*1</td><td rowspan="16">A Only either 1 unit can be connected to the FX3UC-32MT-LT(-2).</td><td rowspan="16">E Up to 5 units in total can be connected to the extension power supply unit.</td></tr> <tr><td>FX2N-8ER</td></tr> <tr><td>FX2N-8EYR</td></tr> <tr><td>FX2N-8EYR-S-ES/UL</td></tr> <tr><td>FX2N-8EYT</td></tr> <tr><td>FX2N-8EYT-H</td></tr> <tr><td>FX0N-8ER*2</td></tr> <tr><td>FX0N-8EYR*2</td></tr> <tr><td>FX0N-8EYT*2</td></tr> <tr><td>FX0N-8EYT-H*2</td></tr> <tr><td>FX0N-16EYR*2</td></tr> <tr><td>FX0N-16EYT*2</td></tr> <tr><td>FX2N-16EYR</td></tr> <tr><td>FX0N-3A*3</td></tr> <tr><td>FX2N-2AD*3</td></tr> <tr><td>FX2N-2DA*3</td></tr> </tbody> </table>		Model name	Connection target and number of connectable units		A FX3UC-32MT-LT(-2)	E FX3UC-1PS-5V	FX2NC-16EYR-T*1	A Only either 1 unit can be connected to the FX3UC-32MT-LT(-2).	E Up to 5 units in total can be connected to the extension power supply unit.	FX2N-8ER	FX2N-8EYR	FX2N-8EYR-S-ES/UL	FX2N-8EYT	FX2N-8EYT-H	FX0N-8ER*2	FX0N-8EYR*2	FX0N-8EYT*2	FX0N-8EYT-H*2	FX0N-16EYR*2	FX0N-16EYT*2	FX2N-16EYR	FX0N-3A*3	FX2N-2AD*3	FX2N-2DA*3
	Model name	Connection target and number of connectable units																							
A FX3UC-32MT-LT(-2)		E FX3UC-1PS-5V																							
FX2NC-16EYR-T*1	A Only either 1 unit can be connected to the FX3UC-32MT-LT(-2).	E Up to 5 units in total can be connected to the extension power supply unit.																							
FX2N-8ER																									
FX2N-8EYR																									
FX2N-8EYR-S-ES/UL																									
FX2N-8EYT																									
FX2N-8EYT-H																									
FX0N-8ER*2																									
FX0N-8EYR*2																									
FX0N-8EYT*2																									
FX0N-8EYT-H*2																									
FX0N-16EYR*2																									
FX0N-16EYT*2																									
FX2N-16EYR																									
FX0N-3A*3																									
FX2N-2AD*3																									
FX2N-2DA*3																									
<ul style="list-style-type: none"> C I/O extension devices D Special function devices <ul style="list-style-type: none"> - Special function units - Special function blocks 																									

*1. Adding more extension power supply units enables connection of 6 or more units.
*2. Cannot be connected to the FX3UC-32MT-LT-2.
*3. Consider the restriction for the number of special extension equipment.

1	Outline
2	External Dimensions
3	Generic Specifications
4	Power Supply Specifications
5	Input Specifications
6	Output Specifications
7	Examples of Wiring for Various Uses
8	Terminal Block
9	CC-Link/LT Master FX3UC-LT(-2) only
10	Display module FX3UC-LT(-2) only

Division	Contents of restrictions	
	Note that the number of connectable units is restricted for the following special function units/blocks.	
	Model name	Restrictions
	FX3U-16CCL-M	<ul style="list-style-type: none"> Only one FX3U-16CCL-M unit can be connected to a single PLC main unit. This master cannot be used together with FX2N-16CCL-M and the FX2N-32ASI-M.
	FX2N-16CCL-M	<ul style="list-style-type: none"> When multiple units are used, a remote I/O station cannot be connected to the second master station or later. This master cannot be used together with FX3U-16CCL-M, FX3U-128ASL-M and FX2N-32ASI-M.
	FX3U-128ASL-M	<ul style="list-style-type: none"> Only one FX3U-128ASL-M unit can be connected to a single PLC main unit. This master cannot be used together with FX2N-16CCL-M and the FX2N-32ASI-M.
	FX2N-32ASI-M	<ul style="list-style-type: none"> Only one FX2N-32ASI-M can be connected to a single PLC main unit. This master cannot be used together with FX3U-16CCL-M, FX3U-128ASL-M and the FX2N-16CCL-M.
	FX2N-16LNK-M FX3U-64DP-M FX3U-32DP	It is not supported by the FX3UC-32MT-LT(-2).
	FX3U-64CCL	Only one FX3U-64CCL unit can be connected to a single PLC main unit.
	FX2N-1RM-SET	Up to 3 units can be sequentially connected to the end of a system. However, when three units are connected, they are counted as one unit, and the number of occupied input/output points is 8.

- C** I/O extension devices
- D** Special function devices
 - Special function units
 - Special function blocks

1.11 Number of occupied I/O points and 5V DC current consumption

The table below shows the number of input/output occupied points for each model and the current consumed from the 5V DC main unit built-in power supply or the 5V DC FX3UC-1PS-5V power supply unit.

1. Main units

A

Division	Model name	Number of input/output points	5V DC current consumption (mA)
A1	FX3UC-16MT/D	16	-
	FX3UC-16MT/DSS	16	-
	FX3UC-16MR/D-T	16	-
	FX3UC-16MR/DS-T	16	-
	FX3UC-32MT/D	32	-
	FX3UC-32MT/DSS	32	-
	FX3UC-32MT-LT-2	32	-
	FX3UC-32MT-LT	32	-
	FX3UC-64MT/D	64	-
	FX3UC-64MT/DSS	64	-
	FX3UC-96MT/D	96	-
	FX3UC-96MT/DSS	96	-

2. Special adapters

B

Division	Model name	Number of input/output points	5V DC current consumption (mA)
B1	FX3U-4AD-ADP	0	15
	FX3U-4DA-ADP	0	15
	FX3U-3A-ADP	0	20
	FX3U-4AD-PT-ADP	0	15
	FX3U-4AD-PTW-ADP	0	15
	FX3U-4AD-PNK-ADP	0	15
	FX3U-4AD-TC-ADP	0	15
B2	FX3U-232ADP(-MB)	0	30
	FX3U-485ADP(-MB)	0	20
	FX3U-ENET-ADP	0	30
B3	FX3U-CF-ADP	0	50

3. Expansion boards

B

Division	Model name	Number of input/output points	5V DC current consumption (mA)
B4	FX3U-232-BD	0	20
	FX3U-422-BD	0	20*1
	FX3U-485-BD	0	40
	FX3U-USB-BD	0	15
	FX3U-8AV-BD	0	20
	FX3U-CNV-BD	0	-

*1. When the FX3U-422-BD is connected, add the current consumed by the GOT/programming tool

F

1

Outline

2

External Dimensions

3

Generic Specifications

4

Power Supply Specifications

5

Input Specifications

6

Output Specifications

7

Examples of Wiring for Various Uses

8

Terminal Block

9

CC-Link/LT Master FX3UC-LT(-2) only

10

Display module FX3UC-LT(-2) only

4. I/O extension devices

C

Division	Model name	Number of input/ output points	5V DC current consumption (mA)
C1	FX2NC-16EX	16	30
	FX2NC-16EX-DS	16	30
	FX2NC-16EX-T	16	30
	FX2NC-16EX-T-DS	16	30
	FX2NC-16EYT	16	50
	FX2NC-16EYT-DSS	16	50
	FX2NC-16EYR-T	16	50
	FX2NC-16EYR-T-DS	16	50
	FX2NC-32EX	32	60
	FX2NC-32EX-DS	32	60
	FX2NC-32EYT	32	100
	FX2NC-32EYT-DSS	32	100
	C2	FX2N-8ER	16
FX2N-8ER-ES/UL		16	25
FX2N-8EX-UA1/UL		8	25
FX2N-8EX		8	25
FX2N-8EX-ES/UL		8	25
FX2N-8EYR		8	30
FX2N-8EYR-ES/UL		8	30
FX2N-8EYR-S-ES/UL		8	30
FX2N-8EYT		8	30
FX2N-8EYT-ESS/UL		8	30
FX2N-8EYT-H		8	30
FX2N-16EX		16	45
FX2N-16EX-ES/UL		16	45
FX2N-16EX-C		16	40
FX2N-16EXL-C		16	35
FX2N-16EYR		16	40
FX2N-16EYR-ES/UL		16	40
FX2N-16EYS		16	160
FX2N-16EYT		16	180
FX2N-16EYT-ESS/UL		16	180
FX2N-16EYT-C	16	180	
C3	FX0N-8ER	16	25
	FX0N-8EX-UA1/UL	8	25
	FX0N-8EX	8	25
	FX0N-8EYR	8	30
	FX0N-8EYT	8	30
	FX0N-8EYT-H	8	30
	FX0N-16EX	16	40
	FX0N-16EYR	16	40
	FX0N-16EYT	16	40

5. Special function devices

- Special function blocks

D

Division	Model name	Number of input/output points	5V DC current consumption (mA)
D1	FX3UC-4AD	8	100
D2	FX2NC-4AD	8	50
	FX2NC-4DA	8	30
D3	FX2NC-1HC	8	90
	FX2N-2AD	8	20
	FX2N-2DA	8	30
	FX2N-4AD	8	30
	FX2N-4DA	8	30
	FX2N-4AD-TC	8	30
	FX2N-4AD-PT	8	30
	FX2N-8AD	8	50
	FX2N-5A	8	70
	FX2N-2LC	8	70
	FX2N-1HC	8	90
	FX2N-1PG	8	55
	FX2N-1PG-E	8	55
	FX2N-10PG	8	120
	FX2N-232IF	8	40
	FX2N-16CCL-M	*1	0
	FX2N-32CCL	8	130
	FX2N-64CL-M	*1	190
	FX2N-32ASI-M	*1	150
	FX2N-16LNK-M	*2	200
	FX3U-4AD	8	110
	FX3U-4DA	8	120
	FX3U-4LC	8	160
	FX3U-2HC	8	245
	FX3U-1PG	8	150
	FX3U-20SSC-H	8	100
FX3U-16CCL-M	*1	0	
FX3U-64CCL	8	0	
FX3U-128ASL-M	*1	130	
FX3U-64DP-M	8	0	
FX3U-32DP	8	0	
D4	FX0N-3A	8	30

*1. For the number of input/output occupied points, refer to the table below.

Model name	Number of input/output occupied points (Use the following formula.)
FX3U-16CCL-M, FX2N-16CCL-M	Remote I/O stations × 32 points + 8 points
FX2N-64CL-M	Total number of input/output points in remote I/O stations + 8 points
FX3U-128ASL-M	Set value of rotary switch + 8 points
FX2N-32ASI-M	For main units Ver. 2.20 or later Number of active slaves × 8 points + 8 points For main units Ver. 2.20 or less Number of active slaves × 4 points + 8 points

*2. Varies depending on the configuration of products connected to the network.
For details, refer to the FX2N-16LNK-M manual.

1

Outline

2

External
Dimensions

3

Generic
Specifications

4

Power Supply
Specifications

5

Input
Specifications

6

Output
Specifications

7

Examples of
Wiring for
Various Uses

8

Terminal Block

9

CC-Link/LT
Master FX3UC-
LT(-Z) only

10

Display module
FX3UC-LT(-Z)
only

- Special function units

Division	Model name	Number of input/output points	5V DC current consumption (mA)
D3	FX2N-10GM	8	0
	FX2N-20GM	8	0
	FX2N-1RM(-E)-SET	8 ^{*1}	0

- *1. When two or more (up to 3) FX2N-1RM units are connected, 8 input/output points are occupied without regard to the number of connected units.

6. Extension power supply unit/Connector conversion adapter

E

Division	Model name	Number of input/output points	5V DC current consumption (mA)
E1	FX3UC-1PS-5V	0	-
E2	FX2NC-CNV-IF	0	-

7. GOT/programming tool

F

Division	Model name	Number of input/output points	5V DC current consumption (mA)
F1	FX-30P	-	115 ^{*1}
	FX-20P(-SET0)	-	150 ^{*2}
	FX-20P-E(-SET0)	-	150 ^{*2}
	FX-10P(-SET0)	-	120
	FX-10P-E	-	120
	FX-232AW	-	220
	FX-232AWC	-	220
	FX-232AWC-H	-	120
	FX-USB-AW	-	15
	FX-10DM(-SET0)	-	220
	F920GOT-BBD5-K	-	220

- *1. When the intensity of the LCD backlight is set at the initial value 4. If the LCD backlight is set at the maximum value 8, it is handled as "155mA".
- *2. When the FX-20P-RWM is used, the current is 180mA.

1.12 Selection Calculation Example 1 for System Configuration

When the main unit is the FX3UC-64MT/D.

1. System equipment

FX3U-485ADP(-MB)	FX3U-232ADP(-MB)	FX3UC-64MT/D	FX2NC-32EX	FX2NC-32EX	FX2NC-16EYR-T	FX2NC-16EYR-T	FX2NC-4DA	FX3UC-4AD	FX2NC-CNV-IF	FX2N-10PG	FX3U-20SSC-H	FX0N-3A
------------------	------------------	--------------	------------	------------	---------------	---------------	-----------	-----------	--------------	-----------	--------------	---------

2. Confirmation of system configuration availability

1) Restriction in number of input/output points

Number of input / occupied output points		
a) Main unit (Number of input / occupied output points)		Total of a)
FX3UC-64MT/D	64 points	64 points
b) I/O extension block (Number of input / occupied output points)		Total of b)
FX2NC-32EX	32 points	32 + 32 + 16 + 16 = 96 96 points
FX2NC-32EX	32 points	
FX2NC-16EYR-T	16 points	
FX2NC-16EYR-T	16 points	
c) Special adapter (Number of input / occupied output points)		Total of c)
FX3U-232ADP(-MB)	0 points	0 + 0 = 0 0 points
FX3U-485ADP(-MB)	0 points	
d) Special function units / blocks (Number of input / occupied output points)		Total of d)
FX2NC-4DA	8 points	8 + 8 + 8 + 8 + 8 = 40 40 points
FX3UC-4AD	8 points	
FX2N-10PG	8 points	
FX3U-20SSC-H	8 points	
FX0N-3A	8 points	
Total number of I/O points		a) + b) + c) + d) = 64 + 96 + 0 + 40 = 200 < 256 points

The I/O points restriction is satisfied since the total number of input/output points is less than 256.

OK

1

Outline

2

External Dimensions

3

Generic Specifications

4

Power Supply Specifications

5

Input Specifications

6

Output Specifications

7

Examples of Wiring for Various Uses

8

Terminal Block

9

CC-Link/LT Master FX3UC-LT(-Z) only

10

Display module FX3UC-LT(-Z) only

- 2) Restriction in 5V DC power supply capacity
Calculate the 5V DC power supply capacity for the main unit or extension power supply unit.

5V DC power supply capacity and current consumption	
a)Supplier side	
FX3UC-64MT/D	480mA
b)Consumer side	
FX3U-232ADP(-MB)	30mA
FX3U-485ADP(-MB)	20mA
FX2NC-32EX	60mA
FX2NC-32EX	60mA
FX2NC-16EYR-T	50mA
FX2NC-16EYR-T	50mA
FX2NC-4DA	30mA
FX3UC-4AD	100mA
FX2NC-CNV-IF	0mA
FX2N-10PG	120mA
FX3U-20SSC-H	100mA
FX0N-3A	30mA

"a)Supplier side" - "b)Consumer side" = 480mA - 650mA = -170mA

- a) It is necessary to add an extension power supply unit since the capacity on the consumer side b) is 170mA larger than the capacity on the supplier side a).

Invalid

→ Refer to Subsection 1.12.1.

- 3) Restriction for the number of connectable units

- a) Special adapter

The FX3UC-□□MT/D(SS) and FX3UC-16MR/D(S)-T cannot use expansion boards. Directly connect the special adapter to the main unit.

There is no problem with this configuration since only 2 special communication adapters are connected.

OK

- b) Special function unit/block

This configuration includes the following 5 special function units/blocks.

Because only up to 4 units can be connected to the main unit, it is necessary to add an extension power supply unit.

- FX2NC-4DA
- FX3UC-4AD
- FX2N-10PG
- FX3U-20SSC-H
- FX0N-3A

Invalid

→ Refer to Subsection 1.12.1.

- c) Other restrictions

In some models, only up to 4 units (or 5 units in certain conditions) can be connected to a single main unit. When connecting 5 or more units, it is necessary to add an extension power supply unit. (Refer to Subsection 1.10.1.)

This configuration includes the following equipment that fall under the restriction for the number of connectable units.

- FX2NC-16EYR-T × 2
- FX0N-3A

There is no problem with this configuration since it satisfies the restriction for the number of connectable units (4 units).

OK

1.12.1 Re-examination of suitability for configuration

In this configuration, it is necessary to add an extension power supply unit FX3UC-1PS-5V due to the restrictions in 5V DC power supply capacity and the restriction regarding the number of connectable units. Construct the system as follows.

1. Components after countermeasures

Connect the extension power supply unit FX3UC-1PS-5V in place of the FX2NC-CNV-IF.

FX3U-485ADP(-MB)	FX3U-232ADP(-MB)	FX3UC-64MT/D	FX2NC-32EX	FX2NC-32EX	FX2NC-16EYR-T	FX2NC-16EYR-T	FX2NC-4DA	FX3UC-4AD	FX3UC-1PS-5V	FX2N-10PG	FX3U-20SSC-H	FX0N-3A
------------------	------------------	--------------	------------	------------	---------------	---------------	-----------	-----------	--------------	-----------	--------------	---------

2. Reexamination of system configuration availability

1) Restriction for the number of input/output points
There is no problem since the number of input/output points in the new system is "200".

OK

2) Restriction for the 5V DC power supply capacity
The 5V DC power supply capacity is as follows after the countermeasures.

- Main unit side

5V DC power supply capacity and current consumption	
a)Supplier side	
FX3UC-64MT/D	480mA
b)Consumer side	
FX3U-232ADP(-MB)	30mA
FX3U-485ADP(-MB)	20mA
FX2NC-32EX	60mA
FX2NC-32EX	60mA
FX2NC-16EYR-T	50mA
FX2NC-16EYR-T	50mA
FX2NC-4DA	30mA
FX3UC-4AD	100mA

"a)Supplier side" - "b)Consumer side" = 480mA - 400mA = 80mA ≥ 0mA

There is no problem since the total current consumption is less than the capacity "480mA" supplied by the main unit.

OK

- Extension power supply unit side

5V DC power supply capacity and current consumption	
FX3UC-1PS-5V	
1A (1000mA)	
b)Consumer side	
FX2N-10PG	120mA
FX3U-20SSC-H	100mA
FX0N-3A	30mA

"a)Supplier side" - "b)Consumer side" = 1000mA - 250mA = 750mA ≥ 0mA

There is no problem since the total current consumption is less than the capacity "1A (1000mA)" supplied by the Extension power supply unit.

OK

1	Outline
2	External Dimensions
3	Generic Specifications
4	Power Supply Specifications
5	Input Specifications
6	Output Specifications
7	Examples of Wiring for Various Uses
8	Terminal Block
9	CC-Link/LT Master FX3UC-LT(-Z) only
10	Display module FX3UC-LT(-Z) only

3) Restriction for the number of connectable units

a) Special adapter

There is no problem since the components are not changed.

OK

b) Special function unit/block

The following units are connected to the main unit.

- FX2NC-4DA
- FX3UC-4AD

There is no problem since up to 4 units can be connected to the main unit.

OK

The following units are connected to the extension power supply units (FX3UC-1PS-5V).

- FX2N-10PG
- FX3U-20SSC-H
- FX0N-3A

For the restriction on the number of units connectable to the extension power supply unit FX3UC-1PS-5V, refer to c) below and Section 1.10.

c) Other restrictions

In some models, only up to 4 units (or 5 units in certain conditions) can be connected to a single main unit. When connecting 5 or more units, it is necessary to add an extension power supply unit. (Refer to Subsection 1.10.1.)

This configuration includes the following equipment that falls under the restriction for the number of connectable units.

- FX2NC-16EYR-T × 2

There is no problem for this configuration since it satisfies the restriction for the number of connectable units (4 units).

OK

This configuration includes the following equipment that fall under the restriction for the number of connectable units to the extension power supply unit FX3UC-1PS-5V.

- FX0N-3A

There is no problem for this configuration since it satisfies the restriction for the number of connectable units (5 units).

OK

The restrictions for the number of input/output points, the restriction for the 5V DC power supply capacity and the restriction for the number of connectable units are satisfied and the configuration is valid when an extension power supply unit FX3UC-1PS-5V is connected instead of an FX2NC-CNV-IF.

1.13 Selection Calculation Example 2 for System Configuration

When the main unit is the FX3UC-32MT-LT(-2).

For the calculation of power supply restrictions in the CC-Link/LT system, refer to Subsection 9.6.3.

1. System equipment

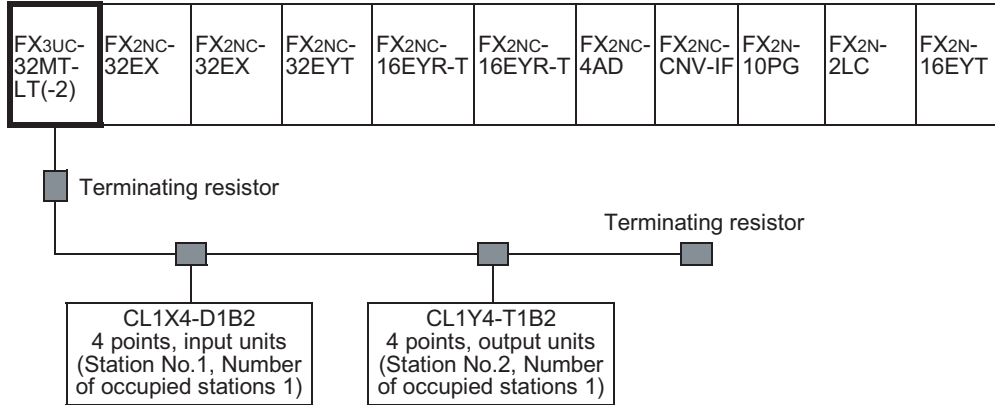

2. Confirmation of system configuration availability

1) Restriction for the number of input/output points

Number of input/output points occupied		
a) Main unit (Number of input / occupied output points)		Total of a)
FX3UC-32MT-LT(-2)	32 Points	32 points
b) I/O extension block (Number of input / occupied output points)		Total of b)
FX2NC-32EX	32 Points	32 + 32 + 32 + 16 + 16 + 16 = 144 points
FX2NC-32EX	32 Points	
FX2NC-32EYT	32 Points	
FX2NC-16EYR-T	16 Points	
FX2NC-16EYR-T	16 Points	
FX2N-16EYT	16 Points	
c) Total number of input/output points in remote I/O stations for built-in CC-Link/LT		Total of c)
CL1X4-D1B2	4 Points	4 + 4 = 8 points
CL1Y4-T1B2	4 Points	
d) Special function units / blocks (Number of input / occupied output points)		Total of d)
FX2NC-4AD	8 Points	8 + 8 + 8 = 24 points
FX2N-10PG	8 Points	
FX2N-2LC	8 Points	
Total number of I/O points		32 + 144 + 8 + 24 = 208 points < 256 points

The restriction for the number of input/output points is satisfied since the total number of input/output points is less than 256.

OK

1

Outline

2

External Dimensions

3

Generic Specifications

4

Power Supply Specifications

5

Input Specifications

6

Output Specifications

7

Examples of Wiring for Various Uses

8

Terminal Block

9

CC-Link/LT Master FX3UC-LT(-2) only

10

Display module FX3UC-LT(-2) only

- 2) Restriction for the 5V DC power supply capacity
Calculate the 5V DC power supply capacity for the main unit or extension power supply unit.

5V DC power supply capacity and current consumption	
a)Supplier side	
FX3UC-32MT-LT(-2)	350mA
b)Consumer side	
FX2NC-32EX	60mA
FX2NC-32EX	60mA
FX2NC-32EYT	100mA
FX2NC-16EYR-T	50mA
FX2NC-16EYR-T	50mA
FX2NC-4AD	50mA
FX2NC-CNV-IF	0mA
FX2N-10PG	120mA
FX2N-2LC	70mA
FX2N-16EYT	180mA

"a)Supplier side" - "b)Consumer side" = 350mA - 740mA = -390mA

- a) It is necessary to add an extension power supply unit since the capacity on the consumer side b) is 390mA larger than the capacity on the supplier side a).

Invalid

→ Refer to Subsection 1.13.1.

- 3) Restriction for the number of connectable units

- a) Expansion board

There is no problem since this configuration does not include an expansion board.

OK

- b) Special function unit/block

This configuration includes the following 3 special function units/blocks.

There is no problem since up to 7 special function units/blocks can be connected.

- FX2NC-4AD
- FX2N-10PG
- FX2N-2LC

OK

- c) Other restriction

In some models, only 1 unit can be connected to the main unit.

When connecting 2 or more units, it is necessary to add the extension power supply unit. (Refer to Subsection 1.10.2.)

This configuration includes the following equipment that falls under the restriction for the number of connectable units.

- FX2NC-16EYR-T × 2

Invalid

→ Refer to Subsection 1.13.1.

1.13.1 Re-examination of suitability for configuration

In this configuration, it is necessary to add the extension power supply unit FX3UC-1PS-5V due to the restrictions in 5V DC power supply capacity and the restriction for the number of connectable units. Construct the system as follows.

1. Components after countermeasures

Insert the extension power supply unit FX3UC-1PS-5V between the FX2NC-16EYR-T and the FX2NC-16EYR-T.

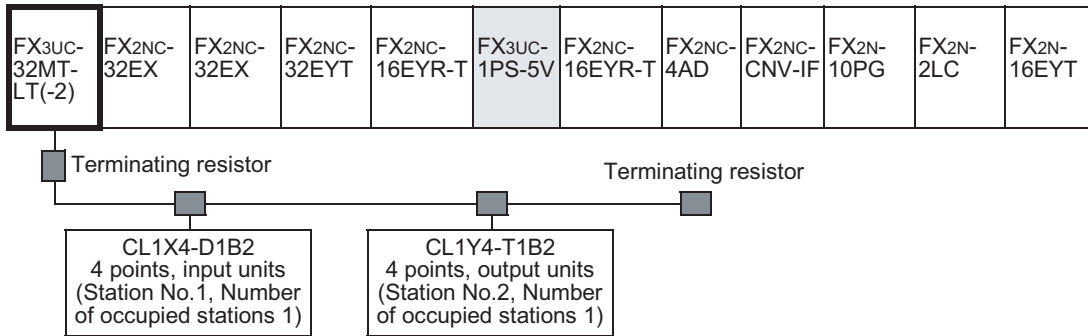

2. Reexamination of system configuration availability

- 1) Restriction in the number of input/output points
There is no problem since the number of input/output points in the new system is "208".
- 2) Restriction for the 5V DC power supply capacity
The 5V DC power supply capacity is as follows after the countermeasures.

OK

- Main unit side

5V DC power supply capacity and current consumption	
a)Supplier side	
FX3UC-32MT-LT(-2)	350mA
b)Consumer side	
FX2NC-32EX	60mA
FX2NC-32EX	60mA
FX2NC-32EYT	100mA
FX2NC-16EYR-T	50mA
	120mA
	220mA
	270mA

"a)Supplier side" - "b)Consumer side" = 350mA - 270mA = 80mA ≥ 0mA

There is no problem since the total current consumption is less than the capacity "350mA" supplied by the main unit.

OK

- Extension power supply unit side

5V DC power supply capacity and current consumption	
a)Supplier side	
FX3UC-1PS-5V	1A (1000mA)
b)Consumer side	
FX2NC-16EYR-T	50mA
FX2NC-4AD	50mA
FX2NC-CNV-IF	0mA
FX2N-10PG	120mA
FX2N-2LC	70mA
FX2N-16EYT	180mA
	100mA
	220mA
	290mA
	470mA

"a)Supplier side" - "b)Consumer side" = 1000mA - 470mA = 530mA ≥ 0mA

There is no problem since the total current consumption is less than the capacity "1A (1000mA)" supplied by the extension power supply unit.

OK

1	Outline
2	External Dimensions
3	Generic Specifications
4	Power Supply Specifications
5	Input Specifications
6	Output Specifications
7	Examples of Wiring for Various Uses
8	Terminal Block
9	CC-Link/LT Master FX3UC-LT(-2) only
10	Display module FX3UC-LT(-2) only

3) Restriction for the number of connectable units

a) Expansion board

There is no problem since the components have not changed.

OK

b) Special function unit/block

There is no problem since the components have not changed.

OK

c) Other restrictions

The new configuration is as follows due to the addition of an extension power supply unit between the FX2NC-16EYR-T and the FX2NC-16EYR-T:

- One FX2NC-16EYR-T unit is connected to the main unit.
There is no problem with this configuration since it satisfies the restriction for the number of connectable units (1 unit).
- One FX2NC-16EYR-T unit is connected to the extension power supply unit.
There is no problem with this configuration since it satisfies the restriction for the number of connectable units (5 units).

OK

OK

The restrictions for the number of input/output points, the restriction for the 5V DC power supply capacity and the restriction for the number of connectable units are satisfied and the configuration is valid when an extension power supply unit is added.

1.14 Selection Calculation Example 3 for System Configuration

When the main unit FX3UC-32MT-LT and CC-Link master are used.

For the calculation of power supply restrictions in the CC-Link/LT system, refer to Subsection 9.6.3.

1. Example system configuration

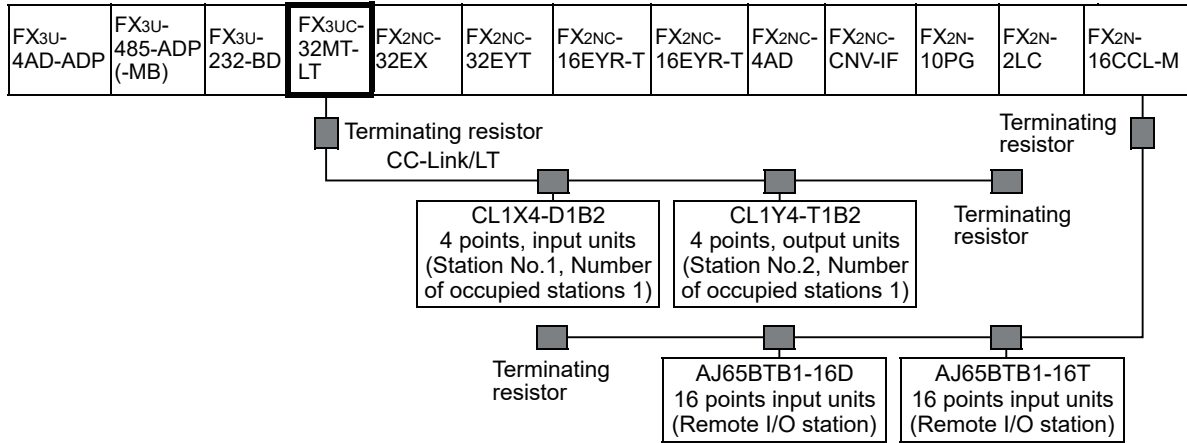

1	Outline
2	External Dimensions
3	Generic Specifications
4	Power Supply Specifications
5	Input Specifications
6	Output Specifications
7	Examples of Wiring for Various Uses
8	Terminal Block
9	CC-Link/LT Master FX3UC-LT(-2) only
10	Display module FX3UC-LT(-2) only

2. Judgment of system configuration availability

Note that the available maximum number of input/output points varies depending on the version of the FX3UC-32MT-LT.

1) Restriction for the number of input/output points

Number of input / occupied output points		Ver. 2.20 or less	Ver. 2.20 or later
a) Main unit (Number of input / occupied output points)		Total of a)	Total of a)
FX3UC-32MT-LT	32 points	32 points	32 points
b) I/O extension block (Number of input / occupied output points)		Total of b)	Total of b)
FX2NC-32EX	32 points	32 + 32 + 16 + 16 = 96 96 points	32 + 32 + 16 + 16 = 96 96 points
FX2NC-32EYT	32 points		
FX2NC-16EYR-T	16 points		
FX2NC-16EYR-T	16 points		
c) Expansion board, Special adapter (Number of input / occupied output points)		Total of c)	Total of c)
FX3U-232-BD	0 points	0 + 0 + 0 = 0 0 points	0 + 0 + 0 = 0 0 points
FX3U-485ADP(-MB)	0 points		
FX3U-4AD-ADP	0 points		
d) Total number of input/output points in remote I/O stations for built-in CC-Link/LT		Total of d)	Total of d)
CL1X4-D1B2	4 points	4 + 4 = 8 points 8 points	4 + 4 = 8 points 8 points
CL1Y4-T1B2	4 points		
e) Special function units / blocks (Number of input / occupied output points)		Total of e)	Total of e)
FX2NC-4AD	8 points	8 + 8 + 8 + 8 + 64 [Input/output occupied points in remote I/O (32points × 2units)] = 96 96 points	8 + 8 + 8 + 8 = 32 *1 Input/output occupied points in remote I/O stations are not included in the calculation here. 32 points
FX2N-10PG	8 points		
FX2N-2LC	8 points		
FX2N-16CCL-M*1	8 points		
Total number of I/O points		a) + b) + c) + d) + e) = f) 32 + 96 + 8 + 96 = 232 f) < 256 points.....①	a) + b) + c) + d) + e) = g) 32 + 96 + 8 + 32 = 168 g) < 256 points.....②

The restriction for the number of input/output points is satisfied since the total number of input/output points in ① and ② is less than 256.

OK

When the FX3UC-32MT-LT is Ver. 2.20 or later, the following calculation is required.
Ver. 2.20 or later

h) Number of input/output occupied points in remote I/O stations in network (CC-Link)		-	Total of h)
AJ65BTB1-16D	32 points		64 [Input/output occupied points in remote I/O (32points × 2units)] = 64 64points
AJ65BTB1-16T	32 points		
Number of input/output occupied points in network		-	h) < 224points

The restriction for the number of input/output points is satisfied since the total number of input/output occupied points in the network is less than 224.

OK

Total number of input/output occupied points + Total number of input/output occupied points in network	-	g) + h) = i) h) < 384points.....③
---	---	--------------------------------------

The restriction for the number of input/output points is satisfied since the total number of input/output points plus the total number of input/output occupied points in the network in ③ is less than 384.

OK

- 2) Restriction for the 5V DC power supply capacity
Calculate the 5V DC power supply capacity of the main unit or extension power supply unit.

5V DC power supply capacity and current consumption	
a)Supplier side	
FX3UC-32MT-LT	350mA
b)Consumer side	
FX3U-232-BD	20mA
FX3U-485ADP(-MB)	20mA
FX3U-4AD-ADP	15mA
FX2NC-32EX	60mA
FX2NC-32EYT	100mA
FX2NC-16EYR-T	50mA
FX2NC-16EYR-T	50mA
FX2NC-4AD	50mA
FX2NC-CNV-IF	0mA
FX2N-10PG	120mA
FX2N-2LC	70mA
FX2N-16CCL-M	0mA

"a)Supplier side" - "b)Consumer side" = 350mA - 555mA = -205mA

It is necessary to add an extension power supply unit since the capacity on the consumer side b) is 205mA larger than the capacity on the supplier side a).

Invalid

→ Refer to the next page

- 3) Restriction for the number of connectable units

- a) Expansion board

There is no problem since this configuration includes only 1 expansion board.

OK

- b) Special adapter

There is no problem since this configuration includes only 1 special communication adapter and 1 special analog adapter.

OK

- c) Special function unit/block

This configuration includes the following 3 special function units/blocks.

There is no problem since up to 7 special function units/blocks can be connected.

- FX2NC-4AD
- FX2N-10PG
- FX2N-2LC

OK

- d) Other restrictions

In some models, only 1 unit can be connected to the main unit. When connecting 2 or more units, it is necessary to add an extension power supply unit. (Refer to Subsection 1.10.2.)

This configuration includes the following equipment, which falls under the restriction for the number of connectable units.

- FX2NC-16EYR-T × 2

Invalid

→ Refer to the next page

1	Outline
2	External Dimensions
3	Generic Specifications
4	Power Supply Specifications
5	Input Specifications
6	Output Specifications
7	Examples of Wiring for Various Uses
8	Terminal Block
9	CC-Link/LT Master FX3UC-LT(-Z) only
10	Display module FX3UC-LT(-Z) only

1.14.1 Judgment of availability after reexamination of configuration

In this configuration, it is necessary to add an extension power supply unit FX3UC-1PS-5V due to the restrictions in the 5V DC power supply capacity and the restriction in the number of connectable units. Construct the system as follows.

1. Example of reexamined system configuration

Insert an extension power supply unit FX3UC-1PS-5V between the FX2NC-16EYR-T and the FX2NC-16EYR-T.

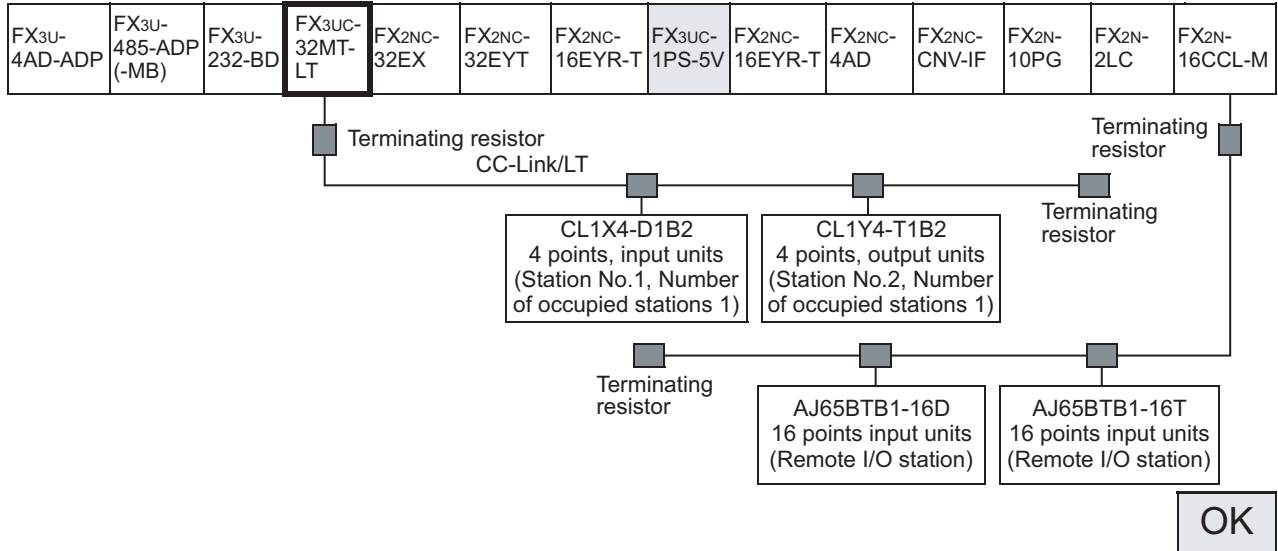

2. Reexamination of system configuration availability

- 1) Restriction for the number of input/output points
There is no problem since the number of input/output points in the new system is "208".
- 2) Restriction for the 5V DC power supply capacity
The 5V DC power supply capacity is as follows after countermeasures.
 - Main unit side

5V DC power supply capacity and current consumption	
a)Supplier side	
FX3UC-32MT-LT	350mA
b)Consumer side	
FX3U-232-BD	20mA
FX3U-485ADP(-MB)	20mA
FX3U-4AD-ADP	15mA
FX2NC-32EX	60mA
FX2NC-32EYT	100mA
FX2NC-16EYR-T	50mA
	265mA

"a)Supplier side" - "b)Consumer side" = 350mA - 265mA = 85mA ≥ 0mA

There is no problem since the total current consumption is less than the capacity "350mA" supplied by the main unit.

OK

- Extension power supply unit side

5V DC power supply capacity and current consumption		
FX3UC-1PS-5V	1A (1000mA)	
FX2N-10PG	120mA	220mA 250mA
FX3U-20SSC-H	100mA	
FX0N-3A	30mA	
"a)Supplier side" - "b)Consumer side" = 1000mA - 250mA = 750mA ≥ 0mA		

There is no problem since the total current consumption is less than the capacity "1A (1000mA)" supplied by the Extension power supply unit.

OK

- 3) Restriction for the number of connectable units

- a) Expansion board

There is no problem since the components have not changed.

OK

- b) Special function unit/block

There is no problem since the components have not changed.

OK

- c) Other restrictions

The new configuration is as follows due to insertion of an extension power supply unit between the FX2NC-16EYR-T and the FX2NC-16EYR-T:

- One FX2NC-16EYR-T unit is connected to the main unit.

There is no problem with this configuration since it satisfies the restriction for the number of connectable units (1 units).

OK

- One FX2NC-16EYR-T unit is connected to the extension power supply unit.

There is no problem with this configuration since it satisfies the restriction for the number of connectable units (5 units).

OK

The restrictions for the number of input/output points, the restriction for the 5V DC power supply capacity and the restriction for the number of connectable units are satisfied and the configuration is valid when an extension power supply unit is added.

1	Outline
2	External Dimensions
3	Generic Specifications
4	Power Supply Specifications
5	Input Specifications
6	Output Specifications
7	Examples of Wiring for Various Uses
8	Terminal Block
9	CC-Link/LT Master FX3UC-LT(-Z) only
10	Display module FX3UC-LT(-Z) only

1.15 Assignment of Input/Output Numbers (X/Y)

When input/output extension blocks are connected to the main unit (CPU), octal numbers are assigned as input/output numbers (X/Y) when the power is turned ON. Accordingly, it is not usually necessary to specify input/output numbers using parameters.

It is necessary, however, to assign input/output numbers to the following special extension unit/blocks.

- FX2N-64CL-M
- FX2N-16LNK-M (Not supported by the FX3UC-32MT-LT(-2).)

1.15.1 Rules for input/output number (X/Y) assignment

When the power is turned on, input/output numbers (X/Y) are assigned in accordance with the following rules. It is assumed that input/output numbers have already been assigned in CONFIG mode for remote I/O units connected to the FX3UC-32MT-LT(-2) built-in CC-Link/LT master.

1. Input/output numbers (X/Y) are octal.

Octal numbers are assigned as input/output numbers (X/Y) as shown below.

- X000 to X007, X010 to X017, X020 to X027....., X070 to X077, X100 to X107...
- Y000 to Y007, Y010 to Y017, Y020 to Y027....., Y070 to Y077, Y100 to Y107...

2. Numbers for added input/output unit/block

For each of the input/output extension blocks connected to the right side of the main unit or input/output extension block, input/output numbers following the input/output numbers on the main unit or extension block on the left side are assigned respectively. However, the last digit is assigned from "0".

For example, when the input number in the main unit or extension block on the left side ends at X043, input numbers starting from X050 are assigned to the extension block on the right side. (When the FX2N-8ER is used, unused numbers are generated in input/output numbers.)

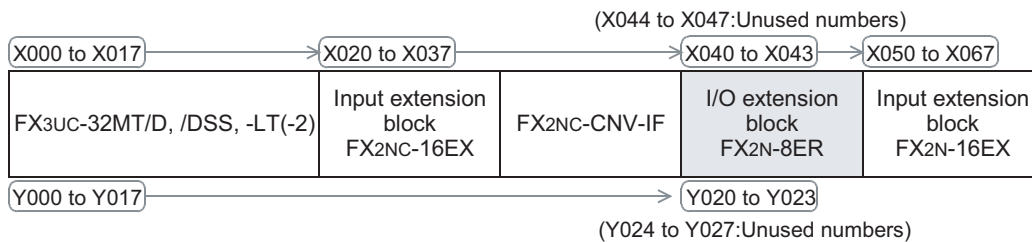

3. Input/output numbers in the FX3UC-32MT-LT(-2) built-in CC-Link/LT master

For each of the remote I/O units connected to the FX3UC-32MT-LT(-2) built-in CC-Link/LT master, input numbers (X) and output numbers (Y) are assigned respectively as a continuation from the input and output numbers on the last input/output extension block*1 connected to the main unit.

→ Refer to "1.15.3 Example of assigning" on the next page.

→ For input and output numbers in remote I/O units connected to the CC-Link/LT master built in the FX3UC-32MT-LT(-2), refer to Section 9.11.

*1. When the FX2N-64CL-M is connected, input numbers (X) and output numbers (Y) are assigned earlier in the FX2N-64CL-M than remote I/O units connected to the CC-Link/LT built-in master.

1.15.2 Caution

1. When the FX3UC-32MT-LT built-in CC-Link/LT master is in CONFIG mode

When the FX3UC-32MT-LT built-in CC-Link/LT master is in CONFIG mode, inputs and outputs in remote I/O stations are not occupied.

Note that input/output extension blocks connected on the right side of the main unit do not operate.

2. When the FX2N-64CL-M or an input/output extension block is added to the FX3UC-32MT-LT(-2)

When an input/output extension block or the FX2N-64CL-M is added (to the existing system) in the future, input/output numbers in remote I/O stations connected to the FX3UC-32MT-LT(-2) built-in master are shifted to positions after the added input/output extension block or FX2N-64CL-M. In this case, shift the input/output numbers used in programs.

→ For special extension blocks such as the FX2N-64CL-M in which input/output numbers in the PLC main unit are assigned to connected remote I/O stations, refer to the manual of each product.

1.15.3 Example of (X/Y) assignment

In this example, input/output numbers (X/Y) are assigned to components in the system whose main unit is the FX3UC-32MT-LT.

When the master station is set to CONFIG mode and the power of the PLC is turned ON, connected remote stations are checked and input/output numbers are assigned to each remote station.

1. Example of configuration

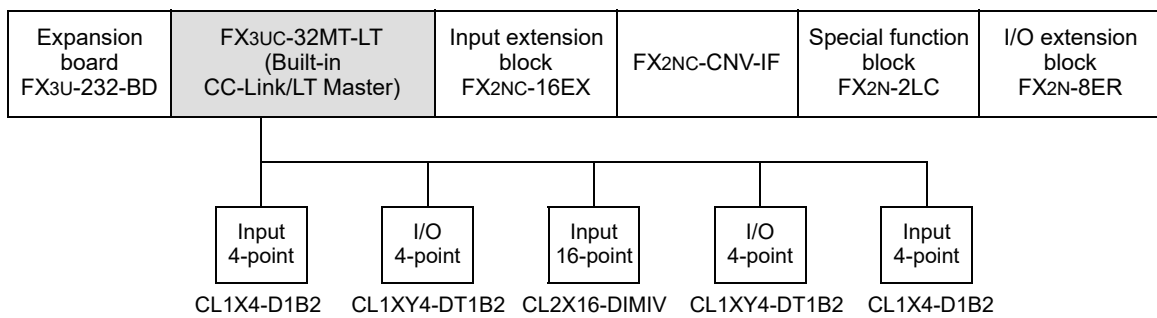

2. Point mode and Number of stations

Point mode/Station No.		Points	I/O assignment number (X)	I/O assignment number (Y)
4 points mode	16 points mode			
Station No.1	Station No.1	Input 4 points	X050 to X053	-
Station No.2	Station No.2	Input 2 points / Output 2 points	X054, X055	Y030, Y031
Station No. 3,4,5,6	Station No.3	Input 16 points	X056 to X075	-
Station No.7	Station No.4	Input 2 points / Output 2 points	X076, X077	Y032, Y033
Station No.8	Station No.5	Input 4 points	X100 to X103	-

The above input/output numbers are assigned as follows in the configuration example. (Station numbers are assigned in the 16-point mode.)

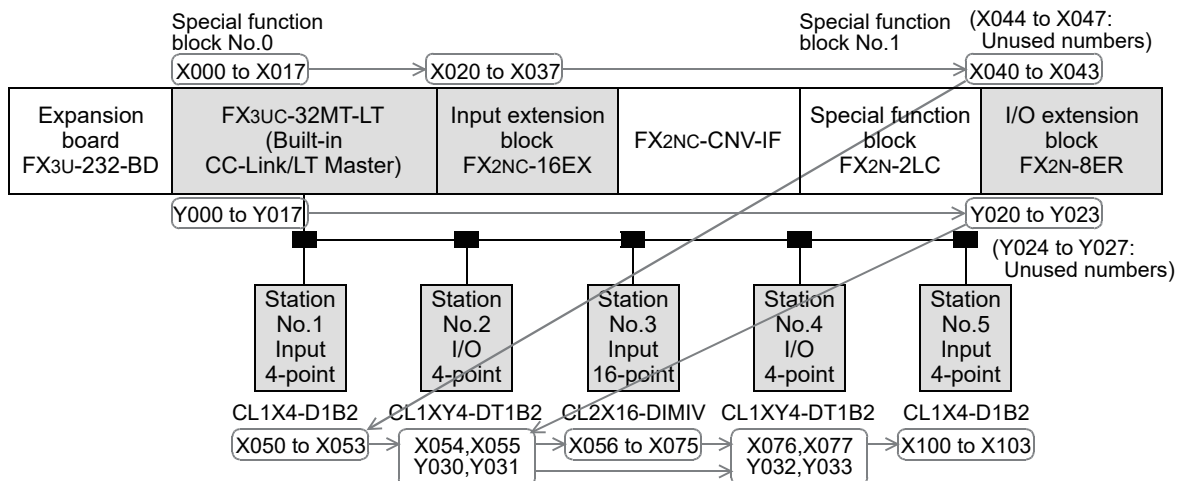

1 Outline
2 External Dimensions
3 Generic Specifications
4 Power Supply Specifications
5 Input Specifications
6 Output Specifications
7 Examples of Wiring for Various Uses
8 Terminal Block
9 CC-Link/LT Master FX3UC-LT(-2) only
10 Display module FX3UC-LT(-2) only

1.16 Unit Numbers of Special Function Units/Blocks

When the power is turned on, the main unit (CPU) automatically assigns the numbers 0 to 7 to special function units/blocks starting from the one closest to the main unit. (Unit Nos. 1, 2 ••• 7 are assigned when the main unit is the FX3UC-32MT-LT(-2).)

Unit numbers are not given to input/output powered extension units/blocks.

1.16.1 Rules of unit number assignment

Unit numbers are automatically assigned to special function units/blocks as follows when the power is turned ON.

1. FX3uc-32MT-LT(-2) built-in CC-Link/LT master

When the main unit is the FX3UC-32MT-LT(-2), the unit No. 0 is assigned to the CC-Link/LT built-in master.

2. Special function units/blocks connected to the right side of the main unit

Unit Nos. 0, 1 ••• 7 are assigned to special function units/blocks (except input/output extension blocks) from the one nearest the main unit. (Unit Nos. 1, 2 ••• 7 are assigned when the main unit is the FX3UC-32MT-LT(-2).)

3. FX2N-1RM(-E)-SET

Up to three FX2N-1RM(-E)-SET can be sequentially connected to the end of one system.

All of these connected units have the same module number as the unit number of the first unit (FX2N-1RM(-E)-SET).

→ For FX2N-1RM-E-SET, refer to FX2N-1RM-E-SET USER'S MANUAL.

4. Products to which unit numbers are not assigned

- Input/output extension blocks: FX2NC-16EX, FX2NC-16EYR, etc.
- Extension power supply unit: FX3UC-1PS-5V
- Special function block: FX2N-16LNK-M
- Connector conversion adapter: FX2NC-CNV-IF, FX2N-CNV-BC
- Expansion boards: FX3U-232-BD, etc.
- Special adapters: FX3U-232ADP(-MB), etc.

1.16.2 Example of assigning

1. In the case of the FX3uc-64MT/D

Unit numbers are assigned to the special function units/blocks in the following configuration.

→ For assignment of input/output numbers, refer to Section 1.15.

Special adapter FX3U-232ADP (-MB)	FX3UC-64MT/D	Input/output extension block FX2NC-16EX	Special function block FX3UC-4AD	Special function block FX2NC-4DA	FX2NC-CNV-IF	Special function block FX2N-10PG
---	--------------	--	---	---	--------------	---

Unit numbers are assigned to the special function units/blocks in the above configuration as shown below.

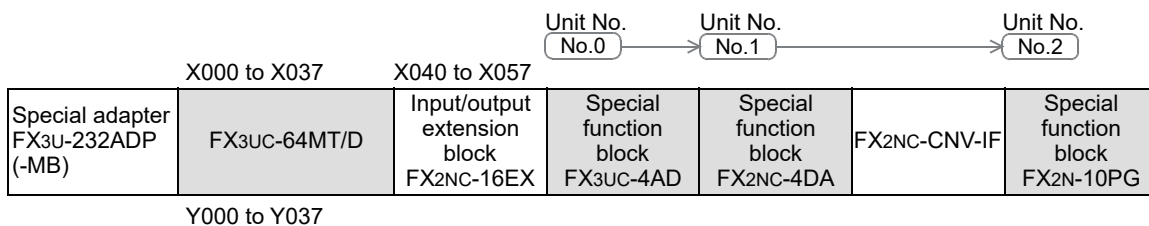

2. In the case of the FX3UC-32MT-LT(-2)

Unit numbers are assigned to special function units/blocks in the following configuration. It is assumed that input/output numbers have already been assigned in CONFIG mode (4-point mode) for the FX3UC-32MT-LT(-2) built-in CC-Link/LT master.

→ For the assignment of input/output numbers, refer to Section 1.15.

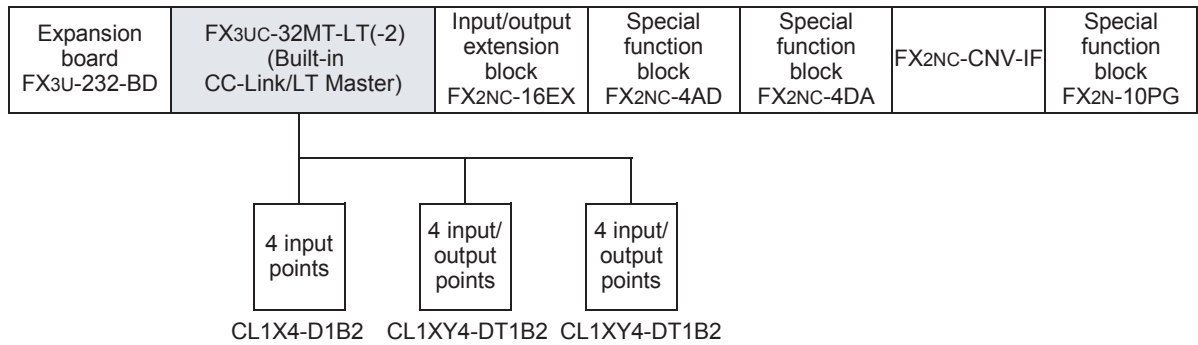

Unit numbers are assigned to the special function units/blocks in the above configuration as shown below.

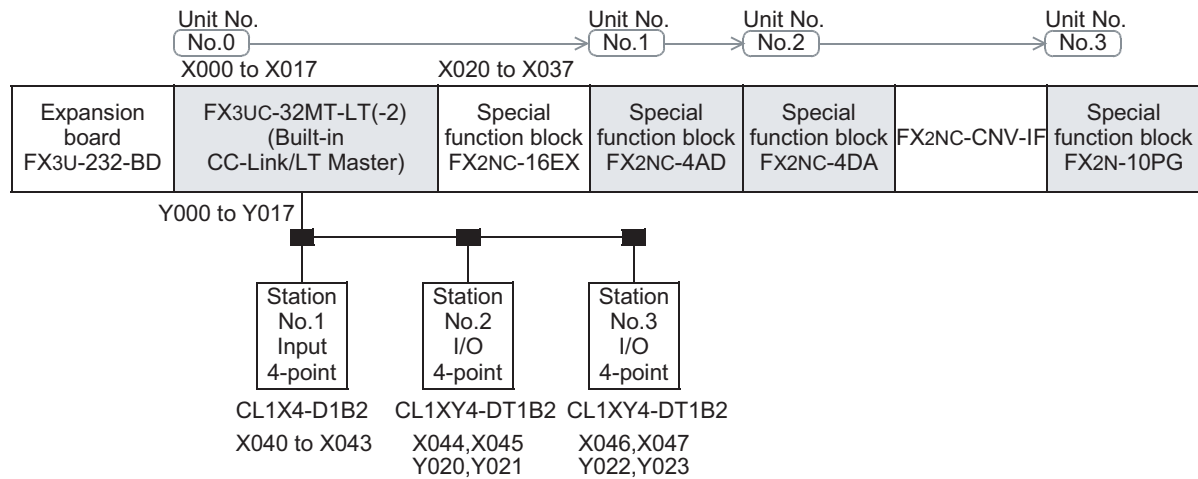

1.16.3 Application of unit number labels

The special function units/blocks come with unit number labels. Apply the unit number labels to spaces on the enclosure (see the following figure) so that the unit numbers can be identified.

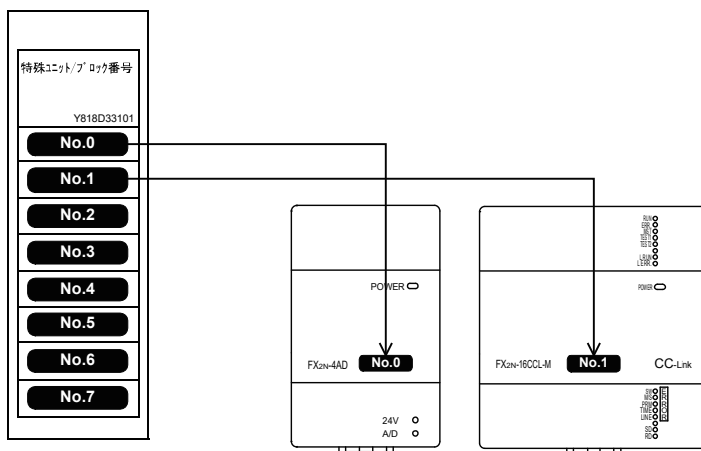

1.16.4 Application of the trimmer layout label

The analog volume expansion board (FX3U-8AV-BD) comes with a trimmer layout label. Apply the trimmer layout label in a position (see the following figure) so that the each trimmer can be identified.

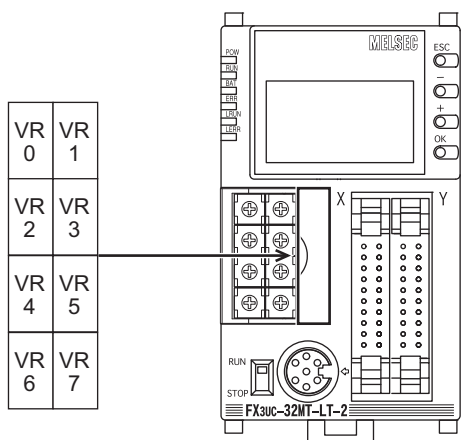

2. External Dimensions and Terminal Arrangement

2.1 External Dimensions (MASS/Installation/Accessories)

2.1.1 Main Units

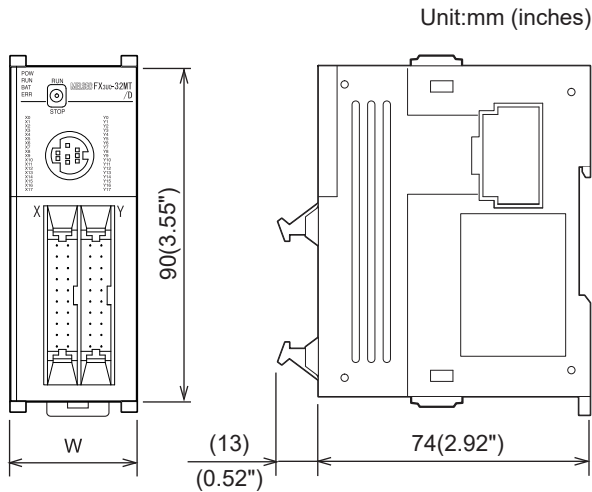

Model name	W:mm (inches)	MASS(Weight): kg (lbs)
FX3UC-16MT/D	34.0 (1.34")	Approx. 0.2 (0.44lbs)
FX3UC-32MT/D	34.0 (1.34")	Approx. 0.2 (0.44lbs)
FX3UC-64MT/D	59.7 (2.36")	Approx. 0.3 (0.66lbs)
FX3UC-96MT/D	85.4 (3.37")	Approx. 0.35 (0.77lbs)
FX3UC-16MT/DSS	34.0 (1.34")	Approx. 0.2 (0.44lbs)
FX3UC-32MT/DSS	34.0 (1.34")	Approx. 0.2 (0.44lbs)
FX3UC-64MT/DSS	59.7 (2.36")	Approx. 0.3 (0.66lbs)
FX3UC-96MT/DSS	85.4 (3.37")	Approx. 0.35 (0.77lbs)

- Installation: DIN rail of 35mm (1.38") in width only
- Accessories:
 - 1) FX3UC-□□MT/D
FX2NC-100MPCB power supply cable (1m (3'33")),
FX2NC-100BPCB power supply cable (1m (3'33")),
Manual supplied with product
 - 2) FX3UC-□□MT/DSS
FX2NC-100MPCB power supply cable (1m (3'33")),
Manual supplied with product

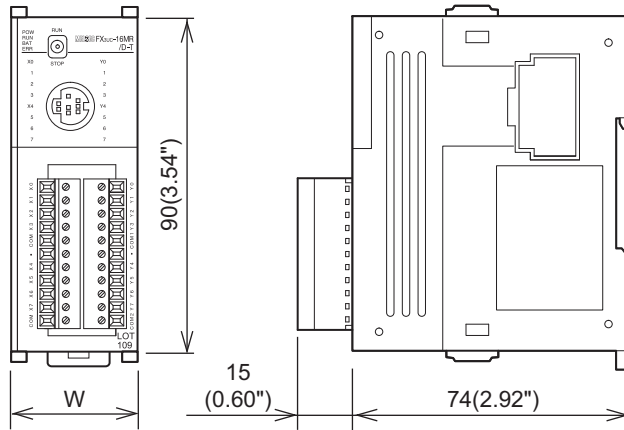

Model name	W:mm (inches)	MASS(Weight): kg (lbs)
FX3UC-16MR/D-T	34.0 (1.34")	Approx. 0.25 (0.55lbs)
FX3UC-16MR/DS-T	34.0 (1.34")	Approx. 0.25 (0.55lbs)

- Installation: DIN rail of 35mm (1.38") in width only
- Accessories:
 - 1) FX3UC-16MR/D-T
 FX2NC-100MPCB power supply cable (1m (3'33")),
 FX2NC-100BPCB power supply cable (1m (3'33")),
 Manual supplied with product
 - 2) FX3UC-16MR/DS-T
 FX2NC-100MPCB power supply cable (1m (3'33")),
 Manual supplied with product

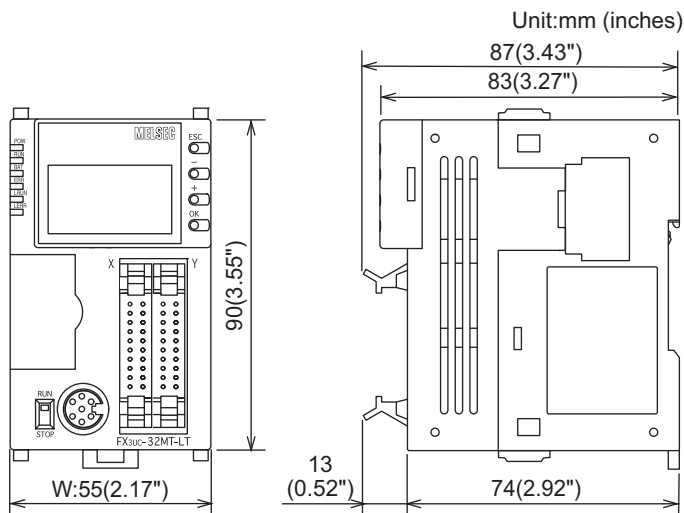
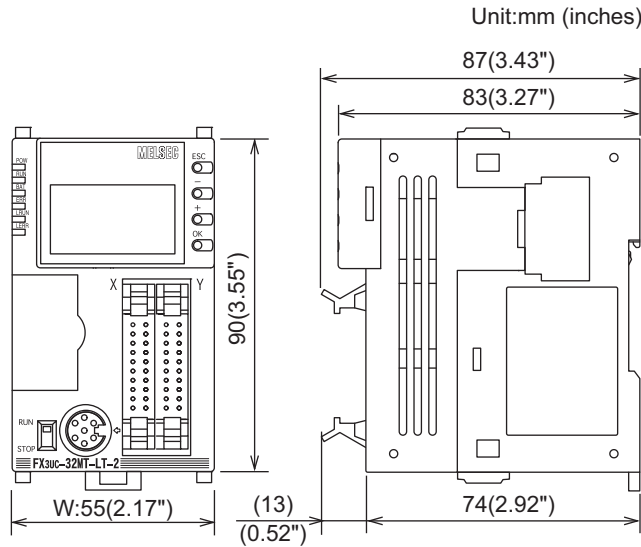

Model name	W:mm (inches)	MASS(Weight): kg (lbs)
FX3UC-32MT-LT-2	55 (2.17")	Approx. 0.25 (0.55lbs)

- Installation: DIN rail of 35mm (1.38") in width only
- Accessories:
 - FX2NC-100MPCB power supply cable (1m (3'33")),
 - FX2NC-100BPCB power supply cable (1m (3'33")),
 - Manual supplied with product

Model name	W:mm (inches)	MASS(Weight): kg (lbs)
FX3UC-32MT-LT	55 (2.17")	Approx. 0.25 (0.55lbs)

- Installation: DIN rail of 35mm (1.38") in width only
- Accessories:
 - FX2NC-100MPCB power supply cable (1m (3'33")),
 - FX2NC-100BPCB power supply cable (1m (3'33")),
 - Manual supplied with product

1 Outline

2 External Dimensions

3 Generic Specifications

4 Power Supply Specifications

5 Input Specifications

6 Output Specifications

7 Examples of Wiring for Various Uses

8 Terminal Block

9 CC-Link/LT Master FX3UC-LT(-2) only

10 Display module FX3UC-LT(-2) only

2.1.2 FX2NC Series Input/output Extension Block

1. Connector type

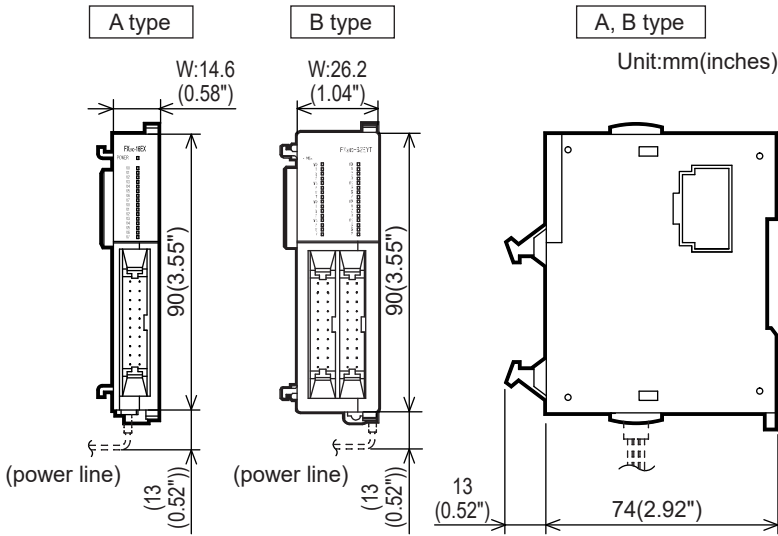

Type	Model name	W:mm (inches)	MASS (Weight): kg (lbs)
A	FX2NC-16EX	14.6 (0.58")	Approx. 0.15 (0.33lbs)
	FX2NC-16EYT		
	FX2NC-16EX-DS		
	FX2NC-16EYT-DSS		
B	FX2NC-32EX	26.2 (1.04")	Approx. 0.2 (0.44lbs)
	FX2NC-32EYT		
	FX2NC-32EX-DS		
	FX2NC-32EYT-DSS		

- Installation: DIN rail of 35mm (1.38") in width only
- Accessories:
 - 1) FX2NC-□□EX
 FX2NC-10BPCB1 power crossover cable (0.1m (0'3"))
 - 2) Other models
 None

2. Terminal type

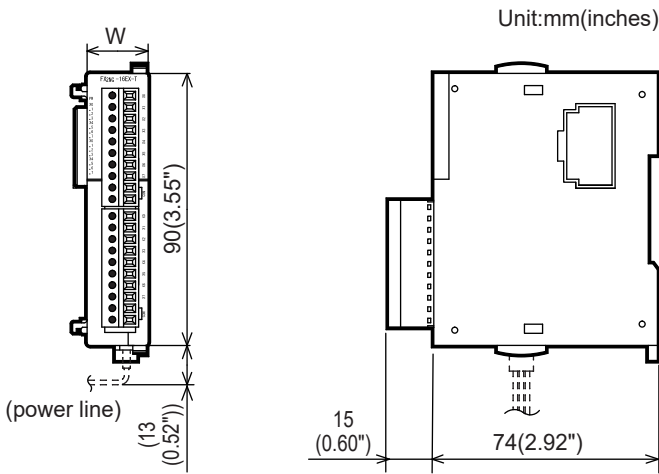

Model name	W:mm (inches)	MASS (Weight): kg (lbs)
FX2NC-16EX-T FX2NC-16EX-T-DS	20.2 (0.80")	Approx. 0.15 (0.33lbs)
FX2NC-16EYR-T FX2NC-16EYR-T-DS	24.2 (0.96")	Approx. 0.2 (0.44lbs)

- Installation: DIN rail of 35mm (1.38") in width only
- Accessories:
 - 1) FX2NC-16EX-T
 FX2NC-10BPCB1 power crossover cable (0.1m (0'3"))
 - 2) Other models
 None

2.1.3 FX2N Series Input/output Extension Block

1. Connector / Terminal type

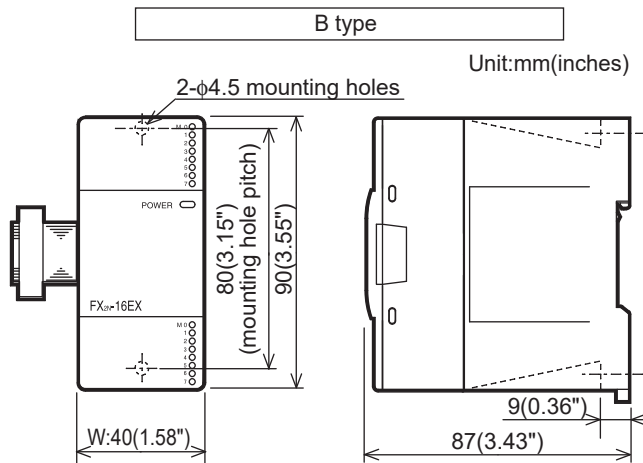
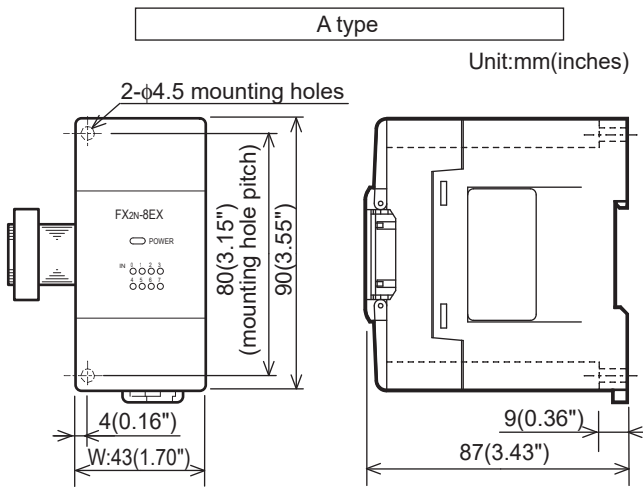

Type	Model name	W:mm (inches)	MASS (Weight): kg (lbs)
A	FX2N-8ER	43 (1.70")	Approx. 0.2 (0.44lbs)
	FX2N-8EX		
	FX2N-8EX-UA1/UL		
	FX2N-8EYR		
	FX2N-8EYT		
	FX2N-8EYT-H		
	FX2N-8ER-ES/UL		
	FX2N-8EX-ES/UL		
	FX2N-8EYR-ES/UL		
FX2N-8EYT-ESS/UL			
B	FX2N-16EX	40 (1.58")	Approx. 0.3 (0.66lbs)
	FX2N-16EX-C		
	FX2N-16EXL-C		
	FX2N-16EYR		
	FX2N-16EYT		
	FX2N-16EYT-C		
	FX2N-16EYS		
	FX2N-16EX-ES/UL		
	FX2N-8EYR-S-ES/UL		
	FX2N-16EYR-ES/UL		
FX2N-16EYT-ESS/UL			

- Installation: DIN rail of 35 mm (1.38") in width or screws
- Accessories: Label for indication of I/O number,
- Terminal block: M3 screws
- The extension cable is already connected to the extension block

1 Outline

2 External Dimensions

3 Generic Specifications

4 Power Supply Specifications

5 Input Specifications

6 Output Specifications

7 Examples of Wiring for Various Uses

8 Terminal Block

9 CC-Link/LT Master FX3UC-LT(-2) only

10 Display module FX3UC-LT(-2) only

2.1.4 FX0N Series Input/output Extension Block

1. Terminal type

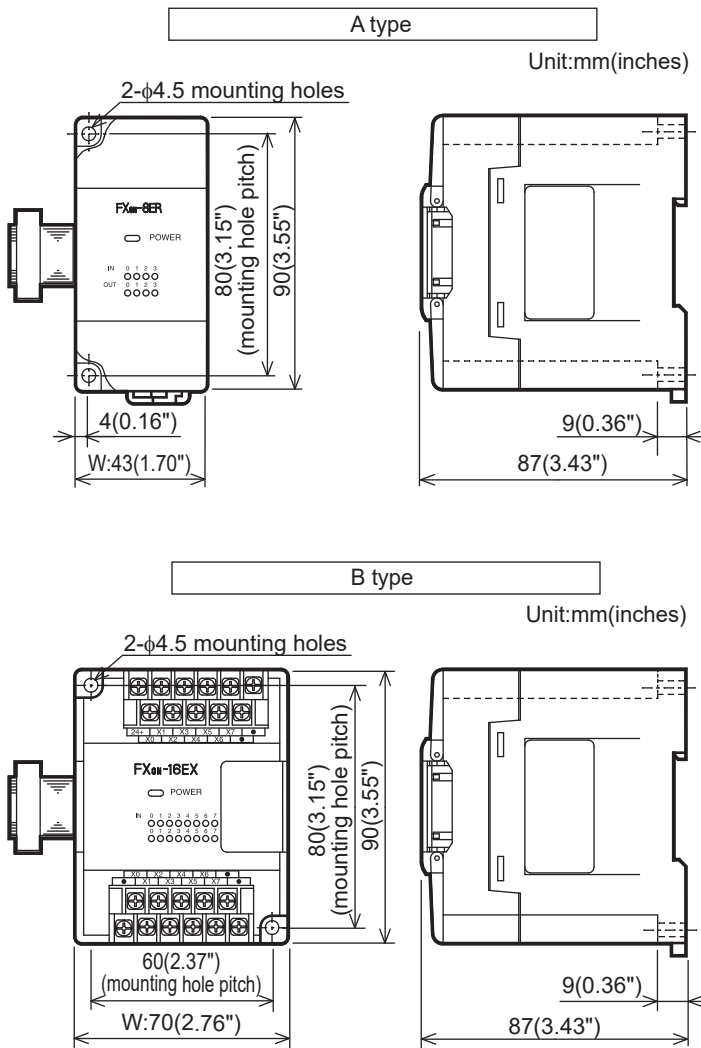

Type	Model name	W:mm (inches)	MASS (Weight): kg (lbs)
A	FX0N-8ER	43 (1.70")	Approx. 0.2 (0.44lbs)
	FX0N-8EX		
	FX0N-8EX-UA1/UL		
	FX0N-8EYR		
	FX0N-8EYT		
	FX0N-8EYT-H		
B	FX0N-16EX	70 (2.76")	Approx. 0.3 (0.66lbs)
	FX0N-16EYR		
	FX0N-16EYT		

- Installation: DIN rail of 35 mm (1.38") in width or screws
- Accessories: Label for indication of I/O number,
- Terminal block: M3 screws
- The extension cable is already connected to the extension block

2.1.5 FX0N/FX2N/FX2NC/FX3U/FX3UC Series special function block

1. Analog control

FX0N Series

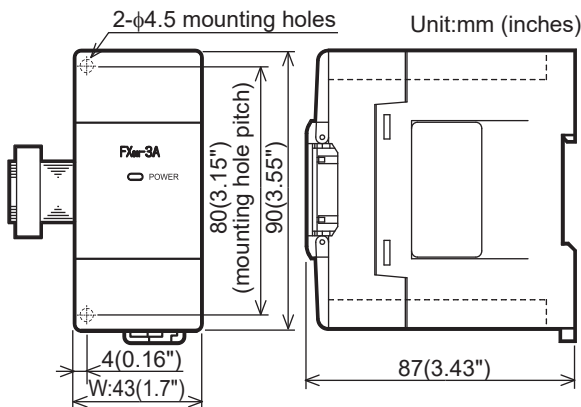

Model name	W:mm (inches)	MASS (Weight): kg (lbs)
FX0N-3A	43 (1.70")	Approx. 0.2 (0.44lbs)

- Installation: DIN rail of 35 mm (1.38") in width or screws
- Accessories: Label for indication of special unit/block number, Manual supplied with product
- Terminal block: M3 screws
- The extension cable is already connected to the extension block

FX2N/FX3U Series

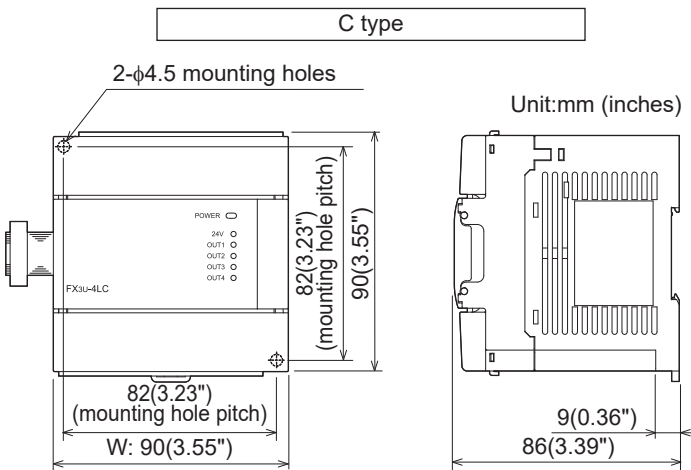
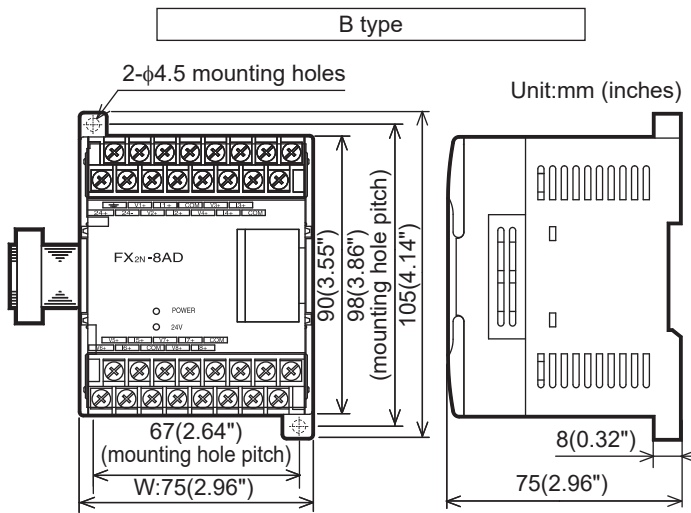
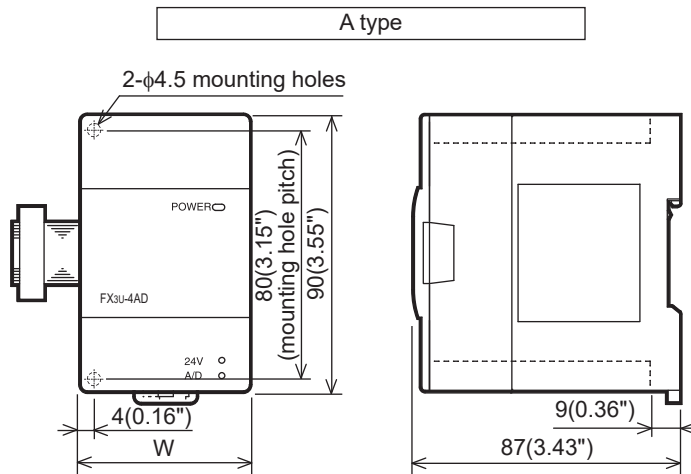

Type	Model name	W:mm (inches)	MASS (Weight): kg (lbs)	
A	FX2N-2AD FX2N-2DA	43 (1.70")	Approx. 0.2 (0.44lbs)	
	FX2N-4AD FX2N-4DA FX2N-4AD-PT FX2N-4AD-TC FX2N-5A FX2N-2LC	55 (2.17")	Approx. 0.3 (0.66lbs)	
	FX3U-4AD FX3U-4DA	55 (2.17")	Approx. 0.2 (0.44lbs)	
	B	FX2N-8AD	75 (2.96")	Approx. 0.4 (0.88lbs)
	C	FX3U-4LC	90 (3.55")	Approx. 0.4 (0.88lbs)

- Installation: DIN rail of 35 mm (1.38") in width or screws
- Accessories: Label for indication of special unit/block number, Dust proof protection sheet, Manual supplied with product
- Terminal block: M3 screws (FX2N-8AD is M3.5 screws)
- The extension cable is already connected to the extension block

1	Outline
2	External Dimensions
3	Generic Specifications
4	Power Supply Specifications
5	Input Specifications
6	Output Specifications
7	Examples of Wiring for Various Uses
8	Terminal Block
9	CC-Link/LT Master FX3UC-LT(-2) only
10	Display module FX3UC-LT(-2) only

FX2NC/FX3UC Series

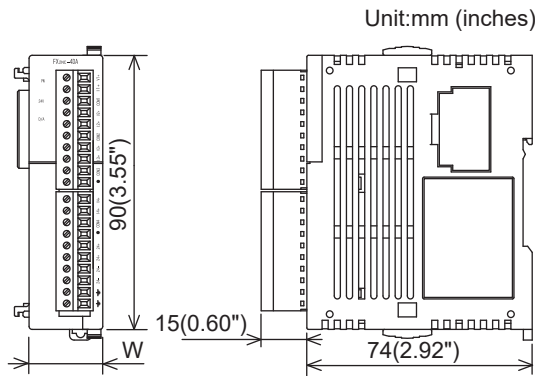

Model name	W:mm (inches)	MASS (Weight): kg (lbs)
FX3UC-4AD	20.2 (0.80")	Approx. 0.13 (0.29lbs)
FX2NC-4AD	20.2 (0.80")	Approx. 0.13 (0.29lbs)
FX2NC-4DA	24.2 (0.96")	Approx. 0.13 (0.29lbs)

- Installation: DIN rail of 35mm (1.38") in width only
- Accessories: FX2NC-10BPCB1 power crossover cable (0.1m (0'3")), Label for indication of special unit/block number, Manual supplied with product

2. High-speed counter

FX2N-1HC

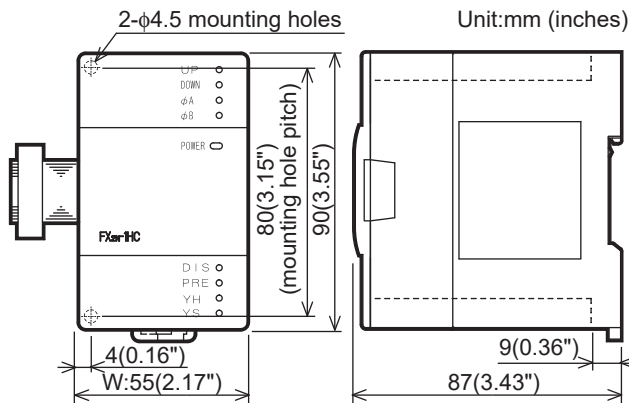

Model name	W:mm (inches)	MASS (Weight): kg (lbs)
FX2N-1HC	55 (2.17")	Approx. 0.3 (0.66lbs)

- Installation: DIN rail of 35 mm (1.38") in width or screws
- Accessories: Label for indication of special unit/block number, Manual supplied with product
- Terminal block: M3 screws
- The extension cable is already connected to the extension block

FX3U-2HC

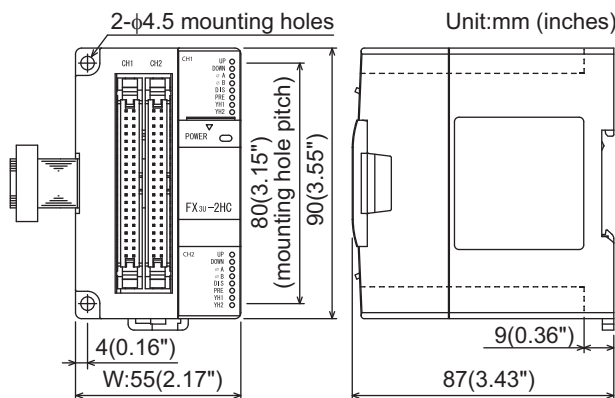

Model name	W:mm (inches)	MASS (Weight): kg (lbs)
FX3U-2HC	55 (2.17")	Approx. 0.2 (0.44lbs)

- Installation: DIN rail of 35 mm (1.38") in width or screws
- Accessories: Label for indication of special unit/block number, Dust proof protection sheet, Manual supplied with product
- Connector: 40-pin
- The extension cable is already connected to the extension block

FX2NC-1HC

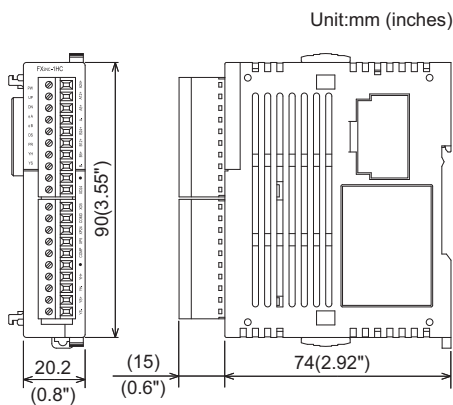

Model name	W:mm (inches)	MASS (Weight): kg (lbs)
FX2NC-1HC	20.2 (0.80")	Approx. 0.13 (0.29lbs)

- Installation: DIN rail of 35 mm (1.38") in width only
- Accessories: Label for indication of special unit/block number, Manual supplied with product

3. Pulse output and positioning

FX3U-1PG/FX2N-1PG(-E)

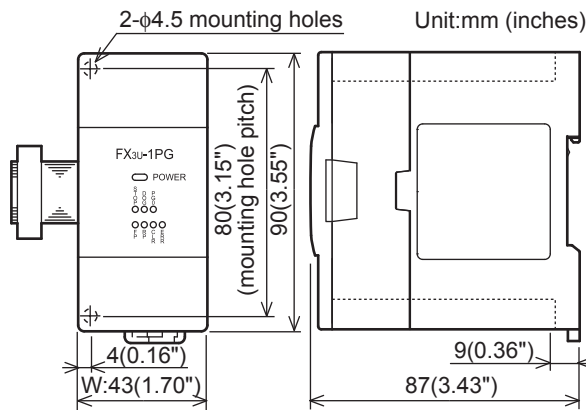

Model name	W:mm (inches)	MASS (Weight): kg (lbs)
FX3U-1PG	43 (1.70")	Approx. 0.2 (0.44lbs)
FX2N-1PG(-E)		

- Installation: DIN rail of 35 mm (1.38") in width or screws
- Accessories: Label for indication of special unit/block number, Manual supplied with product
- Terminal block: M3 screws
- The extension cable is already connected to the extension block

FX2N-10PG

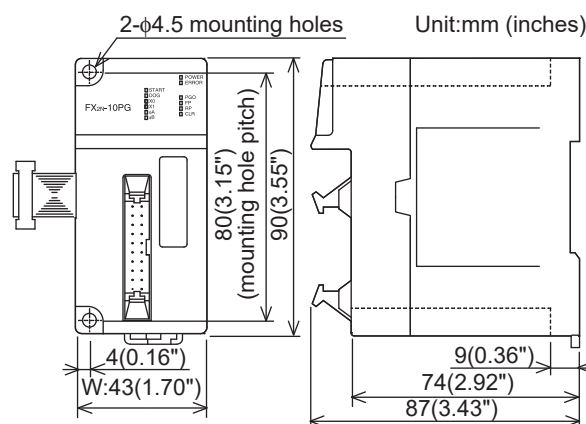

Model name	W:mm (inches)	MASS (Weight): kg (lbs)
FX2N-10PG	43 (1.70")	Approx. 0.2 (0.44lbs)

- Installation: DIN rail of 35 mm (1.38") in width or screws
- Accessories: Label for indication of special unit/block number, Manual supplied with product
- Connector: 20-pin
- The extension cable is already connected to the extension block

1	Outline
2	External Dimensions
3	Generic Specifications
4	Power Supply Specifications
5	Input Specifications
6	Output Specifications
7	Examples of Wiring for Various Uses
8	Terminal Block
9	CC-Link/LT Master FX3UC-LT(-Z) only
10	Display module FX3UC-LT(-Z) only

FX2N-10GM/FX2N-20GM

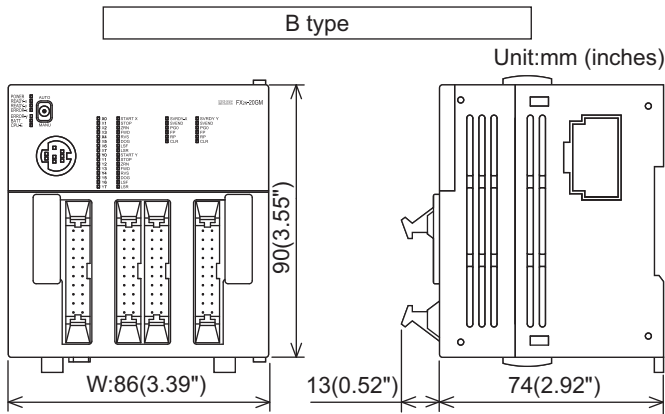
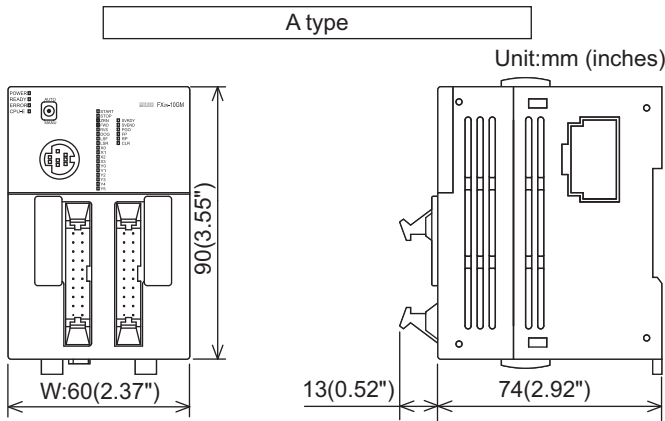

Type	Model name	W:mm (inches)	MASS (Weight): kg (lbs)
A	FX2N-10GM	60 (2.37")	Approx. 0.3 (0.66lbs)
B	FX2N-20GM	86 (3.39")	Approx. 0.4 (0.88lbs)

- Installation: DIN rail of 35mm (1.38") in width
- Accessories: FX2NC-100MPCB power supply cable (1m (3'33")), FX2N-GM-5EC extension cable, label for indication of special unit/block number, FX2NC-100BPCB power supply cable (1m (3'33")) (Only FX2N-20GM), Manual supplied with product
- Connector: 20-pin

FX2N-1RM(-E)-SET

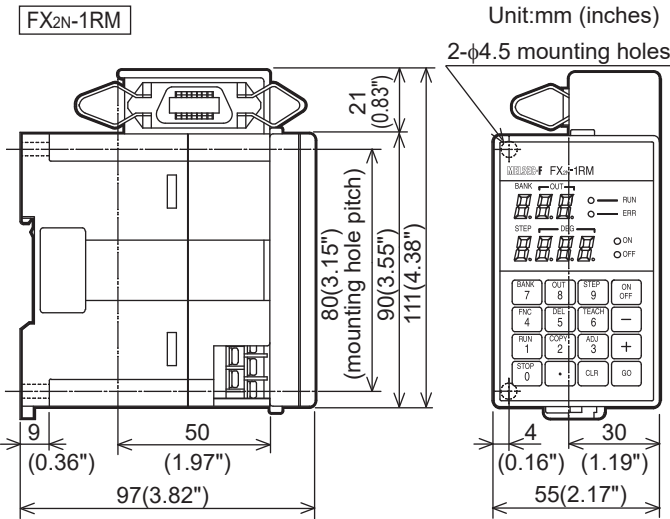

Model name	W:mm (inches)	MASS (Weight): kg (lbs)
FX2N-1RM(-E)-SET	55 (2.17")	Approx. 0.5 (1.1lbs)

- Installation: DIN rail of 35 mm (1.38") in width or screws
- Accessories: Label for indication of special unit/block number, FX2N-RS-5CAB signal cable (5m(16'4")), F2-720RSV resolver, extension cable (55mm(2.06")), Manual supplied with product
- Terminal block: M3 screws

F2-720RSV MASS(Weight): Approx. 0.4kg (0.88lbs)
4-φ4.5 mounting holes Unit:mm (inches)

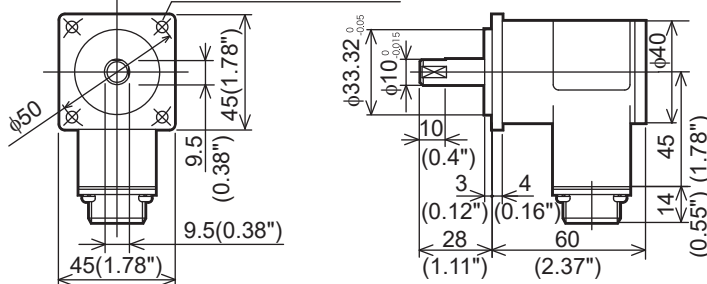

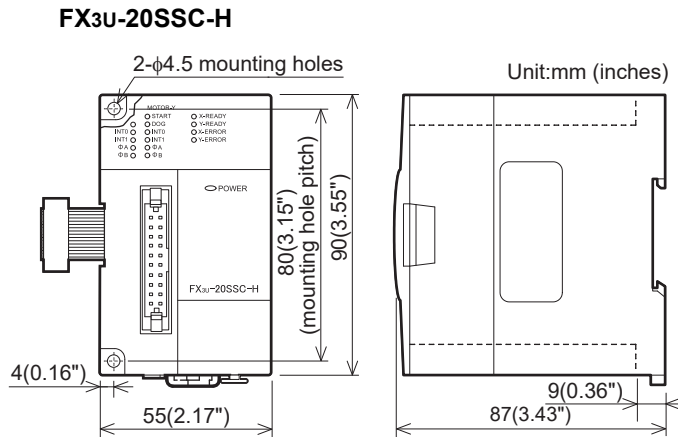

Model name	W:mm (inches)	MASS (Weight): kg (lbs)
FX3U-20SSC-H	55 (2.17")	Approx. 0.3 (0.66lbs)

- Installation: DIN rail of 35 mm (1.38") in width or screws
- Accessories: Label for indication of special unit/block number, FX2NC-100MPCB Power supply cable (1m(3'3")), Manual supplied with product
- Connector: 20-pin
- The extension cable is already connected to the extension block

4. Data link and communication functions

FX2N-232IF/FX2N-32CCL/FX2N-64CL-M/FX2N-32ASI-M/FX2N-16LNK-M

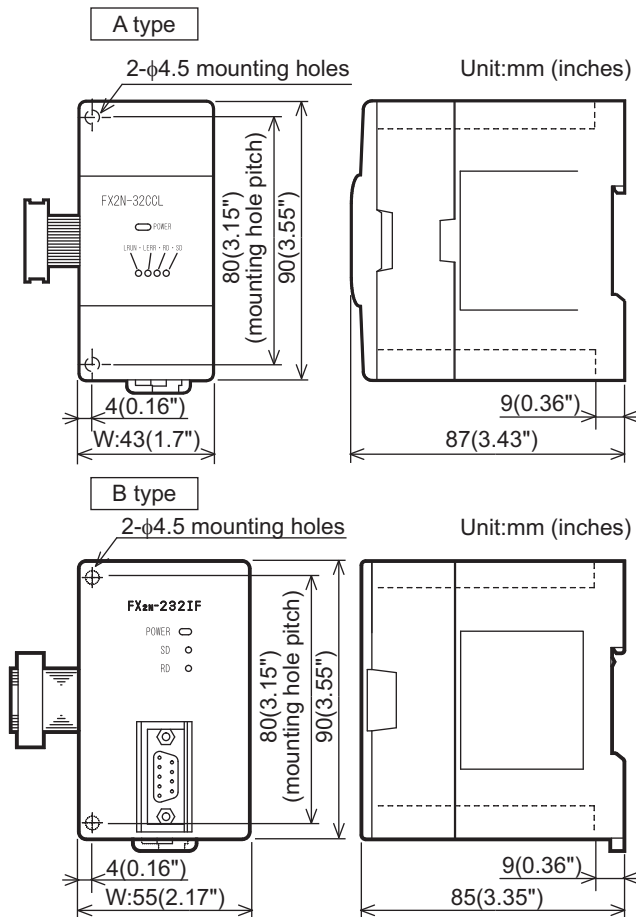

Type	Model name	W:mm (inches)	MASS (Weight): kg (lbs)
A	FX2N-64CL-M	43 (1.70")	Approx. 0.15 (0.33lbs)
	FX2N-32CCL		Approx. 0.2 (0.44lbs)
	FX2N-16LNK-M		Approx. 0.5 (1.1lbs)
B	FX2N-32ASI-M	55 (2.17")	Approx. 0.2 (0.44lbs)
	FX2N-232IF		Approx. 0.3 (0.66lbs)

- Installation: DIN rail of 35 mm (1.38") in width or screws
- Accessories: Label for indication of special unit/block number, Manual supplied with product
- The terminal block of FX2N-32CCL, FX2N-32ASI-M and FX2N-16LNK-M is the M3 screw.
- The RS-232C connector of FX2N-232IF is D-SUB 9Pin (male).
- The CC-Link/LT interface connector of FX2N-64CL-M is in the front panel of the product.
- The extension cable is already connected to the extension block

1	Outline
2	External Dimensions
3	Generic Specifications
4	Power Supply Specifications
5	Input Specifications
6	Output Specifications
7	Examples of Wiring for Various Uses
8	Terminal Block
9	CC-Link/LT Master FX3UC-LT(-2) only
10	Display module FX3UC-LT(-2) only

FX2N-16CCL-M

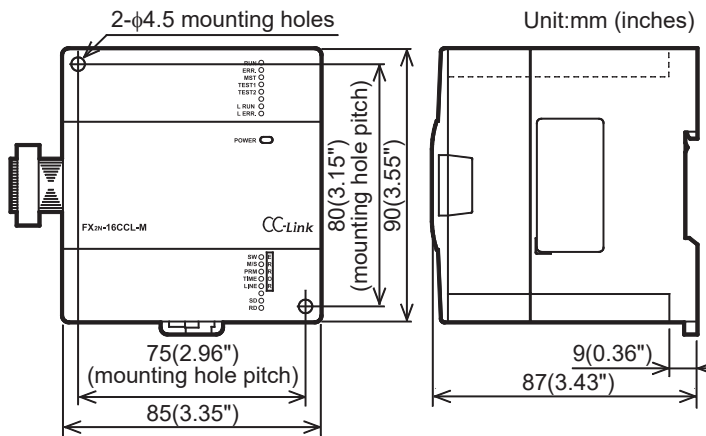

Model name	W:mm (inches)	MASS (Weight): kg (lbs)
FX2N-16CCL-M	85 (3.35")	Approx. 0.4 (0.88lbs)

- Installation: DIN rail of 35 mm (1.38") in width or screws
- Accessories: Label for indication of special unit/block number, Terminal resistor: 2 resistors for CC-Link dedicated cable, 2 resistors for CC-Link dedicated high-performance cable, Manual supplied with product
- Terminal block: M3 screw for power supply terminal, M3.5 screw for signal terminal
- The extension cable is already connected to the extension block

FX3U-64CCL

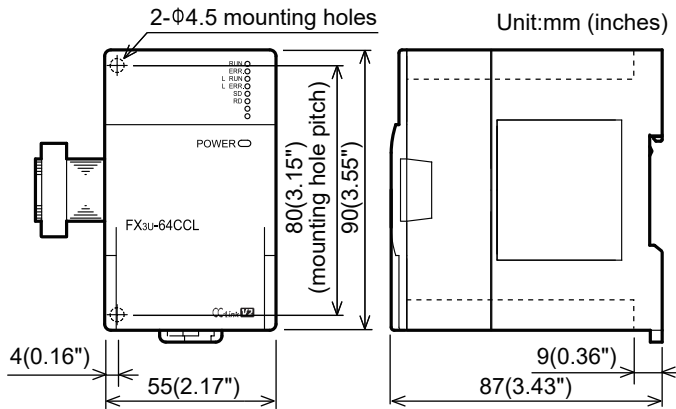

Model name	W:mm (inches)	MASS (Weight): kg (lbs)
FX3U-64CCL	55 (2.17")	Approx. 0.3 (0.66lbs)

- Installation: DIN rail of 35 mm (1.38") in width or screws
- Accessories: Label for indication of special unit/block number, Dust Proof sheet, Manual supplied with product
- Terminal block: M3 screws for power supply terminal, CC-Link connection terminal, M3.5 screws for CC-Link connection terminal block mounting screws (black)
- The extension cable is already connected to the extension block

FX3U-16CCL-M

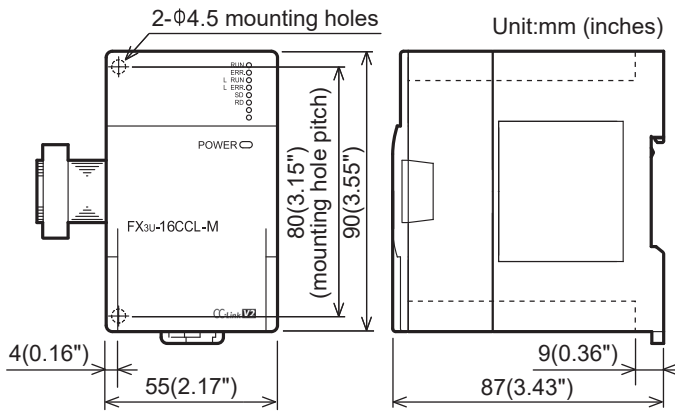

Model name	W:mm (inches)	MASS (Weight): kg (lbs)
FX3U-16CCL-M	55 (2.17")	Approx. 0.3 (0.66lbs)

- Installation: DIN rail of 35 mm (1.38") in width or screws
- Accessories: Label for indication of special unit/block number, Terminal resistor: 2 resistors for CC-Link dedicated cable, 2 resistors for CC-Link dedicated high-performance cable, Dust Proof sheet, Manual supplied with product
- Terminal block: M3 screws for power supply terminal, CC-Link connection terminal, M3.5 screws for CC-Link connection terminal block mounting screws (black)
- The extension cable is already connected to the extension block

FX3U-128ASL-M

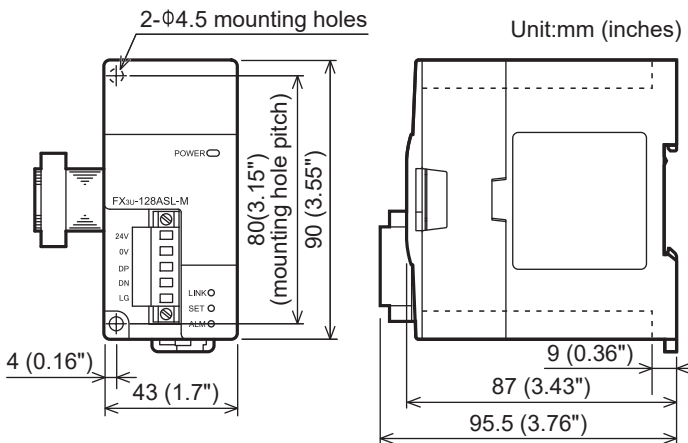

Model name	W:mm (inches)	MASS (Weight): kg (lbs)
FX3U-128ASL-M	43 (1.70")	Approx. 0.2 (0.44lbs)

- Installation: DIN rail of 35 mm (1.38") in width or screws
- Accessories: Label for indication of special unit/block number, Dust proof protection sheet, Manual supplied with product
- The extension cable is already connected to the extension block

1	Outline
2	External Dimensions
3	Generic Specifications
4	Power Supply Specifications
5	Input Specifications
6	Output Specifications
7	Examples of Wiring for Various Uses
8	Terminal Block
9	CC-Link/LT Master FX3UC-LT(-2) only
10	Display module FX3UC-LT(-2) only

FX3U-64DP-M

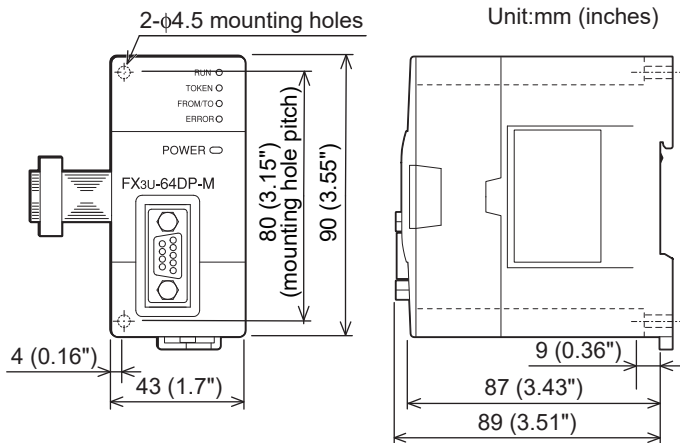

Model name	W:mm (inches)	MASS (Weight): kg (lbs)
FX3U-64DP-M	43 (1.70")	Approx. 0.2 (0.44lbs)

- Installation: DIN rail of 35 mm (1.38") in width or screws
- Accessories: Label for indication of special unit/block number, Dust proof protection sheet, Manual supplied with product
- Connector: PROFIBUS-DP interface connector (D-SUB 9-pin, female)
- The extension cable is already connected to the extension block

FX3U-32DP

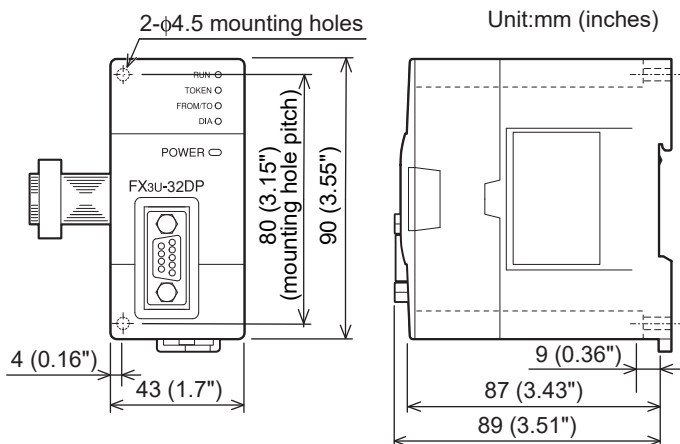

Model name	W:mm (inches)	MASS (Weight): kg (lbs)
FX3U-32DP	43 (1.70")	Approx. 0.2 (0.44lbs)

- Installation: DIN rail of 35 mm (1.38") in width or screws
- Accessories: GSD file (CD-ROM), Label for indication of special unit/block number, Dust proof protection sheet, Manual supplied with product
- Connector: PROFIBUS-DP interface connector (D-SUB 9-pin, female)
- The extension cable is already connected to the extension block

2.1.6 Expansion boards

Expansion boards can only be used with the FX3UC-32MT-LT(-2).

FX3U-USB-BD

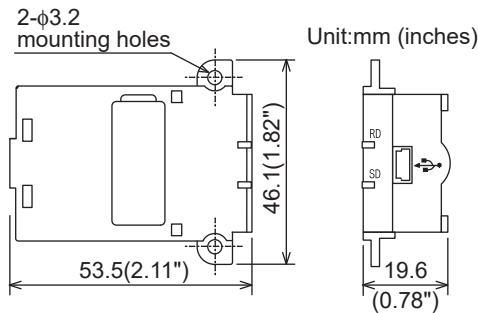

FX3U-232-BD

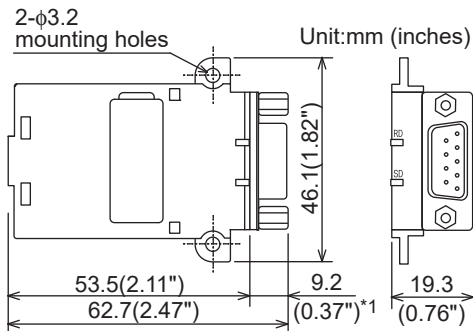

FX3U-422-BD

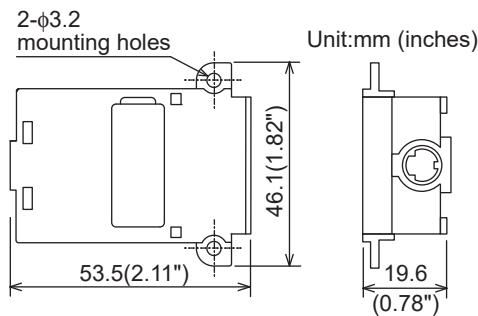

Model name	MASS (Weight): g (lbs)
FX3U-USB-BD	Approx. 20 (0.05lbs)
FX3U-232-BD	Approx. 20 (0.05lbs)
FX3U-422-BD	Approx. 20 (0.05lbs)
FX3U-485-BD	Approx. 20 (0.05lbs)
FX3U-8AV-BD	Approx. 20 (0.05lbs)
FX3U-CNV-BD	Approx. 10 (0.03lbs)

- Accessories: All models
Two M3 tapping screws (for installation of board), Manual supplied with product
Only in FX3U-485-BD
Label for indication of link station number
Only in FX3U-USB-BD
USB cable (3m(9'10"))
Only in FX3U-8AV-BD
Trimmer layout label

*1.The FX3U-232-BD RS-232C connector is D-SUB 9Pin (male).
It is shown as follows when attached to the FX3UC-32MT-LT(-2).

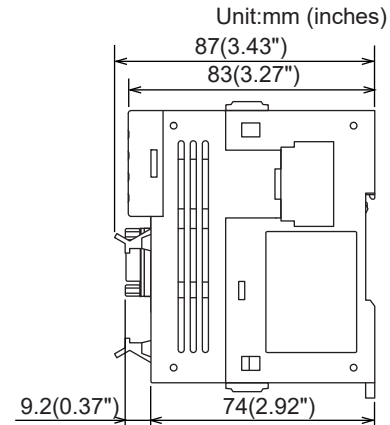

FX3U-485-BD

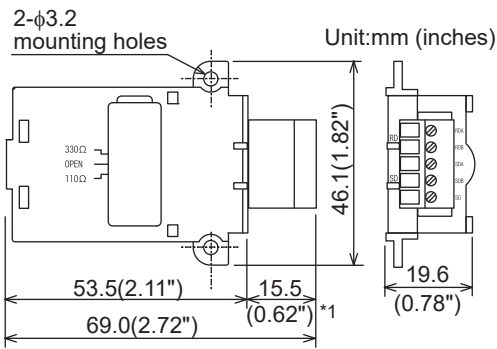

*1.The FX3U-485-BD is European type.
 It is shown as follows when attached to
 the FX3UC-32MT-LT(-2).

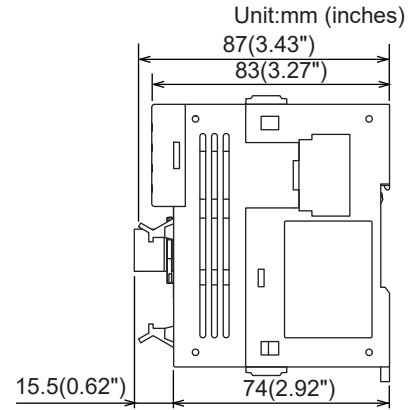

FX3U-8AV-BD

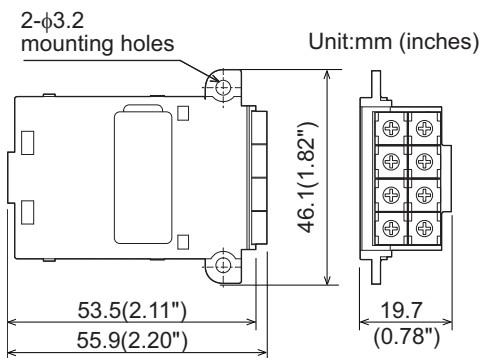

FX3U-CNV-BD

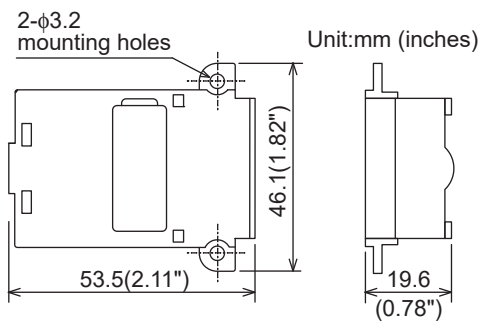

2.1.7 Special adapters

1. Analog special adapters

FX3U-4AD-ADP/FX3U-4DA-ADP/FX3U-3A-ADP/FX3U-4AD-PT-ADP/FX3U-4AD-PTW-ADP/
FX3U-4AD-PNK-ADP/FX3U-4AD-TC-ADP

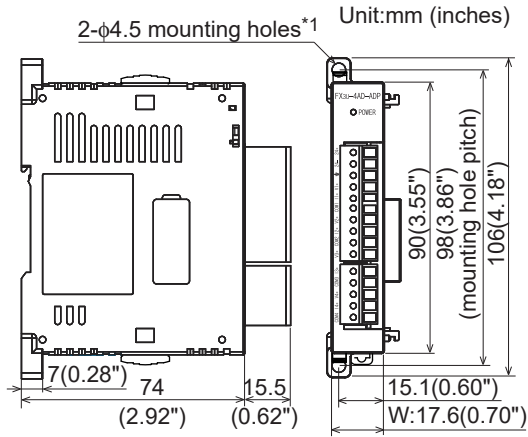

Model name	W:mm (inches)	MASS(Weight): kg (lbs)
FX3U-4AD-ADP	17.6 (0.70")	Approx. 0.1 (0.22lbs)
FX3U-4DA-ADP		
FX3U-3A-ADP		
FX3U-4AD-PT-ADP		
FX3U-4AD-PTW-ADP		
FX3U-4AD-PNK-ADP		
FX3U-4AD-TC-ADP		

- Installation: DIN rail of 35 mm (1.38") in width or screws*1
- Accessories: Manual supplied with product
- Terminal block: European type

*1.When an analog special adapter is connected to the FX3UC PLC, direct screw mounting is not possible.

2. Communication special adapters

FX3U-232ADP(-MB)

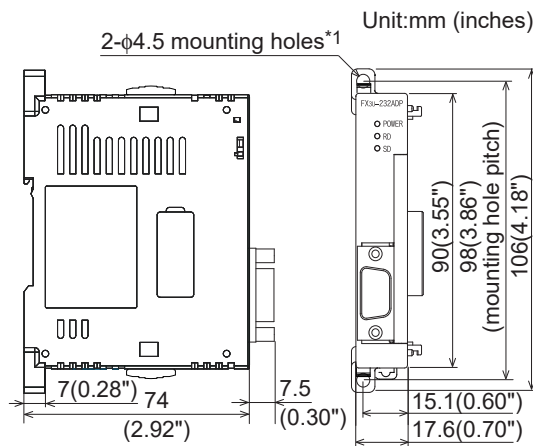

Model name	W:mm (inches)	MASS(Weight): g (lbs)
FX3U-232ADP(-MB)	17.6 (0.70")	Approx. 80 (0.18lbs)

- Installation: DIN rail of 35 mm (1.38") in width or screws*1
- Accessories: Manual supplied with product
- RS-232C connector: D-SUB 9-pin, male

*1.When the FX3U-232ADP(-MB) is connected to the FX3UC PLC, direct screw mounting is not possible.

FX3U-485ADP(-MB)

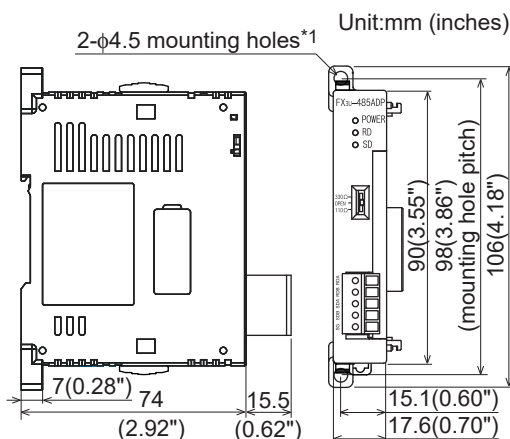

Model name	W:mm (inches)	MASS(Weight): g (lbs)
FX3U-485ADP(-MB)	17.6 (0.70")	Approx. 80 (0.18lbs)

- Installation: DIN rail of 35 mm (1.38") in width or screws*1
- Accessories: Label for indication of link station number, Manual supplied with product

- Terminal block: European type
- Terminal resistance: 330Ω/110Ω, built-in

*1.When the FX3U-485ADP(-MB) is connected to the FX3UC PLC, direct screw mounting is not possible.

External Dimensions

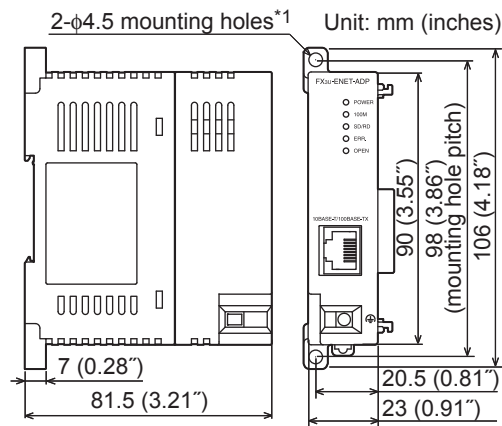

Model name	W:mm (inches)	MASS(Weight): kg (lbs)
FX3U-ENET-ADP	23 (0.91")	Approx. 0.1 (0.22lbs)

- Installation: DIN rail of 35 mm (1.38") in width or screws*1
- Accessories: Manual supplied with product
- Connector: 10BASE-T/100BASE-TX (RJ45)
- Terminal block: External ground terminal (M2.5 terminal block screw)

*1.When the FX3U-ENET-ADP is connected to the FX3UC PLC, direct screw mounting is not possible.

3. CF card special adapter

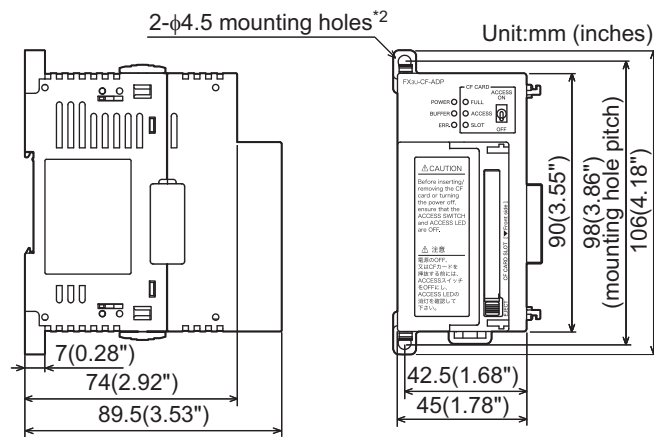

Model name	W:mm (inches)	MASS (Weight): kg (lbs)
FX3U-CF-ADP	45 (1.78")	Approx. 0.3*1 (0.66lbs)

- Installation: DIN rail of 35 mm (1.38") in width or screws*2
- Accessories: FX2NC-100MPCB Power supply cable (1m (3'3"))
Dust proof protection sheet
Manual supplied with product

*1.CF card not attached.

*2.When the FX3U-CF-ADP is connected to the FX3UC PLC, direct screw mounting is not possible.

2.1.8 Power supply unit

1. Extension Power Supply Unit

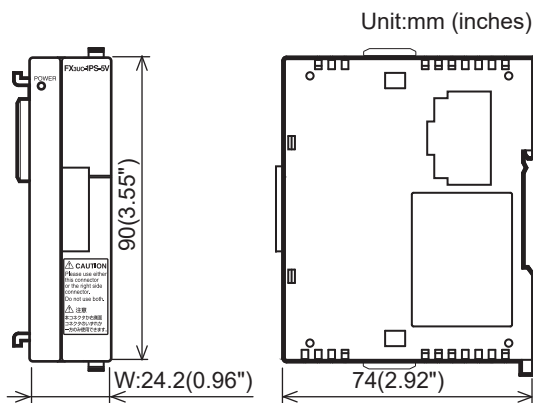

Model name	W:mm (inches)	MASS (Weight): kg (lbs)
FX3UC-1PS-5V	24.2 (0.96")	Approx. 0.15 (0.33lbs)

- Installation: DIN rail of 35mm (1.38") in width only
- Accessories: FX2NC-100MPCB Power supply cable (1m (3'33")), Manual supplied with product

2. 24V DC power supply unit

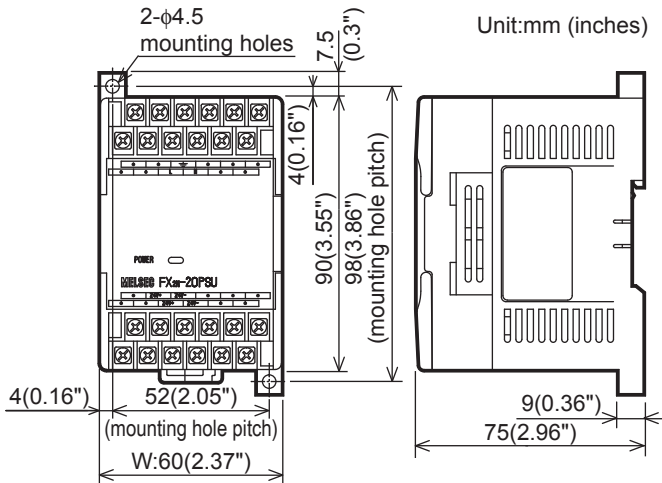

Model name	W:mm (inches)	MASS (Weight): kg (lbs)
FX2N-20PSU	60 (2.37")	Approx. 0.3 (0.66lbs)

- Installation: DIN rail of 35 mm (1.38") in width or screws
- Accessories: Manual supplied with product
- Terminal block: M3.5 screws

2.1.9 Connector conversion adapter

1. FX2NC-CNV-IF

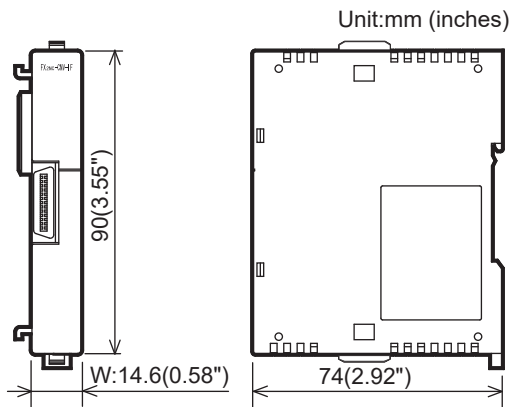

Model name	W:mm (inches)	MASS (Weight): g (lbs)
FX2NC-CNV-IF	14.6 (0.58")	Approx. 60 (0.14lbs)

- Installation: DIN rail of 35mm (1.38") in width only

2. FX2N-CNV-BC

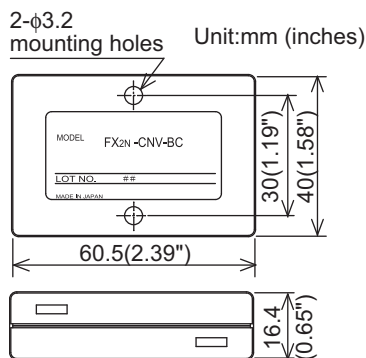

Model name	MASS (Weight): g (lbs)
FX2N-CNV-BC	Approx. 40 (0.09lbs)

- Installation: Direct mounting only

2.1.10 Option

FX3U-7DM-HLD

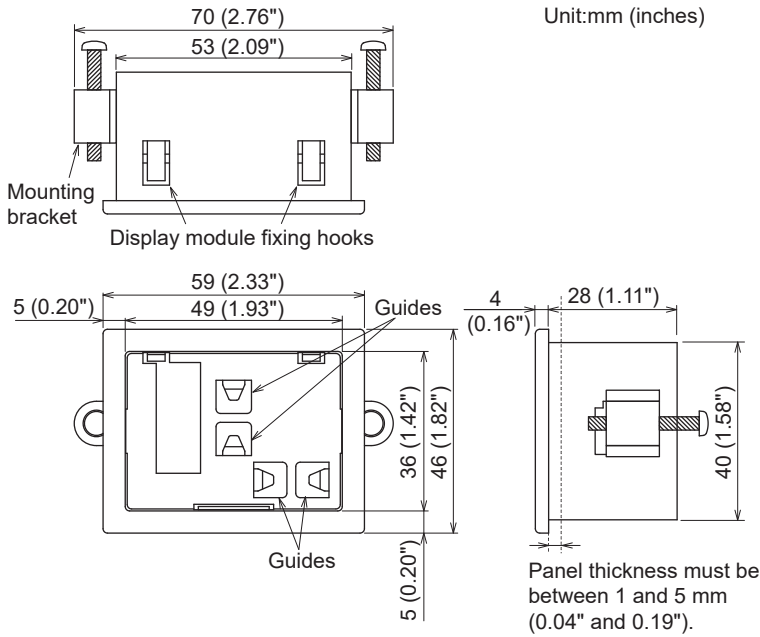

Model name	MASS (Weight): g (lbs)
FX3U-7DM-HLD	Approx. 20 (0.05lbs)

- Accessories: PLC cover, Mounting bracket × 2 pieces, Tightening bolt (M4 × 25) × 2 pieces, Extension cable with ferrite core (1.4m(4'7")), Clamp A × 5 pieces, Clamp B × 1 piece, Cable tie × 1 piece, Manual supplied with product

2.2 Terminal layout

Refer to the respective special function units/blocks manual.

2.2.1 Main units

1. FX3uc-16MT/D, FX3uc-16MT/DSS

- FX3uc-16MT/D
- FX3uc-16MT/DSS

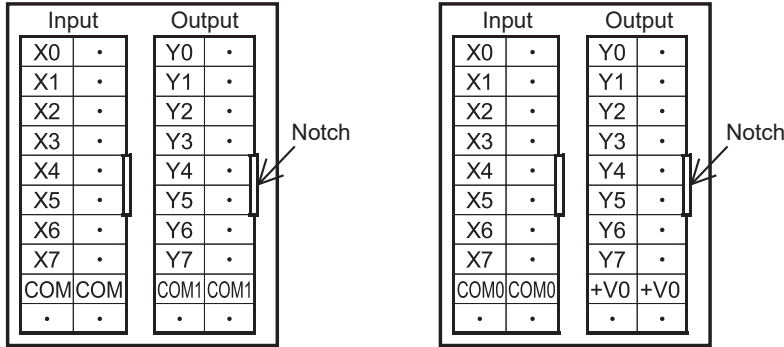

2. FX3uc-32MT/D, FX3uc-32MT/DSS, FX3uc-32MT-LT(-2)

- FX3uc-32MT/D
FX3uc-32MT-LT(-2)
- FX3uc-32MT/DSS

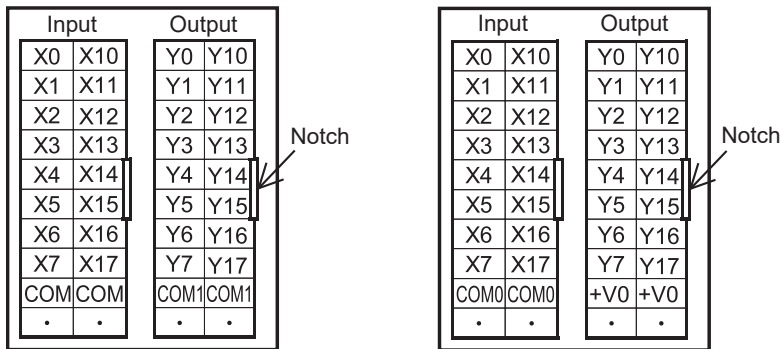

3. FX3uc-64MT/D, FX3uc-64MT/DSS

- FX3uc-64MT/D
- FX3uc-64MT/DSS

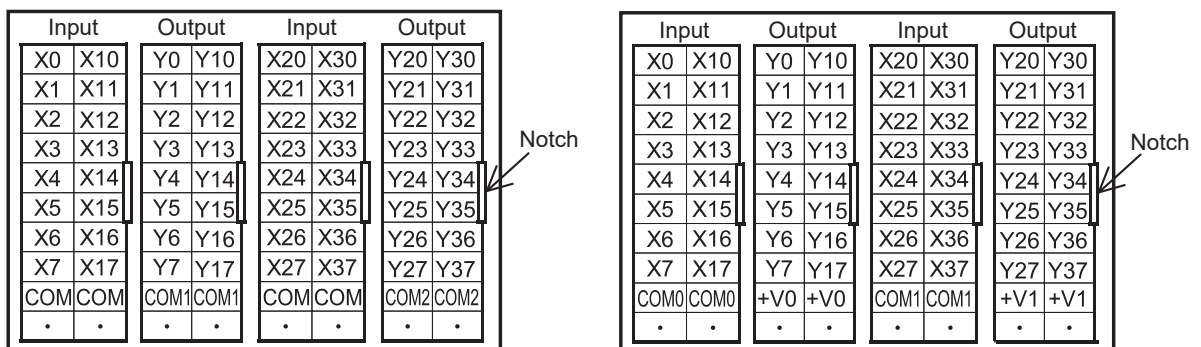

4. FX3uc-96MT/D, FX3uc-96MT/DSS

- FX3uc-96MT/D

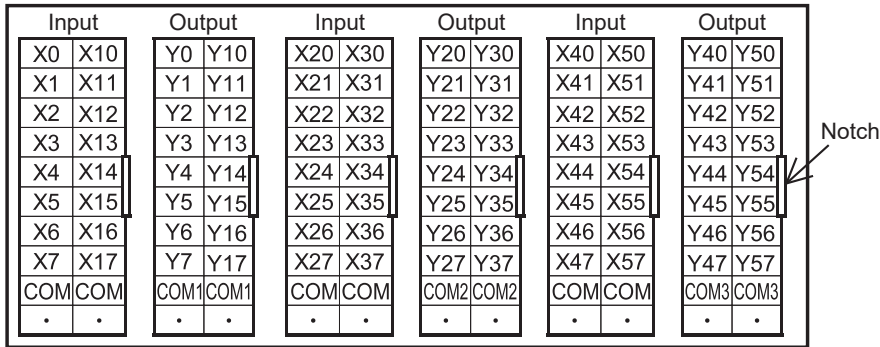

- FX3uc-96MT/DSS

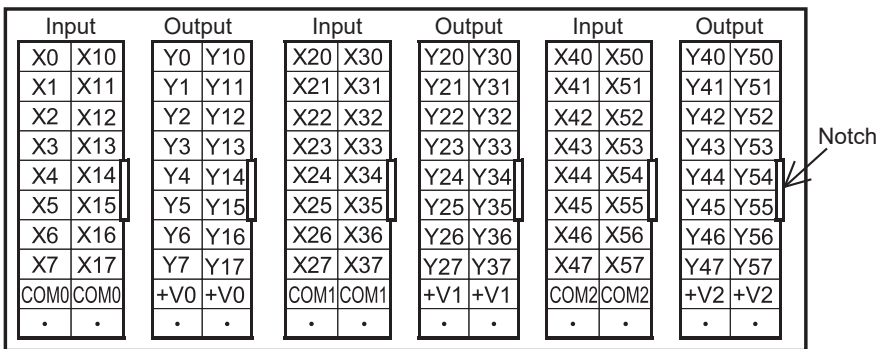

5. FX3uc-16MR/D(S)-T

- FX3uc-16MR/D(S)-T

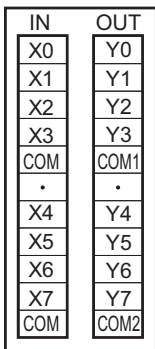

6. FX3uc-□□MT/D(SS), FX3uc-16MR/D(S)-T and FX3uc-32MT-LT(-2) power connector

- FX3uc-□□MT/D(SS), FX3uc-16MR/D(S)-T
- FX3uc-32MT-LT(-2)

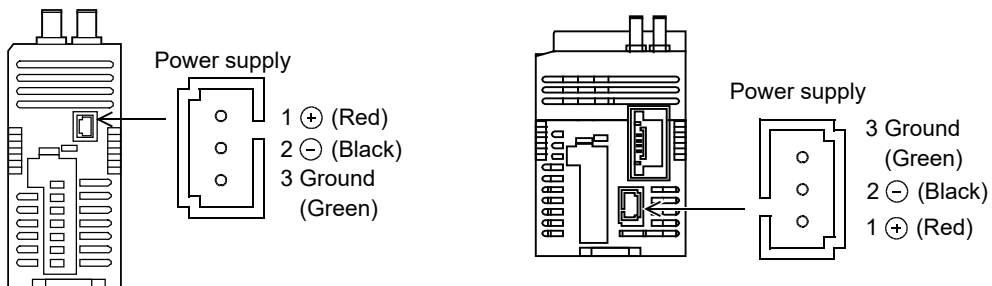

2.2.2 FX2NC series input/output extension block

1. Connector type

FX2NC-16EX

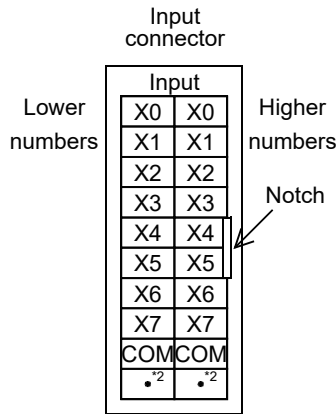
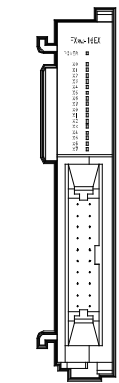

*2 ". " represents vacant terminals

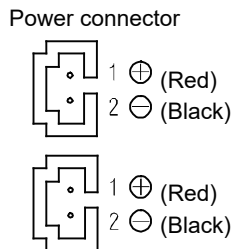
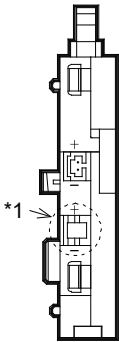

*1. For the handling, refer to Subsection 3.10.2.

FX2NC-16EX-DS

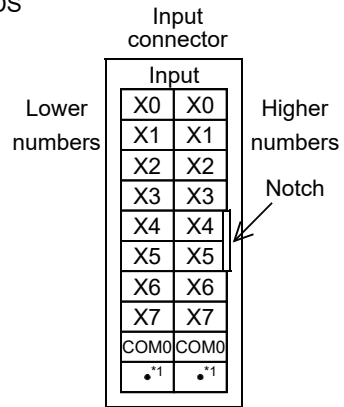
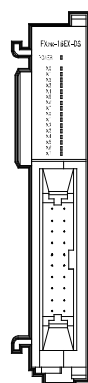

*1 ". " represents vacant terminals

Caution : A power connector is not included in the FX2NC-16EX-DS.

FX2NC-32EX

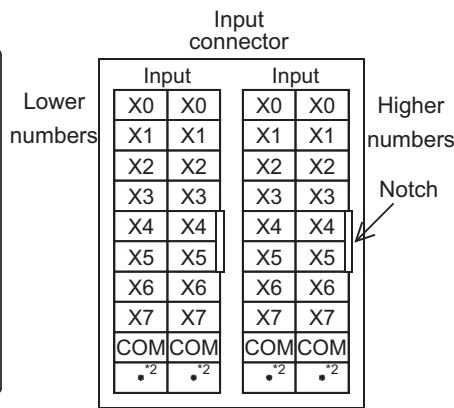
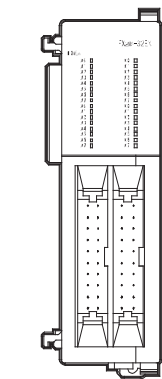

*2 ". " represents vacant terminals

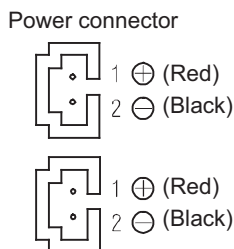
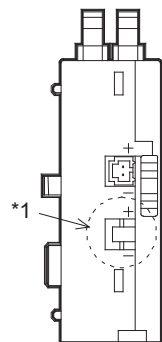

*1. For the handling, refer to Subsection 3.10.2.

FX2NC-32EX-DS

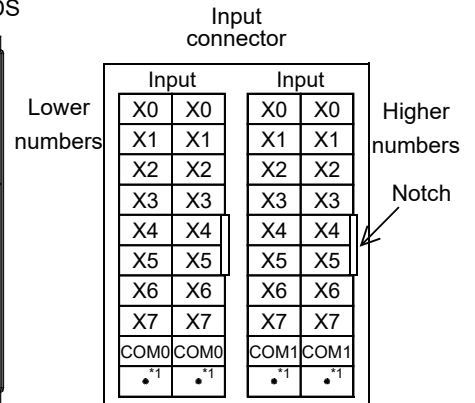
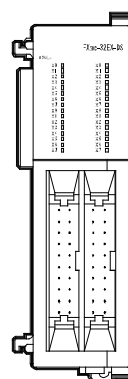

*1 ". " represents vacant terminals

Caution : A power connector is not included in the FX2NC-32EX-DS.

FX2NC-16EYT

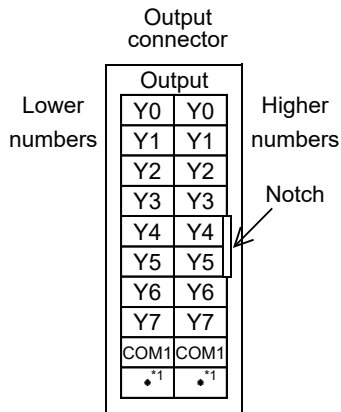
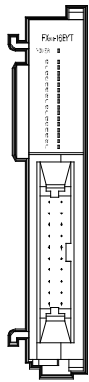

*1 "•" represents vacant terminals

FX2NC-16EYT-DSS

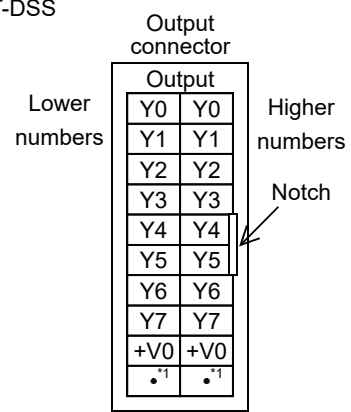
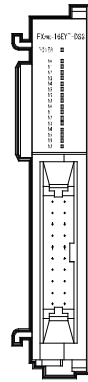

*1 "•" represents vacant terminals

FX2NC-32EYT

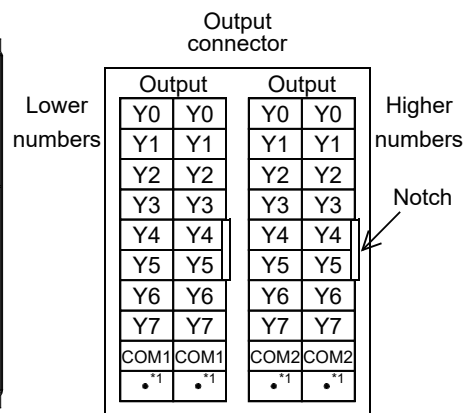
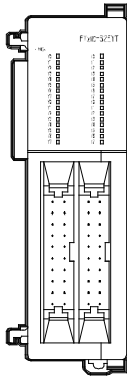

*1 "•" represents vacant terminals

FX2NC-32EYT-DSS

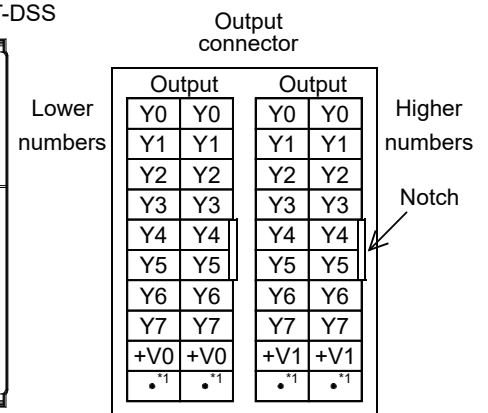
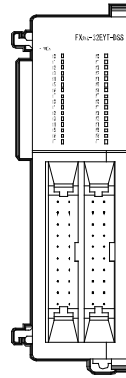

*1 "•" represents vacant terminals

2. Terminal type

FX2NC-16EX-T

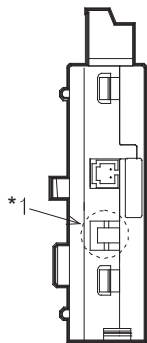
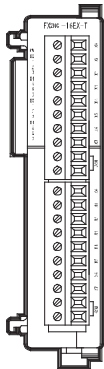

Input terminal



Lower numbers

Higher numbers

Power connector

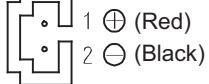
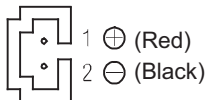

*1. For the handling, refer to Subsection 3.10.2.

FX2NC-16EX-T-DS

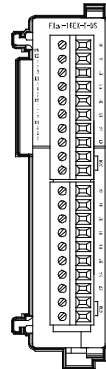

Input terminal



Lower numbers

Higher numbers

Caution : A power connector is not included in the FX2NC-16EX-T-DS.

FX2NC-16EYR-T(-DS)

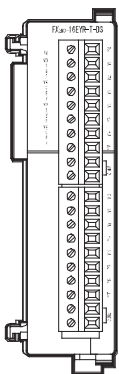

Output terminal

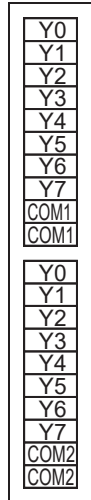

Lower numbers

Higher numbers

2.2.3 FX2N series input/output extension block

1. Terminal type

FX2N-8EX

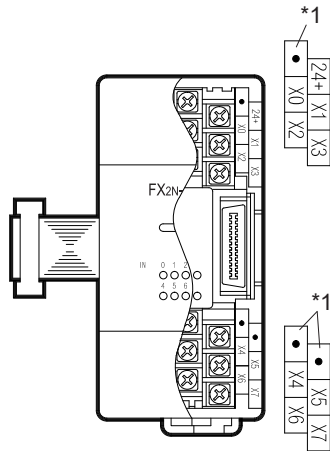

FX2N-8EX-ES/UL

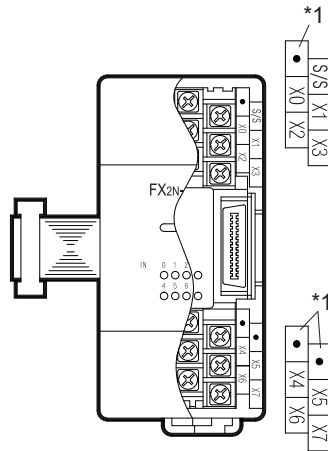

FX2N-8EYR(-ES/UL)
 FX2N-8EYT
 FX2N-8EYT-H

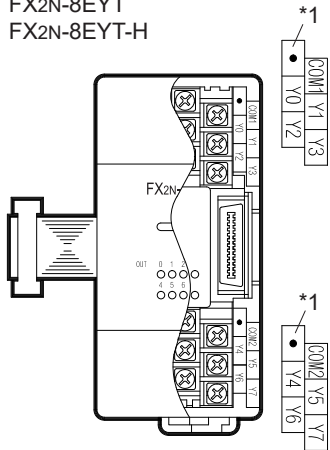

FX2N-8EYT-ESS/UL

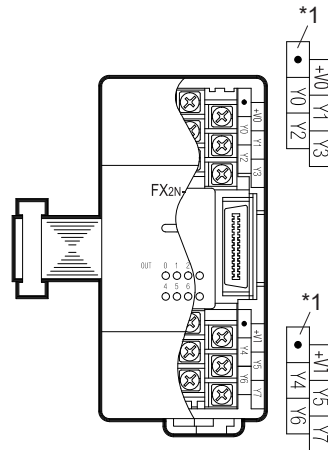

FX2N-8ER

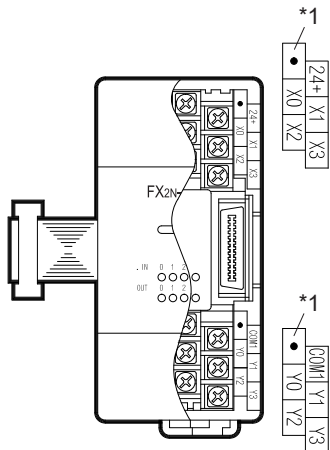

FX2N-8ER-ES/UL

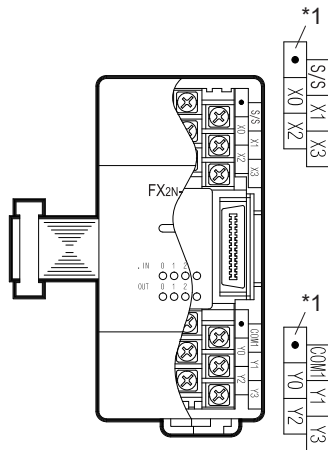

FX2N-8EX-UA1/UL

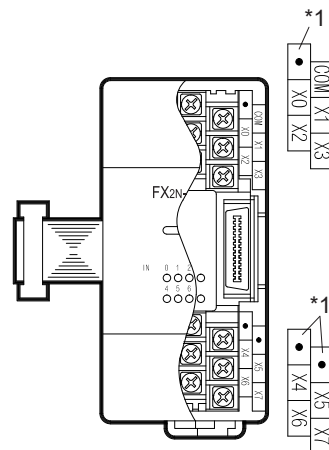

*1. "•" represents vacant terminals

FX2N-8EYR-S-ES/UL

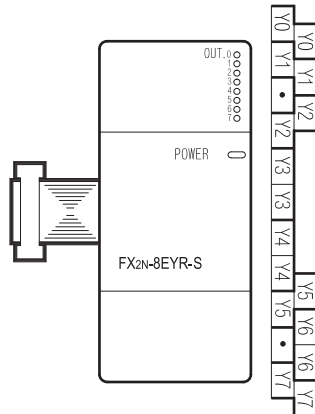

Vertical terminal block
(Example: FX2N-16EX)

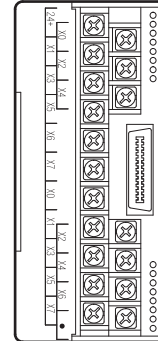

FX2N-16EX

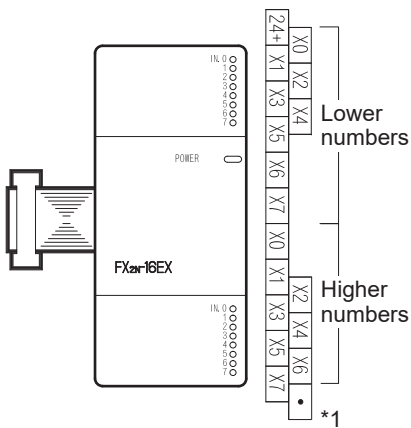

FX2N-16EX-ES/UL

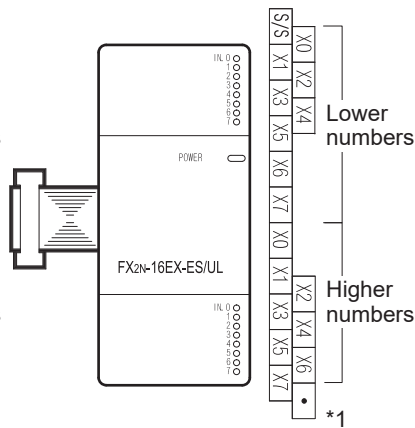

*1. "•" represents vacant terminals

FX2N-16EYR(-ES/UL)
FX2N-16EYS
FX2N-16EYT

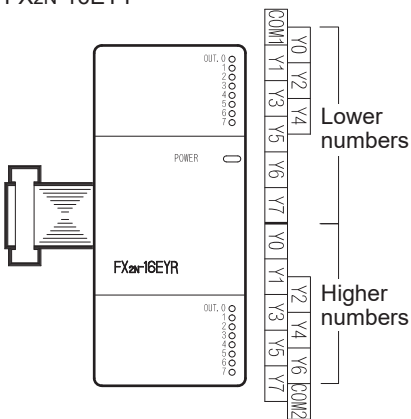

FX2N-16EYT-ESS/UL

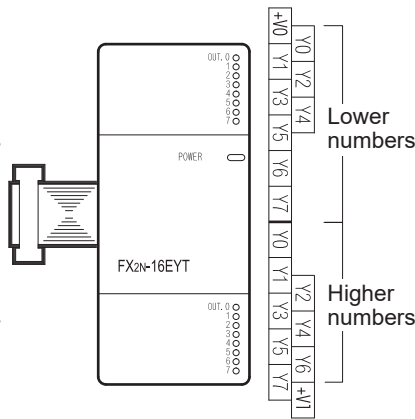

1 Outline

2 External Dimensions

3 Generic Specifications

4 Power Supply Specifications

5 Input Specifications

6 Output Specifications

7 Examples of Wiring for Various Uses

8 Terminal Block

9 CC-Link/LT Master FX3UC-LT(-2) only

10 Display module FX3UC-LT(-2) only

2. Connector type

FX2N-16EX-C

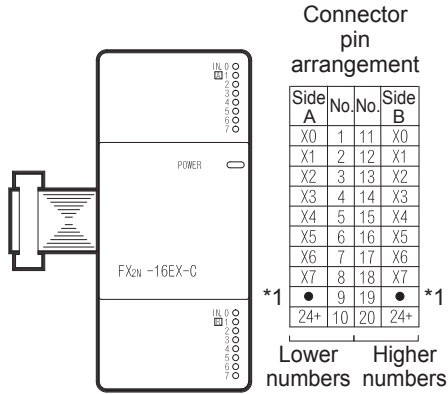

FX2N-16EYT-C

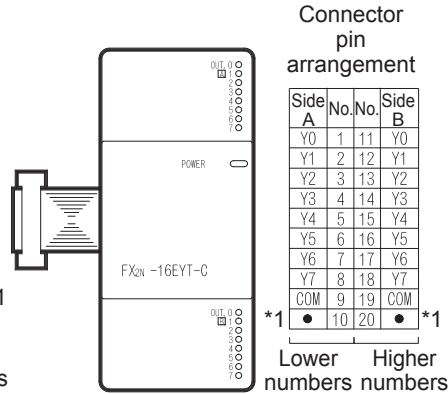

The connector is following places.
 (Example: FX2N-16EX-C)

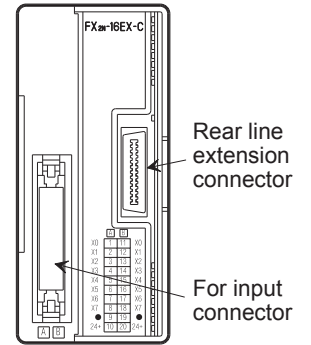

FX2N-16EXL-C

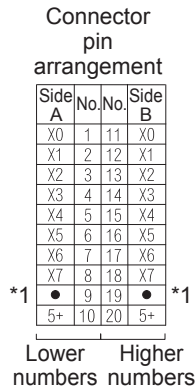
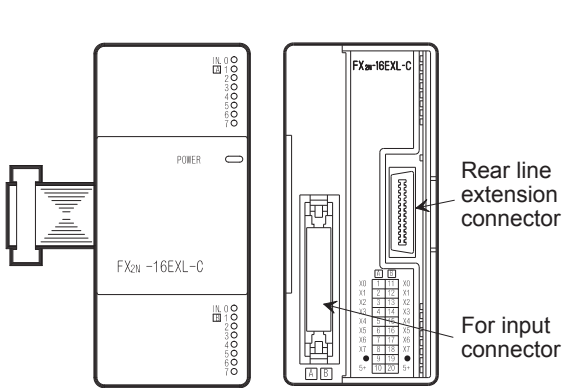

*1. " " represents vacant terminals

2.2.4 FX0N series input/output extension block

1. Terminal type

FX0N-8EX

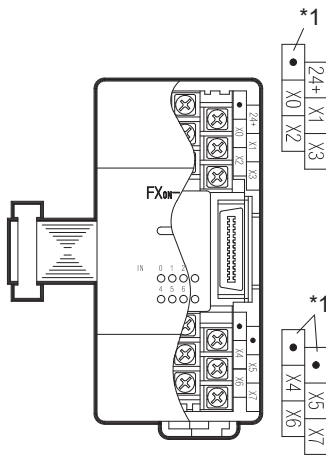

FX0N-8EYR
FX0N-8EYT
FX0N-8EYT-H

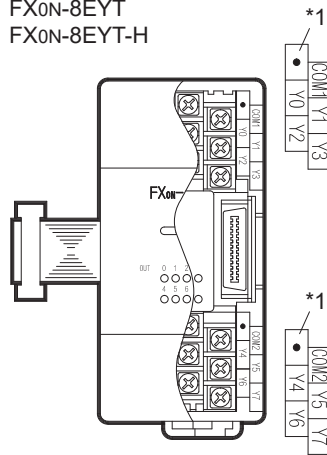

FX0N-8ER

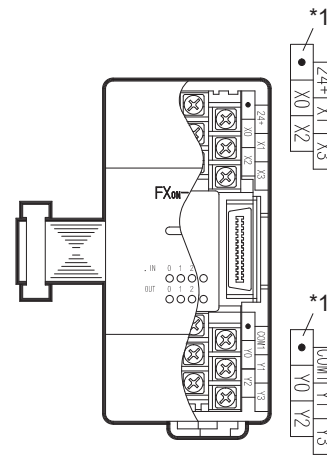

FX0N-8EX-UA1/UL

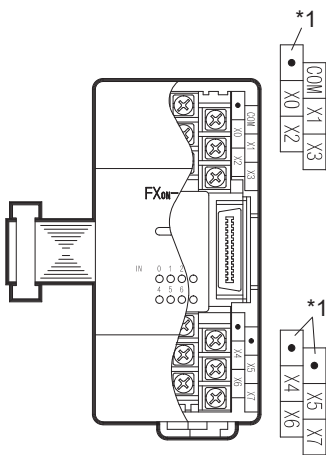

FX0N-16EX

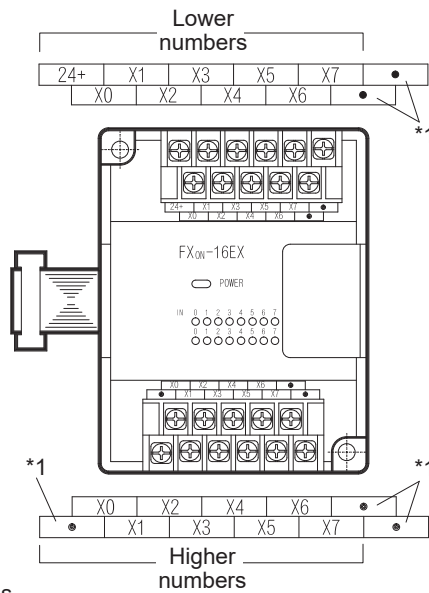

FX0N-16EYR
FX0N-16EYT

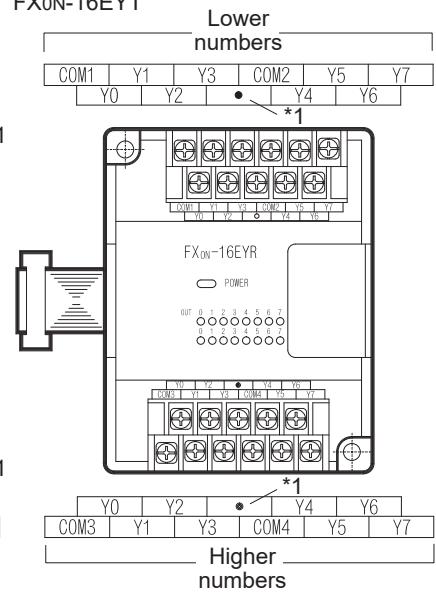

*1. "•" represents vacant terminals

1
Outline

2
External
Dimensions

3
Generic
Specifications

4
Power Supply
Specifications

5
Input
Specifications

6
Output
Specifications

7
Examples of
Wiring for
Various Uses

8
Terminal Block

9
CC-Link/LT
Master FX3UC-
LT(-Z) only

10
Display module
FX3UC-LT(-Z)
only

2.2.5 Expansion boards

FX3U-232-BD

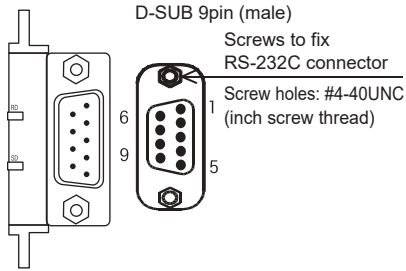

Pin No.	Signal	Name
1	CD(DCD)	Receive carrier detection
2	RD(RXD)	Receive data
3	SD(TXD)	Send data
4	ER(DTR)	Data terminal ready ^{*1}
5	SG(GND)	Signal ground
6	DR(DSR)	Data set ready ^{*2}
7, 8, 9	Not used	

*1.Data terminal ready uses it as a request to send by the handling of the control line.

*2.Data set ready uses it as a possible to send by the handling of the control line.

FX3U-485-BD

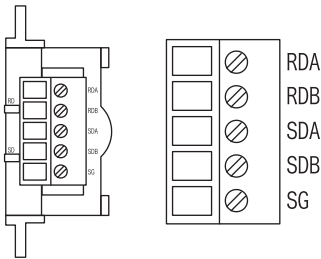

FX3U-8AV-BD

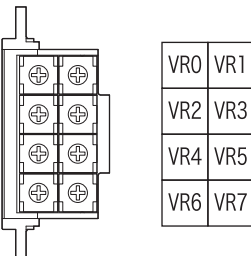

2.2.6 Special adapters

1. Analog special adapter

FX3U-4AD-ADP

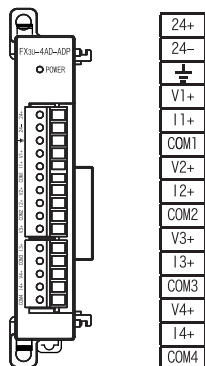

FX3U-4DA-ADP

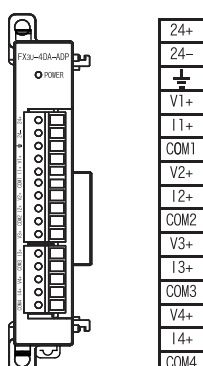

FX3U-3A-ADP

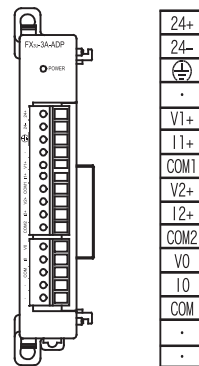

FX3U-4AD-PT(W)-ADP
FX3U-4AD-PNK-ADP

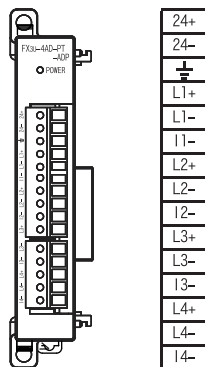

FX3U-4AD-TC-ADP

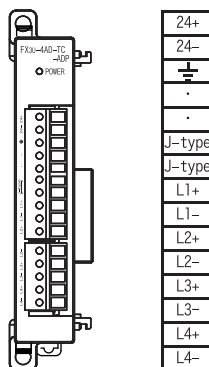

1	Outline
2	External Dimensions
3	Generic Specifications
4	Power Supply Specifications
5	Input Specifications
6	Output Specifications
7	Examples of Wiring for Various Uses
8	Terminal Block
9	CC-Link/LT Master FX3uc-LT(-2) only
10	Display module FX3uc-LT(-2) only

2. Communication special adapter

FX3U-232ADP(-MB)

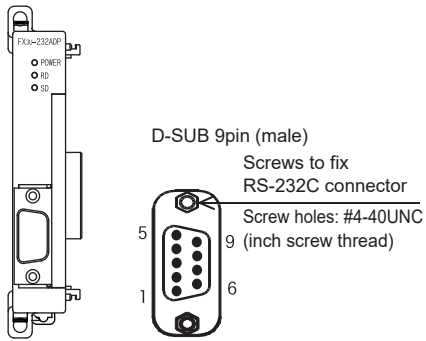

Pin No.	Signal	Name
1	CD(DCD)	Receive carrier detection
2	RD(RXD)	Receive data
3	SD(TXD)	Send data
4	ER(DTR)	Data terminal ready ^{*1}
5	SG(GND)	Signal ground
6	DR(DSR)	Data set ready ^{*2}
7, 8, 9	Not used	

*1.Data terminal ready uses it as a request to send by the handling of the control line.

*2.Data set ready uses it as a possible to send by the handling of the control line.

FX3U-485ADP(-MB)

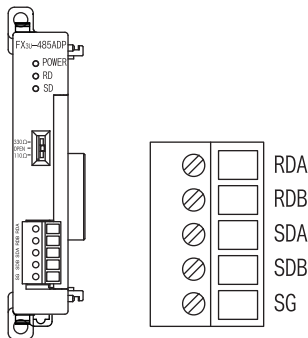

FX3U-ENET-ADP

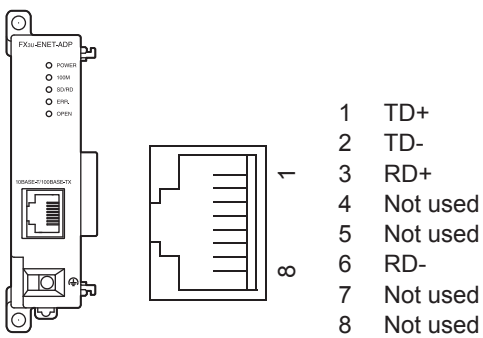

3. CF card special adapter

FX3U-CF-ADP

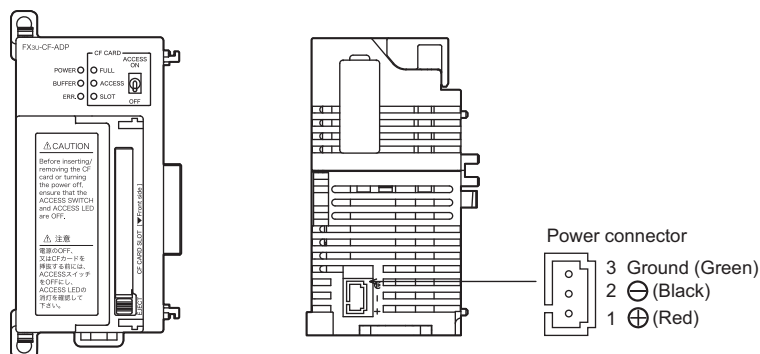

2.2.7 Power supply unit

FX3UC-1PS-5V

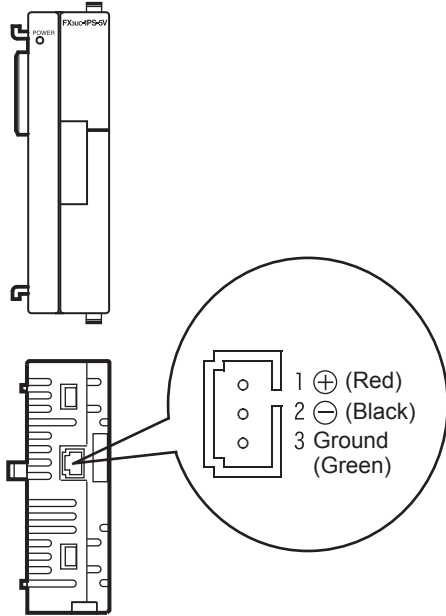

FX2N-20PSU

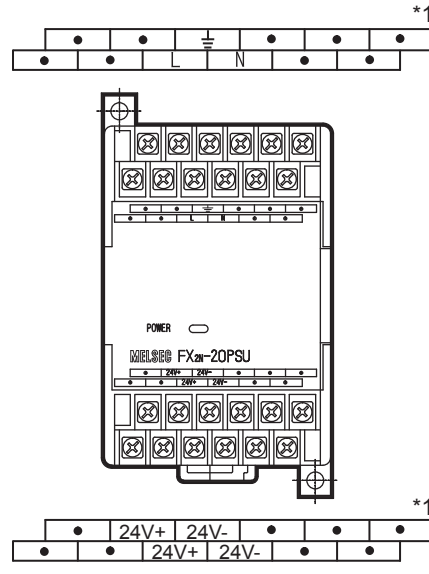

*1. "•" represents vacant terminals

1
Outline

2
External Dimensions

3
Generic Specifications

4
Power Supply Specifications

5
Input Specifications

6
Output Specifications

7
Examples of Wiring for Various Uses

8
Terminal Block

9
CC-Link/LT Master FX3UC-LT(-2) only

10
Display module FX3UC-LT(-2) only

3. Generic Specifications/Installation Work

DESIGN PRECAUTIONS	 WARNING
<ul style="list-style-type: none">• Make sure to have the following safety circuits outside of the PLC to ensure safe system operation even during external power supply problems or PLC failure. Otherwise, malfunctions may cause serious accidents.<ol style="list-style-type: none">1) Most importantly, have the following: an emergency stop circuit, a protection circuit, an interlock circuit for opposite movements (such as normal vs. reverse rotation), and an interlock circuit (to prevent damage to the equipment at the upper and lower positioning limits).2) Note that when the PLC CPU detects an error, such as a watchdog timer error, during self-diagnosis, all outputs are turned off. Also, when an error that cannot be detected by the PLC CPU occurs in an input/output control block, output control may be disabled. External circuits and mechanisms should be designed to ensure safe machinery operation in such a case.3) Note that when an error occurs in a relay, triac or transistor output device, the output could be held either on or off. For output signals that may lead to serious accidents, external circuits and mechanisms should be designed to ensure safe machinery operation in such a case.• Note that when an error occurs in a remote I/O unit, the output could be held either on or off. For output signals that may lead to serious accidents, external circuits for monitoring should be provided.	

DESIGN PRECAUTIONS	 CAUTION
<ul style="list-style-type: none">• Do not bundle the control line and CC-Link/LT connection cables together with or lay them close to the main circuit or power line. As a guideline, lay the control line and CC-Link/LT connection cables at least 100mm (3.94") or more away from the main circuit or power line. Noise may cause malfunctions.• Install the product so that excessive force will not be applied to peripheral device connectors, power connectors, input/output connectors, CC-Link/LT interface connectors or CC-Link/LT connection cables. Failure to do so may result in wire damage/breakage or PLC failure.	

SECURITY PRECAUTIONS	 WARNING
<ul style="list-style-type: none">• To maintain the security (confidentiality, integrity, and availability) of the programmable controller and the system against unauthorized access, denial-of-service (DoS) attacks, computer viruses, and other cyberattacks from unreliable networks and devices via network, take appropriate measures such as firewalls, virtual private networks (VPNs), and antivirus solutions.	

INSTALLATION PRECAUTIONS	 WARNING
<ul style="list-style-type: none">• Make sure to cut off all phases of the power supply externally before attempting installation or wiring work. Failure to do so may cause electric shock or damage to the product.	

INSTALLATION PRECAUTIONS



CAUTION

- Use the product within the generic environment specifications described in Section 3.1 of this manual. Never use the product in areas with excessive dust, oily smoke, conductive dusts, corrosive gas (salt air, Cl₂, H₂S, SO₂ or NO₂), flammable gas, vibration or impacts, or expose it to high temperature, condensation, or rain and wind.
If the product is used in such conditions, electric shock, fire, malfunctions, deterioration or damage may occur.
- Do not touch the conductive parts of the product directly.
Doing so may cause device failures or malfunctions.
- Install the product securely using a DIN rail or mounting screws.

Main unit, FX2NC Series I/O extension blocks, FX2NC/FX3UC Series special function blocks, special adapter, extension power supply unit, FX2NC-CNV-IF, FX2N-10GM, FX2N-20GM, FX Series terminal blocks	DIN rail only
FX0N/FX2N Series I/O extension blocks, FX0N/FX2N/FX3U Series special function blocks, FX2N-1RM(-E)	DIN rail or direct mounting

- Install the product on a flat surface.
If the mounting surface is rough, undue force will be applied to the PC board, thereby causing nonconformities.
- Make sure to affix the expansion board with tapping screws.
Tightening torque should follow the specifications in the manual.
Loose connections may cause malfunctions.
- When drilling screw holes or wiring, make sure that cutting and wiring debris do not enter the ventilation slits.
Failure to do so may cause fire, equipment failures or malfunctions.
- Be sure to remove the dust proof sheet from the PLC's ventilation port when installation work is completed.
Failure to do so may cause fire, equipment failures or malfunctions.
- Connect the extension cables, peripheral device cables, input/output cables and battery connecting cable securely to their designated connectors.
Loose connections may cause malfunctions.
- Connect the display module, memory cassette, FX2NC Series I/O extension blocks, FX2NC-CNV-IF, extension power supply unit and expansion board securely to their designated connectors.
Loose connections may cause malfunctions.
- Turn off the power to the PLC before attaching or detaching the following devices.
Failure to do so may cause equipment failures or malfunctions.
 - Peripheral devices, display modules, expansion boards and special adapters
 - Extension blocks, FX Series terminal blocks, connector conversion adapter and extension power supply unit
 - Battery and memory cassette

Note

- When a dust proof sheet is supplied with an extension unit/ block, keep the sheet applied to the ventilation slits during installation and wiring work.

WIRING PRECAUTIONS



WARNING

- Make sure to cut off all phases of the power supply externally before attempting installation or wiring work.
Failure to do so may cause electric shock or damage to the product.
- Make sure to attach the terminal cover, offered as an accessory, before turning on the power or initiating operation after installation or wiring work.
Failure to do so may cause electric shock.
- The temperature rating of the cable should be 80°C or more.

1	Outline
2	External Dimensions
3	Generic Specifications
4	Power Supply Specifications
5	Input Specifications
6	Output Specifications
7	Examples of Wiring for Various Uses
8	Terminal Block
9	CC-LINK/LT Master FX3UC-LT(-Z) only
10	Display module FX3UC-LT(-Z) only

WIRING PRECAUTIONS

CAUTION

- Connect the DC power supply wiring to the dedicated terminals described in this manual. If an AC power supply is connected to a DC input/output terminal or DC power supply terminal, the PLC will burn out.
- Do not wire vacant terminals externally. Doing so may damage the product.
- Perform class D grounding (grounding resistance: 100Ω or less) to the grounding terminal on the main unit. Do not use common grounding with heavy electrical systems.
- When drilling screw holes or wiring, make sure that cutting and wiring debris do not enter the ventilation slits. Failure to do so may cause fire, equipment failures or malfunctions.
- Make sure to properly wire the FX0N/FX2N/FX3U Series extension equipment in accordance with the following precautions. Failure to do so may cause electric shock, equipment failures, a short-circuit, wire breakage, malfunctions, or damage to the product.
 - The disposal size of the cable end should follow the dimensions described in the manual.
 - Tightening torque should follow the specifications in the manual.
 - Tighten the screws using a Phillips-head screwdriver No.2 (shaft diameter 6mm (0.24") or less). Make sure that the screwdriver does not touch the partition part of the terminal block.
- Make sure to properly wire to the terminal block (European type) in accordance with the following precautions. Failure to do so may cause electric shock, equipment failures, a short-circuit, wire breakage, malfunctions, or damage to the product.
 - The disposal size of the cable end should follow the dimensions described in the manual.
 - Tightening torque should follow the specifications in the manual.
 - Twist the end of strand wire and make sure that there are no loose wires.
 - Do not solder-plate the electric wire ends.
 - Do not connect more than the specified number of wires or electric wires of unspecified size.
 - Affix the electric wires so that neither the terminal block nor the connected parts are directly stressed.
- Make sure to properly wire to the FX Series terminal blocks in accordance with the following precautions. Failure to do so may cause electric shock, equipment failures, a short-circuit, wire breakage, malfunctions, or damage to the product.
 - The disposal size of the cable end should follow the dimensions described in the manual.
 - Tightening torque should follow the specifications in the manual.
 - Tighten the screws using a Phillips-head screwdriver No.2 (shaft diameter 6mm (0.24") or less). Make sure that the screwdriver does not touch the partition part of the terminal block.
- The FX3UC-32MT-LT(-2) has a built-in power supply. When connecting a power supply adapter or dedicated CC-Link/LT power supply, connect the built-in master to the LINK connector in the power supply adapter or dedicated power supply.

Connection to the LINK/POWER connector may cause failures.

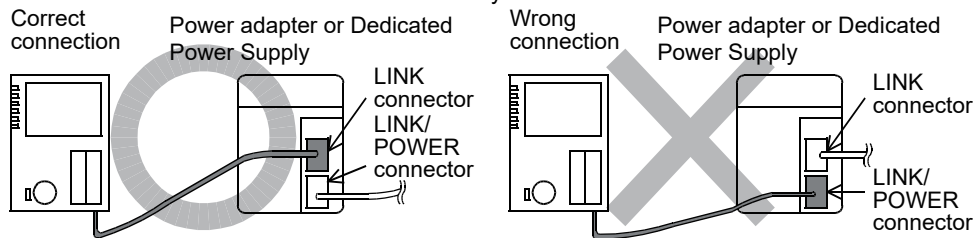

3.1 Generic Specifications

Item	Specification				
Ambient temperature	0 to 55°C (32 to 131°F) when operating and -25 to 75°C (-13 to 167°F) when stored				
Ambient humidity	5 to 95%RH (no condensation) when operating				
Vibration resistance *1	When installed on DIN rail	Frequency (Hz)	Acceleration (m/s ²)	Half amplitude (mm)	Sweep Count for X, Y, Z: 10 times (80 min. in each direction)
		10 to 57	-	0.035	
	When installed directly	57 to 150	4.9	-	
		10 to 57	-	0.075	
		57 to 150	9.8	-	
Shock resistance *1	147m/s ² Acceleration, Action time: 11ms, 3 times by half-sine pulse in each direction X, Y, and Z				
Noise resistance	By noise simulator at noise voltage of 1,000Vp-p, noise width of 1μs, rise time of 1ns and period of 30 to 100Hz				
Dielectric withstand voltage	500V AC for one minute		Between batch of all terminals and ground terminal		
Insulation resistance	5 MΩ or higher by 500 V DC insulation resistance tester				
Grounding	Class D grounding (grounding resistance: 100Ω or less) <Common grounding with a heavy electrical system is not allowed.>*2				
Working atmosphere	Free from corrosive or flammable gas and excessive conductive dusts				
Working altitude	< 2000m*3				
Installation location	Inside a control panel*4				
Overtoltage category	II or less				
Pollution degree	2 or less				

*1. The criterion is shown in IEC61131-2.

*2.

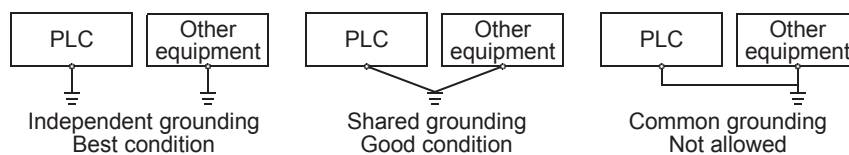

*3. The PLC cannot be used at a pressure higher than the atmospheric pressure to avoid damage.

*4. The programmable controller is assumed to be installed in an environment equivalent to indoor.

3.2 Installation location

Install the PLC in an environment conforming to the generic specifications (section 3.1), installation precautions.

For information on the installation location for remote I/O stations and the CC-Link/LT power supply, refer to the manual of each product.

Notes
<ul style="list-style-type: none"> Keep a space of 50mm (1.97") or more between the unit main body and another device or structure. Install the unit as far away as possible from high-voltage lines, high-voltage devices and power equipment. Failure to do so may cause fire, equipment failures or malfunctions. To prevent temperature rise, do not install the PLC on a floor, a ceiling or a vertical surface. Install it horizontally on a wall as shown below.

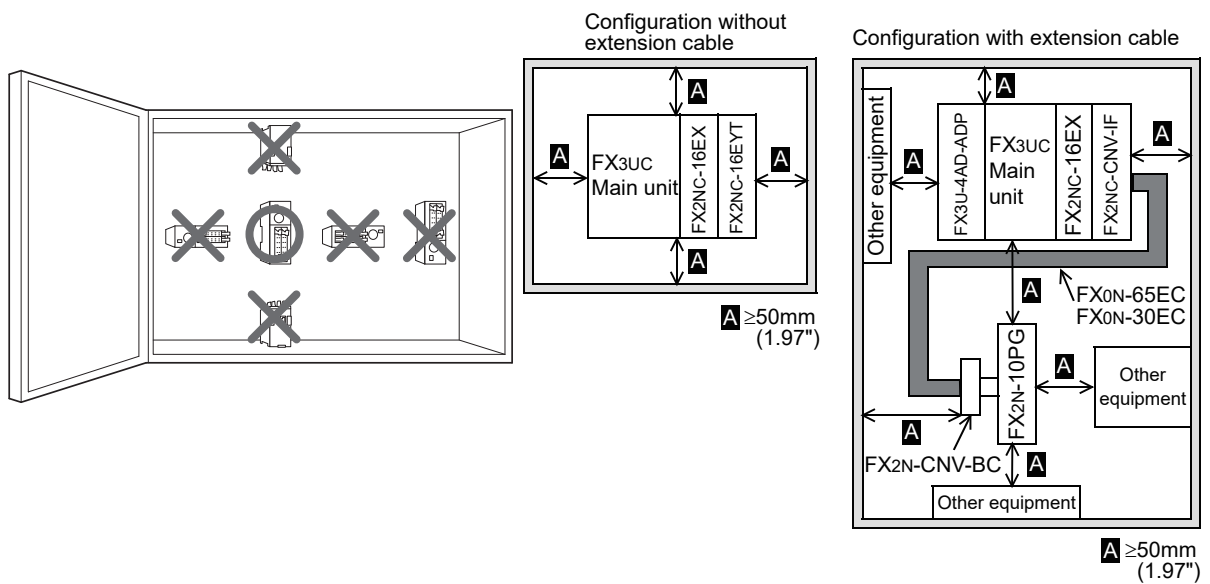

3.3 Procedures for Installing on and Detaching from DIN Rail

The main unit, FX2NC I/O extension block, FX2NC/FX3UC special function block, and FX3U special adapter can be installed on a DIN46277 rail [35mm (1.38") wide]. (It cannot be installed directly with screws.)

The FX0N/FX2N I/O extension block, FX0N/FX2N/FX3U special function block, and FX3U special adapter can be installed on a DIN46277 rail [35mm (1.38") wide] and directly mounted.

→ For the installation of remote I/O stations, dedicated power supply and power supply adapter for CC-Link/LT, refer to the manual of each product.

3.3.1 Procedures for installing to and removing from DIN rail

1. FX3UC Series main unit, FX2NC Series I/O extension block, FX2NC/FX3UC Series special function block, Extension power supply unit, FX2NC-CNV-IF

(Example : FX3UC-32MT/D)

- 1) Connect all of the main unit, I/O extension blocks for FX2NC, special extension blocks for FX2NC/FX3UC, extension power supply unit and FX2NC-CNV-IF.

→ For connecting method, refer to Subsection 3.4.2.

- 2) Push the DIN rail mounting hooks ① of all connected units/ blocks as shown in the figure on the right ①.

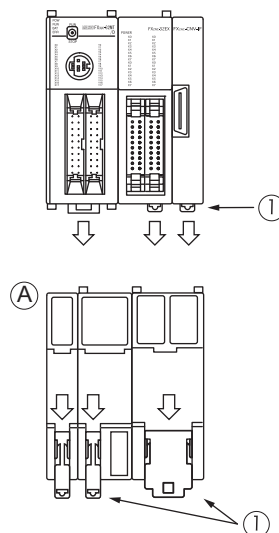

- 3) Align the upper side of the DIN rail mounting groove with the DIN rail (② in the figure on the right).

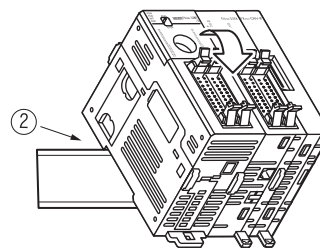

- 4) While pressing the main unit onto the DIN rail, lock the DIN rail mounting hooks as shown in the figure below ③.

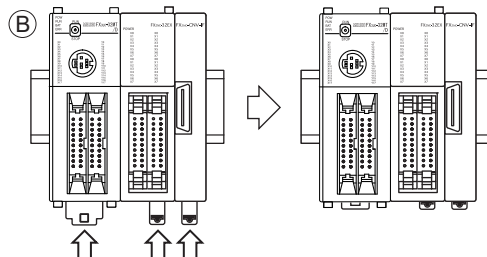

1	Outline
2	External Dimensions
3	Generic Specifications
4	Power Supply Specifications
5	Input Specifications
6	Output Specifications
7	Examples of Wiring for Various Uses
8	Terminal Block
9	CC-Link/LT Master FX3UC-LT(-2) only
10	Display module FX3UC-LT(-2) only

2. FX0N/FX2N Series I/O extension block, FX0N/FX2N/FX3U Series special function unit/block

- 1) Push the DIN rail mounting hooks as shown in ① in the figure on the right.
This step is not required for FX0N series I/O extension blocks, FX2N series 8-point type I/O extension blocks (except for the FX2N-8EYR-S-ES/UL) and FX0N/FX2N/FX3U series special function blocks.
- 2) Align the upper side of the DIN rail mounting groove with the DIN rail (② in the figure on the right).
- 3) Press the product onto the DIN rail as shown in ③ in the figure on the right.
- 4) The extension cable is connected.
For the connection method of the extension cable, refer to Section 3.4.

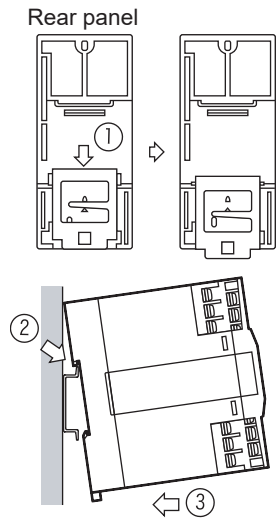

3.3.2 Procedures for removal from DIN rail

- 1) Disconnect connection cables such as power cables, I/O cables, CC-Link/LT connection cables and extension cables.
- 2) Hook a slotted screwdriver to the DIN rail mounting hook (① in the figure on the right).
- 3) Move the slotted screwdriver in the direction ②, pull out the DIN rail mounting hooks from all connected units/blocks, and let the DIN rail mounting hooks come off the DIN rail.
- 4) Remove the main unit from the DIN rail (③ in the figure on the right).
- 5) Push the DIN rail mounting hooks as shown in ④ in the figure below.
This step is not required for FX0N series I/O extension blocks, FX2N series 8-point type I/O extension blocks (except for the FX2N-8EYR-S-ES/UL) and FX0N/FX2N/FX3U series special function blocks.

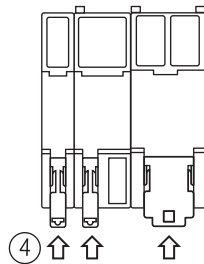
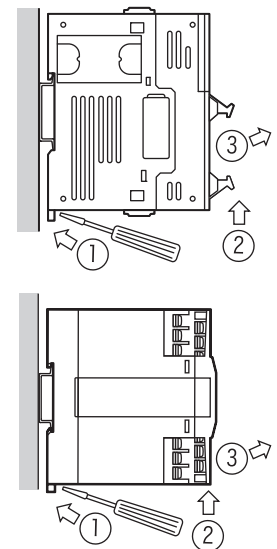

3.3.3 Direct mounting (FX0N/FX2N/FX3U extension units/blocks)

Only I/O extension blocks for FX0N/FX2N and special function units/blocks for FX0N/FX2N/FX3U can be installed directly. Install them with screw holes M4 in reference to "2.1 External Dimensions (MASS/Installation/Accessories)". Assure the space of 1 to 2mm(0.04" to 0.08") between units as shown below.

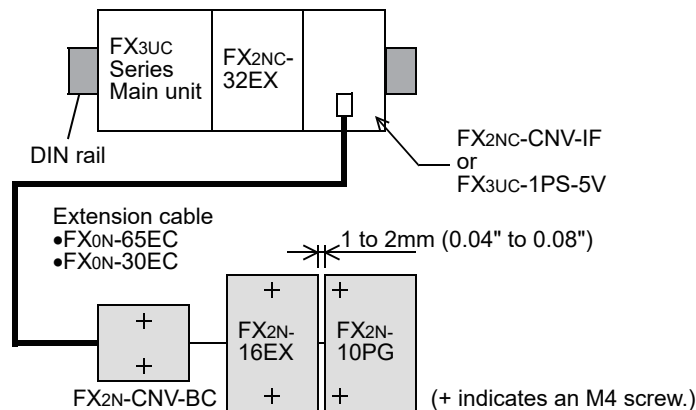

3.4 Connection between main unit and extension equipment

This section explains how to connect extension equipment.

3.4.1 Extension equipment connection configuration

The connection method among the main unit, I/O extension blocks and special extension units/blocks varies depending on the group.

- For the connection method A, refer to Subsection 3.4.2.
- For the connection method B, refer to Subsection 3.4.3.
- For the connection method C, refer to Subsection 3.4.4.
- For the connection method D, refer to Subsection 3.4.5.

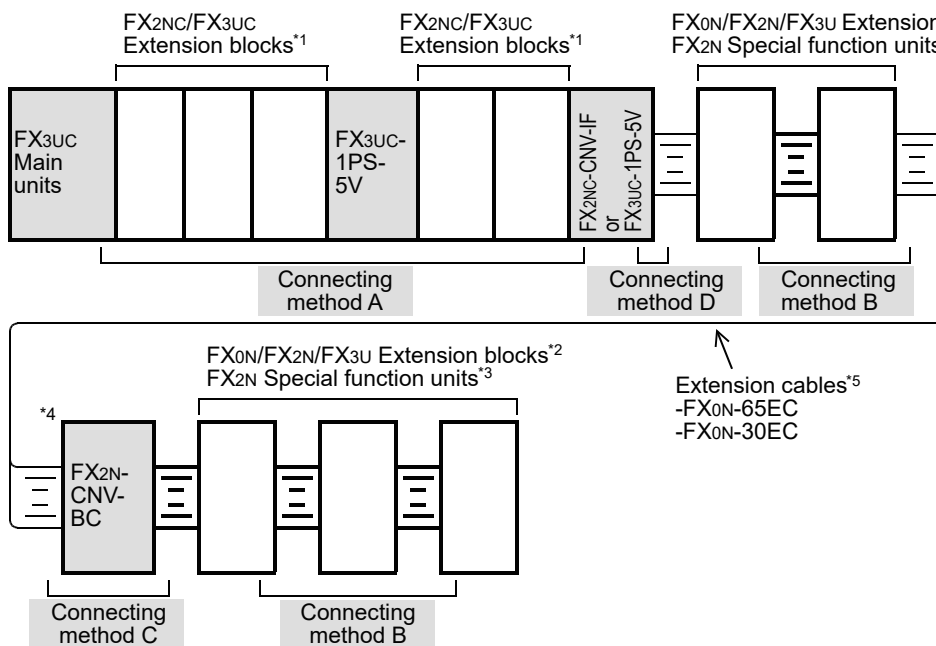

- *1. FX2NC I/O extension blocks and FX2NC/FX3UC special function blocks
- *2. FX0N/FX2N I/O extension blocks and FX0N/FX2N/FX3U special function blocks
- *3. In a special function unit for FX2N, use the extension cable offered as an accessory.
- *4. The FX2N-CNV-BC is not required when the connection destination (right side) is the FX2N-10GM or FX2N-20GM. Do not connect the FX3U-4LC or FX2N-8AD on the right side of the FX2N-CNV-BC. The FX2N-CNV-BC cannot be secured in this case.
- *5. Use the FX2N-GM-65EC when the connection destination is the FX2N-10GM or FX2N-20GM. Extension cables are not available when the connection destination is the FX2N-1RM(-E)-SET.

1	Outline
2	External Dimensions
3	Generic Specifications
4	Power Supply Specifications
5	Input Specifications
6	Output Specifications
7	Examples of Wiring for Various Uses
8	Terminal Block
9	CC-Link/LT Master FX3UC-LT(-2) only
10	Display module FX3UC-LT(-2) only

3.4.2 Connecting method A (Main units and Extension units/blocks connecting)

This subsection explains the procedures for connecting FX2NC/FX3UC Series extension blocks, FX2NC-CNV-IF or FX3UC-1PS-5V.

1. Connection procedure

- 1) Remove the connecting connector cover (A) from the right side of the main unit or existing extension block.
- 2) Pull up the connecting hook ② of the main unit or existing extension block, and connect the hook ① of the extension block to the connection hole of the counterpart (main unit or existing extension block) as shown in the figure on the right.
- 3) Pull down the connecting hook ② of the main unit or existing extension block to fix the extension block to be added.

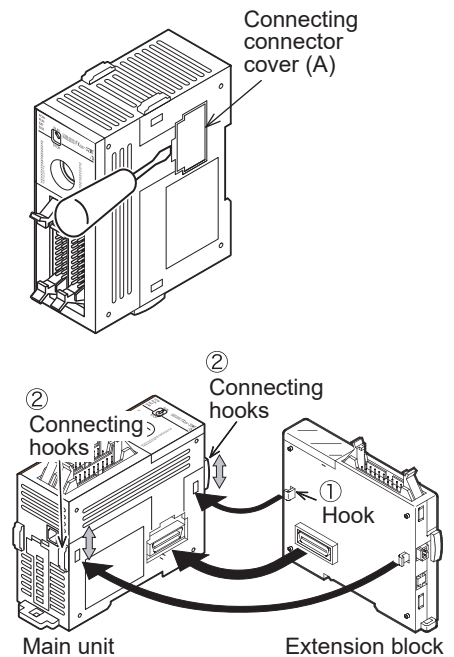

3.4.3 Connecting method B (Connection of FX0N/FX2N/FX3U extension units/blocks)

This subsection explains the procedures for connecting FX0N/FX2N I/O extension blocks or FX0N/FX2N/FX3U special function blocks.

1. Connection procedure

- 1) Remove the top cover of the existing unit/block (left side).
 - When connecting FX2N-10GM or FX2N-20GM, remove the PLC extension block connector cover.
 - When connecting FX2N-1RM(-E), remove the top cover of FX2N-1RM(-E).
- 2) Connect the extension cable of the block to be connected (right side) to the existing unit/block.
 - When the FX2N-10GM, FX2N-20GM or FX2N-1RM(-E) are connected, connect the unit to be added (right side) and the existing unit (left side) with the supplied extension cable.
- 3) Fit the top cover (except when connecting FX2N-10GM or FX2N-20GM).

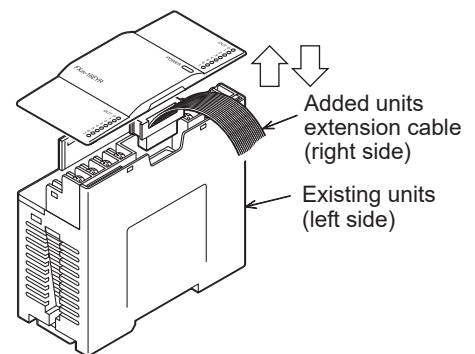

3.4.4 Connecting method C (Extension cable • FX2N-CNV-BC connecting)

This subsection explains the procedures for connecting an extension cable and FX2N-CNV-BC to the extension cable of the extension unit/block.

1. Connection procedure

- 1) Separate the case of FX2N-CNV-BC into two pairs as shown right.
To separate the case, use a precision flathead screwdriver. Slightly insert the tip of a screwdriver in direction ① into part A shown in the right figure. The hook will come off. (4 positions)

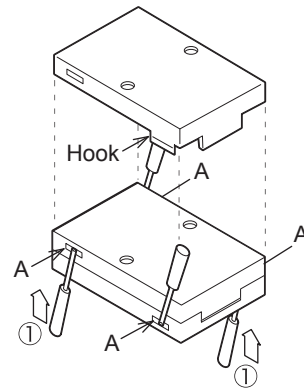

- 2) Connect the extension cable on the upstream side (② in the right figure).
- 3) Connect the extension cable on the downstream side (③ in the right figure).
- 4) Fit the upper cover and the lower cover (④ in the right figure), and press down the upper cover until it is hooked.

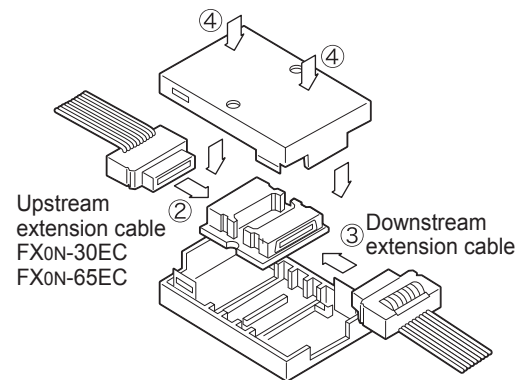

3.4.5 Connecting method D (Connection of FX3UC-1PS-5V/FX2NC-CNV-IF to right side)

This subsection explains the procedures for connecting the extension cable to the extension power supply unit FX3UC-1PS-5V or the connector conversion interface FX2NC-CNV-IF.

1. Connection procedure

- 1) The connector cover (A) of the FX3UC-1PS-5V is removed as shown in the figure to the right. The FX2NC-CNV-IF does not have a connector cover.

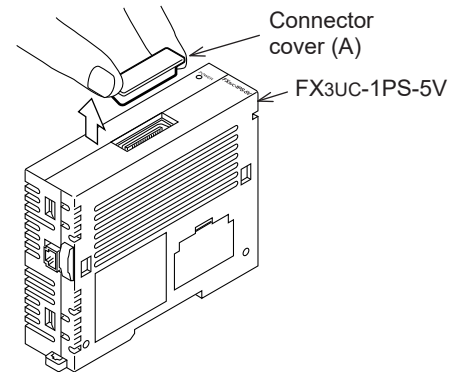

- 2) Connect the extension cable as shown to the right.

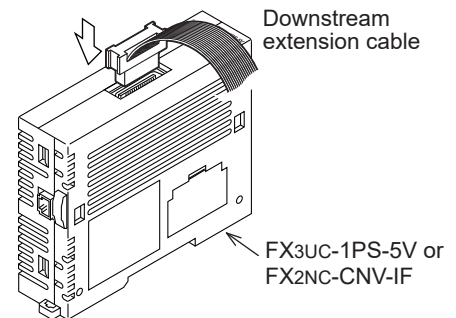

2. Caution on the FX3UC-1PS-5V

Only one connector can be used to attach extra equipment to the FX3UC-1PS-5V.

When the FX2NC/FX3UC extension connector (on the right side) of the FX3UC-1PS-5V is being used

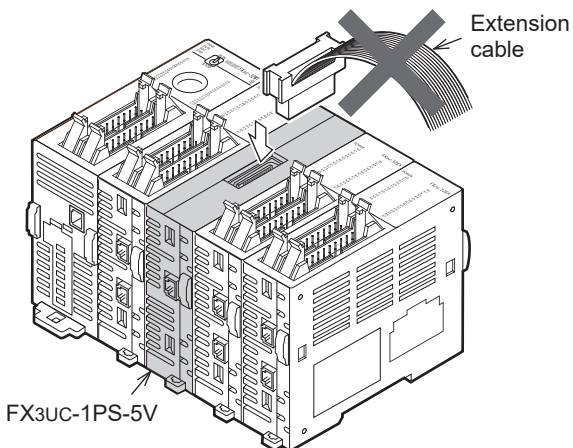

When the FX2NC/FX3UC extension connector (on the right side) of the FX3UC-1PS-5V is being used, the FX0N/FX2N/FX3U extension block connector on the top is not available.

When the FX0N/FX2N/FX3U extension block connector (on the top) of the FX3UC-1PS-5V is being used

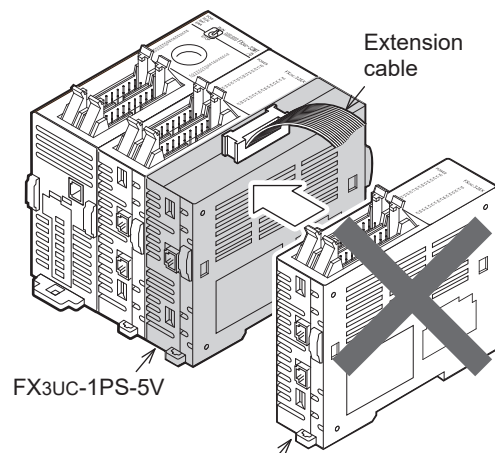

FX2NC/FX3UC extension block
(FX2NC/FX3UC special function block,
FX2NC-CNV-IF, FX3UC-1PS-5V)

When the FX0N/FX2N/FX3U extension block connector (on the top) of the FX3UC-1PS-5V is being used, the FX2NC/FX3UC extension connector on the right side is not available.

3.5 Expansion Board Connection [FX3uc-32MT-LT(-2) Only]

Only the FX3uc-32MT-LT(-2) can have expansion boards connected.

1. Connection procedure

- 1) Disconnect all the cables connected to the PLC.
- 2) Demount the PLC from the DIN rail.
→ For the removal method, refer to Section 3.3.
- 3) Using a flat head screwdriver as shown in the figure on the right, lift the dummy expansion board cover (fig. (A)) making sure not to damage the circuit board or electronic parts. (fig. ①)
- 4) Remove the expansion board dummy cover. (fig. ②)
- 5) Make sure the expansion board is in parallel with the main unit and attach it to the expansion board connector. (fig. ③)
- 6) Fix the expansion board to the main unit using the provided M3 tapping screws. (fig. ④)
Tighten to a torque of 0.3 to 0.6 N•m

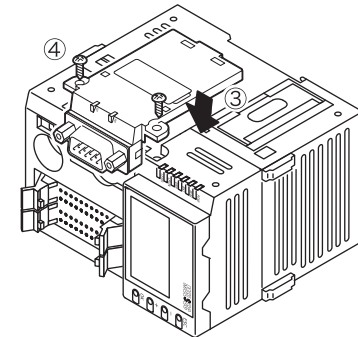
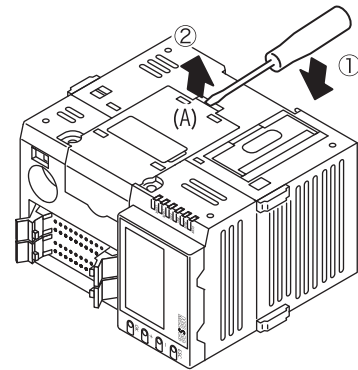

3.6 Special Adapter Connection

The FX3UC-32MT-LT(-2) supports special adapters only when an expansion board is connected.

1. Connection procedure to the FX3UC-□□MT/D(SS) or FX3UC-16MR/D(S)-T

- 1) Turn off the power.
Disconnect all the cables connected to the PLC, and demount the PLC from the DIN rail.
→ **For the removal method, refer to Section 3.3.**
- 2) Remove the special adapter connector cover (fig. A).
- 3) Slide the special adapter slide lock (fig. B) of the main unit when connecting this product to another special adapter, please replace the 'main unit' in the above description with a 'special adapter' and perform the procedure as indicated.
- 4) Connect the special adapter (fig. C) to the main unit as shown on the right.
- 5) Slide back the special adapter slide lock (fig. B) of the main unit to fix the special adapter (fig. C).

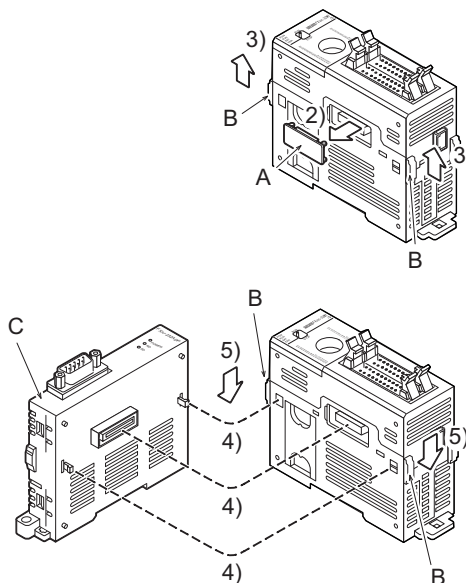

Caution

When using the FX3U-ENET-ADP, connect it to the last adapter position (leftmost position).

2. Connection procedure to the FX3UC-32MT-LT(-2)

- 1) Turn off the power.
Disconnect all the cables connected to the PLC, and demount the PLC from the DIN rail.
→ **For the removal method, refer to Section 3.3.**
- 2) Install an expansion board to the main unit.
→ **For the expansion board installation procedure, refer to the Section 3.5.**
- 3) Remove the special adapter connector cover on the expansion board (fig. A).
When connecting this product to another special adapter, please replace the 'expansion board' in the above description with a 'special adapter' and perform the procedure as indicated.
- 4) Slide the special adapter slide lock (fig. B) of the main unit. When connecting this product to another special adapter, please replace the 'main unit' in the above description with a 'special adapter' and perform the procedure as indicated.
- 5) Connect the special adapter (fig. C) to the main unit as shown on the right.
- 6) Slide back the special adapter slide lock (fig. B) of the main unit to fix the special adapter (fig. C).

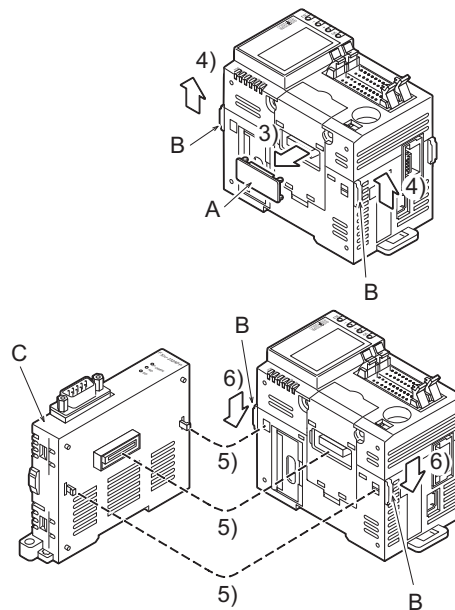

Caution

When using the FX3U-ENET-ADP, connect it to the last adapter position (leftmost position).

3.7 How to remove or install a memory cassette

1. How to remove the memory cassette dummy cover

Note : Some memory cassette dummy covers have the same shape as the memory cassette.
In such a case, refer to "2. How to remove the memory cassette" below.
The figure shows the FX3UC-32MT/D as an example.

- 1) Remove the product from the DIN rail.

→ For the removal method, refer to Section 3.3.

- 2) Hold the memory cassette dummy cover securely as shown in the figure on the right.

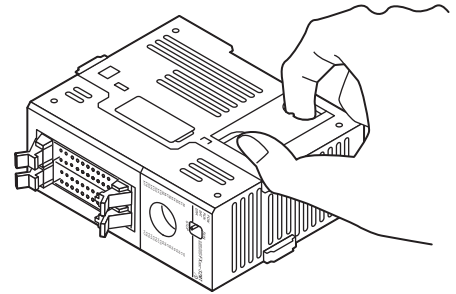

- 3) Pull the memory cassette dummy cover vertically as shown in the figure on the right, and remove it.

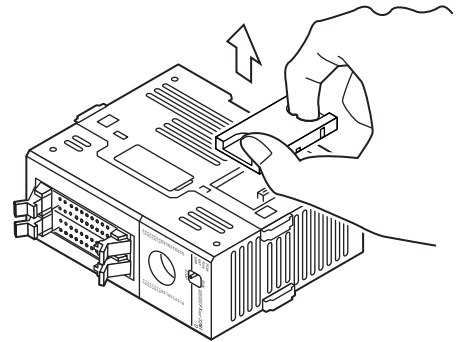

2. How to remove the memory cassette

Note : The figure shows the FX3UC-32MT-LT as an example.

- 1) Remove the product from the DIN rail.

→ For the removal method, refer to Section 3.3.

- 2) Raise the removal lever of the memory cassette (or memory cassette dummy cover) with your nail as shown in the figure on the right.

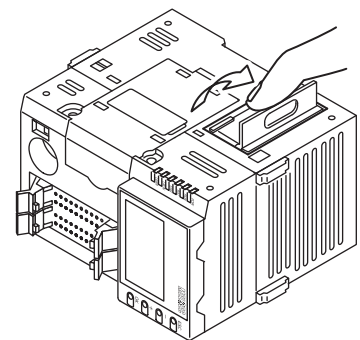

- 3) Pick and pull the removal lever vertically as shown in the figure on the right, and remove the memory cassette (or memory cassette dummy cover).

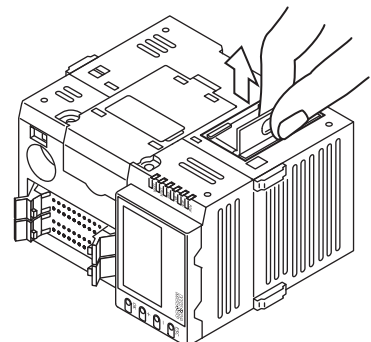

Caution:

Do not twist the removal lever when removing the memory cassette (or memory cassette dummy cover).

3. How to install the memory cassette

Note: The figure shows the FX3UC-32MT/D as an example.

- 1) Fit the memory cassette into the reverse installation prevention slot, and push it completely with your fingers.
 (The FX3UC-□□MT/D(SS) and FX3UC-16MR/D(S)-T becomes the same height as the adjacent area, and the FX3UC-32MT-LT(-2) becomes lower by approximately 1mm(0.04") than the adjacent area.)

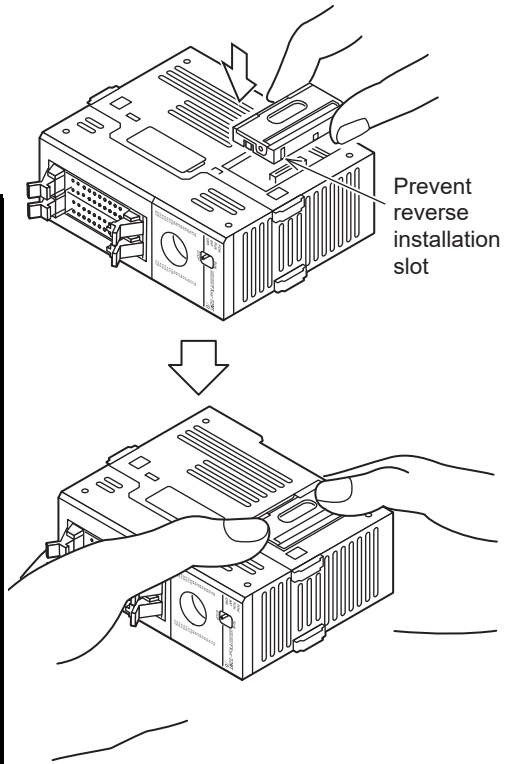

INSTALLATION PRECAUTIONS

⚠ CAUTION

- Connect the memory cassette securely to the prescribed connector. A poor connection can cause malfunctions. Installing the cassette in a raised or tilted posture can also cause malfunctions.

Cross-section drawing (memory cassette installation condition)
 -FX3UC-□□MT/D(SS), FX3UC-16MR/D(S)-T

Good

Bad

Bad

Memory cassette

FX3UC-□□MT/D(SS),
FX3UC-16MR/D(S)-T
body

Raised cassette posture

Tilted cassette posture

Press the 4 corners in approx.
0.4mm(0.02")

Good

Bad

Bad

Memory cassette

FX3UC-32MT-LT(-2)
body

Raised cassette posture

Tilted cassette posture

3.8 Display module Installation / Removal (FX3UC-32MT-LT(-2) Only)

Only the FX3UC-32MT-LT(-2) can have expansion boards connected.

3.8.1 Removal

- 1) Gently place the tip of a flat blade screwdriver to the Display module fixing hooks (right fig. ①).
- 2) Tilt the flat blade screwdriver at the two Display module fixing hooks to lift the display module from the main unit by about 1mm (0.04") (right fig. ②).

Carefully perform the above trying not to bend or break the Display module fixing hooks.

- 3) Hold the display module (right fig.) and remove the display module.

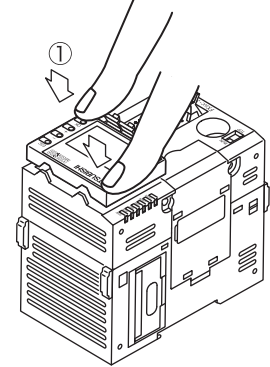
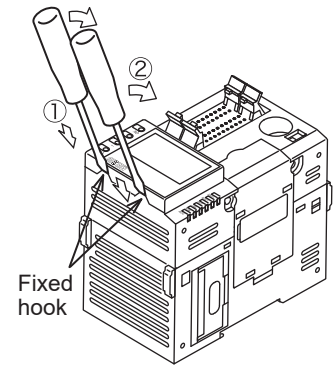

3.8.2 Installing

- 1) Put the connector of the display module on the main unit (figure on the right).
- 2) Push the display module to install it (① in the figure on the right).

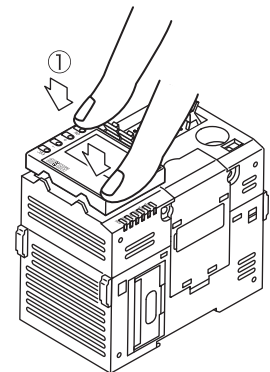

3.9 Connection to peripheral device connecting connector

This section explains how to connect and disconnect communication cables for peripheral devices.

1. FX3uc-□□MT/D(SS), FX3uc-16MR/D(S)-T

When connecting a communication cable, align the "positioning mark" in the cable with the "connector notch" in the peripheral device.

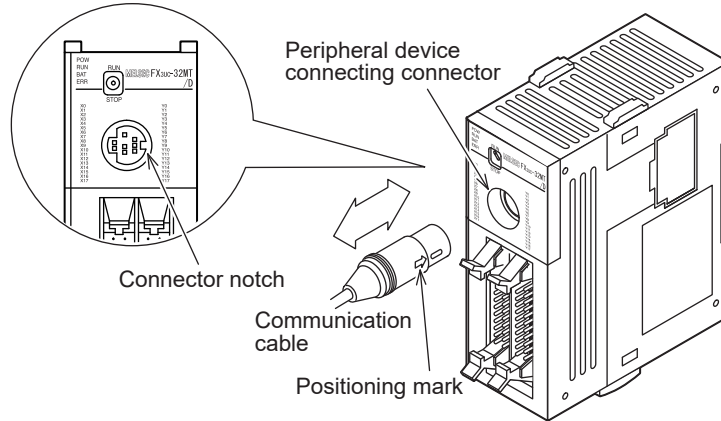

2. FX3uc-32MT-LT(-2)

When connecting the communication cable of a peripheral device, align the positioning mark of the cable with that of the main unit.

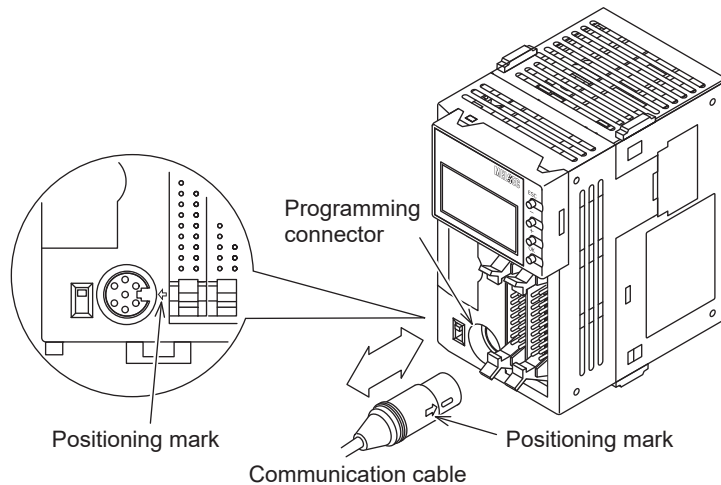

3.10 Connection of power supply cable

3.10.1 Power Cable types

The table below shows three Power Cable types: "A", "B", and "C".

Type	Application	Model	Length	Cable supplied with
A	Power cable for main unit, FX3U series special function blocks, FX2N series special function units, extension power supply unit and special adapters	FX2NC-100MPCB	1m (3' 3")	FX3UC-□□MT/D(SS), FX3UC-16MR/D(S)-T, FX3UC-32MT-LT(-2), FX3U-20SSC-H, FX2N-10GM, FX2N-20GM, FX3UC-1PS-5V, FX3U-CF-ADP
B	Input power cable for FX2NC series input extension blocks and FX2NC/FX3UC series special function blocks	FX2NC-100BPCB	1m (3' 3")	FX3UC-□□MT/D, FX3UC-16MR/D-T, FX3UC-32MT-LT(-2), FX2N-20GM
C	Input power crossover cable for FX2NC series input extension blocks and FX2NC/FX3UC series special function blocks	FX2NC-10BPCB1	0.1m (0' 3")	FX2NC-□□EX, FX2NC-16EX-T, FX2NC-4AD, FX2NC-4DA, FX3UC-4AD

The crossover cable (type "C") can skip up to 4 16-point output blocks to connect units. If more blocks should be skipped to supply power to an input block, use cable type "B".

3.10.2 Connection of power cable to main unit and extension block

The FX3UC PLC receives and supplies power through the built-in dedicated power connector. Power should be supplied to the main unit, FX2NC Series input extension blocks and FX2NC/FX3UC Series special extension blocks. Perform crossover wiring using two (upper and lower) power connectors for FX2NC-□□EX, FX2NC-16EX-T and FX2NC/FX3UC Series special extension blocks. The FX2NC-□□EX-DS and FX2NC-16EX-T-DS do not have a power connector, and receive power from the input connector.

1. FX3UC-□□MT/D(SS), FX3UC-16MR/D(S)-T

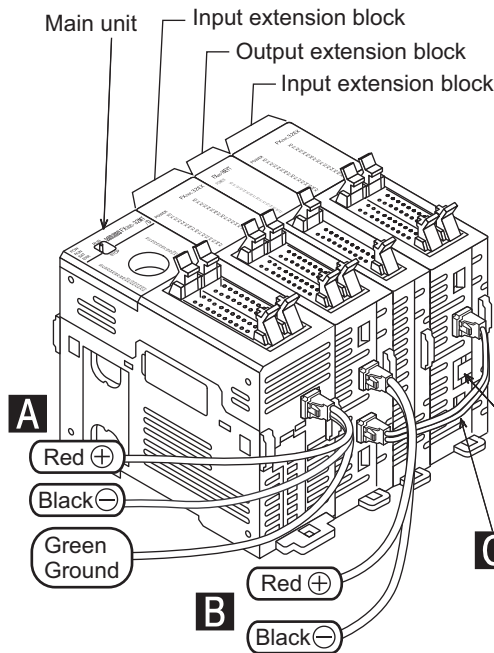

The figure below shows the pin numbers of the power connectors.

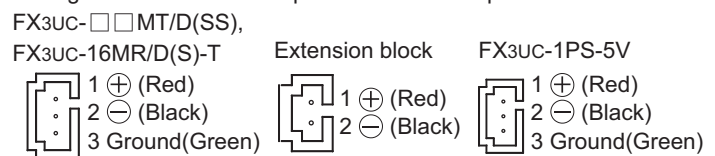

Resin cover

At shipment from the factory, a resin cover is attached to the lower connector.

Connect the upper connector first.

Remove the resin cover from the lower connector when performing crossover wiring for the later block.

C Crossover wiring between the input extension block.

- Wiring from the FX2NC-□□EX, FX2NC-16EX-T or FX2NC/FX3UC Series special extension block to another block.
 Two power connectors of the FX2NC-□□EX, FX2NC-16EX-T and FX2NC/FX3UC Series special extension blocks are connected in parallel inside the block, and there is no distinction between the power inlet side and the power outlet side. Either connector can be used for wiring. At shipment from the factory, a resin cover is attached to the lower connector. Use the upper connector first. Remove the resin cover from the lower connector only when performing crossover wiring for another block.
 (The FX2NC-□□EX-DS and FX2NC-16EX-T-DS do not have a power connector, and receive power from the input connector. It is not necessary to remove the resin cover.)

2. FX3UC-32MT-LT(-2)

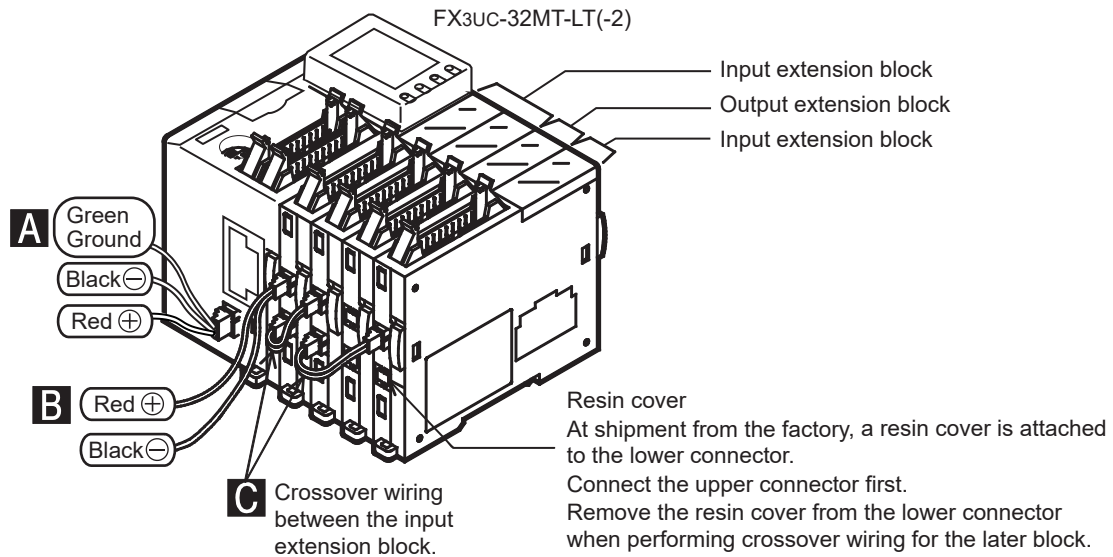

The figure below shows the pin numbers of the power connectors.

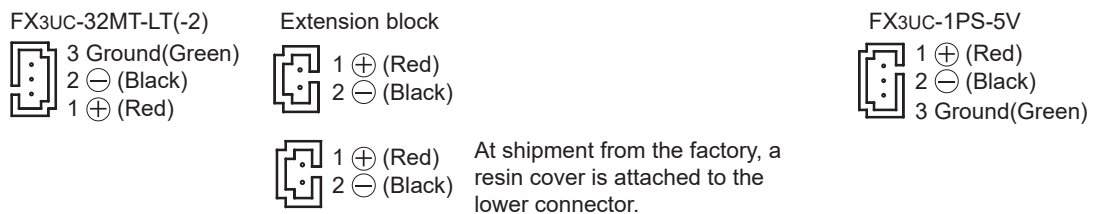

- Wiring from the FX2NC-□□EX, FX2NC-16EX-T or FX2NC/FX3UC Series special function block to another block.
 Two power connectors of the FX2NC-□□EX, FX2NC-16EX-T or FX2NC/FX3UC Series special function blocks are connected in parallel inside the block, and there is no distinction between the power inlet side and the power outlet side. Either connector can be used for wiring.
 At shipment from the factory, a resin cover is attached to the lower connector. Use the upper connector first. Remove the resin cover from the lower connector only when performing crossover wiring for another block.

3.10.3 Removal of the power cable

- 1) Pinch the power cable connector "a" and disconnect it in the direction of the arrow

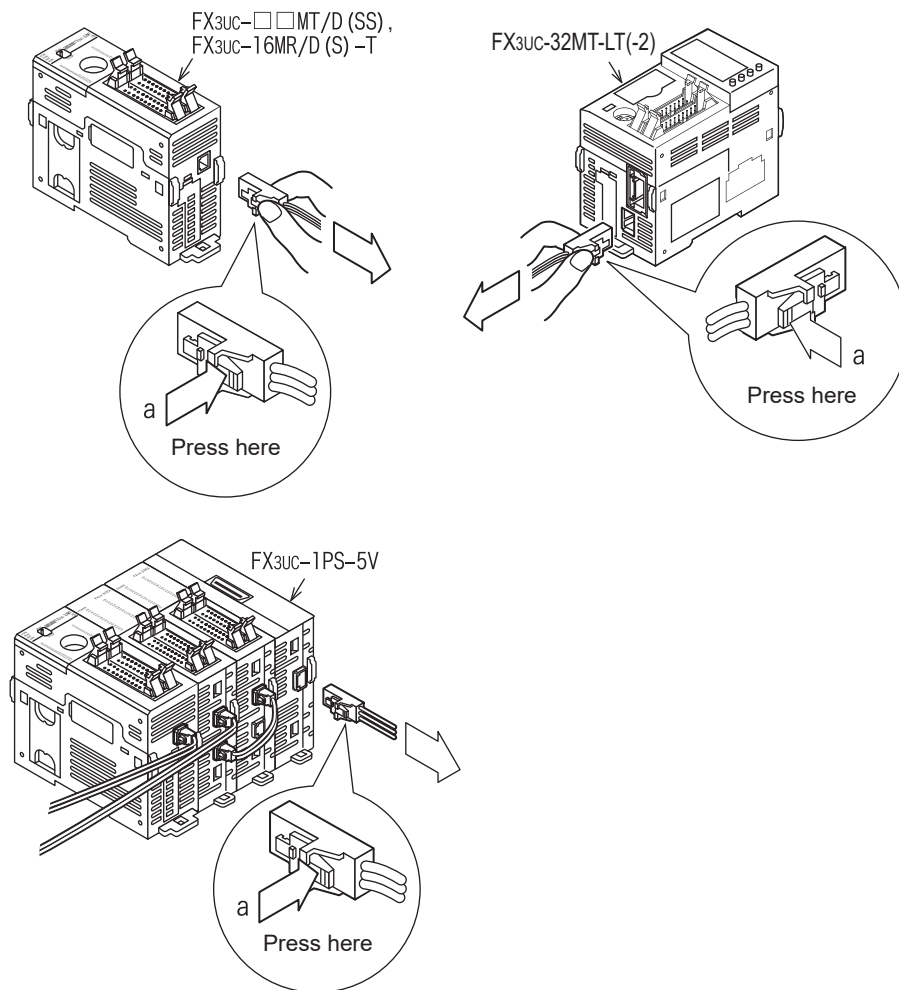

1	Outline
2	External Dimensions
3	Generic Specifications
4	Power Supply Specifications
5	Input Specifications
6	Output Specifications
7	Examples of Wiring for Various Uses
8	Terminal Block
9	CC-Link/LT Master FX3UC-LT(-2) only
10	Display module FX3UC-LT(-2) only

3.11 Connection to Input/Output Connector

3.11.1 Input/output connector [FX3UC Main unit, FX2NC Extension block]

1. Connection to input/output connector

The input and output connectors of the FX3UC main unit and extension blocks for FX2NC conform to the MIL-C-83503. (Note: FX3UC main unit, some of extension blocks for FX2NC are the European terminal block type.)

Procure the input/output cables in reference to the table below and the next page.

→ **For the terminal arrangement, refer to Section 2.2.**

Example : FX3uc-32MT/D Main unit

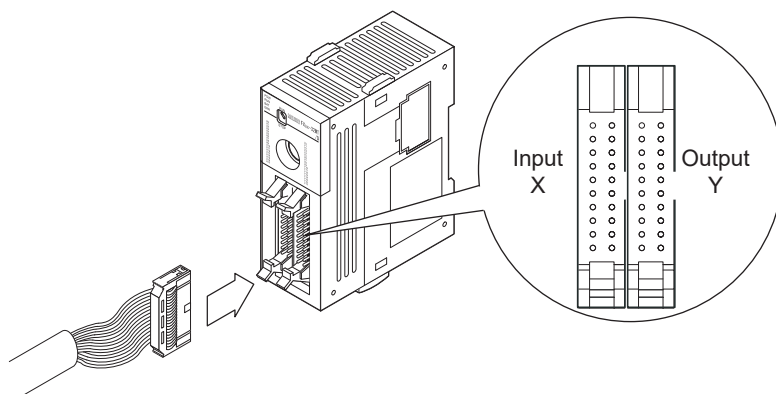

2. Preparation of the I/O connection connector

- 1) Compliant connectors (commercially available connectors)
Use a 20-pin (1-key) socket connector conforming to MIL-C-83503.
Confirm in advance that the connectors do not interfere with other parts including connector covers.
- 2) Input/output cables (available from Mitsubishi)
Input/output cables with attached connectors are available.

Model names	Length	Description	Shape
FX-16E-500CAB-S	5m (16'4")	General-purpose input/output cable	<ul style="list-style-type: none"> • Single wire (Wire color: red) • PLC side: A 20-pin connector
FX-16E-150CAB	1.5m (4'11")	Cables for connecting the FX Series terminal block with input/output connectors. For the connection with FX Series terminal block, refer to "Chapter 8 Terminal Block Specifications and External Wiring".	<ul style="list-style-type: none"> • Flat cables (with tube) • A 20-pin connector at both ends
FX-16E-300CAB	3m (9'10")		
FX-16E-500CAB	5m (16'4")		
FX-16E-150CAB-R	1.5m (4'11")		
FX-16E-300CAB-R	3m (9'10")		
FX-16E-500CAB-R	5m (16'4")		
FX-A32E-150CAB	1.5m (4'11")		
FX-A32E-300CAB	3m (9'10")		
FX-A32E-500CAB	5m (16'4")		
			<ul style="list-style-type: none"> • Flat cables (with tube) • PLC side: Two 20-pin connectors in 16-point units. • Terminal block side: A dedicated connector • One common terminal covers 32 input/output terminals.

- 3) Connectors for user-made input/output cables (available from Mitsubishi)
Users should provide electric wires and a pressure bonding tool.

Model name and composition of input/output connector			Applicable electric wire (UL-1061 are recommended) and tool	
Our model name		Details of part (made by DDK Ltd.)	Electric wire size	Pressure bonding tool (made by DDK Ltd.)
FX2C-I/O-CON for flat cable (20-Pin)	10-piece set	Solderless connector FRC2-A020-30S	AWG28 (0.1mm ²) 1.27 pitch, 20-core	357J-4674D Main body 357J-4664N Attachment
FX2C-I/O-CON-S for bulk wire (20-Pin)	5-piece set	Housing HU-200S2-001 Solderless contact HU-411S	AWG22 (0.3mm ²)	357J-5538
FX2C-I/O-CON-SA for bulk wire (20-Pin)	5-piece set	Housing HU-200S2-001 Solderless contact HU-411SA	AWG20 (0.5mm ²)	357J-13963
FX-I/O-CON2-S for bulk wire (40-Pin)	2-piece set	Housing HU-400S2-001 Solderless contact HU-411S	AWG22 (0.3mm ²)	357J-5538
FX-I/O-CON2-SA for bulk wire (40-Pin)	2-piece set	Housing HU-400S2-001 Solderless contact HU-411SA	AWG20 (0.5mm ²)	357J-13963

- 4) Certified connectors (commercially available connectors)
Connectors made by DDK Ltd. shown in item 3).

3.11.2 Terminal block for Europe [FX3UC-16MR/D(S)-T, FX2NC/FX3UC extension block]

WIRING PRECAUTIONS	 WARNING
<ul style="list-style-type: none"> • Make sure to cut off all phases of the power supply externally before attempting installation or wiring work. Failure to do so may cause electric shock or damage to the product. • Make sure to attach the terminal cover, offered as an accessory, before turning on the power or initiating operation after installation or wiring work. Failure to do so may cause electric shock. • The temperature rating of the cable should be 80°C or more. 	

WIRING PRECAUTIONS	 CAUTION
<ul style="list-style-type: none"> • Make sure to properly wire to the terminal block (European type) in accordance with the following precautions. Failure to do so may cause electric shock, equipment failures, a short-circuit, wire breakage, malfunctions, or damage to the product. <ul style="list-style-type: none"> - The disposal size of the cable end should follow the dimensions described in the manual. - Tightening torque should follow the specifications in the manual. - Twist the end of strand wire and make sure that there are no loose wires. - Do not solder-plate the electric wire ends. - Do not connect more than the specified number of wires or electric wires of unspecified size. - Affix the electric wires so that neither the terminal block nor the connected parts are directly stressed. 	

1. Connection to terminal block

FX3UC-16MR/D(S)-T, terminal block type input/output extension blocks for FX2NC and terminal block type special function blocks for FX2NC/FX3UC have the European type terminal block.

2. Compliant electric wires and tightening torque

	Electric wire size (stranded wire/solid wire)	Tightening torque	End treatment
One electric wire	0.3mm ² to 0.5mm ² (AWG22 to 20)	0.22 to 0.25N•m	<ul style="list-style-type: none"> • Remove the coating of the stranded wire, twist the core wires, and connect the wires directly. • Remove the coating from the solid wire, and connect the wire directly.
Two electric wires	0.3mm ² (AWG22) ×2		
Bar terminal with insulating sleeve	0.3 mm ² to 0.5 mm ² (AWG22 to 20) (Refer to the following outline drawing of bar terminal.)		<ul style="list-style-type: none"> • Bar terminal with insulating sleeve (recommended product) AI 0.5-8WH : Phoenix Contact Co., Ltd • Caulking tool CRIMPFOX 6^{*1} : Phoenix Contact Co., Ltd (CRIMPFOX 6T-F^{*2} : Phoenix Contact Co., Ltd)

*1. Old model name: CRIMPFOX ZA 3

*2. Old model name: CRIMPFOX UD 6

3. Treatment of electric wire ends

Treat the ends of stranded wires and solid wires without coating or using bar terminals with insulating sleeve. Tighten the terminals to a torque of 0.22 to 0.25N•m. Do not tighten terminal screws with a torque outside the above-mentioned range. Failure to do so may cause equipment failures or malfunctions.

- Treatment of stranded wires and solid wires without coating
 - Twist the ends of stranded wires tightly so that loose wires will not stick out.
 - Do not solder-plate the electric wire ends.
- Treatment using bar terminal with insulating sleeve

It may be difficult to insert the electric wire into the insulating sleeve depending on the thickness of the electric wire sheath. Select the electric wire referring to the outline drawing.

<Reference>

Manufacturer	Model names	Caulking tool
Phoenix Contact Co., Ltd	AI 0.5-8WH	CRIMPFOX 6 ^{*3} (CRIMPFOX 6T-F ^{*4})

*3. Old model name: CRIMPFOX ZA 3
*4. Old model name: CRIMPFOX UD 6

4. Tool

- For tightening the terminal, use a commercially available small screwdriver having a straight form that is not widened toward the end as shown right.

Note :

If the diameter of screwdriver grip is too small, tightening torque will not be able to be achieved. To achieve the appropriate tightening torque shown in the table on the previous page, use the following screwdriver or an appropriate replacement (grip diameter: approximately 25mm (0.98")).

<Reference>

Manufacturer	Model names
Phoenix Contact Co., Ltd	SZS 0.4 x 2.5

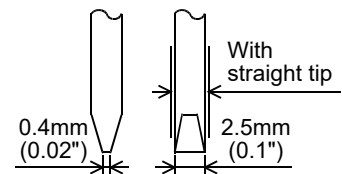
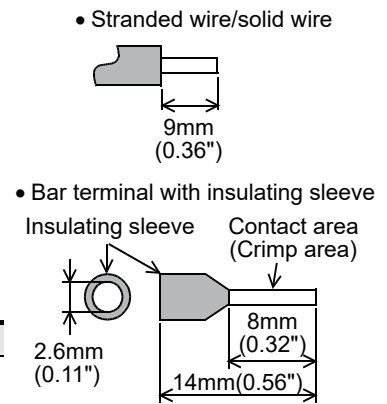

1	Outline
2	External Dimensions
3	Generic Specifications
4	Power Supply Specifications
5	Input Specifications
6	Output Specifications
7	Examples of Wiring for Various Uses
8	Terminal Block
9	CC-Link/LT Master FX3UC-LT(-2) only
10	Display module FX3UC-LT(-2) only

3.11.3 Input/Output Terminal Blocks [FX0N/FX2N/FX3U Extension blocks]

WIRING PRECAUTIONS	WARNING
<ul style="list-style-type: none"> Make sure to cut off all phases of the power supply externally before attempting installation or wiring work. Failure to do so may cause electric shock or damage to the product. Make sure to attach the terminal cover, offered as an accessory, before turning on the power or initiating operation after installation or wiring work. Failure to do so may cause electric shock. The temperature rating of the cable should be 80°C or more. 	

WIRING PRECAUTIONS	CAUTION
<ul style="list-style-type: none"> Make sure to properly wire the FX0N/FX2N/FX3U Series extension equipment in accordance with the following precautions. Failure to do so may cause electric shock, equipment failures, a short-circuit, wire breakage, malfunctions, or damage to the product. <ul style="list-style-type: none"> - The disposal size of the cable end should follow the dimensions described in the manual. - Tightening torque should follow the specifications in the manual. - Tighten the screws using a Phillips-head screwdriver No.2 (shaft diameter 6mm (0.24") or less). Make sure that the screwdriver does not touch the partition part of the terminal block. Make sure to properly wire to the FX Series terminal blocks in accordance with the following precautions. Failure to do so may cause electric shock, equipment failures, a short-circuit, wire breakage, malfunctions, or damage to the product. <ul style="list-style-type: none"> - The disposal size of the cable end should follow the dimensions described in the manual. - Tightening torque should follow the specifications in the manual. - Tighten the screws using a Phillips-head screwdriver No.2 (shaft diameter 6mm (0.24") or less). Make sure that the screwdriver does not touch the partition part of the terminal block. 	

1. Terminal block screw size and tightening torque

The table below shows the screw size of each terminal block. For crimp terminals, refer to "2. Wire end treatment".

Product	Terminal screw	Tightening torque
FX0N extension blocks, FX2N extension blocks (Except for the FX2N-8AD, FX2N-16CCL-M signal terminal)	M3	0.5 to 0.8 N·m
FX Series terminal block, FX2N-20PSU, FX2N-8AD, FX2N-16CCL-M signal terminal	M3.5	
FX3U extension blocks	Refer to the manual for each product.	

2. Wire end treatment

The solderless terminal size depends on the terminal screw size and wiring method.

- Use solderless terminals of the following size.
- Tighten the terminals to a torque of 0.5 to 0.8 N·m.
Do not tighten terminal screws with a torque outside the above-mentioned range.
Failure to do so may cause equipment failures or malfunctions.

In case of M3 terminal screw

- When one wire is connected to one terminal

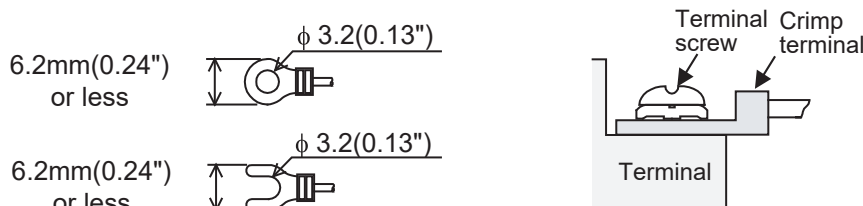

<Reference>

Terminal manufacturer	Type No.	Applicable cable	Certification	Pressure bonding tool
J.S.T. Mfg. Co., Ltd.	FV1.25-B3A	AWG22 to 16	UL Listed	YA-1 (J.S.T. Mfg. Co., Ltd.)
	FV2-MS3	AWG16 to 14		

- When two wires are connected to one terminal*1

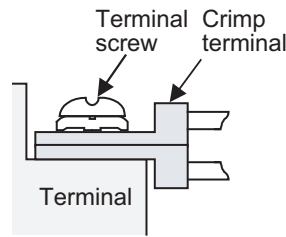
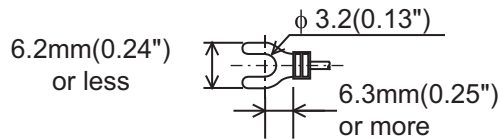
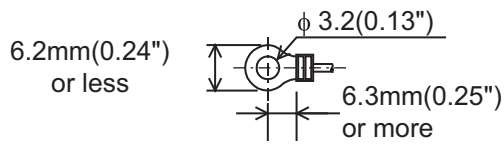

<Reference>

Terminal manufacturer	Type No.	Applicable cable	Certification	Pressure bonding tool
J.S.T. Mfg. Co., Ltd.	FV1.25-B3A	AWG22 to 16	UL Listed	YA-1 (J.S.T. Mfg. Co., Ltd.)

- *1. To adapt the LVD directive (EN61010-2-201:2013) of the EC directive, avoid the wiring with two wires to the built-in terminal, and take an appropriate action such as adding an external terminal.
For the time of compliance with the LVD directive (EN61010-2-201:2013), refer to Requirement for Compliance with LVD directive.

In case of M3.5 terminal screw

- When one wire is connected to one terminal

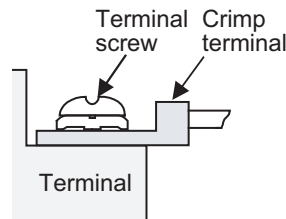
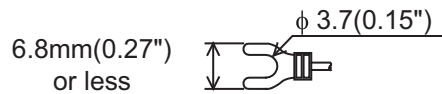
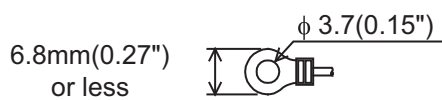

- When two wires are connected to one terminal

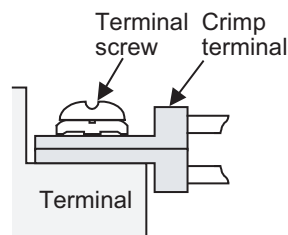
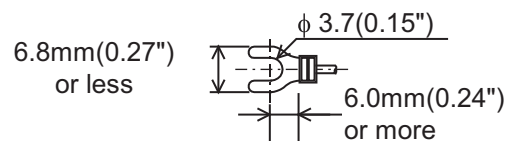
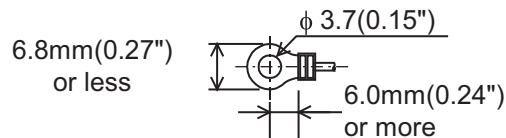

3.12 Grounding terminal of the FX3U-ENET-ADP

The grounding terminal of the FX3U-ENET-ADP is a M2.5 screw.

1. Applicable cables

Electric wire size
0.5 to 1.5 mm ² (AWG 20 to 16)

2. Treatment of electric wire ends

- When using a stranded cable or solid cable as it is
 - Twist the end of the stranded cable so that loose wires will not stick out.
 - Do not solder-plate the end of the cable.

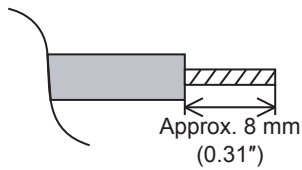

3. Tightening torque

Tighten the terminals to a torque of 0.4 to 0.5 N·m.

Do not tighten terminal screws with a torque outside the above-mentioned range.

Failure to do so may cause equipment failures or malfunctions.

Caution

When tightening a grounding terminal, use a screwdriver suitable for the terminal screw. The screwdriver which does not suit the thread groove is used, tightening torque will not be able to be achieved. To achieve the appropriate tightening torque shown in the above, use the following screwdriver or an appropriate replacement.

<Reference>

Manufacturer	Model name	Model number
Weidmuller Interface GmbH & Co. KG	SDIK PH0	9008560000
Weidmuller Interface GmbH & Co. KG	SD 0.6×3.5×100	9008330000

4. Power Supply Specifications and External wiring

DESIGN PRECAUTIONS	 WARNING
<ul style="list-style-type: none">• Make sure to have the following safety circuits outside of the PLC to ensure safe system operation even during external power supply problems or PLC failure. Otherwise, malfunctions may cause serious accidents.<ol style="list-style-type: none">1) Most importantly, have the following: an emergency stop circuit, a protection circuit, an interlock circuit for opposite movements (such as normal vs. reverse rotation), and an interlock circuit (to prevent damage to the equipment at the upper and lower positioning limits).2) Note that when the PLC CPU detects an error, such as a watchdog timer error, during self-diagnosis, all outputs are turned off. Also, when an error that cannot be detected by the PLC CPU occurs in an input/output control block, output control may be disabled. External circuits and mechanisms should be designed to ensure safe machinery operation in such a case.3) Note that when an error occurs in a relay, triac or transistor output device, the output could be held either on or off. For output signals that may lead to serious accidents, external circuits and mechanisms should be designed to ensure safe machinery operation in such a case.• Note that when an error occurs in a remote I/O unit, the output could be held either on or off. For output signals that may lead to serious accidents, external circuits for monitoring should be provided.	

DESIGN PRECAUTIONS	 CAUTION
<ul style="list-style-type: none">• Do not bundle the control line and CC-Link/LT connection cables together with or lay them close to the main circuit or power line. As a guideline, lay the control line and CC-Link/LT connection cables at least 100mm (3.94") or more away from the main circuit or power line. Noise may cause malfunctions.• Install the product so that excessive force will not be applied to peripheral device connectors, power connectors, input/output connectors, CC-Link/LT interface connectors or CC-Link/LT connection cables. Failure to do so may result in wire damage/breakage or PLC failure.	

SECURITY PRECAUTIONS	 WARNING
<ul style="list-style-type: none">• To maintain the security (confidentiality, integrity, and availability) of the programmable controller and the system against unauthorized access, denial-of-service (DoS) attacks, computer viruses, and other cyberattacks from unreliable networks and devices via network, take appropriate measures such as firewalls, virtual private networks (VPNs), and antivirus solutions.	

WIRING PRECAUTIONS	 WARNING
<ul style="list-style-type: none">• Make sure to cut off all phases of the power supply externally before attempting installation or wiring work. Failure to do so may cause electric shock or damage to the product.• Make sure to attach the terminal cover, offered as an accessory, before turning on the power or initiating operation after installation or wiring work. Failure to do so may cause electric shock.• The temperature rating of the cable should be 80°C or more.	

1
Outline

2
External
Dimensions

3
Generic
Specifications

4
Power Supply
Specifications

5
Input
Specifications

6
Output
Specifications

7
Examples of
Wiring for
Various Uses

8
Terminal Block

9
CC-Link/LT
Master FX3uc-
LT(-2) only

10
Display module
FX3uc-LT(-2)
only

WIRING PRECAUTIONS

CAUTION

- Connect the DC power supply wiring to the dedicated terminals described in this manual. If an AC power supply is connected to a DC input/output terminal or DC power supply terminal, the PLC will burn out.
- Do not wire vacant terminals externally. Doing so may damage the product.
- Perform class D grounding (grounding resistance: 100Ω or less) to the grounding terminal on the main unit. Do not use common grounding with heavy electrical systems.
- When drilling screw holes or wiring, make sure that cutting and wiring debris do not enter the ventilation slits. Failure to do so may cause fire, equipment failures or malfunctions.
- Make sure to properly wire the FX0N/FX2N/FX3U Series extension equipment in accordance with the following precautions. Failure to do so may cause electric shock, equipment failures, a short-circuit, wire breakage, malfunctions, or damage to the product.
 - The disposal size of the cable end should follow the dimensions described in the manual.
 - Tightening torque should follow the specifications in the manual.
 - Tighten the screws using a Phillips-head screwdriver No.2 (shaft diameter 6mm (0.24") or less). Make sure that the screwdriver does not touch the partition part of the terminal block.
- Make sure to properly wire to the terminal block (European type) in accordance with the following precautions. Failure to do so may cause electric shock, equipment failures, a short-circuit, wire breakage, malfunctions, or damage to the product.
 - The disposal size of the cable end should follow the dimensions described in the manual.
 - Tightening torque should follow the specifications in the manual.
 - Twist the end of strand wire and make sure that there are no loose wires.
 - Do not solder-plate the electric wire ends.
 - Do not connect more than the specified number of wires or electric wires of unspecified size.
 - Affix the electric wires so that neither the terminal block nor the connected parts are directly stressed.
- Make sure to properly wire to the FX Series terminal blocks in accordance with the following precautions. Failure to do so may cause electric shock, equipment failures, a short-circuit, wire breakage, malfunctions, or damage to the product.
 - The disposal size of the cable end should follow the dimensions described in the manual.
 - Tightening torque should follow the specifications in the manual.
 - Tighten the screws using a Phillips-head screwdriver No.2 (shaft diameter 6mm (0.24") or less). Make sure that the screwdriver does not touch the partition part of the terminal block.
- The FX3UC-32MT-LT(-2) has a built-in power supply. When connecting a power supply adapter or dedicated CC-Link/LT power supply, connect the built-in master to the LINK connector in the power supply adapter or dedicated power supply.

Connection to the LINK/POWER connector may cause failures.

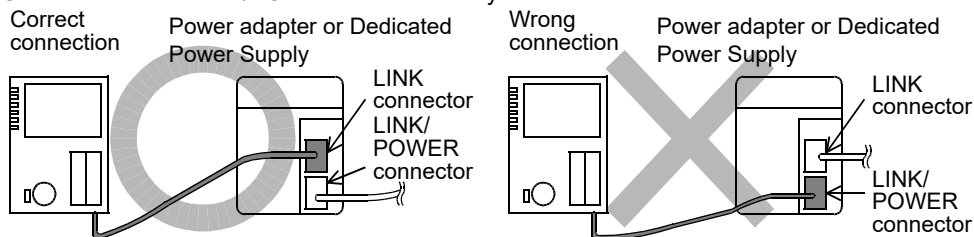

4.1 Selection of the external DC power supply to prepare

4.1.1 Power supply specifications

This subsection explains the power supply input specification of the main unit and extension power supply unit.

For the power consumption of special function units/blocks requiring the external power supply, refer to the manual of the corresponding product.

→ For the built-in power supply for CC-Link/LT networks of the FX3UC-32MT-LT(-2), refer to Subsection 9.2.4.

Item	Specification							
	FX3UC-□□MT/D(SS)				FX3UC-16MR/D(S)-T	FX3UC-32MT-LT	FX3UC-32MT-LT-2	FX3UC-1PS-5V
	16MT/□	32MT/□	64MT/□	96MT/□				
Supply voltage	24 V DC							
Voltage fluctuation range*1	+20% -15%							
Ripple voltage (p-p)	5% or less							
Allowable instantaneous power failure time	Operation can be continued upon occurrence of an instantaneous power failure for 5ms or less.							
Power fuse	125V 3.15A					CPU, I/O operations power supply circuit: 125V 3.15A	125V 3.15A	
						CC-Link/LT built-in power supply circuit*2: 125V 0.8A		
Rush current	30A max.0.5ms / 24V DC							
Power consumption	6W*3	8W*3	11W*3	14W*3	6W*3	7W*3	9W*3	1W*3 (When extension units/blocks are connected max.25W)
5V DC built-in power supply (5V DC)	600mA	560mA	480mA	400mA	600mA	350mA		1A
Built-in power supply for CC-Link/LT networks	-					24V DC 350mA		-

*1. The 24V DC power changes the specifications of the voltage range by system configuration.
→ For details, refer to "Subsection 4.1.2 The input range of power supply voltage".

*2. For fuse blowout in the CC-Link/LT built-in power supply circuit in the FX3UC-32MT-LT(-2), refer to the following.
→ For details, refer to "Subsection 12.7.2 Operation at blowout of built-in power fuse for CC-Link/LT".

*3. Power consumption changes according to the system configuration.
→ For details, refer to "Subsection 4.1.3 Power consumption of the extension equipment".

4.1.2 The input range of power supply voltage

When connecting special function units/blocks shown in the table below, set the voltage supplied to the main unit as follows.

- 1) When the CC-Link/LT master of the FX3UC-32MT-LT(-2) is used
Use an external power supply that satisfies the conditions described in "3. Selection of the general-purpose power supply connected to the main unit" in Subsection 9.6.3.
- 2) When Group A is connected
Please use the external power supply of "24V DC, Voltage fluctuation range $\pm 10\%$, Ripple Voltage (p-p) 5% or less"
- 3) When Group B is connected
Please use the external power supply of "24V DC, Voltage fluctuation range $+10\%$ - 15% , Ripple Voltage (p-p) 5% or less"
- 4) When either group is not used
The external power supply of "24V DC, Voltage fluctuation range $+20\%$ - 15% , Ripple Voltage (p-p) 5% or less" can be used.

Group	Model name	Group	Model name	Group	Model name
A	FX3UC-4AD	A	FX0N-3A	A	FX2N-10PG
	FX2N-2AD		FX2N-5A	B	FX2N-10GM
	FX2NC-4AD		FX2N-2DA		FX2N-20GM
	FX2N-4AD		FX2NC-4DA		FX2N-1RM(-E)
	FX3U-4AD		FX2N-4DA	A	FX2N-232IF
	FX2N-8AD		FX3U-4DA	B	FX2N-32CCL
	FX2N-4AD-PT	B	FX2N-2LC		
	FX2N-4AD-TC	A	A	FX2N-16LNK-M	

4.1.3 Power consumption of the extension equipment

The power consumption shown on the previous page does not include the power consumption of connected extension blocks.

When connecting extension blocks shown below, add the power consumption shown in the table below to the power consumption of the main unit and extension power supply unit.

When you connect special function blocks other than the ones listed in the following table, refer to each manual.

Model name	Power consumption	Model name	Power consumption	Model name	Power consumption
FX2NC-16EX-T	2.2W	FX2N-8EX	1.2W	FX2N-8EYT-H	2.1W
FX2NC-16EX-T-DS	2.2W	FX2N-8EX-ES/UL	1.2W	FX0N-8EYT-H	2.1W
FX2NC-16EX	2.2W	FX0N-8EX	1.2W	FX2N-16EYR	2.2W
FX2NC-16EX-DS	2.2W	FX2N-16EX	2.2W	FX2N-16EYR-ES/UL	2.2W
FX2NC-32EX	4.2W	FX2N-16EX-ES/UL	2.2W	FX0N-16EYR	2.2W
FX2NC-32EX-DS	4.2W	FX0N-16EX	2.2W	FX2N-16EYT	1.2W
FX2NC-16EYR-T	2.2W	FX2N-16EX-C	2.2W	FX2N-16EYT-ESS/UL	1.2W
FX2NC-16EYR-T-DS	2.2W	FX2N-16EXL-C	0.3W ^{*1}	FX0N-16EYT	3.8W
FX2NC-16EYT	0.35W	FX2N-8EYR	1.2W	FX2N-16EYT-C	2.2W
FX2NC-16EYT-DSS	0.35W	FX2N-8EYR-ES/UL	1.2W	FX2N-16EYS	1.0W
FX2NC-32EYT	0.7W	FX2N-8EYR-S-ES/UL	1.2W	FX0N-3A	2.4W
FX2NC-32EYT-DSS	0.7W	FX0N-8EYR	1.2W	FX2N-2AD	1.4W
FX2N-8ER	1.2W	FX2N-8EYT	2.0W	FX2N-2DA	2.3W
FX2N-8ER-ES/UL	1.2W	FX2N-8EYT-ESS/UL	2.0W	FX2N-8EX-UA1/UL	0.2W ^{*2}
FX0N-8ER	1.2W	FX0N-8EYT	2.0W	FX0N-8EX-UA1/UL	0.2W ^{*2}

*1. External 5V power supply is not included.

*2. AC input current is not included.

4.2 Example External Wiring

1. Example External Wiring

A 24V DC power is supplied to the main unit of the FX3UC PLC.
A dedicated connector is used for the power supply.

→ For wiring, refer to Section 3.9.

- Example of the FX3UC-□□MT/D, FX3UC-16MR/D-T, FX3UC-32MT-LT(-2)

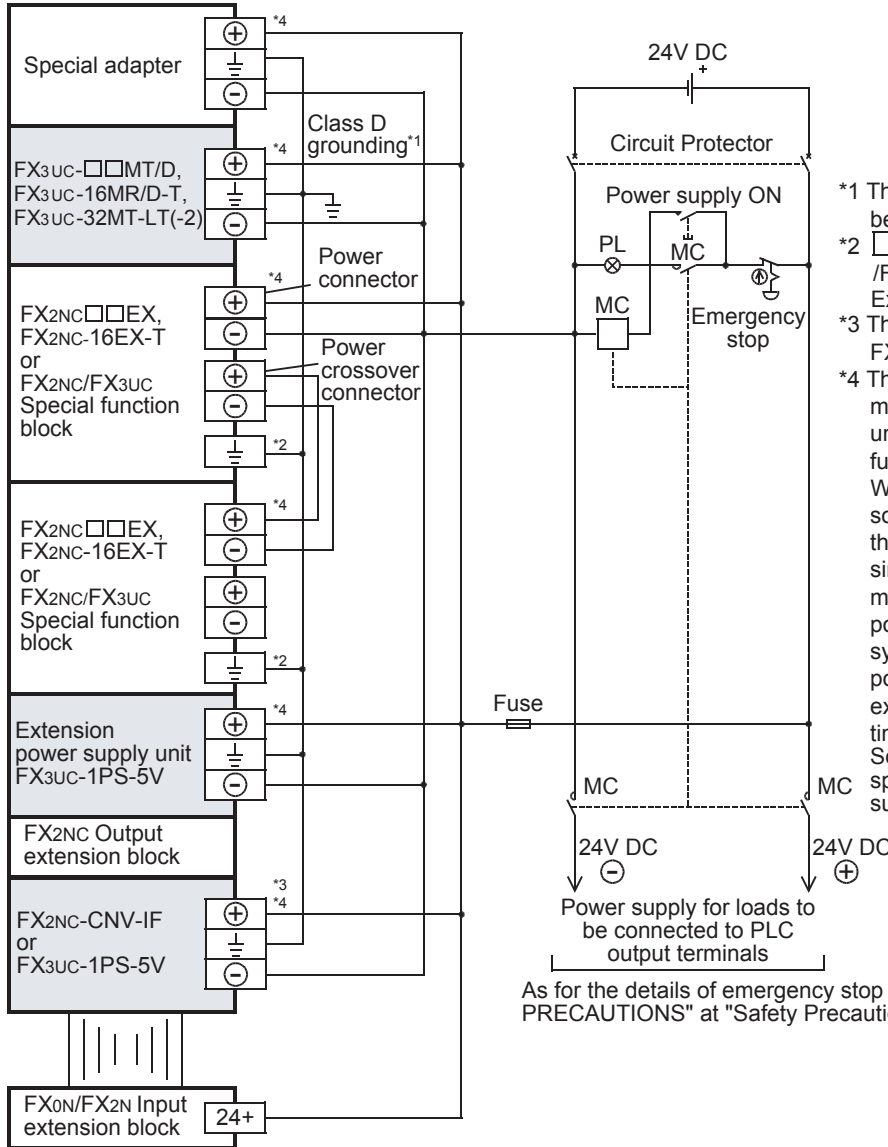

- *1 The grounding resistance should be 100Ω or less.
- *2  terminal is only for the FX2NC /FX3UC special function block. Except for the FX2NC-1HC.
- *3 The power supply input is only for the FX3UC-1PS-5V.
- *4 The same power source for the main unit, extension power supply units, special adapters and special function unit/blocks is preferable. When using the different power source from the main unit, turn ON the peripheral devices' power simultaneously, or earlier than the main unit's. When turning OFF the power, confirm the safety of the system, and then turn OFF the power of the PLC (including special extension equipment) at the same time. Some special function units/blocks or special adapters do not have a power supply terminal.

As for the details of emergency stop operation, see "DESIGN PRECAUTIONS" at "Safety Precautions" field.

- Example of the FX3UC-□□MT/DSS, FX3UC-16MR/DS-T

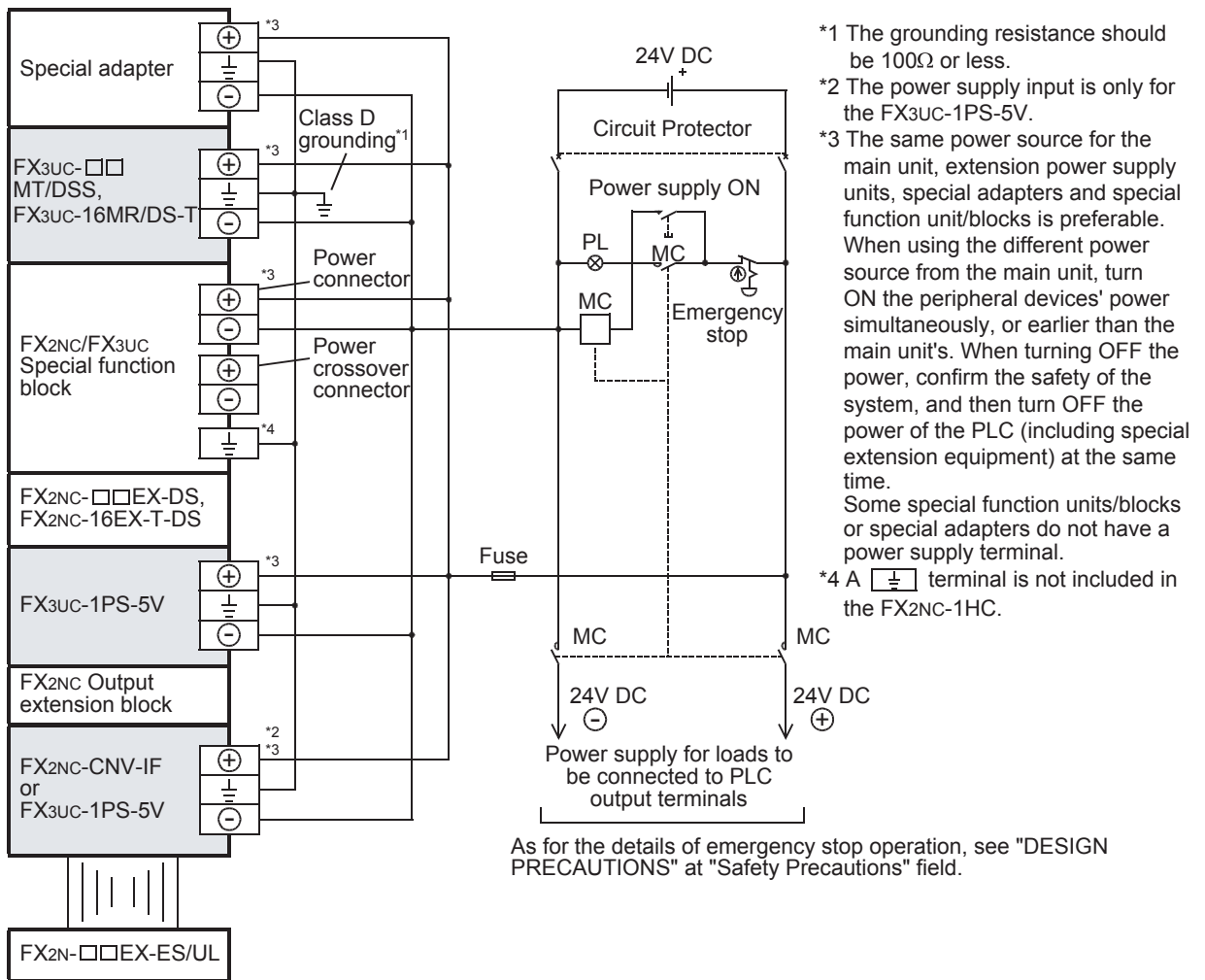

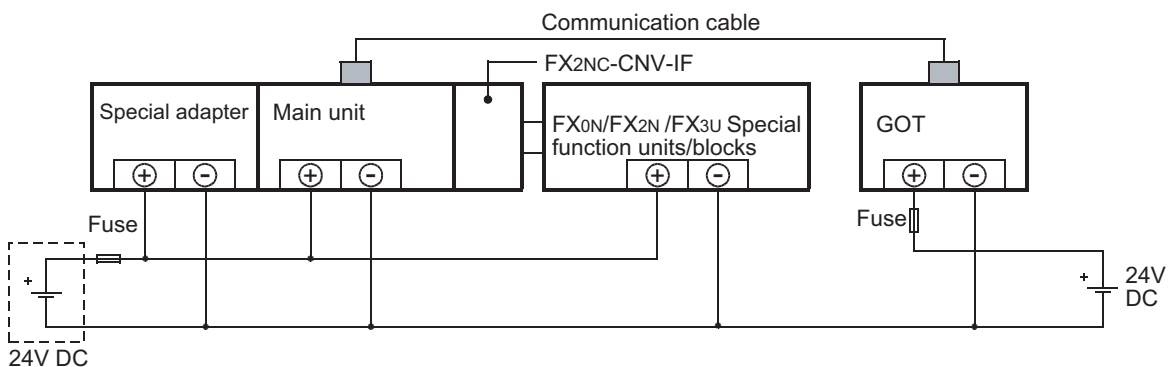

2. Caution on connecting the minus line (when using two or more external DC power supplies)

When supplying power from two or more power supply units due to insufficient capacity of each DC power supply unit, connect the minus line of each power supply unit as shown in the figure below.



5. Input Specifications and External wiring

DESIGN PRECAUTIONS	 WARNING
<ul style="list-style-type: none"> • Make sure to have the following safety circuits outside of the PLC to ensure safe system operation even during external power supply problems or PLC failure. Otherwise, malfunctions may cause serious accidents. <ol style="list-style-type: none"> 1) Most importantly, have the following: an emergency stop circuit, a protection circuit, an interlock circuit for opposite movements (such as normal vs. reverse rotation), and an interlock circuit (to prevent damage to the equipment at the upper and lower positioning limits). 2) Note that when the PLC CPU detects an error, such as a watchdog timer error, during self-diagnosis, all outputs are turned off. Also, when an error that cannot be detected by the PLC CPU occurs in an input/output control block, output control may be disabled. External circuits and mechanisms should be designed to ensure safe machinery operation in such a case. 3) Note that when an error occurs in a relay, triac or transistor output device, the output could be held either on or off. For output signals that may lead to serious accidents, external circuits and mechanisms should be designed to ensure safe machinery operation in such a case. • Note that when an error occurs in a remote I/O unit, the output could be held either on or off. For output signals that may lead to serious accidents, external circuits for monitoring should be provided. 	

DESIGN PRECAUTIONS	 CAUTION
<ul style="list-style-type: none"> • Do not bundle the control line and CC-Link/LT connection cables together with or lay them close to the main circuit or power line. As a guideline, lay the control line and CC-Link/LT connection cables at least 100 mm (3.94") or more away from the main circuit or power line. Noise may cause malfunctions. • Install the product so that excessive force will not be applied to peripheral device connectors, power connectors, input/output connectors, CC-Link/LT interface connectors or CC-Link/LT connection cables. Failure to do so may result in wire damage/breakage or PLC failure. 	

SECURITY PRECAUTIONS	 WARNING
<ul style="list-style-type: none"> • To maintain the security (confidentiality, integrity, and availability) of the programmable controller and the system against unauthorized access, denial-of-service (DoS) attacks, computer viruses, and other cyberattacks from unreliable networks and devices via network, take appropriate measures such as firewalls, virtual private networks (VPNs), and antivirus solutions. 	

WIRING PRECAUTIONS	 WARNING
<ul style="list-style-type: none"> • Make sure to cut off all phases of the power supply externally before attempting installation or wiring work. Failure to do so may cause electric shock or damage to the product. • Make sure to attach the terminal cover, offered as an accessory, before turning on the power or initiating operation after installation or wiring work. Failure to do so may cause electric shock. • The temperature rating of the cable should be 80°C or more. 	

1	Outline
2	External Dimensions
3	Generic Specifications
4	Power Supply Specifications
5	Input Specifications
6	Output Specifications
7	Examples of Wiring for Various Uses
8	Terminal Block
9	CC-Link/LT Master FX3uc-LT(-2) only
10	Display module FX3uc-LT(-2) only

WIRING PRECAUTIONS



- Connect the DC power supply wiring to the dedicated terminals described in this manual.
If an AC power supply is connected to a DC input/output terminal or DC power supply terminal, the PLC will burn out.
- Do not wire vacant terminals externally.
Doing so may damage the product.
- Perform class D grounding (grounding resistance: 100Ω or less) to the grounding terminal on the main unit.
Do not use common grounding with heavy electrical systems.
- Make sure to properly wire the FX₀N/FX₂N/FX₃U Series extension equipment in accordance with the following precautions.
Failure to do so may cause electric shock, equipment failures, a short-circuit, wire breakage, malfunctions, or damage to the product.
 - The disposal size of the cable end should follow the dimensions described in the manual.
 - Tightening torque should follow the specifications in the manual.
 - Tighten the screws using a Phillips-head screwdriver No.2 (shaft diameter 6mm (0.24") or less). Make sure that the screwdriver does not touch the partition part of the terminal block.
- Make sure to properly wire to the terminal block (European type) in accordance with the following precautions.
Failure to do so may cause electric shock, equipment failures, a short-circuit, wire breakage, malfunctions, or damage to the product.
 - The disposal size of the cable end should follow the dimensions described in the manual.
 - Tightening torque should follow the specifications in the manual.
 - Twist the end of strand wire and make sure that there are no loose wires.
 - Do not solder-plate the electric wire ends.
 - Do not connect more than the specified number of wires or electric wires of unspecified size.
 - Affix the electric wires so that neither the terminal block nor the connected parts are directly stressed.
- Make sure to properly wire to the FX Series terminal blocks in accordance with the following precautions.
Failure to do so may cause electric shock, equipment failures, a short-circuit, wire breakage, malfunctions, or damage to the product.
 - The disposal size of the cable end should follow the dimensions described in the manual.
 - Tightening torque should follow the specifications in the manual.
 - Tighten the screws using a Phillips-head screwdriver No.2 (shaft diameter 6mm (0.24") or less). Make sure that the screwdriver does not touch the partition part of the terminal block.

5.1 Sink and source input (24V DC input type)

Inputs (X) in the FX3UC-□□MT/D, FX3UC-16MR/D-T and FX3UC-32MT-LT(-2) are sink input type only. Inputs (X) in the FX3UC-□□MT/DSS and FX3UC-16MR/DS-T are sink/source common input type. Inputs in FX2N/FX2NC Series input/output extension blocks are either sink input type only or sink/source common input type depending on the product.

1. Sink input [-common]

An input (DC input signal) used where the current flows out of the input (X) terminal is called a sink input. NPN open collector transistor outputs are available when transistor output type sensor outputs are connected.

- Examples of the FX3UC-□□MT/D, FX3UC-16MR/D-T, FX3UC-32MT-LT(-2)

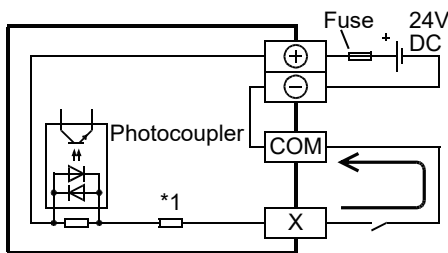

*1.Input impedance

- Examples of the FX3UC-□□MT/DSS, FX3UC-16MR/DS-T

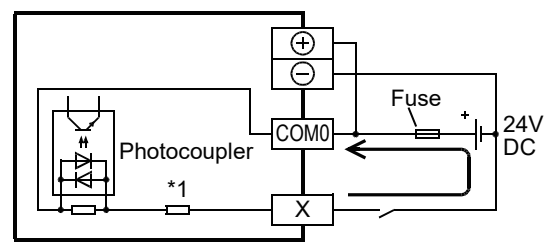

*1.Input impedance

2. Source input [+common]

An input (DC input signal) used where the current flows into the input (X) terminal is called a source input. PNP open collector transistor outputs are available when transistor output type sensor outputs are connected.

- Examples of the FX3UC-□□MT/DSS, FX3UC-16MR/DS-T

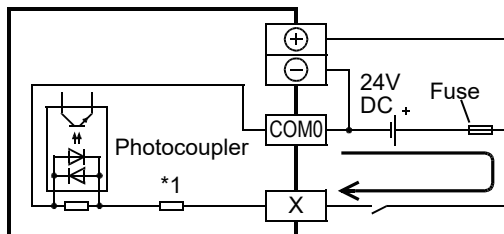

*1.Input impedance

3. How to change a sink input for a source input for the FX3UC-□□MT/DSS, FX3UC-16MR/DS-T

Sink inputs and the source inputs can be changed over in the FX3UC-□□MT/DSS, FX3UC-16MR/DS-T by connection as follows:

- Selected by the connection that makes the current flow out of the input (X) terminal.
- Selected by the connection that makes the current flow into the input (X) terminal.

4. Instructions for using

- Concurrent use of sink/source input
Inputs (X) in the FX3UC-□□MT/DSS, FX3UC-16MR/DS-T can be wired either for sink inputs or source inputs. It is not allowed to use both sink inputs and source inputs together.
- Caution in selecting model
Each input extension block is either sink input type only or sink/source common input type. It is not allowed to use both types of input extension blocks together.

5.2 24V DC Input Type

For 5V DC input (FX2N-16EXL-C), refer to Section 5.3.
For AC input (FX2N-8EX-UA1/UL, FX0N-8EX-UA1/UL), refer to Section 5.4.

5.2.1 24V DC Input Specifications

Inputs in the main unit are restricted by the simultaneous ON ratio.

→ For the restriction in simultaneous ON ratio, refer to Subsection 5.2.2.

Item	24V DC Input Specifications				
	FX3UC-□□MT/D, FX3UC-16MR/D-T, FX3UC-32MT-LT(-2), FX2NC-□□EX(-T) (Sink input)			FX0N / FX2N Input extension blocks (Sink input)	
Number of input points	FX3UC-16MT/D: 8 points FX3UC-32MT/D: 16 points FX3UC-64MT/D: 32 points FX3UC-96MT/D: 48 points FX3UC-16MR/D-T: 8 points FX3UC-32MT-LT(-2): 16 points FX2NC-16EX(-T): 16 points FX2NC-32EX: 32 points			FX0N-8ER: 4 points FX0N-8EX: 8 points FX2N-8ER: 4 points FX2N-8EX: 8 points FX2N-16EX(-C): 16 points	
Input connecting type	Except for the FX3UC-16MR/D-T, FX2NC-16EX-T: Connector			Except for the FX2N-16EX-C: Terminal block	
	FX3UC-16MR/D-T, FX2NC-16EX-T: Terminal block			FX2N-16EX-C: Connector	
Input form	Sink input				
Input signal voltage	24 V DC, Voltage fluctuation range +20% -15%, Ripple voltage (p-p) 5% or less				
Input impedance	Main unit	X000 to X005	3.9 kΩ	4.3 kΩ	
		X006, X007	3.3 kΩ		
		X010 or more	4.3 kΩ		
	FX2NC-□□EX(-T)		4.3 kΩ		
Input signal current	Main unit	X000 to X005	6mA/24V DC	5 mA/24V DC	
		X006, X007	7mA/24V DC		
		X010 or more	5mA/24V DC		
	FX2NC-□□EX(-T)		5mA/24V DC		
Input sensitivity current	ON	Main unit	X000 to X005	3.5mA or more	3.5 mA or more
			X006, X007	4.5mA or more	
			X010 or more	3.5mA or more	
		FX2NC-□□EX(-T)		3.5mA or more	
	OFF	1.5mA or less			
Input response time	Approx. 10ms				
Input signal form (Input sensor form)	No-voltage contact input/NPN open collector transistor				
Circuit insulation	Photocoupler insulation				
Input operation display	FX3UC-□□MT/D, FX3UC-16MR/D-T, FX2NC-□□EX(-T)	Turning on the input will light the LED indicator lamp.		Turning on the input will light the LED indicator lamp.	
	FX3UC-32MT-LT(-2)	Monitor by the display module			

Item	24V DC Input Specifications	
	FX3uc-□□MT/D, FX3uc-16MR/D-T, FX3uc-32MT-LT(-2), FX2Nc-□□EX(-T) (Sink input)	FX0N / FX2N Input extension blocks (Sink input)
Input circuit configuration	<p>*1. Input impedance</p>	<p>*1. Input impedance</p>

1	Outline
2	External Dimensions
3	Generic Specifications
4	Power Supply Specifications
5	Input Specifications
6	Output Specifications
7	Examples of Wiring for Various Uses
8	Terminal Block
9	CC-Link/LT Master FX3uc-LT(-2) only
10	Display module FX3uc-LT(-2) only

Item	24V DC Input Specifications				
	FX3UC-□□MT/DSS, FX3UC-16MR/DS-T, FX2NC-□□EX(-T)-DS (Sink/Source input)	FX0N/FX2N Input extension blocks (Sink/Source input)			
Number of input points	FX3UC-16MT/DSS: 8 points FX3UC-32MT/DSS: 16 points FX3UC-64MT/DSS: 32 points FX3UC-96MT/DSS: 48 points FX3UC-16MR/DS-T: 8 points FX2NC-16EX(-T)-DS: 16 points FX2NC-32EX-DS: 32 points	FX0N-8ER-ES/UL: 4 points FX0N-8EX-ES/UL: 8 points FX2N-8ER-ES/UL: 4 points FX2N-8EX-ES/UL: 8 points FX2N-16EX-ES/UL: 16 points			
Input connecting type	Except for the FX3UC-16MR/DS-T, FX2NC-16EX-T-DS: Connector FX3UC-16MR/DS-T, FX2NC-16EX-T-D: Terminal block	Terminal block			
Input form	Sink/Source input				
Input signal voltage	24 V DC, Voltage fluctuation range +20% -15%, Ripple voltage (p-p) 5% or less				
Input impedance	Main unit	X000 to X005	3.9kΩ	4.3kΩ	
		X006, X007	3.3kΩ		
X010 or more	4.3kΩ				
	FX2NC-□□EX(-T)-DS		4.3kΩ		
Input signal current	Main unit	X000 to X005	6mA/24V DC	5mA/24V DC	
		X006, X007	7mA/24V DC		
X010 or more	5mA/24V DC				
	FX2NC-□□EX(-T)-DS		5mA/24V DC		
Input sensitivity current	ON	Main unit	X000 to X005	3.5mA or more	3.5mA or more
			X006, X007	4.5mA or more	
X010 or more	3.5mA or more				
	FX2NC-□□EX(-T)-DS		3.5mA or more		
	OFF		1.5mA or less		
Input response time	Approx. 10ms				
Input signal form (Input sensor form)	Sink input: No-voltage contact input/NPN open collector transistor Source input: No-voltage contact input/PNP open collector transistor				
Circuit insulation	Photocoupler insulation				
Input operation display	Turning on the input will light the LED indicator lamp.				
Input circuit configuration	Sink input wiring				
	<p>*1. Input impedance</p>	<p>*1. Input impedance</p>			
	Source input wiring				
	<p>*1. Input impedance</p>	<p>*1. Input impedance</p>			

5.2.2 Input Derating Curve

The derating curve below shows the simultaneous ON ratio of available PLC inputs with respect to the ambient temperature. Use the PLC within the simultaneous input ON ratio range shown in the figure.

1. FX3uc-□□MT/D(SS), FX3uc-16MR/D(S)-T

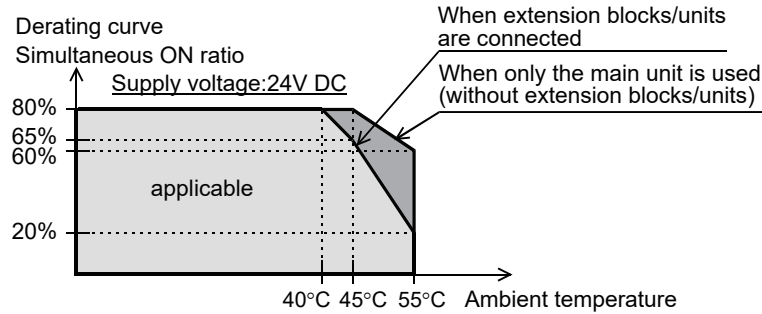

2. FX3uc-32MT-LT(-2)

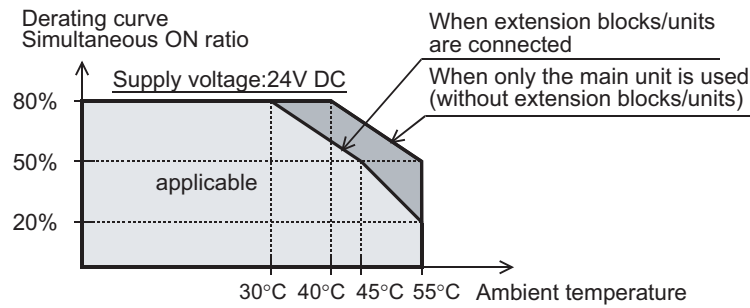

5.2.3 Handling of 24V DC input

1. Input terminals

When an input turns ON, the input indicator LED turns ON in the FX3UC-□□MT/D(SS), FX3UC-16MR/D(S)-T or input/output extension block for FX0N/FX2N/FX2NC. In the FX3UC-32MT-LT(-2), the ON/OFF status can be checked with the display module.

In the FX3UC-64MT/DSS and FX3UC-96MT/DSS, the COM0, COM1 and COM2 terminals are not connected inside the PLC. Wire each COM terminal respectively.

In all models except the FX3UC-64MT/DSS and FX3UC-96MT/DSS, multiple input COM terminals are connected inside the PLC.

One of the input terminals X000 to X017*1 of the main unit can be used as a RUN input terminal by a parameter setting.

*1. X000 to X007 in the FX3UC-16M□.

- Dedicated to sink input types only
 When a no-voltage contact or NPN open collector transistor output is connected between an input (X) terminal and the COM terminal and the circuit is closed, the input (X) turns on. Then, the input display LED lights.

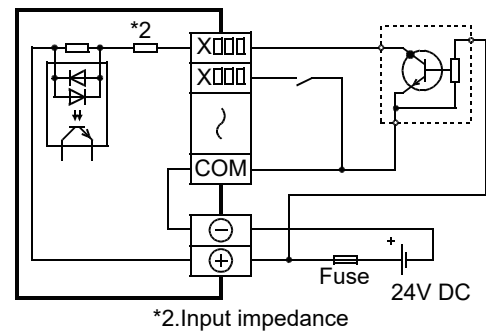

- Common to both sink and source input types
 For sink input in the sink/source common input type, connect the 24V DC+ terminal and COM□ terminal*1, and electrically connect an input terminal and 24V DC with a no-voltage contact or NPN open collector transistor to turn ON the input. For source input, connect the 24V DC- terminal and COM□ terminal*1, and electrically connect an input terminal and 24V DC with a no-voltage contact or PNP open collector transistor to turn ON the input.

*1. S/S terminal in FX2N Series extension blocks

Sink input wiring

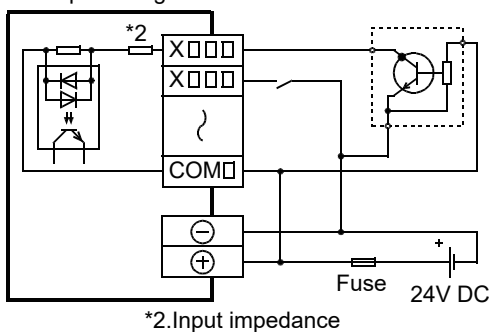

Source input wiring

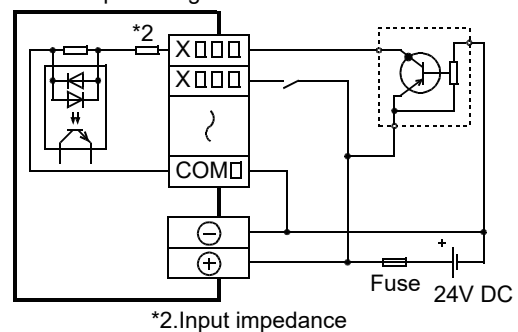

2. Input circuit

The primary and secondary circuits for input are insulated with a photocoupler, and the second circuit is provided with a C-R filter.
The C-R filter is designed to prevent malfunctions caused by chattering of the input contact and noise from the input line.

X000 to X017*1 of the main unit have digital filters, and the filter time can be changed in increments of 1ms in the range from 0 to 60ms through REFF (FNC 51) instruction or special data register (D8020). When 0 is specified for the time, the input filter values are set as shown in the following table.

Input number	Input filter value when 0 is specified
X000 to X005	5 μs^2
X006, X007	50 μs
X010 to X017	200 μs

- *1. X000 to X007 in the FX3UC-16M□.
- *2. When setting the input filter to 5 μs or capturing pulses of a response frequency of 50 to 100kHz with a high-speed counter, wire the terminals as stated below.
 - The wiring length should be 5m or less.
 - Connect a bleeder resistance of 1.5k Ω (1W or more) to the input terminal, so that the sum of the load current of the open collector transistor output on the mating device and the input current of the main body is 20mA or more.

→ For wiring of the input interrupt, pulse catch, or the rotary encoder, refer to Section 7.2 and 7.3.

3. Input sensitivity

The Main units input current and input sensitivity are shown in the following table.
When DC diodes or resistors are provided at input contacts or when parallel resistors or leakage current are present at input contacts, perform wiring in accordance with Subsection 5.2.4.

Item		X000 to X005	X006, X007	X010 or more
Input voltage		24 V DC, Voltage fluctuation range +20% -15%, Ripple voltage (p-p) 5% or less		
Input current		6mA	7mA	5mA
Input sensitivity current	ON	3.5mA or more	4.5mA or more	3.5mA or more
	OFF	1.5mA or less	1.5mA or less	1.5mA or less

1

Outline

2

External Dimensions

3

Generic Specifications

4

Power Supply Specifications

5

Input Specifications

6

Output Specifications

7

Examples of Wiring for Various Uses

8

Terminal Block

9

CC-LINK/LT Master FX3UC-LT(-2) only

10

Display module FX3UC-LT(-2) only

5.2.4 Instructions for connecting input devices

The input current of this PLC is 5 to 7mA/24V DC.
 Use input devices applicable to this minute current.
 If no-voltage contacts (switches) for large current are used, contact failure may occur.

Input number	Input current
X000 to X005	6mA/24V DC
X006, X007	7mA/24V DC
X010 or more	5mA/24V DC

<Example> Products of OMRON

Type	Model name
Microswitch	Models Z, V and D2RV
Proximity switch	Model TL

Type	Model name
Operation switch	Model A3P
Photoelectric switch	Model E3S

1. In the case of input device with built-in series diode

The voltage drop of the series diode should be approx. 4V or less.
 For example, when lead switches with a series LED are used, up to two switches can be connected in series.
 Also make sure that the input current is over the input-sensing level while the switches are ON.

- Examples of wiring (Dedicated to sink input types only)

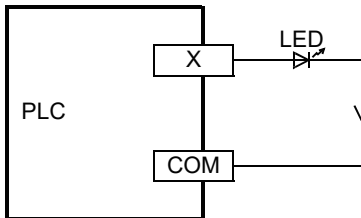

- Examples of wiring (Common to both sink and source input types)

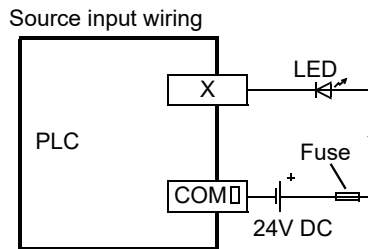
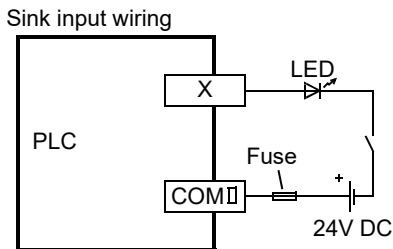

2. In the case of input device with built-in parallel resistance

Use a device having a parallel resistance, R_p , of $15k\Omega$ or more.

If the resistance is less than $15k\Omega$, connect a bleeder resistance, $R_b(k\Omega)$, obtained by the following formula as shown in the following figure.

$$R_b(k\Omega) \leq \frac{4R_p}{15-R_p}$$

- Examples of wiring (Dedicated to sink input types only)

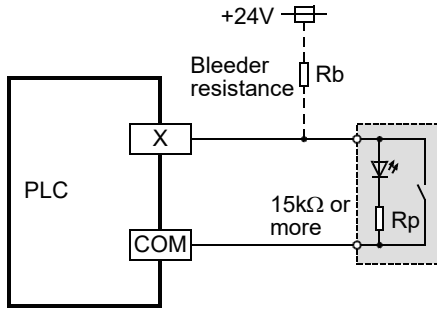

- Examples of wiring (Common to both sink and source input types)

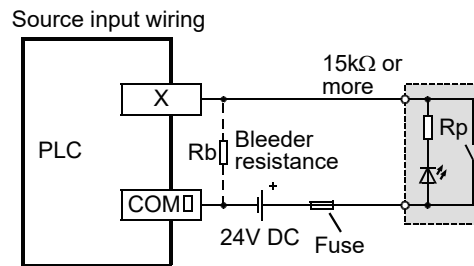
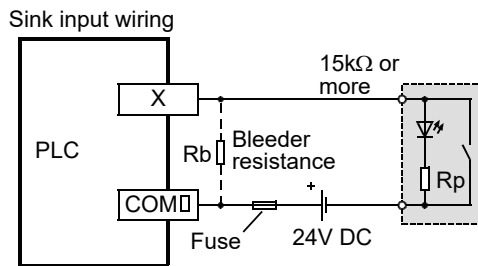

3. In the case of 2-wire proximity switch

Use a two-wire proximity switch whose leakage current, I_l , is $1.5mA$ or less when the switch is off.

When the current is larger than $1.5 mA$, connect a bleeder resistance, $R_b(k\Omega)$, determined by the following formula as shown in the following figure.

$$R_b(k\Omega) \leq \frac{6}{I_l - 1.5}$$

- Examples of wiring (Dedicated to sink input types only)

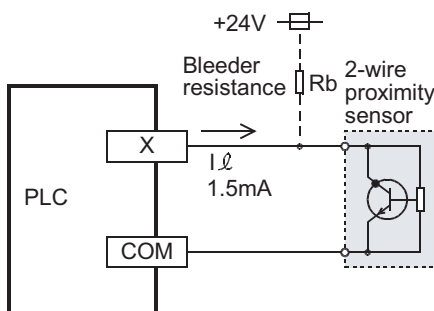

- Examples of wiring (Common to both sink and source input types)

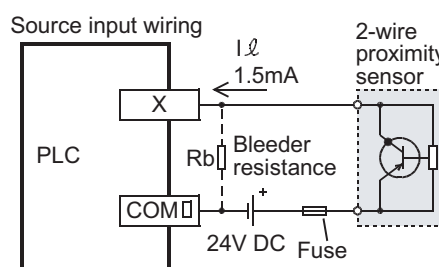
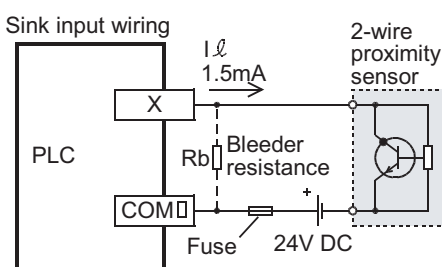

1	Outline
2	External Dimensions
3	Generic Specifications
4	Power Supply Specifications
5	Input Specifications
6	Output Specifications
7	Examples of Wiring for Various Uses
8	Terminal Block
9	CC-Link/LT Master FX3UC-LT(-2) only
10	Display module FX3UC-LT(-2) only

5.2.5 Examples of external wiring

1. Examples of wiring (Dedicated to sink input types only)

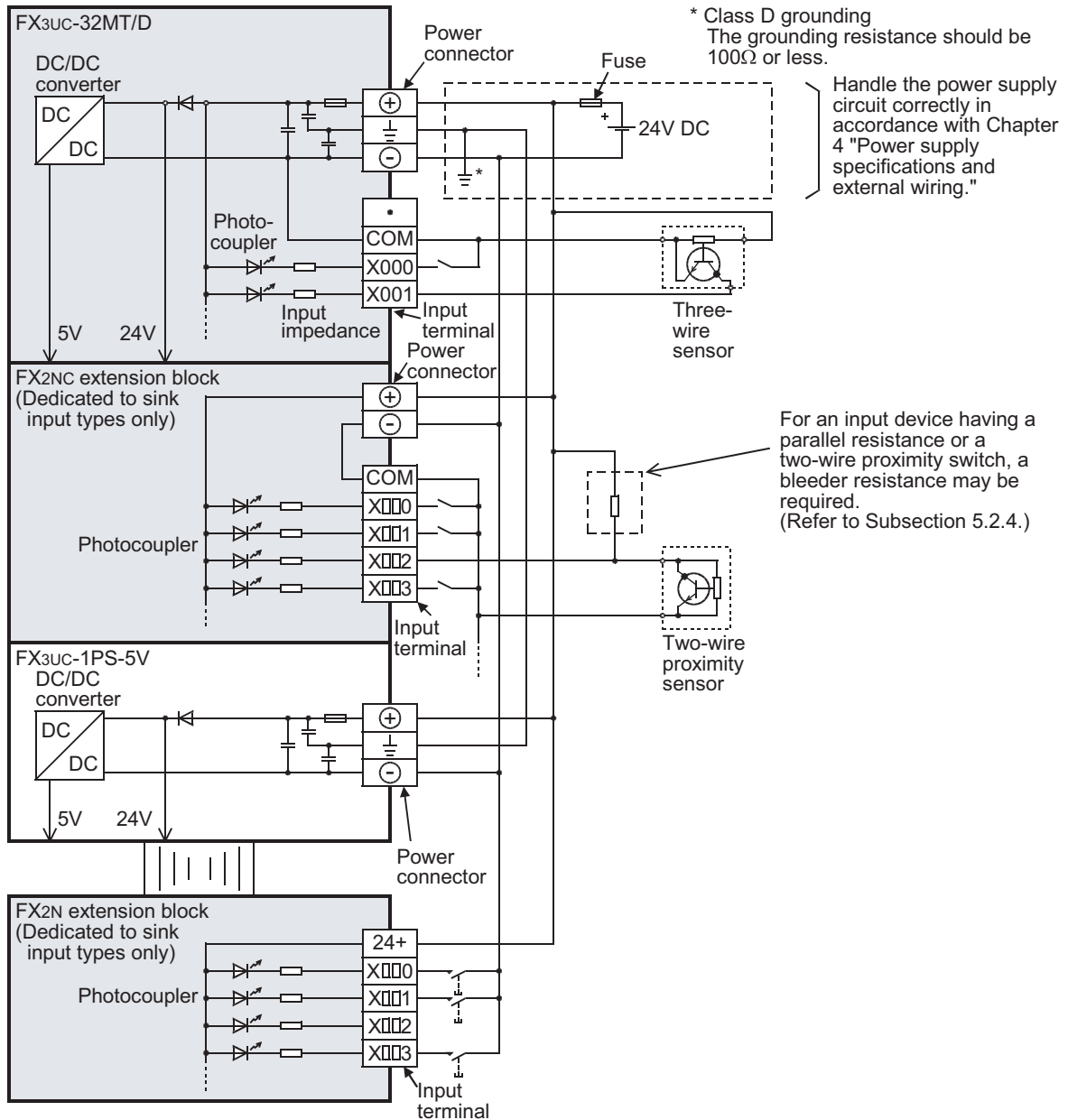

WIRING PRECAUTIONS	⚠ CAUTION
<ul style="list-style-type: none"> • Before cleaning or retightening terminals cut off all phases of the power supply externally. Failure to do so may cause electric shock. 	

2. Examples of sink input wiring (Common to both sink and source input types)

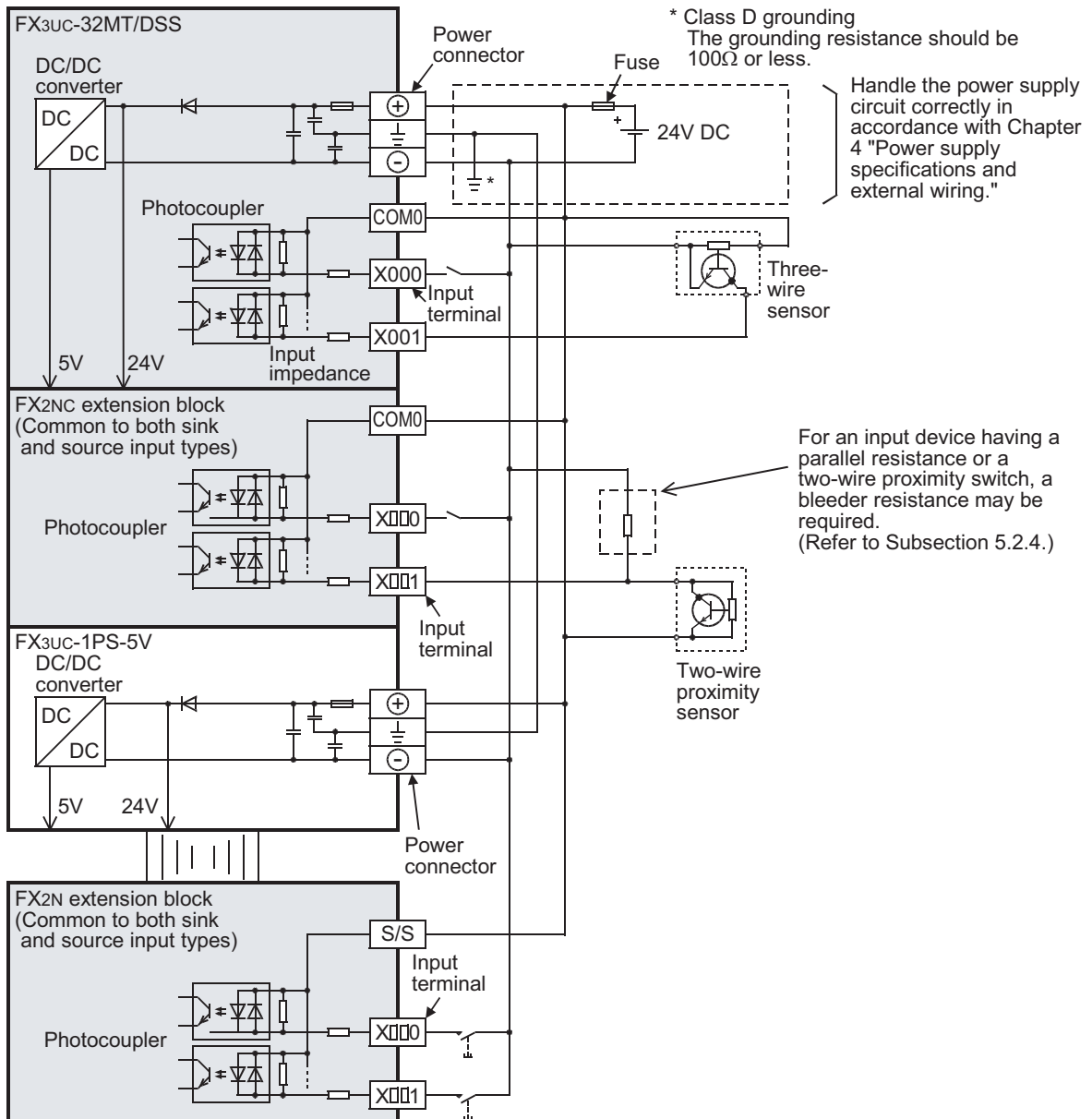

WIRING PRECAUTIONS



- Before cleaning or retightening terminals cut off all phases of the power supply externally. Failure to do so may cause electric shock.

1	Outline
2	External Dimensions
3	Generic Specifications
4	Power Supply Specifications
5	Input Specifications
6	Output Specifications
7	Examples of Wiring for Various Uses
8	Terminal Block
9	CC-Link/LT Master FX3uc-LT(-2) only
10	Display module FX3uc-LT(-2) only

3. Examples of source input wiring (Common to both sink and source input types)

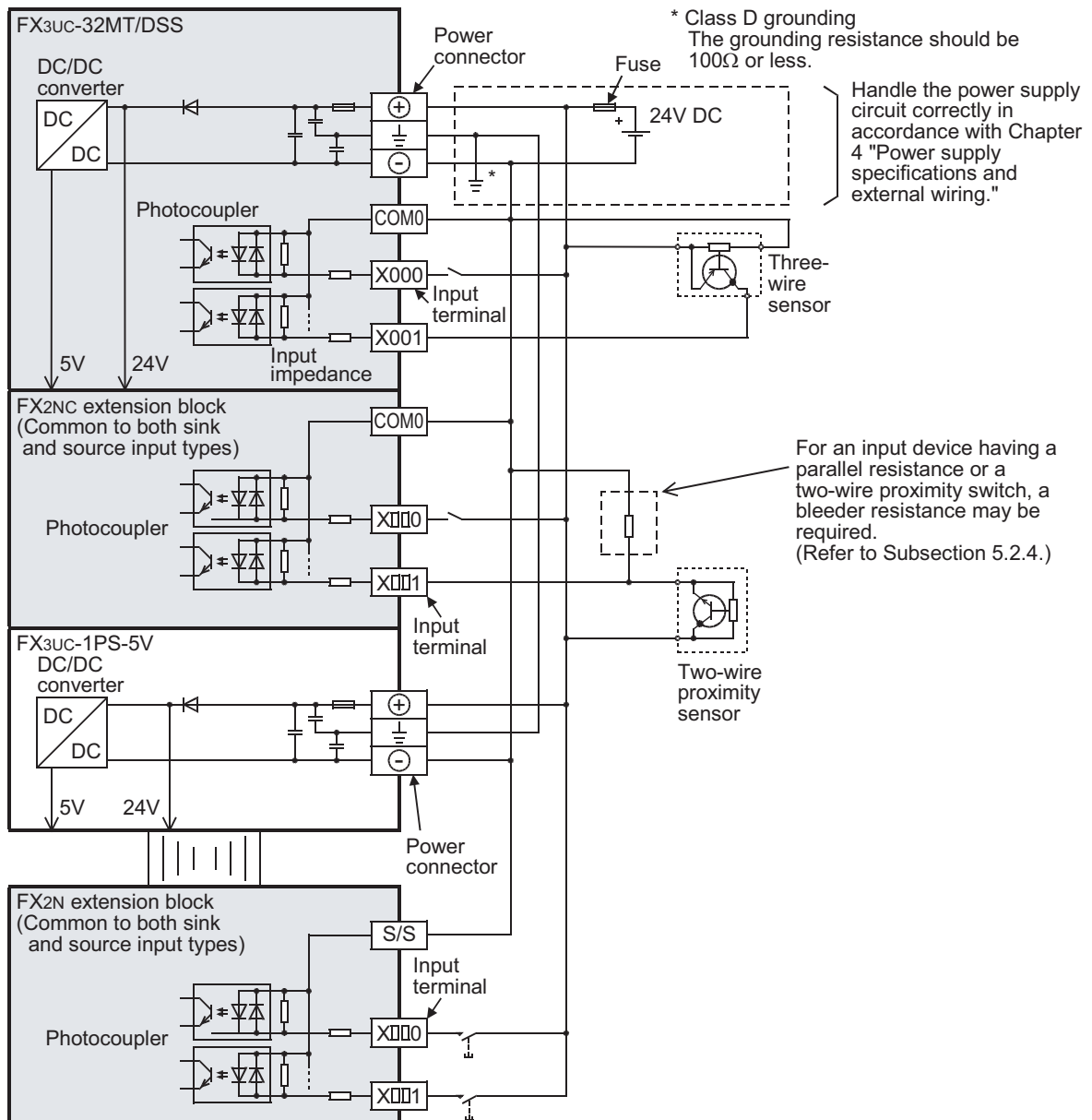

WIRING PRECAUTIONS



- Before cleaning or retightening terminals cut off all phases of the power supply externally. Failure to do so may cause electric shock.

5.3 5V DC Input [FX2N-16EXL-C]

5.3.1 5V DC input specifications

The table below shows the input specifications of the FX2N-16EXL-C.

Item	5V DC input specifications	
Input circuit diagram		
Input signal voltage	5V DC ±5%	
Input impedance	2.2kΩ	
Input signal current	Max.40mA 5V DC (16 points)	
Input sensitivity current	ON (Low)	1mA or more
	OFF (High)	0.4mA or less
Input sensitivity voltage	ON (Low)	1.5V DC or less
	OFF (High)	3.5V DC or more
Input response time	OFF → ON (High → Low)	1ms +1ms, -0.5 ms
	ON → OFF (Low → High)	1ms +1ms, -0.5 ms
Input signal type	TTL input	
Input circuit insulation	Photo-coupler insulation	
Input operation display	Turning on the input will light the LED indicator lamp.	

5.3.2 Handling of 5V DC Input

1. Input terminals

When an input terminal and the 5+ terminal are connected with the 5V DC circuit (shown in the figure on the right), the input turns ON. At this time, the input indicator LED turns ON. Multiple 5+ terminals are connected inside the PLC.

2. Input circuit

The primary and secondary circuits for input are insulated with a photocoupler. Response delay of approximately 1ms is given for a change in the input ("ON → OFF" or "OFF → ON").

3. Input sensitivity

The table below shows the input current and input sensitivity in this PLC.

Item	Specifications	
Input voltage	5V DC ±5%	
Input current	Max.40mA	
Input sensitivity current	ON (Low)	1mA or more
	OFF (High)	0.4mA or less
Input sensitivity voltage	ON (Low)	1.5V DC or less
	OFF (High)	3.5V DC or more

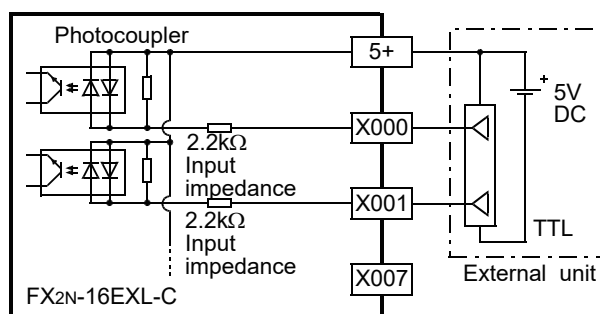

5.3.3 Example of external wiring

Use shielded wires for wiring the 5V DC.

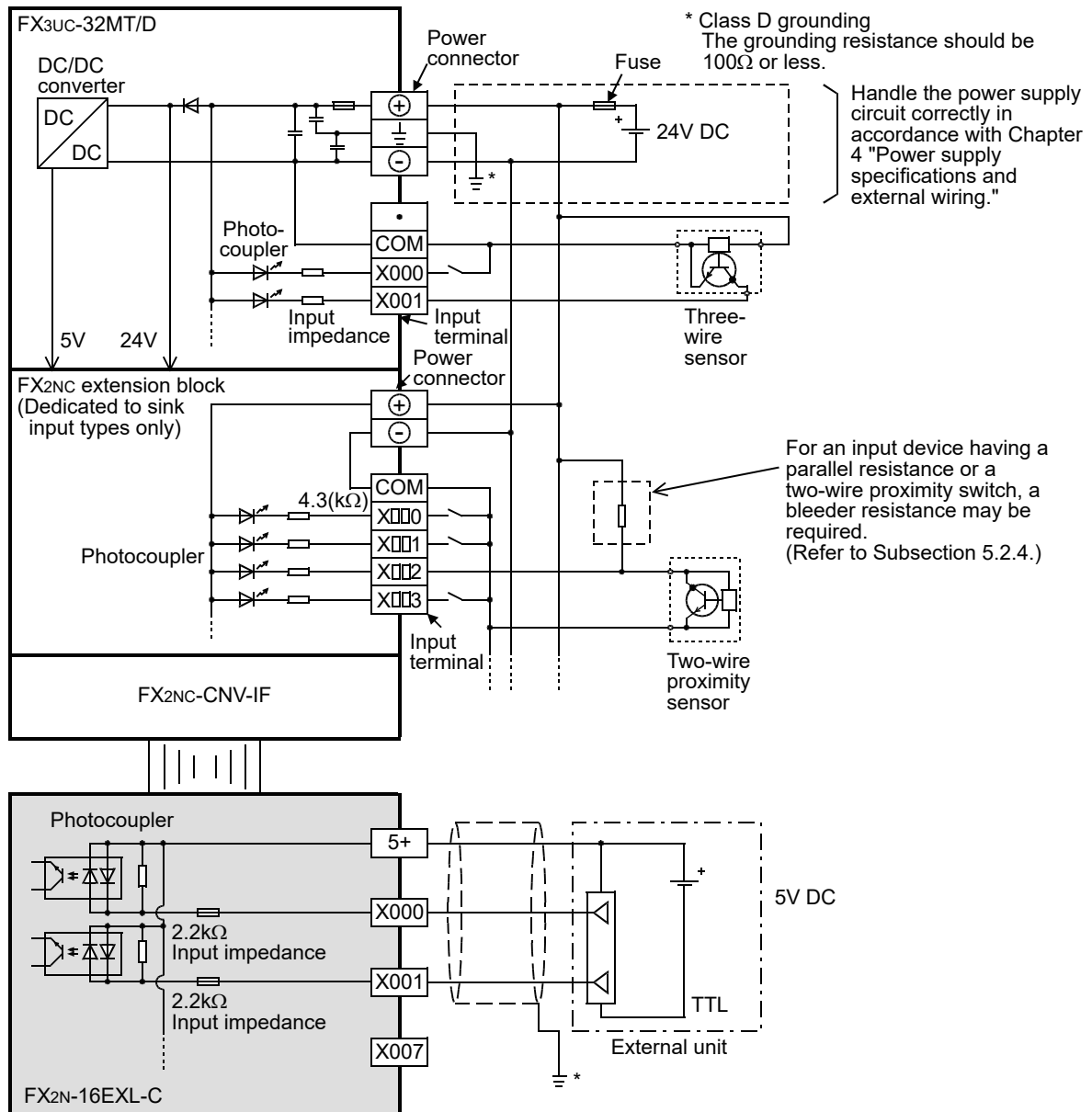

WIRING PRECAUTIONS	CAUTION
<ul style="list-style-type: none"> • Before cleaning or retightening terminals cut off all phases of the power supply externally. Failure to do so may cause electric shock. 	

5.4 AC input [FX2N-8EX-UA1/UL, FX0N-8EX-UA1/UL]

5.4.1 AC input specifications

The table below shows the input specifications of the FX2N-8EX-UA1/UL and FX0N-8EX-UA1/UL.

Item	AC input specifications	
Input circuit diagram		
Input signal voltage	100 to 110V AC +10%, -15% 50/60Hz	
Input impedance	Approx. 21kΩ/50Hz Approx. 18kΩ/60Hz	
Input signal current	6.2mA/110V 60Hz 4.7mA/100V 50Hz	
Input sensitivity	ON	3.8mA/80V AC or more
	OFF	1.7mA/30V AC or less
Input response time	30 ms or less	
Input signal type	Voltage contact	
Input circuit insulation	Photo-coupler insulation	
Input operation display	Turning on the input will light the LED indicator lamp.	

5.4.2 Handling of 100V AC Input

1. Input terminals

When voltage of 100 to 120V AC is applied between the input terminal and COM terminal, the input terminal is turned on.

The input display LED lights.

Do not connect the COM terminal of an AC input extension blocks with the COM terminal of a DC system.

2. Input circuit

The primary input circuit and the secondary input circuit are insulated with a photocoupler.

Response delay of 30 ms or less is given for a change in the input ("ON → OFF" or "OFF → ON").

3. Input sensitivity

The input current and input sensitivity of these PLCs are shown in the following table.

Item	Specifications	
Input voltage	100 to 110V AC +10%, -15% 50/60Hz	
Input current	6.2mA/110V 60Hz 4.7mA/100V 50Hz	
Input sensitivity	ON	3.8mA/80V AC
	OFF	1.7mA/30V AC

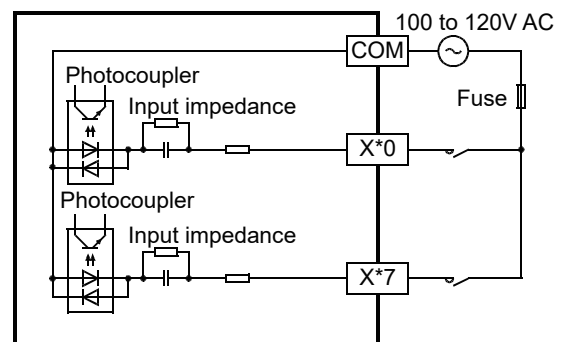

5.4.3 Example of external wiring

Do not bind or lay wires near the AC input wiring and DC input wiring.
 Assure a distance of 100mm (3.93") or more between the wires. Without wire separation, wires are easily affected by noise and power surges.

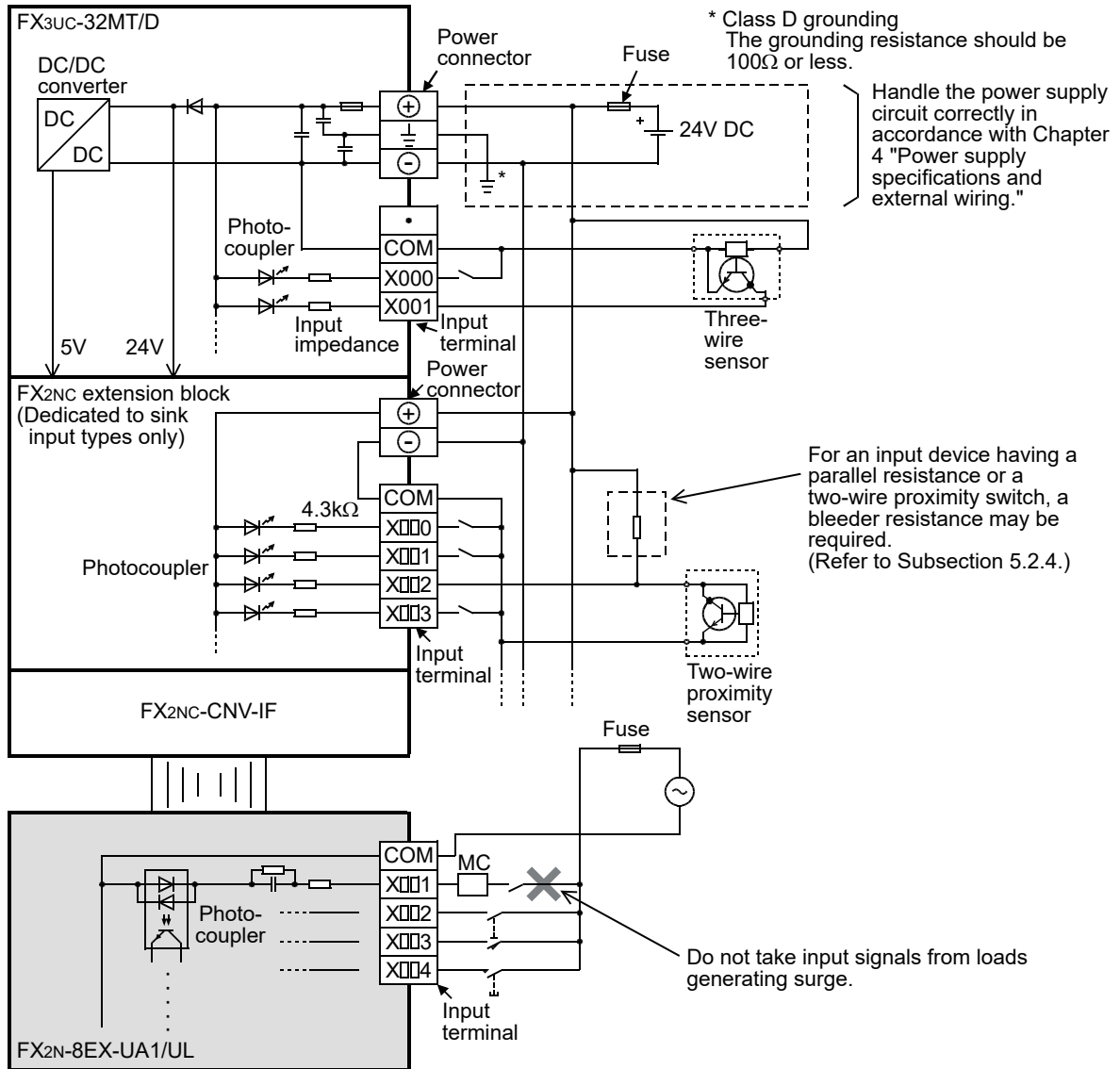

WIRING PRECAUTIONS	⚠ CAUTION
<ul style="list-style-type: none"> • Before cleaning or retightening terminals cut off all phases of the power supply externally. Failure to do so may cause electric shock. 	

5.5 High-speed Counters (C235 to C255)

5.5.1 High-speed counter type and device number

1. High speed counter type

The main unit has built-in 32-bit high speed bi-directional counters (1-phase 1-count input, 1-phase 2-count input and 2-phase 2-count input). These high-speed counters are classified into hardware counters and software counters according to counting method.



For some high-speed counters, external reset input terminals or external start input terminals (start of counting) can be selected.

2. Classification according to counting method

- Hardware counters: Counting by hardware.
May be switched to software counters depending on the operating condition.
→ **For the conditions under which they are handled as software counter, refer to Subsection 5.5.8.**
- Software counters: Counting through interrupt handling by CPU
Each counter must be used within specific limitations on maximum response frequency and overall frequency.
→ **For the restriction in response frequency by the overall frequency, refer to Subsection 5.5.9.**

3. High speed counter type and input signal form

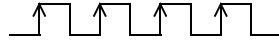
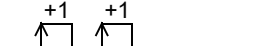
The types and input signals (waveforms) of high-speed counters (1-phase 1-count input, 1-phase 2-count input and 2-phase 2-count input) are shown below.

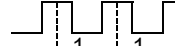
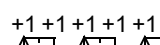
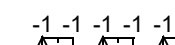
Type of counter	Input signal form	Counting direction
1-phase 1-count input	UP/DOWN 	Down-count or up-count is specified by turning on or off M8235 to M8245. ON: Down-counting OFF: Up-counting
1-phase 2-count input	UP  DOWN 	Up-count or down-count The counting direction can be checked with M8246 to M8250. ON: Down-counting OFF: Up-counting
2-phase 2-count input	1 edge count Phase A  Phase B  Up-counting Down-counting	Automatic up-count or down-count according to change in input status of phase A/B The counting direction can be checked with M8251 to M8255. ON: Down-counting OFF: Up-counting
	4 edge count Phase A  Phase B  Up-counting Down-counting	

4. Cautions when connecting equipment

High speed counter inputs use general-purpose input terminals X000 to X007. Open collector transistor (24V DC) output type equipment can be connected, but equipment having the output type shown below cannot be connected.

Absolute encoders cannot be connected to high-speed counter inputs because the signal type is different.

→ **For wiring, refer to "Section 7.2 Rotary Encoder [High-speed Counters C235 to C255]".**

→ **For programming, refer to programming manual.**

Supported direct connection output type	Open collector output type that supports 24V DC
---	---

5. The device list of the high speed counter

Counter type	Classification	Device No. (counter)	1 edge count/ 4 edge count	Data length	External reset input terminal	External start input terminal
1-phase 1-count input	Hardware counter ^{*1}	C235 ^{*2} C236 ^{*2} C237 ^{*2} C238 ^{*2} C239 ^{*2} C240 ^{*2}	—	32-bit bi-directional counter	None	None
		C244(OP) ^{*3} C245(OP) ^{*3}	—			
	Software counter	C241 C242 C243	—		Provided ^{*5}	None
		C244 ^{*3} C245 ^{*3}	—		Provided ^{*5}	Provided
1-phase 2-count input	Hardware counter ^{*1}	C246 ^{*2} C248(OP) ^{*2*3}	—	32-bit bi-directional counter	None	None
	Software counter	C247 C248 ^{*3}	—		Provided ^{*5}	None
		C249 C250	—		Provided ^{*5}	Provided
2-phase 2-count input	Hardware counter ^{*1}	C251 ^{*2}	1 edge count ^{*4}	32-bit bi-directional counter	None	None
			4 edge count ^{*4}			
		C253 ^{*2}	1 edge count ^{*4}		Provided ^{*5}	
			4 edge count ^{*4}			
	Software counter	C252	1 edge count ^{*4}		Provided ^{*5}	None
			4 edge count ^{*4}			
		C253(OP) ^{*6}	1 edge count ^{*4}		None	
			4 edge count ^{*4}			
C254 C255	1 edge count ^{*4}	Provided ^{*5}	Provided			
	4 edge count ^{*4}					

- *1. These counters are handled as software counters depending on the operating condition. When they are handled as software counters, they have limitations on maximum response frequency and overall frequency.
→ For the conditions under which they are handled as software counters, refer to Subsection 5.5.8.
→ For the overall frequency, refer to Subsection 5.5.9.
- *2. When the input terminals of the main unit receive pulses having a response frequency of 50kHz to 100kHz, wire the terminals as stated below.
- The wiring length should be 5m (16'4") or less.
- Connect a bleeder resistance of 1.5kΩ (1W or more) to the input terminal, so that the load current of the open collector transistor output on the mating device side is 20mA or more.
→ For the wiring, refer to Section 7.3.
- *3. C244, C245 and C248 are usually used as software counters. When they are used in combination with special auxiliary relays (M8388 and M8390 to M8392), they can be used as hardware counters C244(OP), C245(OP) and C248(OP).
→ For the procedures on switching the counter function, refer to Subsection 5.5.6.
- *4. The 2-phase 2-input counters are 1 edge count counters. When they are used in combination with special auxiliary relays (M8388, M8198 and M8199), they can be used as 4 edge count counters.
→ For the procedures on using them as 4 edge count counters, refer to Subsection 5.5.7.

- *5. The external reset input terminals are reset when they are turned on. When they are used in combination with special auxiliary relays (M8388 and M8389), they can be reset when turned off.
→ **For the procedures on changing the external reset input logic, refer to Subsection 5.5.6.**
- *6. C253 is usually used as a hardware counter. When it is used in combination with the special auxiliary relay (M8388 and M8392), it can be used as a counter C253 (OP) without reset input.
In this case, C253 (OP) is handled as a software counter.

1
Outline

2
External
Dimensions

3
Generic
Specifications

4
Power Supply
Specifications

5
Input
Specifications

6
Output
Specifications

7
Examples of
Wiring for
Various Uses

8
Terminal Block

9
CC-Link/LT
Master FX₃UC-
LT(-2) only

10
Display module
FX₃UC-LT(-2)
only

5.5.2 Input allocation of the High-Speed Counter

The high-speed counter numbers are allocated to the input terminals X000 to X007 as shown in the following table.

When high-speed counters are used, the filter constant of the corresponding input numbers automatically change (X000 to X005: 5 μs^{*1}, X006 and X007: 50 μs).

The input terminals not allocated for high-speed counters can be used as general input terminals.

1. Allocation table

H/W: Hardware counter S/W: Software counter U: Up-count input D: Down-count input

A: A-phase input B: B-phase input R: External reset input S: External start input

Type of counter	Counter No.	Classification	Input allocation							
			X000	X001	X002	X003	X004	X005	X006	X007
1-phase 1-count input	C235 ^{*1}	H/W ^{*2}	U/D							
	C236 ^{*1}	H/W ^{*2}		U/D						
	C237 ^{*1}	H/W ^{*2}			U/D					
	C238 ^{*1}	H/W ^{*2}				U/D				
	C239 ^{*1}	H/W ^{*2}					U/D			
	C240 ^{*1}	H/W ^{*2}						U/D		
	C241	S/W	U/D	R						
	C242	S/W			U/D	R				
	C243	S/W					U/D	R		
	C244	S/W	U/D	R						S
	C244(OP) ^{*3}	H/W ^{*2}							U/D	
C245	S/W			U/D	R				S	
C245(OP) ^{*3}	H/W ^{*2}								U/D	
1-phase 2-count input	C246 ^{*1}	H/W ^{*2}	U	D						
	C247	S/W	U	D	R					
	C248	S/W				U	D	R		
	C248(OP) ^{*1*3}	H/W ^{*2}				U	D			
	C249	S/W	U	D	R				S	
C250	S/W				U	D	R		S	
2-phase 2-count input ^{*4}	C251 ^{*1}	H/W ^{*2}	A	B						
	C252	S/W	A	B	R					
	C253 ^{*1}	H/W ^{*2}				A	B	R		
	C253(OP) ^{*3}	S/W				A	B			
	C254	S/W	A	B	R				S	
C255	S/W				A	B	R		S	

*1. When the input terminals of the main unit receive pulses having a response frequency of 50k to 100kHz, wire the terminals as stated below.

- The wiring length should be 5m (16'4") or less.
- Connect a bleeder resistance of 1.5kΩ (1 W or more) to the input terminal, so that the load current of the open collector transistor output on the mating device side to 20mA or more.

→ For the wiring, refer to Section 7.2.

*2. When the comparison set/reset instructions (DHSCS, DHSCR, DHSZ and DHSCT) for high-speed counters are used, the hardware (H/W) counters are switched to software (S/W) counters.

When the input signal logic is inverted by the reset input signal logic switching function (M8388 and M8389), C253 is switched from a hardware counter to a software counter.

→ For the conditions under which it is handled as a software counter, refer to Subsection 5.5.8.

*3. When a special auxiliary relay is driven in a program, the input terminals and their associated functions are switched.

→ For the procedures on switching to hardware counters, refer to Subsection 5.5.6.

- *4. The 2-phase 2-count input counters are 1 edge count counters. The use of special auxiliary relays changes them to 4 edge count counters.
→ **For the procedures on operating them as 4 edge count counters, refer to Subsection 5.5.7.**

2. Restriction of redundant use of input numbers

The input terminals X000 to X007 can be used for high-speed counters, input interruption, pulse catch, SPD, ZRN, DSZR and DVIT instructions and general-purpose inputs. Take care not to overlap the input numbers.

5.5.3 Current Value Update Timing and Comparison of Current Value

1. Current value update timing

When a pulse is input to a high-speed counter input terminal, the counter increments or decrements. The current value of the device is updated at the timing shown in the following table. Therefore, when the hardware counter directly handles the current value of the high-speed counter for MOV instruction or CMP instruction or an applied instruction (such as a contact comparison instruction), it uses the current value updated at the timing shown in the following table. As a result, the counter operation is affected by the scan time.

Classification	Current value update timing
Hardware counter	OUT instruction of counter HCMOV instruction
Software counter	Every time a pulse is input

2. Comparison of current value

To compare and output the current value of a high-speed counter, the following two methods are available.

- 1) Use of comparison instruction (CMP), band comparison instruction (ZCP) or contact comparison instruction
When the comparison results are necessary during counting operation, the value can be compared with the time ^{*1} in the main program by using the HCMOV instruction just before a comparison command (CMP command/ZCP command) or a contact comparison instruction.

*1. To compare the value with the high-speed counter's changing value and to change the output contact (Y), use a Comparison instruction for high-speed counters (HSCS/HSCR/HSZ/HSCT instruction).

- 2) Use of Comparison instruction for high-speed counters (HSCS/HSCR/HSZ/HSCT instruction)
Comparison instructions for high-speed counters (HSCS, HSCR, HSZ and HSCT instructions) perform comparison and output the comparison results with the relevant high-speed counting operation. These instructions have limitations on the number of simultaneously driven instructions as shown in the following table. The HSCT instruction can only be used once in any program.
When the output relay (Y) has been designated for comparison results, the ON/OFF status of the output is affected directly until the END instruction output is refreshed.
When the PLC is a relay output type, a mechanical delay in operation (approx. 10ms) is caused. Therefore, it is best to use a transistor output type PLC.

Applied instruction	Limitation in number of instructions driven at same time
HSCS	32 instructions including HSCT instruction
HSCR	
HSZ ^{*2}	
HSCT ^{*2}	Only 1 (This instruction can only be used once.)

*2. When HSZ or HSCT instruction is used, the maximum response frequencies and overall frequency of all software counters becomes limited.

→ **For the maximum response frequencies and overall frequency of software counters, refer to Subsection 5.5.9.**

5.5.4 Related Devices (High-speed counter)

For switching 1-phase 1-count input counter mode to up-count or down-count

Counter type	Counter No.	Specifying device	Up-counting	Down-counting
1-phase 1-count input	C235	M8235	OFF	ON
	C236	M8236		
	C237	M8237		
	C238	M8238		
	C239	M8239		
	C240	M8240		
	C241	M8241		
	C242	M8242		
	C243	M8243		
	C244	M8244		
C245	M8245			

For monitoring the up-count/down-count counting direction of 1-phase 2-count input and 2-phase 2-count input counters

Counter type	Counter No.	Monitoring device	OFF	ON
1-phase 2-count input	C246	M8246	Up-counting	Down-counting
	C247	M8247		
	C248	M8248		
	C249	M8249		
	C250	M8250		
2-phase 2-count input	C251	M8251		
	C252	M8252		
	C253	M8253		
	C254	M8254		
	C255	M8255		

For switching high-speed counter function

Device No.	Name	Description	Reference
M8388	Contact for changing high-speed counter function	Changes the function of high-speed counter	-
M8389	Function switching devices	Switches the logic of the external reset input	Subsection 5.5.5
M8390		Switches the function of C244	Subsection 5.5.6
M8391		Switches the function of C245	Subsection 5.5.6
M8392		Switches the function of C248 and C253	Subsection 5.5.6
M8198		Device for switching C251, C252 and C254 to single or 4 edge count	Subsection 5.5.7
M8199		Device for switching C253, C255 and C253 (OP) to single or 4 edge count	Subsection 5.5.7

Operation status of hardware counter/software counter

Device No.	Name	Description	ON	OFF
M8380*1	Operation status	Operation status of C235, C241, C244, C246, C247, C249, C251, C252 or C254	Software counter	Hardware counter
M8381*1		Operation status of C236		
M8382*1		Operation status of C237, C242 and C245		
M8383*1		Operation status of C238, C248, C248(OP), C250, C253 or C255		
M8384*1		Operation status of C239 or C243		
M8385*1		Operation status of C240		
M8386*1		Operation status of C244(OP)		
M8387*1		Operation status of C245(OP)		

*1. Cleared when the PLC mode switches from STOP to RUN.

5.5.5 [Function switching] switching of logic of external reset input signal

The external reset input for the counters C241 to C245, C247 to C250 and C252 to C255 normally resets the counters when it is turned ON. If the logic is inverted by the following program, the counters are reset by turning the external reset input to OFF.

Counter No.	Inversion of logic of external reset input signal	Details of change
C241 to C245 C247 to C250 C252 to C255	<pre> graph LR M8388[Inverter M8388] --- M8389((M8389)) M8389 --- C241((C241)) C241 --- K000[Output K000] </pre>	The logic of external reset input is inverted to reset the counters when the input is turned OFF. (The logic for all applicable counter numbers is inverted.)

Cautions in inverting the logic of the external reset input signal

Although C253 is a hardware counter, it is switched to a software counter by inverting the logic of the external reset input signal.

1	Outline
2	External Dimensions
3	Generic Specifications
4	Power Supply Specifications
5	Input Specifications
6	Output Specifications
7	Examples of Wiring for Various Uses
8	Terminal Block
9	CC-Link/LT Master FX3UC-LT(-2) only
10	Display module FX3UC-LT(-2) only

5.5.6 [Function switching] switching of allocation and functions of input terminals

When the software counters C244, C245, C248 and C253 are combined with the following special auxiliary relays, the allocation of the input terminals and functions are changed.
 Program the special auxiliary relays just before the counters.

Counter No.	When used as hardware counter	Details of change
C244(OP)		<ul style="list-style-type: none"> The count input terminal is changed from X000 to X006. Reset input is not given. Start input is not given. The counter functions as a hardware counter.
C245(OP)		<ul style="list-style-type: none"> The count input terminal is changed from X002 to X007. Reset input is not given. Start input is not given. The counter functions as a hardware counter.
C248(OP)		<ul style="list-style-type: none"> Reset input is not given. The counter functions as a hardware counter.
C253(OP)		<ul style="list-style-type: none"> Reset input is not given. The counter functions as a software counter.

5.5.7 [Function switching] procedures for using 2-phase 2-count input counters C251 to C255 in 4 edge count mode

The 2-phase 2-count input counters C251 to C255 are normally set to 1 edge count mode. The counters can be operated in 4 edge count mode through programming as shown below.

Counter No.	To use 4 edge count 2-phase 2-input counter	Details of change
C251		<p>1 edge count (before change)</p> <p>Phase A </p> <p>Phase B </p> <p>Up-counting</p> <p>Phase A </p> <p>Phase B </p> <p>Down-counting</p> <p style="text-align: center;">↓</p> <p>4 edge count (after change)</p> <p>Phase A </p> <p>Phase B </p> <p>Up-counting</p> <p>Phase A </p> <p>Phase B </p> <p>Down-counting</p>
C252		
C253		
C253(OP)		
C254		
C255		

1	Outline
2	External Dimensions
3	Generic Specifications
4	Power Supply Specifications
5	Input Specifications
6	Output Specifications
7	Examples of Wiring for Various Uses
8	Terminal Block
9	CC-LINK/LT Master FX3UC-LT(-2) only
10	Display module FX3UC-LT(-2) only

5.5.8 Conditions for Hardware Counter to be Handled as Software Counter

The high-speed counters are classified into hardware counters and software counters. Some hardware counters are handled as software counters depending on the operating conditions. In this case, use hardware counters within the range of maximum response frequency and total frequency as determined for software counters.

1. Conditions under which counters are handled as software counters

Because hardware counters execute counting at the hardware level of the FX3UC, they can execute counting without regard to the total frequency. However, under the following conditions, they are handled as software counters. When using the counters in the condition below, the maximum response frequencies and overall frequency of the counters are considered to be the same as those for software counters.

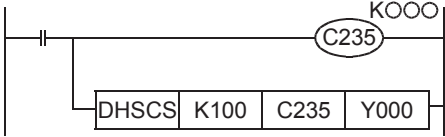
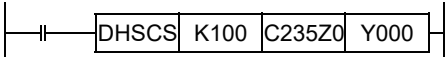
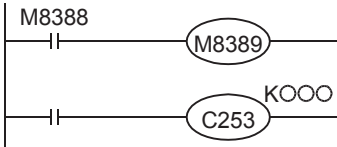
Hardware counter No.	Conditions under which counters are handled as software counters
C235 C236 C237 C238 C239 C240 C244(OP) C245(OP) C246 C248(OP) C251 C253	<p>When DHSCS (FNC 53), DHSCR (FNC 54), DHSZ (FNC 55) or DHSCT (FNC280) instruction is used for a hardware counter number, the hardware counter is handled as a software counter. Ex.: C235</p>  <p>In this case, C235 functions as a software counter.</p> <hr/> <p>When the index register is used for the counter number designated by DHSCS (FNC 53), DHSCR (FNC 54), DHSZ (FNC 55) or DHSCT (FNC280) instruction, all hardware counters are handled as software counters. Ex.: C235Z0</p>  <hr/> <p>When the logic is reversed by the external reset input signal logic change function, C253 (hardware counter) is switched to a software counter. Ex.: The logic of the external reset input signal of C253 is inverted. → For the inversion of the logic of external reset input signal, refer to Subsection 5.5.5.</p> 

5.5.9 Calculation of Response Frequency and Overall Frequency

Response frequencies of hardware counters

The maximum response frequencies of the hardware counters are shown in the following table. When hardware counters are handled as software counters in some operating conditions, their maximum response frequency becomes equivalent to that of software counters, and thus hardware counters are sometimes subject to restrictions in total frequency.

→ For the conditions under which the hardware counters are handled as software counters, refer to the previous page.

Counter type		Counter Nos.	Max. response frequency
1-phase 1-count input		C235, C236, C237, C238, C239, C240	100kHz
		C244(OP), C245(OP)	10kHz
1-phase 2-count input		C246, C248 (OP)	100kHz
2-phase 2-count input	1 edge count	C251, C253	50kHz
	4 edge count		50kHz

Response frequencies and overall frequency of software counters

The maximum response frequencies and overall frequency of software counters are shown below. When HSZ or HSCT instruction is used in the program, limitations are placed on the maximum response frequencies and overall frequency of all software counters regardless of the instruction operand. When examining a system or creating a program, consider the frequency limitations and use the software counters within their allowable ranges.

1. When FX3u/FX3uc Series special function blocks and analog special adapters are not used

Examples of calculation are given in the heavy-line frame.

Counter type	Software counter Nos.	Software counters with HSCS, HSCR, HSZ or HSCT instruction *1	Magnification for calculation of overall frequency	Response frequency and overall frequency depending on instructions being used							
				Neither HSZ nor HSCT instruction		Only HSCT instruction		Only HSZ instruction		Both HSZ and HSCT instructions	
				Max. response frequency (kHz)	Overall frequency (kHz)	Max. response frequency (kHz)	Overall frequency (kHz)	Max. response frequency (kHz)	Overall frequency (kHz)	Max. response frequency (kHz)	Overall frequency (kHz)
1-phase 1-count input	C241 C242 C243 C244 C245	C235 C236 C237 C238 C239 C240	×1	40	80	30	60	40 - (number of instruction) ^{*2}	80 - 1.5 × (number of instruction)	30 - (number of instruction) ^{*2}	60 - 1.5 × (number of instruction)
	—	C244 (OP) C245 (OP)	×1	10		10					
1-phase 2-count input	C247 C248 C249 C250	C246 C248 (OP)	×1	40		30					
2-phase 2-count input	1 edge count 4 edge count	C252 C253 (OP)	C251 C253	×1	40	30					
		C254 C255		×4	10	7.5	(40 - number of instruction) / 4	(30 - number of instruction) / 4			

*1. When an index register is added to a counter number specified by a HSCS, HSCR, HSZ or HSCT instruction, all hardware counters are switched to software counters.

*2. The high-speed counters C244 (OP) and C245 (OP) cannot count signals of 10kHz or more.

1	Outline
2	External Dimensions
3	Generic Specifications
4	Power Supply Specifications
5	Input Specifications
6	Output Specifications
7	Examples of Wiring for Various Uses
8	Terminal Block
9	CC-Link/LT Master FX3uc-LT(-Z) only
10	Display module FX3uc-LT(-Z) only

- 1) Calculation of overall frequency
The overall frequency is calculated using the above table according to the high-speed comparison instructions being used in the program.

Overall frequency ≥ Sum of "response frequency of high-speed counter × Magnification for calculation of overall frequency"

- 2) Example of calculation
When only the HSZ instruction is used 6 times in a program, the frequency is calculated by the formulas shown in the "Only HSZ instruction" column in the above table.

High-speed counter No. to be used		Input frequency	Calculation of max. response frequency	Magnification for calculation of overall frequency	Instruction to be used
C237	Operation as software counter	30kHz	40 - 6(times) = 34kHz	× 1	HSZ instruction is used 6 times.
C241		20kHz	40 - 6(times) = 34kHz	× 1	
C253 (OP) [4 edge count]	Software counter	4kHz	{40 - 6(times)} / 4 = 8.5kHz	× 4	

- 1) Since only HSZ instruction is used for 6 times, the total frequency is as follows:

$$\text{Total frequency} = 80 - 1.5 \times 6 = 71\text{kHz}$$

- 2) The sum of the response frequencies of the high-speed counters being used is calculated as follows:

$$"30\text{kHz} \times 1[\text{C237}]" + "20\text{kHz} \times 1[\text{C241}]" + "4\text{kHz} \times 4[\text{C253(OP)}]" = 66\text{kHz} \leq 71\text{kHz}$$

2. When FX3U/FX3UC Series special function blocks and analog special adapters are used

Examples of calculation are given in the heavy-line frame.

Counter type	Counter Nos.	Software counters with HSCS, HSCR, HSZ or HSCT instruction *1	Magnification for calculation of overall frequency	Response frequency and overall frequency depending on instructions being used							
				Neither HSZ nor HSCT instruction		Only HSCT instruction		Only HSZ instruction		Both HSZ and HSCT instructions	
				Max. response frequency (kHz)	Overall frequency (kHz)	Max. response frequency (kHz)	Overall frequency (kHz)	Max. response frequency (kHz)	Overall frequency (kHz)	Max. response frequency (kHz)	Overall frequency (kHz)
1-phase 1-count input	C241 C242 C243 C244 C245	C235 C236 C237 C238 C239 C240	× 1	30	60	25	50	30 - (number of instructions) ^{*2}	50 - 1.5 × (number of instructions)	25 - (number of instructions) ^{*2}	50 - 1.5 × (number of instructions)
	-	C244(OP) C245(OP)	× 1	10		10					
1-phase 2-count input	C247 C248 C249 C250	C246 C248(OP)	× 1	30		25					
2-phase 2-count input	1 edge count C252	C251 C253	× 1	30		25					
	4 edge count C253 (OP) C254 C255			× 4	7.5	6.2	(30 - number of instructions) / 4	(25 - number of instructions) / 4			

*1. When an index register is added to a counter number specified by a HSCS, HSCR, HSZ or HSCT instruction, all hardware counters are switched to software counters.

*2. The high-speed counters C244 (OP) and C245 (OP) cannot count signals of 10 kHz or more.

- 1) Calculation of overall frequency
The overall frequency is calculated using the above table according to the high-speed comparison instructions being used in the program.

Overall frequency \geq Sum of "response frequency of high-speed counter \times Magnification for calculation of overall frequency"

- 2) Example of calculation
When only the HSZ instruction is used 6 times in a program, the frequency is calculated by the formulas shown in the "Only HSZ instruction" column in the above table.

High-speed counter No. to be used		Input frequency	Calculation of max. response frequency	Magnification for calculation of overall frequency	Instruction to be used
C237	Operation as software counter	20kHz	$30 - 6(\text{times}) = 24\text{kHz}$	$\times 1$	HSZ instruction is used 6 times.
C241	Software counter	10kHz	$30 - 6(\text{times}) = 24\text{kHz}$	$\times 1$	
C253 (OP) [4 edge count]		2kHz	$\{30 - 6(\text{times})\} / 4 = 6\text{kHz}$	$\times 4$	

- 1) Since only HSZ instruction is used for 6 times, the total frequency is as follows:

$$\text{Total frequency} = 50 - 1.5 \times 6 = \underline{41\text{kHz}}$$

- 2) The sum of the response frequencies of the high-speed counters used is calculated as shown below.

$$"20\text{kHz} \times 1[\text{C237}]" + "10\text{kHz} \times 1[\text{C241}]" + "2\text{kHz} \times 4[\text{C253(OP)}]" = 38\text{kHz} \leq \underline{41\text{kHz}}$$

5.5.10 Cautions on Use

→ For programming details, refer to the Programming Manual.

- If the operation of a high-speed counter is triggered by a device such as a switch, the counter may malfunction due to extra noise from switch chattering or contact bounce.
- The input filter of an input terminal for a high-speed counter in the main unit is automatically set to 5 μs (X000 to X005) or 50 μs (X006 and X007). Accordingly, it is not necessary to use the REFF instruction or special data register D8020 (input filter adjustment). The input filter for input relays not being used for high-speed counters remains at 10 ms (initial value).
- The inputs X000 to X007 are used for high-speed counters, input interrupt, pulse catch, SPD/DSZR/DVIT/ZRN instructions and general-purpose inputs. There should be no overlap between each input number.
- Make sure that the signal speed for high-speed counters does not exceed the response frequency described above. If an input signal exceeds the response frequency, a WDT error may occur, or the communication functions such as a parallel link may malfunction.
- The response frequency changes depending on number of used counters, but the input filter value is fixed to 5 μs (X000 to X005) or 50 μs (X006 and X007). Note that noise above the response frequency may be counted depending on the filter value of the used input.

5.6 Input Interruption (I00□ to I50□) - With Delay Function

The PLC (main unit) is provided with an input interruption function (input delay interruption function) and has six interruption input points.

The ON or OFF duration of interruption input signals should be 5μs or more.

1. Allocation of pointers to input numbers (input signal ON/OFF duration)

→ For details on programming, refer to the programming manual.

→ For the wiring, refer to Section 7.3.

Input No.	Interrupt pointer		Interrupt disable control	ON or OFF duration of input signal
	Interruption on leading edge	Interruption on trailing edge		
X000	I001	I000	M8050	5μs or more
X001	I101	I100	M8051	
X002	I201	I200	M8052	
X003	I301	I300	M8053	
X004	I401	I400	M8054	
X005	I501	I500	M8055	

2. Input interruption delay function

This input interruption has a function to delay execution of interruption routine in 1ms units.

With this delay function, the position of the sensor used for input interruption can be adjusted in the sequence program. It is necessary to adjust the actual position of the sensor.

→ For the programming, refer to the programming manual.

3. Non-overlap of input numbers

The input terminals X000 to X007 can be used for high-speed counter, input interruption, pulse catch, SPD, ZRN, DSZR and DVIT instructions and general-purpose inputs.

Take care not to overlap the input numbers.

5.7 Pulse Catch (M8170 to M8177)

The PLC (main unit) is provided with a pulse catch function and has 8 pulse catch input points.

1. Allocation of special memories to input numbers (ON duration of input signals)

→ For details on programming, refer to the programming manual.

→ For the wiring, refer to Section 7.3.

Input No.	Contact on sequence program	ON duration of input signal
X000	M8170	5μs or more
X001	M8171	
X002	M8172	
X003	M8173	
X004	M8174	
X005	M8175	
X006	M8176	50μs or more
X007	M8177	

2. Non-overlap of input numbers

The input terminals X000 to X007 can be used for high-speed counter, input interruption, pulse catch, speed detection (SPD) instructions and general-purpose input.

Take care not to overlap the input numbers.

6. Output Specification and External Wiring

DESIGN PRECAUTIONS



- Make sure to have the following safety circuits outside of the PLC to ensure safe system operation even during external power supply problems or PLC failure.
Otherwise, malfunctions may cause serious accidents.
 - 1) Most importantly, have the following: an emergency stop circuit, a protection circuit, an interlock circuit for opposite movements (such as normal vs. reverse rotation), and an interlock circuit (to prevent damage to the equipment at the upper and lower positioning limits).
 - 2) Note that when the PLC CPU detects an error, such as a watchdog timer error, during self-diagnosis, all outputs are turned off. Also, when an error that cannot be detected by the PLC CPU occurs in an input/output control block, output control may be disabled.
External circuits and mechanisms should be designed to ensure safe machinery operation in such a case.
 - 3) Note that when an error occurs in a relay, triac or transistor output device, the output could be held either on or off.
For output signals that may lead to serious accidents, external circuits and mechanisms should be designed to ensure safe machinery operation in such a case.
- Note that when an error occurs in a remote I/O unit, the output could be held either on or off.
For output signals that may lead to serious accidents, external circuits for monitoring should be provided.

DESIGN PRECAUTIONS



- Do not bundle the control line and CC-Link/LT connection cables together with or lay them close to the main circuit or power line. As a guideline, lay the control line and CC-Link/LT connection cables at least 100mm (3.94") or more away from the main circuit or power line.
Noise may cause malfunctions.
- Install the product so that excessive force will not be applied to peripheral device connectors, power connectors, input/output connectors, CC-Link/LT interface connectors or CC-Link/LT connection cables.
Failure to do so may result in wire damage/breakage or PLC failure.

SECURITY PRECAUTIONS



- To maintain the security (confidentiality, integrity, and availability) of the programmable controller and the system against unauthorized access, denial-of-service (DoS) attacks, computer viruses, and other cyberattacks from unreliable networks and devices via network, take appropriate measures such as firewalls, virtual private networks (VPNs), and antivirus solutions.

WIRING PRECAUTIONS



- Make sure to cut off all phases of the power supply externally before attempting installation or wiring work.
Failure to do so may cause electric shock or damage to the product.
- Make sure to attach the terminal cover, offered as an accessory, before turning on the power or initiating operation after installation or wiring work.
Failure to do so may cause electric shock.
- The temperature rating of the cable should be 80°C or more.

WIRING PRECAUTIONS



- Connect the DC power supply wiring to the dedicated terminals described in this manual.
If an AC power supply is connected to a DC input/output terminal or DC power supply terminal, the PLC will burn out.
- Do not wire vacant terminals externally.
Doing so may damage the product.
- Perform class D grounding (grounding resistance: 100Ω or less) to the grounding terminal on the main unit.
Do not use common grounding with heavy electrical systems.
- Make sure to properly wire the FX0N/FX2N/FX3U Series extension equipment in accordance with the following precautions.
Failure to do so may cause electric shock, equipment failures, a short-circuit, wire breakage, malfunctions, or damage to the product.
 - The disposal size of the cable end should follow the dimensions described in the manual.
 - Tightening torque should follow the specifications in the manual.
 - Tighten the screws using a Phillips-head screwdriver No.2 (shaft diameter 6mm (0.24") or less). Make sure that the screwdriver does not touch the partition part of the terminal block.
- Make sure to properly wire to the terminal block (European type) in accordance with the following precautions.
Failure to do so may cause electric shock, equipment failures, a short-circuit, wire breakage, malfunctions, or damage to the product.
 - The disposal size of the cable end should follow the dimensions described in the manual.
 - Tightening torque should follow the specifications in the manual.
 - Twist the end of strand wire and make sure that there are no loose wires.
 - Do not solder-plate the electric wire ends.
 - Do not connect more than the specified number of wires or electric wires of unspecified size.
 - Affix the electric wires so that neither the terminal block nor the connected parts are directly stressed.
- Make sure to properly wire to the FX Series terminal blocks in accordance with the following precautions.
Failure to do so may cause electric shock, equipment failures, a short-circuit, wire breakage, malfunctions, or damage to the product.
 - The disposal size of the cable end should follow the dimensions described in the manual.
 - Tightening torque should follow the specifications in the manual.
 - Tighten the screws using a Phillips-head screwdriver No.2 (shaft diameter 6mm (0.24") or less). Make sure that the screwdriver does not touch the partition part of the terminal block.

1
Outline

2
External
Dimensions

3
Generic
Specifications

4
Power Supply
Specifications

5
Input
Specifications

6
Output
Specifications

7
Examples of
Wiring for
Various Uses

8
Terminal Block

9
CC-Link/LT
Master FX3UC-
LT(-2) only

10
Display module
FX3UC-LT(-2)
only

6.1 Sink and Source Output (Transistor)

Transistor outputs in the FX3UC Series main unit and FX2N/FX2NC Series I/O extension blocks are classified into sink output type or source output type.

1. Differences in circuit

- Sink output [-common]
Output to make load current flow into the output (Y) terminal is called sink output.

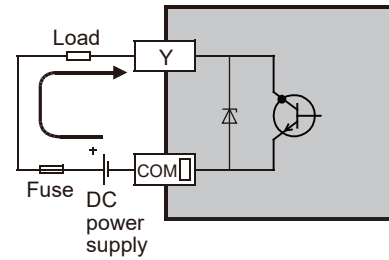

- Source output [+common]
Output to make load current flow out of the output (Y) terminal is called source output.

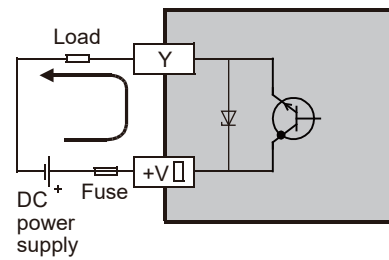

6.2 Transistor Output

6.2.1 Transistor Output Specifications (Sink output type)

The table below shows the output specifications of the FX3UC-□□MT/D, FX3UC-32MT-LT(-2) Main unit, FX0N/FX2N/FX2NC output extension blocks (sink output type).

Outputs in the main unit are restricted by the simultaneous ON ratio.

→ For the restriction in simultaneous ON ratio, refer to Subsection 6.2.3.

Item		Transistor output (sink) specifications				
Number of output points	FX3UC-16MT/D		8 points			
	FX3UC-32MT/D		16 points			
	FX3UC-64MT/D		32 points			
	FX3UC-96MT/D		48 points			
	FX3UC-32MT-LT(-2)		16 points			
	FX0N-8EYT(-H), FX2N-8EYT(-H)		8 points			
	FX2N-16EYT(-C), FX2NC-16EYT		16 points			
	FX2NC-32EYT		32 points			
Connecting type	FX3UC-□□MT/D, FX3UC-32MT-LT(-2), FX2NC-16EYT, FX2NC-32EYT FX2N-16EYT-C		Connector			
	FX0N-8EYT(-H), FX2N-8EYT(-H), FX2N-16EYT		Terminal block			
Output type/form			Transistor/Sink output			
External power supply			5-30 V DC			
Max. load	Resistance load	FX3UC-□□MT/D FX3UC-32MT-LT(-2)	Y000 to Y003	0.3A/1 point	Make sure that the total load current of 8 resistance load points is 0.8A*1 or less.	
			Y004 or later	0.1A/1 point		
		FX2NC-16EYT, FX2NC-32EYT		0.1A/1 point		Make sure that the total load current of 8 resistance load points is 0.8A or less.
		FX2N-16EYT-C		0.3A/1 point		Make sure that the total load current of 16 resistance load points is 1.6A or less.
		FX2N-8EYT FX0N-8EYT FX2N-16EYT FX0N-16EYT		0.5A/1 point		The total load current of resistance loads per common terminal should be the following value. 4points/common: 0.8A 8points/common: 1.6A
		FX2N-8EYT-H FX0N-8EYT-H		1A/1 point		Make sure that the total load current of 4 resistance load points is 2 A or less.
	Inductive load	FX3UC-□□MT/D FX3UC-32MT-LT(-2)	Y000 to Y003	7.2W/1 point (24V DC)	Make sure that the total load of 16 inductive load points is 38.4W/24V DC or less.	
			Y004 or later	2.4W/1 point (24V DC)		
		FX2NC-16EYT, FX2NC-32EYT		2.4W/1 point (24V DC)		
		FX2N-16EYT-C		7.2W/1 point (24V DC)		
		FX2N-8EYT, FX0N-8EYT, FX2N-16EYT, FX0N-16EYT		12W/1 point (24V DC)		
		FX2N-8EYT-H, FX0N-8EYT-H		24W/1 point (24V DC)		
Open circuit leakage current			0.1mA or less/30V DC			

*1. When the two COM□ terminals are connected outside the PLC, resistance load is 1.6A or less.

Item			Transistor output (sink) specifications	
ON voltage			1.5V or less	
Response time	OFF → ON	Main units	Y000 to Y002	5μs or less/10mA or more (5-24 V DC)
			Y003 (FX3uc-□□MT/D)	0.2ms or less/100mA (24V DC)
			Y003 (FX3uc-32MT-LT(-2))	5μs or less/10mA or more (5-24 V DC)
			Y004 or later	0.2ms or less/100mA (24V DC)
		Extension blocks	For FX2Nc Series	0.2ms or less/100mA
			For FX2N/FX0N Series*1	0.2ms or less/200mA
	ON → OFF	Main units	Y000 to Y002	5μs or less/10mA or more (5-24 V DC)
			Y003 (FX3uc-□□MT/D)	0.2ms or less/100mA (24V DC)
			Y003 (FX3uc-32MT-LT(-2))	5μs or less/10mA or more (5-24 V DC)
			Y004 or later	0.2ms or less/100mA (24V DC)
Extension blocks		For FX2Nc Series	0.2ms or less/100mA	
		For FX2N/FX0N Series*1	0.2ms or less/200mA	
Circuit insulation			Photocoupler insulation	
Output operation display		FX3uc-□□MT/D, Extension blocks		LED on panel lights when photocoupler is driven.
		FX3uc-32MT-LT(-2)		Monitor by the display module
Output circuit configuration				

*1. The response time is as follows in the FX2N-8EYT-H and FX0N-8EYT-H.
 OFF → ON: 0.2ms or less/1A
 ON → OFF: 0.4ms or less/1A

6.2.2 Transistor Output Specifications (Source output type)

The table below shows the output specifications of the FX3UC-□□MT/DSS Main unit, FX2NC/FX2N output extension blocks (source output type).

Outputs in the main unit are restricted by the simultaneous ON ratio.

→ For the restriction in simultaneous ON ratio, refer to Subsection 6.2.3.

Item		Transistor output (source) specifications				
Number of output points	FX3UC-16MT/DSS		8 points			
	FX3UC-32MT/DSS		16 points			
	FX3UC-64MT/DSS		32 points			
	FX3UC-96MT/DSS		48 points			
	FX2N-8EYT-ESS/UL		8 points			
	FX2N-16EYT-ESS/UL, FX2NC-16EYT-DSS		16 points			
	FX2NC-32EYT-DSS		32 points			
Connecting type	FX3UC-□□MT/DSS, FX2NC output extension block,		Connector			
	FX2N output extension block		Terminal block			
Output type/form		Transistor/Source output				
External power supply		5-30 V DC				
Max. load	Resistance load	FX3UC-□□MT/DSS	Y000 to Y003	0.3A/1 point	Make sure that the total load current of 8 resistance load points is 0.8A*1 or less.	
			Y004 or later	0.1A/1 point		
		FX2NC-16EYT-DSS, FX2NC-32EYT-DSS		0.1A/1 point		Make sure that the total load current of 8 resistance load points is 0.8A or less.
		FX2N-8EYT-ESS/UL, FX2N-16EYT-ESS/UL		0.5A/1 point		The total load current of resistance loads per common terminal should be the following value. 4 points/common: 0.8A 8 points/common: 1.6A
	Inductive load	FX3UC-□□MT/DSS	Y000 to Y003	7.2W/1 point (24V DC)	Make sure that the total load of 16 inductive load points is 38.4 W/24 V DC or less.	
			Y004 or later	2.4W/1 point (24V DC)		
		FX2NC-16EYT-DSS, FX2NC-32EYT-DSS		2.4W/1 point (24V DC)		
		FX2N-8EYT-ESS/UL, FX2N-16EYT-ESS/UL		12W/1 point (24V DC)		
Open circuit leakage current		0.1mA or less/30V DC				
ON voltage		1.5V or less				
Response time	OFF → ON	FX3UC-□□MT/DSS	Y000 to Y002	5μs or less/10 mA or more (5-24 V DC)		
			Y003 or later	0.2ms or less/100mA (24V DC)		
		Extension blocks	For FX2NC Series	0.2ms or less/100mA		
			For FX2N Series	0.2ms or less/200mA		
	ON → OFF	FX3UC-□□MT/DSS	Y000 to Y002	5μs or less/10mA or more (5-24 V DC)		
			Y003 or later	0.2ms or less/100mA (24V DC)		
Extension blocks		For FX2NC Series	0.2ms or less/100mA			
		For FX2N Series	0.2ms or less/200mA			
Circuit insulation		Photocoupler insulation				
Output operation display		FX3UC-□□MT/DSS, Extension blocks		LED on panel lights when photocoupler is driven.		

*1. When the two +V□ terminals are connected outside the PLC, resistance load is 1.6A or less.

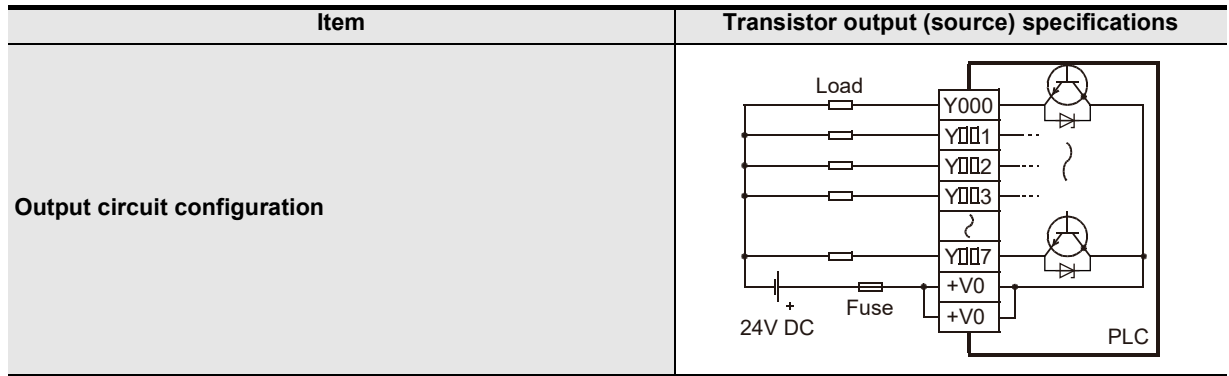

6.2.3 Output Derating Curve

The derating curve below shows the simultaneous ON ratio of available PLC inputs with respect to the ambient temperature. Use the PLC within the simultaneous input ON ratio range shown in the figure.

1. FX3uc-□□MT/D(SS)

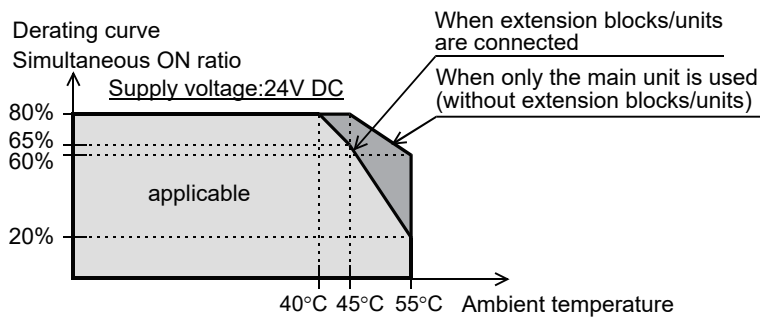

2. FX3uc-32MT-LT(-2)

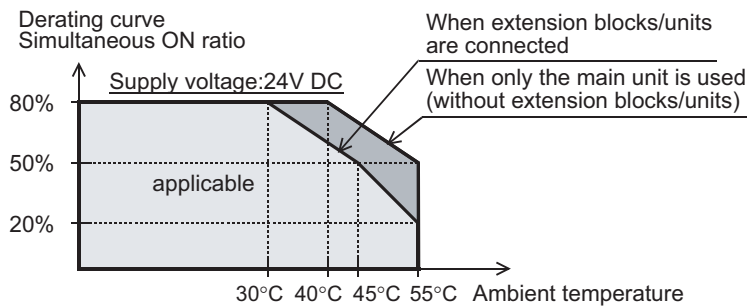

6.2.4 Handling of transistor output

1. Output terminals

4, 8 or 16 transistor output points are covered by one common terminal.

Sink output

Two COM□ terminals connected each other inside the PLC are provided for sink outputs in the FX3UC main unit, transistor output type extension blocks for FX2NC and FX2N-16EYT-C.

For external wiring, connect two COM□ terminals outside the PLC so that the load applied on each COM□ terminal becomes smaller.

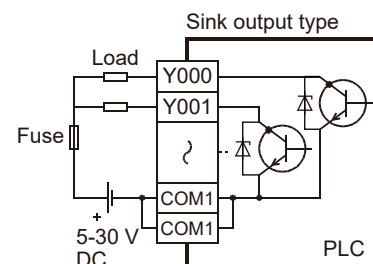

Source output

Two +V□ terminals (connected to each other inside the PLC) are provided for sink outputs in the FX3UC main unit, transistor output type extension blocks (source type) for the FX2NC.

For external wiring, connect two +V□ terminals outside the PLC so that the load applied on each +V□ terminal becomes smaller.

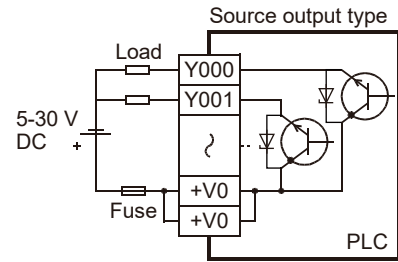

2. External power supply

For driving the load, use a smoothing power supply of 5-30 V DC that can output current two or more times the rated current of the fuse connected to the load circuit.

3. Insulation of circuit

The internal circuit of the PLC and the output transistor are insulated with a photocoupler. The common blocks are separated from one another.

4. Display of operation

Operation indicator LEDs are built into the main unit and output extension blocks, and turn ON when photocouplers are actuated. The FX3UC-32MT-LT(-2) does not have operation indicator LEDs, but the operation can be monitored with the display module.

5. Response time

The time from when the PLC drives (or shuts down) the photocoupler until the transistor is turned on (or off) is shown in the following table.

Classification		Response time	Load current	
Main units	Y000 to Y002	5 μs or less	5-24 V DC 10mA or more	When using an instruction related to pulse train output or positioning, make sure to set the load current to 10 to 100mA (5-24 V DC).
	Y003 (FX3UC-□□MT/D(SS))	0.2 ms or less	24V DC 100 mA*1	
	Y003 (FX3UC-32MT-LT(-2))	5 μs or less	5-24 V DC 10 mA or more	
	Y004 to Y017	0.2 ms or less	24V DC 100 mA *1	
Extension blocks	For FX2NC Series	0.2 ms or less	24V DC 100 mA *1	
	For FX0N/FX2N Series		24V DC 200 mA *1	

*1. The transistor OFF time is longer under lighter loads. For example, under a load of 24V DC 40mA, the response time is approx. 0.3ms. When response performance is required under light loads, provide a dummy resistor as shown below to increase the load current.

- Sink output type

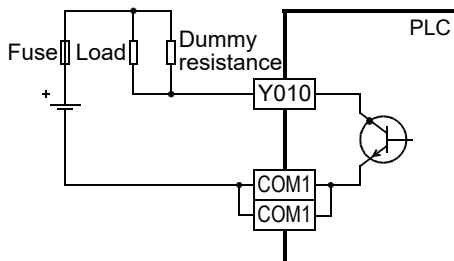

- Source output type

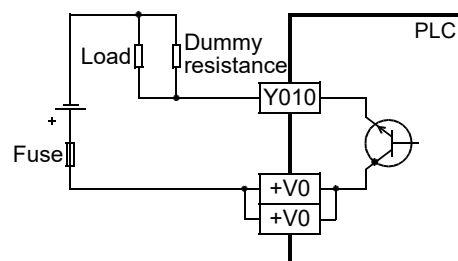

1 Outline
2 External Dimensions
3 Generic Specifications
4 Power Supply Specifications
5 Input Specifications
6 Output Specifications
7 Examples of Wiring for Various Uses
8 Terminal Block
9 CC-LINK/LT Master FX3UC-LT(-2) only
10 Display module FX3UC-LT(-2) only

6. Output current

The ON voltage of the output transistor is approx. 1.5V.

When driving a semiconductor element, carefully check the input voltage characteristics of the applied element.

	Model	Output current	Limitation
Main units	Y000 to Y003	0.3A/1 point*1	Make sure that the total load current of resistance loads per common terminal (16 points/common) is 1.6A so that temperature rise is restrained.
	Y004 or later	0.1A/1 point	
Extension blocks	FX ₂ NC-16EYT(-DSS) FX ₂ NC-32EYT(-DSS)	0.1A/1 point	Make sure that the total load current of 8 resistance load points is 0.8A or less.
	FX ₂ N-16EYT-C	0.3A/1 point	Make sure that the total load current of 16 resistance load points is 1.6A or less.
	FX ₂ N-8EYT(-ESS/UL) FX ₀ N-8EYT FX ₂ N-16EYT(-ESS/UL) FX ₀ N-16EYT	0.5A/1 point	The total load current of resistance loads per common terminal should be the following value. 4 points/common: 0.8A 8 points/common: 1.6A
	FX ₂ N-8EYT-H FX ₀ N-8EYT-H	1A/1 point	Make sure that the total load current of 4 resistance load points is 2A or less.

*1. When using an instruction related to pulse train output or positioning, make sure to set the load current to 10 to 100mA (5-24 V DC).

7. Open circuit leakage current

0.1mA or less

6.2.5 External wiring precautions

1. Protection circuit for load short-circuits

A short-circuit at a load connected to an output terminal could cause burnout at the output element or the PCB. To prevent this, a protection fuse should be inserted at the output.
 Use a load power supply capacity that is at least 2 times larger than the total rated fuse capacity.

- External Wiring of Sink Output Type

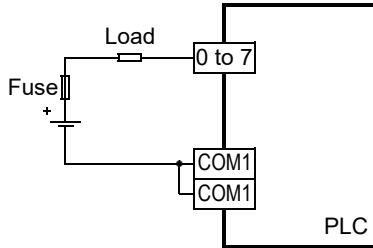

- External Wiring of Source Output Type

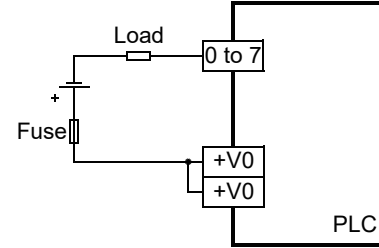

2. Contact protection circuit for inductive loads

When an inductive load is connected, connect a diode (for commutation) in parallel with the load as necessary.
 The diode (for commutation) must comply with the following specifications.

Reverse voltage	5 to 10 times of the load voltage
Forward current	Load current or more

- External Wiring of Sink Output Type

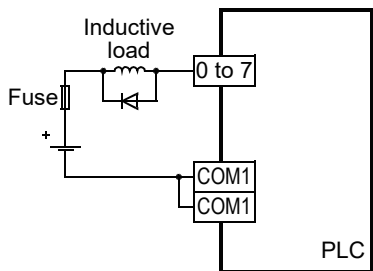

- External Wiring of Source Output Type

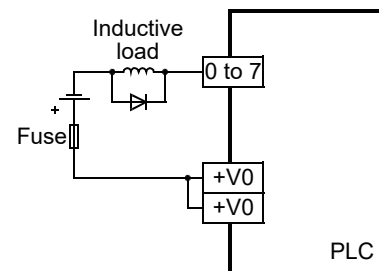

3. Interlock

For loads such as forward/reverse contactors, etc., where a hazardous condition could result if switched ON simultaneously, an external interlock should be provided for interlocking the PLC's internal programs, as shown to the following figure.

- External Wiring of Sink Output Type

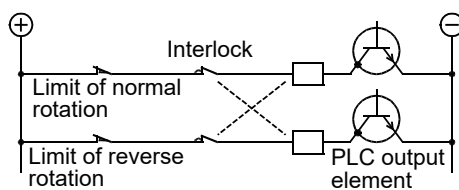

- External Wiring of Source Output Type

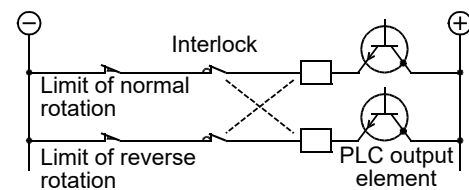

1	Outline
2	External Dimensions
3	Generic Specifications
4	Power Supply Specifications
5	Input Specifications
6	Output Specifications
7	Examples of Wiring for Various Uses
8	Terminal Block
9	CC-LINK/MT Master FX3UC-LT(-2) only
10	Display module FX3UC-LT(-2) only

6.2.6 Example of external wiring

1. Transistor output (Sink)

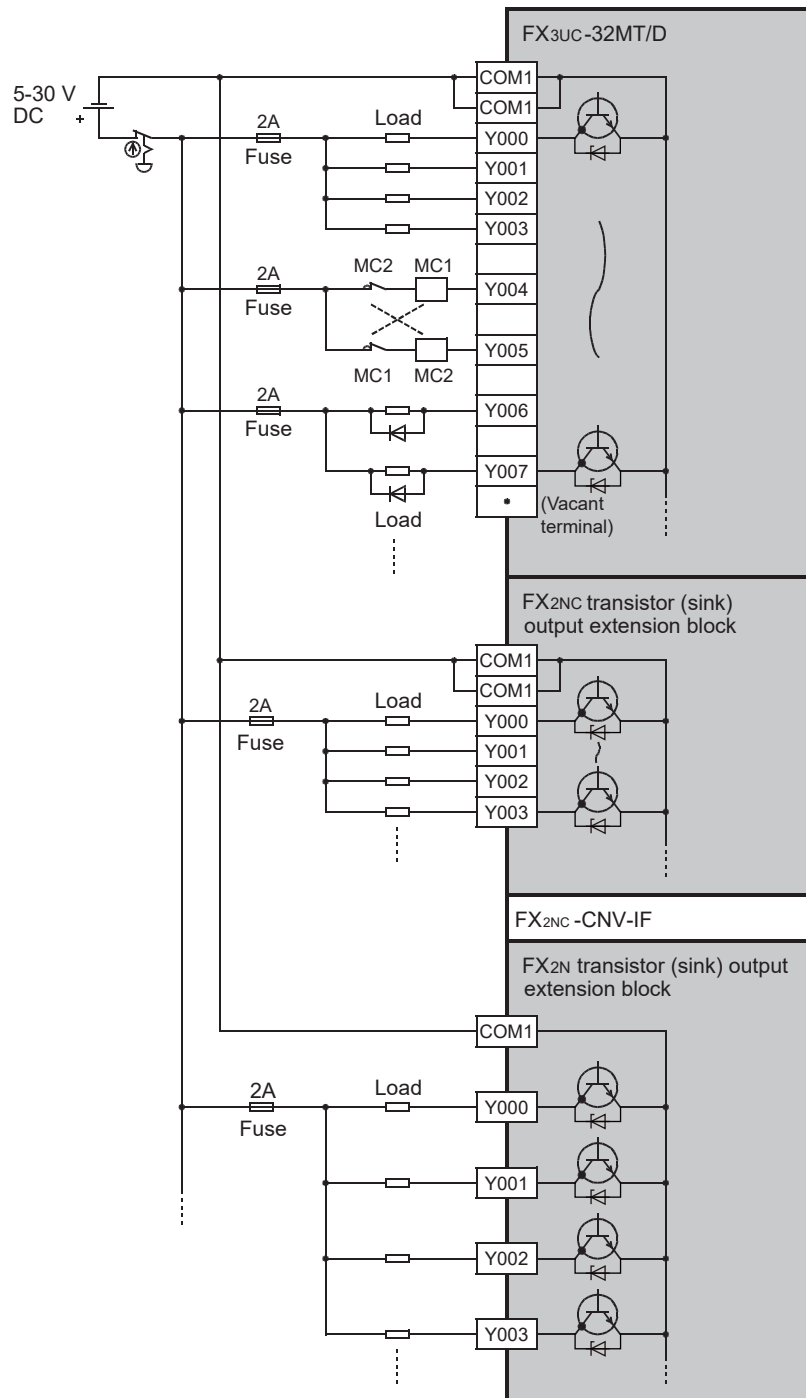

WIRING PRECAUTIONS



- Before cleaning or retightening terminals cut off all phases of the power supply externally. Failure to do so may cause electric shock.

2. Transistor output (Source)

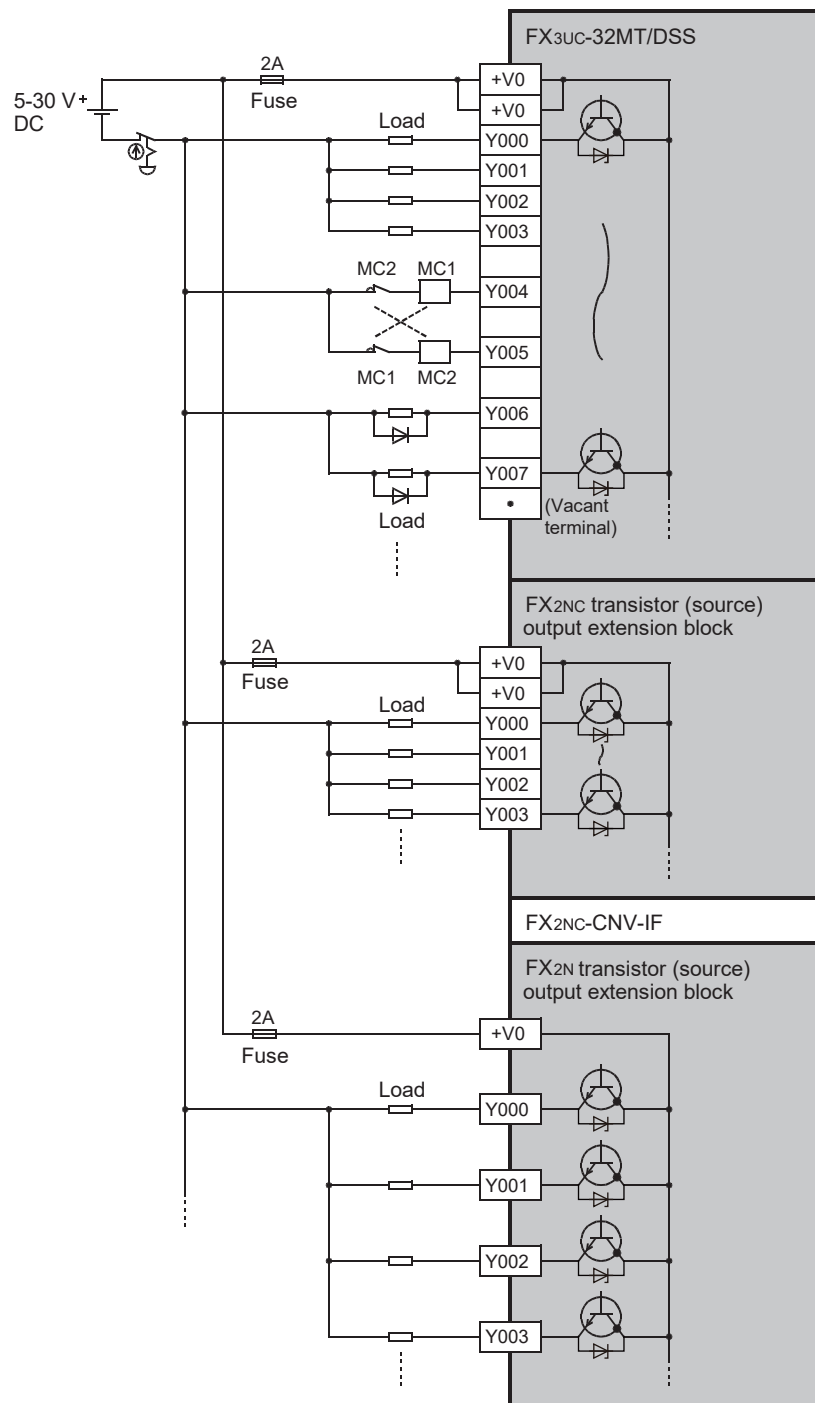

WIRING PRECAUTIONS



- Before cleaning or retightening terminals cut off all phases of the power supply externally. Failure to do so may cause electric shock.

1	Outline
2	External Dimensions
3	Generic Specifications
4	Power Supply Specifications
5	Input Specifications
6	Output Specifications
7	Examples of Wiring for Various Uses
8	Terminal Block
9	CC-Link/LT Master FX3UC-LT(-2) only
10	Display module FX3UC-LT(-2) only

6.3 Relay Output

6.3.1 Relay output specifications

The table below shows the output specifications of the FX3UC-16MR/D(S)-T Main unit and FX2NC/FX2N/FX0N extension blocks (relay output type).

Outputs in the main unit are restricted by the simultaneous ON ratio.

→ For the restriction in simultaneous ON ratio, refer to Subsection 6.3.2.

Item		Relay output specification	
Number of output points	FX3UC-16MR/D(S)-T	8 points	
	FX2NC-16EYR-T(-DS)	16 points	
	FX2N-8ER(-ES/UL)	4 points	
	FX0N-8ER	4 points	
	FX2N-8EYR(-ES/UL)	8 points	
	FX2N-8EYR-S-ES/UL	8 points	
	FX0N-8EYR	8 points	
	FX2N-16EYR(-ES/UL)	16 points	
	FX0N-16EYR	16 points	
Connecting type	FX3UC-16MR/D(S)-T	Terminal block	
	FX2NC-16EYR-T(-DS)		
	FX2N-8ER(-ES/UL)		
	FX0N-8ER		
	FX2N-8EYR(-ES/UL)		
	FX2N-8EYR-S-ES/UL		
	FX0N-8ER		
	FX2N-16EYR(-ES/UL)		
	FX0N-16EYR		
External power supply		30V DC or less or 240V AC or less (250V AC or less when the unit does not comply with CE, UL or cUL standards)	
Max.load	Resistance load	FX3UC-16MR/D(S)-T FX2NC-16EYR-T (-DS)	2A/1 point When using one COM□ terminal, make sure that the total load current of 4 or 8 resistance load points is 4 A or less. When connecting two COM□ terminals outside the PLC, make sure that the total load current of 8 resistance load points is 8A or less.
		FX2N-8ER(-ES/UL) FX0N-8ER FX2N-8EYR(-ES/UL) FX2N-8EYR-S-ES/UL FX0N-8EYR FX2N-16EYR(-ES/UL) FX0N-16EYR	2A/1 point The total resistance load current per common should be as follows: 4 output points/common: 8A or less 8 output points/common: 8A or less
	Inductive load	FX3UC-16MR/D(S)-T FX2NC-16EYR-T(-DS) FX2N-8ER(-ES/UL) FX0N-8ER FX2N-8EYR(-ES/UL) FX2N-8EYR-S-ES/UL FX0N-8EYR FX2N-16EYR(-ES/UL) FX0N-16EYR	80VA For the product life, refer to Subsection 6.3.2. For cautions on external wiring, refer to Subsection 6.3.4
Minimum load		5V DC, 2mA (reference values)	
Open circuit leakage current		-	

Item		Relay output specification
Response time	OFF → ON	Approx. 10 ms
	ON → OFF	Approx. 10 ms
Circuit insulation		Mechanical insulation
Display of output operation		Supplying power to the relay coil will light the LED indicator lamp on panel.
Output circuit diagram		

6.3.2 Output Derating Curve

The derating curve below shows the simultaneous ON ratio of available PLC outputs with respect to the ambient temperature. Use the PLC within the simultaneous output ON ratio range shown in the figure.

- FX3uc-16MR/D(S)-T**

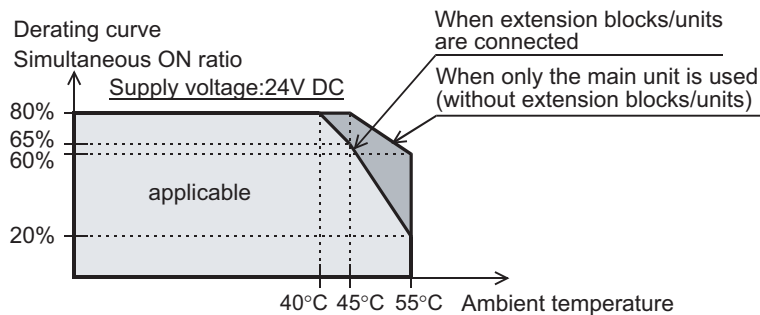

1	Outline
2	External Dimensions
3	Generic Specifications
4	Power Supply Specifications
5	Input Specifications
6	Output Specifications
7	Examples of Wiring for Various Uses
8	Terminal Block
9	CC-Link/LT Master FX3uc-LT(-2) only
10	Display module FX3uc-LT(-2) only

6.3.3 Product life of relay contacts

The product life of relay contacts varies considerably depending on the load type used. Take care that loads generating reverse electromotive force or rush current may cause poor contact or deposition of contacts which may lead to considerable reduction of the contact product life.

1. Inductive load

Inductive loads generate large reverse electromotive force between contacts at shutdown, which may cause arcing. At a fixed current consumption, as the power factor (phase between current and voltage) gets smaller, the arc energy gets larger.

The standard life of contacts used for Inductive loads, such as contactors and solenoid valves, is 500,000 operations at 20VA.

The following table shows the approximate life of a relay based on the results of an operation life test.

Test condition: 1 sec. ON/1 sec. OFF

Load capacity		Contact life
20 VA	0.2A/100V AC	3,000,000 times
	0.1A/200V AC	
35 VA	0.35A/100V AC	1,000,000 times
	0.17A/200V AC	
80 VA	0.8A/100V AC	200,000 times
	0.4A/200V AC	

The product life of relay contacts becomes considerably shorter than the above conditions when the rush over current is shut down.

→ **For precautions on using inductive loads, refer to Subsection 6.3.4-2.**

Some types of inductive loads generate rush current 5 to 15 times the stationary current at activation. Make sure that the rush current does not exceed the current corresponding to the maximum specified resistance load.

2. Lamp load

Lamp loads generally generate rush current 10 to 15 times the stationary current. Make sure that the rush current does not exceed the current corresponding to the maximum specified resistance load.

3. Capacitive load

Capacitive loads can generate rush current 20 to 40 times the stationary current. Make sure that the rush current does not exceed the current corresponding to the maximum specified resistance load. Capacitive loads such as capacitors may be present in electronic circuit loads including inverters.

→ **For the maximum specified resistance load, refer to Subsection 6.3.1.**

6.3.4 Handling of relay output

1. Output terminal

One common terminal is used for 1, 4 or 8 relay output points. The common terminal blocks can drive loads of different circuit voltage systems (for example, 200V AC, 100V AC and 24V DC).

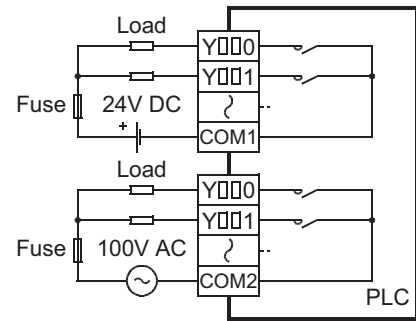

The FX2NC-16EYR-T(-DS) has two COM terminals per 8 output points. Connect two COM terminals outside the PLC so that the load applied on each COM terminal becomes smaller.

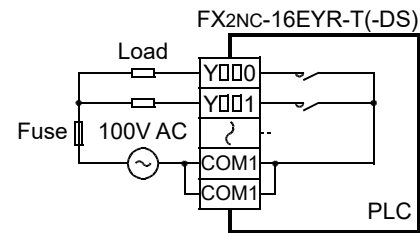

2. External power supply

Use an external power supply of 30V DC or less or 240V AC or less (250V AC or less when the unit does not comply with CE, UL or cUL standards) for loads.

3. Circuit insulation

The PLC internal circuit and external load circuits are electrically insulated between the output relay coil and contact. The common terminal blocks are separated from one another.

4. Display of operation

When power is applied to the output relay coil, the LED is lit, and the output contact is turned on.

5. Response time

The response time of the output relay from when the power is applied to the coil until the output contact is turned on and from when the coil is shut off until the output contact is turned off is approx. 10ms.

6. Output current

At a circuit voltage of 240V AC or less (250V AC or less when the unit does not comply with CE, UL or cUL standards), a resistance load of 2A per point or an inductive load of 80VA or less (100V AC or 200V AC) can be driven.

→ For the life of the contact for switching an inductive load, refer to Subsection 6.2.2.

When an inductive load is switched, connect a diode (for commutation) or a surge absorber in parallel with this load.

DC circuit	Diode (for commutation)
AC circuit	Surge absorber

7. Open circuit leakage current

Because there is no leakage current even while output contacts are OFF, the neon ball, etc. can be driven directly.

6.3.5 External wiring precautions

1. Protection circuit for load short-circuiting

A short-circuit at a load connected to an output terminal could cause burnout at the output element or the PCB. To prevent this, a protection fuse should be inserted at the output.

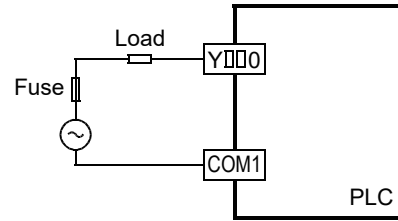

2. Contact protection circuit for inductive loads

An internal protection circuit for the relays is not provided for the relay output circuit. It is recommended to use inductive loads with built-in protection circuits. When using loads without built-in protection circuits, insert an external contact protection circuit, etc. to reduce noise and extend the product life.

1) DC circuit

Connect a diode in parallel with the load. The diode (for commutation) must comply with the following specifications.

Item	Guide
Reverse voltage	5 to 10 times the load voltage
Forward current	Load current or more

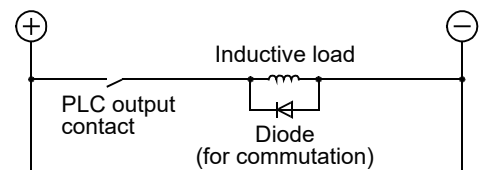

2) AC circuit

Connect the surge absorber (combined CR components such as a surge killer and spark killer, etc.) parallel to the load. Select the rated voltage of a surge absorber that is suitable for the load being used. Refer to the table below for other specifications.

Item	Guide
Electrostatic capacity	Approx. 0.1μF
Resistance value	Approx. 100 to 200Ω

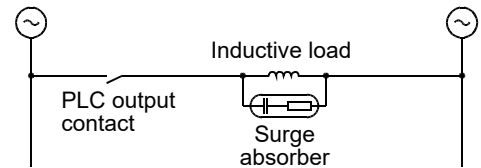

Reference

Manufacturer	Model name	Manufacturer	Model name
Okaya Electric Industries Co., Ltd.	CR-10201	Rubycon Corporation	250MCRA104100M B0325

3. Interlock

For loads such as forward/reverse contactors, etc., where a hazardous condition could result if switched ON simultaneously, an external interlock should be provided for interlocking the PLC's internal programs as shown to the right.

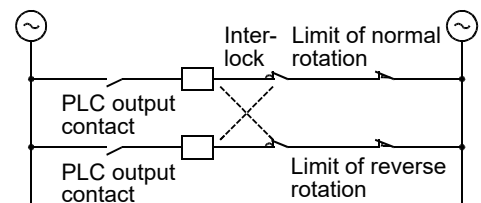

4. In-phase

PLC output contacts (*) should be used in an "in-phase" manner.



6.3.6 Example of external wiring

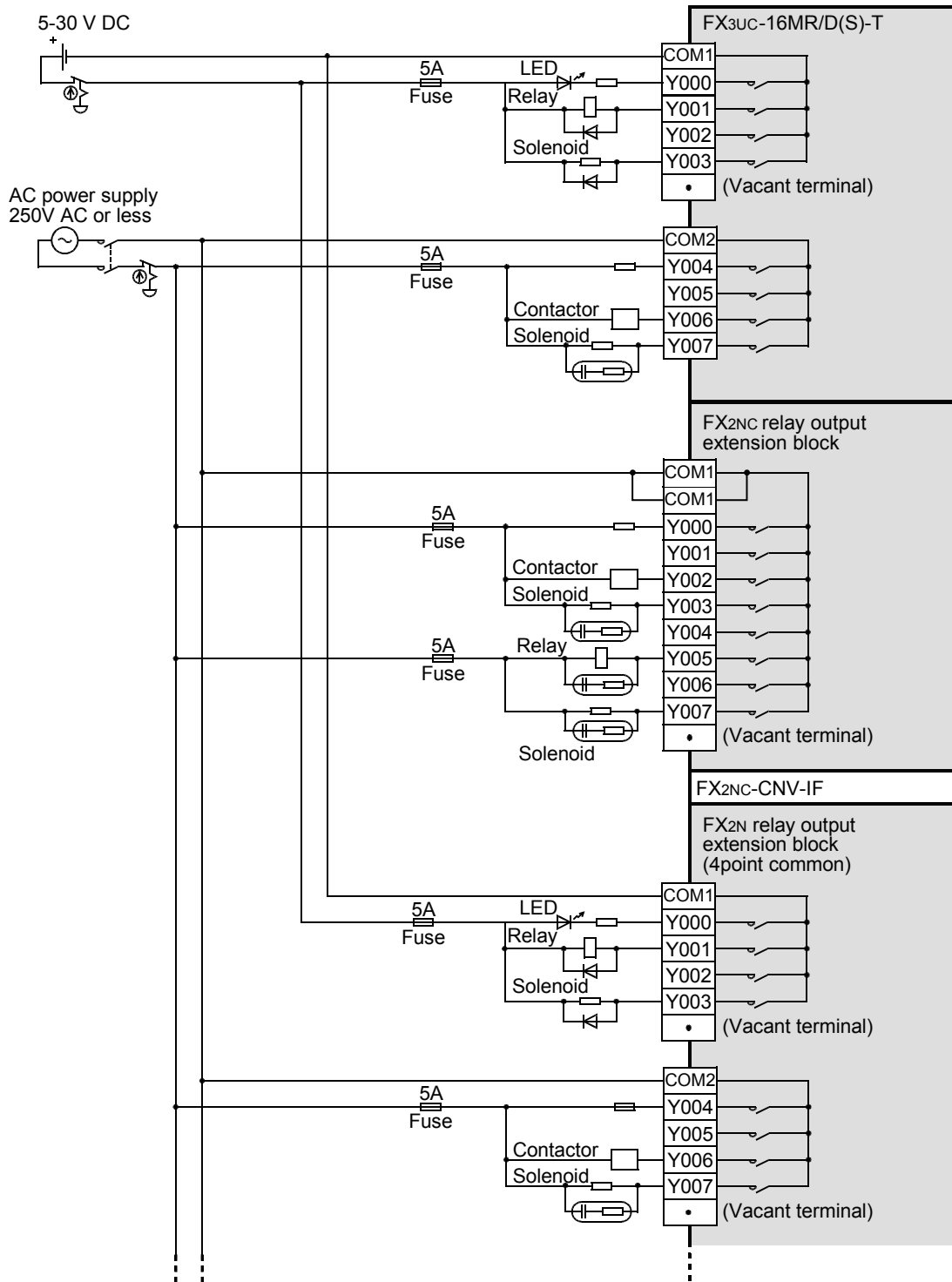

WIRING PRECAUTIONS

CAUTION

- Before cleaning or retightening terminals cut off all phases of the power supply externally. Failure to do so may cause electric shock.

1	Outline
2	External Dimensions
3	Generic Specifications
4	Power Supply Specifications
5	Input Specifications
6	Output Specifications
7	Examples of Wiring for Various Uses
8	Terminal Block
9	CC-Link/LT Master FX3UC-LT(-2) only
10	Display module FX3UC-LT(-2) only

6.4 Triac (SSR) Output [FX2N-16EYS]

6.4.1 Specifications

Item	Triac output specification	
Output circuit diagram		
External power supply	85 to 242V AC	
Max.load	Resistance load	0.3A/point The total load current per common should be as follows: 8 output points/common: 0.8A or less
	Inductive load	15VA/100V AC 36VA/200V AC
Minimum load	0.4VA/100V AC, 1.6VA/200V AC	
Open circuit leakage current	1mA/100V AC, 2mA/200V AC	
Response time	OFF → ON	1ms or less
	ON → OFF	10ms or less
Circuit insulation	Photo-thyristor insulation	
Display of output operation	LED on panel lights when photo-thyristor is driven.	

6.4.2 Handling of triac output

1. Output terminals

On the triac output type units/blocks, one common terminal is used for 8 points.
 Therefore, the common terminal blocks can drive loads of different circuit voltage systems (for example, 100V AC and 200V AC).

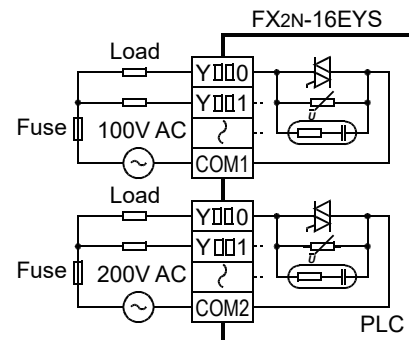

2. Circuit insulation

The PLC internal circuit and the output element (triac) are insulated with a photo-thyristor.
 The common terminal blocks are separate from one another.

3. Display of operation

When the photo-thyristor is driven, the LED is lit, and the output triac is turned on.

4. Response time

The time from when the photo-thyristor is driven or shut down until the output triac is turned on and until it is turned off is 1ms or less and 10ms or less, respectively.

5. Output current

The max current per output point is 0.3A. However, to restrict temperature rise, the max current per one output from four points should be 0.8A (average per point is 0.2A).
When a load with high rush current is turned on and off frequently, the root-mean-square current should be 0.2A or less.

<Example>

$$\sqrt{\frac{4^2 \times 0.02 + 0.4^2 \times 0.7}{0.02 + 0.7 + 10}} = 0.2A$$

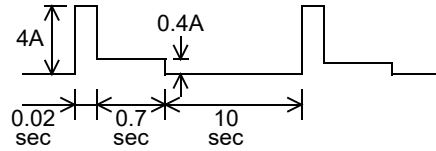

6. Open circuit leakage current

A C-R absorber is connected for turn-off in parallel with the triac output terminal of this type of PLC. Therefore, when the circuit opens, a leakage current will be 1mA at 100V AC and 2mA at 200V AC.

Since the triac output type devices leak current when the circuits are open, small-size relays and micro current loads having low rated operating current may keep operating even when the triac output is turned off. Therefore, use a load of 0.4VA or more at 100V AC or 1.6VA or more at 200V AC. If the load is less than this value, connect a surge absorber as stated below in parallel with the load.

→ For the connection of the surge absorber, refer to Subsection 6.4.3 "External wiring precaution".

6.4.3 External wiring precautions

1. Protection circuit for load short-circuits

A short-circuit at a load connected to an output terminal could cause burnout at the output element or the PCB. To prevent this, a protection fuse should be inserted at the output.

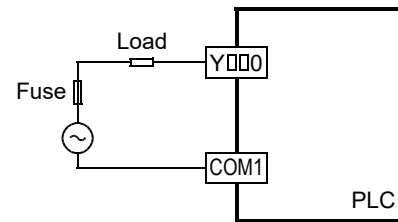

2. Micro current load

The PLC's internal Triac output circuit is equipped with a turn-off C-R absorber. When connecting a very low current load of "0.4VA/100V AC or less, or 1.6VA/200V AC or less", please connect a surge absorber parallel to the load.
Select the rated voltage of a surge absorber that is suitable for the load being used. Refer to the table below for other specifications.

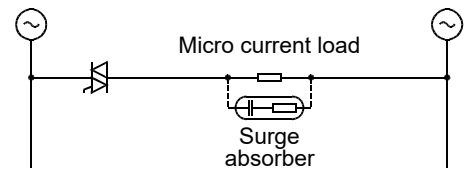

Item	Standard
Static electricity capacity	Approx. 0.1μF
Resistance value	Approx. 100 to 200Ω

Reference

Manufacturer	Model name	Manufacturer	Model name
Okaya Electric Industries Co., Ltd.	CR-10201	Rubycon Corporation	250MCRA104100M B0325

3. Interlock

For loads such as forward/reverse contactors, etc., where a hazardous condition could result if switched ON simultaneously, an external interlock should be provided for interlocking the PLC's internal programs as shown to the right.

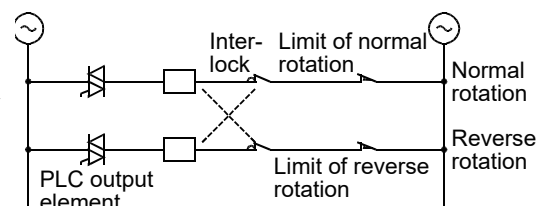

1	Outline
2	External Dimensions
3	Generic Specifications
4	Power Supply Specifications
5	Input Specifications
6	Output Specifications
7	Examples of Wiring for Various Uses
8	Terminal Block
9	CC-Link/LT Master FX3UC-LT(-Z) only
10	Display module FX3UC-LT(-Z) only

4. In-phase

PLC output contacts (*) should be used in an "in-phase" manner.

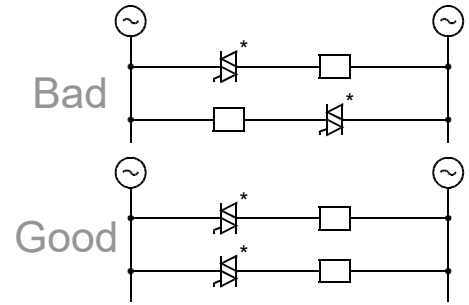

6.4.4 Example of external wiring

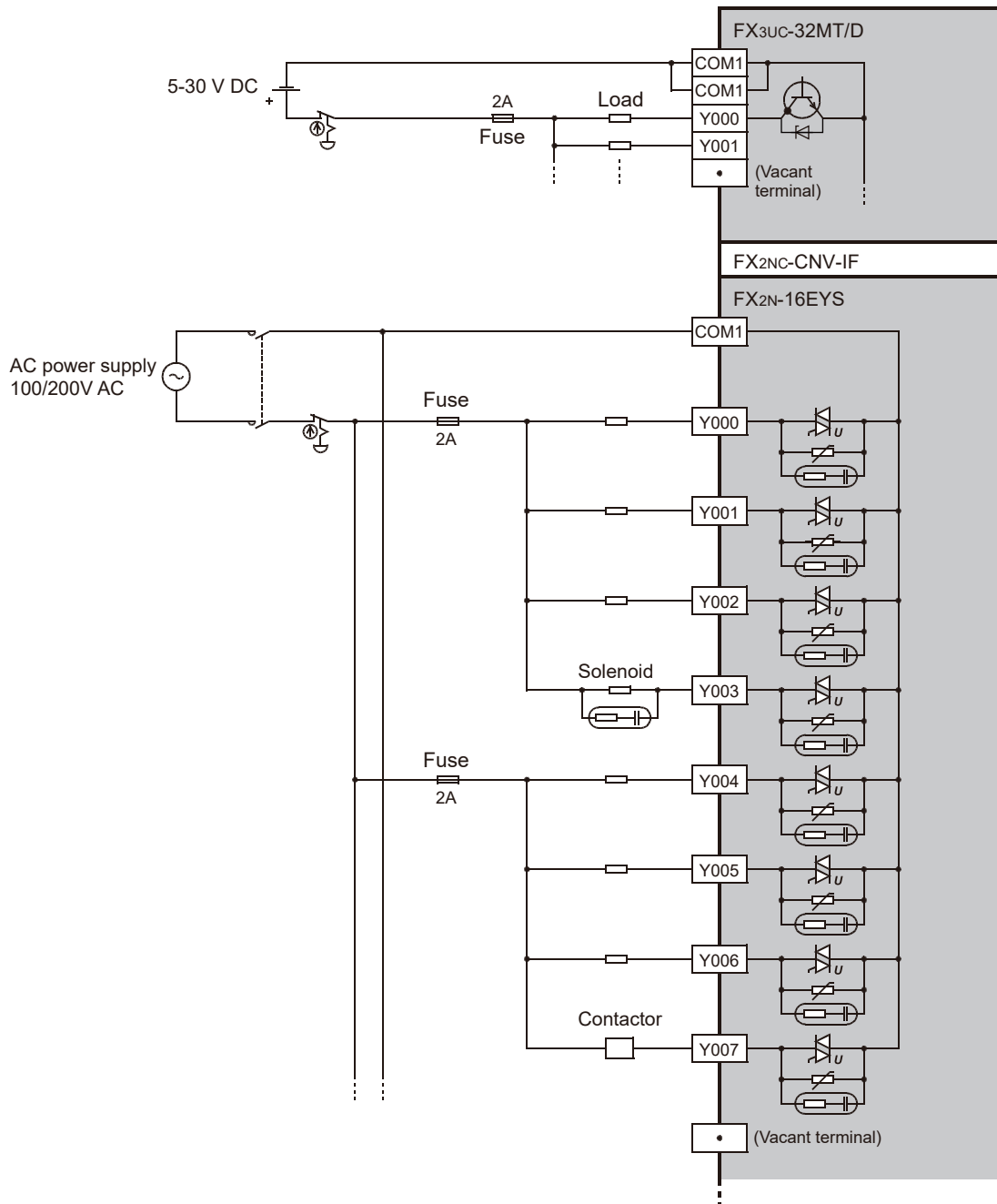



WIRING PRECAUTIONS **CAUTION**

- Before cleaning or retightening terminals cut off all phases of the power supply externally. Failure to do so may cause electric shock.

7. Examples of Wiring for Various Uses

DESIGN PRECAUTIONS	 WARNING
<ul style="list-style-type: none"> • Make sure to have the following safety circuits outside of the PLC to ensure safe system operation even during external power supply problems or PLC failure. Otherwise, malfunctions may cause serious accidents. <ol style="list-style-type: none"> 1) Most importantly, have the following: an emergency stop circuit, a protection circuit, an interlock circuit for opposite movements (such as normal vs. reverse rotation), and an interlock circuit (to prevent damage to the equipment at the upper and lower positioning limits). 2) Note that when the PLC CPU detects an error, such as a watchdog timer error, during self-diagnosis, all outputs are turned off. Also, when an error that cannot be detected by the PLC CPU occurs in an input/output control block, output control may be disabled. External circuits and mechanisms should be designed to ensure safe machinery operation in such a case. 3) Note that when an error occurs in a relay, triac or transistor output device, the output could be held either on or off. For output signals that may lead to serious accidents, external circuits and mechanisms should be designed to ensure safe machinery operation in such a case. • Note that when an error occurs in a remote I/O unit, the output could be held either on or off. For output signals that may lead to serious accidents, external circuits for monitoring should be provided. 	

DESIGN PRECAUTIONS	 CAUTION
<ul style="list-style-type: none"> • Do not bundle the control line and CC-Link/LT connection cables together with or lay them close to the main circuit or power line. As a guideline, lay the control line and CC-Link/LT connection cables at least 100mm (3.94") or more away from the main circuit or power line. Noise may cause malfunctions. • Install the product so that excessive force will not be applied to peripheral device connectors, power connectors, input/output connectors, CC-Link/LT interface connectors or CC-Link/LT connection cables. Failure to do so may result in wire damage/breakage or PLC failure. 	

SECURITY PRECAUTIONS	 WARNING
<ul style="list-style-type: none"> • To maintain the security (confidentiality, integrity, and availability) of the programmable controller and the system against unauthorized access, denial-of-service (DoS) attacks, computer viruses, and other cyberattacks from unreliable networks and devices via network, take appropriate measures such as firewalls, virtual private networks (VPNs), and antivirus solutions. 	

WIRING PRECAUTIONS	 WARNING
<ul style="list-style-type: none"> • Make sure to cut off all phases of the power supply externally before attempting installation or wiring work. Failure to do so may cause electric shock or damage to the product. • Make sure to attach the terminal cover, offered as an accessory, before turning on the power or initiating operation after installation or wiring work. Failure to do so may cause electric shock. • The temperature rating of the cable should be 80°C or more. 	

1	Outline
2	External Dimensions
3	Generic Specifications
4	Power Supply Specifications
5	Input Specifications
6	Output Specifications
7	Examples of Wiring for Various Uses
8	Terminal Block
9	CC-Link/LT Master FX3uc-LT(-2) only
10	Display module FX3uc-LT(-2) only

WIRING PRECAUTIONS



- Connect the DC power supply wiring to the dedicated terminals described in this manual.
If an AC power supply is connected to a DC input/output terminal or DC power supply terminal, the PLC will burn out.
- Do not wire vacant terminals externally.
Doing so may damage the product.
- Perform class D grounding (grounding resistance: 100Ω or less) to the grounding terminal on the main unit.
Do not use common grounding with heavy electrical systems.
- Make sure to properly wire the FX0N/FX2N/FX3U Series extension equipment in accordance with the following precautions.
Failure to do so may cause electric shock, equipment failures, a short-circuit, wire breakage, malfunctions, or damage to the product.
 - The disposal size of the cable end should follow the dimensions described in the manual.
 - Tightening torque should follow the specifications in the manual.
 - Tighten the screws using a Phillips-head screwdriver No.2 (shaft diameter 6mm (0.24") or less). Make sure that the screwdriver does not touch the partition part of the terminal block.
- Make sure to properly wire to the terminal block (European type) in accordance with the following precautions.
Failure to do so may cause electric shock, equipment failures, a short-circuit, wire breakage, malfunctions, or damage to the product.
 - The disposal size of the cable end should follow the dimensions described in the manual.
 - Tightening torque should follow the specifications in the manual.
 - Twist the end of strand wire and make sure that there are no loose wires.
 - Do not solder-plate the electric wire ends.
 - Do not connect more than the specified number of wires or electric wires of unspecified size.
 - Affix the electric wires so that neither the terminal block nor the connected parts are directly stressed.
- Make sure to properly wire to the FX Series terminal blocks in accordance with the following precautions.
Failure to do so may cause electric shock, equipment failures, a short-circuit, wire breakage, malfunctions, or damage to the product.
 - The disposal size of the cable end should follow the dimensions described in the manual.
 - Tightening torque should follow the specifications in the manual.
 - Tighten the screws using a Phillips-head screwdriver No.2 (shaft diameter 6mm (0.24") or less). Make sure that the screwdriver does not touch the partition part of the terminal block.

7.1 Notes about Examples of Wiring

The examples of wiring are given under the following conditions.

→ **For the example of positioning wiring, refer to the Positioning Control Edition.**

- The input/output numbers are the actual numbers on the program. (They may differ from the numbers shown on the product terminals.)
- Product input/output specifications
Check the product input/output specifications when using any example of wiring.
 - Products only for sink input and products both for sink input and for source input are available.
 - Products for sink output and products for source output are available of transistor.
- The examples of programming (applied instructions) are given based on the allocation of the input/output numbers for wiring.

→ **For the applied instructions, refer to the Programming Manual.**

7.2 Rotary Encoder [High-speed Counters C235 to C255]

7.2.1 1-phase 1-input [C235 to C245]

The following examples of wiring apply to the cases where C235 is used. When another high-speed counter number is used, wire the counter referring to the following diagrams.

→ For input allocation in high-speed counters, refer to Subsection 5.5.2.

Caution

As connecting cables, use shielded twisted-pair cables. Ground the shield of each shielded cable only on the PLC side.

When pulses having a response frequency of 50 to 100kHz are captured to the high-speed counter using the input terminals X000 to X005, wire the counter as stated below.

- The wiring length should be 5m (16'4") or less.
- Connect a bleeder resistance of 1.5kΩ (1W or more) to the input terminal, so that the sum of the load current of the open collector transistor output on the mating device side and the input current of the main unit is 20mA or more.

1. NPN open collector transistor output rotary encoder

- 1) FX3UC-□□MT/D, FX3UC-16MR/D-T, FX3UC-32MT-LT(-2)

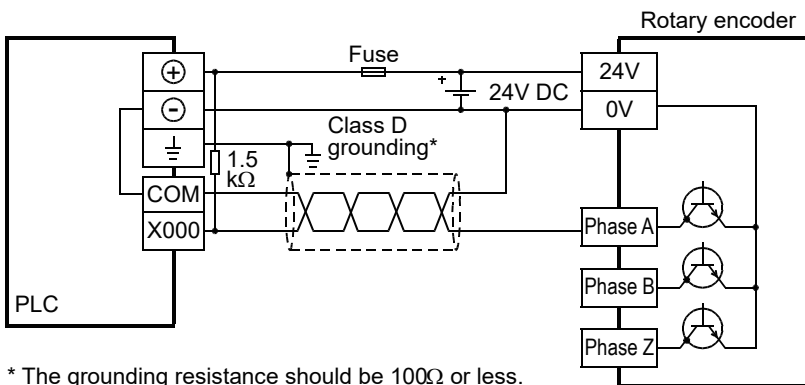

* The grounding resistance should be 100Ω or less.

- 2) FX3UC-□□MT/DSS, FX3UC-16MR/DS-T [Sink input wiring]

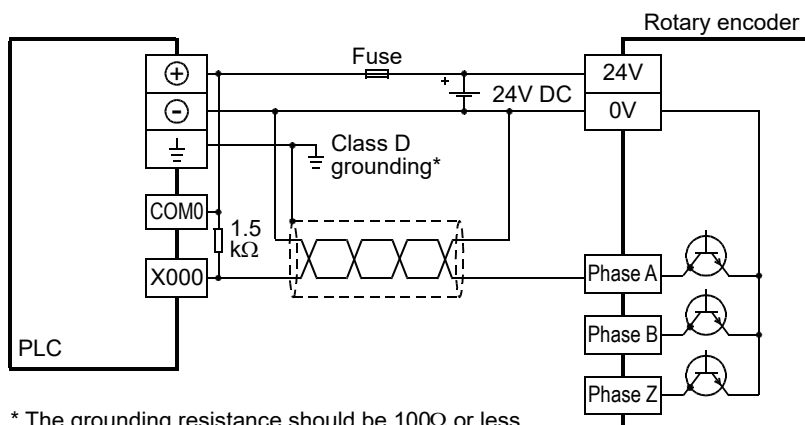

* The grounding resistance should be 100Ω or less.

2. PNP open collector transistor output rotary encoder
 FX3UC-□□MT/DSS, FX3UC-16MR/DS-T [Source input wiring]

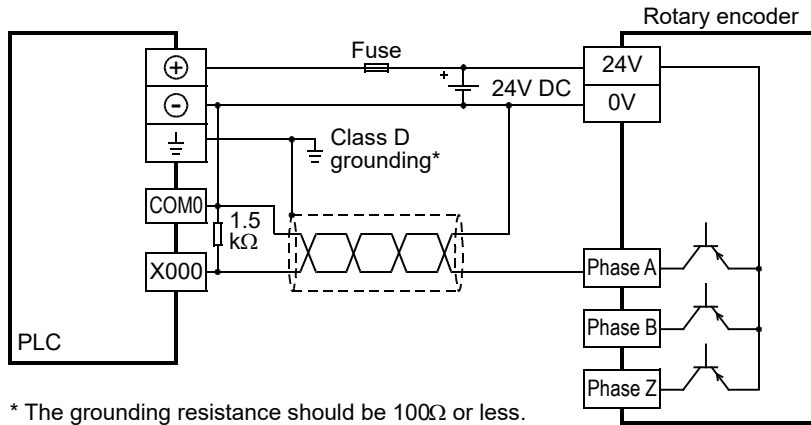

* The grounding resistance should be 100Ω or less.

7.2.2 2-phase 2-input [C251 to C255]

The following examples of wiring apply to the cases where C251 is used. When another high-speed counter number is used, wire the counter referring to the following diagrams.

→ For input allocation in high-speed counters, refer to Subsection 5.5.2.

Caution

As connecting cables, use shielded twisted-pair cables. Ground the shield of each shielded cable only on the PLC side.

When pulses having a response frequency of 50 to 100kHz are captured to the high-speed counter using the input terminals X000 to X005, wire the counter as stated below.

- The wiring length should be 5m (16.4") or less.
- Connect a bleeder resistance of 1.5kΩ (1W or more) to the input terminal, so that the sum of the load current of the open collector transistor output on the mating device side and the input current of the main unit is 20mA or more.

1. NPN open collector transistor output rotary encoder

1) FX3UC-□□MT/D, FX3UC-16MR/D-T, FX3UC-32MT-LT(-2)

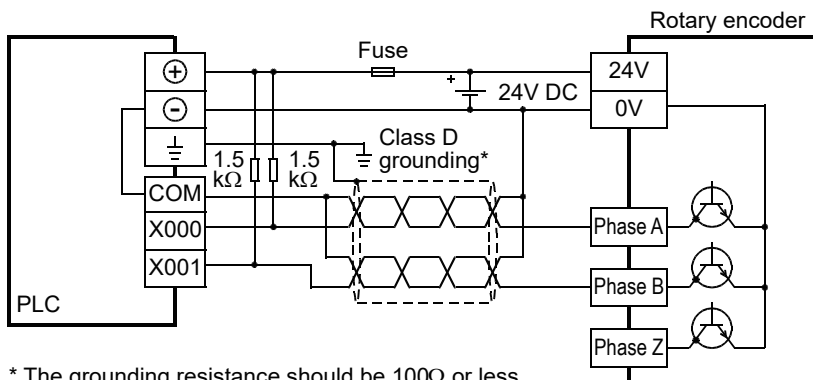

* The grounding resistance should be 100Ω or less.

2) FX3UC-□□MT/DSS, FX3UC-16MR/DS-T [Sink input wiring]

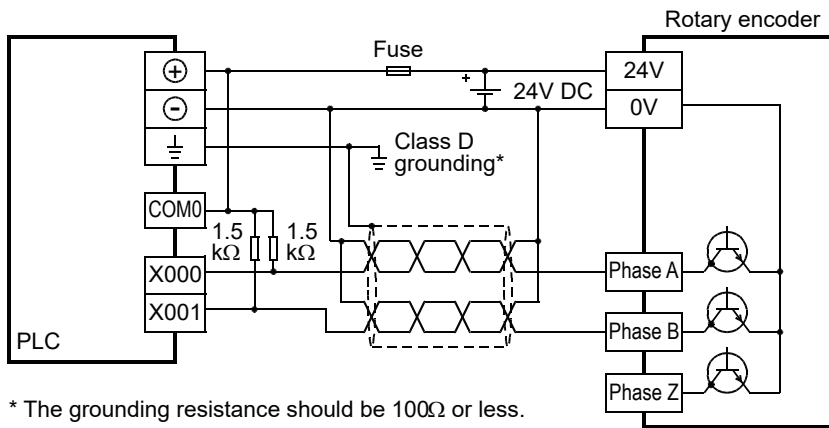

* The grounding resistance should be 100Ω or less.

2. PNP open collector transistor output rotary encoder

FX3UC-□□MT/DSS, FX3UC-16MR/DS-T [Source input wiring]

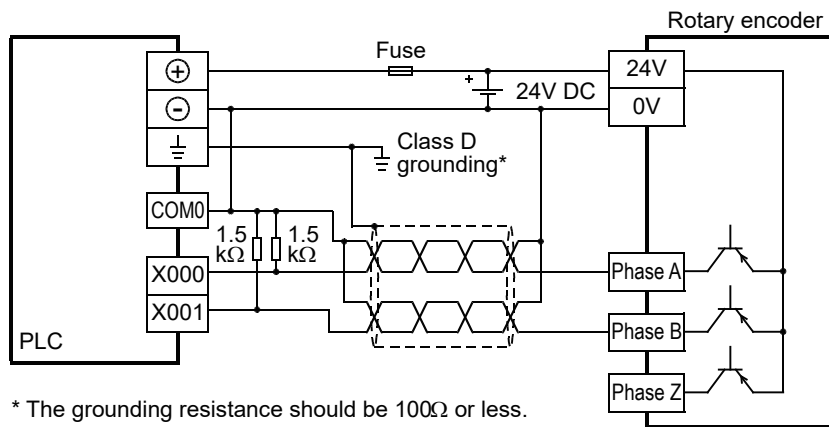

* The grounding resistance should be 100Ω or less.

1	Outline
2	External Dimensions
3	Generic Specifications
4	Power Supply Specifications
5	Input Specifications
6	Output Specifications
7	Examples of Wiring for Various Uses
8	Terminal Block
9	CC-Link/LT Master FX3UC-LT(-2) only
10	Display module FX3UC-LT(-2) only

7.3 Input Interruption - With Delay Function, Pulse Catch

This section shows wiring examples for input interruption (I000 or I001) using X000.

When using another input interruption or pulse catch, perform wiring in reference to the figures below.

→ For input allocation in input interruption, refer to Section 5.6.

→ For input allocation in pulse catch, refer to Section 5.7.

Caution

Use shielded twisted-pair cables for connecting cables.

Ground the shield of each shielded cable only on the PLC side.

Observe the following items for input interruption or pulse catch using the inputs X000 to X005.

- The wiring length should be 5m (16.4") or less.
- Connect a bleeder resistance of 1.5kΩ (1W or more) to the input terminal, so that the sum of the load current of the open collector transistor output on the mating device side and the input current of the main unit is 20mA or more.

1. NPN open collector transistor output three-wire sensor

- 1) FX3UC-□□MT/D, FX3UC-16MR/D-T, FX3UC-32MT-LT(-2)

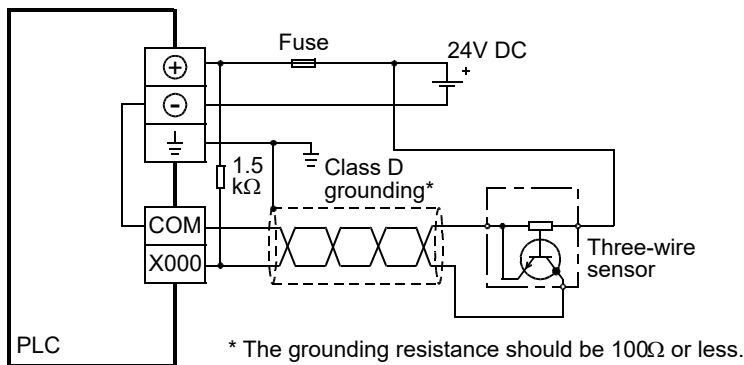

- 2) FX3UC-□□MT/DSS, FX3UC-16MR/DS-T [Sink input wiring]

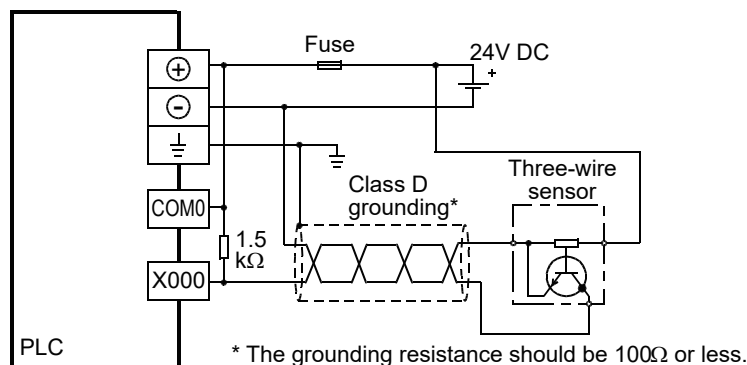

2. PNP open collector transistor output three-wire sensor

FX3UC-□□MT/DSS, FX3UC-16MR/DS-T [Source input wiring]

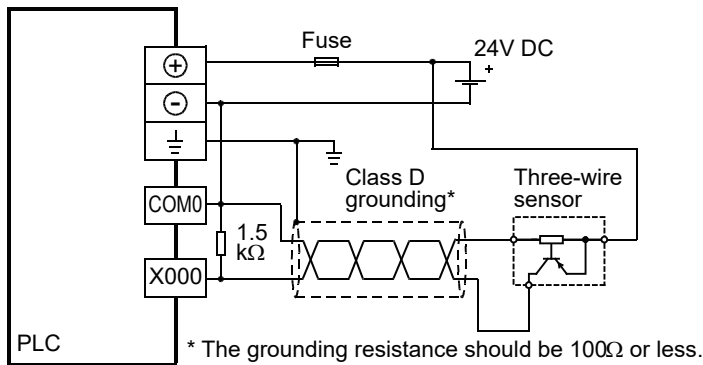

7.4 Digital Switch [DSW (FNC 72)/BIN (FNC 19)]

7.4.1 When DSW instructions are used

Examples of wiring for capturing values from a 4-digit digital switch to the data register D100 are given below.

1. Main unit

Example of program

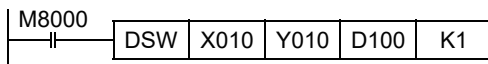

Example of wiring

1) Sink wiring

Use the sink only input, sink only output type main unit.

The wiring example is the FX3UC-32MT/D or FX3UC-32MT-LT(-2).

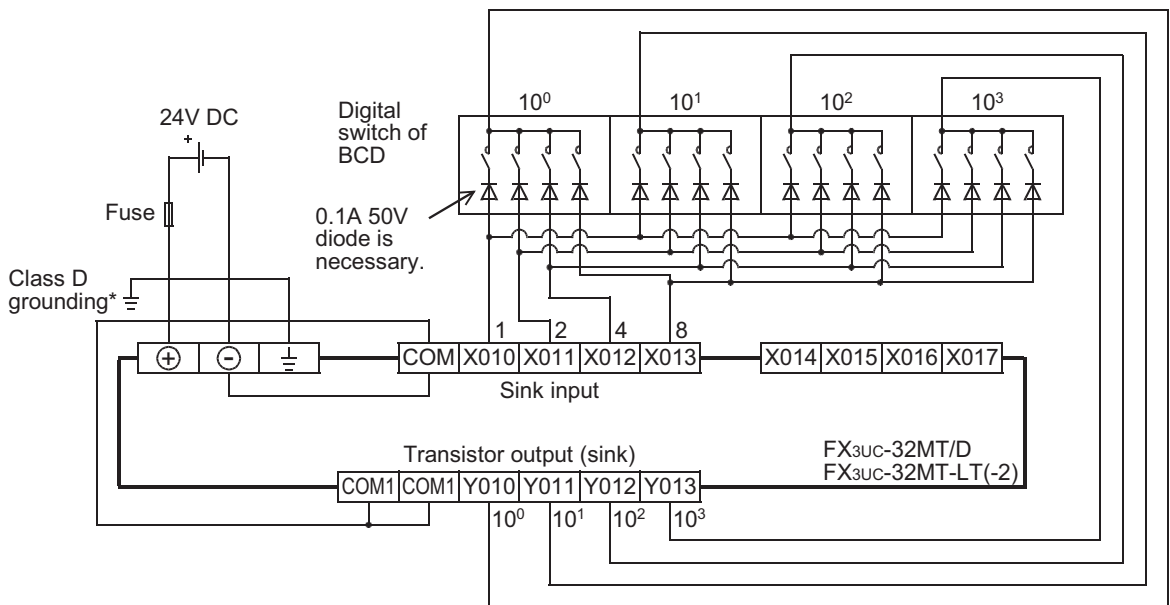

* The grounding resistance should be 100Ω or less.

- 2) Source wiring
 Use the sink/source common input, source only output (transistor output) type main unit.
 The wiring example is the FX3UC-32MT/DSS.

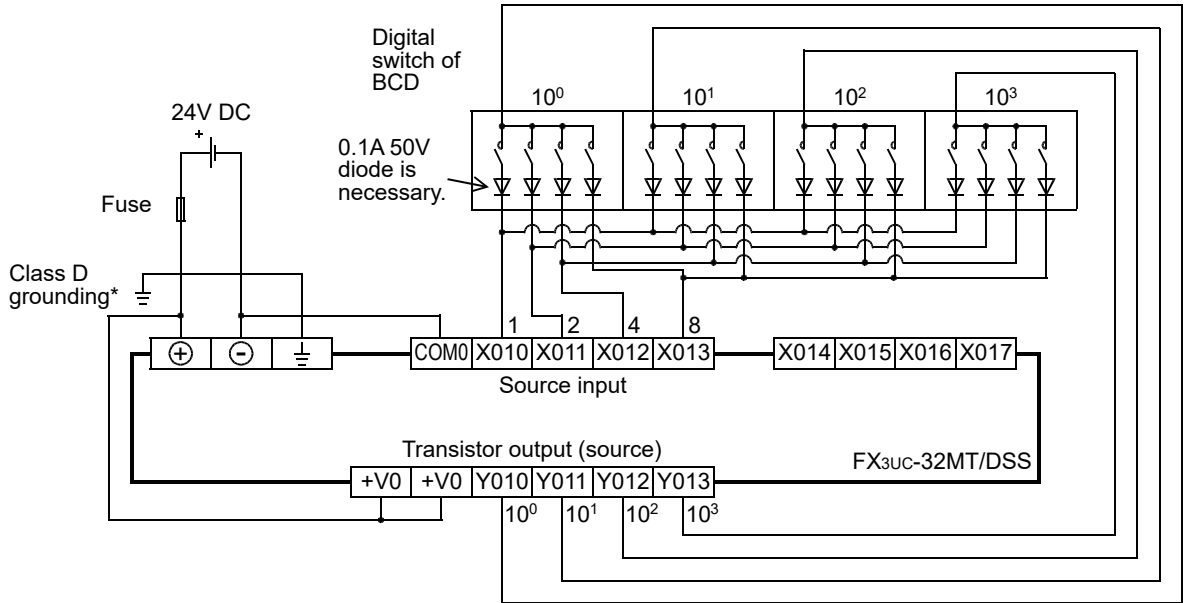

* The grounding resistance should be 100Ω or less.

2. Main unit + Output extension block

Example of program

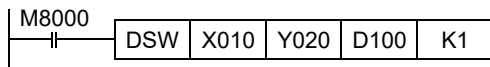

Example of wiring

- 1) Sink wiring
 Use the sink only input, sink only output type main unit and a transistor output (sink only output) type output extension block.
 The wiring example is the [FX3UC-32MT/D or FX3UC-32MT-LT(-2)] + output extension block [FX2NC-16EYT].

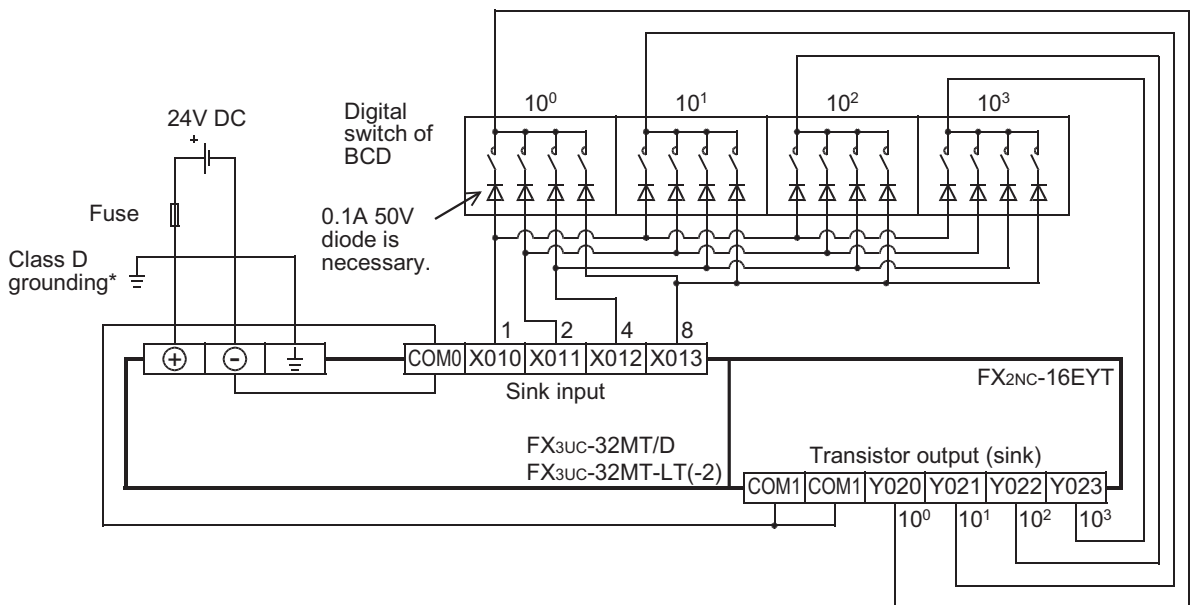

* The grounding resistance should be 100Ω or less.

- 2) Source wiring
Use the sink/source common input, source only output type main unit and a transistor output (source only output) type output extension block.
The wiring example is the [FX3UC-32MT/DSS] + output extension block [FX2NC-16EYT-DSS].

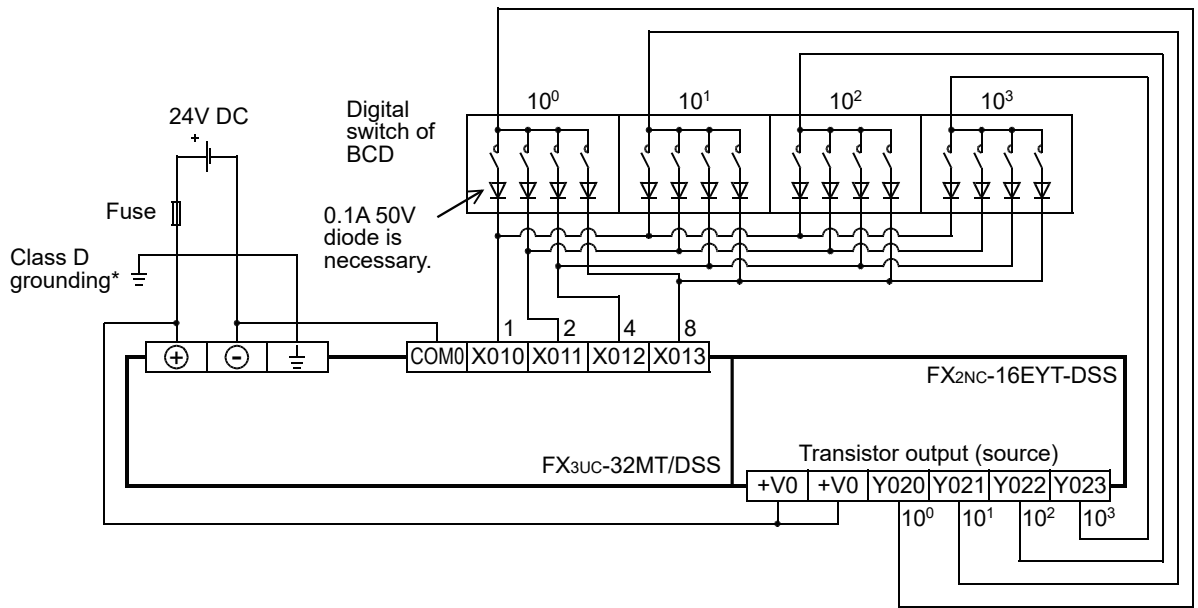

* The grounding resistance should be 100Ω or less.

3. Input extension block + Output extension block

Example of program

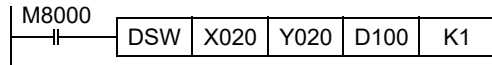

Example of wiring

- 1) Sink wiring
Use the sink only input, sink only output type main unit, a sink only input type input extension block and a transistor output (sink only output) type output extension block.
The wiring example is the [FX3UC-32MT/D or FX3UC-32MT-LT(-2)] + input extension block [FX2NC-16EX] + output extension block [FX2NC-16EYT].

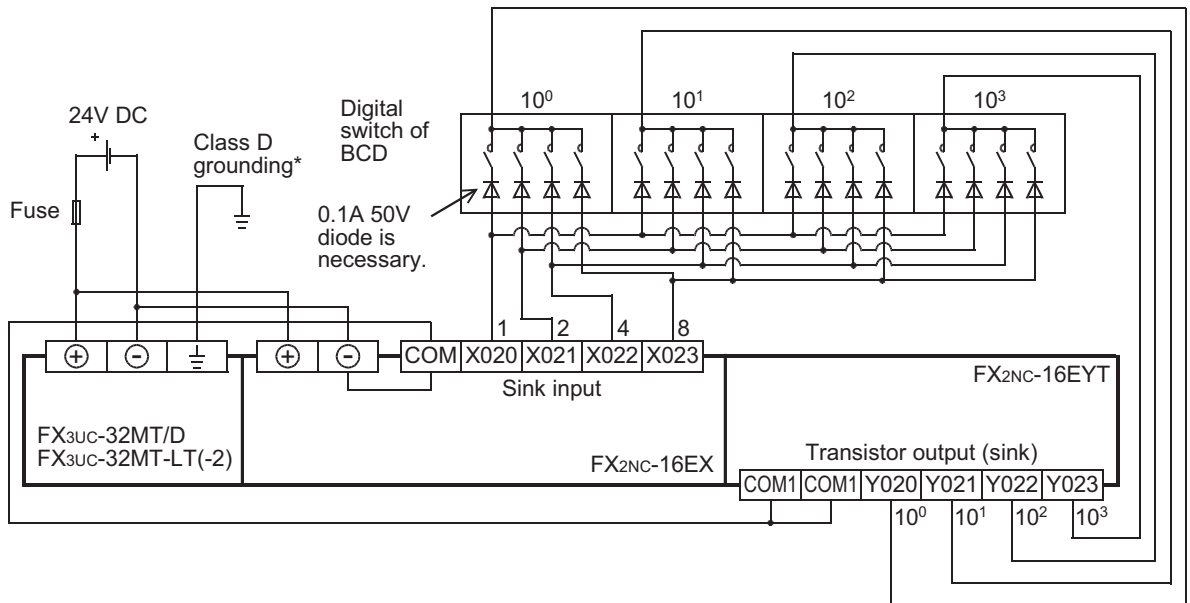

* The grounding resistance should be 100Ω or less.

1	Outline
2	External Dimensions
3	Generic Specifications
4	Power Supply Specifications
5	Input Specifications
6	Output Specifications
7	Examples of Wiring for Various Uses
8	Terminal Block
9	CC-Link/LT Master FX3UC-LT(-2) only
10	Display module FX3UC-LT(-2) only

2) Source wiring

Use the sink/source common input, source only output type main unit, a sink/source common input type input extension block and a transistor output (source only output) type output extension block.
 The wiring example is the [FX3UC-32MT/DSS] + input extension block [FX2NC-16EX-DS] + output extension block [FX2NC-16EYT-DSS].

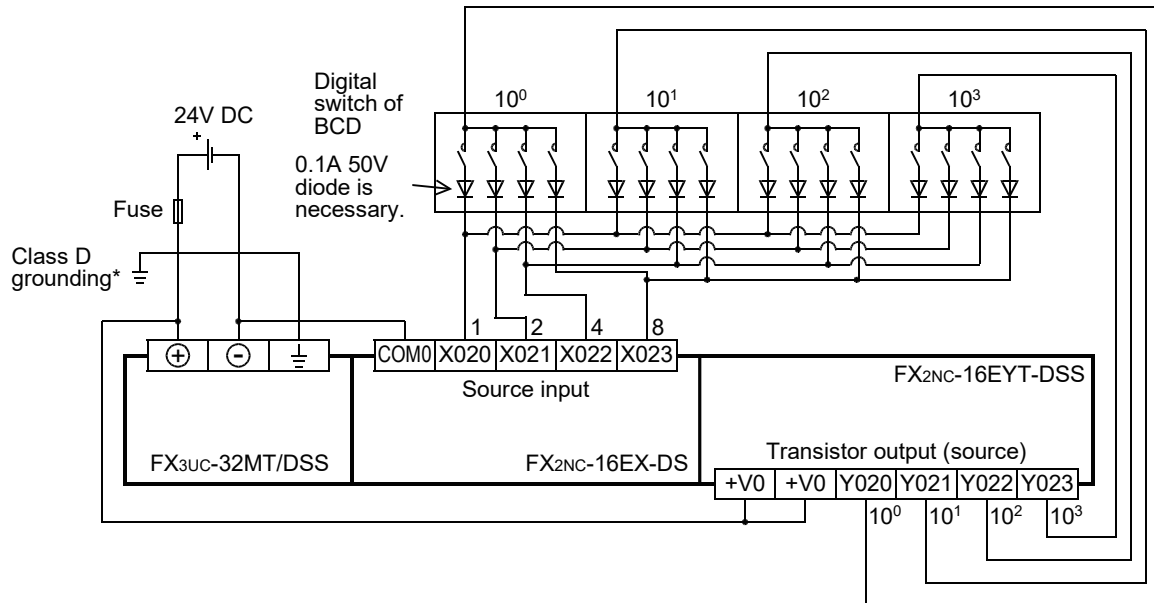

* The grounding resistance should be 100Ω or less.

7.4.2 When BIN instructions are used

Examples of wiring for capturing values from a 2-digit digital switch to the data register D102 are given below.

1. Main unit

Example of program

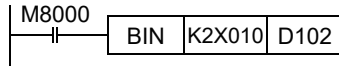

Example of wiring

1) Sink wiring

a) Sink only input type main unit

Use the sink only input, sink only output type main unit.
 The wiring example is the FX₃UC-32MT/D or FX₃UC-32MT-LT(-2).

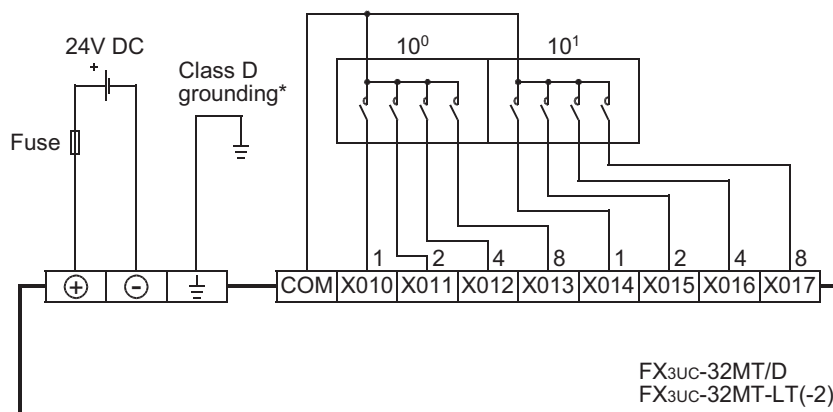

* The grounding resistance should be 100Ω or less.

b) Sink/source common input type main unit

Use the sink/source common input, source only output (transistor output) type main unit.
 The wiring example is the FX₃UC-32MT/DSS.

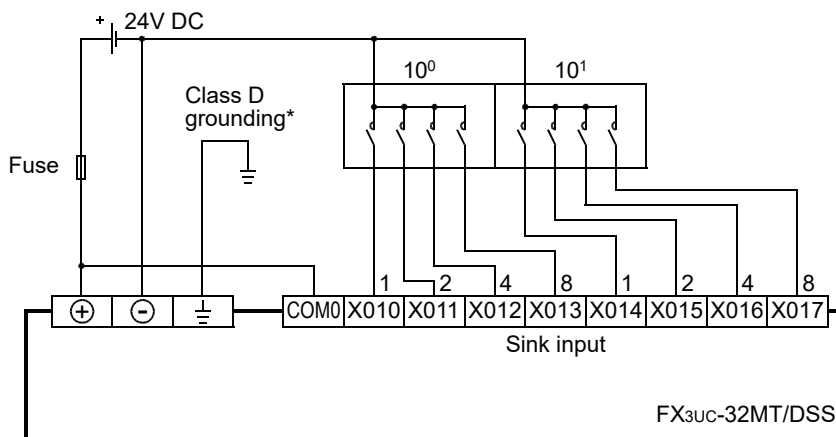

* The grounding resistance should be 100Ω or less.

- 2) Source wiring
 Use the sink/source common input, source only output (transistor output) type main unit.
 The wiring example is the FX₃UC-32MT/DSS.

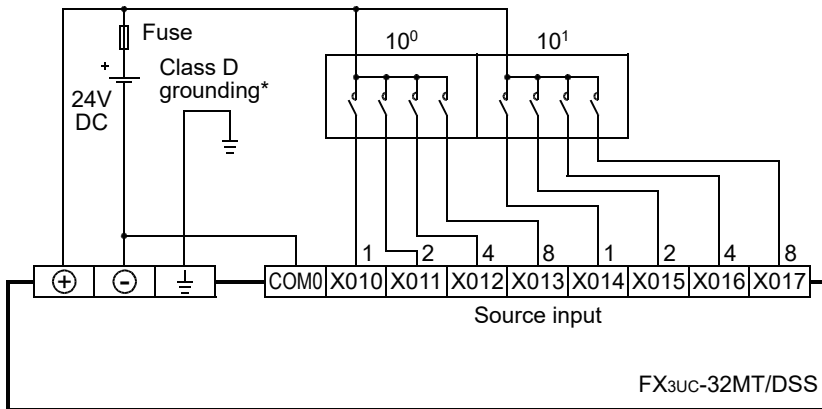

* The grounding resistance should be 100Ω or less.

2. Input extension block

Example of program

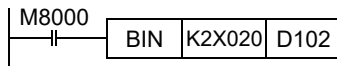

Example of wiring

- 1) Sink wiring
 a) Sink only input type extension block
 Use the sink only input, sink only output type main unit, and a sink only input type input extension block. The wiring example is the [FX₃UC-32MT/D or FX₃UC-32MT-LT(-2)] + input extension block [FX₂NC-16EX].

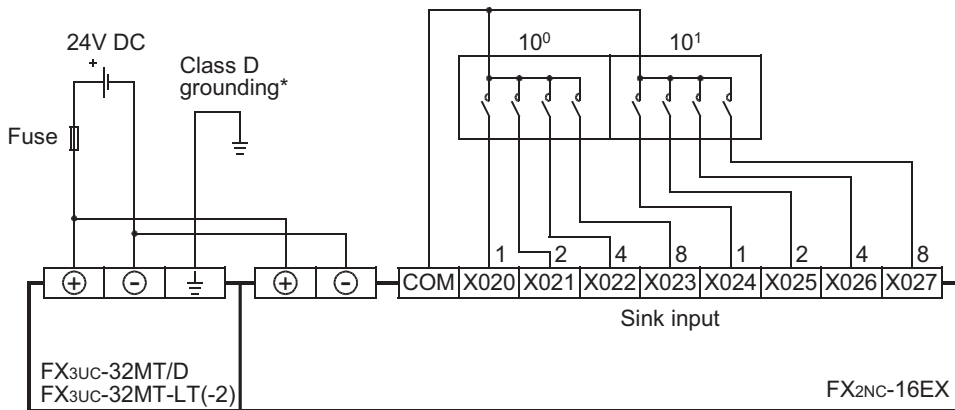

* The grounding resistance should be 100Ω or less.

b) Sink/source common input type extension block

Use the sink/source common input, source only output type main unit, a sink/source common input type input extension block.

The wiring example is the [FX3UC-32MT/DSS] + input extension block [FX2NC-16EX-DS].

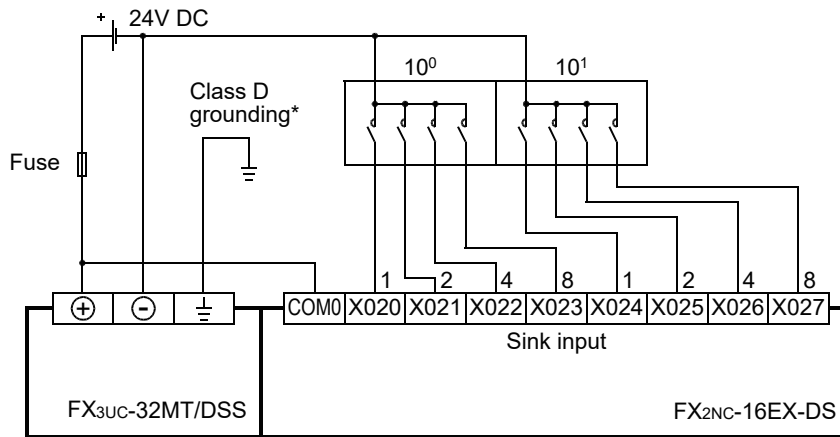

* The grounding resistance should be 100Ω or less.

2) Source wiring

Use the sink/source common input, source only output type main unit, a sink/source common input type input extension block.

The wiring example is the [FX3UC-32MT/DSS] + input extension block [FX2NC-16EX-DS].

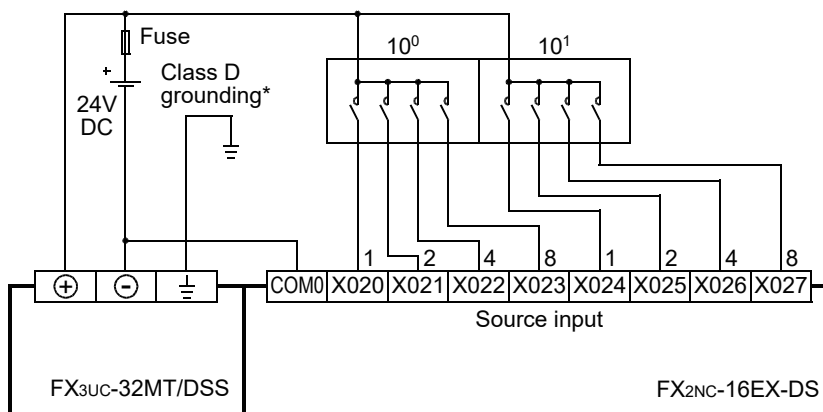

* The grounding resistance should be 100Ω or less.

1	Outline
2	External Dimensions
3	Generic Specifications
4	Power Supply Specifications
5	Input Specifications
6	Output Specifications
7	Examples of Wiring for Various Uses
8	Terminal Block
9	CC-Link/LT Master FX3UC-LT(-2) only
10	Display module FX3UC-LT(-2) only

7.5 Ten Key Input [TKY (FNC 70)]

This section gives examples of wiring for capturing values from ten-key pad to D100 using TKY instructions.

1. Main unit

Example of program

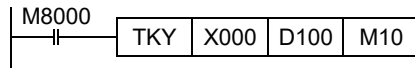

Example of wiring

1) Sink wiring

a) Sink only input type main unit

Use the sink only input, sink only output type main unit.

The wiring example is the FX3UC-32MT/D or FX3UC-32MT-LT(-2).

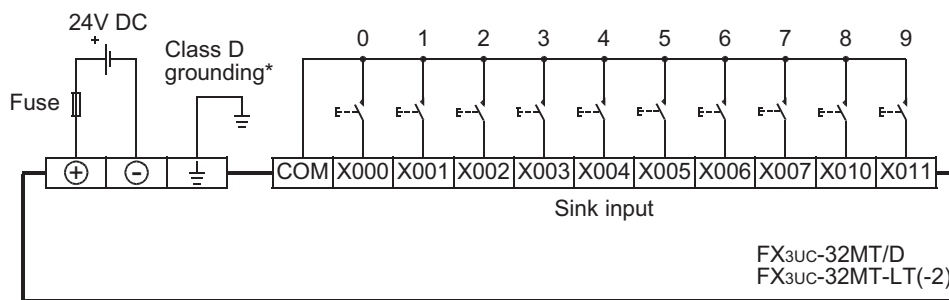

* The grounding resistance should be 100Ω or less.

b) Sink/source common input type main unit

Use the sink/source common input, source only output (transistor output) type main unit.

The wiring example is the FX3UC-32MT/DSS.

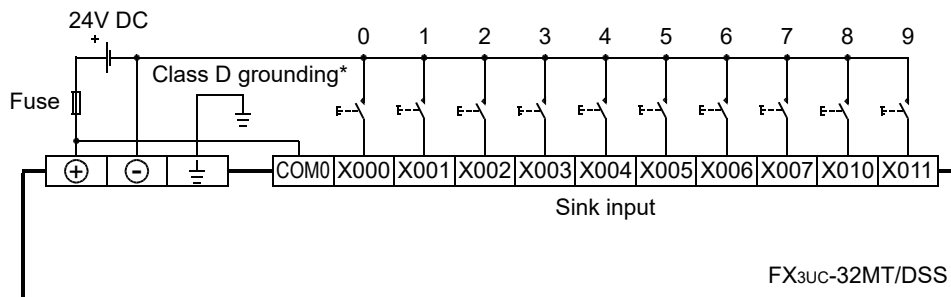

* The grounding resistance should be 100Ω or less.

2) Source wiring

Use the sink/source common input, source only output (transistor output) type main unit.

The wiring example is the FX3UC-32MT/DSS.

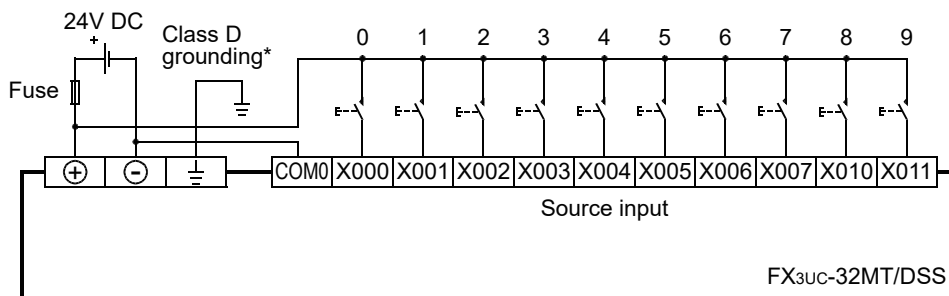

* The grounding resistance should be 100Ω or less.

2. Input extension block

Example of program

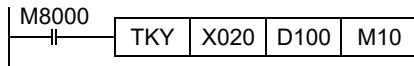

Example of wiring

1) Sink wiring

a) Sink only input type extension block

Use the sink only input, sink only output type main unit, a sink only input type input extension block. The wiring example is the [FX3UC-32MT/D or FX3UC-32MT-LT(-2)] + input extension block [FX2NC-16EX].

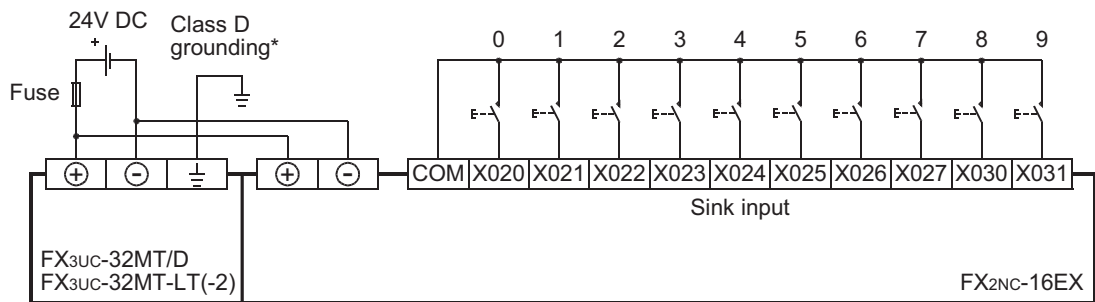

* The grounding resistance should be 100Ω or less.

b) Sink/source common input type extension block

Use the sink/source common input, source only output type main unit, a sink/source common input type input extension block. The wiring example is the [FX3UC-32MT/DSS] + input extension block [FX2NC-16EX-DS].

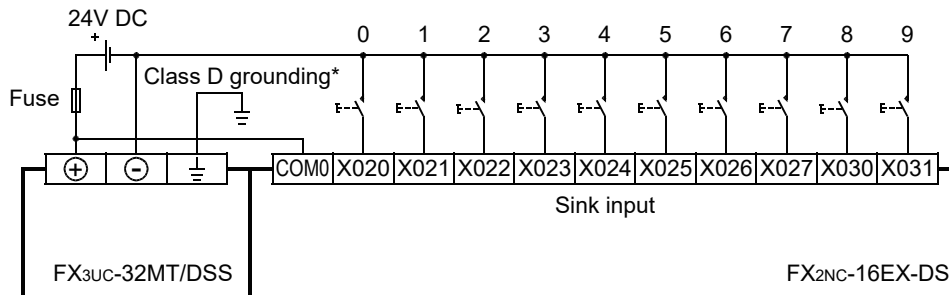

* The grounding resistance should be 100Ω or less.

2) Source wiring

Use the sink/source common input, source only output type main unit, a sink/source common input type input extension block. The wiring example is the [FX3UC-32MT/DSS] + input extension block [FX2NC-16EX-DS].

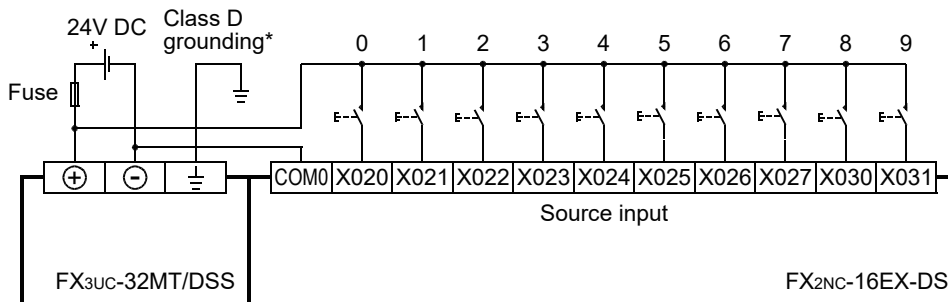

* The grounding resistance should be 100Ω or less.

7.6 Hexadecimal Input [HKY (FNC 71)]

This section gives examples of wiring for capturing values (0 to 9) and function keys (A to F) from 16 switches (16 keys) to D100 and M0 to M5 using HKY instructions. (Hexadecimal values can be captured.)

1. Main unit

Example of program

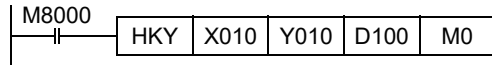

Example of wiring

1) Sink wiring

Use the sink only input, sink only output type main unit.
 The wiring example is the FX3UC-32MT/D or FX3UC-32MT-LT(-2).

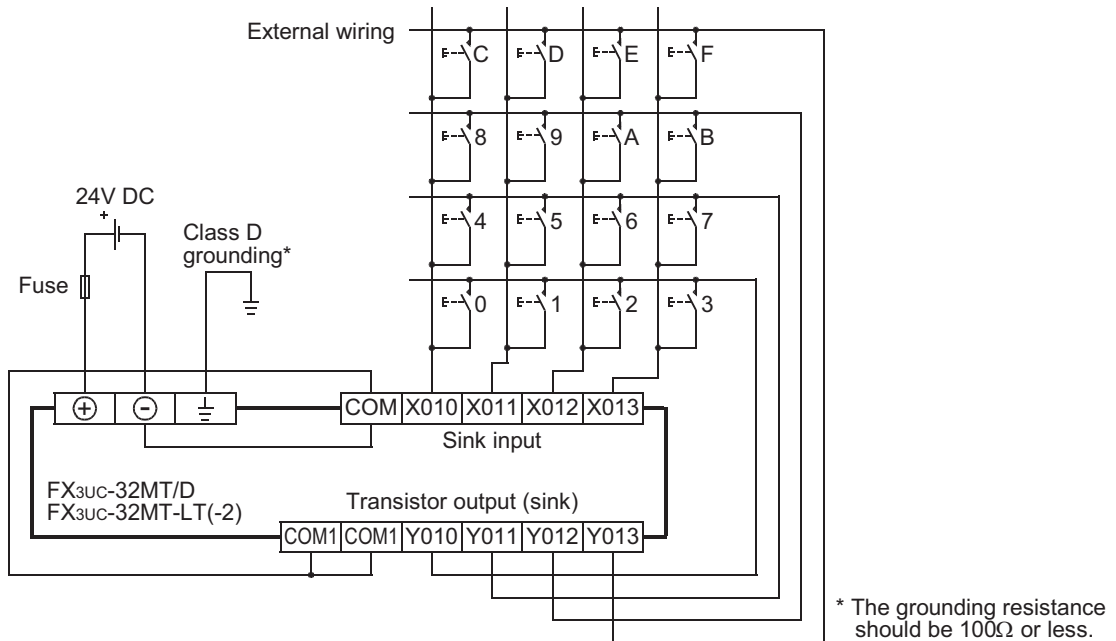

2) Source wiring

Use the sink/source common input, source only output (transistor output) type main unit.
 The wiring example is the FX3UC-32MT/DSS.

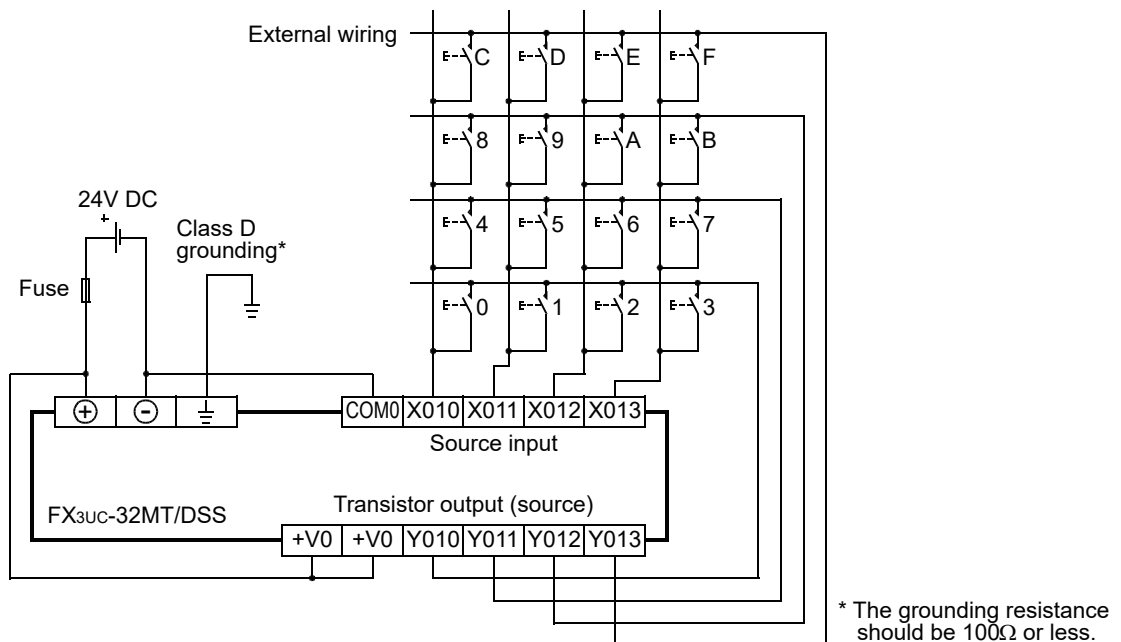

2. Main unit + Output extension block

Example of program

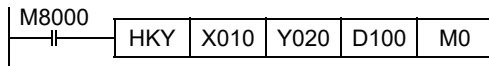

Example of wiring

1) Sink wiring

Use the sink only input, sink only output type main unit and a transistor output (sink only output) type output extension block. The wiring example is the [FX3UC-32MT/D or FX3UC-32MT-LT(-2)] + output extension block [FX2NC-16EYT].

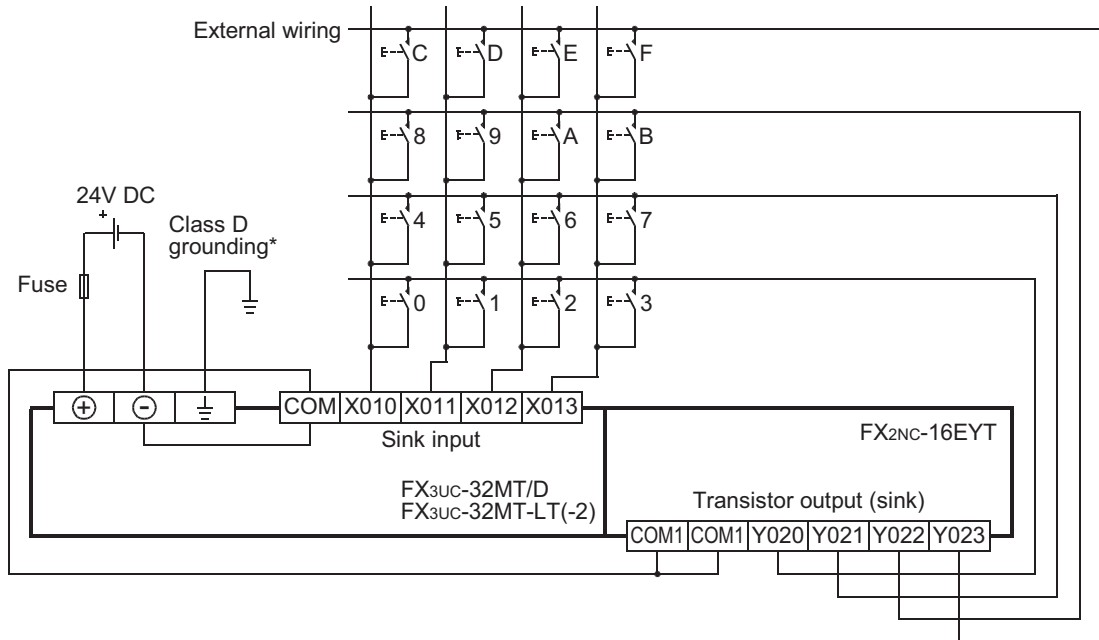

* The grounding resistance should be 100Ω or less.

2) Source wiring

Use the sink/source common input, source only output type main unit and a transistor output (source only output) type output extension block. The wiring example is the [FX3UC-32MT/DSS] + output extension block [FX2NC-16EYT-DSS].

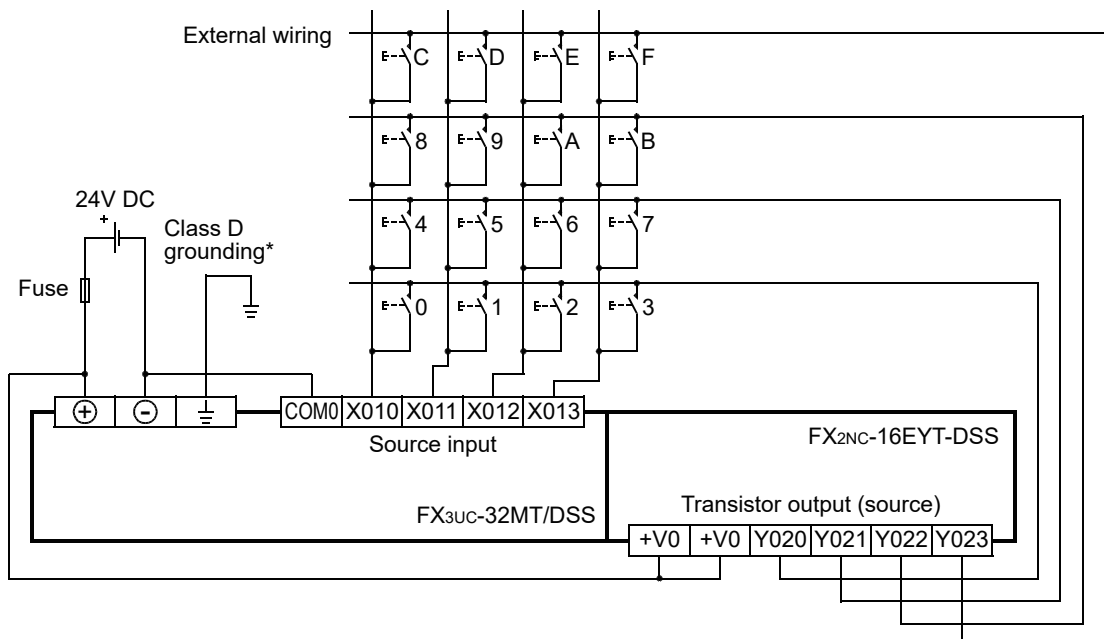

* The grounding resistance should be 100Ω or less.

3. Input extension block + Output extension block

Example of program

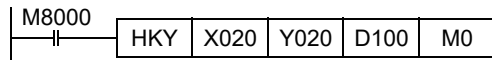

Example of wiring

1) Sink wiring

Use the sink only input, sink only output type main unit, a sink only input type input extension block and a transistor output (sink only output) type output extension block. The wiring example is the [FX3UC-32MT/D or FX3UC-32MT-LT(-2)] + input extension block [FX2NC-16EX] + output extension block [FX2NC-16EYT].

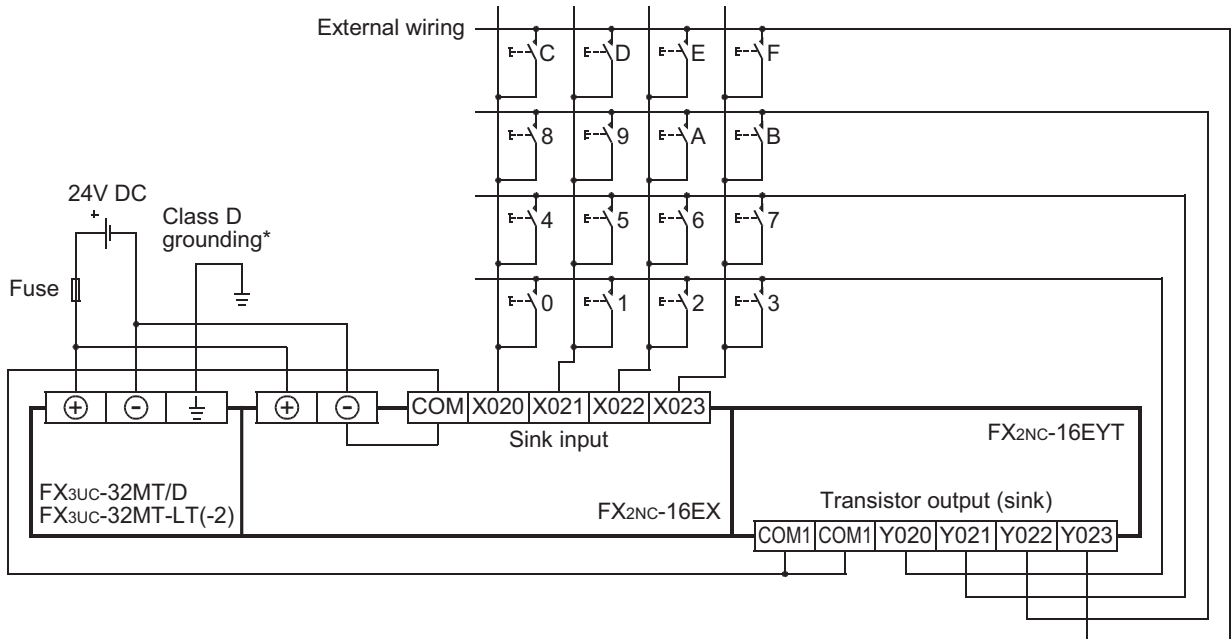

* The grounding resistance should be 100Ω or less.

2) Source wiring

Use the sink/source common input, source only output type main unit, a sink/source common input type input extension block and a transistor output (source only output) type output extension block. The wiring example is the [FX3UC-32MT/DSS] + input extension block [FX2NC-16EX-DS] + output extension block [FX2NC-16EYT-DSS].

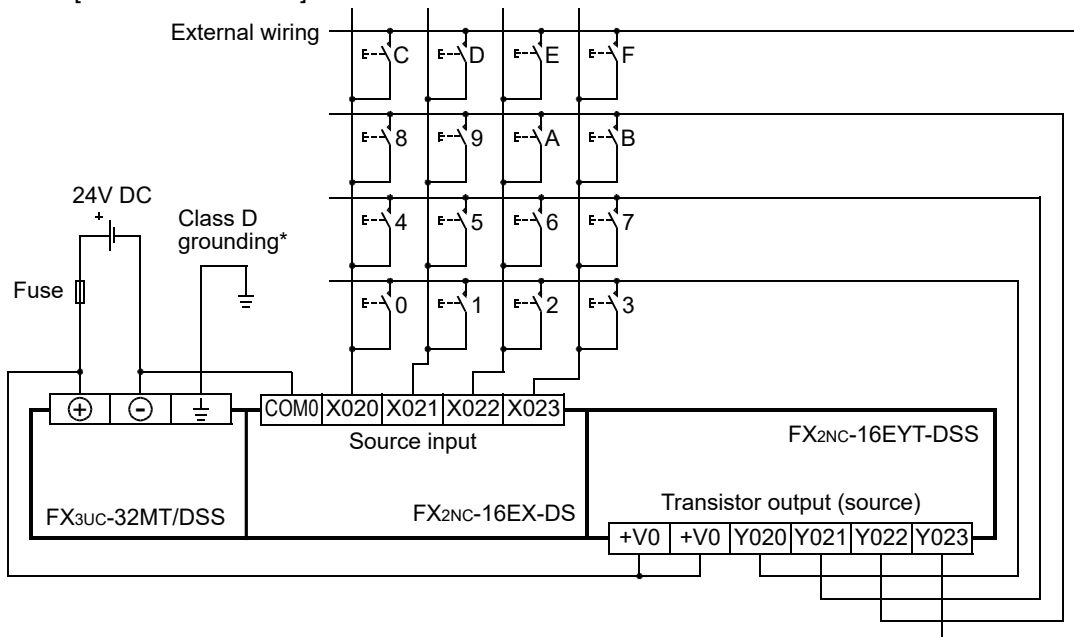

* The grounding resistance should be 100Ω or less.

7.7 Input Matrix [MTR (FNC 52)]

This section gives examples of wiring for capturing the ON/OFF status of 24 switches to M30 to M37, M40 to M47 and M50 to M57 using MTR instructions.

1. Main unit

Example of program

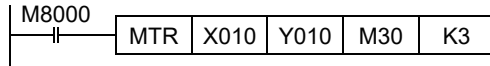

Example of wiring

1) Sink wiring

Use the sink only input, sink only output type main unit.

The wiring example is the FX3UC-32MT/D or FX3UC-32MT-LT(-2).

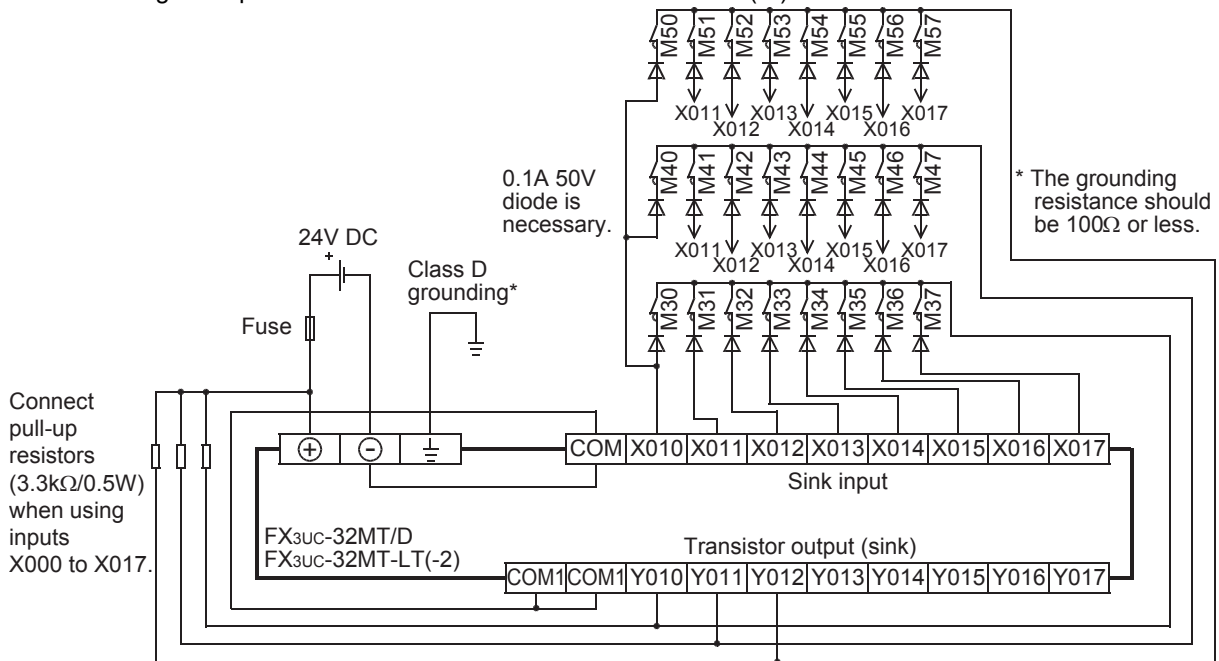

2) Source wiring

Use the sink/source common input, source only output (transistor output) type main unit.

The wiring example is the FX3UC-32MT/DSS.

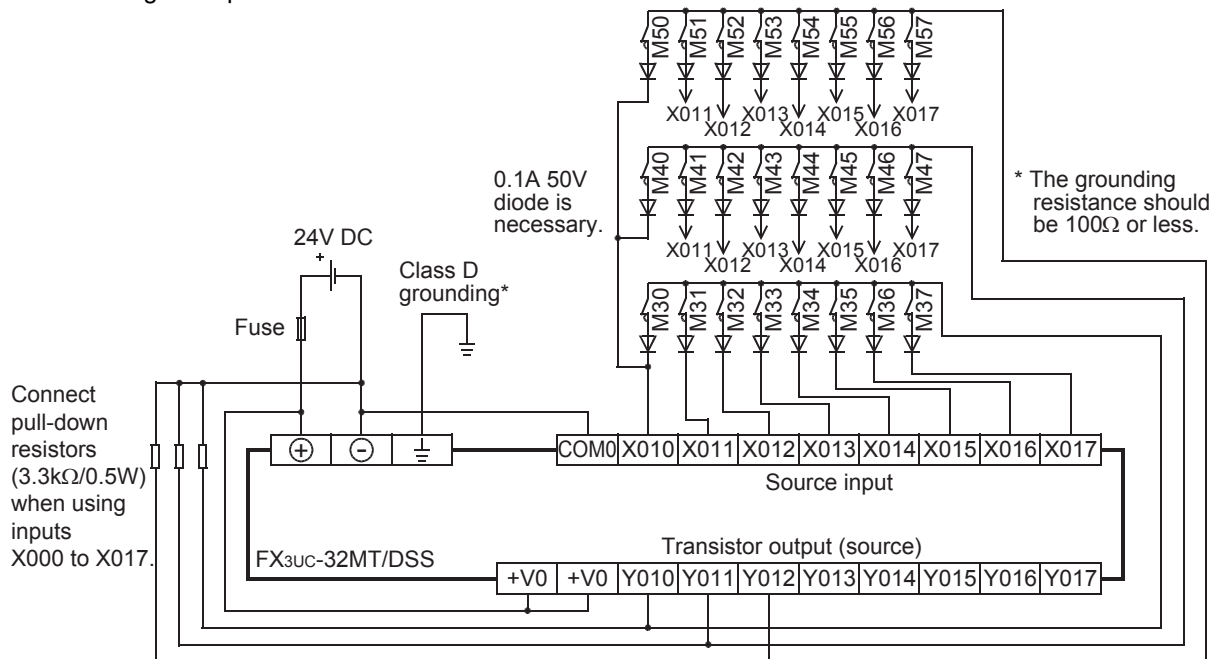

2. Main unit + Output extension block

Example of program

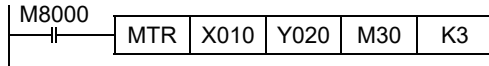

Example of wiring

1) Sink wiring

Use the sink only input, sink only output type main unit and a transistor output (sink only output) type output extension block. The wiring example is the [FX3uc-32MT/D or FX3uc-32MT-LT(-2)] + output extension block [FX2NC-16EYT].

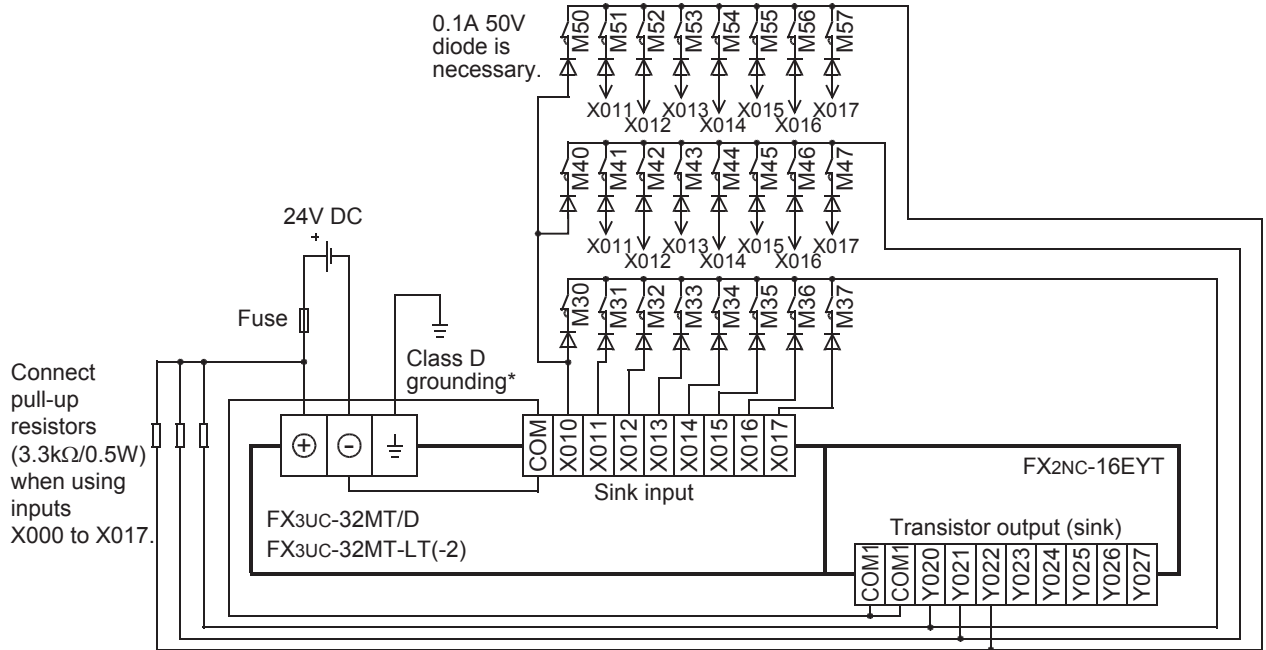

* The grounding resistance should be 100Ω or less.

2) Source wiring

Use the sink/source common input, source only output type main unit and a transistor output (source only output) type output extension block. The wiring example is the [FX3uc-32MT/DSS] + output extension block [FX2NC-16EYT-DSS].

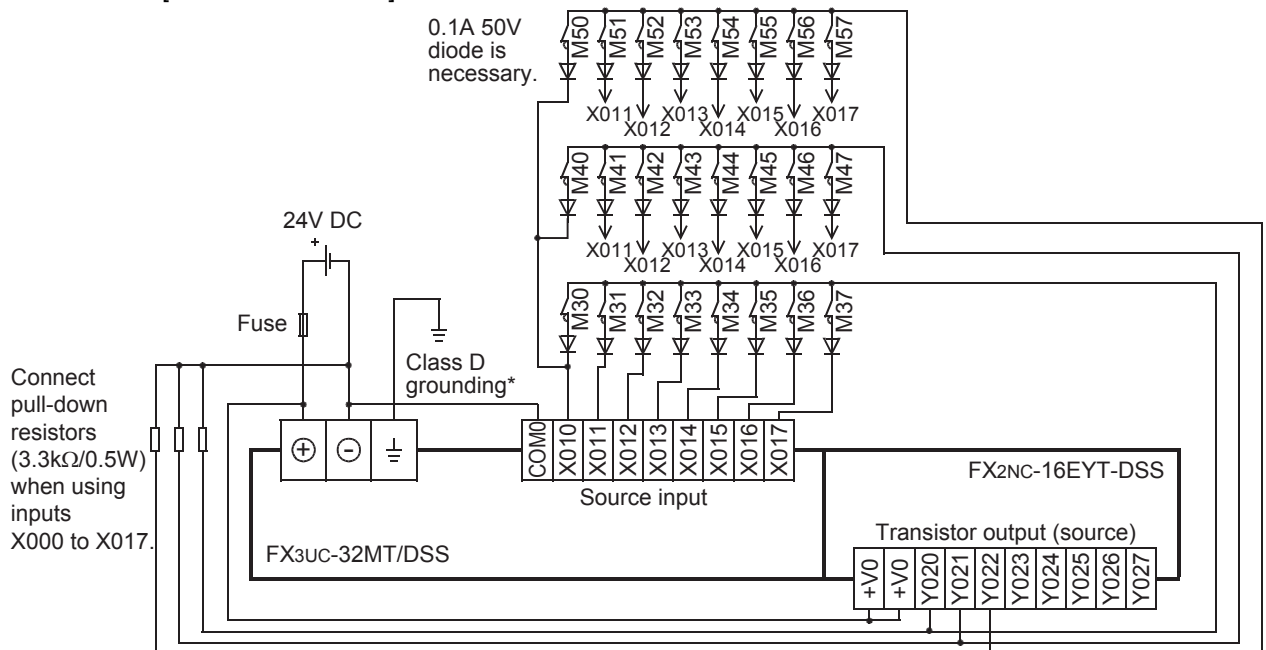

* The grounding resistance should be 100Ω or less.

3. Input extension block + Output extension block

Example of program

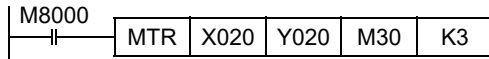

Example of wiring

1) Sink wiring

Use the sink only input, sink only output type main unit, a sink only input type input extension block and a transistor output (sink only output) type output extension block. The wiring example is the [FX3UC-32MT/D or FX3UC-32MT-LT(-2)] + input extension block [FX2NC-16EX] + output extension block [FX2NC-16EYT].

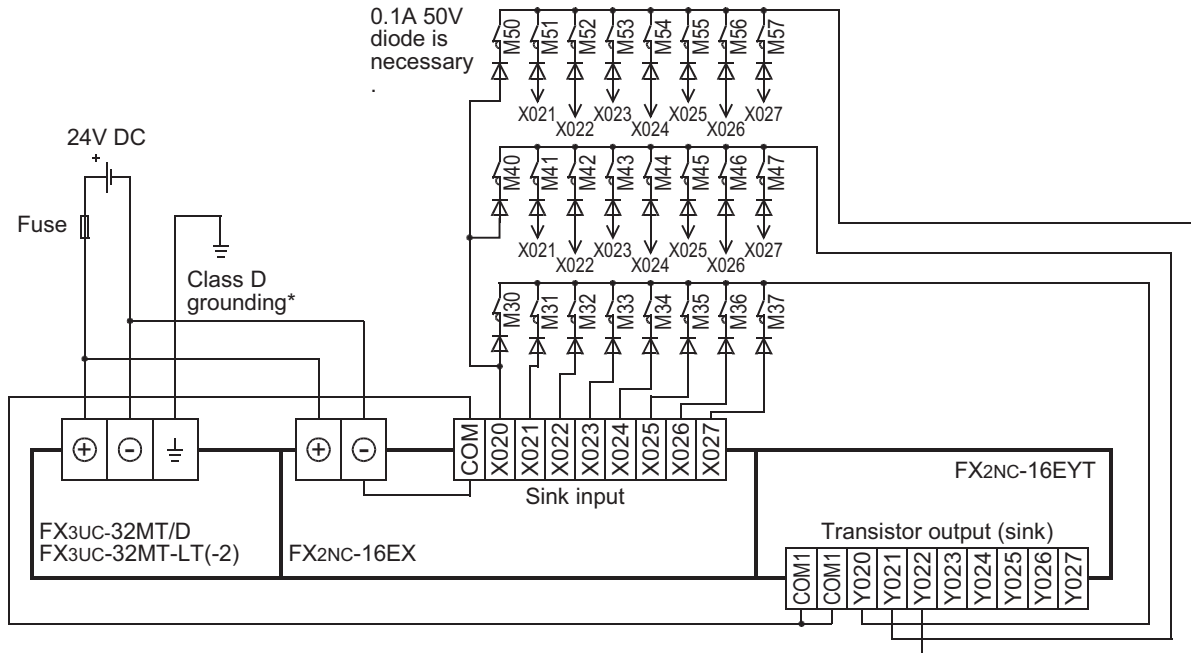

* The grounding resistance should be 100Ω or less.

2) Source wiring

Use the sink/source common input, source only output type main unit, a sink/source common input type input extension block and a transistor output (source only output) type output extension block. The wiring example is the [FX3UC-32MT/DSS] + input extension block [FX2NC-16EX-DS] + output extension block [FX2NC-16EYT-DSS].

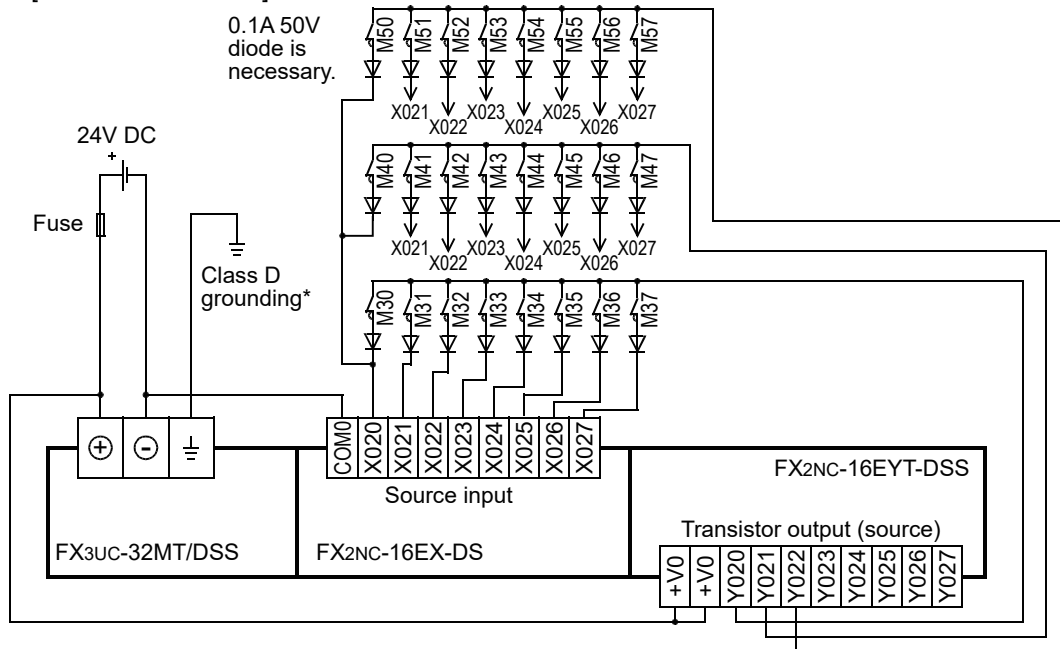

* The grounding resistance should be 100Ω or less.

1	Outline
2	External Dimensions
3	Generic Specifications
4	Power Supply Specifications
5	Input Specifications
6	Output Specifications
7	Examples of Wiring for Various Uses
8	Terminal Block
9	CC-Link/LT Master FX3UC-LT(-2) only
10	Display module FX3UC-LT(-2) only

7.8 Seven Segment with Latch [SEGL (FNC 74)/BCD (FNC 18)]

7.8.1 When SEGL instructions are used

This subsection gives examples of wiring for displaying the current value of D100 on the 4-digit 7-segment display.

1. Main unit

Example of program

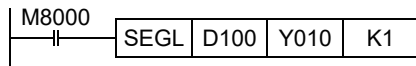

Example of wiring

1) Sink wiring

Use the sink only input, sink only output type main unit.
 The wiring example is the FX3UC-32MT/D or FX3UC-32MT-LT(-2).

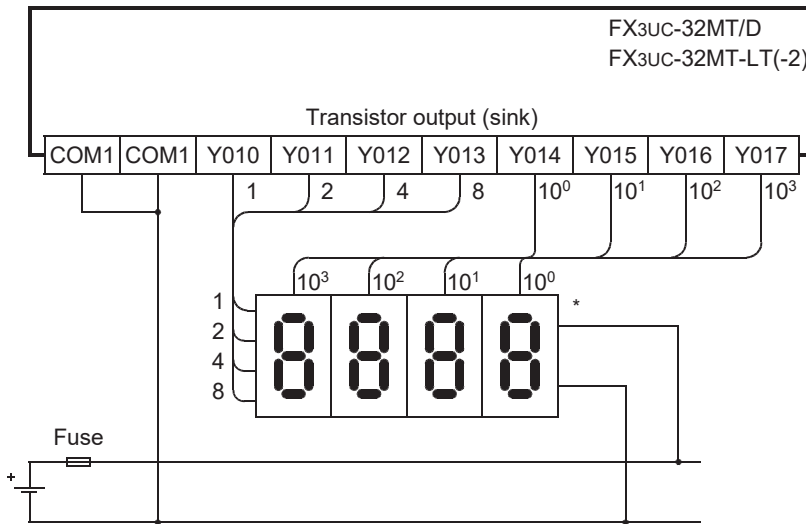

* Use a 7-segment display with a latch and a built-in BCD decoder.

7-segment display to be used for sink wiring (in the case of transistor output)

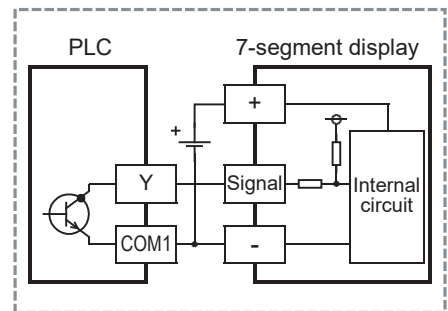

2) Source wiring

Use the sink/source common input, source only output (transistor output) type main unit.
 The wiring example is the FX3UC-32MT/DSS.

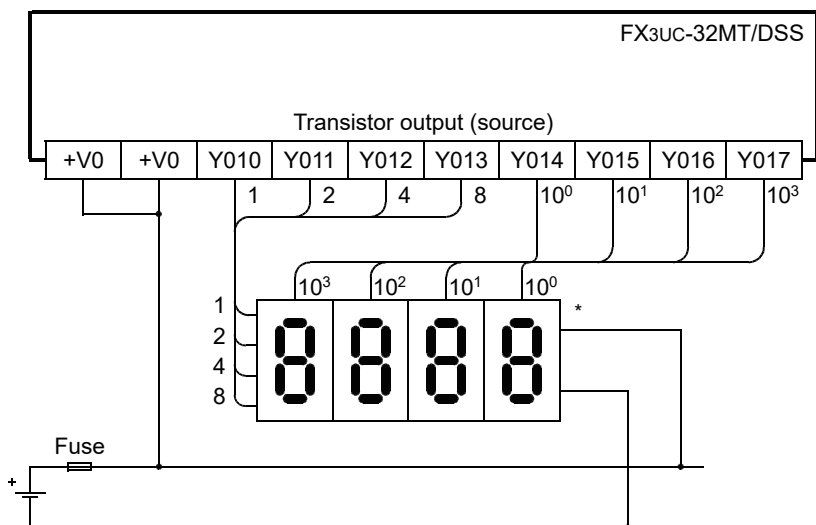

* Use a 7-segment display with a latch and a built-in BCD decoder.

7-segment display to be used for source wiring (in the case of transistor output)

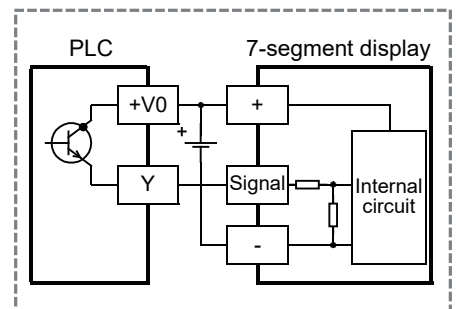

2. Output extension block

Example of program

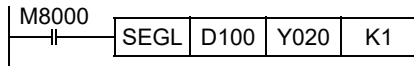

Example of wiring

1) Sink wiring

Use the sink only input, sink only output type main unit and a transistor output (sink only output) type output extension block. The wiring example is the [FX3UC-32MT/D or FX3UC-32MTLT(-2)] + output extension block [FX2NC-16EYT].

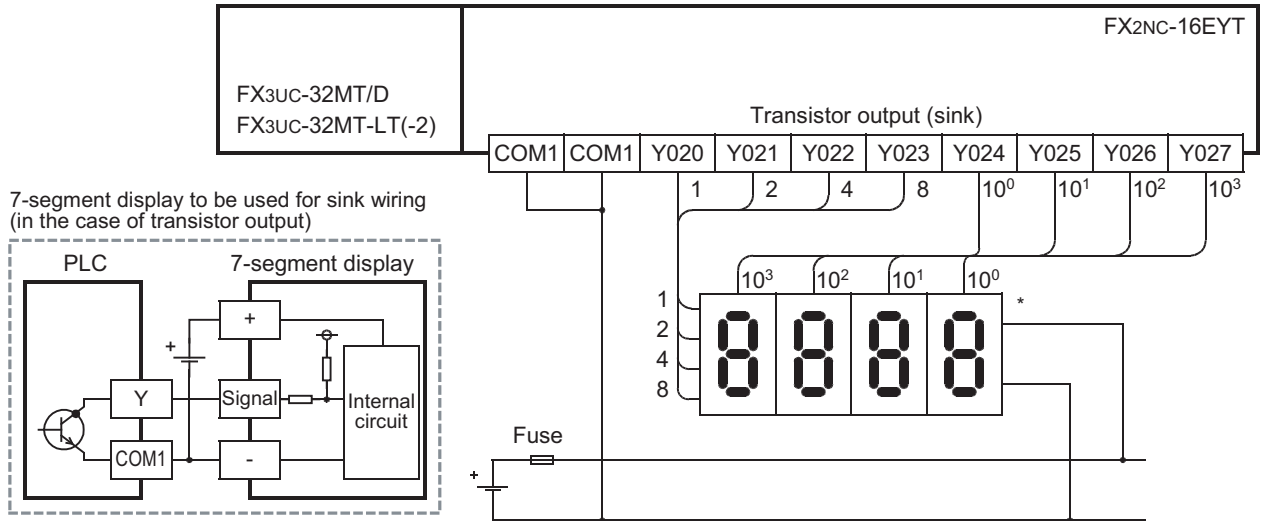

* Use a 7-segment display with a latch and a built-in BCD decoder.

2) Source wiring

Use the sink/source common input, source only output type main unit and a transistor output (source only output) type output extension block. The wiring example is the [FX3UC-32MT/DSS] + output extension block [FX2NC-16EYT-DSS].

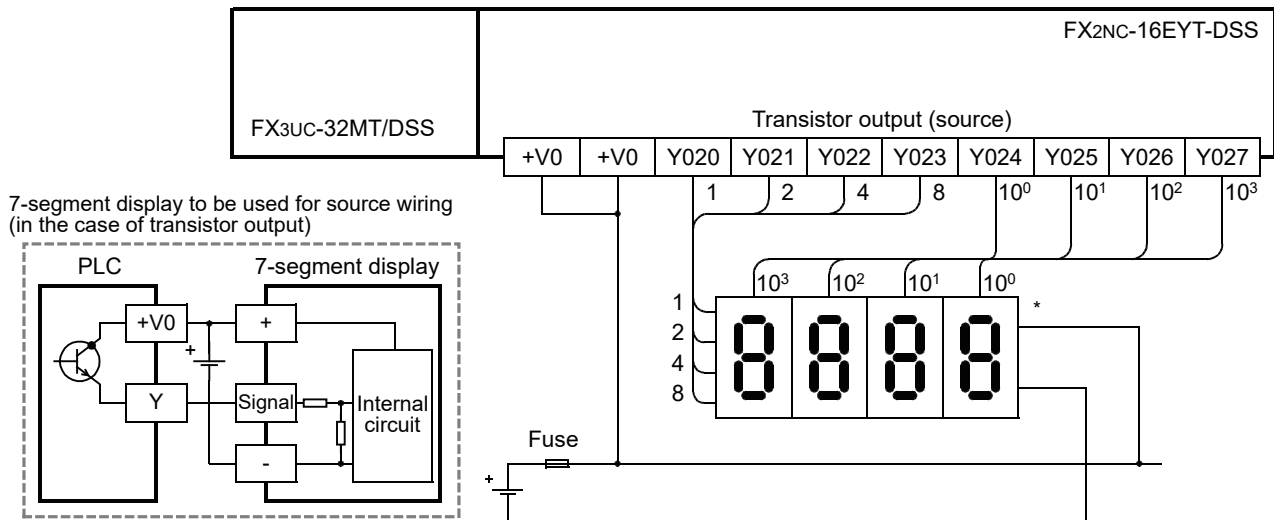

* Use a 7-segment display with a latch and a built-in BCD decoder.

7.8.2 When BCD instructions are used

This subsection gives examples of wiring for displaying the current value of D100 on the 2-digit 7-segment display.

1. Main unit

Example of program

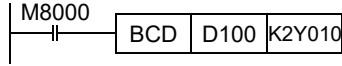

Example of wiring

- 1) Sink wiring
 Use the sink only input, sink only output type main unit.
 The wiring example is the FX3UC-32MT/D or FX3UC-32MT-LT(-2).

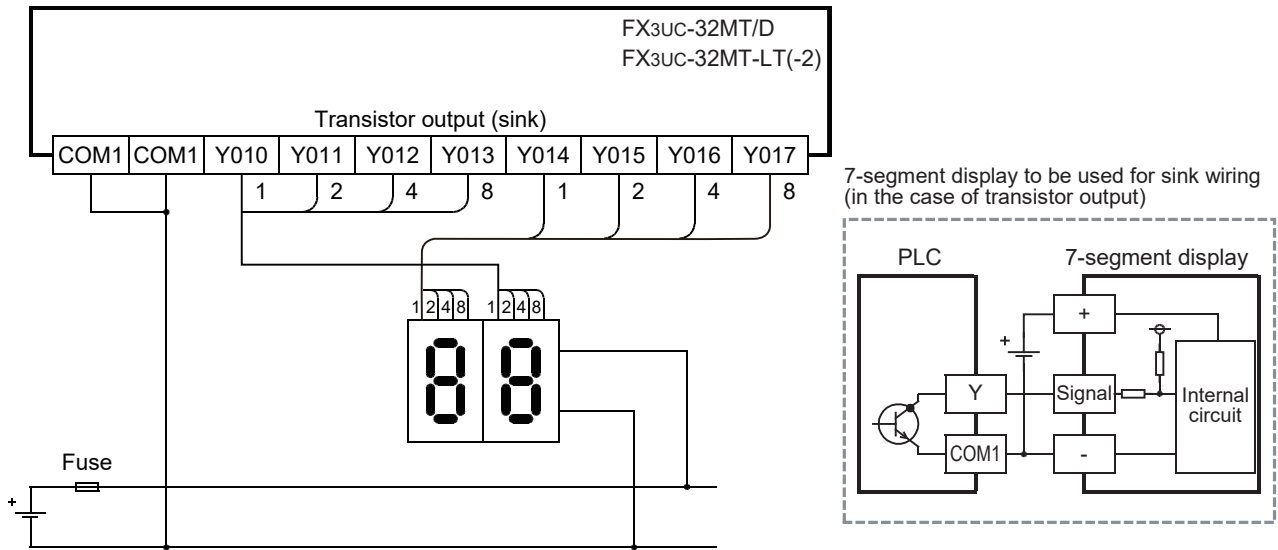

- 2) Source wiring
 Use the sink/source common input, source only output (transistor output) type main unit.
 The wiring example is the FX3UC-32MT/DSS.

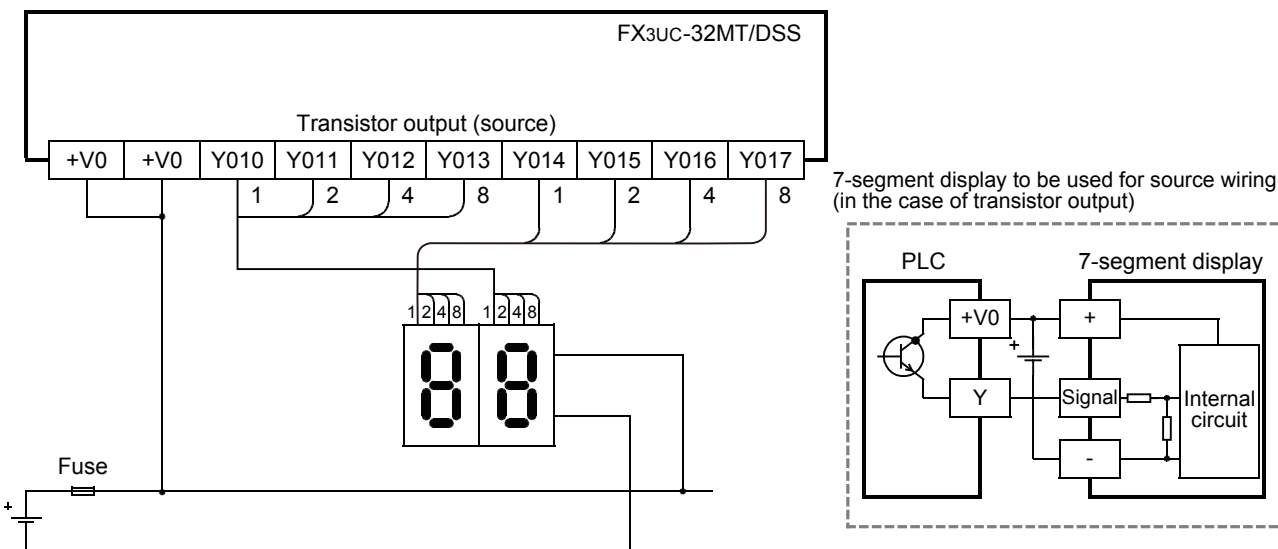

2. Output extension block

Example of program

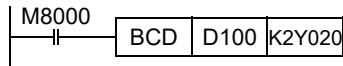

Example of wiring

1) Sink wiring

Use the sink only input, sink only output type main unit and a transistor output (sink only output) type output extension block. The wiring example is the [FX3UC-32MT/D or FX3UC-32MT-LT(-2)] + output extension block [FX2NC-16EYT].

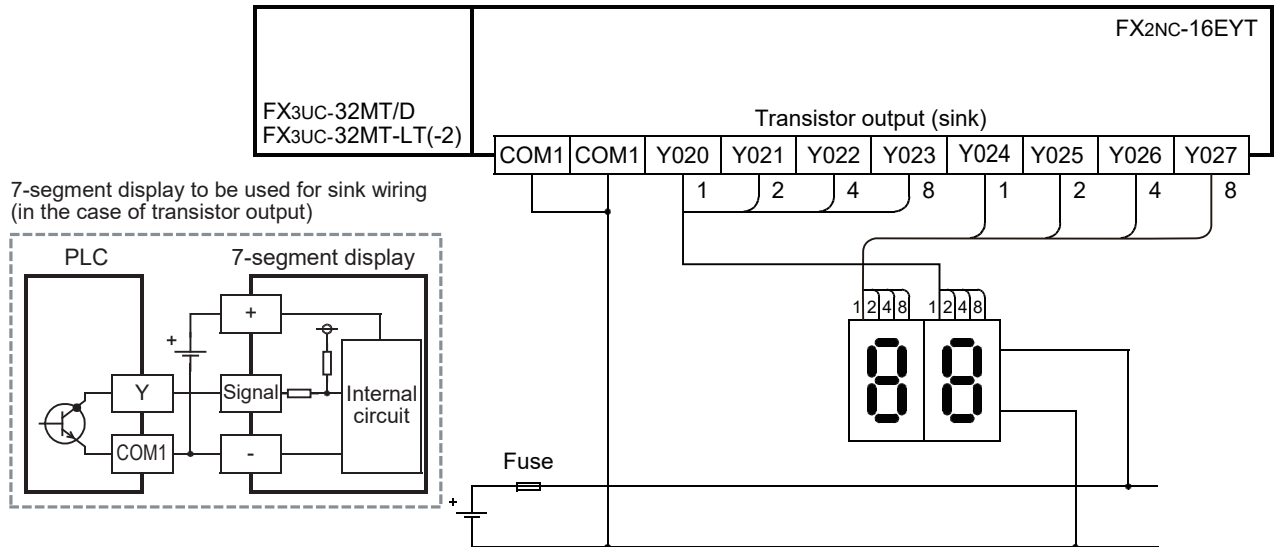

2) Source wiring

Use the sink/source common input, source only output type main unit and a transistor output (source only output) type output extension block. The wiring example is the [FX3UC-32MT/DSS] + output extension block [FX2NC-16EYT-DSS].

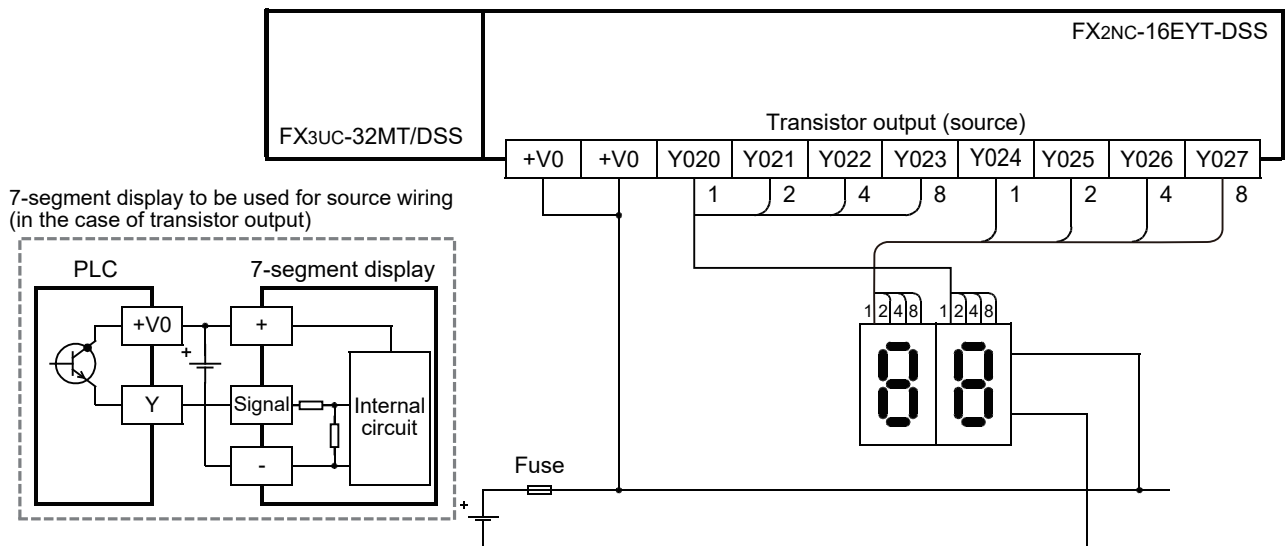

8. Terminal Block Specifications and External Wiring

DESIGN PRECAUTIONS



WARNING

- Make sure to have the following safety circuits outside of the PLC to ensure safe system operation even during external power supply problems or PLC failure.
Otherwise, malfunctions may cause serious accidents.
 - 4) Most importantly, have the following: an emergency stop circuit, a protection circuit, an interlock circuit for opposite movements (such as normal vs. reverse rotation), and an interlock circuit (to prevent damage to the equipment at the upper and lower positioning limits).
 - 5) Note that when the PLC CPU detects an error, such as a watchdog timer error, during self-diagnosis, all outputs are turned off. Also, when an error that cannot be detected by the PLC CPU occurs in an input/output control block, output control may be disabled.
External circuits and mechanisms should be designed to ensure safe machinery operation in such a case.
 - 6) Note that when an error occurs in a relay, triac or transistor output device, the output could be held either on or off.
For output signals that may lead to serious accidents, external circuits and mechanisms should be designed to ensure safe machinery operation in such a case.
- Note that when an error occurs in a remote I/O unit, the output could be held either on or off.
For output signals that may lead to serious accidents, external circuits for monitoring should be provided.

DESIGN PRECAUTIONS



CAUTION

- Do not bundle the control line and CC-Link/LT connection cables together with or lay them close to the main circuit or power line. As a guideline, lay the control line and CC-Link/LT connection cables at least 100mm (3.94") or more away from the main circuit or power line.
Noise may cause malfunctions.
- Install the product so that excessive force will not be applied to peripheral device connectors, power connectors, input/output connectors, CC-Link/LT interface connectors or CC-Link/LT connection cables.
Failure to do so may result in wire damage/breakage or PLC failure.

SECURITY PRECAUTIONS



WARNING

- To maintain the security (confidentiality, integrity, and availability) of the programmable controller and the system against unauthorized access, denial-of-service (DoS) attacks, computer viruses, and other cyberattacks from unreliable networks and devices via network, take appropriate measures such as firewalls, virtual private networks (VPNs), and antivirus solutions.

INSTALLATION PRECAUTIONS



WARNING

- Make sure to cut off all phases of the power supply externally before attempting installation or wiring work.
Failure to do so may cause electric shock or damage to the product.

INSTALLATION PRECAUTIONS



- Use the product within the generic environment specifications described in Section 3.1 of this manual. Never use the product in areas with excessive dust, oily smoke, conductive dusts, corrosive gas (salt air, Cl₂, H₂S, SO₂ or NO₂), flammable gas, vibration or impacts, or expose it to high temperature, condensation, or rain and wind.
If the product is used in such conditions, electric shock, fire, malfunctions, deterioration or damage may occur.
- Do not touch the conductive parts of the product directly.
Doing so may cause device failures or malfunctions.
- Install the product securely using a DIN rail or mounting screws.

Main unit, FX2NC Series I/O extension blocks, FX2NC/FX3UC Series special function blocks, special adapter, extension power supply unit, FX2NC-CNV-IF, FX2N-10GM, FX2N-20GM, FX Series terminal blocks	DIN rail only
FX0N/FX2N Series I/O extension blocks, FX0N/FX2N/FX3U Series special function blocks, FX2N-1RM(-E)	DIN rail or direct mounting

- Install the product on a flat surface.
If the mounting surface is rough, undue force will be applied to the PC board, thereby causing nonconformities.
- Make sure to affix the expansion board with tapping screws.
Tightening torque should follow the specifications in the manual.
Loose connections may cause malfunctions.
- When drilling screw holes or wiring, make sure that cutting and wiring debris do not enter the ventilation slits.
Failure to do so may cause fire, equipment failures or malfunctions.
- Be sure to remove the dust proof sheet from the PLC's ventilation port when installation work is completed.
Failure to do so may cause fire, equipment failures or malfunctions.
- Connect the extension cables, peripheral device cables, input/output cables and battery connecting cable securely to their designated connectors.
Loose connections may cause malfunctions.
- Connect the display module, memory cassette, FX2NC Series I/O extension blocks, FX2NC-CNV-IF, extension power supply unit and expansion board securely to their designated connectors.
Loose connections may cause malfunctions.
- Turn off the power to the PLC before attaching or detaching the following devices.
Failure to do so may cause equipment failures or malfunctions.
 - Peripheral devices, display modules, expansion boards and special adapters
 - Extension blocks, FX Series terminal blocks, connector conversion adapter and extension power supply unit
 - Battery and memory cassette

Note

- When a dust proof sheet is supplied with an extension unit/ block, keep the sheet applied to the ventilation slits during installation and wiring work.

WIRING PRECAUTIONS



- Make sure to cut off all phases of the power supply externally before attempting installation or wiring work.
Failure to do so may cause electric shock or damage to the product.
- Make sure to attach the terminal cover, offered as an accessory, before turning on the power or initiating operation after installation or wiring work.
Failure to do so may cause electric shock.
- The temperature rating of the cable should be 80°C or more.

1
Outline

2
External
Dimensions

3
Generic
Specifications

4
Power Supply
Specifications

5
Input
Specifications

6
Output
Specifications

7
Examples of
Wiring for
Various Uses

8
Terminal Block

9
CC-LINK/LT
Master FX3UC-
LT(-Z) only

10
Display module
FX3UC-LT(-Z)
only

WIRING PRECAUTIONS



- Connect the DC power supply wiring to the dedicated terminals described in this manual.
If an AC power supply is connected to a DC input/output terminal or DC power supply terminal, the PLC will burn out.
- Do not wire vacant terminals externally.
Doing so may damage the product.
- Perform class D grounding (grounding resistance: 100Ω or less) to the grounding terminal on the main unit.
Do not use common grounding with heavy electrical systems.
- Make sure to properly wire the FX₀N/FX₂N/FX₃U Series extension equipment in accordance with the following precautions.
Failure to do so may cause electric shock, equipment failures, a short-circuit, wire breakage, malfunctions, or damage to the product.
 - The disposal size of the cable end should follow the dimensions described in the manual.
 - Tightening torque should follow the specifications in the manual.
 - Tighten the screws using a Phillips-head screwdriver No.2 (shaft diameter 6mm (0.24") or less). Make sure that the screwdriver does not touch the partition part of the terminal block.
- Make sure to properly wire to the terminal block (European type) in accordance with the following precautions.
Failure to do so may cause electric shock, equipment failures, a short-circuit, wire breakage, malfunctions, or damage to the product.
 - The disposal size of the cable end should follow the dimensions described in the manual.
 - Tightening torque should follow the specifications in the manual.
 - Twist the end of strand wire and make sure that there are no loose wires.
 - Do not solder-plate the electric wire ends.
 - Do not connect more than the specified number of wires or electric wires of unspecified size.
 - Affix the electric wires so that neither the terminal block nor the connected parts are directly stressed.
- Make sure to properly wire to the FX Series terminal blocks in accordance with the following precautions.
Failure to do so may cause electric shock, equipment failures, a short-circuit, wire breakage, malfunctions, or damage to the product.
 - The disposal size of the cable end should follow the dimensions described in the manual.
 - Tightening torque should follow the specifications in the manual.
 - Tighten the screws using a Phillips-head screwdriver No.2 (shaft diameter 6mm (0.24") or less). Make sure that the screwdriver does not touch the partition part of the terminal block.

8.1 Overview

A terminal block is used to convert connector type input/output terminals into a terminal block. Moreover, dedicated input and output terminal blocks (built-in element types) can be used to receive AC input signals for conversion to relay / transistor / triac output types.

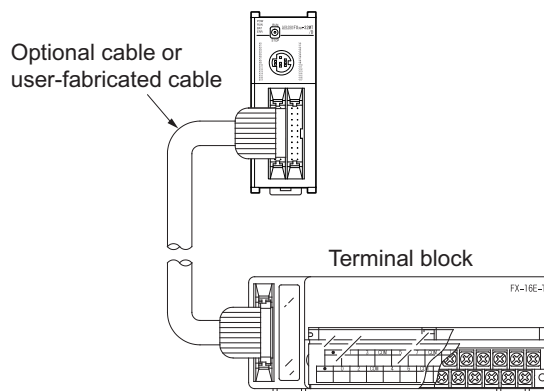

8.1.1 Product configuration

Model Name	Number of Input Points	Number of Output Points	Function	Connection Destination	Drive Power Supply
Connected to sink only input or sink only output (transistor output) type main unit or I/O extension block					
FX-16E-TB	16 input points or 16 output points		Connects directly to PLC input/output terminals.	FX ₃ UC-□□MT/D, FX ₃ UC-32MT-LT(-2), FX ₂ NC-□□EX, FX ₂ NC-□□EYT, FX ₂ N-16EX-C, FX ₂ N-16EYT-C	*1
FX-32E-TB	32 input points, 32 output points, or 16 input & 16 output points				
FX-16EX-A1-TB*2	16	-	100V AC input type	FX ₃ UC-□□MT/D, FX ₃ UC-32MT-LT(-2), FX ₂ NC-□□EX, FX ₂ N-16EX-C	*4
FX-16EYR-TB*3	-	16	Relay output type	FX ₃ UC-□□MT/D, FX ₃ UC-32MT-LT(-2), FX ₂ NC-□□EYT, FX ₂ N-16EYT-C	24V DC 80mA
FX-16EYT-TB*3	-	16	Transistor output (sink) type		24V DC 112mA
FX-16EYT-H-TB*3	-	16			
FX-16EYS-TB*3	-	16	Triac output type		
Connected to sink/source common input type or source only output (transistor output) type main unit or I/O extension block					
FX-16E-TB/UL	16 input points or 16 output points		Connects directly to PLC input/output terminals.	FX ₃ UC-□□MT/DSS, FX ₂ NC-□□EX-DS, FX ₂ NC-□□EYT-DSS	*1
FX-32E-TB/UL	32 input points, 32 output points, or 16 input & 16 output points				
FX-16EYR-ES-TB/UL*3	-	16	Relay output type	FX ₃ UC-□□MT/DSS, FX ₂ NC-□□EYT-DSS	24V DC 80mA
FX-16EYT-ES-TB/UL*3	-	16	Transistor output (sink) type		24V DC 112mA
FX-16EYT-ESS-TB/UL*3	-	16	Transistor output (source) type		
FX-16EYS-ES-TB*3	-	16	Triac output type		

1	Outline
2	External Dimensions
3	Generic Specifications
4	Power Supply Specifications
5	Input Specifications
6	Output Specifications
7	Examples of Wiring for Various Uses
8	Terminal Block
9	CC-Link/LT Master FX ₃ UC-LT(-2) only
10	Display module FX ₃ UC-LT(-2) only

- *1. The table below shows the drive power supply for each connection destination.

Connection destination	Power Supply Voltage	Current Consumption
Input connector		
FX3UC-□□MT/D, FX3UC-32MT-LT(-2), FX2NC-□□EX	Not required	
FX3UC-□□MT/DSS, FX2NC-□□EX-DS, FX2N-16EX-C	24V DC	112mA/ 16 points
Output connector		
FX3UC-□□MT/D, FX3UC-□□MT/DSS, FX3UC-32MT-LT(-2), FX2NC-□□EYT, FX2NC-□□EYT-DSS, FX2N-16EYT-C	Power supply suitable to connected load is required.	

- *2. The applications shown below are not supported.

Unsupported Applications	
High-speed processing	High-speed counter, input interruption, pulse catch, speed detection (SPD) instruction
Time division input	Input matrix (MTR) instruction, hexadecimal input (HKY) instruction, digital switch (DSW) instruction, arrow switch (ARWS) instruction
Other	Refresh and filter adjust (REFF) instruction, ten key input (TKY) instruction, absolute current value read (ABS) instruction

- *3. The applications shown below are not supported.

Unsupported Applications	
Pulse output	Pulse Y output (PLSY) instruction, acceleration/deceleration setup (PLSR) instruction, pulse width modulation (PWM) instruction, DOG search zero return (DSZR) instruction, interruption positioning (DVIT) instruction, batch data positioning mode (TBL) instruction, absolute current value read (ABS) instruction, zero return (ZRN) instruction, variable speed pulse output (PLSV) instruction, drive to increment (DRVI) instruction, drive to absolute (DRVA) instruction
Time division input	Input matrix (MTR) instruction, hexadecimal input (HKY) instruction, digital switch (DSW) instruction, arrow switch (ARWS) instruction
Time division output	Seven segment with latch (SEGL) instruction, print (ASCII Code) (PR) instruction

- *4. The table below shows the drive power supply for each connection destination.

Connection destination	Power Supply Voltage	Current Consumption
FX3UC-□□MT/D, FX3UC-32MT-LT(-2), FX2NC-□□EX	24V DC	48mA
FX2N-16EX-C	24V DC	160mA

8.2 External Dimensions & Component Names

FX-16E-TB, FX-16E-TB/UL

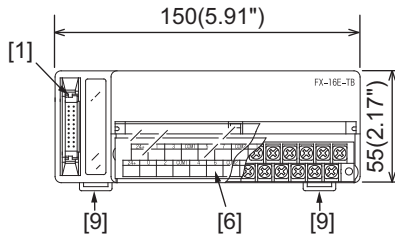

FX-32E-TB, FX-32E-TB/UL

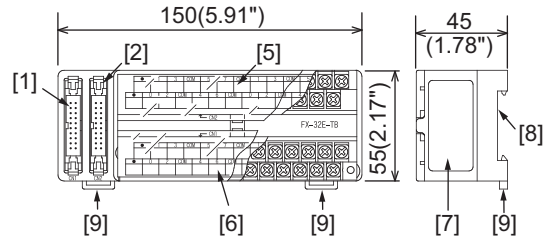

FX-16EX-A1-TB

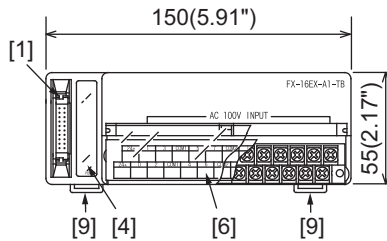

FX-16EYR-TB, FX-16EYR-ES-TB/UL, FX-16EYT-TB,
FX-16EYT-ES-TB/UL, FX-16EYT-ESS-TB/UL,
FX-16EYT-H-TB, FX-16EYS-TB, FX-16EYS-ES-TB/UL

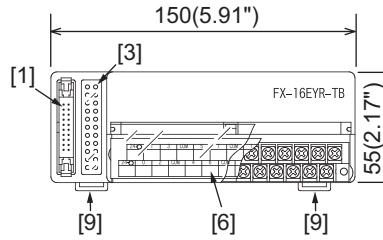

Units: mm (inches)

Accessories: Input/output No. labels,
terminal block arrangement cards

No.	Name	Remarks
[1]	CN1 connector	-
[2]	CN2 connector	Present at FX-32E-TB, FX-32E-TB/UL
[3]	Operation indicator LED	Present at FX-16EYR-TB, FX-16EYR-ES-TB/UL, FX-16EYT-TB, FX-16EYT-ES-TB/UL, FX-16EYT-ESS-TB/UL, FX-16EYT-H-TB, FX-16EYS-TB, FX-16EYS-ES-TB/UL,
[4]	POWER LED	Present at FX-16EX-A1-TB
[5]	CN2 terminal block (M3.5 screws)	Present at FX-32E-TB, FX-32E-TB/UL
[6]	CN1 terminal block (M3.5 screws)	-
[7]	Nameplate	-
[8]	DIN rail mounting groove (DIN rail width: 35mm(1.38"))	-
[9]	DIN rail mounting hook	-

1
Outline

2
External
Dimensions

3
Generic
Specifications

4
Power Supply
Specifications

5
Input
Specifications

6
Output
Specifications

7
Examples of
Wiring for
Various Uses

8
Terminal Block

9
CC-Link/LT
Master FX3UC-
LT(-2) only

10
Display module
FX3UC-LT(-2)
only

8.3 Terminal Arrangement

1. FX-16E-TB, FX-16E-TB/UL

When connected to the FX3UC/FX2NC I/O extension blocks (connector type) or FX2N-16EYT-C

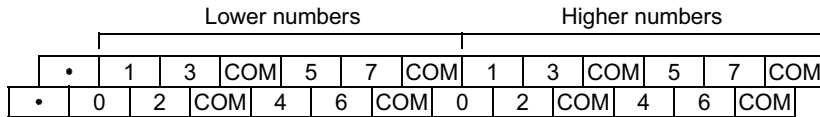
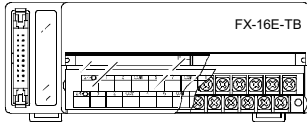

When connected to the FX2N-16EX-C

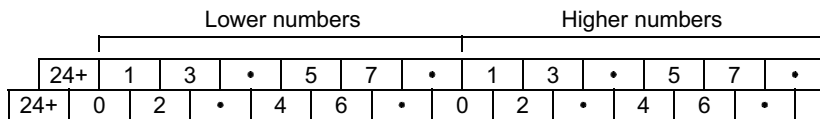
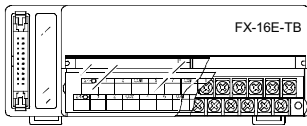

2. FX-32E-TB, FX-32E-TB/UL

When connected to the FX3UC/FX2NC I/O extension blocks (connector type) or FX2N-16EYT-C

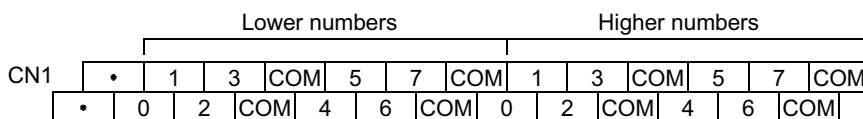
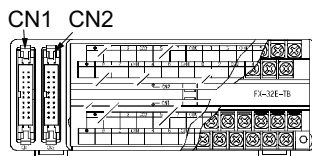
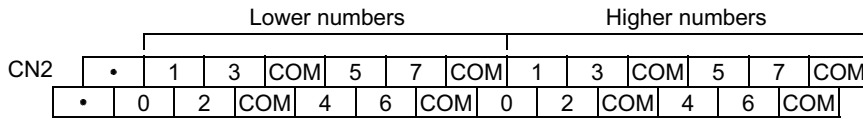

When connected to the FX2N-16EX-C

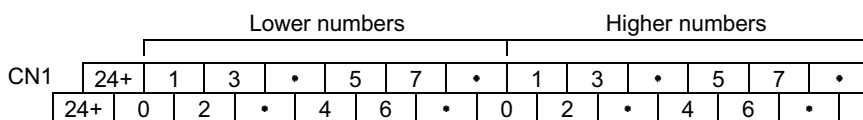
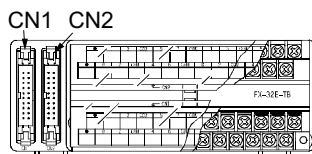
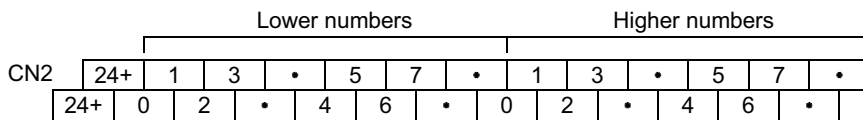

3. FX-16EX-A1-TB

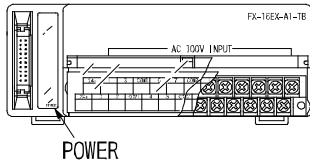

Lower numbers							Higher numbers						
24+	1	3	COM1	5	7	COM2	1	3	COM3	5	7	COM4	
24-	0	2	COM1	4	6	COM2	0	2	COM3	4	6	COM4	

4. FX-16EYR-TB, FX-16EYR-ES-TB/UL, FX-16EYT-TB, FX-16EYT-ES-TB/UL, FX-16EYT-ESS-TB/UL, FX-16EYT-H-TB, FX-16EYS-TB, FX-16EYS-ES-TB/UL

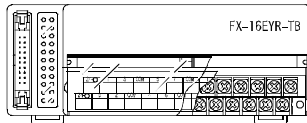

Lower numbers							Higher numbers						
24+	1	3	COM1	5	7	COM2	1	3	COM3	5	7	COM4	
24-	0	2	COM1	4	6	COM2	0	2	COM3	4	6	COM4	

1
Outline

2
External
Dimensions

3
Generic
Specifications

4
Power Supply
Specifications

5
Input
Specifications

6
Output
Specifications

7
Examples of
Wiring for
Various Uses

8
Terminal Block

9
CC-Link/LT
Master FX3UC-
LT(-2) only

10
Display module
FX3UC-LT(-2)
only

8.4 Installation Work

→ Refer to Section 3.2 for installation location.

8.4.1 Mounting/Removal

1. Mounting method

- 1) Turn OFF all power supplies connected to the PLC, input/output devices, and terminal blocks.
- 2) Align the top side of the "DIN rail mounting groove" (refer to ① at right)
- 3) Press the product onto the DIN rail (refer to ② at right).

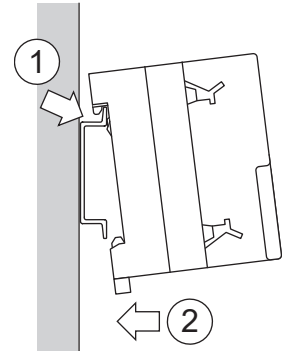

2. Removal method

- 1) Turn the power supply OFF.
- 2) Disconnect the wiring and input/output cables.
- 3) Place a flathead screwdriver against the DIN rail mounting hook in the posture shown (refer to ① at right)
- 4) Move the flathead screwdriver in direction shown at right (refer to ② at right) to detach the DIN rail mounting hook from the DIN rail.
- 5) Remove the product from the DIN rail.

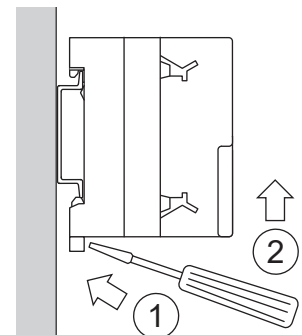

8.4.2 Input/output cable connection

The terminal block's CN1 and CN2 connectors comply with the MIL-83503 standard.

→ Refer to Section 3.11 for input/output cable information.

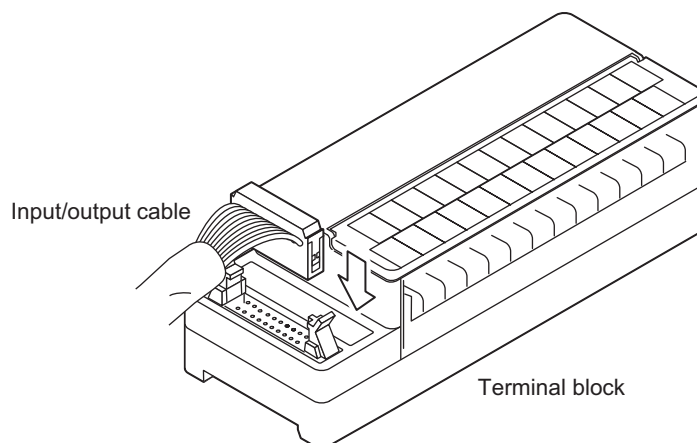

8.4.3 Connection to terminal block

1. The product terminal screws are as shown in the table below.

Model Name	Terminal Screw Size
FX-16E-TB, FX-16E-TB/UL, FX-32E-TB, FX-32E-TB/UL, FX-16EX-A1-TB, FX-16EYR-TB, FX-16EYR-ES-TB/UL, FX-16EYT-TB, FX-16EYT-ES-TB/UL, FX-16EYT-ESS-TB/UL, FX-16EYT-H-TB, FX-16EYS-TB, FX-16EYS-ES-TB/UL	M3.5

2. Crimp terminal sizes vary according to the wiring method.

Use the sizes shown below.

Tighten the terminals to a torque of 0.5 to 0.8 N•m.

Do not tighten terminal screws with a torque outside the above-mentioned range.

Failure to do so may cause equipment failures or malfunctions.

- When 1 wire is connected to 1 terminal:
Use a crimp terminal of the size shown below, and install it as shown in the lower right figure.

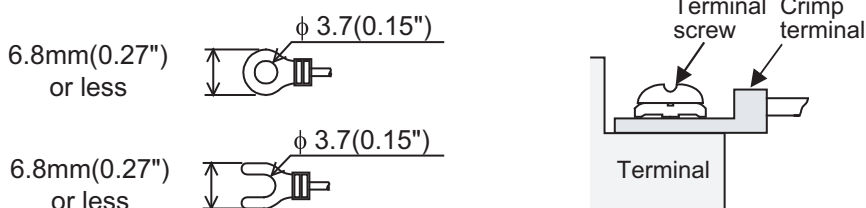

- When 2 wires are connected to 1 terminal:
Use a crimp terminal of the size shown below, and install it as shown in the lower right figure.

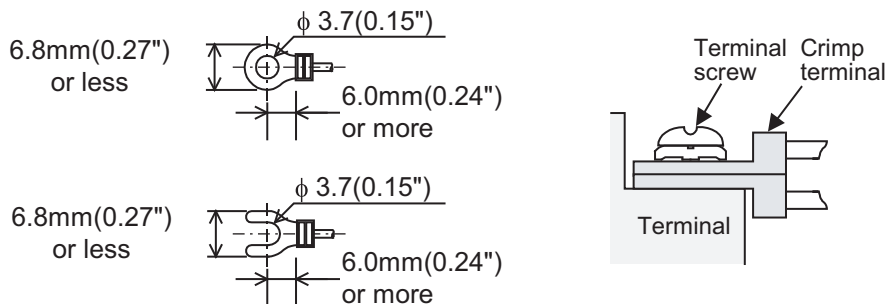

1	Outline
2	External Dimensions
3	Generic Specifications
4	Power Supply Specifications
5	Input Specifications
6	Output Specifications
7	Examples of Wiring for Various Uses
8	Terminal Block
9	CC-Link/LT Master FX3UC-LT(-2) only
10	Display module FX3UC-LT(-2) only

8.5 FX-16E-TB/FX-32E-TB

Connect the FX-16E-TB/FX-32E-TB to the main unit or extension block shown in the table below.

	Input connector	Output connector
Connectable models	FX3UC-□□MT/D, FX3UC-32MT-LT(-2), FX2NC-□□EX, FX2N-16EX-C	FX3UC-□□MT/D, FX3UC-32MT-LT(-2), FX2NC-□□EYT, FX2N-16EYT-C

8.5.1 Internal circuit

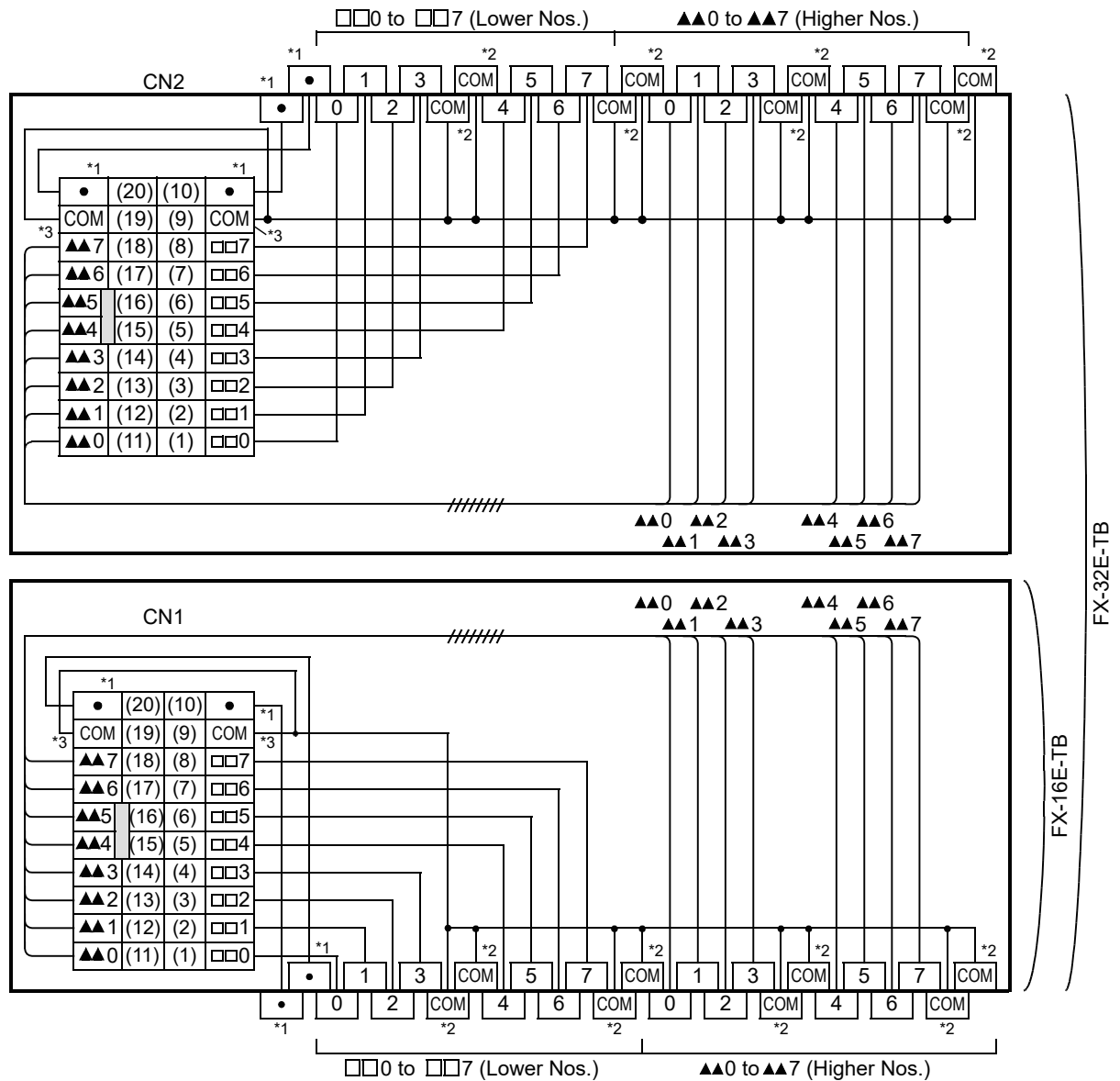

*1 "24+" when connected to FX2N-16EX-C.

*2 "•" when connected to FX2N-16EX-C.

*3 "•" when connected to FX2N-16EX-C.

"COM1", "COM2" or "COM3" in accordance with the connector when connected to output connector.

8.5.2 Example of input external wiring [sink wiring]

WIRING PRECAUTIONS



- Do not wire vacant terminals externally. Doing so may damage the product.

1. When connected to the FX3uc-□□MT/D, FX3uc-32MT-LT(-2) and FX2Nc-□□EX input connector.

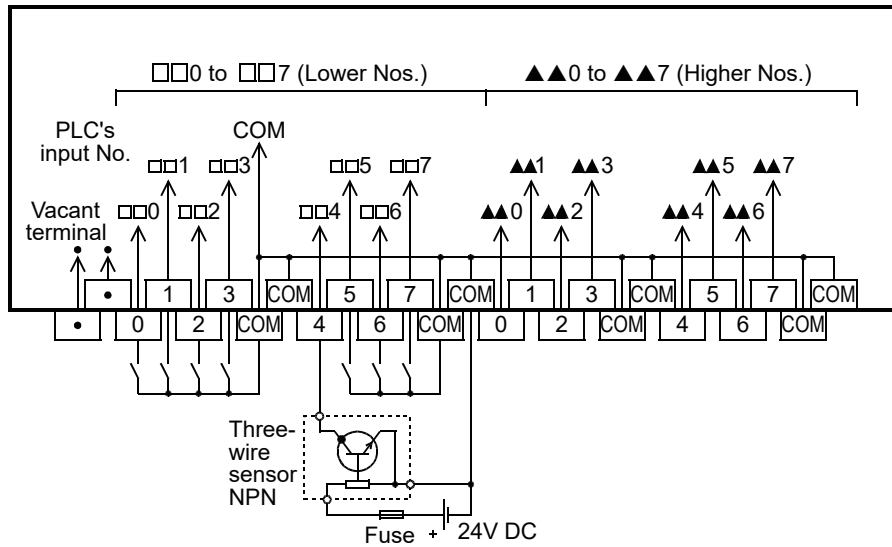

2. When connected to an FX2N-16EX-C input connector

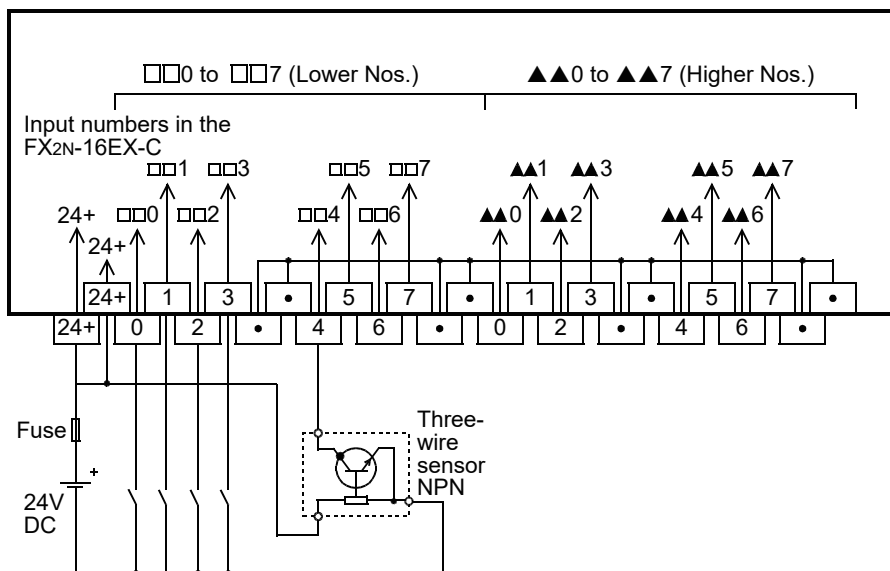

1	Outline
2	External Dimensions
3	Generic Specifications
4	Power Supply Specifications
5	Input Specifications
6	Output Specifications
7	Examples of Wiring for Various Uses
8	Terminal Block
9	CC-Link/LT Master FX3uc-LT(-2) only
10	Display module FX3uc-LT(-2) only

8.5.3 Example of output external wiring [sink wiring]

WIRING PRECAUTIONS



- Do not wire vacant terminals externally.
 Doing so may damage the product.

1. When connected to the FX3UC-□□MT/D, FX3UC-32MT-LT(-2), FX2NC-□□EYT and FX2N-16EYT-C output connector.

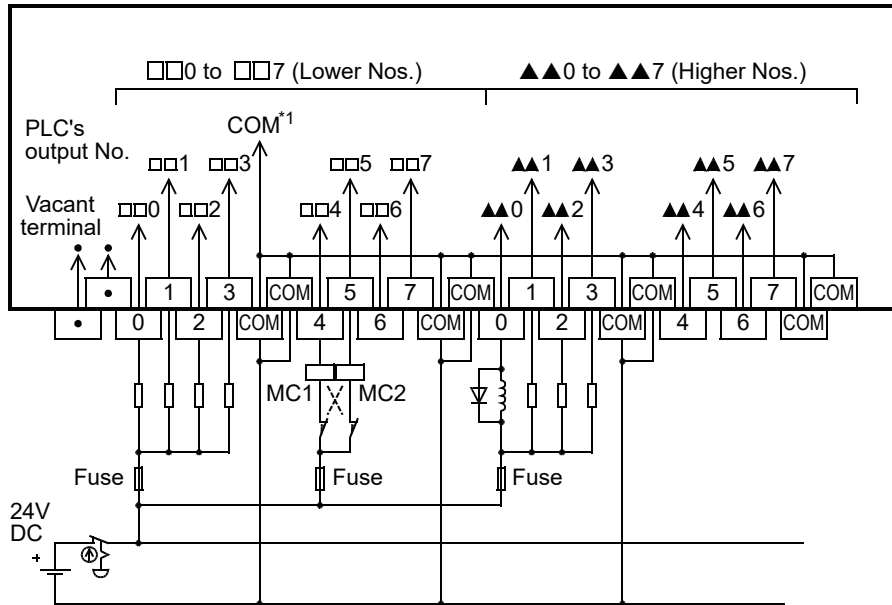

*1. "COM1", "COM2" or "COM3" in accordance with connected connector.

8.6 FX-16E-TB/UL, FX-32E-TB/UL

Connect the FX-16E-TB/FX-32E-TB to the main unit or extension block shown in the table below.

	Input connector	Output connector
Connectable models	FX3UC-□□MT/DSS, FX2NC-□□EX-DS	FX3UC-□□MT/DSS, FX2NC-□□EYT-DSS

8.6.1 Internal circuit

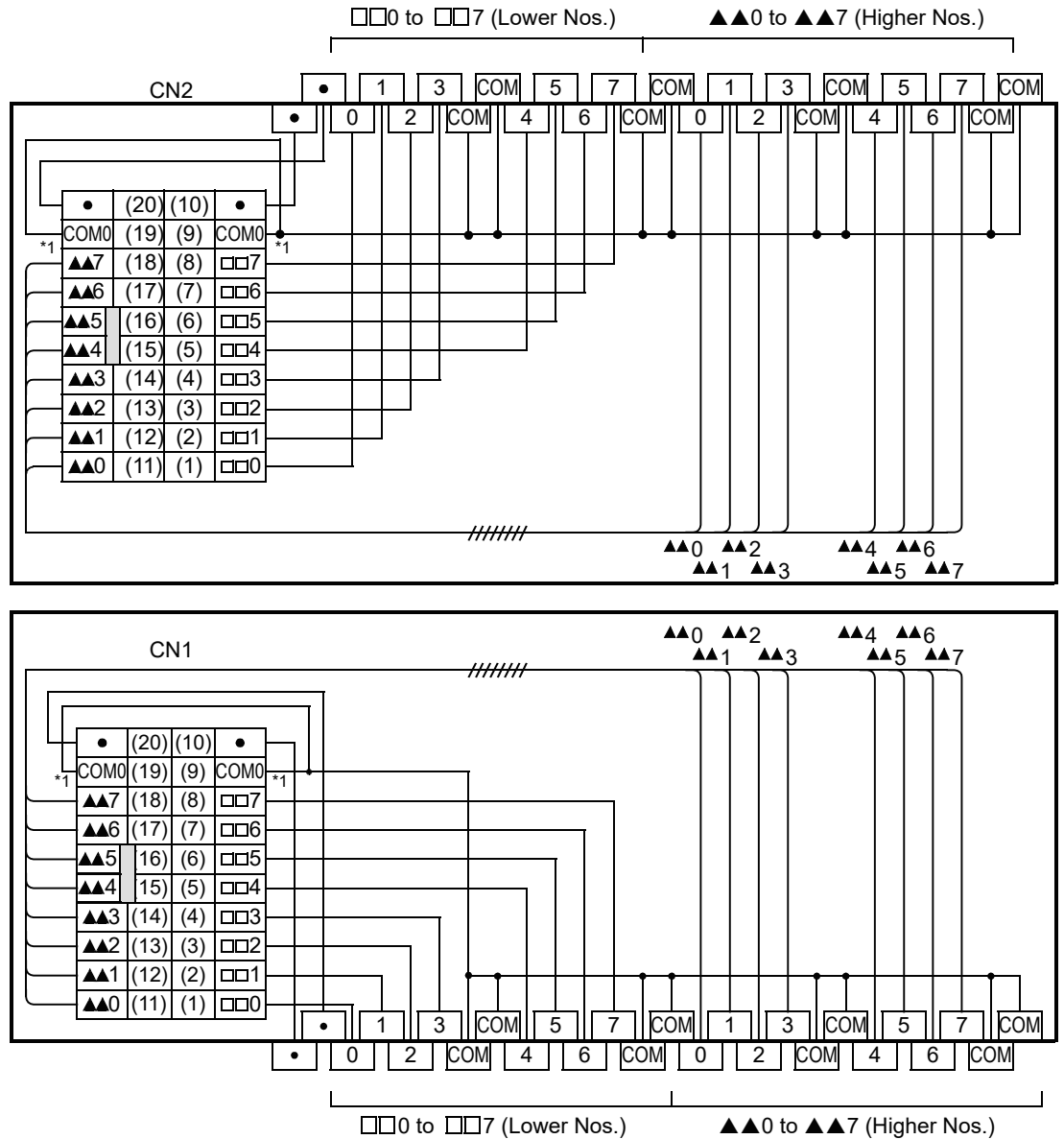

*1. Regard it as follows in accordance with the connected connector.
 - Input connector : "COM1", "COM2"
 - Output connector : "+V0", "+V1", "+V2"

1	Outline
2	External Dimensions
3	Generic Specifications
4	Power Supply Specifications
5	Input Specifications
6	Output Specifications
7	Examples of Wiring for Various Uses
8	Terminal Block
9	CC-LINK/LT Master FX3UC-LT(-2) only
10	Display module FX3UC-LT(-2) only

8.6.2 Example of input external wiring [Sink/Source wiring]

WIRING PRECAUTIONS	⚠ CAUTION
<ul style="list-style-type: none"> • Do not wire vacant terminals externally. Doing so may damage the product. 	

1. Connection to the input connector in the FX3UC-□□MT/DSS or FX2NC-□□EX-DS for sink wiring

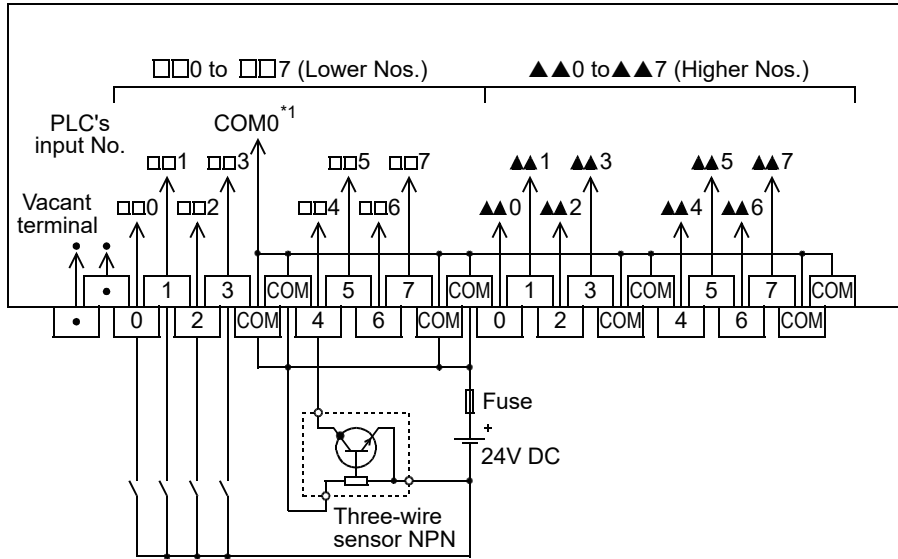

*1."COM1" or "COM2" in accordance with connected connector

2. Connection to the input connector in the FX3UC-□□MT/DSS or FX2NC-□□EX-DS for source wiring

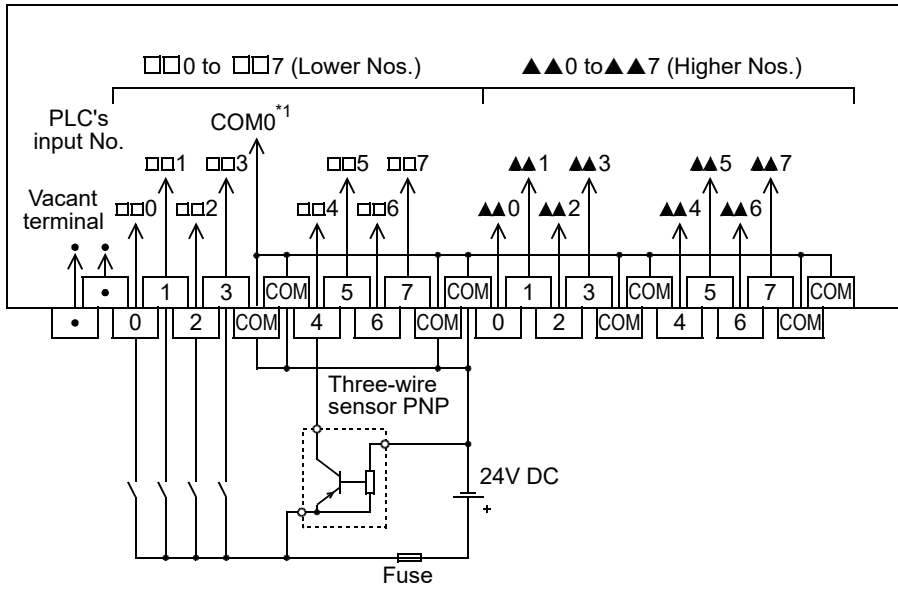

*1."COM1" or "COM2" in accordance with connected connector

8.6.3 Example of output external wiring [Source wiring]

WIRING PRECAUTIONS



- Do not wire vacant terminals externally.
Doing so may damage the product.

1. When connected to the FX3UC-□□MT/DSS and FX2NC-□□EYT-DSS output connector

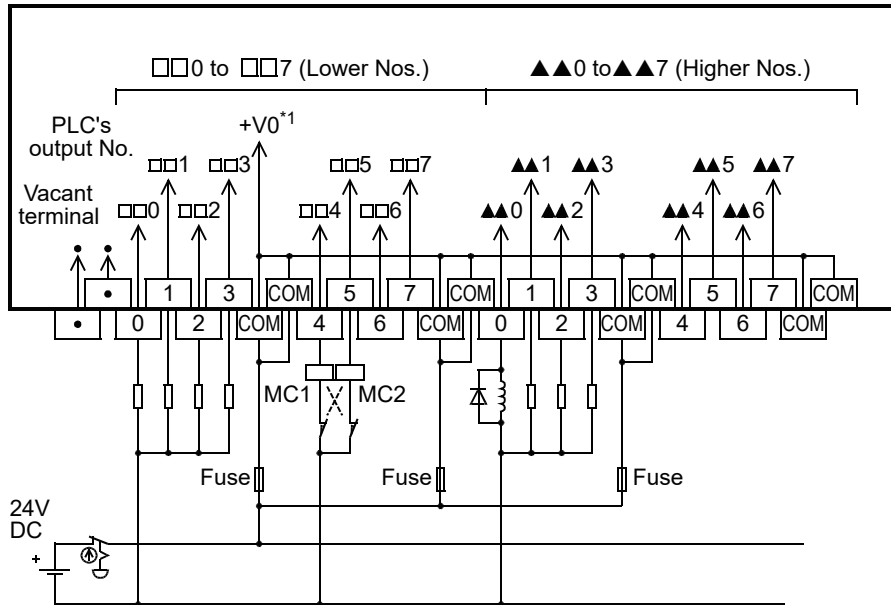

*1. "+V1" or "+V2" in accordance with connected connector

8.7 FX-16EX-A1-TB

Connect the FX-16EX-A1-TB to the input connector in the main unit or extension block shown in the table below.

	Input connector
Connectable models	FX ₃ UC-□□MT/D, FX ₃ UC-32MT-LT(-2), FX ₂ NC-□□EX, FX ₂ N-16EX-C

The applications shown below are not supported.

	Unsupported Applications
Time division input	Input matrix (MTR) instruction, hexadecimal input (HKY) instruction, digital switch (DSW) instruction, arrow switch (ARWS) instruction
High-speed processing	High-speed counter, input interruption, pulse catch, speed detection (SPD) instruction
Other	Refresh and filter adjust (REFF) instruction, ten key input (TKY) instruction, absolute current value read (ABS) instruction

8.7.1 Specifications

Item	FX-16EX-A1-TB
Connection form	Terminal block (M3.5 screw) The connection with the PLC is the connector.
input type	AC input
Input signal voltage	100 to 120V AC +10%, -15% 50/60 Hz
Input signal current	4.7mA/100V AC 50 Hz 6.2mA/110V AC 60 Hz
Input impedance	Approx. 21 kΩ/50 Hz Approx. 18 kΩ/60 Hz
Input sensitivity	ON 3.8mA/80V AC or more
	OFF 1.7mA/30V AC or less
Response time *1	30ms or less
Input signal format	Voltage contact
Circuit isolation	Photocoupler isolation
Input operation display	No input LEDs (equipped with 24V power supply LED indicator)
Power consumption	1.2W (48mA 24V DC)*2
Input/output circuitry	

*1. This response time does not include the response delay at the PLC.

*2. 3.9W (160mA, 24V DC) is required when connected to the FX₂N-16EX-C.

8.7.2 Internal circuit

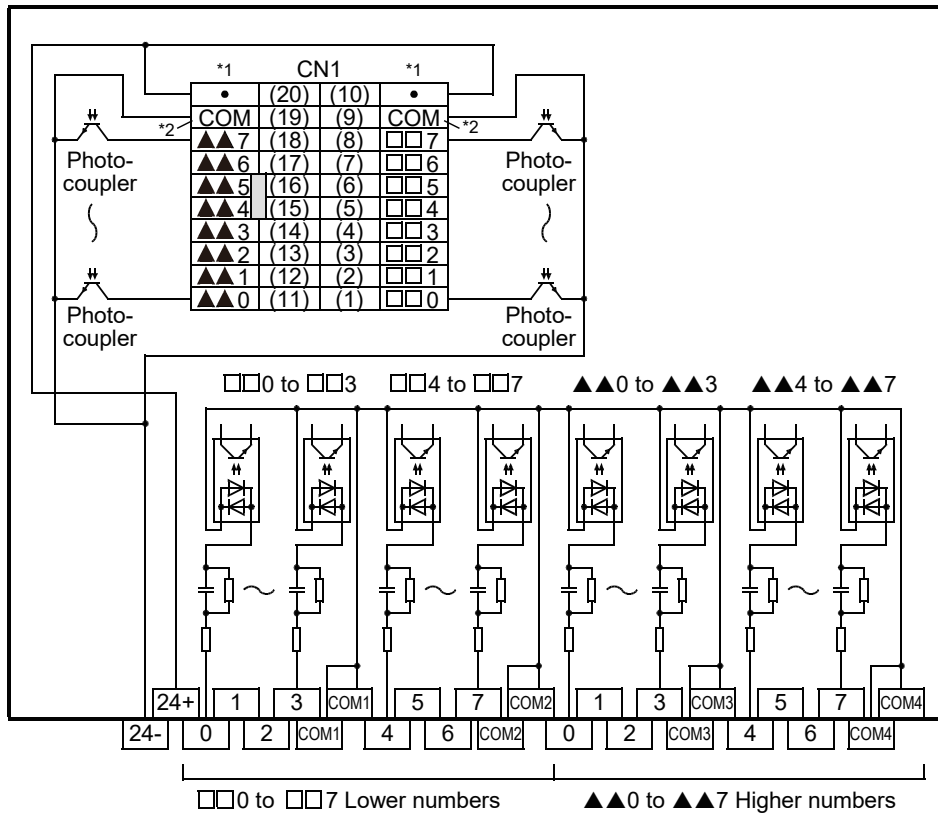

*1. "24+" when connected to FX2N-16EX-C.
*2. "•" when connected to FX2N-16EX-C.

8.7.3 Example of input external wiring

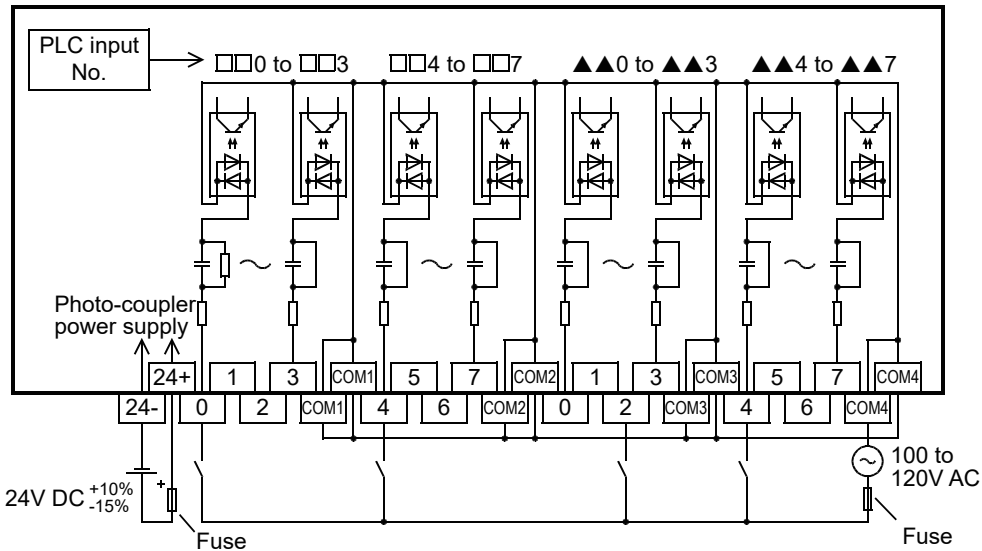

1	Outline
2	External Dimensions
3	Generic Specifications
4	Power Supply Specifications
5	Input Specifications
6	Output Specifications
7	Examples of Wiring for Various Uses
8	Terminal Block
9	CC-Link/LT Master FX3uc-LT(-Z) only
10	Display module FX3uc-LT(-Z) only

8.8 FX-16EYR-TB

Connect the FX-16EYR-TB to the output connector in the main unit or extension block shown in the table below.

	Output connector
Connectable models	FX3UC-□□MT/D, FX3UC-32MT-LT(-2), FX2NC-□□EYT, FX2N-16EYT-C

The applications shown below are not supported.

	Unsupported Applications
Pulse output	Pulse Y output (PLSY) instruction, acceleration/deceleration setup (PLSR) instruction, pulse width modulation (PWM) instruction, DOG search zero return (DSZR) instruction, interruption positioning (DVIT) instruction, batch data positioning mode (TBL) instruction, absolute current value read (ABS) instruction, zero return (ZRN) instruction, variable speed pulse output (PLSV) instruction, drive to increment (DRVI) instruction, drive to absolute (DRVA) instruction
Time division input	Input matrix (MTR) instruction, hexadecimal input (HKY) instruction, digital switch (DSW) instruction, arrow switch (ARWS) instruction
Time division output	Seven segment with latch (SEGL) instruction, print (ASCII Code) (PR) instruction

8.8.1 Specifications

Item	FX-16EYR-TB		
Connection form	Terminal block (M3.5 screw) The connection with the PLC is the connector.		
Output type	Relay		
External power supply	250V AC or less, 30V DC or less		
Max. load	Resistance load	2A/1 point	Make sure that the total load current of 4 resistance load points is 8A or less.
	Inductive load	80 VA	
Min. load	5V DC, 2mA Reference value		
Open-circuit leakage current	-		
Response time *1	Approx. 10ms		
Circuit isolation	Mechanical isolation		
Operation indicators	LED lights when relay coil power is supplied		
Power consumption	1.92 W (80mA 24V DC)		
Input/output circuitry			

*1. This response time does not include the response delay at the PLC.

8.8.2 Internal circuit

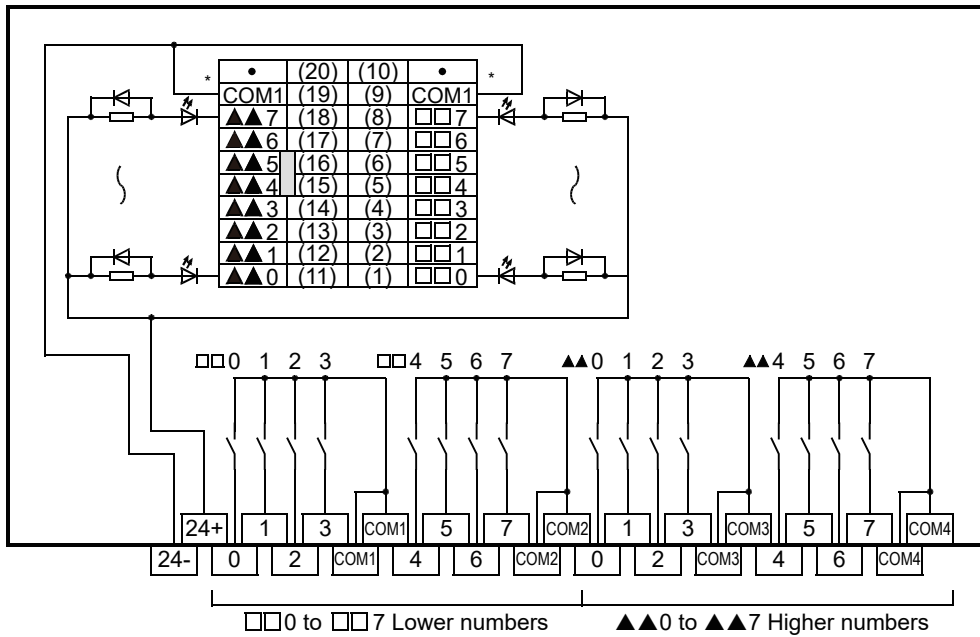

*."COM2" or "COM3" in accordance with connected connector

8.8.3 Example of output external wiring

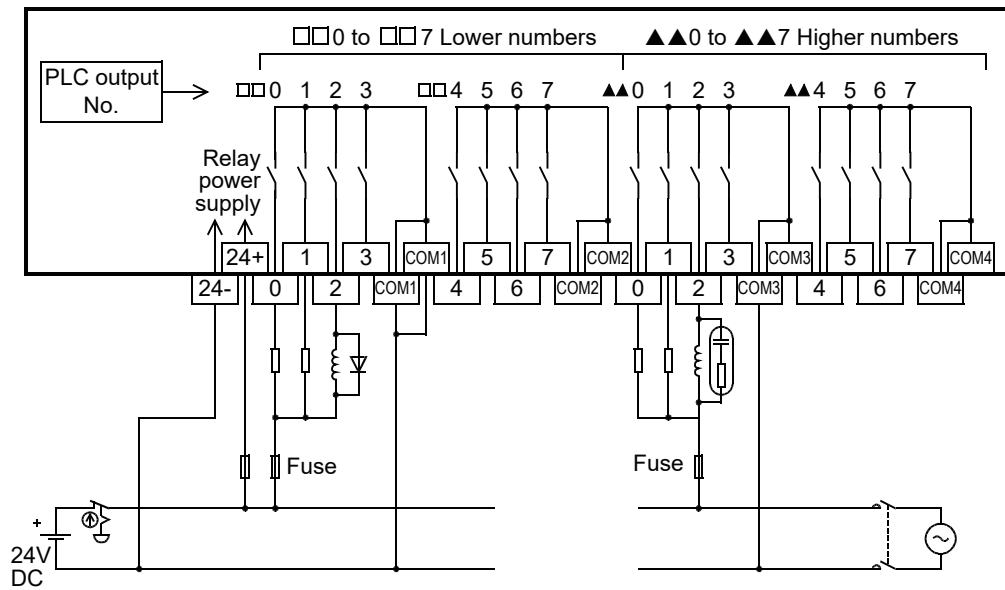

1	Outline
2	External Dimensions
3	Generic Specifications
4	Power Supply Specifications
5	Input Specifications
6	Output Specifications
7	Examples of Wiring for Various Uses
8	Terminal Block
9	CC-Link/LT Master FX3UC-LT(-2) only
10	Display module FX3UC-LT(-2) only

8.8.4 External wiring precautions

1. Protection circuit for load short-circuits

A short-circuit at a load connected to an output terminal could cause burnout at the output element or the PCB. To prevent this, a protection fuse should be inserted at the output.

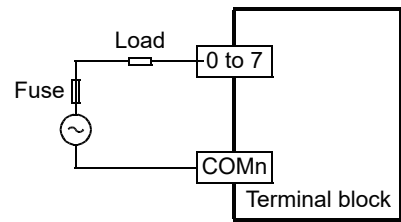

2. Contact protection circuit for inductive loads

An internal protection circuit for the relays is not provided for the relay output circuit in the terminal block. It is recommended to use inductive loads with built-in protection circuits. When using loads without built-in protection circuits, insert an external contact protection circuit, etc. to reduce noise and extend the product life.

1) DC circuit

Connect a diode (for commutation) parallel to the load.

The diode (for commutation) must comply with the following specifications.

	Guide
Counter voltage	5 to 10 times of the load voltage
Forward current	Load current or more

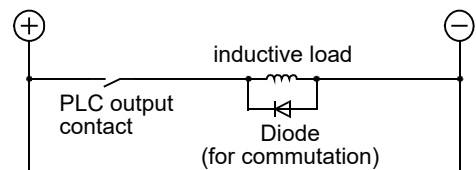

2) AC circuit

Connect the surge absorber (combined CR components such as a surge killer and spark killer, etc.), parallel to the load.

Select the rated voltage of a surge absorber that is suitable for the load being used. Refer to the table below for other specifications.

Item	Guide
Static electricity capacity	Approx. 0.1μF
Forward current	Approx. 100 to 200Ω

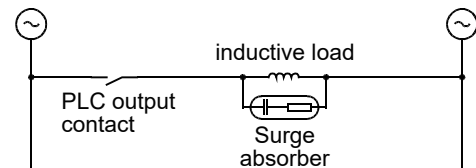

Reference

Manufacturer	Model name
Okaya Electric Industries Co., Ltd.	CR-10201

Manufacturer	Model name
Rubycon Corporation	250MCRA104100M B0325

3. Interlock

For loads such as forward/reverse contactors, etc., where a hazardous condition could result if switched ON simultaneously, an external interlock should be provided for interlocking the PLC's internal programs as shown to the right.

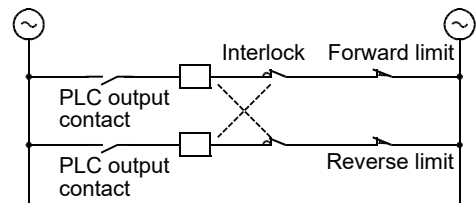

4. In-phase

PLC output contacts (*) should be used in an "in-phase" manner.

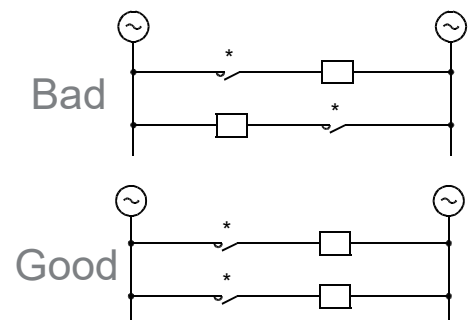

8.8.5 Product life of relay contacts

The product life of relay contacts varies considerably depending on the load type used. Take care that loads generating reverse electromotive force or rush current may cause poor contact or deposition of contacts which may lead to considerable reduction of the contact product life.

1. Inductive load

Inductive loads generate large reverse electromotive force between contacts at shutdown, which may cause arcing. At a fixed current consumption, as the power factor (phase between current and voltage) gets smaller, the arc energy gets larger.

The standard life of contacts used for Inductive loads, such as contactors and solenoid valves, is 500,000 operations at 35VA.

The following table shows the approximate life of a relay based on the results of an operation life test.

Test condition: 1 sec. ON / 1 sec. OFF

Load capacity		Contact life
35VA	0.35A/100V AC	3,000,000 times
	0.17A/200V AC	
80VA	0.8A/100V AC	1,000,000 times
	0.4A/200V AC	
120VA	1.2A/100V AC	200,000 times
	0.6A/200V AC	

The product life of relay contacts becomes considerably shorter than the above conditions when the rush overcurrent is shut down.

→ **For precautions on using inductive loads, refer to Subsection 8.8.4 2.**

Some types of inductive loads generate rush current 5 to 15 times the stationary current at activation. Make sure that the rush current does not exceed the current corresponding to the maximum specified resistance load.

2. Lamp load

Lamp loads generally generate rush current 10 to 15 times the stationary current. Make sure that the rush current does not exceed the current corresponding to the maximum specified resistance load.

3. Capacitive load

Capacitive loads can generate rush current 20 to 40 times the stationary current. Make sure that the rush current does not exceed the current corresponding to the maximum specified resistance load. Capacitive loads such as capacitors may be present in electronic circuit loads including inverters.

→ **For the maximum specified resistance load, refer to Subsection 8.8.1.**

1	Outline
2	External Dimensions
3	Generic Specifications
4	Power Supply Specifications
5	Input Specifications
6	Output Specifications
7	Examples of Wiring for Various Uses
8	Terminal Block
9	CC-LINK/LT Master FX ₃ UC-LT(-Z) only
10	Display module FX ₃ UC-LT(-Z) only

8.9 FX-16EYR-ES-TB/UL

Connect the FX-16EYR-ES-TB/UL to the output connector in the main unit or extension block shown in the table below.

	Output connector
Connectable models	FX ₃ UC-□□MT/DSS, FX ₂ NC-□□EYT-DSS

The applications shown below are not supported.

	Unsupported Applications
Pulse output	Pulse Y output (PLSY) instruction, acceleration/deceleration setup (PLSR) instruction, pulse width modulation (PWM) instruction, DOG search zero return (DSZR) instruction, interruption positioning (DVIT) instruction, batch data positioning mode (TBL) instruction, absolute current value read (ABS) instruction, zero return (ZRN) instruction, variable speed pulse output (PLSV) instruction, drive to increment (DRVI) instruction, drive to absolute (DRVA) instruction
Time division input	Input matrix (MTR) instruction, hexadecimal input (HKY) instruction, digital switch (DSW) instruction, arrow switch (ARWS) instruction
Time division output	Seven segment with latch (SEGL) instruction, print (ASCII Code) (PR) instruction

8.9.1 Specifications

Item	FX-16EYR-ES-TB/UL		
Connection form	Terminal block (M3.5 screw) The connection with the PLC is the connector.		
Output type	Relay		
External power supply	250V AC or less, 30V DC or less		
Max. load	Resistance load	2A/1 point	Make sure that the total load current of 4 resistance load points is 8A or less.
	Inductive load	80VA	
Min. load	5V DC, 2mA Reference value		
Open-circuit leakage current	-		
Response time *1	Approx. 10ms		
Circuit isolation	Mechanical isolation		
Operation indicators	LED lights when relay coil power is supplied		
Power consumption	1.92 W (80mA 24V DC)		
Input/output circuitry			

*1. This response time does not include the response delay at the PLC.

8.9.2 Internal circuit

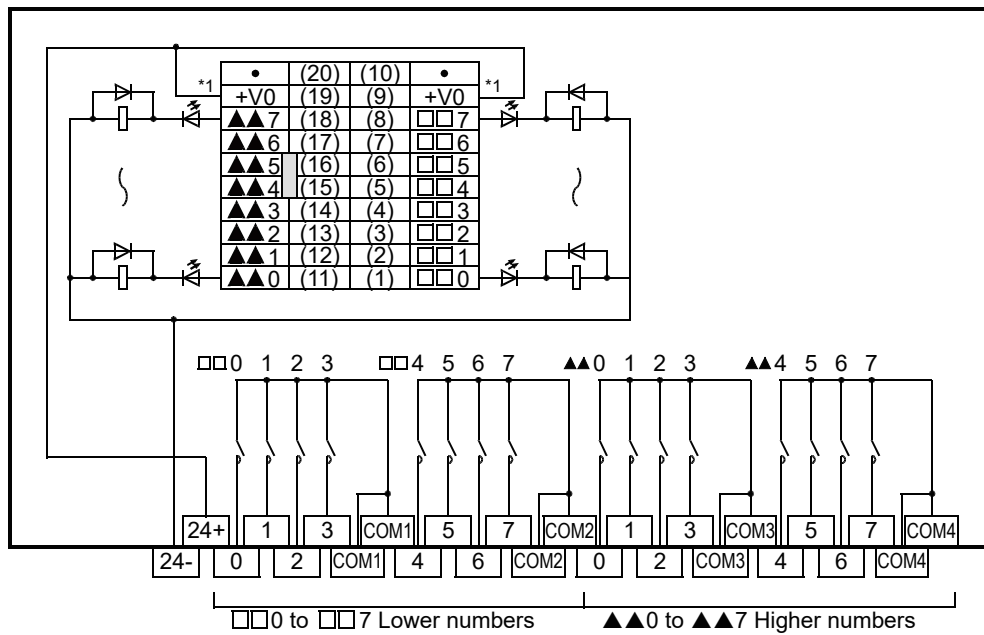

*1. "+V1" or "+V2" in accordance with connected connector

8.9.3 Example of output external wiring

The example of output external wiring is the same as FX-16EYR-TB. Refer to Subsection 8.8.3.

8.9.4 External wiring precautions

The caution on external wiring is the same as FX-16EYR-TB. Refer to Subsection 8.8.4.

8.9.5 Product life of relay contacts

Product life of relay contacts is the same as FX-16EYR-TB. Refer to Subsection 8.8.5.

1	Outline
2	External Dimensions
3	Generic Specifications
4	Power Supply Specifications
5	Input Specifications
6	Output Specifications
7	Examples of Wiring for Various Uses
8	Terminal Block
9	CC-LINK/LT Master FX3UC-LT(-2) only
10	Display module FX3UC-LT(-2) only

8.10 FX-16EYT(-H)-TB

Connect the FX-16EYT(-H)-TB to the output connector in the main unit or extension block shown in the table below.

	Output connector
Connectable models	FX3UC-□□MT/D, FX3UC-32MT-LT(-2), FX2NC-□□EYT, FX2N-16EYT-C

The applications shown below are not supported.

	Unsupported Applications
Pulse output	Pulse Y output (PLSY) instruction, acceleration/deceleration setup (PLSR) instruction, pulse width modulation (PWM) instruction, DOG search zero return (DSZR) instruction, interruption positioning (DVIT) instruction, batch data positioning mode (TBL) instruction, absolute current value read (ABS) instruction, zero return (ZRN) instruction, variable speed pulse output (PLSV) instruction, drive to increment (DRVI) instruction, drive to absolute (DRVA) instruction
Time division input	Input matrix (MTR) instruction, hexadecimal input (HKY) instruction, digital switch (DSW) instruction, arrow switch (ARWS) instruction
Time division output	Seven segment with latch (SEGL) instruction, print (ASCII Code) (PR) instruction

8.10.1 Specifications

Item	FX-16EYT-TB		FX-16EYT-H-TB	
Connection form	Terminal block (M3.5 screw) The connection with the PLC is the connector.		Terminal block (M3.5 screw) The connection with the PLC is the connector.	
input type/form	Transistor/sink output		Transistor/sink output	
External power supply	5-30 V DC		5-30 V DC	
Max. load	Resistance load	0.5A/ 1 points Make sure that the total load current of 4 resistance load points is 0.8A or less.	1A/1 points	Make sure that the total load current of 4 resistance load points is 3A or less.
	Inductive load	12W/24V DC	24W/24V DC	
Open-circuit leakage current	0.1mA/30V DC		0.1mA/30V DC	
Re-sponse time	OFF → ON*1	0.2ms or less/24V DC	0.3ms or less/24V DC	
	ON → OFF*1	1.5ms or less/24V DC	4ms or less/24V DC	
Output element's ON voltage	1.5V		1.5V	
Circuit isolation	Photocoupler isolation		Photocoupler isolation	
Operation indicators	LED lights when photo-thyristor power is supplied		LED lights when photo-thyristor power is supplied	
Power consumption	2.7W (112mA 24V DC)		2.7W (112mA 24V DC)	
Input/output circuitry				

*1. This response time does not include the response delay at the PLC.

8.10.2 Internal circuit

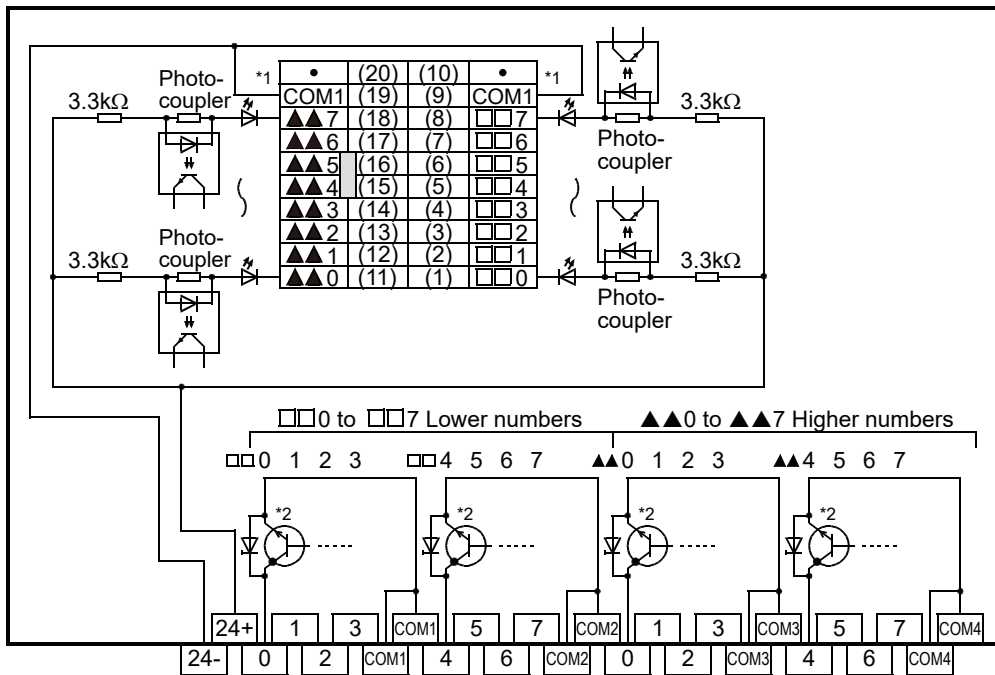

*1. "COM2" or "COM3" in accordance with connected connector

*2. For the FX-16EYT-H-TB, the output transistor elements are as shown in the figure below.

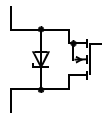

8.10.3 Example of output external wiring

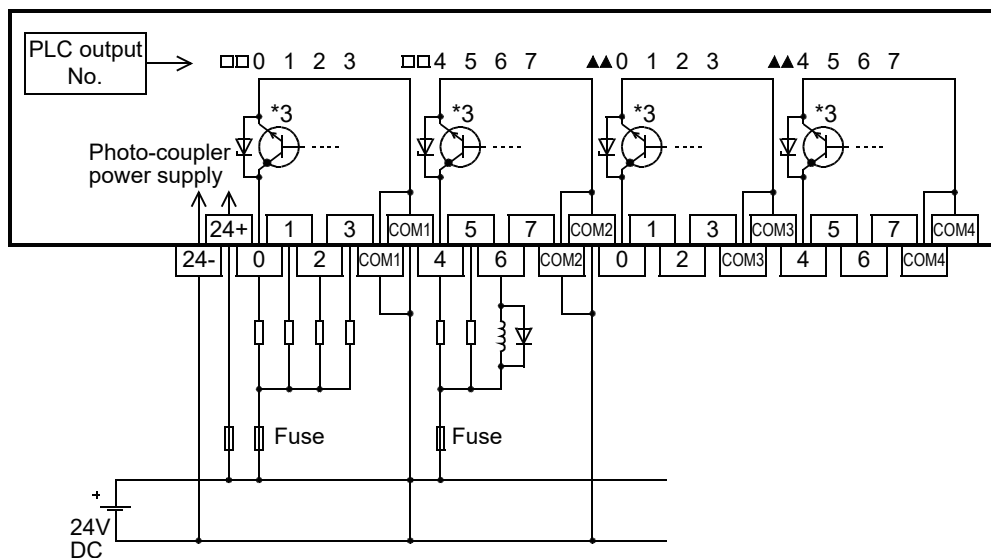

*3 For the FX-16EYT-H-TB, the output transistor elements are as shown in the figure below.

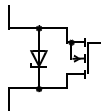

1	Outline
2	External Dimensions
3	Generic Specifications
4	Power Supply Specifications
5	Input Specifications
6	Output Specifications
7	Examples of Wiring for Various Uses
8	Terminal Block
9	CC-Link/LT Master FX3UC-LT(-Z) only
10	Display module FX3UC-LT(-Z) only

8.10.4 External wiring precautions

1. Protection circuit for load short-circuits

A short-circuit at a load connected to an output terminal could cause burnout at the output element or the PCB. To prevent this, a protection fuse should be inserted at the output. Use a load power supply capacity that is at least 2 times larger than the total rated fuse capacity.

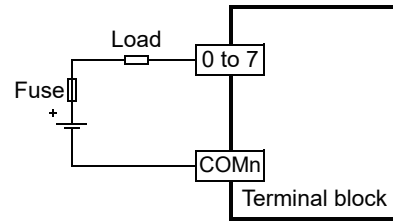

2. Transistor protection circuit for inductive loads

The transistor output circuit in the terminal block is equipped with a Zener diode (50V) for protection. When an inductive load is connected, however, a diode should be connected parallel to the load when required. The diode must comply with the specifications shown below.

Counter voltage	5 to 10 times of the load voltage
Forward current	Load current or more

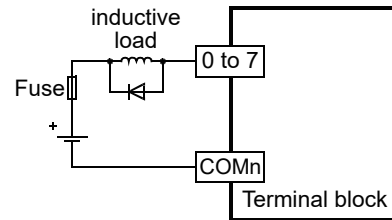

3. Interlock

For loads such as forward/reverse contactors, etc., where a hazardous condition could result if switched ON simultaneously, an external interlock should be provided for interlocking the PLC's internal programs as shown to the right.

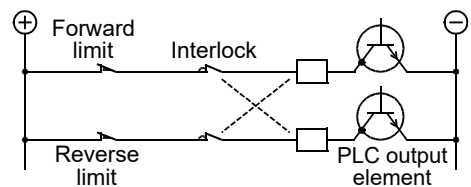

8.11 FX-16EYT-ES-TB/UL

Connect the FX-16EYT-ES-TB/UL to the output connector in the main unit or extension block shown in the table below.

	Output connector
Connectable models	FX3UC-□□MT/DSS, FX2NC-□□EYT-DSS

The applications shown below are not supported.

	Unsupported Applications
Pulse output	Pulse Y output (PLSY) instruction, acceleration/deceleration setup (PLSR) instruction, pulse width modulation (PWM) instruction, DOG search zero return (DSZR) instruction, interruption positioning (DVIT) instruction, batch data positioning mode (TBL) instruction, absolute current value read (ABS) instruction, zero return (ZRN) instruction, variable speed pulse output (PLSV) instruction, drive to increment (DRVI) instruction, drive to absolute (DRVA) instruction
Time division input	Input matrix (MTR) instruction, hexadecimal input (HKY) instruction, digital switch (DSW) instruction, arrow switch (ARWS) instruction
Time division output	Seven segment with latch (SEGL) instruction, print (ASCII Code) (PR) instruction

8.11.1 Specifications

Item	FX-16EYT-ES-TB/UL	
Connection form	Terminal block (M3.5 screw) The connection with the PLC is the connector.	
Output type/form	Transistor/sink output	
External power supply	5-30 V DC	
Max. load	Resistance load	0.5A/1 points Make sure that the total load current of 4 resistance load points is 0.8A or less.
	Inductive load	12W/24V DC
Open-circuit leakage current	0.1mA/30V DC	
Response time	OFF → ON*1	0.2ms or less/24V DC
	ON → OFF*1	1.5ms or less/24V DC
Output element's ON voltage	1.5V	
Circuit isolation	Photocoupler isolation	
Operation indicators	LED lights when photo-thyristor power is supplied	
Power consumption	2.7W (112mA 24V DC)	
Input/output circuitry		

*1. This response time does not include the response delay at the PLC.

8.11.2 Internal circuit

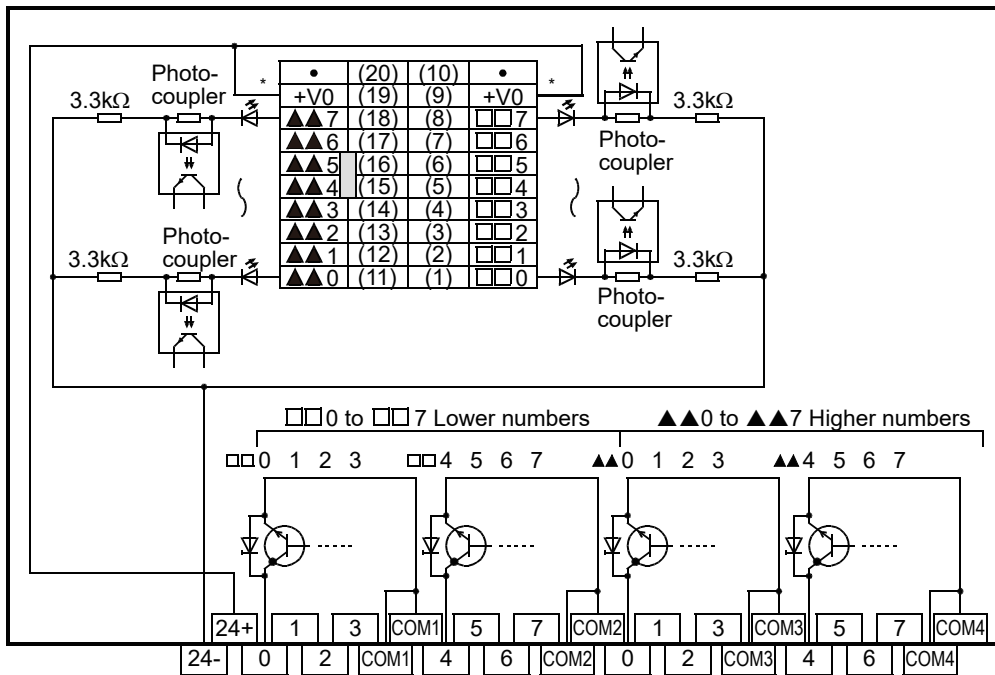

*. "+V1" or "+V2" in accordance with connected connector

8.11.3 Example of output external wiring

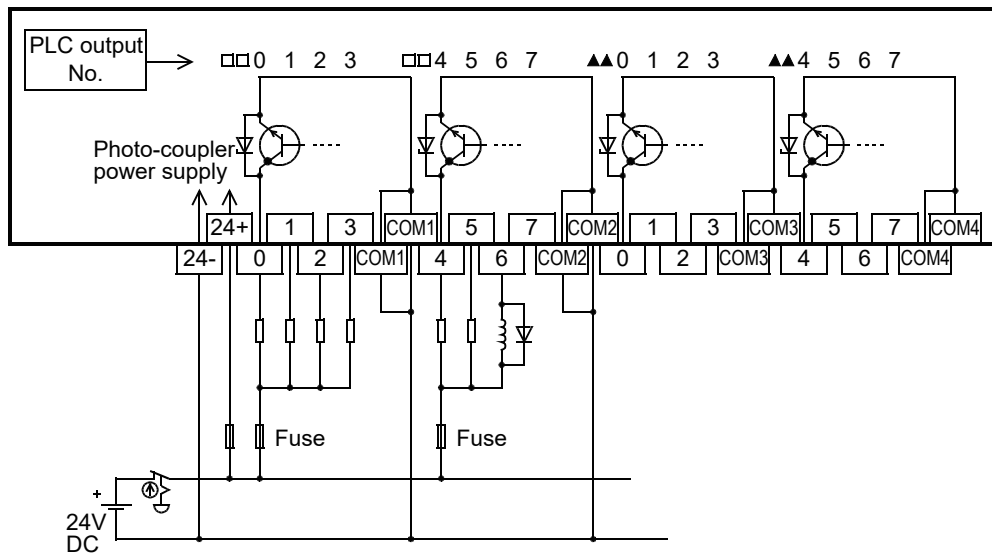

8.11.4 External wiring precautions

The caution on external wiring is the same as FX-16EYT-TB. Refer to Subsection 8.10.4.

8.12 FX-16EYT-ESS-TB/UL

Connect the FX-16EYT-ESS-TB/UL to the output connector in the main unit or extension block shown in the table below.

	Output connector
Connectable models	FX3UC-□□MT/DSS, FX2NC-□□EYT-DSS

The applications shown below are not supported.

	Unsupported Applications
Pulse output	Pulse Y output (PLSY) instruction, acceleration/deceleration setup (PLSR) instruction, pulse width modulation (PWM) instruction, DOG search zero return (DSZR) instruction, interruption positioning (DVIT) instruction, batch data positioning mode (TBL) instruction, absolute current value read (ABS) instruction, zero return (ZRN) instruction, variable speed pulse output (PLSV) instruction, drive to increment (DRVI) instruction, drive to absolute (DRVA) instruction
Time division input	Input matrix (MTR) instruction, hexadecimal input (HKY) instruction, digital switch (DSW) instruction, arrow switch (ARWS) instruction
Time division output	Seven segment with latch (SEGL) instruction, print (ASCII Code) (PR) instruction

8.12.1 Specifications

Item	FX-16EYT-ESS-TB/UL	
Connection form	Terminal block (M3.5 screw) The connection with the PLC is the connector.	
Output type/form	Transistor/source output	
External power supply	5-30 V DC	
Max. load	Resistance load	0.5A/1 points Make sure that the total load current of 4 resistance load points is 0.8A or less.
	Inductive load	12W/24V DC
Open-circuit leakage current	0.1mA/30V DC	
Response time	OFF → ON*1	0.2ms or less/24V DC
	ON → OFF*1	1.5ms or less/24V DC
Output element's ON voltage	1.5V	
Circuit isolation	Photocoupler isolation	
Operation indicators	LED lights when photo-coupler power is supplied	
Power consumption	2.7W (112mA 24V DC)	
Input/output circuitry		

*1. This response time does not include the response delay at the PLC.

8.12.2 Internal circuit

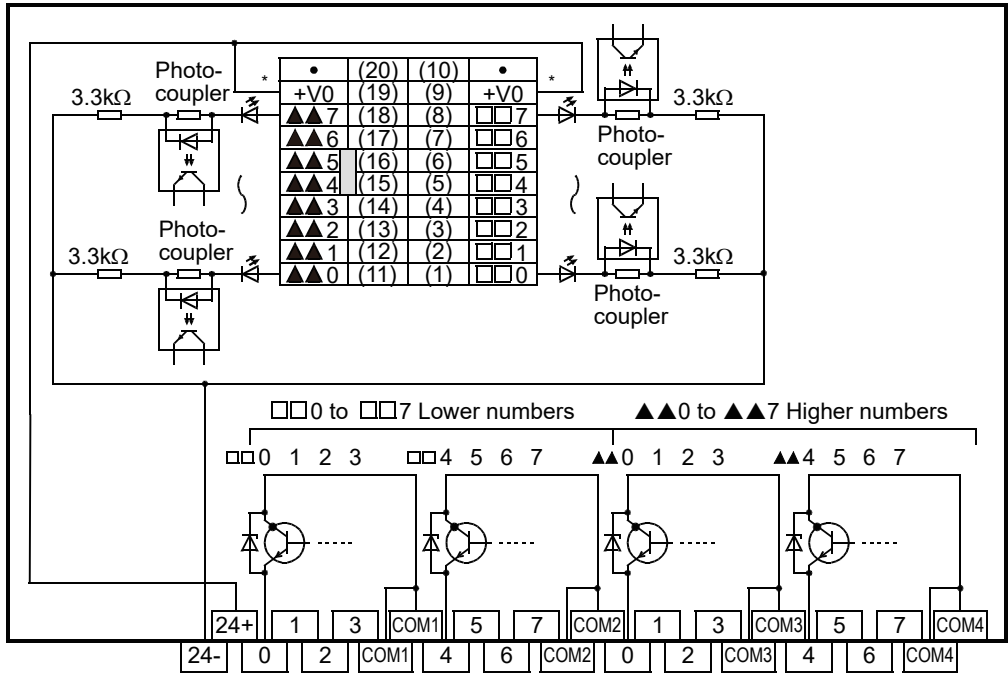

*. "+V1" or "+V2" in accordance with connected connector

8.12.3 Example of output external wiring

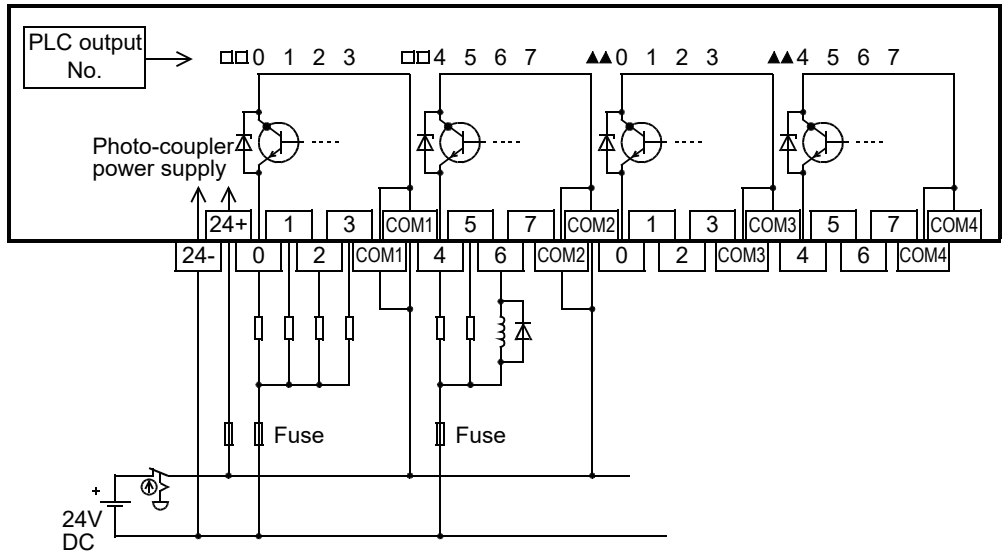

8.12.4 External wiring precautions

1. Protection circuit for load short-circuits

A short-circuit at a load connected to an output terminal could cause burnout at the output element or the PCB. To prevent this, a protection fuse should be inserted at the output. Use a load power supply capacity that is at least 2 times larger than the total rated fuse capacity.

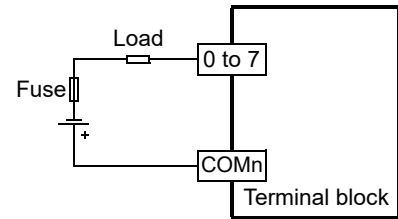

2. Transistor protection circuit for inductive loads

The transistor output circuit in the terminal block is equipped with a Zener diode (50V) for protection. When an inductive load is connected, however, a diode should be connected parallel to the load when required. The diode must comply with the specifications shown below.

Counter voltage	5 to 10 times of the load voltage
Forward current	Load current or more

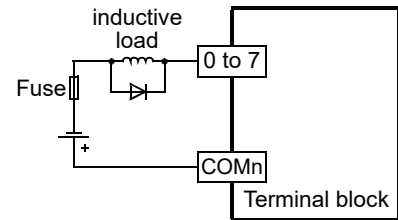

3. Interlock

For loads such as forward/reverse contactors, etc., where a hazardous condition could result if switched ON simultaneously, an external interlock should be provided for interlocking the PLC's internal programs as shown to the right.

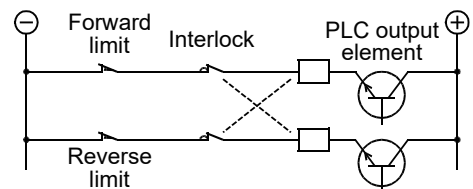

1
Outline

2
External Dimensions

3
Generic Specifications

4
Power Supply Specifications

5
Input Specifications

6
Output Specifications

7
Examples of Wiring for Various Uses

8
Terminal Block

9
CC-LINK/MT Master FX₃UC-LT(-2) only

10
Display module FX₃UC-LT(-2) only

8.13 FX-16EYS-TB

Connect the FX-16EYS-TB to the output connector in the main unit or extension block shown in the table below.

	Output connector
Connectable models	FX3UC-□□MT/D, FX3UC-32MT-LT(-2), FX2NC-□□EYT, FX2N-16EYT-C

The applications shown below are not supported.

	Unsupported Applications
Pulse output	Pulse Y output (PLSY) instruction, acceleration/deceleration setup (PLSR) instruction, pulse width modulation (PWM) instruction, DOG search zero return (DSZR) instruction, interruption positioning (DVIT) instruction, batch data positioning mode (TBL) instruction, absolute current value read (ABS) instruction, zero return (ZRN) instruction, variable speed pulse output (PLSV) instruction, drive to increment (DRVI) instruction, drive to absolute (DRVA) instruction
Time division input	Input matrix (MTR) instruction, hexadecimal input (HKY) instruction, digital switch (DSW) instruction, arrow switch (ARWS) instruction
Time division output	Seven segment with latch (SEGL) instruction, print (ASCII Code) (PR) instruction

8.13.1 Specifications

Item	FX-16EYS-TB	
Connection form	Terminal block (M3.5 screw) The connection with the PLC is the connector.	
Output type	Triac (SSR)	
External power supply	85 to 242V AC	
Max. load	Resistance load	0.3 A/1 point*1 Make sure that the total load current of 4 resistance load points is 0.8A or less.
	Inductive load	15 VA/100V AC 36 VA/200V AC
Min. load	0.4 VA/100V AC 1.6 VA/200V AC	
Open-circuit leakage current	1mA/100V AC 2mA/200V AC	
Response time*2	2ms or less	
Circuit isolation	Photocoupler isolation	
Operation indicator	LED lights when photo-thyristor power is supplied	
Power consumption	2.7 W (112mA 24V DC)	

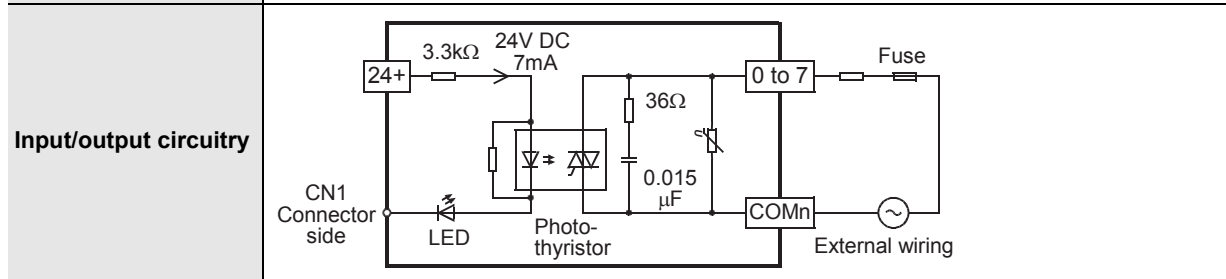

*1. In systems where frequent large-load ON/OFF switching occurs due to rush currents, the root mean square current should be 0.2A or less.

<Example>

$$\sqrt{\frac{4^2 \times 0.02 + 0.4^2 \times 0.7}{0.02 + 0.7 + 10}} = 0.2A$$

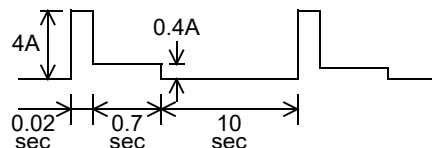

*2. This response time does not include the response delay at the PLC.

8.13.2 Internal circuit

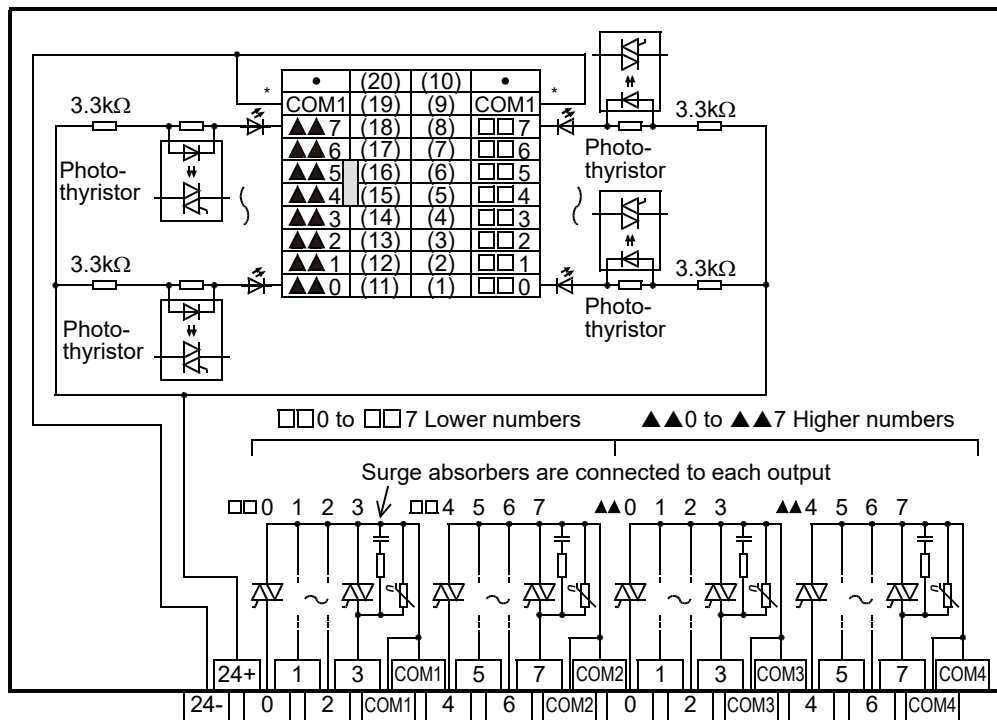

*. "COM2" or "COM3" in accordance with connected connector

8.13.3 Example of output external wiring

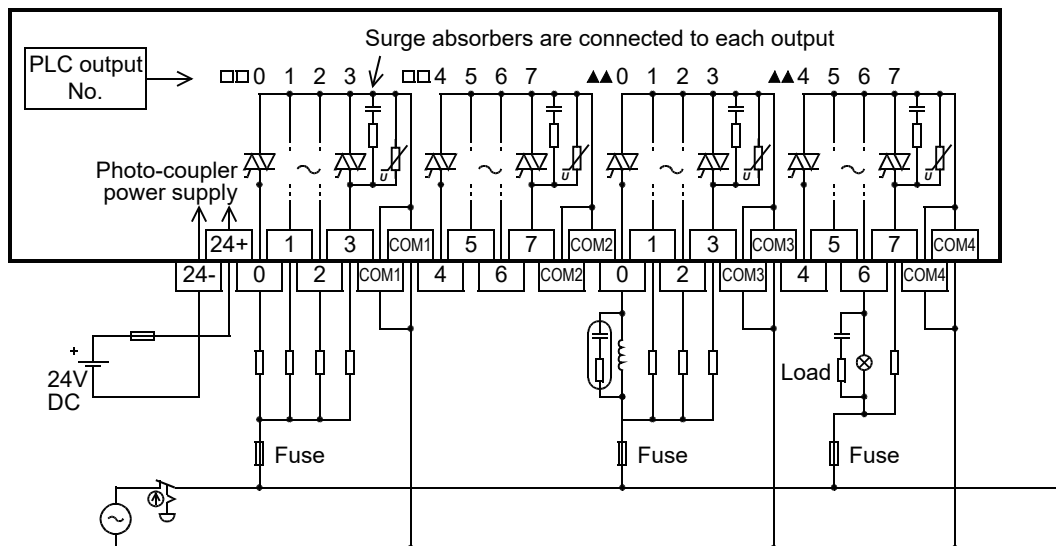

1
Outline

2
External
Dimensions

3
Generic
Specifications

4
Power Supply
Specifications

5
Input
Specifications

6
Output
Specifications

7
Examples of
Wiring for
Various Uses

8
Terminal Block

9
CC-LINK/LT
Master FX3UC-
LT(-Z) only

10
Display module
FX3UC-LT(-Z)
only

8.13.4 External wiring precautions

1. Protection circuit for load short-circuits

A short-circuit at a load connected to an output terminal could cause burnout at the output element or the PCB. To prevent this, a protection fuse should be inserted at the output.

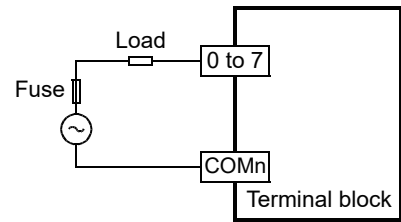

2. Micro current load

The PLC's internal Triac output circuit is equipped with a turn-off C-R absorber. When connecting a very low current load of "0.4VA/100V AC or less or 1.6 VA/200V AC or less", please connect a surge absorber parallel to the load.

Select the rated voltage of a surge absorber that is suitable for the load being used. Refer to the table below for other specifications.

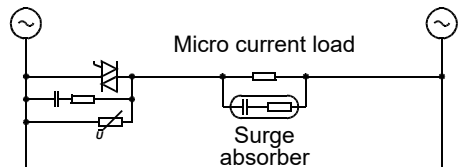

Item	Guide
Static electricity capacity	Approx. 0.1μF
Resistance value	Approx. 100 to 200Ω

Reference

Manufacturer	Model name
Okaya Electric Industries Co., Ltd.	CR-10201

Manufacturer	Model name
Rubycon Corporation	250MCRA104100M B0325

3. Interlock

For loads such as forward/reverse contactors, etc., where a hazardous condition could result if switched ON simultaneously, an external interlock should be provided for interlocking the PLC's internal programs as shown to the right.

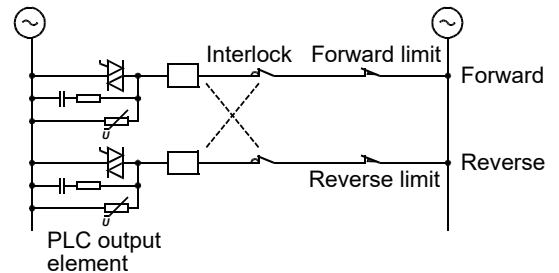

4. In-phase

PLC output contacts (*) should be used in an "in-phase" manner.

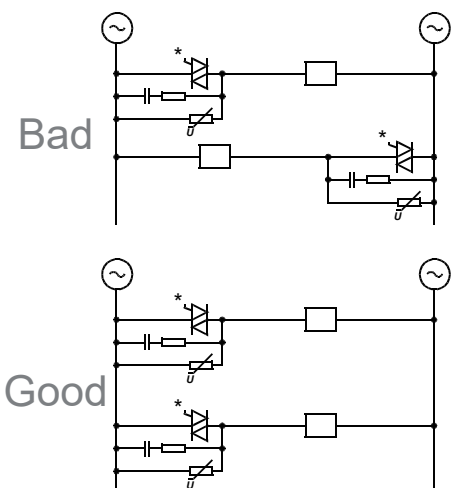

8.14 FX-16EYS-ES-TB/UL

Connect the FX-16EYS-ES-TB/UL to the output connector in the main unit or extension block shown in the table below.

	Output connector
Connectable models	FX3UC-□□MT/DSS, FX2NC-□□EYT-DSS

The applications shown below are not supported.

	Unsupported Applications
Pulse output	Pulse Y output (PLSY) instruction, acceleration/deceleration setup (PLSR) instruction, pulse width modulation (PWM) instruction, DOG search zero return (DSZR) instruction, interruption positioning (DVIT) instruction, batch data positioning mode (TBL) instruction, absolute current value read (ABS) instruction, zero return (ZRN) instruction, variable speed pulse output (PLSV) instruction, drive to increment (DRVI) instruction, drive to absolute (DRVA) instruction
Time division input	Input matrix (MTR) instruction, hexadecimal input (HKY) instruction, digital switch (DSW) instruction, arrow switch (ARWS) instruction
Time division output	Seven segment with latch (SEGL) instruction, print (ASCII Code) (PR) instruction

8.14.1 Specifications

Item	FX-16EYS-ES-TB/UL	
Connection form	Terminal block (M3.5 screw) The connection with the PLC is the connector.	
Output type	Triac (SSR)	
External power supply	85 to 242V AC	
Max. load	Resistance load	0.3 A/1 point*1 Make sure that the total load current of 4 resistance load points is 0.8A or less.
	Inductive load	15 VA/100V AC 36 VA/200V AC
Min. load	0.4 VA/100V AC 1.6 VA/200V AC	
Open-circuit leakage current	1mA/100V AC 2mA/200V AC	
Response time*2	2ms or less	
Circuit isolation	Photocoupler isolation	
Operation indicator	LED lights when photo-thyristor power is supplied	
Power consumption	2.7W (112mA 24V DC)	

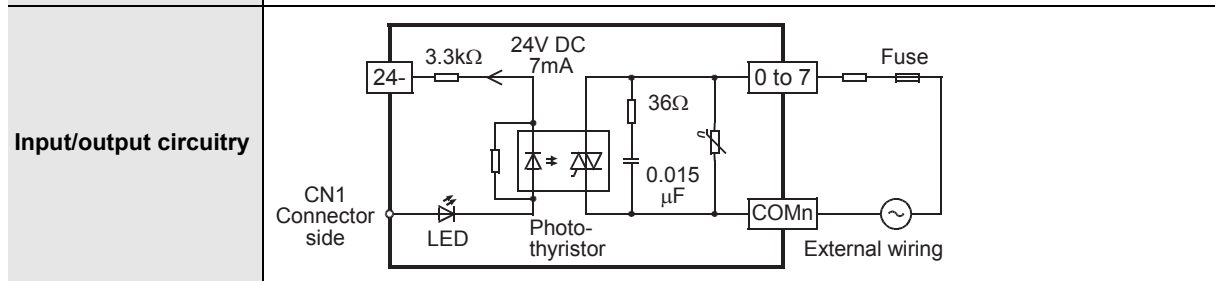

*1. In systems where frequent large-load ON/OFF switching occurs due to rush currents, the root mean square current should be 0.2A or less.

<Example>

$$\sqrt{\frac{4^2 \times 0.02 + 0.4^2 \times 0.7}{0.02 + 0.7 + 10}} = 0.2A$$

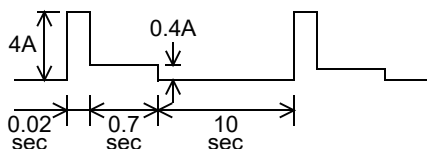

*2. This response time does not include the response delay at the PLC.

8.14.2 Internal circuit

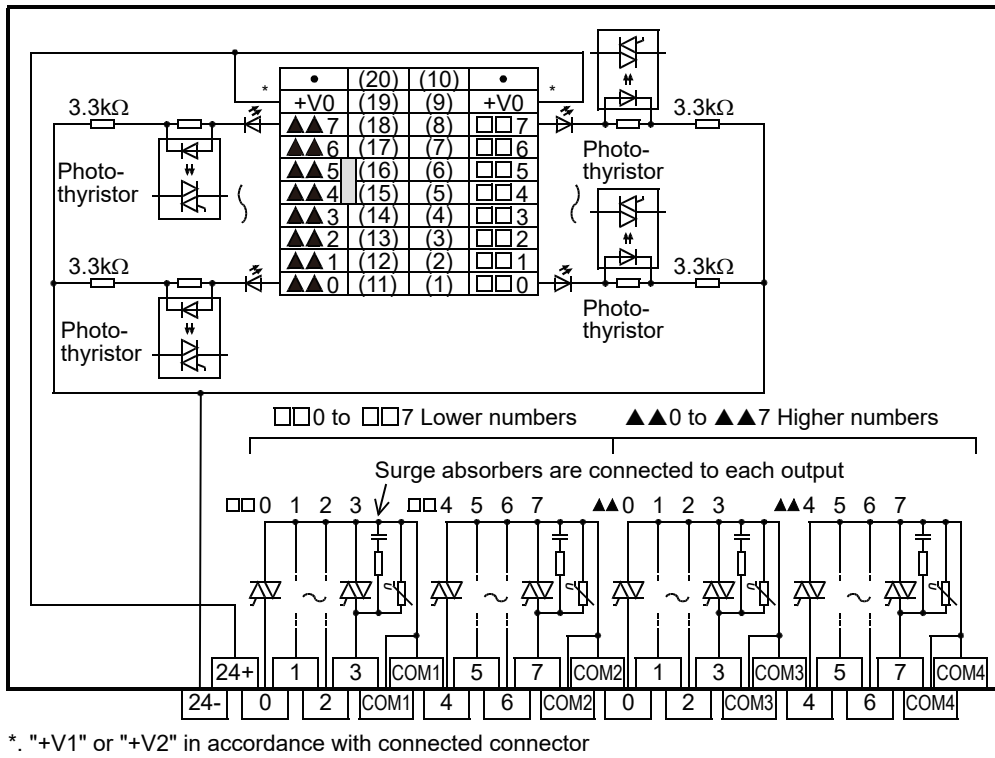

8.14.3 Example of output external wiring

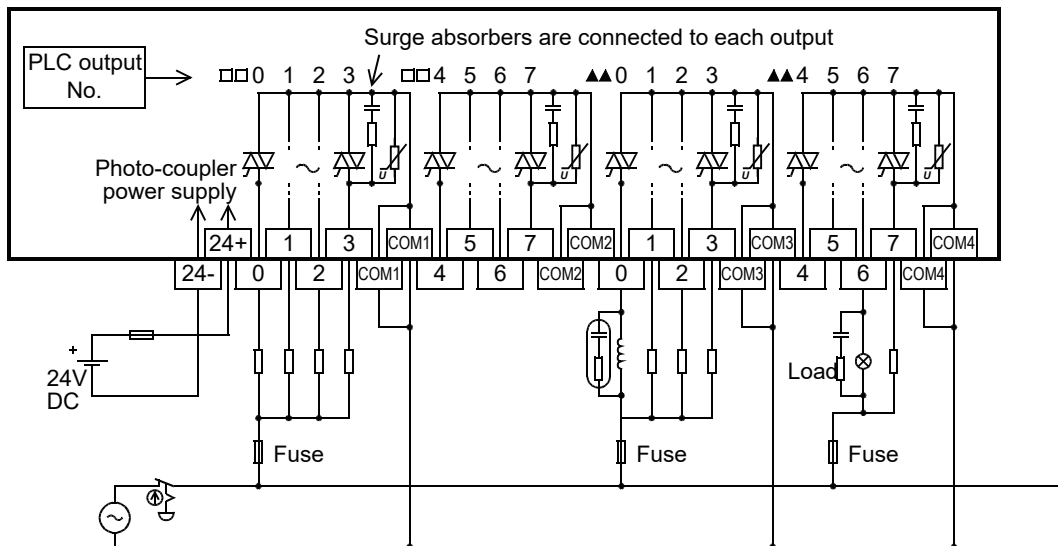



8.14.4 External wiring precautions

The caution on external wiring is the same as FX-16EYS-TB. Refer to Subsection 8.13.4.

9. CC-Link/LT Built-in master [FX3uc-32MT-LT(-2) Only]

DESIGN PRECAUTIONS	 WARNING
<ul style="list-style-type: none"> • Make sure to have the following safety circuits outside of the PLC to ensure safe system operation even during external power supply problems or PLC failure. Otherwise, malfunctions may cause serious accidents. <ol style="list-style-type: none"> 1) Most importantly, have the following: an emergency stop circuit, a protection circuit, an interlock circuit for opposite movements (such as normal vs. reverse rotation), and an interlock circuit (to prevent damage to the equipment at the upper and lower positioning limits). 2) Note that when the PLC CPU detects an error, such as a watchdog timer error, during self-diagnosis, all outputs are turned off. Also, when an error that cannot be detected by the PLC CPU occurs in an input/output control block, output control may be disabled. External circuits and mechanisms should be designed to ensure safe machinery operation in such a case. 3) Note that when an error occurs in a relay, triac or transistor output device, the output could be held either on or off. For output signals that may lead to serious accidents, external circuits and mechanisms should be designed to ensure safe machinery operation in such a case. • Note that when an error occurs in a remote I/O unit, the output could be held either on or off. For output signals that may lead to serious accidents, external circuits for monitoring should be provided. 	

DESIGN PRECAUTIONS	 CAUTION
<ul style="list-style-type: none"> • Do not bundle the control line and CC-Link/LT connection cables together with or lay them close to the main circuit or power line. As a guideline, lay the control line and CC-Link/LT connection cables at least 100 mm (3.94") or more away from the main circuit or power line. Noise may cause malfunctions. • Install the product so that excessive force will not be applied to peripheral device connectors, power connectors, input/output connectors, CC-Link/LT interface connectors or CC-Link/LT connection cables. Failure to do so may result in wire damage/breakage or PLC failure. 	

SECURITY PRECAUTIONS	 WARNING
<ul style="list-style-type: none"> • To maintain the security (confidentiality, integrity, and availability) of the programmable controller and the system against unauthorized access, denial-of-service (DoS) attacks, computer viruses, and other cyberattacks from unreliable networks and devices via network, take appropriate measures such as firewalls, virtual private networks (VPNs), and antivirus solutions. 	

WIRING PRECAUTIONS	 WARNING
<ul style="list-style-type: none"> • Make sure to cut off all phases of the power supply externally before attempting installation or wiring work. Failure to do so may cause electric shock or damage to the product. • Make sure to attach the terminal cover, offered as an accessory, before turning on the power or initiating operation after installation or wiring work. Failure to do so may cause electric shock. • The temperature rating of the cable should be 80°C or more. 	

1	Outline
2	External Dimensions
3	Generic Specifications
4	Power Supply Specifications
5	Input Specifications
6	Output Specifications
7	Examples of Wiring for Various Uses
8	Terminal Block
9	CC-Link/LT Master FX3uc-LT(-2) only
10	Display module FX3uc-LT(-2) only

WIRING PRECAUTIONS

CAUTION

- The FX3UC-32MT-LT(-2) has a built-in power supply. When connecting a power supply adapter or dedicated CC-Link/LT power supply, connect the built-in master to the LINK connector in the power supply adapter or dedicated power supply.

Connection to the LINK/POWER connector may cause failures.

Correct connection

Power adapter or Dedicated Power Supply

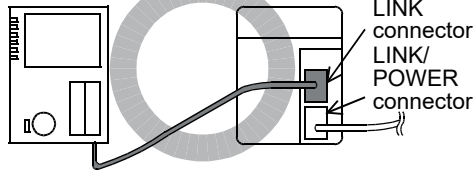

Wrong connection

Power adapter or Dedicated Power Supply

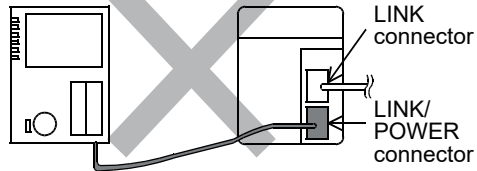

STARTUP AND MAINTENANCE PRECAUTIONS

WARNING

- Do not touch any terminal while the PLC's power is on. Doing so may cause electric shock or malfunctions.
- Before cleaning or retightening terminals cut off all phases of the power supply externally. Failure to do so may cause electric shock.
- Before modifying or disrupting the program in operation or running the PLC, carefully read through this manual and the associated manuals and ensure the safety of the operation. An operation error may damage the machinery or cause accidents.

STARTUP AND MAINTENANCE PRECAUTIONS

CAUTION

- Do not disassemble or modify the PLC. Doing so may cause fire, equipment failures, or malfunctions. For repair, contact your local Mitsubishi Electric representative.
- Turn off the power to the PLC before attaching or detaching the following devices. Failure to do so may cause equipment failures or malfunctions.
 - Peripheral devices, display module, expansion boards and special adapters
 - Extension blocks, FX Series terminal blocks, connector conversion adapter and extension power supply unit
 - Battery and memory cassette

9.1 Outline

This section explains the CC-Link/LT master function built in the FX3UC-32MT-LT(-2).

9.1.1 Differences between FX3UC-32MT-LT and FX3UC-32MT-LT-2

The FX3UC-32MT-LT and the FX3UC-32MT-LT-2 contain the following differences.

- The FX3UC-32MT-LT-2 does not have DIP switches for setting the CC-Link/LT built-in master function, and requires GX Works2, GX Developer (Ver. 8.68W or later) or a display module to setup the built-in CC-Link/LT master.
- The FX3UC-32MT-LT-2 has two operation modes in accordance with the built-in CC-Link/LT settings.
 - parameter CONFIG mode
 - self CONFIG mode
 → For details on the parameter CONFIG mode and self CONFIG mode, refer to Section 9.12.

9.1.2 Outline of System

The CC-Link/LT is an open network offered to conserve wiring inside panels and equipment.

1. **The CC-Link/LT achieves high-speed refresh at 0.3ms for up to 256 points including I/O points in the PLC main unit.**
(When 8 modules are connected in 16-point mode at a transmission rate of 2.5 Mbps)
2. **Dedicated connectors can reduce man-hours for wiring. (CC-Link/LT dedicated flat cables, VCTF cables and high flexible cables are available.)**
3. **Link devices within CC-Link/LT are assigned to X/Y devices in the PLC, therefore, sequence programs can be prepared without recognizing the network.**
(When remote device stations are used, they are accessed through the buffer memory.)
4. **The power supply for the networks is built in.**
Remote I/O stations can be connected without power supply adapters or dedicated power supplies.

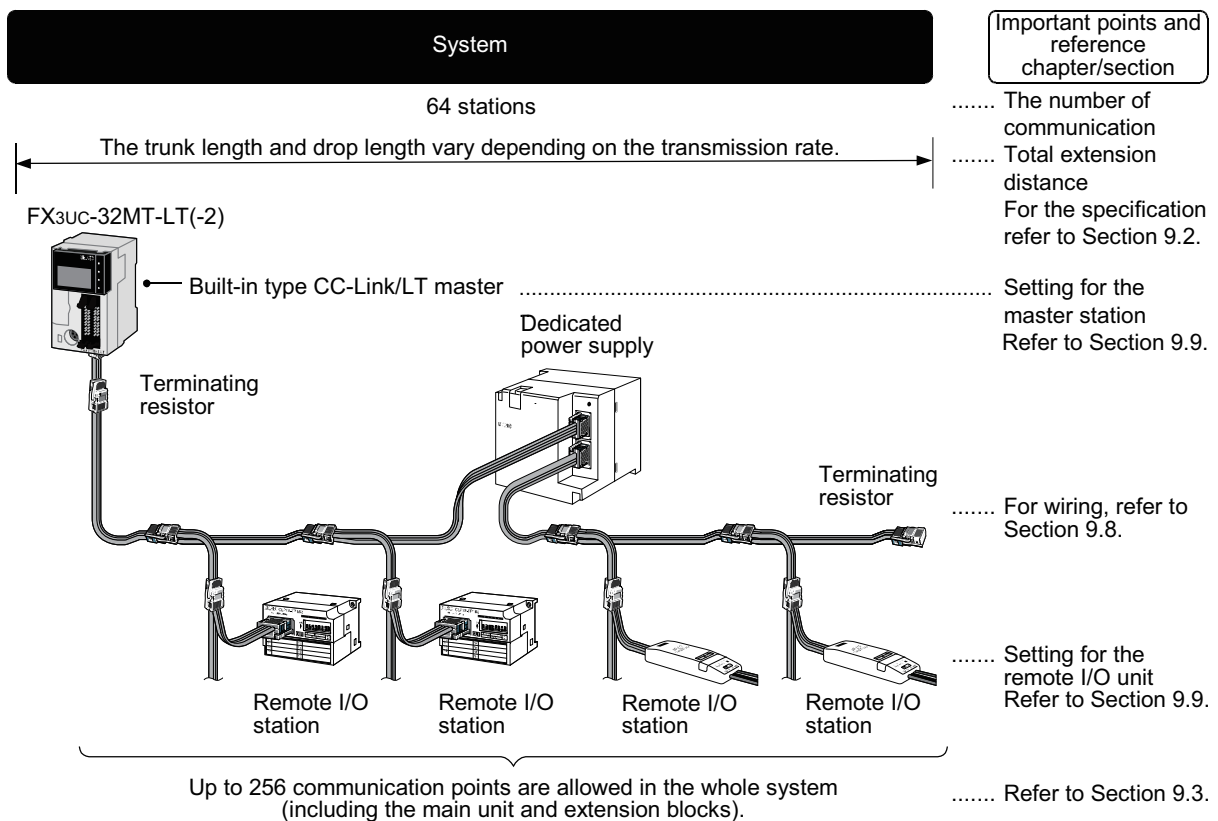

9.1.3 Procedures up until Operation (FX3UC-32MT-LT)

Start up the CC-Link/LT system using the following procedure.

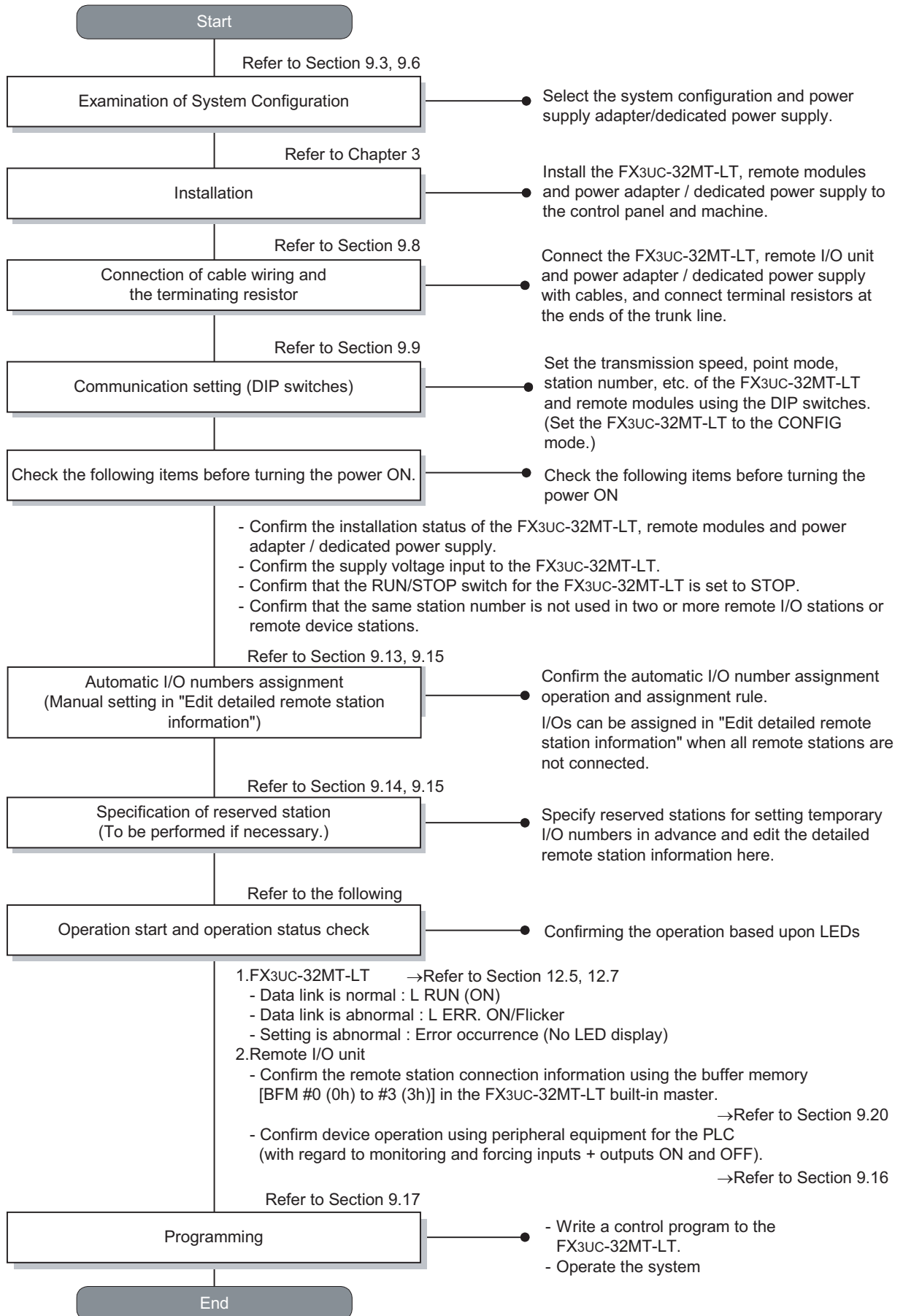

9.1.4 Procedures up until Operation (FX3UC-32MT-LT-2 parameter CONFIG mode)

Start up the CC-Link/LT system using the following procedure.

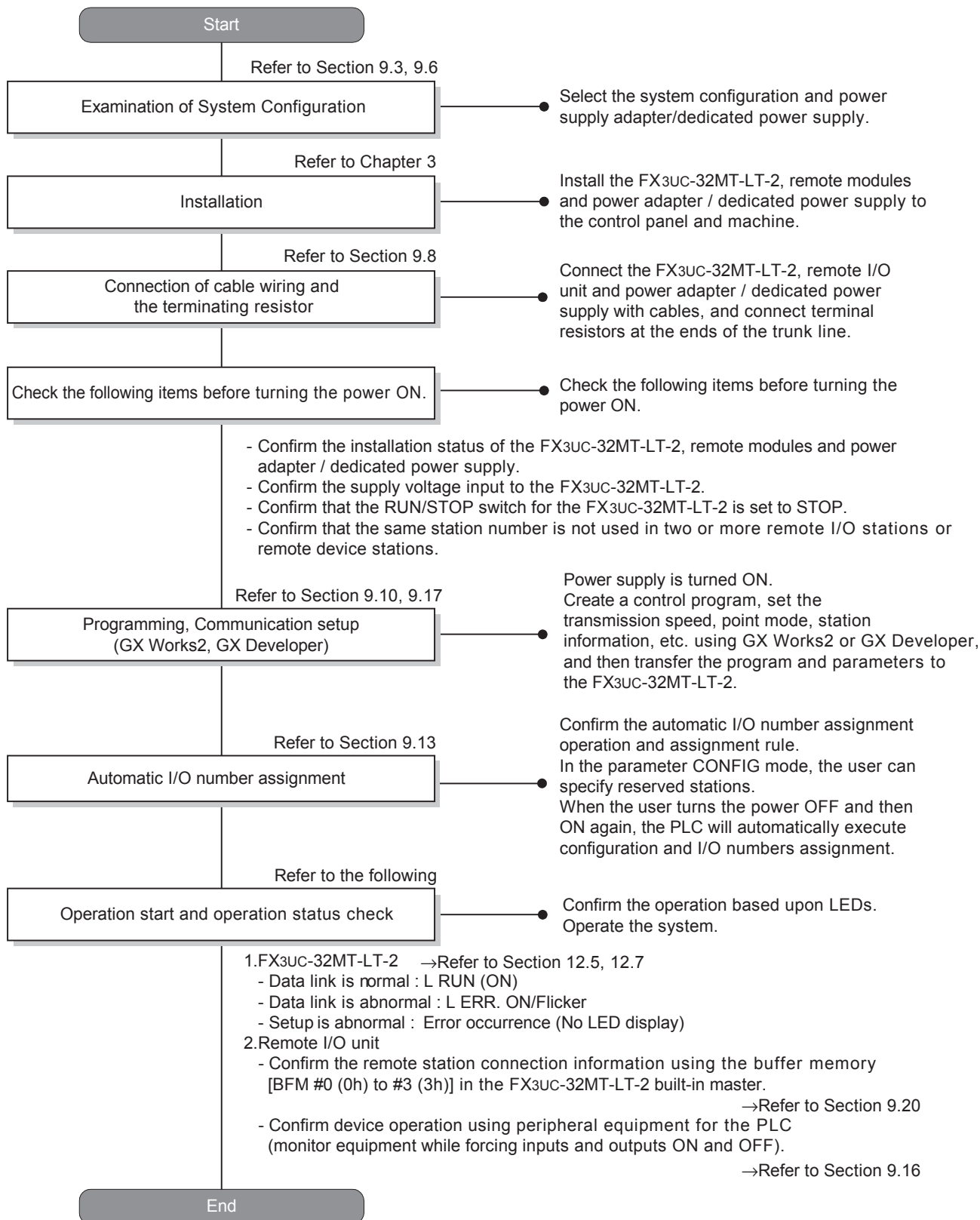

1	Outline
2	External Dimensions
3	Generic Specifications
4	Power Supply Specifications
5	Input Specifications
6	Output Specifications
7	Examples of Wiring for Various Uses
8	Terminal Block
9	CC-Link/LT Master FX3UC-LT(-2) only
10	Display module FX3UC-LT(-2) only

9.1.5 Procedures up until Operation (FX3UC-32MT-LT-2 self CONFIG mode)

Start up the CC-Link/LT system using the following procedure.

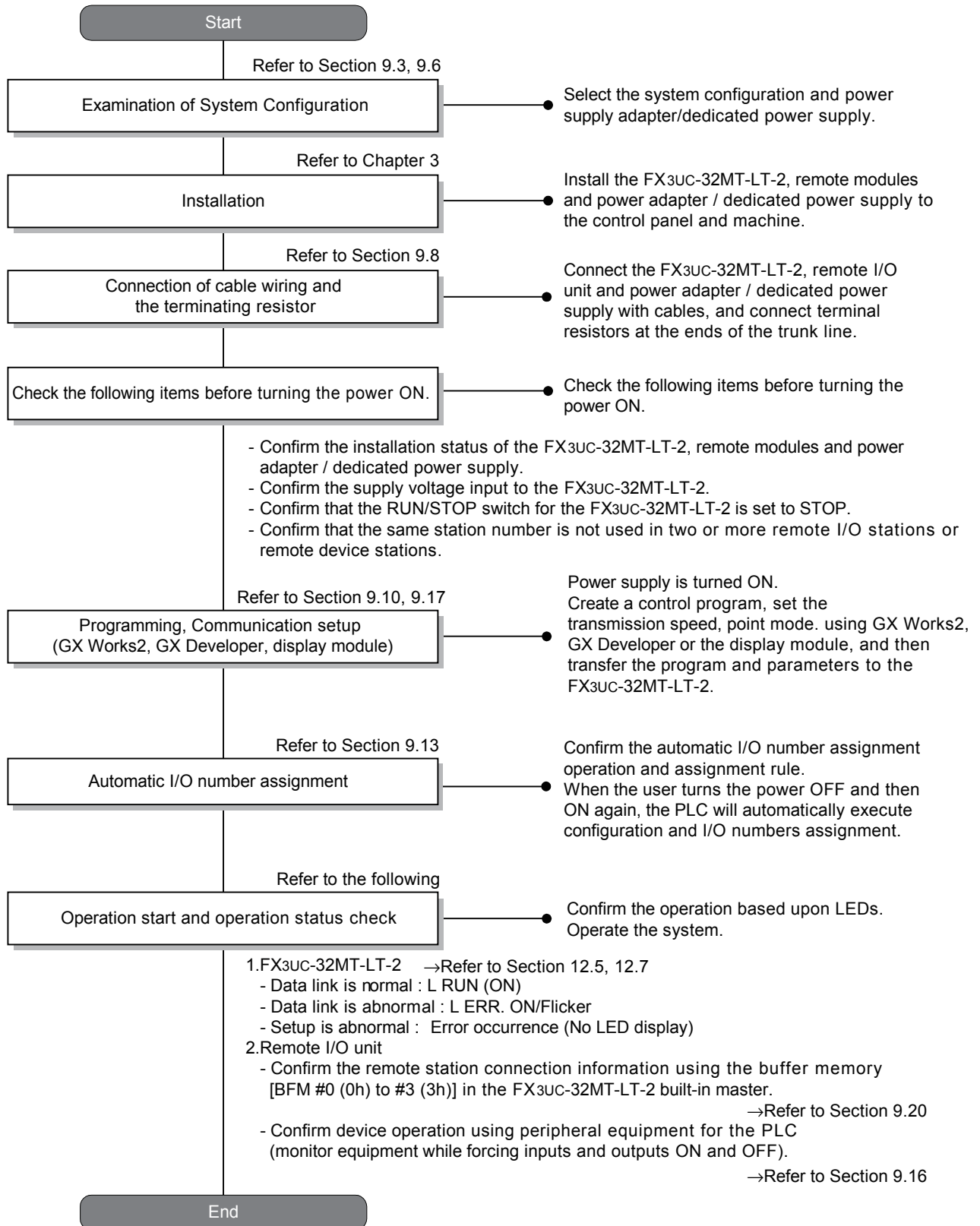

9.2 CC-Link/LT specifications

This section explains the communication function and performance of the built-in CC-Link/LT master function.

9.2.1 Performance specifications

Item		Description		
Number of connectable master station		Built-in type CC-Link/LT master + "Additional CC-Link/LT master (FX2N-64CL-M ^{*2}) 7 maximum"		
Applicable point mode ^{*1}		4-point mode or 16-point mode ^{*3} (selectable by DIP switch)		
Control specifications	Point mode	4-point mode	16-point mode	
	Maximum number of link points	256 points ^{*4} (including the number of I/O points in each PLC)		
	Number of link points per station () shows the number of link points when composite remote module is used.	4points (8points)	16points (32points)	
	Link scan time	32 stations	Points	128 points
			2.5Mbps	0.7ms
			625kbps	2.2ms
		64 stations	156kbps	8.0ms
			Points	256 points
			2.5Mbps	1.2ms
	625kbps	4.3ms		
156kbps	15.6ms			
Communication specifications	Communication speed ^{*1}	2.5 Mbps, 625 kbps and 156 kbps (selectable by DIP switch)		
	Protocol	BITR method (Broadcast polling + Interval Timed Response)		
	Network topology	T-branch		
	Error control method	CRC		
	Number of connected stations	Item	Description	
		Remote I/O station	64 stations maximum	
	Remote station numbers	Remote device station (RD station)	16 stations maximum	
		Remote I/O station	Setting range: 1 to 64	
	Remote device station (RD station)	Remote device station (RD station)	Setting range: 49 to 64	
		Built-in master station connection position	Connected at end of trunk line	
RAS function	Communication error detection, automatic return to disconnection and internal loop back diagnosis			
Connection cable	Dedicated flat cable VCTF cable (cable specifications, refer to Subsection 9.2.3.) High flexible cable (For the accredited cable, refer to Subsection 9.2.3.)			
Number of occupied I/O points	Number of connected remote I/O points			

- *1. In the FX3UC-32MT-LT-2, use GX Works2, GX Developer (Ver. 8.68W or later) or the display module to setup CC-Link/LT parameters.
In the FX3UC-32MT-LT, use its DIP switch to setup CC-Link/LT parameters.
- *2. Additional CC-Link/LT masters consume 190mA/5V DC from the PLC main unit or extension power supply unit.
Make sure that the 5V DC current consumption including other extension blocks and special function blocks does not exceed the supply capacity of the main unit or extension power supply unit.
→ For details, refer to "Section 1.6 System overall configuration".
- *3. Remote device stations support only the 16-point mode.
- *4. The maximum number of link points varies depending on the system configuration.
→ For details, refer to "Section 1.7 Rules of System Configuration".

9.2.2 Network wiring specifications

Item	Specification			Remarks
	2.5Mbps	625kbps	156kbps	
Communication speed	2.5Mbps	625kbps	156kbps	-
Distance between stations	No restriction			-
Maximum number of modules connected in 1 drop line	8 units			Maximum number of remote I/O modules connected per branch in a drop line
Maximum trunk length	35m	100m	500m	Cable length between terminating resistors
T-branch interval	No restriction			-
Maximum drop length	4m	16m	60m	Cable length per branch
Cumulative drop line length	15m	50m	200m	Sum of all drop lines

9.2.3 Cable specifications

CC-Link/LT dedicated flat cables, VCTF cables and high flexible cables are available.

1. CC-Link/LT dedicated flat cable

Type	Service temperature range	Rated voltage	Number of cores	Conductor resistance (at 20°C)	Safety	Flame resistance
Flat cable	-10 to 80 °C	30V	4	23.4 Ω/km or less	UL Subject758	UL VW-1 • -F-

2. VCTF cable specifications (Extract from JIS C 3306)

Type	Number of cores	Conductor			Insulator thickness	Sheath thickness	Conductor resistance (at 20°C)
		Nominal cross sectional area	Number of element wires/Wire diameter	Outside diameter			
Vinyl cabtyre, Round cord	4	0.75mm ²	30/0.18mm	1.1mm	0.6mm	1.0mm	25.1Ω/km

3. High flexible cable

Use the following high flexible cables certified by the CC-Link Association.

Manufacturer name	Cable model name
DAIDEN Co., Ltd.	CM/LT(2586) AWG19/4C
Yoshinogawa Electric Wire & Cable Co.,Ltd	CRFV-A075C04-LT
Kuramo Electric Co., Ltd.	FANC-Z/LT 4×0.75mm ²
Mitsubishi Electric System & Service Co.Ltd	CL9-MV4-075

9.2.4 The built-in power supply specifications for CC-Link/LT networks

Item	Description
Rated-voltage*1	Voltage = Voltage of power supplied to main unit - 1.1 V*2 Ripple (p-p): Within 5%
Rated current	0.35 A Dilating occurs depending on the ambient temperature and supply voltage. [Use the system in the condition that the total current consumption of each station does not exceed 0.35 A during power supply (excluding the time immediately after power ON).]
Power fuse*3	125V 0.8A (CC-Link/LT built-in power supply circuit)

- *1. Assure 20.4 V or more as the driving voltage of remote I/O stations for CC-Link/LT.
If 20.4 V or more cannot be assured due to large voltage drop, combine a power supply adapter or dedicated power supply.
→ **For the system power calculation method, refer to Subsection 9.6.3.**
- *2. Voltage drop becomes larger depending on the quantity of current being used.
- *3. For fuse blowout in the CC-Link/LT built-in power supply circuit, refer to the following.
→ **For details, refer to "Subsection 12.7.2 Operation at blowout of built-in power fuse for CC-Link/LT".**

9.3 System configuration [CC-Link/LT Built-in master functionality]

9.3.1 CC-Link/LT total configuration

WIRING PRECAUTIONS ! **CAUTION**

- The FX3UC-32MT-LT(-2) has a built-in power supply. When connecting a power supply adapter or dedicated CC-Link/LT power supply, connect the built-in master to the LINK connector in the power supply adapter or dedicated power supply. Connection to the LINK/POWER connector may cause failures.

Correct connection

Wrong connection

This paragraph describes the system configuration and cautions for CC-Link/LT.

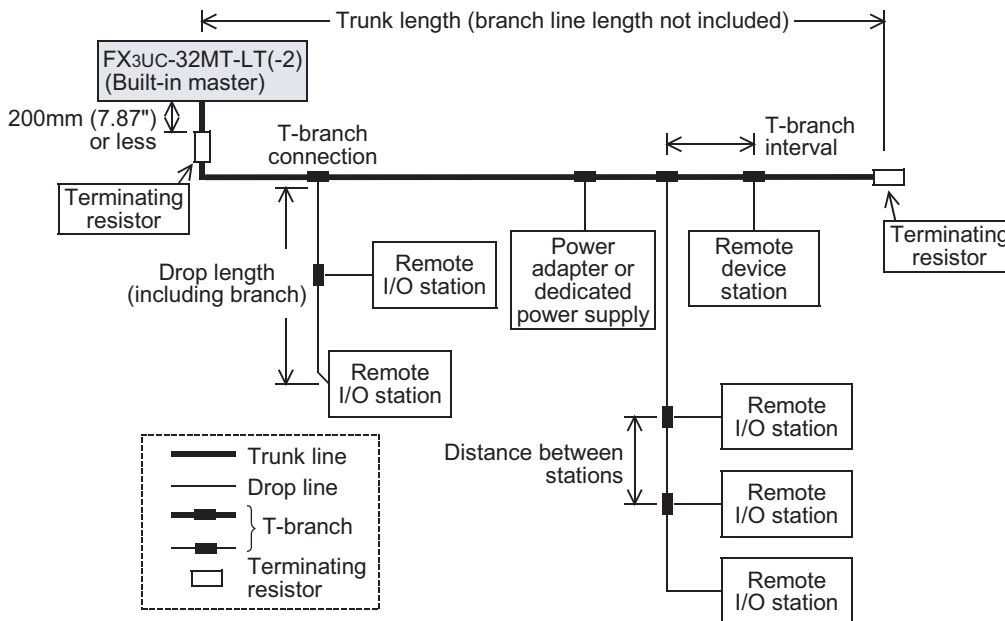

*1. The maximum drop line length and total drop line length include the branch length from the drop line.

1. Connection cable, Connector and Terminal block

Connect the CC-Link/LT built-in master, power supply adapter (dedicated power supply) and remote stations through connectors for cable connection.

1) Connection cable

CC-Link/LT dedicated flat cables, VCTF cables and high flexible cables can be used together.

→ For details on combination and mixed use of cables, refer to Section 9.5.

2) Connecting the trunk line and drop line

The trunk line and drop line can be connected using connectors or terminal blocks.

Terminal blocks are available only when VCTF cables or high flexible cables are used.

→ For details on combination and mixed use of cables, refer to Section 9.5.

2. Connection of the CC-Link/LT built-in master

Make sure to install the Built-in master at the end of the trunk line.

3. Setting of the station number

The connection order of remote stations has no relevance to the station number.
Even if the station number of remote stations is not consecutive, no error will occur in the data link.
Use one station number only for one station.

→ For details, refer to "Subsection 9.9.2 Station number setting of the remote I/O units".

4. Terminating resistor

In the CC-Link/LT system, terminating resistors should be connected to both ends of the trunk line.
Connect the terminating resistor on the CC-Link/LT built-in master side to a position within 200mm (7.87") from the Built-in master.

→ For details on how to attach terminating resistor, refer to Subsection 9.8.7.

5. Number of connectable units per built-in master

Up to 64 remote I/O stations and remote device stations can be connected in total (Up to 16 remote device stations can be connected) only when the conditions described in "Network wiring specifications" is satisfied.

→ For details, refer to "Subsection 9.2.2 Network wiring specifications".

9.3.2 Number of connectable additional CC-Link/LT masters

The FX3UC-32MT-LT(-2) can connect not only one CC-Link/LT built-in master but also up to 7 additional CC-Link/LT masters (FX2N-64CL-M) including special function units/blocks.
However, only up to 256 I/O points can be controlled.

Type	Number of units	Remark
Built-in type CC-Link/LT master	1 units	Built in to the FX3UC-32MT-LT(-2) as a standard feature.
Number of connectable additional CC-Link/LT masters	7 maximum	<ul style="list-style-type: none"> Special unit numbers start from No. 1. The extension power supply unit or FX2NC-CNV-IF is required for connection.

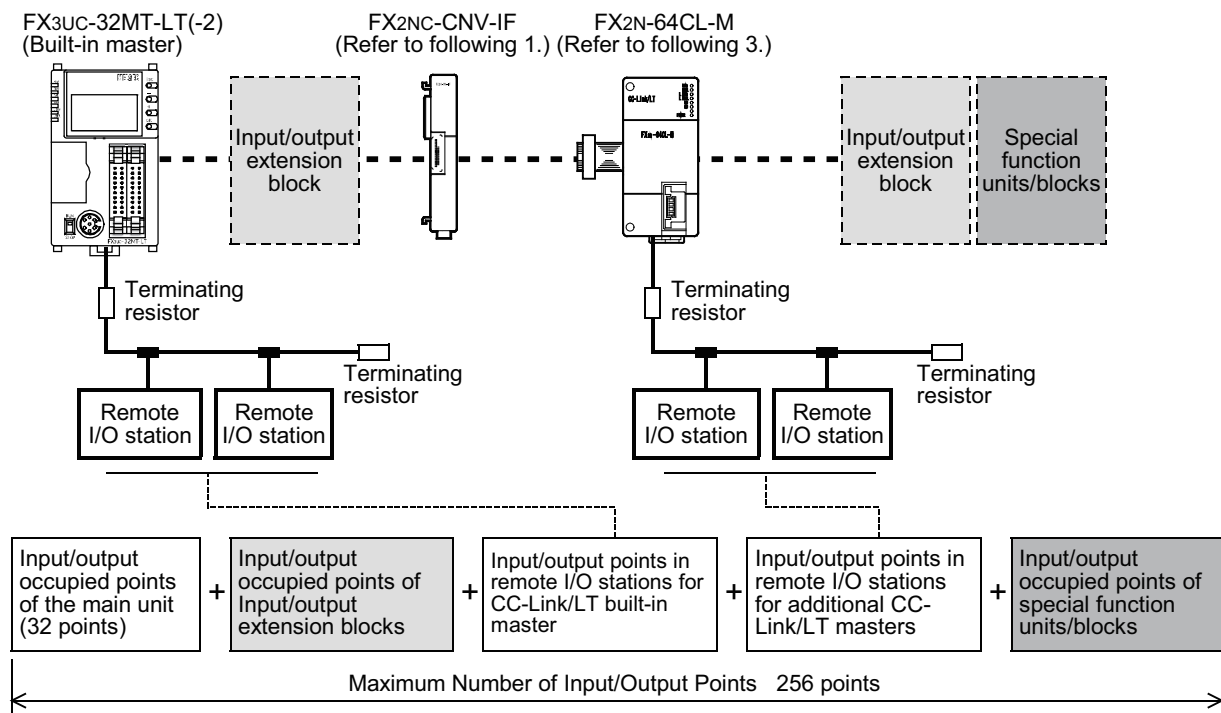

1. Additional CC-Link/LT master connection method

Connect the extension power supply unit or FX2NC-CNV-IF on the right side of the PLC main unit, and then connect the extension cable of the additional CC-Link/LT master (FX2N-64CL-M) to the extension connector for FX0N/FX2N.

→ For details, refer to Chapter 3.

1	Outline
2	External Dimensions
3	Generic Specifications
4	Power Supply Specifications
5	Input Specifications
6	Output Specifications
7	Examples of Wiring for Various Uses
8	Terminal Block
9	CC-Link/LT Master FX3UC-LT(-2) only
10	Display module FX3UC-LT(-2) only

2. Number of input/output occupied points and restriction in number of input/output points

The number of input/output occupied points of the additional CC-Link/LT master is "8 (either input or output) + Number of input/output points in connected remote stations".

Make sure that the total number of input/output points including extension units does not exceed 256.

→ For details, refer to "Section 1.6 System overall configuration".

3. Restriction in current consumption from 5V DC power supply in PLC

The additional CC-Link/LT master (FX2N-64CL-M) consumes 190mA from the 5V DC power supply.

Make sure that the total current consumption from the 5V DC power supply of I/O extension blocks and special function units/blocks connected to the PLC main unit does not exceed the 5V DC power capacity of the main unit and extension power supply unit.

→ For details, refer to "Section 1.6 System overall configuration".

9.3.3 Cautions on use

1. About equipment for CC-Link

Equipment for CC-Link cannot be connected to the CC-Link/LT system.

2. About installation

For the installation conditions of the power adapter (dedicated power supply) and remote module, refer to the appropriate instruction manual. Install each of them correctly.

9.4 Selection of connection cables, connectors and terminal resistors

For the latest information on the connection cables, connectors and terminal resistors, refer to the homepage of the CC-Link Association or catalogs (issued by the CC-Link Association).

→ The homepage of the CC-Link Association (<http://www.cc-link.org/>)

9.4.1 Selection of cables

Connection cable	Reference
CC-Link/LT dedicated flat cable	For specifications, refer to Subsection 9.2.3.
VCTF cable	For specifications, refer to Subsection 9.2.3.
High flexible cable	For specifications, refer to Subsection 9.2.3.

→ For details on terminal resistors, refer to the homepage of the CC-Link Association or CC-Link/LT catalogs.

9.4.2 Selection of connectors

The table below shows the specifications of the VCTF cable connector and high flexible cable connector.

→ For details on terminal resistors, refer to the homepage of the CC-Link Association or CC-Link/LT catalogs.

Connector	Model name (manufacturer name)	Cover color*1	Cable insulator outside diameter
Dedicated flat cable connector	CL-9-CNF-18 (Mitsubishi Electric System & Service Co.Ltd)	Light blue	-
VCTF Cable Connector	CL9-CNR-23 (Mitsubishi Electric System & Service Co.Ltd)	Green	ø 2.1 to 2.4
High Flexible Cable Connector	CL9-CNR-20 (Mitsubishi Electric System & Service Co.Ltd)	Yellowish green	ø 1.8 to 2.1

*1. The color of the body is light-blue

9.4.3 Selection of terminal resistors

Use the CL9-TERM (gray). When only dedicated flat cables are used in the system, the CL9-RYVK (black) is also available.

Make sure to use terminal resistors that have the same model name on both ends of the trunk line.

→ For details on terminal resistors, refer to the homepage of the CC-Link Association or CC-Link/LT catalogs.

9.5 Combination and mixed use of cables

9.5.1 Combination of trunk line cable and drop line cables

The table below shows the combination of cables for the trunk line and drop line.

"Flat" indicates dedicated flat cable. "VCTF" indicates VCTF cable. "Flexible" indicates high flexible cable.

"/" indicates mixed use of cables in the drop line.

For example, "Flat/VCTF" indicates mixed use of dedicated flat cable and VCTF cable in the drop line.

✓ : Combination is allowed. - : Combination is not allowed.

Trunk line	Drop line						
	No mixed use of cables in drop line			Mixed use of cables in drop line			
	Flat	VCTF	Flexible	Flat/VCTF	Flat/flexible	VCTF/flexible	Flat/VCTF/flexible
Dedicated flat cable	✓	✓	✓	✓	✓	✓	✓
VCTF cable	✓	✓	✓	✓	✓	✓	✓
High flexible cable	✓	✓	✓	✓	✓	✓	✓

9.5.2 When using different cables together

1. Trunk line

Different cables cannot be used.

2. Drop line

- 1) Different cables can be used.
- 2) Different cables cannot be used in one drop line. (Refer to the left side of the figure below.)
In the case where a unit includes an attached cable (such as CL1Y2-T1D2S), however, different types of cables can be connected only when the dedicated flat cable of the unit is 200mm (7.87") or less. (Refer to the right side of the figure below.)

Example)

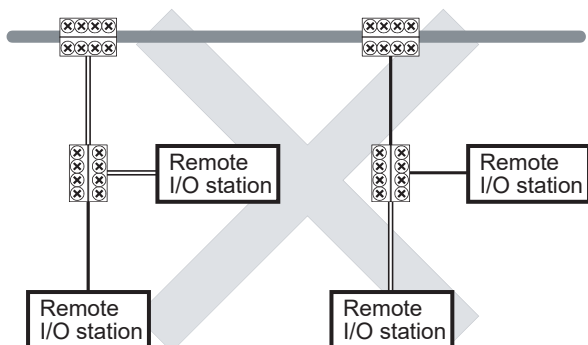

Trunk line (VCTF cable)
 Drop line (Dedicated flat cable)
 Drop line (VCTF cable)

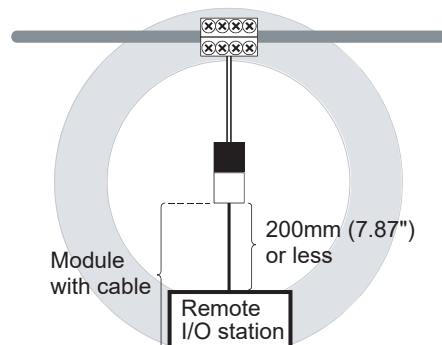

Trunk line (VCTF cable)
 Drop line (Dedicated flat cable)
 Drop line (VCTF cable)

9.5.3 System configuration examples

1. When the dedicated flat cable is used as the trunk line

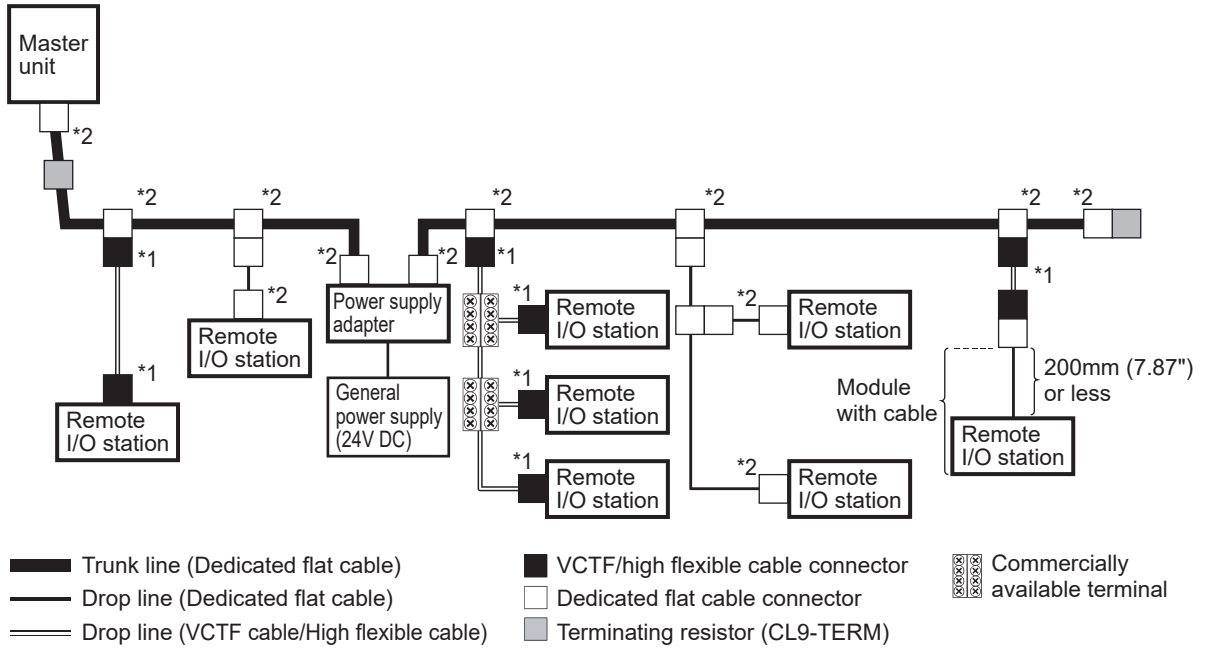

- *1. For the processing procedure of the VCTF cable connector (for connecting the terminal resistor), refer to Subsection 9.8.4.
- *2. For the processing procedure of the dedicated flat cable connector (for connecting the terminal resistor), refer to Subsection 9.8.3.

2. When the VCTF cable is used as the trunk line

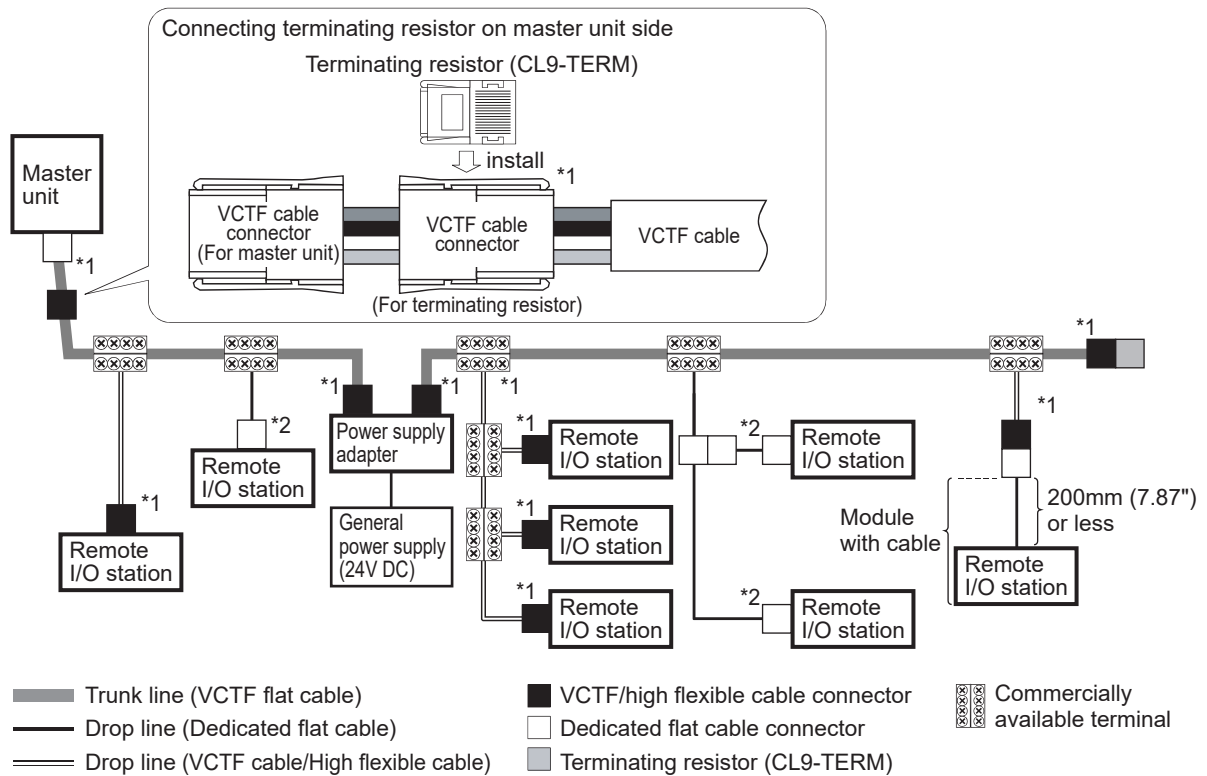

- *1. For the processing procedure of the VCTF cable connector (for connecting the terminal resistor), refer to Subsection 9.8.4.
- *2. For the processing procedure of the dedicated flat cable connector (for connecting the terminal resistor), refer to Subsection 9.8.3.

3. When the high flexible cable is used as the trunk line

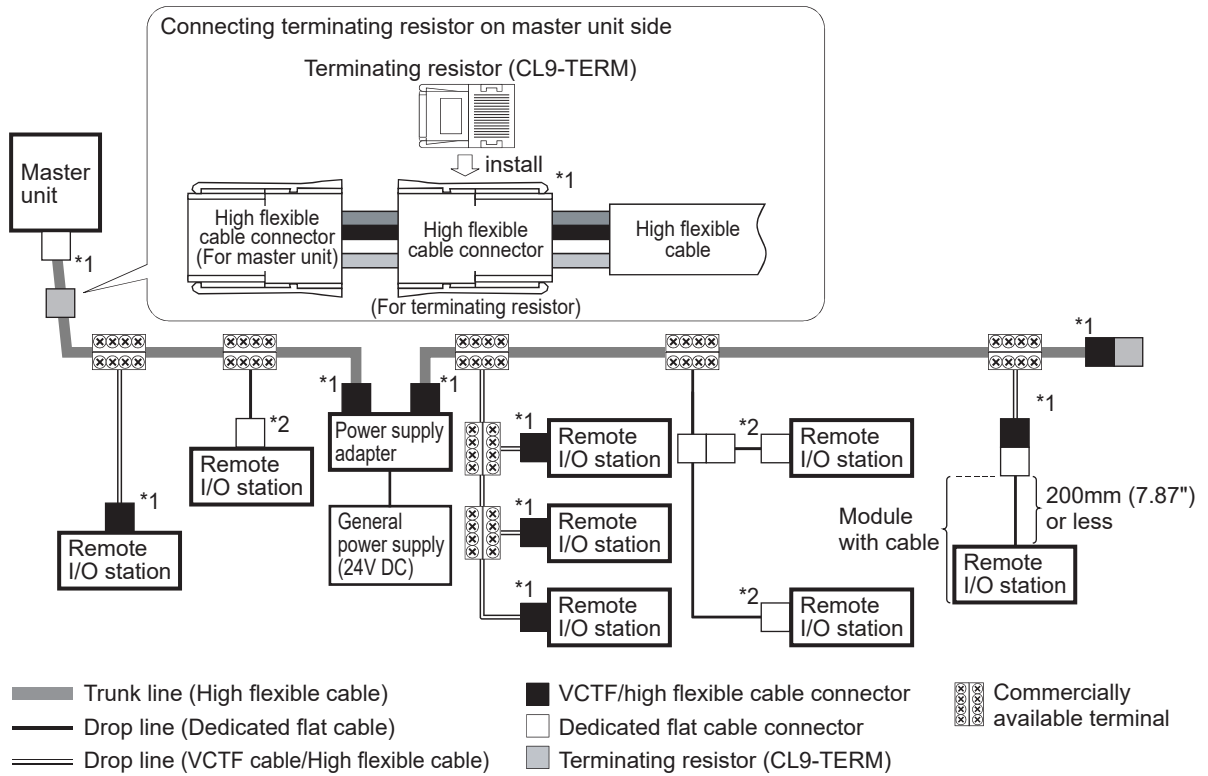

- *1. For the processing procedure of the high flexible cable connector (for connecting the terminal resistor), refer to Subsection 9.8.4.
- *2. For the processing procedure of the dedicated flat cable connector (for connecting the terminal resistor), refer to Subsection 9.8.3.

1	Outline
2	External Dimensions
3	Generic Specifications
4	Power Supply Specifications
5	Input Specifications
6	Output Specifications
7	Examples of Wiring for Various Uses
8	Terminal Block
9	CC-Link/LT Master FX3UC-LT(-2) only
10	Display module FX3UC-LT(-2) only

9.6 Selection of the power supply for CC-Link/LT

9.6.1 System power calculation procedure

Calculate the system power using the following procedure.

When the power supply adapter or dedicated power supply is required, refer to the appropriate manual for the "current consumption" and "voltage drop" of the remote I/O stations connected to the power supply adapter/ dedicated power supply and later positions.

Calculation procedure

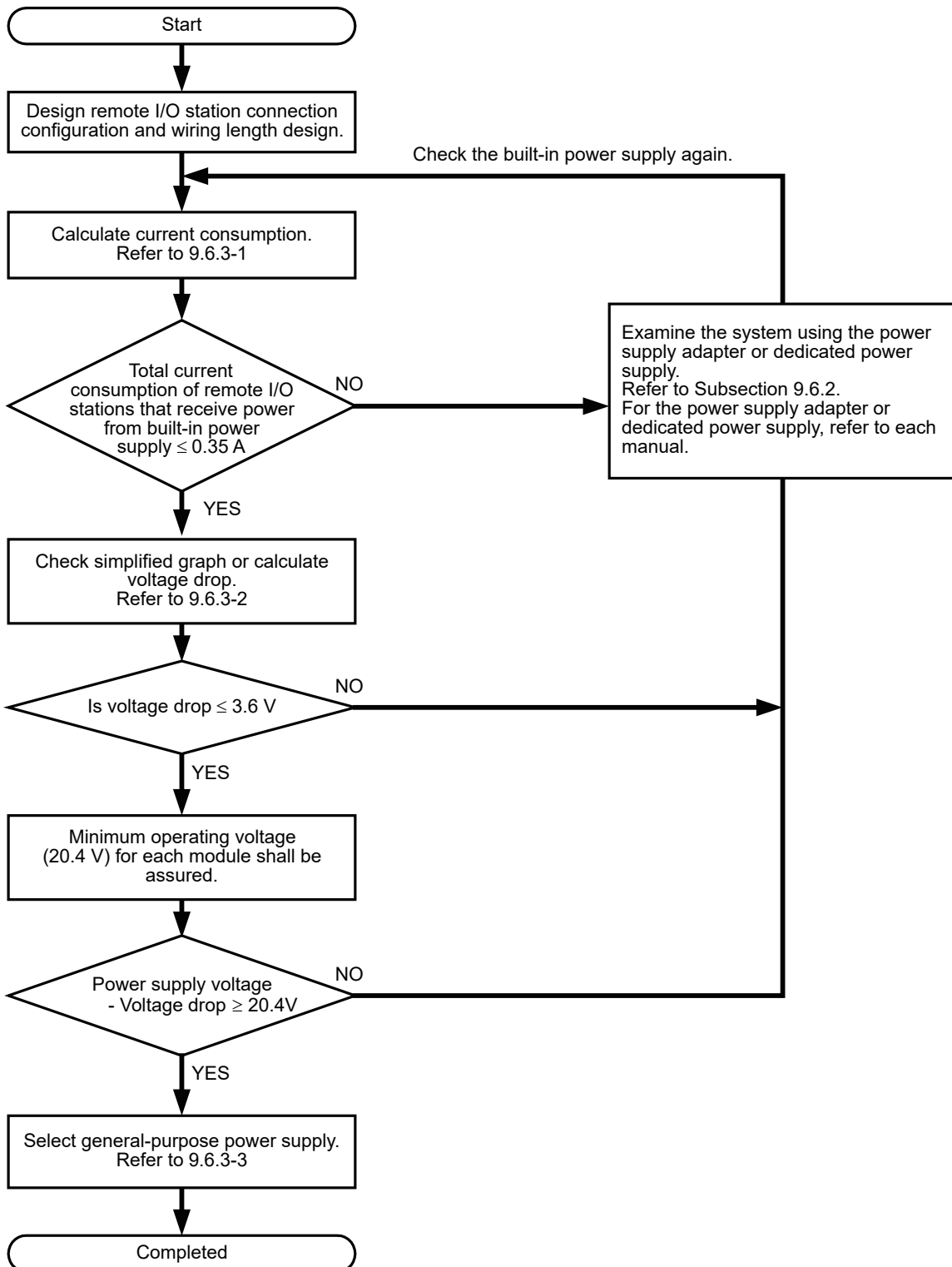

9.6.2 Installation concept of power adapter or dedicated power supply

1. Built-in power supply

The following conditions should be satisfied to construct a system with a built-in power supply. If the following conditions are not satisfied, it is necessary to examine the use of the power supply adapter or dedicated power supply in the system configuration.

- 1) As the current capacity of the built-in power supply is 0.35 A, Total current consumption of remote I/O stations and I/O equipment that receive power from built-in power supply ≤ 0.35 A.
- 2) As the minimum operating voltage from the CC-Link/LT built-in master is 20.4V for each remote module, General-purpose power supply voltage - Voltage drop ≥ 20.4 V
Do not exceed the maximum input voltage (28.8V DC).

There is a formula (Refer to Subsection 9.6.3.) to test the system configuration with regard to the voltage drop of the cable.

If the total current consumption or the voltage drop due to the cable is too large, take the following countermeasures.

When the total current consumption is large or the minimum operating voltage (20.4V DC) for each station is not assured

- Add power adapters or dedicated power supplies.
(Use power adapters or dedicated power supplies so that the power supplied to the system is divided accordingly.)

When the voltage drop is large or the minimum operating voltage (20.4V DC) of each station is not assured

- Shorten the CC-Link/LT dedication flat cable
(Shorten the maximum distance from the Built-in master to remote I/O stations.)
- Add power adapters or dedicated power supplies.
(Use power adapters or dedicated power supplies so that the power supplied to the system is divided accordingly.)

2. Rule when using power adapter or dedicated power supplies

When the capacity of the built-in power supply is insufficient, use the power supply adapter or dedicated power supply in accordance with the system configuration. (The power supply adapter and dedicated power supply can be used together.)

When using the power supply adapter or dedicated power supply, calculate "current consumption", "voltage drop" and "minimum operating voltage (20.4V DC)" for each power supply adapter, and satisfy each condition in the system configuration.

→ For the power supply adapter and dedicated power supply, refer to the manual of the corresponding product.

System configuration examples

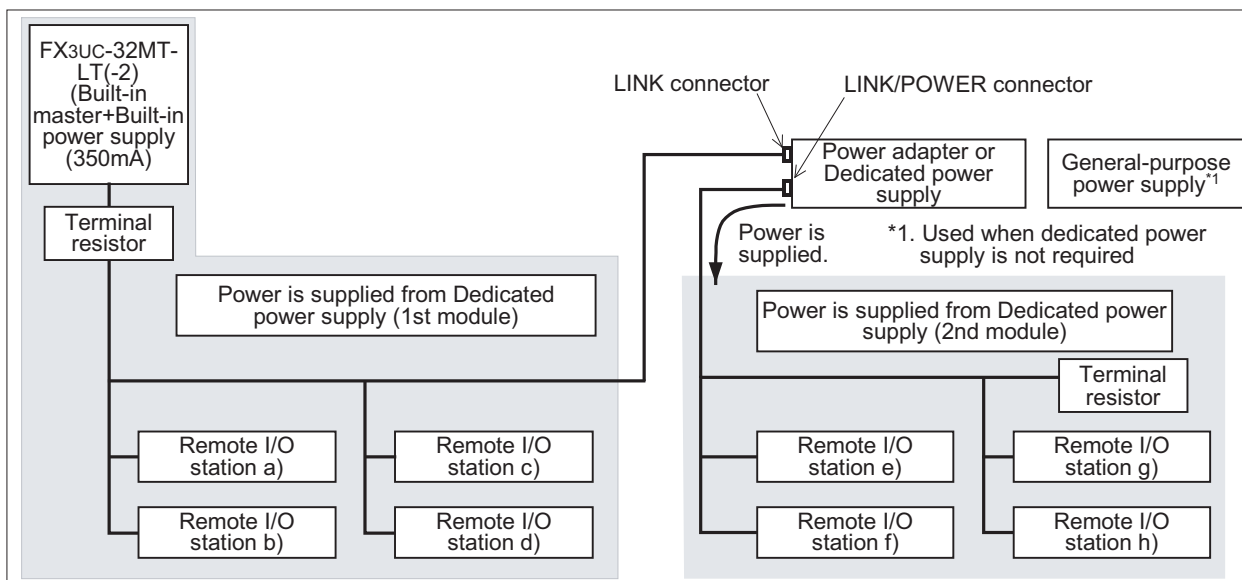

1) Current consumption calculation

Current consumption calculation in built-in power supply (1st module)	=	Total current consumption in master station and remote I/O station a) to d) *1
Current consumption calculation in power adapter or dedicated power supply (2nd module)	=	Total current consumption in remote I/O station e) to h) *1

2) Start-up current calculation

Start-up current calculation supplied from built-in power supply (1st module)	=	Total current of remote I/O station a) to d) at start-up *1
Start-up current calculation supplied from power adapter or dedicated power supply (2nd module)	=	Total current of remote I/O station e) to h) at start-up *1

3) Voltage drop calculation

Voltage drop calculation supplied from built-in power supply (1st module)	=	Calculate voltage drop in remote I/O station a) to d) based on current consumption and distance to the furthest station.
Voltage drop calculation supplied from power adapter or dedicated power supply (2nd module)	=	Calculate voltage drop in remote I/O station e) to h) based on current consumption and distance to the furthest station.

4) Confirmation related to the minimum operating voltage (20.4V DC) of the module

Minimum operating voltage (20.4V DC) from power adapter (1st module)	=	Output voltage of built-in power supply (1st module) - voltage drop \geq 20.4V
Minimum operating voltage (20.4V DC) from power adapter (2nd module)	=	Output voltage of power adapter or dedicated power supply (2nd module) - voltage drop \geq 20.4V

*1. When using remote I/O stations that receive power for connected I/O equipment from the built-in power supply, power supply adapter or dedicated power supply, include the current consumption of the connected I/O equipment.

9.6.3 System power supply calculation [FX3uc-32MT-LT(-2) built-in power supply]

1 Current consumption calculation

Using the formula below, calculate the total current consumption of the remote stations, I/O equipment and the master station receiving power from the built-in power supply.

$$\boxed{\text{Current consumption in CC-Link/LT system}} = \boxed{\text{Total current consumption of each module in CC-Link/LT system}} + \boxed{\text{Total current consumption of I/O equipment (such as sensors) (to which power is supplied via communication cable)*1}} \leq 0.35A$$

*1. Some remote I/O stations for CC-Link/LT supply the power for I/O via a CC-Link/LT dedicated flat cable. For details, refer to the manual of each remote I/O station.

2 Voltage drop

Voltage drop of the built-in power supply can be calculated using "1. Quick reference list" or "2. Calculation formula".

Voltage drop is in proportion to the connection cable length and the current consumption of connected remote I/O stations and I/O equipment.

Calculate the voltage drop with respect to the cable length up to a remote station or the master station that is located furthest from the main unit.

1. Selection based on the simplified graph (at supply voltage: 24V DC, ambient temperature: 20°C)

The graph on the right shows the relationship between current consumption (A) and the cable length (m(inches)) that causes a voltage drop of 3.6 V.

When the relationship between the current consumption and the cable length is located inside the graph (shaded region), the system can be constructed using only the built-in power supply.

However, the available main line length, branch line length and total branch line length are restricted by transmission speed.

- Maximum cable length:
Cable length between remote I/O stations located in farthest positions that receive power from the built-in power supply in the main unit (built-in master), power supply adapter or dedicated power supply.

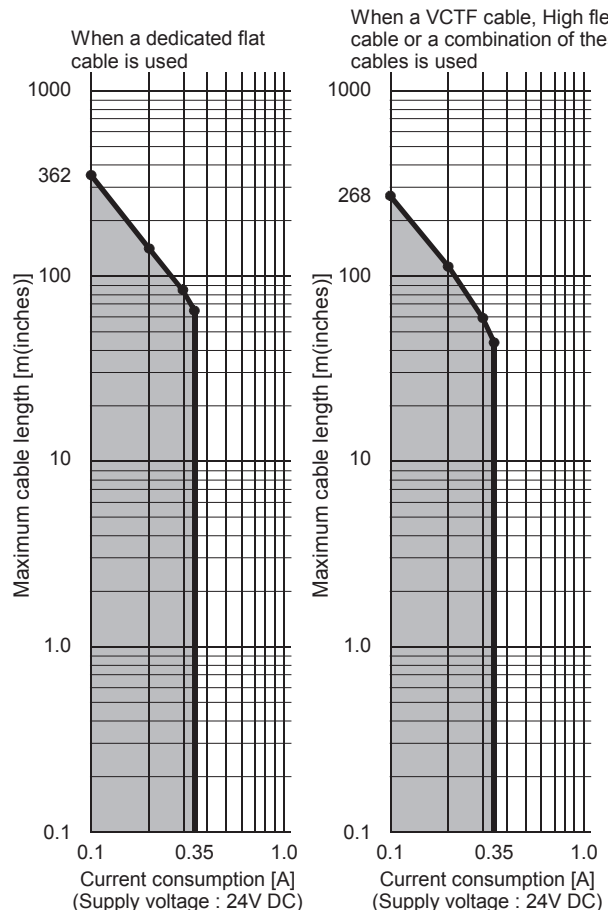

1 Outline

2 External Dimensions

3 Generic Specifications

4 Power Supply Specifications

5 Input Specifications

6 Output Specifications

7 Examples of Wiring for Various Uses

8 Terminal Block

9 CC-Link/LT Master FX3UC-LT(-2) only

10 Display module FX3UC-LT(-2) only

2. Selection based on the calculation formula (at supply voltage: 24V DC, ambient temperature: 20°C)

- 1) When a dedicated flat cable is used
calculation formula

$$\boxed{\text{Voltage drop (V)}} = \boxed{\text{Maximum distance (m) + 55(Constant)}} \times \boxed{0.06 \text{ (Constant)}} \times \boxed{\text{Total current consumption (A)}} + \boxed{1.1V \text{ (Constant)}} \leq 3.6V$$

Maximum distance	Distance from main unit to farthest remote I/O station that receives power from built-in power supply	
Total current consumption	Total current consumption of each CC-Link/LT station that receives power from main unit	+ Total current consumption of I/O equipment (such as sensor) connected to remote I/O stations that receives power from the main unit (through communication cable)*1

- *1. Some remote I/O stations for CC-Link/LT supply power for I/O via a CC-Link/LT dedicated flat cable.
→ **For details, refer to the manual of each remote I/O station.**

When the current consumption is determined, the distance from the main unit to the furthest station can be obtained from the following formula.

$$\boxed{\text{Maximum distance (m)}} \leq \boxed{3.6 \text{ (V)} - 1.1 \text{ (V) (Constant)}} \div \boxed{\text{Total current consumption (A)}} \div \boxed{0.06 \text{ (Constant)}} - \boxed{55 \text{ (Constant)}}$$

Or when the distance from the main unit to the furthest station is determined, the allowable current consumption can be obtained from the formula below.

$$\boxed{\text{Total current consumption (A)}} \leq \boxed{3.6 \text{ (V)} - 1.1 \text{ (V) (Constant)}} \div \boxed{0.06 \text{ (Constant)}} \div \boxed{\text{Maximum distance (m) + 55 (Constant)}}$$

The simplified graph and the calculation formula for voltage drop may not always be accurate as effects such as ambient temperature and the number of connectors used can influence the results.

When the voltage drops considerably, add a power supply adapter or dedicated power supply.

And if the driving voltage (20.4 V) cannot be assured in a remote station, take proper countermeasures.

$$\boxed{\text{General-purpose power supply voltage}} - \boxed{\text{Voltage drop}} \geq 20.4V$$

- 2) When a dedicated flat cable, VCTF cable and high flexible cable are used together
calculation formula

$$\boxed{\text{Voltage drop (V)}} = \boxed{\text{Maximum distance (m) + 45(Constant)}} \times \boxed{0.08 \text{ (Constant)}} \times \boxed{\text{Total current consumption (A)}} + \boxed{1.1V \text{ (Constant)}} \leq 3.6V$$

3. Selection of the general-purpose power supply connected to the Main unit

When using the CC-Link/LT master function, connect a general-purpose power supply that satisfies the following condition to the main unit.

If the following conditions are not satisfied, for example, due to a change in the system, then changing the general-purpose power supply or using a power adapter/dedicated power supply should be considered.

- 1) The power source must supply a minimum of 20.4V DC to the CC-Link/LT system for the I/O modules to operate correctly.

Do not exceed the maximum input voltage (28.8V DC) of the power adapter.

→ For the voltage drop calculation, refer to Subsection 9.6.3.

$$20.4V + \text{voltage drop} \leq \text{General purpose power supply output voltage} \leq 28.8V$$

- 2) Select a general-purpose power supply whose rated output current can cope with the value required in the current consumption calculation (9.6.3)

Rated output current of general-purpose power supply \geq Total current consumption of remote I/O stations that receive power from built-in power supply

- 3) Select a general-purpose power supply whose maximum output current*1 can cope with the calculated current value expected at the start-up of the CC-Link/LT system (when the power is turned on).

Maximum output current of general-purpose power supply \geq 24V DC 30A, 0.5ms

- *1. Maximum output current: May be referred to as "peak output current".
If there is no description concerning maximum output current, use the threshold value of the "high current limiting function".

9.6.4 System configuration example 1

In this system configuration example using only dedicated flat cables, both the current consumption and the voltage drop are small.

System configuration example

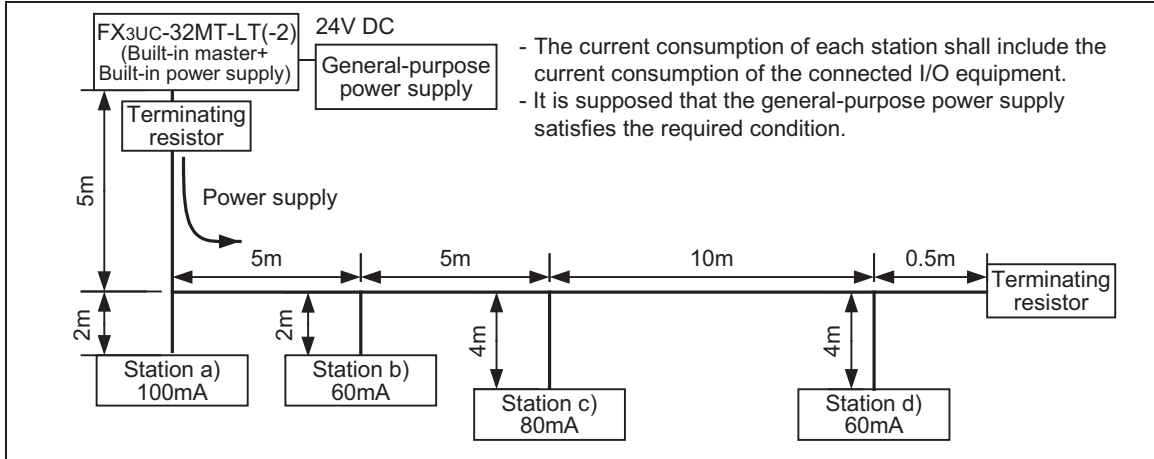

1) Current consumption calculation

Total current consumption

$$\begin{matrix}
 \boxed{100\text{mA}} & + & \boxed{60\text{mA}} & + & \boxed{80\text{mA}} & + & \boxed{60\text{mA}} & = & \boxed{300\text{mA} = 0.30\text{A}} & \leq & \boxed{0.35\text{A}} \\
 \text{station} & & \text{station} & & \text{station} & & \text{station} & & & & \\
 \text{a)} & & \text{b)} & & \text{c)} & & \text{d)} & & & &
 \end{matrix}$$

OK

2) Voltage drop calculation

$$\boxed{(29\text{m (95'1")}) + \text{Constant : 55}} \times \boxed{\text{Constant : 0.06}} \times \boxed{0.3\text{A}} + \boxed{1.1\text{V}} = \boxed{2.612\text{V}} \leq \boxed{3.6\text{V}}$$

OK

Maximum distance : From the main unit to the farthest station, station d)

$$\boxed{5\text{m (16'4")}} + \boxed{5\text{m (16'4")}} + \boxed{5\text{m (16'4")}} + \boxed{10\text{m (32'9")}} + \boxed{4\text{m (13'1")}} = \boxed{29\text{m (95'1")}}$$

3) Confirmation related to the minimum operating voltage (20.4V DC) of the module

$$24\text{V} - 2.612\text{V} = 21.388\text{V} \geq 20.4\text{V}$$

From 1), 2) and 3) above, the system can be configured using only the built-in power supply with regard to both the current and voltage restrictions.

9.6.5 System configuration example 2 (When current consumption and voltage drop are large)

In this system configuration example using only dedicated flat cables, the current consumption is large. Required countermeasures are also described.

When the current consumption is large, use the power supply adapter or dedicated power supply without regard to voltage drop size, and make sure that the total current consumption of each station connected to the built-in power supply is 0.35 A or less.

1. System configuration example whose current consumption is large

The total current consumption of connected stations exceeds 0.35 A in the following system configuration example.

System configuration example

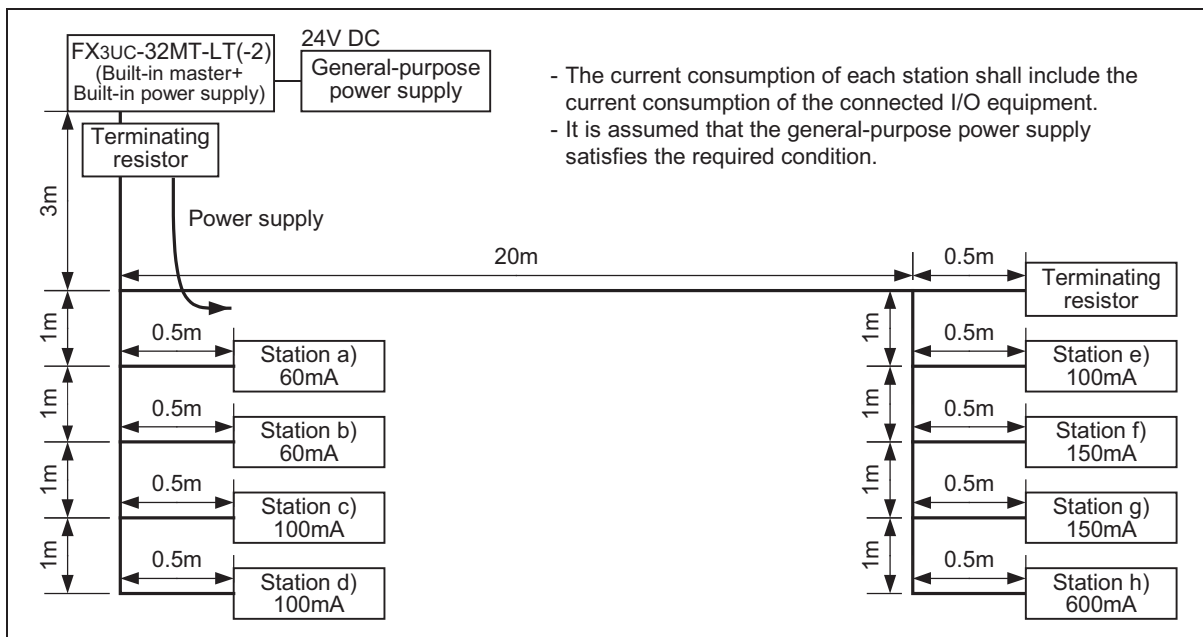

1) Current consumption calculation

Total current consumption

$$\begin{matrix} \boxed{60\text{mA}} & + & \boxed{60\text{mA}} & + & \boxed{100\text{mA}} & + & \boxed{100\text{mA}} & + & \boxed{100\text{mA}} & + & \boxed{150\text{mA}} & + & \boxed{150\text{mA}} & + & \boxed{600\text{mA}} & = & \boxed{1320\text{mA}} = 1.32\text{A} > \boxed{0.35\text{A}} \\ \text{station} & & \text{station} & & \text{station} & & \text{station} & & \text{station} & & \text{station} & & \text{station} & & \text{station} & & & \\ \text{a)} & & \text{b)} & & \text{c)} & & \text{d)} & & \text{e)} & & \text{f)} & & \text{g)} & & \text{h)} & & & \end{matrix}$$

Invalid

2) Voltage drop calculation

$$\boxed{(27.5\text{m (90'2")}) + \text{Constant : 55}} \times \boxed{\text{Constant : 0.06}} \times \boxed{1.32\text{A}} + \boxed{1.1\text{V}} = \boxed{7.634\text{V}} > \boxed{3.6\text{V}}$$

Invalid

Maximum distance : From the main unit to the farthest station, station h)

$$\boxed{3\text{m (9'10")}} + \boxed{20\text{m (65'7")}} + \boxed{1\text{m (3'3")}} + \boxed{1\text{m (3'3")}} + \boxed{1\text{m (3'3")}} + \boxed{1\text{m (3'3")}} + \boxed{0.5\text{m (1'7")}} = \boxed{27.5\text{m (90'2")}$$

3) Confirmation related to the minimum operating voltage (20.4V DC) of the module

$$24\text{V} - 7.634\text{V} = 16.366\text{V} < 20.4\text{V}$$

Invalid

From 1), 2) and 3) above, the system cannot be configured using only built-in power supply regard to both the current restrictions.
Add a power adapter or dedicated power supply as shown in the next page.

- 1 Outline
- 2 External Dimensions
- 3 Generic Specifications
- 4 Power Supply Specifications
- 5 Input Specifications
- 6 Output Specifications
- 7 Examples of Wiring for Various Uses
- 8 Terminal Block
- 9 CC-Link/LT Master FX3UC-LT(-2) only
- 10 Display module FX3UC-LT(-2) only

2. Countermeasures (addition of power adapter (CL1PAD1))

When the current consumption exceeds 0.35A, add the power supply adapter or dedicated power supply, and construct the system so that the total current consumption of stations connected to the built-in power supply is 0.35A or less.

For the dedicated power supply and power supply adapter, refer to the manual of power supply adapter.

System configuration example when one power adapter is used

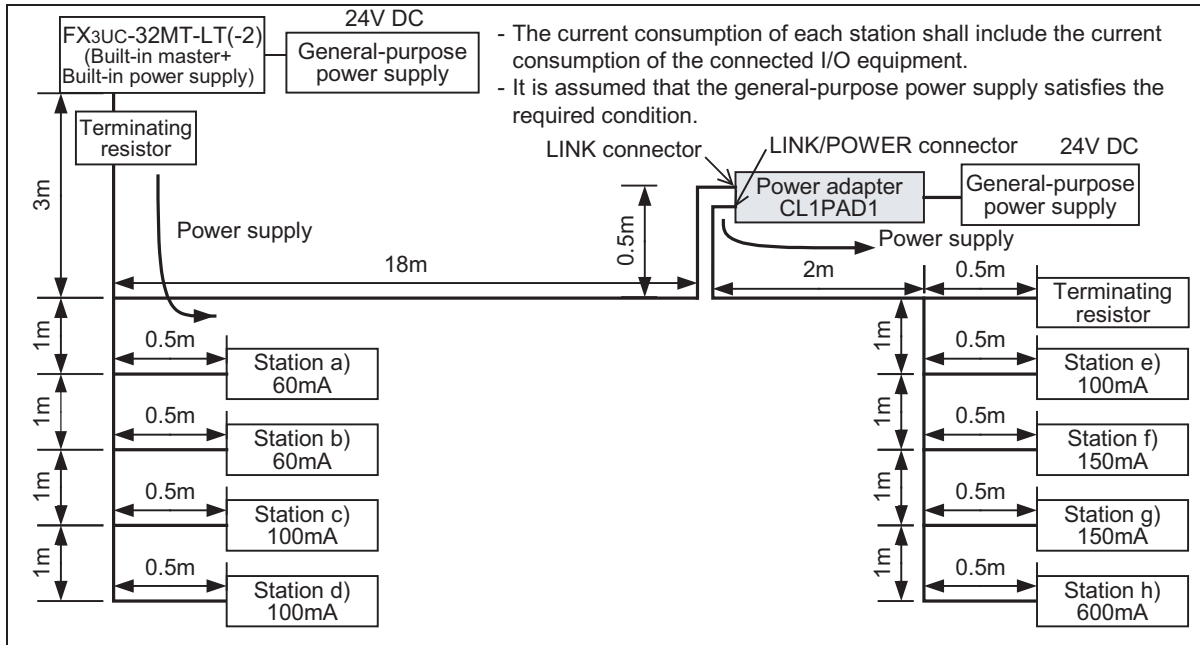

1) Current consumption calculation

Total current consumption in the built-in power supply

$$60\text{mA} + 60\text{mA} + 100\text{mA} + 100\text{mA} = 320\text{mA} = 0.32\text{A} \leq 0.35\text{A}$$

station a) station b) station c) station d)

OK

Total current consumption in the power adapter

$$100\text{mA} + 150\text{mA} + 150\text{mA} + 600\text{mA} = 1000\text{mA} = 1\text{A} \leq 5\text{A}$$

station e) station f) station g) station h)

OK

2) Voltage drop calculation

Voltage drop in the built-in power supply

$$(7.5\text{m (24'7")} + \text{Constant : } 55) \times \text{Constant : } 0.06 \times 0.32\text{A} + 1.1\text{V} = 2.3\text{V} \leq 3.6\text{V}$$

OK

Maximum distance : From the main unit to the farthest station, station d)

$$3\text{m (9'10")} + 1\text{m (3'3")} + 1\text{m (3'3")} + 1\text{m (3'3")} + 1\text{m (3'3")} + 0.5\text{m (1'7")} = 7.5\text{m (24'7")}$$

Voltage drop in the power adapter

$$(7\text{m (22'11")} + \text{Constant : } 11) \times \text{Constant : } 0.06 \times 1\text{A} = 1.08\text{V} \leq 3.6\text{V}$$

OK

Maximum distance : From the power adapter to the farthest station, station h)

$$0.5\text{m (1'7")} + 2\text{m (6'6")} + 1\text{m (3'3")} + 1\text{m (3'3")} + 1\text{m (3'3")} + 1\text{m (3'3")} + 0.5\text{m (1'7")} = 7\text{m (22'11")}$$

3) Confirmation related to the minimum operating voltage (20.4V DC) of the module

Built-in power supply: $24\text{V} - 2.3\text{V} = 21.7\text{V} \geq 20.4\text{V}$

Power adapter : $24\text{V} - 1.08\text{V} = 22.92\text{V} \geq 20.4$

From 1), 2) and 3) above, the system cannot be configured using only built-in power supply regard to both the current restrictions.
Add a power adapter or dedicated power supply.

9.7 Design Precautions

9.7.1 Prevention of erroneous inputs and outputs to/from remote I/O modules

In order to prevent erroneous inputs to and outputs from remote I/O modules, design the system under consideration of the contents described below.

1. When setting the power to ON or OFF

When using a power supply adapter or dedicated power supply, turn ON the power of the remote I/O units (power supply adapter and dedicated power supply) before starting data link.

Stop the data link first, and then turn OFF the power to the remote I/O modules (power adapter or dedicated power supply).

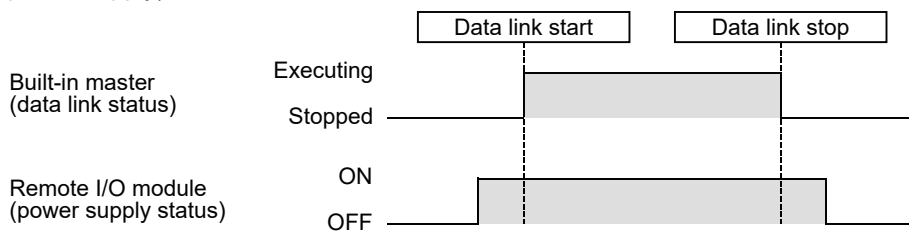

2. When the power is interrupted instantaneously in a remote I/O module

When the power (24V DC) supplied to a remote I/O module is interrupted instantaneously, erroneous inputs may occur.

Cause of erroneous inputs due to instantaneous power interruption

The hardware of a remote I/O module converts the unit power (24V DC) into 5V DC before using it.

If instantaneous power interruption occurs in a remote I/O module:

Time until 5V DC inside remote I/O module turns OFF > Response time for "ON → OFF" of input unit

As a result, if refresh is executed in the period shown in (A) below, erroneous inputs occur.

(Erroneous inputs may occur especially while the input response time is set to high-speed input type.)

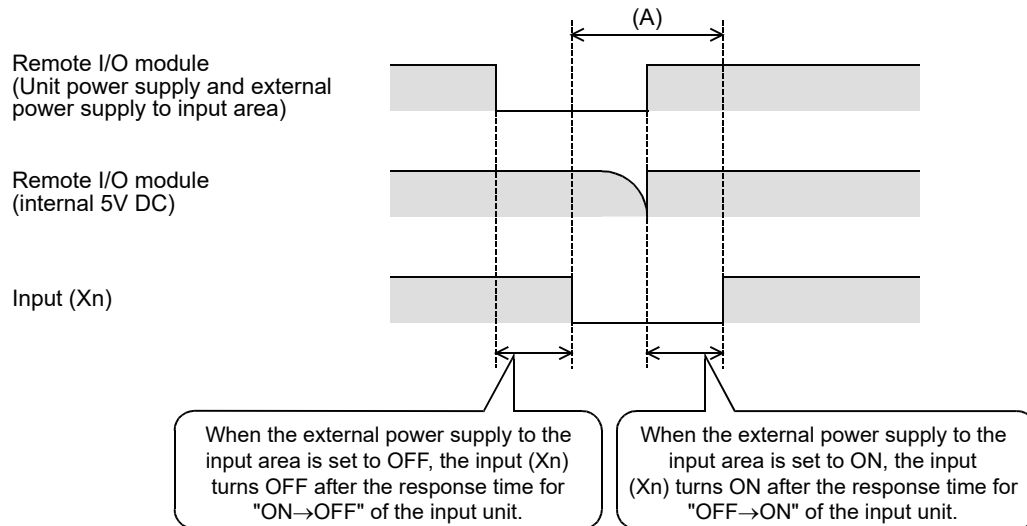

3. Countermeasures against erroneous input

Supply power to the dedicated power supply, power supply adapter, stabilized power supply and AC input units from the same external power source.

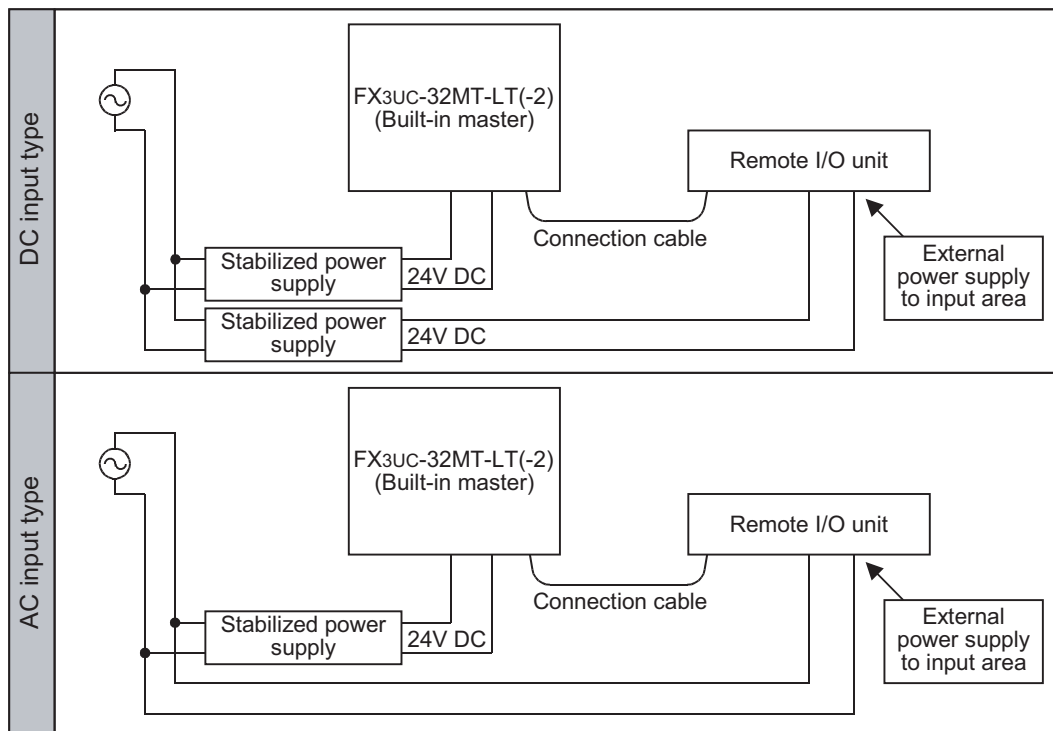

9.7.2 When using high flexible cable

Make sure that stress is not applied on the connector when the high flexible cable is moved.

9.8 Connection of Cables, Connectors and Terminating Resistors

9.8.1 Procedure

Connect connection cables, connectors and terminating resistors using the following procedure.

1 Turn the power supply OFF.

Make sure that the power of the PLC is OFF before starting the wiring work.

2 Attaching connectors

Attach connectors to connection cable ends, T branches, etc.

- When only dedicated flat cables are used, refer to Subsection 9.8.3.
- When different connection cables are used together, refer to Subsection 9.8.4.

3 Connecting connection cables

Connect CC-Link/LT dedicated flat cables, VCTF cables and high flexible cables.

- When only dedicated flat cables are used, refer to Subsection 9.8.3.
- When different connection cables are used together, refer to Subsection 9.8.4.

4 Connecting a connection cable to the CC-Link/LT interface connector in the master

Connect one side of a connection cable of the trunk line equipped with a connector to the CC-Link/LT interface connector in the master.

- For details, refer to Subsection 9.8.6.

5 Connection of Terminating Resistor

Connect a terminal resistor to each end of the system.

- For details, refer to Subsection 9.8.7.

9.8.2 Connection outline for connection cables (Example: CC-Link/LT dedicated flat cables)

This subsection explains how to connect CC-Link/LT dedicated flat cables.

- 1) The connection cable connection order has no relevance to the station number.
- 2) Make sure to place the CC-Link/LT built-in master on one end of the trunk line.
 Connect a terminating resistor for the CC-Link/LT built-in master within 20cm from a connector.
- 3) Make sure to connect a terminating resistor on each end of the CC-Link/LT trunk line.

Connection example for the CC-Link/LT dedicated flat cable

Connect the dedicated flat cable to a T branch or remote I/O unit using dedicated flat cable connectors.

T-branch area

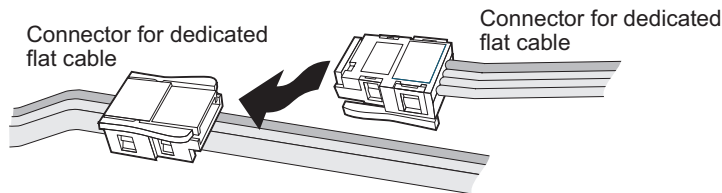

Connection area (built-in master, remote station, power supply)

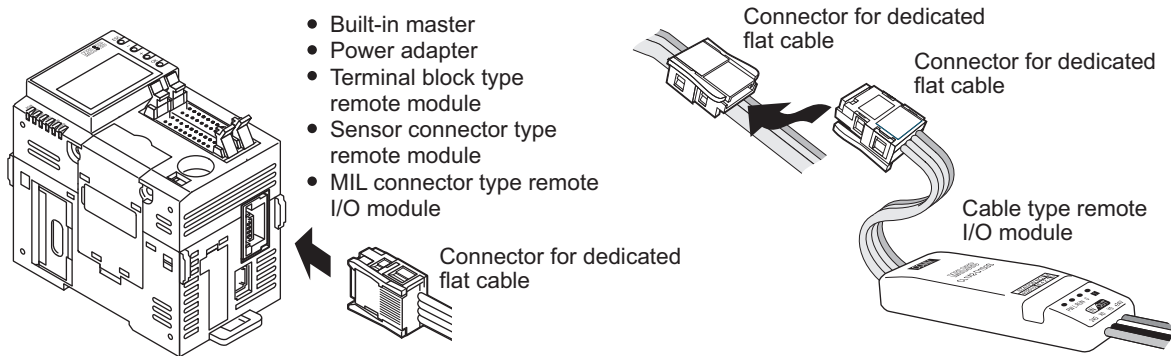

9.8.3 How to attach connectors for the dedicated flat cable (terminal/T-branch processing)

This paragraph explains how to attach connectors for the dedicated flat cable.

1. Components

The components are as shown below.

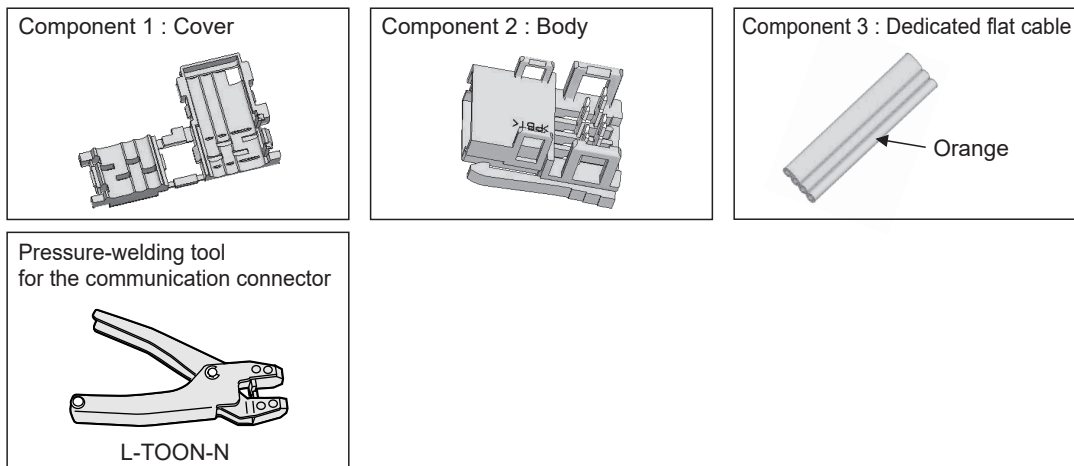

2. Attachment procedure

The procedure is shown below.

1) Terminal processing procedure

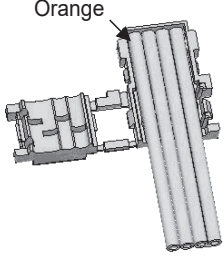
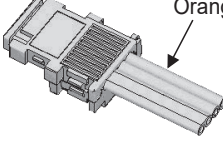
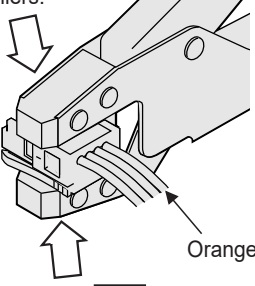
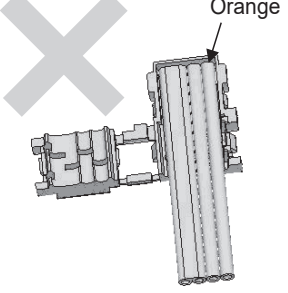
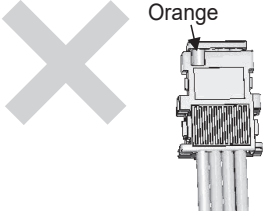
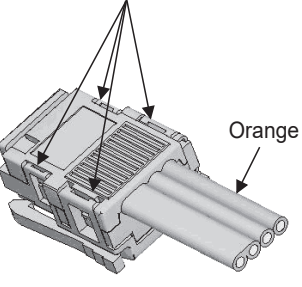
<p>1) Properly place the dedicated flat cable in the cover. (Check that the position of the orange part is correct.)</p> 	<p>2) Close the cover so that the flat cable will be held between both sides of the cover</p> 	<p>3) Assemble the cover with the body and press-fit them with pliers.</p> 
<p>Note1) This setting position is wrong.</p> 	<p>Note2) If the orange part is seen through the guide hole in the front cover, the wiring is not correct. Open the cover and perform the previous step again.</p> 	<p>4) Check that all four latches are engaged. Press-fitting is completed.</p> 

2) T-branch processing procedure

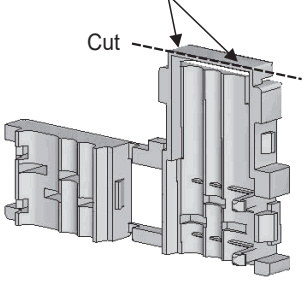
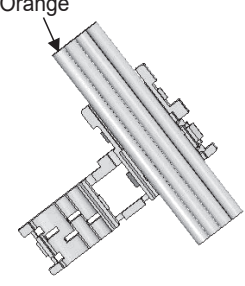
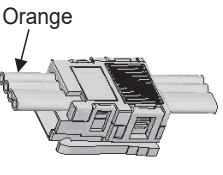
<p>5) Cut 2 portions of the edge of the cover with nippers and remove the edge.</p> 	<p>6) Set the cover to the point where the T-branch is to be set.</p> 	<p>7) Follows the instructions of steps 3 and 4 shown above to execute press-fitting.</p> 
---	---	---

1	Outline
2	External Dimensions
3	Generic Specifications
4	Power Supply Specifications
5	Input Specifications
6	Output Specifications
7	Examples of Wiring for Various Uses
8	Terminal Block
9	CC-Link/LT Master FX3UC-LT(-2) only
10	Display module FX3UC-LT(-2) only

9.8.4 How to attach connectors for the VCTF cable/high flexible cable (terminal/T-branch processing)

This section explains how to attach VCTF cable connectors and high flexible cable connectors.

1. Components

The components are shown below.

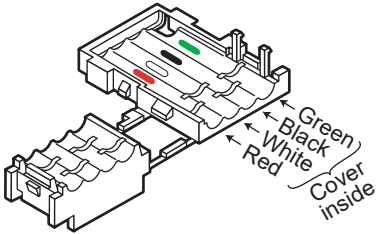
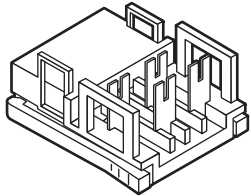
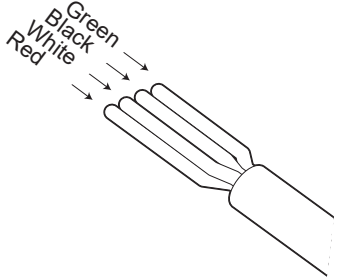
<p>Component 1 : Cover VCTF cable connector : Green Flexible cable connector : Yellow green</p> 	<p>Component 2 : Body (Aqua)</p> 	<p>Component 3 : VCTF cable/ High flexible cable</p>  <p>Relationship between wire color and signal</p> <table border="1"> <thead> <tr> <th>Signal name</th> <th>Wire color</th> </tr> </thead> <tbody> <tr> <td>+24V</td> <td>Red</td> </tr> <tr> <td>DA</td> <td>White</td> </tr> <tr> <td>DB</td> <td>Black</td> </tr> <tr> <td>24G</td> <td>Green</td> </tr> </tbody> </table>	Signal name	Wire color	+24V	Red	DA	White	DB	Black	24G	Green
Signal name	Wire color											
+24V	Red											
DA	White											
DB	Black											
24G	Green											

2. Attachment procedure

The procedure is shown below.

1) Terminal processing procedure

Applicable attachment: Terminal resistor attachment at the trunk line end and terminal processing

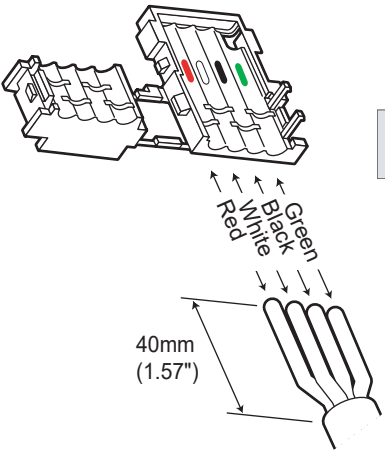
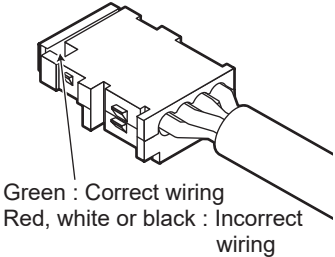
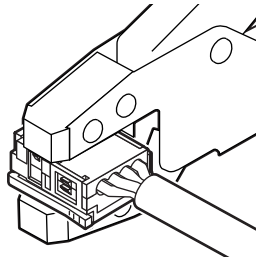
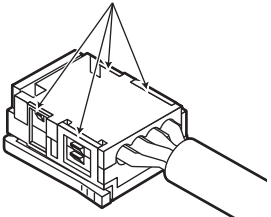
<p>1) Correctly align the VCTF cable/ high flexible cable with the same colored sections.</p> 	<p>2) Close the cover to firmly hold the VCTF cable/high flexible cable in place. When the cable is correctly wired, the green wire can be seen from the notched window. If the red, white or black wire is seen from the notched window, the wiring is wrong. Open the cover, and correctly set the cable. Incorrect wiring causes failures in the unit.</p> 	<p>3) Combine the body with the cover, and press-fit them with pliers, etc.</p>  <p>4) Confirm that the latch is engaged in four positions. Now, press-fitting is finished.</p> 
---	--	--

- 2) T-branch processing procedure
a) When using a terminal block

Applicable attachment: T-branch processing

When wiring a VCTF cable/high flexible cable to a terminal block, connect cables with the same color together.

Applicable cable: Dedicated flat cable, VCTF cable and high flexible cable

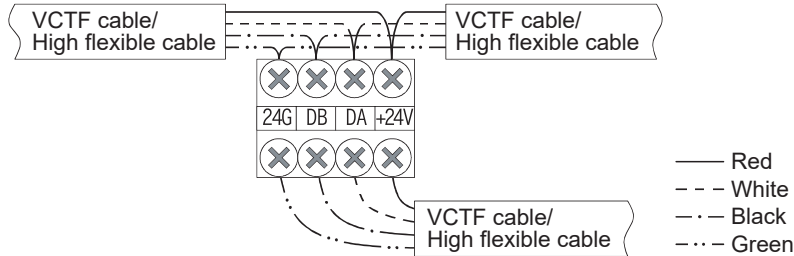

Cautions on use

Align the symbols "+24V", "DA", "DB" and "24G" printed on the dedicated flat cable with the wire colors of the VCTF cable / high flexible cable as shown in the table below when wiring the dedicated flat cable to the terminal block "trunk line = VCTF cable, drop line = dedicated flat cable".
Make sure to separate the dedicated flat cable into four independent wires having the marks "+24V", "DA", "DB" and "24G".

Dedicated flat cable	Wire colors in VCTF cable or high flexible cable
+24V	Red
DA	White
DB	Black
24G	Green

- b) When a dedicated flat cable is used as the trunk line
Branch the trunk line using connectors in the same way as the T-branch processing method for the dedicated flat cable.

Trunk line: Dedicated flat cable Drop line: VCTF cable or high flexible cable

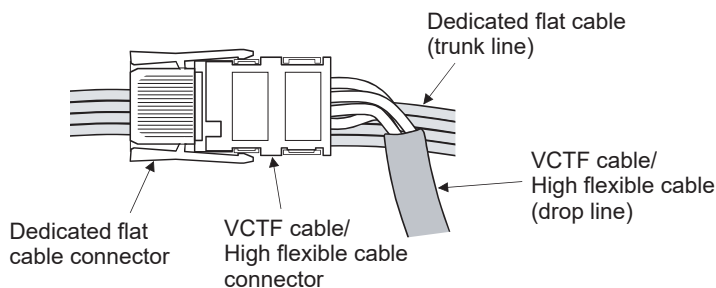
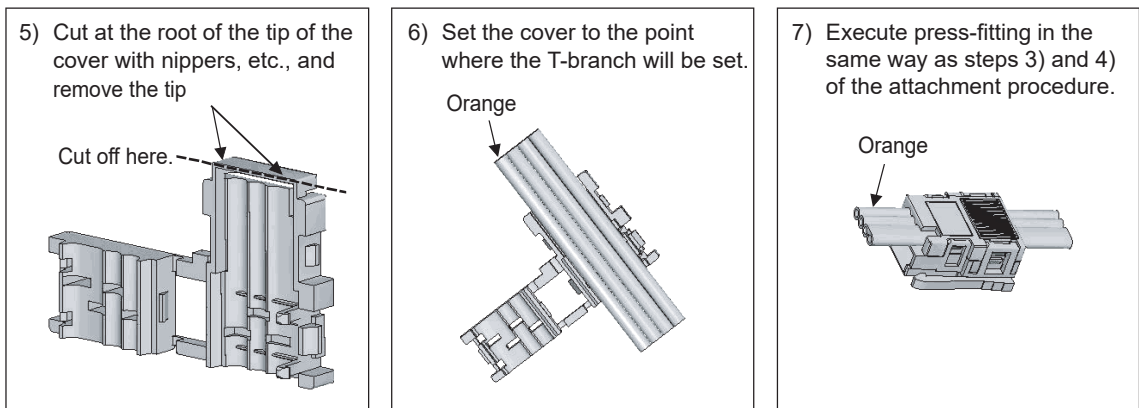

1	Outline
2	External Dimensions
3	Generic Specifications
4	Power Supply Specifications
5	Input Specifications
6	Output Specifications
7	Examples of Wiring for Various Uses
8	Terminal Block
9	CC-Link/LT Master FX3UC-LT(-2) only
10	Display module FX3UC-LT(-2) only

c) When the VCTF cable/high flexible cable is used as the trunk line

Trunk line, Drop line: VCTF cable, High flexible cable

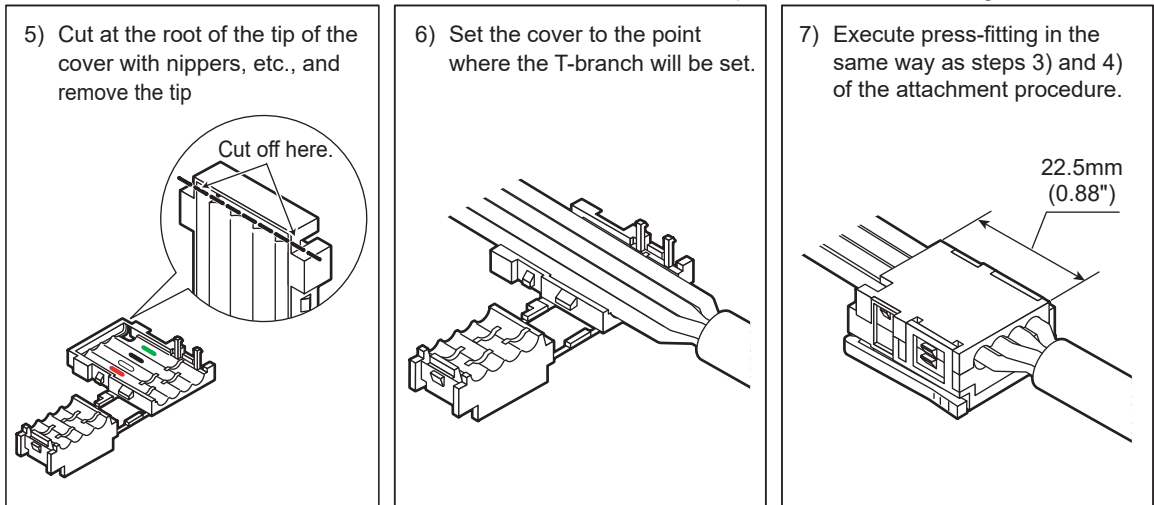

After stripping the sheath by 70mm (2.75") or more, perform the procedure for the dedicated flat cable in the same way as the T-branch.

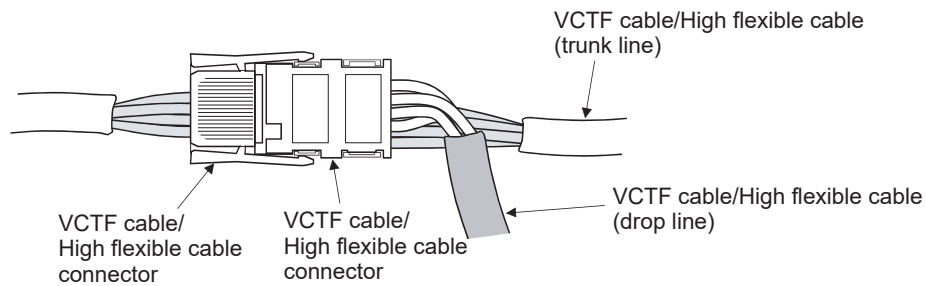

9.8.5 Inserting a connector [to power supply adapter/dedicated power supply]

WIRING PRECAUTIONS **CAUTION**

- The FX3UC-32MT-LT(-2) has a built-in power supply. When connecting a power supply adapter or dedicated CC-Link/LT power supply, connect the built-in master to the LINK connector in the power supply adapter or dedicated power supply. Connection to the LINK/POWER connector may cause failures.

Correct connection

Wrong connection

→ For the main unit, refer to Subsection 9.8.6.
→ For the remote I/O unit, refer to the appropriate manual

1. When a power adapter (CL1PAD1) or dedicated power supply (CL1PSU-2A) is used Handling the LINK connector and LINK/POWER connector

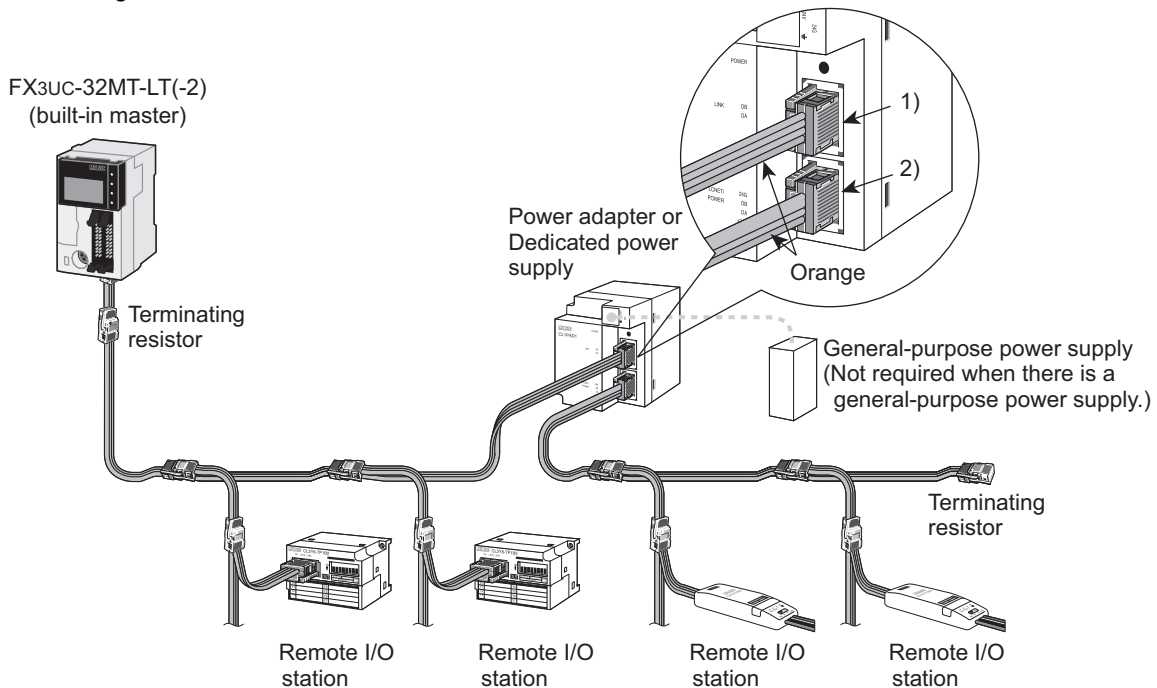

Connector pin assignment

- 1) LINK connector:
Executes only communication (and does not supply power).
Use this connector for relay of communication when connecting the FX3UC-32MT-LT(-2) or multiple power supply adapters (or dedicated power supplies).

Pin assignment

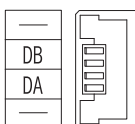

- 2) LINK/POWER connector:
Executes communication, and supplies power to the CC-Link/LT system (remote I/O station).

Pin assignment

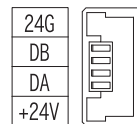

- 1 Outline
- 2 External Dimensions
- 3 Generic Specifications
- 4 Power Supply Specifications
- 5 Input Specifications
- 6 Output Specifications
- 7 Examples of Wiring for Various Uses
- 8 Terminal Block
- 9 CC-Link/LT Master FX3UC-LT(-2) only
- 10 Display module FX3UC-LT(-2) only

9.8.6 Connecting a connection cable to the CC-Link/LT interface connector

1. Connection procedure

Connect a connection cable to the CC-Link interface connector (① in right figure).

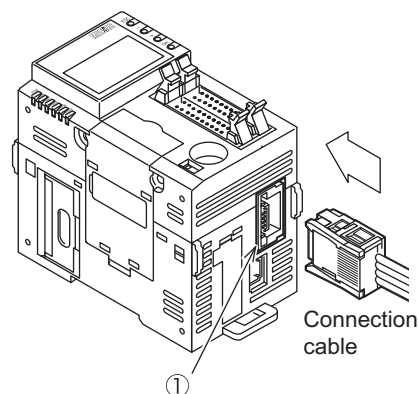

9.8.7 How to attach a terminating resistor

This paragraph explains how to attach terminating resistors to either end of the CC-Link/LT system. Attach a terminal resistor to the cable connector.

Caution:

The following example shows attachment to a CC-Link/LT dedicated cable. Use the same method for a VCTF cable or high flexible cable.

→ For details on the terminating resistor attachment method for the built-in master when using a VCTF or high flexible cable as the trunk line, refer to Subsection 9.5.3.

1. How to attach a terminating resistor on the FX3UC-32MT-LT(-2) built-in master side

Connect a terminating resistor in a position within 200mm (7.87") from the CC-Link/LT interface connector.

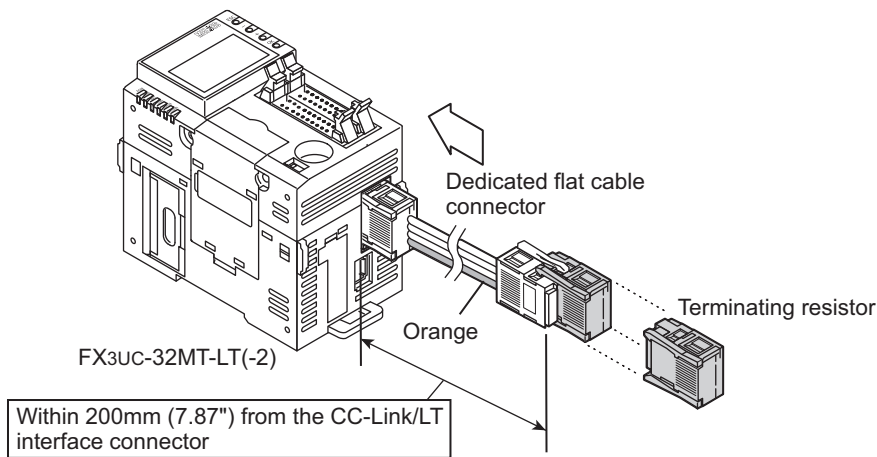

2. How to attach a terminating resistor on the trunk line side

The method to attach a terminating resistor on the opposite side of the FX3UC-32MT-LT(-2) built-in master is shown below.

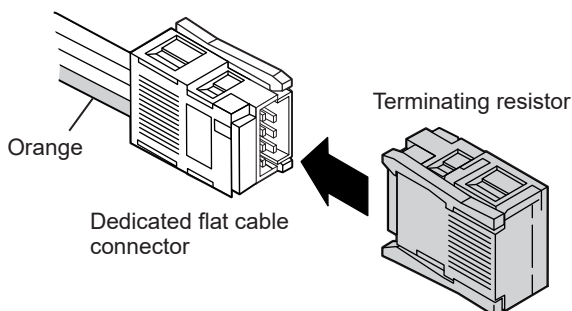

9.9 Setting of CC-Link/LT built-in master and remote I/O units (FX3UC-32MT-LT)

This section explains how to set the DIP switches for setting the operation of the built-in master and how to set the station number of remote I/O stations.

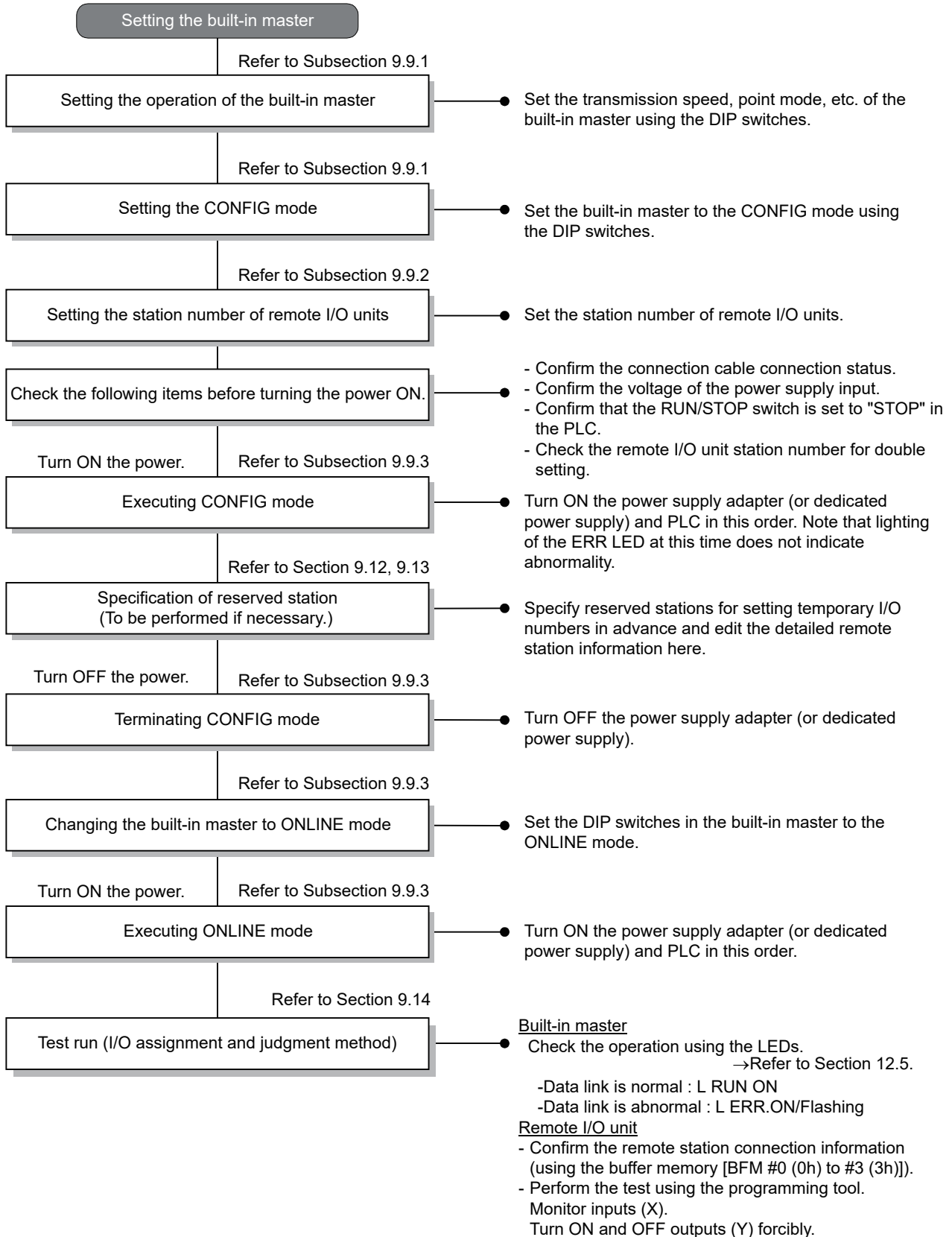

1	Outline
2	External Dimensions
3	Generic Specifications
4	Power Supply Specifications
5	Input Specifications
6	Output Specifications
7	Examples of Wiring for Various Uses
8	Terminal Block
9	CC-Link/LT Master FX3UC-LT(-2) only
10	Display module FX3UC-LT(-2) only

9.9.1 Setting DIP switches in built-in master (operation mode/Communication speed/Point mode)

Note: Setting DIP switches component change

Products manufactured in September 2011 or later have a different component used for the setting DIP switches compared with products produced earlier. Due to the component change, take note of the change in the ON/OFF position of each DIP switch. Even with the component change, the direction for setting each DIP switch ON/OFF is the same.

When product manufactured August, 2011 or earlier

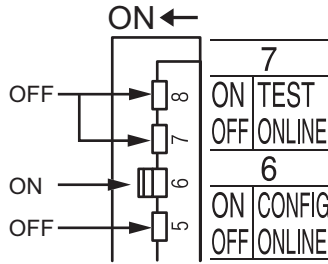

When product manufactured in September 2011 or later

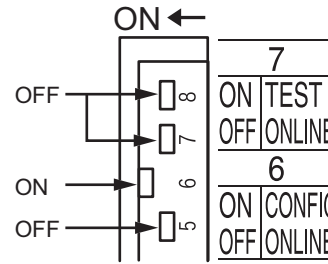

- 1 Turn the power OFF
- 2 Remove the display module of the FX3UC-32MT-LT.
 → For the display module removal method, refer to Section 3.8.
- 3 Setting the TEST mode Transmission rate and Point mode

B RATE (Transmission rate) setting [DIP switch 1, 2]

DIP switch status		Setting Content
1	2	
OFF	OFF	156kbps
ON	OFF	625kbps
OFF	ON	2.5Mbps
ON	ON	Prohibited to use

16pts/4pts (Point mode) setting [DIP switch 3]

DIP switch status	Setting Content
ON	16-point mode
OFF	4-point mode

When product manufactured August, 2011 or earlier

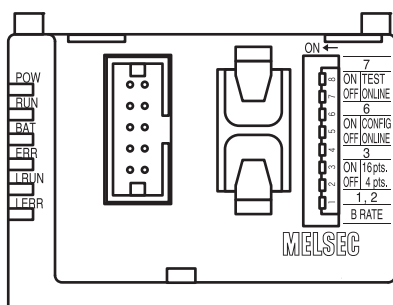

When product manufactured in September 2011 or later

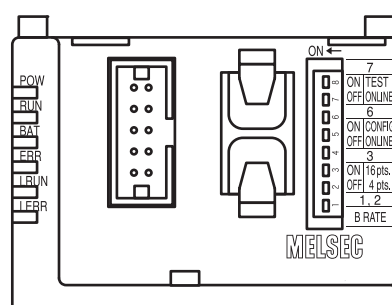

4 Setting the CONFIG mode

Set the operation mode to "CONFIG".

Selecting the Operation mode [DIP switch 6, 7]

DIP switch status		Setting Content
6	7	
OFF	OFF	ONLINE mode
ON	OFF	CONFIG mode
OFF	ON	TEST mode

[DIP switch 4, 5, 8]

The DIP switches 4, 5 and 8 are unavailable. Make sure to set them to OFF.

1. Setting example of Transmission rate (B RATE), point mode (16 pts/4 pts) and operation mode

Set the DIP switches as shown in the following figure to set the following status.

Item	Setting Content
B RATE	2.5Mbps
16pts/4pts	4-point mode
operation mode	CONFIG mode

When product manufactured August, 2011 or earlier

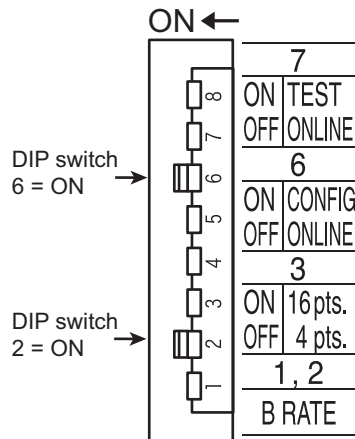

When product manufactured in September 2011 or later

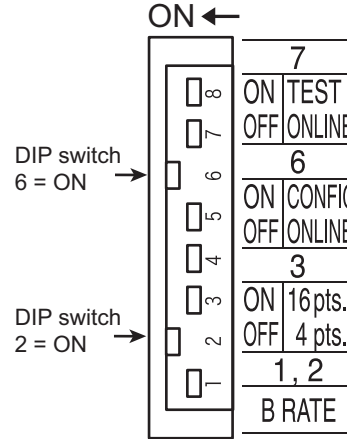

Set the station number of remote I/O units in reference to Subsection 9.9.2.

9.9.2 Station number setting of the remote I/O units

1 Setting the Station number

Set the station number using the DIP switches for operation setting of the remote I/O unit. For the station number setting, refer to the following contents.

1. Unused station numbers do not cause an error.

If station numbers are not used and a remote I/O station is connected to an unused station number in the future, however, the I/O numbers after the added unit are shifted. It is recommended to set serial numbers.

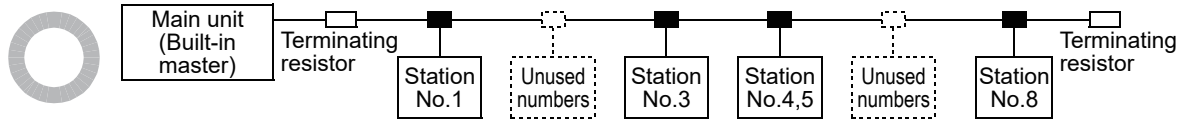

2. It is not necessary to align the order of unit connection from the built-in master with the station number.

However, note that input (X) and output (Y) numbers are assigned in the order of station number.

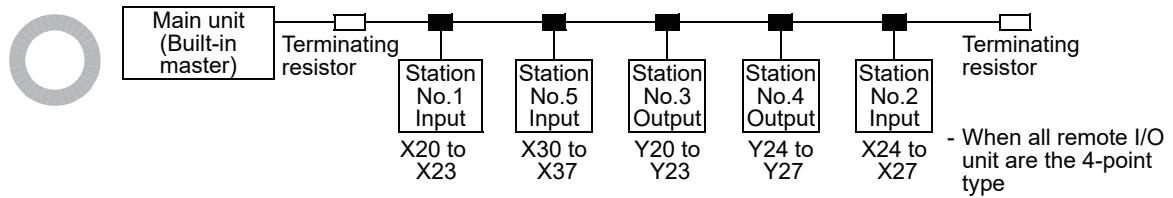

3. Use one station number only once.

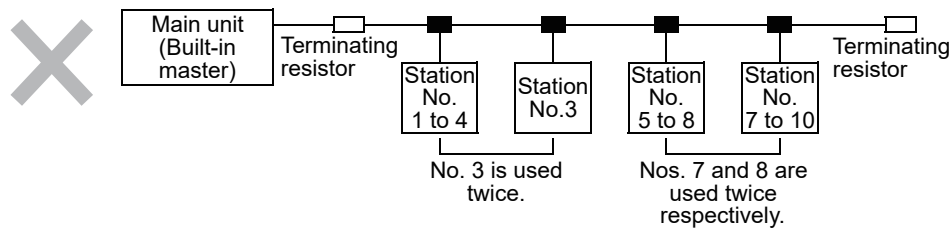

Complete the CONFIG mode in reference to Subsection 9.9.3, and change the operation mode to "ONLINE".

9.9.3 The start of the operation

1 Turn the power ON

Turn ON the power of the PLC.

When the power supply adapter or dedicated power supply is used, turn ON the power in the order "Power supply adapter (or dedicated power supply) → PLC (built-in master)".

2 Confirming completion of the CONFIG mode

When collection of the remote I/O unit information is completed in the CONFIG mode, BFM #28 (1Ch) b4 turns ON.

Caution:

The ERR LED is lit while the power is ON in the CONFIG mode (DIP switch 6: ON, DIP switch 7: OFF), but it does not indicate error.

3 Turn the power OFF

4 Setting the ONLINE mode

Set the DIP switch 6 to OFF and DIP switch 7 to OFF in the built-in master.
(For the switch setting, refer to the previous page.)

5 Turning ON the power again

Turn ON the power of the PLC. When the power supply adapter or dedicated power supply is used, turn ON the power in the order "Power supply adapter (or dedicated power supply) → PLC (built-in master)".

9.10 Setting of CC-Link/LT built-in master and remote I/O units (FX3UC-32MT-LT-2)

Explains how to use GX Works2 or GX Developer (Ver. 8.68W or later) to setup the operation of the built-in master and how to set the station number of remote I/O stations. For setup using by the display module, refer to Section 10.16.

1) Procedures when using parameter CONFIG mode

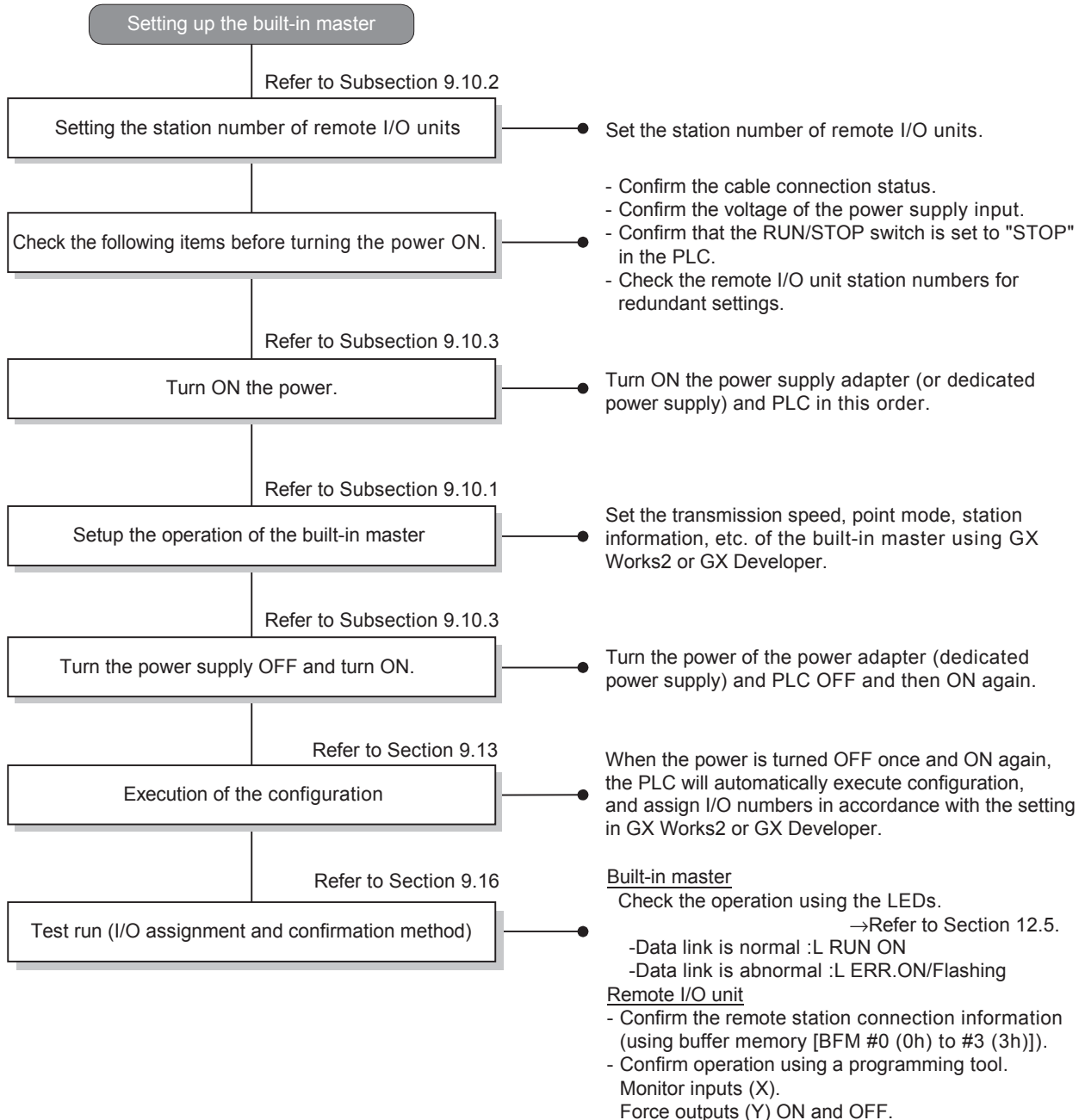

2) Procedures when using self CONFIG mode

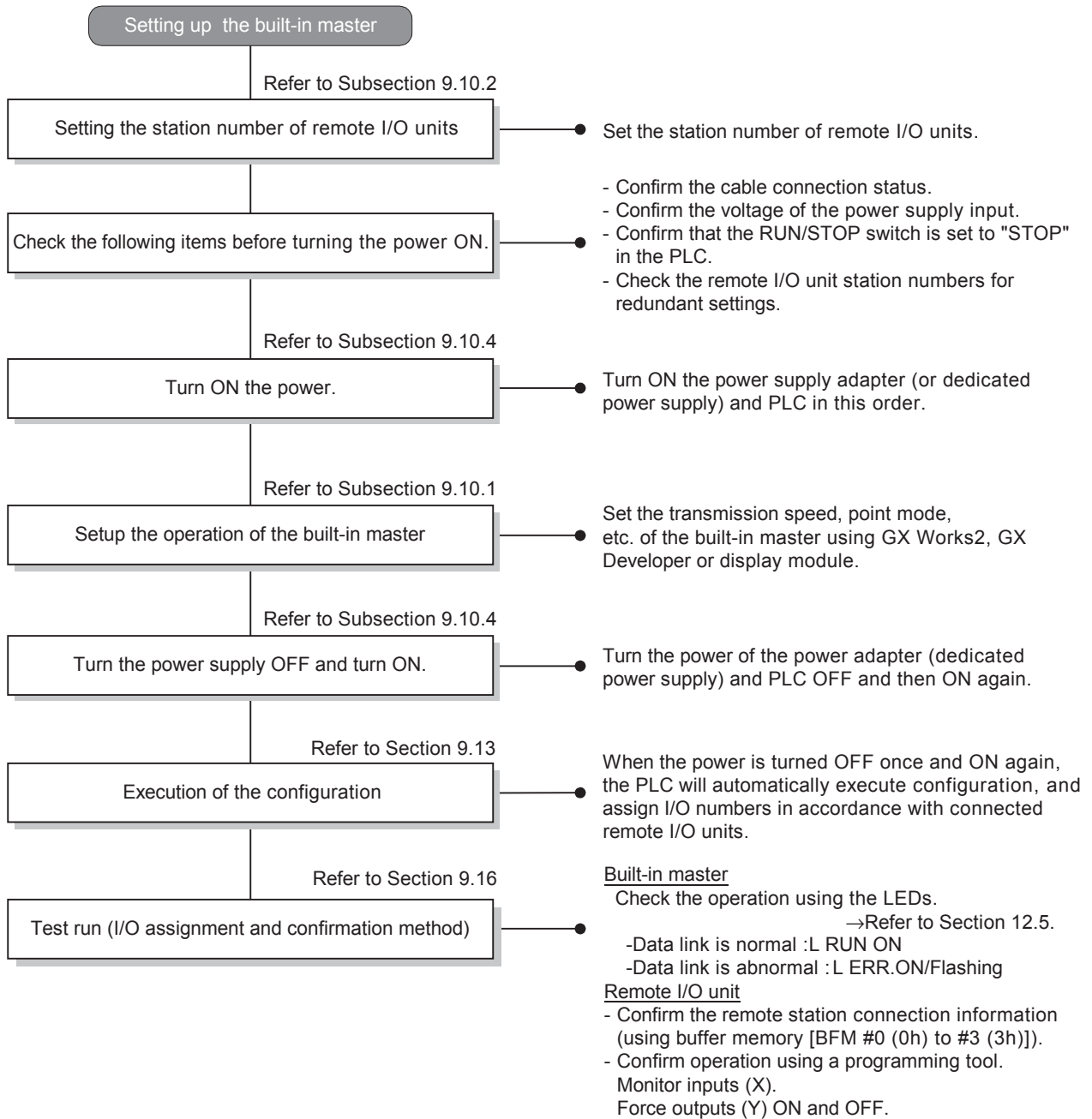

1	Outline
2	External Dimensions
3	Generic Specifications
4	Power Supply Specifications
5	Input Specifications
6	Output Specifications
7	Examples of Wiring for Various Uses
8	Terminal Block
9	CC-Link/LT Master FX3UC-LT(-2) only
10	Display module FX3UC-LT(-2) only

9.10.1 Setting by GX Developer (Transmission rate/Point mode/Station information)

This subsection explains how to setup the built-in CC-Link/LT functionality using GX Developer (Ver. 8.68W or later).

1 Opening the parameter setting screen

In the project tree area provided on the left side of the screen, double-click [Parameter] → [PLC parameter].

If the project tree is not displayed, select [View] → [Project data list] from the toolbar.

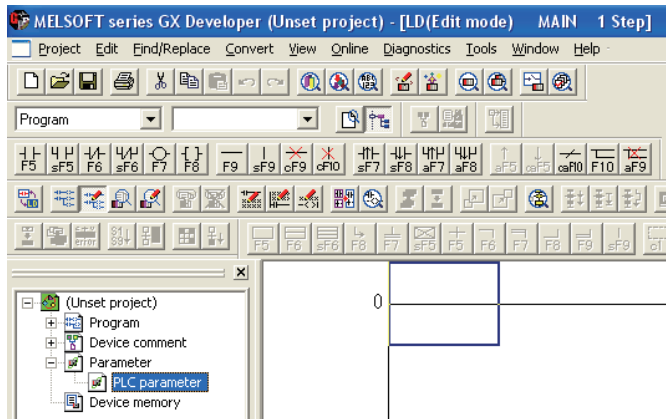

2 Setting memory capacity

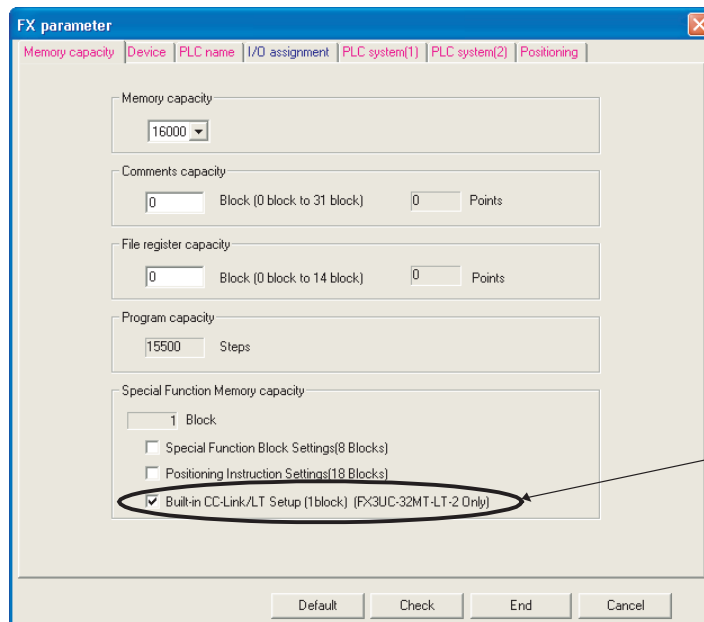

Check this item to select the parameter CONFIG mode.*1

*1. When selecting self CONFIG mode, do not check this item. In self CONFIG mode, the user can only set the transmission rate and point mode.

3 Setting up the built-in CC-Link/LT functionality

1. Setting up the built-in CC-Link/LT functionality.

When setting the station information in 'Built-in CC-Link/LT Setup' on the "I/O assignment" tab, it is necessary to check [Built-in CC-Link/LT Setup] on the "Memory capacity" tab in advance. Click "Setup" in 'Built-in CC-Link/LT Setup' , and then setup the built-in CC-Link/LT parameters.

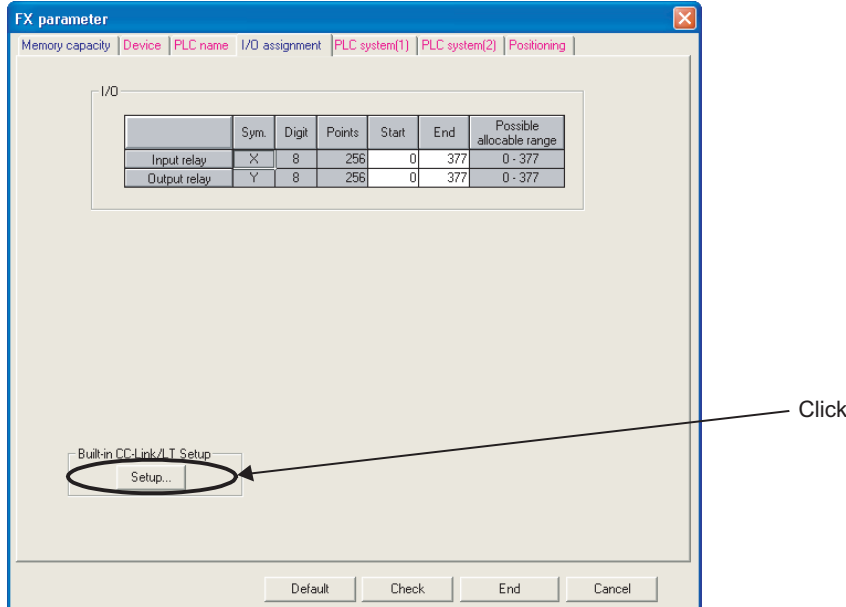

2. Setting up the built-in CC-Link/LT parameters in the "Built-in CC-Link/LT Setup" dialog box

In self CONFIG mode, the user can only set the transmission rate and point mode.

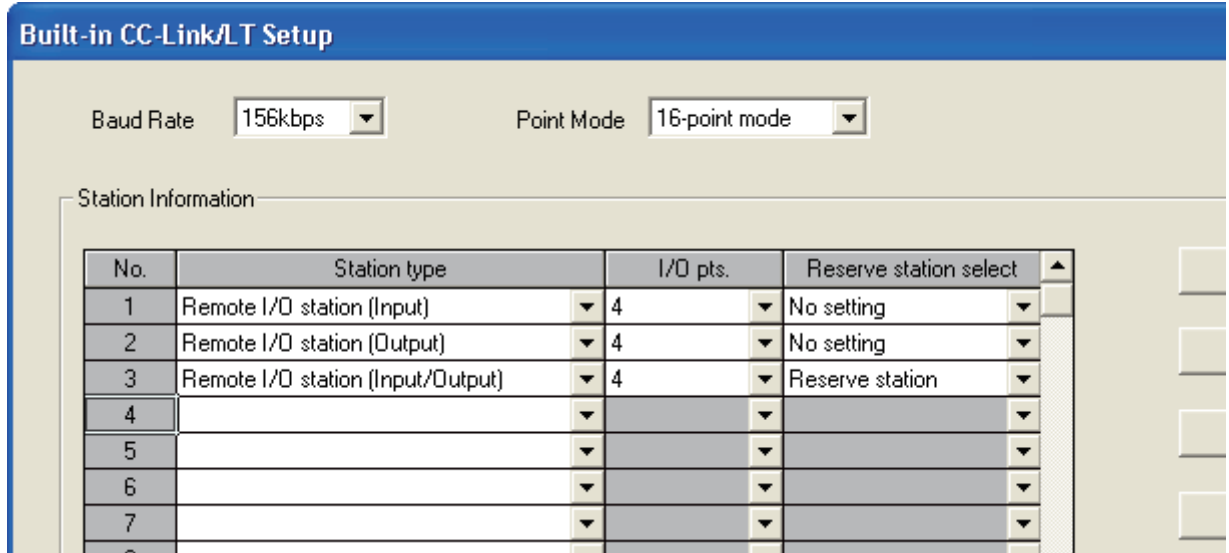

Set item	Contents of setting	Setting range
Transmission rate	Select one of the following supported built-in CC-Link/LT transmission rate: 2.5Mbps 625kbps 156kbps	-
Point mode	Select one of the following supported point modes: 16-point mode 4-point mode	-
Station number	This item indicates the station number of the built-in CC-Link/LT module. Station numbers 1 to 64 are available.	-

- 1 Outline
- 2 External Dimensions
- 3 Generic Specifications
- 4 Power Supply Specifications
- 5 Input Specifications
- 6 Output Specifications
- 7 Examples of Wiring for Various Uses
- 8 Terminal Block
- 9 CC-Link/LT Master FX3UC-LT(-2) only
- 10 Display module FX3UC-LT(-2) only

Set item	Contents of setting	Setting range
Station type	Select one of the following station type: Remote I/O station input type Remote I/O station output type Remote I/O station input/output type Remote device station* ¹	-
I/O points	Select one of the following supported I/O point counts for each remote I/O and remote device station: 1 to 16,32,48,64* ²	1 to 16,32,48,64* ²
Specification of reserved station	Select whether or not the Built-in CC-Link/LT station is specified as a reserved station.	-
Up	This button moves the cursor to the upper line (transposes the upper line).	-
Down	This button moves the cursor to the lower line (transposes the lower line).	-
Insert	This button inserts a line in the currently selected position.	-
Delete	This button deletes the currently selected line.	-
Buffer memory read	Click this button to read the transmission rate, point mode and station information of the built-in CC-Link/LT module. This button also reads the transmission rate, point mode and station information set in the FX3UC-32MT-LT and FX3UC-32-LT-2 (self CONFIG mode).	-

- *1. Select 16-point mode when using remote device stations. Remote device stations cannot be set in 4-point mode.
 Only station numbers 40 to 64 are available for remote device stations.
- *2. The station numbers 32, 48 and 64 are available when a remote device station is selected in Station type.

3. Click the [OK] button to finish the setup and close the "Built-in CC-Link/LT Setup" dialog box.

4 Transferring parameters (and sequence program) to the PLC

1. Select [Online]-[Write to PLC...] from the tool menu to display the "Write to PLC" dialog box.

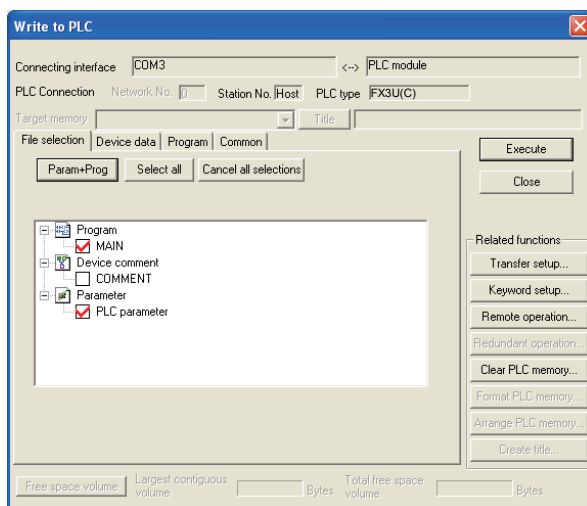

2. Check the program (MAIN) and parameters (PLC parameter), and then click the [Execute] button.

The selected contents are transferred to the PLC.

After transferring the PC parameters, turn the power OFF once and then ON again the power. The PLC will automatically execute configuration using the selected transmission rate, point mode and station information.

Cautions

Data can be transferred while the PLC is in STOP and while the PROTECT switch is set to OFF (when using a memory cassette). After changing the memory capacity setting, make sure to write the program and parameters to the PLC at the same time.
 If only the parameters are written to the PLC, a program error (parameter error, circuit error, syntax error, etc.) may occur in the PLC.

9.10.2 Station number setting of the remote I/O units

1 Setting the Station number

Set the station number using the DIP operation setting switches. Set the station number according to the following contents.

1. Unused station numbers do not cause errors.

Remote I/O stations can be setup inconsecutively without error so that unused station numbers can be saved for the future. However it is recommended to assign consecutive station numbers.

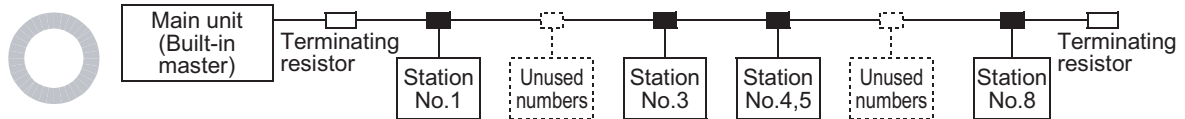

2. It is not necessary to align the unit connection order with the station number.

However, note that input (X) and output (Y) numbers are assigned in the order of station number.

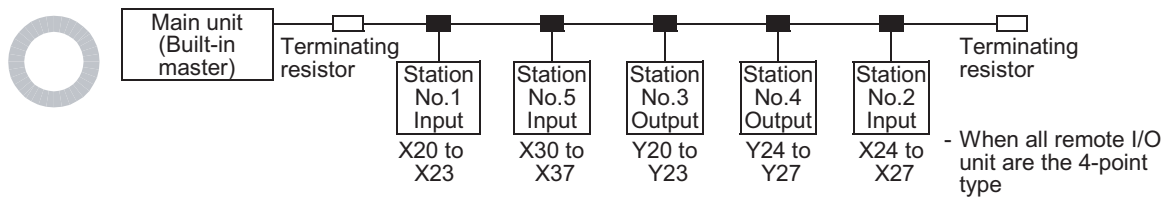

3. Use each station number only once.

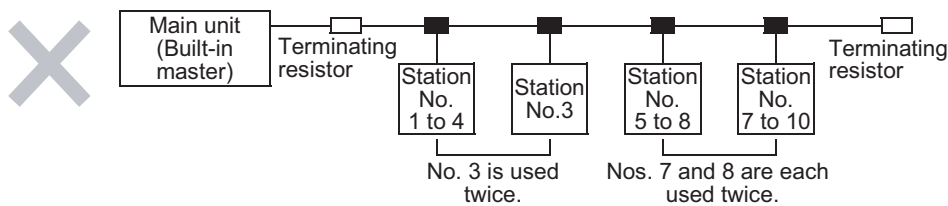

Please refer to Subsections 9.10.3 and 9.10.4 when performing configuration.

1 Outline

2 External Dimensions

3 Generic Specifications

4 Power Supply Specifications

5 Input Specifications

6 Output Specifications

7 Examples of Wiring for Various Uses

8 Terminal Block

9 CC-Link/LT Master FX3UC-LT(-2) only

10 Display module FX3UC-LT(-2) only

9.10.3 Starting operation (parameter CONFIG mode)

1 Turn the power ON

Turn ON the PLC power.

When the power supply adapter or dedicated power supply is used, turn ON the power in the order "Power supply adapter (or dedicated power supply) → PLC (built-in master)".

2 Write the transmission rate, point mode and station information setting using GX Works2 or GX Developer to the FX3UC-32MT-LT-2

For transfer of PLC parameters, refer to Subsection 9.10.1.

3 Turn the power OFF and then ON again.

Turn OFF the PLC power once, and then turn it ON again.

When using the power supply adapter or dedicated power supply, turn ON the power in the order "Power supply adapter (or dedicated power supply) → PLC (built-in master)".

4 The PLC will automatically execute configuration and then start operation

If the station information set using GX Works2 or GX Developer is not consistent with the connected remote I/O units, the L.ERR LED will flicker.

9.10.4 Starting operation (self CONFIG mode)

1 Turn the power ON

Turn ON the PLC power.

When the power supply adapter or dedicated power supply is used, turn ON the power in the order "Power supply adapter (or dedicated power supply) → PLC (built-in master)".

2 Set the transmission rate and point mode using GX Works2, GX Developer or the display module

When using GX Works2 or GX Developer, transfer the PLC parameters.

For transfer of PLC parameters, refer to Subsection 9.10.1.

When using the display module, execute "CONFIG".

3 Turn the power OFF and then ON again.

Turn OFF the PLC power once, and then turn it ON again.

When using the power supply adapter or dedicated power supply, turn ON the power in the order "Power supply adapter (or dedicated power supply) → PLC (built-in master)".

4 The PLC will automatically execute configuration and then start operation

When acquisition of the information on remote I/O units is completed by configuration, M8324 (CC-Link/LT configuration completed flag) turns ON.

Caution

In self CONFIG mode, the PLC executes configuration every time the PLC parameters are updated (written) using GX Works2 or GX Developer. (The PLC actually executes configuration when the power is turned OFF once and ON again.)

9.11 Details on the operation mode (FX3UC-32MT-LT)

The built-in master has three modes; ONLINE mode (operation), CONFIG mode (automatic I/O assignment) and TEST mode (self-loop-back test).

Each mode can be set using the DIP switches for operation setting on the panel.

9.11.1 Setting of an Operation mode and on DIP switch

→ For an example on DIP switch setting, refer to Subsection 9.9.1.

DIP switch status		operation mode	Description	Reference
6	7			
OFF	OFF	ONLINE mode	In ONLINE mode, the built-in master will execute the data link in the CC-Link/LT system. Select this mode for normal use.	Subsection 9.10.2
ON	OFF	CONFIG mode	In CONFIG mode, the built-in master assigns the station number and I/O numbers for remote stations.	Subsection 9.10.3
OFF	ON	TEST mode	In TEST mode (for the self-loop-back test), the built-in master checks for full functionality by receiving data that has already been sent.	Subsection 9.10.4

9.11.2 ONLINE mode

In ONLINE mode, the built-in master will execute data linking in the CC-Link/LT system.
Select this mode for normal use.

Contents indicated by status indicator LEDs and countermeasures

The table below shows the descriptions of errors indicated by the status indicator LEDs and their countermeasures.

Status indicator LEDs	Description		Countermeasures
L RUN	On	Data link is being executed	-
	Off	Data link is stopped	<ul style="list-style-type: none"> Take proper countermeasures according to the LED of L ERR.
L ERR.	On	Unit disconnection error Outside-control-range station error occurred RD station number setting error	<ul style="list-style-type: none"> Securely connect the built-in master, remote I/O station and remote device station. Make the detailed remote station information consistent with connected remote I/O station and remote device station.
	Flash-ing	All stations are abnormal	<ul style="list-style-type: none"> Securely connect the built-in master, remote I/O station and remote device station. Make sure that the connected remote I/O units are consistent with the detailed information on remote stations.
	Off	Data link is being executed normally	-

9.11.3 CONFIG mode

After constructing the CC-Link/LT system, execute the CONFIG mode to automatically assign the I/O numbers.

(After constructing the CC-Link/LT system, assign the I/O numbers by executing the CONFIG mode.)

The FX3UC-32MT-LT built-in master acquires the information (I/O type and number of points) on the connected remote stations, then stores it to the buffer memory [BFM #32 (20h) to #95 (5Fh)] and built-in memory (EEPROM).

If remote stations are to be extended in the future, the I/O numbers can be assigned while skipping some I/O numbers.

→ For details on assignment of the I/O numbers, refer to Section 9.13.

1. Contents indicated by status indicator LEDs and countermeasures

The table below shows the descriptions of errors indicated by the status indicator LEDs and their countermeasures.

Status indicator LEDs	Description		Countermeasures
L RUN	On	Data link is being executed	-
	Off	Data link is stopped	<ul style="list-style-type: none"> Take proper countermeasures according to the LED of L ERR.
L ERR.	On	Use station number discrepancy (when BFM#32(20h) to #95(5Fh) is edited, the station numbers are checked.)	<ul style="list-style-type: none"> Securely connect the built-in master, remote I/O station and remote device station. Make the detailed remote station information consistent with the connected remote I/O station and remote device station.
	Flash-ing	All stations are abnormal (when BFM#32(20h) to #95(5Fh) is edited, the station numbers are checked.)	
	Off	Data link is being executed normally	-

2. Caution on editing the detailed remote station information

In the CONFIG mode, the L ERR. indicator LED turns on or starts to flicker when the detailed remote station information becomes inconsistent with remote stations connected at the time of power ON due to a change in the detailed remote station information.

If the power is set to ON while all remote stations are unconnected or if the remote stations are disconnected after the power is set to ON, the L ERR. indicator LED will not turn on or start to flicker as long as the detailed remote station information is not edited.

3. Caution with CONFIG mode

The ERR LED is lit while the power is ON in the CONFIG mode (DIP switch 6: ON, DIP switch 7: OFF), but it does not indicate an error.

9.11.4 TEST mode (self-loop-back test)

In TEST mode, it is not necessary to connect remote stations.
(Set the DIP switches, and turn ON the power of the PLC.)

→ **For the test mode execution procedure, refer to Subsection 9.10.5.**

Contents indicated by status indicator LEDs and countermeasures

The table below shows the descriptions of errors indicated by the status indicator LEDs and their countermeasures.

Status indicator LEDs	Description		Countermeasures
L RUN	On	Self-loop-back test was finished normally	-
	Off	Self-loop-back test was finished abnormally (Not on while the self-loop-back test is being executed)	<ul style="list-style-type: none"> Make sure that the power is correctly supplied to the PLC. If the L RUN LED is on even after the above check, consult your local Mitsubishi Electric representative.
L ERR.	On	Self-loop-back test was finished abnormally	<ul style="list-style-type: none"> Make sure that the power is correctly supplied to the PLC. If the L RUN LED is on even after the above check, consult your local Mitsubishi Electric representative.
	Off	Self-loop-back test was finished normally (Not on while the self-loop-back test is being executed)	-

9.11.5 Test (TEST mode) execution procedure

Note: Setting DIP switches component change

Products manufactured in September 2011 or later have a different component used for the setting DIP switches compared with products produced earlier. Due to the component change, take note of the change in the ON/OFF position of each DIP switch. Even with the component change, the direction for setting each DIP switch ON/OFF is the same.

When product manufactured August, 2011 or earlier

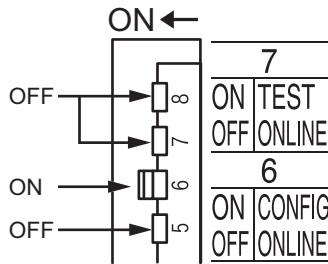

When product manufactured in September 2011 or later

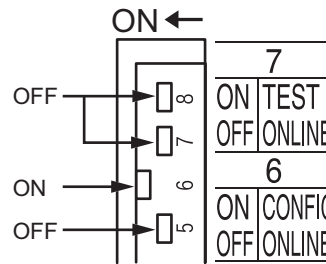

1 Turn the power OFF

Turn the power supply OFF for the PLC, the power supply adapter, and exclusive power supply.

2 Setting the TEST mode

Set the DIP switches as shown in the following figure to set the following status.

Item	Setting Content
B RATE	2.5Mbps
16pts/4pts	4-point mode
operation mode	TEST mode

When product manufactured August, 2011 or earlier

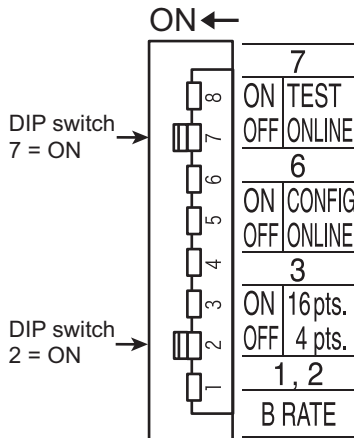

When product manufactured in September 2011 or later

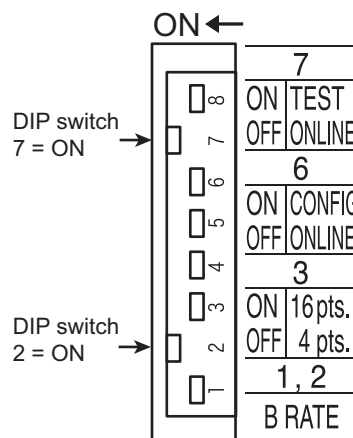

3 Turn the power ON

Turn ON the power of the PLC.

When the power supply adapter or dedicated power supply is used, turn ON the power in the order "Power supply adapter (or dedicated power supply) → PLC".

4 Start the test, and check the status indicator LEDs.

The test (self-loop-back test) is completed in several seconds.
 The L RUN LED turns ON in the normal status. The L ERR LED turns ON in the error status.
 Refer to "Contents indicated by status indicator LEDs and countermeasures" on the previous page.
 When the RUN LED is ON, set the ONLINE mode. (Set the DIP switch 6 to OFF and DIP switch 7 to OFF in the built-in master.)

Set the DIP switches as shown in the following figure to set the following status.

Item	Setting Content
B RATE	2.5Mbps
16pts/4pts	4-point mode
operation mode	ONLINE mode

When product manufactured August, 2011 or earlier

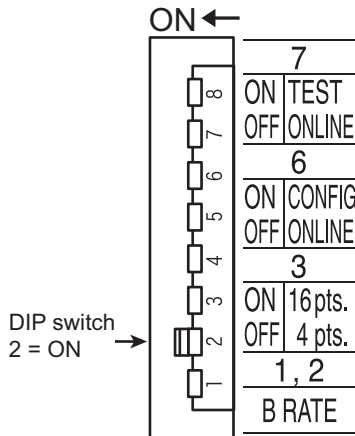

When product manufactured in September 2011 or later

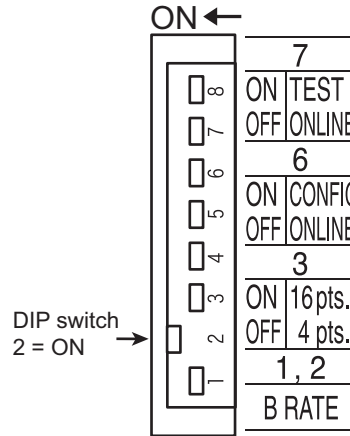

9.12 Details on the operation mode [FX3UC-32MT-LT(-2)]

The built-in master in the FX3UC-32MT-LT-2 has two modes, parameter CONFIG mode and self CONFIG mode.

9.12.1 Parameter CONFIG mode

In this mode, the user can transfer the PLC parameters including the station information set using GX Works2 or GX Developer (Ver. 8.68W or later) together with the user program to the FX3UC-32MT-LT-2. This special setting to save the station information reduces the available program memory by 500 steps. When the user turns the PLC power OFF once and then ON again after transferring the PC parameters, the PLC will automatically execute configuration using the selected transmission rate, point mode and station information.

In the parameter CONFIG mode, the user can set the CC-Link/LT items shown in the table below using GX Works2 or GX Developer.

Set item		Contents of setting	
Transmission rate		2.5Mbps/625kbps/156kbps	
Point mode		16-point mode/4-point mode	
Station information	Station number	Station numbers 1 to 64 are available.	
	Station type	Remote I/O station input type Remote I/O station output type Remote I/O station input/output type Remote device station*1	
	I/O points	Remote I/O station input type Remote I/O station output type Remote I/O station input/output type	1 to 16 points
		Remote device station	16/32/48/64 points*2
Specification of reserved station	Reserved station / No setting		

*1. Remote device stations are available only in 16-point mode.

*2. The number of I/O points depends on the number of occupied stations.

In parameter CONFIG mode, the user can set the following contents using the display module.

- Specification of reserved station
- Transmission rate setting
- Self-Check

→ For the setting method in parameter CONFIG mode, refer to Subsections 10.16.2, 10.16.3 and 10.16.4.

9.12.2 Self CONFIG mode

In this mode, the user can only change transmission rate and point mode, and execute the self-check in the FX3UC-32MT-LT-2.

If it is necessary to set reserved stations, select parameter CONFIG mode.

When shipped from the factory, the FX3UC-32MT-LT-2 is set to self CONFIG mode.

In the initial settings, the transmission rate is 156 kbps, and 4-point mode is selected.

When changing the transmission rate and point mode, use GX Works2, GX Developer or the display module.

When the user writes the user program and PLC parameters to the FX3UC-32MT-LT-2 using GX Works2 or GX Developer, and then turns the power OFF once and then ON again, the PLC will automatically execute configuration and make the change valid.

After changing the transmission rate and point mode using the display module, the user should execute "CONFIG" and turn the power OFF once and then ON again so that the PLC will make the change valid.

In the self CONFIG mode, the user can set the following contents using the display module.

- Transmission rate setting
 - Point mode setting
 - CONFIG
 - Self-Check
- **For the setting method in self CONFIG mode, refer to Subsections 10.16.5, 10.16.6 and 10.16.7.**

9.12.3 Changeover between Parameter CONFIG Mode and Self CONFIG Mode

- 1) Changeover from the self CONFIG mode to the parameter CONFIG mode
Check "Built-in CC-Link/LT Setup" on the "PLC parameter" window in GX Works2 or GX Developer, set the station information, and then write both the user program and PLC parameters to the FX3UC-32MT-LT-2 to change over from self CONFIG mode to parameter CONFIG mode.
→ **For details on the station information setting using GX Developer, refer to Subsection 9.10.1.**
- 2) Changeover from the parameter CONFIG mode to the self CONFIG mode
Self CONFIG mode is set instead of parameter CONFIG mode by executing the following steps in the "PLC parameter window" in GX Works2 or GX Developer:
 - 1) Uncheck "Built-in CC-Link/LT Setup"
 - 2) Set the correct value of "Transmission Speed" and "Number of Unit"
 - 3) Write both "User Program" and "PLC parameters" in the FX3UC-32MT-LT-2
 Or, execute "PC memory clear" using GX Works2 or GX Developer to return the FX3UC-32MT-LT-2 to its initial settings (self CONFIG mode).

9.12.4 Precautions on Use of CC-Link/LT Settings

Pay attention to the following contents when using the CC-Link/LT settings.

- The user can change the CC-Link/LT settings while the PLC is in STOP and or while the PROTECT switch is set to OFF (when using memory cassette).
If the keyword has been set, the user can change the CC-Link/LT setting only after entering the keyword.
- When the user changes the transmission rate and point mode using the display module, and then changes the setting again (that is, writes the PLC parameters to the FX3UC-32MT-LT-2) using GX Works2 or GX Developer, the contents set by GX Works2 or GX Developer will become valid.
After changing the transmission rate and point mode using the display module, read the PLC parameters using GX Works2 or GX Developer so that the setting change will be shown in the GX Developer project.
- The user cannot change over from parameter CONFIG mode to self CONFIG mode or from self CONFIG mode to parameter CONFIG mode using the display module.
Use GX Works2 or GX Developer to change modes.
- When using parameter CONFIG mode, be sure to enter parameters into "Built-in CC-Link/LT Setup" after clearing the PLC memory. When the power supply is cycled without having entered parameters or a memory cassette without "Built-in CC-Link/LT Setup" parameters is inserted and the power is turned on, a parameter error (error code: K6411) will occur.
When the PLC memory is cleared and power supply turned on, self CONFIG mode with a transmission speed of 156 kbps and number of unit: 4 is the default setting.
- In self CONFIG mode, the PLC executes configuration every time the PC parameters are updated (written).
If the user connects remote stations, makes the PLC execute configuration, disconnects remote stations (or turns the power OFF), overwrites the PLC parameters, and then turns the power ON again, the I/O assignment will be changed.

9.13 Assignment of I/O numbers

The Built-in master assigns I/O information for remote I/O modules to devices X (input) and Y (output) in the PLC.

The PLC will assign I/O numbers after executing configuration.

The I/O numbers are assigned in octal serial numbers following the I/O number occupied by the PLC (Main unit, I/O extension block etc.) where eight points are handled as one block.

9.13.1 I/O number assignment types

1. When connecting all remote I/O units and assigning I/O numbers

When all remote I/O units are connected, and the I/O configuration is not changed.

→ For details, refer to "Subsection 9.13.3 Automatic I/O numbers assignment".

2. When assigning unused numbers without connecting remote I/O units

When some remote I/O units (station numbers) are not connected, the user can specify reserved stations (unconnected I/O numbers) so that connected I/O numbers will not change even if other remote I/O units are connected in the future.

- In the FX3UC-32MT-LT-2
 Set the PLC parameters using GX Works2 or GX Developer (Ver. 8.68W or later), and then specify reserved stations (assign I/O numbers).
- In the FX3UC-32MT-LT
 Change the setting of the built-in CC-Link/LT buffer memory using GX Works2 or GX Developer, and then specify reserved stations (assign I/O numbers).
- When assigning I/O numbers without connecting a remote I/O unit and creating a program
 → For details on editing the detailed remote station information, refer to Section 9.15.
- When additionally connecting a remote I/O unit (to the existing system) in the future
 → For details on the specification of a reserved station, refer to Section 9.14.

9.13.2 Setting the point mode (relationship between I/O numbers, station numbers and point mode)

1. Assignment of I/O numbers

The I/O number is not affected by the point mode setting.

X000 to X017

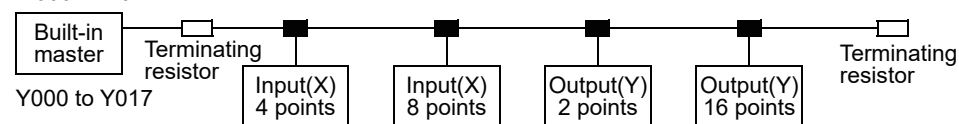

Y000 to Y017

In the case of 16-point mode X020 to X023 X024 to X033 Y020 to Y021 Y022 to Y041

In the case of 4-point mode X020 to X023 X024 to X033 Y020 to Y021 Y022 to Y041

2. Number of occupied stations

The station number of each remote station changes depending on the point mode selection (4-point mode or 16-point mode).

With up to 64 remote stations, more I/O points are available in 16-point mode since I/O modules with more than 4 I/O occupy multiple stations in 4-point mode.

1) When there are many remote I/O units with more than 4 points

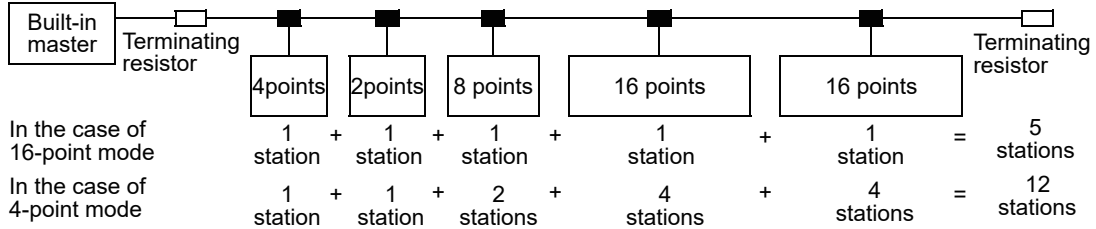

2) When there are many remote I/O units with 4 points or less

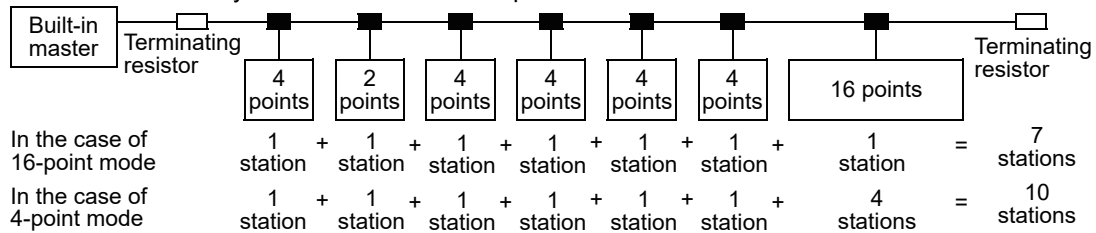

3) When a remote device station is used

Remote Device (RD) stations do not have any effect on the assignment of I/O numbers since buffer memories (BFM) are assigned to RD stations in accordance with the station number.

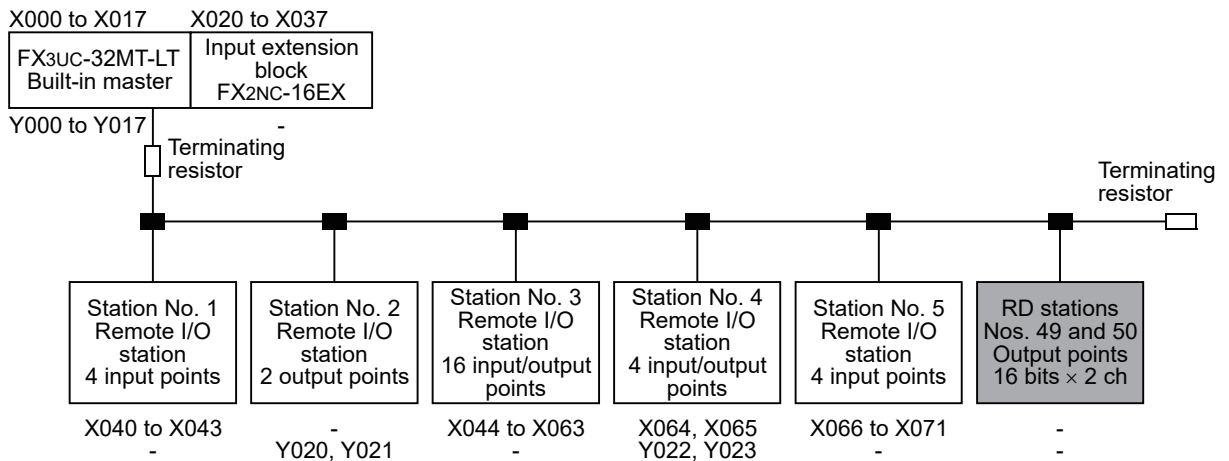

Assignment result

	Station type	Number of points	I/O assignment (X)	I/O assignment (Y)	BFM #
Station No.1	Remote I/O station (input)	4 points	X040 to X043	-	-
Station No.2	Remote I/O station (output)	2 points	-	Y020, Y021	-
Station No.3	Remote I/O station (input)	16 points	X044 to X063	-	-
Station No.4	Remote I/O station(input/output)	4 points	X064, X065	Y022, Y023	-
Station No.5	Remote I/O station (input)	4 points	X066 to X071	-	-
Station No.49	RD station (output)	16 points	-	-	208
Station No.50	RD station (output)	16 points	-	-	209
Unused I/O			X072 to X077	Y024 to Y027	-

→ For details on assignment of BFM, refer to Subsection 9.20.14.

1	Outline
2	External Dimensions
3	Generic Specifications
4	Power Supply Specifications
5	Input Specifications
6	Output Specifications
7	Examples of Wiring for Various Uses
8	Terminal Block
9	CC-Link/LT Master FX3UC-LT(-2) only
10	Display module FX3UC-LT(-2) only

9.13.3 Automatic assignment of I/O numbers (FX3uc-32MT-LT and FX3uc-32MT-LT-2 Self CONFIG Mode)

When the user makes the PLC execute configuration, the PLC will automatically assign I/O numbers. The I/O numbers can be assigned automatically in CONFIG mode. Parameter settings and sequence programs are not necessary for this assignment.

Operating procedure

Execute the steps 1) to 5) below to assign the I/O numbers automatically.

1 Connect each remote I/O unit to the built-in master.

**2 In the FX3uc-32MT-LT, select CONFIG mode.
In the FX3uc-32MT-LT-2, select self CONFIG mode.**

In the FX3uc-32MT-LT, set the DIP switches to "SW6: ON, SW7: OFF" to select CONFIG mode. In the FX3uc-32MT-LT-2, select self CONFIG mode, and then turn OFF the power.

3 Turn the power ON

Turn ON the power supply adapter (or dedicated power supply) and then the FX3uc-32MT-LT(-2) (in this order).

The built-in master collects information (types and numbers of I/O) on connected remote stations, and stores the collected information in the buffer memory [BFM #32 (20h) to #95 (5Fh)] and built-in memory (EEPROM).

4 Check the remote I/O unit connection status.

Confirm that the contents of the buffer memory [BFM #32 (20h) to #95 (5Fh)] are consistent with the actual system configuration.

5 In the FX3uc-32MT-LT, select ONLINE mode, and then turn the power OFF once and then ON again. In the FX3uc-32MT-LT-2, operation can start immediately.

In the FX3uc-32MT-LT, set the DIP switches to "SW6: OFF, SW7: ON", and then turn the PLC power ON again.

When a power supply adapter or dedicated power supply is used, turn ON the power in the order "Power supply adapter (or dedicated power supply) → PLC (built-in master)".

The FX3uc-32MT-LT reads information on connected remote stations from the built-in memory (EEPROM), and assigns the I/O number.

9.13.4 Automatic assignment of I/O numbers (FX3UC-32MT-LT-2 Parameter CONFIG Mode)

When the user sets the PLC parameters using GX Works2 or GX Developer and makes the PLC execute configuration, the PLC will automatically assign I/O numbers. Sequence programs are not necessary for this assignment.

Operating procedure

Execute the steps 1) to 5) below to assign the I/O numbers automatically.

- 1 Connect each remote I/O unit to the built-in master.**
- 2 Set the PLC parameters using GX Works2 or GX Developer.**

Set the PLC parameters using GX Works2 or GX Developer, and write them and the sequence program to the FX3UC-32MT-LT-2.

- 3 Turn the power ON**

Turn ON the power supply adapter (or dedicated power supply) and then the FX3UC-32MT-LT-2 (in this order).

The PLC stores the remote station information (types and numbers of I/O) in the buffer memory [BFM #32 (20h) to #95 (5Fh)] and built-in memory (EEPROM) in accordance with the PLC parameter settings.

- 4 Check the remote I/O unit connection status.**

Confirm that the PLC parameter settings (contents of the buffer memory [BFM #32 (20h) to #95 (5Fh)]) are consistent with the actual system configuration.

- 5 In the FX3UC-32MT-LT-2, operation can start immediately.**

9.13.5 Extension equipment types and I/O number assignment order

1. Rule of assignment order

I/O numbers are automatically assigned consecutively from the main unit (built-in unit).

I/O numbers are always assigned at the end to the remote I/O unit connected to the CC-Link/LT built-in master as shown below.

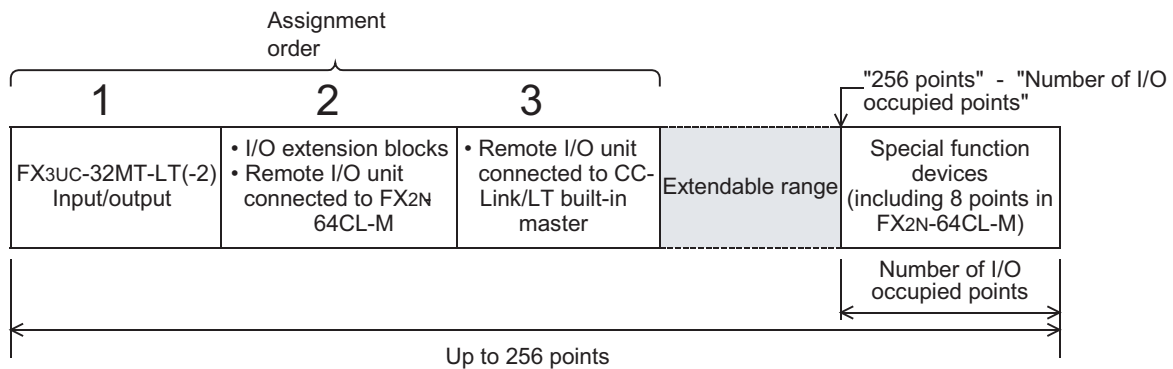

1	Outline
2	External Dimensions
3	Generic Specifications
4	Power Supply Specifications
5	Input Specifications
6	Output Specifications
7	Examples of Wiring for Various Uses
8	Terminal Block
9	CC-Link/LT Master FX3UC-LT(-2) only
10	Display module FX3UC-LT(-2) only

2. Explanation using assignment examples

1) Example of existing system (before addition)

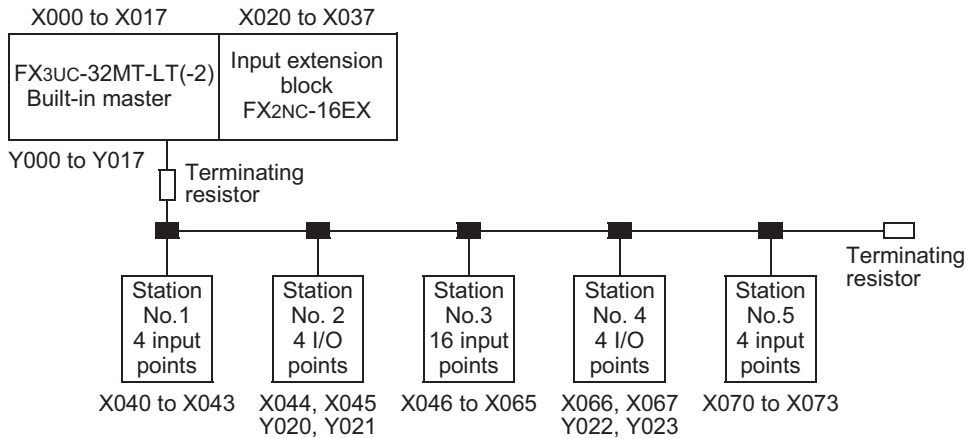

2) Additional example 1 (An input extension block is added.)

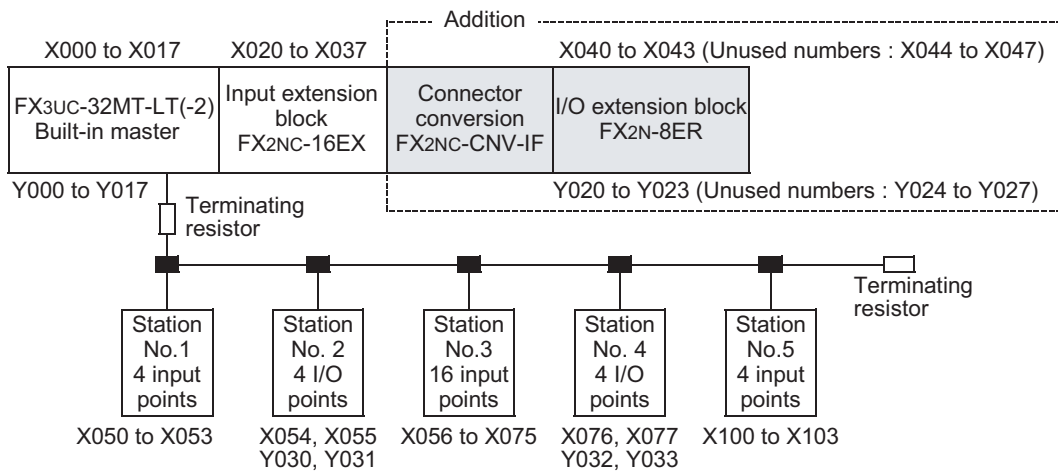

3) Additional example 2 (An FX2N-64CL-M CC-Link/LT master is added.)

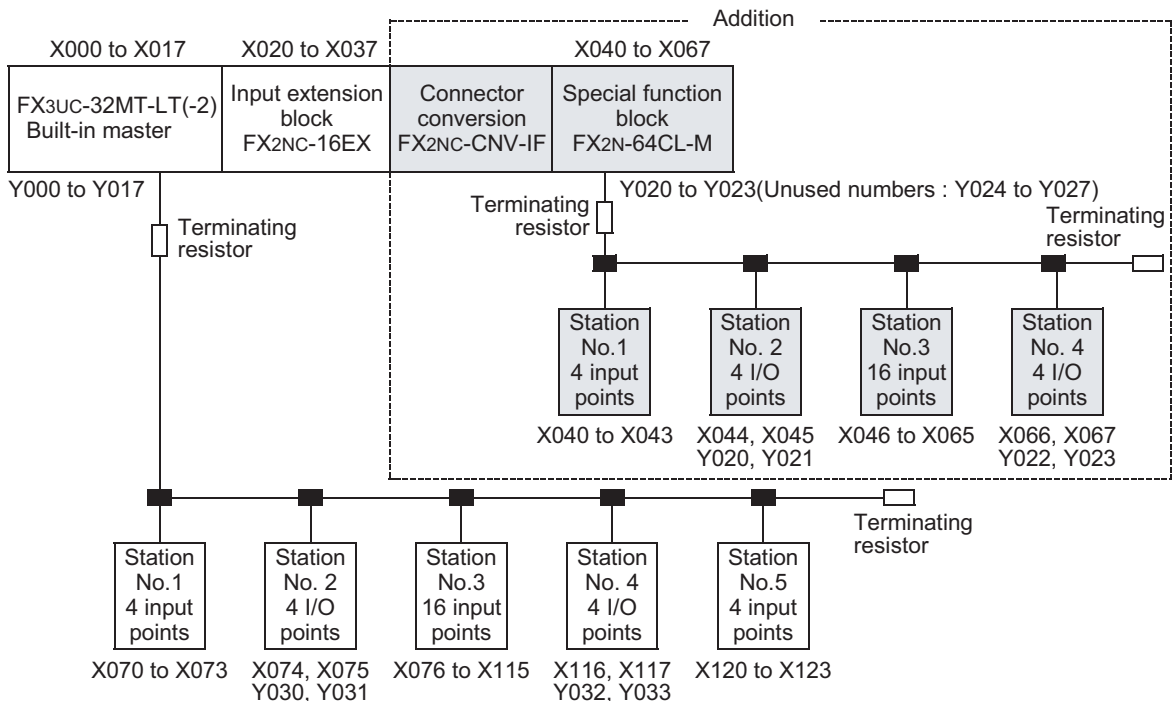

9.13.6 Example in which the point mode setting causes an invalid configuration

1. Configuration

When CL1XY2-DT1D5S (cable type remote I/O unit having 1 input point and 1 output point) x 63 units (station No.s 1 to 63) and CL2X8-D1B2 (terminal block type remote I/O unit having 8 input points) x 1 unit are connected

Configuration applicability for each point mode

- In 16-point mode..... The system can be constructed.
- In 4-point mode..... The system cannot be constructed since the CL2X8-D1B2 occupies 2 stations and the number of remote stations exceeds 64.

2. The example of assignment of the I/O numbers

The I/O number assignment is as follows in the configuration example below.

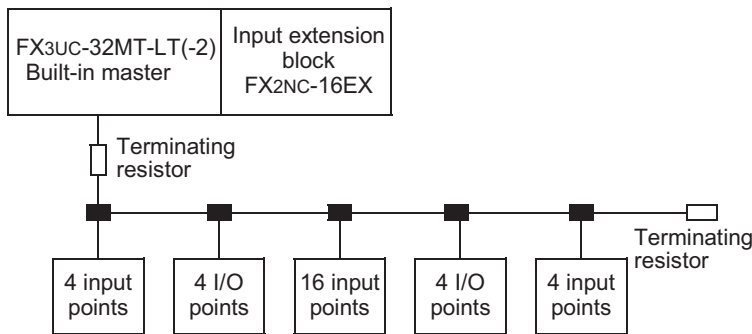

In the FX3UC-32MT-LT and FX3UC-32MT-LT-2 (self CONFIG mode), when the user makes the PLC execute configuration, the PLC will automatically check connected remote stations, and then assign I/O numbers to each remote station. In the FX3UC-32MT-LT-2 (parameter CONFIG mode), set the PLC parameters for the built-in master using GX Works2 or GX Developer, and then turn the PLC power OFF once and then ON again. The PLC will execute configuration, and then assign I/O numbers to remote stations in accordance with the PLC parameter settings.

Point mode and Number of stations

Station No.		Number of points	I/O assignment number (X)	I/O assignment number (Y)
4-point mode	16-point mode			
Station No.1	Station No.1	Input 4points	X040 to X043	-
Station No.2	Station No.2	Input 2points/Output 2points	X044, X045	Y020, Y021
Station No.3, 4, 5, 6	Station No.3	Input 16points	X046 to X065	-
Station No.7	Station No.4	Input 2points/Output 2points	X066, X067	Y022, Y023
Station No.8	Station No.5	Input 4points	X070 to X073	-

Unused numbers in I/O extension

The above I/O numbers are assigned as follows in the configuration example.

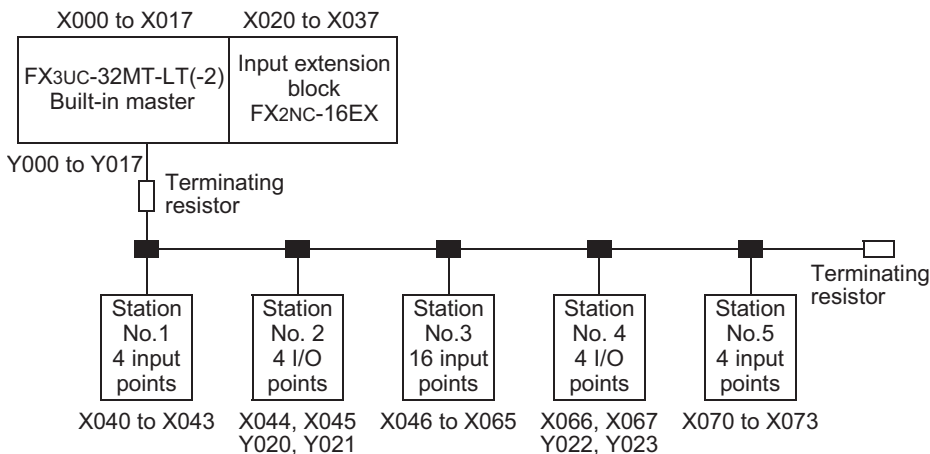

1	Outline
2	External Dimensions
3	Generic Specifications
4	Power Supply Specifications
5	Input Specifications
6	Output Specifications
7	Examples of Wiring for Various Uses
8	Terminal Block
9	CC-Link/LT Master FX3UC-LT(-2) only
10	Display module FX3UC-LT(-2) only

9.13.7 Number of occupied stations and Link scan time

If the number of stations is equivalent, the link scan time is longer in 16-point mode than in 4-point mode.
 → For details Data Link Processing Time, refer to Section 9.18.

9.13.8 Cautions on I/O number assignment

1. I/O operation

The following inputs/outputs do not operate in CONFIG mode of FX3UC-32MT-LT.

- 1) Inputs/outputs in the remote I/O stations connected to the built-in master do not operate.
- 2) I/O extension units/blocks connected to the PLC do not operate.

2. When an I/O extension block or the FX2N-64CL-M is added (to the existing system) in the future

The I/O numbers in the remote I/O station connected to the built-in master are shifted to positions after the I/O numbers in the added I/O extension block or FX2N-64CL-M. In this case, it is also necessary to shift the I/O numbers in programs.

3. When a remote device station is used

Note that the I/O numbers are shifted forward if the following setting is performed by mistake in specifying a reserved station

- 1) The reserved station is set to an I/O station instead of a remote device station (analog unit) by mistake.
- 2) An analog unit is connected, and X/Y numbers are used.
 By operations 1) and 2), an analog unit is activated.
- 3) Configuration is executed again.
- 4) The I/O number assignment shifts backward.
 The analog unit is accessed in the BFM.

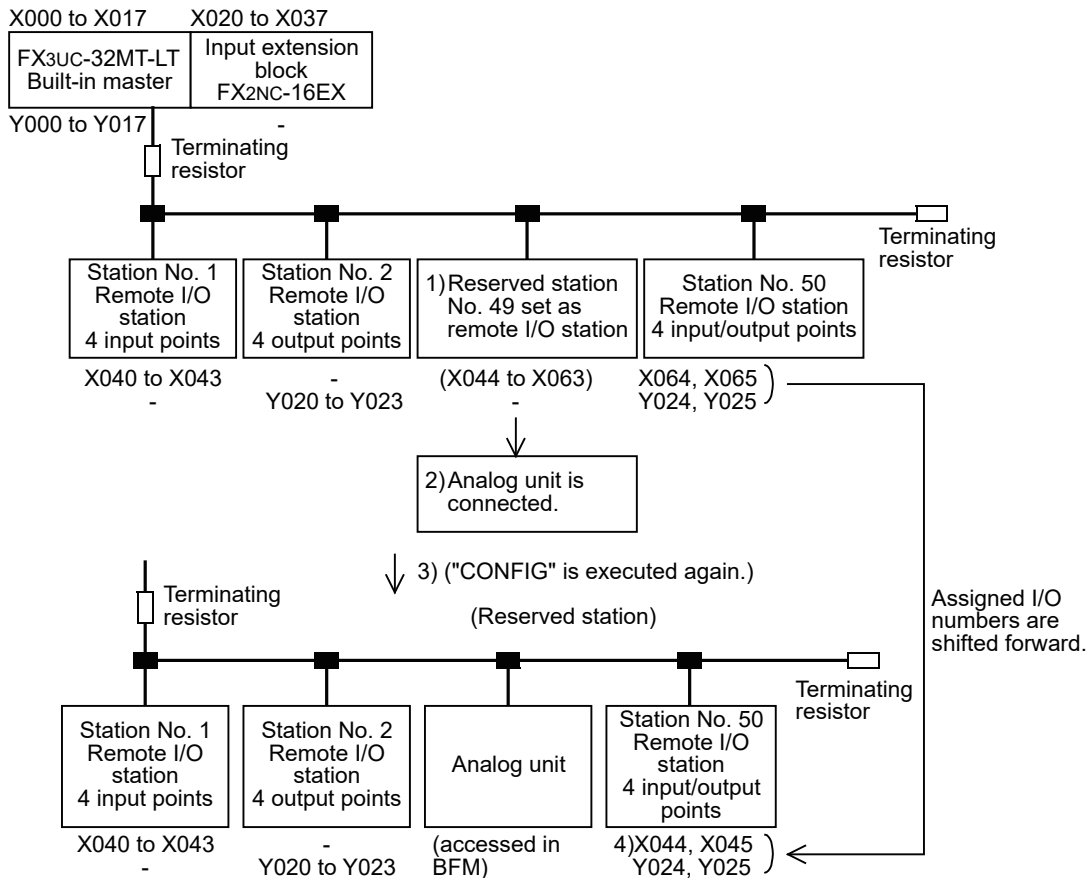

9.14 Specification of reserved station

If remote stations will be added in the future, temporary I/O numbers can be assigned. This function allows the user to change the number of I/O points and assign I/O numbers to unconnected station numbers so that I/O numbers in other remote stations will not be changed when a remote station is added in the future.

In the FX3UC-32MT-LT-2 (parameter CONFIG mode), the user can easily change the reserved station specification using GX Works2, GX Developer (Ver. 8.68W or later) or the display module.

→ In the case of FX3UC-32MT-LT, for the reserved station specification method, refer to "Subsection 9.15.1 How to edit detailed remote station information".

When a remote station is not connected to a reserved station number, the system does not detect wire breakage or other errors (Reserved station flag b15 = ON).

→ For detailed Cautions on use, refer to Subsection 9.15.3.

9.15 Editing the detailed remote station information

After assigning the I/O numbers, the I/O number assignment in each station number can be edited. The number of I/O points can be changed, and the I/O numbers can be assigned to unconnected station numbers for future use. Therefore, if remote stations are added in the future, it is not necessary to change the I/O numbers in other remote stations and extension blocks/units connected to the PLC.

Detailed remote station information can be edited only in the programming software GX Works2 and GX Developer.

→ For the edit method, refer to Subsection 9.15.1.

If a remote station is not connected to an edited station number, errors such as wire breakage may occur. (Reserved station flag b15 = OFF)

→ For detailed Cautions on use, refer to Subsection 9.15.3.

9.15.1 How to edit detailed remote station information (FX3UC-32MT-LT)

This subsection explains the operation procedure to change the detailed remote station information using GX Developer.

1. Configuration example

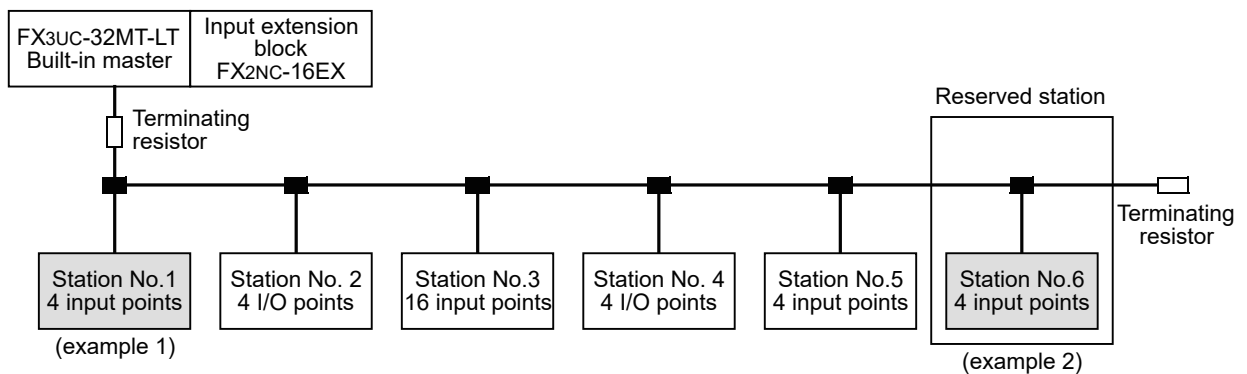

2. Example

(Example1) Detailed remote station information (Station No.1)

Function	Setting Content	Setting Value
Number of I/O points	4 points	H0904
Input flag	Input is given.	
Output flag	Output is not given.	
Head station flag	Head station.	
Input filter setting	General-purpose input	
Output hold/clear setting	CLEAR	
Reserved station flag	Not a reserved station.	

1	Outline
2	External Dimensions
3	Generic Specifications
4	Power Supply Specifications
5	Input Specifications
6	Output Specifications
7	Examples of Wiring for Various Uses
8	Terminal Block
9	CC-Link/LT Master FX3UC-LT(-2) only
10	Display module FX3UC-LT(-2) only

(Example2) Detailed remote station information (Station No.6) (Specification of reserved station)

Function	Setting Content	Setting Value
Number of I/O points	4 points	H8904
Input flag	Input is given.	
Output flag	Output is not given.	
Head station flag	Head station.	
Input filter setting	General-purpose input	
Output hold/clear setting	CLEAR	
Reserved station flag	Reserved station.	

→ For details on Bit assignment of the Detailed remote station information, refer to Subsection 9.15.2.

3. Operating procedure

1 Setting DIP switches for the operation setting to "CONFIG mode" in the built-in master (Setting in the PLC)

Set the built-in master to CONFIG mode (DIP switch 6: ON, DIP switch 7: OFF), and turn ON the power.

2 Opening the buffer memory batch monitor window (Setting in GX Developer)

Click [Online] - [Monitor] - [Buffer memory batch...] from the tool menu to open the buffer memory batch monitor window.

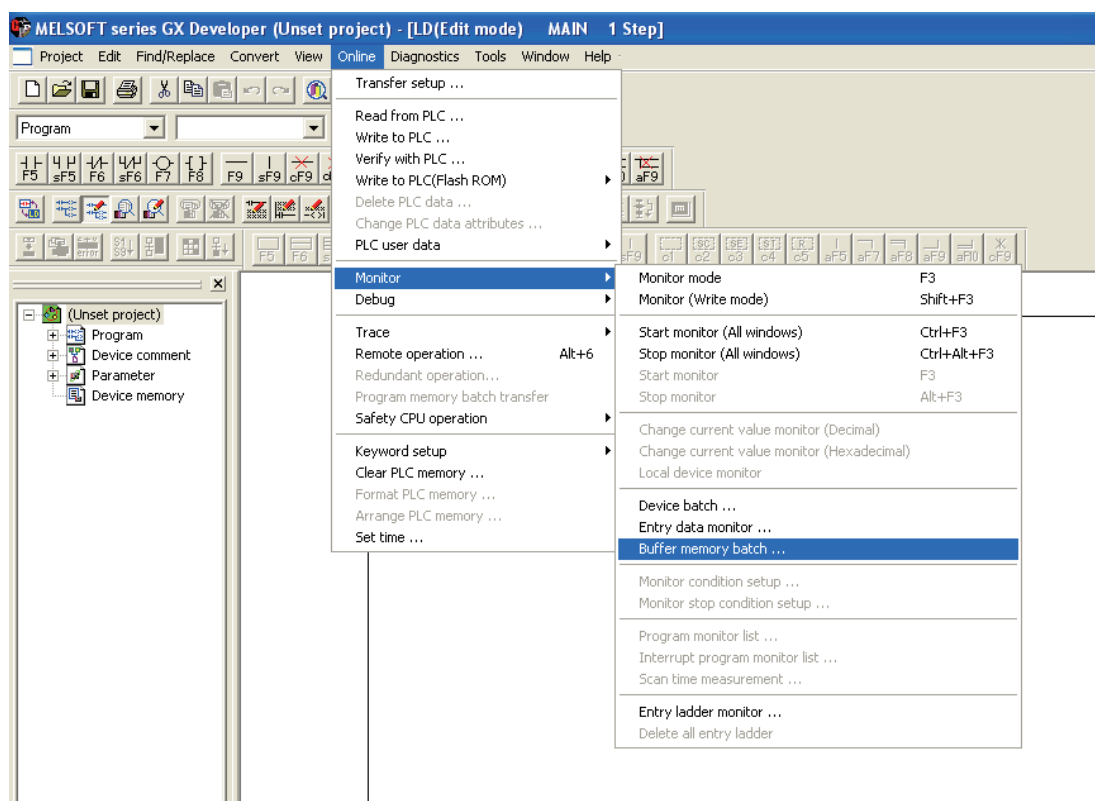

3 Setting the Detailed remote station information (Setting in GX Developer)

- 1) Input the unit head address (0: Fixed) and buffer memory address to be set, and click [Start monitor].

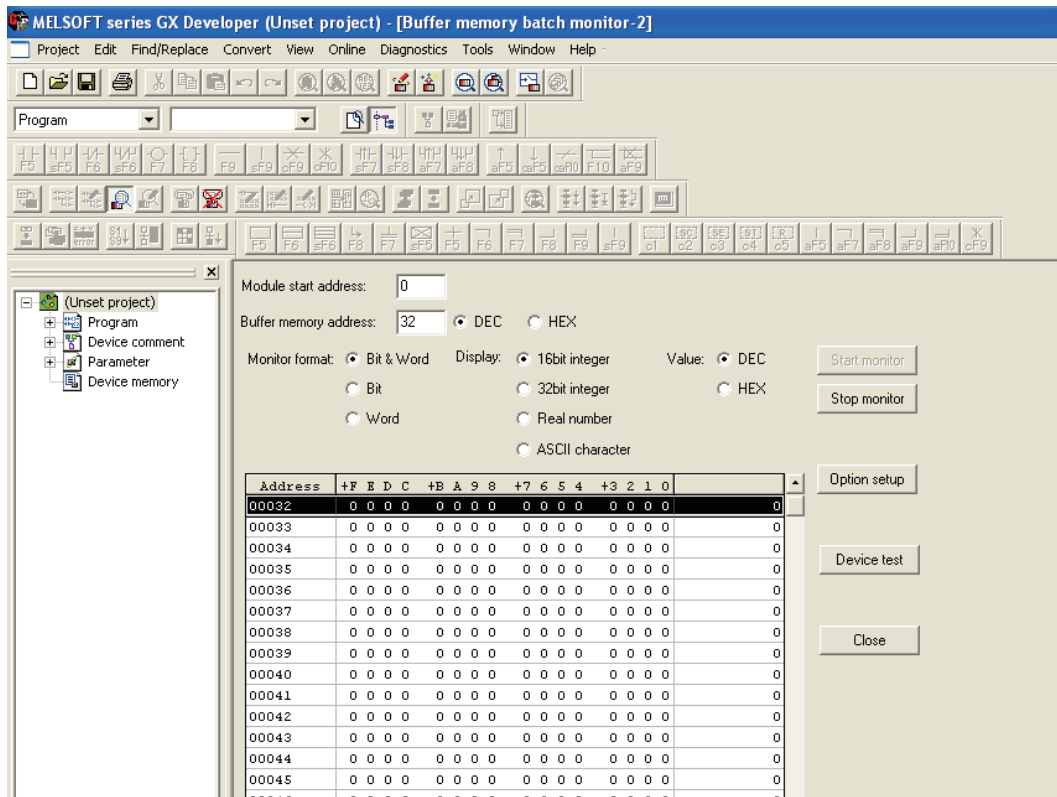

- 2) Click [Buffer memory batch...] - [Device test].

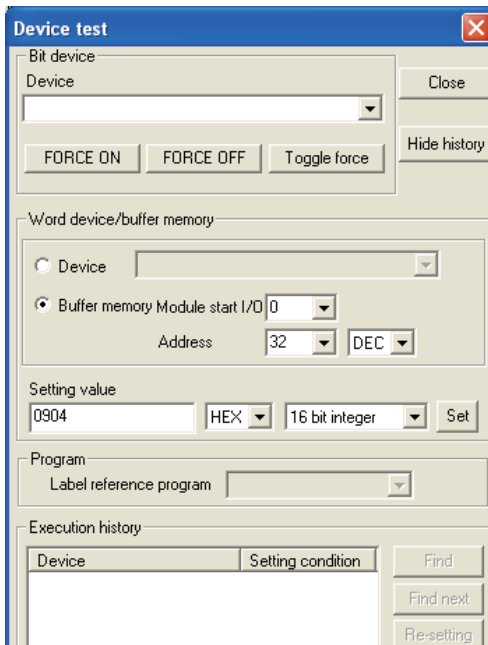

Click [Device test], input the detailed remote station information to [Setting value], and click [Set]. In "Example 1", set [Setting value] to "0904", [Hex] and [16 bit integer], and click [Set]. Repeat the steps 1) and 2) until the station No. 6.

4 Specifying a reserved station (Reserved station flag (b = 15): ON) (Setting in GX Developer)

Input a reserved station specification to [Setting value] on the device test window, and click [Set].
(In "Example 2", set [Setting value] to "8904", [Hex] and [16 bit integer], and click [Set].
When specifying a reserved station, set the reserved station flag (b15) to ON.

- When the reserved station flag is set to ON, the system does not detect wire breakage or other errors for the non-connected remote station.
- When the reserved station flag is set to OFF, the system detects wire breakage or other errors for the non-connected remote station.

5 Writing data to the EEPROM (Setting in GX Developer)

After setting detailed remote station information, specify writing to the EEPROM [BFM #27 (1Bh) b4 OFF → ON].

Set the buffer memory address to #27 [Dec] in the device test window. Set the [Setting value] to "0010", [Hex] and [16 bit integer], and click [Set].

6 Confirming completion of writing to the EEPROM (Setting in GX Developer)

Check whether BFM #28 (1Ch) b4 is ON in the buffer memory batch monitor.

When BFM #28 b4 is ON, writing to the EEPROM is completed.

→ For details on EEPROM write completion, refer to Subsection 9.20.10.

7 Setting the DIP switches for the operation setting to "ONLINE mode" in the built-in master (Setting in the PLC)

Set the built-in master to ONLINE mode (DIP switch 6: OFF), and turn ON the power again.

8 Confirming that the specified reserved station is correct (Setting in GX Developer)

Check in the buffer memory batch monitor whether the detailed remote station information [BFM #32 (20h) to BFM #95 (5Fh)] agrees with the changed contents.

9.15.2 Buffer memory [BFM #32 to #95]

1. Assignment of Buffer Memory

Buffer memory No.	Description
BFM #32(20h)	Remote station information area for station No.1
BFM #33(21h)	Remote station information area for station No.2
⋮	⋮
BFM #95(5Fh)	Remote station information area for station No.64

2. Bit assignment of the Detailed remote station information

Each bit of the buffer memory shown in the above table is assigned as follows.

Bit	Function	1(ON)																0(OFF)															
		Point	1	2	3	4	5	6	7	8	9	10	11	12	13	14	15	16															
b0	Number of I/O points*1	b0	1	0	1	0	1	0	1	0	1	0	1	0	1	0	1	0															
b1		b1	0	1	1	0	0	1	1	0	0	1	1	0	0	1	1	0															
b2		b2	0	0	0	1	1	1	1	0	0	0	0	1	1	1	1	0															
b3		b3	0	0	0	0	0	0	0	1	1	1	1	1	1	1	1	0															
b4		b4	0	0	0	0	0	0	0	0	0	0	0	0	0	0	0	1															
b5 to b7	(Setting prohibited)	Set these bits to 0.																															
b8	Input flag*2	Input is given.																Input is not given.															
b9	Output flag*2	Output is given.																Output is not given.															
b10	RD station flag	It is a RD station.																It is not a RD station.															
b11	Head station flag*3	This is the head station.																This is not the head station.															
b12	Input filter setting	High-speed input																General-purpose input															
b13	Output hold/clear setting	HOLD																CLEAR															
b14	(Setting prohibited)	Set these bits to 0.																															
b15	Reserved station flag	This is specified as a reserved station.																This is not specified as a reserved station.															

*1. In the case of an I/O (composite) module, the number of inputs or the number of outputs becomes the number of I/O points.
Ex.) In the case of the CL1XY2-DT1D5S I/O module, I/O points become "one point".

*2. In the case of an I/O (composite) module, input flag (b8) and output flag (b9) are set to 1 (on).

*3. When there are two or more units, only the bit of the head station is set to 1 (on).

9.15.3 Cautions on use

1. If remote stations are connected in places for a reserved station

The connected remote stations can operate with the existing setting, but errors such as wire breakage will not be detected.

After connecting remote additional stations, execute automatic I/O number assignment in the CONFIG mode again. The system will update the detailed remote station information, and the new remote stations will be able to be used normally (errors will be detected).

2. If a remote station is not connected (Reserved station flag b15 = OFF)

If a remote station is not connected to an edited station number, errors such as wire breakage error will occur.

9.16 Test run (communication test) and confirmation method

This section explains how to execute the communication test for CC-Link/LT using the system configuration example shown below.

9.16.1 System configuration examples

In this example, the head I/O numbers in the built-in master are X020 and Y020, and the 4-point mode is set.

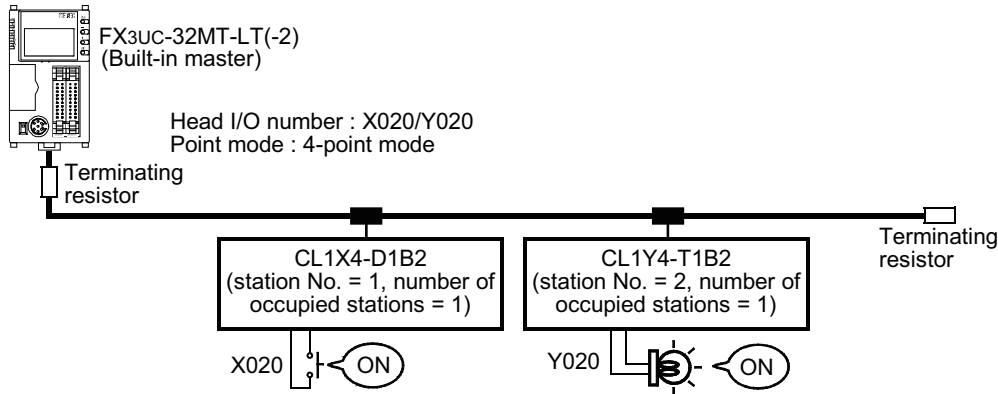

9.16.2 Test run execution procedure (FX3UC-32MT-LT)

Note: Setting DIP switches component change

Products manufactured in September 2011 or later have a different component used for the setting DIP switches compared with products produced earlier. Due to the component change, take note of the change in the ON/OFF position of each DIP switch. Even with the component change, the direction for setting each DIP switch ON/OFF is the same.

When product manufactured August, 2011 or earlier

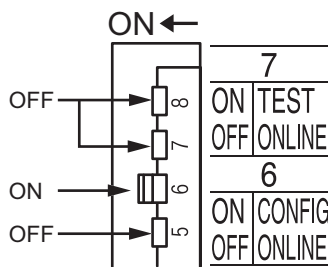

When product manufactured in September 2011 or later

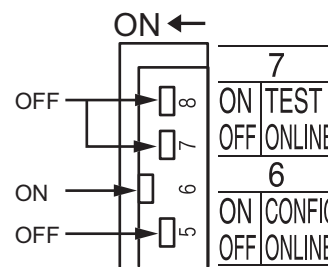

1. Automatic I/O number assignment (CONFIG mode)

Check the automatic assignment operation using the following procedure.

1 Connecting all cables

Connect all CC-Link/LT components (remote I/O units, power supply adapter, dedicated power supply, terminating resistors, etc.) with dedicated flat cables.

→ For cable connection, refer to Chapter 3 and Section 9.8.

2 Setting the station number of remote I/O units

Set the station number of remote I/O units.

3 Setting the transmission rate, point mode of the built-in master

(Switches are provided under the display module in the FX3UC-32MT-LT.)

→ For the setting, refer to Section 9.9.

B RATE (Transmission rate) setting [DIP switch 1, 2]

DIP switch status		Setting Content
1	2	
OFF	OFF	156kbps
ON	OFF	625kbps
OFF	ON	2.5Mbps
ON	ON	Prohibited to use

16pts/4pts (Point mode) setting [DIP switch 3]

DIP switch status	Setting Content
3	
ON	16-point mode
OFF	4-point mode

[DIP switch 4, 5, 8]

The DIP switches 4, 5 and 8 are unavailable. Make sure to set them to OFF.

When product manufactured August, 2011
or earlier

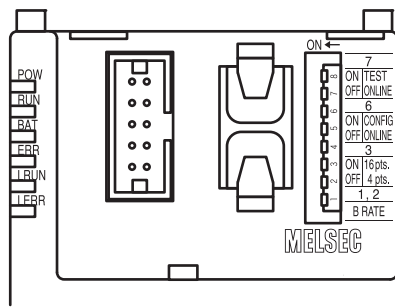

When product manufactured in September
2011 or later

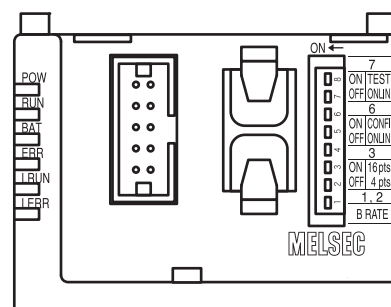

4 Setting the CONFIG mode

Set the DIP switches for operation setting "DIP switch 6: ON, DIP switch 7: OFF" in the built-in master.

Selecting the Operation mode [DIP switch 6, 7]

DIP switch status		Setting Content
6	7	
OFF	OFF	ONLINE mode
ON	OFF	CONFIG mode
OFF	ON	TEST mode

Setting example of transmission rate (B RATE), point mode (16 pts/4 pts) and operation mode
 Set the DIP switches as shown in the following figure to set the following status.

Item	Setting Content
B RATE	2.5Mbps
16pts/4pts	4-point mode
operation mode	CONFIG mode

When product manufactured August, 2011 or earlier

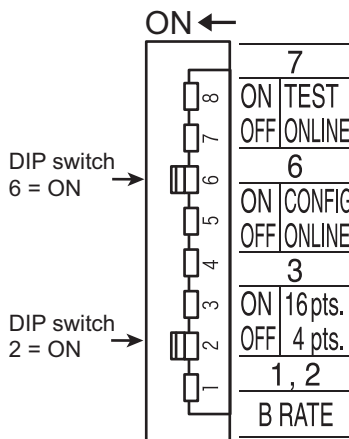

When product manufactured in September 2011 or later

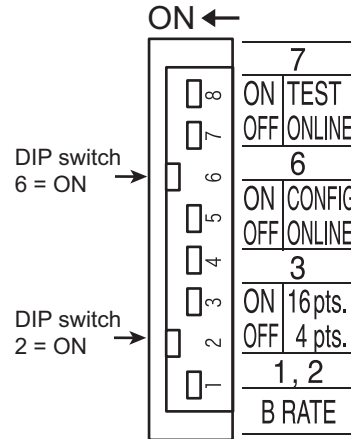

5 Turn the power ON

Turn ON the power of the PLC.

When the power supply adapter or dedicated power supply is used, turn ON the power in the order "Power supply adapter (or dedicated power supply) → PLC (built-in master)".

6 Confirming completion of the CONFIG mode

When collection of the remote I/O unit information is completed in CONFIG mode, BFM #28 (1Ch) b4 turns ON.

7 Turn the power OFF

8 Setting the built-in master to the ONLINE mode

Set the DIP switch 6 to ON and DIP switch 7 to OFF in the built-in master.
 (For the switch setting, refer to the Above No.4.)

9 Turning ON the power again

Turn ON the power of the PLC. When the power supply adapter or dedicated power supply is used, turn ON the power in the order "Power supply adapter (or dedicated power supply) → PLC (built-in master)".

2. Checking the wiring to the external equipment

1 Checking the wiring between the input unit and the external equipment

- 1) Turn ON the switch corresponding to "X020" of the external equipment connected to the input unit whose station No. is 1.
- 2) Monitor X020 using the PLC programming tool.
- 3) When X020 is ON, it means that the input unit is normally connected to the external equipment.

2 Checking the wiring between the output unit and the external equipment

- 1) Turn ON and OFF Y020 by the forcible ON/OFF operation from the PLC programming tool.
- 2) When the output unit is normally connected to the external unit, the LED corresponding to Y020 of the external equipment turns ON.

9.16.3 Test run execution procedure (FX3UC-32MT-LT-2)

1. Automatic I/O number assignment (configuration)

Check the automatic assignment operation using the following procedure.

1 Connecting all cables

Connect all CC-Link/LT components (remote I/O units, power supply adapter, dedicated power supply, terminating resistors, etc.) with dedicated flat cables.

→ For cable connection, refer to Chapter 3 and Section 9.8.

2 Setting the station number of remote I/O units

Set the station number of remote I/O units.

3 Turning the power ON

Turn ON the PLC power.

When using the power supply adapter or dedicated power supply, turn ON the power in the order "Power supply adapter (or dedicated power supply) → PLC (built-in master)".

4 Setting the transmission rate, point mode and station information (in the parameter CONFIG mode) of the built-in master

Set them using GX Works2, GX Developer (Ver. 8.68W or later) or the display module.

When using GX Works2 or GX Developer, write both the sequence program and PLC parameters to the PLC.

→ For setup using GX Developer, refer to Subsection 9.10.1.

→ For setup using the display module, refer to Section 10.16.

In self CONFIG mode or when using the display module, execute "CONFIG".

5 Turn the power OFF and then ON again

2. Checking the wiring to the external equipment

1 Checking the wiring between the input unit and the external equipment

- 1) Turn ON the switch corresponding to "X020" of the external equipment connected to the input unit whose station No. is 1.
- 2) Monitor X020 using a PLC programming tool.
- 3) When X020 is ON, it means that the input unit has been successfully connected to the external equipment.

2 Checking the wiring between the output unit and the external equipment

- 1) Force Y020 ON and OFF using a PLC programming tool.
- 2) If the output unit has been successfully connected to the external unit, the LED corresponding to Y020 of the external equipment will turn ON.

9.17 Practical Program Examples

This section explains practical programs using the CC-Link/LT function.

9.17.1 Practical Example 1 (Pattern 0)

1. System configuration examples

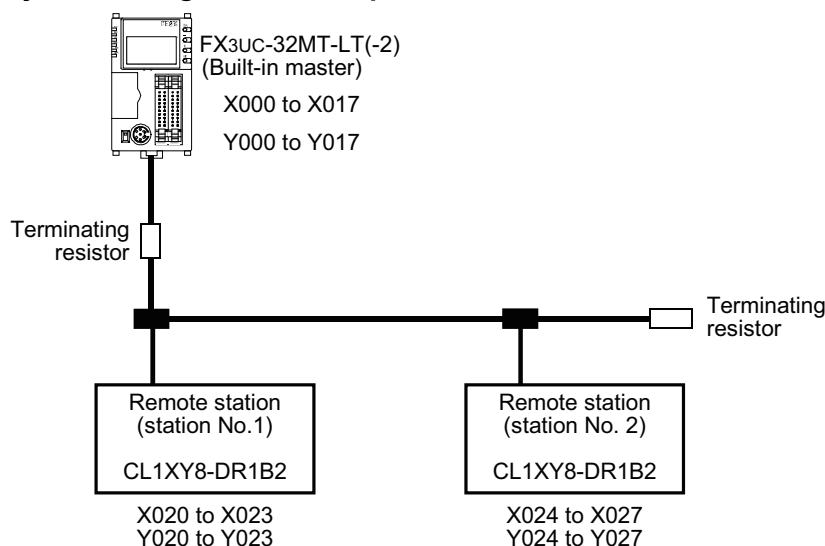

2. Device assignment

In this example, devices in the PLC are used as follows.

Device	Description
Input (X)	X001 Data link stop instruction signal
	X002 Data link restart instruction signal
Output (Y)	Y000 CC-Link/LT error has occurred
	Y001 Data link error occurrence
	Y002 All-station data link error occurrence
	Y003 Remote I/O error occurrence
	Y004 Out-of-control-range station error occurrence
	Y005 Transmission rate setting error occurrence
	Y010 EEPROM error occurrence
	Y011 DIP switch changed*1
	Y012 Hardware error occurrence

Device	Description
M0	For controlling the master
M10 to M25	For reading the detailed error information
M10	Data link error occurrence
M11	All-station data link error occurrence
M12	Remote I/O error occurrence
M13	Out-of-control-range error occurrence
M14	Transmission rate setting error occurrence
M17	EEPROM error occurrence
M18	DIP switch changed*1
M25	Hardware error occurrence
Data register (D)	D10 Reads the error station information

*1. FX3UC-32MT-LT only

1	Outline
2	External Dimensions
3	Generic Specifications
4	Power Supply Specifications
5	Input Specifications
6	Output Specifications
7	Examples of Wiring for Various Uses
8	Terminal Block
9	CC-Link/LT Master FX3UC-LT(-2) only
10	Display module FX3UC-LT(-2) only

3. Program example

→ For information on using PLC instructions, refer to the Programming Manual.
 → Refer to Section 9.17 and 9.18 for the buffer memory (BFM).

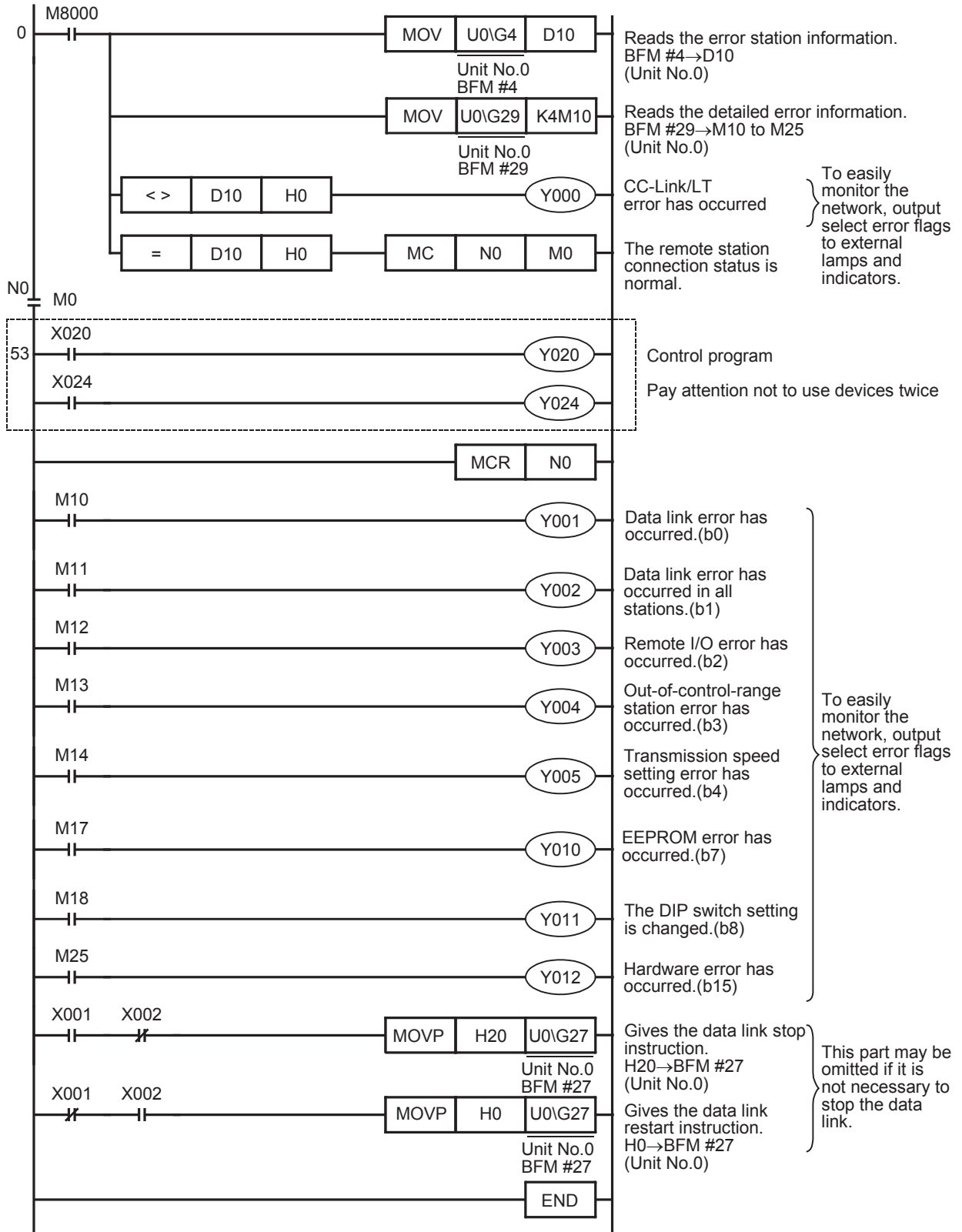

9.18 Data Link Processing Time

This section explains the link scan time and transmission delay time.

9.18.1 Link scan time

This paragraph explains the link scan time for the CC-Link/LT network.

1. Calculation formula

$$\text{Link scan time}[\mu\text{s}] = a + (b \times N) \times c$$

- 1) a: Constant
Depends on the transmission rate

Transmission rate		2.5Mbps	625kbps	156kbps
Value a	4-point, 16-point mode	22	88	353

- 2) b: Constant
Depends on the transmission rate and point mode

Transmission rate		2.5Mbps	625kbps	156kbps
Value b	4-point mode	46	41	37
	16-point mode	76	71	67

- 3) c: Constant
Depends on the transmission rate

Transmission rate		2.5Mbps	625kbps	156kbps
Value c	4-point, 16-point mode	0.4	1.6	6.4

- 4) N: Final station number
As shown in the formula above, if the number of stations is held constant, the link scan time is shorter in 4-point mode than in 16-point mode.

2. Graph

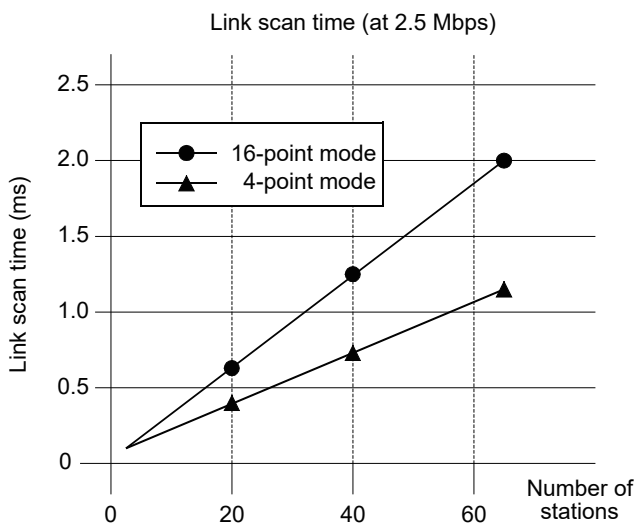

9.18.2 Transmission delay time

The transmission delay time (the time until data is received) can be calculated by the following formula.

1. Transmission delay (Built-in master ← Input remote station)

This paragraph explains how to obtain the time it takes device (X) to turn ON or OFF on the main unit after a signal is input to a remote I/O station.

1) Calculation formula

Transmission delay time [ms] = $SM \times 2 + (2 - n)^{*1} \times LS + \text{Remote station input response time}$

SM: Scan time of the PLC

LS: Link scan time

n: SM/LS (whose decimals are omitted)

*1: 0 if the value "2 - n" is 0 or less

2) Example

The scan time of the PLC is 5 ms, the link scan time is 1.2 ms, and the input response time of the remote I/O station is 1.5 ms

$$\begin{aligned}
 \text{Transmission delay time [ms]} &= SM \times 2 + (2 - n)^{*1} \times LS + \text{Remote station input response time} \\
 &= 5 \times 2 + (2 - 4) \times 1.2 + 1.5 \\
 n &= 4 \quad (5/1.2 = 4.16\dots, \text{ then decimals are omitted}) \\
 &\quad \downarrow \\
 &= 5 \times 2 + (-2)^{*1} \times 1.2 + 1.5 \\
 &= 11.5 \text{ [ms]}
 \end{aligned}$$

*1: 0 if the value "2 - n" is 0 or less

2. Transmission delay time (Built-in master → Output remote station)

This paragraph explains how to obtain the time after a device (Y) turns ON or OFF in the main unit until a corresponding output turns ON or OFF in a remote station.

1) Calculation formula

Transmission delay time[ms] = $SM + LS \times 2 + \text{Remote station output response time}$

SM: Scan time of the PLC

LS: Link scan time

2) Example

The scan time of the PLC is 5 ms, the link scan time is 1.2 ms, and the output response time of the remote I/O station is 0.5 ms

$$\begin{aligned}
 \text{Transmission delay time[ms]} &= SM + LS \times 2 + \text{Remote station output response time} \\
 &= 5 + 1.2 \times 2 + 0.5 \\
 &= 7.9 \text{ [ms]}
 \end{aligned}$$

9.19 Buffer Memory

Data transfer between the PLC main unit and built-in master is executed by a program in the PLC.

9.19.1 Used instruction

1. "Built-in master → CPU" (Data read)

Read (transfer) the contents saved in the buffer memory (BFM) in the built-in master to a data register (D), extension register (R) or auxiliary relay (M) for digit specification, etc. using an application instruction such as FROM, MOV or BMOV instruction.

Example) Program to read the contents of the BFM #4 (abnormal station information) in the built-in master (whose unit No. is fixed to 0) to D0

1) FROM instruction

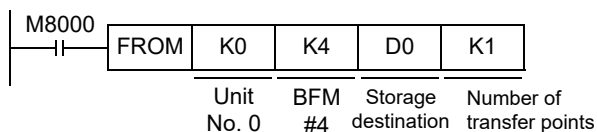

2) Direct Specification of Buffer Memory (U[]\G[])

In case of the MOV instruction

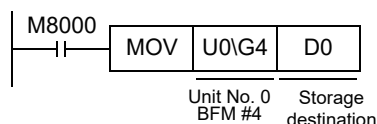

Example) Program to read the contents of the BFM #0 to #3 (remote station connection information) in the built-in master (whose unit No. is fixed to 0) to D10 to D13

1) FROM instruction

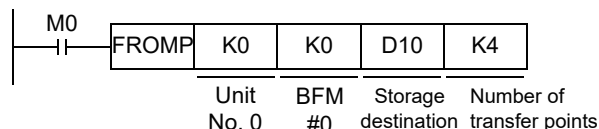

2) Direct Specification of Buffer Memory (U[]\G[])

In case of the BMOV instruction

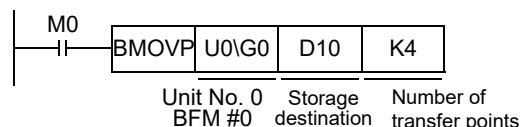

2. "CPU → Built-in master" (Data write)

Write (transfer) the contents of a data register (D), extension register (R) or auxiliary relay (M) for digit specification, constant (K or H), etc. to the buffer memory (BFM) in the built-in master using an application instruction such as TO, MOV or BMOV instruction.

Example) Program to write "H0" to the BFM #27 (command) in the built-in master (whose unit No. is fixed to 0)

1) TO instruction

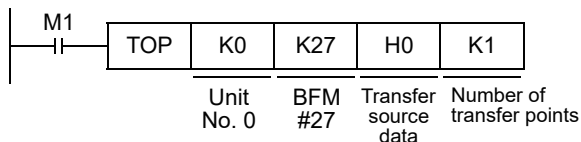

2) Direct Specification of Buffer Memory (U[]\G[])

In case of the MOV instruction

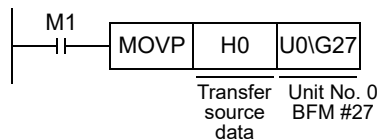

9.19.2 Buffer memory list

Refer to the following section for the function of each buffer memory.

Buffer memory No.		Name	Description	R: Read W: Write	Reference
DEC	HEX				
0 to 3	0h to 3h	Remote station connection information	Stores the connection status of each remote station. (When a remote station is connected, a corresponding bit is ON.)	R	9.18.1
4 to 7	4h to 7h	Link error station information	Stores the data link status of each remote station.	R	9.18.2
8 to 11	8h to Bh	Remote I/O error information	Stores the I/O error occurrence status of each remote station. For the contents of the error, refer to the instruction manual of each remote station.	R	9.18.3
12 to 15	Ch to Fh	-	Prohibited to use	-	-
16 to 19	10h to 13h	Reserved station information	Stores the reserved station setting status.	R	9.18.4
20	14h	Number of required input blocks	Stores the number of input blocks (in the unit of 8 points) required to assign the I/O numbers.	R	9.18.5
21	15h	Number of required of output blocks	Stores the number of output blocks (in the unit of 8 points) required to assign the I/O numbers.	R	9.18.6
22	16h	Data link final station information	Stores the final station number available in the data link. (This information is set according to the station information stored in the EEPROM.)	R	9.18.7
23 to 25	17h to 19h	-	Prohibited to use	-	-
26	1Ah	External switch information	Stores the DIP switch setting status.*1	R	9.18.8
27	1Bh	Command	Gives instructions to the FX2N-64CL-M for stopping or starting up the data link and writing data to the EEPROM.	R/W	9.18.9
28	1Ch	Status information	Stores the status information such as RUN and data link.	R	9.18.10
29	1Dh	Detailed error information	Stores the detailed information on errors detected by the built-in master.	R	9.18.11
30	1Eh	Model code	K7120	R	9.18.12
31	1Fh	-	Prohibited to use	-	-
32	20h	Detailed remote station information (station No.1)	Stores information (I/O type and number of points) for the remote station No.1. The information can be edited in the FX3UC-32MT-LT CONFIG mode.	R/W*2	9.18.13
⋮	⋮	⋮	⋮	⋮	
95	5Fh	Detailed remote station information (station No.64)	Stores information (I/O type and number of points) for the remote station No.64. The information can be edited in the FX3UC-32MT-LT CONFIG mode.	R/W*2	
96 to 143	60h to 8Fh	-	Prohibited to use	-	-
144	90h	Remote input area (station No. 49)	Access the input data from the remote device station.	R	9.18.14
145	91h	Remote input area (station No. 50)			
⋮	⋮	⋮	⋮	⋮	

*1. FX3UC-32MT-LT only.

*2. "W" is enabled only in the FX3UC-32MT-LT CONFIG mode.

Buffer memory No.		Name	Description	R: Read W: Write	Reference
DEC	HEX				
158	9Eh	Remote input area (station No. 63)	Access the input data from the remote device station.	R	9.18.14
159	9Fh	Remote input area (station No. 64)			
160 to 207	A0h to CFh	-	Prohibited to use	-	-
208	D0h	Remote output area (station No. 49)	Access the output data from the remote device station.	R/W	9.18.14
209	D1h	Remote output area (station No. 50)			
⋮	⋮	⋮	⋮	⋮	
222	DEh	Remote output area (station No. 63)	Access the output data from the remote device station.	R/W	
223	DFh	Remote output area (station No. 64)			

9.20 Details of buffer memory

9.20.1 Remote station connection information [BFM #0 (0h) to #3 (3h)]

1. Detailed description

The connection status of remote stations connected in the system are stored in BFM #0 to BFM #3 (bits for connected stations are ON).

0 (OFF): Corresponding remote station is not connected.

1 (ON): Corresponding remote station is connected.

Buffer memory No.	Bit						
	b15	b14	b13	...	b2	b1	b0
BFM #0 (0h)	Station No.16	Station No.15	Station No.14	...	Station No.3	Station No.2	Station No.1
BFM #1 (1h)	Station No.32	Station No.31	Station No.30	...	Station No.19	Station No.18	Station No.17
BFM #2 (2h)	Station No.48	Station No.47	Station No.46	...	Station No.35	Station No.34	Station No.33
BFM #3 (3h)	Station No.64	Station No.63	Station No.62	...	Station No.51	Station No.50	Station No.49

2. Cautions on use

Once a bit for a remote station turns ON, it remains ON even if a communication error occurs in the remote station due to wire breakage, etc. (this information cannot be used to confirm the communication).

9.20.2 Link error station information [BFM #4 (4h) to #7 (7h)]

The data link status of remote stations is stored here (bits for stations with link error are ON).

1. Detailed description

Among remote stations whose I/O numbers are written in the EEPROM^{*1}, remote stations with which communication is disabled are regarded as data link error stations, and corresponding bits are set to ON. When communication with a remote station is restored, the ON status of these bits is cleared.

*1. Remote stations connected in CONFIG mode or remote stations whose information is edited within the detailed remote station information in the FX3UC-32MT-LT.

Remote stations not specified as reserved stations in the FX3UC-32MT-LT-2 parameter CONFIG mode station information.

Remote stations connected when configuration is executed in FX3UC-32MT-LT-2 self CONFIG mode.

The station number of each remote station is assigned to each bit of the buffer memory [BFM #4 (4h) to #7 (7h)]. Normal status/data link error is indicated by the 0 (OFF)/1 (ON) status of each bit.

0 (OFF): The station is normal.

1 (ON): Data link error has occurred in the station.

Buffer memory No.	Bit						
	b15	b14	b13	...	b2	b1	b0
BFM #4 (0h)	Station No.16	Station No.15	Station No.14	...	Station No.3	Station No.2	Station No.1
BFM #5 (1h)	Station No.32	Station No.31	Station No.30	...	Station No.19	Station No.18	Station No.17
BFM #6 (2h)	Station No.48	Station No.47	Station No.46	...	Station No.35	Station No.34	Station No.33
BFM #7 (3h)	Station No.64	Station No.63	Station No.62	...	Station No.51	Station No.50	Station No.49

2. Cautions on use

Unused stations and reserved stations are not regarded as data link error stations.

If a remote station whose parameters are not written in the EEPROM gives a response, it is regarded as control disability (due to I/O non-assignment), and regarded as a data link error.

Inconsistency of the station type is not checked (even if the station type is inconsistent, it is not regarded as data link error).

3. Cautions on using the FX3UC-32MT-LT CONFIG mode or using the FX3UC-32MT-LT-2 parameter CONFIG mode

In the FX3UC-32MT-LT CONFIG mode, if the detailed remote station information [BFM #32 (20h) to #95 (5Fh)] is edited, and if the detailed remote station information is inconsistent with remote stations actually connected at the time of power ON as a result of the editing, there will be a data link error.

(When BFM #32 (20h) to #95 (5Fh) is edited, the station numbers are checked.)

If the power is set to ON while all remote stations are unconnected or if remote stations are disconnected after the power was set to ON, data link error is not detected, as long as the detailed remote station information is not edited.

In the FX3UC-32MT-LT-2 parameter CONFIG mode, when the station information set and transferred to the PLC using GX Works2 or GX Developer (Ver. 8.68W or later) is not consistent with remote stations actually connected when the power is turned ON, such inconsistent status is regarded as data link error. (The PLC checks the data link status also when the user changes the setting of reserved station specification using the display module.)

→ For details on the specification of a reserved station, refer to Section 9.12.

9.20.3 Remote I/O error information [BFM #8 (8h) to #11 (Bh)]

The remote I/O error occurrence status is stored here. (Bits for stations with I/O error are ON.)

For the type of error, refer to the instruction manual of each remote station.

1. Detailed description

The station number of each remote station is assigned to each bit of the buffer memory [BFM #8 (8h) to #11 (Bh)]. The absence/presence of remote I/O errors are indicated by the 0 (OFF)/1 (ON) status of each bit.

0 (OFF): Remote I/O error is absent

1 (ON): Remote I/O error is present

Initial value: 0 (OFF)

Buffer memory No.	Bit						
	b15	b14	b13	...	b2	b1	b0
BFM #8 (0h)	Station No.16	Station No.15	Station No.14	...	Station No.3	Station No.2	Station No.1
BFM #9 (1h)	Station No.32	Station No.31	Station No.30	...	Station No.19	Station No.18	Station No.17
BFM #10 (2h)	Station No.48	Station No.47	Station No.46	...	Station No.35	Station No.34	Station No.33
BFM #11 (3h)	Station No.64	Station No.63	Station No.62	...	Station No.51	Station No.50	Station No.49

9.20.4 Reserved station information [BFM #16 (10h) to #19 (13h)]

Station numbers specified as reserved stations are stored here. (Bits for reserved stations are ON.)

1. Detailed description

The station number of each remote station is assigned to each bit of the buffer memory [BFM #16 (10h) to #19 (13h)]. Whether or not a station is specified as reserved is indicated by the 0 (OFF)/1 (ON) status of each bit.

0 (OFF): The station is not specified as a reserved one.

1 (ON): The station is specified as a reserved one.

Initial value: 0 (OFF)

Buffer memory No.	Bit						
	b15	b14	b13	...	b2	b1	b0
BFM #16 (0h)	Station No.16	Station No.15	Station No.14	...	Station No.3	Station No.2	Station No.1
BFM #17 (1h)	Station No.32	Station No.31	Station No.30	...	Station No.19	Station No.18	Station No.17
BFM #18 (2h)	Station No.48	Station No.47	Station No.46	...	Station No.35	Station No.34	Station No.33
BFM #19 (3h)	Station No.64	Station No.63	Station No.62	...	Station No.51	Station No.50	Station No.49

2. Specify reserved stations

In the FX3UC-32MT-LT, Specify reserved stations by editing the detailed remote station information [BFM #32 (20h) to 95 (5Fh)] in CONFIG mode.

In the FX3UC-32MT-LT-2, select parameter CONFIG mode, and then specify reserved stations using GX Works2, GX Developer (Ver. 8.68W or later) or the display module.

→ For details specification of reserved station, refer to Section 9.12.

9.20.5 Number of required input blocks [BFM #20 (14h)]

The number of input blocks (8 points/block) required to assign the I/O numbers of remote stations is stored here.

9.20.6 Number of required output blocks [BFM #21 (15h)]

The number of output blocks (8 points/block) required to assign the I/O numbers of remote stations is stored here.

9.20.7 Data link final station information [BFM #22 (16h)]

The final station number available in data link is stored here.
 (The available final station number is set by the station information stored in the EEPROM.)
 If the final station number is specified as a reserved station, the reserved station is included.

9.20.8 External switch information [BFM #26 (1Ah)] (FX3UC-32MT-LT only)

The DIP switch for the operation the setting (at the time of power ON) is stored here.

1. Detailed description

Each DIP switch number is assigned to a bit of the buffer memory [BFM #26 (1Ah)]. The ON/OFF status of each bit of the DIP switch is indicated by the 0 (OFF)/1 (ON) status of each bit of the buffer memory.

0 (OFF): The bit of the DIP switch is OFF
 1 (ON): The bit of the DIP switch is ON

Bit	Bit No. of DIP switch	Description
b0	Bit 1	The setting of each bit of the DIP switch is stored. 0: The bit of the DIP switch is OFF. 1: The bit of the DIP switch is ON.
b1	Bit 2	
b2	Bit 3	
b3	Bit 4	
b4	Bit 5	
b5	Bit 6	
b6	Bit 7	
b7	Bit 8	
b8 to b15	-	(Prohibited to use)

9.20.9 Command [BFM #27 (1Bh)]

The command BFM gives the built-in master instructions to stop/restart the data link and write data to the EEPROM.

1. Detailed description

A function is assigned to each bit of the buffer memory [BFM #27 (1Bh)]. Each function is executed according to the 0 (OFF)/1 (ON) status of each bit.

Bit	Function	Description
b0 to b3	-	Prohibited to use
b4	Request to write to the EEPROM*1	Writes the contents of the detailed remote station information [BFM #32 (20h) to #95 (5Fh)] stored in the buffer memory to the built-in EEPROM when it is set from OFF to ON. After the write to the EEPROM is completed (completion is indicated when b4 of BFM #28 turns ON), set this bit to OFF.
b5	Request to stop data link	Stops data link when set from OFF to ON. Restarts data link when set from ON to OFF.
b15 to b6	-	Prohibited to use

*1. Operates only in the FX3UC-32MT-LT CONFIG mode.

1) Request to write to EEPROM (b4)

When this bit is set to ON, the contents of the detailed remote station information [BFM #32 (20h) to #95 (5Fh)] are written to the built-in EEPROM.

This write is unnecessary when reserved stations are not specified or when the detailed remote station information is not edited.

The operation is as shown below.

Request to write EEPROM
[BFM #27 (1Bh) b4]

EEPROM write completion
[BFM #28 (1Ch) b4]

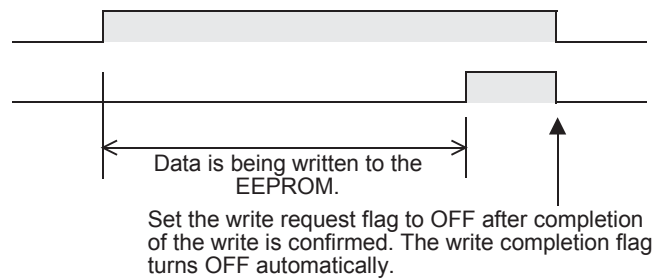

2) Request to stop data link (b5)

Data link is stopped when this bit [BFM #27 (1Bh) b5] is set to ON while the data link is being executed.

The data link is restarted when this bit is set to OFF.

The operation is as shown below.

Request to stop data link
[BFM #27(1Bh) b5]

Data link stopped
[BFM #28(1Ch) b5]

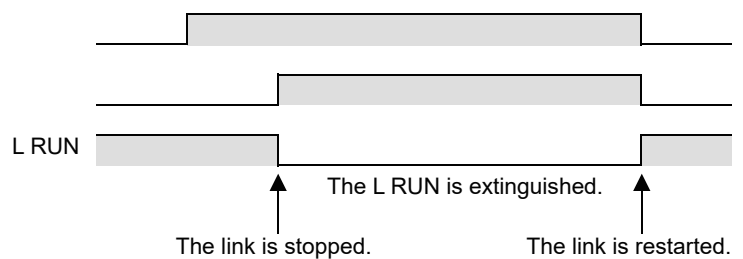

1	Outline
2	External Dimensions
3	Generic Specifications
4	Power Supply Specifications
5	Input Specifications
6	Output Specifications
7	Examples of Wiring for Various Uses
8	Terminal Block
9	CC-Link/LT Master FX3UC-LT(-2) only
10	Display module FX3UC-LT(-2) only

9.20.10 Status information [BFM #28 (1Ch)]

Status information such as RUN and link status are stored here.

1. Detailed description

The status is indicated by the 0 (OFF)/1 (ON) status of each bit.

Bit	Function	Description
b0	Data link status	Remains ON while the I/O image in the built-in master is updated by the data link.
b1	Initial communication*1 status	Turns ON when acquisition of the remote station information is completed.
b2	RUN status	Remains ON while the unit is operating normally. (Indicates the same contents as the LED.)
b3	CONFIG mode	Remains ON while CONFIG mode is selected.
b4	EEPROM write completion*2	Turns ON when write to the EEPROM is completed, then turns OFF when write is completed and the write request flag [BFM #27 (1Bh) b4] is set to OFF.
b5	Data link stopped	Remains ON while the data link is stopped by the request to stop data link.
b6 to b15	-	Prohibited to use

*1. When the power to the PLC is set to ON, the PLC acquires information on connected remote stations from the built-in master.

*2. FX3UC-32MT-LT only.

9.20.11 Detailed error information [BFM #29 (1Dh)]

1. Detailed description

The status is indicated by the 0 (OFF)/1 (ON) status of each bit.

Bit	Function	Description	Error flag restoration operation
b0	Link error in some stations	Turns ON when link error has occurred in some stations. [Turns ON when any bit in BFM #4 (4h) to 7 (7h) have turned ON.] For the station number in which the error has occurred, refer to the link error station information [BFM #4 (4h) to 7 (7h)].	When the cause of the error is eliminated, the error flag is automatically restored.
b1	Link error in all stations	Turns ON when data link error has occurred in all stations.	When the cause of the error is eliminated, the error flag is automatically restored.
b2	Remote I/O error	Turns ON when remote I/O error has occurred. [Turns ON when any bit in BFM #8 (8h) to 11 (Bh) have turned ON.] For the station number, refer to the remote I/O error information [BFM #8 (8h) to 11 (Bh)]. For the type of error, refer to the instruction manual of the appropriate remote station.	When the cause of the error is eliminated, the error flag is automatically restored.
b3	Out-of-control-range station error	Turns ON when a remote station not registered in the detailed remote station information [BFM #32 (20h) to #95 (5Fh)] is connected to the network.	If the station number of the connected remote station is smaller than the final station number, the error flag is automatically restored when the cause of the error is eliminated. If the station number of the connected remote station is larger than the final station number, the error flag is restored when the cause of the error is eliminated and is followed by a power reset.
b4	Transmission rate setting error	Turns ON when the transmission rate setting DIP switch is set to an incompatible position.	When the cause of the error is eliminated, and power is reset, the error flag is automatically restored.

Bit	Function	Description	Error flag restoration operation
b5	-	Prohibited to use	-
b6	RD station setting error	Turns ON when a RD station is connected to a station number outside the range No. 49 to No. 64. Turns ON when a RD station is used in 4-point mode.	When the cause of the error is eliminated and the power is reset, the error flag is automatically restored.
b7	EEPROM error	Turns ON when a EEPROM write / read fault occurs. Turns ON, when the EEPROM write request is performed except the CONFIG mode of the FX3UC-32MT-LT.	In the case that a request to write to the EEPROM is given in any mode other than FX3UC-32MT-LT CONFIG mode, the error flag is automatically restored when the request to write to the EEPROM is cleared. In the case of EEPROM write error or read error, the error flag is not restored.
b8	DIP switch changed*1	Turns ON when the DIP switch setting is changed during FX3UC-32MT-LT operation.	When the DIP switch setting is returned to original status at the time of power ON, the error flag is automatically restored. If the DIP switch setting must be changed, reset the power.
b9 to b14	-	Prohibited to use	-
b15	Hardware error	Turns ON when an abnormality is detected in the self-loop-back test.	This error flag is not restored because something is wrong with the hardware.

*1. FX3UC-32MT-LT only.

9.20.12 Model code [BFM #30 (1Eh)]

The model code (K7120) of the Built-in master is stored here.

1	Outline
2	External Dimensions
3	Generic Specifications
4	Power Supply Specifications
5	Input Specifications
6	Output Specifications
7	Examples of Wiring for Various Uses
8	Terminal Block
9	CC-Link/LT Master FX3UC-LT(-2) only
10	Display module FX3UC-LT(-2) only

6. Head station flag (b11)

When the station is the head of a unit occupying two or more stations or when the unit occupies only one station, "1 (ON)" is stored.

When the station is not the head of a unit occupying two or more stations, "0 (OFF)" is stored.

b11	Head station flag
0	This is not the head station of a unit occupying two or more stations.
1	This is the head station of a unit occupying two or more stations, or a unit occupying only one station.

7. Input filter setting (b12)

When the remote station is an input unit, the input filter setting status of the remote I/O unit is stored here when configuration is executed in the FX3UC-32MT-LT CONFIG mode or the FX3UC-32MT-LT-2 self CONFIG mode.

(If the remote I/O unit settings are changed after configuration is executed in the FX3UC-32MT-LT CONFIG mode or the FX3UC-32MT-LT-2 self CONFIG mode, the remote I/O unit will operate with the new settings, but the new settings will not be reflected in the buffer memory of the master block.) If the remote station is a remote I/O module not equipped with the input filter setting function, "0 (OFF)" is stored.

b12	Input filter setting
0	General-purpose input
1	High-speed input

8. Output clear/hold setting (b13)

When the remote station is an output unit or composite I/O unit, the output hold setting status of the remote I/O unit is stored here when configuration is executed in the FX3UC-32MT-LT CONFIG mode or FX3UC-32MT-LT-2 self CONFIG mode.

If the remote I/O unit settings are changed after configuration is executed in the FX3UC-32MT-LT CONFIG mode or the FX3UC-32MT-LT-2 self CONFIG mode, the remote I/O unit will operate with the new settings, but the new settings will not be reflected in the buffer memory of the master block.

If the remote station is a remote I/O module not equipped with the output clear/hold setting function, "0 (OFF)" is stored.

b13	Clear/hold setting
0	Clear
1	Hold

9. Reserved station flag (b15)

Specification as a reserved station is stored here.

When specifying the station as reserved in CONFIG mode, write "1 (ON)".

→ For details on the specification of a reserved station, refer to Section 9.12.

b15	Reserved station flag
0	This station is not specified as reserved.
1	This station is specified as reserved.

9.20.14 Remote device station input (output) data area [BFM #144 (90h) to #159 (9Fh) and #208 (D0h) to #223 (DFh)]

This area is used to access the input (output) data in the remote device station indirectly using the FROM and TO instructions or directly using the buffer memory specification.

Access is enabled to only BFM#s for which remote device stations are actually connected.

(The TO instruction is ignored and the FROM instruction returns "0" for a station number to which a remote I/O station is connected.)

Station No.	BFM#	
	Remote input area	Remote output area
Station No.49	144	208
Station No.50	145	209
⋮	⋮	⋮
Station No.63	158	222
Station No.64	159	223

1	Outline
2	External Dimensions
3	Generic Specifications
4	Power Supply Specifications
5	Input Specifications
6	Output Specifications
7	Examples of Wiring for Various Uses
8	Terminal Block
9	CC-Link/LT Master FX3UC-LT(-2) only
10	Display module FX3UC-LT(-2) only

9.21 Details on the additional special devices (FX3UC-32MT-LT-2 only)

9.21.1 Details on the additional special auxiliary relays

The table below shows the details on the additional special auxiliary relays M8322 to M8324. (M8322 to M8324 are read-only. Do not overwrite them.)

Device	Name	Details
M8322	FX3UC-32MT-LT/ FX3UC-32MT-LT-2 model indicator	ON: FX3UC-32MT-LT-2 OFF: FX3UC-32MT-LT
M8323	CC-Link/LT configuration required	Turns ON when configuration needs to be executed by turning the power OFF and then ON again.
M8324	CC-Link/LT configuration completed	Turns ON when configuration is completed successfully.

9.21.2 Details on the additional special data register

The table below shows the details on the built-in CC-Link/LT setup information data register D8396. (D8396 is read-only. Do not overwrite if.)

Device	bits	Name	Details															
D8396	b1,b0	Transmission rate	<table border="1"> <thead> <tr> <th>b1</th> <th>b0</th> <th>Set data</th> </tr> </thead> <tbody> <tr> <td>0</td> <td>0</td> <td>156kbps</td> </tr> <tr> <td>0</td> <td>1</td> <td>625kbps</td> </tr> <tr> <td>1</td> <td>0</td> <td>2.5Mbps</td> </tr> <tr> <td>1</td> <td>1</td> <td>No setting</td> </tr> </tbody> </table>	b1	b0	Set data	0	0	156kbps	0	1	625kbps	1	0	2.5Mbps	1	1	No setting
			b1	b0	Set data													
			0	0	156kbps													
			0	1	625kbps													
			1	0	2.5Mbps													
	1	1	No setting															
b2	Point mode	0: 4-point mode 1: 16-point mode																
b7 to b3	Not used	-																
b8	Operation mode	0: Self CONFIG mode 1: Parameter CONFIG mode																
b15 to b9	Not used	-																

10. Display Module [FX3UC-32MT-LT(-2) only]

STARTUP AND MAINTENANCE PRECAUTIONS



WARNING

- Before modifying or disrupting the program in operation or running the PLC, carefully read through this manual and the associated manuals and ensure the safety of the operation.
An operation error may damage the machinery or cause accidents.

STARTUP AND MAINTENANCE PRECAUTIONS



CAUTION

- Do not disassemble or modify the PLC.
Doing so may cause fire, equipment failures, or malfunctions.
For repair, contact your local Mitsubishi Electric representative.
- Turn off the power to the PLC before attaching or detaching the following devices.
Failure to do so may cause equipment failures or malfunctions.
 - Peripheral devices, display module, expansion boards and special adapters
 - Extension blocks, FX Series terminal blocks, connector conversion adapter and extension power supply unit
 - Battery and memory cassette

10.1 Specifications

10.1.1 Display specifications

Item		Description
Display device/backlight		STN monochrome liquid crystal display/Backlight: LED (green)
Displayed letters	Number of letters	16 letters × 4 lines (2 byte letters: 8 letters × 4 lines)
	Characters	English Alphabet, Numbers, Japanese Characters, Shift JIS Level-1, 2
	Language for menu display	Japanese/English
Button		4 operation buttons (OK, ESC, +, and -)

Notes for displaying symbols (ASCII Code)

- ¥ (ASCII Code:5C) symbol is displayed as " ¥ " even if the language display setting at FX3U-7DM is set to English (LANGUAGE: ENGLISH).
- The Character at ASCII Code: 7E "~" can not be displayed.

10.1.2 Operation button list

The display module has 4 operation buttons as shown in the following table.

Name of button	Function of operation button
ESC	Use this button to cancel the operation and to return to the previous screen.
-	Use this button to move the cursor or to set a numeric value.
+	Use this button to move the cursor or to set a numeric value.
OK	Use this button to select an item or to determine the set numeric value.

1

Outline

2

External Dimensions

3

Generic Specifications

4

Power Supply Specifications

5

Input Specifications

6

Output Specifications

7

Examples of Wiring for Various Uses

8

Terminal Block

9

CC-Link/LT Master FX3UC-LT(-2) only

10

Display module FX3UC-LT(-2) only

10.2 Summary of Functions

The display module functions are summarized below.

Item		Function	Remarks	Reference
Main unit I/O operation display		Displays the ON/OFF status of inputs X000 to X017 and outputs Y000 to Y017 built in the main unit.	Button operation	Subsection 10.3.2
Menu screen functions				Subsection 10.3.3
Monitor/Test	Devices	Input (X) ^{*1} , output (Y), auxiliary relay (M), state (S), timer (T), counter (C), data register (D) [16-bit/32-bit], extended register (R), and extended file register (ER) [16-bit/32-bit] monitor/test function.	Button operation	Section 10.5
	User (User-registered device)	Up to 4 data registers (D) [16-bit/32-bit] can be registered.	Requires program	Section 10.6 and Section 10.21
ErrorCheck		Performs error checks and displays the results.	Button operation	Section 10.7
LANGUAGE (selects the menu display language)		Selects either Japanese or English as the menu display language.	Button operation	Section 10.8
Contrast		Adjusts the contrast (-5 to 10); default setting: 0	Button operation	Section 10.9
ClockMenu (Time setting)	Setting	Sets the current time.	Button operation	Subsection 10.10.1
	Display	Displays the current time.		Subsection 10.10.2
EntryCode		The currently specified entry code can be canceled.	Button operation	Section 10.11
ClearAllDev (Device all clear)		Initializes the Input (X) ^{*1} , output (Y), auxiliary relay (M), state (S), timer (T), counter (C), data register (D) [16-bit/32-bit], and extended register (R). The file register (D) is excluded from this function. (Bit devices are turned OFF, and word device current values are set to "0".)	Button operation	Section 10.12
PLC Status		Verifies the version information, entry code status, program memory type status, and battery voltage, etc.	Button operation	Section 10.13
ScanTime		Displays the scan time (max./min./current value)	Button operation	Section 10.14
Cassette (Memory cassette transfer)		Allows data transfers (and consistency checks) between the internal RAM and the memory cassette.	Button operation	Section 10.15
CC-Link/LT setting ^{*2}		<ul style="list-style-type: none"> In parameter CONFIG mode Allows reserved station change, transmission rate setting and self check. In self CONFIG mode Allows transmission rate setting, point mode setting, configuration and self check. 	Button operation	Section 10.16

*1. There is no test function for "Input (X)".

*2. FX3UC-32MT-LT-2 only.

Item	Function	Remarks	Reference
Non-menu functions			
Operation button ON/OFF information	Allows monitoring of operation button ON/OFF status.	Requires program or monitor	Section 10.20
Hexadecimal current value display setting	Changes the display format of the current values and setting values for the timer, counter, data register, extended register, and extended file register to a hexadecimal display format.	Requires program *1	Section 10.19
Display screen protect function	Enables all functions, prohibits change (test) functions, and protects the Main unit I/O operation display.	Requires program	Section 10.18
User message display	The following codes saved at the display device can be used as display commands: Alphanumeric: 20H to 7DH ASCII code Katakana: A1H to DFH ASCII code Japanese character: Shift JIS Level-1, 2	Requires program	Section 10.22

*1. A sequence program is required to enable a hexadecimal display of the timer (T), counter (C), data register (file register) (D), extended register (R) [16-bit/32-bit], and extended file register (ER) [16-bit/32-bit] current values.

→ Refer to Section 10.19 for the setting procedure.

10.3 Procedure for Accessing the Menu Screen from the Title Screen

All operation explanations and display screen examples in this manual are in English. When the menu display language is set to Japanese, please convert the screen messages to their Japanese translations.

→ Refer to Section 10.23 for the Japanese & English display character correspondence table.

→ Refer to Section 10.8 for menu display language setting.

10.3.1 Title screen

The screen shown at right is displayed for 1.5 seconds after the power is turned on.

	Content
[1]	Model name
[2]	Version

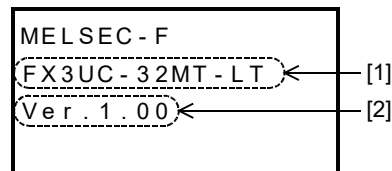

10.3.2 Top screen (Main unit I/O operation display)

Following the title screen display, the top screen (these names are referred to as main unit I/O operation display) is then displayed.

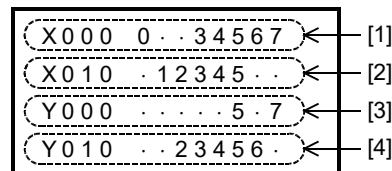

	Content	ON/OFF status
[1]	X000 to X007 operation display	ON: Displays the last digit of the device number. OFF: Displays ".".
[2]	X010 to X017 operation display	For example, the ON/OFF status is displayed as follows in the figure above.
[3]	Y000 to Y007 operation display	
[4]	Y010 to Y017 operation display	ON: X000, X003 to X007, X011 to X015, Y005, Y007, Y012 to Y016 OFF: X001, X002, X010, X016, X017, Y000 to Y004, Y006, Y010, Y011, Y017

A user screen can also be displayed by using the user message display function.

→ Refer to Section 10.21 for user message display function.

10.3.3 Menu screen

As shown in the figure at right, the menu screen displays 4 lines of the total menu. Press the [+] button to scroll downward through the menu.

Button operations at this menu screen are explained below.

Button	Operation Description
ESC	Returns to the "Main unit I/O operation display"
-	Scrolls upward through the menu. Hold for 1 second or longer for high-speed scrolling. This button is disabled when the cursor is located at the beginning of the menu.
+	Scrolls downward through the menu. Hold for 1 second or longer for high-speed scrolling. This button is disabled when the cursor is located at the end of the menu.
OK	Selects the item where the cursor is blinking.

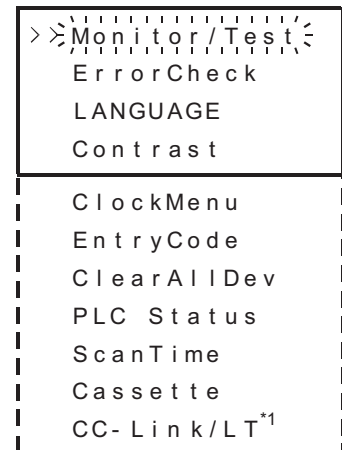

*1. FX3UC-32MT-LT-2 only.

10.4 Menu Structure

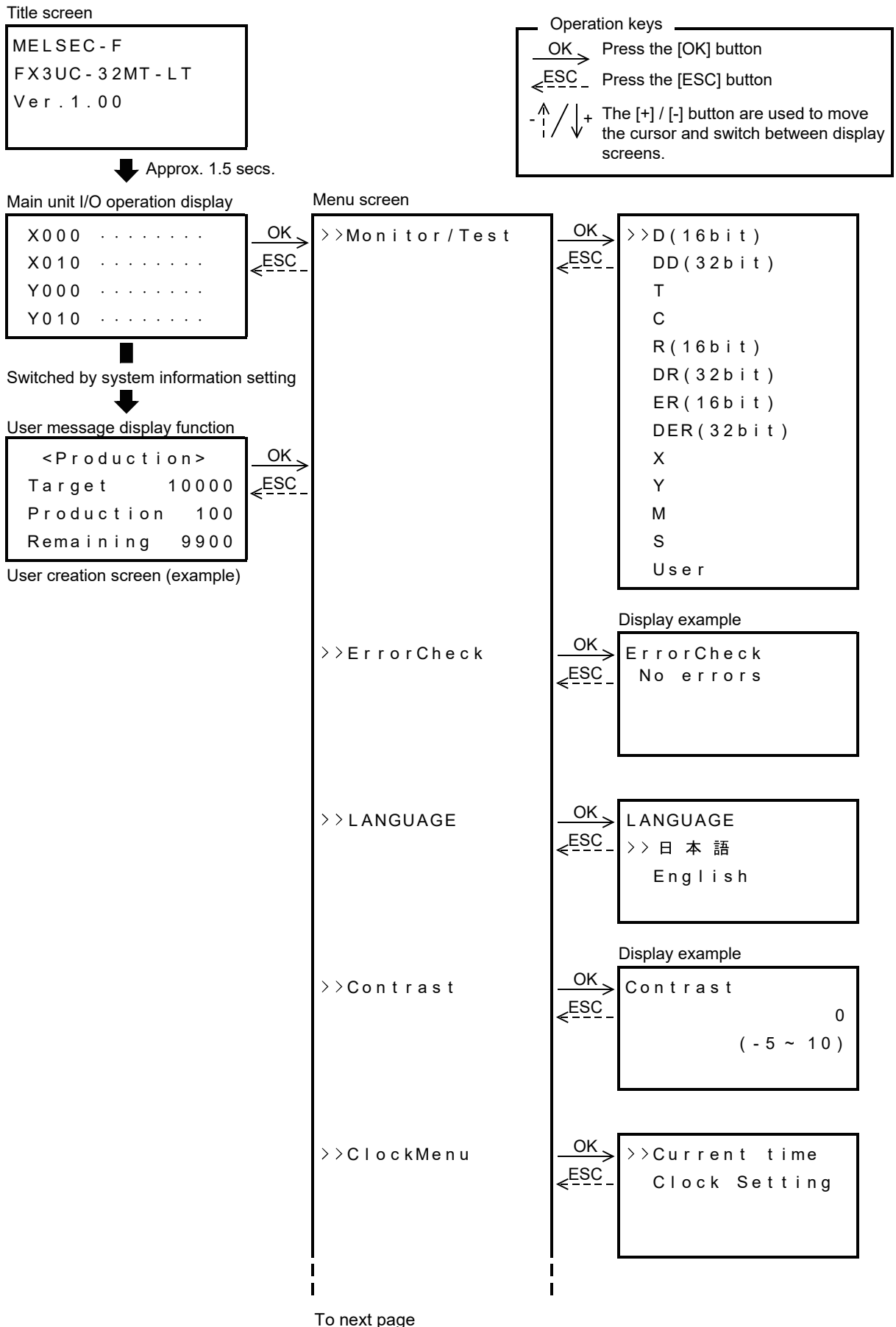

1	Outline
2	External Dimensions
3	Generic Specifications
4	Power Supply Specifications
5	Input Specifications
6	Output Specifications
7	Examples of Wiring for Various Uses
8	Terminal Block
9	CC-Link/LT Master FX3UC-LT(-2) only
10	Display module FX3UC-LT(-2) only

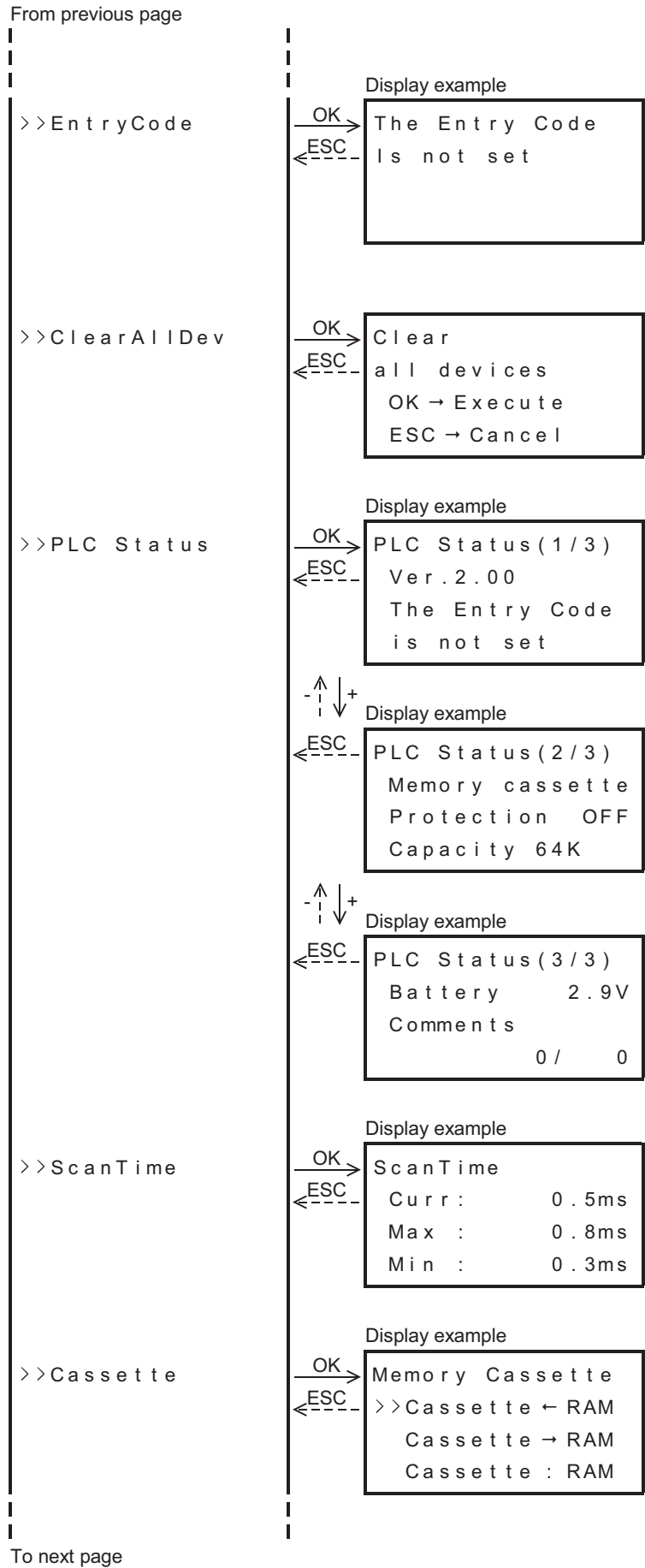

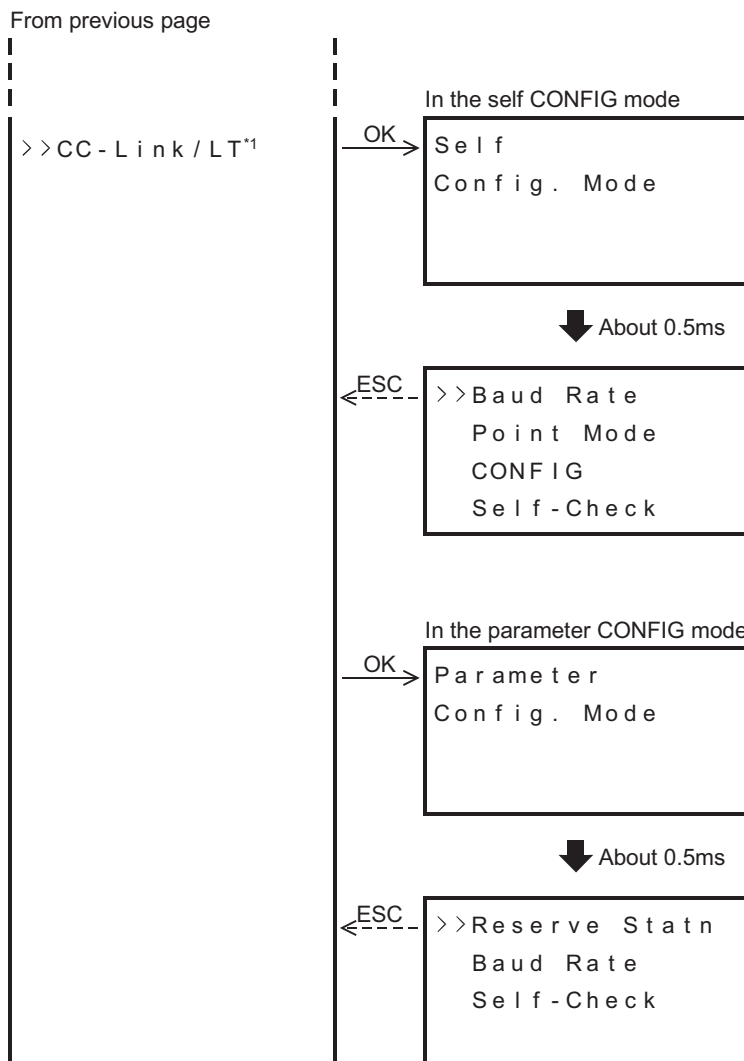

*1. FX3uc-32MT-LT-2 only.

1	Outline
2	External Dimensions
3	Generic Specifications
4	Power Supply Specifications
5	Input Specifications
6	Output Specifications
7	Examples of Wiring for Various Uses
8	Terminal Block
9	CC-Link/LT Master FX3uc-LT(-2) only
10	Display module FX3uc-LT(-2) only

10.5.2 Monitor mode operation

This section explains the procedure for monitoring the input [X], output [Y], auxiliary relay [M], state [S], timer [T], counter [C], data registers [D, DD], extended registers [R, DR], and the extended file registers [ER, DER]. The file register [D] and the index registers [V, Z] cannot be monitored.

→ Refer to Subsection 10.5.3 for a monitor screen display example.

→ Refer to Section 10.20 for user-registered device operation procedures.

→ Refer to Section 10.18 for the procedure used to display the timer, counter, and data register current values as hexadecimal values.

- 1) At the menu screen, use the [+] and [-] buttons to move the cursor to the "Monitor/Test" item, then press [OK] to display the "Main unit I/O operation display" shown at right.

To cancel the operation and return to the "main unit I/O operation display", press [ESC] at the menu screen

- 2) Use the [+] and [-] buttons to move the cursor to the device which is to be monitored.

To cancel the operation and return to the "menu screen", press [ESC].

```

>>D ( 16 b i t )
  DD ( 32 b i t )
  T
  C
  R ( 16 b i t )
  DR ( 32 b i t )
  ER ( 16 b i t )
  DER ( 32 b i t )
  X
  Y
  M
  S
  U s e r
    
```

- 3) Press [OK] to display the monitor screen for the device which was selected for monitoring.

To cancel the operation and return to the "device selection screen", press [ESC].

After the power is turned on, the number of the device to be displayed is shown as follows.

```

>>D   0   0
  D   1   0
  D   2   0
  D   3   0
    
```

- a) The first time the power is turned on, the display begins with device No.1.

- b) At subsequent power ONs, the device which was being monitored at the previous operation is displayed (they are saved in memory for each device type).

```

  D  34   0
  D  35   0
  D  36   0
>>D  37   0
    
```

- 4) Use the [+] and [-] buttons to move the cursor or the screen to the until the device to be monitored is displayed.

→ Refer to Subsection 10.5.3 for status display.

Selected Device Type	Button	Operation Description
• All devices	ESC	Returns to the "device selection screen".
• Data registers (D, DD)	-	Scrolls upward. Press for 1 second or longer for high-speed scrolling. If pressed again at the beginning of the device No. list, the display jumps to the end of the device No. list.
• Extended registers (R, DR)		
• Extended file registers (ER, DER)	+	Scrolls downward. Hold for 1 second or longer for high-speed scrolling. If pressed again at the end of the device No. list, the display jumps to the beginning of the device No. list.
• Timer (T)		
• Counter (C)		
• Input (X)		
• Output (Y)	-	Scrolls the display screen upward. Hold for 1 second or longer for high-speed scrolling. If pressed again at the beginning of the device No. list, the display jumps to the end of the device No. list.
• Auxiliary relay (M)		
• State (S)	+	Scrolls the display screen downward. Hold for 1 second or longer for high-speed scrolling. If pressed again at the end of the device No. list, the display jumps to the beginning of the device No. list.
• All devices except (x)		
• All devices except (x)	OK	Switches to the test mode when hold for 1 second or longer.

10.5.3 Monitor screen & status display

→ Refer to Section 10.19 for the procedure used to display the current values as hexadecimal values.

1. Data register [D (16-bit)]/extended register [R (16-bit)]/extended file register [ER (16-bit)]

	Display Content
[1]	Device No.
[2]	Current value

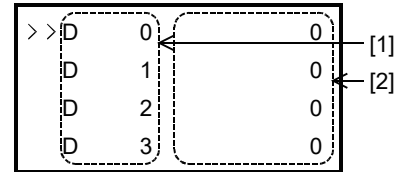

2. Data register [DD (32-bit)]/extended register [DR (32-bit)]/extended file register [DER (32-bit)]

	Display Content
[1]	Device No. [Upper 16-bit device No. (odd number)] [Lower 16-bit device No. (even number)]
[2]	Current value

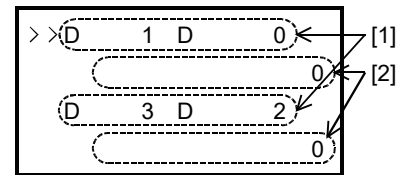

File register (D):

The file register (D) current value cannot be directly monitored at the display module.

3. Timer (T)

	Display Content
[1]	Device No.
[2]	Contact image ON: ■ OFF: Blank
[3]	Reset image ON: ■ OFF: Blank
[4]	Current value
[5]	Setting value or device specified by setting value (if an index modifier is present, the index register's device is also displayed).
[6]	Current value of device specified by setting value.

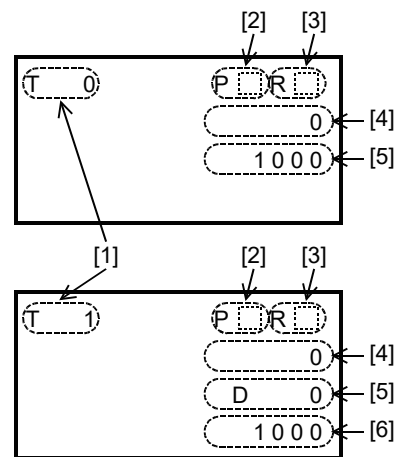

4. Counter [C]

Display Content	
[1]	Device No.
[2]	Contact image ON: ■ OFF: Blank
[3]	Reset image ON: ■ OFF: Blank
[4]	Count direction display UP count: ■ DOWN count: Blank (32-bit up/down counter and high-speed counter only)
[5]	Current value
[6]	Setting value or device specified by setting value (if an index modifier is present, the index register's device is also displayed).
[7]	Current value of device specified by setting value.

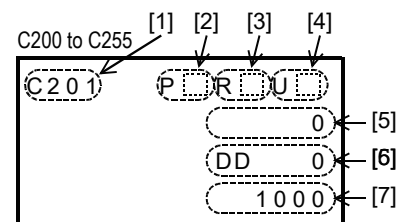
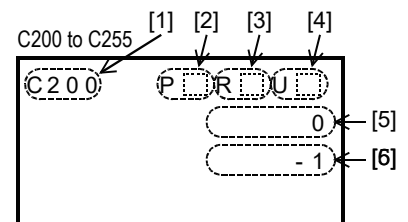
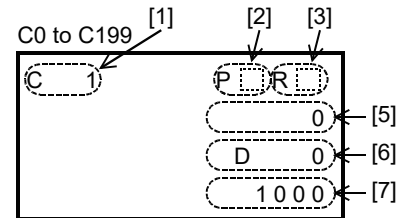
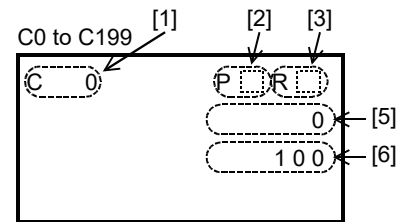

5. Input [X]/Output [Y]/Auxiliary Relay [M]/State [S]

Display Content	
[1]	Device No. at beginning of line. Input (X) and output (Y): 8 points per line. Auxiliary relay (M), special auxiliary relay (M), and state (S): 10 points per line.
[2]	ON/OFF status ON: Last digit of device No. OFF: "•".

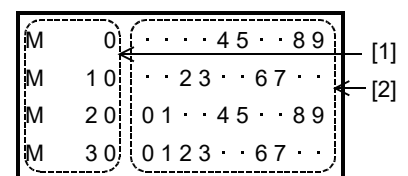
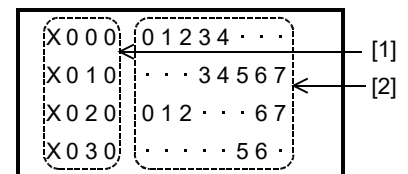

1	Outline
2	External Dimensions
3	Generic Specifications
4	Power Supply Specifications
5	Input Specifications
6	Output Specifications
7	Examples of Wiring for Various Uses
8	Terminal Block
9	CC-Link/LT Master FX3UC-LT(-2) only
10	Display module FX3UC-LT(-2) only

10.5.4 Test mode operation

There are 3 types of test mode operations, depending on the device type. The 3 operations are explained below.

→ Refer to Subsection 10.5.1 for test mode subject devices.

1. Data registers [D: D (16-bit), DD (32-bit)]/extended registers [R: R (16-bit), DR (32-bit)]/extended file registers [ER: ER (16-bit), DER (32-bit)]/user-registered devices

- 1) Perform a monitor mode operation to display the device whose current value is to be changed.

→ Refer to Subsection 10.5.2 for monitor function operation.

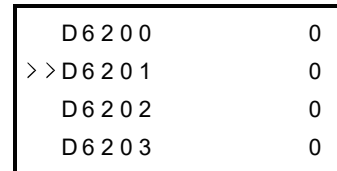

- 2) Hold the [OK] button for 1 second or longer to switch to the test mode. The current value begins blinking (refer to fig. at right).

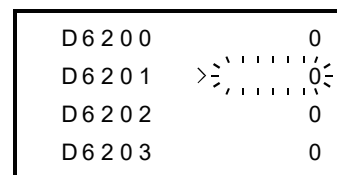

- 3) Use the [+]/[-] buttons to change the value as desired. To cancel the operation and return to the "monitor screen", press [ESC].

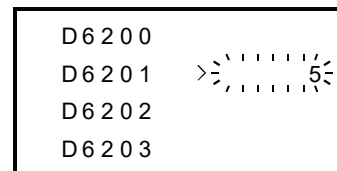

Button	Operation Description
ESC	Cancels the operation and returns to the "monitor screen".
-	Reduces the value. Hold for 1 second or longer for high-speed reduction.
+	Increases the value. Hold for 1 second or longer for high-speed increase.
OK	Registers the current value and returns to the "monitor screen".

- 4) Press [OK] to register the current value and return to the "monitor screen".

- File register (D)

The display module's test function cannot be used to change the current value of the file register (D) which is stored in the program memory.

2. Timer [T], counter [C]

- 1) Perform a monitor mode operation to display the device where the test function is to be used.
 → Refer to Subsection 10.5.2 for monitor function operation.

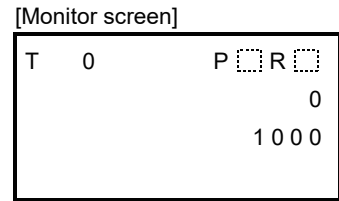

- 2) Press the [OK] button to display the cursor, then select the "test subject selection screen".
 To cancel the operation and return to the "monitor screen", press [ESC].

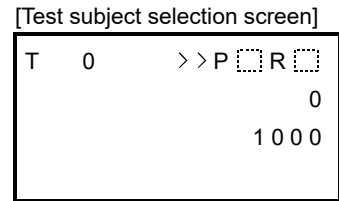

- 3) Use the [+]/[-] buttons to select the test subject.
 To cancel the operation and return to the "monitor screen", press [ESC].

Test Subject	Test Description
[1]	Contact forced ON/OFF
[2]	Current value change
[3]	Setting value change

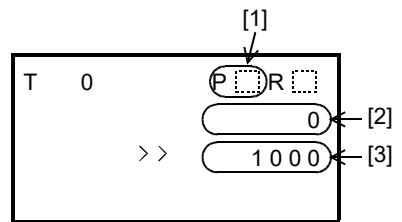

- 4) Hold the [OK] button for 1 second or longer to register the test subject selection, and switch to the test mode.
 To cancel the operation and return to the "test subject selection screen", press [ESC].

Test Subject	Status when [OK] is hold for 1 second or longer
[1]	No change
[2]	Numeric value begins blinking.
[3]	

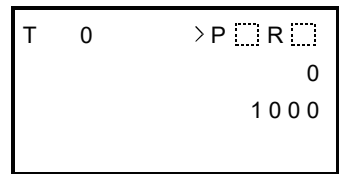

- 5) Operation varies as shown below, depending on the selected test subject.

- a) For "contact forced ON/OFF"
 The contact ON/OFF status is highlighted when [OK] is pressed.

Button	Operation Description
ESC	Cancels the operation and returns to the "test subject selection screen".
-	Disabled
+	Disabled
OK	Highlights the contact ON/OFF status, meaning the current value can not be changed.

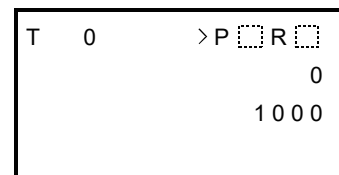

- b) For "current value change"
 Use the [+]/[-] buttons to change the value as desired, then press [OK] to register the changed value.

Button	Operation Description
ESC	Cancels the operation and returns to the "test subject selection screen".
-	Reduces the value. Hold for 1 second or longer for high-speed reduction.
+	Increases the value. Hold for 1 second or longer for high-speed increase.
OK	Registers the current value or the setting value and returns to the "test subject selection screen".

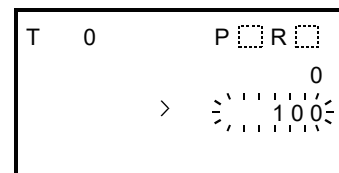

1	Outline
2	External Dimensions
3	Generic Specifications
4	Power Supply Specifications
5	Input Specifications
6	Output Specifications
7	Examples of Wiring for Various Uses
8	Terminal Block
9	CC-Link/LT Master FX3UC-LT(-2) only
10	Display module FX3UC-LT(-2) only

c) For indirect setting format

- ① Use the [+]/[-] buttons to select the desired setting method (refer to table below), then press [OK] to register this selection.

Selectable Setting Values	Changeable Content	Setting Description
Direct setting (without index modifier) [Direct (K, H)]	Direct numeral setting	The directly specified value becomes the setting value.
Direct setting (with index modifier) [direct (K, H) + index register (V0 to V7, Z0 to Z7)]		The [directly specified numerical value] + [index register's current value] becomes the setting value.
Indirect setting (without index modifier) [data register (D), extended register (R)]	Indirectly specified device No.	The specified device's current value becomes the setting value.
Indirect setting (with index modifier) [data register (D) + index register (V0 to V7, Z0 to Z7)], [Extended register (R) + index register (V0 to V7, Z0 to Z7)]		The [directly specified device No.] + [index register's current value] becomes the device No. specified by the setting value. That device's current value becomes the setting value.

- ② Use the [+]/[-] buttons to determine the setting value.

The content that is changed varies according to the selected setting method, as shown below.

- For "direct setting" or "direct setting + index register" method:
 Use the [+]/[-] buttons to change the value as desired, then press [OK] to register the changed value.
- For "indirect setting" or "indirect setting + index register" method:
 Use the [+]/[-] buttons to change the device No. as desired, then press [OK] to register the setting value.

- 6) After the setting operation is completed, return to the "test subject selection screen", where the [ESC] button can then be pressed to return to the "monitor screen".

3. Output [Y]/auxiliary relay [M]/special auxiliary relay [M]/state [S]

Forced ON/OFF operations are possible for the output [Y]/auxiliary relay [M]/special auxiliary relay [M]/state [S] contacts.

- 1) Perform a monitor mode operation to display the device whose ON/OFF status is to be changed.
 → Refer to Subsection 10.5.2 for monitor function operation.

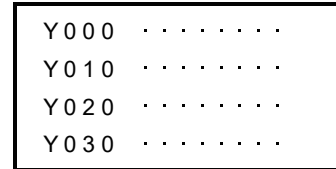

- 2) Hold the [OK] button for 1 second or longer to switch to the test mode. The device then begins blinking (refer to figure at right). To cancel the operation and return to the "test subject selection screen", press [ESC].

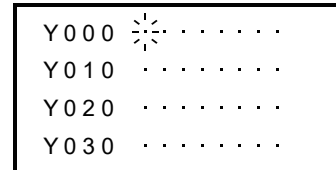

- 3) Use the [+]/[-] buttons to move the blinking position to the device where a forced ON/OFF is desired. To cancel the operation and return to the "monitor screen", press [ESC].

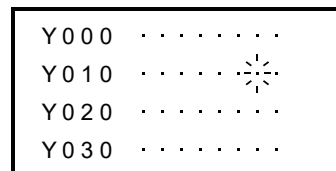

Button	Operation Description
ESC	Cancels the operation and returns to the "monitor screen".
-	Moves in the lower device No. direction (for forced ON/OFF subject selection). Hold for 1 second or longer for high-speed scrolling.
+	Moves in the higher device No. direction (for forced ON/OFF subject selection). Hold for 1 second or longer for high-speed scrolling.
OK	Highlights the contact's ON/OFF status.

- 4) Press the [OK] button to highlight the contact's ON/OFF status. To cancel the operation and return to the "monitor screen", press [ESC].

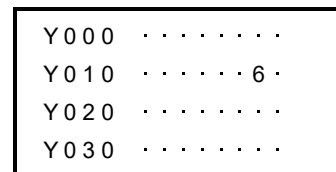

Button	Operation Description
ESC	Cancels the operation and returns to the "monitor screen".
-	Moves in the lower device No. direction (for forced ON/OFF subject selection). Hold for 1 second or longer for high-speed scrolling.
+	Moves in the higher device No. direction (for forced ON/OFF subject selection). Hold for 1 second or longer for high-speed scrolling.
OK	Highlights the contact ON/OFF status.

- 5) Press [ESC] to return to the monitor screen.

10.5.5 Test mode operation notes

When using multiple same-number timers (T) and counters (C).

Operation occurs as follows if multiple timers [T] and counters [C] are used in programs which contain CJ instructions and step ladders.

- When a setting change is performed after switching from the device monitor to the test function mode, the setting change is applied to the timer [T] or counter [C] which is nearest to Step 0.
- When changing the setting values for same-number timers [T] and counters [C], use the programming tool to change the program.

1	Outline
2	External Dimensions
3	Generic Specifications
4	Power Supply Specifications
5	Input Specifications
6	Output Specifications
7	Examples of Wiring for Various Uses
8	Terminal Block
9	CC-Link/LT Master FX3UC-LT(-2) only
10	Display module FX3UC-LT(-2) only

10.6 Monitor/Test Mode [User-Registered Devices]

Regarding user-registered devices at "Monitor/Test" menu, monitor and test operations can be performed for a maximum of 4 data registers (16-bit/32-bit) specified by the system information.

→ Refer to Section 10.20 for the user-registered device setting procedure.

10.6.1 Monitor mode operation

- At the menu screen, use the [+] and [-] buttons to move the cursor to the "Monitor/Test" item, then press [OK] to display the "Main unit I/O operation display" shown to the right.
 To cancel the operation and return to the "main unit I/O operation display", press [ESC] at the menu screen
- "Use the [+] and [-] buttons to move the cursor to the "User" item.
 To cancel the operation and return to the "device selection screen", press [ESC].

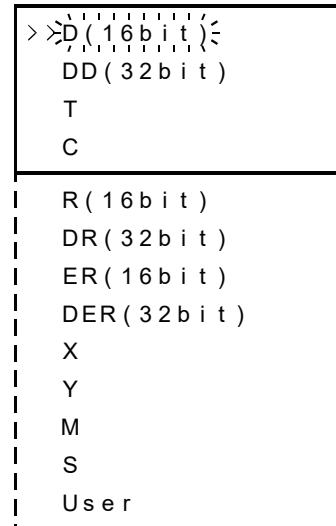

- Press [OK] to display the data registers specified by the system information.
 The first time the power is turned on, the display begins with device No.1 of the "user-registered devices". At subsequent power ONs, the device which was being monitored at the previous operation is displayed.
 If a specified user-registered device has been changed, the newly specified device is displayed.
 To cancel the operation and return to the "device selection screen", press [ESC].

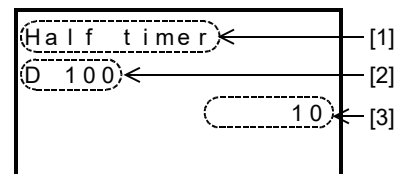

	Display Content
[1]	Device comments (registered at the PLC) are displayed together with the devices. If no device comment has been registered, the device comment area is left blank.
[2]	Device included in the user-registered devices
[3]	Current value

- Use the [+] and [-] buttons to scroll the user-registered devices screen.
 To cancel the operation and return to the "device selection screen", press [ESC].

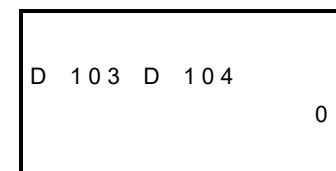

Button	Operation Description
ESC	Returns to the "device selection screen".
-	Scrolls the user-registered devices. (User-specified device 1 → user-specified device 4 → user-specified device 3 → user-specified device 2 → user-specified device 1)
+	Scrolls the user-registered devices. (User-specified device 1 → user-specified device 2 → user-specified device 3 → user-specified device 4 → user-specified device 1)
OK	Switches to the test mode when hold for 1 second or longer.

10.6.2 Test mode operation

- 1) Perform a monitor mode operation to display the user-registered device whose current value is to be changed.
→ Refer to Subsection 10.5.2 for monitor function operation.

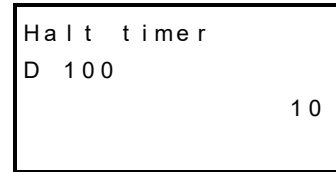

- 2) Hold the [OK] button for 1 second or longer to switch to the test mode. The current value then begins blinking (refer to fig. at right).
- 3) Use the [+] / [-] buttons to change the value as desired. To cancel the operation and return to the "monitor screen", press [ESC].

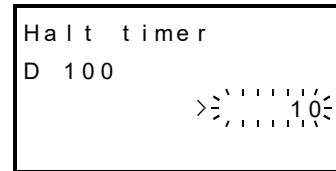

Button	Operation Description
ESC	Cancels the operation and returns to the "monitor screen".
-	Reduces the value. Hold for 1 second or longer for high-speed reduction.
+	Increases the value. Hold for 1 second or longer for high-speed increase.
OK	Registers the current value and returns to the "monitor screen".

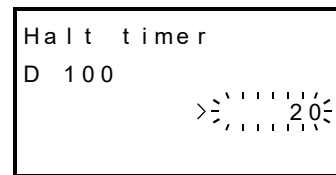

- 4) Press [OK] to register the current value and return to the "user registered devices screen".

10.7 Error Check

The main unit's error status displays at the "ErrorCheck" menu.

- 1) At the menu screen, use the [+] / [-] buttons to move the cursor to the "ErrorCheck" item, then press [OK].
The error check result then displays at the "error display screen" (refer to fig. at right).
To cancel the operation and return to the "Main unit I/O operation display", press [ESC] at the menu screen
- 2) If multiple errors have occurred, the [+] / [-] keys can be used to switch between the error display pages.

Button	Operation Description
ESC	Returns to the "menu screen".
-	1 error or less: Disabled 2 errors or more: Displays the previous-page's error screen.
+	1 error or less: Disabled 2 errors or more: Displays the next-page's error screen.
OK	Returns to the "menu screen".

Display Content

	Display Content
[1]	Active error flag
[2]	Error name
[3]	Error code
[4]	Number of concurrent errors (displays only when multiple errors have occurred)

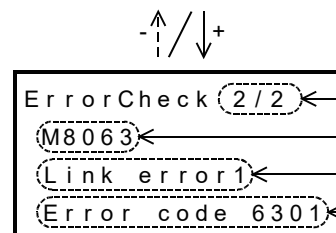
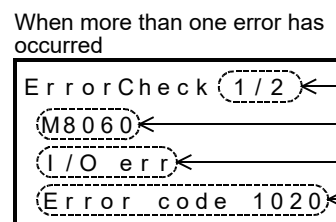
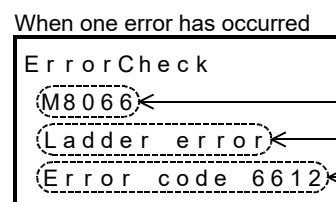
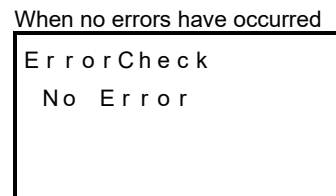

- 3) To cancel the operation and return to the "menu screen", press [ESC].

1	Outline
2	External Dimensions
3	Generic Specifications
4	Power Supply Specifications
5	Input Specifications
6	Output Specifications
7	Examples of Wiring for Various Uses
8	Terminal Block
9	CC-Link/LT Master FX3UC-LT(-2) only
10	Display module FX3UC-LT(-2) only

10.8 LANGUAGE (Menu Display Language Setting)

The language used at the display module menus is specified at the "LANGUAGE" menu. The language setting procedure is described below.

All operation explanations and display screen examples in this manual are in Japanese. When the menu display language is set to English, please convert the screen messages to their English translations.

→ Refer to Section 10.23 for the Japanese & English display character correspondence table.

10.8.1 Changing to Japanese menus

The procedure for changing from English menus to Japanese menus is described below.

- 1) Turn the PLC power on.

Following a brief title screen display (1.5 seconds), the "Main unit I/O operation display" or a "user message" is displayed.

Title screen

```
MELSEC - F
FX3UC - 32MT - LT
Ver . 1 . 00
```

↓ Approx.
1.5 secs.

Main unit I/O operation display

```
X000 .....
X010 .....
Y000 .....
Y010 .....
```

or

User creation screen (example)

```
<Production>
Target      10000
Production  100
Remaining   9900
```

- 2) Press the [OK] button to display the menu screen shown to the right (4 lines of the menu display).

```
> > Monitor / Test < <
  ErrorCheck
  LANGUAGE
  Contrast
```

```
ClockMenu
EntryCode
ClearAllDev
PLC Status
ScanTime
Cassette
CC-Link/LT*1
```

*1. FX3UC-32MT-LT-2 only.

- 3) At the menu screen, use the [+] / [-] buttons to move the cursor to the "LANGUAGE" item, then press [OK] to display the "display language selection screen".

To cancel the operation and return to the "Main unit I/O operation display", press [ESC].

```
LANGUAGE
  日本語
> > English < <
```

- 4) Use the [+]/[-] buttons to move the cursor to "日本語".
To cancel the operation and return to the "menu screen", press [ESC].

Button	Operation Description
ESC	Cancels the operation and returns to the "menu screen".
-	Moves the cursor upward.
+	Moves the cursor downward.
OK	Registers the selected display language and returns to the "menu screen".

- 5) Press [OK] to register the selected display language and return to the "menu screen".

10.8.2 Changing to English menus

Refer to Subsection 10.8.1 "Changing to Japanese menus" for the access procedure from the title screen.

- 1) At the menu screen, use the [+]/[-] buttons to move the cursor to the "LANGUAGE" item, then press [OK] to display the "display language selection screen".
To cancel the operation and return to the "Main unit I/O operation display", press [ESC].

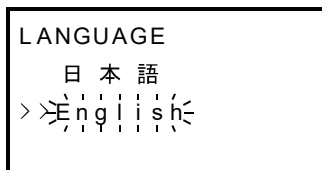

- 2) Use the [+]/[-] buttons to move the cursor to "English".
To cancel the operation and return to the "menu screen", press [ESC].

Button	Operation Description
ESC	Cancels the operation and returns to the "menu screen".
-	Moves the cursor upward.
+	Moves the cursor downward.
OK	Registers the selected display language and returns to the "menu screen".

- 3) Press [OK] to register the selected display language and return to the "menu screen".

10.8.3 D8302 changes by program & related devices

Selections made at this menu are saved at D8302.
D8302 has a battery backup for latch.
D8302 changes by user program can also be specified.

D8302 Current Value	Display Language
K0	Japanese
K1	English
Other	English

When the display language is set to "Japanese"

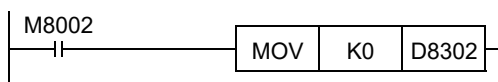

1	Outline
2	External Dimensions
3	Generic Specifications
4	Power Supply Specifications
5	Input Specifications
6	Output Specifications
7	Examples of Wiring for Various Uses
8	Terminal Block
9	CC-Link/LT Master FX3UC-LT(-2) only
10	Display module FX3UC-LT(-2) only

10.9 Contrast

The liquid crystal display contrast setting is specified at the "Contrast" menu. Selections made at this menu are saved at D8302. A contrast setting of "0" is specified at factory default.

- 1) At the menu screen, use the [+]/[-] buttons to move the cursor to the "Contrast" item, then press [OK] to display the "contrast adjustment screen".
 To cancel the operation and return to the "Main unit I/O operation display", press [ESC].

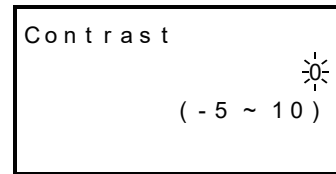

- 2) Use the [+]/[-] buttons to adjust the contrast.
 To cancel the operation and return to the "menu screen", press [ESC].

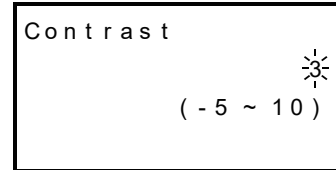

Button	Operation Description
ESC	Cancels the operation and returns to the "menu screen".
-	Lowers the contrast (decreases the numeric value. The value can be decreased to -5.)
+	Increases the contrast (increases the numeric value. The value can be increased to +10.)
OK	Registers the selected setting and returns to the "menu screen".

- 3) Press the [OK] button to register the selected setting and return to the "menu screen".

10.10 Clock Menu (Current Time Setting)

The "ClockMenu" menu consists of "current time display" and the "time setting" items.
 The current time should be set before operating the system.

10.10.1 Current time setting procedure

- 1) At the menu screen, use the [+]/[-] buttons to move the cursor to the "ClockMenu" item, then press [OK] to display the selection screen shown at right.
 To cancel the operation and return to the "Main unit I/O operation display", press [ESC].

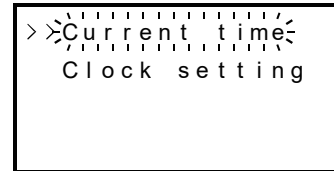

- 2) Use the [+]/[-] buttons to move the cursor to the "Clock setting" item.
 To cancel the operation and return to the "menu screen", press [ESC].

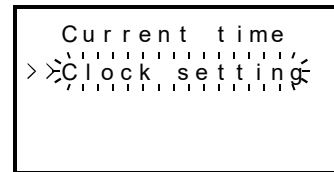

- 3) Press the [OK] button to display the "Clock setting screen".
 To cancel the operation and return to the "selection screen", press [ESC].

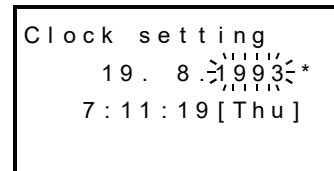

- 4) Use the [+]/[-] buttons to change the blinking data as desired, then press [OK] to register the change.
 Settings are performed in the following sequence: Year → Month → Day → Hours → Minutes → Seconds.
 After pressing [OK] to register the final "seconds" setting, a "Current time is set" message is displayed, completing the current time setting procedure.

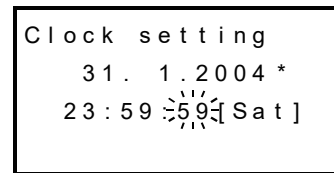

* The default "Year" display is a 2-digit value indicating the Western calendar year.

Button	Operation Description
ESC	Returns to the previous setting item. Returns to the "selection screen", when at the "Year" item ("Year" is blinking) position.
-	Reduces the value. Hold for 1 second or longer for high-speed reduction.
+	Increases the value. Hold for 1 second or longer for high-speed increase.
OK	Proceeds to the next setting item. "Current time is set" message displays if pressed at the "Seconds" item ("Seconds" is blinking).

- 5) Press [OK] or [ESC] to return to the "selection screen".
- 6) Press [ESC] to return to the "menu screen".

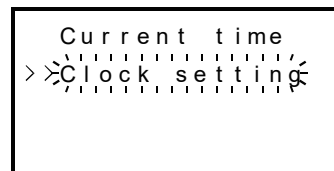

1	Outline
2	External Dimensions
3	Generic Specifications
4	Power Supply Specifications
5	Input Specifications
6	Output Specifications
7	Examples of Wiring for Various Uses
8	Terminal Block
9	CC-Link/LT Master FX3UC-LT(-2) only
10	Display module FX3UC-LT(-2) only

10.10.2 Displaying the current time

- 1) At the menu screen, use the [+] / [-] buttons to move the cursor to the "ClockMenu" item, then press [OK] to display the selection screen shown to the right.
 To cancel the operation and return to the "Main unit I/O operation display", press [ESC].

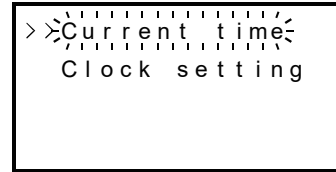

- 2) Use the [+] / [-] buttons to move the cursor to the "Current time" item. To cancel the operation and return to the "menu screen", press [ESC].

- 3) Press the [OK] button to display the current time. To cancel the operation and return to the "selection screen", press [ESC].

Button	Operation Description
ESC	Returns to the "selection screen".
-	Disabled
+	Disabled
OK	Returns to the "selection screen".

2-digit display

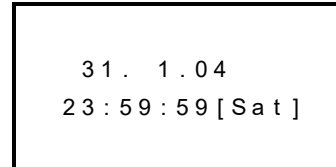

- 4) Press [OK] or [ESC] to return to the "selection screen".
- 5) Press [ESC] to return to the "menu screen".

4-digit display

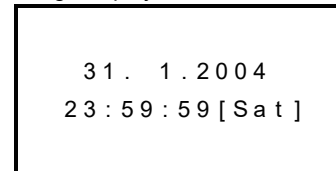

10.10.3 Changing the current time's "Year" from 2-digit format to 4-digit format

The "Year" data displays as 2-digit value with a default. This can be changed to a 4-digit display by the following programming.

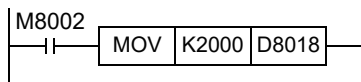

It is also possible to set the current time with a sequence program.

→ Refer to the "time setting" (special devices D8013 to D8019) section of the Programming Manual.

10.11 Keyword (Entry code)

Entry codes registered at the PLC can be canceled from the "EntryCode" menu.
When canceled, all operations are enabled.
Registering or changing entry codes is not possible at the display module.
The programming tool must be used in advance to register new entry codes.

10.11.1 Keyword (Entry code) types & levels

Entry codes can be entered in 2 ways (8-digit or 16-digit^{*1}), depending on the peripheral device in question.

- For a [entry code (8-digit)] + [2nd entry code (8-digit)] = 16-digit input:
FX3UC PLC Ver. 2.20 or later
GX Developer Ver. 8.24A or later
- For an entry code (8-digit) input only:
Processing is possible even with a peripheral device version that is not compatible with the FX3UC PLC.

Number Of Digits	Registration Method	Peripheral device ^{*2}		Entry Code Registration Level	Entry Code Description
		FX3UC Compatible	Not FX3UC Compatible		
16-digit ^{*1}	By selecting the entry code registration level at the GX Works2, etc., setting screen.	✓	-	Reading/writing prohibited	16-digit hexadecimal value (A to F, 0 to 9)
				Writing prohibited	[Ex] FAB05C25DAECF293
				All online operations prohibited	AABCDEFF34509345
8-digit	By entering the level at the first character when entering the entry code.	✓	✓	A (A, 0 to 9 first char.)	8-digit hexadecimal value beginning with "A" or "0" to "9". [Ex] 0ABCDEF2, AABCD345
				B	8-digit hexadecimal value beginning with "B". [Ex] B1234567, BABCDEF7
				C	8-digit hexadecimal value beginning with "C". [Ex] C8904567, CDEF567F

- *1. Customer keyword/permanent PLC lock included. However, permanent PLC lock does not have a keyword input.
FX3UC PLC Ver. 2.61 or later supports the customer keyword and permanent PLC lock.
- *2. GX Works2, GX Developer Ver. 8.89T or later, FX-30P Ver. 1.20 or later supports the customer keyword and permanent PLC lock.

10.11.2 Level-specific restrictions screen list

- ✓: Function enabled
- △: Timer and counter setting values cannot be changed.
- : Function disabled

Function name	None	Entry Code: 8 digits Label entered as the first character at Entry Code input			Entry Code*1: 16 digits Selected at peripheral device setting screen*2		
		A	B	C	All online operations prohibited	Writing prohibited	Reading/ writing prohibited
Main unit I/O operation display	✓	✓		✓	✓		✓
Monitor/ Test	Device	✓	–	△	–		△
	User (User-registered device)	✓	–	✓	–		✓
ScanTime (Scan time display)	✓	–		✓	–		✓
PLC status	✓	–		✓	–		✓
ErrorCheck	✓	–		✓	–		✓
User message display	✓	✓		✓	✓		✓
Display screen protect function	✓	–		–	–		–
Menu display language setting	✓	–		✓	–		✓
Contrast adjustment	✓	–		✓	–		✓
Time	Display	✓	✓	✓	✓		✓
	Setting	✓	–	✓	–		✓
Entry Code (cancel)	–	✓		✓	✓		✓
Clear all device (Device all-clear)	✓	–		✓	–		✓
Memory cassette transfer	✓	–		–	–		–

- *1. Customer keyword/permanent PLC lock included. However, permanent PLC lock does not have a keyword input.
 FX3UC PLC Ver. 2.61 or later supports the customer keyword and permanent PLC lock.
- *2. GX Works2, GX Developer Ver. 8.89T or later, FX-30P Ver. 1.20 or later supports the customer keyword and permanent PLC lock.

10.11.3 Keyword (Entry code) storage

The system has no process for recovering registered entry codes which are forgotten. Therefore, be sure to store the entry codes in a secure location.

10.11.4 Screens requiring keywords (entry codes) for access

At the menu screen, use the [+]/[-] buttons to move the cursor to the "EntryCode" item, then press [OK] to display one of the 4 screens shown below (the screen that displays depends on the entry code status).
 If no entry codes are registered, press [ESC] to return to the "menu screen".
 To cancel the operation and return to the "Main unit I/O operation display", press [ESC].

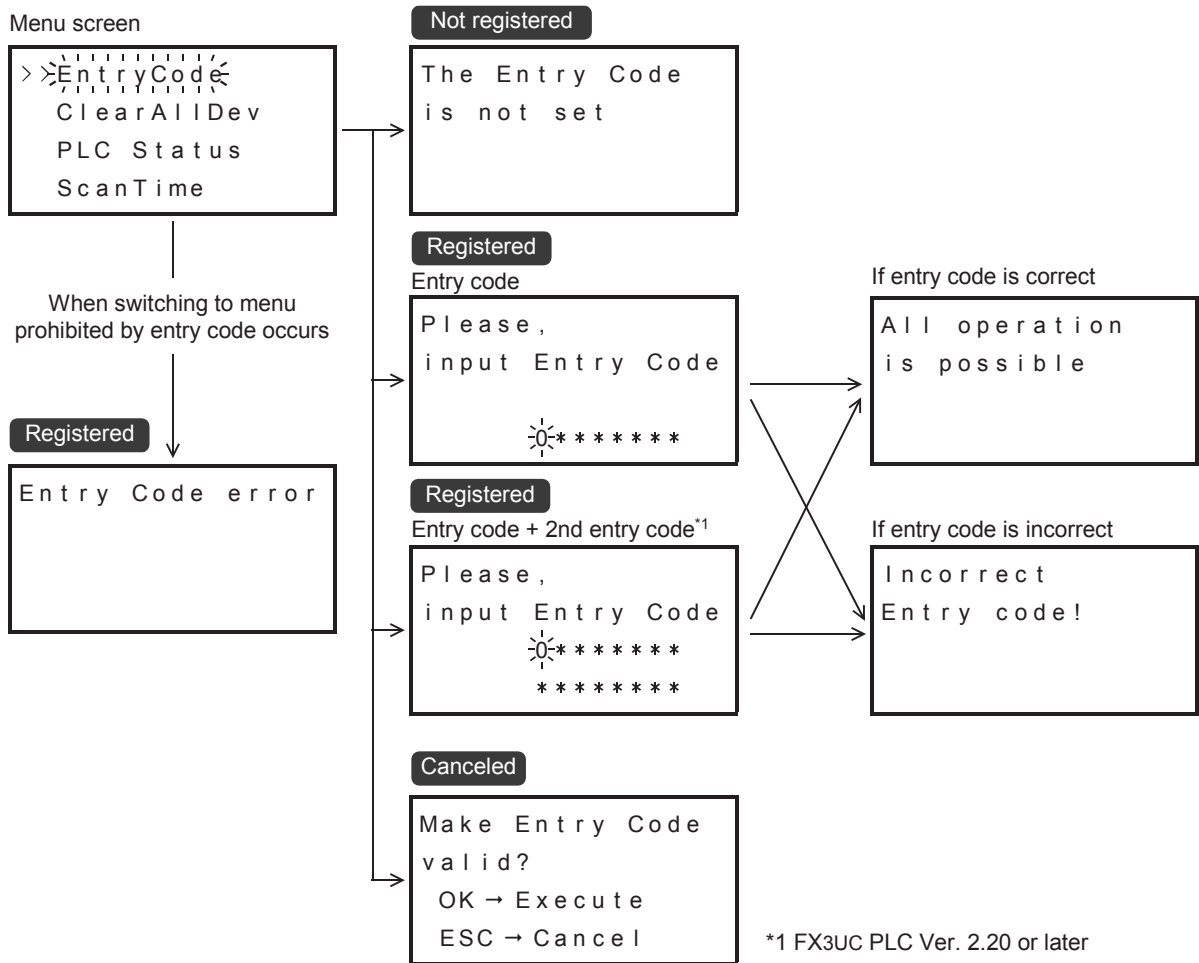

1	Outline
2	External Dimensions
3	Generic Specifications
4	Power Supply Specifications
5	Input Specifications
6	Output Specifications
7	Examples of Wiring for Various Uses
8	Terminal Block
9	CC-Link/LT Master FX3UC-LT(-2) only
10	Display module FX3UC-LT(-2) only

10.11.5 Canceling a keyword (entry code)

- At the menu screen, use the [+]/[-] buttons to move the cursor to the "EntryCode" item, then press [OK] to display the "entry code input screen".
 If an entry code has been registered, one of the following screens is displayed.
 - If a 16-digit entry code is registered, an 8-digit × 2-line screen (shown at left below) is displayed.
 - If an 8-digit entry code is registered, an 8-digit × 1-line screen (shown at right below) is displayed.

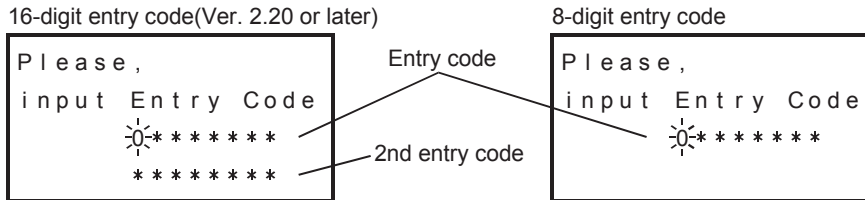

- Use the [+]/[-] buttons to specify the first digit of the entry code, then press [OK] to proceed to the next digit. To cancel the operation and return to the "menu screen", press [ESC].

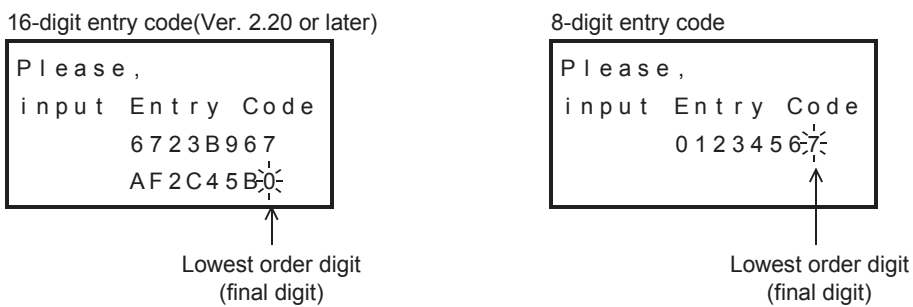

Button		Operation Description	
ESC		Cancels the operation and returns to the "menu screen" if pressed when the entry code's left-most digit (highest order digit) is blinking. Cancels the input and moves leftward to the next digit (higher order digit) if pressed when a digit other than the left-most digit is blinking.	
-		Reduces the value (F → E...2 → 1 → 0). Hold for 1 second or longer for high-speed reduction.	
+		Increases the value (0 → 1 → 2...E → F). Hold for 1 second or longer for high-speed increase.	
OK	Highest order digit to 2nd digit	Registers the specified value and moves to the next digit input position. If [OK] is pressed at the lowest order digit, and if the entered entry code is correct, the Entry Code is canceled.	
	Lowest order digit (final digit)	Correct Entry Code	An "All operation is possible" message appears, and the Entry Code is canceled.
		Incorrect Entry Code	A "Incorrect Entry Code" message appears.

- If the [OK] button is pressed at the lowest order position, the entered Entry Code is registered and the message shown to the right appears.
 If the "Incorrect Entry Code" message appears, press [ESC] and return to step 1).
- Press [OK] or [ESC] to return to the "menu screen".

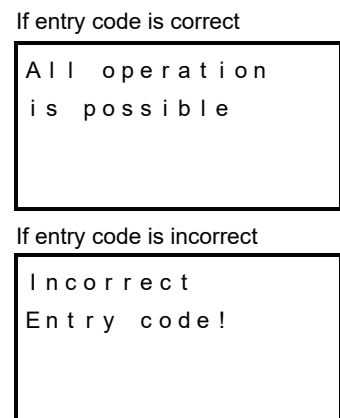

10.11.6 Enabling an entry code

- 1) At the menu screen, use the [+] / [-] buttons to move the cursor to the "EntryCode" item, then press [OK] to display the "enable entry code" screen.
- 2) Press the [OK] button to enable the entry code. Or, to retain the entry code's canceled status, press [ESC].

```
Make Entry Code
valid?
OK → Execute
ESC → Cancel
```

Button	Operation Description
ESC	Cancels the operation and returns to the "menu screen".
-	Disabled
+	Disabled
OK	Enables the Entry Code and returns to the "menu screen".

10.12 Device All-Clear

The devices listed below can be initialized (contact OFF, or current value to "0") from the "Clear all devices" menu when a PLC STOP status is in effect.

Subject devices	Output [Y], auxiliary relay (special relay) [M], state [S], timer [T], counter [C], data register (special data register) [D], extended register [R]. File register [D] is not a subject device.
Non-subject devices	Input [X], file register [D], extended file register [ER].

10.12.1 Device all-clear operation

- 1) At the menu screen, use the [+] / [-] buttons to move the cursor to the "ClearAllDev" item, then press [OK] to display the "Clear all devices" screen.
To cancel the operation and return to the "Main unit I/O operation display", press [ESC].

```
Clear
all devices
OK → Execute
ESC → Cancel
```

- 2) Press the [OK] button to initialize the subject devices. Or, to cancel the operation, press [ESC].
If the PLC is running at this time, a "PLC is running" message is displayed and the all-clear is not executed. In this case, press [OK] or [ESC] to return to the "menu screen".

```
All device
were cleared
```

Button	Operation Description
ESC	Cancels the operation and returns to the "menu screen".
-	Disabled
+	Disabled
OK	Initializes the subject devices and returns to the "menu screen".

When PLC is running

```
PLC is running
```

- 3) Press [OK] or [ESC] to display the "menu screen".

1	Outline
2	External Dimensions
3	Generic Specifications
4	Power Supply Specifications
5	Input Specifications
6	Output Specifications
7	Examples of Wiring for Various Uses
8	Terminal Block
9	CC-Link/LT Master FX3UC-LT(-2) only
10	Display module FX3UC-LT(-2) only

10.13 PLC Status

The PLC statuses shown below can be displayed from the "PLC Status" menu.

→ Refer to Subsection 10.13.2 for display details.

Page Title	Display Item
PLC Status (1/3)	<ul style="list-style-type: none"> Version Entry code status
PLC Status (2/3)	<ul style="list-style-type: none"> Program memory type Memory cassette's write protect status Program memory capacity
PLC Status (3/3)	<ul style="list-style-type: none"> Battery voltage Number of registered comments

10.13.1 Display operation

- 1) At the menu screen, use the [+] / [-] buttons to move the cursor to the "PLC Status" item, then press [OK] to display the "PLC Status (1/3)" screen.

To cancel the operation and return to the "Main unit I/O operation display", press [ESC].

```

PLC Status (1 / 3)
Ver. 1.00
All operation
is unrestricted
    
```

```

PLC Status (1 / 3)
Ver. 1.00
PLC operation
is limited
    
```

- 2) Use the [+] / [-] buttons to switch between the PLC Status screen pages. Press [OK] or [ESC] to return to the "menu screen".

Button	Operation Description
ESC	Returns to the "menu screen".
-	Returns to the previous page. ↳ PLC Status (3/3) → PLC Status (2/3) → PLC Status (1/3) ↳
+	Proceeds to the next page. ↳ PLC Status (1/3) → PLC Status (2/3) → PLC Status (3/3) ↳
OK	Returns to the "menu screen".

```

PLC Status (2 / 3)
Internal Memory
Protection - -
Capacity 64K
    
```

```

PLC Status (3 / 3)
Battery      3.2V
Comments
              1000 / 2000
    
```

- 3) Press [OK] or [ESC] to return to the "menu screen".

10.13.2 PLC status display items

1. PLC Status 1/3

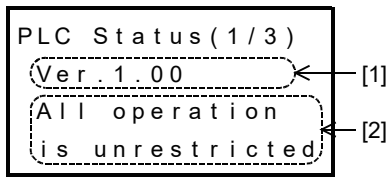

Display Content											
[1]	Main unit's version information.										
[2]	<p>Indicates the PLC's entry code registration status. Messages vary according to the entry code status. When a 16-bit entry code status is "all online operations prohibited", and when an 8-bit entry code status is "level A", the entry code must be canceled in order to view the PLC information.</p> <table border="1"> <thead> <tr> <th>Displayed message</th> <th>PLC status</th> </tr> </thead> <tbody> <tr> <td>PLC operation is limited</td> <td> <ul style="list-style-type: none"> For 16-bit entry code: (Ver. 2.20 or later) A "writing prohibit" or "reading/writing prohibit" entry code is registered. For 8-bit entry code: A "Level B" or "Level C" entry code is registered. </td> </tr> <tr> <td>All operation is unrestricted</td> <td>The registered entry code has been canceled by an "entry code" menu operation.</td> </tr> <tr> <td>The Entry Code is not set</td> <td>No entry codes have been registered.</td> </tr> <tr> <td>Fatal error occurred</td> <td>→ Refer to Subsection 10.22.1 for details.</td> </tr> </tbody> </table>	Displayed message	PLC status	PLC operation is limited	<ul style="list-style-type: none"> For 16-bit entry code: (Ver. 2.20 or later) A "writing prohibit" or "reading/writing prohibit" entry code is registered. For 8-bit entry code: A "Level B" or "Level C" entry code is registered. 	All operation is unrestricted	The registered entry code has been canceled by an "entry code" menu operation.	The Entry Code is not set	No entry codes have been registered.	Fatal error occurred	→ Refer to Subsection 10.22.1 for details.
Displayed message	PLC status										
PLC operation is limited	<ul style="list-style-type: none"> For 16-bit entry code: (Ver. 2.20 or later) A "writing prohibit" or "reading/writing prohibit" entry code is registered. For 8-bit entry code: A "Level B" or "Level C" entry code is registered. 										
All operation is unrestricted	The registered entry code has been canceled by an "entry code" menu operation.										
The Entry Code is not set	No entry codes have been registered.										
Fatal error occurred	→ Refer to Subsection 10.22.1 for details.										

2. PLC Status 2/3

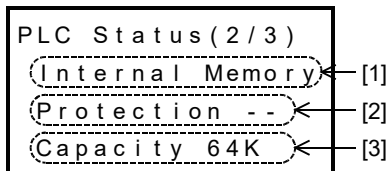

Display Content									
[1]	<p>Program memory type</p> <table border="1"> <thead> <tr> <th>Displayed message</th> <th>Program memory type</th> </tr> </thead> <tbody> <tr> <td>Internal Memory</td> <td>PLC internal RAM memory</td> </tr> <tr> <td>Memory Cassette</td> <td>Memory cassette flash memory</td> </tr> </tbody> </table>	Displayed message	Program memory type	Internal Memory	PLC internal RAM memory	Memory Cassette	Memory cassette flash memory		
Displayed message	Program memory type								
Internal Memory	PLC internal RAM memory								
Memory Cassette	Memory cassette flash memory								
[2]	<p>Memory cassette protect switch status</p> <table border="1"> <thead> <tr> <th>Displayed message</th> <th>Switch Status</th> </tr> </thead> <tbody> <tr> <td>Protection switch - -</td> <td>Internal RAM memory (without protect switch)</td> </tr> <tr> <td>Protection switch ON</td> <td>Memory cassette protect switch is ON</td> </tr> <tr> <td>Protection switch OFF</td> <td>Memory cassette protect switch is OFF</td> </tr> </tbody> </table>	Displayed message	Switch Status	Protection switch - -	Internal RAM memory (without protect switch)	Protection switch ON	Memory cassette protect switch is ON	Protection switch OFF	Memory cassette protect switch is OFF
Displayed message	Switch Status								
Protection switch - -	Internal RAM memory (without protect switch)								
Protection switch ON	Memory cassette protect switch is ON								
Protection switch OFF	Memory cassette protect switch is OFF								
[3]	Program memory's max. setting capacity (in step units)								

3. PLC Status 3/3

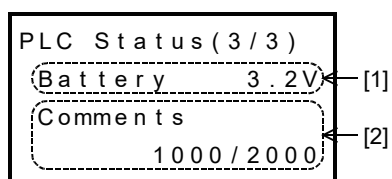

	Display Content
[1]	Battery voltage
[2]	Number of registered comments ([number of registered comments] / [number of parameter-specified comments])

10.14 Scan Time (Scan Time Display)

The scan time's current value, minimum value, and maximum value can be displayed from the "ScanTime" menu.

10.14.1 Scan time display operation

- At the menu screen, use the [+] / [-] buttons to move the cursor to the "ScanTime" item, then press [OK] to display the "scan time screen". To cancel the operation and return to the "Main unit I/O operation display", press [ESC].
- Press [OK] or [ESC] to return to the "menu screen".

ScanTime	
Curr :	0.7ms
Max :	5.6ms
Min :	0.6ms

10.15 Cassette (Memory Cassette Transfers)

Data transfers (and consistency checks) between the internal RAM memory and a connected memory cassette can be performed from the "Cassette" menu when the PLC is in a STOP state. This menu is disabled, however, if an entry code is registered in the internal RAM. In this case, remove the memory cassette and use the programming tool to cancel the internal RAM's entry code.

Item	Operation Description
Cassette ← RAM	Copies internal program memory (RAM) data to a connected memory cassette.
Cassette → RAM	Copies data from a connected memory cassette to the internal program memory (RAM).
Cassette : RAM	Performs a consistency check of the connected memory cassette data and the internal program memory (RAM) data.

10.15.1 Transfer from internal RAM to memory cassette (Cassette ← RAM)

- At the menu screen, use the [+] / [-] buttons to move the cursor to the "Cassette" item, then press [OK] to display the "memory cassette transfer screen". To cancel the operation and return to the "Main unit I/O operation display", press [ESC].
- Use the [+] / [-] buttons to move the cursor to the "Cassette ← RAM" item, then press [OK] to display the screen shown to the right. To cancel the operation and return to the "memory cassette transfer screen", press [ESC].
- Press [OK] to begin the transfer. Or, press [ESC] to cancel the operation.

Memory Cassette
> > Cassette ← RAM
Cassette → RAM
Cassette : RAM

Cassette ← RAM
(Write)
OK → Execute
ESC → Cancel

Cassette ← RAM
(Write)
Please wait...

Button	Operation Description
ESC	Cancels the operation and returns to the "memory cassette transfer screen".
-	Disabled
+	Disabled
OK	Executes the transfer.

- Caution:
Do not turn the PLC power off or perform writing from the programming tool while a program is being transferred by a "memory cassette transfer" menu operation, as these actions could destroy the program, causing incorrect operation of the PLC.
- Press [OK] or [ESC] to return to the "memory cassette transfer screen".

1	Outline
2	External Dimensions
3	Generic Specifications
4	Power Supply Specifications
5	Input Specifications
6	Output Specifications
7	Examples of Wiring for Various Uses
8	Terminal Block
9	CC-Link/LT Master FX3UC-LT(-2) only
10	Display module FX3UC-LT(-2) only

- Result and measures to take:
 - The transfer is not executed if a "PLC is running" message appears.
In this case, set the PLC to the STOP state, then perform step 3) described above.
 - The transfer is not executed if a "Transfer failed" message appears.
In this case, turn the power off, check the memory cassette connection, then attempt the operation again from the first step.
 - The transfer is not executed if a "Memory Cassette is write-protected" message displays.
In this case, turn the power OFF, set the memory cassette PROTECT switch to OFF, then attempt the operation again from the first step.
 - A "Transfer completed" message appears when the transfer is completed.
When this message appears, press [OK] or [ESC] to display the "Cassette screen".

```
PLC is running
```

```
Cassette ← RAM  
          (Write)  
Transfer  
failed
```

```
Memory Cassettes  
is  
write-protected
```

```
Cassette ← RAM  
          (Write)  
Transfer  
completed
```

- 5) Press [ESC] to display the "menu screen".

10.15.2 Transfer from memory cassette to internal RAM (Cassette → RAM)

- At the menu screen, use the [+] / [-] buttons to move the cursor to the "Cassette" item, then press [OK] to display the "memory cassette transfer screen".
 To cancel the operation and return to the "Main unit I/O operation display", press [ESC].

```
Memory Cassette
  Cassette ← RAM
> > Cassette → RAM
  Cassette : RAM
```

- Use the [+] / [-] buttons to move the cursor to the "Cassette → RAM" item, then press [OK] to display the screen shown to the right.
 To cancel the operation and return to the "memory cassette transfer screen", press [ESC].

```
Cassette → RAM
                (Read)
OK → Execute
ESC → Cancel
```

- Press [OK] to begin the transfer.
 Or, press [ESC] to cancel the operation.

Button	Operation Description
ESC	Cancels the operation and returns to the "memory cassette transfer screen".
-	Disabled
+	Disabled
OK	Executes the transfer.

```
Cassette → RAM
                (Read)
Please wait...
```

- Caution:**
 Do not turn the PLC power off or perform writing from the programming tool while a program is being transferred by a "memory cassette transfer" menu operation, doing so may destroy the program and disorder the PLC.

- Press [OK] or [ESC] to return to the "memory cassette transfer screen".

- Result and measures to take:**
 - The transfer is not executed if a "PLC is running" message appears.
 In this case, set the PLC to the STOP state, then perform the step 3) operation described above.

```
PLC is running
```

- The transfer is not executed if a "Transfer failed" message appears.
 In this case, turn the power off, check the memory cassette connection, then attempt the operation again from the first step.

```
Cassette → RAM
                (Read)
Transfer
failed
```

- A "Transfer completed" message appears when the transfer is completed.
 When this message appears, press [OK] or [ESC] to display the "memory cassette transfer screen".

```
Cassette → RAM
                (Read)
Transfer
completed
```

- Press [ESC] to display the "menu screen".

1	Outline
2	External Dimensions
3	Generic Specifications
4	Power Supply Specifications
5	Input Specifications
6	Output Specifications
7	Examples of Wiring for Various Uses
8	Terminal Block
9	CC-Link/LT Master FX3UC-LT(-2) only
10	Display module FX3UC-LT(-2) only

10.15.3 Memory cassette & internal RAM consistency check (Cassette : RAM)

- 1) At the menu screen, use the [+] / [-] buttons to move the cursor to the "Cassette" item, then press [OK] to display the "memory cassette transfer screen".
 To cancel the operation and return to the "Main unit I/O operation display", press [ESC].

```
Memory Cassette
  Cassette ← RAM
  Cassette → RAM
  > > Cassette : RAM <
```

- 2) Use the [+] / [-] buttons to move the cursor to the "Cassette : RAM" item, then press [OK] to display the screen shown at right.
 To cancel the operation and return to the "memory cassette transfer screen", press [ESC].

```
Cassette : RAM
          (Verify)
  OK → Execute
  ESC → Cancel
```

- 3) Press [OK] to begin the consistency check.
 Or, press [ESC] to cancel the operation.

Button	Operation Description
ESC	Cancels the operation and returns to the "memory cassette transfer screen".
-	Disabled
+	Disabled
OK	Executes the consistency check.

```
Cassette : RAM
          (Verify)
  Please wait...
```

- 4) Press [OK] or [ESC] to return to the "memory cassette transfer screen".

```
PLC is running
```

- Result and measures to take:
 - The consistency check is not executed if a "PLC is running" message appears.
 In this case, stop the PLC, then perform step 3) described above.

- 5) Press [ESC] to display the "menu screen".

```
Cassette : RAM
          (Verify)
  Programs match
```

```
Cassette : RAM
          (Verify)
  Programs
  don't match
```

10.16 CC-Link/LT settings (FX3UC-32MT-LT-2 only)

In the CC-Link/LT settings menu, the user can setup the built-in CC-Link/LT module of the FX3UC-32MT-LT-2 while the PLC in STOP.

The built-in CC-Link/LT module has two operation modes (parameter CONFIG mode and self CONFIG mode), and the contents which can be set using the display module depends on the operation mode.

For details on the parameter CONFIG mode and self CONFIG mode, refer to Chapter 9.

- In parameter CONFIG mode
 - Reserved station change
 - Transmission rate setting
 - Self check
 - For parameter CONFIG mode setup, refer to Subsections 10.16.2, 10.16.3 and 10.16.4.
- In self CONFIG mode
 - Transmission rate setting
 - Point mode
 - CONFIG
 - Self check
 - For self CONFIG mode setup, refer to Subsections 10.16.5, 10.16.6 and 10.16.7.

10.16.1 Precautions on Use of CC-Link/LT Settings

→ For the precautions on Use of CC-Link/LT Settings, refer to Subsection 9.12.4.

1
Outline

2
External
Dimensions

3
Generic
Specifications

4
Power Supply
Specifications

5
Input
Specifications

6
Output
Specifications

7
Examples of
Wiring for
Various Uses

8
Terminal Block

9
CC-Link/LT
Master FX3UC-
LT(-2) only

10
Display module
FX3UC-LT(-2)
only

10.16.2 Reserved station change (parameter CONFIG mode)

- 1) On the menu screen, use the [+] or [-] button to move the cursor to "CC-Link/LT", and then press the [OK] button. The "CC-Link/LT Mode confirmation" screen will be displayed for 0.5 seconds, and then the "CC-Link/LT settings menu" screen, shown on the right, will appear.
 Press the [ESC] button to cancel the operation and return to the "Main unit I/O operation display" screen.

```
>>Reserve Statn
    Baud Rate
    Self-Check
```

- 2) Use the [+] or [-] button to move the cursor to "Reserve Statn", and then press the [OK] button. The screen shown on the right will appear.
 Press the [ESC] button to cancel the operation and return to the menu screen.

```
>> 1 No setting
    2 No setting
    3 Reserve
    4 No setting
```

- 3) Use the [+] or [-] button to move the cursor to the station type to be selected, and then press the [OK] button to change the station type. The reserved station specification cannot be changed if there is no station information.
 After changing the station type, press the [ESC] button to display the screen shown on the right.

```
Reserve Statn
select save
OK → Execute
ESC → Cancel
```

Button	Operation Description
ESC	Displays the "Reserved station change confirmation" screen.
-	Moves the cursor upward.
+	Moves the cursor downward.
OK	Switches the display between "No setting" and "Reserve".

- 4) Press the [OK] button to change the reserved station specification. Or, press [ESC] to cancel the operation.

Button	Operation Description
ESC	Cancels the operation and returns to the "CC-Link/LT settings menu".
-	Disabled
+	Disabled
OK	Displays the "Reserved station change completed" screen.

- 5) When the reserved station specification is changed normally, the screen shown on the right appears.

Button	Operation Description
ESC	Returns to the "CC-Link/LT settings menu" screen.
-	Disabled
+	Disabled
OK	Returns to the "menu screen".

```
Reserve Statn
select settings
saved
```

- Result and measures to take:
 - The reserved station specification will not be changed if the "Reserved Statn select settings could not be saved" message is displayed.
 - The reserved station change is not executed if the "PLC is running" message appears.
 In this case, set the PLC to STOP, then perform step 3) described above again.

```
Reserve Statn
select settings
could not be
saved
```

```
PLC is running
```

10.16.3 Transmission rate setting (parameter CONFIG mode)

- 1) On the menu screen, use the [+] or [-] button to move the cursor to "CC-Link/LT", and then press the [OK] button. The "CC-Link/LT Mode confirmation" screen will be displayed for 0.5 seconds, and then the "CC-Link/LT settings menu" screen, shown on the right, will appear.
 Press the [ESC] button to cancel the operation and return to the "Main unit I/O operation display" screen.

```
Reserve Statn
>>Baud Rate
Self-Check
```

- 2) Use the [+] or [-] button to move the cursor to "Baud Rate", and then press the [OK] button. The screen shown on the right will appear.
 Press the [ESC] button to cancel the operation and return to the menu screen.

```
>>156kbps
625kbps
2.5Mbps
```

- 3) Use the [+] or [-] button to move the cursor to the transmission rate to be changed, and then press the [OK] button. The screen shown on the right will appear.
 Or, press [ESC] to cancel the operation.

```
Baud Rate
save
OK → Execute
ESC → Cancel
```

Button	Operation Description
ESC	Cancels the operation and returns to the "CC-Link/LT settings menu".
-	Moves the cursor upward.
+	Moves the cursor downward.
OK	Displays the "Transmission rate setting confirmation" screen.

- 4) Press [OK] to change the CC-Link/LT transmission rate.
 Or, press [ESC] to cancel the operation.

Button	Operation Description
ESC	Cancels the operation and returns to the "CC-Link/LT settings menu".
-	Disabled
+	Disabled
OK	Transmission rate is set and the "transmission rate setting complete" screen is displayed.

- 5) If the transmission rate setting was set successfully, the screen shown on the right will appear. In order to enable the transmission rate change, turn the power OFF and then ON again.

```
Reset system
power to enable
Baud Rate
```

Button	Operation Description
ESC	Returns to the "CC-Link/LT settings menu" screen.
-	Disabled
+	Disabled
OK	Returns to the "menu screen".

- Result and measures to take:
 - The transmission rate specification will not be changed if the message "Baud Rate can not be changed" is displayed.
 - The transmission rate change is not executed if the "PLC is running" message appears.
 In this case, set the PLC to STOP, then perform step 3) described above again.

```
Baud Rate
can not be
changed
```

```
PLC is running
```

1	Outline
2	External Dimensions
3	Generic Specifications
4	Power Supply Specifications
5	Input Specifications
6	Output Specifications
7	Examples of Wiring for Various Uses
8	Terminal Block
9	CC-Link/LT Master FX3UC-LT(-2) only
10	Display module FX3UC-LT(-2) only

10.16.4 Self check (parameter CONFIG mode)

- 1) On the menu screen, use the [+] or [-] button to move the cursor to "CC-Link/LT", and then press the [OK] button. The "CC-Link/LT Mode confirmation" screen will be displayed for 0.5 seconds, and then the "CC-Link/LT settings menu" screen, shown on the right, will appear.
 Press the [ESC] button to cancel the operation and return to the "Main unit I/O operation display" screen.

```

Reserve Statn
Baud Rate
>>Self-Check
    
```

- 2) Use the [+] or [-] button to move the cursor to "Self-Check", and then press the [OK] button. The screen shown on the right will appear.
 Press the [ESC] button to cancel the operation and return to the menu screen.

```

Self-Check
start
OK → Execute
ESC → Cancel
    
```

- 3) Press [OK] to start the self check.
 Or, press [ESC] to cancel the operation.

Button	Operation Description
ESC	Cancels the operation and returns to the "CC-Link/LT settings menu".
-	Disabled
+	Disabled
OK	Displays the "Self check completed" screen.

- 4) If the self check function has been setup successfully, the screen shown on the right will appear. Turn the PLC power OFF and then ON to start the self-check.

```

Reset system
power to begin
Self-Check
    
```

Button	Operation Description
ESC	Returns to the "CC-Link/LT settings menu" screen.
-	Disabled
+	Disabled
OK	Returns to the "menu screen".

- Result and measures to take:
 - The self check function will not be setup if the message "Self-Check can not be started" is displayed. Turn OFF the power, confirm the remote station connection status, and then perform the procedure again from the beginning.
 - The self check will not be executed if a "PLC is running" message appears.
 In this case, set the PLC to STOP, then perform step 3) described above again.

```

Self-Check
can not be
started
    
```

```

PLC is running
    
```

10.16.5 Transmission rate setting (self CONFIG mode)

- 1) On the menu screen, use the [+] or [-] button to move the cursor to "CC-Link/LT", and then press the [OK] button. The "CC-Link/LT Mode confirmation" screen will be displayed for 0.5 seconds, and then the "CC-Link/LT settings menu" screen, shown on the right, will appear.

```
>>Baud Rate
    Point Mode
    CONFIG
    Self-Check
```

Press the [ESC] button to cancel the operation and return to the "Main unit I/O operation display" screen.

- 2) Use the [+] or [-] button to move the cursor to "Baud Rate", and then press the [OK] button. The screen shown on the right will appear. Press the [ESC] button to cancel the operation and return to the menu screen.

```
>>156kbps
    625kbps
    2.5Mbps
```

- 3) Use the [+] or [-] button to move the cursor to the transmission rate to be set, and then press the [OK] button.

Press the [ESC] button to cancel the operation and return to the "CC-Link/LT settings menu" screen.

Button	Operation Description
ESC	Cancels the operation and returns to the "CC-Link/LT setting menu".
-	Moves the cursor upward.
+	Moves the cursor downward.
OK	Set the transmission rate and returns to the "CC-Link/LT settings menu" screen.

- 4) Press the [OK] button to set the transmission rate and return to the "CC-Link/LT settings menu" screen.

10.16.6 Point mode setting (self CONFIG mode)

- 1) On the menu screen, use the [+] or [-] button to move the cursor to "CC-Link/LT", and then press the [OK] button. The "CC-Link/LT Mode confirmation" screen will be displayed for 0.5 seconds, and then the "CC-Link/LT settings menu" screen, shown on the right, will appear.

```
Baud Rate
>>Point Mode
    CONFIG
    Self-Check
```

Press the [ESC] button to cancel the operation and return to the "Main unit I/O operation display" screen.

- 2) Use the [+] or [-] button to move the cursor to "Point Mode", and then press the [OK] button. The screen shown on the right will appear.

```
>>4-Point Mode
    16-Point Mode
```

Press the [ESC] button to cancel the operation and return to the menu screen.

- 3) Use the [+] or [-] button to move the cursor to the point mode to be set, and then press the [OK] button.

Press the [ESC] button to cancel the operation and return to the "CC-Link/LT settings menu" screen.

Button	Operation Description
ESC	Cancels the operation and returns to the "CC-Link/LT settings menu".
-	Moves the cursor upward.
+	Moves the cursor downward.
OK	Sets the point mode and returns to the "CC-Link/LT settings menu" screen.

- 4) Press the [OK] button to set the point mode and return to the "CC-Link/LT settings menu" screen.

1	Outline
2	External Dimensions
3	Generic Specifications
4	Power Supply Specifications
5	Input Specifications
6	Output Specifications
7	Examples of Wiring for Various Uses
8	Terminal Block
9	CC-Link/LT Master FX3UC-LT(-2) only
10	Display module FX3UC-LT(-2) only

10.16.7 CONFIG start (self CONFIG mode)

- 1) On the menu screen, use the [+] or [-] button to move the cursor to "CC-Link/LT", and then press the [OK] button. The "CC-Link/LT Mode confirmation" screen will be displayed for 0.5 seconds, and then the "CC-Link/LT settings menu" screen, shown on the right, will appear.
 Press the [ESC] button to cancel the operation and return to the "Main unit I/O operation display" screen.

```
Baud Rate
Point Mode
>>CONFIG
Self-Check
```

- 2) Use the [+] or [-] button to move the cursor to "CONFIG", and then press the [OK] button. The screen shown on the right will appear.
 Press the [ESC] button to cancel the operation and return to the menu screen.

```
CC-Link/LT
Start CONFIG
OK → Execute
ESC → Cancel
```

- 3) Press [OK] to start the Configuration.
 Or, press [ESC] to cancel the operation.

Button	Operation Description
ESC	Cancels the operation and returns to the "CC-Link/LT settings menu".
-	Disabled
+	Disabled
OK	Displays the "CONFIG started" screen.

- 4) If the Configuration has been setup successfully, the screen shown on the right will appear. Turn the PLC power OFF and then ON to start the Configuration.

```
Reset system
power to begin
CC-Link/LT
CONFIG
```

Button	Operation Description
ESC	Returns to the "CC-Link/LT settings menu" screen.
-	Disabled
+	Disabled
OK	Returns to the "menu screen".

- Result and measures to take:
 - The Configuration will not be executed if the message "CC-Link/LT CONFIG can not be started" is displayed. Turn OFF the power, confirm the remote station connection status, and then perform the procedure again from the beginning.
 - The Configuration will not be executed if the "PLC is running" message appears.
 In this case, set the PLC to STOP, then perform step 3) described above again.

```
CC-Link/LT
CONFIG
can not be
started
```

```
PLC is running
```

10.16.8 Self check (self CONFIG mode)

- 1) On the menu screen, use the [+] or [-] button to move the cursor to "CC-Link/LT", and then press the [OK] button. The "CC-Link/LT Mode confirmation" screen will be displayed for 0.5 seconds, and then the "CC-Link/LT settings menu" screen, shown on the right, will appear.
 Press the [ESC] button to cancel the operation and return to the "Main unit I/O operation display" screen.

```
Baud Rate
Point Mode
CONFIG
>>Self-Check
```

- 2) Use the [+] or [-] button to move the cursor to "Self-Check", and then press the [OK] button. The screen shown on the right will appear.
 Press the [ESC] button to cancel the operation and return to the menu screen.

```
Self-Check
start
OK → Execute
ESC → Cancel
```

- 3) Press [OK] to start the self check.
 Or, press [ESC] to cancel the operation.

Button	Operation Description
ESC	Cancels the operation and returns to the "CC-Link/LT settings menu".
-	Disabled
+	Disabled
OK	Displays the "Self check completed" screen.

- 4) If the self check function has been setup successfully, the screen shown on the right will appear. Turn the PLC power OFF and then ON to start the self check..

```
Reset system
power to begin
Self-Check
```

Button	Operation Description
ESC	Returns to the "CC-Link/LT settings menu" screen.
-	Disabled
+	Disabled
OK	Returns to the "menu screen".

- Result and measures to take:
 - The self check function will not be setup if the message "Self-Check can not be started" is displayed. Turn OFF the power, confirm the remote station connection status, and then perform the procedure again from the beginning.
 - The self check will not be executed if a "PLC is running" message appears.
 In this case, set the PLC to STOP, then perform step 3) described above again.

```
Self-Check
can not be
started
```

```
PLC is running
```

1	Outline
2	External Dimensions
3	Generic Specifications
4	Power Supply Specifications
5	Input Specifications
6	Output Specifications
7	Examples of Wiring for Various Uses
8	Terminal Block
9	CC-Link/LT Master FX3UC-LT(-2) only
10	Display module FX3UC-LT(-2) only

10.17 System Information (Restrictions From PLC)

Some of the display module functions require system information settings in order to enable program control of these functions. Functions which require the use of system information are listed below.

- Monitor/test function
 - For hexadecimal display of current value:
→ **Refer to Section 10.18 for the setting procedure.**
 - To use user-registered devices:
→ **Refer to Section 10.20 for the setting procedure.**
- Display screen protect function
→ **Refer to Section 10.18 for details.**
- Operation button ON/OFF information
→ **Refer to Section 10.20 for details.**
- User message display function
→ **Refer to Section 10.22 for details.**

10.17.1 System information list

Special data register D8300 and D8301 devices with first numbers specified are assigned as system information devices (data register, auxiliary relay). The data register (excluding special data register) should be specified at the system information's "system signal 1", and the auxiliary relay (excluding special auxiliary relay) should be specified at the system information's "system signal 2". Both D8300 and D8301 have default settings of "-1".

→ **Refer to Section 10.18 to 10.22 for explanations of each system signal.**

1. System signal 1

Special data register	System Information	Description	Reference
D8300 = K□□ Occupies 41 points	D□□	Devices for user-registered device settings Only data registers can be specified for user-registered devices.	User-registered device 1 type
	D□□ + 1		User-registered device 1 No.
	D□□ + 2		User-registered device 2 type
	D□□ + 3		User-registered device 2 No.
	D□□ + 4		User-registered device 3 type
	D□□ + 5		User-registered device 3 No.
	D□□ + 6		User-registered device 4 type
	D□□ + 7		User-registered device 4 No.
	D□□ + 8	Device for display screen protect function	Section 10.18
	D□□ + 9	Device where user message display character strings are saved. Use either character data or the data shown below.	Section 10.22
	?	<ul style="list-style-type: none"> • Alphanumeric: 20H to 7DH, A1H to DFH ASCII code • Japanese: Shift JIS code 	
D□□ + 40			

2. System signal 2

Special data register	System Information	Description	Reference
D8301 = K△△△ Occupies 7 points	M△△	[OK] button ON/OFF	Section 10.20
	M△△ + 1	[ESC] button ON/OFF	
	M△△ + 2	[-] button ON/OFF	
	M△△ + 3	[+] button ON/OFF	
	M△△ + 4	User message display command	Section 10.22
	M△△ + 5	Device for specifying the "Monitor/Test" menu's current value and setting the value display format (hexadecimal or decimal).	Section 10.19
	M△△ + 6	Display screen information	ON during "user-registered device monitoring screen" or "user message" display.

10.17.2 System information setting program example

The following is a program example in which the system information has been assigned to D50 to D90 and M50 to M56.

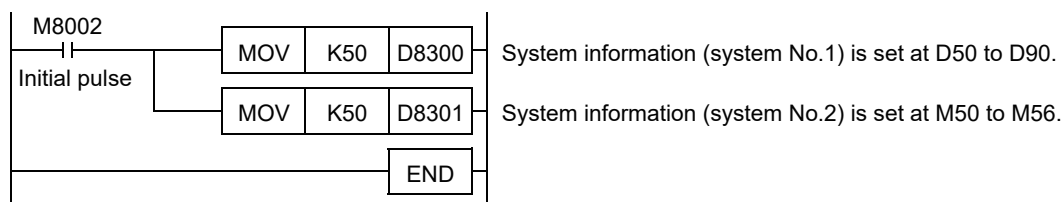

1	Outline
2	External Dimensions
3	Generic Specifications
4	Power Supply Specifications
5	Input Specifications
6	Output Specifications
7	Examples of Wiring for Various Uses
8	Terminal Block
9	CC-Link/LT Master FX3UC-LT(-2) only
10	Display module FX3UC-LT(-2) only

10.18 Display Screen Protect Function

The display screen protect function prevents accidental operation by restricting the display module functions. The display screen protect function is enabled when no entry code is registered. The display screen protect function's protection level is specified in the system information (system signal 1) "D□□ + 8".

- Refer to Section 10.2 for display module function.
- Refer to Subsection 10.11.5 for the "entry code cancel" procedure.
- Refer to Section 10.16 for system information setting.

10.18.1 Keyword (Entry code) & display screen protect function levels and corresponding restrictions

If an entry code has been registered, that entry code related restriction takes priority over the "display screen protect function"

- ✓ : Usable
- △ : Timer and counter settings cannot be changed
- ▲ : Only monitor function is usable (test function is not available)
- : Unusable

Function Name	Entry code				Display Screen Protect		
	None	All online operations prohibited	Writing prohibited	Reading/writing prohibited	None	1	2
16-digit entry code*1 setting → (Ver. 2.20 or later)							
8-digit entry code setting (level) →	None	A (All operations prohibited)	B (Read/Incorrect write protection)	C (Erroneous write prohibited)	None	1	2
Main unit I/O operation display	✓	✓	✓	✓	✓	✓	✓
Monitor/Test	Device	□	△	△	✓	□	▲
	User (User-registered device)	✓	□	✓	✓	□	▲
ScanTime (Scan time display)	✓	□	✓	✓	✓	□	✓
PLC status	✓	□	✓	✓	✓	□	✓
ErrorCheck	✓	□	✓	✓	✓	□	✓
User message display	✓	✓	✓	✓	✓	✓	✓
Display screen protect function	✓	□	□	□	✓	✓	✓
Menu display language setting	✓	□	✓	✓	✓	□	□
Contrast adjustment	✓	□	✓	✓	✓	□	□
Time	Display	✓	✓	✓	✓	□	✓
	Setting	✓	□	✓	✓	□	□
Entry code (cancel)	—	✓	✓	✓	✓	□	□
Clear all device (Device all-clear)	✓	□	✓	✓	✓	□	□
Memory cassette transfer	✓	□	□	□	✓	□	□

*1. Customer keyword/permanent PLC lock included. However, permanent PLC lock does not have a keyword input.
FX3UC PLC Ver. 2.61 or later supports the customer keyword and permanent PLC lock.

10.18.2 Relationship between keyword (entry code) & display screen protect function

If the PLC's entry code registration function is used, that entry code related restriction takes priority over the display module's "display screen protect function". The relationship between entry codes and the display screen protect function is shown below.

Entry code registration	Entry code Status	Display Screen Protect Status	Function Restrictions
Entry code is registered	Entry code is not canceled	Entry code is being used	Restriction of functions is according to the entry code level.
		Entry code is not being used	
	Entry code is canceled	Entry code is being used	All functions are enabled (no restrictions).
		Entry code is not being used	
Entry code is not registered		Entry code is being used	Restriction of functions is according to the display screen protect function.
		Entry code is not being used	All functions are enabled (no restrictions).

10.18.3 Keyword (Entry code) levels

1. For versions prior to Ver. 2.20

8-Digit Entry code Level	Entry code Content	Entry code Input Example
A (All operations prohibited)	8-digit hexadecimal value beginning with "A" or "0 to 9" numeral.	0ABCDEF2 AABCD345
B (Read/Incorrect write protection)	8-digit hexadecimal value beginning with "B".	B1234567 BABCDEF7
C (Erroneous write prohibited)	8-digit hexadecimal value beginning with "C".	C8904567 CDEF567F

2. For Ver. 2.20 and later

16-digit entry codes^{*1} are used.

If an 8-digit entry code is specified, processing occurs in the same manner as in versions prior to Ver.2.20.

16-Digit Entry code Setting Content	Entry code Content	Entry code Input Example
All online operations prohibited	"A to F", "0 to 9" 16-digit value.	0ABCDEF262297529 AABCDEFB34523724
Writing prohibited	"A to F", "0 to 9" 16-digit value.	B123456789012345 7ABCDEF73DAEB93A
Reading/writing prohibited	"A to F", "0 to 9" 16-digit value.	2890445234817567 CDEF567FABDFEA46

*1. Customer keyword/permanent PLC lock included. However, permanent PLC lock does not have a keyword input.

FX3UC PLC Ver. 2.61 or later supports the customer keyword and permanent PLC lock.

10.18.4 System information - display screen protect function

1. System signal 1

System Information	Setting Content (Level)	Function Restriction Summary
D□□ + 8	1	All functions except the "user message display" and "Main unit I/O operation display" functions are disabled.
	2	The following functions are disabled: "monitor/test's 'test' function", "device all-clear", "time change", "contrast setting", "memory cassette transfer", and "menu display language setting".
	Other values	All functions are enabled.

2. System signal 2

System signal 2 is unrelated to this function.

10.18.5 Program example (screen protect function setting)

In this program example, the display screen protect function is set to "level 2". Use this program as a reference when other level settings are specified.

In this program example, system information is assigned from D50 to D90 and from M50 to M56.

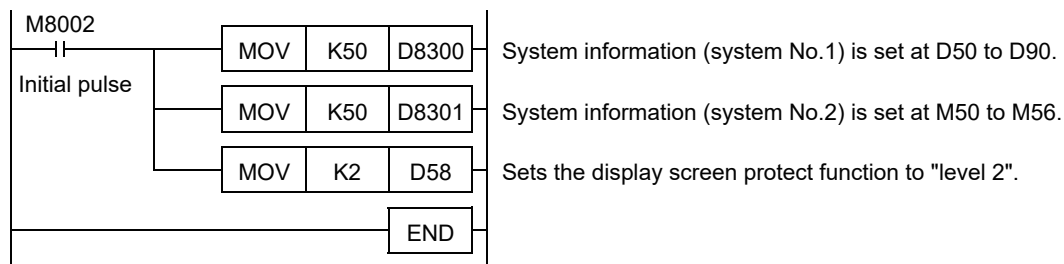

10.18.6 Pointers for using the display screen protect function

The display screen protect function settings should be specified in a sequence program.

- The protect function is enabled by using the display module's "monitor/test function" to change the system information's (system signal 1) "D□□ + 8" current value to "1" or "2".
- Once the setting is made, it cannot be canceled from the display module.
- To cancel the setting, use the programming tool to change the system information's (system signal 1) "D□□ + 8" current value to a value other than "1" and "2".
 If the system information's (system signal 1) "D□□ + 8" is set in a general purpose data register, however, the display screen protect function can be canceled by turning the power off, then on again.

10.19 Specifying a Hexadecimal Current Value Display Format

The procedure for specifying a hexadecimal display format for current values which display at the "Monitor/Test" menu explained below. The display format is specified by the system information's (system signal 2) "M□□ + 5" ON/OFF status.

The display formats which correspond to the ON and OFF statuses are shown in Subsection 10.19.1 below. The display format should either be fixed as decimal or hexadecimal. Switching between the two should be possible by an external operation.

→ Refer to Section 10.17 for system information setting.

10.19.1 System information - specifying a hexadecimal current value display format

1. System signal 1

System signal 1 is unrelated to this function.

2. System signal 2

System Information	Setting Content	Display Format	Display Subjects
M△△ + 5	ON	Hexadecimal	Timer (T) [current value], counter (C) [current value], data register (D) [16-bit/32-bit], extended register (R) [16-bit/32-bit], and extended file register (ER) [16-bit/32-bit]
	OFF	Decimal	

10.19.2 Program example 1 (specifying a hexadecimal data display format)

The following program example specifies a hexadecimal display format for current values and setting values which display at the "Monitor/Test" screen. In this program example, system information is assigned from D50 to D90 and from M50 to M56.

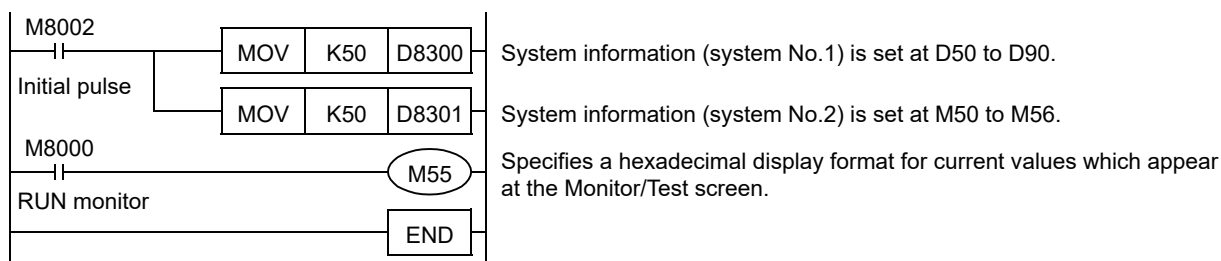

10.19.3 Program example 2 (specifying a decimal data display format)

The following program example specifies a decimal display format for current values and setting values which appear at the "Monitor/Test" screen. In this program example, system information is assigned from D50 to D90 and from M50 to M56.

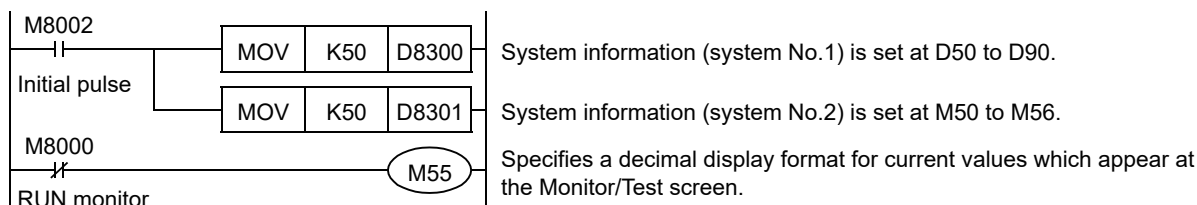

10.20 Operation Button ON/OFF Information

Operation button ON/OFF information can be monitored at the system information (system signal 2) "M△△ to M△△ + 3" while the PLC is running. Various applications of this function are described below.

→ Refer to Section 10.17 for system information setting.

10.20.1 Various applications

1. Operation button function checks

The programming tool can be used to monitor the system information's (system signal 2) "operation button ON/OFF information", to verify that operation buttons are functioning properly.

2. User-registered device changes

The system information's (system signal 2) "display screen information" and "operation button ON/OFF information" can be used together to change and display 4 or more user-registered devices.

→ Refer to Section 10.21 for the user-registered device setting procedure.

→ Refer to Subsection 10.21.3 to 10.21.5 for program examples.

3. User message changes

The system information's (system signal 2) "display screen information" and "user message display command", and "operation button ON/OFF information" can be used together while a user message is displayed in order to change (by [+] / [-] button operation) the user message that the program displays.

→ Refer to Section 10.22 user message display function.

→ Refer to Subsection 10.22.4 to 10.22.6 for program examples.

10.20.2 System information - operation button ON/OFF information

1. System signal 1

System signal 1 has no system information related to this function.

2. System signal 2

System Information	Status	Description
M△△	ON	[OK] button is pressed.
	OFF	[OK] button is not pressed.
M△△ + 1	ON	[ESC] button is pressed.
	OFF	[ESC] button is not pressed.
M△△ + 2	ON	[-] button is pressed.
	OFF	[-] button is not pressed.
M△△ + 3	ON	[+] button is pressed.
	OFF	[+] button is not pressed.

10.21 User (User-Registered Device Setting)

The procedure for specifying the devices which display as "User" at the "Monitor/Test" menu is explained below. The user-registered devices are specified by writing the "device type" and "device No." at "D□□" to "D□□ + 7" in the system information (system signal 1).

→ Refer to Section 10.6 for operation.

→ Refer to Section 10.17 for system information setting.

→ Refer to Subsection 10.21.3 to 10.21.5 for program examples.

10.21.1 System information - user-registered device setting

1. System signal 1

User-Registered Device No.	System Information	Description	Setting Value
1	D□□	Device type	D□□ = K7: Data register [D] (16-bit) D□□ = K8: Data register [D] (32-bit)
	D□□ + 1	Device No.	When D□□ = K7, D□□ + 1 = K0 to K8511 When D□□ = K8, D□□ + 1 = K0 to K7998, K8000 to K8510
2	D□□ + 2	Device type	D□□ + 2 = K7: Data register [D] (16-bit) D□□ + 2 = K8: Data register [D] (32-bit)
	D□□ + 3	Device No.	When D□□ = K7, D□□ + 3 = K0 to K8511 When D□□ = K8, D□□ + 3 = K0 to K7998, K8000 to K8510
3	D□□ + 4	Device type	D□□ + 4 = K7: Data register [D] (16-bit) D□□ + 4 = K8: Data register [D] (32-bit)
	D□□ + 5	Device No.	When D□□ = K7, D□□ + 5 = K0 to K8511 When D□□ = K8, D□□ + 5 = K0 to K7998, K8000 to K8510
4	D□□ + 6	Device type	D□□ + 6 = K7: Data register [D] (16-bit) D□□ + 6 = K8: Data register [D] (32-bit)
	D□□ + 7	Device No.	When D□□ = K7, D□□ + 7 = K0 to K8511 When D□□ = K8, D□□ + 7 = K0 to K7998, K8000 to K8510

2. System signal 2

System Information	Setting Content	Display Screen Status
M△△ + 6	ON	"User-registered device" screen, or "user message" screen is displayed.
	OFF	Other screen is displayed.

10.21.2 Precaution when setting 3 or fewer devices

When 3 or fewer devices are set as user-registered devices, the "type" setting for unused devices should be set to a value other than 7 and 8.

→ Refer to Subsection 10.21.4 for a program example.

10.21.3 Program example 1 (when 4 devices are displayed as user-registered devices)

Use this program example as a reference when setting 4 devices as user-registered devices.

1. Operation

In this program example, the 4 devices shown in the table below are set as user-registered devices, with a hexadecimal format specified for the current value display.

- 1) The hexadecimal display format applies only to current values which display at the "user-registered device" menu. Other current values display in a decimal format.
- 2) In this program example, system information is assigned from D50 to D90 and from M50 to M56.

User-Registered Device No.	Devices Set As User-Registered Devices	Data Length	Display Format
1	D100 (D101)	32Bit	Hexadecimal
2	D102	16Bit	
3	D103	16Bit	
4	D104	16Bit	

2. Program

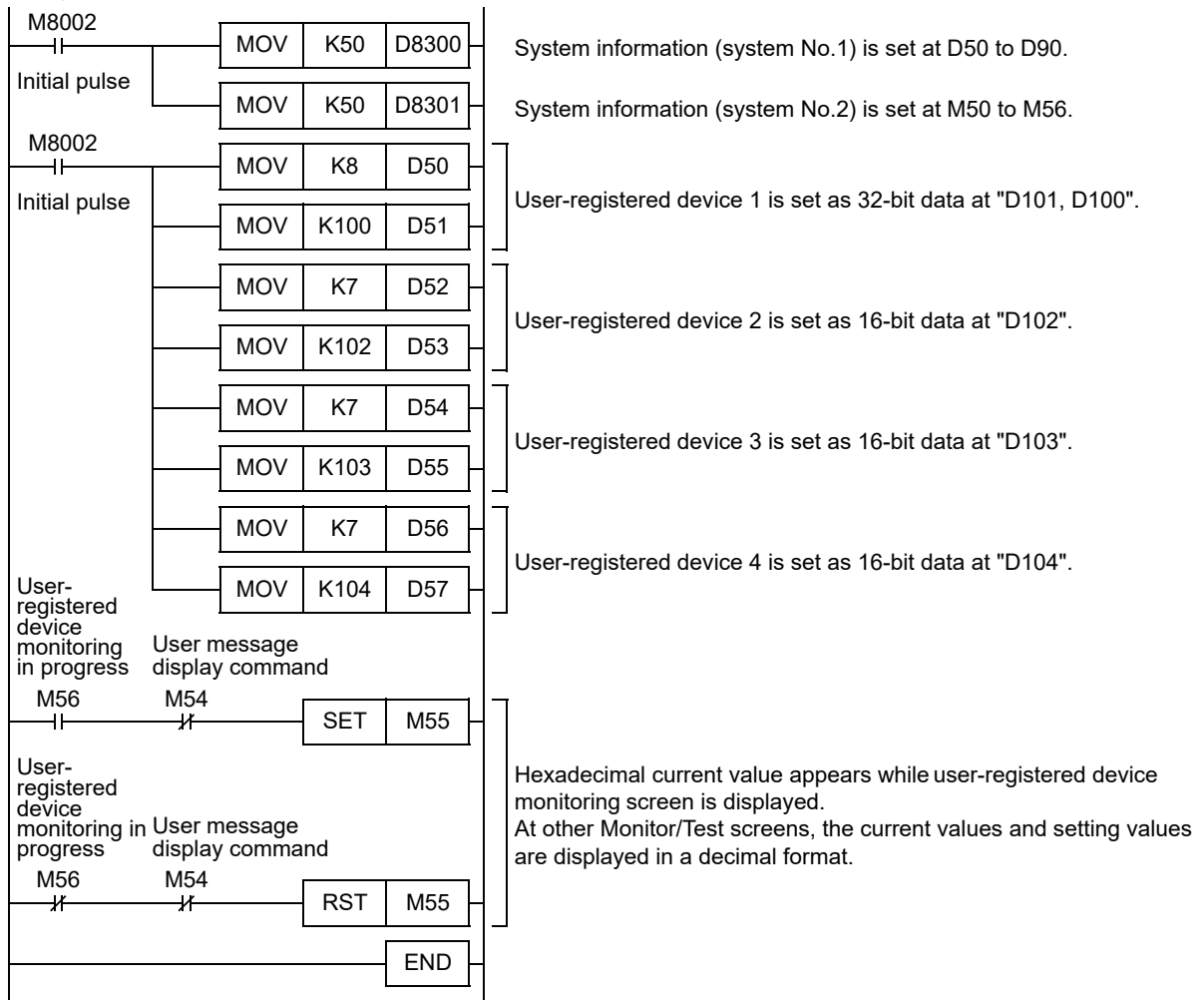

10.21.4 Program example 2 (when 3 or fewer devices are displayed as user-registered devices)

Use this program example as a reference when setting 3 or fewer devices as user-registered devices.

1. Precaution When Setting 3 Or Fewer Devices

When 3 or fewer devices are set as user-registered devices, the "type" setting for unused devices should be set to a value other than 7 and 8.

2. Operation

In this program example, the 3 devices shown in the table below are set as user-registered devices, with a hexadecimal format specified for the current value display.

- 1) The hexadecimal display format applies only to current values which are displayed at the "user-registered device" menu. Other current values are displayed in a decimal format.
- 2) In this program example, system information is assigned from D50 to D90 and from M50 to M56.

User-Registered Device No.	Devices Set As User-Registered Devices	Data Length	Display Format
1	D100 (D101)	32-Bit	Hexadecimal
2	D102	16-Bit	
3	D103	16-Bit	

3. Program

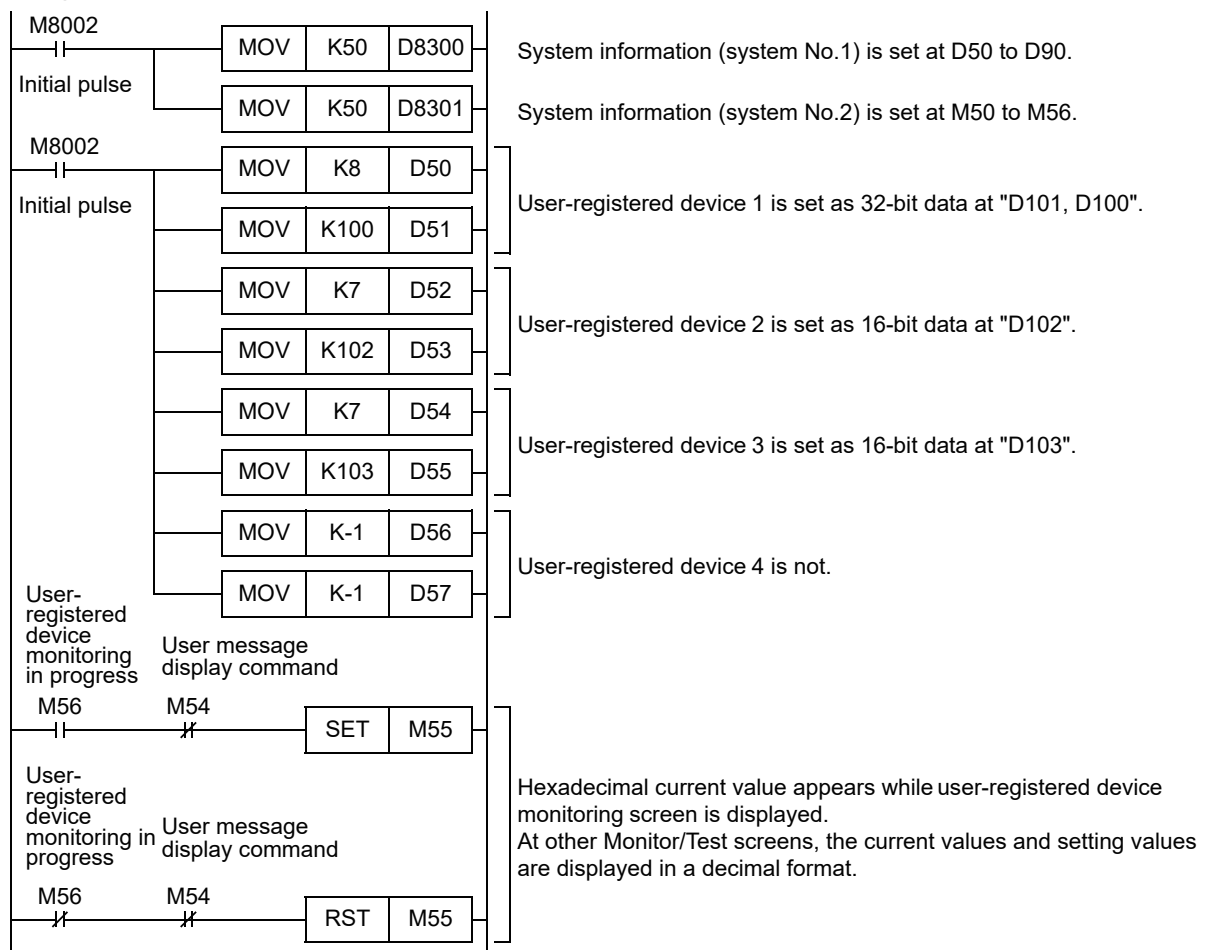

1	Outline
2	External Dimensions
3	Generic Specifications
4	Power Supply Specifications
5	Input Specifications
6	Output Specifications
7	Examples of Wiring for Various Uses
8	Terminal Block
9	CC-Link/LT Master FX3UC-LT(-2) only
10	Display module FX3UC-LT(-2) only

10.21.5 Program example 3 (when 5 or more devices are displayed as user-registered devices)

Use this program example as a reference when setting 5 or more devices as user-registered devices.

1. Operation

In this program example, the 7 devices shown in the table below are set as user-registered devices, with the current value display format set individually for each device.

- 1) The display formats specified here apply only to current values which appear at the "user-registered device" menu. Other current values appear in a decimal format.
- 2) In this program example, system information is assigned from D50 to D90 and from M50 to M56.

User-Registered Device No.	Devices Set As User-Registered Devices	Data Length	Display Format
1	D100 (D101)	32-Bit	Hexadecimal
2	D102	16-Bit	Decimal
3	D103	16-Bit	Decimal
4	D104	16-Bit	Decimal
5	D200	16-Bit	Hexadecimal
6	D210	16-Bit	Decimal
7	D201	16-Bit	Hexadecimal

2. Program

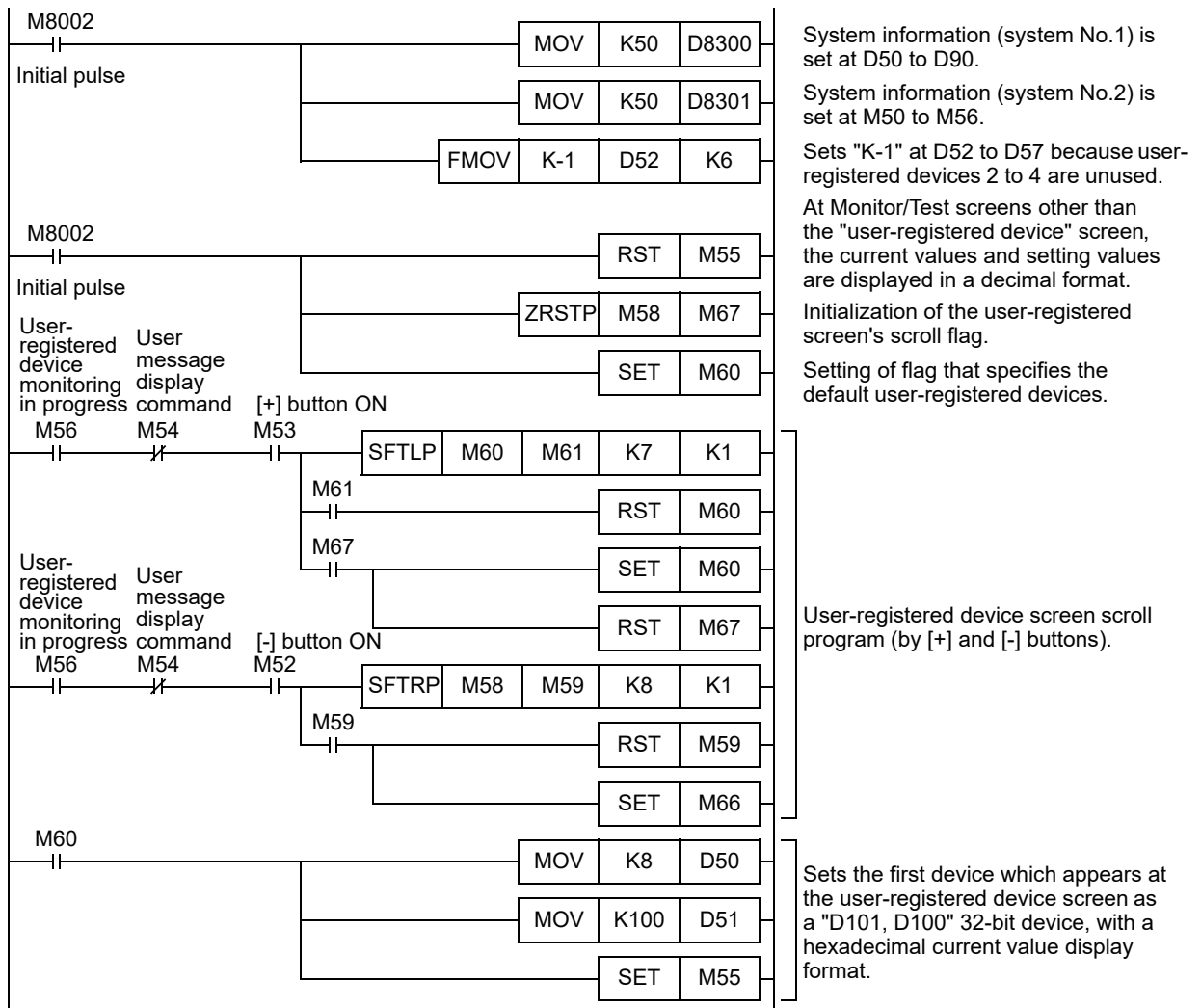

Continued on next page

Continued from previous page

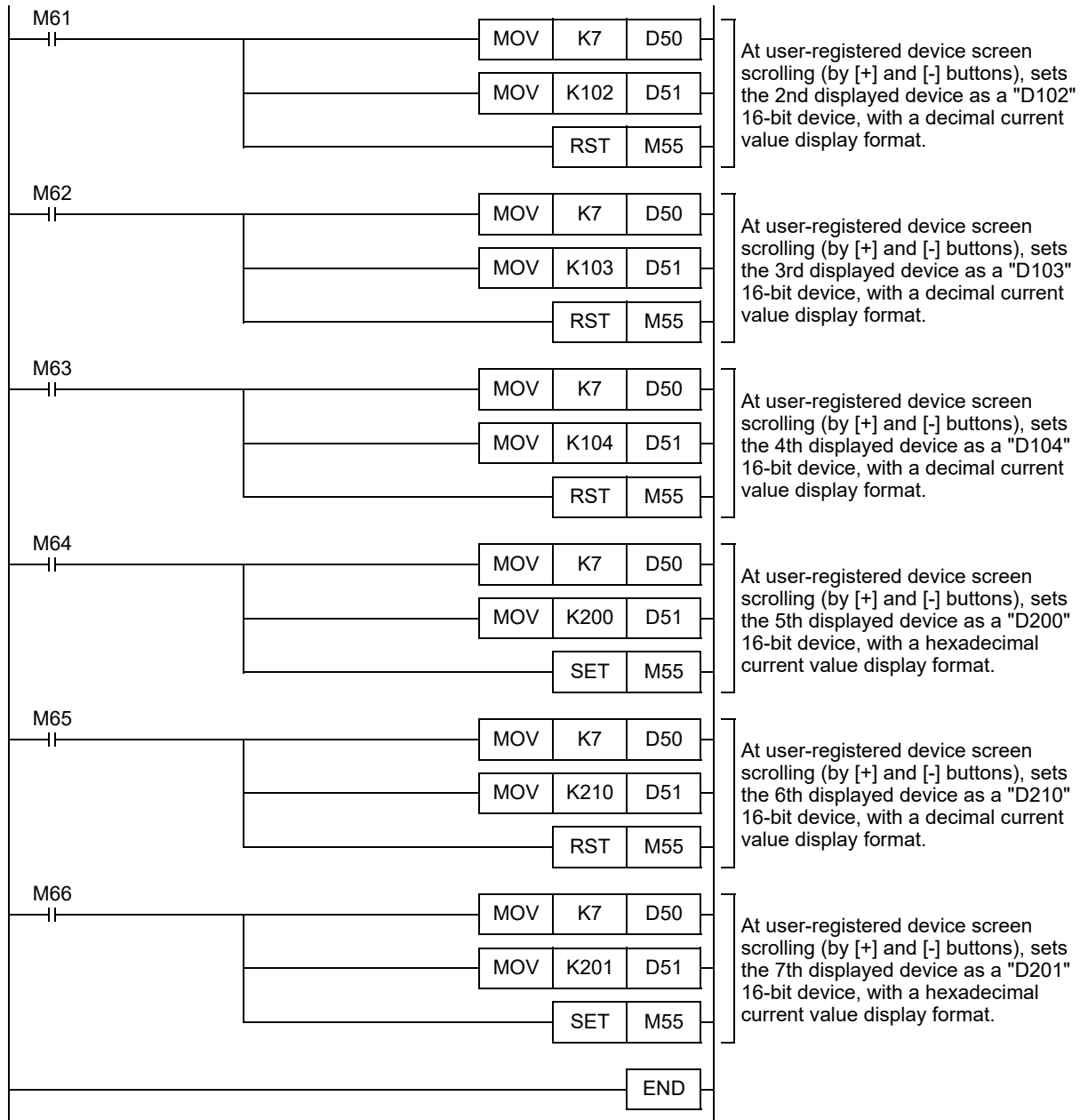

1	Outline
2	External Dimensions
3	Generic Specifications
4	Power Supply Specifications
5	Input Specifications
6	Output Specifications
7	Examples of Wiring for Various Uses
8	Terminal Block
9	CC-Link/LT Master FX3UC-LT(-2) only
10	Display module FX3UC-LT(-2) only

10.22 User Message Display Function

The user message display function allows a user-prepared message to appear in place of the "Main unit I/O operation display".

The [OK] button is then pressed to switch from the "user message screen" to the "menu screen".

If using fixed user messages, the messages (created in GX Works2 or GX Developer's "device memory" window) should be saved individually at $D\Box\Box + 9$ to $D\Box\Box + 40$ of the file register (D), extended register (R), and extended file register (ER).

→ Refer to Section 10.17 for system information setting.

→ Refer to Subsection 10.22.7 for character data input.

10.22.1 System information - user message display function

1. System signal 1

System Information	Description
$D\Box\Box + 9$	Device where the user message character string is saved.
?	
$D\Box\Box + 40$	

1) Displayable Characters & Codes

Character Type	Code
Alphanumeric	20H to 7DH, A1H to DFH ASCII code
Japanese	Shift JIS Level 1-, 2

2) System information's (system signal 1) $D\Box\Box + 9$ to $D\Box\Box + 40$ and display position

		Row (horizontal character position)															
		[1]	[2]	[3]	[4]	[5]	[6]	[7]	[8]	[9]	[10]	[11]	[12]	[13]	[14]	[15]	[16]
Line (vertical character position)	1	$D\Box\Box + 9$		$D\Box\Box + 10$		$D\Box\Box + 11$		$D\Box\Box + 12$		$D\Box\Box + 13$		$D\Box\Box + 14$		$D\Box\Box + 15$		$D\Box\Box + 16$	
		Lower order	Higher order	Lower order	Higher order	Lower order	Higher order	Lower order	Higher order	Lower order	Higher order	Lower order	Higher order	Lower order	Higher order	Lower order	Higher order
	2	$D\Box\Box + 17$		$D\Box\Box + 18$		$D\Box\Box + 19$		$D\Box\Box + 20$		$D\Box\Box + 21$		$D\Box\Box + 22$		$D\Box\Box + 23$		$D\Box\Box + 24$	
		Lower order	Higher order	Lower order	Higher order	Lower order	Higher order	Lower order	Higher order	Lower order	Higher order	Lower order	Higher order	Lower order	Higher order	Lower order	Higher order
	3	$D\Box\Box + 25$		$D\Box\Box + 26$		$D\Box\Box + 27$		$D\Box\Box + 28$		$D\Box\Box + 29$		$D\Box\Box + 30$		$D\Box\Box + 31$		$D\Box\Box + 32$	
		Lower order	Higher order	Lower order	Higher order	Lower order	Higher order	Lower order	Higher order	Lower order	Higher order	Lower order	Higher order	Lower order	Higher order	Lower order	Higher order
	4	$D\Box\Box + 33$		$D\Box\Box + 34$		$D\Box\Box + 35$		$D\Box\Box + 36$		$D\Box\Box + 37$		$D\Box\Box + 38$		$D\Box\Box + 39$		$D\Box\Box + 40$	
		Lower order	Higher order	Lower order	Higher order	Lower order	Higher order	Lower order	Higher order	Lower order	Higher order	Lower order	Higher order	Lower order	Higher order	Lower order	Higher order

2. System signal 2

System Information	Setting Content	Screen Display
$M\Delta\Delta + 4$	ON	User message display command. This command is enabled only when the "Main unit I/O operation display" is displayed.
	OFF	Cancels the user message display, and displays the "Main unit I/O operation display".
$M\Delta\Delta + 6$	ON	ON when the "user-registered device monitor screen" or the "user message screen" is displayed.
	OFF	OFF when other screens are displayed.

10.22.2 Shift JIS code arrangement precautions

To prevent garbled characters when a 2-byte character (shift JIS code) arrangement extends into the next line, the system replaces those characters with 2 spaces.

[Ex] If a full-size character arrangement exists at $D\Box\Box + 16$ (higher order) + $D\Box\Box + 17$ (lower order), spaces will display at those positions. Therefore, the use of full-size characters (shift JIS code) should be avoided at the shaded areas shown in the above table.

10.22.3 Displaying a word device current value as a message

A numeric value can be displayed at the user message by combining BCD (FNC 18), ASCII (FNC 82), and BMOV (FNC 15) instructions.

→ Refer to Subsection 10.22.6 for a program example.

10.22.4 Program example 1 (user messages display switching)

The following program example is for user messages that appear in accordance with the auxiliary relay M100 to M102 ON/OFF statuses.

Note that user messages do not appear when a screen other than the "Main unit I/O operation display" is displayed.

1. Operation

The 3 messages shown below appear in accordance with the auxiliary relay M100 to M102 ON/OFF statuses. When auxiliary relays are ON simultaneously, the messages appear in the No.1 → No.2 → No.3 order.

The following is a program example in which the system information has been assigned from D50 to D90 and from M50 to M56.

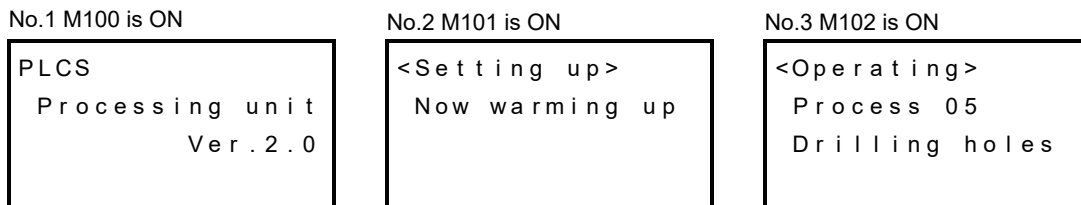

2. Character data

User message data to be displayed is created in GX Works2 or GX Developer, and is assigned to the file registers shown below.

→ Refer to Subsection 10.22.7 for character data input.

Message No.	File Register Where Saved
1	D1000 to D1031
2	D1032 to D1063
3	D1064 to D1095

3. Program

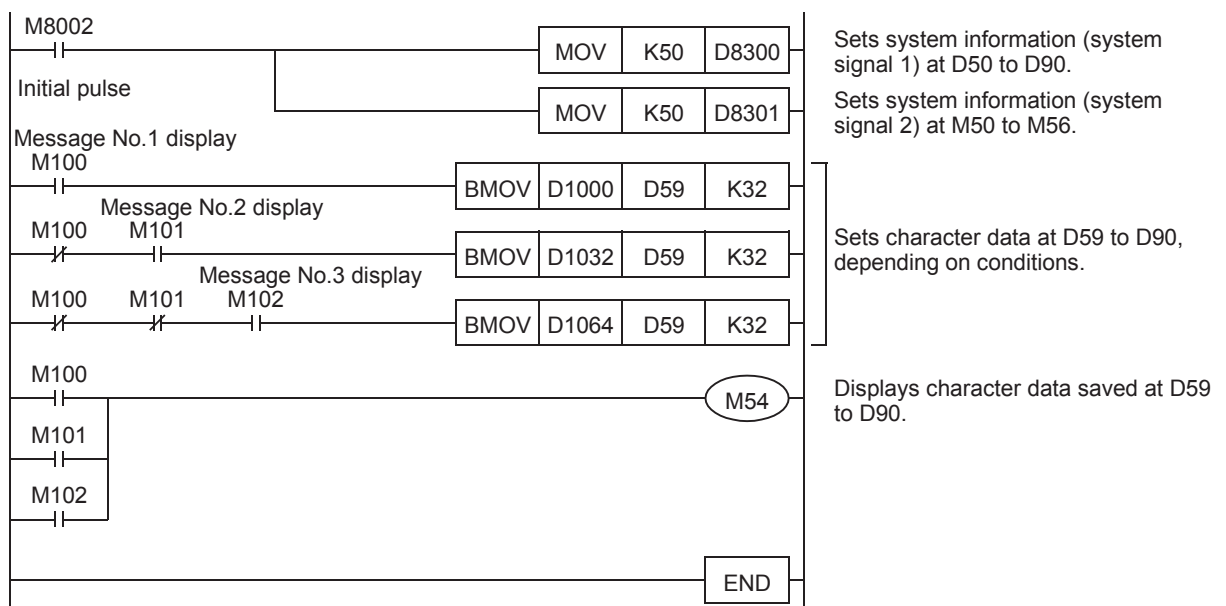

1	Outline
2	External Dimensions
3	Generic Specifications
4	Power Supply Specifications
5	Input Specifications
6	Output Specifications
7	Examples of Wiring for Various Uses
8	Terminal Block
9	CC-Link/LT Master FX3UC-LT(-2) only
10	Display module FX3UC-LT(-2) only

10.22.5 Program example 2 ([+]/[-] buttons of user messages switching)

The following is a program example in which the [+]/[-] buttons are used to switch the displayed user message. Note that user messages do not appear when a screen other than the "Main unit I/O operation display" is displayed.

1. Operation

The No.1 message shown below appears when auxiliary relay M100 switches on, and the [+]/[-] buttons can be used at that time to switch to the other messages as shown below. The system information is assigned from D50 to D90 and from M50 to M56.

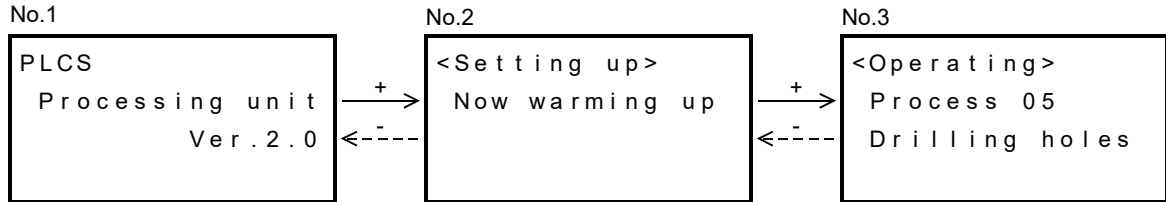

2. Character data

User message data to be displayed is created in GX Works2 or GX Developer, and is assigned to the file registers shown below.

→ Refer to Subsection 10.22.7 for character data input.

Message No.	File Register Where Saved
1	D1000 to D1031
2	D1032 to D1063
3	D1064 to D1095

3. Program

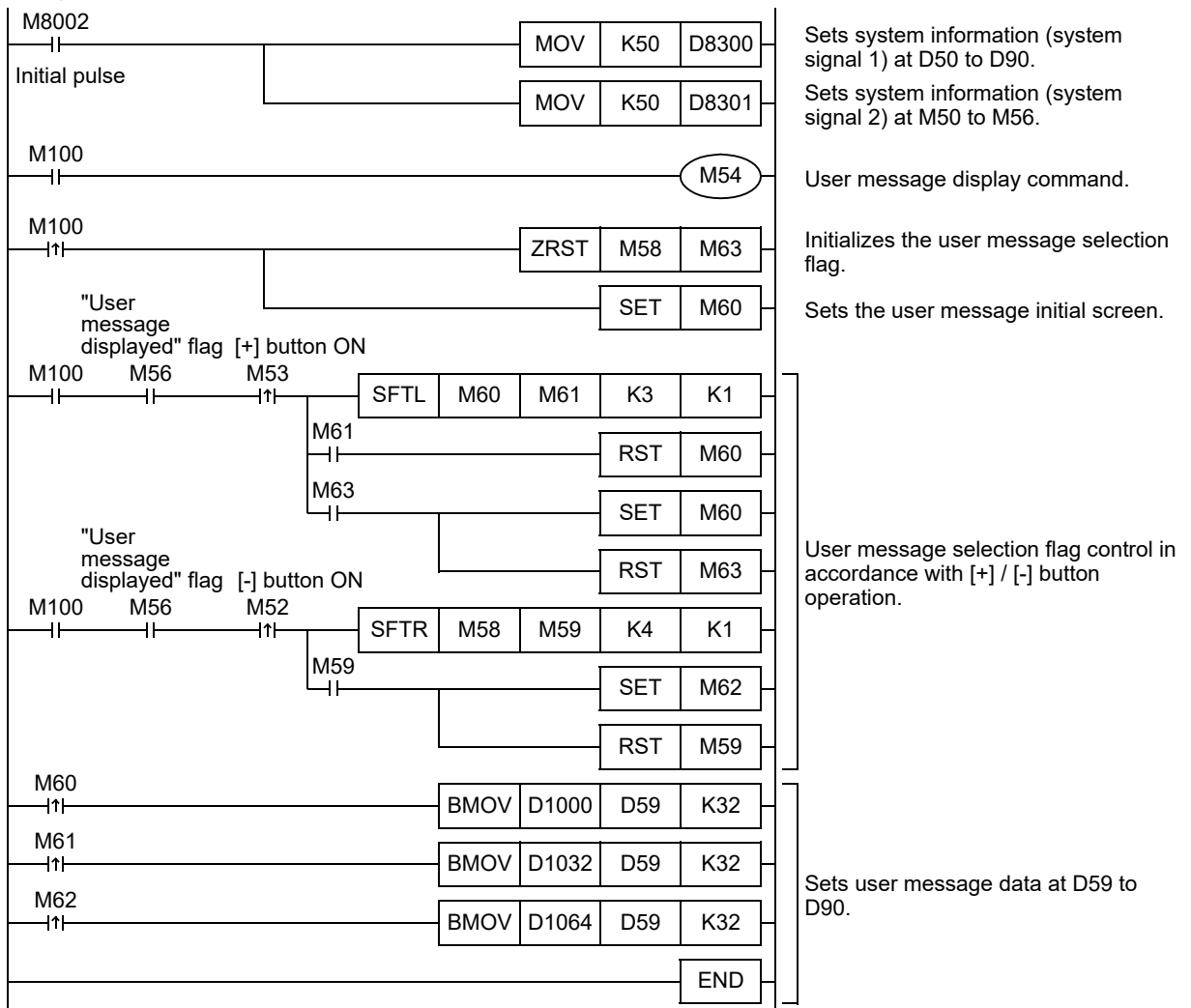

10.22.6 Program example 3 (user messages plus data display)

The following is a program example in which the counter's current value appears at the user message. Note that user messages do not appear when a screen other than the "Main unit I/O operation display" is displayed.

1. Operation

The message shown below appears when auxiliary relay M100 switches on. In this program example, the system information is assigned from D50 to D90 and from M50 to M56.

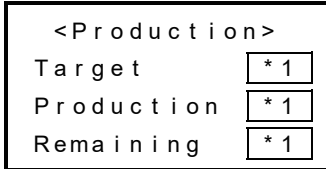

- *1. The current values of the devices shown below appear as the target quantity, the production quantity, and the remaining quantity.

Item	Device	Remarks
Target	D200	Specifies the C0 setting.
Production	C0	Counts the number of M101 ON operations.
Remaining	D201	Remaining (D201) = target (D200) - production (C0).

2. Displaying a word device current value as a message

A numeric value can be displayed at the user message by combining BCD (FNC 18), ASCII (FNC 82), and BMOV (FNC 15) instructions, etc.

3. Character data

User message data to be displayed is created in GX Works2 or GX Developer, and is assigned to file registers D1000 to D1031.

→ Refer to Subsection 10.22.7 for character data input.

4. Program

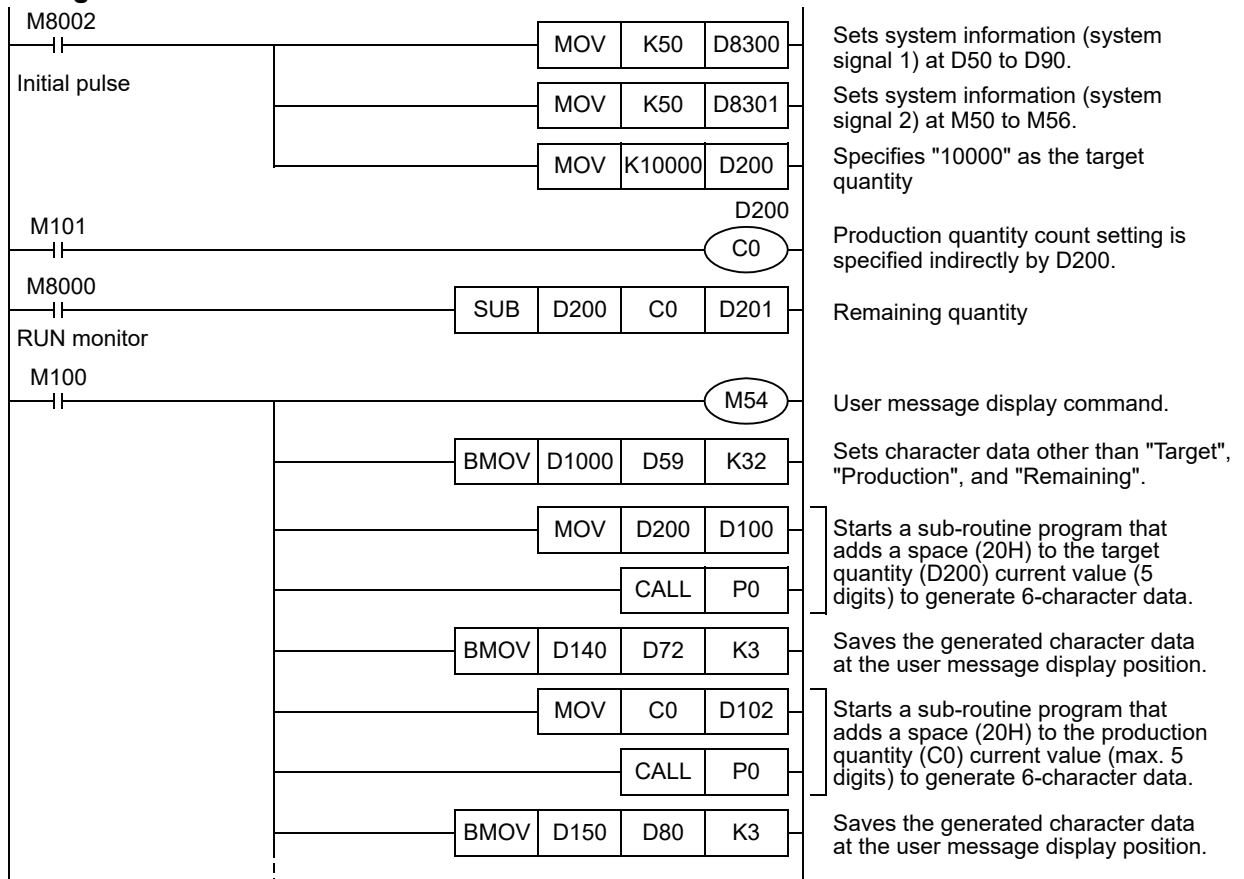

Continued on next page

1	Outline
2	External Dimensions
3	Generic Specifications
4	Power Supply Specifications
5	Input Specifications
6	Output Specifications
7	Examples of Wiring for Various Uses
8	Terminal Block
9	CC-Link/LT Master FX3UC-LT(-2) only
10	Display module FX3UC-LT(-2) only

Continued from previous page

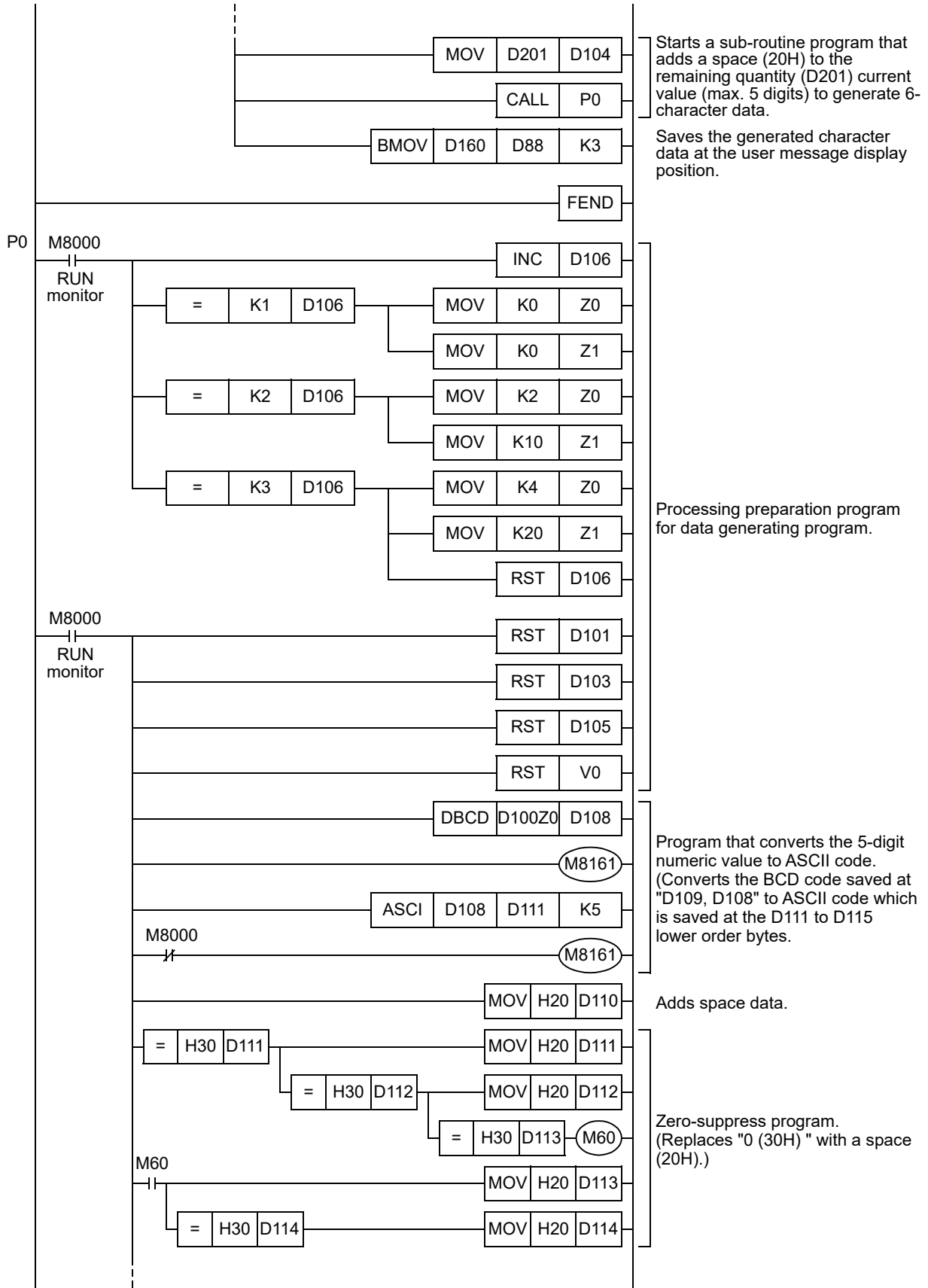

Continued on next page

Continued from previous page

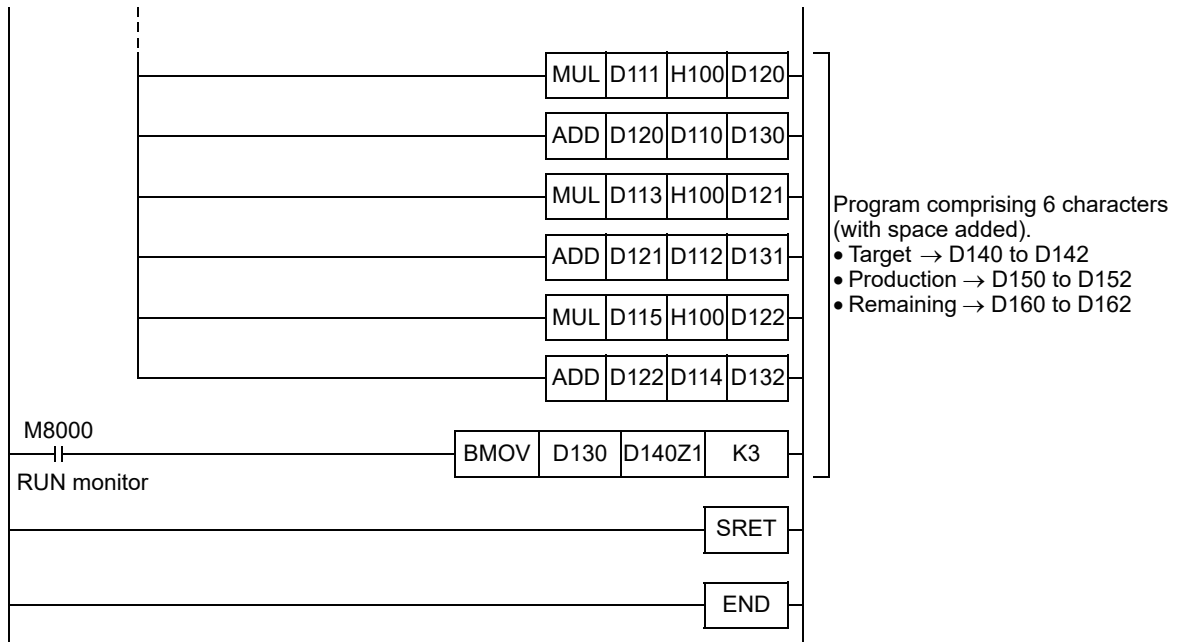

1	Outline
2	External Dimensions
3	Generic Specifications
4	Power Supply Specifications
5	Input Specifications
6	Output Specifications
7	Examples of Wiring for Various Uses
8	Terminal Block
9	CC-Link/LT Master FX ₃ UC-LT(-2) only
10	Display module FX ₃ UC-LT(-2) only

10.22.7 Character data input procedure

User messages are entered and assigned to file registers in advance, using GX Works2 or GX Developer. Messages are displayed by a file register → data register transfer, with the message being created in place of the numeric values, etc.
 32 data register points are assigned to each message.
 This subsection explains the operation procedure using GX Developer.

1 Setting The PLC Model Name

Set the "PLC series" and the "PLC Type" settings as shown below.

Required Setting Items	Setting Content
PLC series	FXCPU
PLC Type	FX3U(C) ^{*1}

*1. For Ver. 8.18U to 8.24A of GX Developer, the PLC type is FX3UC.

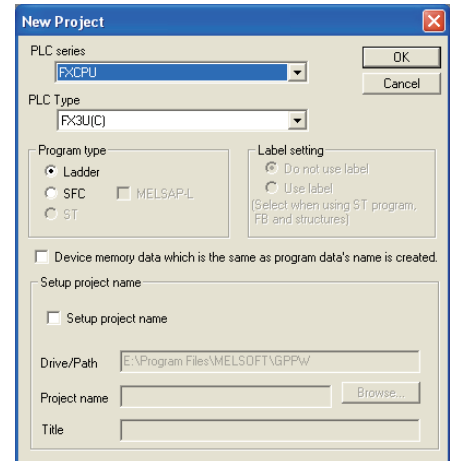

2 Parameter Settings

To specify the parameter settings, select "PLC parameter" from the project data list.

If the project data list does not display, click the toolbar's [Display] - [Project data list] items.

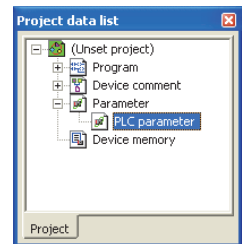

Click the "Memory capacity" tab to perform file register assignments.

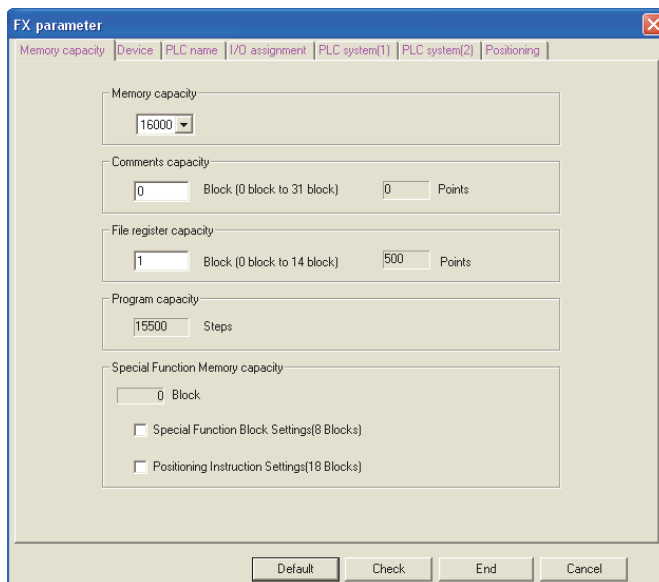

3 Selecting The File Register

1. From the project data list, select "Device memory", then right-click and select [New] at the submenu.
2. The "New" dialog box then appears. Click [OK]

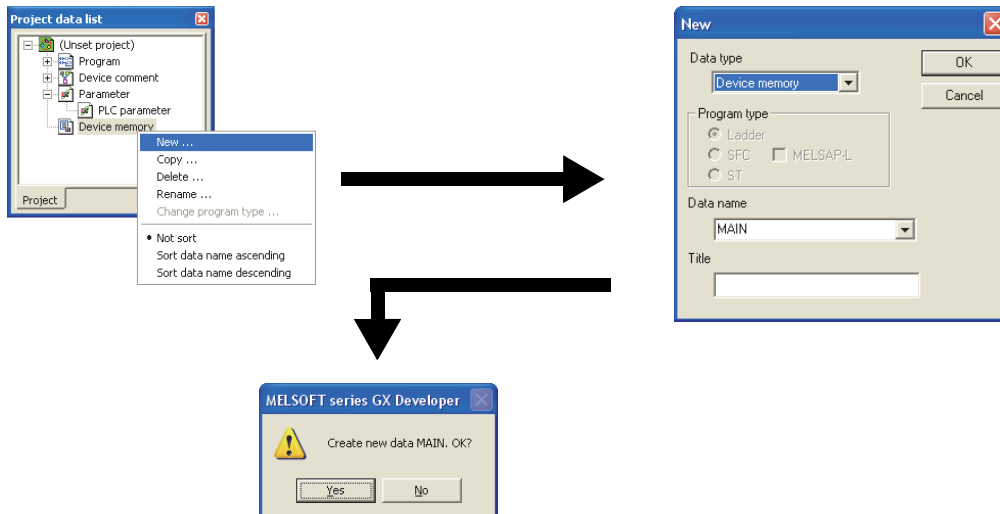

A confirmation dialog box then appears. Click [Yes].

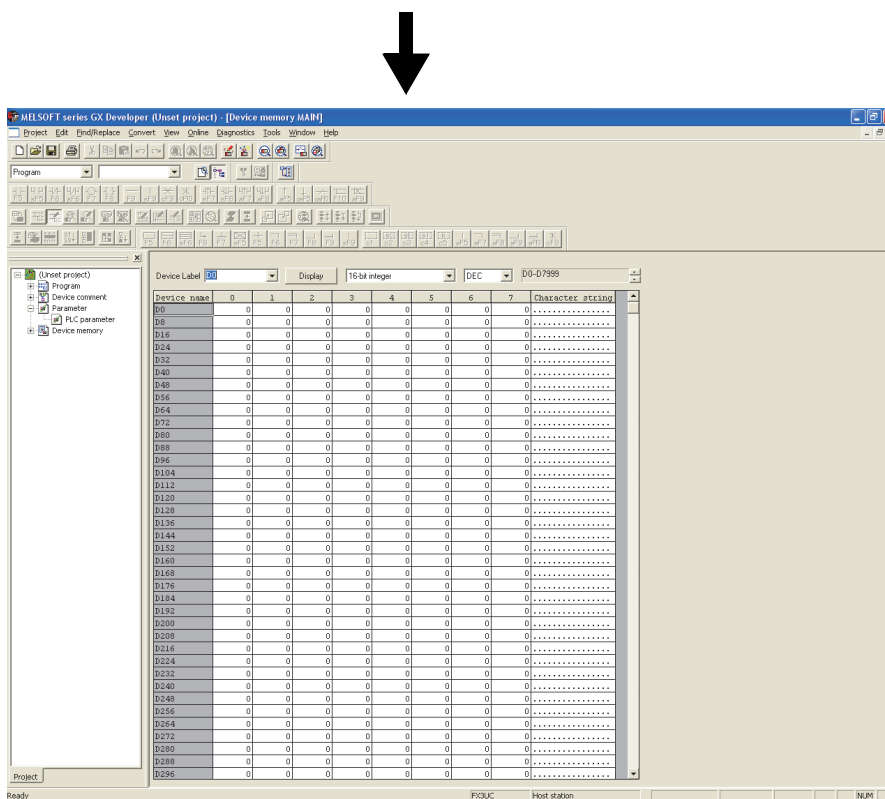

3. Enter "D1000" at the device, then click [Display].
(The first No. of the file register is selected.)
4. At the 2 selection boxes next to the input area, select "16-bit integer" and "HEX".

1	Outline
2	External Dimensions
3	Generic Specifications
4	Power Supply Specifications
5	Input Specifications
6	Output Specifications
7	Examples of Wiring for Various Uses
8	Terminal Block
9	CC-Link/LT Master FX3UC-LT(-2) only
10	Display module FX3UC-LT(-2) only

4 Entering User Messages

As shown in the illustration below, the dialog box for character string inputs is opened by double-clicking on GX Developer's character string display area or the data register display area. When entering Japanese scripts (Chinese characters, etc.), data input automatically occurs in the lower order → higher order sequence, and the input can therefore be used as it is at the display module's user message display.

The GX Developer screen's character string shown below is for "program example 1".
 → Refer to Subsection 10.22.6 for "program example 1" details.

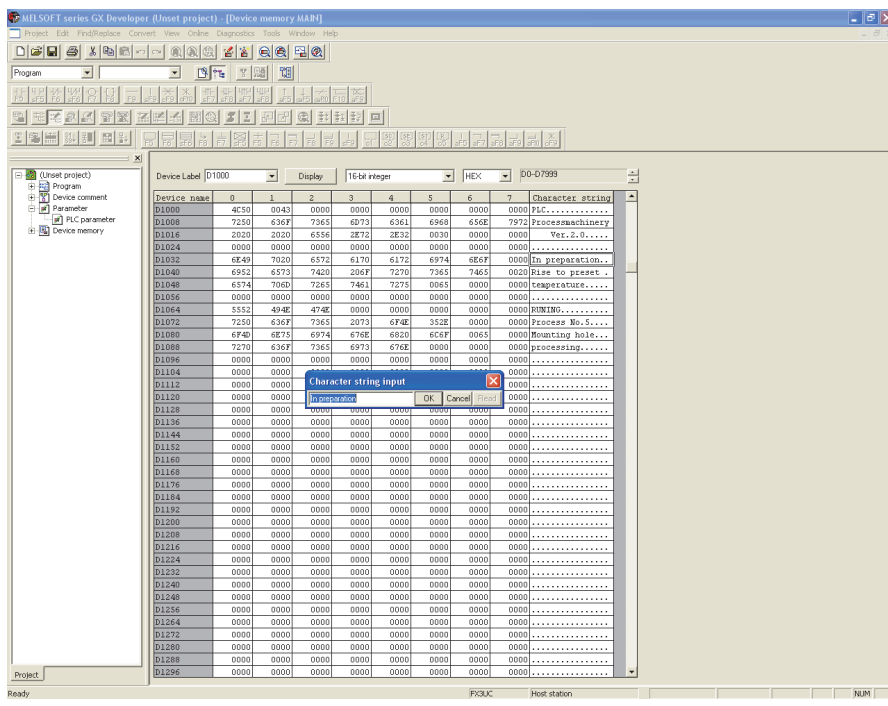

GX Developer character arrangement precautions:

- A single line is comprised of 8 data registers.
- To prevent garbled characters when a 2-byte character (shift JIS code) arrangement extends into the next line, the system replaces those characters with 2 spaces.
- ([Ex] spaces display at the end of the 1st line and at the beginning of the 2nd line.)
- The condition of the display module line must therefore be considered when entering the characters.
- Moreover, the 1st character device should be specified for displaying a 1-line character input.

10.23 Operation Error Messages & Corrective Actions

The following is a list of error messages which the system displays after an operation is performed.

- Both FX3UC-32MT-LT and FX3UC-32MT-LT-2

Relevant Menu Screen	English	Japanese	Corrective Action
• All menus	Entry Code error	操作できません キーワードによって保護されています	Cancel the entry code, then attempt the operation again.
• Entry code	The Entry Code is not set	キーワードが設定されていません	No entry code has been registered. Entry codes cannot be registered from the display module. A programming tool such as GX Works2, etc., is required to register entry codes.
	Incorrect Entry Code!	キーワード不一致	The entered entry code does not match the registered entry code. Verify the registered entry code, then enter the correct entry code.
• Monitor/test (user-registered devices)	The wrong device is registered	存在しないデバイスが登録されています	A device has been specified that does not exist among the system information (system signal 1) "user-registered device" monitor devices. Check the program.
• Monitor/test (setting change) • Memory cassette transfer	PLC is running	RUN中です!	Stop the PLC, then attempt the operation again.
	Memory Cassette is write-protected	書き込み禁止です	Turn the memory cassette's write-protected status to OFF, then attempt the operation again.
	Write error	書き込みエラー	Writing failed. Verify that the memory cassette is properly installed.
	Read error	読み込みエラー	Reading failed. Verify that the memory cassette is properly installed.
• PLC Status • Monitor/test (setting change) • Memory cassette transfer	Fatal error occurred	フェータルエラー発生中	→ Refer to Subsection 10.23.1 for details.
• Memory cassette transfer	Memory Cassette is misconnected	メモカセットが装着されていません	Turn the PLC power OFF, install the memory cassette, then attempt the operation again.
	The Entry Code is set in the Internal Memory	内蔵メモリにキーワードが設定されています	Remove the memory cassette, restart the unit (power OFF → ON), then use the programming tool to cancel the entry code in the internal RAM.
• Memory cassette transfer (consistency check)	Programs match	プログラムが一致しています	The memory cassette program matches the RAM program.
	Programs don't match	プログラム不一致	The memory cassette program does not match the RAM program.
• Memory cassette transfer (reading/writing)	Transfer completed	転送成功しました	Transfer successful.
	Transfer failed	転送失敗しました	Check if the memory cassette is properly installed.
	The program size exceeds target memory capacity	転送先の容量を超えています	The transfer origin memory capacity exceeds the transfer destination memory capacity. Check the memory capacity.

- FX3UC-32MT-LT-2 only

Relevant Menu Screen	English	Japanese	Corrective Action
• CC-Link/LT (CONFIG start)	CC-Link/LT CONFIG can not be started	CONFIGを開始する 準備に失敗しまし た	Turn the PLC power OFF and then ON again, then perform the procedure again.
• CC-Link/LT (Reserved station change)	Reserve Statn select settings saved	予約局指定の変更 を行いました	The Reserved station specification change was completed.
	Reserve Statn select settings could not be saved	予約局指定の変更 に失敗しました	Turn the PLC power OFF and then ON again, then perform the procedure again.
• CC-Link/LT (Transmission rate setting)	Baud Rate can not be changed	伝送速度の変更に 失敗しました	Turn the PLC power OFF and then ON again, then perform the procedure again.
• CC-Link/LT (Self check)	Self-Check can not be started	折返しテストの準 備に失敗しました	Turn the PLC power OFF and then ON again, then perform the procedure again.

10.23.1 When a "Fatal error occurred" message appears

Operation is possible with the "Level C" or "Level B" entry code function restrictions. However, the system is probably in one of the statuses described below. Check these statuses in the order shown below, and take the appropriate corrective action.

1. **Perform an error check at the display module, and if an error is active, take the appropriate corrective action.**

→ Refer to Section 10.7 for the error check procedure.

If a program error is active:

The fatal error was probably activated due to a program error. Use the programming tool to correct the program.

- Refer to Subsection 12.6.4 for error codes and corrective actions.
- Refer to Subsection 12.5.3 for watchdog timer error corrective actions.

If no program error is active:

There may be a problem with the PLC's memory content. Perform the following procedure.

- 1) Use the programming tool to perform a program memory all-clear.
- 2) Rewrite the program.
- 3) Stop the PLC, turn the power ON, display the "PLC Status (1/3)" screen and check to refer to if the "Fatal error occurred" message appears.
 - If the "Fatal error occurred" message appears, perform the corrective action described at item "2" below.
 - If the "Fatal error occurred" message does not appear, set the PLC to a RUN state, then check again if the message appears.
 - If the message appears, a watchdog timer error has probably occurred. In this case, the program should be re-examined.

→ Refer to Subsection 12.5.3 for watchdog timer error corrective actions.

2. **If the "Fatal error occurred" message still appears after performing the corrective actions described in item 1 above, perform the following procedure to check for symptom changes.**

Turn the power OFF and disconnect all extension devices.
(extension connectors, extension cables, and expansion board connectors)

Turn the power ON again at the main unit, display the "PLC Status (1/3)" screen again, and check if the "Fatal error occurred" message appears.

- 1) If the "Fatal error occurred" message appears:
 - The main unit hardware may have failed. Contact your local Mitsubishi Electric representative.
- 2) If the "Fatal error occurred" message does not appear:
 - Turn the power OFF, connect the extension devices, then operate the system again to check for errors. If the problem persists, there may be main unit or extension device hardware failure. Contact your local Mitsubishi Electric representative.

10.24 Menu Display Characters - Japanese & English Display Character Correspondence Table

• Both FX3UC-32MT-LT and FX3UC-32MT-LT-2

Menu Screen	English	Japanese
Menu	Monitor/Test	モニタ/テスト
	ErrorCheck	エラーチェック
	LANGUAGE	LANGUAGE
	Contrast	コントラスト
	ClockMenu	時刻設定
	EntryCode	キーワード
	ClearAllDev	デバイスオールクリア
	PLC Status	PCステータス
	ScanTime	スキャンタイム表示
Cassette	メモリカセット転送	
CC-Link/LT*1	CC-Link/LT設定*1	
ErrorCheck	ErrorCheck	エラーチェック
	No errors	エラー無し
	Error code	エラーコード
LANGUAGE (Menu display language setting)	LANGUAGE 日本語 English	LANGUAGE 日本語 English
Contrast	Contrast	コントラスト
ClockMenu (Current time setting)	Current time	現在時刻
	Clock setting	時刻変更
	Clock setting is set	時刻変更
EntryCode	Please, input Entry Code	キーワードを入力してください
	*****	*****
	Make Entry Code valid? OK → Execute ESC → Cancel	キーワードを有効にしますか OK → 実行 ESC → キャンセル
	All operation is possible	操作が可能になりました
ClearAllDev (Device all-clear)	Incorrect Entry Code	キーワード不一致
	Clear all devices	デバイスオールクリア
	OK → Execute ESC → Cancel	OK → 実行 ESC → キャンセル
	All device were cleared	デバイスオールクリアしました

*1. FX3UC-32MT-LT-2 only.

Menu Screen	English	Japanese	
PLC Status	PLC status(1)	PLC Status (1/3) Ver. ---	PC情報(1/3) Ver. -. --
		Fatal error occurred	フェータルエラー発生中
		The Entry Code is not set	キーワードは設定されていません
		PLC operation is limited	操作が制限されています
		All operation is unrestricted	すべての操作が可能です
		PLC operation is unavailable	操作が禁止されています
	PLC status(2)	PLC Status (2/3)	PC情報(2/3)
		Internal Memory	内蔵RAM
		Memory Cassette	メモリカセット
		Protection -- Capacity --K	プログラムスイッチ -- メモリ容量 --K
PLC status(3)	PLC Status (3/3)	PC情報(3/3)	
	Battery --V	バッテリー電圧 -. -V	
	Comments	登録コメント数	
ScanTime (Scan time display)	ScanTime Curr: -.ms Max: -.ms Min: -.ms	スキャンタイム 現在値: -.ms 最大値: -.ms 最小値: -.ms	
Cassette (Memory cassette transfer)	Memory Cassette Cassette ← RAM Cassette → RAM Cassette : RAM	メモリカセット転送 メモリカセット ← RAM メモリカセット → RAM メモリカセット : RAM	
	Cassette ← RAM	Cassette ← RAM (Write) Please wait...	メモリカセット ← RAM (書き込み) 実行中...
	Cassette → RAM	Cassette → RAM (Read) Please wait...	メモリカセット → RAM (読み出し) 実行中...
	Cassette → RAM Cassette ← RAM	Transfer completed	転送成功しました
		Transfer failed	転送失敗しました
	Cassette : RAM	Cassette : RAM (Verify) Please wait...	メモリカセット : RAM (照合) 実行中...
		Programs match	プログラムが一致しています
		Programs don't match	プログラム不一致

- FX3UC-32MT-LT-2 only

Menu Screen	English	Japanese
self CONFIG mode		
CC-Link/LT settings		
Transmission rate setting	156kbps 625kbps 2.5Mbps	156kbps 625kbps 2.5Mbps
Points mode setting	4-point Mode 16-point Mode	4点モード 16点モード
CONFIG start	CC-Link/LT Start CONFIG OK → Execute ESC → Cancel	CC-Link/LTの CONFIGを開始する OK→実行 ESC→キャンセル
	Reset system power to begin CC-Link/LT CONFIG	CONFIGを開始するため、電源の再投入を行ってください
	CC-Link/LT CONFIG can not be started	CONFIGを開始する準備に失敗しました
Self check	Self-Check start OK → Execute ESC → Cancel	折返しテストを開始する OK→実行 ESC→キャンセル
parameter CONFIG mode		
CC-Link/LT settings		
Reserved station change	1 Reserve 2 Reserve 3 No setting 4 Reserve	1 予約局 2 予約局 3 設定なし 4 予約局
Transmission rate setting	156kbps 625kbps 2.5Mbps	156kbps 625kbps 2.5Mbps
Self check	Self-Check start OK → Execute ESC → Cancel	折返しテストを開始する OK→実行 ESC→キャンセル

1	Outline
2	External Dimensions
3	Generic Specifications
4	Power Supply Specifications
5	Input Specifications
6	Output Specifications
7	Examples of Wiring for Various Uses
8	Terminal Block
9	CC-Link/LT Master FX3UC-LT(-2) only
10	Display module FX3UC-LT(-2) only

11. Memory Cassette/Battery

This chapter explains the memory cassette functions and battery functions.

11.1 Memory Cassette (FX3U-FLROM-16/64/64L/1M)

The memory cassette can be installed at the main unit, and when installed, the memory cassette's internal program is used in place of the internal RAM memory.

→ Refer to Section 3.7 for the removal procedure.

11.1.1 Specifications

Model Name	Max. Memory Capacity	Memory Type	Max. Allowable Write	PROTECT Switch	Loader Function	Compatible Versions
FX3U-FLROM-1M	64000 steps (2k/4k/8k/16k/32k selectable) [There is an area (1300 kB) dedicated to the storage of symbolic information.]	Flash memory	10,000 times	Provided	NA	Ver. 3.00 or later
FX3U-FLROM-64L	64000 steps (2k/4k/8k/16k/32k selectable)	Flash memory	10,000 times	Provided	Provided	Ver. 2.20 or later
FX3U-FLROM-64	64000 steps (2k/4k/8k/16k/32k selectable)	Flash memory	10,000 times	Provided	NA	1st article (Ver. 1.00)
FX3U-FLROM-16	16000 steps (2k/4k/8k selectable)	Flash memory	10,000 times	Provided	NA	Ver. 2.20 or later

→ For the loader function, refer to Section 11.2.

11.1.2 Component names & external dimensions

1. FX3U-FLROM-64L

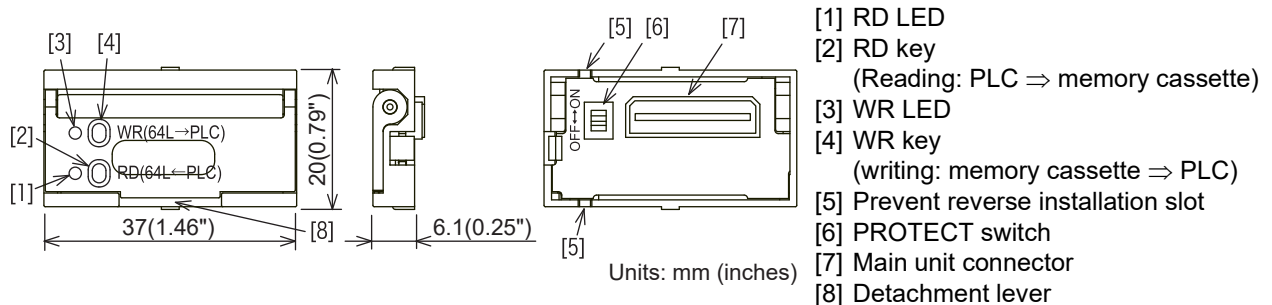

2. FX3U-FLROM-1M, FX3U-FLROM-64, FX3U-FLROM-16

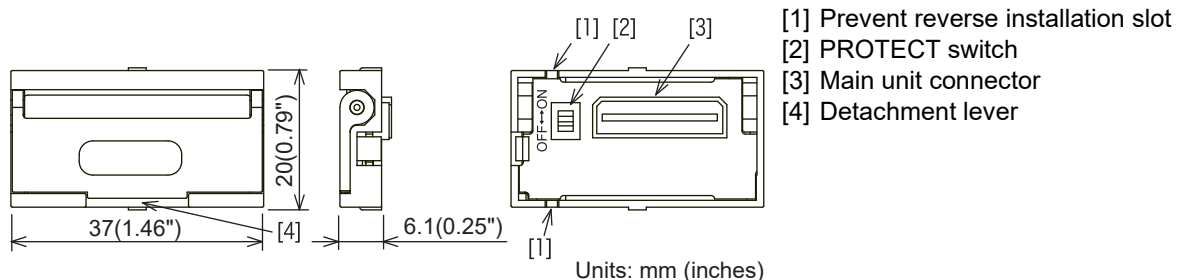

11.1.3 Saved Data Content

The following data is saved on the memory cassette.

Item	Description	Saving Method	
Program Memory	<ul style="list-style-type: none"> Memory capacity setting <ul style="list-style-type: none"> Memory capacity (default setting: 16k steps) 2k/4k/8k/16k steps (FX3U-FLROM-16) 2k/4k/8k/16k/32k/64k steps (FX3U-FLROM-64/64L/1M) Comment capacity File register capacity Special Function Memory capacity 	Programming tool *5	
	Parameters <ul style="list-style-type: none"> Device latch range settings (keep device) Modem initializing settings, battery-free operation, RUN terminal settings RS/RS2 instructions/computer link function communication settings Positioning Instruction Setting Special Function Block Settings Built-in CC-Link/LT settings *1 Special parameters *2*3 		
	Sequence programs		User-created sequence programs
	Comments		Max. 6350 points (0 to 127 blocks, 1 block = 50 points/500 steps)
File registers	Max. 7000 points (0 to 14 blocks, 1 block = 500 points/500 steps)	Comments and file registers can be created in the memory by setting them in the parameter memory capacity. *4	
Symbolic information	<ul style="list-style-type: none"> FX3U-FLROM-16, FX3U-FLROM-64/64L Symbolic information capacity = Max. capacity of memory cassette - Memory capacity set by parameters FX3U-FLROM-1M Symbolic information can be stored in the dedicated area (1300 kB). 	GX Works2 *6	
Extended file registers	ER0 to ER32767 (32768 points)	<ul style="list-style-type: none"> Sequence program GX Works2 GX Developer 	

*1. FX3UC-32MT-LT-2 only.

*2. This function is supported in FX3UC PLC Ver. 3.10 or later.
Do not connect a memory cassette with special parameters saved to any FX3UC PLC earlier than Ver. 3.10.

*3. This function is supported in GX Works2 Ver. 1.73B or later.

*4. The total size of the programs + comments + file registers must not exceed the maximum capacity of the memory cassette.

*5. The maximum number of points for the memory capacity, comments, and file registers, can be specified when the FX3U(C) programming tool is selected. The maximum number of points cannot be specified when a programming tool other than the FX3U(C) is selected.

*6. It is possible to check the symbolic information capacity using the memory capacity calculation (offline) of GX Works2.
Refer to the GX Works2 Version 1 Operating Manual (Common) for details.

Cautions on using the symbolic information

The FX3UC PLC Ver. 3.00 or later can store symbolic information.
Note the following cautions when using symbolic information.

- When symbolic information is stored, it is deleted if the memory capacity set by parameters is changed. After changing the memory capacity, write the symbolic information again.
- Memory cassettes (except for the FX3U-FLROM-1M) which are storing symbolic information can be used by FX3UC PLCs whose version is earlier than Ver. 3.00. In this case, the FX3UC PLC operates, but the written symbolic information is invalid.
- For writing symbolic information and changing the set values of timers and counters using a peripheral device, it is recommended to create programs with set values specified indirectly. If the set values are specified directly, programs cannot be restored from symbolic information after the set values are changed.

11.1.4 PROTECT switch setting

Reading from and writing to memory cassette operations can be performed by using the programming tool.

Because sequence programs are written by an electronic format, a special ROM writer and ultraviolet eraser are not required.

The PROTECT switch must be turned OFF to enable writing.

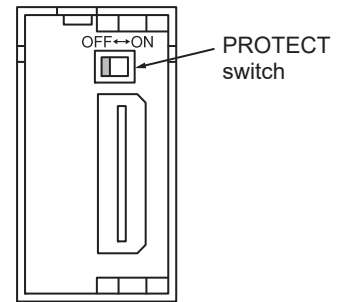

11.1.5 PROTECT switch operation

1. Preparing the operation tools

Set the PROTECT switch knob by using the tip of a pair of tweezers, a precision screwdriver, or a tool with a tip width of approx. 0.8mm (0.04").

Do not use objects with round tips, as the round tip can easily slip off the switch knob, possibly resulting in an incorrect setting.

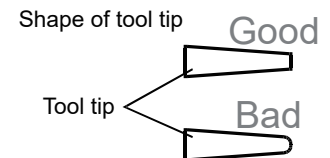

2. Switch operation procedure

As shown in the figure below, the switch knob can be "pushed" or "pulled". When setting the switch, do not set it in an intermediate position.

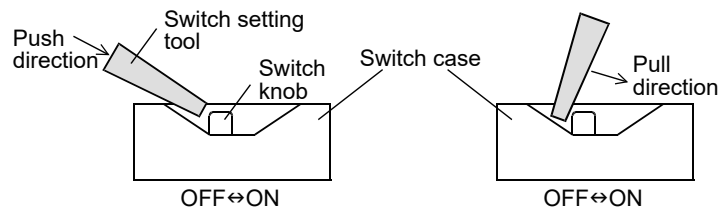

3. Precautions when setting and using the switch

- Leaving the switch knob at an intermediate position for an extended period can cause an equipment failure.
- Also use care to avoid scratching the PCB when setting the switch.

11.2 Memory Cassette <-> PLC (RAM Memory) Transfers by Loader Function

The FX3U-FLROM-64L loader function ([WR] and [RD] key operation) is explained in this section.

- Supported in Ver. 2.20 or later
- Program transfers (reading/writing) are possible between the memory cassette and the PLC's internal RAM memory.
- The loader function is enabled while the PLC is stopped.

11.2.1 Tool for pressing the [WR] and [RD] keys

Use an insulator tool (plastic, ceramic, etc.) to press the [WR] and [RD] keys. The area around the keys is not insulated. Using a metal screwdriver, etc. can cause equipment damage.

11.2.2 Writing (WR: 64L -> PLC)

A memory cassette program is written to the PLC's internal RAM memory.

Required condition: The PLC must be stopped.

1 Install the memory cassette on the main unit.

(Setting the PROTECT switch to ON (on memory cassette's rear face) prevents accidental overwriting of memory cassette program.)

→ Refer to Section 3.7 for the installation procedure.

- Verify that the PLC power is OFF, then install the memory cassette on the PLC.
- Turn the PLC power ON.
- Raise the memory cassette's eject lever.

2 Press the [WR] key 1 time.

The [WR] LED lights, and a preparation status is established.

- To cancel, press the [RD] key.

3 Press the [WR] key again.

Writing is executed, and the [WR] LED goes off.

- Writing to the built-in RAM is completed instantaneously, and the LED goes out soon.

4 Remove the memory cassette from the main unit.

Writing is completed when the [WR] LED goes off.

After turning the PLC power OFF, remove the memory cassette from the PLC.

→ Refer to Section 3.7 for the removal procedure.

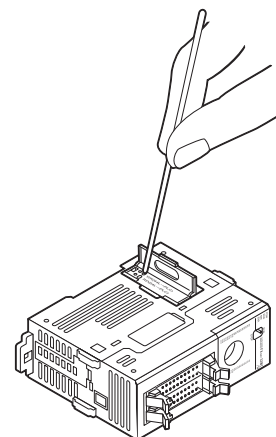
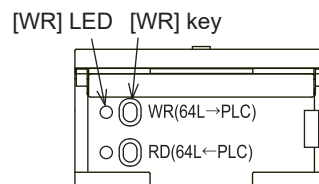

FX3UC-32MT/D

11.2.3 Reading (RD: 64L ←- PLC)

Programs are read from the PLC's internal RAM memory to the memory cassette.

Required condition: The PLC must be stopped, and the PROTECT switch must be OFF.

1 Turn the PROTECT switch OFF on the back of the memory cassette.

The memory cassette must be removed from the PLC in order to turn the PROTECT switch OFF. Make sure that the PLC power is OFF before removing the memory cassette.

→ Refer to Section 3.7 for the removal procedure.

2 Install the memory cassette on the main unit.

→ Refer to Section 3.7 for the installation procedure.

- Verify that the PLC power is OFF, then install the memory cassette on the PLC.
- Turn the PLC power ON.
- Raise the memory cassette's eject lever.

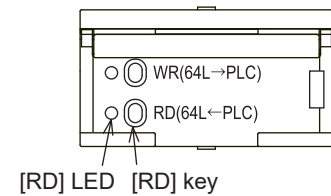

3 Press the [RD] key 1 time.

The [RD] LED lights, and a preparation status is established.

- To cancel, press the [WR] key.

4 Press the [RD] key again.

Reading is executed, and the [RD] LED blinks.

5 Remove the memory cassette from the main unit.

Reading is completed when the [RD] LED goes off. After turning the PLC power OFF, remove the memory cassette from the PLC, then turn the PROTECT switch ON.

→ Refer to Section 3.7 for the removed procedure.

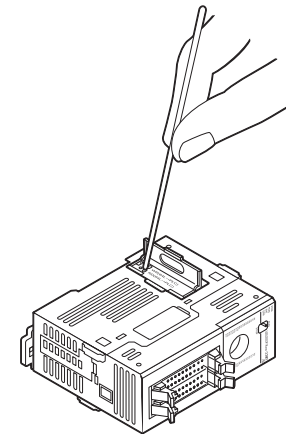

FX3UC-32MT/D

11.3 Transfers By Display Module Operation

Programs can be transferred (reading/writing) between the memory cassette and the PLC's internal RAM memory by a display module operation.

→ Refer to Section 10.15 for the memory cassette transfer function.

11.4 Operation Precautions

Observe the following precautions when writing to file registers (D) and extended file registers (ER) by program.

1. Flash memory writing count

10,000 writing operations are permitted at the flash memory.

2. Precaution for file register usage

Writing to the flash memory occurs at each PLC operation cycle if BMOV instructions are used in a continuous execution format with regard to a file register.

To prevent this, be sure to use "pulse execution format" (BMOV_P) instructions.

Writing data to the flash memory is executed also by writing data to file registers from peripheral equipment (programming software, handy programming panels, and display units).

3. Precaution for extended file register (ER) usage

Do not use continuous constant-execution SAVER and LOGR instructions with regard to extended file registers. Use the individual instructions only when required.

Writing data to the flash memory is executed also by writing data to extended file registers from peripheral equipment (programming software, handy programming panels, and display units).

11.5 FX3U-32BL (Battery)

The main unit of the PLC has a built-in battery.

When the battery voltage drops, the BAT LED lights, and the special auxiliary relay (M8005 or M8006) turns on. In this case, replace the battery FX3U-32BL.

11.5.1 Specifications

Item	Specifications
Nominal voltage	3V

Battery voltage can be monitored with PLC data register D8005.

11.5.2 Battery Purpose

- The battery is required to retain (backup) program memory and "keep device" data and maintain clock operation in the event of a power outage.

	Data Retained By Backup Battery
Program memory	Internal RAM parameters, programs, device comments, file registers, symbolic information
Device memory	<ul style="list-style-type: none"> Auxiliary relay, state (for annunciator included), timer (cumulative type), counter, data register keep device Extended register Sampling trace result
Current time	Current time clock

2. Battery Handling

When the battery voltage is low, a "BAT" LED lights (red) while the power is ON, and M8005 and M8006 are switches ON. (If the battery is not installed, exact voltage can not be detected.)

Although the battery will continue to function for approximately 1 month after the "BAT" LED switches ON, a replacement battery should be ordered and installed as soon as possible.

→ For the replacement procedures, refer to Subsection 12.4.3.

11.5.3 Special "battery low-voltage" device & notification program example

Prepare a system which allows constant external monitoring of the battery status, using an indicator lamp, etc.

- M8005

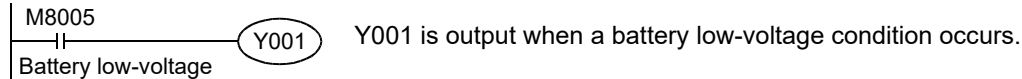

- M8006
Battery low-voltage is latched.
- D8005
Battery voltage can be monitored.

11.5.4 Battery life & replacement guidelines

FX3U-32BL battery life: Approx. 5 years (ambient temperature: 25°C(77°F))

The life of the battery changes with respect to ambient temperature. When planning for battery replacement, please estimate the battery life according to the graph to the right and order the replacement batteries in advance.

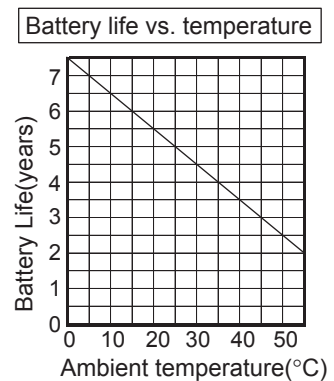

11.5.5 Battery-Free Operation

FX3UC series operation is possible without a battery (PLC's internal battery removed) when the following conditions are satisfied.

→ Refer to the FX3U/FX3UC Programming Manuals for details concerning battery-free operation.

1. A memory cassette must be installed.
2. The following devices must not be used as "keep" devices.
Auxiliary relays, state (for annunciator included), timers (cumulative type), counters, data register "keep" device, extended registers.
3. The sampling trace function must be disabled.
4. The clock function must be disabled.

11.5.6 Differences between main unit's internal battery and the optional battery

Although the optional battery (FX3U-32BL) serves as the same as the main unit's internal battery, they differ in the ways described below.

They may also have different external colors due to dates of manufacture.

	Main Unit Internal Battery	Optional Battery (Spare)
External appearance		<p>A nameplate label indicating the product model and lot No. is affixed.</p>

11.5.7 Reading the date of manufacture

1. Reading the optional battery's lot No. (reference)

Batteries with affixed nameplate labels are optional batteries.

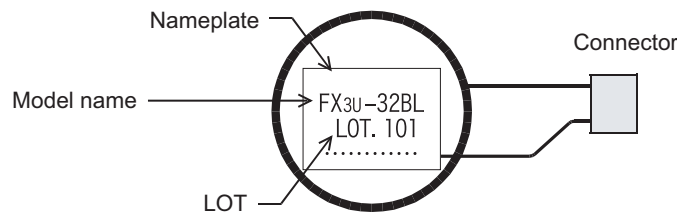

<Product during December, 2009 or earlier>

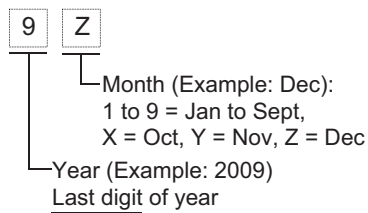

<Product from January, 2010>

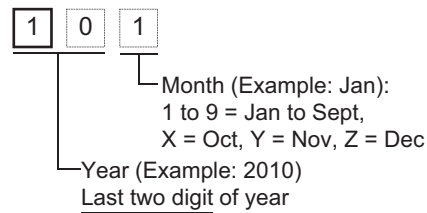

2. Reading the battery's year/month of manufacture [main unit's internal battery] (reference)

Batteries without affixed nameplate labels (refer to item 1. above) are main unit internal batteries.

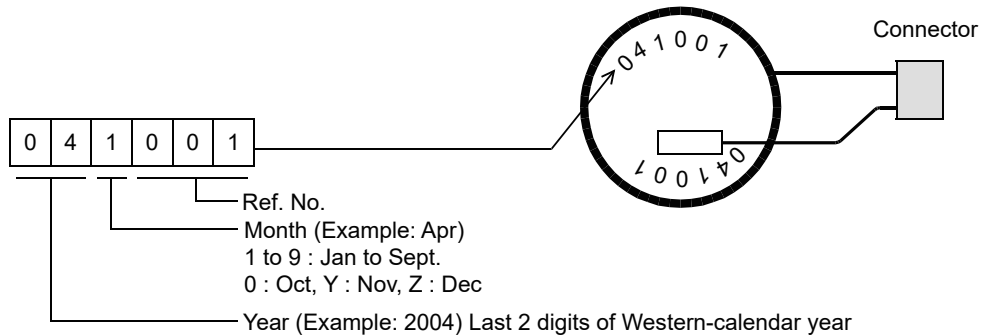

11.5.8 Battery Related Precautions

- 1) The FX3UC series uses a different battery type than those used for the FX2N (F2-40BL) and FX2NC (FX2NC-32BL) series.
- 2) When performing battery-free operation, the clock stops when the main unit power is turned OFF.

12. Test Operation, Adjustment, Maintenance and Troubleshooting

STARTUP AND MAINTENANCE PRECAUTIONS



WARNING

- Do not touch any terminal while the PLC's power is on. Doing so may cause electric shock or malfunctions.
- Before cleaning or retightening terminals cut off all phases of the power supply externally. Failure to do so may cause electric shock.
- Use the battery for memory backup correctly in conformance to this manual.
 - Use the battery only for the specified purpose.
 - Connect the battery correctly.
 - Do not charge, disassemble, heat, put in fire, short-circuit, connect reversely, weld, swallow or burn the battery, or apply excessive forces (vibration, impact, drop, etc.) to the battery.
 - Do not store or use the battery at high temperatures or expose to direct sunlight.
 - Do not expose to water, bring near fire or touch liquid leakage or other contents directly.
 - Incorrect handling of the battery may cause heat excessive generation, bursting, ignition, liquid leakage or deformation, and lead to injury, fire or failures and malfunctions of facilities and other equipment.
 - When replacing the battery, make sure to use our specified product (FX3U-32BL).
 - When a battery error occurs ("BAT" LED is lit in red), follow the description in Manual.
- Before modifying or disrupting the program in operation or running the PLC, carefully read through this manual and the associated manuals and ensure the safety of the operation. An operation error may damage the machinery or cause accidents.

STARTUP AND MAINTENANCE PRECAUTIONS



CAUTION

- Turn off the power to the PLC before attaching or detaching the memory cassette. If the memory cassette is attached or detached while the PLC's power is on, the data in the memory may be destroyed, or the memory cassette may be damaged.
- Do not disassemble or modify the PLC. Doing so may cause fire, equipment failures, or malfunctions. For repair, contact your local Mitsubishi Electric representative.
- Turn off the power to the PLC before connecting or disconnecting any extension cable. Failure to do so may cause equipment failures or malfunctions.
- Turn off the power to the PLC before attaching or detaching the following devices. Failure to do so may cause equipment failures or malfunctions.
 - Peripheral devices, display module, expansion boards and special adapters
 - Extension blocks, FX Series terminal blocks, connector conversion adapter and extension power supply unit
 - Battery and memory cassette
- Do not use the chemicals for cleaning.
- If there is the possibility of touching the PLC inside a control panel in maintenance, make sure to discharge to avoid the influence of static electricity.

DISPOSAL PRECAUTIONS



CAUTION

- Please contact a certified electronic waste disposal company for the environmentally safe recycling and disposal of your device. When disposing of batteries, separate them from other waste according to local regulations. (For details of the Battery Directive in EU countries, refer to Appendix H)

TRANSPORTATION AND STORAGE PRECAUTIONS



CAUTION

- Before transporting the PLC, turn on the power to the PLC to check that the BAT LED is off, and check the battery life. If the PLC is transported with the BAT LED on or the battery exhausted, the battery-backed data may be unstable during transportation.
- The PLC is a precision instrument. During transportation, avoid impacts larger than those specified in Section 3.1. Failure to do so may cause failures in the PLC. After transportation, verify the operations of the PLC.
- When transporting lithium batteries, follow required transportation regulations. (For details of the regulated products, refer to Appendix G)

12.1 Preparation for Test Operation

12.1.1 Preliminary inspection [power OFF]

Incorrect connection of the power supply terminal, contact of the DC input wire and power supply wire, or short-circuiting of output wires may result in serious damage.

Before applying power, check that the power supply and ground terminals are connected correctly and input/output devices are wired properly.

Notes
<p>The dielectric withstand voltage and insulation resistance test of the PLC should be measured in accordance with the following procedures.</p> <ol style="list-style-type: none"> 1) Remove all input/output wires and power supply wires from the PLC. 2) Connect all terminals except the grounding terminal with a crossover wire in the PLC single unit. 3) Measure the voltage between the crossover wire and the grounding terminal. Dielectric withstand voltage: 500V AC for 1min Insulation resistance: 5 MΩ or higher by 500 V DC insulation resistance tester

12.1.2 Connection to built-in programming connector [power ON, PLC STOP]

1 Turn on the PLC power.

Make sure that the RUN/STOP switch of the PLC is set to STOP, and turn the power on.

2 Check the program.

Check for circuit errors and grammatical errors with the program check function of the programming tool.

3 Transfer the sequence program.

Write the program to the memory cassette with the programming tool.

When the memory cassette is used

Make sure to set the PROTECT switch of the memory cassette to OFF (shown right).

→ For details on handling of the memory cassette, refer to Section 11.1.

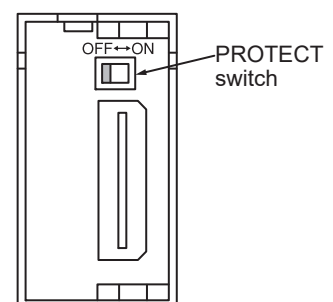

4 Verify the sequence program.

Verify that the program has been correctly written to the memory cassette.

5 Execute PLC diagnosis.

Check for errors in the PLC main body with the PLC diagnostic function of the programming tool.

→ For details on the PLC diagnosis with the display module or GX Developer, refer to Section 12.6.

12.2 Running and Stopping Procedures [Power ON]

12.2.1 Methods of running and stopping

FX3UC PLCs can be started or stopped by any of the following three methods.
Two of the methods can be combined.

1. Operation with built-in RUN/STOP switch

Operate the RUN/STOP switch on the front panel of the main unit to start and stop the PLC (refer to the following figure).

Turn the switch to RUN, and the PLC will start. Turn it to STOP, and the PLC will stop.

FX3UC-□□MT/D(SS), FX3UC-16MR/D(S)-T FX3UC-32MT-LT(-2)

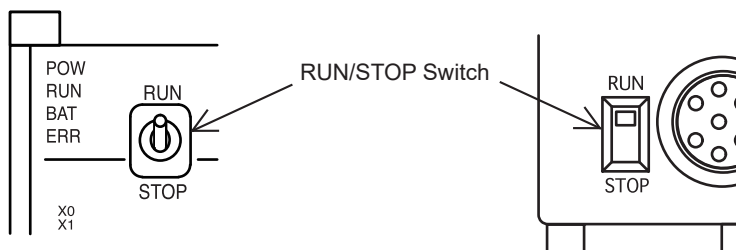

2. Running and stopping with general-purpose input (RUN terminal)

Operation with one switch (RUN)

One of the input terminals X000 to X017*1 of the main unit can be used as a RUN input terminal by a parameter setting (refer to the figure below).

When the specified input terminal is turned on, the PLC starts. When it is turned off, the PLC is started or stopped depending on the state of the built-in RUN/STOP switch.

*1. X000 to X007 for the FX3UC-16M□

- FX3UC-□□MT/D, FX3UC-16MR/D-T, FX3UC-32MT-LT(-2)

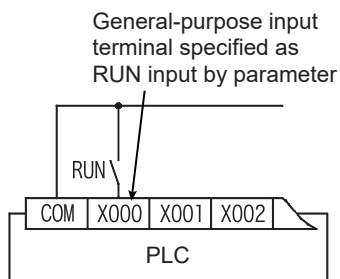

- FX3UC-□□MT/DSS, FX3UC-16MR/DS-T

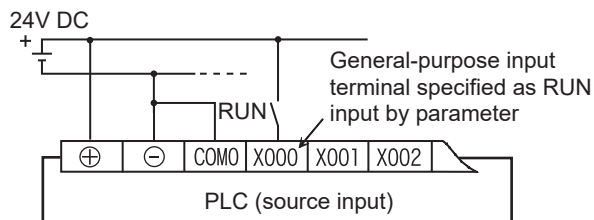
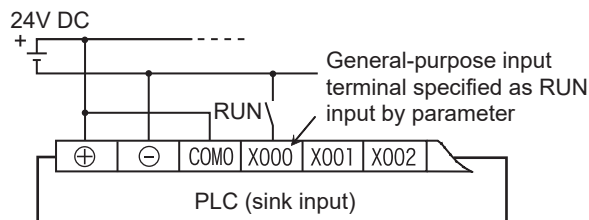

→ For details, refer to "Kinds of Parameters and Settings" in Programming Manual.

Operation with two switches (RUN and STOP)

The PLC can be started and stopped with individual RUN and STOP push button switches.

For this operation, a sequence program using M8035 to M8037 is necessary.

→ For details, refer to "Operations of Special Devices" in Programming Manual.

- FX3UC-□□MT/D, FX3UC-16MR/D-T, FX3UC-32MT-LT(-2)

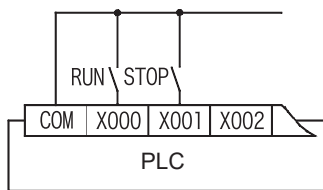

- FX3UC-□□MT/DSS, FX3UC-16MR/DS-T

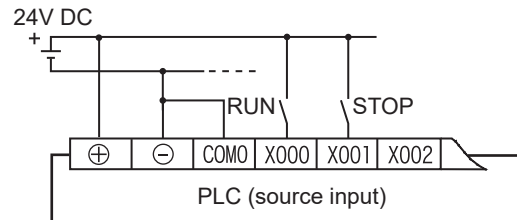
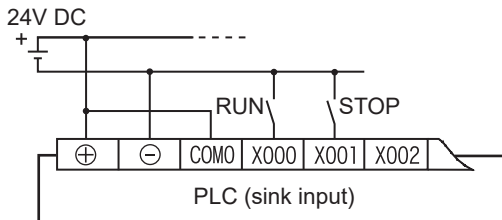

3. Starting and stopping by remote control from programming software

The programming software has a function to forcibly start and stop the PLC by remote control (remote RUN/STOP function).

However, when power is reapplied, the remote RUN/STOP function is disabled. The RUN/STOP status is then determined by the RUN/STOP switch or RUN terminal.

The remote operation for starting and stopping from the programming software is used in combination with the built-in RUN/STOP switch.

12.2.2 Use of several running/stopping methods

1. When the built-in RUN/STOP switch and the general-purpose RUN terminal are used

(without remote running/stopping operation from the programming software)

The RUN/STOP status of the PLC is determined by the conditions shown in the following table.

Condition of built-in RUN/STOP switch	Condition of general-purpose input terminal specified as RUN terminal by parameter	Status of PLC
RUN	OFF	RUN
	ON	RUN
STOP	OFF	STOP
	ON	RUN

Use either built-in RUN/STOP switch or the general input specified as RUN terminal.

(When specifying the general-purpose terminal as the RUN terminal, always set the built-in RUN/STOP switch to STOP.)

2. When the remote running/stopping operation from the programming software is performed

For this operation, keep both the built-in RUN/STOP switch and the general-purpose input RUN terminal in the STOP position.

If the stop command is given from the programming software after the PLC is started by either the built-in RUN/STOP switch or the general-purpose input RUN terminal, the PLC will be restored to the running status by giving the RUN command from the programming software. This can also be accomplished by setting the built-in RUN/STOP switch or the general-purpose input RUN terminal to STOP and then to RUN.

12.3 Operation and Test [Power ON and PLC Running]

12.3.1 Self-diagnostic function

When the PLC's power is turned on, its self-diagnostic function starts automatically. If there are no problems with the hardware, parameters or program, the PLC will start and the RUN command (refer to Section 12.2) is given (RUN LED is lit).

If any problems are found, the "ERR" LED flashes or lights.

12.3.2 Test functions

Functions of the programming tool to turn on/off the PLC devices and change the current values/settings are effective or ineffective depending on the PLC status as shown below.

✓: Effective △: Conditionally effective -: Ineffective

Item		In running status	In stopped status
Forcible ON/OFF*1	Devices used in program	△*1	✓*1
	Devices not in use	✓	✓
Change of current values of timers, counters, data registers, extension registers, extension file registers and file registers*4	Devices used in program	△*2*3	✓*3
	Devices not in use	✓*3	✓*3
Change of settings of timers and counters*5	When the program memory is the built-in RAM	✓	✓
	When the program memory is in the memory cassette and the PROTECT switch is on	-	-
	When the program memory is in the memory cassette and the PROTECT switch is off	-	✓

*1. Forcible ON/OFF

- The forcible ON/OFF function is effective on the input relays (X), output relays (Y), auxiliary relays (M), state (S), timers (T) and counters (C). On the display module, the function cannot be operated for the input relays (X).
- The forcible ON/OFF function can turn on or off the devices only for one scan.
While the PLC is running, the function is substantially effective in clearing the current values of the timers (T), counters (C), data registers (D), index registers (Z and V) and extension registers (R) and in controlling the SET/RST circuit and self-retaining circuit. (The operation to forcibly turn on timers is effective only when the timers are driven by the program.)
- The results of forcible ON/OFF operation performed while the PLC in the stopped state or performed for devices not used in the program are retained.
However, the results of the operation performed for the input relays (X) are not retained because the relays refresh input even while the PLC is in the stopped state. (They are updated according to the input terminal conditions.)

*2. Since the current values may be changed according to MOV instruction in the program and the operation results, the most recently obtained values are retained.

*3. Only display modules can change the current value by the extension file register test function.

*4. The current values of the file registers stored in the program memory cannot be monitored or tested on the display module.

*5. Change of timer and counter settings

The settings of the timers (T) and counters (C) can be changed only when the timers are driven by the program.

12.3.3 Program modification function

The sequence program can be transferred while the PLC is running or in the stopped state as shown below.
✓: Effective -: Ineffective

Item	In running status	In stopped status
Batch writing of file registers (D) and extension file registers (ER)	-	✓
Writing of program to PLC	Partial modification of program	✓*1
	Modification of whole program (batch writing)	✓
Writing of symbolic information to PLC*2	✓	✓
Writing of parameters to PLC	-	✓
Writing of comments to PLC	-	✓

- *1. Since the writing function is used in running status, the programming tool must support the write during RUN function, such as GX Works2 or GX Developer.
→ **For the writing function during running, refer to Appendix A-2-5**
- *2. GX Works2 Ver. 1.62Q or later is required to execute writing of the symbolic information.
→ **Refer to the GX Works2 Version 1 Operating Manual (Common) for the details on the writing of symbolic information.**

12.4 Maintenance

12.4.1 Periodic inspection

Consumable components resulting in a shorter product life are not built in this PLC. However, the following components have a limited life.

Part	Life
Model FX3U-32BL battery	Standard life: 5 years (at ambient temperature of 25°C (77°F))

Standard life of FX3U-32BL: 5 years (at ambient temperature of 25°C (77°F))

→ For detail of the life of the battery and frequency of replacement, refer to Subsection 11.5.4.

- Check that the temperature in the panel is not abnormally increased by other heat generating bodies or direct sunlight.
- Check that dust or conductive dust has not entered the panel.
- Check for loosening of wiring and other abnormalities.

12.4.2 Product life of relay contacts

The product life of relay contacts varies considerably depending on the load type used. Take care that loads generating reverse electromotive force or rush current may cause poor contact or deposition of contacts which may lead to considerable reduction of the contact product life.

1. Inductive load

Inductive loads generate large reverse electromotive force between contacts at shutdown, which may cause arcing. At a fixed current consumption, as the power factor (phase between current and voltage) gets smaller, the arc energy gets larger.

- 1) FX3UC-16MR/D(S)-T, Input/output extension blocks

→ For the applicable models, refer to Subsection 1.4.1, 1.4.2.

The standard life of contacts used for Inductive loads, such as contactors and solenoid valves, is 500,000 operations at 20 VA.

The following table shows the approximate life of a relay based on the results of an operation life test.

Test condition: 1 sec. ON/1 sec. OFF

	Load capacity	Contact life
20VA	0.2A/100V AC	3,000,000 times
	0.1A/200V AC	
35VA	0.35A/100V AC	1,000,000 times
	0.17A/200V AC	
80VA	0.8A/100V AC	200,000 times
	0.4A/200V AC	

2) FX Series terminal blocks

→ For the applicable models, refer to Subsection 1.4.9.

The standard life of contacts used for Inductive loads, such as contactors and solenoid valves, is 500,000 operations at 35VA.

The following table shows the approximate life of a relay based on the results of an operation life test.

Test condition: 1 sec. ON/1 sec. OFF

Load capacity		Contact life
35VA	0.35A/100V AC	3,000,000 times
	0.17A/200V AC	
80VA	0.8A/100V AC	1,000,000 times
	0.4A/200V AC	
120VA	1.2A/100V AC	200,000 times
	0.6A/200V AC	

The product life of relay contacts becomes considerably shorter than the above conditions when the rush overcurrent is shut down.

Please refer to the following measures regarding the inductive load.

→ For precautions on the FX3uc-16MR/D(S)-T, input/output extension block, refer to Subsection 6.3.4-2.

→ For precautions on inductive loads for the terminal block, refer to Subsection 8.8.4-2.

Some types of inductive loads generate rush current 5 to 15 times the stationary current at activation. Make sure that the rush current does not exceed the current corresponding to the maximum specified resistance load.

2. Lamp load

Lamp loads generally generate rush current 10 to 15 times the stationary current. Make sure that the rush current does not exceed the current corresponding to the maximum specified resistance load.

3. Capacitive load

Capacitive loads can generate rush current 20 to 40 times the stationary current. Make sure that the rush current does not exceed the current corresponding to the maximum specified resistance load. Capacitive loads such as capacitors may be present in electronic circuit loads including inverters.

* About the maximum load specifications of the resistance load, refer to the specification for each model.

→ For specifications on the FX3uc-16MR/D(S)-T, input/output extension blocks, refer to Subsection 6.3.1.

→ For specifications on the terminal block, refer to Subsection 8.8.1.

12.4.3 Procedures for replacing battery

When the battery voltage drops while the PLC power is on, the "BAT" LED on the panel is lit in red, and M8005 and M8006 (latch) are turned on.

The memory can be retained for about one month after the lamps turn on. However, the operators may not immediately find the lamps to be on. Prepare a new battery promptly, and replace the battery with the new one.

→ For details on the specifications and functions of the battery, refer to Section 11.5 "FX3U-32BL (Battery)"

Before replacing the battery

Note the followings before replacement work.

- Turn on the power supply of the PLC for more than 10 sec.
- Back up the data of the main unit with the programming tool.

Even with the battery removed, the built-in capacitor holds the data of the memory for the power interruption time (20 sec.). Battery replacement steps 6 and 7 must be completed within the power interruption time (20 sec.). If the time taken for battery replacement is longer than the power interruption time, the data of the memory may be lost.

- 1 Turn the power ON.**
- 2 Back up the data of the main unit with the programming tool.**
- 3 Turn the power OFF.**
- 4 Remove the main unit**

Disconnect all connected cables including the power cable, I/O cable, communication cable and extension cable.

Remove the main unit from the DIN rail.

→ For the removal method, refer to Section 3.3

- 5 Remove the battery cover.**

Attach a screwdriver to the battery cover on the underside of the PLC as shown in the right figure (①).

Slightly move the (②) side of the battery cover.

Grasp the cover (③) between your fingers and remove it.

(The right figure is FX3UC-32MT/D.)

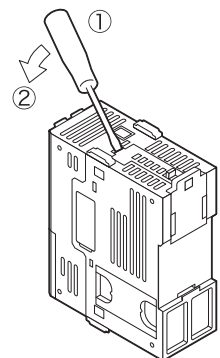

- 6 Remove the old battery.**

Extract the old battery from the battery holder, and disconnect the battery connector.

When extracting the old battery, hold the root part of the cable and pull the old battery straight out.

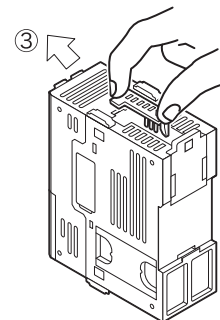

- 7 Install the new battery.**

Connect the battery connector to the new battery, and insert the battery into the battery holder.

8 Attach the battery cover.

Caution

- 1) Battery replacement requires users to verify data integrity such as the PLC program (when a memory cassette is not attached), latched (battery backed) device values and RTC values. Before switching the PLC to RUN, ensure the safety of the operation.
- 2) If the battery backed data becomes unstable, clear the latched (battery backed) devices, and transfer the data again. Set the RTC and default values again if necessary.
→ **For the clear method of keeping devices, refer to the programming manual.**
- 3) If a long time has passed since the battery voltage is reduced, the data may not be retained by the battery. Make sure to back up the data of the main unit with the programming tool before battery replacement.

12.5 Troubleshooting with LEDs

When trouble occurs, check the LEDs on the PLC to identify the problem with the PLC.

12.5.1 POW LED [on/flashing/off]

State of LED	State of PLC	Remedies
On	Power of the specified voltage is being correctly supplied to the power supply terminal.	The power supply is normal.
Flashing	One of the following problems may have occurred. <ul style="list-style-type: none"> • Power of the specified voltage and current is not being supplied to the power supply terminal. • External wiring is incorrect. • Internal error of PLC 	<ul style="list-style-type: none"> • Check the supply voltage. • After disconnecting the cables other than the power cable, re-apply power to the PLC, and check for changes in the state. If the problem persists, consult your local Mitsubishi Electric representative.
Off	One of the following problems may have occurred. <ul style="list-style-type: none"> • The power supply is off. • External wiring is incorrect. • Power of the specified voltage is not being supplied to the power supply terminal. • The power cable is broken. 	<ul style="list-style-type: none"> • If the power is not off, check the power supply and the power supply route. If power is being supplied correctly, consult your local Mitsubishi Electric representative. • After disconnecting the cables other than the power cable, re-apply power to the PLC, and check for changes in the state. If the problem persists, consult your local Mitsubishi Electric representative.

12.5.2 BAT LED [on/off]

State of LED	State of PLC	Remedies
On	The battery voltage is low.	Immediately replace the battery. (Refer to Subsection 12.4.3)
Off	The battery voltage is higher than the value set with D8006.	Normal

→ **For details on the battery, refer to Section 11.5.**

12.5.3 ERR LED [on/flashing/off]

State of LED	State of PLC	Remedies
On	A watchdog timer error may have occurred, or the hardware of the PLC may be damaged.	<ol style="list-style-type: none"> 1) Stop the PLC, and re-apply power. If ERR LED goes off, a watchdog timer error may have occurred. Take any of the following measures. <ul style="list-style-type: none"> - Review the program. The maximum value (D8012) of the scan time should not exceed the setting (D8000) of the watchdog timer. - Check that the input used for input interruption or pulse catch is not being abnormally turned on and off in one scan. - Check that the frequency of the pulse (duty of 50%) input to the high-speed counter does not exceed the specified range. - Add the WDT instructions. Add some WDT instructions to the program, and reset the watchdog timer several times in one scan. - Change the setting of the watchdog timer. Change the watchdog timer setting (D8000) in the program so that the setting is larger than the maximum value of the scan time (D8012). 2) Remove the PLC and supply power to it from another power supply on a desk. If the ERR LED goes off, noise may have affected the PLC. Take the following measures. <ul style="list-style-type: none"> - Check the ground wiring, and reexamine the wiring route and installation location. - Fit a noise filter onto the power supply line. 3) If the ERR LED does not go off even after the measures stated in (1) and (2) are taken, consult your local Mitsubishi Electric representative.
Flashing	One of the following errors has occurred in the PLC. <ul style="list-style-type: none"> • Parameter error • Syntax error • Ladder error 	Perform PLC diagnosis and program check with the programming tool. For the remedies, refer to Section 12.6 "Judgment by Error Codes and Representation of Error Codes".
Off	No errors that stop the PLC have occurred.	If the operations of the PLC are abnormal, perform PLC diagnosis and program check with the programming tool. An I/O error, Comms.error or Runtime error may have occurred.

12.5.4 L RUN LED [FX3UC-32MT-LT(-2) only]

Mode	State of LED	State of PLC	Countermeasures
ONLINE	On	Data link is being executed	-
	Off	Data link is stopped	• Take action according to the L ERR LED status.
CONFIG*1	On	Data link is being executed	-
	Off	Data link is stopped	• Take action according to the L ERR LED status.
TEST	On	Self-loop back Test was finished normally	-
	Off	Self-loop back Test was finished abnormally (Extinguished while the self-loop back Test is being executed)	<ul style="list-style-type: none"> • Make sure that the power is correctly supplied to the PLC. • If the L RUN LED is on even after the above check, consult your local Mitsubishi Electric representative.

*1. FX3UC-32MT-LT-2 only.

12.5.5 L ERR. LED [FX3UC-32MT-LT(-2) only]

Mode	State of LED	State of PLC	Countermeasures
ONLINE	On	Unit disconnection error Outside-control-range station error occurred RD station number setting error	<ul style="list-style-type: none"> Securely connect the built-in master, remote I/O station and remote device station. Make sure that the connected remote I/O units are consistent with the detailed information on remote stations.
	Flashing	All stations are abnormal	<ul style="list-style-type: none"> Securely connect the built-in master, remote I/O station and remote device station. Make sure that the connected remote I/O units are consistent with the detailed information on remote stations.
	Off	Data link is being executed normally	-
CONFIG*1	On	Use station number discrepancy (when BFM#32(20h) to #95(5Fh) is edited, the station numbers are checked.)	<ul style="list-style-type: none"> Securely connect the built-in master, remote I/O station and remote device station. Make sure that the connected remote I/O station and remote device station are consistent with the detailed information on remote stations.
	Flashing	All stations are abnormal (when BFM#32(20h) to #95(5Fh) is edited, the station numbers are checked.)	<ul style="list-style-type: none"> Confirm that the remote device station number is within the allowable range.
	Off	Data link is being executed normally	-
TEST	On	Self-loop back Test was finished abnormally	<ul style="list-style-type: none"> Make sure that the power is correctly supplied to the PLC. If the L RUN LED is on even after the above check, consult your local Mitsubishi Electric representative.
	Off	Self-loop back Test was finished normally (Extinguished while the self-loop back Test is being executed)	-

*1. FX3UC-32MT-LT-2 only.

11	Memory Cassette/Battery
12	Test Run, Maintenance, Troubleshooting
A	Version Information
B	Performance Specifications
C	Special Devices (M8000 -J, D8000 -)
D	Instruction List
E	Character-code
F	Discontinued models
G	Precautions for battery transportation
H	Handling of batteries in EU member states

12.6 Judgment by Error Codes and Representation of Error Codes

Error codes can be checked with the programming tool or on the display module (FX3UC-32MT-LT(-2) only).

12.6.1 Operation and check on display module

- 1) Move the cursor to "ErrorCheck" pressing the + or - button on the menu screen (shown right).
For the menu configuration, refer to Section 10.4.
The buttons on the menu screen work as stated below.

Operation button	Operation
ESC	The screen returns to the top screen (time display).
-	The cursor moves upward. When the button is held for 1 second or more, the cursor moves quickly. When the cursor is in the uppermost position, the button is ineffective.
+	The cursor moves downward. When the button is held for 1 second or more, the cursor moves quickly. When the cursor is in the lowermost position, the button is ineffective.
OK	The flashing item at the cursor is selected.

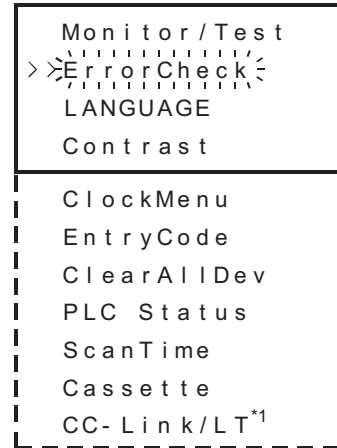

*1. FX3UC-32MT-LT-2 only.

- 2) When the OK button is pressed, an error check is performed. The results are displayed on the error display screen (shown to the right).
Pressing the ESC button on the menu screen cancels the operation and returns the screen to the Main unit I/O operation display.
- 3) If some errors have occurred, the pages can be switched with the + or - button.

Operation button	Operation
ESC	The screen returns to the Menu screen.
-	1 error or less: Ineffective operation 2 errors or more: The previous page of the error display screen is displayed.
+	1 error or less: Ineffective operation 2 errors or more: The following page of the error display screen is displayed.
OK	The screen returns to the Menu screen.

When no errors have occurred

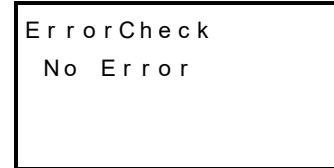

When one error has occurred

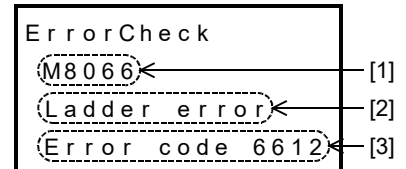

When more than one error has occurred

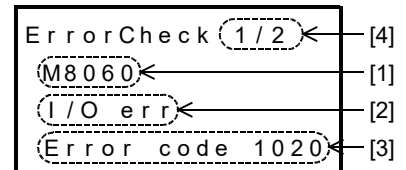

Displayed data

	Displayed data
[1]	Flag of occurred error
[2]	Error name
[3]	Error code
[4]	Number of simultaneously occurring errors (displayed only when more than one error has occurred)

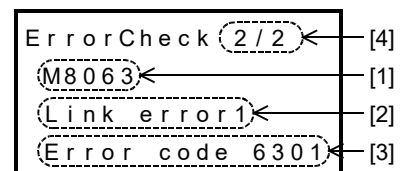

- 4) Pressing the ESC button cancels the operation and returns the screen to the Menu screen.

12.6.2 Operation and check by GX Developer

- 1 Connect the personal computer and the PLC.
- 2 Execute the PLC diagnosis.

Click [Diagnostics] → [PLC diagnostics] on the tool menu, and the diagnosis of PLC will start.

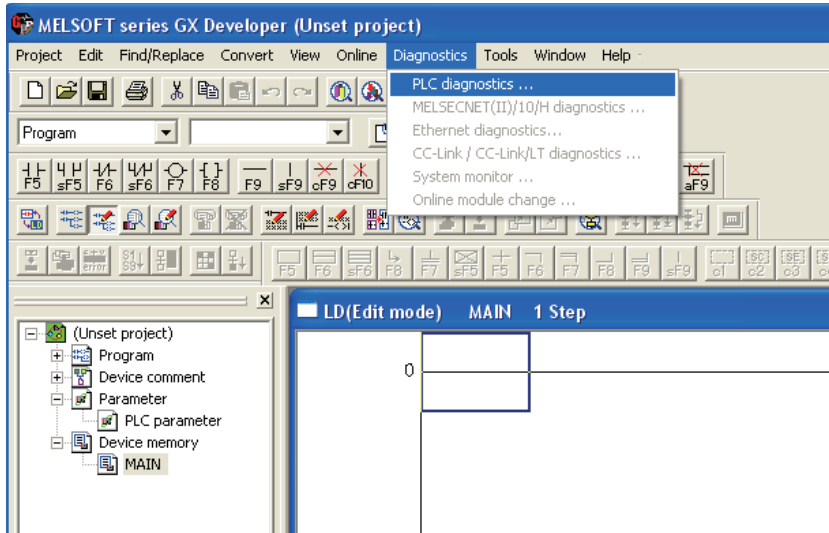

- 3 Check the results of diagnosis.

Display the following window to check the errors.

Example: one error occurs

The screenshot shows the 'PLC diagnostics' window. It includes a 'PLC panel' with LED status indicators for RUN, BATT.V, and PROG.E. The 'Error indication' section shows a table with one error entry:

No.	Detail	Error message	Error step	Year/M
1	6611	Ladder error	0	2005-

Annotations point to the 'LED status of FX PCL is displayed' (PROG.E is lit) and 'The error in PLC is displayed' (the error table entry). A 'Help' button labeled 'PLC error' is also shown, with an annotation: 'Open the help window of GX Developer to check the error details.'

12.6.3 Representation of errors

Errors are represented in this manual, GX Works2, GX Developer, and the display module as shown in the following table.

- Comparison between this manual and GX Works2

This manual	GX Works2	
	SW□DNC-GXW2-E	SW□DNC-GXW2-J
I/O configuration error	I/O Configuration Error	I/O構成エラー
PLC hardware error	PLC Hardware Error	PCハードエラー
PLC/PP communication error	PLC/PP Communication Error	PC/PP通信エラー
Serial communication error 1 [ch1]	Link Error	リンクエラー
Serial communication error 2 [ch2]	Serial Communication Error 2[ch2]	シリアル通信エラー2 [ch2]
Parameter error	Parameter Error	パラメータエラー
Syntax error	Syntax Error	文法エラー
Circuit error	Ladder Error	回路エラー
Operation error	Operation Error	演算エラー
Special block error	Special Block Error	特殊ブロックエラー
Special parameter error	Special Parameter Error	特殊パラメータエラー

- Comparison between this manual and GX Developer

This manual	GX Developer	
	SW□D5C-GPPW-E	SW□D5C-GPPW-J
I/O configuration error	I/O config err	I/O 構成エラー
PLC hardware error	PLC H/W error	PC ハードウェア エラー
PLC/PP communication error	PLC/PP comm err	PC/PP 通信 エラー
Serial communication error 1 [ch1]	Link error	リンク エラー
Serial communication error 2 [ch2]	Link Error 2	シリアル通信エラー (CH2)
Parameter error	Param error	パラメータ エラー
Syntax error	Syntax error	文法 エラー
Circuit error	Ladder error	回路 エラー
Operation error	Operation err	演算 エラー
Special block error	SFB Error	特殊ブロックエラー
Special parameter error	-	-

- Comparison between this manual and the display module

This manual	Display module	
	Display in English	Display in Japanese
I/O configuration error	I/O error	I/O構成エラー
PLC hardware error	PC H/W error	PCハード エラー
PLC/PP communication error	Comms.error	PC/PP通信エラー
Serial communication error 1 [ch1]	Link error1	シリアル通信エラー1
Serial communication error 2 [ch2]	Link error2	シリアル通信エラー2
Parameter error	Parameter error	パラメータエラー
Syntax error	Grammer error	文法エラー
Circuit error	Ladder error	回路エラー
Operation error	Runtime error	演算エラー
Special block error	SFB error	特殊ブロックエラー
Special parameter error	-	-

12.6.4 Error Code List and Action

When a program error occurs in the PLC, the error code is stored in the special data registers D8060 to D8067, D8438, D8449 and D8489, and the error bit turns ON in the special data register D8166 as follows. Take action based on the following information.

Error code	PLC operation at error occurrence	Contents of error	Action				
I/O configuration error [M8060(D8060)]							
Ex-ample: 1020	Continues operation	<p>The head number of unconnected I/O device Example: When X020 is unconnected</p> <div style="display: flex; align-items: center;"> <table border="1" style="border-collapse: collapse; text-align: center;"> <tr> <td style="padding: 2px 5px;">1</td> <td style="padding: 2px 5px;">0</td> <td style="padding: 2px 5px;">2</td> <td style="padding: 2px 5px;">0</td> </tr> </table> <div style="margin-left: 10px;">BCD conversion value</div> </div> <p style="margin-left: 40px;"> </p> <ul style="list-style-type: none"> 1st to 3rd digits: Device number 4th digit: I/O type (1 = input (X), 0 = output (Y)) <p>Example: When 1020 is stored in D8060 Inputs X020 and later are unconnected.</p>	1	0	2	0	Unconnected I/O relay numbers are programmed. The PLC continues its operation. Modify the program, check wiring connection, or add the appropriate unit/block.
1	0	2	0				
Serial communication error 2 [M8438 (D8438)]							
0000	-	No error					
3801	Continues operation	Parity, overrun or framing error	<ul style="list-style-type: none"> Ethernet communication, inverter communication, computer link and programming: Ensure the parameters are correctly set according to their applications. N:N network, parallel link, MODBUS communication, etc.: Check programs according to the applications. Remote maintenance: Ensure modem power is ON and check the settings of the AT commands. Wiring: Check the communication cables for correct wiring. 				
3802		Communication character error					
3803		Communication data sum check error					
3804		Communication data format error					
3805		Command error					
3806		Communication time-out detected					
3807		Modem initialization error					
3808		N:N network parameter error					
3809		N:N Network setting error					
3812		Parallel link character error					
3813		Parallel link sum error					
3814		Parallel link format error					
3820		Inverter communication error					
3821	MODBUS communication error						
3830		Memory access error	When the memory cassette is used, check whether it is mounted correctly. If the problem persists or if the memory cassette is not used, something may be malfunctioning inside the PLC. Consult your local Mitsubishi Electric representative.				
3840		Special adapter connection error	Check connection of the special adapter.				
PLC hardware error [M8061(D8061)]							
0000	-	No error					
6101	Stops operation	Memory access error	When the memory cassette is used, check whether it is mounted correctly. If the problem persists, something may be malfunctioning inside the PLC. Consult your local Mitsubishi Electric representative.				
6102		Operation circuit error	<p>Isolate the PLC and supply power to it using a different power supply. If the ERR LED turns OFF, noise may be affecting the PLC. Take the following measures.</p> <ul style="list-style-type: none"> - Check the ground wiring, and reexamine the wiring route and installation location. - Fit a noise filter onto the power supply line. <p>If the ERR LED does not turn OFF even after the above actions are taken, consult your local Mitsubishi Electric representative.</p>				

11	Memory Cassette/Battery
12	Test Run, Maintenance, Troubleshooting
A	Version Information
B	Performance Specifications
C	Special Devices (M8000 -D8000 -)
D	Instruction List
E	Character-code
F	Discontinued models
G	Precautions for battery transportation
H	Handling of batteries in EU member states

Error code	PLC operation at error occurrence	Contents of error	Action
PLC hardware error [M8061(D8061)]			
6103	Stops operation	I/O bus error (M8069 = ON)	Verify that extension cables are correctly connected.
6104		Powered extension unit 24 V failure (M8069 = ON)	
6105		Watchdog timer error	Check user program. The scan time exceeds the value stored in D8000.
6106		I/O table creation error (CPU error)	When turning the power ON to the main unit, a 24V power failure occurs in a powered extension unit. (The error occurs if the 24V power is not supplied for 10 seconds or more after the main power is turned ON.) When the power was turned ON, I/O assignment was disabled for the built-in FX3UC-32MT-LT CC-Link/LT.
6107		System configuration error	Check the number of the connected special function units/blocks. For certain special function units/blocks, the connectable number is limited.
6108		Extension bus error	Verify that extension cables are correctly connected.
6112		Changed settings for the built-in CC-Link/LT special function block cannot be written to the attached flash memory cassette.	Verify that the memory cassette is installed correctly.
6113		Changed settings for the built-in CC-Link/LT special function block cannot be written to the attached write-protected flash memory cassette.	Set the protect switch to OFF.
6114		CC-Link/LT settings cannot be written to the built-in CC-Link/LT special function block.	Set the configuration again. If the problem persists, something may be malfunctioning inside the PLC. Consult your local Mitsubishi Electric representative.
6115		A built-in CC-Link/LT special function block EEPROM writing time-out error occurred, or the built-in CC-Link/LT special function block configuration could not be completed normally in self CONFIG mode.	
PLC/PP communication error (D8062)			
0000	-	No error	
6201	Continues operation	Parity, overrun or framing error	Check the cable connection between the programming panel (PP)/programming device and the PLC. This error may occur when a cable is disconnected and reconnected during PLC monitoring.
6202		Communication character error	
6203		Communication data sum check error	
6204		Data format error	
6205		Command error	
6230		Memory access error	

Error code	PLC operation at error occurrence	Contents of error	Action		
Serial communication error 1 [M8063 (D8063)]					
0000	-	No error			
6301	Continues operation	Parity, overrun or framing error	<ul style="list-style-type: none"> Ethernet communication, inverter communication, computer link and programming: Ensure the parameters are correctly set according to their applications. N:N network, parallel link, MODBUS communication, etc.: Check programs according to applications. Remote maintenance: Ensure modem power is ON and check the settings of the AT commands. Wiring: Check the communication cables for correct wiring. 		
6302		Communication character error			
6303		Communication data sum check error			
6304		Communication data format error			
6305		Command error			
6306		Communication time-out detected			
6307		Modem initialization error			
6308		N:N network parameter error			
6309		N:N Network setting error			
6312		Parallel link character error			
6313		Parallel link sum error			
6314		Parallel link format error			
6320		Inverter communication error			
6321		MODBUS communication error			
6330		Memory access error	<p>When the memory cassette is used, check whether it is mounted correctly.</p> <p>If the problem persists or if the memory cassette is not used, something may be malfunctioning inside the PLC. Consult your local Mitsubishi Electric representative.</p>		
6340		Special adapter connection error	Check connection of the special adapter.		
Parameter error [M8064(D8064)]					
0000	-	No error			
6401	Stops operation	Program sum check error	<ul style="list-style-type: none"> STOP the PLC, and correctly set the parameters. Check that the following functions are not used with an unsupported PLC version when a memory cassette is attached: <ul style="list-style-type: none"> Permanent PLC lock (supported in Ver. 2.61 or later) Read-protect the execution program for block passwords (supported in Ver. 3.00 or later) FX3U-FLROM-1M (supported in Ver. 3.00 or later) 		
6402		Memory capacity setting error			
6403		Latched device area setting error			
6404		Comment area setting error			
6405		File register area setting error			
6406		Special unit (BFM) initial value setting, positioning instruction setting sum check error			
6407		Special unit (BFM) initial value setting, positioning instruction setting error			
6409		Other setting error			
6411		Built-in CC-Link/LT special function block invalid parameter settings (LT-2 dedicated area).			
6412		Built-in CC-Link/LT special function block parameter settings sum check error (special function settings area).			
6413		Built-in CC-Link/LT special function block parameter settings sum check error (LT-2 dedicated area).			
6420				Special parameter sum check error	<ul style="list-style-type: none"> STOP the PLC, and correctly set the special parameters. Set special parameters correctly, turn OFF the power, and then turn ON the power.
6421				Special parameters setting error	<ul style="list-style-type: none"> Check the contents of the special parameter error code (D8489), confirm troubleshooting for special adapters/special blocks, and set special parameters correctly. Set special parameters correctly, turn OFF the power, and then turn ON the power.

11	Memory Cassette/Battery
12	Test Run, Maintenance, Troubleshooting
A	Version Information
B	Performance Specifications
C	Special Devices (M8000 -D8000 -)
D	Instruction List
E	Character-code
F	Discontinued models
G	Precautions for battery transportation
H	Handling of batteries in EU member states

Error code	PLC operation at error occurrence	Contents of error	Action
Syntax error [M8065(D8065)]			
0000	-	No error	
6501	Stops operation	Incorrect combination of instruction, device symbol and device number	During programming, each instruction is checked. If a syntax error is detected, modify the instruction correctly.
6502		No OUT T or OUT C before setting value	
6503		<ul style="list-style-type: none"> No setting value after OUT T or OUT C Insufficient number of operands for an applied instruction 	
6504		<ul style="list-style-type: none"> Same label number is used more than once. Same interrupt input or high-speed counter input is used more than once. 	
6505		Device number is out of allowed range.	
6506		Invalid instruction	
6507		Invalid label number [P]	
6508		Invalid interrupt input [I]	
6509		Other error	
6510		MC nesting number error	
Circuit error [M8066(D8066)]			
0000	-	No error	
6610	Stops operation	LD, LDI is continuously used 9 times or more.	This error occurs when a combination of instructions is incorrect in the entire circuit block or when the relationship between a pair of instructions is incorrect. Modify the instructions in the program mode so that their mutual relationship becomes correct.
6611		More ANB/ORB instructions than LD/LDI instructions	
6612		Less ANB/ORB instructions than LD/LDI instructions	
6613		MPS is continuously used 12 times or more.	
6614		No MPS instruction	
6615		No MPP instruction	
6616		No coil between MPS, MRD and MPP, or incorrect combination	
6617		Instruction below is not connected to bus line: STL, RET, MCR, P, I, DI, EI, FOR, NEXT, SRET, IRET, FEND or END	
6618		STL, MC or MCR can be used only in main program, but it is used elsewhere (e.g. in interrupt routine or subroutine).	
6619		Invalid instruction is used in FOR-NEXT loop: STL, RET, MC, MCR, I (interrupt pointer) or IRET.	
6620		FOR-NEXT instruction nesting level exceeded	
6621		Numbers of FOR and NEXT instructions do not match.	
6622		No NEXT instruction	
6623		No MC instruction	
6624		No MCR instruction	
6625		STL instruction is continuously used 9 times or more.	
6626		Invalid instruction is programmed within STL-RET loop: MC, MCR, I (interrupt pointer), SRET or IRET.	
6627		No STL instruction	
6628		Invalid instruction is used in main program: I (interrupt pointer), SRET or IRET	
6629		No P or I (interrupt pointer)	
6630	No SRET or IRET instruction STL-RET or MC-MCR instructions in subroutine		
6631	SRET programmed in invalid location		
6632	FEND programmed in invalid location		

Error code	PLC operation at error occurrence	Contents of error	Action	
Operation error [M8067(D8067)]				
0000	-	No error		
6701	Continues operation	<ul style="list-style-type: none"> No jump destination (pointer) for CJ or CALL instruction Label is undefined or out of P0 to P4095 due to indexing Label P63 is executed in CALL instruction; cannot be used in CALL instruction as P63 is for jumping to END instruction. 	<p>This error occurs in the execution of operation. Review the program and check the contents of the operands used in applied instructions. Even if the syntax or circuit design is correct, an operation error may still occur. For example: "T500Z" itself is not an error. But if Z had a value of 100, the timer T600 would attempt to be accessed. This would cause an operation error since there is no T600 device available.</p>	
6702		CALL instruction nesting level is 6 or more		
6703		Interrupt nesting level is 3 or more		
6704		FOR-NEXT instruction nesting level is 6 or more.		
6705		Operand of applied instruction is inapplicable device.		
6706		Device number range or data value for operand of applied instruction exceeds limit.		
6707		File register is accessed without parameter setting of file register.		
6708		FROM/TO instruction error		<p>This error occurs in the execution of operation.</p> <ul style="list-style-type: none"> Review the program and check the contents of the operands used in applied instructions. Verify that the specified buffer memories exist in the counterpart equipment. Verify that extension cables are correctly connected.
6709		Other (e.g. improper branching)		<p>This error occurs in the execution of operation. Review the program and check the contents of the operands used in applied instructions. Even if the syntax or circuit design is correct, an operation error may still occur. For example: "T500Z" itself is not an error. But if Z had a value of 100, the timer T600 would attempt to be accessed. This would cause an operation error since there is no T600 device available.</p>
6710		Mismatch among parameters		<p>This error occurs when the same device is used within the source and destination in a shift instruction, etc.</p>
6730		Incorrect sampling time (TS) ($TS \leq 0$)		<p><PID instruction is stopped.> This error occurs in the parameter setting value or operation data executing PID instruction. Check the contents of the parameters.</p>
6732		Incompatible input filter constant (α) ($\alpha < 0$ or $100 \leq \alpha$)		
6733		Incompatible proportional gain (KP) ($KP < 0$)		
6734		Incompatible integral time (TI) ($TI < 0$)		
6735		Incompatible derivative gain (KD) ($KD < 0$ or $201 \leq KD$)		
6736		Incompatible derivative time (TD) ($TD < 0$)		
6740		Sampling time (TS) \leq Scan time		
6742	Variation of measured value exceeds limit. ($\Delta PV < -32768$ or $+32767 < \Delta PV$)	<p><PID operation is continued.> The operation is continued with each parameter set to the maximum or minimum value.</p>		
6743	Deviation exceeds limit. ($EV < -32768$ or $+32767 < EV$)			
6744	Integral result exceeds limit. (Outside range from -32768 to $+32767$)			
6745	Derivative value exceeds limit due to derivative gain (KD).			
6746	Derivative result exceeds limit. (Outside range from -32768 to $+32767$)			
6747	PID operation result exceeds limit. (Outside range from -32768 to $+32767$)			

11	Memory Cassette/Battery
12	Test Run, Maintenance, Troubleshooting
A	Version Information
B	Performance Specifications
C	Special Devices (M8000 -J, D8000 -)
D	Instruction List
E	Character-code
F	Discontinued models
G	Precautions for battery transportation
H	Handling of batteries in EU member states

Error code	PLC operation at error occurrence	Contents of error	Action
Operation error [M8067(D8067)]			
6748	Continues operation	PID output upper limit set value < PID output lower limit set value.	<Transpose of output upper limit value and output lower limit value. → PID operation is continued.> Check whether the target setting contents are correct.
6749		Abnormal PID input variation alarm set value or output variation alarm set value (Set value < 0)	<Alarm output is not given. → PID operation is continued.> Check whether the target setting contents are correct.
6750		<Step response method> Improper auto tuning result	<Auto tuning is finished. → PID operation is started.> <ul style="list-style-type: none"> When auto tuning was started, the difference between the measured value and the target value was 150 or less. (SV – PV ≤ 150) When auto tuning was started, the difference between the measured value and the target value was 1/3 or more. Check the measured value and target value, and then execute auto tuning again.
6751		<Step response method> Auto tuning operation direction mismatch	<Auto tuning is forcibly finished. → PID operation is not started.> The operation direction estimated from the measured value at the start of auto tuning was different from the actual operation direction of the output during auto tuning. Correct the relationship among the target value, output value for auto tuning, and the measured value, and then execute auto tuning again.
6752		<Step response method> Improper auto tuning operation	<Auto tuning is finished. → PID operation is not started.> Because the set value was fluctuated during auto tuning, auto tuning was not executed correctly. Set the sampling time to a value larger than the output change cycle, or set a larger value for the input filter constant. After changing the setting, execute auto tuning again.
6753		<Limit cycle method> Abnormal output set value for auto tuning [ULV (upper limit) ≤ LLV (lower limit)]	<Auto tuning is forcibly finished. → PID operation is not started.>
6754		<Limit cycle method> Abnormal PV threshold (hysteresis) set value for auto tuning (SHPV < 0)	Check whether the target setting contents are correct.
6755		<Limit cycle method> Abnormal auto tuning transfer status (Data of device controlling transfer status is abnormally overwritten.)	<Auto tuning is forcibly finished. → PID operation is not started.> Ensure that devices occupied by PID instruction are not overwritten in the program.
6756		<Limit cycle method> Abnormal result due to excessive auto tuning measurement time ($\tau_{on} > \tau$, $\tau_{on} < 0$, $\tau < 0$)	<Auto tuning is forcibly finished. → PID operation is not started.> The auto tuning time is longer than necessary. Increase the difference (ULV - LLV) between the upper limit and lower limit of the output value for auto tuning, set a smaller value to the input filter constant (α), or set a smaller value to the PV threshold (SHPV) for auto tuning, and then check the result for improvement.
6757		<Limit cycle method> Auto tuning result exceeds proportional gain. (KP = outside range from 0 to 32767)	<Auto tuning is finished (KP = 32767). → PID operation is started.> The variation of the measured value (PV) is small compared with the output value. Multiply the measured value (PV) by "10" so that the variation of the measured value will increase during auto tuning.

Error code	PLC operation at error occurrence	Contents of error	Action
Operation error [M8067(D8067)]			
6758	Continues operation	<Limit cycle method> Auto tuning result exceeds integral time. (Ti = outside range from 0 to 32767)	<Auto tuning is finished (KP = 32767). → PID operation is started.> The auto tuning time is longer than necessary. Increase the difference (ULV - LLV) between the upper limit and lower limit of the output value for auto tuning, set a smaller value to the input filter constant (α), or set a smaller value to the PV threshold (SHPV) for auto tuning, and then check the result for improvement.
6759		<Limit cycle method> Auto tuning result exceeds derivative time. (Td = outside range from 0 to 32767)	
6760		ABS data read from servo sum check error	Check servo wiring and parameter setting. Also check ABS instruction.
6762		Port specified by inverter communication instruction is already used in another communication.	Check to make sure the port is not specified by another instruction.
6763		1) Input (X) specified by DSZR, DVIT or ZRN instruction is already used in another instruction. 2) The interrupt signal device for DVIT instruction is outside the allowable setting range.	1) Check to make sure the input (X), as specified by DSZR, DVIT or ZRN instruction, is not being used for the following purposes: - Input interrupt (including the delay function) - High-speed counter C235 to C255 - Pulse catch M8170 to M8177 - SPD instruction 2) Check the contents of D8336 for the correct interrupt signal specification for DVIT instruction.
6764		Pulse output number is already used in a positioning instruction or pulse output instruction (PLSY, PWM, etc.).	Check to make sure the pulse output destination is not being driven by another positioning instruction.
6765		Number of applied instruction exceeds limit.	The number of times an applied instruction is used in the program exceeds the specified limit.
6770		Memory access error	When the memory cassette is used, check whether it is mounted correctly. If the problem persists or if the memory cassette is not used, something may be malfunctioning inside the PLC. Consult your local Mitsubishi Electric representative.
6771		Memory cassette is not connected.	Check whether the memory cassette is mounted correctly.
6772		Memory cassette is write protected.	The write-protect switch of the memory cassette was set to ON when data was transferred to the flash memory.
6773		Access error to flash memory during writing in RUN mode	While data was written in the RUN mode, data was transferred to (read from or written to) the flash memory.

Error code	PLC operation at error occurrence	Contents of error	Action
Special block error [M8449 (D8449)]			
□020* ¹	Continues operation	General data sum error	Verify that extension cables are correctly connected.
□021* ¹		General data message error	
□022* ¹		System access error	
□025* ¹		Access sum error in other station via CC-Link	
□026* ¹		Message error in other station via CC-Link	
□030* ¹		Memory access error	When the memory cassette is used, check whether it is mounted correctly. If the problem persists or if the memory cassette is not used, something may be malfunctioning inside the PLC. Consult your local Mitsubishi Electric representative.
□080* ¹	FROM/TO error	This error occurs in the execution of operation. <ul style="list-style-type: none"> Review the program and check the contents of the operands used in applied instructions. Verify that the specified buffer memories exist in the counterpart equipment. Verify that extension cables are correctly connected. 	
□090* ¹	Peripheral equipment access error	<ul style="list-style-type: none"> Check the cable connection between the programming panel (PP)/programming device and the PLC. Verify that extension cables are correctly connected. 	
Special parameter error [M8489 (D8489)]			
□□01* ²	Continues operation	Special parameter setting time-out error	Turn OFF the power, and check the power supply and connection of special adapters/special blocks.
□□02* ²		Special parameter setting error	Special parameters are set improperly. <ul style="list-style-type: none"> Confirm troubleshooting for special adapters/special blocks, and set special parameters correctly. Set special parameters correctly, turn OFF the power, and then turn ON the power.
□□03* ²		Special parameter transfer target unconnected error	Special parameters are set, but special adapters/special blocks are not connected. Check whether special adapters/special blocks are connected.
□□04* ²		Special parameter unsupported function	Check that special parameters with unsupported settings are not set for connected special adapters/special blocks.

*1. The unit number 0 to 7 of the special function unit/block error is put in □.

*2. "□□" indicates the following values for each special adapter/special block where an error has occurred.

If an error has occurred in 2 or more special adapters/special blocks, "□□" indicates the lowest unit number among the special adapters/special blocks in which an error has occurred.

Value of □□ (decimal)	Special adapter/special block where an error has occurred
00	Unit number 0 (Special block)
10	Unit number 1 (Special block)
20	Unit number 2 (Special block)
30	Unit number 3 (Special block)
40	Unit number 4 (Special block)
50	Unit number 5 (Special block)
60	Unit number 6 (Special block)
70	Unit number 7 (Special block)
81	Communication channel 1 (Special adapter)
82	Communication channel 2 (Special adapter)

Error code	PLC operation at error occurrence	Contents of error	Action
Special block error condition [D8166]			
b0	Continues operation	Unit 0 access error	This error occurs when an operation is executed or when the END instruction is executed. <ul style="list-style-type: none"> Review the program and check the contents of the operands used in applied instructions. Verify that the specified buffer memories exist in the counterpart equipment. Verify that extension cables are correctly connected.
b1		Unit 1 access error	
b2		Unit 2 access error	
b3		Unit 3 access error	
b4		Unit 4 access error	
b5		Unit 5 access error	
b6		Unit 6 access error	
b7		Unit 7 access error	
b8 to b15	-	Not used	

11
Memory
Cassette/Battery

12
Test Run,
Maintenance,
Troubleshooting

A
Version
Information

B
Performance
Specifications

C
Special Devices
(M8000 -J, D8000 -)

D
Instruction List

E
Character-code

F
Discontinued
models

G
Precautions for
battery
transportation

H
Handling of
batteries in EU
member states

12.7 FX3UC-32MT-LT(-2) Built-in CC-Link/LT Troubleshooting

12.7.1 Status of each station during abnormal operation

The table below shows the status of each station when an abnormal operation has occurred.

Data link status		Status of each station			
		Built-in master station		Remote station	
		Remote input	Remote output	Input	Output
When an abnormality has occurred in the PLC, the PLC is stopped. (The data link in the entire system is continued.)	Program error	-	Clears.	Continues the operation. (Input LED is lit.)	Clears.
	CPU error	-	Clears.		Clears.
When a remote station becomes abnormal (by data link error, etc.) (The data link in the entire system is continued.)		Clears inputs from a remote station in the abnormal status.	Continues the operation.	Continues the operation, but disables data transfer to the master station. (Input LED is lit.)	Depends on the DIP switch status.
When the power is interrupted in a remote station (The data link in the entire system is continued.)		Clears inputs from a remote station where the power is interrupted.	Continues the operation.	Depends on the external signal.	Turns OFF all points.

Holds the status.

Holds the ON/OFF status just before abnormality occurrence.

Continues the operation.

Executes the same operation as that in the normal status even if abnormality has occurred.

Clears.

Turns OFF inputs or outputs when abnormality has occurred.

- When monitoring a remote station and a program error occurs in the PLC, inputs on the monitoring device may turn ON and OFF repeatedly. When the program error is cleared, inputs will return to their correct state.

12.7.2 Operation at blowout of built-in power fuse for CC-Link/LT

A dedicated fuse is built into the built-in power supply circuit for CC-Link/LT. The system does not have a function to detect a blown fuse, but the following abnormality occurs when the fuse is blown.

- Link error in all stations (BFM#29 b1)
- The power is turned OFF in a remote station that normally receives power from the main unit.

When the above abnormalities occur at the same time, the power fuse for CC-Link/LT may be blown out. Consult your local Mitsubishi Electric representative.

12.7.3 Detailed error information [BFM #29 (1Dh)]

1. Detailed description

Each type of error is assigned to a bit of the buffer memory [BFM #29 (1Dh)]. The status is indicated by the 0 (OFF)/1 (ON) status of each bit.

Bit	Function	Description	Error flag restoration operation
b0	Link error in some stations	Turns ON when link error has occurred in some stations. [Turns ON when any bit in BFM #4 (4h) to 7 (7h) have turned ON.] For the station number in which the error has occurred, refer to the link error station information [BFM #4 (4h) to 7 (7h)].	When the cause of the error is eliminated, the error flag is automatically restored.
b1	Link error in all stations	Turns ON when data link error has occurred in all stations.	When the cause of the error is eliminated, the error flag is automatically restored.
b2	Remote I/O error	Turns ON when remote I/O error has occurred. [Turns ON when any bit in BFM #8 (8h) to 11 (Bh) have turned ON.] For the station number, refer to the remote I/O error information [BFM #8 (8h) to 11 (Bh)]. For the type of error, refer to the instruction manual of the appropriate remote station.	When the cause of the error is eliminated, the error flag is automatically restored.
b3	Out-of-control-range station error	Turns ON when a remote station not registered in the detailed remote station information [BFM #32 (20h) to #95 (5Fh)] is connected to the network.	If the station number of the connected remote station is smaller than the final station number, the error flag is automatically restored when the cause of the error is eliminated. If the station number of the connected remote station is larger than the final station number, the error flag is restored when the cause of the error is eliminated and is followed by a power reset.
b4	Transmission speed setting error	Turns ON when the transmission speed setting DIP switch is set to an incompatible position.	When the cause of the error is eliminated, and power is reset, the error flag is automatically restored.
b5	-	Prohibited to use	-
b6	RD station setting error	Turns ON when a RD station is connected to a station number outside the range No. 49 to No. 64. Turns ON when a RD station is used in 4-point mode.	When the cause of the error is eliminated and the power is reset, the error flag is automatically restored.
b7	EEPROM error	Turns ON when a RD station is connected to a station number outside the range No. 49 to No. 64. Turns ON when a RD station is used in 4-point mode.	If the case that a request to write to the EEPROM is given in any mode other than CONFIG mode, the error flag is automatically restored when the request to write to the EEPROM is cleared. In the case of EEPROM write error or read error, the error flag is not restored.
b8	DIP switch changed	Turns ON when the DIP switch setting is changed during operation.	When the DIP switch setting is returned to original status at the time of power ON, the error flag is automatically restored. If the DIP switch setting must be changed, reset the power.
b9 to b14	-	Prohibited to use	-
b15	Hardware error	Turns ON when an abnormality is detected in the self-loop-back test.	This error flag is not restored because something is wrong with the hardware.

12.7.4 Self check (FX3UC-32MT-LT-2)

Use the FX3UC-32MT-LT-2 display module.
It is not necessary to connect remote stations in this test.

1. Procedure

1 STOP the PLC

2 Setup Self Check

- 1) On the menu screen, use the [+] or [-] button to move the cursor to "CC-Link/LT", and then press the [OK] button. The "CC-Link/LT Mode confirmation" screen will be displayed for 0.5 seconds, and then the "CC-Link/LT settings menu" screen, shown on the right, will appear.

```
Reserve Statn
Baud Rate
>>Self-Check
```

Press the [ESC] button to cancel the operation and return to the "Main unit I/O operation display" screen.

- 2) Use the [+] or [-] button to move the cursor to "Self-Check", and then press the [OK] button. The screen shown on the right will appear.

```
Self-Check
start
OK → Execute
ESC → Cancel
```

Press the [ESC] button to cancel the operation and return to the menu screen.

- 3) Press [OK] to start the self check.
Or, press [ESC] to cancel the operation.

Button	Operation Description
ESC	Cancels the operation and returns to the "CC-Link/LT settings menu".
-	Disabled
+	Disabled
OK	Displays the "Self check completed" screen.

- 4) If the self check function is setup successfully, the screen shown on the right will appear.

```
Reset system
power to begin
Self-Check
```

Button	Operation Description
ESC	Returns to the "CC-Link/LT settings menu" screen.
-	Disabled
+	Disabled
OK	Returns to the "menu screen".

- Result and measures to take:
 - The self check function will not be setup if the message "Self-Check can not be started" is displayed. Turn OFF the power, confirm the remote station connection status, and then perform the procedure again from the beginning.

```
Self-Check
can not be
started
```

3 Turn the power OFF and then ON again

Turn the PLC power OFF and then ON again.

When using a power supply adapter or dedicated power supply, turn ON the power in the order "Power supply adapter (or dedicated power supply) → PLC (built-in master)".

4 Start the test, and check the status indicator LEDs.

The test (self-loop-back test) is completed in several seconds.
The L RUN LED turns ON during normal status. The L ERR LED turns ON during error status.
Refer to "Contents indicated by status indicator LEDs and countermeasures" below.

2. Contents indicated by status indicator LEDs and countermeasures

The table below shows the descriptions of errors indicated by the status indicator LEDs and their countermeasures.

Status indicator LEDs	Description		Countermeasures
L RUN	On	Self-loop-back Test was finished normally	-
	Off	Self-loop-back Test was finished abnormally (Not on while the self-loop-back test is being executed)	<ul style="list-style-type: none"> Make sure that the power is correctly supplied to the PLC. If the L RUN LED is on even after the above check, consult your local Mitsubishi Electric representative.
L ERR.	On	Self-loop back Test was finished abnormally	<ul style="list-style-type: none"> Make sure that the power is correctly supplied to the PLC. If the L RUN LED is on even after the above check, consult your local Mitsubishi Electric representative.
	Off	Self-loop back Test was finished normally (Not on while the self-loop-back test is being executed)	-

12.7.5 Self check (FX3UC-32MT-LT)

Use the DIP switches in the FX3UC-32MT-LT.
 It is not necessary to connect remote stations in this test.

Note: Setting DIP switches component change

Products manufactured in September 2011 or later have a different component used for the setting DIP switches compared with products produced earlier.
 Due to the component change, take note of the change in the ON/OFF position of each DIP switch.
 Even with the component change, the direction for setting each DIP switch ON/OFF is the same.

When product manufactured August, 2011 or earlier

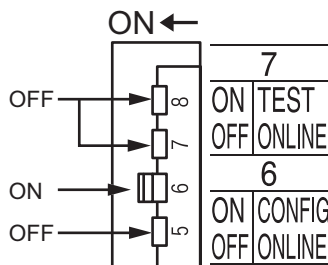

When product manufactured in September 2011 or later

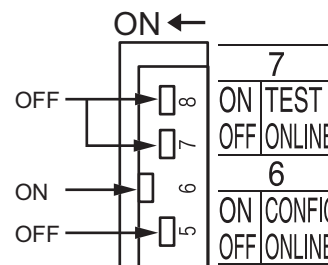

1. Procedure

1 Turn the power OFF

Turn OFF the power for the PLC, power supply adapter or dedicated power supply.

2 Setting the TEST mode

Set the DIP switches as shown in the following figure to set the following status.

Item	Setting Content
B RATE	2.5Mbps
16pts/4pts	4-point mode
operation mode	TEST mode

When product manufactured August, 2011 or earlier

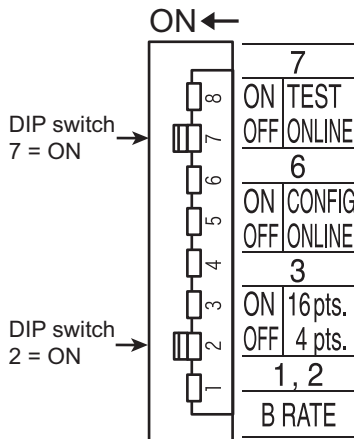

When product manufactured in September 2011 or later

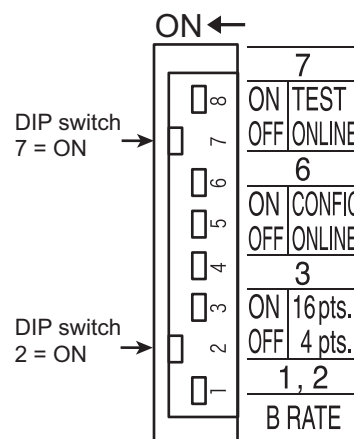

3 Turn the power ON

Turn ON the power of the PLC.

When the power supply adapter or dedicated power supply is used, turn ON the power in the order "Power supply adapter (or dedicated power supply) → PLC (built-in master)".

4 Start the test, and check the status indicator LEDs.

The test (self-loop-back test) is completed in several seconds.

The L RUN LED turns ON in the normal status. The L ERR LED turns ON in the error status.

Refer to "Contents indicated by status indicator LEDs and countermeasures" on the previous page.

When the RUN LED is ON, set the ONLINE mode. (Set the DIP switch 6 to OFF and DIP switch 7 to OFF in the built-in master.)

Set the DIP switches as shown in the following figure to set the following status.

Item	Setting Content
B RATE	2.5Mbps
16pts/4pts operation mode	4-point mode ONLINE mode

When product manufactured August, 2011
or earlier

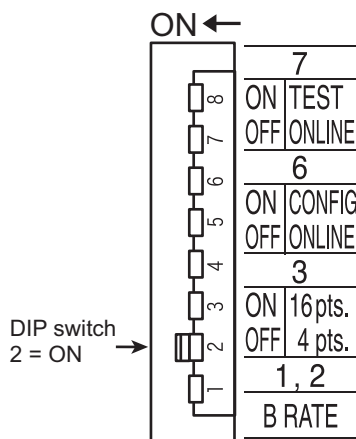

When product manufactured in September
2011 or later

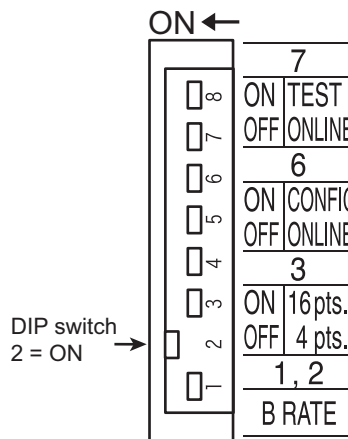

2. Contents indicated by status indicator LEDs and countermeasures

The table below shows the descriptions of errors indicated by the status indicator LEDs and their countermeasures.

Status indicator LEDs	Description		Countermeasures
L RUN	On	Self-loop-back Test was finished normally	-
	Off	Self-loop-back Test was finished abnormally (Not on while the self-loop-back test is being executed)	<ul style="list-style-type: none"> Make sure that the power is correctly supplied to the PLC. If the L RUN LED is on even after the above check, consult your local Mitsubishi Electric representative.
L ERR.	On	Self-loop back Test was finished abnormally	<ul style="list-style-type: none"> Make sure that the power is correctly supplied to the PLC. If the L RUN LED is on even after the above check, consult your local Mitsubishi Electric representative.
	Off	Self-loop back Test was finished normally (Not on while the self-loop-back test is being executed)	-

11 Memory Cassette/Battery
12 Test Run, Maintenance, Troubleshooting
A Version Information
B Performance Specifications
C Special Devices (M8000 -J, D8000 -J)
D Instruction List
E Character-code
F Discontinued models
G Precautions for battery transportation
H Handling of batteries in EU member states

12.7.6 Prevention of erroneous inputs and outputs to/from remote I/O modules

In order to prevent erroneous inputs to and outputs from remote I/O modules, design the system under consideration of the contents described below.

1. When setting the power to ON or OFF

When using a power supply adapter or dedicated power supply, turn ON the power of the remote I/O units (power supply adapter and dedicated power supply) before starting data link.
 Stop the data link first, and then turn OFF the power to the remote I/O modules (power adapter or dedicated power supply).

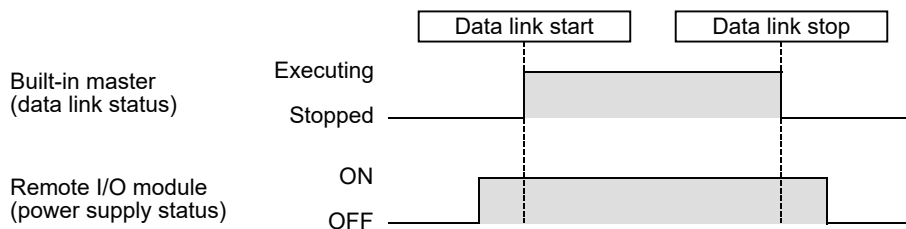

2. When the power is interrupted instantaneously in a remote I/O module

When the power (24V DC) supplied to a remote I/O module is interrupted instantaneously, erroneous inputs may occur.

3. Cause of erroneous inputs due to instantaneous power interruption

The hardware of a remote I/O module converts the unit power (24V DC) into 5V DC before using it. If instantaneous power interruption occurs in a remote I/O module:

Time until 5V DC inside remote I/O module turns OFF > Response time for "ON → OFF" of input unit
 As a result, if refresh is executed in the period shown in (A) below, erroneous inputs occur.
 (Erroneous inputs may occur especially while the input response time is set to high-speed input type.)

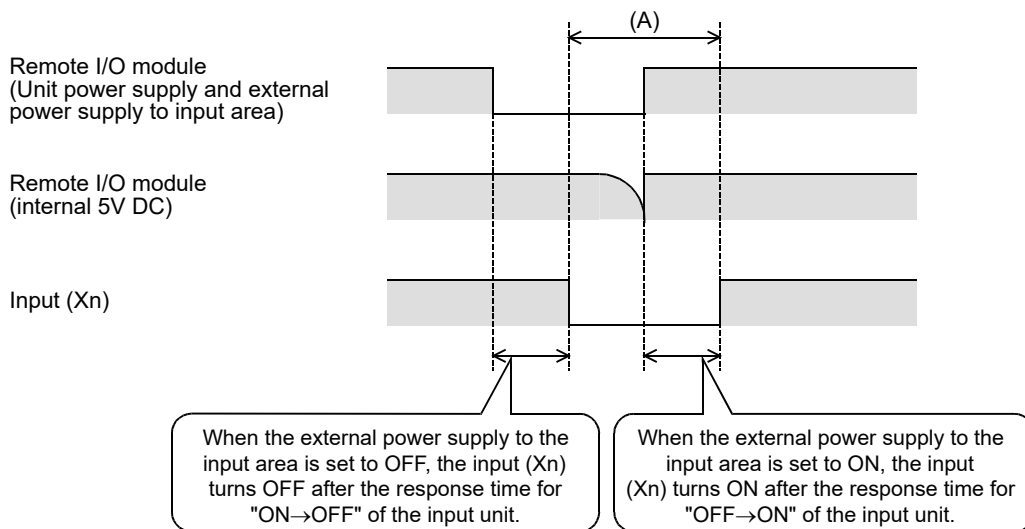

4. Countermeasures against erroneous input

Connect the power supply unit, stabilized power supply and external power supply for AC input from the same power source.

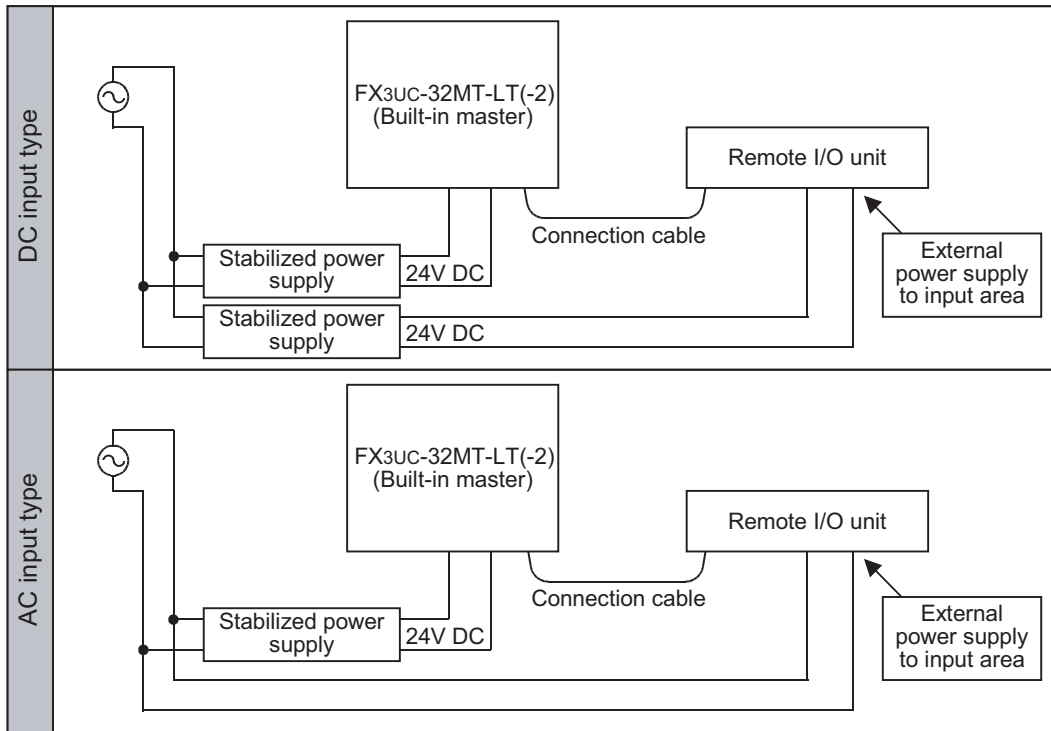

12.8 Troubleshooting

- For the procedures on running and stopping the PLC, refer to Section 12.2.
- For the procedures on operating the display module, refer to Chapter 10.
- For the procedures on operating peripheral devices, refer to the manuals for the peripheral devices.

12.8.1 Output does not operate (main unit and input/output extension blocks)

- For the remote I/O station connected to the CC-Link/LT built-in master, refer to Section 12.7.
- For inputs and outputs of special function units/blocks, refer to each manual.

1. Output does not turn on.

Stop the PLC, and forcibly turn the inoperable output on then off with a peripheral device or the display module to check its operation.

Check for troubles with external wiring.

- When the output operates
The output may be turned off unintentionally in the program. Reexamine the program.
(Duplicate coil or RST instructions)
- When the output does not operate
Check the configuration of the connected devices and the connection of the extension cables.
If the configuration of the external wiring and connected devices and the connection of the extension cables are acceptable, the output circuit may be damaged.
Consult your local Mitsubishi Electric representative.

2. Output does not turn off.

Stop the PLC, and check that the output turns off.

Check for trouble with external wiring.

- For the procedures on running and stopping the PLC, refer to Section 12.2.

- When the output turns off
The output may be turned on unintentionally in the program.
Check that there are no duplicate coils in the program.
- When the output does not turn off
The output circuit may be damaged. Consult your local Mitsubishi Electric representative.

12.8.2 24V DC input does not operate (main unit and input/output extension blocks)

- For the remote I/O station connected to the CC-Link/LT built-in master, refer to Section 12.7.
→ For inputs and outputs of special function units/blocks, refer to each manual.

1. Input does not turn on.

In the FX3UC-□□MT/D, FX3UC-16MR/D-T or FX3UC-32MT-LT(-2), remove the external wiring, short-circuit the COM terminal and an input terminal, and then check using the LED, display module or programming tool whether the input turns ON.

In the FX3UC-□□MT/DSS, FX3UC-16MR/DS-T, remove the external wiring, and apply 24V DC between the COM△ terminal and an input terminal in reference to Section 5.2. Check using the LED or programming tool whether the input turns ON.

After confirmation, take the countermeasures shown in the table below.

	Countermeasures
When the input turns ON	Check whether a diode or parallel resistors is not built in the input equipment. If a diode or parallel resistors is built in, refer to Subsection 5.2.4.
When the input does not turn ON	In the FX3UC-□□MT/D, FX3UC-16MR/D-T or FX3UC-32MT-LT, remove the external wiring, and confirm using the tester that the voltage between the COM terminal and an input terminal is approximately 24V DC. <ul style="list-style-type: none"> When the input voltage is less than 20.4V DC, check whether the supply voltage in the PLC and extension power supply unit is "24V DC, Voltage fluctuation range +20% -15%, ripple (p-p) within 5%". Check the external wiring, connected equipment configuration and extension cable connection. In the FX3UC-□□MT/DSS, FX3UC-16MR/DS-T, confirm using the tester that the voltage between the COM△ terminal and an input terminal is approximately 24V DC. <ul style="list-style-type: none"> When the input voltage is less than 20.4V DC, check whether the supply voltage in the PLC and extension power supply is "24V DC, Voltage fluctuation range +20% -15%, ripple (p-p) within 5%". Check the external wiring, connected equipment configuration and extension cable connection.

2. Input does not turn off.

Check for leakage current from input devices.

If the leakage current is larger than 1.5 mA, it is necessary to connect a bleeder resistance.

→ For details on the measures, refer to Subsection 5.2.4.

12.8.3 Cautions in registering keyword

1. Cautions in registering keyword

The keyword limits access to the program prepared by the user from peripheral devices.

Keep the keyword carefully.

If you forget the keyword, you cannot operate the PLC online from the programming tool depending on the type of the programming tool and the registered keyword.

2. Cautions in using peripheral devices not supporting the 2nd keyword

Sequence programs where the second keyword has been registered cannot be all-cleared using a peripheral device that does not support the second keyword (such as GX Developer earlier than Ver. 8.24A)

3. Cautions in using peripheral devices not supporting the customer keyword

Sequence programs where the customer keyword has been registered cannot be all-cleared using a peripheral device that does not support the customer keyword (such as GX Developer earlier than Ver. 8.89T)

4. Non-resettable protect function

When the non-resettable protect function is set, the protect function cannot be reset.

5. Cautions in using a memory cassette in which keywords are already set

In an FX3UC PLCs whose version is earlier than Ver. 2.61, do not use a memory cassette where the customer keyword and permanent PLC lock are set.

If a memory cassette where the permanent PLC lock is set is used in an FX3UC PLC whose version is earlier than Ver. 2.61, the PLC does not function normally.

If the PLC memory is cleared or the keyword is canceled in an FX3UC PLC whose version is earlier than Ver. 2.61 for a memory cassette where the customer keyword and permanent PLC lock are set, access restrictions set by the keyword may not be able to be removed normally.

12.8.4 Cautions on using block password

Note the following cautions when using a block password for which the setting "Read-protect the execution program." is valid.

- In a PLC that has been written to by a computer using a project including a block password for which the setting "Read-protect the execution program." is valid, restoration of programs is enabled only when the PLC is able to store symbolic information.
To allow for editing of the program by peripheral devices that do not support symbolic information (only supported in GX Works2 Ver. 1.62Q or later), do not use a block password for which the setting "Read-protect the execution program." is valid.
- When a peripheral device tries to read an execution program from a PLC that has been written to by a computer using a project including a block password for which the setting "Read-protect the execution program." is valid, a communication error occurs and reading is disabled.
- For writing a program using a peripheral device other than GX Works2 (Ver. 1.62Q or later) to a PLC that has been written to by a computer using a project including a block password for which the setting "Read-protect the execution program." is valid, execute "Clear PLC memory" to clear programs before writing. If a program is written without executing "Clear PLC memory" in advance, the written program cannot be read.
- It is not possible to write programs including a block password for which the setting "Read-protect the execution program." is valid to a FX3UC PLC whose version is earlier than Ver. 3.00.
- If a memory cassette storing a program that includes a block password for which the setting "Read-protect the execution program." is valid is used for a FX3UC PLC whose version is earlier than Ver. 3.00, the FX3UC PLC does not run normally.

Appendix A: Version Information and Peripheral Equipment Connect ability

Appendix A-1 Version Upgrade History

Appendix A-1-1 How to look at manufacturer's serial number

The year and month of production of the product can be checked on the name plate, and "LOT" indicated on the front of the product.

1. Checking the name plate

The year and month of production of the product can be checked from the manufacturer's serial number S/N indicated on the label adhered to the right side of the product.

- 1) In case of the FX3UC-□□MT/D(SS), FX3UC-16MR/D(S)-T, FX3UC-32MT-LT-2

Example nameplate (manufacturer's serial number: 1010001)

<Product during December, 2009 or earlier>

9	Z	0	0	0	1
---	---	---	---	---	---

Control number: 9 Z 0 0 0 1
 Month (Example: Dec.): 1 to 9 = January to September, X = October, Y = November, Z = December
 Year (Example: 2009): Last digit of year

<Product from January, 2010>

1	0	1	0	0	0	1
---	---	---	---	---	---	---

Control number: 1 0 1 0 0 0 1
 Month (Example: Jan.): 1 to 9 = January to September, X = October, Y = November, Z = December
 Year (Example: 2010): Last two digit of year

- 2) In case of the FX3UC-32MT-LT

Example nameplate (manufacturer's serial number: 1010001)

<Product during December, 2009 or earlier>

9	Z	0	0	0	1
---	---	---	---	---	---

Control number: 9 Z 0 0 0 1
 Month (Example: Dec.): 1 to 9 = January to September, X = October, Y = November, Z = December
 Year (Example: 2009): Last digit of year

<Product from January, 2010>

1	0	1	0	0	0	1
---	---	---	---	---	---	---

Control number: 1 0 1 0 0 0 1
 Month (Example: Jan.): 1 to 9 = January to September, X = October, Y = November, Z = December
 Year (Example: 2010): Last two digit of year

11	Memory Cassette/Battery
12	Test Run, Maintenance, Troubleshooting
A	Version Information
B	Performance Specifications
C	Special Devices (M8000 - , D8000 -)
D	Instruction List
E	Character-code
F	Discontinued models
G	Precautions for battery transportation
H	Handling of batteries in EU member states

2. Checking the front of the product

The year and month of production of the product can be checked from the manufacturer's serial number "LOT" on the front (at the bottom) of the product.

* Products manufactured in and after January 2009 or later.

- 1) In case of the FX3UC-□□MT/D(SS), FX3UC-16MR/D(S)-T

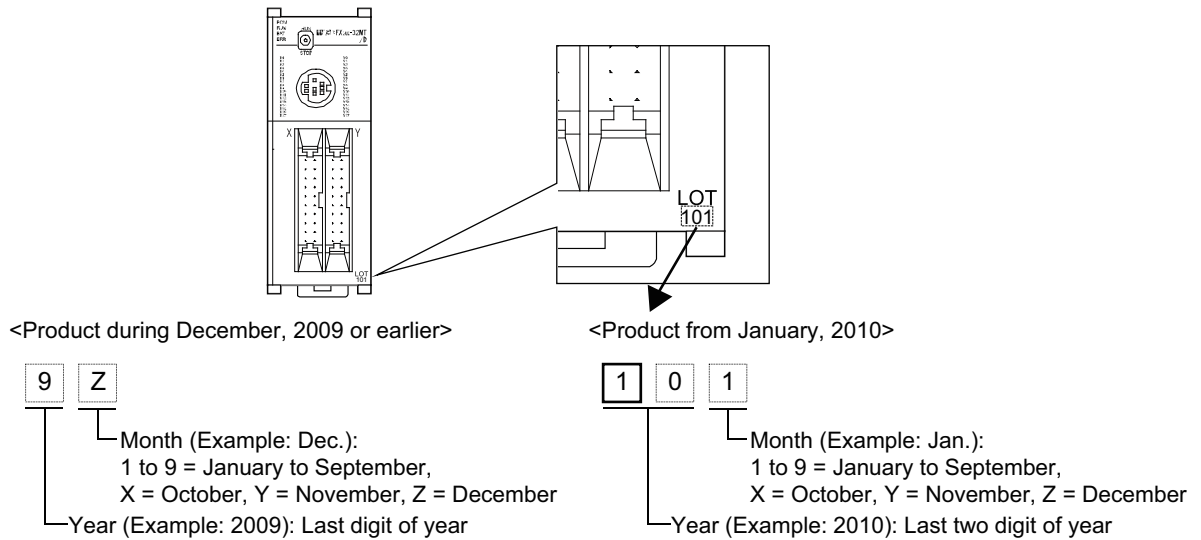

- 2) In case of the FX3UC-32MT-LT, FX3UC-32MT-LT-2

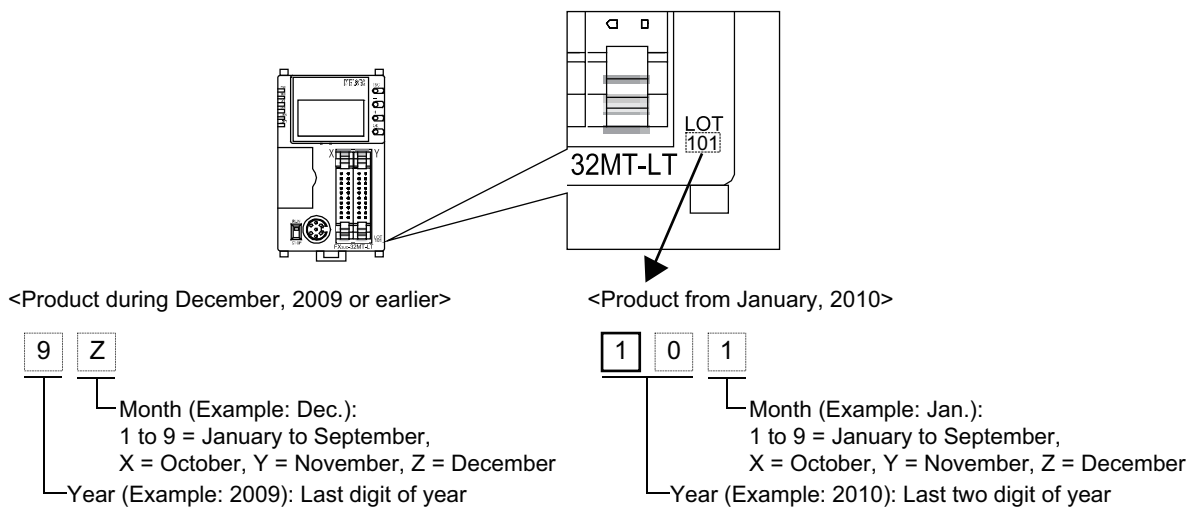

Appendix A-1-2 Version check method

The PLC version can be checked by reading the last three digits of device D8001/D8101, or the PLC version can be checked in "PLC Status" with the display module (Only FX3UC-32MT-LT(-2)).

→ For the operating procedure of the display module, refer to Subsection 10.13.1.

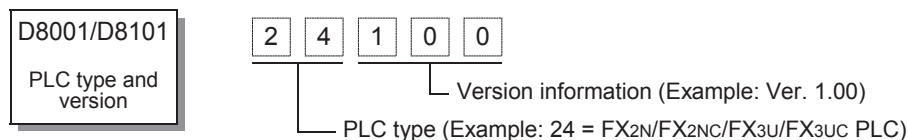

Appendix A-1-3 Version upgrade history

FX3UC Series performed the following upgrade.

Version	Manufacturer's serial number	Contents of version upgrade
Ver. 1.00	41**** (January, 2004)	FX3UC-32MT-LT (First product)
Ver. 1.20	44**** (April, 2004)	Supports connection of following special analog adapters <ul style="list-style-type: none"> - FX3U-4AD-ADP - FX3U-4DA-ADP
Ver. 1.30	48**** (August, 2004)	<ul style="list-style-type: none"> • Supports connection of following special analog adapters <ul style="list-style-type: none"> - FX3U-4AD-PT-ADP - FX3U-4AD-TC-ADP • Supports connection of following special function block <ul style="list-style-type: none"> - FX3UC-4AD • Adding the following instructions and function upgrade <ul style="list-style-type: none"> - Adding SCL2 (FNC269) instruction - Adding RWER (FNC294) instruction - Adding INITER (FNC295) instruction - Function upgrade of DVIT (FNC151) instruction
Ver. 2.20	55**** (May, 2005)	<ul style="list-style-type: none"> • Support of the following 28 instructions ZPUSH (FNC102), ZPOP (FNC103), WSUM (FNC140), WTOB (FNC141), BTOW (FNC142), UNI (FNC143), DIS (FNC144), SORT2 (FNC149), TBL (FNC152), COMRD (FNC182), DUTY (FNC186), BK + (FNC192), BK (FNC193), BKCMP = (FNC194), BKCMP > (FNC195), BKCMP < (FNC196), BKCMP <> (FNC197), BKCMP <= (FNC198), BKCMP >= (FNC199), STR(FNC200), VAL (FNC201), INSTR (FNC208), FDEL (FNC210), FINS (FNC211), DABIN (FNC260), BINDA (FNC261), RBFM (FNC278), WBFM (FNC279) • Adds function of following 5 instructions SPD (FNC 56), DSZR (FNC150), DVIT (FNC151), ZRN (FNC156), PLSV (FNC157), HCMOV (FNC189) • Supports connection of FREQROL-F700/A700 inverters supporting following 5 instructions IVCK (FNC270), IVDR (FNC271), IVRD (FNC272), IVWR (FNC273), IVBWR (FNC274) • Adds second entry code (when GX Developer SW8.24A (Ver. 8.24A or later) is used). • Supports BFM initial value setting function (when GX Developer SW8.24A (Ver. 8.24A or later) is used). • Mitigates restriction in writing during RUN (when GX Developer SW8.24A (Ver. 8.24A or later) is used). <ul style="list-style-type: none"> - Number of steps which can be changed by one-time write during RUN is changed. 127 steps → 256 steps - Handling of circuit blocks which can be changed by one-time write during RUN is changed. Program of continuous circuit blocks having 127 steps or less →Program of circuit blocks having 256 steps or less in total
Ver. 2.30	5Y**** (November, 2005)	The following instructions are added or their functions are enhanced: MEP and MEF instructions are added. The functions of the MUL (FNC 22), DIV (FNC 23) and RS2 (FNC 87) instructions are enhanced.
Ver. 2.40	74**** (April, 2007)	<ul style="list-style-type: none"> • Supports of the MODBUS communication function. • Supports the following instruction. ADPRW (FNC276)

11	Memory Cassette/Battery
12	Test Run, Maintenance, Troubleshooting
A	Version Information
B	Performance Specifications
C	Special Devices (M8000 -D8000 -)
D	Instruction List
E	Character-code
F	Discontinued models
G	Precautions for battery transportation
H	Handling of batteries in EU member states

Version	Manufacturer's serial number	Contents of version upgrade
Ver. 2.41	79**** *1 (September, 2007)	<ul style="list-style-type: none"> FX3UC-□□MT/D(SS) (First product) The functions of the following instructions are enhanced: The baud rate "38400 bps" is supported in RS and RS2 instructions, inverter communication and computer link.
Ver. 2.53	84**** (April, 2008)	FX3UC-32MT-LT-2 (First product)
Ver. 2.61*2	97**** (July, 2009)	<ul style="list-style-type: none"> Support of the following 6 instructions: FLCRT (FNC300), FLDEL (FNC301), FLWR (FNC302), FLRD (FNC303), FLCMD (FNC304), FLSTRD (FNC305) Supports customer keyword and permanent PLC lock. Supports connection of following special adapters: <ul style="list-style-type: none"> - FX3U-3A-ADP - FX3U-CF-ADP Supports the hardware error function of FX3U-4DA-ADP.
Ver. 2.70	107**** (July, 2010)	<ul style="list-style-type: none"> FX3UC-16MR/D-T, FX3UC-16MR/DS-T (First product) Support of the following 3 instructions: VRRD (FNC 85), VRSC (FNC 86), IVMC (FNC275) Supports connection of following analog volume expansion board: <ul style="list-style-type: none"> - FX3U-8AV-BD*3 Supports the under-scale detection function of the FX3U-4AD-ADP and FX3U-3A-ADP.
Ver. 3.00	115**** (May, 2011)	<ul style="list-style-type: none"> Supports storage of symbolic information. Support of the setting "Read-protect the execution program." for block passwords. Special block error condition (D8166) is added. Supports connection of following memory cassette. <ul style="list-style-type: none"> - FX3U-FLROM-1M
Ver. 3.10	11Y**** (November, 2011)	<ul style="list-style-type: none"> Supports the following functions of the FX3U-16CCL-M: <ul style="list-style-type: none"> - Network parameter - Accessing the other station from CC-Link - Remote device station initialization procedure registration - CC-Link diagnostics Supports connection of following special adapter: <ul style="list-style-type: none"> - FX3U-ENET-ADP Special parameter error (M8489 and D8489) is added.

*1. The FX3UC-32MT-LT supports Ver. 2.41 from the manufacturer's serial number "7X****" (October 2007).

*2. Available in Ver. 2.70 or later of the FX3UC-32MT-LT-2 PLC.

*3. This function is supported only in the FX3UC-32MT-LT(-2).

Appendix A-2 Programming Tool Applicability

Appendix A-2-1 Applicable versions of programming tool

1. GX Works2

- GX Works2 English version (SW□DNC-GXW2-E) is applicable to FX3uc PLCs from the following versions.

FX3uc PLC version	Model name (Media model name is shown below.)	Applicable GX Works2 version	Remarks
Before Ver. 2.70	GX Works2 SW□DNC-GXW2-E	Ver. 1.08J or later	-
Before Ver. 3.00		Ver. 1.48A or later	
Before Ver. 3.10		Ver. 1.62Q or later	
Ver. 3.10		Ver. 1.73B or later	

- GX Works2 Japanese version (SW□DNC-GXW2-J) is applicable to FX3uc PLCs from the following versions.

FX3uc PLC version	Model name (Media model name is shown below.)	Applicable GX Works2 version	Remarks
Before Ver. 2.70	GX Works2 SW□DNC-GXW2-J	Ver. 1.07H or later	-
Before Ver. 3.00		Ver. 1.45X or later	
Before Ver. 3.10		Ver. 1.56J or later	
Ver. 3.10		Ver. 1.73B or later	The setting of FX3U-ENET-ADP is supported in Ver. 1.90U or later.

2. GX Developer

- GX Developer English version (SW□D5C-GPPW-E) is applicable to FX3uc PLCs from the following versions.

FX3uc PLC version	Model name (Media model name is shown below.)	Applicable GX Developer version	Remarks
Before Ver. 2.20	GX Developer SW□D5C-GPPW-E	Ver. 8.18U or later	Ver. 8.89T and later versions support the baud rate "38400 bps" in the communication setting for RS and RS2 instructions, inverter communication and computer link.
Before Ver. 2.30		Ver. 8.24A or later	
Before Ver. 2.41		Ver. 8.29F or later	
Before Ver. 2.53		Ver. 8.29F or later	
Before Ver. 2.61		Ver. 8.68W or later	
Ver. 2.61		Ver. 8.82L or later	

- GX Developer Japanese version (SW□D5C-GPPW-J) is applicable to FX3uc PLCs from the following versions.

FX3uc PLC version	Model name (Media model name is shown below.)	Applicable GX Developer version	Remarks
Before Ver. 1.30	GX Developer SW□D5C-GPPW-J	Ver. 8.13P or later	Ver. 8.88S and later versions support the baud rate "38400 bps" in the communication setting for RS and RS2 instructions, inverter communication and computer link.
Before Ver. 2.20		Ver. 8.18U or later	
Before Ver. 2.30		Ver. 8.23Z or later	
Before Ver. 2.41		Ver. 8.29F or later	
Before Ver. 2.53		Ver. 8.29F or later	
Before Ver. 2.61		Ver. 8.68W or later	
Ver. 2.61		Ver. 8.82L or later	

3. FX-30P

FX-30P is applicable to FX3UC PLCs from the following version.

FX3UC PLC version	Model name	Applicable FX-30P version	Remarks
Before Ver. 2.41	FX-30P	Ver. 1.00 or later	-
Ver. 2.70		Ver. 1.20 or later	

Appendix A-2-2 In the case of programming tool (version) not applicable

Inapplicable programming tools can programme by setting alternative model.

1. Alternative model setting

Model to be programmed	Model to be set	Priority High → Low
FX3UC PLC	FX3UC →	FX2N → FX2

2. Contents of restrictions

- Programming is enabled only in the function ranges such as instructions, device ranges and program sizes available in a PLC selected as the alternative model.
- Use a programming tool that can select either FX3U(C) or FX3UC to change parameters, i.e. memory capacity, file register capacity, etc.

Appendix A-2-3 Program transfer speed and programming tools

1. RS-422/RS-232C/USB communication

The FX3UC PLC can write and read programs and perform monitoring at 115.2 kbps through RS-422/RS-232C/USB communication.

- 1) 115.2 kbps supported programming tools
GX Works2 (Ver. 1.08J or later), GX Developer (Ver. 8.18U or later), FX-30P (Ver. 1.00 or later)
- 2) 115.2 kbps supported interfaces
 - Standard built-in port or expansion board FX3U-422-BD for RS-422
When the RS-232C/RS-422 converter FX-232AWC-H or USB/RS-422 converter FX-USB-AW is connected.
 - Expansion board FX3U-232-BD for RS-232C
 - Special adapter FX3U-232ADP(-MB) for RS-232C
 - Expansion board FX3U-USB-BD for USB
- 3) In programming tools not supporting 115.2 kbps
Communication is executed at 9,600 or 19,200 bps.

Appendix A-2-4 Cautions on connecting peripheral equipment by way of expansion board or special adapter

When connecting peripheral equipment (programming tool or GOT [CPU direct connection]) by way of the FX3U-232-BD, FX3U-422-BD, FX3U-USB-BD or FX3U-232ADP(-MB), set the connection channel (CH1 or CH2) as follows. If the connection channel is not specified with the status below, communication error may occur in the connected peripheral equipment.

→ For details, refer to the Data Communication Edition.

- Set to "K0" the special data register for communication format setting of the channel connecting the peripheral equipment (CH1: D8400 or D8120, CH2: D8420).
- Set the communication parameter "PLC system [2]" of the channel connecting the peripheral equipment to "Not set" (as shown in the window below).

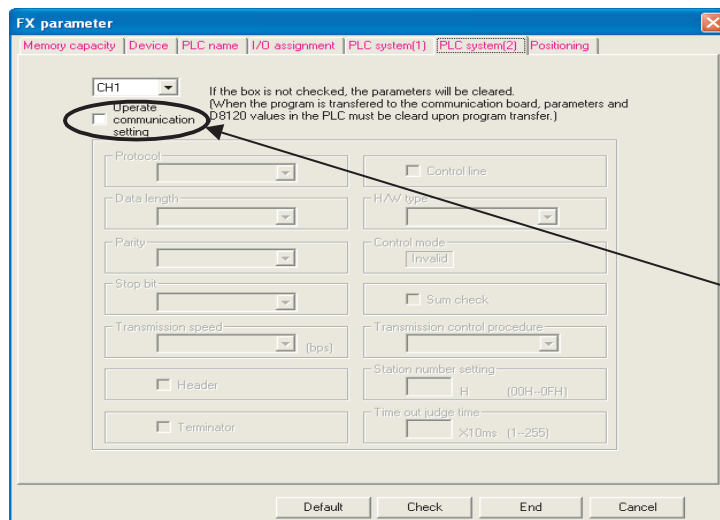

Leave this unchecked.

Appendix A-2-5 Cautions on write during RUN

In FX3UC PLCs, write during RUN (program changes in the RUN mode) is enabled using the following programming tools.

→ For the operating procedure of and cautions on write during RUN, refer to the manual of the used programming tool.

Programming tools supporting write during RUN

- English version

Programming tool	PLC	Version	Remarks
GX Works2*1 (SW□DNC-GXW2-E)	FX3UC	Ver. 1.08J or later	Writing in the instruction and device ranges during RUN is supported in FX3U and FX3UC PLCs earlier than Ver. 2.70.
		Ver. 1.48A or later	Writing in the instruction and device ranges during RUN is supported in FX3U and FX3UC PLCs Ver. 2.70.
GX Developer*2 (SW□D5C-GPPW-E)	FX3UC	Ver. 7.00A or later	Writing in the instruction and device ranges during RUN is supported in FX2N PLCs Ver. 3.00.
		Ver. 8.18U or later	Writing in the instruction and device ranges during RUN is supported in FX3UC PLCs earlier than Ver. 2.20.
		Ver. 8.24A or later	Writing in the instruction and device ranges during RUN is supported in FX3U and FX3UC PLCs earlier than Ver. 2.30.
		Ver. 8.29F or later	Writing in the instruction and device ranges during RUN is supported in FX3U and FX3UC PLCs earlier than Ver. 2.61.
		Ver. 8.82L or later	Writing in the instruction and device ranges during RUN is supported in FX3U and FX3UC PLCs Ver. 2.61.
FX-PCS/WIN-E*2	FX3UC	Ver. 1.00 or later	Writing in the instruction and device ranges during RUN is supported in FX2N PLCs Ver. 1.00.
		Ver. 3.10 or later	Writing in the instruction and device ranges during RUN is supported in FX2N PLCs Ver. 3.00.

- Japanese version

Programming tool	PLC	Version	Remarks
GX Works2*1 (SW□DNC-GXW2-J)	FX3UC	Ver. 1.07H or later	Writing in the instruction and device ranges during RUN is supported in FX3U and FX3UC PLCs earlier than Ver. 2.70.
		Ver. 1.45X or later	Writing in the instruction and device ranges during RUN is supported in FX3U and FX3UC PLCs Ver. 2.70.
GX Developer*2 (SW□D5C-GPPW-J)	FX3UC	Ver. 7.00A or later	Writing in the instruction and device ranges during RUN is supported in FX2N PLCs Ver. 3.00.
		Ver. 8.13P or later	Writing in the instruction and device ranges during RUN is supported in FX3UC PLCs earlier than Ver. 1.30.
		Ver. 8.18U or later	Writing in the instruction and device ranges during RUN is supported in FX3UC PLCs earlier than Ver. 2.20.
		Ver. 8.23Z or later	Writing in the instruction and device ranges during RUN is supported in FX3U and FX3UC PLCs earlier than Ver. 2.30.
		Ver. 8.29F or later	Writing in the instruction and device ranges during RUN is supported in FX3U and FX3UC PLCs earlier than Ver. 2.61.
		Ver. 8.82L or later	Writing in the instruction and device ranges during RUN is supported in FX3U and FX3UC PLCs Ver. 2.61.
FX-PCS/WIN*2	FX3UC	Ver. 1.00 or later	Writing in the instruction and device ranges during RUN is supported in FX2 PLCs Ver. 3.30.
		Ver. 2.00 or later	Writing in the instruction and device ranges during RUN is supported in FX2N PLCs Ver. 1.00.
		Ver. 4.20 or later	Writing in the instruction and device ranges during RUN is supported in FX2N PLCs Ver. 3.00.

*1. Write during RUN is not possible with a SFC program.

*2. Write during RUN is not possible with a list program or a SFC program.

Cautions on write during RUN

Item	Caution
Program memories which can be written in RUN mode	Built-in RAM and optional memory cassette (whose write protect switch is set to OFF)
Number of program steps which can be written for circuit change in RUN mode	Ver. 2.20 or later 256 steps or less after edition (addition/deletion) (including NOP immediately after circuit blocks except final circuit)
	• GX Works2 Ver. 1.08J or later • GX Developer Ver. 8.24A or later Ver. 2.20 or less 127 steps or less after edition (addition/deletion) (including NOP immediately after circuit blocks except final circuit)
	• GX Developer Ver. 8.22Y or former • FX-PCS/WIN(-E) 127 steps or less after edition (addition/deletion) (including NOP immediately after circuit blocks except final circuit)
Circuit blocks which cannot be written in RUN mode	Circuit blocks* ¹ in which labels P and I are added, deleted or changed in edited circuits
	Circuit blocks in which 1-ms timers (T246 to T249 and T256 to T511) are added in edited circuits
	Circuit blocks in which the following instructions are included in edited circuits <ul style="list-style-type: none"> • Instruction to output high-speed counters C235 to C255 (OUT instruction) • SORT2 (FNC149), TBL (FNC152), RBFM (FNC278) and WBFM (FNC279) instruction

*1. Circuit blocks cannot be edited to insert a label as shown below when written during RUN.

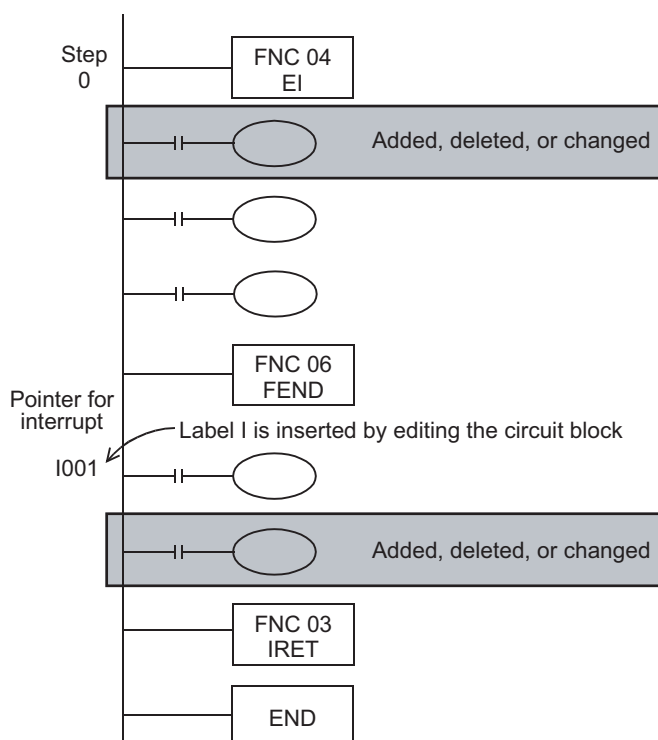

Item	Caution								
<p>Circuit blocks which require attention on operation after write during RUN</p>	<p>Avoid write during RUN to a circuit block including the following instructions during execution. If write during RUN is executed to such a circuit block, the PLC decelerates and stops pulse output. DSZR (FNC150), DVIT (FNC151), ZRN (FNC156), PLSV (FNC157) instructions [with acceleration/deceleration operation], DRVI (FNC158) and DRVA (FNC159) instructions</p>								
	<p>Avoid write during RUN to a circuit block including the following instruction during execution. If write during RUN is executed to such a circuit block, the PLC immediately stops pulse output. PLSV (FNC157) instruction [without acceleration/deceleration operation]</p>								
	<p>Avoid write during RUN to a circuit block including the following instructions during execution.</p> <ul style="list-style-type: none"> • PLSY (FNC 50), PWM (FNC 58) and PLSR (FNC 59) instructions 								
	<p>Avoid write during RUN to a circuit block including the following instructions during execution of communication. If write during RUN is executed to such a circuit block, the PLC may stop communication after that. If the PLC stops communication, set the PLC to the STOP mode once, and then set it to the RUN mode again.</p> <ul style="list-style-type: none"> • IVCK (FNC270), IVDR (FNC271), IVRD (FNC272), IVWR (FNC273), IVBWR(FNC274), IVMC (FNC275) and ADPRW (FNC276) instructions 								
	<p>Avoid write during RUN to a circuit block including the following instructions during execution. If write during RUN is executed to such a circuit block, instructions being executed are canceled.</p> <ul style="list-style-type: none"> • FLCRT (FNC300), FLDEL (FNC301), FLWR (FNC302), FLRD (FNC303), FLCMD (FNC304) and FLSTRD (FNC305) instructions 								
	<ul style="list-style-type: none"> • Instructions for falling edge pulse When write during RUN is completed for a circuit including an instruction for falling edge pulse (LDF, ANDF, or ORF instruction), the instruction for falling edge pulse is not executed without regard to the ON/OFF status of the target device. When write during RUN is completed for a circuit including an instruction for falling edge pulse (PLF instruction), the instruction for falling edge pulse is not executed without regard to the ON/OFF status of the device that is set as the operation condition. It is necessary to set to ON the target device or operation condition device once and then set it to OFF for executing the instruction for falling edge pulse. • Instructions for rising edge pulse When write during RUN is completed for a circuit including an instruction for rising edge pulse, the instruction for rising edge pulse is executed if a target device of the instruction for rising edge pulse or the operation condition device is ON. Target instructions for rising edge pulse: LDP, ANDP, ORP, and pulse operation type applied instructions (such as MOV_P) <table border="1" data-bbox="722 1608 1437 1787"> <thead> <tr> <th>Contact ON/OFF status (while write during RUN is executed)</th> <th>Instruction for rising edge pulse</th> <th>Instruction for falling edge pulse</th> </tr> </thead> <tbody> <tr> <td>OFF</td> <td>Not executed</td> <td>Not executed</td> </tr> <tr> <td>ON</td> <td>Executed*1</td> <td>Not executed</td> </tr> </tbody> </table> <p>*1. The PLS instruction is not executed.</p>	Contact ON/OFF status (while write during RUN is executed)	Instruction for rising edge pulse	Instruction for falling edge pulse	OFF	Not executed	Not executed	ON	Executed*1
Contact ON/OFF status (while write during RUN is executed)	Instruction for rising edge pulse	Instruction for falling edge pulse							
OFF	Not executed	Not executed							
ON	Executed*1	Not executed							

Item	Caution									
<p>Circuit blocks which require attention on operation after write during RUN</p>	<ul style="list-style-type: none"> • MEP instruction (Conversion of operation result to leading edge pulse instruction) When completing Write during RUN to a circuit including the MEP instruction, the execution result of the MEP instruction turns ON (conducting state) if the operation result up to the MEP instruction is ON. • MEF instruction (Conversion of operation result to trailing edge pulse instruction) When completing Write during RUN to a circuit including the MEF instruction, the execution result of the MEF instruction turns OFF (nonconducting state) regardless of the operation result (ON or OFF) up to the MEF instruction. When the operation result up to the MEF instruction is set to ON once and then set to OFF, the execution result of the MEF instruction turns ON (conducting state). <table border="1" data-bbox="719 678 1449 869"> <thead> <tr> <th data-bbox="719 678 979 741">Operation result up to MEP/MEF instruction</th> <th data-bbox="979 678 1214 741">MEP instruction</th> <th data-bbox="1214 678 1449 741">MEF instruction</th> </tr> </thead> <tbody> <tr> <td data-bbox="719 741 979 806">OFF</td> <td data-bbox="979 741 1214 806">OFF (nonconducting)</td> <td data-bbox="1214 741 1449 806">OFF (nonconducting)</td> </tr> <tr> <td data-bbox="719 806 979 869">ON</td> <td data-bbox="979 806 1214 869">ON (conducting)</td> <td data-bbox="1214 806 1449 869">OFF (nonconducting)</td> </tr> </tbody> </table>	Operation result up to MEP/MEF instruction	MEP instruction	MEF instruction	OFF	OFF (nonconducting)	OFF (nonconducting)	ON	ON (conducting)	OFF (nonconducting)
Operation result up to MEP/MEF instruction	MEP instruction	MEF instruction								
OFF	OFF (nonconducting)	OFF (nonconducting)								
ON	ON (conducting)	OFF (nonconducting)								
<p>Others</p>	<ul style="list-style-type: none"> • When writing during RUN with GX Works2 Ver. 1.08J or later, GX Developer Ver. 8.18U or later, the program is as follows. When the number of program steps is reduced by deletion of contacts, coils and applied instructions, the program capacity becomes smaller by as many as the reduced number of steps. • FX3UC Ver. 3.00 or later, GX Works2 Ver. 1.62Q or later. Writing during RUN is enabled only when the protection status (valid or invalid) by the setting "Read-protect the execution program." for the block password is same as the protection status of the PLC designated as the target of writing during RUN. • Errors cannot be detected in write during RUN even in a circuit which causes errors. Errors are detected after the PLC is stopped once, and then run again. 									

11	Memory Cassette/Battery
12	Test Run, Maintenance, Troubleshooting
A	Version Information
B	Performance Specifications
C	Special Devices (M8000 -J, D8000 -J)
D	Instruction List
E	Character-code
F	Discontinued models
G	Precautions for battery transportation
H	Handling of batteries in EU member states

Appendix A-2-6 Cautions on using transparent function by way of USB in GOT1000 Series

When monitoring circuits, device registration, etc. or reading/writing programs in an FX3UC PLC from GX Developer Ver. 8.22Y or later using the transparent function by way of USB in the GOT1000 Series, make sure to execute the following setting.

If the following setting is not provided, a communication error occurs.

	GX Developer Ver. 8.21X or former	GX Developer Ver. 8.22Y or later
When using transparent function by way of USB in GOT1000 Series	Not supported (not available)	Setting shown below is required.
When using transparent function by way of RS-232 in GOT1000 Series	Set "COM port" and "Transmission speed" on "PC side I/F Serial setting" dialog box.	Select "RS-232C" in setting shown below, and set "COM port" and "Transmission speed".
When directly connecting GX Developer to PLC		

Setting in GX Developer (Ver. 8.22Y or later)

- 1 Select [Online] → [Transfer setup...] to open the "Transfer setup" dialog box.
- 2 Double-click [Serial] in [PC side I/F] to open the "PC side I/F Serial setting" dialog box.
- 3 Select "USB (GOT Transparent mode)".

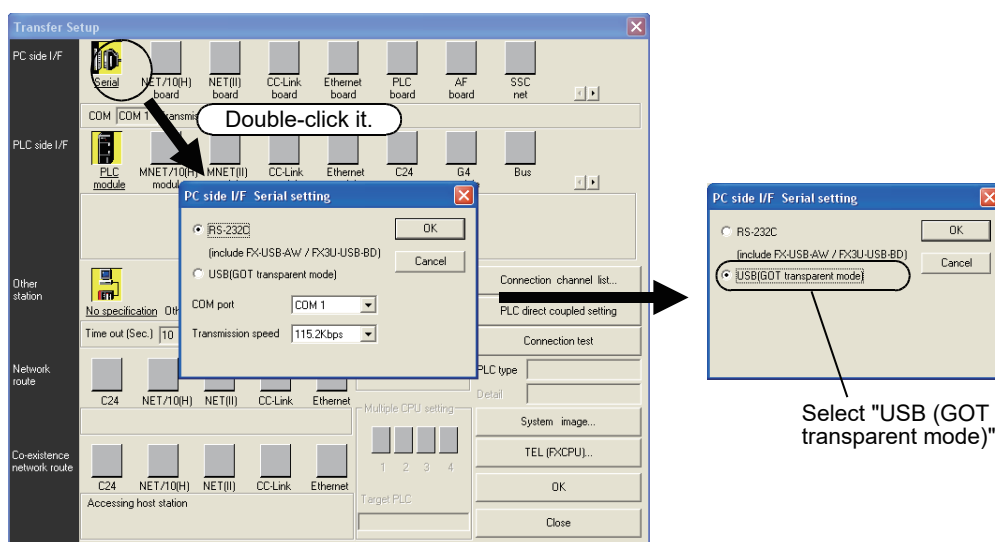

- 4 Click the [OK] button to finish the setting.

Appendix A-2-7 Cautions on using transparent port (2-port) function of GOT-F900 Series

When monitoring circuits, device registration, etc. in an FX3UC PLC from GX Developer Ver. 8.18U or later using the transparent (2-port) function in the GOT-F900 Series, make sure to execute the following setting.

- If the following setting is not provided, write to PLC, read from PLC, verify with PLC, etc. operate normally, but monitoring (ladder monitor, entry data monitor, etc.) cannot be normally executed.
- This setting is not necessary when the FX3UC Series PLC is directly connected to GX Developer for monitoring without using the transparent function of the GOT-F900 Series.

	GX Developer Ver. 8.12N or earlier	GX Developer Ver. 8.18U or later	GX Developer Ver. 8.22Y or later
When directly connecting GX Developer to PLC	Set "COM port" and "Transmission speed" on "PC side I/F Serial setting" dialog box.		Select "RS-232C" on "PC side I/F Serial setting" dialog box, and set "COM port" and "Transmission speed."
When using transparent function in GOT-F900 Series	Setting shown below is required.	Setting shown below is not required.	Select "RS-232C" on "PC side I/F Serial setting" dialog box, and execute setting shown below.

Setting in GX Developer (Ver. 8.18U or later)

- 1 Select [Online] → [Transfer setup...] to open the "Transfer Setup" dialog box.
- 2 Double-click [PLC module] in [PLC side I/F] to open the [PLC side I/F Detailed setting of PLC module] dialog box.
- 3 Put a check mark to the check box [via GOT-F900 transparent mode] as shown below.

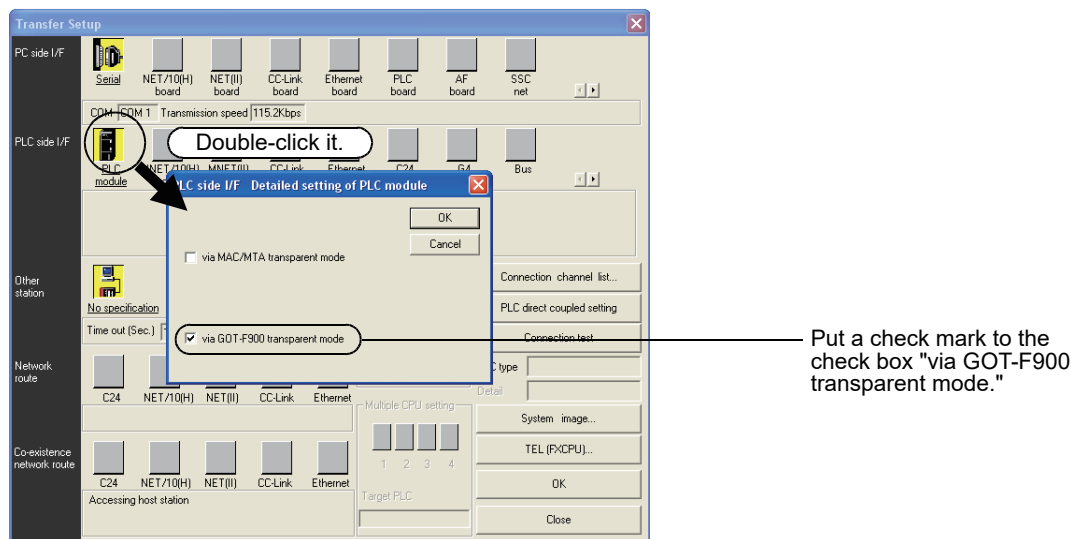

- 4 Click the [OK] button to finish the setting.

Appendix A-3 Other Peripheral Equipment Applicability

Appendix A-3-1 Other Peripheral Equipment Applicability

Model name	Applicability	Remarks
GOT1000 Series	Applicable (From first product)	The GOT1000 Series is applicable to the device ranges in the FX ₃ UC PLCs. Check the applicability of other items in the GOT manual.
F940WGOT	Applicable	For connection using the 2-port interface function*1, refer to Appendix A-2-7.
F940GOT F940 Handy GOT	Applicable	
F930GOT(-K)	Applicable	The following restriction applies when connected.
F920GOT(-K)	Applicable	
ET-940	Applicable	Contents of restrictions Programming is enabled only in the function ranges such as instructions, device ranges and program sizes available in the FX ₂ N and FX ₂ NC PLCs. For applicable models, refer to the GOT manual.
FX-10DM (-SET0)	Applicable	The following restriction applies when connected. Contents of restrictions Programming is enabled only in the function ranges such as instructions, device ranges and program sizes available in the FX ₂ N and FX ₂ NC PLCs. For supported models and device ranges, refer to the FX-10DM USER'S MANUAL (JY992D86401).
FX-10DU(-E)	Applicable	The following restriction applies when connected. Contents of restrictions It is limited to the device range and function range supported by the highest class model (FX ₂ N or FX ₂) applicable in the product version. For supported models and device ranges, refer to the FX-10DU-E/ FX-20DU-E User's Manual (JY992D54801).

- *1. The F940GOT and ET-940 whose version is former than Ver. 1.10 do not support the transparent (2-port) function of the GX Developer.

Appendix B: Performance Specifications

For the built-in CC-Link/LT master ability and network specifications, refer to Section 9.2.

Item		Performance
Operation control system		Stored program repetitive operation system (dedicated LSI) with interruption function
I/O control system		Batch processing system (when END instruction is executed) Input/output refresh instruction and pulse catch function are provided.
Programming language		Relay symbol system + step-ladder system (SFC notation possible)
Program memory	Max. memory capacity	64000-step (2k-, 4k-, 8k-, 16k- or 32k-step memory can be selected by parameter settings.) Comments, file registers, etc. can be created in the program memory by parameter settings. <ul style="list-style-type: none"> • Comments: Up to 6350 points (50 points/500 steps) • File registers: Up to 7000 points (500 points/500 steps) Ver. 2.20 or later • Initial values of special function blocks/units*1: 8-blocks (4000 steps) • Positioning settings*1: 18-blocks (9000 steps) Ver. 2.53 or later • built-in CC-Link/LT settings*2: 1-block (500 steps)
	Built-in memory capacity/type	64000-step (Symbolic information can be stored.*3)/ RAM (backed up by built-in lithium battery) <ul style="list-style-type: none"> • Battery life: Approx. 5 years (For details, refer to Subsection 11.5.4.)
	Memory cassette (Option)	Flash memory (The max. memory capacity varies depending on the model of the memory cassette.) <ul style="list-style-type: none"> • FX3U-FLROM-1M*4: 64000 steps (no loader function, symbolic information can be stored in the dedicated area (1300 kB).) • FX3U-FLROM-64L*5: 64000 steps (loader function, symbolic information can be stored.*3) • FX3U-FLROM-64: 64000 steps (no loader function, symbolic information can be stored.*3) • FX3U-FLROM-16*5: 16000 steps (no loader function, symbolic information can be stored.*3) Max. allowable write: 10,000 times
	Writing function during running	Provided (Program can be modified while the PLC is running.) → For the writing function during running, refer to Appendix A-2-5.
	Password protection	Provided (with entry code function)

*1. GX Developer Ver. 8.24A or later

*2. FX3UC-32MT-LT-2 only.
GX Developer Ver. 8.68W or later

*3. Storage of symbolic information is supported in Ver. 3.00 or later. The writable symbolic information capacity varies depending on the parameter setting contents and memory cassette type. Refer to Subsection 11.1.3 and the GX Works2 Version 1 Operating Manual (Common) for symbolic information capacity.

*4. Supported in Ver. 3.00 or later.

*5. Supported in Ver. 2.20 or later.

Item		Performance		
Display Module ^{*1}	Display device	STN monochrome liquid crystal display, Backlight: LED (green)		
	Displayed letters	16 letters × 4 lines, 2 byte letters: 8 letters × 4 lines Japanese Characters (Shift JIS Level-1, 2), English Alphabet Language for menu display: Japanese/English		
	Function	Monitor / Test, User-registered monitor, Error Check, PLC Status (Error, Program memory type status, Battery voltage, Main unit I/O operation display), CC-Link/LT settings ^{*2} User message display		
Real-time clock	Clock function	Built-in 1980 to 2079 (with correction for leap year) 2- or 4-digit year, accuracy within ±45 seconds/month at 25°C		
Kinds of instructions	Basic instructions	Ver. 2.30 or later • Sequence instructions: 29 • Step-ladder instructions: 2 Former than Ver. 2.30 • Sequence instructions: 27 • Step-ladder instructions: 2		
	Applied instructions	Ver. 2.70 or later • 219 kinds 498 instructions Ver. 2.61 or later • 216 kinds 493 instructions Ver. 2.20 or later • 209 kinds 486 instructions Former than Ver. 2.20 • 181 kinds 407 instructions		
Processing speed	Basic instructions	0.065 μs/instruction		
	Applied instructions	0.642 μs to several hundred μs/instruction		
Number of input/output points	Ver. 2.20 or later			
	(1)Extension combined number of input points	248 points ^{*3}	(3) Total number of points	(1) + (2) ≤ (3) total number of points is 256 or less.
	(2)Extension combined number of output points	248 points ^{*3}		
	(4)Remote I/O number of points (CC-Link)	256 points or less ^{*4}		The total number of remote I/O points in CC-Link and AnyWireASLINK must be 256 points or less.
	(4)Remote I/O number of points (AnyWireASLINK)	128 points or less		
	(4)Remote I/O number of points (AS-i)	248 points or less		
	(3) + (4) total number of points	384 points or less		
	Former than Ver. 2.20			
	Extension combined number of input points	240 points	The device numbers are octal.	
	Extension combined number of output points	240 points		
Extension combined total number of points	256 points			
Input/output relay	Input relay	X000 to X367 ^{*5}	248 points ^{*3}	The device numbers are octal. The total number of input and output points is 256.
	Output relay	Y000 to Y367 ^{*5}	248 points ^{*3}	

*1. Supports the FX3UC-32MT-LT(-2).

*2. FX3UC-32MT-LT-2 only.

*3. 240 points for the FX3UC-32MT-LT(-2).

*4. 224 points or less when the FX2N-16CCL-M is used.

*5. X000 to X357, and Y000 to Y357 for the FX3UC-32MT-LT(-2).

Item		Performance		
Auxiliary relay	For general [changeable]	M0 to M499	500 points	The retentive status can be changed by parameter settings.
	For keeping [changeable]	M500 to M1023	524 points	
	For keeping [fixed]	M1024 to M7679	6656 points	-
	For special	M8000 to M8511	512 points	-
State	Initial state (for general)	S0 to S9	10 points	The retentive status can be changed by parameter settings.
	For general [changeable]	S10 to S499	490 points	
	For keeping [changeable]	S500 to S899	400 points	
	For annunciator	S900 to S999	100 points	
	For keeping [fixed]	S1000 to S4095	3096 points	
Timer (on-delay timer)	100 ms	T0 to T191	192 points	0.1 to 3,276.7 sec
	100 ms [for subroutine/interruption subroutine]	T192 to T199	8 points	0.1 to 3,276.7 sec
	10 ms	T200 to T245	46 points	0.01 to 327.67 sec
	1 ms accumulating type	T246 to T249	4 points	0.001 to 32.767 sec
	100 ms accumulating type	T250 to T255	6 points	0.1 to 3,276.7 sec
	1 ms	T256 to T511	256 points	0.001 to 32.767 sec
Counter	Increment for general (16 bits) [changeable]	C0 to C99	100 points	Counting from 0 to 32,767 The retentive status can be changed by parameter settings.
	Increment for keeping (16 bits) [changeable]	C100 to C199	100 points	
	Both directions for general (32 bits) [changeable]	C200 to C219	20 points	Counting from -2,147,483,648 to +2,147,483,647 The retentive status can be changed by parameter settings.
	Increment for keeping (32 bits) [changeable]	C220 to C234	15 points	
High-speed counter	1-phase 1-count input in both directions (32 bits) [changeable]	C235 to C245	Up to 8 points can be used in range from C235 to C255. [For keeping] The retentive status can be changed by parameter settings.	
	1-phase 2-count input in both directions (32 bits) [changeable]	C246 to C250	Counting from -2,147,483,648 to +2,147,483,647 Hardware counter 1-phase: 100 kHz x 6 points, 10 kHz x 2 points	
	2-phase 2-count input in both directions (32 bits) [changeable]	C251 to C255	Software counter 1-phase: 40kHz 2-phase: 40 kHz (multiply by 1), 10 kHz (multiply by 4)	

11	Memory Cassette/Battery
12	Test Run, Maintenance, Troubleshooting
A	Version Information
B	Performance Specifications
C	Special Devices (M8000 -J, D8000 -)
D	Instruction List
E	Character-code
F	Discontinued models
G	Precautions for battery transportation
H	Handling of batteries in EU member states

Item		Performance		
Data register (32 bits when paired)	For general (16 bits) [changeable]	D0 to D199	200 points	The retentive status can be changed by parameter settings.
	For keeping (16 bits) [changeable]	D200 to D511	312 points	
	For keeping (16 bits) [fixed] <File register>	D512 to D7999 <D1000 to D7999>	7488 points <7000 points>	D1000 and later in 7488 points of fixed data register for keeping can be set as file register points in 500-point units by changing the parameter settings.
	For special (16 bits)	D8000 to D8511	512 points	–
	For index (16 bits)	V0 to V7 Z0 to Z7	16 points	–
Extension register (16 bits)		R0 to R32767	32768 points	Retained by battery during power failure
Extension file register (16 bits)		ER0 to ER32767	32768 points	Usable only when memory cassette is mounted
Pointer	For branching of JUMP and CALL	P0 to P4095	4096 points	For CJ instructions and CALL instructions
	Input interruption and input delay interruption	I0□□ to I5□□	6 points	–
	Timer interruption	I6□□ to I8□□	3 points	
	Counter interruption	I010 to I060	6 points	For HSCS instructions
Nesting	For master control	N0 to N7	8 points	For MC instructions
Constant	Decimal number (K)	16 bits	-32,768 to +32,767	
		32 bits	-2,147,483,648 to +2,147,483,647	
	Hexadecimal number (H)	16 bits	0 to FFFF	
		32 bits	0 to FFFFFFFF	
	Real number (E)	32 bits	-1.0 x 2 ¹²⁸ to -1.0 x 2 ⁻¹²⁶ , 0, 1.0 x 2 ⁻¹²⁶ to 1.0 x 2 ¹²⁸ Decimal-point and exponential notations are possible.	
Character string (" ")	Character string	Designation by characters enclosed with " " Up to 32 one-byte characters can be used for a constant in an instruction.		

Appendix C: Operation of Special Devices (M8000 -, D8000 -)

The device numbers and functions of the special auxiliary relays (indicated as "special M" in tables) and special data registers (indicated as "special D" in tables) are shown below.





Note that functions of certain devices vary depending on the series of the PLC.

Do not use the undefined / blank special auxiliary relays and special data registers in the sequence program since they are occupied by the CPU.

In addition, do not activate or write to the devices with brackets on the first letter such as [M]8000 or [D]8001 in the program.

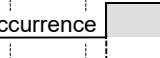
→ For detailed explanation, refer to the Programming Manual.

Appendix C-1 Special Auxiliary Relay (M8000 to M8511)

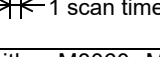
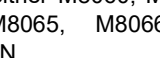
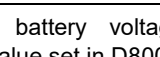
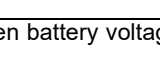
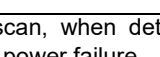
Number and name	Operation and function	Corresponding special device
PLC Status		
[M]8000 RUN monitor NO contact	RUN input 	-
[M]8001 RUN monitor NC contact	M8061 Error occurrence 	-
[M]8002 Initial pulse NO contact	M8000 	-
[M]8003 Initial pulse NC contact	M8001 	-
[M]8004 Error occurrence	M8002 	-
[M]8005 Battery voltage low	M8003 	-
[M]8006 Battery error latch		-
[M]8007 Momentary power failure		-
[M]8008 Power failure detected		-
[M]8009 24V DC down		-
Clock		
[M]8010	Not used	-
[M]8011 10 ms clock pulse	ON and OFF in 10 ms cycle (ON: 5 ms, OFF: 5 ms)	-

Number and name	Operation and function	Corresponding special device
Clock		
[M]8012 100 ms clock pulse	ON and OFF in 100 ms cycle (ON: 50 ms, OFF: 50 ms)	-
[M]8013 1 sec clock pulse	ON and OFF in 1 sec cycle (ON: 500 ms, OFF: 500 ms)	-
[M]8014 1 min clock pulse	ON and OFF in 1 min cycle (ON: 30 sec, OFF: 30 sec)	-
M 8015	Clock stop and preset For real time clock	-
M 8016	Time read display is stopped For real time clock	-
M 8017	±30 seconds correction For real time clock	-
[M]8018	Installation detection (Always ON) For real time clock	-
M 8019	Real time clock (RTC) error For real time clock	-
Flag		
[M]8020 Zero	ON when the result of addition/ subtraction is 0.	-
[M]8021 Borrow	ON when the result of subtraction is less than the min. negative number.	-
M 8022 Carry	ON when 'carry' occurs as a result of addition or when an overflow occurs as a result of shift operation.	-
[M]8023	Not used	-
M 8024*1	BMOV direction specification (FNC 15)	-
M 8025*1	HSC mode (FNC 53 to 55)	-
M 8026*1	RAMP mode (FNC 67)	-
M 8027*1	PR mode (FNC 77)	-
M 8028	Interrupt permission during FROM/ TO (FNC 78 and 79) instruction execution	-
[M]8029 Instruction execution complete	ON when operation such as DSW (FNC 72) is completed.	-

*1. Cleared when PLC switches from RUN to STOP.

Number and name	Operation and function	Corresponding special device
PLC Mode		
M 8030*1 Battery LED OFF	When M8030 set to ON, LED on PLC is not lit even if low battery voltage is detected.	—
M 8031*1 Non-latch memory all clear	If this special auxiliary relay is activated, the ON/OFF image memory of Y, M, S, T, and C, and present values of T, C, D, special data registers and R are cleared to zero.	—
M 8032*1 Latch memory all clear	However, file registers (D) in program memory, and extension file registers (ER) in the memory cassette are not cleared.	—
M 8033 Memory hold STOP	When PLC is switched from RUN to STOP, image memory and data memory are retained.	—
M 8034*1 All outputs disable	All external output contacts of PLC are turned OFF.	—
M 8035 Forced RUN mode	→Refer to Programming Manual for details.	—
M 8036 Forced RUN signal		—
M 8037 Forced STOP signal		—
[M]8038 Parameter setting	Communication parameter setting flag (for N:N network setting)	D8176 to D8180
M 8039 Constant scan mode	When M8039 is ON, PLC waits until scan time specified in D8039 and then executes cyclic operation.	D8039

*1. Executed at END instruction

Step Ladder and Annunciator

M 8040 Transfer disable	While M8040 is turned ON, transfer between states is disabled.	—
[M]8041*2 Transfer start	Transfer from initial state is enabled in automatic operation mode.	—
[M]8042 Start pulse	Pulse output is given in response to a start input.	—
M 8043*2 Zero return complete	Set this in the last state of zero return mode.	—
M 8044*2 Zero point condition	Set this when machine zero return is detected.	—
M 8045 All output reset disable	Disables the 'all output reset' function when the operation mode is changed.	—
[M]8046*3 STL state ON	ON when M8047 is ON and either of S0 to S899 or S1000 to S4095 is active.	M8047
M 8047*3 STL monitoring enable	D8040 to D8047 are enabled when M8047 is ON.	D8040 to D8047
[M]8048*3 Annunciator operate	ON when M8049 is ON and either of S900 to S999 is ON.	—
M 8049*2 Annunciator enable	D8049 is enabled when M8049 is ON.	D8049 M8048

*2. Cleared when PLC switches from RUN to STOP.

*3. Executed at END instruction.

Number and name	Operation and function	Corresponding special device
Interrupt Disable		
M8050 (input interrupt) I00□ disable*4	<ul style="list-style-type: none"> If an input interrupt or timer interrupt occurs while a special auxiliary relay for that interrupt (M8050 - M8058) is ON, the interrupt will not operate. For example, turning M8050 ON disables the I00□ interrupt; hence, the interrupt routine is not processed even in an allowable program area. If an input interrupt or timer interrupt occurs while a special auxiliary relay for that interrupt (M8050 - M8058) is OFF, <ol style="list-style-type: none"> The interrupt will be accepted. The interrupt routine will be processed promptly if it is permitted by the EI (FNC 04) instruction. However, if the DI (FNC 05) instruction disables interrupts, the interrupt program will not be processed until EI (FNC 04) permits the interrupts. 	—
M8051 (input interrupt) I10□ disable*4		—
M8052 (input interrupt) I20□ disable*4		—
M8053 (input interrupt) I30□ disable*4		—
M8054 (input interrupt) I40□ disable*4		—
M8055 (input interrupt) I50□ disable*4		—
M8056 (Timer interrupt) I6□□ disable*4		—
M8057 (Timer interrupt) I7□□ disable*4		—
M8058 (Timer interrupt) I8□□ disable*4		—
M8059 Counter interrupt disable*4		Interrupt of I010 to I060 disabled

*4. Cleared when PLC switches from RUN to STOP.

Error Detection

[M]8060	I/O configuration error	D8060
[M]8061	PLC hardware error	D8061
[M]8062	Not used	—
[M]8063*5*6	Serial communication error 1 [ch1]	D8063
[M]8064	Parameter error	D8064
[M]8065	Syntax error	D8065 D8069 D8314 D8315
[M]8066	Ladder error	D8066 D8069 D8314 D8315
[M]8067*7	Operation error	D8067 D8069 D8314 D8315
M 8068	Operation error latch	D8068 D8312 D8313
M 8069*8	I/O bus check	—

*5. Cleared when PLC power supply is turned from OFF to ON.

*6. Serial communication error 2 [ch2] PLC is detected by M8438.

*7. Cleared when PLC switches from STOP to RUN.

*8. When M8069 is ON, I/O bus check is executed.

Number and name	Operation and function	Corresponding special device
Parallel Link		
M 8070*1	Parallel link Set M8070 when using master station.	-
M 8071*1	Parallel link Set M8071 when using slave station.	-
[M]8072	Parallel link ON when operating	-
[M]8073	Parallel link ON when M8070 or M8071 setting is incorrect	-

*1. Cleared when PLC switches from STOP to RUN.

Sampling Trace		
[M]8074	Not used	-
[M]8075	Ready request for sampling trace	D8075 to D8098
[M]8076	Start request for sampling trace	
[M]8077	ON during sampling trace	
[M]8078	ON when sampling trace is completed	
[M]8079	Sampling trace system area	
[M]8080	Not used	-
[M]8081		-
[M]8082		-
[M]8083		-
[M]8084		-
[M]8085		-
[M]8086		-
[M]8087		-
[M]8088		-
[M]8089		-

Flag		
[M]8090*2	BKCOMP (FNC194 to FNC199) instructions - Block comparison signal	-
M 8091*2	COMRD (FNC182) and BINDA (FNC261) instructions - Output character quantity selector signal	-
[M]8092	Not used	-
[M]8093		-
[M]8094		-
[M]8095		-
[M]8096		-
[M]8097		-
[M]8098		-

High Speed Ring Counter		
M 8099*3	High speed ring counter operation (in units of 0.1ms, 16 bits)	D8099
[M]8100	Not used	-

*2. Supported in Ver. 2.20 or later

*3. 0.1ms high speed ring counter D8099 will operate after M8099 turns ON.

Number and name	Operation and function	Corresponding special device
Memory Information		
[M]8101	Not used	-
[M]8102		-
[M]8103		-
[M]8104		-
[M]8105	ON during writing in RUN mode*4	-
[M]8106	Not used	-
[M]8107	Device comment registration check	D8107
[M]8108	Not used	-

Output Refresh Error		
[M]8109	Output refresh error	-
[M]8110	Not used	-
[M]8111		-
M 8112		-
M 8113		-
M 8114		-
M 8115		-
M 8116		-
M 8117		-
[M]8118		-
[M]8119		-

RS (FNC 80) and Computer Link [ch1]		
[M]8120	Not used	-
[M]8121*5	RS (FNC 80) instruction: Send wait flag	-
M 8122*5	RS (FNC 80) instruction: Send request	D8122
M 8123*5	RS (FNC 80) instruction: Receive complete flag	D8123
[M]8124	RS (FNC 80) instruction: Carrier detection flag	-
[M]8125	Not used	-
[M]8126	Computer link [ch1]: Global ON	D8127 D8128 D8129
[M]8127	Computer link [ch1]: On-demand send processing	
M 8128	Computer link [ch1]: On-demand error flag	
M 8129	Computer link [ch1]: On-demand Word/Byte changeover RS (FNC 80) instruction: Time-out check flag	

*4. Enabled only when a memory cassette is installed.

*5. Cleared when PLC switches from RUN to STOP or RS instruction is OFF.

11	Memory Cassette/Battery
12	Test Run, Maintenance, Troubleshooting
A	Version Information
B	Performance Specifications
C	Special Devices (M8000 -, D8000 -)
D	Instruction List
E	Character-code
F	Discontinued models
G	Precautions for battery transportation
H	Handling of batteries in EU member states

Number and name	Operation and function	Corresponding special device	
High-Speed Counter Comparison, High-Speed Table, and Positioning			
M 8130	HSZ (FNC 55) instruction: Table comparison mode	D8130	
[M]8131	HSZ (FNC 55) instruction: Table comparison mode completion flag		
M 8132	HSZ (FNC 55) and PLSY (FNC 57) instructions: Speed pattern mode	D8131 to D8134	
[M]8133	HSZ (FNC 55) and PLSY (FNC 57) instructions: Speed pattern mode completion flag		
[M]8134	Not used		-
[M]8135			-
[M]8136			-
[M]8137		-	
[M]8138	HSCT (FNC280) instruction: Instruction execution complete flag	D8138	
[M]8139	HSCS (FNC 53), HSCR (FNC 54), HS2 (FNC 55), HSCT (FNC280) instructions: High-speed counter comparison instruction executing	D8139	
M 8140	ZRN (FNC156) instruction: CLR signal output function enable	-	
[M]8141	Not used	-	
[M]8142		-	
[M]8143		-	
[M]8144		-	
M 8145		-	
M 8146		-	
[M]8147		-	
[M]8148		-	
[M]8149		-	
Inverter Communication Function			
[M]8150	Not used	-	
[M]8151	Inverter communication in execution [ch1]	D8151	
[M]8152*1	Inverter communication error [ch1]	D8152	
[M]8153*1	Inverter communication error latch [ch1]	D8153	
[M]8154*1	IVBWR (FNC274) instruction error [ch1]	D8154	
[M]8155	Not used	-	
[M]8156	Inverter communication in execution [ch2]	D8156	
[M]8157*1	Inverter communication error [ch2]	D8157	
[M]8158*1	Inverter communication error latch [ch2]	D8158	
[M]8159*1	IVBWR (FNC274) instruction error [ch2]	D8159	

*1. Cleared when PLC switches from STOP to RUN.

Number and name	Operation and function	Corresponding special device
Advanced Function		
M 8160*2	SWAP function of XCH (FNC 17)	-
M 8161*2*3	8-bit process mode	-
M 8162	High-speed parallel link mode	-
[M]8163	Not used	-
M 8164		-
M 8165*2*4	SORT2 (FNC149) instruction: Sorting in descending order	-
[M]8166	Not used	-
M 8167*2	HKY (FNC 71) instruction: HEX data handling function	-
M 8168*2	SMOV (FNC 13) instruction: HEX data handling function	-
[M]8169	Not used	-

*2. Cleared when PLC switches from RUN to STOP.

*3. Applicable to ASC (FNC 76), RS (FNC 80), ASCII (FNC 82), HEX (FNC 83), CCD (FNC 84), and CRC (FNC188) instructions.

*4. Supported in Ver. 2.20 or later.

Pulse Catch		
M 8170*5	Input X000 pulse catch	-
M 8171*5	Input X001 pulse catch	-
M 8172*5	Input X002 pulse catch	-
M 8173*5	Input X003 pulse catch	-
M 8174*5	Input X004 pulse catch	-
M 8175*5	Input X005 pulse catch	-
M 8176*5	Input X006 pulse catch	-
M 8177*5	Input X007 pulse catch	-

*5. Cleared when PLC switches from STOP to RUN. EI (FNC 04) instruction is necessary.

Communication Port Channel Setting		
M 8178	Parallel link channel switch (OFF: ch1/ON: ch2)	-
M 8179	N:N network channel switch*6	-

*6. The channel is specified by either creating or not creating M8179 in setting program.

- ch1: not creating M8179 in setting program
- ch2: creating M8179 in setting program

Number and name	Operation and function	Corresponding special device
N:N Network		
[M]8180	Not used	-
[M]8181		-
[M]8182		-
[M]8183	Data communication error (Master station)	D8201 to D8218
[M]8184	Data communication error (Slave station No.1)	
[M]8185	Data communication error (Slave station No.2)	
[M]8186	Data communication error (Slave station No.3)	
[M]8187	Data communication error (Slave station No.4)	
[M]8188	Data communication error (Slave station No.5)	
[M]8189	Data communication error (Slave station No.6)	
[M]8190	Data communication error (Slave station No.7)	
[M]8191	Data communication in execution	
[M]8192	Not used	
[M]8193		-
[M]8194		-
[M]8195		-
[M]8196		-
[M]8197		-
High Speed Counter Edge Count Specification		
M 8198*1*2	C251, C252, C254: 1/4 edge count selector	-
M 8199*1*2	C253, C255, or C253 (OP): 1/4 edge count selector	-

*1. OFF: 1 edge count
ON: 4 edge count

*2. Cleared when PLC switches from RUN to STOP.

Number and name	Operation and function	Corresponding special device
Counter Up/down Counter Counting Direction		
M 8200	C200	-
M 8201	C201	-
M 8202	C202	-
M 8203	C203	-
M 8204	C204	-
M 8205	C205	-
M 8206	C206	-
M 8207	C207	-
M 8208	C208	-
M 8209	C209	-
M 8210	C210	-
M 8211	C211	-
M 8212	C212	-
M 8213	C213	-
M 8214	C214	-
M 8215	C215	-
M 8216	C216	-
M 8217	C217	-
M 8218	C218	-
M 8219	C219	-
M 8220	C220	-
M 8221	C221	-
M 8222	C222	-
M 8223	C223	-
M 8224	C224	-
M 8225	C225	-
M 8226	C226	-
M 8227	C227	-
M 8228	C228	-
M 8229	C229	-
M 8230	C230	-
M 8231	C231	-
M 8232	C232	-
M 8233	C233	-
M 8234	C234	-
High Speed Counter Up/down Counter Counting Direction		
M 8235	C235	-
M 8236	C236	-
M 8237	C237	-
M 8238	C238	-
M 8239	C239	-
M 8240	C240	-
M 8241	C241	-
M 8242	C242	-
M 8243	C243	-
M 8244	C244	-
M 8245	C245	-

When M8□□□ is ON, the corresponding C□□□ is changed to down mode.
 • ON: Down count operation
 • OFF: Up count operation

When M8□□□ is ON, the corresponding C□□□ is changed to down mode.
 • ON: Down count operation
 • OFF: Up count operation

11	Memory Cassette/Battery
12	Test Run, Maintenance, Troubleshooting
A	Version Information
B	Performance Specifications
C	Special Devices (M8000 -, D8000 -)
D	Instruction List
E	Character-code
F	Discontinued models
G	Precautions for battery transportation
H	Handling of batteries in EU member states

Number and name	Operation and function	Corresponding special device
High Speed Counter Up/down Counter Monitoring		
[M]8246	C246	When C□□□ of 1-phase 2-input or 2-phase 2-input counter is in down mode, the corresponding M8□□□ turns ON. • ON: Down count operation • OFF: Up count operation
[M]8247	C247	
[M]8248	C248	
[M]8249	C249	
[M]8250	C250	
[M]8251	C251	
[M]8252	C252	
[M]8253	C253	
[M]8254	C254	
[M]8255	C255	
[M]8256 to [M]8259	Not used	—
Analog Special Adapter (Refer to Appendix C-3)		
M 8260 to M 8269	1st special adapter ^{*1*2}	—
M 8270 to M 8279	2nd special adapter ^{*1*2}	—
M 8280 to M 8289	3rd special adapter ^{*1*2}	—
M 8290 to M 8299	4th special adapter ^{*1*2}	—

*1. The number of connected analog special adapter is counted from the main unit side.

*2. Supported in Ver. 1.20 or later

Flag		
[M]8300 to [M]8303	Not used	—
[M]8304 ^{*3} Zero	Turns ON when the multiplication or division result is 0.	—
[M]8305	Not used	—
[M]8306 ^{*3} Carry	Turns ON when the division result overflows.	—
[M]8307 to [M]8315	Not used	—

*3. Supported in Ver. 2.30 or later

Number and name	Operation and function	Corresponding special device
Unconnected I/O Designation Error and flag		
[M]8316 ^{*4}	Unconnected I/O designation error	D8316 D8317
[M]8317	Not used	—
[M]8318 ^{*5}	BFM initialization failure ON when a FROM/TO error has occurred in a special function block/unit as specified in the BFM initialization function at changing PLC from STOP to RUN. When M8318 turns ON, the unit number in which the error has occurred is stored in D8318, and the BFM number is stored in D8319.	D8318 D8319
[M]8319 to [M]8321	Not used	—
[M]8322 ^{*6}	FX3UC-32MT-LT/ FX3UC-32MT-LT-2 model indicator 1: FX3UC-32MT-LT-2 0: FX3UC-32MT-LT	—
[M]8323 ^{*6}	CC-Link/LT configuration required	—
[M]8324 ^{*6}	CC-Link/LT configuration completed	—
[M]8325 to [M]8327	Not used	—
[M]8328 ^{*5}	Instruction non-execution	—
[M]8329	Instruction execution abnormal end	—

*4. If the I/O device numbers are unavailable, M8316 turns ON when its directly designated to device numbers including LD, AND, OR, and OUT instructions or indirectly designated by index.

*5. Supported in Ver. 2.20 or later

*6. FX3UC-32MT-LT-2 only

Number and name	Operation and function	Corresponding special device
Timing Clock		
[M]8330* ¹	DUTY (FNC186) instruction: Timing clock output 1	D8330
[M]8331* ¹	DUTY (FNC186) instruction: Timing clock output 2	D8331
[M]8332* ¹	DUTY (FNC186) instruction: Timing clock output 3	D8332
[M]8333* ¹	DUTY (FNC186) instruction: Timing clock output 4	D8333
[M]8334* ¹	DUTY (FNC186) instruction: Timing clock output 5	D8334
[M]8335	Not used	-
Positioning		
M 8336* ^{2,3}	DVIT (FNC151) instruction: Interrupt input specification function enabled	D8336
[M]8337	Not used	-
M 8338* ^{1,3}	PLSV (FNC157) instruction: Acceleration/deceleration operation	-
[M]8339	Not used	-
[M]8340	[Y000] Pulse output monitor (ON:BUSY/ OFF: READY)	-
M 8341* ³	[Y000] Clear signal output function enable	-
M 8342* ³	[Y000] Zero return direction specification	-
M 8343	[Y000] Forward limit	-
M 8344	[Y000] Reverse limit	-
M 8345* ³	[Y000] DOG signal logic reverse	-
M 8346* ³	[Y000] Zero point signal logic reverse	-
M 8347* ³	[Y000] Interrupt signal logic reverse	-
[M]8348	[Y000] Positioning instruction activation	-
M 8349* ³	[Y000] Pulse output stop command	-
[M]8350	[Y001] Pulse output monitor (ON: BUSY/ OFF: READY)	-
M 8351* ³	[Y001] Clear signal output function enable	-
M 8352* ³	[Y001] Zero return direction specification	-
M 8353	[Y001] Forward limit	-
M 8354	[Y001] Reverse limit	-
M 8355* ³	[Y001] DOG signal logic reverse	-
M 8356* ³	[Y001] Zero point signal logic reverse	-
M 8357* ³	[Y001] Interrupt signal logic reverse	-
[M]8358	[Y001] Positioning instruction activation	-
M 8359* ³	[Y001] Pulse output stop command	-

Number and name	Operation and function	Corresponding special device
Positioning		
[M]8360	[Y002] Pulse output monitor (ON: BUSY/ OFF: READY)	-
M 8361* ³	[Y002] Clear signal output function enable	-
M 8362* ³	[Y002] Zero return direction specification	-
M 8363	[Y002] Forward limit	-
M 8364	[Y002] Reverse limit	-
M 8365* ³	[Y002] DOG signal logic reverse	-
M 8366* ³	[Y002] Zero point signal logic reverse	-
M 8367* ³	[Y002] Interrupt signal logic reverse	-
[M]8368	[Y002] Positioning instruction activation	-
M 8369* ³	[Y002] Pulse output stop command	-
[M]8370 to [M]8379	Not used	-

*1. Supported in Ver. 2.20 or later

*2. Supported in Ver. 1.30 or later

*3. Cleared when PLC switches from RUN to STOP.

11	Memory Cassette/Battery
12	Test Run, Maintenance, Troubleshooting
A	Version Information
B	Performance Specifications
C	Special Devices (M8000 -, D8000 -)
D	Instruction List
E	Character-code
F	Discontinued models
G	Precautions for battery transportation
H	Handling of batteries in EU member states

Number and name	Operation and function	Corresponding special device
High Speed Counter Function		
[M]8380*1	Operation status of C235, C241, C244, C246, C247, C249, C251, C252, and C254	-
[M]8381*1	Operation status of C236	-
[M]8382*1	Operation status of C237, C242, and C245	-
[M]8383*1	Operation status of C238, C248, C248 (OP), C250, C253, and C255	-
[M]8384*1	Operation status of C239 and C243	-
[M]8385*1	Operation status of C240	-
[M]8386*1	Operation status of C244 (OP)	-
[M]8387*1	Operation status of C245 (OP)	-
[M]8388	Contact for high speed counter function change	-
M 8389	External reset input logic reverse	-
M 8390	Function changeover device for C244	-
M 8391	Function changeover device for C245	-
M 8392	Function changeover device for C248 and C253	-

*1. Cleared when PLC switches from STOP to RUN.

Interrupt Program		
[M]8393	Contact for delay time setting	D8393
[M]8394	HCMOV (FNC189): Drive contact for interrupt program	-
[M]8395		-
[M]8396	Not used	-
[M]8397		-

Ring Counter		
M 8398	Ring counter operation (in units of 1ms, 32 bits)*2	D8398, D8399
[M]8399	Not used	-

*2. 1ms ring counter (D8399, D8398) will operate after M8398 turns ON.

RS2 (FNC 87) [ch1]		
[M]8400	Not used	-
[M]8401*3	RS2 (FNC 87) [ch1] Send wait flag	-
M 8402*3	RS2 (FNC 87) [ch1] Send request	D8402
M 8403*3	RS2 (FNC 87) [ch1] Receive complete flag	D8403
[M]8404	RS2 (FNC 87) [ch1] Carrier detection flag	-
[M]8405*4	RS2 (FNC 87) [ch1] Data set ready (DSR) flag	-
[M]8406		-
[M]8407	Not used	-
[M]8408		-
M 8409	RS2 (FNC 87) [ch1] Time-out check flag	-

*3. Cleared when PLC switches from RUN to STOP or when RS2 instruction [ch1] is OFF.

*4. Supported in Ver. 2.30 or later

Number and name	Operation and function	Corresponding special device
RS2 (FNC 87) [ch2] and Computer Link [ch2]		
[M]8410 to [M]8420	Not used	-
[M]8421*5	RS2 (FNC 87) [ch2] Send wait flag	-
M 8422*5	RS2 (FNC 87) [ch2] Send request	D8422
M 8423*5	RS2 (FNC 87) [ch2] Receive complete flag	D8423
[M]8424	RS2 (FNC 87) [ch2] Carrier detection flag	-
[M]8425*6	RS2 (FNC 87) [ch2] Data set ready (DSR) flag	-
[M]8426	Computer link [ch2] Global ON	D8427 D8428 D8429
[M]8427	Computer link [ch2] On-demand send processing	
M 8428	Computer link [ch2] On-demand error flag	
M 8429	Computer link [ch2] On-demand Word/Byte changeover RS2 (FNC 87) [ch2] Time-out check flag	

*5. Cleared when PLC switches from RUN to STOP or when RS2 instruction [ch2] is OFF.

*6. Supported in Ver. 2.30 or later

MODBUS communication [ch1]		
[M]8401*7	MODBUS request in process	-
[M]8402*7	MODBUS communication error	D8402
[M]8403*7	MODBUS communication error (latched)	D8403
[M]8404*7	Listen only mode	-
[M]8405 to [M]8407	Not used	-
[M]8408*7	Retry	-
[M]8409*7	Timeout	-
[M]8410	Not used	-

MODBUS communication [ch2]		
[M]8421*7	MODBUS request in process	-
[M]8422*7	MODBUS communication error	D8422
[M]8423*7	MODBUS communication error (latched)	D8423
[M]8424*7	Listen only mode	-
[M]8425 to [M]8427	Not used	-
[M]8428*7	Retry	-
[M]8429*7	Timeout	-
[M]8430	Not used	-

MODBUS communication [ch1, ch2]		
M 8411*7	MODBUS configuration request flag	-

*7. Supported in Ver. 2.40 or later.

Number and name	Operation and function	Corresponding special device
FX3U-CF-ADP [ch1]		
[M]8402*1	CF-ADP instruction executing	-
[M]8403	Not used	-
[M]8404*1	CF-ADP unit ready	-
[M]8405*1	CF card mount status	-
[M]8406 to [M]8409	Not used	-
M 8410*1	CF-ADP status renewal stop	-
[M]8411 to [M]8417	Not used	-
M 8418*1*2	CF-ADP instruction error	-
FX3U-CF-ADP [ch2]		
[M]8422*1	CF-ADP instruction executing	-
[M]8423	Not used	-
[M]8424*1	CF-ADP unit ready	-
[M]8425*1	CF card mount status	-
[M]8426 to [M]8429	Not used	-
M 8430*1	CF-ADP status renewal stop	-
[M]8431 to [M]8437	Not used	-
M 8438*1*2	CF-ADP instruction error	-

*1. Supported in Ver. 2.61 or later.

*2. Cleared when the PLC mode is changed from STOP to RUN.

FX3U-ENET-ADP [ch1]		
[M]8404*3	FX3U-ENET-ADP unit ready	-
[M]8405	Not used	-
[M]8406*3*4	Time setting execution	-
[M]8407 to [M]8410	Not used	-
M 8411*3*4	Execute time setting	-
[M]8063*3	Error occurrence	D8063
FX3U-ENET-ADP [ch2]		
[M]8424*3	FX3U-ENET-ADP unit ready	-
[M]8425	Not used	-
[M]8426*3*4	Time setting execution	-
[M]8427 to [M]8430	Not used	-
M 8431*3*4	Execute time setting	-
[M]8438*3	Error occurrence	D8438

*3. Supported in Ver. 3.10 or later.

*4. Used when the SNTP function setting is set to "Use" in the time setting parameters.

Number and name	Operation and function	Corresponding special device
Error Detection		
[M]8430 to [M]8437	Not used	-
M 8438*5	Serial communication error 2 [ch2]	D8438
[M]8439 to [M]8448	Not used	-
[M]8449*6	Special block error flag	D8449
[M]8450 to [M]8459	Not used	-

*5. Cleared when PLC power supply is turned from OFF to ON.

*6. Supported in Ver. 2.20 or later.

Positioning		
M 8460*7	DVIT (FNC151) instruction [Y000] User interrupt input command	D8336
M 8461*7	DVIT (FNC151) instruction [Y001] User interrupt input command	D8336
M 8462*7	DVIT (FNC151) instruction [Y002] User interrupt input command	D8336
M 8463	Not used	-
M 8464*7	DSZR (FNC150), ZRN (FNC156) instructions [Y000] Clear signal device specification function enabled	D8464
M 8465*7	DSZR (FNC150), ZRN (FNC156) instructions [Y001] Clear signal device specification function enabled	D8465
M 8466*7	DSZR (FNC150), ZRN (FNC156) instructions [Y002] Clear signal device specification function enabled	D8466
M 8467	Not used	-
Error Detection		
[M]8468 to [M]8488	Not used	-
M 8489*8	Special parameter error	D8489
[M]8490 to [M]8511	Not used	-

*7. Supported in Ver. 2.20 or later.

*8. Supported in Ver. 3.10 or later.

11	Memory Cassette/Battery
12	Test Run, Maintenance, Troubleshooting
A	Version Information
B	Performance Specifications
C	Special Devices (M8000 -, D8000 -)
D	Instruction List
E	Character-code
F	Discontinued models
G	Precautions for battery transportation
H	Handling of batteries in EU member states

Appendix C-2 Special Data Register (D8000 to D8511)

Number and name	Content of register	Corresponding special device	Number and name	Content of register	Corresponding special device					
PLC Status			Clock							
D 8000 Watchdog timer	An initial value is 200ms (in 1ms steps) (Writes from system ROM at power ON) Value overwritten by program is valid after END or WDT instruction execution.	—	[D]8010 Present scan time*2	Accumulated instruction-execution time from 0 step (in units of 0.1 ms)	—					
[D]8001 PLC type and system version	<table border="1" style="display: inline-table; vertical-align: middle;"> <tr> <td>2</td><td>4</td><td>1</td><td>0</td><td>0</td> </tr> </table> ↑ Version 1.00 ↑ FX3U, FX3UC, FX2N, FX2NC Series	2	4	1	0	0	D8101	[D]8011 Minimum scan time*2	Minimum value of scan time (in units of 0.1 ms)	—
2	4	1	0	0						
[D]8002 Memory capacity	<ul style="list-style-type: none"> • 2...2K steps • 4...4K steps • 8...8K steps • If 16K steps or more "K8" is written to D8002 and "16" or "64" is written to D8102. 	D8102	[D]8012 Maximum scan time*2	Maximum value of scan time (in units of 0.1 ms)	—					
[D]8003 Memory type	Type of cassette or ON/OFF status of memory protect switch is stored.*1	—	D 8013 Second data	0 to 59 seconds (for real time clock)	—					
[D]8004 Error number M	<table border="1" style="display: inline-table; vertical-align: middle;"> <tr> <td>8</td><td>0</td><td>6</td><td>0</td> </tr> </table> ↑ 8060 to 8068 (when M8004 is ON)	8	0	6	0	M8004	D 8014 Minute data	0 to 59 minutes (for real time clock)	—	
8	0	6	0							
[D]8005 Battery voltage	<table border="1" style="display: inline-table; vertical-align: middle;"> <tr> <td> </td><td> </td><td> </td><td>3</td><td>0</td> </tr> </table> (in units of 0.1V) Battery voltage present value (Example: 3.0V)				3	0	M8005	D 8015 Hour data	0 to 23 hours (for real time clock)	—
			3	0						
[D]8006 Low battery voltage detection level	Default: 2.7V (in units of 0.1V) (Writes from system ROM at power ON)	M8006	D 8016 Day data	1 to 31 days (for real time clock)	—					
[D]8007 Momentary power failure count	Operation frequency of M8007 is stored. Cleared at power-off.	M8007	D 8017 Month data	1 to 12 months (for real time clock)	—					
D 8008 Power failure detection	Default: 5 ms	M8008	D 8018 Year data	2 digits of year data (0 to 99) (for real time clock)	—					
[D]8009	Not used	—	D 8019 Day-of-the-week data	0 (Sunday) to 6 (Saturday) (for real time clock)	—					

*2. Indicated value includes waiting time of constant scan operation (when M8039 is activated).

Input Filter		
D 8020 Input filter adjustment	Input filter value of X000 to X017*3 (Default: 10 ms)	—
[D]8021	Not used	—
[D]8022		—
[D]8023		—
[D]8024		—
[D]8025		—
[D]8026		—
[D]8027		—
Index Register Z0 and V0		
[D]8028	Value of Z0 (Z) register*4	—
[D]8029	Value of V0 (V) register*4	—

*1. D8003 becomes the under mentioned content.

Present value	Type of memory	Protect switch
02H	Flash memory cassette	OFF
0AH	Flash memory cassette	ON
10H	Built-in memory in PLC	—

*3. X000 to X007 in FX3UC-16M□.

*4. The values of Z1 to Z7 and V1 to V7 are stored in D8182 to D8195.

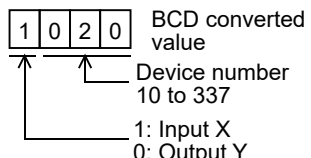
Number and name	Content of register	Corresponding special device	Number and name	Content of register	Corresponding special device
Constant Scan			Error Detection (For the error code, refer to Subsection 12.6.4)		
[D]8030	Not used	—	[D]8060	If the unit or block corresponding to a programmed I/O number is not actually loaded, M8060 is set to ON and the first device number of the erroneous block is written to D8060. Example: If X020 is unconnected. 	M8060
[D]8031					
[D]8032					
[D]8033					
[D]8034					
[D]8035					
[D]8036					
[D]8037					
[D]8038					
D 8039 Constant scan duration	Default: 0 ms (in 1 ms steps) (Writes from system ROM at power ON) Can be overwritten by program	M8039	[D]8061	Error code for PLC hardware error	M8061
Stepladder and Annunciator			[D]8062 ^{*2}	Error code for PLC/PP communication error	M8062
[D]8040 ^{*1} ON state number 1	The smallest number out of active state ranging from S0 to S899 and S1000 to S4095 is stored in D8040 and the second-smallest state number is stored in D8041. Active state numbers are then sequentially stored in registers up to D8047 (Max. 8 points).	M8047	[D]8063 ^{*2}	Error code for serial communication error 1 [ch1]	M8063
[D]8041 ^{*1} ON state number 2					
[D]8042 ^{*1} ON state number 3					
[D]8043 ^{*1} ON state number 4					
[D]8044 ^{*1} ON state number 5					
[D]8045 ^{*1} ON state number 6					
[D]8046 ^{*1} ON state number 7					
[D]8047 ^{*1} ON state number 8					
[D]8048			Not used	—	[D]8064
[D]8049 ^{*1} On state minimum number	When M8049 is ON, the smallest number out of active annunciator relay ranging from S900 to S999 is stored in D8049.	M8049	[D]8065	Error code for syntax error	M8065
[D]8050 to [D]8059	Not used	—	[D]8066	Error code for ladder error	M8066
			[D]8067 ^{*3}	Error code for operation error	M8067
			D 8068	Operation error step number latched ^{*4}	M8068
			[D]8069 ^{*3}	Error step number of M8065 to M8067 ^{*5}	M8065 to M8067
			Parallel Link (Refer to Data Communication Edition for details.)		
			[D]8070	Parallel link error time-out check time: 500 ms	—
			[D]8071	Not used	—
			[D]8072		—
			[D]8073		—

*1. Executed at END instruction.

- *2. Cleared when PLC power supply is turned from OFF to ON.
- *3. Cleared when PLC switches from STOP to RUN.
- *4. In case of 32K steps or more, step number is stored in [D8313, D8312].
- *5. In case of 32K steps or more, step number is stored in [D8315, D8314].

11	Memory Cassette/Battery
12	Test Run, Maintenance, Troubleshooting
A	Version Information
B	Performance Specifications
C	Special Devices (M8000 -, D8000 -)
D	Instruction List
E	Character-code
F	Discontinued models
G	Precautions for battery transportation
H	Handling of batteries in EU member states

Number and name	Content of register	Corresponding special device
Sampling Trace*1		
[D]8074	These devices are occupied by the PLC system when the sampling trace function is used in the personal computer*1.	M8075 to M8079
[D]8075		
[D]8076		
[D]8077		
[D]8078		
[D]8079		
[D]8080		
[D]8081		
[D]8082		
[D]8083		
[D]8084		
[D]8085		
[D]8086		
[D]8087		
[D]8088		
[D]8089		
[D]8090		
[D]8091		
[D]8092		
[D]8093		
[D]8094		
[D]8095		
[D]8096		
[D]8097		
[D]8098		

*1. The sampling trace devices are used by peripheral equipment.

High Speed Ring Counter		
D 8099	Up-operation high speed ring counter of 0 to 32,767 (in units of 0.1ms, 16-bit)*2	M8099
[D]8100	Not used	-

*2. 0.1ms high speed ring counter D8099 will operate after M8099 turns ON.

Memory Information		
[D]8101 PLC type and system version		-
[D]8102	2..... 2K steps 4..... 4K steps 8..... 8K steps 16.... 16K steps 64.... 64K steps	-
[D]8103	Not used	-
[D]8104		-
[D]8105		-
[D]8106		-
[D]8107	Number of registered device comments	M8107
[D]8108	Number of special function units/blocks connected	-

Number and name	Content of register	Corresponding special device
Output Refresh Error		
[D]8109	Y number where output refresh error occurs	M8109
[D]8110 to [D]8119	Not used	-
RS (FNC 80) and Computer Link [ch1]		
D 8120*3	RS (FNC 80) instruction and computer link [ch1] Communication format setting	-
D 8121*3	Computer link [ch1] Station number setting	-
[D]8122*4	RS (FNC 80) instruction: Remaining points of transmit data	M8122
[D]8123*4	RS (FNC 80) instruction: Monitoring receive data points	M8123
D 8124	RS (FNC 80) instruction: Header <Default: STX>	-
D 8125	RS (FNC 80) instruction: Terminator <Default: ETX>	-
[D]8126	Not used	-
D 8127	Computer link [ch1] Specification of on-demand head device register	M8126 to M8129
D 8128	Computer link [ch1] Specification of on-demand data length register	
D 8129*3	RS (FNC 80) instruction, computer link [ch1] Time-out time setting	

*3. Latch (battery backed) device. For details, refer to the programming manual.

*4. Cleared when PLC switches from RUN to STOP.

Number and name	Content of register		Corresponding special device
High-Speed Counter Comparison, High-Speed Table, and Positioning			
[D]8130	HSZ (FNC 55) instruction: High-speed comparison table counter		M8130
[D]8131	HSZ (FNC 55) and PLSY (FNC 57) instructions: Speed pattern table counter		M8132
[D]8132	Lower	HSZ (FNC 55) and PLSY (FNC 57) instructions: Speed pattern frequency	M8132
[D]8133	Upper		
[D]8134	Lower	HSZ (FNC 55) and PLSY (FNC 57) instructions: Number of target pulses for speed pattern	M8132
[D]8135	Upper		
D 8136	Lower	PLSY (FNC 57), PLSR (FNC 59) instructions: Accumulated total number of pulses output to Y000 and Y001	-
D 8137	Upper		
[D]8138	HSCT (FNC280) instruction: Table count		D8138
[D]8139	HSCS (FNC 53), HSCR (FNC 54), HSZ (FNC 55), and HSCT (FNC280) instructions: Number of instructions being executed		D8139
D 8140	Lower	Accumulated number of pulses output to Y000 for PLSY (FNC 57) and PLSR (FNC 59) instructions	-
D 8141	Upper		
D 8142	Lower	Accumulated number of pulses output to Y001 for PLSY (FNC 57) and PLSR (FNC 59) instructions	-
D 8143	Upper		
[D]8144 to [D]8149	Not used		-
Inverter Communication Function			
D 8150*1	Response wait time of inverter communication [ch1]		-
[D]8151	Step number of instruction during inverter communication [ch1] Default: -1		M8151
[D]8152*2	Error code for inverter communication [ch1]		M8152
[D]8153*2	Inverter communication error step number latched [ch1] Default: -1		M8153
[D]8154*2	Parameter number when error occurs during IVBWR (FNC274) instruction [ch1] Default: -1		M8154
D 8155*1	Response wait time of inverter communication [ch2]		-
[D]8156	Step number of instruction during inverter communication [ch2] Default: -1		M8156
[D]8157*2	Error code for inverter communication [ch2]		M8157

Number and name	Content of register		Corresponding special device
[D]8158*2	Inverter communication error step number latched [ch2] Default: -1		M8158
[D]8159*2	Parameter number when error occurs during IVBWR (FNC274) instruction [ch2] Default: -1		M8159
*1. Cleared when PLC power supply is turned from OFF to ON. *2. Cleared when PLC switches from STOP to RUN.			
Advanced Function			
[D]8160	Not used		-
[D]8161			-
[D]8162			-
[D]8163			-
D 8164			-
[D]8165			-
[D]8166*3	Special block error condition		-
[D]8167	Not used		-
[D]8168	Not used		-
[D]8169*4	Access restriction status*5		-

- *3. Supported in Ver. 3.00 or later.
For details on the special block error condition, refer to Subsection 12.6.4 Error Code List and Action.
- *4. Supported in Ver. 2.20 or later.
- *5. Access restriction status

Present value	Access restriction status	Program		Monitoring	Present value change
		Read	Write		
H**00*7	2nd keyword is not set.	✓*6	✓*6	✓*6	✓*6
H**10*7	Write protection	✓	-	✓	✓
H**11*7	Read / write protection	-	-	✓	✓
H**12*7	All online operation protection	-	-	-	-
H**20*7	Keyword cancel	✓	✓	✓	✓

- *6. The accessibility is restricted depending on the keyword setting status.
- *7. "****" indicates areas used by the system.

11	Memory Cassette/Battery
12	Test Run, Maintenance, Troubleshooting
A	Version Information
B	Performance Specifications
C	Special Devices (M8000 -, D8000 -)
D	Instruction List
E	Character-code
F	Discontinued models
G	Precautions for battery transportation
H	Handling of batteries in EU member states

Number and name	Content of register	Corresponding special device	Number and name	Content of register	Corresponding special device
N:N Network (setting)			N:N Network (monitoring)		
[D]8170	Not used	—	[D]8200	Not used	—
[D]8171		—	[D]8201	Current link scan time	—
[D]8172		—	[D]8202	Maximum link scan time	—
[D]8173	Station number	—	[D]8203	Number of communication error at master station	M8183 to M8191
[D]8174	Total number of slave stations	—	[D]8204	Number of communication error at slave station No.1	
[D]8175	Refresh range	—	[D]8205	Number of communication error at slave station No.2	
D 8176	Station number setting	M8038	[D]8206	Number of communication error at slave station No.3	
D 8177	Total slave station number setting		[D]8207	Number of communication error at slave station No.4	
D 8178	Refresh range setting		[D]8208	Number of communication error at slave station No.5	
D 8179	Retry count setting		[D]8209	Number of communication error at slave station No.6	
D 8180	Comms time-out setting		[D]8210	Number of communication error at slave station No.7	
[D]8181	Not used	—	[D]8211	Code of communication error at master station	
Index Register Z1 to Z7 and V1 to V7			[D]8212	Code of communication error at slave station No.1	
[D]8182	Value of Z1 register	—	[D]8213	Code of communication error at slave station No.2	
[D]8183	Value of V1 register	—	[D]8214	Code of communication error at slave station No.3	
[D]8184	Value of Z2 register	—	[D]8215	Code of communication error at slave station No.4	
[D]8185	Value of V2 register	—	[D]8216	Code of communication error at slave station No.5	
[D]8186	Value of Z3 register	—	[D]8217	Code of communication error at slave station No.6	
[D]8187	Value of V3 register	—	[D]8218	Code of communication error at slave station No.7	
[D]8188	Value of Z4 register	—	[D]8219 to [D]8259	Not used	—
[D]8189	Value of V4 register	—	Analog Special Adapter (For details, refer to Appendix C-3.)		
[D]8190	Value of Z5 register	—	D 8260 to D 8269	1st special adapter*1*2	
[D]8191	Value of V5 register	—	D 8270 to D 8279	2nd special adapter*1*2	
[D]8192	Value of Z6 register	—	D 8280 to D 8289	3rd special adapter*1*2	
[D]8193	Value of V6 register	—	D 8290 to D 8299	4th special adapter*1*2	
[D]8194	Value of Z7 register	—			
[D]8195	Value of V7 register	—			
[D]8196	Not used	—			
[D]8197		—			
[D]8198		—			
[D]8199		—			

*1. Supported in Ver. 1.20 or later

*2. The number of connected analog special adapter is counted from the main unit side.

Number and name	Content of register		Corresponding special device
Display Module Function FX3U-7DM			
D 8300	Control device (D) for display module • Default: K-1		-
D 8301	Control device (M) for display module • Default: K-1		-
D 8302*1	Language display setting • Japanese: K0 • English: Other than K0		-
D 8303	LCD contrast setting value • Default: K0		-
[D]8304 to [D]8309	Not used		-
*1. Latch (battery backed) device			
RND (FNC184)			
[D]8310	Lower	RND (FNC184) instruction: Data for generating random number • Default: K1	-
[D]8311	Upper		
Syntax, Circuit, Operation, or Unconnected I/O Designation Error Step Number			
D 8312	Lower	Operation error step number latched (32-bit)	M8068
D 8313	Upper		
[D]8314*2	Lower	Error step number of M8065 to M8067 (32-bit)	M8065 to M8067
[D]8315*2	Upper		
[D]8316	Lower	Step number of instruction specifying an unconnected I/O number (directly or indirectly using index register)	M8316
[D]8317	Upper		
[D]8318*3	BFM initialization function: Error unit number		M8318
[D]8319*3	BFM initialization function: Error BFM number		M8318
[D]8320 to [D]8329	Not used		-
Timing Clock			
[D]8330*3	DUTY (FNC186) instruction: Scan counting for timing clock output 1		M8330
[D]8331*3	DUTY (FNC186) instruction: Scan counting for timing clock output 2		M8331
[D]8332*3	DUTY (FNC186) instruction: Scan counting for timing clock output 3		M8332
[D]8333*3	DUTY (FNC186) instruction: Scan counting for timing clock output 4		M8333
[D]8334*3	DUTY (FNC186) instruction: Scan counting for timing clock output 5		M8334
[D]8335	Not used		-

Number and name	Content of register		Corresponding special device
Positioning			
D 8336*4	DVIT (FNC151) instruction: Specification of interrupt input		M8336
[D]8337 to [D]8339	Not used		-
D 8340	Lower	[Y000] Current value register • Default: 0	-
D 8341	Upper		
D 8342	[Y000] Bias speed Default: 0		-
D 8343	Lower	[Y000] Maximum speed • Default: 100000	-
D 8344	Upper		
D 8345	[Y000] Creep speed • Default: 1000		-
D 8346	Lower	[Y000] Zero return speed Default: 50000	-
D 8347	Upper		
D 8348	[Y000] Acceleration time • Default: 100		-
D 8349	[Y000] Deceleration time • Default: 100		-
D 8350	Lower	[Y001] Current value register • Default: 0	-
D 8351	Upper		
D 8352	[Y001] Bias speed Default: 0		-
D 8353	Lower	[Y001] Maximum speed • Default: 100000	-
D 8354	Upper		
D 8355	[Y001] Creep speed • Default: 1000		-
D 8356	Lower	[Y001] Zero return speed • Default: 50000	-
D 8357	Upper		
D 8358	[Y001] Acceleration time • Default: 100		-
D 8359	[Y001] Deceleration time • Default: 100		-
D 8360	Lower	[Y002] Current value register • Default: 0	-
D 8361	Upper		
D 8362	[Y002] Bias speed Default: 0		-
D 8363	Lower	[Y002] Maximum speed • Default: 100000	-
D 8364	Upper		
D 8365	[Y002] Creep speed • Default: 1000		-
D 8366	Lower	[Y002] Zero return speed • Default: 50000	-
D 8367	Upper		
D 8368	[Y002] Acceleration time • Default: 100		-
D 8369	[Y002] Deceleration time • Default: 100		-
[D]8370 to [D]8392	Not used		-

*2. Cleared when PLC switches from STOP to RUN.

*3. Supported in Ver. 2.20 or later

*4. Supported in Ver. 1.30 or later

11	Memory Cassette/Battery
12	Test Run, Maintenance, Troubleshooting
A	Version Information
B	Performance Specifications
C	Special Devices (M8000 -, D8000 -)
D	Instruction List
E	Character-code
F	Discontinued models
G	Precautions for battery transportation
H	Handling of batteries in EU member states

Number and name	Content of register		Corresponding special device
Interrupt Program			
D 8393	Delay time		M8393
[D]8394	Not used		-
[D]8395*1	Symbolic information, Block password status*2		-
[D]8396	CC-Link/LT setting		-
[D]8397	Not used		-
Ring Counter			
D 8398	Lower	Up-operation ring counter of 0 to 2,147,483,647 (in units of 1ms, 32-bit)*4	M8398
D 8399	Upper		

*1. Supported in Ver. 3.00 or later.

*2. Symbolic information storage status and execution program protection status using the block password.

Present value	Symbolic information storage	Protection of execution program
H**00*3	None	None
H**01*3	None	Provided
H**10*3	Provided	None
H**11*3	Provided	Provided

*3. "****" indicates areas used by the system.

*4. 1ms ring counter (D8399, D8398) will operate after M8398 turns ON.

RS2 (FNC 87) [ch1]		
D 8400	RS2 (FNC 87) [ch1] Communication format setting	-
[D]8401	Not used	-
[D]8402*5	RS2 (FNC 87) [ch1] Remaining points of transmit data	M8402
[D]8403*5	RS2 (FNC 87) [ch1] Monitoring receive data points	M8403
[D]8404	Not used	-
[D]8405	Communication parameter display [ch1]	-
[D]8406		-
[D]8407	Not used	-
[D]8408		-
D 8409	RS2 (FNC 87) [ch1] Time-out time setting	-
D 8410	RS2 (FNC 87) [ch1] Header 1 and 2 <Default: STX>	-
D 8411	RS2 (FNC 87) [ch1] Header 3 and 4	-
D 8412	RS2 (FNC 87) [ch1] Terminator 1 and 2 <Default: ETX>	-
D 8413	RS2 (FNC 87) [ch1] Terminator 3 and 4	-
[D]8414	RS2 (FNC 87) [ch1] Receive sum (received data)	-
[D]8415	RS2 (FNC 87) [ch1] Receive sum (calculated result)	-
[D]8416	RS2 (FNC 87) [ch1] Send sum	-
[D]8417		-
[D]8418	Not used	-
[D]8419	Operation mode display [ch1]	-

Number and name	Content of register		Corresponding special device
RS2 (FNC 87) [ch2] and Computer Link [ch2]			
D 8420	RS2 (FNC 87) [ch2] Communication format setting		-
D 8421	Computer link [ch2] Station number setting		-
[D]8422*5	RS2 (FNC 87) [ch2] Remaining points of transmit data		M8422
[D]8423*5	RS2 (FNC 87) [ch2] Monitoring receive data points		M8423
[D]8424	Not used		-
[D]8425	Communication parameter display [ch2]		-
[D]8426	Not used		-
D 8427	Computer link [ch2] Specification of on-demand head device register		M8426 to M8429
D 8428	Computer link [ch2] Specification of on-demand data length register		
D 8429	RS2 (FNC 87) [ch2], computer link [ch2] Time-out time setting		
D 8430	RS2 (FNC 87) [ch2] Header 1 and 2 <Default: STX>		-
D 8431	RS2 (FNC 87) [ch2] Header 3 and 4		-
D 8432	RS2 (FNC 87) [ch2] Terminator 1 and 2 <Default: ETX>		-
D 8433	RS2 (FNC 87) [ch2] Terminator 3 and 4		-
[D]8434	RS2 (FNC 87) [ch2] Receive sum (received data)		-
[D]8435	RS2 (FNC 87) [ch2] Receive sum (calculated result)		-
[D]8436	RS2 (FNC 87) [ch2] Send sum		-
[D]8437	Not used		-

*5. Cleared when PLC switches from RUN to STOP.

Number and name	Content of register	Corresponding special device	Number and name	Content of register	Corresponding special device
MODBUS communication [ch1]			MODBUS communication [ch1, ch2]		
D 8400 ^{*1}	Communication format	-	D 8470 ^{*1}	Lower	MODBUS device mapping 1
D 8401 ^{*1}	Protocol	-	D 8471 ^{*1}	Upper	
D 8402 ^{*1}	Communication error code	M8402	D 8472 ^{*1}	Lower	MODBUS device mapping 2
D 8403 ^{*1}	Error details	M8403	D 8473 ^{*1}	Upper	
D 8404 ^{*1}	Error step number	-	D 8474 ^{*1}	Lower	MODBUS device mapping 3
[D]8405 ^{*1}	Communication format display	-	D 8475 ^{*1}	Upper	
D 8406 ^{*1}	ASCII input delimiter	-	D 8476 ^{*1}	Lower	MODBUS device mapping 4
[D]8407 ^{*1}	Step number being executed	-	D 8477 ^{*1}	Upper	
[D]8408 ^{*1}	Current retry value	-	D 8478 ^{*1}	Lower	MODBUS device mapping 5
D 8409 ^{*1}	Slave response timeout	-	D 8479 ^{*1}	Upper	
D 8410 ^{*1}	Turn around delay	-	D 8480 ^{*1}	Lower	MODBUS device mapping 6
D 8411 ^{*1}	Message to message delay	-	D 8481 ^{*1}	Upper	
D 8412 ^{*1}	Number of retries	-	D 8482 ^{*1}	Lower	MODBUS device mapping 7
[D]8413	Not used	-	D 8483 ^{*1}	Upper	
D 8414 ^{*1}	Slave node address	-	D 8484 ^{*1}	Lower	MODBUS device mapping 8
D 8415 ^{*1}	Communication status information setup	-	D 8485 ^{*1}	Upper	
D 8416 ^{*1}	Communication status device range setup	-	*1. Supported in Ver. 2.40 or later.		
[D]8417 to [D]8418	Not used	-			
[D]8419 ^{*1}	Communication mode	-			
MODBUS communication [ch2]					
D 8420 ^{*1}	Communication format	-			
D 8421 ^{*1}	Protocol	-			
D 8422 ^{*1}	Communication error code	M8422			
D 8423 ^{*1}	Error details	M8423			
D 8424 ^{*1}	Error step number	-			
[D]8425 ^{*1}	Communication format display	-			
D 8426 ^{*1}	ASCII input delimiter	-			
[D]8427 ^{*1}	Step number being executed	-			
[D]8428 ^{*1}	Current retry value	-			
D 8429 ^{*1}	Slave response timeout	-			
D 8430 ^{*1}	Turn around delay	-			
D 8431 ^{*1}	Message to message delay	-			
D 8432 ^{*1}	Number of retries	-			
[D]8433	Not used	-			
D 8434 ^{*1}	Slave node address	-			
D 8435 ^{*1}	Communication status information setup	-			
D 8436 ^{*1}	Communication status device range setup	-			
[D]8437 to [D]8438	Not used	-			
[D]8439 ^{*1}	Communication mode	-			

11	Memory Cassette/Battery
12	Test Run, Maintenance, Troubleshooting
A	Version Information
B	Performance Specifications
C	Special Devices (M8000 -, D8000 -)
D	Instruction List
E	Character-code
F	Discontinued models
G	Precautions for battery transportation
H	Handling of batteries in EU member states

Number and name	Content of register		Corresponding special device
FX3U-CF-ADP [ch1]			
[D]8400 to [D]8401	Not used		—
[D]8402 ^{*1*2}	Lower	Step number of executing CF-ADP instruction	—
[D]8403 ^{*1*2}	Upper		
[D]8404 to [D]8405	Not used		—
[D]8406 ^{*1}	CF-ADP status		—
[D]8407	Not used		—
[D]8408 ^{*1}	CF-ADP version		—
[D]8409 to [D]8413	Not used		—
[D]8414 ^{*1*2}	Lower	Error step number of M8418	—
[D]8415 ^{*1*2}	Upper		
[D]8416 to [D]8417	Not used		—
[D]8418 ^{*1*2*3}	Error code for CF-ADP instructions		—
[D]8419 ^{*1}	Operation mode display		—
FX3U-CF-ADP [ch2]			
[D]8420 to [D]8421	Not used		—
[D]8422 ^{*1*2}	Lower	Step number of executing CF-ADP instruction	—
[D]8423 ^{*1*2}	Upper		
[D]8424 to [D]8425	Not used		—
[D]8426 ^{*1}	CF-ADP status		—
[D]8427	Not used		—
[D]8428 ^{*1}	CF-ADP version		—
[D]8429 to [D]8433	Not used		—
[D]8434 ^{*1*2}	Lower	Error step number of M8438	—
[D]8435 ^{*1*2}	Upper		
[D]8436 to [D]8437	Not used		—
[D]8438 ^{*1*2*3}	Error code for CF-ADP instructions		—
[D]8439 ^{*1}	Operation mode display		—

*1. Available in Ver. 2.61 or later.

*2. Cleared when the PLC switches from STOP to RUN.

*3. For details on the error code is stored in special data register, refer to the FX3U-CF-ADP User's Manual.

FX3U-ENET-ADP [ch1]		
[D]8400 ^{*4}	IP Address (Low-order)	—
[D]8401 ^{*4}	IP Address (High-order)	—
[D]8402 ^{*4}	Subnet mask (Low-order)	—
[D]8403 ^{*4}	Subnet mask (High-order)	—
[D]8404 ^{*4}	Default router IP Address (Low-order)	—
[D]8405 ^{*4}	Default router IP Address (High-order)	—
[D]8406 ^{*4}	Status information	—
[D]8407 ^{*4}	Connection condition of the Ethernet port	—

Number and name	Content of register	Corresponding special device
[D]8408 ^{*4}	FX3U-ENET-ADP version	—
D 8409 ^{*4}	Communication timeout time	—
D 8410 ^{*4}	Connection forcible nullification	—
[D]8411 ^{*4}	Time setting functional operation result	—
[D]8412 to [D]8414 ^{*4}	Host MAC address	—
[D]8415	Not used	—
[D]8416 ^{*4}	Model code	—
[D]8417 ^{*4}	Error code of the Ethernet adapter	—
[D]8418	Not used	—
[D]8063 ^{*4}	Error code	M8063
[D]8419 ^{*4}	Operation mode display	—
FX3U-ENET-ADP [ch2]		
[D]8420 ^{*4}	IP Address (Low-order)	—
[D]8421 ^{*4}	IP Address (High-order)	—
[D]8422 ^{*4}	Subnet mask (Low-order)	—
[D]8423 ^{*4}	Subnet mask (High-order)	—
[D]8424 ^{*4}	Default router IP Address (Low-order)	—
[D]8425 ^{*4}	Default router IP Address (High-order)	—
[D]8426 ^{*4}	Status information	—
[D]8427 ^{*4}	Connection condition of the Ethernet port	—
[D]8428 ^{*4}	FX3U-ENET-ADP version	—
D 8429 ^{*4}	Communication timeout time	—
D 8430 ^{*4}	Connection forcible nullification	—
[D]8431 ^{*4}	Time setting functional operation result	—
[D]8432 to [D]8434 ^{*4}	Host MAC address	—
[D]8435	Not used	—
[D]8436 ^{*4}	Model code	—
[D]8437 ^{*4}	Error code of the Ethernet adapter	—
[D]8438 ^{*4}	Error code	M8438
[D]8439 ^{*4}	Operation mode display	—

*4. Supported in Ver. 3.10 or later.

Number and name	Content of register	Corresponding special device
Error Detection		
[D]8438*1	Error code for serial communication error 2 [ch2]	M8438
RS2 (FNC 87) [ch2] and Computer Link [ch2]		
[D]8439	Operation mode display [ch2]	—
Error Detection		
[D]8440 to [D]8448	Not used	—
[D]8449*2	Special block error code	M8449
[D]8450 to [D]8459	Not used	—
Positioning [FX3U and FX3UC PLCs]		
[D]8460 to [D]8463	Not used	—
D 8464*2	DSZR (FNC150) and ZRN (FNC156) instructions: [Y000] Clear signal device specification	M8464
D 8465*2	DSZR (FNC150) and ZRN (FNC156) instructions: [Y001] Clear signal device specification	M8465
D 8466*2	DSZR (FNC150) and ZRN (FNC156) instructions: [Y002] Clear signal device specification	M8466
Error Detection		
[D]8468 to [D]8488	Not used	—
[D]8489*3	Error code for special parameter error	M8489
[D]8490 to [D]8511	Not used	—

*1. Cleared when PLC power supply is turned from OFF to ON.

*2. Supported in Ver. 2.20 or later.

*3. Supported in Ver. 3.10 or later.

11	Memory Cassette/Battery
12	Test Run, Maintenance, Troubleshooting
A	Version Information
B	Performance Specifications
C	Special Devices (M8000 -, D8000 -)
D	Instruction List
E	Character-code
F	Discontinued models
G	Precautions for battery transportation
H	Handling of batteries in EU member states

Appendix C-3 Analog special adapters special devices

When analog special adapters are connected, operations and functions are assigned to the devices shown in the tables below in accordance with the number of connected analog special adapters.

Devices which cannot be written are shaded in "Operation and function" column.

→ For details, refer to the manual of each product.

Appendix C-3-1 Special auxiliary relays (M8260 to M8299)

Number	Operation and function		
	FX3U-4AD-ADP	FX3U-4DA-ADP	FX3U-3A-ADP
Compatible Versions	Ver. 1.20 or later	Ver. 1.20 or later	Ver. 2.61 or later
1st analog special adapter			
M 8260	Input mode switching Ch1	Output mode switching Ch1	Input mode switching Ch1
M 8261	Input mode switching Ch2	Output mode switching Ch2	Input mode switching Ch2
M 8262	Input mode switching Ch3	Output mode switching Ch3	Output mode switching
M 8263	Input mode switching Ch4	Output mode switching Ch4	Not used
M 8264	Not used	Output hold mode cancel Ch1	Not used
M 8265	Not used	Output hold mode cancel Ch2	Not used
M 8266	Not used	Output hold mode cancel Ch3	Output hold mode cancel
M 8267	Not used	Output hold mode cancel Ch4	Sets whether or not input channel 1 is used.
M 8268	Not used	Not used	Sets whether or not input channel 2 is used.
M 8269	Not used	Not used	Sets whether or not output channel is used.
2nd analog special adapter			
M 8270	Input mode switching Ch1	Output mode switching Ch1	Input mode switching Ch1
M 8271	Input mode switching Ch2	Output mode switching Ch2	Input mode switching Ch2
M 8272	Input mode switching Ch3	Output mode switching Ch3	Output mode switching
M 8273	Input mode switching Ch4	Output mode switching Ch4	Not used
M 8274	Not used	Output hold mode cancel Ch1	Not used
M 8275	Not used	Output hold mode cancel Ch2	Not used
M 8276	Not used	Output hold mode cancel Ch3	Output hold mode cancel
M 8277	Not used	Output hold mode cancel Ch4	Sets whether or not input channel 1 is used.
M 8278	Not used	Not used	Sets whether or not input channel 2 is used.
M 8279	Not used	Not used	Sets whether or not output channel is used.
3rd analog special adapter			
M 8280	Input mode switching Ch1	Output mode switching Ch1	Input mode switching Ch1
M 8281	Input mode switching Ch2	Output mode switching Ch2	Input mode switching Ch2
M 8282	Input mode switching Ch3	Output mode switching Ch3	Output mode switching
M 8283	Input mode switching Ch4	Output mode switching Ch4	Not used
M 8284	Not used	Output hold mode cancel Ch1	Not used
M 8285	Not used	Output hold mode cancel Ch2	Not used
M 8286	Not used	Output hold mode cancel Ch3	Output hold mode cancel
M 8287	Not used	Output hold mode cancel Ch4	Sets whether or not input channel 1 is used.
M 8288	Not used	Not used	Sets whether or not input channel 2 is used.
M 8289	Not used	Not used	Sets whether or not output channel is used.
4th analog special adapter			
M 8290	Input mode switching Ch1	Output mode switching Ch1	Input mode switching Ch1
M 8291	Input mode switching Ch2	Output mode switching Ch2	Input mode switching Ch2
M 8292	Input mode switching Ch3	Output mode switching Ch3	Output mode switching
M 8293	Input mode switching Ch4	Output mode switching Ch4	Not used
M 8294	Not used	Output hold mode cancel Ch1	Not used
M 8295	Not used	Output hold mode cancel Ch2	Not used
M 8296	Not used	Output hold mode cancel Ch3	Output hold mode cancel
M 8297	Not used	Output hold mode cancel Ch4	Sets whether or not input channel 1 is used.
M 8298	Not used	Not used	Sets whether or not input channel 2 is used.
M 8299	Not used	Not used	Sets whether or not output channel is used.

Number	Operation and function		
	FX3U-4AD-PT(W)-ADP	FX3U-4AD-TC-ADP	FX3U-4AD-PNK-ADP
Compatible Versions	Ver. 1.30 or later	Ver. 1.30 or later	Ver. 1.30 or later
1st analog special adapter			
M 8260	Temperature unit selection	Temperature unit selection	Temperature unit selection
M 8261	Not used	Type-K/-J switching	Input sensor selection
M 8262	Not used	Not used	Not used
M 8263	Not used	Not used	Not used
M 8264	Not used	Not used	Not used
M 8265	Not used	Not used	Not used
M 8266	Not used	Not used	Not used
M 8267	Not used	Not used	Not used
M 8268	Not used	Not used	Not used
M 8269	Not used	Not used	Not used
2nd analog special adapter			
M 8270	Temperature unit selection	Temperature unit selection	Temperature unit selection
M 8271	Not used	Type-K/-J switching	Input sensor selection
M 8272	Not used	Not used	Not used
M 8273	Not used	Not used	Not used
M 8274	Not used	Not used	Not used
M 8275	Not used	Not used	Not used
M 8276	Not used	Not used	Not used
M 8277	Not used	Not used	Not used
M 8278	Not used	Not used	Not used
M 8279	Not used	Not used	Not used
3rd analog special adapter			
M 8280	Temperature unit selection	Temperature unit selection	Temperature unit selection
M 8281	Not used	Type-K/-J switching	Input sensor selection
M 8282	Not used	Not used	Not used
M 8283	Not used	Not used	Not used
M 8284	Not used	Not used	Not used
M 8285	Not used	Not used	Not used
M 8286	Not used	Not used	Not used
M 8287	Not used	Not used	Not used
M 8288	Not used	Not used	Not used
M 8289	Not used	Not used	Not used
4th analog special adapter			
M 8290	Temperature unit selection	Temperature unit selection	Temperature unit selection
M 8291	Not used	Type-K/-J switching	Input sensor selection
M 8292	Not used	Not used	Not used
M 8293	Not used	Not used	Not used
M 8294	Not used	Not used	Not used
M 8295	Not used	Not used	Not used
M 8296	Not used	Not used	Not used
M 8297	Not used	Not used	Not used
M 8298	Not used	Not used	Not used
M 8299	Not used	Not used	Not used

11	Memory Cassette/Battery
12	Test Run, Maintenance, Troubleshooting
A	Version Information
B	Performance Specifications
C	Special Devices (M8000 -, D8000 -)
D	Instruction List
E	Character-code
F	Discontinued models
G	Precautions for battery transportation
H	Handling of batteries in EU member states

Appendix C-3-2 Special data registers (D8260 to D8299)

Number	Operation and function		
	FX3U-4AD-ADP	FX3U-4DA-ADP	FX3U-3A-ADP
Compatible Versions	Ver. 1.20 or later	Ver. 1.20 or later	Ver. 2.61 or later
1st analog special adapter			
D 8260	Input data Ch1	Output data Ch1	Input data Ch1
D 8261	Input data Ch2	Output data Ch2	Input data Ch2
D 8262	Input data Ch3	Output data Ch3	Output data
D 8263	Input data Ch4	Output data Ch4	Not used
D 8264	Number of averaging times for Ch1 (1 to 4095)	Not used	Number of averaging times for Ch1 (1 to 4095)
D 8265	Number of averaging times for Ch2 (1 to 4095)	Not used	Number of averaging times for Ch2 (1 to 4095)
D 8266	Number of averaging times for Ch3 (1 to 4095)	Not used	Not used
D 8267	Number of averaging times for Ch4 (1 to 4095)	Not used	Not used
D 8268	Error status	Error status	Error status
D 8269	Model code: K1	Model code: K2	Model code: K50
2nd analog special adapter			
D 8270	Input data Ch1	Output data Ch1	Input data Ch1
D 8271	Input data Ch2	Output data Ch2	Input data Ch2
D 8272	Input data Ch3	Output data Ch3	Output data
D 8273	Input data Ch4	Output data Ch4	Not used
D 8274	Number of averaging times for Ch1 (1 to 4095)	Not used	Number of averaging times for Ch1 (1 to 4095)
D 8275	Number of averaging times for Ch2 (1 to 4095)	Not used	Number of averaging times for Ch2 (1 to 4095)
D 8276	Number of averaging times for Ch3 (1 to 4095)	Not used	Not used
D 8277	Number of averaging times for Ch4 (1 to 4095)	Not used	Not used
D 8278	Error status	Error status	Error status
D 8279	Model code: K1	Model code: K2	Model code: K50
3rd analog special adapter			
D 8280	Input data Ch1	Output data Ch1	Input data Ch1
D 8281	Input data Ch2	Output data Ch2	Input data Ch2
D 8282	Input data Ch3	Output data Ch3	Output data
D 8283	Input data Ch4	Output data Ch4	Not used
D 8284	Number of averaging times for Ch1 (1 to 4095)	Not used	Number of averaging times for Ch1 (1 to 4095)
D 8285	Number of averaging times for Ch2 (1 to 4095)	Not used	Number of averaging times for Ch2 (1 to 4095)
D 8286	Number of averaging times for Ch3 (1 to 4095)	Not used	Not used
D 8287	Number of averaging times for Ch4 (1 to 4095)	Not used	Not used
D 8288	Error status	Error status	Error status
D 8289	Model code: K1	Model code: K2	Model code: K50
4th analog special adapter			
D 8290	Input data Ch1	Output data Ch1	Input data Ch1
D 8291	Input data Ch2	Output data Ch2	Input data Ch2
D 8292	Input data Ch3	Output data Ch3	Output data
D 8293	Input data Ch4	Output data Ch4	Not used
D 8294	Number of averaging times for Ch1 (1 to 4095)	Not used	Number of averaging times for Ch1 (1 to 4095)
D 8295	Number of averaging times for Ch2 (1 to 4095)	Not used	Number of averaging times for Ch2 (1 to 4095)
D 8296	Number of averaging times for Ch3 (1 to 4095)	Not used	Not used
D 8297	Number of averaging times for Ch4 (1 to 4095)	Not used	Not used
D 8298	Error status	Error status	Error status
D 8299	Model code: K1	Model code: K2	Model code: K50

Number	Operation and function		
	FX3U-4AD-PT(W)-ADP	FX3U-4AD-TC-ADP	FX3U-4AD-PNK-ADP
Compatible Versions	Ver. 1.30 or later	Ver. 1.30 or later	Ver. 1.30 or later
1st analog special adapter			
D 8260	Measured temperature Ch1	Measured temperature Ch1	Measured temperature Ch1
D 8261	Measured temperature Ch2	Measured temperature Ch2	Measured temperature Ch2
D 8262	Measured temperature Ch3	Measured temperature Ch3	Measured temperature Ch3
D 8263	Measured temperature Ch4	Measured temperature Ch4	Measured temperature Ch4
D 8264	Number of averaging times for Ch1 (1 to 4095)	Number of averaging times for Ch1 (1 to 4095)	Number of averaging times for Ch1 (1 to 4095)
D 8265	Number of averaging times for Ch2 (1 to 4095)	Number of averaging times for Ch2 (1 to 4095)	Number of averaging times for Ch2 (1 to 4095)
D 8266	Number of averaging times for Ch3 (1 to 4095)	Number of averaging times for Ch3 (1 to 4095)	Number of averaging times for Ch3 (1 to 4095)
D 8267	Number of averaging times for Ch4 (1 to 4095)	Number of averaging times for Ch4 (1 to 4095)	Number of averaging times for Ch4 (1 to 4095)
D 8268	Error status	Error status	Error status
D 8269	Model code: K20 (PT), K21 (PTW)	Model code: K10	Model code: K11
2nd analog special adapter			
D 8270	Measured temperature Ch1	Measured temperature Ch1	Measured temperature Ch1
D 8271	Measured temperature Ch2	Measured temperature Ch2	Measured temperature Ch2
D 8272	Measured temperature Ch3	Measured temperature Ch3	Measured temperature Ch3
D 8273	Measured temperature Ch4	Measured temperature Ch4	Measured temperature Ch4
D 8274	Number of averaging times for Ch1 (1 to 4095)	Number of averaging times for Ch1 (1 to 4095)	Number of averaging times for Ch1 (1 to 4095)
D 8275	Number of averaging times for Ch2 (1 to 4095)	Number of averaging times for Ch2 (1 to 4095)	Number of averaging times for Ch2 (1 to 4095)
D 8276	Number of averaging times for Ch3 (1 to 4095)	Number of averaging times for Ch3 (1 to 4095)	Number of averaging times for Ch3 (1 to 4095)
D 8277	Number of averaging times for Ch4 (1 to 4095)	Number of averaging times for Ch4 (1 to 4095)	Number of averaging times for Ch4 (1 to 4095)
D 8278	Error status	Error status	Error status
D 8279	Model code: K20 (PT), K21 (PTW)	Model code: K10	Model code: K11
3rd analog special adapter			
D 8280	Measured temperature Ch1	Measured temperature Ch1	Measured temperature Ch1
D 8281	Measured temperature Ch2	Measured temperature Ch2	Measured temperature Ch2
D 8282	Measured temperature Ch3	Measured temperature Ch3	Measured temperature Ch3
D 8283	Measured temperature Ch4	Measured temperature Ch4	Measured temperature Ch4
D 8284	Number of averaging times for Ch1 (1 to 4095)	Number of averaging times for Ch1 (1 to 4095)	Number of averaging times for Ch1 (1 to 4095)
D 8285	Number of averaging times for Ch2 (1 to 4095)	Number of averaging times for Ch2 (1 to 4095)	Number of averaging times for Ch2 (1 to 4095)
D 8286	Number of averaging times for Ch3 (1 to 4095)	Number of averaging times for Ch3 (1 to 4095)	Number of averaging times for Ch3 (1 to 4095)
D 8287	Number of averaging times for Ch4 (1 to 4095)	Number of averaging times for Ch4 (1 to 4095)	Number of averaging times for Ch4 (1 to 4095)
D 8288	Error status	Error status	Error status
D 8289	Model code: K20 (PT), K21 (PTW)	Model code: K10	Model code: K11
4th analog special adapter			
D 8290	Measured temperature Ch1	Measured temperature Ch1	Measured temperature Ch1
D 8291	Measured temperature Ch2	Measured temperature Ch2	Measured temperature Ch2
D 8292	Measured temperature Ch3	Measured temperature Ch3	Measured temperature Ch3
D 8293	Measured temperature Ch4	Measured temperature Ch4	Measured temperature Ch4
D 8294	Number of averaging times for Ch1 (1 to 4095)	Number of averaging times for Ch1 (1 to 4095)	Number of averaging times for Ch1 (1 to 4095)
D 8295	Number of averaging times for Ch2 (1 to 4095)	Number of averaging times for Ch2 (1 to 4095)	Number of averaging times for Ch2 (1 to 4095)
D 8296	Number of averaging times for Ch3 (1 to 4095)	Number of averaging times for Ch3 (1 to 4095)	Number of averaging times for Ch3 (1 to 4095)
D 8297	Number of averaging times for Ch4 (1 to 4095)	Number of averaging times for Ch4 (1 to 4095)	Number of averaging times for Ch4 (1 to 4095)
D 8298	Error status	Error status	Error status
D 8299	Model code: K20 (PT), K21 (PTW)	Model code: K10	Model code: K11

11	Memory Cassette/Battery
12	Test Run, Maintenance, Troubleshooting
A	Version Information
B	Performance Specifications
C	Special Devices (M8000 -, D8000 -)
D	Instruction List
E	Character-code
F	Discontinued models
G	Precautions for battery transportation
H	Handling of batteries in EU member states

Appendix D: Instruction List

Appendix D-1 Basic Instructions

Mnemonic	Function
Contact Instruction	
LD	Initial logical operation contact type NO (normally open)
LDI	Initial logical operation contact type NC (normally closed)
LDP	Initial logical operation of Rising edge pulse
LDF	Initial logical operation of Falling/trailing edge pulse
AND	Serial connection of NO (normally open) contacts
ANI	Serial connection of NC (normally closed) contacts
ANDP	Serial connection of Rising edge pulse
ANDF	Serial connection of Falling/trailing edge pulse
OR	Parallel connection of NO (normally open) contacts
ORI	Parallel connection of NC (normally closed) contacts
ORP	Parallel connection of Rising edge pulse
ORF	Parallel connection of Falling/trailing edge pulse
Connection Instruction	
ANB	Serial connection of multiple parallel circuits
ORB	Parallel connection of multiple contact circuits
MPS	Stores the current result of the internal PLC operations
MRD	Reads the current result of the internal PLC operations
MPP	Pops (recalls and removes) the currently stored result
INV	Invert the current result of the internal PLC operations
MEP	Conversion of operation result to leading edge pulse*1
MEF	Conversion of operation result to trailing edge pulse*1

*1. Supported in Ver. 2.30 or later

Mnemonic	Function
Out Instruction	
OUT	Final logical operation type coil drive
SET	SET Bit device latch ON
RST	RESET Bit device OFF
PLS	Rising edge pulse
PLF	Falling/trailing edge pulse
Master Control Instruction	
MC	Denotes the start of a master control block
MCR	Denotes the end of a master control block
Other Instruction	
NOP	No operation or null step
End Instruction	
END	Program END, I/O refresh and Return to Step 0

Appendix D-2 Step Ladder Instructions

Mnemonic	Function
STL	Starts step ladder
RET	Completes step ladder

Appendix D-3 Applied Instructions ... in Ascending Order of FNC Number

FNC No.	Mnemonic	Function
Program Flow		
00	CJ	Conditional Jump
01	CALL	Call Subroutine
02	SRET	Subroutine Return
03	IRET	Interrupt Return
04	EI	Enable Interrupt
05	DI	Disable Interrupt
06	FEND	Main Routine Program End
07	WDT	Watchdog Timer Refresh
08	FOR	Start a FOR/NEXT Loop
09	NEXT	End a FOR/NEXT Loop
Move and Compare		
10	CMP	Compare
11	ZCP	Zone Compare
12	MOV	Move
13	SMOV	Shift Move
14	CML	Complement
15	BMOV	Block Move
Move and Compare		
16	FMOV	Fill Move
17	XCH	Exchange
18	BCD	Conversion to Binary Coded Decimal
19	BIN	Conversion to Binary
Arithmetic and Logical Operation (+, -, ×, ÷)		
20	ADD	Addition
21	SUB	Subtraction
22	MUL	Multiplication
23	DIV	Division
24	INC	Increment
25	DEC	Decrement
26	WAND	Logical Word AND
27	WOR	Logical Word OR
28	WXOR	Logical Exclusive OR
29	NEG	Negation
Rotation and Shift Operation		
30	ROR	Rotation Right
31	ROL	Rotation Left
32	RCR	Rotation Right with Carry
33	RCL	Rotation Left with Carry
34	SFTR	Bit Shift Right
35	SFTL	Bit Shift Left
36	WSFR	Word Shift Right
37	WSFL	Word Shift Left
38	SFWR	Shift Write [FIFO/FILO Control]
39	SFRD	Shift Read [FIFO Control]

FNC No.	Mnemonic	Function
Data Operation		
40	ZRST	Zone Reset
41	DECO	Decode
42	ENCO	Encode
43	SUM	Sum of Active Bits
44	BON	Check Specified Bit Status
45	MEAN	Mean
46	ANS	Timed Annunciator Set
47	ANR	Annunciator Reset
48	SQR	Square Root
49	FLT	Conversion to Floating Point
High Speed Processing		
50	REF	Refresh
51	REFF	Refresh and Filter Adjust
52	MTR	Input Matrix
53	HSCS	High Speed Counter Set
54	HSCR	High Speed Counter Reset
55	HSZ	High Speed Counter Zone Compare
56	SPD	Speed Detection
57	PLSY	Pulse Y Output
58	PWM	Pulse Width Modulation
59	PLSR	Acceleration/Deceleration Setup
Handy Instruction		
60	IST	Initial State
61	SER	Search a Data Stack
62	ABSD	Absolute Drum Sequencer
63	INCD	Incremental Drum Sequencer
64	TTMR	Teaching Timer
65	STMR	Special Timer
66	ALT	Alternate State
67	RAMP	Ramp Variable Value
68	ROTC	Rotary Table Control
69	SORT	SORT Tabulated Data
External FX I/O Device		
70	TKY	Ten Key Input
71	HKY	Hexadecimal Input
72	DSW	Digital Switch (Thumbwheel Input)
73	SEGD	Seven Segment Decoder
74	SEGL	Seven Segment With Latch
75	ARWS	Arrow Switch
76	ASC	ASCII Code Data Input
77	PR	Print (ASCII Code)
78	FROM	Read From A Special Function Block
79	TO	Write To A Special Function Block

11 Memory Cassette/Battery

12 Test Run, Maintenance, Troubleshooting

A Version Information

B Performance Specifications

C Special Devices (M8000 - J8000 -)

D Instruction List

E Character-code

F Discontinued models

G Precautions for battery transportation

H Handling of batteries in EU member states

FNC No.	Mnemonic	Function
External FX Device		
80	RS	Serial Communication
81	PRUN	Parallel Run (Octal Mode)
82	ASCI	Hexadecimal to ASCII Conversion
83	HEX	ASCII to Hexadecimal Conversion
84	CCD	Check Code
85	VRRD	Volume Read* ²
86	VRSC	Volume Scale* ²
87	RS2	Serial Communication 2
88	PID	PID Control Loop
89 to 99	–	
Data Transfer 2		
100, 101	–	
102	ZPUSH	Batch Store of Index Register* ¹
103	ZPOP	Batch POP of Index Register* ¹
104 to 109	–	
Floating Point		
110	ECMP	Floating Point Compare
111	EZCP	Floating Point Zone Compare
112	EMOV	Floating Point Move
113 to 115	–	
116	ESTR	Floating Point to Character String Conversion
117	EVAL	Character String to Floating Point Conversion
118	EBCD	Floating Point to Scientific Notation Conversion
119	EBIN	Scientific Notation to Floating Point Conversion
120	EADD	Floating Point Addition
121	ESUB	Floating Point Subtraction
122	EMUL	Floating Point Multiplication
123	EDIV	Floating Point Division
124	EXP	Floating Point Exponent
125	LOGE	Floating Point Natural Logarithm
126	LOG10	Floating Point Common Logarithm
127	ESQR	Floating Point Square Root
128	ENEG	Floating Point Negation
129	INT	Floating Point to Integer Conversion
130	SIN	Floating Point Sine
131	COS	Floating Point Cosine
132	TAN	Floating Point Tangent
133	ASIN	Floating Point Arc Sine
134	ACOS	Floating Point Arc Cosine
135	ATAN	Floating Point Arc Tangent

FNC No.	Mnemonic	Function
Floating Point		
136	RAD	Floating Point Degree to Radian Conversion
137	DEG	Floating Point Radian to Degree Conversion
138, 139	–	
Data Operation 2		
140	WSUM	Sum of Word Data* ¹
141	WTOB	WORD to BYTE* ¹
142	BTOW	BYTE to WORD* ¹
143	UNI	4-bit Linking of Word Data* ¹
144	DIS	4-bit Grouping of Word Data* ¹
145, 146	–	
147	SWAP	Byte Swap
148	–	
149	SORT2	Sort Tabulated Data 2* ¹
Positioning Control		
150	DSZR	DOG Search Zero Return
151	DVIT	Interrupt Positioning
152	TBL	Batch Data Positioning Mode* ¹
153, 154	–	
155	ABS	Absolute Current Value Read
156	ZRN	Zero Return
157	PLSV	Variable Speed Pulse Output
158	DRVI	Drive to Increment
159	DRVA	Drive to Absolute
Real Time Clock Control		
160	TCMP	RTC Data Compare
161	TZCP	RTC Data Zone Compare
162	TADD	RTC Data Addition
163	TSUB	RTC Data Subtraction
164	HTOS	Hour to Second Conversion
165	STOH	Second to Hour Conversion
166	TRD	Read RTC data
167	TWR	Set RTC data
168	–	
169	HOUR	Hour Meter
External Device		
170	GRY	Decimal to Gray Code Conversion
171	GBIN	Gray Code to Decimal Conversion
172 to 175	–	
176	RD3A	Read form Dedicated Analog Block
177	WR3A	Write to Dedicated Analog Block
178, 179	–	
Extension Function		
180	–	

*1. Supported in Ver. 2.20 or later

*2. Supported in Ver. 2.70 or later

FNC No.	Mnemonic	Function
Others		
181	–	
182	COMRD	Read Device Comment Data* ¹
183	–	
184	RND	Random Number Generation
185	–	
186	DUTY	Timing Pulse Generation* ¹
187	–	
188	CRC	Cyclic Redundancy Check
189	HCMOV	High Speed Counter Move
Block Data Operation		
190, 191	–	
192	BK+	Block Data Addition* ¹
193	BK-	Block Data Subtraction* ¹
194	BKCMP=	Block Data Compare (S1) = (S2)* ¹
195	BKCMP>	Block Data Compare (S1) > (S2)* ¹
196	BKCMP<	Block Data Compare (S1) < (S2)* ¹
197	BKCMP<>	Block Data Compare (S2) ≠ (S2)* ¹
198	BKCMP<=	Block Data Compare (S1) ≤ (S2)* ¹
199	BKCMP>=	Block Data Compare (S1) ≥ (S2)* ¹
Character String Control		
200	STR	BIN to Character String Conversion* ¹
201	VAL	Character String to BIN Conversion* ¹
202	\$+	Link Character Strings
203	LEN	Character String Length Detection
204	RIGHT	Extracting Character String Data from the Right
205	LEFT	Extracting Character String Data from the Left
206	MIDR	Random Selection of Character Strings
207	MIDW	Random Replacement of Character Strings
208	INSTR	Character string search* ¹
209	\$MOV	Character String Transfer
Data Operation 3		
210	FDEL	Deleting Data from Tables* ¹
211	FINS	Inserting Data to Tables* ¹
212	POP	Shift Last Data Read [FILO Control]
213	SFR	Bit Shift Right with Carry
214	SFL	Bit Shift Left with Carry
215 to 219	–	

FNC No.	Mnemonic	Function
Data Comparison		
220 to 223	–	
224	LD=	Load Compare (S1) = (S2)
225	LD>	Load Compare (S1) > (S2)
226	LD<	Load Compare (S1) < (S2)
227	–	
228	LD<>	Load Compare (S1) ≠ (S2)
229	LD<=	Load Compare (S1) ≤ (S2)
230	LD>=	Load Compare (S1) ≥ (S2)
231	–	
232	AND=	AND Compare (S1) = (S2)
233	AND>	AND Compare (S1) > (S2)
234	AND<	AND Compare (S1) < (S2)
235	–	
236	AND<>	AND Compare (S1) ≠ (S2)
237	AND<=	AND Compare (S1) ≤ (S2)
238	AND>=	AND Compare (S1) ≥ (S2)
239	–	
Data Comparison		
240	OR=	OR Compare (S1) = (S2)
241	OR>	OR Compare (S1) > (S2)
242	OR<	OR Compare (S1) < (S2)
243	–	
244	OR<>	OR Compare (S1) ≠ (S2)
245	OR<=	OR Compare (S1) ≤ (S2)
246	OR>=	OR Compare (S1) ≥ (S2)
247 to 249	–	
Data Table Operation		
250 to 255	–	
256	LIMIT	Limit Control
257	BAND	Dead Band Control
258	ZONE	Zone Control
259	SCL	Scaling (Coordinate by Point Data)
260	DABIN	Decimal ASCII to BIN Conversion* ¹
261	BINDA	BIN to Decimal ASCII Conversion* ¹
262 to 268	–	
269	SCL2	Scaling 2 (Coordinate by X/Y Data)* ²

*1. Supported in Ver. 2.20 or later

*2. Supported in Ver. 1.30 or later

11	Memory Cassette/Battery
12	Test Run, Maintenance, Troubleshooting
A	Version Information
B	Performance Specifications
C	Special Devices (M8000 - J8000 -)
D	Instruction List
E	Character-code
F	Discouraged models
G	Precautions for battery transportation
H	Handling of batteries in EU member states

FNC No.	Mnemonic	Function
External Device Communication		
270	IVCK	Inverter Status Check
271	IVDR	Inverter Drive
272	IVRD	Inverter Parameter Read
273	IVWR	Inverter Parameter Write
274	IVBWR	Inverter Parameter Block Write
275	IVMC	Inverter Multi Command ^{*4}
276	ADPRW	MODBUS Read/Write ^{*5}
277	–	
Data Transfer 3		
278	RBFM	Divided BFM Read ^{*1}
279	WBFM	Divided BFM Write ^{*1}
High Speed Processing 2		
280	HSCT	High Speed Counter Compare With Data Table
281 to 289	–	
Extension File Register Control		
290	LOADR	Load From ER
291	SAVER	Save to ER
292	INITR	Initialize R and ER
293	LOGR	Logging R and ER
294	RWER	Rewrite to ER ^{*2}
295	INITER	Initialize ER ^{*2}
296 to 299	–	
FX3U-CF-ADP		
300	FLCRT	File create/check ^{*3}
301	FLDEL	File delete/CF card format ^{*3}
302	FLWR	Data write ^{*3}
303	FLRD	Data read ^{*3}
304	FLCMD	FX3U-CF-ADP command ^{*3}
305	FLSTRD	FX3U-CF-ADP status read ^{*3}

*1. Supported in Ver. 2.20 or later

*2. Supported in Ver. 1.30 or later

*3. Supported in Ver. 2.61 or later

*4. Supported in Ver. 2.70 or later

*5. Supported in Ver. 2.40 or later

Appendix E: Character-code

Appendix E-1 ASCII Code Table

- ¥ (ASCII Code: 5C) symbol is displayed as " ¥ " even if the language display setting at FX3U-7DM is set to English (LANGUAGE: ENGLISH).
- The Character at ASCII Code: 7E "~" is not displayed.

1. ASCII code table (7-bit code expressed in hexadecimal)

Example. "A " becomes 41H (hexadecimal number) by ASCII code.

Hexadecimal	0	1	2	3	4	5	6	7	8	9	A	B	C	D	E	F	
0			SP	0	@	P	`	p			As for this range, the Japanese syllabary is displayed.						
1			!	1	A	Q	a	q									
2			"	2	B	R	b	r									
3			#	3	C	S	c	s									
4			\$	4	D	T	d	t									
5			%	5	E	U	e	u									
6			&	6	F	V	f	v									
7			'	7	G	W	g	w									
8			(8	H	X	h	x									
9)	9	I	Y	i	y									
A			*	:	J	Z	j	z									
B			+	;	K	[k	{									
C			,	<	L	¥	l										
D			-	=	M]	m	}									
E			.	>	N	^	n										
F			/	?	O	_	o										

2. Examples of ASCII codes

Decimal	ASCII (hexadecimal)
0	30
1	31
2	32
3	33
4	34
5	35
6	36
7	37
8	38
9	39

Alphabet	ASCII (hexadecimal)	Alphabet	ASCII (hexadecimal)
A	41	N	4E
B	42	O	4F
C	43	P	50
D	44	Q	51
E	45	R	52
F	46	S	53
G	47	T	54
H	48	U	55
I	49	V	56
J	4A	W	57
K	4B	K	58
L	4C	Y	59
M	4D	Z	5A

Symbol	ASCII (hexadecimal)
#	23
&	26
=	3D
¥	5C

11
Memory
Cassette/Battery

12
Test Run,
Maintenance,
Troubleshooting

A
Version
Information

B
Performance
Specifications

C
Special Devices
(M8000 -J, D8000 -)

D
Instruction List

E
Character-code

F
Discontinued
models

G
Precautions for
battery
transportation

H
Handling of
batteries in EU
member states

MEMO

Appendix F: Discontinued models

The table below shows discontinued models of MELSEC-F Series PLCs and programming tools described in this manual.

Discontinued model	Production stop date	Repair acceptance period
FX2N-2LC	March 31, 2018	Until March 31, 2025
FX-10DM(-E)(-SET0)	September 30, 2017	Until September 30, 2024
FX2N-1PG(-E)	December 31, 2015	Until December 31, 2022
FX2N-20PSU		
FX2N-4AD		
FX2N-4DA		
FX2NC-4AD		
FX2NC-4DA		
FX2N-4AD-PT		
FX2N-4AD-TC		
FX0N-3A		
FX3U-232ADP		
FX3U-485ADP		
FX-PCS/WIN(-E)	March 31, 2013	-
FX-20P(-E)	December 31, 2012	Until December 31, 2019
FX-10DU(-E)		
FX2N-16CCL-M	September 30, 2012	Until September 30, 2019
FX2N-16LNK-M		
FX2N-32ASI-M	June 30, 2010	Until June 30, 2017
FX-16EYT-H-TB	August 31, 2009	Until August 31, 2016
FX-10P (-E)	June 30, 2008	Until June 30, 2015
FX0N-8EX	January 31, 2006	Until January 31, 2013
FX0N-8EX-UA1/UL		
FX0N-8ER		
FX0N-8EYR		
FX0N-8EYT		
FX0N-8EYT-H		
FX0N-16EX		
FX0N-16EYR		
FX0N-16EYT		
FX-232AW		
FX-232AWC	June 30, 2004	Until June 30, 2011

MEMO

Appendix G: Precautions for Battery Transportation

When transporting lithium batteries, follow the transportation regulations.
The batteries for the FX3UC Series CPU unit are classified as shown in following table.

Appendix G-1 Regulated FX3UC Series products

- 1) Included modules and batteries

Series name/product name	Used battery name	Battery type	Product supply status	Lithium Content (gram/unit)
FX3UC Series main unit	FX3U-32BL	lithium metal battery	Cell	0.15

- 2) Batteries to be built in modules (spare parts and optional parts)

Product name	Battery type	Product supply status	Lithium Content (gram/unit)	Mass *1 (gram/unit)
FX3U-32BL	lithium metal battery	Cell	0.15	30

*1. The value indicates the mass with packaging.

Appendix G-2 Transport guidelines

Comply with IATA Dangerous Goods Regulations, IMDG code and the local transport regulations when transporting products listed above.
Also, consult with the shipping carrier.

MEMO

Appendix H: Handling of Batteries and Devices with Built-in Batteries in EU Member States

This section describes the precautions for disposing of waste batteries in EU member states and exporting batteries and/or devices with built-in batteries to EU member states.

Appendix H-1 Disposal precautions

In EU member states, there is a separate collection system for waste batteries. Dispose of batteries properly at the local community waste collection/recycling center. The symbol shown in following figure is printed on the batteries and packaging of batteries and devices with built-in batteries used for Mitsubishi programmable controllers.



*1. This symbol to the left is for EU member states only. The symbol is specified in the new EU Battery Directive (2006/66/EC) Article 20 "Information for end-users" and Annex II.

The symbol to the left indicates that batteries need to be disposed of separately from other wastes.

Appendix H-2 Exportation precautions

The new EU Battery Directive (2006/66/EC) requires the following when marketing or exporting batteries and/or devices with built-in batteries to EU member states.

- To print the symbol on batteries, devices, or their packaging
 - To explain the symbol in the manuals of the products
- 1) Labelling
To market or export batteries and/or devices with built-in batteries, which have no symbol, to EU member states on September 26, 2008 or later, print the symbol shown in the figure above on the batteries, devices, or their packaging.
 - 2) Explaining the symbol in the manuals
To export devices incorporating Mitsubishi programmable controller to EU member states on September 26, 2008 or later, provide the latest manuals that include the explanation of the symbol. If no Mitsubishi manuals or any old manuals without the explanation of the symbol are provided, separately attach an explanatory note regarding the symbol to each manual of the devices.

POINT

The requirements apply to batteries and/or devices with built-in batteries manufactured before the enforcement date of the new EU Battery Directive(2006/66/EC).

Appendix H-3 Regulated FX3UC Series products

- 1) Included modules and batteries

Series name/product name	Used battery name	Battery type
FX3UC Series main unit	FX3U-32BL	Lithium Manganese Dioxide Battery

- 2) Batteries to be built in modules (spare parts and optional parts)

Product name	Battery type
FX3U-32BL	Lithium Manganese Dioxide Battery

MEMO

Warranty

Please confirm the following product warranty details before using this product.

1. Gratis Warranty Term and Gratis Warranty Range

If any faults or defects (hereinafter "Failure") found to be the responsibility of Mitsubishi occurs during use of the product within the gratis warranty term, the product shall be repaired at no cost via the sales representative or Mitsubishi Service Company. However, if repairs are required onsite at domestic or overseas location, expenses to send an engineer will be solely at the customer's discretion. Mitsubishi shall not be held responsible for any re-commissioning, maintenance, or testing on-site that involves replacement of the failed module.

[Gratis Warranty Term]

The gratis warranty term of the product shall be for one year after the date of purchase or delivery to a designated place. Note that after manufacture and shipment from Mitsubishi, the maximum distribution period shall be six (6) months, and the longest gratis warranty term after manufacturing shall be eighteen (18) months. The gratis warranty term of repair parts shall not exceed the gratis warranty term before repairs.

[Gratis Warranty Range]

- (1) The range shall be limited to normal use within the usage state, usage methods and usage environment, etc., which follow the conditions and precautions, etc., given in the instruction manual, user's manual and caution labels on the product.
- (2) Even within the gratis warranty term, repairs shall be charged for in the following cases.
 1. Failure occurring from inappropriate storage or handling, carelessness or negligence by the user. Failure caused by the user's hardware or software design.
 2. Failure caused by unapproved modifications, etc., to the product by the user.
 3. When the Mitsubishi product is assembled into a user's device, Failure that could have been avoided if functions or structures, judged as necessary in the legal safety measures the user's device is subject to or as necessary by industry standards, had been provided.
 4. Failure that could have been avoided if consumable parts (battery, backlight, fuse, etc.) designated in the instruction manual had been correctly serviced or replaced.
 5. Relay failure or output contact failure caused by usage beyond the specified Life of contact (cycles).
 6. Failure caused by external irresistible forces such as fires or abnormal voltages, and failure caused by force majeure such as earthquakes, lightning, wind and water damage.
 7. Failure caused by reasons unpredictable by scientific technology standards at time of shipment from Mitsubishi.
 8. Any other failure found not to be the responsibility of Mitsubishi or that admitted not to be so by the user.

2. Onerous repair term after discontinuation of production

- (1) Mitsubishi shall accept onerous product repairs for seven (7) years after production of the product is discontinued.
Discontinuation of production shall be notified with Mitsubishi Technical Bulletins, etc.
- (2) Product supply (including repair parts) is not available after production is discontinued.

3. Overseas service

Overseas, repairs shall be accepted by Mitsubishi's local overseas FA Center. Note that the repair conditions at each FA Center may differ.

4. Exclusion of loss in opportunity and secondary loss from warranty liability

Regardless of the gratis warranty term, Mitsubishi shall not be liable for compensation to:

- (1) Damages caused by any cause found not to be the responsibility of Mitsubishi.
- (2) Loss in opportunity, lost profits incurred to the user by Failures of Mitsubishi products.
- (3) Special damages and secondary damages whether foreseeable or not, compensation for accidents, and compensation for damages to products other than Mitsubishi products.
- (4) Replacement by the user, maintenance of on-site equipment, start-up test run and other tasks.

5. Changes in product specifications

The specifications given in the catalogs, manuals or technical documents are subject to change without prior notice.

6. Product application

- (1) In using the Mitsubishi MELSEC programmable logic controller, the usage conditions shall be that the application will not lead to a major accident even if any problem or fault should occur in the programmable logic controller device, and that backup and fail-safe functions are systematically provided outside of the device for any problem or fault.
- (2) The Mitsubishi programmable logic controller has been designed and manufactured for applications in general industries, etc. Thus, applications in which the public could be affected such as in nuclear power plants and other power plants operated by respective power companies, and applications in which a special quality assurance system is required, such as for Railway companies or Public service purposes shall be excluded from the programmable logic controller applications.
In addition, applications in which human life or property that could be greatly affected, such as in aircraft, medical applications, incineration and fuel devices, manned transportation, equipment for recreation and amusement, and safety devices, shall also be excluded from the programmable logic controller range of applications. However, in certain cases, some applications may be possible, providing the user consults their local Mitsubishi representative outlining the special requirements of the project, and providing that all parties concerned agree to the special circumstances, solely at the users discretion.
- (3) Mitsubishi shall have no responsibility or liability for any problems involving programmable controller trouble and system trouble caused by DoS attacks, unauthorized access, computer viruses, and other cyberattacks.

Revised History

Date Created	Revision	Description
11/2007	A	<ul style="list-style-type: none"> • First Edition
6/2008	B	<ul style="list-style-type: none"> • FX3UC-32MT-LT-2 main unit is added. • The following product is added to List of Products (Section 1.4), Connection to programming tool (Section 1.5), External Dimensions and Terminal Arrangement (Chapter 2), etc. <ul style="list-style-type: none"> - FX3U-4AD-PTW-ADP, FX3U-4AD-PNK-ADP - FX3U-64CCL, FX2NC-1HC • Built-in CC-Link/LT setting method of FX3UC-32MT-LT-2 is added (Chapter 9). • Display module operation method of FX3UC-32MT-LT-2 is added (Chapter 10).
11/2009	C	<ul style="list-style-type: none"> • The following product is added to Outline (Chapter 1), External Dimensions and Terminal Arrangement (Chapter 2), programming tool applicability (Appendix A-2), etc. <ul style="list-style-type: none"> - FX3U-3A-ADP, FX3U-CF-ADP - FX-30P • Ver. 2.41 is supported. <ul style="list-style-type: none"> - The baud rate "38400 bps" is supported in RS and RS2 instructions, inverter communication and computer link. • Ver. 2.61 is supported. <ul style="list-style-type: none"> - Supports FX3U-CF-ADP <ul style="list-style-type: none"> Six types of instructions are added (Appendix D-3) For the details of these instructions, refer to the FX3U-CF-ADP user's manual. Special auxiliary relays and special data registers are added (Appendix C-2) - Supports FX3U-3A-ADP <ul style="list-style-type: none"> Special auxiliary relays and special data registers are added (Appendix C-2) - Customer keyword/permanent PLC lock is supported. • Precautions for Battery Transportation are added (Appendix G) • Handling of Batteries and Devices with Built-in Batteries in EU Member States are added (Appendix H) • Errors are corrected.
3/2010	D	<ul style="list-style-type: none"> • Explanation corrections for manufacturer's serial number and lot number. • Explanation corrections for battery's lot number.
9/2010	E	<ul style="list-style-type: none"> • FX3UC-16MR/D-T, FX3UC-16MR/DS-T relay output type main units are added. • Ver. 2.70 is supported. <ul style="list-style-type: none"> - Three types of instructions are added (Appendix D-3) For the details of these instructions, refer to the FX3G/FX3U/FX3UC Programming Manuals. - Supports connection of following analog volume expansion board. <ul style="list-style-type: none"> FX3U-8AV-BD - Supports the under-scale detection function of the FX3U-4AD-ADP and FX3U-3A-ADP. • The following product is added to Outline (Chapter 1), External Dimensions and Terminal Arrangement (Chapter 2), etc. <ul style="list-style-type: none"> - FX2N-8EYR-S-ES/UL, FX3U-4LC, FX3U-2HC, FX3U-8AV-BD • GX Works2 is added. • Errors are corrected.
12/2010	F	<ul style="list-style-type: none"> • The caution for CC-Link/LT products is added to the Caution for compliance with EC Directive. • Errors are corrected.

Date Created	Revision	Description
7/2011	G	<ul style="list-style-type: none"> • The following product is added to Outline (Chapter 1), Memory Cassette/Battery (Chapter 11), etc. <ul style="list-style-type: none"> - FX3U-FLROM-1M • Ver. 3.00 is supported. <ul style="list-style-type: none"> - Supports storage of symbolic information. - Support of the setting "Read-protect the execution program." for block passwords. - Special block error condition (D8166) is added. - Supports connection of following memory cassette. FX3U-FLROM-1M • Errors are corrected.
8/2011	H	<ul style="list-style-type: none"> • Note for setting DIP switches component change for the built-in CC-Link/LT of the FX3UC-32MT-LT is added. • Errors are corrected.
3/2012	J	<ul style="list-style-type: none"> • The following product is added to Outline (Chapter 1), External Dimensions and Terminal Arrangement (Chapter 2), etc. <ul style="list-style-type: none"> - FX3U-16CCL-M • Ver. 3.10 is supported. <ul style="list-style-type: none"> - Supports parameter setting in the FX3U-16CCL-M. - Supports accessing the other station from CC-Link - Special parameter error (M8489 and D8489) is added. Description of special auxiliary relays and special data registers is added. (Appendix C) - The error code for parameter error is added. (Subsection 12.6.4) - The error code for special block error is added. (Subsection 12.6.4) • Errors are corrected.
11/2013	K	<ul style="list-style-type: none"> • The following product is added to Outline (Chapter 1), External Dimensions and Terminal Arrangement (Chapter 2), etc. <ul style="list-style-type: none"> - Special adapter FX3U-ENET-ADP - Special function block FX3U-1PG, FX3U-128ASL-M • Ver. 2.40 is supported. <ul style="list-style-type: none"> - Supports MODBUS communication function. - Description of special auxiliary relays and special data registers for MODBUS communication is added. (Appendix C) - One types of instructions are added (Appendix D-3). • Ver. 3.10 is supported. <ul style="list-style-type: none"> - Description of special auxiliary relays and special data registers for FX3U-ENET-ADP is added. (Appendix A) • "Maximum number of input/output points when AnyWireASLINK master is used" is added. (Subsection 1.8.3) • Errors are corrected.
8/2014	L	<ul style="list-style-type: none"> • "Self-made power cable" is deleted. (Subsection 3.10.4) • Errors are corrected.
4/2015	M	<ul style="list-style-type: none"> • A part of the cover design is changed.
2/2018	N	<ul style="list-style-type: none"> • The contents of standards are changed.
1/2020	P	<ul style="list-style-type: none"> • The following product is added to Outline (Chapter 1), External Dimensions and Terminal Arrangement (Chapter 2), etc. <ul style="list-style-type: none"> - Special function block FX3U-64DP-M, FX3U-32DP • Errors are corrected.
8/2020	Q	<ul style="list-style-type: none"> • Precautions for product security are added. • The contents of Procedures for replacing battery are changed. (Subsection 12.4.3)
4/2021	R	<ul style="list-style-type: none"> • Notes are added for Precaution for file register (D) usage and Precaution for extended file register (ER) usage. (Section 11.4)
7/2021	S	<ul style="list-style-type: none"> • Zener diodes are added to the figures in Output Specifications and External Wiring (Chapter 6). • Extension bus error is added. (Subsection 12.6.4)

Date Created	Revision	Description
12/2021	T	• Compliance with UKCA marking is added.
8/2022	U	• The input response time is changed. (Subsection 5.4.1)

Japanese manual number: JY997D11601AD

FX₃UC SERIES PROGRAMMABLE CONTROLLERS

USER'S MANUAL

Hardware Edition

MITSUBISHI ELECTRIC CORPORATION

HEAD OFFICE: TOKYO BUILDING, 2-7-3 MARUNOUCHI, CHIYODA-KU, TOKYO 100-8310, JAPAN

MODEL	FX3UC-HW-E
MODEL CODE	09R519