

FX2N

This manual contains text, diagrams and explanations which will guide the reader in the correct installation and operation of the FX2N-32CCL-NP CC-Link SYSTEM LOCAL BLOCK. It should be read and understood before attempting to install or use the unit. Further information can be found in the FX series PLC hardware manuals.

Guidelines for the safety of the user and protection of the FX2N-32CCL-NP CC-Link SYSTEM LOCAL BLOCK

- If in doubt at any stage during the installation of the FX2N-32CCL-NP CC-Link SYSTEM LOCAL BLOCK always consult a professional electrical engineer who is qualified and trained to the local and national standards. If in doubt about the operation or use of the FX2N-32CCL-NP CC-Link SYSTEM LOCAL BLOCK please consult the nearest Mitsubishi Electric distributor.
- Under no circumstances will Mitsubishi Electric be liable or responsible for any consequential damage that may arise as a result of the installation or use of this equipment.
- All examples and diagrams shown in this manual are intended only as an aid to understanding the text, not to guarantee operation. Mitsubishi Electric will accept no responsibility for actual use of the product based on these illustrative examples.
- Owing to the very great variety in possible application of this equipment, you must satisfy yourself as to its suitability for your specific application.

Note's on the symbology used in this manual

At various times through out this manual certain symbols will be used to highlight points of information which are intended to ensure the user's personal safety and protect the integrity of the equipment. Whenever any of the following symbols are encountered, its associated note must be read and understood. Each of the symbols used will now be listed with a brief description of its meaning.

Hardware warnings



1) Indicates that the identified danger WILL cause physical and property damage.



2) Indicates that the identified danger could POSSIBLY cause physical and property damage.

1. INTRODUCTION

The FX2N-32CCL-NP is the interface block that connects the FX series PLC to the CC-Link system. It is connected as a local station.

- Master station Station which controls the remote I/O station, remote device station, and local stations
- Remote I/O station Remote station which handles only on/off data
- Remote device station Remote station which handles both on/off data and numeric data
- Local station Station which has a CPU and can communicate with the master station and other local stations

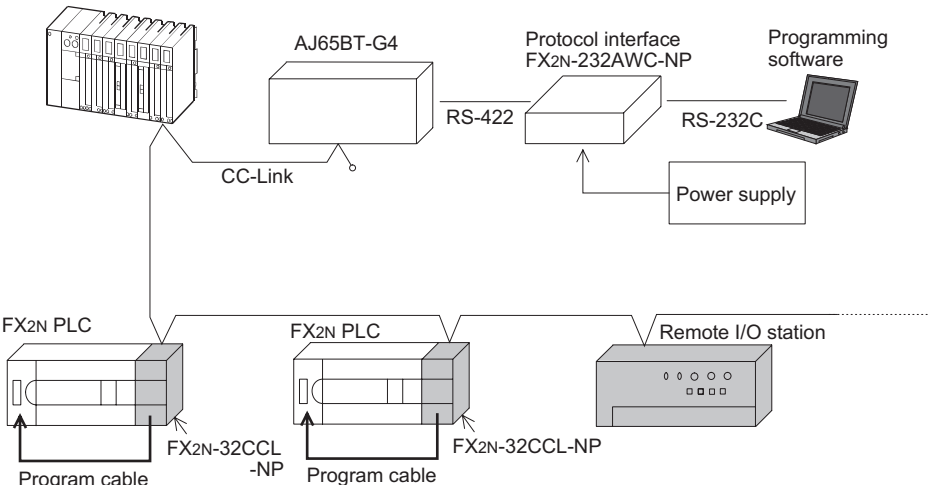

Master Station

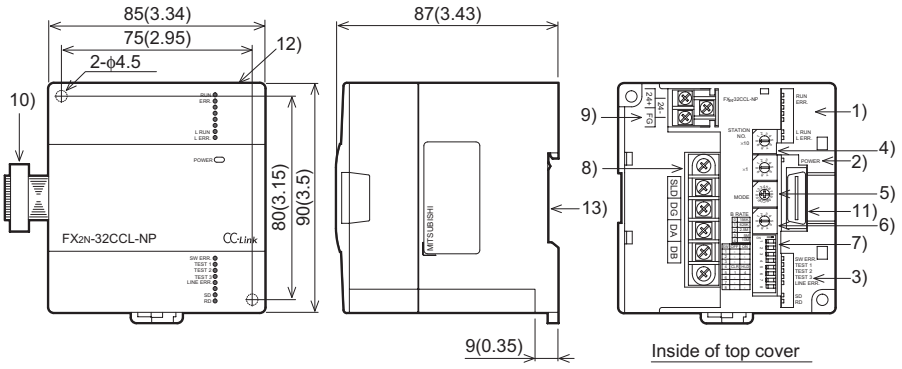

1.1 Dimensions and Setting

Dimensions: mm (inches) MASS (Weight): 0.4 kg (0.88 lbs)

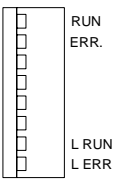

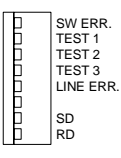
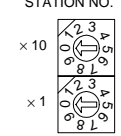
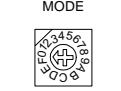
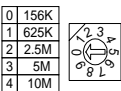
Number	Name	Description				
1)	LED indicators 1 	LED name	Description	LED status		
				Normal	Error	
		RUN	ON : Module is normal. OFF: Watchdog timer error has occurred.	ON	OFF	
		ERR.	Indicates the communication status with the stations set in the parameters. ON : Communication error has occurred in all stations. Flashing : Communication error has occurred in some stations.	OFF	ON or flashing	
		L RUN	ON : Data link is being executed (host station).	ON	OFF	
2)	Power indicator 	POWER	ON : 24V DC is supplied from the outside.	ON	OFF	
		LED indicators 2 	SW ERR.	ON : Switch setting error has occurred.	OFF	ON
			TEST 1	Test result indication	OFF except during test	
			TEST 2			
		TEST 3				
		LINE ERR.	ON : The cable is broken the transmission route is affected by noise, etc.	OFF	ON	
		SD	ON : Data is being transmitted.	ON	OFF	
RD	ON : Data is being received.	ON	OFF			
4)	Station number setting switch 	Sets the station number of the module. (Default setting at shipment: 00) <Setting range> Local station : 1 to 64 If "65" or larger number is set, the "SW" and "L ERR." LED indicators turn ON.				
5)	Mode setting switch 	Sets the operation status of the module. (Default setting at shipment: 0)				
		Number	Name	Description		
		0	Online	Sets connection to data link.		
		1	(Unusable)	—		
		2	Offline	Sets disconnection from data link.		
		3	(Unusable)	—		
		4	(Unusable)	—		
		5	(Unusable)	—		
		6	Hardware test	—		
		7	(Unusable)	Setting error (The SW LED indicator turns ON.)		
8 to A	(Unusable)	Used in PLC internal operations.				
B to F	(Unusable)	Setting error (The SW LED indicator turns ON.)				
6)	Transmission speed setting switch 	Sets the transmission speed of the module. (Default setting at shipment: 0)				
		Number	Setting contents			
		0	156 kbps			
		1	625 kbps			
		2	2.5 Mbps			
		3	5 Mbps			
4	10 Mbps					
5 to 9	Setting error (The SW and L ERR. LED indicators turn ON.)					

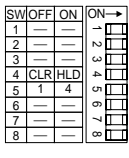
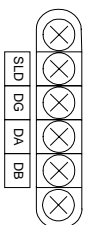
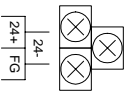
Number	Name	Description			
7)	Condition setting switch 	Sets the operation condition. (Default setting at shipment: All OFF)			
		Number	Setting description	Switch status	
				ON	OFF
		SW1 to SW3	(Unusable)	Always OFF	
		SW4	Input data status in data link faulty station	Keep (HLD)	Clear (CLR)
		SW5	Number of occupied stations	4	1
		SW6 to SW8	(Unusable)	Always OFF	
8)	Terminal block 	Connects dedicated CC-Link cables to enable data link. For the connection method, refer to Section 2.3.			
		The terminals SLD and FG are connected inside.			
9)	Terminal block 	Connects the power supply to operate the master block.			
10)	Extension bus cable	Connects the PLC.			
11)	Expansion bus port	Connects an extension equipment.			
12)	Program port	A connector for program cable			
13)	DIN rail mounting groove	DIN46277: DIN rail mounting groove of 35 mm (1.38") in width			

2. Installation and wiring

INSTALLATION PRECAUTIONS



- Use the module in the environment described in the HARDWARE MANUAL General Specification. Do not use the PLC in a place with dust, soot, conductive dust, corrosive gas or combustible gas, place exposed to high temperature, condensation, wind or rain or place with vibration or impact. Using the module outside the range of the general specification may result in electrical shock, fire, malfunctions, or may damage the PLC.
- When drilling screw holes or performing wiring, make sure that cutting chips, wire chips or other foreign matter does not enter the ventilation window of the module. Such matter may cause fire, failure or malfunction.
- When the installation work is completed, remove the dust protection sheet from the ventilation window of the PLC. If the sheet remains attached, it may cause fire, failure or malfunction.
- Securely connect extension cables to specified connectors. Poor contact may cause malfunction.

WIRING PRECAUTIONS



- Before beginning any installation or wiring work, make sure all phases of the power supply have been shut down from the outside. Incomplete shutdown of the power supply phases may cause electrical shock or damage in the module.
- Following an installation or wiring work, when turning on the power supply and operating the PLC, make sure that the terminal cover provided as an accessory has been attached to the module. A missing cover may cause electrical shock.
- For the CC-Link system, use dedicated cables specified by the manufacturer. The performance of the CC-Link system cannot be guaranteed with any cable other than the ones specified by the manufacturer. With wiring outside the specification range, normal data transfer cannot be guaranteed.
- Make sure to fix communication cables and power cables connected to the module by placing them in the duct or clamping them. Cables not placed in duct or not clamped may hang or shift, allowing them to be accidentally pulled, which may result in malfunction or damage to the module and the cables.
- The number of times to disconnect/connect the program cable for FX2N-32CCL-NP should be kept to a minimum.

- When disconnecting a communication/power cable connected to the module, do not hold the cable area.
For a cable with connector, hold the connector attached to the module.
For a cable connected to a terminal block, loosen screws of the terminal block, then disconnect the cable.
If a cable is pulled while it is connected to a module, the module may malfunction or the module and the cable may be damaged.

WIRING PRECAUTIONS



- Perform Class D grounding (solid grounding) with a wire of 2 mm² or more to the grounding terminal in the PLC main units. However, never perform common grounding with a high voltage system.

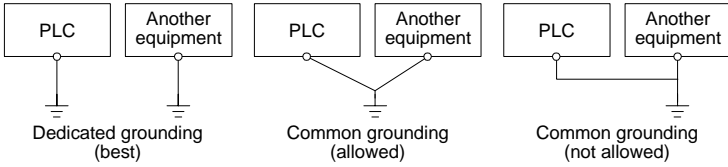

- Do not bundle control cables and communication cables with the main circuit and power cables. Keep control cables and communication cables at least 100 mm away from the main circuit and power cables.
Otherwise, electric noise may cause a malfunction.

2.1 Installation

Install the FX2N-32CCL-NP on the right side of an FX2N Series main unit, extension unit, or other extension block.

The FX2N-32CCL-NP can be installed using a DIN rail (DIN 46277, width: 35 mm (1.38 in.)) or directly with M4 (0.16 in.) screws.

In the case of direct installation, provide space of 1 to 2 mm (0.04 to 0.08 in.) between units.

2.2 Dedicated CC-Link Cable

Use dedicated CC-Link cables in the CC-Link system.

If any other cable is used, the performance of the CC-Link system cannot be guaranteed.

2.3 Module Wiring with Dedicated CC-Link Cables

This section describes the connection method of dedicated CC-Link cables.

- The cables can be connected without regard to the station number.
- Make sure to connect a terminal resistor (offered as an accessory of the module) between the DA and DB terminals in the modules at both ends.
- In the CC-Link system, the terminal resistor to be connected varies depending on the cable used.
 - When a dedicated CC-Link cable is used: 110 Ω, 1/2 W (brown, brown and brown)
 - When a dedicated high-performance CC-Link cable is used: 130 Ω, 1/2 W (brown, orange and brown)
- Star connection is not allowed.
- The figure below shows the connection method.

Important

Make sure to use only one type of cable (dedicated CC-Link cables OR dedicated CC-Link high-performance cables).
If both types of cables are used together, normal data transmission cannot be guaranteed.

Point

The shielded dedicated CC-Link cable should go through the terminals SLD and FG in each module, and both ends should be grounded (Class D = solid grounding).
The terminals SLD and FG are connected inside the module.

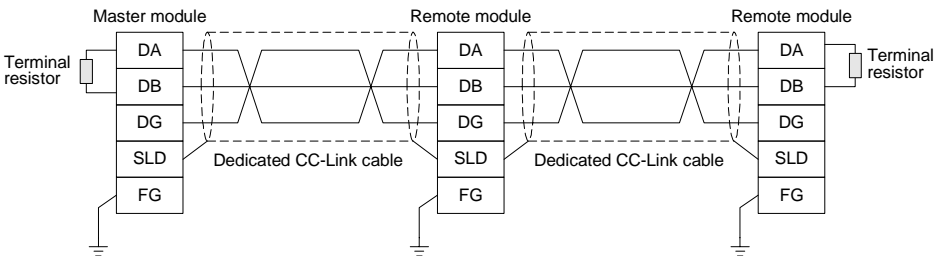

2.4 Connection diagram of program cable

Length: 1 m (3.3 ft)

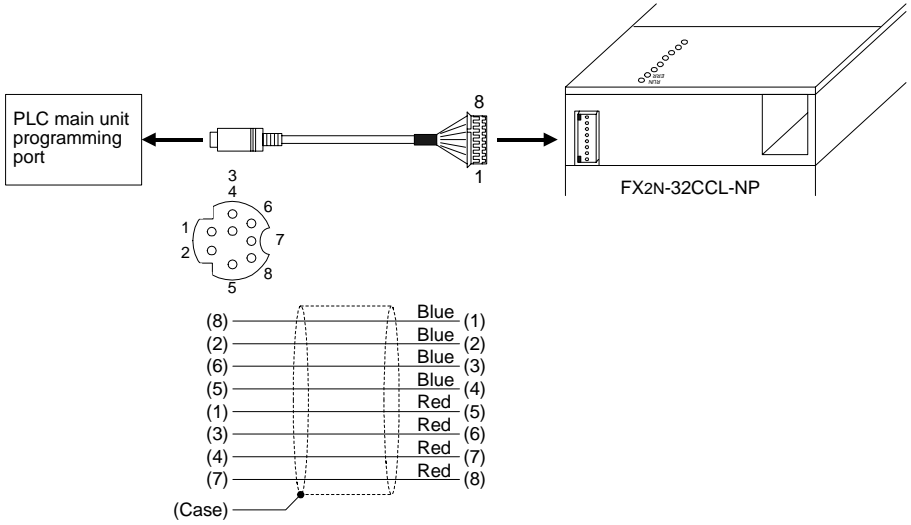

3. SPECIFICATION

3.1 General Specification

Dielectric strength: 500V AC for 1 minute (between the case and the PLC ground)
 Other specification is equivalent to that of the PLC main unit.

3.2 Performance Specification

Item	Specification
Applicable function	Local station function (The master station and standby master station functions are not provided.)
CC-Link version	Ver.1.10
Transmission speed	Selectable (by rotary switch) among 156 kbps, 625 kbps, 2.5 Mbps, 5 Mbps and 10 Mbps
Station number	1 to 64 (set by rotary switch)
Maximum total cable length (maximum transmission distance)	1,200 m maximum Varies depending on the transmission speed.
Number of link points per station	Remote I/O station : Remote I/O = 32/32 (RX/Ry) points Remote device station : Remote I/O = 32/32 (RX/Ry) points Remote register = 4 (RWw) points Remote register = 4 (RWr) points
Transmission path type	Bus (RS-485)
Connection cable	Dedicated CC-Link cable/Dedicated high-performance CC-Link cable ^{*1}
RAS function	<ul style="list-style-type: none"> Automatic return function Offline test Error detection by link special relay/register
Applicable PLC	FX2N Series PLC
Number of occupied I/O points	8 I/O points of FX Series PLC (8 points in total. The ratio between inputs and outputs is arbitrary.)
Communication with PLC	By FROM/TO instructions via the buffer memory
Note	<ul style="list-style-type: none"> Scan method: Asynchronous mode Automatic refresh: Not provided Master station function: Not provided Standby master station function: Not provided
Operation indication	POWER : Lit while 24V DC is supplied from outside. L RUN : Lit while communication is normal. L ERR : Lit when communication error has occurred. SD : Lit while data is being transmitted. RD : Lit while data is being received.
Program forwarding and monitoring	With AJ65BT-G4 and FX2N-232AWC-NP, sequence programs can be forwarded and monitored through CC-Link. Applicable software: GX Developer FX-PCS/WIN-E
24V DC external power supply	Supplied from 24V DC (150 mA) external terminal blocks.
5V DC internal power supply	5V DC power is converted from the input power. The 5V DC PLC bus is not used.
Accessories	Program cable Lengths 1.0 m (3.2 ft) Special block number label
MASS (Weight)	0.4 kg (0.88 lbs)

*1 Dedicated CC-Link cables and dedicated high-performance CC-Link cables cannot be used at the same time. Only one type of cable can be used simultaneously.
 Attach a terminal resistor in accordance with the cable type.

3.3 Buffer Memory List

BFM number		Item	Description
Hex.	Dec.		
#AH to #BH	#10 to #11	I/O signal	Refer to 3.4
#1CH	#28	FROM/TO instruction access error judgement time	Set the FROM/TO instruction access error judgement time (unit:10ms).Default:200ms
#1EH	#30	Model code	K7041
#E0H to #15FH	#224 to #351	Remote input (RX)	Stores the input status from a remote station.
#160H to #1DFH	#352 to #479	Remote output (RY)	Stores the output status from a remote station.
#1E0H to #2DFH	#480 to #735	Remote register(RWw)	Stores the transmission data to a remote station.
#2E0H to #3DFH	#736 to #991	Remote register(RWr)	Stores the received data from a remote station.
#5E0H to #5FFH	#1504 to #1535	Link special relay (SB)	Stores the data link status.
#600H to #7FFH	#1536 to #2047	Link special register (SW)	Stores the data link status.

3.4 I/O Signals to PLC

PLC to local block Write (when TO instruction is used)			
BFM number		Write bit	Output signal name
Hex.	Dec.		
#AH	#10	b0	Refresh command
		b1 to b3	(Prohibited to use)
		b4	Request for module reset
		b5 to b15	(Prohibited to use)
#BH	#11	b0 to b15	(Prohibited to use)

PLC to local block Read (when FROM instruction is used)			
BFM number		Read bit	Input signal name
Hex.	Dec.		
#AH	#10	b0	Module error
		b1	Data link status in host station
		b2	(Prohibited to use)
		b3	Data link status in other stations
		b4	Module reset acceptance completion
		b5 to b14	(Prohibited to use)
		b15	Module ready
#BH	#11	b0 to b15	(Prohibited to use)

Manual number : JY992D96001

Manual revision : A

Date : April 2001



HEAD OFFICE : MITSUBISHI DENKI BLDG MARUNOUTI TOKYO 100-8310 TELEX : J24532 CABLE MELCO TOKYO
HIMEJI WORKS : 840, CHIYODA CHO, HIMEJI, JAPAN



This manual contains text, diagrams and explanations which will guide the reader in the correct installation and operation of the FX2N-32CCL-NP CC-Link SYSTEM LOCAL BLOCK. It should be read and understood before attempting to install or use the unit. Further information can be found in the FX series PLC hardware manuals.

Guidelines for the safety of the user and protection of the FX2N-32CCL-NP CC-Link SYSTEM LOCAL BLOCK

- If in doubt at any stage during the installation of the FX2N-32CCL-NP CC-Link SYSTEM LOCAL BLOCK always consult a professional electrical engineer who is qualified and trained to the local and national standards. If in doubt about the operation or use of the FX2N-32CCL-NP CC-Link SYSTEM LOCAL BLOCK please consult the nearest Mitsubishi Electric distributor.
- Under no circumstances will Mitsubishi Electric be liable or responsible for any consequential damage that may arise as a result of the installation or use of this equipment.
- All examples and diagrams shown in this manual are intended only as an aid to understanding the text, not to guarantee operation. Mitsubishi Electric will accept no responsibility for actual use of the product based on these illustrative examples.
- Owing to the very great variety in possible application of this equipment, you must satisfy yourself as to its suitability for your specific application.

Note's on the symbology used in this manual

At various times through out this manual certain symbols will be used to highlight points of information which are intended to ensure the user's personal safety and protect the integrity of the equipment. Whenever any of the following symbols are encountered, its associated note must be read and understood. Each of the symbols used will now be listed with a brief description of its meaning.

Hardware warnings

- ⚡ 1) Indicates that the identified danger WILL cause physical and property damage.
- ⚠ 2) Indicates that the identified danger could POSSIBLY cause physical and property damage.

1. INTRODUCTION

The FX2N-32CCL-NP is the interface block that connects the FX series PLC to the CC-Link system. It is connected as a local station.

- Master station Station which controls the remote I/O station, remote device station, and local stations
- Remote I/O station Remote station which handles only on/off data
- Remote device station Remote station which handles both on/off data and numeric data
- Local station Station which has a CPU and can communicate with the master station and other local stations

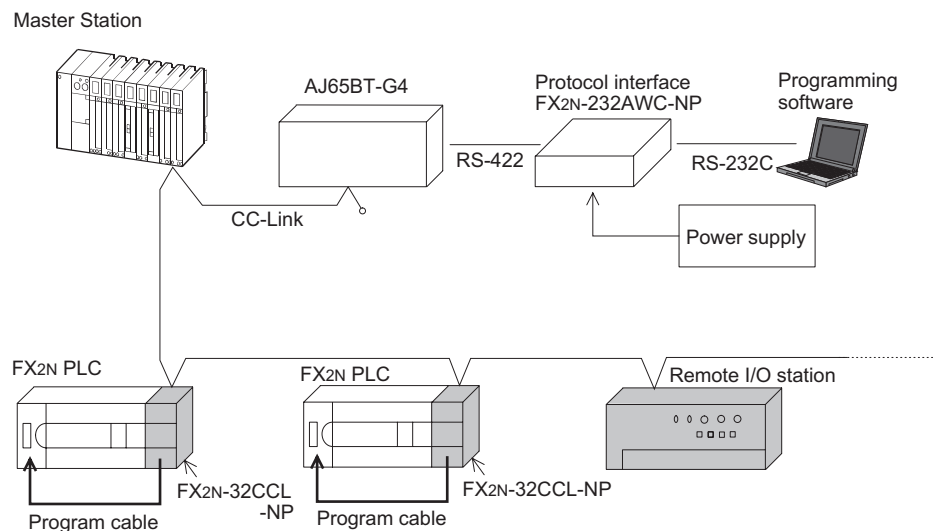

1.1 Dimensions and Setting

Dimensions: mm (inches) MASS (Weight): 0.4 kg (0.88 lbs)

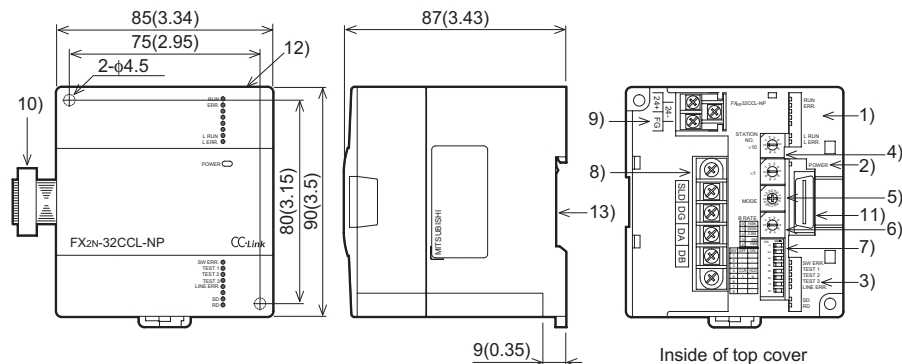

Number	Name	Description				
1)	LED indicators 1	LED name	Description		LED status	
		RUN	ON : Module is normal. OFF: Watchdog timer error has occurred.		ON	OFF
		ERR.	Indicates the communication status with the stations set in the parameters. ON : Communication error has occurred in all stations. Flashing : Communication error has occurred in some stations.		OFF	ON or flashing
		L RUN	ON : Data link is being executed (host station).		ON	OFF
		L ERR.	ON : Communication error has occurred (host station). Flashing : The settings of the switches 4) to 7) are changed while the power is ON.		OFF	ON or flashing
2)	Power inductor	POWER	ON : 24V DC is supplied from the outside.		ON	OFF
3)	LED indicators 2	SW ERR.	ON : Switch setting error has occurred.		OFF	ON
		TEST 1	Test result indication		OFF except during test	
		TEST 2				
		TEST 3				
		LINE ERR.	ON : The cable is broken the transmission route is affected by noise, etc.		OFF	ON
		SD	ON : Data is being transmitted.		ON	OFF
		RD	ON : Data is being received.		ON	OFF
4)	Station number setting switch	Sets the station number of the module. (Default setting at shipment: 00) <Setting range> Local station : 1 to 64 If "65" or larger number is set, the "SW" and "L ERR." LED indicators turn ON.				
5)	Mode setting switch	Sets the operation status of the module. (Default setting at shipment: 0)				
		Number	Name	Description		
		0	Online	Sets connection to data link.		
		1	(Unusable)	—		
		2	Offline	Sets disconnection from data link.		
		3	(Unusable)	—		
		4	(Unusable)	—		
		5	(Unusable)	—		
		6	Hardware test	—		
		7	(Unusable)	Setting error (The SW LED indicator turns ON.)		
8 to A	(Unusable)	Used in PLC internal operations.				
B to F	(Unusable)	Setting error (The SW LED indicator turns ON.)				
6)	Transmission speed setting switch	Sets the transmission speed of the module. (Default setting at shipment: 0)				
		Number	Setting contents			
		0	156 kbps			
		1	625 kbps			
		2	2.5 Mbps			
		3	5 Mbps			
		4	10 Mbps			
5 to 9	Setting error (The SW and L ERR. LED indicators turn ON.)					

Number	Name	Description				
7)	Condition setting switch	Sets the operation condition. (Default setting at shipment: All OFF)				
		Number	Setting description		Switch status	
		SW OFF ON ON →			ON	OFF
		1	(Unusable)		Always OFF	
		SW4	Input data status in data link faulty station		Keep (HLD)	Clear (CLR)
SW5	Number of occupied stations		4	1		
SW6 to SW8	(Unusable)		Always OFF			
8)	Terminal block	Connects dedicated CC-Link cables to enable data link. For the connection method, refer to Section 2.3.				
		The terminals SLD and FG are connected inside.				
9)	Terminal block	Connects the power supply to operate the master block.				
10)	Extension bus cable	Connects the PLC.				
11)	Expansion bus port	Connects an extension equipment.				
12)	Program port	A connector for program cable				
13)	DIN rail mounting groove	DIN46277: DIN rail mounting groove of 35 mm (1.38") in width				

2. Installation and wiring

INSTALLATION PRECAUTIONS

- Use the module in the environment described in the HARDWARE MANUAL General Specification. Do not use the PLC in a place with dust, soot, conductive dust, corrosive gas or combustible gas, place exposed to high temperature, condensation, wind or rain or place with vibration or impact. Using the module outside the range of the general specification may result in electrical shock, fire, malfunctions, or may damage the PLC.
- When drilling screw holes or performing wiring, make sure that cutting chips, wire chips or other foreign matter does not enter the ventilation window of the module. Such matter may cause fire, failure or malfunction.
- When the installation work is completed, remove the dust protection sheet from the ventilation window of the PLC. If the sheet remains attached, it may cause fire, failure or malfunction.
- Securely connect extension cables to specified connectors. Poor contact may cause malfunction.

WIRING PRECAUTIONS

- Before beginning any installation or wiring work, make sure all phases of the power supply have been shut down from the outside. Incomplete shutdown of the power supply phases may cause electrical shock or damage in the module.
- Following an installation or wiring work, when turning on the power supply and operating the PLC, make sure that the terminal cover provided as an accessory has been attached to the module. A missing cover may cause electrical shock.
- For the CC-Link system, use dedicated cables specified by the manufacturer. The performance of the CC-Link system cannot be guaranteed with any cable other than the ones specified by the manufacturer. With wiring outside the specification range, normal data transfer cannot be guaranteed.
- Make sure to fix communication cables and power cables connected to the module by placing them in the duct or clamping them. Cables not placed in duct or not clamped may hang or shift, allowing them to be accidentally pulled, which may result in malfunction or damage to the module and the cables.
- The number of times to disconnect/connect the program cable for FX2N-32CCL-NP should be kept to a minimum.

- When disconnecting a communication/power cable connected to the module, do not hold the cable area.
For a cable with connector, hold the connector attached to the module.
For a cable connected to a terminal block, loosen screws of the terminal block, then disconnect the cable.
If a cable is pulled while it is connected to a module, the module may malfunction or the module and the cable may be damaged.

WIRING PRECAUTIONS



- Perform Class D grounding (solid grounding) with a wire of 2 mm² or more to the grounding terminal in the PLC main units. However, never perform common grounding with a high voltage system.

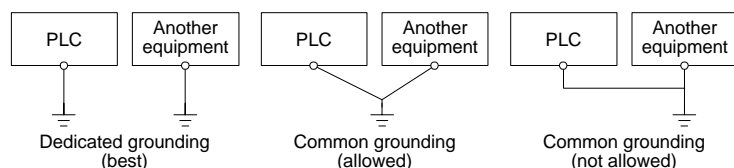

- Do not bundle control cables and communication cables with the main circuit and power cables. Keep control cables and communication cables at least 100 mm away from the main circuit and power cables.
Otherwise, electric noise may cause a malfunction.

2.1 Installation

Install the FX2N-32CCL-NP on the right side of an FX2N Series main unit, extension unit, or other extension block.
The FX2N-32CCL-NP can be installed using a DIN rail (DIN 46277, width: 35 mm (1.38 in.)) or directly with M4 (0.16 in.) screws.
In the case of direct installation, provide space of 1 to 2 mm (0.04 to 0.08 in.) between units.

2.2 Dedicated CC-Link Cable

Use dedicated CC-Link cables in the CC-Link system.
If any other cable is used, the performance of the CC-Link system cannot be guaranteed.

2.3 Module Wiring with Dedicated CC-Link Cables

This section describes the connection method of dedicated CC-Link cables.

- The cables can be connected without regard to the station number.
- Make sure to connect a terminal resistor (offered as an accessory of the module) between the DA and DB terminals in the modules at both ends.
- In the CC-Link system, the terminal resistor to be connected varies depending on the cable used.
 - When a dedicated CC-Link cable is used: 110 Ω, 1/2 W (brown, brown and brown)
 - When a dedicated high-performance CC-Link cable is used: 130 Ω, 1/2 W (brown, orange and brown)
- Star connection is not allowed.
- The figure below shows the connection method.

Important
Make sure to use only one type of cable (dedicated CC-Link cables OR dedicated CC-Link high-performance cables).
If both types of cables are used together, normal data transmission cannot be guaranteed.

Point
The shielded dedicated CC-Link cable should go through the terminals SLD and FG in each module, and both ends should be grounded (Class D = solid grounding).
The terminals SLD and FG are connected inside the module.

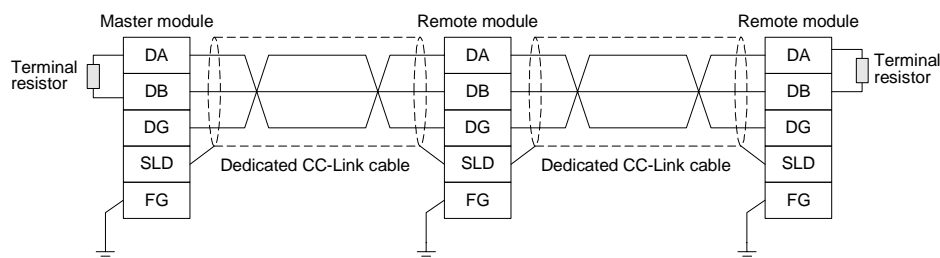

2.4 Connection diagram of program cable

Length: 1 m (3.3 ft)

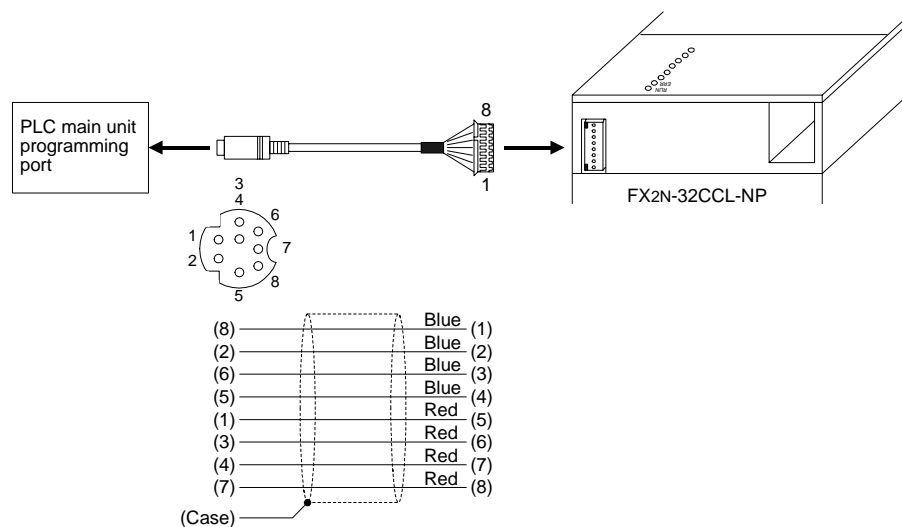

3. SPECIFICATION

3.1 General Specification

Dielectric strength: 500V AC for 1 minute (between the case and the PLC ground)
Other specification is equivalent to that of the PLC main unit.

3.2 Performance Specification

Item	Specification
Applicable function	Local station function (The master station and standby master station functions are not provided.)
CC-Link version	Ver.1.10
Transmission speed	Selectable (by rotary switch) among 156 kbps, 625 kbps, 2.5 Mbps, 5 Mbps and 10 Mbps
Station number	1 to 64 (set by rotary switch)
Maximum total cable length (maximum transmission distance)	1,200 m maximum Varies depending on the transmission speed.
Number of link points per station	Remote I/O station : Remote I/O = 32/32 (RX/RX) points Remote device station : Remote I/O = 32/32 (RX/RX) points Remote register = 4 (RWw) points Remote register = 4 (RWw) points
Transmission path type	Bus (RS-485)
Connection cable	Dedicated CC-Link cable/Dedicated high-performance CC-Link cable ^{*1}
RAS function	<ul style="list-style-type: none"> Automatic return function Offline test Error detection by link special relay/register
Applicable PLC	FX2N Series PLC
Number of occupied I/O points	8 I/O points of FX Series PLC (8 points in total. The ratio between inputs and outputs is arbitrary.)
Communication with PLC	By FROM/TO instructions via the buffer memory
Note	<ul style="list-style-type: none"> Scan method: Asynchronous mode Automatic refresh: Not provided Master station function: Not provided Standby master station function: Not provided
Operation indication	POWER : Lit while 24V DC is supplied from outside. L RUN : Lit while communication is normal. L ERR : Lit when communication error has occurred. SD : Lit while data is being transmitted. RD : Lit while data is being received.
Program forwarding and monitoring	With AJ65BT-G4 and FX2N-232AWC-NP, sequence programs can be forwarded and monitored through CC-Link. Applicable software: GX Developer FX-PCS/WIN-E
24V DC external power supply	Supplied from 24V DC (150 mA) external terminal blocks.
5V DC internal power supply	5V DC power is converted from the input power. The 5V DC PLC bus is not used.
Accessories	Program cable Lengths 1.0 m (3.2 ft) Special block number label
MASS (Weight)	0.4 kg (0.88 lbs)

^{*1} Dedicated CC-Link cables and dedicated high-performance CC-Link cables cannot be used at the same time. Only one type of cable can be used simultaneously.
Attach a terminal resistor in accordance with the cable type.

3.3 Buffer Memory List

BFM number		Item	Description
Hex.	Dec.		
#AH to #BH	#10 to #11	I/O signal	Refer to 3.4
#1CH	#28	FROM/TO instruction access error judgement time	Set the FROM/TO instruction access error judgement time (unit:10ms).Default:200ms
#1EH	#30	Model code	K7041
#E0H to #15FH	#224 to #351	Remote input (RX)	Stores the input status from a remote station.
#160H to #1DFH	#352 to #479	Remote output (RY)	Stores the output status from a remote station.
#1E0H to #2DFH	#480 to #735	Remote register(RWw)	Stores the transmission data to a remote station.
#2E0H to #3DFH	#736 to #991	Remote register(RWr)	Stores the received data from a remote station.
#5E0H to #5FFH	#1504 to #1535	Link special relay (SB)	Stores the data link status.
#600H to #7FFH	#1536 to #2047	Link special register (SW)	Stores the data link status.

3.4 I/O Signals to PLC

PLC to local block Write (when TO instruction is used)			
BFM number		Write bit	Output signal name
Hex.	Dec.		
#AH	#10	b0	Refresh command
		b1 to b3	(Prohibited to use)
		b4	Request for module reset
		b5 to b15	(Prohibited to use)
#BH	#11	b0 to b15	(Prohibited to use)

PLC to local block Read (when FROM instruction is used)			
BFM number		Read bit	Input signal name
Hex.	Dec.		
#AH	#10	b0	Module error
		b1	Data link status in host station
		b2	(Prohibited to use)
		b3	Data link status in other stations
		b4	Module reset acceptance completion
		b5 to b14	(Prohibited to use)
#BH	#11	b15	Module ready
#BH	#11	b0 to b15	(Prohibited to use)

Manual number : JY992D96001
Manual revision : A
Date : April 2001



HEAD OFFICE : MITSUBISHI DENKI BLDG MARUNOUCHI TOKYO 100-8310 TELEX : J24532 CABLE MELCO TOKYO
HIMEJI WORKS : 840, CHIYODA CHO, HIMEJI, JAPAN