

Dec.2011 / Vol.136

MITSUBISHI ELECTRIC

ADVANCE

Latest Factory Automation Engineering Software and (FA) Technologies

- **Editorial-Chief**

Kiyoshi Takakuwa

- **Editorial Advisors**

*Toshio Masujima
Kanae Ishida
Kazuhiro Oka
Tetsuji Sorita
Hiroaki Kawachi
Hideaki Okada
Takahiro Nishikawa
Tetsuyuki Yanase
Ichiro Fujii
Taizo Kittaka
Masato Nagasawa
Daisuke Kawai
Keiichiro Tsuchiya
Toshitaka Aoyagi*

- **Vol. 136 Feature Articles Editor**

Junichi Mito

- **Editorial Inquiries**

*Kazuhiro Oka
Corporate Total Productivity Management
& Environmental Programs
Fax +81-3-3218-2465*

- **Product Inquiries**

*Masahiro Fujisawa (p.2-8, p.12-14)
Regional Strategy Section
Overseas Marketing Department
Fax +81-3-3218-6820*

*Gota Yoshiyama (p.9-11)
Strategic Planning Section
Numerical Controller Business Development
Dept.
Fax +81-3-3218-6570*

*Akira Hayashi (p.15-17)
Overseas Marketing Section
Industrial Automation Machinery Dept.
Fax +81-3-3218-6555*

*Hitoshi Namba (p.18-20)
Low Voltage Switchgear & Environment
Section
Overseas Marketing Department
Fax +81-3-3218-6820*

Mitsubishi Electric Advance is published on line quarterly by Mitsubishi Electric Corporation.
Copyright © 2011 by Mitsubishi Electric Corporation; all rights reserved.
Printed in Japan.

CONTENTS

Technical Reports

Overview	1
by <i>Keiichi Shirase</i>	
Performance Improvement Technology of "MELSOFT iQ Works" Integrated FA Engineering Software	2
by <i>Koji Morita</i>	
Simple Motion Module LD77MH4/ LD77MH16	5
by <i>Tomoyuki Furutachi and Kensuke Nagumo</i>	
Premium High-Efficiency Motor "MM-EFS" and Energy-Saving Inverter "FR-F700P/ F700PJ"	7
by <i>Tomokazu Kimura and Naoki Kojima</i>	
Easy-to-Use Functions for Inclined Surface Machining in the "MITSUBISHI CNC M700V Series"	9
by <i>Naoki Nakamura</i>	
CC-Link IE Field Safety Communication Technology	12
by <i>Shunsuke Igarashi</i>	
The Latest Model of Laser Drilling Machine for Printed Wiring Board "ML605GTW III-5200U" and Processing Application	15
by <i>Yutaka Motoki and Kazunobu Katase</i>	
Energy Measuring Unit for MELSEC-Q Series	18
by <i>Masayoshi Shimoe</i>	

Overview



Author: *Keiichi Shirase**

Sustainable and Flexible Automation for a New Era of MONOZUKURI

“Monozukuri (Manufacturing)” has been a source of rapid growth in Japan, and has been supported by Factory Automation (FA) technology. However, such rapid growth based on mass production and consumption has caused environmental problems on a global scale, and these problems force us to turn our attention to a new “Monozukuri”. In particular, the global warming and rare earth issues require further energy savings and effective use of limited natural resources. In response, “Sustainable Manufacturing (Monozukuri)” has been proposed as a solution. Today, conventional FA needs to evolve to Sustainable and Flexible Automation (SFA), which supports “Sustainable Monozukuri” and is sufficiently flexible to be applied to a variety of production systems.

SFA can be characterized by openness, reconfigurability, evolution, reliability and maintainability. To achieve SFA, it is important not only to provide high performance, high functionality software and hardware that are characterized by these key words, but also to consider the usability of the total system and to find ways to reduce the labor cost of system development. It is also essential for system operations to enhance the learning, judgment, recognition and prediction, that is, functions that automatically comprehend past situations and then deal with future problems.

As Japan’s manufacturing industry continues to globalize, we intend to maintain the world’s leading Monozukuri through cooperation with industry, academia and government.

Performance Improvement Technology of “MELSOFT iQ Works” Integrated FA Engineering Software

Author: Koji Morita*

1. Introduction

In today's manufacturing industries, where products must meet the demand for increasingly greater sophistication and precision, the product life cycles are shorter, the production volume tends to change quickly and more often, and the pressure to reduce product prices remains strong. Under these conditions, the total costs for production facilities must be further reduced, from the development and startup stages to the operation and maintenance of the facilities. With this as the background, Mitsubishi Electric has developed “MELSOFT iQ Works”, an integrated engineering software suite. iQ Works is used in various engineering environments including: system design, programming for iQ Platform compatible products, display screen design, and the start up, operation and maintenance of the facilities. Since iQ Works is often operated on older generation notebook PCs, there is a strong demand for comfortable operability even with a low-end PC. This paper describes the performance improvements of MELSOFT GX Works2 (hereafter referred to as GX

Works2), which is engineering software for a programmable logic controller (PLC) and one of the software packages that constitute iQ Works.

2. Improvement of Online Program Change Function of GX Works2

GX Works2 is PLC engineering software, aiming at the development and debugging of the programs that control the PLC, as well as a reduction in the engineering costs for system operation and maintenance in facilities equipped with PLCs.

When a program is changed, the online program change function allows the user to load the new program without stopping the PLC (in the run state). Because of its convenience, the online program change function is used frequently and we have received a request to reduce the write time of the function.

In response, we have analyzed the processing time of the online program change, and found that the source information accounted for a significant part of the written data. The source information is the data that

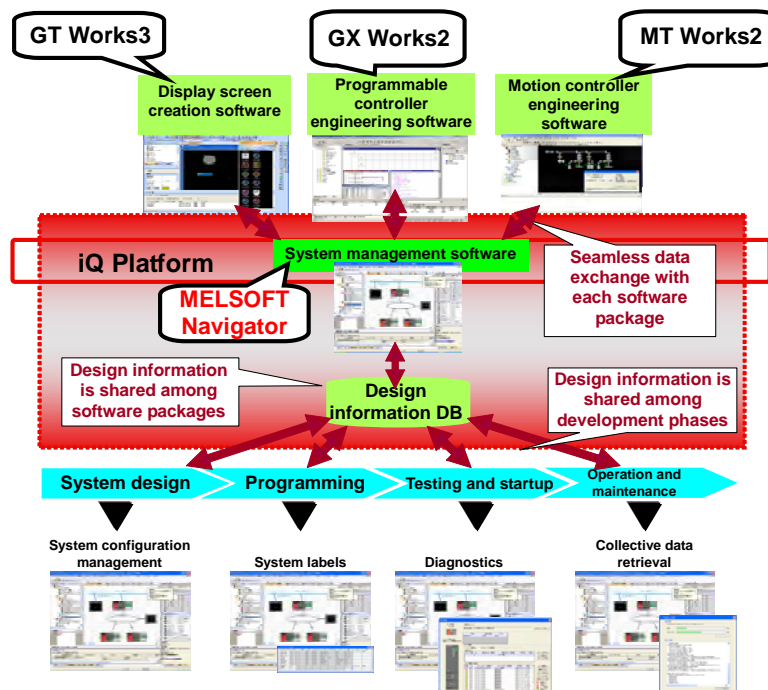

Fig. 1 MELSOFT iQ Works

describes the structures, labels and other components of a program, and is generated as a project together with the relevant program codes. When a program is read out from the PLC, the source information written in the PLC along with the program codes enables reconstruction of the project generated by GX Works2. To reduce the write time of the online program change function, we focused on reducing the amount of source information loaded into the PLC, and worked on achieving the following two objectives:

- i) Reduction in the file size of source information
- ii) Reduction in the amount of source information written to the PLC

(1) Reduction in the file size of source information

GX Works2 compresses the source information and then writes it to the PLC. As a solution for objective i), we have switched to a more efficient file compression scheme in terms of both compression ratio and compression time. For effective use of the PLC memory, GX Works2 compresses the source information before writing it to the PLC. We examined compressed file sizes and compression time for various compression types, and selected one that provided high efficiency for both the compression ratio and compression time. As a result, as shown in Fig. 2, the compressed file size has been reduced by 80% from the previous level without increasing the compression time.

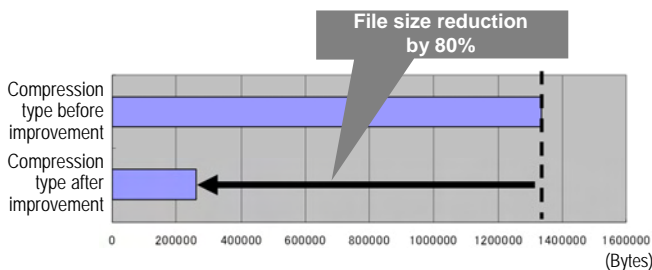

Fig. 2 File sizes before and after the change of compression type

- (2) Reduction in the amount of source information written to the PLC

As a solution for objective ii), we have reviewed and modified the process of writing data to the PLC to

reduce the amount of written data. The source information includes global label data, which describes the mapping information between labels and actual devices. If the label setting is modified, the corresponding devices are also changed and thus the program is modified. In the previous processing of online program changes, both global label data and program codes were always written to the PLC. This process has been modified as shown in Fig. 3 to reduce the processing time of the online program change, where segments of source information actually written to the PLC are appropriately selected according to the modification made by the user.

By implementing these measures, we have successfully reduced the file size of source information and the amount of source information written to the PLC; thus, the total processing time, from the start to the completion of the online program change by GX Works2, has been reduced by 50–70% from the level before the performance improvements. In addition, since the amount of data written to the PLC has been reduced, more effective use can be made of the PLC memory.

3. Conclusion

This paper has presented the technologies for improving the performance of iQ Works, the iQ Platform compatible integrated FA engineering software. Since iQ Works was first launched, it has been helping users reduce the total cost of ownership (TCO) for system development by providing various operability improvements and other functionality for reducing man hours. Additional performance improvements make it more convenient for users to apply the abundant software functions, thus providing a more comfortable engineering environment.

In the future, it is anticipated that larger-scale, more complicated systems will require engineering software to handle increasingly larger amounts of data. By reviewing and improving the data structure and processing scheme to avoid performance deterioration due to an increase in data, we will continue to provide users with a comfortable engineering environment.

Operation by the user: Editing the program

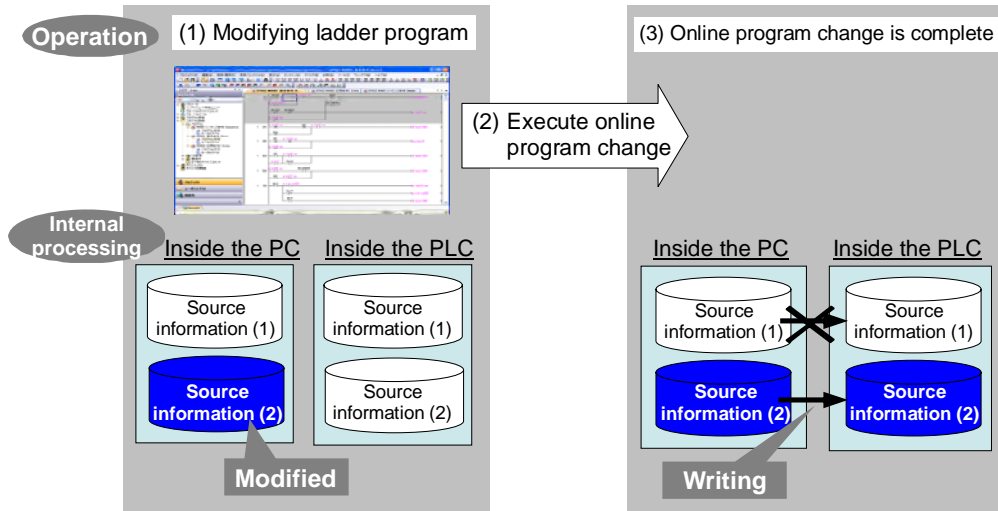

Operation by the user: Editing global labels (no longer used)

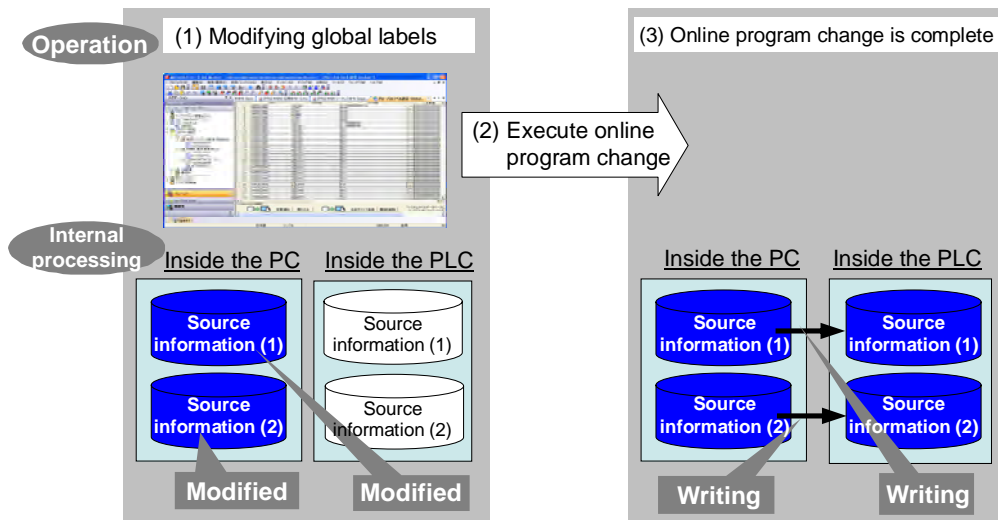

Fig. 3 Conceptual diagram of online program change by file division

Simple Motion Module

LD77MH4/ LD77MH16

Authors: Tomoyuki Furutachi* and Kensuke Nagumo*

1. Introduction

In response to the demand for relatively high performance and additional functions for small system applications, we have developed LD77MH4 and LD77MH16, the MELSEC-L series compatible Simple Motion Modules, which are equipped with an advanced positioning unit having higher performance and functionality. This paper describes the main features as listed below:

- (1) Built-in external input interfaces
- (2) High performance and functionality
- (3) Newly developed engineering environment

2. Built-in External Input Interfaces

To realize sophisticated functions in the target products for small system applications, it is necessary to implement the interfaces for, e.g., mark detection signals and input from incremental and absolute synchronous encoders.

LD77MH has those input interfaces built in either as a direct input or via a servo amplifier. As a result, advanced functions such as synchronous control can be realized without installing any additional modules, thus resulting in a cost advantage.

For the input from an absolute synchronous encoder, an existing interface on the servo amplifier is used. The controller obtains an absolute position from the synchronous encoder via the servo amplifier through the servo system controller network. This method is possible because of the high-speed and high-capacity data transmission of the network.

3. High Performance and Functionality

Table 1 compares the performance and functionality of the LD77MH, the QD75MH positioning module (for small system applications), and the Q17□DCPU motion controller (for large-scale, high-functionality and high-performance system applications).

As for performance, the LD77MH series lineup includes the LD77MH16, which has, in comparison with the conventional QD75MH, four times the number of control axes and a two times faster operation cycle time of 0.8 ms. These features meet the need for performance improvements such as a smaller equipment footprint, lower cost and shorter takt time.

As for functionality, the new Simple Motion Mod-

ules are equipped with synchronous control, electronic cam control, and a mark detection function, which are equivalent to those found on the motion controller. These functions allow the new series to be used for packaging machines and other applications that require synchronous control for multiple axes and compensation using sensors.

Table 1 Performance and functionality comparison of LD77MH, QD75MH and Q17□DCPU

Item	LD77MH	QD75MH	Q17□DCPU
Number of control axes	4/16 axes	1/2/4 axes	8/32 axes
Operation cycle	0.8/1.7ms	1.7ms	0.4/0.8/1.7/3.5ms
Point to point control	○	○	○
Linear and circular interpolation control	○	○	○
Helical interpolation control	x	x	○
Speed and torque control	○	x	△*1
Continuous operation to torque control	○	x	x
Synchronous control (cam control)	○	x	○
OPR control	5 methods	4 methods	11 methods
Mark detection	○	x	○
Optional data monitor	○	x	○
Module error collection	○	x	○

*1: Optional model available

In addition, the LD77MH is equipped with a speed and torque control function, which was previously an optional function with the motion controller, as well as a continuous operation to torque (COT) control function, which was not installed in the motion controller. These functions allow the application of the LD77MH to winding machines and simple servo press machines.

The COT control is a new torque control method, which was developed in collaboration with the Advanced Technology R&D Center of Mitsubishi Electric Corporation. The problem with the conventional torque control method is that immediately after being switched to torque control in the middle of position control operation, the torque control command is disrupted. The COT control solves this problem, as shown in Fig. 1, where the control is smoothly switched from position control to COT control. Since the torque level is not affected when the control method is being switched, no excessive load is exerted on the machine, resulting in an extended service life.

4. Engineering Environment with Simple Motion Modules

To satisfy the market's demand for efficiency, quick start-up and adjustment of the servo system controller, we have developed a Simple Motion Module Setting Tool for the concept of "Easy to use". The tool provides good operability and easy adjustment through the following features:

- (1) An assistant function is provided so that the user can input the settings for the LD77MH just by following the instructions.
- (2) "Specified purpose probes" are installed to provide a wizard that allows the user to manage the settings according to the intended purpose.
- (3) A "positioning data setting assistant" function enables collective setup of the axes to be interpolated, relevant data, etc.
- (4) Monitor functions are renewed to improve operability and legibility.
- (5) Setting of electronic gears is simplified by automatically calculating relevant parameters from their given mechanical specifications.

- (6) To simplify the operation of synchronous control, a graphical user interface is installed. By clicking the screen image that represents the synchronous control drive system, setting of relevant parameters can be intuitively performed (Refer to Fig. 2).
- (7) A cam curve chart and parameters, which perform the actions of a given command, are displayed on the same screen. This layout has improved the previous cam data setting by providing greater operability, legibility, and thus usability (Refer to Fig. 2).

5. Conclusion

In response to the demand from the small-scale, high-performance systems sector, we have developed LD77MH4/LD77MH16 and their engineering tools, which provide additional advanced control functions such as synchronous control, cam control, and speed/torque control. We will continue to release timely servo system controller products that best match the market needs, striving to expand the respective application fields.

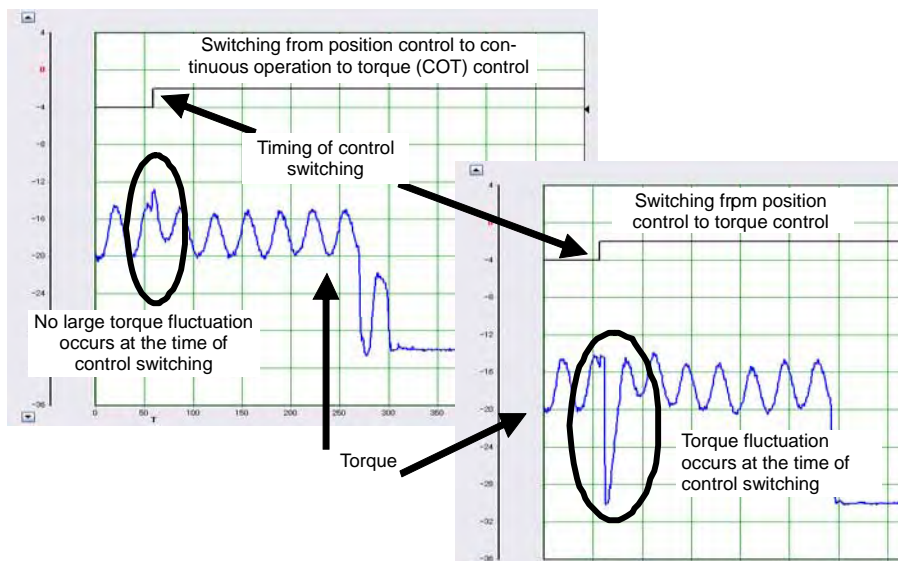

Fig. 1 Torque waveform when control method is switched

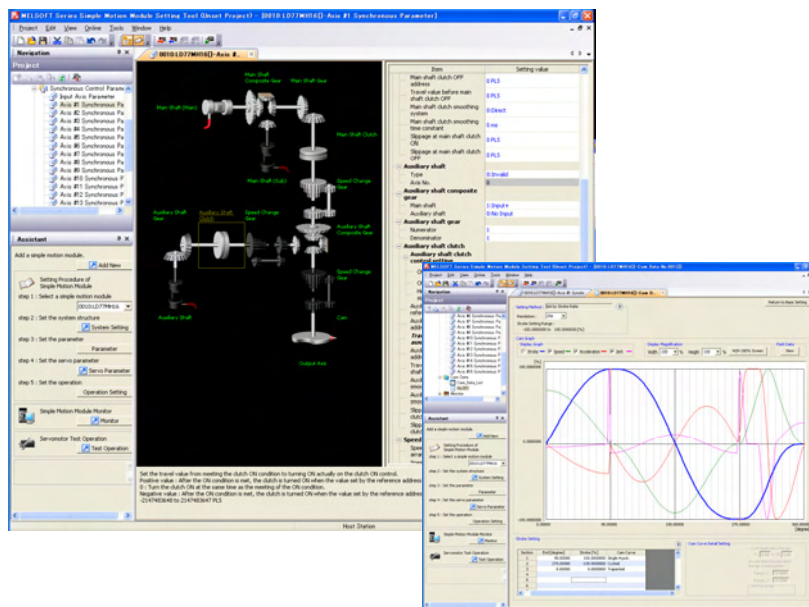

Fig. 2 Setup screen for LD77MH synchronous control

Premium High-Efficiency Motor “MM-EFS” and Energy-Saving Inverter “FR-F700P/ F700PJ”

Authors: Tomokazu Kimura* and Naoki Kojima*

1. Introduction

In response to the need to conserve energy, we have developed and commercialized the MM-EFS series of premium high-efficiency interior permanent magnet (IPM) motors. We have also developed and commercialized the energy-saving FR-F700P and FR-F700PJ inverter series for small fan and pump applications. These series can drive both induction and IPM motors.

The MM-EFS series of premium high-efficiency IPM motors has realized a level of efficiency equivalent to IE4 (super premium efficiency). The FR-F700P/F700PJ series inverter can drive both induction and IPM motors by simply switching the setting.

2. Premium High-Efficiency IPM Motor MM-EFS Series

For the newly developed MM-EFS series, high-performance magnet and iron core materials have been adopted and the magnetic circuit has been optimized. As a result, as shown in Fig. 1, all models have achieved a level of efficiency exceeding IE4.

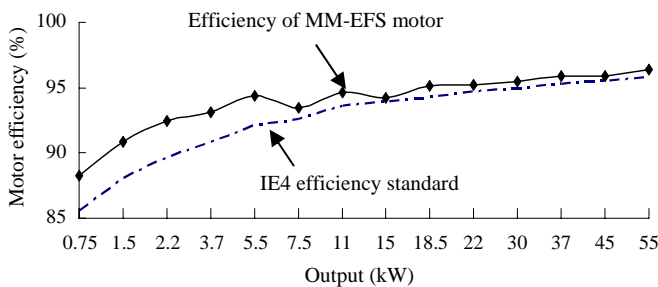

Fig. 1 Motor efficiency at rated operation

2.1 Adoption of high-performance magnet and iron core materials

By adopting a high-performance magnet, which exhibits increased flux density and coercive force (high temperature resistance), both high efficiency and optimum reliability have been achieved.

In addition, the high-performance thin-sheet iron core, which has both low iron loss and high saturation flux density, further increases the efficiency.

2.2 Optimization of magnetic circuit

By utilizing electromagnetic field analysis, the ratio between iron loss and copper loss has been set close to 50:50, which is the ideal value for high efficiency. Also, the distribution of magnetic flux density has been optimized to reduce iron loss and increase the efficiency (Fig. 2).

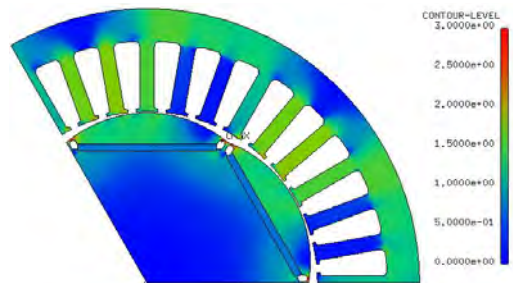

Fig. 2 Electromagnetic field analysis of 3.7 kW IPM motor

2.3 Results of efficiency improvements (comparison with conventional model)

Figure 3 compares the loss generated by MM-EF and MM-EFS IPM motors. Compared to MM-EF, the overall loss of MM-EFS is reduced by 43%, of which copper loss and iron loss are reduced by approximately 50% and 20%, respectively.

Figure 4 compares the overall efficiency when operated using an FR-F700P series inverter with a square reduced-torque load. At a rotation speed between 1000 and 1800 r/min, the range in which most fans and

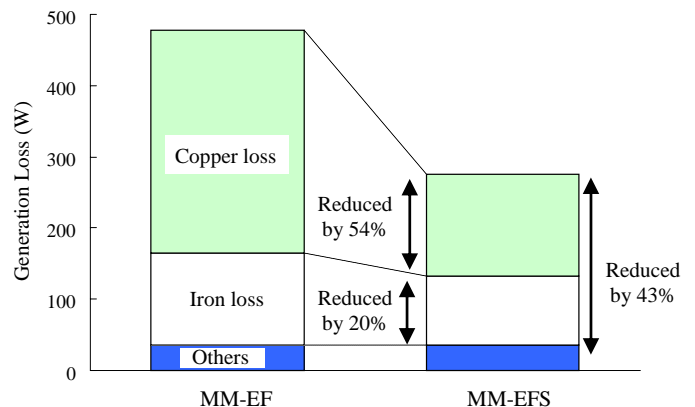

Fig. 3 Comparison of loss generated by 3.7 kW IPM motors

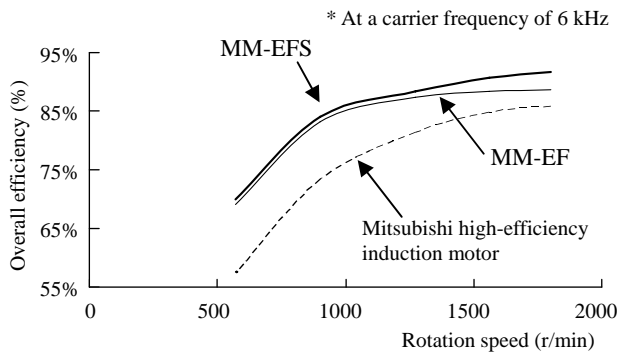

Fig.4 Comparison of overall efficiency of 3.7 kW IPM motors

pumps are operated, the motor efficiency of MM-EFS is improved by about 6% from Mitsubishi's high-efficiency motor and by 1–3% from the MM-EF level.

3. Energy-Saving Inverter FR-F700P/F700PJ

3.1 Dual driving capability for general-purpose motor and IPM motor

To drive a Mitsubishi IPM motor, a special amplifier for the IPM drive was previously required, and thus, when general-purpose and IPM motors were used, it was necessary to maintain a stock of spare units of both general-purpose and IPM drive inverters.

The FR-F700P/F700PJ series inverter can drive both general-purpose and IPM motors by a simple setting change. This eliminates the need to keep spare units of both general-purpose and IPM drive inverters, and spare inverters can be commonly used (Fig. 5).

3.2 IPM parameter initialization function

To drive an IPM motor, various parameters need to be adjusted, because the frequency rating is either 90 Hz (6 poles) or 120 Hz (8 poles), not 60 Hz (4 poles) assumed for a general-purpose inverter.

To reduce the setup time and lower the risk of making a mistake in the setting, an IPM parameter initialization function is installed in the FR-F700P/F700PJ series. This function is easy to use and can automatically and collectively set up about 30 parameters according to the motor specifications to be used.

4. Conclusion

This paper has described the MM-EFS series of premium high-efficiency IPM motors, and the FR-F700P/F700PJ series of energy-saving inverters. As a result of the increasing demand for saving energy, the market of IPM motors and inverters is expected to expand in the future. We will continue to work on innovative technological development to contribute to this market growth.

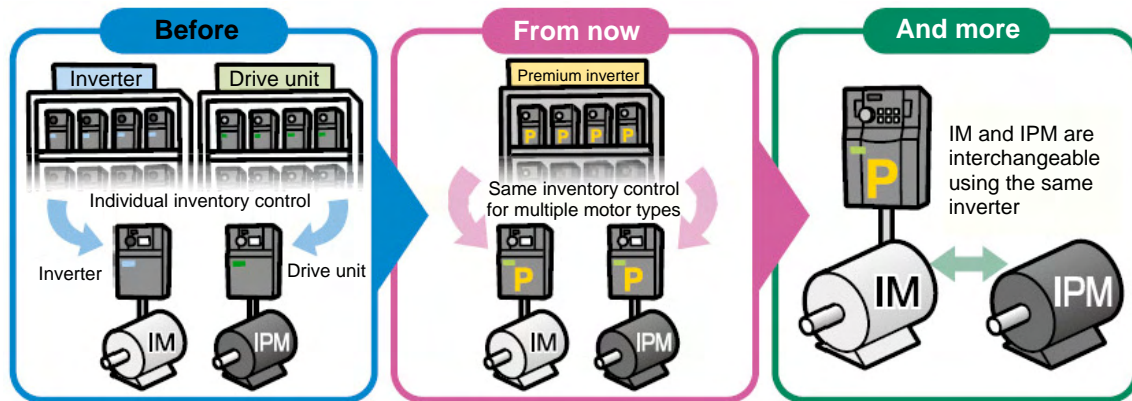

Fig. 5 Renewal types

Easy-to-Use Functions for Inclined Surface Machining in the “MITSUBISHI CNC M700V Series”

Author: Naoki Nakamura*

1. Introduction

An increasing number and variety of machine tools are now equipped with a rotary axis, which enables the machining of a complex shaped workpiece without changing the work setup. A typical example can be seen with index machining, where the rotary axis is pre-rotated to change the posture of a tool with respect to the workpiece, and then simultaneous 3-axis machining is performed along three orthogonal axes. Index machining requires index-specific operability for defining an inclined coordinate system along the machining surface, indexing the machining surface and other operations that are not performed by ordinary 3-axis machine tools.

In response, we have developed the “R-Navi” function for machine tools with a rotary axis, which require complicated operations, to improve the usability of index machining, and we installed it in the MITSUBISHI CNC M700V series (Fig. 1).

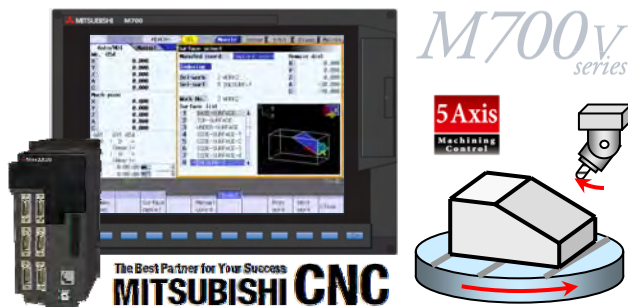

Fig. 1 MITSUBISHI CNC M700V Series

2. Index Machining

Figure 2 shows the general processes of index machining such as the machining of an inclined surface and multiple-surface machining. To improve the usability of index machining, the following two points are essential:

- (1) Definition of coordinate system: From the drawing, an inclined coordinate system can be easily defined and verified on site.
- (2) Indexing of machining surface: The coordinate system is linked to the rotary axis, and indexing can

be performed either by automatic or manual operation.

In addition to the improvement of each process step, smooth operation in series from the work setup to machining is also important.

3. “R-Navi” Improves the Usability of Index Machining

3.1 Easy definition and verification of inclined coordinate system

For defining the coordinate system, the R-Navi design concept is “Easy to define as seen on the drawing”. R-Navi provides five methods for defining the coordinate system, namely by specifying: single point, two points, longitude/latitude, longitude/projection angle, or indexing angle, from which a coordinate system is independently selectable for each axis depending on the information from the drawing (Fig. 3 (1)). In addition, the selected coordinate system can be displayed in 3D on the screen and thus can be verified for accuracy on site (Fig. 3 (2)).

3.2 Selection and indexing of machining surface

At the stage of “selection of machining surface”, by manipulating the display screen, the operator selects the coordinate system corresponding to the machining surface from those registered at the “definition of coordinate system” stage. The 3D display of the coordinate system on the screen helps to select the right machining surface without any mistakes (Fig. 4 (1)). The registered coordinate systems can also be read out from the machining program.

During the “indexing of machining surface”, where the rotary axis is rotated to set the cutting tool to be perpendicular to the selected machining surface, the rotary axis can be rotated either by manual or automatic operation and the coordinate system for which a machining surface is being indexed moves together with the rotation of the rotary axis, thus eliminating the need to redefine the coordinate system after indexing is completed (Fig. 4 (2)). Once the indexing of the machining surface is completed, machining is performed,

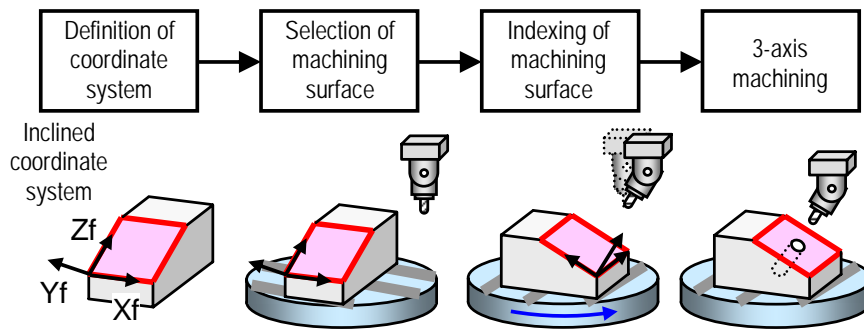

Fig. 2 Index machining process

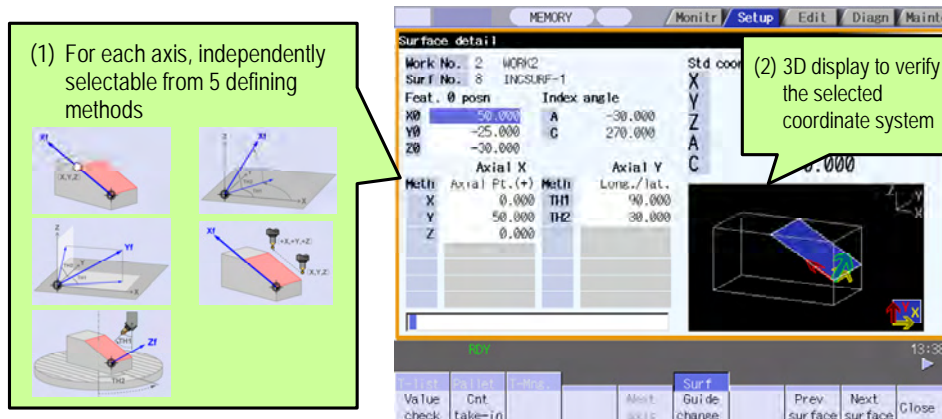

Fig. 3 Easy definition and verification of inclined coordinate system

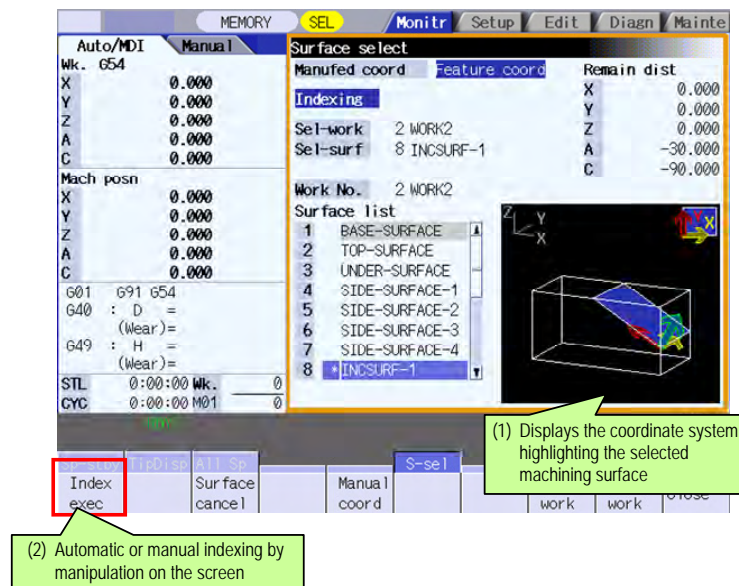

Fig. 4 Selection and indexing of machining surface

either manually or automatically, along the coordinated system that is in line with the machining surface, and thus programs for 3-axis machining can be used without any modification.

3.3 Comparison with inclined surface machining command

Table 1 shows the differences in operability between R-Navi and the inclined surface machining command (ISMC). The ISMC has long been installed as

an indexing machining function. While R-Navi follows the operability of ISMC, it is equipped with additional functions to improve the ease of use.

which provides innovative operability to allow secure, simple and smooth operation of index machining. We will continue to improve the ease of use and develop products for higher precision machining and greater productivity.

4. Conclusion

We have developed the new function "R-Navi",

Table 1 Comparison between R-Navi and inclined surface machining command

		Inclined surface machining command		R-Navi
Definition of coordinate system	Defining method	Machining program	/	Manipulation on the screen
	Definition other than by angle	Yes	=	Yes
	Individual defining method for each axis	No	<	Yes
	Verification of the direction of defined coordinate axis	Verify by operating the machine	<	Verify on site when defined
	Dependence on the workpiece position	No	=	No
Selection of machining surface	Selection method	Selection at the time of definition	/	Selection from registered surfaces
	Selection by machining program	Yes	=	Yes
	Selection on the screen	No	<	Yes
Indexing of machining surface	Indexing method	Automatic only	<	Automatic and manual
	Linkage between coordinate system and rotary axis	Linked	=	Linked
3-axis machining	Operation on an inclined coordinate system	Possible	=	Possible

CC-Link IE Field Safety Communication Technology

Author: Shunsuke Igarashi*

1. Introduction

The CC-Link IE Field Network developed for the MELSEC-QS series is now equipped with a safety communication function. The CC-Link IE Field Network with safety communication function (hereafter referred to as CC-Link IE Field Network with safety communication) follows all superior features of the CC-Link IE Field Network and complies with the relevant safety standards. While each manufacturing process was previously equipped with an independent safety programmable controller, the CC-Link IE Field Network with safety communication connects multiple safety programmable controllers to realize a safety control function across the manufacturing processes.

To realize the safety communication function for the CC-Link IE Field Network, a safety layer has been implemented in the protocol layer of the CC-Link IE Field Network, and functions required for the safety communication have been added. Also, the CC-Link IE Field Network with safety communication allows the coexistence of stations for either standard or safety communications, and thus both safety and standard

communications can be provided on the same network.

2. Specifications and Functionality

The CC-Link IE Field Network with safety communication is capable of high-speed and real-time communications conforming to IEEE 802.3ab (1000BASE-T), and is applicable to various network topologies. In addition to the functions relevant to safety communication, it follows the superior features of the CC-Link IE Field Network. In each network, up to 32 safety communication stations can be connected (specification of the MELSEC-QS series), and up to 8 words of I/O data can be assigned to each safety connection. The CC-Link IE Field Network with safety communication also conforms to the IEC 61508 and IEC 61784-3 safety standards.

Additional functions implemented in the safety communication station are as follows.

(1) Error logging function

When an anomaly occurs during safety communication or an abnormal condition shuts down

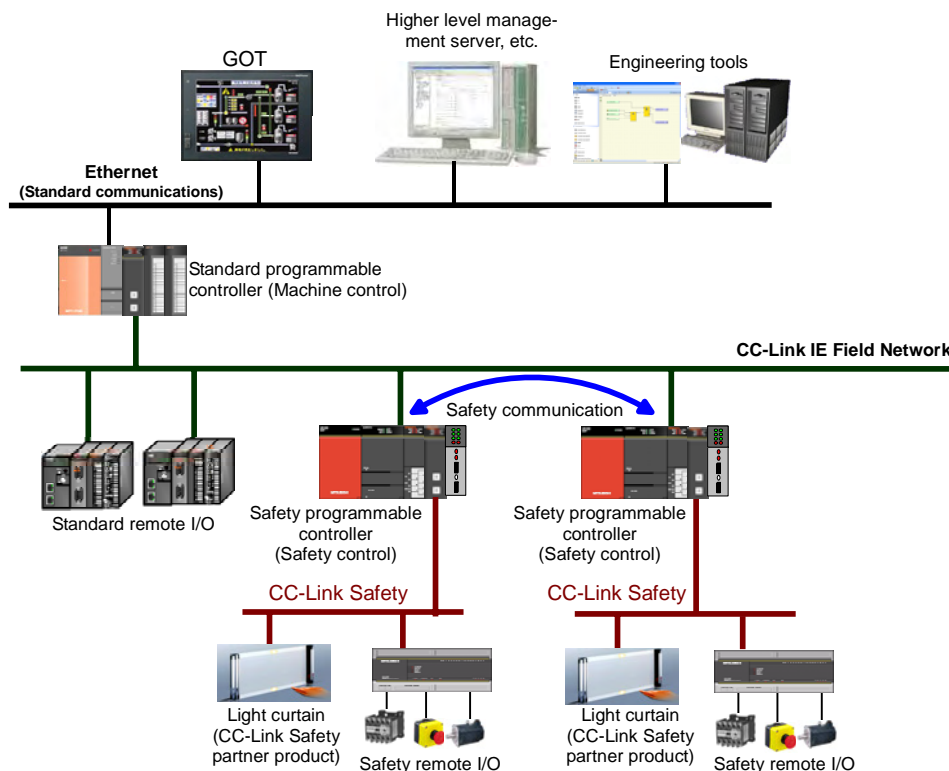

Fig. 1 System configuration

any I/O at a safety communication station, error information is registered as an error log in the safety CPU module. In the case of a safety communication problem in the system, reviewing the registered error logs makes it possible to quickly respond and take corrective measures for restoration.

(2) Safety communication interlock function

The safety communication interlock function is implemented to stop and restart safety communications. While the safety system is interrupted and in safe mode due to, e.g., communication trouble, if the output is automatically re-activated without an alert immediately after the cause of the trouble has been removed, a safety problem may result. The safety communication interlock function solves this problem and removes any risks when the system is restarted.

3. Technologies for Safety Communication

The following technologies have been adopted to implement safety communication in conformance to the safety standards.

(1) Safety communication layer

The protocol layers are configured with the Ethernet (IEEE 802.3) layer, CC-Link IE Field Network fieldbus application layer (FAL), safety communication layer, and safety-relevant applications. The safety communication layer is responsible for most of the operations relevant to safety communication. The main functions installed in this layer are as follows:

Functions of safety communication layer:

- (a) To establish connections: Start and stop safety communication
- (b) To transmit and receive data: Transmission and reception of safety data

- (c) To manage information: Information about stations, Setup and readout of parameters
- (d) To monitor safety communication: Detection of anomalies in safety communication

(2) Safety connection management

Any station that performs safety communication establishes a 1:1 safety connection with the counterpart safety communication station according to the predetermined parameters. After the safety connection has been established, safety data is periodically communicated between the connected stations. If no data is transmitted or received for a certain time period, or a data anomaly occurs, the safety connection is disconnected and the output information is controlled to the safe side.

(3) Monitoring of safety communication

A time stamp, connection ID, CRC and other data monitoring functions are implemented in the safety communication data to deal with the transmission errors specified in IEC 61784-3.

4. Conclusion

On the manufacturing floor, there is growing demand for seamless communication with unobtrusive network layers plus wire saving and maintainability. In addition, in cases where safety communication is needed, the network system must be dedicated for safety and not be affected by other standard communications. The CC-Link IE Field Network with safety communication function effectively meets these requirements. Focusing on the CC-Link IE, we will expand the application area, enhance the functionality, and improve the usability, striving for product development to maximize users' benefit.

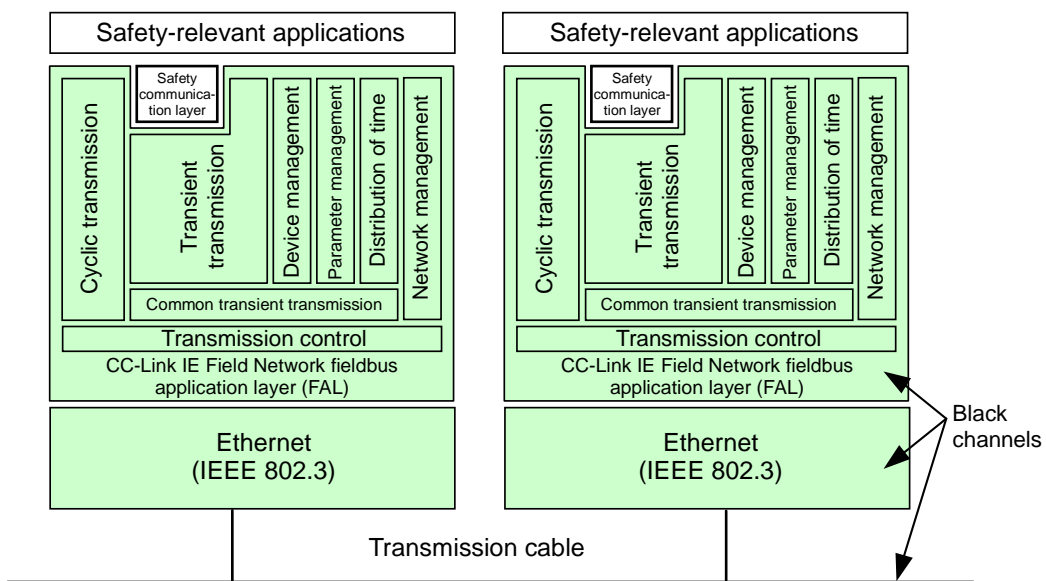

Fig. 2 Protocol layers

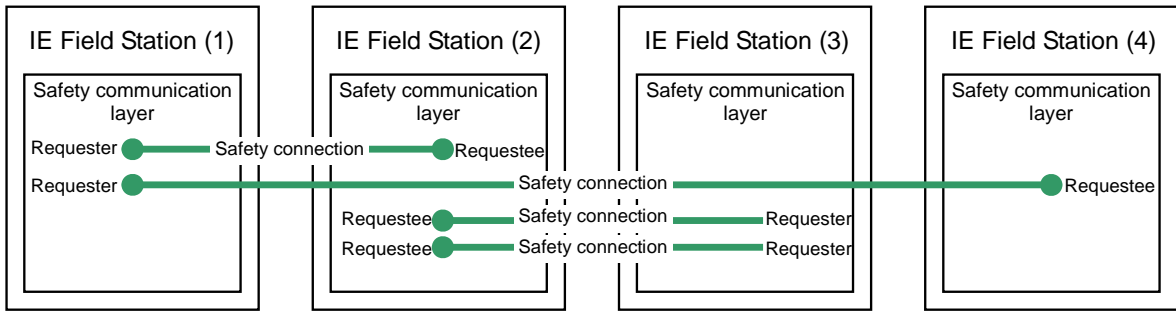

Fig. 3 Schematic diagram of safety communication

The Latest Model of Laser Drilling Machine for Printed Wiring Board “ML605GTW III-5200U” and Processing Application

Authors: Yutaka Motoki* and Kazunobu Katase*

High-end smartphones, the trend-setter in the electronics industry, employ multilayer buildup boards, and laser drilling is an indispensable process for their fabrication. This paper reports on the application of laser processing for the drilling of printed wiring boards (PWBs) not only for blind holes on a buildup board but also for through holes for which laser processing is now being applied.

1. Industry Trend and Problems with Mechanical Drilling Machine

Competition for higher-density wiring and miniaturization of PWBs is intensifying. As a result, laser processing is required to fabricate increasingly smaller holes. This trend is now seen in the fabrication of through holes on the core board.

For the conventional fabrication of through holes on the core board, mechanical drilling machines have been the mainstay. However, since the mechanical drilling machine makes the through hole by contact processing, i.e., by rotating the drill bit at a high speed, the limited service life inevitably gives rise to such problems as the thin drill bit being easily broken, espe-

cially in the case of a small hole diameter. In addition, while the mechanical machine drills a hole through a stack of boards at a time to increase productivity, the stack number, i.e., the number of stacked boards, must be reduced when drilling a small diameter hole due to the high risk of drill breakage. The stack number directly affects the productivity of the mechanical drilling machine, and the productivity lowers as the diameter of drilled hole becomes smaller. Figure 1 shows the results of investigating the productivity and stack number vs. the drill diameter. Consequently, the PWB industry urgently needs to improve productivity for the fabrication of small-diameter through holes on the core board.

2. ML605GTW III-5200U and Copper Layer Penetration

When a through hole is drilled on a core board, the copper surface layer must be penetrated. This process is called copper foil penetration. The laser oscillator mounted on the ML605GTW III-5200U, Mitsubishi Electric's laser drilling machine, has an outstanding feature in that high-peak/short-pulse oscillation can be repeated at a high frequency. This feature provides various advantages for the processing operation, especially for the copper foil penetration because of the following reasons.

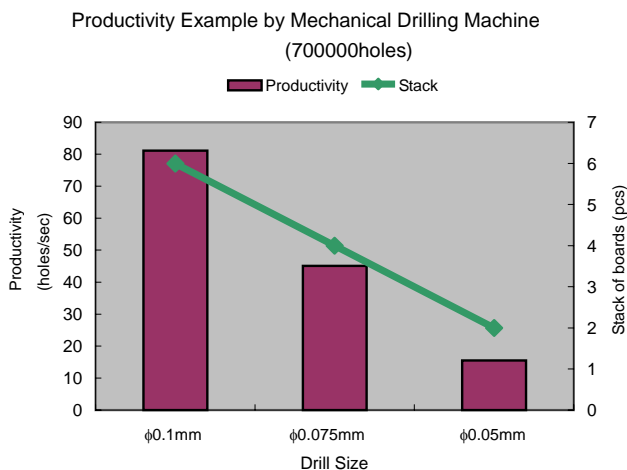

Fig. 1 Reduction in productivity of mechanical drilling machine when drilling small holes



Fig. 2 Laser drilling machine for printed wiring boards: ML605GTW III-5200U

Generally, copper is a highly reflective (greater than 90%) material for the CO₂ laser. Therefore, the copper is treated to remove the glossy outer surface and thus increase the absorption rate. That is, improvement of the absorption rate is essential for the copper foil penetration processing. Figure 3 shows the temperature distribution of the copper foil in the thickness direction when the surface is irradiated by the high-peak/short-pulse laser beam or other company's low-peak/long-pulse beam, both under the same energy conditions. It was observed that the temperature at the copper surface irradiated by the high-peak/short-pulse laser was more than two times higher than in the other case. Generally, as the temperature of metal material increases, the laser absorption rate tends to be higher. The laser beam with Mitsubishi Electric's characteristic high peak and short pulse effectively raises the copper surface temperature, increases the laser absorption rate, and thus brings about stable processing of copper foils. This is why Mitsubishi Electric's laser drilling machine provides superior performance for copper foil penetration processing.

For the through hole fabrication of the core board,

this superior performance of copper foil penetration provides various advantages including: (1) no-contact processing without wear, (2) relatively easier transition to small hole diameter, and (3) no plating penetration into the wall of the drilled hole.

As a result, the number of application cases has been increasing, and Fig. 4 shows some examples of the through hole laser processing of $\phi 0.1$ mm holes through a 0.4 mm thick board.

3. Comparison of Productivity

Figure 5 shows the productivity of laser processing in comparison with mechanical drilling, indicating that the laser processing is two times faster (higher productivity) for $\phi 0.1$ mm and as much as four times faster for $\phi 0.075$ mm through hole fabrication.

4. Conclusion

We will strive to promote laser processing as the standard method for the fabrication of small through holes, which will help to reduce the production cost for printed wiring boards, and we will also enhance its performance for the benefit of the PWB industry.

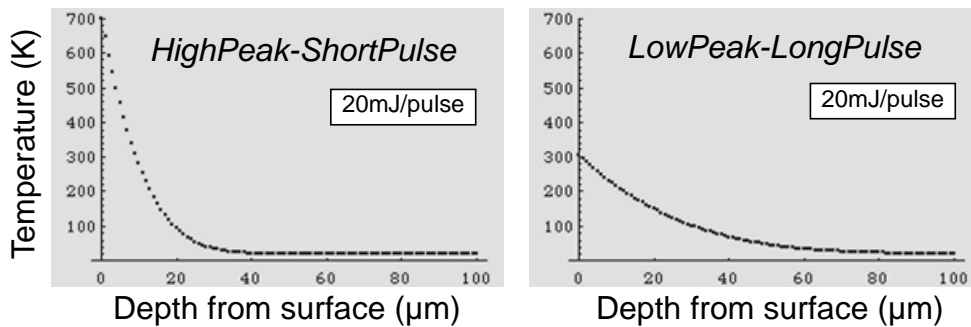

Fig. 3 Temperature profile of copper foil when irradiated by laser beam

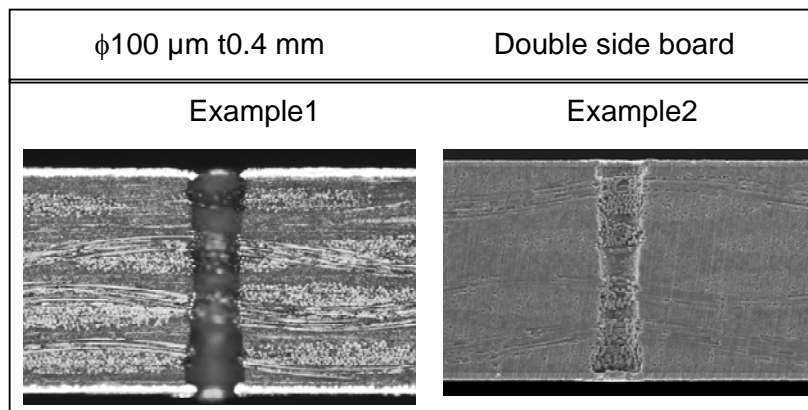

Fig. 4 Examples of through hole laser processing

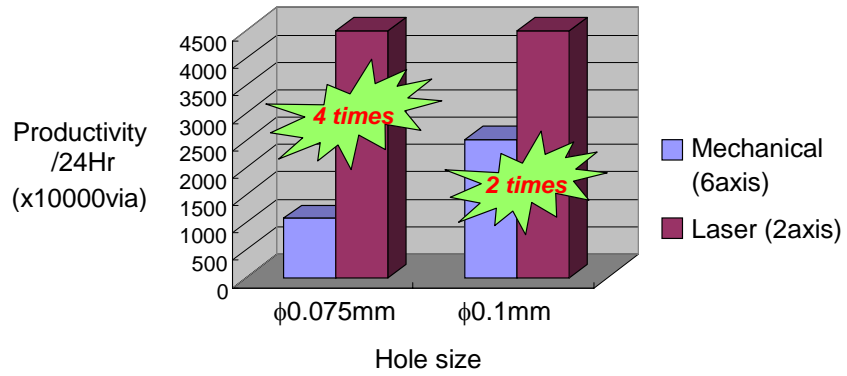

Fig. 5 Productivity comparison between laser drilling and mechanical drilling

Energy Measuring Unit for MELSEC-Q Series

Author: Masayoshi Shimoe*

When the Kyoto Protocol came into effect in February 2005, each country was required to set a target for the reduction of greenhouse gases from the 1990 level and achieve the target during the period of 2008–2012. As a result, manufacturing industries are also required to strengthen energy-saving efforts on the production floor. To improve energy efficiency and promote environmental friendliness in the manufacturing industries, Mitsubishi Electric has proposed “e&eco-F@ctory” for simultaneously improving productivity and reducing cost by conducting detailed energy-saving management for each production facility. This paper presents the “Energy measuring unit for MELSEC-Q series”, an electric power measurement module mountable in the programmable controller, which is the key component embodying the concept of “e&eco-F@ctory”.

1. Product Concepts of Energy Measuring Unit

Figure 1 shows the external appearance of the energy measuring unit for the MELSEC-Q series and an example of the system configuration. Our product concepts for the energy measuring unit are: (1) realizing space-saving, wire-saving and easy-to-use energy measurement, (2) easily managing specific consumption of energy (one of the energy productivity

measures expressed as the “amount of energy consumption divided by production quantity”) based on the production information from the programmable controller CPU unit and the energy information from the energy measuring unit, and (3) easily building a data logging and visualization system of electric energy by combining graphical operation terminals (GOTs) and high-speed data logger units (QD81DL96).

2. EMC Measures for External Input Signals

The power measuring unit must receive input signals from the voltage and current across a given load in order to measure the electric power. If an AC 220V input is directly connected to the unit, a malfunction may result from the noise, and/or other units may be affected due to incorrect wiring or a failure.

Development has been conducted based on the following design concepts:

(1) Any failure that occurs in this unit originating from an external input terminal (noise, connection error, etc.) would not propagate to other units, and (2) noise or other disturbance from an external input terminal would not cause a malfunction in this or any other unit.

To realize these design concepts, the unit has been configured so that the measuring circuit to which

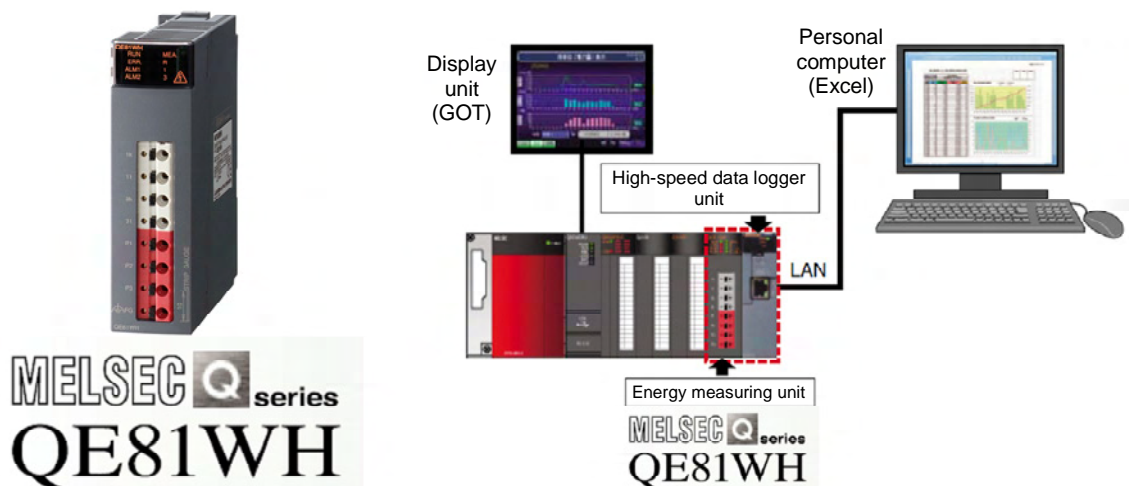

Fig. 1 Energy measuring unit for MELSEC-Q Series, example of system configuration

an AC 220V input is provided is electrically insulated from the digital circuit that performs data exchange with the CPU unit. Figure 2 shows the circuit configuration of this energy measuring unit.

In addition to the above, the following measures for electromagnetic compatibility (EMC) have been implemented:

- (1) A discharge pattern is added to the circuit board pattern of the voltage input part (lightning impulse protection),
- (2) a high-frequency filter for noise protection is added to the current input part (burst noise protection) and
- (3) a guard pattern (GND pattern) is added to the circuit board patterns of the outer edge of the circuit board and the area along the juncture line of the enclosure (electrostatic noise protection).

EMC tests were performed in conformance with EN 61326 and 61131-2 (CE marking certification). The test results are shown in Table 1. In addition, a

simulator noise test and lightning surge voltage test were performed on the external input terminals, and the results confirmed that no failures occurred in the measuring unit and no other units were affected.

3. Measurements Synchronized with the Control Timing of Production Facilities

This unit measures the amount of electricity consumed in the production facilities, and thus a "term power consumption measurement function" has been implemented to measure the power consumption in synchronization with the control timing of the production facilities. Figure 3 shows an example of using this function.

In addition to the total power consumption of the whole production line, this function makes it easy to measure the power consumption of a certain process or each production device in the line, as well as during

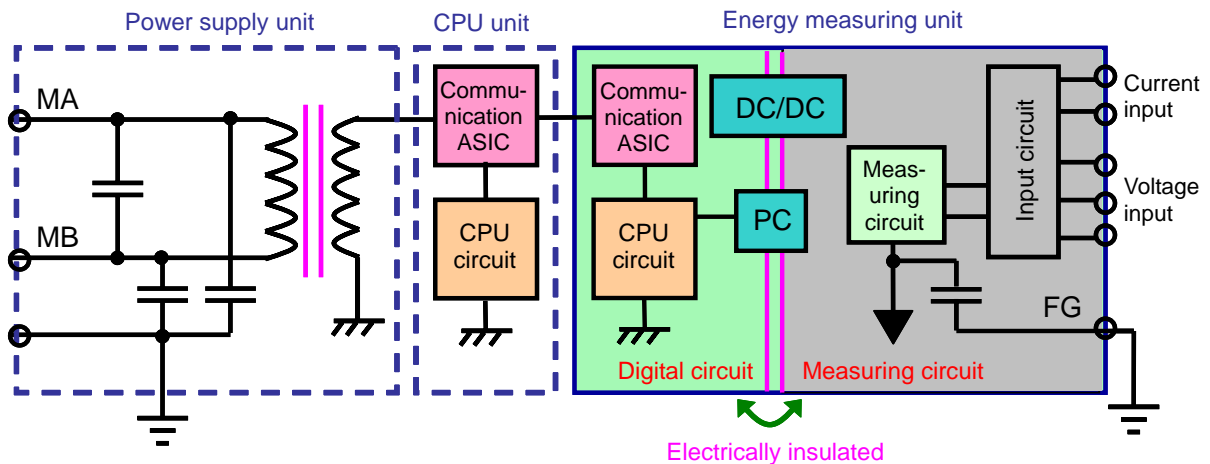

Fig. 2 Circuit configuration of energy measuring unit

Table 1 Results of EMC testing

Test Item	Standard	Subject Area	Test Conditions	Result
Radiated electric field emission	EN61326 EN61131-2	ENCLOSURE	30-1000MHz	Pass
Electrostatic discharge immunity	EN61000-4-2	ENCLOSURE	±2, 4kV	Pass
			±2, 4, 8kV	Pass
Radiated electromagnetic field immunity	EN61000-4-3	ENCLOSURE	80MHz-1GHz 10V/m, 80%AM	Pass
			1.4GHz-2GHz 3V/m, 80%AM	Pass
			2GHz-2.7GHz 1V/m, 80%AM	Pass
EFT/ burst	EN61000-4-4	I/O	±2kV	Pass
Conducted immunity	EN61000-4-6	I/O	0.15MHz-80MHz 10V, 80%AM	Pass
Power frequency magnetic field immunity	EN61000-4-8	ENCLOSURE	30-1000MHz	Pass

production time and non-production time. These detailed measurements help save energy.

4. Improvement of Engineering Environment

As a tool for the visualization of electric energy data measured by this unit, the following sample files are downloadable from Mitsubishi Electric's website for control devices (H@ISEIweb): (1) Sample GOT screen data for measurement display, and (2) Sample files for logging electric energy data by using this unit in combination with the MELSEC-Q series high-speed data logger unit, and verifying the data and displaying specific consumption charts, etc., on the PC screen.

Figure 4 is a GOT sample screen, which shows specific consumption charts generated by linking the production quantity data held in a programmable controller and the electric energy data measured by this energy measuring unit.

This paper has presented the new energy measuring unit for the MELSEC-Q series, which realizes detailed management of the specific energy consumption for each production facility. We will continue to enhance the functionality of this unit and expand the product lineup, striving for further penetration of "e&eco-F@ctory" that simultaneously realizes productivity improvement and cost reduction.

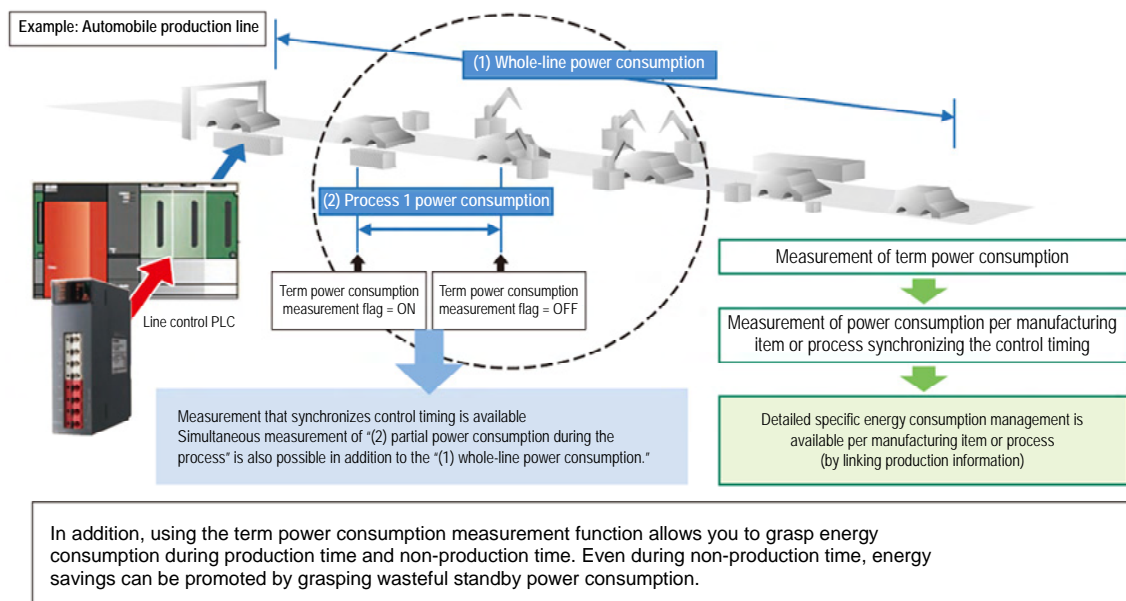

Fig. 3 Usage example of term power consumption measurement function

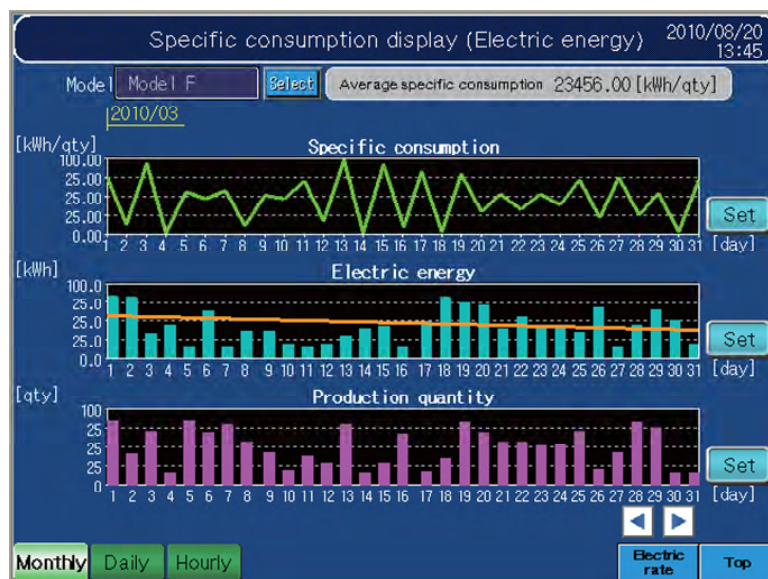

Fig. 4 GOT sample screen data (specific consumption charts)

